

MARKS PUBLISHED FOR OPPOSITION

The following marks are published in compliance with section 12(a) of the Trademark Act of 1946. Applications for the registration of marks in more than one class have been filed as provided in section 30 of said act as amended by Public Law 772, 87th Congress, approved Oct. 9, 1962, 76 Stat. 769. Opposition under section 13 may be filed within thirty days of the date of this publication. See rules 2.101 to 2.105.

A separate fee of three hundred dollars (\$300.00) for opposing each mark in each class must accompany the opposition.

SECTION 1.— INTERNATIONAL CLASSIFICATION

The short titles associated below with the international class numbers are terms designed merely for quick identification and are not an official part of the international classification. The full names of international classes are given in section 6.1 of the trademark rules of practice.

The designation "U.S. Cl." appearing in this section refers to the U.S. class in effect prior to Sep. 1, 1973 rather than the international class which applies to applications filed on or after that date. For adoption of international classification see notice in the OFFICIAL GAZETTE of Jun. 26, 1973 (911 O.G. TM 210).

Application in more than one class

SN 76-708,452. NATIONAL AGRICULTURAL COOPERATIVE FEDERATION, SEOUL 100-707, REPUBLIC OF KOREA, FILED 11-6-2007.



OWNER OF JAPAN REG. NO. 955105, DATED 5-21-2010, EXPIRES 5-21-2020.

NO CLAIM IS MADE TO THE EXCLUSIVE RIGHT TO USE "NONGHYUP", APART FROM THE MARK AS SHOWN.

THE MARK CONSISTS OF A CIRCULAR IMAGE WITH AN ARROW IN BETWEEN A BOW POINTING DOWN INTO THE TOP OF THE IMAGE FOLLOWED BY THE LARGE LETTERS "NH", FOLLOWED BY THE WORD "NONGHYUP" IN SMALLER FONT SIZE LETTERS.

THE ENGLISH TRANSLATION OF THE WORD "NONGHYUP" IN THE MARK IS "AGRICULTURAL FEDERATION".

CLASS 29—MEATS AND PROCESSED FOODS

FOR ALBUMEN FOR FOOD; ALGINATES FOR FOOD; GROUND ALMONDS; PROCESSED ANCHOVIES; ANIMAL MARROW FOR FOOD; APPLE PUREE; BACON; PRESERVED BEANS; EDIBLE BONE OIL; BOUILLON; PREPARATIONS FOR MAKING BOUILLON; BOUILLON CONCENTRATES; BROTH; BROTH CONCENTRATES; BUTTER; COCOA BUTTER FOR FOOD PURPOSES; COCONUT BUTTER; PEANUT BUTTER; BUTTER-CREAM; CASEIN FOR FOOD; CAVIAR; CHARCUTERIE; CHEESE; FRUIT CHIPS; POTATO CHIPS; CHOCOLATE NUT BUTTER; CLAMS, NOT LIVE; COCONUT FAT; COCONUT OIL; DESICCATED COCONUT; COLZA OIL FOR FOOD; CORN OIL; CRANBERRY SAUCE COMPOTE; CRAYFISH, NOT LIVE; FISH CROQUETTES; CRUSTACEANS, NOT LIVE; CRYSTALLIZED FRUITS; CURD; PROCESSED DATES; EDIBLE BIRD'S NESTS; EDIBLE FATS; EDIBLE OILS; POWDERED EGGS; SNAIL EGGS FOR CONSUMPTION; EGGS; FAT-CONTAINING MIXTURES FOR BREAD SLICES; FATTY SUBSTANCES FOR THE MANUFACTURE OF EDIBLE FATS; FERMENTED VEGETABLE FOODS (KIMCHI); SALTED FISH; FOOD PRODUCTS MADE FROM FISH, NAMELY, PROCESSED FISH ROE; FISH FILLETS; FISH, NOT LIVE; PRESERVED FISH; POTATO FLAKES;

CANNED FISH; FISHMEAL FOR HUMAN CONSUMPTION; FOODS PREPARED FROM FISH, NAMELY, FISH CAKES; FROSTED FRUITS; FROZEN FRUITS; FRUIT JELLIES FOR FOOD; FRUIT PEEL; FRUIT PULP; FRUIT PRESERVED IN ALCOHOL; FRUIT SALADS; PRESERVED FRUIT; STEWED FRUIT; FRUIT-BASED SNACK FOOD; GAME, NOT LIVE; CANNED FRUITS; UNFLAVORED, UNSWEETENED GELATIN FOR FOOD; GHERKINS; GINGER JAM; HAM; HERRINGS; HUMMUS CHICKPEA PASTE; ISINGLASS FOR FOOD; JAMS; VEGETABLE JUICES FOR COOKING; KEFIR MILK BEVERAGE; KUMIS MILK BEVERAGE; LARD FOR FOOD; WHIPPED CREAM; CREAM; TOASTED LAVER; PRESERVED LENTILS; LIVER; LIVER PATE; SPINY LOBSTERS, NOT LIVE; MAIZE OIL; MARGARINE; MARMALADE; MEAT; MEAT EXTRACTS; MEAT JELLIES; CANNED MEAT; SALTED MEAT; MILK; MILK BEVERAGES WITH HIGH MILK CONTENT; MILK PRODUCTS, NAMELY, POWDERED MILK; PRESERVED MUSHROOMS; MUSSELS, NOT LIVE; PREPARED NUTS; OLIVE OIL FOR FOOD; PRESERVED OLIVES; PRESERVED MEAT; PRESERVED ONIONS; OYSTERS, NOT LIVE; PALM OIL FOR FOOD; PALM KERNEL OIL FOR FOOD; LIVER PASTES; PROCESSED PEANUTS; PRESERVED PEAS; FRUIT PECTIN FOR FOOD; PICCALILLI; PICKLES; PREPARED BEE POLLEN AS FOODSTUFF; PORK; POTATO FRITTERS; POULTRY, NOT LIVE; PRAWNS, NOT LIVE; PROTEIN BEING FOODSTUFFS FOR HUMAN CONSUMPTION; BLACK PUDDING; BLOOD SAUSAGE; RAISINS; RAPE OIL FOR FOOD; RENNET; VEGETABLE SALADS; SALMON; SALTED MEATS; SARDINES; SAUERKRAUT; SAUSAGES; SAUSAGES IN BATTER; SEA-CUCUMBERS, NOT LIVE; SESAME OIL; SHELLFISH, NOT LIVE; SHRIMPS, NOT LIVE; SILKWORM CHRYSALIS FOR HUMAN CONSUMPTION; SNAIL EGGS FOR CONSUMPTION; VEGETABLE SOUP PREPARATIONS; PRESERVED SOYA BEANS FOR FOOD; SUET FOR FOOD; SOYA MILK AS A MILK SUBSTITUTE; SUNFLOWER OIL FOR FOOD; TAHINI SESAME SEED PASTE; TOFU; TOMATO JUICE FOR COOKING PURPOSES; TOMATO PUREE; TRIPE; PRESERVED TRUFFLES; TUNA FISH; COOKED VEGETABLES; DRIED VEGETABLES; PRESERVED VEGETABLES; CANNED VEGETABLES; WHEY; EGG WHITES; YOGURT; EGG YOLKS (U.S. CL. 46).

CLASS 30—STAPLE FOODS

FOR CONDIMENTS, NAMELY, PEPPER SAUCE; RIBBON VERMICELLI; RICE; RICE CAKES; RICE-BASED SNACK FOOD; RUSKS; SAFFRON FOR USE AS SEASONING; SAGO; SALAD DRESSINGS; COOKING SALT; SALT FOR PRESERVING FOODSTUFFS; SANDWICHES; TOMATO SAUCE; SAUCES; SEA WATER FOR COOKING; PROCESSED SEMOLINA; SHERBETS AS ICES; CEREAL-BASED SNACK FOOD; SORBETS AS ICES; SOYA FLOUR; SOYA SAUCE; SPAGHETTI; SPICES; SPRING ROLLS; STAR ANISEED FOR SPICES; STARCH FOR FOOD; STICK LICORICE; SUGAR; SUSHI; NATURAL SWEETENERS; SWEETMEATS; PEPPERMINT CANDY; TABBOULEH; TACOS; TAPIOCA; TARTS; FLOUR FOR FOOD; TEA; ICED TEA; TEA-BASED BEVERAGES; TORTILLAS; THICKENING AGENTS FOR COOKING FOODSTUFFS; EDIBLE TURMERIC; UNLEAVENED BREAD; VANILLA FLAVORING; VANILLIN FOR USE AS A VANILLA SUBSTITUTE; VEGETAL PREPARATIONS FOR USE AS COFFEE SUBSTITUTES; VERMICELLI NOODLES; VINEGAR; WAFFLES; WHEAT FLOUR; PREPARATIONS FOR STIFFENING WHIPPED CREAM; YEAST; YEAST IN PILL FORM NOT FOR MEDICAL USE; FROZEN YOGURT AS CONFECTIONERY ICES; ALLSPICE; ALMOND CANDY; ALMOND PASTE; ANISEED AS A SPICE; ARTIFICIAL COFFEE; BAKING POWDER; CRUSHED BARLEY; HUSKED BARLEY; BAKING SODA; BARLEY MEAL; BEAN MEAL FOR HUMAN CONSUMPTION; BEER VINEGAR; BEE GLUE PROPOLIS FOR HUMAN CONSUMPTION; CHOCOLATE-BASED BEVERAGES; COCOA-BASED BEVERAGES; COFFEE-BASED BEVERAGES; FLAVORINGS, OTHER THAN ESSENTIAL OILS, FOR BEVERAGES; STARCH-BASED BINDING AGENTS FOR ICE CREAM; BISCUITS; GINGER BREAD; BREAD ROLLS; BREADCRUMBS; BUNS; BREAD; CAKES; RICE CAKES; CAPERS; EDIBLE DECORATION FOR CAKES; CANDY FOR FOOD; FLAVORINGS, OTHER THAN ESSENTIAL OILS, FOR CAKES; CARAMELS AS CANDY; CELERY SALT; CEREAL PREPARATIONS, NAMELY, BREAKFAST CEREALS; CHEWING GUM NOT FOR MEDICAL PURPOSES; CHOCOLATE; CHICORY COFFEE SUBSTITUTE; CEREAL-BASED CHIPS; CHOCOLATE-BASED BEVERAGES WITH MILK; CHOW-CHOW; CHUTNEYS; CONFECTIONERY FOR DECORATING CHRISTMAS TREES; COCOA; CINNAMON; CLOVES; COCOA-BASED BEVERAGES WITH MILK; COFFEE; UNROASTED COFFEE; COFFEE-BASED BEVERAGES WITH MILK; COFFEE FLAVORINGS; CONFECTIONERY, NAMELY, CANDY; COOKIES; POPCORN; CORN FLAKES; CORN FLOUR; ROASTED CORN; COUSCOUS; CRACKERS; ICE CREAM; CUSTARD; EDIBLE ICES; FARINACEOUS FOOD PASTES; FERMENTS FOR FOOD PASTES FOR HUMAN CONSUMPTION; OAT FLAKES; ESSENCES FOR FOODSTUFFS EXCEPT FOR ETHERIC ESSENCES, NAMELY, COFFEE ESSENCES; FOOD FLAVORINGS OTHER THAN ESSENTIAL OILS; FLAVORINGS OTHER THAN ESSENTIAL OILS FOR BEVERAGES; FLOUR FOR FOOD; FONDANTS; FRUIT JELLIES AS CONFECTIONERY; PRESERVED GARDEN HERBS AS SEASONINGS; GINGER AS A SPICE; GINGERBREAD; GLUCOSE FOR FOOD; GLUTEN FOR FOOD; GOLDEN SYRUP FOR FOOD MADE OF STARCH; MEAT GRAVIES; GROATS FOR HUMAN FOOD; CEREAL-BASED GRUEL WITH A MILK BASE FOR FOOD; LICORICE CONFECTIONERY; HALVAH; HOMINY; HOMINY GRITS; HONEY; HUSKED OATS; BINDING AGENTS FOR ICE CREAM; ICE FOR REFRESHMENT; ICE; STARCH-BASED BINDING AGENTS FOR EDIBLE ICES; POWDER FOR EDIBLE ICES; HERBAL INFUSIONS NOT MEDICAL; KETCHUP; ROYAL JELLY FOR HUMAN CONSUMPTION NOT FOR MEDICAL PURPOSES; NON-MEDICATED LOZENGES AS CONFECTIONERY; MACARONI; MACAROONS; ROASTED MAIZE; MALT BISCUITS; MALT EXTRACT FOR FOOD; MALT FOR HUMAN CONSUMPTION; MALTOSE FOR HUMAN CONSUMPTION; MARZIPAN; MAYONNAISE; CORN MEAL; MEAT PIES; MINT FOR CONFECTIONERY; MEAT TENDERIZERS FOR HOUSEHOLD PURPOSES; MOLASSES FOR FOOD; MUESLI; MUSTARD; MUSTARD MEAL; NOODLES; NUTMEGS; OAT-BASED FOOD, NAMELY, ROLLED OATS; OATMEAL; CRUSHED OATS; PANCAKES; PASTA; SOYA BEAN PASTE; PASTILLES; PASTRIES; PASTY; PEANUT-BASED CANDY; PEPPER; PEPPERMINT SWEETS; PEPPER POWDER AND PEPPER SPICE; PETIT-BEURRE BISCUITS; PETITS FOURS; PIES; PIZZAS; POPCORN;

POTATO FLOUR FOR FOOD; POWDERS FOR ICE CREAM; PRALINES; PUDDINGS; QUICHES; RAVIOLI; RELISH (U.S. CL. 46).

CLASS 31—NATURAL AGRICULTURAL PRODUCTS

FOR RAW ALMONDS; ANIMAL FATTENING PREPARATIONS IN THE NATURE OF ANIMAL FEED; ANIMAL FOODSTUFFS; ANIMAL LITTER; EDIBLE CHEWS FOR ANIMALS; LIVE ANIMALS; LIVE MENAGERIE ANIMALS; AROMATIC SAND FOR PETS; LIVE FISHING BAIT; RAW BARKS; RAW LOCUST BEANS; FRESH BEANS; FRESH BEETS; FRESH BERRIES AS FRUITS; BEVERAGES FOR PETS; BIRD FOOD; DOG BISCUITS; RICE BRAN AS ANIMAL FEED; BRAN MASH FOR ANIMAL CONSUMPTION; LIVE POULTRY FOR BREEDING; BULBS FOR AGRICULTURAL PURPOSES; LIVE BUSHES; BY-PRODUCTS OF THE PROCESSING OF CEREALS FOR ANIMAL CONSUMPTION; OIL CAKE AS ANIMAL FEED; RAPE CAKE FOR CATTLE FEED; CATTLE FOOD; UNPROCESSED CEREAL SEEDS; FRESH CHESTNUTS; RAW SUGAR CANE; RAW CHICORY; RAW CHICORY ROOTS; CHRISTMAS TREES; RAW COCOA BEANS; RAW COCONUT SHELL; RAW COCONUTS; RAW COLA NUTS; HOP CONES; PINE CONES; COPRA; ROUGH CORK; LIVE CRAYFISH; LIVE CRUSTACEANS; FRESH CUCUMBERS; DRAFF, NAMELY, FRUIT PRESSING RESIDUE FOR ANIMAL CONSUMPTION; EGGS FOR HATCHING; FISH SPAWN FOR AGRICULTURAL PURPOSES; LIVE FISH; FLAX MEAL FOR ANIMAL FODDER; FISH MEAL FOR ANIMAL CONSUMPTION; FLOWER BULBS; WREATHS OF NATURAL FLOWERS; NATURAL FLOWERS; DRIED FLOWERS FOR DECORATION; PET FOOD; FORAGE, NAMELY, PLANT MATERIAL FOR ANIMAL FEED; FRUIT RESIDUE FOR ANIMAL FEED; FRESH FRUIT; FRESH GARDEN HERBS; SEED GERM FOR BOTANICAL PURPOSES; UNPROCESSED GRAINS; UNPROCESSED GRAINS FOR SEEDING; GRAINS FOR ANIMAL CONSUMPTION; FRESH GRAPES; GROATS FOR POULTRY FEED; HAY; RAW HAZELNUTS; RAW HOPS; FRESH JUNIPER BERRIES; RAW LEEKS; FRESH LEMONS; FRESH LENTILS; FRESH LETTUCE; LIME FOR ANIMAL FORAGE; PEAT FOR USE AS ANIMAL LITTER; LIVESTOCK FATTENING PREPARATIONS IN THE NATURE OF FEED; LIVE SPINY LOBSTERS; LIVE LOBSTERS; MAIZE CAKE FOR CATTLE; MALT FOR BREWING AND DISTILLING; MASH FOR FATTENING LIVESTOCK; STRAW MULCH; MUSHROOM SPAWN FOR PROPAGATION; FRESH MUSHROOMS; LIVE MUSSELS; FLOWERING PLANTS, NAMELY, NETTLES; RAW NUTS; RAW OATS; FRESH OLIVES; FRESH ONIONS; FRESH ORANGES; LIVE OYSTERS; PALM TREES; PALMS LEAVES OF THE PALM TREE; PEANUT CAKE FOR ANIMALS; PEANUT MEAL FOR ANIMALS; FRESH PEAS; FRESH PEPPER PLANTS; PLANT SEEDS; LIVE PLANTS; SANDED PAPER FOR PETS; PLANTS DRIED FOR DECORATION; BEE POLLEN BEING RAW MATERIAL FOR INDUSTRIAL USE; FRESH POTATOES; LIVE POULTRY; PROTEIN FOR ANIMAL CONSUMPTION; RESIDUE IN A STILL AFTER DISTILLATION FOR USE AS ANIMAL FEED; FRESH RHUBARB; RICE MEAL FOR ANIMAL FORAGE; UNPROCESSED RICE; LIVE ROSE BUSHES; RYE SEED; SALT LICKS FOR CATTLE; LIVE SEA-CUCUMBERS; SEEDLINGS; RAW SESAME SEED; LIVE SHELLFISH; LIVE SHRUBS; SILKWORM EGGS; LIVE SILKWORMS; SOD; FRESH SQUASHES; STRAW FORAGE FOR ANIMAL FEED; STRAW LITTER FOR ANIMAL BEDDING; SUGAR CANE; UNDRRESSED TIMBER; LIVE TREES; FRESH TRUFFLES; NATURAL TURF; UNSAWN TIMBER; FRESH VEGETABLES; LIVE VINE PLANTS; RAW WHEAT; LIVE WEEDS FOR HUMAN OR ANIMAL CONSUMPTION; WOOD CHIPS FOR THE MANUFACTURE OF WOOD PULP; YEAST FOR ANIMAL FEED; LIVE ALGAE FOR ANIMAL OR HUMAN CONSUMPTION (U.S. CLS. 1 AND 46).

CLASS 32—LIGHT BEVERAGES

FOR AERATED WATER; PREPARATIONS FOR MAKING AERATED WATER; ALMOND MILK AS A BEVERAGE; NON-ALCOHOLIC APERITIFS; BEER; BEER WORT; NON-ALCOHOLIC BEVERAGES, NAMELY, CARBONATED BEVERAGES; NON-ALCOHOLIC CIDER; NON-ALCOHOLIC COCKTAILS; BEVERAGES; NON-ALCOHOLIC FRUIT EXTRACTS USED IN BEVERAGES; FRUIT JUICES; NON-ALCOHOLIC FRUIT JUICE BEVERAGES; NON-ALCOHOLIC FRUIT NECTARS; GINGER ALE; GINGER BEER; UNFERMENTED GRAPE MUST; NON-ALCOHOLIC HONEY-BASED BEVERAGES; EXTRACTS OF HOPS FOR MAKING BEER; ISOTONIC BEVERAGES; NON-ALCOHOLIC KVASS; LEMONADES; LITHIA WATER; MALT BEER; MALT WORT; PEANUT MILK-BASED SOFT DRINK; MINERAL WATER; PREPARATIONS FOR MAKING MINERAL WATER; MUST; ORGEAT SYRUP FOR BEVERAGES; SARSAPARILLA SOFT DRINK; SELTZER WATER; SHERBETS AS BEVERAGES; SODA WATER; SYRUPS FOR BEVERAGES; SYRUPS FOR LEMONADE; TABLE WATERS; TOMATO JUICE; VEGETABLE JUICES; WATERS; WHEY BEVERAGES (U.S. CLS. 45, 46 AND 48).

CLASS 36—INSURANCE AND FINANCIAL

FOR ACCIDENT INSURANCE UNDERWRITING; ACCOMMODATION BUREAU SERVICES, NAMELY, LOCATING AND LEASING OF APARTMENTS; ACTUARIAL SERVICES; FINANCIAL ANALYSIS; ANTIQUE APPRAISAL; APARTMENT HOUSE MANAGEMENT; RENTING OF APARTMENTS; ART APPRAISAL; JEWELRY APPRAISAL; NUMISMATIC APPRAISAL; REAL ESTATE APPRAISAL; STAMP APPRAISAL; BAIL-BONDING; BANKING; HOME BANKING; BUSINESS LIQUIDATION SERVICES; CAPITAL INVESTMENT SERVICES; CHARITABLE FUND RAISING; CHECK VERIFICATION; FINANCIAL CLEARING HOUSES; RENT COLLECTION; ORGANIZATION OF DEBT COLLECTIONS; FINANCIAL CONSULTANCY; INSURANCE CONSULTANCY; CREDIT BUREAUS; CREDIT CARD SERVICES; ISSUANCE OF CREDIT CARDS; CUSTOMS BROKERAGE; DEBIT CARD SERVICES; DEBT COLLECTION AGENCIES; SAFE DEPOSITS OF VALUABLES; REAL ESTATE AGENCIES; REAL ESTATE MANAGEMENT; FINANCIAL EVALUATIONS IN THE FIELDS OF INSURANCE, BANKING, AND REAL ESTATE; FINANCIAL APPRAISAL, NAMELY, REPAIR COSTS EVALUATIONS; MONETARY EXCHANGE; FACTORING AGENCIES; FIDUCIARY REPRESENTATIVES; PROVIDING FINANCIAL INFORMATION; FINANCIAL MANAGEMENT; FINANCIAL SERVICES, NAMELY, MONEY LENDING; FIRE INSURANCE UNDERWRITING; FISCAL ASSESSMENTS; FUND INVESTMENTS; ELECTRONIC FUNDS TRANSFER; FINANCIAL GUARANTEE SERVICES; HEALTH INSURANCE UNDERWRITING; HIRE-PURCHASE FINANCING; HOUSING AGENCIES; INSURANCE INFORMATION; INSTALLMENT LOANS; INSURANCE BROKERAGE; INSURANCE UNDERWRITING CONSULTATION; ISSUE OF TOKENS OF VALUE; LEASE-PURCHASE FINANCING; LEASING OF FARMS; LEASING OF REAL ESTATE; LIFE INSURANCE UNDERWRITING; LOAN FINANCING; MARINE INSURANCE UNDERWRITING; MORTGAGE BANKING; MUTUAL FUND BROKERAGE; PAWN BROKERAGE; RENTAL OF OFFICE REAL ESTATE; RENTING OF FLATS; RETIREMENT PAYMENT SERVICES; SAFE DEPOSIT BOX SERVICES; SAVING BANKS; SECURITIES BROKERAGE; STOCKS EXCHANGE PRICE QUOTATIONS; SURETY SERVICES; TRUSTEESHIP REPRESENTATIVES; ISSUING OF TRAVELLERS' CHECKS; DEPOSIT OF VALUABLES, NAMELY, SAFE DEPOSIT BOX SERVICES (U.S. CLS. 100, 101 AND 102).

CLASS 39—TRANSPORTATION AND STORAGE

FOR AIR TRANSPORT; ARRANGING OF CRUISES; ARRANGING OF TOURS; BARGE TRANSPORT; BOAT RENTAL; BOAT STORAGE; BOAT TRANSPORT; BOOKING OF SEATS FOR TRAVEL; FREIGHT BROKERAGE; TRANSPORT BROKERAGE; BUS TRANSPORT; OPERATING CANAL LOCKS; CAR PARKING; CAR RENTAL; CAR TRANSPORT; CHAUFFEUR SERVICES; COACH BUS RENTAL; COURIER SERVICES FOR MESSAGES OR MERCHANDISE; FLOWER DELIVERY; MESSAGE DELIVERY; DELIVERY OF GOODS; DELIVERY OF GOODS BY MAIL ORDER; DELIVERY OF NEWSPAPERS; RENTAL OF DIVING BELLS; RENTAL OF DIVING SUITS; ELECTRICITY DISTRIBUTION; DISTRIBUTION OF ENERGY; ESCORTING OF TRAVELLERS; FERRY-BOAT TRANSPORT; FRANKING OF MAIL; FREIGHT SHIPPING OF GOODS; FREIGHT FORWARDING; FREIGHT BROKERAGE AND FORWARDING; ICE-BREAKING FOR THE SHIPPING INDUSTRY; FROZEN-FOOD LOCKER RENTAL; TRANSPORTING FURNITURE; GARAGE RENTAL; STORAGE OF GOODS; GUARDED TRANSPORT OF VALUABLES; TRUCK HAULING; HORSE RENTAL; PROVIDING STORAGE INFORMATION; TRANSPORTATION INFORMATION; LAUNCHING OF SATELLITES FOR OTHERS; LIGHTERAGE; MARINE TRANSPORT; PACKAGING OF GOODS FOR TRANSPORTATION; PARCEL DELIVERY; PARKING PLACE RENTAL; PASSENGER TRANSPORT; PILOTING; TRANSPORT BY PIPELINE; PLEASURE BOAT TRANSPORT; PORTERAGE; RAILWAY TRANSPORT; REFLOATING OF SHIPS; REFRIGERATOR RENTAL; ANIMAL REMOVAL SERVICES; RENTAL OF MOTOR RACING CARS; RENTAL OF STORAGE CONTAINERS; RENTAL OF VEHICLE ROOF RACKS; RENTAL OF WAREHOUSES; RENTAL OF WHEELCHAIRS; RESCUE OPERATIONS TRANSPORT; TRANSPORT RESERVATION SERVICES; TRAVEL RESERVATIONS FOR TRANSPORTATION; RIVER TRANSPORT BY BOAT; UNDERWATER SALVAGE; SALVAGE OF SHIPS; VESSEL SALVAGING; ORGANIZATION OF SIGHTSEEING TOURS; STEVEDORING; STREETCAR TRANSPORT; AMBULANCE TRANSPORT; TAXI TRANSPORT; MARINE TOWING; TRAFFIC INFORMATION; TRANSPORT BY AIR; ARMORED-CAR TRANSPORT; TRANSPORT OF TRAVELLERS; TRUCK RENTAL; UNLOADING CARGO; VEHICLE RENTAL; VEHICLE TOWING; WAREHOUSING SERVICES; WATER DISTRIBUTION; WATER SUPPLYING; WRAPPING OF GOODS FOR PROTECTION DURING TRAVEL; PHYSICAL STORAGE OF ELECTRONICALLY STORED DATA OR DOCUMENTS (U.S. CLS. 100 AND 105).

RONALD DELGIZZI, EXAMINING ATTORNEY

SN 76-708,869. PETRINO, PAUL D., BAYSHORE, NY. FILED 8-26-2011.

TREE STAND BUDDY

THE MARK CONSISTS OF STANDARD CHARACTERS WITHOUT CLAIM TO ANY PARTICULAR FONT, STYLE, SIZE, OR COLOR.

NO CLAIM IS MADE TO THE EXCLUSIVE RIGHT TO USE "TREE STAND", APART FROM THE MARK AS SHOWN.

CLASS 25—CLOTHING

FOR (BASED ON INTENT TO USE) CLOTHING, NAMELY, SHIRTS AND SWEATSHIRTS (U.S. CLS. 22 AND 39).

CLASS 28—TOYS AND SPORTING GOODS

FOR (BASED ON USE IN COMMERCE) A KIT FOR A TREE-ATTACHED SUPPORT, NAMELY, HUNTING STANDS (U.S. CLS. 22, 23, 38 AND 50).

FIRST USE 2-7-2010; IN COMMERCE 2-7-2010.
MATTHEW MCDOWELL, EXAMINING ATTORNEY

SN 76-709,042. PETRINO, PAUL, BAYSHORE, NY. FILED 9-12-2011.



NO CLAIM IS MADE TO THE EXCLUSIVE RIGHT TO USE "TREE STAND", APART FROM THE MARK AS SHOWN.

THE MARK CONSISTS OF A TREE WITH ROOTS WITH A DEER SKULL AT THE TOP OF THE TREE TRUNK JUST BELOW THE BRANCHES WHICH ALSO REPRESENT THE ANTLERS OF THE DEER SKULL. THE WORDS "TREE STAND BUDDY" APPEARS BELOW THE DEER SKULL, ACROSS THE BOTTOM OF THE TRUNK AND ABOVE THE ROOTS OF THE TREE.

CLASS 25—CLOTHING

FOR (BASED ON INTENT TO USE) CLOTHING, NAMELY, SHIRTS AND SWEATSHIRTS (U.S. CLS. 22 AND 39).

CLASS 28—TOYS AND SPORTING GOODS

FOR (BASED ON USE IN COMMERCE) A KIT FOR A TREE-ATTACHED SUPPORT, NAMELY, HUNTING STANDS (U.S. CLS. 22, 23, 38 AND 50).

FIRST USE 2-7-2010; IN COMMERCE 2-7-2010.
MATTHEW MCDOWELL, EXAMINING ATTORNEY

SN 76-709,879. DWECK, RALPH H., BROOKLYN, NY. FILED 12-1-2011.

MR. SWIM

THE MARK CONSISTS OF STANDARD CHARACTERS WITHOUT CLAIM TO ANY PARTICULAR FONT, STYLE, SIZE, OR COLOR.

CLASS 24—FABRICS

FOR TOWELS (U.S. CLS. 42 AND 50).

CLASS 25—CLOTHING

FOR MEN'S SWIMWEAR AND ACCESSORIES, NAMELY, SWIMSUITS, FLIP FLOPS, AND T-SHIRTS (U.S. CLS. 22 AND 39).

SUZANNE BLANE, EXAMINING ATTORNEY

SN 76-710,382. EFORCITY CORPORATION, EL MONTE, CA. FILED 1-27-2012.

BasAcc

THE MARK CONSISTS OF STANDARD CHARACTERS WITHOUT CLAIM TO ANY PARTICULAR FONT, STYLE, SIZE, OR COLOR.

CLASS 9—ELECTRICAL AND SCIENTIFIC APPARATUS

FOR SMALL ELECTRONICS ACCESSORIES, NAMELY, BATTERIES, ELECTRONIC CABLES, BATTERY CHARGERS, HEADSETS FOR USE WITH PDAS, MP3 PLAYERS, CELL PHONES, AND OTHER SMALL ELECTRONIC GOODS, AND FM RADIO TRANSMITTERS; CARRYING CASES IN LEATHER, IMITATION LEATHER, AND OTHER MATERIALS WHICH ARE SPECIALLY ADAPTED FOR CARRYING SMALL ELECTRONICS, NAMELY, PDAS, MP3 PLAYERS AND CELL PHONES (U.S. CLS. 21, 23, 26, 36 AND 38).

CLASS 18—LEATHER GOODS

FOR CARRYING CASES IN LEATHER, IMITATION LEATHER, AND OTHER MATERIALS FOR SMALL ELECTRONICS, NAMELY, PDAS, MP3 PLAYERS AND CELL PHONES WHICH ARE NOT SPECIALLY ADAPTED FOR CARRYING SMALL ELECTRONICS, NAMELY, PDAS, MP3 PLAYERS AND CELL PHONES (U.S. CLS. 1, 2, 3, 22 AND 41).

TINA BROWN, EXAMINING ATTORNEY

SN 76-710,965. PFI WESTERN STORES, INC., SPRINGFIELD, MO. FILED 3-20-2012.

BOOTDADDY

THE MARK CONSISTS OF STANDARD CHARACTERS WITHOUT CLAIM TO ANY PARTICULAR FONT, STYLE, SIZE, OR COLOR.

CLASS 3—COSMETICS AND CLEANING PREPARATIONS

FOR COLOGNE (U.S. CLS. 1, 4, 6, 50, 51 AND 52).
FIRST USE 10-15-2010; IN COMMERCE 10-15-2010.

CLASS 21—HOUSEWARES AND GLASS

FOR CUPS (U.S. CLS. 2, 13, 23, 29, 30, 33, 40 AND 50).
FIRST USE 10-15-2010; IN COMMERCE 10-15-2010.

CLASS 25—CLOTHING

FOR BOOTS; CLOTHING, NAMELY, SHIRTS, PANTS AND HATS (U.S. CLS. 22 AND 39).
FIRST USE 10-15-2010; IN COMMERCE 10-15-2010.

CLASS 33—WINES AND SPIRITS

FOR WINE (U.S. CLS. 47 AND 49).
FIRST USE 10-15-2010; IN COMMERCE 10-15-2010.
PAM WILLIS, EXAMINING ATTORNEY

SN 76-711,165. STAR BEDDING CO., ST LOUIS, MO. FILED 4-10-2012.

NO CLAIM IS MADE TO THE EXCLUSIVE RIGHT TO USE "BUCKET", APART FROM THE MARK AS SHOWN.

CLASS 18—LEATHER GOODS

FOR TOOL BAGS SOLD EMPTY (U.S. CLS. 1, 2, 3, 22 AND 41).
FIRST USE 9-0-2007; IN COMMERCE 12-0-2007.

CLASS 21—HOUSEWARES AND GLASS

FOR BUCKETS; BUCKETS OF WOVEN FABRIC (U.S. CLS. 2, 13, 23, 29, 30, 33, 40 AND 50).
FIRST USE 9-0-2007; IN COMMERCE 12-0-2007.
DAVID MURRAY, EXAMINING ATTORNEY

SN 77-185,958. VENYON OY, HELSINKI, FINLAND, FILED 5-21-2007.

Star



THE MARK CONSISTS OF STANDARD CHARACTERS WITHOUT CLAIM TO ANY PARTICULAR FONT, STYLE, SIZE, OR COLOR.
OWNER OF U.S. REG. NO. 1,076,456.

CLASS 20—FURNITURE AND ARTICLES NOT OTHERWISE CLASSIFIED

FOR CUSHIONS, MATTRESSES, FEATHER BEDS AND PILLOWS (U.S. CLS. 2, 13, 22, 25, 32 AND 50).
FIRST USE 11-0-1884; IN COMMERCE 11-0-1884.

CLASS 22—CORDAGE AND FIBERS

FOR PADDING, FILLING AND STUFFING, MATERIALS, NAMELY, DOWN AND FEATHERS USED IN MANUFACTURING COMFORTERS, QUILTS AND PILLOWS (U.S. CLS. 1, 2, 7, 19, 22, 42 AND 50).
FIRST USE 11-11-1884; IN COMMERCE 11-11-1884.

CLASS 24—FABRICS

FOR QUILTS, COMFORTERS, MATTRESS PADS (U.S. CLS. 42 AND 50).
FIRST USE 11-0-1884; IN COMMERCE 11-0-1884.
CARYN GLASSER, EXAMINING ATTORNEY

SN 76-711,224. TUFF BUCKET, INC., TWIN FALLS, ID. FILED 4-16-2012.

TUFF BUCKET

THE MARK CONSISTS OF STANDARD CHARACTERS WITHOUT CLAIM TO ANY PARTICULAR FONT, STYLE, SIZE, OR COLOR.

PRIORITY CLAIMED UNDER SEC. 44(D) ON FED REP GERMANY APPLICATION NO. 30676211.0, FILED 12-13-2006, REG. NO. 30676211, DATED 2-12-2007, EXPIRES 12-31-2016.

THE COLOR(S) BLUE, WHITE AND BLACK IS/ARE CLAIMED AS A FEATURE OF THE MARK.

THE MARK CONSISTS OF A WHITE STYLIZED "V" ON A BLUE SQUARE TO THE LEFT OF THE WORD "VENYON" IN BLACK STYLIZED LETTERS.

CLASS 9—ELECTRICAL AND SCIENTIFIC APPARATUS

FOR ELECTRICAL DEVICES, NAMELY, DATA PROCESSORS FOR COMMUNICATIONS WITH ELECTRONIC CHIP CARDS HAVING AN INTEGRATED CIRCUIT AND ELECTRONIC CHIP CARDS HAVING A CONTACTLESS INTERFACE; DATA PROCESSING DEVICES, NAMELY, DATA PROCESSORS FOR WRITING DATA INTO AND ONTO BLANK AND ENCODED ELECTRONIC CHIP CARDS, FOR READING OUT OF AND FROM ENCODED ELECTRONIC CHIP CARDS, AND FOR DISPLAYING DATA FROM AN ENCODED ELECTRONIC CHIP CARD ON A DISPLAY; DATA PROCESSING DEVICES, NAMELY, DATA PROCESSORS FOR PERSONALIZING BLANK AND ENCODED ELECTRONIC CHIP CARDS; CARDS HAVING AN INTEGRATED CIRCUIT, NAMELY, ENCODED ELECTRONIC CHIP CARDS HAVING MICROPROCESSORS AND CONTAINING PROGRAMMING FOR COMMUNICATION WITH EXTERNAL DATA PROCESSORS AND WITH MOBILE RADIO TERMINALS; INTEGRATED CIRCUITS HAVING CHARACTERISTIC PHYSICAL PROPERTIES FOR PROTECTION AGAINST FORGERY IN CONNECTION WITH ENCODED ELECTRONIC CHIP CARDS; ELECTRICAL DEVICES FOR ENCRYPTING DATA FOR CASH-LESS PAYMENT TRANSACTIONS USING MAGNETIC STRIPE CARDS AND ENCODED ELECTRONIC CHIP CARDS, BOTH IN ONLINE OPERATION AND IN OFFLINE OPERATION; COMPUTER SOFTWARE THAT ALLOWS DATA PROCESSORS TO COMMUNICATE WITH ENCODED ELECTRONIC CHIP CARDS (U.S. CLS. 21, 23, 26, 36 AND 38).

CLASS 35—ADVERTISING AND BUSINESS

FOR DATA MANAGEMENT SERVICES FOR COMPUTER NETWORKS, NAMELY, PROCESSING OF COMPUTER SOFTWARE DATA FOR TRANSMISSION OF SOFTWARE VIA CONTACT-LESS INTERFACES; SECURE DATA MANAGEMENT SERVICES FOR COMPUTER NETWORKS, NAMELY, PROCESSING OF COMPUTER SOFTWARE DATA FOR TRANSMISSION OF SOFTWARE VIA CONTACT-LESS INTERFACES FOR USE IN CONNECTION WITH ELECTRONIC DEVICE MANAGEMENT SOFTWARE, MOBILE DEVICE MANAGEMENT SOFTWARE, AND ELECTRONIC CHIP CARD AND APPLICATION MANAGEMENT SOFTWARE (U.S. CLS. 100, 101 AND 102).

CLASS 38—COMMUNICATION

FOR PROVIDING OF ACCESS TO DATA STORED ELECTRONICALLY IN COMPUTER NETWORKS FOR REMOTE CONSULTATION; ELECTRONIC TRANSMISSION OF DATA VIA COMPUTER NETWORKS (U.S. CLS. 100, 101 AND 104).

CLASS 42—SCIENTIFIC AND COMPUTER SERVICES

FOR DEVELOPING, PROGRAMMING, INSTALLING AND MAINTAINING OF SOFTWARE; CONSULTATION IN THE FIELD OF COMPUTER SOFTWARE RELATING TO THE TRANSMISSION OF SOFTWARE VIA CONTACT-LESS INTERFACES; RENTAL OF SOFTWARE; TECHNICAL CONSULTATION IN THE FIELD OF COMPUTER SECURITY, NAMELY, SECURING OF DATA AGAINST IMITATION, FALSIFICATION AND UNAUTHORIZED EAVESDROPPING IN ELECTRONIC COMMUNICATION SYSTEMS AND PREPARATION OF CONCEPTS FOR SUCH TECHNICAL CONSULTATION, NAMELY, PROVISION OF COMPUTER SECURITY INFORMATION; ANALOG RECORDING OF DATA, NAMELY, RECORDING DATA FOR OTHERS ON A MAGNETIC MEDIUM FOR ELECTRONIC STORAGE; DIGITAL RECORDING OF DATA, NAMELY, RECORDING OF DATA FOR OTHERS ON DIGITAL MEDIA, NAMELY, COMPACT DISCS, FLOPPY DISCS, MEMORY STICKS, RAM AND HARD DRIVES, FOR ELECTRONIC STORAGE; LEASING OF SOFTWARE, NAMELY, CLOSED-END LEASING OF SOFTWARE (U.S. CLS. 100 AND 101).

CLASS 45—PERSONAL AND LEGAL SERVICES

FOR SERVICES OF A CERTIFYING AUTHORITY IN THE NATURE OF AN INTERNET TRUST CENTER, NAMELY, ISSUANCE AND AUTHENTICATION OF DIGITAL KEYS, ENCRYPTION ALGORITHMS AND DIGITAL SIGNATURES (U.S. CLS. 100 AND 101).
JAMES MACFARLANE, EXAMINING ATTORNEY

SN 77-250,859. AMSC AUSTRIA GMBH, KLAGENFURT, AUSTRIA, FILED 8-9-2007.



OWNER OF ERPN CMNTY TM OFC REG. NO. 006298491, DATED 8-8-2008, EXPIRES 9-3-2017.
THE MARK CONSISTS OF THE TERM "WINDTEK" WITH A WINDMILL DESIGN AT THE TOP OF THE "T".

CLASS 16—PAPER GOODS AND PRINTED MATTER

FOR DRAWINGS AND PLANS OF WIND TURBINES AND COMPONENTS THEREOF (U.S. CLS. 2, 5, 22, 23, 29, 37, 38 AND 50).

CLASS 42—SCIENTIFIC AND COMPUTER SERVICES

FOR SCIENTIFIC RESEARCH AND TECHNOLOGICAL CONSULTATION IN THE TECHNOLOGY FIELD OF WIND TURBINES AND COMPONENTS THEREOF; DESIGN FOR OTHERS IN THE FIELD OF WIND TURBINES AND COMPONENTS THEREOF; DESIGN AND DEVELOPMENT OF COMPUTER HARDWARE AND SOFTWARE, WITH REGARD TO WIND TURBINES AND COMPONENTS THEREOF (U.S. CLS. 100 AND 101).

CLASS 45—PERSONAL AND LEGAL SERVICES

FOR LICENSING OF TECHNOLOGY AND PATENTS FOR WIND TURBINES AND COMPONENTS THEREOF (U.S. CLS. 100 AND 101).
CAROLINE WOOD, EXAMINING ATTORNEY

SN 77-278,132. TRINITY HEALTH CORPORATION, NOVI, MI. FILED 9-12-2007.

SANCTUARY

THE MARK CONSISTS OF STANDARD CHARACTERS WITHOUT CLAIM TO ANY PARTICULAR FONT, STYLE, SIZE, OR COLOR.

CLASS 35—ADVERTISING AND BUSINESS

FOR BUSINESS MANAGEMENT AND CONSULTATION IN THE FIELD OF RETIREMENT HOMES AND LONG TERM CARE FACILITIES (U.S. CLS. 100, 101 AND 102).

CLASS 36—INSURANCE AND FINANCIAL

FOR RENTAL OF RESIDENTIAL HOMES FOR SENIORS; RENTAL OF RESIDENTIAL APARTMENTS FOR SENIORS (U.S. CLS. 100, 101 AND 102).

CLASS 42—SCIENTIFIC AND COMPUTER SERVICES

FOR INSPECTION OF HOMES FOR ASSESSING SAFETY ISSUES FOR SENIORS; CONSULTING SERVICES IN THE FIELD OF ARCHITECTURAL DESIGN, NAMELY, SMALL SPACE DESIGN FOR RETIREMENT HOMES AND LONG TERM CARE FACILITIES (U.S. CLS. 100 AND 101).

CLASS 43—HOTEL AND RESTAURANT SERVICES

FOR RETIREMENT HOMES, EXCLUDING PSYCHIATRIC CARE SERVICES AND HEALTH SPA SERVICES (U.S. CLS. 100 AND 101).

CLASS 44—MEDICAL, BEAUTY AND AGRICULTURAL SERVICES

FOR PROVIDING LONG-TERM CARE FACILITIES EXCLUDING PSYCHIATRIC CARE SERVICES AND HEALTH SPA SERVICES; NURSING HOMES EXCLUDING PSYCHIATRIC CARE SERVICES AND HEALTH SPA SERVICES; NURSING CARE, HEALTH CARE, HOME HEALTH CARE SERVICES, AND MEDICAL SERVICES FOR SENIORS, NAMELY, PERSONAL PHYSICAL HEALTH ASSESSMENTS, EMERGENCY MEDICAL RESPONSE SERVICES, DIETICIAN, PHYSICIAN, PODIATRIST, DENTIST, AND OPTOMETRIST SERVICES, AND MEDICAL ASSISTANCE IN THE FIELD OF MEMORY LOSS EXCLUDING PSYCHIATRIC CARE SERVICES AND HEALTH SPA SERVICES; PHYSICAL REHABILITATION EXCLUDING PSYCHIATRIC CARE SERVICES AND HEALTH SPA SERVICES; PROVIDING PHYSICAL REHABILITATION FACILITIES EXCLUDING PSYCHIATRIC CARE SERVICES AND HEALTH SPA SERVICES (U.S. CLS. 100 AND 101).

ERIN FALK, EXAMINING ATTORNEY

SN 77-397,129. ZENITH OPTIMEDIA GROUP LIMITED, LONDON W14 8DG, UNITED KINGDOM, FILED 2-14-2008.

MOXIE

THE MARK CONSISTS OF STANDARD CHARACTERS WITHOUT CLAIM TO ANY PARTICULAR FONT, STYLE, SIZE, OR COLOR.

PRIORITY CLAIMED UNDER SEC. 44(D) ON ERPN CMNTY TM OFC APPLICATION NO. 006380241, FILED 10-19-2007, REG. NO. 006380241, DATED 1-23-2009, EXPIRES 1-23-2019.

OWNER OF U.S. REG. NO. 3,034,671.

CLASS 35—ADVERTISING AND BUSINESS

FOR ADVERTISING AND MARKETING SERVICES; ADVERTISING AND PROMOTIONAL SERVICES; PUBLIC RELATIONS SERVICES; BRAND CONSULTANCY AND BRAND CREATION SERVICES; BRAND EVALUATION SERVICES; BRAND POSITIONING; BRAND EVALUATION SERVICES, NAMELY, BRAND TESTING; MARKETING AND BRANDING SERVICES, NAMELY, PERFORMING CONSUMER INSIGHT AND BRAND STRATEGY OF COMPANY LOGOS; BUSINESS MANAGEMENT SERVICES RELATED TO FRANCHISING IN THE AREA OF ADVERTISING, MARKETING, BRAND MANAGEMENT, MEDIA BUYING, MEDIA MANAGEMENT; MARKETING AND ADVERTISING MEDIA MANAGEMENT SERVICES; MEDIA BUYING SERVICES, NAMELY, PURCHASING TIME AND SPACE FOR THE DELIVERY OF ADVERTISING MESSAGES THROUGH BROADCAST TIME, PRINT SPACE, INDOOR SPACE, OUTDOOR SPACE OR OTHER MEDIA SUCH AS CDS AND DVDS OR WEBSITE SPACE/TIME; EVENT MARKETING AND MANAGEMENT SERVICES, NAMELY, ARRANGING AND CONDUCTING MARKETING PROMOTIONAL EVENTS FOR OTHERS; PROFESSIONAL BUSINESS CONSULTATION AND BUSINESS ADVICE RELATING TO EVENTS MARKETING AND MANAGEMENT; SPONSORSHIP CONSULTANCY SERVICES RELATED TO PROMOTING THE GOODS AND SERVICES OF OTHERS BY ARRANGING FOR SPONSORS TO AFFILIATE THEIR GOODS WITH OTHERS; BUSINESS CONSULTANCY SERVICES RELATING TO THE PROVISION OF SPONSORSHIP OF THE ARTS, SPORTS, MUSIC AND THEATRE EVENTS; MANAGEMENT AND REPRESENTATION OF ATHLETES, SPORTS PEOPLE, ARTISTS AND CELEBRITIES; BUSINESS MANAGEMENT AND BUSINESS RESEARCH; MARKET RESEARCH; BUSINESS ADMINISTRATION AND BUSINESS CONSULTANCY SERVICES; BUSINESS MANAGEMENT OF EVENT HOSPITALITY

SERVICES; PERSONNEL RECRUITMENT SERVICES; CONDUCTING PUBLIC OPINION POLLS; COMPILATION, PROCESSING AND ANALYSIS OF MARKET RESEARCH STATISTICS; BUSINESS NETWORKING, NAMELY, BUSINESS INTRODUCTION SERVICES; ARRANGING AND CONDUCTING OF COMMERCIAL EXHIBITIONS AND SHOWS; PRODUCTION OF ADVERTISEMENTS FOR RADIO, VIDEO, FILM, COMPUTERS, INTERNET WEB SITES, TELEVISION AND MOBILE DEVICES; ALL THE AFORESAID SERVICES ALSO PROVIDED ON-LINE VIA COMPUTER WEBSITES OR THROUGH WIRELESS TRANSMISSIONS; ADVERTISING BY MAIL ORDER; COMPILATION OF DIRECT MAILING LISTS; COMPILATION OF MAILING LISTS; DIRECT MAIL ADVERTISING; MARKETING BY MAIL; PREPARATION OF MAILING LISTS; PREPARATION OF MAILING LISTS FOR DIRECT MAIL ADVERTISING SERVICES; DIRECT MARKETING, DATABASE MARKETING, NAMELY, COMPILING AND SYSTEMIZATION OF INFORMATION INTO CONSUMER SPECIFIC DATABASES FOR MARKETING PURPOSES; TELEMARKETING; STATISTICAL ANALYSIS AND REPORTING FOR BUSINESS PURPOSES; DATABASE MANAGEMENT; BUSINESS INFORMATION SERVICES; MAILING ADVERTISING SERVICES, DIRECT MAIL ADVERTISING SERVICES; BUSINESS CONSULTING SERVICES IN THE FIELD OF ELECTRONIC COMMERCE; ADVERTISING AND MARKETING MANAGEMENT AGENCY SERVICES, NAMELY, THE CREATION, DEVELOPMENT AND DISSEMINATION OF ADVERTISING AND PROMOTIONAL MATERIALS VIA DIRECT MAIL, NEWSPAPER, RADIO, TELEVISION, MOBILE DEVICES, A GLOBAL COMPUTER NETWORK AND OTHER INTERACTIVE MEDIA; RESEARCH SERVICES AND INFORMATION SERVICES RELATING TO ADVERTISING, MARKETING, BRAND MANAGEMENT, MEDIA BUYING, AND MEDIA MANAGEMENT; DESIGN OF PUBLICITY AND ADVERTISING MATERIALS; CREATION, RESEARCH, DEVELOPMENT AND IMPLEMENTATION OF BRAND NAMES, SLOGANS, LETTERING AND LOGOS; MOBILE ADVERTISEMENTS AND DIRECT MAIL ADVERTISEMENTS; COMPUTER SERVICES, NAMELY, DESIGN OF INTERNET ADVERTISING, NAMELY, DESIGNING AND IMPLEMENTING BANNER ADVERTISEMENTS; PROVIDING WEBSITES THAT PROMOTE THE GOODS AND SERVICES OF OTHERS; PROVIDING NEWS AND INFORMATION RELATING TO POLITICS AND ADVERTISING AND PROMOTIONAL EVENTS, PRODUCTS AND SERVICES; PROVIDING AN INTERACTIVE WEBSITE IN THE FIELD OF MARKETING, ADVERTISING, ADVERTISING MEDIA, AND POLITICS; INFORMATION, CONSULTANCY AND ADVISORY SERVICES, IN THE FIELD OF MARKETING AND ADVERTISING (U.S. CLS. 100, 101 AND 102).

CLASS 36—INSURANCE AND FINANCIAL

FOR PROVIDING SCHOLARSHIPS, FUNDING AND TUITION FOR EDUCATION, TRAINING AND INSTRUCTION CONCERNING RADIO, TELEVISION, OR ONLINE MEDIA; AND PROVIDING SCHOLARSHIPS, FUNDING AND TUITION FOR EDUCATION, TRAINING AND INSTRUCTION IN ENTERTAINMENT, MARKETING, ADVERTISING, MEDIA, RADIO AND TELEVISION (U.S. CLS. 100, 101 AND 102).

CLASS 38—COMMUNICATION

FOR PROVISION OF ONLINE CHAT ROOMS AND MESSAGE BOARDS FOR THE TRANSMISSION OF MESSAGES AMONG USERS IN THE AREA OF ENTERTAINMENT, CELEBRITIES, FILM, RADIO, TELEVISION, MUSIC, SPORTS, PHOTOGRAPHY AND EDUCATION (U.S. CLS. 100, 101 AND 104).

CLASS 39—TRANSPORTATION AND STORAGE

FOR INTERNET ONLINE STORAGE, NAMELY, ELECTRONIC STORAGE OF FILES AND DOCUMENTS; ELECTRONIC STORAGE OF DIGITAL MEDIA, PHOTOGRAPHS, FILM, VIDEO TAPE, SOUND TRACKS, E-MAIL; ELECTRONIC STORAGE OF DOCUMENTARY RECORDS; PHYSICAL STORAGE OF DOCUMENTS; ELECTRONIC STORAGE OF ELECTRONICALLY STORED DATA OR DOCUMENTS; PROVIDING ELECTRONIC INTERNET BASED STORAGE SPACE; REMOTE ELECTRONIC FILE STORAGE; PROVIDING ELECTRONIC ARCHIVES OF FILES AND DOCUMENTS; SECURE INTERNET ELECTRONIC STORAGE OF FILES AND DOCUMENTS; ELECTRONIC STORAGE OF SECURE DIGITAL MEDIA, PHOTOGRAPHS, FILM, VIDEO TAPE, SOUND TRACKS, EMAILS; SECURE ELECTRONIC STORAGE OF DOCUMENTARY RECORDS; SECURE ELECTRONIC STORAGE OF DOCUMENTS; PROVIDING SECURE ELECTRONIC STORAGE OF ELECTRONICALLY STORED DATA OR DOCUMENTS; SECURE INTERNET BASED ELECTRONIC STORAGE SPACE; SECURE REMOTE ELECTRONIC FILE STORAGE; PROVIDING SECURE ELECTRONIC ARCHIVES (U.S. CLS. 100 AND 105).

CLASS 40—MATERIAL TREATMENT

FOR PRINTING SERVICES, NAMELY, DIGITAL PHOTO PRINTING SERVICES, DIGITAL PRINTING SERVICES OF BOOKS AND OTHER DOCUMENTS; RESTORATION OF FILM, DIGITAL MEDIA AND VIDEO TAPE; CONVERSION OF FILM, DIGITAL MEDIA AND VIDEO TAPE TO ONE ANOTHER AND TO OTHER DIGITAL MEDIA FORMATS; REFORMATTING OF FILM, DIGITAL MEDIA AND VIDEO TAPE TO ONE ANOTHER AND TO OTHER DIGITAL MEDIA FORMATS (U.S. CLS. 100, 103 AND 106).

CLASS 41—EDUCATION AND ENTERTAINMENT

FOR SOUND AND VIDEO RECORDING PRODUCTION AND POST PRODUCTION SERVICES TO THE ADVERTISING, MOTION PICTURE, VIDEO, BROADCAST, SATELLITE, CABLE AND TELEVISION INDUSTRIES; PRODUCTION OF SOUND RECORDINGS; SOUND EDITING AND ENHANCEMENT; SOUND EDITING, NAMELY, MIXING OF DIALOGUE, MUSIC, SOUND EFFECTS, DIALOGUE AND NARRATION; SOUND EDITING, NAMELY, AUTOMATED DIALOGUE REPLACEMENT; RECORDING LIVE SOUND EFFECTS; SOUND EDITING, NAMELY, AUDIO POST-PRODUCTION, AUDIO PLAYBACK AND AUGMENTATION; SOUND EDITING, NAMELY, LOOPING/FOREIGN LANGUAGE DUBBING AND RECORDING; VIDEO POST-PRODUCTION, ADDING VISUAL EFFECTS AND GRAPHICS TO VIDEO TAPE, AUDIO TAPE, DIGITAL MEDIA AND FILM; POST-PRODUCTION EDITING SERVICES, NAMELY, MASTERING, EDITING, AND AUGMENTING, FILM, DIGITAL MEDIA AND VIDEO TAPE; POST-PRODUCTION EDITING SERVICES OF FILM, DIGITAL MEDIA AND VIDEO TAPE EDITING; CD, DVD AND ELECTRONIC MEDIA MASTERING; PRODUCTION OF SPECIAL EFFECTS FOR ADVERTISEMENTS, FILMS AND TELEVISION; RENTING OF EQUIPMENT FOR USE IN CREATING FILM, DIGITAL MEDIA AND VIDEO TAPE, AND FOR USE IN POST-PRODUCTION WORK, NAMELY, CAMERAS, AUDIO-VISUAL EQUIPMENT AND LIGHTING; CONSULTATION SERVICES RELATED TO SOUND, VIDEO AND ANCILLARY PRODUCTION AND POST PRODUCTION IN THE FIELD OF MUSIC, VIDEO, AND FILM; PROVIDING EDUCATION, TRAINING AND INSTRUCTION ON A WIDE VARIETY OF TOPICS, NAMELY, WORKSHOPS, CONFERENCES, SYMPOSIUM, SEMINARS, CLASSES, COURSES, PRESENTATIONS, IN THE FIELDS OF ENTERTAINMENT, CELEBRITIES, FILM, RADIO, TELEVISION, MUSIC, SPORTS, PHOTOGRAPHY AND EDUCATION; PROVIDING ENTERTAINMENT BY THE INTERNET, RADIO AND TELEVISION, RELATED TO ENTERTAINMENT THAT BENEFITS ADVERTISERS AND OR MEDIA VENDORS, NAMELY, AN ONGOING SERIES IN THE FIELD OF ENTERTAINMENT, CELEBRITIES, FILM, RADIO, TELEVISION, MUSIC, SPORTS, PHOTOGRAPHY AND EDUCATION;

PRODUCTION, PRESENTATION, DISTRIBUTION, SYNDICATION, NETWORKING AND RENTAL OF TELEVISION AND RADIO PROGRAMS INCORPORATING ADVERTISEMENTS, INTERACTIVE ENTERTAINMENT, FILMS AND SOUND AND VIDEO RECORDINGS, INTERACTIVE COMPACT DISCS AND CD-ROMS; PRODUCTION AND RENTAL OF EDUCATIONAL AND INSTRUCTIONAL AUDIO AND VIDEO MATERIALS IN THE AREA OF ENTERTAINMENT, CELEBRITIES, FILM, RADIO, TELEVISION, MUSIC, SPORTS, PHOTOGRAPHY AND EDUCATION; PROVISION OF ONLINE ELECTRONIC PUBLICATIONS, NAMELY, MAGAZINES, NEWSLETTERS, BLOGS, NEWSPAPERS, AND EDITORIALS, IN THE AREA OF ENTERTAINMENT, CELEBRITIES, FILM, RADIO, TELEVISION, MUSIC, SPORTS, PHOTOGRAPHY AND EDUCATION; PROVIDING ONLINE NON DOWNLOADABLE DIGITAL MUSIC AND DIGITAL ENTERTAINMENT, NAMELY, VIDEO GAMES, MOVIES; ORGANIZING AND CONDUCTING EXHIBITIONS FOR OTHERS FOR EDUCATIONAL PURPOSES IN THE FIELDS OF ADVERTISING, ENTERTAINMENT AND MARKETING; RENTAL OF RADIO AND TELEVISION BROADCASTING FACILITIES; FILM AND ANIMATION PRODUCTION SERVICES; ONLINE JOURNALS, NAMELY, BLOGS FEATURING INFORMATION ON ENTERTAINMENT, FILM, TELEVISION AND ANIMATION; PROVIDING WEBSITES PERTAINING TO ENTERTAINMENT, CELEBRITY APPEARANCES, FILMS, TELEVISION, MUSIC, SPORTS, PHOTOGRAPHY AND EDUCATION; PROVIDING NEWS AND INFORMATION RELATING TO ENTERTAINMENT, CELEBRITY APPEARANCES, FILMS, TELEVISION, MUSIC, SPORTS, PHOTOGRAPHY, AND EDUCATION VIA SATELLITE, TELEVISION, RADIO, LAND LINE, MOBILE PHONE, ONLINE, INTERNET, EXTRANET, MOBILE, DIRECT, CABLE, OR AIRWAVES; PROVIDING AN INTERACTIVE WEBSITE IN THE FIELD OF ENTERTAINMENT, PHOTOGRAPHY, MUSIC, SPORTS, AND EDUCATION; INFORMATION, CONSULTANCY AND ADVISORY SERVICES, IN THE FIELD OF ENTERTAINMENT (U.S. CLS. 100, 101 AND 107).

CLASS 42—SCIENTIFIC AND COMPUTER SERVICES

FOR PUBLIC AND PRIVATE FILE AND DOCUMENT RETRIEVAL; SECURE PUBLIC AND PRIVATE FILE AND DOCUMENT RETRIEVAL; HOSTING ONLINE WEB FACILITIES FOR OTHERS FOR ORGANIZING AND CONDUCTING INTERACTIVE DISCUSSIONS (U.S. CLS. 100 AND 101).

LINDSEY RUBIN, EXAMINING ATTORNEY

SN 77-409,177. AGGRESSIVE DEVELOPMENT INTERNATIONAL LIMITED, KOWLOON, HONG KONG, FILED 2-28-2008.



THE COLORS BLACK, WHITE AND/OR GRAY REPRESENT BACKGROUND, OUTLINING, SHADING AND/OR TRANSPARENT AREAS AND ARE NOT PART OF THE MARK.

THE MARK CONSISTS OF A DRAGON HEAD BETWEEN THE WORDS "DRAGON" AND "FIRE".

CLASS 9—ELECTRICAL AND SCIENTIFIC APPARATUS

FOR PROTECTIVE SPORT HELMETS FOR SKATING, SKATE BOARDING, BICYCLING, AND HOCKEY (U.S. CLS. 21, 23, 26, 36 AND 38).

CLASS 16—PAPER GOODS AND PRINTED MATTER

FOR PENS, PENCILS, BOOKS (U.S. CLS. 2, 5, 22, 23, 29, 37, 38 AND 50).

CLASS 28—TOYS AND SPORTING GOODS

FOR ICE SKATES, IN-LINE SKATES; ROLLER SKATES; QUAD SKATES; TWO-WHEELED SKATES WHICH AFFIX TO FOOTWEAR FOR PLEASURE AND SPORTS USE; SKATE BOARDS; BICYCLES; PROTECTIVE GEAR, NAMELY, KNEE GUARDS, ELBOW GUARDS, AND WRIST GUARDS FOR ATHLETIC USE; HOCKEY GOALS (U.S. CLS. 22, 23, 38 AND 50).
IRA J. GOODSaid, EXAMINING ATTORNEY

SN 77-539,440. ALLEN-VANGUARD CORPORATION, OTTAWA, ONTARIO, CANADA, FILED 8-5-2008.

ALLEN VANGUARD

THE MARK CONSISTS OF STANDARD CHARACTERS WITHOUT CLAIM TO ANY PARTICULAR FONT, STYLE, SIZE, OR COLOR.

PRIORITY CLAIMED UNDER SEC. 44(D) ON CANADA APPLICATION NO. 1382732, FILED 2-8-2008, REG. NO. TMA790034, DATED 2-8-2011, EXPIRES 2-8-2026.

OWNER OF U.S. REG. NOS. 3,647,582 AND 3,647,583.

THE NAME(S), PORTRAIT(S), AND/OR SIGNATURE(S) SHOWN IN THE MARK DOES NOT IDENTIFY A PARTICULAR LIVING INDIVIDUAL.

CLASS 1—CHEMICALS

FOR (BASED ON SECTIONS 44(E)(BASED ON INTENT TO USE) CHEMICALS USED IN INDUSTRY; CHEMICAL, BIOLOGICAL AND RADIOLOGICAL DECONTAMINATING FOAM USED FOR BOMB DISPOSAL; (BASED ON INTENT TO USE) CHEMICALS USED IN INDUSTRY; CHEMICAL, BIOLOGICAL AND RADIOLOGICAL DECONTAMINATING CHEMICALS USED FOR BOMB DISPOSAL (U.S. CLS. 1, 5, 6, 10, 26 AND 46).

CLASS 5—PHARMACEUTICALS

FOR (BASED ON SECTIONS 44(E)(BASED ON INTENT TO USE) SKIN DECONTAMINATING LOTION USED AS DISINFECTANTS FOR INDIVIDUALS EXPOSED TO NUCLEAR, BIOLOGICAL OR CHEMICAL DECONTAMINATION (U.S. CLS. 6, 18, 44, 46, 51 AND 52).

CLASS 6—METAL GOODS

FOR (BASED ON SECTIONS 44(E)(BASED ON INTENT TO USE) KITS FOR THE DETECTION AND DIFFUSION OF EXPLOSIVE DEVICES, AND SINGLE LINE KITS FOR MINE/MUNITIONS CLEARANCE AND HIGH RISK SEARCHES, COMPRISING HOOK AND LINE COMPONENTS, NAMELY, SNATCH BLOCKS, REELS, PULLING HANDLES, EYE RINGS, SEIZERS USED TO HOLD, FASTEN OR BIND OBJECTS, ANCHORS, PITONS, FISH HOOKS, SPRING GRIPS, JAW GRIPS, SUCTION PAD ANCHORS, SELF-ADHESIVE ANCHORS, GROUND ANCHORS, CORKSCREW STAKES, EXTENSION RODS, PULLEYS, GROUND PEGS, HOOKS, RINGS, BELT SLINGS, WIRE SLINGS, SLEDGES, PITONS, KARABINERS, WEDGES, BLOCKS, MAIN LINES; HEAVY DUTY HOOK AND LINE KITS FOR MOVING VEHICLES AND HEAVY IMPROVISED EXPLOSIVE DEVICES, WITH REELS, LINES, WEBBING SLINGS, ROUND SLINGS, GROUND ANCHORS, SHACKLES, SNATCH BLOCKS, HOOKS; METAL GOODS, NAMELY, ANCHORS, PITONS AND WIRE SLINGS AND HOOKS; ALL OF THE FOREGOING PRIMARILY OF METAL; (BASED ON INTENT TO USE) SMALL ITEMS OF METAL HARDWARE, NAMELY, NAILS, ADJUSTING SCREWS, EYELETS, METAL HOOKS, METAL CONNECTIVE HINGES, METAL FASTENING COLLARS, METAL CABLES AND WIRES NOT FOR ELECTRICAL PURPOSES, METAL CABLE ROLLERS, AND REELS, NON-ELECTRIC METAL WIRE CLAMPS (U.S. CLS. 2, 12, 13, 14, 23, 25 AND 50).

CLASS 7—MACHINERY

FOR (BASED ON SECTIONS 44(E)(BASED ON INTENT TO USE) EQUIPMENT AND SYSTEMS FOR CONTAINMENT AND MITIGATION OF WEAPONS OF MASS DESTRUCTION AND CHEMICAL, BIOLOGICAL, RADIOLOGICAL AND NUCLEAR EXPLOSIVE DEVICES AND MATERIALS, NAMELY, FOAM INJECTION MACHINES, CONTROLLERS, PUMPS, AERATING NOZZLES AND REUSABLE ENCLOSURES MADE OF BALLISTIC MATERIAL FOR CONTAINING THE EFFECT OF EXPLOSIVE DEVICES AND FOR DECONTAMINATING CHEMICAL AND BIOLOGICAL AGENTS SOLD AS A UNIT; FOAM APPLICATION EQUIPMENT, NAMELY, PORTABLE SELF CONTAINING DECONTAMINATING FOAM APPLICATION EQUIPMENT UNITS DESIGNED FOR PERFORMING EMERGENCY SPOT DECONTAMINATION OF CHEMICAL AND BIOLOGICAL AGENTS ON HARDWARE, STRUCTURAL SURFACES, TERRAIN AND DRUG LABELS; HYDRAULIC RAMS, PNEUMATIC RAMS; (BASED ON INTENT TO USE) MACHINES AND MACHINE TOOLS, NAMELY, POWER DRILLS; AIR AND WATER TANKS (U.S. CLS. 13, 19, 21, 23, 31, 34 AND 35).

CLASS 8—HAND TOOLS

FOR (BASED ON SECTIONS 44(E)(BASED ON INTENT TO USE) SECURITY, SURVEILLANCE AND SEARCH TOOL KITS, COMPRISED OF RETRACTABLE KNIVES, STEEL MEASURING TAPE, LINOLEUM KNIVES, SCISSORS, PAD SAWS, HACKSAWS, TACK EXTRACTORS, CLAW HAMMERS, CLUB HAMMERS, COLD CHISELS, WRECKING BARS, WIRE CUTTERS; BOLT CUTTERS, SCREWDRIVER SETS, WRENCHES, PLIERS, VICES, CLAMPS, CRIMPING IRONS, CABLE STRIPPERS, SEIZERS USED TO HOLD, FASTEN OR BIND OBJECTS, TWEEZERS, SOCKETS SETS AND BITS, HEXAGON WRENCHES, COMBINATION WRENCHES, TELESCOPIC SEARCH MIRRORS, HAND OPERATED SURVEILLANCE APPARATUS AND INSTRUMENTS, NAMELY, DOOR RIPPERS, FLOOR AND CAR ENTRY TOOLS; HAND OPERATED TOOLS USED FOR THE DETECTION AND DIFFUSION OF EXPLOSIVE DEVICES, NAMELY, SCREWDRIVERS, ADJUSTABLE WRENCHES, WRENCH SETS, VICE GRIP WRENCHES, PLIERS, SEIZERS, TWEEZERS, WIRE CUTTERS, TIN SNIPS, KNIVES, BLADE DISPENSERS, FLEXI SAWS, MINI SAWS, SCISSORS, HOOKS, WRECKING BARS, CLAW HAMMERS, TACK LIFTERS, NON-MAGNETIC TOOLS FOR EXPLOSIVE ORDNANCE DISPOSAL, NAMELY, TWEEZERS, PROBES, KNIVES, SCISSORS, HACKSAWS, BLADES, SCRAPERS, WIRE BRUSHES, SCREWDRIVERS, PLIERS, WIRE CUTTERS, WRENCHES, HAMMERS, CHISELS, BARS, SAWS, WIRE STRIPPERS, AND KITS COMPRISING THE FORE-

GOING; HAND OPERATED EXCAVATION TOOLS FOR EXPLOSIVE ORDNANCE DISPOSAL, NAMELY, SHOVELS, PICKS, PRY BARS, SLEDGEHAMMERS, CLUB HAMMERS, CHISELS, SCRAPERS, WRENCH SETS, NON MAGNETIC SHOVELS USED ON UNEXPLODED ORDNANCE, TRIPODS DESIGNED FOR LIFTING HEAVY OBJECTS DURING EXPLOSIVE ORDNANCE DISPOSAL OPERATIONS, HAND OPERATED LIGHTWEIGHT TRIPODS DESIGNED FOR LIFTING SMALLER OBJECTS DURING IMPROVISED EXPLOSIVE ORDNANCE DISPOSAL OPERATIONS; VEHICLE ACCESS HAND-OPERATED TOOLS, NAMELY, REMOTE WINDOW BREAKERS, VEHICLE DOOR HANDLE LIFTERS, VEHICLE KEY/HANDLE CLAMPS, VEHICLE DOOR BUTTON PUSHERS, VEHICLE DOOR TRIM/PANEL REMOVING TOOLS; TOOLS USED FOR EXPLOSIVE ORDNANCE DISPOSAL AND IMPROVISED EXPLOSIVE DEVICE DISPOSAL, NAMELY, TELESCOPIC MANIPULATORS, TOOL CARTS, TRIPODS; (BASED ON INTENT TO USE) HAND OPERATED TOOLS AND IMPLEMENTS, NAMELY, HAMMERS, SHEARS, STRAP ROLLERS, DRILLS, HANDJACKS, AUGERS, AWLS, CLAMPS, FILES, PINCERS, PLANERS, PUNCHES, WRENCHES, SAWS, SCREWDRIVERS, TONGS, NIPPERS, WIRE STRIPPERS, VICES, PRUNERS, CHISELS, DRILL FILES, KNIVES, PLIERS; RATCHET WRENCH SETS (U.S. CLS. 23, 28 AND 44).

CLASS 9—ELECTRICAL AND SCIENTIFIC APPARATUS

FOR (BASED ON SECTIONS 44(E))(BASED ON INTENT TO USE) SCIENTIFIC, SURVEYING, PHOTOGRAPHIC, CINEMATOGRAPHIC, OPTICAL, MEASURING, SIGNALING, LIFE-SAVING APPARATUS AND INSTRUMENTS, NAMELY, SECURITY AND SURVEILLANCE INSTRUMENTS FOR USE IN THE FIELDS OF SECURITY, CONTRABAND AND COUNTER-TERRORIST SEARCHING, NAMELY, HAND HELD METAL DETECTORS, GENERAL PURPOSE METAL DETECTORS, HIGH SENSITIVITY METAL DETECTORS, DUAL PURPOSE METAL DETECTORS AND WALK THROUGH METAL DETECTORS, PORTABLE EXPLOSIVES DETECTORS, CONTRABAND DETECTORS, NAMELY, HAND HELD ELECTRONIC CONTRABAND DETECTORS THAT INDICATE THE PRESENCE OF HIDDEN MATERIALS BY SIGNALING UNEXPECTED CHANGES IN THE DENSITY OR THICKNESS OF A SURFACE THROUGH THE RELEASE OF GAMMA RAYS; OPTICAL APPARATUS AND INSTRUMENTS FOR USE IN THE FIELDS OF SECURITY AND CONTRABAND AND COUNTER-TERRORISTS SEARCHING, AND IN FORENSIC POST BLAST EXAMINATIONS, NAMELY, LIGHT PROBES, FLEXIBLE AND RIGID ENDOSCOPES, TELESCOPIC ARMS FOR ENDOSCOPES; ZOOM CAMERAS, INFRARED CAMERAS FOR DAY AND NIGHT OPERATIONS; FERROUS ORDNANCE LOCATORS, NAMELY, PORTABLE DETECTORS FOR LOCATING FERROUS OBJECTS UNDER GROUND OR WATER AND SUITABLE FOR THE ACCURATE LOCATION OF BOMBS, PIPES AND WRECKAGE; COMPUTER MONITORS, COMPUTER HARDWARE, COMPUTER SOFTWARE, NAMELY, APPLICATIONS SOFTWARE FOR USE IN ASSOCIATION WITH LOCATING FERROUS OBJECTS UNDER GROUND AND WATER AND FOR THE ACCURATE LOCATION OF BOMBS, PIPES AND WRECKAGE; APPARATUS FOR THE DETECTION AND DIFFUSION OF EXPLOSIVE DEVICES, USED IN IMPROVISED EXPLOSIVE DEVICE DISPOSAL, NAMELY, ELECTRONIC BOMB DETECTORS AND DIFFUSERS, ELECTRONIC COUNTER MEASURES EQUIPMENT, NAMELY, PORTABLE COMMUNICATION JAMMERS, MODULAR JAMMERS, NAMELY, ELECTRONIC APPARATUS THAT INHIBIT RADIO CONTROLLED IMPROVISED EXPLOSIVE DEVICE SIGNALS THAT MAY BE USED TO DETONATE EXPLOSIVE DEVICES, ELECTRONIC STETHOSCOPIES FOR THE DETECTION OF MECHANICAL RUN BACK TIMERS AND ELECTRONIC TIMING SYSTEMS IN IMPROVISED EXPLOSIVE DEVICES, NON-LINEAR JUNCTION DETECTORS, NAMELY, ELECTRONIC APPARATUS AND INSTRUMENTS FOR DETECTING ELECTRONIC CIRCUITS FOUND IN EXPLOSIVE DEVICES AND RADIO TRANSMITTERS, ELECTRONIC CABLE DETECTORS USED TO LOCATE UNDERGROUND COMMAND WIRE CABLES, ELECTRONIC LETTER BOMB DETECTORS, X-RAY PARCEL BOMB DETECTORS, PORTABLE X-RAY GENERATORS, PORTABLE X-RAY COMPUTER USED TO EXAMINE SUS-

PECT PACKAGES THAT MAY CONTAIN IMPROVISED EXPLOSIVE DEVICES OR OTHER INACCESSIBLE AREAS WHERE CONTRABAND MAY BE HIDDEN; LAND MINE CLEARING APPARATUS AND EQUIPMENT, NAMELY, LAND MINE DETECTORS, NAMELY, NON MAGNETIC LAND MINE PRODDERS, REPLICA LAND MINE TRAINING AIDS; ELECTRONIC DISRUPTORS, NAMELY, RECOILLESS DISPOSABLE DISRUPTORS USED TO DISRUPT EXPLOSIVE DEVICES, NAMELY, WATER JET DISRUPTORS USED TO DISRUPT THIN WALLED EXPLOSIVE DEVICES, DISPOSABLE CAR TRUNK DISRUPTORS USED TO DISRUPT EXPLOSIVE DEVICES IN VEHICLES, PERSONAL PROTECTIVE EQUIPMENT FOR THE PROTECTION OF INDIVIDUALS FROM CHEMICAL AND BIOLOGICAL WARFARE AGENTS, NAMELY, PROTECTIVE SUITS, PROTECTIVE GLOVES AND PROTECTIVE OVER BOOTS, GAS MASKS, ELECTRO-VOICE AMPLIFIERS FOR GAS MASKS, CANISTERS DESIGNED TO HELP PROVIDE RESPIRATORY PROTECTION AGAINST AIRBORNE CONTAMINANTS, NEXT TO SKIN PROTECTIVE EQUIPMENT, NAMELY, WET SUITS, DRY SUITS, LIGHT WEIGHT PROTECTIVE SUITS, CHEMICAL PROTECTIVE UNDERGARMENTS; PROTECTIVE CLOTHING USED IN IMPROVISED EXPLOSIVE DEVICE DISPOSAL, NAMELY, BOMB SUITS, LIQUID COOLING UNDER SUITS; SEARCH SUITS, NAMELY, BODY ARMOUR SUITS DESIGNED FOR USE WHEN SEARCHING FOR IMPROVISED EXPLOSIVE DEVICES; WIRELESS RADIO SYSTEMS FOR USE WITH BOMB SUITS COMPOSED OF RADIOS, MOBILE RADIOS, RADIO TRANSMITTERS, RADIO RECEIVERS, ANTENNAS, AMPLIFIERS, ELECTRICAL AND POWER WIRES, CABLE AND ELECTRICAL CONNECTORS, SIGNAL PROCESSORS, CONVERTERS, DIGITAL FILTERS TO PROTECT AGAINST CHANNEL INTERFERENCE; DEMINING BALLISTIC PROTECTION, NAMELY, LAND MINE CLEARANCE VESTS AND HELMETS WITH VISORS; SAFETY EQUIPMENT, NAMELY, FOREARM PROTECTION FOR USE IN ASSOCIATION WITH MANUAL DOOR RAMS OR DOOR RIPPERS; SURVEILLANCE SCOPES, HAND HELD THERMAL IMAGERS, SPOTTING SCOPES, NAMELY, LIGHTWEIGHT TELESCOPES, INFRARED TELESCOPIC CAMERAS, SURVEILLANCE PROBES, NAMELY, UNDER DOOR REMOTE VIEWING TOOLS, MICRO-THROUGH-WALL VIEWING TOOLS, AUDIO PROBES, PEEPHOLE VIEWERS, REVERSE PEEPHOLE SCOPES, MIRRORS, TELESCOPIC MIRRORS, TELESCOPIC SEARCH MIRRORS, CONVEX MIRRORS, PLAIN MIRRORS, RECTANGULAR MIRRORS, MIRROR SLEEVES, CLIP ON MIRRORS, TELESCOPIC ARMS FOR SEARCH MIRRORS, POCKET SEARCH MIRRORS, UNDER VEHICLE SEARCH MIRRORS, SEARCH MIRRORS WITH NON-ROTATIONAL ALUMINUM POLES, PADDED FOREARM RESTS AND FOAM GRIPS, FOREARM STRAPS FOR USE WITH TELESCOPIC ARMS FOR SEARCH MIRRORS, BATTERY HANDLES; PORTABLE COMMAND AND CONTROL CONSOLES, NAMELY, COMPUTER HARDWARE AND SOFTWARE FOR THE OPERATION OF ROBOTS AND RF WIRELESS CONTROL SYSTEMS, COMPRISED OF RF TRANSMITTERS AND RECEIVERS, INTEGRATED SPREAD SPECTRUM RF CONTROL SYSTEMS, NAMELY, ELECTRONIC VIDEO APPARATUS THAT GIVE CONTROL AND FLICKER FREE VIDEO OVER LONG DISTANCES IN BUILT UP AREAS AND INSIDE BUILDINGS, SLIP RING DRUM CABLES, ZOOM CAMERAS, INFRARED CAMERAS FOR DAY AND NIGHT OPERATIONS, LASERS NOT FOR MEDICAL USE, SHOCK TUBE INITIATORS, EXTENSION BOOMS, DISRUPT OR MOUNTS; BLAST PROTECTION ARMOR FOR VEHICLES; BLAST PROTECTION SEATS FOR USE IN MILITARY AND SECURITY/POLICE VEHICLES; RECHARGERS FOR FLASHLIGHTS, BATTERY PACKS, BATTERY CHARGES, BATTERY HANDLES; BALLISTIC TESTING EQUIPMENT, NAMELY, MULTI-BARREL FIRING RECEIVER FOR FIRING AMMUNITION, HYDRAULIC TARGET RETENTION TEST FRAMES, ADJUSTABLE TORSO MOULDS FOR ARMOR AND BODY ARMOR, AMMUNITIONS AND WEAPONS; INSTRUMENTS FOR THE MEASUREMENT OF BALLISTIC VELOCITY AND RATE OF FIRE; PERSONAL PROTECTIVE EQUIPMENT FOR HANDS AND FEET OF DEMINING AND MINE CLEARANCE PERSONNEL, NAMELY, CONICAL HAND PROTECTORS, OVERHAND HAND PROTECTORS, RAISED FOOT PROTECTION PLATFORM FOR WALKING; PERSONAL PROTECTIVE EQUIPMENT USED TO REDUCE RISK OF INJURY FROM BLAST AND BAL-

LISTIC THREATS, NAMELY, MODULAR INTEGRATED SUITS, NAMELY, UPPER BODY VESTS, REMOVABLE SLEEVES, TROUSERS, GROIN PROTECTORS, NECK PROTECTORS, HELMET-MOUNTED RIGID FACIAL PROTECTORS; PERSONAL PROTECTIVE EQUIPMENT USED TO PROTECT PERSONNEL FROM HEAT STRESS, NAMELY, ELECTRONIC CHILLERS, ICE-BASED CHILLERS, TETHERS, LIQUID CONNECTORS, COOLING VESTS, LIQUID CIRCULATING GARMENTS; PROTECTIVE CLOTHING USED IN IMPROVISED EXPLOSIVE DEVICE DISPOSAL, NAMELY, BOMB DISPOSAL SUITS, BOMB DISPOSAL HELMETS WITH VISORS; SEARCH SUITS, NAMELY, BODY ARMOR SUITS DESIGNED FOR USE WHEN SEARCHING FOR IMPROVISED EXPLOSIVE DEVICES; TACTICAL ROBOTS FOR USE IN LAW ENFORCEMENT AND MILITARY APPLICATIONS, SURVEILLANCE, BOMB DISPOSAL, HAZARDOUS MATERIAL ACCIDENT CLEAN-UP AND HOSTAGE TAKING SITUATIONS, RECONNAISSANCE AND WEAPON DELIVERY IN RAPID DEPLOYMENT SCENARIOS WITHIN AREAS OF RESTRICTED PHYSICAL AREAS AND STRUCTURAL PARTS AND ACCESSORIES THEREFOR, NAMELY, BATTERY PACKS AND CHARGERS SOLD AS A UNIT; POWER OPERATED SEARCH TOOL KITS COMPRISED OF POWER OPERATED CORDLESS DRILLS WITH CORDLESS DRILL CHARGERS AND DRILL BITS, CENTRE PUNCHES; (BASED ON SECTION (B)): REMOVABLE CLAWS BEING PARTS OF FLEXIBLE AND RIGID ENDOSCOPES AND TELESCOPIC ARMS; PHOTOGRAPHIC AND CINEMATOGRAPHIC APPARATUS AND INSTRUMENTS, NAMELY, DIGITAL AND VIDEO CAMERAS, USED WITH UNDER VEHICLE TROLLEYS, CAMERAS WITH INFRARED SENSORS, FIBER OPTIC SCOPES FOR VISUAL INSPECTION BEHIND OR INSIDE CLOSED AREAS, ILLUMINATED MAGNIFIERS; X-RAY KITS COMPRISED OF PORTABLE X-RAY MACHINES FOR NON-MEDICAL USE, NOTEBOOK PERSONAL COMPUTER, BATTERY, AND CASES THEREFOR; COMPUTER SOFTWARE, NAMELY, APPLICATION SOFTWARE FOR BALLISTICS TESTING; BOMB SUPPRESSION BLANKETS, SECURITY MIRRORS ON POLES WITH A LIGHT FIXTURE; VIDEO SEARCH KITS COMPOSED OF VIDEO CAMERAS AFFIXED TO FLEXIBLE UNDER VEHICLE TROLLEYS AND LCD SCREENS FOR VIEWING IMAGES; COMPUTER SOFTWARE, NAMELY, APPLICATION SOFTWARE USED FOR STORING MEASUREMENTS OVER SCANNED AREAS FOR DOWNLOADING AND PRESENTATION ON A PERSONAL COMPUTER, ELECTRONIC SENSORS USED TO RECOGNIZE AND RECORD THE SEVERITY OF BLASTS AND BLUNT IMPACTS, WIRELESS RADIO SYSTEM FOR USE WITH BOMB SUITS; COMPUTER HARDWARE COMMUNICATION SERVERS FOR USE IN CONNECTION WITH BOMB SUITS; HAND-HELD RADIATION DETECTORS FOR LOCATING AND IDENTIFYING CONCEALED NUCLEAR MATERIALS, PORTABLE CARBON DIOXIDE SENSORS FOR THE DETECTION OF CARBON DIOXIDE AND LIFE SOURCES, FALSE PANEL DISTANCE METERS, NAMELY, ULTRASONIC DISTANCE ESTIMATORS USED TO DETERMINE THE DISTANCE OF CONTAINERS AND OTHER CAVITIES WHEN SEARCHING FOR FALSE PANELS; PROTECTIVE LEATHER GLOVES FOR HANDLING EXPLOSIVE MATERIALS (U.S. CLS. 21, 23, 26, 36 AND 38).

CLASS 11—ENVIRONMENTAL CONTROL APPARATUS

FOR (BASED ON SECTIONS 44(E)(BASED ON INTENT TO USE) APPARATUS FOR LIGHTING, NAMELY, FLORESCENT LAMPS, SPARE LAMPS, FLASHLIGHTS, FLASHLIGHTS AND RECHARGES SOLD AS A UNIT, SEARCHLIGHTS, PORTABLE FLOODLIGHTS, POCKET ULTRAVIOLET LAMPS NOT FOR MEDICAL PURPOSES AND SPOTLIGHTS, FLASHLIGHTS INCORPORATING A MIRROR (U.S. CLS. 13, 21, 23, 31 AND 34).

CLASS 12—VEHICLES

FOR (BASED ON SECTIONS 44(E)(BASED ON INTENT TO USE) RESPONSE VEHICLES, NAMELY, LAND VEHICLES EQUIPPED WITH EXPLOSIVE ORDNANCE AND IMPROVISED EXPLOSIVE DEVICE DISPOSAL EQUIPMENT; EMERGENCY RESPONSE TRAILERS CONTAINING BLAST SUPPRESSANT FOAM APPLICATION EQUIPMENT (U.S. CLS. 19, 21, 23, 31, 35 AND 44).

CLASS 13—FIREARMS

FOR (BASED ON SECTIONS 44(E)(BASED ON INTENT TO USE) APPARATUS AND INSTRUMENTS USED IN EXPLOSIVE ORDNANCE DISPOSAL, NAMELY, SMALL SHAPED AND LARGE SHAPED COPPER CONE CHARGES, SMALL SHAPED MAGNESIUM CONE CHARGES, SMALL SHAPED LIQUESCENT CONE CHARGES, LARGE SELF FORGING FRAGMENT CONES; DE-ARMERS DESIGNED TO PROJECT A VARIETY OF STEEL SLUGS AT HIGH VELOCITY INTO THE FUZES OR PISTOLS OF AIR DROPPED BOMBS; INTEGRATED WEAPONS CARRIERS; NON-ELECTRIC-EXPLOSIVE-DELIVERY TOOL KITS SPECIFICALLY DESIGNED TO BREAK THROUGH WINDOWS, NAMELY, DUAL INITIATORS USED AS DETONATORS, INITIATOR POLE MOUNTS, INITIATOR REEL MOUNTS, INDEXING JOINTS, POLE EXTENSIONS, HITCH PINS, POLE SIDE GRIP HANDLES, POLE TRANSITIONS, CHARGE PLATES, SHOCK TUBE STORAGE REELS; FORCED-ENTRY TOOLS, NAMELY, SAFETY INITIATORS AS DETONATORS USED FOR EXPLOSIVE FIRING; (BASED ON INTENT TO USE) EXPLOSIVE WALL BREACHING EQUIPMENT COMPRISED OF A PLASTIC SHELL AND EXPLOSIVE DEVICES; MOBILE COOLING CASES USED TO PROTECT ELECTRONICS FROM HEAT (U.S. CLS. 2 AND 9).

CLASS 16—PAPER GOODS AND PRINTED MATTER

FOR (BASED ON SECTIONS 44(E)(BASED ON INTENT TO USE) PRINTED MATERIALS, NAMELY, INSTRUCTION MANUALS DETAILING THE USE OF TACTICAL HOOK AND LINE TECHNIQUES IN EXPLOSIVE ORDNANCE DISPOSAL OPERATIONS; OWNER MANUALS AND DOCUMENTATION IN THE NATURE OF TRAINING MANUALS RELATING TO TACTICAL ROBOTS, COMPUTER HARDWARE AND SOFTWARE FOR THE OPERATION OF SAID ROBOTS AND RF WIRELESS CONTROL SYSTEMS; PRINTED SECURITY SEALS USED TO SEAL PARCELS; (BASED ON INTENT TO USE) PRINTED MATTER AND INSTRUCTIONAL AND TEACHING MATERIAL, NAMELY, BOOKS AND MANUALS IN THE FIELDS OF EQUIPMENT TRAINING, NAMELY, NUCLEAR, BIOLOGICAL AND CHEMICAL CLEAN-UP, EXPLOSIVE ORDNANCE DETECTION AND DISPOSAL, SECURITY SURVEILLANCE AND SEARCH, SECURITY CONTRABAND AND COUNTER-TERRORIST SEARCHING, IMPROVISED EXPLOSIVE DEVICE DISPOSAL (U.S. CLS. 2, 5, 22, 23, 29, 37, 38 AND 50).

CLASS 20—FURNITURE AND ARTICLES NOT OTHERWISE CLASSIFIED

FOR (BASED ON SECTIONS 44(E)(BASED ON INTENT TO USE) BOMB BLAST INHIBITORS, NAMELY, NON-METAL BOMB BLAST SUPPRESSION BINS, NON-METAL LIGHTWEIGHT CONTAINERS FOR THE ISOLATION AND TRANSPORT, CONTAINMENT, MITIGATION AND DESTRUCTION OF SUSPECT PACKAGES; (BASED ON INTENT TO USE) NON-METAL DOOR WEDGES, NON-METAL FASTENING ANCHORS FOR GRIPPING TO FLAT SURFACES AND FOR HOOKS AND LINES AND ATTACHING SNATCH BLOCKS AND OTHER LINKS; DOORSTOP OF PLASTIC; NON-METAL CLAMPS; NON-METAL GROUND PEGS; NON-METAL PULLEYS; HAND-OPERATED NON-METAL REELS FOR STORING AND DEPLOYING LINES; NON-METAL SECURITY AND SURVEILLANCE TOOL KITS COMPRISED OF ANCHORS, CLAMPS, GROUND PEGS, HAND-OPERATED REELS, AND METAL SNATCH BLOCKS, REELS, GRIPS, SEIZERS, CORDS, STRINGS AND LINES, ANCHORS, PITONS AND WIRE SLINGS, HOOKS AND ROPE; NON-METAL EXPLOSIVE DEVICE DETECTION AND DIFFUSION TOOL KITS COMPRISED OF ANCHORS, CLAMPS, GROUND PEGS, HAND-OPERATED REELS, AND METAL SNATCH BLOCKS, REELS, GRIPS, SEIZERS, CORDS, STRINGS AND LINES, ANCHORS, PITONS, WIRE SLINGS, HOOKS AND ROPE (U.S. CLS. 2, 13, 22, 25, 32 AND 50).

CLASS 22—CORDAGE AND FIBERS

FOR (BASED ON INTENT TO USE) ROPES, STRINGS; ROPES, NON-METAL LINES AND CABLE STRAPS, TEXTILE CORDS, NON-METAL SLINGS FOR HOISTING AND HANDLING LOADS; SECURITY AND SURVEILLANCE KITS COMPRISING OF NON-METAL GOODS, NAMELY, ROPES, NON-METAL STRAPS AND LINES, SLINGS, TEXTILE CORDS AND SNATCH BLOCKS, REELS, GRIPS, SEIZERS, CORDS, STRINGS AND LINES; DETECTION AND DIFFUSION OF EXPLOSIVE DEVICES KITS COMPRISING OF NON-METAL GOODS, NAMELY, ROPES, NON-METAL SNAPS AND LINES, SLINGS, TEXTILE CORDS, AND METAL SNATCH BLOCKS, REELS, GRIPS, SEIZERS, CORDS, STRINGS AND LINES, ANCHORS, PITONS AND WIRE SLINGS, HOOKS, ROPE; NYLON CORD; LETTER BOMB CONTAINMENT BAGS, STRINGS AND LINES THERETO, SHOCK CORDS, ALL-PURPOSE STRAPS AND LINES THERETO (U.S. CLS. 1, 2, 7, 19, 22, 42 AND 50).

CLASS 35—ADVERTISING AND BUSINESS

FOR (BASED ON SECTIONS 44(E)(BASED ON INTENT TO USE) MAIL ORDER CATALOG, ELECTRONIC CATALOG, MAIL ORDER, ON-LINE ORDERING SERVICES FEATURING SECURITY APPARATUS AND HARDWARE; (BASED ON INTENT TO USE) ADVERTISING; BUSINESS MANAGEMENT; BUSINESS ADMINISTRATION (U.S. CLS. 100, 101 AND 102).

CLASS 41—EDUCATION AND ENTERTAINMENT

FOR (BASED ON SECTIONS 44(E)(BASED ON INTENT TO USE) EDUCATION SERVICES, NAMELY, PROVIDING CLASSES, SEMINARS, WORKSHOPS IN THE FIELDS OF EQUIPMENT TRAINING, NAMELY, NUCLEAR, BIOLOGICAL AND CHEMICAL CLEAN-UP, EXPLOSIVE ORDNANCE DETECTION AND DISPOSAL, SECURITY SURVEILLANCE AND SEARCH, SECURITY CONTRABAND AND COUNTER-TERRORIST SEARCHING, IMPROVISED EXPLOSIVE DEVICE DISPOSAL; PROVIDING OF EDUCATION TRAINING IN THE FIELDS OF EQUIPMENT TRAINING, NAMELY, NUCLEAR, BIOLOGICAL AND CHEMICAL CLEAN-UP, EXPLOSIVE ORDNANCE DETECTION AND DISPOSAL, SECURITY SURVEILLANCE AND SEARCH, SECURITY CONTRABAND AND COUNTER-TERRORISM SEARCHING, IMPROVISED EXPLOSIVE DEVICE DISPOSAL; EDUCATION AND TRAINING SERVICES, NAMELY, EDUCATIONAL TRAINING SERVICES IN RESPECT OF THE OPERATION, INSTALLATION, MAINTENANCE, AND REPAIR OF APPARATUS AND INSTRUMENTS USED IN THE FIELDS OF SECRET AND IN CONTRABAND AND COUNTER-TERRORIST SEARCHING; EDUCATIONAL TRAINING SERVICES, NAMELY, TRAINING FOR PROCEDURES FOR DEALING WITH CHEMICAL, BIOLOGICAL, NUCLEAR AND RADIOLOGICAL INCIDENTS, COUNTER-TERRORIST AND CONTRABAND SEARCH TRAINING, BOMB AWARENESS AND COUNTER-MEASURES TRAINING, THREAT ANALYSIS AND PLANNING TRAINING, IMPROVISED EXPLOSIVE DEVICE DISPOSAL TRAINING (U.S. CLS. 100, 101 AND 107).

CLASS 42—SCIENTIFIC AND COMPUTER SERVICES

FOR (BASED ON SECTIONS 44(E)(BASED ON INTENT TO USE) SCIENTIFIC RESEARCH AND TECHNOLOGICAL CONSULTATION IN THE TECHNOLOGY FIELD OF BALLISTIC TESTING SERVICES, NAMELY, TESTING AND EVALUATION OF WEAPON, AMMUNITION AND ARMOR; DESIGN, DEVELOPMENT AND TESTING FOR OTHERS OF APPARATUS AND INSTRUMENTS USED IN THE FIELD OF SECURITY AND IN CONTRABAND ENCOUNTER SEARCHING, APPARATUS AND INSTRUMENTS USED IN EXPLOSIVE ORDNANCE DISPOSAL, APPARATUS AND INSTRUMENTS USED IN IMPROVISED EXPLOSIVE DEVICE DISPOSAL, PERSONAL PROTECTIVE EQUIPMENT FOR THE PROTECTION OF INDIVIDUALS FROM CHEMICAL AND BIOLOGICAL WARFARE AGENTS, SURVEILLANCE APPARATUS AND INSTRUMENTS, VEHICLE BARRIER SYSTEMS, TACTICAL ROBOTS FOR USE IN LAW

ENFORCEMENT AND MILITARY APPLICATIONS, SURVEILLANCE, BOMB DISPOSAL, HAZARDOUS MATERIAL ACCIDENT CLEAN-UP AND HOSTAGE TAKING SITUATIONS, EQUIPMENT AND SYSTEMS FOR CONTAINMENT AND MITIGATION OF WEAPONS OF MASS DESTRUCTION AND CHEMICAL, BIOLOGICAL, RADIOLOGICAL AND NUCLEAR EXPLOSIVE DEVICES AND MATERIALS, CHEMICAL BIOLOGICAL AND RADIOLOGICAL DECONTAMINATION SYSTEMS AND EQUIPMENT, BALLISTIC TESTING EQUIPMENT, BLAST PROTECTION ARMOR FOR VEHICLES AND BLAST PROTECTION SEATS; TECHNOLOGY CONSULTING SERVICES IN THE FIELDS OF THE TECHNICAL PROCEDURES FOR DEALING WITH CHEMICAL, BIOLOGICAL, NUCLEAR AND RADIOLOGICAL INCIDENTS, COUNTER-TERRORIST TRAINING AND TACTICS, CONTRABAND SEARCH AND DETECTION TRAINING AND TACTICS, BOMB COUNTERMEASURES TACTICS, THREAT ANALYSIS SECURITY CONSULTING; IMPACT TESTING SERVICES, NAMELY, TESTING OF DATA RECORDERS AND HIGH G SHOCK TESTING OF AIR, LAND AND SEA VEHICLE; DEVELOPMENT OF TOOLS AND EQUIPMENT FOR USE IN THE MAINTENANCE, REPAIR AND OVERHAUL OF AIRCRAFT, TECHNOLOGICAL CONSULTANCY, ADVISORY AND INFORMATION SERVICES RELATING TO THE ABOVE SERVICES (U.S. CLS. 100 AND 101).
ALYSSA STEEL, EXAMINING ATTORNEY

SN 77-539,465. ALLEN-VANGUARD CORPORATION, OTTAWA, ONTARIO, CANADA, FILED 8-5-2008.

DEFEATING THE THREAT

THE MARK CONSISTS OF STANDARD CHARACTERS WITHOUT CLAIM TO ANY PARTICULAR FONT, STYLE, SIZE, OR COLOR.

PRIORITY CLAIMED UNDER SEC. 44(D) ON CANADA APPLICATION NO. 1382733, FILED 2-8-2008, REG. NO. TMA790037, DATED 2-8-2011, EXPIRES 2-8-2026.

CLASS 1—CHEMICALS

FOR (BASED ON SECTIONS 44(E)(BASED ON INTENT TO USE) CHEMICALS USED IN INDUSTRY; CHEMICAL, BIOLOGICAL AND RADIOLOGICAL DECONTAMINATING FOAM USED FOR BOMB DISPOSAL; (BASED ON INTENT TO USE)CHEMICALS USED IN INDUSTRY; CHEMICAL, BIOLOGICAL AND RADIOLOGICAL DECONTAMINATING CHEMICALS USED FOR BOMB DISPOSAL (U.S. CLS. 1, 5, 6, 10, 26 AND 46).

CLASS 5—PHARMACEUTICALS

FOR (BASED ON SECTIONS 44(E)(BASED ON INTENT TO USE)SKIN DECONTAMINATING LOTION USED AS DISINFECTANTS FOR INDIVIDUALS EXPOSED TO NUCLEAR, BIOLOGICAL OR CHEMICAL DECONTAMINATION (U.S. CLS. 6, 18, 44, 46, 51 AND 52).

CLASS 6—METAL GOODS

FOR (BASED ON SECTIONS 44(E)(BASED ON INTENT TO USE)KITS FOR THE DETECTION AND DIFFUSION OF EXPLOSIVE DEVICES, AND SINGLE LINE KITS FOR MINE/MUNITIONS CLEARANCE AND HIGH RISK SEARCHES, COMPRISING HOOK AND LINE COMPONENTS, NAMELY, SNATCH BLOCKS, REELS, PULLING HANDLES, EYE RINGS, SEIZERS USED TO HOLD, FASTEN OR BIND OBJECTS, ANCHORS, PITONS, FISH HOOKS, SPRING GRIPS, JAW GRIPS, SUCTION PAD ANCHORS, SELF-ADHESIVE ANCHORS, GROUND ANCHORS, CORKSCREW STAKES, EXTENSION RODS, PULLEYS, GROUND PEGS, HOOKS, RINGS, BELT SLINGS, WIRE SLINGS, SLEDGES, PITONS, KARABINERS, WEDGES, BLOCKS, MAIN LINES; HEAVY DUTY HOOK AND LINE KITS FOR MOVING VEHICLES AND HEAVY IMPROVISED EXPLOSIVE DEVICES, WITH REELS, LINES, WEBBING SLINGS, ROUND SLINGS, GROUND ANCHORS, SHACKLES, SNATCH BLOCKS, HOOKS; METAL GOODS, NAMELY, ANCHORS, PITONS AND WIRE SLINGS AND HOOKS; ALL OF THE FOREGOING PRIMARILY OF METAL;(BASED ON INTENT TO USE)SMALL ITEMS OF METAL HARDWARE, NAMELY, NAILS, ADJUSTING SCREWS, EYELETS, METAL HOOKS, METAL CONNECTIVE HINGES, METAL FASTENING COLLARS, METAL CABLES AND WIRES NOT FOR ELECTRICAL PURPOSES, METAL CABLE ROLLERS, AND REELS, NON-ELECTRIC METAL WIRE CLAMPS (U.S. CLS. 2, 12, 13, 14, 23, 25 AND 50).

CLASS 7—MACHINERY

FOR (BASED ON SECTIONS 44(E)(BASED ON INTENT TO USE) EQUIPMENT AND SYSTEMS FOR CONTAINMENT AND MITIGATION OF WEAPONS OF MASS DESTRUCTION AND CHEMICAL, BIOLOGICAL, RADIOLOGICAL AND NUCLEAR EXPLOSIVE DEVICES AND MATERIALS, NAMELY, FOAM INJECTION MACHINES, CONTROLLERS, PUMPS, AERATING NOZZLES AND REUSABLE ENCLOSURES MADE OF BALLISTIC MATERIAL FOR CONTAINING THE EFFECT OF EXPLOSIVE DEVICES AND FOR DECONTAMINATING CHEMICAL AND BIOLOGICAL AGENTS SOLD AS A UNIT; FOAM APPLICATION EQUIPMENT, NAMELY, PORTABLE SELF CONTAINING DECONTAMINATING FOAM APPLICATION EQUIPMENT UNITS DESIGNED FOR PERFORMING EMERGENCY SPOT DECONTAMINATION OF CHEMICAL AND BIOLOGICAL AGENTS ON HARDWARE, STRUCTURAL SURFACES, TERRAIN AND DRUG LABELS; HYDRAULIC RAMS, PNEUMATIC RAMS; (BASED ON INTENT TO USE)MACHINES AND MACHINE TOOLS, NAMELY, POWER DRILLS; AIR AND WATER TANKS (U.S. CLS. 13, 19, 21, 23, 31, 34 AND 35).

CLASS 8—HAND TOOLS

FOR (BASED ON SECTIONS 44(E)(BASED ON INTENT TO USE)SECURITY, SURVEILLANCE AND SEARCH TOOL KITS, COMPRISED OF RETRACTABLE KNIVES, STEEL MEASURING TAPE, LINOLEUM KNIVES, SCISSORS, PAD SAWS, HACKSAWS, TACK EXTRACTORS, CLAW HAMMERS, CLUB HAMMERS, COLD CHISELS, WRECKING BARS, WIRE CUTTERS; BOLT CUTTERS, SCREWDRIVER SETS, WRENCHES, PLIERS, VICES, CLAMPS, CRIMPING IRONS, CABLE STRIPPERS, SEIZERS USED TO HOLD, FASTEN OR BIND OBJECTS, TWEEZERS, SOCKETS SETS AND BITS, HEXAGON WRENCHES, COMBINATION WRENCHES, TELESCOPIC SEARCH MIRRORS, HAND OPERATED SURVEILLANCE APPARATUS AND INSTRUMENTS, NAMELY, DOOR RIPPERS, FLOOR AND CAR ENTRY TOOLS; HAND OPERATED TOOLS USED FOR THE DETECTION AND DIFFUSION OF EXPLOSIVE DEVICES, NAMELY, SCREWDRIVERS, ADJUSTABLE WRENCHES, WRENCH SETS, VICE GRIP WRENCHES, PLIERS, SEIZERS, TWEEZERS, WIRE CUTTERS, TIN SNIPS, KNIVES, BLADE DISPENSERS, FLEXI SAWS, MINI SAWS, SCISSORS, HOOKS, WRECKING BARS, CLAW HAMMERS, TACK LIFTERS, NON-MAGNETIC TOOLS FOR EXPLOSIVE ORDNANCE DISPOSAL, NAMELY, TWEEZERS, PROBES, KNIVES, SCISSORS, HACKSAWS, BLADES, SCRAPERS, WIRE BRUSHES, SCREWDRIVERS, PLIERS, WIRE CUTTERS, WRENCHES, HAMMERS, CHISELS, BARS, SAWS, WIRE STRIPPERS, AND KITS COMPRISING THE FORE-

GOING; HAND OPERATED EXCAVATION TOOLS FOR EXPLOSIVE ORDNANCE DISPOSAL, NAMELY, SHOVELS, PICKS, PRY BARS, SLEDGEHAMMERS, CLUB HAMMERS, CHISELS, SCRAPERS, WRENCH SETS, NON MAGNETIC SHOVELS USED ON UNEXPLODED ORDNANCE, TRIPODS DESIGNED FOR LIFTING HEAVY OBJECTS DURING EXPLOSIVE ORDNANCE DISPOSAL OPERATIONS, HAND OPERATED LIGHTWEIGHT TRIPODS DESIGNED FOR LIFTING SMALLER OBJECTS DURING IMPROVISED EXPLOSIVE ORDNANCE DISPOSAL OPERATIONS; VEHICLE ACCESS HAND-OPERATED TOOLS, NAMELY, REMOTE WINDOW BREAKERS, VEHICLE DOOR HANDLE LIFTERS, VEHICLE KEY/HANDLE CLAMPS, VEHICLE DOOR BUTTON PUSHERS, VEHICLE DOOR TRIM/PANEL REMOVING TOOLS; TOOLS USED FOR EXPLOSIVE ORDNANCE DISPOSAL AND IMPROVISED EXPLOSIVE DEVICE DISPOSAL, NAMELY, TELESCOPIC MANIPULATORS, TOOL CARTS, TRIPODS;(BASED ON INTENT TO USE)HAND OPERATED TOOLS AND IMPLEMENTS, NAMELY, HAMMERS, SHEARS, STRAP ROLLERS, DRILLS, HANDJACKS, AUGERS, AWLS, CLAMPS, FILES, PINCERS, PLANERS, PUNCHES, WRENCHES, SAWS, SCREWDRIVERS, TONGS, NIPPERS, WIRE STRIPPERS, VICES, PRUNERS, CHISELS, DRILL FILES, KNIVES, PLIERS; RATCHET WRENCH SETS (U.S. CLS. 23, 28 AND 44).

CLASS 9—ELECTRICAL AND SCIENTIFIC APPARATUS

FOR (BASED ON SECTIONS 44(E)(BASED ON INTENT TO USE)SCIENTIFIC, SURVEYING, PHOTOGRAPHIC, CINEMATOGRAPHIC, OPTICAL, MEASURING, SIGNALING, LIFE-SAVING APPARATUS AND INSTRUMENTS, NAMELY, SECURITY AND SURVEILLANCE INSTRUMENTS FOR USE IN THE FIELDS OF SECURITY, CONTRABAND AND COUNTER-TERRORIST SEARCHING, NAMELY, HAND HELD METAL DETECTORS, GENERAL PURPOSE METAL DETECTORS, HIGH SENSITIVITY METAL DETECTORS, DUAL PURPOSE METAL DETECTORS AND WALK THROUGH METAL DETECTORS, PORTABLE EXPLOSIVES DETECTORS, CONTRABAND DETECTORS, NAMELY, HAND HELD ELECTRONIC CONTRABAND DETECTORS THAT INDICATE THE PRESENCE OF HIDDEN MATERIALS BY SIGNALING UNEXPECTED CHANGES IN THE DENSITY OR THICKNESS OF A SURFACE THROUGH THE RELEASE OF GAMMA RAYS; OPTICAL APPARATUS AND INSTRUMENTS FOR USE IN THE FIELDS OF SECURITY AND CONTRABAND AND COUNTER-TERRORISTS SEARCHING, AND IN FORENSIC POST BLAST EXAMINATIONS, NAMELY, LIGHT PROBES, FLEXIBLE AND RIGID ENDOSCOPES, TELESCOPIC ARMS FOR ENDOSCOPES; ZOOM CAMERAS, INFRARED CAMERAS FOR DAY AND NIGHT OPERATIONS; FERROUS ORDNANCE LOCATORS, NAMELY, PORTABLE DETECTORS FOR LOCATING FERROUS OBJECTS UNDER GROUND OR WATER AND SUITABLE FOR THE ACCURATE LOCATION OF BOMBS, PIPES AND WRECKAGE; COMPUTER MONITORS, COMPUTER HARDWARE, COMPUTER SOFTWARE, NAMELY, APPLICATIONS SOFTWARE FOR USE IN ASSOCIATION WITH LOCATING FERROUS OBJECTS UNDER GROUND AND WATER AND FOR THE ACCURATE LOCATION OF BOMBS, PIPES AND WRECKAGE; APPARATUS FOR THE DETECTION AND DIFFUSION OF EXPLOSIVE DEVICES, USED IN IMPROVISED EXPLOSIVE DEVICE DISPOSAL, NAMELY, ELECTRONIC BOMB DETECTORS AND DIFFUSERS, ELECTRONIC COUNTER MEASURES EQUIPMENT, NAMELY, PORTABLE COMMUNICATION JAMMERS, MODULAR JAMMERS, NAMELY, ELECTRONIC APPARATUS THAT INHIBIT RADIO CONTROLLED IMPROVISED EXPLOSIVE DEVICE SIGNALS THAT MAY BE USED TO DETONATE EXPLOSIVE DEVICES, ELECTRONIC STETHOSCOPES FOR THE DETECTION OF MECHANICAL RUN BACK TIMERS AND ELECTRONIC TIMING SYSTEMS IN IMPROVISED EXPLOSIVE DEVICES, NON-LINEAR JUNCTION DETECTORS, NAMELY, ELECTRONIC APPARATUS AND INSTRUMENTS FOR DETECTING ELECTRONIC CIRCUITS FOUND IN EXPLOSIVE DEVICES AND RADIO TRANSMITTERS, ELECTRONIC CABLE DETECTORS USED TO LOCATE UNDERGROUND COMMAND WIRE CABLES, ELECTRONIC LETTER BOMB DETECTORS, X-RAY PARCEL BOMB DETECTORS, PORTABLE X-RAY GENERATORS, PORTABLE X-RAY COMPUTER USED TO EXAMINE SUS-

PECT PACKAGES THAT MAY CONTAIN IMPROVISED EXPLOSIVE DEVICES OR OTHER INACCESSIBLE AREAS WHERE CONTRABAND MAY BE HIDDEN; LAND MINE CLEARING APPARATUS AND EQUIPMENT, NAMELY, LAND MINE DETECTORS, NAMELY, NON MAGNETIC LAND MINE PRODDERS, REPLICA LAND MINE TRAINING AIDS; ELECTRONIC DISRUPTORS, NAMELY, RECOILLESS DISPOSABLE DISRUPTORS USED TO DISRUPT EXPLOSIVE DEVICES, NAMELY, WATER JET DISRUPTORS USED TO DISRUPT THIN WALLED EXPLOSIVE DEVICES, DISPOSABLE CAR TRUNK DISRUPTORS USED TO DISRUPT EXPLOSIVE DEVICES IN VEHICLES, PERSONAL PROTECTIVE EQUIPMENT FOR THE PROTECTION OF INDIVIDUALS FROM CHEMICAL AND BIOLOGICAL WARFARE AGENTS, NAMELY, PROTECTIVE SUITS, PROTECTIVE GLOVES AND PROTECTIVE OVER BOOTS, GAS MASKS, ELECTRO-VOICE AMPLIFIERS FOR GAS MASKS, CANISTERS DESIGNED TO HELP PROVIDE RESPIRATORY PROTECTION AGAINST AIRBORNE CONTAMINANTS, NEXT TO SKIN PROTECTIVE EQUIPMENT, NAMELY, WET SUITS, DRY SUITS, LIGHT WEIGHT PROTECTIVE SUITS, CHEMICAL PROTECTIVE UNDERGARMENTS; PROTECTIVE CLOTHING USED IN IMPROVISED EXPLOSIVE DEVICE DISPOSAL, NAMELY, BOMB SUITS, LIQUID COOLING UNDER SUITS; SEARCH SUITS, NAMELY, BODY ARMOUR SUITS DESIGNED FOR USE WHEN SEARCHING FOR IMPROVISED EXPLOSIVE DEVICES; WIRELESS RADIO SYSTEMS FOR USE WITH BOMB SUITS COMPOSED OF RADIOS, MOBILE RADIOS, RADIO TRANSMITTERS, RADIO RECEIVERS, ANTENNAS, AMPLIFIERS, ELECTRICAL AND POWER WIRES, CABLE AND ELECTRICAL CONNECTORS, SIGNAL PROCESSORS, CONVERTERS, DIGITAL FILTERS TO PROTECT AGAINST CHANNEL INTERFERENCE; DEMINING BALLISTIC PROTECTION, NAMELY, LAND MINE CLEARANCE VESTS AND HELMETS WITH VISORS; SAFETY EQUIPMENT, NAMELY, FOREARM PROTECTION FOR USE IN ASSOCIATION WITH MANUAL DOOR RAMS OR DOOR RIPPERS; SURVEILLANCE SCOPES, HAND HELD THERMAL IMAGERS, SPOTTING SCOPES, NAMELY, LIGHTWEIGHT TELESCOPES, INFRARED TELESCOPIC CAMERAS, SURVEILLANCE PROBES, NAMELY, UNDER DOOR REMOTE VIEWING TOOLS, MICRO-THROUGH-WALL VIEWING TOOLS, AUDIO PROBES, PEEPHOLE VIEWERS, REVERSE PEEPHOLE SCOPES, MIRRORS, TELESCOPIC MIRRORS, TELESCOPIC SEARCH MIRRORS, CONVEX MIRRORS, PLAIN MIRRORS, RECTANGULAR MIRRORS, MIRROR SLEEVES, CLIP ON MIRRORS, TELESCOPIC ARMS FOR SEARCH MIRRORS, POCKET SEARCH MIRRORS, UNDER VEHICLE SEARCH MIRRORS, SEARCH MIRRORS WITH NON-ROTATIONAL ALUMINUM POLES, PADDED FOREARM RESTS AND FOAM GRIPS, FOREARM STRAPS FOR USE WITH TELESCOPIC ARMS FOR SEARCH MIRRORS, BATTERY HANDLES; PORTABLE COMMAND AND CONTROL CONSOLES, NAMELY, COMPUTER HARDWARE AND SOFTWARE FOR THE OPERATION OF ROBOTS AND RF WIRELESS CONTROL SYSTEMS, COMPRISED OF RF TRANSMITTERS AND RECEIVERS, INTEGRATED SPREAD SPECTRUM RF CONTROL SYSTEMS, NAMELY, ELECTRONIC VIDEO APPARATUS THAT GIVE CONTROL AND FLICKER FREE VIDEO OVER LONG DISTANCES IN BUILT UP AREAS AND INSIDE BUILDINGS, SLIP RING DRUM CABLES, ZOOM CAMERAS, INFRARED CAMERAS FOR DAY AND NIGHT OPERATIONS, LASERS NOT FOR MEDICAL USE, SHOCK TUBE INITIATORS, EXTENSION BOOMS, DISRUPT OR MOUNTS; BLAST PROTECTION ARMOR FOR VEHICLES; BLAST PROTECTION SEATS FOR USE IN MILITARY AND SECURITY/POLICE VEHICLES; RECHARGERS FOR FLASHLIGHTS, BATTERY PACKS, BATTERY CHARGES, BATTERY HANDLES; BALLISTIC TESTING EQUIPMENT, NAMELY, MULTI-BARREL FIRING RECEIVER FOR FIRING AMMUNITION, HYDRAULIC TARGET RETENTION TEST FRAMES, ADJUSTABLE TORSO MOULDS FOR ARMOR AND BODY ARMOR, AMMUNITIONS AND WEAPONS; INSTRUMENTS FOR THE MEASUREMENT OF BALLISTIC VELOCITY AND RATE OF FIRE; PERSONAL PROTECTIVE EQUIPMENT FOR HANDS AND FEET OF DEMINING AND MINE CLEARANCE PERSONNEL, NAMELY, CONICAL HAND PROTECTORS, OVERHAND HAND PROTECTORS, RAISED FOOT PROTECTION PLATFORM FOR WALKING; PERSONAL PROTECTIVE EQUIPMENT USED TO REDUCE RISK OF INJURY FROM BLAST AND BAL-

LISTIC THREATS, NAMELY, MODULAR INTEGRATED SUITS, NAMELY, UPPER BODY VESTS, REMOVABLE SLEEVES, TROUSERS, GROIN PROTECTORS, NECK PROTECTORS, HELMET-MOUNTED RIGID FACIAL PROTECTORS; PERSONAL PROTECTIVE EQUIPMENT USED TO PROTECT PERSONNEL FROM HEAT STRESS, NAMELY, ELECTRONIC CHILLERS, ICE-BASED CHILLERS, TETHERS, LIQUID CONNECTORS, COOLING VESTS, LIQUID CIRCULATING GARMENTS; PROTECTIVE CLOTHING USED IN IMPROVISED EXPLOSIVE DEVICE DISPOSAL, NAMELY, BOMB DISPOSAL SUITS, BOMB DISPOSAL HELMETS WITH VISORS; SEARCH SUITS, NAMELY, BODY ARMOR SUITS DESIGNED FOR USE WHEN SEARCHING FOR IMPROVISED EXPLOSIVE DEVICES; TACTICAL ROBOTS FOR USE IN LAW ENFORCEMENT AND MILITARY APPLICATIONS, SURVEILLANCE, BOMB DISPOSAL, HAZARDOUS MATERIAL ACCIDENT CLEAN-UP AND HOSTAGE TAKING SITUATIONS, RECONNAISSANCE AND WEAPON DELIVERY IN RAPID DEPLOYMENT SCENARIOS WITHIN AREAS OF RESTRICTED PHYSICAL AREAS AND STRUCTURAL PARTS AND ACCESSORIES THEREFOR, NAMELY, BATTERY PACKS AND CHARGERS SOLD AS A UNIT; POWER OPERATED SEARCH TOOL KITS COMPRISED OF POWER OPERATED CORDLESS DRILLS WITH CORDLESS DRILL CHARGERS AND DRILL BITS, CENTRE PUNCHES; (BASED ON SECTION (B)): REMOVABLE CLAWS BEING PARTS OF FLEXIBLE AND RIGID ENDOSCOPES AND TELESCOPIC ARMS; PHOTOGRAPHIC AND CINEMATOGRAPHIC APPARATUS AND INSTRUMENTS, NAMELY, DIGITAL AND VIDEO CAMERAS, USED WITH UNDER VEHICLE TROLLEYS, CAMERAS WITH INFRARED SENSORS, FIBER OPTIC SCOPES FOR VISUAL INSPECTION BEHIND OR INSIDE CLOSED AREAS, ILLUMINATED MAGNIFIERS; X-RAY KITS COMPRISED OF PORTABLE X-RAY MACHINES FOR NON-MEDICAL USE, NOTEBOOK PERSONAL COMPUTER, BATTERY, AND CASES THEREFOR; COMPUTER SOFTWARE, NAMELY, APPLICATION SOFTWARE FOR BALLISTICS TESTING; BOMB SUPPRESSION BLANKETS, SECURITY MIRRORS ON POLES WITH A LIGHT FIXTURE; VIDEO SEARCH KITS COMPRISED OF VIDEO CAMERAS AFFIXED TO FLEXIBLE UNDER VEHICLE TROLLEYS AND LCD SCREENS FOR VIEWING IMAGES; COMPUTER SOFTWARE, NAMELY, APPLICATION SOFTWARE USED FOR STORING MEASUREMENTS OVER SCANNED AREAS FOR DOWNLOADING AND PRESENTATION ON A PERSONAL COMPUTER, ELECTRONIC SENSORS USED TO RECOGNIZE AND RECORD THE SEVERITY OF BLASTS AND BLUNT IMPACTS, WIRELESS RADIO SYSTEM FOR USE WITH BOMB SUITS; COMPUTER HARDWARE COMMUNICATION SERVERS FOR USE IN CONNECTION WITH BOMB SUITS; HAND-HELD RADIATION DETECTORS FOR LOCATING AND IDENTIFYING CONCEALED NUCLEAR MATERIALS, PORTABLE CARBON DIOXIDE SENSORS FOR THE DETECTION OF CARBON DIOXIDE AND LIFE SOURCES, FALSE PANEL DISTANCE METERS, NAMELY, ULTRASONIC DISTANCE ESTIMATORS USED TO DETERMINE THE DISTANCE OF CONTAINERS AND OTHER CAVITIES WHEN SEARCHING FOR FALSE PANELS; PROTECTIVE LEATHER GLOVES FOR HANDLING EXPLOSIVE MATERIALS (U.S. CLS. 21, 23, 26, 36 AND 38).

CLASS 11—ENVIRONMENTAL CONTROL APPARATUS

FOR (BASED ON SECTIONS 44(E)(BASED ON INTENT TO USE) APPARATUS FOR LIGHTING, NAMELY, FLORESCENT LAMPS, SPARE LAMPS, FLASHLIGHTS, FLASHLIGHTS AND RECHARGES SOLD AS A UNIT, SEARCHLIGHTS, PORTABLE FLOODLIGHTS, POCKET ULTRAVIOLET LAMPS NOT FOR MEDICAL PURPOSES AND SPOTLIGHTS, FLASHLIGHTS INCORPORATING A MIRROR (U.S. CLS. 13, 21, 23, 31 AND 34).

CLASS 12—VEHICLES

FOR (BASED ON SECTIONS 44(E)(BASED ON INTENT TO USE) RESPONSE VEHICLES, NAMELY, LAND VEHICLES EQUIPPED WITH EXPLOSIVE ORDNANCE AND IMPROVISED EXPLOSIVE DEVICE DISPOSAL EQUIPMENT; EMERGENCY RESPONSE TRAILERS CONTAINING BLAST SUPPRESSANT FOAM APPLICATION EQUIPMENT (U.S. CLS. 19, 21, 23, 31, 35 AND 44).

CLASS 13—FIREARMS

FOR (BASED ON SECTIONS 44(E))(BASED ON INTENT TO USE) APPARATUS AND INSTRUMENTS USED IN EXPLOSIVE ORDNANCE DISPOSAL, NAMELY, SMALL SHAPED AND LARGE SHAPED COPPER CONE CHARGES, SMALL SHAPED MAGNESIUM CONE CHARGES, SMALL SHAPED LIQUESCENT CONE CHARGES, LARGE SELF FORGING FRAGMENT CONES; DE-ARMERS DESIGNED TO PROJECT A VARIETY OF STEEL SLUGS AT HIGH VELOCITY INTO THE FUZES OR PISTOLS OF AIR DROPPED BOMBS; INTEGRATED WEAPONS CARRIERS; NON-ELECTRIC-EXPLOSIVE-DELIVERY TOOL KITS SPECIFICALLY DESIGNED TO BREAK THROUGH WINDOWS, NAMELY, DUAL INITIATORS USED AS DETONATORS, INITIATOR POLE MOUNTS, INITIATOR REEL MOUNTS, INDEXING JOINTS, POLE EXTENSIONS, HITCH PINS, POLE SIDE GRIP HANDLES, POLE TRANSITIONS, CHARGE PLATES, SHOCK TUBE STORAGE REELS; FORCED-ENTRY TOOLS, NAMELY, SAFETY INITIATORS AS DETONATORS USED FOR EXPLOSIVE FIRING; (BASED ON INTENT TO USE) EXPLOSIVE WALL BREACHING EQUIPMENT COMPRISED OF A PLASTIC SHELL AND EXPLOSIVE DEVICES; MOBILE COOLING CASES USED TO PROTECT ELECTRONICS FROM HEAT (U.S. CLS. 2 AND 9).

CLASS 16—PAPER GOODS AND PRINTED MATTER

FOR (BASED ON SECTIONS 44(E))(BASED ON INTENT TO USE) PRINTED MATERIALS, NAMELY, INSTRUCTION MANUALS DETAILING THE USE OF TACTICAL HOOK AND LINE TECHNIQUES IN EXPLOSIVE ORDNANCE DISPOSAL OPERATIONS; OWNER MANUALS AND DOCUMENTATION IN THE NATURE OF TRAINING MANUALS RELATING TO TACTICAL ROBOTS, COMPUTER HARDWARE AND SOFTWARE FOR THE OPERATION OF SAID ROBOTS AND RF WIRELESS CONTROL SYSTEMS; PRINTED SECURITY SEALS USED TO SEAL PARCELS; (BASED ON INTENT TO USE)PRINTED MATTER AND INSTRUCTIONAL AND TEACHING MATERIAL, NAMELY, BOOKS AND MANUALS IN THE FIELDS OF EQUIPMENT TRAINING, NAMELY, NUCLEAR, BIOLOGICAL AND CHEMICAL CLEAN-UP, EXPLOSIVE ORDNANCE DETECTION AND DISPOSAL, SECURITY SURVEILLANCE AND SEARCH, SECURITY CONTRABAND AND COUNTER-TERRORIST SEARCHING, IMPROVISED EXPLOSIVE DEVICE DISPOSAL (U.S. CLS. 2, 5, 22, 23, 29, 37, 38 AND 50).

CLASS 20—FURNITURE AND ARTICLES NOT OTHERWISE CLASSIFIED

FOR (BASED ON SECTIONS 44(E))(BASED ON INTENT TO USE) BOMB BLAST INHIBITORS, NAMELY, NON-METAL BOMB BLAST SUPPRESSION BINS, NON-METAL LIGHTWEIGHT CONTAINERS FOR THE ISOLATION AND TRANSPORT, CONTAINMENT, MITIGATION AND DESTRUCTION OF SUSPECT PACKAGES;(BASED ON INTENT TO USE)NON-METAL DOOR WEDGES, NON-METAL FASTENING ANCHORS FOR GRIPPING TO FLAT SURFACES AND FOR HOOKS AND LINES AND ATTACHING SNATCH BLOCKS AND OTHER LINKS; DOORSTOP OF PLASTIC; NON-METAL CLAMPS; NON-METAL GROUND PEGS; NON-METAL PULLEYS; HAND-OPERATED NON-METAL REELS FOR STORING AND DEPLOYING LINES; NON-METAL SECURITY AND SURVEILLANCE TOOL KITS COMPRISED OF ANCHORS, CLAMPS, GROUND PEGS, HAND-OPERATED REELS, AND METAL SNATCH BLOCKS, REELS, GRIPS, SEIZERS, CORDS, STRINGS AND LINES, ANCHORS, PITONS AND WIRE SLINGS, HOOKS AND ROPE; NON-METAL EXPLOSIVE DEVICE DETECTION AND DIFFUSION TOOL KITS COMPRISED OF ANCHORS, CLAMPS, GROUND PEGS, HAND-OPERATED REELS, AND METAL SNATCH BLOCKS, REELS, GRIPS, SEIZERS, CORDS, STRINGS AND LINES, ANCHORS, PITONS, WIRE SLINGS, HOOKS AND ROPE (U.S. CLS. 2, 13, 22, 25, 32 AND 50).

CLASS 22—CORDAGE AND FIBERS

FOR (BASED ON INTENT TO USE)ROPES, STRINGS; ROPES, NON-METAL LINES AND CABLE STRAPS, TEXTILE CORDS, NON-METAL SLINGS FOR HOISTING AND HANDLING LOADS; SECURITY AND SURVEILLANCE KITS COMPRISING OF NON-METAL GOODS, NAMELY, ROPES, NON-METAL STRAPS AND LINES, SLINGS, TEXTILE CORDS AND SNATCH BLOCKS, REELS, GRIPS, SEIZERS, CORDS, STRINGS AND LINES; DETECTION AND DIFFUSION OF EXPLOSIVE DEVICES KITS COMPRISING OF NON-METAL GOODS, NAMELY, ROPES, NON-METAL SNAPS AND LINES, SLINGS, TEXTILE CORDS, AND METAL SNATCH BLOCKS, REELS, GRIPS, SEIZERS, CORDS, STRINGS AND LINES, ANCHORS, PITONS AND WIRE SLINGS, HOOKS, ROPE; NYLON CORD; LETTER BOMB CONTAINMENT BAGS, STRINGS AND LINES THERETO, SHOCK CORDS, ALL-PURPOSE STRAPS AND LINES THERETO (U.S. CLS. 1, 2, 7, 19, 22, 42 AND 50).

CLASS 35—ADVERTISING AND BUSINESS

FOR (BASED ON 44(E))(BASED ON INTENT TO USE) MAIL ORDER CATALOG, ELECTRONIC CATALOG, MAIL ORDER, ON-LINE ORDERING SERVICES FEATURING SECURITY APPARATUS AND HARDWARE;(-BASED ON INTENT TO USE)ADVERTISING; BUSINESS MANAGEMENT; BUSINESS ADMINISTRATION (U.S. CLS. 100, 101 AND 102).

CLASS 41—EDUCATION AND ENTERTAINMENT

FOR (BASED ON SECTIONS 44(E))(BASED ON INTENT TO USE) EDUCATION SERVICES, NAMELY, PROVIDING CLASSES, SEMINARS, WORKSHOPS IN THE FIELDS OF EQUIPMENT TRAINING, NAMELY, NUCLEAR, BIOLOGICAL AND CHEMICAL CLEAN-UP, EXPLOSIVE ORDNANCE DETECTION AND DISPOSAL, SECURITY SURVEILLANCE AND SEARCH, SECURITY CONTRABAND AND COUNTER-TERRORIST SEARCHING, IMPROVISED EXPLOSIVE DEVICE DISPOSAL; PROVIDING OF EDUCATION TRAINING IN THE FIELDS OF EQUIPMENT TRAINING, NAMELY, NUCLEAR, BIOLOGICAL AND CHEMICAL CLEAN-UP, EXPLOSIVE ORDNANCE DETECTION AND DISPOSAL, SECURITY SURVEILLANCE AND SEARCH, SECURITY CONTRABAND AND COUNTER-TERRORISM SEARCHING, IMPROVISED EXPLOSIVE DEVICE DISPOSAL; EDUCATION AND TRAINING SERVICES, NAMELY, EDUCATIONAL TRAINING SERVICES IN RESPECT OF THE OPERATION, INSTALLATION, MAINTENANCE, AND REPAIR OF APPARATUS AND INSTRUMENTS USED IN THE FIELDS OF SECRET AND IN CONTRABAND AND COUNTER-TERRORIST SEARCHING; EDUCATIONAL TRAINING SERVICES, NAMELY, TRAINING FOR PROCEDURES FOR DEALING WITH CHEMICAL, BIOLOGICAL, NUCLEAR AND RADIOLOGICAL INCIDENTS, COUNTER-TERRORIST AND CONTRABAND SEARCH TRAINING, BOMB AWARENESS AND COUNTER-MEASURES TRAINING, THREAT ANALYSIS AND PLANNING TRAINING, IMPROVISED EXPLOSIVE DEVICE DISPOSAL TRAINING (U.S. CLS. 100, 101 AND 107).

CLASS 42—SCIENTIFIC AND COMPUTER SERVICES

FOR (BASED ON SECTIONS 44(E))(BASED ON INTENT TO USE) SCIENTIFIC RESEARCH AND TECHNOLOGICAL CONSULTATION IN THE TECHNOLOGY FIELD OF BALLISTIC TESTING SERVICES, NAMELY, TESTING AND EVALUATION OF WEAPON, AMMUNITION AND ARMOR; DESIGN, DEVELOPMENT AND TESTING FOR OTHERS OF APPARATUS AND INSTRUMENTS USED IN THE FIELD OF SECURITY AND IN CONTRABAND ENCOUNTER SEARCHING, APPARATUS AND INSTRUMENTS USED IN EXPLOSIVE ORDNANCE DISPOSAL, APPARATUS AND INSTRUMENTS USED IN IMPROVISED EXPLOSIVE DEVICE DISPOSAL, PERSONAL PROTECTIVE EQUIPMENT FOR THE PROTECTION OF INDIVIDUALS FROM CHEMICAL AND BIOLOGICAL WARFARE AGENTS, SURVEILLANCE APPARATUS AND INSTRUMENTS, VEHICLE BARRIER SYSTEMS, TACTICAL ROBOTS FOR USE IN LAW

ENFORCEMENT AND MILITARY APPLICATIONS, SURVEILLANCE, BOMB DISPOSAL, HAZARDOUS MATERIAL ACCIDENT CLEAN-UP AND HOSTAGE TAKING SITUATIONS, EQUIPMENT AND SYSTEMS FOR CONTAINMENT AND MITIGATION OF WEAPONS OF MASS DESTRUCTION AND CHEMICAL, BIOLOGICAL, RADIOLOGICAL AND NUCLEAR EXPLOSIVE DEVICES AND MATERIALS, CHEMICAL BIOLOGICAL AND RADIOLOGICAL DECONTAMINATION SYSTEMS AND EQUIPMENT, BALLISTIC TESTING EQUIPMENT, BLAST PROTECTION ARMOR FOR VEHICLES AND BLAST PROTECTION SEATS; TECHNOLOGY CONSULTING SERVICES IN THE FIELDS OF THE TECHNICAL PROCEDURES FOR DEALING WITH CHEMICAL, BIOLOGICAL, NUCLEAR AND RADIOLOGICAL INCIDENTS, COUNTER-TERRORIST TRAINING AND TACTICS, CONTRABAND SEARCH AND DETECTION TRAINING AND TACTICS, BOMB COUNTERMEASURES TACTICS, THREAT ANALYSIS SECURITY CONSULTING; IMPACT TESTING SERVICES, NAMELY, TESTING OF DATA RECORDERS AND HIGH G SHOCK TESTING OF AIR, LAND AND SEA VEHICLE; DEVELOPMENT OF TOOLS AND EQUIPMENT FOR USE IN THE MAINTENANCE, REPAIR AND OVERHAUL OF AIRCRAFT, TECHNOLOGICAL CONSULTANCY, ADVISORY AND INFORMATION SERVICES RELATING TO THE ABOVE SERVICES (U.S. CLS. 100 AND 101).

ALYSSA STEEL, EXAMINING ATTORNEY

SN 77-539,484. ALLEN-VANGUARD CORPORATION, OTTAWA, ONTARIO, CANADA, FILED 8-5-2008.

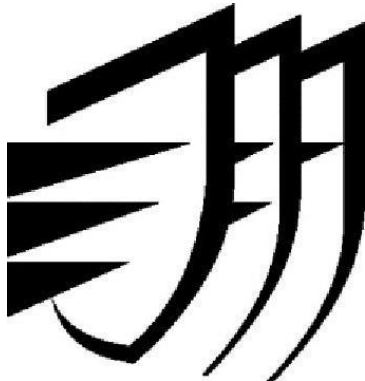

PRIORITY CLAIMED UNDER SEC. 44(D) ON CANADA APPLICATION NO. 1382734, FILED 2-8-2008, REG. NO. TMA790035, DATED 2-8-2011, EXPIRES 2-8-2026.

THE MARK CONSISTS OF A GRAPHIC OF THREE OVERLAPPING SHIELDS FEATURING THREE TRIANGLES.

CLASS 1—CHEMICALS

FOR (BASED ON SECTIONS 44(E)(BASED ON INTENT TO USE) CHEMICALS USED IN INDUSTRY; CHEMICAL, BIOLOGICAL AND RADIOLOGICAL DECONTAMINATING FOAM USED FOR BOMB DISPOSAL; (BASED ON INTENT TO USE)CHEMICALS USED IN INDUSTRY; CHEMICAL, BIOLOGICAL AND RADIOLOGICAL DECONTAMINATING CHEMICALS USED FOR BOMB DISPOSAL (U.S. CLS. 1, 5, 6, 10, 26 AND 46).

CLASS 5—PHARMACEUTICALS

FOR (BASED ON SECTIONS 44(E)(BASED ON INTENT TO USE)SKIN DECONTAMINATING LOTION USED AS DISINFECTANTS FOR INDIVIDUALS EXPOSED TO NUCLEAR, BIOLOGICAL OR CHEMICAL DECONTAMINATION (U.S. CLS. 6, 18, 44, 46, 51 AND 52).

CLASS 6—METAL GOODS

FOR (BASED ON SECTIONS 44(E)(BASED ON INTENT TO USE) KITS FOR THE DETECTION AND DIFFUSION OF EXPLOSIVE DEVICES, AND SINGLE LINE KITS FOR MINE/MUNITIONS CLEARANCE AND HIGH RISK SEARCHES, COMPRISING HOOK AND LINE COMPONENTS, NAMELY, SNATCH BLOCKS, REELS, PULLING HANDLES, EYE RINGS, SEIZERS USED TO HOLD, FASTEN OR BIND OBJECTS, ANCHORS, PITONS, FISH HOOKS, SPRING GRIPS, JAW GRIPS, SUCTION PAD ANCHORS, SELF-ADHESIVE ANCHORS, GROUND ANCHORS, CORKSCREW STAKES, EXTENSION RODS, PULLEYS, GROUND PEGS, HOOKS, RINGS, BELT SLINGS, WIRE SLINGS, SLEDGES, PITONS, KARABINERS, WEDGES, BLOCKS, MAIN LINES; HEAVY DUTY HOOK AND LINE KITS FOR MOVING VEHICLES AND HEAVY IMPROVISED EXPLOSIVE DEVICES, WITH REELS, LINES, WEBBING SLINGS, ROUND SLINGS, GROUND ANCHORS, SHACKLES, SNATCH BLOCKS, HOOKS; METAL GOODS, NAMELY, ANCHORS, PITONS AND WIRE SLINGS AND HOOKS; ALL OF THE FOREGOING PRIMARILY OF METAL; (BASED ON INTENT TO USE)SMALL ITEMS OF METAL HARDWARE, NAMELY, NAILS, ADJUSTING SCREWS, EYELETS, METAL HOOKS, METAL CONNECTIVE HINGES, METAL FASTENING COLLARS, METAL CABLES AND WIRES NOT FOR ELECTRICAL PURPOSES, METAL CABLE ROLLERS, AND REELS, NON-ELECTRIC METAL WIRE CLAMPS (U.S. CLS. 2, 12, 13, 14, 23, 25 AND 50).

CLASS 7—MACHINERY

FOR (BASED ON SECTIONS 44(E)(BASED ON INTENT TO USE) EQUIPMENT AND SYSTEMS FOR CONTAINMENT AND MITIGATION OF WEAPONS OF MASS DESTRUCTION AND CHEMICAL, BIOLOGICAL, RADIOLOGICAL AND NUCLEAR EXPLOSIVE DEVICES AND MATERIALS, NAMELY, FOAM INJECTION MACHINES, CONTROLLERS, PUMPS, AERATING NOZZLES AND REUSABLE ENCLOSURES MADE OF BALLISTIC MATERIAL FOR CONTAINING THE EFFECT OF EXPLOSIVE DEVICES AND FOR DECONTAMINATING CHEMICAL AND BIOLOGICAL AGENTS SOLD AS A UNIT; FOAM APPLICATION EQUIPMENT, NAMELY, PORTABLE SELF CONTAINING DECONTAMINATING FOAM APPLICATION EQUIPMENT UNITS DESIGNED FOR PERFORMING EMERGENCY SPOT DECONTAMINATION OF CHEMICAL AND BIOLOGICAL AGENTS ON HARDWARE, STRUCTURAL SURFACES, TERRAIN AND DRUG LABELS; HYDRAULIC RAMS, PNEUMATIC RAMS; (BASED ON INTENT TO USE)MACHINES AND MACHINE TOOLS, NAMELY, POWER DRILLS; AIR AND WATER TANKS (U.S. CLS. 13, 19, 21, 23, 31, 34 AND 35).

CLASS 8—HAND TOOLS

FOR (BASED ON SECTIONS 44(E)(BASED ON INTENT TO USE)SECURITY, SURVEILLANCE AND SEARCH TOOL KITS, COMPRISED OF RETRACTABLE KNIVES, STEEL MEASURING TAPE, LINOLEUM KNIVES, SCISSORS, PAD SAWS, HACKSAWS, TACK EXTRACTORS, CLAW HAMMERS, CLUB HAMMERS, COLD CHISELS, WRECKING BARS, WIRE CUTTERS; BOLT CUTTERS, SCREWDRIVER SETS, WRENCHES, PLIERS, VICES, CLAMPS, CRIMPING IRONS, CABLE STRIPPERS, SEIZERS USED TO HOLD, FASTEN OR BIND OBJECTS, TWEEZERS, SOCKETS SETS AND BITS, HEXAGON WRENCHES, COMBINATION WRENCHES, TELESCOPIC SEARCH MIRRORS, HAND OPERATED SURVEILLANCE APPARATUS AND INSTRUMENTS, NAMELY, DOOR RIPPERS, FLOOR AND CAR ENTRY TOOLS; HAND OPERATED TOOLS USED FOR THE DETECTION AND DIFFUSION OF EXPLOSIVE DEVICES, NAMELY, SCREWDRIVERS, ADJUSTABLE WRENCHES, WRENCH SETS, VICE GRIP WRENCHES, PLIERS, SEIZERS, TWEEZERS, WIRE CUTTERS, TIN SNIPS, KNIVES, BLADE DISPENSERS, FLEXI SAWS, MINI SAWS, SCISSORS, HOOKS, WRECKING BARS, CLAW HAMMERS, TACK LIFTERS, NON-MAGNETIC TOOLS FOR EXPLOSIVE ORDNANCE DISPOSAL, NAMELY, TWEEZERS, PROBES, KNIVES, SCISSORS, HACKSAWS, BLADES, SCRAPERS, WIRE BRUSHES, SCREWDRIVERS, PLIERS, WIRE CUTTERS, WRENCHES, HAMMERS, CHISELS, BARS, SAWS, WIRE STRIPPERS, AND KITS COMPRISING THE FORE-

GOING; HAND OPERATED EXCAVATION TOOLS FOR EXPLOSIVE ORDNANCE DISPOSAL, NAMELY, SHOVELS, PICKS, PRY BARS, SLEDGEHAMMERS, CLUB HAMMERS, CHISELS, SCRAPERS, WRENCH SETS, NON MAGNETIC SHOVELS USED ON UNEXPLODED ORDNANCE, TRIPODS DESIGNED FOR LIFTING HEAVY OBJECTS DURING EXPLOSIVE ORDNANCE DISPOSAL OPERATIONS, HAND OPERATED LIGHTWEIGHT TRIPODS DESIGNED FOR LIFTING SMALLER OBJECTS DURING IMPROVISED EXPLOSIVE ORDNANCE DISPOSAL OPERATIONS; VEHICLE ACCESS HAND-OPERATED TOOLS, NAMELY, REMOTE WINDOW BREAKERS, VEHICLE DOOR HANDLE LIFTERS, VEHICLE KEY/HANDLE CLAMPS, VEHICLE DOOR BUTTON PUSHERS, VEHICLE DOOR TRIM/PANEL REMOVING TOOLS; TOOLS USED FOR EXPLOSIVE ORDNANCE DISPOSAL AND IMPROVISED EXPLOSIVE DEVICE DISPOSAL, NAMELY, TELESCOPIC MANIPULATORS, TOOL CARTS, TRIPODS;(BASED ON INTENT TO USE)HAND OPERATED TOOLS AND IMPLEMENTS, NAMELY, HAMMERS, SHEARS, STRAP ROLLERS, DRILLS, HANDJACKS, AUGERS, AWLS, CLAMPS, FILES, PINCERS, PLANERS, PUNCHES, WRENCHES, SAWS, SCREWDRIVERS, TONGS, NIPPERS, WIRE STRIPPERS, VICES, PRUNERS, CHISELS, DRILL FILES, KNIVES, PLIERS; RATCHET WRENCH SETS (U.S. CLS. 23, 28 AND 44).

CLASS 9—ELECTRICAL AND SCIENTIFIC APPARATUS

FOR (BASED ON SECTIONS 44(E))(BASED ON INTENT TO USE)SCIENTIFIC, SURVEYING, PHOTOGRAPHIC, CINEMATOGRAPHIC, OPTICAL, MEASURING, SIGNALING, LIFE-SAVING APPARATUS AND INSTRUMENTS, NAMELY, SECURITY AND SURVEILLANCE INSTRUMENTS FOR USE IN THE FIELDS OF SECURITY, CONTRABAND AND COUNTER-TERRORIST SEARCHING, NAMELY, HAND HELD METAL DETECTORS, GENERAL PURPOSE METAL DETECTORS, HIGH SENSITIVITY METAL DETECTORS, DUAL PURPOSE METAL DETECTORS AND WALK THROUGH METAL DETECTORS, PORTABLE EXPLOSIVES DETECTORS, CONTRABAND DETECTORS, NAMELY, HAND HELD ELECTRONIC CONTRABAND DETECTORS THAT INDICATE THE PRESENCE OF HIDDEN MATERIALS BY SIGNALING UNEXPECTED CHANGES IN THE DENSITY OR THICKNESS OF A SURFACE THROUGH THE RELEASE OF GAMMA RAYS; OPTICAL APPARATUS AND INSTRUMENTS FOR USE IN THE FIELDS OF SECURITY AND CONTRABAND AND COUNTER-TERRORISTS SEARCHING, AND IN FORENSIC POST BLAST EXAMINATIONS, NAMELY, LIGHT PROBES, FLEXIBLE AND RIGID ENDOSCOPES, TELESCOPIC ARMS FOR ENDOSCOPES; ZOOM CAMERAS, INFRARED CAMERAS FOR DAY AND NIGHT OPERATIONS; FERROUS ORDNANCE LOCATORS, NAMELY, PORTABLE DETECTORS FOR LOCATING FERROUS OBJECTS UNDER GROUND OR WATER AND SUITABLE FOR THE ACCURATE LOCATION OF BOMBS, PIPES AND WRECKAGE; COMPUTER MONITORS, COMPUTER HARDWARE, COMPUTER SOFTWARE, NAMELY, APPLICATIONS SOFTWARE FOR USE IN ASSOCIATION WITH LOCATING FERROUS OBJECTS UNDER GROUND AND WATER AND FOR THE ACCURATE LOCATION OF BOMBS, PIPES AND WRECKAGE; APPARATUS FOR THE DETECTION AND DIFFUSION OF EXPLOSIVE DEVICES, USED IN IMPROVISED EXPLOSIVE DEVICE DISPOSAL, NAMELY, ELECTRONIC BOMB DETECTORS AND DIFFUSERS, ELECTRONIC COUNTER MEASURES EQUIPMENT, NAMELY, PORTABLE COMMUNICATION JAMMERS, MODULAR JAMMERS, NAMELY, ELECTRONIC APPARATUS THAT INHIBIT RADIO CONTROLLED IMPROVISED EXPLOSIVE DEVICE SIGNALS THAT MAY BE USED TO DETONATE EXPLOSIVE DEVICES, ELECTRONIC STETHOSCOPIES FOR THE DETECTION OF MECHANICAL RUN BACK TIMERS AND ELECTRONIC TIMING SYSTEMS IN IMPROVISED EXPLOSIVE DEVICES, NON-LINEAR JUNCTION DETECTORS, NAMELY, ELECTRONIC APPARATUS AND INSTRUMENTS FOR DETECTING ELECTRONIC CIRCUITS FOUND IN EXPLOSIVE DEVICES AND RADIO TRANSMITTERS, ELECTRONIC CABLE DETECTORS USED TO LOCATE UNDERGROUND COMMAND WIRE CABLES, ELECTRONIC LETTER BOMB DETECTORS, X-RAY PARCEL BOMB DETECTORS, PORTABLE X-RAY GENERATORS, PORTABLE X-RAY COMPUTER USED TO EXAMINE SUS-

PECT PACKAGES THAT MAY CONTAIN IMPROVISED EXPLOSIVE DEVICES OR OTHER INACCESSIBLE AREAS WHERE CONTRABAND MAY BE HIDDEN; LAND MINE CLEARING APPARATUS AND EQUIPMENT, NAMELY, LAND MINE DETECTORS, NAMELY, NON MAGNETIC LAND MINE PRODDERS, REPLICA LAND MINE TRAINING AIDS; ELECTRONIC DISRUPTORS, NAMELY, RECOILLESS DISPOSABLE DISRUPTORS USED TO DISRUPT EXPLOSIVE DEVICES, NAMELY, WATER JET DISRUPTORS USED TO DISRUPT THIN WALLED EXPLOSIVE DEVICES, DISPOSABLE CAR TRUNK DISRUPTORS USED TO DISRUPT EXPLOSIVE DEVICES IN VEHICLES, PERSONAL PROTECTIVE EQUIPMENT FOR THE PROTECTION OF INDIVIDUALS FROM CHEMICAL AND BIOLOGICAL WARFARE AGENTS, NAMELY, PROTECTIVE SUITS, PROTECTIVE GLOVES AND PROTECTIVE OVER BOOTS, GAS MASKS, ELECTRO-VOICE AMPLIFIERS FOR GAS MASKS, CANISTERS DESIGNED TO HELP PROVIDE RESPIRATORY PROTECTION AGAINST AIRBORNE CONTAMINANTS, NEXT TO SKIN PROTECTIVE EQUIPMENT, NAMELY, WET SUITS, DRY SUITS, LIGHT WEIGHT PROTECTIVE SUITS, CHEMICAL PROTECTIVE UNDERGARMENTS; PROTECTIVE CLOTHING USED IN IMPROVISED EXPLOSIVE DEVICE DISPOSAL, NAMELY, BOMB SUITS, LIQUID COOLING UNDER SUITS; SEARCH SUITS, NAMELY, BODY ARMOUR SUITS DESIGNED FOR USE WHEN SEARCHING FOR IMPROVISED EXPLOSIVE DEVICES; WIRELESS RADIO SYSTEMS FOR USE WITH BOMB SUITS COMPOSED OF RADIOS, MOBILE RADIOS, RADIO TRANSMITTERS, RADIO RECEIVERS, ANTENNAS, AMPLIFIERS, ELECTRICAL AND POWER WIRES, CABLE AND ELECTRICAL CONNECTORS, SIGNAL PROCESSORS, CONVERTERS, DIGITAL FILTERS TO PROTECT AGAINST CHANNEL INTERFERENCE; DEMINING BALLISTIC PROTECTION, NAMELY, LAND MINE CLEARANCE VESTS AND HELMETS WITH VISORS; SAFETY EQUIPMENT, NAMELY, FOREARM PROTECTION FOR USE IN ASSOCIATION WITH MANUAL DOOR RAMS OR DOOR RIPPERS; SURVEILLANCE SCOPES, HAND HELD THERMAL IMAGERS, SPOTTING SCOPES, NAMELY, LIGHTWEIGHT TELESCOPES, INFRARED TELESCOPIC CAMERAS, SURVEILLANCE PROBES, NAMELY, UNDER DOOR REMOTE VIEWING TOOLS, MICRO-THROUGH-WALL VIEWING TOOLS, AUDIO PROBES, PEEPHOLE VIEWERS, REVERSE PEEPHOLE SCOPES, MIRRORS, TELESCOPIC MIRRORS, TELESCOPIC SEARCH MIRRORS, CONVEX MIRRORS, PLAIN MIRRORS, RECTANGULAR MIRRORS, MIRROR SLEEVES, CLIP ON MIRRORS, TELESCOPIC ARMS FOR SEARCH MIRRORS, POCKET SEARCH MIRRORS, UNDER VEHICLE SEARCH MIRRORS, SEARCH MIRRORS WITH NON-ROTATIONAL ALUMINUM POLES, PADDED FOREARM RESTS AND FOAM GRIPS, FOREARM STRAPS FOR USE WITH TELESCOPIC ARMS FOR SEARCH MIRRORS, BATTERY HANDLES; PORTABLE COMMAND AND CONTROL CONSOLES, NAMELY, COMPUTER HARDWARE AND SOFTWARE FOR THE OPERATION OF ROBOTS AND RF WIRELESS CONTROL SYSTEMS, COMPRISED OF RF TRANSMITTERS AND RECEIVERS, INTEGRATED SPREAD SPECTRUM RF CONTROL SYSTEMS, NAMELY, ELECTRONIC VIDEO APPARATUS THAT GIVE CONTROL AND FLICKER FREE VIDEO OVER LONG DISTANCES IN BUILT UP AREAS AND INSIDE BUILDINGS, SLIP RING DRUM CABLES, ZOOM CAMERAS, INFRARED CAMERAS FOR DAY AND NIGHT OPERATIONS, LASERS NOT FOR MEDICAL USE, SHOCK TUBE INITIATORS, EXTENSION BOOMS, DISRUPT OR MOUNTS; BLAST PROTECTION ARMOR FOR VEHICLES; BLAST PROTECTION SEATS FOR USE IN MILITARY AND SECURITY/POLICE VEHICLES; RECHARGERS FOR FLASHLIGHTS, BATTERY PACKS, BATTERY CHARGES, BATTERY HANDLES; BALLISTIC TESTING EQUIPMENT, NAMELY, MULTI-BARREL FIRING RECEIVER FOR FIRING AMMUNITION, HYDRAULIC TARGET RETENTION TEST FRAMES, ADJUSTABLE TORSO MOULDS FOR ARMOR AND BODY ARMOR, AMMUNITIONS AND WEAPONS; INSTRUMENTS FOR THE MEASUREMENT OF BALLISTIC VELOCITY AND RATE OF FIRE; PERSONAL PROTECTIVE EQUIPMENT FOR HANDS AND FEET OF DEMINING AND MINE CLEARANCE PERSONNEL, NAMELY, CONICAL HAND PROTECTORS, OVERHAND HAND PROTECTORS, RAISED FOOT PROTECTION PLATFORM FOR WALKING; PERSONAL PROTECTIVE EQUIPMENT USED TO REDUCE RISK OF INJURY FROM BLAST AND BAL-

LISTIC THREATS, NAMELY, MODULAR INTEGRATED SUITS, NAMELY, UPPER BODY VESTS, REMOVABLE SLEEVES, TROUSERS, GROIN PROTECTORS, NECK PROTECTORS, HELMET-MOUNTED RIGID FACIAL PROTECTORS; PERSONAL PROTECTIVE EQUIPMENT USED TO PROTECT PERSONNEL FROM HEAT STRESS, NAMELY, ELECTRONIC CHILLERS, ICE-BASED CHILLERS, TETHERS, LIQUID CONNECTORS, COOLING VESTS, LIQUID CIRCULATING GARMENTS; PROTECTIVE CLOTHING USED IN IMPROVISED EXPLOSIVE DEVICE DISPOSAL, NAMELY, BOMB DISPOSAL SUITS, BOMB DISPOSAL HELMETS WITH VISORS; SEARCH SUITS, NAMELY, BODY ARMOR SUITS DESIGNED FOR USE WHEN SEARCHING FOR IMPROVISED EXPLOSIVE DEVICES; TACTICAL ROBOTS FOR USE IN LAW ENFORCEMENT AND MILITARY APPLICATIONS, SURVEILLANCE, BOMB DISPOSAL, HAZARDOUS MATERIAL ACCIDENT CLEAN-UP AND HOSTAGE TAKING SITUATIONS, RECONNAISSANCE AND WEAPON DELIVERY IN RAPID DEPLOYMENT SCENARIOS WITHIN AREAS OF RESTRICTED PHYSICAL AREAS AND STRUCTURAL PARTS AND ACCESSORIES THEREFOR, NAMELY, BATTERY PACKS AND CHARGERS SOLD AS A UNIT; POWER OPERATED SEARCH TOOL KITS COMPRISED OF POWER OPERATED CORDLESS DRILLS WITH CORDLESS DRILL CHARGERS AND DRILL BITS, CENTRE PUNCHES; (BASED ON INTENT TO USE) REMOVABLE CLAWS BEING PARTS OF FLEXIBLE AND RIGID ENDOSCOPES AND TELESCOPIC ARMS; PHOTOGRAPHIC AND CINEMATOGRAPHIC APPARATUS AND INSTRUMENTS, NAMELY, DIGITAL AND VIDEO CAMERAS, USED WITH UNDER VEHICLE TROLLEYS, CAMERAS WITH INFRARED SENSORS, FIBER OPTIC SCOPES FOR VISUAL INSPECTION BEHIND OR INSIDE CLOSED AREAS, ILLUMINATED MAGNIFIERS; X-RAY KITS COMPRISED OF PORTABLE X-RAY MACHINES FOR NON-MEDICAL USE, NOTEBOOK PERSONAL COMPUTER, BATTERY, AND CASES THEREFOR; COMPUTER SOFTWARE, NAMELY, APPLICATION SOFTWARE FOR BALLISTICS TESTING; BOMB SUPPRESSION BLANKETS, SECURITY MIRRORS ON POLES WITH A LIGHT FIXTURE; VIDEO SEARCH KITS COMPRISED OF VIDEO CAMERAS AFFIXED TO FLEXIBLE UNDER VEHICLE TROLLEYS AND LCD SCREENS FOR VIEWING IMAGES; COMPUTER SOFTWARE, NAMELY, APPLICATION SOFTWARE USED FOR STORING MEASUREMENTS OVER SCANNED AREAS FOR DOWNLOADING AND PRESENTATION ON A PERSONAL COMPUTER, ELECTRONIC SENSORS USED TO RECOGNIZE AND RECORD THE SEVERITY OF BLASTS AND BLUNT IMPACTS, WIRELESS RADIO SYSTEM FOR USE WITH BOMB SUITS; COMPUTER HARDWARE COMMUNICATION SERVERS FOR USE IN CONNECTION WITH BOMB SUITS; HAND-HELD RADIATION DETECTORS FOR LOCATING AND IDENTIFYING CONCEALED NUCLEAR MATERIALS, PORTABLE CARBON DIOXIDE SENSORS FOR THE DETECTION OF CARBON DIOXIDE AND LIFE SOURCES, FALSE PANEL DISTANCE METERS, NAMELY, ULTRASONIC DISTANCE ESTIMATORS USED TO DETERMINE THE DISTANCE OF CONTAINERS AND OTHER CAVITIES WHEN SEARCHING FOR FALSE PANELS; PROTECTIVE LEATHER GLOVES FOR HANDLING EXPLOSIVE MATERIALS (U.S. CLS. 21, 23, 26, 36 AND 38).

CLASS 11—ENVIRONMENTAL CONTROL APPARATUS

FOR (BASED ON SECTIONS 44(E))(BASED ON INTENT TO USE) APPARATUS FOR LIGHTING, NAMELY, FLORESCENT LAMPS, SPARE LAMPS, FLASHLIGHTS, FLASHLIGHTS AND RECHARGES SOLD AS A UNIT, SEARCHLIGHTS, PORTABLE FLOODLIGHTS, POCKET ULTRAVIOLET LAMPS NOT FOR MEDICAL PURPOSES AND SPOTLIGHTS, FLASHLIGHTS INCORPORATING A MIRROR (U.S. CLS. 13, 21, 23, 31 AND 34).

CLASS 12—VEHICLES

FOR (BASED ON SECTIONS 44(E))(BASED ON INTENT TO USE) RESPONSE VEHICLES, NAMELY, LAND VEHICLES EQUIPPED WITH EXPLOSIVE ORDNANCE AND IMPROVISED EXPLOSIVE DEVICE DISPOSAL EQUIPMENT; EMERGENCY RESPONSE TRAILERS CONTAINING BLAST SUPPRESSANT FOAM APPLICATION EQUIPMENT (U.S. CLS. 19, 21, 23, 31, 35 AND 44).

CLASS 13—FIREARMS

FOR (BASED ON SECTIONS 44(E))(BASED ON INTENT TO USE) APPARATUS AND INSTRUMENTS USED IN EXPLOSIVE ORDNANCE DISPOSAL, NAMELY, SMALL SHAPED AND LARGE SHAPED COPPER CONE CHARGES, SMALL SHAPED MAGNESIUM CONE CHARGES, SMALL SHAPED LIQUESCENT CONE CHARGES, LARGE SELF FORGING FRAGMENT CONES; DE-ARMERS DESIGNED TO PROJECT A VARIETY OF STEEL SLUGS AT HIGH VELOCITY INTO THE FUZES OR PISTOLS OF AIR DROPPED BOMBS; INTEGRATED WEAPONS CARRIERS; NON-ELECTRIC-EXPLOSIVE-DELIVERY TOOL KITS SPECIFICALLY DESIGNED TO BREAK THROUGH WINDOWS, NAMELY, DUAL INITIATORS USED AS DETONATORS, INITIATOR POLE MOUNTS, INITIATOR REEL MOUNTS, INDEXING JOINTS, POLE EXTENSIONS, HITCH PINS, POLE SIDE GRIP HANDLES, POLE TRANSITIONS, CHARGE PLATES, SHOCK TUBE STORAGE REELS; FORCED-ENTRY TOOLS, NAMELY, SAFETY INITIATORS AS DETONATORS USED FOR EXPLOSIVE FIRING; (BASED ON INTENT TO USE) EXPLOSIVE WALL BREACHING EQUIPMENT COMPRISED OF A PLASTIC SHELL AND EXPLOSIVE DEVICES; MOBILE COOLING CASES USED TO PROTECT ELECTRONICS FROM HEAT (U.S. CLS. 2 AND 9).

CLASS 16—PAPER GOODS AND PRINTED MATTER

FOR (BASED ON SECTIONS 44(E))(BASED ON INTENT TO USE) PRINTED MATERIALS, NAMELY, INSTRUCTION MANUALS DETAILING THE USE OF TACTICAL HOOK AND LINE TECHNIQUES IN EXPLOSIVE ORDNANCE DISPOSAL OPERATIONS; OWNER MANUALS AND DOCUMENTATION IN THE NATURE OF TRAINING MANUALS RELATING TO TACTICAL ROBOTS, COMPUTER HARDWARE AND SOFTWARE FOR THE OPERATION OF SAID ROBOTS AND RF WIRELESS CONTROL SYSTEMS; PRINTED SECURITY SEALS USED TO SEAL PARCELS; (BASED ON INTENT TO USE) PRINTED MATTER AND INSTRUCTIONAL AND TEACHING MATERIAL, NAMELY, BOOKS AND MANUALS IN THE FIELDS OF EQUIPMENT TRAINING, NAMELY, NUCLEAR, BIOLOGICAL AND CHEMICAL CLEAN-UP, EXPLOSIVE ORDNANCE DETECTION AND DISPOSAL, SECURITY SURVEILLANCE AND SEARCH, SECURITY CONTRABAND AND COUNTER-TERRORIST SEARCHING, IMPROVISED EXPLOSIVE DEVICE DISPOSAL (U.S. CLS. 2, 5, 22, 23, 29, 37, 38 AND 50).

CLASS 20—FURNITURE AND ARTICLES NOT OTHERWISE CLASSIFIED

FOR (BASED ON SECTIONS 44(E))(BASED ON INTENT TO USE) BOMB BLAST INHIBITORS, NAMELY, NON-METAL BOMB BLAST SUPPRESSION BINS, NON-METAL LIGHTWEIGHT CONTAINERS FOR THE ISOLATION AND TRANSPORT, CONTAINMENT, MITIGATION AND DESTRUCTION OF SUSPECT PACKAGES; (BASED ON INTENT TO USE) NON-METAL DOOR WEDGES, NON-METAL FASTENING ANCHORS FOR GRIPPING TO FLAT SURFACES AND FOR HOOKS AND LINES AND ATTACHING SNATCH BLOCKS AND OTHER LINKS; DOORSTOP OF PLASTIC; NON-METAL CLAMPS; NON-METAL GROUND PEGS; NONMETAL PULLEYS; HAND-OPERATED NON-METAL REELS FOR STORING AND DEPLOYING LINES; NON-METAL SE-

CURITY AND SURVEILLANCE TOOL KITS COMPRISED OF ANCHORS, CLAMPS, GROUND PEGS, HAND-OPERATED REELS, AND METAL SNATCH BLOCKS, REELS, GRIPS, SEIZERS, CORDS, STRINGS AND LINES, ANCHORS, PITONS AND WIRE SLINGS, HOOKS AND ROPE; NON-METAL EXPLOSIVE DEVICE DETECTION AND DIFFUSION TOOL KITS COMPRISED OF ANCHORS, CLAMPS, GROUND PEGS, HAND-OPERATED REELS, AND METAL SNATCH BLOCKS, REELS, GRIPS, SEIZERS, CORDS, STRINGS AND LINES, ANCHORS, PITONS, WIRE SLINGS, HOOKS AND ROPE (U.S. CLS. 2, 13, 22, 25, 32 AND 50).

CLASS 22—CORDAGE AND FIBERS

FOR (BASED ON INTENT TO USE) ROPES, STRINGS; ROPES, NON-METAL LINES AND CABLE STRAPS, TEXTILE CORDS, NON-METAL SLINGS FOR HOISTING AND HANDLING LOADS; SECURITY AND SURVEILLANCE KITS COMPRISING OF NON-METAL GOODS, NAMELY, ROPES, NON-METAL STRAPS AND LINES, SLINGS, TEXTILE CORDS AND SNATCH BLOCKS, REELS, GRIPS, SEIZERS, CORDS, STRINGS AND LINES; DETECTION AND DIFFUSION OF EXPLOSIVE DEVICES KITS COMPRISING OF NON-METAL GOODS, NAMELY, ROPES, NON-METAL SNAPS AND LINES, SLINGS, TEXTILE CORDS, AND METAL SNATCH BLOCKS, REELS, GRIPS, SEIZERS, CORDS, STRINGS AND LINES, ANCHORS, PITONS AND WIRE SLINGS, HOOKS, ROPE; NYLON CORD; LETTER BOMB CONTAINMENT BAGS, STRINGS AND LINES THERETO, SHOCK CORDS, ALL-PURPOSE STRAPS AND LINES THERETO (U.S. CLS. 1, 2, 7, 19, 22, 42 AND 50).

CLASS 35—ADVERTISING AND BUSINESS

FOR (BASED ON SECTIONS 44(E)(BASED ON INTENT TO USE) MAIL ORDER CATALOG, ELECTRONIC CATALOG, MAIL ORDER, ON-LINE ORDERING SERVICES FEATURING SECURITY APPARATUS AND HARDWARE; (BASED ON INTENT TO USE) ADVERTISING; BUSINESS MANAGEMENT; BUSINESS ADMINISTRATION (U.S. CLS. 100, 101 AND 102).

CLASS 41—EDUCATION AND ENTERTAINMENT

FOR (BASED ON SECTIONS 44(E)(BASED ON INTENT TO USE) EDUCATION SERVICES, NAMELY, PROVIDING CLASSES, SEMINARS, WORKSHOPS IN THE FIELDS OF EQUIPMENT TRAINING, NAMELY, NUCLEAR, BIOLOGICAL AND CHEMICAL CLEAN-UP, EXPLOSIVE ORDNANCE DETECTION AND DISPOSAL, SECURITY SURVEILLANCE AND SEARCH, SECURITY CONTRABAND AND COUNTER-TERRORIST SEARCHING, IMPROVISED EXPLOSIVE DEVICE DISPOSAL; PROVIDING OF EDUCATION TRAINING IN THE FIELDS OF EQUIPMENT TRAINING, NAMELY, NUCLEAR, BIOLOGICAL AND CHEMICAL CLEAN-UP, EXPLOSIVE ORDNANCE DETECTION AND DISPOSAL, SECURITY SURVEILLANCE AND SEARCH, SECURITY CONTRABAND AND COUNTER-TERRORISM SEARCHING, IMPROVISED EXPLOSIVE DEVICE DISPOSAL; EDUCATION AND TRAINING SERVICES, NAMELY, EDUCATIONAL TRAINING SERVICES IN RESPECT OF THE OPERATION, INSTALLATION, MAINTENANCE, AND REPAIR OF APPARATUS AND INSTRUMENTS USED IN THE FIELDS OF SECRET AND IN CONTRABAND AND COUNTER-TERRORIST SEARCHING; EDUCATIONAL TRAINING SERVICES, NAMELY, TRAINING FOR PROCEDURES FOR DEALING WITH CHEMICAL, BIOLOGICAL, NUCLEAR AND RADIOLOGICAL INCIDENTS, COUNTER-TERRORIST AND CONTRABAND SEARCH TRAINING, BOMB AWARENESS AND COUNTER-MEASURES TRAINING, THREAT ANALYSIS AND PLANNING TRAINING, IMPROVISED EXPLOSIVE DEVICE DISPOSAL TRAINING (U.S. CLS. 100, 101 AND 107).

CLASS 42—SCIENTIFIC AND COMPUTER SERVICES

FOR (BASED ON SECTIONS 44(E)(BASED ON INTENT TO USE) SCIENTIFIC RESEARCH AND TECHNOLOGICAL CONSULTATION IN THE TECHNOLOGY FIELD OF BALLISTIC TESTING SERVICES, NAMELY, TESTING AND EVALUATION OF WEAPON, AMMUNITION AND ARMOR; DESIGN, DEVELOPMENT AND TESTING FOR OTHERS OF APPARATUS AND INSTRUMENTS USED IN THE FIELD OF SECURITY AND IN CONTRABAND ENCOUNTER SEARCHING, APPARATUS AND INSTRUMENTS USED IN EXPLOSIVE ORDNANCE DISPOSAL, APPARATUS AND INSTRUMENTS USED IN IMPROVISED EXPLOSIVE DEVICE DISPOSAL, PERSONAL PROTECTIVE EQUIPMENT FOR THE PROTECTION OF INDIVIDUALS FROM CHEMICAL AND BIOLOGICAL WARFARE AGENTS, SURVEILLANCE APPARATUS AND INSTRUMENTS, VEHICLE BARRIER SYSTEMS, TACTICAL ROBOTS FOR USE IN LAW ENFORCEMENT AND MILITARY APPLICATIONS, SURVEILLANCE, BOMB DISPOSAL, HAZARDOUS MATERIAL ACCIDENT CLEAN-UP AND HOSTAGE TAKING SITUATIONS, EQUIPMENT AND SYSTEMS FOR CONTAINMENT AND MITIGATION OF WEAPONS OF MASS DESTRUCTION AND CHEMICAL, BIOLOGICAL, RADIOLOGICAL AND NUCLEAR EXPLOSIVE DEVICES AND MATERIALS, CHEMICAL BIOLOGICAL AND RADIOLOGICAL DECONTAMINATION SYSTEMS AND EQUIPMENT, BALLISTIC TESTING EQUIPMENT, BLAST PROTECTION ARMOR FOR VEHICLES AND BLAST PROTECTION SEATS; TECHNOLOGY CONSULTING SERVICES IN THE FIELDS OF THE TECHNICAL PROCEDURES FOR DEALING WITH CHEMICAL, BIOLOGICAL, NUCLEAR AND RADIOLOGICAL INCIDENTS, COUNTER-TERRORIST TRAINING AND TACTICS, CONTRABAND SEARCH AND DETECTION TRAINING AND TACTICS, BOMB COUNTERMEASURES TACTICS, THREAT ANALYSIS SECURITY CONSULTING; IMPACT TESTING SERVICES, NAMELY, TESTING OF DATA RECORDERS AND HIGH G SHOCK TESTING OF AIR, LAND AND SEA VEHICLE; DEVELOPMENT OF TOOLS AND EQUIPMENT FOR USE IN THE MAINTENANCE, REPAIR AND OVERHAUL OF AIRCRAFT, TECHNOLOGICAL CONSULTANCY, ADVISORY AND INFORMATION SERVICES RELATING TO THE ABOVE SERVICES (U.S. CLS. 100 AND 101).
ALYSSA STEEL, EXAMINING ATTORNEY

SN 77-539,503. ALLEN-VANGUARD CORPORATION, OTTAWA, ONTARIO, CANADA, FILED 8-5-2008.

ALLEN  VANGUARD

PRIORITY CLAIMED UNDER SEC. 44(D) ON CANADA APPLICATION NO. 1382735, FILED 2-8-2008, REG. NO. TMA790036, DATED 2-8-2011, EXPIRES 2-5-2026.

OWNER OF U.S. REG. NOS. 3,647,582 AND 3,647,583.
THE NAME(S), PORTRAIT(S), AND/OR SIGNATURE(S) SHOWN IN THE MARK DOES NOT IDENTIFY A PARTICULAR LIVING INDIVIDUAL.

THE MARK CONSISTS OF THE WORDING "ALLEN VANGUARD" WITH A GRAPHIC OF THREE OVERLAPPING SHIELDS FEATURING THREE TRIANGLES BETWEEN THE TERMS.

CLASS 1—CHEMICALS

FOR (BASED ON SECTIONS 44(E)(BASED ON INTENT TO USE) CHEMICALS USED IN INDUSTRY; CHEMICAL, BIOLOGICAL AND RADIOLOGICAL DECONTAMINATING FOAM USED FOR BOMB DISPOSAL; (BASED ON INTENT TO USE) CHEMICALS USED IN INDUSTRY; CHEMICAL, BIOLOGICAL AND RADIOLOGICAL DECONTAMINATING CHEMICALS USED FOR BOMB DISPOSAL (U.S. CLS. 1, 5, 6, 10, 26 AND 46).

CLASS 5—PHARMACEUTICALS

FOR (BASED ON SECTIONS 44(E)(BASED ON INTENT TO USE) SKIN DECONTAMINATING LOTION USED AS DISINFECTANTS FOR INDIVIDUALS EXPOSED TO NUCLEAR, BIOLOGICAL OR CHEMICAL DECONTAMINATION (U.S. CLS. 6, 18, 44, 46, 51 AND 52).

CLASS 6—METAL GOODS

FOR (BASED ON SECTIONS 44(E)(BASED ON INTENT TO USE) KITS FOR THE DETECTION AND DIFFUSION OF EXPLOSIVE DEVICES, AND SINGLE LINE KITS FOR MINE/MUNITIONS CLEARANCE AND HIGH RISK SEARCHES, COMPRISING HOOK AND LINE COMPONENTS, NAMELY, SNATCH BLOCKS, REELS, PULLING HANDLES, EYE RINGS, SEIZERS USED TO HOLD, FASTEN OR BIND OBJECTS, ANCHORS, PITONS, FISH HOOKS, SPRING GRIPS, JAW GRIPS, SUCTION PAD ANCHORS, SELF-ADHESIVE ANCHORS, GROUND ANCHORS, CORKSCREW STAKES, EXTENSION RODS, PULLEYS, GROUND PEGS, HOOKS, RINGS, BELT SLINGS, WIRE SLINGS, SLEDGES, PITONS, KARABINERS, WEDGES, BLOCKS, MAIN LINES; HEAVY DUTY HOOK AND LINE KITS FOR MOVING VEHICLES AND HEAVY IMPROVISED EXPLOSIVE DEVICES, WITH REELS, LINES, WEBBING SLINGS, ROUND SLINGS, GROUND ANCHORS, SHACKLES, SNATCH BLOCKS, HOOKS; METAL GOODS, NAMELY, ANCHORS, PITONS AND WIRE SLINGS AND HOOKS; ALL OF THE FOREGOING PRIMARILY OF METAL; (BASED ON INTENT TO USE) SMALL ITEMS OF METAL HARDWARE, NAMELY, NAILS, ADJUSTING SCREWS, EYELETS, METAL HOOKS, METAL CONNECTIVE HINGES, METAL FASTENING COLLARS, METAL CABLES AND WIRES NOT FOR ELECTRICAL PURPOSES, METAL CABLE ROLLERS, AND REELS, NON-ELECTRIC METAL WIRE CLAMPS (U.S. CLS. 2, 12, 13, 14, 23, 25 AND 50).

CLASS 7—MACHINERY

FOR (BASED ON SECTIONS 44(E)(BASED ON INTENT TO USE) EQUIPMENT AND SYSTEMS FOR CONTAINMENT AND MITIGATION OF WEAPONS OF MASS DESTRUCTION AND CHEMICAL, BIOLOGICAL, RADIOLOGICAL AND NUCLEAR EXPLOSIVE DEVICES AND MATERIALS, NAMELY, FOAM INJECTION MACHINES, CONTROLLERS, PUMPS, AERATING NOZZLES AND REUSABLE ENCLOSURES MADE OF BALLISTIC MATERIAL FOR CONTAINING THE EFFECT OF EXPLOSIVE DEVICES AND FOR DECONTAMINATING CHEMICAL AND BIOLOGICAL AGENTS SOLD AS A UNIT; FOAM APPLICATION EQUIPMENT, NAMELY, PORTABLE SELF CONTAINING DECONTAMINATING FOAM APPLICATION EQUIPMENT UNITS DESIGNED FOR PERFORMING EMERGENCY SPOT DECONTAMINATION OF CHEMICAL AND BIOLOGICAL AGENTS ON HARDWARE, STRUCTURAL SURFACES, TERRAIN AND DRUG LABELS; HYDRAULIC RAMS, PNEUMATIC RAMS; (BASED ON INTENT TO USE) MACHINES AND MACHINE TOOLS, NAMELY, POWER DRILLS; AIR AND WATER TANKS (U.S. CLS. 13, 19, 21, 23, 31, 34 AND 35).

CLASS 8—HAND TOOLS

FOR (BASED ON SECTIONS 44(E)(BASED ON INTENT TO USE) SECURITY, SURVEILLANCE AND SEARCH TOOL KITS, COMPRISED OF RETRACTABLE KNIVES, STEEL MEASURING TAPE, LINOLEUM KNIVES, SCISSORS, PAD SAWS, HACKSAWS, TACK EXTRACTORS, CLAW HAMMERS, CLUB HAMMERS, COLD CHISELS, WRECKING BARS, WIRE CUTTERS; BOLT CUTTERS, SCREWDRIVER SETS, WRENCHES, PLIERS, VICES, CLAMPS, CRIMPING IRONS, CABLE STRIPPERS, SEIZERS USED TO HOLD, FASTEN OR BIND OBJECTS, TWEEZERS, SOCKETS SETS AND BITS, HEXAGON WRENCHES, COMBINATION WRENCHES, TELESCOPIC SEARCH MIRRORS, HAND OPERATED SURVEILLANCE APPARATUS AND INSTRUMENTS, NAMELY, DOOR RIPPERS, FLOOR AND CAR ENTRY TOOLS; HAND OPERATED TOOLS USED FOR THE DETECTION AND DIFFUSION OF EXPLOSIVE DEVICES, NAMELY, SCREWDRIVERS, ADJUSTABLE WRENCHES, WRENCH SETS, VICE GRIP WRENCHES, PLIERS, SEIZERS, TWEEZERS, WIRE CUTTERS, TIN

SNIPS, KNIVES, BLADE DISPENSERS, FLEXI SAWS, MINI SAWS, SCISSORS, HOOKS, WRECKING BARS, CLAW HAMMERS, TACK LIFTERS, NON-MAGNETIC TOOLS FOR EXPLOSIVE ORDNANCE DISPOSAL, NAMELY, TWEEZERS, PROBES, KNIVES, SCISSORS, HACKSAWS, BLADES, SCRAPERS, WIRE BRUSHES, SCREWDRIVERS, PLIERS, WIRE CUTTERS, WRENCHES, HAMMERS, CHISELS, BARS, SAWS, WIRE STRIPPERS, AND KITS COMPRISING THE FOREGOING; HAND OPERATED EXCAVATION TOOLS FOR EXPLOSIVE ORDNANCE DISPOSAL, NAMELY, SHOVELS, PICKS, PRY BARS, SLEDGEHAMMERS, CLUB HAMMERS, CHISELS, SCRAPERS, WRENCH SETS, NON MAGNETIC SHOVELS USED ON UNEXPLODED ORDNANCE, TRIPODS DESIGNED FOR LIFTING HEAVY OBJECTS DURING EXPLOSIVE ORDNANCE DISPOSAL OPERATIONS, HAND OPERATED LIGHTWEIGHT TRIPODS DESIGNED FOR LIFTING SMALLER OBJECTS DURING IMPROVISED EXPLOSIVE ORDNANCE DISPOSAL OPERATIONS; VEHICLE ACCESS HAND-OPERATED TOOLS, NAMELY, REMOTE WINDOW BREAKERS, VEHICLE DOOR HANDLE LIFTERS, VEHICLE KEY/HANDLE CLAMPS, VEHICLE DOOR BUTTON PUSHERS, VEHICLE DOOR TRIM/PANEL REMOVING TOOLS; TOOLS USED FOR EXPLOSIVE ORDNANCE DISPOSAL AND IMPROVISED EXPLOSIVE DEVICE DISPOSAL, NAMELY, TELESCOPIC MANIPULATORS, TOOL CARTS, TRIPODS; (BASED ON INTENT TO USE) HAND OPERATED TOOLS AND IMPLEMENTS, NAMELY, HAMMERS, SHEARS, STRAP ROLLERS, DRILLS, HANDJACKS, AUGERS, AWLS, CLAMPS, FILES, PINCERS, PLANERS, PUNCHES, WRENCHES, SAWS, SCREWDRIVERS, TONGS, NIPPERS, WIRE STRIPPERS, VICES, PRUNERS, CHISELS, DRILL FILES, KNIVES, PLIERS; RATCHET WRENCH SETS (U.S. CLS. 23, 28 AND 44).

CLASS 9—ELECTRICAL AND SCIENTIFIC APPARATUS

FOR (BASED ON SECTIONS 44(E)(BASED ON INTENT TO USE) SCIENTIFIC, SURVEYING, PHOTOGRAPHIC, CINEMATOGRAPHIC, OPTICAL, MEASURING, SIGNALING, LIFE-SAVING APPARATUS AND INSTRUMENTS, NAMELY, SECURITY AND SURVEILLANCE INSTRUMENTS FOR USE IN THE FIELDS OF SECURITY, CONTRABAND AND COUNTER-TERRORIST SEARCHING, NAMELY, HAND HELD METAL DETECTORS, GENERAL PURPOSE METAL DETECTORS, HIGH SENSITIVITY METAL DETECTORS, DUAL PURPOSE METAL DETECTORS AND WALK THROUGH METAL DETECTORS, PORTABLE EXPLOSIVES DETECTORS, CONTRABAND DETECTORS, NAMELY, HAND HELD ELECTRONIC CONTRABAND DETECTORS THAT INDICATE THE PRESENCE OF HIDDEN MATERIALS BY SIGNALING UNEXPECTED CHANGES IN THE DENSITY OR THICKNESS OF A SURFACE THROUGH THE RELEASE OF GAMMA RAYS; OPTICAL APPARATUS AND INSTRUMENTS FOR USE IN THE FIELDS OF SECURITY AND CONTRABAND AND COUNTER-TERRORISTS SEARCHING, AND IN FORENSIC POST BLAST EXAMINATIONS, NAMELY, LIGHT PROBES, FLEXIBLE AND RIGID ENDOSCOPES, TELESCOPIC ARMS FOR ENDOSCOPES; ZOOM CAMERAS, INFRARED CAMERAS FOR DAY AND NIGHT OPERATIONS; FERROUS ORDNANCE LOCATORS, NAMELY, PORTABLE DETECTORS FOR LOCATING FERROUS OBJECTS UNDER GROUND OR WATER AND SUITABLE FOR THE ACCURATE LOCATION OF BOMBS, PIPES AND WRECKAGE; COMPUTER MONITORS, COMPUTER HARDWARE, COMPUTER SOFTWARE, NAMELY, APPLICATIONS SOFTWARE FOR USE IN ASSOCIATION WITH LOCATING FERROUS OBJECTS UNDER GROUND AND WATER AND FOR THE ACCURATE LOCATION OF BOMBS, PIPES AND WRECKAGE; APPARATUS FOR THE DETECTION AND DIFFUSION OF EXPLOSIVE DEVICES, USED IN IMPROVISED EXPLOSIVE DEVICE DISPOSAL, NAMELY, ELECTRONIC BOMB DETECTORS AND DIFFUSERS, ELECTRONIC COUNTER MEASURES EQUIPMENT, NAMELY, PORTABLE COMMUNICATION JAMMERS, MODULAR JAMMERS, NAMELY, ELECTRONIC APPARATUS THAT INHIBIT RADIO CONTROLLED IMPROVISED EXPLOSIVE DEVICE SIGNALS THAT MAY BE USED TO DETONATE EXPLOSIVE DEVICES, ELECTRONIC STETHOSCOPES FOR THE DETECTION OF MECHANICAL RUN BACK TIMERS AND ELECTRONIC TIMING SYSTEMS IN IMPROVISED EXPLOSIVE DEVICES, NON-

LINEAR JUNCTION DETECTORS, NAMELY, ELECTRONIC APPARATUS AND INSTRUMENTS FOR DETECTING ELECTRONIC CIRCUITS FOUND IN EXPLOSIVE DEVICES AND RADIO TRANSMITTERS, ELECTRONIC CABLE DETECTORS USED TO LOCATE UNDERGROUND COMMAND WIRE CABLES, ELECTRONIC LETTER BOMB DETECTORS, X-RAY PARCEL BOMB DETECTORS, PORTABLE X-RAY GENERATORS, PORTABLE X-RAY COMPUTER USED TO EXAMINE SUSPECT PACKAGES THAT MAY CONTAIN IMPROVISED EXPLOSIVE DEVICES OR OTHER INACCESSIBLE AREAS WHERE CONTRABAND MAY BE HIDDEN; LAND MINE CLEARING APPARATUS AND EQUIPMENT, NAMELY, LAND MINE DETECTORS, NAMELY, NON MAGNETIC LAND MINE PRODDERS, REPLICAS LAND MINE TRAINING AIDS; ELECTRONIC DISRUPTORS, NAMELY, RECOILLESS DISPOSABLE DISRUPTORS USED TO DISRUPT EXPLOSIVE DEVICES, NAMELY, WATER JET DISRUPTORS USED TO DISRUPT THIN WALLED EXPLOSIVE DEVICES, DISPOSABLE CAR TRUNK DISRUPTORS USED TO DISRUPT EXPLOSIVE DEVICES IN VEHICLES, PERSONAL PROTECTIVE EQUIPMENT FOR THE PROTECTION OF INDIVIDUALS FROM CHEMICAL AND BIOLOGICAL WARFARE AGENTS, NAMELY, PROTECTIVE SUITS, PROTECTIVE GLOVES AND PROTECTIVE OVER BOOTS, GAS MASKS, ELECTRO-VOICE AMPLIFIERS FOR GAS MASKS, CANISTERS DESIGNED TO HELP PROVIDE RESPIRATORY PROTECTION AGAINST AIRBORNE CONTAMINANTS, NEXT TO SKIN PROTECTIVE EQUIPMENT, NAMELY, WET SUITS, DRY SUITS, LIGHT WEIGHT PROTECTIVE SUITS, CHEMICAL PROTECTIVE UNDERGARMENTS; PROTECTIVE CLOTHING USED IN IMPROVISED EXPLOSIVE DEVICE DISPOSAL, NAMELY, BOMB SUITS, LIQUID COOLING UNDER SUITS; SEARCH SUITS, NAMELY, BODY ARMOUR SUITS DESIGNED FOR USE WHEN SEARCHING FOR IMPROVISED EXPLOSIVE DEVICES; WIRELESS RADIO SYSTEMS FOR USE WITH BOMB SUITS COMPOSED OF RADIOS, MOBILE RADIOS, RADIO TRANSMITTERS, RADIO RECEIVERS, ANTENNAS, AMPLIFIERS, ELECTRICAL AND POWER WIRES, CABLE AND ELECTRICAL CONNECTORS, SIGNAL PROCESSORS, CONVERTERS, DIGITAL FILTERS TO PROTECT AGAINST CHANNEL INTERFERENCE; DEMINING BALLISTIC PROTECTION, NAMELY, LAND MINE CLEARANCE VESTS AND HELMETS WITH VISORS; SAFETY EQUIPMENT, NAMELY, FOREARM PROTECTION FOR USE IN ASSOCIATION WITH MANUAL DOOR RAMS OR DOOR RIPPERS; SURVEILLANCE SCOPES, HAND HELD THERMAL IMAGERS, SPOTTING SCOPES, NAMELY, LIGHTWEIGHT TELESCOPES, INFRARED TELESCOPIC CAMERAS, SURVEILLANCE PROBES, NAMELY, UNDER DOOR REMOTE VIEWING TOOLS, MICRO-THROUGH-WALL VIEWING TOOLS, AUDIO PROBES, PEEPHOLE VIEWERS, REVERSE PEEPHOLE SCOPES, MIRRORS, TELESCOPIC MIRRORS, TELESCOPIC SEARCH MIRRORS, CONVEX MIRRORS, PLAIN MIRRORS, RECTANGULAR MIRRORS, MIRROR SLEEVES, CLIP ON MIRRORS, TELESCOPIC ARMS FOR SEARCH MIRRORS, POCKET SEARCH MIRRORS, UNDER VEHICLE SEARCH MIRRORS, SEARCH MIRRORS WITH NON-ROTATIONAL ALUMINUM POLES, PADDED FOREARM RESTS AND FOAM GRIPS, FOREARM STRAPS FOR USE WITH TELESCOPIC ARMS FOR SEARCH MIRRORS, BATTERY HANDLES; PORTABLE COMMAND AND CONTROL CONSOLES, NAMELY, COMPUTER HARDWARE AND SOFTWARE FOR THE OPERATION OF ROBOTS AND RF WIRELESS CONTROL SYSTEMS, COMPRISED OF RF TRANSMITTERS AND RECEIVERS, INTEGRATED SPREAD SPECTRUM RF CONTROL SYSTEMS, NAMELY, ELECTRONIC VIDEO APPARATUS THAT GIVE CONTROL AND FLICKER FREE VIDEO OVER LONG DISTANCES IN BUILT UP AREAS AND INSIDE BUILDINGS, SLIP RING DRUM CABLES, ZOOM CAMERAS, INFRARED CAMERAS FOR DAY AND NIGHT OPERATIONS, LASERS NOT FOR MEDICAL USE, SHOCK TUBE INITIATORS, EXTENSION BOOMS, DISRUPT OR MOUNTS; BLAST PROTECTION ARMOR FOR VEHICLES; BLAST PROTECTION SEATS FOR USE IN MILITARY AND SECURITY/POLICE VEHICLES; RECHARGERS FOR FLASHLIGHTS, BATTERY PACKS, BATTERY CHARGES, BATTERY HANDLES; BALLISTIC TESTING EQUIPMENT, NAMELY, MULTI-BARREL FIRING RECEIVER FOR FIRING AMMUNITION, HYDRAULIC TARGET RETENTION TEST FRAMES, ADJUSTABLE TORSO MOULDS FOR ARMOR AND BODY ARMOR,

AMMUNITIONS AND WEAPONS; INSTRUMENTS FOR THE MEASUREMENT OF BALLISTIC VELOCITY AND RATE OF FIRE; PERSONAL PROTECTIVE EQUIPMENT FOR HANDS AND FEET OF DEMINING AND MINE CLEARANCE PERSONNEL, NAMELY, CONICAL HAND PROTECTORS, OVERHAND HAND PROTECTORS, RAISED FOOT PROTECTION PLATFORM FOR WALKING; PERSONAL PROTECTIVE EQUIPMENT USED TO REDUCE RISK OF INJURY FROM BLAST AND BALLISTIC THREATS, NAMELY, MODULAR INTEGRATED SUITS, NAMELY, UPPER BODY VESTS, REMOVABLE SLEEVES, TROUSERS, GROIN PROTECTORS, NECK PROTECTORS, HELMET-MOUNTED RIGID FACIAL PROTECTORS; PERSONAL PROTECTIVE EQUIPMENT USED TO PROTECT PERSONNEL FROM HEAT STRESS, NAMELY, ELECTRONIC CHILLERS, ICE-BASED CHILLERS, TETHERS, LIQUID CONNECTORS, COOLING VESTS, LIQUID CIRCULATING GARMENTS; PROTECTIVE CLOTHING USED IN IMPROVISED EXPLOSIVE DEVICE DISPOSAL, NAMELY, BOMB DISPOSAL SUITS, BOMB DISPOSAL HELMETS WITH VISORS; SEARCH SUITS, NAMELY, BODY ARMOR SUITS DESIGNED FOR USE WHEN SEARCHING FOR IMPROVISED EXPLOSIVE DEVICES; TACTICAL ROBOTS FOR USE IN LAW ENFORCEMENT AND MILITARY APPLICATIONS, SURVEILLANCE, BOMB DISPOSAL, HAZARDOUS MATERIAL ACCIDENT CLEAN-UP AND HOSTAGE TAKING SITUATIONS, RECONNAISSANCE AND WEAPON DELIVERY IN RAPID DEPLOYMENT SCENARIOS WITHIN AREAS OF RESTRICTED PHYSICAL AREAS AND STRUCTURAL PARTS AND ACCESSORIES THEREFOR, NAMELY, BATTERY PACKS AND CHARGERS SOLD AS A UNIT; POWER OPERATED SEARCH TOOL KITS COMPRISED OF POWER OPERATED CORDLESS DRILLS WITH CORDLESS DRILL CHARGERS AND DRILL BITS, CENTRE PUNCHES; (BASED ON INTENT TO USE) REMOVABLE CLAWS BEING PARTS OF FLEXIBLE AND RIGID ENDOSCOPES AND TELESCOPIC ARMS; PHOTOGRAPHIC AND CINEMATOGRAPHIC APPARATUS AND INSTRUMENTS, NAMELY, DIGITAL AND VIDEO CAMERAS, USED WITH UNDER VEHICLE TROLLEYS, CAMERAS WITH INFRARED SENSORS, FIBER OPTIC SCOPES FOR VISUAL INSPECTION BEHIND OR INSIDE CLOSED AREAS, ILLUMINATED MAGNIFIERS; X-RAY KITS COMPRISED OF PORTABLE X-RAY MACHINES FOR NON-MEDICAL USE, NOTEBOOK PERSONAL COMPUTER, BATTERY, AND CASES THEREFOR; COMPUTER SOFTWARE, NAMELY, APPLICATION SOFTWARE FOR BALLISTICS TESTING; BOMB SUPPRESSION BLANKETS, SECURITY MIRRORS ON POLES WITH A LIGHT FIXTURE; VIDEO SEARCH KITS COMPRISED OF VIDEO CAMERAS AFFIXED TO FLEXIBLE UNDER VEHICLE TROLLEYS AND LCD SCREENS FOR VIEWING IMAGES; COMPUTER SOFTWARE, NAMELY, APPLICATION SOFTWARE USED FOR STORING MEASUREMENTS OVER SCANNED AREAS FOR DOWNLOADING AND PRESENTATION ON A PERSONAL COMPUTER, ELECTRONIC SENSORS USED TO RECOGNIZE AND RECORD THE SEVERITY OF BLASTS AND BLUNT IMPACTS, WIRELESS RADIO SYSTEM FOR USE WITH BOMB SUITS; COMPUTER HARDWARE COMMUNICATION SERVERS FOR USE IN CONNECTION WITH BOMB SUITS; HAND-HELD RADIATION DETECTORS FOR LOCATING AND IDENTIFYING CONCEALED NUCLEAR MATERIALS, PORTABLE CARBON DIOXIDE SENSORS FOR THE DETECTION OF CARBON DIOXIDE AND LIFE SOURCES, FALSE PANEL DISTANCE METERS, NAMELY, ULTRASONIC DISTANCE ESTIMATORS USED TO DETERMINE THE DISTANCE OF CONTAINERS AND OTHER CAVITIES WHEN SEARCHING FOR FALSE PANELS; PROTECTIVE LEATHER GLOVES FOR HANDLING EXPLOSIVE MATERIALS (U.S. CLS. 21, 23, 26, 36 AND 38).

CLASS 11—ENVIRONMENTAL CONTROL APPARATUS

FOR (BASED ON SECTIONS 44(E)(BASED ON INTENT TO USE) APPARATUS FOR LIGHTING, NAMELY, FLORESCENT LAMPS, SPARE LAMPS, FLASHLIGHTS, FLASHLIGHTS AND RECHARGES SOLD AS A UNIT, SEARCHLIGHTS, PORTABLE FLOODLIGHTS, POCKET ULTRAVIOLET LAMPS NOT FOR MEDICAL PURPOSES AND SPOTLIGHTS, FLASHLIGHTS INCORPORATING A MIRROR (U.S. CLS. 13, 21, 23, 31 AND 34).

CLASS 12—VEHICLES

FOR (BASED ON SECTIONS 44(E)(BASED ON INTENT TO USE) RESPONSE VEHICLES, NAMELY, LAND VEHICLES EQUIPPED WITH EXPLOSIVE ORDNANCE AND IMPROVED EXPLOSIVE DEVICE DISPOSAL EQUIPMENT; EMERGENCY RESPONSE TRAILERS CONTAINING BLAST SUPPRESSANT FOAM APPLICATION EQUIPMENT (U.S. CLS. 19, 21, 23, 31, 35 AND 44).

CLASS 13—FIREARMS

FOR (BASED ON SECTIONS 44(E)(BASED ON INTENT TO USE) APPARATUS AND INSTRUMENTS USED IN EXPLOSIVE ORDNANCE DISPOSAL, NAMELY, SMALL SHAPED AND LARGE SHAPED COPPER CONE CHARGES, SMALL SHAPED MAGNESIUM CONE CHARGES, SMALL SHAPED LIQUESCENT CONE CHARGES, LARGE SELF FORGING FRAGMENT CONES; DE-ARMERS DESIGNED TO PROJECT A VARIETY OF STEEL SLUGS AT HIGH VELOCITY INTO THE FUZES OR PISTOLS OF AIR DROPPED BOMBS; INTEGRATED WEAPONS CARRIERS; NON-ELECTRIC-EXPLOSIVE-DELIVERY TOOL KITS SPECIFICALLY DESIGNED TO BREAK THROUGH WINDOWS, NAMELY, DUAL INITIATORS USED AS DETONATORS, INITIATOR POLE MOUNTS, INITIATOR REEL MOUNTS, INDEXING JOINTS, POLE EXTENSIONS, HITCH PINS, POLE SIDE GRIP HANDLES, POLE TRANSITIONS, CHARGE PLATES, SHOCK TUBE STORAGE REELS; FORCED-ENTRY TOOLS, NAMELY, SAFETY INITIATORS AS DETONATORS USED FOR EXPLOSIVE FIRING; (BASED ON INTENT TO USE) EXPLOSIVE WALL BREACHING EQUIPMENT COMPRISED OF A PLASTIC SHELL AND EXPLOSIVE DEVICES; MOBILE COOLING CASES USED TO PROTECT ELECTRONICS FROM HEAT (U.S. CLS. 2 AND 9).

CLASS 16—PAPER GOODS AND PRINTED MATTER

FOR (BASED ON SECTIONS 44(E)(BASED ON INTENT TO USE) PRINTED MATERIALS, NAMELY, INSTRUCTION MANUALS DETAILING THE USE OF TACTICAL HOOK AND LINE TECHNIQUES IN EXPLOSIVE ORDNANCE DISPOSAL OPERATIONS; OWNER MANUALS AND DOCUMENTATION IN THE NATURE OF TRAINING MANUALS RELATING TO TACTICAL ROBOTS, COMPUTER HARDWARE AND SOFTWARE FOR THE OPERATION OF SAID ROBOTS AND RF WIRELESS CONTROL SYSTEMS; PRINTED SECURITY SEALS USED TO SEAL PARCELS; (BASED ON INTENT TO USE)PRINTED MATTER AND INSTRUCTIONAL AND TEACHING MATERIAL, NAMELY, BOOKS AND MANUALS IN THE FIELDS OF EQUIPMENT TRAINING, NAMELY, NUCLEAR, BIOLOGICAL AND CHEMICAL CLEAN-UP, EXPLOSIVE ORDNANCE DETECTION AND DISPOSAL, SECURITY SURVEILLANCE AND SEARCH, SECURITY CONTRABAND AND COUNTER-TERRORIST SEARCHING, IMPROVED EXPLOSIVE DEVICE DISPOSAL (U.S. CLS. 2, 5, 22, 23, 29, 37, 38 AND 50).

CLASS 20—FURNITURE AND ARTICLES NOT OTHERWISE CLASSIFIED

FOR (BASED ON SECTIONS 44(E)(BASED ON INTENT TO USE) BOMB BLAST INHIBITORS, NAMELY, NON-METAL BOMB BLAST SUPPRESSION BINS, NON-METAL LIGHTWEIGHT CONTAINERS FOR THE ISOLATION AND TRANSPORT, CONTAINMENT, MITIGATION AND DESTRUCTION OF SUSPECT PACKAGES; (BASED ON INTENT TO USE)NON-METAL DOOR WEDGES, NON-METAL FASTENING ANCHORS FOR GRIPPING TO FLAT SURFACES AND FOR HOOKS AND LINES AND ATTACHING SNATCH BLOCKS AND OTHER LINKS; DOORSTOP OF PLASTIC; NON-METAL CLAMPS; NON-METAL GROUND PEGS; NONMETAL PULLEYS; HAND-OPERATED NON-METAL REELS FOR STORING AND DEPLOYING LINES; NON-METAL SE-

CURITY AND SURVEILLANCE TOOL KITS COMPRISED OF ANCHORS, CLAMPS, GROUND PEGS, HAND-OPERATED REELS, AND METAL SNATCH BLOCKS, REELS, GRIPS, SEIZERS, CORDS, STRINGS AND LINES, ANCHORS, PITONS AND WIRE SLINGS, HOOKS AND ROPE; NON-METAL EXPLOSIVE DEVICE DETECTION AND DIFFUSION TOOL KITS COMPRISED OF ANCHORS, CLAMPS, GROUND PEGS, HAND-OPERATED REELS, AND METAL SNATCH BLOCKS, REELS, GRIPS, SEIZERS, CORDS, STRINGS AND LINES, ANCHORS, PITONS, WIRE SLINGS, HOOKS AND ROPE (U.S. CLS. 2, 13, 22, 25, 32 AND 50).

CLASS 22—CORDAGE AND FIBERS

FOR (BASED ON INTENT TO USE) ROPES, STRINGS; ROPES, NON-METAL LINES AND CABLE STRAPS, TEXTILE CORDS, NON-METAL SLINGS FOR HOISTING AND HANDLING LOADS; SECURITY AND SURVEILLANCE KITS COMPRISING OF NON-METAL GOODS, NAMELY, ROPES, NON-METAL STRAPS AND LINES, SLINGS, TEXTILE CORDS AND SNATCH BLOCKS, REELS, GRIPS, SEIZERS, CORDS, STRINGS AND LINES; DETECTION AND DIFFUSION OF EXPLOSIVE DEVICES KITS COMPRISING OF NON-METAL GOODS, NAMELY, ROPES, NON-METAL SNAPS AND LINES, SLINGS, TEXTILE CORDS, AND METAL SNATCH BLOCKS, REELS, GRIPS, SEIZERS, CORDS, STRINGS AND LINES, ANCHORS, PITONS AND WIRE SLINGS, HOOKS, ROPE; NYLON CORD; LETTER BOMB CONTAINMENT BAGS, STRINGS AND LINES THERETO, SHOCK CORDS, ALL-PURPOSE STRAPS AND LINES THERETO (U.S. CLS. 1, 2, 7, 19, 22, 42 AND 50).

CLASS 35—ADVERTISING AND BUSINESS

FOR (BASED ON SECTIONS 44(E)(BASED ON INTENT TO USE) MAIL ORDER CATALOG, ELECTRONIC CATALOG, MAIL ORDER, ON-LINE ORDERING SERVICES FEATURING SECURITY APPARATUS AND HARDWARE; (BASED ON INTENT TO USE) ADVERTISING; BUSINESS MANAGEMENT; BUSINESS ADMINISTRATION (U.S. CLS. 100, 101 AND 102).

CLASS 41—EDUCATION AND ENTERTAINMENT

FOR (BASED ON SECTIONS 44(E)(BASED ON INTENT TO USE) EDUCATION SERVICES, NAMELY, PROVIDING CLASSES, SEMINARS, WORKSHOPS IN THE FIELDS OF EQUIPMENT TRAINING, NAMELY, NUCLEAR, BIOLOGICAL AND CHEMICAL CLEAN-UP, EXPLOSIVE ORDNANCE DETECTION AND DISPOSAL, SECURITY SURVEILLANCE AND SEARCH, SECURITY CONTRABAND AND COUNTER-TERRORIST SEARCHING, IMPROVED EXPLOSIVE DEVICE DISPOSAL; PROVIDING OF EDUCATION TRAINING IN THE FIELDS OF EQUIPMENT TRAINING, NAMELY, NUCLEAR, BIOLOGICAL AND CHEMICAL CLEAN-UP, EXPLOSIVE ORDNANCE DETECTION AND DISPOSAL, SECURITY SURVEILLANCE AND SEARCH, SECURITY CONTRABAND AND COUNTER-TERRORISM SEARCHING, IMPROVED EXPLOSIVE DEVICE DISPOSAL; EDUCATION AND TRAINING SERVICES, NAMELY, EDUCATIONAL TRAINING SERVICES IN RESPECT OF THE OPERATION, INSTALLATION, MAINTENANCE, AND REPAIR OF APPARATUS AND INSTRUMENTS USED IN THE FIELDS OF SECRET AND IN CONTRABAND AND COUNTER-TERRORIST SEARCHING; EDUCATIONAL TRAINING SERVICES, NAMELY, TRAINING FOR PROCEDURES FOR DEALING WITH CHEMICAL, BIOLOGICAL, NUCLEAR AND RADIOLOGICAL INCIDENTS, COUNTER-TERRORIST AND CONTRABAND SEARCH TRAINING, BOMB AWARENESS AND COUNTER-MEASURES TRAINING, THREAT ANALYSIS AND PLANNING TRAINING, IMPROVED EXPLOSIVE DEVICE DISPOSAL TRAINING (U.S. CLS. 100, 101 AND 107).

CLASS 42—SCIENTIFIC AND COMPUTER SERVICES

FOR (BASED ON SECTIONS 44(E)(BASED ON INTENT TO USE) SCIENTIFIC RESEARCH AND TECHNOLOGICAL CONSULTATION IN THE TECHNOLOGY FIELD OF BALLISTIC TESTING SERVICES, NAMELY, TESTING AND EVALUATION OF WEAPON, AMMUNITION AND ARMOR; DESIGN, DEVELOPMENT AND TESTING FOR OTHERS OF APPARATUS AND INSTRUMENTS USED IN THE FIELD OF SECURITY AND IN CONTRABAND ENCOUNTER SEARCHING, APPARATUS AND INSTRUMENTS USED IN EXPLOSIVE ORDNANCE DISPOSAL, APPARATUS AND INSTRUMENTS USED IN IMPROVISED EXPLOSIVE DEVICE DISPOSAL, PERSONAL PROTECTIVE EQUIPMENT FOR THE PROTECTION OF INDIVIDUALS FROM CHEMICAL AND BIOLOGICAL WARFARE AGENTS, SURVEILLANCE APPARATUS AND INSTRUMENTS, VEHICLE BARRIER SYSTEMS, TACTICAL ROBOTS FOR USE IN LAW ENFORCEMENT AND MILITARY APPLICATIONS, SURVEILLANCE, BOMB DISPOSAL, HAZARDOUS MATERIAL ACCIDENT CLEAN-UP AND HOSTAGE TAKING SITUATIONS, EQUIPMENT AND SYSTEMS FOR CONTAINMENT AND MITIGATION OF WEAPONS OF MASS DESTRUCTION AND CHEMICAL, BIOLOGICAL, RADIOLOGICAL AND NUCLEAR EXPLOSIVE DEVICES AND MATERIALS, CHEMICAL BIOLOGICAL AND RADIOLOGICAL DECONTAMINATION SYSTEMS AND EQUIPMENT, BALLISTIC TESTING EQUIPMENT, BLAST PROTECTION ARMOR FOR VEHICLES AND BLAST PROTECTION SEATS; TECHNOLOGY CONSULTING SERVICES IN THE FIELDS OF THE TECHNICAL PROCEDURES FOR DEALING WITH CHEMICAL, BIOLOGICAL, NUCLEAR AND RADIOLOGICAL INCIDENTS, COUNTER-TERRORIST TRAINING AND TACTICS, CONTRABAND SEARCH AND DETECTION TRAINING AND TACTICS, BOMB COUNTERMEASURES TACTICS, THREAT ANALYSIS SECURITY CONSULTING; IMPACT TESTING SERVICES, NAMELY, TESTING OF DATA RECORDERS AND HIGH G SHOCK TESTING OF AIR, LAND AND SEA VEHICLE; DEVELOPMENT OF TOOLS AND EQUIPMENT FOR USE IN THE MAINTENANCE, REPAIR AND OVERHAUL OF AIRCRAFT, TECHNOLOGICAL CONSULTANCY, ADVISORY AND INFORMATION SERVICES RELATING TO THE ABOVE SERVICES (U.S. CLS. 100 AND 101).
ALYSSA STEEL, EXAMINING ATTORNEY

SN 77-609,980. HOLDFAST CAPITAL PTE. LTD., ONE MARINA BOULEVARD, SINGAPORE, FILED 11-7-2008.



OWNER OF SINGAPORE REG. NO. T0815221A, DATED 4-11-2008, EXPIRES 4-11-2018.
THE MARK CONSISTS OF A SINGLE FOUR-POINTED STAR MADE FROM FOUR ABUTTING CHEVRONS.

CLASS 16—PAPER GOODS AND PRINTED MATTER

FOR PRINTED MATTER, NAMELY, PRINTED PUBLICATIONS IN THE NATURE OF BOOKS, BROCHURES, PAMPHLETS, MAGAZINES, NEWSLETTERS, PERIODICALS, AND PROSPECTUSES, ALL IN THE FIELDS OF FINANCE, SECURITIES AND REAL ESTATE; STATIONERY; WRITING PADS AND PAPER; ENVELOPES; FOLDERS; POSTERS; ADVERTISEMENT BOARDS OF PAPER OR CARDBOARD; BAGS AND POUCHES OF PAPER FOR PACKAGING; BOXES OF CARDBOARD OR PAPER; PAPER LABELS; STICKERS (U.S. CLS. 2, 5, 22, 23, 29, 37, 38 AND 50).

CLASS 36—INSURANCE AND FINANCIAL

FOR FINANCIAL SERVICES, NAMELY, FUND MANAGEMENT, INVESTMENT MANAGEMENT, ASSET MANAGEMENT, UNIT TRUST MANAGEMENT, FINANCIAL AND INVESTMENT PORTFOLIO MANAGEMENT, FINANCIAL ADVISORY SERVICES, FINANCIAL INVESTMENT ADVISORY SERVICES, INVESTMENT ADVISORY SERVICES, ADVISORY SERVICES RELATING TO UNIT TRUSTS, INVESTMENT ANALYSIS, FUND INVESTMENTS, CAPITAL INVESTMENTS, UNIT TRUST INVESTMENTS IN THE NATURE OF INVESTING OF FUNDS FOR OTHERS, MUTUAL FUND DISTRIBUTION, MUTUAL FUND ADMINISTRATION, ALTERNATIVE INVESTMENTS IN THE NATURE OF INVESTING OF FUNDS FOR OTHERS, PRIVATE EQUITY INVESTMENT MANAGEMENT, VENTURE CAPITAL INVESTMENT MANAGEMENT, REAL ESTATE INVESTMENT MANAGEMENT, AND UNIT TRUST SERVICES, NAMELY, INVESTMENT AND TRUST COMPANY SERVICES, ALL INCLUDING SUCH SERVICES PROVIDED ON-LINE OR VIA THE INTERNET (U.S. CLS. 100, 101 AND 102).
GINA HAYES, EXAMINING ATTORNEY

SN 77-656,826. EMERSON RADIO CORP., HACKENSACK, NJ. FILED 1-26-2009.



THE MARK CONSISTS OF A STYLIZED FORM OF THE WORD "EMERSON" ALONG WITH A SQUARE DESIGN PARTIALLY SHADED TO FORM A CLEF SYMBOL.

CLASS 7—MACHINERY

FOR ELECTRONIC FOOD PROCESSORS, ELECTRIC COFFEE GRINDERS, JUICE EXTRACTORS (U.S. CLS. 13, 19, 21, 23, 31, 34 AND 35).

CLASS 11—ENVIRONMENTAL CONTROL APPARATUS

FOR ELECTRONIC TOASTER OVENS, ELECTRONIC TOASTERS, COMPACT REFRIGERATORS, COMPACT FREEZERS, ELECTRIC COFFEE MAKERS, ELECTRIC ESPRESSO MACHINES, ELECTRIC KETTLE, ELECTRONIC SLOW COOKER, ELECTRIC GRILLS, MICROWAVE OVENS, COMPACT WINE COOLERS, NAMELY, REFRIGERATED CABINETS CONTAINING RACKS FOR WINE BOTTLES AND STORAGE SHELVES, ELECTRONIC WINE BOTTLE COOLERS AND WARMERS AND ELECTRONIC ICE BUCKETS, NAMELY, ELECTRONIC TEMPERATURE CONTROL HOUSINGS FOR WINE BOTTLES, PORTABLE ICE MAKING MACHINES (U.S. CLS. 13, 21, 23, 31 AND 34).

CLASS 21—HOUSEWARES AND GLASS

FOR WINE ACCESSORIES, NAMELY, ELECTRONIC WINE BOTTLE OPENERS, BATTERY OPERATED WINE BOTTLE OPENERS (U.S. CLS. 2, 13, 23, 29, 30, 33, 40 AND 50).

ANNE E. GUSTASON, EXAMINING ATTORNEY

SN 77-721,936, VIRTUAL TOYS, S.L., MADRID, SPAIN, FILED 4-24-2009.



OWNER OF ERPN CMNTY TM OFC REG. NO. 008271173, DATED 11-22-2009, EXPIRES 11-22-2019.

THE COLOR(S) WHITE, BLACK, GRAY AND YELLOW IS/ARE CLAIMED AS A FEATURE OF THE MARK.

"THE MARK CONSISTS OF THE WORDS "SPACEBALL REVOLUTION" SHOWN IN THE COLORS WHITE AND YELLOW (WITH THE COLOR YELLOW SHOWN IN THE TERM BALL) ALL OUTLINED IN THE COLOR BLACK, AND A BALL DESIGN SHOWN IN THE COLORS GRAY AND WHITE.

CLASS 9—ELECTRICAL AND SCIENTIFIC APPARATUS

FOR VIDEO AND COMPUTER GAME PROGRAMS; VIDEO GAME CARTRIDGES, DISCS AND CASSETTES; VIDEO GAME CONSOLES FOR USE WITH AN EXTERNAL DISPLAY SCREEN OR MONITOR (U.S. CLS. 21, 23, 26, 36 AND 38).

CLASS 28—TOYS AND SPORTING GOODS

FOR GAMES AND PLAYTHINGS, NAMELY, HAND-HELD UNITS FOR PLAYING ELECTRONIC GAMES AND VIDEO GAMES (U.S. CLS. 22, 23, 38 AND 50).

PAM WILLIS, EXAMINING ATTORNEY

SN 77-814,225, RUGGEDCOM INC., CONCORD, ONTARIO, CANADA, FILED 8-27-2009.

RUGGEDPING

THE MARK CONSISTS OF STANDARD CHARACTERS WITHOUT CLAIM TO ANY PARTICULAR FONT, STYLE, SIZE, OR COLOR.

PRIORITY CLAIMED UNDER SEC. 44(D) ON CANADA APPLICATION NO. 1440472, FILED 6-4-2009, REG. NO. TMA827255, DATED 6-28-2012, EXPIRES 6-28-2027.

OWNER OF U.S. REG. NOS. 2,861,221, 3,342,227 AND 3,350,474.

CLASS 9—ELECTRICAL AND SCIENTIFIC APPARATUS

FOR COMPUTER HARDWARE; COMPUTER UTILITY SOFTWARE FOR SENDING ECHO MESSAGES AND PROCESSING RESPONSES; COMPUTER SOFTWARE TO CONDUCT PERFORMANCE TESTING ON COMPUTER NETWORKS; COMPUTER SOFTWARE TO PERFORM PING SWEEPS ON NETWORKS; COMPUTER SOFTWARE TO AUTOMATICALLY DISCOVER DEVICES CONNECTED TO COMPUTER NETWORKS; COMPUTER SOFTWARE TO DETERMINE OUTAGE DURATIONS OF DEVICES CONNECTED TO A COMPUTER NETWORK; COMPUTER SOFTWARE FOR VISUALIZING A COMPUTER NETWORK; COMPUTER SOFTWARE FOR DISCOVERING DEVICES CONNECTED TO A COMPUTER NETWORK; COMMUNICATION ROUTERS, SWITCHES, COMPUTERS AND MODEMS; GATEWAY ROUTERS IN THE NATURE OF COMPUTER CONTROL HARDWARE; FIBER OPTIC CABLES, CONNECTORS AND FILTERS; FIBER OPTICAL NETWORKS COMPRISED PRIMARILY OF HUBS, COMPUTER SWITCHES AND FIBER-TO-ELECTRICAL MEDIA CONVERTERS, COMMUNICATION HUBS, COMMUNICATION ROUTERS AND SWITCHES HAVING MIXED FIBER OPTICAL AND ELECTRICAL MEDIA PORTS; COMPUTER NETWORK HUBS, COMPUTER SWITCHES AND ROUTERS HAVING FIBER OPTICAL PORTS; COMPUTER HUBS, ROUTERS AND COMPUTER SWITCHES HAVING MIXED FIBER OPTICAL AND ELECTRICAL MEDIA PORTS; FIBER OPTICAL ETHERNET NETWORKS COMPRISED OF COMMUNICATION HUBS, SWITCHES, FIBER-TO-ELECTRICAL MEDIA CONVERTERS, SERIAL TO ETHERNET SERVERS, COMMUNICATION HUBS, COMMUNICATION ROUTERS, COMPUTER HUBS, COMPUTER NETWORK ROUTERS, COMPUTER SWITCHES AND SERIAL TO ETHERNET SERVERS HAVING MIXED FIBER OPTIC TO ELECTRICAL MEDIA PORTS; COMPUTER NETWORK HUBS, SWITCHES AND ROUTERS HAVING OPTICAL PORTS; COMPUTER HUBS, ROUTERS, SWITCHES, SERIAL TO ETHERNET COMPUTER SERVERS AND SERIAL DEVICE COMPUTER SERVERS HAVING MIXED FIBER OPTIC AND COPPER PORTS; VIDEO ENCODERS; FIBER OPTIC TO CABLE CONVERTERS; FIBER OPTICAL TO ELECTRICAL MEDIA CONVERTERS; SERIAL TO ETHERNET GATEWAY ROUTERS IN THE NATURE OF COMPUTER CONTROL HARDWARE; SERIAL DEVICE COMPUTER SERVERS (U.S. CLS. 21, 23, 26, 36 AND 38).

CLASS 35—ADVERTISING AND BUSINESS

FOR ON-LINE RETAIL STORE SERVICES FEATURING FIBER OPTICAL NETWORKS, ROUTERS, SWITCHES, GATEWAYS, MODEMS, FIBER OPTIC CABLES, CONNECTORS AND FILTERS, FIBER OPTICAL NETWORKS, FIBER OPTICAL ETHERNET NETWORKS, COMPUTER HARDWARE, COMPUTER SOFTWARE AND COMMUNICATION EQUIPMENT; COMPUTERIZED ON-LINE RETAIL STORE SERVICES IN THE FIELD OF FIBER OPTICAL NETWORKS, ROUTERS, SWITCHES, GATEWAYS, MODEMS, FIBER OPTIC CABLES, CONNECTORS AND FILTERS, FIBER OPTICAL NETWORKS, FIBER OPTICAL ETHERNET NETWORKS, COMPUTER HARDWARE, COMPUTER SOFTWARE AND COMMUNICATION EQUIPMENT; ONLINE RETAIL STORE FEATURING COMMUNICATION ROUTERS, SWITCHES, GATEWAYS, COMPUTERS, MODEMS, FIBER OPTIC CABLES, CONNECTORS AND FILTERS, FIBER OPTICAL NETWORKS, FIBER OPTICAL ETHERNET NETWORKS, FIBER OPTICAL ETHERNET NETWORKS; RETAIL STORE SERVICES FEATURING FIBER OPTICAL NETWORKS, ROUTERS, SWITCHES, GATEWAYS, MODEMS, FIBER OPTIC CABLES, CONNECTORS AND FILTERS, FIBER OPTICAL NETWORKS, FIBER OPTICAL ETHERNET NETWORKS, COMPUTER HARDWARE, COMPUTER SOFTWARE AND COMMUNICATION EQUIPMENT; ARRANGING AND CONDUCTING COMMERCIAL EXHIBITIONS OF FIBER OPTICAL NETWORKS, COMPUTER HARDWARE, COMPUTER SOFTWARE AND COMMUNICATIONS EQUIPMENT FOR RETAIL PURPOSE ON COMMUNICATION

MEDIA; PROVIDING ON-LINE BUSINESS INFORMATION SERVICES IN THE FIELD OF THE COMMERCIAL USES OF FIBER OPTICAL NETWORKS, COMPUTER HARDWARE, COMPUTER SOFTWARE AND COMMUNICATIONS EQUIPMENT; SALES PROMOTION SERVICES FEATURING FIBER OPTICAL NETWORKS, COMPUTER HARDWARE, COMPUTER SOFTWARE AND COMMUNICATIONS; TELECOMMUNICATIONS NETWORK MANAGEMENT SERVICES, NAMELY, THE OPERATION AND ADMINISTRATION OF TELECOMMUNICATION SYSTEMS AND NETWORKS FOR OTHERS (U.S. CLS. 100, 101 AND 102).

CLASS 42—SCIENTIFIC AND COMPUTER SERVICES

FOR TECHNICAL SUPPORT, NAMELY, MONITORING OF NETWORK SYSTEMS; COMPUTER DIAGNOSTIC SERVICES FOR NETWORK SYSTEM; COMPUTER NETWORK DESIGN FOR OTHERS; COMPUTER NETWORK CONSULTING SERVICES; DESIGN, DEPLOYMENT AND MANAGEMENT OF COMPUTER NETWORKS FOR OTHERS; COMPUTER COMMUNICATION NETWORK CONSULTING SERVICES; MONITORING OF COMPUTER NETWORK SYSTEMS FOR SYSTEM FAILURE OR DECREASE IN PERFORMANCE; MONITORING OF THE PERFORMANCE AND PHYSICAL STRUCTURE OF A COMPUTER NETWORK (U.S. CLS. 100 AND 101).

CLASS 45—PERSONAL AND LEGAL SERVICES

FOR MONITORING OF COMPUTER NETWORK SYSTEMS FOR SECURITY PURPOSES (U.S. CLS. 100 AND 101).

JOHN DALIER, EXAMINING ATTORNEY

CLASS 9—ELECTRICAL AND SCIENTIFIC APPARATUS

FOR COMPUTER HARDWARE; COMPUTER SOFTWARE TO TRANSFER FILES AND FIRMWARE TO AND FROM DEVICES CONNECTED TO A NETWORK; COMPUTER SOFTWARE TO CONFIGURE DEVICES CONNECTED TO A COMPUTER NETWORK; COMPUTER SOFTWARE BUILT INTO DEVICES CONNECTED TO A NETWORK TO FACILITATE UPLOAD AND DOWNLOAD OF FILES FROM A CONSOLE; COMPUTER SOFTWARE FOR VISUALIZING A COMPUTER NETWORK; COMPUTER SOFTWARE FOR DISCOVERING DEVICES CONNECTED TO A COMPUTER NETWORK; COMMUNICATION ROUTERS, SWITCHES, COMPUTERS AND MODEMS; GATEWAY ROUTERS IN THE NATURE OF COMPUTER CONTROL HARDWARE; FIBER OPTIC CABLES, CONNECTORS AND FILTERS; FIBER OPTICAL NETWORKS COMPRISED PRIMARILY OF HUBS, COMPUTER SWITCHES AND FIBER-TO-ELECTRICAL MEDIA CONVERTERS, COMMUNICATION HUBS, COMMUNICATION ROUTERS AND SWITCHES HAVING MIXED FIBER OPTICAL AND ELECTRICAL MEDIA PORTS; COMPUTER NETWORK HUBS, COMPUTER SWITCHES AND ROUTERS HAVING FIBER OPTICAL PORTS; COMPUTER HUBS, ROUTERS AND COMPUTER SWITCHES HAVING MIXED FIBER OPTICAL AND ELECTRICAL MEDIA PORTS; FIBER OPTICAL ETHERNET NETWORKS COMPRISED OF COMMUNICATION HUBS, SWITCHES, FIBER-TO-ELECTRICAL MEDIA CONVERTERS, SERIAL TO ETHERNET SERVERS, COMMUNICATION HUBS, COMMUNICATION ROUTERS, COMPUTER HUBS, COMPUTER NETWORK ROUTERS, COMPUTER SWITCHES AND SERIAL TO ETHERNET SERVERS HAVING MIXED FIBER OPTIC TO ELECTRICAL MEDIA PORTS; COMPUTER NETWORK HUBS, SWITCHES AND ROUTERS HAVING OPTICAL PORTS; COMPUTER HUBS, ROUTERS, SWITCHES, SERIAL TO ETHERNET COMPUTER SERVERS AND SERIAL DEVICE COMPUTER SERVERS HAVING MIXED FIBER OPTIC AND COPPER PORTS; VIDEO ENCODERS; FIBER OPTIC TO CABLE CONVERTERS; FIBER OPTICAL TO ELECTRICAL MEDIA CONVERTERS; SERIAL TO ETHERNET GATEWAY ROUTERS IN THE NATURE OF COMPUTER CONTROL HARDWARE; SERIAL DEVICE COMPUTER SERVERS (U.S. CLS. 21, 23, 26, 36 AND 38).

CLASS 35—ADVERTISING AND BUSINESS

FOR ON-LINE RETAIL STORE SERVICES FEATURING FIBER OPTICAL NETWORKS, ROUTERS, SWITCHES, GATEWAYS, MODEMS, FIBER OPTIC CABLES, CONNECTORS AND FILTERS, FIBER OPTICAL NETWORKS, FIBER OPTICAL ETHERNET NETWORKS, COMPUTER HARDWARE, COMPUTER SOFTWARE AND COMMUNICATION EQUIPMENT; COMPUTERIZED ON-LINE RETAIL STORE SERVICES IN THE FIELD OF FIBER OPTICAL NETWORKS, ROUTERS, SWITCHES, GATEWAYS, MODEMS, FIBER OPTIC CABLES, CONNECTORS AND FILTERS, FIBER OPTICAL NETWORKS, FIBER OPTICAL ETHERNET NETWORKS, COMPUTER HARDWARE, COMPUTER SOFTWARE AND COMMUNICATION EQUIPMENT; ONLINE RETAIL STORE FEATURING COMMUNICATION ROUTERS, SWITCHES, GATEWAYS, COMPUTERS, MODEMS, FIBER OPTIC CABLES, CONNECTORS AND FILTERS, FIBER OPTICAL NETWORKS, FIBER OPTICAL ETHERNET NETWORKS; RETAIL STORE SERVICES FEATURING FIBER OPTICAL NETWORKS, ROUTERS, SWITCHES, GATEWAYS, MODEMS, FIBER OPTIC CABLES, CONNECTORS AND FILTERS, FIBER OPTICAL NETWORKS, FIBER OPTICAL ETHERNET NETWORKS, COMPUTER HARDWARE, COMPUTER SOFTWARE AND COMMUNICATION EQUIPMENT; ARRANGING AND CONDUCTING COMMERCIAL EXHIBITIONS OF FIBER OPTICAL NETWORKS, COMPUTER HARDWARE, COMPUTER SOFTWARE AND COMMUNICATIONS EQUIPMENT FOR RETAIL PURPOSE ON COMMUNICATION MEDIA; PROVIDING ON-LINE BUSINESS INFORMATION SERVICES IN THE FIELD OF THE COMMERCIAL USES OF FIBER OPTICAL NETWORKS, COMPUTER HARDWARE, COMPUTER SOFTWARE AND COMMUNICATIONS EQUIPMENT; SALES PROMOTION SERVICES FEATURING FIBER OPTICAL NETWORKS, COMPUTER HARDWARE, COMPUTER SOFTWARE AND COMMUNICATIONS; TELECOMMUNICATIONS

SN 77-875,780, RUGGEDCOM INC., CONCORD, CANADA,
FILED 11-18-2009.

RUGGEDEXPLORER

THE MARK CONSISTS OF STANDARD CHARACTERS WITHOUT CLAIM TO ANY PARTICULAR FONT, STYLE, SIZE, OR COLOR.

PRIORITY CLAIMED UNDER SEC. 44(D) ON CANADA APPLICATION NO. 1439984, FILED 6-1-2009, REG. NO. TMA827128, DATED 6-26-2012, EXPIRES 6-26-2027.

OWNER OF U.S. REG. NOS. 2,861,221, 3,342,227 AND 3,350,474.

NETWORK MANAGEMENT SERVICES, NAMELY, THE OPERATION AND ADMINISTRATION OF TELECOMMUNICATION SYSTEMS AND NETWORKS FOR OTHERS (U.S. CLS. 100, 101 AND 102).

CLASS 42—SCIENTIFIC AND COMPUTER SERVICES

FOR TECHNICAL SUPPORT, NAMELY, MONITORING OF NETWORK SYSTEMS; COMPUTER DIAGNOSTIC SERVICES FOR NETWORK SYSTEM; COMPUTER NETWORK DESIGN FOR OTHERS; COMPUTER NETWORK CONSULTING SERVICES; DESIGN, DEPLOYMENT AND MANAGEMENT OF COMPUTER NETWORKS FOR OTHERS; COMPUTER COMMUNICATION NETWORK CONSULTING SERVICES; MONITORING OF COMPUTER NETWORK SYSTEMS FOR SYSTEM FAILURE OR DECREASE IN PERFORMANCE; MONITORING OF THE PERFORMANCE AND PHYSICAL STRUCTURE OF A COMPUTER NETWORK (U.S. CLS. 100 AND 101).

CLASS 45—PERSONAL AND LEGAL SERVICES

FOR MONITORING OF COMPUTER NETWORK SYSTEMS FOR SECURITY PURPOSES (U.S. CLS. 100 AND 101).

JOHN DALIER, EXAMINING ATTORNEY

SN 77-881,709. HARRISON MORGAN, NEW YORK, NY. FILED 11-28-2009.

Harrison Morgan

THE MARK CONSISTS OF STANDARD CHARACTERS WITHOUT CLAIM TO ANY PARTICULAR FONT, STYLE, SIZE, OR COLOR.

THE NAME "HARRISON MORGAN" IDENTIFIES A LIVING INDIVIDUAL WHOSE CONSENT IS OF RECORD.

CLASS 14—JEWELRY

FOR JEWELRY; JEWELRY WATCHES (U.S. CLS. 2, 27, 28 AND 50).
FIRST USE 11-11-2009; IN COMMERCE 11-11-2009.

CLASS 25—CLOTHING

FOR BOLEROS; CAPES; FUR COATS AND JACKETS; HATS; SCARFS; SHAWLS AND STOLE; SHRUGS; SLEEVED OR SLEEVELESS JACKETS; SWEATERS; TRAVEL CLOTHING CONTAINED IN A PACKAGE COMPRISING REVERSIBLE JACKETS, PANTS, SKIRTS, TOPS AND A BELT OR SCARF; WRAPS (U.S. CLS. 22 AND 39).

FIRST USE 2-1-1995; IN COMMERCE 2-1-1995.
JAY FLOWERS, EXAMINING ATTORNEY

SN 77-891,033. INTERCOIFFURE AMERICA/CANADA CORP., BAYSIDE, ND. FILED 12-10-2009.

INTERCOIFFURE AMERICA·CANADA

THE MARK CONSISTS OF STANDARD CHARACTERS WITHOUT CLAIM TO ANY PARTICULAR FONT, STYLE, SIZE, OR COLOR.

OWNER OF U.S. REG. NO. 1,787,172.

NO CLAIM IS MADE TO THE EXCLUSIVE RIGHT TO USE "AMERICA" OR "CANADA", APART FROM THE MARK AS SHOWN.

CLASS 35—ADVERTISING AND BUSINESS

FOR BUSINESS ORGANIZATION AND MANAGEMENT ADVICE FOR SALONS (U.S. CLS. 100, 101 AND 102).

CLASS 41—EDUCATION AND ENTERTAINMENT

FOR ARRANGING AND CONDUCTING EDUCATIONAL CONFERENCES, CONVENTIONS, AND SYMPOSIUMS; PRESENTATION OF LIVE SHOW PERFORMANCES; TRAINING AND INSTRUCTION IN THE FIELDS OF HAIR COLORING AND STYLING, HAIR CARE, HEALTH, COSMETICS, BEAUTY CARE, AND FASHION; ENTERTAINMENT IN THE NATURE OF FASHION SHOWS; DANCE EVENTS; CONDUCTING SHOWS, EXHIBITIONS AND COMPETITIONS IN THE FIELD OF HAIR CARE, HAIR COLORING, BEAUTY AND HAIR STYLING; CONDUCTING MEDIA EVENTS IN THE NATURE OF HAIR CARE, HAIR COLORING, BEAUTY AND HAIR STYLING SHOWS, EXHIBITIONS AND COMPETITIONS (U.S. CLS. 100, 101 AND 107).

CLASS 44—MEDICAL, BEAUTY AND AGRICULTURAL SERVICES

FOR HAIR SALON SERVICES; HEALTH SPA SERVICES FOR HEALTH AND WELLNESS OF THE BODY AND SPIRIT; MEDICAL SPA SERVICES, NAMELY, MINIMALLY AND NON-INVASIVE COSMETIC AND BODY FITNESS THERAPIES; BEAUTY SALON SERVICES; COSMETIC SKIN CARE SERVICES (U.S. CLS. 100 AND 101).

SUNG IN, EXAMINING ATTORNEY

SN 77-891,141. IUCN, INTERNATIONAL UNION FOR CONSERVATION OF NATURE AND NATURAL RESOURCES, GLAND, SWITZERLAND, FILED 12-11-2009.

UICN, Union Internacional para la Conservacion de la Naturaleza

THE MARK CONSISTS OF STANDARD CHARACTERS WITHOUT CLAIM TO ANY PARTICULAR FONT, STYLE, SIZE, OR COLOR.

OWNER OF SWITZERLAND REG. NO. 599951, DATED 12-17-2009, EXPIRES 12-17-2019.

OWNER OF U.S. REG. NO. 2,415,447.

NO CLAIM IS MADE TO THE EXCLUSIVE RIGHT TO USE "UNION INTERNACIONAL PARA LA CONSERVACION DE LA NATURALEZA", APART FROM THE MARK AS SHOWN.

THE ENGLISH TRANSLATION OF "UNION INTERNACIONAL PARA LA CONSERVACION DE LA NATURALEZA" IN THE MARK IS "INTERNATIONAL UNION FOR CONSERVATION OF NATURE".

CLASS 16—PAPER GOODS AND PRINTED MATTER

FOR PAMPHLETS, BROCHURES, PERIODICAL PUBLICATIONS, BOOKS, NEWSPAPERS AND MAGAZINES ALL RELATING TO CONSERVATION OF NATURE AND THE ENVIRONMENT (U.S. CLS. 2, 5, 22, 23, 29, 37, 38 AND 50).

CLASS 38—COMMUNICATION

FOR TELECOMMUNICATION SERVICES, NAMELY, PROVIDING ON-LINE ACCESS ON A GLOBAL COMPUTER NETWORK TO INFORMATION RELEVANT TO CONSERVATION OF NATURE AND THE ENVIRONMENT (U.S. CLS. 100, 101 AND 104).

CLASS 41—EDUCATION AND ENTERTAINMENT

FOR EDUCATION AND TRAINING SERVICES, NAMELY, CONDUCTING AND ARRANGING SEMINARS, CLASSES AND SYMPOSIA RELATING TO CONSERVATION OF NATURE AND THE ENVIRONMENT (U.S. CLS. 100, 101 AND 107).

CLASS 42—SCIENTIFIC AND COMPUTER SERVICES

FOR SCIENTIFIC AND STATISTICAL RESEARCH RELEVANT TO CONSERVATION OF NATURE AND THE ENVIRONMENT (U.S. CLS. 100 AND 101).

JORDAN BAKER, EXAMINING ATTORNEY

CLASS 9—ELECTRICAL AND SCIENTIFIC APPARATUS

FOR COMPUTER SOFTWARE THAT ANALYZES AND IDENTIFIES CONCEPTS CONTAINED IN INFORMATION STORED IN DATABASES, E-MAIL ARCHIVES, DOCUMENT MANAGEMENT SYSTEMS, MULTIMEDIA FILES, INTRANET SITES, AND INTERNET SITES AND CREATES AND DISPLAYS LINKS TO CONTENT AVAILABLE ON INTERNET SITES THAT IS CONCEPTUALLY RELATED TO THE CONTENT OF THE ANALYZED INFORMATION, NAMELY, SEARCH ENGINE SOFTWARE; COMPUTER SOFTWARE THAT ALLOWS USERS TO SPECIFY INFORMATION OF INTEREST THAT IS STORED IN INFORMATION STORED IN DATABASES, E-MAIL ARCHIVES, DOCUMENT MANAGEMENT SYSTEMS, MULTIMEDIA FILES, INTRANET SITES, AND INTERNET SITES AND CREATE AND DYNAMICALLY UPDATE INDEXES OF AUDIO, VIDEO, TEXT, AND GRAPHIC FILES AVAILABLE ON THE INTERNET THAT ARE CONCEPTUALLY RELATED TO THE USER-SPECIFIED INFORMATION, NAMELY, SOFTWARE FOR CREATING HYPERLINKS AND ONLINE BANNERS (U.S. CLS. 21, 23, 26, 36 AND 38).

FIRST USE 6-0-2004; IN COMMERCE 10-0-2004.

CLASS 42—SCIENTIFIC AND COMPUTER SERVICES

FOR PROVIDING TEMPORARY USE OF NONDOWNLOADABLE COMPUTER SOFTWARE THAT ANALYZES AND IDENTIFIES CONCEPTS CONTAINED IN INFORMATION STORED IN DATABASES, E-MAIL ARCHIVES, DOCUMENT MANAGEMENT SYSTEMS, MULTIMEDIA FILES, INTRANET SITES, AND INTERNET SITES AND CREATES AND DISPLAYS LINKS TO CONTENT AVAILABLE ON INTERNET SITES THAT IS CONCEPTUALLY RELATED TO THE CONTENT OF THE ANALYZED INFORMATION, NAMELY, SEARCH ENGINE SOFTWARE; COMPUTER SERVICES, NAMELY, HOSTING AN SEARCH ENGINE INTERNET WEB SITE THAT PERMITS USERS TO PERFORM CONCEPT-BASED SEARCHES OF INTERNET WEB SITES AND OF AUDIO, VIDEO AND GRAPHICAL FILES AVAILABLE VIA THE INTERNET (U.S. CLS. 100 AND 101).

FIRST USE 6-0-2004; IN COMMERCE 10-0-2004.

JASON TURNER, EXAMINING ATTORNEY

SN 77-894,442. BLINKX UK LIMITED, CAMBRIDGE, UNITED KINGDOM, FILED 12-16-2009.

SN 77-944,387. EMAAR PROPERTIES PJSC, DUBAI, UNITED ARAB EMIR., FILED 2-25-2010.

BLINKX

THE MARK CONSISTS OF STANDARD CHARACTERS WITHOUT CLAIM TO ANY PARTICULAR FONT, STYLE, SIZE, OR COLOR.

BURJ KHALIFA

THE MARK CONSISTS OF STANDARD CHARACTERS WITHOUT CLAIM TO ANY PARTICULAR FONT, STYLE, SIZE, OR COLOR.

OWNER OF UNITED ARAB EMIR. REG. NO. 137850, DATED 5-22-2012, EXPIRES 1-6-2020.

OWNER OF UNITED ARAB EMIR. REG. NO. 137846, DATED 5-22-2012, EXPIRES 1-6-2020.

OWNER OF UNITED ARAB EMIR. REG. NO. 137845, DATED 5-22-2012, EXPIRES 1-6-2020.

THE ENGLISH TRANSLATION OF "BURJ KHALIFA" IN THE MARK IS "KHALIFA TOWER" OR "TOWER OF KHALIFA".

CLASS 35—ADVERTISING AND BUSINESS

FOR ADVERTISING AGENCIES, ADVERTISING MATERIAL, NAMELY, DISTRIBUTION OF ADVERTISING MATERIAL, BUSINESS MANAGEMENT OF PERFORMING ARTISTS, COMMERCIAL INFORMATION AGENCIES, COMMERCIAL OR INDUSTRIAL MANAGEMENT, NAMELY, MANAGEMENT ASSISTANCE, DEMONSTRATION OF GOODS FOR ADVERTISING PURPOSES, DIRECT MAIL DISSEMINATION OF ADVERTISING MATTER, DISTRIBUTION OF SAMPLES, EXHIBITIONS FOR COMMERCIAL OR ADVERTISING PURPOSES, NAMELY, ORGANIZATION EXHIBITIONS FOR COMMERCIAL OR ADVERTISING PURPOSES, COMMERCIAL MANAGEMENT ASSISTANCE, MARKETING RESEARCH, MARKETING STUDIES, MODELING FOR ADVERTISING OR SALES PROMOTION, PROVIDING OUTDOOR ADVERTISING FOR OTHERS, DISSEMINATION OF ADVERTISING MATERIALS; PROPERTY MARKETING (U.S. CLS. 100, 101 AND 102).

CLASS 36—INSURANCE AND FINANCIAL

FOR ARRANGING MORTGAGE FINANCING; SECURED LENDING; ARRANGING OF LOANS; PROPERTY INVESTMENT SERVICES; ALL THE AFORESAID SERVICES PROVIDED IN CONNECTION WITH AND AS AN ADJUNCT TO THE REGISTRANT'S PROPERTY DEVELOPMENTS AND ANY DISPOSITION OR PROMOTION THEREOF OR DEALING THEREWITH; BUILDINGS, NAMELY, BUILDING MANAGEMENT; RENTAL OF ACCOMMODATIONS, NAMELY, ROOMS, APARTMENTS, VILLAS, TOWNHOUSES; LEASING AND BROKERAGE OF PROPERTY; REAL ESTATE VALUATIONS; REAL ESTATE MANAGEMENT; ADVICE, CONSULTANCY AND INFORMATION SERVICES IN THE FIELD OF REAL ESTATE (U.S. CLS. 100, 101 AND 102).

CLASS 43—HOTEL AND RESTAURANT SERVICES

FOR CATERING SERVICES FOR MEALS AND BEVERAGES, SERVICES PROVIDED BY INDIVIDUALS OR FIRMS INVOLVED IN PREPARING FOODS OR BEVERAGES FOR CONSUMPTION, CAFÉ'S, CAFETERIAS, RESTAURANTS, SNACK-BARS, SERVICES OF PROVISION OF ACCOMMODATION AND MEALS IN HOTELS OR HOMES OR ANY OTHER INSTITUTIONS THAT PROVIDE TEMPORARY ACCOMMODATION, ACCOMMODATION RESERVATION SERVICES FOR PASSENGERS, PARTICULARLY BY USING TRAVEL AGENTS (U.S. CLS. 100 AND 101).

BRIAN NEVILLE, EXAMINING ATTORNEY

SN 78-477,310. AURUM CERAMIC DENTAL LABORATORIES LTD., CALGARY, ALBERTA, CANADA, FILED 9-1-2004.

**ECONOLINE
RESTORATIONS**

THE MARK CONSISTS OF STANDARD CHARACTERS WITHOUT CLAIM TO ANY PARTICULAR FONT, STYLE, SIZE, OR COLOR.

OWNER OF CANADA REG. NO. TMA824805, DATED 5-25-2012, EXPIRES 5-25-2027.

NO CLAIM IS MADE TO THE EXCLUSIVE RIGHT TO USE "RESTORATIONS", APART FROM THE MARK AS SHOWN.

CLASS 5—PHARMACEUTICALS

FOR DENTAL VENEERS (U.S. CLS. 6, 18, 44, 46, 51 AND 52).

CLASS 10—MEDICAL APPARATUS

FOR DENTAL PROSTHESES, NAMELY, DENTAL CROWNS, DENTAL BRIDGES, DENTAL INLAYS, DENTAL ONLAYS AND DENTURES (U.S. CLS. 26, 39 AND 44).

CAROLINE WOOD, EXAMINING ATTORNEY

SN 78-534,870. S.M.L. SUCCESS LTD, TEL AVIV, ISRAEL, FILED 12-17-2004.



PRIORITY CLAIMED UNDER SEC. 44(D) ON ERPNTY TM OFC APPLICATION NO. 003877801, FILED 6-17-2004, REG. NO. 003877801, DATED 4-7-2011, EXPIRES 6-17-2014.

THE COLOR(S) BLUE, GREEN AND WHITE IS/ARE CLAIMED AS A FEATURE OF THE MARK.

THE BACKGROUND OF THE MARK IS A BLUE OVAL, PARTIALLY OUTLINED ON THE LEFT SIDE WITH A STRIP OF GREEN. THE LETTER "B" IS IN GREEN. THE WORD "FREE" IS IN WHITE.

CLASS 10—MEDICAL APPARATUS

FOR BABY BOTTLES; CUPS ADAPTED FOR FEEDING BABIES AND INFANTS; PARTS OF BABY BOTTLES AND CUPS ADAPTED FOR FEEDING BABIES AND INFANTS, NAMELY, NON-SPILL VALVES FOR CUPS AND BABY BOTTLES, SPOUTS FOR CUPS AND BABY BOTTLES, AND HANDLES FOR BABY BOTTLES (U.S. CLS. 26, 39 AND 44).

CLASS 21—HOUSEWARES AND GLASS

FOR FEEDING DISHES ADAPTED FOR USE BY BABIES AND INFANTS; BABY BOTTLE AND TEAT CLEANING BRUSHES (U.S. CLS. 2, 13, 23, 29, 30, 33, 40 AND 50).

MARCIE MILONE, EXAMINING ATTORNEY

SN 78-765,121. MUHAMMAD ALI ENTERPRISES LLC, BERRIEN SPRINGS, MI. FILED 12-1-2005.

G.O.A.T.

THE MARK CONSISTS OF STANDARD CHARACTERS WITHOUT CLAIM TO ANY PARTICULAR FONT, STYLE, SIZE, OR COLOR.

CLASS 3—COSMETICS AND CLEANING PREPARATIONS

FOR AFTER-SHAVE LOTION, BATH GEL, BODY POWDER, COLOGNE, HAIR CONDITIONER, SKIN CONDITIONER, BODY CREAM, SKIN CREAM, PERSONAL DEODORANT, FACIAL CLEANSERS, HAIR CARE PREPARATIONS, HAND CREAM, SKIN SOAP, MOUTHWASH, BATH OIL, MASSAGE OIL, PERFUME, BATH POWDER, HAIR SHAMPOO, SHAVING CREAM, SKIN CLEANSERS, SKIN MOISTURIZERS, SUN SCREEN PREPARATIONS AND TOOTHPASTE (U.S. CLS. 1, 4, 6, 50, 51 AND 52).

CLASS 9—ELECTRICAL AND SCIENTIFIC APPARATUS

FOR COMPUTER GAME PROGRAMS, COMPUTER GAME SOFTWARE, COMPUTER GAME TAPES, INTERACTIVE VIDEO GAME PROGRAMS, TELEPHONES, MUSICAL SOUND RECORDINGS, MUSICAL VIDEO RECORDINGS, SUNGLASSES (U.S. CLS. 21, 23, 26, 36 AND 38).

CLASS 16—PAPER GOODS AND PRINTED MATTER

FOR ADDRESS BOOKS, PHOTO ALBUMS, AUTOGRAPH BOOKS, PAPER BAGS, BALL POINT PENS, PAPER BANNERS, BLANK NOTE CARDS, POSTER BOARDS, BULLETIN BOARDS, CHILDREN'S BOOKS, COLORING BOOKS, COOK BOOKS, EXERCISE BOOKS, PICTURE BOOKS, SERIES OF FICTION BOOKS, ARTISTS' BRUSHES, CALENDARS, GIFT CARDS, GREETING CARDS, PEN AND PENCIL CASES, DAILY PLANNERS, DECALS, PAPER PARTY DECORATIONS, DESK SETS, DIARIES, ERASERS, FILE CARDS, GIFT WRAPPING PAPER, BLANK JOURNAL BOOKS, SHEET MUSIC, NEWSPAPERS FOR GENERAL CIRCULATION, DESK PADS, BOND PAPER, WRITING PAPER, FOUNTAIN PENS, PENCILS, POSTCARDS, SCRAPBOOKS, POSTERS, STATIONERY, STICKERS, PAPER TAPE, TRADING CARDS AND WRITING PADS (U.S. CLS. 2, 5, 22, 23, 29, 37, 38 AND 50).

CLASS 28—TOYS AND SPORTING GOODS

FOR TOYS AND SPORTING GOODS, NAMELY, ACTION FIGURES AND ACCESSORIES THEREFOR; BENDABLE TOY FIGURINES; PLUSH TOYS; STUFFED TOYS; PUPPETS; INFLATABLE VINYL TOY FIGURES; DOLLS, DOLL CLOTHING AND ACCESSORIES THEREFOR; PAPER DOLLS, PRINTED PAPER DOLL CLOTHING AND ACCESSORIES THEREFOR; TOY PLASTIC DISHES; COSTUME MASKS; TOY JEWELRY; COIN-OPERATED PINBALL MACHINES; EQUIPMENT SOLD AS UNITS FOR PURPOSES OF PLAYING BOARD, PARLOR AND SKILL AND ACTION-TYPE GAMES; BOXED JIGSAW PUZZLES; JIGSAW PUZZLES SOLD AS UNITS IN THEIR ASSEMBLED FORM; HAND-HELD MANIPULATIVE PUZZLES; CARD GAMES; SELF-ERASING TOY WRITING AND DRAWING BOARD DEVICE INTENDED FOR TEMPORARILY RECEIVING WRITTEN AND/OR DRAWN IMPRESSIONS; MARBLES; YO-YO'S; TOY BANKS; TOY BUILDING BLOCKS; BATH TUB TOYS; KITES; FLYING DISKS; BALLOONS; RIDE-ON TOYS; TOY VEHICLES; SKATEBOARDS; ROLLER SKATES; CASES FOR PLAY ACCESSORIES; BOXING GLOVES; PLAYING CARDS (U.S. CLS. 22, 23, 38 AND 50).

CLASS 41—EDUCATION AND ENTERTAINMENT

FOR ENTERTAINMENT IN THE NATURE OF PERSONAL APPEARANCES BY A CELEBRITY AND SPORTS STAR, BOXING CONTESTS, ATHLETIC COMPETITIONS, NAMELY, BOXING COMPETITIONS, ENTERTAINMENT IN THE NATURE OF THEATER PRODUCTIONS, EDUCATIONAL DEMONSTRATIONS, PRODUCTION AND DISTRIBUTION OF MOTION PICTURES, PROVIDING MOTIVATIONAL AND EDUCATIONAL SPEAKERS, SPORT CAMPS (U.S. CLS. 100, 101 AND 107).

SETH A. RAPPAPORT, EXAMINING ATTORNEY

SN 79-044,201. RHEINMETALL AIR DEFENCE AG, SWITZERLAND, FILED 9-7-2007.

Oerlikon Skyranger

THE MARK CONSISTS OF STANDARD CHARACTERS WITHOUT CLAIM TO ANY PARTICULAR FONT, STYLE, SIZE, OR COLOR.

PRIORITY DATE OF 3-12-2007 IS CLAIMED.
OWNER OF INTERNATIONAL REGISTRATION 0938446 DATED 9-7-2007, EXPIRES 9-7-2017.
OWNER OF U.S. REG. NOS. 3,587,266 AND 3,924,812.

CLASS 12—VEHICLES

FOR MILITARY VEHICLES, NAMELY, ARMORED MILITARY VEHICLES WITH AT LEAST THREE AXLES (U.S. CLS. 19, 21, 23, 31, 35 AND 44).

CLASS 13—FIREARMS

FOR WEAPON SYSTEMS FOR SHORT OR MEDIUM RANGE SURFACE-TO-AIR MISSILES AND/OR CANNONS COMPRISING A FIRE-CONTROL APPARATUS, NAMELY, A GUN DATA COMPUTER, A DIRECTOR, AND RADAR THAT ARE DESIGNED TO ASSIST THE WEAPON SYSTEM IN HITTING ITS TARGET; MOBILE WEAPON SYSTEMS DESIGNED FOR AIR DEFENSE NAMELY, VEHICLE MOUNTED SHORT OR MEDIUM RANGE SURFACE-TO-AIR MISSILE WEAPONS AND/OR CANNONS (U.S. CLS. 2 AND 9).

ANNE E. GUSTASON, EXAMINING ATTORNEY

SN 79-078,281. IAN NICHOLAS HART, UNITED KINGDOM, AND ALICE CLAIRE HART, LONDON N6 4QS, UNITED KINGDOM, AND JAMES SAMUEL HART, LONDON N6 4QS, UNITED KINGDOM, FILED 9-21-2009.

Sacred

THE MARK CONSISTS OF STANDARD CHARACTERS WITHOUT CLAIM TO ANY PARTICULAR FONT, STYLE, SIZE, OR COLOR.

OWNER OF INTERNATIONAL REGISTRATION 1027306 DATED 9-21-2009, EXPIRES 9-21-2019.

CLASS 32—LIGHT BEVERAGES

FOR NON-ALCOHOLIC DRINKS, NAMELY, COLAS, TONIC WATER, FRUIT JUICES AND CARBONATED FLAVORED BEVERAGES, AND EXCLUDING BOTTLED DRINKING WATER (U.S. CLS. 45, 46 AND 48).

CLASS 33—WINES AND SPIRITS

FOR SPIRITS OF 35% PROOF AND ABOVE; NONE OF THE FOREGOING INCLUDING WINE OR WINE BASED BEVERAGES AND ALSO NOT TO INCLUDE TEQUILA OR AGAVE BASED BEVERAGES (U.S. CLS. 47 AND 49).
CHRISTINE MARTIN, EXAMINING ATTORNEY

SN 79-092,454. KUKKIWON, SEOUL 135-908, REPUBLIC OF KOREA, FILED 8-13-2010.



PRIORITY DATE OF 8-2-2010 IS CLAIMED.
OWNER OF INTERNATIONAL REGISTRATION 1064823
DATED 8-13-2010, EXPIRES 8-13-2020.

CLASS 25—CLOTHING

FOR TAEKWONDO SUITS; BELTS (GARMENTS);
WARM UP SUITS (U.S. CLS. 22 AND 39).

CLASS 41—EDUCATION AND ENTERTAINMENT

FOR EDUCATIONAL SERVICES NAMELY, PROVIDING CLASSES, SEMINARS AND WORKSHOPS IN THE FIELD OF TAEKWONDO; TAEKWONDO INSTRUCTION; ORGANIZING TAEKWONDO EVENTS; PROVIDING TAEKWONDO COMPETITIONS; PUBLICATION OF ELECTRONIC BOOKS AND JOURNALS ON-LINE, NOT DOWNLOADABLE; PROVIDING PROMOTION TESTS IN THE FIELD OF TAEKWONDO (U.S. CLS. 100, 101 AND 107).

RICHARD WHITE, EXAMINING ATTORNEY

SN 79-093,811. BNA CLAUDIO TOMMASO, ITALY, FILED 11-19-2010.



OWNER OF INTERNATIONAL REGISTRATION 1067768
DATED 11-19-2010, EXPIRES 11-19-2020.

NO CLAIM IS MADE TO THE EXCLUSIVE RIGHT TO USE "MILANO", APART FROM THE MARK AS SHOWN.

THE NAME(S), PORTRAIT(S), AND/OR SIGNATURE(S) SHOWN IN THE MARK DOES NOT IDENTIFY A PARTICULAR LIVING INDIVIDUAL.

THE COLOR(S) BLUE IS/ARE CLAIMED AS A FEATURE OF THE MARK.

THE MARK CONSISTS OF THE WORDS "NAVIGLI MILANO", AND TWO STYLIZED WAVES ONE ON TOP OF THE OTHER. THE WORDS AND DESIGN ARE IN THE COLOR BLUE.

THE ENGLISH TRANSLATION OF "NAVIGLI" IN THE MARK IS "SHIPS".

CLASS 9—ELECTRICAL AND SCIENTIFIC APPARATUS

FOR SPECTACLE CASES; FRAMES FOR SPECTACLES AND SUNGLASSES; SPECTACLE FRAMES (U.S. CLS. 21, 23, 26, 36 AND 38).

CLASS 18—LEATHER GOODS

FOR BAGS FOR SCHOOL; BAGS, NAMELY, ALL-PURPOSE CARRYING BAGS, HANDBAGS, GYM BAGS, RUCKSACKS, REUSABLE SHOPPING BAGS, COSMETIC CASES SOLD EMPTY, PURSES, SPORT BAGS AND GENERAL PURPOSE TROLLEY BAGS (U.S. CLS. 1, 2, 3, 22 AND 41).

CLASS 25—CLOTHING

FOR CLOTHING, NAMELY, T-SHIRTS, SWEATERS, SHIRTS, SWEATSHIRTS, JACKETS, COATS, PANTS, SKIRTS, OVERALLS, SUITS, LEGGINGS, DRESSES, VESTS, GOLF SHIRTS, SCARVES, GLOVES, SOCKS, GYM SUITS, SHORTS, SINGLETS, TOPS, EVENING DRESSES, JEANS, TIES, BOXER SHORTS, BRAS, PANTYHOSE, PAJAMAS, NIGHTGOWNS, DRESSING GOWNS, BATHROBES, GARTERS, SUSPENDERS, STOCKINGS, UNDERWEAR, BELTS, BEACHWEAR, NAMELY, SHORTS, BIKINI, AND SWIMSUITS; FOOTWEAR, NAMELY, SHOES, BOOTS, SLIPPERS, CLOGS, SNEAKERS, FLIP-FLOPS; HEADGEAR, NAMELY, HATS, CAPS (U.S. CLS. 22 AND 39).

PAUL MORENO, EXAMINING ATTORNEY

SN 79-094,315. ROCK GUITAR ACADEMY S.R.L., ITALY, FILED 11-24-2010.



OWNER OF INTERNATIONAL REGISTRATION 1069022
DATED 11-24-2010, EXPIRES 11-24-2020.

NO CLAIM IS MADE TO THE EXCLUSIVE RIGHT TO USE "ROCK GUITAR ACADEMY", APART FROM THE MARK AS SHOWN.

THE MARK CONSISTS OF THE STYLIZED WORDING "ROCK GUITAR ACADEMY" ABOVE THE WORDING IS THE LETTERS "RGA", WITH A STYLIZED GUITAR OUTLINE DESIGN PARTIALLY SURROUNDING THE "RGA".

CLASS 25—CLOTHING

FOR BATH ROBES, BATHING CAPS, BATHING SUITS, BERETS, BOOTS, BRACES FOR CLOTHING, HATS, PYJAMAS, SANDALS, SHIRTS, SHOES, SLIPPERS, SOCKS, SWEATERS, TEE-SHIRTS, TROUSERS, UNDERWEAR (U.S. CLS. 22 AND 39).

CLASS 41—EDUCATION AND ENTERTAINMENT

FOR EDUCATIONAL INFORMATION IN THE ACADEMIC FIELD OF MUSIC, ARRANGING AND CONDUCTING OF CONCERTS, ARRANGING AND CONDUCTING OF WORKSHOPS IN THE FIELD OF MUSIC, INSTRUCTION SERVICES IN THE FIELD OF MUSIC, MUSIC-HALLS, PRODUCTION OF SHOWS, NAMELY, OPERAS AND TELEVISION SHOWS, TEACHING IN THE FIELD OF MUSIC (U.S. CLS. 100, 101 AND 107).

SCOTT BIBB, EXAMINING ATTORNEY

SN 79-094,593. CASUCCI GERARDO, ITALY, FILED 12-14-2010.



OWNER OF INTERNATIONAL REGISTRATION 1069749 DATED 12-14-2010, EXPIRES 12-14-2020.

NO CLAIM IS MADE TO THE EXCLUSIVE RIGHT TO USE "BAR" AS TO CLASS 43, APART FROM THE MARK AS SHOWN.

THE COLOR(S) RED, BLUE, ORANGE, YELLOW, GREEN AND PURPLE IS/ARE CLAIMED AS A FEATURE OF THE MARK.

THE MARK CONSISTS OF THE STYLIZED WORDING "LIGHT BAR" IN SHADING THAT GRADUATES ACROSS THE WORDING FROM PURPLE, RED, ORANGE, YELLOW, GREEN, BLUE, BACK TO PURPLE. THE LETTERS ARE OUTLINED IN WHITE AND APPEAR AGAINST A BLUE BACKGROUND WHOSE RECTANGULAR SHAPE IS NOT CLAIMED AS A FEATURE OF THE MARK. A SHADOW OF THE WORDING APPEARS IN GRAY UNDERNEATH IN THE WORDING, SLANTING TO THE LEFT. THE COLORS GRAY AND WHITE ARE NOT CLAIMED AS FEATURES OF THE MARK AND ARE USED TO REPRESENT OUTLINING, SHADING AND TRANSPARENT AREAS IN THE MARK.

CLASS 5—PHARMACEUTICALS

FOR PHARMACEUTICAL AND VETERINARY PREPARATION, NAMELY, PHARMACEUTICAL PREPARATIONS FOR THE TREATMENT AND PREVENTION OF CARDIOVASCULAR DISORDERS AND OBESITY, SANITARY PREPARATIONS FOR MEDICAL PURPOSES, DIETETIC SUGAR FOR MEDICAL USE, FOOD FOR BABIES, MEDICAL PLASTERS, MATERIALS FOR DRESSINGS, MATERIAL FOR STOPPING TEETH, DENTAL WAX, ALL PURPOSE DISINFECTANTS, PREPARATION FOR DESTROYING VERMIN, FUNGICIDES, HERBICIDES (U.S. CLS. 6, 18, 44, 46, 51 AND 52).

CLASS 29—MEATS AND PROCESSED FOODS

FOR MEAT, FISH, POULTRY AND GAME; MEAT EXTRACTS; PRESERVED, FROZEN, DRIED AND COOKED FRUITS AND VEGETABLES; JELLIES, JAMS, COMPOTES; EGGS, MILK AND MILK PRODUCTS, NAMELY, MILK POWDER FOR FOOD PURPOSES AND MILK PROTEIN; EDIBLE FATS, EDIBLE OILS (U.S. CL. 46).

CLASS 30—STAPLE FOODS

FOR COFFEE, TEA, COCOA, SUGAR, RICE, TAPIOCA, SAGO, ARTIFICIAL COFFEE; FLOUR AND PREPARATIONS MADE FROM CEREALS, NAMELY, READY TO EAT CEREALS, BREAKFAST CEREALS; BREAD, PASTRY AND CONFECTIONERY MADE OF SUGAR, NAMELY, PASTILLES; ICES, HONEY, TREA-CLE, YEAST, BAKING-POWDER, SALT, MUSTARD, VINEGAR, SAUCES, SPICES, ICE FOR REFRESHMENT (U.S. CL. 46).

CLASS 31—NATURAL AGRICULTURAL PRODUCTS

FOR AGRICULTURAL, HORTICULTURAL AND FORESTRY PRODUCTS AND GRAINS, NAMELY, BULBS FOR AGRICULTURAL PURPOSES; LIVE ANIMALS, FRESH FRUITS AND VEGETABLES, SEEDS FOR FLOWERS, NATURAL PLANTS AND FLOWERS; FOODSTUFFS FOR ANIMALS CONTAINING BOTANICAL EXTRACTS, MALT FOR BREWING AND DISTILLING (U.S. CLS. 1 AND 46).

CLASS 32—LIGHT BEVERAGES

FOR BEERS; MINERAL AND AERATED WATERS AND OTHER NON-ALCOHOLIC DRINKS, NAMELY, ISOTONIC NON-ALCOHOLIC DRINKS; FRUIT DRINKS AND FRUIT JUICES; SYRUPS, CONCENTRATE AND POWDERS USED IN PREPARATION OF SOFT DRINKS (U.S. CLS. 45, 46 AND 48).

CLASS 33—WINES AND SPIRITS

FOR ALCOHOLIC BEVERAGES EXCEPT BEERS, WINES (U.S. CLS. 47 AND 49).

CLASS 40—MATERIAL TREATMENT

FOR TREATMENT OF MATERIALS, NAMELY, TREATMENT OF MATERIALS FOR THE MANUFACTURE OF CERAMIC GOODS (U.S. CLS. 100, 103 AND 106).

CLASS 43—HOTEL AND RESTAURANT SERVICES

FOR RESTAURANT SERVICES; PROVIDING TEMPORARY ACCOMMODATION (U.S. CLS. 100 AND 101).
JERI J. FICKES, EXAMINING ATTORNEY

SN 79-095,200. KREAKHENATON, FRANCE, FILED 2-9-2011.

Z CHROMOZOME

THE MARK CONSISTS OF STANDARD CHARACTERS WITHOUT CLAIM TO ANY PARTICULAR FONT, STYLE, SIZE, OR COLOR.

PRIORITY DATE OF 9-1-2010 IS CLAIMED.
OWNER OF INTERNATIONAL REGISTRATION 1071430 DATED 2-9-2011, EXPIRES 2-9-2021.

CLASS 9—ELECTRICAL AND SCIENTIFIC APPARATUS

FOR BLANK COMPACT DISCS AND DVDS; APPARATUS FOR RECORDING AND REPRODUCING SOUNDS, IMAGES, SIGNALS AND DATA (U.S. CLS. 21, 23, 26, 36 AND 38).

CLASS 41—EDUCATION AND ENTERTAINMENT

FOR EDUCATION, NAMELY PROVIDING SEMINARS AND WORKSHOPS IN THE FIELD OF VISUAL ARTS, FILM PRODUCTION, STAGE PRODUCTION AND SCRIPTWRITING; ENTERTAINMENT IN THE NATURE OF PRODUCTION AND DISTRIBUTION OF STAGE PRODUCTIONS, DANCE PERFORMANCES AND LIVE VISUAL AND AUDIO PERFORMANCES BY ACTORS, MUSICAL BANDS, DANCERS; VIDEOTAPING, FILM PRODUCTION; SCRIPTWRITING SERVICES; ORGANIZING SPORTING AND CULTURAL ACTIVITIES (U.S. CLS. 100, 101 AND 107).

MATTHEW EINSTEIN, EXAMINING ATTORNEY

SN 79-095,532. DCL SCHWEIZ GMBH, ZÜRICH, SWITZERLAND, FILED 2-1-2011.

MINE-X pDPF

THE MARK CONSISTS OF STANDARD CHARACTERS WITHOUT CLAIM TO ANY PARTICULAR FONT, STYLE, SIZE, OR COLOR.

PRIORITY DATE OF 9-30-2010 IS CLAIMED.

OWNER OF INTERNATIONAL REGISTRATION 1072409 DATED 2-1-2011, EXPIRES 2-1-2021.

NO CLAIM IS MADE TO THE EXCLUSIVE RIGHT TO USE "pDPF", APART FROM THE MARK AS SHOWN.

CLASS 7—MACHINERY

FOR ENGINES, NAMELY, BOAT ENGINES, AIRPLANE ENGINES AND DIESEL ENGINES FOR MACHINES; MOTORS, NAMELY, ELECTRIC MOTORS, AND THEIR PARTS, NOT FOR LAND VEHICLES; CATALYTIC CONVERTERS; TAIL GAS PURIFIERS FOR COMBUSTION ENGINES; DIESEL PARTICULATE FILTERS; PARTIAL FLOW DIESEL PARTICULATE FILTERS; ENGINE EXHAUST EMISSION CONTROL APPARATUS, NAMELY, EMISSION REDUCTION UNITS FOR ENGINES IN THE NATURE OF CATALYTIC CONVERTERS; ENGINE EXHAUST SCRUBBERS; ENGINE EXHAUST PURIFIERS, SILENCERS FOR CATALYTIC CONVERTERS; CATALYTIC ENGINE MUFFLERS; POLLUTION CONTROL CATALYST APPARATUS BEING ENHANCEMENT PARTS OF INTERNAL COMBUSTION ENGINES, NAMELY, EXHAUST CATALYSTS; TAIL GAS DILUTING AGENTS AND SILENCERS FOR COMBUSTION ENGINES, NAMELY, EXHAUST TAILPIPES, EXHAUST STACKS; SILENCERS FOR COMBUSTION ENGINES; STRUCTURAL PARTS AND REPLACEMENT PARTS FOR ALL THE AFOREMENTIONED GOODS (U.S. CLS. 13, 19, 21, 23, 31, 34 AND 35).

CLASS 12—VEHICLES

FOR MOTORS AND ENGINES FOR LAND VEHICLES (U.S. CLS. 19, 21, 23, 31, 35 AND 44).

CLASS 37—CONSTRUCTION AND REPAIR

FOR REPAIR OF MOTORS AND ENGINES AND PARTS THEREOF; INSTALLATION OF MOTORS AND ENGINES AND PARTS THEREOF; SERVICES FOR MODERNIZING, EXTENDING OR CONSOLIDATING EXISTING PLANTS, NAMELY, RETROFIT OF MOTORS AND ENGINES AND PARTS THEREOF (U.S. CLS. 100, 103 AND 106).

BRENDAN MCCAULEY, EXAMINING ATTORNEY

SN 79-095,568. DCL SCHWEIZ GMBH, ZÜRICH, SWITZERLAND, FILED 2-1-2011.

MARINE-X

THE MARK CONSISTS OF STANDARD CHARACTERS WITHOUT CLAIM TO ANY PARTICULAR FONT, STYLE, SIZE, OR COLOR.

PRIORITY DATE OF 9-30-2010 IS CLAIMED.

OWNER OF INTERNATIONAL REGISTRATION 1072541 DATED 2-1-2011, EXPIRES 2-1-2021.

CLASS 7—MACHINERY

FOR ENGINES, NAMELY, BOAT ENGINES, AIRPLANE ENGINES AND DIESEL ENGINES FOR MACHINES; MOTORS, NAMELY, ELECTRIC MOTORS, AND THEIR PARTS, NOT FOR LAND VEHICLES; CATALYTIC CONVERTERS; TAIL GAS PURIFIERS FOR COMBUSTION ENGINES; DIESEL PARTICULATE FILTERS; PARTIAL FLOW DIESEL PARTICULATE FILTERS; ENGINE EXHAUST EMISSION CONTROL APPARATUS, NAMELY, EMISSION REDUCTION UNITS FOR ENGINES IN THE NATURE OF CATALYTIC CONVERTERS; ENGINE EXHAUST SCRUBBERS; ENGINE EXHAUST PURIFIERS; SILENCERS FOR CATALYTIC CONVERTERS; CATALYTIC ENGINE MUFFLERS; POLLUTION CONTROL CATALYST APPARATUS BEING ENHANCEMENT PARTS OF INTERNAL COMBUSTION ENGINES, NAMELY, EXHAUST CATALYSTS; TAIL GAS DILUTING AGENTS FOR COMBUSTION ENGINES, NAMELY, EXHAUST TAILPIPES, EXHAUST STACKS; SILENCERS FOR COMBUSTION ENGINES; STRUCTURAL PARTS AND REPLACEMENT PARTS FOR ALL THE AFOREMENTIONED GOODS (U.S. CLS. 13, 19, 21, 23, 31, 34 AND 35).

CLASS 12—VEHICLES

FOR MOTORS AND ENGINES FOR LAND VEHICLES (U.S. CLS. 19, 21, 23, 31, 35 AND 44).

CLASS 37—CONSTRUCTION AND REPAIR

FOR REPAIR OF MOTORS AND ENGINES AND PARTS THEREOF; INSTALLATION OF MOTORS AND ENGINES AND PARTS THEREOF; SERVICES FOR MODERNIZING, EXTENDING OR CONSOLIDATING EXISTING PLANTS, NAMELY, RETROFIT OF MOTORS AND ENGINES AND PARTS THEREOF (U.S. CLS. 100, 103 AND 106).

BRENDAN MCCAULEY, EXAMINING ATTORNEY

SN 79-096,167. RARECELLS, FRANCE, FILED 3-30-2011.



PRIORITY DATE OF 9-30-2010 IS CLAIMED.

OWNER OF INTERNATIONAL REGISTRATION 1073921 DATED 3-30-2011, EXPIRES 3-30-2021.

NO CLAIM IS MADE TO THE EXCLUSIVE RIGHT TO USE "RARE CELLS", APART FROM THE MARK AS SHOWN.

THE COLOR(S) RED, GRAY, WHITE AND BLACK IS/ARE CLAIMED AS A FEATURE OF THE MARK.

THE MARK CONSISTS OF A DESIGN OF A DROP THAT IS WHITE, GRAY AND BLACK ON THE TOP AND RED ON THE BOTTOM AND THE SAME DROP CONTAINS A DESIGN OF A WHITE, GRAY AND BLACK CELL REPRESENTED BY TWO CONCENTRIC CIRCULAR SHAPES. TO THE RIGHT OF THE DROP DESIGN IS THE WORDING "RARECELLS" IN GRAY AND UNDERNEATH IS A STRAIGHT HORIZONTAL GRAY LINE THAT BISECTS THROUGH THE DROP DESIGN AND ENDS WITH A RED ARROW TIP.

CLASS 5—PHARMACEUTICALS

FOR DIAGNOSTIC PREPARATIONS FOR MEDICAL PURPOSES; CULTURES OF MICROORGANISMS FOR MEDICAL AND VETERINARY USE; NUTRITIVE SUBSTANCES FOR MICROORGANISMS; BLOOD PLASMA; BLOOD FOR MEDICAL PURPOSES; VACCINES (U.S. CLS. 6, 18, 44, 46, 51 AND 52).

CLASS 9—ELECTRICAL AND SCIENTIFIC APPARATUS

FOR DIAGNOSTIC APPARATUS FOR LABORATORY OR RESEARCH USE, NAMELY, DIAGNOSTIC APPARATUS FOR TESTING FOOD, FOR TESTING OF BIOLOGICAL FLUIDS AND LIQUIDS, AND FOR DETECTING PATHOGENS, AND DIAPHRAGMS SPECIALLY ADAPTED FOR USE WITH THE FOREGOING (U.S. CLS. 21, 23, 26, 36 AND 38).

CLASS 10—MEDICAL APPARATUS

FOR DIAGNOSTIC APPARATUS FOR MEDICAL PURPOSES, NAMELY, DIAGNOSTIC APPARATUS FOR THE DETECTION OF CANCER, GENETIC DISEASES, CARDIOLOGICAL DISEASES, INFECTIOUS DISEASES (U.S. CLS. 26, 39 AND 44).

CLASS 42—SCIENTIFIC AND COMPUTER SERVICES

FOR BIOLOGICAL RESEARCH, BACTERIOLOGICAL RESEARCH, CHEMICAL RESEARCH, COSMETICS RESEARCH, MECHANICAL RESEARCH, TECHNICAL RESEARCH IN THE FIELDS OF BLOOD AND/OR CELL AND/OR TISSUE SAMPLE PREPARATION AND TESTING (U.S. CLS. 100 AND 101).

ANDREW LEASER, EXAMINING ATTORNEY

CLASS 9—ELECTRICAL AND SCIENTIFIC APPARATUS

FOR THERMOSTAT HOUSINGS (U.S. CLS. 21, 23, 26, 36 AND 38).

CLASS 11—ENVIRONMENTAL CONTROL APPARATUS

FOR COOLANT COMPENSATION TANKS; FAN SHROUDS BEING PARTS FOR VENTILATING APPARATUS; VACUUM AIR-WATER SEPARATORS BEING PARTS FOR VENTILATING, AIR-CONDITIONING OR REFRIGERATING APPARATUS; AIR INTAKE FILTERS BEING PARTS FOR VENTILATING, AIR-CONDITIONING OR REFRIGERATING APPARATUS; BELLOWS OF RUBBER OR PLASTIC FOR USE IN VENTILATING, AIR-CONDITIONING OR REFRIGERATING CIRCUITS OR INSTALLATIONS (U.S. CLS. 13, 21, 23, 31 AND 34).

CLASS 12—VEHICLES

FOR LAND VEHICLES; FLEXIBLE PIPES AND HOSES, AND COUPLINGS THEREFORE, BEING PARTS OF HYDRAULIC CIRCUITS OR BRAKE CIRCUITS FOR VEHICLES; SHAPED PARTS OF RUBBER AND RUBBER-METAL COMPOUNDS, FOR VIBRATION DAMPING AND POWER TRANSMISSION IN VEHICLES, INCLUDED IN THIS CLASS, NAMELY, RUBBER VIBRATION DAMPERS, RUBBER-METAL VIBRATION DAMPERS, AND POWER TRANSMISSION BELTS MADE FROM RUBBER OR RUBBER-METAL COMPOUNDS; PLASTIC GUIDE PLATES BEING PARTS OF MOTOR VEHICLES; FUEL LINES FOR VEHICLES; WINDSHIELD CLEANING FLUID CONTAINERS BEING PARTS OF MOTOR VEHICLES; AIR GUIDE PLATES BEING PARTS OF VEHICLES (U.S. CLS. 19, 21, 23, 31, 35 AND 44).

CLASS 17—RUBBER GOODS

FOR NON-METALLIC HOSES; FLEXIBLE PIPES AND HOSES OF PLASTIC AND COUPLINGS THEREFORE, FOR COOLING CIRCUITS IN VEHICLES, INCLUDED IN THIS CLASS, NAMELY, RUBBER HOSES FOR VEHICLE HEATERS, RUBBER COOLANT HOSES FOR COOLING CIRCUITS AND HEATING CIRCUITS IN VEHICLES; QUICK CONNECTORS MADE FROM RUBBER OR PLASTIC FOR HOSES OR FLEXIBLE PIPES, NAMELY, COUPLINGS AND ADAPTERS FOR CONNECTING NON-METAL HOSES AND FLEXIBLE PIPES FOR MOTOR VEHICLE USE; RUBBER HOSES FOR ENGINE OIL CIRCUITS; RUBBER BRAKE, FUEL, CHARGE AIR, OIL AND/OR HYDRAULIC HOSES, BEING PARTS OR ACCESSORIES FOR VEHICLES, INCLUDED IN THIS CLASS, NAMELY, FOR VEHICLE RADIATORS AND HEATERS; PLASTICS IN EXTRUDED FORM IN THE FORM OF BARS, BLOCKS, PELLETS, RODS, SHEETS AND TUBES FOR USE IN MANUFACTURING; CONNECTOR HOSES, NOT OF METAL, AND HOSE CONDUIT SYSTEMS OF RUBBER OR PLASTIC CONSTRUCTED THEREFROM, FOR THE TRANSFER OF AIR, FLUID MATERIALS OR FOR INSULATION, NAMELY, CONNECTING HOSES FOR PARTS OF THE ENGINE AND PERIPHERAL CONTAINERS CONTAINING AIR, OIL, OR OTHER FLUIDS; NON-METAL HOSE CONNECTORS, NAMELY, NON-METAL COUPLINGS AND ADAPTERS FOR CONNECTING NON-METAL HOSES AND FLEXIBLE PLASTIC PIPES FOR MOTOR VEHICLE USE; HOSE CONDUIT SYSTEMS OF RUBBER OR PLASTIC, NAMELY, ENGINE BATTERY COOLING ASSEMBLIES; RUBBER LEVELING PARTS FOR HOSES AND PIPELINE SYSTEMS, NAMELY, ADJUSTMENT OR COMPENSATION PARTS FOR HOSES OR PIPE SYSTEMS WITH DIFFERENT DIAMETERS, NAMELY, INSULATED PIPE SUPPORTS, NON-METAL PIPE MUFFS FOR USE WITH PLASTIC AND RUBBER PIPES USED IN MOTOR VEHICLES, PIPE GASKETS, NON-METAL PIPE JACKETS FOR USE WITH PLASTIC AND RUBBER PIPE USED IN MOTOR VEHICLES, AND RINGS OF RUBBER FOR USE AS PIPE CONNECTION SEALS; PIPE GASKETS; INSULATION CUFFS FOR PIPES; NON-METAL SEALING RINGS AND DIAPHRAGMS FOR USE AS CONNECTION SEALS; RUBBER, RAW OR SEMI-WORKED; RUBBER SUBSTITUTE MATERIALS, NAMELY, PLASTICS IN EXTRUDED FORM IN THE

SN 79-096,272. TRISTONE FLOWTECH GERMANY GMBH, FED REP GERMANY, FILED 12-27-2010.



OWNER OF INTERNATIONAL REGISTRATION 1074159 DATED 12-27-2010, EXPIRES 12-27-2020.

THE COLOR(S) YELLOW, BLUE AND GRAY IS/ARE CLAIMED AS A FEATURE OF THE MARK.

THE MARK CONSISTS OF A DESIGN OF THREE TRIANGLES IN A ROW WITH THE MIDDLE TRIANGLE SLIGHTLY LARGER AND PARTIALLY SUPERIMPOSED OVER THE OTHER TWO TRIANGLES. THE TRIANGLE ON THE LEFT IS YELLOW, THE TRIANGLE IN THE MIDDLE IS BLUE AND THE TRIANGLE ON THE RIGHT IS GRAY.

CLASS 6—METAL GOODS

FOR METAL TUBING; HOSE COUPLINGS MADE OF METAL; HOSE ADAPTERS OF METAL, NAMELY, COUPLINGS AND ADAPTERS FOR CONNECTING PIPES OF METAL (U.S. CLS. 2, 12, 13, 14, 23, 25 AND 50).

CLASS 7—MACHINERY

FOR RUBBER-METAL VIBRATION DAMPERS BEING PARTS OF MOTORS AND ENGINES, AIR INTAKE FILTERS BEING PARTS OF MOTORS AND ENGINES; CHARGE-AIR HOSES AND CHARGE-AIR CONDUITS BEING PARTS OF MOTORS AND ENGINES, AND ADAPTED CONNECTORS THEREFOR; HOSES FOR EXHAUST GAS RECIRCULATION, BEING PARTS OF MOTORS AND ENGINES; VACUUM CONDUITS, BEING PARTS OF MOTORS AND ENGINES; HOSES, BEING PARTS OF MOTORS AND ENGINES, FOR TURBOCHARGERS (U.S. CLS. 13, 19, 21, 23, 31, 34 AND 35).

FORM OF BARS, BLOCKS, PELLETS, RODS, SHEETS AND TUBES FOR USE IN MANUFACTURING; PLASTICS FILMS, OTHER THAN FOR PACKAGING FOR COMMERCIAL AND INDUSTRIAL USE; BELLOWS OF RUBBER OR PLASTIC FOR INSULATION; MULTIPLE HOSE CONNECTORS OF RUBBER OR PLASTIC FOR THE TRANSFER OF AIR, FLUID MATERIALS OR FOR INSULATION, NAMELY, CONNECTORS SUCH AS T-CONNECTORS WITH 3 CONNECTING OPENINGS FOR MOTOR VEHICLE USE TO CONNECT PLASTIC AND RUBBER HOSES OR CONNECT ELEMENTS OF AIR OR FLUID HOSE ASSEMBLY SYSTEMS; NON-METALLIC FLEXIBLE PIPES (U.S. CLS. 1, 5, 12, 13, 35 AND 50).

CLASS 19—NON-METALLIC BUILDING MATERIALS

FOR VENTILATING OR VENT CONDUITS, NAMELY, CONDUITS, NOT OF METAL, FOR VENTILATING AND AIR-CONDITIONING INSTALLATIONS (U.S. CLS. 1, 12, 33 AND 50).

STEVEN PEREZ, EXAMINING ATTORNEY

SN 79-096,340. PATRICK ENSSLIN, SWITZERLAND, FILED 2-18-2011.

vandeyk

THE MARK CONSISTS OF STANDARD CHARACTERS WITHOUT CLAIM TO ANY PARTICULAR FONT, STYLE, SIZE, OR COLOR.

PRIORITY DATE OF 12-3-2010 IS CLAIMED.

OWNER OF INTERNATIONAL REGISTRATION 1074322 DATED 2-18-2011, EXPIRES 2-18-2021.

CLASS 12—VEHICLES

FOR BICYCLES, BRAKES FOR BICYCLES, CYCLES, FRAMES FOR BICYCLES, CYCLES, BICYCLE SADDLES, BICYCLE RIMS, HANDLE BARS FOR BICYCLES, CYCLES, BELLS FOR BICYCLES, CYCLES, BASKETS ADAPTED FOR CYCLES, CYCLE HUBS, PEDALS FOR CYCLES, PUMPS FOR BICYCLES, CYCLES, WHEELS FOR BICYCLES, CYCLES, BICYCLE TIRES, INNER TUBES FOR BICYCLES, CYCLES, SPOKES FOR BICYCLES, CYCLES, CYCLE STANDS (U.S. CLS. 19, 21, 23, 31, 35 AND 44).

CLASS 25—CLOTHING

FOR CLOTHING, NAMELY, T-SHIRTS, JACKETS, JERSEYS, COATS, OUTER WEAR, NAMELY, DOWN JACKETS, PULLOVERS, SWEATERS, WAISTCOATS, KNITWEAR, NAMELY, KNITTED GLOVES, CYCLIST'S CLOTHING, NAMELY, CYCLING SHORTS WATER-PROOF CLOTHING, NAMELY, RAINCOATS, TROUSERS, PANTS, WHICH CAN BE USED BECAUSE OF THEIR TECHNICAL PROPERTIES ONLY IN CYCLING OR IN CYCLING TRAFFIC, FOOTWEAR, NAMELY, SHOES, SANDALS, SPORTS SHOES, HEADGEAR, NAMELY, HATS, CAPS (U.S. CLS. 22 AND 39).

ARETHA SOMERVILLE, EXAMINING ATTORNEY

SN 79-096,399. HINKLER EDUCATION PTY LTD, AUSTRALIA, FILED 11-8-2010.

ENGAGE LITERACY

THE MARK CONSISTS OF STANDARD CHARACTERS WITHOUT CLAIM TO ANY PARTICULAR FONT, STYLE, SIZE, OR COLOR.

PRIORITY DATE OF 7-12-2010 IS CLAIMED.

OWNER OF INTERNATIONAL REGISTRATION 1074468 DATED 11-8-2010, EXPIRES 11-8-2020.

NO CLAIM IS MADE TO THE EXCLUSIVE RIGHT TO USE "LITERACY", APART FROM THE MARK AS SHOWN.

CLASS 9—ELECTRICAL AND SCIENTIFIC APPARATUS

FOR CDS, CASSETTES, RECORDS, DVDS, AUDIO AND VIDEO TAPES FEATURING EDUCATIONAL, ENTERTAINMENT AND REFERENCE MATERIALS FOR LITERACY PROGRAMS; MAGNETIC DATA CARRIERS FEATURING EDUCATIONAL, ENTERTAINMENT AND REFERENCE MATERIALS FOR LITERACY PROGRAMS; AUDIO AND VIDEO RECORDINGS FEATURING EDUCATIONAL, ENTERTAINMENT AND REFERENCE MATERIALS FOR LITERACY PROGRAMS; CINEMATOGRAPHIC FILMS; COMPUTER AND VIDEO GAMES SOFTWARE; COMPUTER AND VIDEO GAME PROGRAMS AND SOFTWARE; COMPUTER SOFTWARE CONTAINING EDUCATIONAL AND INSTRUCTIONAL MATERIAL FEATURING EDUCATIONAL, ENTERTAINMENT AND REFERENCE MATERIALS FOR LITERACY PROGRAMS; COMPUTER PROGRAM SOFTWARE FEATURING EDUCATIONAL, ENTERTAINMENT AND REFERENCE MATERIALS FOR LITERACY PROGRAMS; APPLICATION SOFTWARE FOR COMPUTER SYSTEMS AND FEATURING EDUCATIONAL, ENTERTAINMENT AND REFERENCE MATERIALS FOR LITERACY PROGRAMS; COMMUNICATIONS SOFTWARE FOR CONNECTING WITH COMPUTER USERS; PERSONAL COMPUTER APPLICATION SOFTWARE; HANDHELD AND MOBILE DIGITAL AND ELECTRONIC TELEPHONES; ELECTRONIC GAMES CONSOLES ADAPTED FOR USE WITH AN EXTERNAL DISPLAY SCREEN OR MONITOR; COMPUTER PROGRAMS FOR ACCESSING, BROWSING AND SEARCHING ONLINE DATABASES; INTERACTIVE MULTIMEDIA SOFTWARE FOR LITERACY PROGRAMS FEATURING AUDIO AND VIDEO EDUCATIONAL INFORMATION, ENTERTAINMENT, AND REFERENCE MATERIALS IN THE FIELD OF LITERACY; COMPUTER SOFTWARE FOR DATA AND CONTENT RETRIEVAL; COMPUTER SOFTWARE THAT PROVIDES WEB-BASED ACCESS TO DATA AND CONTENT APPLICATIONS FEATURING EDUCATIONAL, ENTERTAINMENT AND REFERENCE MATERIALS FOR LITERACY PROGRAMS; RECORDED DATA CARRIERS FEATURING EDUCATIONAL, ENTERTAINMENT AND REFERENCE MATERIALS FOR LITERACY PROGRAMS; BLANK DATA CARRIERS; RECORDED COMPUTER PROGRAMS FOR LITERACY PROGRAMS FEATURING EDUCATIONAL INFORMATION ENTERTAINMENT AND REFERENCE MATERIALS IN THE FIELD OF LITERACY; DOWNLOADABLE ELECTRONICALLY RECORDED BOOKS AND TEACHING MANUALS FEATURING EDUCATIONAL, ENTERTAINMENT AND REFERENCE MATERIALS IN THE FIELD OF LITERACY; DOWNLOADABLE ELECTRONIC PUBLICATIONS IN THE NATURE OF BOOKS AND TEACHING MANUALS FEATURING EDUCATIONAL, ENTERTAINMENT AND REFERENCE MATERIALS IN THE FIELD OF LITERACY; AUDIO AND AUDIOVISUAL RECORDINGS FEATURING EDUCATIONAL, ENTERTAINMENT AND REFERENCE MATERIALS FOR LITERACY PROGRAMS; PRE-RECORDED COMPACT DISCS, DVDS, VIDEOS, AND AUDIOTAPES FEATURING EDUCATIONAL, ENTERTAINMENT AND REFERENCE MATERIALS FOR LITERACY PROGRAMS; INTERACTIVE COMPUTER APPLICATION SOFTWARE FOR LITERACY PROGRAMS; DOWNLOADABLE DIGITAL MUSIC AND DOWNLOADABLE DIGITAL AUDIOVISUAL WORKS FEATURING EDUCATIONAL, ENTERTAINMENT AND REFERENCE MATERIALS FOR LITERACY PROGRAMS; INTERACTIVE MULTIMEDIA COMPUTER APPLICATION PROGRAMS AND COMPUTER APPLICATION SOFTWARE FOR LITERACY PROGRAMS; AUDIO AND AUDIOVISUAL ACCESSORIES BEING AMPLIFIERS AND RECEIVERS; PRE-RECORDED COMPACT DISCS FEATURING INTERACTIVE COMPUTER APPLICATION PROGRAMS FEATURING EDUCATIONAL, ENTERTAINMENT AND REFERENCE MATERIALS IN THE FIELD OF LITERACY; NONE OF THE FOREGOING RELATING TO ONLINE BETTING OR GAMBLING (U.S. CLS. 21, 23, 26, 36 AND 38).

CLASS 16—PAPER GOODS AND PRINTED MATTER

FOR PRINTED MATTER, NAMELY, BOOKS, POSTERS, STATIONERY AND TEACHING MANUALS, FEATURING EDUCATIONAL, ENTERTAINMENT AND REFERENCE MATERIALS IN THE FIELD OF LITERACY; PRINTED INSTRUCTIONAL AND TEACHING MATERIAL FEATURING EDUCATIONAL, ENTERTAINMENT AND REFERENCE MATERIALS FOR LITERACY PROGRAMS; PRINTED EDUCATIONAL MATERIALS FEATURING EDUCATIONAL, ENTERTAINMENT AND REFERENCE MATERIALS FOR LITERACY PROGRAMS; STUDY BOOKS FEATURING EDUCATIONAL, ENTERTAINMENT AND REFERENCE MATERIALS FOR LITERACY PROGRAMS; COURSE OUTLINES FEATURING EDUCATIONAL, ENTERTAINMENT AND REFERENCE MATERIALS FOR LITERACY PROGRAMS; TEXT BOOKS FEATURING EDUCATIONAL, ENTERTAINMENT AND REFERENCE MATERIALS FOR LITERACY PROGRAMS; BOOKS FEATURING EDUCATIONAL, ENTERTAINMENT AND REFERENCE MATERIALS FOR LITERACY PROGRAMS; BOOKS FOR USE IN THE TEACHING OF READING AND WRITING; GENERAL FEATURE MAGAZINES; PRINTED ALBUMS FOR PHOTOGRAPHS, CARDS AND REFERENCE MATERIAL; SCRAPBOOKS; COLORING BOOKS; NOTEBOOKS; ADDRESS BOOKS; DATE BOOKS; AUTOGRAPH BOOKS; DIARIES; REMINDER BOOKS IN THE NATURE OF CALENDARS; GUIDE BOOKS FEATURING TEACHING GUIDANCE IN THE NATURE OF EDUCATIONAL, ENTERTAINMENT AND REFERENCE MATERIALS; MAPS; BOOK-BINDING MATERIALS; PHOTOGRAPHS; STATIONERY; PLASTIC MATERIALS IN CLASS 16 FOR PACKAGING, NAMELY, PLASTIC BAGS AND WRAPPINGS; POSTERS; PLACEMATS OF PAPER; COASTERS OF PAPER; PAPER; CARDBOARD; GOODS MADE FROM PAPER AND CARDBOARD, NAMELY, STATIONERY, WRAPPING, BOXES, BOOKS, POSTERS; STICKERS, SEALS, AND DRY TRANSFERS; WRITING INSTRUMENTS, PENS AND PENCILS; WRITING PAPER, NOTE PAPER; PAPER PARTY PRODUCTS IN THIS CLASS, NAMELY, PARTY BAGS AND PARTY DECORATIONS; PAPER PARTY DECORATIONS; PRINTED BOOKS FEATURING GAMES IN THE FIELD OF LITERACY; PRINTED RULE BOOKS; PRINTED SCORE CARDS; PRINTED SCORE PADS; PRINTED MATTER IN THE NATURE OF VIDEO GAME MANUALS; SCORE CARDS; SCORE PADS; WALL AND DOOR PAPER PARTY AND CELEBRATORY DECORATIONS AND PAPER STREAMERS; NONE OF THE FOREGOING RELATING TO ONLINE BETTING OR GAMING (U.S. CLS. 2, 5, 22, 23, 29, 37, 38 AND 50).

CLASS 41—EDUCATION AND ENTERTAINMENT

FOR PUBLISHING OF PRINTED AND ELECTRONIC BOOKS, MAGAZINES AND OTHER TEACHING MATERIALS FEATURING EDUCATIONAL, ENTERTAINMENT AND REFERENCE MATERIALS FOR LITERACY PROGRAMS; PUBLISHING SERVICES FOR DIGITAL WORKS FEATURING EDUCATIONAL, ENTERTAINMENT AND REFERENCE MATERIALS FOR LITERACY PROGRAMS, NAMELY, CDS, CASSETTES, RECORDS, DVDS, AUDIO AND VIDEO RECORDINGS, CINEMATOGRAPHIC FILMS, COMPUTER AND VIDEO GAMES; PUBLISHING SERVICES FOR PRINTED MATTER FEATURING EDUCATIONAL, ENTERTAINMENT AND REFERENCE MATERIALS FOR LITERACY PROGRAMS BEING BOOKS, MAGAZINES, ALBUMS, SCRAPBOOKS, COLOURING BOOKS, NOTEBOOKS, ADDRESS BOOKS, DATE BOOKS, AUTOGRAPH BOOKS, DIARIES, REMINDER BOOKS, GUIDE BOOKS, MAPS, PRINTED MATTER, PHOTOGRAPHS, PLAYING CARDS, POSTERS, PLACEMATS, COASTERS, GOODS MADE FROM PAPER AND CARDBOARD, STICKERS, SEALS, TRANSFERS, GAME BOOKS, RULE BOOKS, SCORE CARDS AND SCORE PADS, WALL AND DOOR PAPER DECORATIONS AND PAPER STREAMERS; TEACHING IN THE FIELD OF LITERACY; ORGANISATION OF TEACHING ACTIVITIES, NAMELY, TEACHER TRAINING AND WORKSHOPS, AND STUDENT CLASSES AND WORKSHOPS, FEATURING EDUCATIONAL, ENTERTAINMENT AND REFERENCE MATERIALS FOR LITERACY PROGRAMS; PRESCHOOL TEACHING; TEACHING IN THE FIELD OF LITERACY

WITH EDUCATIONAL, ENTERTAINMENT AND REFERENCE MATERIALS FOR LITERACY PROGRAMS; ADULT EDUCATION, NAMELY, CLASSES AND WORKSHOPS IN THE FIELD OF LITERACY; CONDUCTING LITERACY COURSES WITH EDUCATIONAL, ENTERTAINMENT AND REFERENCE MATERIALS FOR LITERACY PROGRAMS; EDUCATION INFORMATION; EDUCATION SERVICES IN THE NATURE OF CLASSES AND WORKSHOPS IN THE FIELD OF LITERACY AND FEATURING EDUCATIONAL, ENTERTAINMENT AND REFERENCE MATERIALS FOR LITERACY PROGRAMS; PROVIDING EDUCATIONAL INFORMATION IN THE FIELD OF LITERACY; PROVIDING INFORMATION ON TEACHER TRAINING IN THE FIELD OF LITERACY; PROVIDING ENTERTAINMENT INFORMATION IN THE FIELD OF LITERACY; ONLINE PUBLICATION OF BOOKS AND JOURNALS; ELECTRONIC PUBLICATION OF INFORMATION IN THE FIELD OF LITERACY PROVIDED ONLINE AND OVER A GLOBAL COMPUTER NETWORK; ARRANGING AND CONDUCTING CONFERENCES AND SEMINARS FOR LITERACY PROGRAMS; EDUCATIONAL SERVICES, NAMELY, PROVIDING LITERACY CLASSES AND WORKSHOPS; PROVISION OF EDUCATION COURSES FOR LITERACY PROGRAMS; PROVISION OF EDUCATION SERVICES IN THE NATURE OF ONLINE INSTRUCTOR-LED EDUCATION LITERACY PROGRAMS; PUBLICATION OF ELECTRONIC MULTIMEDIA PUBLICATIONS; ON-LINE PUBLICATION OF JOURNALS, DIARIES AND BLOGS FOR LITERACY PROGRAMS; EDUCATIONAL SERVICES, NAMELY, CLASSES AND WORKSHOPS IN THE FIELD OF LITERACY; PROVIDING OF EDUCATIONAL TRAINING FOR LITERACY; PROVISION OF TECHNICAL EDUCATION FOR LITERACY PROGRAMS AND TRAINING FOR LITERACY PROGRAMS; PROVIDING ONLINE TRAINING SERVICES IN THE FIELD OF LITERACY; PROVIDING ONLINE DATABASES FEATURING EDUCATIONAL INFORMATION IN THE FIELD OF LITERACY; PROVISION OF COACHING AND MENTORING SERVICES FOR LITERACY PROGRAMS; ORGANISATION OF COURSES FOR LITERACY PROGRAMS; NONE OF THE FOREGOING RELATING TO ONLINE BETTING OR GAMING (U.S. CLS. 100, 101 AND 107).

KAREN SEVERSON, EXAMINING ATTORNEY

SN 79-096,401. ASSOCIATION POUR LA DEFENSE ET LA PROMOTION DE L'OEUVRE DE MARC CHAGALL DITE COMITE MARC CHAGALL, FRANCE, FILED 12-28-2010.

CHAGALL

THE MARK CONSISTS OF STANDARD CHARACTERS WITHOUT CLAIM TO ANY PARTICULAR FONT, STYLE, SIZE, OR COLOR.

PRIORITY DATE OF 6-29-2010 IS CLAIMED.

OWNER OF INTERNATIONAL REGISTRATION 1074475 DATED 12-28-2010, EXPIRES 12-28-2020.

OWNER OF U.S. REG. NO. 3,916,357.

THE NAME(S), PORTRAIT(S), AND/OR SIGNATURE(S) SHOWN IN THE MARK DOES NOT IDENTIFY A PARTICULAR LIVING INDIVIDUAL.

CLASS 4—LUBRICANTS AND FUELS

FOR INDUSTRIAL OILS AND GREASES; ALL PURPOSES LUBRICANTS; DUST ABSORBING AND WETTING COMPOSITIONS FOR SWEEPING; DUST BINDING COMPOSITIONS; FUELS, INCLUDING MOTOR SPIRIT, AND ILLUMINANT OILS FOR CANDLES AND OIL LAMPS; CANDLES AND WICKS FOR LIGHTING; CHRISTMAS TREE CANDLES; CANDLES; OILS FOR PAINTS (U.S. CLS. 1, 6 AND 15).

CLASS 9—ELECTRICAL AND SCIENTIFIC APPARATUS

FOR MAGNETS (U.S. CLS. 21, 23, 26, 36 AND 38).

CLASS 16—PAPER GOODS AND PRINTED MATTER

FOR PAPER, REVIEWS, MAGAZINES, BOOKS, AND NEWSPAPERS ALL IN THE FIELD OF FINE ARTS, GRAPHIC ARTS, ADVERTISING, COMMUNICATION, COMPUTER GRAPHICS AND FIGURATIVE ARTS; PRINTED ART AND ENGRAVING REPRODUCTIONS ON PAPER OR CANVAS OR CARD; POSTCARDS, NOTE CARDS AND PRINTED CARDS FEATURING FINE ART IMAGES; BOOKBINDINGS AND CLOTH FOR BOOKBINDING; PHOTOGRAPHS, ADHESIVES, NAMELY, GLUES FOR STATIONERY OR HOUSEHOLD PURPOSES; PRINTED INSTRUCTIONAL AND TEACHING MATERIAL IN THE FIELD OF ART, PRINTING TYPE, PRINTING BLOCKS, POSTERS; PHOTOGRAPH AND STAMP ALBUMS; AQUARELLES; WRITING SLATES; STATIONERY PADS, CARDBOARD OR PAPER BOXES; COMIC STRIPS; WRITING OR DRAWING BOOKS; AGENDAS; BLOTTERS; WRITING PADS; CALENDARS; NOTE BOOKS; MUSICAL GREETING CARDS; FOLDERS FOR PAPERS; PAPER FILES AND PAPER EXPANDING FILES; GLUES FOR STATIONERY; PAPER CUTTERS FOR HOME AND OFFICE USE; WRITING CHALK, PENCILS, PENCIL HOLDERS, ELECTRIC OR NON-ELECTRIC PENCIL SHARPENERS, PENS; ETCHINGS, INKSTANDS, ENVELOPES, PAPER ANNOUNCEMENT CARDS; SCHOOL WRITING BOOKS; DRAWING MATERIALS, NAMELY, ARTISTS' PAPER AND CANVAS, DRAWING INSTRUMENTS, ARTISTS' MATERIALS, NAMELY, PAINTBRUSHES, ARTISTS' WATER-COLOR SAUCERS, PALETTES FOR PAINTERS, PAINTBRUSHES, DRAWING PADS, PAPER-CLIPS, DRAWING BOARDS, PEN NIBS, CHECK-BOOK HOLDERS, PAPER-WEIGHTS, PROSPECTUSES FEATURING ART EXHIBITS, TELEPHONE INDEXES; BOOKMARKERS; BOOKENDS; CATALOGS FEATURING ART EXHIBITS; PAMPHLETS FEATURING ART EXHIBITS; PAPER FLAGS, PRINTED PICTURES, LITHOGRAPHS, PHOTOENGRAVINGS, PRINTED GREETING CARDS; BLACKBOARDS; CARDBOARD TUBES; HANDKERCHIEFS OF PAPER; TABLECLOTHS OF PAPER; TABLE NAPKINS OF PAPER; PAPER COASTERS FOR BEER GLASSES (U.S. CLS. 2, 5, 22, 23, 29, 37, 38 AND 50).

CLASS 21—HOUSEWARES AND GLASS

FOR NON-ELECTRIC UTENSILS, NAMELY, POT AND PAN SCRAPERS, ROLLING PINS, SPATULAS, TURNERS AND WHISKS; CONTAINERS FOR HOUSEHOLD OR KITCHEN USE NOT OF PRECIOUS METAL OR COATED THEREWITH; COMBS; BATH AND CLEANING SPONGES; CLEANING BRUSHES AND ELECTRIC TOOTHBRUSHES; METAL WOOL FOR CLEANING AND CLEANING CLOTH; GLASS, UNWORKED OR SEMI-WORKED, EXCEPT BUILDING GLASS, MOSAICS OF GLASS, NOT FOR BUILDING; GLASSWARE, PORCELAIN AND EARTHENWARE, NAMELY, BOXES; CANDLE HOLDERS NOT OF PRECIOUS METAL, DRINKING GLASSES, FLASKS NOT OF PRECIOUS METAL, GLASS STORAGE JARS, GLASS STOPPERS, BOTTLES SOLD EMPTY; BOXES FOR SWEETMEATS, DEMIJOHNS, BEER MUGS, BUTTER DISHES, COOKIE JARS, LANTERNS, DECANTERS, COASTERS NOT OF PAPER AND OTHER THAN TABLE LINEN; CANDLESTICKS; CHEESE-DISH COVERS, BUTTER-DISH COVERS, FRUIT CUPS, KNIFE RESTS FOR THE TABLE, CRYSTAL AS BEVERAGE GLASSWARE; POTS; TABLEWARE, NAMELY, DISHES, SALAD DISHES, SOUP TUREENS, PEPPERPOTS, HAND-OPERATED PEPPER MILLS, SALT SHAKERS, SUGAR BOWLS, CUPS, SAUCERS, BOWLS, PLATES, VASES, CANDLE POTS; GLASS COSMETIC JARS FOR STORAGE; EGG CUPS; POWDER COMPACTS, TEA SERVICES, TEAPOTS, TEA INFUSERS, COFFEE SERVICES, ENAMELED GLASS, ICE PAILS; PERFUME SPRAYS, PERFUME VAPORIZERS AND SMALL PERFUME BOTTLES ALL SOLD EMPTY; PERFUME BURNERS; PERFUME CASES SOLD EMPTY; TOILET SPONGES; COSMETIC BRUSHES; BREAD BASKETS, DOMESTIC; WORKS OF ART OF PORCELAIN, TERRA-COTTA OR GLASS; STATUES OF PORCELAIN, TERRA-COTTA OR GLASS; SOAP BOXES; CORKSCREWS; KETTLES, NON-ELECTRIC, BOTTLE OPENERS, INSULATED VACUUM FLASKS; CANDELABRAS AS CANDLESTICKS, MENU CARD HOLDERS, STEWPANS; CAKE, CHOCOLATE AND ICE CUBE MOLDS; KITCHEN CONTAINERS; KITCHEN UTENSILS, NAMELY, TONGS, SPLATTER SCREENS, POURING

AND STRAINING SPOUTS; TOOTHPICK HOLDERS, TABLE MATS, NAMELY, DRIP MATS FOR TEA; COOKIE CUTTERS, SIGNBOARDS OF PORCELAIN OR GLASS; EARTHENWARE, NAMELY, MUGS, BASINS AND FIGURINES; NON-ELECTRIC FRUIT PRESSES FOR HOUSEHOLD PURPOSES, GOBLET, VEGETABLE DISHES, DECANTERS; PIE SERVERS; SOAP HOLDERS, NAPKIN HOLDERS, CRUMB TRAYS, CHEESE GRATERS, DRINKING VESSELS, NAPKIN RINGS, METAL ICE CUBE TRAYS AND MOLDS, SPATULAS FOR COOKING; PIPETTES FOR WINE-TASTING; PAINTED BEVERAGE GLASSWARE, DRINKING GLASSES; SPRAYER NOZZLES AND SPRINKLERS FOR GARDEN HOSES, WATERING CANS, NOZZLES FOR WATERING CANS; FLOWER POTS, HOLDERS FOR FLOWERS AND PLANTS FOR FLOWER ARRANGING PURPOSES, FLOWER POT COVERS NOT OF PAPER, GARDENING GLOVES (U.S. CLS. 2, 13, 23, 29, 30, 33, 40 AND 50).

CLASS 26—FANCY GOODS

FOR LACE AND EMBROIDERY, RIBBONS AND BRAID; BUTTONS, HOOKS AND EYES, SEWING PINS AND NEEDLES, ARTIFICIAL FLOWERS; ORNAMENTAL NOVELTY BADGES; HAIR BANDS; HAIR PINS; HAIR ORNAMENTS; HAIR GRIPS, NAMELY, SLIDES (U.S. CLS. 37, 39, 40, 42 AND 50).

CLASS 28—TOYS AND SPORTING GOODS

FOR BOARD GAMES; ELECTRONIC ACTION AND INTERACTIVE ACTION TOYS; DOLLS AND DOLL ACCESSORIES, NAMELY, CLOTHING FOR DOLLS, DOLL ROOMS, DOLL BEDS, DOLL HOUSES, TOY FABRICS AND LINENS FOR DOLLS AND STROLLERS FOR DOLLS; TOY AIRPLANES; BALLS FOR SPORT; TOY COOKING SETS AND GAMES; BATH TOYS, TOY BUILDING BLOCKS AND GAMES; MUSICAL TOYS; STICKS AND LIQUIDS FOR MAKING BUBBLES; NOISE MAKERS, FLYING DISKS; PUZZLES, JUMP ROPES, KITES, STACKING SHAPE RECOGNITION TOYS, WATER PISTOLS AND WATER TOYS; MINIATURE HOUSES AND PLAYHOUSES; RACKET GAMES, NAMELY, BADMINTON, TENNIS AND RACQUET BALL SETS; COIN-OPERATED ARCADE GAMES FOR AMUSEMENT; PLASTIC TOY HOOPS, BRAIN TEASERS, NAMELY, TRIVIA GAME PLAYED WITH CARDS AND GAME COMPONENTS; PLAYING CARDS, MAKE-UP KITS FOR CHILDREN, MOBILES FOR CHILDREN; PORCELAIN DOLLS, PAPER AND CARDBOARD DOLLS, DOLLS' HOUSES, FURNITURE FOR DOLL HOUSES, NAMELY, TOY BEDS, CUPBOARDS, COOKING SETS, AND TABLEWARE; BOXES AND CARDBOARD BOXES SPECIALLY FITTED AND ADAPTED FOR STORAGE OF DOLLS; ICE SKATES, ROLLER SKATES; TOYS FOR SWIMMING POOLS, NAMELY, POOL RINGS; PLUSH TOYS AND PUPPETS; RIDING PUSH TOYS FOR CHILDREN; HOLLOWED OUT TOY DISKS TO BE RAISED AND LOWERED ALONG A STRING, NAMELY, YO-YOS; PARLOR GAMES FOR ADULTS AND CHILDREN; COLLECTIBLE MOLDED PLASTIC TOY FIGURINES; TOYS FOR DRAWING, PLAY TENTS; MINIATURE TOY VEHICLES; SMALL TOY CARS THAT TURN INTO ROBOTS; RACE TRACK FOR TOY MINIATURE CARS AND MINIATURE VEHICLES; TOY BABY STROLLERS; ARCADE GAMES OTHER THAN THOSE ADAPTED FOR USE WITH A TELEVISION SET; HAND HELD UNITS FOR PLAYING ELECTRONIC GAMES OTHER THAN THOSE ADAPTED FOR USE WITH AN EXTERNAL DISPLAY SCREEN OR MONITOR; MAGIC WANDS AND PLAY STICKS; BABY RATTLES; NON-ELECTRIC DECORATIONS FOR CHRISTMAS TREES; CHRISTMAS STOCKINGS (U.S. CLS. 22, 23, 38 AND 50).

CLASS 31—NATURAL AGRICULTURAL PRODUCTS

FOR BULBS FOR HORTICULTURAL PURPOSE; AGRICULTURAL SEEDS; LIVE ANIMALS; FRESH FRUITS AND VEGETABLES; UNPROCESSED GRAINS FOR BREWING AND DISTILLING; UNPROCESSED HAZELNUTS AND NUTS; ANIMAL FOODSTUFFS; MALT FOR BREWING AND DISTILLING; NATURAL PLANTS AND FLOWERS; WREATHS OF NATURAL FLOWERS; FLOWERS, DRIED, FOR DECORATION; PLANTS, DRIED, FOR DECORATION; SHRUBS, SEEDLINGS, LIVE ROSE BUSHES FOR PLANTING, LIVE VINE STOCKS FOR PLANTING (U.S. CLS. 1 AND 46).

TASNEEM HUSSAIN, EXAMINING ATTORNEY

SN 79-096,478. EBILLING S.P.A., ITALY, FILED 11-15-2010.



PRIORITY DATE OF 9-6-2010 IS CLAIMED.
OWNER OF INTERNATIONAL REGISTRATION 1074675
DATED 11-15-2010, EXPIRES 11-15-2020.

THE MARK CONSISTS OF A PRINT REPRESENTING THE WORDING "DOXEE" WRITTEN IN FANCY CHARACTERS PLACED INSIDE A SUBSTANTIALLY RECTANGULAR, SHAPED LABEL.

THE WORD(S) "DOXEE" HAS NO MEANING IN A FOREIGN LANGUAGE.

CLASS 9—ELECTRICAL AND SCIENTIFIC APPARATUS

FOR COMPUTER DATABASE MANAGEMENT SOFTWARE FOR USE IN PERSONALIZING THE CONTENT OF E-MAIL COMMUNICATIONS; COMPUTER SOFTWARE FOR USE IN CUSTOMER RELATIONSHIP MANAGEMENT (CRM); COMPUTER SOFTWARE FOR THE MANAGEMENT OF COMMERCIAL PRINTING COMPANIES IN THE FIELD OF COST ESTIMATING, PRODUCTION PLANNING AND SCHEDULING PRODUCTION; COMPUTER SOFTWARE THAT PROVIDES REAL-TIME, INTEGRATED BUSINESS MANAGEMENT INTELLIGENCE BY COMBINING INFORMATION FROM VARIOUS DATABASES AND PRESENTING IT IN AN EASY-TO-UNDERSTAND USER INTERFACE; DOWNLOADABLE ELECTRONIC DATA FILES AND DATABASES, NAMELY, BUSINESS AND TAX FORMS, FOR USE WITH COMPUTER SOFTWARE; ELECTRONIC DATABASE IN THE FIELD OF BUSINESS COMMUNICATION RECORDED ON COMPUTER MEDIA; ELECTRONIC DATA LOGGERS (U.S. CLS. 21, 23, 26, 36 AND 38).

CLASS 35—ADVERTISING AND BUSINESS

FOR BILLING SERVICES; DATA PROCESSING SERVICES FOR BUSINESSES; COMPUTERIZED FILE MANAGEMENT; DATA PROCESSING; SYSTEMATIZATION OF DATA IN COMPUTER DATABASES; COMPILATION OF INFORMATION INTO COMPUTER DATABASES; DATA PROCESSING SERVICES IN THE NATURE OF DOCUMENT CREATION, EDITING AND PROCESSING SERVICES; BUSINESS DATA ANALYSIS; BUSINESS DEVELOPMENT SERVICES, NAMELY, PROVIDING START-UP SUPPORT FOR BUSINESS OF OTHERS; BUSINESS INFORMATION MANAGEMENT, NAMELY, ELECTRONIC REPORTING OF BUSINESS INFORMATION, BUSINESS ANALYTICS, NAMELY, BUSINESS INVESTIGATIONS, EVALUATIONS, EXPERT APPRAISALS, INFORMATION AND RESEARCH, TRADE SPEND BUSINESS MANAGEMENT; BUSINESS INVOICING SERVICES; COMMERCIAL MAIL RECEIVING AGENCY, NAMELY, PROVIDING SPECIALIZED MAIL MANAGEMENT SERVICES; COMPILATION AND SYSTEMATIZATION OF INFORMATION INTO COMPUTER DATABASE AND DATABANKS; COMPUTERIZED AND CENTRAL FILE MANAGEMENT AND BUSINESS FILE MANAGEMENT; COMPUTERIZED WORD PROCESSING; COST ASSESSMENT SERVICES; DATABASE MANAGEMENT; DISPLAYING ADVERTISEMENTS FOR OTHERS; DISTRIBUTION OF PROSPECTUSES AND SAMPLES; MANAGEMENT AND COMPILATION OF COMPUTERISED DATABASE; MANAGEMENT OF COMPUTERISED FILES; MANAGEMENT SERVICES, NAMELY, ON-LINE BUSINESS DEVELOPMENT SERVICES, NAMELY, PROVIDING START-UP SUPPORT FOR BUSINESS OF OTHERS (U.S. CLS. 100, 101 AND 102).

CLASS 38—COMMUNICATION

FOR RECEIPT AND DELIVERY OF MESSAGES; ELECTRONIC TRANSMISSION OF DOCUMENTS AND DATA FOR THE CREATION AND CUSTOMIZATION OF BUSINESS COMMUNICATIONS VIA ELECTRONIC TRANSMISSION; COMMUNICATIONS BY ELECTRONIC COMPUTER TERMINALS; PROVIDING ACCESS TO DATABASES; COMPUTER-AIDED TRANSMISSION OF MESSAGES AND IMAGES; COMMUNICATION BY ELECTRONIC COMPUTER TERMINALS; COMMUNICATION SERVICES, NAMELY, ELECTRONIC TRANSMISSION OF DATA AND DOCUMENTS AMONG USERS OF COMPUTERS; COMPUTER AIDED TRANSMISSION OF MESSAGES, INFORMATION AND IMAGES; CONSULTING SERVICES IN THE FIELD OF COMMUNICATIONS; DATA COMMUNICATION BY ELECTRONIC MAIL; DATA TRANSMISSION AND RECEPTION SERVICES VIA TELECOMMUNICATION MEANS; ELECTRONIC DATA INTERCHANGE (EDI) SERVICES; INFORMATION ABOUT TELECOMMUNICATION; INTERNET SERVICES, NAMELY, PROVIDING MULTIPLE-USER ACCESS TO INFORMATION ON THE INTERNET CONCERNING THE DEVELOPMENT OF COMPUTER SOFTWARE FOR USE IN BUSINESS AS WELL AS THE FUNCTIONS AND APPLICATION OF SUCH BUSINESS SOFTWARE; ON-LINE TITLE DOCUMENT DELIVERY; PROVIDING TELECOMMUNICATION CONNECTIVITY SERVICES FOR TRANSFER OF IMAGES, MESSAGES, AUDIO, VISUAL, AUDIOVISUAL AND MULTIMEDIA WORKS; PROVISION OF ACCESS TO DATA OR DOCUMENTS STORED ELECTRONICALLY IN CENTRAL FILES FOR REMOTE CONSULTATION TELECOMMUNICATION SERVICES, NAMELY, PERSONAL COMMUNICATION SERVICES; TRANSFER OF DATA BY TELECOMMUNICATION; TRANSMISSION OF INFORMATION THROUGH VIDEO COMMUNICATIONS SYSTEMS; SENDING, RECEIVING AND FORWARDING OF ELECTRONIC MESSAGES (U.S. CLS. 100, 101 AND 104).

CLASS 40—MATERIAL TREATMENT

FOR PRINTING SERVICES FOR OTHERS; PRINTING OF ADVERTISING MATTER (U.S. CLS. 100, 103 AND 106).

CLASS 42—SCIENTIFIC AND COMPUTER SERVICES

FOR DEVELOPMENT OF COMPUTER SOFTWARE FOR VIEWING, RECORDING AND RETRIEVAL OF DATA RELATING TO THE PROCESSES OF CREATING AND CUSTOMIZATION DOCUMENTS USED BY ENTERPRISES IN BUSINESS COMMUNICATIONS WITH THEIR CUSTOMERS; DEVELOPMENT OF COMPUTER SOFTWARE AND TECHNICAL SUPPORT SERVICES RELATING TO SOFTWARE IN THE NATURE OF TROUBLESHOOTING OF COMPUTER SOFTWARE PROBLEMS FOR DOCUMENT MANAGEMENT, DATA CONTENT CREATION, PRODUCTION, ANALYSIS, ORGANISATION AND PUBLICATION; CREATION AND DESIGN OF COMPUTER PROGRAMS FOR PROCESSING BUSINESS DATA AND TEXTS; DESIGN OF COMPUTERIZED DOCUMENT MANAGEMENT SYSTEMS; CONVERSION OF DATA DOCUMENTS FROM PHYSICAL TO ELECTRONIC MEDIA; COMPUTER SOFTWARE DESIGN; COMPUTER SOFTWARE INSTALLATION; RENTAL OF COMPUTER SOFTWARE; MAINTENANCE OF COMPUTER SOFTWARE; DESIGN OF COMPUTER SYSTEMS; UPDATING OF COMPUTER SOFTWARE; BUSINESS TECHNOLOGY SOFTWARE CONSULTATION SERVICES; COMPUTER NETWORK CONFIGURATION SERVICES; COMPUTER PROGRAMMING SERVICES; COMPUTER PROGRAMMING AND SOFTWARE DESIGN; COMPUTER PROGRAMMING SERVICES FOR OTHERS IN THE FIELD OF SOFTWARE CONFIGURATION MANAGEMENT; COMPUTER PROGRAMMING SERVICES FOR COMMERCIAL ANALYSIS AND REPORTING; COMPUTER PROJECT MANAGEMENT SERVICES; COMPUTER SERVICES IN THE NATURE OF CUSTOMIZED WEB PAGES FEATURING USER-DEFINED INFORMATION, PERSONAL PROFILES AND INFORMATION; COMPUTER SERVICES, NAMELY, CREATING AND MAINTAINING WEB SITES FOR OTHERS; COMPUTER SERVICES, NAMELY, PROVIDING TEMPORARY USE OF A WEB-BASED SOFTWARE APPLICATION FOR CUSTOMERS TO REMOTELY MANAGE, ADMINISTER, MODIFY AND CONTROL THEIR AND USER COMPUTER DEVICES, DATA AND SOFTWARE APPLICATIONS; COMPUTER SOFTWARE DEVELOPMENT; COMPUTER SOFTWARE DESIGN AND UPDATING; COMPUTER SOFTWARE INSTALLATION AND MAINTENANCE; COMPUTER TECHNICAL SUPPORT SERVICES, NAMELY, HELP DESK SERVICES; CONSULTING SERVICES IN THE FIELD OF COMPUTER-BASED INFORMATION SYSTEMS FOR BUSINESS; CONSULTING SERVICES IN THE FIELD OF PROVIDING ONLINE, NON-DOWNLOADABLE SOFTWARE AND APPLICATIONS; DATA CONVERSION OF COMPUTER PROGRAM DATA OR INFORMATION; DATA CONVERSION OF ELECTRONIC INFORMATION; DATA MIGRATION SERVICES; DATABASE DEVELOPMENT SERVICES; DESIGN AND DEVELOPMENT OF MULTIMEDIA PRODUCTS; DESIGN AND DEVELOPMENT OF SOFTWARE SYSTEMS; DESIGN AND WRITING COMPUTER SOFTWARE; DESIGN OF COMPUTER DATABASES; DESIGN OF INFORMATION GRAPHICS AND DATA VISUALIZATION MATERIALS; DESIGN, DEVELOPMENT, INSTALLATION, UPDATING, REPAIR, MAINTENANCE AND RENTAL OF COMPUTER SOFTWARE AND DATABASE; DEVELOPMENT AND CREATION OF COMPUTER PROGRAMMES FOR DATA PROCESSING; PROVIDING TEMPORARY USE ON-LINE NON-DOWNLOADABLE SOFTWARE FOR USE IN BUSINESS COMMUNICATIONS; RESEARCH AND DEVELOPMENT OF COMPUTER SOFTWARE; SERVICES FOR UPDATING COMPUTER SOFTWARE (U.S. CLS. 100 AND 101).

KRISTINA MORRIS, EXAMINING ATTORNEY

SN 79-096,529. ANTON PFANNER, AUSTRIA, FILED 1-18-2011.

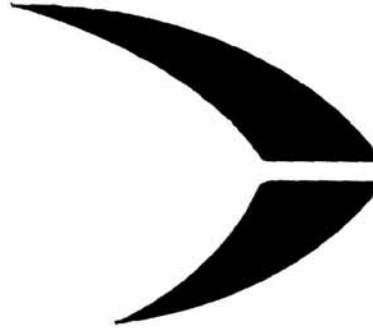

PRIORITY DATE OF 7-21-2010 IS CLAIMED.
OWNER OF INTERNATIONAL REGISTRATION 1074796
DATED 1-18-2011, EXPIRES 1-18-2021.
THE MARK CONSISTS OF TWO CURVED TRIANGLES
THAT ARE CONCAVE.

CLASS 9—ELECTRICAL AND SCIENTIFIC APPARATUS

FOR APPARATUS FOR CONDUCTING, SWITCHING, TRANSFORMING, ACCUMULATING, REGULATING AND CONTROLLING ELECTRICITY; WORK PROTECTION GARMENTS, NAMELY, PROTECTIVE WORK GLOVES AND CLOTHING FOR PROTECTION AGAINST CHAINSAWS, OUTDOOR WEATHER CONDITIONS, DISEASES, AND STAB WOUNDS, NAMELY, SLASH AND STAB RESISTANT CLOTHING, ASBESTOS CLOTHING FOR PROTECTION AGAINST FIRE, CLOTHING FOR PROTECTION AGAINST ACCIDENTS AND FIRE; GLOVES FOR PROTECTION AGAINST ACCIDENTS; PROTECTIVE GARMENTS FOR FORESTRY WORKERS AND FORESTRY SUPERVISORS, NAMELY, SLASH AND STAB RESISTANT CLOTHING, ASBESTOS CLOTHING FOR PROTECTION AGAINST FIRE, CLOTHING FOR PROTECTION AGAINST ACCIDENTS AND FIRE; CLOTHING FOR PROTECTION AGAINST CHAINSAWS, OUTDOOR WEATHER CONDITIONS, DISEASES AND STAB WOUNDS, NAMELY, SLASH AND STAB RESISTANT CLOTHING, DISPOSABLE GARMENT FOR PROTECTION AGAINST SPONTANEOUS FLASH, INDUSTRIAL AND MANUFACTURING ENVIRONMENTS, ASBESTOS CLOTHING FOR PROTECTION AGAINST FIRE, CLOTHING FOR PROTECTION AGAINST ACCIDENT, IRRADIATION AND FIRE; PROTECTIVE GARMENTS FOR WORKING WITH SAWS, NAMELY, SLASH AND STAB RESISTANT CLOTHING, CLOTHING FOR PROTECTION AGAINST CHAINSAW ACCIDENTS IN THE NATURE OF ARM AND HAND PROTECTIVE CLOTHING AND FOREARM PROTECTIVE CLOTHING; PROTECTIVE HELMETS INCLUDING PROTECTIVE HELMETS FOR RIDERS, FOR SPORTS, FOR AVIATION, FOR MOUNTAIN CLIMBERS, FOR USE IN ALPINE RESCUE SERVICES, FOR CONSTRUCTION WORKERS AND FOR FORESTRY WORKERS; PROTECTIVE MASKS FOR WORKERS; PROTECTION GARMENTS AGAINST ACCIDENTS, RADIATION AND FIRE; DEEP FREEZE PROTECTIVE CLOTHING, NAMELY, HEATED GARMENTS IN THE NATURE OF APPAREL CONSISTING OF CARBON FIBER WHICH PRODUCES HEAT; HEAT PROTECTIVE CLOTHING, NAMELY, HEATED GARMENTS IN THE NATURE OF APPAREL CONSISTING OF CARBON FIBER WHICH PRODUCES HEAT; KNEE PADS FOR WORKERS; BULLET PROOF AND STAB PROOF VESTS; MOUTH PROTECTORS, NAMELY, PROTECTIVE HELMET ACCESSORIES, NAMELY, MOUTH GUARDS NOT FOR MEDICAL OR ATHLETIC USE; CLOTHING FOR WEAR FOR THE PREVENTION OF TRAFFIC ACCIDENTS; LIFE VESTS; LIFE JACKETS; SOCKS ELECTRICALLY HEATED FOR USE AS PROTECTIVE CLOTHING FOR PROTECTION AGAINST ACCIDENTS AND COLD WEATHER; DIVING SUITS; COLD AND HEAT RESISTANT PROTECTIVE GARMENTS FOR PROTECTION AGAINST ACCIDENTS AND FIRES; PROTECTIVE WORKING SHOES (U.S. CLS. 21, 23, 26, 36 AND 38).

CLASS 12—VEHICLES

FOR UPHOLSTERY FOR VEHICLES; VEHICLE SEATS; HEAD RESTRAINTS FOR VEHICLE SEATS; SEAT COVERS FOR VEHICLE SEATS; WARM AND COLD CAR SEATS AND CAR SEAT CUSHIONS FOR PASSENGER CARS, LORRIES AND BUSES; CAR SEATS AND CAR SEAT CUSHIONS; SEATS FOR BICYCLES AND MOTORBIKES; SEAT COVERS FOR BICYCLES AND MOTORBIKES; COUCHES AND BEDS FOR VEHICLES (U.S. CLS. 19, 21, 23, 31, 35 AND 44).

SN 79-096,685. AWS GROUP AG, FED REP GERMANY, FILED 3-15-2011.

**CLASS 25—CLOTHING**

FOR OUTER AND UNDER CLOTHING FOR LADIES, GENTLEMEN AND CHILDREN, NAMELY, PANTS, CAPRIS, JUMPSUITS, GAITERS, COVERALLS, BIB OVERALLS, VESTS, SHORTS, SHIRTS, POLO SHIRTS, T-SHIRTS, PULLOVERS, SWEATERS, WORK COATS, COATS, JACKETS, CHAPS, SOCKS, UNDERWEAR, HATS, CAPS; READY-MADE CLOTHING, NAMELY, PANTS, JUMPSUITS, COVERALLS, BIB OVERALLS, VESTS, SHORTS, SHIRTS, POLO SHIRTS, T-SHIRTS, PULLOVERS, SWEATERS, WORK COATS, COATS, JACKETS, CHAPS, SOCKS, UNDERWEAR, HATS, CAPS; TRICOT CLOTHING, NAMELY, COATS, JACKETS, SHIRTS, PANTS, SHORTS, VESTS, OVERALLS, CHAPS, SOCKS, UNDERWEAR, CAPS, BASEBALL CAPS; PULLOVERS, SWEATERS, COATS, OVERCOATS, UNDERCLOTHES; SHOES, BOOTS, SHOES FOR LEISURE WEAR; WORKING SHOES, ALPINE SHOES, HIKING SHOES, WINTER BOOTS, SHOES AND BOOTS MADE FROM RUBBER, PVC OR FOAMED MATERIALS; INSOLES FOR SHOES NOT FOR ORTHOPEDIC PURPOSES; HEADGEAR, NAMELY, HATS, CAPS; BELTS; GLOVES; SHIRTS; JACKETS; TIES; EAR MUFFS, HEADBANDS; SCARVES, SOCKS, STOCKINGS, PANTYHOSE; RAIN CLOTHING, NAMELY, BOOTS, JACKETS AND PANTS; RAINCOATS, RAIN PROOF JACKETS, RAIN PROOF TROUSERS; WINTER CLOTHING, NAMELY, COATS, JACKETS, SHIRTS, PANTS, SHORTS, VESTS, OVERALLS, CHAPS, SOCKS, UNDERWEAR, CAPS, BASEBALL CAPS; HIKING CLOTHING, NAMELY, COATS, JACKETS, SHIRTS, PANTS, SHORTS, VESTS, OVERALLS, CHAPS, SOCKS, UNDERWEAR, CAPS, BASEBALL CAPS; TREKKING CLOTHING, NAMELY, COATS, JACKETS, SHIRTS, PANTS, SHORTS, VESTS, OVERALLS, CHAPS, SOCKS, UNDERWEAR, CAPS, BASEBALL CAPS; CLOTHING FOR MOTORISTS, MOTORCYCLISTS, BICYCLISTS AND BIKERS, NAMELY, COATS, JACKETS, SHIRTS, PANTS, SHORTS, VESTS, OVERALLS, CHAPS, SOCKS, UNDERWEAR, CAPS, BASEBALL CAPS; HUNTING GARMENTS, NAMELY, COATS, JACKETS, SHIRTS, PANTS, SHORTS, VESTS, OVERALLS, CHAPS, SOCKS, UNDERWEAR, CAPS, BASEBALL CAPS (U.S. CLS. 22 AND 39).

PRIORITY DATE OF 9-22-2010 IS CLAIMED.
OWNER OF INTERNATIONAL REGISTRATION 1075162 DATED 3-15-2011, EXPIRES 3-15-2021.

THE MARK CONSISTS OF THE WORD "DESORBATOR" IN FRONT OF A SWIRL DESIGN.

THE WORDING "DESORBATOR" HAS NO MEANING IN A FOREIGN LANGUAGE.

CLASS 11—ENVIRONMENTAL CONTROL APPARATUS

FOR PARTS OF AIR FILTERING APPARATUSES, NAMELY, REGENERATION UNITS FOR AIR PURIFYING LIQUIDS SOLD AS AN INTEGRAL COMPONENT OF AIR FILTERS FOR AIR CONDITIONING UNITS AND INDUSTRIAL AIR FILTER MACHINES; PARTS OF AIR PURIFYING APPARATUSES AND MACHINES, NAMELY, REGENERATION UNITS FOR AIR PURIFYING LIQUIDS SOLD AS AN INTEGRAL COMPONENT OF AIR PURIFIERS (U.S. CLS. 13, 21, 23, 31 AND 34).

CLASS 37—CONSTRUCTION AND REPAIR

FOR INSTALLATION, ASSEMBLY, REPAIR AND MAINTENANCE OF AIR FILTERING APPARATUSES, AIR PURIFYING APPARATUSES AND MACHINES (U.S. CLS. 100, 103 AND 106).

CLASS 42—SCIENTIFIC AND COMPUTER SERVICES

FOR TECHNICAL DEVELOPMENT, CONSULTATION AND DESIGN OF AIR FILTERING APPARATUSES, AIR PURIFYING APPARATUSES AND MACHINES (U.S. CLS. 100 AND 101).

MAYUR VAGHANI, EXAMINING ATTORNEY

SN 79-096,733. CLINICAL DESIGNS LIMITED, CAMBRIDGE, CB4 0AB, UNITED KINGDOM, FILED 3-29-2011.

K-HALER

THE MARK CONSISTS OF STANDARD CHARACTERS WITHOUT CLAIM TO ANY PARTICULAR FONT, STYLE, SIZE, OR COLOR.

OWNER OF INTERNATIONAL REGISTRATION 0904271 DATED 1-11-2006, EXPIRES 1-11-2016.

OWNER OF U.S. REG. NO. 2,958,981.

CLASS 28—TOYS AND SPORTING GOODS

FOR SHIN PROTECTORS, NAMELY, SHIN GUARDS FOR ATHLETIC USE, KNEE PADS FOR ATHLETIC USE, HEAD PROTECTORS, BACK PROTECTORS, ELBOW PROTECTORS EACH FOR SPORTS EQUIPMENT, NAMELY, ELBOW GUARDS FOR ATHLETIC USE; FENCING, GOLFING, BOXING, BASEBALL AND OTHER SPORTING GLOVES NOT INCLUDED IN OTHER CLASSES, NAMELY, GOALKEEPERS' GLOVES, WORK-OUT GLOVES, WEIGHT LIFTING GLOVES AND HOCKEY GLOVES; CLIMBING BELTS FOR USE IN HUNTING AND MOUNTAINEERING; PROTECTIVE CUSHIONS FOR SPORTS EQUIPMENT, NAMELY, PROTECTIVE PADDING FOR ELBOWS AND SHOULDERS FOR USE IN ICE HOCKEY, FIELD HOCKEY AND BASEBALL (U.S. CLS. 22, 23, 38 AND 50).

RAMONA ORTIGA, EXAMINING ATTORNEY

CLASS 5—PHARMACEUTICALS

FOR PHARMACEUTICAL PREPARATIONS FOR THE TREATMENT OF RESPIRATORY DISEASES AND DISORDERS, ASTHMA, CHRONIC OBSTRUCTIVE PULMONARY DISEASE (COPD), EMPHYSEMA, DIABETES AND HUMAN IMMUNODEFICIENCY VIRUS (HIV); PHARMACEUTICAL PREPARATIONS FOR USE IN PULMONARY DELIVERY SYSTEMS IN THE NATURE OF INHALERS FOR THE TREATMENT OF RESPIRATORY DISEASES AND DISORDERS, ASTHMA, CHRONIC OBSTRUCTIVE PULMONARY DISEASE (COPD), EMPHYSEMA, DIABETES AND HUMAN IMMUNODEFICIENCY VIRUS (HIV); INHALERS FILLED WITH PHARMACEUTICAL PREPARATIONS FOR THE TREATMENT OF RESPIRATORY DISEASES AND DISORDERS, ASTHMA, CHRONIC OBSTRUCTIVE PULMONARY DISEASE (COPD), EMPHYSEMA, DIABETES AND HUMAN IMMUNODEFICIENCY VIRUS (HIV); DRUG DELIVERY AGENTS IN THE FORM OF INHALANTS THAT RELEASE THE ACTIVE INGREDIENTS FOR A WIDE RANGE OF PHARMACEUTICALS; PHARMACEUTICAL PREPARATIONS FOR USE IN INHALERS, INHALATION APPARATUS, DEVICES AND DISPENSERS, NAMELY, DRUG DELIVERY AGENTS CONSISTING OF COMPOUNDS THAT FACILITATE THE DELIVERY OF A WIDE RANGE OF PHARMACEUTICALS (U.S. CLS. 6, 18, 44, 46, 51 AND 52).

SN 79-097,058. STIFTUNG PREUSSISCHER KULTURBESITZ DES ÖFFENTLICHEN RECHTS, FED REP GERMANY, FILED 3-17-2011.

**CLASS 10—MEDICAL APPARATUS**

FOR MEDICAL DEVICES, NAMELY, NEBULIZERS FOR RESPIRATION THERAPY; AEROSOL DISPENSERS FOR MEDICAL USE; INHALERS FOR MEDICAL PURPOSES SOLD EMPTY AND INHALERS FOR THERAPEUTIC USE SOLD EMPTY; METERED DOSE INHALERS FOR THERAPEUTIC USE SOLD EMPTY; NEBULIZERS FOR ADMINISTERING MEDICATION IN THE FORM OF A MIST INHALED INTO THE LUNGS FOR TREATMENT OF RESPIRATORY DISEASES; AND PARTS AND FITTINGS FOR ALL THE AFORESAID GOODS (U.S. CLS. 26, 39 AND 44).

CLASS 16—PAPER GOODS AND PRINTED MATTER

FOR PRINTED MATTER, NAMELY, BOOKLETS, MANUALS, MAGAZINES, BOOKS, GUIDES, PAMPHLETS, CATALOGUES, JOURNALS, NEWSLETTERS, SERIES OF WRITTEN ARTICLES, REPORTS, PRINTED PRESS RELEASES, PROMOTIONAL LITERATURE AND PRODUCT GUIDES IN THE FIELDS OF RESPIRATORY DISEASES AND DISORDERS, DIABETES AND HUMAN IMMUNODEFICIENCY VIRUS (HIV); PACKING PAPER AND CARDBOARD FOR PHARMACEUTICAL PACKAGING; PRINTED PATIENT RECORD CARDS AND PRESCRIPTION PADS; PHARMACEUTICAL INFORMATION LEAFLETS; BOOKS IN THE FIELDS OF MEDICINE AND PHARMACEUTICALS; PRINTED PUBLICATIONS, NAMELY, MAGAZINES, NEWSLETTERS, PAMPHLETS, REPORTS, INSTRUCTIONAL AND INFORMATIONAL LEAFLETS, AND POSTERS, IN THE FIELDS OF MEDICINE AND PHARMACEUTICALS; PACKING PAPER; STATIONERY; PRINTED INSTRUCTIONAL AND TEACHING MATERIALS IN THE FIELDS OF PHARMACEUTICALS, HEALTH CARE AND MEDICINE RELATING TO THE PHARMACEUTICAL, HEALTH CARE AND MEDICAL FIELDS (U.S. CLS. 2, 5, 22, 23, 29, 37, 38 AND 50).

SUSAN RICHARDS, EXAMINING ATTORNEY

PRIORITY DATE OF 12-22-2010 IS CLAIMED.
OWNER OF INTERNATIONAL REGISTRATION 1076256 DATED 3-17-2011, EXPIRES 3-17-2021.

THE MARK CONSISTS OF THE DESIGN OF A HEAD OF AN EAGLE WITH A CURVED WING TO THE RIGHT ON A SHADED BACKGROUND WITHIN A SQUARE.

CLASS 9—ELECTRICAL AND SCIENTIFIC APPARATUS

FOR APPARATUS FOR RECORDING, TRANSMISSION OR REPRODUCTION OF SOUND OR IMAGES; RECORDED AND UNRECORDED DATA CARRIERS, NAMELY, CDS, DVDS, USB COMPUTER MEMORIES, EXPOSED CAMERA FILMS, VIDEO CASSETTES, VIDEO TAPES, AUDIO CASSETTES, ALL RECORDED DATA CARRIERS FEATURING MUSIC, IMAGES, MOVIES; DATA PROCESSING EQUIPMENT AND COMPUTERS INCLUSIVELY AUDIOVISUAL TEACHING APPARATUS (U.S. CLS. 21, 23, 26, 36 AND 38).

CLASS 14—JEWELRY

FOR PRECIOUS METALS AND THEIR ALLOYS AND GOODS IN PRECIOUS METALS OR COATED THEREWITH, NOT INCLUDED IN OTHER CLASSES, NAMELY, RINGS, EARRINGS, NECKLACES, BRACELETS, TIE TACKS, PINS, ARTWORK COMPRISED OF PRECIOUS METALS, WATCHES, CLOCKS; JEWELLERY, PRECIOUS STONES; HOROLOGICAL AND CHRONOMETRIC INSTRUMENTS (U.S. CLS. 2, 27, 28 AND 50).

CLASS 16—PAPER GOODS AND PRINTED MATTER

FOR PRINTED MATTER, NAMELY, WRITINGS, NAMELY, BOOKS IN THE FIELDS OF ART, PHOTOGRAPHY, MUSIC, HISTORY, HERITAGE AND CULTURE, BROCHURES IN THE FIELDS OF ART, PHOTOGRAPHY, MUSIC, HISTORY, HERITAGE AND CULTURE; PUBLICATIONS, NAMELY, BOOKS IN THE FIELDS OF ART, PHOTOGRAPHY, MUSIC, HISTORY, HERITAGE AND CULTURE, BROCHURES IN THE FIELDS OF ART, PHOTOGRAPHY, MUSIC, HISTORY, HERITAGE AND CULTURE; COLLECTION AND PRESENTATION CATALOGUES IN THE FIELDS OF ART, PHOTOGRAPHY, MUSIC, HISTORY, HERITAGE AND CULTURE, INSTRUCTIONAL AND TEACHING MATERIAL EXCEPT APPARATUS IN THE FIELD OF SCIENCE, EDUCATION AND PRUSSIAN AND POPULAR CULTURE; PHOTOGRAPHS; TICKETS, NAMELY, ENTRY TICKETS AND EXHIBITION TICKETS; STAMPS, NAMELY, RUBBER STAMPS AND POSTAL STAMPS; POST CARDS, CALENDARS, GIFT PAPER AND DECORATION STRIPS OF PLASTIC FOR GIFT PACKAGES; STATIONERY; PAINT BRUSHES; ARTISTS' MATERIALS, NAMELY, PENCILS, PENS, COLORED PENCILS, CHALK, SKETCHBOOKS, NOTEPADS, CONSTRUCTION PAPER, CARD STOCK, MARKERS; PLASTIC MATERIALS FOR PACKAGING NOT INCLUDED IN OTHER CLASSES, NAMELY, PLASTIC BAGS, PLASTIC WRAP (U.S. CLS. 2, 5, 22, 23, 29, 37, 38 AND 50).

CLASS 18—LEATHER GOODS

FOR LEATHER AND IMITATIONS OF LEATHER, AND GOODS MADE OF THESE MATERIALS NOT INCLUDED IN OTHER CLASSES, NAMELY, BAGS; ANIMAL SKINS, HIDES; TRUNKS AND TRAVELLING BAGS; UMBRELLAS, PARASOLS AND WALKING STICKS; WHIPS, HARNESS AND SADDLERY (U.S. CLS. 1, 2, 3, 22 AND 41).

CLASS 20—FURNITURE AND ARTICLES NOT OTHERWISE CLASSIFIED

FOR FURNITURE, MIRRORS, PICTURE FRAMES; GOODS NOT INCLUDED IN OTHER CLASSES OF WOOD, CORK, REED, CANE, WICKER, HORN, BONE, IVORY, WHALEBONE, SHELL, AMBER, MOTHER-OF-PEARL, MEERSCHAUM AND SUBSTITUTES FOR ALL THESE MATERIALS, OR OF PLASTICS, NAMELY, LETTER BOXES NOT OF METAL OR MASONRY, STATUETTES, ANIMAL BONE, ANIMAL CLAWS, ANIMAL TEETH, BUSTS OF IVORY, PLASTER, PLASTIC AND WOOD; COLD CAST RESIN FIGURINES, CONTAINERS, NOT OF METAL, FOR STORAGE AND TRANSPORT; GIFT PACKAGE DECORATIONS MADE OF PLASTIC, GLASS FOR USE IN FRAMING ART, IDENTITY PLATES, NOT OF METAL, NON-METAL KEY HOLDERS, NON-METAL KEY RINGS, SCULPTURES OF BONE, IVORY, PLASTER, PLASTIC, WAX AND WOOD, STOPPERS OF CORK OR CORK IMITATIONS, WORKS OF ART OF WOOD, WAX, PLASTER OR PLASTIC (U.S. CLS. 2, 13, 22, 25, 32 AND 50).

CLASS 25—CLOTHING

FOR CLOTHING, NAMELY, SHIRTS, PANTS, T-SHIRTS, SWEATERS, SWEATSHIRTS, JEANS, SLACKS, SHORTS, BLOUSES, TANK TOPS, NECKTIES, JUMPERS, UNDERWEAR, BOXERS, SOCKS, JACKETS, GLOVES, SCARVES, FOOTWEAR, HEADGEAR, NAMELY, HATS, CAPS, BANDANAS (U.S. CLS. 22 AND 39).

CLASS 28—TOYS AND SPORTING GOODS

FOR GAMES, NAMELY, BOARD GAMES, PUZZLES, AND PLAYTHINGS, NAMELY, RATTLES, TOY BUILDING BLOCKS, KITES, MODEL TOYS, SCALE MODEL KITS; DECORATIONS FOR CHRISTMAS TREES (U.S. CLS. 22, 23, 38 AND 50).

CLASS 35—ADVERTISING AND BUSINESS

FOR ADVERTISING SERVICES; BUSINESS MANAGEMENT SERVICES; BUSINESS ADMINISTRATION AND MANAGEMENT; PROVIDING OFFICE FUNCTIONS; BUSINESS MANAGEMENT OF MUSEUMS; RETAIL STORE SERVICES, NAMELY, A MUSEUM FEATURING A RETAIL STORE SELLING GOODS IN THE FIELDS OF ART, PHOTOGRAPHY, MUSIC, HISTORY, HERITAGE AND CULTURE (U.S. CLS. 100, 101 AND 102).

CLASS 41—EDUCATION AND ENTERTAINMENT

FOR CULTURAL ACTIVITIES, NAMELY, MUSEUM SERVICES; INSTRUCTION AND EDUCATION SERVICES, NAMELY, PROVIDING LECTURES, CLASSES, SEMINARS, WORKSHOPS AND DISCUSSION GROUPS IN THE FIELDS OF ART, PHOTOGRAPHY, MUSIC, HISTORY, HERITAGE AND CULTURE; TRAINING SERVICES IN THE FIELDS OF ART, PHOTOGRAPHY, MUSIC, HISTORY, HERITAGE AND CULTURE; ENTERTAINMENT SERVICES, NAMELY, WINE TASTINGS; BUSINESS OF MUSEUMS, NAMELY, RUNNING OF MUSEUMS; ORGANIZATION OF EXHIBITIONS FOR CULTURAL OR EDUCATIONAL TEACHING PURPOSES; EDUCATIONAL SERVICES, NAMELY, PROVIDING EDUCATIONAL COURSES IN THE FIELDS OF ART, PHOTOGRAPHY, MUSIC, HISTORY, HERITAGE AND CULTURE; EDUCATIONAL SERVICES, NAMELY, LECTURES IN THE FIELDS OF ART, PHOTOGRAPHY, MUSIC, HISTORY, HERITAGE AND CULTURE; ORGANIZATION OF EVENTS FOR CULTURAL PURPOSES; ORGANIZATION OF EDUCATIONAL CONFERENCES; CONDUCTING EDUCATIONAL EXHIBITIONS IN THE NATURE OF ART COLLECTIONS, MUSIC COLLECTIONS, AND PHOTOGRAPHY COLLECTIONS; EDUCATIONAL SERVICES, NAMELY, PROVIDING MUSEUM PEDAGOGICAL PROGRAMS IN THE FIELDS OF ART, PHOTOGRAPHY, MUSIC, HISTORY, HERITAGE AND CULTURE FOR THE PURPOSE OF ADVANCEMENT OF SCIENCE, EDUCATION AND CULTURE; EVENTS OF CULTURAL, ENTERTAINING AND EDUCATIONAL KIND, NAMELY, ART EXHIBITIONS, PHOTOGRAPHY EXHIBITIONS, MUSIC EXHIBITIONS, HISTORICAL DOCUMENT EXHIBITIONS; PUBLICATION OF BOOKS, ONLINE PUBLICATION OF ELECTRONICAL BOOKS AND MAGAZINES; CONDUCTING WORKSHOPS AND SEMINARS IN THE FIELDS OF ART, PHOTOGRAPHY, MUSIC, HISTORY, HERITAGE AND CULTURE; ART EXHIBITION SERVICES, NAMELY, RENTING OF ARTWORKS FOR THE PURPOSE OF ENTERTAINMENT AND TRAINING AND FURTHER EDUCATION; TICKET SEAT RESERVATIONS AND TICKET BOOKING SERVICES FOR ENTERTAINMENT EVENTS (U.S. CLS. 100, 101 AND 107).

CLASS 42—SCIENTIFIC AND COMPUTER SERVICES

FOR SCIENTIFIC AND TECHNOLOGICAL SERVICES, NAMELY, RESEARCH AND DESIGN IN THE FIELDS OF COMPUTER HARDWARE AND COMPUTER SOFTWARE; DESIGN AND DEVELOPMENT OF COMPUTER HARDWARE AND SOFTWARE (U.S. CLS. 100 AND 101).
JESSICA FATHY, EXAMINING ATTORNEY

SN 79-097,062. DEUTSCHE TELEKOM AG, 53113 BONN, FED REP GERMANY, FILED 3-7-2011.

The Great Experience

THE MARK CONSISTS OF STANDARD CHARACTERS WITHOUT CLAIM TO ANY PARTICULAR FONT, STYLE, SIZE, OR COLOR.

PRIORITY DATE OF 9-7-2010 IS CLAIMED.

OWNER OF INTERNATIONAL REGISTRATION 1076266 DATED 3-7-2011, EXPIRES 3-7-2021.

CLASS 35—ADVERTISING AND BUSINESS

FOR BUSINESS MANAGEMENT SERVICES; HUMAN RESOURCE MANAGEMENT; HUMAN RESOURCE CONSULTATION; HUMAN RESOURCE SERVICES, NAMELY, PERSONNEL SELECTION FOR OTHERS; PROFESSIONAL PERSONNEL RECRUITMENT (U.S. CLS. 100, 101 AND 102).

SN 79-097,248. HUMÖR A/S, DENMARK, FILED 4-11-2011.



THE MARK CONSISTS OF STANDARD CHARACTERS WITHOUT CLAIM TO ANY PARTICULAR FONT, STYLE, SIZE, OR COLOR.

OWNER OF INTERNATIONAL REGISTRATION 1034992 DATED 3-18-2010, EXPIRES 3-18-2020.

THE WORDING "RÜTME" HAS NO MEANING IN A FOREIGN LANGUAGE.

CLASS 38—COMMUNICATION

FOR TELECOMMUNICATIONS SERVICES, NAMELY, PERSONAL COMMUNICATION SERVICES AND BUSINESS COMMUNICATION BY TELEPHONE, COMPUTER TERMINALS, MOBILE PHONES, RADIO, TELEFAX, TELEGRAPH AND TELEVISION TRANSMISSIONS (U.S. CLS. 100, 101 AND 104).

CLASS 42—SCIENTIFIC AND COMPUTER SERVICES

FOR CONSULTING IN THE FIELDS OF TELECOMMUNICATIONS TECHNOLOGY AND INFORMATION TECHNOLOGY (U.S. CLS. 100 AND 101).

TARA PATE, EXAMINING ATTORNEY

CLASS 18—LEATHER GOODS

FOR LEATHER AND IMITATIONS OF LEATHER AND GOODS MADE OF LEATHER AND IMITATION LEATHER, NAMELY, BRIEFCASES, LEATHER AND IMITATION LEATHER BAGS, LEATHER HANDBAGS, LEATHER KEY CHAINS, LEATHER PURSES, LEATHER STRAPS, TRAVELLING CASES OF LEATHER; ANIMAL SKINS AND HIDES, TRUNKS AND BAGS, NAMELY, VALISES, TRAVELLING BAGS, HANDBAGS, SHOPPING BAGS, SCHOOL BAGS, VANITY CASES NOT FITTED, BAGS OF LEATHER FOR PACKAGING; UMBRELLAS, PARASOLS, PURSES AND POCKET WALLETS (U.S. CLS. 1, 2, 3, 22 AND 41).

SN 79-097,158. DOUCET, FRANCE, FILED 4-6-2011.



THE MARK CONSISTS OF STANDARD CHARACTERS WITHOUT CLAIM TO ANY PARTICULAR FONT, STYLE, SIZE, OR COLOR.

PRIORITY DATE OF 10-15-2010 IS CLAIMED.

OWNER OF INTERNATIONAL REGISTRATION 1076555 DATED 4-6-2011, EXPIRES 4-6-2021.

CLASS 25—CLOTHING

FOR CLOTHING, NAMELY, TROUSERS, PANTS, PULLOVERS, SWEATERS, WAISTCOATS, T-SHIRTS, UNDERWEAR, STOCKINGS, SHORTS, OUTDOOR WEAR, NAMELY, JACKETS, COATS, SNOWSUITS; BELTS, TIES, BLOUSES AND JERSEYS, CARDIGANS, SHIRTS, SWIMWEAR, BATHROBES, DRESSES, SKIRTS, NIGHTWEAR, TRAINING WEAR, NAMELY, TRAINING SUITS, TRAINING SHOES, SNEAKERS; SPORTSWEAR, NAMELY, SPORTS PANTS, SPORTS SHIRTS, SPORTS JERSEYS, SPORTS SHOES; RAINWEAR, SCARVES; FOOTWEAR; HEADGEAR, NAMELY, HATS AND CAPS (U.S. CLS. 22 AND 39).

CLASS 3—COSMETICS AND CLEANING PREPARATIONS

FOR BLEACHING PREPARATIONS FOR HOUSEHOLD USE; SUBSTANCES FOR LAUNDRY USE, NAMELY, LAUNDRY DETERGENT, PRE-SOAK AND FABRIC SOFTENERS; CLEANING PREPARATIONS; DEGREASERS AND DETERGENTS FOR HOUSEHOLD USE; SKIN SOAP; SOAP FOR HOUSEHOLD USE; DISINFECTANT SOAP; FRAGRANCES FOR THE HOME; PRESERVATIVE CREAMS FOR LEATHER; CLEANING PREPARATIONS FOR WASTE PIPES; FLOOR CLEANING PREPARATIONS, POLISHES AND WAXES (U.S. CLS. 1, 4, 6, 50, 51 AND 52).

CLASS 35—ADVERTISING AND BUSINESS

FOR BUSINESS MANAGEMENT AND BUSINESS ADMINISTRATION; RETAIL STORE SERVICES FEATURING GOODS MADE OF LEATHER AND IMITATIONS OF LEATHER, TRUNKS AND BAGS, UMBRELLAS, PARASOLS, PURSES AND POCKET WALLETS, CLOTHING, FOOTWEAR AND HEADGEAR; MAIL ORDER SERVICE FEATURING GOODS MADE OF LEATHER AND IMITATIONS OF LEATHER, TRUNKS AND BAGS, UMBRELLAS, PARASOLS, PURSES, AND POCKET WALLETS, CLOTHING, FOOTWEAR AND HEADGEAR; ONLINE RETAIL STORE SERVICE FEATURING GOODS MADE OF LEATHER AND IMITATIONS OF LEATHER, TRUNKS AND BAGS, UMBRELLAS, PARASOLS, PURSES AND POCKET WALLETS, CLOTHING, FOOTWEAR, AND HEADGEAR; BUSINESS CONSULTANCY CONCERNING THE COMMERCIAL MANAGEMENT OF RETAIL STORES (U.S. CLS. 100, 101 AND 102).

JOSETTE BEVERLY, EXAMINING ATTORNEY

CLASS 5—PHARMACEUTICALS

FOR DISINFECTANTS FOR SANITARY PURPOSES; INSECTICIDES; FUNGICIDES; HERBICIDES; DEODORANTS, HOUSEHOLD DEODORANTS; DISINFECTANTS FOR CHEMICAL TOILETS; CLEANSING SOLUTIONS, NAMELY, DETERGENTS FOR MEDICAL USE; AIR PURIFYING PREPARATIONS (U.S. CLS. 6, 18, 44, 46, 51 AND 52).

CLASS 21—HOUSEWARES AND GLASS

FOR CONTAINERS FOR HOUSEHOLD USE; SPONGES FOR HOUSEHOLD PURPOSES; BROOMS; CLEANING INSTRUMENTS, NAMELY, DISH SCRUBBERS, CLEANING CLOTHS, SCOURING PADS, MOPS, TOILET BOWL SCRUBBERS, DUSTING CLOTHS, DUSTERS, FABRIC CLEANING MITTS, SQUEEGEES, AND DUST PANS; STEEL WOOL FOR CLEANING; DISH BRUSHES, BOTTLE BRUSHES, AND SCRUB BRUSHES; BUCKETS (U.S. CLS. 2, 13, 23, 29, 30, 33, 40 AND 50).

CHRISTOPHER BUONGIORNO, EXAMINING ATTORNEY

SN 79-097,261. JAPAN FINANCIAL ACADEMY CO., LTD., JAPAN, FILED 11-8-2010.



PRIORITY DATE OF 10-13-2010 IS CLAIMED.

OWNER OF INTERNATIONAL REGISTRATION 1076774 DATED 11-8-2010, EXPIRES 11-8-2020.

NO CLAIM IS MADE TO THE EXCLUSIVE RIGHT TO USE "FINANCIAL", APART FROM THE MARK AS SHOWN.

THE MARK CONSISTS OF THE WORDING "FINANCIAL ACADEMY" IN STYLIZED FONT.

CLASS 9—ELECTRICAL AND SCIENTIFIC APPARATUS

FOR ELECTRONIC CIRCUITS AND CD-ROMS RECORDED WITH COMPUTER PROGRAMS FOR HANDHELD GAMES WITH LIQUID CRYSTAL DISPLAYS; PHONOGRAPH RECORDS FEATURING MUSIC, SELF-IMPROVEMENT, MATHEMATICS INSTRUCTION, ART INSTRUCTION; ELECTRONIC CIRCUITS AND CD-ROMS RECORDED WITH AUTOMATIC PERFORMANCE PROGRAMS FOR ELECTRONIC MUSICAL INSTRUMENTS; SLIDE-RULES; EXPOSED CINEMATOGRAPHIC FILMS; EXPOSED SLIDE FILMS; SLIDE FILM MOUNTS; RECORDED VIDEO DISCS AND VIDEO TAPES FEATURING SELF-IMPROVEMENT HELP, MATHEMATICS INSTRUCTION, ART INSTRUCTION; ELECTRONIC PUBLICATIONS, NAMELY, BOOKS, MAGAZINES, MANUALS FEATURING SELF-IMPROVEMENT HELP, MATHEMATICS INSTRUCTION, ART INSTRUCTION RECORDED ON COMPUTER MEDIA (U.S. CLS. 21, 23, 26, 36 AND 38).

CLASS 35—ADVERTISING AND BUSINESS

FOR ADVERTISING AND PUBLICITY SERVICES; PROMOTING THE GOODS AND SERVICES OF OTHERS BY MEANS OF THE ISSUANCE OF TRADING STAMPS; BUSINESS MANAGEMENT ANALYSIS OR BUSINESS CONSULTANCY; MARKETING RESEARCH; PROVIDING INFORMATION ON SALES OF MERCHANDISE; BUSINESS MANAGEMENT OF HOTELS; ACCOUNTING SERVICES, NAMELY, DRAWING UP OF STATEMENTS OF ACCOUNTS; EMPLOYMENT AGENCIES; AUCTIONEERING; IMPORT-EXPORT AGENCIES; ARRANGING NEWSPAPER SUBSCRIPTIONS FOR OTHERS; SHORT-HAND SERVICES; MESSAGE TRANSCRIPTION; DOCUMENT REPRODUCTION; OFFICE FUNCTIONS, NAMELY, FILING, IN PARTICULAR DOCUMENTS OR MAGNETIC TAPE; OFFERING BUSINESS MANAGEMENT ASSISTANCE IN OPERATION OF COMPUTERS, TYPEWRITERS OR OTHER OFFICE MACHINES AND EQUIPMENT; RECEPTION SERVICES FOR VISITORS IN BUILDINGS; PUBLICITY MATERIAL RENTAL; RENTAL OF TYPEWRITERS AND COPYING MACHINES; PROVIDING EMPLOYMENT INFORMATION; RENTAL OF VENDING MACHINES (U.S. CLS. 100, 101 AND 102).

CLASS 36—INSURANCE AND FINANCIAL

FOR FINANCIAL CONSULTANCY IN THE FIELD OF ASSET MAINTENANCE AND MANAGEMENT FOR ECONOMIC DESIGN OF LIVING; FINANCIAL MANAGEMENT; INSURANCE CONSULTANCY; PROVIDING TAX INFORMATION; CAPITAL INVESTMENT SERVICES; CAPITAL INVESTMENTS CONSULTANCY; PROVIDING FINANCIAL AND INVESTMENT INFORMATION ON BUILDINGS, LAND OR REAL ESTATE AFFAIRS; ACCEPTANCE OF SECURITIES DEPOSITS, INCLUDING SUBSTITUTE BOND ISSUANCE, AND ACCEPTANCE OF FIXED INTERVAL INSTALLMENT SECURITIES DEPOSITS; LOANS, FINANCING AND DISCOUNT OF BILLS; FINANCIAL DOMESTIC EXCHANGE FOR DEBT, ESTATE, AND TRANSACTIONAL SETTLEMENTS; FINANCIAL LIABILITY GUARANTEE AND SURETY ACCEPTANCE OF BILLS; SECURITIES LENDING; ACQUISITION AND TRANSFER OF MONETARY CLAIMS; SAFE DEPOSIT SERVICES, NAMELY, SAFEKEEPING OF VALUABLES INCLUDING SECURITIES AND PRECIOUS METALS; MONEY EXCHANGE; TRUSTEESHIP REPRESENTATIVES FOR FINANCIAL FUTURES CONTRACTS; TRUSTEESHIP REPRESENTATIVE FOR MONEY, SECURITIES, MONETARY CLAIMS, PERSONAL PROPERTY, LAND, RIGHTS ON LAND FIXTURES, SURFACE RIGHTS OR LEASE ON LAND; AGENCIES FOR BOND SUBSCRIPTIONS; FOREIGN EXCHANGE TRANSACTIONS; ISSUING LETTERS-OF-CREDIT; BROKERAGE OF CREDIT PURCHASE IN FINANCIAL TRANSACTIONS; BUYING AND SELLING OF SECURITIES; TRADING OF SECURITIES INDEX FUTURES; TRAD-

ING OF SECURITIES OPTIONS; TRADING OF OVERSEAS MARKET SECURITIES FUTURES; AGENCIES FOR BROKERAGE OF TRADING OF SECURITIES, SECURITIES INDEX FUTURES, SECURITIES OPTIONS, AND OVERSEAS MARKET SECURITIES FUTURES; AGENCIES OR BROKERAGE FOR ENTRUSTING AGENTS WITH ON-COMMISSION TRADING IN DOMESTIC MARKETS OF SECURITIES, SECURITIES INDEX FUTURES AND SECURITIES OPTIONS; AGENCIES OR BROKERAGE FOR ENTRUSTING AGENTS WITH ON-COMMISSION TRADING IN OVERSEAS MARKETS OF SECURITIES, AND SECURITIES INDEX FUTURES; AGENCIES OR BROKERAGE FOR FORWARD AGREEMENT OF SECURITIES, FOR FORWARD AGREEMENT OF SECURITIES INDEX FUTURES, FOR FORWARD AGREEMENT OF SECURITIES OPTIONS, SPOT AND FORWARD TRANSACTION OF SECURITIES INDEX FUTURES; BROKERAGE FOR SECURITIES LIQUIDATION; SECURITIES UNDERWRITING; SECURITIES BROKERAGE OFFERING SERVICES; TRADE EXECUTION TRANSACTION OF SECURITIES SUBSCRIPTION OR OFFERING; PROVIDING STOCK MARKET INFORMATION; LIFE INSURANCE BROKERAGE; LIFE INSURANCE UNDERWRITING; INSURANCE AGENCIES FOR NON-LIFE INSURANCE; CLAIM ADJUSTMENT FOR NON-LIFE INSURANCE; NON-LIFE INSURANCE UNDERWRITING IN THE FIELD OF SECURITIES, MARINE, COMMERCIAL LIABILITY, PRE-PAID LEGAL SERVICES; INSURANCE PREMIUM RATE COMPUTING; MANAGEMENT OF BUILDINGS; AGENCIES OF BROKERAGE FOR RENTING OF BUILDINGS; LEASING OR RENTING OF BUILDINGS; BROKERAGE FOR THE PURCHASE AND SALE OF BUILDINGS; REAL ESTATE AGENCIES OR BROKERAGE FOR PURCHASE AND SALE OF BUILDINGS; REAL ESTATE APPRAISAL; REAL ESTATE LAND MANAGEMENT; REAL ESTATE AGENCY SERVICES FOR THE LEASING OF LAND; LEASING OF LAND; REAL ESTATE BROKERAGE FOR THE PURCHASE AND SALE OF LAND; REAL ESTATE AGENCIES OR BROKERAGE FOR PURCHASE OR SALES OF LAND; FINANCIAL INFORMATION (U.S. CLS. 100, 101 AND 102).

CLASS 42—SCIENTIFIC AND COMPUTER SERVICES

FOR COMPUTER SOFTWARE DESIGN, COMPUTER PROGRAMMING, OR MAINTENANCE OF COMPUTER SOFTWARE; RENTAL OF WEB SERVERS FOR WEBSITES; RENTAL OF COMPUTERS; PROVIDING COMPUTER PROGRAMS FOR WEBSITE; PROVIDING INFORMATION ON PROVIDING SEARCH ENGINES FOR THE INTERNET; RENTAL OF WEB SERVERS; PROVIDING SEARCH ENGINES FOR THE INTERNET; INTERNET WEBSITE DESIGN, CREATION OF INTERNET WEBSITE, OR MAINTENANCE OF INTERNET WEBSITE; CONSULTANCY IN THE FIELD OF THE SECURITY OF COMMUNICATION NETWORK THROUGH THE INTERNET, THE MOBILE PHONE OR OTHER COMMUNICATION TOOL (U.S. CLS. 100 AND 101).

JOSETTE BEVERLY, EXAMINING ATTORNEY

SN 79-097,413. DUBANTON MARC-ANTOINE, P-1200-781 LISBONNE, PORTUGAL, FILED 3-15-2011.

MARC ANTONA

THE MARK CONSISTS OF STANDARD CHARACTERS WITHOUT CLAIM TO ANY PARTICULAR FONT, STYLE, SIZE, OR COLOR.

OWNER OF INTERNATIONAL REGISTRATION 1077225 DATED 3-15-2011, EXPIRES 3-15-2021.

THE NAME "MARC ANTONA" IDENTIFIES THE STAGE NAME OF DUBANTON MARC-ANTOINE, A LIVING INDIVIDUAL WHOSE CONSENT IS OF RECORD.

CLASS 9—ELECTRICAL AND SCIENTIFIC APPARATUS

FOR DATA PROCESSING EQUIPMENT; AUDIO, VIDEO, MAGNETIC, OPTICAL AND/OR DIGITAL DATA CARRIERS, NAMELY, BLANK RECORDABLE CD-RS AND DVD-RS, BLANK CD-ROMS FOR SOUND OR VIDEO RECORDING, BLANK OPTICAL DATA CARRIERS; AUDIO AND VIDEO RECORDINGS, WHETHER OR NOT DOWNLOADABLE, FEATURING MUSIC; CARRIERS FOR RECORDING AND REPRODUCTION OF SOUNDS, IMAGES, SIGNALS AND DATA, NAMELY, BLANK RECORDABLE CD-RS AND DVD-RS, BLANK CD-ROMS FOR SOUND OR VIDEO RECORDING, BLANK OPTICAL DATA CARRIERS; APPARATUS FOR BROADCASTING, RECORDING, TRANSMISSION OR REPRODUCTION OF SOUND, DATA OR IMAGES, NAMELY, COMPUTER, RADIO, TELEVISION; DATA CARRIERS ESPECIALLY OPTICAL, TELEMATIC OR MAGNETIC, NAMELY, BLANK RECORDABLE CD-RS AND DVD-RS, BLANK CD-ROMS FOR SOUND OR VIDEO RECORDING, BLANK OPTICAL DATA CARRIERS; TELECOMMUNICATION TRANSMITTERS, NAMELY, CABLE TELEVISION TRANSMITTER, SATELLITE TRANSMITTERS; DOWNLOADABLE SOFTWARE FOR ENTERING, STORING, AND PROCESSING INFORMATION OR DATA, SOFTWARE PACKAGES, NAMELY, FOR ENTERING, STORING, AND PROCESSING INFORMATION OR DATA, AUDIOVISUAL APPARATUS, TELECOMMUNICATIONS APPARATUS, AND INSTRUMENTS FOR ENTERING, STORING AND PROCESSING INFORMATION OR DATA, NAMELY, AUDIOVISUAL RECEIVERS, COMPUTERS, MODEMS; PHONOGRAPH RECORDS FEATURING MUSIC; CD-ROMS AND DVDS, NAMELY, BLANK RECORDABLE CD-ROMS AND DVDS, PRE-RECORDED CD-ROMS AND DVDS FEATURING MUSIC; AUDIO AND VIDEO COMPACT DISKS FEATURING MUSIC; APPARATUS FOR GAMES ADAPTED FOR USE ONLY WITH TELEVISION SETS, NAMELY, AMUSEMENT APPARATUS FOR USE WITH TELEVISION RECEIVERS OR WITH VIDEO OR COMPUTER MONITORS, VIDEO GAME MACHINES FOR USE WITH TELEVISION; COMPUTER GAME PROGRAMS; VIDEO GAME CARTRIDGES; FLOPPY DISKS, NAMELY, BLANK FLOPPY DISCS, FLOPPY DISCS FOR COMPUTERS FEATURING MUSIC; BLANK VIDEO DISKS; PRE-RECORDED VIDEO DISKS FEATURING MUSIC; COMPACT DISK PLAYERS, PERSONAL STEREOS; MIXING CONSOLES, NAMELY, ELECTRONIC SOUND MIXING APPARATUS; CD DECKS, NAMELY, DJ SETS IN THE NATURE OF CD PLAYERS; VINYL DECKS, NAMELY, DJ SETS IN THE NATURE OF RECORD PLAYERS; RECORD PLAYERS, AMPLIFIERS AND OTHER APPARATUS FOR AMPLIFYING SOUND, NAMELY, AUDIO AMPLIFIERS, BASS AMPLIFIERS, GUITAR AMPLIFIERS; PHOTOGRAPHIC CAMERAS, CAMCORDERS, PHOTOGRAPHY CAMERAS AND CINEMATOGRAPHIC CAMERAS; VIDEO SCREENS, PROJECTION SCREENS; DVD PLAYERS, AUDIO CASSETTES, NAMELY, AUDIO CASSETTE FEATURING MUSIC, BLANK AUDIO CASSETTES, VIDEO CASSETTES, NAMELY, VIDEO CASSETTE FEATURING MUSIC, BLANK VIDEO CASSETTES; HEADPHONES; LOUDSPEAKERS, MICROPHONES; DOWNLOADABLE ELECTRONIC PUBLICATIONS, NAMELY, BOOK, MAGAZINE, MANUAL, FEATURING MUSIC; COMPUTERS, DOWNLOADABLE COMPUTER PROGRAMS FOR USE IN DATABASE MANAGEMENT, FOR USE AS A SPREADSHEET, FOR WORD PROCESSING; RADIOS, RADIOTELEPHONY SETS, AUDIO AND VIDEO RECEIVERS; OPTICAL GOODS, NAMELY, SUNGLASSES, SPECTACLE FRAMES, SPECTACLE CASES; ELECTRONIC PERSONAL ORGANIZERS (U.S. CLS. 21, 23, 26, 36 AND 38).

CLASS 41—EDUCATION AND ENTERTAINMENT

FOR ENTERTAINMENT IN THE NATURE OF MUSICAL GROUP, MUSIC FESTIVAL; SPORTING AND CULTURAL ACTIVITIES, NAMELY, PROVIDING INFORMATION RELATED TO SPORTS EVENTS, MUSIC EVENTS, TICKET RESERVATION AND BOOKING SERVICES FOR SPORTING, MUSIC AND CULTURAL ACTIVITIES; PROVIDING RECREATION FACILITIES; AUDIOVISUAL, NAMELY, FILM, VIDEO, AND MUSICAL PRODUCTION AND EDITING; ENTERTAINER SERVICES, NAMELY, LIVE, TELEVISED AND MOVIE APPEARANCES BY A PROFESSIONAL ENTERTAINER; ENTERTAINMENT SERVICES, NAMELY, ORGANIZATION AND CONDUCTING OF CULTURAL, FASHION SHOWS, MUSIC SHOWS AND CONCERTS; PROVIDING AMUSEMENT ARCADE SERVICES; AGENCIES FOR ARTISTS, NAMELY, ARTISTIC MANAGEMENT, NAMELY, TICKET AGENCIES FOR ARTIST ENTERTAINMENT EVENTS; EDUCATIONAL AND ENTERTAINMENT SERVICES, NAMELY, ARRANGING AND CONDUCTING OF EDUCATIONAL CONFERENCES, LEARNING FORUMS, CONGRESSES, COLLOQUIUMS, SEMINARS, SYMPOSIUMS, FASHION, LASER, LIGHT SHOWS AND EXHIBITIONS, PROFESSIONAL OR OTHERWISE, FOR CULTURAL, EDUCATIONAL OR ENTERTAINMENT PURPOSES IN MUSIC, ART APPRECIATION; ORGANIZATION OF EVENTS AND EVENING EVENTS FOR CULTURAL OR MUSIC PURPOSES; ORGANIZATION OF EVENTS, NAMELY, SPECIAL EVENT PLANNING FOR SOCIAL ENTERTAINMENT PURPOSES; ORGANIZATION OF GAMES; ORGANIZATION OF INFORMATION CAMPAIGNS AND EVENTS, PROFESSIONAL OR OTHERWISE, IN THE FIELD OF CULTURE, EDUCATION AND ENTERTAINMENT, NAMELY, MUSIC; ORGANIZATION OF EXHIBITIONS FOR CULTURAL, EDUCATIONAL OR ENTERTAINMENT PURPOSES; CULTURAL, EDUCATION AND ENTERTAINMENT INFORMATION, NAMELY, PROVIDING INFORMATION RELATING TO CULTURAL, MUSIC AND LIVE THEATRICAL PRODUCTIONS, PROVISION OF INFORMATION RELATING TO THE ORGANIZING OF EDUCATIONAL, CULTURAL, MUSIC OR ENTERTAINMENT EXHIBITIONS; OPERATING LOTTERIES; PRODUCTION AND CARRYING OUT OF MUSICAL AND/OR AUDIOVISUAL WORKS, NAMELY, PRODUCTION OF MUSIC VIDEOS, PRODUCTION OF MUSICAL SOUND RECORDING; EDITING AND PUBLICATION OF PRINTED MATTER, NAMELY, BOOKS, JOURNALS, NEWSPAPERS, PERIODICALS, MAGAZINES, PRINTED PUBLICATIONS, ILLUSTRATIONS AND TEXTS OTHER THAN PUBLICITY TEXTS; PUBLICATION OF ELECTRONIC BOOKS, JOURNALS, NEWSPAPERS, PERIODICALS, MAGAZINES, PRINTED PUBLICATIONS, ILLUSTRATIONS AND TEXTS OTHER THAN PUBLICITY TEXTS; TELEVISION AND RADIO ENTERTAINMENT, NAMELY, ENTERTAINMENT IN THE NATURE OF TELEVISION NEWS SHOWS, ONGOING REALITY BASED TELEVISION PROGRAM, LIVE RADIO PERSONALITY PERFORMANCES; ENTERTAINMENT SERVICES, NAMELY, PRODUCTION OF THEATER PLAYS, TELEVISION AND RADIO PROGRAMS AND AUDIOVISUAL PROGRAMS IN THE NATURE OF TELEVISION PROGRAMS, CABLE TELEVISION PROGRAMS; RENTAL AND LOAN OF MUSICAL AND AUDIOVISUAL RECORDINGS, RENTAL OF VIDEO TAPES AND SOUND RECORDINGS, RENTAL OF FILMS AND VIDEOTAPE CASSETTES; GAMES LIBRARIES, NAMELY, FUN ACTIVITIES IN THE NATURE OF RENTAL OF VIDEO GAMES, RENTAL OF COMPUTER GAME PROGRAMS, AND RENTAL OF VIDEO GAMES AND PLAYTHINGS IN THE NATURE OF GAME EQUIPMENT RENTAL, RENTAL OF AMUSEMENT MACHINES AND APPARATUS; RECORDING STUDIO SERVICES; VIDEO TAPE EDITING; VIDEO TAPE FILM PRODUCTION, VIDEOTAPING; SERVICES FOR RECORDING ON VIDEO TAPES, NAMELY, VIDEO TAPE RECORDING FOR OTHERS; EDITING OF RECORDING OF SOUND, VISUAL MEDIA IN THE NATURE OF IMAGES; EDITING OF AUDIOVISUAL PROGRAMS, NAMELY, MUSIC EDITING, VIDEO EDITING, PHOTO EDITING, FILM EDITING; MOVIE RECORDING STUDIOS; NIGHT CLUB SERVICES; FAN CLUB SERVICES; DISCOTHEQUE SERVICES, MUSIC-HALLS, ORCHESTRA SERVICES, ORGANIZATION OF BALLS IN THE NATURE OF DANCING EVENTS AND LIVE MUSIC CONCERTS; RENTAL OF SHOW SCENERY; FILM PRODUCTION, PRODUCTION OF RADIO

OR TELEVISION PROGRAMS; AMUSEMENT PARKS; CULTURAL THEME PARKS SERVICES; BOOKING OF SEATS FOR SHOWS; ARTISTIC DIRECTOR SERVICES, NAMELY, ORGANIZATION OF MUSICAL SHOWS, CULTURAL SHOWS; ORGANIZATION OF SHOWS FOR MUSICAL AND CULTURAL PURPOSES; PARTY PLANNING; PHOTOGRAPHIC REPORTING; MUSIC COMPOSITION SERVICES FOR OTHERS; VIDEO LIBRARIES, NAMELY, RENTAL OF VIDEO CASSETTE TAPES (U.S. CLS. 100, 101 AND 107).

MAYUR VAGHANI, EXAMINING ATTORNEY

SN 79-097,945. ERNST MÜHLBAUER GMBH & CO. KG, FED REP GERMANY, FILED 2-4-2011.



SN 79-097,739. HUMÖR A/S, DENMARK, FILED 3-29-2011.

HUMÖR

THE MARK CONSISTS OF STANDARD CHARACTERS WITHOUT CLAIM TO ANY PARTICULAR FONT, STYLE, SIZE, OR COLOR.

OWNER OF INTERNATIONAL REGISTRATION 0952220 DATED 12-4-2007, EXPIRES 12-4-2017.

THE WORDING "HUMÖR" HAS NO MEANING IN A FOREIGN LANGUAGE.

CLASS 18—LEATHER GOODS

FOR LEATHER AND IMITATIONS OF LEATHER AND GOODS MADE OF LEATHER AND IMITATION LEATHER, NAMELY, BRIEFCASES, LEATHER AND IMITATION LEATHER BAGS, LEATHER HANDBAGS, LEATHER KEY CHAINS, LEATHER PURSES, LEATHER STRAPS, TRAVELLING CASES OF LEATHER; ANIMAL SKINS AND HIDES, TRUNKS AND BAGS, NAMELY, VALISES, TRAVELLING BAGS, HANDBAGS, SHOPPING BAGS, SCHOOL BAGS, VANITY CASES NOT FITTED, BAGS OF LEATHER FOR PACKAGING; UMBRELLAS, PARASOLS, PURSES AND POCKET WALLETS (U.S. CLS. 1, 2, 3, 22 AND 41).

CLASS 25—CLOTHING

FOR CLOTHING, NAMELY, TROUSERS, PANTS, PULLOVERS, SWEATERS, WAISTCOATS, T-SHIRTS, UNDERWEAR, STOCKINGS, SHORTS, OUTDOOR WEAR, NAMELY, JACKETS, COATS, SNOWSUITS; BELTS, TIES, BLOUSES AND JERSEYS, CARDIGANS, SHIRTS, SWIMWEAR, BATHROBES, DRESSES, SKIRTS, NIGHTWEAR, TRAINING WEAR, NAMELY, TRAINING SUITS, TRAINING SHOES, SNEAKERS; SPORTSWEAR, NAMELY, SPORTS PANTS, SPORTS SHIRTS, SPORTS JERSEYS, SPORTS SHOES; RAINWEAR, SCARVES; FOOTWEAR; HEADGEAR, NAMELY, HATS AND CAPS (U.S. CLS. 22 AND 39).

CLASS 35—ADVERTISING AND BUSINESS

FOR BUSINESS MANAGEMENT AND BUSINESS ADMINISTRATION; RETAIL STORE SERVICES FEATURING GOODS MADE OF LEATHER AND IMITATIONS OF LEATHER, TRUNKS AND BAGS, UMBRELLAS, PARASOLS, PURSES AND POCKET WALLETS, CLOTHING, FOOTWEAR AND HEADGEAR; MAIL ORDER SERVICE FEATURING GOODS MADE OF LEATHER AND IMITATIONS OF LEATHER, TRUNKS AND BAGS, UMBRELLAS, PARASOLS, PURSES AND POCKET WALLETS, CLOTHING, FOOTWEAR, AND HEADGEAR; BUSINESS CONSULTANCY CONCERNING THE COMMERCIAL MANAGEMENT OF RETAIL STORES (U.S. CLS. 100, 101 AND 102).

JOSETTE BEVERLY, EXAMINING ATTORNEY

PRIORITY DATE OF 8-7-2010 IS CLAIMED.
OWNER OF INTERNATIONAL REGISTRATION 1078871 DATED 2-4-2011, EXPIRES 2-4-2021.

OWNER OF U.S. REG. NOS. 1,943,389, 2,822,233 AND 3,505,570.

THE COLOR(S) WHITE AND BLUE IS/ARE CLAIMED AS A FEATURE OF THE MARK.

THE MARK CONSISTS OF A BLUE SQUARE, WHEREIN AN ARROW DESIGN, ALSO SHOWN IN BLUE SAVE FOR A CHEVRON SHAPED PORTION OF THE ARROWHEAD SHOWN IN WHITE, IS IMPOSED ON A WHITE SQUARE BACKGROUND.

CLASS 1—CHEMICALS

FOR SYNTHETIC AND ARTIFICIAL RESINS, UNPROCESSED FOR RAPID PROTOTYPING; PLASTIC MOULDING COMPOUNDS, NAMELY MODELLING UNPROCESSED PLASTIC FOR THE MAKING OF EARPLUGS (U.S. CLS. 1, 5, 6, 10, 26 AND 46).

CLASS 3—COSMETICS AND CLEANING PREPARATIONS

FOR NON-MEDICATED PREPARATIONS FOR ORAL HYGIENE PURPOSES, NAMELY, MOUTHWASHES, MOUTH RINSE, TOOTHPASTE (U.S. CLS. 1, 4, 6, 50, 51 AND 52).

CLASS 5—PHARMACEUTICALS

FOR DENTAL MATERIAL FOR STOPPING TEETH; FASTENING AND MOULDING MATERIAL FOR DENTAL PURPOSES, NAMELY, FIXING MATERIALS FOR DENTAL PURPOSES AND MATERIALS FOR MAKING DENTAL IMPRESSIONS; PHARMACEUTICAL PRODUCTS AND PREPARATIONS FOR DENTAL PURPOSES; BONDING PRODUCTS, ADHESIVE CEMENTS AND SELF OR LIGHT-CURED CEMENTS FOR DENTAL USE (U.S. CLS. 6, 18, 44, 46, 51 AND 52).

CLASS 7—MACHINERY

FOR MIXING MACHINES FOR DENTAL IMPRESSION MATERIALS; FILLING MACHINES (U.S. CLS. 13, 19, 21, 23, 31, 34 AND 35).

CLASS 10—MEDICAL APPARATUS

FOR DENTAL APPARATUS AND INSTRUMENTS, NAMELY, MILLING APPARATUS FOR DENTAL PURPOSES, PROGRAMMABLE MILLING APPARATUS FOR DENTAL PURPOSES, MECHANICAL DISPENSERS FOR ADMINISTERING DENTAL FILLING MATERIAL, DRILLS FOR DENTAL APPLICATIONS, SYRINGES FOR THE APPLICATION OF DENTAL FILLING MATERIAL (U.S. CLS. 26, 39 AND 44).

CLASS 41—EDUCATION AND ENTERTAINMENT

FOR PROVIDING OF TRAINING IN THE DENTAL FIELD (U.S. CLS. 100, 101 AND 107).
KAREN SEVERSON, EXAMINING ATTORNEY

CLASS 41—EDUCATION AND ENTERTAINMENT

FOR PROVIDING OF TRAINING IN THE DENTAL FIELD (U.S. CLS. 100, 101 AND 107).
KAREN SEVERSON, EXAMINING ATTORNEY

SN 79-097,946. ERNST MÜHLBAUER GMBH & CO. KG, FED REP GERMANY, FILED 2-4-2011.



PRIORITY DATE OF 8-7-2010 IS CLAIMED.
OWNER OF INTERNATIONAL REGISTRATION 1078872 DATED 2-4-2011, EXPIRES 2-4-2021.
OWNER OF U.S. REG. NOS. 1,943,389, 2,822,233 AND OTHERS.

THE COLOR(S) WHITE AND BLUE IS/ARE CLAIMED AS A FEATURE OF THE MARK.

THE MARK CONSISTS OF A BLUE RECTANGLE, SURROUNDING THE LETTERS "DMG", IN WHITE, WHEREIN AN ARROW DESIGN, SHOWN IN BLUE SAVE FOR A CHEVRON SHAPED PORTION OF THE ARROW-HEAD SHOWN IN WHITE, IS IMPOSED ON A WHITE SQUARE BACKGROUND.

CLASS 1—CHEMICALS

FOR SYNTHETIC AND ARTIFICIAL RESINS, UNPROCESSED FOR RAPID PROTOTYPING; PLASTIC MOULDING COMPOUNDS, NAMELY MODELLING UNPROCESSED PLASTIC FOR THE MAKING OF EARPLUGS (U.S. CLS. 1, 5, 6, 10, 26 AND 46).

CLASS 3—COSMETICS AND CLEANING PREPARATIONS

FOR NON-MEDICATED PREPARATIONS FOR ORAL HYGIENE PURPOSES, NAMELY, MOUTHWASHES, MOUTH RINSE, TOOTHPASTE (U.S. CLS. 1, 4, 6, 50, 51 AND 52).

CLASS 5—PHARMACEUTICALS

FOR DENTAL MATERIAL FOR STOPPING TEETH; FASTENING AND MOULDING MATERIAL FOR DENTAL PURPOSES, NAMELY, FIXING MATERIALS FOR DENTAL PURPOSES AND MATERIALS FOR MAKING DENTAL IMPRESSIONS; PHARMACEUTICAL PRODUCTS AND PREPARATIONS FOR DENTAL PURPOSES; BONDING PRODUCTS, ADHESIVE CEMENTS AND SELF OR LIGHT-CURED CEMENTS FOR DENTAL USE (U.S. CLS. 6, 18, 44, 46, 51 AND 52).

CLASS 7—MACHINERY

FOR MIXING MACHINES FOR DENTAL IMPRESSION MATERIALS; FILLING MACHINES (U.S. CLS. 13, 19, 21, 23, 31, 34 AND 35).

CLASS 10—MEDICAL APPARATUS

FOR DENTAL APPARATUS AND INSTRUMENTS, NAMELY, MILLING APPARATUS FOR DENTAL PURPOSES, PROGRAMMABLE MILLING APPARATUS FOR DENTAL PURPOSES, MECHANICAL DISPENSERS FOR ADMINISTERING DENTAL FILLING MATERIAL, DRILLS FOR DENTAL APPLICATIONS, SYRINGES FOR THE APPLICATION OF DENTAL FILLING MATERIAL (U.S. CLS. 26, 39 AND 44).

SN 79-098,378. LIOS TECHNOLOGY GMBH, 51063 COLOGNE, FED REP GERMANY, FILED 5-20-2011.



PRIORITY DATE OF 4-27-2011 IS CLAIMED.
OWNER OF INTERNATIONAL REGISTRATION 1079942 DATED 5-20-2011, EXPIRES 5-20-2021.

THE COLOR(S) BLUE, GREY AND WHITE IS/ARE CLAIMED AS A FEATURE OF THE MARK.

THE MARK CONSISTS OF THE WORDING "DE.TECT" INSIDE A GREY RECTANGLE, THE WORDING "DE." IS GREY, THE WORDING "TECT" IS BLUE. TO THE LEFT OF THE WORDING IS A WHITE FLAME AND WAVY LINE DESIGN INSIDE A BLUE SQUARE.

CLASS 9—ELECTRICAL AND SCIENTIFIC APPARATUS

FOR APPARATUS FOR THE STORAGE, EVALUATION AND VISUALIZATION OF DATA, NAMELY, LASER BASED SYSTEMS FOR SPATIALLY DISTRIBUTED OPTICAL HEAT DETECTION CONSISTING PRIMARILY OF AN EVALUATION UNIT IN THE NATURE OF AN ELECTRONIC SENSOR AND A FIBER OPTICAL SENSOR CABLE; MEASURING APPARATUS AND MEASURING DEVICES AND MEASURING INSTRUMENTS, NAMELY, LASER BASED SYSTEMS FOR SPATIALLY DISTRIBUTED OPTICAL HEAT DETECTION WITH OPTICAL SENSORS AND OPTICAL FREQUENCY DOMAIN REFLECTOMETERS CONSISTING PRIMARILY OF AN EVALUATION UNIT IN THE NATURE OF AN ELECTRONIC SENSOR AND A FIBER OPTICAL SENSOR CABLE; CHECKING/SUPERVISION APPARATUS, NAMELY, LASER BASED SYSTEMS FOR SPATIALLY DISTRIBUTED OPTICAL HEAT DETECTION CONSISTING PRIMARILY OF AN EVALUATION UNIT IN THE NATURE OF AN ELECTRONIC SENSOR AND A FIBER OPTICAL SENSOR CABLE; CHECKING/SUPERVISION INSTRUMENTS, NAMELY, LASER BASED SYSTEMS FOR SPATIALLY DISTRIBUTED OPTICAL HEAT DETECTION WITH OPTICAL SENSORS AND OPTICAL FREQUENCY DOMAIN REFLECTOMETERS CONSISTING PRIMARILY OF AN EVALUATION UNIT IN THE NATURE OF AN ELECTRONIC SENSOR AND A FIBER OPTICAL SENSOR CABLE; SIGNALING APPARATUS AND SIGNAL INSTRUMENTS, NAMELY, LASER BASED SYSTEMS FOR SPATIALLY DISTRIBUTED OPTICAL HEAT DETECTION WITH OPTICAL SENSORS AND OPTICAL FREQUENCY DOMAIN REFLECTOMETERS CONSISTING PRIMARILY OF AN EVALUATION UNIT IN THE NATURE OF AN ELECTRONIC SENSOR AND A FIBER OPTICAL SENSOR CABLE; ELECTRONIC CONTROLS FOR VENTILATING EQUIPMENT; ELECTRONIC CONTROLS FOR FIRE EXTINGUISHING INSTALLATIONS (U.S. CLS. 21, 23, 26, 36 AND 38).

CLASS 42—SCIENTIFIC AND COMPUTER SERVICES

FOR TECHNOLOGICAL SERVICES, NAMELY, ENGINEERING, PLANNING, AND DESIGNING OF LASER BASED SYSTEMS FOR SPATIALLY DISTRIBUTED OPTICAL HEAT DETECTION WITH OPTICAL SENSORS AND OPTICAL FREQUENCY DOMAIN REFLECTOMETERS; INDUSTRIAL ANALYSIS OF LASER BASED SYSTEMS FOR SPATIALLY DISTRIBUTED OPTICAL HEAT DETECTION WITH OPTICAL SENSORS AND OPTICAL FREQUENCY DOMAIN REFLECTOMETERS (U.S. CLS. 100 AND 101).

ALICIA COLLINS, EXAMINING ATTORNEY

SN 79-098,638. FIRMENICH SA, SWITZERLAND, FILED 4-28-2011.

NORLIMBANOL

THE MARK CONSISTS OF STANDARD CHARACTERS WITHOUT CLAIM TO ANY PARTICULAR FONT, STYLE, SIZE, OR COLOR.

PRIORITY DATE OF 12-20-2010 IS CLAIMED.

OWNER OF INTERNATIONAL REGISTRATION 1080620 DATED 4-28-2011, EXPIRES 4-28-2021.

OWNER OF U.S. REG. NO. 1,403,634.

CLASS 1—CHEMICALS

FOR CHEMICALS, NAMELY, RAW MATERIALS INTENDED FOR USE IN THE FRAGRANCE AND FLAVOR INDUSTRY (U.S. CLS. 1, 5, 6, 10, 26 AND 46).

CLASS 3—COSMETICS AND CLEANING PREPARATIONS

FOR NATURAL AND ARTIFICIAL PERFUMES; ESSENTIAL OILS; ESSENTIAL OILS FOR FOOD FLAVORINGS; ESSENTIAL OILS FOR THE MANUFACTURE OF COSMETIC PREPARATIONS (U.S. CLS. 1, 4, 6, 50, 51 AND 52).

SHAILA SETTLES, EXAMINING ATTORNEY

SN 79-098,647. CHANCE BYRON BURNS AS TRUSTEE FOR THE BURNS FAMILY TRUST, PALM BEACH QLD 4221, AUSTRALIA, FILED 12-23-2010.

CHEDDAR POCKET

THE MARK CONSISTS OF STANDARD CHARACTERS WITHOUT CLAIM TO ANY PARTICULAR FONT, STYLE, SIZE, OR COLOR.

PRIORITY DATE OF 11-25-2010 IS CLAIMED.

OWNER OF INTERNATIONAL REGISTRATION 1080662 DATED 12-23-2010, EXPIRES 12-23-2020.

NO CLAIM IS MADE TO THE EXCLUSIVE RIGHT TO USE "POCKET", APART FROM THE MARK AS SHOWN.

CLASS 18—LEATHER GOODS

FOR GOODS MADE OF LEATHER, ANIMAL SKINS AND HIDES, AND IMITATIONS OF THE AFOREGOING MATERIALS, NAMELY, SUITCASES, BRIEFCASES AND ATTACHE CASES, CHAMOIS LEATHER OTHER THAN FOR CLEANING PURPOSES; BAGS, NAMELY, OVERNIGHT BAGS, TRAVEL BAGS, BELT BAGS, SPORTS BAGS, GYM BAGS, SHOULDER BAGS, DUFFEL BAGS, HOLDALL BAGS, MESSENGER BAGS, NEWSBOY BAGS, BACKPACKS, BEACH BAGS, TOTES; BAGS OF LEATHER, ANIMAL SKINS AND HIDES, AND IMITATIONS OF THE AFOREGOING MATERIALS; WALLETS AND PURSES, BEING MADE OF LEATHER, ANIMAL SKINS AND HIDES, AND IMITATIONS OF THE AFOREGOING MATERIALS; CASES INCLUDING TRAVEL CASES, OVERNIGHT CASES, BRIEF CASES, DOCUMENT CASES, CREDIT CARD CASES, BUSINESS CARD CASES, COSMETIC CASES SOLD EMPTY, TOILETRY CASES AND VANITY CASES SOLD EMPTY, ALL BEING OF LEATHER, ANIMAL SKINS AND HIDES, AND IMITATIONS OF THE AFOREGOING MATERIALS; JEWELRY BAGS IN THIS CLASS, NAMELY, JEWELRY POUCHES, KEY CASES AND KEY TAGS, ALL BEING OF LEATHER, ANIMAL HIDES AND IMITATIONS OF THE AFOREGOING MATERIALS; UMBRELLAS AND UMBRELLA COVERS (U.S. CLS. 1, 2, 3, 22 AND 41).

CLASS 25—CLOTHING

FOR CLOTHING, NAMELY, SHIRTS, T-SHIRTS, VESTS, PANTS, SHORTS, JACKETS, JERSEYS, UNDERWEAR, SWIMWEAR, BELTS, HEADWEAR; FOOTWEAR; BELTS BEING CLOTHING; LEATHER BELTS BEING CLOTHING (U.S. CLS. 22 AND 39).

CLASS 35—ADVERTISING AND BUSINESS

FOR RETAIL STORE SERVICES FEATURING CLOTHING, HEADWEAR, FOOTWEAR, SWIMWEAR, LUGGAGE, BAGS, CASES, BACKPACKS, WALLETS, AND BELTS; RETAIL STORE, ON-LINE RETAIL STORE, WHOLESALE DISTRIBUTORSHIPS, ON-LINE WHOLESALE DISTRIBUTORSHIPS, MAIL ORDER AND DISTRIBUTORSHIP SERVICES ALL FEATURING MEN'S CLOTHING ACCESSORIES; RETAIL STORE, ONLINE RETAIL STORE, WHOLESALE DISTRIBUTORSHIPS, ON-LINE WHOLESALE DISTRIBUTORSHIPS, MAIL ORDER AND DISTRIBUTORSHIP SERVICES ALL FEATURING BAGS, WALLETS, CASES AND BELTS MADE OF LEATHER, ANIMAL SKINS AND HIDES, AND IMITATIONS OF THE AFOREGOING; ON-LINE RETAIL STORE SERVICES FEATURING CLOTHING, HEADWEAR, FOOTWEAR, SWIMWEAR, LUGGAGE, BAGS, CASES, BACKPACKS, WALLETS, AND BELTS (U.S. CLS. 100, 101 AND 102).

BRIAN CALLAGHAN, EXAMINING ATTORNEY

SN 79-098,940. DERBY SPEZIALFUTTER GMBH, FED REP GERMANY, FILED 5-3-2011.

Mobility HCC

THE MARK CONSISTS OF STANDARD CHARACTERS WITHOUT CLAIM TO ANY PARTICULAR FONT, STYLE, SIZE, OR COLOR.

OWNER OF INTERNATIONAL REGISTRATION 1065716 DATED 12-10-2010, EXPIRES 12-10-2020.

NO CLAIM IS MADE TO THE EXCLUSIVE RIGHT TO USE "MOBILITY", APART FROM THE MARK AS SHOWN.

CLASS 30—STAPLE FOODS

FOR TEA; GREEN TEA; OOLONG TEA; JASMINE TEA; BLACK TEA; TEA BAGS; TEA-BASED BEVERAGES; GREEN TEA-BASED BEVERAGES; OOLONG TEA-BASED BEVERAGES; JASMINE TEA-BASED BEVERAGES; BLACK TEA-BASED BEVERAGES; COFFEE; COFFEE-BASED BEVERAGES; UNROASTED COFFEE; COCOA; COCOA-BASED BEVERAGES; CONFECTIONERY, NAMELY, PASTILLES, CONFECTIONERY MADE OF SUGAR, CHOCOLATE CONFECTIONS, FROZEN CONFECTIONERY AND CONFECTIONERY CHIPS FOR BAKING; ALMOND CONFECTIONERY, NAMELY, ALMOND BRITTLE, AND ALMOND BUTTER CONFECTIONERY CHIPS; BREAD ROLLS; BUNS; CAKES; CONFECTIONERY, NAMELY, LICORICE; PASTRIES; BISCUITS; PEPPERMINT SWEETS; SUGAR CONFECTIONERY; TARTS; WAFFLES; CANDY FOR FOOD; CHEWING GUM, NOT FOR MEDICAL PURPOSES; CHOCOLATE; POPCORN; CRACKERS; EDIBLE DECORATIONS FOR CAKES; CONFECTIONERY, NAMELY, FRUIT JELLIES; GINGERBREAD; PEANUT CONFECTIONERY, NAMELY, PEANUT BRITTLE, AND PEANUT BUTTER CONFECTIONERY CHIPS; CONFECTIONERY ICES, NAMELY, FROZEN YOGHURT; ICE CREAM; SHERBETS; CEREAL PREPARATIONS, NAMELY, BREAKFAST CEREALS, CEREAL-BASED SNACK FOODS, PROCESSED CEREALS, READY-TO-EAT CEREALS; CHIPS, NAMELY, BAGEL CHIPS, CORN CHIPS, FLOUR BASED CHIPS, PITA CHIPS, TORTILLA CHIPS; CORN FLAKES; OAT FLAKES; FARINACEOUS FOODS, NAMELY, FARINACEOUS FOOD PASTES FOR HUMAN CONSUMPTION; NOODLES; PASTA; AROMATIC PREPARATIONS FOR FOOD, NAMELY, CLOVES, ALLSPICE, EDIBLE SPICES, CURRY, NOT BEING ESSENTIAL OILS; ESSENCES FOR FOOD STUFFS, NAMELY, INFUSED OILS, NOT BEING ESSENTIAL OILS; FLAVORINGS, OTHER THAN ESSENTIAL OILS; VANILLA FLAVORING; ICE CREAM MIXES (U.S. CL. 46).

CLASS 32—LIGHT BEVERAGES

FOR CARBONATED DRINKS, NAMELY, CARBONATED SOFT DRINKS, CARBONATED WATERS, FROZEN CARBONATED BEVERAGES, FRUIT FLAVORED CARBONATED DRINKS; MINERAL WATER BEVERAGES; ISOTONIC BEVERAGES; NON-ALCOHOLIC FRUIT JUICE BEVERAGES; VEGETABLE JUICE BEVERAGES; WHEY BEVERAGES; EXTRACTS OF HOPS FOR MAKING BEER; BEER (U.S. CLS. 45, 46 AND 48).
TAMARA FRAZIER, EXAMINING ATTORNEY

SN 79-099,618. FLECOTEC AG, 79379 MÜLLHEIM, FED REP GERMANY, FILED 7-22-2010.

flecozip

THE MARK CONSISTS OF STANDARD CHARACTERS WITHOUT CLAIM TO ANY PARTICULAR FONT, STYLE, SIZE, OR COLOR.

OWNER OF INTERNATIONAL REGISTRATION 1083233 DATED 7-22-2010, EXPIRES 7-22-2020.

CLASS 16—PAPER GOODS AND PRINTED MATTER

FOR PACKAGING MATERIALS OF PAPER OR CARDBOARD; CONTAINERS FOR STORAGE OR TRANSPORT MADE OF PAPER OR CARDBOARD; PAPER BAGS AND POUCHES FOR PACKAGING; PLASTIC BAGS AND POUCHES FOR PACKAGING (U.S. CLS. 2, 5, 22, 23, 29, 37, 38 AND 50).

CLASS 17—RUBBER GOODS

FOR PLASTIC TAPE FOR USE IN SEALING BAGS AND TUBES; NON-METAL COUPLINGS FOR USE WITH BAGS, TUBES AND FLEXIBLE PIPES; NON-METAL SEALING RINGS FOR USE AS CONNECTION SEALS; ADHESIVE BANDS FOR SEALING CONTAINERS FOR INDUSTRIAL OR COMMERCIAL USE (U.S. CLS. 1, 5, 12, 13, 35 AND 50).

CLASS 20—FURNITURE AND ARTICLES NOT OTHERWISE CLASSIFIED

FOR PLASTIC PACKAGING CONTAINERS; NON-METAL CLOSURES FOR CONTAINERS; NON-METAL VALVES FOR CONTAINERS; PLASTIC ZIPPER TAPES FOR USE AS CLOSURES FOR PACKAGING CONTAINERS AND PACKAGING BAGS OF PLASTIC (U.S. CLS. 2, 13, 22, 25, 32 AND 50).

TEJBIR SINGH, EXAMINING ATTORNEY

SN 79-099,956. GELITA AG, FED REP GERMANY, FILED 5-27-2011.

FORTIBONE

THE MARK CONSISTS OF STANDARD CHARACTERS WITHOUT CLAIM TO ANY PARTICULAR FONT, STYLE, SIZE, OR COLOR.

OWNER OF INTERNATIONAL REGISTRATION 1084013 DATED 5-27-2011, EXPIRES 5-27-2021.

CLASS 1—CHEMICALS

FOR PROTEINS AND PRODUCTS CONTAINING PROTEINS, NAMELY, COLLAGENOUS PROTEINS IN SOLID, LIQUID OR DISSOLVED FORM AS RAW INGREDIENTS FOR USE IN THE MANUFACTURE OF FOODSTUFFS, PHARMACEUTICALS, COSMETIC AND VETERINARY PRODUCTS, DIETARY PRODUCTS AND FOOD SUPPLEMENTS (U.S. CLS. 1, 5, 6, 10, 26 AND 46).

CLASS 5—PHARMACEUTICALS

FOR PROTEINS AND PRODUCTS CONTAINING PROTEINS, NAMELY, PROTEIN SUPPLEMENTS IN SOLID, LIQUID OR DISSOLVED FORM AS END PRODUCTS, NAMELY, FOR USE AS DIETARY FOODS FOR MEDICINAL PURPOSES OR AS PHARMACEUTICAL PREPARATIONS FOR BONE HEALTH; VETERINARY PRODUCTS, NAMELY, MEDICAL FOODSTUFF ADDITIVES FOR VETERINARY USE; FOOD SUPPLEMENTS FOR MEDICINAL PURPOSES (U.S. CLS. 6, 18, 44, 46, 51 AND 52).

CLASS 29—MEATS AND PROCESSED FOODS

FOR FOOD SUPPLEMENTS FOR NON-MEDICINAL PURPOSES FOR USE AS FOOD ADDITIVES, NAMELY, ALBUMEN FOR USE IN FOOD AND EDIBLE FATS (U.S. CL. 46).

MARLENE BELL, EXAMINING ATTORNEY

SN 79-100,011. BLACKSTAR AMPLIFICATION LTD, UNITED KINGDOM, FILED 4-13-2011.

THE SOUND IN YOUR HEAD

THE MARK CONSISTS OF STANDARD CHARACTERS WITHOUT CLAIM TO ANY PARTICULAR FONT, STYLE, SIZE, OR COLOR.

OWNER OF INTERNATIONAL REGISTRATION 1084180 DATED 4-13-2011, EXPIRES 4-13-2021.

CLASS 9—ELECTRICAL AND SCIENTIFIC APPARATUS

FOR APPARATUS FOR RECORDING, TRANSMISSION OR REPRODUCTION OF SOUND OR IMAGES; COMPUTER SOFTWARE FOR PROCESSING AND EDITING ELECTRIC GUITAR SIGNALS; SOFTWARE DOWNLOADABLE FROM THE INTERNET FOR PROCESSING AND EDITING ELECTRIC GUITAR SIGNALS; DOWNLOADABLE ELECTRONIC PUBLICATIONS, NAMELY, MAGAZINES, INFORMATIONAL BROCHURES, NEWSLETTERS IN THE FIELD OF ELECTRIC GUITAR AMPLIFICATION, EXTENSION SPEAKER CABINETS, EFFECTS PROCESSORS AND ASSOCIATED ACCESSORIES; MOBILE PHONE ACCESSORIES, NAMELY, COVERS AND FACEPLATES (U.S. CLS. 21, 23, 26, 36 AND 38).

CLASS 16—PAPER GOODS AND PRINTED MATTER

FOR PAPER, CARDBOARD AND GOODS MADE FROM PAPER AND CARDBOARD, NAMELY, POINT OF SALE PROMOTIONAL DISPLAYS, BUSINESS CARDS; PRINTED MATTER, NAMELY, PRINTED AWARDS AND PRINTED CALENDARS; PACKAGING MATERIALS, NAMELY, CARDBOARD CONTAINERS, PACKING PAPERS; PRINTED PUBLICATIONS, NAMELY, MAGAZINES, INFORMATIONAL BROCHURES AND NEWSLETTERS IN THE FIELD OF ELECTRIC GUITAR AMPLIFICATION, EXTENSION SPEAKER CABINETS, EFFECTS PROCESSORS AND ASSOCIATED ACCESSORIES (U.S. CLS. 2, 5, 22, 23, 29, 37, 38 AND 50).

CLASS 25—CLOTHING

FOR CLOTHING, NAMELY, SHIRTS, T-SHIRTS, SWEAT SHIRTS, HOODED SWEAT SHIRTS, HEADGEAR, NAMELY, CAPS AND HATS (U.S. CLS. 22 AND 39).

TRACY FLETCHER, EXAMINING ATTORNEY

SN 79-100,137. K+S KALI GMBH, FED REP GERMANY, FILED 5-28-2011.

KaliSel

THE MARK CONSISTS OF STANDARD CHARACTERS WITHOUT CLAIM TO ANY PARTICULAR FONT, STYLE, SIZE, OR COLOR.

PRIORITY DATE OF 1-18-2011 IS CLAIMED.

OWNER OF INTERNATIONAL REGISTRATION 1084471 DATED 5-28-2011, EXPIRES 5-28-2021.

CLASS 5—PHARMACEUTICALS

FOR DIETETIC PRODUCTS, NAMELY, NUTRITIONAL SUPPLEMENTS FOR NON-MEDICAL PURPOSES, SAID SUPPLEMENTS CONTAINING MINERAL SALT (U.S. CLS. 6, 18, 44, 46, 51 AND 52).

CLASS 30—STAPLE FOODS

FOR SALT; SPICES; PRESERVATION SALT FOR FOODSTUFFS (U.S. CL. 46).

MARC LEIPZIG, EXAMINING ATTORNEY

SN 79-100,608. UNIVERSITÀ COMMERCIALE LUIGI BOCCONI, MILANO, ITALY, FILED 3-31-2011.



**Università Commerciale
Luigi Bocconi**

OWNER OF INTERNATIONAL REGISTRATION 1085598 DATED 3-31-2011, EXPIRES 3-31-2021.

NO CLAIM IS MADE TO THE EXCLUSIVE RIGHT TO USE "UNIVERSITÀ COMMERCIALE", APART FROM THE MARK AS SHOWN.

THE NAME "LUIGI BOCCONI" DOES NOT IDENTIFY A LIVING INDIVIDUAL.

THE COLOR(S) BLUE AND BLACK IS/ARE CLAIMED AS A FEATURE OF THE MARK.

THE MARK CONSISTS OF THE STYLIZED WORDING "UNIVERSITÀ COMMERCIALE LUIGI BOCCONI" AND CREST DESIGN. THE WORDING APPEARS IN TWO LINES IN BLACK, SEPARATED FROM THE CREST ON THE LEFT BY A VERTICAL BLUE LINE. THE WORD "UNIVERSITÀ COMMERCIALE" APPEARS ON TOP OF "LUIGI BOCCONI". ONLY THE INITIAL LETTERS IN THE WORDS ARE IN UPPER CASE. THE CREST IS IN BLUE, AND SHOWS A CLOSED BOOK, BOUND ON THE LEFT, SURROUNDED BY A CIRCULAR WREATH OF LEAVES. THE COVER OF THE BOOK SHOWS A WINGED HAT SUPERIMPOSED OVER ANOTHER CLOSED BOOK.

THE ENGLISH TRANSLATION OF "UNIVERSITÀ COMMERCIALE" IN THE MARK IS COMMERCIAL UNIVERSITY.

CLASS 41—EDUCATION AND ENTERTAINMENT

FOR EDUCATION SERVICES IN THE NATURE OF PROVIDING COURSES OF INSTRUCTION AT THE UNDERGRADUATE, GRADUATE AND POST-GRADUATE LEVELS AND DISTRIBUTING COURSE MATERIALS IN CONNECTION THEREWITH; PROVIDING EDUCATIONAL SPEAKERS; CONDUCTING CLASSES, CONFERENCES, MASTER COURSES AND WORKSHOPS ON VARIOUS TOPICS IN DIFFERENT EDUCATIONAL DISCIPLINES, NAMELY, ECONOMICS, LAW, BUSINESS, SCIENCES, SOCIAL SCIENCES AND STUDIES, CULTURE CARE, STATISTICS; ENTERTAINMENT IN THE NATURE OF LIVE STAGE PERFORMANCES IN THE NATURE OF MUSIC CONCERTS, ORCHESTRA PERFORMANCES, PLAYS AND LECTURES; ART EXHIBITIONS; ENTERTAINMENT IN THE NATURE OF ORGANIZING SPORTING ACTIVITIES, NAMELY, UNIVERSITY SPORTING EVENTS, TOURNAMENTS AND COMPETITIONS IN THE FIELD OF TENNIS, SOCCER AND FOOTBALL; PROFESSIONAL CONSULTANCY FOR OTHERS REGARDING EDUCATIONAL METHODS AND TECHNIQUES IN DIFFERENT EDUCATIONAL DISCIPLINES, NAMELY, ECONOMICS, LAW, BUSINESS, SCIENCES, SOCIAL SCIENCES AND STUDIES, CULTURAL STUDIES AND STATISTICS (U.S. CLS. 100, 101 AND 107).

CLASS 42—SCIENTIFIC AND COMPUTER SERVICES

FOR SCIENTIFIC AND TECHNOLOGICAL SERVICES, NAMELY, RESEARCH AND DESIGN IN THE FIELD OF INTEGRATED SYSTEM ARCHITECTURE THAT ALLOWS FOR THE RAPID DEVELOPMENT OF HIGHLY INTERACTIVE AND CUSTOMIZABLE LEARNING APPLICATIONS; INDUSTRIAL ANALYSIS AND RESEARCH SERVICES IN THE FIELD OF ECONOMICS, BUSINESS, LAW, SCIENCES, SOCIAL SCIENCES AND STUDIES, CULTURE CARE, STATISTICS; DESIGN AND DEVELOPMENT OF COMPUTER HARDWARE AND SOFTWARE (U.S. CLS. 100 AND 101).

JERI J. FICKES, EXAMINING ATTORNEY

SN 79-101,085. ROVIO ENTERTAINMENT LTD, FINLAND,
FILED 4-15-2011.



PRIORITY DATE OF 3-31-2011 IS CLAIMED.
OWNER OF INTERNATIONAL REGISTRATION 1086866
DATED 4-15-2011, EXPIRES 4-15-2021.

OWNER OF U.S. REG. NO. 3,988,064.

THE COLOR(S) RED, BLACK, YELLOW, BEIGE AND
WHITE IS/ARE CLAIMED AS A FEATURE OF THE MARK.

THE MARK CONSISTS OF A STYLIZED HEAD OF A
BIRD, WHICH IS RED WITH A BEIGE BOTTOM, WITH A
YELLOW BEAK WITH WHITE TEETH SHOWING, WHITE
EYES WITH BLACK PUPILS AND EYEBROWS, AND WITH
THE WHOLE DRAWING OUTLINED IN BLACK.

CLASS 3—COSMETICS AND CLEANING PREPARATIONS

FOR BLEACHING PREPARATIONS FOR LAUNDRY
USE; CLEANING, POLISHING, SCOURING AND ABRASIVE
PREPARATIONS; SOAPS; PERFUMERY, ESSEN-
TIAL OILS, COSMETICS, HAIR LOTIONS;
DENTIFRICES; NON-MEDICATED TOILETRIES; PRO-
DUCTS AND PREPARATIONS FOR THE CARE AND
CLEANSING OF HAIR AND SKIN; ADHESIVES FOR
COSMETIC PURPOSES; AFTER-SHAVE LOTIONS;
ANTIPERSPIRANTS FOR PERSONAL USE; ANTI-
STATIC PREPARATIONS FOR HOUSEHOLD PUR-
POSES; AROMATICS, NAMELY, AROMATIC OILS
AND POTPOURRIS; QUILLAIA BARK FOR WASHING;
BATH SALTS; COSMETIC PREPARATIONS FOR BATHS;
BEAUTY MASKS; BLEACHING SALTS; BLEACHING
SODA; BLUING FOR LAUNDRY; COLOR-BRIGHTEN-
ING CHEMICALS FOR HOUSEHOLD PURPOSES,
NAMELY, LAUNDRY; PAINT REMOVING PREPARA-
TIONS; COSMETIC KITS COMPRISED OF COSMETICS;
COSMETIC PREPARATIONS FOR SLIMMING PUR-
POSES; COSMETICS FOR ANIMALS; COTTON STICKS
FOR COSMETIC PURPOSES; COTTON WOOL FOR
COSMETIC PURPOSES; COSMETIC CREAMS; SKIN
WHITENING CREAMS; CREAMS FOR LEATHER; DEN-
TURE POLISHES; PREPARATIONS FOR CLEANING
DENTURES; DEODORANTS FOR PERSONAL USE;
EAU DE COLOGNE; TOILET WATER; HAIR CREAM,
HAIR GEL, SHAMPOOS, HAIR CONDITIONER AND
HAIR MOISTENING PREPARATIONS; PERFUMES; LIP-
STICKS; SKIN AND FACE CREAMS AND LOTIONS;
FALSE NAILS; NAIL POLISHES AND VARNISHES AND
THINNERS THEREFOR; SUN BLOCK; CAKE FLA-
VOURINGS OF ESSENTIAL OILS; CLEANSING MILK
FOR TOILET PURPOSES; EYEBROW COSMETICS; EYE-
BROW PENCILS; FABRIC SOFTENERS FOR LAUNDRY
USE; FALSE EYELASHES; FLOOR WAX; HAIR DYES;
HAIR SPRAY; LAUNDRY BLEACH; LAUNDRY SOAK-
ING PREPARATIONS; LAUNDRY STARCH; LOTIONS
FOR COSMETIC PURPOSES; MAKE-UP; MAKE-UP
POWDER; MAKE-UP PREPARATIONS; MAKE-UP RE-
MOVING PREPARATIONS; MASCARA; MOUTH
WASHES, NOT FOR MEDICAL PURPOSES; NAIL CARE
PREPARATIONS; COSMETIC PENCILS; POLISH FOR
FURNITURE AND FLOORING; POMADES FOR COS-
METIC PURPOSES; POTPOURRIS; PUMICE STONE FOR
PERSONAL USE; SAND CLOTH; SANDPAPER;
SCENTED WOOD; SHAMPOOS FOR PETS; SHOE
CREAM; SHOE POLISH; SHOE WAX; SOAP FOR
BRIGHTENING TEXTILE; STARCH GLAZE FOR LAUN-
DRY PURPOSES; SUN-TANNING PREPARATIONS; TIS-

SUES IMPREGNATED WITH COSMETIC LOTIONS;
VARNISH-REMOVING PREPARATIONS; DEPILATORY
WAX; LAUNDRY WAX; POLISHING WAX; WAXES FOR
LEATHER; DEPILATORY PREPARATIONS; PETRO-
LEUM JELLY FOR COSMETIC PURPOSES; DECORA-
TIVE DECALS FOR COSMETIC PURPOSES, NAMELY,
REMOVABLE TATTOOS FOR COSMETIC PURPOSES;
INCENSE; FRAGRANCES; GEL SOAP, BAR SOAP;
BUBBLE BATH; SHOWER GEL; TOOTHPASTE;
MOUTHWASH; CLEANSING, TONING, MOISTURIZING
AND EXFOLIATING PREPARATIONS AND SUB-
STANCES FOR THE BODY; BODY CREAM AND LO-
TION; HAND CREAM AND LOTION; SKIN CLEANSER
AND NON-MEDICATED BODY SOAKS; PERFUMED
BODY POWDER; BATH OIL; BABY OIL, BABY POW-
DER, BABY GEL AND BABY LOTION; LIP GLOSS,
NON-MEDICATED LIP BALM; SACHETS FOR PER-
FUMING LINEN; MASSAGE OILS AND LOTIONS;
ESSENTIAL OILS FOR AROMATHERAPY USE (U.S.
CLS. 1, 4, 6, 50, 51 AND 52).

CLASS 14—JEWELRY

FOR PRECIOUS METALS AND THEIR ALLOYS;
JEWELLERY, PRECIOUS STONES; HOROLOGICAL
AND CHRONOMETRIC INSTRUMENTS; IMITATION
JEWELLERY AND ORNAMENTS IN THE NATURE OF
JEWELRY; BROOCHES; JEWELRY CHAINS; PEN-
DANTS; NON-MONETARY COINS; CUFFLINKS; EARR-
INGS; GOLD THREAD JEWELRY; ORNAMENTS OF
PRECIOUS METAL; JEWELLERY OBJECTS OF IMA-
TATION GOLD; JEWELLERY CASES; NECKLACES;
RINGS; BRACELETS; MEDALS; MEDALLIONS; UN-
WROUGHT AND SEMI-WROUGHT PRECIOUS STONES
AND THEIR IMITATIONS; STATUES AND STATU-
ETTES OF PRECIOUS METAL; TIE CLIPS; CLOCKS,
WATCHES AND PARTS AND FITTINGS THEREFOR;
WATCH STRAPS, WATCH BANDS, WATCH CHAINS;
CASES FOR POCKET WATCHES; CLOCKS AND
WATCHES HAVING A GAME FUNCTION; ELECTRIC
CLOCKS AND ELECTRIC WATCHES; TABLE CLOCKS;
POCKET WATCHES; STOPWATCHES; WALL CLOCKS;
ALARM CLOCKS; CHRONOMETERS; ORNAMENTAL
PINS, KEY RINGS AND FOBS OF PRECIOUS METAL;
KEY CHAINS AND KEY CASES/CARRIERS OF PRE-
CIOUS METAL AND/OR PRECIOUS STONES; BADGES
OF PRECIOUS METAL; CASES FOR WATCHES AND
CLOCKS; SUN DIALS; DIAMONDS; COSTUME JEWEL-
LERY; SEMI-PRECIOUS STONES; WORKS OF ART OF
PRECIOUS METAL; CASES AND BOXES OF PRECIOUS
METAL; CHENILLE CUFF LINKS; FIGURINES OF
PRECIOUS METAL; TROPHIES OF PRECIOUS METALS;
COMMEMORATIVE COINS; INSIGNIAS OF PRECIOUS
METAL; BADGES OF PRECIOUS METAL; BONNET
PINS OF PRECIOUS METAL; PEARL; ARTIFICIAL
GEMSTONES; CHARMS, NAMELY, JEWELRY OF PRE-
CIOUS METAL (U.S. CLS. 2, 27, 28 AND 50).

CLASS 18—LEATHER GOODS

FOR LEATHER AND IMITATIONS OF LEATHER,
ANIMAL SKINS, HIDES; TRUNKS AND TRAVELLING
BAGS; UMBRELLAS, PARASOLS AND WALKING
STICKS; WHIPS, HARNESS AND SADDLERY; BAGS,
NAMELY, ATHLETIC BAGS; ALL-PURPOSE CARRY-
ING BAGS THAT MAY BE USED AS BATH TOY BAGS;
BOOK BAGS; DIAPER BAGS; DUFFEL BAGS; SHOE
BAGS FOR TRAVEL; TOILETRY BAGS SOLD EMPTY;
SUIT CARRIERS BEING TRAVELLING BAGS; GAR-
MENT BAGS FOR TRAVEL; WAIST BAGS; ALL-PUR-
POSE CARRYING BAGS, WEEKEND BAGS;
BACKPACKS; RUCKSACKS; KNAPSACKS; PURSES
AND WALLETS; SUITCASES; POUCHES OF LEATHER;
ATTACHE CASES; SHOPPING BAGS MADE OF
LEATHER; BANDS OF LEATHER; LEATHER
SHOULDER BELTS; CALLING CARD CASES, COLLARS
FOR ANIMALS OR PETS; KEY CASES; VANITY CASES
SOLD EMPTY; MUZZLES; SCHOOL SATCHELS; SUIT-
CASE HANDLES; TRAVELLING TRUNKS; UMBRELLA
COVERS; UMBRELLA HANDLES; WALKING STICK
SEATS; LUGGAGE STRAPS; LUGGAGE TAGS, BEACH
BAGS; BRIEFCASES; BOXES AND CASES OF LEATHER
OR LEATHER BOARD; HAND-BAGS; LEATHER
STRAPS; MOUNTAINEERING STICKS; MESH BAGS
FOR SHOPPING; SCHOOL BAGS; TOOL BAGS OF
LEATHER OR IMITATIONS OF LEATHER SOLD
EMPTY; VALISES; ANIMAL GAME BAGS; BAGS, EN-

VELOPES AND POUCHES OF LEATHER FOR PACKAGING OF MERCHANDISE; FURNITURE COVERINGS OF LEATHER OR IMITATIONS OF LEATHER, NOT FITTED; HANDBAG FRAMES; SLING BAGS FOR CARRYING INFANTS; WHEELED SHOPPING BAGS; WHEELED BACKPACKS; DUFFEL BAGS AND SUITCASES; CARD HOLDERS AND CASES; CARDBOARD TRUNKS AND CASES; FABRIC OF IMITATION ANIMAL SKINS; CHAIN MESH PURSES, NOT OF PRECIOUS METAL; CLUTCH PURSES; COIN PURSES; COSMETIC PURSES; EVENING PURSES; LEATHER PURSES; PURSES, NOT OF PRECIOUS METAL (U.S. CLS. 1, 2, 3, 22 AND 41).

CLASS 20—FURNITURE AND ARTICLES NOT OTHERWISE CLASSIFIED

FOR FURNITURE, MIRRORS, PICTURE FRAMES; OFFICE FURNITURE, PHOTOGRAPH FRAMES; DRESSING TABLES; EASY CHAIRS; BEDS AND WATER BEDS, NOT FOR MEDICAL PURPOSES, WOOD AND PLASTIC BEDSTEADS; FURNITURE SCREENS; ARMCHAIRS; BASKETS FOR DOMESTIC USE, NOT OF METAL; BENCHES; BOXES OF WOOD OR PLASTIC; CABINETS; CHESTS FOR TOYS; CORKS; HAIRDRESSER'S CHAIRS, DECK CHAIRS; DESKS; TABLES, DINER WAGONS; HEADRESTS FOR FURNITURE; DIVANS; LIBRARY SHELVING; LOCKERS; LOCKS OTHER THAN ELECTRIC, NOT OF METAL; RACKS, NAMELY, BOTTLE RACKS, COAT RACKS, DISPLAY RACKS, HAT RACKS, MAGAZINE RACKS, PLANT RACKS, SHOE RACKS, STORAGE RACKS, TOWEL RACKS, WINE RACKS; SAW HORSES; SCHOOL FURNITURE; SEATS; SOFAS; TEA CARTS; UMBRELLA STANDS; COTS; CUPBOARDS; DISPLAY BOARDS; FOOTSTOOLS AND STOOLS; SHELVES; AIR MATTRESSES AND AIR PILLOWS FOR USE WHEN CAMPING; SLEEPING BAGS; BED FITTINGS, NOT OF METAL; CURTAIN HOLDERS, NOT OF TEXTILE; CURTAIN HOOKS; CURTAIN RAILS; CURTAIN RINGS; CURTAIN RODS; CURTAIN ROLLERS; CURTAIN TIE-BACKS, NOT OF TEXTILE; CUSHIONS; FIXED TOWEL DISPENSERS NOT OF METAL; MATTRESSES; PILLOWS; NON-METAL CLOTHES HOOKS AND COAT HANGERS; COAT STANDS; HAT STANDS; LADDERS OF WOOD AND PLASTICS; NON-METAL DOOR FITTINGS; EMBROIDERY FRAMES; STATUES OF WOOD, WAX, PLASTER AND PLASTIC; FIRE SCREENS FOR DOMESTIC USE; STORAGE TANKS NOT OF METAL OR MASONRY, FOR FLUID; CONTAINERS OF PLASTIC FOR PACKAGING PURPOSES; METAL-SUBSTITUTE PLASTIC FASTENERS, NAILS, WEDGES, NUTS, SCREWS, TACKS, BOLTS, RIVETS AND CASTERS, ALL NOT OF METAL; DOOR STOPS OF PLASTIC OR WOOD; INFANT WALKERS; PLAYPENS FOR BABIES; SUPPORT PILLOWS FOR USE IN BABY SEATING; DECORATIVE MOBILES; CRADLES; COTS AND CRIBS; HIGH CHAIRS FOR BABIES; FURNITURE CHESTS; WIND CHIMES; NESTING BOXES FOR PETS; BEDS FOR HOUSEHOLD PETS; NESTING BOXES FOR SMALL BIRDS, SCRATCHING POSTS FOR CATS; FLOWER-POT PEDESTALS; FLOWER-STANDS; DECORATIVE EDGING STRIPS OF PLASTICS AND/OR WOOD FOR USE WITH WINDOW FITTINGS; ORNAMENTS AND DECORATIONS FOR WINDOWS OR DOORS MADE OF OR FROM PLASTICS, WAX, WOOD, CORK, REED, CANE, WICKER, HORN, BONE, IVORY, WHALEBONE, SHELL, AMBER, MOTHER-OF-PEARL, MEERSCHAUM AND SUBSTITUTES FOR THESE MATERIALS; STEP LADDERS AND LADDERS NOT OF METAL, TOOL BOXES NOT OF METAL, NON-METAL STAKES FOR PLANTS OR TREES, FLAGPOLES, WORKS OF ART, FIGURINES AND STATUETTES AND SMALL DECORATIONS OR ORNAMENTS OF WOOD, CORK, REED, CANE, WICKER, HORN, BONE, IVORY, WHALEBONE, SHELL, AMBER, MOTHER-OF-PEARL, MEERSCHAUM AND SUBSTITUTES FOR THESE MATERIALS, OR OF WAX, PLASTER OR PLASTICS; KEY CARDS NOT ENCODED, OF PLASTIC; BINS, NOT OF METAL; BOTTLE CLOSURES; BOTTLE RACKS; CORKS FOR BOTTLES; HOUSE NUMBERS, NOT OF METAL, NON-LUMINOUS; IDENTITY PLATES, NOT OF METAL; INFLATABLE PUBLICITY OBJECTS; LETTER BOXES NOT OF METAL; MAGAZINE RACKS; PLATE RACKS; CUP RACKS; SIGN-BOARDS OF PLASTIC; TOOL HANDLES NOT OF METAL; UPRIGHT SIGNBOARDS OF WOOD OR PLASTICS, SEALING CLIPS FOR BAGS; INFLATABLE HEADRESTS; DECORATIONS OF PLASTICS FOR

FOODSTUFFS OR LUNCH BOXES; KEY RINGS AND KEY CHAINS, NOT OF METAL, MADE OF PLASTIC; HANDHELD FLAT FANS, HAND-HELD FOLDING FANS, FANS NON-ELECTRIC, FOR PERSONAL USE; BAMBOO CURTAINS; BAMBOO BLINDS, BEAD CURTAINS FOR DECORATION; ORIENTAL SINGLE PANEL STANDING PARTITION, ORIENTAL FOLDING PARTITION SCREENS; DRINKING STRAWS; FURNITURE, NAMELY, KEYBOARDS FOR HANGING KEYS; MANNEQUINS; DRAIN TRAP VALVES OF PLASTIC; MEDICINE CABINETS; MATS, REMOVABLE, FOR SINKS; NAME PLATES, NOT OF METAL; NUMBER PLATES, NOT OF METAL; MIRROR TILES; PEGS, NOT OF METAL; PILL CASES MADE OF WOOD, PLASTIC; PLASTIC DOORKNOBS; PORCELAIN OR EARTHENWARE DOORKNOBS; WOOD DOORKNOBS; BEANBAG CHAIRS; LEATHER AND IMITATION LEATHER KEY CHAINS; BATHROOM STOOLS; BED PADS; CRIB BUMPERS (U.S. CLS. 2, 13, 22, 25, 32 AND 50).

CLASS 21—HOUSEWARES AND GLASS

FOR HOUSEHOLD OR KITCHEN UTENSILS AND CONTAINERS; COMBS AND SPONGES FOR HOUSEHOLD PURPOSES; BRUSH-MAKING MATERIALS; STEEL WOOL; UNWORKED OR SEMI-WORKED GLASS; BEVERAGE GLASSWARE, PORCELAIN AND EARTHENWARE; PORTABLE BABY BATH TUBS; BASKETS, FOR DOMESTIC USE, NOT OF METAL; MUGS; BIRDCAGES; NON-ELECTRIC FOOD BLENDERS; IRONING BOARDS; BOOT JACKS; STOPPERS FOR BOTTLES MADE OF/FROM CERAMICS, CHINA, GLASS, CRYSTAL, EARTHENWARE, TERRA-COTTA AND PORCELAIN; BOWLS; IRON KETTLES, NON-ELECTRIC; SALAD BOWLS; WHISKS NON-ELECTRIC; RICE CHESTS; COLANDERS; COOKING STRAINERS; COOKING FUNNELS; FOOD PRESERVING JARS OF GLASS; COOKING GRATERS; CHOPSTICK CASES; ROLLING PINS FOR COOKING PURPOSES; COOKING GRILLS; LEMON SQUEEZERS; TOILET UTENSILS, NAMELY, HOLDERS FOR TOILET PAPER, TOILET BRUSHES, TOILET BRUSH HOLDERS, TOILET PAPER DISPENSERS, TOILET ROLL HOLDERS, TOILET TISSUE HOLDERS; SHOE BRUSHES; SHOE HORNS; SHOE SHINE CLOTHS; FEEDING VESSELS FOR PETS; BRUSHES FOR PETS; BOXES OF METAL FOR DISPENSING PAPER TOWELS; BIRD BATHS; MOUSE TRAPS; FLY SWATTERS; CANDLE EXTINGUISHERS NOT OF PRECIOUS METAL; FLOWER VASES; UPRIGHT SIGNBOARDS OF GLASS OR CERAMICS; COOKING SETS FOR OUTDOOR USE CONSISTING OF TIN CANS, TIN PANS, TIN POTS AND TIN PLATES; SOAP BOXES; BREAD BOARDS; BUCKETS; TRAYS FOR DOMESTIC PURPOSES; CAGES FOR HOUSEHOLD PETS; CAKE MOULDS; WAFFLE MOULDS; CANDLE RINGS; CANDLESTICKS; CANDY BOXES; COMB CASES; CHINA ORNAMENTS; CHINA WARES, NAMELY, COFFEE SETS; CHOPSTICKS; CLOTHES DRYING RACKS; CLOTHING STRETCHERS; CLOTHS FOR CLEANING; COCKTAIL STIRRERS; COFFEE FILTERS, NOT OF PAPER BEING PART OF NON-ELECTRIC COFFEE MAKERS; NON-ELECTRIC COFFEE GRINDERS; COFFEE SERVICES; ELECTRIC HAIR COMBS; COMBS FOR ANIMALS; PASTRY BAGS; COOKERY MOULDS; COOKING POTS; ICE PAILS; PORTABLE COOLERS; CORK-SCREWS; BOTTLES SOLD EMPTY; PLASTIC WATER BOTTLES, SOLD EMPTY; BOTTLE OPENERS; DISHES; PLATES NOT OF PRECIOUS METAL; CHAMPAGNE BUCKETS; SHOWER CADDIES, NOT OF PRECIOUS METAL; HAIR BRUSHES; BRUSHES FOR CLOTHES; PLASTIC COASTERS; COFFEE CUPS; DRINKING GLASSES; DEMITASSE SETS CONSISTING OF CUPS AND SAUCERS; THERMAL INSULATED CONTAINERS FOR FOOD OR BEVERAGES; CORN COB HOLDERS; DECANTERS; SUGAR AND CREAMER SETS; INFANT CUPS; PAPER CUPS; NON-METAL PIGGY BANKS; PLASTIC CUPS; TOOTHBRUSH CASES; SERVING UTENSILS, NAMELY, PIE SERVERS, CAKE TURNERS, SPATULAS, SCRAPERS AND CAKE SERVERS; COVERS FOR DISHES; COVERS FOR FLOWER POTS, NOT OF PAPER; CUPS; DECANTERS; NON-ELECTRIC DEEP FRYERS; DISHES FOR SOAP; SOAP DISPENSERS; DRYING RACKS FOR WASHING OF DISHES; DUST-BINS; EGG CUPS; FEEDING TROUGHES; FLOWER POTS; GLOVES FOR HOUSEHOLD PURPOSES; GOBLET; COOKING GRATERS; NON-ELECTRIC GRIDDLES; HEAT-INSULATED CONTAINERS FOR FOOD OR BEVERAGE FOR DOMESTIC USE; HEATERS FOR FEEDING

BOTTLES, NON-ELECTRIC; HOLDERS FOR FLOWERS AND PLANTS; HOT POTS; ICE BUCKETS; ICE CUBE MOULDS; BEER MUGS, JUGS; KNIFE RESTS; KNOBS OF PORCELAIN; LAZY SUSANS; LUNCH BOXES; MENU CARD HOLDERS; MESS-TINS; MIXING SPOONS; MOPS; NAPKIN HOLDERS; NAPKIN RINGS; PLASTIC NOZZLES FOR WATERING CANS; PADS OF METAL FOR CLEANING; PANS; PAPER PLATES; PASTRY CUTTERS; PEPPER MILLS; PERFUME SPRAYERS; PERFUME VAPORIZERS, SOLD EMPTY; PICNIC BASKETS, SOLD EMPTY; PIGGY BANKS, NOT OF METAL; POT LIDS; POTS; PRESSURE COOKERS, NON-ELECTRIC; SALT SHAKERS; PEPPER SHAKERS; SAUCEPANS; SAUCERS; SCOOPS; SCOURING PADS; SHAVING BRUSHES; SHIRT STRETCHERS; SHOE TREES; SOAP HOLDERS; SOUP BOWLS; SPONGE HOLDERS; SPONGES FOR HOUSEHOLD PURPOSES; STANDS FOR SHAVING BRUSHES; STATUES OF PORCELAIN, TERRA-COTTA OR GLASS; STATUETTES OF PORCELAIN, TERRA-COTTA OR GLASS; SYRINGES FOR WATERING FLOWERS AND PLANTS; TANKARDS; TEA STRAINERS; TEA CADDIES; COFFEE CADDIES; TEA INFUSERS; TEA SERVICES; TEAPOTS, NOT OF PRECIOUS METAL; TOOTHBRUSHES; TOOTHBRUSHES, ELECTRIC; TOOTHPICK HOLDERS, NOT OF PRECIOUS METAL; TOOTHPICKS; NAIL BRUSHES; LITTER TRAYS, NAMELY, ANIMAL LITTER PANS; TRIVETS; TROUSER PRESSES, NON-ELECTRIC; TROUSER STRETCHERS; VACUUM BOTTLES; WAFFLE AND PANCAKE IRONS, NON-ELECTRIC; WASHING BOARDS; WASH TUBS, NAMELY, RINSING TUBS; WATERING CANS; POLISHING APPARATUS AND MACHINES FOR HOUSEHOLD PURPOSES, NON-ELECTRIC; WORKS OF ART, OF PORCELAIN, TERRA-COTTA OR GLASS; DECORATIVE ORNAMENTS FOR WINDOW OR DOORS MADE OF/FROM CERAMICS, CHINA, GLASS, CRYSTAL, EARTHENWARE, TERRA-COTTA OR PORCELAIN; HOUSEHOLD CONTAINERS FOR STORING AROMATICS AND FRAGRANCES; REFRIGERATING BOTTLES, SOLD EMPTY, TO KEEP BEVERAGES COLD; BOXES OF GLASS; BROOMS; BUTTER DISHES; BUTTER DISH COVERS; CHEESE-DISH COVERS; CANDY BOXES, NOT OF PRECIOUS METAL; CLEANING INSTRUMENTS HAND-OPERATED, NAMELY, BRUSHES; CLOTHES-PEGS; PORTABLE COLD BOXES, NON-ELECTRIC; COOKIE JARS; COOKING UTENSILS, NON-ELECTRIC, NAMELY, WIRE BASKETS, GRILLS; EYEBROW BRUSHES; FRYING PANS; GARDENING GLOVES; POWDER PUFFS; COOKIE CUTTERS; CRUETS, CRUET STANDS; DUSTERS; COCKTAIL SHAKERS; POWDER COMPACTS, NOT OF PRECIOUS METAL; PILL OR TABLET BOXES, FOR PERSONAL USE; STANDS FOR TOOTH BRUSHES; FLOSS FOR DENTAL PURPOSES; HANDLES FOR DENTAL FLOSS; HOUSEHOLD CONTAINERS OF PRECIOUS METAL; HOUSEHOLD UTENSILS OF PRECIOUS METAL NAMELY, SPATULAS, STRAINERS; COFFEE SERVICES OF PRECIOUS METAL; COFFEE-POTS, NON-ELECTRIC, OF PRECIOUS METAL; KITCHEN CONTAINERS OF PRECIOUS METAL; NAPKIN HOLDERS AND RINGS OF PRECIOUS METAL; POWDER COMPACTS OF PRECIOUS METAL; OVEN MITTS; PORCELAIN OR EARTHENWARE DOORKNOBS; BARBECUE MITTS; POT HOLDERS (U.S. CLS. 2, 13, 23, 29, 30, 33, 40 AND 50).

CLASS 24—FABRICS

FOR TEXTILES AND TEXTILE GOODS, NAMELY, BED AND TABLE COVERS; HANDKERCHIEFS; NAPKINS; BANNERS; BATH LINEN; BED LINEN; BEDSPREADS; BED BLANKETS; CLOTH, NAMELY, TABLE CLOTH NOT OF PAPER; COVERS FOR CUSHIONS; DOOR CURTAINS; TOWELS; FLAGS OF CLOTH; TOILET GLOVES IN THE NATURE OF FITTED TOILED LID COVERS MADE OF FABRIC; HOUSEHOLD LINEN; LABELS OF CLOTH; TEXTILE NAPKINS FOR REMOVING MAKE-UP; PLACE MATS MADE OF TEXTILE; MATTRESS COVERS; WASHING MITTS; MOSQUITO NETS; CURTAINS OF TEXTILE; PILLOWCASES; QUILTS; TRAVELLING RUGS; BED SHEETS OF TEXTILE; SHROUDS; SILK FABRICS; SLEEPING BAGS; TABLE LINEN; TABLE MATS NOT OF PAPER; TAPES, MADE OF TEXTILE; UPHOLSTERY FABRICS; WALL HANGINGS OF TEXTILE; TEXTILE COVERS FOR NAPKIN OR TISSUE HOLDERS; TOILET SEAT COVERS, NOT OF PAPER; COVERINGS FOR LIDS FOR TOILET VESSELS, MADE OF TEXTILE; CURTAIN

HOLDERS OR TIEBACKS OF TEXTILE; COTTON FABRICS; COVERLETS; FABRICS FOR TEXTILE USE; FACE TOWELS OF TEXTILE; FELT; FRIEZE CLOTH; HEMP FABRIC; VELVET; WOOLEN CLOTH; TISSUE PAPER BOX COVERS OF TEXTILE; COVERS OF FABRIC FOR DOOR KNOBS; TEXTILE NAME LABELS; WOVEN LABELS; POUCHES OF TEXTILE, OR OF SILK, FOR CHARMS; BED CANOPIES; TABLE RUNNERS OF FABRIC; KITCHEN LINENS, NAMELY, BARBECUE MITTS, DISH CLOTHS FOR DRYING, KITCHEN TOWELS, FABRIC PLACE MATS, OVEN MITTS, WASHING MITTS, FABRIC TABLE RUNNERS, POT HOLDERS, CLOTH COASTERS; BATH TOWELS; MATS OF LINEN; COVERINGS OF TEXTILE AND OF PLASTIC FOR FURNITURE; SHOWER CURTAINS; COTTON, POLYESTER AND NYLON FABRIC, FABRIC OF IMITATION ANIMAL SKINS; GOLF TOWELS; DAMASK; ELASTIC WOVEN MATERIAL, NAMELY, ELASTIC FABRICS FOR CLOTHING; SILK FABRICS FOR PRINTING PATTERNS; PRINTERS' BLANKETS OF TEXTILE; OIL-CLOTH FOR USE AS TABLECLOTHS; LINGERIE FABRIC; JERSEY FABRIC FOR CLOTHING; FABRIC IMPERVIOUS TO GASES FOR AERONAUTICAL BALLOON; CRIB BUMPERS; DOOR KNOB COVERS MADE OF TEXTILE (U.S. CLS. 42 AND 50).

CLASS 25—CLOTHING

FOR CLOTHING, FOOTWEAR, AND HEADGEAR, NAMELY, APRONS; BEACH CLOTHES, NAMELY, SWIMWEAR, SWIMSUITS, BATHING SUITS, GLOVES, MITTENS, BELTS; BABIES' CLOTHING, NAMELY, ROMPERS; CLOTH BIBS, SLEEP WEAR AND PAJAMAS, BATH ROBES, SUSPENDERS, HATS, CAPS, SUN VISORS, BERETS, BATHING AND SHOWER CAPS, MUFFS, EAR MUFFS, NECKWEAR, NECK TIES, CRAVATS, BOW TIES, SOCKS AND STOCKINGS, PANTY HOSES, GARTER BELTS, STOCKING AND PANTY HOSE SUSPENDERS, SHOES, SPORTS SHOES, SLIPPERS, BEACH SHOES, MASQUERADE COSTUMES, WORKING SLEEVES, NAMELY, SUN SLEEVES, BANDANAS; NECKERCHIEFS, BATH SANDALS, BATH SLIPPERS, SKI BOOTS, BOOTS, BRACES FOR CLOTHING, BRASSIERES, BREECHES FOR WEAR, CAMISOLES, COATS, CUFFS, FUR STOLETS, HEADBANDS, JACKETS, JERSEYS, JUMPERS; OVERCOATS, PANTS, PARKAS, PULLOVERS, SANDALS, SCARVES, SHAWLS, SHIRTS, UNDERWEAR, SMOCKS, SPATS, BOOTS FOR SPORTS, SPORTS JERSEYS, SUITS, TROUSERS, UNIFORMS, WET SUITS FOR WATER SKIING, WRISTBANDS, GYMNASTICS SHOES; CLOTHING FOR GYMNASTICS, NAMELY, LEOTARDS AND SPORT BRAS FOR GYMNASTICS; SASHES FOR WEAR, JOGGING SUITS, TROUSERS, JEANS, PANTS, TANK TOPS, SKIRTS, BLOUSES, SNOW SUITS, ROBES, SNEAKERS, BOOTIES, SLIPPER SOCKS, CLOAKS, CLOTH BIBS, CHAPS, BEACH COVER-UPS, DRESSES, JACKETS, LEOTARDS, OVERALLS, PONCHOS, RAINWEAR, SHORTS, SWEATERS, SWEATSHIRTS, BABIES' PANTS, WELTS FOR BOOTS; COLLAR PROTECTORS, COLLARS, DETACHABLE COLLARS, CORSETS, FOOTBALL BOOTS, FOOTBALL SHOES; POCKETS FOR CLOTHING, NAMELY, POCKET SQUARES; SARIS, SKULL CAPS, SPORTS SHOES, TEDDIES UNDERGARMENTS, WOODEN SHOES, VESTS, UNDERPANTS, TOP HATS, TO-GAS, NON-SLIPPING DEVICES FOR BOOTS AND SHOES, NAMELY, NON-SLIP SOLES; LEGGINGS, HOODS, HEELS, HEELPIECES FOR BOOTS AND SHOES, HALF-BOOTS, GYMNASTIC SHOES, GALOSHES, GARTERS; FOOT MUFFS, NOT ELECTRICALLY HEATED, T-SHIRTS, TOPS, HOODED SWEATSHIRTS, FLEECE SHIRTS, LOUNGEWEAR, LONG SLEEVE TOPS, ZIP THROUGH TOPS, JOGGING PANTS, FLEECE TOPS, KNIT FLEECE HATS; FLIP FLOPS, PLUSH SLIPPERS, PLUSH NOVELTY HATS (U.S. CLS. 22 AND 39).

CLASS 27—FLOOR COVERINGS

FOR CARPETS, RUGS, MATS AND MATTING, AND LINOLEUM FOR COVERING EXISTING FLOORS; WALL HANGINGS, NON-TEXTILE; AUTOMOBILE CARPETS; BATH MATS; FLOOR COVERINGS; DOOR MATS; GYMNASIUM MATS; GYMNASIUM MATS; VINYL FLOOR COVERINGS; WALLPAPER, WALL PAPER OF VINYL, WALL PAPER STENCILS; PLAY MATS, MADE OF FOAM, FOR USE ON PLAY AREA SURFACES; CHILDRENS PRINTED PLAY MATS; BEACH MATS; TAPESTRY WALL HANGINGS, NOT OF TEXTILE; REED MATS; NON-SLIP MATS FOR BATHS (U.S. CLS. 19, 20, 37, 42 AND 50).

CLASS 28—TOYS AND SPORTING GOODS

FOR DECORATIONS FOR CHRISTMAS TREES; DOLLS; PUPPET; PLUSH TOYS; SOFT SCULPTURE DOLLS; TEDDY BEARS; TOY FIGURES AND PLAY SETS; ACTION FIGURES AND ACCESSORIES THEREFOR; TOY FIGURES ATTACHABLE TO MOBILE PHONES, PENCILS OR KEY RINGS; BATHTUB TOYS; RIDE-ON TOYS; BALLS FOR SPORTS; BALLOONS; YO-YOS; BALLS FOR GAMES; PLAYING BALLS; PLAY-GROUND BALLS; SOCCER BALLS; BASEBALLS; BASKETBALLS; RUBBER BALLS; TOY VEHICLES; ELECTRIC TOY VEHICLES; SURF BOARDS; SNOW BOARDS; ICE SKATES; SKATEBOARDS; TOY AIR PISTOLS; BACKGAMMON GAMES; BELLS FOR CHRISTMAS TREES; BILLIARD BALLS; BILLIARD TABLES; TOY BUILDING BLOCKS; BOARD GAMES; CHESS GAMES; CHESS BOARDS; SKATING BOOTS WITH SKATES ATTACHED; BUILDING GAMES; CANDLE HOLDERS FOR CHRISTMAS TREES; CHECKERBOARDS; CHECKERS; CHESSBOARDS; CHRISTMAS TREES OF SYNTHETIC MATERIALS; COSAQUES, NAMELY, TOY FIREWORKS; CUPS FOR DICE; DARTS; DICE; DOLLS' BEDS; DOLLS' CLOTHES; DOLLS' HOUSES; DOLLS' ROOMS; DOMINOES; DRAUGHT BOARDS; DRAUGHTS; DUMB-BELLS; ELBOW GUARDS FOR ATHLETIC USE; FAIRGROUND RIDE APPARATUS, NAMELY, ROLLER COASTERS, CAROUSELS; PLAYGROUND EQUIPMENT, NAMELY, CLIMBING UNITS, SAND BOXES, SWING SETS; DOLLS' FEEDING BOTTLES; FISH HOOKS; FISHING TACKLE; FLIPPERS FOR SWIMMING; FLOATS FOR FISHING; FLYING DISCS; BATS FOR GAMES; APPARATUS FOR ELECTRONIC GAMES OTHER THAN THOSE ADAPTED FOR USE WITH TELEVISION RECEIVERS ONLY; ELECTRONIC GAME EQUIPMENT FOR PLAYING VIDEO GAMES, NAMELY, HAND HELD UNITS FOR PLAYING VIDEO GAMES OTHER THAN THOSE ADAPTED FOR USE WITH AN EXTERNAL DISPLAY SCREEN OR MONITOR; GOLF BAGS; GOLF CLUBS; GOLF GLOVES; KITE REELS; KITES; KNEE GUARDS FOR ATHLETIC USE; MAHJONG; MARBLES FOR GAMES; MARIONETTES; THEATRICAL MASKS; TOY MASKS; TOY MOBILES; SCALE MODEL VEHICLES; PARLOR GAMES; PERCUSSION CAPS; TOY PISTOLS; RACKETS; INFANT RATTLES; RING GAMES; ROCKING HORSES; ROLLER SKATES; SAILBOARDS; SKIS; SLEIGHS, NAMELY, BOB-SLEIGHS; SLIDES FOR PLAYGROUNDS; SOAP BUBBLES DISPENSER TOYS; SPINNING TOPS; SPRING BOARDS; STATIONARY EXERCISE BICYCLES; PLAY SWIMMING POOLS; SWIMMING WEBS, FLIPPERS; SWINGS; TABLES FOR TABLE TENNIS; TOYS FOR DOMESTIC PETS; WATER SKIS; BEACH BALLS; AMUSEMENT GAME MACHINES, AUTOMATIC AND COIN-OPERATED; BAGS ESPECIALLY DESIGNED FOR SKIS AND SURFBOARDS; BINGO CARD; BUTTERFLY NETS; PLAYING CARDS; CONFETTI; IN-LINE ROLLER SKATES; KALEIDOSCOPES; MASTS FOR SAILBOARDS; LANDING NETS FOR ANGLERS; RADIO-CONTROLLED TOY VEHICLES; ROULETTE WHEELS; SNOW GLOBES; SNOWSHOES; AMUSEMENT APPARATUS FOR USE IN ARCADES, INCORPORATING A VIDEO MONITOR; STAND ALONE VIDEO OUTPUT GAME MACHINES; COIN OR COUNTER OPERATED ARCADE GAMES; PINBALL GAME MACHINES; NON ELECTRIC HAND-HELD ACTION SKILL GAMES; GAME EQUIPMENT SOLD AS A UNIT FOR PLAYING A BOARD GAME, A CARD GAME, A MANIPULATIVE GAME, A PARLOR GAME, A PARLOR-TYPE COMPUTER GAME AND AN ACTION TYPE TARGET GAME; PUZZLES; PAPER FACE MASKS; MASQUERADE AND HALLOWEEN MASKS, NAMELY, TOY AND NOVELTY FACE MASKS; WATER SQUIRTING TOYS; DART-

BOARDS; BASEBALL GLOVES; SURFBOARDS; SWIM FINS; TOY ZIP GUNS; TOY BAKE WARE AND TOY COOKWARE; TOY BANK MACHINES; TOY SNOW GLOBES; BOXING GLOVES; HOCKEY STICKS; CHRISTMAS STOCKINGS; SLING SHOTS (U.S. CLS. 22, 23, 38 AND 50).

CLASS 29—MEATS AND PROCESSED FOODS

FOR MEAT, FISH, POULTRY AND GAME; MEAT EXTRACTS; PRESERVED, FROZEN, DRIED AND COOKED FRUITS AND VEGETABLES; JELLIES, JAMS, COMPOTES; EGGS, MILK AND MILK PRODUCTS, EXCLUDING ICE CREAM, ICE MILK AND FROZEN YOGURT; EDIBLE OILS AND FATS; BOUILLON; BOUILLON CONCENTRATES; BROTH; BROTH CONCENTRATES; BUTTER; CAVIAR; CHEESE; CHEESE IN THE FORM OF DIPS, SPREADS AND STICKS; DAIRY PRODUCTS, NAMELY, YOGURT, YOGURT DRINKS; CURD; DAIRY-BASED BEVERAGES; FROSTED FRUITS; FROZEN FRUITS; PROCESSED AND DRIED FRUITS; VEGETABLE AND FRUIT JUICES FOR COOKING; FRUIT CHIPS; PROCESSED AND DRIED VEGETABLES; MARGARINE; MARMALADE; MEAT JELLIES; MEAT TINNED; SOYBEAN-BASED FOOD BEVERAGE USED AS A MILK SUBSTITUTE; MILK SHAKES; DAIRY PRODUCTS FOR MAKING MILK SHAKES, NAMELY, MILK; PRESERVED MUSHROOMS; PRESERVED ONIONS, PRESERVED OLIVES; GHERKIN; PREPARED NUTS; GINGER JAM; LIVER PASTES; PATE; COCOA BUTTER AND PEANUT BUTTER, FOR FOOD PURPOSES; PEANUTS, PROCESSED; LENTILS, PRESERVED; PEAS, PRESERVED; FRUIT PEEL; POTATO CHIPS; POTATO CRISPS; POTATO FRITTERS; SALADS EXCEPT MACARONI, RICE, AND PASTA SALAD; SAUERKRAUT; SAUSAGES; SESAME OIL; PREPARATIONS FOR MAKING SOUP; SOUPS; TOFU; VEGETABLE SALADS; VEGETABLE SOUP PREPARATIONS; WHIPPED CREAM; YOGHURT; POTATO-BASED SNACKS FOOD; DRIED EDIBLE SEaweeds; PROCESSED, DRIED AND PRESERVED MEAT, FISH, POULTRY AND GAME; BACON; PREPARATIONS FOR MAKING BOUILLON; CHOCOLATE NUT BUTTER; CHARCUTERIE; HAM; CRYSTALLIZED FRUITS; FISH, TINNED; FRUIT JELLIES; FRUIT SALADS; MAIZE OIL; OLIVE OIL FOR FOOD; RAISINS; TOMATO PUREE; TINNED FRUITS AND VEGETABLES; SEAFOOD; PROCESSED AND PRESERVED SEAFOOD; SEAFOOD, TINNED; PICKLES; PATE (U.S. CL. 46).

CLASS 30—STAPLE FOODS

FOR COFFEE, TEA, COCOA, SUGAR, RICE, TAPIOCA, SAGO, ARTIFICIAL COFFEE; EDIBLE FLOUR; BREAD; PASTRY; ICES; HONEY, TREACLE; YEAST, BAKING-POWDER; SALT, MUSTARD; VINEGAR, SAUCES; SPICES; ICE; BREAKFAST CEREAL; BISCUITS; CAKE POWDER MIXES; EDIBLE DECORATIONS FOR CAKES; MALT FOR FOOD; SOYBEAN MALT; MALT BISCUITS; RICE CAKES; SWEETS AND CANDIES; SUGAR CONFECTIONERY, CANDY BARS, CANDY MINTS; CHOCOLATE CONFECTIONERY; CHOCOLATE; CHOCOLATE BEVERAGES WITH MILK; CHOCOLATE FOOD BEVERAGES NOT BEING DAIRY BASED OR VEGETABLE BASED; CONFECTIONERY FOR DECORATING CHRISTMAS TREES, NAMELY, CANDY, CHOCOLATE CONFECTIONERY; COFFEE-BASED BEVERAGES; COFFEE-BASED BEVERAGES WITH MILK; COFFEE FLAVOURINGS, NAMELY, SYRUPS; MIXTURES AND PREPARATIONS FOR USE AS SUBSTITUTES FOR COFFEE; COFFEE AND COFFEE-BASED BEVERAGES; TEA, NAMELY, GINSENG TEA, BLACK TEA, OOLONG TEA, BARLEY AND BARLEY-LEAF TEA; COOKIES; POPCORN; FLAVOURED POPCORN; CORN FLAKES; CONFECTIONERY CHIPS; ICE-CREAM; CURRY; CAPERS; CUSTARD; CUSTARD MIXES AND POWDER; FLAVOURINGS, OTHER THAN ESSENTIAL OILS; CONFECTIONERY ICES; FRUIT JELLIES; GINGERBREAD; CHOCOLATE SYRUP; KETCHUP; LIQUORICE; LOZENGES, NOT MEDICATED; MEAT PIES; MEAT TENDERIZERS FOR HOUSEHOLD PURPOSES; PANCAKES; PASTILLES; PASTRIES; CORN CHIPS; TORTILLAS; PEPPER; PIZZAS; PUDDINGS; RAVIOLI; ROYAL JELLY FOR HUMAN CONSUMPTION, NOT FOR MEDICAL PURPOSES; THICKENING AGENTS FOR COOKING FOODSTUFFS; WASABI PASTE; SOY SAUCE; PASTAS, NOODLES AND VERMI-

CELLI; SUSHI; VANILLA; WAFFLES; FROZEN YOGHURT; FROZEN CONFECTIONS; PRETZELS; ALMOND CONFECTIONERY; STARCH BINDING AGENTS FOR ICE CREAM; EDIBLE ICES; BREAD ROLLS; CAKES; CARAMELS CANDY; CHEWING GUM, NOT FOR MEDICAL PURPOSES; CORN MEAL; CRACKERS; CRISP BREAD SNACKS; CEREAL BASED SNACK FOODS; GOLDEN SYRUP; ICE, NATURAL OR ARTIFICIAL; MACARONI; MARZIPAN; MAYONNAISE; OATMEAL; PEPPERS SEASONINGS; PIES; RELISH; RUSKS; COOKING SALT; SANDWICHES; TOMATO SAUCE; SEASONINGS; SHERBETS; SPAGHETTI; SWEETMEATS CANDY; TARTS; WHEAT FLOUR; SALAD DRESSINGS; MEAT GRAVIES; FRUIT SAUCES, EXCLUDING CRANBERRY SAUCE AND APPLESAUCE; CONES FOR ICE CREAM; CORN-BASED SNACK FOODS; DESSERT PUDDINGS; CANNED PASTA FOODS (U.S. CL. 46).

CLASS 32—LIGHT BEVERAGES

FOR BEERS; MINERAL AND AERATED WATERS; FRUIT DRINKS AND FRUIT JUICES; ALES; ALCOHOLIC AND NON-ALCOHOLIC BEERS; NON-ALCOHOLIC FRUIT DRINKS; NON-ALCOHOLIC FRUIT JUICES; NON-ALCOHOLIC FRUIT EXTRACTS USED IN THE PREPARATION OF BEVERAGES; NON-ALCOHOLIC WINES; PINEAPPLE JUICE BEVERAGES; APERITIFS, NON-ALCOHOLIC; COCKTAILS, NON-ALCOHOLIC; ENERGY DRINKS; NON-ALCOHOLIC BEVERAGES CONTAINING FRUIT JUICES; SYRUP FOR MAKING FRUIT JUICES AND FRUIT DRINKS; FRUIT NECTARS, NON-ALCOHOLIC; WHEY BEVERAGES; PREPARATIONS IN THE NATURE OF ESSENCES FOR MAKING AERATED WATER; HOPS EXTRACTS FOR MAKING BEER; NON-ALCOHOLIC HONEY-BASED BEVERAGES, NON-ALCOHOLIC; GINGER BEVERAGES; GINGER BEERS; ISOTONIC BEVERAGES; ICED FRUIT BEVERAGES; POWDERS FOR EFFERVESCING BEVERAGES; DRINKING WATER; VEGETABLE JUICES; PREPARATIONS IN THE NATURE OF ESSENCES FOR MAKING MINERAL WATER; COLA; COLA BEVERAGES; KVASS NON-ALCOHOLIC BEVERAGES; SPRING WATER; LITHIA WATER; PREPARATIONS IN THE NATURE OF ESSENCES FOR MAKING LIQUEURS; LEMONADES; MILK OF ALMONDS BEVERAGES; PEANUT MILK SOFT DRINK; MALT BEER; MALT-BASED PREPARATIONS FOR MAKING BEVERAGES; ALMOND BEVERAGES; FLAVOURED WATERS; BEER WORT; FROZEN FRUIT BEVERAGES; LAGERS; PASTILLES FOR EFFERVESCING BEVERAGES; TABLE WATERS; BOTTLED WATER; GRAPE JUICE; MUST; SARSAPARILLA SOFT DRINK; SELTZER WATER; SHANDY; CIDER, NON-ALCOHOLIC; SODA WATER; SORBETS IN THE FORM OF BEVERAGES; STOUT; SPORTS DRINKS; VEGETABLE JUICE BEVERAGE; SOFT DRINKS; SYRUPS FOR MAKING SOFT DRINKS (U.S. CLS. 45, 46 AND 48).

CLASS 33—WINES AND SPIRITS

FOR ALCOHOLIC BEVERAGES EXCEPT BEERS; RICE ALCOHOL; APERITIFS; ALCOHOLIC BEVERAGES CONTAINING FRUIT; ALCOHOLIC EXTRACTS; ALCOHOLIC FRUIT EXTRACTS; DISTILLED BEVERAGES, NAMELY, DISTILLED SPIRITS; ALCOHOL ESSENCES; BRANDY; HARD CIDER; MEAD; PREPARED ALCOHOLIC COCKTAILS; LIQUEURS; SAKE; RAKI; SPIRITS; VODKA; WHISKY; RUM; GIN; WINE; COOKING WINE (U.S. CLS. 47 AND 49).

CLASS 34—SMOKERS' ARTICLES

FOR TOBACCO; MATCHES; ASHTRAYS; CIGARETTE PAPER; CIGAR CASES; CIGARETTE CASES; CIGAR CUTTERS; CIGAR HOLDERS; CIGARETTE FILTERS; MOUTHPIECES FOR CIGARETTE HOLDERS; CIGARETTE HOLDERS; CIGARETTE TIPS; CIGARETTES; CIGARETTES CONTAINING TOBACCO SUBSTITUTES; CIGARILLOS; CIGARS; LIGHTERS FOR SMOKERS; MATCH BOXES; MATCH HOLDERS; TOBACCO PIPE CLEANERS; SMOKING PIPE RACKS; TOBACCO PIPES; TOBACCO POUCHES; SNUFFBOXES; TOBACCO JARS (U.S. CLS. 2, 8, 9 AND 17).

CLASS 35—ADVERTISING AND BUSINESS

FOR ADVERTISING; BUSINESS MANAGEMENT; BUSINESS ADMINISTRATION ASSISTANCE; PROVIDING OFFICE FUNCTIONS; PROVIDING WHOLESALE AND RETAIL STORE SERVICES AND MAIL ORDER SERVICES RELATING TO THE SALE OF GAMES FOR MOBILE DEVICES, GAMES FOR PERSONAL COMPUTERS, GAMES FOR CONSOLES, GAMES FOR TABLETS, ELECTRONIC GAME PROGRAMS, DOWNLOADABLE ELECTRONIC GAME PROGRAMS, ELECTRONIC GAME SOFTWARE, COMPUTER GAME PROGRAMS, DOWNLOADABLE COMPUTER GAME PROGRAMS, INTERACTIVE GAME PROGRAMS, INTERACTIVE GAME SOFTWARE, PROTECTIVE CARRYING CASES SPECIALLY ADAPTED FOR PHONES AND HANDHELD COMPUTERS, MOUSE PADS, PARTY FAVOURS AND FESTIVE DECORATIONS AND ORNAMENTS, GIFTS AND NOVELTY ITEMS, SOAPS, PERFUMERY, ESSENTIAL OILS, COSMETICS, HAIR LOTIONS, HAIR CARE PRODUCTS, TOILETRIES, DENTIFRICES, PERSONAL HYGIENE PRODUCTS, CLEANING, POLISHING AND ABRASIVE PREPARATIONS, SUBSTANCES FOR LAUNDRY USE, MANICURE TOOLS, NAIL CARE PREPARATIONS, NAIL POLISH, NAIL VARNISH, FALSE NAILS, DIETETIC SUBSTANCES, FOOD FOR BABIES, SANITARY PREPARATIONS, CANDLES, WICKS, SPILLS FOR LIGHTING, GREASES, LUBRICANTS, OILS FOR PAINTS, CUTLERY, CROCKERY, MANICURE SETS, SHAVING INSTRUMENTS, RAZORS, MACHINES AND MACHINE TOOLS FOR KITCHEN OR HOUSEHOLD PURPOSES, HAND-HELD TOOLS, FILMS, CAMERAS, PHOTO DISCS, VIDEO RECORDERS, AUDIO AND VIDEO TAPES, RECORDS AND DISCS, INSTRUMENTS AND APPARATUS FOR THE RECORDING, TRANSMITTING AND/OR REPRODUCTION OF SOUNDS AND/OR IMAGES, TELEVISIONS, CASSETTE TAPE PLAYERS AND/OR RECORDERS, VIDEO CASSETTE AND/OR DISC PLAYERS AND/OR RECORDERS, RADIOS, TELEPHONES, WIRELESS PHONES, MOBILE PHONES, MOBILE PHONE CASES, DECORATIONS AND STRAPS FOR PHONES, CALL INDICATORS, CALCULATING MACHINES, CALCULATORS, ELECTRONIC AND COMPUTER GAMES, CINEMATOGRAPHIC FILMS, LIGHTS, FANS, COOKING UTENSILS, CAKE AND PASTRY MOULDS, TOASTERS, OVENS, KITCHEN UTENSILS, UTENSILS AND CONTAINERS FOR SERVING OR STORING FOOD AND/OR BEVERAGES, CHOP STICKS, CUTTING INSTRUMENTS, PORCELAIN, CHINAWARE, CRYSTAL WARE, ENAMELWARE, SILVERWARE, GLASSWARE, TERRA-COTTA WARE, EARTHENWARE, CERAMICS, HAIR DRYERS, LAMPS, LAMP SHADES AND PARTS AND FITTINGS THEREFOR, BABY CARRIAGES, BALLOONS, BICYCLE HORNS, CLOCKS AND WATCHES AND ACCESSORIES AND PARTS AND FITTINGS THEREFOR, JEWELLERY AND IMITATION JEWELLERY, ORNAMENTS, GOODS IN PRECIOUS METAL OR COATED THEREWITH, MUSIC BOXES, MUSICAL INSTRUMENTS, PICTURES, PHOTOGRAPHS, STATIONERY, PAPER AND CARDBOARD AND GOODS MADE FROM THESE MATERIALS, ARTISTS MATERIALS, PAINT BRUSHES, WRITING INSTRUMENTS, PRINTED MATTER, BOOKS, NEWSPAPERS, MAGAZINES AND PERIODICALS, GREETING AND CHRISTMAS CARDS, PLAYING CARDS, PACKING AND PACKAGING MATERIALS, PICTURE FRAMES AND STANDS, ADHESIVES FOR STATIONERY OR HOUSEHOLD PURPOSES, GOODS MADE OF LEATHER AND/OR IMITATIONS OF LEATHER, BAGS AND LUGGAGE, PURSES AND WALLETS, UMBRELLAS, WALKING STICKS, FURNITURE, MIRRORS, COAT HANGERS AND PEGS, BOXES AND CONTAINERS, NAME PLATES, SMALL HOUSEHOLD FITTINGS, HOUSEHOLD OR KITCHEN UTENSILS AND CONTAINERS, COMBS, SPONGES, BRUSHES, ARTICLES FOR CLEANING PURPOSES, SPECTACLES, SPECTACLE FRAMES AND SUNGLASSES AND CASES AND ACCESSORIES THEREFOR, TEXTILE AND TEXTILE GOODS, BEDDING, AND TABLE LINENS AND COVERS, NAPKINS, TABLE MATS, HABERDASHERY, HANDKERCHIEFS, ARTICLES OF CHILDREN, WOMEN AND MEN'S CLOTHING, FOOTWEAR, HEADGEAR AND GLOVES, BUTTONS, BADGES, RIBBONS AND BRAID, LACE AND EMBROIDERY, HAIR PINS AND ORNAMENTS, BRACES, SHOE ORNAMENTS, HAT ORNAMENTS, ZIPPER AND ZIPPER FASTENERS, CARPETS, RUGS AND MATS, TOYS, GAMES AND PLAYTHINGS, DOLLS, PLUSH TOYS; SOFT DOLLS, FIGURINES, SPORTING ARTICLES, DECORATIONS

FOR CHRISTMAS TREES, FOOD AND BEVERAGES, CONFECTIONERY, FLORAL PRODUCTS, MATCHES, CIGARS, CIGARETTES AND SMOKERS' ARTICLES; ORGANIZATION OF EXHIBITIONS FOR COMMERCIAL OR ADVERTISING PURPOSES; PUBLICATION OF PUBLICITY TEXTS; SALES PROMOTION SERVICES; ARRANGING OF ADVERTISING SERVICES; BUSINESS MANAGEMENT OF PERFORMING ARTISTS; GOODS IMPORT-EXPORT AGENCIES; COMPILATION AND SYSTEMIZATION OF INFORMATION INTO COMPUTER DATABASES; DIRECT MAIL ADVERTISING; BUSINESS MANAGEMENT OF HOTELS; MARKETING RESEARCH; OUTDOOR ADVERTISING; PERSONNEL RECRUITMENT; ADVERTISING AGENCY SERVICES; RADIO ADVERTISING; TELEVISION ADVERTISING; ON-LINE ADVERTISING ON A COMPUTER NETWORK; PROCUREMENT SERVICES FOR OTHERS, NAMELY, PURCHASING GOODS AND SERVICES FOR OTHER BUSINESSES; RENTAL OF ADVERTISING TIME ON COMMUNICATION MEDIA; RENTAL OF OFFICE MACHINES AND EQUIPMENT; VENDING MACHINE RENTAL SERVICES; AUCTIONEERING (U.S. CLS. 100, 101 AND 102).

CLASS 36—INSURANCE AND FINANCIAL

FOR INSURANCE UNDERWRITING SERVICES FOR ALL TYPES OF INSURANCE, INSURANCE CONSULTATION; FINANCIAL AFFAIRS AND MONETARY AFFAIRS, NAMELY, FINANCIAL INFORMATION; COMPUTERISED FINANCIAL SERVICES FOR RETAIL BUSINESSES, NAMELY, FINANCIAL TRANSACTION SERVICES, NAMELY, PROVIDING SECURE COMMERCIAL TRANSACTIONS AND PAYMENT OPTIONS; APARTMENT HOUSE MANAGEMENT; BANKING; CAPITAL INVESTMENTS SERVICES; CHARITABLE FUND RAISING; CREDIT CARD SERVICES; ISSUANCE OF CREDIT CARDS; DEBIT CARD SERVICES; FINANCIAL INFORMATION; FINANCING SERVICES; ISSUE OF TOKENS OF VALUE; ISSUING OF CHEQUES AND TRAVELLERS' CHECKS; LEASING OF REAL ESTATE; REAL ESTATE MANAGEMENT SERVICES; RENT COLLECTION; RENTAL OF OFFICES; RENTING OF APARTMENTS; RENTING OF FLATS; SAVINGS BANKS; ELECTRONIC FUNDS TRANSFER; REAL ESTATE AGENCIES; TRUSTEESHIP SERVICES; FIRE INSURANCE UNDERWRITING; FUND INVESTMENTS; HEALTH INSURANCE UNDERWRITING; INSURANCE BROKERAGE; LIFE INSURANCE UNDERWRITING; MARINE INSURANCE UNDERWRITING; MUTUAL FUND INVESTMENTS; HOME BANKING; FINANCING OF LOANS (U.S. CLS. 100, 101 AND 102).

CLASS 38—COMMUNICATION

FOR CABLE TELEVISION BROADCASTING; TELEVISION BROADCASTING; CELLULAR TELEPHONE COMMUNICATION; COMMUNICATIONS BY FIBER OPTIC NETWORKS; COMMUNICATIONS BY TELEGRAMS; COMMUNICATIONS BY TELEPHONE; PROVIDING INFORMATION ON COMMUNICATION BY TELEPHONES AND CELLULAR TELEPHONES; COMPUTER AIDED TRANSMISSION OF MESSAGES AND IMAGES; ELECTRONIC MAIL; FACSIMILE TRANSMISSION; RADIO BROADCASTING; SENDING OF TELEGRAMS; TELEPHONE SERVICES; PAGING SERVICES; PROVIDING TELECOMMUNICATIONS CONNECTIONS TO A GLOBAL COMPUTER NETWORK; PROVIDING USER ACCESS TO A GLOBAL COMPUTER NETWORK; TELECOMMUNICATIONS ROUTING AND JUNCTION SERVICES; ELECTRONIC BULLETIN BOARD SERVICES AND PROVIDING INFORMATION THEREON; TELECONFERENCING SERVICES; COMMUNICATION BY CONSUMER VIDEO GAME APPARATUS; PROVIDING INFORMATION ON COMMUNICATION BY CONSUMER VIDEO GAME APPARATUS; COMMUNICATION BY ARCADE VIDEO GAME MA-

CHINES; PROVIDING INFORMATION ON COMMUNICATION BY ARCADE VIDEO GAME MACHINES; COMMUNICATION BY HANDHELD GAME APPARATUS; PROVIDING INFORMATION ON COMMUNICATION BY HANDHELD GAME APPARATUS; COMMUNICATION BY MESSAGES AND PICTURES BY USING COMPUTERS; NEWS AGENCIES SERVICES FOR ELECTRONIC TRANSMISSION; RENTAL OF TELECOMMUNICATION EQUIPMENT INCLUDING TELEPHONES AND FACSIMILE APPARATUS; RENTAL OF MODEMS; ELECTRONIC MESSAGE SENDING; SATELLITE TRANSMISSION (U.S. CLS. 100, 101 AND 104).

CLASS 43—HOTEL AND RESTAURANT SERVICES

FOR SERVICES FOR PROVIDING FOOD AND DRINK IN RESTAURANTS AND BARS; PROVIDING TEMPORARY ACCOMMODATION; CATERING FOR GUESTS; RESTAURANTS; CAFES; CAFETERIAS; BARS; CANTEN SERVICES; CATERING SERVICES; SELF-SERVICE RESTAURANTS; SNACK BARS; COCKTAIL LOUNGES; PROVIDING OF INFORMATION IN RELATION TO FOOD AND DRINKS; PROVISION AND RESERVATION OF TEMPORARY ACCOMMODATION AND LODGING FACILITIES, HOTELS, MOTELS, BOARDING HOUSES AND THE PROVISION OF INFORMATION THERETO; HOLIDAY CAMP SERVICES; RESTAURANTS, CAFES, CAFETERIAS, BARS, FOOD HALLS, CANTEENS AND LOUNGES INSTALLED WITH AUDIO AND VISUAL APPARATUS WITH SING ALONG DEVICES; CHILD CARE CENTERS; DAY-NURSERIES; TOURIST HOMES; BAR SERVICES; PROVIDING FACILITIES FOR EXHIBITIONS (U.S. CLS. 100 AND 101).

JORDAN BAKER, EXAMINING ATTORNEY

SN 79-101,537. RODRIGUEZ GROUP SA, F-06400 CANNES, FRANCE, FILED 7-27-2011.

**RODRIGUEZ
GROUP**

PRIORITY DATE OF 1-27-2011 IS CLAIMED.
OWNER OF INTERNATIONAL REGISTRATION 1087983 DATED 7-27-2011, EXPIRES 7-27-2021.
THE MARK CONSISTS OF THE WORDING "RODRIGUEZ GROUP".

CLASS 12—VEHICLES

FOR VEHICLES, NAMELY, BOATS (U.S. CLS. 19, 21, 23, 31, 35 AND 44).

CLASS 25—CLOTHING

FOR CLOTHING, NAMELY, FOOTWEAR; CLOTHING, NAMELY, HEADGEAR, NAMELY, HATS AND CAPS (U.S. CLS. 22 AND 39).

CLASS 37—CONSTRUCTION AND REPAIR

FOR CONSTRUCTION OF BOATS; SHIPBUILDING (U.S. CLS. 100, 103 AND 106).

CLASS 39—TRANSPORTATION AND STORAGE

FOR TRANSPORT OF GOODS; PACKAGING ARTICLES FOR TRANSPORTATION AND STORAGE OF GOODS; ARRANGING OF TOURS (U.S. CLS. 100 AND 105).

RAMONA ORTIGA, EXAMINING ATTORNEY

SN 79-102,104. FABORY NEDERLAND B.V., NETHERLANDS, FILED 3-11-2011.



PRIORITY DATE OF 10-4-2010 IS CLAIMED.
OWNER OF INTERNATIONAL REGISTRATION 1089560 DATED 3-11-2011, EXPIRES 3-11-2021.

THE COLOR(S) BLACK (PANTONE PROCESS BLACK U), GREY (PANTONE 50 PROCESS BLACK), ORANGE (PANTONE 144 U) IS/ARE CLAIMED AS A FEATURE OF THE MARK.

THE MARK CONSISTS OF A BLACK QUADRILATERAL WITH THE WORD "MAXXFAST" WITHIN; THE WORD "MAXX" IS IN ORANGE WITH A HORIZONTAL REPEATING LINE DESIGN; THE WORD "FAST" IS IN GREY WITH A HORIZONTAL REPEATING LINE DESIGN.

CLASS 1—CHEMICALS

FOR INDUSTRIAL CHEMICALS, PHOTOGRAPHIC CHEMICALS, CHEMICAL PREPARATIONS FOR SCIENTIFIC PURPOSES; CHEMICALS FOR USE IN AGRICULTURE, HORTICULTURE AND FORESTRY, EXCEPT HERBICIDES, FUNGICIDES, INSECTICIDES AND PARACITICIDES; SEALANTS, NAMELY, TIRE PUNCTURE SEALANTS, AUTOMOBILE BRAKE SYSTEM LEAK SEALANTS, CHEMICAL SEALANTS FOR USE IN MACHINE BUILDING AND CONSTRUCTION, AND CHEMICAL SEALANTS USED FOR BUILDINGS WHICH PENETRATE THROUGH WALLS, FLOORS AND CEILINGS FOR FIRE PREVENTION; UNPROCESSED ARTIFICIAL RESINS, UNPROCESSED PLASTICS; MANURES; FIRE EXTINGUISHING COMPOSITIONS; TEMPERING AND SOLDERING PREPARATIONS; CHEMICAL SUBSTANCES FOR PRESERVING FOODSTUFFS; TANNING AGENTS FOR USE IN THE MANUFACTURE OF LEATHER; ADHESIVES USED IN INDUSTRY (U.S. CLS. 1, 5, 6, 10, 26 AND 46).

CLASS 2—PAINTS

FOR PAINTS, VARNISHES, LACQUERS; RUST PRESERVATIVES IN THE NATURE OF A COATING; WOOD PRESERVATIVES; COLORANTS; MORDANTS FOR USE IN THE WOODWORKING AND BUILDING CONSTRUCTION INDUSTRY; RAW NATURAL RESINS; METALS IN FOIL AND POWDER FORM FOR PAINTERS, DECORATORS, PRINTERS AND ARTISTS (U.S. CLS. 6, 11 AND 16).

CLASS 3—COSMETICS AND CLEANING PREPARATIONS

FOR CLEANING, POLISHING, SCOURING AND ABRASIVE PREPARATIONS; SOAPS (U.S. CLS. 1, 4, 6, 50, 51 AND 52).

CLASS 4—LUBRICANTS AND FUELS

FOR INDUSTRIAL OILS AND GREASES; INDUSTRIAL AND AUTOMOTIVE LUBRICANTS; DUST BINDING COMPOSITIONS; PETROLEUM-BASED DUST WETTING AGENTS; PETROLEUM-BASED DUST ABSORBING COMPOSITIONS FOR SWEEPING, DUSTLAYING AND STREET PAVING; FUELS; LAMP OIL; CANDLES, WICKS FOR LIGHTING CANDLES (U.S. CLS. 1, 6 AND 15).

CLASS 6—METAL GOODS

FOR COMMON METALS AND THEIR ALLOYS; METAL BUILDING MATERIALS, NAMELY, METAL SOFFITS AND METAL CLADDING; TRANSPORTABLE BUILDINGS OF METAL; MATERIALS OF METAL FOR RAILWAY TRACKS; NON-ELECTRIC CABLES AND WIRES OF COMMON METAL; METAL IRONMONGERY AND SMALL ITEMS OF METAL HARDWARE FOR LOCKSMITHING APPLICATIONS, NAMELY, PINS, DEADBOLTS, LOCK RINGS AND KEYS, METAL STRAP-HINGES AND CLOSURES FOR DOORS, WINDOWS AND VIEWING WINDOWS FOR USE IN INDUSTRIAL MACHINERY; METAL SAFES; METAL HARDWARE, NAMELY, SCREWS, NUTS, BOLTS, BUFFERS, SNAP RINGS, CLAMPING PLATES, PINS, THREADED RODS, PLUGS, NAILS, RIVETS, STAPLES; GOODS OF COMMON METAL NOT INCLUDED IN OTHER CLASSES, NAMELY, METAL FASTENING INSERTS, NAMELY, METAL CONCRETE INSERTS, METAL EXPANSION SHIELDS, METAL WEDGE ANCHORS, METAL DRILLING ANCHORS AND METAL SAFETY ANCHORS, METAL FRAME FIXINGS IN THE NATURE OF BRACKETS AND ANCHORS, METAL CAVITY FIXINGS IN THE NATURE OF BRACKETS, METAL TOGGLE PLUGS, METAL WALL PLUGS, METAL CLAMPS, METAL BEAM CLIPS, METAL ROPE CLIPS, METAL CHAIN SHACKLES, METAL GATE HOOKS, METAL U-BOLTS, METAL HOSE CLAMPS, METAL WASHERS FOR SPACING OR SECUREMENT OF FASTENERS, METAL PUSH-IN CAPS FOR TUBING ENDS, METAL PEGS, NAILS, METAL RIVETS, METAL CRAMPS, METAL WATTLE FOR USE IN BUILDING CONSTRUCTION, WIRE MESH, BINDING SCREWS OF METAL FOR CABLES, METAL CRANK HANDLES IN THE FORM OF BARS AND NON-PLASTICIZED RINGS, PLASTIC-COATED METAL GARDEN DOORS, METAL BUSHINGS; METAL CHAINS; METAL SPLIT PINS, METAL TURNBUCKLES FOR TENSIONING BELTS, METAL TURNBUCKLES FOR TENSIONING CABLES AND FENCING; PIPES AND TUBES OF METAL; FLANGES OF METAL; WIRE ROPE FITTINGS OF METAL, NAMELY, SOCKETS OF METAL FOR TUBES AND PIPES; METAL ORES (U.S. CLS. 2, 12, 13, 14, 23, 25 AND 50).

CLASS 7—MACHINERY

FOR MACHINE TOOLS, NAMELY, ELECTRIC KNIVES, ELECTRIC SAWING MACHINES, ELECTRIC SCREWDRIVERS, ELECTRIC DRILLING MACHINES, ELECTRIC SANDERS; ELECTRIC MILLING MACHINES AND ELECTRIC GRINDERS; MOTORS AND ENGINES NOT FOR LAND VEHICLES; EMISSION REDUCTION UNITS FOR MOTORS AND ENGINES, NAMELY, EGR VALVES; MACHINE COUPLING AND TRANSMISSION COMPONENTS NOT FOR LAND VEHICLES (U.S. CLS. 13, 19, 21, 23, 31, 34 AND 35).

CLASS 8—HAND TOOLS

FOR HAND-OPERATED TOOLS AND IMPLEMENTS, NAMELY, SCREWDRIVERS, KNIVES, SAWS, SHEARS, WRENCHES, PUTTY KNIVES, DRILLS, GENERAL PURPOSE HAND GRINDERS FOR USE IN WOODWORKING AND METALWORKING, AXES, CHISELS, DIES, HAMMERS, SHOVELS, PLIERS, SCISSORS, PUNCHES, PIPE CUTTERS, RASPS, REAMERS, SCRAPERS, SHARPENING WHEELS, SOCKET WRENCHES, SOCKET SPANNERS AND SQUARES, EARTH DRILLS, PRUNE SAWS, RAKES AND SPADES; PARTS FOR HAND-OPERATED TOOLS, NAMELY, CUTTING BITS; CUTLERY; RAZORS (U.S. CLS. 23, 28 AND 44).

CLASS 9—ELECTRICAL AND SCIENTIFIC APPARATUS

FOR WEIGHING SCALES, MICROMETERS AND CALIPERS, NAMELY, SLIDE CALIPERS, POCKET CALIPERS FOR MEASURING; LABORATORY EQUIPMENT AND SUPPLIES, NAMELY, CALIPERS; APPARATUS AND INSTRUMENTS FOR CONDUCTING, SWITCHING, TRANSFORMING, ACCUMULATING, REGULATING OR CONTROLLING ELECTRICITY, NAMELY, ELECTRICAL CONDUCTORS, ELECTRIC SWITCHES AND STATIC VOLTAGE REGULATORS; ELECTRIC CABLES AND WIRES; CIRCUIT BREAKERS; ELECTRICAL CONNECTORS; APPARATUS FOR RECORDING, TRANSMISSION OR REPRODUCTION OF SOUND OR IMAGES; BLANK MAGNETIC DATA CARRIERS, BLANK MAGNETIC AND OPTICAL RECORDING DISCS; AUTOMATIC VENDING MACHINES AND MECHANISMS FOR COIN-OPERATED APPARATUS; CASH REGISTERS, CALCULATING MACHINES, DATA PROCESSING EQUIPMENT AND COMPUTERS; FIRE-EXTINGUISHING APPARATUS (U.S. CLS. 21, 23, 26, 36 AND 38).

CLASS 17—RUBBER GOODS

FOR RAW OR SEMI-WORKED RUBBER, GUTTA-PERCHA, GUM, ASBESTOS, AND MICA; PLASTICS IN EXTRUDED FORM FOR USE IN MANUFACTURE; PACKING, SEALING AND INSULATING MATERIALS; LUTING AGENTS, NAMELY, FILLING AGENT IN THE NATURE OF PIPE JOINT COMPOUND, AND NON-METAL SEALS FOR METAL AND NON-METAL PIPE CONNECTIONS; FLEXIBLE PIPES, NOT OF METAL; ADHESIVE TAPE FOR INDUSTRIAL OR COMMERCIAL USE (U.S. CLS. 1, 5, 12, 13, 35 AND 50).

CLASS 19—NON-METALLIC BUILDING MATERIALS

FOR NON-METALLIC BUILDING MATERIALS, NAMELY, WALL PANELS AND PLASTERBOARDS; NON-METALLIC RIGID PIPES FOR BUILDING; ASPHALT, PITCH AND BITUMEN; NON-METALLIC TRANSPORTABLE BUILDINGS; MONUMENTS, NOT OF METAL (U.S. CLS. 1, 12, 33 AND 50).

CLASS 20—FURNITURE AND ARTICLES NOT OTHERWISE CLASSIFIED

FOR NON-METALLIC FASTENING MATERIALS, NAMELY, NON-METALLIC STRAP-HINGES AND NON-METALLIC AND NON-PAPER CLOSURES FOR CONTAINERS, BOTTLES AND BAGS (U.S. CLS. 2, 13, 22, 25, 32 AND 50).

MAYUR VAGHANI, EXAMINING ATTORNEY

SN 79-102,652. BACCARAT, F-54120 BACCARAT, FRANCE, FILED 8-11-2011.



PRIORITY DATE OF 2-24-2011 IS CLAIMED. OWNER OF INTERNATIONAL REGISTRATION 1090939 DATED 8-11-2011, EXPIRES 8-11-2021. NO CLAIM IS MADE TO THE EXCLUSIVE RIGHT TO USE "BAR", APART FROM THE MARK AS SHOWN.

CLASS 41—EDUCATION AND ENTERTAINMENT

FOR NIGHT CLUBS, NIGHT CLUB SERVICES, DISCOTHEQUE SERVICES (U.S. CLS. 100, 101 AND 107).

CLASS 43—HOTEL AND RESTAURANT SERVICES

FOR RESTAURANTS, BARS, COCKTAIL LOUNGES, RESTAURANT SERVICES, BAR SERVICES, COCKTAIL LOUNGE SERVICES, COFFEE SHOPS, SNACK BARS (U.S. CLS. 100 AND 101).
JACLYN KIDWELL WALKER, EXAMINING ATTORNEY

SN 79-103,010. SMS MEER GMBH, FED REP GERMANY, FILED 8-2-2011.



THE MARK CONSISTS OF STANDARD CHARACTERS WITHOUT CLAIM TO ANY PARTICULAR FONT, STYLE, SIZE, OR COLOR.
PRIORITY DATE OF 2-8-2011 IS CLAIMED.
OWNER OF INTERNATIONAL REGISTRATION 1091922 DATED 8-2-2011, EXPIRES 8-2-2021.
OWNER OF U.S. REG. NO. 3,261,330.

CLASS 7—MACHINERY

FOR ROLLING MILLS AND STRUCTURAL PARTS THEREFOR (U.S. CLS. 13, 19, 21, 23, 31, 34 AND 35).

CLASS 9—ELECTRICAL AND SCIENTIFIC APPARATUS

FOR ELECTRONIC CONTROLLERS FOR CONTROLLING AND REGULATING ROLLING MILLS, COMPUTERS FOR CONTROLLING ROLLING MILLS, COMPUTER PROGRAMS FOR CONTROLLING ROLLING MILLS (U.S. CLS. 21, 23, 26, 36 AND 38).

CLASS 11—ENVIRONMENTAL CONTROL APPARATUS

FOR FURNACES FOR ROLLING MILLS (U.S. CLS. 13, 21, 23, 31 AND 34).
STEVEN PEREZ, EXAMINING ATTORNEY

SN 79-103,276. GAVAZZI TESSUTI TECNICI S.P.A., ITALY, FILED 7-6-2011.



PRIORITY DATE OF 6-27-2011 IS CLAIMED. OWNER OF INTERNATIONAL REGISTRATION 1092636 DATED 7-6-2011, EXPIRES 7-6-2021. THE STRUCTURE OF THE MARK IS COMPLEX, COMPRISING GRAPHICAL AND VERBAL ELEMENTS; IN PARTICULAR, IT FEATURES THE WORD "GAVAZZI" IN SPECIAL CHARACTERS, INSIDE A NUMBER OF SUPERIMPOSED RECTANGULAR SHAPES.

CLASS 19—NON-METALLIC BUILDING MATERIALS

FOR BUILDING CONSTRUCTION MATERIALS, NAMELY, FIBERGLASS NETTING FOR BUILDING; FABRICS FOR BUILDING, NAMELY, FABRIC UNDERLAYMENT OF FLOORING; FABRICS FOR IMPREGNATIONS AND RENDERING, NAMELY, EROSION CONTROL FABRIC FOR CONSTRUCTION USE; BUILDING MATERIALS, NAMELY, FLY ASH, PLASTIC PIPE SUPPORTS; NATURAL AND ARTIFICIAL STONES; BRICKS; FLAGSTONES; STUCCO TILES, NON-METAL TILES; CEMENT; HYDRATED LIME FOR BUILDING PURPOSES; MORTAR; PLASTER AND GRAVEL; TUBING OF SANDSTONE AND CEMENT; ROAD-BUILDING MATERIALS, NAMELY, CONCRETE ROAD PAVEMENT BOARDS; ASPHALT; PITCH AND BITUMEN; TRANSPORTABLE NON-METAL BUILDINGS; MONUMENTS OF STONE; NON-METAL CHIMNEYS; SEMI-FINISHED WOOD; SEMI-WORKED WOOD FOR BUILDING; CONCRETE BEAMS, WOOD BEAMS; PANELS, NAMELY, NON-METAL ROOFING PANELS, WALL PANELS NOT OF METAL; ROOF SHEATHING BOARD; COMPOUND WOOD JOISTS; WINDOW GLASS FOR BUILDING; COMMON SHEET GLASS; GLASS TILES (U.S. CLS. 1, 12, 33 AND 50).

CLASS 24—FABRICS

FOR FIBERGLASS FABRICS, FOR TEXTILE USE; DENIM FABRIC; COTTON FABRIC; ELASTIC WOVEN MATERIAL, IN THE NATURE OF ELASTIC YARN MIXED FABRICS; HEAT-ACTIVATED ADHESIVE FABRICS; WOOLLEN FABRICS; BED BLANKETS, TRAVEL BLANKETS; TEXTILE TABLECLOTHS; TEXTILE CURTAINS; TEXTILE FACE TOWELS; FABRIC WALL HANGINGS; HANDKERCHIEFS OF TEXTILE; FLAGS, NAMELY, CLOTH FLAGS, TEXTILE FLAGS AND FABRIC FLAGS; TOWELS; CRIB SHEETS; FLAT BED SHEETS; PILLOWCASES (U.S. CLS. 42 AND 50).
SHANNON TWOHIG, EXAMINING ATTORNEY

SN 79-103,353. ANDRITZ MAERZ GMBH, FED REP GERMANY, FILED 8-1-2011.

Direct-To-Wire

THE MARK CONSISTS OF STANDARD CHARACTERS WITHOUT CLAIM TO ANY PARTICULAR FONT, STYLE, SIZE, OR COLOR.

PRIORITY DATE OF 2-4-2011 IS CLAIMED.
OWNER OF INTERNATIONAL REGISTRATION 1092876 DATED 8-1-2011, EXPIRES 8-1-2021.

CLASS 7—MACHINERY

FOR MACHINES, NAMELY, CONTINUOUS METAL CASTING MACHINES, WIRE DRAWING MACHINES, WIRE EXTRUDING MACHINES AND WIRE FORMING MACHINES; FOUNDRY MACHINES, NAMELY, METAL CASTING MACHINES; METAL-WORKING MACHINES (U.S. CLS. 13, 19, 21, 23, 31, 34 AND 35).

CLASS 11—ENVIRONMENTAL CONTROL APPARATUS

FOR OVENS, NAMELY, INDUSTRIAL OVENS FOR MELTING AND TREATING METALS; FURNACES FOR SMELTING METALS (U.S. CLS. 13, 21, 23, 31 AND 34).

CLASS 37—CONSTRUCTION AND REPAIR

FOR BUILDING CONSTRUCTION; MACHINERY MAINTENANCE AND REPAIR, MAINTENANCE AND REPAIR OF BURNERS, MAINTENANCE AND REPAIR OF HEATING INSTALLATIONS; MACHINERY INSTALLATION, MAINTENANCE AND REPAIR; INSTALLATION OF BURNERS, AND INSTALLATION, REPAIR AND MAINTENANCE OF HEATING EQUIPMENT; FURNACE INSTALLATION, MAINTENANCE AND REPAIR (U.S. CLS. 100, 103 AND 106).

CLASS 42—SCIENTIFIC AND COMPUTER SERVICES

FOR SCIENTIFIC AND TECHNOLOGICAL SERVICES AND RESEARCH AND DESIGN RELATING THERETO; ENGINEERING; CONSTRUCTION DRAFTING; TECHNICAL CONSULTANCY IN THE FIELD OF FURNACES, FOUNDRY MACHINES AND METAL-WORKING MACHINES; TECHNICAL PROJECT STUDIES (U.S. CLS. 100 AND 101).

SHAILA SETTLES, EXAMINING ATTORNEY

SN 79-103,357. STORA ENSO OYJ, FINLAND, FILED 8-22-2011.



PRIORITY DATE OF 2-25-2011 IS CLAIMED.
OWNER OF INTERNATIONAL REGISTRATION 1092886 DATED 8-22-2011, EXPIRES 8-22-2021.

OWNER OF U.S. REG. NO. 2,705,718.
A STYLIZED FLOWER WITH TEXT "STORAENSO".
THE WORDING "STORAENSO" HAS NO MEANING IN A FOREIGN LANGUAGE.

CLASS 1—CHEMICALS

FOR CHEMICALS USED IN INDUSTRY AND SCIENCE, AS WELL AS IN AGRICULTURE, HORTICULTURE AND FORESTRY EXCEPT FUNGICIDES, HERBICIDES, INSECTICIDES AND PARASITICIDES; PULP OF WOOD; PAPER PULP; FLUFFPULP OF WOOD (U.S. CLS. 1, 5, 6, 10, 26 AND 46).

CLASS 16—PAPER GOODS AND PRINTED MATTER

FOR PAPER AND CARDBOARD; BOOKBINDING MATERIAL; PHOTOGRAPHS; STATIONERY; ADHESIVES FOR STATIONERY OR HOUSEHOLD PURPOSES; PRINTED INSTRUCTIONAL AND TEACHING MATERIAL IN THE FIELD OF PAPERMAKING, PRINTING, CONVERTING, FORESTRY, BUILDING CONSTRUCTION; PLASTIC MATERIALS FOR PACKAGING, NAMELY, BAGS, BUBBLE PACKS; PAPER AND CARDBOARD FOR MULTIPLE PURPOSES; PAPER AND CARDBOARD FOR PACKAGING PURPOSES; PAPER AND CARDBOARD FOR GRAPHIC AND PRINTING PURPOSES; CORRUGATED PAPER AND CARDBOARD; PAPER CORES AND PAPER COREBOARD; BOOK AND PRINTING PAPER (U.S. CLS. 2, 5, 22, 23, 29, 37, 38 AND 50).

CLASS 19—NON-METALLIC BUILDING MATERIALS

FOR BUILDING MATERIALS, NAMELY, SAWN TIMBER FOR USE IN JOINERY, FURNITURE AND CONSTRUCTION, SAWN TIMBER FOR USE AS BUILDING MATERIALS FOR FURNITURE, BEAMS, DOORS, DOOR FRAMES, WINDOWS, WINDOW FRAMES, INTERIOR PANELS, INTERIOR AND EXTERIOR WALLS AND WALL ELEMENTS, PARTITION ELEMENTS, FLOORING, ROOFING, CEILING, SCAFFOLDINGS, GARDEN FURNITURE, EXTERIOR CLADDINGS, SAUNAS, ROUGH AND SEMI-FINISHED SAWN WOOD PRODUCTS AND COMPONENTS; GLUE-LAMINATED WOOD FOR BUILDING AND CONSTRUCTION; PREFABRICATED NON-METAL CONSTRUCTION ELEMENTS, NAMELY, SUPPORTS FOR EXTERNAL AND INTERNAL WALLS, CEILINGS AND ROOFS (U.S. CLS. 1, 12, 33 AND 50).

DAVID HOFFMAN, EXAMINING ATTORNEY

CLASS 16—PAPER GOODS AND PRINTED MATTER

FOR PAPER AND CARDBOARD; BOOKBINDING MATERIAL; PHOTOGRAPHS; STATIONERY; ADHESIVES FOR STATIONERY OR HOUSEHOLD PURPOSES; PRINTED INSTRUCTIONAL AND TEACHING MATERIAL IN THE FIELD OF PAPERMAKING, PRINTING, CONVERTING, FORESTRY, BUILDING CONSTRUCTION; PLASTIC MATERIALS FOR PACKAGING, NAMELY, BAGS, BUBBLE PACKS; PAPER AND CARDBOARD FOR MULTIPLE PURPOSES; PAPER AND CARDBOARD FOR PACKAGING PURPOSES; PAPER AND CARDBOARD FOR GRAPHIC AND PRINTING PURPOSES; CORRUGATED PAPER AND CARDBOARD; PAPER CORES AND PAPER COREBOARD; BOOK AND PRINTING PAPER (U.S. CLS. 2, 5, 22, 23, 29, 37, 38 AND 50).

CLASS 19—NON-METALLIC BUILDING MATERIALS

FOR BUILDING MATERIALS, NAMELY, SAWN TIMBER FOR USE IN JOINERY, FURNITURE AND CONSTRUCTION, SAWN TIMBER FOR USE AS BUILDING MATERIALS FOR FURNITURE, BEAMS, DOORS, DOOR FRAMES, WINDOWS, WINDOW FRAMES, INTERIOR PANELS, INTERIOR AND EXTERIOR WALLS AND WALL ELEMENTS, PARTITION ELEMENTS, FLOORING, ROOFING, CEILING, SCAFFOLDINGS, GARDEN FURNITURE, EXTERIOR CLADDINGS, SAUNAS, ROUGH AND SEMI-FINISHED SAWN WOOD PRODUCTS AND COMPONENTS; GLUE-LAMINATED WOOD FOR BUILDING AND CONSTRUCTION; PREFABRICATED NON-METAL CONSTRUCTION ELEMENTS, NAMELY, SUPPORTS FOR EXTERNAL AND INTERNAL WALLS, CEILINGS AND ROOFS (U.S. CLS. 1, 12, 33 AND 50).

DAVID HOFFMAN, EXAMINING ATTORNEY

SN 79-103,359. STORA ENSO OYJ, FINLAND, FILED 8-22-2011.



PRIORITY DATE OF 3-2-2011 IS CLAIMED.
OWNER OF INTERNATIONAL REGISTRATION 1092888 DATED 8-22-2011, EXPIRES 8-22-2021.
OWNER OF U.S. REG. NO. 2,705,718.
A STYLIZED FLOWER WITH TEXT "STORAENSO" AND RETHINK.
THE WORDING "STORAENSO" HAS NO MEANING IN A FOREIGN LANGUAGE.

CLASS 1—CHEMICALS

FOR CHEMICALS USED IN INDUSTRY AND SCIENCE, AS WELL AS IN AGRICULTURE, HORTICULTURE AND FORESTRY EXCEPT FUNGICIDES, HERBICIDES, INSECTICIDES AND PARASITICIDES; PULP OF WOOD; PAPER PULP; FLUFFPULP OF WOOD (U.S. CLS. 1, 5, 6, 10, 26 AND 46).

SN 79-103,803. BRINGWELL AB (PUBL), SWEDEN, FILED 9-28-2011.



PRIORITY DATE OF 5-9-2011 IS CLAIMED.
OWNER OF INTERNATIONAL REGISTRATION 1085464 DATED 6-28-2011, EXPIRES 6-28-2021.
THE MARK CONSISTS OF SEMICIRCULAR SHAPED PETALS IN A FALLING SCALE TO THE LEFT OF THE WORD "BRINGWELL".

CLASS 3—COSMETICS AND CLEANING PREPARATIONS

FOR ESSENTIAL OILS; COSMETICS (U.S. CLS. 1, 4, 6, 50, 51 AND 52).

CLASS 5—PHARMACEUTICALS

FOR DIETETIC SUBSTANCES ADAPTED FOR MEDICAL USE, NAMELY, DIETETIC FOODSTUFFS AND BEVERAGES; VITAMIN AND MINERAL SUPPLEMENTS; DIETARY SUPPLEMENTS ADAPTED FOR MEDICAL USE, NAMELY, WEIGHT LOSS PREPARATIONS, CALMING PREPARATIONS, HAIR IMPROVEMENT PREPARATIONS, MUSCULAR PERFORMANCE IMPROVEMENT PREPARATIONS, AND CARDIOVASCULAR PREPARATIONS (U.S. CLS. 6, 18, 44, 46, 51 AND 52).

CLASS 35—ADVERTISING AND BUSINESS

FOR ADVERTISING; BUSINESS MANAGEMENT; BUSINESS ADMINISTRATION; PROVIDING OFFICE FUNCTIONS (U.S. CLS. 100, 101 AND 102).
JAMES GRIFFIN, EXAMINING ATTORNEY

SN 79-103,903. BIG C'S MARINE LIMITED, UNITED KINGDOM, FILED 9-1-2011.



OWNER OF INTERNATIONAL REGISTRATION 1094160 DATED 9-1-2011, EXPIRES 9-1-2021.

CLASS 12—VEHICLES

FOR BOATS AND SAILING VEHICLES; POWERED WATERCRAFT (U.S. CLS. 19, 21, 23, 31, 35 AND 44).

CLASS 42—SCIENTIFIC AND COMPUTER SERVICES

FOR SCIENTIFIC AND TECHNOLOGICAL SERVICES AND RESEARCH AND DESIGN ALL RELATING TO THE DESIGN OF BOATS (U.S. CLS. 100 AND 101).
DEBORAH LOBO, EXAMINING ATTORNEY

SN 79-104,178. HEURTEY PETROCHEM, FRANCE, FILED 8-25-2011.

HEURTEY PETROCHEM

THE MARK CONSISTS OF STANDARD CHARACTERS WITHOUT CLAIM TO ANY PARTICULAR FONT, STYLE, SIZE, OR COLOR.

PRIORITY DATE OF 3-9-2011 IS CLAIMED.

OWNER OF INTERNATIONAL REGISTRATION 1094845 DATED 8-25-2011, EXPIRES 8-25-2021.

NO CLAIM IS MADE TO THE EXCLUSIVE RIGHT TO USE "PETROCHEM", APART FROM THE MARK AS SHOWN.

CLASS 11—ENVIRONMENTAL CONTROL APPARATUS

FOR HEATING APPARATUS, NAMELY, PROCESS TUBULAR FIRED HEATERS, DIRECT FIRED HEATERS, REFINING AND PETROCHEMICAL FURNACES, WASTE HEAT RECOVERY UNITS, HEAT RECOVERY UNITS, STEAM GENERATING APPARATUS, NAMELY, WASTE HEAT BOILERS, INDUSTRIAL BOILERS, CARBON MONOXIDE INDUSTRIAL BOILERS; DISTILLATION APPARATUS AND INSTALLATIONS FOR DISTILLATION, NAMELY, PROCESS TUBULAR FIRED HEATERS, DIRECT FIRED HEATERS, ATMOSPHERIC AND VACUUM DISTILLATION FURNACES; EQUIPMENT AND INSTALLATIONS FOR PETROLEUM REFINING AND PARTICULARLY STILLS, NAMELY, PROCESS TUBULAR FIRED HEATERS, DIRECT FIRED HEATERS, REFINING AND PETROCHEMICAL FURNACES FOR HEATING, VAPORIZATION AND THERMAL CRACKING OF PETROLEUM PRODUCTS OR FRACTIONS; APPARATUS AND INSTALLATIONS FOR PROCESSING SLOP AND PETROLEUM RESIDUES INTO GASOIL AND HEAVY FUEL, NAMELY, DIRECT FIRED HEATING INSTALLATIONS TO VAPORIZE THE PETROLEUM RESIDUES AND TO RECTIFY THE VAPORIZED FEED IN A VACUUM DISTILLATION COLUMN UNIT; EQUIPMENT AND INSTALLATIONS FOR MANUFACTURING CHEMICALS FROM HYDROCARBONS IN THE NATURE OF STILLS FOR MANUFACTURING AND REFINING HYDROGEN AND ETHYLENE, NAMELY, STEAM METHANE REFORMERS FOR PRODUCTION OF HYDROGEN USING NATURAL GAS; FURNACES USED TO STEAM CRACK FOR ETHYLENE PRODUCTION FOR USING ETHANE, AND EDC (ETHYLENE DICHLORIDE CRACKING) FOR VCM (VINYL CHLORIDE MONOMER) PRODUCTION (U.S. CLS. 13, 21, 23, 31 AND 34).

CLASS 37—CONSTRUCTION AND REPAIR

FOR SERVICES OF BUILDING, RENOVATING AND REPAIRING PERMANENT BUILDINGS, REFINING PLANTS AND HYDROCARBON MANUFACTURING PLANTS; DEMOLITION OF BUILDINGS (U.S. CLS. 100, 103 AND 106).

CLASS 42—SCIENTIFIC AND COMPUTER SERVICES

FOR SCIENTIFIC AND INDUSTRIAL RESEARCH SERVICES IN THE FIELDS OF ENERGY, THE ENVIRONMENT, PETROLEUM AND HYDROCARBONS; TECHNICAL PROJECT STUDIES, NAMELY, SCIENTIFIC STUDY AND RESEARCH IN THE FIELDS OF ENERGY, ENVIRONMENT, PETROLEUM AND HYDROCARBONS; ENGINEERING SERVICES, NAMELY, SURVEYING, ENGINEERING, CONSTRUCTION DRAFTING, ARCHITECTURAL CONSULTATION, SCIENTIFIC RESEARCH AND DEVELOPMENT IN THE FIELD OF NEW PROCESSES FOR PROCESSING AND REFINING PETROLEUM OR FOR MANUFACTURING HYDROCARBONS; INDUSTRIAL DESIGN, QUALITY CONTROL FOR OTHERS (U.S. CLS. 100 AND 101).

JEFF DEFORD, EXAMINING ATTORNEY

SN 79-104,222. LÖFBERGS LILA AKTIEBOLAG, SWEDEN, FILED 9-19-2011.

Familjen Löfbergs Kafferosteri

THE MARK CONSISTS OF STANDARD CHARACTERS WITHOUT CLAIM TO ANY PARTICULAR FONT, STYLE, SIZE, OR COLOR.

PRIORITY DATE OF 5-2-2011 IS CLAIMED.

OWNER OF INTERNATIONAL REGISTRATION 1094944 DATED 9-19-2011, EXPIRES 9-19-2021.

OWNER OF U.S. REG. NO. 2,343,587.

NO CLAIM IS MADE TO THE EXCLUSIVE RIGHT TO USE "FAMILJEN" OR "KAFFEROSTERI", APART FROM THE MARK AS SHOWN.

THE ENGLISH TRANSLATION OF THE FOREIGN WORD(S) IN THE MARK IS COFFEE-ROASTING BUSINESS OF THE FAMILY LÖFBERG.

CLASS 21—HOUSEWARES AND GLASS

FOR COFFEE GLASSES, COFFEE CUPS, COFFEE MUGS (NOT OF PRECIOUS METAL); INSULATING FLASKS; TEA STRAINERS, NOT OF PRECIOUS METAL, TEA MUGS, TEA CUPS, TEA SERVICES NOT OF PRECIOUS METAL, TEAPOTS NOT OF PRECIOUS METAL, TEA INFUSERS NOT OF PRECIOUS METAL (U.S. CLS. 2, 13, 23, 29, 30, 33, 40 AND 50).

CLASS 30—STAPLE FOODS

FOR COFFEE, COFFEE-BASED BEVERAGES, TEA, ICED TEA, TEA-BASED BEVERAGES (U.S. CL. 46).

CLASS 43—HOTEL AND RESTAURANT SERVICES

FOR SERVICES PROVIDING FOOD AND DRINK, SELF-SERVICE RESTAURANTS, RESTAURANTS, CAFES, CANTEENS (U.S. CLS. 100 AND 101).
DOMINIC J. FERRAUOLO, EXAMINING ATTORNEY

SN 79-104,264. SCHIAPPARELLI S.P.A., ITALY, FILED 9-28-2011.



OWNER OF INTERNATIONAL REGISTRATION 1095062 DATED 9-28-2011, EXPIRES 9-28-2021.

NO CLAIM IS MADE TO THE EXCLUSIVE RIGHT TO USE "1824", APART FROM THE MARK AS SHOWN.

THE MARK CONSISTS OF TWO STYLIZED BIRDS WITH WINGS OUTSTRETCHED, ABOVE THE WORDING "SCHIAPPARELLI 1824".

CLASS 5—PHARMACEUTICALS

FOR MEDICATED CANDIES, COUGH TREATMENT PREPARATIONS, MEDICATED CREAMS FOR TREATING DERMATOLOGICAL CONDITIONS, DISINFECTANTS FOR HYGIENE PURPOSES, DIETETIC SUGAR AND SUGAR SUBSTITUTES FOR MEDICAL USE; NUTRITIONAL SUBSTANCES, NAMELY, VITAMINS, NUTRITIONAL SUPPLEMENTS, DIETARY SUPPLEMENTS, DIETARY FOOD SUPPLEMENTS, DIETETIC PREPARATIONS FOR DRINKS, NAMELY, SUGAR SUBSTITUTES ADAPTED FOR MEDICAL PURPOSES; DIETETIC SEASONINGS ADAPTED FOR MEDICAL USE, DIETETIC SALTS ADAPTED FOR MEDICAL USE, DIETETIC FOODS FOR MEDICAL PURPOSES, BABY FOOD (U.S. CLS. 6, 18, 44, 46, 51 AND 52).

CLASS 29—MEATS AND PROCESSED FOODS

FOR EDIBLE OILS (U.S. CL. 46).

CLASS 30—STAPLE FOODS

FOR COFFEE, TEA, COCOA, SUGAR AND SUGAR SUBSTITUTES; RICE, PROCESSED CEREALS, FLOUR, HONEY, PEPPER AND SPICES (U.S. CL. 46).

CLASS 32—LIGHT BEVERAGES

FOR ISOTONIC NON ALCOHOLIC DRINKS, ENERGY DRINKS (U.S. CLS. 45, 46 AND 48).
JAMES GRIFFIN, EXAMINING ATTORNEY

SN 79-104,368. BAUMER OPTRONIC GMBH, RADEBERG, FED REP GERMANY, FILED 7-14-2011.

FEXLoc

THE MARK CONSISTS OF STANDARD CHARACTERS WITHOUT CLAIM TO ANY PARTICULAR FONT, STYLE, SIZE, OR COLOR.

PRIORITY DATE OF 1-20-2011 IS CLAIMED.
OWNER OF INTERNATIONAL REGISTRATION 1095311 DATED 7-14-2011, EXPIRES 7-14-2021.

CLASS 9—ELECTRICAL AND SCIENTIFIC APPARATUS

FOR SCIENTIFIC, SURVEYING, PHOTOGRAPHIC, CINEMATOGRAPHIC, OPTICAL, MEASURING, SIGNALLING, CHECKING AND TEACHING APPARATUS AND INSTRUMENTS, NAMELY, CODE READERS, ESPECIALLY BAR CODE READERS AND MATRIX CODE READERS, AND SENSORS FOR DETECTION OF POSITION AND/OR SHAPE OF GOODS AND PARTS OF ALL TYPES OF GOODS INCLUDING ANGLE, LENGTH, THICKNESS, HEIGHT, INCLINATION, POSITION, SHAPE, SIZE, EDGE, PRESENCE, DISTANCE, CIRCLE, NUMBER OF EDGES, POINTS, CONTOURS, AREAS, PATTERN OR POSITIONING OF GOODS THEMSELVES OR WITHIN THEIR PRODUCT PACKAGING OR WITHOUT THEIR PRODUCT PACKAGING, ESPECIALLY GOODS PRODUCED IN GREAT QUANTITIES IN ASSEMBLY LINES; DIGITAL CAMERAS, DIGITAL SENSORS FOR OPTICAL DETECTION OF POSITION AND/OR SHAPE OF GOODS AND PARTS OF ALL TYPES OF GOODS INCLUDING ANGLE, LENGTH, THICKNESS, HEIGHT, INCLINATION, POSITION, SHAPE, SIZE, EDGE, PRESENCE, DISTANCE, CIRCLE, NUMBER OF EDGES, POINTS, CONTOURS, AREAS, PATTERN OR POSITIONING OF GOODS THEMSELVES OR WITHIN THEIR PRODUCT PACKAGING, ESPECIALLY GOODS PRODUCED IN GREAT QUANTITIES IN ASSEMBLY LINES; DATA PROCESSING APPARATUS; COMPUTERS; PERIPHERAL COMPONENT INTERFACE (PCI) HARDWARE, NAMELY, PCI BOARDS; COMPUTER SOFTWARE FOR OPTICAL DETECTION OF POSITION AND/OR SHAPE INCLUDING ANGLE, LENGTH, THICKNESS, HEIGHT, INCLINATION, POSITION, SHAPE, SIZE, EDGE, PRESENCE, DISTANCE, CIRCLE, NUMBER OF EDGES, POINTS, CONTOURS, AREAS, PATTERN OR POSITIONING OF GOODS AND PARTS OF ALL TYPES OF GOODS THEMSELVES OR WITHIN THEIR PRODUCT PACKAGING, ESPECIALLY GOODS PRODUCED IN GREAT QUANTITIES IN ASSEMBLY LINES (U.S. CLS. 21, 23, 26, 36 AND 38).

CLASS 42—SCIENTIFIC AND COMPUTER SERVICES

FOR SCIENTIFIC AND INDUSTRIAL RESEARCH FOR OTHERS CONCERNING NEW PRODUCTS IN THE FIELD OF SENSOR SYSTEMS AND OPTOELECTRONIC INFORMATION ACQUISITION AND INFORMATION PROCESSING; WRITING OF DATA PROCESSING PROGRAMS, ESPECIALLY FOR DIGITAL INFORMATION ACQUISITION WITH SENSORS AND THE CONTROL OF ACTORS; TECHNICAL CONSULTATION IN THE FIELDS OF SENSOR SYSTEMS AND OPTOELECTRONIC AND INFORMATION PROCESSING (U.S. CLS. 100 AND 101).

KAREN SEVERSON, EXAMINING ATTORNEY

SN 79-104,456. LÖFBERGS LILA AKTIEBOLAG, SWEDEN, FILED 9-19-2011.

Löfbergs Kafferosteri

THE MARK CONSISTS OF STANDARD CHARACTERS WITHOUT CLAIM TO ANY PARTICULAR FONT, STYLE, SIZE, OR COLOR.

PRIORITY DATE OF 5-2-2011 IS CLAIMED.

OWNER OF INTERNATIONAL REGISTRATION 1095524 DATED 9-19-2011, EXPIRES 9-19-2021.

OWNER OF U.S. REG. NO. 2,343,587.

NO CLAIM IS MADE TO THE EXCLUSIVE RIGHT TO USE "KAFFEROSTERI", APART FROM THE MARK AS SHOWN.

THE ENGLISH TRANSLATION OF THE FOREIGN WORD(S) IN THE MARK IS: LÖFBERGS (SWEDISH FAMILY NAME) COFFEE-ROASTING BUSINESS.

CLASS 21—HOUSEWARES AND GLASS

FOR COFFEE GLASSES, COFFEE CUPS, COFFEE MUGS (NOT OF PRECIOUS METAL); INSULATING FLASKS; TEA STRAINERS, NOT OF PRECIOUS METAL, TEA MUGS, TEA CUPS, TEA SERVICES NOT OF PRECIOUS METAL, TEAPOTS NOT OF PRECIOUS METAL, TEA INFUSERS NOT OF PRECIOUS METAL (U.S. CLS. 2, 13, 23, 29, 30, 33, 40 AND 50).

CLASS 30—STAPLE FOODS

FOR COFFEE, COFFEE-BASED BEVERAGES, TEA, ICED TEA, TEA-BASED BEVERAGES (U.S. CL. 46).

CLASS 43—HOTEL AND RESTAURANT SERVICES

FOR SERVICES PROVIDING FOOD AND DRINK, SELF-SERVICE RESTAURANTS, RESTAURANTS, CAFÉS, CANTEENS (U.S. CLS. 100 AND 101).

DOMINIC J. FERRAIUOLO, EXAMINING ATTORNEY

SN 79-104,532. WORLD WIDE FUND FOR NATURE AUSTRALIA, ULTIMO NSW 2007, AUSTRALIA, FILED 7-11-2011.



PRIORITY DATE OF 1-21-2011 IS CLAIMED.

OWNER OF INTERNATIONAL REGISTRATION 1095687 DATED 7-11-2011, EXPIRES 7-11-2021.

OWNER OF U.S. REG. NOS. 3,578,485 AND 3,578,486.

THE COLOR(S) BLUE, WHITE, GREEN, TAN AND BLACK IS/ARE CLAIMED AS A FEATURE OF THE MARK.

THE MARK CONSISTS OF THE WORDING "60 EARTH HOUR", WITH THE "60" FORMED BY A BLUE, GREEN, WHITE, AND TAN MAP OF THE EARTH, ABOVE THE WORDING "EARTH HOUR" IN WHITE, ALL ON A BLACK BACKGROUND.

CLASS 36—INSURANCE AND FINANCIAL

FOR CHARITABLE FUNDRAISING; CHARITY COLLECTION SERVICES AND ORGANISATION OF CHARITABLE COLLECTIONS, NAMELY, CHARITABLE FUNDRAISING SERVICES BY MEANS OF SELLING GOODS AND SERVICES, AND HOSTING PARTIES OR BARBEQUES, TO RAISE FUNDS; MANAGEMENT AND DISTRIBUTION OF CHARITABLE FUNDS; ACCEPTING AND ADMINISTERING MONETARY CHARITABLE CONTRIBUTIONS; OTHER CHARITABLE ACTIVITIES IN THIS CLASS, NAMELY, PROVIDING FINANCIAL SUPPORT TO ENVIRONMENTAL CONSERVATION EFFORTS IN THE UNITED STATES AND OTHER COUNTRIES FOR THE PURPOSE OF CONSERVING THE WORLD'S BIOLOGICAL DIVERSITY, ENSURING THE USE OF NATURAL RESOURCES IS SUSTAINABLE AND PROMOTING THE REDUCTION OF POLLUTION AND WASTEFUL CONSUMPTION (U.S. CLS. 100, 101 AND 102).

CLASS 38—COMMUNICATION

FOR TRANSMISSION OF INFORMATION, MESSAGES, VIDEO, PHOTOGRAPHS AND OTHER CONTENT ONLINE, NAMELY, AUDIO, VOICE AND DATA VIA A GLOBAL COMPUTER NETWORK OR OTHER COMPUTER AND COMMUNICATION NETWORKS, INCLUDING UPLOADING, DOWNLOADING, POSTING, DISPLAYING, TAGGING AND SHARING INFORMATION, MESSAGES, VIDEO, PHOTOGRAPHS AND OTHER CONTENT, NAMELY, AUDIO, VOICE AND DATA; INTERACTIVE RADIO, AND TELEVISION BROADCASTING SERVICES; WEBCASTING AND DATACASTING; TRANSMISSION OF INFORMATION, MESSAGES, VIDEO, PHOTOGRAPHS AND OTHER CONTENT, NAMELY, AUDIO, VOICE AND DATA BY ELECTRONIC MAIL, INSTANT MESSAGING AND TEXT MESSAGING; PROVIDING ONLINE CHAT ROOMS AND OTHER COMMUNITY FORUMS FOR THE TRANSMISSION OF INFORMATION, MESSAGES, COMMENTS, VIDEO, PHOTOGRAPHS, BLOGS AND OTHER CONTENT, NAMELY, AUDIO, VOICE AND DATA; ELECTRONIC BULLETIN BOARD SERVICES; INTERNET SERVICE PROVIDER (U.S. CLS. 100, 101 AND 104).

CLASS 41—EDUCATION AND ENTERTAINMENT

FOR ENTERTAINMENT SERVICES RELATING TO LOTTERIES, GAMING, GAMBLING, QUIZZES, GAMES AND COMPETITIONS, NAMELY, OPERATING LOTTERIES, CASINO GAMING, GAMBLING SERVICES, PRODUCTION AND DISTRIBUTION OF QUIZ GAMES AND QUIZ COMPETITIONS; PROVIDING ON-LINE COMPUTER GAMES, QUIZZES, NAMELY, GAMES OF SKILL RELATING TO TRIVIA AND COMPETITIONS, NAMELY, ARTISTIC AND CREATIVE COMPETITIONS; PRIZE DRAWS, NAMELY, LOTTERY AND RAFFLE SERVICES; ADVISORY, AND CONSULTANCY AND INFORMATION SERVICES RELATING TO THE FOREGOING (U.S. CLS. 100, 101 AND 107).

CLASS 42—SCIENTIFIC AND COMPUTER SERVICES

FOR CREATING AND MAINTAINING WEBSITES, INCLUDING CUSTOMISED WEB PAGES FEATURING USER GENERATED INFORMATION AND CONTENT; HOSTING OF BLOGS; CREATING AND MAINTAINING BLOGS WEBSITES FOR OTHERS; CREATING AND HOSTING ONLINE COMMUNITIES AND FORUMS FOR USERS TO UPLOAD, DOWNLOAD, POST, DISPLAY, TAG AND SHARE INFORMATION, MESSAGES, VIDEO, PHOTOGRAPHS AND OTHER CONTENT; OPERATION OF SEARCH ENGINES; DESIGN AND DEVELOPMENT OF COMPUTER HARDWARE AND SOFTWARE RELATING TO LOTTERIES, GAMBLING,

QUIZZES, GAMES AND COMPETITIONS; DESIGN AND DEVELOPMENT OF LOTTERIES, QUIZZES, GAMES AND COMPETITIONS, INCLUDING THOSE PROVIDED ONLINE, VIA A GLOBAL COMPUTER NETWORK OR OTHER COMPUTER AND COMMUNICATION NETWORK; HOSTING A VIDEO SHARING PORTAL; HOSTING AN INTERNET WEBSITE AND OTHER ONLINE INTERACTIVE DATABASES FOR THE PURPOSE OF SOCIAL NETWORKING AND SHARING OF USER GENERATED INFORMATION, MESSAGES, VIDEO, PHOTOGRAPHS AND OTHER CONTENT (U.S. CLS. 100 AND 101).

CLASS 45—PERSONAL AND LEGAL SERVICES

FOR PERSONAL AND SOCIAL SERVICES RENDERED BY OTHERS TO MEET THE NEEDS OF INDIVIDUALS PROVIDED ONLINE, VIA A GLOBAL COMPUTER NETWORK OR OTHER COMPUTER AND COMMUNICATION NETWORKS, NAMELY, SOCIAL NETWORKING SERVICES (U.S. CLS. 100 AND 101).

MATTHEW EINSTEIN, EXAMINING ATTORNEY

SN 79-104,537. RENTSCH PARTNER AG, CH-8022 ZÜRICH, SWITZERLAND, FILED 8-8-2011.



OWNER OF INTERNATIONAL REGISTRATION 1095694 DATED 8-8-2011, EXPIRES 8-8-2021.

THE MARK CONSISTS OF TWO OVERLAPPING DIAMOND SHAPES THAT TOGETHER FORM A THIRD DIAMOND SHAPE BETWEEN THEM.

CLASS 35—ADVERTISING AND BUSINESS

FOR BUSINESS MANAGEMENT; BUSINESS ADMINISTRATION, NAMELY, BUSINESS ADMINISTRATION ASSISTANCE, BUSINESS ADMINISTRATION AND OFFICE WORK, BUSINESS ADMINISTRATION AND MANAGEMENT; PROVIDING OFFICE FUNCTIONS; BUSINESS CONSULTATION FOR COMPANIES AND IN ORGANIZATIONS; BUSINESS MANAGEMENT, NAMELY, RECORDING, MANAGEMENT AND PROCESSING OF DATA AND INFORMATION FOR BUSINESS (U.S. CLS. 100, 101 AND 102).

CLASS 38—COMMUNICATION

FOR TELECOMMUNICATION SERVICES, NAMELY, WIRELESS TELEPHONE SERVICES, TELECOMMUNICATIONS BY EMAIL, PERSONAL COMMUNICATION SERVICES; TELECOMMUNICATIONS SERVICES, NAMELY, ELECTRONIC COLLECTION, PROVISION AND TRANSMISSION OF DATA AND MESSAGES; SERVICES IN CONNECTION WITH A DATA BANK, NAMELY, TRANSMISSION AND RECEPTION OF DATABASE INFORMATION TO AND FROM DATABASE USERS VIA THE TELECOMMUNICATION NETWORK (U.S. CLS. 100, 101 AND 104).

CLASS 42—SCIENTIFIC AND COMPUTER SERVICES

FOR SCIENTIFIC AND TECHNOLOGICAL SERVICES, NAMELY, SCIENTIFIC RESEARCH AND DESIGN RELATING THERETO IN THE FIELD OF INTELLECTUAL PROPERTY CONSULTING; INDUSTRIAL ANALYSIS AND RESEARCH SERVICES IN THE FIELD OF INTELLECTUAL PROPERTY CONSULTING; DESIGN AND DEVELOPMENT OF COMPUTERS AND SOFTWARE; ENGINEERS' SERVICES, NAMELY, ENGINEERING SERVICES; COMPUTER SPECIALISTS' OR SCIENTISTS' SERVICES, NAMELY CREATION OF TECHNICAL OR SCIENTIFIC DRAWINGS IN THE NATURE OF ENGINEERING DRAWING SERVICES AS WELL AS SCIENTIFIC AND TECHNOLOGICAL PROJECT STUDY AND RESEARCH SERVICES IN THE FIELD OF INTELLECTUAL PROPERTY CONSULTING; INFORMATION AND CONSULTING WITH RESPECT TO NEW TECHNOLOGIES IN THE FIELD OF INTELLECTUAL PROPERTY CONSULTING (U.S. CLS. 100 AND 101).

CLASS 45—PERSONAL AND LEGAL SERVICES

FOR LEGAL CONSULTING AND REPRESENTATION, PARTICULARLY IN THE FIELD OF INTELLECTUAL PROPERTY LAW, COPYRIGHT, COMPETITION LAW, LICENSING LAW AND COMPANY LAW; LEGAL SERVICES OF A LEGAL OR PATENT ATTORNEY; GRANTING OF INTELLECTUAL PROPERTY LICENSES; CONSULTANCY IN RESPECT OF INTELLECTUAL PROPERTY LAW, NAMELY, CONSULTING IN THE FIELD OF INTELLECTUAL PROPERTY LICENSING (U.S. CLS. 100 AND 101).

LINDSEY RUBIN, EXAMINING ATTORNEY

SN 79-104,610. INFORMA IP GMBH, SWITZERLAND, FILED 8-11-2011.



PRIORITY DATE OF 2-18-2011 IS CLAIMED. OWNER OF INTERNATIONAL REGISTRATION 1095933 DATED 8-11-2011, EXPIRES 8-11-2021.

NO CLAIM IS MADE TO THE EXCLUSIVE RIGHT TO USE "RETURN", APART FROM THE MARK AS SHOWN.

THE MARK CONSISTS OF THE WORD "SUPER" APPEARING ABOVE THE WORD "RETURN" APPEARING ABOVE A SEMICIRCLE WITH AN ARROW POINTING BACK AT THE WORD "SUPER".

CLASS 9—ELECTRICAL AND SCIENTIFIC APPARATUS

FOR PRERECORDED VIDEOTAPES, MAGNETIC TAPES, RECORDABLE COMPACT DISKS (CDS), VIDEO CASSETTES, LASER DISCS, BLANK RECORDABLE DIGITAL VERSATILE DISKS (DVDs), AND COMPACT DISK READ-ONLY MEMORIES (CD-ROMS) IN THE FIELDS OF PRIVATE EQUITY, VENTURE CAPITAL, PENSION PLANS, ENDOWMENTS AND INVESTMENTS; DOWNLOADABLE ELECTRONIC PUBLICATIONS IN THE NATURE OF NEWSLETTERS IN THE FIELDS OF PRIVATE EQUITY, VENTURE CAPITAL, PENSION PLANS, ENDOWMENTS AND INVESTMENTS; DIGITAL MEDIA, NAMELY, PRE-RECORDED DVDs, DOWNLOADABLE AUDIO AND VIDEO RECORDINGS, AND CDS FEATURING AND PROMOTING PRIVATE EQUITY, VENTURE CAPITAL, PENSION PLANS, ENDOWMENTS AND INVESTMENTS; AUDIO BOOKS IN THE FIELDS OF PRIVATE EQUITY, VENTURE CAPITAL, PENSION PLANS, ENDOWMENTS AND INVESTMENTS; ELECTRONIC BOOKS FEATURING INFORMATION ON PRIVATE EQUITY, VENTURE CAPITAL, PENSION PLANS, ENDOWMENTS AND INVESTMENTS RECORDED ON COMPUTER MEDIA; CINEMATO-

GRAPHIC FILMS FEATURING INFORMATION ON PRIVATE EQUITY, VENTURE CAPITAL, PENSION PLANS, ENDOWMENTS AND INVESTMENTS; DOWNLOADABLE DIGITAL RECORDINGS AND MEDIA FEATURING INFORMATION ON PRIVATE EQUITY, VENTURE CAPITAL, PENSION PLANS, ENDOWMENTS AND INVESTMENTS; DOWNLOADABLE DIGITAL RECORDINGS AND MEDIA WITH SOUNDS, IMAGES, TEXT, INFORMATION, AND SIGNALLING FEATURING INFORMATION ON PRIVATE EQUITY, VENTURE CAPITAL, PENSION PLANS, ENDOWMENTS AND INVESTMENTS AND DOWNLOADABLE COMPUTER SOFTWARE FOR USE IN DATABASE MANAGEMENT IN THE FIELDS OF PRIVATE EQUITY, VENTURE CAPITAL, PENSION PLANS, ENDOWMENTS AND INVESTMENTS; DOWNLOADABLE WEBCASTS IN THE FIELDS OF PRIVATE EQUITY, VENTURE CAPITAL, PENSION PLANS, ENDOWMENTS AND INVESTMENTS; DOWNLOADABLE PODCASTS IN THE FIELD OF PRIVATE EQUITY, VENTURE CAPITAL, PENSION PLANS, ENDOWMENTS AND INVESTMENTS; DOWNLOADABLE IMAGE FILES TO BE RUN ON PERSONAL STEREOS, NAMELY, PODSCROLLS IN THE FIELD OF EQUITY, VENTURE CAPITAL, PENSION PLANS, ENDOWMENTS AND INVESTMENTS; DOWNLOADABLE ELECTRONIC FILES AND DATA BANKS FEATURING INFORMATION ON PRIVATE EQUITY, VENTURE CAPITAL, PENSION PLANS, ENDOWMENTS AND INVESTMENTS; ELECTRONIC DATABASE IN THE FIELD OF PRIVATE EQUITY, VENTURE CAPITAL, PENSION PLANS, ENDOWMENTS AND INVESTMENTS RECORDED ON COMPUTER MEDIA; DOWNLOADABLE DIGITAL RECORDINGS AND MEDIA COMPRISING TRAINING APPARATUS AND INSTRUMENTS IN THE FIELDS OF PRIVATE EQUITY, VENTURE CAPITAL, PENSION PLANS, ENDOWMENTS AND INVESTMENTS; COMPUTER GAME SOFTWARE; EDUCATIONAL COMPUTER GAME SOFTWARE FOR TRAINING PURPOSES; DOWNLOADABLE COMPUTER GAME SOFTWARE; COMPUTER SOFTWARE FOR USE IN DATABASE MANAGEMENT IN THE FIELDS OF PRIVATE EQUITY, VENTURE CAPITAL, PENSION PLANS, ENDOWMENTS AND INVESTMENTS; COMPUTER PROGRAMS FOR CREATING SEARCHABLE DATABASES OF INFORMATION AND DATA IN THE FIELDS OF PRIVATE EQUITY, VENTURE CAPITAL, PENSION PLANS, ENDOWMENTS AND INVESTMENTS; DATA PROCESSING SOFTWARE; ANIMATED MOTION PICTURE FILMS; COMPACT DISK (CD) PLAYERS; TAPE RECORDERS AND CASSETTE PLAYERS; RECORD PLAYERS; MPEG PLAYERS; MP4 PLAYERS; MP3 PLAYERS; DIGITAL VERSATILE DISK (DVD) PLAYERS AND RECORDERS; ALL INSTRUMENTS NECESSARY FOR RECORDING, REPRODUCTION AND TRANSMISSION OF SOUND, IMAGE AND VIDEO MATERIALS AND OF DATA; EXTENSION SOFTWARE FOR SOCIAL NETWORKS, FOR DEVELOPING SOCIAL NETWORK APPLICATIONS TO FACILITATE THE REQUESTING AND DOWNLOADING OF DATA, FOR ACCESS TO AND MANAGEMENT OF DATA; REPLACEMENT PARTS AND ACCESSORIES FOR ALL THE AFORESAID GOODS (U.S. CLS. 21, 23, 26, 36 AND 38).

CLASS 35—ADVERTISING AND BUSINESS

FOR ORGANIZATION AND HOLDING OF EXHIBITIONS AND TRADE FAIRS FOR ADVERTISING AND SALES PURPOSES; SALES EXHIBITIONS FOR SALES OR ADVERTISING PURPOSES; MARKET STUDIES; MARKETING STUDIES; PROVISION OF MARKETING INFORMATION; MARKETING STRATEGIES PLANNING; ANALYSIS AND GRAPHICAL REPRESENTATION OF MARKETING RESEARCH DATA AND STATISTICS; MARKET OPINION POLLING AND COMPILATION OF DATA AND DRAWING UP OF REPORTS FOR THE SAME; CONDUCTING OF INTERVIEWS FOR MARKET STUDY PURPOSES; PROVISION OF STATISTICAL INFORMATION RELEVANT TO COMMERCIAL PURPOSES; PROFESSIONAL BUSINESS CONSULTING AND ANALYSIS, NAMELY CORPORATE AND SALES RESEARCH; MARKETING RESEARCH AND MARKETING ANALYSIS NAMELY CORPORATE SURVEYS AND ASSESSMENTS; CORPORATE BUSINESS MANAGEMENT; CONSULTING SERVICES FOR OPERATION OF A BUSINESS FOR OTHERS; BUSINESS CONSULTING; CORPORATE PLANNING AND CORPORATE ADMINISTRATIVE SERVICES; DISSEMINATION OF ADVERTISING MATTER; ADVERTISING, MARKETING AND

SERVICES FOR SALES PROMOTION PURPOSES AND ANALYSIS OF THE EFFECTIVENESS OF THESE STRATEGIES; COMPILATION AND SYSTEMIZATION OF BUSINESS AND MARKETING INFORMATION BY ELECTRONIC DATABASES; RENTAL OF SPACE FOR ADVERTISING PURPOSES; RENTAL OF ADVERTISING SPACE ON INTERNET SITES; ANALYSIS, RESEARCH AND PROFESSIONAL BUSINESS CONSULTING, NAMELY IN THE FIELDS OF MARKETING, BUSINESS COMMUNICATION AND BUSINESS SALES, BRANDS, BRAND IDENTITY, PUBLIC RELATIONS AND DIRECT MARKETING; NEWS CLIPPING SERVICES, NAMELY, MONITORING OF THE NEWS AND THE INTERNET AND SUPPLYING OF THE RESULTS OF SUCH MONITORING ACTIVITIES TO OTHERS; PROVISION OF INFORMATION TO FACILITATE THE LOCATION OF EXPERTS WITH RESPECT TO RECRUITMENT IN THE SECTORS OF EDUCATION, TECHNOLOGY AND RESEARCH; PROVISION OF COMMERCIAL AND MARKETING INFORMATION TO DOCTORS' SURGERIES; DISTRIBUTION OF PAMPHLETS FOR ADVERTISING PURPOSES; PROVISION OF INFORMATION CONCERNING ECONOMIC DEVELOPMENTS NAMELY CORPORATE INFORMATION; ARRANGING SUBSCRIPTIONS TO FINANCIAL AND CORPORATE PUBLICATIONS ON THE INTERNET AND THE GLOBAL COMMUNICATIONS NETWORK FOR OTHERS; CREATION OF ADVERTISING DOCUMENTS; MANAGEMENT OF COMPUTER FILES; PROVISION OF ADVERTISEMENTS AND ADVERTISING MATTER CONTAINING ECONOMIC INFORMATION TO THE PUBLIC IN RESPECT OF FINANCIAL PRODUCTS; ORGANIZATION AND HOLDING OF EXHIBITIONS AND TRADE FAIRS FOR ECONOMIC AND ADVERTISING PURPOSES (U.S. CLS. 100, 101 AND 102).

CLASS 36—INSURANCE AND FINANCIAL

FOR FINANCIAL ADVISORY AND CONSULTANT SERVICES; FINANCIAL ADVISORY SERVICES AND INSURANCE BROKERAGE SERVICES; REAL ESTATE BROKERAGE SERVICES; RESEARCH AND ANALYSIS IN CONNECTION WITH FINANCIAL AND INSURANCE SERVICES AS WELL AS IN CONNECTION WITH REAL ESTATE AFFAIRS; PROVISION OF INFORMATION RELATING TO FINANCIAL TRANSACTIONS; PROVISION OF INFORMATION AND ON-LINE INFORMATION IN THE FINANCIAL, INSURANCE, AND REAL ESTATE SECTORS; PROVISION OF INFORMATION AND CONSULTING SERVICES THROUGH ALL MEDIA IN REGARD TO THE AFORESAID LIST (U.S. CLS. 100, 101 AND 102).

CLASS 41—EDUCATION AND ENTERTAINMENT

FOR EDUCATION SERVICES NAMELY, PROVIDING EDUCATIONAL SEMINARS, CONFERENCES, CLASSES AND WORKSHOPS IN THE FIELDS OF PRIVATE EQUITY, VENTURE CAPITAL, PENSION PLANS, ENDOWMENTS AND INVESTMENTS; TRAINING SERVICES IN THE FIELDS OF PRIVATE EQUITY, VENTURE CAPITAL, PENSION PLANS, ENDOWMENTS AND INVESTMENTS; ARRANGING AND CONDUCTING OF RECREATION, ENTERTAINMENT, CULTURAL, TRAINING AND EDUCATIONAL CONFERENCES, COURSES, SEMINARS AND EXHIBITIONS IN THE FIELDS OF PRIVATE EQUITY, VENTURE CAPITAL, PENSION PLANS, ENDOWMENTS AND INVESTMENTS; ORGANIZATION AND HOLDING OF EXHIBITIONS FOR CULTURAL AND EDUCATIONAL PURPOSES; PUBLISHING SERVICES; ELECTRONIC PUBLISHING SERVICES; THE PROVISION OF NEWS ONLINE IN THE NATURE OF NEWS AGENCIES, NAMELY, GATHERING AND DISSEMINATION OF NEWS; NON-DOWNLOADABLE ELECTRONIC PUBLICATIONS IN THE NATURE OF JOURNALS, NEWSLETTERS, REPORTS, AND DIRECTORIES AND INFORMATION SUPPLIED OVER THE INTERNET IN THE FIELDS OF PRIVATE EQUITY, VENTURE CAPITAL, PENSION PLANS, ENDOWMENTS AND INVESTMENTS; PROVISION OF INFORMATION AND CONSULTING SERVICES IN CONNECTION WITH THE ABOVE-MENTIONED SERVICES (U.S. CLS. 100, 101 AND 107).

KELLY TRUSILO, EXAMINING ATTORNEY

SN 79-104,620. MYCELIUM S.A., L-1645 LUXEMBOURG, LUXEMBOURG, FILED 9-29-2011.

MYCELIUM

THE MARK CONSISTS OF STANDARD CHARACTERS WITHOUT CLAIM TO ANY PARTICULAR FONT, STYLE, SIZE, OR COLOR.

PRIORITY DATE OF 9-26-2011 IS CLAIMED.

OWNER OF INTERNATIONAL REGISTRATION 1095951 DATED 9-29-2011, EXPIRES 9-29-2021.

CLASS 9—ELECTRICAL AND SCIENTIFIC APPARATUS

FOR MEMORY BOARDS; HANDHELD DIGITAL ELECTRONIC DEVICES AND CARDS FOR DATA PROCESSING, INFORMATION PROCESSING, STORING AND DISPLAYING DATA, TRANSMITTING AND RECEIVING DATA; ELECTRONIC HANDHELD UNITS AND CARDS FOR THE WIRELESS RECEIPT, STORAGE AND TRANSMISSION OF DATA AND MESSAGES, AND ELECTRONIC DEVICES THAT ENABLE THE USER TO KEEP TRACK OF OR MANAGE PERSONAL INFORMATION; APPARATUS FOR RECORDING, TRANSMISSION AND REPRODUCTION OF SOUND AND IMAGES; ELECTRONIC MICROCHIPS; TRANSMITTERS AND TRANSMITTING SETS, NAMELY, RF TRANSCEIVERS AND RECEIVERS (U.S. CLS. 21, 23, 26, 36 AND 38).

CLASS 38—COMMUNICATION

FOR COMMUNICATION AND TELECOMMUNICATION SERVICES, NAMELY, ELECTRONIC TRANSMISSION OF DATA, IMAGES, AND DOCUMENTS VIA PEER-TO-PEER AND ELECTRONIC COMMUNICATIONS NETWORKS; PERSONAL COMMUNICATIONS SERVICES; SUPPLY OF DATA AND NEWS BY ELECTRONIC TRANSMISSION, NAMELY, PROVIDING WIRELESS TELECOMMUNICATIONS VIA ELECTRONIC COMMUNICATIONS NETWORKS; WIRELESS DIGITAL MESSAGING, PAGING SERVICES, AND ELECTRONIC MAIL SERVICES, NAMELY, SERVICES THAT ENABLE A USER TO SEND AND RECEIVE MESSAGES THROUGH A WIRELESS DATA NETWORK; TELECOMMUNICATIONS ROUTING AND JUNCTION SERVICES (U.S. CLS. 100, 101 AND 104).

JAY FLOWERS, EXAMINING ATTORNEY

SN 79-104,757. BASF SE, 67063 LUDWIGSHAFEN AM RHEIN, FED REP GERMANY, FILED 9-6-2011.

ABACUSTICA

THE MARK CONSISTS OF STANDARD CHARACTERS WITHOUT CLAIM TO ANY PARTICULAR FONT, STYLE, SIZE, OR COLOR.

OWNER OF INTERNATIONAL REGISTRATION 1002413 DATED 3-25-2009, EXPIRES 3-25-2019.

CLASS 1—CHEMICALS

FOR UNPROCESSED PLASTICS IN THE FORM OF POWDERS, LIQUIDS, GRANULES OR PASTES (U.S. CLS. 1, 5, 6, 10, 26 AND 46).

CLASS 17—RUBBER GOODS

FOR SEMI-PROCESSED PLASTICS IN THE FORM OF FLAKES, CHIPS, BOARDS, SHEETS AND SHAPED OR MOLDED PARTS; PACKING AND INSULATING MATERIAL (U.S. CLS. 1, 5, 12, 13, 35 AND 50).

CLASS 19—NON-METALLIC BUILDING MATERIALS

FOR BUILDING MATERIALS, NAMELY, CEILING, ROOFING AND WALL PANELS AND ARCHITECTURAL MOULDINGS AND FINISHED TRIM, ALL NOT OF METAL (U.S. CLS. 1, 12, 33 AND 50).

ROBERT STRUCK, EXAMINING ATTORNEY

SN 79-104,880. REED ELSEVIER (UK) LIMITED, UNITED KINGDOM, FILED 9-6-2011.

HALSBURY'S

THE MARK CONSISTS OF STANDARD CHARACTERS WITHOUT CLAIM TO ANY PARTICULAR FONT, STYLE, SIZE, OR COLOR.

PRIORITY DATE OF 3-11-2011 IS CLAIMED.

OWNER OF INTERNATIONAL REGISTRATION 1096377 DATED 9-6-2011, EXPIRES 9-6-2021.

CLASS 9—ELECTRICAL AND SCIENTIFIC APPARATUS

FOR DOWNLOADABLE ELECTRONIC PUBLICATIONS IN THE NATURE OF PERIODICALS, MAGAZINES, JOURNALS, REVIEWS, BOOKS, NEWSPAPERS, NEWSLETTERS, AGENDAS IN THE FIELD OF LAW AND LEGAL INFORMATION; COMPUTER SOFTWARE FOR PROVIDING ACCESS TO COMPUTER DATABASES IN THE FIELD OF LAW AND TO GLOBAL COMPUTER NETWORKS; DOWNLOADABLE MULTIMEDIA FILES CONTAINING TEXT, IMAGES RELATING TO THE LAW AND LEGAL INFORMATION; OPTICAL DATA MEDIA, NAMELY, PRE-RECORDED COMPACT DISCS, CD-ROMS, AND DVDS IN THE FIELD OF LAW AND LEGAL INFORMATION (U.S. CLS. 21, 23, 26, 36 AND 38).

CLASS 16—PAPER GOODS AND PRINTED MATTER

FOR PRINTED MATTER IN THE NATURE OF PUBLICATIONS, NAMELY, PERIODICALS, MAGAZINES, JOURNALS, REVIEWS, BOOKS, NEWSPAPERS, NEWSLETTERS IN THE FIELD OF LAW AND LEGAL INFORMATION; PRINTED INSTRUCTIONAL AND TEACHING MATERIALS IN THE FIELD OF LAW AND LEGAL INFORMATION (U.S. CLS. 2, 5, 22, 23, 29, 37, 38 AND 50).

CLASS 41—EDUCATION AND ENTERTAINMENT

FOR PUBLISHING OF ONLINE ELECTRONIC PUBLICATIONS; PUBLISHING OF MAGAZINES AND NEWS MAGAZINES BY ELECTRONIC MEANS; PUBLICATION, IN ELECTRONIC OR NON-ELECTRONIC FORMAT, OF PERIODICALS, JOURNALS, NEWSPAPERS, NEWSLETTERS, AGENDAS, TEXTS, BOOKS, REVIEWS AND MAGAZINES; PROVIDING ONLINE PUBLICATIONS WITH A NAVIGATION FUNCTION; NAMELY, PERIODICALS, JOURNALS, NEWSPAPERS, NEWSLETTERS, AGENDAS, TEXTS, BOOKS, REVIEWS, MAGAZINES ALL IN THE FIELD OF LEGAL INFORMATION VIA THE INTERNET; PROVIDING INFORMATION ABOUT WORKSHOPS, LECTURES, CONVENTIONS, SEMINARS, AND SYMPOSIUMS OFFERING TRAINING IN THE FIELD OF LAW; ARRANGING AND CONDUCTING CONTINUING LEGAL EDUCATION COURSES AND TRAINING WORKSHOPS; ORGANIZATION OF EDUCATIONAL LECTURES, CONVENTIONS, SEMINARS, WORKSHOPS AND RESEARCH GROUPS IN THE FIELD OF LAW; EDUCATIONAL SERVICES, NAMELY, PROVIDING WORKSHOPS, SEMINARS, SYMPOSIUMS, CONFERENCES, LECTURES AND TRAINING SERVICES IN THE FIELD OF LEGAL INFORMATION; DISTRIBUTION OF COURSE MATERIALS IN CONNECTION WITH ALL OF THE ABOVE EDUCATIONAL SERVICES; PUBLISHING SERVICES, NAMELY, DESKTOP PUBLISHING FOR OTHERS; PUBLISHING OF PERIODICALS, MAGAZINES, JOURNALS, REVIEWS, BOOKS, NEWSPAPERS, NEWSLETTERS AND AGENDAS FOR USE IN CONNECTION WITH EDUCATIONAL PRESENTATIONS, LECTURES, CONVENTIONS, SEMINARS WORKSHOPS AND EVENTS (U.S. CLS. 100, 101 AND 107).

EVELYN BRADLEY, EXAMINING ATTORNEY

SN 79-104,962. NSENSE DANMARK A/S, DENMARK, FILED 10-19-2011.

KARHU

THE MARK CONSISTS OF STANDARD CHARACTERS WITHOUT CLAIM TO ANY PARTICULAR FONT, STYLE, SIZE, OR COLOR.

PRIORITY DATE OF 4-19-2011 IS CLAIMED.

OWNER OF INTERNATIONAL REGISTRATION 1096580 DATED 10-19-2011, EXPIRES 10-19-2021.

THE ENGLISH TRANSLATION OF "KARHU" IN THE MARK IS "BEAR".

CLASS 9—ELECTRICAL AND SCIENTIFIC APPARATUS

FOR COMPUTER SOFTWARE FOR SCANNING, MONITORING AND ANALYSIS OF SOFTWARE APPLICATIONS, WEB APPLICATIONS AND COMPUTER NETWORKS FOR THE ASSESSMENT OF SECURITY VULNERABILITIES AND DATA RISKS (U.S. CLS. 21, 23, 26, 36 AND 38).

CLASS 35—ADVERTISING AND BUSINESS

FOR ADVERTISING; BUSINESS MANAGEMENT; BUSINESS ADMINISTRATION; PROVIDING OFFICE FUNCTIONS (U.S. CLS. 100, 101 AND 102).

CLASS 38—COMMUNICATION

FOR RENTAL OF ACCESS TIME TO A GLOBAL COMPUTER NETWORK; PROVIDING USER ACCESS TO A GLOBAL COMPUTER NETWORK (U.S. CLS. 100, 101 AND 104).

LINDA LAVACHE, EXAMINING ATTORNEY

SN 79-105,123. PARTY LAND CO., LTD., OSAKA 564-0051, JAPAN, FILED 10-3-2011.

Party Land

THE MARK CONSISTS OF STANDARD CHARACTERS WITHOUT CLAIM TO ANY PARTICULAR FONT, STYLE, SIZE, OR COLOR.

PRIORITY DATE OF 4-26-2011 IS CLAIMED.

OWNER OF INTERNATIONAL REGISTRATION 1096938 DATED 10-3-2011, EXPIRES 10-3-2021.

CLASS 30—STAPLE FOODS

FOR BINDING AGENTS FOR ICE CREAM; MEAT TENDERIZERS FOR HOUSEHOLD PURPOSES; PREPARATIONS FOR STIFFENING WHIPPED CREAM; FROZEN YOGURT; BREAD AND BUNS (U.S. CL. 46).

CLASS 43—HOTEL AND RESTAURANT SERVICES

FOR PROVIDING FROZEN YOGURT, NAMELY, FROZEN YOGURT SHOP SERVICES IN THE NATURE OF A RESTAURANT; PROVIDING FOODS AND BEVERAGES (U.S. CLS. 100 AND 101).

ELIZABETH KAJUBI, EXAMINING ATTORNEY

SN 79-105,145. CODEPLAY SOFTWARE LIMITED, UNITED KINGDOM, FILED 10-6-2011.



OWNER OF INTERNATIONAL REGISTRATION 1096999 DATED 10-6-2011, EXPIRES 10-6-2021.

THE COLOR(S) PURPLE, BLACK, BLUE, YELLOW AND WHITE IS/ARE CLAIMED AS A FEATURE OF THE MARK.

THE MARK CONSISTS OF THE WORD "CODEPLAY" IN PURPLE LETTERING WITH A PURPLE HANDPRINT DESIGN TO THE RIGHT OF THE WORDING AND A SPHERICAL DESIGN TO THE LEFT OF THE WORDING. THE SPHERICAL DESIGN CONSISTS OF A YELLOW SPHERE IN THE CENTER SURROUNDED BY A BLACK SPHERE THAT GIVES THE APPEARANCE OF BEING CUT OPEN TO REVEAL A BLUE CENTER AND THE YELLOW SPHERE WITHIN. THERE IS A PURPLE ARC SURROUNDING THE LEFT HALF OF THIS DESIGN ELEMENT. THE DESIGN IS SHADED WITH WHITE AND THE MARK APPEARS ON A WHITE BACKGROUND.

CLASS 9—ELECTRICAL AND SCIENTIFIC APPARATUS

FOR COMPUTER HARDWARE, NAMELY, COMPUTER PROCESSORS (CPUS) AND GRAPHIC PROCESSORS (GPUS); COMPUTER SOFTWARE, NAMELY, COMPUTER PROGRAMS FOR USE WITH PROGRAMMABLE GRAPHICS AND COMPILERS (U.S. CLS. 21, 23, 26, 36 AND 38).

CLASS 42—SCIENTIFIC AND COMPUTER SERVICES

FOR COMPUTER PROGRAMMING SERVICES; CONSULTANCY SERVICES IN RESPECT OF COMPUTER PROGRAMMING; PROVISION OF INFORMATION IN RESPECT OF COMPUTER PROGRAMMING; AND COMPUTER SOFTWARE DEVELOPMENT, ALL THE AFORESAID BEING IN THE FIELD OF COMPUTER GAMES AND COMPILER TECHNOLOGY AND PROGRAMMABLE GRAPHICS (U.S. CLS. 100 AND 101).

MATTHEW MCDOWELL, EXAMINING ATTORNEY

SN 79-105,187. FRANCE TELECOM, PARIS, FRANCE,
FILED 9-9-2011.

TWINMEE

THE MARK CONSISTS OF STANDARD CHARACTERS WITHOUT CLAIM TO ANY PARTICULAR FONT, STYLE, SIZE, OR COLOR.

PRIORITY DATE OF 3-10-2011 IS CLAIMED.
OWNER OF INTERNATIONAL REGISTRATION 1097103
DATED 9-9-2011, EXPIRES 9-9-2021.

THE WORDING "TWINMEE" HAS NO MEANING IN A FOREIGN LANGUAGE.

CLASS 9—ELECTRICAL AND SCIENTIFIC APPARATUS

FOR COMPUTER PROGRAMS FOR DATABASE MANAGEMENT IN THE FIELD OF TELECOMMUNICATIONS; COMPUTER PROGRAMS FOR PROCESSING SIGNALS, DIGITIZING SPEECH, TEXT/SPEECH CONVERSION AND ENCODING AND COMPRESSING SPEECH AND MUSIC SOUNDS; COMPUTERS, DATA AND WORD-PROCESSING COMPUTERS, COMPUTERS FITTED WITH EQUIPMENT FOR RECORDING, PROCESSING, AND REPRODUCING MUSIC, FOR RECOGNIZING SPEECH, ENCODING SPEECH AND REPRODUCING SYNTHETIC SPEECH; SPEECH CODING SOFTWARE; COMPUTER SOFTWARE FOR IMPROVING TELEPHONE SOUND QUALITY BY ALL TELECOMMUNICATION MEANS, NAMELY, TELEPHONE, MOBILE TELEPHONY AND THE INTERNET; BLANK MAGNETIC DISKS FOR DATA MEDIA; COMPUTER SOFTWARE ENABLING THE GENERATION AND SENDING BY MEANS OF MESSAGING, OF SYNTHETIC SPEECH (U.S. CLS. 21, 23, 26, 36 AND 38).

CLASS 38—COMMUNICATION

FOR TELECOMMUNICATION SERVICES, NAMELY, WIRELESS TELEPHONE SERVICES; SATELLITE COMMUNICATION SERVICES; MOBILE TELECOMMUNICATION SERVICES BY SATELLITE ENABLING THE TRANSFER OF SPEECH AND DATA; SECURED ELECTRONIC DATA TRANSMISSION SERVICES, COMMUNICATION VIA COMPUTER TERMINALS, TRANSMITTING INFORMATION VIA ELECTRONIC DATA TRANSMISSION, ELECTRONIC TRANSMISSION AND RECEPTION OF INFORMATION VIA SATELLITE, ELECTRONIC TRANSMISSION OF ENCODED IMAGES, MESSAGES AND SOUNDS; PROVIDING USER ACCESS TO A GLOBAL COMPUTER NETWORK; PROVIDING TELECOMMUNICATIONS CONNECTIONS TO A GLOBAL COMPUTER NETWORK, INTERNET SERVICE PROVIDER CONNECTION SERVICES, NAMELY, SERVICES FOR CONNECTING TO THE INTERNET OR TO LOCAL NETWORKS; GATEWAY SERVICES, NAMELY, INTERNET ADDRESS ROUTING SERVICES; RENTAL OF TELECOMMUNICATION APPARATUS AND INSTALLATIONS; COMMUNICATIONS BY TELEPHONE, ELECTRONIC MULTIMEDIA DATA TRANSMISSION SERVICES; ELECTRONIC AND ELECTRONIC COMPUTER MESSAGE AND MAIL SERVICES, ELECTRONIC TRANSMISSION OF INFORMATION HELD IN DATA BANKS AND IMAGE BANKS, ELECTRONIC INFORMATION TRANSMISSION SERVICES, FOR GLOBAL COMMUNICATION NETWORKS, PRIVATE AND RESTRICTED ACCESS NETWORKS; ELECTRONIC TRANSMISSION OF MESSAGES BY MEANS OF SYNTHETIC SPEECH (U.S. CLS. 100, 101 AND 104).

CLASS 41—EDUCATION AND ENTERTAINMENT

FOR RECORDING OF SOUNDS AND RECORDING OF IMAGES ON DIGITAL AND ANALOG MEDIA, RECORDING STUDIO SERVICES (U.S. CLS. 100, 101 AND 107).

CLASS 42—SCIENTIFIC AND COMPUTER SERVICES

FOR CONVERTING OF DIGITAL CODES AND FORMATS, OTHER THAN PHYSICAL CONVERSION, BETWEEN DIFFERENT KINDS OF DIGITAL CONTENT BY MEANS OF DATA PROCESSING SOFTWARE FOR OTHERS; CONVERTING OF TEXT TO SPEECH AND CONVERTING DATA INTO SOUND, NAMELY, CONVERTING DATA AND COMPUTER PROGRAM DIGITAL CONTENT TO OTHER FORMS OF DIGITAL CONTENT; COMPUTER SYSTEM DESIGN AND DEVELOPMENT, NAMELY, DESIGN AND DEVELOPMENT OF COMPUTER SOFTWARE SYSTEMS AND OPERATIONS SOFTWARE FOR USE IN APPLICATIONS USING SPEECH SYNTHESIS TECHNOLOGY OR SYNTHESIZED SPEECH; COMPUTER SOFTWARE SYSTEM DESIGN AND DEVELOPMENT, NAMELY, DESIGN AND DEVELOPMENT OF APPLICATIONS USING SPEECH SYNTHESIS TECHNOLOGY; DEVELOPMENT OF COMPUTER PROGRAMS AND SOFTWARE FOR DEVICES FOR MASS STORAGE, SPEECH CAPTURE AND EDITING, SPEECH RECORDING, SPEECH ARCHIVING AND SPEECH ANALYSIS (U.S. CLS. 100 AND 101).

JASON TURNER, EXAMINING ATTORNEY

SN 79-105,206. SEMEIOTICS GROUP (EUROPE) SAS,
FRANCE, FILED 10-5-2011.

RdM

THE MARK CONSISTS OF STANDARD CHARACTERS WITHOUT CLAIM TO ANY PARTICULAR FONT, STYLE, SIZE, OR COLOR.

OWNER OF INTERNATIONAL REGISTRATION 1097175
DATED 10-5-2011, EXPIRES 10-5-2021.

CLASS 3—COSMETICS AND CLEANING PREPARATIONS

FOR SOAP; PERFUMERY, ESSENTIAL OILS, COSMETICS, HAIR LOTIONS; DENTIFRICES (U.S. CLS. 1, 4, 6, 50, 51 AND 52).

CLASS 18—LEATHER GOODS

FOR LEATHER AND IMITATIONS OF LEATHER; ANIMAL SKINS; TRUNKS; VALISES; BACKPACKS, HANDBAGS, WALLETS; BRIEFCASES; PURSES NOT OF PRECIOUS METAL, UNFITTED VANITY CASES; UMBRELLAS (U.S. CLS. 1, 2, 3, 22 AND 41).

CLASS 25—CLOTHING

FOR READY-MADE AND READY-TO-WEAR CLOTHING, NAMELY, BELTS, CRAVATS, GLOVES, SCARVES, TIES, HEADBANDS, BLOUSES, DRESSES, SUITS, PULL-OVERS, SHIRTS, SHORTS, SWEATSHIRTS, TOPS, BOTTOMS, WAISTCOATS, TROUSERS, TEE SHIRTS, SKIRTS, JEANS, JACKETS, UNDERWEAR, SOCKS AND STOCKINGS, HOSIERY, BATHING SUITS, BEACHWEAR, BATH ROBES; WEDDING DRESSES; OUTER CLOTHING, NAMELY, COATS, FUR COATS, RAINCOATS; BABY LAYETTES FOR CLOTHING; CLOTHING OF LEATHER, NAMELY, LEATHER PANTS, LEATHER JACKETS, LEATHER BOOTS, LEATHER SKIRTS, LEATHER VESTS, LEATHER BELTS; IMITATION LEATHER CLOTHING, NAMELY, IMITATION LEATHER PANTS, IMITATION LEATHER JACKETS, IMITATION LEATHER BELTS, IMITATION LEATHER BOOTS, IMITATION LEATHER SKIRTS AND IMITATION LEATHER VESTS; FOOTWEAR; BOOTS, SHOES, SLIPPERS (U.S. CLS. 22 AND 39).

MATTHEW MCDOWELL, EXAMINING ATTORNEY

SN 79-105,296. ZAPPAREL LTD, UNITED KINGDOM, FILED 9-13-2011.



PRIORITY DATE OF 6-28-2011 IS CLAIMED.
OWNER OF INTERNATIONAL REGISTRATION 1097413 DATED 9-13-2011, EXPIRES 9-13-2021.

THE MARK CONSISTS OF THE STYLIZED WORD, "ZAPPAREL", AND THE DESIGN OF A T-SHIRT FEATURING THE LETTER "Z" ON THE FRONT AND STARS, CIRCLES, DIAMONDS, AND AN ADDITIONAL LETTER "Z" ARCHING OUT FROM THE SHIRT.

CLASS 9—ELECTRICAL AND SCIENTIFIC APPARATUS

FOR COMPUTER SOFTWARE FOR ENABLING IMAGE RECOGNITION AND/OR AUGMENTED REALITY TECHNOLOGY ON MOBILE PHONES, TABLETS, AND HANDHELD GAMING DEVICES; COMPUTER SOFTWARE USING IMAGE RECOGNITION AND/OR AUGMENTED REALITY TECHNOLOGY FOR BROWSING, SEARCHING AND DELIVERY OF ADVERTISING INFORMATION AND ENTERTAINMENT CONTENT FOR USE WITH MOBILE PHONES, TABLETS AND HANDHELD GAMING DEVICES (U.S. CLS. 21, 23, 26, 36 AND 38).

CLASS 14—JEWELRY

FOR PRECIOUS METALS AND THEIR ALLOYS AND GOODS IN PRECIOUS METALS OR COATED THEREWITH, NOT INCLUDED IN OTHER CLASSES, NAMELY EARRINGS, RINGS, BRACELETS, BANGLES, NECKLACES, PENDANTS, CHARMS, CUFFLINKS, BROOCHES, PINS BEING JEWELRY, AND BADGES; JEWELRY, PRECIOUS STONES; HOROLOGICAL AND CHRONOMETRIC INSTRUMENTS; IMITATION JEWELRY; SEMI-PRECIOUS STONES (U.S. CLS. 2, 27, 28 AND 50).

CLASS 18—LEATHER GOODS

FOR LEATHER AND IMITATIONS OF LEATHER AND GOODS MADE OF THESE MATERIALS AND NOT INCLUDED IN OTHER CLASSES, NAMELY, ATTACHE CASES, BRIEFCASES, KEY CHAINS, BAGS, BACK PACKS, PURSES, HANDBAGS, WALLETS, SUITCASES, CREDIT CARD CASES AND CREDIT CARD WALLETS; TRUNKS AND TRAVELLING BAGS; TRAVEL CASES; LUGGAGE; SUITCASES; HOLDALLS; BAGS; HANDBAGS; SHOULDER BAGS; TOILETRY BAGS SOLD EMPTY; RUCKSACKS; BACKPACKS; CASUAL BAGS, NAMELY, BOOK BAGS, CARRY ALL BAGS, DRAWSTRING BAGS, FLIGHT BAGS AND REUSABLE SHOPPING BAGS; BRIEFCASES; ATTACHE CASES; SATCHELS; GARMENT BAGS FOR TRAVEL AND CARRIERS FOR COATS, SUITS, JACKETS, TROUSERS, SHIRTS, TOPS, DRESSES, DINNER JACKETS; TIE CASES; DOCUMENT CASES; CREDIT CARD CASES AND HOLDERS; WALLETS; PURSES; UMBRELLAS (U.S. CLS. 1, 2, 3, 22 AND 41).

CLASS 25—CLOTHING

FOR CLOTHING, NAMELY, COATS, OVERCOATS, SPORTS COATS, RAINCOATS, SUITS, JACKETS, TROUSERS, PANTS, JEANS, SHORTS, SHIRTS, T-SHIRTS, POLO SHIRTS, TOPS, TANK TOPS, PULLOVERS, SWEATERS, JERSEYS, CARDIGANS, SWEATSHIRTS, JUMPERS, FLEECE PULLOVERS, DRESSES, BLOUSES, SKIRTS, OVERALLS, BELTS, SUSPENDERS, UNDERWEAR, VESTS, DINNER JACKETS, TIES, CRAVATS, ROBES, AND PYJAMAS, FOOTWEAR AND HEADGEAR, NAMELY, HATS AND CAPS (U.S. CLS. 22 AND 39).

CLASS 35—ADVERTISING AND BUSINESS

FOR ADVERTISING COMMUNICATION MEDIA FOR ADVERTISING SERVICES PROVIDED BY WAY OF IMAGE RECOGNITION AND/OR AUGMENTED REALITY TECHNOLOGY, NAMELY, ADVERTISING THROUGH ALL PUBLIC COMMUNICATION MEANS (U.S. CLS. 100, 101 AND 102).

CLASS 42—SCIENTIFIC AND COMPUTER SERVICES

FOR APPLICATION SERVICE PROVIDER (ASP) SERVICES FEATURING SOFTWARE FOR USE IN CONNECTION WITH VISION BASED AND/ OR AUGMENTED REALITY TECHNOLOGY THAT ENABLES USERS TO ACCESS AUDIO, VIDEO, TEXT AND MULTIMEDIA CONTENT FROM HANDHELD DEVICES; COMPUTER SERVICES, NAMELY, CLOUD HOSTING PROVIDER SERVICES, PROVIDING VIRTUAL AND NON VIRTUAL APPLICATION SERVERS, WEB SERVERS, FILE SERVERS, CO-LOCATION SERVERS, MEDIA SERVERS AND DATABASE SERVERS OF VARIABLE CAPACITY TO THIRD PARTY COMPUTING AND DATA STORAGE FACILITIES AND DOCUMENT RETRIEVAL SERVICES FOR DIGITAL TEXT, DATA, IMAGE, AUDIO, AND VIDEO WORKS; PROVISION OF DATA ANALYTICS AND EVALUATION REPORTS AND SERVICES BASED ON THE USE OF THE IMAGE RECOGNITION TECHNOLOGY, NAMELY, DATA AUTOMATION AND COLLECTION SERVICES USING PROPRIETARY SOFTWARE AND TOOLS TO EVALUATE, ANALYSE AND COLLECT DATA (U.S. CLS. 100 AND 101).

KATHRYN COWARD, EXAMINING ATTORNEY

SN 79-105,387. QUARZWERKE GMBH, 50226 FRECHEN, FED REP GERMANY, FILED 1-10-2011.

SILMIKRON

THE MARK CONSISTS OF STANDARD CHARACTERS WITHOUT CLAIM TO ANY PARTICULAR FONT, STYLE, SIZE, OR COLOR.

OWNER OF INTERNATIONAL REGISTRATION 0754587 DATED 1-8-2001, EXPIRES 1-8-2021.

CLASS 1—CHEMICALS

FOR INDUSTRIAL RAW MINERALS, NAMELY, MINERAL FINE POWDERS BASED ON DIFFERENT SILICATES; MINERAL-BASED FILLING MATERIALS FOR SYNTHETIC MATERIALS, FOR PLASTIC MATERIALS FOR CASTING, FOR CEMENT LATEX MORTAR, FOR CONCRETE MADE OF SYNTHETIC RESINS, FOR LUTING MATERIALS, FOR LUTING AGENTS, FOR MASTICS AND FOR FLOOR COVERINGS (U.S. CLS. 1, 5, 6, 10, 26 AND 46).

CLASS 19—NON-METALLIC BUILDING MATERIALS

FOR MILLED MINERALS FOR INDUSTRIAL PURPOSES, NAMELY, QUARTZ IN POWDER FORM (U.S. CLS. 1, 12, 33 AND 50).

KAREN SEVERSON, EXAMINING ATTORNEY

SN 79-105,537. REINDER G. TAMBOEZER, NETHERLANDS,
FILED 10-27-2011.



PRIORITY DATE OF 10-12-2011 IS CLAIMED.
OWNER OF INTERNATIONAL REGISTRATION 1097684
DATED 10-27-2011, EXPIRES 10-27-2021.

NO CLAIM IS MADE TO THE EXCLUSIVE RIGHT TO
USE "PUSH-APP", APART FROM THE MARK AS SHOWN.
THE COLOR(S) BLACK, WHITE, RED IS/ARE CLAIMED
AS A FEATURE OF THE MARK.

THE MARK CONSISTS OF A STYLIZED BLACK FIGURE
WITH WHITE OUTLINES, ABOVE THE CAPITAL LETTERS
"PUSH-APP" IN RED. ALL ON WHITE BACKGROUND.

CLASS 9—ELECTRICAL AND SCIENTIFIC APPARATUS

FOR DATA PROCESSING EQUIPMENT AND COMPU-
TERS; SOFTWARE FOR APPLICATION PROGRAM-
MING INTERFACES FOR THE USE IN SMART-PHONE
AND TABLET (U.S. CLS. 21, 23, 26, 36 AND 38).

CLASS 42—SCIENTIFIC AND COMPUTER SERVICES

FOR SCIENTIFIC AND TECHNOLOGICAL SERVICES,
NAMELY, SCIENTIFIC RESEARCH AND DESIGN IN
THE FIELD OF APPLICATION PROGRAMMING IN-
TERFACES AND RELATED SOFTWARE; INDUSTRIAL
RESEARCH IN THE FIELD OF APPLICATION PRO-
GRAMMING INTERFACES AND RELATED SOFT-
WARE; DESIGN AND DEVELOPMENT OF COMPUTER
HARDWARE AND SOFTWARE (U.S. CLS. 100 AND 101).
STEVEN JACKSON, EXAMINING ATTORNEY

SN 79-105,695. CVDM SOLUTIONS, PARIS, FRANCE, FILED
10-6-2011.

PLANORAMA

THE MARK CONSISTS OF STANDARD CHARACTERS
WITHOUT CLAIM TO ANY PARTICULAR FONT, STYLE,
SIZE, OR COLOR.

OWNER OF INTERNATIONAL REGISTRATION 1098153
DATED 10-6-2011, EXPIRES 10-6-2021.

THE WORD(S) "PLANORAMA" HAS NO MEANING IN A
FOREIGN LANGUAGE.

CLASS 9—ELECTRICAL AND SCIENTIFIC APPARATUS

FOR SCIENTIFIC OTHER THAN MEDICAL, NAUTI-
CAL, SURVEYING, PHOTOGRAPHIC, CINEMATO-
GRAPHIC, OPTICAL, WEIGHING, MEASURING,
SIGNALING, CHECKING IN THE NATURE OF SUPER-
VISION, LIFE-SAVING AND TEACHING APPARATUS
AND INSTRUMENTS, NAMELY, CAMERAS AND VI-
DEO CAMERAS; APPARATUS FOR RECORDING,
TRANSMITTING, REPRODUCING OR PROCESSING
IMAGES; CALCULATING MACHINES; DATA PROCES-
SING EQUIPMENT, NAMELY, DATA PROCESSORS,
SMARTPHONES, HANDHELD TABLET COMPUTERS;
COMPUTERS; COMPUTER SOFTWARE, NAMELY,
COMPUTER OPERATING RECORDED PROGRAMS
FOR USE IN CONNECTION WITH MERCHANDISING
TECHNIQUES; COMPUTER PERIPHERAL DEVICES;
DETECTORS, NAMELY, PRESENCE DETECTORS FOR
BURGLAR AND ALARM SYSTEMS, HEAT DETEC-
TORS, RFID DETECTORS FOR DETECTING AND
RECEIVING SIGNALS FROM RFID TAGS (U.S. CLS.
21, 23, 26, 36 AND 38).

CLASS 35—ADVERTISING AND BUSINESS

FOR ADVERTISING; BUSINESS MANAGEMENT;
BUSINESS ADMINISTRATION; DIRECT MAIL ADVER-
TISING; ARRANGING NEWSPAPER SUBSCRIPTIONS
FOR OTHERS; BUSINESS MANAGEMENT AND ORGA-
NIZATION CONSULTANCY; DOCUMENT REPRODUC-
TION; COMPUTERIZED FILE MANAGEMENT;
RENTAL OF ADVERTISING TIME ON COMMUNICA-
TION MEDIA; PUBLIC RELATIONS (U.S. CLS. 100, 101
AND 102).

CLASS 42—SCIENTIFIC AND COMPUTER SERVICES

FOR MEASUREMENT EVALUATIONS IN THE SCIE-
NTIFIC AND TECHNOLOGICAL FIELDS, SCIENTIFIC
AND TECHNOLOGY RESEARCH IN THE FIELD OF
SOFTWARE PROGRAMMING, ALL OF WHICH ARE
PROVIDED BY ENGINEERS; DESIGN AND DEVELOP-
MENT OF COMPUTERS AND SOFTWARE; DEVELOP-
MENT, DESIGN, INSTALLATION, MAINTENANCE,
UPDATING OR RENTAL OF COMPUTER SOFTWARE;
COMPUTER PROGRAMMING; TECHNOLOGICAL
CONSULTATION IN THE TECHNOLOGY FIELD OF
COMPUTER HARDWARE SYSTEMS; DATA CONVER-
SION OF COMPUTER PROGRAMS AND DATA NOT
PHYSICAL CONVERSION; CONVERSION OF DATA OR
DOCUMENTS FROM PHYSICAL TO ELECTRONIC
MEDIA; ALL THESE SERVICES ARE IN CONNECTION
WITH MERCHANDISING TECHNIQUES (U.S. CLS. 100
AND 101).

JEFF DEFORD, EXAMINING ATTORNEY

SN 79-105,727. CHRISTIAN T. HANSEN, HUSBY, FED REP
GERMANY, FILED 9-8-2011.



PRIORITY DATE OF 4-29-2011 IS CLAIMED.
OWNER OF INTERNATIONAL REGISTRATION 1098251
DATED 9-8-2011, EXPIRES 9-8-2021.

THE COLOR(S) GREEN AND WHITE IS/ARE CLAIMED AS A FEATURE OF THE MARK.

THE MARK CONSISTS OF THE FOLLOWING: A GREEN SPLATTER DESIGN WITH AN IRREGULAR WHITE CIRCLE AT ITS CENTER, ALSO IN GREEN, ALL AGAINST A WHITE BACKGROUND.

SN 79-105,755. SIENN AG, SWITZERLAND, FILED 5-6-2011.



CLASS 10—MEDICAL APPARATUS

FOR ORTHOPEDIC ARTICLES, IN PARTICULAR ORTHOPAEDIC FOOTWEAR, SOLES, INSOLES, SHOE-PADS AND BANDAGES; PHYSICAL EXERCISE EQUIPMENT FOR MEDICAL PURPOSES AND FOR PHYSIOTHERAPY (U.S. CLS. 26, 39 AND 44).

OWNER OF INTERNATIONAL REGISTRATION 1098351 DATED 5-6-2011, EXPIRES 5-6-2021.

THE COLOR(S) BLACK AND GRAY IS/ARE CLAIMED AS A FEATURE OF THE MARK.

THE MARK CONSISTS OF THE WORD "SIENN" IN BLACK STYLIZED FONT WITH A GRAY SHADOW OF EACH LETTER APPEARING BELOW THE WORD.

THE WORDING "SIENN" HAS NO MEANING IN A FOREIGN LANGUAGE.

CLASS 18—LEATHER GOODS

FOR BAGS, IN PARTICULAR SPORT BAGS; RUCK-SACKS; LEATHER AND LEATHER IMITATIONS OF LEATHER, AND GOODS MADE OF THESE MATERIALS, NAMELY, BACKPACKS, SUITCASES, BANDS OF LEATHER, LEATHER SHOULDER BELTS, STRAPS FOR SKATES, KID, CASES OF LEATHER OR LEATHERBOARD, BRIEFCASES, CANES, PURSES, COLLARS FOR ANIMALS, CASINGS OF LEATHER FOR PLATE SPRINGS, EXCEPT FOR BAGS MADE FOR CARRYING SHOES OR ORTHOTICS (U.S. CLS. 1, 2, 3, 22 AND 41).

CLASS 9—ELECTRICAL AND SCIENTIFIC APPARATUS

FOR COMPUTER TERMINALS FOR USE WITH NAVIGATION SYSTEMS, ROUTE PLANNERS AND DIGITAL MAPS; SOFTWARE AND SOFTWARE PACKAGES FOR THE SETTING UP AND MANAGEMENT OF WEBSITES, INTRANETS AND WEB SHOPS; COMPUTER SOFTWARE APPLICATIONS FOR CONTENT MANAGEMENT AND DATA MANAGEMENT; COMPUTERS; COMPUTER PROGRAMS FOR DATABASE MANAGEMENT, CONTENT MANAGEMENT, DOCUMENT MANAGEMENT, WEB SHOP CREATIONS, OPERATING AND CREATING E-COMMERCE WEBSITES, CONNECTING VARIOUS INTERNET BUSINESSES AND SEARCH ENGINE OPTIMIZATION; COMPUTER PERIPHERAL EQUIPMENT; TELECOMMUNICATIONS EQUIPMENT AND DATA COMMUNICATIONS EQUIPMENT, NAMELY, TELECOMMUNICATION EXCHANGERS, DATA PROCESSORS (U.S. CLS. 21, 23, 26, 36 AND 38).

CLASS 25—CLOTHING

FOR OUTER CLOTHING AND UNDERWEAR, IN PARTICULAR CLOTHING FOR SPORTS AND GYMNASTICS IN THE NATURE OF SPORTS BRAS, SPORTS JERSEYS, SPORTS JACKETS, SPORTS OVER-UNIFORMS, LEOTARDS, COATS, PARKAS, PONCHOS, SPORTS DRESSES, SPORTS SKIRTS, PINAFORE DRESSES, SPORTS SHIRTS, SPORTS GLOVES, COLLAR PROTECTORS, SWEATERS FOR SPORTS, PULLOVERS FOR SPORTS, VESTS, BEACH CLOTHES, SWIMMING COSTUMES, SWIMMING TRUNKS, SWIMMING SUITS, T-SHIRTS, JERSEYS, SINGLETS, SWEAT-ABSORBENT UNDERCLOTHING, SLIPS, BRASSIERES, CORSETS UNDERCLOTHING, CORSETS, CORSELETS, HOSIERY, TIGHTS, PETTICOATS, LEGGINGS, LEG WARMERS, SPATS, BREECHES, PANTS, TROUSERS, SCARVES; SHOES, IN PARTICULAR SPORTS SHOES; SOLES FOR FOOTWEAR; INNER SOLES; SHOE INSOLES; STOCKINGS AND SOCKS; HEADGEAR, IN PARTICULAR CAPS AND HATS (U.S. CLS. 22 AND 39).

CLASS 35—ADVERTISING AND BUSINESS

FOR ADVERTISING AND SALES PROMOTION; BUSINESS MANAGEMENT AND PROVIDING OF ADVERTISING SPACE; PUBLIC RELATIONS; BUSINESS MANAGEMENT; BUSINESS ADMINISTRATION; MARKETING, NAMELY, ADVERTISING IN THE NATURE OF SEARCH ENGINE MARKETING, MARKET ASSESSMENTS AND MARKET STUDIES; BUSINESS ECONOMIC, BUSINESS MANAGEMENT AND BUSINESS ORGANIZATION CONSULTANCY, INCLUDING, WITHIN THE FRAMEWORK OF INFORMATION POLICY; CONSULTANCY RELATING TO ELECTRONIC COMMERCE SERVICES IN THE NATURE OF PROVIDING INFORMATION ABOUT PRODUCTS VIA TELECOMMUNICATION NETWORKS FOR ADVERTISING AND SALES PURPOSES, BUSINESS MANAGEMENT AND ON THE MANAGEMENT OF DATABASES WITHIN THE FRAMEWORK OF INFORMATION MANAGEMENT; SYSTEMIZATION OF INFORMATION INTO COMPUTER DATABASES, NAMELY, SYSTEMATIC ORDERING AND INDEXING OF INFORMATION VIA WORLD-WIDE COMPUTER NETWORKS FOR THE PURPOSES OF PROVIDING ACCESS TO SEARCH FACILITIES AND INFORMATION; COMPILATION OF DATA IN COMPUTER DATABASES; PROVIDING OFFICE FUNCTIONS RELATING TO SEARCHING FOR INFORMATION IN DATABASES; BUSINESS DATA ANALYSIS, NAMELY, MAKING INVENTORIES OF AND CLASSIFYING DATA; COMPILATION AND SYSTEMIZATION OF INFORMATION INTO COMPUTER DATABASES, NAMELY, SETTING UP AND MANAGING DATABASES, INCLUDING, THE POSITIONING, OPTIMIZATION, NOTIFICATION, MONITORING AND ADJUSTMENT OF THE FINDABILITY OF OTHERS' WEBSITES USING SEARCH ENGINES; PROFESSIONAL BUSINESS CONSULTANCY; UPDATING OF ADVERTISING MATERIAL; ORGANIZATION OF DATA IN A MASTER FILE, NAMELY, DATABASE MANAGEMENT; SEARCHING FOR INFORMATION IN COMPUTER FILES FOR OTHERS, NAMELY, COMPUTER FILE MANAGEMENT; PROVIDING OFFICE FUNCTIONS; ARRANGING COMMERCIAL TRANSACTIONS OVER ELECTRONIC COM-

CLASS 28—TOYS AND SPORTING GOODS

FOR GYMNASTICS AND SPORTING ARTICLES, NAMELY, SHIN GUARDS, PROTECTIVE SUPPORTS FOR SHOULDERS AND ELBOWS; BASEBALL GLOVES, BOXING GLOVES, FENCING GLOVES, GOLF GLOVES, GLOVES FOR GAMES, BOXING GLOVES, BATTING GLOVES, BATS FOR GAMES, PROTECTIVE PADDING FOR SNOWBOARDING AND SKATEBOARDING, WEIGHT LIFTING BELTS, BAGS ESPECIALLY DESIGNED FOR SKIS AND SURFBOARDS, GOLF BAGS, WITH OR WITHOUT WHEELS, ASCENDERS, BARBELLS, BALLS FOR GAMES, IN-LINE ROLLER SKATES, ROLLER SKATES, ICE SKATES, SKIS, HOCKEY STICKS, MEN'S ATHLETIC SUPPORTERS, FLIPPERS FOR SWIMMING, STARTING BLOCKS FOR SPORTS; STATIONARY EXERCISE BICYCLES AND ROLLERS THEREFOR, MANUALLY OPERATED EXERCISE EQUIPMENT FOR PHYSICAL FITNESS PURPOSES; IN-LINE ROLLER SKATES, ROLLER SKATES, ICE SKATES, SKIS, SOLE COVERINGS FOR SKIS, SKATING BOOTS WITH SKATES ATTACHED; APPLIANCES FOR GYMNASTICS IN THE NATURE OF GYMNASTIC APPARATUS (U.S. CLS. 22, 23, 38 AND 50).

SUZANNE BLANE, EXAMINING ATTORNEY

MUNICATION NETWORKS; BUSINESS CONSULTANCY RELATING TO E-COMMERCE; BUSINESS MEDIATION OF TRADE FOR THIRD PARTIES IN THE ONLINE TRADING OF GOODS, KNOWN AS E-COMMERCE; BUSINESS CONSULTANCY, PROMOTION AND ONLINE MARKETING, NAMELY, ADVERTISING OF E-COMMERCE SITES; ADVERTISING SERVICES, NAMELY, PROMOTION AND MARKETING OF WEBSITES; PROVIDING OFFICE FUNCTIONS IN THE CLAIMING OF DOMAIN NAMES; BUSINESS MEDIATION OF TRADE BUSINESS FOR THIRD PARTIES IN THE PURCHASE AND SALE, IMPORT AND EXPORT OF MAGNETIC DATA CARRIERS AND RECORDING DISCS, SOFTWARE AND SOFTWARE PACKAGES, INCLUDING, FOR THE SETTING UP AND MANAGEMENT OF WEBSITES, INTRANETS AND WEB SHOPS AND APPLICATIONS IN THE FIELD OF CONTENT MANAGEMENT AND DATA MANAGEMENT, COMPUTERS, COMPUTER PROGRAMS, COMPUTER PERIPHERAL DEVICES, TELECOMMUNICATION APPARATUS AND DATA COMMUNICATION APPARATUS; INTERIM BUSINESS MANAGEMENT; BUSINESS PROJECT MANAGEMENT; BUSINESS SERVICES IN THE CLAIMING OF DOMAIN NAMES, NAMELY, SERVICES RELATING TO THE ANALYSIS, EVALUATION, CREATION AND BRAND ESTABLISHMENT OF TRADEMARKS, TRADE NAMES AND DOMAIN NAMES; CONSULTANCY, INFORMATION AND PROVIDING INFORMATION REGARDING THE AFORESAID SERVICES, INCLUDING, CONSULTANCY AND INFORMATION PROVIDED VIA ELECTRONIC NETWORKS SUCH AS THE INTERNET (U.S. CLS. 100, 101 AND 102).

CLASS 38—COMMUNICATION

FOR TELECOMMUNICATIONS SERVICES, NAMELY, PROVIDING ACCESS TO TELECOMMUNICATION NETWORKS AND INFORMATION ABOUT TELECOMMUNICATION; PROVIDING ACCESS TO ELECTRONIC COMMUNICATION NETWORKS AND THE INTERNET; ELECTRONIC TRANSMISSION OF MAIL AND MESSAGES; INTERNET SERVICE PROVIDER SERVICES; INFORMATION RELATING TO ALL THE AFORESAID SERVICES, INCLUDING, SUCH INFORMATION PROVIDED ONLINE FROM A COMPUTER NETWORK AND VIA THE INTERNET; TRANSFERRING AND DISSEMINATING INFORMATION AND DATA VIA COMPUTER NETWORKS AND THE INTERNET, NAMELY, PROVIDING MULTIPLE USE ACCESS TO GLOBAL COMPUTER INFORMATION NETWORKS FOR THE TRANSFER AND DISSEMINATION OF A WIDE RANGE OF INFORMATION AND PROVIDING ON-LINE COMMUNICATIONS LINKS WHICH TRANSFER THE WEB SITE USER TO OTHER LOCAL AND GLOBAL WEB PAGES; PROVISION OF TELECOMMUNICATION SERVICES RELATING TO SEARCH ENGINES, E-MAIL AND WORKING GROUPS, NAMELY, ELECTRONIC MAIL SERVICES, PROVIDING ON-LINE CHAT ROOMS AND ELECTRONIC BULLETIN BOARDS FOR TRANSMISSION OF MESSAGES AMONG USERS IN THE FIELD OF GENERAL INTEREST; TELECOMMUNICATIONS CONSULTATION, NAMELY, CONSULTANCY AND ADVICE RELATING TO TELECOMMUNICATION SERVICES IN THE FIELD OF THE MARKETING OF SEARCH ENGINES AND ONLINE ADVERTISING; INTERNET ACCESS PROVIDER SERVICES, NAMELY, PROVIDING ACCESS TO SEARCH ENGINES FOR SEEKING, RETRIEVING, INDEXING, LINKING AND ORGANIZING DATA FOR THE INTERNET, ELECTRONIC COMMUNICATIONS NETWORKS AND ELECTRONIC DATABASES; PROVIDING ACCESS TO DATABASES, NAMELY, PROVIDING ACCESS TO PROPRIETARY COLLECTIONS OF INFORMATION; RENTAL OF TELECOMMUNICATIONS APPARATUS AND DATA COMMUNICATION APPARATUS; PROVIDING AND RENTAL OF ACCESS TIME TO GLOBAL COMPUTER NETWORKS TO ACCESS SEARCH ENGINES FOR SEEKING, RETRIEVING, INDEXING, LINKING AND ORGANIZING DATA FOR THE INTERNET, ELECTRONIC COMMUNICATIONS NETWORKS AND ELECTRONIC DATABASES; CONSULTANCY, INFORMATION AND PROVIDING INFORMATION REGARDING THE AFORESAID SERVICES, INCLUDING, CONSULTANCY AND INFORMATION PROVIDED VIA ELECTRONIC NETWORKS SUCH AS THE INTERNET (U.S. CLS. 100, 101 AND 104).

CLASS 42—SCIENTIFIC AND COMPUTER SERVICES

FOR SCIENTIFIC AND TECHNOLOGICAL SERVICES AND RESEARCH AND DESIGN RELATING THERETO, NAMELY, SCIENTIFIC RESEARCH, INFORMATION TECHNOLOGY CONSULTATION, NEW PRODUCT DESIGN SERVICES; DESIGN, DEVELOPMENT, UPDATING, UPGRADING, IMPLEMENTING AND MAINTENANCE OF COMPUTER SOFTWARE; DESIGN AND DEVELOPMENT OF COMPUTERS; UPDATING AND UPGRADING OF COMPUTERS, NAMELY, REMOTE COMPUTER NETWORK TECHNICAL MONITORING AND SOFTWARE MAINTENANCE SERVICES; DESIGN, DEVELOPMENT, UPDATING, IMPLEMENTING, MAINTENANCE, GRAPHIC DESIGN AND CREATION OF WEBSITES AND OF ACCESS PORTALS FOR WEBSITES; PROVIDING OF SEARCH ENGINES, NAMELY, PROVIDING ONLINE NON-DOWNLOADABLE SOFTWARE FOR SEARCHING WEBSITES AND THE PROVISION OF INTERNET SEARCH ENGINES; HOSTING OF WEB SITES; DESIGN AND DEVELOPMENT OF TECHNICAL APPLICATIONS; COMPUTER SYSTEMS ANALYSIS; COMPUTER PROGRAMMING; AUTOMATION SERVICES, NAMELY, DATA AUTOMATION AND COLLECTION SERVICE USING PROPRIETARY SOFTWARE TO EVALUATE, ANALYZE AND COLLECT SERVICE DATA; CONSULTANCY, INFORMATION AND PROVIDING INFORMATION REGARDING THE AFORESAID SERVICES, INCLUDING, CONSULTANCY AND INFORMATION PROVIDED VIA ELECTRONIC NETWORKS SUCH AS THE INTERNET (U.S. CLS. 100 AND 101).

TINA BROWN, EXAMINING ATTORNEY

SN 79-105,826, HANS GEORG HAGLEITNER, AUSTRIA, FILED 12-17-2010.

HAGLEITNER

THE MARK CONSISTS OF STANDARD CHARACTERS WITHOUT CLAIM TO ANY PARTICULAR FONT, STYLE, SIZE, OR COLOR.

OWNER OF INTERNATIONAL REGISTRATION 0742846 DATED 8-18-2000, EXPIRES 8-18-2020.

CLASS 3—COSMETICS AND CLEANING PREPARATIONS

FOR BLEACHING PREPARATIONS FOR LAUNDRY USE; SUBSTANCES FOR LAUNDRY USE, NAMELY, BLEACHING SALTS, BLEACHING SODA, WASHING PREPARATIONS AND LAUNDRY BLEACH, LAUNDRY DETERGENTS, LAUNDRY SOAP, FABRIC SOFTENERS FOR LAUNDRY USE, LAUNDRY FABRIC CONDITIONER, LAUNDRY STARCH AND LAUNDRY WAX; CLEANING, POLISHING, SCOURING AND ABRASIVE PREPARATIONS; SOAPS, NAMELY, ANTIBACTERIAL SOAP, LIQUID SOAPS, SOAPS AND DETERGENTS, SOAPS FOR PERSONAL USE, SOAPS FOR BODY CARE, COSMETIC SOAPS, SOAPS FOR TOILET PURPOSES, WATERLESS SOAP, INDUSTRIAL SOAP, HAND SOAPS, DISINFECTANT SOAPS AND DEODORANT SOAP; SHOWER GELS, BUBBLE BATHS, PERFUMERY, COSMETICS; CLEANING PRODUCTS IN COMPACT FORM, NAMELY, HAIR SHAMPOOS AND CONDITIONERS SOLD IN SMALL, COMPACT FORMS OR TRAVEL SIZES, SOAPS FOR PERSONAL USE AND BODY CARE SOLD IN SMALL, COMPACT FORMS OR TRAVEL SIZES, CLEANING PREPARATIONS, ALL PURPOSE CLEANING PREPARATIONS, ALL PURPOSE CLEANING PREPARATION WITH DEODORIZING PROPERTIES, CLEANING PREPARATIONS FOR KITCHENS AND BATHROOMS, AND CLEANING PREPARATIONS FOR CLEANING SURFACES, EACH IN TABLET, SMALL BOTTLE OR SMALL CONTAINER OR SMALL SPRAY BOTTLE OR CONTAINER FORM, AND DISHWASHING DETERGENTS IN TABLET FORM; PRE-MOISTENED COSMETIC WIPES, DISPOSABLE WIPES IMPREGNATED WITH CLEANING CHEMICALS OR COMPOUNDS FOR INDUSTRIAL AND COMMERCIAL USE AND WIPES IMPREGNATED WITH A CLEANING PREPARATION (U.S. CLS. 1, 4, 6, 50, 51 AND 52).

CLASS 16—PAPER GOODS AND PRINTED MATTER

FOR PAPER PRODUCTS NOT INCLUDED IN OTHER CLASSES, NAMELY, TOILET PAPER, PAPER TOWEL ROLLS FOR DRYING THE HANDS, PAPER FACE TOWELS, DISPOSABLE WIPES NOT IMPREGNATED WITH CHEMICALS OR COMPOUNDS, CLEANING PAPER IN THE NATURE OF PAPER TOWELS, PAPER NAPKINS, NAPKINS OF PAPER FOR REMOVING MAKE-UP, COSMETIC REMOVING PAPER, PAPER TISSUES, PAPER TISSUES FOR COSMETIC USE, PAPER HAND TOWELS AND PAPER WASHCLOTHS, ABSORBENT PAPER IN THE NATURE OF BLOTTING PAPER, ABSORBENT PADS OF PAPER AND CELLULOSE FOR USE IN FOOD PACKAGING, ABSORBENT SHEETS OF PAPER OR PLASTIC FOR FOODSTUFF PACKAGING; SANITARY SACHETS OF PAPER OR PLASTIC, NAMELY, PAPER REFUSE BAGS, PLASTIC DISPOSABLE DIAPER BAGS, CREPE PAPER FOR MEDICAL, SANITARY OR DOMESTIC USE, PLASTIC BAGS IN THE SHAPE OF TUBES FOR THE STORAGE AND DISPOSAL OF WASTE, INCLUDING SANITARY WASTE SUCH AS DIAPERS AND NAPPIES, FEMININE HYGIENE PRODUCTS AND INCONTINENCE PRODUCTS, PAPER OR PLASTIC SACHET BAGS FOR HOUSEHOLD USE FOR CARRYING COSMETICS AND TOILETRIES, PAPER OR PLASTIC TRASH BAGS FOR DISPOSING WASTE (U.S. CLS. 2, 5, 22, 23, 29, 37, 38 AND 50).

CLASS 21—HOUSEWARES AND GLASS

FOR TOILETRY ARTICLES, NAMELY, DISPENSERS FOR HOUSEHOLD OR COMMERCIAL USE FOR SOAP, PAPER TOWELS, PAPER NAPKINS, TOILET PAPER, CLEANING AND DISINFECTING SOLUTIONS; TOILETRY ARTICLES, NAMELY, DISPENSING UNITS FOR HOUSEHOLD OR COMMERCIAL PURPOSES FOR HOLDING AND DISPENSING SANITARY SACHETS IN THE NATURE OF PAPER REFUSE BAGS, PLASTIC DISPOSABLE DIAPER BAGS, CREPE PAPER FOR MEDICAL, SANITARY OR DOMESTIC USE, PLASTIC BAGS IN THE SHAPE OF TUBES FOR THE STORAGE AND DISPOSAL OF WASTE, INCLUDING SANITARY WASTE SUCH AS DIAPERS AND NAPPIES, FEMININE HYGIENE PRODUCTS AND INCONTINENCE PRODUCTS, PAPER OR PLASTIC SACHET BAGS FOR HOUSEHOLD USE FOR CARRYING COSMETICS AND TOILETRIES, PAPER OR PLASTIC TRASH BAGS FOR DISPOSING

WASTE; TOILETRY ARTICLES IN THE NATURE OF BATHROOM FITTINGS, NAMELY, DISPENSING UNITS FOR HOUSEHOLD OR COMMERCIAL PURPOSES FOR DISPENSING DISPOSABLE DIAPERS AND DIAPER LINERS AND DISPENSING UNITS FOR HOUSEHOLD OR COMMERCIAL PURPOSES FOR DISPENSING WRAPPING MATERIALS FOR SANITARY WASTE SUCH AS DIAPERS, NAPPIES, FEMININE HYGIENE PRODUCTS AND INCONTINENCE PRODUCTS; TOILETRY ARTICLES, NAMELY, DISPENSING UNITS FOR HOUSEHOLD OR COMMERCIAL PURPOSES FOR HOLDING AND DISPENSING COSMETIC ITEMS, NAMELY, DISPENSERS FOR COSMETIC COTTON BALLS, SOAPS AND FACIAL TISSUES; CLEANING RAGS (U.S. CLS. 2, 13, 23, 29, 30, 33, 40 AND 50).

ANDREW LEASER, EXAMINING ATTORNEY

SN 79-105,882. GIORGIO ARMANI S.P.A., MILAN.; SWISS BRANCH MENDRISIO, SWITZERLAND, FILED 9-30-2011.



OWNER OF INTERNATIONAL REGISTRATION 1028641 DATED 12-15-2009, EXPIRES 12-15-2019.

OWNER OF U.S. REG. NOS. 3,853,927, 4,037,082 AND OTHERS.

NO CLAIM IS MADE TO THE EXCLUSIVE RIGHT TO USE "EMPORIO", APART FROM THE MARK AS SHOWN.

THE MARK CONSISTS OF THE STYLIZED WORDING "EA7 EMPORIO ARMANI" WITH AN EAGLE WITH SPREAD WINGS CONTAINING THE STYLIZED WORDING "GA" BETWEEN THE WORDS "EMPORIO" AND "ARMANI".

THE ENGLISH TRANSLATION OF THE WORD "EMPORIO" IN THE MARK IS EMPORIUM.

CLASS 3—COSMETICS AND CLEANING PREPARATIONS

FOR BLEACHING PREPARATIONS, DETERGENTS AND FABRIC SOFTENERS FOR LAUNDRY USE; CLEANING PREPARATIONS FOR BATHROOMS, KITCHENS, CABINETS AND APPLIANCES AND FOR LAUNDRY USE; POLISHING PREPARATIONS FOR USE IN BATHROOMS, ON KITCHEN CABINETS, APPLIANCES AND ON FURNITURE; SCOURING PREPARATIONS FOR USE IN BATHROOMS AND KITCHEN APPLIANCES AND FIXTURES; ABRASIVE CLEANING PREPARATIONS FOR USE IN BATHROOMS AND KITCHEN APPLIANCES AND FIXTURES; HAND, FACIAL AND BATH SOAPS; PERFUMERY, ESSENTIAL OILS FOR PERSONAL USE, COSMETICS, HAIR LOTIONS; DENTIFRICES (U.S. CLS. 1, 4, 6, 50, 51 AND 52).

CLASS 9—ELECTRICAL AND SCIENTIFIC APPARATUS

FOR SCIENTIFIC, NAUTICAL, SURVEYING, PHOTOGRAPHIC, CINEMATOGRAPHIC, OPTICAL, WEIGHING, MEASURING, SIGNALING, CHECKING, SUPERVISION, LIFE SAVING AND TEACHING APPARATUS AND INSTRUMENTS, NAMELY, SPECTACLES, EYEGLASSES, SUNGLASSES, SPORT GLASSES, PINCENES, CASES FOR EYEGLASSES AND SUNGLASSES, CHAINS FOR EYEGLASSES AND SUNGLASSES, FRAMES FOR EYEGLASSES AND SUNGLASSES, LENSES FOR EYEGLASSES AND SUNGLASSES, PHOTOGRAPHIC CAMERAS, OPTICAL FILTERS, CINEMATOGRAPHIC CAMERAS; APPARATUS FOR RECORDING, TRANSMITTING AND REPRODUCING SOUND OR IMAGES, NAMELY, MAGNETIC RECORDING MEDIA AND RECORDING DISCS, NAMELY, BLANK COMPACT DISCS, DVD DISCS, PRE-RECORDED COMPACT DISCS, AUDIO CASSETTES, PHONOGRAPH RECORDS, VIDEOTAPE AND DIGITAL VIDEO DISCS, ALL FEATURING MUSIC AND FASHION, COMPACT DISC PLAYERS; AUTOMATIC VENDING MACHINES, DATA PROCESSORS AND COMPUTERS (U.S. CLS. 21, 23, 26, 36 AND 38).

CLASS 11—ENVIRONMENTAL CONTROL APPARATUS

FOR APPARATUS FOR LIGHTING, NAMELY, LAMPS, LIGHTING FIXTURES, ELECTRIC LIGHTING FIXTURES, STRIP LIGHTING, LANTERNS FOR LIGHTING, LIGHTING TRACKS, SCONCE LIGHTING FIXTURES, SOLAR LIGHT FIXTURES, AND LED LIGHTING FIXTURES (U.S. CLS. 13, 21, 23, 31 AND 34).

CLASS 14—JEWELRY

FOR PRECIOUS METALS AND THEIR ALLOYS AND GOODS MADE OF THESE MATERIALS OR PLATED THEREWITH INCLUDED IN THIS CLASS, NAMELY, WATCH STRAPS, JEWELRY AND WATCH CASES MADE OF PRECIOUS METALS; JEWELRY, NAMELY, EARRINGS, BRACELETS, NECKLACES, RINGS, PENDANTS, BROOCHES, CHAINS, PINS, MEDALLIONS, CUFFLINKS, TIE CLIPS; PRECIOUS STONES, TIMEPIECES AND CHRONOMETRIC INSTRUMENTS, NAMELY, WATCHES (U.S. CLS. 2, 27, 28 AND 50).

CLASS 16—PAPER GOODS AND PRINTED MATTER

FOR PAPER, CARDBOARD AND GOODS MADE THEREOF, NAMELY, ADDRESS BOOKS; AGENDAS, PHOTOGRAPHS, PHOTOGRAPH ALBUMS, ANNIVERSARY BOOKS, ANNOUNCEMENT CARDS, APPOINTMENT BOOKS, BLANK CARDS, BLANK NOTE CARDS, BLANK OR PARTIALLY PRINTED PAPER LABELS, BLANK OR PARTIALLY PRINTED POSTCARDS, BOOK COVERS, BOOK HOLDERS, BOOKENDS, BOOKMARKS, BUSINESS CARDS, CALENDARS, POCKET MEMORANDUM BOOKS, STATIONERY, WRITING PAPER, NOTEBOOKS, MEMO PAPER, POSTERS, GREETING CARDS, NOTE CARDS, CATALOGUES IN THE FIELD OF FASHION, HOME DESIGN, FURNITURE, ACCESSORIES, ART, SHOPPING, GARDENING AND GARDEN FURNITURE; ENVELOPES, BOXES FOR PENS, PAPER BOXES, CARDBOARD CONTAINERS, PRINTED PAPER OR CARDBOARD SIGNS, PRICE TAGS, PRODUCT COMPOSITION TAGS AND CARE INSTRUCTION TAGS OF PAPER, COIN AND STAMP ALBUMS; PRINTED MATTER, NAMELY, BOOKS, MAGAZINES AND BROCHURES IN THE FIELDS OF FASHION, HOME DESIGN, FURNITURE, ACCESSORIES, ART, SHOPPING, GARDENING AND GARDEN FURNITURE; BOOK-BINDING MATERIAL, NAMELY, BINDING, WIRE AND TAPE; STATIONERY, ADHESIVES FOR STATIONERY OR HOUSEHOLD PURPOSES; ARTISTS' SUPPLIES, NAMELY, ARTISTS' PENS, ARTISTS' BRUSHES, ARTISTS' PASTELS, ART PAPER, ART PRINTS, ART

PICTURES, SKETCH PADS; PAINTBRUSHES; TYPEWRITERS AND OFFICE ARTICLES, NAMELY, PENCILS, PEN HOLDERS, FOUNTAIN PENS, ERASERS, WRITING INKS, INKWELLS, BALL POINT PENS, PENCIL CASES, PAPER CLIPS; PRINTED INSTRUCTIONAL AND TEACHING MATERIALS IN THE FIELD OF FASHION, HOME DESIGN, FURNITURE, ACCESSORIES, ART, SHOPPING, GARDENING AND GARDEN FURNITURE; PLASTIC BAGS AND PLASTIC BUBBLE PACKS FOR WRAPPING AND FOR PACKAGING; PRINTER'S TYPE, PRINTING BLOCKS (U.S. CLS. 2, 5, 22, 23, 29, 37, 38 AND 50).

CLASS 20—FURNITURE AND ARTICLES NOT OTHERWISE CLASSIFIED

FOR FURNITURE, MIRRORS AND PICTURE FRAMES, MADE OF WOOD, CORK, REED, CANE, WICKER, HORN, BONE, IVORY, WHALEBONE, SHELL, AMBER, MOTHER OF PEARL, MEERSCHAUM AND SUBSTITUTES FOR ALL THESE MATERIALS, OR OF PLASTICS; EARTHENWARE AND CRYSTAL PICTURE AND MIRROR FRAMES; DECORATIVE PLASTIC BOXES (U.S. CLS. 2, 13, 22, 25, 32 AND 50).

CLASS 21—HOUSEWARES AND GLASS

FOR HOUSEHOLD OR KITCHEN UTENSILS AND CONTAINERS NOT OF PRECIOUS METAL OR COATED THEREWITH, NAMELY, EMPTY PERFUME ATOMIZERS, PLASTIC BATH RACKS, SOAP BOXES, SOAP DISPENSERS, PAPER TOWEL DISPENSERS, SHAVING BRUSHES, SHAVING BRUSH STANDS, FOOTWEAR BRUSHES, COSMETIC BRUSHES, HAIR BRUSHES, ELECTRIC AND NON-ELECTRIC TOOTH BRUSHES, FITTED VANITY CASES, CLEANING COTTON, COMBS, FACIAL SPONGES, CLEANING SPONGES, COMB CASES, HAIR COMBS, SPONGE HOLDERS, TOILET TISSUE HOLDERS, HOUSEHOLD SPONGES, POWDER PUFFS, TOWEL BARS AND RINGS, WASH BASINS; BAKEWARE AND COOKWARE, NAMELY, NON-ELECTRIC STEEL METALLIC GRILLS, CONFECTIONER'S DECORATING BAGS, SERVING SPOONS, SLOTTED SPOONS, BASTING SPOONS, MIXING SPOONS, CUTTING BOARDS, BREAD BOXES, CAKE SERVERS, CASEROLES, STRAINERS, SIEVES AND COLANDERS FOR HOUSEHOLD USE, COOKERY MOLDS, COOKIE CUTTERS, CORN COB HOLDERS, CRUETS NOT OF PRECIOUS METALS FOR OIL AND VINEGAR, GARLIC PRESSES, PEPPER GRINDERS, NON-ELECTRIC GRIDDLES, GRATERS, SPATULAS, TURNERS, WHISKS, ICE-CUBE MOLDS FOR REFRIGERATORS, KITCHEN LADLES, LEMON SQUEEZERS, SCOOPS, SALT AND PEPPER SHAKERS, BASINS FOR HOLDING AND STORING FOOD ITEMS AND BEVERAGES, BOWLS, CANISTER SETS, CHINA ORNAMENTS, CONTAINERS FOR FOOD, INSULATING JARS, PITCHERS, POTS, VASES NOT OF PRECIOUS METAL, GRAVY BOATS, COVERS FOR DISHES AND POTS, BUTTER DISHES, NAPKIN HOLDERS, TOOTHPICK HOLDERS, NON-ELECTRIC KETTLES, NON-ELECTRIC PRESSURE COOKERS, PANS, PLATES, SERVING PLATTERS, SAUCEPANS, SAUCERS, SOUP TUREENS, SERVING TRAYS NOT OF PRECIOUS METALS; BARWARE, NAMELY, SELTZER BOTTLES, CAVIAR COOLERS, COCKTAIL PICKS, COCKTAIL SHAKERS, DECANTERS, BEVERAGE STIRRERS, SWIZZLE STICKS, WINE TASTERS, SODA SIPHONS; BEVERAGeware, NAMELY, WINE BOTTLE CRADLES, BOTTLE OPENERS, ICE BUCKETS, CUPS, CORK SCREWS, JUGS, MUGS, DRINKING GLASSES, DRINKING VESSELS, REAMERS FOR FRUIT JUICES, NON-ELECTRIC JUICERS, TEA AND COFFEE SERVICES, NOT OF PRECIOUS METAL, COFFEE STIRRERS, HAND OPERATED COFFEE GRINDERS, DOMESTIC COFFEE MEASURERS, NON-ELECTRIC COFFEE PERCOLATORS AND POTS, TEA BALLS NOT PRECIOUS METALS, TEA INFUSERS AND TEA POTS NOT PRECIOUS METALS; TEA CADDIES; STEEL WOOL FOR CLEANING; NON-ELECTRIC CARPET BEATERS AND CARPET CLEANERS, WASTEPAPER BASKETS, DUST BINS, IRONING BOARDS AND SHAPED COVERS THEREFOR, DECORATIVE BOXES MADE OF GLASS OR PORCELAIN, DECORATIVE PLATES, CLOTHES BRUSHES, CRUMB BRUSHES, DISHWASHING BRUSHES, STOVE BURNER COVERS, NON-ELECTRIC CANDELABRAS NOT PRECIOUS METAL, CANDLESTICKS NOT OF PRECIOUS METALS, FLOWER POTS,

FLOWER POT HOLDERS; UNWORKED OR SEMI-WORKED GLASS EXCEPT BUILDING GLASS; GLASS, PORCELAIN OR EARTHENWARE DOORKNOBS AND DOOR HANDLES, CLOTHES DRYING RACKS, ALL-PURPOSE PORTABLE HOUSEHOLD CONTAINERS, ENAMELED GLASS, OPALINE GLASS, STAINED GLASS, UNWROUGHT GLASS, GLASS TUBES FOR NON-SCIENTIFIC PURPOSES, CINDER SIFTERS FOR HOUSEHOLD USE, COAL SCUTTLES, DUTCH OVENS, PLASTIC COASTERS, DECORATIVE CRYSTAL PRISMS, PORCELAIN EGGS; EARTHENWARE AND CRYSTAL VASES, BOWLS, MUGS, CUPS, DISHES, PITCHERS, PLATTERS, SERVING TRAYS AND PICTURE FRAMES; PORCELAIN FIGURES, FUNNELS, GARDENING GLOVES, LAWN SPRINKLERS, PAILS (U.S. CLS. 2, 13, 23, 29, 30, 33, 40 AND 50).

CLASS 24—FABRICS

FOR TEXTILES AND TEXTILE GOODS, NAMELY, FABRIC FOR UPHOLSTERY, FABRIC FOR MAKING CLOTHES; BED AND TABLE COVERS, NAMELY, BED SPREADS, BED SHEETS, COMFORTERS, DUVETS, DUVET COVERS, BLANKETS, TABLE CLOTHS NOT OF PAPER, TEXTILE NAPKINS (U.S. CLS. 42 AND 50).

CLASS 41—EDUCATION AND ENTERTAINMENT

FOR ARRANGING AND CONDUCTING EDUCATIONAL CONFERENCES, CONGRESSES, SEMINARS, AND SYMPOSIUMS IN THE FIELDS OF FASHION, FASHION MERCHANDISING, BEAUTY, BOOKS AND MUSIC, FURNISHING, TRAVELS, GARDENING; ENTERTAINMENT IN THE NATURE OF BEAUTY CONTESTS; PUBLICATION OF BOOKS, MUSIC PRODUCTION SERVICES; MUSIC PUBLISHING SERVICES; ORGANIZATION OF EXHIBITIONS FOR CULTURAL, EDUCATIONAL, SPORTING AND ENTERTAINMENT PURPOSES; ENTERTAINMENT IN THE NATURE OF FASHION SHOWS; PRESENTATION OF LIVE PERFORMANCES, NAMELY, FASHION SHOWS, MUSIC, SINGING; PHOTOGRAPHIC REPORTING; ENTERTAINMENT IN THE NATURE OF THEATRE PRODUCTIONS (U.S. CLS. 100, 101 AND 107).

KRISTIN DAHLING, EXAMINING ATTORNEY

SN 79-105,901, FDD-MB STUDY GROUP ASSOCIATION, ISHIKAWA-KEN, JAPAN, FILED 10-19-2011.

FDD—MB

THE MARK CONSISTS OF STANDARD CHARACTERS WITHOUT CLAIM TO ANY PARTICULAR FONT, STYLE, SIZE, OR COLOR.

OWNER OF INTERNATIONAL REGISTRATION 1057175 DATED 7-1-2010, EXPIRES 7-1-2020.

CLASS 42—SCIENTIFIC AND COMPUTER SERVICES

FOR TESTING, INSPECTION OR RESEARCH IN THE FIELD OF MEDICAL TECHNOLOGY, INFORMATION AND CONSULTANCY SERVICES RELATING THERETO (U.S. CLS. 100 AND 101).

CLASS 44—MEDICAL, BEAUTY AND AGRICULTURAL SERVICES

FOR MEDICAL ANALYSIS SERVICES FOR THE TREATMENT OF PERSONS; MEDICAL ADVICE OR CONSULTING; MEDICAL SERVICES IN THE NATURE OF PHYSICAL EXAMINATION SERVICES; PROVIDING MEDICAL INFORMATION, SPECIFICALLY, PHYSICAL EXAMINATION INFORMATION (U.S. CLS. 100 AND 101).

EVELYN BRADLEY, EXAMINING ATTORNEY

SN 79-105,940, CROSS COMPANY CO., LTD., OKAYAMA 700-0903, JAPAN, FILED 9-30-2011.



OWNER OF INTERNATIONAL REGISTRATION 1098559 DATED 9-30-2011, EXPIRES 9-30-2021.

THE MARK CONSISTS OF DESIGNS OF BUTTERFLIES, LEAVES, BIRDS, FLOWERS AND HEARTS FORMING THE SHAPE OF A CIRCLE.

CLASS 14—JEWELRY

FOR JEWELRY MADE OF PRECIOUS METALS OR COATED THEREWITH, NAMELY, EARRINGS, NECKLACES, BRACELETS, BROOCHES, PENDANTS, CHAINS, RINGS, TIE PINS, TIE CLIPS AND CUFF LINKS; JEWELRY MADE OF GEMS, NAMELY, GEM BROOCHES, GEM PENDANT HEADS AND GEM RINGS, GEM EARRINGS; PRECIOUS AND SEMI-PRECIOUS STONES; CHARMS; KEY RINGS OF PRECIOUS METAL OR COATED THEREWITH; HOROLOGICAL AND CHRONOMETRIC INSTRUMENTS (U.S. CLS. 2, 27, 28 AND 50).

CLASS 18—LEATHER GOODS

FOR BAGS, NAMELY, HAND BAGS, SHOULDER BAGS, BRIEFCASES, LEATHER AND CANVAS SHOPPING BAGS, BACKPACKS, SUITCASES, LUGGAGE AND TRAVELING BAGS; PRODUCTS MADE OF LEATHER AND IMITATION LEATHER, NAMELY, PURSES, WALLETS, CREDIT CARD CASES, BUSINESS CARD CASES, KEY CASES; COSMETIC BAGS SOLD EMPTY; UMBRELLAS AND PARASOLS (U.S. CLS. 1, 2, 3, 22 AND 41).

CLASS 25—CLOTHING

FOR CLOTHING, NAMELY, SUITS, DRESSES, COATS, OVERCOATS, JACKETS, RAINWEAR, PANTS, SKIRTS, JEANS, BLOUSES, SHIRTS, T-SHIRTS, VESTS, SWEATERS, UNDERWEAR, NIGHTWEAR, SWEAT SUITS, SWIMWEAR, TIES, SCARVES, SHAWLS, MUFFLERS, GLOVES, SOCKS, TIGHTS, SOCK SUSPENDERS, STOCKING SUSPENDERS, BRACES FOR CLOTHING, JAPANESE STYLE CLOTHING BEING KIMONOS; SASHES; WEDDING DRESSES; WAIST BELTS FOR CLOTHING; HEADGEAR, NAMELY, CAPS AND HATS; FOOTWEAR, NAMELY, SHOES, BOOTS, SANDALS, SLIPPERS, JAPANESE STYLE CLOGS AND SANDALS (U.S. CLS. 22 AND 39).

ERIN FALK, EXAMINING ATTORNEY

SN 79-106,114. HERSI HASSAN-MOHAMED, FED REP GERMANY, FILED 10-11-2011.

CANEEO

THE MARK CONSISTS OF STANDARD CHARACTERS WITHOUT CLAIM TO ANY PARTICULAR FONT, STYLE, SIZE, OR COLOR.

PRIORITY DATE OF 4-14-2011 IS CLAIMED.
OWNER OF INTERNATIONAL REGISTRATION 1099143 DATED 10-11-2011, EXPIRES 10-11-2021.

THE WORDING "CANEEO" HAS NO MEANING IN A FOREIGN LANGUAGE.

CLASS 14—JEWELRY

FOR JEWELLERY; WRISTLET WATCHES; CHRONOGRAPHS FOR USE AS WATCHES; POCKET WATCHES; CLOCKS (U.S. CLS. 2, 27, 28 AND 50).

CLASS 18—LEATHER GOODS

FOR LEATHER AND IMITATIONS OF LEATHER, AND GOODS MADE OF THESE MATERIALS INCLUDED IN THIS CLASS, NAMELY, LUGGAGE; SKINS AND HIDES; TRUNKS AND SUITCASES; UMBRELLAS; PARASOLS; WALKING-STICKS (U.S. CLS. 1, 2, 3, 22 AND 41).

CLASS 25—CLOTHING

FOR CLOTHING, NAMELY, SHIRTS, PANTS, AND SHOES; FOOTWEAR; HEADGEAR, NAMELY, CAPS AND HATS (U.S. CLS. 22 AND 39).

CLASS 35—ADVERTISING AND BUSINESS

FOR RETAIL STORE AND ONLINE RETAIL STORE SERVICES IN THE FIELD OF: CLOCKS AND JEWELLERY, BAG-MAKER PRODUCTS AND SADDLERY, CLOTHING, FOOTWEAR AND TEXTILE ARTICLES (U.S. CLS. 100, 101 AND 102).

AHSEN KHAN, EXAMINING ATTORNEY

SN 79-106,229. VIBRAM S.P.A., ITALY, FILED 3-24-2011.



PRIORITY DATE OF 10-5-2010 IS CLAIMED.
OWNER OF INTERNATIONAL REGISTRATION 1099482 DATED 3-24-2011, EXPIRES 3-24-2021.

OWNER OF U.S. REG. NOS. 822,309, 988,983 AND OTHERS.

THE COLOR(S) YELLOW AND BLACK IS/ARE CLAIMED AS A FEATURE OF THE MARK.

THE MARK CONSISTS OF THE WORD "VIBRAM" IN YELLOW AND BLACK STYLIZED SCRIPT POSITIONED INTO A YELLOW AND BLACK OCTAGONAL DESIGN.

CLASS 9—ELECTRICAL AND SCIENTIFIC APPARATUS

FOR OPTICAL AND PHOTOGRAPHIC APPARATUS AND INSTRUMENTS, NAMELY, SUNGLASSES, EYEGLASSES AND GOGGLES, NAMELY, GOGGLES FOR SPORTS AND SAFETY GOGGLES, FRAMES FOR SUNGLASSES AND REPLACEMENT PARTS THEREOF, STRAPS USED FOR SUNGLASSES, CONTACT LENSES, SPECTACLE LENSES, CORRECTIVE LENSES, NAMELY, OPHTHALMIC LENSES, CONTACT LENSES CASES, PHOTOGRAPHIC CAMERAS, PACKS AND BAGS FOR CARRYING PHOTOGRAPHIC GEAR, SHUTTERS FOR CAMERAS, CAMERA STANDS, FILTERS FOR ULTRAVIOLET RAYS FOR PHOTOGRAPHY, TELESCOPES, BINOCULARS, NIGHT VISION GOGGLES, EYE PIECES, VIEW FINDERS, LENSES, NAMELY, LENSES FOR CAMERAS, PRISMS, LENS FILTERS, POLARIZING LENSES FOR CAMERAS, OPTICAL MIRRORS FOR SCIENTIFIC AND TECHNICAL USE, TRIPODS, MOUNTS AND BALANCE WEIGHTS FOR TELESCOPES, MICROSCOPES, ADAPTERS FOR MOUNTING PHOTOGRAPHIC EQUIPMENT TO TELESCOPES, FOCUSING MECHANISMS FOR OPTICAL APPARATUS IN THE NATURE OF TELESCOPES AND CAMERAS, ELECTRONIC DRIVE APPARATUS FOR TELESCOPES, KEYPADS AND HAND CONTROLLERS FOR TELESCOPES, ELECTRONIC FOCUSING APPARATUS FOR TELESCOPES, OPTICAL IMAGING APPARATUS FOR TELESCOPES AND BINOCULARS, AND CHARGE COUPLED IMAGING DEVICE FOR CAMERAS; LAPTOP CARRYING CASES; AUTOMATIC VENDING MACHINES; MECHANISMS FOR COIN-OPERATED APPARATUS; CASH REGISTERS, CALCULATING MACHINES, DATA PROCESSING EQUIPMENT AND COMPUTERS; FIRE-EXTINGUISHING APPARATUS; AND FOOTWEAR, CLOTHING AND MASKS FOR PROTECTION AGAINST ACCIDENTS, IRRADIATION AND FIRE (U.S. CLS. 21, 23, 26, 36 AND 38).

CLASS 10—MEDICAL APPARATUS

FOR SURGICAL APPARATUS AND INSTRUMENTS; ARTIFICIAL LIMBS, EYES AND TEETH; ORTHOPEDIC ARTICLES, NAMELY, ORTHOPEDIC SUPPORTS; SUTURE MATERIALS; ORTHOPAEDIC FOOTWEAR; ORTHOPAEDIC SOLES (U.S. CLS. 26, 39 AND 44).

CLASS 17—RUBBER GOODS

FOR RUBBER, GUTTA-PERCHA ALL IN THE FORM OF SHEETS, GUM FOR USE AS ADHESIVES FOR INDUSTRIAL AND COMMERCIAL USE; PLASTICS IN EXTRUDED FORM FOR USE IN MANUFACTURE; PACKING, STOPPING AND INSULATING MATERIALS; FLEXIBLE PIPES, NOT OF METAL (U.S. CLS. 1, 5, 12, 13, 35 AND 50).

CLASS 18—LEATHER GOODS

FOR BAGS, NAMELY, HANDBAGS, HOLDALLS, SPORTS BAGS, SHOULDER BAGS, RUCKSACKS, TRAVELLING BAGS, TRUNKS, VALISES, GARMENT CARRIERS FOR SUITS, SHIRTS AND DRESSES, NAMELY, GARMENT BAGS FOR TRAVEL, SOUVENIR BAGS, CLUTCH BAGS, LEATHER KEY CASES, BOOK BAGS, UNFITTED VANITY CASES, SHOULDER BAGS, AT-TACHÉ CASES, TROLLEY CASES WITH WHEELS, NAMELY, GENERAL PURPOSE SPORT TROLLEY BAGS; NOTECASES, NAMELY, BUSINESS CARD CASES; WALLETS; CARD CASES, NAMELY, CREDIT CARD CASES; BRIEFCASES; BUSINESS CARD HOLDERS IN THE NATURE OF DESKTOP BUSINESS CARD HOLDERS; TELEPHONE CARD AND CREDIT CARD HOLDERS; VISITING CARD HOLDERS IN THE NATURE OF BUSINESS CARD CASES; POUCHES, NAMELY, LEATHER POUCHES; CHANGE PURSES; UMBRELLAS; PARASOLS; WALKING STICKS; WHIPS, HARNESS AND SADDLERY (U.S. CLS. 1, 2, 3, 22 AND 41).

CLASS 25—CLOTHING

FOR CLOTHING, NAMELY, COATS, MANTLES, RAINCOATS, DRESSES, SUITS, SKIRTS, JACKETS, TROUSERS, PANTS, JEANS, WAISTCOATS, SHIRTS, T-SHIRTS, BLOUSES, JERSEYS, SWEATERS, BLAZERS, CARDIGANS, STOCKINGS, SOCKS, SHORTS, UNDERWEAR, CORSETS, NIGHTGOWNS, PAJAMAS, GIRDLES, GARTER BELTS, BATHROBES, BATHING SUITS, SUN SUITS, SPORT JACKETS, WIND-RESISTANT JACKETS, ANORAKS, SKI PANTS, SWEAT SUITS, TIES, NECKTIES, SCARVES, SHAWLS, FOULARDS, GLOVES, SASHES, BELTS; FOOTWEAR; HEADGEAR, NAMELY, HATS AND CAPS (U.S. CLS. 22 AND 39).

CLASS 28—TOYS AND SPORTING GOODS

FOR RUBBER BALLS; TOYS FOR ANIMALS; BAGS FOR SKIS, SKATING BOOTS WITH SKATES ATTACHED, CLIMBERS' HARNESS, SOLE COVERING FOR SKIS, EDGES OF SKIS, ELBOW GUARDS FOR ATHLETIC USE, GOLF BAGS WITH OR WITHOUT WHEELS, KNEE GUARDS FOR ATHLETIC USE, SCOOTER TOY, SKATEBOARD, SKIS, SKI BOOTS, SNOW BOARDS, SURF BOARDS, TOYS FOR DOMESTIC PETS, WATER SKIS (U.S. CLS. 22, 23, 38 AND 50).

GEORGE LORENZO, EXAMINING ATTORNEY

CLASS 28—TOYS AND SPORTING GOODS

FOR TOY CHRISTMAS TREES AND OTHER TOYS, NAMELY, PLUSH TOYS, DOLLS, ACTION SKILL GAMES, BOARD GAMES, CARD GAMES, MANIPULATIVE PUZZLES, TOY ACTION FIGURES AND ACCESSORIES THEREFOR, MANIPULATIVE GAMES, PLAYING CARDS, ACTION SKILLS GAMES, HAND-HELD UNITS FOR PLAYING ELECTRONIC GAMES AND VIDEO GAMES OTHER THAN THOSE ADAPTED FOR USE WITH AN EXTERNAL DISPLAY SCREEN OR MONITOR, SQUEEZE TOYS, TOY FIGURES AND ACCESSORIES THEREFOR, PLAY SETS FOR ACTION FIGURES, ROLE-PLAYING GAME SETS, TARGET GAMES, BATH TOYS, SAND TOYS, MULTIPLE ACTIVITY BABY TOYS, PUPPETS, TOY FILM CARTRIDGES AND VIEWERS, BEAN BAGS, PULL TOYS, BABY RATTLES, RIDE-ON TOYS, ELECTRONIC LEARNING TOYS, CHRISTMAS TREE DECORATIONS AND CHRISTMAS TREE ORNAMENTS, WIND UP TOYS, BALLOONS, TOY BUILDING BLOCKS, CONSTRUCTION TOYS, TOY BANKS, TOY SHOVELS, TOY STATUETTES; PREFABRICATED SWIMMING POOLS, NAMELY, INFLATABLE SWIMMING POOLS, PLAY SWIMMING POOLS; SKIPPING ROPES; SWINGS; GYMNASTIC AND SPORTING ARTICLES NOT INCLUDED IN OTHER CLASSES, NAMELY, GOLF TEES, GOLF BALLS, BASKETBALLS, FISHING LURES, TENNIS BALLS, TENNIS RACKETS, BASEBALL BATS, SOFTBALL BATS, BASKETBALL BACKBOARDS, BALANCE BEAMS, SPRING BOARDS; FISHING TACKLE; GAME MACHINES AND APPARATUS, NAMELY, AMUSEMENT GAME MACHINES, STAND ALONE VIDEO GAME MACHINES; BILLIARD EQUIPMENT; DICE; SUGOROKU GAMES IN THE NATURE OF A JAPANESE BOARD GAME; CHESS GAMES; CONJURING APPARATUS, NAMELY, MAGIC TRICKS; DOMINOES; MAH-JONG (U.S. CLS. 22, 23, 38 AND 50).

SN 79-106,307, KABUSHIKI KAISHA SHOGAKUKAN; SHUEISHA PRODUCTION; (ALSO TRADING AS SHOGAKUKAN-SHUEISHA; PRODUCTIONS CO., LTD.), TOKYO 101-8415, JAPAN, FILED 6-20-2011.

CLASS 30—STAPLE FOODS

FOR BREAD, PASTRY AND CONFECTIONERY, NAMELY, FROZEN CONFECTIONERY, BONBONS, WAFFLES, WAFERS, COOKIES, CRACKERS, CREPES, FRUIT JELLY CANDY, BUNS, PASTRIES, CHOCOLATES, BISCUITS, CANDIES, CHEWING GUMS, PRETZELS, FONDANTS; ARTIFICIAL COFFEE, COFFEE; BEVERAGES WITH A CHOCOLATE BASE, COCOA, TEA; MISO BEING FERMENTED SOYBEAN PASTE; WORCESTERSHIRE SAUCE, KETCHUP, SOY SAUCE, VINEGAR, VINEGAR MIXES, SOBA-TSUYU BEING A DIPPING SAUCE FOR SOBA NOODLES, SALAD DRESSINGS, WHITE SAUCE, NAMELY, BÉCHAMEL, CHEESE SAUCE; MAYONNAISE, SAUCES FOR BARBECUED MEAT, CUBE SUGAR, FRUCTOSE FOR FOOD, CRYSTAL SUGAR, MALTOSE FOR FOOD, HONEY, GLUCOSE FOR FOOD, POWDERED STARCH SYRUP, STARCH SYRUP, TABLE SALT MIXED WITH SESAME SEEDS, COOKING SALT, ROASTED AND GROUND SESAME SEEDS, CELERY SALT, CHEMICAL SEASONINGS, NAMELY, MONOSODIUM GLUTAMATE USED AS A FLAVOR ENHANCER FOR FOOD; OAT FLAKES, CEREAL PREPARATIONS, NAMELY, HIGH-PROTEIN CEREAL BARS, CEREAL BASED SNACK FOOD; SANDWICHES, SUSHI, TAKOYAKI BEING FRIED BALLS OF BATTER MIX WITH SMALL PIECES OF OCTOPUS, HAMBURGER SANDWICHES, PIZZAS, HOT DOG SANDWICHES; INSTANT CONFECTIONERY MIXES, NAMELY, INSTANT PUDDING MIXES, INSTANT CAKE MIXES, ICE CREAM MIXES, SHERBET MIXES (U.S. CL. 46).

OWNER OF INTERNATIONAL REGISTRATION 0764354 DATED 6-18-2001, EXPIRES 6-18-2021.
OWNER OF U.S. REG. NOS. 2,946,402 AND 3,058,286.

CLASS 25—CLOTHING

FOR OUTERCLOTHING, NAMELY, JACKETS, TOPS, SUITS, COATS, SWEATERS; T-SHIRTS, SHIRTS, NIGHTWEAR, UNDERWEAR, SWIMWEAR, SWIMMING CAPS; JAPANESE TRADITIONAL CLOTHING, NAMELY, KIMONOS, SASH BANDS FOR KIMONO (OBI), JAPANESE SLEEPING ROBES; APRONS, COLLAR PROTECTORS, SOCKS AND STOCKINGS, SHAWLS, SCARVES, GLOVES AND MITTENS, BABIES' DIAPERS OF TEXTILE, NECKTIES, NECKERCHIEFS, BANDANAS, MUFFLERS, EAR MUFFS, HOODS, HELMETS, NAMELY, KNITTED CAPS, SKULL CAPS; HEADGEAR FOR WEAR, NAMELY, HATS, CAPS, AND HEADWEAR; WAISTBANDS, BELT FOR CLOTHING, SANDALS, FOOTWEAR (U.S. CLS. 22 AND 39).

CLASS 32—LIGHT BEVERAGES

FOR MINERAL WATER; SYRUPS FOR BEVERAGES; AERATED WATER; NON-ALCOHOLIC CARBONATED DRINKS, NON-ALCOHOLIC FRUIT JUICE BEVERAGES; VEGETABLE JUICES; WHEY BEVERAGES (U.S. CLS. 45, 46 AND 48).

ANDREW LEASER, EXAMINING ATTORNEY

Hamtaro

SN 79-106,345. MODA TEKSTIL KUYUMCULUK; SANAYI VE TICARET LIMITED SIRKETI, MERTER; ISTANBUL, TURKEY, FILED 7-27-2011.



OWNER OF INTERNATIONAL REGISTRATION 0972699 DATED 6-18-2008, EXPIRES 6-18-2018.

THE COLOR(S) YELLOW AND BLACK IS/ARE CLAIMED AS A FEATURE OF THE MARK.

THE MARK CONSISTS OF THE COLOR YELLOW APPEARING IN THE WORDING "SS SASSOFONO" WITH THE SECOND LETTER "S" INVERTED IN BOTH PAIRS OF LETTERS "SS" ALL WITHIN A BLACK RECTANGLE DESIGN.

THE ENGLISH TRANSLATION OF "SASSOFONO" IN THE MARK IS "SAXOPHONE".

CLASS 18—LEATHER GOODS

FOR LEATHER AND IMITATIONS OF LEATHER AND GOODS MADE OF THESE MATERIALS AND NOT INCLUDED IN OTHER CLASSES, NAMELY, LEATHER BAGS, SUITCASES, WALLETTS AND IMITATION LEATHER KEY CHAINS; ANIMAL SKINS, HIDES; TRUNKS AND TRAVELLING BAGS; UMBRELLAS, PARASOLS AND WALKING STICKS; WHIPS, HARNESS AND SADDLERY (U.S. CLS. 1, 2, 3, 22 AND 41).

CLASS 25—CLOTHING

FOR CLOTHING, NAMELY, PULLOVERS; SKIRTS; DRESSES; BLOUSES; JEANS; TROUSERS; JACKETS; COATS, RAINCOATS, ANORAKS; SPORTSWEAR, NAMELY, SHIRTS, SHORTS, PANTS AND JACKETS; SHIRTS; T-SHIRTS; SWEATSHIRTS; BEACH CLOTHES, NAMELY, BATHING SUITS AND BEACH COVER-UPS; SHORTS; KNITWEAR, NAMELY, SHIRTS, SHORTS, SWEATERS AND SCARVES; OVERALLS; UNDERCLOTHING; BODICES; BRASSIERES; CAMISOLES; UNDERPANTS; DRESSING GOWNS; BATH ROBES; BATHING SUITS; PYJAMAS; GLOVES AS CLOTHING; SKI SUITS; HEADGEAR, NAMELY, HATS, CAPS, KNITTED CAPS, BERETS; FOOTWEAR, NAMELY, SHOES EXCLUDING ORTHOPAEDIC SHOES, SLIPPERS, BOOTS, SANDALS, BEACH SHOES, SPORTS SHOES, LACE BOOTS AND PARTS THEREOF; SHOE PARTS, NAMELY, HEELPIECES; HEELS; FOOTWEAR UPPERS; STOCKINGS; BELTS CLOTHING; TIES; NECKTIES; SHAWLS; SCARVES; MUFFLERS; NECK SCARVES; SARONGS; COLLARS FOR DRESSES; MANIPLES; MUFFS; SUSPENDERS; BRACES FOR CLOTHING; GARTERS; BANDANAS; HEADBANDS; CLOTHING FOR BABIES, NAMELY, BABIES' DIAPERS OF TEXTILE (U.S. CLS. 22 AND 39).

WARREN L. OLANDRIA, EXAMINING ATTORNEY

SN 79-106,491. CHERIF MACHICHI OMAR, PARIS, FRANCE, FILED 10-21-2011.



PRIORITY DATE OF 5-6-2011 IS CLAIMED.

OWNER OF INTERNATIONAL REGISTRATION 1099985 DATED 10-21-2011, EXPIRES 10-21-2021.

THE MARK CONSISTS OF THE LITERAL ELEMENT "OC SPECIAL" WITH THE "!" IN "SPECIAL" BEING REPRESENTED WITH AN EXCLAMATION POINT!

CLASS 39—TRANSPORTATION AND STORAGE

FOR ARRANGING OF TOURS; ARRANGING OF EXCURSIONS; ARRANGING OF CRUISES; ORGANIZATION OF SIGHTSEEING TOURS; TRAVEL TICKET RESERVATION; BOOKING OF SEATS FOR TRAVEL; TRANSPORT OF TRAVELERS BY ROAD, RAIL, SEA, AND AIR; TRANSPORTATION RESERVATION; ESCORTING OF TRAVELERS; INFORMATION AND ADVICE (UNRELATED TO BUSINESS DEALINGS) RELATING TO TRAVEL AND TRANSPORT; VEHICLE RENTAL; BOAT RENTAL; PLEASURE BOAT TRANSPORT; CHAUFFEUR SERVICES; HORSE RENTAL (U.S. CLS. 100 AND 105).

CLASS 41—EDUCATION AND ENTERTAINMENT

FOR ENTERTAINMENT SERVICES, NAMELY, ENTERTAINMENT IN THE NATURE OF LIVE PERFORMANCES BY THEATER GROUPS, ETHNIC FESTIVALS, TOURIST AND CULTURE SHOWS, LIVE THEATRICAL AND MUSICAL PERFORMANCES; PROVIDING RECREATION FACILITIES; ORGANIZING COMMUNITY SPORTING AND CULTURAL ACTIVITIES AND EVENTS; SHOW ORGANIZATION, PRODUCTION AND PERFORMANCE SERVICES IN THE FIELD OF THEATER, MUSIC, CINEMA, AND TELEVISION FOR ENTERTAINMENT PURPOSES; BOOKING OF SEATS FOR SHOWS; TICKET AGENCY SERVICES (ENTERTAINMENT) IN THE FIELD OF THEATER, CINEMA, NIGHT CLUBS, COMEDY CLUBS, COUNTRY CLUBS, AND DANCE CLUBS; CLUB SERVICES (ENTERTAINMENT); ORGANIZATION OF EXHIBITIONS FOR CULTURAL OR EDUCATIONAL PURPOSES; PUBLICATION OF BOOKS; PUBLICATION OF ELECTRONIC BOOKS AND JOURNALS ON-LINE; WRITING, EDITING AND PUBLICATION OF TEXTS, OTHER THAN ADVERTISING TEXTS; PHOTOGRAPHIC REPORTING; VIDEOTAPING; PRODUCTION OF FILMS AND VIDEOTAPES; ENTERTAINMENT SERVICE, NAMELY, ORGANIZATION OF COMPETITIONS IN THE FIELD OF CULTURAL AND SPORTING EVENTS; PARTY PLANNING (ENTERTAINMENT); AMUSEMENT PARKS AND GARDENS; HOLIDAY CAMP SERVICES (ENTERTAINMENT); ARRANGING AND CONDUCTING OF EDUCATIONAL COLLOQUIUMS, CONFERENCES, SEMINARS AND CONGRESSES IN THE FIELD OF TOURISM AND TRAVEL (U.S. CLS. 100, 101 AND 107).

THOMAS MANOR, EXAMINING ATTORNEY

SN 79-106,494. CODEPLAY SOFTWARE LIMITED, UNITED KINGDOM, FILED 10-5-2011.

CODEPLAY OFFLOAD

THE MARK CONSISTS OF STANDARD CHARACTERS WITHOUT CLAIM TO ANY PARTICULAR FONT, STYLE, SIZE, OR COLOR.

OWNER OF INTERNATIONAL REGISTRATION 1099989 DATED 10-5-2011, EXPIRES 10-5-2021.

NO CLAIM IS MADE TO THE EXCLUSIVE RIGHT TO USE "OFFLOAD", APART FROM THE MARK AS SHOWN.

CLASS 9—ELECTRICAL AND SCIENTIFIC APPARATUS

FOR COMPUTER HARDWARE, NAMELY, COMPUTER PROCESSORS (CPUS) AND GRAPHIC PROCESSORS (GPUS); COMPUTER SOFTWARE, NAMELY, COMPUTER PROGRAMS FOR USE WITH PROGRAMMABLE GRAPHICS AND COMPILERS (U.S. CLS. 21, 23, 26, 36 AND 38).

CLASS 42—SCIENTIFIC AND COMPUTER SERVICES

FOR COMPUTER PROGRAMMING SERVICES; CONSULTANCY SERVICES IN RESPECT OF COMPUTER PROGRAMMING; PROVISION OF INFORMATION IN RESPECT OF COMPUTER PROGRAMMING; AND COMPUTER SOFTWARE DEVELOPMENT, ALL THE AFORESAID BEING IN THE FIELD OF COMPUTER GAMES AND COMPILER TECHNOLOGY AND PROGRAMMABLE GRAPHICS (U.S. CLS. 100 AND 101).

MATTHEW MCDOWELL, EXAMINING ATTORNEY

SN 79-106,504. FERMERSKE GOSPODARSTVO "TAVIFA", MIKOLAYIVSKA OBL. 57210, UKRAINE, FILED 7-26-2011.



PRIORITY DATE OF 6-17-2011 IS CLAIMED. OWNER OF INTERNATIONAL REGISTRATION 1100019 DATED 7-26-2011, EXPIRES 7-26-2021.

THE MARK CONSISTS OF AN OVAL FRAME WITH TWO ROWS OF CYRILLIC CHARACTERS. A DESIGN OF A PLANT APPEARS WITHIN THE FIRST ROW OF CHARACTERS.

THE ENGLISH TRANSLATION OF THE FOREIGN WORD(S) IN THE MARK IS TAVIFA PEACE TO YOU!

THE TRANSLITERATION OF THE NON-LATIN CHARACTERS IN THE MARK IS TAVIFA MIR YAM!.

CLASS 29—MEATS AND PROCESSED FOODS

FOR BACON; BOUILLON CONCENTRATES; JAMS; CREAM BEING DAIRY PRODUCTS; PEAS, PRESERVED; MUSHROOMS, PRESERVED; JELLIES FOR FOOD; EDIBLE FATS, NAMELY, SUET FOR FOOD; FAT-CONTAINING MIXTURES FOR BREAD SLICES, NAMELY, SPREAD COMPRISING EDIBLE FATS FOR USE ON BREAD SLICES; FROZEN FRUITS; SALTED FISH; CRYSTALLIZED FRUITS; RAISINS; CAVIAR; GINGER JAM; YOGHURT; COCOA BUTTER FOR FOOD PURPOSES; SAUERKRAUT; POTATO FLAKES; POTATO CHIPS; KEFIR BEING A MILK BEVERAGE; CHARCUTERIE; BLACK PUDDING; BLOOD SAUSAGE; CHICKEN CROQUETTES; MEAT FISH CROQUETTES; CORN OIL; MEAT EXTRACTS; MEAT, TINNED; MEAT; MEAT, PRESERVED; SALTED MEATS; MARGARINE; MARMALADE; BUTTER; CHOCOLATE NUT BUTTER; BUTTER CREAM BEING DAIRY PRODUCTS; MILK; MILK PRODUCTS EXCLUDING ICE CREAM, ICE MILK AND FROZEN YOGURT; VEGETABLES, TINNED; VEGETABLE SALADS; VEGETABLES, PRESERVED; VEGETABLES, DRIED; GHERKINS; OLIVES, PRESERVED; LIVER PASTES; LIVER; PICCALILLI; FISH FILLETS; FISH, TINNED; FOODS PREPARED FROM FISH, NAMELY, PREPARED ENTREES CONSISTING PRIMARILY OF FISH; FRUIT SALADS; PORK; CHEESE; WHEY; RENNET; TOFU; SOYA BEANS, PRESERVED, FOR FOOD; SUNFLOWER OIL FOR FOOD; SAUSAGES; SAUSAGES IN BATTER; SOUPS; PREPARATIONS FOR MAKING SOUPS; VEGETABLE SOUP PREPARATIONS; TOMATO PUREE; TOMATO JUICE FOR COOKING; TUNA FISH; FRUIT, PRESERVED; FROSTED FRUITS; FRUIT PEEL; FRUIT PULP; FRUIT JELLIES; FRUIT, STEWED; FRUITS, TINNED; EDIBLE FATS; EDIBLE OILS; APPLE PUREE; POWDERED EGGS; EGGS (U.S. CL. 46).

CLASS 30—STAPLE FOODS

FOR FLOUR FOR FOOD; FARINACEOUS FOODS, NAMELY, PASTA; PASTRIES; BREAD ROLLS; BUNS; SANDWICHES; WAFFLES; VERMICELLI; OATMEAL; OAT FLAKES; OAT-BASED FOOD, NAMELY, ROLLED OATS; BISCUITS; MUSTARD; MUSTARD MEAL; CUSTARD; LEAVEN, NAMELY, FOOD LEAVENING AGENTS; ARTIFICIAL COFFEE; AROMATIC PREPARATIONS FOR FOOD, NAMELY, FOOD FLAVORINGS; CEREAL PREPARATIONS, NAMELY, PROCESSED CEREALS, BREAKFAST CEREALS; COFFEE-BASED BEVERAGES; COFFEE BEVERAGES WITH MILK; COCOA; COCOA BEVERAGES WITH MILK; COCOA-BASED BEVERAGES; CARAMEL CANDY; POTATO FLOUR FOR FOOD; KETCHUP; TORTILLAS; STARCH FOR FOOD; PROCESSED CEREALS, NAMELY, GROATS FOR HUMAN FOOD; CORN, ROASTED; CORN FLOUR; POPCORN; TURMERIC FOR FOOD; COOKING SALT; LIQUORICE BEING CONFECTIONERY; MEAT PIES; PEPPERMINT SWEETS; MAYONNAISE; MACARONI; FARINACEOUS FOOD PASTES FOR HUMAN CONSUMPTION; PROCESSED SEMOLINA; CHOW-CHOW; MARZIPAN; ROYAL JELLY FOR HUMAN CONSUMPTION, NOT FOR MEDICAL PURPOSES; HONEY; MOLASSES FOR FOOD; ALMOND CONFECTIONERY, NAMELY, SUGAR-COATED ALMONDS; FLOUR-MILLING PRODUCTS, NAMELY, FLOUR; PANCAKES; SPRING ROLLS; GRUEL, NAMELY, THIN PORRIDGE, WITH A MILK BASE, FOR FOOD; TEA-BASED BEVERAGES; HERBAL INFUSIONS, NOT MEDICINAL; RAVIOLI; PEPPER; PEPPERS BEING SEASONINGS; ALLSPICE; COOKIES; QUICHES; PIZZAS; CHIPS BEING CEREAL PRODUCTS; CORN FLAKES; PIES; FONDANTS; CONDIMENTS; GINGERBREAD; SPICES; PUDDINGS; RICE; VEGETAL PREPARATIONS FOR USE AS COFFEE SUBSTITUTES; SOYA SAUCE; MALT FOR HUMAN CONSUMPTION; TOMATO SAUCE; SAUCES; GARDEN HERBS, PRESERVED SEASONINGS; SPAGHETTI; RUSKS; BREADCRUMBS; PETIT-BEURRE BISCUITS; CAKES; FRUIT JELLY CANDY; BREAD; CHICORY BEING COFFEE SUBSTITUTE; SWEETMEATS BEING CANDY; SUGAR; SUGAR CONFECTIONERY; TEA; SAFFRON BEING FOOD SEASONING (U.S. CL. 46).

CLASS 31—NATURAL AGRICULTURAL PRODUCTS

FOR FRESH ORANGES; FRESH PEANUTS; BEANS, FRESH; BEET; GRAPES, FRESH; MARROWS, NAMELY, FRESH SQUASH; UNPROCESSED NUTS; PEAS, FRESH; MUSHROOMS, FRESH; MUSHROOM SPAWN FOR PROPAGATION; LIVE ANIMALS; UNPROCESSED RYE; CEREAL SEEDS, UNPROCESSED; GRAINS FOR ANIMAL CONSUMPTION, NAMELY, RICE BRAN; UNPROCESSED FISH SPAWN; POTATOES, FRESH; CHESTNUTS, FRESH; FLOWERS, NATURAL; FLOWER BULBS; ROOTS FOR FOOD, NAMELY, RAW HORSE RADISH ROOT; NETTLES BEING LIVE PLANTS; GROATS FOR POULTRY, NAMELY, CHICKEN FEED; UNPROCESSED MAIZE; SESAME BEING UNPROCESSED EDIBLE SEEDS; FRESH LEMONS; UNPROCESSED GRAINS; UNPROCESSED OATS; VEGETABLES, FRESH; FRESH CUCUMBERS; LIVE PEPPERS PLANTS; FORAGE, NAMELY, ANIMAL FEED; FRUIT, FRESH; UNPROCESSED WHEAT; FISH, LIVE; FISHMEAL FOR ANIMAL CONSUMPTION; SEEDLINGS; LIVE PLANTS; UNPROCESSED LETTUCE; HAY; TRUFFLES, FRESH; CATTLE FOOD, NAMELY, CATTLE FEED; UNPROCESSED HOP CONES; UNPROCESSED HOPS; FRESH LEEKS; RAW ONIONS; FRESH VEGETABLES; FRESH CITRUS FRUIT; LIVE ROSE BUSHES; BERRIES, FRESH FRUITS; UNPROCESSED BARLEY (U.S. CLS. 1 AND 46).

CLASS 32—LIGHT BEVERAGES

FOR APERITIFS, NON-ALCOHOLIC; NON-ALCOHOLIC BEVERAGES, NAMELY, CARBONATED BEVERAGES; NON-ALCOHOLIC FRUIT JUICE BEVERAGES; GRAPE MUST, UNFERMENTED; SELTZER WATER; DRINKING WATER; TABLE WATERS; AERATED WATER; COCKTAILS, NON-ALCOHOLIC; LEMONADES; MINERAL WATER BEING BEVERAGES; ESSENCES FOR THE PREPARATION OF MINERAL WATER; WHEY BEVERAGES; PREPARATIONS FOR MAKING BEVERAGES, NAMELY, FRUIT DRINKS; FRUIT NECTARS, NON-ALCOHOLIC; VEGETABLE JUICES BEING BEVERAGES; BEER; SARSAPARILLA BEING SOFT DRINKS; SYRUPS FOR BEVERAGES; SYRUPS FOR LEMONADE; SODA WATER; FRUIT JUICES; MALT BEER; MUST; TOMATO JUICE BEVERAGES; NON-ALCOHOLIC FRUIT EXTRACTS USED IN THE PREPARATION OF BEVERAGES (U.S. CLS. 45, 46 AND 48).

BERNICE MIDDLETON, EXAMINING ATTORNEY

SN 79-106,527. AMPCONTROL PTY LTD, AUSTRALIA, FILED 7-22-2011.

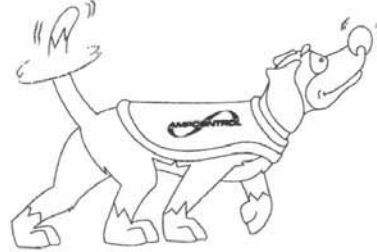

SN 79-106,514. MENZOLIT GMBH, FED REP GERMANY, FILED 10-7-2011.

AdvancedSMC

THE MARK CONSISTS OF STANDARD CHARACTERS WITHOUT CLAIM TO ANY PARTICULAR FONT, STYLE, SIZE, OR COLOR.

PRIORITY DATE OF 4-12-2011 IS CLAIMED.
OWNER OF INTERNATIONAL REGISTRATION 1100031 DATED 10-7-2011, EXPIRES 10-7-2021.

CLASS 1—CHEMICALS

FOR CHEMICALS USED IN INDUSTRY, SCIENCE AND PHOTOGRAPHY, AS WELL AS IN AGRICULTURE, HORTICULTURE AND FORESTRY; UNPROCESSED ARTIFICIAL RESINS, UNPROCESSED PLASTICS; UNPROCESSED PLASTICS FOR FIBRE-REINFORCED PLASTICS; CARBONATES (U.S. CLS. 1, 5, 6, 10, 26 AND 46).

CLASS 17—RUBBER GOODS

FOR RUBBER, GUTTA-PERCHA, INSULATING MATERIALS; PLASTICS IN EXTRUDED FORM FOR USE IN MANUFACTURE, NAMELY, FIBRE-REINFORCED PLASTICS (U.S. CLS. 1, 5, 12, 13, 35 AND 50).

CLASS 40—MATERIAL TREATMENT

FOR TREATMENT OF MATERIALS, NAMELY, COMPRESSION MOULDINGS OF PLASTIC MATERIALS (U.S. CLS. 100, 103 AND 106).

CLASS 42—SCIENTIFIC AND COMPUTER SERVICES

FOR SCIENTIFIC AND TECHNOLOGICAL SERVICES, NAMELY, ENGINEERING, RESEARCH AND DEVELOPMENT SERVICES, AND DESIGN SERVICES RELATING THERETO IN THE FIELD OF PRODUCTION AND MANUFACTURING OF PLASTICS; INDUSTRIAL ANALYSIS AND RESEARCH SERVICES IN THE FIELD OF PRODUCTION AND MANUFACTURING OF PLASTICS (U.S. CLS. 100 AND 101).

RAMONA ORTIGA, EXAMINING ATTORNEY

PRIORITY DATE OF 5-25-2011 IS CLAIMED.
OWNER OF INTERNATIONAL REGISTRATION 1100058 DATED 7-22-2011, EXPIRES 7-22-2021.

OWNER OF U.S. REG. NO. 2,722,951.
THE MARK CONSISTS OF WORDING AND STYLIZED DOG WEARING A CUSTOM WITH THE WORDING "AMP-CONTROL" IMPRINTED IN THE CUSTOM.

CLASS 9—ELECTRICAL AND SCIENTIFIC APPARATUS

FOR ELECTRICAL AND ELECTRONIC SENSORS FOR MONITORING AND DETECTING GASES IN MINING ENVIRONMENTS; CONTROL SYSTEMS COMPRISED OF ELECTRICAL RELAYS FOR COMMUNICATION WITH SWITCH GEAR AND SENSORS IN RESPONSE TO THE PRESENCE OF MINE GASES; PROGRAMMABLE ELECTRONIC CONTROLLERS FOR SWITCH GEAR AND GAS SENSORS; GAS ANALYSIS INSTRUMENTS, NAMELY, GAS DETECTORS FOR DETECTING THE PRESENCE OF GAS, GAS MONITORS USED FOR DETECTING OXYGEN OR COMBUSTIBLE GASES OR TOXIC GASES IN THE ATMOSPHERE, GAS ALARMS, COMBUSTIBLE AND TOXIC GAS INDICATORS, GAS TRANSMITTERS FOR DETECTING HAZARDOUS ACCUMULATIONS OF TOXIC GASES, NAMELY, TOXIC GAS SENSORS, FLAMMABLE GAS SENSORS, DISPLAY DEVICES NAMELY, LED DISPLAYS; GAS SENSING SYSTEMS COMPRISED OF ELECTRONIC LED DISPLAYS WHICH INDICATE GAS LEVELS IN MINE ENVIRONMENTS; GAS SENSORS FOR MONITORING OXYGEN, HYDROGEN SULPHIDE AND CARBON MONOXIDE; CATALYTIC METHANE GAS SENSORS AND TRANSMITTERS, DISPLAYS, NAMELY, LED DISPLAYS; CALIBRATORS FOR CALIBRATION OF INSTALLATIONS AND INSTRUMENTS; COMMUNICATION SYSTEMS USED FOR THE DETECTION OF GASES IN MINING ENVIRONMENTS; ELECTRIC AND ELECTRONIC SWITCHES AND RELAYS, POWER SWITCHES; VOLTAGE AND CURRENT REGULATORS, ELECTRICAL AND ELECTRONIC RELAYS FOR PROTECTION OF UNDERGROUND MINING EQUIPMENT, ELECTRIC RELAYS FOR DATA TRANSMISSION; AND PARTS FOR THE AFOREMENTIONED GOODS (U.S. CLS. 21, 23, 26, 36 AND 38).

CLASS 37—CONSTRUCTION AND REPAIR

FOR INSTALLATION, MAINTENANCE AND REPAIR OF ELECTRICAL AND ELECTRONIC PRODUCTS, APPARATUS AND EQUIPMENT, NAMELY, ELECTRICAL AND ELECTRONIC SENSORS AND CONTROL SYSTEMS, PROGRAMMABLE CONTROLLERS, GAS ANALYSIS INSTRUMENTS, MONITORS, ALARMS, INDICATORS, TRANSMITTERS, TOXIC GAS SENSORS, FLAMMABLE GAS SENSORS, CONTROL AND DISPLAY DEVICES, GAS SENSING SYSTEMS INCLUDING SYSTEMS FOR MONITORING OXYGEN, HYDROGEN SULPHIDE, CARBON MONOXIDE; INSTALLATION, MAINTENANCE AND REPAIR OF CATALYTIC METHANE GAS SENSORS AND TRANSMITTERS, DISPLAYS INCLUDING LED DISPLAYS; INSTALLATIONS, MAINTENANCE AND REPAIR OF CALIBRATION INSTALLATIONS AND INSTRUMENTS, COMMUNICATION SYSTEMS, SWITCHES, VOLTAGE AND CURRENT REGULATORS, RELAYS FOR PROTECTION OF UNDERGROUND MINING EQUIPMENT, EQUIPMENT FOR DATA TRANSMISSION PARTS AND FITTINGS ALONG WITH ALL ACCESSORIES; TECHNICAL SUPPORT SERVICES RELATED TO THE MAINTENANCE, INSTALLATION AND REPAIR OF ELECTRICAL AND ELECTRONIC SENSORS AND SYSTEMS AND CONSULTANCY SERVICES RELATING TO ALL OF THE FOREGOING (U.S. CLS. 100, 103 AND 106).

ALICE BENMAMAN, EXAMINING ATTORNEY

SN 79-106,721. CODEPLAY SOFTWARE LIMITED, UNITED KINGDOM, FILED 10-5-2011.

CODEPLAY

THE MARK CONSISTS OF STANDARD CHARACTERS WITHOUT CLAIM TO ANY PARTICULAR FONT, STYLE, SIZE, OR COLOR.

OWNER OF INTERNATIONAL REGISTRATION 1100574 DATED 10-5-2011, EXPIRES 10-5-2021.

CLASS 9—ELECTRICAL AND SCIENTIFIC APPARATUS

FOR COMPUTER HARDWARE, NAMELY, COMPUTER PROCESSORS (CPUS) AND GRAPHIC PROCESSORS (GPUS); COMPUTER SOFTWARE, NAMELY, COMPUTER PROGRAMS FOR USE WITH PROGRAMMABLE GRAPHICS AND COMPILERS (U.S. CLS. 21, 23, 26, 36 AND 38).

CLASS 42—SCIENTIFIC AND COMPUTER SERVICES

FOR COMPUTER PROGRAMMING SERVICES; CONSULTANCY SERVICES IN RESPECT OF COMPUTER PROGRAMMING; PROVISION OF INFORMATION IN RESPECT OF COMPUTER PROGRAMMING; AND COMPUTER SOFTWARE DEVELOPMENT, ALL THE AFORESAID BEING IN THE FIELD OF COMPUTER GAMES AND COMPILER TECHNOLOGY AND PROGRAMMABLE GRAPHICS (U.S. CLS. 100 AND 101).

MATTHEW MCDOWELL, EXAMINING ATTORNEY

SN 79-106,743. ELITECH GROUP SAS, FRANCE, FILED 10-12-2011.

ELITech

PRIORITY DATE OF 4-18-2011 IS CLAIMED.

OWNER OF INTERNATIONAL REGISTRATION 1100617 DATED 10-12-2011, EXPIRES 10-12-2021.

CLASS 1—CHEMICALS

FOR CHEMICAL PREPARATIONS AND CHEMICALS FOR INDUSTRIAL AND SCIENTIFIC PURPOSES, DIAGNOSTIC REAGENTS AND PREPARATIONS, NOT FOR MEDICAL PURPOSES, FOR USE IN CHEMICAL OR BIOLOGICAL TESTING (U.S. CLS. 1, 5, 6, 10, 26 AND 46).

CLASS 5—PHARMACEUTICALS

FOR DIAGNOSTIC AGENTS AND SUBSTANCES FOR MEDICAL PURPOSES, DIAGNOSTIC PREPARATIONS AND REAGENTS, FOR MEDICAL PURPOSES, IN THE FIELDS OF BIOCHEMISTRY, HEMATOLOGY, MICROBIOLOGY, IMMUNOLOGY, ELECTROPHORESIS AND MOLECULAR BIOLOGY; REAGENTS FOR MEDICAL PURPOSES (U.S. CLS. 6, 18, 44, 46, 51 AND 52).

CLASS 10—MEDICAL APPARATUS

FOR APPARATUS FOR CLINICAL DIAGNOSIS, TO BE USED BY HEALTH CARE PROFESSIONALS IN THE FIELDS OF BIOCHEMISTRY, HEMATOLOGY, MICROBIOLOGY, IMMUNOLOGY, ELECTROPHORESIS AND MOLECULAR BIOLOGY (U.S. CLS. 26, 39 AND 44).

AISHA SALEM, EXAMINING ATTORNEY

SN 79-106,749. REDARC ELECTRONICS PTY LTD, AUSTRALIA, FILED 10-12-2011.



PRIORITY DATE OF 6-21-2011 IS CLAIMED.
OWNER OF INTERNATIONAL REGISTRATION 1100631 DATED 10-12-2011, EXPIRES 10-12-2021.

THE COLOR(S) GREEN, YELLOW, ORANGE AND WHITE IS/ARE CLAIMED AS A FEATURE OF THE MARK. THE COLORS GREEN, YELLOW AND ORANGE APPEAR IN THE DESIGN OF A SQUARE WITH TWO ROUNDED CORNERS; THE COLOR WHITE APPEARS IN THE DESIGN OF A SLIGHTLY CURVED LINE.

CLASS 9—ELECTRICAL AND SCIENTIFIC APPARATUS

FOR RENEWABLE ENERGY EQUIPMENT, NAMELY, PHOTOVOLTAIC SOLAR MODULES, SOLAR PANELS AND SOLAR CELLS, POWER INVERTERS AND REGULATORS; APPARATUS AND INSTRUMENTS FOR CONDUCTING, SWITCHING, TRANSFORMING, ACCUMULATING, REGULATING OR CONTROLLING ELECTRICITY, INCLUDING SOLAR ENERGY; APPARATUS AND INSTRUMENTS FOR COLLECTING AND CONVERTING SOLAR ENERGY INTO ELECTRICITY, NAMELY, PHOTOVOLTAIC SOLAR MODULES, SOLAR PANELS AND SOLAR CELLS, POWER INVERTERS AND CHARGE CONTROLLERS; PHOTOVOLTAIC CELLS ALSO INCLUDING FIXED AND PORTABLE SOLAR ENERGY COLLECTORS SOLD AS A UNIT; PHOTOVOLTAIC SOLAR PANELS FOR THE PRODUCTION OF ENERGY, PHOTOVOLTAIC SOLAR MODULES FOR THE PRODUCTION OF ENERGY, PHOTOVOLTAIC CELLS, SOLAR PANELS FOR THE PRODUCTION OF ENERGY, PHOTOVOLTAIC SOLAR MODULES, SOLAR CELLS AND SOLAR REGULATORS FOR ELECTRICITY GENERATION; POWER INVERTERS, BATTERIES, BATTERY CHARGERS, DISPLAY APPARATUS, NAMELY, TOUCH SCREENS, COMPUTER TABLETS AND OTHER PORTABLE COMPUTER DEVICES, ANALOG, DIGITAL AND LED DISPLAYS; ALARM MONITORING SYSTEMS COMPRISED OF ALARMS AND WARNING DEVICES; MEASUREMENT SYSTEMS, NAMELY, MEASURING APPARATUS FOR MEASURING VOLTAGE, CURRENT, POWER, ENERGY CREATION, CONSUMPTION AND USAGE; SENSORS, NAMELY, TEMPERATURE, WATER LEVEL, VOLTAGE, CURRENT AND POWER SENSORS; TIMING DEVICES, NAMELY, TIMERS, INCLUDING FOR SOLAR ENERGY GENERATION APPLICATIONS; SOLAR ENERGY EQUIPMENT DESIGNED FOR USE IN AUTOMOTIVE AND RECREATIONAL VEHICLES AND MARINE APPLICATIONS, NAMELY, PHOTOVOLTAIC SOLAR MODULES, SOLAR PANELS AND SOLAR CELLS, POWER INVERTERS, REGULATORS, CHARGE CONTROLLERS, BATTERIES AND BATTERY CHARGERS; PARTS AND ACCESSORIES FOR THE AFOREMENTIONED GOODS (U.S. CLS. 21, 23, 26, 36 AND 38).

CLASS 42—SCIENTIFIC AND COMPUTER SERVICES

FOR RESEARCH AND ELECTRICAL/ELECTRONIC DESIGN SERVICES FOR THE DEVELOPMENT OF AUTOMOTIVE, MARINE AND INDUSTRIAL ELECTRONIC PRODUCTS; RESEARCH AND ELECTRICAL/ELECTRONIC DESIGN SERVICES FOR THE DEVELOPMENT OF SOLAR ENERGY EQUIPMENT, APPARATUS AND INSTRUMENTS FOR USE IN COLLECTING AND CONVERTING SOLAR ENERGY INTO ELECTRICITY (U.S. CLS. 100 AND 101).

AISHA SALEM, EXAMINING ATTORNEY

SN 79-106,774. HANNES ROETHER, FED REP GERMANY, FILED 10-12-2011.



PRIORITY DATE OF 4-12-2011 IS CLAIMED.

OWNER OF INTERNATIONAL REGISTRATION 1100697 DATED 10-12-2011. EXPIRES 10-12-2021.

THE MARK CONSISTS OF TWO VERTICAL STRAIGHT LINES ON A CONTRASTING SQUARE BACKGROUND.

CLASS 14—JEWELRY

FOR PRECIOUS METALS AND THEIR ALLOYS AND GOODS MADE FROM THESE MATERIALS OR COATED THEREWITH, INCLUDED IN THIS CLASS, NAMELY, CHARMS IN PRECIOUS METAL OR COATED THEREWITH, BADGES OF PRECIOUS METAL, BRACELETS OF PRECIOUS METAL, FANCY KEY RINGS OF PRECIOUS METAL, JEWELLERY PLATED WITH PRECIOUS METAL, JEWELLERY CHAINS PLATED WITH PRECIOUS METAL, ORNAMENTAL PINS PLATED WITH PRECIOUS METAL, ORNAMENTS OF PRECIOUS METAL IN THE NATURE OF JEWELLERY, WATCHES MADE OF PRECIOUS METALS OR COATED THEREWITH, TIE CLIPS OF PRECIOUS METAL, TIE-PINS OF PRECIOUS METAL, HAT ORNAMENTS OF PRECIOUS METAL, KEY CHAINS OF PRECIOUS METAL, KEY HOLDERS OF PRECIOUS METALS; JEWELLERY, PRECIOUS STONES; HOROLOGICAL AND CHRONOMETRIC INSTRUMENTS; JEWELLERY CASES; ALARM CLOCKS; KEY RINGS OF PRECIOUS METAL (U.S. CLS. 2, 27, 28 AND 50).

CLASS 18—LEATHER GOODS

FOR LEATHER AND IMITATIONS OF LEATHER, AND GOODS MADE OF THESE MATERIALS, INCLUDED IN THIS CLASS, NAMELY, CASES OF IMITATION LEATHER, LEATHER OR IMITATION LEATHER KEY CHAINS, KEY CASES OF LEATHER, SKINS OR IMITATION LEATHER, LEATHER AND IMITATION LEATHER BAGS, LEATHER AND IMITATION LEATHER SPORT BAGS AND GENERAL PURPOSE TROLLEY BAGS, POUCHES MADE FROM IMITATION LEATHER, ATTACHE CASES MADE OF IMITATION LEATHER, BANDS OF LEATHER, BRIEFCASES, BRIEFCASE-TYPE LEATHER BUSINESS FOLDERS, GARMENT BAGS FOR TRAVEL MADE OF LEATHER, HAT BOXES OF LEATHER, LEATHER BAGS AND WALLETS, LEATHER CASES, LEATHER CREDIT CARD CASES, LEATHER FOR SHOES, LEATHER LEADS, LEATHER LEASHES, LEATHER OR LEATHER-BOARD BOXES, LEATHER OR IMITATION LEATHER POUCHES, LEATHER PURSES, LEATHER SHOULDER BELTS, LEATHER STRAPS, THONGS, THREADS, SADDLERY OF LEATHER, TANNED LEATHER, TRAVELLING CASES, POLYURETHANE LEATHER, WORKED OR SEMI-WORKED HIDES AND OTHER LEATHER; ANIMAL SKINS AND HIDES; COVERINGS OF SKIN MADE FROM FUR, NAMELY, FUR PELTS; TRUNKS AND TRAVELLING BAGS; UMBRELLAS, PARASOLS AND WALKING STICKS, WHIPS, HARNESSES AND SADDLERY; BAGS, IN PARTICULAR HANDBAGS, POCKET WALLETS, SHOPPING BAGS, NAMELY, LEATHER SHOPPING BAGS, CANVAS SHOPPING BAGS, MESH SHOPPING BAGS, SHOPPING BAGS MADE OF SKIN, TEXTILE SHOPPING BAGS, WHEELED SHOPPING BAGS, STRING BAGS FOR SHOPPING; RUCKSACKS; KEY CASES (U.S. CLS. 1, 2, 3, 22 AND 41).

CLASS 24—FABRICS

FOR TEXTILE AND TEXTILE GOODS, INCLUDED IN THIS CLASS, NAMELY, WOVEN FABRIC FOR TEXTILE PURPOSES; KNITTED FABRICS FOR TEXTILE PURPOSES, TEXTILE FABRICS FOR THE MANUFACTURE OF CLOTHING; COTTON FABRIC; TOWELS MADE OF TEXTILE MATERIALS, HANDKERCHIEFS OF TEXTILE; LABELS OF TEXTILES FOR IDENTIFYING CLOTHES, MOISTURE ABSORBENT MICROFIBER TEXTILE FABRICS FOR USE IN THE MANUFACTURE OF ATHLETIC APPAREL, NAMELY, SHIRTS, PANTS, SHORTS, JACKETS, BAGS, TOWELS AND ATHLETIC UNIFORMS; NATURAL AND SYNTHETIC FABRICS AND TEXTILES, NAMELY, COTTON, SILK, POLYESTER AND NYLON FABRIC; PLACE MATS OF TEXTILES, PRINTED TEXTILE LABELS, TEXTILE LABELS; TEXTILE HANG TAGS, CURTAINS OF TEXTILE MATERIALS; FIBERGLASS FABRICS FOR TEXTILE USE;

SERVIETTES OF TEXTILE; TABLE CLOTH OF TEXTILE, TABLE LINEN OF TEXTILE, TAPESTRIES OF TEXTILE; TEXTILE FABRICS FOR THE MANUFACTURE HOUSEHOLD FURNISHINGS; TEXTILE FABRICS FOR LINGERIE; TEXTILE FABRICS FOR HOME INTERIORS; TEXTILE USED AS LINING FOR CLOTHING; TEXTILE WALL HANGINGS, BED COVERS; TABLE COVERS, NAMELY, TABLE LINEN, TABLE RUNNERS, AND TABLE MATS NOT OF PAPER; BATH LINEN, EXCLUDING CLOTHING; BED LINEN; HOME TEXTILES, NAMELY, FURNITURE FABRICS, CURTAINS, TAPESTRIES OF TEXTILES (U.S. CLS. 42 AND 50).

CLASS 25—CLOTHING

FOR CLOTHING, NAMELY, BABY CLOTHING, NAMELY, PANTS, SHIRTS, JACKETS, SOCKS; BELTS; BOTTOMS; CLOTHING FOR SPORTS USE, NAMELY, TROUSERS, SHIRTS, VESTS, STOCKINGS, HATS, CAPS, BRAS, JERSEYS, JACKETS, COATS; CLOTHING FOR WOMEN AND MEN, NAMELY, SHIRTS, PANTS, TROUSERS, VESTS, SHORTS, TIES, SKIRTS, DRESSES, JERSEYS, TOPS, UNDERWEAR, JACKETS, COATS, MANTLES, BLOUSES, KNITWEAR, NAMELY, PANTS, SHIRTS, JACKETS, SOCKS, VESTS, STOCKINGS, DRESSES, TOPS, UNDERWEAR, COATS, MANTLES, AND GLOVES; COMBINATIONS, FOULARDS, GLOVES, HEADBANDS; FURS, NAMELY, FUR CAPS, FUR COATS, AND FUR JACKETS; FOOTWEAR; HEADGEAR, NAMELY, HATS, CAPS, KNITTED CAPS, SPORTS CAPS AND HATS, BONNETS, VISORS (U.S. CLS. 22 AND 39).

CLASS 35—ADVERTISING AND BUSINESS

FOR RETAIL STORE SERVICES FEATURING JEWELLERY, LEATHER GOODS, BAGS, WOVEN FABRICS, TEXTILES, BED AND TABLE COVERS, HOME TEXTILES, CLOTHING, FOOTWEAR, HEADGEAR (U.S. CLS. 100, 101 AND 102).

AISHA SALEM, EXAMINING ATTORNEY

SN 79-106,898. HÅKAN BJÖRKSTEDT, SWEDEN, FILED 9-1-2011.

& other Stories

PRIORITY DATE OF 3-2-2011 IS CLAIMED.
OWNER OF INTERNATIONAL REGISTRATION 1100907 DATED 9-1-2011, EXPIRES 9-1-2021.
THE MARK CONSISTS OF THE STYLIZED WORDING " & OTHER STORIES".

CLASS 3—COSMETICS AND CLEANING PREPARATIONS

FOR BLEACHING PREPARATIONS FOR LAUNDRY USE; CLEANING, POLISHING; SCOURING AND ABRASIVE PREPARATIONS; SOAPS; PERFUMERY, ESSENTIAL OILS, COSMETICS, HAIR LOTIONS; DENTIFRICES (U.S. CLS. 1, 4, 6, 50, 51 AND 52).

CLASS 9—ELECTRICAL AND SCIENTIFIC APPARATUS

FOR APPARATUS AND INSTRUMENT FOR CONDUCTING, SWITCHING, TRANSFORMING, ACCUMULATING, REGULATING OR CONTROLLING ELECTRICITY; APPARATUS FOR RECORDING, TRANSMISSION OR REPRODUCTION OF SOUND OR IMAGES; AUTOMATIC VENDING MACHINES AND MECHANISMS FOR COIN-OPERATED APPARATUS; CASH REGISTERS, CALCULATING MACHINES, DATA PROCESSING EQUIPMENT AND COMPUTERS; FIRE-EXTINGUISHING APPARATUS; SUNGLASSES, CASES AND BAGS ADAPTED THEREFORE; EYEGLASS CASES; SPECTACLE GLASSES; SUNGLASSES; GOGGLES FOR SPORTS; SWIMMING GOGGLES; EYEGLASS CORDS; SPECTACLE FRAMES; EYEGLASS FRAMES; SPECTACLE CASES; ANTI-GLARE GLASSES; EYEGLASS CHAINS (U.S. CLS. 21, 23, 26, 36 AND 38).

CLASS 14—JEWELRY

FOR PRECIOUS METALS AND THEIR ALLOYS; JEWELLERY, PRECIOUS STONES; HOROLOGICAL AND CHRONOMETRIC INSTRUMENTS (U.S. CLS. 2, 27, 28 AND 50).

CLASS 16—PAPER GOODS AND PRINTED MATTER

FOR PAPER; CARDBOARD; BOOKBINDING MATERIAL; PHOTOGRAPHS; STATIONERY; ADHESIVES FOR STATIONERY OR HOUSEHOLD PURPOSES; PAINT BRUSHES; TYPEWRITERS; PRINTERS' TYPE; PRINTING BLOCKS (U.S. CLS. 2, 5, 22, 23, 29, 37, 38 AND 50).

CLASS 18—LEATHER GOODS

FOR LEATHER AND IMITATIONS OF LEATHER; ANIMAL SKINS, HIDES; TRUNKS AND TRAVELLING BAGS; UMBRELLAS, PARASOLS AND WALKING STICKS; WHIPS, HARNESS AND SADDLERY (U.S. CLS. 1, 2, 3, 22 AND 41).

CLASS 21—HOUSEWARES AND GLASS

FOR HOUSEHOLD OR KITCHEN CONTAINERS; COMBS; BRUSH-MAKING MATERIALS; STEEL WOOL (U.S. CLS. 2, 13, 23, 29, 30, 33, 40 AND 50).

CLASS 24—FABRICS

FOR BED COVERS (U.S. CLS. 42 AND 50).

CLASS 25—CLOTHING

FOR FOOTWEAR (U.S. CLS. 22 AND 39).

CLASS 35—ADVERTISING AND BUSINESS

FOR ADVERTISING; BUSINESS MANAGEMENT; BUSINESS ADMINISTRATION; OFFICE FUNCTIONS (U.S. CLS. 100, 101 AND 102).

TOBY BULLOFF, EXAMINING ATTORNEY

SN 79-107,056. BIASI MANUELA, ITALY, FILED 10-13-2011.

MANUELA BIASI

THE MARK CONSISTS OF STANDARD CHARACTERS WITHOUT CLAIM TO ANY PARTICULAR FONT, STYLE, SIZE, OR COLOR.

PRIORITY DATE OF 6-7-2011 IS CLAIMED.
OWNER OF INTERNATIONAL REGISTRATION 1101356 DATED 10-13-2011, EXPIRES 10-13-2021.

THE NAME SHOWN IN THE MARK IDENTIFIES "MANUELA BIASI", WHOSE CONSENT TO REGISTER IS MADE OF RECORD.

CLASS 18—LEATHER GOODS

FOR LEATHER AND IMITATIONS OF LEATHER AND GOODS MADE OF THESE MATERIALS, NAMELY BAGS, HANDBAGS, WALLETS AND BRIEFCASE; WHIPS, HARNESS AND SADDLERY NAMELY, HORSE BLANKETS (U.S. CLS. 1, 2, 3, 22 AND 41).

CLASS 25—CLOTHING

FOR CLOTHING NAMELY, DRESSES, COATS, OVERCOATS, RAINCOATS, JACKETS, SPORTS JACKETS, TROUSERS, JEANS, SHORTS, SKIRTS, TRACK SUITS, SWEATERS, SHIRTS, T-SHIRTS, CARDIGANS, DRESSING GOWNS, NIGHTGOWNS, PYJAMAS, PETTICOATS, SOCKS, STOCKINGS, TIGHTS, GLOVES, SCARVES, FOULARDS, BELTS, WAISTCOATS, BATHING SUITS; HEADGEAR NAMELY, HATS, CAPS; FOOTWEAR NAMELY, SHOES, BOOTS, SANDALS, SLIPPERS (U.S. CLS. 22 AND 39).

CLASS 35—ADVERTISING AND BUSINESS

FOR RETAIL STORE SERVICES IN RELATION TO LEATHER AND IMITATIONS OF LEATHER AND GOODS MADE OF THESE MATERIALS, NAMELY BAGS, HANDBAGS, WALLETS AND BRIEFCASE; RETAIL STORE SERVICES IN RELATION TO WHIPS, HARNESS AND SADDLERY NAMELY, HORSE BLANKETS; RETAIL STORE SERVICES IN RELATION TO CLOTHING NAMELY, DRESSES, COATS, OVERCOATS, RAINCOATS, JACKETS, SPORTS JACKETS, TROUSERS, JEANS, SHORTS, SKIRTS, TRACK SUITS, SWEATERS, SHIRTS, T-SHIRTS, CARDIGANS, DRESSING GOWNS, NIGHTGOWNS, PYJAMAS, PETTICOATS, SOCKS, STOCKINGS, TIGHTS, GLOVES, SCARVES, FOULARDS, BELTS, WAISTCOATS, BATHING SUITS, HEADGEAR NAMELY, HATS, CAPS, FOOTWEAR NAMELY, SHOES, BOOTS, SANDALS, SLIPPERS; ELECTRONIC COMMERCE SERVICES, NAMELY, PROVIDING INFORMATION ABOUT PRODUCTS VIA TELECOMMUNICATION NETWORK FOR ADVERTISING AND SALES PURPOSES (U.S. CLS. 100, 101 AND 102).

BRETT J. GOLDEN, EXAMINING ATTORNEY

SN 79-107,059. SOGEFI S.P.A., I-46100 MANTOVA, ITALY, FILED 11-9-2011.



PRIORITY DATE OF 10-21-2011 IS CLAIMED. OWNER OF INTERNATIONAL REGISTRATION 1101367 DATED 11-9-2011, EXPIRES 11-9-2021.

THE COLOR(S) BLACK AND RED IS/ARE CLAIMED AS A FEATURE OF THE MARK.

THE MARK CONSISTS OF THE BLACK TERMS "SO GEFI" WITH A THICK RED DIAGONAL ARROW SEPARATING "SO" AND "GEFI".

THE WORDING "SO GEFI" HAS NO MEANING IN A FOREIGN LANGUAGE.

CLASS 7—MACHINERY

FOR ENGINE AIR FILTERS FOR CARS, ENGINE AIR FILTERS FOR INDUSTRIAL VEHICLES, HYDRAULIC FLUID FILTERS FOR INDUSTRIAL VEHICLES; PETROL, OIL, DIESEL FILTERS FOR MOTORS AND ENGINES; OIL AND GAS FILTERS FOR MOTORS AND ENGINES; SUB-MICRON FUEL FILTERS FOR DIESEL EXHAUST FLUID (U.S. CLS. 13, 19, 21, 23, 31, 34 AND 35).

CLASS 11—ENVIRONMENTAL CONTROL APPARATUS

FOR AIR FILTERS FOR AIR CONDITIONERS IN VEHICLE PASSENGER COMPARTMENTS (U.S. CLS. 13, 21, 23, 31 AND 34).

ANTHONY RINKER, EXAMINING ATTORNEY

SN 79-107,173. TEAMOBILITY AG, FED REP GERMANY, FILED 9-15-2011.



PRIORITY DATE OF 3-17-2011 IS CLAIMED. OWNER OF INTERNATIONAL REGISTRATION 1101651 DATED 9-15-2011, EXPIRES 9-15-2021.

THE COLOR(S) BLACK AND WHITE IS/ARE CLAIMED AS A FEATURE OF THE MARK.

THE MARK CONSISTS OF THE STYLIZED TERM "TEAMOBILITY", WHERE THE LETTERS "TEAMO" APPEAR TO BE CUT IN HALF. THE LETTERS APPEAR IN BLACK AND ARE PARTIALLY OUTLINED IN WHITE. THE COLOR GRAY IN THE MARK IS FOR BACKGROUND PURPOSES ONLY AND IS NOT INTENDED AS A FEATURE OF THE MARK.

CLASS 9—ELECTRICAL AND SCIENTIFIC APPARATUS

FOR APPARATUS AND INSTRUMENTS FOR CONDUCTING, SWITCHING, TRANSFORMING, ACCUMULATING, REGULATING OR CONTROLLING ELECTRICITY; CHARGERS AND CHARGING DEVICES IN THE NATURE OF BATTERY CHARGERS FOR ACCUMULATORS IN VEHICLES, MOTOR BICYCLES AND BICYCLES; ELECTRIC BATTERIES; BATTERIES FOR LIGHTING; DATA-PROCESSING EQUIPMENT AND COMPUTERS; WIRELESS CHARGERS AND CHARGING DEVICES IN THE NATURE OF BATTERY CHARGERS FOR ACCUMULATORS IN VEHICLES, MOTOR BICYCLES AND BICYCLES (U.S. CLS. 21, 23, 26, 36 AND 38).

CLASS 12—VEHICLES

FOR VEHICLES, NAMELY, LAND VEHICLES, MOTOR CARS, VANS, LORRIES, MOTORCYCLES, MOPEDS, OMNIBUSES; ELECTRIC VEHICLES, NAMELY, ELECTRIC LAND VEHICLES, MOTOR CARS, VANS, LORRIES, MOTORCYCLES, MOPEDS, OMNIBUSES; CHASSIS FOR AUTOMOBILES, MOTOR VEHICLES, LAND VEHICLES, MOTOR CARS, VANS, LORRIES, MOTORCYCLES, MOPEDS, OMNIBUSES (U.S. CLS. 19, 21, 23, 31, 35 AND 44).

AMY ALFIERI, EXAMINING ATTORNEY

SN 79-107,249. CRODA INTERNATIONAL PLC, UNITED KINGDOM, FILED 12-1-2011.



THE MARK CONSISTS OF STANDARD CHARACTERS WITHOUT CLAIM TO ANY PARTICULAR FONT, STYLE, SIZE, OR COLOR.

OWNER OF INTERNATIONAL REGISTRATION 1101861 DATED 12-1-2011, EXPIRES 12-1-2021.

NO CLAIM IS MADE TO THE EXCLUSIVE RIGHT TO USE "VET", APART FROM THE MARK AS SHOWN.

CLASS 1—CHEMICALS

FOR CHEMICALS AND OLEOCHEMICALS FOR USE IN FOOD STUFFS FOR ANIMALS, NAMELY, ADDITIVES FOR USE IN THE MANUFACTURE OF FOODSTUFFS FOR ANIMALS; CHEMICAL SUBSTANCES FOR PRESERVING FOODSTUFFS FOR ANIMALS; CHEMICAL ADDITIVES FOR USE IN THE MANUFACTURE OF DIETARY SUPPLEMENTS, FOODSTUFFS AND VETERINARY PREPARATIONS FOR ANIMALS; FATTY ACIDS FOR USE IN THE MANUFACTURE OF DIETARY SUPPLEMENTS, FOODSTUFFS AND VETERINARY PREPARATIONS FOR ANIMALS (U.S. CLS. 1, 5, 6, 10, 26 AND 46).

CLASS 5—PHARMACEUTICALS

FOR VETERINARY PRODUCTS, NAMELY, NUTRITIONAL OILS, AND FOOD ADDITIVES FOR VETERINARY USE BASED ON MARINE OILS, ALL FOR USE AS DIETARY SUPPLEMENTS; DIETARY FOOD SUPPLEMENTS FOR ANIMALS; ANIMAL HEALTH FOOD SUPPLEMENTS; ANIMAL FOOD SUPPLEMENTS; VITAMIN SUPPLEMENTS FOR ANIMALS; DIETARY FOOD SUPPLEMENTS FOR VETERINARY USE; VETERINARY HEALTH FOOD SUPPLEMENTS; VETERINARY FOOD SUPPLEMENTS; VITAMIN SUPPLEMENTS FOR VETERINARY PURPOSES; EDIBLE OILS AND FATS AND DERIVATIVES THEREOF, IN THE NATURE OF MARINE OILS, ALL FOR VETERINARY USE; CASTOR OIL FOR VETERINARY PURPOSES (U.S. CLS. 6, 18, 44, 46, 51 AND 52).

APRIL ROACH, EXAMINING ATTORNEY

CLASS 9—ELECTRICAL AND SCIENTIFIC APPARATUS

FOR WIRELESS ADAPTERS FOR PERSONAL COMPUTERS; ACCUMULATORS; PC WEB CAMERAS; WIRELESS HEADSETS FOR MOBILE PHONES; WIRED HEADSETS FOR MOBILE PHONES; MOBILE PHONE HOLDERS; HOLDERS FOR DIGITAL DEVICES, NAMELY, MOBILE PHONES, TABLET COMPUTERS, LAPTOPS AND NOTEBOOK COMPUTERS, GPS NAVIGATORS, TELEVISIONS, CAMERAS, AND CAMCORDERS; FIBRE OPTIC CABLES; ELECTRIC CABLES; COMPUTER KEYBOARDS; MOUSE DATA PROCESSING EQUIPMENT; WIRELESS HEADPHONES; STEREO HEADPHONES; STEREO HEADPHONES WITH MICROPHONE; BLANK OPTICAL DATA MEDIA, NAMELY, COMPACT DISCS (CDS), DIGITAL VIDEO DISCS (DVDS), OPTICAL DISCS, AND HIGH DEFINITION VIDEO DISCS; CABLE CONNECTORS AND ADAPTERS; OPTICAL DRIVES FOR READING AND RECORDING COMPACT DISCS (CDS), DIGITAL VIDEO DISCS (DVDS), OPTICAL DISCS, AND HIGH DEFINITION VIDEO DISCS; ELECTRIC CONVERTERS; HANDS-FREE KITS FOR MOBILE PHONES, CARRYING CASES FOR COMPUTERS; CARRYING CASES FOR LAPTOPS; CASES ESPECIALLY MADE FOR PHOTOGRAPHIC APPARATUS AND INSTRUMENTS; COVERS FOR MEDIA PLAYERS; COVERS FOR STORAGE AND CARRYING OF COMPUTERS; DECORATION FOR MOBILE PHONES, NAMELY, CELLULAR PHONE ACCESSORY CHARMS; HANDS-FREE DEVICES FOR MOBILE PHONES, CHARGERS FOR ELECTRIC ACCUMULATORS; COVERS FOR MOBILE PHONES, LACES AND STRAPS FOR MOBILE PHONES (U.S. CLS. 21, 23, 26, 36 AND 38).

SN 79-107,298. OBSHCHESTVO S OGRANICHENNOY OTVETSTVENNOSTYU "FONTINALIS", RU-195221 SAINT-PETERSBURG, RUSSIAN FED., FILED 9-1-2011.



OWNER OF INTERNATIONAL REGISTRATION 1101978 DATED 9-1-2011, EXPIRES 9-1-2021.

NO CLAIM IS MADE TO THE EXCLUSIVE RIGHT TO USE "COLLECTION FOR MEN", APART FROM THE MARK AS SHOWN.

THE NAME(S), PORTRAIT(S), AND/OR SIGNATURE(S) SHOWN IN THE MARK DOES NOT IDENTIFY A PARTICULAR LIVING INDIVIDUAL.

THE COLOR(S) YELLOW AND BLACK IS/ARE CLAIMED AS A FEATURE OF THE MARK.

THE MARK CONSISTS OF A BLACK RECTANGLE INSIDE WHICH THE YELLOW SHIELD WITH THREE YELLOW CROWNS AND YELLOW INSCRIPTION "R. BLAKE COLLECTION FOR MEN" ARE LOCATED.

CLASS 17—RUBBER GOODS

FOR PLASTIC FILM OTHER THAN FOR WRAPPING, NAMELY, PLASTIC FILM TO PROTECT SCREENS AND CASES OF PORTABLE DEVICES, NAMELY, MOBILE PHONES, TABLET COMPUTERS, LAPTOPS AND NOTEBOOK COMPUTERS, GPS NAVIGATORS, TELEVISIONS, CAMERAS, AND CAMCORDERS (U.S. CLS. 1, 5, 12, 13, 35 AND 50).

CLASS 18—LEATHER GOODS

FOR WALLETS; BUSINESS CARD CASES; BRIEF-CASES; KEY CASES MADE OF LEATHER; LEATHER STRAPS; AND BAGS, NAMELY, PURSES, HAVERSACKS, RUCKSACKS, GARMENT BAGS FOR TRAVEL, BAGS FOR SPORTS, MONEY PURSES NOT OUT OF PRECIOUS METALS, HANDBAGS, BACKPACKS, WHEELED DUFFLE BAGS, WHEELED MESSENGER BAGS, WHEELED TOTE BAGS, ALL PURPOSE CARRYING BAGS FOR CLIMBERS AND CAMPERS, TRAVELING BAGS, BEACH BAGS, SCHOOL SATCHELS, TOILETRY CASES SOLD EMPTY, TRAVELING CASES OF LEATHER, ATTACHE CASES, WASH BAGS FOR CARRYING TOILETRIES AND MAKE-UP BAGS SOLD EMPTY, LEATHER AND IMITATION LEATHER SHOPPING BAGS, MESH SHOPPING BAGS, AND LEATHER BAGS FOR MERCHANDISING PACKAGING (U.S. CLS. 1, 2, 3, 22 AND 41).

SHANNON TWOHIG, EXAMINING ATTORNEY

SN 79-107.422. MESSE FRANKFURT EXHIBITION GMBH,
FED REP GERMANY, FILED 8-2-2011.

SN 79-107.611. PEKER YÜZEY TASARIMLARI; SANAYI VE
TİCARET ANONİM ŞİRKETİ, TURKEY, FILED 9-9-2011.

IFFFA

THE MARK CONSISTS OF STANDARD CHARACTERS WITHOUT CLAIM TO ANY PARTICULAR FONT, STYLE, SIZE, OR COLOR.

OWNER OF INTERNATIONAL REGISTRATION 1102307
DATED 8-2-2011, EXPIRES 8-2-2021.

OWNER OF U.S. REG. NO. 1,237,607.

CLASS 35—ADVERTISING AND BUSINESS

FOR ADVERTISING; MARKETING RESEARCH; TELEMARKETING; PERSONNEL MANAGEMENT CONSULTANCY, EMPLOYMENT AGENCIES; ORGANIZATION AND CONDUCTING OF TRADE FAIRS, EXHIBITIONS AND SPECIAL SHOWS FOR COMMERCIAL OR ADVERTISING PURPOSES; BUSINESS MANAGEMENT, PARTICULARLY IN RESPECT OF ORGANIZING AND CONDUCTING TRADE FAIRS, EXHIBITIONS, SPECIAL SHOWS AND SELLING EVENTS; PRESENTATION OF BUSINESS COMPANIES AND THEIR PRODUCTS AND SERVICES, ALSO VIA THE INTERNET; SALES PROMOTION FOR OTHERS; PRODUCT MERCHANDISING; DEMONSTRATION OF GOODS FOR PUBLICITY PURPOSES; ARRANGING CONTACTS BETWEEN COMMERCIAL PARTNERS IN TRADE AND INDUSTRY, ALSO VIA THE INTERNET; RENTAL OF ADVERTISING SPACE AND ADVERTISING MATERIAL; RENTAL OF BOOTHS FOR EXHIBITIONS AND TRADE FAIRS; MANAGEMENT CONSULTANCY, PARTICULARLY IN RESPECT OF ORGANIZING AND CONDUCTING TRADE FAIRS, EXHIBITIONS, SPECIAL SHOWS AND SELLING EVENTS; COMPILATION OF INFORMATION INTO COMPUTER DATABASES (U.S. CLS. 100, 101 AND 102).

CLASS 41—EDUCATION AND ENTERTAINMENT

FOR EDUCATION SERVICES, NAMELY, PROVIDING SEMINARS AND WORKSHOPS IN THE FIELD OF MEAT PROCESSING, PACKAGING, AND SALES; TRAINING SERVICES IN THE FIELD OF MEAT PROCESSING, PACKAGING, AND SALES; ENTERTAINMENT SERVICES IN THE NATURE OF LIVE MUSICAL PERFORMANCES; ORGANIZING COMMUNITY SPORTING AND CULTURAL EVENTS; VOCATIONAL GUIDANCE; ORGANIZATION OF EXHIBITIONS FOR CULTURAL OR EDUCATIONAL PURPOSES; CONDUCTING SEMINARS, CONFERENCES, SYMPOSIA AND WORKSHOPS IN THE FIELD OF MEAT PROCESSING, PACKAGING, AND SALES; EDUCATIONAL SERVICES, NAMELY, DEVELOPING, ARRANGING, AND CONDUCTING EDUCATIONAL CONFERENCES AND PROGRAMS AND PROVIDING COURSES OF INSTRUCTION IN THE FIELD OF MEAT PROCESSING, PACKAGING, AND SALES; SPECIAL EVENT, PARTY PLANNING AND COORDINATION SERVICES, NAMELY, ORGANIZING AND CONDUCTING BALLS; ARRANGING AND CONDUCTING ATHLETIC COMPETITIONS; PRESENTATION OF LIVE SHOW PERFORMANCES; ORCHESTRA SERVICES; PARTY PLANNING; BOOKING OF SEATS FOR SHOWS (U.S. CLS. 100, 101 AND 107).

SANJEEV VOHRA, EXAMINING ATTORNEY

belenco

OWNER OF INTERNATIONAL REGISTRATION 1102777
DATED 9-9-2011, EXPIRES 9-9-2021.

THE WORD(S) "BELENCO" HAS NO MEANING IN A FOREIGN LANGUAGE

CLASS 19—NON-METALLIC BUILDING MATERIALS

FOR MATERIALS FOR CONSTRUCTING, COATING, REPAIRING ROADS, NAMELY, ASPHALT, PITCH AND TAR, BITUMEN ASPHALT; SAND, GRAVEL, SLAG STONE; AGGREGATE MATERIAL COMPOSED OF SAND AND SAND STONE, GRAVEL, NON-AGRICULTURAL LIME FOR USE IN CONSTRUCTION, SLAG-LIME CEMENT, GYPSUM; BLOCKS OF CONCRETE, PLASTER AND COLORED PLASTER FOR BUILDING PURPOSES; ARTICLES OF ARTIFICIAL STONE FOR BUILDING PURPOSES; SHAPED BUILDING, CONSTRUCTION AND ROAD CONSTRUCTION MATERIALS IN THE NATURE OF FLOORBOARDS, PIPES, BLOCKS MADE OF CONCRETE, GYPSUM, EARTHENWARE, CLAY, SAND, NATURAL STONE, ARTIFICIAL STONE, WOODEN, PLASTIC OR SYNTHETIC MATERIALS; NON-METAL UTILITY POLES, PORTABLE NON-METAL TRAFFIC BARRIERS; CONCRETE, CLAY ROOFING TILES, NATURAL STONES, ARTIFICIAL STONES, BUILDING MATERIALS, NAMELY, SEMI-WORKED WOODS, PLASTIC TILES; FLOORING OR WALL-CLADDINGS OF SYNTHETIC MATERIALS; NATURAL MARBLES, ARTIFICIAL MARBLES, INNER AND OUTER FACINGS OF NATURAL OR ARTIFICIAL STONES, PLACE AND FLOOR COATINGS IN THE NATURE OF FIREPROOF CEMENT COATINGS; CONCRETE PANELS, CONCRETE PIPES, CONCRETE BEAMS, CONCRETE BLOCKS, CONCRETE BOLLARDS, CONCRETE WALLS, CONCRETE FENCES, CONCRETE ROOF REPAIR COMPOUNDS IN THE NATURE OF ROOFING CEMENT, CONCRETE SLABS, CONCRETE ROOF TILES, CRASH BARRIERS OF CONCRETE, CONCRETE POLES FOR ELECTRIC POWER LINES; PLASTER FOR BUILDING PURPOSE, NAMELY, PLASTER BOARDS, PLASTER PANELS, PLASTER WALLS, PLASTER FOR PREFABRICATED BUILDINGS; BRICKS, NON-METAL RIGID GUTTER PIPES, NON-METAL TUBING AND PIPE CONNECTORS FOR JOINING AND TERMINATING PIPES; NON-LUMINOUS, NON-MECHANICAL SIGNS NOT OF METAL; MONUMENTS OF STONE, CONCRETE OR MARBLE; STATUES OF STONE, CONCRETE OR MARBLE; NATURAL OR SYNTHETIC SURFACE COATINGS, NAMELY, NON-METAL SIDING WITH HEAT ADHESIVE FOR BUILDING PURPOSES IN FORM OF PLATES OR STRIPS; GLASS BLOCKS FOR BUILDING, GLASS BRICKS, GLASS TILES, GLASS PANES, GLASS PANELS FOR BUILDING CONSTRUCTION; AQUARIUM SAND (U.S. CLS. 1, 12, 33 AND 50).

CLASS 20—FURNITURE AND ARTICLES NOT OTHERWISE CLASSIFIED

FOR FURNITURE, DISPLAY STANDS AND BOARDS, INDEX CABINETS, MEDICINE CABINETS, WRITING AND DRAWING DESKS, SERVICE CARTS, NAMELY, TEA CARTS, DECK CHAIRS, TABLE COUNTERS NOT OF METAL, WORK BENCHES, VICE BENCHES, FURNITURE CHESTS, NON-METAL MAILBOXES, FIXED NONMETAL TOWEL DISPENSERS, COAT HANGERS, COAT STANDS; MIRRORS; BEEHIVES, COMB FOUNDATIONS FOR BEEHIVES, SECTIONS OF WOOD FOR BEEHIVES; PLAYPENS FOR BABIES, HIGH CHAIRS FOR BABIES, BASSINETTES, INFANT WALKERS; VEHICLE LICENSE PLATES NOT OF METAL, INFLATABLE PLASTIC SIGNS, PLASTIC AND WOODEN SIGNBOARDS, DISPLAY BOARDS, PICTURE FRAMES, NON-METAL PICTURE FRAME BRACKETS, MOLDINGS FOR PICTURE FRAMES, IDENTITY PLATES, NOT OF METAL; NAMEPLATES, NOT OF METAL;

REGISTRATION PLATES, NOT OF METAL; NUMBER PLATES, NOT OF METAL; WOODEN BARRELS, CASKS, AND KEGS; NON-METAL LIQUID FUEL CONTAINERS; WOOD BOXES, WOODEN BOXES FOR TRANSPORTATION PURPOSES, NON-METAL CHESTS, TRANSPORT PALETTES, PACKAGING CONTAINERS OF PLASTIC, PLASTIC BARRELS, PLASTIC BOXES, NON-METAL VALVES FOR CONTAINERS, NON-METAL TAPS FOR CASKS; WOOD AND NON-METAL TOOL HANDLES; LATCHES NOT OF METAL, BOTTLE CLOSURES, NOT OF METAL; BOTTLE CAPS, NOT OF METAL; CORKS FOR BOTTLES, CORK BANDS, WINDOW FITTINGS, NOT OF METAL; DOOR FITTINGS, NOT OF METAL; LOCKS, NOT OF METAL; DISPLAY RACKS; DOOR HANDLES, NOT OF METAL; DRAWER RAILS; CASTERS, NOT OF METAL; BOLTS, NOT OF METAL; SCREWS, NOT OF METAL; DOWELS, NOT OF METAL; NONMETAL PIPE AND CABLE CLIPS, NONMETAL PLUGS IN THE NATURE OF DOWELS; WORKS OF ART, OF WOOD, WAX, PLASTER OR PLASTIC; SCULPTURES AND BUSTS OF WOOD, WAX, PLASTER OR PLASTIC; MANNEQUINS; DECORATIVE MOBILES, WALL PLAQUES MADE OF PLASTIC OR WOOD; STUFFED ANIMALS; BASKETS, NAMELY, BAKERS' BREAD BASKETS, HAMPERS IN THE NATURE OF BASKETS FOR TRANSPORTING GOODS FOR COMMERCIAL PURPOSES, REED BASKETS FOR COMMERCIAL OR INDUSTRIAL PURPOSES, FISHING BASKETS FOR TRANSPORTING FISH FOR COMMERCIAL PURPOSES; DOG KENNELS, NESTING BOXES FOR ANIMALS, CUSHIONS AND BEDS FOR HOUSEHOLD PETS; NON METAL PORTABLE STEP LADDERS OF WOOD OR PLASTIC; MOBILE BOARDING STAIRS NOT OF METAL FOR PASSENGERS; CURTAIN HOLDERS, NOT OF TEXTILE MATERIAL; CURTAIN HOOKS, CURTAIN RAILS, CURTAIN RINGS, CURTAIN RODS, CURTAIN ROLLERS, CURTAIN TIE-BACKS IN THE NATURE OF NON-TEXTILE CURTAIN HOLDERS, BAMBOO CURTAINS, INDOOR WINDOW BLINDS IN THE NATURE OF SHADES, SLATTED INDOOR BLINDS, BEAD CURTAINS FOR DECORATION (U.S. CLS. 2, 13, 22, 25, 32 AND 50).

CLASS 35—ADVERTISING AND BUSINESS

FOR ADVERTISING AGENCIES SERVICES, MARKETING AND PUBLICITY BUREAUS SERVICES INCLUDING COMMERCIAL OR ADVERTISEMENT EXHIBITION AND TRADE FAIR ORGANIZATION SERVICES; PROVIDING OFFICE FUNCTIONS; BUSINESS MANAGEMENT; BUSINESS ADMINISTRATION; IMPORT AND EXPORT AGENCIES; BUSINESS INVESTIGATIONS, EVALUATIONS, EXPERT APPRAISALS, INFORMATION AND RESEARCH OF INDUSTRIAL AND COMMERCIAL GOODS, AUCTIONEERING; THE BRINGING TOGETHER, FOR THE BENEFIT OF OTHERS A VARIETY OF GOODS ENABLING CUSTOMERS TO CONVENIENTLY VIEW AND PURCHASE THOSE GOODS, NAMELY, NON-METALLIC BUILDING MATERIALS, NON-METALLIC RIGID PIPES FOR BUILDING, ASPHALT, PITCH AND BITUMEN, NON-METALLIC TRANSPORTABLE BUILDINGS, MONUMENTS, NOT OF METAL, FURNITURE, MIRRORS, PICTURE FRAMES, GOODS OF WOOD, CORK, REED, CANE, WICKER, HORN, BONE, IVORY, WHALEBONE, SHELL, AMBER, MOTHER-OF-PEARL, MEERSCHAUM AND SUBSTITUTES FOR ALL THESE MATERIALS ALL PROVIDED VIA RETAIL STORE SERVICES, WHOLESALE OUTLET STORE SERVICES, MAIL ORDER CATALOGUE SERVICES, ONLINE ORDERING SERVICES, AND TELEVISION HOME SHOPPING SERVICES (U.S. CLS. 100, 101 AND 102).

SUE LAWRENCE, EXAMINING ATTORNEY

SN 79-107,622. SCHIESSER AG, FED REP GERMANY, FILED 8-29-2011.



PRIORITY DATE OF 3-8-2011 IS CLAIMED.

OWNER OF INTERNATIONAL REGISTRATION 1102796 DATED 8-29-2011, EXPIRES 8-29-2021.

THE COLOR(S) BLUE (PANTONE 294) AND WHITE IS/ARE CLAIMED AS A FEATURE OF THE MARK.

THE MARK CONSISTS OF A CROSSBOW IN WHITE WITH A WHITE STAR ON EITHER SIDE OF IT, ALL AGAINST A BLUE BACKGROUND SHIELD OUTLINED IN WHITE AND BLUE.

CLASS 18—LEATHER GOODS

FOR LEATHER AND IMITATION LEATHER BAGS; LEATHER BAGS; SMALL LEATHER GOODS, NAMELY, WALLETS; TRAVEL CASES; SUITCASES; ALL PURPOSE CARRYING BAGS; SPORT BAGS; BEACH BAGS; COSMETIC BAGS SOLD EMPTY; HANDBAGS; PURSES; TRAVEL BAGS (U.S. CLS. 1, 2, 3, 22 AND 41).

CLASS 25—CLOTHING

FOR CLOTHING, NAMELY, HATS, GLOVES, MITTENS AND SCARVES; OUTER CLOTHING FOR WOMEN, MEN AND CHILDREN, NAMELY, COATS AND SWEATERS; READY MADE CLOTHING, NAMELY, DRESSES, CARDIGANS, SLACKS AND SHORTS; SUITS, SHIRTS, TROUSERS, BERMUDA SHORTS; LADIES' DRESSES, BLOUSES, LADIES' SHIRTS, SKIRTS; JACKETS, HEAVY JACKETS, WAISTCOATS, COATS, JUMP SUITS, PARKAS, RAINCOATS, WIND RESISTANT JACKETS; HOSIERY; PULLOVERS, SWEATERS, BANDANAS, JERSEYS, T-SHIRTS, SWEATSHIRTS; TERRY TOWELLING CLOTHING, NAMELY, MOISTURE OR LIQUID ABSORBANT AND PERSPIRATION ABSORBANT UNDERWEAR AND BATHROBES; MEN'S, WOMEN'S AND CHILDREN'S UNDERWEAR; UNDERWEAR, BRASSIERES, WOMEN'S BRIEFS, KNICKERS, WOMEN'S VESTS, BUSTIERS, CORSELETS, BODICES, TEDDIES, BODYSUITS; SHIRTS AND SHORTS COMBINATIONS, UNDERSKIRTS; NEGLIGENCE; LINGERIE; LINGERIE IN THE NATURE OF COMBINATIONS OF VESTS AND SLIPS, SLIPS; MEN'S UNDERPANTS, BOXER SHORTS, MEN'S UNDERSHIRTS; MEN'S VESTS; CHILDREN'S BRIEFS AND UNDERPANTS, CHILDREN'S VESTS; WOMEN'S, MEN'S AND CHILDREN'S SPORTS UNDERWEAR; SPORTS BRAS; SOCKS; STOCKINGS; TIGHTS; LEGGINGS; SOCK SUSPENDERS; GARTERS, SUSPENDERS; SPORTS OUTER CLOTHING, NAMELY, JACKETS, GLOVES, MITTENS, SCARVES, SKI SHELLS, NAMELY, SKI VESTS, SKI HOODED JACKETS, HIKING JACKETS, HIKING HOODED JACKETS, HOODED SWEATSHIRTS, RUNNING JACKETS, WIND VESTS, HIKING PANTS, PARKAS, INSULATED VESTS, HATS FOR OUTDOOR PURSUITS AND SPORTS; GYMNASIUM CLOTHING, NAMELY, GYM SHORTS, GYM SUITS, LEOTARDS, TIGHTS; JOGGING SUITS; CYCLISTS' CLOTHING, NAMELY, CYCLING SHORTS AND SHIRTS, AND CYCLISTS' JERSEYS; KNITWEAR, NAMELY, KNITTED UNDERWEAR, SWEATERS AND DRESSES; SPORTS JERSEYS; FASHION SWIMWEAR; BATH LINEN, NAMELY, BATH ROBES AND ROBES; BATHING SUITS; BATHING TRUNKS; SWIMWEAR FOR MEN, WOMEN

AND CHILDREN; SWIMSUITS; SWIM TRUNKS; BATH-ROBES; BEACH CLOTHES, NAMELY, BEACH COVER-UPS; BEACHWEAR; NIGHTWEAR FOR WOMEN, MEN AND CHILDREN; PYJAMAS; NIGHTGOWNS; DRESSING GOWNS; LAYETTES; BABIES' CLOTHING, NAMELY, INFANTWEAR; BABY SLEEP SUITS; BABIES' UNDERWEAR; BABIES' NAPKIN-PANTS, NAMELY, INFANT DIAPER COVERS OF TEXTILE; BABIES' DIAPERS OF TEXTILE; TEXTILE GLOVES; WRISTBANDS; SWEATBANDS; HEADBANDS; BELTS; LEATHER BELTS; BRACES, NECKTIES, SCARVES, COLLAR PROTECTORS, EAR MUFFS; APRONS; FOOTWEAR; BATH SANDALS, BATH SLIPPERS, SANDALS, SPORT SHOES, ESPARTO SHOES, ESPARTO SANDALS, BEACH SHOES; HEADWEAR; SWIM CAPS, BATHING CAPS, SHOWER CAPS, HATS, HOODS, AND CAPS (U.S. CLS. 22 AND 39).
SUE LAWRENCE, EXAMINING ATTORNEY

SN 79-107,790. FRANCE TELECOM, FRANCE, FILED 5-16-2011.

JUKEVOX

THE MARK CONSISTS OF STANDARD CHARACTERS WITHOUT CLAIM TO ANY PARTICULAR FONT, STYLE, SIZE, OR COLOR.

PRIORITY DATE OF 11-25-2010 IS CLAIMED.

OWNER OF INTERNATIONAL REGISTRATION 1103257 DATED 5-16-2011, EXPIRES 5-16-2021.

THE WORDING "JUKEVOX" HAS NO MEANING IN A FOREIGN LANGUAGE.

SN 79-107,676. MGM GROUP AG, ZÜRICH, SWITZERLAND, FILED 11-29-2011.

banoush

THE MARK CONSISTS OF STANDARD CHARACTERS WITHOUT CLAIM TO ANY PARTICULAR FONT, STYLE, SIZE, OR COLOR.

PRIORITY DATE OF 8-18-2011 IS CLAIMED.

OWNER OF INTERNATIONAL REGISTRATION 1102953 DATED 11-29-2011, EXPIRES 11-29-2021.

THE WORD(S) "BANOUSH" HAS NO MEANING IN A FOREIGN LANGUAGE.

CLASS 29—MEATS AND PROCESSED FOODS

FOR MEAT, FISH, POULTRY AND GAME; MEAT EXTRACTS; PRESERVED, DRIED AND COOKED FRUITS AND VEGETABLES; JELLIES, JAMS, COM- POTES; EGGS, MILK AND MILK PRODUCTS EXCLUDING ICE CREAM, ICE MILK AND FROZEN YOGURT; EDIBLE OILS AND EDIBLE FATS (U.S. CL. 46).

CLASS 30—STAPLE FOODS

FOR COFFEE, TEA, COCOA, SUGAR, RICE, TAPI- CA, SAGO, ARTIFICIAL COFFEE; FLOUR AND PRE- PARATIONS MADE FROM CEREALS, NAMELY, CEREAL-BASED READY MEALS, CEREAL-BASED SNACK FOODS, AND PRECOOKED CEREALS; BREAD, PASTRY AND CONFECTIONERY, ICES; HONEY, TREA- CLE; YEAST, BAKING-POWDER; SALT, MUSTARD; VINEGAR; CONDIMENTS, NAMELY, COOKING SAUCES, DIPPING SAUCES, SEASONING SAUCES; SPICES; ICE FOR REFRESHMENT (U.S. CL. 46).

CLASS 32—LIGHT BEVERAGES

FOR BEER; MINERAL AND AERATED WATERS AND OTHER NON-ALCOHOLIC DRINKS, NAMELY, SOFT DRINKS, ENERGY DRINKS, ISOTONIC DRINKS, NON-ALCOHOLIC FRUIT JUICE BEVERAGES, NON-ALCO- HOLIC FRUIT EXTRACTS USED IN THE PREPARA- TION OF BEVERAGES, VEGETABLE JUICES, VEGETABLE-FRUIT JUICES, AND SMOOTHIES; FRUIT DRINKS AND FRUIT JUICES; SYRUPS AND OTHER PREPARATIONS FOR MAKING BEVERAGES (U.S. CLS. 45, 46 AND 48).

ROBIN CHOSID, EXAMINING ATTORNEY

CLASS 9—ELECTRICAL AND SCIENTIFIC APPARATUS

FOR APPARATUS FOR RECORDING, TRANSMIT- TING OR REPRODUCING SOUND, DATA OR IMAGES USING HANDS-FREE AND VOICE-OPERATED MEANS; WIRELESS OPTICAL, ELECTRONIC AND ELECTRO- TECHNICAL COMMUNICATION DEVICES FOR VOICE, DATA, OR IMAGE TRANSMISSION, FOR USE IN COMMUNICATION BY VOICE, IMAGE, TEXT, DATA AND ANIMATED IMAGES; COMPUTER HARDWARE AND SOFTWARE FOR VOICE RECORDING, VOICE RECOGNITION AND COMPUTER GENERATED SIMU- LATION OF HUMAN SPEECH; VOICEMAIL SYSTEMS COMPRISED OF TELEPHONE ANSWERING APPARA- TUS; APPARATUS FOR TRANSMISSION OF SOUND, NAMELY, VOICE TRANSMISSION INSTALLATIONS AND APPARATUS; APPARATUS AND EQUIPMENT FOR DECODING AND ENCODING AUDIO, VISUAL, AND AUDIO-VISUAL DATA, FOR USE IN VOICE CONTROL AND TRANSLATION; AUDIOVISUAL APPA- RATUS, NAMELY, APPARATUS FOR THE RECORD- ING, TRANSMISSION, AND REPRODUCTION OF SOUND AND IMAGES; COMPUTER HARDWARE FOR THE CAPTURE, METERING, COLLECTING, STORING, CONVERTING, PROCESSING, INPUT, EMISSION AND TRANSMISSION OF DATA, SOUNDS, IMAGES AND SIGNALS; COMPUTER SOFTWARE FOR USE IN AUTHENTICATING AND CODING OF ELECTRONIC TELECOMMUNICATIONS TRANSMISSIONS FOR THE INPUT, STORAGE AND PROCESSING OF INFORMA- TION AND DATA; AUDIO AND VIDEO INTERACTIVE COMMUNICATIONS SERVERS; COMPUTERS FITTED WITH EQUIPMENT FOR RECORDING, PROCESSING, AND REPRODUCING MUSIC, FOR VOICE RECOGNI- TION, FOR VOICE ENCODING, AND FOR VOICE REPRODUCTION; MESSAGE TRANSMISSION EQUIP- MENT, NAMELY, APPARATUS FOR TRANSMISSION OF MESSAGES COMPRISED OF SOUND, IMAGES OR DATA; COMPUTER SOFTWARE FOR VOICE RECOGNI- TION (U.S. CLS. 21, 23, 26, 36 AND 38).

CLASS 35—ADVERTISING AND BUSINESS

FOR DIRECT MARKETING SERVICES OF APPLICA- TIONS USING VOICE SYNTHESIS TECHNOLOGY; SUB- SCRIPTON TO A COMPUTER DATABASE SERVICE, SUBSCRIPTION TO COMPUTER DATABASE SERVER SERVICE, SUBSCRIPTIONS TO A COMPUTER SERVICE THAT PROVIDES ACCESS TO COMPUTER AND DATA COMMUNICATIONS NETWORKS, PARTICULARLY TO GLOBAL COMMUNICATION NETWORKS IN THE NATURE OF THE INTERNET AND PRIVATE ACCESS NET- WORKS IN THE NATURE OF INTRANET NETWORKS; ARRANGING FOR SUBSCRIPTIONS TO TELECOMMU- NICATIONS SERVICES FEATURING AUDIO AUDIOVI- SUAL PROGRAMS, SUBSCRIPTION TO A TELEPHONE SERVICE FOR PROVIDING CONSULTING INFORMA- TION RELATING TO INFORMATION PROVIDED VIA AN ON-LINE NETWORK (U.S. CLS. 100, 101 AND 102).

CLASS 38—COMMUNICATION

FOR TELECOMMUNICATIONS SERVICES, NAMELY, LOCAL AND LONG DISTANCE TRANSMISSION OF VOICE, DATA, GRAPHICS, AND VIDEO BY MEANS OF BROADBAND, COPPER, AND OPTICAL OR WIRELESS NETWORKS, COMMUNICATIONS VIA TELEPHONE, RADIOTELEPHONE, TELEVISION, GLOBAL COMMUNICATION NETWORKS, AND VIA FIBER-OPTIC NETWORKS; COMMUNICATION SERVICES, NAMELY, ELECTRONIC TRANSMISSION OF DATA, SOUNDS AND IMAGES, ELECTRONIC TRANSMISSION OF DATA VIA DATA COMMUNICATIONS MEANS ACCESSIBLE BY ACCESS CODES AND TERMINALS; ELECTRONIC TRANSMISSION OF MESSAGES AND DATA TRANSMISSION VIA DATA COMMUNICATIONS APPARATUS USED FOR OBTAINING INFORMATION HELD IN DATA BANKS AND IMAGE BANKS; ELECTRONIC EXCHANGE OF CORRESPONDENCE IN THE NATURE OF DATA STORED IN DATABASES ACCESSIBLE VIA TELECOMMUNICATIONS NETWORKS, ELECTRONIC MAIL SERVICES, ELECTRONIC MESSAGING, ELECTRONIC DATA TRANSMISSION VIA A GLOBAL COMMUNICATIONS NETWORK AND PRIVATE ACCESS NETWORKS IN THE NATURE OF INTRANET NETWORKS, TELECONFERENCING SERVICES, INFORMATION TRANSMISSION SERVICES VIA ELECTRONIC INFORMATION COMMUNICATION NETWORKS, NAMELY INTERNET, EXTRANET AND INTRANET NETWORKS; ELECTRONIC TRANSMISSION OF DATA VIA SECURED MESSAGING SYSTEMS; PROVIDING ACCESS TO AN ON-LINE TELECOMMUNICATIONS NETWORK, WHICH ALLOWS USERS TO TRANSFER DATA ON THEIR PERSONAL IDENTITY AND TO SHARE SAID PERSONAL DATA WITH AND VIA VARIOUS INTERNET SITES, TO CREATE THEIR OWN CONTENT IN THE NATURE OF TEXTS, AND TO CONVERT TEXT MESSAGES INTO VOICE MESSAGES (U.S. CLS. 100, 101 AND 104).

CLASS 41—EDUCATION AND ENTERTAINMENT

FOR TRAINING IN THE FIELD OF COMPUTING, TELECOMMUNICATIONS, MULTIMEDIA EQUIPMENT, AND COMPUTER SOFTWARE FOR APPLICATIONS USING VOICE SYNTHESIS TECHNOLOGY; EDITING OF SOUNDS AND IMAGES CONTAINED IN MULTIMEDIA PROGRAMS FOR INTERACTIVE AND OTHER USE (U.S. CLS. 100, 101 AND 107).

CLASS 42—SCIENTIFIC AND COMPUTER SERVICES

FOR PRODUCT DEVELOPMENT IN THE FIELD OF TELECOMMUNICATIONS SYSTEMS DESIGNED FOR APPLICATIONS USING VOICE SYNTHESIS TECHNOLOGY AND SYNTHESIZED VOICE TECHNOLOGY; DESIGN AND DEVELOPMENT OF COMPUTER SOFTWARE APPLICATIONS USING VOICE SYNTHESIS TECHNOLOGY, FOR MASS STORAGE OF MEDIA, VOICE INPUT AND VOICE EDITING, VOICE RECORDING, VOICE ARCHIVING AND VOICE ANALYSIS; TECHNICAL SUPPORT SERVICES, NAMELY, TROUBLESHOOTING IN THE NATURE OF DIAGNOSING COMPUTER HARDWARE AND SOFTWARE PROBLEMS RELATING TO APPARATUS FOR RECORDING, REPRODUCING AND PROCESSING DATA, SOUNDS AND IMAGES, TELECOMMUNICATIONS TERMINALS, DATABASE SERVERS, PROVIDER CENTERS FOR ACCESS TO COMPUTER AND DATA TRANSMISSION NETWORKS, AND THE MONITORING AND EFFICIENCY OF THE ABOVE APPARATUS AND INSTRUMENTS; DATA CONVERSION OF ELECTRONIC INFORMATION, NAMELY, CONVERSION OF DATA AND DOCUMENTS FROM PHYSICAL TO ELECTRONIC MEDIA (U.S. CLS. 100 AND 101).

CLASS 45—PERSONAL AND LEGAL SERVICES

FOR PERSONAL AND SOCIAL SERVICES PROVIDED BY THIRD PARTIES TO MEET THE NEEDS OF INDIVIDUALS, NAMELY, ONLINE SOCIAL NETWORKING SERVICES, DATING SERVICES, AND MEDIATION SERVICES; ON-LINE DATING SERVICES; LEGAL RESEARCH (U.S. CLS. 100 AND 101).
SUE LAWRENCE, EXAMINING ATTORNEY

SN 79-107,892. NVT AG, SWITZERLAND, FILED 9-23-2011.

THE MARK CONSISTS OF STANDARD CHARACTERS WITHOUT CLAIM TO ANY PARTICULAR FONT, STYLE, SIZE, OR COLOR.

PRIORITY DATE OF 3-25-2011 IS CLAIMED.
OWNER OF INTERNATIONAL REGISTRATION 1103570 DATED 9-23-2011, EXPIRES 9-23-2021.

CLASS 5—PHARMACEUTICALS

FOR SURGICAL IMPLANTS COMPRISING LIVING TISSUE, NOT INCLUDING USE IN THE FIELDS OF OPHTHALMOLOGY AND VISION (U.S. CLS. 6, 18, 44, 46, 51 AND 52).

CLASS 10—MEDICAL APPARATUS

FOR SURGICAL INTRAVASCULAR IMPLANTS COMPRISING ARTIFICIAL MATERIAL AND ASSOCIATED SURGICAL INSTRUMENT SETS; SYNTHETIC STENT GRAFTS; ARTIFICIAL CARDIAC VALVES; CARDIAC VALVES FOR SURGICAL PROSTHESES; MEDICAL INSTRUMENTS FOR INTRALUMINAL PLACEMENT OF STENTS, SYNTHETIC STENT GRAFTS AND ARTIFICIAL CARDIAC VALVES, NAMELY, STENT DELIVERY SYSTEMS, SYNTHETIC STENT GRAFTS DELIVERY SYSTEMS AND ARTIFICIAL CARDIAC VALVES DELIVERY SYSTEMS; MEDICAL AND SURGICAL CATHETERS; ALL THE FOREGOING NOT INCLUDING USE IN THE FIELDS OF OPHTHALMOLOGY AND VISION (U.S. CLS. 26, 39 AND 44).

JASON BLAIR, EXAMINING ATTORNEY

SN 79-107,998. KETTENBACH GMBH & CO. KG, 35713 ESCHENBURG, FED REP GERMANY, FILED 7-5-2011.

THE MARK CONSISTS OF STANDARD CHARACTERS WITHOUT CLAIM TO ANY PARTICULAR FONT, STYLE, SIZE, OR COLOR.

PRIORITY DATE OF 5-10-2011 IS CLAIMED.
OWNER OF INTERNATIONAL REGISTRATION 1103867 DATED 7-5-2011, EXPIRES 7-5-2021.

NO CLAIM IS MADE TO THE EXCLUSIVE RIGHT TO USE "TRAY", APART FROM THE MARK AS SHOWN.

CLASS 5—PHARMACEUTICALS

FOR TOOTH FILLING MATERIAL AND DENTAL IMPRESSION MATERIALS, MODELLING WAX FOR DENTAL PURPOSES; DENTAL MATERIALS, NAMELY, DENTAL COMPOSITE MATERIALS; DENTAL BITE REGISTRATION MATERIALS AND CERAMIC MATERIALS FOR DENTAL USE OF FILINGS; HYGIENE PRODUCTS, NAMELY, SKIN DISINFECTANT, COTTON SWABS AND TAMPONS FOR MEDICAL USE AS ABSORBENT MATERIAL, GOLD AMALGAM FOR DENTAL PURPOSES; DENTAL MASTICS; ADHESIVE FOR DENTURES, PORCELAIN FOR DENTAL PROSTHESES AND DENTAL PORCELAIN MATERIALS; DENTAL LACQUERS (U.S. CLS. 6, 18, 44, 46, 51 AND 52).

CLASS 10—MEDICAL APPARATUS

FOR DENTAL AND DENTAL INSTRUMENTS AND APPARATUS, NAMELY, ORAL IRRIGATORS, PICKS, BURRS AND MIRRORS; AND CROWN AND BRIDGE REMOVERS; ARTIFICIAL TEETH, DENTAL IMPLANTS OF ARTIFICIAL MATERIALS AND DENTAL PROSTHESES; ELECTRICAL EQUIPMENT FOR USE IN DENTISTRY, NAMELY, DENTAL DRILLS, DENTAL OPERATING LAMPS; AND MILLING APPARATUS FOR DENTAL PURPOSES; ARTIFICIAL JAWS, DENTAL PINS FOR MEDICAL USE (U.S. CLS. 26, 39 AND 44).
ELLEN PERKINS, EXAMINING ATTORNEY

SN 79-108,324. GEORGE P. JOHNSON GMBH, FED REP GERMANY, FILED 9-5-2011.



OWNER OF INTERNATIONAL REGISTRATION 1104667 DATED 9-5-2011, EXPIRES 9-5-2021.

THE COLOR(S) BLACK, YELLOW, GREEN AND BLUE IS/ARE CLAIMED AS A FEATURE OF THE MARK.

BLACK: LETTERS "TOUCHSCOPE" AND DIAMOND-SHAPED ELEMENT ALONGSIDE LETTERS; GREEN, BLUE AND YELLOW: STYLISED REPRESENTATION OF THREE OVERLAPPING HANDS IN A BLACK DIAMOND-SHAPED BACKGROUND.

THE MARK CONSISTS OF THE STYLIZED WORDING "TOUCHSCOPE" APPEARING TO THE RIGHT OF THE DESIGN OF THREE INTERSECTING AND OVERLAPPING HANDS SURROUNDED BY A QUADRILATERAL. THE COLOR BLACK APPEARS IN THE WORDING "TOUCHSCOPE" AS WELL AS IN THE DECEPTION OF THE QUADRILATERAL SURROUNDING THE INTERSECTING AND OVERLAPPING HANDS. THE COLOR YELLOW APPEARS IN THE DEPICTION OF THE INTERSECTING AND OVERLAPPING HAND ON THE LEFT. THE COLOR GREEN APPEARS IN THE DEPICTION OF THE INTERSECTING AND OVERLAPPING HAND IN THE MIDDLE. THE COLOR BLUE APPEARS IN THE DEPICTION OF THE INTERSECTING AND OVERLAPPING HANDS ON THE RIGHT.

CLASS 9—ELECTRICAL AND SCIENTIFIC APPARATUS

FOR COMPUTER SOFTWARE FOR DOCUMENT MANAGEMENT AND DATABASE MANAGEMENT; COMPUTER SOFTWARE FOR ACCESSING INFORMATION DIRECTORIES THAT CAN BE DOWNLOADED FROM GLOBAL COMPUTER NETWORKS; COMPUTER SOFTWARE TO ENABLE THE SECURE TRANSMISSION AND SECURE RECEIPT OF DATA, SIGNALS, IMAGES AND SOUND OVER COMPUTER NETWORKS; COMPUTER SOFTWARE FOR APPLICATION AND DATABASE INTEGRATION; COMPUTER SOFTWARE TO AUTOMATE DATA WAREHOUSING; COMPUTER SOFTWARE FOR WIRELESS CONTENT DELIVERY; COMPUTER COMMUNICATIONS SOFTWARE FOR CONNECTING COMPUTER USERS VIA GLOBAL COMPUTER NETWORKS; COMPUTER SOFTWARE FOR THE COLLECTION, EDITING, ORGANIZING, MODIFYING, BOOK MARKING, TRANSMISSION, STORAGE AND SHARING OF DATA FOR OTHERS VIA THE INTERNET (U.S. CLS. 21, 23, 26, 36 AND 38).

CLASS 38—COMMUNICATION

FOR PROVIDING TELECOMMUNICATIONS CONNECTIONS TO A GLOBAL COMPUTER NETWORK; COMMUNICATIONS BY COMPUTER TERMINALS; COMMUNICATIONS, NAMELY ELECTRONIC TRANSMISSION OF DATA AND DOCUMENTS BETWEEN COMPUTER USERS (U.S. CLS. 100, 101 AND 104).

CLASS 42—SCIENTIFIC AND COMPUTER SERVICES

FOR SERVICES OF AN APPLICATION SERVICE PROVIDER, NAMELY, HOSTING OF COMPUTER SOFTWARE APPLICATIONS FOR OTHERS; INSTALLATION AND CUSTOMIZATION OF APPLICATION SOFTWARE FOR COMPUTERS; CONSULTANCY WITH REGARD TO COMPUTER NETWORKS WITH DIFFERENT SOFTWARE ENVIRONMENTS; TECHNOLOGY RESEARCH IN THE FIELD OF COMPUTER HARDWARE AND SOFTWARE; COMPUTER TECHNOLOGY SUPPORT SERVICES, NAMELY, HELP DESK SERVICES PROVIDED ONLINE FOR USERS OF COMPUTER PROGRAMS; DEVELOPMENT OF COMPUTER SOFTWARE; DESIGN, MAINTENANCE OR UPDATING OF COMPUTER SOFTWARE; DATA CONVERSION OF COMPUTER PROGRAMS AND DATA, NOT PHYSICAL CONVERSION; SOFTWARE DESIGN; RENTAL OF COMPUTER SOFTWARE; RENTAL OF WEB SERVERS (U.S. CLS. 100 AND 101).

MICHAEL TANNER, EXAMINING ATTORNEY

SN 79-108,332. AGRINOS AS, NORWAY, FILED 10-3-2011.

AGRINOS

THE MARK CONSISTS OF STANDARD CHARACTERS WITHOUT CLAIM TO ANY PARTICULAR FONT, STYLE, SIZE, OR COLOR.

PRIORITY DATE OF 8-31-2011 IS CLAIMED.

OWNER OF INTERNATIONAL REGISTRATION 1104686 DATED 10-3-2011, EXPIRES 10-3-2021.

CLASS 1—CHEMICALS

FOR CHEMICALS FOR USE IN AGRICULTURE, HORTICULTURE AND FORESTRY EXCEPT FUNGICIDES, HERBICIDES, INSECTICIDES AND PARASITICIDES; FERTILIZERS (U.S. CLS. 1, 5, 6, 10, 26 AND 46).

CLASS 31—NATURAL AGRICULTURAL PRODUCTS

FOR AGRICULTURAL, HORTICULTURAL AND FORESTRY PRODUCTS, NAMELY, SEEDS FOR LAWN GRASS; AGRICULTURAL GRAINS FOR PLANTING; CROP SEEDS; GRASS SEEDS; PLANT SEEDS; SEEDS FOR AGRICULTURAL PURPOSES; SEEDS FOR HORTICULTURAL PURPOSES; SEEDS FOR FIBER CROPS; SEEDS FOR OILSEED CROPS; UNPROCESSED SEEDS FOR AGRICULTURAL PURPOSES; FRESH FRUITS AND VEGETABLES, LIVE PLANTS AND LIVE FLOWERS (U.S. CLS. 1 AND 46).

CLASS 44—MEDICAL, BEAUTY AND AGRICULTURAL SERVICES

FOR CONSULTING SERVICES IN AGRICULTURE, HORTICULTURE AND FORESTRY, NAMELY, AGRONOMIC CONSULTING SERVICES (U.S. CLS. 100 AND 101).

BRENDAN MCCAULEY, EXAMINING ATTORNEY

CLASS 44—MEDICAL, BEAUTY AND AGRICULTURAL SERVICES

FOR CONSULTING SERVICES IN AGRICULTURE, HORTICULTURE AND FORESTRY, NAMELY, AGRONOMIC CONSULTING SERVICES (U.S. CLS. 100 AND 101).

BRENDAN MCCAULEY, EXAMINING ATTORNEY

SN 79-108,358. LABATE & CO. GMBH & CO. KG, FED REP GERMANY, FILED 6-28-2011.

SN 79-108,334. AGRINOS AS, NORWAY, FILED 10-3-2011.

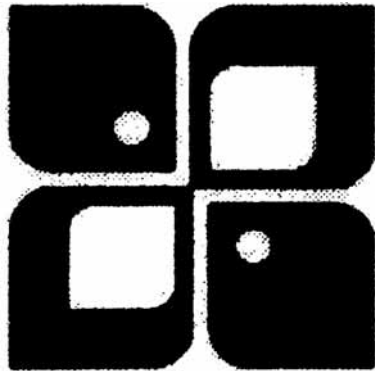

PRIORITY DATE OF 8-31-2011 IS CLAIMED.
 OWNER OF INTERNATIONAL REGISTRATION 1104688 DATED 10-3-2011, EXPIRES 10-3-2021.
 THE MARK CONSISTS OF AN ABSTRACT FOUR-LEAF CLOVER DESIGN WITH FOUR SQUARE-LIKE SHAPES WITH TWO DIAGONAL CIRCLES AND TWO DIAGONAL INNER SQUARES.

CLASS 1—CHEMICALS

FOR CHEMICALS FOR USE IN AGRICULTURE, HORTICULTURE AND FORESTRY EXCEPT FUNGICIDES, HERBICIDES, INSECTICIDES AND PARASITICIDES; FERTILIZERS (U.S. CLS. 1, 5, 6, 10, 26 AND 46).

CLASS 31—NATURAL AGRICULTURAL PRODUCTS

FOR AGRICULTURAL, HORTICULTURAL AND FORESTRY PRODUCTS, NAMELY, SEEDS FOR LAWN GRASS; AGRICULTURAL GRAINS FOR PLANTING; CROP SEEDS; GRASS SEEDS; PLANT SEEDS; SEEDS FOR AGRICULTURAL PURPOSES; SEEDS FOR HORTICULTURAL PURPOSES; SEEDS FOR FIBER CROPS; SEEDS FOR OILSEED CROPS; UNPROCESSED SEEDS FOR AGRICULTURAL PURPOSES; FRESH FRUITS AND VEGETABLES, LIVE PLANTS AND LIVE FLOWERS (U.S. CLS. 1 AND 46).



OWNER OF INTERNATIONAL REGISTRATION 1104777 DATED 6-28-2011, EXPIRES 6-28-2021.

THE COLOR(S) RED IS/ARE CLAIMED AS A FEATURE OF THE MARK.

THE MARK CONSISTS OF THE COLOR RED AS APPLIED TO THE DESIGN OF AN OVERLAPPING AND INTERSECTING CURVED AND LOOPED LINE.

CLASS 6—METAL GOODS

FOR VARIABLE AND PLUG-IN FRAMES OR RAILS, AND STRUCTURAL FASTENINGS THEREFOR, ALL OF METAL, WHICH ARE ATTACHABLE TO FACADES OR OTHER LOAD-BEARING STRUCTURES, AND ARE TENSIONABLE OR SLIDABLE, FOR USE IN INSERTING OR MOUNTING ADVERTISING CARRIERS AND COVERINGS OF TEXTILE, NAMELY, ADVERTISEMENT COLUMNS OF METAL, FRAMEWORKS OF METAL FOR USE IN MOUNTING AND SUPPORTING ADVERTISING SIGNAGE, METAL RAILS AND RAILING FOR USE IN MOUNTING AND SUPPORTING ADVERTISING SIGNAGE, IN PARTICULAR ADVERTISING CARRIERS OF TEXTILE; GOODS OF METAL, INCLUDED IN THIS CLASS, NAMELY, PROFILES, IN PARTICULAR SYSTEM PROFILES, PROFILE CONNECTORS, END CAPS FOR PROFILES, SUSPENSION DEVICES AND FRAMES FOR VARIABLE AND PLUG-IN FRAMES OR RAILS, WHICH ARE TENSIONABLE OR SLIDABLE, FOR USE IN INSERTING AND MOUNTING ADVERTISING CARRIERS, NAMELY, METAL PROFILES FOR ARRANGING DEVICES ON AND IN WALLS, CEILINGS AND OTHER SURFACES, METAL BRACKETS FOR USE IN MOUNTING AND SUPPORTING ADVERTISING SIGNAGE, METAL WASHERS, NUTS AND MOUNTING PLATES FOR USE IN MOUNTING AND SUPPORTING ADVERTISING SIGNAGE, METAL END CAPS FOR USE IN MOUNTING AND SUPPORTING ADVERTISING SIGNAGE; ALL THE AFORESAID GOODS MADE OF METAL, IN PARTICULAR OF ALUMINUM ALLOYS; STEEL ROPES, METAL ROPES (U.S. CLS. 2, 12, 13, 14, 23, 25 AND 50).

CLASS 20—FURNITURE AND ARTICLES NOT OTHERWISE CLASSIFIED

FOR VARIABLE AND PLUG-IN FRAMES OR RAILS, AND STRUCTURAL FASTENINGS THEREFOR, ALL OF PLASTIC OR MAINLY OF PLASTIC, WHICH ARE ATTACHABLE TO FACADES OR OTHER LOAD-BEARING STRUCTURES, AND ARE TENSIONABLE OR SLIDABLE, FOR USE IN INSERTING OR MOUNTING ADVERTISING CARRIERS AND COVERINGS OF TEXTILE, IN PARTICULAR ADVERTISING CARRIERS OF TEXTILE, NAMELY, PICTURE FRAMES, PICTURE FRAME BRACKETS, MOLDINGS FOR PICTURE FRAMES, CURTAIN RAILS, WALL-FRAMES FOR THE DISPLAY OF MEDIA STORAGE CONTAINERS, NON-METAL CEILING MOUNTS FOR DECORATIVE MOBILES; PREFABRICATED, MODULAR FURNITURE, RACKS AND PRODUCT PRESENTATION RACKS FOR USE IN SHOPS AND TRADE FAIRS, NAMELY, PREFABRICATED MODULAR FURNITURE, PREFABRICATED DISPLAY RACKS, PREFABRICATED DISPLAY STANDS, PREFABRICATED ADVERTISING DISPLAY STANDS; PARTS FOR THE AFORESAID GOODS, INCLUDED IN THIS CLASS, NAMELY, FITTED PROFILES, IN PARTICULAR SYSTEM PROFILES, PROFILE CONNECTORS, END CAPS FOR PROFILES, SUSPENSION DEVICES AND FRAMES FOR VARIABLE AND PLUG-IN FRAMES OR RAILS, WHICH ARE TENSIONABLE OR SLIDABLE, FOR USE IN INSERTING OR MOUNTING ADVERTISING CARRIERS, NAMELY, NON-METAL THREADED FASTENERS, NON-METAL FASTENERS IN THE NATURE OF BOLTS, NAILS, RIVETS, AND SCREWS, NON-METAL PROFILES FOR ARRANGING DEVICES ON AND IN WALLS, CEILINGS AND OTHER SURFACES; FASTENINGS, NOT OF METAL, FOR SUSPENDING ADVERTISING CARRIERS AND FOR ATTACHING INDUSTRIAL TEXTILES TO FRAME SYSTEMS OR TO FASTENINGS FOR MOUNTING ADVERTISING CARRIERS, IN PARTICULAR, NON-METAL EYES FOR FASTENING (U.S. CLS. 2, 13, 22, 25, 32 AND 50).

CLASS 22—CORDAGE AND FIBERS

FOR ROPES, NOT INCLUDING STEEL WIRE ROPE; TARPULINS; PIPING IN THE NATURE OF EDGE REINFORCEMENTS OF RUBBER AND PLASTIC, BEING PARTS FOR ROPES (U.S. CLS. 1, 2, 7, 19, 22, 42 AND 50).

MICHAEL TANNER, EXAMINING ATTORNEY

SN 79-108,360. MANIFATTURE BELLET S.P.A., SAN MARTINO DI LUPARI (PD), ITALY, FILED 7-21-2011.



PRIORITY DATE OF 4-12-2011 IS CLAIMED.
OWNER OF INTERNATIONAL REGISTRATION 1104779
DATED 7-21-2011, EXPIRES 7-21-2021.

THE MARK CONSISTS OF THE WORDING "EKLE" IN FANCY CHARACTERS WITH AN APOSTROPHE AT THE END OF THE WORDING.

THE WORDING "EKLE" HAS NO MEANING IN A FOREIGN LANGUAGE.

CLASS 3—COSMETICS AND CLEANING PREPARATIONS

FOR BEAUTY SOAPS, PERFUMES, TOILET WATER, PERSONAL DEODORANTS, INCENSE, ESSENTIAL OILS FOR PERSONAL USE, BODY LOTIONS, SHOWER GEL, BATH OILS, BATH PEARLS, NON-MEDICATED BATH SALTS, SHAVING CREAM, AFTERSHAVE LOTIONS, EYE SHADOWS, COSMETIC PENCILS, FOUNDATION MAKE-UP, FACE POWDERS, TALCUM POWDER, ROUGES, LIPSTICKS, MASCARAS, SKIN CLEANSING CREAMS, SKIN CLEANSING LOTIONS, SUN SCREEN PREPARATIONS; FACE CREAMS; HAIR SHAMPOOS (U.S. CLS. 1, 4, 6, 50, 51 AND 52).

CLASS 24—FABRICS

FOR BEACH TOWELS, BATH TOWELS, BATH LINEN, FABRIC TABLE RUNNERS, TEXTILE PLACE MATS, TEXTILE DISH MATS AND TEXTILE CARAFE MATS, TABLE LINEN, COASTERS OF TEXTILE, BED BLANKETS, BED LINEN, TOWELS, CLOTH NAPKINS FOR REMOVING MAKE-UP, WASHCLOTHS, FABRIC HANDKERCHIEFS, TABLE NAPKINS OF TEXTILE, KITCHEN TOWELS, MOSQUITO NETS, BED COVERS AND TEXTILE TABLE COVERS; PILLOW CASES, MATTRESS COVERS, COVERS FOR CUSHIONS; CLOTH LABELS; TEXTILE USED AS LINING FOR CLOTHING; WASHING MITTS (U.S. CLS. 42 AND 50).

CLASS 25—CLOTHING

FOR SOCKS; STOCKINGS; TIGHTS; UNDERWEAR; BEACHWEAR; LEGGINGS; BATH ROBES; PULLOVERS; GLOVES BEING CLOTHING; CARDIGANS; JERSEYS BEING CLOTHING; SWEATERS; TROUSERS; SKIRTS; JACKETS BEING CLOTHING; SHIRTS; VESTS; WAISTCOATS; JUMPERS; TRACK SUITS; BLOUSES; BLOUSONS; JEANS; SWEAT PANTS; GYM SUITS; KNICKERS; PANTS; SHORTS; T-SHIRTS; SWEAT SHIRTS; SUITS AND DRESSES; OVERCOATS; COATS; ANORAKS; RAINWEAR; BELTS BEING CLOTHING; SLEEPWEAR; FOOTWEAR; HEADWEAR (U.S. CLS. 22 AND 39).

WILLIAM VERHOSEK, EXAMINING ATTORNEY

SN 79-108,362. REMOTEREPORT TRADING LIMITED, UNITED KINGDOM, FILED 8-16-2011.

AVIOS

THE MARK CONSISTS OF STANDARD CHARACTERS WITHOUT CLAIM TO ANY PARTICULAR FONT, STYLE, SIZE, OR COLOR.

PRIORITY DATE OF 2-22-2011 IS CLAIMED.

OWNER OF INTERNATIONAL REGISTRATION 1104783
DATED 8-16-2011, EXPIRES 8-16-2021.

CLASS 35—ADVERTISING AND BUSINESS

FOR ADVERTISING, MARKETING AND PROMOTIONAL SERVICES FOR AIRLINES; CONSUMER LOYALTY SERVICES FOR COMMERCIAL, PROMOTIONAL, OR ADVERTISING PURPOSES, NAMELY, ADMINISTRATION OF FREQUENT Flier PROGRAM THAT ALLOWS MEMBER TO REDEEM MILES FOR POINTS OR AWARDS OFFERED BY OTHER LOYALTY PROGRAMS; PROVIDING BUSINESS INFORMATION, ADVICE AND BUSINESS MANAGEMENT ASSISTANCE, ALL RELATING TO THE AFORESAID SERVICES (U.S. CLS. 100, 101 AND 102).

CLASS 39—TRANSPORTATION AND STORAGE

FOR AIRLINE TRANSPORTATION SERVICES; TRAVEL SERVICES, NAMELY AIR TRANSPORT SERVICES; TRAVEL BOOKING AGENCY SERVICES; PROVIDING TRANSPORTATION BOOKING AND RESERVATION AND TRANSPORTATION INFORMATION; AIRCRAFT CHARTERING SERVICES; PACKAGE HOLIDAY SERVICES FOR ARRANGING TRAVEL, NAMELY, ARRANGING TRAVEL TOURS, MAKING RESERVATIONS AND BOOKINGS FOR TRANSPORTATION; TRAVEL INFORMATION SERVICES RELATING TO ALL THE FOREMENTIONED SERVICES (U.S. CLS. 100 AND 105).

MICHAEL TANNER, EXAMINING ATTORNEY

SN 79-108,610. FIAGON GMBH, FED REP GERMANY, FILED 11-7-2011.



SN 79-108,392. TRANSFAR GROUP CO.,LTD., ZHEJIANG PROVINCE, CHINA, FILED 11-24-2011.



OWNER OF INTERNATIONAL REGISTRATION 1104878 DATED 11-24-2011, EXPIRES 11-24-2021.

THE MARK CONSISTS OF THE WORDING "TRANSFAR" WITH TWO CHINESE CHARACTERS ABOVE THE WORDING, ALL ON A DARK ROUNDED SQUARE BACKGROUND.

THE ENGLISH TRANSLATION OF THE FOREIGN WORD(S) IN THE MARK IS: THE FIRST CHINESE CHARACTER MEANS SPREAD, AND THE SECOND CHINESE CHARACTER MEANS CHEMISTRY; THE WHOLE TRADEMARK HAS NO MEANING.

THE TRANSLITERATION OF THE NON-LATIN CHARACTERS IN THE MARK IS: "CHUANHUA".

CLASS 3—COSMETICS AND CLEANING PREPARATIONS

FOR SOAP, SHAMPOOS, WASHING PREPARATIONS, COSMETICS IN THE FORMS OF MILKS FOR WASHING THE FACE, CLEANING CHALK, POLISHING WAX, ESSENTIAL OILS, COSMETICS, DENTIFRICES, INCENSE (U.S. CLS. 1, 4, 6, 50, 51 AND 52).

CLASS 31—NATURAL AGRICULTURAL PRODUCTS

FOR LIVE TREES; UNPROCESSED GRAINS CEREALS; NATURAL FLOWERS; LIVE ANIMALS; UNPROCESSED BERRIES, NAMELY, STRAWBERRY, BLUEBERRY, RASPBERRY, BLACKBERRY; FRESH FRUITS; FRESH VEGETABLES; PLANT SEEDS; ANIMAL FOODSTUFFS; MALT FOR BREWING AND DISTILLING; ANIMAL LITTER (U.S. CLS. 1 AND 46).

ROSELLE HERRERA, EXAMINING ATTORNEY

PRIORITY DATE OF 5-13-2011 IS CLAIMED. OWNER OF INTERNATIONAL REGISTRATION 1105333 DATED 11-7-2011, EXPIRES 11-7-2021.

THE COLOR(S) GREEN AND WHITE IS/ARE CLAIMED AS A FEATURE OF THE MARK.

THE MARK CONSISTS OF THE STYLIZED WORDING "F." IN WHITE INSIDE A GREEN CIRCLE.

CLASS 9—ELECTRICAL AND SCIENTIFIC APPARATUS

FOR COMPUTER IMAGING SOFTWARE FOR USE IN GUIDING SURGICAL NAVIGATION SYSTEMS AND SOFTWARE FOR GATHERING AND TRANSMITTING PATIENT IMAGE DATA FOR USE DURING SURGICAL PROCEDURES; COMPUTER SOFTWARE FOR PLANNING SURGICAL PROCEDURES; COMPUTER SOFTWARE, FOR USE WITH MEDICAL PATIENT IMAGING OR MONITORING EQUIPMENT, FOR RECEIVING, PROCESSING, TRANSMITTING AND DISPLAYING DATA; DOWNLOADABLE COMPUTER IMAGING SOFTWARE FOR USE IN GUIDING SURGICAL NAVIGATION SYSTEMS AND SOFTWARE FOR GATHERING AND TRANSMITTING PATIENT IMAGE DATA FOR USE DURING SURGICAL PROCEDURES; DOWNLOADABLE COMPUTER SOFTWARE FOR PLANNING SURGICAL PROCEDURES; DOWNLOADABLE COMPUTER SOFTWARE, FOR USE WITH MEDICAL PATIENT IMAGING OR MONITORING EQUIPMENT, FOR RECEIVING, PROCESSING, TRANSMITTING AND DISPLAYING DATA (U.S. CLS. 21, 23, 26, 36 AND 38).

CLASS 10—MEDICAL APPARATUS

FOR SURGICAL APPARATUS AND INSTRUMENTS; ANALYZERS FOR MEDICAL PURPOSES, NAMELY, FOR ANALYZING THE POSITION OF THE PATIENT AND SURGICAL INSTRUMENTS FOR PROVIDING SURGICAL NAVIGATION; MEDICAL APPARATUS AND INSTRUMENTS FOR PROVIDING SURGICAL NAVIGATION AND PLANNING (U.S. CLS. 26, 39 AND 44).

CLASS 38—COMMUNICATION

FOR PROVIDING ACCESS TO COMPUTER PROGRAMS IN DATA NETWORKS (U.S. CLS. 100, 101 AND 104).

CLASS 45—PERSONAL AND LEGAL SERVICES

FOR LICENSING OF COMPUTER SOFTWARE (U.S. CLS. 100 AND 101).

NELSON SNYDER, EXAMINING ATTORNEY

SN 79-108,862. BANCA DI CREDITO COOPERATIVO; DI MANZANO (UDINE); SOCIETA' COOPERATIVA, MANZANO (UD), ITALY, FILED 8-10-2011.

SN 79-108,867. H.A.G. IMPORT CORPN. (AUSTRALIA) PTY LTD, BROOKLYN VIC 3012, AUSTRALIA, FILED 9-22-2011.



PRIORITY DATE OF 7-12-2011 IS CLAIMED.
OWNER OF INTERNATIONAL REGISTRATION 1105949
DATED 8-10-2011, EXPIRES 8-10-2021.

NO CLAIM IS MADE TO THE EXCLUSIVE RIGHT TO USE "WINE" FOR THE GOODS AND SERVICES IN INTERNATIONAL CLASSES 33 AND 35 AND "CHAIR" FOR THE GOODS AND SERVICES IN INTERNATIONAL CLASSES 20 AND 35, APART FROM THE MARK AS SHOWN.

THE MARK CONSISTS OF A PARTIAL WINE GLASS HALF-FILLED; UNDERNEATH APPEARS THE WORD "WINE" FOLLOWED BY A STYLIZED AMPERSAND, FOLLOWED BY THE TERM "CHAIR"; UNDERNEATH APPEARS THE WORDING "ENJOY AND RELAX".

CLASS 20—FURNITURE AND ARTICLES NOT OTHERWISE CLASSIFIED

FOR CHAIRS, ARMCHAIRS, SMALL ARMCHAIRS, DIVANS, SMALL DIVANS, SOFAS, TABLES, STOOLS, CHAISES LOUNGES, DECK CHAIRS, ROCKING CHAIRS, LOVE SEATS, FURNITURE, NAMELY, POUFS (U.S. CLS. 2, 13, 22, 25, 32 AND 50).

CLASS 33—WINES AND SPIRITS

FOR WINE (U.S. CLS. 47 AND 49).

CLASS 35—ADVERTISING AND BUSINESS

FOR ADVERTISING AND PROMOTION, NAMELY, PUBLICITY AND SALES PROMOTION SERVICES; PROVIDING MARKETING AND PROMOTION OF SPECIAL EVENTS; ADVERTISING, MARKETING, AND PROMOTION SERVICES IN THE FIELDS OF WINE, FOOD, FURNITURE, INTERIOR DESIGN, TOURISM AND TRAVEL; ORGANIZATION OF EXHIBITIONS FOR COMMERCIAL OR ADVERTISING PURPOSES (U.S. CLS. 100, 101 AND 102).

CHRISTOPHER BUONGIORNO, EXAMINING ATTORNEY



PRIORITY DATE OF 3-23-2011 IS CLAIMED.
OWNER OF INTERNATIONAL REGISTRATION 1105961
DATED 9-22-2011, EXPIRES 9-22-2021.

THE MARK CONSISTS OF A HERALDIC LION WITH LONG HAIR AND A LONG TAIL STANDING ON ITS HIND LEGS WITH ITS FORE LEGS IN A STRIKING POSITION.

CLASS 8—HAND TOOLS

FOR CUTLERY, NAMELY, KNIVES, FORKS AND SPOONS; HAND-OPERATED SPREADERS FOR FOOD, NAMELY, SPREADERS IN THE NATURE OF A SMALL KNIFE FOR BUTTER OR CHEESE; MORTAR AND PESTLES; HAND TOOLS AND HAND-OPERATED IMPLEMENTS, NAMELY, TONGS, NUTCRACKERS, NON-ELECTRIC CAN OPENERS, HAND-OPERATED FOOD DICERS, HAND OPERATED FOOD SLICERS, HAND-OPERATED FOOD PROCESSORS, HAND-OPERATED CUTTING TOOLS, HAND OPERATED TOOLS FOR MAKING SHAVED ICE, NON-ELECTRIC FRUIT AND VEGETABLE PEELERS, NON-ELECTRIC PIZZA CUTTERS AND SLICERS, KNIFE SHARPENERS, NON-ELECTRIC ICE CRUSHERS; HAND-OPERATED IMPLEMENTS FOR THE SERVING OF FOOD, NAMELY, SERVING KNIVES; SERVING KNIVES; SERVING UTENSILS, NAMELY, CARVING KNIVES (U.S. CLS. 23, 28 AND 44).

CLASS 16—PAPER GOODS AND PRINTED MATTER

FOR GOODS MADE FROM PAPER AND CARDBOARD, NAMELY, STORAGE CONTAINERS MADE OF PAPER, TABLE MATS AND PLACE MATS OF PAPER, PAPER TABLE CLOTHS, DECORATIVE PAPER CENTERPIECES, PAPER TOWELS, HANDKERCHIEFS OF PAPER, PAPER BABY BIBS, PAPER CAKE DECORATIONS, PAPER DOILIES, PAPER FLOOR MATS, PAPER TRAY COVERS, PAPER WASHCLOTHS, SCENTED PAPER DRAWER LINERS, SPECIALTY PAPERS, NAMELY, VEGETABLE PARCHMENT FOR USE IN FOOD WRAPPING, PREPARATION, PROCESSING AND PACKAGING APPLICATIONS; TABLE LINEN OF PAPER; NAPERY OF PAPER, NAMELY, PAPER NAPKINS; PACKAGING CONTAINERS COMPRISED PREDOMINANTLY OF PAPER WITH PLASTIC-LINED PAPER BOARD FOR SOLIDS OR LIQUIDS; PACKAGING MATERIAL MADE OF STARCHES, NAMELY, PACKAGING COMPRISED OF STARCH-BASED MATERIALS IN THE NATURE OF A PAPER SUBSTITUTE FOR FOOD, BEVERAGES AND CONSUMER PRODUCTS (U.S. CLS. 2, 5, 22, 23, 29, 37, 38 AND 50).

CLASS 21—HOUSEWARES AND GLASS

FOR HOUSEHOLD OR KITCHEN UTENSILS AND CONTAINERS NOT OF PRECIOUS METAL OR COATED THEREWITH, NAMELY, CANISTER SETS, BREAD BINS, BREAD BOARDS, CONTAINERS FOR HOUSEHOLD OR KITCHEN USE, SPICE RACKS, CONTAINERS FOR FOODS, HOUSEHOLD STORAGE CONTAINERS FOR PET FOOD, INSULATED CONTAINERS FOR FOOD OR BEVERAGE FOR DOMESTIC USE, SOAP CONTAINERS, TRASH CONTAINERS FOR HOUSEHOLD USE, LUNCH BOXES, HAND OPERATED COFFEE GRINDERS, CHOPSTICKS, COOKERY MOULDS, COOKIE CUTTERS, COOKIE JARS, COOKING SKEWERS, CRUET STANDS FOR OIL AND VINEGAR, CRUETS, CUTTING BOARDS, NON-ELECTRIC FRUIT PRESSES FOR HOUSEHOLD USE, GLASS JARS, INSULATING JARS, FOOD PRESERVING JARS OF GLASS, NON-ELECTRIC KETTLES, TEA KETTLES, WHISKS, CORN COB HOLDERS, MIXING SPOONS, NON-ELECTRIC KITCHEN MIXERS, JUGS, FLASKS, GRATERS, SPATULAS, SIEVES, STRAINERS, TURNERS, COOKING UTENSILS, NAMELY, GRILL COVERS, ROLLING PINS, POT AND PAN SCRAPERS, SPLATTER SCREENS, KITCHEN TONGS, FOOD SCOOPS, DOG FOOD SCOOPS, TEA INFUSERS, TEA STRAINERS, TEA POTS, TEA SERVICE, TEA SETS, TEA BALLS, NON-ELECTRIC WAFFLE IRONS, PORTABLE COOLERS, COOLERS FOR WINE, VESSELS OF METAL FOR MAKING ICES AND ICED DRINKS IN THE NATURE OF COCKTAIL SHAKERS, ICE PAILS, CORKSCREWS, URNS, ICE CUBE MOULDS, ICE SCOOPS, ICE CREAM SCOOPS, CONTAINERS FOR ICE, BASINS, BUTTER DISHES AND COVERS, EGG CUPS, NON-ELECTRIC EGG BEATERS, PITCHERS, DISH COVERS, COFFEE MEASURES, COFFEE POTS, COFFEE SERVERS, COFFEE SERVICE, COFFEE STIRRERS, NON-ELECTRIC COFFEE MAKERS, COFFEE PLUNGERS IN THE NATURE OF NON-ELECTRIC COFFEE POTS, NON-ELECTRIC COFFEE PERCOLATORS, NON-ELECTRIC COFFEE GRINDERS, VACUUM BOTTLE STOPPERS, BOTTLE OPENERS, BOTTLE STOPPERS SPECIALLY ADAPTED FOR USE WITH WINE BOTTLES, BOWLS, PLATES, LAZY SUSANS, DRINKING VESSELS, SUGAR BOWLS, MUGS, CUPS, DISHES, UTENSILS FOR BARBECUES, NAMELY, FORKS, TONGS AND TURNERS; GLASSWARE, NAMELY, BEVERAGE GLASSWARE, DRINKING VESSELS, COFFEE PLUNGERS IN THE NATURE OF NON-ELECTRIC COFFEE POTS, TEA PLUNGERS IN THE NATURE OF NON-ELECTRIC TEA POTS, NON-ELECTRIC COFFEE PERCOLATORS, COFFEE SERVICE, COFFEE POTS, CANDLE RINGS, CANDLESTICKS, DECANTERS, SALT AND PEPPER SHAKERS, SALT CELLARS, GLASS STOPPERS, TOOTHPICK HOLDERS NOT OF PRECIOUS METAL, SALT AND PEPPER GRINDERS, SUGAR BOWLS, NAPKIN RINGS, GOBLETS, BEER MUGS, COCKTAIL SHAKERS, KNIFE RESTS, TEA POTS, TEA SERVICE, NAPKIN HOLDERS, PEPPER POTS, WINE TASTERS; DINNERWARE; COOKWARE, NAMELY, CASSEROLE DISHES, FRYING PANS, MUFFIN TINS, CAKE TINS, CUP CAKE MOULDS, PAPER BAKING CUPS, COOKING STEAMERS, SAUCEPANS, WAFFLE IRONS, GRILLS, PORTABLE COOKING KITS FOR OUTDOOR USE, RICE COOKING POTS, WIRE BASKETS, BAKING DISHES, BASTING SPOONS, COOKING FORKS, POTS, PANS; SERVINGWARE, NAMELY, SERVINGWARE FOR SERVING FOOD AND DRINKS, SERVING TRAYS, PIE SERVERS; SERVING WARE FOR SERVING FOOD AND DRINKS; CROCKERY, NAMELY, POTS, DISHES, PLATES, DRINKING CUPS AND SAUCERS, BOWLS, SERVING BOWLS AND TRAYS; CHINAWARE, PORCELAIN AND EARTHENWARE, NAMELY, NON-ELECTRIC KETTLES, TEA KETTLES, TEA INFUSERS, TEA STRAINERS, TEA POTS, TEA SERVICE, TEA SETS, TEA BALLS, COFFEE PLUNGERS IN THE NATURE OF NON-ELECTRIC COFFEE POTS, COFFEE PERCOLATORS, COFFEE SERVICE, COFFEE POTS, CANDLE RINGS, CANDLESTICKS, DECANTERS, SALT AND PEPPER SHAKERS, SALT CELLARS, TOOTHPICK HOLDERS, SALT AND PEPPER GRINDERS, SUGAR BOWLS, NAPKIN RINGS, OIL AND VINEGAR CRUETS, GOBLETS, BEER MUGS, COCKTAIL SHAKERS, KNIFE RESTS, NAPKIN HOLDERS, JARS FOR JAMS AND JELLIES; PEPPER POTS, WINE TASTERS, BOWLS, PLATES, MUGS, CUPS, DISHES, SOUP TUREENS, LAZY SUSANS; VASES; HAND-OPERATED FOOD GRINDERS (U.S. CLS. 2, 13, 23, 29, 30, 33, 40 AND 50).

CLASS 24—FABRICS

FOR TEXTILES AND TEXTILE GOODS, NAMELY, BED LINEN, TOWELS OF TEXTILE, HANDKERCHIEFS OF TEXTILE, PLACE MATS OF TEXTILE, TEXTILE SERVIETTES, QUILTS OF TEXTILE, TEXTILE TABLE-CLOTHS, LAP RUGS, TRAVELLING RUGS, CLOTH COASTERS, OVEN MITTS; TABLE LINEN; TEXTILE NAPERY, NAMELY, LINEN TABLE CLOTHS, COASTERS, NAPKINS AND PLACE MATS (U.S. CLS. 42 AND 50).

CHRISTOPHER BUONGIORNO, EXAMINING ATTORNEY

SN 79-108,908. MAZZA GRAZIANO, I-63017 PORTO SAN GIORGIO (FERMO), ITALY, FILED 6-30-2011.

PREMIATA

THE MARK CONSISTS OF STANDARD CHARACTERS WITHOUT CLAIM TO ANY PARTICULAR FONT, STYLE, SIZE, OR COLOR.

PRIORITY DATE OF 3-11-2011 IS CLAIMED.
OWNER OF INTERNATIONAL REGISTRATION 1106135 DATED 6-30-2011, EXPIRES 6-30-2021.
OWNER OF U.S. REG. NO. 2,335,000.

THE ENGLISH TRANSLATION OF THE FOREIGN WORD(S) IN THE MARK IS: "PREMIATA" MEANS "REWARDED".

CLASS 18—LEATHER GOODS

FOR HANDBAGS; SHOULDER BAGS; ALL PURPOSE SPORTS BAGS; CANVAS SHOPPING BAGS; LEATHER SHOPPING BAGS; SHOPPING BAGS MADE OF SKIN; TEXTILE SHOPPING BAGS; CLUTCH BAGS; WALLETS; TRAVELLING BAGS; VANITY CASES NOT FITTED AND SOLD EMPTY; POUCHES OF LEATHER FOR PACKAGING; LUGGAGE; GARMENT BAGS FOR TRAVEL; BEACH BAGS; ATTACHE CASES; SCHOOL BAGS; TOTE BAGS; CARD CASES, NAMELY, NOTE CARD CASES; KEYCASES; KNAPSACKS; RUCKSACKS; BRIEFCASES; PURSES; TRAVELLING TRUNKS; SUITCASES; UMBRELLAS (U.S. CLS. 1, 2, 3, 22 AND 41).

CLASS 35—ADVERTISING AND BUSINESS

FOR RETAIL AND WHOLESALE STORE SERVICES, ALSO ON-LINE, FEATURING NECKTIES, SCARVES, BELTS FOR CLOTHING, OVERCOATS, CLOAKS, COATS, RAINCOATS, JACKETS, SWEATERS, PULL-OVERS, T-SHIRTS, SKIRTS, TROUSERS, SUITS AND DRESSES, HOSIERY, SWEATSHIRTS, EVENING DRESSES, WAISTCOATS, PANTS, BLOUSES, JUMPERS, JEANS, CARDIGANS, POLO SHIRTS, FOOTWEAR, HEADWEAR, HANDBAGS, SHOULDER BAGS, ALL PURPOSE SPORTS BAGS, SHOPPING BAGS, CLUTCH BAGS, WALLETS, TRAVELLING BAGS, VANITY CASES NOT FITTED, POUCHES OF LEATHER FOR PACKAGING, LUGGAGE, GARMENT BAGS FOR TRAVEL, BEACH BAGS, ATTACH CASES, SCHOOL BAGS, TOTE BAGS, CARD CASES, NAMELY, NOTECASES, KEYCASES, KNAPSACKS, RUCKSACKS, BRIEFCASES, PURSES, TRAVELLING TRUNKS, SUITCASES (U.S. CLS. 100, 101 AND 102).

FRANK LATTUCA, EXAMINING ATTORNEY

SN 79-109,037. SIRTEX MEDICAL LIMITED, AUSTRALIA,
FILED 10-24-2011.

SN 79-109,231. SOTHYS AURIAC (SOCIÉTÉ À RESPONSABILITÉ LIMITÉE À ASSOCIÉ UNIQUE), F-19220 AUR-
IAC, FRANCE, FILED 1-10-2012.

SIRTEX

THE MARK CONSISTS OF STANDARD CHARACTERS WITHOUT CLAIM TO ANY PARTICULAR FONT, STYLE, SIZE, OR COLOR.

PRIORITY DATE OF 9-5-2011 IS CLAIMED.
OWNER OF INTERNATIONAL REGISTRATION 1106527
DATED 10-24-2011, EXPIRES 10-24-2021.

CLASS 5—PHARMACEUTICALS

FOR PHARMACEUTICAL PREPARATIONS FOR THE TREATMENT OF CANCER; BIOLOGICAL PREPARATIONS FOR MEDICAL AND VETERINARY PURPOSES, NAMELY, FOR THE TREATMENT OF CANCER; CAPSULES AND PARTICLES IN THE NATURE OF RADIO-ISOTOPES, RADIONUCLIDES, CHEMOTHERAPEUTIC AGENTS AND MAGNETIC MATERIALS FOR MEDICAL AND PHARMACEUTICAL PURPOSES FOR THE TREATMENT OF CANCER; CHEMICAL PREPARATIONS FOR MEDICAL AND PHARMACEUTICAL PURPOSES FOR THE TREATMENT OF CANCER; CHEMICAL PREPARATIONS FOR VETERINARY PURPOSES FOR THE TREATMENT OF CANCER; DRUGS FOR MEDICAL PURPOSES FOR THE TREATMENT OF CANCER; MICROCAPSULES FOR THE TREATMENT OF CANCER; MICROSCOPIC PARTICLES IN THE NATURE OF RADIO-ISOTOPES, RADIONUCLIDES, CHEMOTHERAPEUTIC AGENTS AND MAGNETIC MATERIALS CONTAINING RADIOACTIVE MATERIAL FOR MEDICAL THERAPEUTIC USE FOR THE TREATMENT OF CANCER; MICROCAPSULES CONTAINING PHARMACEUTICAL, VETERINARY OR MEDICAL PREPARATIONS FOR THE TREATMENT OF CANCER; MICROCAPSULES AND MICROPARTICLES IN THE NATURE OF RADIO-ISOTOPES, RADIONUCLIDES, CHEMOTHERAPEUTIC AGENTS AND MAGNETIC MATERIALS ADAPTED TO SELECTIVELY DELIVER MATERIAL, INCLUDING RADIOACTIVE MATERIALS, CHEMICAL AGENTS AND HEAT, TO A TARGET SITE SUCH AS A CELL OR ORGAN FOR THE TREATMENT OF CANCER; MICROSCOPIC PARTICLES IN THE NATURE OF RADIO-ISOTOPES, RADIONUCLIDES, CHEMOTHERAPEUTIC AGENTS AND MAGNETIC MATERIALS ADAPTED TO SELECTIVELY DELIVER MATERIAL, INCLUDING RADIOACTIVE MATERIALS, CHEMICAL AGENTS AND HEAT, TO A TARGET SITE SUCH AS A CELL OR ORGAN FOR THE TREATMENT OF CANCER (U.S. CLS. 6, 18, 44, 46, 51 AND 52).

CLASS 42—SCIENTIFIC AND COMPUTER SERVICES

FOR MEDICAL RESEARCH; SCIENTIFIC RESEARCH FOR MEDICAL PURPOSES; RESEARCH AND DEVELOPMENT OF MEDICAL AND VETERINARY PRODUCTS FOR MEDICAL AND VETERINARY PURPOSES, INCLUDING PHARMACEUTICALS, MICROCAPSULES, MICROPARTICLES, RADIOACTIVE MATERIALS, CHEMICAL AGENTS AND PREPARATIONS, CANCER TREATMENTS AND TREATMENTS FOR DISEASED CELLS; MEDICAL AND SCIENTIFIC RESEARCH RELATING TO MOLECULAR SCIENCES, PHARMACEUTICALS, DRUGS, CHEMICALS AND BIOTECHNOLOGY (U.S. CLS. 100 AND 101).

JAMES MACFARLANE, EXAMINING ATTORNEY

LES JARDINS SOTHYS

PRIORITY DATE OF 12-29-2011 IS CLAIMED.
OWNER OF INTERNATIONAL REGISTRATION 1107016
DATED 1-10-2012, EXPIRES 1-10-2022.
THE ENGLISH TRANSLATION OF "LES JARDINS" IN THE MARK IS "THE GARDENS".

CLASS 3—COSMETICS AND CLEANING PREPARATIONS

FOR BLEACHING PREPARATIONS AND OTHER SUBSTANCES FOR LAUNDRY USE IN THE NATURE OF LAUNDRY DETERGENT, FABRIC SOFTENERS, AND LAUNDRY PRE-SOAK; ALL PURPOSE CLEANING, POLISHING, DEGREASING PREPARATIONS FOR HOUSEHOLD USE AND NOT FOR USE IN MANUFACTURING PROCESSES, AND ABRASIVE PREPARATIONS; SOAP; PERFUMERY, ESSENTIAL OILS, COSMETICS, HAIR LOTIONS; DENTIFRICES; PUMICE STONES FOR PERSONAL USE; FOOT SMOOTHING STONES; POLISHING STONES; SHAVING STONES, ANTISEPTIC; PETROLEUM JELLY FOR COSMETIC PURPOSES; ADHESIVE MATERIALS FOR COSMETIC USE; BREATH FRESHENING SPRAYS; FABRIC SOFTENERS FOR LAUNDRY USE; DEODORANTS FOR PERSONAL USE; ALMOND MILK FOR COSMETIC PURPOSES; ALMOND SOAP; AMBER BEING PERFUMERY; SUNSCREENS AND COSMETIC PREPARATIONS FOR SKIN TANNING; SUN-TANNING PREPARATIONS BEING COSMETICS; AROMATICS BEING ESSENTIAL OILS; ASTRINGENTS FOR COSMETIC PURPOSES; COSMETIC PREPARATIONS FOR BATHS; BATH SALTS NOT FOR MEDICAL PURPOSES; SHAVING SOAP; BEARD DYES; BEAUTY MASKS; NON-MEDICATED CREAM FOR WHITENING THE SKIN; MOUTH WASHES NOT FOR MEDICAL PURPOSES; ESSENTIAL OILS OF CEDARWOOD; HAIR COLORANTS; HAIR-WAVING PREPARATIONS; HAIR DYES; COSMETIC PREPARATIONS FOR EYELASHES; FALSE EYELASHES; ADHESIVES FOR AFFIXING FALSE EYELASHES; DEPILATORY WAX; MOUSTACHE WAX; ESSENTIAL OILS OF LEMONS; EAU-DE-COLOGNE; COLORANTS FOR TOILET PURPOSES IN THE NATURE OF HAIR COLORANTS; DECORATIVE TRANSFERS FOR COSMETIC PURPOSES; COSMETIC KITS CONSISTING PRIMARILY OF TOOTHPASTE, SHAMPOO, CONDITIONER, AND DEODORANT; COSMETIC PREPARATIONS FOR SLIMMING PURPOSES; COSMETIC PENCILS; COSMETIC CREAMS; BLEACHING PREPARATIONS FOR COSMETIC PURPOSES; MAKE-UP REMOVING PREPARATIONS; TOILET WATER; SCENTED WATER; INCENSE; DEPILATORY PREPARATIONS; MAKE-UP; FLOWER EXTRACTS BEING PERFUMERY; ESSENTIAL OIL BASES FOR FLOWER PERFUMES; JASMINE OIL; CLEANSING MILKS; HAIR SPRAYS; NAIL POLISH; LACQUER-REMOVING PREPARATIONS; LIPSTICK; LOTIONS FOR COSMETIC PURPOSES; AFTER-SHAVE LOTIONS; TISSUES IMPREGNATED WITH COSMETIC LOTIONS; MAKE-UP PREPARATIONS; MINT ESSENTIAL OIL ESSENCE; MUSK; NAIL CARE PREPARATIONS; COSMETIC PREPARATIONS FOR SKIN CARE; NEUTRALIZERS FOR PERMANENT HAIR WAVING; POMADES FOR COSMETIC HAIR PURPOSES; MAKE-UP POWDER; SHAVING PREPARATIONS; SHAMPOOS; SHAMPOOS FOR PETS; EYEBROW COSMETICS; TALCUM POWDER FOR TOILETRY USE; NON-MEDICATED TOILETRIES; VARNISH-REMOVING PREPARATIONS (U.S. CLS. 1, 4, 6, 50, 51 AND 52).

CLASS 44—MEDICAL, BEAUTY AND AGRICULTURAL SERVICES

FOR HYGIENIC AND BEAUTY CARE FOR HUMAN BEINGS, NAMELY, BEAUTY SALONS; AROMATHERAPY SERVICES; TURKISH BATHS; BEAUTY SALONS; PLASTIC SURGERY SERVICES; HAIRDRESSING SALONS; HAIR IMPLANTATION; MANICURING; MASSAGE; PHYSICAL THERAPY (U.S. CLS. 100 AND 101).

JACLYN KIDWELL WALKER, EXAMINING ATTORNEY

SN 79-109,281. KONE CORPORATION, FINLAND, FILED 2-1-2012.

SN 79-109,723. KEMATIS PROJECTS LTD, UNITED KINGDOM, FILED 10-26-2011.

KONE 4L



THE MARK CONSISTS OF STANDARD CHARACTERS WITHOUT CLAIM TO ANY PARTICULAR FONT, STYLE, SIZE, OR COLOR.

PRIORITY DATE OF 1-25-2012 IS CLAIMED.
OWNER OF INTERNATIONAL REGISTRATION 1107171 DATED 2-1-2012, EXPIRES 2-1-2022.
OWNER OF U.S. REG. NOS. 1,572,871, 2,984,683 AND OTHERS.

THE ENGLISH TRANSLATION OF "KONE" IN THE MARK IS "MACHINE" OR "ENGINE".
SEC. 2(F) AS TO "KONE".

CLASS 7—MACHINERY

FOR NON-METALLIC CABLES AND ROPES FOR LIFTS (U.S. CLS. 13, 19, 21, 23, 31, 34 AND 35).

CLASS 22—CORDAGE AND FIBERS

FOR NON-METALLIC CABLES AND ROPES (U.S. CLS. 1, 2, 7, 19, 22, 42 AND 50).
ROBIN MITTLER, EXAMINING ATTORNEY

SN 79-109,560. SIEMENS AKTIENGESELLSCHAFT, 80333 MÜNCHEN, FED REP GERMANY, FILED 12-21-2011.

TrueShape

THE MARK CONSISTS OF STANDARD CHARACTERS WITHOUT CLAIM TO ANY PARTICULAR FONT, STYLE, SIZE, OR COLOR.

PRIORITY DATE OF 10-7-2011 IS CLAIMED.
OWNER OF INTERNATIONAL REGISTRATION 1107847 DATED 12-21-2011, EXPIRES 12-21-2021.

CLASS 9—ELECTRICAL AND SCIENTIFIC APPARATUS

FOR SOFTWARE FOR APPLICATIONS IN APPARATUS AND DEVICES FOR MAGNETIC RESONANCE TOMOGRAPHY; SOFTWARE FOR APPLICATIONS IN DEVICES FOR PROTON IMAGING (U.S. CLS. 21, 23, 26, 36 AND 38).

CLASS 10—MEDICAL APPARATUS

FOR MEDICAL APPARATUS AND DEVICES, IN PARTICULAR, APPARATUS AND DEVICES FOR MAGNETIC RESONANCE TOMOGRAPHY, MEDICAL DEVICES FOR PROTON IMAGING; PARTS OF THE APPARATUS AND DEVICES MENTIONED ABOVE (U.S. CLS. 26, 39 AND 44).
VERNA BETH RIRIE, EXAMINING ATTORNEY

PRIORITY DATE OF 5-13-2011 IS CLAIMED.
OWNER OF INTERNATIONAL REGISTRATION 1108231 DATED 10-26-2011, EXPIRES 10-26-2021.

THE MARK CONSISTS OF THE WORDING "THERMOBRAKES" WITH A CIRCULAR DESIGN CONSISTING OF CONCENTRIC SEMI-CIRCLES IN VARIOUS WIDTHS.

CLASS 12—VEHICLES

FOR PARTS AND COMPONENTS FOR VEHICLES AND FOR APPARATUS FOR LOCOMOTION BY LAND, AIR OR WATER, NAMELY, BRAKES, BRAKE COMPONENTS, PARTS AND FITTINGS OF BRAKES, CLUTCH PLATES, PARTS AND FITTINGS OF CLUTCH PLATES (U.S. CLS. 19, 21, 23, 31, 35 AND 44).

CLASS 17—RUBBER GOODS

FOR RUBBER, GUTTA-PERCHA, GUM FOR INSULATING, ASBESTOS, MICA AND MICA IN THE FORM OF MICA TUBES, FIREPROOF MICA PAPER TAPE, MICA SHEETS AND MICA PADS FOR USE IN FURTHER MANUFACTURING; PLASTICS IN EXTRUDED FORM FOR USE IN MANUFACTURE; PACKING AND INSULATING MATERIALS; STOPPING MATERIALS, NAMELY, FIRE STOPPING MATERIALS IN THE NATURE OF FIRE RETARDANT COVERINGS OF RUBBER, GUTTA-PERCHA, GUM FOR INSULATING, ASBESTOS, OR MICA; FLEXIBLE PIPES, NOT OF METAL; HEAT INSULATING MATERIALS; HEAT PROTECTION MATERIALS, NAMELY, PROTECTIVE COVERINGS OF RUBBER, GUTTA-PERCHA, GUM FOR INSULATING, ASBESTOS, OR MICA TO BE APPLIED TO PARTS AND FITTINGS FOR VEHICLES AND FOR APPARATUS FOR LOCOMOTION BY LAND, AIR OR WATER; HEAT RESISTANT FABRICS FOR USE AS INSULATION; INSULATION ARTICLES FOR USE ON JOINTS OF ELECTRIC CABLES, NAMELY, ELECTRICAL INSULATING TAPES, INSULATORS FOR ELECTRICAL CABLES, INSULATING SPLICE COVERS FOR ELECTRICAL CABLES; INSULATING NON-METALLIC JOINT COVERS; INSULATING JOINTING MATERIALS, NAMELY, INSULATING TAPES AND COVERS FOR USE WITH ELECTRICAL CABLES; NON METALLIC FLEXIBLE PIPES MADE OF HEAT INSULATING MATERIALS; INSULATING COATING MATERIALS FOR PIPES, NAMELY, PIPE COATING TAPES AND COVERS; COMPOSITE PANELS FOR USE IN CONSTRUCTION OF BUILDINGS HAVING INSULATING PROPERTIES (U.S. CLS. 1, 5, 12, 13, 35 AND 50).

DAVID HOFFMAN, EXAMINING ATTORNEY

SN 79-109,799. DELLA FOGLIA S.R.L., ITALY, FILED 12-20-2011.

DELLA FOGLIA

THE MARK CONSISTS OF STANDARD CHARACTERS WITHOUT CLAIM TO ANY PARTICULAR FONT, STYLE, SIZE, OR COLOR.

PRIORITY DATE OF 10-17-2011 IS CLAIMED.
OWNER OF INTERNATIONAL REGISTRATION 1108443 DATED 12-20-2011, EXPIRES 12-20-2021.

THE ENGLISH TRANSLATION OF "DELLA FOGLIA" IN THE MARK IS OF THE LEAF.

CLASS 6—METAL GOODS

FOR MANUALLY-OPERATED VALVES MADE OF METAL, NAMELY, CONTROL VALVES, ONE-WAY VALVES, NON-RETURN VALVES, DISCHARGE VALVES AND ISOLATION VALVES MADE OF METAL; METAL JOINTS FOR MANUALLY-OPERATED VALVES; PARTS AND ACCESSORIES FOR MANUALLY-OPERATED VALVES; MANUALLY-OPERATED CONTROL VALVES OF METAL FOR REGULATING GAS AND HYDROCARBONS FLOW IN GAS PIPELINES OR OIL PIPELINES (U.S. CLS. 2, 12, 13, 14, 23, 25 AND 50).

CLASS 7—MACHINERY

FOR CONTROL VALVES AS PARTS OF MACHINES FOR PLANTS AND PIPELINES, NAMELY, PROPORTIONAL FLOW VALVES, MECHANICALLY ACTIVABLE AUTOMATIC OR MANUAL VALVES, ELECTRO VALVES, ELECTROMAGNETIC VALVES, REMOTELY CONTROLLED VALVES (U.S. CLS. 13, 19, 21, 23, 31, 34 AND 35).

KATHLEEN LORENZO, EXAMINING ATTORNEY

SN 79-109,849. DIGISEC MEDIA AS, N-1364 FORNEBU, NORWAY, FILED 9-15-2011.

VICTORIA MILAN

THE MARK CONSISTS OF STANDARD CHARACTERS WITHOUT CLAIM TO ANY PARTICULAR FONT, STYLE, SIZE, OR COLOR.

OWNER OF INTERNATIONAL REGISTRATION 1108588 DATED 9-15-2011, EXPIRES 9-15-2021.

THE NAME(S), PORTRAIT(S), AND/OR SIGNATURE(S) SHOWN IN THE MARK DOES NOT IDENTIFY A PARTICULAR LIVING INDIVIDUAL.

CLASS 35—ADVERTISING AND BUSINESS

FOR MARKETING, ADVERTISING AND PROMOTIONAL SERVICES; MARKET RESEARCH AND STUDIES; ADVERTISING SERVICES, NAMELY, PROMOTING THE GOODS AND SERVICES OF OTHERS VIA DIRECT MARKETING; BUSINESS SERVICES, NAMELY, SYSTEMIZATION OF DATA IN COMPUTERS AND COMPUTER DATABASES (U.S. CLS. 100, 101 AND 102).

CLASS 38—COMMUNICATION

FOR PROVIDING ONLINE CHAT ROOMS AND BULLETIN BOARDS FOR USERS FOR TRANSMISSION OF MESSAGES AND PHOTOGRAPHIC IMAGES; PROVIDING INSTANT MESSAGING SERVICES FOR TRANSMISSION OF MESSAGES AMONG USERS; PROVIDING ACCESS TO DATABASES RELATING TO USER PROFILES; TELECOMMUNICATION ACCESS SERVICES (U.S. CLS. 100, 101 AND 104).

CLASS 41—EDUCATION AND ENTERTAINMENT

FOR ENTERTAINMENT SERVICES, NAMELY, PROVIDING INFORMATION TO USERS RELATING TO ENTERTAINMENT ACTIVITIES; ORGANIZING RECREATIONAL AND LEISURE ACTIVITIES IN THE NATURE OF SOCIAL ENTERTAINMENT EVENTS; PUBLISHING OF FILMS, PHOTOGRAPHS, BOOKS, CATALOGS, NEWSLETTERS AND JOURNALS IN PHYSICAL MEDIA OR VIA THE INTERNET OR ELECTRONIC NETWORK; ENTERTAINMENT AND EDUCATIONAL SERVICES, NAMELY, EDITING, PRODUCTION, PUBLISHING, AND RENTAL OF FILMS, VIDEO CASSETTES, CD-ROMS, DVDS, AND MAGNETIC STORAGE MEDIUM, AND DOWNLOADABLE FILES (U.S. CLS. 100, 101 AND 107).

CLASS 42—SCIENTIFIC AND COMPUTER SERVICES

FOR DEVELOPMENT AND PROGRAMMING OF COMPUTER HARDWARE AND SOFTWARE; ONLINE SERVICES, NAMELY, PROVIDING A WEBSITE FEATURING A SEARCH FUNCTION FOR IDENTIFYING AND CONNECTING POTENTIAL SOCIAL AND PERSONAL RELATIONSHIPS; TECHNICAL SUPPORT SERVICES, NAMELY, TROUBLESHOOTING ONLINE DATABASE PROBLEMS (U.S. CLS. 100 AND 101).

CLASS 45—PERSONAL AND LEGAL SERVICES

FOR PERSONAL AND SOCIAL SERVICES RENDERED BY OTHERS TO MEET PERSONAL NEEDS, NAMELY, OFFERING ADVICE REGARDING PERSONAL RELATIONSHIPS AND PERSONAL WELL-BEING VIA THE INTERNET; SOCIAL NETWORKING SERVICES FOR PERSONS INTERESTED IN DATING AND FORMING RELATIONSHIPS PROVIDED VIA RADIO, TELEVISION, TELEPHONE, INTERNET, CALL CENTERS AND SMS SERVICES; DATING SERVICES; COUNSELING, NAMELY, OFFERING ADVICE REGARDING PERSONAL RELATIONSHIPS AND PERSONAL WELL-BEING VIA A GLOBAL COMPUTER NETWORK; SOCIAL INTRODUCTION AGENCIES; SOCIAL ESCORT SERVICES; PROVIDING PERSONALITY AND PHYSICAL ATTRACTIVENESS TESTING FOR SOCIAL PURPOSES; PROVIDING INFORMATION IN THE FIELD OF ONLINE DATING AND INTRODUCTION SERVICES (U.S. CLS. 100 AND 101).

KAREN SEVERSON, EXAMINING ATTORNEY

SN 79-109,856. MICHAEL FOX, AUSTRALIA, FILED 12-7-2011.

Sneaking Duck

THE MARK CONSISTS OF STANDARD CHARACTERS WITHOUT CLAIM TO ANY PARTICULAR FONT, STYLE, SIZE, OR COLOR.

PRIORITY DATE OF 6-8-2011 IS CLAIMED.

OWNER OF INTERNATIONAL REGISTRATION 1108600 DATED 12-7-2011, EXPIRES 12-7-2021.

CLASS 9—ELECTRICAL AND SCIENTIFIC APPARATUS

FOR OPTICAL APPARATUS AND INSTRUMENTS, NAMELY, LENSES FOR SPECTACLES AND SUNGLASSES; SPECTACLES; SUNGLASSES; CONTACT LENSES; EYEWEAR, NAMELY, NON-PRESCRIPTION SPECTACLES AND SUNGLASSES, CONTACT LENSES, FRAMES FOR SPECTACLES; FRAMES FOR SUNGLASSES; CONTACT LENS CASES; GLASSES CASES; SPECTACLES CASES; SUNGLASS CASES; STRAPS FOR SPECTACLES; STRAPS FOR SUNGLASSES; CHAINS FOR GLASSES; CHAINS FOR SPECTACLES; CORDS FOR EYEGLASSES; CORDS FOR SPECTACLES; DOWNLOADABLE ELECTRONIC PUBLICATIONS IN THE NATURE OF DOWNLOADABLE ARTICLES, NEWSLETTERS AND GUIDELINES FOR READING AND UNDERSTANDING PRESCRIPTIONS IN THE FIELD OF OPTICAL PRODUCTS AND ACCESSORIES; DOWNLOADABLE IMAGE FILES CONTAINING IMAGES OF EYEWEAR, NAMELY, SUNGLASSES, SPECTACLES, FRAMES FOR SUNGLASSES, FRAMES FOR SPECTACLES AND IMAGERY TO PROVIDE GUIDANCE ABOUT WHAT FRAMES WILL SUIT PROSPECTIVE CUSTOMERS; DOWNLOADABLE MUSIC FILES; DOWNLOADABLE VIDEO FILES FEATURING FASHION, FASHION ACCESSORIES, NAMELY, FASHION SPECTACLES AND SUNGLASSES WITHOUT PRESCRIPTION LENSES; DOWNLOADABLE SOFTWARE MADE AVAILABLE FOR USERS DELIVERED VIA APPLICATIONS ON MOBILE PHONES, COMPUTER NOTEBOOKS, COMPUTER TABLETS, COMPUTERS AND WEBSITES FOR ANALYSING FACE SHAPE TO PROVIDE RECOMMENDATIONS FOR SPECTACLE AND SUNGLASS FRAMES AND TO ENABLE THE PROSPECTIVE PURCHASER TO VIEW IMAGE OF FACE WEARING SPECTACLE AND SUNGLASS FRAMES AND TO ENABLE VIEWING, SHARING AND EDITING OF IMAGES, PROVISION OF PRESCRIPTIONS, PROVIDING MEASUREMENTS FOR EYEWEAR PRODUCT ORDERING AND PURCHASING IN THE FIELD OF FASHION, CLOTHING, EYEWEAR, SAFETY AND PROTECTIVE EYEWEAR (U.S. CLS. 21, 23, 26, 36 AND 38).

CLASS 35—ADVERTISING AND BUSINESS

FOR RETAIL AND WHOLESALE STORE SERVICES FEATURING JEWELLERY, FASHION ACCESSORIES, LENSES FOR SPECTACLES, SPECTACLES, LENSES FOR SUNGLASSES, SUNGLASSES, CONTACT LENSES, EYEWEAR, FRAMES FOR SPECTACLES, FRAMES FOR SUNGLASSES, CONTACT LENS CASES, GLASSES CASES, SPECTACLE CASES, SUNGLASS CASES, STRAPS FOR EYEGLASSES, STRAPS FOR SUNGLASSES, CHAINS FOR GLASSES, CHAINS FOR SPECTACLES, CHAINS FOR SUNGLASSES, CORDS FOR EYEGLASSES, CORDS FOR SPECTACLES; RETAIL AND WHOLESALE STORE SERVICES FOR CONTACT LENS CLEANING PREPARATIONS AND SOLUTIONS, SPECTACLE AND SUNGLASS LENS CLEANING PREPARATIONS AND SOLUTIONS, CLEANING CLOTHS FOR EYE GLASSES; WHOLESALE DISTRIBUTORSHIP SERVICES IN THE FIELD OF JEWELLERY, FASHION ACCESSORIES AND EYEWEAR; SALES PROMOTION AND MARKETING SERVICES IN THE FIELD OF SPECTACLES, SUNGLASSES, LENSES FOR SPECTACLES AND SUNGLASSES, SPECTACLE FRAMES, SUNGLASS FRAMES AND CONTACT LENSES; IMPORT AND EXPORT AGENCY SERVICES; BUYING AND SELLING AGENCY SERVICES, NAMELY, IN THE FIELD OF JEWELLERY, FASHION ACCESSORIES AND EYEWEAR, NAMELY, SPECTACLES, SUNGLASSES, FRAMES FOR SPECTACLES, FRAMES FOR SUNGLASSES, LENSES FOR SPECTACLES AND LENSES FOR SUNGLASSES; SELECTION AND PROCUREMENT OF GOODS FOR OTHERS, NAMELY, JEWELLERY, FASHION ACCESSORIES, EYEWEAR, NAMELY, SPECTACLES, SUNGLASSES, FRAMES FOR SPECTACLES, FRAMES FOR SUNGLASSES, LENSES FOR SPECTACLES AND LENSES FOR SUNGLASSES; PROVISION OF BUSINESS INFORMATION IN THE FIELD OF SALES OF JEWELLERY, FASHION ACCESSORIES AND EYEWEAR, NAMELY, SPECTACLES, SUNGLASSES, FRAMES FOR SPECTACLES, FRAMES FOR SUNGLASSES, LENSES FOR SPECTACLES AND LENSES FOR SUNGLASSES; OPERATING ONLINE MARKETPLACE FOR JEWELLERY, FASHION ACCESSORIES, EYEWEAR, NAMELY, SPECTACLES, SUNGLASSES,

FRAMES FOR SPECTACLES, FRAMES FOR SUNGLASSES, LENSES FOR SPECTACLES AND LENSES FOR SUNGLASSES, CONTACT LENSES, CONTACT LENS SOLUTION, EYE WASH SOLUTION, CLEANING AND POLISHING PREPARATIONS FOR USE WITH EYEWEAR; PROVIDING INFORMATION ABOUT THE RETAIL AND WHOLESALE AVAILABILITY OF CONTACT LENSES, SPECTACLES, SPECTACLE FRAMES, SUNGLASSES, CONTACT LENS SOLUTION, CLEANING AND POLISHING PREPARATIONS FOR USE WITH EYEWEAR POSTED TO BE SOLD ON AN ONLINE WEBSITE AND VIA APPLICATIONS AVAILABLE ON MOBILE PHONES, COMPUTER TABLETS AND COMPUTERS (U.S. CLS. 100, 101 AND 102).

JORDAN BAKER, EXAMINING ATTORNEY

SN 79-110,088, BCP FLUTED PACKAGING LIMITED, LAN-CASHIRE BBI 2JT, UNITED KINGDOM, FILED 12-21-2011.

DITTO

THE MARK CONSISTS OF STANDARD CHARACTERS WITHOUT CLAIM TO ANY PARTICULAR FONT, STYLE, SIZE, OR COLOR.

PRIORITY DATE OF 8-8-2011 IS CLAIMED.

OWNER OF INTERNATIONAL REGISTRATION 1109388 DATED 12-21-2011, EXPIRES 12-21-2021.

CLASS 16—PAPER GOODS AND PRINTED MATTER

FOR PAPER; CARDBOARD; PAPER BOARD; UNCOATED PAPER, CARDBOARD OR PAPER BOARD; COATED PAPER, CARDBOARD OR PAPER BOARD; PAPER, CARDBOARD OR PAPER BOARD LAMINATED WITH FILM OR FOIL; COATED, UNCOATED AND LAMINATED PAPER, CARDBOARD OR PAPER BOARD PRE-CUT INTO SHEETS; ADVERTISING BOARD MADE FROM PAPER, CARDBOARD OR PAPER BOARD; ADVERTISING BOARD MADE FROM COATED, UNCOATED OR LAMINATED PAPER, CARDBOARD OR PAPER BOARD; ADVERTISING BOARD MADE FROM CORRUGATED BOARD OR FOAM CENTERED BOARD (U.S. CLS. 2, 5, 22, 23, 29, 37, 38 AND 50).

CLASS 20—FURNITURE AND ARTICLES NOT OTHERWISE CLASSIFIED

FOR PLASTIC OR POLYPROPYLENE ADVERTISING BOARDS, NAMELY, SIGN BOARDS IN THE NATURE OF POINT OF SALE SIGNAGE, POINT OF PURCHASE SIGNAGE, RETAIL AISLE SIGNAGE, AND EXTERNAL AND INTERNAL RETAIL SIGNAGE (U.S. CLS. 2, 13, 22, 25, 32 AND 50).

JAY FLOWERS, EXAMINING ATTORNEY

SN 79-110,186, KARL STORZ GMBH & CO. KG, FED REP GERMANY, FILED 1-19-2012.



PRIORITY DATE OF 7-27-2011 IS CLAIMED.

OWNER OF INTERNATIONAL REGISTRATION 1109812 DATED 1-19-2012, EXPIRES 1-19-2022.

NO CLAIM IS MADE TO THE EXCLUSIVE RIGHT TO USE "BICEPS TENDON RELEASER", APART FROM THE MARK AS SHOWN.

CLASS 10—MEDICAL APPARATUS

FOR SURGICAL, MEDICAL, DENTAL AND VETERINARY INSTRUMENTS AND APPARATUS FOR USE IN GENERAL, ORTHOPEDIC, AND ENDOSCOPIC SURGERY (U.S. CLS. 26, 39 AND 44).

CLASS 16—PAPER GOODS AND PRINTED MATTER

FOR PRINTED MATTER, NAMELY, BROCHURES AND INFORMATIONAL FLYERS, LETTERS, SHEETS, AND CATALOGUES IN THE FIELD OF MEDICAL TECHNOLOGY; PRINTED TEACHING AND INSTRUCTIONAL MATERIAL IN THE FIELD OF MEDICAL TECHNOLOGY; PHOTOGRAPHS (U.S. CLS. 2, 5, 22, 23, 29, 37, 38 AND 50).

PATRICIA EVANKO, EXAMINING ATTORNEY

SN 79-111,189. BROUWERIJ L. HUYGHE.; NAAMLOZE VENNOOTSCHAP, BELGIUM, FILED 2-23-2012.

BLANCHE DES NEIGES

THE MARK CONSISTS OF STANDARD CHARACTERS WITHOUT CLAIM TO ANY PARTICULAR FONT, STYLE, SIZE, OR COLOR.

OWNER OF INTERNATIONAL REGISTRATION 1012072 DATED 8-17-2009, EXPIRES 8-17-2019.

NO CLAIM IS MADE TO THE EXCLUSIVE RIGHT TO USE "BLANCHE". APART FROM THE MARK AS SHOWN.

THE ENGLISH TRANSLATION OF "BLANCHE DES NEIGES" IN THE MARK IS WHITE OF SNOW.

CLASS 32—LIGHT BEVERAGES

FOR BEERS, ALES (U.S. CLS. 45, 46 AND 48).

CLASS 43—HOTEL AND RESTAURANT SERVICES

FOR CAFES, BARS, PUBS AND RESTAURANT SERVICES (U.S. CLS. 100 AND 101).

KAREN SEVERSON, EXAMINING ATTORNEY

SN 79-111,329. GEA PROCOMAC S.P.A., ITALY, FILED 1-23-2012.

PROCOMAC

THE MARK CONSISTS OF STANDARD CHARACTERS WITHOUT CLAIM TO ANY PARTICULAR FONT, STYLE, SIZE, OR COLOR.

PRIORITY DATE OF 1-16-2012 IS CLAIMED.

OWNER OF INTERNATIONAL REGISTRATION 1112049 DATED 1-23-2012, EXPIRES 1-23-2022.

OWNER OF U.S. REG. NO. 1,654,741.

CLASS 7—MACHINERY

FOR MACHINE PARTS, NAMELY, COMPLETE BOTTLING LINES AND STERILE CONDITIONERS FOR CONTAINERS; FILLING MACHINES FOR CONTAINERS; RINSING MACHINES FOR CONTAINERS; BOTTLE RINSING MACHINES; MACHINE PARTS, NAMELY, CONTAINER STRAIGHTENER ARRANGERS; CONTAINER CAPPING/SEALING MACHINES; CONVEYORS; CONTAINER CONVEYORS FOR BOTTLING INSTALLATIONS; AUTOMATIC CONTAINER STORAGE MACHINES IN THE NATURE OF ACCUMULATION TABLES; MACHINES IN THE NATURE OF PALLETISERS AND DEPALLETISERS; ROBOTS BEING MACHINES FOR INDUSTRIAL PURPOSES; ANTHROPOMORPHOUS AND CARTESIAN ROBOTS BEING MACHINES FOR INDUSTRIAL PURPOSES; PACKING MACHINES; STERILE PACKAGING INSTALLATIONS IN THE NATURE OF MACHINES; LABELLING MACHINES; INDUSTRIAL ELECTRIC MIXERS; MIXING MACHINES; LIQUID AND GAS MIXER MACHINES IN THE NATURE OF SATURATORS; LIQUID AND SOLID MIXER MACHINES IN THE NATURE OF SUGAR DISSOLVERS; SEAMING MACHINES; BLOWING MACHINES FOR THE MANUFACTURE OF PLASTIC CONTAINERS USING THERMOPLASTIC PREFORMS MADE BY MOLDING; CARTONING MACHINES; MACHINES IN THE NATURE OF BUNDLERS; PACKAGING MACHINES USING BAGS, BOXES, CASES, JARS; MACHINES CONSISTING OF COMPLETE PRODUCTION LINES FOR VEGETABLE PRODUCTS, MEAT, FISH AND MACHINES CONSISTING OF COMPLETE PRODUCTION LINES FOR FROZEN CHIPS AND FROZEN PREFRIED CHIPS ALL CONTAINING AS PART OF MACHINE PRODUCTION LINE PEELING MACHINES, PULPERS, WASHING APPARATUS AND CLEANING MACHINES FOR VEGETABLE WASHING AND SAND REMOVAL; MACHINES IN THE NATURE OF FOOD SEPARATORS AND FOOD PEEL SEPARATORS; MACHINES IN THE NATURE OF CORERS; CHOPPING MACHINES; PUREE EXTRACTION MACHINES; CUTTING MACHINES; HEAT-EXCHANGERS BEING PARTS OF MACHINES; DEAERATION MACHINES FOR FOODSTUFFS (U.S. CLS. 13, 19, 21, 23, 31, 34 AND 35).

CLASS 11—ENVIRONMENTAL CONTROL APPARATUS

FOR WATER STERILIZERS; PASTEURIZERS FOR USE IN THE FOOD INDUSTRY; FILTERS BEING PARTS OF INDUSTRIAL INSTALLATIONS; WATER AND AIR PURIFYING APPARATUS, AIR CONDITIONING APPLIANCES; COOKING AND DISTILLATION INSTALLATIONS AND FITTINGS THEREFOR; ELECTRIC HEATERS, NAMELY, INSTALLATIONS FOR THE HEAT TREATMENT OF FOODSTUFFS IN ORDER TO OBTAIN CONCENTRATES; EVAPORATORS; ELECTRIC HEATERS, NAMELY, INSTALLATIONS FOR THE HEAT TREATMENT OF FOODSTUFFS IN ORDER TO DEACTIVATE ENZYMES; FOOD STERILIZERS; COMPLETE PRODUCTION LINES SOLD AS INDIVIDUAL GOODS FOR FROZEN CHIPS AND FROZEN PREFRIED CHIPS, NAMELY, ELECTRIC FRYERS AND ELECTRIC AUTOCLAVES; COOKING AND FRYING APPARATUS, NAMELY, COOKTOPS AND FRYERS; COOLING APPARATUS AND INSTALLATIONS, NAMELY, RAPID FOOD CHILLING UNITS; INDUSTRIAL DRYERS USED IN THE FOOD STUFFS INDUSTRY (U.S. CLS. 13, 21, 23, 31 AND 34).

CLASS 37—CONSTRUCTION AND REPAIR

FOR INSTALLATION AND REPAIR OF INDUSTRIAL INSTALLATIONS USED IN THE FOODSTUFFS INDUSTRY, CONTAINER CONVEYOR SYSTEMS, MACHINES IN THE NATURE OF PALLETISERS AND DEPALLETISERS, MACHINE ROBOTS, AND COMPLETE PROCESSING LINES FOR VEGETABLE PRODUCTS, MEAT, AND FISH (U.S. CLS. 100, 103 AND 106).

JACLYN KIDWELL WALKER, EXAMINING ATTORNEY

SN 79-111,419. DENTSU INC, TOKYO 105-7001, JAPAN, FILED 1-19-2012.

;Dcloud

PRIORITY DATE OF 1-5-2012 IS CLAIMED.
OWNER OF INTERNATIONAL REGISTRATION 1112232
DATED 1-19-2012, EXPIRES 1-19-2022.

CLASS 9—ELECTRICAL AND SCIENTIFIC APPARATUS

FOR SMART PHONES; MOBILE PHONES; TELEVISION SETS; PERSONAL DIGITAL ASSISTANTS; COMPUTER HARDWARE; COMPUTER SOFTWARE FOR DRAFTING, EDITING AND SENDING EMAILS, MESSAGES AND TEXT; COMPUTER SOFTWARE FOR USE IN THE FIELD OF CONTENT MANAGEMENT SYSTEM (CMS) FOR UPLOAD, STORAGE, RETRIEVAL, DOWNLOAD, TRANSMISSION, DISPLAY AND DELIVERY OF DIGITAL CONTENT; COMPUTER GAME PROGRAMS; DOWNLOADABLE RINGTONES FOR MOBILE PHONES AND COMPUTERS; DOWNLOADABLE MUSIC FILES; DOWNLOADABLE IMAGE FILES CONTAINING PICTOGRAMS, STILL IMAGES AND MOVING IMAGES FOR DECORATING EMAILS, MESSAGES AND TEXT; DOWNLOADABLE ELECTRONIC PUBLICATIONS, NAMELY, NOVELS AND PICTURE BOOKS; DOWNLOADABLE ELECTRONIC PUBLICATIONS, NAMELY, GENERAL FEATURE MAGAZINES ON A WIDE VARIETY OF TOPICS OF GENERAL INTEREST (U.S. CLS. 21, 23, 26, 36 AND 38).

CLASS 41—EDUCATION AND ENTERTAINMENT

FOR PROVIDING NON-DOWNLOADABLE ELECTRONIC PUBLICATIONS, NAMELY, NOVELS AND PICTURE BOOKS; NON-DOWNLOADABLE ELECTRONIC PUBLICATIONS, NAMELY, GENERAL FEATURE MAGAZINES ON A WIDE VARIETY OF TOPICS OF GENERAL INTEREST; PROVIDING NON-DOWNLOADABLE IMAGE FILES CONTAINING PICTOGRAMS, STILL IMAGES AND MOVING IMAGES FOR DECORATING EMAILS, MESSAGES AND TEXT; ENTERTAINMENT SERVICES, NAMELY, PROVIDING NON-DOWNLOADABLE RINGTONES AND PRERECORDED MUSIC PRESENTED TO MOBILE COMMUNICATION DEVICES AND COMPUTERS VIA A GLOBAL COMMUNICATIONS NETWORK; PROVIDING ON-LINE COMPUTER GAMES (U.S. CLS. 100, 101 AND 107).

EVELYN BRADLEY, EXAMINING ATTORNEY

OWNER OF U.S. REG. NOS. 742,533, 3,449,655 AND 3,488,793.

THE MARK CONSISTS OF A STYLIZED SALAMANDER INSIDE OF A CIRCLE; UNDERNEATH THE DESIGN IS THE WORDING "SALAMANDER" IN CAPITAL LETTERS.

CLASS 25—CLOTHING

FOR FOOTWEAR, EXCEPT INSOLES; CLOTHING, NAMELY, COATS, SUITS, DRESSES, JACKETS, TROUSERS, PANTS, SKIRTS, BLOUSES, PULLOVERS, SWEATSHIRTS, SHIRTS, T-SHIRTS, SHAWLS, UNDERWEAR; HOSIERY, SOCKS, GLOVES, BELTS; HEADGEAR, NAMELY, HATS, CAPS AND KNITTED CAPS (U.S. CLS. 22 AND 39).

CLASS 35—ADVERTISING AND BUSINESS

FOR WHOLESALE STORE AND RETAIL STORE SERVICES FEATURING MAINTENANCE PRODUCTS FOR SHOES, CLEANING AGENTS FOR SHOES, CLEANING UTENSILS FOR SHOES, SHOETREES, INSOLES, SHOE-LACES, GOODS MADE OF PRECIOUS METALS AND THEIR ALLOYS, GOODS OF A JEWELER, JEWELRY, JEWELS, WATCHES AND TIMING DEVICES, GOODS MADE OF LEATHER AND LEATHER IMITATIONS, IN PARTICULAR HANDBAGS, BRIEF CASES, KEY CASES AND WALLETS, CASES AND SUITCASES, UMBRELLAS, FOOTWEAR, PIECES OF CLOTHING, SOCKS, STOCKINGS, BELTS AND HEADGEAR; CUSTOMER SERVICE MANAGEMENT FOR OTHERS; BUSINESS MANAGEMENT CONSULTATION IN THE FIELDS OF ORGANIZATION AND MARKETING, STORE STRUCTURE, SALES STRATEGY, MARKETING AND ADVERTISING; RENTAL OF STORE ADJUSTMENTS AND STORE EQUIPMENT, SALES ADDITIVES AND STORE DECORATIONS, NAMELY, RENTAL OF BILLBOARDS, OFFICE MACHINERY AND EQUIPMENT, PUBLICITY AND MARKETING PRESENTATION MATERIALS, EXHIBITION STANDS AND BOOTHS INCLUDING RESPECTIVE EQUIPMENT, SALES STANDS, SIGNS FOR ADVERTISING PURPOSES AND VENDING MACHINES; FRANCHISE SERVICES FOR WHOLESALE AND RETAIL COMPANIES, NAMELY, SERVICES RENDERED BY A FRANCHISOR, NAMELY, ASSISTANCE IN THE RUNNING OR MANAGEMENT OF INDUSTRIAL OR COMMERCIAL ENTERPRISES; FRANCHISING, NAMELY, CONSULTATION AND ASSISTANCE IN BUSINESS MANAGEMENT AND ORGANIZATION; PROVIDING INFORMATION AND ANALYSIS IN THE FIELDS OF ECONOMICS AND BUSINESS; SUPPORT OF THE BUSINESS MANAGEMENT IN THE FIELD OF FRANCHISING, NAMELY, MANAGEMENT SERVICES, NAMELY, ONLINE BUSINESS DEVELOPMENT SERVICES, NAMELY, PROVIDING START-UP SUPPORT FOR BUSINESSES OF OTHERS (U.S. CLS. 100, 101 AND 102).

SCOTT BIBB, EXAMINING ATTORNEY

SN 79-111,626. SALAMANDER GMBH, 40764 LANGENFELD, FED REP GERMANY, FILED 3-12-2012.



SALAMANDER

PRIORITY DATE OF 9-21-2011 IS CLAIMED.
OWNER OF INTERNATIONAL REGISTRATION 1102927
DATED 11-3-2011, EXPIRES 11-3-2021.

SN 79-111,676. RUMPF HANDELS GMBH, FED REP GERMANY, FILED 12-22-2011.



OWNER OF INTERNATIONAL REGISTRATION 1112868
DATED 12-22-2011, EXPIRES 12-22-2021.

THE MARK CONSISTS OF AN INVERTED SHADED TRIANGLE, INSIDE OF WHICH APPEARS A CIRCLE, ABOVE WHICH CURVES A SEMI-CIRCLE ARCHING AROUND THE LEFT SIDE OF THE CIRCLE AND TO THE RIGHT, BELOW WHICH APPEARS A SEMI-CIRCLE ARCHING UPWARDS FROM THE RIGHT, BELOW THE CIRCLE AND UPWARDS TO THE LEFT, AND EXTENDING BEYOND THE LEFT SIDE OF THE TRIANGLE.

CLASS 18—LEATHER GOODS

FOR LEATHER AND IMITATIONS OF LEATHER, LEATHER GOODS, NAMELY, BAGS, HANDBAGS, ALL PURPOSE SPORT BAGS; ANIMAL SKINS, HIDES; TRUNKS AND TRAVELLING BAGS; BAGS FOR SPORTS CLOTHING, NAMELY, FOR DANCING CLOTHES; LEATHER POUCHES FOR DANCING SHOES AND DANCING CLOTHES; DANCING SHOE BAGS FOR TRAVEL (U.S. CLS. 1, 2, 3, 22 AND 41).

CLASS 25—CLOTHING

FOR CLOTHES FOR DANCE AND BALLET, NAMELY, TOPS AND BOTTOMS, BALLROOM DANCING DRESSES, BALLET DRESSES, EVENING GOWNS; SKIRTS, PANTS; KNIT CLOTHES, NAMELY, TOPS AND BOTTOMS, SHIRTS, TIGHTS, GYM CLOTHES, NAMELY, TOPS AND BOTTOMS; FOOTWEAR FOR SPORTS, DANCE SHOES AND BALLET SHOES, SOLES FOR SHOES, INSOLES, HEADGEAR, NAMELY, HATS AND CAPS (U.S. CLS. 22 AND 39).

EDWARD FENNESSY, EXAMINING ATTORNEY

SN 79-111,888. OBSHCHESTVO S OGRANICHENOV; OT-VETSTVENNOSTYU; "MEBELNAYA FABRIKA MARIYA"; (MARIYA FURNITURE FACTORY LTD), SARATOV OBLAST, RUSSIAN FED., FILED 11-14-2011.



OWNER OF INTERNATIONAL REGISTRATION 1113414 DATED 11-14-2011, EXPIRES 11-14-2021.

THE NAME(S), PORTRAIT(S), AND/OR SIGNATURE(S) SHOWN IN THE MARK DOES NOT IDENTIFY A PARTICULAR LIVING INDIVIDUAL.

THE COLOR(S) RED, WHITE IS/ARE CLAIMED AS A FEATURE OF THE MARK.

THE LITERAL WORDING "MARIA" IS IMPLEMENTED IN RED COLOR. THE SIGN BACKGROUND IS WHITE.

THE MARK CONSISTS OF THE FOLLOWING: THE LITERAL WORDING "MARIA" IN RED LATIN ALPHABET LETTERS WITH A WHITE BACKGROUND.

THE ENGLISH TRANSLATION OF THE FOREIGN WORD(S) IN THE MARK IS: MARY (WOMAN'S NAME).

CLASS 20—FURNITURE AND ARTICLES NOT OTHERWISE CLASSIFIED

FOR REELS, NOT OF METAL, NON-MECHANICAL, FOR FLEXIBLE HOSES; PULLEYS OF PLASTICS FOR BLINDS; CORK BANDS; CASKS OF WOOD FOR DECANTING WINE; MOORING BUOYS, NOT OF METAL; CASKS, NOT OF METAL; BARRELS, NOT OF METAL; IDENTIFICATION BRACELETS, NOT OF METAL, FOR HOSPITALS; SIDEBOARDS; BUSTS OF WOOD, WAX, PLASTER OR PLASTIC; COSTUME STANDS; BOLLERS; FANS FOR PERSONAL USE, NON-ELECTRIC; WORK BENCHES; VICE BENCHES, NOT OF METAL; COATSTANDS; COAT HANGERS; SHOULDER POLES YOKES; DISPLAY STANDS; SHOWCASES FURNITURE; NEWSPAPER DISPLAY STANDS; ARTIFICIAL HONEYCOMBS; SIGNBOARDS OF WOOD OR PLASTICS; LOADING GAUGE RODS, NOT OF METAL, FOR RAILWAY WAGONS; NUTS, NOT OF METAL; NESTING BOXES; COFFINS; DOORS FOR FURNITURE; CURTAIN HOLDERS, NOT OF TEXTILE MATERIAL; BOLTS, DOWELS, PEGS PINS, SCREWS, NOT OF METAL; DIVANS; KEYBOARDS FOR HANGING KEYS; DIS-

PLAY BOARDS; FLAGPOLES; CONTAINERS, NOT OF METAL, FOR LIQUID FUEL; PACKAGING CONTAINERS OF PLASTIC; FLOWER-STANDS FURNITURE; CURTAIN TIE-BACKS; WALL PLUGS, NOT OF METAL; BINDING SCREWS, NOT OF METAL, FOR CABLES; CABLE OR PIPE CLIPS OF PLASTICS; RIVETS, NOT OF METAL; TORTOISESHELL IMITATION; LOCKS, OTHER THAN ELECTRIC, NOT OF METAL; LOCKS, NOT OF METAL, FOR VEHICLES; BEAD CURTAINS FOR DECORATION; STOPPERS FOR BOTTLES, NOT OF GLASS, METAL OR RUBBER; CLOSURES, NOT OF METAL, FOR CONTAINERS; MIRRORS LOOKING GLASSES; HAND-HELD MIRRORS OR TOILET MIRRORS; SCRATCHING POSTS FOR CATS; ANIMAL CLAWS; ANIMAL HOOVES; CORAL; MEERSCHAUM; WHALE-BONE, UNWORKED OR SEMI-WORKED; STAG ANTLERS; TORTOISESHELL; SEA SHELLS; ANIMAL OR ARTIFICIAL HORNS, UNWORKED OR SEMI-WORKED; ANIMAL HORNS; RATTAN; IVORY, UNWORKED OR SEMI-WORKED; COROZO; WICKERWORK, NAMELY, CHAIRS, TABLES AND BOXES; WORKS OF ART, OF WOOD, WAX, PLASTER OR PLASTIC, NAMELY, CHAIRS, TABLES AND BOXES; CABINET WORK; REEDS PLAINTING MATERIALS; SETTEES; CURTAIN RODS; VALVES, NOT OF METAL, OTHER THAN PARTS OF MACHINES; WATER-PIPE VALVES OF PLASTIC OTHER THAN PARTS OF MACHINES; DRAIN TRAPS VALVES OF PLASTIC; STAVES OF WOOD; PLASTIC KEY CARDS, NOT ENCODED; MATS FOR INFANT PLAYPENS; SAW HORSES; BED CASTERS, NOT OF METAL; FURNITURE CASTERS, NOT OF METAL; BRUSH MOUNTINGS, NAMELY, NON-METAL MOUNTING BRACKETS FOR BRUSHES; WIND CHIMES DECORATION; CRADLES; TENT PEGS, NOT OF METAL; CURTAIN RINGS; CHESTS OF DRAWERS; CONTAINERS, NOT OF METAL FOR STORAGE AND TRANSPORTATION IN COMMERCE; FLOATING CONTAINERS, NOT OF METAL FOR COMMERCIAL USE; LECTERNS; DOG KENNELS; BASKETS, NOT OF METAL; HAMPERS IN THE NATURE OF BASKETS FOR TRANSPORTING GOODS FOR COMMERCIAL PURPOSES; BAKERS' BREAD BASKETS; TRAYS, NOT OF METAL; BOTTLE CASINGS OF WOOD; TAPS FOR CASKS, NOT OF METAL; ARMCHAIRS; HAIRDRESSERS' CHAIRS; HOSPITAL BEDS; BEDSTEDS OF WOOD; BEDS; TABLE TOPS; COATHOOKS, NOT OF METAL; CURTAIN HOOKS; CLOTHES HOOKS, NOT OF METAL; LADDERS OF WOOD OR PLASTICS; PLAYPENS FOR BABIES; DRESSMAKERS' DUMMIES; AIR MATTRESSES, NOT FOR MEDICAL PURPOSES; SPRING MATTRESSES; MATTRESSES; HYDROSTATIC BEDS, NOT FOR MEDICAL PURPOSES; FURNITURE OF METAL; OFFICE FURNITURE; SCHOOL FURNITURE; SLEEPING BAGS FOR CAMPING; MOBILES DECORATION; CURTAIN RAILS; HOUSE NUMBERS, NOT OF METAL, NON-LUMINOUS; INDEX CABINETS FURNITURE; BARREL HOOPS, NOT OF METAL; FURNITURE; FURNITURE PARTITIONS OF WOOD; FURNITURE PRODUCT OF MOTHER-OF-PEARL, UNWORKED OR SEMI-WORKED; MIRROR TILES; AMBROID PLATES; NUMBER PLATES, NOT OF METAL; IDENTITY PLATES, NOT OF METAL; LOADING PALLETS, NOT OF METAL; TRANSPORT PALLETS, NOT OF METAL; HANDLING PALLETS, NOT OF METAL; HEAD-RESTS FURNITURE; NONMETAL STAKES FOR PLANTS OR TREES; NONMETAL TRESTLES FURNITURE; MAGAZINE RACKS; BOOK RESTS FURNITURE; NONMETAL FURNITURE STANDS FOR CALCULATING MACHINES; FLOWER-POT PEDESTALS; PET CUSHIONS; PILLOWS; CUSHIONS; AIR CUSHIONS, NOT FOR MEDICAL PURPOSES; MATS, REMOVABLE, FOR SINKS; RACKS FURNITURE; LIBRARY SHELVES; SHELVES FOR FILING-CABINETS FURNITURE; FURNITURE SHELVES; SHELVES FOR STORAGE; WOOD RIBBON; TOWEL CLOSETS FURNITURE; HAT STANDS; CASK STANDS, NOT OF METAL; INFLATABLE PUBLICITY OBJECTS; BEDS FOR HOUSEHOLD PETS; BEDDING, EXCEPT LINEN, NAMELY, BEDS, BEDROOM FURNITURE, MATTRESS; LATCHES, NOT OF METAL; BUNGS, NOT OF METAL, NAMELY, CORKS FOR BARRELS; CORKS FOR BOTTLES; CORKS; FURNITURE, NAMELY, STAIR RODS; DESKS; EMBROIDERY FRAMES; PICTURE FRAMES; SECTIONS OF WOOD FOR BEEHIVES; RESERVOIRS, NOT OF METAL NOR OF MASONRY IN THE NATURE OF STORAGE TANKS; FODDER RACKS; CURTAIN ROLLERS; TOOL HANDLES, NOT OF METAL; KNIFE HANDLES, NOT OF METAL; DOOR HANDLES, NOT OF METAL; SCYTHE HANDLES, NOT OF METAL; BROOM

HANDLES, NOT OF METAL; FISHING BASKETS; WRITING DESKS; FURNITURE, NAMELY, SEATS OF METAL; BENCHES FURNITURE; STRAWS PLAITS FOR DRINKING; VATS, NOT OF METAL; HONEYCOMBS; SOFAS; SEALING CAPS, NOT OF METAL; BOTTLE CAPS, NOT OF METAL; STATUES OF WOOD, WAX, PLASTER OR PLASTIC; FIGURINES STATUETTES OF WOOD, WAX, PLASTER OR PLASTIC; OYSTER SHELLS; SILVERED GLASS MIRRORS; FILING CABINETS; AMBROID BARS; COUNTERS TABLES; UMBRELLA STANDS; GUN RACKS; NONMETAL CARTS FOR COMPUTERS FURNITURE; DRESSING TABLES; SHELVES FOR TYPEWRITERS; DRAUGHTMAN'S TABLES; CHOPPING BLOCKS TABLES; MASSAGE TABLES; TABLES OF METAL; DESKS FURNITURE; TEA CARTS; DINNER WAGONS FURNITURE; TABLES; STEPS LADDERS, NOT OF METAL; CHAIRS SEATS; HIGH CHAIRS FOR BABIES; CHESTS, NOT OF METAL; PLACARDS OF WOOD OR PLASTICS; FOOTSTOOLS; CRATES; TROUGHS, NOT OF METAL, FOR MIXING MORTAR; TROLLEYS FURNITURE; STRAW PLAITS; BOARDING STAIRS, NOT OF METAL, MOBILE, FOR PASSENGERS; STRAW MATTRESSES; EDGINGS OF PLASTIC FOR FURNITURE; DECORATIONS OF PLASTIC FOR FOODSTUFFS; BEEHIVES; WASHSTANDS FURNITURE; FUNERARY URNS; WAX FIGURES; DOOR FITTINGS, NOT OF METAL; COFFIN FITTINGS, NOT OF METAL; BED FITTINGS, NOT OF METAL; MOLDINGS FOR PICTURE FRAMES; FURNITURE FITTINGS, NOT OF METAL; WINDOW FITTINGS, NOT OF METAL; INFANT WALKERS; COVERS FOR CLOTHING WARDROBE; STUFFED ANIMALS; STUFFED BIRDS; HINGES, NOT OF METAL; DECK CHAIRS; POLES, NOT OF METAL; SCREENS FURNITURE; CUPBOARDS; MEDICINE CABINETS; MEAT CHESTS, NOT OF METAL; PLATE RACKS; BAMBOO CURTAINS; SLATTED INDOOR BLINDS; WOVEN TIMBER BLINDS FURNITURE; INDOOR WINDOW BLINDS SHADES FURNITURE; FIRE SCREENS FOR DOMESTIC USE; YELLOW AMBER; LOCKERS; BINS OF WOOD OR PLASTIC; CHESTS FOR TOYS; LETTER BOXES, NOT OF METAL OR MASONRY; BOTTLE RACKS; TOWEL DISPENSERS, FIXED, NOT OF METAL (U.S. CLS. 2, 13, 22, 25, 32 AND 50).

CLASS 35—ADVERTISING AND BUSINESS

FOR BUSINESS MANAGEMENT; BUSINESS ADMINISTRATION; OFFICE FUNCTIONS; ARRANGING SUBSCRIPTIONS TO TELECOMMUNICATION SERVICES FOR OTHERS; IMPORT-EXPORT AGENCIES; COMMERCIAL INFORMATION AGENCIES; COST PRICE ANALYSIS; BUSINESS AUDITING SERVICES; EMPLOYMENT AGENCIES; COMPUTERIZED FILE MANAGEMENT; BOOK-KEEPING; INVOICING; TRANSCRIPTION; OPINION POLLING; CONDUCTING MARKETING STUDIES; BUSINESS INFORMATION; COMMERCIAL INFORMATION AND ADVICE FOR CONSUMERS CONSUMER ADVICE SHOP; BUSINESS INVESTIGATIONS; MARKETING RESEARCH; PERSONNEL RECRUITMENT; BUSINESS MANAGEMENT AND ORGANIZATION CONSULTANCY; PERSONNEL MANAGEMENT CONSULTANCY; BUSINESS ORGANIZATION CONSULTANCY; BUSINESS MANAGEMENT CONSULTANCY; PROFESSIONAL BUSINESS CONSULTANCY; BUSINESS MANAGEMENT OF PERFORMING ARTISTS; NEWS CLIPPING SERVICES; WORD PROCESSING; SECRETARIAL SERVICES; SHORTHAND; ORGANIZATION OF EXHIBITIONS FOR COMMERCIAL OR ADVERTISING PURPOSES; ARRANGING NEWSPAPER SUBSCRIPTIONS FOR OTHERS; ORGANIZATION OF TRADE FAIRS FOR COMMERCIAL OR ADVERTISING PURPOSES; SHOP WINDOW DRESSING; BUSINESS APPRAISALS; EVALUATION OF STANDING TIMBER; EVALUATION OF WOOL; PAYROLL PREPARATION; DATA MANAGEMENT IN COMPUTER FILES FOR OTHERS; SPONSORSHIP SEARCH; BUSINESS MANAGEMENT ASSISTANCE; COMMERCIAL OR INDUSTRIAL MANAGEMENT ASSISTANCE; ECONOMIC FORECASTING; AUCTIONEERING; SALES PROMOTION FOR OTHERS; OFFICE MACHINES AND EQUIPMENT RENTAL; RENTAL OF VENDING MACHINES; RENTAL OF PHOTOCOPYING MACHINES; TYPING; DOCUMENT REPRODUCTION; COMPILATION OF STATISTICS; COMPILATION OF INFORMATION INTO COMPUTER DATABASES; BUSINESS INQUIRIES; SYSTEMIZATION OF INFORMATION INTO COMPUTER DATABASES; TAX PREPARATION; DRAWING UP OF

STATEMENTS OF ACCOUNTS; PSYCHOLOGICAL TESTING FOR THE SELECTION OF PERSONNEL; BUSINESS MANAGEMENT OF HOTELS; COMMERCIAL ADMINISTRATION OF THE LICENSING OF THE GOODS AND SERVICES OF OTHERS; ADMINISTRATIVE PROCESSING OF PURCHASE ORDERS; PUBLIC RELATIONS; RELOCATION SERVICES FOR BUSINESSES; PRICE COMPARISON SERVICES; PROCUREMENT SERVICES FOR OTHERS PURCHASING GOODS AND SERVICES FOR OTHER BUSINESSES; OUTSOURCING SERVICES BUSINESS ASSISTANCE; TELEPHONE ANSWERING FOR UNAVAILABLE SUBSCRIBERS; PHOTOCOPYING SERVICES; EFFICIENCY EXPERTS (U.S. CLS. 100, 101 AND 102).

ZACHARY BELLO, EXAMINING ATTORNEY

SN 79-111,950. PRADA S.A., L-1118 LUXEMBOURG, LUXEMBOURG, FILED 3-2-2012.



PRIORITY DATE OF 2-2-2012 IS CLAIMED.

OWNER OF INTERNATIONAL REGISTRATION 1113505 DATED 3-2-2012, EXPIRES 3-2-2022.

OWNER OF U.S. REG. NOS. 1,264,243, 4,037,037 AND OTHERS.

NO CLAIM IS MADE TO THE EXCLUSIVE RIGHT TO USE "MILANO", APART FROM THE MARK AS SHOWN.

THE MARK CONSISTS OF A DESIGN OF TWO CONCENTRIC, INVERTED TRIANGULAR SHAPES WITH ROUNDED CORNERS CONTAINING A THIRD INNER TRIANGLE PRESENTED AS DASHED LINES OR STITCHING. ABOVE THE DESIGN IS A SMALLER RECTANGULAR STRIP CONTAINING THE WORDING "PRADA - MILANO" IN A STYLIZED FONT WITH HORIZONTAL BANDS RESEMBLING ROPE PLACED ABOVE AND BELOW THE WORDING.

CLASS 18—LEATHER GOODS

FOR GOODS MADE OF LEATHER AND IMITATIONS OF LEATHER, NAMELY, BRIEFCASES, SUITCASES, HANDBAGS, TOTE BAGS, FANNY PACKS, CHANGE PURSES, BRIEF CASE-TYPE PORTFOLIOS, WALLETS, ALL-PURPOSE SPORT BAGS, SHOULDER BAGS, GARMENT BAGS FOR TRAVELLING, KEY CASES; UMBRELLAS; TRUNKS AND TRAVELLING BAGS; ALL OF THE FOREGOING ORIGINATING FROM MILANO, ITALY (U.S. CLS. 1, 2, 3, 22 AND 41).

CLASS 25—CLOTHING

FOR CLOTHING, NAMELY, SHIRTS, SKIRTS, COATS, DRESSES, PULLOVERS, PAJAMAS, SOCKS, JUMPERS, UNDERWEAR, LINGERIE, SWEATERS, SCARVES, TIES, RAINCOATS, OVERCOATS, SWIMWEAR, SKI WEAR, BELTS, FUR COATS, HEADSCARVES, GLOVES, DRESSING GOWNS AND BATHROBES, JACKETS, PANTS, SHORTS, CAPES, SUITS, TUXEDOS, DINNER JACKETS, FORMAL DRESS SUITS, VESTS; FOOTWEAR; HEADWEAR; ALL OF THE FOREGOING ORIGINATING FROM MILANO, ITALY (U.S. CLS. 22 AND 39).

STEVEN PEREZ, EXAMINING ATTORNEY

SN 79-111,979. CHINA NATIONAL AVIATION FUEL GROUP CORPORATION, BEIJING, CHINA, FILED 12-9-2011.



OWNER OF INTERNATIONAL REGISTRATION 1113584 DATED 12-9-2011, EXPIRES 12-9-2021.

THE MARK CONSISTS OF A DESIGN OF A RAINDROP SURROUNDED BY THREE CIRCULAR BANDS AND THE LETTERS "CNAF" APPEARING BENEATH THE RAIN-DROP DESIGN.

CLASS 1—CHEMICALS

FOR PROTECTIVE GASES FOR WELDING; SOLIDIFIED GASES FOR INDUSTRIAL PURPOSES; ACIDS; ALKALIES; SALTS, NAMELY, CHEMICAL PREPARATIONS FOR USE IN INDUSTRY; CHEMICAL PREPARATIONS, NAMELY, ETHENE; ETHYL ALCOHOL; CHEMICAL PREPARATIONS, NAMELY, GLYCERINE FOR INDUSTRIAL PURPOSES; FORMIC ALDEHYDE FOR CHEMICAL PURPOSES; ESTERS, NAMELY, METHYL ESTERS; CHEMICAL ADDITIVES, NAMELY, CHEMICAL ADDITIVES FOR MOTOR FUELS; PETROLEUM DISPERSANTS; CARBON BLACK FOR INDUSTRIAL PURPOSES; CHEMICAL ADDITIVES FOR DRILLING MUDS; INDUSTRIAL CHEMICALS; ANTI-FREEZE; FLUIDS FOR HYDRAULIC CIRCUITS; TRANSMISSION FLUID; CHEMICAL ADDITIVES FOR OILS; STARTING OIL, NAMELY, CHEMICAL ADDITIVES FOR OILS; DETERGENTS FOR USE IN MANUFACTURING PROCESSES; BIOCHEMICAL CATALYSTS; SYNTHETIC RESINS, UNPROCESSED; FERTILIZER MANURE; FIREPROOFING PREPARATIONS; ADHESIVES FOR INDUSTRIAL PURPOSES (U.S. CLS. 1, 5, 6, 10, 26 AND 46).

CLASS 4—LUBRICANTS AND FUELS

FOR PETROLEUM, RAW OR REFINED; MOTOR OIL; LUBRICATING OIL; MAZUT BEING FUEL OIL; INDUSTRIAL OIL; APPARATUS LUBRICANT; LUBRICATING OIL; LIGHT OILS; PETROL; DIESEL OIL; KEROSENE; FUEL; VAPORIZED FUEL MIXTURES; COMBUSTIBLE OIL; FUEL GAS; COAL; MINERAL FUEL; INDUSTRIAL WAX; CANDLES; DUST REMOVING PREPARATIONS, IN THE NATURE OF DUST-BINDING COMPOSITIONS; FIBRE LUBRICANTS FOR ALL PURPOSE LUBRICANTS (U.S. CLS. 1, 6 AND 15).

CLASS 7—MACHINERY

FOR AGRICULTURAL MACHINES, NAMELY, CULTIVATORS; PAPERMAKING MACHINES; MINE WORKING MACHINES; OIL REFINING MACHINES; PETROLEUM CHEMICAL AND INDUSTRY EQUIPMENT, NAMELY, REFINING MACHINES; PETROLEUM DRILLING MACHINE; OIL-WELL CLEANING MACHINES; AGITATORS FOR CIRCULATING LIQUID MEDIA; MACHINES, NAMELY, DIGGERS; HOISTS; CARBURETTER FEEDERS; DRIVING MOTORS OTHER THAN FOR LAND VEHICLES; MACHINES, NAMELY, PUMPS; VALVES, BEING PARTS OF MACHINES; AEROCONDENSERS; WASHING MACHINES FOR CLOTHES (U.S. CLS. 13, 19, 21, 23, 31, 34 AND 35).

CLASS 37—CONSTRUCTION AND REPAIR

FOR BUILDING CONSTRUCTION SUPERVISION; CONSTRUCTION OF BUILDINGS; WAREHOUSE CONSTRUCTION AND REPAIR; PIPELINE CONSTRUCTION AND MAINTENANCE; MINING EXTRACTION; DRILLING OF WELLS; UPHOLSTERY REPAIR; HEATING EQUIPMENT INSTALLATION AND REPAIR; MACHINERY INSTALLATION, MAINTENANCE AND REPAIR; AIR CONDITIONING APPARATUS INSTALLATION AND REPAIR; MOTOR VEHICLE MAINTENANCE AND REPAIR; VEHICLE LUBRICATION SERVICES; VEHICLE SERVICE STATIONS IN THE NATURE OF REFUELLING AND MAINTENANCE; VEHICLE MAINTENANCE; VEHICLE GAS STATIONS; AIRPLANE MAINTENANCE AND REPAIR; SHIPBUILDING; SAFE MAINTENANCE AND REPAIR; SPRAY SMEAR SERVICE; VULCANIZATION OF AUTOMOBILE TIRES; PRESSURE OR POWER WASHING SERVICES; VERMIN EXTERMINATING OTHER THAN FOR AGRICULTURE; ELEVATOR INSTALLATION AND REPAIR SERVICES (U.S. CLS. 100, 103 AND 106).

CLASS 39—TRANSPORTATION AND STORAGE

FOR FREIGHTING BROKERAGE SERVICE; TRANSPORT OF GOODS; PORTERAGE; UNLOADING CARGO; FREIGHT FORWARDING; TRANSPORT OF TRAVELERS; TRANSPORT BROKERAGE; PACKAGING OF GOODS FOR TRANSPORTATION; FREIGHT SERVICES, NAMELY, SHIPPING OF GOODS; MARINE TRANSPORT; BOAT RENTAL; SHIPPING BROKERAGE; STEVEDORING; CAR TRANSPORT; RAILWAY TRANSPORT; AIR TRANSPORT; VEHICLE RENTAL; STORAGE OF GOODS; WAREHOUSING SERVICE; RENTAL OF STORAGE CONTAINERS; DISTRIBUTION OF ENERGY; COAL GAS DISTRIBUTION SERVICES; LIQUEFACTION GAS DISTRIBUTION SERVICES; COURIER SERVICES, NAMELY, DELIVERY OF MESSAGES OR MERCHANDISE; CONDUCTING SIGHTSEEING FOR TOURISM; ARRANGING OF TOURS; ARRANGING AND BOOKING OF TOURIST TRAVEL AND SIGHTSEEING TOURS; TRANSPORT BY PIPELINE (U.S. CLS. 100 AND 105).

CLASS 40—MATERIAL TREATMENT

FOR BURNISHING BY ABRASION; PROVIDING MATERIAL TREATMENT INFORMATION; METAL TREATING; APPLYING FINISHES TO TEXTILES; WOODWORKING; PAPER FINISHING; POTTERY FIRING; PROCESSING OF OIL; DRESSMAKING; PATTERN PRINTING; RECYCLING OF WASTE AND TRASH; AIR PURIFICATION; RENTAL OF SPACE HEATING APPARATUS; WATER PURIFICATION; PRODUCTION OF ENERGY; FUEL PROCESSING; CHEMICAL REAGENT PROCESSING AND TREATING (U.S. CLS. 100, 103 AND 106).

CLASS 42—SCIENTIFIC AND COMPUTER SERVICES

FOR TECHNICAL RESEARCH IN THE FIELD OF OIL AND GAS; CONDUCTING TECHNICAL PROJECT STUDIES IN THE FIELD OF DESIGN OF COMPUTERS; ENGINEERING SERVICES IN THE FIELD OF COMPUTERS; QUALITY CONTROL FOR OTHERS; CONSULTANCY IN THE FIELD OF ENERGY-SAVING TECHNIQUES AND INNOVATIONS; ENGINEERING DRAWING SERVICES; ANALYSIS FOR OIL-FIELD EXPLOITATION; ANALYSIS FOR OIL-FIELD EXPLOITATION; OIL-WELL TESTING; OIL PROSPECTING; GEOLOGICAL PROSPECTING; GEOLOGICAL RESEARCH; CHEMICAL RESEARCH; WEATHER FORECASTING; VEHICLE ROADWORTHINESS TESTING; MECHANICAL RESEARCH; INDUSTRIAL DESIGN; ARCHITECTURAL CONSULTATION; CONSTRUCTION PROJECTS DEVELOPMENT; DRESS DESIGNING; COMPUTER SOFTWARE CONSULTANCY; AUTHENTICATING WORKS OF ART; GRAPHIC ARTS DESIGNING (U.S. CLS. 100 AND 101).

ELIZABETH KAJUBI, EXAMINING ATTORNEY

SN 79-112,048. ADAMCO AG, ALTSTÄTTEN, SWITZERLAND, FILED 2-14-2012.



PRIORITY DATE OF 2-2-2012 IS CLAIMED.
OWNER OF INTERNATIONAL REGISTRATION 1113750
DATED 2-14-2012, EXPIRES 2-14-2022.
THE MARK CONSISTS OF THE WORDING "ADAMCO"
WITH A TILTED OVAL SHAPE AND FIVE POINTED STAR
DESIGN.

CLASS 6—METAL GOODS

FOR COMMON METALS AND THEIR ALLOYS; BUILDING MATERIALS OF METAL, NAMELY, BEAMS, CLAMPS, FASTENERS, REINFORCEMENTS, CLADDINGS; BUILDINGS, TRANSPORTABLE, OF METAL; RAILWAY MATERIAL OF METAL; NON-ELECTRIC CABLES AND WIRES OF COMMON METAL; IRON-MONGERY, SMALL ITEMS OF METAL HARDWARE, NAMELY, SCREWS, BOLTS, RIVETS, SLIDES; PIPES OF METAL; SAFES; GOODS OF COMMON METAL, INCLUDED IN THIS CLASS; ORES OF METAL (U.S. CLS. 2, 12, 13, 14, 23, 25 AND 50).

CLASS 42—SCIENTIFIC AND COMPUTER SERVICES

FOR SCIENTIFIC AND TECHNOLOGICAL SERVICES, NAMELY, DESIGN OF MECHANICAL PARTS, ELECTROMECHANICAL AND OPTOELECTRONIC APPARATUS AND INSTRUMENTS; INDUSTRIAL ANALYSIS AND RESEARCH SERVICES; DESIGN AND DEVELOPMENT OF COMPUTER HARDWARE AND SOFTWARE (U.S. CLS. 100 AND 101).

JOHN DALIER, EXAMINING ATTORNEY

SN 79-112,291. ELMO & MONTEGRAPPA S.P.A., ITALY, FILED 5-11-2011.

OWNER OF INTERNATIONAL REGISTRATION 1114357
DATED 5-11-2011, EXPIRES 5-11-2021.

OWNER OF U.S. REG. NO. 1,840,475.
THE MARK CONSISTS OF A SIGN DEPICTING THE
WORDING "MONTEGRAPPA" IN FANCY CHARACTERS.
THE WORDING "MONTEGRAPPA" HAS NO MEANING
IN A FOREIGN LANGUAGE.

CLASS 3—COSMETICS AND CLEANING PREPARATIONS

FOR EAU DE TOILETTE, EAU DE PARFUM, PERFUMES, EAU DE COLOGNE, TOILETTE WATER, DEODORANTS FOR PERSONAL USE; AFTER-SHAVE LOTIONS; MOISTURISING CREAMS, FACE CREAMS; ESSENTIAL OILS FOR PERSONAL USE; POTPOURRIS (U.S. CLS. 1, 4, 6, 50, 51 AND 52).

CLASS 9—ELECTRICAL AND SCIENTIFIC APPARATUS

FOR EYEGLASSES, SUNGLASSES, ANTI-GLARE GLASSES, GOGGLES FOR SPORTS, EYEGLOSS AND SUNGLASS CASES, EYEGLOSS AND SUNGLASS LENSES, EYEGLOSS AND SUNGLASS FRAMES, EYEGLOSS AND SUNGLASS CHAINS, EYEGLOSS AND SUNGLASS CORDS, PINCE-NEZ, PINCE-NEZ CASES, PINCE-NEZ CHAINS, PINCE-NEZ CORDS, PINCE-NEZ MOUNTINGS, MAGNIFYING GLASSES; CREDIT CARD CASES, CASES FOR CELLULAR PHONES, CASES FOR CDS AND DVDS, CASES FOR CD PLAYERS, MP3 PLAYERS AND DVD PLAYERS; BAGS AND CASES ADAPTED FOR COMPUTERS (U.S. CLS. 21, 23, 26, 36 AND 38).

CLASS 14—JEWELRY

FOR WATCHES, WRISTWATCHES, CLOCKS, ELECTRONIC WATCHES AND CLOCKS, WATCH CASES, CLOCK CASES, CHRONOMETERS, CHRONOGRAPHS FOR USE AS WATCHES; WATCH STRAPS, WATCH CHAINS, WATCH BRACELETS; CUFF-LINKS; TIE CLIPS; JEWELRY, IMITATION JEWELRY, JEWELRY CASES, KEY RINGS, BEING TRINKETS OR FOBS OF PRECIOUS METAL; KEY HOLDERS OF PRECIOUS METAL; BOXES OF PRECIOUS METAL; SILVER ORNAMENTS; TIE PINS; STATUES OF PRECIOUS METAL; BADGES OF PRECIOUS METAL; FIGURINES AND STATUETTES OF PRECIOUS METAL; WORKS OF ART OF PRECIOUS METAL; DECORATIVE CHARMS FOR CELLULAR PHONES (U.S. CLS. 2, 27, 28 AND 50).

CLASS 16—PAPER GOODS AND PRINTED MATTER

FOR PENS, BEING OFFICE REQUISITES; FOUNTAIN PENS, ROLLERBALL PENS, BALLPOINT PENS, CAPPED BALLPOINT PENS, TWIST ACTION BALLPOINTS, PENCILS, MECHANICAL PENCILS, MECHANICAL PENCILS WITH ROTATION SYSTEM; FOUNTAIN PENS OF PRECIOUS METAL, ROLLERBALL PENS OF PRECIOUS METAL, BALLPOINT PENS OF PRECIOUS METAL, CAPPED BALLPOINT PENS OF PRECIOUS METAL, MECHANICAL PENCILS OF PRECIOUS METAL, MECHANICAL PENCILS WITH ROTATION SYSTEM OF PRECIOUS METAL; PEN INK CARTRIDGES, PEN FEEDERS, PEN REFILLS, CONVERTER-INK BOTTLES, INK BOTTLES, WRITING INK, STAMP INK, WRITING INK STICKS, STAMP INK STICKS, INKING PADS, PEN NIBS, WRITING INSTRUMENT NIBS, WRITING INSTRUMENT NIBS OF GOLD; PEN CASES, PENCIL CASES, PEN HOLDERS, PENCIL HOLDERS; WRITING CASES SETS, CONTAINING PENS, A PAIR OF GLOVES, A MAGNIFYING GLASS, A CLOTH FOR CLEANING GOLD AND SILVER SURFACES AND A BOTTLE OF INK, BEING STATIONERY ARTICLES SOLD AS A UNIT; REFILL HOLDERS; RUBBER ERASERS; PEN TIPS, PEN CLIPS, PEN WIPERS, PENCIL LEAD HOLDERS, ELECTRIC OR NON-ELECTRIC PENCIL SHARPENERS, PENCIL LEADS; WRITING CASES, BEING STATIONERY ARTICLES, STANDS FOR PENS AND PENCILS; PASSPORT CASES MADE OF LEATHER OR IMITATION LEATHER (U.S. CLS. 2, 5, 22, 23, 29, 37, 38 AND 50).

CLASS 18—LEATHER GOODS

FOR PEN POUCHES OF LEATHER AND IMITATION LEATHER SOLD EMPTY; HANDBAGS, SHOULDER BAGS, CLUTCH BAGS, ALL PURPOSE SPORTS BAGS, ATTACHÉ CASES, SCHOOL BAGS, SCHOOL SATCHELS, TOTE BAGS, TRAVELLING BAGS, CASES OF LEATHER OR LEATHERBOARD, CARD CASES, BEING NOTE-CASES, DOCUMENT CASES MADE OF LEATHER OR IMITATION LEATHER, COSMETIC CASES SOLD EMPTY, KEY CASES OF LEATHER OR IMITATION LEATHER, KNAPSACKS, RUCKSACKS, BRIEFCASES, PURSES, POCKET WALLETS, TRAVELLING TRUNKS, SUITCASES, GARMENT BAGS FOR TRAVEL, TRAVELLING SETS IN THE NATURE OF A COMBINATION OF SUITCASES, VANITY CASES, TRAVELLING BAGS, WHEELED SUITCASES AND WHEELED TRAVELLING BAGS; UMBRELLAS, PARASOLS, WALKING STICKS (U.S. CLS. 1, 2, 3, 22 AND 41).

JOSETTE BEVERLY, EXAMINING ATTORNEY

SN 79-112,308. NINGBO MH INDUSTRY CO., LTD., 315100
NINGBO ZHEJIANG, CHINA, FILED 1-3-2012.

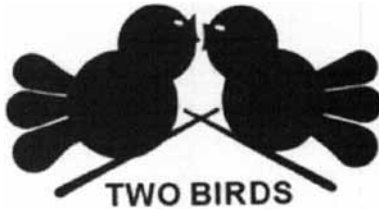

OWNER OF INTERNATIONAL REGISTRATION 1114408
DATED 1-3-2012, EXPIRES 1-3-2022.

THE MARK CONSISTS OF THE WORDING "TWO BIRDS"
BELOW A STYLIZED REPRESENTATION OF TWO BIRDS
PERCHED ON STICKS FACING EACH OTHER.

CLASS 23—YARNS AND THREADS

FOR THREAD; COTTON THREAD AND YARN; EM-
BROIDERY THREAD AND YARN; SEWING THREAD
AND YARN; RAYON THREAD AND YARN; DARNING
THREAD AND YARN; SILK THREADS AND YARNS;
FILAMENT YARN; NYLON THREAD; WOOLEN
THREAD AND YARN (U.S. CL. 43).

CLASS 24—FABRICS

FOR FABRIC OF IMITATION ANIMAL SKINS; TEX-
TILE FABRICS FOR USE IN MAKING CLOTHING AND
HOUSEHOLD FURNISHINGS; ELASTIC WOVEN FAB-
RICS FOR CLOTHING; TRACED CLOTHS FOR EM-
BROIDERY; TAFFETA CLOTH; KNITTED FABRIC;
TEXTILE FABRICS FOR THE MANUFACTURE OF
CLOTHING; OXFORD CLOTH; NON-WOVEN FABRICS;
RAYON FABRIC (U.S. CLS. 42 AND 50).

CLASS 26—FANCY GOODS

FOR LACE FOR EDGINGS; LACE TRIMMINGS;
METAL THREAD FOR EMBROIDERY; SEWING PINS;
BUTTONS; ZIPPERS; NYLON HOOK AND PILE FAS-
TENING TAPE; NEEDLES; EMBROIDERING CROCHET
HOOKS; SEWING NEEDLES (U.S. CLS. 37, 39, 40, 42
AND 50).

TRACY FLETCHER, EXAMINING ATTORNEY

SN 79-112,966. INTERPOOL S.P.A., I-36016 THIENE (VICE-
NZA), ITALY, FILED 11-24-2011.



PRIORITY DATE OF 10-27-2011 IS CLAIMED.
OWNER OF INTERNATIONAL REGISTRATION 1116073
DATED 11-24-2011, EXPIRES 11-24-2021.

THE MARK CONSISTS OF A GRAPHICAL COMPO-
SITION SHOWING THE STYLIZED REPRESENTATION OF A
FRONT OF A TEMPLE.

CLASS 9—ELECTRICAL AND SCIENTIFIC APPARATUS

FOR SPECTACLES, SUNGLASSES, SPECTACLE
CASES AND FRAMES (U.S. CLS. 21, 23, 26, 36 AND 38).

CLASS 18—LEATHER GOODS

FOR LEATHER AND IMITATIONS OF LEATHER;
BAGS, NAMELY, HANDBAGS, RUCKSACKS, TRAVEL-
LING BAGS, SHOULDER BAGS, PURSES, COIN
PURSES, LUGGAGE, BRIEFCASES, WALLETS, KEY
WALLETS, LEATHER WALLETS AND WALLETS WITH
CARD COMPARTMENTS, TRAVELLING TRUNKS,
SUITCASES; UMBRELLAS (U.S. CLS. 1, 2, 3, 22 AND 41).

CLASS 25—CLOTHING

FOR CLOTHING FOR MEN, WOMEN AND CHIL-
DREN, NAMELY, JACKETS, COATS, RAINCOATS,
OVERCOATS, SPORT COATS, ANORAKS, PARKAS,
WINDCHEATERS, MEN'S SUITS, T-SHIRTS, SWEA-
TERS, SWEATSHIRTS, PULLOVERS, POLO SHIRTS,
SHIRTS, SKIRTS, BLOUSES, TROUSERS, SHORTS, BER-
MUDA SHORTS, JEANS, JERSEYS, NECKTIES, SOCKS,
SCARVES, BELTS, UNDERWEAR; FOOTWEAR AND
HEADGEAR, NAMELY, HATS AND CAPS (U.S. CLS. 22
AND 39).

APRIL ROACH, EXAMINING ATTORNEY

SN 79-113,074. QINGDAO SUNNY SUN SEWING CO., LTD.,
SHANDONG PROVINCE, CHINA, FILED 2-20-2012.

DANANA GRACCE

OWNER OF INTERNATIONAL REGISTRATION 1116380
DATED 2-20-2012, EXPIRES 2-20-2022.

THE NAME(S), PORTRAIT(S), AND/OR SIGNATURE(S)
SHOWN IN THE MARK DOES NOT IDENTIFY A PARTI-
CULAR LIVING INDIVIDUAL.

THE MARK CONSISTS OF THE WORDING "DANANA
GRACCE".

THE WORDING "DANANA GRACCE" HAS NO MEAN-
ING IN A FOREIGN LANGUAGE.

CLASS 18—LEATHER GOODS

FOR SCHOOL SACHELS; BACKPACKS; HANDBAGS;
BRIEFCASES; TRAVELLING BAGS; SUITCASES; BAGS
FOR SPORTS; LEATHER BED SHEET; FUR PELTS;
UMBRELLAS (U.S. CLS. 1, 2, 3, 22 AND 41).

CLASS 24—FABRICS

FOR BEDSPREADS; BED CLOTHES; PILLOWSLIPS;
BED COVERS; SLEEPING BAGS; COTTON BLANKETS;
SILK BLANKETS; QUILT COVERS; FABRIC FOR BOOTS
AND SHOES; SILK CLOTH; UNFITTED LOOSE COVERS
FOR FURNITURE (U.S. CLS. 42 AND 50).

CLASS 25—CLOTHING

FOR GLOVES; HATS; SCARVES; SHOES; GIRDLES;
SLIPPERS; CLOTHING, NAMELY, PANTS, TOPS,
COATS, SKIRTS, SHIRTS, JACKETS, T-SHIRTS,
SHORTS; UNDERWEAR; SOCKS; WEDDING GOWNS
(U.S. CLS. 22 AND 39).

TRACY FLETCHER, EXAMINING ATTORNEY

SN 79-113,513. HORASIS AG, SWITZERLAND, FILED 4-2-2012.

HORASIS

THE MARK CONSISTS OF STANDARD CHARACTERS WITHOUT CLAIM TO ANY PARTICULAR FONT, STYLE, SIZE, OR COLOR.

PRIORITY DATE OF 4-2-2012 IS CLAIMED.

OWNER OF INTERNATIONAL REGISTRATION 1117752 DATED 4-2-2012, EXPIRES 4-2-2022.

CLASS 35—ADVERTISING AND BUSINESS

FOR ADVERTISING; BUSINESS MANAGEMENT; BUSINESS ADMINISTRATION; OFFICE FUNCTIONS (U.S. CLS. 100, 101 AND 102).

CLASS 41—EDUCATION AND ENTERTAINMENT

FOR EDUCATIONAL SERVICES, NAMELY, DEVELOPING, ARRANGING AND CONDUCTING EDUCATIONAL CONFERENCES AND PROGRAMS FOR BUSINESS LEADERS IN THE FIELD OF GLOBAL SUSTAINABLE GROWTH; PROVIDING OF BUSINESS TRAINING; ENTERTAINMENT SERVICES, NAMELY, ARRANGING, CONDUCTING AND HOSTING SOCIAL ENTERTAINMENT EVENTS FOR BUSINESS LEADERS; ORGANIZING COMMUNITY SPORTING AND CULTURAL ACTIVITIES; ARRANGING AND CONDUCTING OF EDUCATIONAL CONGRESSES AND SYMPOSIUMS IN THE FIELD OF GLOBAL SUSTAINABLE GROWTH (U.S. CLS. 100, 101 AND 107).

PATRICIA EVANKO, EXAMINING ATTORNEY

SN 79-114,319. TEN CATE THOLON B.V., NETHERLANDS, FILED 4-19-2012.

TRIMENSION

THE MARK CONSISTS OF STANDARD CHARACTERS WITHOUT CLAIM TO ANY PARTICULAR FONT, STYLE, SIZE, OR COLOR.

OWNER OF INTERNATIONAL REGISTRATION 1119900 DATED 4-19-2012, EXPIRES 4-19-2022.

CLASS 17—RUBBER GOODS

FOR SYNTHETIC FIBRES FOR MAKING ARTIFICIAL TURF, NOT FOR TEXTILE USE; SEMI-PROCESSED PLASTICS IN THE FORM OF GRANULES, NOT FOR TEXTILE USE; ARTIFICIAL GRASS YARNS, NOT FOR TEXTILE USE (U.S. CLS. 1, 5, 12, 13, 35 AND 50).

CLASS 23—YARNS AND THREADS

FOR YARNS, SPUN THREADS AND PLASTIC OR RUBBER THREADS FOR TEXTILE USE (U.S. CL. 43).

CLASS 27—FLOOR COVERINGS

FOR ARTIFICIAL TURF; BACKINGS FOR ARTIFICIAL TURF MATS; ARTIFICIAL TURF MATS; UNDERLAYS FOR ARTIFICIAL TURF FIELDS (U.S. CLS. 19, 20, 37, 42 AND 50).

DOUGLAS LEE, EXAMINING ATTORNEY

SN 85-015,047. OVD KINEGRAM AG, ZUG, SWITZERLAND, FILED 4-15-2010.

KINEGRAM

THE MARK CONSISTS OF STANDARD CHARACTERS WITHOUT CLAIM TO ANY PARTICULAR FONT, STYLE, SIZE, OR COLOR.

OWNER OF SWITZERLAND REG. NO. 612582, DATED 7-16-1993, EXPIRES 7-16-2013.

OWNER OF U.S. REG. NOS. 1,546,701, 3,692,735 AND OTHERS.

CLASS 9—ELECTRICAL AND SCIENTIFIC APPARATUS

FOR (BASED ON INTENT TO USE) MAGNETIC, OPTICAL OR ELECTRONIC DATA CARRIERS IN THE FORM OF FOIL STRIPS, STICKERS, LABELS, VIGNETTES, BANDS, TOKENS, COINS, DISCS, CARDS AND PLATES; ALL THE AFORESAID GOODS CONTAINING ENCODING DEVICES, DIFFRACTION STRUCTURES, HOLOGRAPHIC STRUCTURES OR COMBINATIONS THEREOF, FOR USE AS IDENTIFICATION DEVICES, AUTHENTICATION DEVICES, MONEY REPLACEMENT MEANS OR FOR USE WITH BANKNOTES, BILLS OR PAYMENT MEANS; IDENTIFICATION AND AUTHENTICATION DEVICES FOR THE STORAGE, PROCESSING AND/OR DISPLAY OF INFORMATION, NAMELY, FOIL SHEETINGS AND FOIL BANDS, STICKERS, LABELS, BANDS, THREADS, DISCS, CARDS OR PLATES WITH MAGNETIC, OPTICAL OR ELECTRICALLY CONDUCTIVE STRUCTURES FOR THE STORAGE, PROCESSING AND/OR DISPLAY OF INFORMATION; ELECTRIC AND/OR ELECTRONIC AND/OR OPTICAL AND/OR OPTO-ELECTRONIC CIRCUITS, NAMELY, FOIL SHEETINGS AND FOIL BANDS, STICKERS, LABELS, BANDS, THREADS, DISCS, CARDS OR PLATES, EACH WITH MICROPROCESSORS, PRINTED COILS AND

SN 79-113,727. NEVEPLAST S.R.L., ITALY, FILED 2-3-2012.



PRIORITY DATE OF 1-20-2012 IS CLAIMED.
OWNER OF INTERNATIONAL REGISTRATION 1118374 DATED 2-3-2012, EXPIRES 2-3-2022.

THE MARK CONSISTS OF A SHADED SQUARE AT THE CENTER OF WHICH IS A SNOWFLAKE. TO THE RIGHT OF THE DESIGN ELEMENT IS THE WORDING "SNOWPLAST" IN STYLIZED LETTERING.

CLASS 27—FLOOR COVERINGS

FOR MATS FOR ARTIFICIAL SKI SLOPES; CARPETS, RUGS, MATS AND MATTING, LINOLEUM FOR COVERING EXISTING FLOORS; NON-TEXTILE WALL HANGING (U.S. CLS. 19, 20, 37, 42 AND 50).

CLASS 28—TOYS AND SPORTING GOODS

FOR SKI TUBES, NAMELY, INFLATABLE INNER TUBES FOR RECREATIONAL SNOW SLIDING USE AND FOR RECREATIONAL SLIDING USE ON ARTIFICIAL SKI SLOPES; GAMES AND PLAYTHINGS, NAMELY, BOARD GAMES, DOLLS; GYMNAS TIC AND SPORTING ARTICLES NOT INCLUDED IN OTHER CLASSES, NAMELY, GYMNAS TIC APPARATUS, TENNIS RACQUETS; DECORATIONS FOR CHRISTMAS TREES (U.S. CLS. 22, 23, 38 AND 50).

MICHAEL WIENER, EXAMINING ATTORNEY

PRINTED CIRCUITS, ALL FOR USE IN THE FIELD OF PASSIVE LABELLING, TRACING OR TRACKING OF GOODS OR IDENTIFICATION OF PERSONS AND OBJECTS; IDENTIFICATION, AUTHENTICATION OR MONEY REPLACEMENT MEANS, NAMELY, ELECTRONIC DATA CARRIERS IN THE FORM OF TOKENS, CARDS, DISCS, TAGS, BANDS AND SHEETS AND FOILS OF PAPER OR PLASTIC; (BASED ON USE IN COMMERCE) DIFFRACTION GRATING STRUCTURES AND HOLOGRAPHIC GRATINGS, BOTH FOR USE AS IDENTIFICATION DEVICES; OPTICAL SECURITY DEVICES FOR BANKNOTES IN THE FORM OF DIFFRACTION GRATING STRUCTURES AND HOLOGRAPHIC GRATINGS FOR USE AS IDENTIFICATION DEVICES; (BASED ON INTENT TO USE) INTEGRATED CIRCUITS AND ELECTRONIC COMPONENTS, NAMELY, PRINTED CIRCUITS, FOIL SHEETINGS AND FOIL BANDS, STICKERS, LABELS, BANDS, THREADS, DISCS, CARDS OR PLATES MADE OF POLYMERS; OPTO-ELECTRIC ENERGY CONVERTERS, SOLAR CELLS, LIGHT EMITTING DIODES, OR LASER DIODES; ANTENNAE; OPTICAL DISPLAYING DEVICES, NAMELY, LIQUID CRYSTAL DISPLAYS (LCD) AND ORGANIC LIGHT EMITTING DIODES; ALL THE AFOREMENTIONED GOODS ALSO CODABLE AND PROVIDED WITH OPTICALLY ACTIVE INTERFERENCE, POLARISATION AND/OR LIQUID CRYSTAL LAYERS AND/OR OPTICALLY ACTIVE SPATIAL STRUCTURES; BLANK MAGNETIC OR OPTICAL DEVICES AND COMPONENTS IN THE FORM OF FOIL SHEETINGS AND FOIL BANDS, STICKERS, LABELS, BANDS, THREADS, DISCS, CARDS OR PLATES FOR STORAGE, PROCESSING AND/OR DISPLAY OF INFORMATION; (BASED ON INTENT TO USE AND 44(E)) IDENTIFICATION AND AUTHENTICATION MEANS, NAMELY, DISCS OR CARDS WITH MAGNETIC, OPTICAL OR ELECTRICALLY CONDUCTIVE STRUCTURES FOR THE STORAGE, PROCESSING AND/OR DISPLAY OF INFORMATION; DISCS OR CARDS, EACH WITH MICROPROCESSORS, PRINTED COILS AND PRINTED CIRCUITS, ALL FOR USE IN THE FIELD OF IDENTIFICATION OF PERSONS AND OBJECTS; IDENTIFICATION, AUTHENTICATION OR MONEY REPLACEMENT MEANS, NAMELY, ELECTRONIC DATA CARRIERS IN THE FORM OF TOKENS, CARDS, AND DISCS OF PAPER OR PLASTIC (U.S. CLS. 21, 23, 26, 36 AND 38).

FIRST USE 5-31-2003; IN COMMERCE 5-31-2003.

CLASS 16—PAPER GOODS AND PRINTED MATTER

FOR (BASED ON INTENT TO USE) STICKERS, LABELS, STAMPS, VIGNETTES, PACKAGING COATINGS AND SLEEVES OF PAPER OR PLASTIC, NAMELY, BAGS, FOILS, SHEATHS AND ENVELOPES; BANDS, MAINLY OF PAPER, FOR STATIONERY OR HOUSEHOLD PURPOSES, INCLUDING PAPER SHEETS, COVERS, CARDS AND SLEEVES; ALL THE AFORESAID GOODS INTENDED TO CONTAIN ENCODING DEVICES AND/OR DIFFRACTION STRUCTURES AND/OR HOLOGRAPHIC STRUCTURES; PACKAGING MATERIALS OF SYNTHETIC MATERIALS, NAMELY, OF PLASTICS AND/OR POLYMERS OR PAPER, NAMELY, SHEATHS AND ENVELOPES, BAGS AND FOILS AND SLEEVES; STAMPING FOILS, NAMELY, HOT STAMPING FOILS AND COLD STAMPING FOILS, MADE PRIMARILY OF PAPER FOR USE AS IDENTIFICATION OR AUTHENTICATION OR MONEY REPLACEMENT MEANS, OR FOR USE WITH BANKNOTES, BILLS OR PAYMENT MEANS; (BASED ON INTENT TO USE) STICKERS, STAMPING, TRANSFER AND LAMINATING FOILS AND FOIL STRIPS; STICKERS; PAPER WITH UV-CURABLE ADHESIVES FOR COLD STAMPING; PAPER LABELS AND SELF-ADHESIVE LABELS NOT OF TEXTILES; LABELS PRIMARILY MADE OF PAPER, LABELS AND SELF-ADHESIVE LABELS, PRIMARILY MADE OF PAPER; TOKENS, CARDS, DISCS, TAGS, BANDS OF PAPER, SHEETS AND FOILS OF PAPER OR PRIMARILY OF PAPER FOR USE AS NON-ELECTRONIC DATA CARRIERS FOR IDENTIFICATION, AUTHENTICATION AND MONEY REPLACEMENT MEANS; PLASTIC STAMPING FOILS AND PLASTIC TRANSFER FOILS AND PLASTIC FOIL STRIPS; SEMI-FINISHED PLASTIC GOODS, NAMELY, SELF-ADHESIVE PLASTIC FOILS AND PLASTIC STAMPING FOILS FOR IDENTIFICATION OR AUTHENTICATION OR MONEY REPLACEMENT OR

FOR USE WITH BANKNOTES, BILLS OR PAYMENT MEANS; (BASED ON INTENT TO USE AND 44(E)) PACKAGING COATINGS AND SLEEVES OF PAPER OR PLASTIC, NAMELY, ENVELOPES; PACKAGING MATERIALS OF SYNTHETIC MATERIALS, NAMELY, OF PLASTICS AND/OR POLYMERS OR PAPER, NAMELY, ENVELOPES; STAMPING FOILS, NAMELY, HOT STAMPING FOILS AND COLD STAMPING FOILS, MADE PRIMARILY OF PAPER FOR USE AS IDENTIFICATION OR AUTHENTICATION OR MONEY REPLACEMENT MEANS (U.S. CLS. 2, 5, 22, 23, 29, 37, 38 AND 50).

FIRST USE 5-31-2003; IN COMMERCE 5-31-2003.

CLASS 17—RUBBER GOODS

FOR (BASED ON INTENT TO USE) COVERS, SLEEVES, INHERENTLY STABLE SLEEVES OF PLASTIC, OTHER THAN FOR PACKAGING; STAMPING FOILS, NAMELY, HOT STAMPING FOILS AND LAMINATING FOILS, ALSO IN THE FORM OF BANDS, OTHER THAN FOR PACKAGING; ALL THE AFORESAID GOODS CONTAINING ENCODING DEVICES, DIFFRACTION STRUCTURES, HOLOGRAPHIC STRUCTURES OR COMBINATIONS THEREOF, FOR USE AS IDENTIFICATION, AUTHENTICATION OR MONEY REPLACEMENT MEANS, OR FOR USE WITH BANKNOTES, BILLS OR PAYMENT MEANS; LAMINATING FOILS CONSISTING PRIMARILY OF PLASTIC WITH OR WITHOUT A METAL LAYER FOR APPLICATION TO A SUBSTRATE, NAMELY, PLASTIC LAMINATING FOILS CONSISTING OF A CARRIER FILM FOR LAMINATING ON A SUBSTRATE, SAID CARRIER FILM BEING PROVIDED WITH IDENTIFICATION ELEMENTS OR AUTHENTICATION ELEMENTS; PLASTIC LAMINATING FOILS FOR APPLICATION TO A SUBSTRATE; LAMINATING FOILS CONSISTING PRIMARILY OF PLASTIC WITH OR WITHOUT A METAL LAYER FOR APPLICATION TO A SUBSTRATE, NAMELY, PLASTIC LAMINATING FOILS CONSISTING OF A CARRIER SHEET MATERIAL MADE PRIMARILY OF PLASTICS AND AT LEAST ONE TRANSFER LAYER WHICH IS REMOVABLE FROM SAID CARRIER SHEET MATERIAL AND TRANSFERABLE TO A SUBSTRATE; PLASTIC LAMINATES, AND LAMINATING FOILS CONSISTING PRIMARILY OF PLASTIC WITH OR WITHOUT A METAL LAYER FOR APPLICATION TO A SUBSTRATE; SECURITY THREADS OF PLASTICS IN THE FORM OF NARROW STAMPING, TRANSFER OR LAMINATING FOIL STRIPS; (BASED ON USE IN COMMERCE) LAMINATING FOILS CONSISTING PRIMARILY OF PLASTIC WITH OR WITHOUT A METAL LAYER FOR APPLICATION TO A SUBSTRATE; PLASTIC FILM FOR INDUSTRIAL USE IN THE FIELD OF OPTICAL SECURITY; (BASED ON USE IN COMMERCE) STAMPING AND TRANSFER FOILS, NAMELY, FOILS CONSISTING OF A CARRIER SHEET MATERIAL MADE PRIMARILY OF PLASTICS AND AT LEAST ONE TRANSFER LAYER WHICH IS REMOVABLE FROM SAID CARRIER SHEET MATERIAL AND TRANSFERABLE TO A SUBSTRATE; STAMPING FOILS, NAMELY, HOT AND COLD STAMPING FOILS CONSISTING OF A CARRIER FILM MADE PRIMARILY OF PLASTICS AND A CONSUMPTION LAYER REMOVABLE FROM SAID CARRIER FILM WHILE STAMPING FOR APPLICATION TO A SUBSTRATE, NAMELY, PAPER (U.S. CLS. 1, 5, 12, 13, 35 AND 50).

FIRST USE 4-30-2008; IN COMMERCE 4-30-2008.

CLASS 45—PERSONAL AND LEGAL SERVICES

FOR (BASED ON USE IN COMMERCE) (BASED ON 44(E)) TECHNOLOGICAL CONSULTANCY WITH RESPECT TO IDENTIFICATION MEANS AND AUTHENTICATION MEANS AND REPLACEMENT MONEY MEANS USING DATA CARRIERS IN THE FORM OF FOIL SHEETINGS, LABELS, TOKENS, CARDS, DISCS, AS WELL AS SHEETS OF PLASTIC, PAPER OR METAL; (BASED ON USE IN COMMERCE) TECHNOLOGICAL CONSULTANCY WITH RESPECT TO IDENTIFICATION MEANS AND AUTHENTICATION MEANS AND REPLACEMENT MONEY MEANS USING DATA CARRIERS IN THE FORM OF FOIL STRIPS, AND FOIL BANDS, STICKERS, THREADS, PLATES, TAGS, BANDS, AS WELL AS FOILS OF PLASTIC, PAPER OR METAL; TECHNICAL CONSULTANCY WITH RESPECT TO USE

AND APPLICATION OF SECURITY ELEMENTS IN THE FORM OF FOIL STRIPS, FOIL SHEETINGS AND FOIL BANDS, STICKERS, LABELS, THREADS, TOKENS, BANDS, SHEETS AND FOILS OF PLASTIC, PAPER OR METAL ON BANKNOTES, BILLS OR PAYMENT MEANS; TECHNICAL CONSULTANCY WITH RESPECT TO INCREASING SECURITY AGAINST FORGERY BY USING AND APPLYING OF SECURITY ELEMENTS IN THE FORM OF FOIL STRIPS, FOIL SHEETINGS AND FOIL BANDS, STICKERS, LABELS, THREADS, TOKENS, BANDS, SHEETS AND FOILS OF PLASTIC, PAPER OR METAL ON BANKNOTES, BILLS OR PAYMENT MEANS (U.S. CLS. 100 AND 101).

FIRST USE 3-1-1995; IN COMMERCE 3-1-1995.
TEJBIR SINGH, EXAMINING ATTORNEY

SN 85-029,645. FAFCO INCORPORATED, CHICO, CA. FILED 5-4-2010.



NO CLAIM IS MADE TO THE EXCLUSIVE RIGHT TO USE "SOLAR WATER HEATING", APART FROM THE MARK AS SHOWN.

THE MARK CONSISTS OF A SQUARE SHAPED SYMBOL COMPRISED OF FOUR LIQUID DROPS AND TO THE RIGHT, THE WORD "FAFCO" IN CUSTOM LARGE STYLIZED UPPERCASE FONT AND THE WORDS "SOLAR WATER HEATING" BELOW IT IN SMALLER CUSTOMIZED UPPERCASE FONT.

SN 85-028,744. JETMAX LTD., SHATIN, NEW TERRITORIES, HONG KONG, FILED 5-3-2010.



NO CLAIM IS MADE TO THE EXCLUSIVE RIGHT TO USE "ENERGY", APART FROM THE MARK AS SHOWN.

THE MARK CONSISTS OF A PARTIAL SUNBURST AND THE WORDS "SMART ENERGY".

CLASS 7—MACHINERY

FOR SOLAR-POWERED ELECTRICITY GENERATORS (U.S. CLS. 13, 19, 21, 23, 31, 34 AND 35).

CLASS 9—ELECTRICAL AND SCIENTIFIC APPARATUS

FOR SOLAR-POWERED ELECTRIC ACCUMULATORS AND BATTERIES; SOLAR-POWERED CHARGING APPLIANCES FOR RECHARGEABLE EQUIPMENT (U.S. CLS. 21, 23, 26, 36 AND 38).

CLASS 11—ENVIRONMENTAL CONTROL APPARATUS

FOR SOLAR LIGHT FIXTURES, NAMELY, INDOOR AND OUTDOOR SOLAR-POWERED LIGHTING UNITS AND FIXTURES; SOLAR-POWERED DECORATIVE LUMINAIRES; SOLAR-POWERED FANS AND VENTILATORS FOR HOMES AND COMMERCIAL BUILDINGS; SOLAR-POWERED COOLING UNITS; SOLAR-POWERED ALL-WEATHER LIGHTS; SOLAR-POWERED LANTERNS; SOLAR-POWERED ANIMATED HOLIDAY LIGHTS (U.S. CLS. 13, 21, 23, 31 AND 34).

CLASS 28—TOYS AND SPORTING GOODS

FOR HOBBY CRAFT KITS COMPRISING PARTS FOR MAKING SOLAR DEVICES; EDUCATIONAL TOYS FOR THE PURPOSE OF DEMONSTRATION OF SOLAR ENERGY (U.S. CLS. 22, 23, 38 AND 50).

JAY FLOWERS, EXAMINING ATTORNEY

CLASS 11—ENVIRONMENTAL CONTROL APPARATUS

FOR SOLAR HEATING SYSTEMS COMPRISING SOLAR COLLECTORS, PANEL CONTROLS, VALVES, WATER TANKS, FLOW METERS AND CIRCULATION PUMPS SOLD TOGETHER AS A UNIT (U.S. CLS. 13, 21, 23, 31 AND 34).

CLASS 37—CONSTRUCTION AND REPAIR

FOR INSTALLATION OF SOLAR HEATING SYSTEMS (U.S. CLS. 100, 103 AND 106).

CLASS 42—SCIENTIFIC AND COMPUTER SERVICES

FOR CUSTOM DESIGN OF SOLAR HEATING SYSTEMS (U.S. CLS. 100 AND 101).

AHSEN KHAN, EXAMINING ATTORNEY

SN 85-056,522. SYMPPLICITY CORPORATION, ARLINGTON, VA. FILED 6-7-2010.

Symplicity

THE MARK CONSISTS OF STANDARD CHARACTERS WITHOUT CLAIM TO ANY PARTICULAR FONT, STYLE, SIZE, OR COLOR.

CLASS 9—ELECTRICAL AND SCIENTIFIC APPARATUS

FOR COMPUTER SOFTWARE FOR PERSONALIZING E-MAIL COMMUNICATIONS; COMPUTER SOFTWARE FOR UPLOADING TRANSACTIONAL DATA, PROVIDING STATISTICAL ANALYSIS, AND PRODUCING NOTIFICATIONS AND REPORTS; COMPUTER SOFTWARE FOR CUSTOMER RELATIONSHIP MANAGEMENT (CRM) (U.S. CLS. 21, 23, 26, 36 AND 38).

FIRST USE 9-1-1997; IN COMMERCE 9-1-1997.

CLASS 42—SCIENTIFIC AND COMPUTER SERVICES

FOR APPLICATION SERVICE PROVIDER SERVICES FOR TRANSACTION PROCESSING, UPLOADING TRANSACTIONAL DATA, PROVIDING STATISTICAL ANALYSIS, AND PRODUCING NOTIFICATIONS AND REPORTS; APPLICATION SERVICE PROVIDER SERVICES FOR DELIVERING INFORMATION FOR WIRELESS COMMUNICATION, MOBILE INFORMATION ACCESS, AND DELIVERY OF CONTENT TO HANDHELD COMPUTERS, LAPTOPS AND MOBILE ELECTRONIC DEVICES; APPLICATION SERVICE PROVIDER SERVICES FOR MANAGING, DEVELOPING, RESEARCHING, ANALYZING, REPORTING AND MAINTAINING APPLICATIONS AND SOFTWARE OF OTHERS IN THE FIELDS OF HEALTHCARE, BENEFITS PROGRAMS, EMPLOYEE PRODUCTIVITY AND RISK MANAGEMENT; COMPUTER SERVICES, NAMELY, PROVIDING A WEB-BASED SYSTEM AND ONLINE PORTAL FOR CUSTOMERS TO REMOTELY MANAGE, ADMINISTER, MODIFY AND CONTROL THEIR END USER COMPUTER DEVICES AND SOFTWARE APPLICATIONS; COMPUTER SOFTWARE DEVELOPMENT SERVICES FOR MOBILE APPLICATIONS; CONSULTING IN THE FIELD OF SOFTWARE AND PRODUCT DEVELOPMENT IN THE FIELD OF STUDENT AFFAIRS, RECRUITMENT, SURVEY, SCHEDULING, HOUSING, CRM, AND BUSINESS PROCESS IMPROVEMENT; DESIGN AND DEVELOPMENT OF ON-LINE COMPUTER SOFTWARE SYSTEMS; SOFTWARE AS A SERVICE (SAAS) SERVICES, NAMELY, HOSTING SOFTWARE FOR MANAGING ONLINE CONTENT, APPLICATIONS, AND RECEIVING DATA ON WEB SITES IN THE FIELDS OF STUDENT AFFAIRS, RECRUITMENT, SURVEYS, SCHEDULING, HOUSING, CRM, AND BUSINESS PROCESSES IMPROVEMENT (U.S. CLS. 100 AND 101).

FIRST USE 9-1-1997; IN COMMERCE 9-1-1997.

PATRICIA EVANKO, EXAMINING ATTORNEY

CLASS 11—ENVIRONMENTAL CONTROL APPARATUS

FOR EQUIPMENT AND SYSTEMS FOR ODOR CONTROL FOR INDUSTRIAL USE, NAMELY, VENTILATING EXHAUST FANS, AIR FILTERS, AND AIR FILTRATION UNITS USED TO ELIMINATE ODORS; EQUIPMENT AND SYSTEMS FOR DEGASSING, NAMELY, PRESSURE SWING ADSORPTION EQUIPMENT, TEMPERATURE SWING ADSORPTION EQUIPMENT, PERM SELECTIVE MEMBRANE EQUIPMENT, SOLVENT EXTRACTION EQUIPMENT, PERVAPORATION EQUIPMENT OR SOLID ADSORPTION EQUIPMENT, FOR THE RECOVERY, PURIFICATION AND RETURN OF GASES IN INDUSTRIAL APPLICATIONS; EQUIPMENT AND SYSTEMS FOR THERMAL OXIDATION EXHAUST GAS REMOVAL, NAMELY, VENTILATING EXHAUST FANS (U.S. CLS. 13, 21, 23, 31 AND 34).

BERNICE MIDDLETON, EXAMINING ATTORNEY

SN 85-086,431. BARROCOS OF FLORIDA, INC., MIAMI, FL. FILED 7-16-2010.



SN 85-074,445. GLOBAL VAPOR CONTROL, INC., HOUSTON, TX. FILED 6-30-2010.

Global Vapor Control

THE MARK CONSISTS OF STANDARD CHARACTERS WITHOUT CLAIM TO ANY PARTICULAR FONT, STYLE, SIZE, OR COLOR.

NO CLAIM IS MADE TO THE EXCLUSIVE RIGHT TO USE "VAPOR CONTROL", APART FROM THE MARK AS SHOWN.

CLASS 1—CHEMICALS

FOR CHEMICALS FOR INDUSTRIAL USE, NAMELY, CHEMICALS FOR USE IN ODOR CONTROL, DEGASSING, AND VOLATILE ORGANIC COMPOUND CONTROL (U.S. CLS. 1, 5, 6, 10, 26 AND 46).

NO CLAIM IS MADE TO THE EXCLUSIVE RIGHT TO USE "SILVER COLLECTION", APART FROM THE MARK AS SHOWN.

THE NAME(S), PORTRAIT(S), AND/OR SIGNATURE(S) SHOWN IN THE MARK DOES NOT IDENTIFY A PARTICULAR LIVING INDIVIDUAL.

THE MARK CONSISTS OF THE STYLIZED LETTERS "FRONAY" WITH THE FIRST TWO LETTERS CAPITALIZED, AND DIRECTLY BELOW THE WORDS "SILVER COLLECTION".

CLASS 14—JEWELRY

FOR PRECIOUS GEMSTONES; PRECIOUS STONES; JEWELRY, JEWELRY CHAINS, AMULETS, JEWELRY, NAMELY, CROSSES, JEWELRY BOXES OF PRECIOUS METALS, PRECIOUS METALS, PRECIOUS METALS AND THEIR ALLOYS SOLD IN BULK, HOROLOGICAL AND CHRONOMETRIC INSTRUMENTS, NAMELY, WATCHES AND CLOCKS, ALL OF THE AFOREMENTIONED MADE IN WHOLE OR SIGNIFICANT PART OF SILVER (U.S. CLS. 2, 27, 28 AND 50).

FIRST USE 8-1-1969; IN COMMERCE 3-25-1987.

CLASS 16—PAPER GOODS AND PRINTED MATTER

FOR PRECIOUS METAL MONEY CLIPS MADE IN WHOLE OR SIGNIFICANT PART OF SILVER (U.S. CLS. 2, 5, 22, 23, 29, 37, 38 AND 50).

FIRST USE 8-1-1969; IN COMMERCE 3-25-1987.

JULIE GUTTADAURO, EXAMINING ATTORNEY

SN 85-086,864. PATCH NYC, INC., CAMBRIDGE, MA. FILED 7-16-2010.

SN 85-087,551. BANQUE AFRIQUE-AMERIQUE GIDEPPE, 60300 SENLIS, FRANCE, FILED 7-19-2010.

PATCH NYC

THE MARK CONSISTS OF STANDARD CHARACTERS WITHOUT CLAIM TO ANY PARTICULAR FONT, STYLE, SIZE, OR COLOR.

NO CLAIM IS MADE TO THE EXCLUSIVE RIGHT TO USE "NYC", APART FROM THE MARK AS SHOWN.

CLASS 4—LUBRICANTS AND FUELS

FOR CANDLES (U.S. CLS. 1, 6 AND 15).
FIRST USE 1-0-2010; IN COMMERCE 1-0-2010.

CLASS 14—JEWELRY

FOR JEWELRY (U.S. CLS. 2, 27, 28 AND 50).
FIRST USE 1-0-1998; IN COMMERCE 1-0-1998.

CLASS 16—PAPER GOODS AND PRINTED MATTER

FOR PAINTINGS AND THEIR REPRODUCTIONS; ART PRINTS ON CANVAS; PAINTINGS IN MIXED MEDIA; PRINTED ART REPRODUCTIONS (U.S. CLS. 2, 5, 22, 23, 29, 37, 38 AND 50).

FIRST USE 1-0-2006; IN COMMERCE 1-0-2006.
AISHA SALEM, EXAMINING ATTORNEY

SN 85-087,034. ASH GAMING LIMITED, WEST SUSSEX, UNITED KINGDOM, FILED 7-16-2010.



THE MARK CONSISTS OF A STYLIZED VERSION OF THE WORDS "VIRTUAL HORSES".

CLASS 28—TOYS AND SPORTING GOODS

FOR SCRATCH CARDS FOR PLAYING LOTTERY GAMES (U.S. CLS. 22, 23, 38 AND 50).

CLASS 41—EDUCATION AND ENTERTAINMENT

FOR ENTERTAINMENT SERVICES, NAMELY, CONDUCTING LIVE BLACKJACK CARD GAME TOURNAMENTS (U.S. CLS. 100, 101 AND 107).
TRICIA SONNEBORN, EXAMINING ATTORNEY

DIVAS

THE MARK CONSISTS OF STANDARD CHARACTERS WITHOUT CLAIM TO ANY PARTICULAR FONT, STYLE, SIZE, OR COLOR.

OWNER OF FRANCE REG. NO. 99784244, DATED 4-1-1999, RENEWED AS REG. NO. 99784244, DATED 4-22-2009, EXPIRES 4-1-2019.

CLASS 16—PAPER GOODS AND PRINTED MATTER

FOR PRINTED MATTER, NAMELY, MAGAZINES, BOOKS, JOURNALS AND PERIODICALS IN THE FIELD OF FASHION, STYLE, BEAUTY AND ENTERTAINMENT DIRECTED TO WOMEN OF COLOR; STATIONERY; PRINTING BLOCKS (U.S. CLS. 2, 5, 22, 23, 29, 37, 38 AND 50).

FIRST USE 2-28-2000; IN COMMERCE 12-31-2003.

CLASS 41—EDUCATION AND ENTERTAINMENT

FOR PUBLISHING OF BOOKS, MAGAZINES, ALL NOT CONCERNING OPERA SINGERS, IN THE FIELD OF FASHION, STYLE, BEAUTY AND ENTERTAINMENT RELATING TO WOMEN OF COLOR (U.S. CLS. 100, 101 AND 107).

BRIAN CALLAGHAN, EXAMINING ATTORNEY

SN 85-094,354. THE TRUSTEES OF THE GRAVEYARD BBQ TRUST, DBA GRAVEYARD BBQ, WALTHAM, MA, FILED 7-27-2010.

BBQ GIRLZ

THE MARK CONSISTS OF STANDARD CHARACTERS WITHOUT CLAIM TO ANY PARTICULAR FONT, STYLE, SIZE, OR COLOR.

NO CLAIM IS MADE TO THE EXCLUSIVE RIGHT TO USE "GIRLS" FOR INTERNATIONAL CLASS 41 AND "BBQ" FOR INTERNATIONAL CLASS 43, APART FROM THE MARK AS SHOWN.

CLASS 41—EDUCATION AND ENTERTAINMENT

FOR ENTERTAINMENT IN THE NATURE OF LIVE PERFORMANCES BY A MUSICAL BAND AND DANCERS; ENTERTAINMENT IN THE NATURE OF VISUAL AND AUDIO PERFORMANCES BY A MUSICAL BAND AND DANCERS; ENTERTAINMENT SERVICES IN THE NATURE OF LIVE MUSICAL PERFORMANCES (U.S. CLS. 100, 101 AND 107).

CLASS 43—HOTEL AND RESTAURANT SERVICES

FOR PROVIDING OF FOOD AND DRINK; RESTAURANT AND BAR SERVICES; RESTAURANT AND CATERING SERVICES (U.S. CLS. 100 AND 101).
KELLEY WELLS, EXAMINING ATTORNEY

SN 85-108,670. WISELOGIC CO., LTD., SEOUL, REPUBLIC OF KOREA, FILED 8-16-2010.



PRIORITY CLAIMED UNDER SEC. 44(D) ON REPUBLIC OF KOREA APPLICATION NO. 452010000073, FILED 2-22-2010, REG. NO. 0036560, DATED 10-12-2011, EXPIRES 10-12-2021.

THE COLOR(S) BLUE, GREEN, YELLOW, ORANGE, SILVER, BLACK, AND WHITE IS/ARE CLAIMED AS A FEATURE OF THE MARK.

THE MARK CONSISTS OF A SILVER STYLIZED SHIELD DESIGN WITH WHITE HIGHLIGHTS AND BLACK SHADING AND FOUR TRIANGLES APPEARING INSIDE THE SHIELD. THE TRIANGLES ARE BLUE, YELLOW, GREEN, AND ORANGE WITH WHITE HIGHLIGHTING. BENEATH THE SHIELD DESIGN APPEARS THE TERM "X-TRAP" IN STYLIZED BLACK LETTERING. THE OVERALL BACKGROUND OF THE ENTIRE MARK IS TRANSLUCENT.

CLASS 9—ELECTRICAL AND SCIENTIFIC APPARATUS

FOR SECURE TERMINALS FOR ELECTRONIC TRANSACTIONS; SOFTWARE FOR ENSURING THE SECURITY OF ELECTRONIC MAIL; VIRTUAL REALITY GAME SOFTWARE; COMPUTER PROGRAMS FOR PRE-RECORDED GAMES; DOWNLOADABLE COMPUTER SOFTWARE FOR WIRELESS CONTENT DELIVERY; COMPUTER SOFTWARE FOR ENCRYPTION; GAMES ADAPTED FOR USE WITH AN EXTERNAL DISPLAY SCREEN OR MONITOR; AMUSEMENT APPARATUS ADAPTED FOR USE WITH AN EXTERNAL DISPLAY SCREEN OR MONITOR; COMPUTER PROGRAMS FOR THE ENABLING OF ACCESS OR ENTRANCE CONTROL; COMPUTER GAME PROGRAMS; COMPUTER SOFTWARE, NAMELY, COMPUTER SOFTWARE FOR PROVIDING NETWORK, INTERNET AND COMPUTER SECURITY; COMPUTER SOFTWARE FOR ENCRYPTION OF DATA FOR USE IN PROVIDING ONLINE IDENTITY PROTECTION, PRIVACY CONTROL, AND PARENTAL CONTROL OF COMPUTER SYSTEMS; COMPUTER SOFTWARE FOR SCANNING, DETECTING, AND REMOVING VIRUSES, WORMS, TROJAN HORSES, ADWARE, SPYWARE AND OTHER MALWARE; COMPUTER SOFTWARE FOR MONITORING AND CONTROLLING COMMUNICATION BETWEEN COMPUTERS AND AUTOMATED MACHINE SYSTEMS; COMPUTER E-COMMERCE SOFTWARE TO ALLOW USERS TO PERFORM ELECTRONIC BUSINESS TRANSACTIONS VIA A GLOBAL COMPUTER NETWORK; COMPUTER SEARCH ENGINE OPTIMIZATION SOFTWARE; COMPUTER UTILITY PROGRAMS, NAMELY, PROGRAMS FOR PERFORMING COMPUTER MAINTENANCE WORK; COMPUTER SOFTWARE FOR THE BACK-UP, STORAGE, RESTORATION AND RECOVERY OF DATA, FOLDERS, AND FILES; ELECTRONIC SOFTWARE UPDATES, NAMELY, DOWNLOADABLE COMPUTER SOFTWARE AND ASSOCIATED DATA FILES FOR UPDATING COMPUTER SOFTWARE IN THE FIELD OF COMPUTER SECURITY PROGRAMS; COMPUTER PERIPHERALS (U.S. CLS. 21, 23, 26, 36 AND 38).

CLASS 42—SCIENTIFIC AND COMPUTER SERVICES

FOR DEVELOPMENT OF COMPUTER GAME SOFTWARE; COMPUTER PROJECT MANAGEMENT SERVICES; MAINTENANCE OF WEBSITES AND HOSTING ONLINE WEB FACILITIES FOR OTHERS; WEB SITE DEVELOPMENT FOR OTHERS; PROVIDING ONLINE NON-DOWNLOADABLE COMPUTER SOFTWARE FOR ENCRYPTION OF DATA FOR USE IN PROVIDING ONLINE IDENTITY PROTECTION, PRIVACY CONTROL, AND PARENTAL CONTROL OF COMPUTER SYSTEMS; DUPLICATION OF COMPUTER GAME SOFTWARE; MAINTENANCE OF COMPUTER GAME SOFTWARE; COMPUTER GAME PROGRAMMING FOR OTHERS; COMPUTER VIRUS PROTECTION SERVICES; COMPUTER CONSULTATION IN THE FIELD OF COMPUTER SECURITY; COMPUTER SOFTWARE DEVELOPMENT; COMPUTER SOFTWARE UPDATING; COMPUTER SOFTWARE MAINTENANCE; COMPUTER SOFTWARE CONSULTATION; COMPUTER PROGRAMMING; COMPUTER DIAGNOSTIC SERVICES; REMOTE COMPUTER BACKUP SERVICES; UPDATING OF COMPUTER SOFTWARE FOR OTHERS; COMPUTER SECURITY SERVICES, NAMELY, RESTRICTING ACCESS TO AND BY COMPUTER NETWORKS TO AND OF UNDESIRED WEB SITES, MEDIA AND INDIVIDUALS AND FACILITIES; MAINTENANCE OF COMPUTER SOFTWARE; UPDATING OF COMPUTER SOFTWARE; MAINTENANCE OF ON-LINE DATABASES FOR OTHERS; PROVIDING TECHNICAL INFORMATION IN THE FIELD OF COMPUTER NETWORK AND INTERNET SECURITY; PROVIDING TECHNICAL INFORMATION IN THE FIELD OF COMPUTER SOFTWARE APPLICATION DESIGN (U.S. CLS. 100 AND 101).

JIM RINGLE, EXAMINING ATTORNEY

SN 85-110,741. THEORY LLC, NEW YORK, NY. FILED 8-18-2010.

THEORY

THE MARK CONSISTS OF STANDARD CHARACTERS WITHOUT CLAIM TO ANY PARTICULAR FONT, STYLE, SIZE, OR COLOR.

OWNER OF U.S. REG. NOS. 2,067,427, 2,802,700 AND OTHERS.

CLASS 20—FURNITURE AND ARTICLES NOT OTHERWISE CLASSIFIED

FOR FURNITURE, WINDOW SHADES, WINDOW BLINDS AND PILLOWS (U.S. CLS. 2, 13, 22, 25, 32 AND 50).

CLASS 21—HOUSEWARES AND GLASS

FOR NAPKIN RINGS OF NON-PRECIOUS MATERIAL (U.S. CLS. 2, 13, 23, 29, 30, 33, 40 AND 50).

CLASS 24—FABRICS

FOR BATH LINEN, BATH TOWELS, BED LINENS, COMFORTERS, DRAPERY, DUVET COVERS, HOUSEHOLD LINENS, NAMELY BED SHEETS, MATTRESS COVERS AND PILLOW CASES, KITCHEN TOWELS, PILLOW COVERS, PILLOW SHAMS, TABLE LINENS, NAMELY PLACEMATS, NAPKINS AND TOWELS, UNFITTED FABRIC FURNITURE COVERS (U.S. CLS. 24 AND 50).

CLASS 27—FLOOR COVERINGS

FOR CARPETING, CLOTH AND NON-TEXTILE WALL COVERINGS AND FLOOR COVERINGS (U.S. CLS. 19, 20, 37, 42 AND 50).

THOMAS MANOR, EXAMINING ATTORNEY

SN 85-130,902. ROWLING, JOANNE, LONDON, UNITED KINGDOM, FILED 9-16-2010.



PRIORITY CLAIMED UNDER SEC. 44(D) ON ERP N CMNTY TM OFC APPLICATION NO. 009238213, FILED 7-12-2010, REG. NO. 009238213, DATED 7-12-2010, EXPIRES 7-12-2020.

OWNER OF U.S. REG. NOS. 2,757,849 AND 2,818,636.

THE NAME "JK ROWLING" IDENTIFIES THE NICK-NAME OF JOANNE ROWLING, A LIVING INDIVIDUAL WHOSE CONSENT IS OF RECORD.

THE MARK CONSISTS OF THE SIGNATURE OF "JK ROWLING".

CLASS 9—ELECTRICAL AND SCIENTIFIC APPARATUS

FOR PRE-RECORDED AUDIO TAPES, AUDIO-VIDEO TAPES, AUDIO-VIDEO CASSETTES, AUDIO-VIDEO DISCS, AND DIGITAL VERSATILE DISCS FEATURING COMEDY, DRAMA, ACTION AND ADVENTURE; DOWNLOADABLE AUDIO RECORDINGS FEATURING COMEDY, DRAMA, ACTION AND ADVENTURE; ELECTRONIC GAMES, NAMELY, COMPUTER GAME CONSOLES AND GAME SOFTWARE ADAPTED FOR USE WITH AN EXTERNAL DISPLAY SCREEN OR MONITOR; HAND HELD UNITS FOR PLAYING ELECTRONIC GAMES FOR USE WITH AN EXTERNAL DISPLAY SCREEN OR MONITOR; ELECTRONIC COMPUTER GAME PROGRAMS; CD ROM COMPUTER GAME DISCS; INTERACTIVE VIDEO GAME PROGRAMS; INTERACTIVE MULTIMEDIA GAME PROGRAMS; VIDEO GAME CARTRIDGES AND CASSETTES; PORTABLE ELECTRONIC BOOK READING DEVICES AND OPERATING SOFTWARE THEREFOR; MOUSE PADS; COMPUTER PROGRAMS, NAMELY, SOFTWARE LINKING DIGITIZED VIDEO AND AUDIO MEDIA TO A GLOBAL COMPUTER INFORMATION NETWORK; DOWNLOADABLE COMPUTER SOFTWARE APPLICATIONS FOR MOBILE TELEPHONES, NAMELY, COMPUTER GAME SOFTWARE FOR USE ON MOBILE AND CELLULAR PHONES; DOWNLOADABLE ELECTRONIC PUBLICATIONS, NAMELY, MAGAZINES AND JOURNALS ON THE TOPICS OF LITERATURE, MOVIES, READING AND LITERACY; DOWNLOADABLE ELECTRONIC BOOKS, MAGAZINES AND JOURNALS ON THE SUBJECT OF LITERATURE, MOVIES, READING AND LITERACY; DOWNLOADABLE ELECTRONIC NEWSPAPERS; DOWNLOADABLE CHILDREN'S BOOKS; DOWNLOADABLE INTERACTIVE ELECTRONIC PUBLICATIONS, NAMELY, MAGAZINES AND JOURNALS ON THE SUBJECT OF LITERATURE, MOVIES, READING AND LITERACY; DOWNLOADABLE INTERACTIVE ELECTRONIC BOOKS ON THE SUBJECT OF LITERATURE, MOVIES, READING AND LITERACY; DOWNLOADABLE INTERACTIVE ELECTRONIC CHILDREN'S BOOKS; FRIDGE MAGNETS (U.S. CLS. 21, 23, 26, 36 AND 38).

CLASS 16—PAPER GOODS AND PRINTED MATTER

FOR BOOKS FEATURING COMEDY, DRAMA, ACTION AND ADVENTURE; PERIODICAL PUBLICATIONS, NAMELY, NEWSPAPERS AND MAGAZINES IN THE FIELD OF COMEDY, DRAMA, ACTION AND ADVENTURE; COLORING BOOKS; PUZZLE BOOKS; CHILDREN'S ACTIVITIES BOOKS; SCRAP BOOKS; WRITING OR DRAWING BOOKS; MOUNTED AND/OR UNMOUNTED PHOTOGRAPHS; STATIONERY; PRINTED INSTRUCTIONAL AND TEACHING MATERIALS, NAMELY, WORKBOOKS FEATURING INSTRUCTION REGARDING COMEDY, DRAMA, ACTION, ADVENTURE, AND ADVENTURE SPORTS; WRITING BOOKS; POSTERS; PENS; BOOKMARKS; CALENDARS; WRAPPING PAPER; NOTEPADS; GREETING CARDS; ADDRESS BOOKS; NOTE BOOKS; TRADING CARDS; LITHOGRAPHS; PHOTOGRAPH ALBUMS; FILES, NAMELY, CARD FILES, DOCUMENT FILES, LETTER FILES AND PAPER EXPANDING FILES; BOOK COVERS; PAINTING SETS FOR CHILDREN (U.S. CLS. 2, 5, 22, 23, 29, 37, 38 AND 50).

CLASS 25—CLOTHING

FOR CLOTHING, NAMELY, T-SHIRTS, SWEAT-SHIRTS, SHIRTS, TROUSERS, SHORTS, SKIRTS, BLOUSES, DRESSES, JACKETS, COATS, SLEEPWEAR, UNDERWEAR, SWIMWEAR, JUMPERS, HATS, CAPS, BASEBALL CAPS, HEADBANDS; SCARVES, WOOLY HATS AND GLOVES; SHOES, TRAINING SHOES, SANDALS, BOOTS AND SLIPPERS; BELTS FOR WEAR (U.S. CLS. 22 AND 39).

CLASS 28—TOYS AND SPORTING GOODS

FOR GAMES, NAMELY, BOARD GAMES, CARD GAMES, PARLOR GAMES, ARCADE GAMES, TARGET GAMES; JIGSAW PUZZLES; HANDHELD UNITS FOR PLAYING ELECTRONIC GAMES, NAMELY, HAND HELD UNITS FOR PLAYING ELECTRONIC GAMES OTHER THAN THOSE ADAPTED FOR USE WITH AN EXTERNAL DISPLAY SCREEN OR MONITOR; TOYS, NAMELY, PLUSH TOYS, WIND-UP TOYS, BATH TOYS, TOY VEHICLES, DOLLS, DOLL ACCESSORIES AND PLAYING CARDS; AND CHRISTMAS TREE ORNAMENTS (U.S. CLS. 22, 23, 38 AND 50).

CLASS 38—COMMUNICATION

FOR PROVIDING MULTIPLE-USER ACCESS TO A GLOBAL COMPUTER INFORMATION NETWORK; PROVIDING ON-LINE CHAT ROOMS, ELECTRONIC BULLETIN BOARDS FOR COMMUNICATION, ALL FOR THE TRANSMISSION OF MESSAGES AMONG USERS IN THE FIELD OF GENERAL INTEREST; PROVIDING AN ONLINE COMMUNITY FORUM IN THE FIELD OF GENERAL INTEREST FOR COMMUNICATION AMONG USERS BY ALLOWING USERS TO POST AND SHARE INFORMATION, PHOTOS, AUDIO AND VIDEO CONTENT AND TEXT AND OTHER USER-GENERATED CONTENT, WRITE COMMENTS AND TRANSMIT MESSAGES TO OTHER USERS; PROVIDING ON-LINE COMMUNICATIONS LINKS WHICH TRANSFER THE WEB SITE USER TO OTHER LOCAL AND GLOBAL WEB PAGES; PROVIDING ON-LINE FACILITIES IN THE NATURE OF VIDEO CONFERENCING SERVICES, INSTANT MESSAGING SERVICES, ONLINE CHAT-RELATED AUDIO STREAMING AND VIDEO STREAMING SERVICES FOR REAL TIME INTERACTION WITH OTHER COMPUTER USERS CONCERNING TOPICS OF GENERAL INTEREST; AUDIO, TEXT AND VIDEO BROADCASTING SERVICES OVER A GLOBAL COMPUTER NETWORK AND OVER TELEVISION COMMUNICATION NETWORKS, NAMELY, ELECTRONICALLY TRANSMITTING DATA, INFORMATION, AUDIO AND VIDEO IMAGES, AND TEXT; BROADCASTING PROGRAMS FEATURING TEXT AND VIDEO VIA GLOBAL COMPUTER NETWORKS AND VIA TELEVISION (U.S. CLS. 100, 101 AND 104).

CLASS 41—EDUCATION AND ENTERTAINMENT

FOR ENTERTAINMENT SERVICES IN THE NATURE OF AN ON-LINE INTERACTIVE WEBSITE FEATURING ENTERTAINMENT INFORMATION SPECIFICALLY RELATED TO BOOKS AND MOVIES IN THE NATURE OF NEWS, ONLINE GAMES THAT PROVIDE ENTERTAINMENT INFORMATION REGARDING BOOKS AND MOVIES, AND INTERACTIVE ACTIVITIES PROVIDING ENTERTAINMENT INFORMATION REGARDING BOOKS AND MOVIES; PROVIDING ENTERTAINMENT INFORMATION RELATING TO BOOKS, MOVIES, GAMES AND TOYS, ONLINE TRIVIA ABOUT BOOKS, MOVIES, GAMES AND TOYS, ONLINE GAMES AND ONLINE CONTESTS PROVIDED BY MEANS OF GLOBAL AND LOCAL AREA COMPUTER NETWORKS; ENTERTAINMENT SERVICES, NAMELY, PROVIDING A WEB SITE FEATURING FILM CLIPS, PHOTOGRAPHS AND OTHER MULTIMEDIA MATERIALS FEATURING ENTERTAINMENT INFORMATION AND FEATURING INSTRUCTION DELIVERED IN AN ENTERTAINING MANNER, ALL IN THE FIELDS OF LITERATURE, MOVIES, READING AND LITERACY; PROVIDING ON-LINE COMPUTER GAMES; PROVIDING ONLINE COMPUTER GAMES THAT ARE ACCESSIBLE BY A TELECOMMUNICATIONS NETWORK; EDUCATIONAL SERVICES, NAMELY, PROVIDING INFORMATION THAT MAY BE ACCESSED BY A TELECOMMUNICATIONS NETWORK RELATING SPECIFICALLY TO EDUCATIONAL ACTIVITIES FEATURING CHILDREN'S BOOKS, EDUCATIONAL READING AND LITERACY PROGRAMS, PROGRAMS FOR THE TEACHING OF READING AND LITERACY, MATERIALS AND PROGRAMS FOR THE FACILITATION OF READING AND LEARNING FOR INDIVIDUALS WITH LEARNING DISABILITIES AND LANGUAGE AND LITERACY DIFFICULTIES; PROVIDING ON-LINE PUBLICATIONS, NAMELY, E-BOOKS AND JOURNALS, ALL IN THE FIELDS OF LITERATURE, MOVIES, READING AND LITERACY; PUBLISHING SERVICES, NAMELY, PUBLICATION OF BOOKS, MAGAZINES, JOURNALS AND NEWSLETTERS; ELECTRONIC PUBLISHING SERVICES, NAMELY, THE PUBLICATION OF TEXT AND GRAPHIC WORKS OF OTHERS ON CDS, DVDS AND ONLINE IN THE FIELD OF LITERATURE, MOVIES, READING AND RECENT LITERARY WORKS; ARRANGING AND CONDUCTING OF SPELLING COMPETITIONS AND QUIZ COMPETITIONS; PRODUCTION OF FILMS, VIDEOS, TELEVISION PROGRAMS AND SOUND RECORDINGS; SYNDICATION OF TELEVISION PROGRAMS; SYNDICATION OF FILMS, VIDEOS, AND SOUND RECORDINGS, ALL FEATURING TELEVISION AND RADIO PROGRAMS; ORGANIZATION OF AND CONDUCTING OF EDUCATIONAL CONFERENCES IN THE FIELD OF PUBLISHING; ORGANIZATION OF AND CONDUCTING OF CULTURAL AND ENTERTAINMENT EXHIBITIONS; ENTERTAINMENT ORGANIZATION SERVICES IN THE NATURE OF LIVE THEATER PRODUCTION SERVICES AND CONDUCTING OF LIVE THEATRICAL PLAYS PERFORMED BY A CAST OF CHARACTERS; ORGANIZATION OF AND CONDUCTING OF LIVE DANCE PERFORMANCES BY A CAST OF CHARACTERS; ENTERTAINMENT, NAMELY, LIVE THEATRICAL PLAYS AND DANCE PERFORMANCES BY A CAST OF CHARACTERS; PROVIDING ONLINE NON-DOWNLOADABLE ELECTRONIC PUBLICATIONS AND NON-DOWNLOADABLE INTERACTIVE ELECTRONIC PUBLICATIONS, NAMELY, BOOKS, MAGAZINES, JOURNALS, AND NEWSLETTERS IN THE FIELDS OF LITERATURE, MOVIES, READING AND LITERACY; PROVISION OF INFORMATION RELATING TO ALL OF THE AFORESAID SERVICES (U.S. CLS. 100, 101 AND 107).

CLASS 45—PERSONAL AND LEGAL SERVICES

FOR INTERNET BASED SOCIAL NETWORKING SERVICES FEATURING THE CREATION OF PERSONAL PROFILES THAT FEATURE SOCIAL NETWORKING INFORMATION (U.S. CLS. 100 AND 101).
MAUREEN DALL, EXAMINING ATTORNEY

SN 85-137,427. CATNIP LICENSING, LLC, BOULDER, CO.
FILED 9-24-2010.

CATNIPS

THE MARK CONSISTS OF STANDARD CHARACTERS WITHOUT CLAIM TO ANY PARTICULAR FONT, STYLE, SIZE, OR COLOR.

CLASS 3—COSMETICS AND CLEANING PREPARATIONS

FOR NON MEDICATED MINTS, IN THE NATURE OF BREATH MINTS FOR USE AS A BREATH FRESHENER (U.S. CLS. 1, 4, 6, 50, 51 AND 52).

CLASS 30—STAPLE FOODS

FOR SWEET BAKERY GOODS; CANDY (U.S. CL. 46).
HENRY S. ZAK, EXAMINING ATTORNEY

SN 85-137,707. HUTCHISON WHAMPOA ENTERPRISES LIMITED, ROAD TOWN, TORTOLA, BR.VIRGIN ISLANDS, FILED 9-24-2010.



HUTCHISON CHINA MEDITECH LTD

OWNER OF U.S. REG. NOS. 3,108,256, 3,128,293 AND 3,263,585.

NO CLAIM IS MADE TO THE EXCLUSIVE RIGHT TO USE "CHI-MED", "CHINA" OR "LTD", APART FROM THE MARK AS SHOWN.

THE MARK CONSISTS OF "CHI-" IN A RECTANGLE WITH ROUNDED CORNERS ABOVE "MED" IN A RECTANGLE WITH ROUNDED CORNERS, WITH THE WORDS "HUTCHISON CHINA MEDITECH LTD" APPEARING UNDERNEATH.

CLASS 5—PHARMACEUTICALS

FOR MEDICINAL AND PHARMACEUTICAL PREPARATIONS FOR USE IN THE TREATMENT OF HEART DISEASE, SKIN CONDITIONS, BONE DISEASE, DIABETES, CANCER, MEMORY LOSS, OSTEOPOROSIS, ARTHRITIS, DEMENTIA, HEPATITIS, BLOOD DISEASES, GASTROINTESTINAL DISEASES, DISEASES AFFECTING THE INTERNAL ORGANS, NERVOUS SYSTEM, RESPIRATORY SYSTEM AND IMMUNE SYSTEMS; DIGESTIVE PREPARATIONS FOR MEDICAL USE; MEDICINAL HERBAL PREPARATIONS FOR USE IN THE TREATMENT OF HEART DISEASE, SKIN CONDITIONS, BONE DISEASE, DIABETES, CANCER, MEMORY LOSS, OSTEOPOROSIS, ARTHRITIS, DEMENTIA, HEPATITIS, BLOOD DISEASES, GASTROINTESTINAL DISEASES, DISEASES AFFECTING THE INTERNAL ORGANS, NERVOUS SYSTEM, RESPIRATORY SYSTEM AND IMMUNE SYSTEMS; HERBAL SUPPLEMENTS; CHINESE MEDICINAL PREPARATIONS FOR USE IN THE TREATMENT OF HEART DISEASE, SKIN CONDITIONS, BONE DISEASE, DIABETES, CANCER, MEMORY LOSS, OSTEOPOROSIS, ARTHRITIS, DEMENTIA, HEPATITIS, BLOOD DISEASES, GASTROINTESTINAL DISEASES, DISEASES AFFECTING THE INTERNAL ORGANS, NERVOUS SYSTEM, RESPIRATORY SYSTEM AND IMMUNE SYSTEMS; VITAMIN PREPARATIONS; VITAMIN AND MINERAL SUPPLEMENTS; MINERAL PREPARATIONS FOR MEDICAL USE; CHINESE MEDICINES FOR THE TREATMENT OF GASTROINTESTINAL DISEASES; DIETETIC FOODS FOR MEDICALLY RESTRICTED DIETS; DIETETIC FOOD AND BEVERAGES FOR MEDICALLY RESTRICTED DIETS; HEALTH FOOD SUPPLEMENTS, NUTRITIONAL SUPPLEMENTS, AND NUTRITIONAL FOOD ADDITIVES FOR MEDICALLY RESTRICTED DIETS; BABY AND INFANT FOOD; MEDICINAL OILS, FISH OILS, COD LIVER OIL, TUNA OIL, EVENING PRIMROSE OIL, MICRO-ENCAPSULATED OILS, EMULSIFIED OIL, ALL FOR USE IN THE TREATMENT OF HEART DISEASE, SKIN CONDITIONS, BONE DISEASE, DIABETES, CANCER, MEMORY LOSS, OSTEOPOROSIS, ARTHRITIS, DEMENTIA, HEPATITIS, BLOOD DISEASES, GASTROINTESTINAL DISEASES, DISEASES AFFECTING THE INTERNAL ORGANS, NERVOUS SYSTEM, RESPIRATORY SYSTEM AND IMMUNE SYSTEMS (U.S. CLS. 6, 18, 44, 46, 51 AND 52).

CLASS 35—ADVERTISING AND BUSINESS

FOR RETAIL STORE SERVICES PROVIDED ON-LINE FROM A COMPUTER DATABASE AND THE INTERNET AND RETAIL STORE SERVICES, ALL FEATURING MEDICINAL AND PHARMACEUTICAL PREPARATIONS, DIGESTIVE PREPARATIONS, HERBAL PREPARATIONS AND SUPPLEMENTS, CHINESE MEDICINES, VITAMIN AND MINERAL PREPARATIONS AND SUPPLEMENTS, DIETETIC SUBSTANCES, DIETETIC FOOD AND BEVERAGES ADAPTED FOR MEDICINAL PURPOSES, BIOLOGICAL AND DIETETIC FOOD PREPARATIONS FOR MEDICINAL PURPOSES, HEALTH FOOD SUPPLEMENTS, AND FOOD ADDITIVES FOR MEDICINAL PURPOSES, BABY AND INFANT FOOD, MEDICINAL OILS, FISH OILS, COD LIVER OIL, TUNA OIL, EVENING PRIMROSE OIL, MICRO-ENCAPSULATED OILS, EMULSIFIED OIL, NUTRITIONAL AND DIETETIC SUBSTANCES IN CAPSULE OR TABLET FORM, ALL FOR MEDICINAL PURPOSES; ADVERTISING AGENCY SERVICES; PROVIDING BUSINESS INFORMATION; PROMOTION AND MARKETING SERVICES; BUSINESS MANAGEMENT AND ADVISORY SERVICES, NAMELY, ASSISTING BUSINESS IN THE FORMATION OF BUSINESS PLANS AND POLICIES RELATING TO MEDICINE, PERSONAL HEALTH, DIET AND NUTRITION; BUSINESS ADVISORY AND CONSULTANCY SERVICES; FRANCHISING SERVICES, NAMELY, CONSULTANCY AND ASSISTANCE IN BUSINESS MANAGEMENT, ORGANIZATION AND PROMOTION; PRESCRIPTION SERVICES, NAMELY, PROVIDING RETAIL PHARMACY SERVICES (U.S. CLS. 100, 101 AND 102).

CLASS 42—SCIENTIFIC AND COMPUTER SERVICES

FOR MEDICAL RESEARCH IN THE DIAGNOSIS OF HEART DISEASE, SKIN CONDITIONS, BONE DISEASE, DIABETES, CANCER, MEMORY LOSS, OSTEOPOROSIS, ARTHRITIS, DEMENTIA, HEPATITIS, BLOOD DISEASES, GASTROINTESTINAL DISEASES, DISEASES AFFECTING THE INTERNAL ORGANS, NERVOUS SYSTEM, RESPIRATORY SYSTEM AND IMMUNE SYSTEMS; PROVIDING SPECIFIC MEDICAL AND SCIENTIFIC RESEARCH INFORMATION IN THE FIELD OF PHARMACEUTICAL PRODUCTS, HERBAL PREPARATIONS, CHINESE MEDICINES, DIETETIC SUBSTANCES, ON-LINE AND BY THE INTERNET TO CUSTOMERS UPON REQUEST; PROVIDING TEMPORARY USE OF NON-DOWNLOADABLE SOFTWARE OVER THE INTERNET FOR TRACKING DOCUMENTS AND FOR PROVIDING INFORMATION IN THE FIELD OF PHARMACEUTICAL PRODUCTS, HERBAL PREPARATIONS, CHINESE MEDICINES, DIETETIC SUBSTANCES (U.S. CLS. 100 AND 101).

CLASS 44—MEDICAL, BEAUTY AND AGRICULTURAL SERVICES

FOR PRESCRIPTION SERVICES, NAMELY, DISPENSING OF PHARMACEUTICALS AND PROVIDING PHARMACEUTICAL ADVICE (U.S. CLS. 100 AND 101).
NELSON SNYDER, EXAMINING ATTORNEY

SN 85-147,489, DIVERSIFIED GLOBAL TECHNOLOGIES, LLC, WOONSOCKET, RI. FILED 10-7-2010.

SOFTEX

THE MARK CONSISTS OF STANDARD CHARACTERS WITHOUT CLAIM TO ANY PARTICULAR FONT, STYLE, SIZE, OR COLOR.

CLASS 3—COSMETICS AND CLEANING PREPARATIONS

FOR FOOT CARE OINTMENTS NOT FOR MEDICAL USE, NON-MEDICATED FOOT CARE CREAMS (U.S. CLS. 1, 4, 6, 50, 51 AND 52).

CLASS 8—HAND TOOLS

FOR FOOT FILES (U.S. CLS. 23, 28 AND 44).

CLASS 20—FURNITURE AND ARTICLES NOT OTHERWISE CLASSIFIED

FOR TOE SEPARATORS FOR APPLYING OINTMENT, CREAM, OR NAIL POLISH (U.S. CLS. 2, 13, 22, 25, 32 AND 50).

CLASS 25—CLOTHING

FOR SHOE INSERTS FOR PRIMARILY NON-ORTHOPEDIC PURPOSES, SHOE INSOLES (U.S. CLS. 22 AND 39).
BARNEY CHARLON, EXAMINING ATTORNEY

SN 85-174,257, SONY CORPORATION, TOKYO, JAPAN,
FILED 11-11-2010.

Clear Phase

THE MARK CONSISTS OF STANDARD CHARACTERS WITHOUT CLAIM TO ANY PARTICULAR FONT, STYLE, SIZE, OR COLOR.

OWNER OF JAPAN REG. NO. 2010-087898, DATED 10-7-2011, EXPIRES 10-7-2021.

NO CLAIM IS MADE TO THE EXCLUSIVE RIGHT TO USE "PHASE", APART FROM THE MARK AS SHOWN.

CLASS 9—ELECTRICAL AND SCIENTIFIC APPARATUS

FOR LOUDSPEAKERS; AUDIO AMPLIFIERS; HOME AUDIO AND VIDEO PLAYERS AND/OR RECORDERS; PORTABLE AND PERSONAL AUDIO AND VIDEO PLAYERS AND/OR RECORDERS; MP3 AND OTHER DIGITAL FORMAT AUDIO AND VIDEO PLAYERS AND/OR RECORDERS; CAMERAS; VIDEO CAMERAS; TELEVISIONS; PORTABLE TELEVISIONS; CAR AUDIO PLAYERS AND SPEAKERS; CAR NAVIGATION SYSTEMS COMPRISED OF RECEIVERS, TRANSMITTERS, DECODERS, DISC PLAYERS AND MONITORS FOR SIGNALS FROM GLOBAL POSITIONING SYSTEM (GPS) SATELLITES; DIGITAL PHOTO FRAMES; COMPUTERS; TABLET COMPUTERS; PERSONAL DIGITAL ASSISTANTS; PORTABLE AND HANDHELD DIGITAL ELECTRONIC DEVICES FOR RECORDING, ORGANIZING, TRANSMITTING, MANIPULATING, AND REVIEWING TEXT, DATA, AUDIO AND VIDEO FILES; PORTABLE AND HANDHELD DIGITAL ELECTRONIC DEVICES FOR DATA PROCESSING, INFORMATION PROCESSING, STORING AND DISPLAYING DATA, TRANSMITTING AND RECEIVING DATA, TRANSMISSION OF DATA BETWEEN COMPUTERS, GLOBAL POSITIONING SYSTEM (GPS) DEVICES AND TELEPHONES; WIRED AND WIRELESS REMOTE CONTROLS FOR PORTABLE AND HANDHELD DIGITAL ELECTRONIC DEVICES; TELEPHONES; MOBILE PHONES (U.S. CLS. 21, 23, 26, 36 AND 38).

CLASS 28—TOYS AND SPORTING GOODS

FOR HAND HELD UNITS FOR PLAYING VIDEO GAMES OTHER THAN THOSE ADAPTED FOR USE WITH AN EXTERNAL DISPLAY SCREEN OR MONITOR (U.S. CLS. 22, 23, 38 AND 50).

DORITT L. CARROLL, EXAMINING ATTORNEY

SN 85-177,864, THE SYSTEMS BIOLOGY INSTITUTE, TOKYO, JAPAN, FILED 11-16-2010.

GARUDA

THE MARK CONSISTS OF STANDARD CHARACTERS WITHOUT CLAIM TO ANY PARTICULAR FONT, STYLE, SIZE, OR COLOR.

PRIORITY CLAIMED UNDER SEC. 44(D) ON JAPAN APPLICATION NO. 2010-079130, FILED 10-8-2010, REG. NO. 5495618, DATED 5-25-2012, EXPIRES 5-25-2022.

CLASS 9—ELECTRICAL AND SCIENTIFIC APPARATUS

FOR (BASED ON SECTION 44(E)) COMPUTER SOFTWARE AND KNOWLEDGE PLATFORM FOR DATA MANAGEMENT, PROCESSING DATA, DATA ANALYSIS, AND DATA VISUALIZATION FOR RESEARCH AND SERVICES ON BIOLOGY, DRUG DISCOVERY, HEALTHCARE, MEDICINE, AND BIOTECHNOLOGY; COMPUTER SOFTWARE PLATFORM TO PROVIDE SOFTWARE INTEROPERABILITY AMONG SOFTWARE MODULES BEARING DIFFERENT FUNCTIONS FOR BIOMEDICAL RESEARCH AND SERVICES; SOFTWARE MODULES INCLUDING EMBEDDED SOFTWARE IN MEASUREMENT AND CLINICAL EQUIPMENT FOR DATA MANAGEMENT, PROCESSING DATA, DATA ANALYSIS, AND DATA VISUALIZATION; COMPUTER SOFTWARE FOR USE IN DATABASE MANAGEMENT, FOR USE AS A SPREADSHEET, FOR WORD PROCESSING, AND FOR USE IN CALCULATION; PRE-RECORDED VIDEO TAPES AND VIDEO DISKS FEATURING INFORMATION IN THE FIELD OF BIOLOGY, DRUG DISCOVERY, HEALTHCARE MEDICINE, AND BIOTECHNOLOGY; DOWNLOADABLE ELECTRONIC PUBLICATIONS, NAMELY, BOOKS, MAGAZINES, NEWSPAPERS, MANUALS, AND CATALOGS FEATURING INFORMATION IN THE FIELD OF BIOLOGY, DRUG DISCOVERY, HEALTHCARE, MEDICINE, AND BIOTECHNOLOGY; DOWNLOADABLE IMAGE FILES IN THE FIELD OF BIOLOGY, DRUG DISCOVERY, HEALTHCARE, MEDICINE, AND BIOTECHNOLOGY; VIDEO AND COMPUTER GAME PROGRAMS; ELECTRONIC CIRCUITS AND CD-ROMS RECORDED WITH PROGRAMS FOR HAND-HELD GAMES WITH LIQUID CRYSTAL DISPLAYS; LABORATORY ROBOTS; ELECTRICAL AND ELECTRONIC APPARATUS AND INSTRUMENTS AND CONTROL SYSTEMS FOR CONTROLLING OR OPERATING ROBOTS, NAMELY, ELECTRONIC CONTROL PANELS, ELECTRICAL CONTROLLING DEVICES, TOUCH SENSITIVE PANELS; COMPUTER SOFTWARE WHICH ENABLES CONNECTION TO DATABASES AND THE INTERNET, INCLUDING WEBSITES; MODEMS; MOBILE AND FIXED TELEPHONE APPARATUS AND INSTRUMENTS, NAMELY, CELLULAR TELEPHONES, MOBILE PHONES, SMART PHONES, TOUCH-BASED PERSONAL COMPUTER TABLETS WITH WIRELESS COMMUNICATION CAPABILITIES; ELECTRONIC MEMORY CARDS; LABORATORY APPARATUS AND INSTRUMENTS FOR BIOTECHNOLOGY AND LIFE SCIENCES, NAMELY, DATA ANALYZERS FOR PURPOSE OF COLLECTING AND ANALYZING DATA IN BASIC RESEARCH IN BIOLOGY, DRUG DISCOVERY, MEDICINE, HEALTHCARE AND BIOTECHNOLOGY, SEQUENCERS FOR GENOME, RNA, AND SPECIFIC FRAGMENTS OF DNA, MICROARRAYS, MASS SPECTROMETRY EQUIPMENT, NAMELY, APPARATUS AND INSTRUMENTS FOR MASS SPECTROMETRY; PHOTOGRAPHIC INSTRUMENTS AND APPARATUS, NAMELY, MICROSCOPES, CAMERAS USING SEMI-CONDUCTOR IMAGING DEVICES FOR USE IN FLOW CYTOMETRY, CAMERAS USING SEMI-CONDUCTOR IMAGING DEVICES FOR USE IN INFRARED CYTOMETRY, INFRARED IMAGERS, MICROPLATE LUMINOMETER; CINEMATOGRAPHIC INSTRUMENTS AND APPARATUS, NAMELY, HIGH RESOLUTION CAMERAS FOR CELLULAR IMAGING AND HIGH CONTENT ANALYSIS, COLOR IMAGE ANALYSIS SYSTEM CONSISTING PRIMARILY OF RASTER IMAGE PROCESSORS, DIGITAL PHOTO IMAGE CONVERTERS, SCANNERS; OPTICAL APPARATUS AND INSTRUMENTS, NAMELY, OPTICAL MICROSCOPES; (BASED ON INTENT TO USE) PRE-RECORDED AUDIO TAPES, COMPACT DISCS, CD-ROMS AND DVDS, ALL FEATURING INFORMATION IN THE FIELD OF BIOLOGY, DRUG DISCOVERY, HEALTHCARE MEDICINE, AND BIOTECHNOLOGY; PRE-RECORDED MAGNETIC AND OPTICAL DISCS FEATURING INFORMATION IN THE FIELD OF BIOLOGY, DRUG DISCOVERY, HEALTHCARE, MEDICINE, AND BIOTECHNOLOGY (U.S. CLS. 21, 23, 26, 36 AND 38).

CLASS 41—EDUCATION AND ENTERTAINMENT

FOR (BASED ON SECTION 44(E)) COMPUTER SERVICES, NAMELY, PROVIDING ON-LINE PUBLICATIONS IN THE NATURE OF BOOKS, MAGAZINES, NEWSPAPERS, MANUALS AND CATALOGS IN THE FIELD OF BIOLOGY, DRUG DISCOVERY, HEALTHCARE, MEDICINE, AND BIOTECHNOLOGY; (BASED ON INTENT TO USE) PROVIDING NON-DOWNLOADABLE ELECTRONIC PUBLICATION IN THE NATURE OF ON-LINE BOOKS, MAGAZINES, NEWSPAPERS, MANUALS AND CATALOGS IN THE FIELD OF BIOLOGY, DRUG DISCOVERY, HEALTHCARE, MEDICINE, AND BIOTECHNOLOGY (U.S. CLS. 100, 101 AND 107).

CLASS 42—SCIENTIFIC AND COMPUTER SERVICES

FOR (BASED ON SECTION 44(E)) COMPUTER SERVICES, NAMELY, PROVIDING TEMPORARY USE OF NON-DOWNLOADABLE ON-LINE COMPUTER SOFTWARE AND KNOWLEDGE PLATFORM FOR DATA MANAGEMENT, PROCESSING DATA, DATA ANALYSIS, AND DATA VISUALIZATION FOR RESEARCH AND SERVICES ON BIOLOGY, DRUG DISCOVERY, HEALTHCARE, MEDICINE, AND BIOTECHNOLOGY; COMPUTER SERVICES, NAMELY, PROVIDING TEMPORARY USE OF NON-DOWNLOADABLE ON-LINE COMPUTER SOFTWARE PLATFORM TO PROVIDE SOFTWARE INTEROPERABILITY AMONG SOFTWARE MODULES BEARING DIFFERENT FUNCTIONS FOR BIOMEDICAL RESEARCH AND SERVICES; COMPUTER SERVICES, NAMELY, PROVIDING TEMPORARY USE OF NON-DOWNLOADABLE ON-LINE SOFTWARE MODULES FOR DATA MANAGEMENT, PROCESSING DATA, DATA ANALYSIS, AND DATA VISUALIZATION; COMPUTER SERVICES, NAMELY, PROVIDING ON-LINE COMPUTER DATABASE FEATURING REFERENCE MATERIALS FEATURING INFORMATION ON BIOMEDICAL, PHARMACOLOGICAL, CLINICAL COMPONENTS, INFORMATION RELATED TO MEDICAL AND SCIENTIFIC RESEARCH, AND INFORMATION RELATED TO NEW PRODUCT DEVELOPMENT IN THE FIELD OF BIOLOGY, DRUG DISCOVERY, HEALTHCARE, MEDICINE, AND BIOTECHNOLOGY; LABORATORY RESEARCH, TESTING AND INSPECTION IN THE FIELD OF BIOLOGY, DRUG DISCOVERY, HEALTHCARE, MEDICINE, AND BIOTECHNOLOGY; CONSULTING SERVICES RELATING TO SCIENTIFIC AND MEDICAL RESEARCH AND NEW PRODUCT DEVELOPMENT IN THE FIELD OF BIOLOGY, DRUG DISCOVERY, HEALTHCARE MEDICINE, AND BIOTECHNOLOGY; COMPUTER PROGRAMMING FOR OTHERS; COMPUTER SOFTWARE DESIGN FOR OTHERS; MAINTENANCE AND UPDATING OF COMPUTER SOFTWARE; COMPUTER DIAGNOSTIC SERVICES; RENTAL OF COMPUTERS AND SOFTWARE; DESIGNING OF MACHINES, APPARATUS, INSTRUMENTS AND SYSTEMS COMPOSED OF SUCH MACHINES, APPARATUS AND INSTRUMENTS; TECHNICAL ADVICE RELATING TO PERFORMANCE AND OPERATION OF COMPUTERS THAT REQUIRE HIGH LEVELS OF PERSONAL KNOWLEDGE, SKILL OR EXPERIENCE OF THE OPERATORS TO MEET THE REQUIRED ACCURACY IN OPERATING THEM; TESTING, INSPECTION AND RESEARCH OF COSMETICS OR FOODSTUFF; TESTING, INSPECTION AND RESEARCH ON AGRICULTURE, LIVESTOCK BREEDING OR FISHERIES; TESTING AND RESEARCH ON MACHINES, APPARATUS AND INSTRUMENTS (U.S. CLS. 100 AND 101).

CLASS 44—MEDICAL, BEAUTY AND AGRICULTURAL SERVICES

FOR (BASED ON INTENT TO USE) COMPUTER SERVICES, NAMELY, PROVIDING ON-LINE COMPUTER DATABASE FEATURING REFERENCE MATERIALS FEATURING MEDICAL INFORMATION IN THE FIELD OF HEALTHCARE AND MEDICINE; CONSULTING SERVICES RELATING TO MEDICAL INFORMATION IN THE FIELD OF HEALTHCARE MEDICINE (U.S. CLS. 100 AND 101).

TINA BROWN, EXAMINING ATTORNEY

SN 85-178,799, ELECTROMATE INDUSTRIAL SALES LIMITED, WOODBRIDGE, ONTARIO, CANADA, FILED 11-17-2010.

MOTION CONTROL AT THE SPEED OF TECHNOLOGY

THE MARK CONSISTS OF STANDARD CHARACTERS WITHOUT CLAIM TO ANY PARTICULAR FONT, STYLE, SIZE, OR COLOR.

PRIORITY CLAIMED UNDER SEC. 44(D) ON CANADA APPLICATION NO. 1481304, FILED 5-17-2010, REG. NO. TMA806707, DATED 9-14-2011, EXPIRES 9-14-2026.

NO CLAIM IS MADE TO THE EXCLUSIVE RIGHT TO USE "MOTION CONTROL" AND "TECHNOLOGY", APART FROM THE MARK AS SHOWN.

CLASS 7—MACHINERY

FOR LINEAR SHAFT SERVO MOTORS; CONNECTING RODS FOR MACHINES; GEAR BOXES OTHER THAN FOR LAND VEHICLES, NAMELY, RIGHT ANGLE GEARBOXES; MOTORS OTHER THAN FOR LAND VEHICLES, NAMELY, DIRECT CURRENT MINI MOTORS AND FRACTIONAL HP PERMANENT MAGNET MOTORS, FRACTIONAL HP PERMANENT MAGNET GEAR MOTORS, AND INTEGRATED STEPPER MOTORS; SERVO MOTORS, NAMELY, ALTERNATING CURRENT SERVO MOTORS, DIRECT CURRENT SERVO MOTORS, BRUSHLESS DIRECT CURRENT SERVO MOTORS, PERMANENT MAGNET DIRECT CURRENT SERVO MOTORS, DISC ARMATURE SERVO MOTORS, LINEAR SERVO MOTORS; ELECTRONIC MOTORS FOR MACHINES, NAMELY, DISK MAGNET STEPPER MOTORS, LINEAR STEPPER MOTORS, DIRECT CURRENT STEP MOTORS; MACHINE TOOLS, NAMELY, ROTARY TABLE INDEXERS; MACHINE POSITIONING TOOLS, NAMELY, ROTARY TABLES; GEARBOXES OTHERS THAN FOR LAND VEHICLES, NAMELY, PLANETARY GEARBOXES, SPUR GEARBOXES, HARMONIC GEARBOXES AND COMPONENT PARTS THEREOF, FOR USE IN MOTION CONTROL APPLICATIONS; BRAKES FOR MACHINES; CLUTCHES FOR MACHINES; PULLEYS BEING PART OF MACHINES; GEAR COMPONENTS FOR MACHINES; MECHANICAL COUPLINGS FOR MACHINES; MOTORIZED LINEAR SLIDES FOR MACHINES; MACHINE PARTS, NAMELY, MECHANICAL, ELECTRICAL AND ELECTROMECHANICAL POSITIONING SYSTEMS, NAMELY, RODLESS CYLINDERS, LINEAR ACTUATORS, POSITIONING TABLES, SELECTIVE COMPLIANCE ASSEMBLY ROBOT ARM INDUSTRIAL ROBOTS, LINEAR BEARINGS AND GUIDEWAYS, ACME SCREWS, BALL SCREWS, LINEAR MODULES AND SHAFTINGS (U.S. CLS. 13, 19, 21, 23, 31, 34 AND 35).

CLASS 9—ELECTRICAL AND SCIENTIFIC APPARATUS

FOR PROGRAMMABLE COMPUTER CONTROL PRODUCTS, NAMELY, PROGRAMMABLE LOGIC CONTROLLERS, SINGLE-BOARD COMPUTERS, MICRO EMBEDDED ELECTRICAL CONTROLLERS, COMPUTER NETWORK INTERFACE DEVICES, AND PROGRAMMABLE ELECTRONIC SERVO MOTION CONTROLLERS; ELECTRONIC RESOLVERS; PULSE WIDTH MODULATED SERVO AMPLIFIERS, LINEAR SERVO AMPLIFIERS, SINUSOIDAL SERVO AMPLIFIERS; STEPPER DRIVERS, NAMELY, ELECTRICAL CONTROLLERS; ROTARY ENCODERS, LINEAR ENCODERS; ELECTRIC COUPLINGS; ELECTRONIC DISPLAY INTERFACE; POWER SUPPLIES; GONIOMETERS USED TO MEASURE TILTING STAGE CONTACT ANGLES POSITIONED ABOVE STAGE SURFACES; ELECTRIC SIGNS, NAMELY, PROGRAMMABLE DIGITAL SIGNS; ELECTRONIC DISPLAY INTERFACES, NAMELY, HMI (HUMAN MACHINE INTERFACE) USED AS INTERFACES FOR CONTROL AND AUTOMATION APPLICATIONS AND HMI (HUMAN MACHINE INTERFACE) OPERATING SOFTWARE; ELECTRIC BALL SCREW ACTUATORS (U.S. CLS. 21, 23, 26, 36 AND 38).

ROBERT C. CLARK JR., EXAMINING ATTORNEY

SN 85-199,426. CAIXA DE AFORROS DE GALICIA, VIGO, OURENSE E PONTEVEDRA, A CORUNA, SPAIN, FILED 12-16-2010.



PRIORITY CLAIMED UNDER SEC. 44(D) ON SPAIN APPLICATION NO. 2.958.963, FILED 12-3-2010, REG. NO. 2958963, DATED 8-1-2011, EXPIRES 12-3-2020.

OWNER OF U.S. REG. NOS. 2,597,072, 3,118,504 AND 3,182,627.

THE COLOR(S) BLUE, LIGHT BLUE, WHITE AND GREEN IS/ARE CLAIMED AS A FEATURE OF THE MARK.

THE MARK CONSISTS OF "NOVACAIXAGALICIA" IN STYLIZED LETTERS THE WORDS "NOVA" AND "GALICIA" ARE IN WHITE AND THE WORD "CAIXA" IS IN LIGHT BLUE. ALL THIS IS WRITTEN OVER A BLUE RIBBON, TO THE LEFT OF THE WORDS "NOVACAIXAGALICIA" IS THE DESIGN IN LIGHT BLUE AND GREEN.

THE ENGLISH TRANSLATION OF "NOVA" AND "CAIXA" IN THE MARK IS "NEW" AND "BOX" RESPECTIVELY.

SN 85-182,581. DYNAMIC COMMODITIES (PTY) LIMITED, PORT ELIZABETH, SOUTH AFRICA, FILED 11-22-2010.



PRIORITY CLAIMED UNDER SEC. 44(D) ON ERPN CMNTY TM OFC APPLICATION NO. 009320904, FILED 8-18-2010, REG. NO. 009320904, DATED 1-28-2011, EXPIRES 8-18-2020.

NO CLAIM IS MADE TO THE EXCLUSIVE RIGHT TO USE "FRUITY SUSHI SORBET", APART FROM THE MARK AS SHOWN.

THE COLOR(S) GREY, HOT PINK, ORANGE AND LIME GREEN IS/ARE CLAIMED AS A FEATURE OF THE MARK.

THE MARK CONSISTS OF THE LITERAL ELEMENT "SO" AND "SHI" APPEARING IN GREY, WITH AN ORANGE COLORED COLON BETWEEN "SO" AND "SHI" AND A HOT PINK DOT APPEARING IN THE CENTER OF THE LETTER "O" IN THE WORD "SO", APPEARING DIRECTLY UNDERNEATH IS THE WORD "FRUITY" IN HOT PINK, THE WORD "SUSHI" IN ORANGE AND THE WORD "SORBET" IN LIME GREEN.

CLASS 29—MEATS AND PROCESSED FOODS

FOR PRESERVED, DRIED AND COOKED FRUITS; JELLIES AND JAMS (U.S. CL. 46).

CLASS 30—STAPLE FOODS

FOR EDIBLE ICES AND SHERBETS; PASTRIES AND CONFECTIONARIES, NAMELY, FROZEN CONFECTIONS (U.S. CL. 46).

LINDA LAVACHE, EXAMINING ATTORNEY

CLASS 16—PAPER GOODS AND PRINTED MATTER

FOR PAPER, CARDBOARD AND GOODS MADE FROM THESE MATERIALS, NOT INCLUDED IN OTHER CLASSES, NAMELY, BOXES, FOLDERS AND DROP CLOTHS, COPIER PAPER, COPY PAPER, DRAWING PAPER, CRAFT PAPER, DIGITAL PRINTING PAPER, LETTERHEAD PAPER, PADS OF PAPER, LASER PRINTING PAPER, LOOSE LEAF PAPER, MAGAZINE PAPER, NOTE PAPER, NOTE CARDS, PAPER LABELS, PAPER BOXES, CARDBOARD BOXES, CARDBOARD PACKAGING, CORRUGATED CARDBOARD, PLAIN PAPER FOR OFFSET PRINTING, PHOTOGRAPHS; PRINTED MATTER, NAMELY, PAPER SIGNS, BOOKS, MANUALS, CURRICULUM, NEWSLETTERS, INFORMATIONAL CARDS AND BROCHURES IN THE FIELD OF BANKING; BOOKBINDING MATERIALS FOR CREATING HARDCOVER BOOKS, NAMELY, BOOK COVERS, CRACK-AND-PEEL BINDING PAPER, REINFORCEMENT STRIPS, PEEL-AND-STICK LABELS, STAPLER AND STAPLES; PHOTOGRAPHS; STATIONERY; ADHESIVES FOR STATIONERY OR HOUSEHOLD PURPOSES; ARTISTS' MATERIALS, NAMELY, MOLDS FOR MODELING CLAYS; PAINT BRUSHES; TYPEWRITERS AND OFFICE REQUISITES, EXCEPT FURNITURE, NAMELY, PENCILS, PENS, MARKERS, CALENDAR DESK PADS, CALENDARS, BUSINESS CARD PAPER, NOTEBOOKS, DESK SETS, RUBBER BANDS, PAPER CLIPS, STAPLERS, BINDERS, PAPER CUTTERS, PAPER KNIVES, PAPER HOLE PUNCHES, PAPER WEIGHTS, INK PADS AND STAMP PADS, ELECTRIC PAPER WHOLE PUNCHES, EMBOSSERS, CORRECTING FLUID FOR TYPE; PRINTED INSTRUCTIONAL AND TEACHING MATERIAL IN THE FIELD OF BANKING; PLASTIC MATERIALS FOR PACKAGING, NOT INCLUDED IN OTHER CLASSES, NAMELY, PLASTIC BAGS, PLASTIC BUBBLE PACKS, PLASTIC WRAPPING; PRINTERS' TYPE; PRINTING BLOCKS (U.S. CLS. 2, 5, 22, 23, 29, 37, 38 AND 50).

CLASS 35—ADVERTISING AND BUSINESS

FOR ADVERTISING AND BUSINESS MANAGEMENT CONSULTATION; BUSINESS ADMINISTRATION AND OFFICE WORK; IMPORTATION AND EXPORTATION AGENCIES; FRANCHISING SERVICES, NAMELY, OFFERING BUSINESS MANAGEMENT ASSISTANCE IN THE ESTABLISHMENT AND/OR OPERATION OF RETAIL BUSINESSES, SPECIFICALLY BANKING, MONETARY SERVICES AND REAL ESTATE AFFAIRS (U.S. CLS. 100, 101 AND 102).

CLASS 36—INSURANCE AND FINANCIAL

FOR INSURANCE AGENCIES; FINANCIAL AFFAIRS AND MONETARY AFFAIRS, NAMELY, FINANCIAL INFORMATION, MANAGEMENT AND ANALYSIS SERVICES; BANKING; REAL ESTATE SERVICES, NAMELY, RENTAL, BROKERAGE, LEASING AND MANAGEMENT OF COMMERCIAL PROPERTY, OFFICES AND OFFICE SPACE, RENTAL PROPERTY MANAGEMENT, PROPERTY MANAGEMENT SERVICES FOR CONDOMINIUM ASSOCIATIONS, HOMEOWNER ASSOCIATIONS AND APARTMENT BUILDINGS, REAL ESTATE NOTE BROKERAGE, MASS APPRAISALS, TAX APPRAISALS (U.S. CLS. 100, 101 AND 102).

CLASS 38—COMMUNICATION

FOR TELECOMMUNICATION SERVICES, NAMELY, TRANSMISSION OF VOICE, DATA, GRAPHICS, IMAGES, AUDIO AND VIDEO BY MEANS OF TELECOMMUNICATIONS NETWORKS, WIRELESS COMMUNICATION NETWORKS, AND THE INTERNET (U.S. CLS. 100, 101 AND 104).

RONALD AIKENS, EXAMINING ATTORNEY

SN 85-208,499. INDUSTRIAS METALURGICAS PESCARMONA S.A.I. C. Y F., M5503AHY MENDOZA PROV., ARGENTINA, FILED 12-31-2010.



SN 85-201,079. TEXAS CHILDREN'S HOSPITAL, HOUSTON, TX. FILED 12-17-2010.

TRACS

THE MARK CONSISTS OF STANDARD CHARACTERS WITHOUT CLAIM TO ANY PARTICULAR FONT, STYLE, SIZE, OR COLOR.

CLASS 42—SCIENTIFIC AND COMPUTER SERVICES

FOR MEDICAL AND SCIENTIFIC RESEARCH IN THE FIELD OF HEALTHCARE SERVICES; COMPILING INFORMATION AND DATA FOR RESEARCH PURPOSES IN THE FIELD OF MEDICAL SCIENCE AND MEDICAL CONSULTANCY (U.S. CLS. 100 AND 101).

CLASS 44—MEDICAL, BEAUTY AND AGRICULTURAL SERVICES

FOR COUNSELING IN THE FIELD OF HEALTH CARE SERVICES AND MEDICAL SERVICES; PROVIDING HEALTH INFORMATION; PROVIDING MEDICAL INFORMATION; MAINTAINING FILES AND RECORDS CONCERNING THE MEDICAL CONDITION OF INDIVIDUALS; MEDICAL ASSISTANCE CONSULTANCY PROVIDED BY SPECIALIZED MEDICAL PERSONNEL; PROVIDING A WEB SITE FEATURING MEDICAL INFORMATION; PROVIDING HEALTH CARE AND MEDICAL SERVICES BY HEALTH CARE PROFESSIONALS VIA THE INTERNET OR TELECOMMUNICATION NETWORKS; PROVIDING ASSISTANCE, FITNESS EVALUATION AND CONSULTATION TO INDIVIDUALS TO HELP THEM MAKE HEALTHCARE AND MEDICAL DECISIONS (U.S. CLS. 100 AND 101).

SUZANNE BLANE, EXAMINING ATTORNEY

NO CLAIM IS MADE TO THE EXCLUSIVE RIGHT TO USE "HYDRO", APART FROM THE MARK AS SHOWN.

THE COLOR(S) DARK BLUE AND LIGHT BLUE IS/ARE CLAIMED AS A FEATURE OF THE MARK.

THE MARK CONSISTS OF "IMPSA" IN STYLIZED FORM IN DARK BLUE WITH "HYDRO" UNDERNEATH IN ITALICS IN LIGHT BLUE, WITH A DARK BLUE CURVED ARROW POINTING UPWARDLY TO THE RIGHT UNDERNEATH "HYDRO" AND A LIGHT BLUE CURVED ARROW POINTING DOWNWARDLY TO THE LEFT ABOVE "IMPSA".

CLASS 7—MACHINERY

FOR TURBINES AND GENERATORS OF ELECTRIC ENERGY; HYDROMECHANICAL EQUIPMENT FOR POWER PLANTS, NAMELY, EQUIPMENT FOR CONDUCTING, CONTROLLING AND REGULATING WATER FLOW WITHIN HYDROELECTRIC POWER PLANTS AND WATERWAYS IN THE NATURE OF PUMPS, PUMP CONTROL VALVES, FLOWGATES, TRASH RACKS, STOPLOGS AND PENSTOCKS; CRANES; ELECTROMECHANICAL EQUIPMENT FOR POWER PLANTS, NAMELY, HYDRAULIC TURBINES, TRANSFORMERS; PUMPING EQUIPMENT, NAMELY, PUMP TURBINES FOR PUMP STORAGE POWER STATIONS (U.S. CLS. 13, 19, 21, 23, 31, 34 AND 35).

CLASS 9—ELECTRICAL AND SCIENTIFIC APPARATUS

FOR SPEED GOVERNORS FOR MACHINES, NAMELY, ELECTRONIC SPEED CONTROLLERS AND POWER-FREQUENCY GOVERNORS FOR PRIME MOVERS USED FOR POWER GENERATION; EXCITATION SYSTEM COMPRISED OF STATIC EXCITERS; AUTOMATIC VOLTAGE REGULATORS; ELECTROMECHANICAL EQUIPMENT FOR POWER PLANTS, NAMELY, TRANSFORMERS, TURBINE AND GENERATOR SWITCHES, VOLTAGE REGULATORS, AUXILIARY POWER SUPPLIES, EMERGENCY POWER SUPPLIES, VOLTAGE SWITCHGEARS, ELECTRICAL MOTOR CONTROLLERS, ELECTRICAL GROUNDING DEVICES, TEMPERATURE SENSORS, VOLTAGE SENSORS, VIBRATION SENSORS, DISCHARGE SENSORS, HYDROELECTRIC DAM WATER LEVEL MONITORS, ALARM INSTALLATIONS AND ALARMS, CIRCUIT BREAKERS AND ELECTRICAL TRANSDUCERS, MAIN GRIDS AND GRID STATIONS FOR PRODUCTION AND DISTRIBUTION OF ELECTRICITY (U.S. CLS. 21, 23, 26, 36 AND 38).

WILLIAM JACKSON, EXAMINING ATTORNEY

SN 85-208,505. INDUSTRIAS METALURGICAS PESCARMONA S.A.I. C. Y F., M5503AHY MENDOZA PROV., ARGENTINA, FILED 12-31-2010.

SN 85-208,510. INDUSTRIAS METALURGICAS PESCARMONA S.A.C. Y F., M5503AHY MENDOZA PROV., ARGENTINA, FILED 12-31-2010.



IMPSA
Corporation

NO CLAIM IS MADE TO THE EXCLUSIVE RIGHT TO USE "WIND", APART FROM THE MARK AS SHOWN.

THE COLOR(S) DARK BLUE AND GREEN IS/ARE CLAIMED AS A FEATURE OF THE MARK.

THE MARK CONSISTS OF "IMPSA" IN STYLIZED FORM IN DARK BLUE WITH "WIND" UNDERNEATH IN ITALICS IN GREEN, WITH A DARK BLUE CURVED ARROW POINTING DOWNWARDLY TO THE RIGHT TO THE RIGHT OF "WIND", A GREEN CURVED ARROW POINTING UPWARDLY TO THE RIGHT LOCATED TO THE UPPER RIGHT OF SAID BLUE ARROW, AND A SECOND GREEN CURVED ARROW POINTING UPWARDLY AND TO THE LEFT LOCATED TO THE UPPER LEFT OF SAID FIRST GREEN CURVED ARROW.

CLASS 7—MACHINERY

FOR TURBINES AND GENERATORS OF ELECTRIC ENERGY; CRANES; WIND DRIVEN GENERATORS FOR PRODUCING WIND POWER; ELECTROMECHANICAL EQUIPMENT FOR WIND POWER PLANTS, NAMELY, WIND GENERATORS; PUMPING EQUIPMENT, NAMELY, PUMP TURBINES FOR PUMP STORAGE POWER STATIONS (U.S. CLS. 13, 19, 21, 23, 31, 34 AND 35).

CLASS 9—ELECTRICAL AND SCIENTIFIC APPARATUS

FOR SPEED GOVERNORS FOR MACHINES, NAMELY, ELECTRONIC SPEED CONTROLLERS AND POWER FREQUENCY GOVERNORS FOR PRIME MOVERS USED FOR POWER GENERATION; EXCITATION SYSTEM COMPRISED OF STATIC EXCITERS; AUTOMATIC VOLTAGE REGULATORS; ELECTROMECHANICAL EQUIPMENT FOR WIND POWER PLANTS, NAMELY, MAIN GRIDS AND GRID STATIONS FOR PRODUCTION AND DISTRIBUTION OF ELECTRICITY; WIND GENERATOR FARM ELECTRIC SYSTEMS AND SUBSYSTEMS COMPRISED OF WIND TURBINE TOWERS, TURBINE AND GENERATOR SWITCHES, VOLTAGE REGULATORS, TRANSFORMERS AND WIND TURBINE CONTROLLERS, AUXILIARY POWER SUPPLIES, EMERGENCY POWER SUPPLIES, VOLTAGE SWITCHGEARS, ELECTRICAL GROUNDING DEVICES, TEMPERATURE SENSORS, VOLTAGE SENSORS, VIBRATION SENSORS, DISCHARGE SENSORS, ALARM INSTALLATIONS AND ALARMS, CIRCUIT BREAKERS AND ELECTRICAL TRANSDUCERS (U.S. CLS. 21, 23, 26, 36 AND 38).

WILLIAM JACKSON, EXAMINING ATTORNEY

NO CLAIM IS MADE TO THE EXCLUSIVE RIGHT TO USE "CORPORATION", APART FROM THE MARK AS SHOWN.

THE COLOR(S) BLUE IS/ARE CLAIMED AS A FEATURE OF THE MARK.

THE MARK CONSISTS OF "IMPSA CORPORATION" IN STYLIZED FORM IN BLUE.

CLASS 7—MACHINERY

FOR TURBINES AND GENERATORS OF ELECTRIC ENERGY; HYDROMECHANICAL EQUIPMENT FOR POWER PLANTS, NAMELY, EQUIPMENT FOR CONDUCTING, CONTROLLING AND REGULATING WATER FLOW WITHIN HYDROELECTRIC POWER PLANTS AND WATERWAYS IN THE NATURE OF PUMPS, PUMP CONTROL VALVES, FLOWGATES, TRASH RACKS, STOPLOGS AND PENSTOCKS; CRANES; WIND-DRIVEN GENERATORS FOR PRODUCING ELECTRICITY; ELECTROMECHANICAL EQUIPMENT FOR POWER PLANTS, NAMELY, HYDRAULIC TURBINES, TRANSFORMERS; ELECTROMECHANICAL EQUIPMENT FOR WIND POWER PLANTS, NAMELY, WIND GENERATORS; ELECTROMECHANICAL EQUIPMENT FOR NUCLEAR POWER PLANTS, NAMELY, VAPOR TURBINES; PUMPING EQUIPMENT, NAMELY, PUMP TURBINES FOR PUMP STORAGE POWER STATIONS (U.S. CLS. 13, 19, 21, 23, 31, 34 AND 35).

CLASS 9—ELECTRICAL AND SCIENTIFIC APPARATUS

FOR SPEED GOVERNORS FOR MACHINES, NAMELY, ELECTRONIC SPEED CONTROLLERS AND POWER-FREQUENCY GOVERNORS FOR PRIME MOVERS USED FOR POWER GENERATION; EXCITATION SYSTEM COMPRISED OF STATIC EXCITERS; AUTOMATIC VOLTAGE REGULATORS; ELECTROMECHANICAL EQUIPMENT FOR WIND POWER PLANTS, NAMELY, MAIN GRIDS AND GRID STATIONS FOR PRODUCTION AND DISTRIBUTION OF ELECTRICITY; MACHINES FOR CONTROL, SUPERVISION, MONITORING AND PROTECTION OF HYDROELECTRIC, WIND AND NUCLEAR POWERPLANTS, NAMELY, TRANSFORMERS, TURBINE AND GENERATOR SWITCHES, AUXILIARY POWER SUPPLIES, EMERGENCY POWER SUPPLIES, VOLTAGE SWITCHGEARS, ELECTRICAL MOTOR CONTROLLERS, ELECTRICAL GROUNDING DEVICES, TEMPERATURE SENSORS, VOLTAGE SENSORS, VIBRATION SENSORS, DISCHARGE SENSORS, HYDROELECTRIC DAM WATER LEVEL MONITORS, ALARM INSTALLATIONS AND ALARMS, CIRCUIT BREAKERS AND ELECTRICAL TRANSDUCERS, MAIN GRIDS AND GRID STATIONS FOR PRODUCTION AND DISTRIBUTION OF ELECTRICITY; WIND GENERATOR FARM ELECTRIC SYSTEMS AND SUBSYSTEMS COMPRISED OF WIND TURBINE TOWERS, TURBINE AND GENERATOR SWITCHES, VOLTAGE REGULATORS, TRANSFORMERS AND WIND TURBINE CONTROLLERS, AUXILIARY POWER SUPPLIES, EMERGENCY POWER SUPPLIES, VOLTAGE SWITCHGEARS, ELECTRICAL GROUNDING DEVICES, TEMPERATURE SENSORS, VOLTAGE SENSORS, VIBRATION SENSORS, DISCHARGE SENSORS, ALARM INSTALLATIONS AND ALARMS, CIRCUIT BREAKERS AND ELECTRICAL TRANSDUCERS (U.S. CLS. 21, 23, 26, 36 AND 38).

CLASS 11—ENVIRONMENTAL CONTROL APPARATUS

FOR ELECTROMECHANICAL EQUIPMENT FOR NUCLEAR POWER PLANTS, NAMELY, NUCLEAR REACTORS (U.S. CLS. 13, 21, 23, 31 AND 34).

WILLIAM JACKSON, EXAMINING ATTORNEY

CLASS 11—ENVIRONMENTAL CONTROL APPARATUS

FOR ELECTROMECHANICAL EQUIPMENT FOR NUCLEAR POWER PLANTS, NAMELY, NUCLEAR REACTORS (U.S. CLS. 13, 21, 23, 31 AND 34).

WILLIAM JACKSON, EXAMINING ATTORNEY

SN 85-208,522. INDUSTRIAS METALURGICAS PESCARMONA S.A.I.C. Y F., M5503AHY MENDOZA PROV., ARGENTINA, FILED 12-31-2010.

WE BELIEVE IN THE POWER OF
NATURE

THE MARK CONSISTS OF STANDARD CHARACTERS WITHOUT CLAIM TO ANY PARTICULAR FONT, STYLE, SIZE, OR COLOR.

CLASS 7—MACHINERY

FOR TURBINES AND GENERATORS OF ELECTRIC ENERGY; HYDROMECHANICAL EQUIPMENT FOR POWER PLANTS, NAMELY, EQUIPMENT FOR CONDUCTING, CONTROLLING AND REGULATING WATER FLOW WITHIN HYDROELECTRIC POWER PLANTS AND WATERWAYS IN THE NATURE OF PUMPS, PUMP CONTROL VALVES, FLOWGATES, TRASH RACKS, STOPLOGS AND PENSTOCKS; CRANES; WIND-DRIVEN GENERATORS FOR PRODUCING ELECTRICITY; ELECTROMECHANICAL EQUIPMENT FOR POWER PLANTS, NAMELY, HYDRAULIC TURBINES, TRANSFORMERS; ELECTROMECHANICAL EQUIPMENT FOR WIND POWER PLANTS, NAMELY, WIND GENERATORS; ELECTROMECHANICAL EQUIPMENT FOR NUCLEAR POWER PLANTS, NAMELY, VAPOR TURBINES; PUMPING EQUIPMENT, NAMELY, PUMP TURBINES FOR PUMP STORAGE POWER STATIONS (U.S. CLS. 13, 19, 21, 23, 31, 34 AND 35).

CLASS 9—ELECTRICAL AND SCIENTIFIC APPARATUS

FOR SPEED GOVERNORS FOR MACHINES, NAMELY, ELECTRONIC SPEED CONTROLLERS AND POWER-FREQUENCY GOVERNORS FOR PRIME MOVERS USED FOR POWER GENERATION; EXCITATION SYSTEM COMPRISED OF STATIC EXCITERS; AUTOMATIC VOLTAGE REGULATORS; ELECTROMECHANICAL EQUIPMENT FOR WIND POWER PLANTS, NAMELY, MAIN GRIDS AND GRID STATIONS FOR PRODUCTION AND DISTRIBUTION OF ELECTRICITY; MACHINES FOR CONTROL, SUPERVISION, MONITORING AND PROTECTION OF HYDROELECTRIC, WIND AND NUCLEAR POWERPLANTS, NAMELY, TRANSFORMERS, TURBINE AND GENERATOR SWITCHES, AUXILIARY POWER SUPPLIES, EMERGENCY POWER SUPPLIES, VOLTAGE SWITCHGEARS, ELECTRICAL MOTOR CONTROLLERS, ELECTRICAL GROUNDING DEVICES, TEMPERATURE SENSORS, VOLTAGE SENSORS, VIBRATION SENSORS, DISCHARGE SENSORS, HYDROELECTRIC DAM WATER LEVEL MONITORS, ALARM INSTALLATIONS AND ALARMS, CIRCUIT BREAKERS AND ELECTRICAL TRANSDUCERS, MAIN GRIDS AND GRID STATIONS FOR PRODUCTION AND DISTRIBUTION OF ELECTRICITY; WIND GENERATOR FARM ELECTRIC SYSTEMS AND SUBSYSTEMS COMPRISED OF WIND TURBINE TOWERS, TURBINE AND GENERATOR SWITCHES, VOLTAGE REGULATORS, TRANSFORMERS AND WIND TURBINE CONTROLLERS, AUXILIARY POWER SUPPLIES, EMERGENCY POWER SUPPLIES, VOLTAGE SWITCHGEARS, ELECTRICAL GROUNDING DEVICES, TEMPERATURE SENSORS, VOLTAGE SENSORS, VIBRATION SENSORS, DISCHARGE SENSORS, ALARM INSTALLATIONS AND ALARMS, CIRCUIT BREAKERS AND ELECTRICAL TRANSDUCERS (U.S. CLS. 21, 23, 26, 36 AND 38).

SN 85-216,898. NAV CANADA, OTTAWA, ONTARIO K1P 5L6, CANADA, FILED 1-13-2011.

NAV CANADA

OWNER OF CANADA REG. NO. TMA573400, DATED 1-10-2003, EXPIRES 1-10-2018.

OWNER OF U.S. REG. NOS. 2,835,653, 2,889,379 AND OTHERS.

NO CLAIM IS MADE TO THE EXCLUSIVE RIGHT TO USE "CANADA", APART FROM THE MARK AS SHOWN.

THE MARK CONSISTS OF THE STYLIZED LETTERS "NAV" IN UPPER CASE AND THE STYLIZED WORD "CANADA" IN UPPER CASE.

CLASS 9—ELECTRICAL AND SCIENTIFIC APPARATUS

FOR (BASED ON INTENT TO USE) DOWNLOADABLE ELECTRONIC PUBLICATIONS IN THE NATURE OF PERIODICALS, NEWSLETTERS, MANUALS, PAMPHLETS, MAPS, TABLES AND CHARTS IN THE FIELDS OF AVIATION, AIR TRAFFIC CONTROL AND WEATHER; EDUCATIONAL KIT COMPRISING CDS FEATURING TRAINING COURSES IN THE FIELDS OF AVIATION AND AIR TRAFFIC CONTROL; EDUCATIONAL SOFTWARE FEATURING INSTRUCTION IN AVIATION AND AIR TRAFFIC CONTROL; DIGITAL MATERIALS, NAMELY, CDS AND DVDS IN THE FIELDS OF AVIATION AND AIR TRAFFIC CONTROL; COMPUTER HARDWARE AND SOFTWARE FOR CIVIL AIRCRAFT FLIGHT PLAN, NAVIGATION AND GUIDANCE MANAGEMENT; INTEGRATED SUITES OF COMPUTER HARDWARE AND SOFTWARE FOR CIVIL AIRCRAFT FLIGHT PLAN, NAVIGATION AND GUIDANCE MANAGEMENT; COMPUTER WORKSTATIONS COMPRISING ELECTRONIC DISPLAY INTERFACES, AND HARDWARE AND SOFTWARE FOR MANAGING AIR TRAFFIC (U.S. CLS. 21, 23, 26, 36 AND 38).

CLASS 16—PAPER GOODS AND PRINTED MATTER

FOR (BASED ON INTENT TO USE) PRINTED MATTER, NAMELY, PRINTED PERIODICALS, NEWSLETTERS, MANUALS, PAMPHLETS, MAPS, TABLES AND CHARTS IN THE FIELDS OF AVIATION, AIR TRAFFIC CONTROL AND WEATHER; PRINTED INSTRUCTIONAL, EDUCATIONAL, AND TEACHING MATERIALS IN THE FIELDS OF AVIATION, AIR TRAFFIC CONTROL AND WEATHER (U.S. CLS. 2, 5, 22, 23, 29, 37, 38 AND 50).

CLASS 35—ADVERTISING AND BUSINESS

FOR (BASED ON INTENT TO USE) (BASED ON 44(E)) OPERATION OF COMMUNICATIONS AND SURVEILLANCE FACILITIES, NAMELY, OPERATION OF COMMUNICATIONS FACILITIES AND NETWORKS FOR AIRCRAFT NAVIGATION; OPERATION OF FLIGHT SERVICE STATIONS, NAMELY, AERONAUTICAL FACILITIES THAT PROVIDE MOBILE AND FIXED COMMUNICATIONS; OPERATION AND MANAGEMENT OF AIR TRAFFIC CONTROL CENTERS, NAMELY, OPERATION OF FACILITIES FOR AIRCRAFT NAVIGATION AND AUTOMATED FLIGHT DATA RECORDING AND DISPLAY SYSTEMS; OPERATION OF RADAR SYSTEMS, NAMELY, OPERATING FACILITIES FOR SURVEILLANCE AND RADAR DETECTION OF AIRCRAFT; BUSINESS CONSULTING RELATED TO AIR TRAFFIC CONTROL EFFICIENCY, NAMELY, ESTABLISHING AND PROMOTING OPERATIONAL EFFICIENCY OF AIR NAVIGATION AND AIR TRAFFIC CONTROL, NAMELY, REVIEWING STANDARDS AND PRACTICES OF AIR NAVIGATION AND AIR TRAFFIC CONTROL TO ASSURE OPERATIONAL EFFICIENCY (U.S. CLS. 100, 101 AND 102).

CLASS 37—CONSTRUCTION AND REPAIR

FOR (BASED ON INTENT TO USE) (BASED ON 44(E)) INSTALLATION, MAINTENANCE AND REPAIR OF COMPUTER HARDWARE FOR AIR TRAFFIC CONTROL SYSTEMS USED FOR CIVIL AIRCRAFT FLIGHT PLAN, NAVIGATION AND GUIDANCE MANAGEMENT (U.S. CLS. 100, 103 AND 106).

CLASS 38—COMMUNICATION

FOR (BASED ON INTENT TO USE) (BASED ON 44(E)) AERONAUTICAL COMMUNICATION SERVICES, NAMELY, RADIO COMMUNICATION SERVICES FOR AIRCRAFT NAVIGATION; SATELLITE AND ELECTRONIC TRANSMISSION OF MESSAGES AND DATA FOR AIRCRAFT NAVIGATION (U.S. CLS. 100, 101 AND 104).

CLASS 39—TRANSPORTATION AND STORAGE

FOR (BASED ON INTENT TO USE) (BASED ON 44(E)) AERONAUTICAL TRANSPORTATION AND NAVIGATION INFORMATION SERVICES, NAMELY, AIR TRAFFIC CONTROL AND AIRCRAFT NAVIGATION SERVICES, NAMELY, AIRCRAFT NAVIGATION INFORMATION SERVICES; AIR TRAFFIC CONTROL SERVICES; FLIGHT INFORMATION SERVICES, NAMELY, PROVIDING INFORMATION, NEWS, AND COMMENTARY IN THE FIELD OF TRAVEL; PROVIDING INFORMATION TO THIRD PARTIES REGARDING AIR TRAFFIC CONTROL; PROVIDING INFORMATION TO THIRD PARTIES REGARDING AIR TRAVEL AND AIR TRAFFIC NAVIGATION AND CONTROL BY MEANS OF A GLOBAL COMPUTER INFORMATION NETWORK; OPERATION AND MANAGEMENT OF AIR TRAFFIC CONTROL CENTERS, NAMELY, OPERATION OF AIR TRAFFIC CENTERS, TERMINAL CONTROL UNITS AND CONTROL TOWERS ALL IN THE NATURE OF AIR TRAFFIC CONTROL SERVICES; PROVIDING FLIGHT PLAN REGISTRATION SERVICES; AERONAUTICAL TRANSPORTATION AND NAVIGATION INFORMATION SERVICES, NAMELY, INFORMATION SERVICES, NAMELY, PROVIDING A WEB SITE FEATURING INFORMATION, AS WELL AS AUDIO, VIDEO, PHOTOGRAPHIC AND PROSE PRESENTATIONS, IN THE FIELDS OF AVIATION, AIR TRAFFIC CONTROL, AND AIR TRAFFIC CONTROL FEES; AERONAUTICAL TRANSPORT AND NAVIGATION INFORMATION SERVICES, NAMELY, PROVIDING AND UPDATING NAVIGATIONAL, ENROUTE, AND AIRPORT INFORMATION (U.S. CLS. 100 AND 105).

CLASS 41—EDUCATION AND ENTERTAINMENT

FOR (BASED ON INTENT TO USE) (BASED ON 44(E)) EDUCATIONAL AND TRAINING SERVICES RELATING TO AIR NAVIGATION, AERONAUTICS AND AIR TRAFFIC CONTROL, NAMELY, PROVIDING CLASSES, COURSES, WORKSHOPS, SEMINARS, CONFERENCES, DEMONSTRATIONS, COMPUTER-BASED TRAINING AND DISTRIBUTION OF EDUCATIONAL MATERIALS IN CONNECTION THEREWITH (U.S. CLS. 100, 101 AND 107).

CLASS 42—SCIENTIFIC AND COMPUTER SERVICES

FOR (BASED ON INTENT TO USE) (BASED ON 44(E)) RADAR DETECTION; RESEARCH AND DEVELOPMENT RELATING TO AIR TRAFFIC SERVICES, NAMELY, TECHNICAL CONSULTING AND RESEARCH AND DEVELOPMENT SERVICES IN THE FIELD OF AIR NAVIGATION AND AIR TRAFFIC CONTROL SYSTEMS; AVIATION WEATHER INFORMATION AND REPORTING SERVICES, NAMELY, AVIATION WEATHER REPORTING AND FORECASTING SERVICES; WEATHER INFORMATION AND REPORTING SERVICES TO PILOTS AND OTHER USERS; TECHNOLOGICAL AND SCIENTIFIC SERVICES, NAMELY, TESTING, ANALYZING AND EVALUATING THE EFFICIENCY, SAFETY AND REGULATORY COMPLIANCE OF THE AIR NAVIGATION SERVICES PERFORMED BY OTHERS FOR SCIENTIFIC AND TECHNICAL PURPOSES, AND TECHNICAL AND SCIENTIFIC CONSULTING RELATED THERETO; TECHNOLOGY SUPERVISION AND INSPECTION IN THE FIELD OF AIR TRAFFIC CONTROL, AND AIR TRAFFIC CONTROL EQUIPMENT AND COMPUTER SOFTWARE; INSTALLATION, MAINTENANCE AND REPAIR OF COMPUTER SOFTWARE FOR AIR TRAFFIC CONTROL SYSTEMS USED FOR CIVIL AIRCRAFT FLIGHT PLAN, NAVIGATION AND GUIDANCE MANAGEMENT; TECHNICAL SUPPORT SERVICES, NAMELY, TROUBLESHOOTING IN THE NATURE OF DIAGNOSING COMPUTER HARDWARE AND SOFTWARE PROBLEMS; TRANSPORTATION AND TRAFFIC PLANNING SERVICES FOR DETERMINING THE LEVEL OF CIVIL AIR NAVIGATION SERVICES NEEDED FOR A GIVEN AREA; LAND USE PLANNING SERVICES TO EVALUATE HOW LAND USE PROJECTS MAY IMPACT AIR NAVIGATION; PROVIDING A WEB SITE FEATURING INFORMATION, AS WELL AS AUDIO, VIDEO, PHOTOGRAPHIC AND PROSE PRESENTATIONS, IN THE FIELDS OF WEATHER AFFECTING AERONAUTICAL TRANSPORTATION AND NAVIGATION; PROVIDING AND UPDATING WEATHER INFORMATION AFFECTING AERONAUTICAL TRANSPORTATION AND NAVIGATION (U.S. CLS. 100 AND 101).

CLASS 45—PERSONAL AND LEGAL SERVICES

FOR (BASED ON INTENT TO USE) (BASED ON 44(E)) OFFERING NON-MEDICAL COORDINATION ASSISTANCE TO EMERGENCY RESPONSE PROVIDERS, NAMELY, ALERTING RESCUE COORDINATION, PROVIDING EMERGENCY AIR TRAFFIC CONSULTATION, ARRANGING FOR THE DISPATCH OF EMERGENCY VEHICLES AND STAFF, AND MONITORING AND NOTIFYING EMERGENCY AND MEDICAL FACILITIES; CONSULTING RELATED TO SAFE AIRCRAFT OPERATION, NAMELY, ESTABLISHING SAFETY OF AIR NAVIGATION AND AIR TRAFFIC CONTROL, NAMELY, REVIEWING STANDARDS AND PRACTICES OF AIR NAVIGATION AND AIR TRAFFIC CONTROL SERVICE PROVIDERS FOR SAFETY PURPOSES AND TO ASSURE COMPLIANCE WITH SAFETY LAWS AND REGULATIONS; PROVIDING AND UPDATING REGULATORY COMPLIANCE INFORMATION, AS WELL AS NON-MEDICAL INFORMATION FOR USE BY EMERGENCY RESPONSE PROVIDERS, AFFECTING AERONAUTICAL TRANSPORTATION AND NAVIGATION (U.S. CLS. 100 AND 101).

FONG HSU, EXAMINING ATTORNEY

SN 85-216,917. NAV CANADA, OTTAWA, ONTARIO K1P 5L6, CANADA, FILED 1-13-2011.



OWNER OF CANADA REG. NO. TMA573401, DATED 1-10-2003, EXPIRES 1-10-2018.

OWNER OF U.S. REG. NOS. 2,835,653, 2,889,379 AND OTHERS.

NO CLAIM IS MADE TO THE EXCLUSIVE RIGHT TO USE "CANADA", APART FROM THE MARK AS SHOWN.

THE MARK CONSISTS OF THE STYLIZED LETTERS "NAV" IN UPPER CASE AND THE STYLIZED WORD "CANADA" IN UPPER CASE UNDERLINED WITH A SOLID ANGLED LINE APPEARING WITHIN AN INCOMPLETE OVAL.

CLASS 9—ELECTRICAL AND SCIENTIFIC APPARATUS

FOR (BASED ON INTENT TO USE) DOWNLOADABLE ELECTRONIC PUBLICATIONS IN THE NATURE OF PERIODICALS, NEWSLETTERS, MANUALS, PAMPHLETS, MAPS, TABLES AND CHARTS IN THE FIELDS OF AVIATION, AIR TRAFFIC CONTROL AND WEATHER; EDUCATIONAL KIT COMPRISING CDS FEATURING TRAINING COURSES IN THE FIELDS OF AVIATION AND AIR TRAFFIC CONTROL; EDUCATIONAL SOFTWARE FEATURING INSTRUCTION IN AVIATION AND AIR TRAFFIC CONTROL; DIGITAL MATERIALS, NAMELY, CDS AND DVDS IN THE FIELDS OF AVIATION AND AIR TRAFFIC CONTROL; COMPUTER HARDWARE AND SOFTWARE FOR CIVIL AIRCRAFT FLIGHT PLAN, NAVIGATION AND GUIDANCE MANAGEMENT; INTEGRATED SUITES OF COMPUTER HARDWARE AND SOFTWARE FOR CIVIL AIRCRAFT FLIGHT PLAN, NAVIGATION AND GUIDANCE MANAGEMENT; COMPUTER WORKSTATIONS COMPRISING ELECTRONIC DISPLAY INTERFACES, AND HARDWARE AND SOFTWARE FOR MANAGING AIR TRAFFIC (U.S. CLS. 21, 23, 26, 36 AND 38).

CLASS 16—PAPER GOODS AND PRINTED MATTER

FOR (BASED ON INTENT TO USE) PRINTED MATTER, NAMELY, PRINTED PERIODICALS, NEWSLETTERS, MANUALS, PAMPHLETS, MAPS, TABLES AND CHARTS IN THE FIELDS OF AVIATION, AIR TRAFFIC CONTROL AND WEATHER; PRINTED INSTRUCTIONAL, EDUCATIONAL, AND TEACHING MATERIALS IN THE FIELDS OF AVIATION, AIR TRAFFIC CONTROL AND WEATHER (U.S. CLS. 2, 5, 22, 23, 29, 37, 38 AND 50).

CLASS 35—ADVERTISING AND BUSINESS

FOR (BASED ON INTENT TO USE) (BASED ON 44(E)) OPERATION OF COMMUNICATIONS AND SURVEILLANCE FACILITIES, NAMELY, OPERATION OF COMMUNICATIONS FACILITIES AND NETWORKS FOR AIRCRAFT NAVIGATION; OPERATION OF FLIGHT SERVICE STATIONS, NAMELY, AERONAUTICAL FACILITIES THAT PROVIDE MOBILE AND FIXED COMMUNICATIONS; OPERATION AND MANAGEMENT OF AIR TRAFFIC CONTROL CENTERS, NAMELY, OPERATION OF FACILITIES FOR AIRCRAFT NAVIGATION AND AUTOMATED FLIGHT DATA RECORDING AND DISPLAY SYSTEMS; OPERATION OF RADAR SYSTEMS, NAMELY, OPERATING FACILITIES FOR SURVEILLANCE AND RADAR DETECTION OF AIRCRAFT; BUSINESS CONSULTING RELATED TO AIR TRAFFIC CONTROL EFFICIENCY, NAMELY, ESTABLISHING AND PROMOTING OPERATIONAL EFFICIENCY OF AIR NAVIGATION AND AIR TRAFFIC CONTROL, NAMELY, REVIEWING STANDARDS AND PRACTICES OF AIR NAVIGATION AND AIR TRAFFIC CONTROL TO ASSURE OPERATIONAL EFFICIENCY (U.S. CLS. 100, 101 AND 102).

CLASS 37—CONSTRUCTION AND REPAIR

FOR (BASED ON INTENT TO USE) (BASED ON 44(E)) INSTALLATION, MAINTENANCE AND REPAIR OF COMPUTER HARDWARE FOR AIR TRAFFIC CONTROL SYSTEMS USED FOR CIVIL AIRCRAFT FLIGHT PLAN, NAVIGATION AND GUIDANCE MANAGEMENT (U.S. CLS. 100, 103 AND 106).

CLASS 38—COMMUNICATION

FOR (BASED ON INTENT TO USE) (BASED ON 44(E)) AERONAUTICAL COMMUNICATION SERVICES, NAMELY, RADIO COMMUNICATION SERVICES FOR AIRCRAFT NAVIGATION; SATELLITE AND ELECTRONIC TRANSMISSION OF MESSAGES AND DATA FOR AIRCRAFT NAVIGATION (U.S. CLS. 100, 101 AND 104).

CLASS 39—TRANSPORTATION AND STORAGE

FOR (BASED ON INTENT TO USE) (BASED ON 44(E)) AERONAUTICAL TRANSPORTATION AND NAVIGATION INFORMATION SERVICES, NAMELY, AIR TRAFFIC CONTROL AND AIRCRAFT NAVIGATION SERVICES, NAMELY, AIRCRAFT NAVIGATION INFORMATION SERVICES; AIR TRAFFIC CONTROL SERVICES; FLIGHT INFORMATION SERVICES, NAMELY, PROVIDING INFORMATION, NEWS, AND COMMENTARY IN THE FIELD OF TRAVEL; PROVIDING INFORMATION TO THIRD PARTIES REGARDING AIR TRAFFIC CONTROL; PROVIDING INFORMATION TO THIRD PARTIES REGARDING AIR TRAVEL AND AIR TRAFFIC NAVIGATION AND CONTROL BY MEANS OF A GLOBAL COMPUTER INFORMATION NETWORK; OPERATION AND MANAGEMENT OF AIR TRAFFIC CONTROL CENTERS, NAMELY, OPERATION OF AIR TRAFFIC CENTERS, TERMINAL CONTROL UNITS AND CONTROL TOWERS ALL IN THE NATURE OF AIR TRAFFIC CONTROL SERVICES; PROVIDING FLIGHT PLAN REGISTRATION SERVICES; AERONAUTICAL TRANSPORTATION AND NAVIGATION INFORMATION SERVICES, NAMELY, INFORMATION SERVICES, NAMELY, PROVIDING A WEB SITE FEATURING INFORMATION, AS WELL AS AUDIO, VIDEO, PHOTOGRAPHIC AND PROSE PRESENTATIONS, IN THE FIELDS OF AVIATION, AIR TRAFFIC CONTROL, AND AIR TRAFFIC CONTROL FEES; AERONAUTICAL TRANSPORT AND NAVIGATION INFORMATION SERVICES, NAMELY, PROVIDING AND UPDATING NAVIGATIONAL, ENROUTE, AND AIRPORT INFORMATION (U.S. CLS. 100 AND 105).

CLASS 41—EDUCATION AND ENTERTAINMENT

FOR (BASED ON INTENT TO USE) (BASED ON 44(E)) EDUCATIONAL AND TRAINING SERVICES RELATING TO AIR NAVIGATION, AERONAUTICS AND AIR TRAFFIC CONTROL, NAMELY, PROVIDING CLASSES, COURSES, WORKSHOPS, SEMINARS, CONFERENCES, DEMONSTRATIONS, COMPUTER-BASED TRAINING AND DISTRIBUTION OF EDUCATIONAL MATERIALS IN CONNECTION THEREWITH (U.S. CLS. 100, 101 AND 107).

CLASS 42—SCIENTIFIC AND COMPUTER SERVICES

FOR (BASED ON INTENT TO USE) (BASED ON 44(E)) RADAR DETECTION; RESEARCH AND DEVELOPMENT RELATING TO AIR TRAFFIC SERVICES, NAMELY, TECHNICAL CONSULTING AND RESEARCH AND DEVELOPMENT SERVICES IN THE FIELD OF AIR NAVIGATION AND AIR TRAFFIC CONTROL SYSTEMS; AVIATION WEATHER INFORMATION AND REPORTING SERVICES, NAMELY, AVIATION WEATHER REPORTING AND FORECASTING SERVICES; WEATHER INFORMATION AND REPORTING SERVICES TO PILOTS AND OTHER USERS; TECHNOLOGICAL AND SCIENTIFIC SERVICES, NAMELY, TESTING, ANALYZING AND EVALUATING THE EFFICIENCY, SAFETY AND REGULATORY COMPLIANCE OF THE AIR NAVIGATION SERVICES PERFORMED BY OTHERS FOR SCIENTIFIC AND TECHNICAL PURPOSES, AND TECHNICAL AND SCIENTIFIC CONSULTING RELATED THERETO; TECHNOLOGY SUPERVISION AND INSPECTION IN THE FIELD OF AIR TRAFFIC CONTROL AND AIR TRAFFIC CONTROL EQUIPMENT AND COMPUTER SOFTWARE; INSTALLATION, MAINTENANCE AND REPAIR OF COMPUTER SOFTWARE FOR AIR TRAFFIC CONTROL SYSTEMS USED FOR CIVIL AIRCRAFT FLIGHT PLAN, NAVIGATION AND GUIDANCE MANAGEMENT; TECHNICAL SUPPORT SERVICES, NAMELY, TROUBLESHOOTING IN THE NATURE OF DIAGNOSING COMPUTER HARDWARE AND SOFTWARE PROBLEMS; TRANSPORTATION AND TRAFFIC PLANNING SERVICES FOR DETERMINING THE LEVEL OF CIVIL AIR NAVIGATION SERVICES NEEDED FOR A GIVEN AREA; LAND USE PLANNING SERVICES TO EVALUATE HOW LAND USE PROJECTS MAY IMPACT AIR NAVIGATION; PROVIDING A WEB SITE FEATURING INFORMATION, AS WELL AS AUDIO, VIDEO, PHOTOGRAPHIC AND PROSE PRESENTATIONS, IN THE FIELDS OF WEATHER AFFECTING AERONAUTICAL TRANSPORTATION AND NAVIGATION; PROVIDING AND UPDATING WEATHER INFORMATION AFFECTING AERONAUTICAL TRANSPORTATION AND NAVIGATION (U.S. CLS. 100 AND 101).

CLASS 45—PERSONAL AND LEGAL SERVICES

FOR (BASED ON INTENT TO USE) (BASED ON 44(E)) OFFERING NON-MEDICAL COORDINATION ASSISTANCE TO EMERGENCY RESPONSE PROVIDERS, NAMELY, ALERTING RESCUE COORDINATION, PROVIDING EMERGENCY AIR TRAFFIC CONSULTATION, ARRANGING FOR THE DISPATCH OF EMERGENCY VEHICLES AND STAFF, AND MONITORING AND NOTIFYING EMERGENCY AND MEDICAL FACILITIES; CONSULTING RELATED TO SAFE AIRCRAFT OPERATION, NAMELY, ESTABLISHING SAFETY OF AIR NAVIGATION AND AIR TRAFFIC CONTROL, NAMELY, REVIEWING STANDARDS AND PRACTICES OF AIR NAVIGATION AND AIR TRAFFIC CONTROL SERVICE PROVIDERS FOR SAFETY PURPOSES AND TO ASSURE COMPLIANCE WITH SAFETY LAWS AND REGULATIONS; PROVIDING AND UPDATING REGULATORY COMPLIANCE INFORMATION, AS WELL AS NON-MEDICAL INFORMATION FOR USE BY EMERGENCY RESPONSE PROVIDERS, AFFECTING AERONAUTICAL TRANSPORTATION AND NAVIGATION (U.S. CLS. 100 AND 101).

FONG HSU, EXAMINING ATTORNEY

SN 85-216,929. NAV CANADA, OTTAWA, ONTARIO K1P 5L6, CANADA, FILED 1-13-2011.

NAV CANADA

THE MARK CONSISTS OF STANDARD CHARACTERS WITHOUT CLAIM TO ANY PARTICULAR FONT, STYLE, SIZE, OR COLOR.

OWNER OF CANADA REG. NO. TMA573800, DATED 1-16-2003, EXPIRES 1-16-2018.

OWNER OF U.S. REG. NOS. 2,835,653, 2,889,379 AND OTHERS.

NO CLAIM IS MADE TO THE EXCLUSIVE RIGHT TO USE "CANADA", APART FROM THE MARK AS SHOWN.

CLASS 9—ELECTRICAL AND SCIENTIFIC APPARATUS

FOR (BASED ON INTENT TO USE) DOWNLOADABLE ELECTRONIC PUBLICATIONS IN THE NATURE OF PERIODICALS, NEWSLETTERS, MANUALS, PAMPHLETS, MAPS, TABLES AND CHARTS IN THE FIELDS OF AVIATION, AIR TRAFFIC CONTROL AND WEATHER; EDUCATIONAL KIT COMPRISING CDS FEATURING TRAINING COURSES IN THE FIELDS OF AVIATION AND AIR TRAFFIC CONTROL; EDUCATIONAL SOFTWARE FEATURING INSTRUCTION IN AVIATION AND AIR TRAFFIC CONTROL; DIGITAL MATERIALS, NAMELY, CDS AND DVDS IN THE FIELDS OF AVIATION AND AIR TRAFFIC CONTROL; COMPUTER HARDWARE AND SOFTWARE FOR CIVIL AIRCRAFT FLIGHT PLAN, NAVIGATION AND GUIDANCE MANAGEMENT; INTEGRATED SUITES OF COMPUTER HARDWARE AND SOFTWARE FOR CIVIL AIRCRAFT FLIGHT PLAN, NAVIGATION AND GUIDANCE MANAGEMENT; COMPUTER WORKSTATIONS COMPRISING ELECTRONIC DISPLAY INTERFACES, AND HARDWARE AND SOFTWARE FOR MANAGING AIR TRAFFIC (U.S. CLS. 21, 23, 26, 36 AND 38).

CLASS 16—PAPER GOODS AND PRINTED MATTER

FOR (BASED ON INTENT TO USE) PRINTED MATTER, NAMELY, PRINTED PERIODICALS, NEWSLETTERS, MANUALS, PAMPHLETS, MAPS, TABLES AND CHARTS IN THE FIELDS OF AVIATION, AIR TRAFFIC CONTROL AND WEATHER; PRINTED INSTRUCTIONAL, EDUCATIONAL, AND TEACHING MATERIALS IN THE FIELDS OF AVIATION, AIR TRAFFIC CONTROL AND WEATHER (U.S. CLS. 2, 5, 22, 23, 29, 37, 38 AND 50).

CLASS 35—ADVERTISING AND BUSINESS

FOR (BASED ON INTENT TO USE) (BASED ON 44(E)) OPERATION OF COMMUNICATIONS AND SURVEILLANCE FACILITIES, NAMELY, OPERATION OF COMMUNICATIONS FACILITIES AND NETWORKS FOR AIRCRAFT NAVIGATION; OPERATION OF FLIGHT SERVICE STATIONS, NAMELY, AERONAUTICAL FACILITIES THAT PROVIDE MOBILE AND FIXED COMMUNICATIONS; OPERATION AND MANAGEMENT OF AIR TRAFFIC CONTROL CENTERS, NAMELY, OPERATION OF FACILITIES FOR AIRCRAFT NAVIGATION AND AUTOMATED FLIGHT DATA RECORDING AND DISPLAY SYSTEMS; OPERATION OF RADAR SYSTEMS, NAMELY, OPERATING FACILITIES FOR SURVEILLANCE AND RADAR DETECTION OF AIRCRAFT; BUSINESS CONSULTING RELATED TO AIR TRAFFIC CONTROL EFFICIENCY, NAMELY, ESTABLISHING AND PROMOTING OPERATIONAL EFFICIENCY OF AIR NAVIGATION AND AIR TRAFFIC CONTROL, NAMELY, REVIEWING STANDARDS AND PRACTICES OF AIR NAVIGATION AND AIR TRAFFIC CONTROL TO ASSURE OPERATIONAL EFFICIENCY (U.S. CLS. 100, 101 AND 102).

CLASS 37—CONSTRUCTION AND REPAIR

FOR (BASED ON INTENT TO USE) (BASED ON 44(E)) INSTALLATION, MAINTENANCE AND REPAIR OF COMPUTER HARDWARE FOR AIR TRAFFIC CONTROL SYSTEMS USED FOR CIVIL AIRCRAFT FLIGHT PLAN, NAVIGATION AND GUIDANCE MANAGEMENT (U.S. CLS. 100, 103 AND 106).

CLASS 38—COMMUNICATION

FOR (BASED ON INTENT TO USE) (BASED ON 44(E)) AERONAUTICAL COMMUNICATION SERVICES, NAMELY, RADIO COMMUNICATION SERVICES FOR AIRCRAFT NAVIGATION; SATELLITE AND ELECTRONIC TRANSMISSION OF MESSAGES AND DATA FOR AIRCRAFT NAVIGATION (U.S. CLS. 100, 101 AND 104).

CLASS 39—TRANSPORTATION AND STORAGE

FOR (BASED ON INTENT TO USE) (BASED ON 44(E)) AERONAUTICAL TRANSPORTATION AND NAVIGATION INFORMATION SERVICES, NAMELY, AIR TRAFFIC CONTROL AND AIRCRAFT NAVIGATION SERVICES, NAMELY, AIRCRAFT NAVIGATION INFORMATION SERVICES; AIR TRAFFIC CONTROL SERVICES; FLIGHT INFORMATION SERVICES, NAMELY, PROVIDING INFORMATION, NEWS, AND COMMENTARY IN THE FIELD OF TRAVEL; PROVIDING INFORMATION TO THIRD PARTIES REGARDING AIR TRAFFIC CONTROL; PROVIDING INFORMATION TO THIRD PARTIES REGARDING AIR TRAVEL AND AIR TRAFFIC NAVIGATION AND CONTROL BY MEANS OF A GLOBAL COMPUTER INFORMATION NETWORK; OPERATION AND MANAGEMENT OF AIR TRAFFIC CONTROL CENTERS, NAMELY, OPERATION OF AIR TRAFFIC CENTERS, TERMINAL CONTROL UNITS AND CONTROL TOWERS ALL IN THE NATURE OF AIR TRAFFIC CONTROL SERVICES; PROVIDING FLIGHT PLAN REGISTRATION SERVICES; AERONAUTICAL TRANSPORTATION AND NAVIGATION INFORMATION SERVICES, NAMELY, INFORMATION SERVICES, NAMELY, PROVIDING A WEB SITE FEATURING INFORMATION, AS WELL AS AUDIO, VIDEO, PHOTOGRAPHIC AND PROSE PRESENTATIONS, IN THE FIELDS OF AVIATION, AIR TRAFFIC CONTROL, AND AIR TRAFFIC CONTROL FEES; AERONAUTICAL TRANSPORT AND NAVIGATION INFORMATION SERVICES, NAMELY, PROVIDING AND UPDATING NAVIGATIONAL, ENROUTE, AND AIRPORT INFORMATION (U.S. CLS. 100 AND 105).

CLASS 41—EDUCATION AND ENTERTAINMENT

FOR (BASED ON INTENT TO USE) (BASED ON 44(E)) EDUCATIONAL AND TRAINING SERVICES RELATING TO AIR NAVIGATION, AERONAUTICS AND AIR TRAFFIC CONTROL, NAMELY, PROVIDING CLASSES, COURSES, WORKSHOPS, SEMINARS, CONFERENCES, DEMONSTRATIONS, COMPUTER-BASED TRAINING AND DISTRIBUTION OF EDUCATIONAL MATERIALS IN CONNECTION THEREWITH (U.S. CLS. 100, 101 AND 107).

CLASS 42—SCIENTIFIC AND COMPUTER SERVICES

FOR (BASED ON INTENT TO USE) (BASED ON 44(E)) RADAR DETECTION; RESEARCH AND DEVELOPMENT RELATING TO AIR TRAFFIC SERVICES, NAMELY, TECHNICAL CONSULTING AND RESEARCH AND DEVELOPMENT SERVICES IN THE FIELD OF AIR NAVIGATION AND AIR TRAFFIC CONTROL SYSTEMS; AVIATION WEATHER INFORMATION AND REPORTING SERVICES, NAMELY, AVIATION WEATHER REPORTING AND FORECASTING SERVICES; WEATHER INFORMATION AND REPORTING SERVICES TO PILOTS AND OTHER USERS; TECHNOLOGICAL AND SCIENTIFIC SERVICES, NAMELY, TESTING, ANALYZING AND EVALUATING THE EFFICIENCY, SAFETY AND REGULATORY COMPLIANCE OF THE AIR NAVIGATION SERVICES PERFORMED BY OTHERS FOR SCIENTIFIC AND TECHNICAL PURPOSES, AND TECHNICAL AND SCIENTIFIC CONSULTING RELATED THERETO; TECHNOLOGY SUPERVISION AND INSPECTION IN THE FIELD OF AIR TRAFFIC CONTROL, AND AIR TRAFFIC CONTROL EQUIPMENT AND COMPUTER SOFTWARE; INSTALLATION, MAINTENANCE AND REPAIR OF COMPUTER SOFTWARE FOR AIR TRAFFIC CONTROL SYSTEMS USED FOR CIVIL AIRCRAFT FLIGHT PLAN, NAVIGATION AND GUIDANCE MANAGEMENT; TECHNICAL SUPPORT SERVICES, NAMELY, TROUBLESHOOTING IN THE NATURE OF DIAGNOSING COMPUTER HARDWARE AND SOFTWARE PROBLEMS; TRANSPORTATION AND TRAFFIC PLANNING SERVICES FOR DETERMINING THE LEVEL OF CIVIL AIR NAVIGATION SERVICES NEEDED FOR A GIVEN AREA; LAND USE PLANNING SERVICES TO EVALUATE HOW LAND USE PROJECTS MAY IMPACT AIR NAVIGATION; PROVIDING A WEB SITE FEATURING INFORMATION, AS WELL AS AUDIO, VIDEO, PHOTOGRAPHIC AND PROSE PRESENTATIONS, IN THE FIELDS OF WEATHER AFFECTING AERONAUTICAL TRANSPORTATION AND NAVIGATION; PROVIDING AND UPDATING WEATHER INFORMATION AFFECTING AERONAUTICAL TRANSPORTATION AND NAVIGATION (U.S. CLS. 100 AND 101).

POSSES, AND TECHNICAL AND SCIENTIFIC CONSULTING RELATED THERETO; TECHNOLOGY SUPERVISION AND INSPECTION IN THE FIELD OF AIR TRAFFIC CONTROL, AND AIR TRAFFIC CONTROL EQUIPMENT AND COMPUTER SOFTWARE; INSTALLATION, MAINTENANCE AND REPAIR OF COMPUTER SOFTWARE FOR AIR TRAFFIC CONTROL SYSTEMS USED FOR CIVIL AIRCRAFT FLIGHT PLAN, NAVIGATION AND GUIDANCE MANAGEMENT; TECHNICAL SUPPORT SERVICES, NAMELY, TROUBLESHOOTING IN THE NATURE OF DIAGNOSING COMPUTER HARDWARE AND SOFTWARE PROBLEMS; TRANSPORTATION AND TRAFFIC PLANNING SERVICES FOR DETERMINING THE LEVEL OF CIVIL AIR NAVIGATION SERVICES NEEDED FOR A GIVEN AREA; LAND USE PLANNING SERVICES TO EVALUATE HOW LAND USE PROJECTS MAY IMPACT AIR NAVIGATION; PROVIDING A WEB SITE FEATURING INFORMATION, AS WELL AS AUDIO, VIDEO, PHOTOGRAPHIC AND PROSE PRESENTATIONS, IN THE FIELDS OF WEATHER AFFECTING AERONAUTICAL TRANSPORTATION AND NAVIGATION; PROVIDING AND UPDATING WEATHER INFORMATION AFFECTING AERONAUTICAL TRANSPORTATION AND NAVIGATION (U.S. CLS. 100 AND 101).

CLASS 45—PERSONAL AND LEGAL SERVICES

FOR (BASED ON INTENT TO USE) (BASED ON 44(E)) OFFERING NON-MEDICAL COORDINATION ASSISTANCE TO EMERGENCY RESPONSE PROVIDERS, NAMELY, ALERTING RESCUE COORDINATION, PROVIDING EMERGENCY AIR TRAFFIC CONSULTATION, ARRANGING FOR THE DISPATCH OF EMERGENCY VEHICLES AND STAFF, AND MONITORING AND NOTIFYING EMERGENCY AND MEDICAL FACILITIES; CONSULTING RELATED TO SAFE AIRCRAFT OPERATION, NAMELY, ESTABLISHING SAFETY OF AIR NAVIGATION AND AIR TRAFFIC CONTROL, NAMELY, REVIEWING STANDARDS AND PRACTICES OF AIR NAVIGATION AND AIR TRAFFIC CONTROL SERVICE PROVIDERS FOR SAFETY PURPOSES AND TO ASSURE COMPLIANCE WITH SAFETY LAWS AND REGULATIONS; PROVIDING AND UPDATING REGULATORY COMPLIANCE INFORMATION, AS WELL AS NON-MEDICAL INFORMATION FOR USE BY EMERGENCY RESPONSE PROVIDERS, AFFECTING AERONAUTICAL TRANSPORTATION AND NAVIGATION (U.S. CLS. 100 AND 101).

FONG HSU, EXAMINING ATTORNEY

SN 85-216,942. NAV CANADA, OTTAWA, ONTARIO K1P 5L6, CANADA, FILED 1-13-2011.

SERVING A WORLD IN MOTION

THE MARK CONSISTS OF STANDARD CHARACTERS WITHOUT CLAIM TO ANY PARTICULAR FONT, STYLE, SIZE, OR COLOR.

OWNER OF CANADA REG. NO. TMA577137, DATED 3-7-2003, EXPIRES 3-7-2018.

OWNER OF U.S. REG. NO. 2,875,140.

CLASS 9—ELECTRICAL AND SCIENTIFIC APPARATUS

FOR (BASED ON INTENT TO USE) DOWNLOADABLE ELECTRONIC PUBLICATIONS IN THE NATURE OF PERIODICALS, NEWSLETTERS, MANUALS, PAMPHLETS, MAPS, TABLES AND CHARTS IN THE FIELDS OF AVIATION, AIR TRAFFIC CONTROL AND WEATHER; EDUCATIONAL KIT COMPRISING CDS FEATURING TRAINING COURSES IN THE FIELDS OF AVIATION AND AIR TRAFFIC CONTROL; EDUCATIONAL SOFTWARE FEATURING INSTRUCTION IN AVIATION AND AIR TRAFFIC CONTROL; DIGITAL MATERIALS, NAMELY, CDS AND DVDS IN THE FIELDS OF AVIATION AND AIR TRAFFIC CONTROL; COMPUTER HARDWARE AND SOFTWARE FOR CIVIL AIRCRAFT FLIGHT PLAN, NAVIGATION AND GUIDANCE MANAGEMENT; INTEGRATED SUITES OF COMPUTER HARDWARE AND SOFTWARE FOR CIVIL AIRCRAFT FLIGHT PLAN, NAVIGATION AND GUIDANCE MANAGEMENT; COMPUTER WORKSTATIONS COMPRISING ELECTRONIC DISPLAY INTERFACES, AND HARDWARE AND SOFTWARE FOR MANAGING AIR TRAFFIC (U.S. CLS. 21, 23, 26, 36 AND 38).

CLASS 16—PAPER GOODS AND PRINTED MATTER

FOR (BASED ON INTENT TO USE) PRINTED MATTER, NAMELY, PRINTED PERIODICALS, NEWSLETTERS, MANUALS, PAMPHLETS, MAPS, TABLES AND CHARTS IN THE FIELDS OF AVIATION, AIR TRAFFIC CONTROL AND WEATHER; PRINTED INSTRUCTIONAL, EDUCATIONAL, AND TEACHING MATERIALS IN THE FIELDS OF AVIATION, AIR TRAFFIC CONTROL AND WEATHER (U.S. CLS. 2, 5, 22, 23, 29, 37, 38 AND 50).

CLASS 35—ADVERTISING AND BUSINESS

FOR (BASED ON INTENT TO USE) (BASED ON 44(E)) OPERATION OF COMMUNICATIONS AND SURVEILLANCE FACILITIES, NAMELY, OPERATION OF COMMUNICATIONS FACILITIES AND NETWORKS FOR AIRCRAFT NAVIGATION; OPERATION OF FLIGHT SERVICE STATIONS, NAMELY, AERONAUTICAL FACILITIES THAT PROVIDE MOBILE AND FIXED COMMUNICATIONS; OPERATION AND MANAGEMENT OF AIR TRAFFIC CONTROL CENTERS, NAMELY, OPERATION OF FACILITIES FOR AIRCRAFT NAVIGATION AND AUTOMATED FLIGHT DATA RECORDING AND DISPLAY SYSTEMS; OPERATION OF RADAR SYSTEMS, NAMELY, OPERATING FACILITIES FOR SURVEILLANCE AND RADAR DETECTION OF AIRCRAFT; BUSINESS CONSULTING RELATED TO AIR TRAFFIC CONTROL EFFICIENCY, NAMELY, ESTABLISHING AND PROMOTING OPERATIONAL EFFICIENCY OF AIR NAVIGATION AND AIR TRAFFIC CONTROL, NAMELY, REVIEWING STANDARDS AND PRACTICES OF AIR NAVIGATION AND AIR TRAFFIC CONTROL TO ASSURE OPERATIONAL EFFICIENCY (U.S. CLS. 100, 101 AND 102).

CLASS 37—CONSTRUCTION AND REPAIR

FOR (BASED ON INTENT TO USE) (BASED ON 44(E)) INSTALLATION, MAINTENANCE AND REPAIR OF COMPUTER HARDWARE FOR AIR TRAFFIC CONTROL SYSTEMS USED FOR CIVIL AIRCRAFT FLIGHT PLAN, NAVIGATION AND GUIDANCE MANAGEMENT (U.S. CLS. 100, 103 AND 106).

CLASS 38—COMMUNICATION

FOR (BASED ON INTENT TO USE) (BASED ON 44(E)) AERONAUTICAL COMMUNICATION SERVICES, NAMELY, RADIO COMMUNICATION SERVICES FOR AIRCRAFT NAVIGATION; SATELLITE AND ELECTRONIC TRANSMISSION OF MESSAGES AND DATA FOR AIRCRAFT NAVIGATION (U.S. CLS. 100, 101 AND 104).

CLASS 39—TRANSPORTATION AND STORAGE

FOR (BASED ON INTENT TO USE) (BASED ON 44(E)) AERONAUTICAL TRANSPORTATION AND NAVIGATION INFORMATION SERVICES, NAMELY, AIR TRAFFIC CONTROL AND AIRCRAFT NAVIGATION SERVICES, NAMELY, AIRCRAFT NAVIGATION INFORMATION SERVICES; AIR TRAFFIC CONTROL SERVICES; FLIGHT INFORMATION SERVICES, NAMELY, PROVIDING INFORMATION, NEWS, AND COMMENTARY IN THE FIELD OF TRAVEL; PROVIDING INFORMATION TO THIRD PARTIES REGARDING AIR TRAFFIC CONTROL; PROVIDING INFORMATION TO THIRD PARTIES REGARDING AIR TRAVEL AND AIR TRAFFIC NAVIGATION AND CONTROL BY MEANS OF A GLOBAL COMPUTER INFORMATION NETWORK; OPERATION AND MANAGEMENT OF AIR TRAFFIC CONTROL CENTERS, NAMELY, OPERATION OF AIR TRAFFIC CENTERS, TERMINAL CONTROL UNITS AND CONTROL TOWERS ALL IN THE NATURE OF AIR TRAFFIC CONTROL SERVICES; PROVIDING FLIGHT PLAN REGISTRATION SERVICES; AERONAUTICAL TRANSPORTATION AND NAVIGATION INFORMATION SERVICES, NAMELY, INFORMATION SERVICES, NAMELY, PROVIDING A WEB SITE FEATURING INFORMATION, AS WELL AS AUDIO, VIDEO, PHOTOGRAPHIC AND PROSE PRESENTATIONS, IN THE FIELDS OF AVIATION, AIR TRAFFIC CONTROL, AND AIR TRAFFIC CONTROL FEES; AERONAUTICAL TRANSPORT AND NAVIGATION INFORMATION SERVICES, NAMELY, PROVIDING AND UPDATING NAVIGATIONAL, ENROUTE, AND AIRPORT INFORMATION (U.S. CLS. 100 AND 105).

CLASS 41—EDUCATION AND ENTERTAINMENT

FOR (BASED ON INTENT TO USE) (BASED ON 44(E)) EDUCATIONAL AND TRAINING SERVICES RELATING TO AIR NAVIGATION, AERONAUTICS AND AIR TRAFFIC CONTROL, NAMELY, PROVIDING CLASSES, COURSES, WORKSHOPS, SEMINARS, CONFERENCES, DEMONSTRATIONS, COMPUTER-BASED TRAINING AND DISTRIBUTION OF EDUCATIONAL MATERIALS IN CONNECTION THEREWITH (U.S. CLS. 100, 101 AND 107).

CLASS 42—SCIENTIFIC AND COMPUTER SERVICES

FOR (BASED ON INTENT TO USE) (BASED ON 44(E)) RADAR DETECTION; RESEARCH AND DEVELOPMENT RELATING TO AIR TRAFFIC SERVICES, NAMELY, TECHNICAL CONSULTING AND RESEARCH AND DEVELOPMENT SERVICES IN THE FIELD OF AIR NAVIGATION AND AIR TRAFFIC CONTROL SYSTEMS; AVIATION WEATHER INFORMATION AND REPORTING SERVICES, NAMELY, AVIATION WEATHER REPORTING AND FORECASTING SERVICES; WEATHER INFORMATION AND REPORTING SERVICES TO PILOTS AND OTHER USERS; TECHNOLOGICAL AND SCIENTIFIC SERVICES, NAMELY, TESTING, ANALYZING AND EVALUATING THE EFFICIENCY, SAFETY AND REGULATORY COMPLIANCE OF THE AIR NAVIGATION SERVICES PERFORMED BY OTHERS FOR SCIENTIFIC AND TECHNICAL PURPOSES, AND TECHNICAL AND SCIENTIFIC CONSULTING RELATED THERETO; TECHNOLOGY SUPERVISION AND INSPECTION IN THE FIELD OF AIR TRAFFIC CONTROL, AND AIR TRAFFIC CONTROL EQUIPMENT AND COMPUTER SOFTWARE; INSTALLATION, MAINTENANCE AND REPAIR OF COMPUTER SOFTWARE FOR AIR TRAFFIC CONTROL SYSTEMS USED FOR CIVIL AIRCRAFT FLIGHT PLAN, NAVIGATION AND GUIDANCE MANAGEMENT; TECHNICAL SUPPORT SERVICES, NAMELY, TROUBLESHOOTING IN THE NATURE OF DIAGNOSING COMPUTER HARDWARE AND SOFTWARE PROBLEMS; TRANSPORTATION AND TRAFFIC PLAN-

NING SERVICES FOR DETERMINING THE LEVEL OF CIVIL AIR NAVIGATION SERVICES NEEDED FOR A GIVEN AREA; LAND USE PLANNING SERVICES TO EVALUATE HOW LAND USE PROJECTS MAY IMPACT AIR NAVIGATION; PROVIDING A WEB SITE FEATURING INFORMATION, AS WELL AS AUDIO, VIDEO, PHOTOGRAPHIC AND PROSE PRESENTATIONS, IN THE FIELDS OF WEATHER AFFECTING AERONAUTICAL TRANSPORTATION AND NAVIGATION; PROVIDING AND UPDATING WEATHER INFORMATION AFFECTING AERONAUTICAL TRANSPORTATION AND NAVIGATION (U.S. CLS. 100 AND 101).

CLASS 45—PERSONAL AND LEGAL SERVICES

FOR (BASED ON INTENT TO USE) (BASED ON 44(E)) OFFERING NON-MEDICAL COORDINATION ASSISTANCE TO EMERGENCY RESPONSE PROVIDERS, NAMELY, ALERTING RESCUE COORDINATION, PROVIDING EMERGENCY AIR TRAFFIC CONSULTATION, ARRANGING FOR THE DISPATCH OF EMERGENCY VEHICLES AND STAFF, AND MONITORING AND NOTIFYING EMERGENCY AND MEDICAL FACILITIES; CONSULTING RELATED TO SAFE AIRCRAFT OPERATION, NAMELY, ESTABLISHING SAFETY OF AIR NAVIGATION AND AIR TRAFFIC CONTROL, NAMELY, REVIEWING STANDARDS AND PRACTICES OF AIR NAVIGATION AND AIR TRAFFIC CONTROL SERVICE PROVIDERS FOR SAFETY PURPOSES AND TO ASSURE COMPLIANCE WITH SAFETY LAWS AND REGULATIONS; PROVIDING AND UPDATING REGULATORY COMPLIANCE INFORMATION, AS WELL AS NON-MEDICAL INFORMATION FOR USE BY EMERGENCY RESPONSE PROVIDERS, AFFECTING AERONAUTICAL TRANSPORTATION AND NAVIGATION (U.S. CLS. 100 AND 101).

FONG HSU, EXAMINING ATTORNEY

SN 85-219,372. MANPOWER INC., MILWAUKEE, WI. FILED 1-17-2011.

EXPERIS

THE MARK CONSISTS OF STANDARD CHARACTERS WITHOUT CLAIM TO ANY PARTICULAR FONT, STYLE, SIZE, OR COLOR.

OWNER OF U.S. REG. NO. 4,080,315.

CLASS 9—ELECTRICAL AND SCIENTIFIC APPARATUS

FOR (BASED ON INTENT TO USE) COMPUTER SOFTWARE FOR ASSESSING JOB AND BUSINESS SKILLS; COMPUTER SOFTWARE FOR WORD PROCESSING TRAINING; COMPUTER SOFTWARE FOR USE IN JOB, BUSINESS, AND OFFICE AUTOMATION TRAINING; COMPUTER SOFTWARE FOR USE IN MANAGEMENT OF JOB APPLICANT DATA (U.S. CLS. 21, 23, 26, 36 AND 38).

CLASS 16—PAPER GOODS AND PRINTED MATTER

FOR (BASED ON INTENT TO USE) PRINTED EDUCATIONAL, TEACHING AND TESTING MATERIALS AND INSTRUCTIONAL TEXTBOOKS FOR USE IN ASSESSING JOB SKILLS; PRINTED INSTRUCTIONAL MATERIALS AND INSTRUCTIONAL TEXTBOOKS FOR USE IN JOB SKILL TRAINING; PRINTED INSTRUCTIONAL MATERIALS AND INSTRUCTIONAL TEXTBOOKS IN THE FIELD OF HUMAN RESOURCES; PRINTED TRAINING MANUALS FOR JOB SKILL TRAINING; PRINTED MONOGRAPHS, NEWSLETTERS AND BULLETINS, ALL IN THE FIELD OF HUMAN RESOURCES (U.S. CLS. 2, 5, 22, 23, 29, 37, 38 AND 50).

CLASS 35—ADVERTISING AND BUSINESS

FOR (BASED ON INTENT TO USE) BUSINESS MANAGEMENT; BUSINESS ADMINISTRATION; OFFICE FUNCTIONS; EMPLOYMENT AGENCY SERVICES; TEMPORARY AND PERMANENT EMPLOYMENT AGENCY SERVICES; EMPLOYMENT RELATED SERVICES, NAMELY, PROVIDING JOB PLACEMENT, CAREER DEVELOPMENT, EMPLOYMENT RECRUITMENT, AND GENERAL EMPLOYMENT INFORMATION TO OTHERS; PERSONNEL MANAGEMENT SERVICES; HUMAN RESOURCES MANAGEMENT SERVICES; PROVIDING AND MANAGING CONTRACT PERSONNEL PROGRAMS; PERSONNEL MANAGEMENT AND CONSULTANCY SERVICES; PROVIDING EMPLOYEE SCREENING AND ASSESSMENT TOOLS, NAMELY, ONLINE VIDEO, AUDIO AND TEXTUAL INTERVIEWING APPLICATIONS TO SUPPORT GENERAL CANDIDATE SCREENING PROCESS VIA A WEBSITE ON A GLOBAL INFORMATION NETWORK; EMPLOYMENT COUNSELING SERVICES; CAREER MANAGEMENT CONSULTATION SERVICES; EMPLOYMENT OUTPLACEMENT SERVICES; PROFESSIONAL BUSINESS CONSULTANCY SERVICES; ACCOUNTING AND INTERNAL BUSINESS AUDIT SERVICES FOR OTHERS, BUSINESS INVESTIGATION SERVICES; BUSINESS ADVICE AND INFORMATION SERVICES; BUSINESS ORGANIZATION CONSULTANCY SERVICES; TAX PREPARATION AND CONSULTING SERVICES; EMPLOYMENT OUTPLACEMENT SERVICES; CAREER TRANSITION SERVICES, NAMELY, EMPLOYMENT OUTPLACEMENT SERVICES (U.S. CLS. 100, 101 AND 102).

CLASS 41—EDUCATION AND ENTERTAINMENT

FOR (BASED ON INTENT TO USE) EDUCATIONAL SERVICES, NAMELY, PROVIDING CLASSES, SEMINARS AND WORKSHOPS IN THE FIELDS OF BUSINESS AND JOB SKILLS, JOB SEARCHING, CAREER DEVELOPMENT, SELF MARKETING AND INTERVIEW SKILLS AND EMPLOYER RESEARCH; PROVIDING TRAINING IN BUSINESS AND JOB SKILLS AND OFFICE TECHNOLOGY; PROVIDING TRAINING IN THE FIELD OF JOB SEARCHING, CAREER DEVELOPMENT, SELF MARKETING, INTERVIEW SKILLS AND RESEARCH WORKSHOPS; TRAINING SERVICES FOR PERSONNEL, NAMELY, TRAINING IN BUSINESS AND JOB SKILLS AND OFFICE TECHNOLOGY; PROVIDING ON-LINE COURSES OF STUDY IN THE FIELDS OF INFORMATION TECHNOLOGY, SOFTWARE USE, JOB AND BUSINESS SKILLS; CAREER MANAGEMENT SERVICES, NAMELY, CAREER COUNSELING SERVICES (U.S. CLS. 100, 101 AND 107).

CLASS 42—SCIENTIFIC AND COMPUTER SERVICES

FOR (BASED ON USE IN COMMERCE) DESIGN AND DEVELOPMENT OF COMPUTER HARDWARE AND SOFTWARE; BUSINESS INFORMATION TECHNOLOGY SECURITY SERVICES, NAMELY, COMPUTER SECURITY SERVICES, NAMELY, MONITORING OF COMPUTER INFORMATION TECHNOLOGY SYSTEMS FOR SECURITY PURPOSES, NAMELY, CONSULTING SERVICES IN THE FIELD OF MAINTAINING THE SECURITY AND INTEGRITY OF DATABASES; PROVIDING TEMPORARY USE OF ON-LINE NON-DOWNLOADABLE COMPUTER SOFTWARE FOR ACCESSING, INPUTTING, STORING, PROCESSING AND RETRIEVING EMPLOYMENT AND CAREER RELATED INFORMATION; PROVIDING TEMPORARY USE OF ON-LINE NON-DOWNLOADABLE SOFTWARE FOR EVALUATING JOB AND CAREER SKILLS; CONSULTANCY, DESIGN AND DEVELOPMENT SERVICES IN THE FIELD OF COMPUTER HARDWARE AND SOFTWARE (U.S. CLS. 100 AND 101).

FIRST USE 1-1-2001; IN COMMERCE 1-1-2001.

BRIAN CALLAGHAN, EXAMINING ATTORNEY

SN 85-230,686. CRISP MEDIA, INC., NEW YORK, NY. FILED 1-31-2011.

CRISP MEDIA

THE MARK CONSISTS OF STANDARD CHARACTERS WITHOUT CLAIM TO ANY PARTICULAR FONT, STYLE, SIZE, OR COLOR.

NO CLAIM IS MADE TO THE EXCLUSIVE RIGHT TO USE "MEDIA", APART FROM THE MARK AS SHOWN.

CLASS 35—ADVERTISING AND BUSINESS

FOR BUSINESS CONSULTING SERVICES IN THE FIELD OF CREATION, DELIVERY AND MEASUREMENT OF DIGITAL ADVERTISING AND MARKETING; COORDINATING AND PLACING ADVERTISING FOR OTHERS ON WIRED, MOBILE AND WIRELESS NETWORKS USING SPECIALIZED COMPUTER SOFTWARE (U.S. CLS. 100, 101 AND 102).

FIRST USE 12-2-2010; IN COMMERCE 12-2-2010.

CLASS 42—SCIENTIFIC AND COMPUTER SERVICES

FOR PROVIDING TEMPORARY USE OF ONLINE, NON-DOWNLOADABLE COMPUTER SOFTWARE PLATFORMS THAT CREATE SPACE FOR DIGITAL ADVERTISEMENTS AND DELIVER DIGITAL ADVERTISEMENTS ON WIRED, MOBILE AND WIRELESS DEVICES AND THAT MEASURE AND GENERATE REPORTS RELATING TO THE SUCCESS OF DIGITAL ADVERTISING AND MARKETING CAMPAIGNS; PROVIDING TEMPORARY USE OF ONLINE, NON-DOWNLOADABLE COMPUTER SOFTWARE FOR CREATING DIGITAL ADVERTISEMENTS DISPLAYED ON WIRED, MOBILE AND WIRELESS DEVICES; COMPUTER SERVICES, NAMELY, CREATION, DESIGN AND DEVELOPMENT OF WEBSITES, MICROSITES AND COMPUTER APPLICATION SOFTWARE FOR THIRD PARTIES (U.S. CLS. 100 AND 101).

JOHN GARTNER, EXAMINING ATTORNEY

SN 85-219,821. DROPOUT & TRUANCY PREVENTION NETWORK, LLC, DALLAS, TX. FILED S.R. 1-18-2011; AM. P.R. 10-18-2011.



NO CLAIM IS MADE TO THE EXCLUSIVE RIGHT TO USE "MENTORING PROGRAM", APART FROM THE MARK AS SHOWN.

THE COLOR(S) BLUE, DARK BLUE, LIGHT BLUE AND WHITE IS/ARE CLAIMED AS A FEATURE OF THE MARK.

THE MARK CONSISTS OF A BLUE, DARK BLUE AND LIGHT BLUE BOX WITH THE WORDS "RIGHT BACK ON TRACK" WRITTEN IN WHITE AND OUTLINED IN BLUE WITH A WHITE ROAD BELOW. BELOW THE BLUE BOX ARE THE WORDS "MENTORING PROGRAM" WRITTEN IN BLUE.

CLASS 41—EDUCATION AND ENTERTAINMENT

FOR PROVIDING PHONE-BASED MENTORING AND COACHING SERVICES TO COMBAT TRUANCY (U.S. CLS. 100, 101 AND 107).

FIRST USE 11-18-2010; IN COMMERCE 11-18-2010.

CLASS 45—PERSONAL AND LEGAL SERVICES

FOR LOCATION VERIFICATION TECHNOLOGY SUPPORT PROGRAMS TO COMBAT TRUANCY, NAMELY, TRACKING, LOCATING AND MONITORING SERVICES FOR RECOVERING STUDENTS (U.S. CLS. 100 AND 101).

FIRST USE 11-18-2010; IN COMMERCE 11-18-2010.

SANI KHOURI, EXAMINING ATTORNEY

SN 85-236,131. SCOTWORK, GLASGOW, UNITED KINGDOM, FILED 2-7-2011.

SCOTWORK

THE MARK CONSISTS OF STANDARD CHARACTERS WITHOUT CLAIM TO ANY PARTICULAR FONT, STYLE, SIZE, OR COLOR.

OWNER OF ERPN CMNTY TM OFC REG. NO. 009594714, DATED 3-18-2012, EXPIRES 12-14-2020.

OWNER OF U.S. REG. NOS. 1,972,594 AND 3,315,439.

CLASS 9—ELECTRICAL AND SCIENTIFIC APPARATUS

FOR ELECTRONIC PUBLICATIONS DOWNLOADABLE FROM THE INTERNET OR FROM A COMPUTER NETWORK IN THE NATURE OF BOOKS, MANUALS AND TEXT IN THE FIELD OF NEGOTIATION SKILLS, TECHNIQUES, TACTICS AND STRATEGIES; ELECTRONIC PUBLICATIONS, NAMELY, REPORTS FEATURING NEGOTIATING TECHNIQUES, TACTICS AND STRATEGIES RECORDED ON COMPUTER MEDIA; ELECTRONIC PUBLICATIONS, NAMELY, BOOKS, MANUALS AND TEXT FEATURING NEGOTIATING TECHNIQUES, TACTICS AND STRATEGIES RECORDED ON COMPUTER MEDIA; PRERECORDED ELECTRONIC, DIGITAL AND/OR MAGNETIC CARRIER MEDIA FEATURING NEGOTIATING TECHNIQUES, TACTICS AND STRATEGIES; INTERACTIVE COMPUTERS FOR USE IN TRAINING; INTERACTIVE COMPUTER SOFTWARE FOR USE IN ANALYZING STORED INFORMATION IN THE FIELD OF NEGOTIATING TECHNIQUES, TACTICS AND STRATEGIES; DATA RECORDED ELECTRONICALLY AND/OR IN MACHINE-READABLE FORM FROM THE INTERNET, NAMELY, COMPUTER SOFTWARE PROGRAMS DOWNLOADABLE VIA THE INTERNET; DATA RECORDED ELECTRONICALLY AND/OR IN MACHINE-READABLE FORM FROM THE INTERNET, NAMELY, COMPUTER SOFTWARE PROGRAMS DOWNLOADABLE VIA THE INTERNET; EDUCATIONAL COMPUTER SOFTWARE FEATURING NEGOTIATION TECHNIQUES, TACTICS AND STRATEGIES; SOUND RECORDINGS AND AUDIO-VISUAL RECORDS FEATURING NEGOTIATION TECHNIQUES, TACTICS AND STRATEGIES; DIGITAL, PRE-RECORDED VIDEOTAPES, COMPACT DISCS, DVDS AND LASER DISCS, ALL FEATURING NEGOTIATION TECHNIQUES, TACTICS AND STRATEGIES; AUDIO CASSETTES FEATURING NEGOTIATION TECHNIQUES, TACTICS AND STRATEGIES; PHONOGRAPHIC RECORDS FEATURING NEGOTIATION TECHNIQUES, TACTICS AND STRATEGIES; DOWNLOADABLE PODCASTS IN THE FIELD OF NEGOTIATION TECHNIQUES, TACTICS AND STRATEGIES; DATA CARRIERS, NAMELY, DISC MEMORIES, COMPUTER MEMORIES AND MEMORY CARDS; PRERECORDED MAGNETIC DATA CARRIERS FEATURING NEGOTIATION TECHNIQUES, TACTICS AND STRATEGIES; AND BLANK RECORDABLE OPTICAL DISCS (U.S. CLS. 21, 23, 26, 36 AND 38).

CLASS 41—EDUCATION AND ENTERTAINMENT

FOR EDUCATIONAL, INSTRUCTIONAL AND TEACHING SERVICES, NAMELY, ORGANIZATION AND RUNNING OF TRAINING COURSES IN THE FIELD OF NEGOTIATING SKILLS, TECHNIQUES, TACTICS AND STRATEGIES; PUBLICATION OF BOOKS AND TEXTS; INFORMATION RELATING TO EDUCATION AND TRAINING, PROVIDED ON-LINE FROM A COMPUTER DATABASE OR THE INTERNET; PROVIDING ON-LINE ELECTRONIC PUBLICATIONS IN THE NATURE OF BOOKS, MANUALS AND TEXT FEATURING NEGOTIATION TECHNIQUES, TACTICS AND STRATEGIES; INTERACTIVE ONLINE TRAINING SERVICES FEATURING NEGOTIATION TECHNIQUES, TACTICS AND STRATEGIES; EDUCATIONAL ASSESSMENT OF SKILLS IN THE FIELD OF NEGOTIATION TECHNIQUES, TACTICS AND STRATEGIES; PROVIDING EDUCATIONAL MENTORING SERVICES IN THE FIELD OF NEGOTIATION TECHNIQUES, TACTICS AND STRATEGIES; EDUCATIONAL, INSTRUCTIONAL AND TEACHING SERVICES IN THE FORM OF E-LEARNING FOR DISTANCE LEARNING PROGRAMS, NAMELY, ORGANIZATION AND RUNNING OF ON-LINE TRAINING COURSES IN THE FIELD OF NEGOTIATING TECHNIQUES, TACTICS AND STRATEGIES; EDUCATIONAL SERVICES, NAMELY, PROVIDING DISTANCE LEARNING INSTRUCTION, INCLUDING THOSE PROVIDED ONLINE, AT THE BUSINESS LEVEL; EDUCATION IN THE FIELD OF NEGOTIATING TECHNIQUES, TACTICS AND STRATEGIES RENDERED THROUGH CORRESPONDENCE COURSES, INCLUDING THOSE PROVIDED ON-LINE; INFORMATION, ADVISORY AND CONSULTANCY SERVICES RELATING TO ALL THE FOREGOING (U.S. CLS. 100, 101 AND 107).

JOHN GARTNER, EXAMINING ATTORNEY

SN 85-236,291. THE MORGAN CRUCIBLE COMPANY PLC, WINDSOR, BERKSHIRE, UNITED KINGDOM, FILED 2-8-2011.

MORGAN THERMAL CERAMICS

THE MARK CONSISTS OF STANDARD CHARACTERS WITHOUT CLAIM TO ANY PARTICULAR FONT, STYLE, SIZE, OR COLOR.

OWNER OF U.S. REG. NOS. 2,294,862 AND 3,328,173.
NO CLAIM IS MADE TO THE EXCLUSIVE RIGHT TO USE "CERAMICS", APART FROM THE MARK AS SHOWN, SEC. 2(F) AS TO "THERMAL CERAMICS".

CLASS 17—RUBBER GOODS

FOR HIGH TEMPERATURE INSULATING AND FIRE RESISTANT CERAMIC MATERIALS AND RELATED GOODS CONSISTING OF, CERAMIC INSULATION FOR USE IN HIGH TEMPERATURE APPLICATIONS IN THE METALS, CERAMIC, CEMENT, GLASS, REFRACTORY, UTILITY, CHEMICAL, AND PETROLEUM INDUSTRIES IN THE FORM OF FIBERS, BLANKETS, INDIVIDUALLY INSTALLABLE REFRACTORY FIBER INSULATION MODULES, COMPRISING REFRACTORY FIBER INSULATION IN PREFABRICATED, PRESIZED PIECES, WHICH MAY CONTAIN MOUNTING HARDWARE, WHICH MAY BE BOARDS, BATTING, NAMELY, LAYERS OR SHEETS OF REFRACTORY INSULATIVE FIBER, GASKETS, YARNS, ROPES, CLOTH, PAPER, NAMELY, THIN LAYERS OF REFRACTORY FIBER AND ORGANIC BINDER, FELT, NAMELY, LAYERS OF REFRACTORY FIBER AND INORGANIC BINDER, AND MOLDED AND CAST REFRACTORY INSULATING SHAPES; FIRE PROTECTION BARRIER MATERIALS IN THE FORM OF FIBERS, BLANKETS, BOARDS, PUTTIES, CABLE TRAY PROTECTION SYSTEMS, COMPRISING FIRE PROTECTIVE INSULATIVE BLANKET, DUCT PROTECTION SYSTEMS COMPRISING FIRE PROTECTIVE INSULATIVE BLANKET, PLASTIC PIPE PROTECTION SYSTEMS COMPRISING FIRE PROTECTIVE INSULATIVE BLANKET, STRUCTURAL STEEL PROTECTION SYSTEMS COMPRISING FIRE PROTECTIVE INSULATIVE BLANKET, SEAL AND JOINT PROTECTION SYSTEMS COMPRISING FIRE PROTECTIVE INSULATIVE BLANKET; INDIVIDUALLY INSTALLABLE CERAMIC FIBER FURNACE INSULATION MODULES COMPRISING REFRACTORY FIBER INSULATION AND MOUNTING HARDWARE; CERAMIC INSULATIVE LININGS FOR FURNACES AND KILNS; INSULATION FOAM FOR USE IN REFRACTORY LININGS; FURNACE AND BOILER INSULATION IN THE FORM OF FIBERS, BLANKETS, INDIVIDUALLY INSTALLABLE REFRACTORY FIBER INSULATION MODULES COMPRISING REFRACTORY FIBER INSULATION IN PREFABRICATED PRESIZED PIECES WHICH MAY CONTAIN MOUNTING HARDWARE, BOARDS, BATTING, NAMELY, LAYERS OR SHEETS OF REFRACTORY INSULATIVE FIBER, GASKETS, YARNS, ROPES, CLOTH, PAPER, NAMELY, THIN LAYERS OF REFRACTORY FIBER AND ORGANIC BINDER, FELT, NAMELY, LAYERS OF REFRACTORY FIBER AND INORGANIC BINDER, AND MOLDED AND CAST REFRACTORY INSULATING SHAPES (U.S. CLS. 1, 5, 12, 13, 35 AND 50).

CLASS 19—NON-METALLIC BUILDING MATERIALS

FOR REFRACTORY MONOLITHICS; STRUCTURAL FIRE BRICKS WITH INSULATING QUALITIES AND HIGH TEMPERATURE BRICKS, REFRACTORY OR CERAMIC FIBER TILES, REFRACTORY OR CERAMIC FIBER CONSTRUCTION BLOCKS; REFRACTORY CAST, CASTABLE, MOLDABLE, AND GUNNABLE CEMENTS IN POWDER, PLASTIC, AND GRANULAR FORMS; MORTARS AND REFRACTORY TUBES AND PIPES; REFRACTORY CERAMIC SHAPES; AND MOLDABLE MODELING CLAYS USED TO MAKE BRICKS, MONOLITHICS, MOLDS FOR BRICKS AND MOLDS FOR MONOLITHICS (U.S. CLS. 1, 12, 33 AND 50).

TAMARA FRAZIER, EXAMINING ATTORNEY

CLASS 41—EDUCATION AND ENTERTAINMENT

FOR RADIO AND TELEVISION PROGRAMS PRODUCTION; PRESENTATION OF LIVE SHOW PERFORMANCES; VIDEOTAPE FILM PRODUCTION; DIGITAL IMAGING SERVICES; LIVE, TELEVISED AND MOVIE APPEARANCES BY A PROFESSIONAL ENTERTAINER; ENTERTAINMENT INFORMATION; MODELING FOR ARTISTS; RENTAL OF MOTION PICTURES; MOVIE STUDIOS; MOVIE THEATRES; MUSIC COMPOSITION SERVICES FOR OTHERS; NEWS REPORTER SERVICES; ENTERTAINMENT SERVICES, NAMELY, LIVE AND RECORDED KARAOKE SERVICES; RECORDING STUDIOS SERVICES; RENTAL OF VIDEOTAPES; AND VIDEO EDITING (U.S. CLS. 100, 101 AND 107).

DOMINIC J. FERRAIUOLO, EXAMINING ATTORNEY

SN 85-236,661. BANGKOK BROADCASTING & TV CO., LTD., JOMPOL, JATUJAK BANGKO, THAILAND, FILED 2-8-2011.



NO CLAIM IS MADE TO THE EXCLUSIVE RIGHT TO USE "TV", APART FROM THE MARK AS SHOWN.

THE COLOR(S) RED, GREEN, AND BLUE ARE CLAIMED AS PART OF THE MARK. THE WHITE IN THE DRAWING REPRESENTS BACKGROUND, OUTLINING, SHADING, AND/OR TRANSPARENT AREAS AND IS NOT PART OF THE MARK. IS/ARE CLAIMED AS A FEATURE OF THE MARK.

THE MARK CONSISTS OF A RED FILLED RECTANGLE WITH AN OUTLINE OF THE LETTER "B" REMOVED, TO THE LEFT OF A GREEN FILLED RECTANGLE WITH AN OUTLINE OF THE LETTER "B" REMOVED, TO THE LEFT OF A BLUE FILLED RECTANGLE WITH THE LETTERS "TV" REMOVED, ALL THREE RECTANGLES SEPARATED AND SURROUNDED BY SPACE.

CLASS 9—ELECTRICAL AND SCIENTIFIC APPARATUS

FOR COMPUTERS; PRE-RECORDED ELECTRONIC AND DIGITAL MEDIA FEATURING ENTERTAINMENT AND ENTERTAINMENT INFORMATION IN THE NATURE OF AUDIO, VIDEO, AND DATA; PRERECORDED MAGNETIC DATA CARRIERS FEATURING ENTERTAINMENT AND ENTERTAINMENT INFORMATION IN THE NATURE OF AUDIO, VIDEO, AND DATA; PHONOGRAPH RECORDS; VISUAL AND AUDIO RECORDINGS FEATURING ENTERTAINMENT AND ENTERTAINMENT INFORMATION; EXPOSED CINEMATOGRAPHIC FILM (U.S. CLS. 21, 23, 26, 36 AND 38).

CLASS 38—COMMUNICATION

FOR TELEVISION BROADCASTING; RADIO BROADCASTING; CELLULAR TELEPHONE COMMUNICATION; TRANSMISSION OF NEWS; NEWS AGENCY SERVICES FOR ELECTRONIC TRANSMISSION; SATELLITE TRANSMISSION; TELECONFERENCING SERVICES, BROADCASTING SERVICES AND PROVISION OF BOTH WIRE AND WIRELESS TELECOMMUNICATION ACCESS TO VIDEO AND AUDIO CONTENT PROVIDED VIA A VIDEO-ON-DEMAND SERVICE VIA THE INTERNET (U.S. CLS. 100, 101 AND 104).

SN 85-237,937. GE-HITACHI GLOBAL LASER ENRICHMENT LLC, WILMINGTON, NC. FILED 2-9-2011.

GLOBAL LASER ENRICHMENT

THE MARK CONSISTS OF STANDARD CHARACTERS WITHOUT CLAIM TO ANY PARTICULAR FONT, STYLE, SIZE, OR COLOR.

NO CLAIM IS MADE TO THE EXCLUSIVE RIGHT TO USE "LASER ENRICHMENT" FOR SERVICES IN INTERNATIONAL CLASSES 40 AND 42, APART FROM THE MARK AS SHOWN.

CLASS 1—CHEMICALS

FOR URANIUM FUEL FOR USE IN COMMERCIAL NUCLEAR POWER PLANTS (U.S. CLS. 1, 5, 6, 10, 26 AND 46).

CLASS 37—CONSTRUCTION AND REPAIR

FOR MINING EXTRACTION OF URANIUM (U.S. CLS. 100, 103 AND 106).

CLASS 40—MATERIAL TREATMENT

FOR NUCLEAR FUEL RECYCLING; NUCLEAR FUEL REPROCESSING; TREATMENT OF MATERIALS, NAMELY, URANIUM ENRICHMENT, URANIUM CONVERSION, URANIUM RE-CONVERSION AND LASER ISOTOPE SEPARATION (U.S. CLS. 100, 103 AND 106).

CLASS 42—SCIENTIFIC AND COMPUTER SERVICES

FOR MINING EXPLORATION AND MINERAL EXPLORATION SERVICES IN THE FIELD OF URANIUM; RESEARCH, DEVELOPMENT AND ENGINEERING SERVICES IN THE FIELDS OF ISOTOPE SEPARATION AND ENRICHMENT OF URANIUM (U.S. CLS. 100 AND 101).

REBECCA EISINGER, EXAMINING ATTORNEY

SN 85-244,215. SONOMAX TECHNOLOGIES INC., MONTREAL, QUEBEC, CANADA, FILED 2-16-2011.

SONOMAX

THE MARK CONSISTS OF STANDARD CHARACTERS WITHOUT CLAIM TO ANY PARTICULAR FONT, STYLE, SIZE, OR COLOR.

CLASS 9—ELECTRICAL AND SCIENTIFIC APPARATUS

FOR (BASED ON INTENT TO USE) CUSTOM FITTING SYSTEM NOT FOR MEDICAL PURPOSES FOR CUSTOM-FIT IN-EAR DEVICES COMPRISED PRIMARILY OF A HEADBAND, A MODULAR EARPIECE, INFLATION PUMPS, SILICONE COMPOUNDS, ALL SOLD TOGETHER AS A UNIT; CUSTOM FIT EARPHONES; CUSTOM-FIT HEADPHONES; CUSTOM-FIT HEARING DEVICES, NAMELY, HEADSETS, HEADPHONES, EAR BUDS, EARPHONES AND EARPIECES, NOT FOR MEDICAL USE; CUSTOM-FIT HEARING PROTECTION DEVICES, NAMELY, HEADSETS, HEADPHONES, EAR BUDS, EARPHONES AND EARPIECES, NOT FOR MEDICAL USE; CUSTOM-FIT WIRELESS COMMUNICATIONS HEADSETS FOR TELEPHONES AND MOBILE TELEPHONES; CUSTOM CUSTOM-FIT HEARING DEVICES, NAMELY, AMPLIFIERS NOT FOR MEDICAL USE; (BASED ON USE IN COMMERCE) HEARING PROTECTION SYSTEM NOT FOR MEDICAL USE COMPRISED OF AN EAR PLUG WITH SOUND FILTERS AND AMPLIFICATION MODULES HAVING DIGITAL SIGNAL PROCESSING CAPABILITIES (U.S. CLS. 21, 23, 26, 36 AND 38).

FIRST USE 12-31-2003; IN COMMERCE 12-31-2003.

CLASS 10—MEDICAL APPARATUS

FOR (BASED ON INTENT TO USE) CUSTOM-FIT HEARING DEVICES, NAMELY, AMPLIFIERS FOR USE WITH HEARING AIDS; HEARING AIDS; (BASED ON USE IN COMMERCE) HEARING PROTECTION SYSTEM FOR MEDICAL USE COMPRISED OF AN EAR PLUG WITH HEARING PROTECTION FILTERS AND AMPLIFIERS WITH DIGITAL SIGNAL PROCESSING CAPABILITIES (U.S. CLS. 26, 39 AND 44).

FIRST USE 12-31-2003; IN COMMERCE 12-31-2003.

KYLE PEETE, EXAMINING ATTORNEY

SN 85-245,623. ELITE PARTNERS, LLC, POMPTON PLAINS, NJ. FILED 2-18-2011.

FOUNTAIN

THE MARK CONSISTS OF STANDARD CHARACTERS WITHOUT CLAIM TO ANY PARTICULAR FONT, STYLE, SIZE, OR COLOR.

CLASS 7—MACHINERY

FOR FITTED AND SEMI-FITTED EQUIPMENT COVERS FOR POWER-OPERATED LAWN MOWERS, LAWN TRACTORS, ELECTRIC GENERATORS, PRESSURE WASHERS, SNOW THROWERS/BLOWERS, ROTOTILLERS AND LOG SPLITTERS (U.S. CLS. 13, 19, 21, 23, 31, 34 AND 35).

CLASS 11—ENVIRONMENTAL CONTROL APPARATUS

FOR FITTED AND SEMI-FITTED GRILL COVERS (U.S. CLS. 13, 21, 23, 31 AND 34).

CLASS 12—VEHICLES

FOR FITTED AND SEMI-FITTED VEHICLE AND MOTORIZED GOLF CART COVERS (U.S. CLS. 19, 21, 23, 31, 35 AND 44).

CLASS 20—FURNITURE AND ARTICLES NOT OTHERWISE CLASSIFIED

FOR FITTED FABRIC AND SEMI-FITTED FABRIC HOME PATIO FURNITURE COVERS (U.S. CLS. 2, 13, 22, 25, 32 AND 50).

MARLENE BELL, EXAMINING ATTORNEY

SN 85-246,404. ALPHABUYER, LLC, PAOLI, PA. FILED 2-18-2011.



THE COLOR(S) BLUE, WHITE AND BLACK IS/ARE CLAIMED AS A FEATURE OF THE MARK.

THE MARK CONSISTS OF A BLUE CIRCLE INLAID WITH A WHITE IMAGE OF THE LOWER-CASE LETTERS "A" AND "B" JOINED TOGETHER TO FORM A FIGURE-EIGHT DESIGN, ADJACENT TO THE LOWER-CASE TITLE "ALPHABUYER" IN A CUSTOM FONT THAT RESEMBLES AVIAN, WITH "ALPHA" SPELLED IN BLACK AND "BUYER" SPELLED IN BLUE.

CLASS 35—ADVERTISING AND BUSINESS

FOR ADMINISTRATION OF A PROGRAM FOR ENABLING PARTICIPANTS TO OBTAIN DISCOUNTS ON PRODUCTS AND SERVICES (U.S. CLS. 100, 101 AND 102).

FIRST USE 12-13-2010; IN COMMERCE 12-13-2010.

CLASS 45—PERSONAL AND LEGAL SERVICES

FOR ONLINE SOCIAL NETWORKING SERVICES IN THE FIELD OF COMMERCE PROVIDED VIA A WEBSITE (U.S. CLS. 100 AND 101).

FIRST USE 12-13-2010; IN COMMERCE 12-13-2010.

GINA HAYES, EXAMINING ATTORNEY

SN 85-246,748. ZIJA INTERNATIONAL, INC., LEHI, UT.
FILED 2-18-2011.

XM PLUS

THE MARK CONSISTS OF STANDARD CHARACTERS WITHOUT CLAIM TO ANY PARTICULAR FONT, STYLE, SIZE, OR COLOR.

OWNER OF U.S. REG. NOS. 3,758,664 AND 3,758,665.

CLASS 5—PHARMACEUTICALS

FOR DIETARY SUPPLEMENTS; NUTRITIONAL SUPPLEMENTS; DIETARY SUPPLEMENTS DRINK MIXES; DIETARY BEVERAGE SUPPLEMENTS FOR HUMAN CONSUMPTION IN DRY MIX FORM FOR THERAPEUTIC PURPOSE (U.S. CLS. 6, 18, 44, 46, 51 AND 52).

CLASS 32—LIGHT BEVERAGES

FOR ENERGY DRINKS (U.S. CLS. 45, 46 AND 48).
TRACY WHITTAKER-BROWN, EXAMINING ATTORNEY

SN 85-249,508. LOANDEPOT.COM, LLC, IRVINE, CA. FILED
2-23-2011.

EQUITY FREEDOM

THE MARK CONSISTS OF STANDARD CHARACTERS WITHOUT CLAIM TO ANY PARTICULAR FONT, STYLE, SIZE, OR COLOR.

OWNER OF U.S. REG. NO. 3,654,651.

NO CLAIM IS MADE TO THE EXCLUSIVE RIGHT TO USE "EQUITY", APART FROM THE MARK AS SHOWN.

CLASS 9—ELECTRICAL AND SCIENTIFIC APPARATUS

FOR COMPUTER SOFTWARE, NAMELY, ELECTRONIC FINANCIAL AND LOAN SERVICES PLATFORM THAT ACCOMMODATES MULTIPLE TYPES OF PAYMENT AND DEBT TRANSACTIONS IN AN INTEGRATED MOBILE PHONE, PDA OR WEB BASED ENVIRONMENT; SOFTWARE FOR USE IN COMMUNICATION OF DATA BETWEEN COMPUTERS AND OTHER COMPUTERS OR COMPUTER PERIPHERALS; COMPUTER SOFTWARE FOR USE IN FINANCIAL AND LOAN MATTERS, NAMELY, SOFTWARE FOR ACCESSING AND CONDUCTING ELECTRONIC LOAN SERVICES VIA GLOBAL COMPUTER NETWORKS AND TELECOMMUNICATION NETWORKS; EDUCATIONAL SOFTWARE FOR USE IN MONEY LENDING, LOAN PROCESSING, AND LOAN SERVICING; COMPUTER E-COMMERCE SOFTWARE TO ALLOW USERS TO PERFORM ELECTRONIC BUSINESS TRANSACTIONS VIA A GLOBAL COMPUTER NETWORK; AND COMPUTER SOFTWARE THAT PROVIDES REAL-TIME, INTEGRATED BUSINESS MANAGEMENT INTELLIGENCE BY COMBINING INFORMATION FROM VARIOUS DATABASES AND PRESENTING IT IN AN EASY-TO-UNDERSTAND USER INTERFACE (U.S. CLS. 21, 23, 26, 36 AND 38).

CLASS 16—PAPER GOODS AND PRINTED MATTER

FOR PUBLICATIONS, NAMELY, PRINTED INFORMATIONAL, INSTRUCTIONAL AND EDUCATIONAL MATERIALS FOR USE IN MONEY LENDING, LOAN PROCESSING, AND LOAN SERVICING (U.S. CLS. 2, 5, 22, 23, 29, 37, 38 AND 50).

KAREN K. BUSH, EXAMINING ATTORNEY

SN 85-254,369. CRAFTWORK CARDS LIMITED, LEEDS, WEST YORKSHIRE, UNITED KINGDOM, FILED 3-1-2011.

CANDI

THE MARK CONSISTS OF STANDARD CHARACTERS WITHOUT CLAIM TO ANY PARTICULAR FONT, STYLE, SIZE, OR COLOR.

PRIORITY CLAIMED UNDER SEC. 44(D) ON UNITED KINGDOM APPLICATION NO. 2569589, FILED 1-19-2011, REG. NO. 2569589, DATED 1-19-2011, EXPIRES 1-19-2021.

CLASS 16—PAPER GOODS AND PRINTED MATTER

FOR PAPER, PAPERBOARD AND CARDBOARD; PLASTIC BUBBLE PACKS FOR WRAPPING OR PACKAGING; PLASTIC CARDS FOR USE AS STENCILS OR TEMPLATES; PLASTIC COATED COPYING PAPER; STATIONERY IN THE NATURE OF PLASTIC DOCUMENT COVERS; PLASTIC ENVELOPES; PLASTIC STICKERS; PAPERBOARD IN THE FORM OF DISC SHAPES FOR USE IN CRAFTS; PAPER CRAFTS MATERIALS, NAMELY, CRAFT PAPER; PAPER RIBBONS AND BOWS FOR USE IN CRAFTS; PAPERBOARD DIE CUT SHAPES AND PAPERBOARD DIE CUT LETTER SHAPES; GLITTER GLUE FOR CRAFT PURPOSES; RUB DOWN STICKERS AND TRANSFERS; IRON ON TRANSFERS; STICKERS; RUBBER AND ACRYLIC STAMPS AND PUNCHES; PAPER DIE CUT LETTER SHAPES; PAPER DOILIES; STENCILS; DRAWING TEMPLATES; NOTE CARDS AND GREETINGS CARDS; ENVELOPES; ARTISTS' KITS FOR MAKING GREETINGS CARDS; PAPERBOARD BOXES; GIFT BOXES; STATIONERY; PENS AND PENCILS; ADHESIVES FOR CRAFT PURPOSES; ADHESIVE FOAM BACKED PADS; DRAWING MATERIALS, NAMELY, DRAWING PADS; PRINTED MATTER, NAMELY, MAGAZINES IN THE FIELD OF CRAFTS (U.S. CLS. 2, 5, 22, 23, 29, 37, 38 AND 50).

CLASS 21—HOUSEWARES AND GLASS

FOR PLASTIC CONTAINERS FOR USE IN STORING CRAFT MATERIALS (U.S. CLS. 2, 13, 23, 29, 30, 33, 40 AND 50).

CLASS 26—FANCY GOODS

FOR LACES AND EMBROIDERY, RIBBONS, BRAIDS, BUTTONS, ORNAMENTAL BOWS OF TEXTILE FOR DECORATION, BEADS OTHER THAN FOR MAKING JEWELRY, SEQUINS, HOOKS AND EYES, EYELETS, ORNAMENTAL NOVELTY BADGES AND ARTIFICIAL FLOWERS, ALL OF THE FOREGOING FOR USE IN CONNECTION WITH CRAFTS (U.S. CLS. 37, 39, 40, 42 AND 50).

STEVEN PEREZ, EXAMINING ATTORNEY

SN 85-255,019. FIVE GUYS HOLDINGS, INC., LORTON, VA.
FILED 3-1-2011.

FIVE GUYS

THE MARK CONSISTS OF STANDARD CHARACTERS WITHOUT CLAIM TO ANY PARTICULAR FONT, STYLE, SIZE, OR COLOR.

OWNER OF U.S. REG. NOS. 3,079,591, 3,571,563 AND OTHERS.

CLASS 12—VEHICLES

FOR LICENSE PLATE FRAMES (U.S. CLS. 19, 21, 23, 31, 35 AND 44).

FIRST USE 5-31-2007; IN COMMERCE 5-31-2007.

CLASS 25—CLOTHING

FOR CLOTHING, NAMELY, SHIRTS, PULL-OVERS; HEADWEAR; HATS (U.S. CLS. 22 AND 39).

FIRST USE 5-31-1988; IN COMMERCE 5-31-2007.

CLASS 29—MEATS AND PROCESSED FOODS

FOR FRIED POTATOES; PROCESSED PEANUTS; HOT DOGS; HAMBURGERS (U.S. CL. 46).

FIRST USE 8-31-1986; IN COMMERCE 4-30-2004.

CLASS 30—STAPLE FOODS

FOR SANDWICHES; HOTDOG SANDWICHES; HAMBURGER SANDWICHES; CHEESEBURGER SANDWICHES (U.S. CL. 46).

FIRST USE 8-31-1986; IN COMMERCE 4-30-2004.

CLASS 32—LIGHT BEVERAGES

FOR NON-ALCOHOLIC BEVERAGES, NAMELY, CARBONATED BEVERAGES; SOFT DRINKS; NON-ALCOHOLIC BEVERAGES, NAMELY, BOTTLED WATER (U.S. CLS. 45, 46 AND 48).

FIRST USE 8-31-1986; IN COMMERCE 4-30-2004.

CLASS 35—ADVERTISING AND BUSINESS

FOR FRANCHISE SERVICES, NAMELY, OFFERING BUSINESS MANAGEMENT ASSISTANCE IN THE ESTABLISHMENT AND OPERATION OF RESTAURANTS (U.S. CLS. 100, 101 AND 102).

FIRST USE 4-30-2003; IN COMMERCE 4-30-2003.
CHRISTINE MARTIN, EXAMINING ATTORNEY

SN 85-255,682. AEROMOVEL USA INCORPORATED, WESTLAKE VILLAGE, CA. FILED 3-2-2011.

AEROMOVEL

THE MARK CONSISTS OF STANDARD CHARACTERS WITHOUT CLAIM TO ANY PARTICULAR FONT, STYLE, SIZE, OR COLOR.

OWNER OF U.S. REG. NO. 1,819,209.
THE WORDING "AEROMOVEL" HAS NO MEANING IN A FOREIGN LANGUAGE.

CLASS 35—ADVERTISING AND BUSINESS

FOR BUSINESS MANAGEMENT AND CONSULTING (U.S. CLS. 100, 101 AND 102).

CLASS 42—SCIENTIFIC AND COMPUTER SERVICES

FOR ENGINEERING SERVICES (U.S. CLS. 100 AND 101).

CURTIS FRENCH, EXAMINING ATTORNEY

SN 85-256,095. ALSTOM, 92300 LEVALLOIS-PERRET, FRANCE, FILED 3-2-2011.

TRAINTRACER

THE MARK CONSISTS OF STANDARD CHARACTERS WITHOUT CLAIM TO ANY PARTICULAR FONT, STYLE, SIZE, OR COLOR.

OWNER OF FRANCE REG. NO. 013105257, DATED 5-31-2001, RENEWED AS REG. NO. 013105257, DATED 5-31-2011, EXPIRES 5-31-2021.

CLASS 9—ELECTRICAL AND SCIENTIFIC APPARATUS

FOR DATA PROCESSORS, DATA MANAGEMENT IN THE NATURE OF MICRO PROCESSORS AND COMPUTER SOFTWARE FOR USE IN DATABASE MANAGEMENT IN DATABASE SEARCHES AND QUERIES AND FOR DISPLAYING RETRIEVED INFORMATION IN THE FIELD OF PASSENGER AND FREIGHT TRANSPORT SYSTEMS MAINTENANCE (U.S. CLS. 21, 23, 26, 36 AND 38).

CLASS 35—ADVERTISING AND BUSINESS

FOR DATA MANAGEMENT, NAMELY, DATABASE MANAGEMENT IN DATABASE SEARCHES AND QUERIES AND FOR DISPLAYING RETRIEVED INFORMATION IN THE FIELD OF PASSENGER AND FREIGHT TRANSPORT SYSTEMS MAINTENANCE (U.S. CLS. 100, 101 AND 102).

CLASS 37—CONSTRUCTION AND REPAIR

FOR PASSENGER AND FREIGHT TRANSPORT SYSTEMS MAINTENANCE, NAMELY, MAINTENANCE SERVICES FOR RAIL VEHICLES, LOCOMOTIVES, TRAINS, WAGONS, AUTOMOBILES, BUSES, SHIPS AND VESSELS (U.S. CLS. 100, 103 AND 106).

MARK RADEMACHER, EXAMINING ATTORNEY

SN 85-257,167. RECYCOAL HOLDINGS LIMITED, DONCASTER, UNITED KINGDOM, FILED 3-3-2011.

RECYCOAL

THE MARK CONSISTS OF STANDARD CHARACTERS WITHOUT CLAIM TO ANY PARTICULAR FONT, STYLE, SIZE, OR COLOR.

PRIORITY CLAIMED UNDER SEC. 44(D) ON ERPN CMNTY TM OFC APPLICATION NO. 9417635, FILED 10-1-2010, REG. NO. 9417635, DATED 6-3-2011, EXPIRES 10-1-2020.

CLASS 1—CHEMICALS

FOR CHEMICALS FOR USE IN CLEANSING AND DECONTAMINATION PREPARATIONS FOR TREATMENT OF COAL, COAL MINING WASTE MATERIALS AND COAL MINING SITES (U.S. CLS. 1, 5, 6, 10, 26 AND 46).

CLASS 3—COSMETICS AND CLEANING PREPARATIONS

FOR CLEANING, POLISHING, SCOURING AND ABRASIVE PREPARATIONS (U.S. CLS. 1, 4, 6, 50, 51 AND 52).

CLASS 4—LUBRICANTS AND FUELS

FOR COAL; COAL DUST; COAL NAPHTHA; COAL TAR OIL; FUELS MADE FROM COAL AND COKE; INDUSTRIAL OILS AND GREASES; INDUSTRIAL LUBRICANTS; DUST ABSORBING, WETTING AND BINDING COMPOSITIONS; FUELS, NAMELY, MOTOR FUEL (U.S. CLS. 1, 6 AND 15).

CLASS 7—MACHINERY

FOR MACHINES AND MACHINE TOOLS FOR USE IN THE COAL INDUSTRY, NAMELY, DRILLING MACHINES, CRUSHING MACHINES, WASHING TROMMELS, CYCLONES, PUMPS AND FILTER PRESSES; MOTORS AND ENGINES, EXCEPT FOR LAND VEHICLES, NAMELY, ELECTRIC MOTORS FOR MACHINES AND DIESEL ENGINES FOR MACHINES; MACHINES FOR THE EXTRACTION OF NATURAL MATERIALS AND COAL; SEPARATING MACHINES FOR PROCESSING COAL MINING WASTE MATERIALS; CLEANSING AND WASHING APPARATUS, NAMELY, MACHINES FOR SEPARATING COAL FROM DIRT (U.S. CLS. 13, 19, 21, 23, 31, 34 AND 35).

CLASS 11—ENVIRONMENTAL CONTROL APPARATUS

FOR DECONTAMINATION APPARATUS, NAMELY, STERILIZERS NOT FOR MEDICAL PURPOSES, LAND DECONTAMINATION APPARATUS, NAMELY, STERILIZERS NOT FOR MEDICAL PURPOSES; WATER DECONTAMINATION APPARATUS, NAMELY, WATER FILTERING UNITS FOR INDUSTRIAL USE; WATER STERILIZERS; CLARIFYING UNITS, NAMELY, CLARIFICATION APPARATUS FOR USE IN TREATMENT OF LIQUIDS IN THE NATURE OF WATER, WASTE WATER AND INDUSTRIAL WATER (U.S. CLS. 13, 21, 23, 31 AND 34).

CLASS 35—ADVERTISING AND BUSINESS

FOR ADVERTISING SERVICES; BUSINESS MANAGEMENT; BUSINESS ADMINISTRATION AND OFFICE FUNCTIONS; RETAIL STORE SERVICES FEATURING COAL AND COAL MINING WASTE PRODUCTS (U.S. CLS. 100, 101 AND 102).

CLASS 37—CONSTRUCTION AND REPAIR

FOR BUILDING CONSTRUCTION; REPAIR OF COAL MINING MACHINES; MACHINERY INSTALLATION SERVICES; QUARRYING SERVICES; MINING EXTRACTION SERVICES; COAL MINING EXTRACTION SERVICES; BUILDING CONSTRUCTION, REPAIR AND INSTALLATION SERVICES ALL RELATED TO THE RECLAMATION OF COAL MINING SITES FOR ALTERNATIVE USES (U.S. CLS. 100, 103 AND 106).

CLASS 39—TRANSPORTATION AND STORAGE

FOR TRANSPORTATION, PACKAGING AND STORAGE OF GOODS AND MATERIALS, NAMELY, COAL AND COAL MINING WASTE PRODUCTS AND COAL PROCESSING EQUIPMENT; TRANSPORTATION, PACKAGING AND STORAGE OF COAL AND COAL MINING WASTE PRODUCTS (U.S. CLS. 100 AND 105).

CLASS 40—MATERIAL TREATMENT

FOR TREATMENT OF MATERIALS, NAMELY, COAL AND COAL MINING WASTE PRODUCTS; TREATMENT OF COAL AND COAL MINING WASTE PRODUCTS; CLEANSING AND DECONTAMINATING OF COAL AND COAL MINING WASTE PRODUCTS; PRODUCTION OF ENERGY; CONVERSION OF COAL MINING WASTE INTO FUEL; RECYCLING OF MINERALS, WASTE AND INDUSTRIAL GOODS; CLEANSING AND DECONTAMINATION OF HAZARDOUS MATERIALS; CLEANSING AND DECONTAMINATION OF SUBSURFACE SOIL SITES; SEPARATION OF COAL AND COAL MINING WASTE PRODUCTS THROUGH WATER PROCESSES (U.S. CLS. 100, 103 AND 106).

CLASS 42—SCIENTIFIC AND COMPUTER SERVICES

FOR SCIENTIFIC AND TECHNOLOGICAL SERVICES AND RESEARCH AND DESIGN RELATING TO WASTE COAL RECOVERY AND COAL PREPARATION; SCIENTIFIC AND TECHNOLOGICAL SERVICES AND RESEARCH AND DESIGN RELATING TO WASTE COAL RECOVERY AND COAL PREPARATION AND COAL MINING SITES; INDUSTRIAL TECHNICAL ANALYSIS AND RESEARCH SERVICES IN THE FIELD OF WASTE COAL RECOVERY AND COAL PREPARATION; DESIGN AND DEVELOPMENT OF MATERIAL TREATMENT APPARATUS AND PROCESSES FOR USE IN THE COAL MINING INDUSTRY; LOCATING NATURAL MINERALS, NAMELY, COAL EXPLORATION SERVICES (U.S. CLS. 100 AND 101).

MARLENE BELL, EXAMINING ATTORNEY

SN 85-259,627. CULINARY DEVELOPMENT GROUP, INC., AKRON, OH. FILED 3-7-2011.



OWNER OF U.S. REG. NO. 2,137,452.

THE MARK CONSISTS OF A DESIGN FEATURING A CHEF HOLDING A BOTTLE AND POURING IT INTO A WINE GLASS OVER A POT INSIDE A CIRCLE WITH THE CHEF'S HAT EXTENDING OVER THE TOP OF THE CIRCLE. IN AN OUTER RING FORMED BY DOUBLE LINES THAT IS DIVIDED IN TWO BY CURVED LINES APPEARING MIDWAY AROUND THE RING ON THE RIGHT AND THE LEFT APPEAR THE WORDS "MORE THAN" IN THE UPPER HALF OF THE RING AND THE WORD "GOURMET" IN THE LOWER HALF OF THE RING. SEC. 2(F) AS TO "GOURMET".

CLASS 29—MEATS AND PROCESSED FOODS

FOR MEAT, POULTRY, FISH, SEAFOOD, AND VEGETABLE STOCKS; SOUPS; MEAT, POULTRY, FISH, SEAFOOD, AND VEGETABLE BASES FOR SOUPS AND SAUCES; CUSTOM BLENDED MEAT, POULTRY, FISH, SEAFOOD, AND VEGETABLE STOCKS, SOUPS, AND BASES (U.S. CL. 46).

FIRST USE 6-0-2008; IN COMMERCE 6-0-2008.

CLASS 30—STAPLE FOODS

FOR SAUCES AND SAUCE BASES; CUSTOM BLENDED SAUCES AND SAUCE BASES (U.S. CL. 46).

FIRST USE 6-0-2009; IN COMMERCE 6-0-2009.

TRACY WHITTAKER-BROWN, EXAMINING ATTORNEY

CLASS 42—SCIENTIFIC AND COMPUTER SERVICES

FOR FEASIBILITY STUDIES IN THE FIELD OF CONSTRUCTION; DESIGN SERVICES FOR OTHERS IN THE FIELD OF CONSTRUCTION FOR THE CONSTRUCTION OF NEW BUILDINGS AND FOR THE RENOVATION OF PRE-EXISTING BUILDINGS, NAMELY ARCHITECTURAL DESIGN, STRUCTURAL ENGINEERING DESIGN, ELECTRICAL SYSTEMS DESIGN, MECHANICAL DESIGN, CIVIL ENGINEERING DESIGN, INTERIOR DESIGN, DESIGN OF ACOUSTICAL PANELS, INSULATION AND TILES, FIRE PROTECTION DESIGN, NAMELY, DESIGN OF FIRE ALARM, DETECTION AND SUPPRESSION SYSTEMS, GEOTECHNICAL ENGINEERING DESIGN, AND THE DESIGN OF CAFETERIAS AND OTHER BUILDINGS FOR THE DELIVERY, SALE AND/OR PROCESSING OF FOOD; DESIGN CONSULTATION IN THE FIELD OF CONSTRUCTION FOR THE CONSTRUCTION OF NEW BUILDINGS AND FOR THE RENOVATION OF PRE-EXISTING BUILDINGS (U.S. CLS. 100 AND 101).

ERIN FALK, EXAMINING ATTORNEY

SN 85-260,620. FORRESTER CONSTRUCTION COMPANY, ROCKVILLE, MD. FILED 3-8-2011.

SN 85-261,151. MOOSE & WALLABY CONSULTING, INC., SAN RAFAEL, CA. FILED 3-8-2011.



OWNER OF U.S. REG. NOS. 2,564,768 AND 2,669,670. THE COLORS BLACK, WHITE AND/OR GRAY REPRESENT BACKGROUND, OUTLYING, SHADING AND/OR TRANSPARENT AREAS AND ARE NOT PART OF THE MARK.

THE MARK CONSISTS OF A ZIPPER ABOVE THE WORD "FORRESTER".

CLASS 37—CONSTRUCTION AND REPAIR

FOR CONSTRUCTION SERVICES, NAMELY, CONSTRUCTION OF COMMERCIAL BUILDINGS, INDUSTRIAL BUILDINGS, AND INDUSTRIAL, MANUFACTURING, ASSEMBLY AND PROCESSING PLANTS, AND THE RENOVATION OF PRE-EXISTING BUILDINGS; CONSTRUCTION SUPERVISION AND INSPECTION OF BUILDINGS IN THE PROCESS OF CONSTRUCTION; CONSTRUCTION PLANNING; CONSTRUCTION MANAGEMENT; REAL PROPERTY DEVELOPMENT, NAMELY, REPAIR, IMPROVEMENT AND NEW CONSTRUCTION; SITE ANALYSIS SERVICES IN THE FIELD OF CONSTRUCTION, NAMELY, REAL ESTATE AND CONSTRUCTION SITE SELECTION; TECHNICAL CONSULTATION IN THE FIELD OF CONSTRUCTION FOR THE CONSTRUCTION OF NEW BUILDINGS AND FOR THE RENOVATION OF PRE-EXISTING BUILDINGS; PLUMBING CONTRACTOR SERVICES (U.S. CLS. 100, 103 AND 106).

THE MARK CONSISTS OF STANDARD CHARACTERS WITHOUT CLAIM TO ANY PARTICULAR FONT, STYLE, SIZE, OR COLOR.

NO CLAIM IS MADE TO THE EXCLUSIVE RIGHT TO USE "SOCIAL", APART FROM THE MARK AS SHOWN.

CLASS 9—ELECTRICAL AND SCIENTIFIC APPARATUS

FOR PRE-RECORDED DVDS, DOWNLOADABLE AUDIO AND VIDEO RECORDINGS, AND CDS FEATURING TRAINING MATERIALS ON THE USE OF SOCIAL MEDIA IN THE FIELDS OF BUSINESS, MARKETING, AND ADVERTISING; PRE-RECORDED DVDS, DOWNLOADABLE AUDIO AND VIDEO RECORDINGS, AND CDS IN THE FIELDS OF BUSINESS, MARKETING, AND ADVERTISING (U.S. CLS. 21, 23, 26, 36 AND 38).

CLASS 16—PAPER GOODS AND PRINTED MATTER

FOR PRINTED TRAINING AND EDUCATIONAL MATERIALS AND PUBLICATIONS IN THE NATURE OF BOOKS, MANUALS, MAGAZINES, NEWSLETTERS, BOOKLETS, PERIODICALS, JOURNALS, PAMPHLETS, BROCHURES, AND TEACHING MATERIALS, ALL RELATING TO THE USE OF SOCIAL MEDIA IN THE FIELDS OF BUSINESS, MARKETING, AND ADVERTISING (U.S. CLS. 2, 5, 22, 23, 29, 37, 38 AND 50).

CLASS 35—ADVERTISING AND BUSINESS

FOR BUSINESS CONSULTING SERVICES RELATING TO SOCIAL MEDIA AND ITS APPLICATION IN THE FIELDS OF BUSINESS, MARKETING, AND ADVERTISING (U.S. CLS. 100, 101 AND 102).

CLASS 41—EDUCATION AND ENTERTAINMENT

FOR EDUCATIONAL SERVICES, NAMELY, CONDUCTING EDUCATIONAL PROGRAMS IN THE FIELD OF SOCIAL MEDIA AND ITS APPLICATION IN THE FIELDS OF BUSINESS, MARKETING, AND ADVERTISING; VIDEO AND FILM PRODUCTION FOR OTHERS (U.S. CLS. 100, 101 AND 107).

CLASS 42—SCIENTIFIC AND COMPUTER SERVICES

FOR COMPUTER SERVICES, NAMELY, COMPUTER CONSULTING SERVICES FOR OTHERS CONCERNING COMPUTER-BASED SYSTEMS IN THE FIELDS OF SOCIAL MEDIA, BUSINESS, MARKETING, AND ADVERTISING; COMPUTER SERVICES, NAMELY, DESIGN AND DEVELOPMENT OF SOCIAL MEDIA COMPUTER SOFTWARE FOR OTHERS IN THE FIELDS OF BUSINESS, MARKETING, AND ADVERTISING (U.S. CLS. 100 AND 101).

STEVEN PEREZ, EXAMINING ATTORNEY

SN 85-262,747. GETHER, LLC, EL SEGUNDO, CA. FILED 3-9-2011.

GETHER

THE MARK CONSISTS OF STANDARD CHARACTERS WITHOUT CLAIM TO ANY PARTICULAR FONT, STYLE, SIZE, OR COLOR.

CLASS 9—ELECTRICAL AND SCIENTIFIC APPARATUS

FOR MOBILE DEVICE APPLICATIONS, NAMELY, COMPUTER SOFTWARE FOR MOBILE DEVICES THAT CONNECTS SOCIAL NETWORK USERS TO EACH OTHER OR TO MARKETERS FOR THE PURPOSE OF TAKING POLLS AND GETTING OPINIONS, RESULTS OR RECOMMENDATIONS ON ANY GIVEN TOPIC, EXCLUDING THE FIELD OF DATING (U.S. CLS. 21, 23, 26, 36 AND 38).

CLASS 35—ADVERTISING AND BUSINESS

FOR POLLING SERVICES, NAMELY, MARKET AND PUBLIC OPINION POLLING (U.S. CLS. 100, 101 AND 102).

CHARISMA HAMPTON, EXAMINING ATTORNEY

SN 85-267,271. HUMANITY UNITED, REDWOOD CITY, CA. FILED 3-15-2011.

ATEST Alliance To End
Slavery & Trafficking

THE MARK CONSISTS OF THE WORD "ATEST" IN STYLIZED, TALL CAPITAL LETTERS WITH THE LETTERS "ST" SUPERIMPOSED OVER A SILHOUETTE OF A BIRD IN FLIGHT, ON THE LEFT AND THE WORDING "ALLIANCE TO END SLAVERY & TRAFFICKING" TO THE RIGHT IN SMALLER, UPPER-AND-LOWER-CASE LETTERING ON TWO LINES.

SEC. 2(F) AS TO "ALLIANCE TO END SLAVERY & TRAFFICKING".

CLASS 35—ADVERTISING AND BUSINESS

FOR PUBLIC POLICY RESEARCH SERVICES AIMED AT ENDING HUMAN TRAFFICKING AND SLAVERY; ADVOCATING ON BEHALF OF OTHERS BY PROMOTING PUBLIC AWARENESS OF THE NEED FOR, AND PROMOTING PUBLIC SUPPORT OF AND PARTICIPATION IN EFFORTS AIMED AT ENDING HUMAN TRAFFICKING AND SLAVERY; ADVOCATING ON BEHALF OF OTHERS BY PROMOTING THE DEVELOPMENT OF SOLUTIONS FOR THE PROTECTION OF HUMAN RIGHTS AND THE PROMOTION OF HUMAN DIGNITY THROUGH INFORMATION GATHERING, STUDY, FIELD-BASED ANALYSIS, INVESTIGATION OF NEW APPROACHES, AND ITERATIVE REFINEMENT OF IDEAS AND PLANS IN COLLABORATION WITH OTHERS; ADVOCATING ON BEHALF OF OTHERS THROUGH LOBBYING OF COMMERCIAL, NOT-FOR-PROFIT, GOVERNMENTAL, AND NON-GOVERNMENTAL ORGANIZATIONS IN SUPPORT OF ADOPTING AND SUPPORTING MEASURES FOR THE ENDING OF HUMAN TRAFFICKING AND SLAVERY; CHARITABLE SERVICES, NAMELY, ORGANIZING NETWORKS OF INDIVIDUALS AND INSTITUTIONS WITH THE PURPOSE OF FACILITATING AND FURTHERING THE IMPLEMENTATION OF CHARITABLE AND PHILANTHROPIC PROGRAMS; MARKET RESEARCH; PUBLIC OPINION POLLING; PUBLIC OPINION SURVEYS; CONDUCTING MARKET RESEARCH SURVEYS; PROMOTING PUBLIC AWARENESS OF HUMAN NEEDS, NAMELY, PROMOTING PUBLIC AWARENESS OF THE SCOPE OF, THE NEED TO ADDRESS, INSTITUTIONAL OBSTACLES TO, SOLUTIONS FOR, AND THE ROLE OF VARIOUS ACTORS IN RELATION TO HUMAN TRAFFICKING AND SLAVERY; EMPLOYMENT AND NETWORK RECRUITING, NAMELY, RECRUITING PROFESSIONALS, VOLUNTEERS AND WORKERS IN THE FIELD OF CHARITABLE ACTIVITIES RELATING TO ENDING HUMAN TRAFFICKING AND SLAVERY; CHARITABLE SERVICES, NAMELY, SUPPORTING NETWORKS OF CHARITABLE AND PHILANTHROPIC INDIVIDUALS AND INSTITUTIONS BY PROVIDING CONSULTATION AND ADVICE REGARDING ADVERTISING, AND CREATION AND DISSEMINATION OF ADVERTISING MATERIALS FOR EDUCATIONAL ACTIVITIES AND ENTERTAINMENT EVENTS, WITH THE PURPOSE OF FACILITATING AND FURTHERING THE IMPLEMENTATION OF CHARITABLE AND PHILANTHROPIC PROGRAMS (U.S. CLS. 100, 101 AND 102).

CLASS 41—EDUCATION AND ENTERTAINMENT

FOR DEVELOPMENT AND DISSEMINATION OF EDUCATIONAL MATERIALS FOR OTHERS IN THE FIELDS OF HUMAN TRAFFICKING AND SLAVERY, PUBLIC AND PRIVATE SECTOR ANTI-HUMAN TRAFFICKING POLICIES, INTERNATIONAL HUMAN RIGHTS AND PEACE; ARRANGING AND CONDUCTING OF EDUCATIONAL CONFERENCES, DISCUSSIONS, AND COLLOQUIA IN THE FIELDS OF HUMAN TRAFFICKING AND SLAVERY, PUBLIC AND PRIVATE SECTOR ANTI-HUMAN TRAFFICKING POLICIES, INTERNATIONAL HUMAN RIGHTS AND PEACE; ARRANGING AND CONDUCTING OF ONLINE DISCUSSIONS, CONFERENCES, AND COLLOQUIA VIA COMPUTER AND COMMUNICATION NETWORKS IN THE FIELDS OF HUMAN TRAFFICKING AND SLAVERY, PUBLIC AND PRIVATE SECTOR ANTI-HUMAN TRAFFICKING POLICIES, INTERNATIONAL HUMAN RIGHTS AND PEACE (U.S. CLS. 100, 101 AND 107).

RAUL CORDOVA, EXAMINING ATTORNEY

SN 85-268,872. PETHE, TRAVIS, LITTLETON, CO. FILED 3-16-2011.



NO CLAIM IS MADE TO THE EXCLUSIVE RIGHT TO USE "AEROSPACE", APART FROM THE MARK AS SHOWN.

THE COLOR(S) RED AND TEAL IS/ARE CLAIMED AS A FEATURE OF THE MARK.

THE MARK CONSISTS OF LITERAL ELEMENT "EAGLE AEROSPACE" WHERE IN THERE IS HALF CIRCLE OUTLINED WITH RED AND TEAL COLOR AND ON THE HALF CIRCLE THERE IS TEAL COLOR IMAGE OF FLYING EAGLE BELOW WHICH "EAGLE AEROSPACE" IS WRITTEN IN RED AND TEAL COLOR RESPECTIVELY AS SHOWN IN THE MARK.

CLASS 39—TRANSPORTATION AND STORAGE

FOR TRANSPORT AND STORAGE SERVICES, NAMELY, AIR TRANSPORTATION OF PASSENGERS AND FREIGHT; TRANSPORTATION AND DELIVERY SERVICES BY GROUND AND SEA OF AEROSPACE SYSTEMS AND COMPONENTS; SAFE STORAGE OF POTENTIALLY HAZARDOUS AEROSPACE SYSTEMS, COMPONENTS, PARTS AND MATERIALS (U.S. CLS. 100 AND 105).

FIRST USE 9-26-2006; IN COMMERCE 11-7-2006.

CLASS 41—EDUCATION AND ENTERTAINMENT

FOR TRAINING SERVICES IN THE FIELD OF PROFESSIONAL DEVELOPMENT TRAINING AND TECHNICAL TRAINING PROVIDED TO AEROSPACE AND AEROSPACE SAFETY PROFESSIONALS; EDUCATIONAL SERVICES, NAMELY, PROVIDING ONLINE INSTRUCTION VIA AN ONLINE WEBSITE IN THE FIELD OF PROFESSIONAL DEVELOPMENT TRAINING AND TECHNICAL TRAINING PROVIDED TO AEROSPACE AND AEROSPACE SAFETY PROFESSIONALS (U.S. CLS. 100, 101 AND 107).

FIRST USE 9-26-2006; IN COMMERCE 11-7-2006.
CHRIS WELLS, EXAMINING ATTORNEY

SN 85-269,957. EDLEUN, INC., CALGARY, ALBERTA, CANADA, FILED 3-17-2011.

EDUCATION LEARNING UNIVERSE

THE MARK CONSISTS OF STANDARD CHARACTERS WITHOUT CLAIM TO ANY PARTICULAR FONT, STYLE, SIZE, OR COLOR.

PRIORITY CLAIMED UNDER SEC. 44(D) ON CANADA APPLICATION NO. 1498637, FILED 10-5-2010, REG. NO. TMA825,278, DATED 6-1-2012, EXPIRES 6-1-2027.

NO CLAIM IS MADE TO THE EXCLUSIVE RIGHT TO USE "EDUCATION LEARNING", APART FROM THE MARK AS SHOWN.

CLASS 9—ELECTRICAL AND SCIENTIFIC APPARATUS

FOR COMPUTER BAGS; COMPUTER SOFTWARE FOR USE IN ON-LINE COMMUNICATIONS FOR THE DELIVERY OF EDUCATIONAL COURSES AND TUTORING; VIDEOS CONTAINING EDUCATIONAL INSTRUCTION, NAMELY, INSTRUCTIONAL VIDEOS CREATED TO ENHANCE READING AND WRITING SKILLS, MATHEMATICAL SKILLS, STUDY SKILLS, AND TO ASSIST WITH TEST PREPARATION AND HOMEWORK; AND INSTRUCTIONAL VIDEO RECORDINGS FOR STAFF FOR OPERATIONAL PROCEDURE TRAINING, REGARDING THE TRANSPORTATION OF CHILDREN AND BUS SAFETY (U.S. CLS. 21, 23, 26, 36 AND 38).

CLASS 16—PAPER GOODS AND PRINTED MATTER

FOR PRINTED MATTER, NAMELY, NEWSLETTERS, TEACHING MANUALS, EDUCATIONAL BOOKS, AND INSTRUCTION MANUALS AND CURRICULUM, ALL IN THE FIELD OF CHILD CARE, TUTORING, ADVANCED EDUCATION AND TECHNOLOGY; LUNCH BAGS (U.S. CLS. 2, 5, 22, 23, 29, 37, 38 AND 50).

CLASS 35—ADVERTISING AND BUSINESS

FOR PROVIDING A DATABASE FEATURING REFERRALS FOR SPECIALISTS IN THE AREAS OF NUTRITION, SPEECH PATHOLOGY, OCCUPATIONAL THERAPY, PHYSIOTHERAPY AND MENTAL HEALTH (U.S. CLS. 100, 101 AND 102).

CLASS 41—EDUCATION AND ENTERTAINMENT

FOR EDUCATIONAL SERVICES, NAMELY, PROVIDING COURSES OF INSTRUCTION AT THE PRIMARY AND ELEMENTARY LEVEL; EDUCATION SERVICES, NAMELY, PROVIDING KINDERGARTEN CLASSROOM INSTRUCTION; EDUCATION SERVICES, NAMELY, PROVIDING SEMINARS, CLASSES AND WORKSHOPS IN THE FIELDS OF PARENTING, CHILD DEVELOPMENT AND SPECIAL NEEDS EDUCATION; SUMMER CAMPS, DAY CAMPS, HOLIDAY CAMPS AND CONDUCTING FIELD TRIPS FOR CHILDREN FEATURING POINTS OF INTEREST AND LOCAL ATTRACTIONS, NAMELY, ZOOS, SCIENCE EXHIBITIONS AND COMMUNITY BUILDINGS; EDUCATIONAL PROGRAMS IN THE FIELDS OF DANCE, MUSIC, STORYTELLING AND PUPPET SHOWS; PROVIDING A WEBSITE FEATURING INFORMATION RELATING TO CHILDHOOD EDUCATION PROGRAMS, ACTIVITIES, WORK AND FAMILY EDUCATION PROGRAMS; TUTORING SERVICES, NAMELY, PROVIDING ASSISTANCE TO CHILDREN TO ENHANCE EDUCATIONAL SKILLS IN THE AREAS OF READING, WRITING, MATHEMATICS, TEST PREPARATION, HOMEWORK AND STUDYING; OPERATION OF SCHOOLS (U.S. CLS. 100, 101 AND 107).

CLASS 42—SCIENTIFIC AND COMPUTER SERVICES

FOR PROVIDING TEMPORARY USE OF ONLINE NON-DOWNLOADABLE SOFTWARE FOR THE DELIVERY OF EDUCATIONAL COURSE INSTRUCTION AND TUTORING (U.S. CLS. 100 AND 101).

CLASS 43—HOTEL AND RESTAURANT SERVICES

FOR DAY CARE AND CHILDCARE SERVICES, AND PROVIDING EMPLOYERS WITH CHILDCARE PROGRAMS FOR EMPLOYEES (U.S. CLS. 100 AND 101).

LAURA KOVALSKY, EXAMINING ATTORNEY

SN 85-270,022. EDLEUN, INC., CALGARY, ALBERTA, CANADA, FILED 3-17-2011.

edleun 

PRIORITY CLAIMED UNDER SEC. 44(D) ON CANADA APPLICATION NO. 1498638, FILED 10-5-2010, REG. NO. TMA825,279, DATED 6-1-2012, EXPIRES 6-1-2027.

THE MARK CONSISTS OF THE WORD "EDLEUN" WITH THREE BLOCKS ABOVE THE LETTER "N" THAT CONTAIN THE LETTERS "EDU".

CLASS 9—ELECTRICAL AND SCIENTIFIC APPARATUS

FOR COMPUTER BAGS; COMPUTER SOFTWARE FOR USE IN ON-LINE COMMUNICATIONS FOR THE DELIVERY OF EDUCATIONAL COURSES AND TUTORING; VIDEOS CONTAINING EDUCATIONAL INSTRUCTION, NAMELY, INSTRUCTIONAL VIDEOS CREATED TO ENHANCE READING AND WRITING SKILLS, MATHEMATICAL SKILLS, STUDY SKILLS, AND TO ASSIST WITH TEST PREPARATION AND HOMEWORK; AND INSTRUCTIONAL VIDEO RECORDINGS FOR STAFF FOR OPERATIONAL PROCEDURE TRAINING, REGARDING THE TRANSPORTATION OF CHILDREN AND BUS SAFETY (U.S. CLS. 21, 23, 26, 36 AND 38).

CLASS 16—PAPER GOODS AND PRINTED MATTER

FOR PRINTED MATTER, NAMELY, NEWSLETTERS, TEACHING MANUALS, EDUCATIONAL BOOKS, AND INSTRUCTION MANUALS AND CURRICULUM, ALL IN THE FIELD OF CHILD CARE, TUTORING, ADVANCED EDUCATION AND TECHNOLOGY; LUNCH BAGS (U.S. CLS. 2, 5, 22, 23, 29, 37, 38 AND 50).

CLASS 35—ADVERTISING AND BUSINESS

FOR PROVIDING A DATABASE FEATURING REFERRALS FOR SPECIALISTS IN THE AREAS OF NUTRITION, SPEECH PATHOLOGY, OCCUPATIONAL THERAPY, PHYSIOTHERAPY AND MENTAL HEALTH (U.S. CLS. 100, 101 AND 102).

CLASS 41—EDUCATION AND ENTERTAINMENT

FOR EDUCATIONAL SERVICES, NAMELY, PROVIDING COURSES OF INSTRUCTION AT THE PRIMARY AND ELEMENTARY LEVEL; EDUCATION SERVICES, NAMELY, PROVIDING KINDERGARTEN CLASSROOM INSTRUCTION; EDUCATION SERVICES, NAMELY, PROVIDING SEMINARS, CLASSES AND WORKSHOPS IN THE FIELDS OF PARENTING, CHILD DEVELOPMENT AND SPECIAL NEEDS EDUCATION; SUMMER CAMPS, DAY CAMPS, HOLIDAY CAMPS AND CONDUCTING FIELD TRIPS FOR CHILDREN FEATURING POINTS OF INTEREST AND LOCAL ATTRACTIONS, NAMELY, ZOOS, SCIENCE EXHIBITIONS AND COMMUNITY BUILDINGS; EDUCATIONAL PROGRAMS IN THE FIELDS OF DANCE, MUSIC, STORYTELLING AND PUPPET SHOWS; PROVIDING A WEBSITE FEATURING INFORMATION RELATING TO CHILDHOOD EDUCATION PROGRAMS, ACTIVITIES, WORK AND FAMILY EDUCATION PROGRAMS; TUTORING SERVICES, NAMELY, PROVIDING ASSISTANCE TO CHILDREN TO ENHANCE EDUCATIONAL SKILLS IN THE AREAS OF READING, WRITING, MATHEMATICS, TEST PREPARATION, HOMEWORK AND STUDYING; OPERATION OF SCHOOLS (U.S. CLS. 100, 101 AND 107).

CLASS 42—SCIENTIFIC AND COMPUTER SERVICES

FOR PROVIDING TEMPORARY USE OF ONLINE NON-DOWNLOADABLE SOFTWARE FOR THE DELIVERY OF EDUCATIONAL COURSE INSTRUCTION AND TUTORING (U.S. CLS. 100 AND 101).

CLASS 43—HOTEL AND RESTAURANT SERVICES

FOR DAY CARE AND CHILDCARE SERVICES, AND PROVIDING EMPLOYERS WITH CHILDCARE PROGRAMS FOR EMPLOYEES (U.S. CLS. 100 AND 101).
LAURA KOVALSKY, EXAMINING ATTORNEY

SN 85-270,111. COMMUNITY UNITED AGAINST VIOLENCE, SAN FRANCISCO, CA. FILED 3-17-2011.

COMMUNITY UNITED AGAINST
VIOLENCE

THE MARK CONSISTS OF STANDARD CHARACTERS WITHOUT CLAIM TO ANY PARTICULAR FONT, STYLE, SIZE, OR COLOR.

NO CLAIM IS MADE TO THE EXCLUSIVE RIGHT TO USE "COMMUNITY" AND "VIOLENCE", APART FROM THE MARK AS SHOWN.

CLASS 35—ADVERTISING AND BUSINESS

FOR PUBLIC ADVOCACY TO PROMOTE PUBLIC AWARENESS OF THE NEED TO PREVENT AND ELIMINATE DOMESTIC ABUSE, SEXUAL ASSAULT AND HATE CRIMES; PROMOTING THE PUBLIC AWARENESS OF THE NEED TO PREVENT AND ELIMINATE DOMESTIC ABUSE, SEXUAL ASSAULT AND HATE CRIMES (U.S. CLS. 100, 101 AND 102).
FIRST USE 6-0-1979; IN COMMERCE 6-0-1979.

CLASS 44—MEDICAL, BEAUTY AND AGRICULTURAL SERVICES

FOR MENTAL HEALTH AND WELLNESS COUNSELING FOR VICTIMS OF DOMESTIC ABUSE, SEXUAL ASSAULT AND HATE CRIMES (U.S. CLS. 100 AND 101).
FIRST USE 6-0-1979; IN COMMERCE 6-0-1979.

MICHELE SWAIN, EXAMINING ATTORNEY

SN 85-271,566. DAS DISTRIBUTORS, INC., PALMYRA, PA.
FILED 3-19-2011.

TruckSpec

THE MARK CONSISTS OF STANDARD CHARACTERS WITHOUT CLAIM TO ANY PARTICULAR FONT, STYLE, SIZE, OR COLOR.

CLASS 9—ELECTRICAL AND SCIENTIFIC APPARATUS

FOR CB RADIO ACCESSORIES, NAMELY, ANTENNAS, CABLES, ANTENNA MOUNTS, ADAPTERS AND CONNECTORS; ELECTRICAL OUTLETS; AND AUDIO SPEAKERS (U.S. CLS. 21, 23, 26, 36 AND 38).

FIRST USE 6-30-1984, THE MARK WAS FIRST USED ANYWHERE IN A DIFFERENT FORM OTHER THAN THAT SOUGHT TO BE REGISTERED AT LEAST AS EARLY AS 06/30/1984.; IN COMMERCE 6-30-1984, THE MARK WAS FIRST USED IN COMMERCE IN A DIFFERENT FORM OTHER THAN THAT SOUGHT TO BE REGISTERED AT LEAST AS EARLY AS 06/30/1984..

CLASS 12—VEHICLES

FOR LICENSE PLATE FRAMES AND MIRRORS FOR VEHICLES, NAMELY, REAR VIEW MIRRORS AND VANITY MIRRORS (U.S. CLS. 19, 21, 23, 31, 35 AND 44).

FIRST USE 6-30-1984, THE MARK WAS FIRST USED ANYWHERE IN A DIFFERENT FORM OTHER THAN THAT SOUGHT TO BE REGISTERED AT LEAST AS EARLY AS 06/30/1984; IN COMMERCE 6-30-1984, THE MARK WAS FIRST USED IN COMMERCE IN A DIFFERENT FORM OTHER THAN THAT SOUGHT TO BE REGISTERED AT LEAST AS EARLY AS 06/30/1984.

JOHN KELLY, EXAMINING ATTORNEY

SN 85-272,466. G.P. ENTERPRISES, LLC, SANTA MONICA, CA. FILED 3-21-2011.

ROY ORBISON

THE MARK CONSISTS OF STANDARD CHARACTERS WITHOUT CLAIM TO ANY PARTICULAR FONT, STYLE, SIZE, OR COLOR.

THE NAME(S), PORTRAIT(S), AND/OR SIGNATURE(S) SHOWN IN THE MARK DOES NOT IDENTIFY A PARTICULAR LIVING INDIVIDUAL.

CLASS 3—COSMETICS AND CLEANING PREPARATIONS

FOR MEN'S TOILETRIES AND COSMETICS, NAMELY, SHOWER GEL, FACIAL WASHES, FACIAL SCRUBS, FACE CREAMS, EYE CREAM, HAIR GEL, BATH SOAPS IN SOLID FORM, SHAVING CREAM, SHAVING GEL, SHAVING PREPARATIONS, SHAVING BALM, AFTER-SHAVE; PERFUMES, EAU DE TOILETTE, ESSENTIAL OILS FOR PERSONAL USE, PERFUME OILS; BODY AND BEAUTY CARE COSMETICS AND TOILETRIES, NAMELY, SOAPS FOR BODY CARE, LIQUID SOAPS FOR HANDS, FACE AND BODY, FACIAL CLEANSERS, SKIN TONERS, SKIN CLEANSERS AND EMOLLIENTS, CLEANSING CREAMS, BODY SCRUB, FACIAL SCRUB, SKIN LOTIONS, SKIN CLEANSING LOTIONS, FACE LOTIONS, BODY LOTIONS, SKIN MOISTURIZERS, COSMETIC CREAMS FOR SKIN CARE, NUTRITIONAL OILS FOR COSMETIC PURPOSES, BODY OIL, BATH OIL, LIP BALM, DENTIFRICES, TOOTHPASTE, NON-MEDICAL MOUTHWASH AND GARGLE, BATH GEL, SHAMPOOS, HAIR CONDITIONERS, HAIR CARE PREPARATIONS, HAIR STYLING GELS, HAIR LOTIONS, HAIR STYLING PREPARATIONS, HAIR COLORING PREPARATIONS, HAIR DYES, DEODORANTS FOR BODY CARE, BODY POWDER, ANTI-PERSPIRANTS, COSMETIC SUNTAN LOTIONS, COSMETIC SUN-PROTECTING AND SUN-TANNING PREPARATIONS, COCOA BUTTER FOR COSMETIC PURPOSES (U.S. CLS. 1, 4, 6, 50, 51 AND 52).

CLASS 9—ELECTRICAL AND SCIENTIFIC APPARATUS

FOR PRE-RECORDED CDS FEATURING MUSIC, PRE-RECORDED DVDS FEATURING MUSIC, PRE-RECORDED ELECTRONIC AND DIGITAL MEDIA FEATURING MUSIC; EYEWEAR, EYEGASSES, SUNGLASSES, GOGGLES FOR SPORTS, MOTORCYCLE GOGGLES, SKI GOGGLES, SNOW GOGGLES AND SWIM GOGGLES; SPECTACLE FRAMES, EYEGASS FRAMES AND OPTICAL FRAMES, LENSES AND PROTECTIVE CASES FOR EYEWEAR, EYEGASSES, SUNGLASSES AND GOGGLES FOR SPORTS, MOTORCYCLE GOGGLES, SKI GOGGLES, SNOW GOGGLES AND SWIM GOGGLES; EYEWEAR ACCESSORIES, NAMELY, STRAPS, NECK CORDS AND CHAINS; HEADPHONES; EARPHONES; MP3 PLAYERS; CD PLAYERS; PROTECTIVE CARRYING CASES FOR MP3 PLAYERS, CD PLAYERS, CELL PHONES, LAPTOP COMPUTERS, NOTEBOOK COMPUTERS, AND PERSONAL DIGITAL ASSISTANTS (U.S. CLS. 21, 23, 26, 36 AND 38).

CLASS 18—LEATHER GOODS

FOR LEATHER KEY CHAINS, KEY CASES, HANDBAGS, WALLETS, PURSES, COIN PURSES, CLUTCH PURSES, BACKPACKS, KNAPSACKS, DAYPACKS, FANNY PACKS, MESSENGER BAGS, SHOULDER BAGS, TOTE BAGS, DUFFEL BAGS, OVERNIGHT BAGS, ATHLETIC BAGS, CARRY-ON BAGS AND LUGGAGE, COSMETICS CASES SOLD EMPTY, TOILETRY BAGS SOLD EMPTY; AND PET ACCESSORIES, NAMELY, CLOTHING FOR PETS, COLLARS FOR ANIMALS, COVERS FOR ANIMALS, LEATHER LEASHES AND DOG COLLARS (U.S. CLS. 1, 2, 3, 22 AND 41).

CLASS 24—FABRICS

FOR BEDSHEETS, BEDSPREADS, BED SHAMS, BED SKIRTS, COMFORTERS, BED BLANKETS, DUVET COVERS, PILLOW CASES, PILLOW SHAMS, PILLOW COVERS, TOWELS, SHOWER CURTAINS, TEXTILE NAPKINS, FABRIC PLACEMATS AND FABRIC TABLECLOTHS (U.S. CLS. 42 AND 50).

CLASS 25—CLOTHING

FOR CLOTHING, NAMELY, T-SHIRTS, SHIRTS, TANK TOPS, SWEAT SHIRTS, SWEAT PANTS, SWEAT SUITS, JEANS, PANTS, SHORTS, OVERALLS, JUMPSUITS, SKIRTS, DRESSES, BLOUSES, JACKETS, SWEATERS, VESTS, SWIMWEAR, BATHING SUITS, COVERUPS, SLEEPWEAR, PAJAMAS, ROBES, NIGHTGOWNS, LEOTARDS, LINGERIE, PANTIES, BRAS, BOXER SHORTS, UNDERWEAR, SCARVES, BELTS, SOCKS, STOCKINGS, TIGHTS, LEGGINGS, GLOVES; OUTERWEAR, NAMELY, COATS AND RAINCOATS; HEADGEAR, NAMELY, HATS, CAPS, HEADBANDS, VISORS AND BANDANAS; FOOTWEAR, NAMELY, SHOES, SLIPPERS, BOOTS, SANDALS, FLIP-FLOPS, AND ATHLETIC SHOES (U.S. CLS. 22 AND 39).

CLASS 34—SMOKERS' ARTICLES

FOR LIGHTERS NOT OF PRECIOUS METAL; CIGARETTE LIGHTERS NOT OF PRECIOUS METAL (U.S. CLS. 2, 8, 9 AND 17).

CLASS 38—COMMUNICATION

FOR INTERNET RADIO SERVICES, NAMELY, TRANSMISSION OF AUDIO MATERIAL VIA THE INTERNET; STREAMING OF AUDIO, VISUAL AND AUDIOVISUAL MATERIAL VIA A GLOBAL COMPUTER NETWORK; DIGITAL AUDIO BROADCASTING AND PODCASTING SERVICES PROVIDED VIA A GLOBAL COMMUNICATIONS NETWORK (U.S. CLS. 100, 101 AND 104).

CLASS 41—EDUCATION AND ENTERTAINMENT

FOR ENTERTAINMENT SERVICES, NAMELY, PROVIDING RADIO PROGRAMS IN THE FIELD OF MUSIC VIA A GLOBAL COMPUTER NETWORK, AND PROVIDING A WEBSITE FEATURING NON-DOWNLOADABLE MUSICAL PERFORMANCES, MUSIC VIDEOS, RELATED FILM CLIPS, PHOTOGRAPHS, AND OTHER MULTIMEDIA MATERIALS IN THE FIELDS OF MUSIC AND RADIO, AND PROVIDING NON-DOWNLOADABLE PRERECORDED MUSIC, COMMENTARY AND ARTICLES ABOUT MUSIC AND RADIO ONLINE VIA A GLOBAL COMMUNICATIONS NETWORK (U.S. CLS. 100, 101 AND 107).

RAMONA ORTIGA, EXAMINING ATTORNEY

SN 85-272,484. G.P. ENTERPRISES, LLC, SANTA MONICA, CA. FILED 3-21-2011.

ROY ORBISON RADIO

THE MARK CONSISTS OF STANDARD CHARACTERS WITHOUT CLAIM TO ANY PARTICULAR FONT, STYLE, SIZE, OR COLOR.

NO CLAIM IS MADE TO THE EXCLUSIVE RIGHT TO USE "RADIO", APART FROM THE MARK AS SHOWN.

THE NAME(S), PORTRAIT(S), AND/OR SIGNATURE(S) SHOWN IN THE MARK DOES NOT IDENTIFY A PARTICULAR LIVING INDIVIDUAL.

CLASS 38—COMMUNICATION

FOR INTERNET RADIO SERVICES, NAMELY, TRANSMISSION OF AUDIO MATERIAL VIA THE INTERNET; STREAMING OF AUDIO, VISUAL AND AUDIOVISUAL MATERIAL VIA A GLOBAL COMPUTER NETWORK; DIGITAL AUDIO BROADCASTING AND PODCASTING SERVICES PROVIDED VIA A GLOBAL COMMUNICATIONS NETWORK (U.S. CLS. 100, 101 AND 104).

CLASS 41—EDUCATION AND ENTERTAINMENT

FOR ENTERTAINMENT SERVICES, NAMELY, PROVIDING RADIO PROGRAMS IN THE FIELD OF MUSIC VIA A GLOBAL COMPUTER NETWORK, AND PROVIDING A WEBSITE FEATURING NON-DOWNLOADABLE MUSICAL PERFORMANCES, MUSIC VIDEOS, RELATED FILM CLIPS, PHOTOGRAPHS, AND OTHER MULTIMEDIA MATERIALS IN THE FIELDS OF MUSIC AND RADIO, AND PROVIDING NON-DOWNLOADABLE PRERECORDED MUSIC, COMMENTARY AND ARTICLES ABOUT MUSIC AND RADIO ONLINE VIA A GLOBAL COMMUNICATIONS NETWORK (U.S. CLS. 100, 101 AND 107).

RAMONA ORTIGA, EXAMINING ATTORNEY

SN 85-272,503. G.P. ENTERPRISES, LLC, SANTA MONICA, CA. FILED 3-21-2011.

ROY RADIO

THE MARK CONSISTS OF STANDARD CHARACTERS WITHOUT CLAIM TO ANY PARTICULAR FONT, STYLE, SIZE, OR COLOR.

NO CLAIM IS MADE TO THE EXCLUSIVE RIGHT TO USE "RADIO", APART FROM THE MARK AS SHOWN.

CLASS 38—COMMUNICATION

FOR INTERNET RADIO SERVICES, NAMELY, TRANSMISSION OF AUDIO MATERIAL VIA THE INTERNET; STREAMING OF AUDIO, VISUAL AND AUDIOVISUAL MATERIAL VIA A GLOBAL COMPUTER NETWORK; DIGITAL AUDIO BROADCASTING AND PODCASTING SERVICES PROVIDED VIA A GLOBAL COMMUNICATIONS NETWORK (U.S. CLS. 100, 101 AND 104).

CLASS 41—EDUCATION AND ENTERTAINMENT

FOR ENTERTAINMENT SERVICES, NAMELY, PROVIDING RADIO PROGRAMS IN THE FIELD OF MUSIC VIA A GLOBAL COMPUTER NETWORK, AND PROVIDING A WEBSITE FEATURING NON-DOWNLOADABLE MUSICAL PERFORMANCES, MUSIC VIDEOS, RELATED FILM CLIPS, PHOTOGRAPHS, AND OTHER MULTIMEDIA MATERIALS IN THE FIELDS OF MUSIC AND RADIO, AND PROVIDING NON-DOWNLOADABLE PRERECORDED MUSIC, COMMENTARY AND ARTICLES ABOUT MUSIC AND RADIO ONLINE VIA A GLOBAL COMMUNICATIONS NETWORK (U.S. CLS. 100, 101 AND 107).

RAMONA ORTIGA, EXAMINING ATTORNEY

SN 85-273,852. SALESFORCE.COM, INC., SAN FRANCISCO, CA. FILED 3-22-2011.

SN 85-275,012. IZZAZU, INC., PITTSBURGH, PA. FILED 3-23-2011.



OWNER OF U.S. REG. NOS. 3,330,398 AND 3,592,166.
THE MARK CONSISTS OF THE STYLIZED WORD "FORCE".

CLASS 9—ELECTRICAL AND SCIENTIFIC APPARATUS

FOR DOWNLOADABLE COMPUTER SOFTWARE FOR USE IN DEVELOPING AND CUSTOMIZING COMPUTER SOFTWARE APPLICATIONS AND COMPUTER SOFTWARE APPLICATION USER INTERFACES; COMPUTER SOFTWARE FOR STORING, MANAGING, TRACKING, ANALYZING, AND REPORTING DATA IN THE FIELD OF MARKETING, PROMOTION, SALES, CUSTOMER INFORMATION, CUSTOMER RELATIONSHIP MANAGEMENT, SALES SUPPORT, AND EMPLOYEE EFFICIENCY; COMPUTER SOFTWARE TO FACILITATE COMMUNICATING AMONG PEER PROFESSIONALS IN THE ADVERTISING, MARKETING, AND BUSINESS SERVICES FIELDS, AND FOR CUSTOMIZING COMPUTER APPLICATION USER INTERFACES (U.S. CLS. 21, 23, 26, 36 AND 38).

FIRST USE 2-1-2003; IN COMMERCE 2-1-2003.

CLASS 42—SCIENTIFIC AND COMPUTER SERVICES

FOR PROVIDING TEMPORARY USE OF ON-LINE NON-DOWNLOADABLE SOFTWARE TO STORE, MANAGE, TRACK, ANALYZE, AND REPORT DATA IN THE FIELD OF MARKETING, PROMOTION, SALES, CUSTOMER INFORMATION, CUSTOMER RELATIONSHIP MANAGEMENT, SALES SUPPORT AND EMPLOYEE EFFICIENCY; PROVIDING TEMPORARY USE OF ON-LINE NON-DOWNLOADABLE SOFTWARE TO FACILITATE COMMUNICATING AMONG PEER PROFESSIONALS IN THE ADVERTISING, MARKETING AND BUSINESS SERVICES FIELDS, AND FOR CUSTOMIZING COMPUTER APPLICATION USER INTERFACES; COMPUTER SERVICES, NAMELY, DESIGNING, DEVELOPING, AND MAINTAINING COMPUTER SOFTWARE APPLICATIONS FOR OTHERS AND CONSULTING SERVICES RELATED THERETO; PROVIDING TEMPORARY USE OF ONLINE NON-DOWNLOADABLE COMPUTER SOFTWARE APPLICATION DEVELOPMENT TOOLS AND PROGRAMMING LANGUAGE FOR USE IN DEVELOPING, ANALYZING, CODING, CHECKING, AND CONTROLLING OTHER COMPUTER SOFTWARE; PROVIDING TEMPORARY USE OF ONLINE NON-DOWNLOADABLE COMPUTER SOFTWARE THAT IMPLEMENTS A PROCEDURAL AND OBJECT-ORIENTED PROGRAMMING LANGUAGE; ONLINE HOSTED COMPUTER SERVICES, NAMELY, DESIGNING, DEVELOPING, CUSTOMIZING, AND MAINTAINING COMPUTER SOFTWARE APPLICATIONS FOR OTHERS; AND CONSULTING SERVICES RELATED TO ALL OF THE FOREGOING (U.S. CLS. 100 AND 101).

FIRST USE 2-1-2003; IN COMMERCE 2-1-2003.
LAURIE MAYES, EXAMINING ATTORNEY



THE MARK CONSISTS OF STANDARD CHARACTERS WITHOUT CLAIM TO ANY PARTICULAR FONT, STYLE, SIZE, OR COLOR.

THE ENGLISH TRANSLATION OF THE WORD "SERATA" IN THE MARK IS EVENING.

CLASS 3—COSMETICS AND CLEANING PREPARATIONS

FOR NON-MEDICATED COSMETIC AND BEAUTY PRODUCTS, NAMELY, BEAUTY GELS, BEAUTY LOTIONS, EYE PENCILS, EYE LINER; EYE LINER, NAMELY, MATTE CAKE LINER FOR THE EYES, EYELINER SEAL; COSMETIC OILS, NAMELY, EYE LID OIL; EYE SHADOW, GEL EYE MASKS, SKIN LIGHTENER, EYE MAKEUP REMOVER; EYEBROW COSMETICS, NAMELY, EYEBROW SEAL, EYEBROW PENCIL; MASCARA; FOUNDATIONS, NAMELY, COVER BASE, FOUNDATION MAKE UP, FACE POWDER, LIQUID POWDER, POWDER BLUSH, CREAM BLUSH; COSMETIC PENCILS, NAMELY, LIP PENCIL; LIPSTICK, LIP GLOSS, LIPSTICK SEALER, MAKEUP REMOVER, COTTON MAKEUP REMOVER PADS, SKIN MOISTURIZING LOTION, SKIN MOISTURIZER, SKIN TONER, SKIN FRESHENER, CLEANSING CREAM, BEAUTY MASK, LIP BALM, EYE MOISTURIZING CREAM, EYE GEL, BODY POWDER, BODY TONER, BATH POWDER, TALCUM POWDER, LIP CREAM, LIP LINER, EYE MAKE-UP, AND MAKE-UP FOUNDATIONS, BATH OILS, SKIN CLEANSERS, SUN BLOCK, SUN CREAMS, SUNSCREEN, SUN TANNING PREPARATIONS, CREAMS, MOISTURIZERS AND LOTIONS FOR THE SKIN, FACE AND BODY; NAIL CREAMS, NAMELY, NAIL CUTICLE CREAMS, CONDITIONERS AND REMOVES; NAIL POLISHES AND NAIL CARE PREPARATIONS; FALSE NAILS; BEAUTY PRODUCTS AND ACCESSORIES, NAMELY, BEAUTY CREAMS, EYE GELS, LIP GLOSS; EYE PENCILS, EYE LINER AND MAKEUP; EYE LINER, NAMELY, MATTE CAKE LINER FOR THE EYES, EYELINER SEAL; COSMETIC OILS, NAMELY, EYE LID OIL; EYE SHADOW, GEL EYE MASKS, SKIN LIGHTENER, MAKEUP FOUNDATION, EYE MAKEUP REMOVER; EYEBROW COSMETICS, NAMELY, EYEBROW SEAL, EYEBROW PENCIL; MASCARA; FOUNDATIONS, NAMELY, COVER BASE, FOUNDATION MAKE UP, FACE POWDER, LIQUID POWDER, POWDER BLUSH, CREAM BLUSH; COSMETIC PENCILS, NAMELY, LIP PENCIL; LIPSTICK, LIP GLOSS, LIPSTICK SEALER, MAKEUP REMOVER, COTTON MAKEUP REMOVER PADS, SKIN MOISTURIZING LOTION, SKIN MOISTURIZER, SKIN TONER, SKIN FRESHENER, CLEANSING CREAM, BEAUTY MASK, LIP BALM, LIP CREAM, LIP LINER, EYE MOISTURIZING CREAM, EYE GEL, BODY POWDER, BODY TONER, BATH POWDER, TALCUM POWDER; NON-MEDICATED HAIR CARE PREPARATIONS, NAMELY, HAIR SHAMPOO, AND CLEANSERS, HAIR SPRAY, VOLUMIZERS, HAIR CONDITIONER, HAIR GEL, HAIR MOUSSE, HAIR RINSES, AND HAIR STYLING PREPARATIONS; SKIN LOTION; PERFUME AND COLOGNE; SOAPS; HAIR CLEANING AND SKIN CLEANSING PREPARATIONS, NAMELY, HAIR AND SKIN CLEANSING MATERIALS; BATH OILS, SKIN CLEANSERS, SUN BLOCK, SUN CREAMS, SUNSCREEN, SUN TANNING PREPARATIONS; CREAMS, MOISTURIZERS AND LOTIONS FOR THE SKIN, FACE AND BODY; NON-MEDICATED HAIR TREATMENT PREPARATIONS FOR COSMETIC PURPOSES, NAMELY, NON-MEDICATED HAIR COLORING AND DYES (U.S. CLS. 1, 4, 6, 50, 51 AND 52).

CLASS 16—PAPER GOODS AND PRINTED MATTER

FOR NEWSLETTERS IN THE FIELD OF WELLNESS, CONTAINING CONTENT ON THE SUBJECTS OF PROPER FITNESS, FOOD, NUTRITION, VITAMINS AND NUTRICEUTICALS, HEALTH, TRAINING, AND MENTAL AND SPIRITUAL HEALTH; NEWSLETTERS IN THE FIELD OF BEAUTY, HAIR, BODY CARE; NEWSLETTERS IN THE FIELD OF PERSONAL/GROUP EVENT PLANNING CONTAINING CONTENT ON THE SUBJECTS OF THE SELECTION OF THE VENUE, INVITATIONS, MEDIA, CALENDAR LOGISTICS, WINE, BEER, LIQUOR, ALCOHOLIC AND NON-ALCOHOLIC BEVERAGES, FOOD, DESERTS, DÉCOR, WAIT STAFF, FAVORS AND DECORATIONS; NEWSLETTERS IN THE FIELD OF WEDDING PLANNING; CALENDARS (U.S. CLS. 2, 5, 22, 23, 29, 37, 38 AND 50).

BENJAMIN OKEKE, EXAMINING ATTORNEY

CLASS 35—ADVERTISING AND BUSINESS

FOR BUSINESS MANAGEMENT PLANNING OF BUSINESS PROCESSES IN THE FIELD OF SECURITY FOR ORGANIZATIONS; BUSINESS RISK MANAGEMENT FOR BUSINESS ENTERPRISES; BUSINESS STRATEGIC PLANNING SERVICES (U.S. CLS. 100, 101 AND 102).

FIRST USE 6-7-2005; IN COMMERCE 6-7-2005.

CLASS 45—PERSONAL AND LEGAL SERVICES

FOR SECURITY CONSULTING FOR ORGANIZATIONS, NAMELY, CONSULTING RELATING TO ANTI-TERRORISM, COUNTER-TERRORISM, AND PERSONAL AND EXECUTIVE SECURITY; SECURITY SERVICES, NAMELY, PROVIDING ANTI-TERRORISM CONSULTING SERVICES FOR BUSINESSES (U.S. CLS. 100 AND 101).

FIRST USE 6-7-2005; IN COMMERCE 6-7-2005.

MARTHA SANTOMARTINO, EXAMINING ATTORNEY

SN 85-277,082. AYOUB'S DRIED FRUITS & NUTS INC., NORTH VANCOUVER, BC, CANADA, FILED 3-25-2011.

AYOUB'S

THE MARK CONSISTS OF STANDARD CHARACTERS WITHOUT CLAIM TO ANY PARTICULAR FONT, STYLE, SIZE, OR COLOR.

PRIORITY CLAIMED UNDER SEC. 44(D) ON CANADA APPLICATION NO. 1498020, FILED 9-30-2010, REG. NO. TMA815,580, DATED 1-16-2012, EXPIRES 1-16-2027.

CLASS 29—MEATS AND PROCESSED FOODS

FOR EDIBLE ROASTED NUTS, EDIBLE ROASTED SEEDS, DRIED FRUITS, FRUIT AND NUT-BASED SNACK MIXES (U.S. CL. 46).

CLASS 30—STAPLE FOODS

FOR CANDY, COOKIES, DRIED HERBS AND SPICES FOR FOOD PURPOSES; TEA (U.S. CL. 46).

JACLYN KIDWELL WALKER, EXAMINING ATTORNEY

SN 85-277,427. THE FLYNT GROUP, INC., KANSAS CITY, MO. FILED 3-25-2011.

FLYNT GROUP

THE MARK CONSISTS OF STANDARD CHARACTERS WITHOUT CLAIM TO ANY PARTICULAR FONT, STYLE, SIZE, OR COLOR.

OWNER OF U.S. REG. NO. 3,113,737.

NO CLAIM IS MADE TO THE EXCLUSIVE RIGHT TO USE "GROUP", APART FROM THE MARK AS SHOWN.

SEC. 2(F).

SN 85-278,658. INNODATA SYNODEX, LLC, HACKENSACK, NJ. FILED 3-28-2011.

SYNODEX

THE MARK CONSISTS OF STANDARD CHARACTERS WITHOUT CLAIM TO ANY PARTICULAR FONT, STYLE, SIZE, OR COLOR.

CLASS 35—ADVERTISING AND BUSINESS

FOR (BASED ON USE IN COMMERCE) MEDICAL RECORDS MANAGEMENT SERVICES, NAMELY, DOCUMENT INDEXING FOR OTHERS; TRANSCRIPTION OF MEDICAL DATA AND RECORDS; BILLING AND MEDICAL CODING FOR INSURANCE AND COMPLIANCE PURPOSES; RECORDS MANAGEMENT SERVICES, NAMELY, INDEXING AND SUMMARIZING OF MEDICAL RECORDS AND MEDICAL CONDITION AND TREATMENT DATA FOR OTHERS; COMPUTER ANALYSIS OF ELECTRONIC INFORMATION FOR USE IN ORGANIZATION OF MEDICAL RECORDS, INDEXING OF MEDICAL RECORDS, SUMMARIZATION OF MEDICAL RECORDS, ANALYSIS OF MEDICAL RECORDS AND PROVISION OF TRANSCRIPTS OF MEDICAL DATA AND RECORDS FOR RECORDS MANAGEMENT PURPOSES (U.S. CLS. 100, 101 AND 102).

FIRST USE 3-31-2010; IN COMMERCE 3-31-2010.

CLASS 39—TRANSPORTATION AND STORAGE

FOR (BASED ON INTENT TO USE) STORAGE OF ELECTRONIC MEDIA IN THE NATURE OF MEDICAL DATA AND RECORDS IN COMPLIANCE WITH HEALTH INFORMATION PRIVACY LEGISLATION (U.S. CLS. 100 AND 105).

CLASS 42—SCIENTIFIC AND COMPUTER SERVICES

FOR (BASED ON INTENT TO USE) CONVERSION OF MEDICAL RECORDS FROM PHYSICAL TO ELECTRONIC MEDIA AND FROM ONE DIGITAL FORMAT TO ANOTHER DIGITAL FORMAT; COMPUTER ANALYSIS OF ELECTRONIC INFORMATION FOR USE IN DIGITAL CONVERSION OF MEDICAL RECORDS (U.S. CLS. 100 AND 101).

JULIE VEPPUMTHARA, EXAMINING ATTORNEY

SN 85-281,691. LOCUS DEVELOPMENT, INC., SAN FRANCISCO, CA. FILED 3-30-2011.

SN 85-281,700. LOCUS DEVELOPMENT, INC., SAN FRANCISCO, CA. FILED 3-30-2011.

LOCUS

LOCUS DEVELOPMENT

THE MARK CONSISTS OF STANDARD CHARACTERS WITHOUT CLAIM TO ANY PARTICULAR FONT, STYLE, SIZE, OR COLOR.

THE MARK CONSISTS OF STANDARD CHARACTERS WITHOUT CLAIM TO ANY PARTICULAR FONT, STYLE, SIZE, OR COLOR.

NO CLAIM IS MADE TO THE EXCLUSIVE RIGHT TO USE "DEVELOPMENT", APART FROM THE MARK AS SHOWN.

CLASS 9—ELECTRICAL AND SCIENTIFIC APPARATUS

FOR COMPUTER SOFTWARE PROGRAMS FOR ANALYZING, STORING, QUERYING AND COMPUTING BIOLOGICAL SEQUENCE DATA, FOR USE IN THE FIELDS OF BIOINFORMATICS AND BIOTECHNOLOGIES (U.S. CLS. 21, 23, 26, 36 AND 38).

CLASS 9—ELECTRICAL AND SCIENTIFIC APPARATUS

FOR COMPUTER SOFTWARE PROGRAMS FOR ANALYZING, STORING, QUERYING AND COMPUTING BIOLOGICAL SEQUENCE DATA, FOR USE IN THE FIELDS OF BIOINFORMATICS AND BIOTECHNOLOGIES (U.S. CLS. 21, 23, 26, 36 AND 38).

CLASS 42—SCIENTIFIC AND COMPUTER SERVICES

FOR GENOMIC AND BIOINFORMATICS TESTING, NAMELY, GENETIC TESTING FOR MEDICAL RESEARCH AND SCIENTIFIC RESEARCH PURPOSES; PROVIDING MEDICAL AND SCIENTIFIC RESEARCH INFORMATION IN THE FIELD OF MOLECULAR GENETICS; CONSULTING SERVICES IN THE FIELD OF GENOMICS AND BIOLOGICAL SEQUENCE PROCESSING AND ANALYSIS FOR SCIENTIFIC RESEARCH AND MEDICAL RESEARCH PURPOSES; DEVELOPMENT OF NEW TECHNOLOGY FOR OTHERS IN THE FIELD OF MOLECULAR GENETICS; DNA ANALYSIS AND SCREENING FOR SCIENTIFIC RESEARCH PURPOSES; COMPILING DATA FOR RESEARCH PURPOSES IN THE FIELD OF MEDICAL SCIENCE AND MEDICAL CONSULTANCY; DNA ANALYSIS SERVICES; DNA SCREENING FOR SCIENTIFIC RESEARCH PURPOSES; GENETIC MAPPING FOR SCIENTIFIC PURPOSES (U.S. CLS. 100 AND 101).

CLASS 42—SCIENTIFIC AND COMPUTER SERVICES

FOR GENOMIC AND BIOINFORMATICS TESTING, NAMELY, GENETIC TESTING FOR MEDICAL RESEARCH AND SCIENTIFIC RESEARCH PURPOSES; PROVIDING MEDICAL AND SCIENTIFIC RESEARCH INFORMATION IN THE FIELD OF MOLECULAR GENETICS; CONSULTING SERVICES IN THE FIELD OF GENOMICS AND BIOLOGICAL SEQUENCE PROCESSING AND ANALYSIS FOR SCIENTIFIC RESEARCH AND MEDICAL RESEARCH PURPOSES; DEVELOPMENT OF NEW TECHNOLOGY FOR OTHERS IN THE FIELD OF MOLECULAR GENETICS; DNA ANALYSIS AND SCREENING FOR SCIENTIFIC RESEARCH PURPOSES; COMPILING DATA FOR RESEARCH PURPOSES IN THE FIELD OF MEDICAL SCIENCE AND MEDICAL CONSULTANCY; DNA ANALYSIS SERVICES; DNA SCREENING FOR SCIENTIFIC RESEARCH PURPOSES; GENETIC MAPPING FOR SCIENTIFIC PURPOSES (U.S. CLS. 100 AND 101).

CLASS 44—MEDICAL, BEAUTY AND AGRICULTURAL SERVICES

FOR DIAGNOSTIC SERVICES IN THE FIELD OF MEDICINE; MEDICAL TESTING FOR DIAGNOSIS OF DISEASES; GENOMIC AND BIOINFORMATICS TESTING, NAMELY, GENETIC TESTING FOR MEDICAL DIAGNOSTIC AND TREATMENT PURPOSES; DNA SCREENING FOR MEDICAL DIAGNOSTIC AND TREATMENT PURPOSES; DNA ANALYSIS AND SCREENING FOR MEDICAL DIAGNOSTIC AND TREATMENT PURPOSES; DNA SCREENING FOR MEDICAL PURPOSES; CONSULTING SERVICES IN THE FIELD OF GENOMICS AND BIOLOGICAL SEQUENCE PROCESSING AND ANALYSIS FOR MEDICAL DIAGNOSIS AND TREATMENT PURPOSES; PROVIDING MEDICAL INFORMATION FOR THE PURPOSES OF MEDICAL DIAGNOSIS AND TREATMENT IN THE FIELD OF MOLECULAR GENETICS (U.S. CLS. 100 AND 101).

JERI J. FICKES, EXAMINING ATTORNEY

CLASS 44—MEDICAL, BEAUTY AND AGRICULTURAL SERVICES

FOR DIAGNOSTIC SERVICES IN THE FIELD OF MEDICINE; MEDICAL TESTING FOR DIAGNOSIS OF DISEASES; GENOMIC AND BIOINFORMATICS TESTING, NAMELY, GENETIC TESTING FOR MEDICAL DIAGNOSTIC AND TREATMENT PURPOSES; DNA SCREENING FOR MEDICAL DIAGNOSTIC AND TREATMENT PURPOSES; DNA ANALYSIS AND SCREENING FOR MEDICAL DIAGNOSTIC AND TREATMENT PURPOSES; DNA SCREENING FOR MEDICAL PURPOSES; CONSULTING SERVICES IN THE FIELD OF GENOMICS AND BIOLOGICAL SEQUENCE PROCESSING AND ANALYSIS FOR MEDICAL DIAGNOSIS AND TREATMENT PURPOSES; PROVIDING MEDICAL INFORMATION FOR THE PURPOSES OF MEDICAL DIAGNOSIS AND TREATMENT IN THE FIELD OF MOLECULAR GENETICS (U.S. CLS. 100 AND 101).

JERI J. FICKES, EXAMINING ATTORNEY

SN 85-282,496. HORIZON GROUP USA, INC, WARREN, NJ.
FILED 3-31-2011.

MADE BY ME!

THE MARK CONSISTS OF STANDARD CHARACTERS WITHOUT CLAIM TO ANY PARTICULAR FONT, STYLE, SIZE, OR COLOR.

CLASS 14—JEWELRY

FOR CRAFT AND ACTIVITY KITS FOR CHILDREN TO CREATE PLAY JEWELRY INCLUDING BEADS, PENDANTS, RINGS AND ACRYLIC STONES (U.S. CLS. 2, 27, 28 AND 50).

FIRST USE 3-0-2010; IN COMMERCE 3-0-2010.

CLASS 16—PAPER GOODS AND PRINTED MATTER

FOR CRAFT AND ACTIVITY KITS FOR CHILDREN, NAMELY, HOBBY PAINT KITS TO PAINT AND PERSONALIZE BIRD HOUSES AND PIGGY BANKS; CRAFT AND ACTIVITY KITS FOR CHILDREN, NAMELY, PAINT AND CLAY OR PLASTER KITS; CRAFT AND ACTIVITY KITS FOR CHILDREN FOR DECORATING A BACKPACK, NAMELY, MARKERS AND A BACKPACK; CRAFT AND ACTIVITY KITS FOR CHILDREN FOR PAINTING AND DECORATING FRIENDSHIP STONES, NAMELY, PAINT, PAINT BRUSHES, PLASTER AND MOLDS; CRAFT AND ACTIVITY KITS FOR CHILDREN FOR PAINTING AND DECORATING A CLOCK, NAMELY, PAINT, PAINT BRUSHES AND A CLOCK; CRAFT AND ACTIVITY KITS FOR CHILDREN FOR PAINTING AND DECORATING TOY CARS, NAMELY, PAINT, PAINT BRUSHES AND TOY CARS; CRAFT AND ACTIVITY KITS FOR CHILDREN FOR PAINTING AND DECORATING MAGNETS, NAMELY, PAINT, PAINT BRUSHES AND MAGNETS; CRAFT AND ACTIVITY KITS FOR CHILDREN FOR PAINTING, DECORATING AND BURNING WOOD OBJECTS, NAMELY, PAINT, PAINT BRUSHES, WOODEN OBJECTS AND WOOD BURNING IRON; CRAFT AND ACTIVITY KITS FOR CHILDREN FOR PAINTING AND DECORATING A TIME CAPSULE, NAMELY, PAINT, PAINT BRUSHES AND A TIME CAPSULE; CRAFT AND ACTIVITY KITS FOR CHILDREN FOR PAINTING AND DECORATING TOY PETS, NAMELY, PAINT, PAINT BRUSHES AND TOY PETS; CRAFT AND ACTIVITY KITS FOR CHILDREN FOR PAINTING AND DECORATING BOBBLE HEADS OBJECT, NAMELY, PAINT, PAINT BRUSHES AND BOBBLE HEAD OBJECTS; CRAFT AND ACTIVITY KITS FOR CHILDREN FOR PAINTING AND DECORATING FIGURINES, NAMELY, PAINT, PAINT BRUSHES AND FIGURINES; CRAFT AND ACTIVITY KITS FOR CHILDREN FOR CREATING SAND ART, NAMELY, SAND AND A CONTAINER; CRAFT AND ACTIVITY KITS FOR CHILDREN FOR DECORATING FRAMES, NAMELY, PAINT, BRUSH AND FRAME; ARTS AND CRAFT KITS CONTAINING VARIOUS COMBINATIONS OF SELECTED ART AND CRAFT SUPPLIES, NAMELY, PAINT, PAINT BRUSHES AND CLAY (U.S. CLS. 2, 5, 22, 23, 29, 37, 38 AND 50).

FIRST USE 3-0-2010; IN COMMERCE 3-0-2010.

CLASS 26—FANCY GOODS

FOR CRAFT AND ACTIVITY KITS FOR CHILDREN FOR WEAVING OBJECTS INCLUDING A WEAVING LOOM, WEAVING HOOK AND WEAVING LOOPS; WEAVING LOOPS; CRAFT AND ACTIVITY KITS FOR CHILDREN FOR WEAVING OR CREATING FRIENDSHIP BRACELETS (U.S. CLS. 37, 39, 40, 42 AND 50).

FIRST USE 3-0-2010; IN COMMERCE 3-0-2010.

CLASS 28—TOYS AND SPORTING GOODS

FOR CRAFT AND ACTIVITY KITS FOR CHILDREN, NAMELY, HOBBY CRAFT KITS FOR TIE-DYE; CRAFT AND ACTIVITY KITS FOR CHILDREN, NAMELY, HOBBY CRAFT MOLDS FOR TOY CARS AND TOY TRUCKS (U.S. CLS. 22, 23, 38 AND 50).

FIRST USE 3-0-2010; IN COMMERCE 3-0-2010.

DAVID TOOLEY, EXAMINING ATTORNEY

SN 85-286,551. GRAY, ERIC A, ROSELLE, NJ. AND GRAY, EMILIENCE, ROSELLE, NJ. FILED 4-5-2011.



OWNER OF U.S. REG. NO. 3,211,875.

THE COLOR(S) YELLOW GOLD, RED, GREEN, BLACK AND WHITE IS/ARE CLAIMED AS A FEATURE OF THE MARK.

THE MARK CONSISTS OF A SHIELD WITH A YELLOW GOLD CROWN ABOVE IT; "HHRR", IN RED TYPE, APPEARS ON A WHITE RIBBON BETWEEN THE SHIELD AND THE CROWN; THE BORDER AROUND THE SHIELD IS YELLOW GOLD; BELOW THE SHIELD IS A SECOND WHITE RIBBON THAT HAS ON IT "HIPHOPRASTAROCKER", IN BLACK TYPE; THE LEFT SIDE OF THE SHIELD IS RED INSIDE OF THE YELLOW GOLD BORDER AND HAS A LION FACING RIGHT HOLDING A BLACK MICROPHONE, WITH ITS PAW OVER A BLACK AND YELLOW TURNTABLE; THE RIGHT SIDE OF THE SHIELD IS GREEN INSIDE OF THE BORDER AND HAS A LION FACING LEFT HOLDING A BLACK GUITAR; THE RIBBONS, THE SHIELD, THE CROWN AND THE DIVISION BETWEEN THE RIGHT AND LEFT SIDES OF THE SHIELD ARE DELINEATED BY BLACK LINES.

CLASS 25—CLOTHING

FOR BELTS; BELTS FOR CLOTHING; BOTTOMS; HEADBANDS FOR CLOTHING; HOODS; JACKETS; JERSEYS; TOPS; WEARABLE GARMENTS AND CLOTHING, NAMELY, SHIRTS; WOMEN'S CLOTHING, NAMELY, SHIRTS, DRESSES, SKIRTS, BLOUSES (U.S. CLS. 22 AND 39).

CLASS 41—EDUCATION AND ENTERTAINMENT

FOR PROVIDING A WEBSITE FEATURING ENTERTAINMENT INFORMATION; PROVIDING A WEBSITE FEATURING INFORMATION IN THE FIELD OF MUSIC AND ENTERTAINMENT; PROVIDING AN EDUCATIONAL WEBSITE IN THE FIELDS OF MUSIC AND ENTERTAINMENT; PROVIDING AN INTERNET WEBSITE PORTAL IN THE FIELD OF MUSIC (U.S. CLS. 100, 101 AND 107).

HENRY S. ZAK, EXAMINING ATTORNEY

SN 85-286,810. THE HUMPTY DUMPTY INSTITUTE, NEW YORK, NY. FILED 4-5-2011.



THE MARK CONSISTS OF THE STYLIZED WORDING "NAMUS" APPEARING TO THE RIGHT OF STYLIZED INTERTWINING IMAGES OF A MUSHROOM AND A HEART.

CLASS 29—MEATS AND PROCESSED FOODS
FOR PROCESSED MUSHROOMS (U.S. CL. 46).

CLASS 31—NATURAL AGRICULTURAL PRODUCTS

FOR RAW MUSHROOMS (U.S. CLS. 1 AND 46).
ELI HELLMAN, EXAMINING ATTORNEY

SN 85-288,919. A.L.HANSEN MANUFACTURING, WAUKEGAN, IL. FILED 4-7-2011.

A.L.HANSEN MANUFACTURING
CO.

THE MARK CONSISTS OF STANDARD CHARACTERS WITHOUT CLAIM TO ANY PARTICULAR FONT, STYLE, SIZE, OR COLOR.

NO CLAIM IS MADE TO THE EXCLUSIVE RIGHT TO USE "MANUFACTURING CO.", APART FROM THE MARK AS SHOWN.

THE NAME(S), PORTRAIT(S), AND/OR SIGNATURE(S) SHOWN IN THE MARK DOES NOT IDENTIFY A PARTICULAR LIVING INDIVIDUAL.

CLASS 6—METAL GOODS

FOR METAL HARDWARE, NAMELY, HINGES, TIE-DOWN BUCKLES AND ANCHOR POINTS USED FOR SECURING LOADS ON TRUCKS, GRAB HANDLES FOR TOOL BOXES AND DRAWERS, HANDLES FOR METAL CABINETS AND TRUCK CABS, DOOR LATCHES, DOOR HOLDERS, SLIDING DOOR LOCKS, AND BAR LOCKS, BOLTS, CAB LOCKS, DOOR STOPS WITH STEEL SPRING AND ROD TO HOLD DOORS OPEN OR KEEP THEM FROM SLAMMING, HOOD LATCHES, LOCK KITS COMPRISED OF LOCK, RODS, SHANKS, NAMELY, METAL KEY SHANKS, ROD GUIDES AND WASHERS, ROTARY LATCHES AND DOOR STRIKES, NON-POWERED DOOR ACTUATOR ARMS AND STRIKER PLATES, SPECIALTY ITEMS, NAMELY, PUSH BUTTON LATCHES, MANUAL DOOR SUPPORT ARMS, NAMELY, DOOR SUPPORT ROLLERS, METAL SWIVEL HOOKS, CAM HANDLE LOCKS, BALL LOCK PINS, D-RINGS (U.S. CLS. 2, 12, 13, 14, 23, 25 AND 50).
FIRST USE 2-2-1920; IN COMMERCE 2-2-1920.

CLASS 40—MATERIAL TREATMENT

FOR MANUFACTURE OF CUSTOM INTEGRATED HARDWARE SERVICES NAMELY PROTOTYPE FABRICATION OF NEW PRODUCTS FOR OTHERS, DIE CASTING, METAL STAMPING, MACHINING PARTS FOR OTHERS, WELDING, ASSEMBLY OF PRODUCTS FOR OTHERS (U.S. CLS. 100, 103 AND 106).

FIRST USE 2-2-1920; IN COMMERCE 2-2-1920.
NAKIA HENRY, EXAMINING ATTORNEY

SN 85-289,892. GRÖTSCH, KURT, SEVILLA, SPAIN, FILED 4-8-2011.

NO CLAIM IS MADE TO THE EXCLUSIVE RIGHT TO USE "CHINESE" AND THE NON-LATIN CHARACTERS THAT TRANSLITERATE TO ZHONG GUO, APART FROM THE MARK AS SHOWN.

THE COLOR(S) RED AND GRAY IS/ARE CLAIMED AS A FEATURE OF THE MARK.

THE MARK CONSISTS OF THE TERM "CHINESE FRIENDLY" IN GRAY, WITH CHINESE CHARACTERS IN RED.

THE NON-LATIN CHARACTERS IN THE MARK TRANSLITERATE TO YOU HAO ZHONG GUO AND THIS MEANS FRIENDLY CHINA IN ENGLISH.

CLASS 35—ADVERTISING AND BUSINESS

FOR ADVERTISING; BUSINESS MANAGEMENT; PUBLIC RELATIONS (U.S. CLS. 100, 101 AND 102).

CLASS 41—EDUCATION AND ENTERTAINMENT

FOR EDUCATIONAL SERVICES, NAMELY, CLASSES AND SEMINARS IN THE FIELDS OF INTERCULTURAL STUDIES IN THE NATURE OF KNOWLEDGE OF CHINESE CULTURE, PROBLEMS AND OPPORTUNITIES IN THE COEXISTENCE AND INTEGRATION INTO OTHER CULTURES, WORKING WITH CHINA AND WORKING IN CHINA, KNOWLEDGE OF CULTURAL AND SOCIAL STRUCTURES IN CHINA, ECONOMICS IN CHINA, AND DEVELOPING INTERNATIONAL STUDENT EXCHANGE PROGRAMS; TRAINING SERVICES IN THE FIELDS OF CHINESE TOURISM, EXPECTATIONS, NEEDS AND DEMANDS OF CHINESE TOURISTS AND DEVELOPMENT OF NEW PRODUCTS AND OFFERINGS FOR CHINESE TOURISTS AND AMERICAN TOURISTS WHO TRAVEL TO CHINA; ENTERTAINMENT, NAMELY, MULTIMEDIA ENTERTAINMENT SERVICES IN THE NATURE OF VIDEO AND FILM PRODUCTION, ENTERTAINMENT IN THE NATURE OF ORGANIZATION OF GOLF TOURNAMENTS, FOOTBALL GAMES, HIKING, CAMPING, MOUNTAINEERING AND ROCK CLIMBING, CULTURAL EVENTS AND CONCERTS, ART EXHIBITIONS IN CHINA AND OUTSIDE OF CHINA BY CHINESE ARTISTS; DEVELOPING INTERNATIONAL ARTIST EXCHANGE PROGRAMS; PUBLICATION OF ART BOOKS AND CATALOGS; ORGANIZATION OF CULTURAL SHOWS (U.S. CLS. 100, 101 AND 107).

CLASS 43—HOTEL AND RESTAURANT SERVICES

FOR RESTAURANT SERVICES; TEMPORARY ACCOMMODATIONS (U.S. CLS. 100 AND 101).
ALEX KEAM, EXAMINING ATTORNEY

SN 85-292,003. SYSMEX CORPORATION, KOBE, HYOGO, JAPAN, FILED 4-11-2011.

SN 85-292,238. PROMONTORY INTERFINANCIAL NETWORK, LLC, ARLINGTON, VA. FILED 4-11-2011.

SAFLAS

THE MARK CONSISTS OF STANDARD CHARACTERS WITHOUT CLAIM TO ANY PARTICULAR FONT, STYLE, SIZE, OR COLOR.

PRIORITY CLAIMED UNDER SEC. 44(D) ON JAPAN APPLICATION NO. T2011-024297, FILED 4-6-2011, REG. NO. 5447422, DATED 10-28-2011, EXPIRES 10-28-2021.

THE WORDING "SAFLAS" HAS NO MEANING IN A FOREIGN LANGUAGE.

CLASS 9—ELECTRICAL AND SCIENTIFIC APPARATUS

FOR COMPUTER PROGRAM FOR ANALYZING MEASUREMENT DATA FOR USE IN THE FIELD OF HEMATOLOGY ANALYSIS OR DIAGNOSIS; COMPUTER SOFTWARE FOR ANALYZING MEASUREMENT DATA FOR USE IN THE FIELD OF HEMATOLOGY ANALYSIS OR DIAGNOSIS; CLINICAL LABORATORY ANALYZERS FOR MEASURING, TESTING AND ANALYZING BLOOD; AND STRUCTURAL PARTS AND STRUCTURAL FITTINGS THEREFOR (U.S. CLS. 21, 23, 26, 36 AND 38).

CLASS 10—MEDICAL APPARATUS

FOR DIAGNOSTIC OR MEASURING APPARATUS AND INSTRUMENTS FOR MEDICAL PURPOSES, NAMELY, HEMATOLOGICAL ANALYZING APPARATUS AND INSTRUMENTS, BLOOD CELL ANALYZERS, SAMPLE TRANSFER APPARATUS, SAMPLE CONTAINER TRANSFER APPARATUS, SAMPLE RACK TRANSFER APPARATUS; AND STRUCTURAL PARTS AND STRUCTURAL FITTINGS FOR ALL THE AFOREMENTIONED GOODS (U.S. CLS. 26, 39 AND 44).

CLASS 42—SCIENTIFIC AND COMPUTER SERVICES

FOR CLINICAL LABORATORY TESTING IN THE FIELD OF SCIENTIFIC ANALYSIS OF BLOOD, URINE OR CELL; PROVIDING SCIENTIFIC INFORMATION ABOUT CLINICAL LABORATORY TESTS IN THE FIELD OF SCIENTIFIC ANALYSIS OF BLOOD, URINE OR CELL; AND SCIENTIFIC ANALYSIS AND EVALUATION OF RESULTS OF CLINICAL LABORATORY TESTS IN THE FIELD OF SCIENTIFIC ANALYSIS OF BLOOD, URINE OR CELL (U.S. CLS. 100 AND 101).

CLASS 44—MEDICAL, BEAUTY AND AGRICULTURAL SERVICES

FOR PROVIDING MEDICAL INFORMATION; AND RENTAL OF MEDICAL APPARATUS AND INSTRUMENTS (U.S. CLS. 100 AND 101).

SETH A. RAPPAPORT, EXAMINING ATTORNEY

CDARS

THE MARK CONSISTS OF STANDARD CHARACTERS WITHOUT CLAIM TO ANY PARTICULAR FONT, STYLE, SIZE, OR COLOR.

OWNER OF U.S. REG. NO. 2,783,334.

CLASS 35—ADVERTISING AND BUSINESS

FOR FINANCIAL TRANSACTION SERVICES, NAMELY, MAINTAINING CUSTOMER RECORDS FOR FINANCIAL TRANSACTIONS (U.S. CLS. 100, 101 AND 102).

FIRST USE 12-0-2002; IN COMMERCE 12-0-2002.

CLASS 36—INSURANCE AND FINANCIAL

FOR BANKING SERVICES; FINANCIAL SERVICES, NAMELY, ASSISTING FINANCIAL INSTITUTIONS WITH THE MANAGEMENT OF CUSTOMER CASH FUNDS AND FACILITATING THE TRANSFER OF FUNDS BETWEEN FUND SOURCES AND DEPOSIT ACCOUNTS; FINANCIAL SERVICES, NAMELY, THE MANAGEMENT OF DEPOSIT ACCOUNTS AND FACILITATING THE TRANSFER OF FUNDS BETWEEN FUND SOURCES AND DEPOSIT ACCOUNTS; FINANCIAL SERVICES, NAMELY, CASH MANAGEMENT SERVICES, CASH FUNDS TRANSFER AND TRANSACTION SERVICES; FINANCIAL SERVICES, NAMELY, ALLOCATION OF FUNDS TO AND PLACEMENT OF FUNDS IN DEPOSIT ACCOUNTS; CUSTODIAL AND SUB-CUSTODIAL SERVICES FOR DEPOSIT ACCOUNTS, AND DEPOSIT ACCOUNT SETTLEMENT SERVICES; FDIC CLAIM PROCESSING SERVICES (U.S. CLS. 100, 101 AND 102).

FIRST USE 12-0-2002; IN COMMERCE 12-0-2002.

MICHAEL WEBSTER, EXAMINING ATTORNEY

SN 85-292,741. JFC, INC., ST. CLOUD, MN. FILED 4-12-2011.



NO CLAIM IS MADE TO THE EXCLUSIVE RIGHT TO USE "COMPANY", APART FROM THE MARK AS SHOWN. THE COLOR(S) YELLOW IS/ARE CLAIMED AS A FEATURE OF THE MARK.

THE MARK CONSISTS OF THE WORDING "GNP COMPANY" AND A DESIGN OF A CHICKEN ALL WITHIN A YELLOW OVAL. THE COLORS BLACK AND WHITE ARE NOT CLAIMED AS FEATURES OF THE MARK BUT ARE FOR SHADING PURPOSES ONLY.

CLASS 29—MEATS AND PROCESSED FOODS

FOR CHICKEN; POULTRY (U.S. CL. 46).

CLASS 35—ADVERTISING AND BUSINESS

FOR WHOLESALE DISTRIBUTORSHIP SERVICES IN THE FIELD OF CHICKENS AND CHICKEN PARTS (U.S. CLS. 100, 101 AND 102).

CLASS 40—MATERIAL TREATMENT

FOR CHICKEN BUTCHERING SERVICES (U.S. CLS. 100, 103 AND 106).
SOPHIA S. KIM, EXAMINING ATTORNEY

SN 85-293,157. PROMONTORY INTERFINANCIAL NETWORK, LLC, ARLINGTON, VA. FILED 4-12-2011.

**ONE RELATIONSHIP ONE RATE
ONE STATEMENT**

SN 85-292,961. SAO PAULO ALPARGATAS S.A., SAO PAULO, BRAZIL, FILED 4-12-2011.

THE MARK CONSISTS OF STANDARD CHARACTERS WITHOUT CLAIM TO ANY PARTICULAR FONT, STYLE, SIZE, OR COLOR.
OWNER OF U.S. REG. NO. 3,365,765.



THE COLOR(S) RED, ORANGE, YELLOW, BLUE, DARK BLUE, LIGHT BLUE, LIME GREEN, GREEN, AND GREY IS/ARE CLAIMED AS A FEATURE OF THE MARK.

THE MARK CONSISTS OF A DESIGN OF AN ARROW FORMED BY TRIANGLES IN RED, ORANGE, YELLOW, BLUE, DARK BLUE, LIGHT BLUE, LIME GREEN AND GREEN TO THE LEFT OF THE TERM "ALPA" IN GREY.

THE WORD(S) "ALPA" HAS NO MEANING IN A FOREIGN LANGUAGE.

CLASS 35—ADVERTISING AND BUSINESS

FOR FINANCIAL TRANSACTION SERVICES, NAMELY, MAINTAINING CUSTOMER RECORDS FOR FINANCIAL TRANSACTIONS; FINANCIAL RECORDS MANAGEMENT; FINANCIAL RECORD-KEEPING RELATING TO DEPOSIT ACCOUNTS (U.S. CLS. 100, 101 AND 102).

FIRST USE 0-0-2008; IN COMMERCE 0-0-2008.

CLASS 36—INSURANCE AND FINANCIAL

FOR BANKING SERVICES; FINANCIAL SERVICES, NAMELY, ASSISTING FINANCIAL INSTITUTIONS WITH THE MANAGEMENT OF CUSTOMER CASH FUNDS AND FACILITATING THE TRANSFER OF FUNDS BETWEEN FUND SOURCES AND DEPOSIT ACCOUNTS; FINANCIAL SERVICES, NAMELY, THE MANAGEMENT OF DEPOSIT ACCOUNTS AND FACILITATING THE TRANSFER OF FUNDS BETWEEN FUND SOURCES AND DEPOSIT ACCOUNTS; FINANCIAL SERVICES, NAMELY, CASH MANAGEMENT SERVICES, CASH FUNDS TRANSFER AND TRANSACTION SERVICES; FINANCIAL SERVICES, NAMELY, ALLOCATION OF FUNDS TO AND PLACEMENT OF FUNDS IN DEPOSIT ACCOUNTS; CUSTODIAL AND SUB-CUSTODIAL SERVICES FOR DEPOSIT ACCOUNTS, AND DEPOSIT ACCOUNT SETTLEMENT SERVICES; FDIC CLAIM PROCESSING SERVICES (U.S. CLS. 100, 101 AND 102).

FIRST USE 0-0-2008; IN COMMERCE 0-0-2008.

MICHAEL WEBSTER, EXAMINING ATTORNEY

CLASS 25—CLOTHING

FOR GARMENTS, NAMELY, SHORTS, JACKETS, BERMUDA SHORTS, KNICKERS, T-SHIRTS, JOGGING SUITS, DRESSES, SWEAT PANTS, SWEAT SHIRTS, STOCKINGS, CAPS, SOCKS, UNDERPANTS, UNIFORMS, POLO SHIRTS, SOCIAL SHIRTS, SOCIAL PANTS, SPORTS PANTS, BIKINIS, BODY SUITS, LONG SKIRTS, SHORT SKIRTS, HATS, OVERCOATS, COATS, SUITS, BLAZERS, PARKAS; FOOTWEAR, NAMELY, TENNIS SHOES, SPORTS SHOES, SHOES FOR PRACTICING SPORTS, SOCCER SHOES, BOOTS FOR PRACTICING SPORTS, BOOTS IN GENERAL, ANKLE BOOTS, GYMNASTICS SHOES, BATHING SANDALS, BATHING THONGS, SANDALS AND SOCIAL SHOES (U.S. CLS. 22 AND 39).

CLASS 28—TOYS AND SPORTING GOODS

FOR ELBOW PADS FOR ATHLETIC USE, KNEE PADS FOR ATHLETIC USE; GLOVES, NAMELY, BASEBALL GLOVES, BATTING GLOVES, BOXING GLOVES, FENCING GLOVES, GOLF GLOVES, PLAYING BALLS, NAMELY, BALLS FOR SPORTS, SHINBONE PADS FOR ATHLETIC USE; BALLS, NAMELY, BALLS FOR GAMES, BILLIARD BALLS, BLADDERS OF BALLS FOR GAMES, PLAYING BALLS, NAMELY, SOCCER BALLS, FOOT BALLS, BASKET BALLS, VOLLEY BALLS, TENNIS BALLS (U.S. CLS. 22, 23, 38 AND 50).

CLASS 35—ADVERTISING AND BUSINESS

FOR ADVERTISING; BUSINESS MANAGEMENT; BUSINESS ADMINISTRATION AND OFFICE WORK; RETAIL STORE SERVICES FEATURING FOOTWEAR, SANDALS, FLIP FLOPS, BALLET SHOES, BOOTS, KEY RINGS, MAGNETS, SOCKS, TOWELS (U.S. CLS. 100, 101 AND 102).

ALICE BENMAMAN, EXAMINING ATTORNEY

SN 85-293,474. HARBAUGH, LYNNE, LOS ANGELES, CA. FILED 4-12-2011.

WINTERGRAVE

THE MARK CONSISTS OF STANDARD CHARACTERS WITHOUT CLAIM TO ANY PARTICULAR FONT, STYLE, SIZE, OR COLOR.

CLASS 9—ELECTRICAL AND SCIENTIFIC APPARATUS

FOR COMPACT DISCS FEATURING SPOKEN WORD POETRY, SHORT STORIES AND FICTIONAL WORKS (U.S. CLS. 21, 23, 26, 36 AND 38).

CLASS 16—PAPER GOODS AND PRINTED MATTER

FOR PRINTED PUBLICATIONS, NAMELY, BOOKLETS FEATURING POETRY, PROSE, PRAYERS, COLLECTIONS OF POEMS, FICTIONAL WORKS, ARTWORK, PAINTINGS AND GICLÉE (U.S. CLS. 2, 5, 22, 23, 29, 37, 38 AND 50).

CLASS 41—EDUCATION AND ENTERTAINMENT

FOR ENTERTAINMENT SERVICES, NAMELY, PROVIDING A WEB SITE FOR DISPLAYING WORKS OF ART ONLINE FEATURING POETRY, PROSE, PRAYERS, MUSIC, FICTIONAL WORKS, ARTWORK, PHOTOGRAPHS, PAINTINGS, ILLUSTRATIONS AND GICLÉE; LIVE SPOKEN WORD PERFORMANCES OF POETRY, PROSE, PRAYERS, SHORT STORIES, FICTIONAL WORKS AND MUSIC; AND ENTERTAINMENT SERVICES, NAMELY, POETRY READING AND STORYTELLING (U.S. CLS. 100, 101 AND 107).

MARK SPARACINO, EXAMINING ATTORNEY

SN 85-294,981. DESIGN FORCE AB, NORRKÖPING, SWEDEN, FILED 4-14-2011.

RE-BOARD HYBRID

THE MARK CONSISTS OF STANDARD CHARACTERS WITHOUT CLAIM TO ANY PARTICULAR FONT, STYLE, SIZE, OR COLOR.

PRIORITY CLAIMED UNDER SEC. 44(D) ON ERP CMNTY TM OFC APPLICATION NO. 009521246, FILED 11-15-2010, REG. NO. 009521246, DATED 4-5-2011, EXPIRES 11-15-2020.

OWNER OF U.S. REG. NO. 4,078,551.

NO CLAIM IS MADE TO THE EXCLUSIVE RIGHT TO USE "HYBRID" FOR PAPER IN CLASS 16, APART FROM THE MARK AS SHOWN.

CLASS 16—PAPER GOODS AND PRINTED MATTER

FOR PAPER, CARDBOARD (U.S. CLS. 2, 5, 22, 23, 29, 37, 38 AND 50).

CLASS 40—MATERIAL TREATMENT

FOR TREATMENT OF MATERIALS, NAMELY, FOR THE MANUFACTURE OF PAPER AND CARDBOARD (U.S. CLS. 100, 103 AND 106).

REBECCA EISINGER, EXAMINING ATTORNEY

SN 85-295,000. DESTINATION WEDDING TRAVEL, INC., FRAMINGHAM, MA. FILED 4-14-2011.



NO CLAIM IS MADE TO THE EXCLUSIVE RIGHT TO USE "DESTINATIONWEDDINGS.COM", APART FROM THE MARK AS SHOWN.

THE MARK CONSISTS OF THE WORDING, "DESTINATIONWEDDINGS.COM" WITH THREE, SQUARE ICONS; THE FIRST OF WHICH CONTAINS A SILHOUETTE OF A JET PLANE, THE SECOND OF WHICH CONTAINS THE WORDING, "I DO", AND THE THIRD OF WHICH CONTAINS A SILHOUETTE OF A PALM TREE.

SEC. 2(F) AS TO "DESTINATIONWEDDINGS.COM".

CLASS 39—TRANSPORTATION AND STORAGE

FOR TRAVEL PLANNING FOR INDIVIDUALS, FAMILIES, AND GROUPS FOR SPECIAL OCCASIONS (U.S. CLS. 100 AND 105).

FIRST USE 10-13-2006; IN COMMERCE 10-13-2006.

CLASS 41—EDUCATION AND ENTERTAINMENT

FOR WEDDING PLANNING, COORDINATION, AND CONSULTATION SERVICES (U.S. CLS. 100, 101 AND 107).

FIRST USE 10-13-2006; IN COMMERCE 10-13-2006.

SUSAN LESLIE DUBOIS, EXAMINING ATTORNEY

SN 85-295,132. KURT MANUFACTURING COMPANY, INC., FRIDLEY, MN. FILED 4-14-2011.

KINETIC

THE MARK CONSISTS OF STANDARD CHARACTERS WITHOUT CLAIM TO ANY PARTICULAR FONT, STYLE, SIZE, OR COLOR.

OWNER OF U.S. REG. NO. 2,587,483.

CLASS 9—ELECTRICAL AND SCIENTIFIC APPARATUS

FOR SENSOR IN THE FORM OF AN INSOLE TO BE DISPOSED IN A SHOE TO MEASURE PRESSURE; AND DISPLAY UNITS IN THE NATURE OF AN ELECTRONIC DISPLAY PANEL FOR USE WITH A BICYCLE FOR DISPLAYING PERFORMANCE OF A RIDER (U.S. CLS. 21, 23, 26, 36 AND 38).

CLASS 12—VEHICLES

FOR STRUCTURAL PARTS FOR BICYCLES, NAMELY, BICYCLE AXLE SKEWERS AND BICYCLE TIRES (U.S. CLS. 19, 21, 23, 31, 35 AND 44).

CLASS 25—CLOTHING

FOR CLOTHING, NAMELY, CYCLING JERSEYS, CYCLING SHORTS, T-SHIRTS, SWEATSHIRTS, POLO SHIRTS, HATS, SOCKS AND TRIATHLON SUITS (U.S. CLS. 22 AND 39).

CLASS 28—TOYS AND SPORTING GOODS

FOR STRUCTURAL PARTS FOR A STAND AND ATTACHMENT FOR SUPPORTING A BICYCLE FOR STATIONARY RESISTANCE EXERCISE, NAMELY, RESISTANCE DEVICES MOUNTED TO THE STAND, FLYWHEELS FOR THE RESISTANCE DEVICES, ADAPTERS TO POSITION RESISTANCE DEVICES ON THE STANDS; FRONT WHEEL SUPPORTS FOR A BICYCLE WHEN THE BICYCLE IS SECURED TO THE STAND (U.S. CLS. 22, 23, 38 AND 50).

BRENDAN MCCAULEY, EXAMINING ATTORNEY

SN 85-295,423. SYLVIA KURPANEK, PALO ALTO, CA.
FILED 4-14-2011.

SN 85-295,543. ENDEMOL UK PLC, W14 0EE LONDON,
UNITED KINGDOM. AND ENDEMOL USA, INC., LOS
ANGELES, CA. FILED 4-14-2011.

LIMBIC COACHING

THE MARK CONSISTS OF STANDARD CHARACTERS WITHOUT CLAIM TO ANY PARTICULAR FONT, STYLE, SIZE, OR COLOR.

NO CLAIM IS MADE TO THE EXCLUSIVE RIGHT TO USE "COACHING", APART FROM THE MARK AS SHOWN.

CLASS 9—ELECTRICAL AND SCIENTIFIC APPARATUS

FOR DIGITAL MATERIALS, NAMELY, CDS, DVDS, AND DOWNLOADABLE AUDIO AND VIDEO FILES FEATURING PERSONAL COACHING AND COACHING IN THE FIELD OF MENTAL PREPARATION FOR PEAK PERFORMANCE, INCREASE OF STRESS-RESILIENCE, CREATIVITY, SHORT-TERM COACHING, AND OVERALL WELL-BEING; ELECTRONIC PUBLICATIONS, NAMELY, BOOKS AND JOURNALS FEATURING PERSONAL COACHING AND COACHING IN THE FIELD OF MENTAL PREPARATION FOR PEAK PERFORMANCE, INCREASE OF STRESS-RESILIENCE, CREATIVITY, SHORT-TERM COACHING, AND OVERALL WELL-BEING RECORDED ON COMPUTER MEDIA (U.S. CLS. 21, 23, 26, 36 AND 38).

CLASS 16—PAPER GOODS AND PRINTED MATTER

FOR BOOKS IN THE FIELD OF PERSONAL COACHING, MENTAL PREPARATION FOR PEAK PERFORMANCE, INCREASE OF STRESS-RESILIENCE, CREATIVITY, SHORT-TERM COACHING, AND OVERALL WELL-BEING; PUBLICATIONS, NAMELY, BOOKS, WRITTEN ARTICLES, HANDOUTS AND WORKBOOKS IN THE FIELDS OF PERSONAL COACHING AND MENTAL PREPARATION FOR PEAK PERFORMANCE, INCREASE OF STRESS-RESILIENCE, CREATIVITY, SHORT-TERM COACHING, AND OVERALL WELL-BEING; SERIES OF NON-FICTION BOOKS IN THE FIELD OF PERSONAL COACHING AND MENTAL PREPARATION FOR PEAK PERFORMANCE, INCREASE OF STRESS-RESILIENCE, CREATIVITY, SHORT-TERM COACHING, AND OVERALL WELL-BEING (U.S. CLS. 2, 5, 22, 23, 29, 37, 38 AND 50).

CLASS 41—EDUCATION AND ENTERTAINMENT

FOR EDUCATION SERVICES, NAMELY, PROVIDING CLASSES, SEMINARS AND WORKSHOPS IN THE FIELD OF SHORT-TERM COACHING AND PERSONAL COACHING; EDUCATIONAL SERVICES, NAMELY, DEVELOPING, ARRANGING, AND CONDUCTING EDUCATIONAL CONFERENCES AND PROGRAMS AND PROVIDING COURSES OF INSTRUCTION IN THE FIELD OF EFFECTIVE SHORT-TERM COACHING AND PERSONAL COACHING SERVICES; PEER TO PEER COACHING SERVICES IN THE FIELD OF MENTAL PREPARATION FOR PEAK PERFORMANCE, INCREASE OF STRESS-RESILIENCE, CREATIVITY, SHORT-TERM COACHING, AND OVERALL WELL-BEING; PROFESSIONAL COACHING SERVICES IN THE FIELD OF MENTAL PREPARATION FOR PEAK PERFORMANCE, INCREASE OF STRESS-RESILIENCE, CREATIVITY, SHORT-TERM COACHING, AND OVERALL WELL-BEING (U.S. CLS. 100, 101 AND 107).
JAY FLOWERS, EXAMINING ATTORNEY

101 WAYS TO LEAVE A GAMESHOW

THE MARK CONSISTS OF STANDARD CHARACTERS WITHOUT CLAIM TO ANY PARTICULAR FONT, STYLE, SIZE, OR COLOR.

OWNER OF ERPN CMNTY TM OFC REG. NO. 09296815,
DATED 2-18-2011, EXPIRES 5-8-2020.

CLASS 9—ELECTRICAL AND SCIENTIFIC APPARATUS

FOR AUDIO AND VIDEO RECORDINGS FEATURING A TELEVISION GAME SHOW; PRERECORDED MAGNETIC DATA CARRIERS FEATURING A TELEVISION GAME SHOW; PRE-RECORDED VIDEO DISCS, VIDEO RECORDINGS AND VIDEO TAPES FEATURING COMEDY FILMS AND TELEVISION GAME SHOWS; MUSICAL SOUND RECORDINGS; PRERECORDED AUDIO AND VIDEO CASSETTES FEATURING GAME SHOWS; COMPACTS DISCS FEATURING MUSIC; LP RECORDS, NAMELY, PHONOGRAPH RECORDS FEATURING MUSIC; DVDS AND CD-ROMS FEATURING MUSIC AND TELEVISION SHOWS; SOFTWARE FOR COMPUTER GAMES; COMPUTER GAMES, NAMELY, COMPUTER GAME CARTRIDGES AND DISCS; DOWNLOADABLE VIDEO RECORDINGS FEATURING GAMES AND GAME SHOWS PROVIDED VIA THE INTERNET; DOWNLOADABLE ELECTRONIC PUBLICATIONS IN THE NATURE OF MAGAZINES IN THE FIELD OF COMPUTER GAMING AND GAMES; ELECTRONIC PUBLICATIONS, NAMELY, MAGAZINES FEATURING COMPUTER GAMING AND GAMES RECORDED ON COMPUTER MEDIA; DOWNLOADABLE IMAGE FILES CONTAINING ARTWORK RELATING TO MUSIC, SOUND AND POPULAR CULTURE; COMPUTER SCREEN SAVER PROGRAMS; AMUSEMENT APPARATUS ADAPTED FOR USE WITH TELEVISION SETS AND TELEVISION SCREENS; COMPUTER GAME SOFTWARE ADAPTED FOR USE WITH TELEVISION SETS; ELECTRONIC AMUSEMENT APPARATUS ADAPTED FOR USE WITH TELEVISION SETS; COMPUTER GAME SOFTWARE AND GAMING APPARATUS, NAMELY, GAMING MACHINES FEATURING A DEVICE THAT ACCEPTS WAGERS, JOYSTICKS FOR VIDEO GAMES; VIDEO GAME TAPE CASSETTES FOR TELEVISION GAME SETS; LASER DISCS FEATURING ELECTRONIC GAMES; MOUSE PADS; DOWNLOADABLE GAMES FOR MOBILE PHONES (U.S. CLS. 21, 23, 26, 36 AND 38).

CLASS 16—PAPER GOODS AND PRINTED MATTER

FOR PAPER, CARDBOARD AND GOODS MADE FROM THESE MATERIALS, NAMELY, CARDBOARD BOXES, CARDBOARD SIGNBOARDS, ART PAPER; PRINTED MATTER, NAMELY, BOOKS FEATURING GRAPHIC ART REPRODUCTIONS, PRINTED CERTIFICATES, PRINTED CHILDREN'S COLORING PAGES, PRINTED AWARDS; BOOK BINDING MATERIALS; PHOTOGRAPHS; STATIONERY; ADHESIVES FOR STATIONERY OR HOUSEHOLD PURPOSES; ARTISTS' MATERIALS, NAMELY, MOLDS FOR MODELING CLAYS, ART PADS, ARTISTS' PENCILS AND PASTELS; PAINT BRUSHES; TYPEWRITERS AND OFFICE REQUISITES EXCEPT FURNITURE, NAMELY, RUBBER BANDS, PUNCHES, ENVELOPE SEALING MACHINES, PUNCHES; PLASTIC BAGS AND BUBBLE PACKS FOR PACKAGING; PRINTERS' TYPE; PRINTING BLOCKS (U.S. CLS. 2, 5, 22, 23, 29, 37, 38 AND 50).

CLASS 25—CLOTHING

FOR CLOTHING, NAMELY, SHIRTS, PANTS, SKIRTS, TOPS, JACKETS, COATS, VESTS, DRESSES; FOOTWEAR; HEADWEAR (U.S. CLS. 22 AND 39).

SN 85-296,101. XCCENT LLC, WYOMING, MN. FILED 4-15-2011.

CLASS 28—TOYS AND SPORTING GOODS

FOR PORTABLE AMUSEMENT APPARATUS, NAMELY, HAND HELD UNITS FOR PLAYING ELECTRONIC GAMES OTHER THAN THOSE ADAPTED FOR USE WITH AN EXTERNAL DISPLAY SCREEN OR MONITOR; TOYS, NAMELY, TOY WHISTLES, CHILDREN'S DRESS-UP ACCESSORIES, TOY VEHICLES, GAMES, NAMELY, BOARD GAMES, CARD GAMES, DART GAMES, BILLIARD GAME PLAYING EQUIPMENT; PUZZLES AND PLAYTHINGS, NAMELY, PUPPET THEATRES; GYMNASTIC AND SPORTING ARTICLES NOT INCLUDED IN OTHER CLASSES, NAMELY, GYMNASTIC VAULTING HORSES, BALANCE BEAMS, POMMEL HORSES; ATHLETIC SPORTING GOODS, NAMELY, GAME BALLS, ADHESIVE TAPE FOR HOCKEY STICKS AND UNIFORM SUPPORT; DECORATIONS FOR CHRISTMAS TREES; APPARATUS FOR PLAYING GAMES, NAMELY, APPARATUS FOR ELECTRONIC GAMES OTHER THAN THOSE ADAPTED FOR USE WITH AN EXTERNAL DISPLAY SCREEN OR MONITOR; ELECTRIC AND ELECTRONIC GAMES OTHER THAN THOSE ADAPTED FOR USE WITH TELEVISION RECEIVERS ONLY; ELECTRONIC AMUSEMENT GAME MACHINES, ELECTRONIC AMUSEMENT APPARATUS INCORPORATING A TELEVISION SCREEN; COIN-OPERATED OR CHIP-OPERATED AMUSEMENT MACHINES; PORTABLE COMPUTER GAMES, NAMELY, BATTERY-POWERED COMPUTER GAME WITH LCD SCREEN; VIDEO GAME APPARATUS, NAMELY, STAND ALONE VIDEO GAME MACHINES; PLAYING CARDS (U.S. CLS. 22, 23, 38 AND 50).

XCCENT

THE MARK CONSISTS OF STANDARD CHARACTERS WITHOUT CLAIM TO ANY PARTICULAR FONT, STYLE, SIZE, OR COLOR.

OWNER OF U.S. REG. NO. 2,997,064.

CLASS 20—FURNITURE AND ARTICLES NOT OTHERWISE CLASSIFIED

FOR OUTDOOR FURNITURE, NAMELY, BENCHES, PICNIC TABLES, TABLES, AND TABLE EXTENSIONS; HOSPITAL BED PARTS, NAMELY, HOSPITAL BED RAILINGS AND FITTED COVERS FOR THE BED MECHANISMS (U.S. CLS. 2, 13, 22, 25, 32 AND 50).

FIRST USE 11-30-2003; IN COMMERCE 11-30-2003.

CLASS 21—HOUSEWARES AND GLASS

FOR TRASH AND TRASH RECYCLING RECEPTACLES, NAMELY, TRASH CANS AND NON-METAL BINS FOR HOUSEHOLD USE (U.S. CLS. 2, 13, 23, 29, 30, 33, 40 AND 50).

FIRST USE 11-30-2003; IN COMMERCE 11-30-2003.

CLASS 28—TOYS AND SPORTING GOODS

FOR OUTDOOR FITNESS PRODUCTS, NAMELY, MANUALLY OPERATED CARDIOVASCULAR, STRENGTH, AND FLEXIBILITY EXERCISE EQUIPMENT (U.S. CLS. 22, 23, 38 AND 50).

FIRST USE 10-31-2005; IN COMMERCE 10-31-2005.

CLASS 41—EDUCATION AND ENTERTAINMENT

FOR ENTERTAINMENT SERVICES, NAMELY, PRODUCTION OF TELEVISION PROGRAMS; ORGANIZING COMMUNITY SPORTING AND CULTURAL ACTIVITIES; PUBLISHING OF BOOKS, E-BOOKS, AUDIO BOOKS, MUSIC AND ILLUSTRATIONS; PRODUCTION OF AUDIO AND/OR VIDEO RECORDINGS, NAMELY, PRODUCTION OF SOUND AND IMAGE RECORDINGS ON SOUND AND IMAGE CARRIERS; PRODUCTION AND DISTRIBUTION RADIO AND TELEVISION PROGRAMS AND FILMS; RENTAL OF AUDIO AND VIDEO RECORDINGS, FILMS AND PRERECORDED DVDS FEATURING RADIO AND TELEVISION PROGRAMS; ENTERTAINMENT SERVICES IN THE FIELD OF THEATRE, MUSIC, TELEVISION AND FILM, NAMELY, LIVE MUSIC CONCERTS, TELEVISION GAME SHOWS, PLANNING AND CONDUCTING A SERIES OF FILM FESTIVALS; PROVIDING ON-LINE NON-DOWNLOADABLE ELECTRONIC PUBLICATIONS IN THE NATURE OF MAGAZINES IN THE FIELD OF GAMES AND GAME SHOWS; ONLINE PUBLICATION OF BOOKS, TEXTS AND MAGAZINES; ENTERTAINMENT SERVICES, NAMELY, PROVIDING NON-DOWNLOADABLE PRERECORDED MUSIC; PROVIDING ONLINE DATABASE OF ELECTRONIC IMAGES OF ARTWORK; EDUCATIONAL SERVICES, NAMELY, PROVIDING CLASSES, SEMINARS, WORKSHOPS IN THE FIELD OF ENTERTAINMENT VIA ONGOING TELEVISION PROGRAMS; PRODUCTION OF TELEVISION PROGRAMS; ENTERTAINMENT SERVICES, NAMELY, PROVIDING ON-LINE COMPUTER GAMES; PROVIDING GAME SOFTWARE, NAMELY, NON-DOWNLOADABLE SOFTWARE FOR ONLINE GAMES (U.S. CLS. 100, 101 AND 107).

JENNIFER MARTIN, EXAMINING ATTORNEY

CLASS 35—ADVERTISING AND BUSINESS

FOR WHOLESALE AND DIRECT RETAIL STORE, ONLINE RETAIL STORE AND MAIL ORDER RETAIL STORE SERVICES OF COMMERCIAL AND RESIDENTIAL PLAYGROUND AND RECREATION EQUIPMENT AND PARTS FOR INDOOR AND OUTDOOR PLAYGROUNDS AND PLAYGROUND STRUCTURES, NAMELY, PLAY ENCLOSURES, BRIDGES, ACTIVITY PANELS, PLATFORMS AND DECKS, CRAWL TUBES, SLIDES, MONKEY BARS, SWINGS, SEE-SAWS, CLIMBING WALLS, CARGO NETS, STAIRS, RIDERS, SPINNING UNITS, AND GLIDERS; WHOLESALE AND DIRECT RETAIL STORE, ONLINE RETAIL STORE AND MAIL ORDER RETAIL STORE SERVICES OF OUTDOOR FITNESS PRODUCTS, NAMELY, MANUALLY OPERATED CARDIOVASCULAR, STRENGTH, AND FLEXIBILITY EQUIPMENT (U.S. CLS. 100, 101 AND 102).

FIRST USE 10-31-2010; IN COMMERCE 10-31-2010.

CLASS 37—CONSTRUCTION AND REPAIR

FOR SURFACE TREATMENT SERVICES, NAMELY, APPLICATION OF PROTECTIVE COATING OF PREFABRICATED METAL AND PLASTIC PRODUCTS WITH VINYL OR RUBBER, NAMELY, BUS BARS, ELECTRICAL COMPONENTS, AND DIVING WEIGHTS, MATERIAL HANDLING EQUIPMENT, HAND TOOLS, AND COVERS (U.S. CLS. 100, 103 AND 106).

FIRST USE 6-30-2005; IN COMMERCE 6-30-2005.

CLASS 40—MATERIAL TREATMENT

FOR MOLDING OF VINYL AND RUBBER PRODUCTS, NAMELY, MOLDING TUBES, COVERS, BAGS, BELLOWS, AND GLOVES; CUSTOM MANUFACTURE OF COMMERCIAL AND RESIDENTIAL PLAYGROUND AND RECREATION EQUIPMENT AND PARTS FOR INDOOR AND OUTDOOR PLAYGROUNDS AND PLAYGROUND STRUCTURES, NAMELY, PLAY ENCLOSURES, BRIDGES, ACTIVITY PANELS, PLATFORMS AND DECKS, CRAWL TUBES, SLIDES, MONKEY BARS, SWINGS, SEE-SAWS, CLIMBING WALLS, CARGO NETS, STAIRS, RIDERS, SPINNING UNITS, AND GLIDERS (U.S. CLS. 100, 103 AND 106).

FIRST USE 6-30-2005; IN COMMERCE 6-30-2005.

CLASS 42—SCIENTIFIC AND COMPUTER SERVICES

FOR DESIGN OF COMMERCIAL AND RESIDENTIAL PLAYGROUND PLAY SYSTEMS, PARTS, AND EQUIPMENT FOR INDOOR AND OUTDOOR PLAYGROUNDS; CUSTOM DESIGN OF MOLDED VINYL AND RUBBER PRODUCTS, NAMELY, POLYMER MOTION DEVICES, HINGES, AND LEGS (U.S. CLS. 100 AND 101).

FIRST USE 3-31-2005; IN COMMERCE 3-31-2005.

DOMINIC FATHY, EXAMINING ATTORNEY

SN 85-300,926. IGNITE! LEARNING, INC., AUSTIN, TX. FILED 4-21-2011.



THE MARK CONSISTS OF A STYLIZED EXCLAMATION POINT TOPPED BY A STYLIZED FLAME IMAGE.

CLASS 9—ELECTRICAL AND SCIENTIFIC APPARATUS

FOR EDUCATIONAL SERVICES, NAMELY, PROVIDING PRIMARY AND SECONDARY SCHOOL CURRICULUM IN THE NATURE OF PROVIDING DOWNLOADABLE VIDEO RECORDINGS FEATURING INSTRUCTION IN THE FIELDS OF MATH, SCIENCE AND SOCIAL STUDIES, DOWNLOADABLE AUDIO FILES, MULTIMEDIA FILES, TEXT FILES, E-MAILS, WRITTEN DOCUMENTS, AUDIO MATERIAL, VIDEO MATERIAL AND GAMES FEATURING INFORMATION IN THE FORM OF DOWNLOADABLE EDUCATIONAL COMMUNICATIONS IN THE FIELDS OF MATH, SCIENCE AND SOCIAL STUDIES, AND PROVIDING INTERACTIVE EDUCATIONAL MATERIALS IN THE NATURE OF EDUCATIONAL SOFTWARE FEATURING INSTRUCTION IN THE FIELDS OF MATH, SCIENCE AND SOCIAL STUDIES, ALL COORDINATED WITH COMMON, STATE, LOCAL AND GRADE-LEVEL CURRICULUM AND TESTING STANDARDS (U.S. CLS. 21, 23, 26, 36 AND 38).

FIRST USE 2-9-2010; IN COMMERCE 2-9-2010.

CLASS 41—EDUCATION AND ENTERTAINMENT

FOR EDUCATIONAL SERVICES, NAMELY, PROVIDING ON-LINE COURSES OF INSTRUCTION AT THE PRIMARY AND SECONDARY SCHOOL LEVELS USING INTERACTIVE EDUCATIONAL MATERIAL; PROVIDING INSTRUCTIONAL SUPPORT, NAMELY, DEVELOPING CURRICULUM FOR EDUCATORS, OFFERING OF ASSESSMENTS AND SURVEYS IN THE FIELD OF EDUCATOR TRAINING AND PERFORMANCE FOR THE PURPOSE OF IMPROVING TEACHING PROCEDURES, AND PROVIDING INTEGRATED EDUCATIONAL TESTING, IN ELECTRONIC FORM (U.S. CLS. 100, 101 AND 107).

FIRST USE 2-9-2010; IN COMMERCE 2-9-2010.

ANDREW LEASER, EXAMINING ATTORNEY

SN 85-303,287. JOHNSON & JOHNSON, NEW BRUNSWICK, NJ. FILED 4-25-2011.



NO CLAIM IS MADE TO THE EXCLUSIVE RIGHT TO USE "6 BENEFITS IN 1", APART FROM THE MARK AS SHOWN.

THE COLOR(S) WHITE, PURPLE, RED, ORANGE, YELLOW, GREEN, LIGHT BLUE AND BLUE IS/ARE CLAIMED AS A FEATURE OF THE MARK.

THE MARK CONSISTS OF THE PHRASE "6 BENEFITS IN 1" IN WHITE IN A PURPLE CIRCLE SURROUNDED BY RED, ORANGE, YELLOW, GREEN, LIGHT BLUE AND BLUE LINES FORMING AN OUTER CIRCLE.

CLASS 3—COSMETICS AND CLEANING PREPARATIONS

FOR NON-MEDICATED MOUTHWASH (U.S. CLS. 1, 4, 6, 50, 51 AND 52).

CLASS 5—PHARMACEUTICALS

FOR MEDICATED MOUTHWASH (U.S. CLS. 6, 18, 44, 46, 51 AND 52).

TOBY BULLOFF, EXAMINING ATTORNEY

SN 85-303,427. CONTOUR PRECISION GROUP, LLC, CLOVER, SC. FILED 4-25-2011.



NO CLAIM IS MADE TO THE EXCLUSIVE RIGHT TO USE "PRECISION", APART FROM THE MARK AS SHOWN.

THE MARK CONSISTS OF THE WORDS "CONTOUR PRECISION" IN STYLIZED LETTERS SUPERIMPOSED ON A RIBBON-LIKE DESIGN.

CLASS 40—MATERIAL TREATMENT

FOR CUSTOM MANUFACTURING AND PRODUCTION SERVICES FOR OTHERS IN THE FIELD OF MACHINE TOOLS; TREATMENT OF MATERIALS FOR THE MANUFACTURE OF MACHINE TOOL GOODS (U.S. CLS. 100, 103 AND 106).

CLASS 42—SCIENTIFIC AND COMPUTER SERVICES

FOR ENGINEERING SERVICES FOR OTHERS IN THE FIELD OF MACHINE TOOLS (U.S. CLS. 100 AND 101).
COURTNEY ALVAREZ, EXAMINING ATTORNEY

SN 85-304,786. ANDREW WILLIAM WRIGHT, VIRGINIA WATER, SURREY, UNITED KINGDOM, FILED 4-26-2011.

WITNESS PROTECTION PROGRAMME

THE MARK CONSISTS OF STANDARD CHARACTERS WITHOUT CLAIM TO ANY PARTICULAR FONT, STYLE, SIZE, OR COLOR.

PRIORITY CLAIMED UNDER SEC. 44(D) ON ERP N CMNTY TM OFC APPLICATION NO. 009920273, FILED 4-26-2011, REG. NO. 009920273, DATED 9-30-2011, EXPIRES 4-26-2021.

NO CLAIM IS MADE TO THE EXCLUSIVE RIGHT TO USE "PROGRAMME", APART FROM THE MARK AS SHOWN.

CLASS 9—ELECTRICAL AND SCIENTIFIC APPARATUS

FOR COMPUTER SOFTWARE PROGRAMS FOR MANAGING DATABASES OF INFORMATION RELATING TO LAND VEHICLE OR WATERBORNE CRAFT CRASH MANAGEMENT SYSTEMS; COMPUTER SOFTWARE FOR MANAGING DATABASES OF INFORMATION RELATING TO LAND VEHICLE OR WATERBORNE CRAFT CRASH MANAGEMENT SYSTEMS; COMPUTER GRAPHICS SOFTWARE; COMPUTER SOFTWARE FOR ANALYSING LAND VEHICLE OR WATERBORNE CRAFT CRASHES AND DISTURBANCES; COMPUTER SOFTWARE AND COMPUTER APPLICATION SOFTWARE FOR MOBILE TELEPHONES, SMART PHONES, SATELLITE NAVIGATION SYSTEMS, NOTEBOOK AND TABLET COMPUTERS, NAMELY, SOFTWARE FOR MANAGING DATABASES OF INFORMATION RELATING TO LAND VEHICLE OR WATERBORNE CRAFT CRASH MANAGEMENT SYSTEMS; COMMUNICATION SOFTWARE USED TO ACCESS DATA STORED IN LAND VEHICLE OR WATERBORNE CRAFT CRASH MANAGEMENT SYSTEMS AND TO TRANSFER DATA TO ANOTHER DEVICE; COMPUTER SOFTWARE FOR DATA COMMUNICATION AND TRANSLATING AND TRANSMITTING DATA; COMPUTER SOFTWARE FOR USE IN PROCESSING DATA FROM LAND VEHICLE OR WATERBORNE CRAFT CRASH MANAGEMENT SYSTEMS; COMPUTER SOFTWARE PROGRAMS FOR THE INTEGRATION OF TEXT, AUDIO, GRAPHICS, STILL IMAGES AND MOVING PICTURES INTO AN INTERACTIVE DELIVERY FOR MULTIMEDIA APPLICATIONS; APPARATUS FOR RECORDING OF SOUND AND IMAGES; APPARATUS FOR BEARING VISUAL RECORDINGS, NAMELY, CAMERAS AND COMPUTER MONITORS AND LIQUID CRYSTAL DISPLAY (LCD) MONITORS; APPARATUS FOR ELECTRONIC RECORDING OF SOUND; APPARATUS FOR PROCESSING RECORDED SOUND; APPARATUS FOR READING RECORDED DATA, NAMELY,

COMPUTERS; APPARATUS FOR RECORDING AUDIO SIGNALS; APPARATUS FOR RECORDING DIGITAL INFORMATION; APPARATUS FOR RECORDING ELECTRICAL INFORMATION; APPARATUS FOR RECORDING IMAGES, NAMELY, CAMERAS; APPARATUS FOR RECORDING VISUAL SIGNALS, NAMELY, CAMERAS; APPARATUS FOR RECORDING SOUND; VIDEO RECORDERS; APPARATUS FOR RECORDING AND REPRODUCTION OF DATA; DATA RECORDING MATERIALS, DATA RECORDED ELECTRONICALLY, DATA BEING ELECTRICALLY RECORDED FOR COMPUTERS, DATA RECORDED IN COMPUTER ACCESSIBLE FORM, DATA RECORDED IN MACHINE-READABLE FORM AND DATA RECORDED IN MACHINE-READABLE FORM FROM THE INTERNET, NAMELY, PRERECORDED AUDIO TAPES, VIDEO TAPES, VIDEO DISKS, CDS AND DVDS RELATING TO LAND VEHICLE OR WATERBORNE CRAFT CRASH MANAGEMENT SYSTEMS; DISTANCE MEASURING APPARATUS; IMAGE RECORDING INSTRUMENTS, ELECTRONIC IMAGE RECORDING APPARATUS AND ELECTRONIC IMAGE RECORDING INSTRUMENTS, NAMELY, ELECTRIC CAMERAS FOR RECORDING IMAGES; ELECTRONIC INSTRUMENTS FOR RECORDING INFORMATION, NAMELY, COMPUTERS; ELECTRONIC SPEED RECORDERS, NAMELY, SPEED INDICATORS; ELECTRONIC TIME RECORDING APPARATUS; INSTRUMENTS FOR THE RECORDING OF SOUND; MILEAGE RECORDING INSTRUMENTS, NAMELY, ODOMETERS; COMPUTERIZED MONITORS FOR RECORDING PERFORMANCE DISTURBANCES IN LAND VEHICLES OR WATERBORNE CRAFT; ELECTRONIC MONITORS FOR RECORDING EVENTS, NAMELY, DISPLAY MONITORS, COMPUTERS, IMAGE SENSORS, VIDEO CAMERAS, AND OPERATING SYSTEM AND APPLICATION SOFTWARE TO DETECT LAND VEHICLE OR WATERBORNE CRAFT CRASHES; COMPUTERIZED MONITORS FOR USE IN THE RECORDAL OF FAULTS, NAMELY, HIGH IMPACT COLLISIONS AND SPEEDING, IN LAND VEHICLES OR WATERBORNE CRAFT; SHOCK RECORDERS, NAMELY, VEHICLE SAFETY EQUIPMENT IN THE NATURE OF ELECTRONIC SHOCK MONITORS; VISUAL DISPLAY APPARATUS FOR THE RECORDING OF DATA, NAMELY, CAMERAS AND COMPUTER MONITORS, AND LIQUID CRYSTAL DISPLAY (LCD) MONITORS; APPARATUS FOR MOUNTING CAMERAS AND MONITORS IN LAND VEHICLES OR WATERBORNE CRAFT FOR DISPLAY; MOBILE TELEPHONES; MOBILE TELEPHONES FOR USE IN LAND VEHICLES OR WATERBORNE CRAFT; CASES ADAPTED FOR MOBILE TELEPHONES; CARRYING CASES ADAPTED FOR MOBILE TELEPHONES (U.S. CLS. 21, 23, 26, 36 AND 38).

CLASS 38—COMMUNICATION

FOR TELECOMMUNICATIONS SERVICES, NAMELY, PROVIDING TELECOMMUNICATIONS ADVISORY, INFORMATION AND CONSULTANCY SERVICES; TRANSMISSION OF INFORMATION BY COMPUTER, ELECTRONIC MEANS AND SATELLITE; COMMUNICATION SERVICES, NAMELY, THE ELECTRONIC DELIVERY OF EMERGENCY MESSAGES, ELECTRONIC TRANSMISSION OF IMAGES, ELECTRONIC TRANSMISSION OF VOICES, AND COMPUTER-AIDED TRANSMISSION OF INFORMATION; INFORMATION TRANSMISSION VIA ELECTRONIC COMMUNICATIONS NETWORKS; DATA COMMUNICATION SERVICES BY ELECTRONIC MAIL AND MOBILE TELEPHONES; MOBILE RADIO AND TELEPHONE COMMUNICATION SERVICES; WIRELESS COMMUNICATION SERVICES, NAMELY, TRANSMISSION OF VOICE, DATA, GRAPHICS, IMAGES, AUDIO AND VIDEO BY MEANS OF WIRELESS COMMUNICATIONS NETWORKS; OPERATING OF ELECTRONIC COMMUNICATIONS SYSTEMS, NAMELY, PROVIDING ELECTRONIC TRANSMISSION OF INFORMATION STORED

IN A DATABASE VIA INTERACTIVELY COMMUNICATING COMPUTER SYSTEMS; CELLULAR TELEPHONE COMMUNICATION; LEASING OF TELECOMMUNICATION EQUIPMENT; INFORMATION, ADVISORY AND CONSULTANCY SERVICES IN RESPECT OF THE AFOREMENTIONED SERVICES; ALL OF THE AFORESAID SERVICES RELATING TO TELECOMMUNICATIONS SYSTEMS FOR MONITORING LAND VEHICLES AND WATERBORNE CRAFT FOR MECHANICAL, ELECTRICAL AND ELECTRONIC FAILURES, AND CRASHES (U.S. CLS. 100, 101 AND 104).

CLASS 42—SCIENTIFIC AND COMPUTER SERVICES

FOR DESIGN AND DEVELOPMENT OF COMPUTER HARDWARE AND SOFTWARE; CUSTOM DESIGN OF COMPUTER SOFTWARE; COMPUTER SOFTWARE DEVELOPMENT, NAMELY, DEVELOPMENT OF COMPUTER SOFTWARE APPLICATION SOLUTIONS FOR OTHERS; DESIGN OF TELECOMMUNICATION SYSTEMS, APPARATUS, INSTRUMENTS AND EQUIPMENT; DESIGN, DEVELOPMENT, PROGRAMMING AND RESEARCH IN THE AREA OF CONFIGURATION MANAGEMENT, ENGINEERING, INSTALLATION AND MAINTENANCE, UPDATING, UPGRADING, WRITING AND LEASING OF COMPUTER SOFTWARE FOR OTHERS; TECHNICAL ADVISORY SERVICES RELATING TO THE RENTAL OF COMPUTERS OR COMPUTER SOFTWARE; RENTAL OF TIME RECORDING APPARATUS; INFORMATION, ADVISORY AND CONSULTANCY SERVICES IN RESPECT OF THE AFOREMENTIONED SERVICES; ALL OF THE AFORESAID SERVICES RELATING TO COMPUTER HARDWARE AND SOFTWARE SYSTEMS FOR MONITORING LAND VEHICLES AND WATERBORNE CRAFT FOR MECHANICAL, ELECTRICAL AND ELECTRONIC FAILURES, AND CRASHES (U.S. CLS. 100 AND 101).

CLASS 45—PERSONAL AND LEGAL SERVICES

FOR PREPARATION AND PROVISION OF ACCIDENT REPORTS RELATING TO THE SAFETY OF LAND VEHICLE OR WATERBORNE CRAFT CRASH MANAGEMENT SYSTEMS (U.S. CLS. 100 AND 101).
DAVID ELTON, EXAMINING ATTORNEY

SN 85-308,005. INTERPACIFIC INTERNATIONAL LIMITED, NASSAU, BAHAMAS, FILED 4-29-2011.

ZUELLIG

THE MARK CONSISTS OF STANDARD CHARACTERS WITHOUT CLAIM TO ANY PARTICULAR FONT, STYLE, SIZE, OR COLOR.

PRIORITY CLAIMED UNDER SEC. 44(D) ON HONG KONG APPLICATION NO. 301897174, FILED 4-23-2011, REG. NO. 300526356AA, DATED 11-9-2005, EXPIRES 11-8-2015.

OWNER OF U.S. REG. NOS. 2,903,981 AND 3,474,230.
SEC. 2(F).

CLASS 35—ADVERTISING AND BUSINESS

FOR PROVIDING PROFESSIONAL BUSINESS CONSULTATION FOR PHARMACEUTICAL COMPANIES, INCLUDING ONLINE AND VIA TELECOMMUNICATIONS; PROVIDING STATEMENTS ENCAPSULATING AND ANALYZING SALES OF PHARMACEUTICAL PRODUCTS; PROVIDING BUSINESS INFORMATION RELATING TO PHARMACEUTICAL GOODS AND THE PHARMACEUTICAL SECTOR; PROVIDING STATISTICAL INFORMATION RELATING TO PHARMACEUTICAL GOODS AND THE PHARMACEUTICAL SECTOR; PROVIDING AN ONLINE COMPUTER DATABASE IN THE FIELD OF THE PHARMACEUTICAL INDUSTRY (U.S. CLS. 100, 101 AND 102).

CLASS 38—COMMUNICATION

FOR PROVIDING ONLINE DELIVERY OF INFORMATION CONCERNING PHARMACEUTICAL GOODS (U.S. CLS. 100, 101 AND 104).

CLASS 39—TRANSPORTATION AND STORAGE

FOR PROVIDING ONLINE ELECTRONIC STORAGE FOR OTHERS OF INFORMATION CONCERNING PHARMACEUTICAL GOODS (U.S. CLS. 100 AND 105).

CLASS 42—SCIENTIFIC AND COMPUTER SERVICES

FOR PROVIDING AN ONLINE COMPUTER DATABASE IN THE FIELD OF PHARMACEUTICAL RESEARCH AND DEVELOPMENT (U.S. CLS. 100 AND 101).
MICHAEL ENGEL, EXAMINING ATTORNEY

SN 85-308,235. ABIQUO, INC., REDWOOD CITY, CA. FILED 4-29-2011.

abiquo

THE COLOR(S) BLACK AND ORANGE IS/ARE CLAIMED AS A FEATURE OF THE MARK.

THE MARK CONSISTS OF THE STYLIZED WORDING "ABIQUO" IN WHICH THE LETTERS "ABI" AND "UO" ARE IN BLACK, THE LETTER "Q" IS IN ORANGE AND BLACK.

THE WORDING "ABIQUO" HAS NO MEANING IN A FOREIGN LANGUAGE.

CLASS 9—ELECTRICAL AND SCIENTIFIC APPARATUS

FOR COMPUTER SOFTWARE FOR THE OPERATION AND MANAGEMENT OF VIRTUALIZED COMPUTING ENVIRONMENTS; COMPUTER SOFTWARE PROVIDING USER ACCESS FOR VIRTUALIZED COMPUTING ENVIRONMENTS; DOWNLOADABLE COMPUTER SOFTWARE FOR ON-LINE ACCESS TO CLOUD COMPUTING SERVICES; PRE-RECORDED REMOVABLE DIGITAL MEDIA STORING COMPUTER SOFTWARE FOR THE OPERATION AND MANAGEMENT OF VIRTUALIZED COMPUTING ENVIRONMENTS; COMPUTER HARDWARE, NAMELY, FIREWALLS (U.S. CLS. 21, 23, 26, 36 AND 38).

FIRST USE 2-17-2010; IN COMMERCE 12-7-2010.

CLASS 42—SCIENTIFIC AND COMPUTER SERVICES

FOR CLOUD COMPUTING SERVICES, NAMELY, CONSULTING SERVICES IN THE FIELD OF CLOUD COMPUTING, REMOTE AND ON-SITE MANAGEMENT OF THE INFORMATION TECHNOLOGY CLOUD COMPUTING SYSTEMS OF OTHERS; TECHNICAL SUPPORT SERVICES, NAMELY, REMOTE AND ON-SITE INFRASTRUCTURE MANAGEMENT SERVICES FOR MONITORING, ADMINISTRATION AND MANAGEMENT OF PUBLIC AND PRIVATE CLOUD COMPUTING IT AND APPLICATION SYSTEMS, NAMELY, PROVIDING NON-DOWNLOADABLE COMPUTER SOFTWARE, RESOURCES AND SERVICES FOR THE MANAGEMENT OF VIRTUALIZED COMPUTING ENVIRONMENTS; ONLINE PROVISION OF NON-DOWNLOADABLE SOFTWARE FOR THE SCALING, AND MANAGEMENT OF SERVERS, STORAGE, NETWORKS, VIRTUAL NETWORK DEVICES, AND APPLICATIONS USED IN VIRTUALIZED COMPUTING ENVIRONMENTS; PLATFORM-AS-A-SERVICE FEATURING COMPUTER SOFTWARE PLATFORMS FOR USE IN DATABASE MANAGEMENT, FOR USE AS A SPREADSHEET, AND FOR WORD PROCESSING AND SOFTWARE-AS-A-SERVICE FEATURING SOFTWARE IN THE FIELD OF DATABASE MANAGEMENT, FOR USE AS A SPREADSHEET, FOR WORD PROCESSING, AND INFRASTRUCTURE-AS-A-SERVICE COMPUTER SERVICES, NAMELY, TECHNICAL SUPPORT SERVICES, NAMELY, REMOTE AND ON-SITE INFRASTRUCTURE MANAGEMENT SERVICES FOR MONITORING, ADMINISTRATION AND MANAGEMENT OF PUBLIC AND PRIVATE CLOUD COMPUTING IT AND APPLICATION SYSTEMS; RENTAL OF COMPUTER SOFTWARE AND HARDWARE; HOSTING WEBSITES ON THE INTERNET; COMPUTER SOFTWARE CONSULTANCY; MAINTENANCE AND INSTALLATION OF COMPUTER SOFTWARE; COMPUTER SERVICES, NAMELY, REMOTE AND ON-SITE MANAGEMENT OF VIRTUALIZED COMPUTING ENVIRONMENTS FOR OTHERS; LEASING OF COMPUTERS, LEASING COMPUTER FACILITIES, RENTAL OF COMPUTER HARDWARE AND SOFTWARE; PROVISION OF IP ASSIGNMENT AND DNS MANAGEMENT SERVICES, NAMELY, CREATING WEBSITES AND HOSTING DOMAIN NAMES FOR OTHERS BY PROVIDING DOMAIN NAME SYSTEM ROUTING AND MAPPING BETWEEN NETWORK NAMES AND ADDRESSES ON A GLOBAL ELECTRONIC COMMUNICATIONS NETWORK; CLOUD COMPUTING SERVICES, NAMELY, CREATING A DISTRIBUTED COMPUTING PLATFORM AMONG NETWORKED COMPUTERS; COMPUTER SERVICES, NAMELY, PROVIDING SERVER LOAD BALANCING (U.S. CLS. 100 AND 101).

FIRST USE 2-17-2010; IN COMMERCE 12-7-2010.
ELIZABETH KAJUBI, EXAMINING ATTORNEY

SN 85-308,871. TVN ENTERTAINMENT CORPORATION, DBA AVAIL-TVN, SHERMAN OAKS, CA. FILED 4-29-2011.

ANYVIEW

THE MARK CONSISTS OF STANDARD CHARACTERS WITHOUT CLAIM TO ANY PARTICULAR FONT, STYLE, SIZE, OR COLOR.

CLASS 38—COMMUNICATION

FOR PROVISION OF TELECOMMUNICATION ACCESS TO MOVIES, EVENTS, TELEVISION PROGRAMS, PROMOTIONAL MATERIAL AND OTHER VIDEO AND AUDIO CONTENT PROVIDED VIA A VIDEO-ON-DEMAND SERVICE; VIDEO ON DEMAND TRANSMISSION SERVICES; SATELLITE, CABLE, INTERNET PROTOCOL (IP), NETWORK TRANSMISSION OF SOUNDS, IMAGES, SIGNALS AND DATA; TRANSMISSION OF DATA, SOUND AND IMAGES BY SATELLITE; TRANSMISSION OF DATA, VIDEO AND AUDIO PROGRAMMING OVER THE INTERNET; TRANSMISSION OF DIGITAL FILES, DATA AND/OR AUDIO VISUAL IMAGES VIA A GLOBAL COMPUTER NETWORK OR THE INTERNET TO BROADBAND CONNECTED OR IP CONNECTED CONSUMER ELECTRONIC DEVICES AND MOBILE NETWORK CONSUMER ELECTRONIC DEVICES (U.S. CLS. 100, 101 AND 104).

CLASS 41—EDUCATION AND ENTERTAINMENT

FOR CABLE TELEVISION PROGRAMMING; PRODUCTION AND DISTRIBUTION OF VIDEOS IN THE FIELD OF EDUCATION, ENTERTAINMENT, NEWS, AND SPORTS TO CABLE TELEVISION SYSTEMS; PRODUCTION AND DISTRIBUTION OF VIDEOS IN THE FIELD OF EDUCATION, ENTERTAINMENT, NEWS, AND SPORTS TO INTERNET PROTOCOL TELEVISION OR TRANSMISSION (IPTV) SYSTEMS; DISTRIBUTION OF MOVIES, MOTION PICTURES, TELEVISION PROGRAMS FOR OTHERS (U.S. CLS. 100, 101 AND 107).

MICHAEL SOUDERS, EXAMINING ATTORNEY

SN 85-308,890. TVN ENTERTAINMENT CORPORATION, DBA AVAIL-TVN, SHERMAN OAKS, CA. FILED 4-29-2011.

VIEWNOW

THE MARK CONSISTS OF STANDARD CHARACTERS WITHOUT CLAIM TO ANY PARTICULAR FONT, STYLE, SIZE, OR COLOR.

CLASS 38—COMMUNICATION

FOR PROVISION OF TELECOMMUNICATION ACCESS TO MOVIES, EVENTS, TELEVISION PROGRAMS, PROMOTIONAL MATERIAL AND OTHER VIDEO AND AUDIO CONTENT PROVIDED VIA A VIDEO-ON-DEMAND SERVICE; PROVISION OF TELECOMMUNICATION ACCESS TO MOVIES, EVENTS, TELEVISION PROGRAMS, PROMOTIONAL MATERIAL AND OTHER VIDEO AND AUDIO CONTENT PROVIDED VIA A PAYER-VIEW SERVICE; VIDEO ON DEMAND TRANSMISSION SERVICES; PAY PER VIEW TRANSMISSION SERVICES; SUBSCRIPTION VIDEO ON DEMAND TRANSMISSION SERVICES; SATELLITE, CABLE, INTERNET PROTOCOL (IP), NETWORK TRANSMISSION OF SOUNDS, IMAGES, SIGNALS AND DATA; TRANSMISSION OF DATA, SOUND AND IMAGES BY SATELLITE; TRANSMISSION OF DIGITAL FILES, DATA AND/OR AUDIO VISUAL IMAGES VIA A GLOBAL COMPUTER NETWORK OR THE INTERNET TO BROADBAND CONNECTED OR IP CONNECTED CONSUMER ELECTRONIC DEVICES AND MOBILE NETWORK CONSUMER ELECTRONIC DEVICES (U.S. CLS. 100, 101 AND 104).

CLASS 41—EDUCATION AND ENTERTAINMENT

FOR CABLE TELEVISION PROGRAMMING; DISTRIBUTION OF MOTION PICTURE FILMS; DISTRIBUTION OF TELEVISION PROGRAMS FOR OTHERS; PRODUCTION AND DISTRIBUTION OF VIDEOS IN THE FIELD OF EDUCATION, ENTERTAINMENT, NEWS, AND SPORTS (U.S. CLS. 100, 101 AND 107).

MICHAEL SOUDERS, EXAMINING ATTORNEY

CLASS 9—ELECTRICAL AND SCIENTIFIC APPARATUS

FOR COMPUTER GAME SOFTWARE; VIDEO GAME SOFTWARE; COMPUTER GAME SOFTWARE FOR USE WITH PERSONAL COMPUTERS, HOME VIDEO GAME CONSOLES USED WITH TELEVISIONS AND ARCADE-BASED VIDEO GAME CONSOLES; COMPUTER GAME SOFTWARE DOWNLOADABLE FROM A GLOBAL COMPUTER NETWORK; DIGITAL MEDIA, NAMELY, PRE-RECORDED CD-ROMS, TAPES, CARTRIDGES, DIGITAL VIDEO DISCS, DIGITAL VERSATILE DISCS, DVDS, AND HIGH DEFINITION DIGITAL DISCS FEATURING COMPUTER GAMES AND VIDEO GAMES (U.S. CLS. 21, 23, 26, 36 AND 38).

SN 85-315,377. NOVARTIS AG, BASEL, SWITZERLAND, FILED 5-9-2011.

PARADIGM-HF

THE MARK CONSISTS OF STANDARD CHARACTERS WITHOUT CLAIM TO ANY PARTICULAR FONT, STYLE, SIZE, OR COLOR.

CLASS 42—SCIENTIFIC AND COMPUTER SERVICES

FOR PROVIDING SCIENTIFIC RESEARCH INFORMATION IN THE FIELD OF PHARMACEUTICALS AND CLINICAL TRIALS TO MEDICAL AND RESEARCH PROFESSIONALS (U.S. CLS. 100 AND 101).

CLASS 44—MEDICAL, BEAUTY AND AGRICULTURAL SERVICES

FOR MEDICAL SERVICES, NAMELY, PROVIDING MEDICAL INFORMATION IN THE FIELD OF PHARMACEUTICALS AND CLINICAL TRIALS TO MEDICAL AND RESEARCH PROFESSIONALS (U.S. CLS. 100 AND 101).

BENJAMIN OKEKE, EXAMINING ATTORNEY

SN 85-323,318. NOTCH DEVELOPMENT AB, JOHANNE-SHOV, SWEDEN, FILED 5-17-2011.

MINECRAFT

THE MARK CONSISTS OF STANDARD CHARACTERS WITHOUT CLAIM TO ANY PARTICULAR FONT, STYLE, SIZE, OR COLOR.

PRIORITY CLAIMED UNDER SEC. 44(D) ON ERPNCMNTY TM OFC APPLICATION NO. 009649691, FILED 1-11-2011, REG. NO. 009649691, DATED 10-11-2011, EXPIRES 1-11-2021.

CLASS 25—CLOTHING

FOR ARTICLES OF CLOTHING, NAMELY, T-SHIRTS, SHIRTS, DRESS SHIRTS, TROUSERS, PANTS, SKIRTS, BLOUSES, DRESSES, SWEATERS, SWEATSHIRTS, HOODED SWEAT SHIRTS, JACKETS; HEADWEAR; KNITWEAR, NAMELY, KNIT DRESS, KNIT SHIRTS, KNIT SKIRTS, KNIT TOPS, KNIT CAPS, KNIT GLOVES, KNIT JACKETS AND POLO KNIT TOPS; HATS; CAPS; NECKWEAR; GARMENTS FOR CHILDREN, NAMELY, SHORTS, SHIRTS, PANTS, BLOUSES, SHORTS, JUMPERS, SWEAT PANTS, SWEAT SHIRTS, HOODED SWEAT SHIRTS; FOOTWEAR; SHOES; SOCKS (U.S. CLS. 22 AND 39).

CLASS 28—TOYS AND SPORTING GOODS

FOR GAME CONTROLLERS FOR COMPUTER GAMES; ELECTRONIC INTERACTIVE BOARD GAMES FOR USE WITH EXTERNAL MONITOR; VIDEO GAME CONSOLES FOR USE WITH AN EXTERNAL DISPLAY SCREEN OR MONITOR; VIDEO GAME INTERACTIVE REMOTE CONTROL UNITS; STAND ALONE VIDEO OUTPUT GAME MACHINES; ARCADE-TYPE ELECTRONIC VIDEO GAMES; BOARD GAMES; MANIPULATIVE PUZZLES; PLAYING CARDS AND CARD GAMES (U.S. CLS. 22, 23, 38 AND 50).

CLASS 41—EDUCATION AND ENTERTAINMENT

FOR ENTERTAINMENT SERVICES, NAMELY, PROVIDING ON-LINE COMPUTER GAMES AND VIDEO GAMES, MOBILE TELEPHONE AND OTHER REMOTE COMMUNICATIONS DEVICE; PROVIDING TEMPORARY USE OF NON-DOWNLOADABLE INTERNET COMPUTER GAMES; PROVIDING TEMPORARY USE OF NON-DOWNLOADABLE ON-LINE ELECTRONIC GAMES PLAYED VIA A GLOBAL COMPUTER NETWORK; EDUCATION AND ENTERTAINMENT SERVICES IN THE FORM OF PRODUCTION OF CINEMATOGRAPHIC, TELEVISUAL, DIGITAL AND MOTION PICTURE FILMS, RADIO AND TELEVISION PROGRAMS AND SHOWS; PRODUCTION OF EDUCATIONAL COMPUTER GAME SOFTWARE AND VIDEO GAME SOFTWARE CONCERNING NATURE AND THE ENVIRONMENT; EDITING AND PRODUCTION OF CINEMATOGRAPHIC, TELEVISUAL, DIGITAL AND MOTION PICTURE FILMS, RADIO AND TELEVISION PROGRAMS; ENTERTAINMENT SERVICES IN THE FORM OF ELECTRONIC, NON-DOWNLOADABLE COMPUTER AND VIDEO GAMES PROVIDED BY MEANS OF THE INTERNET, MOBILE TELEPHONE AND OTHER REMOTE COMMUNICATIONS DEVICE (U.S. CLS. 100, 101 AND 107).

WILLIAM ROSSMAN, EXAMINING ATTORNEY

SN 85-324,706. FEDERATION EMPLOYMENT AND GUIDANCE SERVICE, INC. (F.E.G.S.), NEW YORK, NY. FILED 5-19-2011.

SN 85-329,627. HALDIRAM INDIA PVT. LTD., NEW DELHI, INDIA, FILED 5-25-2011.

SUCCESS BY EVERY MEASURE

THE MARK CONSISTS OF STANDARD CHARACTERS WITHOUT CLAIM TO ANY PARTICULAR FONT, STYLE, SIZE, OR COLOR.

CLASS 35—ADVERTISING AND BUSINESS

FOR PROVIDING REFERRAL SERVICES IN THE FIELDS OF EMPLOYMENT, CAREER DEVELOPMENT, TRAINING, BEHAVIORAL HEALTH, REHABILITATION, DEVELOPMENTAL DISABILITIES, EDUCATION, FAMILY AND YOUTH SERVICES, ECONOMIC DEVELOPMENT, HOUSING AND RESIDENTIAL SERVICES AND HOMECARE; EMPLOYMENT COUNSELING; CAREER COUNSELING, NAMELY, CAREER PLACEMENT; PUBLIC ADVOCACY TO PROMOTE AWARENESS TO INDIVIDUALS AND GROUPS IN THE FIELDS OF EMPLOYMENT, CAREER DEVELOPMENT, TRAINING, BEHAVIORAL HEALTH, REHABILITATION, DEVELOPMENTAL DISABILITIES, EDUCATION, FAMILY AND YOUTH SERVICES, WOMEN'S HEALTH SERVICES, ECONOMIC DEVELOPMENT, HOUSING, RESIDENTIAL AND HOMECARE NEEDS; BUSINESS SUPPORT SERVICES, NAMELY, BUSINESS CONSULTATION TO INDIVIDUALS AND GROUPS IN THE FIELDS OF EMPLOYMENT, CAREER DEVELOPMENT, TRAINING, BEHAVIORAL HEALTH, REHABILITATION, DEVELOPMENTAL DISABILITIES, EDUCATION, FAMILY AND YOUTH SERVICES, WOMEN'S HEALTH SERVICES, ECONOMIC DEVELOPMENT, HOUSING, RESIDENTIAL AND HOMECARE NEEDS (U.S. CLS. 100, 101 AND 102).

CLASS 41—EDUCATION AND ENTERTAINMENT

FOR EDUCATIONAL SERVICES, NAMELY, CONDUCTING CLASSES, SEMINARS, CONFERENCES, WORKSHOPS AND TUTORING FOCUSING ON LITERACY, AFTER-SCHOOL RECREATION AND MENTORING; DISTRIBUTING COURSE MATERIALS IN CONNECTION THEREWITH; CAREER COUNSELING, NAMELY, PROVIDING ADVICE CONCERNING EDUCATIONAL OPTIONS; EDUCATIONAL COUNSELING TO INDIVIDUALS AND GROUPS TO ASSIST STUDENTS WITH PLANNING AND PREPARING FOR THEIR EDUCATION; TRAINING SERVICES IN THE FIELD OF COMPUTERS, BUSINESS APPLICATIONS, AND HOME HEALTHCARE TO INDIVIDUALS AND GROUPS (U.S. CLS. 100, 101 AND 107).

CLASS 44—MEDICAL, BEAUTY AND AGRICULTURAL SERVICES

FOR PROVIDING COUNSELING SERVICES TO INDIVIDUALS AND GROUPS IN THE FIELDS OF BEHAVIORAL HEALTH, AND MENTAL AND PHYSICAL REHABILITATION, DEVELOPMENTAL DISABILITIES, WOMEN'S HEALTH SERVICES; MENTAL HEALTH COUNSELING, AND HOME HEALTH CARE NEEDS (U.S. CLS. 100 AND 101).

NAKIA HENRY, EXAMINING ATTORNEY

MINUTE KHANA

THE MARK CONSISTS OF STANDARD CHARACTERS WITHOUT CLAIM TO ANY PARTICULAR FONT, STYLE, SIZE, OR COLOR.

NO CLAIM IS MADE TO THE EXCLUSIVE RIGHT TO USE "KHANA", APART FROM THE MARK AS SHOWN.

THE ENGLISH TRANSLATION OF THE WORD "KHANA" IN THE MARK IS "FOOD".

CLASS 29—MEATS AND PROCESSED FOODS

FOR PRE-PACKAGED MEALS CONSISTING PRIMARILY OF VEGETABLES, NAMELY, YELLOW DAL TADKA, DILLI STYLE DAL MAKHANI, DILLI STYLE KADHAI PANEER, ALOO PALAK, DAL CHAWAL TADKA, PAO BHAJI, MUTTER PANEER, DILLI STYLE PANEER MAKHANI, BHINDI MASALA, DUM ALOO, DILLI STYLE RAJMA RASEELA, DILLI STYLE PALAK PANEER, DILLI STYLE CHOLEY, NAVRATTAN MIX VEG, HYDERABADI BIRYANI, PUNJABI SARSON DA SAAG, ALOO MUTTER, RAJMA WITH JEERA RICE, SHAHI PANEER WITH PLAIN RICE, DAL MAKHANI WITH PEAS PULAO, YELLOW DAL WITH PLAIN RICE, CHOLEY WITH JEERA RICE, JEERA RICE, PEAS RICE, PLAIN RICE, CARROT HALWA, AND MOONG HALWA (U.S. CL. 46).

FIRST USE 7-10-2007; IN COMMERCE 7-10-2007.

CLASS 30—STAPLE FOODS

FOR PRE-PACKAGED MEALS CONSISTING PRIMARILY OF RICE, NAMELY, JEERA RICE, PEAS RICE, PLAIN RICE (U.S. CL. 46).

FIRST USE 3-21-2009; IN COMMERCE 3-21-2009.

MARK SPARACINO, EXAMINING ATTORNEY

SN 85-330,176. MI PIACI, S.R.L., CASTELFRANCO VENETO TV, ITALY, FILED 5-25-2011.



THE MARK CONSISTS OF THE STYLIZED LETTER "P" WITH A FOUR POINT STAR DESIGN ALL WITHIN A SHADED CIRCLE.

CLASS 14—JEWELRY

FOR PRECIOUS METALS AND THEIR ALLOYS; GOODS IN PRECIOUS METALS OR COATED THEREWITH, NAMELY, JEWELRY AND WATCHES; JEWELRY; HOROLOGICAL AND CHRONOMETRIC INSTRUMENTS (U.S. CLS. 2, 27, 28 AND 50).

CLASS 16—PAPER GOODS AND PRINTED MATTER

FOR PAPER, CARDBOARD AND GOODS MADE FROM THESE MATERIALS, NAMELY, ADDRESS BOOKS AND DIARIES; AGENDAS; BASEBALL CARDS; BALL POINT PENS; BOOK MARKERS OF PRECIOUS METAL; BOOK COVERS; BOOK BINDINGS; BUSINESS CARDS; CASES FOR CHECKS; CHECK BOOK COVERS; CHECK BOOKS; HOLDERS FOR PENS, PENCILS AND INK; DAILY PLANNERS; DESK STANDS AND HOLDERS FOR PENS, PENCILS, AND INK; DESKTOP BUSINESS CARD HOLDERS; DESKTOP DOCUMENT RACKS; DESKTOP PLANNERS; DISPLAY CARDS PRIMARILY COMPOSED OF CARDBOARD; DOCUMENT FILE RACKS; FRAMED ART PAINTINGS; HOLDERS FOR DESK ACCESSORIES; HOLDERS FOR NOTEPADS; LETTER OPENERS OF PRECIOUS METAL; MECHANICAL PENCILS; MONEY CLIPS; PASSPORT HOLDERS AND PEN AND PENCIL CASES AND BOXES; PHOTOGRAPHS; STATIONERY (U.S. CLS. 2, 5, 22, 23, 29, 37, 38 AND 50).

CLASS 18—LEATHER GOODS

FOR LEATHER AND IMITATION LEATHER, AND GOODS MADE OF THESE MATERIALS, NAMELY, GYM BAGS; PET COLLARS; DOG CARRYING CASES; LEASHES FOR ANIMALS; HANDBAGS; BEAUTY-CASES, NAMELY, COSMETIC CASES SOLD EMPTY; BRIEFCASES, BUSINESS CARD CASES; CREDIT CARD CASES; CLUTCHES; HANDBAGS; POCHETTES; SHOULDER BAGS; LUGGAGE; LEATHER POUCHES; SUITCASES; RAW ANIMAL SKINS AND HIDES; TRUNKS AND TRAVEL BAGS; UMBRELLAS, PARASOLS AND WALKING STICKS; WHIPS, HARNESS AND SADDLERY (U.S. CLS. 1, 2, 3, 22 AND 41).

CLASS 24—FABRICS

FOR TEXTILES FABRICS FOR THE MANUFACTURE OF CLOTHING; TOWELS, NAMELY, FACE TOWELS OF TEXTILES AND HAND TOWELS OF TEXTILE, HANDKERCHIEFS OF TEXTILE; INDIVIDUAL PLACE MATS MADE OF TEXTILE; TABLE NAPKINS OF TEXTILE; TOWELS MADE OF TEXTILE; BED LINEN, NAMELY, BED COVERS; BED LINEN; TABLE LINEN, NAMELY, TABLE CLOTHS OF TEXTILE; BED BLANKETS; BED COVERS; BED LINEN, NAMELY, BED SHEETS; BED LINEN, NAMELY, BED SKIRTS, BED SPREADS BEING BED COVERS OF TEXTILE; TABLE COVERS OF TEXTILES, NAMELY, FABRIC TABLE TOPPERS; DUVET COVERS; QUILT COVERS (U.S. CLS. 42 AND 50).

CLASS 25—CLOTHING

FOR FOOTWEAR; BELTS, BEING CLOTHING; BELTS MADE FROM IMITATION LEATHER; BELTS MADE OF LEATHER; BELTS MADE OUT OF CLOTH; BELTS OF TEXTILE; FABRIC BELTS; GARTER BELTS; MONEY BELTS; SUSPENDER BELTS; FOULARDS BEING CLOTHING ARTICLES; GLOVES; GLOVES MADE OF SKIN, HIDE OR FUR; KNITTED GLOVES, RIDING GLOVES; HEADBANDS; ATHLETIC APPAREL, NAMELY, SHIRTS, PANTS, JACKETS, FOOTWEAR, HATS AND CAPS AND ATHLETIC UNIFORMS; BASEBALL CAPS AND HATS; FUR HATS; HATS; LEATHER HATS; SCARVES; SHAWLS AND HEADSCARVES; SHOULDER SCARVES; STOLE; TIES BEING CLOTHING; BEACHWEAR; BLOUSES; CAPES; BOMBER JACKETS; DOWN JACKETS; FUR COATS AND JACKETS; FUR CLOAKS; FUR MUFFS; JACKETS; LEATHER JACKETS; MEN'S AND WOMEN'S JACKETS; COATS; TROUSERS; VESTS; SUEDE JACKETS; DRESSES; PANTS; SKIRTS; SPORTS JERSEYS; TRENCH COATS; ANKLE BOOTS; BOOTS; SANDALS; SNEAKERS; SHOES; HEELS; STILETTO HEELS; ASCOTS; BERETS; BOAS; BOLEROS; BOLO TIES; CLOAKS; CUMMERBUNDS; DRESSING GOWNS; BATH ROBES; LINGERIE; SHIRTS; SHORTS; SUITS; SUSPENDERS; TUXEDOS; VEILS; VESTS (U.S. CLS. 22 AND 39).

CLASS 28—TOYS AND SPORTING GOODS

FOR GYMNAS TIC AND SPORTING ARTICLES, NAMELY, BASEBALLS, BASEBALL GLOVES, BASKETBALLS, SOFTBALL BATS, FOOTBALLS, GOLF BAGS, GOLF GLOVES, GOLF CLUBS, HOCKEY PUCKS; RUGBY BALLS; VOLLEY BALLS; SOCCER BALLS, AND COVERS FOR SPORTING GOODS, NAMELY, GOLF BAG COVERS, SKI COVERS, SQUASH RACKET COVERS, TENNIS RACKET COVERS; CHRISTMAS TREE DECORATIONS; CHRISTMAS TREE ORNAMENTS; CHRISTMAS TREES DECORATIONS, NAMELY, BELLS FOR CHRISTMAS TREES (U.S. CLS. 22, 23, 38 AND 50).

EVELYN BRADLEY, EXAMINING ATTORNEY

SN 85-330,802. MI PIACI, S.R.L., CASTELFRANCO VENETO TV, ITALY, FILED 5-26-2011.



THE MARK CONSISTS OF THE STYLIZED LETTER "M".

CLASS 14—JEWELRY

FOR PRECIOUS METALS AND THEIR ALLOYS; GOODS IN PRECIOUS METALS OR COATED THEREWITH, NAMELY, JEWELRY AND WATCHES; JEWELRY; PRECIOUS STONES; HOROLOGICAL AND CHRONOMETRIC INSTRUMENTS; CUFFLINKS AND TIE CLIPS; BRACELETS; ALL THE FOREGOING COATED IN GOLD OR OTHER PRECIOUS METALS (U.S. CLS. 2, 27, 28 AND 50).

CLASS 18—LEATHER GOODS

FOR LEATHER AND IMITATION LEATHER; BEAUTY CASES, NAMELY, COSMETIC CASES SOLD EMPTY; BRIEFCASES; HAND BAGS; POCHETTES; SHOULDER BAGS; TRUNKS AND TRAVEL BAGS; RAW ANIMAL SKINS AND HIDES; TRUNKS AND TRAVELING BAGS; UMBRELLAS, PARASOLS AND WALKING STICKS; WHIPS, HARNESS AND SADDLERY; TRAVELING TRUNKS (U.S. CLS. 1, 2, 3, 22 AND 41).

CLASS 24—FABRICS

FOR TEXTILES FABRICS FOR THE MANUFACTURE OF CLOTHING; BED COVERS; TOWELS, NAMELY, BEACH TOWELS, FACE TOWELS, AND HAND TOWELS OF TEXTILE; TOWELS OF TEXTILE; BED LINEN; BED BLANKETS; TEXTILE TABLE NAPKINS; INDIVIDUAL PLACE MATS MADE OF TEXTILE; TABLE CLOTHS OF TEXTILE; QUILT COVERS; BEDS COVERS OF TEXTILE; TABLE COVERS BEING TABLE LINEN OF TEXTILE; HANDKERCHIEFS OF TEXTILE (U.S. CLS. 42 AND 50).

CLASS 25—CLOTHING

FOR CLOTHING, NAMELY, MEN AND WOMEN BEACHWEAR; BELTS; BELTS MADE FROM IMITATION LEATHER; BLOUSES; CAPES; JACKETS; JACKETS, NAMELY, LEATHER JACKETS, MEN'S AND WOMEN'S JACKETS; DOWN JACKETS; DRESSES; BOMBER JACKETS; FUR COATS; GLOVES; GLOVES MADE OF SKIN, HIDE OR FUR; JACKETS WITH POCKETS FOR HOLDING HANDKERCHIEFS; PANTS; SHAWLS; SKIRTS; SPORTSWEAR, NAMELY, SPORTS JERSEYS; TIES, NAMELY, BOLO TIES; TRENCH COATS; FOOTWEAR, NAMELY, BOOTS, ANKLE BOOTS, SANDALS, SNEAKERS, SHOES, HEELS AND STILETTO HEELS; SCARVES; SHOULDER SCARVES; STOLE; FOOTWEAR; HEADGEAR, NAMELY, HATS, SPECIFICALLY, BASEBALL HATS, FUR HATS, HATS, LEATHER HATS; BATH ROBES; BELTS, NAMELY, BELTS MADE OF LEATHER (U.S. CLS. 22 AND 39).

EVELYN BRADLEY, EXAMINING ATTORNEY

CLASS 25—CLOTHING

FOR CLOTHING, NAMELY, MEN AND WOMEN BEACHWEAR; BELTS; BELTS MADE FROM IMITATION LEATHER; BLOUSES; CAPES; JACKETS; JACKETS, NAMELY, LEATHER JACKETS, MEN'S AND WOMEN'S JACKETS; DOWN JACKETS; DRESSES; BOMBER JACKETS; FUR COATS; GLOVES; GLOVES MADE OF SKIN, HIDE OR FUR; JACKETS WITH POCKETS FOR HOLDING HANDKERCHIEFS; PANTS; SHAWLS; SKIRTS; SPORTSWEAR, NAMELY, SPORTS JERSEYS; TIES, NAMELY, BOLO TIES; TRENCH COATS; FOOTWEAR, NAMELY, BOOTS, ANKLE BOOTS, SANDALS, SNEAKERS, SHOES, HEELS AND STILETTO HEELS; SCARVES; SHOULDER SCARVES; STOLE; FOOTWEAR; HEADGEAR, NAMELY, HATS, SPECIFICALLY, BASEBALL HATS, FUR HATS, HATS, LEATHER HATS; BATH ROBES; BELTS, NAMELY, BELTS MADE OF LEATHER (U.S. CLS. 22 AND 39).

EVELYN BRADLEY, EXAMINING ATTORNEY

SN 85-330,856. MI PIACI, S.R.L., CASTELFRANCO VENETO TV, ITALY, FILED 5-26-2011.



THE MARK CONSISTS OF THE STYLIZED WORDING "MIPIACI".

THE ENGLISH TRANSLATION OF "MIPIACI" IN THE MARK IS I LIKE YOU.

CLASS 14—JEWELRY

FOR PRECIOUS METALS AND THEIR ALLOYS; GOODS IN PRECIOUS METALS OR COATED THEREWITH, NAMELY, JEWELRY AND WATCHES; JEWELRY; PRECIOUS STONES; HOROLOGICAL AND CHRONOMETRIC INSTRUMENTS; CUFFLINKS AND TIE CLIPS; BRACELETS; ALL THE FOREGOING COATED IN GOLD OR OTHER PRECIOUS METALS (U.S. CLS. 2, 27, 28 AND 50).

CLASS 18—LEATHER GOODS

FOR LEATHER AND IMITATION LEATHER; BEAUTY CASES, NAMELY, COSMETIC CASES SOLD EMPTY; BRIEFCASES; HAND BAGS; POCHETTES; SHOULDER BAGS; TRUNKS AND TRAVEL BAGS; RAW ANIMAL SKINS AND HIDES; TRUNKS AND TRAVELING BAGS; UMBRELLAS, PARASOLS AND WALKING STICKS; WHIPS, HARNESS AND SADDLERY; TRAVELING TRUNKS (U.S. CLS. 1, 2, 3, 22 AND 41).

CLASS 24—FABRICS

FOR TEXTILES FABRICS FOR THE MANUFACTURE OF CLOTHING; BED COVERS; TOWELS, NAMELY, BEACH TOWELS, FACE TOWELS, AND HAND TOWELS OF TEXTILE; TOWELS OF TEXTILE; BED LINEN; BED BLANKETS; TEXTILE TABLE NAPKINS; INDIVIDUAL PLACE MATS MADE OF TEXTILE; TABLE CLOTHS OF TEXTILE; QUILT COVERS; BEDS COVERS OF TEXTILE; TABLE COVERS BEING TABLE LINEN OF TEXTILE; HANDKERCHIEFS OF TEXTILE (U.S. CLS. 42 AND 50).

SN 85-330,924. SISTER TO SISTER EVERYONE HAS A HEART FOUNDATION, INC, CHEVY CHASE, MD. FILED 5-26-2011.



Everyone Has A Heart

THE MARK CONSISTS OF THREE STYLIZED FEMALE FIGURES INSIDE A SQUARE. THE WORDING "SISTER TO SISTER" APPEARS AT THE BOTTOM OF THE STYLIZED FIGURES INSIDE THE SQUARE. THE WORDING "EVERYONE HAS A HEART" APPEARS BENEATH THE SQUARE.

CLASS 35—ADVERTISING AND BUSINESS

FOR PROMOTING PUBLIC AWARENESS OF THE NEED FOR GOOD CARDIOVASCULAR HEALTH CARE FOR WOMEN (U.S. CLS. 100, 101 AND 102).

CLASS 44—MEDICAL, BEAUTY AND AGRICULTURAL SERVICES

FOR PROVIDING HEALTH INFORMATION; MEDICAL SCREENING (U.S. CLS. 100 AND 101).

SHAUNIA CARLYLE, EXAMINING ATTORNEY

SN 85-334,045. HARBOR GUARD BOATS, INC., CORONA, CA. FILED 5-31-2011.

HARBOR GUARD BOATS

THE MARK CONSISTS OF STANDARD CHARACTERS WITHOUT CLAIM TO ANY PARTICULAR FONT, STYLE, SIZE, OR COLOR.

NO CLAIM IS MADE TO THE EXCLUSIVE RIGHT TO USE "GUARD BOATS", APART FROM THE MARK AS SHOWN.

SEC. 2(F).

CLASS 9—ELECTRICAL AND SCIENTIFIC APPARATUS

FOR FIREFIGHTING BOATS (U.S. CLS. 21, 23, 26, 36 AND 38).

FIRST USE 7-25-2005; IN COMMERCE 7-25-2005.

CLASS 12—VEHICLES

FOR LAW ENFORCEMENT BOATS AND RESCUE BOATS (U.S. CLS. 19, 21, 23, 31, 35 AND 44).

FIRST USE 7-25-2005; IN COMMERCE 7-25-2005.
DAVID C. REIHNER, EXAMINING ATTORNEY

SN 85-335,315. RESMARK EQUITY PARTNERS, LLC, LOS ANGELES, CA. FILED 6-1-2011.

RESMARK

THE MARK CONSISTS OF STANDARD CHARACTERS WITHOUT CLAIM TO ANY PARTICULAR FONT, STYLE, SIZE, OR COLOR.

CLASS 35—ADVERTISING AND BUSINESS

FOR SHOPPING MALL SERVICES, NAMELY, MANAGEMENT AND OPERATION ASSISTANCE TO COMMERCIAL BUSINESSES AND ADVERTISING AND MARKETING SERVICES, NAMELY, PROMOTING THE GOODS AND SERVICES OF OTHERS BY DISTRIBUTING ADVERTISING MATERIALS THROUGH A VARIETY OF MEANS (U.S. CLS. 100, 101 AND 102).

SN 85-334,733. T.F.H. PUBLICATIONS, INC., NEPTUNE CITY, NJ. FILED 6-1-2011.

CLASS 36—INSURANCE AND FINANCIAL

FOR REAL ESTATE LEASING, OPERATION, AND MANAGEMENT SERVICES; LEASING AND RENTAL OF RESIDENTIAL APARTMENTS; SHOPPING MALL SERVICES, NAMELY, LEASING AND OPERATING SHOPPING MALL SPACE FOR SELLERS AND CONSUMERS OF GOODS AND SERVICES (U.S. CLS. 100, 101 AND 102).

ADVANCED ORAL CARE

CLASS 37—CONSTRUCTION AND REPAIR

FOR REAL ESTATE DEVELOPMENT; REAL ESTATE MAINTENANCE SERVICES (U.S. CLS. 100, 103 AND 106).

THE MARK CONSISTS OF STANDARD CHARACTERS WITHOUT CLAIM TO ANY PARTICULAR FONT, STYLE, SIZE, OR COLOR.

NO CLAIM IS MADE TO THE EXCLUSIVE RIGHT TO USE "ORAL CARE", APART FROM THE MARK AS SHOWN.

CLASS 45—PERSONAL AND LEGAL SERVICES

FOR RESIDENTIAL CONCIERGE SERVICES FOR APARTMENT RESIDENTS COMPRISING MAKING REQUESTED PERSONAL ARRANGEMENTS (U.S. CLS. 100 AND 101).

ALICE BENMAMAN, EXAMINING ATTORNEY

CLASS 3—COSMETICS AND CLEANING PREPARATIONS

FOR NON-MEDICATED HOME DENTAL HEALTH ITEMS FOR PETS, NAMELY, TOOTHPASTE, DENTAL RINSES FOR USE IN PET WATER, DENTAL SPRAYS AND DENTAL FOAMS (U.S. CLS. 1, 4, 6, 50, 51 AND 52).

FIRST USE 12-8-2011; IN COMMERCE 12-8-2011.

SN 85-342,886. MANHATTAN KIDS, LLC, NEW YORK, NY. FILED 6-10-2011.

CLASS 21—HOUSEWARES AND GLASS

FOR HOME DENTAL HEALTH ITEMS FOR PETS, NAMELY, TOOTHBRUSHES (U.S. CLS. 2, 13, 23, 29, 30, 33, 40 AND 50).

FIRST USE 12-8-2011; IN COMMERCE 12-8-2011.

CLASS 28—TOYS AND SPORTING GOODS

FOR NON-EDIBLE PET CHEW TOYS AND PET TOYS (U.S. CLS. 22, 23, 38 AND 50).

FIRST USE 12-8-2011; IN COMMERCE 12-8-2011.

NO CLAIM IS MADE TO THE EXCLUSIVE RIGHT TO USE "MANHATTAN" AND "KIDS", APART FROM THE MARK AS SHOWN.

THE COLOR(S) BLUE, RED, GREEN AND WHITE IS/ARE CLAIMED AS A FEATURE OF THE MARK.

THE MARK CONSISTS OF THE WORDING "MANHATTAN KIDS" IN BLUE STYLIZED FONT WITH AN APPLE BETWEEN THE TWO WORDS. THE APPLE IS WHITE AND IS OUTLINED IN RED, WITH A RED STEM AND WHITE LEAF OUTLINED IN GREEN. THERE IS A SMILING FACE ON THE APPLE WHICH IS FORMED BY TWO RED DOTS AND A RED CURVED LINE.

CLASS 31—NATURAL AGRICULTURAL PRODUCTS

FOR EDIBLE PET CHEWS (U.S. CLS. 1 AND 46).

FIRST USE 12-8-2011; IN COMMERCE 12-8-2011.
JEFFERY COWARD, EXAMINING ATTORNEY

CLASS 24—FABRICS

FOR TEXTILES FOR HOUSEHOLD USE, FOR CHILDREN AND BABIES AND ADULTS, NAMELY, PILLOW CASES, PILLOW SHAMS, PILLOW COVERS, TOWELS, BED LINENS, NAMELY, BED SHEETS, SHEET SETS, BED SPREADS, QUILTS, COMFORTERS, DUVETS, DUVET COVERS, BED BLANKETS, LAP BLANKETS, CHILDREN'S BLANKETS, THROWS, TABLE-TOP LINENS, NAMELY, TABLE CLOTHS OF TEXTILE, FABRIC TABLE RUNNERS, CLOTH COASTERS, TEXTILE NAPKINS AND PLACE MATS OF TEXTILE MATERIAL, FABRIC THROWS, FABRIC WINDOW TREATMENTS, NAMELY, CURTAINS, DRAPERIES, SHEERS, SWAGS AND VALANCES, AND BATH LINENS, NAMELY, BATH TOWELS, HAND TOWELS, WASH CLOTHS AND BEACH TOWELS (U.S. CLS. 42 AND 50).

FIRST USE 11-0-2005; IN COMMERCE 11-0-2005.

CLASS 25—CLOTHING

FOR CLOTHING FOR CHILDREN AND BABIES AND ADULTS, NAMELY, SLEEPWEAR, LOUNGEWEAR, PJAMAS, NIGHTGOWNS, ONE-PIECE GARMENTS FOR CHILDREN, ROBES, LINGERIE, UNDERGARMENTS, BRAS, CAMISOLES, CHEMISES, HOSIERY, STOCKINGS, TIGHTS, PANTIES, BATHING SUITS, AND ACCESSORIES, NAMELY, BELTS, SCARVES, HATS, AND FOOTWEAR (U.S. CLS. 22 AND 39).

FIRST USE 11-0-2005; IN COMMERCE 11-0-2005.

TINA BROWN, EXAMINING ATTORNEY

SN 85-343,501. STRUCTURAL GROUP, INC., HANOVER, MD. FILED 6-10-2011.

OWNER OF U.S. REG. NOS. 2,916,947 AND 3,033,591.
NO CLAIM IS MADE TO THE EXCLUSIVE RIGHT TO USE "STRUCTURAL" AS TO CLASS 042, APART FROM THE MARK AS SHOWN.

THE MARK CONSISTS OF THE WORD "STRUCTURAL" WITH A TRIANGLE-SHAPED APOSTROPHE DESIGN BETWEEN THE LETTERS "C" AND "T" AND THE LETTERS "R" AND "A".

CLASS 37—CONSTRUCTION AND REPAIR

FOR SPECIALTY CONSTRUCTION, REPAIR AND MAINTENANCE SERVICES FOR THE COMMERCIAL, ENERGY, GOVERNMENT, INDUSTRIAL AND TRANSPORTATION MARKETS; CONSTRUCTION PROJECT MANAGEMENT SERVICES (U.S. CLS. 100, 103 AND 106).
FIRST USE 5-3-2011; IN COMMERCE 5-3-2011.

CLASS 42—SCIENTIFIC AND COMPUTER SERVICES

FOR ENGINEERING SERVICES FOR THE COMMERCIAL, ENERGY, GOVERNMENT, INDUSTRIAL AND TRANSPORTATION MARKETS (U.S. CLS. 100 AND 101).
FIRST USE 5-3-2011; IN COMMERCE 5-3-2011.
DAVID HOFFMAN, EXAMINING ATTORNEY

SN 85-343,806. CANDIDMARKETS, INC., WILMINGTON, DE. FILED 6-10-2011.

CANDIDMARKETS

THE MARK CONSISTS OF STANDARD CHARACTERS WITHOUT CLAIM TO ANY PARTICULAR FONT, STYLE, SIZE, OR COLOR.

OWNER OF U.S. REG. NO. 4,174,606.

CLASS 41—EDUCATION AND ENTERTAINMENT

FOR PROVIDING RECOGNITION AND INCENTIVES BY THE WAY OF AWARDS TO DEMONSTRATE EXCELLENCE IN THE FIELDS OF INVESTMENT MARKETS, STOCKS, BONDS, REAL ESTATE AND NATIONAL ECONOMIC CONDITIONS (U.S. CLS. 100, 101 AND 107).

CLASS 42—SCIENTIFIC AND COMPUTER SERVICES

FOR APPLICATION SERVICE PROVIDER, NAMELY, HOSTING, MANAGING, DEVELOPING, AND MAINTAINING APPLICATIONS, SOFTWARE, AND WEB SITES, IN THE FIELDS OF INVESTMENT MARKETS, STOCKS, BONDS, REAL ESTATE AND NATIONAL ECONOMIC CONDITIONS; COMPUTER SERVICES, NAMELY, HOSTING AND MAINTAINING AN ON-LINE WEB SITE FOR USERS TO NETWORK AND TO EXCHANGE THEIR ANALYSIS OF INVESTMENT MARKETS, STOCKS, BONDS, REAL ESTATE AND NATIONAL ECONOMIC CONDITIONS (U.S. CLS. 100 AND 101).

SARA BENJAMIN, EXAMINING ATTORNEY

SN 85-346,719. FLORENCE DE DAMPIERRE DESIGN LLC, LITCHFIELD, CT. FILED 6-15-2011.

FLORENCE DE DAMPIERRE DESIGN

THE MARK CONSISTS OF STANDARD CHARACTERS WITHOUT CLAIM TO ANY PARTICULAR FONT, STYLE, SIZE, OR COLOR.

NO CLAIM IS MADE TO THE EXCLUSIVE RIGHT TO USE "DESIGN", APART FROM THE MARK AS SHOWN.

THE NAME SHOWN IN THE MARK IDENTIFIES "FLORENCE DE DAMPIERRE", WHOSE CONSENT TO REGISTER IS MADE OF RECORD.

CLASS 11—ENVIRONMENTAL CONTROL APPARATUS

FOR COORDINATED HOME DECOR ACCENT PIECES, NAMELY, LIGHTING IN THE NATURE OF LAMPS, LIGHTING FIXTURES, INCLUDING SCONCE LIGHTING FIXTURES (U.S. CLS. 13, 21, 23, 31 AND 34).
FIRST USE 5-5-2003; IN COMMERCE 5-5-2003.

CLASS 16—PAPER GOODS AND PRINTED MATTER

FOR COORDINATED HOME DECOR ACCENT PIECES, NAMELY, WALL ART IN THE NATURE OF FRAMED ART PICTURES (U.S. CLS. 2, 5, 22, 23, 29, 37, 38 AND 50).

FIRST USE 5-5-2003; IN COMMERCE 5-5-2003.

CLASS 20—FURNITURE AND ARTICLES NOT OTHERWISE CLASSIFIED

FOR BED FRAMES; BEDROOM STORAGE, NAMELY, BUREAUS, CHESTS, STORAGE BENCHES, TABLES, WARDROBES, DRESSING TABLES AND CABINETS; DINING FURNITURE, NAMELY, TABLES, CHAIRS, CABINETS, SERVING STANDS IN THE NATURE OF ROLLING TEA CARTS, ROLLING SIDE BOARDS AND LIQUOR CABINETS FEATURING WHEELS, WORK ISLANDS IN THE NATURE OF CENTER TABLES; CONSOLE TABLES; OCCASIONAL FURNITURE, NAMELY, MEDIA CONSOLE TABLES AND MEDIA CABINETS; COFFEE TABLES; SIDE TABLES; BOOK-CASES; DESKS; UPHOLSTERED FURNITURE, NAMELY, SOFAS, LOUNGE CHAIRS, CHAISE LOUNGES, OTTOMANS, CHAIRS, SETTEES AND LOVE-SEATS; PILLOWS AND MIRRORS (U.S. CLS. 2, 13, 22, 25, 32 AND 50).

FIRST USE 5-5-2003; IN COMMERCE 5-5-2003.

CLASS 21—HOUSEWARES AND GLASS

FOR COORDINATED HOME DECOR ACCENTS PIECES, NAMELY, VASES, PLANTERS FOR FLOWERS AND PLANTS, BOWLS, CANDLESTICKS, DINNERWARE AND NAPKIN RINGS (U.S. CLS. 2, 13, 23, 29, 30, 33, 40 AND 50).

FIRST USE 5-5-2003; IN COMMERCE 5-5-2003.

CLASS 42—SCIENTIFIC AND COMPUTER SERVICES

FOR INTERIOR DECORATING (U.S. CLS. 100 AND 101).

FIRST USE 5-5-2003; IN COMMERCE 5-5-2003.
ANDREW LEASER, EXAMINING ATTORNEY

SN 85-349,041. VIETNAM CUSTOM TAILORS LLC, PHILADELPHIA, PA. FILED 6-17-2011.



NO CLAIM IS MADE TO THE EXCLUSIVE RIGHT TO USE "QUALITY, FIT, COMFORT & AFFORDABILITY", APART FROM THE MARK AS SHOWN.

THE MARK CONSISTS OF THE STYLIZED LETTERS "VCT" WITH THE DESIGN OF A NEEDLE AND THREAD EMANATING FROM THE "T" AND PASSING THROUGH BOTH THE "V" AND THE "C" PLACED ABOVE THE WORDS "QUALITY, FIT, COMFORT, & AFFORDABILITY".

CLASS 18—LEATHER GOODS

FOR WALLETS, BAGS, HANDBAGS, PURSES, MESSENGER BAGS, BUSINESS CARD CASES, SUITCASES, LEATHER KEY CHAINS, TRAVELING CASES, ALL-PURPOSE CARRYING BAGS (U.S. CLS. 1, 2, 3, 22 AND 41).

CLASS 25—CLOTHING

FOR CLOTHING, NAMELY, CUSTOM MEN'S SUITS, SPORTS JACKETS, BLAZERS, FORMAL WEAR IN THE NATURE OF TUXEDOS, WAISTCOATS, SLACKS, SHIRTS, TOPCOATS, OVERCOATS, CUSTOM LADIES' SUITS, WEDDING DRESSES, CASUAL WEAR FOR TEENS AND ADULTS IN THE NATURE OF SWEAT-SHIRTS AND SWEATPANTS, HANDMADE TIES AND SCARVES, AND LEATHER BELTS (U.S. CLS. 22 AND 39).

CLASS 35—ADVERTISING AND BUSINESS

FOR RETAIL STORE SERVICES FEATURING MEN'S AND WOMEN'S CLOTHING AND ACCESSORIES (U.S. CLS. 100, 101 AND 102).

CLASS 40—MATERIAL TREATMENT

FOR TAILORING SERVICES (U.S. CLS. 100, 103 AND 106).

AHSEN KHAN, EXAMINING ATTORNEY

SN 85-350,378. PLAYGROUND ENTERTAINMENT GROUP, INC., CHINO HILLS, CA. FILED 6-20-2011.

PLAYGROUND ENTERTAINMENT

THE MARK CONSISTS OF STANDARD CHARACTERS WITHOUT CLAIM TO ANY PARTICULAR FONT, STYLE, SIZE, OR COLOR.

NO CLAIM IS MADE TO THE EXCLUSIVE RIGHT TO USE "ENTERTAINMENT", APART FROM THE MARK AS SHOWN.

CLASS 9—ELECTRICAL AND SCIENTIFIC APPARATUS

FOR GAMES, NAMELY, COMPUTER GAME SOFTWARE; COMPUTER APPLICATION SOFTWARE FOR MOBILE PHONES AND COMPUTER SOFTWARE FOR TEACHING CHILDREN ABOUT SPORTS; DOWNLOADABLE VIDEO RECORDINGS FEATURING SPORTS PARTICIPATION INSTRUCTIONS; AND VIDEO RECORDINGS ABOUT SPORTS (U.S. CLS. 21, 23, 26, 36 AND 38).

CLASS 41—EDUCATION AND ENTERTAINMENT

FOR ENTERTAINMENT SERVICES IN THE NATURE OF A TELEVISION PROGRAMMING SERIES ON SPORTS FOR CHILDREN; PROVIDING A WEB SITE FEATURING NON-DOWNLOADABLE INSTRUCTIONAL VIDEOS IN THE FIELD OF AND INFORMATION RELATING TO THE SPORTS OF SOCCER, BASEBALL, BASKETBALL, HOCKEY, SWIMMING, TENNIS, MARTIAL ARTS, DANCE, RUGBY, VOLLEYBALL, CRICKET, CHEERLEADING, SOFTBALL, GYMNASTICS, SNOW SKIING, WATER SKIING, LACROSSE, CRICKET, SAILING, ICE SKATING, ROLLER SKATING, TABLE TENNIS, SNOWBOARDING, SURFING, CYCLING, FISHING, BOWLING, ATHLETICS, SKATEBOARDING, AUSSIE RULES FOOTBALL, ARCHERY WAKE BOARDING, EQUINE SPORTS, FLYING DISC, AND FIELD HOCKEY (U.S. CLS. 100, 101 AND 107).

STEPHANIE ALI, EXAMINING ATTORNEY

SN 85-353,264. LILYPAD, LLC, PORTLAND, ME. FILED 6-22-2011.

Lilypad

THE MARK CONSISTS OF STANDARD CHARACTERS WITHOUT CLAIM TO ANY PARTICULAR FONT, STYLE, SIZE, OR COLOR.

CLASS 35—ADVERTISING AND BUSINESS

FOR BUSINESS ASSISTANCE, ADVISORY AND CONSULTING SERVICES, EXCLUDING BRANDING, MARKETING AND PROMOTION SERVICES, IN THE FIELD OF STRATEGY DEVELOPMENT, STRATEGY EXECUTION AND PERFORMANCE IMPROVEMENT MONITORING FOR HEALTH CARE ORGANIZATIONS (U.S. CLS. 100, 101 AND 102).

CLASS 42—SCIENTIFIC AND COMPUTER SERVICES

FOR PROVIDING ON-LINE NON-DOWNLOADABLE SOFTWARE FOR COLLECTING, DISPLAYING AND MANAGING BUSINESS STRATEGY AND BUSINESS PERFORMANCE IMPROVEMENT DATA, EXCLUDING INFORMATION RELATING TO BRANDING, MARKETING AND PROMOTION, IN THE FORM OF DASHBOARDS, SCORECARDS AND OTHER ANALYTIC TOOLS FOR HEALTH CARE ORGANIZATIONS (U.S. CLS. 100 AND 101).

ERIN FALK, EXAMINING ATTORNEY

SN 85-358,572. SUPERIOR SHOOTING SYSTEM, INC., CANADIAN, TX. FILED 6-28-2011.

DAVID TUBB GO THE DISTANCE

THE MARK CONSISTS OF STANDARD CHARACTERS WITHOUT CLAIM TO ANY PARTICULAR FONT, STYLE, SIZE, OR COLOR.

THE NAME(S), PORTRAIT(S), AND/OR SIGNATURE(S) SHOWN IN THE MARK IDENTIFIES "DAVID TUBB", WHOSE CONSENT(S) TO REGISTER IS MADE OF RECORD.

CLASS 9—ELECTRICAL AND SCIENTIFIC APPARATUS

FOR RIFLE SCOPES (U.S. CLS. 21, 23, 26, 36 AND 38).

CLASS 13—FIREARMS

FOR AUTOMATIC RIFLES; BAGS SPECIALLY ADAPTED TO HOLD RIFLES; BUTT PLATES FOR PISTOLS, RIFLES, AND SHOTGUNS; COMBINATION PISTOLS AND RIFLES; COMPONENT PARTS FOR RIFLES; GUN AND RIFLE CASES; HUNTING RIFLES; MILITARY RIFLES; MUZZLE BREAKS THAT SCREW ONTO A RIFLE BARREL; RIFLE AMMUNITION; RIFLE BARRELS; RIFLE CARTRIDGES; RIFLE CASES; RIFLE COVERS; RIFLE FORE ARMS; RIFLE FORE ENDS; RIFLE HAND GRIPS; RIFLE HAND GUARDS; RIFLE MAGAZINE CLAMPS; RIFLE MOUNTS; RIFLE RAILS; RIFLE RINGS; RIFLE SLINGS; RIFLE STOCKS; RIFLE STRAPS; RIFLES AND PARTS THEREOF; SPORTING RIFLES (U.S. CLS. 2 AND 9).

EMILY CARLSEN, EXAMINING ATTORNEY

SN 85-360,569. ZAWYA LIMITED, GRAND CAYMAN, CAYMAN ISLANDS, FILED 6-30-2011.



OWNER OF UNITED ARAB EMIR. REG. NO. 159560, DATED 1-12-2011, EXPIRES 1-12-2021.

OWNER OF UNITED ARAB EMIR. REG. NO. 159559, DATED 1-12-2011, EXPIRES 1-12-2021.

OWNER OF UNITED ARAB EMIR. REG. NO. 159558, DATED 1-12-2011, EXPIRES 1-12-2021.

OWNER OF UNITED ARAB EMIR. REG. NO. 159557, DATED 1-12-2011, EXPIRES 1-12-2021.

OWNER OF UNITED ARAB EMIR. REG. NO. 159556, DATED 1-12-2011, EXPIRES 1-12-2021.

THE COLOR(S) YELLOW, WHITE AND BLUE IS/ARE CLAIMED AS A FEATURE OF THE MARK.

THE MARK CONSISTS OF THE TERM "ZAWYA" IN BLUE BELOW A YELLOW WEDGE SHAPE DIVIDED INTO TWO PIECES BY A WHITE LINE.

THE ENGLISH TRANSLATION OF "ZAWYA" IN THE MARK IS "CORNER".

CLASS 35—ADVERTISING AND BUSINESS

FOR ONLINE ADVERTISING ON A COMPUTER NETWORK; BUSINESS CONSULTING AND BUSINESS INFORMATION FOR ENTERPRISES; PROVIDING ONLINE BUSINESS INFORMATION OF OTHERS, NAMELY, ADVERTISEMENTS OR SOLICITATIONS; PROVIDING ONLINE DATA COLLECTION; BUSINESS INFORMATION; ADVERTISING SERVICES; PROMOTING, ADVERTISING AND MARKETING THE ON-LINE DATABASES AND ELECTRONIC PUBLICATIONS OF OTHERS; ON-LINE AND INTERNET ADVERTISING FOR OTHERS; CONDUCTING ON-LINE BUSINESS MANAGEMENT RESEARCH SURVEYS; MARKET ANALYSIS AND RESEARCH STUDIES; PROVIDING STATISTICAL INFORMATION FOR BUSINESS OR COMMERCIAL PURPOSES ONLINE; PROVIDING BUSINESS INFORMATION OVER THE INTERNET; COMPI- LATION OF INFORMATION INTO COMPUTER DATABASES; PROVIDING BUSINESS INFORMATION VIA ON-LINE ELECTRONIC COMMUNICATIONS NET- WORKS; PROVIDING AND UPDATING A FINANCIAL INDEX OF SECURITIES VALUES AND CLASSIFICA- TION, ANALYSIS, AND REPORTING THEREOF; ON- LINE INFORMATION IN THE FIELD OF TRADE; PROVIDING ON-LINE INFORMATION, NEWS AND COMMENTARY IN THE FIELD OF BUSINESS (U.S. CLS. 100, 101 AND 102).

CLASS 36—INSURANCE AND FINANCIAL

FOR PROVIDING ONLINE CASH AND DERIVATIVES STOCK EXCHANGE QUOTATIONS, OVER-THE-COUNTER DATA AND MACROECONOMIC INDICATORS; ONLINE INFORMATION IN THE FIELD OF FINANCE AND TRADE SERVICES, NAMELY, EQUITIES, BONDS, FINANCIAL CERTIFICATES, COMMODITIES AND EN- ERGY, FOREX AND MONEY MARKET, EXCHANGE TRADED VOLUMES, COMPANIES FINANCIALS, COR- PORATE ACTIONS, BROKER AND SECTOR RE- SEARCH, CONSTRUCTION PROJECTS VOLUME; PROVIDING ONLINE FINANCIAL INFORMATION RE- GARDING RATING CHANGES THAT AFFECT SPEC- IFIC MARKETS, COMPANIES OR BONDS; PROVIDING ONLINE FINANCIAL INFORMATION FOR ASSES- SMENT OF SECURITIES; FINANCIAL INFORMATION SERVICES PROVIDED ON-LINE FROM A COMPUTER DATABASE OR A GLOBAL COMPUTER NETWORK, NAMELY, PROVIDING INFORMATION IN THE FIELD OF FINANCIAL CLASSIFICATION OF PUBLICLY LISTED OR PRIVATE COMPANIES AND OTHER IN- VESTMENTS VEHICLES SUCH AS MUTUAL FUNDS, PRIVATE EQUITY, INITIAL PUBLIC OFFERINGS, BONDS AND FINANCIAL CERTIFICATES; PROVIDING ON-LINE INFORMATION, NEWS AND COMMENTARY IN THE FIELD OF FINANCE AND INVESTMENT (U.S. CLS. 100, 101 AND 102).

CLASS 38—COMMUNICATION

FOR NEWS TRANSMISSION VIA ELECTRONIC COM- MUNICATIONS NETWORKS IN THE FIELD OF FI- NANCE; TRANSMISSION OF INFORMATION BY ELECTRONIC COMMUNICATIONS NETWORKS; ON- LINE TRANSMISSION OF FINANCIAL INFORMATION ON BUSINESS AND ENTERPRISE; MESSAGE SENDING AND IMAGES VIA A WEBSITE; ONLINE NEWS AGEN- CIES, NAMELY, TRANSMITTING LIVE MIDDLE EAST FINANCIAL AND ECONOMIC NEWS TO FINANCIAL INSTITUTIONS, CORPORATE AND MEDIAS; COMPU- TER AIDED TRANSMISSION OF IMAGES; TRANSMIS- SION AND DISTRIBUTION OF DATA OR AUDIO VISUAL IMAGES VIA A GLOBAL COMPUTER NET- WORK OR THE INTERNET; ELECTRONIC TRANSMIS- SION OF INFORMATION THROUGH THE INTERNET; TRANSMISSION OF INFORMATION THROUGH VIDEO COMMUNICATION SYSTEMS; TRANSMISSION OF SOUND, VIDEO, AND INFORMATION; STREAMING OF VIDEO MATERIAL ON THE INTERNET; ELECTRO- NIC MAIL; INTERNET SERVICE PROVIDER SERVICES, NAMELY, TRANSMITTING INFORMATION VIA THE INTERNET CONCERNING GLOBAL COMPUTER NET- WORK DATA IN THE FIELD OF FINANCIAL, ECO- NOMIC AND BUSINESS, COMPANIES AND SECTORS; PROVIDING ACCESS TO AN INTERACTIVE OR ELEC- TRONIC DATABASE THAT CONTAINS STREAMING NEWS, INTELLIGENCE REPORTS AND ANALYSIS (U.S. CLS. 100, 101 AND 104).

CLASS 41—EDUCATION AND ENTERTAIN- MENT

FOR PROVIDING CURRENT EVENTS INFORMA- TION VIA THE INTERNET AND ON-LINE ELECTRO- NIC COMMUNICATIONS NETWORKS; ONLINE PUBLICATION OF PRINTED MATTER, NEWS ARTI- CLES, PAMPHLETS, PROSPECTUSES, NEWSPAPER AR- TICLES, BOOKLETS, LEAFLETS, DATABASES, FINANCIAL NEWS BULLETINS, FINANCIAL REPORTS, PUBLICITY MATERIALS, BROCHURES, CATALOGS, AND INDEXES; PROVIDING ON-LINE NON-DOWN- LOADABLE PUBLICATIONS IN THE NATURE OF NEWSLETTERS IN THE FIELD OF BUSINESS, FI- NANCE AND INVESTMENT; ONLINE ORGANIZATION AND ARRANGEMENT OF EDUCATIONAL CONFER- ENCES AND SEMINARS; ONLINE EDITORIAL CON- SULTATION (U.S. CLS. 100, 101 AND 107).

CLASS 42—SCIENTIFIC AND COMPUTER SERVICES

FOR MAINTENANCE OF COMPUTER DATABASE SOFTWARE FOR OTHERS; CREATING AND MAIN- TAINING A WEB SITE CONTAINING INFORMATION IN A WIDE VARIETY OF FIELDS; DESIGN AND CREATION OF PROPRIETARY COMPUTER DATA- BASES TO BE ACCESSED BY SUBSCRIBERS OR GE- NERAL USERS OF THE INTERNET (U.S. CLS. 100 AND 101).

 NAAKWAMA ANKRAH, EXAMINING ATTORNEY

SN 85-364,507. H2O PLUS, LLC, CHICAGO, IL. FILED 7-6- 2011.

MARINE CALM

THE MARK CONSISTS OF STANDARD CHARACTERS WITHOUT CLAIM TO ANY PARTICULAR FONT, STYLE, SIZE, OR COLOR.

NO CLAIM IS MADE TO THE EXCLUSIVE RIGHT TO USE "MARINE", APART FROM THE MARK AS SHOWN.

CLASS 3—COSMETICS AND CLEANING PREPARATIONS

FOR COSMETIC AND PERSONAL CARE PRODUCTS CONTAINING SEA DERIVED INGREDIENTS IN THE NATURE OF SKIN CARE PRODUCTS, SKIN CALMING PRODUCTS AND PREPARATIONS, NAMELY, COSMETICS, SKIN CREAMS, SKIN LOTIONS, SKIN MOISTURIZERS, SKIN TONERS, AGE SPOT REDUCING CREAMS, HYDRATING GELS, AGE SPOT REDUCING GELS, FACIAL CLEANSERS, HAND CLEANSERS, CLEANSING MOUSSE, SKIN CLEANSING GELS; NON-MEDICATED ACNE TREATMENT CREAMS, FACIAL SCRUBS, BODY SCRUBS, FOOT SCRUBS, SKIN SOAP, BODY WASH, BATH GELS, SHOWER GELS; PERSONAL CARE PRODUCTS CONTAINING SEA DERIVED INGREDIENTS IN THE NATURE OF BATH PREPARATIONS AND ADDITIVES, NAMELY, BATH SALTS; NON-MEDICATED BATH SOAKS, BATH SCRUBS, BATH LOTIONS, COSMETIC PREPARATIONS FOR THE BATH, NON-MEDICATED BODY MOISTURIZING BALM, BODY BUTTER, FACE MUD, BODY MUD, SKIN PEELS, BODY MASKS, SKIN MOISTURE MASKS, FACIAL MASKS, GEL EYE MASKS, EMOLLIENT CREAMS AND GELS FOR DARK CIRCLES, DULLNESS AND DISCOLORATION OF THE SKIN; NON-MEDICATED PORE REFINING CREAMS AND LOTIONS, NON-MEDICATED ANTI-AGING SKINCARE SERUMS, HYDRATING FACIAL AND BODY CREAMS, LOTIONS AND MISTS; BODY RUBS, SKIN POLISHING PREPARATIONS IN THE NATURE OF SKIN CREAM, SKIN EXFOLIATORS, SUN BLOCK PREPARATIONS, SUN TANNING LOTIONS AND NON-MEDICATED SUN RELIEF GELS; PERSONAL CARE PRODUCTS CONTAINING SEA DERIVED INGREDIENTS IN THE NATURE OF HAIR PRODUCTS, NAMELY, HAIR SHAMPOO, HAIR CONDITIONER, HAIR GELS, NON-MEDICATED SCALP TREATMENT CREAM; PERSONAL CARE PRODUCTS CONTAINING SEA DERIVED INGREDIENTS IN THE NATURE OF NON-MEDICATED LIP CARE PREPARATIONS, NAMELY, LIP BALMS, NON-MEDICATED AMPLIFYING LIP TREATMENT PREPARATIONS, LIP MENDERS, LIP GLOSSES, PERSONAL CARE PRODUCTS CONTAINING SEA DERIVED INGREDIENTS IN THE NATURE OF HAND, NAIL AND EYE CREAMS AND EYE CARE PREPARATIONS, NAMELY, EYE GELS; CONCEALER; MAKE-UP REMOVER; EYE MAKE-UP REMOVER; AFTER-SHAVE LOTION; SHAVING CREAM; SHAVING GELS; EAU DU PARFUM (U.S. CLS. 1, 4, 6, 50, 51 AND 52).

CLASS 5—PHARMACEUTICALS

FOR MEDICATED SUNSCREEN CONTAINING SEA DERIVED INGREDIENTS, NAMELY, LOTIONS CONTAINING SUNSCREEN; ACNE TREATMENT PREPARATIONS CONTAINING SEA DERIVED INGREDIENTS, NAMELY, CLEANSING PADS, LOTIONS, CREAMS, AND CLEANSERS (U.S. CLS. 6, 18, 44, 46, 51 AND 52).
WON TEAK OH, EXAMINING ATTORNEY

SN 85-365,928. JAMISON WEST CONSULTING SERVICES, INC., DBA ARTERIAN, SEATTLE, WA. FILED 7-7-2011.

ARTERIAN

THE MARK CONSISTS OF STANDARD CHARACTERS WITHOUT CLAIM TO ANY PARTICULAR FONT, STYLE, SIZE, OR COLOR.

CLASS 37—CONSTRUCTION AND REPAIR

FOR INSTALLATION AND MAINTENANCE OF COMPUTERS, SERVERS, COMPUTER PERIPHERALS, COMPUTER NETWORKS, AND TELECOMMUNICATIONS SYSTEMS ON COMPUTER NETWORKS; COMPUTER NETWORK TECHNICAL SUPPORT SERVICES, NAMELY, TROUBLESHOOTING IN THE NATURE OF REPAIR OF COMPUTER HARDWARE; TECHNICAL SUPPORT SERVICES, NAMELY, TECHNICAL ADVICE RELATED TO THE REPAIR OF COMPUTER HARDWARE (U.S. CLS. 100, 103 AND 106).

FIRST USE 7-1-2011; IN COMMERCE 7-1-2011.

CLASS 42—SCIENTIFIC AND COMPUTER SERVICES

FOR COMPUTER NETWORK AND SOFTWARE CONSULTING SERVICES; PLANNING, DESIGNING, AND CONFIGURING COMPUTER NETWORKS; INSTALLATION, MAINTENANCE, AND REPAIR OF COMPUTER SOFTWARE; COMPUTER NETWORK AND SOFTWARE TECHNICAL SUPPORT SERVICES, NAMELY, TROUBLESHOOTING IN THE NATURE OF DIAGNOSING COMPUTER HARDWARE AND SOFTWARE PROBLEMS; COMPUTER NETWORK AND SOFTWARE TECHNICAL SUPPORT SERVICES, NAMELY, TROUBLESHOOTING OF COMPUTER SOFTWARE PROBLEMS; HELP DESK SERVICES, NAMELY, TROUBLESHOOTING IN THE NATURE OF DIAGNOSING COMPUTER HARDWARE AND SOFTWARE PROBLEMS; HELP DESK SERVICES, NAMELY, TROUBLESHOOTING OF COMPUTER SOFTWARE PROBLEMS; COMPUTER SECURITY CONSULTANCY, NAMELY, ANALYSIS AND DESIGN OF TECHNICAL SECURITY AND FIREWALL SYSTEMS FOR COMPUTER NETWORKS; SOFTWARE APPLICATION DEVELOPMENT SERVICES; DATABASE DESIGN AND INTEGRATION; COMPUTER CONSULTATION IN THE FIELD OF NETWORK SECURITY; COMPUTER CONSULTATION IN THE AREAS OF COMPUTER NETWORK INFRASTRUCTURE SYSTEMS ANALYSIS AND INTEGRATION; COMPUTER NETWORK AND SOFTWARE CONSULTING IN THE FIELD OF TELECOMMUNICATIONS (U.S. CLS. 100 AND 101).

FIRST USE 7-1-2011; IN COMMERCE 7-1-2011.

CLASS 45—PERSONAL AND LEGAL SERVICES

FOR REMOTE MONITORING OF COMPUTER NETWORKS FOR SECURITY PURPOSES TO PREVENT UNAUTHORIZED INFORMATION DISCLOSURE (U.S. CLS. 100 AND 101).

FIRST USE 7-1-2011; IN COMMERCE 7-1-2011.

ELLEN B. AWRICH, EXAMINING ATTORNEY

SN 85-367,989. CYRIL BATH COMPANY, MONROE, NC. FILED 7-11-2011.

HSF

THE MARK CONSISTS OF STANDARD CHARACTERS WITHOUT CLAIM TO ANY PARTICULAR FONT, STYLE, SIZE, OR COLOR.

CLASS 6—METAL GOODS

FOR CUSTOM METAL PARTS MADE OF ALUMINUM, STEEL, IRON, NICKEL, TITANIUM AND OTHER METALS AND THEIR ALLOYS FOR USE IN STRUCTURAL FRAMES (U.S. CLS. 2, 12, 13, 14, 23, 25 AND 50).

CLASS 40—MATERIAL TREATMENT

FOR METAL FABRICATION SERVICES; CUSTOM METAL STRETCHING AND FORMING SERVICES; AND METAL TREATMENT SERVICES (U.S. CLS. 100, 103 AND 106).

JORDAN BAKER, EXAMINING ATTORNEY

SN 85-377,780. VOLCANO CORPORATION, RANCHO CORDOVA, CA. FILED 7-21-2011.

CENTRIQ

THE MARK CONSISTS OF STANDARD CHARACTERS WITHOUT CLAIM TO ANY PARTICULAR FONT, STYLE, SIZE, OR COLOR.

CLASS 9—ELECTRICAL AND SCIENTIFIC APPARATUS

FOR SOFTWARE FOR MULTI-MODAL MEDICAL SYSTEM, NAMELY, SOFTWARE FOR RECEIVING, PROCESSING, TRANSMITTING, AND DISPLAYING PHYSIOLOGICAL DATA, IMAGES, OR BOTH, USED IN MEDICAL PATIENT DIAGNOSIS AND TREATMENT (U.S. CLS. 21, 23, 26, 36 AND 38).

CLASS 10—MEDICAL APPARATUS

FOR MULTI-MODAL MEDICAL SYSTEM CONNECTED TO A PATIENT FOR RECEIVING, PROCESSING, TRANSMITTING, AND DISPLAYING PHYSIOLOGICAL DATA, IMAGES, OR BOTH, USED IN THE IMMEDIATE DIAGNOSIS AND TREATMENT OF MEDICAL PATIENTS, COMPRISED PRIMARILY OF COMPUTER SOFTWARE, COMPUTER HARDWARE, AND A CONTROLLER FOR USE WITH CATHETERS AND WIRES (U.S. CLS. 26, 39 AND 44).

TARAH HARDY, EXAMINING ATTORNEY

SN 85-379,370. PARTNERS HEALTHCARE SYSTEM, INC., BOSTON, MA. FILED 7-24-2011.

Center for Connected Health

THE MARK CONSISTS OF STANDARD CHARACTERS WITHOUT CLAIM TO ANY PARTICULAR FONT, STYLE, SIZE, OR COLOR.

NO CLAIM IS MADE TO THE EXCLUSIVE RIGHT TO USE "CONNECTED HEALTH", APART FROM THE MARK AS SHOWN.

SEC. 2(F).

CLASS 35—ADVERTISING AND BUSINESS

FOR PROMOTING THE EXCHANGE OF INFORMATION AND RESOURCES WITHIN THE SCIENTIFIC RESEARCH AND MEDICAL COMMUNITIES TO ACHIEVE ADVANCES IN THE FIELD OF HEALTHCARE (U.S. CLS. 100, 101 AND 102).

FIRST USE 12-31-1995; IN COMMERCE 12-31-1995.

CLASS 42—SCIENTIFIC AND COMPUTER SERVICES

FOR SCIENTIFIC STUDY AND RESEARCH IN THE FIELDS OF HEALTH CARE DELIVERY, HEALTH AND WELLNESS, AND THE PREVENTION, TREATMENT AND MANAGEMENT OF ILLNESS (U.S. CLS. 100 AND 101).

FIRST USE 12-31-1995; IN COMMERCE 12-31-1995.

JORDAN BAKER, EXAMINING ATTORNEY

SN 85-379,685. WIN-VECTOR LLC, SAN FRANCISCO, CA. FILED 7-25-2011.

Pragmatic Machine Learning

THE MARK CONSISTS OF STANDARD CHARACTERS WITHOUT CLAIM TO ANY PARTICULAR FONT, STYLE, SIZE, OR COLOR.

NO CLAIM IS MADE TO THE EXCLUSIVE RIGHT TO USE "MACHINE LEARNING", APART FROM THE MARK AS SHOWN.

CLASS 35—ADVERTISING AND BUSINESS

FOR BUSINESS MANAGEMENT SERVICES, NAMELY, MANAGING LOGISTICS, REVERSE LOGISTICS, SUPPLY CHAIN SERVICES, SUPPLY CHAIN VISIBILITY AND SYNCHRONIZATION, SUPPLY AND DEMAND FORECASTING AND PRODUCT DISTRIBUTION PROCESSES FOR OTHERS; BUSINESS MONITORING AND CONSULTING SERVICES, NAMELY, TRACKING WEB SITES AND APPLICATIONS OF OTHERS TO PROVIDE STRATEGY, INSIGHT, MARKETING, SALES, OPERATION, PRODUCT DESIGN, PARTICULARLY SPECIALIZING IN THE USE OF ANALYTIC AND STATISTIC MODELS FOR THE UNDERSTANDING AND PREDICTING OF CONSUMERS, BUSINESSES, AND MARKET TRENDS AND ACTIONS; CONSUMER STRATEGY BUSINESS CONSULTING IN THE FIELDS OF MARKETING, SALES, OPERATION, AND PRODUCT DESIGN PARTICULARLY SPECIALIZING IN THE USE OF ANALYTIC MODELS FOR THE UNDERSTANDING AND PREDICTING OF CONSUMER, BUSINESS, AND RETAIL MARKET TRENDS AND ACTIONS; ECONOMIC FORECASTING AND ANALYSIS; PROVIDING STATISTICAL INFORMATION (U.S. CLS. 100, 101 AND 102).

CLASS 42—SCIENTIFIC AND COMPUTER SERVICES

FOR MEDICAL AND SCIENTIFIC RESEARCH, NAMELY, CONDUCTING CLINICAL TRIALS; SCIENTIFIC AND TECHNOLOGICAL SERVICES, NAMELY, RESEARCH AND DESIGN IN THE FIELD OF INTEGRATED SYSTEM ARCHITECTURE THAT ALLOWS FOR THE RAPID DEVELOPMENT OF HIGHLY INTERACTIVE AND CUSTOMIZABLE LEARNING APPLICATIONS; SCIENTIFIC RESEARCH; SCIENTIFIC RESEARCH AND DEVELOPMENT (U.S. CLS. 100 AND 101).

JEFF DEFORD, EXAMINING ATTORNEY

SN 85-383,238. QUANTUM, INC., EUGENE, OR. FILED 7-28-2011.

QUANTUM

THE MARK CONSISTS OF STANDARD CHARACTERS WITHOUT CLAIM TO ANY PARTICULAR FONT, STYLE, SIZE, OR COLOR.
OWNER OF U.S. REG. NOS. 1,929,540, 3,115,882 AND OTHERS.

CLASS 5—PHARMACEUTICALS

FOR ADHESIVE BANDAGES; ATHLETES' FOOT PREPARATIONS; COLD SORE TREATMENT PREPARATIONS; COUGH SYRUPS; COUGH TREATMENT PREPARATIONS; DIETARY SUPPLEMENTS; HERBAL SUPPLEMENTS; HERBAL TOPICAL CREAMS, GELS, SALVES, SPRAYS, POWDER, BALMS, LINIMENT AND OINTMENTS FOR THE RELIEF OF ACHES AND PAIN; INSECT REPELLENT IN CANDLE FORM; INSECT REPELLENTS; INSECT REPELLENTS IN PRE-MOISTENED TOWELETTE FORM; LYSINE PREPARATIONS; MEDICATED CREAMS FOR TREATING DERMATOLOGICAL CONDITIONS; MEDICATED LIP BALM; MEDICATED MOUTH CARE AND TREATMENT PREPARATIONS; MEDICATED OINTMENTS FOR TREATING DERMATOLOGICAL CONDITIONS; MEDICATED SKIN CARE PREPARATIONS; MEDICATED THROAT SPRAYS; MIGRAINE TREATMENT PREPARATIONS; MINERAL SUPPLEMENTS; NON-MEDICATED, THERAPEUTIC SKIN CREAMS FOR THE TREATMENT OF SCAR TISSUE AND CRACKED SKIN; NUTRACEUTICALS FOR USE AS A DIETARY SUPPLEMENT; NUTRITIONAL SUPPLEMENTS; PAIN RELIEF MEDICATION; PREPARATIONS FOR TREATING COLDS; SYRUPS FOR PHARMACEUTICAL PURPOSES FOR THE TREATMENT OF FLU; THROAT LOZENGES; TOPICAL DERMATOLOGICAL PREPARATIONS THAT TREAT INSECT BITES AND STINGS; VITAMIN SUPPLEMENTS; ZINC SUPPLEMENT LOZENGES (U.S. CLS. 6, 18, 44, 46, 51 AND 52).

FIRST USE 7-31-1986; IN COMMERCE 7-31-1986.

CLASS 10—MEDICAL APPARATUS

FOR LICE COMBS (U.S. CLS. 26, 39 AND 44).
FIRST USE 2-11-2000; IN COMMERCE 2-11-2000.

CLASS 35—ADVERTISING AND BUSINESS

FOR RETAIL STORE AND ON-LINE RETAIL STORE SERVICES FEATURING DIETARY SUPPLEMENTS, MINERAL SUPPLEMENTS, VITAMIN SUPPLEMENTS, HERBAL SUPPLEMENTS, NUTRACEUTICALS FOR USE AS A DIETARY SUPPLEMENT, NUTRITIONAL SUPPLEMENTS, ADHESIVE BANDAGES, PAIN RELIEF MEDICATION, HERBAL TOPICAL CREAMS, GELS, SALVES, SYRUP, POWDER, BALMS, LINIMENT AND OINTMENTS FOR THE RELIEF OF ACHES AND PAINS, MEDICATED LIP BALM, ZINC SUPPLEMENT LOZENGES, THROAT LOZENGES, MEDICATED THROAT SPRAY, MIGRAINE TREATMENT PREPARATIONS, MEDICATED SKIN CARE PREPARATIONS, COLD SORE TREATMENT PREPARATIONS, COUGH TREATMENT PREPARATIONS, COUGH SYRUPS, PREPARATIONS FOR TREATING COLDS, SYRUPS FOR PHARMACEUTICAL PURPOSE FOR THE TREATMENT OF FLU, LYSINE PREPARATIONS, MEDICATED MOUTH CARE AND TREATMENT PREPARATIONS, INSECT REPELLENTS, INSECT REPELLENTS IN CANDLE FORM, INSECT REPELLENT IN PRE-MOISTENED TOWELETTE FORM, TOPICAL DERMATOLOGICAL PREPARATIONS THAT TREAT INSECT BITES AND STINGS, ATHLETE'S FOOT PREPARATIONS, MEDICATED OINTMENTS FOR TREATING DERMATOLOGICAL CONDITIONS, MEDICATED CREAMS FOR TREATING DERMATOLOGICAL CONDITIONS, NON-MEDICATED THERAPEUTIC SKIN CREAMS FOR THE TREATMENT OF SCAR TISSUE AND CRACKED SKIN, AND LICE COMBS (U.S. CLS. 100, 101 AND 102).

FIRST USE 10-31-2000; IN COMMERCE 10-31-2000.
ANTHONY RINKER, EXAMINING ATTORNEY

SN 85-383,465. CNG TRANS LTD., COLUMBUS, OH. FILED 7-28-2011.



THE COLOR(S) GREEN, BLUE AND WHITE IS/ARE CLAIMED AS A FEATURE OF THE MARK.

THE MARK CONSISTS OF A GREEN AND BLUE LEAF WITH A STYLIZED WHITE ROADWAY, HAVING A BLUE DIVIDING LINE, FORMING THE STEM.

CLASS 4—LUBRICANTS AND FUELS

FOR COMPRESSED NATURAL GAS AND FUELS, NAMELY, COMPRESSED NATURAL GAS (U.S. CLS. 1, 6 AND 15).

CLASS 6—METAL GOODS

FOR NATURAL GAS CONVERSION KITS, COMPRISED OF A HIGH PRESSURE METAL STORAGE CYLINDER FOR COMPRESSED GAS SOLD EMPTY, HIGH PRESSURE AND LOW PRESSURE STEEL BRAIDED LINES, A REGULATOR, VALVES, A FUEL RAIL, FUEL INJECTORS, FUEL ADAPTORS, AND AN ELECTRONIC CONTROL UNIT AND ASSOCIATED WIRING THAT CONVERTS LIGHT DUTY TRUCKS AND AUTOMOBILES INTO COMPRESSED NATURAL GAS VEHICLES (U.S. CLS. 2, 12, 13, 14, 23, 25 AND 50).

CLASS 7—MACHINERY

FOR NATURAL GAS DISPENSING UNITS COMPRISED OF COMPRESSORS, HOSES, ELECTRIC MOTORS AND VALVES FOR REFUELING VEHICLES EQUIPPED FOR BURNING NATURAL GAS AS A TRANSPORTATION FUEL, AND COMPONENT PARTS THEREOF; VEHICLE REFUELING APPLIANCES THAT TAKES NATURAL GAS, COMPRESSES IT, AND PUMPS IT INTO A COMPRESSED NATURAL GAS VEHICLE, NAMELY, A UNIT COMPRISED OF COMPRESSORS, PUMPS, HOSES AND NOZZLES AND ALL COMPONENT PARTS THEREOF; NATURAL GAS FUELING SYSTEMS COMPRISED OF COMPRESSORS, PUMPS, HOSES AND NOZZLES AND ALL COMPONENT PARTS THEREOF (U.S. CLS. 13, 19, 21, 23, 31, 34 AND 35).

CLASS 35—ADVERTISING AND BUSINESS

FOR RETAIL AND WHOLESALE STORE SERVICES FEATURING ALTERNATIVE FUEL PRODUCTS, NAMELY, COMPRESSED NATURAL GAS, COMPRESSED NATURAL GAS FUELING SYSTEMS, AND VEHICLE REFUELING APPLIANCES, AND ALL PARTS THEREOF; COMPRESSED NATURAL GAS BASE MANAGEMENT SERVICES BEING BUSINESS MANAGEMENT SERVICES IN THE FIELD OF COMPRESSED NATURAL GAS STATIONS; PROMOTING PUBLIC AWARENESS OF THE BENEFITS OF COMPRESSED NATURAL GAS AS A FUEL FOR VEHICLES; PROMOTING THE PUBLIC AWARENESS OF THE NEED TO USE COMPRESSED NATURAL GAS AS A TRANSPORTATION FUEL (U.S. CLS. 100, 101 AND 102).

CLASS 37—CONSTRUCTION AND REPAIR

FOR INSTALLATION, MAINTENANCE AND REPAIR OF COMPRESSED NATURAL GAS FUELING SYSTEMS AND VEHICLE REFUELING APPLIANCES; COMPRESSED NATURAL GAS STATION MAINTENANCE SERVICES (U.S. CLS. 100, 103 AND 106).

RUDY R. SINGLETON, EXAMINING ATTORNEY

CLASS 9—ELECTRICAL AND SCIENTIFIC APPARATUS

FOR DOWNLOADABLE SOFTWARE IN THE NATURE OF MOBILE APPLICATIONS FOR THE COLLECTION, EDITING, MODIFYING, TRANSMISSION, STORAGE AND SHARING OF DATA RELATING TO THE EDUCATIONAL PROGRESS OF CHILDREN WITH SPEECH OR LANGUAGE DISABILITIES; DOWNLOADABLE SOFTWARE IN THE NATURE OF MOBILE APPLICATIONS FOR USE IN CREATING, MODIFYING AND UPDATING INDIVIDUALIZED EDUCATION PLANS FOR CHILDREN (U.S. CLS. 21, 23, 26, 36 AND 38).

CLASS 39—TRANSPORTATION AND STORAGE

FOR PROVIDING A WEB SITE FOR THE ELECTRONIC STORAGE OF USER-UPLOADED ELECTRONIC INFORMATION VIA A COMPUTER NETWORK, THE INFORMATION RELATING TO THE EDUCATIONAL PROGRESS OF CHILDREN WITH SPEECH OR LANGUAGE DISABILITIES; ELECTRONIC STORAGE OF USER-UPLOADED ELECTRONIC INFORMATION, THE INFORMATION RELATING TO THE EDUCATIONAL PROGRESS OF CHILDREN WITH SPEECH OR LANGUAGE DISABILITIES (U.S. CLS. 100 AND 105).

CLASS 42—SCIENTIFIC AND COMPUTER SERVICES

FOR PROVIDING INTERNET-BASED SERVICES IN THE NATURE OF SOFTWARE AS A SERVICE (SAAS) FEATURING WEBSITE-ACCESSIBLE INFORMATION TO BE USED BY TEACHERS, SPEECH AND LANGUAGE PATHOLOGISTS AND SCHOOL ADMINISTRATORS FOR CREATING, MODIFYING AND UPDATING INDIVIDUALIZED EDUCATION PLANS FOR CHILDREN, FOR TRACKING THE PROGRESS OF STUDENTS AND FOR GENERATING REPORTS REGARDING THE SAME (U.S. CLS. 100 AND 101).

LINDA MICKLEBURGH, EXAMINING ATTORNEY

SN 85-386,190. PERCEPTUM SOLUTIONS LLC, BEACHWOOD, OH. FILED 8-1-2011.

SN 85-386,626. SIFTEO, INC., SAN FRANCISCO, CA. FILED 8-2-2011.



Moon Marble

NO CLAIM IS MADE TO THE EXCLUSIVE RIGHT TO USE "IEP", APART FROM THE MARK AS SHOWN.

THE COLOR(S) GREEN AND ORANGE IS/ARE CLAIMED AS A FEATURE OF THE MARK.

THE MARK CONSISTS OF THE LETTERS "IEP" TO THE LEFT OF AND SLIGHTLY ABOVE THE WORD "PAL", WITH THREE ARCS OF INCREASING SIZE ABOVE THE LETTER "A" IN "PAL". THE THREE ARCS AND THE LETTERS "IEP" ARE IN GREEN, AND THE WORD "PAL" IS IN ORANGE. THE LETTERS ARE SHADED FROM DARK TO LIGHT, BOTTOM TO TOP.

THE MARK CONSISTS OF STANDARD CHARACTERS WITHOUT CLAIM TO ANY PARTICULAR FONT, STYLE, SIZE, OR COLOR.

CLASS 9—ELECTRICAL AND SCIENTIFIC APPARATUS

FOR MULTIPLE DISTRIBUTED TANGIBLE COMPUTER HARDWARE DEVICES THAT INTERFACE AND RESPOND TO A USER'S PHYSICAL MANIPULATION AND ACT IN CONCERT TO FORM A SINGLE INTERFACE (U.S. CLS. 21, 23, 26, 36 AND 38).

FIRST USE 9-0-2011; IN COMMERCE 9-0-2011.

CLASS 28—TOYS AND SPORTING GOODS

FOR ELECTRONIC TOY COMPRISING MULTIPLE DISTRIBUTED TANGIBLE COMPUTER INTERFACES THAT ARE RESPONSIVE TO A USER'S PHYSICAL MANIPULATION AND ACT IN CONCERT TO FORM A SINGLE INTERFACE; ELECTRONIC ACTION TOY, NAMELY, A TOY OF EXPLORATION IN WHICH MOVEMENT OF THE BLOCK(S) ENABLES A USER TO MANEUVER AN OBJECT THROUGHOUT A MAZE (U.S. CLS. 22, 23, 38 AND 50).

FIRST USE 9-0-2011; IN COMMERCE 9-0-2011.
EDWARD NELSON, EXAMINING ATTORNEY

SN 85-386,631. SIFTEO, INC., SAN FRANCISCO, CA. FILED 8-2-2011.

Mount Brainiac

THE MARK CONSISTS OF STANDARD CHARACTERS WITHOUT CLAIM TO ANY PARTICULAR FONT, STYLE, SIZE, OR COLOR.

CLASS 9—ELECTRICAL AND SCIENTIFIC APPARATUS

FOR MULTIPLE DISTRIBUTED TANGIBLE COMPUTER HARDWARE DEVICES THAT INTERFACE AND RESPOND TO A USER'S PHYSICAL MANIPULATION AND ACT IN CONCERT TO FORM A SINGLE INTERFACE (U.S. CLS. 21, 23, 26, 36 AND 38).

FIRST USE 9-0-2011; IN COMMERCE 9-0-2011.

CLASS 28—TOYS AND SPORTING GOODS

FOR ELECTRONIC TOY COMPRISING MULTIPLE DISTRIBUTED TANGIBLE COMPUTER INTERFACES THAT ARE RESPONSIVE TO A USER'S PHYSICAL MANIPULATION AND ACT IN CONCERT TO FORM A SINGLE INTERFACE; ELECTRONIC LEARNING TOY, NAMELY, MULTIPLE DISTRIBUTED TANGIBLE COMPUTER INTERFACES IN THE FORM OF ELECTRONIC BLOCKS THAT PRESENT LETTERS AND/OR NUMBERS FOR ASSOCIATED GAMES (U.S. CLS. 22, 23, 38 AND 50).

FIRST USE 9-0-2011; IN COMMERCE 9-0-2011.
EDWARD NELSON, EXAMINING ATTORNEY

SN 85-387,106. GLOBAL MEDICAL EDUCATION, INC., NEW YORK, NY. FILED 8-2-2011.



GLOBAL MEDICAL EDUCATION

NO CLAIM IS MADE TO THE EXCLUSIVE RIGHT TO USE "GLOBAL MEDICAL EDUCATION", APART FROM THE MARK AS SHOWN.

THE MARK CONSISTS OF THE WORDING "GME GLOBAL MEDICAL EDUCATION" AND A CIRCLE WITH A STYLIZED CADUCEUS.

CLASS 9—ELECTRICAL AND SCIENTIFIC APPARATUS

FOR DOWNLOADABLE VIDEO RECORDINGS IN THE FIELD OF MEDICINE; PRE-RECORDED DVDS, MP3S AND CDS IN THE FIELD OF MEDICINE (U.S. CLS. 21, 23, 26, 36 AND 38).

CLASS 41—EDUCATION AND ENTERTAINMENT

FOR PROVIDING EDUCATIONAL COURSES IN THE FIELD OF MEDICINE OFFERED BY ONLINE NON-DOWNLOADABLE VIDEOS AND INSTRUCTOR ASSISTANCE, AND DISTRIBUTION OF EDUCATIONAL MATERIALS IN CONNECTION THEREWITH (U.S. CLS. 100, 101 AND 107).

CLASS 44—MEDICAL, BEAUTY AND AGRICULTURAL SERVICES

FOR PROVIDING A WEBSITE FEATURING NON-DOWNLOADABLE VIDEOS IN THE FIELD OF MEDICINE; PROVIDING A WEBSITE FEATURING INFORMATIONAL, NON-DOWNLOADABLE AUDIO, AND VIDEO PRESENTATIONS IN THE FIELD OF MEDICINE; PROVIDING A WEBSITE FEATURING INFORMATION IN THE FIELD OF MEDICINE (U.S. CLS. 100 AND 101).

ANNE MADDEN, EXAMINING ATTORNEY

SN 85-387,609. "DEPESCHE" VERTRIEB GMBH & CO. KG, GEESTHACHT, FED REP GERMANY, FILED 8-2-2011.

STYLEModel

THE MARK CONSISTS OF THE COMBINED TERMS "STYLEMODEL" IN STYLIZED FORM WHERE THE LETTERS FOR THE TERM "STYLE" ARE COMPRISED OF DOTS.

CLASS 3—COSMETICS AND CLEANING PREPARATIONS

FOR SOAPS, ESPECIALLY COSMETIC PREPARATIONS FOR BATH, SHOWER GEL; PERFUMERY, ESPECIALLY DEODORANTS FOR PERSONAL USE, EAU DE PERFUME, EAU DE PERFUME SPRAY, EAU DE TOILETTE AND EAU DE TOILETTE SPRAY; COSMETICS, ESPECIALLY BODY POWDER, BATH AND SHOWER LOTION, LIPSTICK, NON-MEDICATED LIP BALM AND LIP GLOSS, MASCARA, FACE POWDER, NAIL POLISH, SHAMPOOS; HAIR LOTIONS; ESSENTIAL OILS; DENTIFRICES (U.S. CLS. 1, 4, 6, 50, 51 AND 52).

CLASS 6—METAL GOODS

FOR GOODS OF METAL, INCLUDED IN THIS CLASS, IN PARTICULAR MONEY BOXES, SIGN-BOARDS, DOOR KICK PLATES, NAME PLATES, BOXES AND CASES, CLOTHES HOOKS; METAL KEY RINGS; METAL DOOR PLATES AND NAME PLATES (U.S. CLS. 2, 12, 13, 14, 23, 25 AND 50).

CLASS 14—JEWELRY

FOR JEWELRY, IN PARTICULAR EARRINGS, SEMI-PRECIOUS STONES, NECKLACES, BRACELETS, RINGS, BROOCHES, PRECIOUS STONES; HOROLOGICAL AND CHRONOMETRIC INSTRUMENTS, IN PARTICULAR WRISTWATCHES, ALARM CLOCKS, CLOCKS AND WATCHES, ELECTRIC WALL CLOCKS, WATCHES; PRECIOUS METALS AND THEIR ALLOYS AND GOODS OF PRECIOUS METALS OR COATED THEREWITH, INCLUDED IN THIS CLASS, IN PARTICULAR KEY RINGS, NAMELY, TRINKETS OR FOBS, WORKS OF ART, FIGURINES, CANS; CHARMS FOR MOBILE TELEPHONES (U.S. CLS. 2, 27, 28 AND 50).

CLASS 16—PAPER GOODS AND PRINTED MATTER

FOR PAPER, CARDBOARD; PRINTED MATTER, NAMELY, ART REPRODUCTIONS, GREETING CARDS, INVITATIONS, LECTURES, MUSIC BOOKS, AND TICKETS; PHOTOGRAPHS; STATIONERY; ADHESIVES FOR STATIONERY OR HOUSEHOLD PURPOSES; ARTISTS' MATERIALS, NAMELY, BRUSHES, PASTELS, PENCILS, PENS AND CANVAS PANELS; BRUSHES FOR PAINTING AND WRITING; STATIONERY AND OFFICE REQUISITES EXCEPT FURNITURE, NAMELY, RUBBER BANDS, STAPLERS, ADHESIVE TAPE DISPENSERS, PENCIL SHARPENERS, PENCIL CASES; INSTRUCTIONAL AND TEACHING MATERIAL EXCEPT APPARATUS IN THE FIELD OF CHILDREN'S INTERACTIVE EDUCATIONAL AND ACTIVITY BOOKS; PLASTIC MATERIALS FOR PACKAGING, INCLUDED IN THIS CLASS, NAMELY, PLASTIC BAGS FOR PACKAGING AND PLASTIC BUBBLE PACKS FOR WRAPPING OR PACKAGING; BOOKS, NAMELY, SONG BOOKS, COMIC BOOKS, CHILDREN'S BOOKS, PAINTING BOOKS, PICTURE BOOKS; MAGAZINES IN THE FIELD OF CHILDREN'S EDUCATION, ACTIVITIES, TOYS, GAMES AND FASHION; NEWSPAPERS; CALENDARS, TEAR-OFF CALENDARS, PERSONAL ORGANIZERS, DIARIES; ADDRESS BOOKS; BROCHURES; GREETING CARDS, MUSICAL GREETING CARDS, ANNOUNCEMENT CARDS, POSTCARDS, INVITATION CARDS; GRAPHIC REPRESENTATIONS, PLACARDS OF PAPER OR CARDBOARD, POSTERS, FRAMED OR UNFRAMED PAINTINGS; BOOK AND BOOKLET BINDINGS; BOOK AND NOTEBOOK COVERS; BOOKMARKERS; STICKERS AND TRANSFERS, STICKERS FOR CARS; TEMPORARY MOBILE PHONE TATTOOS AND MOBILE PHONE STICKERS; LABELS AND TABS MADE OF PAPER OR CARDBOARD; SCRATCH-IMAGES MADE OF PAPER AND VINYL SCRATCH PADS AND CARDS; ALBUMS FOR STICKERS AND FOR PHOTOS; NOTE PADS AND DESK PADS, BLANK WRITING CARDS, PAPER AND ENVELOPES, PAPER SHEETS FOR NOTE-TAKING; SCHOOL SUPPLIES, NAMELY, THREE-RING BINDERS, CRAYONS, LAB BOOKS, EXERCISE-BOOKS, NOTE BOOKS, DRAWING PADS; INDEX CARDS; LETTER AND PAPER-EXPANDING FILES MADE OF PAPER, CARDBOARD OR PLASTIC, INCLUDING RING BINDERS AND DOCUMENT FILES; WRITING CASES, NAMELY, STATIONERY CASES, PEN CASES, AND PENCIL CASES; FOLDERS; LOOSE LEAF BINDERS MADE OF PAPER, CARDBOARD OR PLASTIC; DESK PADS MADE OF PAPER; STAMPS, HOLDERS FOR STAMPS, INKING PADS, CASES FOR STAMPS; PENS, IN PARTICULAR PENCILS, INK STICKS, COLORED CRAYONS, BALLPOINT PENS, PASTELS; FOUNTAIN PENS; FOUNTAIN PEN INK CARTRIDGES; REFILLS FOR BALLPOINT PENS; PENCIL LEADS; INK ERASERS; ERASING PRODUCTS, NAMELY, RUBBER ERASERS AND ERASING PENS; SQUARE, DRAWING, AND UNGRADUATED RULERS; OFFICE PERFORATORS; PAINT BOXES AS ARTICLES FOR USE IN SCHOOL; PENCIL SHARPENERS; PEN BOXES FOR WRITING INSTRUMENTS, PEN CASES; PAPERWEIGHTS; LETTER TRAYS; HANDKERCHIEFS OF PAPER, TABLE NAPKINS OF PAPER; BABIES' DIAPERS MADE OF PAPER AND CELLULOSE; SWEET BAGS, NAMELY, PLASTIC OR PAPER BAGS FOR PACKAGING SWEETS; PLACE MATS OF PAPER, TABLE MATS OF PAPER; FLAGS OF PAPER; FIGURINES OF PAPIER MÂCHÉ; BOOKENDS; PHOTOGRAPH HOLDERS IN THE NATURE OF ALBUMS, FOLDERS AND CLIPS; DESK MOUNTED CABINETS FOR STATIONERY; BAGS OF PAPER OR PLASTICS FOR PACKAGING; PLASTIC FILM FOR WRAPPING NOT FOR INDUSTRIAL OR COMMERCIAL

PURPOSES; WRAPPING PAPER, GIFT WRAP PAPER; ENVELOPES; CONICAL PAPER BAGS; PAPER CARRIER BAGS FOR FOOD AND BEVERAGES; CASES AND BOXES OF PAPER OR CARDBOARD FOR PENS, PENCILS, FILES, AND NOTE PADS; PLASTIC ARTICLES, NAMELY, ENVELOPES, SMALL SACKS, BAGS, POUCHES AND FILMS FOR PACKAGING; DESK PADS MADE OF PAPER, CARDBOARD, OR CARTON; DESK PADS MADE OF LEATHER OR IMITATION LEATHER; BLACKBOARDS FOR FIXING DECORATIVE MAGNETS (U.S. CLS. 2, 5, 22, 23, 29, 37, 38 AND 50).

CLASS 18—LEATHER GOODS

FOR LEATHER AND IMITATIONS OF LEATHER AND GOODS MADE OF THESE MATERIALS, IN PARTICULAR BANDS OF LEATHER, LEATHER STRAPS, LEASHES; UMBRELLAS, PARASOLS AND WALKING STICKS; TRAVELLING TRUNKS AND SUITCASES; BAGS, NAMELY BEACH BAGS, BAGS FOR CAMPERS, SHOPPING BAGS OF TEXTILES AND LEATHER, HANDBAGS, SLING BAGS FOR CARRYING INFANTS, TRAVELLING BAGS, SCHOOL BAGS, PLAY SCHOOL BAGS, BAGS FOR SPORTS, WHEELED SHOPPING BAGS, SHOULDER BAGS, RUCKSACKS, GYM BAGS, NECK POUCHES, TRAVELLING SETS MADE OF LEATHER CONSISTING OF LUGGAGE; VANITY CASES SOLD EMPTY, MAKE-UP CASES SOLD EMPTY; PURSES, POCKET WALLETS (U.S. CLS. 1, 2, 3, 22 AND 41).

CLASS 20—FURNITURE AND ARTICLES NOT OTHERWISE CLASSIFIED

FOR MIRRORS, IN PARTICULAR HAND-HELD TOILET MIRRORS; NON-METAL DOOR PLATES AND NAME PLATES; TREASURE CHESTS IN THE NATURE OF TOY CHESTS; DISPLAY CASES FOR TOYS (U.S. CLS. 2, 13, 22, 25, 32 AND 50).

CLASS 21—HOUSEWARES AND GLASS

FOR HOUSEHOLD KITCHEN UTENSILS NOT OF PRECIOUS METAL OR COATED THEREWITH, NAMELY, SALT CELLARS AND PEPPER POTS, BISCUIT CUTTERS, BAKING DISHES; GLASSWARE, PORCELAIN WARE AND EARTHEN WARE, NAMELY, MUGS, DRINKING CUPS, TABLE PLATES, CUPS, SAUCERS, BOWLS, CANS, AND JUGS; TABLE WARE MADE OF PLASTIC, PAPER OR CARDBOARD, NAMELY, MUGS, DRINKING CUPS, TABLE PLATES, CUPS, SAUCERS, BOWLS, CANS, JUGS, AND DRINKING GLASSES; BEER MUGS; EGG CUPS, NOT OF METAL; CONTAINERS, NOT MADE OF PRECIOUS METAL OR BONDED, FOR HOUSEHOLD AND KITCHEN, IN PARTICULAR FLOWERPOTS, SOAP DISHES, BOXES FOR STORING FOOD AND RECIPES, TEA BOXES, SUGAR BOXES, BOXES FOR SOAPS, POWDER COMPACTS, BREAD BOXES, BUTTER BOXES, BOXES FOR COOKIES, LUNCH BOXES, DUSTBINS; SOAP DISPENSERS, GLASS, NAMELY, JUGS AND MUGS; BOXES OF GLASS; THERMO MUGS AND BOTTLES, NAMELY, THERMAL INSULATED CONTAINERS FOR BEVERAGES OR FOOD; NON-ELECTRIC BOTTLE COVERS; NAPKIN RINGS, NOT MADE OF PRECIOUS METAL; BUSTS OF CHINA, TERRA-COTTA OR GLASS; FIGURINES OF PORCELAIN, TERRA-COTTA OR GLASS; TOOTHBRUSHES, ELECTRIC TOOTHBRUSHES, TOOTHBRUSH HOLDERS; TOILET CASES, NAMELY, TOOTHBRUSH AND FITTED VANITY CASES; SMALL BOTTLES SOLD EMPTY, NOT MADE OF PRECIOUS METALS; FLASKS, NOT OF PRECIOUS METAL; CANDLE AND TEA CANDLE HOLDERS, NOT MADE OF PRECIOUS METAL; COMBS, BATH CLEANING AND SCOURING SPONGES; BRUSHES EXCEPT PAINT BRUSHES FOR BATHS, CLOTHES, COSMETICS, CRUMBS, DUSTING, HAIR, NAILS, PETS AND SHOES; CLEANING UTENSILS, NAMELY, CLEANING CLOTHS, CLEANING SPONGES, CLEANING MITTS, CLEANING PADS; DUSTBINS MADE OF PAPER FOR HOUSEHOLD PURPOSES; SAVING BOXES, NOT MADE OF METAL, IN THE NATURE OF NON-METAL PIGGY BANKS; CANDLES AND TEA CANDLES HOLDERS, TABLETS FOR THE HOUSEHOLD IN THE NATURE OF SERVICE TRAYS, PLATES, CUPS; GENERAL STORAGE, BREAD, AND TRASH BINS FOR HOUSEHOLD AND KITCHEN,

TINS, NAMELY, TEA TINS, SUGAR TINS, POWDER TINS, ALL SOLD EMPTY AND MADE OF PRECIOUS METAL AND OTHER ALLOYS (U.S. CLS. 2, 13, 23, 29, 30, 33, 40 AND 50).

CLASS 24—FABRICS

FOR TOWELS OF TEXTILE; BATH LINEN, NOT BEING CLOTHING; TABLE MATS NOT MADE OF PAPER, EXCEPT LINENS (U.S. CLS. 42 AND 50).

CLASS 25—CLOTHING

FOR CLOTHING FOR WOMEN, MEN AND CHILDREN NAMELY, SHIRTS, PANTS, TEE-SHIRTS, TANK TOPS, PULLOVERS, JERSEYS, JUMPERS, JACKETS, AND TROUSERS; BABY LAYETTES; SLEEPWEAR, PJAMAS; WOMEN'S, MEN'S AND CHILDREN'S UNDERWEAR, SOCKS, STOCKINGS, TIGHTS; BATHING WEAR, BATHING SUITS, BIKINIS, BATHING TRUNKS, BATH ROBES, BATHING CAPS; OUTERCLOTHING, NAMELY, JACKETS AND COATS, NECK-TIES, BELTS, SASHES FOR WEAR; SCARVES, CHILDREN'S CLOTH EATING BIBS, NOT OF PAPER, GLOVES, HEADBANDS, EAR MUFFS, COATS, WATERPROOF CLOTHING, NAMELY, SHOES, BOOTS, JACKETS, COATS AND PONCHOS; JACKETS, FROCKS, TROUSERS, SWEATERS, PULLOVERS, COMBINATIONS, TEE-SHIRTS, SPORTSWEAR, INCLUDED IN THIS CLASS, NAMELY, SOCKS, SHOES, SHORTS, PANTS, TIGHTS, SHIRTS, JACKETS, BRAS, SWEATSHIRTS, AND SWEAT BANDS; CLOTHING FOR GYMNASTICS, NAMELY, TIGHTS, LEOTARDS, AND BODYSUITS; CYCLING SHORTS; HALLOWEEN AND DANCE COSTUMES; FOOTWEAR, NAMELY, SHOES, BOOTS FOR SPORTS, BATH SANDALS, BATH SLIPPERS; HEADGEAR, NAMELY, BEANIES, BONNETS, BERETS, HEADBANDS, BASEBALL CAPS, CAPS, BANDANAS (U.S. CLS. 22 AND 39).

CLASS 28—TOYS AND SPORTING GOODS

FOR GAMES AND PLAYTHINGS, NAMELY, BOARD GAMES, FURNITURE FOR DOLL'S HOUSES, PINBALL GAMES, PLAY FIGURES, PLAY HOUSES, PLAYSETS FOR DOLLS, TOY BOATS, TOY CARS, TOY FIGURES; GYMNASTIC AND SPORTING ARTICLES, INCLUDED IN THIS CLASS, IN PARTICULAR INLINE-SKATES, ROLLER SKATES, SKATEBOARDS, TOY SCOOTERS, ICE SKATES, MASKS FOR CARNIVAL, TEDDY BEARS, DOLLS, DOLLS' CLOTHES, PLUSH TOYS AND PLUSH FIGURINES, SOFT SCULPTURE PLUSH TOYS, FANTASY FIGURINES FOR PLAYING PURPOSES IN MOLDED PLASTIC AND PLUSH, PLAYING FIGURINES, PLAYING TOY ANIMALS, HAND PUPPETS, CLOTHING AND ACCESSORIES FOR PLUSH PLAYING FIGURINES, NAMELY, CLOTHING FOR FIGURINES, DOLL HOUSES AND DOLL BEDS, VENTRILOQUIST DUMMIES, PLAYING CARDS, PUZZLES, PARLOUR GAMES, BALLOONS; ELECTRONIC GAMES, IN PARTICULAR VIDEO GAMES OTHER THAN THOSE ADAPTED FOR USE WITH TELEVISION RECEIVERS; PADDLES AS A HAND-HELD UNIT, NAMELY, TABLE TENNIS PADDLES; WATER AND BATHING TOYS, FLIPPERS FOR SWIMMING; DECORATIONS FOR CHRISTMAS TREES (U.S. CLS. 22, 23, 38 AND 50).

ALAIN LAPTER, EXAMINING ATTORNEY

SN 85-387,693. VETERANS OF FOREIGN WARS OF THE UNITED STATES, KANSAS CITY, MO. FILED 8-2-2011.

UNWAVERING SUPPORT FOR
UNCOMMON HEROES

THE MARK CONSISTS OF STANDARD CHARACTERS WITHOUT CLAIM TO ANY PARTICULAR FONT, STYLE, SIZE, OR COLOR.

CLASS 16—PAPER GOODS AND PRINTED MATTER

FOR PAPER GOODS, NAMELY, STATIONERY AND PRINTED CERTIFICATES; PRINTED MATTER, NAMELY, VETERANS ASSOCIATION MAGAZINES AND PRINTED INFORMATIONAL MATERIALS, NAMELY, FLYERS IN THE FIELD OF PROGRAMS AND AWARDS (U.S. CLS. 2, 5, 22, 23, 29, 37, 38 AND 50).

CLASS 25—CLOTHING

FOR CLOTHING, NAMELY, SHIRTS, JACKETS, CAPS AND VISORS (U.S. CLS. 22 AND 39).

SHANNON TWOHIG, EXAMINING ATTORNEY

SN 85-388,147. CHOLE, ALICIA, ROGERSVILLE, MO. FILED 8-3-2011.

The 7th Year

THE MARK CONSISTS OF STANDARD CHARACTERS WITHOUT CLAIM TO ANY PARTICULAR FONT, STYLE, SIZE, OR COLOR.

CLASS 41—EDUCATION AND ENTERTAINMENT

FOR EDUCATIONAL SERVICES, NAMELY, DEVELOPING CURRICULUM FOR OTHERS IN THE FIELD OF SPIRITUAL FORMATION AND DEVELOPMENT (U.S. CLS. 100, 101 AND 107).

CLASS 45—PERSONAL AND LEGAL SERVICES

FOR PROVIDING INFORMATION IN THE FIELD OF PERSONAL DEVELOPMENT, NAMELY, PERSONAL IMPROVEMENT; PROVIDING ON-LINE INFORMATION IN THE FIELD OF SPIRITUALITY, SELF-HELP, AND PERSONAL EMPOWERMENT SUBJECT MATTERS; RELIGIOUS AND SPIRITUAL SERVICES, NAMELY, PROVIDING GATHERINGS AND RETREATS TO DEVELOP AND ENHANCE THE SPIRITUAL LIVES OF INDIVIDUALS (U.S. CLS. 100 AND 101).

FIRST USE 2-28-2010; IN COMMERCE 2-28-2011.

MARK SPARACINO, EXAMINING ATTORNEY

SN 85-388,290. AMERISTAR CASINOS, INC., LAS VEGAS, NV. FILED 8-3-2011.

AMERISTAR

THE MARK CONSISTS OF STANDARD CHARACTERS WITHOUT CLAIM TO ANY PARTICULAR FONT, STYLE, SIZE, OR COLOR.

OWNER OF U.S. REG. NOS. 1,971,539, 2,132,916 AND 2,697,230.

CLASS 35—ADVERTISING AND BUSINESS

FOR RETAIL STORE SERVICES AND RETAIL BOUTIQUE SERVICES FEATURING SPA PRODUCTS, HEALTH SPA PRODUCTS, BEAUTY SPA PRODUCTS, HEALTH CARE COSMETICS, BEAUTY CARE COSMETICS, FACIAL CARE COSMETICS, HAIR CARE COSMETICS, AND BODY CARE COSMETICS (U.S. CLS. 100, 101 AND 102).

FIRST USE 11-25-1996; IN COMMERCE 11-25-1996.

CLASS 44—MEDICAL, BEAUTY AND AGRICULTURAL SERVICES

FOR SPA, DAY SPA, HEALTH SPA AND BEAUTY SPA SERVICES, NAMELY, FACIAL AND BODY TREATMENT SERVICES, COSMETIC BODY CARE SERVICES, MASSAGE SERVICES, NAMELY, PROVIDING MASSAGES, BODY MASSAGES, BACK MASSAGES, ARM MASSAGES, LEG MASSAGES, CHAIR MASSAGES, SHOULDER MASSAGES, NECK MASSAGES, HAND MASSAGES, FOOT MASSAGES AND FACE MASSAGES, BEAUTY CARE SERVICES, BEAUTY CARE FOR THE FACE AND BODY, FACIAL TREATMENT SERVICES, NAMELY, FACIALS, COSMETIC PEELS, IMMERSIONS, MANICURES, PEDICURES, HAIR REMOVAL, HAIR STYLING, HAIR COLORING, HAIR CONDITIONING, MAKEUP APPLICATIONS, AROMATHERAPY, BODY AND FACIAL SCRUBS, BODY AND FACIAL SOAKS, AND HYDROTHERAPY; PROVIDING HEALTH SPA FACILITIES FOR HEALTH AND WELLNESS, NAMELY, PROVIDING HEALTH AND DAY SPA FACILITIES, HYDRO-POOL FACILITIES, WATER MASSAGE FACILITIES, HOT TUB FACILITIES, WHIRLPOOL FACILITIES, SAUNA FACILITIES, STEAM ROOM FACILITIES, BATH FACILITIES, SHOWER FACILITIES, SWIM POOL FACILITIES, HEALTH AND EXERCISE ROOM FACILITIES, AND CONDITIONING ROOM FACILITIES; AND PROVIDING INFORMATION IN THE FIELDS OF SPA AND DAY SPA SERVICES, HEALTH SPA SERVICES, BEAUTY SPA SERVICES, FACIAL AND BODY TREATMENT SERVICES, COSMETIC BODY CARE SERVICES, MASSAGE SERVICES, MASSAGES, BODY MASSAGES, BACK MASSAGES, ARM MASSAGES, LEG MASSAGES, CHAIR MASSAGES, SHOULDER MASSAGES, NECK MASSAGES, HAND MASSAGES, FOOT MASSAGES, FACE MASSAGES, BEAUTY CARE, BEAUTY CARE FOR THE FACE AND BODY, FACIALS, PEELS, IMMERSIONS, MANICURES, PEDICURES, HAIR REMOVAL, HAIR STYLING, HAIR COLORING, HAIR CONDITIONING, MAKEUP APPLICATIONS, AROMATHERAPY, BODY AND FACIAL SCRUBS, BODY AND FACIAL SOAKS, HYDROTHERAPY, HEALTH AND DAY SPA FACILITIES, HYDRO-POOL FACILITIES, WATER MASSAGE FACILITIES, HOT TUB FACILITIES, WHIRLPOOL FACILITIES, SAUNA FACILITIES, STEAM ROOM FACILITIES, BATH FACILITIES, SHOWER FACILITIES, SWIM POOL FACILITIES, HEALTH AND EXERCISE ROOM FACILITIES, AND CONDITIONING ROOM FACILITIES (U.S. CLS. 100 AND 101).

FIRST USE 11-25-1996; IN COMMERCE 11-25-1996.
RAMONA ORTIGA, EXAMINING ATTORNEY

THE COLOR(S) GREY AND ORANGE IS/ARE CLAIMED AS A FEATURE OF THE MARK.

THE MARK CONSISTS OF THE WORDS "EDUCATIONSTARS" IN GREY ABOVE THE WORDS "INTERNATIONAL RATING AGENCY" IN GREY AND FIVE FIVE-POINTED ORANGE STARS.

CLASS 35—ADVERTISING AND BUSINESS

FOR E-COMMERCE SERVICES, NAMELY, PROVIDING INFORMATION ON THE SUBJECT OF COMMERCIAL EVALUATION AND RATING OF EDUCATIONAL PROGRAMS FOR OTHERS VIA GLOBAL TELECOMMUNICATION NETWORK FOR RESERVATION PURPOSES RELATING TO EDUCATIONAL INSTITUTIONS AND INSTITUTIONS PROVIDING CONTINUING EDUCATION; PROVIDING INFORMATION ON THE RATING AND COMMERCIAL EVALUATION OF EDUCATIONAL PROGRAMS REGARDING EDUCATIONAL INSTITUTIONS AND INSTITUTIONS PROVIDING CONTINUING EDUCATION (U.S. CLS. 100, 101 AND 102).

CLASS 38—COMMUNICATION

FOR ONLINE INFORMATION SERVICES, NAMELY, PROVIDING ACCESS TO COMPUTER NETWORKS, INTERNET PLATFORMS, AND DATA BASES (U.S. CLS. 100, 101 AND 104).

CLASS 41—EDUCATION AND ENTERTAINMENT

FOR INFORMATION SERVICES ON THE SUBJECT OF EDUCATIONAL PROGRAMS REGARDING EDUCATIONAL INSTITUTIONS AND INSTITUTIONS PROVIDING CONTINUING EDUCATION; BOOKING OF SPACES IN CLASSES FOR EDUCATION AND CONTINUING EDUCATION; PROVIDING APPRAISALS AND REVIEWS OF EDUCATIONAL INSTITUTIONS AND INSTITUTIONS PROVIDING CONTINUING EDUCATION VIA GLOBAL TELECOMMUNICATIONS NETWORK FOR EDUCATIONAL PURPOSES (U.S. CLS. 100, 101 AND 107).

AMY HELLA, EXAMINING ATTORNEY

SN 85-388,775. ES EDUCATIONSTARS AG, MEILEN, SWITZERLAND, FILED 8-3-2011.

EducationStars
international rating agency ★★★★★

INSPIRING SUCCESS BY EVERY
MEASURE

PRIORITY CLAIMED UNDER SEC. 44(D) ON SWITZERLAND APPLICATION NO. 57254/2011, FILED 6-20-2011, REG. NO. 621355, DATED 10-13-2011, EXPIRES 6-20-2021.

NO CLAIM IS MADE TO THE EXCLUSIVE RIGHT TO USE "INTERNATIONAL RATING AGENCY", APART FROM THE MARK AS SHOWN.

THE MARK CONSISTS OF STANDARD CHARACTERS WITHOUT CLAIM TO ANY PARTICULAR FONT, STYLE, SIZE, OR COLOR.

SN 85-390,345. FEDERATION EMPLOYMENT AND GUIDANCE SERVICES, INC. (F.E.G.S.), NEW YORK, NY, FILED 8-5-2011.

CLASS 35—ADVERTISING AND BUSINESS

FOR PROVIDING REFERRAL SERVICES IN THE FIELDS OF EMPLOYMENT, CAREER DEVELOPMENT, TRAINING, BEHAVIORAL HEALTH, REHABILITATION, DEVELOPMENTAL DISABILITIES, EDUCATION, FAMILY AND YOUTH SERVICES, ECONOMIC DEVELOPMENT, HOUSING AND RESIDENTIAL SERVICES AND HOMECARE; EMPLOYMENT COUNSELING; CAREER COUNSELING, NAMELY, CAREER PLACEMENT; PUBLIC ADVOCACY TO PROMOTE AWARENESS TO INDIVIDUALS AND GROUPS IN THE FIELDS OF EMPLOYMENT, CAREER DEVELOPMENT, TRAINING, BEHAVIORAL HEALTH, REHABILITATION, DEVELOPMENTAL DISABILITIES, EDUCATION, FAMILY AND YOUTH SERVICES, WOMEN'S HEALTH SERVICES, ECONOMIC DEVELOPMENT, HOUSING, RESIDENTIAL AND HOMECARE NEEDS; BUSINESS SUPPORT SERVICES, NAMELY, BUSINESS CONSULTATION TO INDIVIDUALS AND GROUPS IN THE FIELDS OF EMPLOYMENT, CAREER DEVELOPMENT, TRAINING, BEHAVIORAL HEALTH, REHABILITATION, DEVELOPMENTAL DISABILITIES, EDUCATION, FAMILY AND YOUTH SERVICES, WOMEN'S HEALTH SERVICES, ECONOMIC DEVELOPMENT, HOUSING, RESIDENTIAL AND HOMECARE NEEDS (U.S. CLS. 100, 101 AND 102).

CLASS 41—EDUCATION AND ENTERTAINMENT

FOR EDUCATIONAL SERVICES, NAMELY, CONDUCTING CLASSES, SEMINARS, CONFERENCES, WORKSHOPS AND TUTORING FOCUSING ON LITERACY, AFTER-SCHOOL RECREATION AND MENTORING; DISTRIBUTING COURSE MATERIALS IN CONNECTION THEREWITH; CAREER COUNSELING, NAMELY, PROVIDING ADVICE CONCERNING EDUCATIONAL OPTIONS; EDUCATIONAL COUNSELING TO INDIVIDUALS AND GROUPS TO ASSIST STUDENTS WITH PLANNING AND PREPARING FOR THEIR EDUCATION; TRAINING SERVICES IN THE FIELD OF COMPUTERS, BUSINESS APPLICATIONS, AND HOME HEALTHCARE TO INDIVIDUALS AND GROUPS (U.S. CLS. 100, 101 AND 107).

CLASS 44—MEDICAL, BEAUTY AND AGRICULTURAL SERVICES

FOR PROVIDING COUNSELING SERVICES TO INDIVIDUALS AND GROUPS IN THE FIELDS OF BEHAVIORAL HEALTH, AND MENTAL AND PHYSICAL REHABILITATION, DEVELOPMENTAL DISABILITIES, WOMEN'S HEALTH SERVICES; MENTAL HEALTH COUNSELING, AND HOME HEALTH CARE NEEDS (U.S. CLS. 100 AND 101).

NAKIA HENRY, EXAMINING ATTORNEY

SN 85-391.206. ADJACENT APPLICATIONS, INC., SAN FRANCISCO, CA. FILED 8-5-2011.

ADJACENT APPLICATIONS

THE MARK CONSISTS OF STANDARD CHARACTERS WITHOUT CLAIM TO ANY PARTICULAR FONT, STYLE, SIZE, OR COLOR.

NO CLAIM IS MADE TO THE EXCLUSIVE RIGHT TO USE "APPLICATIONS", APART FROM THE MARK AS SHOWN.

CLASS 9—ELECTRICAL AND SCIENTIFIC APPARATUS

FOR DOWNLOADABLE SOFTWARE IN THE NATURE OF A MOBILE APPLICATION FOR SOCIAL NETWORKING; DOWNLOADABLE SOFTWARE IN THE NATURE OF A MOBILE APPLICATION FOR REAL-TIME DELIVERY OF DATA, MESSAGES, LOCATION, PHOTOGRAPHS, LINKS, TEXT AND OTHER DATA RELATED THERETO; DOWNLOADABLE SOFTWARE TO FACILITATE ONLINE ADVERTISING, BUSINESS PROMOTION, CONNECTING SOCIAL NETWORK USERS WITH BUSINESSES AND FOR TRACKING USERS AND ADVERTISING OF OTHERS TO PROVIDE STRATEGY, INSIGHT, MARKETING, AND PREDICTING CONSUMER BEHAVIOR; COMPUTER E-COMMERCE SOFTWARE TO ALLOW USERS TO PERFORM ELECTRONIC BUSINESS TRANSACTIONS VIA A GLOBAL COMPUTER NETWORK; DOWNLOADABLE SOFTWARE IN THE NATURE OF A MOBILE APPLICATION FOR DISPLAYING A USER'S LOCATION AND INTERACTING WITH OTHER USERS BY LEAVING GEO-SPECIFIC MESSAGES AT ANY GEO-COORDINATE ON A MAP FOR OTHER USERS TO SEE; COMPUTER SOFTWARE FOR PROCESSING ELECTRONIC PAYMENTS AND TRANSFERRING FUNDS TO AND FROM OTHERS (U.S. CLS. 21, 23, 26, 36 AND 38).

CLASS 35—ADVERTISING AND BUSINESS

FOR OPERATING ON-LINE MARKETPLACES FOR SELLERS OF GOODS AND/OR SERVICES; PROVIDING A WEBSITE FOR CONNECTING SELLERS WITH BUYERS; PROMOTING THE GOODS AND SERVICES OF OTHERS BY PROVIDING A COMMUNITY-DRIVEN WEB SITE FEATURING USER-SUBMITTED CONTENT IN THE NATURE OF PRODUCT OR SERVICE INFORMATION, LOCATION, PRICE AND COUPONS; PROVIDING INFORMATION PERTAINING TO PROCUREMENT, BUYING, SELLING AND TENDERING INFORMATION AND OPPORTUNITIES RELATING TO GOODS AND SERVICES VIA COMPUTER, COMPUTER NETWORKS, TELEPHONE, THE INTERNET OR ELECTRONIC MAIL; ADVERTISING AND ADVERTISEMENT SERVICES; CUSTOMER LOYALTY SERVICES AND CUSTOMER CLUB SERVICES FOR COMMERCIAL, PROMOTIONAL AND ADVERTISING PURPOSES; PROVIDING AN ON-LINE SEARCHABLE DATABASE FEATURING CLASSIFIED AD LISTINGS; ADVERTISING AND MARKETING SERVICES, NAMELY, PROMOTING THE GOODS AND SERVICES OF OTHERS; PROVIDING A SEARCHABLE ONLINE ADVERTISING GUIDE FEATURING THE GOODS AND SERVICES OF ONLINE VENDORS; CUSTOMER LOYALTY SERVICES FOR COMMERCIAL, PROMOTIONAL AND/OR ADVERTISING PURPOSES; PROMOTIONAL SERVICES, NAMELY, PROMOTING THE GOODS OF OTHERS BY MEANS OF PROVIDING ONLINE COUPONS (U.S. CLS. 100, 101 AND 102).

DAVID HOFFMAN, EXAMINING ATTORNEY

SN 85-395,159. TSA STORES, INC., ENGLEWOOD, CO.
FILED 8-11-2011.



OWNER OF U.S. REG. NOS. 1,527,526, 3,979,257 AND OTHERS.

NO CLAIM IS MADE TO THE EXCLUSIVE RIGHT TO USE "SPORTS" AND "FIELD", APART FROM THE MARK AS SHOWN.

THE MARK CONSISTS OF A CREST CONTAINING MOUNTAINS OVER THE WORDS "SPORTS AUTHORITY FIELD AT MILE HIGH" IN STYLIZED FORM, WITH THE WORD "FIELD" ENCLOSED WITHIN A BANNER.

CLASS 35—ADVERTISING AND BUSINESS

FOR PROMOTING BUSINESS, SPORTS, AND ENTERTAINMENT EVENTS OF OTHERS; ARRANGING AND CONDUCTING CONFERENCES AND EXHIBITIONS FOR BUSINESS PURPOSES; PROVIDING FACILITIES FOR BUSINESS MEETINGS AND EVENTS; PROVIDING FACILITIES FOR TRADE SHOWS; AND PROVIDING CONCESSION STANDS FEATURING FOOD AND SOUVENIRS (U.S. CLS. 100, 101 AND 102).

CLASS 43—HOTEL AND RESTAURANT SERVICES

FOR ARENA SERVICES, NAMELY, PROVIDING FACILITIES FOR SPORTS, CONCERTS, CONVENTIONS AND EXHIBITIONS (U.S. CLS. 100 AND 101).

NANCY CLARKE, EXAMINING ATTORNEY

SN 85-395,430. TSA STORES, INC., ENGLEWOOD, CO.
FILED 8-11-2011.

SPORTS AUTHORITY FIELD AT
MILE HIGH

THE MARK CONSISTS OF STANDARD CHARACTERS WITHOUT CLAIM TO ANY PARTICULAR FONT, STYLE, SIZE, OR COLOR.

OWNER OF U.S. REG. NOS. 1,527,526, 3,979,257 AND OTHERS.

NO CLAIM IS MADE TO THE EXCLUSIVE RIGHT TO USE "SPORTS" AND "FIELD", APART FROM THE MARK AS SHOWN.

CLASS 35—ADVERTISING AND BUSINESS

FOR PROMOTING BUSINESS, SPORTS, AND ENTERTAINMENT EVENTS OF OTHERS; ARRANGING AND CONDUCTING CONFERENCES AND EXHIBITIONS FOR BUSINESS PURPOSES; PROVIDING FACILITIES FOR BUSINESS MEETINGS AND EVENTS; PROVIDING FACILITIES FOR TRADE SHOWS; AND PROVIDING CONCESSION STANDS FEATURING FOOD AND SOUVENIRS (U.S. CLS. 100, 101 AND 102).

CLASS 43—HOTEL AND RESTAURANT SERVICES

FOR ARENA SERVICES, NAMELY, PROVIDING FACILITIES FOR SPORTS, CONCERTS, CONVENTIONS AND EXHIBITIONS (U.S. CLS. 100 AND 101).

NANCY CLARKE, EXAMINING ATTORNEY

SN 85-395,975. THIE, MATTHEW, LOS ANGELES, CA.
FILED 8-11-2011.

TOUCH FOR HEALTH

THE MARK CONSISTS OF STANDARD CHARACTERS WITHOUT CLAIM TO ANY PARTICULAR FONT, STYLE, SIZE, OR COLOR.

CLASS 9—ELECTRICAL AND SCIENTIFIC APPARATUS

FOR PRERECORDED AUDIO TAPES AND VIDEO TAPES FEATURING INFORMATION IN THE FIELD OF HOLISTIC HEALTH (U.S. CLS. 21, 23, 26, 36 AND 38).
FIRST USE 1-25-1973; IN COMMERCE 1-25-1973.

CLASS 16—PAPER GOODS AND PRINTED MATTER

FOR PRINTED BOOKS, CHARTS AND MANUALS IN THE FIELD OF HOLISTIC HEALTH (U.S. CLS. 2, 5, 22, 23, 29, 37, 38 AND 50).

FIRST USE 1-25-1973; IN COMMERCE 1-25-1973.

CLASS 41—EDUCATION AND ENTERTAINMENT

FOR EDUCATIONAL SERVICES, NAMELY, PROVIDING WORKSHOPS IN THE FIELD OF HOLISTIC HEALTH (U.S. CLS. 100, 101 AND 107).

FIRST USE 1-1-1973; IN COMMERCE 1-1-1973.

WENDY GOODMAN, EXAMINING ATTORNEY

SN 85-398,755. LSI CORPORATION, MILPITAS, CA. FILED 8-16-2011.

STORAGE. NETWORKING.
ACCELERATED.

THE MARK CONSISTS OF STANDARD CHARACTERS WITHOUT CLAIM TO ANY PARTICULAR FONT, STYLE, SIZE, OR COLOR.

NO CLAIM IS MADE TO THE EXCLUSIVE RIGHT TO USE "STORAGE" AND "NETWORKING", APART FROM THE MARK AS SHOWN.

SN 85-401,810. WILSON'S SIGNATURE, INC., DBA BELLO SIGNATURE, HUNTINGTON BEACH, CA. FILED 8-18-2011.



CLASS 9—ELECTRICAL AND SCIENTIFIC APPARATUS

FOR INTEGRATED CIRCUITS; SEMICONDUCTORS; COMPUTER HARDWARE FOR NETWORKING AND COMMUNICATIONS, NAMELY, DATA PROCESSORS IN THE NATURE OF NETWORK PROCESSORS, MEDIA PROCESSORS, COMMUNICATION PROCESSORS, CONTENT AND SECURITY PROCESSORS, SYNCHRONOUS OPTICAL NETWORKING (SONET) AND SYNCHRONOUS DIGITAL HIERARCHY (SDH) PROCESSORS AND TRANSPORT FRAMER PROCESSORS, LINK COMMUNICATION PROCESSORS, LINK LAYER PROCESSORS AND LINK MAPPER PROCESSORS IN THE NATURE OF NETWORK PROCESSORS, MODEMS, SERIAL BUS INTERFACES, AND ETHERNET TRANSCEIVERS; COMPUTER HARDWARE FOR INFORMATION STORAGE, NAMELY, DISK DRIVE CONTROLLERS, TAPE DRIVE CONTROLLERS, DIGITAL SIGNAL PROCESSORS, READ CHANNELS, PREAMPLIFIERS, MOTOR CONTROLLERS, REDUNDANT ARRAY OF INDEPENDENT DISKS (RAID) CONTROLLERS, SERIAL ADVANCED TECHNOLOGY ATTACHMENT (SATA) CABLES; COMPUTER NETWORK INTERFACE DEVICES AND CONTROLLERS; SMALL COMPUTER SYSTEM INTERFACE (SCSI) COMPUTER NETWORK INTERFACE DEVICES AND CONTROLLERS; SERIAL ATTACHED SCSI (SAS) COMPUTER NETWORK INTERFACE DEVICES AND CONTROLLERS, AND PERIPHERAL COMPONENT INTERCONNECT EXPRESS (PCI EXPRESS) COMPUTER NETWORK INTERFACES AND CONTROLLERS, SAS, SATA, SCSI AND FIBRE CHANNEL HOST BUS ADAPTERS, COMPUTER NETWORK BRIDGES IN THE NATURE OF SAS TO SATA PROTOCOL BRIDGES, COMPUTER NETWORK SWITCHES IN THE NATURE OF SAS SWITCHES, SOLID STATE DRIVES; COMPUTER SOFTWARE FOR INFORMATION STORAGE, NAMELY, RAID SOFTWARE AND COMPUTER PROGRAMS FOR PROCESSING AND STORAGE OF DATA UTILIZING SOLID STATE STORAGE; COMPUTER SOFTWARE DRIVERS, NAMELY, COMPUTER PROGRAMS FOR CONTROLLING NETWORK COMMUNICATION DEVICES, AND PROTOCOL STACK SOFTWARE; COMPUTER PROGRAMS FOR CONTROLLING COMPUTER PERIPHERALS; APPLICATION SPECIFIC INTEGRATED CIRCUITS (ASICS) (U.S. CLS. 21, 23, 26, 36 AND 38).

THE MARK CONSISTS OF THE GRAY WORDING "BELLO SIGNATURE." THE WORD "BELLO" IS SHOWN AS UPPER CASE WHILE ONLY THE LETTER "B" HAS A SPECIAL DESIGN WITH ALTERNATIVE GRAY SOLID BLOCKS. THE GRAY WORD "SIGNATURE" IS SHOWN WITH A CAPITAL LETTER "S" AND THE REMAINING LETTERS IN LOWER CASE AND LOCATED RIGHT BENEATH THE WORD "BELLO".

THE ENGLISH TRANSLATION OF "BELLO" IN THE MARK IS SMART.

CLASS 3—COSMETICS AND CLEANING PREPARATIONS

FOR AFTER-SHAVE CREAMS; AGE RETARDANT LOTION; ANTI-AGING CREAMS; ANTI-FRECKLE CREAMS; ANTI-WRINKLE CREAMS; BEAUTY LOTIONS; BEAUTY SERUMS; BODY DEODORANTS; CREAMS FOR CELLULITE REDUCTION; EYE CREAM; EYE GELS; FACE AND BODY CREAMS; FACIAL CLEANSING MILK; FACIAL EMULSIONS; FACIAL MASKS; FACIAL MOISTURIZER WITH SPF; FACIAL SCRUBS; FOAM CLEANSERS FOR PERSONAL USE; LOTIONS FOR FACE AND BODY CARE; NIGHT CREAM; NON-MEDICATED FACIAL AND EYE SERUM CONTAINING ANTIOXIDANTS; SHAVING GELS; SKIN CLEANSERS; SKIN CONDITIONERS; SKIN CREAMS; SKIN EMOLLIENTS; SKIN GELS FOR ACCELERATING, ENHANCING OR EXTENDING TANS; SKIN LIGHTENING CREAMS; SKIN LOTIONS; SKIN MASKS; SKIN MOISTURIZER; SKIN TEXTURIZERS; SKIN TONERS; SKIN WHITENING CREAMS; SUNSCREEN CREAMS; WATERPROOF SUNSCREEN (U.S. CLS. 1, 4, 6, 50, 51 AND 52).

CLASS 25—CLOTHING

FOR BELTS FOR CLOTHING; BELTS MADE FROM IMITATION LEATHER; BELTS MADE OF LEATHER; BELTS MADE OUT OF CLOTH; BELTS OF TEXTILE; FABRIC BELTS; HAT BANDS; HATS; LEATHER HATS; PAPER HATS FOR USE AS CLOTHING ITEMS; PARTY HATS; SPORTS CAPS AND HATS; TUXEDO BELTS; WAIST BELTS; WOOLLY HATS (U.S. CLS. 22 AND 39).
RAMONA ORTIGA, EXAMINING ATTORNEY

SN 85-402,905. WENDY, INC., NEW YORK, NY. FILED 8-19-2011.

CLASS 42—SCIENTIFIC AND COMPUTER SERVICES

FOR DESIGN FOR OTHERS OF INTEGRATED CIRCUITS, COMPUTER HARDWARE AND SOFTWARE FOR COMMUNICATIONS; DESIGN FOR OTHERS OF INTEGRATED CIRCUITS, COMPUTER HARDWARE AND SOFTWARE FOR INFORMATION STORAGE; TECHNICAL CONSULTATION IN THE FIELDS OF INTEGRATED CIRCUITS, REFERENCE DESIGNS FOR INTEGRATED CIRCUITS, INFORMATION AND DATA STORAGE SYSTEMS AND COMMUNICATIONS SYSTEMS FOR OTHERS (U.S. CLS. 100 AND 101).
AMY ALFIERI, EXAMINING ATTORNEY

ADORN BY WENDY WILLIAMS

THE MARK CONSISTS OF STANDARD CHARACTERS WITHOUT CLAIM TO ANY PARTICULAR FONT, STYLE, SIZE, OR COLOR.

THE NAME(S), PORTRAIT(S), AND/OR SIGNATURE(S) SHOWN IN THE MARK IDENTIFIES "WENDY WILLIAMS", WHOSE CONSENT(S) TO REGISTER IS MADE OF RECORD.

CLASS 14—JEWELRY

FOR JEWELRY (U.S. CLS. 2, 27, 28 AND 50).

CLASS 18—LEATHER GOODS

FOR HANDBAGS; TOTE BAGS; CLUTCHES; PURSES; WALLETS (U.S. CLS. 1, 2, 3, 22 AND 41).
KATHLEEN KOLACZ, EXAMINING ATTORNEY

CLASS 35—ADVERTISING AND BUSINESS

FOR RETAIL STORE SERVICES IN THE FIELD OF PERSONAL CARE PRODUCTS, BEAUTY PRODUCTS AND SKIN CARE PRODUCTS ALL MADE OF SEA DERIVED INGREDIENTS; ON-LINE RETAIL STORE SERVICES FEATURING PERSONAL CARE PRODUCTS, BEAUTY PRODUCTS AND SKIN CARE PRODUCTS ALL MADE OF SEA DERIVED INGREDIENTS (U.S. CLS. 100, 101 AND 102).
WON TEAK OH, EXAMINING ATTORNEY

SN 85-404,556. H2O PLUS, LLC, CHICAGO, IL. FILED 8-23-2011.

**THE SCIENCE OF MARINE
SKINCARE**

THE MARK CONSISTS OF STANDARD CHARACTERS WITHOUT CLAIM TO ANY PARTICULAR FONT, STYLE, SIZE, OR COLOR.

NO CLAIM IS MADE TO THE EXCLUSIVE RIGHT TO USE "MARINE SKINCARE", APART FROM THE MARK AS SHOWN.

CLASS 3—COSMETICS AND CLEANING PREPARATIONS

FOR FACIAL CLEANSERS; SKIN CLEANSERS; WIPES IMPREGNATED WITH A SKIN CLEANSER; SKIN SOAP, ANTIBACTERIAL SOAP, HAND SOAP, BAR SOAP, LIQUID SOAP, CLEANSING MOUSSE, SKIN CLEANSING GELS, CLEANSING BODY OIL, BODY WASH, BODY CLEANSERS, BATH AND SHOWER GELS, DEODORANTS AND ANTIPERSPIRANT.; COMBINATION BODY SCRUB AND CLEANSER, SKIN TONERS, FACIAL POLISH, BODY SCRUBS, FACIAL SCRUBS, FOOT SCRUBS, EXFOLIANTS FOR SKIN, BEAUTY SERUMS, NON-MEDICATED EYE SERUMS, NON-MEDICATED ANTI-AGING SERUMS, NON-MEDICATED ANTIOXIDANT SERUMS AND NON-MEDICATED PORE-REFINING SERUMS FOR SKIN, FACE MUD, BODY MUD; SKIN CARE PREPARATIONS, NAMELY, SKIN PEELS, SKIN CREAMS, SKIN LOTIONS, SKIN MOISTURIZERS, NON-MEDICATED SKIN GELS, SKIN MOISTURIZING GEL, SKIN LIGHTENING CREAMS, BODY CREAM, BODY OIL, BODY BUTTER, BODY BALMS, BODY LOTION, NON-MEDICATED SKIN CARE PREPARATIONS, NAMELY, FACE AND BODY MISTS; FACIAL MOISTURIZER WITH SPF; SKIN LOTION CONTAINING SUNSCREEN; AFTER SUN GELS, LOTIONS AND CREAMS; SUNSCREEN CREAM; AFTERSHAVE PREPARATIONS; SKIN MASKS; GEL EYE MASKS; BODY MASKS; NON-MEDICATED ACNE TREATMENT PREPARATIONS; NON-MEDICATED BATH SALTS, NON-MEDICATED BATH PREPARATIONS AND BUBBLE BATH PREPARATIONS; NON-MEDICATED BODY AND FOOT SOAKS; EYE CREAMS, GELS AND LOTIONS; EYE MAKEUP REMOVER; MAKE-UP REMOVER; HAIR CONDITIONERS; HAIR SHAMPOOS; HAIR GELS; NON-MEDICATED SCALP TREATMENT CREAM; LIP BALM; LIP POLISHER; NON-MEDICATED LIP CARE PREPARATIONS; HAND CREAM; NAIL CREAM; SHAVING CREAM; FRAGRANCES FOR PERSONAL USE, ALL THE FOREGOING CONTAINING SEA DERIVED INGREDIENTS (U.S. CLS. 1, 4, 6, 50, 51 AND 52).

CLASS 5—PHARMACEUTICALS

FOR MEDICATED SUNSCREEN CONTAINING SEA DERIVED INGREDIENTS, NAMELY, LOTIONS CONTAINING SUNSCREEN; ACNE TREATMENT PREPARATIONS CONTAINING SEA DERIVED INGREDIENTS, NAMELY, CLEANSING PADS, LOTIONS, CREAMS, AND CLEANSERS (U.S. CLS. 6, 18, 44, 46, 51 AND 52).

SN 85-404,779. THULE IP AB, MALMO, SWEDEN, FILED 8-23-2011.



OWNER OF U.S. REG. NOS. 1,207,137 AND 1,209,629.
THE MARK CONSISTS OF THE WORD "SPORTRACK" BENEATH A LINE IN THE SHAPE OF A MOUNTAIN.

CLASS 12—VEHICLES

FOR ROOF RACKS FOR TRUCKS, CARS AND SUVs; ROOF RACK STORAGE CONTAINERS FOR TRUCKS, CARS AND SUVs; STORAGE ORGANIZERS SPECIFICALLY DESIGNED TO BE MOUNTED TO AND USED WITH WINDSHIELD VISORS, DOORS, GLOVE COMPARTMENTS, TRUNKS, CONSOLES AND SEATS OF CARS, TRUCKS AND SUVs; CARGO CARRIERS FOR TRUCKS, CARS AND SUVs; LUGGAGE CARRIERS FOR TRUCKS, CARS AND SUVs; ROOF RACKS FOR VEHICLES FOR SKIS, BICYCLES, SNOWBOARDS, WINDSURFING BOARDS, KAYAKS AND BOATS; REAR MOUNTED CARGO, BICYCLE AND SKI CARRIERS FOR TRUCKS, CARS AND SUVs; ANTI-THEFT DEVICES FOR TRUCKS, CARS AND SUVs AND STRUCTURAL PARTS AND FITTINGS THEREFOR (U.S. CLS. 19, 21, 23, 31, 35 AND 44).

CLASS 16—PAPER GOODS AND PRINTED MATTER

FOR VEHICLE TRASH BAGS (U.S. CLS. 2, 5, 22, 23, 29, 37, 38 AND 50).

CLASS 22—CORDAGE AND FIBERS

FOR CARGO AND CARRIER EQUIPMENT FOR VEHICLES, NAMELY, ELASTIC ROPES, TIE DOWN STRAPS AND LASHING STRAPS FOR CARS, TRUCKS AND SUVs, FABRIC NETS FOR STRAPPING DOWN CARGO FOR USE IN CARS, TRUCKS AND SUVs (U.S. CLS. 1, 2, 7, 19, 22, 42 AND 50).
MICHAEL TANNER, EXAMINING ATTORNEY

SN 85-409,351. IRVING TISSUE CORPORATION, DIEPPE, NEW BRUNSWICK, CANADA, FILED 8-29-2011.

SN 85-410,525. MARS, INCORPORATED, MCLEAN, VA. FILED 8-30-2011.



PLANTING 3 FOR 1

THE MARK CONSISTS OF STANDARD CHARACTERS WITHOUT CLAIM TO ANY PARTICULAR FONT, STYLE, SIZE, OR COLOR.

PRIORITY CLAIMED UNDER SEC. 44(D) ON CANADA APPLICATION NO. 1539622, FILED 8-12-2011.

CLASS 16—PAPER GOODS AND PRINTED MATTER

FOR ABSORBENT CONSUMER PAPER PRODUCTS, NAMELY, FACIAL TISSUE, BATHROOM TISSUE, PAPER TOWELS AND PAPER NAPKINS (U.S. CLS. 2, 5, 22, 23, 29, 37, 38 AND 50).

CLASS 35—ADVERTISING AND BUSINESS

FOR PROMOTING THE SALE OF GOODS AND SERVICES OF OTHERS THROUGH PROMOTIONAL CONTESTS; PROVIDING INCENTIVE AWARD PROGRAMS FOR CUSTOMERS THROUGH THE ISSUANCE AND PROCESSING OF LOYALTY COUPONS FOR FREQUENT USE OF PARTICIPATING BUSINESSES (U.S. CLS. 100, 101 AND 102).

CLASS 36—INSURANCE AND FINANCIAL

FOR PROVIDING EDUCATIONAL SCHOLARSHIPS AND INFORMATION ABOUT EDUCATIONAL SCHOLARSHIPS; PROVIDING INFORMATION ABOUT EDUCATION SAVINGS PLANS (U.S. CLS. 100, 101 AND 102).

CLASS 40—MATERIAL TREATMENT

FOR PROVIDING INFORMATION ABOUT ENVIRONMENTAL INITIATIVES, NAMELY, RECYCLING IN THE FOREST, PAPER AND WOOD PRODUCTS INDUSTRY (U.S. CLS. 100, 103 AND 106).

CLASS 41—EDUCATION AND ENTERTAINMENT

FOR PROVIDING INFORMATION ABOUT INSTITUTIONS OFFERING ELEMENTARY, SECONDARY AND HIGHER EDUCATION; CONDUCTING CONTESTS TO WIN EDUCATIONAL FUNDS AND EDUCATIONAL RESOURCES; CONDUCTING CONTESTS PERTAINING TO A LINE OF ABSORBENT CONSUMER PAPER PRODUCTS (U.S. CLS. 100, 101 AND 107).

AMY ALFIERI, EXAMINING ATTORNEY

THE COLOR(S) BLUE AND BROWN IS/ARE CLAIMED AS A FEATURE OF THE MARK.

THE MARK CONSISTS OF A LIGHT BLUE SPOON DISPLAYED HORIZONTALLY, WITH A BROWN WAVE DESIGN SITTING ATOP THE SPOON, SET AGAINST A BLUE BACKGROUND.

CLASS 29—MEATS AND PROCESSED FOODS

FOR CHOCOLATE MILK, DAIRY-BASED BEVERAGES, DAIRY-BASED CHOCOLATE FOOD BEVERAGES, DAIRY-BASED FOOD BEVERAGES, DAIRY-BASED SNACK FOODS EXCLUDING ICE CREAM, ICE MILK AND FROZEN YOGURT, DRINKING YOGURTS, DRINKS BASED ON YOGURT, YOGURT, MILK BEVERAGES WITH HIGH MILK CONTENT, MILK-BASED BEVERAGE CONTAINING COFFEE, SOY MILK, SOY-BEAN MILK, CHOCOLATE CHEESES, CREAM CHEESE; MILK SHAKES, BASES FOR MAKING MILK SHAKES (U.S. CL. 46).

CLASS 30—STAPLE FOODS

FOR FROZEN OR CHILLED CHOCOLATE-BASED SNACKS, CHOCOLATE-BASED MOUSSE, CHOCOLATE-BASED DESSERT PUDDING, CHOCOLATE SAUCE, COOKIES, HOT AND COLD COCOA BEVERAGES, BROWNIES, CROISSANTS, CAKES, PIES, CHOCOLATE FONDUE, SNACK PACKS COMPRISED OF CHOCOLATE GELATIN, SORBET, SHAKES, PARFAITS, CAKE AND OTHER BAKED GOODS FILLINGS, NAMELY, CHOCOLATE GELATIN FILLING, CHOCOLATE GANACHE AND CHOCOLATE PUDDING FILLING, OATMEAL, CHOCOLATE SPREADS, CHOCOLATE DIPS, FROZEN DESSERTS CONSISTING OF CHOCOLATE GELATIN, "DO-IT-YOURSELF" DESSERTS CONSISTING OF CHOCOLATE, CRACKERS, COOKIES AND DIPPING SAUCES, CHOCOLATE DIP, COCOA DIP, CHOCOLATE SPREAD/DIP PACKED WITH FRUIT AND/OR NUTS AND/OR GRANOLA AND/OR PRETZEL, BEVERAGES MADE OF COFFEE, CHOCOLATE FOOD BEVERAGES NOT BEING DAIRY-BASED OR VEGETABLE BASED, COCOA BEVERAGES WITH MILK, COCOA MIXES, FLAVORINGS FOR BEVERAGES, FROZEN CONFECTIONS, NAMELY, FREEZER POPS, FROZEN CUSTARDS, FROZEN DESSERT CONSISTING OF FRUIT AND CREAM OR CREAM SUBSTITUTES, FROZEN YOGURT, FROZEN YOGURT MIXES, GELATO, ICE CREAM, ICE CREAM MIXES, ICE CREAM SANDWICHES, ICE CREAM SUBSTITUTE, ICE MILK, ICE MILK BARS, ICE-CREAM CAKES, CHOCOLATE POWDER, CHOCOLATE SYRUP, CHOCOLATE TOPPING, CHOCOLATE-BASED FILLINGS FOR CAKES AND PIES, CHOCOLATE BASED READY-TO-EAT FOOD CUPS, CHOCOLATE FILLED CUPS, COCOA SPREADS, COCOA-BASED INGREDIENT IN CONFECTIONERY PRODUCTS, CONFECTIONERY, NAMELY, PASTILLES, CUSTARD-BASED FILLINGS FOR CAKES AND PIES, DESSERT MOUSSE, DESSERT PUDDINGS, DESSERT SOUFFLES, DIPPING SAUCES, DONUTS, DULCE DE LECHE, FILLED CHOCOLATE, FLAVORED SWEETENED GELATIN DESSERTS, FLAVORINGS FOR CAKES AND OTHER THAN ESSENTIAL OILS, CONVENIENCE FOOD PACKAGE COMBINATIONS CONSISTING PRIMARILY OF BREAD, FRESH AND DRIED FRUIT, CRACKERS AND/OR COOKIES AND/OR YOGURT; MIXES FOR BAKERY GOODS, PREPARED

COCOA AND COCOA-BASED BEVERAGES, PUDDINGS, NAMELY, CHOCOLATE PUDDINGS, SAUCE MIXES, SAUCES (U.S. CL. 46).

CLASS 32—LIGHT BEVERAGES

FOR CONCENTRATES, SYRUPS OR POWDERS USED IN THE PREPARATION OF SOFT DRINKS; DRINKING WATER; ENERGY DRINKS; ESSENCES FOR USE IN MAKING SOFT DRINKS; FLAVORED WATERS, GLACIAL WATER, SMOOTHIES (U.S. CLS. 45, 46 AND 48).
BRIAN NEVILLE, EXAMINING ATTORNEY

SN 85-410,526, MARS, INCORPORATED, MCLEAN, VA. FILED 8-30-2011.



THE COLOR(S) BLUE AND BROWN IS/ARE CLAIMED AS A FEATURE OF THE MARK.

THE MARK CONSISTS OF A BLUE SPOON DISPLAYED VERTICALLY, WITH THE BOTTOM PORTION OF THE SPOON SURROUNDED BY A BLUE CIRCLE, SET AGAINST A BROWN BACKGROUND.

CLASS 29—MEATS AND PROCESSED FOODS

FOR CHOCOLATE MILK, DAIRY-BASED BEVERAGES, DAIRY-BASED CHOCOLATE FOOD BEVERAGES, DAIRY-BASED FOOD BEVERAGES, DAIRY BASED SNACK FOODS EXCLUDING ICE CREAM, ICE MILK AND FROZEN YOGURT, DRINKING YOGURTS, DRINKS BASED ON YOGURT, YOGURT, MILK BEVERAGES WITH HIGH MILK CONTENT, MILK-BASED BEVERAGE CONTAINING COFFEE, SOY MILK, SOY-BEAN MILK, CHOCOLATE CHEESES, CREAM CHEESE; MILK SHAKES, BASES FOR MAKING MILK SHAKES (U.S. CL. 46).

CLASS 30—STAPLE FOODS

FOR FROZEN OR CHILLED CHOCOLATE-BASED SNACKS, CHOCOLATE-BASED MOUSSE, CHOCOLATE-BASED DESSERT PUDDING, CHOCOLATE SAUCE, COOKIES, HOT AND COLD COCOA BEVERAGES, BROWNIES, CROISSANTS, CAKES, PIES, CHOCOLATE FONDUE, SNACK PACKS COMPRISED OF CHOCOLATE GELATIN, SORBET, SHAKES, PARFAITS, CAKE AND OTHER BAKED GOODS FILLINGS, NAMELY, CHOCOLATE GELATIN FILLING, CHOCOLATE GANACHE AND CHOCOLATE PUDDING FILLING, OATMEAL, CHOCOLATE SPREADS, CHOCOLATE DIPS, FROZEN DESSERTS CONSISTING OF CHOCOLATE GELATIN, "DO-IT-YOURSELF" DESSERTS CONSISTING OF CHOCOLATE, CRACKERS, COOKIES AND DIPPING SAUCES, CHOCOLATE DIP, COCOA DIP, CHOCOLATE SPREAD/DIP PACKED WITH FRUIT AND/OR NUTS AND/OR GRANOLA AND/OR PRETZEL, BEVERAGES MADE OF COFFEE, CHOCOLATE FOOD BEVERAGES NOT BEING DAIRY-BASED OR VEGETABLE BASED, COCOA BEVERAGES WITH MILK, COCOA MIXES, FLAVORINGS FOR BEVERAGES, FROZEN CONFECTIONS, NAMELY, FREEZER POPS, FROZEN CUSTARDS, FROZEN DESSERT CONSISTING OF FRUIT AND CREAM OR CREAM SUBSTITUTES, FROZEN YOGURT, FROZEN YOGURT MIXES, GELATO, ICE CREAM, ICE CREAM MIXES, ICE CREAM SANDWICHES, ICE CREAM SUBSTITUTE, ICE MILK, ICE MILK BARS, ICE-CREAM CAKES, CHOCOLATE POWDER, CHOCOLATE SYRUP, CHOCOLATE TOPPING, CHOCOLATE-BASED FILLINGS FOR CAKES AND PIES, CHOCOLATE BASED READY-TO-EAT FOOD CUPS, CHOCOLATE FILLED CUPS, COCOA SPREADS, COCOA-BASED INGREDIENT IN CONFECTIONERY PRODUCTS, CONFECTIONERY, NAMELY, PASTILLES, CUSTARD-BASED FILLINGS FOR CAKES AND PIES, DESSERT MOUSSE, DESSERT PUDDINGS, DESSERT SOUFFLES, DIPPING SAUCES, DONUTS, DULCE DE LECHE, FILLED CHOCOLATE, FLAVORED SWEETENED GELATIN DESSERTS, FLAVORINGS FOR CAKES AND OTHER THAN ESSENTIAL OILS, CONVENIENCE FOOD PACKAGE COMBINATIONS CONSISTING PRIMARILY OF BREAD, FRESH AND DRIED FRUIT, CRACKERS AND/OR COOKIES AND/OR YOGURT; MIXES FOR BAKERY GOODS, PREPARED COCOA AND COCOA-BASED BEVERAGES, PUDDINGS, NAMELY, CHOCOLATE PUDDINGS, SAUCE MIXES, SAUCES (U.S. CL. 46).

CLASS 32—LIGHT BEVERAGES

FOR CONCENTRATES, SYRUPS OR POWDERS USED IN THE PREPARATION OF SOFT DRINKS; DRINKING WATER; ENERGY DRINKS; ESSENCES FOR USE IN MAKING SOFT DRINKS; FLAVORED WATERS, GLACIAL WATER, SMOOTHIES (U.S. CLS. 45, 46 AND 48).
BRIAN NEVILLE, EXAMINING ATTORNEY

SN 85-411,425, EBE, INC., EAST MOLINE, IL. FILED 8-31-2011.

SHIPS

THE MARK CONSISTS OF STANDARD CHARACTERS WITHOUT CLAIM TO ANY PARTICULAR FONT, STYLE, SIZE, OR COLOR.

CLASS 9—ELECTRICAL AND SCIENTIFIC APPARATUS

FOR (BASED ON USE IN COMMERCE) SOFTWARE USED TO ENABLE CARRIERS AND MANAGERS OF FREIGHT TO AUTOMATE REPETITIVE PROCESSES, NAMELY, BILLING, SETTLEMENT, RECRUITING, SAFETY AND DRIVER QUALIFICATION MANAGEMENT IN THE TRANSPORTATION AND LOGISTICS INDUSTRY (U.S. CLS. 21, 23, 26, 36 AND 38).

FIRST USE 9-1-1999; IN COMMERCE 9-1-1999.

CLASS 42—SCIENTIFIC AND COMPUTER SERVICES

FOR (BASED ON INTENT TO USE) PROVIDING A WEBSITE FEATURING NON-DOWNLOADABLE SOFTWARE USED TO ENABLE CARRIERS AND MANAGERS OF FREIGHT TO AUTOMATE REPETITIVE PROCESSES, NAMELY, BILLING, SETTLEMENT, RECRUITING, SAFETY AND DRIVER QUALIFICATION MANAGEMENT IN THE TRANSPORTATION AND LOGISTICS INDUSTRY (U.S. CLS. 100 AND 101).

COURTNEY ALVAREZ, EXAMINING ATTORNEY

CLASS 41—EDUCATION AND ENTERTAINMENT

FOR EDUCATIONAL EXAMINATION SERVICES; EDUCATIONAL RESEARCH IN THE FIELDS OF ENGLISH LANGUAGE, KOREAN LANGUAGE, MATHEMATICS AND SCIENCE; PROVIDING INFORMATION RELATING TO EDUCATIONAL SERVICES; LANGUAGE EDUCATIONAL SERVICES, NAMELY, CONDUCTING CLASSES IN THE FIELD OF THE ENGLISH LANGUAGE, KOREAN LANGUAGE, MATHEMATICS AND SCIENCE; ONLINE EDUCATIONAL EXAMINATION SERVICES; ONLINE EDUCATIONAL SERVICES, NAMELY, CONDUCTING CLASSES IN THE FIELD OF ENGLISH LANGUAGE, KOREAN LANGUAGE, MATHEMATICS AND SCIENCE (U.S. CLS. 100, 101 AND 107).

JOHN DALIER, EXAMINING ATTORNEY

SN 85-412,906. INTERTAPE POLYMER CORP., BRADENTON, FL. FILED 9-1-2011.

SN 85-412,832. IODINE CO., LTD., SEOUL, REPUBLIC OF KOREA, FILED 9-1-2011.

 The logo for K-maru features the letter 'K' in red, followed by a hyphen, and the letters 'maru' in a multi-colored font where 'm' is yellow, 'a' is green, 'r' is blue, and 'u' is purple.

PRIORITY CLAIMED UNDER SEC. 44(D) ON REPUBLIC OF KOREA APPLICATION NO. 2011-0000961, FILED 3-8-2011, REG. NO. 0039002, DATED 3-16-2012, EXPIRES 3-16-2022.

THE COLOR(S) RED, ORANGE, YELLOW, GREEN, BLUE AND PURPLE IS/ARE CLAIMED AS A FEATURE OF THE MARK.

THE MARK CONSISTS OF A RED LETTER "K", AN ORANGE HYPHEN "-", A YELLOW LETTER "M", A GREEN LETTER "A", A BLUE LETTER "R" AND A PURPLE LETTER "U".

THE WORDING "K-MARU" HAS NO MEANING IN A FOREIGN LANGUAGE.

CLASS 9—ELECTRICAL AND SCIENTIFIC APPARATUS

FOR DOWNLOADABLE ELECTRONIC PUBLICATIONS, NAMELY, E-ZINES FEATURING ENGLISH LANGUAGE, KOREAN LANGUAGE, MATHEMATICS, AND SCIENCE; DOWNLOADABLE ELECTRONIC BOOKS, NAMELY, E-ZINES FEATURING ENGLISH LANGUAGE, KOREAN LANGUAGE, MATHEMATICS, AND SCIENCE; DOWNLOADABLE ELECTRONIC NEWSPAPERS; DOWNLOADABLE ELECTRONIC MUSIC; DOWNLOADABLE ELECTRONIC STUDY MATERIALS, NAMELY, E-ZINES FEATURING ENGLISH LANGUAGE, KOREAN LANGUAGE, MATHEMATICS, AND SCIENCE; DOWNLOADABLE COMPUTER PROGRAMS FOR USE IN STUDYING OF ENGLISH LANGUAGE, KOREAN LANGUAGE, MATHEMATICS, AND SCIENCE (U.S. CLS. 21, 23, 26, 36 AND 38).

iTape

THE MARK CONSISTS OF STANDARD CHARACTERS WITHOUT CLAIM TO ANY PARTICULAR FONT, STYLE, SIZE, OR COLOR.

CLASS 16—PAPER GOODS AND PRINTED MATTER

FOR PAPER PLYWOOD TAPE FOR HOUSEHOLD OR STATIONERY USAGE; PAPER CARTON SEALING TAPE; PAPER TAPE FOR HOUSEHOLD OR STATIONERY USAGE (U.S. CLS. 2, 5, 22, 23, 29, 37, 38 AND 50).

CLASS 17—RUBBER GOODS

FOR PRESSURE SENSITIVE ADHESIVE TAPE FOR COMMERCIAL AND INDUSTRIAL USE, NAMELY, GUMMED REINFORCED TAPE, SEALING TAPE, WATER RESISTANT TAPE, PACKAGING TAPE, SPLICING TAPE, MENDING TAPE, HOLDING TAPE, BUNDLING TAPE, DOUBLE FACE TAPE, REINFORCED TAPE, STRAPPING TAPE, PROTECTIVE TAPE, DUCT TAPE, MOISTURE RESISTANT TAPE, ELECTRICAL TAPE, AISLE MARKING TAPE, ELECTROPLATING TAPE, ALL WEATHER TAPE, LABEL PROTECTION TAPE, CELLOPHANE TAPE, DRYWALL JOINT TAPE, PLASTIC TAPE FOR SAFETY AND SECURITY PURPOSES, ADHESIVE TAPE WITH RELEASE LINER AND REINFORCED STRAPPING TAPE; PAPER MASKING TAPE FOR INDUSTRIAL OR COMMERCIAL USE; PAPER PLYWOOD PATCH TAPE FOR INDUSTRIAL OR COMMERCIAL USE; MASKING TAPE; PAPER STRAPPING TAPE FOR INDUSTRIAL OR COMMERCIAL USE; CLOTH TAPE, NAMELY, MASKING TAPE; MASKING TAPE (U.S. CLS. 1, 5, 12, 13, 35 AND 50).

JOHN SCHUYLER YARD, EXAMINING ATTORNEY

SN 85-413,918. DIGI UNLIMITED, INC., CASPER, WY.
FILED 9-2-2011.

DIGI UNLIMITED

THE MARK CONSISTS OF STANDARD CHARACTERS WITHOUT CLAIM TO ANY PARTICULAR FONT, STYLE, SIZE, OR COLOR.

NO CLAIM IS MADE TO THE EXCLUSIVE RIGHT TO USE "UNLIMITED", APART FROM THE MARK AS SHOWN.

CLASS 9—ELECTRICAL AND SCIENTIFIC APPARATUS

FOR AUDIO AND VISUAL HEADSETS FOR USE IN PLAYING VIDEO GAMES; COMPUTER PROGRAMS FOR VIDEO AND COMPUTER GAMES; GAME CONTROLLERS FOR COMPUTER GAMES; GAMING HEADSETS FOR USE IN PLAYING VIDEO GAMES; HAND HELD JOY STICK UNITS FOR PLAYING VIDEO GAMES; INTERACTIVE VIDEO GAME PROGRAMS; JOYSTICKS FOR VIDEO GAMES; PLAYER-OPERATED ELECTRONIC CONTROLLERS FOR ELECTRONIC VIDEO GAME MACHINES; VIDEO AND COMPUTER GAME PROGRAMS; VIDEO GAME INTERACTIVE HAND HELD REMOTE CONTROLS FOR PLAYING ELECTRONIC GAMES; VIDEO GAME INTERACTIVE REMOTE CONTROL UNITS; VIDEO GAME JOYSTICKS; VIDEO GAME SOFTWARE (U.S. CLS. 21, 23, 26, 36 AND 38).

CLASS 35—ADVERTISING AND BUSINESS

FOR COMPUTERIZED ON-LINE ORDERING SERVICES IN THE FIELD OF DOWNLOADABLE INTERACTIVE COMPUTER VIDEO GAME FILES AND VIDEO GAME ACCESSORIES, NAMELY, HANDHELD VIDEO GAME CONTROLLERS AND HEADSETS; COMPUTERIZED ON-LINE RETAIL STORE SERVICES IN THE FIELD OF DOWNLOADABLE INTERACTIVE COMPUTER VIDEO GAME FILES AND VIDEO GAME ACCESSORIES, NAMELY, HANDHELD VIDEO GAME CONTROLLERS AND HEADSETS; DISTRIBUTORSHIP SERVICES IN THE FIELD OF VIDEO GAME ACCESSORIES, NAMELY, HANDHELD VIDEO GAME CONTROLLERS AND HEADSETS; MULTI-LEVEL MARKETING BUSINESS SERVICES; ONLINE RETAIL SERVICES THROUGH DIRECT SOLICITATION BY DISTRIBUTORS DIRECTED TO END-USERS FEATURING DOWNLOADABLE INTERACTIVE COMPUTER VIDEO GAME FILES AND VIDEO GAME ACCESSORIES, NAMELY, HANDHELD VIDEO GAME CONTROLLERS AND HEADSETS; OPERATING AN ON-LINE SHOPPING SITE IN THE FIELD OF DOWNLOADABLE INTERACTIVE COMPUTER VIDEO GAME FILES AND VIDEO GAME ACCESSORIES, NAMELY, HANDHELD VIDEO GAME CONTROLLERS AND HEADSETS; PLANNING, DESIGN, DEVELOPMENT, MAINTENANCE, TRACKING AND REPORTING OF ONLINE MARKETING ACTIVITIES FOR THIRD PARTIES (U.S. CLS. 100, 101 AND 102).

CLASS 38—COMMUNICATION

FOR STREAMING OF AUDIO, VISUAL AND AUDIO-VISUAL MATERIAL VIA A GLOBAL COMPUTER NETWORK (U.S. CLS. 100, 101 AND 104).

CLASS 41—EDUCATION AND ENTERTAINMENT

FOR ENTERTAINMENT SERVICES, NAMELY, PROVIDING ONLINE VIDEO GAMES; ENTERTAINMENT SERVICES, NAMELY, PROVIDING TEMPORARY USE OF NON-DOWNLOADABLE VIDEO GAMES; PROVIDING A WEB SITE THROUGH WHICH PEOPLE LOCATE INFORMATION ABOUT TOURNAMENTS, EVENTS, AND COMPETITIONS IN THE VIDEO GAME FIELD (U.S. CLS. 100, 101 AND 107).

ANTHONY RINKER, EXAMINING ATTORNEY

SN 85-413,930. READABILITY LLC, NEW YORK, NY. FILED 9-2-2011.

 **Readability**

THE MARK CONSISTS OF A DESIGN ELEMENT THAT INCLUDES A STYLIZED REPRESENTATION OF A CHAIR ADJACENT TO THE LITERAL ELEMENT "READABILITY" APPEARING IN A STYLIZED FONT.

CLASS 9—ELECTRICAL AND SCIENTIFIC APPARATUS

FOR DOWNLOADABLE COMPUTER APPLICATION SOFTWARE FOR PERSONAL COMPUTERS AND MOBILE DEVICES THAT ALLOW A USER TO SAVE AND ARCHIVE ARTICLES PUBLISHED ONLINE AND TO REMOVE EXTRANEOUS MATERIAL FROM SAID ARTICLES (U.S. CLS. 21, 23, 26, 36 AND 38).

FIRST USE 3-1-2009; IN COMMERCE 3-1-2009.

CLASS 42—SCIENTIFIC AND COMPUTER SERVICES

FOR SOFTWARE AS A SERVICE (SAAS) FEATURING NON-DOWNLOADABLE COMPUTER APPLICATION SOFTWARE FOR PERSONAL COMPUTERS AND MOBILE DEVICES THAT ALLOW A USER TO SAVE AND ARCHIVE ARTICLES PUBLISHED ONLINE AND TO REMOVE EXTRANEOUS MATERIAL FROM SAID ARTICLES (U.S. CLS. 100 AND 101).

FIRST USE 3-1-2009; IN COMMERCE 3-1-2009.
ZHALEH DELANEY, EXAMINING ATTORNEY

SN 85-413,958. MBLOX INCORPORATED, SUNNYVALE, CA. FILED 9-2-2011.

SN 85-414,586. ONI GLOBAL PTE. LTD., SINGAPORE, SINGAPORE, FILED 9-2-2011.



THE MARK CONSISTS OF THE LETTER "M" HAVING A DOT WITH CURVED BANDS ENCLOSED IN A SQUARE.

CLASS 35—ADVERTISING AND BUSINESS

FOR FINANCIAL SERVICES, NAMELY, BILLING OF MOBILE CONTENT AND MOBILE SERVICES (U.S. CLS. 100, 101 AND 102).

CLASS 36—INSURANCE AND FINANCIAL

FOR FINANCIAL SERVICES, NAMELY, DEBT COLLECTION AND DEBT SETTLEMENT OF PAYMENTS BETWEEN THIRD PARTIES (U.S. CLS. 100, 101 AND 102).

KATHRYN COWARD, EXAMINING ATTORNEY

SN 85-414,021. EMERGE CLINICAL SOLUTIONS, LLC, DALLAS, TX. FILED 9-2-2011.

EMERGE CLINICAL SOLUTIONS

THE MARK CONSISTS OF STANDARD CHARACTERS WITHOUT CLAIM TO ANY PARTICULAR FONT, STYLE, SIZE, OR COLOR.

OWNER OF U.S. REG. NOS. 3,731,716, 3,883,624 AND 3,999,183.

NO CLAIM IS MADE TO THE EXCLUSIVE RIGHT TO USE "CLINICAL SOLUTIONS", APART FROM THE MARK AS SHOWN.

CLASS 9—ELECTRICAL AND SCIENTIFIC APPARATUS

FOR SOFTWARE FOR MANAGING AND EVALUATING CLINICAL INFORMATION AND FOR FACILITATING AND ENHANCING CLINICAL DECISION-MAKING PROCESSES AND PATIENT CARE IN GENERAL (U.S. CLS. 21, 23, 26, 36 AND 38).

CLASS 44—MEDICAL, BEAUTY AND AGRICULTURAL SERVICES

FOR CONSULTING SERVICES FOR MANAGING AND EVALUATING CLINICAL INFORMATION AND FOR FACILITATING AND ENHANCING CLINICAL DECISION-MAKING PROCESSES AND PATIENT CARE IN GENERAL (U.S. CLS. 100 AND 101).

KATHRYN COWARD, EXAMINING ATTORNEY

ONI GLOBAL

THE MARK CONSISTS OF STANDARD CHARACTERS WITHOUT CLAIM TO ANY PARTICULAR FONT, STYLE, SIZE, OR COLOR.

PRIORITY CLAIMED UNDER SEC. 44(D) ON SINGAPORE APPLICATION NO. T1111939D, FILED 8-29-2011.

NO CLAIM IS MADE TO THE EXCLUSIVE RIGHT TO USE "GLOBAL", APART FROM THE MARK AS SHOWN.

THE WORDING "ONI" HAS NO MEANING IN A FOREIGN LANGUAGE.

CLASS 5—PHARMACEUTICALS

FOR TRADITIONAL CHINESE HERBAL PREPARATIONS FOR MEDICAL PURPOSES; MEDICINAL TONIC PREPARATIONS, NAMELY, TONICS USED FOR THE TREATMENT OF THE SCALP TO HELP REGENERATE HAIR, TO BOOST THE BODY'S IMMUNE SYSTEM AND ENABLE THE BODY'S NATURAL RESISTANCE TO FIGHT AGAINST DISEASES AND ILLNESSES, TO REDUCE FATIGUE AND IMPROVE QUALITY OF SLEEP, TO AID IN RECOVERY FROM SURGERY AND ILLNESSES, TO STRENGTHEN AND IMPROVE VITAL ORGANS SUCH AS THE HEART, LIVER, LUNGS AND KIDNEYS, TO PROTECT THE HEART AND BLOOD VESSEL AND IMPROVE BLOOD CIRCULATION, TO SLOW DOWN THE SIGNS OF AGING, TO REDUCE WATER RETENTION, AND TO AID IN DETOXIFICATION; CHINESE MEDICINES FOR THE TREATMENT OF THE SCALP TO HELP REGENERATE HAIR, TO BOOST THE BODY'S IMMUNE SYSTEM AND ENABLE THE BODY'S NATURAL RESISTANCE TO FIGHT AGAINST DISEASES AND ILLNESSES, TO REDUCE FATIGUE AND IMPROVE QUALITY OF SLEEP, TO AID IN RECOVERY FROM SURGERY AND ILLNESSES, TO STRENGTHEN AND IMPROVE VITAL ORGANS SUCH AS THE HEART, LIVER, LUNGS AND KIDNEYS, TO PROTECT THE HEART AND BLOOD VESSEL AND IMPROVE BLOOD CIRCULATION, TO SLOW DOWN THE SIGNS OF AGING, TO REDUCE WATER RETENTION, TO AID IN DETOXIFICATION, TO SUPPORT VITALITY AND WELL BEING, TO SUPPORT PROSTATE AND URINARY HEALTH AND TO PROTECT THE LIVER; GINSENG FOR MEDICINAL USE; HERBAL BEVERAGES AND COMPOUNDS FOR MEDICINAL USE, NAMELY, HERBAL BEVERAGE AND COMPOUNDS FOR MEDICINAL USE THAT PROMOTE SKIN HEALING, TREAT CHRONIC PIMPLE OUTBREAKS, IMPROVE SKIN'S ELASTICITY AND STRENGTH, BUILD AND MAINTAIN HEALTHY BONES AND TEETH, BOOST THE IMMUNE SYSTEM, IMPROVE BLOOD CIRCULATION, AID IN RECOVERY AFTER SURGERY AND ILLNESS, PROTECT AND ENHANCE BRAIN, EYES, HEART, BONE AND JOINT HEALTH AND INCREASE ENERGY, VITALITY AND STRENGTH; HERBAL EXTRACTS FOR MEDICINAL PURPOSES; MEDICINAL HERBAL INFUSIONS TO BOOST THE IMMUNE SYSTEM AND TO PROMOTE BRAIN, EYES, HEART, BONE, JOINT HEALTH AND TO BOOST ENERGY AND STRENGTH; MEDICINAL FUNGUS, NAMELY, CORDYCEPS FOR MEDICAL PURPOSES; MEDICINAL HEALTH DRINKS CONTAINING MEDICINAL FUNGI, NAMELY, CORDYCEPS AND LINGZHI; HEALTH FOOD SUPPLEMENT CONTAINING MEDICINAL FUNGI, NAMELY, LINGZHI AND CORDYCEPS; HEALTH FOOD CONTAINING LINGZHI AND CORDYCEPS ADAPTED FOR MEDICAL USE, NAMELY, EXTRACTS AND CAPSULES; MINERAL FOOD SUPPLEMENTS, MINERAL DIETARY SUPPLEMENTS FOR HUMANS ADAPTED FOR MEDICAL USE, VITAMINS, VITAMIN PREPARATIONS, VITAMIN SUPPLEMENTS, VITAMIN TABLETS, HEALTH FOOD SUPPLEMENTS, FOOD AND DIETARY FOOD SUPPLEMENTS ADAPTED FOR MEDICAL USE; DIETARY NUTRITIONAL SUPPLEMENTS ADAPTED FOR MEDICAL USE; PROTEIN AND YEAST DIETARY SUPPLEMENTS ADAPTED FOR MEDICAL USE; NUTRITIONAL

SUPPLEMENTS; COLLAGEN BASED MEDICATED FOOD SUPPLEMENTS; MEDICAL PREPARATIONS CONTAINING COLLAGEN FOR THE PURPOSE OF FIRING THE SKIN, CARING FOR THE SKIN AND IMPROVING THE IMMUNITY SYSTEM; PREPARATIONS CONTAINING COLLAGEN DIETARY SUPPLEMENTS PRINCIPALLY OF ROYAL JELLY FOR MEDICAL USE; ROYAL JELLY FOR HUMAN CONSUMPTION FOR MEDICINAL PURPOSES; HEALTH FOOD SUPPLEMENTS MADE PRINCIPALLY OF MINERALS; HEALTH FOOD SUPPLEMENTS MADE PRINCIPALLY OF VITAMINS; HEALTH SUPPLEMENTS FOR MEDICAL USE; NATURAL HEALTHCARE PREPARATIONS FOR THE PURPOSE OF SUPPORTING HEALTHY HEART, LUNGS, LIVER, PROSTATE AND DIGESTIVE FUNCTIONS, EASING DIGESTION, TO RELIEVE WATER RETENTION, AND TO REGULATE BOWEL MOVEMENT, PROMOTING BRAIN, EYES, HEART, BONE AND JOINT HEALTH, CONTROLLING CHOLESTEROL AND IMPROVING BLOOD CIRCULATION, PROMOTING WEIGHT LOSS AND REDUCTION OF BODY FAT, PROMOTING WEIGHT GAIN, SUPPORTING PROSTATE AND URINARY HEALTH AND TO ENHANCE MEN'S REPRODUCTIVE HEALTH AND PROMOTING GENERAL WELL BEING; CAPSULES OF HERBS FOR THE PURPOSE OF SUPPORTING HEALTHY HEART, LUNGS, LIVER, PROSTATE AND DIGESTIVE FUNCTIONS, EASING DIGESTION, TO RELIEVE WATER RETENTION, AND TO REGULATE BOWEL MOVEMENT, PROMOTING BRAIN, EYES, HEART, BONE AND JOINT HEALTH, CONTROLLING CHOLESTEROL AND IMPROVING BLOOD CIRCULATION, PROMOTING WEIGHT LOSS AND REDUCTION OF BODY FAT, PROMOTING WEIGHT GAIN AND SUPPORTING PROSTATE AND URINARY HEALTH AND TO ENHANCE MEN'S REPRODUCTIVE HEALTH (U.S. CLS. 6, 18, 44, 46, 51 AND 52).

CLASS 35—ADVERTISING AND BUSINESS

FOR ORGANISATION, OPERATION AND SUPERVISION OF CUSTOMER INCENTIVE AWARDS PROGRAMS, CUSTOMER LOYALTY PROGRAMS AND CUSTOMER BONUS INCENTIVE REWARD PROGRAMS VIA REWARD AND DISCOUNT CARDS, COUPONS AND GLOBAL COMMUNICATIONS NETWORK; SALES PROMOTION SERVICES THROUGH CUSTOMER LOYALTY PROGRAMS; BUSINESS ADVICE, BUSINESS CONSULTANCY AND BUSINESS INFORMATION SERVICES RELATING TO THE ORGANIZATION, OPERATION AND SUPERVISION OF INCENTIVE SCHEMES, LOYALTY SCHEMES AND BONUS SCHEMES; ADVERTISING, MARKETING, PROMOTIONAL AND PUBLICITY SERVICES; PREPARATION, NAMELY, WRITING FOR OTHERS AND PUBLICATION OF PUBLICITY TEXTS; ARRANGEMENT OF ADVERTISING, NAMELY, ARRANGING AND CONDUCTING SPECIAL EVENTS FOR COMMERCIAL, PROMOTIONAL OR ADVERTISING PURPOSES; COMPILATION OF ADVERTISEMENTS FOR USE AS WEB PAGES ON THE INTERNET; COMPILED, PRODUCTION, DISSEMINATION AND UPDATING OF ADVERTISING MATERIAL; BUSINESS ADVICE AND INFORMATION; BUSINESS MARKETING SERVICES IN THE FIELDS OF HEALTH, BEAUTY AND NUTRITIONAL CARE; RENDERING BUSINESS MANAGEMENT ASSISTANCE IN CONNECTION WITH THE ESTABLISHMENT AND/OR OPERATION OF PERSON TO PERSON WHOLESALE AND RETAIL MERCHANTISING OF VARIOUS GOODS, NAMELY, NUTRITIONAL, DIETARY AND/OR FOOD SUPPLEMENTS, HEALTH SUPPLEMENTS, HEALTH FOODS, HERBS, VITAMINS, COSMETICS AND TOILETRIES, HAIR AND SKIN CARE PRODUCTS, ORAL AND BODY PRODUCTS, MEDICINAL, DIAGNOSTIC AND EXERCISE EQUIPMENT, CALORIE CONTROL PRODUCTS AND COMFORT AND RELAXATION PRODUCTS; THE BRINGING TOGETHER FOR THE BENEFIT OF OTHERS A VARIETY OF GOODS, ENABLING CUSTOMERS TO CONVENIENTLY VIEW AND PURCHASE THOSE GOODS FROM A RETAIL STORE, IN A WHOLESALE OUTLET, FROM A MAIL ORDER CATALOGUE, AND FROM A GENERAL MERCHANDISE CATALOGUE, ALL BY TELECOMMUNICATIONS OR FROM A GLOBAL COMPUTER NETWORK WEB SITE, ALL IN THE FIELD OF GENERAL MERCHANDISE, NAMELY, NUTRITIONAL, DIETARY AND/OR FOOD SUPPLEMENTS, HEALTH SUPPLEMENTS, HEALTH FOODS, HERBS, VITAMINS, COSMETICS AND TOILETRIES,

HAIR AND SKIN CARE PRODUCTS, ORAL AND BODY PRODUCTS, MEDICINAL, DIAGNOSTIC AND EXERCISE EQUIPMENT, CALORIE CONTROL PRODUCTS AND COMFORT AND RELAXATION PRODUCTS; COMPUTERIZED DATABASE MANAGEMENT SERVICES, NAMELY, COMPUTERIZED POINT-OF-SALE DATA COLLECTION SERVICES FOR RETAILERS; COMPUTERIZED RETAIL STORE SERVICES IN THE FIELDS OF NUTRITIONAL, DIETARY AND/OR FOOD SUPPLEMENTS, HEALTH SUPPLEMENTS, HEALTH FOODS, HERBS, VITAMINS, COSMETICS AND TOILETRIES, HAIR AND SKIN CARE PRODUCTS, ORAL AND BODY PRODUCTS, MEDICINAL, DIAGNOSTIC AND EXERCISE EQUIPMENT, CALORIE CONTROL PRODUCTS AND COMFORT AND RELAXATION PRODUCTS; ADMINISTRATION OF THE BUSINESS AFFAIRS OF FRANCHISES, NAMELY, ADVICE IN THE RUNNING OF ESTABLISHMENTS AS FRANCHISES; PROVISION OF BUSINESS MANAGEMENT ASSISTANCE IN THE ESTABLISHMENT AND OPERATION OF RETAIL STORE FRANCHISES FEATURING GENERAL CONSUMER HEALTHCARE, PERSONAL CARE AND NUTRITION MERCHANDISE; BUSINESS MANAGEMENT ADVISORY, INFORMATION AND CONSULTANCY SERVICES RELATING TO FRANCHISING (U.S. CLS. 100, 101 AND 102).

SOPHIA S. KIM, EXAMINING ATTORNEY

SN 85-415,216. EMERGE CLINICAL SOLUTIONS, LLC, DALLAS, TX. FILED 9-6-2011.

EMERGE

THE MARK CONSISTS OF STANDARD CHARACTERS WITHOUT CLAIM TO ANY PARTICULAR FONT, STYLE, SIZE, OR COLOR.

OWNER OF U.S. REG. NOS. 3,731,716, 3,883,624 AND 3,999,183.

CLASS 9—ELECTRICAL AND SCIENTIFIC APPARATUS

FOR SOFTWARE FOR MANAGING AND EVALUATING CLINICAL INFORMATION AND FOR FACILITATING AND ENHANCING CLINICAL DECISION-MAKING PROCESSES AND PATIENT CARE IN GENERAL (U.S. CLS. 21, 23, 26, 36 AND 38).

CLASS 44—MEDICAL, BEAUTY AND AGRICULTURAL SERVICES

FOR CONSULTING SERVICES FOR MANAGING AND EVALUATING CLINICAL INFORMATION AND FOR FACILITATING AND ENHANCING CLINICAL DECISION-MAKING PROCESSES AND PATIENT CARE IN GENERAL (U.S. CLS. 100 AND 101).

MATTHEW EINSTEIN, EXAMINING ATTORNEY

SN 85-415,497. SCOTTSDALE WEIGHT LOSS CENTER, PLLC, SCOTTSDALE, AZ. FILED 9-6-2011.

SCOTTSDALE
Weight Loss Center

NO CLAIM IS MADE TO THE EXCLUSIVE RIGHT TO USE "WEIGHT LOSS CENTER" AS TO CLASSES 41 AND 44, APART FROM THE MARK AS SHOWN.

THE MARK CONSISTS OF THE WORD "SCOTTSDALE" ABOVE THE WORDS "WEIGHT LOSS CENTER".
SEC. 2(F).

CLASS 5—PHARMACEUTICALS

FOR NUTRITIONAL BARS FOR USE AS MEAL REPLACEMENTS (U.S. CLS. 6, 18, 44, 46, 51 AND 52).
FIRST USE 4-19-2006; IN COMMERCE 4-19-2006.

CLASS 41—EDUCATION AND ENTERTAINMENT

FOR EDUCATIONAL SERVICES, NAMELY, CLASSES RELATED TO WEIGHT LOSS (U.S. CLS. 100, 101 AND 107).
FIRST USE 4-19-2006; IN COMMERCE 4-19-2006.

CLASS 44—MEDICAL, BEAUTY AND AGRICULTURAL SERVICES

FOR MEDICAL SERVICES RELATED TO WEIGHT LOSS (U.S. CLS. 100 AND 101).
FIRST USE 4-19-2006; IN COMMERCE 4-19-2006.
LEIGH CAROLINE CASE, EXAMINING ATTORNEY

CLASS 29—MEATS AND PROCESSED FOODS

FOR DAIRY PRODUCTS EXCLUDING ICE CREAM, ICE MILK AND FROZEN YOGURT; A FULL LINE OF FOOD PRODUCTS, NAMELY, MEAT, FISH, SEAFOOD, POULTRY, CHEESE, PROCESSED, CANNED, DRIED AND PRESERVED FRUITS AND VEGETABLES, SOUPS, SOUP MIXES, FRUIT SAUCES, NAMELY, APPLESAUCE AND CRANBERRY SAUCE, POTATO AND FRUIT-BASED SNACK FOODS, POTATO, VEGETABLE AND FRUIT CHIPS, FROZEN FRUITS, PROCESSED TOMATOES, CHILI, FROZEN MASHED POTATOES, PROCESSED BEANS, EGGS, BEAN DIP, DRIED FRUIT, PROCESSED NUTS, TRAIL SNACK MIX MADE PRIMARILY OF PROCESSED NUTS; NUT BUTTERS, JAMS, MARMALADE, FRUIT SPREADS, OLIVE OIL, COOKING OIL, MARGARINE, CANNED TUNA FISH, MILK, HALF AND HALF, CREAM CHEESE, SOY-BASED FOOD BEVERAGES AND RICE MILK USED AS A MILK SUBSTITUTE, CHEESE, YOGURT, FRUIT OR VEGETABLE BASED SNACK FOODS; PREPARED, PACKAGED, AND FROZEN MEALS CONSISTING PRIMARILY OF MEAT FISH, POULTRY, VEGETABLES OR SOY-BASED FOOD, NAMELY, PROCESSED SOY BEANS, AND PATTIES MADE OF SOY BEANS; FROZEN VEGETABLES, PROCESSED POTATOES, PROCESSED VEGETABLES, PROCESSED FRUITS, TOMATO PASTE, BUTTER, SOY-BASED FOOD BARS, LUNCHEON MEATS; PROCESSED MEAT, NAMELY, BACON, BEEF, CHICKEN, HAM, SAUSAGE LINKS, AND TURKEY; FRUIT SALADS; VEGETABLE SALADS; LEGUME SALADS, GARDEN SALADS; OIL, NAMELY, FOR COOKING AND SALADS; PRE-CUT VEGETABLE SALADS (U.S. CL. 46).

SN 85-415,517. LYFE KITCHEN IP HOLDINGS, LLC, CHICAGO, IL. FILED 9-6-2011.



NO CLAIM IS MADE TO THE EXCLUSIVE RIGHT TO USE "KITCHEN", APART FROM THE MARK AS SHOWN. THE COLOR(S) GREY AND ORANGE IS/ARE CLAIMED AS A FEATURE OF THE MARK.

THE MARK CONSISTS OF A STYLIZED FORK IN ORANGE. TO THE LEFT OF THE DESIGN IS THE WORDING "LYFE KITCHEN LOVE YOUR FOOD EVERYDAY" IN STYLIZED FONT. THERE ARE TWO GREY LINES ON EITHER SIDE OF THE WORD "KITCHEN". THE LETTERS "L", "F" AND "E" OF THE WORD "LYFE" IN GREY AND THE LETTER "Y" OF THE WORD "LYFE" IN ORANGE; THE WORD "KITCHEN" IN GREY; THE WORDS "LOVE", "YOUR", "FOOD", "EVERYDAY" IN GREY, THE WORD "YOUR" IS UNDERLINED IN GREY.

THE WORD(S) "LYFE" HAS NO MEANING IN A FOREIGN LANGUAGE.

CLASS 30—STAPLE FOODS

FOR BREAD, BAKERY PRODUCTS, CONFECTIONERY, NAMELY, BAKERY DESSERTS, BROWNIES, CAKES, CAKE MIXES, CANDIES, CHOCOLATES AND CHOCOLATE BASED READY TO EAT CANDIES AND SNACKS, COOKIES, FROZEN CONFECTIONS, COOKIES MIXES, CARAMELS; CONFECTIONERY, NAMELY, PASTILLES; MIXES FOR BAKERY GOODS; SAUCES, FROZEN CONFECTIONERY; COFFEE, COCOA, TEA, GRAVIES, PROCESSED HERBS, SPICES AND SEASONINGS, PROCESSED CEREALS, PROCESSED GRAINS, PASTA, MACARONI AND CHEESE, GRANOLA, READY TO EAT CEREAL DERIVED FOOD BARS, CHOCOLATE BASED READY-TO-EAT FOOD BARS, WHOLE GRAIN-BASED FOOD BARS, RICE-BASED FOOD BARS, WHEAT-BASED FOOD BARS, CORN CHIPS, TORTILLA CHIPS, CHEESE FLAVORED PUFFED CORN SNACKS, FLOUR-BASED CHIPS, CRACKERS, PROCESSED POPCORN, CONFECTIONERY CHIPS FOR BAKING, PRETZELS, SALAD DRESSING, MAYONNAISE, KETCHUP, MUSTARD, RELISH, HOT SAUCE, SPICES, NATURAL SWEETENERS, HONEY, EXTRACTS USED AS A FLAVORING, PASTA SAUCE, MARINADES, CHOCOLATE SYRUP, CHOCOLATE CHIPS, BARBECUE SAUCES, VINEGAR, CHEESE SAUCE, SALSAS, PIZZA, CEREAL-BASED SNACK FOODS, RICE-BASED SNACK FOODS, WHEAT-BASED SNACK FOODS, BAKERY GOODS, CANDY, FROZEN YOGURT, FRUIT ICE BARS, ICE CREAM, SORBET, COOKIES, WAFFLES AND FROZEN MEALS CONSISTING PRIMARILY OF PASTA OR RICE, TRAIL SNACK MIX MADE PRIMARILY OF CHOCOLATE; TOMATO SAUCE; UNPOPPED POPCORN FOR MAKING POPCORN; TEA AND COFFEE BASED BEVERAGES, NAMELY, TEA, COFFEE, TEA BASED BEVERAGES WITH FRUIT FLAVORING; COOKING SAUCES; COMBINATION MEALS CONSISTING PRIMARILY OF PASTA OR RICE-BASED ENTREES AND SOUP OR SALAD FOR CONSUMPTION ON OR OFF THE PREMISES; PASTA SALAD; RICE SALAD, PROCESSED QUINOA; RICE, PROCESSED BULGAR WHEAT (U.S. CL. 46).
WENDY JUN, EXAMINING ATTORNEY

SN 85-415,689. ADVANCED ENTERTAINMENT TECHNOLOGIES, INC., BALTIMORE, MD. FILED 9-6-2011.

IMAGE ENGINEERING

THE MARK CONSISTS OF STANDARD CHARACTERS WITHOUT CLAIM TO ANY PARTICULAR FONT, STYLE, SIZE, OR COLOR.

NO CLAIM IS MADE TO THE EXCLUSIVE RIGHT TO USE "IMAGE" FOR INTERNATIONAL CLASS 41, APART FROM THE MARK AS SHOWN.

CLASS 37—CONSTRUCTION AND REPAIR

FOR INSTALLATION OF SPECIAL EFFECTS AND ENTERTAINMENT EQUIPMENT, NAMELY, LASER DISPLAY EQUIPMENT, LIGHTING EQUIPMENT, AND CONTROL EQUIPMENT IN THE NATURE OF CONSOLES AND COMPUTERS (U.S. CLS. 100, 103 AND 106).

FIRST USE 0-0-2002; IN COMMERCE 0-0-2002.

CLASS 41—EDUCATION AND ENTERTAINMENT

FOR ENTERTAINMENT SERVICES, NAMELY, PRODUCTION OF LASER SHOWS, LIGHT SHOWS FEATURING PYROTECHNICS AND FIREWORKS, AND SPECIAL EFFECTS SHOWS; ENTERTAINMENT SERVICES, NAMELY, PRODUCTION OF VIDEO AND LIGHT PROJECTION DISPLAYS IN THE NATURE OF DISPLAYING AND PROJECTING VIDEO AND/OR LIGHTING ONTO STRUCTURES, BUILDINGS, AND LANDMARKS; ENTERTAINMENT SERVICES, NAMELY, CONDUCTING LASER SHOWS, LIGHT SHOWS FEATURING PYROTECHNICS AND FIREWORKS, AND SPECIAL EFFECTS SHOWS; ENTERTAINMENT SERVICES, NAMELY, CONDUCTING VIDEO AND LIGHT PROJECTION DISPLAYS IN THE NATURE OF DISPLAYING AND PROJECTING VIDEO AND/OR LIGHTING ONTO STRUCTURES, BUILDINGS, AND LANDMARKS (U.S. CLS. 100, 101 AND 107).

FIRST USE 2-19-1980; IN COMMERCE 2-19-1980.
AMY KERTGATE, EXAMINING ATTORNEY

SN 85-415,714. GLOBALFOUNDRIES INC., GRAND CAYMAN, CAYMAN ISLANDS, FILED 9-6-2011.

BCDLITE

THE MARK CONSISTS OF STANDARD CHARACTERS WITHOUT CLAIM TO ANY PARTICULAR FONT, STYLE, SIZE, OR COLOR.

CLASS 40—MATERIAL TREATMENT

FOR CUSTOM MANUFACTURE OF SEMICONDUCTORS AND INTEGRATED CIRCUITS (U.S. CLS. 100, 103 AND 106).

FIRST USE 3-29-2010; IN COMMERCE 3-29-2010.

CLASS 42—SCIENTIFIC AND COMPUTER SERVICES

FOR CUSTOM DESIGN, ENGINEERING AND TESTING FOR NEW PRODUCT DEVELOPMENT OF SEMICONDUCTORS AND INTEGRATED CIRCUITS; TECHNOLOGY CONSULTATION SERVICES REGARDING SEMICONDUCTORS AND INTEGRATED CIRCUITS (U.S. CLS. 100 AND 101).

FIRST USE 3-29-2010; IN COMMERCE 3-29-2010.
MARY ROSSMAN, EXAMINING ATTORNEY

SN 85-415,790. SEIKO EPSON KABUSHIKI KAISHA, TA SEIKO EPSON CORPORATION, TOKYO, JAPAN, FILED 9-6-2011.

MegaPlex

THE MARK CONSISTS OF STANDARD CHARACTERS WITHOUT CLAIM TO ANY PARTICULAR FONT, STYLE, SIZE, OR COLOR.

PRIORITY CLAIMED UNDER SEC. 44(D) ON JAPAN APPLICATION NO. 2011-059870, FILED 8-18-2011, REG. NO. 5474787, DATED 3-2-2012, EXPIRES 3-2-2022.

CLASS 9—ELECTRICAL AND SCIENTIFIC APPARATUS

FOR LIQUID CRYSTAL DISPLAY (LCD) PROJECTORS; HOME THEATER SYSTEMS, COMPRISING, DVD PLAYERS, CD PLAYERS AND MP3 PLAYERS, AUDIO AMPLIFIERS, AUDIO SPEAKERS, TV SETS, AUDIO TUNERS, REMOTE CONTROLS FOR AFOREMENTIONED GOODS; PROJECTOR PERIPHERAL DEVICES, NAMELY, PROJECTION SCREENS, PROJECTOR MOUNTS, DOCUMENT CAMERAS, PROJECTOR CASES, PROJECTOR CABLES, PROJECTOR BATTERY PACKS, PROJECTOR BATTERY CHARGERS, AUDIO SPEAKERS, BASS SPEAKERS, REMOTE CONTROLS FOR AFOREMENTIONED GOODS, AIR FILTERS FOR PROJECTORS; TELECOMMUNICATION DEVICES AND APPARATUS, NAMELY, MOBILE PHONES, HANDHELD TERMINAL DEVICES, NAMELY, PDA, SMART PHONE, TABLET PC, SIGNAL RECEIVERS FOR TV, RADIO AND GPS; COMPUTER SOFTWARE FOR PROJECTORS, MOBILE PHONE, VIDEO PLAYER AND AUDIO PLAYER, NAMELY, COMPUTER SOFTWARE FOR USE IN AUTHORIZING, DOWNLOADING, TRANSMITTING, RECEIVING, EDITING, EXTRACTING, ENCODING, DECODING, PLAYING, STORING AND ORGANIZING TEXT, DATA, IMAGES, AUDIO FILES AND VIDEO FILES (U.S. CLS. 21, 23, 26, 36 AND 38).

CLASS 11—ENVIRONMENTAL CONTROL APPARATUS

FOR PROJECTOR OPTICAL LAMP, PROJECTOR OPTICAL LAMP UNITS (U.S. CLS. 13, 21, 23, 31 AND 34).
RON FAIRBANKS, EXAMINING ATTORNEY

SN 85-417,936. NEWSCO DIRECTIONAL SUPPORT SERVICES INC., CALGARY, AB, CANADA, FILED 9-8-2011.



NO CLAIM IS MADE TO THE EXCLUSIVE RIGHT TO USE "DOWNHOLE TECHNOLOGIES INC.", APART FROM THE MARK AS SHOWN.

THE MARK CONSISTS OF "TELEMETRIX DOWNHOLE TECHNOLOGIES INC.", WITH A STYLIZED "X" IN THE WORD "TELEMETRIX".

CLASS 37—CONSTRUCTION AND REPAIR

FOR REPAIR, SERVICING AND MAINTENANCE OF OIL RELATED TOOLS; RENTAL OF OIL WELL DRILLING TOOLS (U.S. CLS. 100, 103 AND 106).

FIRST USE 1-8-2007; IN COMMERCE 1-8-2007.

CLASS 40—MATERIAL TREATMENT

FOR MANUFACTURE OF OILFIELD TOOLS TO THE ORDER AND/OR SPECIFICATION OF OTHERS (U.S. CLS. 100, 103 AND 106).

FIRST USE 1-8-2007; IN COMMERCE 1-8-2007.

JACQUELINE A. LAVINE, EXAMINING ATTORNEY

SN 85-418,392. BLINDOW, WOLFGANG, AHRENSBURG, FED REP GERMANY, FILED 9-9-2011.

BADGETEC

THE MARK CONSISTS OF STANDARD CHARACTERS WITHOUT CLAIM TO ANY PARTICULAR FONT, STYLE, SIZE, OR COLOR.

CLASS 6—METAL GOODS

FOR COMPONENTS COMPRISED OF METAL, EXCLUSIVELY FOR USE BY, AND SOLD EXCLUSIVELY TO, PROFESSIONAL NAME PLATE MANUFACTURERS AND DEALERS FOR MANUFACTURING OR ASSEMBLING NAME PLATES FOR ATTACHING TO CLOTHING, NAMELY, METAL CLIPS, METAL BADGE HOLDERS, NAMELY, METAL PLATES ONTO WHICH BADGES ARE ATTACHED, AND METAL BADGE HOLDERS COMPRISED OF METAL PLATES AND MAGNETS SOLD AS A UNIT; COMPONENTS COMPRISED OF METAL AND PLASTIC, EXCLUSIVELY FOR USE BY, AND SOLD EXCLUSIVELY TO, PROFESSIONAL NAME PLATE MANUFACTURERS AND DEALERS FOR MANUFACTURING OR ASSEMBLING NAME PLATES FOR ATTACHING TO CLOTHING, NAMELY, BACK PANELS AND FRONT PANELS FOR NAME PLATES IN THE NATURE OF PLATES PRIMARILY OF METAL WITH PLASTIC (U.S. CLS. 2, 12, 13, 14, 23, 25 AND 50).

CLASS 20—FURNITURE AND ARTICLES NOT OTHERWISE CLASSIFIED

FOR COMPONENTS COMPRISED OF PLASTIC AND METAL, EXCLUSIVELY FOR USE BY, AND SOLD EXCLUSIVELY TO, PROFESSIONAL NAME PLATE MANUFACTURERS AND DEALERS FOR MANUFACTURING OR ASSEMBLING NAME PLATES FOR ATTACHING TO CLOTHING, NAMELY, BACK PANELS AND FRONT PANELS FOR NAME PLATES IN THE NATURE OF PLATES PRIMARILY OF PLASTIC WITH METAL (U.S. CLS. 2, 13, 22, 25, 32 AND 50).

CLASS 26—FANCY GOODS

FOR COMPONENTS EXCLUSIVELY FOR USE BY, AND SOLD EXCLUSIVELY TO, PROFESSIONAL NAME PLATE MANUFACTURERS AND DEALERS FOR MANUFACTURING OR ASSEMBLING NAME PLATES FOR ATTACHING TO CLOTHING, NAMELY, FASTENERS FOR NAME PLATES COMPRISED OF METAL, PLASTIC AND MAGNETS SOLD AS A UNIT, AND FASTENERS FOR NAME PLATES COMPRISED OF PLASTIC AND MAGNETS SOLD AS A UNIT (U.S. CLS. 37, 39, 40, 42 AND 50).

SARA BENJAMIN, EXAMINING ATTORNEY

SN 85-418,693. FULL AZIMUTH SHEAR TECHNOLOGY, LLC, GEORGETOWN, TX, FILED 9-9-2011.

VERTISHEAR

THE MARK CONSISTS OF STANDARD CHARACTERS WITHOUT CLAIM TO ANY PARTICULAR FONT, STYLE, SIZE, OR COLOR.

CLASS 42—SCIENTIFIC AND COMPUTER SERVICES

FOR ANALYSIS SERVICES FOR OIL, GAS AND PETROLEUM EXPLORATION; EXPLORATION AND SEARCHING OF OIL, GAS AND PETROLEUM, AND OF OIL, GAS AND PETROLEUM FIELDS; MINING EXPLORATION AND MINERAL EXPLORATION SERVICES; TECHNOLOGICAL CONSULTING SERVICES IN THE FIELD OF GEOPHYSICS AND SEISMIC IMAGING (U.S. CLS. 100 AND 101).

CLASS 45—PERSONAL AND LEGAL SERVICES

FOR LICENSING OF INTELLECTUAL PROPERTY (U.S. CLS. 100 AND 101).

SANJEEV VOHRA, EXAMINING ATTORNEY

SN 85-418,959. ZENSHO CO., LTD., TOKYO, JAPAN, FILED 9-9-2011.

SUKIYA

THE MARK CONSISTS OF STANDARD CHARACTERS WITHOUT CLAIM TO ANY PARTICULAR FONT, STYLE, SIZE, OR COLOR.

OWNER OF JAPAN REG. NO. 4952326, DATED 5-12-2006, EXPIRES 5-12-2016.
OWNER OF U.S. REG. NO. 3,455,892.

CLASS 29—MEATS AND PROCESSED FOODS

FOR PREPARED AND PREPACKAGED MEALS CONSISTING PRINCIPALLY OF BEEF (U.S. CL. 46).

CLASS 30—STAPLE FOODS

FOR STARCHED-BASED BINDING AGENTS FOR ICE CREAM, MEAT TENDERIZERS FOR HOUSEHOLD PURPOSES, TEA, COFFEE AND COCOA, ICE, CONFECTIONERY MADE OF SUGAR, BREAD AND BUNS; SEASONINGS OTHER THAN SPICES, SPICES, ICE CREAM MIXES, SHERBET MIXES, UNROASTED COFFEE, CEREAL PREPARATIONS, NAMELY, UDON NOODLES, OAT FLAKES, OATMEAL, DRIED COOKED-RICE, ENRICHED RICE, PASTA-WRAPPINGS FOR GYOZA, CORN FLAKES, ARTIFICIAL RICE, SPAGHETTI, SOMEN NOODLES, INSTANT UDON NOODLES, INSTANT SOBA NOODLES, INSTANT CHINESE NOODLES, SOBA NOODLES, CHINESE NOODLES, BEAN-STARCH NOODLES (HARUSAME, UNCOOKED), BREAD CRUMB, CHINESE NOODLES (BIFUN, UNCOOKED), DRIED PIECES OF WHEAT GLUTEN (FU, UNCOOKED), MACARONI, POUNDED RICE CAKES (MOCHI); ALMOND PASTE, CHINESE STUFFED DUMPLINGS, NAMELY, COOKED GYOZA; SANDWICHES; CHINESE STEAMED DUMPLINGS, NAMELY, COOKED SHUMAI; SUSHI, FRIED BALLS OF BATTER MIX WITH SMALL PIECES OF OCTOPUS, NAMELY, TAKOYAKI; STEAMED BUNS STUFFED WITH MINCED MEAT, NAMELY, NIKU-MANJU; HAMBURGER SANDWICHES, PIZZAS, PREPARED MEALS CONSISTING PRINCIPALLY OF RICE BUT ALSO CONTAINING BEEF; HOT DOG SANDWICHES, MEAT PIES, RAVIOLI, YEAST POWDER, FERMENTING MALTED RICE, NAMELY, KOJI; YEAST, BAKING POWDER, INSTANT CONFECTIONERY MIXES, NAMELY, INSTANT DOUGHNUT MIXES, INSTANT PUDDING MIXES, INSTANT PANCAKE MIXES, MIXES OF SWEET ADZUKI-BEAN JELLY (MIZU-YOKAN-NO-MOTO); HUSKED RICE, HUSKED OATS, HUSKED BARLEY, FLOUR FOR FOOD, GLUTEN ADDITIVES FOR CULINARY PURPOSES (U.S. CL. 46).

KATHERINE E. HALMEN, EXAMINING ATTORNEY

SN 85-419,101. QRC, INC., FREDERICKSBURG, VA. FILED 9-9-2011.

QRC

THE MARK CONSISTS OF STANDARD CHARACTERS WITHOUT CLAIM TO ANY PARTICULAR FONT, STYLE, SIZE, OR COLOR.

CLASS 9—ELECTRICAL AND SCIENTIFIC APPARATUS

FOR TEST EQUIPMENT IN THE NATURE OF COMMUNICATIONS HARDWARE AND SOFTWARE USED IN THE CHARACTERIZATION AND ANALYSIS OF WIRELESS NETWORKS AND PHONES, AND SOFTWARE USED IN THE CHARACTERIZATION AND ANALYSIS OF WIRELESS NETWORKS AND PHONES (U.S. CLS. 21, 23, 26, 36 AND 38).

FIRST USE 9-30-2005; IN COMMERCE 9-30-2005.

CLASS 41—EDUCATION AND ENTERTAINMENT

FOR TRAINING SERVICES IN THE FIELD OF CELLULAR PROTOCOLS AND CELLULAR EXPLOITATION (U.S. CLS. 100, 101 AND 107).

FIRST USE 9-30-2005; IN COMMERCE 9-30-2005.

CLASS 42—SCIENTIFIC AND COMPUTER SERVICES

FOR DESIGN AND DEVELOPMENT OF TEST EQUIPMENT AND SOFTWARE USED IN THE CHARACTERIZATION AND ANALYSIS OF WIRELESS NETWORKS AND PHONES; CONSULTING IN THE FIELD OF DESIGN AND DEVELOPMENT OF TEST EQUIPMENT AND SOFTWARE USED IN THE CHARACTERIZATION AND ANALYSIS OF WIRELESS NETWORKS AND PHONES (U.S. CLS. 100 AND 101).

FIRST USE 9-30-2005; IN COMMERCE 9-30-2005.

MICHELLE DUBOIS, EXAMINING ATTORNEY

SN 85-419,206. QRC, INC., FREDERICKSBURG, VA. FILED 9-9-2011.

QRC TECHNOLOGIES

THE MARK CONSISTS OF STANDARD CHARACTERS WITHOUT CLAIM TO ANY PARTICULAR FONT, STYLE, SIZE, OR COLOR.

NO CLAIM IS MADE TO THE EXCLUSIVE RIGHT TO USE "TECHNOLOGIES", APART FROM THE MARK AS SHOWN.

CLASS 9—ELECTRICAL AND SCIENTIFIC APPARATUS

FOR TEST EQUIPMENT IN THE NATURE OF COMMUNICATIONS HARDWARE AND SOFTWARE USED IN THE CHARACTERIZATION AND ANALYSIS OF WIRELESS NETWORKS AND PHONES, AND SOFTWARE USED IN THE CHARACTERIZATION AND ANALYSIS OF WIRELESS NETWORKS AND PHONES (U.S. CLS. 21, 23, 26, 36 AND 38).

FIRST USE 9-30-2005; IN COMMERCE 9-30-2005.

CLASS 41—EDUCATION AND ENTERTAINMENT

FOR TRAINING SERVICES IN THE FIELD OF CELLULAR PROTOCOLS AND CELLULAR EXPLOITATION (U.S. CLS. 100, 101 AND 107).

FIRST USE 9-30-2005; IN COMMERCE 9-30-2005.

CLASS 42—SCIENTIFIC AND COMPUTER SERVICES

FOR DESIGN AND DEVELOPMENT OF TEST EQUIPMENT AND SOFTWARE USED IN THE CHARACTERIZATION AND ANALYSIS OF WIRELESS NETWORKS AND PHONES; CONSULTING IN THE FIELD OF DESIGN AND DEVELOPMENT OF TEST EQUIPMENT AND SOFTWARE USED IN THE CHARACTERIZATION AND ANALYSIS OF WIRELESS NETWORKS AND PHONES (U.S. CLS. 100 AND 101).

FIRST USE 9-30-2005; IN COMMERCE 9-30-2005.

MICHELLE DUBOIS, EXAMINING ATTORNEY

SN 85-421,182. GOLDSHINE LIMITED, GRAND CAYMAN, CAYMAN ISLANDS, FILED 9-13-2011.

SN 85-421,323. INTUIT INC., MOUNTAIN VIEW, CA. FILED 9-13-2011.



OWNER OF U.S. REG. NO. 3,195,810.
THE MARK CONSISTS OF TWO INTERLOCKING RECTANGLES FORMING AN "X" WITH A DOT IN THE UPPER RIGHT HAND CORNER.

CLASS 9—ELECTRICAL AND SCIENTIFIC APPARATUS

FOR COMPUTER APPLICATION SOFTWARE FOR MOBILE PHONES, HANDHELD COMPUTERS, PERSONAL DIGITAL ASSISTANTS AND MP3 PLAYERS, NAMELY, SOFTWARE FOR USE IN DATABASE MANAGEMENT, USE IN ELECTRONIC STORAGE OF DATA, ANIMATION AND GAMES, PUBLICATION AND E-COMMERCE; PRE-RECORDED DVDS FEATURING ANIMATED CARTOONS; COMPUTER GAME PROGRAMS; DOWNLOADABLE COMPUTER SOFTWARE FOR USE IN DATABASE MANAGEMENT, USE IN ELECTRONIC STORAGE OF DATA, ANIMATION AND GAMES, PUBLICATION AND E-COMMERCE; AND COMPUTER GAME SOFTWARE FOR ENTERTAINMENT (U.S. CLS. 21, 23, 26, 36 AND 38).

CLASS 16—PAPER GOODS AND PRINTED MATTER

FOR GRAPHIC REPRESENTATIONS; GRAPHIC REPRODUCTIONS; PRINTED HANDBOOKS IN THE FIELD OF ENTERTAINMENT, CARTOONS; PRINTED PUBLICATIONS, NAMELY, BOOKS, MAGAZINES, LEAFLETS AND CATALOGS IN THE FIELD OF EDUCATION, ENTERTAINMENT, CARTOONS, MOVIES AND COMPUTER GAMES; POSTERS; NEWSLETTERS IN THE FIELD OF EDUCATION, ENTERTAINMENT, CARTOONS, MOVIES AND COMPUTER GAMES; PHOTOGRAPHS; AND PICTURES (U.S. CLS. 2, 5, 22, 23, 29, 37, 38 AND 50).

CLASS 42—SCIENTIFIC AND COMPUTER SERVICES

FOR ADVISORY SERVICES RELATING TO COMPUTER SOFTWARE DESIGN; DESIGN OF COMPUTER SOFTWARE; GRAPHIC ARTS DESIGN; AND COMPUTER PROGRAMMING (U.S. CLS. 100 AND 101).
KATHRYN COWARD, EXAMINING ATTORNEY

OPEN VISIT

THE MARK CONSISTS OF STANDARD CHARACTERS WITHOUT CLAIM TO ANY PARTICULAR FONT, STYLE, SIZE, OR COLOR.

CLASS 35—ADVERTISING AND BUSINESS

FOR ADVERTISING, MARKETING AND PROMOTION SERVICES; ADVERTISING AND MARKETING SERVICES PROVIDED BY MEANS OF INDIRECT METHODS OF MARKETING COMMUNICATIONS, NAMELY, SOCIAL MEDIA, SEARCH ENGINE MARKETING, INQUIRY MARKETING, INTERNET MARKETING, MOBILE MARKETING, BLOGGING AND OTHER FORMS OF PASSIVE, SHARABLE OR VIRAL COMMUNICATIONS CHANNELS; SOCIAL MEDIA STRATEGY AND MARKETING CONSULTANCY TO ASSIST CLIENTS IN CREATING AND EXTENDING THEIR PRODUCT AND BRAND STRATEGIES; MARKETING ANALYSIS SERVICES; CUSTOMER RELATIONSHIP MANAGEMENT SERVICES; PROVIDING A WEBSITE WHERE USERS CAN POST RATINGS, REVIEWS AND RECOMMENDATIONS ON PRODUCTS AND SERVICES FOR COMMERCIAL PURPOSES; PROMOTING AND MARKETING THE GOODS AND SERVICES OF OTHERS BY DISTRIBUTING ADVERTISING MATERIAL, COUPONS, DISCOUNT OFFERS, AND BUSINESS APPOINTMENT REMINDERS ONLINE AND VIA TEXT MESSAGING AND EMAIL; PROVIDING A WEBSITE WHERE USERS CAN MANAGE THE REPUTATION OF THEIR BUSINESS AND MANAGE AND RESPOND TO CONSUMER REVIEWS (U.S. CLS. 100, 101 AND 102).

CLASS 42—SCIENTIFIC AND COMPUTER SERVICES

FOR APPLICATION SERVICE PROVIDER, NAMELY, HOSTING, MANAGING, DEVELOPING, ANALYZING, AND MAINTAINING APPLICATIONS, SOFTWARE AND WEBSITES, OF OTHERS IN THE FIELDS OF ADVERTISING, MARKETING, AND CUSTOMER RELATIONSHIP MANAGEMENT; PROVIDING ON-LINE NON-DOWNLOADABLE SOFTWARE FOR USE IN ACCESSING AND MANAGING MARKETING AND PROMOTIONAL EFFORTS AND CAMPAIGNS PROVIDED ONLINE AND VIA MOBILE DEVICES; PROVIDING ON-LINE NON-DOWNLOADABLE SOFTWARE FOR SCHEDULING APPOINTMENTS, DISPLAYING AND RESPONDING TO CONSUMER REVIEWS, AND OFFERING COUPONS AND OTHER OFFERS ONLINE, VIA MOBILE DEVICES AND THROUGH SOCIAL MEDIA PLATFORMS; SOFTWARE AS A SERVICE (SAAS) SERVICES FEATURING SOFTWARE FOR SCHEDULING APPOINTMENTS, POSTING AND RESPONDING TO REVIEWS, AND PROVIDING COUPONS AND OTHER OFFERS ONLINE, VIA MOBILE DEVICES AND THROUGH SOCIAL NETWORKING ENVIRONMENTS; SOFTWARE AS A SERVICE (SAAS) SERVICES FEATURING SOFTWARE FOR MEASURING AND MANAGING ONLINE MARKETING AND PROMOTIONAL CAMPAIGNS (U.S. CLS. 100 AND 101).

RUDY R. SINGLETON, EXAMINING ATTORNEY

SN 85-422,320. BRACEWELL & GIULIANI LLP, HOUSTON, TX. FILED 9-14-2011.

ENERGY LEGAL BLOG

THE MARK CONSISTS OF STANDARD CHARACTERS WITHOUT CLAIM TO ANY PARTICULAR FONT, STYLE, SIZE, OR COLOR.

NO CLAIM IS MADE TO THE EXCLUSIVE RIGHT TO USE "LEGAL BLOG", APART FROM THE MARK AS SHOWN.

SEC. 2(F).

CLASS 41—EDUCATION AND ENTERTAINMENT

FOR PROVIDING ON-LINE PUBLICATIONS IN THE NATURE OF NEWSLETTERS, ARTICLES, LEGAL CASE SUMMARIES AND ADVISORIES, AND RANKINGS IN THE FIELD OF LAW, AIR QUALITY LAW, CLIMATE CHANGE LAW, ENVIRONMENTAL LAW, ENERGY LAW, OIL AND GAS LAW, NUCLEAR POWER LAW, OFFSHORE ENERGY PRODUCTION LAW, OIL AND GAS REFINING LAW, ENERGY GRID SYSTEMS LAW, ENERGY TRANSMISSION LAW, CLEAN TECHNOLOGY LAW, RENEWABLE ENERGY LAW, REGULATORY LAW, MERGERS AND ACQUISITIONS LAW, AND COMMODITIES TRADING LAW; ON-LINE JOURNALS, NAMELY, BLOGS FEATURING LEGISLATIVE AND LEGAL ISSUES, INFORMATION ON RECENT COURT DECISIONS, CURRENT EVENTS, NEWS, INFORMATION, AND LEGAL ANALYSIS RELATING TO THE ENERGY, OIL, GAS, NUCLEAR POWER, CLEAN TECHNOLOGY, OFFSHORE ENERGY, AND RENEWABLE ENERGY INDUSTRIES; EDUCATIONAL SERVICES, NAMELY, PROVIDING SPEECHES AND EVENTS IN THE NATURE OF SEMINARS, CONFERENCES, AND SYMPOSIUMS IN THE FIELD OF LAW, AIR QUALITY LAW, CLIMATE CHANGE LAW, ENVIRONMENTAL LAW, ENERGY LAW, OIL AND GAS LAW, NUCLEAR POWER LAW, OFFSHORE ENERGY PRODUCTION LAW, OIL AND GAS REFINING LAW, ENERGY GRID SYSTEMS LAW, ENERGY TRANSMISSION LAW, CLEAN TECHNOLOGY LAW, RENEWABLE ENERGY LAW, REGULATORY LAW, MERGERS AND ACQUISITIONS LAW, AND COMMODITIES TRADING LAW (U.S. CLS. 100, 101 AND 107).

FIRST USE 5-8-2005; IN COMMERCE 5-8-2005.

CLASS 45—PERSONAL AND LEGAL SERVICES

FOR PROVIDING ON-LINE INFORMATION AND NEWS IN THE FIELD OF LAW (U.S. CLS. 100 AND 101).

FIRST USE 5-8-2005; IN COMMERCE 5-8-2005.

NICHOLAS COLEMAN, EXAMINING ATTORNEY

SN 85-422,410. FUJIKIN INCORPORATED, OSAKA-SHI, OSAKA, JAPAN, FILED 9-14-2011.

LSCS

THE MARK CONSISTS OF STANDARD CHARACTERS WITHOUT CLAIM TO ANY PARTICULAR FONT, STYLE, SIZE, OR COLOR.

CLASS 7—MACHINERY

FOR LIQUID MATERIAL GAS SUPPLYING APPARATUS, NAMELY, GAS DIVERTERS CONSISTING OF A PUMP, STORAGE AND REFILLING TANK, PRE-HEATER, VAPORIZER, RECUPERATOR, CONDENSER AND VALVES; PRESSURE REGULATORS AS PARTS OF MACHINES; PRESSURE REGULATING APPARATUS, NAMELY, PRESSURE REGULATING VALVES AS PARTS OF MACHINES (U.S. CLS. 13, 19, 21, 23, 31, 34 AND 35).

CLASS 9—ELECTRICAL AND SCIENTIFIC APPARATUS

FOR AUTOMATIC CONTROL MACHINES FOR LIQUID AND GAS, NAMELY, AUTOMATIC-LIQUID-FLOW, LIQUID-LEVEL, AND PRESSURE CONTROL MACHINES; AUTOMATIC CONTROL INSTRUMENTS FOR LIQUID AND GAS, NAMELY, AUTOMATIC-LIQUID-FLOW, LIQUID-LEVEL AND PRESSURE CONTROL INSTRUMENTS; AUTOMATIC REGULATING MACHINES AND INSTRUMENTS, NAMELY, TEMPERATURE SENSORS, PRESSURE SENSORS AND FLOW SENSORS; AUTOMATIC REGULATING INSTRUMENTS, NAMELY, AUTOMATIC FLOW REGULATORS FOR COMMERCIAL USE; AUTOMATIC REGULATING INSTRUMENTS, NAMELY, VALVES FOR CONTROLLING AND REGULATING THE FLOW OF GASES OR LIQUIDS NOT AS PARTS OF PLUMBING, HEATING, COOLING INSTALLATIONS OR MACHINES; AUTOMATIC FLOW RATE CONTROL MACHINES FOR GAS OR LIQUID; AUTOMATIC FLOW RATE CONTROL INSTRUMENTS FOR GAS OR LIQUID; AUTOMATIC PRESSURE CONTROL MACHINES FOR STORAGE AND DISTRIBUTION OF PRESSURIZED GAS AND LIQUEFIED GAS; AUTOMATIC PRESSURE CONTROL INSTRUMENTS FOR STORAGE AND DISTRIBUTION OF PRESSURIZED GAS AND LIQUEFIED GAS; PRESSURE REGULATING APPARATUS, NAMELY, AUTOMATIC VALVES; FLOW RATE CONTROL APPARATUS, NAMELY, FLOW REGULATORS FOR COMMERCIAL USE; ELECTRICAL MEASURING DEVICE, NAMELY, TECHNICAL MEASURING INSTRUMENT FOR MEASURING THE TEMPERATURE, PRESSURE, QUANTITY AND CONCENTRATION OF GAS AND LIQUIDS (U.S. CLS. 21, 23, 26, 36 AND 38).

MAYUR VAGHANI, EXAMINING ATTORNEY

SN 85-423,376. CLOUD REMOTE CONTROL TECHNOLOGIES, S.L., MADRID, SPAIN, FILED 9-15-2011.

CLOUD MC

THE MARK CONSISTS OF STANDARD CHARACTERS WITHOUT CLAIM TO ANY PARTICULAR FONT, STYLE, SIZE, OR COLOR.

OWNER OF ERPN CMNTY TM OFC REG. NO. 009814401, DATED 7-18-2011, EXPIRES 3-16-2021.

NO CLAIM IS MADE TO THE EXCLUSIVE RIGHT TO USE "CLOUD", APART FROM THE MARK AS SHOWN.

CLASS 9—ELECTRICAL AND SCIENTIFIC APPARATUS

FOR MEASURING, SIGNALING, CHECKING (SUPERVISION) APPARATUS AND INSTRUMENTS, NAMELY, APPARATUS AND INSTRUMENTS FOR MANAGING AND CONTROLLING HAIR REMOVAL SYSTEMS; COMMUNICATIONS SOFTWARE FOR COMMUNICATING BETWEEN COMPUTERS; COMMUNICATIONS COMPUTERS; COMPUTER HARDWARE (U.S. CLS. 21, 23, 26, 36 AND 38).

CLASS 38—COMMUNICATION

FOR TELECOMMUNICATIONS, NAMELY, TRANSMISSION OF ACCESS TO COMPUTER SOFTWARE IN DATA NETWORKS TO REMOTELY MANAGE AND CONTROL HAIR REMOVAL APPARATUS AND INSTRUMENTS; TRANSMISSION AND DISTRIBUTION OF DATA VIA A GLOBAL COMPUTER NETWORK OR THE INTERNET (U.S. CLS. 100, 101 AND 104).

SN 85-423,903. JAGR, LLC, NEW YORK, NY. FILED 9-15-2011.

CLASS 42—SCIENTIFIC AND COMPUTER SERVICES

FOR SCIENTIFIC AND TECHNOLOGICAL SERVICES, NAMELY, SOFTWARE AS A SERVICE FEATURING SOFTWARE FOR REMOTELY CONTROLLING AND MANAGING HAIR REMOVAL APPARATUS AND INSTRUMENTS; COMPUTER SERVICES, NAMELY, CLOUD HOSTING PROVIDER SERVICES (U.S. CLS. 100 AND 101).

TINA MAI, EXAMINING ATTORNEY



NO CLAIM IS MADE TO THE EXCLUSIVE RIGHT TO USE "JOE", APART FROM THE MARK AS SHOWN.

THE COLOR(S) DARK BROWN, LIGHT BLUE, AND WHITE IS/ARE CLAIMED AS A FEATURE OF THE MARK.

THE MARK CONSISTS OF THE STYLIZED WORD "JOE" IN LIGHT BLUE WITH A DARK BROWN DESIGN OF A STEAMING COFFEE CUP IN THE CENTER OF THE LETTER "O" IN THE WORD "JOE", AND SURROUNDED BY A DARK BROWN BACKGROUND WITHIN TWO NARROW CONCENTRIC CIRCLES, THE INNER CIRCLE BEING WHITE AND THE OUTER CIRCLE BEING DARK BROWN.

SN 85-423,749. TYEROH, INC., TAMPA, FL. FILED 9-15-2011.

CLASS 30—STAPLE FOODS

FOR COFFEE (U.S. CL. 46).
FIRST USE 12-0-2009; IN COMMERCE 12-0-2009.

CLASS 43—HOTEL AND RESTAURANT SERVICES

FOR COFFEE HOUSE SERVICES; CATERING SERVICES (U.S. CLS. 100 AND 101).
DARRYL SPRUILL, EXAMINING ATTORNEY

PLAY FOR IT ALL

SN 85-424,009. DOCTORS IN TRAINING.COM, LLC, FORT WORTH, TX. FILED 9-15-2011.

DOCTORS IN TRAINING

THE MARK CONSISTS OF STANDARD CHARACTERS WITHOUT CLAIM TO ANY PARTICULAR FONT, STYLE, SIZE, OR COLOR.

CLASS 16—PAPER GOODS AND PRINTED MATTER

FOR PUBLICATIONS, NAMELY, PRINTED INSTRUCTIONAL AND TEACHING MATERIALS, MANUALS, BOOKS, MAGAZINES, BUSINESS CARDS, STICKERS, POSTCARDS, CALENDARS AND PRINTED EDUCATIONAL MATERIALS IN THE FIELDS OF EDUCATION AND SPORTS (U.S. CLS. 2, 5, 22, 23, 29, 37, 38 AND 50).

THE MARK CONSISTS OF STANDARD CHARACTERS WITHOUT CLAIM TO ANY PARTICULAR FONT, STYLE, SIZE, OR COLOR.

OWNER OF U.S. REG. NO. 3,625,732.
SEC. 2(F).

CLASS 25—CLOTHING

FOR BASEBALL CAPS AND HATS; BLAZERS; PULL-OVERS; SHIRTS; SHORTS; VESTS; SOCKS; SPORTS JERSEYS; T-SHIRTS; TANK TOPS; TIES; TRACK SUITS; UNDERGARMENTS (U.S. CLS. 22 AND 39).

RUDY R. SINGLETON, EXAMINING ATTORNEY

CLASS 16—PAPER GOODS AND PRINTED MATTER

FOR MEDICAL EDUCATION BOOKS AND OTHER PRINTED MEDICAL EDUCATION MATERIALS, NAMELY, STUDY GUIDES AND TRAINING MATERIALS FOR MEDICAL STUDENTS AND HEALTHCARE PROFESSIONALS (U.S. CLS. 2, 5, 22, 23, 29, 37, 38 AND 50).

FIRST USE 3-0-2008; IN COMMERCE 3-0-2008.

CLASS 41—EDUCATION AND ENTERTAINMENT

FOR EDUCATIONAL SERVICES IN THE FIELD OF MEDICAL EDUCATION, NAMELY, CONDUCTING AND PROVIDING MEDICAL EDUCATION SEMINARS AND VIDEO LECTURES (U.S. CLS. 100, 101 AND 107).

FIRST USE 3-0-2008; IN COMMERCE 3-0-2008.
ARETHA SOMERVILLE, EXAMINING ATTORNEY

SN 85-424,655. AL-KO KOBER A.G., KOTZE, FED REP GERMANY, FILED 9-16-2011.

AL-KO

SN 85-424,569. EPFF, LLC, DOVER, DE. FILED 9-16-2011.

CONEY ISLAND SURF COMPANY

THE MARK CONSISTS OF STANDARD CHARACTERS WITHOUT CLAIM TO ANY PARTICULAR FONT, STYLE, SIZE, OR COLOR.

OWNER OF U.S. REG. NO. 3,975,645.
NO CLAIM IS MADE TO THE EXCLUSIVE RIGHT TO USE "CONEY ISLAND" AND "COMPANY", APART FROM THE MARK AS SHOWN.

THE MARK CONSISTS OF STANDARD CHARACTERS WITHOUT CLAIM TO ANY PARTICULAR FONT, STYLE, SIZE, OR COLOR.

CLASS 7—MACHINERY

FOR GARDENING TOOLS, NAMELY, POWER BLOWERS AND LAWN VACUUMS, CHAINSAWS, COMPOSTERS, POWER OPERATED CULTIVATORS, TRACTOR TOWED AGRICULTURAL IMPLEMENTS, NAMELY, ROLLERS, POWER OPERATED HEDGE TRIMMERS, LAWNMOWERS, MIXING MACHINES, SCYTHE MOWERS, POWER SHREDDERS, MECHANICAL SPREADERS FOR SEED AND DRY LAWN CHEMICALS, AND POWER MACHINES FOR SPLITTING WOOD (U.S. CLS. 13, 19, 21, 23, 31, 34 AND 35).

CLASS 9—ELECTRICAL AND SCIENTIFIC APPARATUS

FOR SUNGLASSES; CASES FOR EYEGLASSES AND SUNGLASSES; MP3 PLAYERS; CD PLAYERS; AUDIO AND VIDEO CASSETTE RECORDERS; CAMERAS; CAMCORDERS; VIDEO CAMERAS; ACCESSORIES FOR MP3, AUDIO, AND VIDEO DEVICES, NAMELY, PROTECTIVE CASES, CHARGERS, TRANSMITTERS, SPEAKERS, ADAPTORS, CABLES, HEADPHONES AND EAR BUDS; CELLULAR TELEPHONE ACCESSORIES, NAMELY, PROTECTIVE CASES, CHARGERS, HEADPHONES, AND CABLES; MOBILE ELECTRONICS ACCESSORIES, NAMELY, NOTEBOOK COMPUTER CASES, COMPUTER STANDS SPECIALLY DESIGNED FOR HOLDING NOTEBOOK COMPUTERS, AND DOCKING STATIONS; COMPUTER PERIPHERAL EQUIPMENT, NAMELY, KEYBOARDS, MICE, MOUSE PADS, TRACKBALLS, JOYSTICKS, AND DOCKING STATIONS; TELEPHONY EQUIPMENT, NAMELY, TELEPHONES, MICROPHONES, HEADSETS, AND HEADPHONES; USB CABLES; USB HARDWARE, NAMELY, USB HUBS, USB CONNECTORS, AND USB CHARGERS (U.S. CLS. 21, 23, 26, 36 AND 38).

CLASS 11—ENVIRONMENTAL CONTROL APPARATUS

FOR HEATING INSTALLATIONS AND HEATING ELEMENTS; VENTILATING APPARATUS, NAMELY, ELECTRIC AND CEILING FANS AND VENTILATING EXHAUST FANS; AND AIR CONDITIONING APPARATUS AND AIR CONDITIONING UNITS (U.S. CLS. 13, 21, 23, 31 AND 34).

CLASS 12—VEHICLES

FOR VEHICLE COMPONENTS, NAMELY, AXLES, WHEEL BRAKES, WHEEL HUBS FOR TRAILERS AND TOWABLE VEHICLES, BRAKE DRUMS, VEHICLE TRAILER COUPLING HITCHES, AND VEHICLE CHASSIS (U.S. CLS. 19, 21, 23, 31, 35 AND 44).

FIRST USE 10-31-1984; IN COMMERCE 10-31-1984.
ELLEN PERKINS, EXAMINING ATTORNEY

CLASS 18—LEATHER GOODS

FOR HANDBAGS; PURSES; WALLETS; BACKPACKS, TOTE BAGS (U.S. CLS. 1, 2, 3, 22 AND 41).

SN 85-424,704. SOCIAL DYNAMX INC., AUSTIN, TX. FILED 9-16-2011.

SOCIAL DYNAMX

CLASS 21—HOUSEWARES AND GLASS

FOR COMBS; HAIR BRUSHES (U.S. CLS. 2, 13, 23, 29, 30, 33, 40 AND 50).

THE MARK CONSISTS OF STANDARD CHARACTERS WITHOUT CLAIM TO ANY PARTICULAR FONT, STYLE, SIZE, OR COLOR.

NO CLAIM IS MADE TO THE EXCLUSIVE RIGHT TO USE "SOCIAL", APART FROM THE MARK AS SHOWN.

CLASS 26—FANCY GOODS

FOR BARRETTES; BRAIDS; HAIR PINS; RIBBONS (U.S. CLS. 37, 39, 40, 42 AND 50).

CLASS 28—TOYS AND SPORTING GOODS

FOR BASEBALLS; BASEBALL BATS; BASEBALL GLOVES; BASKETBALLS; FOOTBALLS; FOOTBALL SHOULDER PADS; SOCCER BALLS; TENNIS BALLS; TENNIS RACQUETS; VOLLEYBALLS; FISHING POLES; FISHING REELS; FISHING TACKLE; SKATEBOARDS (U.S. CLS. 22, 23, 38 AND 50).

MATTHEW KLINE, EXAMINING ATTORNEY

CLASS 35—ADVERTISING AND BUSINESS

FOR (BASED ON USE IN COMMERCE) BUSINESS CONSULTATION SERVICES, NAMELY, SOCIAL MEDIA STRATEGY, MANAGING AND ENHANCING CUSTOMER CARE THROUGH SOCIAL INTERACTIONS AND MANAGING AND ENHANCING CUSTOMER RELATIONSHIP MANAGEMENT (U.S. CLS. 100, 101 AND 102).

FIRST USE 1-20-2011; IN COMMERCE 2-1-2011.

CLASS 42—SCIENTIFIC AND COMPUTER SERVICES

FOR (BASED ON INTENT TO USE) PROVIDING ONLINE NON-DOWNLOADABLE SOFTWARE FOR SOCIAL MEDIA MANAGEMENT, MANAGING AND ENHANCING CUSTOMER CARE AND MANAGING AND ENHANCING CUSTOMER RELATIONSHIP MANAGEMENT; COMPUTER CONSULTING SERVICES IN THE FIELDS OF SOCIAL MEDIA MANAGEMENT, MANAGING AND ENHANCING CUSTOMER CARE AND MANAGING AND ENHANCING CUSTOMER RELATIONSHIP MANAGEMENT; MAINTENANCE OF COMPUTER SOFTWARE IN THE FIELDS OF SOCIAL MEDIA MANAGEMENT, MANAGING AND ENHANCING CUSTOMER CARE AND MANAGING AND ENHANCING CUSTOMER RELATIONSHIP MANAGEMENT (U.S. CLS. 100 AND 101).

KAPIL BHANOT, EXAMINING ATTORNEY

SN 85-424,889. GHC SPECIALTY BRANDS, LLC, JANESVILLE, WI. FILED 9-16-2011.

GEMPLER'S

THE MARK CONSISTS OF STANDARD CHARACTERS WITHOUT CLAIM TO ANY PARTICULAR FONT, STYLE, SIZE, OR COLOR.

OWNER OF U.S. REG. NOS. 1,680,275 AND 3,065,921. SEC. 2(F).

CLASS 1—CHEMICALS

FOR BACTERIAL ADDITIVE FOR BREAKDOWN OF ORGANIC WASTE; DEFOAMER (SILICONE EMULSIFIER) TO BE ADDED TO PESTICIDE AND FERTILIZER SPRAY TANKS FOR PREVENTING OR SUPPRESSING FOAM AND FOAM BUILD-UP; BIODEGRADABLE WASTE DIGESTANT FOR USE IN SEPTIC SYSTEMS; CHEMICAL TEST KITS FOR SOIL FOR LABORATORY OR RESEARCH USE; CHEMICAL TEST KITS FOR TESTING MACRO AND MICRO NUTRIENTS, SOIL RESPIRATION, SALINITY, AGGREGATE STABILITY, SOIL STRUCTURE, INFILTRATION, PH, EARTH-WORMS, SOIL TEXTURE, BULK DENSITY, SOIL NITRATE, COMPACTION AND WATER QUALITY OF SOIL AND FOR TESTING E. COLI, COLIFORM BACTERIA, NITRATE/NITRITE, PH, CHLORINE, HARDNESS, ALKALINITY, BACTERIA, LEAD, PESTICIDES, AMMONIA, IRON OR COPPER IN WATER FOR LABORATORY OR RESEARCH USE; CHEMICAL TEST KITS FOR TESTING NITRATE LEVELS IN PLANTS FOR LABORATORY OR RESEARCH USE; CHEMICAL TEST KITS FOR LIVESTOCK FEED FOR LABORATORY OR RESEARCH USE (U.S. CLS. 1, 5, 6, 10, 26 AND 46).

FIRST USE 1-1-2003; IN COMMERCE 1-1-2003.

CLASS 3—COSMETICS AND CLEANING PREPARATIONS

FOR HAND CLEANING PREPARATIONS; WIPES IMPREGNATED WITH A SKIN CLEANSER; CLEANER FOR USE ON PESTICIDE AND FERTILIZER SPRAYER TANKS; RUST REMOVING PREPARATIONS; LAUNDRY DETERGENTS (U.S. CLS. 1, 4, 6, 50, 51 AND 52).

FIRST USE 1-1-2003; IN COMMERCE 1-1-2003.

CLASS 5—PHARMACEUTICALS

FOR FIRST AID KITS (U.S. CLS. 6, 18, 44, 46, 51 AND 52).

FIRST USE 6-30-2006; IN COMMERCE 6-30-2006.

CLASS 8—HAND TOOLS

FOR MANUALLY OPERATED TOOLS FOR WORK ON ALL TERRAIN VEHICLES, NAMELY, TIRE BEAD BREAKER TOOL (U.S. CLS. 23, 28 AND 44).

FIRST USE 1-1-2003; IN COMMERCE 1-1-2003.

CLASS 9—ELECTRICAL AND SCIENTIFIC APPARATUS

FOR PESTICIDE SAFETY KITS FOR PROVIDING PROTECTION AGAINST LOW-TOXICITY PESTICIDES COMPRISED OF NITRILE GLOVES, DISPOSABLE COVERALLS, GOGGLES, FACE SHIELDS, APRONS, RESPIRATORS WITH CARTRIDGES AND PREFILTERS, URETHANE STORAGE BAG, LATEX-RUBBER OVERSHOES, WARNING SIGNS AND HANDBOOK; PROTECTIVE WORK GLOVES; RESPIRATORS OTHER THAN FOR ARTIFICIAL RESPIRATION; MEASURING TUBES; MEASURING CUPS; PROTECTIVE INDUSTRIAL BOOTS (U.S. CLS. 21, 23, 26, 36 AND 38).

FIRST USE 1-1-2003; IN COMMERCE 1-1-2003.

CLASS 16—PAPER GOODS AND PRINTED MATTER

FOR BLANK CARDS; BINDERS; LOG BOOKS; REFERENCE BOOKS IN THE FIELD OF WORKER PROTECTION; POSTERS; PUBLICATIONS, NAMELY, POSTERS AND APPLICATION POSTING SHEETS FOR TRACKING PESTICIDE USE; PUBLICATIONS, NAMELY, REFERENCE GUIDES, WORKER HANDBOOKS, HANDLER HANDBOOKS, TRAINING NOTEBOOKS FOR WORKER TRAINING, ALL IN THE FIELD OF WORKPLACE SAFETY, FIRST AID AND HANDLING HAZARDOUS MATERIALS; PAPER AND CARDBOARD PESTICIDE APPLICATION WARNING SIGNS; FLIP CHARTS WITH EASELS; PAPER AND CARDBOARD EMERGENCY INFORMATION SIGNS IN THE FIELD OF PESTICIDE APPLICATION; PRINTED FORMS; BUSINESS RECORD BOOKS; DRY ERASE POSTERS; PRE-PRINTED NOTE PADS; PRE-PRINTED ADHESIVE LABELS; SELF-ADHESIVE DECALS; DISPOSABLE WIPES NOT IMPREGNATED WITH CHEMICALS OR COMPOUNDS (U.S. CLS. 2, 5, 22, 23, 29, 37, 38 AND 50).

FIRST USE 1-1-2003; IN COMMERCE 1-1-2003.

CLASS 18—LEATHER GOODS

FOR UMBRELLAS (U.S. CLS. 1, 2, 3, 22 AND 41).

FIRST USE 4-24-2009; IN COMMERCE 4-24-2009.

CLASS 19—NON-METALLIC BUILDING MATERIALS

FOR NON-LUMINOUS, NON-MECHANICAL SIGNS NOT MADE OF METAL (U.S. CLS. 1, 12, 33 AND 50).

FIRST USE 1-1-2003; IN COMMERCE 1-1-2003.

CLASS 20—FURNITURE AND ARTICLES NOT OTHERWISE CLASSIFIED

FOR WALL-MOUNTED BINDER RACKS MADE OF METAL; NON-METAL FLUID STORAGE TANKS; WALL-MOUNTED TOOL RACKS (U.S. CLS. 2, 13, 22, 25, 32 AND 50).

FIRST USE 1-1-2003; IN COMMERCE 1-1-2003.

CLASS 21—HOUSEWARES AND GLASS

FOR DISPOSABLE LATEX, NITRILE AND VINYL GLOVES FOR GENERAL USE; ALUMINUM WATER BOTTLES SOLD EMPTY; ELECTRIC DEVICES FOR ATTRACTING AND KILLING INSECTS (U.S. CLS. 2, 13, 23, 29, 30, 33, 40 AND 50).

FIRST USE 1-1-2003; IN COMMERCE 1-1-2003.

CLASS 22—CORDAGE AND FIBERS

FOR STORAGE BAGS FOR INDUSTRIAL USE; INSECT PROTECTION NETS (U.S. CLS. 1, 2, 7, 19, 22, 42 AND 50).

FIRST USE 1-1-2003; IN COMMERCE 1-1-2003.

CLASS 25—CLOTHING

FOR APRONS; HATS; RAIN JACKETS; RAIN SUITS; RAIN PANTS; CHAPS; COVERALLS; WATERPROOF PANTS (U.S. CLS. 22 AND 39).

FIRST USE 1-1-2003; IN COMMERCE 1-1-2003.
SHAUNIA CARLYLE, EXAMINING ATTORNEY

SN 85-425,968. AMAINEZING, LLC, ALEXANDRIA, VA. FILED 9-19-2011.

amainezing

THE MARK CONSISTS OF STANDARD CHARACTERS WITHOUT CLAIM TO ANY PARTICULAR FONT, STYLE, SIZE, OR COLOR.

SN 85-425,059. IVEDA SOLUTIONS, INC., MESA, AZ. FILED 9-16-2011.

SAFECITI POWERED BY IVEDA
SOLUTIONS

THE MARK CONSISTS OF STANDARD CHARACTERS WITHOUT CLAIM TO ANY PARTICULAR FONT, STYLE, SIZE, OR COLOR.

OWNER OF U.S. REG. NOS. 3,589,688, 3,589,689 AND 3,589,690.

NO CLAIM IS MADE TO THE EXCLUSIVE RIGHT TO USE "SOLUTIONS", APART FROM THE MARK AS SHOWN.

CLASS 37—CONSTRUCTION AND REPAIR

FOR INSTALLATION OF SECURITY AND SURVEILLANCE EQUIPMENT AND SYSTEMS; INSTALLATION OF COMPUTER HARDWARE (U.S. CLS. 100, 103 AND 106).

FIRST USE 8-24-2011; IN COMMERCE 8-24-2011.

CLASS 39—TRANSPORTATION AND STORAGE

FOR ELECTRONIC STORAGE SERVICES FOR VIDEO, IMAGES AND OTHER ELECTRONIC DATA IN THE FIELD OF PHYSICAL SECURITY SYSTEMS (U.S. CLS. 100 AND 105).

FIRST USE 8-24-2011; IN COMMERCE 8-24-2011.

CLASS 42—SCIENTIFIC AND COMPUTER SERVICES

FOR COMPUTER SERVICES, NAMELY, CLOUD HOSTING PROVIDER SERVICES IN CONNECTION WITH LIVE AND RECORDED SECURITY SYSTEM DIGITAL VIDEO OF OTHERS FOR THE PURPOSE OF ENABLING USERS OF PHYSICAL SECURITY SYSTEMS TO VIEW THE CONTENT; INSTALLATION AND PROGRAMMING OF COMPUTER SOFTWARE AND PROGRAMMING OF COMPUTER HARDWARE (U.S. CLS. 100 AND 101).

FIRST USE 8-24-2011; IN COMMERCE 8-24-2011.

CLASS 45—PERSONAL AND LEGAL SERVICES

FOR REMOTE VIDEO MONITORING OF PHYSICAL SECURITY SYSTEMS (U.S. CLS. 100 AND 101).

FIRST USE 8-24-2011; IN COMMERCE 8-24-2011.
STEVEN PEREZ, EXAMINING ATTORNEY

CLASS 18—LEATHER GOODS

FOR BACKPACKS, BOOK BAGS, SPORTS BAGS, BUM BAGS, WALLETS AND HANDBAGS; BEACH BAGS; CANVAS SHOPPING BAGS; CLOTHING FOR DOMESTIC PETS; PET PRODUCTS, NAMELY, PET RESTRAINING DEVICES CONSISTING OF LEASHES, COLLARS, HARNESES, RESTRAINING STRAPS, AND LEASHES WITH LOCKING DEVICES (U.S. CLS. 1, 2, 3, 22 AND 41).

CLASS 21—HOUSEWARES AND GLASS

FOR ALUMINUM WATER BOTTLES SOLD EMPTY; BEER JUGS; BEER MUGS; BOTTLE OPENERS; CUPS AND MUGS; DRINKING CUPS FOR BABIES AND CHILDREN AND PARTS AND FITTINGS THEREFOR, NAMELY, CUPS FOR BABIES AND CHILDREN SOLD AS A UNIT WITH VALVES AND LIDS; DRINKING CUPS FOR INFANTS AND PARTS AND FITTINGS THEREFOR, NAMELY, VALVES AND LIDS SOLD AS A UNIT; DRINKING FLASKS; INSULATING SLEEVE HOLDER FOR BEVERAGE CUPS; INSULATING SLEEVE HOLDER FOR BOTTLES; INSULATING SLEEVE HOLDERS FOR BEVERAGE CANS; NEOPRENE ZIPPERED BOTTLE HOLDERS; PET FEEDING AND DRINKING BOWLS; PILSNER DRINKING GLASSES; PLASTIC COASTERS; REUSABLE STAINLESS STEEL WATER BOTTLES SOLD EMPTY; SHOT GLASSES (U.S. CLS. 2, 13, 23, 29, 30, 33, 40 AND 50).

CLASS 25—CLOTHING

FOR BASEBALL CAPS AND HATS; BELTS; BIBS NOT OF CLOTH OR PAPER; BOTTOMS; CHILDREN'S AND INFANTS' CLOTH BIBS; CLOTH BIBS FOR ADULT DINERS; CLOTHING FOR BABIES, TODDLERS AND CHILDREN, TREATED WITH FIRE AND HEAT RETARDANTS, NAMELY, PAJAMAS, JACKETS, SHIRTS, PANTS, JUMPERS; DRESSES; GLOVES; HATS; INFANT AND TODDLER ONE PIECE CLOTHING; JACKETS; LONG SLEEVE PULLOVERS; LONG-SLEEVED SHIRTS; MATERNITY CLOTHING, NAMELY, SHIRTS, PANTS AND DRESSES; MITTENS; PANTS; SHORT-SLEEVED OR LONG-SLEEVED T-SHIRTS; SHORTS; SKIRTS; SLEEP PANTS; SLEEP SHIRTS; SWADDLING CLOTHES; SWEAT PANTS; SWEAT SHIRTS; TIES; WRAPS (U.S. CLS. 22 AND 39).

CLASS 28—TOYS AND SPORTING GOODS

FOR ARTICLES OF CLOTHING FOR TOYS; STUFFED TOYS; TOSsing DISC TOYS; TOYS FOR DOMESTIC PETS (U.S. CLS. 22, 23, 38 AND 50).

CLASS 35—ADVERTISING AND BUSINESS

FOR ON-LINE WHOLESALE AND RETAIL STORE SERVICES FEATURING CLOTHING, PET CLOTHING, PET ACCESSORIES, TOYS, ARTICLES OF CLOTHING FOR TOYS AND TOYS FOR PETS; RETAIL CLOTHING BOUTIQUES; RETAIL CLOTHING STORES; RETAIL STORES FEATURING CLOTHING, PET CLOTHING, PET ACCESSORIES, TOYS, ARTICLES OF CLOTHING FOR TOYS AND TOYS FOR PETS (U.S. CLS. 100, 101 AND 102).

MARY CRAWFORD, EXAMINING ATTORNEY

SN 85-426,754. INVESTMENT ANSWERS MEDIA, INC., LOUISVILLE, KY. FILED 9-20-2011.

LEAVE UNCERTAINTY BEHIND

THE MARK CONSISTS OF STANDARD CHARACTERS WITHOUT CLAIM TO ANY PARTICULAR FONT, STYLE, SIZE, OR COLOR.

CLASS 36—INSURANCE AND FINANCIAL

FOR EDUCATIONAL AND GLOSSARY WEB PAGE SERVICES, NAMELY, PROVIDING A WEBSITE FEATURING INFORMATION RELATING TO INVESTMENT, FINANCIAL, AND RETIREMENT PLANNING FOR CLIENTS AND PROSPECTIVE CLIENTS INCLUDING INDIVIDUALS, FAMILIES, ESTATES, COMPANIES, SMALL BUSINESSES, CORPORATIONS, AND CHARITIES; PROVIDING FINANCIAL ADVICE AND CONSULTANCY SERVICES AND PROVIDING INVESTMENT ADVICE ALL FOR PLANNING, BUDGETING AND DEVELOPING FINANCIAL RESOURCES FOR CLIENTS UTILIZING INVESTMENTS IN STOCKS, BONDS, CDS, MUTUAL FUNDS, EXCHANGE TRADED FUNDS, INDEX ACCOUNTS, RETIREMENT PLANNING, 401 K AND OTHER RETIREMENT PLANS, MANAGED PORTFOLIOS, REITS, UNIT INVESTMENT TRUSTS, FIXED ANNUITIES, FIXED INDEXED ANNUITIES, VARIABLE ANNUITIES, OPTIONS, COMMODITIES, FUTURES AND OTHER SECURITIES, AND INDICES OF SAME; FINANCIAL PLANNING, FINANCIAL ANALYSIS, INCOME PLANNING, ESTATE PLANNING, INVESTMENT PLANNING AND RETIREMENT PLANNING, AND IMPLEMENTATION OF STRATEGIES, NAMELY, FINANCIAL INVESTMENT BROKERAGE; INSURANCE CONSULTATION, RECOMMENDATION, AND IMPLEMENTATION, NAMELY, INSURANCE ADVISORY, CONSULTATION AND BROKERAGE SERVICES FOR INVESTMENT, RETIREMENT OR BUDGETING PURPOSES FOR CLIENTS OR PROSPECTIVE CLIENTS; FINANCIAL PLANNING FOR RETIREMENT FOR CLIENTS AND PROSPECTIVE CLIENTS; INVESTMENT CONSULTATION FOR CLIENTS AND PROSPECTIVE CLIENTS; INVESTMENT MANAGEMENT FOR CLIENTS OR PROSPECTIVE CLIENTS; INVESTMENT ADVISORY SERVICES FOR CLIENTS OR PROSPECTIVE CLIENTS; INVESTMENT SERVICES, NAMELY, FINANCIAL ADVISING SERVICES, FOR CLIENTS OR PROSPECTIVE CLIENTS; FINANCIAL ADVICE FOR CLIENTS OR PROSPECTIVE CLIENTS; FINANCIAL ANALYSIS AND RESEARCH SERVICES FOR CLIENTS OR PROSPECTIVE CLIENTS; FINANCIAL EVALUATION FOR INSURANCE PURPOSES FOR CLIENTS OR PROSPECTIVE CLIENTS; FINANCIAL PLANNING AND ADVISORY SERVICES, NAMELY, CREATION OF PERSONALIZED STRATEGIES TO ACHIEVE FINANCIAL GOALS FOR CLIENTS OR PROSPECTIVE CLIENTS; FINANCIAL PORTFOLIO ANALYSES SERVICES FOR CLIENTS OR PROSPECTIVE CLIENTS; FINANCIAL SERVICE PROVIDERS AND CONSULTANTS UTILIZING INVESTMENT ADVISOR SERVICES, NAMELY, PROVIDING INVESTMENT ADVICE FOR PLANNING AND DEVELOPMENT OF FINANCIAL RESOURCES FOR CLIENTS UTILIZING INVESTMENTS IN STOCKS, BONDS, CDS, MUTUAL FUNDS, EXCHANGE TRADED FUNDS, INDEX ACCOUNTS, RETIREMENT PLANNING, MANAGED PORTFOLIOS, REITS, UNIT INVESTMENT TRUSTS, AND VARIABLE ANNUITIES; FINANCIAL PLANNING, FINANCIAL ANALYSIS AND IMPLEMENTATION OF STRATEGIES, NAMELY, CAPITAL INVESTMENT SERVICES ALL FOR USE IN CONNECTION WITH INVESTMENT PLANNING AND FINANCIAL PORTFOLIO ANALYSES SERVICES FOR CLIENTS OR PROSPECTIVE CLIENTS; FINANCIAL EVALUATION FOR INSURANCE; FINANCIAL SPONSORSHIP OF RADIO SHOW RELATING TO INVESTMENT AND FINANCIAL PLANNING (U.S. CLS. 100, 101 AND 102).

CLASS 41—EDUCATION AND ENTERTAINMENT

FOR EDUCATIONAL SERVICES, NAMELY, CONDUCTING SEMINARS, WORKSHOPS, AND CONFERENCES IN THE FIELDS OF INVESTMENT, FINANCE, FINANCIAL PLANNING FINANCIAL PORTFOLIO MANAGEMENT, FINANCIAL AND RETIREMENT PLANNING; ARRANGING AND ORGANIZATION OF EDUCATIONAL CONFERENCES IN THE FIELDS OF INVESTMENT, FINANCE, FINANCIAL PLANNING FINANCIAL PORTFOLIO MANAGEMENT, FINANCIAL AND RETIREMENT PLANNING; PUBLICATION OF PRINTED MEDIA, NAMELY, ARTICLES, WHITE PAPERS, PAMPHLETS, COMPUTER GENERATED PRESENTATION PAPERS, AND PUBLICATIONS IN THE NATURE OF BOOKS, PAMPHLETS, NEWSLETTERS, AND BROCHURES RELATING TO INVESTMENT, FINANCIAL, AND RETIREMENT PLANNING; ENTERTAINMENT, NAMELY, PROVIDING A CONTINUING NEWS SHOW RELATING TO INVESTMENT AND FINANCIAL PLANNING BROADCAST OVER RADIO; PARTICIPATION IN A RADIO SHOW RELATING TO INVESTMENT AND FINANCIAL PLANNING, NAMELY, PROVIDING ENTERTAINMENT IN THE NATURE OF LIVE RADIO PERSONALITY PERFORMANCES (U.S. CLS. 100, 101 AND 107).

MEGHAN REINHART, EXAMINING ATTORNEY

SN 85-427,667. CRY BABY, INC., LOS ANGELES, CA. FILED 9-20-2011.

CRYBABY PRESENTS

THE MARK CONSISTS OF STANDARD CHARACTERS WITHOUT CLAIM TO ANY PARTICULAR FONT, STYLE, SIZE, OR COLOR.

NO CLAIM IS MADE TO THE EXCLUSIVE RIGHT TO USE "PRESENTS", APART FROM THE MARK AS SHOWN.

CLASS 35—ADVERTISING AND BUSINESS

FOR ADVERTISING AND PROMOTING OF AND GALLERY EXHIBITS FEATURING ARTISTS AND ARTWORKS, MUSICIANS AND MUSIC, CLOTHING DESIGNERS AND CLOTHING, ART EVENTS, FASHION SHOWS, MUSIC PERFORMANCES AND VIDEO SCREENINGS BY MEANS OF PROVIDING AN E-COMMERCE STORE, ONLINE EVENTS CALENDAR AND PHOTO ARCHIVE, ONLINE JOURNALS OR BLOGS, ORIGINAL ARTICLES, PHOTOS, VIDEOS, INTERVIEWS, AND INFORMATION ABOUT ART, MUSIC, FASHION, ARTISTS, DESIGNERS, MUSICIANS, AND EVENTS VIA AN INTERNET WEB SITE; ADVERTISING AND MARKETING SERVICES, NAMELY, PROMOTING THE GOODS AND SERVICES OF OTHERS; BUSINESS SERVICES, NAMELY, REGISTERING, SCREENING, CREDENTIALING, AND ORGANIZING THIRD-PARTY VENDORS, SUPPLIERS, AND CONTRACTORS, AND DOCUMENTATION AND INFORMATION ON BEHALF OF OTHERS; ADVERTISING ON THE INTERNET FOR OTHERS, NAMELY, IN WEBSITES, SOCIAL CONVERSATIONS OVER THE INTERNET, EMAILS, MICROBLOGS, BLOGS, ELECTRONIC MESSAGES, INSTANT MESSAGES, TEXT MESSAGES, MULTIMEDIA MESSAGES, SOCIAL NETWORKS, STATUS UPDATES, FORUMS, ELECTRONIC BULLETIN BOARDS; ADVERTISING AND MARKETING SERVICES PROVIDED BY MEANS OF INDIRECT METHODS OF MARKETING COMMUNICATIONS, NAMELY, SOCIAL MEDIA, SEARCH ENGINE MARKETING, INTERNET MARKETING, MOBILE MARKETING, BLOGGING AND PASSIVE, SHARABLE AND VIRAL COMMUNICATIONS CHANNELS; ADVERTISING AND PUBLICITY SERVICES, NAMELY, PROMOTING THE GOODS, SERVICES, BRAND IDENTITY AND COMMERCIAL INFORMATION AND NEWS OF THIRD PARTIES

THROUGH PRINT, AUDIO, VIDEO, DIGITAL AND ON-LINE MEDIA; COMPUTERIZED ON-LINE ORDERING FEATURING ITEMS OF FASHION, NAMELY, CLOTHING AND ACCESSORIES, NAMELY, WOMEN'S CLOTHING, NAMELY, BLOUSES, T-SHIRTS, SKIRTS, DRESSES, HATS, PANTS, SOCKS, SHOES, SWEATERS, JACKETS, COATS, HOSIERY, SHORTS, LINGERIE, PAJAMAS, MEN'S CLOTHING, NAMELY, T-SHIRTS, SHIRTING, SHORTS, PANTS, JACKETS, COATS, SOCKS, SWEATERS, HATS, PAJAMAS, WOMEN'S SHOES, WOMEN'S BAGS, JEWELRY, HATS, SUNGLASSES, BEAUTY PRODUCTS, ART AND MUSIC EVENTS, ART BOOKS, NOTEBOOKS, MUGS, CANDLESTICKS, CANDLES, VASES, MAGNETS, KEY CHAINS, FURNITURE AND FURNITURE ACCESSORIES, PENCILS, MATCHES, ART OBJECTS BY DESIGNERS, FINE ART, PAINTING, DRAWINGS, SCULPTURE, PRINTS; COMPUTERIZED ON-LINE RETAIL STORE SERVICES IN THE FIELD OF FASHION, NAMELY, CLOTHING AND ACCESSORIES, NAMELY, WOMEN'S CLOTHING, NAMELY, BLOUSES, T-SHIRTS, SKIRTS, DRESSES, HATS, PANTS, SOCKS, SHOES, SWEATERS, JACKETS, COATS, HOSIERY, SHORTS, LINGERIE, PAJAMAS, MEN'S CLOTHING, NAMELY, T-SHIRTS, SHIRTING, SHORTS, PANTS, JACKETS, COATS, SOCKS, SWEATERS, HATS, PAJAMAS, WOMEN'S SHOES, WOMEN'S BAGS, JEWELRY, HATS, SUNGLASSES, BEAUTY PRODUCTS, ART AND MUSIC EVENTS, ART BOOKS, NOTEBOOKS, MUGS, CANDLESTICKS, CANDLES, VASES, MAGNETS, KEY CHAINS, FURNITURE AND FURNITURE ACCESSORIES, PENCILS, MATCHES, ART OBJECTS BY DESIGNERS, FINE ART, PAINTING, DRAWINGS, SCULPTURE, PRINTS; ON-LINE ADVERTISING AND MARKETING SERVICES; ON-LINE ADVERTISING SERVICES FOR OTHERS; ON-LINE RETAIL STORE SERVICES FEATURING FASHION, NAMELY, CLOTHING AND ACCESSORIES, NAMELY, WOMEN'S CLOTHING, NAMELY, BLOUSES, T-SHIRTS, SKIRTS, DRESSES, HATS, PANTS, SOCKS, SHOES, SWEATERS, JACKETS, COATS, HOSIERY, SHORTS, LINGERIE, PAJAMAS, MEN'S CLOTHING, NAMELY, T-SHIRTS, SHIRTING, SHORTS, PANTS, JACKETS, COATS, SOCKS, SWEATERS, HATS, PAJAMAS, WOMEN'S SHOES, WOMEN'S BAGS, JEWELRY, HATS, SUNGLASSES, BEAUTY PRODUCTS, ART AND MUSIC EVENTS, ART BOOKS, NOTEBOOKS, MUGS, CANDLESTICKS, CANDLES, VASES, MAGNETS, KEY CHAINS, FURNITURE AND FURNITURE ACCESSORIES, PENCILS, MATCHES, ART OBJECTS BY DESIGNERS, FINE ART, PAINTING, DRAWINGS, SCULPTURE, PRINTS; ON-LINE RETAIL STORE SERVICES FEATURING DOWNLOADABLE PRE-RECORDED MUSIC AND VIDEO; ON-LINE RETAIL STORE SERVICES FEATURING DOWNLOADABLE SOUND, MUSIC, IMAGES, AND VIDEOS; RETAIL STORE SERVICES FEATURING FASHION, NAMELY, CLOTHING AND ACCESSORIES, NAMELY, WOMEN'S CLOTHING, NAMELY, BLOUSES, T-SHIRTS, SKIRTS, DRESSES, HATS, PANTS, SOCKS, SHOES, SWEATERS, JACKETS, COATS, HOSIERY, SHORTS, LINGERIE, PAJAMAS, MEN'S CLOTHING, NAMELY, T-SHIRTS, SHIRTING, SHORTS, PANTS, JACKETS, COATS, SOCKS, SWEATERS, HATS, PAJAMAS, WOMEN'S SHOES, WOMEN'S BAGS, JEWELRY, HATS, SUNGLASSES, BEAUTY PRODUCTS, ART AND MUSIC EVENTS, ART BOOKS, NOTEBOOKS, MUGS, CANDLESTICKS, CANDLES, VASES, MAGNETS, KEY CHAINS, FURNITURE AND FURNITURE ACCESSORIES, PENCILS, MATCHES, ART OBJECTS BY DESIGNERS, FINE ART, PAINTING, DRAWINGS, SCULPTURE, PRINTS; OPERATING AN ON-LINE SHOPPING SITE IN THE FIELD OF FASHION, NAMELY, CLOTHING AND ACCESSORIES, NAMELY, WOMEN'S CLOTHING, NAMELY, BLOUSES, T-SHIRTS, SKIRTS, DRESSES, HATS, PANTS, SOCKS, SHOES, SWEATERS, JACKETS, COATS, HOSIERY, SHORTS, LINGERIE, PAJAMAS, MEN'S CLOTHING, NAMELY, T-SHIRTS, SHIRTING, SHORTS, PANTS, JACKETS, COATS, SOCKS, SWEATERS, HATS, PAJAMAS, WOMEN'S SHOES, WOMEN'S BAGS, JEWELRY, HATS, SUNGLASSES, BEAUTY PRODUCTS, ART AND MUSIC EVENTS, ART BOOKS, NOTEBOOKS, MUGS, CANDLESTICKS, CANDLES, VASES, MAGNETS, KEY CHAINS, FURNITURE AND FURNITURE ACCESSORIES, PENCILS, MATCHES, ART OBJECTS BY DESIGNERS, FINE ART, PAINTING, DRAWINGS, SCULPTURE, PRINTS; OPERATING ON-LINE MARKETPLACES FOR SELLERS OF ITEMS OF FASHION, NAMELY, CLOTHING AND ACCESSORIES, NAMELY, WOMEN'S CLOTHING, NAMELY, BLOUSES, T-SHIRTS, SKIRTS, DRESSES, HATS, PANTS, SOCKS,

SHOES, SWEATERS, JACKETS, COATS, HOSIERY, SHORTS, LINGERIE, PAJAMAS, MEN'S CLOTHING, NAMELY, T-SHIRTS, SHIRTING, SHORTS, PANTS, JACKETS, COATS, SOCKS, SWEATERS, HATS, PAJAMAS, WOMEN'S SHOES, WOMEN'S BAGS, JEWELRY, HATS, SUNGLASSES, BEAUTY PRODUCTS, ART AND MUSIC EVENTS, ART BOOKS, NOTEBOOKS, MUGS, CANDLESTICKS, CANDLES, VASES, MAGNETS, KEY CHAINS, FURNITURE AND FURNITURE ACCESSORIES, PENCILS, MATCHES, ART OBJECTS BY DESIGNERS, FINE ART, PAINTING, DRAWINGS, SCULPTURE, PRINTS; ON-LINE EXHIBITION SERVICES FOR ADVERTISING PURPOSES FEATURING ARTISTS AND ARTWORKS, MUSICIANS AND MUSIC AND CLOTHING DESIGNERS AND CLOTHING, ART EVENTS, FASHION SHOWS, MUSIC PERFORMANCES AND VIDEO SCREENINGS; ON-LINE ADVERTISING FEATURING THE GOODS OF OTHERS; RETAIL STORE SERVICES FEATURING THE GOODS AND SERVICES OF OTHERS, NAMELY, GOODS AND SERVICES IN THE FIELD OF FASHION, NAMELY, CLOTHING AND ACCESSORIES, NAMELY, WOMEN'S CLOTHING, NAMELY, BLOUSES, T-SHIRTS, SKIRTS, DRESSES, HATS, PANTS, SOCKS, SHOES, SWEATERS, JACKETS, COATS, HOSIERY, SHORTS, LINGERIE, PAJAMAS, MEN'S CLOTHING, NAMELY, T-SHIRTS, SHIRTING, SHORTS, PANTS, JACKETS, COATS, SOCKS, SWEATERS, HATS, PAJAMAS, WOMEN'S SHOES, WOMEN'S BAGS, JEWELRY, HATS, SUNGLASSES, BEAUTY PRODUCTS, ART AND MUSIC EVENTS, ART BOOKS, NOTEBOOKS, MUGS, CANDLESTICKS, CANDLES, VASES, MAGNETS, KEY CHAINS, FURNITURE AND FURNITURE ACCESSORIES, PENCILS, MATCHES, ART OBJECTS BY DESIGNERS, FINE ART, PAINTING, DRAWINGS, SCULPTURE, PRINTS; AND EXHIBITION SERVICES FOR BUSINESS AND ADVERTISING PURPOSES FEATURING THE GOODS AND SERVICES OF OTHERS (U.S. CLS. 100, 101 AND 102).

CLASS 42—SCIENTIFIC AND COMPUTER SERVICES

FOR COMPUTER SERVICES, NAMELY, HOSTING ON-LINE WEB FACILITIES FOR OTHERS TO SHOW-CASE MUSICAL AND ARTISTIC TALENTS AND FOR PROVIDING CALENDARS OF EVENTS AND FACILITATING THE OPERATION OF GALLERY EXHIBITS THAT PROVIDE AMUSEMENT, ENTERTAINMENT, AND RETAIL STORE SERVICES (U.S. CLS. 100 AND 101).

MICHAEL WIENER, EXAMINING ATTORNEY

SN 85-428,220. TIAN YANG, ASH, ALDRSHOT, UNITED KINGDOM, FILED 9-21-2011.

PHOMAX

THE MARK CONSISTS OF STANDARD CHARACTERS WITHOUT CLAIM TO ANY PARTICULAR FONT, STYLE, SIZE, OR COLOR.

OWNER OF UNITED KINGDOM REG. NO. 2487062, DATED 5-9-2008, EXPIRES 5-9-2018.

CLASS 9—ELECTRICAL AND SCIENTIFIC APPARATUS

FOR ACCESSORIES FOR LIGHTING FIXTURES, NAMELY, PLASTIC POLE WITH ELECTRICAL SOURCE IN PROTECTIVE COVER; AN OPTICAL METROLOGY INSPECTION SYSTEM COMPRISED OF A LIGHT SOURCE, ONE OR MORE CAMERAS AND SENSORS IN COMMUNICATION WITH COMPUTER SOFTWARE AND HARDWARE; APPARATUS THAT EMPLOYS LIGHT CONCENTRATING OPTICS TO CONCENTRATE SUNLIGHT AND TO AID IN THE CONVERSION OF SUNLIGHT INTO ELECTRIC AND THERMAL ENERGY; BAGS FOR CAMERAS AND PHOTOGRAPHIC EQUIPMENT; BATTERIES FOR LIGHTING; CASES FOR PHOTOGRAPHIC APPARATUS; COLLAPSIBLE LIGHT DIRECTORS AND DIFFUSERS FOR USE WITH PHOTOGRAPHIC LIGHTING EQUIPMENT FOR PROFESSIONAL AND HIGH-END PHOTOGRAPHY; COMPUTER SOFTWARE FOR ORGANIZING AND VIEWING DIGITAL IMAGES AND PHOTOGRAPHS; COMPUTER SOFTWARE TO ENABLE THE TRANSMISSION OF PHOTOGRAPHS TO MOBILE TELEPHONES; CONNECTING DEVICES FOR PHOTOGRAPHIC EQUIPMENT, NAMELY, CABLE CONNECTORS; DRYING APPARATUS FOR PHOTOGRAPHIC PRINTS; EXPOSED PHOTOGRAPHIC FILM; EXPOSURE METERS FOR PHOTOGRAPHIC DEVICES; FLASHLIGHTS WITH LIGHT EMITTING DIODES FOR USE IN PHOTOGRAPHY; FLUORESCENT LAMP BALLAST FOR ELECTRIC LIGHTS; LIGHT DIRECTORS AND PHOTOGRAPHIC LIGHTING TENTS, ALL FOR USE WITH PHOTOGRAPHIC LIGHTING EQUIPMENT FOR PROFESSIONAL AND HIGH-END PHOTOGRAPHY; LIGHTING CONTROL PANELS; LIGHTING CONTROL SOFTWARE FOR USE IN COMMERCIAL AND INDUSTRIAL FACILITIES; LIGHTING CONTROLS; LIGHTING DEVICES FOR TAKING PICTURES; LIGHTING PANEL CONTROL BOARDS; METAL DEPOSITORY HOUSING SOLD EMPTY THAT IS SPECIALLY ADAPTED TO CONTAIN PHOTOGRAPHIC AND COMPUTER COMPONENTS; MOUNTING DEVICES FOR PHOTOGRAPHIC EQUIPMENT; NAUTICAL AND PHOTOGRAPHIC APPARATUS AND INSTRUMENTS, NAMELY, UNDERWATER HOUSINGS FOR CAMERAS, UNDERWATER ENCLOSURES FOR CAMERAS AND UNDERWATER ENCLOSURES FOR PHOTOGRAPHIC LENSES; PHOTOGRAPHIC ACCESSORY, NAMELY, FILM BACKS; PHOTOGRAPHIC CAMERAS; PHOTOGRAPHIC EXPOSURE METERS; PHOTOGRAPHIC FILTERS; PHOTOGRAPHIC FINDERS, NAMELY, STRAIGHT VIEWFINDERS AND ANGLED VIEWFINDERS; PHOTOGRAPHIC FLASH UNITS; PHOTOGRAPHIC FLASHBULBS; PHOTOGRAPHIC PROJECTORS; PHOTOGRAPHIC SLIDE TRANSPARENCIES; PHOTOGRAPHIC SLIDES; PHOTOGRAPHIC TRANSPARENCIES; PHOTOGRAPHIC VIEWFINDERS; PORTABLE PHOTOGRAPHY EQUIPMENT, NAMELY, REFLECTORS, TRIPODS, LIGHT STANDS AND SUPPORTS AND BAGS SPECIALLY ADAPTED FOR THESE GOODS; POWER SUPPLIES FOR LIGHTS, SIRENS AND PUBLIC ADDRESS SYSTEMS; RADIO RECEIVERS AND TRANSMITTERS FOR MONITORING AND CONTROLLING LIGHT EMITTING DIODES IN A NETWORK OF STREET LIGHTS AND FOR PROCESSING EMERGENCY SIGNALS TRANSMITTED TO INDIVIDUAL STREET LIGHTS; RADIO TRANSMITTERS, RECEIVERS, AND CONTROLLERS FOR MONITORING AND CONTROLLING PUBLIC LIGHTING; SLIDE OR PHOTOGRAPH PROJECTION APPARATUS; STANDS FOR PHOTOGRAPHIC APPARATUS; STROBE LIGHT APPARATUS FOR USE IN PROFESSIONAL QUALITY PHOTOGRAPHY; UNDERWATER ENCLOSURES FOR PHOTOGRAPHIC FLASH UNITS; UNDERWATER PHOTOGRAPHIC FLASH UNITS; VIEWING DEVICES, NAMELY, DIGITAL PHOTOGRAPH VIEWERS, 3D DIGITAL PHOTOGRAPH VIEWERS, UNDERWATER DIGITAL PHOTOGRAPH VIEWERS, UNDERWATER 3D DIGITAL PHOTOGRAPHS VIEWERS, UNDERWATER LCD DISPLAYS, UNDERWATER ENCLOSURES FOR LCD DISPLAYS AND UNDERWATER ENCLOSURES FOR VIDEO PLAYERS (U.S. CLS. 21, 23, 26, 36 AND 38).

FIRST USE 8-8-2008; IN COMMERCE 8-8-2008.

CLASS 11—ENVIRONMENTAL CONTROL APPARATUS

FOR ELECTRIC LIGHT BULBS; FILM STAGE LIGHTING APPARATUS; FLASHING STROBE LIGHT APPARATUS; FLAT PANEL LIGHTING APPARATUS; FLUORESCENT ELECTRIC LIGHT BULBS; FLUORESCENT LIGHTING TUBES; HALOGEN LIGHT BULBS; LAMP WHOSE LIGHT CAN BE TURNED IN ALL DIRECTIONS; LANDSCAPE LIGHTING INSTALLATIONS; LANTERNS FOR LIGHTING; LED (LIGHT EMITTING DIODE) LIGHTING FIXTURES; LED (LIGHT EMITTING DIODES) LIGHTING FIXTURES FOR USE IN DISPLAY, COMMERCIAL, INDUSTRIAL, RESIDENTIAL, AND ARCHITECTURAL ACCENT LIGHTING APPLICATIONS; LED AND HID LIGHT FIXTURES; LED LANDSCAPE LIGHTS; LED LIGHT ASSEMBLIES FOR STREET LIGHTS, SIGNS, COMMERCIAL LIGHTING, AUTOMOBILES, BUILDINGS, AND OTHER ARCHITECTURAL USES; LED LIGHT BULBS; LED LIGHTING FIXTURES FOR INDOOR AND OUTDOOR LIGHTING APPLICATIONS; LED LIGHTING SYSTEMS, NAMELY, LED MODULES, POWER SUPPLIES, AND WIRING; LED LIGHTS FOR LIGHTING PURPOSES INCORPORATED INTO KEY CHAINS, SMALL TOYS OR OTHER SIMILAR PERSONAL ITEMS; LED UNDERWATER LIGHTS; LIGHT BULBS; LIGHT DIFFUSERS; LIGHT REFLECTORS; LIGHTED DISCO BALLS; LIGHTED PARTY-THEMED DECORATIONS, ELECTRIC LIGHT DECORATIVE STRINGS; LIGHTING FIXTURES; LIGHTING TUBES (U.S. CLS. 13, 21, 23, 31 AND 34).

FIRST USE 8-8-2008; IN COMMERCE 8-8-2008.
TEJBIR SINGH, EXAMINING ATTORNEY

SN 85-428,656. HEATWAVE LAB. INC., 35 CYBER CITY, EBENE, MAURITIUS, FILED 9-22-2011.

TAILFREE

THE MARK CONSISTS OF STANDARD CHARACTERS WITHOUT CLAIM TO ANY PARTICULAR FONT, STYLE, SIZE, OR COLOR.

CLASS 9—ELECTRICAL AND SCIENTIFIC APPARATUS

FOR COMPUTER MONITORS, COMPUTER MEMORIES, MICRO-PROCESSORS, CENTRAL PROCESSING UNITS BEING COMPUTER HARDWARE, COMPUTERS, RANDOM ACCESS MEMORY MODULES, COMPUTER TERMINALS, COMPUTER PROGRAMS FOR USING THE INTERNET AND THE WORLD WIDE WEB, INTERNET SERVERS, NETWORK ACCESS SERVER HARDWARE, NETWORK ACCESS SERVER OPERATING SOFTWARE, MOTHERBOARDS, VIDEO DISPLAY CARDS, GRAPHICS CARDS, SLIDE OR PHOTOGRAPH PROJECTION APPARATUS, TELEVISION APPARATUS FOR PROJECTION PURPOSES, AMPLIFIERS, PRE-AMPLIFIERS, LIQUID CRYSTAL DISPLAY TELEVISIONS, LIQUID CRYSTAL DISPLAY MONITORS, VIDEO SCREENS, VIDEO AND COMPUTER GAME PROGRAMS, BATTERIES, FUEL CELLS, SOLAR CELLS, RADAR, RADAR DETECTORS, RADIO RECEIVERS AND TRANSMITTER, LIGHT EMITTING DIODES, ELECTRIC LIGHT DIMMERS, LIGHTING BALLASTS, COMPUTER CHIPS, SILICON CHIPS, MICROCIRCUITS, INTEGRATED CIRCUITS, HEAT SINKS FOR USE IN COMPUTERS, HEAT SINKS FOR USE IN ELECTRONIC COMPONENTS, CENTRAL PROCESSING UNIT COOLERS, VAPOR CHAMBERS FOR USE IN COMPUTERS, VAPOR CHAMBERS FOR USE IN ELECTRONIC COMPONENTS; ELECTRONIC CONTROLLERS FOR LAND VEHICLE ENGINES (U.S. CLS. 21, 23, 26, 36 AND 38).

CLASS 11—ENVIRONMENTAL CONTROL APPARATUS

FOR ELECTRIC LIGHT BULBS, ELECTRIC LIGHTING FIXTURES, SOLAR LIGHT FIXTURES, NAMELY, INDOOR AND OUTDOOR SOLAR POWERED LIGHTING UNITS AND FIXTURES, LED LIGHTING FIXTURES, LED LIGHT BULBS (U.S. CLS. 13, 21, 23, 31 AND 34).

CLASS 12—VEHICLES

FOR ELECTRIC CARS, ELECTRIC LOCOMOTIVES, ELECTRIC MOTORCYCLES, ELECTRIC MOTORS FOR MOTOR CARS, LAND VEHICLES AND STRUCTURAL PARTS THEREFOR, MOTORCYCLES AND STRUCTURAL PARTS THEREFOR (U.S. CLS. 19, 21, 23, 31, 35 AND 44).

DAVID TOOLEY, EXAMINING ATTORNEY

SN 85-428,978. GRYPHON NETWORKS CORP., NORWOOD, MA. FILED 9-22-2011.

GRYPHON CORE

THE MARK CONSISTS OF STANDARD CHARACTERS WITHOUT CLAIM TO ANY PARTICULAR FONT, STYLE, SIZE, OR COLOR.

CLASS 35—ADVERTISING AND BUSINESS

FOR PROVIDING AN ON-LINE COMPUTER DATABASE FOR USERS WITH SPECIFIC INFORMED RECOMMENDATIONS OF SPECIFIC CONSUMER SERVICES WITH RELATION TO DO-NOT-CALL, DO-NOT-TEXT, DO-NOT-EMAIL, DO-NOT-MAIL, DO-NOT-FAX AND CALL RECORDING (U.S. CLS. 100, 101 AND 102).

FIRST USE 1-28-2011; IN COMMERCE 1-28-2011.

CLASS 38—COMMUNICATION

FOR ON-LINE WEB SITE INFORMATION SERVICES IN THE FIELD OF TELECOMMUNICATION, NAMELY, PROVIDING COMPUTER USERS WITH DATABASES AND WEB SITE LINKS TO FACILITATE DO-NOT-CALL, DO-NOT-TEXT, DO-NOT-EMAIL, DO-NOT-MAIL, DO-NOT-FAX AND CALL RECORDING INFORMATION GATHERING AND IMPLEMENTATION; PROVIDING AN ON-LINE COMPUTER DATABASE IN THE FIELD OF TELECOMMUNICATION, NAMELY, DO-NOT-CALL, DO-NOT-TEXT, DO-NOT-EMAIL, DO-NOT-MAIL, DO-NOT-FAX AND CALL RECORDING BEST PRACTICES AND CONSUMER PREFERENCES (U.S. CLS. 100, 101 AND 104).

FIRST USE 1-28-2011; IN COMMERCE 1-28-2011.

CLASS 42—SCIENTIFIC AND COMPUTER SERVICES

FOR CLOUD COMPUTING FEATURING SOFTWARE PLATFORM FOR USE IN CUSTOMER CONTACT COMPLIANCE, CUSTOMER CONTACT PREFERENCE AND EXEMPTION MANAGEMENT OF CUSTOMER CONTACT COMPLIANCE AND PREFERENCE INFORMATION, AND TRACKING OF SALES REPRESENTATIVE PRODUCTIVITY FOR MARKETING MANAGEMENT PURPOSES, ALL OF THE FOREGOING IN COMPLIANCE WITH DO-NOT-CALL, DO-NOT-TEXT, DO-NOT-EMAIL, DO-NOT-MAIL, DO-NOT-FAX AND CALL RECORDING LAWS AND BEST PRACTICES; SOFTWARE AS A SERVICE (SAAS) SERVICES, NAMELY, HOSTING SOFTWARE FOR USE BY OTHERS FOR USE IN CUSTOMER CONTACT COMPLIANCE, CUSTOMER

CONTACT PREFERENCE AND EXEMPTION MANAGEMENT OF CUSTOMER CONTACT COMPLIANCE AND PREFERENCE INFORMATION, AND TRACKING OF SALES REPRESENTATIVE PRODUCTIVITY FOR MARKETING MANAGEMENT PURPOSES, ALL OF THE FOREGOING IN COMPLIANCE WITH DO-NOT-CALL, DO-NOT-TEXT, DO-NOT-EMAIL, DO-NOT-MAIL, DO-NOT-FAX AND CALL RECORDING LAWS AND BEST PRACTICES; SOFTWARE AS A SERVICE (SAAS) SERVICES FEATURING SOFTWARE IN THE FIELD OF MANAGEMENT OF CUSTOMER CONTACT COMPLIANCE, CUSTOMER CONTACT PREFERENCE AND EXEMPTION MANAGEMENT OF CUSTOMER CONTACT COMPLIANCE AND PREFERENCE INFORMATION, AND TRACKING OF SALES REPRESENTATIVE PRODUCTIVITY FOR MARKETING MANAGEMENT PURPOSES, ALL OF THE FOREGOING IN COMPLIANCE WITH DO-NOT-CALL, DO-NOT-TEXT, DO-NOT-EMAIL, DO-NOT-MAIL, DO-NOT-FAX AND CALL RECORDING LAWS AND BEST PRACTICES; SOFTWARE AS A SERVICE (SAAS) SERVICES FEATURING SOFTWARE FOR USE IN MANAGEMENT OF CUSTOMER CONTACT COMPLIANCE, CUSTOMER CONTACT PREFERENCE AND EXEMPTION MANAGEMENT OF CUSTOMER CONTACT COMPLIANCE AND PREFERENCE INFORMATION, AND TRACKING OF SALES REPRESENTATIVE PRODUCTIVITY FOR MARKETING MANAGEMENT PURPOSES, ALL OF THE FOREGOING IN COMPLIANCE WITH DO-NOT-CALL, DO-NOT-TEXT, DO-NOT-EMAIL, DO-NOT-MAIL, DO-NOT-FAX AND CALL RECORDING LAWS AND BEST PRACTICES; SOFTWARE AS A SERVICE (SAAS) SERVICES FEATURING SOFTWARE FOR USE IN EXPANSION OF CONSUMER CONTACT MARKETING USING CLOUD-BASED INTERNET CONNECTIONS; PLATFORM AS A SERVICE (PAAS) FEATURING COMPUTER SOFTWARE PLATFORMS FOR THE PURPOSE OF PROVIDING REAL TIME NO-CALL AND CONSUMER PREFERENCE AND LOYALTY INFORMATION; SOFTWARE AS A SERVICE (SAAS) SERVICES, NAMELY, HOSTING SOFTWARE FOR USE BY OTHERS FOR USE THE PURPOSE OF PROVIDING REAL TIME NO-CALL AND CONSUMER PREFERENCE AND LOYALTY INFORMATION; SOFTWARE AS A SERVICE (SAAS) SERVICES FEATURING SOFTWARE IN THE FIELD OF THE PURPOSE OF PROVIDING CUSTOMER CONTACT COMPLIANCE, CUSTOMER CONTACT PREFERENCE AND EXEMPTION MANAGEMENT OF CUSTOMER CONTACT COMPLIANCE AND PREFERENCE INFORMATION, AND TRACKING OF SALES REPRESENTATIVE PRODUCTIVITY FOR MARKETING MANAGEMENT PURPOSES, ALL OF THE FOREGOING IN COMPLIANCE WITH DO-NOT-CALL, DO-NOT-TEXT, DO-NOT-EMAIL, DO-NOT-MAIL, DO-NOT-FAX AND CALL RECORDING LAWS AND BEST PRACTICES; SOFTWARE AS A SERVICE (SAAS) SERVICES FEATURING SOFTWARE FOR THE PURPOSE OF PROVIDING CUSTOMER CONTACT COMPLIANCE, CUSTOMER CONTACT PREFERENCE AND EXEMPTION MANAGEMENT OF CUSTOMER CONTACT COMPLIANCE AND PREFERENCE INFORMATION, AND TRACKING OF SALES REPRESENTATIVE PRODUCTIVITY FOR MARKETING MANAGEMENT PURPOSES, ALL OF THE FOREGOING IN COMPLIANCE WITH DO-NOT-CALL, DO-NOT-TEXT, DO-NOT-EMAIL, DO-NOT-MAIL, DO-NOT-FAX AND CALL RECORDING LAWS AND BEST PRACTICES; PROVIDING TEMPORARY USE OF NON-DOWNLOADABLE SOFTWARE FOR USE IN MANAGING DO-NOT-CALL, DO-NOT-TEXT, DO-NOT-EMAIL, DO-NOT-MAIL, DO-NOT-FAX AND CALL RECORDING INFORMATION GATHERED IN COMPLIANCE WITH LAWS AND BEST PRACTICES GOVERNING ALL OF THE FOREGOING; AND ACCESS CONTROL SERVICES FOR OTHERS, NAMELY, PROVIDING ONLINE NON-DOWNLOADABLE SOFTWARE FOR MONITORING, RESTRICTING AND ACCESSING ONLINE INFORMATION AND SERVICES IN THE FIELD OF COMPLIANCE WITH DO-NOT-CALL, DO-NOT-TEXT, DO-NOT-EMAIL, DO-NOT-MAIL, DO-NOT-FAX AND CALL RECORDING LAWS AND BEST PRACTICES AND CONSUMER PREFERENCES (U.S. CLS. 100 AND 101).

FIRST USE 1-28-2011; IN COMMERCE 1-28-2011.

CLASS 45—PERSONAL AND LEGAL SERVICES

FOR PROVIDING AN ON-LINE COMPUTER DATABASE IN THE FIELDS OF DO-NOT-CALL, DO-NOT-TEXT, DO-NOT-EMAIL, DO-NOT-MAIL, DO-NOT-FAX AND CALL RECORDING LAWS (U.S. CLS. 100 AND 101).

FIRST USE 1-28-2011; IN COMMERCE 1-28-2011.
LINDSEY RUBIN, EXAMINING ATTORNEY

SN 85-429,398. IMPERSONA LLC, POTOMAC, MD. FILED 9-22-2011.

Idea Merchant

THE MARK CONSISTS OF STANDARD CHARACTERS WITHOUT CLAIM TO ANY PARTICULAR FONT, STYLE, SIZE, OR COLOR.

CLASS 35—ADVERTISING AND BUSINESS

FOR PROVIDING A WEBSITE FOR CONNECTING SELLERS WITH BUYERS (U.S. CLS. 100, 101 AND 102).

FIRST USE 11-1-2010; IN COMMERCE 9-16-2011.

CLASS 42—SCIENTIFIC AND COMPUTER SERVICES

FOR PROVIDING A WEB SITE FEATURING TECHNOLOGY THAT ENABLES USERS TO SEEK AND PROVIDE ONLINE CONSULTING SERVICES (U.S. CLS. 100 AND 101).

FIRST USE 11-1-2010; IN COMMERCE 9-16-2011.

CLASS 45—PERSONAL AND LEGAL SERVICES

FOR ON-LINE SOCIAL NETWORKING SERVICES (U.S. CLS. 100 AND 101).

FIRST USE 11-1-2010; IN COMMERCE 9-16-2011.
TIMOTHY FINNEGAN, EXAMINING ATTORNEY

SN 85-429,444. BROMS, MICHAEL E., AURORA, CO. AND BROMS, JOSEPH T., GLEN CARBON, IL. AND BROMS, WILLIAM R., DENVER, CO. FILED 9-22-2011.

LESSON LEADERS

THE MARK CONSISTS OF STANDARD CHARACTERS WITHOUT CLAIM TO ANY PARTICULAR FONT, STYLE, SIZE, OR COLOR.

NO CLAIM IS MADE TO THE EXCLUSIVE RIGHT TO USE "LESSON", APART FROM THE MARK AS SHOWN.

CLASS 9—ELECTRICAL AND SCIENTIFIC APPARATUS

FOR COMPUTER SOFTWARE FOR TEACHING INTERACTIVE EDUCATIONAL COURSES FEATURING USER-GENERATED LESSONS COVERING A WIDE VARIETY OF SUBJECTS; COMPUTER SOFTWARE FOR LEARNING INTERACTIVE EDUCATIONAL COURSES FEATURING USER-GENERATED LESSONS COVERING A WIDE VARIETY OF SUBJECTS (U.S. CLS. 21, 23, 26, 36 AND 38).

CLASS 41—EDUCATION AND ENTERTAINMENT

FOR EDUCATIONAL SERVICES, NAMELY, PROVIDING ONLINE INTERACTIVE EDUCATIONAL USER-GENERATED LESSONS COMPRISING TEXT, GRAPHIC, AUDIO, AND VIDEO FILES COVERING A WIDE VARIETY OF SUBJECTS; AND ONLINE INTERACTIVE USER-GENERATED FLASH CARDS COVERING A WIDE VARIETY OF SUBJECTS (U.S. CLS. 100, 101 AND 107).

MARILYN IZZI, EXAMINING ATTORNEY

SN 85-429,562. UNITED STATES DEPARTMENT OF HOMELAND SECURITY, WASHINGTON, DC. FILED 9-22-2011.

Resilience STAR

THE MARK CONSISTS OF STANDARD CHARACTERS WITHOUT CLAIM TO ANY PARTICULAR FONT, STYLE, SIZE, OR COLOR.

CLASS 41—EDUCATION AND ENTERTAINMENT

FOR TRAINING AND EDUCATION SERVICES, NAMELY, CLASSES, WORKSHOPS, SEMINARS, AND CONFERENCES RELATED TO THE PROMOTION OF BUILDING RESILIENT COMMERCIAL PROPERTIES AND PRIVATE RESIDENCES, NAMELY, PROPERTIES RESISTANT TO NATURAL OR MAN-MADE HAZARDS (U.S. CLS. 100, 101 AND 107).

CLASS 42—SCIENTIFIC AND COMPUTER SERVICES

FOR EVALUATION OF BUILDINGS AND PRIVATE RESIDENCES FOR THE PURPOSE OF DEPARTMENT OF HOMELAND SECURITY CERTIFICATION ALIGNED TO GENERATED RESILIENCE OPERATIONAL REQUIREMENTS; ENGINEERING CONSULTING RELATED TO THE PROMOTION OF BUILDING RESILIENT COMMERCIAL PROPERTIES AND PRIVATE RESIDENCES, NAMELY, PROPERTIES RESISTANT TO NATURAL OR MAN-MADE HAZARDS (U.S. CLS. 100 AND 101).

LEIGH CAROLINE CASE, EXAMINING ATTORNEY

SN 85-429,587. BENDZIEWICZ-TRACY, JILL, DBA CREATAIVE B'STRO, SAN FRANCISCO, CA. FILED 9-22-2011.



OWNER OF U.S. REG. NO. 3,328,918.
THE MARK CONSISTS OF A GEOMETRIC SQUARE WITH AN APOSTROPHE SYMBOL SUPERIMPOSED ON THE UPPER RIGHT CORNER FOLLOWED BY "B'STRO". THE WORDING "B'STRO" HAS NO MEANING IN A FOREIGN LANGUAGE.

CLASS 35—ADVERTISING AND BUSINESS

FOR ADVERTISING AND MARKETING CONSULTANCY; ADVERTISING AND MARKETING SERVICES PROVIDED BY MEANS OF INDIRECT METHODS OF MARKETING COMMUNICATIONS, NAMELY, SOCIAL MEDIA, SEARCH ENGINE MARKETING, INQUIRY MARKETING, INTERNET MARKETING, MOBILE MARKETING, BLOGGING AND OTHER FORMS OF PASSIVE, SHARABLE OR VIRAL COMMUNICATIONS CHANNELS; ADVERTISING SERVICES, NAMELY, CREATING CORPORATE AND BRAND IDENTITY FOR OTHERS; ADVERTISING SERVICES, NAMELY, CREATING CORPORATE LOGOS FOR OTHERS; ADVERTISING, PROMOTION AND MARKETING SERVICES IN THE NATURE OF E-MAIL BLAST CAMPAIGNS FOR OTHERS; CREATING AND UPDATING ADVERTISING MATERIAL; DESIGN OF ADVERTISING BROCHURES FOR OTHERS; DESIGN OF INTERNET ADVERTISING; PREPARATION AND REALIZATION OF MEDIA AND ADVERTISING PLANS AND CONCEPTS; PREPARATION OF CUSTOM OR NON-CUSTOM ADVERTISING FOR BUSINESSES FOR DISSEMINATION VIA THE WEB, CD OR DVD FOR OPTIONAL UPLOAD OR DOWNLOAD TO A COMPUTER; SOCIAL MEDIA STRATEGY AND MARKETING CONSULTANCY FOCUSING ON HELPING CLIENTS CREATE AND EXTEND THEIR PRODUCT AND BRAND STRATEGIES BY BUILDING VIRALLY ENGAGING MARKETING SOLUTIONS (U.S. CLS. 100, 101 AND 102).
FIRST USE 10-1-2010; IN COMMERCE 10-1-2010.

CLASS 42—SCIENTIFIC AND COMPUTER SERVICES

FOR CREATING AND DESIGNING WEB PAGES FOR OTHERS; CREATING AND MAINTAINING WEB SITES FOR OTHERS (U.S. CLS. 100 AND 101).
FIRST USE 10-1-2010; IN COMMERCE 10-1-2010.
RAMONA ORTIGA, EXAMINING ATTORNEY

SN 85-429,619. BENDZIEWICZ-TRACY, JILL, DBA CREATAIVE B'STRO, SAN FRANCISCO, CA. FILED 9-22-2011.

B'STRO

THE MARK CONSISTS OF STANDARD CHARACTERS WITHOUT CLAIM TO ANY PARTICULAR FONT, STYLE, SIZE, OR COLOR.
OWNER OF U.S. REG. NO. 3,328,918.
THE WORDING "B'STRO" HAS NO MEANING IN A FOREIGN LANGUAGE.

CLASS 35—ADVERTISING AND BUSINESS

FOR ADVERTISING AND MARKETING CONSULTANCY; ADVERTISING AND MARKETING SERVICES PROVIDED BY MEANS OF INDIRECT METHODS OF MARKETING COMMUNICATIONS, NAMELY, SOCIAL MEDIA, SEARCH ENGINE MARKETING, INQUIRY MARKETING, INTERNET MARKETING, MOBILE MARKETING, BLOGGING AND OTHER FORMS OF PASSIVE, SHARABLE OR VIRAL COMMUNICATIONS CHANNELS; ADVERTISING SERVICES, NAMELY, CREATING CORPORATE AND BRAND IDENTITY FOR OTHERS; ADVERTISING SERVICES, NAMELY, CREATING CORPORATE LOGOS; ADVERTISING, PROMOTION AND MARKETING SERVICES IN THE NATURE OF E-MAIL BLAST CAMPAIGNS FOR OTHERS; CREATING AND UPDATING ADVERTISING MATERIAL; DESIGN OF ADVERTISING BROCHURES FOR OTHERS; DESIGN OF INTERNET ADVERTISING; PREPARATION AND REALIZATION OF MEDIA AND ADVERTISING PLANS AND CONCEPTS; PREPARATION OF CUSTOM OR NON-CUSTOM ADVERTISING FOR BUSINESSES FOR DISSEMINATION VIA THE WEB, CD OR DVD FOR OPTIONAL UPLOAD OR DOWNLOAD TO A COMPUTER; SOCIAL MEDIA STRATEGY AND MARKETING CONSULTANCY FOCUSING ON HELPING CLIENTS CREATE AND EXTEND THEIR PRODUCT AND BRAND STRATEGIES BY BUILDING VIRALLY ENGAGING MARKETING SOLUTIONS (U.S. CLS. 100, 101 AND 102).

FIRST USE 4-23-2007; IN COMMERCE 4-23-2007.

CLASS 42—SCIENTIFIC AND COMPUTER SERVICES

FOR CREATING AND DESIGNING WEB PAGES FOR OTHERS; CREATING AND MAINTAINING WEB SITES FOR OTHERS (U.S. CLS. 100 AND 101).
FIRST USE 4-23-2007; IN COMMERCE 4-23-2007.
RAMONA ORTIGA, EXAMINING ATTORNEY

SN 85-429,623. MAGIC MOMENTS MEDIA, LLC, TROY, MI. FILED 9-22-2011.

MAGIC MOMENTS

THE MARK CONSISTS OF STANDARD CHARACTERS WITHOUT CLAIM TO ANY PARTICULAR FONT, STYLE, SIZE, OR COLOR.

CLASS 9—ELECTRICAL AND SCIENTIFIC APPARATUS

FOR DOWNLOADABLE SOFTWARE FOR MOBILE DEVICES, NAMELY, SOFTWARE FOR USE IN THE TRANSMISSION OF DIGITAL IMAGES AND THE ORDERING AND SELLING OF PERSONALIZED GOODS (U.S. CLS. 21, 23, 26, 36 AND 38).

CLASS 35—ADVERTISING AND BUSINESS

FOR ON-LINE ORDERING SERVICES VIA MOBILE DEVICES IN THE FIELD OF GOODS PERSONALIZED WITH CUSTOMER'S DIGITAL IMAGES (U.S. CLS. 100, 101 AND 102).
ANDREA BUTLER, EXAMINING ATTORNEY

SN 85-430,354. IP HOLDINGS, LLC, LEXINGTON, KY.
FILED 9-23-2011.

URBAN AMPED

THE MARK CONSISTS OF STANDARD CHARACTERS WITHOUT CLAIM TO ANY PARTICULAR FONT, STYLE, SIZE, OR COLOR.

CLASS 25—CLOTHING

FOR CLOTHING, NAMELY, SPORTS BRAS, SHIRTS, TANK TOPS, SHORTS, PANTS, JACKETS, HEADBANDS, SWEATBANDS, SOCKS (U.S. CLS. 22 AND 39).

CLASS 41—EDUCATION AND ENTERTAINMENT

FOR PHYSICAL FITNESS STUDIO SERVICES, NAMELY, PROVIDING EXERCISE CLASSES, BODY SCULPTING CLASSES, AND GROUP FITNESS CLASSES (U.S. CLS. 100, 101 AND 107).

GISELLE AGOSTO, EXAMINING ATTORNEY

CLASS 16—PAPER GOODS AND PRINTED MATTER

FOR PAINTING PALETTES; PAPER PAINTING PALETTES; PAINT STIRRERS AND PADDLES; ART SUPPLIES BOXES IN THE NATURE OF PENCIL BOXES; CANVAS FOR PAINTING IN ROLL, PRE-STRETCHED AND BOARD FORM; GLUE FOR STATIONERY, OFFICE, AND HOUSEHOLD PURPOSES; EASELS; ART PAPER, NAMELY, PAPER FOR PRINT MAKING AND DRAWING, CONSTRUCTION PAPER, OAK TAG PAPER, CHIPBOARD RAILROAD BOARD IN THE NATURE OF PAPER BOARD, NEWSPRINT PAPER PADS, TRACING PAPER AND SKETCH BOOKS; ARTISTS' PRESENTATION CASES AND PORTFOLIOS IN THE NATURE OF ART AND PHOTOGRAPH PORTFOLIO CASES; CHARCOAL STICKS FOR DRAWING AND SKETCHING, PENCILS, CRAYONS, AND PENS; AND DRAFTING AND DRAWING INSTRUMENTS, NAMELY, RULING PENS, COMPASSES, FRICTION DIVIDERS, TRIANGLES, CURVES AND RULERS (U.S. CLS. 2, 5, 22, 23, 29, 37, 38 AND 50).

FIRST USE 7-8-1998; IN COMMERCE 7-8-1998.

CLASS 35—ADVERTISING AND BUSINESS

FOR MAIL ORDER CATALOG SERVICES FEATURING ART SUPPLIES; AND WHOLESALE AND RETAIL STORES FEATURING ART SUPPLIES (U.S. CLS. 100, 101 AND 102).

FIRST USE 7-8-1998; IN COMMERCE 7-8-1998.

NICHOLAS COLEMAN, EXAMINING ATTORNEY

SN 85-430,395. UTRECHT MANUFACTURING CORPORATION, CRANBURY, NJ. FILED 9-23-2011.



THE COLOR(S) RED AND WHITE IS/ARE CLAIMED AS A FEATURE OF THE MARK.

THE MARK CONSISTS OF STYLIZED WHITE LETTERS "UTRECHT" SURROUNDED BY A RED SHAPE RESEMBLING AN ARTIST'S PALETTE.

CLASS 2—PAINTS

FOR PAINT FOR ARTISTS, VARNISH; OIL PAINTS IN THE FORM OF STICKS AND BARS; AND PAINT PRIMERS FOR USE ON A VARIETY OF SURFACES; PAINTING SETS FOR ARTISTS; ART SUPPLIES BOXES IN THE NATURE OF BOXES FOR HOLDING PAINTS AND WATER-COLORS (U.S. CLS. 6, 11 AND 16).

FIRST USE 7-8-1998; IN COMMERCE 7-8-1998.

CLASS 8—HAND TOOLS

FOR ETCHING AND DRY POINT TOOLS, NAMELY, SCRIBERS, ETCHING NEEDLES, SCRAPERS AND BURNISHERS (U.S. CLS. 23, 28 AND 44).

FIRST USE 7-8-1998; IN COMMERCE 7-8-1998.

SN 85-430,604. HARD ROCK CAFE INTERNATIONAL (USA), INC., ORLANDO, FL. FILED 9-23-2011.

HARD ROCK RECORDS

THE MARK CONSISTS OF STANDARD CHARACTERS WITHOUT CLAIM TO ANY PARTICULAR FONT, STYLE, SIZE, OR COLOR.

OWNER OF U.S. REG. NO. 2,478,328.

NO CLAIM IS MADE TO THE EXCLUSIVE RIGHT TO USE "RECORDS", APART FROM THE MARK AS SHOWN. SEC. 2(F) AS TO "HARD ROCK".

CLASS 35—ADVERTISING AND BUSINESS

FOR PROMOTION OF PERFORMING ARTISTS, MUSICAL BANDS AND MUSICAL ARTISTS (U.S. CLS. 100, 101 AND 102).

CLASS 41—EDUCATION AND ENTERTAINMENT

FOR ENTERTAINMENT, NAMELY, LIVE PERFORMANCES BY MUSICAL BANDS AND MUSICAL ARTISTS; ENTERTAINMENT, NAMELY, LIVE MUSIC CONCERTS (U.S. CLS. 100, 101 AND 107).

MICHAEL WEBSTER, EXAMINING ATTORNEY

SN 85-431,092. ORPHIONICS, LLC, SAN CLEMENTE, CA.
FILED 9-23-2011.

CHRONICLR

THE MARK CONSISTS OF STANDARD CHARACTERS WITHOUT CLAIM TO ANY PARTICULAR FONT, STYLE, SIZE, OR COLOR.

CLASS 9—ELECTRICAL AND SCIENTIFIC APPARATUS

FOR COMPUTER SOFTWARE FOR SOCIAL NETWORKING, BUILDING SOCIAL NETWORKING APPLICATIONS AND FOR ALLOWING DATA RETRIEVAL, UPLOAD, ACCESS AND MANAGEMENT; APPLICATION PROGRAMMING INTERFACE (API) COMPUTER SOFTWARE FOR SOCIAL NETWORKING, BUILDING SOCIAL NETWORKING APPLICATIONS AND FOR ALLOWING DATA RETRIEVAL, UPLOAD, ACCESS AND MANAGEMENT (U.S. CLS. 21, 23, 26, 36 AND 38).
FIRST USE 7-22-2011; IN COMMERCE 7-22-2011.

CLASS 35—ADVERTISING AND BUSINESS

FOR PROVIDING ONLINE INFORMATION IN THE FIELD OF SOCIAL MEDIA FOR BUSINESS PURPOSES (U.S. CLS. 100, 101 AND 102).
FIRST USE 7-22-2011; IN COMMERCE 7-22-2011.

CLASS 38—COMMUNICATION

FOR PROVIDING ONLINE FORUMS AND BULLETIN BOARDS FOR USERS FOR TRANSMISSION OF MESSAGES CONCERNING SOCIAL AND/OR BUSINESS EVENTS, NEWS AND COMMUNICATIONS; PROVIDING ACCESS TO COMPUTER DATABASES; ELECTRONIC TRANSMISSION OF INSTANT MESSAGES AND DATA; PROVIDING ONLINE CHAT ROOMS FOR REGISTERED USERS FOR TRANSMISSION OF MESSAGES IN THE FIELD OF GENERAL INTEREST AND SOCIAL NETWORKING (U.S. CLS. 100, 101 AND 104).
FIRST USE 7-22-2011; IN COMMERCE 7-22-2011.

CLASS 41—EDUCATION AND ENTERTAINMENT

FOR ELECTRONIC PUBLISHING SERVICES, NAMELY, PUBLISHING OF ONLINE WORKS OF OTHERS FEATURING USER-CREATED TEXT AND GRAPHICS FEATURING SOCIAL AND/OR BUSINESS EVENTS, NEWS AND COMMUNICATIONS; PROVIDING ON-LINE EVENT PAGES FEATURING USER-CREATED CONTENT, NAMELY, PROVIDING A WEBSITE FOR ENTERTAINMENT PURPOSES WHERE USERS CAN VIEW AND POST MESSAGES, PHOTOS, VIDEOS AND DIGITAL CONTENT FEATURING SOCIAL AND/OR BUSINESS EVENTS, NEWS AND COMMUNICATIONS (U.S. CLS. 100, 101 AND 107).
FIRST USE 7-22-2011; IN COMMERCE 7-22-2011.

CLASS 42—SCIENTIFIC AND COMPUTER SERVICES

FOR PROVIDING TEMPORARY USE OF NON-DOWNLOADABLE SOFTWARE APPLICATIONS FOR VIRTUAL COMMUNITY, SOCIAL NETWORKING, PHOTO SHARING, AND TRANSMISSION OF PHOTOGRAPHIC IMAGES; COMPUTER SERVICES, NAMELY, HOSTING ONLINE WEB FACILITIES FOR OTHERS FOR ORGANIZING AND CONDUCTING ONLINE MEETINGS, GATHERINGS, AND INTERACTIVE DISCUSSIONS; COMPUTER SERVICES, NAMELY, PROVIDING CUSTOMIZED WEB PAGES FEATURING USER-DEFINED INFORMATION AND PERSONAL PROFILES; COMPUTER SERVICES, NAMELY, CREATING AN ON-LINE COMMUNITY FOR REGISTERED USERS TO PARTICIPATE IN DISCUSSION, GET FEEDBACK FROM THEIR PEERS, FORM VIRTUAL COMMUNITIES, AND ENGAGE IN SOCIAL NETWORKING IN THE FIELD OF SOCIAL AND/OR BUSINESS EVENTS, NEWS AND COMMUNICATIONS; PEER-TO-BROWSER PHOTO SHARING SERVICES, NAMELY, PROVIDING A WEBSITE FEATURING TECHNOLOGY ENABLING USERS TO UPLOAD, VIEW AND DOWNLOAD DIGITAL FILES AND MEDIA, INCLUDING DIGITAL PHOTOS (U.S. CLS. 100 AND 101).

FIRST USE 7-22-2011; IN COMMERCE 7-22-2011.

CLASS 45—PERSONAL AND LEGAL SERVICES

FOR INTERNET BASED INTRODUCTION AND SOCIAL NETWORKING SERVICES; PROVIDING ON-LINE COMPUTER DATABASES AND ON-LINE SEARCHABLE DATABASES IN THE FIELD OF SOCIAL NETWORKING (U.S. CLS. 100 AND 101).

FIRST USE 7-22-2011; IN COMMERCE 7-22-2011.
REBECCA SMITH, EXAMINING ATTORNEY

SN 85-432,047. DISCO, INC., PHILADELPHIA, PA. FILED 9-26-2011.



THE MARK CONSISTS OF THE WORD "CELLUCAP" IN UPPERCASE LETTERS, TO THE LEFT OF WHICH IS A GLOBE DESIGN COMPRISED OF A SPHERE DIVIDED INTO SHADED SEGMENTS BY HORIZONTAL AND VERTICAL LINES.

CLASS 9—ELECTRICAL AND SCIENTIFIC APPARATUS

FOR PROTECTIVE FACE MASKS NOT FOR MEDICAL PURPOSES (U.S. CLS. 21, 23, 26, 36 AND 38).

CLASS 10—MEDICAL APPARATUS

FOR DISPOSABLE SURGICAL FACE MASKS (U.S. CLS. 26, 39 AND 44).

CLASS 11—ENVIRONMENTAL CONTROL APPARATUS

FOR FILTRATION UNIT FOR FILTERING AND TREATING COOKING OIL BEING PART OF COMMERCIAL DEEP FRYERS (U.S. CLS. 13, 21, 23, 31 AND 34).

CLASS 21—HOUSEWARES AND GLASS

FOR SCOURING PADS; CLEANING PADS AND CLEANING BLOCKS FOR GRILL COOKING GRIDS AND COOKING GRATES (U.S. CLS. 2, 13, 23, 29, 30, 33, 40 AND 50).

CLASS 25—CLOTHING

FOR DISPOSABLE WEARING APPAREL, NAMELY, COVERALLS, GOWNS, SCRUBS, SHIRTS, TOPS, APRONS, LAB COATS, SMOCKS, GLOVES, COATS; HEAD WEAR, NAMELY, CAPS; FOOTWEAR, NAMELY, BOOTS (U.S. CLS. 22 AND 39).

CLASS 26—FANCY GOODS

FOR DISPOSABLE APPAREL, NAMELY, HAIRNETS (U.S. CLS. 37, 39, 40, 42 AND 50).
TEJBIR SINGH, EXAMINING ATTORNEY

SN 85-432,293. RIMAGE CORPORATION, EDINA, MN.
FILED 9-26-2011.

QUMU

THE MARK CONSISTS OF STANDARD CHARACTERS WITHOUT CLAIM TO ANY PARTICULAR FONT, STYLE, SIZE, OR COLOR.

CLASS 9—ELECTRICAL AND SCIENTIFIC APPARATUS

FOR COMPUTER SOFTWARE, NAMELY, ENTERPRISE VIDEO COMMUNICATIONS SOFTWARE FOR USE IN MANAGING A DATABASE FOR NON-TRANSACTIONAL DATA AND COMPUTER SEARCH ENGINE SOFTWARE FOR USE WITH DATABASE CONTENT; COMPUTER SOFTWARE FOR MANAGING COMPUTER HARDWARE AND SOFTWARE USED TO STORE AND BROADCAST VIDEO RECORDINGS; COMPUTER SOFTWARE FOR SCHEDULING, MANAGING, AND BROADCASTING VIDEO RECORDINGS, AND FOR USE WITH BROADCASTING LIVE VIDEO TV PROGRAMS ACROSS AN ENTERPRISE INTRANET AND OVER THE INTERNET AS WELL AS VIA A VIDEO-ON-DEMAND SERVICE; COMPUTER SOFTWARE FOR BROADCASTING VIDEO ON-DEMAND PROGRAMS; COMPUTER SOFTWARE FOR MANAGING AND CONTROLLING EQUIPMENT IN THE NATURE OF VIDEO RECORDERS AND VIDEO ENCODERS AND COMPUTER HARDWARE APPLIANCES USED FOR WEBCASTING LIVE VIDEO TV PROGRAMS FEATURING MANAGEMENT TRAINING PROGRAMS, PRODUCT TRAINING PROGRAMS AND PROGRAMS ABOUT EXECUTIVE COMMUNICATIONS PROVIDED VIA A VIDEO-ON-DEMAND SERVICE OR TO DIGITAL ELECTRIC SIGNS, AND USED FOR DIGITAL STORAGE, AND FOR PROVIDING BUSINESS VIDEO CONFERENCING SERVICES OVER THE INTERNET; COMPUTER SOFTWARE FOR CREATING AND ADMINISTERING PLAYLISTS FOR AUTOMATIC PLAY-OUT OF VIDEO RECORDINGS TO DIGITAL ELECTRIC SIGNAGE DISPLAY SCREENS; COMPUTER SOFTWARE FOR PUSHING VIDEO CONTENT SIMULTANEOUSLY TO REMOTE VIEWERS ON COMPUTERS AND DIGITAL ELECTRIC SIGNAGE DISPLAY SCREENS; COMPUTER SOFTWARE FOR USE IN BROADCASTING LIVE EVENT TV PROGRAMS TO DIGITAL ELECTRIC SIGNAGE DISPLAY SCREENS; COMPUTER SOFTWARE FOR AUTOMATICALLY FORMATTING VIDEO CONTENT FOR BROADCAST TO DIGITAL ELECTRIC SIGNAGE DISPLAY SCREENS AND FOR MONITORING QUALITY OF BROADCAST CONTENT; COMPUTER SOFTWARE FOR MANAGING

THE BROADCASTING OF VIDEO CONTENT FROM A CENTRAL LOCATION VIA THE INTERNET (U.S. CLS. 21, 23, 26, 36 AND 38).

FIRST USE 2-1-2008; IN COMMERCE 2-1-2008.

CLASS 42—SCIENTIFIC AND COMPUTER SERVICES

FOR COMPUTER SERVICES, NAMELY, ACTING AS AN APPLICATION SERVICE PROVIDER IN THE FIELD OF KNOWLEDGE MANAGEMENT TO HOST COMPUTER APPLICATION SOFTWARE FOR CREATING SEARCHABLE DATABASES OF INFORMATION AND DATA ACCESSIBLE VIA THE INTERNET, ON-LINE PORTALS, AND TELECOMMUNICATION DEVICES, ALL FOR MANAGING VIDEO APPLICATIONS; CONSULTING SERVICES IN THE FIELD OF INFORMATION TECHNOLOGY, NAMELY, PROVIDING CONSULTATION IN THE FIELDS OF HARDWARE AND SOFTWARE INFRASTRUCTURE FOR USE IN CREATING SEARCHABLE DATABASES OF INFORMATION AND DATA ACCESSIBLE VIA THE INTERNET, ON-LINE PORTALS, AND TELECOMMUNICATION DEVICES, ALL FOR MANAGING VIDEO APPLICATIONS; COMPUTER SERVICES, NAMELY, DIGITAL FORMATTING AND COMPRESSION OF MUSIC AND IMAGES, NAMELY, PROCESSING OF DIGITAL MUSIC AND VIDEO IMAGES INTO DOWNLOADABLE PRODUCTS FOR BROADCAST TO DIGITAL ELECTRIC SIGNAGE DISPLAY SCREENS; CONSULTATION SERVICES IN THE FIELDS OF SELECTION, IMPLEMENTATION AND USE OF COMPUTER HARDWARE AND SOFTWARE SYSTEMS FOR OTHERS; COMPUTER HARDWARE AND SOFTWARE CONSULTING SERVICES IN THE FIELDS OF ENTERPRISE VIDEO COMMUNICATIONS HARDWARE AND SOFTWARE (U.S. CLS. 100 AND 101).

FIRST USE 2-1-2008; IN COMMERCE 2-1-2008.
DAVID HOFFMAN, EXAMINING ATTORNEY

SN 85-432,425. LUCIDO, DANIELLE L, PORTLAND, ME.
FILED 9-26-2011.

Awaqi

THE MARK CONSISTS OF STANDARD CHARACTERS WITHOUT CLAIM TO ANY PARTICULAR FONT, STYLE, SIZE, OR COLOR.

THE ENGLISH TRANSLATION OF "QI" IN THE MARK IS LIFE ENERGY (APPROXIMATELY) IN CHINESE. THE WORDING "AWAQI" ITSELF HAS NO MEANING IN A FOREIGN LANGUAGE.

CLASS 25—CLOTHING

FOR HATS; SWEATSHIRTS; T-SHIRTS; WEARABLE GARMENTS AND CLOTHING, NAMELY, SHIRTS (U.S. CLS. 22 AND 39).

FIRST USE 7-0-2011; IN COMMERCE 7-0-2011.

CLASS 35—ADVERTISING AND BUSINESS

FOR ON-LINE RETAIL STORE SERVICES FEATURING CLOTHING AND ACCESSORIES (U.S. CLS. 100, 101 AND 102).

FIRST USE 7-0-2011; IN COMMERCE 7-0-2011.
DEZMONA MIZELLE, EXAMINING ATTORNEY

SN 85-432,940. TREASUREBUG.COM, LLC, SUMMERLAND KEY, FL. FILED 9-27-2011.

SN 85-433,908. ADVENTIST HEALTH SYSTEM/SUNBELT, INC., WINTER PARK, FL. FILED 9-28-2011.

TREASUREBUG

THE MARK CONSISTS OF STANDARD CHARACTERS WITHOUT CLAIM TO ANY PARTICULAR FONT, STYLE, SIZE, OR COLOR.

CLASS 35—ADVERTISING AND BUSINESS

FOR REFERRAL AND PROMOTIONAL SERVICES, NAMELY, DIRECT SOLICITATION BY SALES AGENTS ENROLLING PARTICIPANTS IN LIVE INTERACTIVE TREASURE HUNTING GAMING ADVENTURES (U.S. CLS. 100, 101 AND 102).

CLASS 41—EDUCATION AND ENTERTAINMENT

FOR ARRANGING AND CONDUCTING LIVE, INTERACTIVE, TREASURE HUNT GAMING ADVENTURES (U.S. CLS. 100, 101 AND 107).
CURTIS FRENCH, EXAMINING ATTORNEY

SN 85-433,471. J & J INDUSTRIES, INC., DALTON, GA. FILED 9-27-2011.

SENTIR

THE MARK CONSISTS OF STANDARD CHARACTERS WITHOUT CLAIM TO ANY PARTICULAR FONT, STYLE, SIZE, OR COLOR.

THE ENGLISH TRANSLATION OF "SENTIR" IN THE MARK IS TO FEEL.

CLASS 1—CHEMICALS

FOR CHEMICAL TREATMENT, NAMELY, SPRAY APPLIED TO CARPET TO CONTROL OR ELIMINATE AMBIENT ODORS IN THE AIR AND IN THE CARPET (U.S. CLS. 1, 5, 6, 10, 26 AND 46).

CLASS 27—FLOOR COVERINGS

FOR CARPET TREATED WITH A CHEMICAL PREPARATION TO CONTROL OR ELIMINATE AMBIENT ODORS IN THE AIR AND IN THE CARPET (U.S. CLS. 19, 20, 37, 42 AND 50).
SCOTT BIBB, EXAMINING ATTORNEY



OWNER OF U.S. REG. NOS. 3,440,069, 3,931,737 AND OTHERS.

THE MARK CONSISTS OF AN OVERALL HEXAGONAL SHAPE FORMED BY THREE INTERLOCKED LETTER "F" "I" "S".

CLASS 42—SCIENTIFIC AND COMPUTER SERVICES

FOR MEDICAL TESTING FOR RESEARCH PURPOSES; MEDICAL AND SCIENTIFIC RESEARCH SERVICES, NAMELY, CONDUCTING MEDICAL RESEARCH, CLINICAL TRIALS, PHARMACEUTICAL TRIALS, MEDICAL DEVICE TRIALS, AND CLINICAL RESEARCH STUDIES; CONSULTING SERVICES IN THE FIELD OF MEDICAL RESEARCH, RESEARCH AND DEVELOPMENT FOR MEDICAL TECHNOLOGY AND SURGICAL METHODS (U.S. CLS. 100 AND 101).
FIRST USE 12-15-1985; IN COMMERCE 12-15-1985.

CLASS 44—MEDICAL, BEAUTY AND AGRICULTURAL SERVICES

FOR MEDICAL TESTING FOR DIAGNOSTIC OR TREATMENT PURPOSES; MEDICAL SCREENING SERVICES (U.S. CLS. 100 AND 101).

FIRST USE 12-15-1985; IN COMMERCE 12-15-1985.
MICHAEL WEBSTER, EXAMINING ATTORNEY

SN 85-434,027. EGO HEROIN PRODUCTIONS, INC., ST. PETERSBURG, FL. FILED 9-28-2011.

EGO HEROIN

THE MARK CONSISTS OF STANDARD CHARACTERS WITHOUT CLAIM TO ANY PARTICULAR FONT, STYLE, SIZE, OR COLOR.

CLASS 25—CLOTHING

FOR T-SHIRTS, SHIRTS, SWEATSHIRTS, SWEATPANTS, HATS AND CAPS (U.S. CLS. 22 AND 39).

CLASS 35—ADVERTISING AND BUSINESS

FOR ON-LINE RETAIL STORE AND ORDERING SERVICES FEATURING DOWNLOADABLE PRE-RECORDED MUSIC AND VIDEO; RETAIL STORE, ON-LINE RETAIL STORE, ONLINE ORDERING SERVICES AND DISTRIBUTORSHIPS FEATURING DOWNLOADABLE, PUBLISHED, PRINTED OR PRE-RECORDED WORKS ON RECORDED ON DIGITAL VIDEO DISCS, DIGITAL VERSATILE DISCS, COMPACT DISCS, AND OTHER DIGITAL AND AUDIO-VIDEO RECORDING MEDIA IN THE NATURE OF LITERARY WORKS, BOOKS, ELECTRONIC BOOKS, AUDIO BOOKS, SHORT STORY BOOKS, TEXTS, SCREENPLAYS, SCRIPTS, SPEECHES, PLAYS, POETRY, GRAPHIC WORKS, AUDIO RECORDINGS, MUSIC, MUSIC VIDEOS, VIDEOS, FILM AND MOTION PICTURES AND OTHER AUDIO-VISUAL WORKS PRIMARILY WITHIN THE THEMES OF FICTION, PARODY, SATIRE, AND COMEDY, AND MERCHANDISE RELATED THERETO (U.S. CLS. 100, 101 AND 102).

CLASS 41—EDUCATION AND ENTERTAINMENT

FOR ENTERTAINMENT SERVICES, NAMELY, PROVIDING A WEB SITE FEATURING NON-DOWNLOADABLE MUSICAL PERFORMANCES, MUSICAL VIDEOS, RELATED FILM CLIPS, PHOTOGRAPHS, AND OTHER MULTIMEDIA MATERIALS WITHIN THE THEMES OF FICTION, PARODY, SATIRE, AND COMEDY; ENTERTAINMENT SERVICES, NAMELY, PROVIDING NON-DOWNLOADABLE PRERECORDED AUDIO RECORDINGS, MUSIC AND MUSICAL PERFORMANCES, INFORMATION IN THE FIELD OF MUSIC, AND COMMENTARY AND ARTICLES ABOUT MUSIC, ALL ON-LINE VIA A GLOBAL COMPUTER NETWORK; PROVIDING INFORMATION AND ARTICLES IN THE FIELD OF FILM, FILMMAKING, AND ENTERTAINMENT VIA A GLOBAL COMPUTER NETWORK WITHIN THE THEMES OF FICTION, PARODY, SATIRE, AND COMEDY; PROVIDING INFORMATION IN THE FIELD OF ENTERTAINMENT OR EDUCATION VIA A GLOBAL COMPUTER NETWORK, NAMELY, INFORMATION IN THE FIELD OF BOOKS, ELECTRONIC BOOKS AND OTHER LITERARY WORKS, MOVIES, MOTION PICTURES, FILMS, GRAPHICS, MULTIMEDIA PRESENTATIONS, VIDEOS AND PRE-RECORDED DIGITAL VIDEO DISCS AND DIGITAL VERSATILE DISCS, AND OTHER AUDIOVISUAL WORKS WITHIN THE THEMES OF FICTION, PARODY, SATIRE, AND COMEDY; PROVIDING A WEBSITE FEATURING BLOGS AND NON-DOWNLOADABLE PUBLICATIONS IN THE NATURE OF ARTICLES, BOOKS, ELECTRONIC BOOKS, AUDIO BOOKS, SHORT STORY BOOKS, TEXTS, SCRIPTS, SCREENPLAYS, SPEECHES, PLAYS OR POETRY IN THE FIELDS OF FICTION, PARODY, SATIRE, AND COMEDY; NON-DOWNLOADABLE ELECTRONIC PUBLICATIONS IN THE NATURE OF ARTICLES, BOOKS, ELECTRONIC BOOKS, AUDIO BOOKS, SHORT STORY BOOKS, TEXTS, SCRIPTS, SCREENPLAYS SPEECHES, PLAYS OR POETRY IN THE FIELDS OF FICTION, PARODY, SATIRE, AND COMEDY; PROVIDING A WEBSITE FEATURING NON-DOWNLOADABLE VIDEOS, NAMELY, VIDEO PRESENTATIONS OF A COMEDIC NATURE; PROVISION OF NON-DOWNLOADABLE FILMS AND MOVIES VIA A VIDEO-ON-DEMAND SERVICE; PROVIDING A WEBSITE FEATURING ENTERTAINMENT MATERIALS IN THE NATURE OF NON-DOWNLOADABLE AUDIO RECORDINGS, MUSICAL VIDEOS, VIDEOS, FILM, MOTION PICTURES AND OTHER AUDIO-VISUAL WORKS PRIMARILY WITHIN THE THEMES OF FICTION, PARODY, SATIRE, AND COMEDY; PROVIDING AN INTERNET NEWS PORTAL FEATURING LINKS TO NEWS STORIES AND ARTICLES IN THE FIELD OF CURRENT EVENTS WITHIN THE THEMES OF FICTION, PARODY, SATIRE, AND COMEDY; ENTERTAINMENT SERVICES, NAMELY, PROVIDING INFORMATION FOR MUSIC, MUSIC VIDEO, VIDEO AND FILM CONCEPT AND SCRIPT DEVELOPMENT; PROVIDING AN INTERNET WEB SITE CONTAINING ENTERTAINMENT REFERENCE MATERIAL ON LITERARY WORKS, FILMS, ACTORS, DIRECTORS, BACKGROUND ON LITERARY WORKS, FILMS AND OTHER INFORMATION ABOUT THE LITERARY FILM INDUSTRY IN THE FIELDS OF FICTION, PARODY, SATIRE, AND COMEDY; CUSTOM WRITING SERVICES; SCRIPT

WRITING SERVICES; POEM AND LYRIC WRITING; SONG WRITING SERVICES; WRITING OF TEXTS OTHER THAN PUBLICITY TEXTS (U.S. CLS. 100, 101 AND 107).

HENRY S. ZAK, EXAMINING ATTORNEY

SN 85-434,046. KNUCKLE SANDWICH, LLC, SANTA ROSA, CA. FILED 9-28-2011.

OWNER OF U.S. REG. NOS. 3,943,861 AND 3,988,866.
THE NAME(S), PORTRAIT(S), AND/OR SIGNATURE(S) SHOWN IN THE MARK IDENTIFIES GUY FIERI, WHOSE CONSENT(S) TO REGISTER IS MADE OF RECORD.
THE MARK CONSISTS OF THE SIGNATURE "GUY!" WITH AN EXCLAMATION POINT.

CLASS 11—ENVIRONMENTAL CONTROL APPARATUS

FOR BARBECUE SMOKER BOXES (U.S. CLS. 13, 21, 23, 31 AND 34).
FIRST USE 8-1-2011; IN COMMERCE 8-1-2011.

CLASS 21—HOUSEWARES AND GLASS

FOR HOUSEHOLD UTENSILS, NAMELY, SPATULAS, SCRAPERS, GRILL CLEANING SPONGES, GRILL CLEANING BRUSHES, BARBECUE TONGS, SKEWERS, GRILLING FORKS, SERVING SPOONS, BASTING BRUSHES, COOKING SKEWERS; UTENSILS FOR BARBECUES, NAMELY, FORKS, TONGS, TURNERS; WOOD COOKING PLANKS FOR USE IN GRILLING (U.S. CLS. 2, 13, 23, 29, 30, 33, 40 AND 50).
FIRST USE 8-1-2011; IN COMMERCE 8-1-2011.

CLASS 24—FABRICS

FOR BARBECUE MITTS (U.S. CLS. 42 AND 50).
FIRST USE 8-1-2011; IN COMMERCE 8-1-2011.
JOHN GARTNER, EXAMINING ATTORNEY

SN 85-434,182. BIOREGEN BIOMEDICAL (CHANGZHOU) CO., LTD., CHANGZHOU JIANGSU, CHINA, FILED 9-28-2011.

PRIORITY CLAIMED UNDER SEC. 44(D) ON CHINA APPLICATION NO. 9734426, FILED 7-19-2011.
PRIORITY CLAIMED UNDER SEC. 44(D) ON CHINA APPLICATION NO. 9734427, FILED 7-19-2011.

THE MARK CONSISTS OF THE WORD "PUREREGEN" WITH A CAPITAL "P" AND A CAPITAL "R".

NO CLAIM IS MADE TO THE EXCLUSIVE RIGHT TO USE "EQUINE", APART FROM THE MARK AS SHOWN.

CLASS 5—PHARMACEUTICALS

FOR DRESSING, MEDICAL; SURGICAL DRESSING; WADDING FOR MEDICAL PURPOSES; ABSORBENT COTTON FOR MEDICAL PURPOSES; ABSORBENT WADDING FOR MEDICAL PURPOSES (U.S. CLS. 6, 18, 44, 46, 51 AND 52).

CLASS 8—HAND TOOLS

FOR MANUALLY OPERATED HAND TOOLS, NAMELY, HOOF PICKS, HOOF KNIVES, HOOF NIPPERS, SWEAT SCRAPERS, THINNING BLADES FOR THINNING HAIR, RAZORS, HAND SHEARS, AND SCISSORS, ALL BEING USED IN THE GROOMING AND MAINTENANCE OF HORSES (U.S. CLS. 23, 28 AND 44).

CLASS 10—MEDICAL APPARATUS

FOR SURGICAL IMPLANTS AND MESH MADE OF SYNTHETIC MATERIALS FOR USE IN SOFT TISSUE REPAIR OR THE RECONSTRUCTION OF SOFT TISSUE DEFICIENCIES; MEDICAL, SURGICAL AND ORTHOPEDIC IMPLANTS MADE OF ARTIFICIAL MATERIALS; IMPLANTABLE SCAFFOLDS COMPRISING ARTIFICIAL MATERIALS FOR MAINTAINING TISSUE CONTOUR (U.S. CLS. 26, 39 AND 44).

DOMINIC J. FERRAIUOLO, EXAMINING ATTORNEY

CLASS 21—HOUSEWARES AND GLASS

FOR BRUSHES AND COMBS FOR GROOMING HORSES; CURRY COMBS, SPONGES, CLOTHS, DANDY BRUSHES, BODY BRUSHES, MANE COMBS, GROOMING GLOVES, AND HOOF OIL BRUSHES, ALL BEING USED FOR THE GROOMING AND MAINTENANCE OF HORSES (U.S. CLS. 2, 13, 23, 29, 30, 33, 40 AND 50).

FIRST USE 8-0-2011; IN COMMERCE 8-0-2011.

ALEX KEAM, EXAMINING ATTORNEY

SN 85-434,683. FLIGHT SHOPS INC., THE, VANCOUVER, BRITISH COLUMBIA, FILED 9-28-2011.

GOVOLUNTOURING

THE MARK CONSISTS OF STANDARD CHARACTERS WITHOUT CLAIM TO ANY PARTICULAR FONT, STYLE, SIZE, OR COLOR.

CLASS 35—ADVERTISING AND BUSINESS

FOR DEVELOPING AND COORDINATING VOLUNTEER PROJECTS FOR CHARITABLE ORGANIZATIONS; CHARITABLE SERVICES, NAMELY, PROVIDING A FREE ONLINE RESOURCE IN THE NATURE OF A WEBSITE FOR CONNECTING PEOPLE WHO HAVE SERVICES NEEDS WITH PEOPLE WHO ARE WILLING TO PROVIDE VOLUNTEER SERVICES; ADVERTISING SERVICES, NAMELY, ON-LINE ADVERTISING SERVICES PROVIDED TO VOLUNTEERS AND IN THE FIELD OF VOLUNTEER OPPORTUNITIES (U.S. CLS. 100, 101 AND 102).

FIRST USE 5-31-2011; IN COMMERCE 6-30-2011.

CLASS 39—TRANSPORTATION AND STORAGE

FOR ARRANGING TRAVEL TOURS FOR VOLUNTEERS (U.S. CLS. 100 AND 105).

FIRST USE 5-31-2011; IN COMMERCE 6-30-2011.

REBECCA SMITH, EXAMINING ATTORNEY

SN 85-434,748. MJ EQUINE TOOLS, INC., CHICAGO, IL, FILED 9-28-2011.

MJ EQUINE

THE MARK CONSISTS OF STANDARD CHARACTERS WITHOUT CLAIM TO ANY PARTICULAR FONT, STYLE, SIZE, OR COLOR.

SN 85-434,776. WHITE TRASH BEAUTIFUL, LLC, LOS ANGELES, CA. FILED 9-28-2011.

Nikki Rich

THE NAME "NIKKI RICH" DOES NOT IDENTIFY A LIVING INDIVIDUAL.

THE MARK CONSISTS OF THE WORDS "NIKKI RICH" IN A STYLIZED SCRIPT.

CLASS 3—COSMETICS AND CLEANING PREPARATIONS

FOR MAKE-UP; PERFUME (U.S. CLS. 1, 4, 6, 50, 51 AND 52).

FIRST USE 7-7-2011; IN COMMERCE 8-4-2011.

CLASS 14—JEWELRY

FOR JEWELRY; WATCHES (U.S. CLS. 2, 27, 28 AND 50).

FIRST USE 7-7-2011; IN COMMERCE 8-4-2011.

CLASS 18—LEATHER GOODS

FOR BACKPACKS; HANDBAGS; PURSES; TRAVEL BAGS (U.S. CLS. 1, 2, 3, 22 AND 41).

FIRST USE 7-7-2011; IN COMMERCE 8-4-2011.

CLASS 25—CLOTHING

FOR BATHING SUITS; BELTS; DRESSES; GLOVES; HATS; JACKETS; LINGERIE; PANTS; SHIRTS; SHOES; SKIRTS; UNDERWEAR (U.S. CLS. 22 AND 39).

FIRST USE 7-7-2011; IN COMMERCE 8-4-2011.

ALEX KEAM, EXAMINING ATTORNEY

SN 85-435,220. ALIPHCOM, SAN FRANCISCO, CA. FILED 9-29-2011.

EAT UP

THE MARK CONSISTS OF STANDARD CHARACTERS WITHOUT CLAIM TO ANY PARTICULAR FONT, STYLE, SIZE, OR COLOR.

CLASS 9—ELECTRICAL AND SCIENTIFIC APPARATUS

FOR PERSONAL ELECTRONIC DEVICES FOR RECORDING, ORGANIZING, TRANSMITTING, MANIPULATING, REVIEWING, AND RECEIVING TEXT, DATA, IMAGES AND AUDIO FILES; PERSONAL ELECTRONIC DEVICES FOR RECORDING, ORGANIZING, TRANSMITTING, MANIPULATING, REVIEWING, AND RECEIVING TEXT, DATA, IMAGES AND AUDIO FILES RELATING TO HEALTH AND WELLNESS; COMPUTER SOFTWARE USED FOR RECORDING, ORGANIZING, TRANSMITTING, RECEIVING, AND REVIEWING TEXT, DATA, IMAGES AND AUDIO FILES; COMPUTER SOFTWARE USED FOR RECORDING, ORGANIZING, TRANSMITTING, RECEIVING, AND REVIEWING TEXT, DATA, IMAGES AND AUDIO FILES RELATING TO HEALTH AND WELLNESS (U.S. CLS. 21, 23, 26, 36 AND 38).

CLASS 42—SCIENTIFIC AND COMPUTER SERVICES

FOR TECHNICAL SUPPORT SERVICES, NAMELY, TROUBLESHOOTING IN THE NATURE OF DIAGNOSING PERSONAL ELECTRONIC DEVICE PROBLEMS (U.S. CLS. 100 AND 101).

CLASS 45—PERSONAL AND LEGAL SERVICES

FOR INTERNET-BASED SOCIAL NETWORKING SERVICES (U.S. CLS. 100 AND 101).
NICHOLAS COLEMAN, EXAMINING ATTORNEY

SN 85-435,242. ALIPHCOM, SAN FRANCISCO, CA. FILED 9-29-2011.

STEP UP

THE MARK CONSISTS OF STANDARD CHARACTERS WITHOUT CLAIM TO ANY PARTICULAR FONT, STYLE, SIZE, OR COLOR.

CLASS 9—ELECTRICAL AND SCIENTIFIC APPARATUS

FOR PERSONAL ELECTRONIC DEVICES FOR RECORDING, ORGANIZING, TRANSMITTING, MANIPULATING, REVIEWING, AND RECEIVING TEXT, DATA, IMAGES AND AUDIO FILES; PERSONAL ELECTRONIC DEVICES FOR RECORDING, ORGANIZING, TRANSMITTING, MANIPULATING, REVIEWING, AND RECEIVING TEXT, DATA, IMAGES AND AUDIO FILES RELATING TO HEALTH AND WELLNESS; COMPUTER SOFTWARE USED FOR RECORDING, ORGANIZING, TRANSMITTING, RECEIVING, AND REVIEWING TEXT, DATA, IMAGES AND AUDIO FILES; COMPUTER SOFTWARE USED FOR RECORDING, ORGANIZING, TRANSMITTING, RECEIVING, AND REVIEWING TEXT, DATA, IMAGES AND AUDIO FILES RELATING TO HEALTH AND WELLNESS (U.S. CLS. 21, 23, 26, 36 AND 38).

CLASS 42—SCIENTIFIC AND COMPUTER SERVICES

FOR TECHNICAL SUPPORT SERVICES, NAMELY, TROUBLESHOOTING IN THE NATURE OF DIAGNOSING PERSONAL ELECTRONIC DEVICE PROBLEMS (U.S. CLS. 100 AND 101).

CLASS 45—PERSONAL AND LEGAL SERVICES

FOR INTERNET-BASED SOCIAL NETWORKING SERVICES (U.S. CLS. 100 AND 101).
NICHOLAS COLEMAN, EXAMINING ATTORNEY

SN 85-435,740. RESTAURANT HOLDING COMPANY, LLC, DENVER, CO. FILED 9-29-2011.

NAFI'S

THE MARK CONSISTS OF STANDARD CHARACTERS WITHOUT CLAIM TO ANY PARTICULAR FONT, STYLE, SIZE, OR COLOR.

CLASS 29—MEATS AND PROCESSED FOODS

FOR PACKAGED MEALS CONSISTING PRIMARILY OF MEAT, FISH, POULTRY AND/OR VEGETABLES; SALADS, NAMELY, GARDEN SALADS, FRUIT SALADS AND VEGETABLES SALADS (U.S. CL. 46).

CLASS 35—ADVERTISING AND BUSINESS

FOR RETAIL BAKERY SHOPS (U.S. CLS. 100, 101 AND 102).

CLASS 40—MATERIAL TREATMENT

FOR BAKERY SERVICES, NAMELY, THE MANUFACTURE OF BAKERY PRODUCTS TO ORDER AND/OR SPECIFICATION OF OTHERS (U.S. CLS. 100, 103 AND 106).

CLASS 43—HOTEL AND RESTAURANT SERVICES

FOR CAFÉ, RESTAURANT AND CATERING SERVICES (U.S. CLS. 100 AND 101).
CHRISTOPHER LAW, EXAMINING ATTORNEY

SN 85-436,148. TOWN OF PENNINGTON GAP, PENNINGTON GAP, VA. FILED 9-30-2011.

MT. RACEMORE

THE MARK CONSISTS OF STANDARD CHARACTERS WITHOUT CLAIM TO ANY PARTICULAR FONT, STYLE, SIZE, OR COLOR.

CLASS 25—CLOTHING

FOR CLOTHING, NAMELY, SHIRTS AND PANTS, FOOTWEAR, HEADGEAR, NAMELY, HATS AND CAPS (U.S. CLS. 22 AND 39).

CLASS 35—ADVERTISING AND BUSINESS

FOR ADVERTISING; BUSINESS MANAGEMENT; BUSINESS ADMINISTRATION; OFFICE FUNCTIONS (U.S. CLS. 100, 101 AND 102).

KATHLEEN M. VANSTON, EXAMINING ATTORNEY

SN 85-436,166. TOWN OF PENNINGTON GAP, PENNINGTON GAP, VA. FILED 9-30-2011.

MOUNT RACEMORE

THE MARK CONSISTS OF STANDARD CHARACTERS WITHOUT CLAIM TO ANY PARTICULAR FONT, STYLE, SIZE, OR COLOR.

CLASS 25—CLOTHING

FOR CLOTHING, NAMELY, SHIRTS AND PANTS, FOOTWEAR, HEADGEAR, NAMELY, HATS AND CAPS (U.S. CLS. 22 AND 39).

CLASS 35—ADVERTISING AND BUSINESS

FOR ADVERTISING, BUSINESS MANAGEMENT; BUSINESS ADMINISTRATION; OFFICE FUNCTIONS (U.S. CLS. 100, 101 AND 102).

KATHLEEN M. VANSTON, EXAMINING ATTORNEY

SN 85-436,317. FASTCAP, LLC, BELLINGHAM, WA. FILED 9-30-2011.

2 SECOND LEAN

THE MARK CONSISTS OF STANDARD CHARACTERS WITHOUT CLAIM TO ANY PARTICULAR FONT, STYLE, SIZE, OR COLOR.

CLASS 35—ADVERTISING AND BUSINESS

FOR PROVIDING A WEBSITE FEATURING INFORMATION IN THE FIELD OF BUSINESS ORGANIZATION AND TIME MANAGEMENT TECHNIQUES FOR BUSINESS PURPOSES (U.S. CLS. 100, 101 AND 102).
FIRST USE 2-28-2010; IN COMMERCE 2-28-2010.

CLASS 41—EDUCATION AND ENTERTAINMENT

FOR PROVIDING ON-LINE AND IN-PERSON TRAINING COURSES, SEMINARS, WORKSHOPS IN THE FIELD OF PROFESSIONAL AND PERSONAL ORGANIZATION TIME MANAGEMENT TECHNIQUES; PUBLISHING SERVICES, NAMELY, PUBLISHING ELECTRONIC PUBLICATIONS AND PRINTED PUBLICATIONS IN THE NATURE OF E-BOOKS, E-MAGAZINES, ONLINE NEWSLETTERS, AND BOOKS AND AUDIO/VISUAL PROGRAMMING RELATED TO PROFESSIONAL AND PERSONAL ORGANIZATION AND TIME MANAGEMENT TECHNIQUES (U.S. CLS. 100, 101 AND 107).

FIRST USE 2-28-2010; IN COMMERCE 2-28-2010.

CLASS 45—PERSONAL AND LEGAL SERVICES

FOR PROVIDING A WEBSITE THAT FEATURES INFORMATION IN THE FIELD OF PERSONAL ORGANIZATION AND TIME MANAGEMENT TECHNIQUES TO INDIVIDUALS FOR PERSONAL PURPOSES (U.S. CLS. 100 AND 101).

FIRST USE 2-28-2010; IN COMMERCE 2-28-2010.

AMY C. KEAN, EXAMINING ATTORNEY

SN 85-436,439. CALVIN BROADUS, LOS ANGELES, CA. FILED 9-30-2011.



OWNER OF U.S. REG. NOS. 2,278,013, 2,697,128 AND 3,498,736.

THE MARK CONSISTS OF THE TERM "SNOOP" SUPERIMPOSED OVER A STYLIZED "S" BOTH OF WHICH ARE SUPERIMPOSED OVER A DESIGN OF A CIRCLE. THE GRAY IN THE MARK INDICATES SHADING AND IS NOT CLAIMED AS A FEATURE OF THE MARK.

CLASS 6—METAL GOODS

FOR WALL PLAQUES MADE OF COMMON METAL; TROPHIES MADE OF COMMON METAL (U.S. CLS. 2, 12, 13, 14, 23, 25 AND 50).

CLASS 9—ELECTRICAL AND SCIENTIFIC APPARATUS

FOR (BASED ON USE) FOOTBALL HELMETS; (BASED ON INTENT-TO-USE) AUDIOVISUAL RECORDINGS IN THE FIELDS OF FOOTBALL AND CHEERLEADING; DOWNLOADABLE AUDIOVISUAL RECORDINGS IN THE FIELDS OF FOOTBALL AND CHEERLEADING (U.S. CLS. 21, 23, 26, 36 AND 38).

FIRST USE 6-0-2005; IN COMMERCE 6-0-2005.

CLASS 16—PAPER GOODS AND PRINTED MATTER

FOR PENCILS; PENS; FOLDERS; LETTERHEAD PAPER; STATIONERY (U.S. CLS. 2, 5, 22, 23, 29, 37, 38 AND 50).

CLASS 18—LEATHER GOODS

FOR (BASED ON USE) DRAWSTRING BAGS; (BASED ON INTENT-TO-USE) BACKPACKS (U.S. CLS. 1, 2, 3, 22 AND 41).

FIRST USE 6-0-2005; IN COMMERCE 6-0-2005.

CLASS 21—HOUSEWARES AND GLASS

FOR CUPS AND MUGS (U.S. CLS. 2, 13, 23, 29, 30, 33, 40 AND 50).

CLASS 22—CORDAGE AND FIBERS

FOR TENTS; CANOPY TENTS; POP-UP TENTS; CANOPIES NOT OF METAL (U.S. CLS. 1, 2, 7, 19, 22, 42 AND 50).

CLASS 24—FABRICS

FOR BANNER AND FLAGS OF TEXTILE; BLANKETS FOR OUTDOOR USE, LAP BLANKETS, AND BLANKET THROWS (U.S. CLS. 42 AND 50).

CLASS 25—CLOTHING

FOR (BASED ON USE) CLOTHING, NAMELY, T-SHIRTS, JERSEYS, JACKETS; (BASED ON INTENT-TO-USE) CLOTHING, NAMELY, SWEATSHIRTS, HOODED SWEATSHIRTS, SWEATPANTS, FOOTBALL PANTS, SOCKS; HEADWEAR, BASEBALL CAPS, KNIT CAPS (U.S. CLS. 22 AND 39).

FIRST USE 6-0-2005; IN COMMERCE 6-0-2005.

CLASS 26—FANCY GOODS

FOR EMBROIDERED PATCHES FOR CLOTHING; CLOTH PATCHES (U.S. CLS. 37, 39, 40, 42 AND 50).

FIRST USE 6-0-2005; IN COMMERCE 6-0-2005.

CLASS 28—TOYS AND SPORTING GOODS

FOR GOAL POST COVERS; FOOTBALLS (U.S. CLS. 22, 23, 38 AND 50).

CLASS 41—EDUCATION AND ENTERTAINMENT

FOR ARRANGING AND CONDUCTING YOUTH FOOTBALL PROGRAMS; ARRANGING YOUTH CHEERLEADING PROGRAMS; PROVIDING A WEBSITE WITH INFORMATION ON FOOTBALL, TEAMS, FOOTBALL NEWS, FOOTBALL PHOTOGRAPHS, GAME SCHEDULES, INFORMATION ON SCHOLASTIC OPPORTUNITIES, CHEERLEADING (U.S. CLS. 100, 101 AND 107).

FIRST USE 6-0-2005; IN COMMERCE 6-0-2005.

KAREN BRACEY, EXAMINING ATTORNEY

SN 85-437,096. KONSTAR INDUSTRIES LIMITED, HONG KONG, HONG KONG, FILED 10-1-2011.

KONSTAR

THE MARK CONSISTS OF THE WORD "KONSTAR" WITH THE LETTERS "K" AND "S" STYLIZED, AND WITH LETTERS "O", "N", "S", "T", AND "A" BEING BLOCK LETTERS.

CLASS 8—HAND TOOLS

FOR HAND OPERATED HAND TOOLS AND IMPLEMENTS, NAMELY, NON-ELECTRIC EGG SLICERS, TONGS, CHOPPERS, CUTTERS FOR MAKING PASTA, FOOD PROCESSOR, SLICERS, SCISSORS FOR HOUSEHOLD USE ; CUTLERY; RAZORS; CUTLERY BEING TABLEWARE; TABLE FORKS; HAND OPERATED NON-ELECTRIC VEGETABLE AND FRUIT PEELERS; HAND OPERATED TOOLS, NAMELY, MEAT CHOPPERS; HAND-HELD MILLING CUTTERS; TABLEWARE, NAMELY, KNIVES, FORKS AND SPOONS; HAND OPERATED VEGETABLE SHREDDERS; HAND OPERATED TOOLS, NAMELY, VEGETABLE AND FRUIT SHREDDERS, OTHER THAN FOR KITCHEN USE, SLICERS; VEGETABLE SLICERS; NON-ELECTRIC MACHINES, NAMELY, VEGETABLE AND FRUIT PEELERS; NON-ELECTRIC CAN OPENERS (U.S. CLS. 23, 28 AND 44).

CLASS 21—HOUSEWARES AND GLASS

FOR HOUSEHOLD OR KITCHEN UTENSILS AND CONTAINERS, NAMELY, HOUSEHOLD CONTAINERS FOR FOODS, KITCHEN CONTAINERS, GRATERS, SIEVES, SPATULAS, STRAINERS, TURNERS, SKIMMERS, KITCHEN TONGS, ROLLING PINS; WASHING BRUSHES; BRUSHES, EXCEPT PAINT BRUSHES FOR PETS AND DUSTING; NON-ELECTRIC ARTICLES FOR CLEANING PURPOSES, NAMELY, SPONGES; CLEANING INSTRUMENTS, HAND-OPERATED, NAMELY, COMBINATION SQUEEGEE AND SCRUBBER FOR CLEANING WINDOWS; UNWORKED OR SEMI-WORKED GLASS, EXCEPT GLASS USED IN BUILDINGS; BEVERAGE GLASSWARE; PORCELAIN MUGS; EARTHENWARE MUGS; HOUSEHOLD UTENSILS, NAMELY, GRATERS, COOKING SIFTERS, SIEVES; NON-ELECTRIC KITCHEN FOOD MIXERS; CUTTING BOARDS FOR THE KITCHEN; KITCHEN UTENSILS, NAMELY, COOKERY MOLDS; FLOUR SIFTERS; BOTTLE OPENERS; PEPPER MILLS, HAND-OPERATED; PEPPER AND SALT MILLS FOR DOMESTIC PURPOSES, HAND OPERATED; TRAYS FOR DOMESTIC PURPOSES; CLOTHING STRETCHERS; CLOTHES DRYING HANGERS; TABLEWARE, OTHER THAN KNIVES, FORKS AND SPOONS, NAMELY, COFFEE SERVICES AND TEA SERVICES ; KITCHEN UTENSILS, NAMELY, COOKERY MOULDS; SALAD SPINNERS; SALAD BOWLS NOT OF PRECIOUS METAL; NON-ELECTRIC KITCHEN MACHINES, NAMELY, COLANDERS IN THE NATURE OF SALAD DRAINERS; DOMESTIC FOOD AND MEAT GRINDERS, NON-ELECTRIC; HOUSEHOLD STRAINERS; PITCHERS (U.S. CLS. 2, 13, 23, 29, 30, 33, 40 AND 50).

TINA MAI, EXAMINING ATTORNEY

SN 85-437,101. INTERNET KEEP SAFE COALITION, AKA IKEEPSAFE, WASHINGTON, D.C., DC. FILED 10-1-2011.

IKEEPCURRENT

THE MARK CONSISTS OF STANDARD CHARACTERS WITHOUT CLAIM TO ANY PARTICULAR FONT, STYLE, SIZE, OR COLOR.

CLASS 9—ELECTRICAL AND SCIENTIFIC APPARATUS

FOR DOWNLOADABLE ELECTRONIC PUBLICATIONS, NAMELY, BOOKS AND BROCHURES ON THE SUBJECT OF DIGITAL CITIZENSHIP AND INTERNET SAFETY, RECORDED ON COMPUTER MEDIA (U.S. CLS. 21, 23, 26, 36 AND 38).

CLASS 16—PAPER GOODS AND PRINTED MATTER

FOR PRINTED MATERIALS, NAMELY, PERIODICALS FOR PARENTS, EDUCATORS, SCHOOLS AND STUDENTS IN THE FIELD OF DIGITAL CITIZENSHIP AND INTERNET SAFETY (U.S. CLS. 2, 5, 22, 23, 29, 37, 38 AND 50).

CLASS 41—EDUCATION AND ENTERTAINMENT

FOR EDUCATIONAL SERVICES, NAMELY, DEVELOPING CURRICULA IN THE FIELD OF DIGITAL CITIZENSHIP AND INTERNET SAFETY; EDUCATIONAL SERVICES, NAMELY, PROVIDING CLASSES IN THE FIELD OF DIGITAL CITIZENSHIP AND INTERNET SAFETY AND DISTRIBUTION OF PRINTED COURSE MATERIALS IN CONNECTION THEREWITH; PROVIDING NON-DOWNLOADABLE ELECTRONIC PUBLICATIONS, NAMELY, BROCHURES ON THE SUBJECT OF DIGITAL CITIZENSHIP AND INTERNET SAFETY (U.S. CLS. 100, 101 AND 107).

MARK SPARACINO, EXAMINING ATTORNEY

SN 85-437,139. LABARDOR MARQUES (SARL), SAINT BARTHELEMY, FRANCE, FILED 10-1-2011.



NO CLAIM IS MADE TO THE EXCLUSIVE RIGHT TO USE "I REG INFO WORLD", APART FROM THE MARK AS SHOWN.

THE COLOR(S) WHITE, BLUE AND GREY IS/ARE CLAIMED AS A FEATURE OF THE MARK.

THE MARK CONSISTS OF A BLUE SHADED SQUARE WITH A WHITE LETTER "I" SUPERIMPOSED THEREIN, APPEARING TO THE LEFT OF THE WORD "REGINFO" APPEARING IN BLUE ABOVE THE WORD "WORLD" APPEARING IN GREY.

CLASS 36—INSURANCE AND FINANCIAL

FOR INFORMATION SERVICES RELATING TO FINANCE (U.S. CLS. 100, 101 AND 102).

CLASS 38—COMMUNICATION

FOR COMMUNICATION SERVICES, NAMELY, PROVIDING ELECTRONIC TRANSMISSION OF INFORMATION STORED IN A DATABASE VIA INTERACTIVELY COMMUNICATING COMPUTER SYSTEMS; INFORMATION TRANSMISSION VIA ELECTRONIC COMMUNICATIONS NETWORKS (U.S. CLS. 100, 101 AND 104).

CLASS 41—EDUCATION AND ENTERTAINMENT

FOR PUBLICATION OF TEXTS, BOOKS, MAGAZINES AND OTHER PRINTED MATTER (U.S. CLS. 100, 101 AND 107).

CLASS 42—SCIENTIFIC AND COMPUTER SERVICES

FOR DATABASE DESIGN AND DEVELOPMENT (U.S. CLS. 100 AND 101).
KELLY TRUSILO, EXAMINING ATTORNEY

SN 85-437,311. IFIXIT, DBA DOZUKI, SAN LUIS OBISPO, CA. FILED 10-2-2011.

Dozuki

THE MARK CONSISTS OF STANDARD CHARACTERS WITHOUT CLAIM TO ANY PARTICULAR FONT, STYLE, SIZE, OR COLOR.

CLASS 35—ADVERTISING AND BUSINESS

FOR DISSEMINATION OF ADVERTISING MATERIAL IN A DIGITAL FORMAT (U.S. CLS. 100, 101 AND 102).
FIRST USE 5-1-2011; IN COMMERCE 9-1-2011.

CLASS 38—COMMUNICATION

FOR ELECTRONIC TRANSMISSION OF DIGITAL MEDIA, DIGITAL DOCUMENTS AND OTHER DIGITAL CONTENT, NAMELY, TEXT, DOCUMENTS, PHOTOGRAPHS, IMAGES, VIDEOS AND AUDIO FILES; PROVIDING MULTIPLE USERS ACCESS TO THE INTERNET ALLOWING THEM TO ACCESS A SPECIFIC SET OF DIGITAL DATA (U.S. CLS. 100, 101 AND 104).
FIRST USE 5-1-2011; IN COMMERCE 9-1-2011.

CLASS 41—EDUCATION AND ENTERTAINMENT

FOR PROVIDING ONLINE PUBLICATION OF EDUCATIONAL TRAINING MATERIALS IN THE FORM OF TEACHING GUIDES WITH ANSWER KEYS; PUBLISHING AND EDITING OF INTERNET PUBLICATIONS FOR OTHERS (U.S. CLS. 100, 101 AND 107).
FIRST USE 5-1-2011; IN COMMERCE 9-1-2011.

CLASS 42—SCIENTIFIC AND COMPUTER SERVICES

FOR PROVIDING ONLINE NON-DOWNLOADABLE SOFTWARE FOR ALLOWING USERS TO CREATE CUSTOMIZED INTERNET PUBLICATIONS; DESIGN AND DEVELOPMENT OF ONLINE SOFTWARE; COMPUTER PROGRAMMING; DEVELOPMENT AND UPDATING OF SOFTWARE; DATA CONVERSION OF ELECTRONIC INFORMATION IN THE FORM OF COMPUTER DATA; HOSTING OF INTERNET SITES FOR OTHERS WHICH FEATURE FORUMS, ONLINE COMMUNITIES AND INFORMATION; HOSTING AND DEVELOPMENT OF WEBSITES FOR OTHERS FEATURING ONLINE APPLICATIONS (U.S. CLS. 100 AND 101).

FIRST USE 5-1-2011; IN COMMERCE 9-1-2011.
COLLEEN KEARNEY, EXAMINING ATTORNEY

CLASS 41—EDUCATION AND ENTERTAINMENT

FOR EDUCATIONAL SERVICES, NAMELY, DEVELOPING, ARRANGING, AND CONDUCTING EDUCATIONAL CONFERENCES AND PROGRAMS AND PROVIDING COURSES OF INSTRUCTION IN THE FIELDS OF HUMAN HEALTH, HEALTHCARE, PHARMACEUTICALS, MEDICAL DEVICES, MEDICAL RESEARCH, SURGERY, MEDICAL SCIENCE AND MEDICINE; DISTRIBUTION OF COURSE MATERIALS IN CONNECTION THEREWITH; EDUCATIONAL SERVICES, NAMELY, MENTORING IN THE FIELD OF SURGERY AND WOUND-CARE MANAGEMENT; CONTINUING EDUCATION SERVICES, NAMELY, PROVIDING LIVE AND ON-LINE CONTINUING PROFESSIONAL EDUCATION SEMINARS IN THE MEDICAL FIELD; TRAINING IN THE USE OF MEDICAL EQUIPMENT; MEDICAL AND SURGICAL TRAINING AND TEACHING (U.S. CLS. 100, 101 AND 107).

SN 85-437,437. COVIDIEN AG, NEUHAUSEN AM RHEINFALL, SWITZERLAND, FILED 10-3-2011.

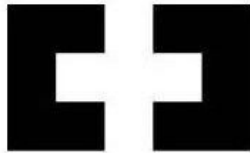

PRIORITY CLAIMED UNDER SEC. 44(D) ON SWITZERLAND APPLICATION NO. 54054/2011, FILED 4-4-2011, REG. NO. 619218, DATED 8-29-2011, EXPIRES 8-29-2021.

OWNER OF U.S. REG. NOS. 3,728,372, 3,823,883 AND OTHERS.

THE MARK CONSISTS OF TWO BLOCK LETTER "C"'S, WITH ONE REVERSED SO THEY ARE FACING EACH OTHER.

CLASS 35—ADVERTISING AND BUSINESS

FOR PROMOTING PUBLIC AWARENESS OF ENVIRONMENTAL MATTERS; PROMOTING PUBLIC AWARENESS OF PROPER MEDICAL WASTE DISPOSAL; PROMOTING PUBLIC AWARENESS OF BARIATRIC MEDICAL PROCEDURES; PROMOTING PUBLIC AWARENESS OF INFECTION PREVENTION IN HOSPITALS (U.S. CLS. 100, 101 AND 102).

CLASS 37—CONSTRUCTION AND REPAIR

FOR TECHNICAL SUPPORT SERVICES, NAMELY, TROUBLESHOOTING IN THE NATURE OF REPAIR OF MEDICAL EQUIPMENT; MAINTENANCE AND REPAIR OF MEDICAL EQUIPMENT; PROVIDING INFORMATION REGARDING THE DISPOSAL OF HAZARDOUS SUBSTANCES (U.S. CLS. 100, 103 AND 106).

CLASS 38—COMMUNICATION

FOR PROVIDING MULTIPLE USER ACCESS TO PROPRIETARY COLLECTIONS OF INFORMATION BY MEANS OF GLOBAL COMPUTER INFORMATION NETWORKS, NAMELY, CLINICAL STUDIES, CASE STUDIES, WHITE PAPERS, AND REFERENCE GUIDES IN THE MEDICAL FIELD (U.S. CLS. 100, 101 AND 104).

CLASS 40—MATERIAL TREATMENT

FOR CUSTOM PHARMACEUTICAL MANUFACTURING SERVICES; RECYCLING OF MEDICAL PRODUCTS FOR THE RE-MANUFACTURE AND REUSE OF THE PRODUCTS (U.S. CLS. 100, 103 AND 106).

CLASS 42—SCIENTIFIC AND COMPUTER SERVICES

FOR COMPUTER SERVICES, NAMELY, CREATING AN ONLINE COMMUNITY FOR REGISTERED USERS, SUCH AS PATIENTS AND HEALTH CARE PROFESSIONALS TO SHARE INFORMATION REGARDING MEDICAL PROCEDURES; PROVIDING AN INTERACTIVE WEBSITE THAT ENABLES USERS TO ACCESS MEDICAL RESEARCH INFORMATION, NAMELY, CLINICAL STUDIES, CASE STUDIES, WHITE PAPERS, AND REFERENCE GUIDES IN THE MEDICAL FIELD (U.S. CLS. 100 AND 101).

CLASS 44—MEDICAL, BEAUTY AND AGRICULTURAL SERVICES

FOR PROVIDING INFORMATION IN THE FIELD OF MINIMALLY INVASIVE SURGERY; PROVIDING MEDICAL INFORMATION; PROVIDING AN INTERNET WEBSITE FOR MEDICAL PROFESSIONALS AND PATIENTS FEATURING MEDICAL INFORMATION FROM REMOTE LOCATIONS VIA ELECTRONIC PATIENT MONITORING DEVICES THAT FEED INFORMATION TO THE WEBSITE THAT CAN BE ACCESSED IN REAL-TIME BY MEDICAL PROFESSIONALS FOR PURPOSES OF MONITORING AND DIAGNOSING MEDICAL CONDITIONS; PROVIDING INFORMATION IN THE FIELD OF BARIATRIC MEDICAL PROCEDURES; PROVIDING INFORMATION, ADVICE AND DATA ON MEDICAL IMAGING; PROVIDING MEDICAL INFORMATION, CONSULTANCY AND ADVISORY SERVICES; MEDICAL DIAGNOSTIC SERVICES; MEDICAL IMAGING SERVICES; CHARITABLE SERVICES IN THE FIELD OF MEDICINE AND MEDICAL PRODUCT DONATIONS; PHILANTHROPIC SERVICES IN THE AREA OF MEDICINE AND MEDICAL PRODUCTS TO VICTIMS OF DISASTERS AND HUMANITARIAN CRISES; PHILANTHROPIC SERVICES IN THE AREA OF MEDICINE AND MEDICAL PRODUCTS FOR MEDICAL MISSIONS; PROVIDING TEMPORARY RENTAL OF MEDICAL EQUIPMENT (U.S. CLS. 100 AND 101).

CLASS 45—PERSONAL AND LEGAL SERVICES

FOR PROVIDING INFORMATION CONCERNING MEDICAL PRODUCT SAFETY; PROVIDING PERSONAL SUPPORT SERVICES FOR PATIENTS AND THEIR FAMILIES, NAMELY, PROVIDING FOLLOW-UP INFORMATION RELATING TO EMOTIONAL COUNSELING TO PATIENTS AFTER SURGERY (U.S. CLS. 100 AND 101).

CURTIS FRENCH, EXAMINING ATTORNEY

SN 85-437,465. COVIDIEN AG, NEUHAUSEN AM RHEINFALL, SWITZERLAND, FILED 10-3-2011.



PRIORITY CLAIMED UNDER SEC. 44(D) ON SWITZERLAND APPLICATION NO. 54052/2011, FILED 4-4-2011, REG. NO. 614090, DATED 4-14-2011, EXPIRES 4-14-2021.

OWNER OF U.S. REG. NOS. 3,728,372, 3,816,667 AND OTHERS.

THE COLOR(S) BLUE IS/ARE CLAIMED AS A FEATURE OF THE MARK.

THE MARK CONSISTS OF TWO BLOCK LETTER "C"'S, WITH ONE REVERSED SO THEY ARE FACING EACH OTHER. THE ENTIRE MARK APPEARS IN THE COLOR BLUE.

CLASS 35—ADVERTISING AND BUSINESS

FOR PROMOTING PUBLIC AWARENESS OF ENVIRONMENTAL MATTERS; PROMOTING PUBLIC AWARENESS OF PROPER MEDICAL WASTE DISPOSAL; PROMOTING PUBLIC AWARENESS OF BARIATRIC MEDICAL PROCEDURES; PROMOTING PUBLIC AWARENESS OF INFECTION PREVENTION IN HOSPITALS (U.S. CLS. 100, 101 AND 102).

CLASS 37—CONSTRUCTION AND REPAIR

FOR TECHNICAL SUPPORT SERVICES, NAMELY, TROUBLESHOOTING IN THE NATURE OF REPAIR OF MEDICAL EQUIPMENT; MAINTENANCE AND REPAIR OF MEDICAL EQUIPMENT; PROVIDING INFORMATION REGARDING THE DISPOSAL OF HAZARDOUS SUBSTANCES (U.S. CLS. 100, 103 AND 106).

CLASS 38—COMMUNICATION

FOR PROVIDING MULTIPLE USER ACCESS TO PROPRIETARY COLLECTIONS OF INFORMATION BY MEANS OF GLOBAL COMPUTER INFORMATION NETWORKS, NAMELY, CLINICAL STUDIES, CASE STUDIES, WHITE PAPERS, AND REFERENCE GUIDES IN THE MEDICAL FIELD (U.S. CLS. 100, 101 AND 104).

CLASS 40—MATERIAL TREATMENT

FOR CUSTOM PHARMACEUTICAL MANUFACTURING SERVICES; RECYCLING OF MEDICAL PRODUCTS FOR THE RE-MANUFACTURE AND REUSE OF THE PRODUCTS (U.S. CLS. 100, 103 AND 106).

CLASS 41—EDUCATION AND ENTERTAINMENT

FOR EDUCATIONAL SERVICES, NAMELY, DEVELOPING, ARRANGING, AND CONDUCTING EDUCATIONAL CONFERENCES AND PROGRAMS AND PROVIDING COURSES OF INSTRUCTION IN THE FIELDS OF HUMAN HEALTH, HEALTHCARE, PHARMACEUTICALS, MEDICAL DEVICES, MEDICAL RESEARCH, SURGERY, MEDICAL SCIENCE AND MEDICINE; DISTRIBUTION OF COURSE MATERIALS IN CONNECTION THEREWITH; EDUCATIONAL SERVICES, NAMELY, MENTORING IN THE FIELD OF SURGERY AND WOUND-CARE MANAGEMENT; CONTINUING EDUCATION SERVICES, NAMELY, PROVIDING LIVE AND ON-LINE CONTINUING PROFESSIONAL EDUCATION SEMINARS IN THE MEDICAL FIELD; TRAINING IN THE USE OF MEDICAL EQUIPMENT; MEDICAL AND SURGICAL TRAINING AND TEACHING (U.S. CLS. 100, 101 AND 107).

CLASS 42—SCIENTIFIC AND COMPUTER SERVICES

FOR COMPUTER SERVICES, NAMELY, CREATING AN ONLINE COMMUNITY FOR REGISTERED USERS, SUCH AS PATIENTS AND HEALTH CARE PROFESSIONALS TO SHARE INFORMATION REGARDING MEDICAL PROCEDURES; PROVIDING AN INTERACTIVE WEBSITE THAT ENABLES USERS TO ACCESS TO MEDICAL RESEARCH INFORMATION, NAMELY, CLINICAL STUDIES, CASE STUDIES, WHITE PAPERS, AND REFERENCE GUIDES IN THE MEDICAL FIELD (U.S. CLS. 100 AND 101).

CLASS 44—MEDICAL, BEAUTY AND AGRICULTURAL SERVICES

FOR CLINICAL STUDIES, CASE STUDIES, WHITE PAPERS, AND REFERENCE GUIDES IN THE MEDICAL FIELD, PROVIDING INFORMATION IN THE FIELD OF MINIMALLY INVASIVE SURGERY; PROVIDING MEDICAL INFORMATION; PROVIDING AN INTERNET WEBSITE FOR MEDICAL PROFESSIONALS AND PATIENTS FEATURING MEDICAL INFORMATION FROM REMOTE LOCATIONS VIA ELECTRONIC PATIENT MONITORING DEVICES THAT FEED INFORMATION TO THE WEBSITE THAT CAN BE ACCESSED IN REAL-TIME BY MEDICAL PROFESSIONALS FOR PURPOSES OF MONITORING AND DIAGNOSING MEDICAL CONDITIONS; PROVIDING INFORMATION IN THE FIELD OF BARIATRIC MEDICAL PROCEDURES; PROVIDING INFORMATION, ADVICE AND DATA ON MEDICAL IMAGING; PROVIDING MEDICAL INFORMATION, CONSULTANCY AND ADVISORY SERVICES; MEDICAL DIAGNOSTIC SERVICES; MEDICAL IMAGING SERVICES; CHARITABLE SERVICES IN THE FIELD OF MEDICINE AND MEDICAL PRODUCT DONATIONS; PHILANTHROPIC SERVICES IN THE AREA OF MEDICINE AND MEDICAL PRODUCTS TO VICTIMS OF DISASTERS AND HUMANITARIAN CRISES; PHILANTHROPIC SERVICES IN THE AREA OF MEDICINE AND MEDICAL PRODUCTS FOR MEDICAL MISSIONS; PROVIDING TEMPORARY RENTAL OF MEDICAL EQUIPMENT (U.S. CLS. 100 AND 101).

CLASS 45—PERSONAL AND LEGAL SERVICES

FOR PROVIDING INFORMATION CONCERNING MEDICAL PRODUCT SAFETY; PROVIDING PERSONAL SUPPORT SERVICES FOR PATIENTS AND THEIR FAMILIES, NAMELY, PROVIDING FOLLOW-UP INFORMATION RELATING TO EMOTIONAL COUNSELING TO PATIENTS AFTER SURGERY (U.S. CLS. 100 AND 101).

CURTIS FRENCH, EXAMINING ATTORNEY

SN 85-437,489. COVIDIEN AG, NEUHAUSEN AM RHEINFALL, SWITZERLAND, FILED 10-3-2011.

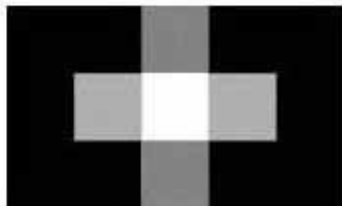

PRIORITY CLAIMED UNDER SEC. 44(D) ON SWITZERLAND APPLICATION NO. 54055/2011, FILED 4-4-2011, REG. NO. 619217, DATED 8-29-2011, EXPIRES 8-29-2021.

OWNER OF U.S. REG. NOS. 3,448,172, 3,823,883 AND OTHERS.

THE MARK CONSISTS OF TWO BLOCK LETTER "C"'S, WITH ONE REVERSED SO THEY ARE FACING EACH OTHER AND WITH SQUARES FILLING IN THE SPACE BETWEEN THE "C"'S.

CLASS 35—ADVERTISING AND BUSINESS

FOR PROMOTING PUBLIC AWARENESS OF ENVIRONMENTAL MATTERS; PROMOTING PUBLIC AWARENESS OF PROPER MEDICAL WASTE DISPOSAL; PROMOTING PUBLIC AWARENESS OF BARIATRIC MEDICAL PROCEDURES; PROMOTING PUBLIC AWARENESS OF INFECTION PREVENTION IN HOSPITALS (U.S. CLS. 100, 101 AND 102).

CLASS 37—CONSTRUCTION AND REPAIR

FOR TECHNICAL SUPPORT SERVICES, NAMELY, TROUBLESHOOTING IN THE NATURE OF REPAIR OF MEDICAL EQUIPMENT; MAINTENANCE AND REPAIR OF MEDICAL EQUIPMENT; PROVIDING INFORMATION REGARDING THE DISPOSAL OF HAZARDOUS SUBSTANCES (U.S. CLS. 100, 103 AND 106).

CLASS 38—COMMUNICATION

FOR PROVIDING MULTIPLE USER ACCESS TO PROPRIETARY COLLECTIONS OF INFORMATION BY MEANS OF GLOBAL COMPUTER INFORMATION NETWORKS, NAMELY, CLINICAL STUDIES, CASE STUDIES, WHITE PAPERS, AND REFERENCE GUIDES IN THE MEDICAL FIELD (U.S. CLS. 100, 101 AND 104).

CLASS 40—MATERIAL TREATMENT

FOR CUSTOM PHARMACEUTICAL MANUFACTURING SERVICES; RECYCLING OF MEDICAL PRODUCTS FOR THE RE-MANUFACTURE AND REUSE OF THE PRODUCTS (U.S. CLS. 100, 103 AND 106).

CLASS 41—EDUCATION AND ENTERTAINMENT

FOR EDUCATIONAL SERVICES, NAMELY, DEVELOPING, ARRANGING, AND CONDUCTING EDUCATIONAL CONFERENCES AND PROGRAMS AND PROVIDING COURSES OF INSTRUCTION IN THE FIELDS OF HUMAN HEALTH, HEALTHCARE, PHARMACEUTICALS, MEDICAL DEVICES, MEDICAL RESEARCH, SURGERY, MEDICAL SCIENCE AND MEDICINE; DISTRIBUTION OF COURSE MATERIALS IN CONNECTION THEREWITH; EDUCATIONAL SERVICES, NAMELY, MENTORING IN THE FIELD OF SURGERY AND WOUND-CARE MANAGEMENT; CONTINUING EDUCATION SERVICES, NAMELY, PROVIDING LIVE AND ON-LINE CONTINUING PROFESSIONAL EDUCATION SEMINARS IN THE MEDICAL FIELD; TRAINING IN THE USE OF MEDICAL EQUIPMENT; MEDICAL AND SURGICAL TRAINING AND TEACHING, PROVIDING INFORMATION IN THE FIELD OF MINIMALLY INVASIVE SURGERY; PROVIDING MEDICAL INFORMATION; PROVIDING AN INTERNET WEBSITE FOR MEDICAL PROFESSIONALS AND PATIENTS FEATURING MEDICAL INFORMATION FROM REMOTE LOCATIONS VIA ELECTRONIC PATIENT MONITORING DEVICES THAT FEED INFORMATION TO THE WEBSITE THAT CAN BE ACCESSED IN REAL-TIME BY MEDICAL PROFESSIONALS FOR PURPOSES OF MONITORING AND DIAGNOSING MEDICAL CONDITIONS; PROVIDING INFORMATION IN THE FIELD OF BARIATRIC MEDICAL PROCEDURES; PROVIDING INFORMATION, ADVICE AND DATA ON MEDICAL IMAGING; PROVIDING MEDICAL INFORMATION, CONSULTANCY AND ADVISORY SERVICES; MEDICAL DIAGNOSTIC SERVICES; MEDICAL IMAGING SERVICES; CHARITABLE SERVICES IN THE FIELD OF MEDICINE AND MEDICAL PRODUCT DONATIONS; PHILANTHROPIC SERVICES IN THE AREA OF MEDICINE AND MEDICAL PRODUCTS TO VICTIMS OF DISASTERS AND HUMANITARIAN CRISES; PHILANTHROPIC SERVICES IN THE AREA OF MEDICINE AND MEDICAL PRODUCTS FOR MEDICAL MISSIONS; PROVIDING TEMPORARY RENTAL OF MEDICAL EQUIPMENT (U.S. CLS. 100, 101 AND 107).

CLASS 42—SCIENTIFIC AND COMPUTER SERVICES

FOR COMPUTER SERVICES, NAMELY, CREATING AN ONLINE COMMUNITY FOR REGISTERED USERS, SUCH AS PATIENTS AND HEALTH CARE PROFESSIONALS TO SHARE INFORMATION REGARDING MEDICAL PROCEDURES; PROVIDING AN INTERACTIVE WEBSITE THAT ENABLES USERS TO ACCESS TO MEDICAL RESEARCH INFORMATION, NAMELY, CLINICAL STUDIES, CASE STUDIES, WHITE PAPERS, AND REFERENCE GUIDES IN THE MEDICAL FIELD (U.S. CLS. 100 AND 101).

CLASS 44—MEDICAL, BEAUTY AND AGRICULTURAL SERVICES

FOR PROVIDING INFORMATION IN THE FIELD OF MINIMALLY INVASIVE SURGERY; PROVIDING MEDICAL INFORMATION; PROVIDING AN INTERNET WEBSITE FOR MEDICAL PROFESSIONALS AND PATIENTS FEATURING MEDICAL INFORMATION FROM REMOTE LOCATIONS VIA ELECTRONIC PATIENT MONITORING DEVICES THAT FEED INFORMATION TO THE WEBSITE THAT CAN BE ACCESSED IN REAL-TIME BY MEDICAL PROFESSIONALS FOR PURPOSES OF MONITORING AND DIAGNOSING MEDICAL CONDITIONS; PROVIDING INFORMATION IN THE FIELD OF BARIATRIC MEDICAL PROCEDURES; PROVIDING INFORMATION, ADVICE AND DATA ON MEDICAL

IMAGING; PROVIDING MEDICAL INFORMATION, CONSULTANCY AND ADVISORY SERVICES; MEDICAL DIAGNOSTIC SERVICES; MEDICAL IMAGING SERVICES; CHARITABLE SERVICES IN THE FIELD OF MEDICINE AND MEDICAL PRODUCT DONATIONS; PHILANTHROPIC SERVICES IN THE AREA OF MEDICINE AND MEDICAL PRODUCTS TO VICTIMS OF DISASTERS AND HUMANITARIAN CRISES; PHILANTHROPIC SERVICES IN THE AREA OF MEDICINE AND MEDICAL PRODUCTS FOR MEDICAL MISSIONS; PROVIDING TEMPORARY RENTAL OF MEDICAL EQUIPMENT (U.S. CLS. 100 AND 101).

CLASS 45—PERSONAL AND LEGAL SERVICES

FOR PROVIDING INFORMATION CONCERNING MEDICAL PRODUCT SAFETY; PROVIDING PERSONAL SUPPORT SERVICES FOR PATIENTS AND THEIR FAMILIES, NAMELY, PROVIDING FOLLOW-UP INFORMATION RELATING TO EMOTIONAL COUNSELING TO PATIENTS AFTER SURGERY (U.S. CLS. 100 AND 101).

CURTIS FRENCH, EXAMINING ATTORNEY

SN 85-437,564. BIOREGEN BIOMEDICAL (CHANGZHOU) CO., LTD., CHANGZHOU JIANGSU, CHINA, FILED 10-3-2011.

HyaRegen

PRIORITY CLAIMED UNDER SEC. 44(D) ON CHINA APPLICATION NO. 9734424, FILED 7-19-2011.

PRIORITY CLAIMED UNDER SEC. 44(D) ON CHINA APPLICATION NO. 9734425, FILED 7-19-2011.

THE MARK CONSISTS OF THE WORD "HYAREGEN" WITH A CAPITAL "H" AND A CAPITAL "R".

CLASS 5—PHARMACEUTICALS

FOR DRESSING, MEDICAL; SURGICAL DRESSING; WADDING FOR MEDICAL PURPOSES; ABSORBENT COTTON FOR MEDICAL PURPOSES; ABSORBENT WADDING FOR MEDICAL PURPOSES (U.S. CLS. 6, 18, 44, 46, 51 AND 52).

CLASS 10—MEDICAL APPARATUS

FOR SURGICAL IMPLANTS AND MESH MADE OF SYNTHETIC MATERIALS FOR USE IN SOFT TISSUE REPAIR OR THE RECONSTRUCTION OF SOFT TISSUE DEFICIENCIES; MEDICAL, SURGICAL AND ORTHOPAEDIC IMPLANTS MADE OF ARTIFICIAL MATERIALS; IMPLANTABLE SCAFFOLDS COMPRISING ARTIFICIAL MATERIALS FOR MAINTAINING TISSUE CONTOUR (U.S. CLS. 26, 39 AND 44).

DOMINIC J. FERRAIUOLO, EXAMINING ATTORNEY

SN 85-437,753. FIDELITY NATIONAL INFORMATION SERVICES, INC., JACKSONVILLE, FL. FILED 10-3-2011.

CLIENT POINT

THE MARK CONSISTS OF STANDARD CHARACTERS WITHOUT CLAIM TO ANY PARTICULAR FONT, STYLE, SIZE, OR COLOR.

NO CLAIM IS MADE TO THE EXCLUSIVE RIGHT TO USE "CLIENT", APART FROM THE MARK AS SHOWN.

CLASS 36—INSURANCE AND FINANCIAL

FOR FINANCIAL SERVICES, NAMELY, WEALTH MANAGEMENT SERVICES; PROVIDING A WEBSITE THAT PROVIDES CUSTOMER ACCESS TO FINANCIAL ACCOUNT INFORMATION (U.S. CLS. 100, 101 AND 102).
FIRST USE 3-28-2011; IN COMMERCE 3-28-2011.

CLASS 42—SCIENTIFIC AND COMPUTER SERVICES

FOR PROVIDING ONLINE NON-DOWNLOADABLE SOFTWARE FOR ACCESSING BANKING SERVICES AND FINANCIAL ACCOUNT INFORMATION (U.S. CLS. 100 AND 101).

FIRST USE 3-28-2011; IN COMMERCE 3-28-2011.
TASHIA BUNCH, EXAMINING ATTORNEY

SN 85-437,777. COMMONWEALTH EQUITY SERVICES, LLP, WALTHAM, MA. FILED 10-3-2011.

COMMONWEALTH CARES

THE MARK CONSISTS OF STANDARD CHARACTERS WITHOUT CLAIM TO ANY PARTICULAR FONT, STYLE, SIZE, OR COLOR.

OWNER OF U.S. REG. NOS. 2,504,924, 3,245,384 AND OTHERS.

NO CLAIM IS MADE TO THE EXCLUSIVE RIGHT TO USE "CARES", APART FROM THE MARK AS SHOWN.

CLASS 35—ADVERTISING AND BUSINESS

FOR CHARITABLE SERVICES, NAMELY, COORDINATION OF NON-MONETARY CONTRIBUTIONS TO CHARITIES AND NON-PROFITS; CHARITABLE SERVICES, NAMELY, ORGANIZING AND CONDUCTING VOLUNTEER PROGRAMS AND COMMUNITY SERVICES PROJECTS (U.S. CLS. 100, 101 AND 102).

CLASS 36—INSURANCE AND FINANCIAL

FOR ACCEPTING AND ADMINISTERING MONETARY CHARITABLE CONTRIBUTIONS; PHILANTHROPIC SERVICES CONCERNING MONETARY DONATIONS; CHARITABLE FUNDRAISING SERVICES (U.S. CLS. 100, 101 AND 102).

ALEXANDER L. POWERS, EXAMINING ATTORNEY

SN 85-438,092. SEPTEMBEARD, SAN FRANCISCO, CA.
FILED 10-3-2011.

SN 85-438,134. SINGSONG FOOD CORP., YEONGDEUNG-
PO-GU, SEOUL, REPUBLIC OF KOREA, FILED 10-3-2011.

SEPTEMBEARD

THE MARK CONSISTS OF STANDARD CHARACTERS WITHOUT CLAIM TO ANY PARTICULAR FONT, STYLE, SIZE, OR COLOR.

CLASS 25—CLOTHING

FOR MEN'S, WOMEN'S AND CHILDREN'S CLOTHING, NAMELY, SHIRTS, T-SHIRTS, GOLF SHIRTS, POLO SHIRTS, SWEATSHIRTS, JACKETS, WIND-JACKETS, SHORTS, PANTS, SLACKS, HEADWEAR, HATS, BANDANAS, SCARVES, SWEATBANDS, WRIST BANDS AND SOCKS (U.S. CLS. 22 AND 39).

CLASS 35—ADVERTISING AND BUSINESS

FOR CHARITABLE SERVICES, NAMELY, PROMOTING PUBLIC AWARENESS REGARDING PROSTATE CANCER AND EFFORTS TO CURE PROSTATE CANCER; PROMOTING THE CHARITABLE GIVING OF OTHERS, NAMELY, TRACKING AND PUBLICIZING CHARITABLE DONATIONS IN THE FIELD OF CANCER AWARENESS, TREATMENT AND PREVENTION; BUSINESS SERVICES, NAMELY, DEVELOPING FUNDRAISING CAMPAIGNS FOR OTHERS (U.S. CLS. 100, 101 AND 102).

CLASS 36—INSURANCE AND FINANCIAL

FOR CHARITABLE FUNDRAISING SERVICES; CHARITABLE FOUNDATION SERVICES, NAMELY, PROVIDING FUNDRAISING ACTIVITIES AND INVESTMENT MANAGEMENT SERVICES TO SUPPORT MEDICAL EDUCATION, RESEARCH AND THE DEVELOPMENT OF DRUGS, TREATMENTS AND CURES IN THE FIELD OF PROSTATE CANCER; CHARITABLE FUNDRAISING SERVICES FOR PROMOTING RESEARCH, EDUCATION AND OTHER ACTIVITIES RELATING TO THE DEVELOPMENT OF DRUGS, TREATMENTS AND CURES IN THE FIELD OF PROSTATE CANCER; ACCEPTING AND ADMINISTERING MONETARY CHARITABLE CONTRIBUTIONS TO FUND MEDICAL RESEARCH IN THE FIELD OF PROSTATE CANCER; ON-LINE CHARITABLE FUNDRAISING SERVICES; CHARITABLE FUNDRAISING SERVICES BY MEANS OF SELLING MEN'S, WOMEN'S AND CHILDREN'S CLOTHING TO RAISE FUNDS TO SUPPORT RESEARCH, EDUCATION AND OTHER ACTIVITIES RELATED TO THE DEVELOPMENT OF DRUGS, TREATMENTS AND CURES IN THE FIELD OF PROSTATE CANCER (U.S. CLS. 100, 101 AND 102).

CLASS 44—MEDICAL, BEAUTY AND AGRICULTURAL SERVICES

FOR PROVIDING A WEBSITE VIA A GLOBAL COMPUTER NETWORK FEATURING INFORMATION AND COMPREHENSIVE CONTENT IN THE FIELDS OF HEALTH, CANCER, CANCER RECOVERY AND SURVIVAL; PROVIDING A WEBSITE FEATURING INFORMATION AND PROVIDING LINKS TO THE WEBSITES OF OTHERS FEATURING INFORMATION ABOUT THE DIAGNOSIS AND TREATMENT OF PROSTATE CANCER (U.S. CLS. 100 AND 101).

SUNG IN, EXAMINING ATTORNEY

SINGSONG

THE MARK CONSISTS OF STANDARD CHARACTERS WITHOUT CLAIM TO ANY PARTICULAR FONT, STYLE, SIZE, OR COLOR.

CLASS 29—MEATS AND PROCESSED FOODS

FOR DRIED FRUITS; DRIED FRUIT MIXES; KIMCHI, NAMELY, FERMENTED VEGETABLES; PRESERVED FRUIT; FOOD PREPARED FROM BEAN CURDS, NAMELY, TOFU; SHORTENING; HARDENED OILS; PERILLA OIL FOR FOOD; SUET FOR FOOD; CORN OIL; OLIVE OIL FOR FOOD; SESAME OIL; EDIBLE OILS; BLENDED OIL; SUNFLOWER OIL FOR FOOD; SALT-FERMENTED COD ROE; PROCESSED ANCHOVIES; SALT-FERMENTED SEA URCHIN ROE; SWEET LAVER; PROCESSED TOASTED LAVER; PROCESSED EDIBLE SEA TANGLE, NAMELY, SEAWEED; PROCESSED EDIBLE BROWN SEAWEED; PROCESSED EDIBLE SEAWEED; STEAMED OR TOASTED CAKES OF FISH PASTE (U.S. CL. 46).

FIRST USE 4-27-2004; IN COMMERCE 12-20-2006.

CLASS 30—STAPLE FOODS

FOR NOODLES; NAENG-MYUN, NAMELY, KOREAN BUCKWHEAT NOODLES; STARCH SYRUP; MAPLE SYRUP; WHITE SUGAR; POWDERED STARCH SYRUP; SOYA SAUCE; GOCHU-JANG PASTE, NAMELY, SOYA BEAN PASTE; SOY SAUCE AND SOY BEAN PASTE; CHONGGUG-JANG, NAMELY, FERMENTED SOYBEAN PASTE FOR USE AS A CONDIMENT; VINEGAR; FLAVOURED VINEGAR; HOT PEPPER POWDER; GINGER; POWDERED SESAME SEEDS MIXED WITH TABLE SALT AND PEPPER (U.S. CL. 46).

FIRST USE 4-27-2004; IN COMMERCE 12-20-2006.

JULIE GUTTADAURO, EXAMINING ATTORNEY

SN 85-438,361. PANSUR HERMANOS PINEDA RIVERA, S.
L., SEVILLE, SPAIN, FILED 10-4-2011.



NO CLAIM IS MADE TO THE EXCLUSIVE RIGHT TO USE "HERMANOS", APART FROM THE MARK AS SHOWN.

THE COLOR(S) RED, BLUE AND WHITE IS/ARE CLAIMED AS A FEATURE OF THE MARK.

THE MARK CONSISTS OF THE BLUE WORDING "PANSUR" WITH EACH LETTER OUTLINED IN RED AND WHITE. BELOW THE WORD ARE THREE WAVY LINES THAT ARE BLUE, WHITE AND RED. BELOW THE WAVY LINES IS THE BLUE WORDING "HERMANOS PINEDA RIVERA".

THE ENGLISH TRANSLATION OF "PANSUR HERMANOS PINEDA RIVERA" IN THE MARK IS "SOUTHBREAD PINEDA RIVERA BROTHERS".

CLASS 30—STAPLE FOODS

FOR BREAD, PREPARATIONS MADE FROM CEREALS, NAMELY, PASTRIES, CONFECTIONERY, NAMELY, PASTILLES MADE FROM CEREALS (U.S. CL. 46).

CLASS 35—ADVERTISING AND BUSINESS

FOR ASSISTANCE IN BUSINESS MANAGEMENT AND PRODUCT COMMERCIALIZATION WITHIN THE FRAMEWORK OF A FRANCHISE CONTRACT; ADVERTISING SERVICES; BUSINESS MANAGEMENT IN THE NATURE OF SUPPLY CHAIN LOGISTICS FOR THE FOODSTUFFS INDUSTRY; GOODS IMPORT-EXPORT AGENCIES IN THE FIELD OF FOODSTUFFS; RETAIL BAKERY SHOPS; RETAIL BAKERY SHOPS VIA THE INTERNET (U.S. CLS. 100, 101 AND 102).

CLASS 39—TRANSPORTATION AND STORAGE

FOR TRANSPORT, PACKAGING AND STORAGE OF GOODS, NAMELY, BREADS, CAKES, MUFFINS, PASTRIES AND CONFECTIONERY SNACK FOODS MADE OF CHOCOLATE (U.S. CLS. 100 AND 105).
ZHALEH DELANEY, EXAMINING ATTORNEY

SN 85-438,400. YOUNG, TRACY L., CYPRESS, TX. FILED 10-4-2011.

WHITTY

THE MARK CONSISTS OF STANDARD CHARACTERS WITHOUT CLAIM TO ANY PARTICULAR FONT, STYLE, SIZE, OR COLOR.

CLASS 25—CLOTHING

FOR ATHLETIC APPAREL, NAMELY, SHIRTS, PANTS, JACKETS, FOOTWEAR, SOCKS, COLD-WEATHER LEG COVERS FOR BICYCLISTS, COLD-WEATHER ANKLE COVERS FOR BICYCLISTS, COLD-WEATHER SHOE COVERS FOR BICYCLISTS AND HATS (U.S. CLS. 22 AND 39).

CLASS 28—TOYS AND SPORTING GOODS

FOR ATHLETIC EQUIPMENT, NAMELY, ATHLETIC PROTECTIVE AND SUPPORTIVE COVERINGS FOR LEGS, FEET, AND ANKLES OF BICYCLISTS (U.S. CLS. 22, 23, 38 AND 50).
DORITT L. CARROLL, EXAMINING ATTORNEY

SN 85-438,596. SCANA CORPORATION, CAYCE, SC. FILED 10-4-2011.

FIXED-FOR-SIX

THE MARK CONSISTS OF STANDARD CHARACTERS WITHOUT CLAIM TO ANY PARTICULAR FONT, STYLE, SIZE, OR COLOR.

OWNER OF U.S. REG. NO. 3,067,209.

CLASS 35—ADVERTISING AND BUSINESS

FOR BILLING SERVICES (U.S. CLS. 100, 101 AND 102).

CLASS 39—TRANSPORTATION AND STORAGE

FOR UTILITY SERVICES, NAMELY, THE TRANSPORTATION BY PIPELINE AND STORAGE OF NATURAL GAS (U.S. CLS. 100 AND 105).

MAYUR VAGHANI, EXAMINING ATTORNEY

SN 85-439,044. R.J. DUNHAM & COMPANY, INC., PLANO, TX. FILED 10-4-2011.

Dunham+Company

THE MARK CONSISTS OF STANDARD CHARACTERS WITHOUT CLAIM TO ANY PARTICULAR FONT, STYLE, SIZE, OR COLOR.

NO CLAIM IS MADE TO THE EXCLUSIVE RIGHT TO USE "COMPANY", APART FROM THE MARK AS SHOWN. SEC. 2(F).

CLASS 35—ADVERTISING AND BUSINESS

FOR MARKETING, PUBLIC RELATIONS CONSULTING AND MARKETING RESEARCH SERVICES FOR NONPROFITS (U.S. CLS. 100, 101 AND 102).
FIRST USE 7-1-2006; IN COMMERCE 7-1-2006.

CLASS 36—INSURANCE AND FINANCIAL

FOR CHARITABLE FUNDRAISING FOR NONPROFITS (U.S. CLS. 100, 101 AND 102).
FIRST USE 7-1-2006; IN COMMERCE 7-1-2006.
ROBERT STRUCK, EXAMINING ATTORNEY

SN 85-439,149. C & J OUTLET STORE, LLC, DBA CHICAGO CANDY & NUT, CHICAGO, IL. FILED 10-4-2011.



NO CLAIM IS MADE TO THE EXCLUSIVE RIGHT TO USE "CHICAGO CANDY AND NUT", APART FROM THE MARK AS SHOWN.

THE MARK CONSISTS OF THE WORD "CHICAGO" IN THEATRE LIGHTS APPEARING ABOVE THE WORDING "CANDY AND NUT" OVER A BLACK RECTANGLE WITH ROUNDED EDGES WITH INDIVIDUAL DESIGNS CONSISTING OF A FERRIS WHEEL, A SKYSCRAPER, A WOMAN BALANCING ON A BALL, A HOT DOG, A SKYSCRAPER, A VULTURE, AND A LION, APPEARING IN THAT ORDER FROM LEFT TO RIGHT ABOVE THE WORD "CHICAGO".

CLASS 29—MEATS AND PROCESSED FOODS

FOR ROASTED NUTS, CANDIED NUTS (U.S. CL. 46).

CLASS 30—STAPLE FOODS

FOR CHOCOLATE, CHOCOLATE CONFECTIONS, CHOCOLATE COVERED NUTS, SUGARED NUTS (U.S. CL. 46).

DAVID ELTON, EXAMINING ATTORNEY

SN 85-439,198. CARDIO CORE, LLC, LONG ISLAND CITY, NY. FILED 10-4-2011.

JCORE

THE MARK CONSISTS OF STANDARD CHARACTERS WITHOUT CLAIM TO ANY PARTICULAR FONT, STYLE, SIZE, OR COLOR.

CLASS 5—PHARMACEUTICALS

FOR MEAL REPLACEMENT DRINKS; DIETARY SUPPLEMENTS IN THE NATURE OF POWDERS AND VITAMINS (U.S. CLS. 6, 18, 44, 46, 51 AND 52).

CLASS 9—ELECTRICAL AND SCIENTIFIC APPARATUS

FOR DVDS IN THE FIELD OF FITNESS (U.S. CLS. 21, 23, 26, 36 AND 38).

CLASS 32—LIGHT BEVERAGES

FOR SPORTS DRINKS; POWDERS USED IN THE PREPARATION OF ISOTONIC SPORTS DRINKS AND SPORTS BEVERAGES (U.S. CLS. 45, 46 AND 48).

CLASS 35—ADVERTISING AND BUSINESS

FOR RETAIL STORE AND ONLINE RETAIL STORE SERVICES FEATURING MEAL REPLACEMENT DRINKS, FITNESS BEVERAGES, RECOVERY POWDER DRINKS, DIETARY POWDERS, VITAMINS AND DVDS IN THE FIELD OF FITNESS (U.S. CLS. 100, 101 AND 102).

CLASS 41—EDUCATION AND ENTERTAINMENT

FOR PHYSICAL FITNESS INSTRUCTION AND CONSULTATION; CONDUCTING FITNESS CLASSES (U.S. CLS. 100, 101 AND 107).

CAROLINE WOOD, EXAMINING ATTORNEY

SN 85-439,219. HOTEL CALIFORNIA BAJA LLC, BEVERLY HILLS, CA. FILED 10-4-2011.

HOTEL CALIFORNIA

THE MARK CONSISTS OF STANDARD CHARACTERS WITHOUT CLAIM TO ANY PARTICULAR FONT, STYLE, SIZE, OR COLOR.

OWNER OF U.S. REG. NO. 3,771,896.

NO CLAIM IS MADE TO THE EXCLUSIVE RIGHT TO USE "CALIFORNIA", APART FROM THE MARK AS SHOWN.

CLASS 3—COSMETICS AND CLEANING PREPARATIONS

FOR FRAGRANCES, PERFUMES, EAU DE TOILETTE, ESSENTIAL OILS FOR PERSONAL USE, PERFUME OILS; TOILETRIES AND COSMETICS, NAMELY, SHOWER GEL, FACIAL WASHES, FACIAL SCRUBS, FACE CREAMS, EYE CREAM, HAIR GEL, BATH SOAPS IN SOLID FORM, SHAVING CREAM, SHAVING GEL, SHAVING PREPARATIONS, SHAVING BALM, AFTER-SHAVE; BODY AND BEAUTY CARE COSMETICS AND TOILETRIES, NAMELY, SOAPS FOR BODY CARE, LIQUID SOAPS FOR HANDS, FACE AND BODY, FACIAL CLEANSERS, SKIN TONERS, SKIN CLEANSERS AND EMOLLIENTS, CLEANSING CREAMS, BODY SCRUB, FACIAL SCRUB, SKIN LOTIONS, SKIN CLEANSING LOTIONS, FACE LOTIONS, BODY LOTIONS, SKIN MOISTURIZERS, COSMETIC CREAMS FOR SKIN CARE, NUTRITIONAL OILS FOR COSMETIC PURPOSES, BODY OIL, BATH OIL, LIP BALM, DENTIFRICES, TOOTHPASTE, NON-MEDICAL MOUTHWASH AND GARGLE, BATH GEL, SHAMPOOS, HAIR CONDITIONERS, HAIR CARE PREPARATIONS, HAIR STYLING GELS, HAIR LOTIONS, HAIR STYLING PREPARATIONS, DEODORANTS FOR BODY CARE, BODY POWDER, ANTI-PERSPIRANTS, COSMETIC SUNTAN LOTIONS, SUN-PROTECTING AND SUN-TANNING PREPARATIONS, COCOA BUTTER FOR COSMETIC PURPOSES (U.S. CLS. 1, 4, 6, 50, 51 AND 52).

CLASS 18—LEATHER GOODS

FOR BACKPACKS, KNAPSACKS, DAYPACKS, FANNY PACKS, MESSENGER BAGS, SHOULDER BAGS, TOTE BAGS, DUFFEL BAGS, OVERNIGHT BAGS, ATHLETIC BAGS, CARRY-ON BAGS AND LUGGAGE, LEATHER KEY CHAINS, KEY CASES, HANDBAGS, WALLETS, PURSES, COIN PURSES, CLUTCH PURSES, COSMETICS CASES SOLD EMPTY, TOILETRY BAGS SOLD EMPTY; PET ACCESSORIES, NAMELY, CLOTHING FOR PETS, COLLARS FOR ANIMALS, COVERS FOR ANIMALS, LEATHER LEASHES AND DOG COLLARS (U.S. CLS. 1, 2, 3, 22 AND 41).

CLASS 25—CLOTHING

FOR FOOTWEAR, NAMELY, SHOES, SLIPPERS, BOOTS, SANDALS, FLIP-FLOPS, AND ATHLETIC SHOES; CLOTHING, NAMELY, SHIRTS, TANK TOPS, SWEAT PANTS, SWEAT SUITS, JEANS, PANTS, SHORTS, OVERALLS, JUMPSUITS, SKIRTS, DRESSES, BLOUSES, JACKETS, SWEATERS, VESTS, SWIMWEAR, BATHING SUITS, COVER-UPS, SLEEPWEAR, PAJAMAS, ROBES, NIGHTGOWNS, LEOTARDS, LINGERIE, PANTIES, BRAS, BOXER SHORTS, UNDERWEAR, SCARVES, BELTS, SOCKS, STOCKINGS, TIGHTS, LEGGINGS, GLOVES; OUTERWEAR, NAMELY, COATS AND RAINCOATS; HEADGEAR, NAMELY, HATS, HEADBANDS, VISORS AND BANDANAS (U.S. CLS. 22 AND 39).

BRENDAN MCCAULEY, EXAMINING ATTORNEY

SN 85-439,616. EAGLE PUBLISHING, INC., WASHINGTON, DC. FILED 10-5-2011.

THE ALPHA INVESTOR LETTER

THE MARK CONSISTS OF STANDARD CHARACTERS WITHOUT CLAIM TO ANY PARTICULAR FONT, STYLE, SIZE, OR COLOR.

NO CLAIM IS MADE TO THE EXCLUSIVE RIGHT TO USE "INVESTOR LETTER", APART FROM THE MARK AS SHOWN.

CLASS 16—PAPER GOODS AND PRINTED MATTER

FOR FINANCIAL NEWSLETTERS (U.S. CLS. 2, 5, 22, 23, 29, 37, 38 AND 50).

FIRST USE 4-20-2011; IN COMMERCE 4-20-2011.

CLASS 41—EDUCATION AND ENTERTAINMENT

FOR ON-LINE PUBLICATION OF NEWSLETTERS RELATING TO FINANCE AND INVESTING (U.S. CLS. 100, 101 AND 107).

FIRST USE 4-20-2011; IN COMMERCE 4-20-2011.

KATHY DE JONGE, EXAMINING ATTORNEY

SN 85-439,790. H&A LOCATION SAS, BORDEAUX, FRANCE, FILED 10-5-2011.

H&A

THE MARK CONSISTS OF STANDARD CHARACTERS WITHOUT CLAIM TO ANY PARTICULAR FONT, STYLE, SIZE, OR COLOR.

CLASS 35—ADVERTISING AND BUSINESS

FOR RESELLER SERVICES, NAMELY, DISTRIBUTORSHIP SERVICES FEATURING EMPTY WINE BARRELS AND CASKS; BUSINESS MANAGEMENT, ADMINISTRATION, ASSISTANCE, AND CONSULTING SERVICES IN THE WINE BUSINESS (U.S. CLS. 100, 101 AND 102).

FIRST USE 9-20-2004; IN COMMERCE 10-8-2010.

CLASS 36—INSURANCE AND FINANCIAL

FOR EQUIPMENT FINANCING SERVICES, FINANCIAL CONSULTING, ANALYSIS, AND EVALUATION IN THE WINE INDUSTRY; PROVIDING FINANCIAL ADVICE AND CONSULTING CONCERNING WINERY OPERATIONS (U.S. CLS. 100, 101 AND 102).

FIRST USE 11-12-2004; IN COMMERCE 5-18-2011.

MARK SPARACINO, EXAMINING ATTORNEY

SN 85-439,984. JAMES G. PARKER INSURANCE ASSOCIATES, FRESNO, CA. FILED 10-5-2011.

VANTAGE ADVANCED RISK ASSESSMENT

THE MARK CONSISTS OF STANDARD CHARACTERS WITHOUT CLAIM TO ANY PARTICULAR FONT, STYLE, SIZE, OR COLOR.

NO CLAIM IS MADE TO THE EXCLUSIVE RIGHT TO USE "ADVANCED RISK ASSESSMENT", APART FROM THE MARK AS SHOWN.

CLASS 35—ADVERTISING AND BUSINESS

FOR CONSULTING SERVICES IN THE FIELD OF BUSINESS RISK ASSESSMENT (U.S. CLS. 100, 101 AND 102).

CLASS 36—INSURANCE AND FINANCIAL

FOR INSURANCE SERVICES, NAMELY, UNDERWRITING, ISSUANCE, AND ADMINISTRATION OF LIFE, HEALTH, WORKERS COMPENSATION, PROPERTY, AND CASUALTY INSURANCE (U.S. CLS. 100, 101 AND 102).

BRENDAN MCCAULEY, EXAMINING ATTORNEY

SN 85-440,105. SCHOOL SPECIALTY, INC., APPLETON, WI. FILED 10-5-2011.

AUTOSKILL

THE MARK CONSISTS OF STANDARD CHARACTERS WITHOUT CLAIM TO ANY PARTICULAR FONT, STYLE, SIZE, OR COLOR.

OWNER OF U.S. REG. NO. 2,501,650.

CLASS 16—PAPER GOODS AND PRINTED MATTER

FOR PRINTED MATERIALS, NAMELY, INSTRUCTOR'S RESOURCE GUIDES IN THE FIELDS OF READING AND MATH FOR USE IN CONNECTION WITH SOFTWARE FOR USE BY ELEMENTARY AND SECONDARY SCHOOL STUDENTS AND TEACHERS (U.S. CLS. 2, 5, 22, 23, 29, 37, 38 AND 50).

FIRST USE 9-0-2009; IN COMMERCE 9-0-2009.

CLASS 42—SCIENTIFIC AND COMPUTER SERVICES

FOR PROVIDING TEMPORARY USE OF ON-LINE NON-DOWNLOADABLE SOFTWARE FOR COMPUTER-BASED INSTRUCTION IN READING AND MATH, FOR USE BY ELEMENTARY AND SECONDARY SCHOOL STUDENTS AND TEACHERS (U.S. CLS. 100 AND 101).

FIRST USE 9-0-2009; IN COMMERCE 9-0-2009.
LAURIE KAUFMAN, EXAMINING ATTORNEY

SN 85-440,471. SCHAACK, MARKUS, KERPEN, FED REP GERMANY, FILED 10-6-2011.

SRXL

THE MARK CONSISTS OF STANDARD CHARACTERS WITHOUT CLAIM TO ANY PARTICULAR FONT, STYLE, SIZE, OR COLOR.

OWNER OF ERPN CMNTY TM OFC REG. NO. 009921669, DATED 9-8-2011, EXPIRES 9-8-2021.

CLASS 9—ELECTRICAL AND SCIENTIFIC APPARATUS

FOR ELECTRONIC CONDUCTORS; ELECTRONIC SWITCHES; ELECTRONIC TRANSFORMERS; ELECTRONIC ACCUMULATORS; ELECTRONIC CONTROLLERS; DATA PROCESSING EQUIPMENT AND COMPUTERS; ELECTRONIC CONTROLLERS FOR REGULATING THE FLIGHT ALTITUDE OF AIRCRAFTS, IN PARTICULAR MODEL AIRCRAFTS OR REMOTE CONTROL MODEL AIRCRAFTS, IN PARTICULAR REMOTE CONTROL MODEL HELICOPTERS (U.S. CLS. 21, 23, 26, 36 AND 38).

CLASS 28—TOYS AND SPORTING GOODS

FOR SCALE MODEL AIRPLANES, SCALE MODEL HELICOPTERS, REMOTE CONTROLLED TOY MODEL AIRPLANES, REMOTE CONTROLLED TOY MODEL HELICOPTERS AND PARTS AND ACCESSORIES THEREFOR (U.S. CLS. 22, 23, 38 AND 50).

DANIEL CAPSHAW, EXAMINING ATTORNEY

SN 85-440,675. UNITED WAY FOR THE GREATER NEW ORLEANS AREA, INC., NEW ORLEANS, LA. FILED 10-6-2011.

NO PLACE LIKE HOME

THE MARK CONSISTS OF STANDARD CHARACTERS WITHOUT CLAIM TO ANY PARTICULAR FONT, STYLE, SIZE, OR COLOR.

CLASS 35—ADVERTISING AND BUSINESS

FOR CHARITABLE SERVICES, NAMELY, ORGANIZING, CONDUCTING AND RECRUITING VOLUNTEER PROGRAMS IN THE FIELD OF HOME BUILDING FOR THE PURPOSE OF COORDINATING THE BUILDING EFFORTS OF VOLUNTEERS AND CONSTRUCTION COMPANIES AT CONSTRUCTION SITES; PROVIDING A WEBSITE FEATURING INFORMATION IN THE FIELD OF COORDINATING BUILDING EFFORTS OF VOLUNTEERS AT CONSTRUCTION SITES (U.S. CLS. 100, 101 AND 102).

FIRST USE 4-29-2010; IN COMMERCE 4-29-2010.

CLASS 45—PERSONAL AND LEGAL SERVICES

FOR ONLINE SOCIAL NETWORKING SERVICES IN THE FIELD OF SOUTHEAST LOUISIANA HOME BUILDING FOR COORDINATING THE BUILDING EFFORTS AT HOUSING CONSTRUCTION SITES (U.S. CLS. 100 AND 101).

FIRST USE 4-29-2010; IN COMMERCE 4-29-2010.
ALYSSA STEEL, EXAMINING ATTORNEY

SN 85-440,819. UNIVERSITY OF SOUTH CAROLINA, COLUMBIA, SC. FILED 10-6-2011.



NO CLAIM IS MADE TO THE EXCLUSIVE RIGHT TO USE "APPRECIATIVE", APART FROM THE MARK AS SHOWN.

THE MARK CONSISTS OF A REPRESENTATION OF A FIGURE JUGGLING 6 BALLS IN THE AIR THAT IS PART OF A STYLIZED VERSION OF THE LETTER "A" IN THE WORD "ADVISING" WITH THE WORD "APPRECIATIVE" POSITIONED ABOVE THE WORD "ADVISING".

CLASS 16—PAPER GOODS AND PRINTED MATTER

FOR A SERIES OF WRITTEN MATERIALS, NAMELY, ASSESSMENT INVENTORY TESTS, NEWSLETTERS, JOURNALS, EDUCATIONAL REPORTS AND TRANSCRIPTS, MONOGRAPHS, AND SURVEY AND ASSESSMENT REPORTS ALL ON THE SUBJECT OF ENHANCING STUDENTS' EDUCATIONAL EXPERIENCES (U.S. CLS. 2, 5, 22, 23, 29, 37, 38 AND 50).

CLASS 41—EDUCATION AND ENTERTAINMENT

FOR EDUCATIONAL SERVICES, NAMELY, CONDUCTING CONFERENCES, SEMINARS, WORKSHOPS AND COLLEGE COURSES ON THE SUBJECT OF ENHANCING STUDENTS' EDUCATIONAL EXPERIENCES; PREPARING, ADMINISTERING, AND SCORING ASSESSMENT INVENTORY TESTS (U.S. CLS. 100, 101 AND 107).

JOHN HWANG, EXAMINING ATTORNEY

SN 85-441,302. ADCO CLEANING PRODUCTS LLC, SEDALIA, MO. FILED 10-6-2011.

Adco
Where clean begins.

OWNER OF U.S. REG. NOS. 210,592, 2,467,818 AND OTHERS.

THE MARK CONSISTS OF THE STYLIZED WORDING "ADCO" SET ABOVE THE STYLIZED WORDING "WHERE CLEAN BEGINS.", WITH A STYLIZED DEPICTION OF WAVES OF WATER SET INSIDE THE LETTER "O" IN THE TERM "ADCO".

CLASS 1—CHEMICALS

FOR FULL LINE OF DRY CLEANING CHEMICALS IN THE NATURE OF FABRIC PROTECTANTS FOR COMMERCIAL DRY CLEANING USE (U.S. CLS. 1, 5, 6, 10, 26 AND 46).

FIRST USE 1-2-2010; IN COMMERCE 1-2-2010.

CLASS 3—COSMETICS AND CLEANING PREPARATIONS

FOR FULL LINE OF LAUNDRY WASHING CHEMICALS, LAUNDRY DETERGENTS, AND DRY CLEANING CHEMICAL FLUIDS (U.S. CLS. 1, 4, 6, 50, 51 AND 52).

FIRST USE 1-2-2010; IN COMMERCE 1-2-2010.
NORA BUCHANAN WILL, EXAMINING ATTORNEY

SN 85-441,411. INDUSTRIAL RESEARCH LIMITED, LOWER HUTT, NEW ZEALAND, FILED 10-6-2011.

GlycoSyn

THE MARK CONSISTS OF STANDARD CHARACTERS WITHOUT CLAIM TO ANY PARTICULAR FONT, STYLE, SIZE, OR COLOR.

PRIORITY CLAIMED UNDER SEC. 44(D) ON NEW ZEALAND APPLICATION NO. 843186, FILED 6-2-2011, REG. NO. 843186, DATED 6-2-2011, EXPIRES 6-2-2021.

CLASS 1—CHEMICALS

FOR CARBOHYDRATE-DERIVED CHEMICALS AND PEPTIDES FOR USE IN INDUSTRY; CHEMICAL ADDITIVES FOR USE IN THE MANUFACTURE OF PHARMACEUTICALS AND COSMETICS (U.S. CLS. 1, 5, 6, 10, 26 AND 46).

CLASS 5—PHARMACEUTICALS

FOR ACTIVE PHARMACEUTICAL INGREDIENTS SOLD AS AN INTEGRAL COMPONENT OF PHARMACEUTICAL PREPARATIONS FOR THE TREATMENT OF PAIN, INFLAMMATION, INFECTION, DIABETES, CANCERS AND FOR WOUND REPAIR; PHARMACEUTICAL INGREDIENTS USED IN ENZYME REPLACEMENT THERAPIES, THERAPEUTIC VACCINES (ADJUVANTS), STEM CELL THERAPIES, AND FOR ENHANCED DRUG DELIVERY; ANTIOXIDANTS; VACCINES FOR THE TREATMENT OF CANCER; ADJUVANTS AND ANTIGENS FOR VACCINES; ACTIVE VETERINARY INGREDIENTS SOLD AS AN INTEGRAL COMPONENT OF VETERINARY PREPARATIONS FOR THE TREATMENT OF BLOAT AND FOR IMPROVING FECUNDITY; HERBICIDES AND PESTICIDES FOR COMMERCIAL, AGRICULTURAL OR INDUSTRIAL USE (U.S. CLS. 6, 18, 44, 46, 51 AND 52).

CLASS 42—SCIENTIFIC AND COMPUTER SERVICES

FOR SCIENTIFIC AND TECHNOLOGICAL RESEARCH SERVICES IN THE FIELDS OF BIOTECHNOLOGY, CARBOHYDRATE CHEMISTRY AND PHARMACEUTICALS INCLUDING RESEARCH SERVICES IN THE FIELD OF PHARMACEUTICAL AND DRUG MANUFACTURE; BIOLOGICAL, PHARMACEUTICAL AND MEDICAL RESEARCH; TESTING SERVICES, NAMELY, TESTING, INSPECTION OR RESEARCH OF PHARMACEUTICALS AND DRUGS; LABORATORY SERVICES, NAMELY, CHEMICAL SYNTHESIS OF ACTIVE PHARMACEUTICAL INTERMEDIATES (APIS) FOR USE IN PRE-CLINICAL AND HUMAN CLINICAL TRIALS; PHARMACEUTICAL RESEARCH AND DEVELOPMENT SERVICES, NAMELY, ACTIVE PHARMACEUTICAL INTERMEDIATES (APIS) RESEARCH AND DEVELOPMENT TO SUPPORT PRE-CLINICAL AND EARLY PHASE HUMAN CLINICAL TRIALS; CHEMICAL LABORATORY ANALYTICAL SERVICES, NAMELY, ANALYZING PHARMACEUTICALS AND POTENTIAL PHARMACEUTICAL INGREDIENTS (U.S. CLS. 100 AND 101).

CHERYL CLAYTON, EXAMINING ATTORNEY

SN 85-441,529. CLARINS S.A., NEUILLY SUR SEINE, FRANCE, FILED 10-7-2011.

INSTANT BEAUTY

THE MARK CONSISTS OF STANDARD CHARACTERS WITHOUT CLAIM TO ANY PARTICULAR FONT, STYLE, SIZE, OR COLOR.

PRIORITY CLAIMED UNDER SEC. 44(D) ON FRANCE APPLICATION NO. 11/3822451, FILED 4-11-2011, REG. NO. 11/3822451, DATED 4-11-2011, EXPIRES 4-11-2021.

CLASS 3—COSMETICS AND CLEANING PREPARATIONS

FOR MAKE-UP PREPARATIONS (U.S. CLS. 1, 4, 6, 50, 51 AND 52).

CLASS 16—PAPER GOODS AND PRINTED MATTER

FOR PAMPHLETS IN THE FIELD OF COSMETICS, PROSPECTUSES IN THE FIELD OF COSMETICS, SIGNBOARD OF PAPER OR CARDBOARD, BAGS OF CARDBOARD AND PLASTIC FOR PACKAGING (U.S. CLS. 2, 5, 22, 23, 29, 37, 38 AND 50).

RAMONA ORTIGA, EXAMINING ATTORNEY

SN 85-441,566. JACKSON, LAKEISHA, SANTA CLARA, CA.
FILED 10-7-2011.

K-DOT-J

THE MARK CONSISTS OF STANDARD CHARACTERS WITHOUT CLAIM TO ANY PARTICULAR FONT, STYLE, SIZE, OR COLOR.

CLASS 9—ELECTRICAL AND SCIENTIFIC APPARATUS

FOR PRE RECORDED COMPACT DISCS FEATURING MUSIC; DIGITAL MUSIC AND DIGITAL MUSIC VIDEOS DOWNLOADABLE FROM THE INTERNET; DOWNLOADABLE RING TONES, GRAPHICS AND MUSIC VIA A GLOBAL COMPUTER NETWORK AND WIRELESS DEVICES; VIDEO GAME SOFTWARE (U.S. CLS. 21, 23, 26, 36 AND 38).

CLASS 25—CLOTHING

FOR CLOTHING, NAMELY, TOPS, BOTTOMS, TEE SHIRTS, BANDANAS AND CAPS (U.S. CLS. 22 AND 39).

CLASS 41—EDUCATION AND ENTERTAINMENT

FOR ENTERTAINMENT RENDERED BY A MUSICAL ARTIST, NAMELY, ENTERTAINMENT IN THE NATURE OF VISUAL AND AUDIO PERFORMANCES BY A MUSICAL ACT; LIVE PERFORMANCES BY A MUSICAL ACT; MULTIMEDIA ENTERTAINMENT SERVICES IN THE NATURE OF RECORDING, PRODUCTION AND POST-PRODUCTION SERVICES IN THE FIELD OF MUSIC AND VIDEO; ENTERTAINMENT SERVICES BY A MUSICAL ARTIST, NAMELY, MUSIC SONGWRITING, RECORDING, PRODUCTION, PUBLISHING, MUSIC VIDEO PRODUCTION, MUSICAL COMPOSITION AND PRODUCTION OF MUSICAL SOUND RECORDINGS; PROVIDING AN INTERNET WEBSITE IN THE FIELD OF MUSIC; ENTERTAINMENT, NAMELY, A CONTINUING VARIETY SHOW BROADCAST OVER TELEVISION, RADIO, AND INTERNET (U.S. CLS. 100, 101 AND 107).

DAWN FELDMAN, EXAMINING ATTORNEY

SN 85-441,777. EMSUR MACDONELL S.A., MADRID, SPAIN, FILED 10-7-2011.



THE COLOR(S) BLUE, DARK BLUE AND LIGHT BLUE IS/ARE CLAIMED AS A FEATURE OF THE MARK.

THE MARK CONSISTS OF THE BLUE STYLIZED WORD "EMSUR" TO THE LEFT OF WHICH IS A DESIGN OF CONCENTRIC CIRCULAR LINES WHICH ARE DARK BLUE ON THE OUTER EDGES, BLUE IN THE MIDDLE, AND LIGHT BLUE WITHIN THE CENTER OF THE CIRCULAR DESIGN.

CLASS 16—PAPER GOODS AND PRINTED MATTER

FOR WRAPPING MATERIAL OF PLASTICS, NAMELY, PLASTIC GIFT WRAP, PLASTIC WRAP, PLASTIC BUBBLE PACKS FOR WRAPPING, AND FOOD WRAPPING PLASTIC FILM FOR HOUSEHOLD USE (U.S. CLS. 2, 5, 22, 23, 29, 37, 38 AND 50).

CLASS 35—ADVERTISING AND BUSINESS

FOR IMPORT AND EXPORT AGENCIES; ADVERTISING SERVICES; BUSINESS MANAGEMENT; BUSINESS ADMINISTRATION; PROVIDING OFFICE FUNCTIONS; SALES PROMOTION FOR OTHERS PROVIDED ON INTERNET RETAIL WEBSITES FEATURING INFORMATION TECHNOLOGY PRODUCTS (U.S. CLS. 100, 101 AND 102).

CLASS 39—TRANSPORTATION AND STORAGE

FOR TRANSPORT BY FERRY, BOAT, RAIL, AND AIR; PACKAGING OF CONTAINERS TO THE ORDER AND SPECIFICATION OF OTHERS AND STORAGE OF CONTAINERS (U.S. CLS. 100 AND 105).

CLASS 40—MATERIAL TREATMENT

FOR PATTERN PRINTING; CUSTOM IMPRINTING OF PLASTIC, CELLULOSE AND METALLIC SUCH AS MUGS AND CLOTHING (U.S. CLS. 100, 103 AND 106).
BRENDAN MCCAULEY, EXAMINING ATTORNEY

SN 85-441,833. STONE & WEBSTER PROCESS TECHNOLOGY, INC., HOUSTON, TX. FILED 10-7-2011.



OWNER OF U.S. REG. NO. 871,924.

THE COLOR(S) GREEN AND DARK GRAY IS/ARE CLAIMED AS A FEATURE OF THE MARK.

THE MARK CONSISTS OF A STYLIZED SERIES OF GREEN DOTS OF VARYING SIZE FORMING A SWOOP DESIGN IMMEDIATELY ADJACENT TO AND PARTIALLY ABOVE THE TERM "BADGER", SUCH TERM APPEARING IN A STYLIZED DARK GRAY FONT.

CLASS 35—ADVERTISING AND BUSINESS

FOR PROCUREMENT, NAMELY, PURCHASING OF CONSTRUCTION MATERIALS (U.S. CLS. 100, 101 AND 102).

FIRST USE 6-7-2011; IN COMMERCE 6-7-2011.

CLASS 37—CONSTRUCTION AND REPAIR

FOR CONSTRUCTION OF INDUSTRIAL PLANTS, SUCH AS CHEMICAL MANUFACTURING AND/OR PROCESS PLANTS, AND CONSTRUCTION OF BUILDINGS AND ROADS ANCILLARY TO SAID PLANTS (U.S. CLS. 100, 103 AND 106).

FIRST USE 6-7-2011; IN COMMERCE 6-7-2011.

CLASS 42—SCIENTIFIC AND COMPUTER SERVICES

FOR EVALUATION, DESIGN, AND ENGINEERING OF INDUSTRIAL PROCESSES AND PLANTS, PARTICULARLY FOR MANUFACTURING AND/OR PROCESSING OF CHEMICALS AND INITIAL OPERATION OF SAID PROCESSES AND PLANTS; ANALYSIS, PLANNING, AND SUPERVISION OF MAINTENANCE OPERATIONS IN THE NATURE OF TECHNOLOGY SUPERVISION AND INSPECTION IN THE FIELD OF PROCESS INDUSTRIES (U.S. CLS. 100 AND 101).

FIRST USE 6-7-2011; IN COMMERCE 6-7-2011.

TASNEEM HUSSAIN, EXAMINING ATTORNEY

SN 85-442,082. BIODEFENSE CORPORATION, BOSTON, MA. FILED 10-7-2011.

MEDICALDEFENDER

THE MARK CONSISTS OF STANDARD CHARACTERS WITHOUT CLAIM TO ANY PARTICULAR FONT, STYLE, SIZE, OR COLOR.

CLASS 10—MEDICAL APPARATUS

FOR STERILIZATION UNITS FOR MEDICAL INSTRUMENTS (U.S. CLS. 26, 39 AND 44).

CLASS 11—ENVIRONMENTAL CONTROL APPARATUS

FOR DECONTAMINATION UNITS FOR THE TREATMENT AND NEUTRALIZATION OF MEDICAL AND BIOLOGICAL WASTE (U.S. CLS. 13, 21, 23, 31 AND 34).

BRIDGETT SMITH, EXAMINING ATTORNEY

SN 85-442,286. G.U.C. S.A., MEDELLÍN, COLOMBIA, FILED 10-7-2011.

AMERICANINO

THE MARK CONSISTS OF STANDARD CHARACTERS WITHOUT CLAIM TO ANY PARTICULAR FONT, STYLE, SIZE, OR COLOR.

THE WORDING "AMERICANINO" HAS NO MEANING IN A FOREIGN LANGUAGE.

CLASS 3—COSMETICS AND CLEANING PREPARATIONS

FOR SOAPS; PERFUMERY; ESSENTIAL OILS, COSMETICS (U.S. CLS. 1, 4, 6, 50, 51 AND 52).

CLASS 14—JEWELRY

FOR JEWELLERY, PRECIOUS STONES, HOROLOGIC AND CHRONOMETRIC INSTRUMENTS (U.S. CLS. 2, 27, 28 AND 50).

CLASS 18—LEATHER GOODS

FOR LEATHER AND IMITATIONS OF LEATHER; AND GOODS MADE OF THESE MATERIALS, NAMELY, WALLETS, BAGS, AND HANDBAGS (U.S. CLS. 1, 2, 3, 22 AND 41).

CLASS 25—CLOTHING

FOR CLOTHING, NAMELY, MEN'S, WOMEN'S AND CHILDREN'S PANTS, SHORTS, JEANS, DRESSES, SHIRTS, SWEATERS, SKIRTS, COATS, JACKETS, BATHING SUITS, SCARVES, T-SHIRTS AND SOCKS; FOOTWEAR AND HEADGEAR, NAMELY, HATS AND CAPS; GOODS MADE OF LEATHER AND IMITATION LEATHER, NAMELY, JACKETS, VESTS, COATS, BELTS, SHOES, BOOTS AND HATS (U.S. CLS. 22 AND 39).

CLASS 35—ADVERTISING AND BUSINESS

FOR ADVERTISING; BUSINESS MANAGEMENT; BUSINESS ADMINISTRATION AND OFFICE FUNCTIONS (U.S. CLS. 100, 101 AND 102).

JAMES A. RAUEN, EXAMINING ATTORNEY

SN 85-442,449. CHICAGO BLACKHAWK HOCKEY TEAM, INC., CHICAGO, IL. FILED 10-7-2011.

A Step aHead

THE MARK CONSISTS OF STANDARD CHARACTERS WITHOUT CLAIM TO ANY PARTICULAR FONT, STYLE, SIZE, OR COLOR.

CLASS 41—EDUCATION AND ENTERTAINMENT

FOR CHARITABLE EDUCATIONAL SERVICES, NAMELY, ORGANIZING AND DEVELOPING EDUCATIONAL PROGRAMS THAT AIM TO EDUCATE YOUNG HOCKEY PLAYERS ABOUT PREVENTING CONCUSSIONS AND HEAD INJURIES (U.S. CLS. 100, 101 AND 107).

CLASS 44—MEDICAL, BEAUTY AND AGRICULTURAL SERVICES

FOR CHARITABLE MEDICAL SERVICES, NAMELY, PROVIDING BASELINE CONCUSSION TESTING PROGRAMS FOR YOUNG HOCKEY PLAYERS (U.S. CLS. 100 AND 101).

BRENDAN REGAN, EXAMINING ATTORNEY

SN 85-442,547. ARCHIE COMIC PUBLICATIONS, INC., MAMARONECK, NY. FILED 10-7-2011.

NEW CRUSADERS

THE MARK CONSISTS OF STANDARD CHARACTERS WITHOUT CLAIM TO ANY PARTICULAR FONT, STYLE, SIZE, OR COLOR.

CLASS 16—PAPER GOODS AND PRINTED MATTER

FOR PRINTED MATTER AND PAPER GOODS, NAMELY, COMIC MAGAZINES, JOKE BOOK MAGAZINES, COMIC MAGAZINE SERIES, COMICS, AND MAGAZINES FEATURING CHARACTERS FROM ANIMATED FILMS; CHILDREN'S BOOKS; MAGAZINES FEATURING CHARACTERS FROM ANIMATED, ACTION ADVENTURE, COMEDY AND DRAMA FEATURES; COLORING BOOKS; CHILDREN'S ACTIVITY BOOKS; STATIONERY, WRITING PAPER, ENVELOPES, NOTEBOOKS, DIARIES, NOTE CARDS, GREETING CARDS, TRADING CARDS; LITHOGRAPHS; PENS, PENCILS, PEN AND PENCIL CASES, ERASERS, CRAYONS, MARKERS, COLORED PENCILS, PAINTING SETS FOR CHILDREN, DECALS, IRON-ON HEAT TRANSFERS, PLASTIC HEAT TRANSFERS; POSTERS; MOUNTED PHOTOGRAPHS AND UNMOUNTED PHOTOGRAPHS; BOOK COVERS, BOOK MARKS, CALENDARS, GIFT WRAPPING PAPER; PAPER PARTY FAVORS AND PAPER PARTY DECORATIONS, NAMELY, PAPER NAPKINS, PAPER DOILIES, PAPER PLACE MATS, CREPE PAPER, PRINTED INVITATIONS, PAPER TABLE CLOTHS, AND PAPER CAKE DECORATIONS; PRINTED TRANSFERS FOR EMBROIDERY OR FABRIC APPLIQUÉS; PRINTED PATTERNS FOR COSTUMES, PAJAMAS, SWEATSHIRTS AND T-SHIRTS; PAPER COASTERS FOR GLASSES (U.S. CLS. 2, 5, 22, 23, 29, 37, 38 AND 50).

CLASS 41—EDUCATION AND ENTERTAINMENT

FOR EDUCATIONAL SERVICES, NAMELY, PROVIDING CLASSES, SEMINARS, AND WORKSHOPS IN THE FIELD OF ENTERTAINMENT; PROVIDING EDUCATIONAL INFORMATION IN THE FIELD OF ENTERTAINMENT VIA A GLOBAL COMPUTER NETWORK; PROVIDING INFORMATION IN THE FIELD OF ENTERTAINMENT THAT FEATURES ANIMATION, RENDERED BY MEANS OF A GLOBAL COMPUTER NETWORK; ENTERTAINMENT IN THE NATURE OF ON-GOING TELEVISION PROGRAMS, MOTION PICTURE FILMS AND MOTION PICTURE ANIMATED FILMS FEATURING ACTION, COMEDY, DRAMA, AND CHILDREN'S ENTERTAINMENT; PRODUCTION OF TELEVISION PROGRAMS; FILM PRODUCTION; ORGANIZING COMMUNITY SPORTING AND CULTURAL EVENTS; ORGANIZING AND CONDUCTING ENTERTAINMENT EXHIBITIONS IN THE NATURE OF BOOK FAIRS FEATURING BOOKS AND COMIC BOOKS; PUBLISHING OF BOOKS, MAGAZINES AND COMICS (U.S. CLS. 100, 101 AND 107).

CHERYL CLAYTON, EXAMINING ATTORNEY

SN 85-442,600. HANDY BUTTON MACHINE CO., WHEELING, IL. FILED 10-7-2011.

iRelax

THE MARK CONSISTS OF STANDARD CHARACTERS WITHOUT CLAIM TO ANY PARTICULAR FONT, STYLE, SIZE, OR COLOR.

CLASS 9—ELECTRICAL AND SCIENTIFIC APPARATUS

FOR AUDIO SPEAKERS; SOUND AND VIDEO SYSTEMS COMPRISING REMOTE CONTROLS, AMPLIFIERS, LOUDSPEAKERS AND COMPONENTS THEREOF; APPARATUS FOR RECORDING, TRANSMITTING AND REPRODUCING SOUND AND IMAGES; APPARATUS FOR MANIPULATING AND REVIEWING AUDIO, VIDEO AND OTHER DIGITAL CONTENT, NAMELY, COMPUTERS, DIGITAL VIDEO AND AUDIO RECORDERS AND PLAYERS, PORTABLE AND HANDHELD DIGITAL ELECTRONIC DEVICES FOR RECORDING, ORGANIZING, TRANSMITTING, MANIPULATING, AND REVIEWING TEXT, DATA, IMAGE, AND AUDIO FILES; ELECTRONIC DOCKING STATIONS; POWER SUPPLY CONNECTORS FOR USE WITH PORTABLE ELECTRONIC DEVICES AND WIRELESS CONTROLLER TO MONITOR AND CONTROL THE FUNCTIONING OF OTHER ELECTRONIC DEVICES; WIRELESS TRANSMITTERS AND RECEIVERS; BATTERY CHARGERS FOR USE WITH HANDHELD DIGITAL ELECTRONIC DEVICES; REMOTE CONTROLS FOR TELEVISIONS, STEREOS, MASSAGE UNITS, RECLINING MECHANISMS, TASK LIGHTING; HEADPHONES, AMPLIFIERS, BATTERY CHARGERS, ELECTRICAL POWER CONNECTORS; APPARATUS FOR RECORDING, TRANSMITTING AND REPRODUCING SOUND AND IMAGES, ALL SOLD FOR USE AS FEATURES OR COMPONENTS OF FURNITURE (U.S. CLS. 21, 23, 26, 36 AND 38).

CLASS 20—FURNITURE AND ARTICLES NOT OTHERWISE CLASSIFIED

FOR FURNITURE, UPHOLSTERED FURNITURE, SHELVES AND BEDS, AND STRUCTURAL COMPONENTS THEREOF, RECLINING FURNITURE AND RECLINING MECHANISMS THEREFOR; WORK SURFACES, FURNITURE FEATURING ONE OR MORE OF THE FOLLOWING: REMOTE CONTROLS, SPEAKERS, AMPLIFIERS, BATTERY CHARGING DEVICES, POWER SUPPLY CONNECTORS, ELECTRONIC DOCKING STATIONS; FURNITURE WITH INTEGRATED APPARATUS FOR ONE OR MORE OF THE FOLLOWING FUNCTIONS: RECORDING, TRANSMITTING, MANIPULATING, AND REVIEWING AUDIO, VIDEO OR OTHER DIGITAL CONTENT (U.S. CLS. 2, 13, 22, 25, 32 AND 50).

SUSAN STIGLITZ, EXAMINING ATTORNEY

SN 85-442,703. RED 5 STUDIOS, INC., LAGUNA HILLS, CA. FILED 10-7-2011.

STAGE 5

THE MARK CONSISTS OF STANDARD CHARACTERS WITHOUT CLAIM TO ANY PARTICULAR FONT, STYLE, SIZE, OR COLOR.

CLASS 9—ELECTRICAL AND SCIENTIFIC APPARATUS

FOR DOWNLOADABLE ELECTRONIC PUBLICATIONS, NAMELY, COMIC BOOKS AND GRAPHIC NOVELS; ELECTRONIC PUBLICATIONS, NAMELY, COMIC BOOKS AND GRAPHIC NOVELS RECORDED ON COMPUTER MEDIA; DOWNLOADABLE VIRTUAL GOODS FOR USE IN ONLINE COMPUTER GAMES AND ONLINE VIRTUAL WORLDS (U.S. CLS. 21, 23, 26, 36 AND 38).

CLASS 35—ADVERTISING AND BUSINESS

FOR OPERATING ONLINE MARKETPLACES FOR BUYING AND SELLING FREE AND PURCHASABLE COMPUTER SOFTWARE; OPERATING ONLINE MARKETPLACES FOR BUYING AND SELLING FREE AND PURCHASABLE COMPUTER GAME SOFTWARE; RETAIL STORE SERVICES FEATURING VIRTUAL GOODS FOR USE IN ONLINE COMPUTER GAMES AND ONLINE VIRTUAL WORLDS (U.S. CLS. 100, 101 AND 102).

CLASS 41—EDUCATION AND ENTERTAINMENT

FOR FILM AND VIDEO PRODUCTION AND DISTRIBUTION SERVICES; PRODUCTION OF VIDEOS AND MOVIES FOR DISTRIBUTION VIA THE WEB AND OTHER COMPUTER NETWORKS; PRODUCTION OF VIDEOS AND MOVIES FOR BROADCAST VIA TELEVISION, CABLE, AND SATELLITE; PRODUCTION OF VIDEOS AND MOVIES FOR DISTRIBUTION ON MEDIA, INCLUDING COMPUTER MEDIA AND DVDS; ENTERTAINMENT SERVICES, NAMELY, PROVIDING WEBSITES FEATURING FILMS AND VIDEOS; ENTERTAINMENT SERVICES, NAMELY, PROVIDING ONLINE, NON-DOWNLOADABLE VIRTUAL GOODS FOR USE IN ONLINE COMPUTER GAMES AND ONLINE VIRTUAL WORLDS; PROVIDING NON-DOWNLOADABLE ELECTRONIC PUBLICATIONS, NAMELY, COMIC BOOKS AND GRAPHIC NOVELS (U.S. CLS. 100, 101 AND 107).

CLASS 42—SCIENTIFIC AND COMPUTER SERVICES

FOR PROVIDING TEMPORARY USE OF ONLINE, NON-DOWNLOADABLE SOFTWARE FOR USE IN CREATING, EDITING, PRODUCING AND DISTRIBUTING FILMS AND VIDEOS; PROVIDING TEMPORARY USE OF ONLINE, NON-DOWNLOADABLE SOFTWARE FOR USE IN CREATING, EDITING, AND DISTRIBUTING VIRTUAL GOODS (U.S. CLS. 100 AND 101).

MICHAEL ENGEL, EXAMINING ATTORNEY

SN 85-442,898. BABYISPEECH LLC, ATLANTA, GA. FILED 10-9-2011.

intelligent interaction

THE MARK CONSISTS OF STANDARD CHARACTERS WITHOUT CLAIM TO ANY PARTICULAR FONT, STYLE, SIZE, OR COLOR.

NO CLAIM IS MADE TO THE EXCLUSIVE RIGHT TO USE "INTERACTION", APART FROM THE MARK AS SHOWN.

CLASS 9—ELECTRICAL AND SCIENTIFIC APPARATUS

FOR DIGITAL MATERIALS, NAMELY, PRE-RECORDED DVDS AND ELECTRONIC BOOKS, ALL FEATURING SPOKEN WORDS, VIDEO, AND PHOTOGRAPHIC AND GRAPHIC IMAGES DESIGNED TO STIMULATE THE LEARNING CAPABILITIES OF INFANTS AND YOUNG CHILDREN; AUDIOVISUAL COMPUTER APPLICATION SOFTWARE FOR USE IN STIMULATING THE LEARNING CAPABILITIES OF INFANTS AND YOUNG CHILDREN FEATURING SPOKEN WORDS, VIDEO, AND PHOTOGRAPHIC AND GRAPHIC IMAGES (U.S. CLS. 21, 23, 26, 36 AND 38).

CLASS 41—EDUCATION AND ENTERTAINMENT

FOR PROVIDING A WEBSITE FEATURING INFORMATION IN THE FIELD OF CHILDREN'S EDUCATION FEATURING LANGUAGE LEARNING AND COGNITIVE DEVELOPMENT IN INFANTS AND YOUNG CHILDREN (U.S. CLS. 100, 101 AND 107).

JAY BESCH, EXAMINING ATTORNEY

SN 85-443,039. MERCK KGAA, 64293 DARMSTADT, FED REP GERMANY, FILED 10-10-2011.

SIRTAINTY

THE MARK CONSISTS OF STANDARD CHARACTERS WITHOUT CLAIM TO ANY PARTICULAR FONT, STYLE, SIZE, OR COLOR.

PRIORITY CLAIMED UNDER SEC. 44(D) ON FED REP GERMANY APPLICATION NO. 302011021155, FILED 4-12-2011, REG. NO. 302011021155, DATED 4-21-2011, EXPIRES 4-21-2021.

CLASS 1—CHEMICALS

FOR CHEMICALS USED IN INDUSTRY AND SCIENCE; FLUOROMETRIC ASSAYS FOR THE MEASUREMENT ANALYSIS OF ENZYME ACTIVITY; ASSAY KITS COMPRISING COLLECTIONS OF BUFFERS, ENZYMES, SUBSTRATES AND INHIBITORS FOR RESEARCH PURPOSES (U.S. CLS. 1, 5, 6, 10, 26 AND 46).

CLASS 5—PHARMACEUTICALS

FOR BIOCHEMICAL FLUOROMETRIC ASSAYS FOR TESTING ENZYMIC ACTIVITY FOR MEDICAL PURPOSES; AND MEDICAL DIAGNOSTIC ASSAY KITS COMPRISING COLLECTIONS OF BUFFERS, ENZYMES, SUBSTRATES AND INHIBITORS FOR MEDICAL PURPOSES (U.S. CLS. 6, 18, 44, 46, 51 AND 52).

CLASS 9—ELECTRICAL AND SCIENTIFIC APPARATUS

FOR ELECTRICAL APPARATUS FOR THE EVALUATION OF ENZYMIC ACTIVITY (U.S. CLS. 21, 23, 26, 36 AND 38).

SALLY SHIH, EXAMINING ATTORNEY

SN 85-443,389. RESOLUTE FOREST PRODUCTS INC., MONTREAL, CANADA, FILED 10-10-2011.

RESOLUTE FOREST PRODUCTS

THE MARK CONSISTS OF STANDARD CHARACTERS WITHOUT CLAIM TO ANY PARTICULAR FONT, STYLE, SIZE, OR COLOR.

NO CLAIM IS MADE TO THE EXCLUSIVE RIGHT TO USE "FOREST PRODUCTS", APART FROM THE MARK AS SHOWN.

CLASS 1—CHEMICALS

FOR WOOD PULP, PAPER PULP AND WOOD PULP FOR MANUFACTURING PURPOSES; PULP FOR MANUFACTURING PURPOSES; SOFTWOOD PULP; HARDWOOD PULP; FLUFF PULP; SULPHITE PULP (U.S. CLS. 1, 5, 6, 10, 26 AND 46).

SN 85-443,405. RESOLUTE FOREST PRODUCTS INC., MONTREAL, CANADA, FILED 10-10-2011.

CLASS 16—PAPER GOODS AND PRINTED MATTER

FOR PAPER, NAMELY, GROUND WOOD PAPER, NEWSPRINT PAPER, NEWSPRINT, COATED PAPER, PRINTING PAPER, COMPUTER PAPER, RECYCLED PAPER, FINE PAPER, COATED PRINTING PAPER, COATED AND UNCOATED PAPER WITH RECYCLED CONTENT, SUPER CALENDERED GRADE PAPER, FREE SHEET HYBRID PAPER, BLANK DIRECTORY PAPER, GRAPHIC ARTS CONVERTING PAPER, CONTINUOUS FORM PAPER, PHOTOCOPY PAPER, AND KRAFT PAPER; CORRUGATED CONTAINERS MADE OF CARDBOARD (U.S. CLS. 2, 5, 22, 23, 29, 37, 38 AND 50).



NO CLAIM IS MADE TO THE EXCLUSIVE RIGHT TO USE "FOREST PRODUCTS", APART FROM THE MARK AS SHOWN.

THE MARK CONSISTS OF A STYLIZED LETTER "R" ABOVE THE WORD RESOLUTE, BOTH ABOVE THE WORDS "FOREST PRODUCTS".

CLASS 19—NON-METALLIC BUILDING MATERIALS

FOR PLYWOOD; LUMBER; BUILDING BOARDS COMPOSED OF WOOD; HARDBOARDS; HARDBOARDS SIDING; WOOD POLES; TREATED WOOD PRODUCTS, NAMELY, DIMENSION LUMBER, STUD LUMBER, MACHINE STRESS RATED (MSR) LUMBER, FINGER-JOINTED LUMBER, VISUAL GRADE LUMBER, FURRING STRIPS, FINGER-JOINTED STUD AND STRUCTURAL COMPONENTS, NAMELY, FINGER-JOINTED STUD AND STRUCTURAL LUMBER, NON-METAL FENCE COMPONENTS, NAMELY, POSTS, SLATS, GATES, PANELS, RAILS, PICKETS, FLOOR JOIST FLANGES, AND TRUSS CHORDS FOR USE IN SPECIALIZED APPLICATIONS, NAMELY, MOBILE HOMES, ROOFING AND FLOORING MATERIAL AND DECKING (U.S. CLS. 1, 12, 33 AND 50).

CLASS 1—CHEMICALS

FOR WOOD PULP, PAPER PULP AND WOOD PULP FOR MANUFACTURING PURPOSES; PULP FOR MANUFACTURING PURPOSES; SOFTWOOD PULP; HARDWOOD PULP; FLUFF PULP; SULPHITE PULP (U.S. CLS. 1, 5, 6, 10, 26 AND 46).

CLASS 16—PAPER GOODS AND PRINTED MATTER

FOR PAPER, NAMELY, GROUND WOOD PAPER, NEWSPRINT PAPER, NEWSPRINT, COATED PAPER, PRINTING PAPER, COMPUTER PAPER, RECYCLED PAPER, FINE PAPER, COATED PRINTING PAPER, COATED AND UNCOATED PAPER WITH RECYCLED CONTENT, SUPER CALENDERED GRADE PAPER, FREE SHEET HYBRID PAPER, BLANK DIRECTORY PAPER, GRAPHIC ARTS CONVERTING PAPER, CONTINUOUS FORM PAPER, PHOTOCOPY PAPER, AND KRAFT PAPER; CORRUGATED CONTAINERS MADE OF CARDBOARD (U.S. CLS. 2, 5, 22, 23, 29, 37, 38 AND 50).

CLASS 37—CONSTRUCTION AND REPAIR

FOR PAPER COLLECTION FOR RECYCLING PURPOSES; AND MAINTENANCE OF POWER TRANSMISSION AND DISTRIBUTION FACILITIES (U.S. CLS. 100, 103 AND 106).

CLASS 19—NON-METALLIC BUILDING MATERIALS

FOR PLYWOOD; LUMBER; BUILDING BOARDS COMPOSED OF WOOD; HARDBOARDS; HARDBOARDS SIDING; WOOD POLES; TREATED WOOD PRODUCTS, NAMELY, DIMENSION LUMBER, STUD LUMBER, MACHINE STRESS RATED (MSR) LUMBER, FINGER-JOINTED LUMBER, VISUAL GRADE LUMBER, FURRING STRIPS, FINGER-JOINTED STUD AND STRUCTURAL COMPONENTS, NAMELY, FINGER-JOINTED STUD AND STRUCTURAL LUMBER, NON-METAL FENCE COMPONENTS, NAMELY, POSTS, SLATS, GATES, PANELS, RAILS, PICKETS, FLOOR JOIST FLANGES, AND TRUSS CHORDS FOR USE IN SPECIALIZED APPLICATIONS, NAMELY, MOBILE HOMES, ROOFING AND FLOORING MATERIAL AND DECKING (U.S. CLS. 1, 12, 33 AND 50).

CLASS 40—MATERIAL TREATMENT

FOR MATERIAL TREATMENT SERVICES IN CONNECTION WITH RECYCLING, PRODUCTION OF NEWSPRINT, PRODUCTION OF COMMERCIAL PRINTING PAPERS, PRODUCTION OF MARKET PULP, LUMBER PRODUCTION, RECYCLED FIBER PRODUCTION, REMANUFACTURING AND ENGINEERING OF WOOD; PAPER TREATMENT AND FINISHING SERVICES; SERVICES OF OPERATION OF PULP AND PAPER MILLS, NAMELY, CUSTOM PRODUCTION OF PAPER, NEWSPRINT AND MARKET PULP FOR OTHERS; RECYCLING SERVICES, NAMELY, CARDBOARD, PLASTIC, ALUMINUM, TEXTILES, GLASS AND STEEL RECYCLING SERVICES; PAPER RECYCLING SERVICES; ENERGY GENERATION SERVICES (U.S. CLS. 100, 103 AND 106).

LIEF MARTIN, EXAMINING ATTORNEY

CLASS 37—CONSTRUCTION AND REPAIR

FOR PAPER COLLECTION FOR RECYCLING PURPOSES; AND MAINTENANCE OF POWER TRANSMISSION AND DISTRIBUTION FACILITIES (U.S. CLS. 100, 103 AND 106).

CLASS 40—MATERIAL TREATMENT

FOR MATERIAL TREATMENT SERVICES IN CONNECTION WITH RECYCLING, PRODUCTION OF NEWSPRINT, PRODUCTION OF COMMERCIAL PRINTING PAPERS, PRODUCTION OF MARKET PULP, LUMBER PRODUCTION, RECYCLED FIBER PRODUCTION, REMANUFACTURING AND ENGINEERING OF WOOD; PAPER TREATMENT AND FINISHING SERVICES; SERVICES OF OPERATION OF PULP AND PAPER MILLS, NAMELY, CUSTOM PRODUCTION OF PAPER, NEWS-PRINT AND MARKET PULP FOR OTHERS; RECYCLING SERVICES, NAMELY, CARDBOARD, PLASTIC, ALUMINUM, TEXTILES, GLASS AND STEEL RECYCLING SERVICES; PAPER RECYCLING SERVICES; ENERGY GENERATION SERVICES (U.S. CLS. 100, 103 AND 106).

LIEF MARTIN, EXAMINING ATTORNEY

SN 85-443,418. RESOLUTE FOREST PRODUCTS INC., MONTREAL, CANADA, FILED 10-10-2011.

RESOLUTE

THE MARK CONSISTS OF STANDARD CHARACTERS WITHOUT CLAIM TO ANY PARTICULAR FONT, STYLE, SIZE, OR COLOR.

CLASS 1—CHEMICALS

FOR WOOD PULP, PAPER PULP AND WOOD PULP FOR MANUFACTURING PURPOSES; PULP FOR MANUFACTURING PURPOSES; SOFTWOOD PULP; HARDWOOD PULP; FLUFF PULP; SULPHITE PULP (U.S. CLS. 1, 5, 6, 10, 26 AND 46).

CLASS 16—PAPER GOODS AND PRINTED MATTER

FOR PAPER, NAMELY, GROUND WOOD PAPER, NEWSPRINT PAPER, NEWSPRINT, COATED PAPER, PRINTING PAPER, COMPUTER PAPER, RECYCLED PAPER, FINE PAPER, COATED PRINTING PAPER, COATED AND UNCOATED PAPER WITH RECYCLED CONTENT, SUPER CALENDERED GRADE PAPER, FREE SHEET HYBRID PAPER, BLANK DIRECTORY PAPER, GRAPHIC ARTS CONVERTING PAPER, CONTINUOUS FORM PAPER, PHOTOCOPY PAPER, AND KRAFT PAPER; CORRUGATED CONTAINERS MADE OF CARDBOARD (U.S. CLS. 2, 5, 22, 23, 29, 37, 38 AND 50).

CLASS 19—NON-METALLIC BUILDING MATERIALS

FOR PLYWOOD; LUMBER; BUILDING BOARDS COMPOSED OF WOOD; HARDBOARDS; HARDBOARDS SIDING; WOOD POLES; TREATED WOOD PRODUCTS, NAMELY, DIMENSION LUMBER, STUD LUMBER, MACHINE STRESS RATED (MSR) LUMBER, FINGER-JOINTED LUMBER, VISUAL GRADE LUMBER, FURRING STRIPS, FINGER-JOINTED STUD AND STRUCTURAL COMPONENTS, NAMELY, FINGER-JOINTED STUD AND STRUCTURAL LUMBER, NON-METAL FENCE COMPONENTS, NAMELY, POSTS, SLATS, GATES, PANELS, RAILS, PICKETS, FLOOR JOIST FLANGES, AND TRUSS CHORDS FOR USE IN SPECIALIZED APPLICATIONS, NAMELY, MOBILE HOMES, ROOFING AND FLOORING MATERIAL AND DECKING (U.S. CLS. 1, 12, 33 AND 50).

CLASS 37—CONSTRUCTION AND REPAIR

FOR PAPER COLLECTION FOR RECYCLING PURPOSES; AND MAINTENANCE OF POWER TRANSMISSION AND DISTRIBUTION FACILITIES (U.S. CLS. 100, 103 AND 106).

CLASS 40—MATERIAL TREATMENT

FOR MATERIAL TREATMENT SERVICES IN CONNECTION WITH RECYCLING, PRODUCTION OF NEWSPRINT, PRODUCTION OF COMMERCIAL PRINTING PAPERS, PRODUCTION OF MARKET PULP, LUMBER PRODUCTION, RECYCLED FIBER PRODUCTION, REMANUFACTURING AND ENGINEERING OF WOOD; PAPER TREATMENT AND FINISHING SERVICES; SERVICES OF OPERATION OF PULP AND PAPER MILLS, NAMELY, CUSTOM PRODUCTION OF PAPER, NEWS-PRINT AND MARKET PULP FOR OTHERS; RECYCLING SERVICES, NAMELY, CARDBOARD, PLASTIC, ALUMINUM, TEXTILES, GLASS AND STEEL RECYCLING SERVICES; PAPER RECYCLING SERVICES; ENERGY GENERATION SERVICES (U.S. CLS. 100, 103 AND 106).

LIEF MARTIN, EXAMINING ATTORNEY

SN 85-443,433. POSITIVELY POSITIVE LLC, LOS ANGELES, CA. FILED 10-10-2011.

POSITIVELY POSITIVE

THE MARK CONSISTS OF STANDARD CHARACTERS WITHOUT CLAIM TO ANY PARTICULAR FONT, STYLE, SIZE, OR COLOR.

CLASS 38—COMMUNICATION

FOR ELECTRONIC TRANSMISSION OF VOICE, AUDIO, AND VISUAL DATA, ELECTRONIC DOCUMENTS, GRAPHICS, AND WEBLINKS BY TELECOMMUNICATIONS NETWORKS, WIRELESS COMMUNICATIONS NETWORKS, AND THE INTERNET; PROVIDING ONLINE CHAT ROOMS AND ELECTRONIC BULLETIN BOARDS FOR TRANSMISSION OF MESSAGES AMONG USERS CONCERNING TOPICS OF GENERAL INTEREST; PROVIDING ACCESS TO ELECTRONIC SITES FOR INFORMATION, AUDIO, AND VIDEO VIA WEBSITES, ONLINE FORUMS, CHAT ROOMS, MAIL FUNCTIONS AND BLOGS OVER THE INTERNET; PROVIDING ACCESS TO COMPUTER DATABASES; ELECTRONIC TRANSMISSION OF INSTANT MESSAGES AND DATA; PROVIDING MULTIPLE USER ACCESS TO PROPRIETARY COLLECTIONS OF INFORMATION BY MEANS OF GLOBAL COMPUTER INFORMATION NETWORKS (U.S. CLS. 100, 101 AND 104).

CLASS 41—EDUCATION AND ENTERTAINMENT

FOR ENTERTAINMENT AND EDUCATIONAL SERVICES, NAMELY, PROVIDING A WEBSITE FEATURING NON-DOWNLOADABLE AUDIO CLIPS, VIDEOS, PHOTOGRAPHS, PICTURES, TEXT AND OTHER MULTIMEDIA MATERIALS FEATURING MOTIVATIONAL AND EDUCATIONAL SPEAKERS IN THE FIELD OF SELF- AND PERSONAL IMPROVEMENT FOR MOTIVATIONAL AND INSPIRATIONAL PURPOSES; PROVIDING ONLINE JOURNALS, NAMELY, BLOGS FEATURING MOTIVATIONAL AND EDUCATIONAL SPEAKERS IN THE FIELD OF SELF- AND PERSONAL IMPROVEMENT; ONLINE DIGITAL VIDEO, AUDIO AND MULTIMEDIA PUBLISHING SERVICES (U.S. CLS. 100, 101 AND 107).

TARAH HARDY, EXAMINING ATTORNEY

SN 85-443,437. RESOLUTE FOREST PRODUCTS INC., MONTREAL, CANADA, FILED 10-10-2011.



THE MARK CONSISTS OF A STYLIZED LETTER "R".

CLASS 1—CHEMICALS

FOR WOOD PULP, PAPER PULP AND WOOD PULP FOR MANUFACTURING PURPOSES; PULP FOR MANUFACTURING PURPOSES; SOFTWOOD PULP; HARDWOOD PULP; FLUFF PULP; SULPHITE PULP (U.S. CLS. 1, 5, 6, 10, 26 AND 46).

CLASS 16—PAPER GOODS AND PRINTED MATTER

FOR PAPER, NAMELY, GROUND WOOD PAPER, NEWSPRINT PAPER, NEWSPRINT, COATED PAPER, PRINTING PAPER, COMPUTER PAPER, RECYCLED PAPER, FINE PAPER, COATED PRINTING PAPER, COATED AND UNCOATED PAPER WITH RECYCLED CONTENT, SUPER CALENDERED GRADE PAPER, FREE SHEET HYBRID PAPER, BLANK DIRECTORY PAPER, GRAPHIC ARTS CONVERTING PAPER, CONTINUOUS FORM PAPER, PHOTOCOPY PAPER, AND KRAFT PAPER; CORRUGATED CONTAINERS MADE OF CARDBOARD (U.S. CLS. 2, 5, 22, 23, 29, 37, 38 AND 50).

CLASS 19—NON-METALLIC BUILDING MATERIALS

FOR PLYWOOD; LUMBER; BUILDING BOARDS COMPOSED OF WOOD; HARDBOARDS; HARDBOARDS SIDING; WOOD POLES; TREATED WOOD PRODUCTS, NAMELY, DIMENSION LUMBER, STUD LUMBER, MACHINE STRESS RATED (MSR) LUMBER, FINGER-JOINTED LUMBER, VISUAL GRADE LUMBER, FURRING STRIPS, FINGER-JOINTED STUD AND STRUCTURAL COMPONENTS, NAMELY, FINGER-JOINTED STUD AND STRUCTURAL LUMBER, NON-METAL FENCE COMPONENTS, NAMELY, POSTS, SLATS, GATES, PANELS, RAILS, PICKETS, FLOOR JOIST FLANGES, AND TRUSS CHORDS FOR USE IN SPECIALIZED APPLICATIONS, NAMELY, MOBILE HOMES, ROOFING AND FLOORING MATERIAL AND DECKING (U.S. CLS. 1, 12, 33 AND 50).

CLASS 37—CONSTRUCTION AND REPAIR

FOR PAPER COLLECTION FOR RECYCLING PURPOSES; AND MAINTENANCE OF POWER TRANSMISSION AND DISTRIBUTION FACILITIES (U.S. CLS. 100, 103 AND 106).

CLASS 40—MATERIAL TREATMENT

FOR MATERIAL TREATMENT SERVICES IN CONNECTION WITH RECYCLING, PRODUCTION OF NEWSPRINT, PRODUCTION OF COMMERCIAL PRINTING PAPERS, PRODUCTION OF MARKET PULP, LUMBER PRODUCTION, RECYCLED FIBER PRODUCTION, REMANUFACTURING AND ENGINEERING OF WOOD; PAPER TREATMENT AND FINISHING SERVICES; SERVICES OF OPERATION OF PULP AND PAPER MILLS, NAMELY, CUSTOM PRODUCTION OF PAPER, NEWSPRINT AND MARKET PULP FOR OTHERS; RECYCLING SERVICES, NAMELY, CARDBOARD, PLASTIC, ALUMINUM, TEXTILES, GLASS AND STEEL RECYCLING SERVICES; PAPER RECYCLING SERVICES; ENERGY GENERATION SERVICES (U.S. CLS. 100, 103 AND 106).

LIEF MARTIN, EXAMINING ATTORNEY

SN 85-443,475. POSITIVELY POSITIVE LLC, LOS ANGELES, CA. FILED 10-10-2011.



THE MARK CONSISTS OF A SOLID BLACK CIRCLE, INSIDE OF WHICH IS A WHITE RING. WITHIN THE WHITE RING ARE TWO OF THE LETTER "P", ONE INVERTED AGAINST THE OTHER FORMING A LOOP.

CLASS 38—COMMUNICATION

FOR ELECTRONIC TRANSMISSION OF VOICE, AUDIO, AND VISUAL DATA, ELECTRONIC DOCUMENTS, GRAPHICS, AND WEBLINKS BY TELECOMMUNICATIONS NETWORKS, WIRELESS COMMUNICATIONS NETWORKS, AND THE INTERNET; PROVIDING ONLINE CHAT ROOMS AND ELECTRONIC BULLETIN BOARDS FOR TRANSMISSION OF MESSAGES AMONG USERS CONCERNING TOPICS OF GENERAL INTEREST; PROVIDING ACCESS TO ELECTRONIC SITES FOR INFORMATION, AUDIO, AND VIDEO VIA WEBSITES, ONLINE FORUMS, CHAT ROOMS, MAIL FUNCTIONS AND BLOGS OVER THE INTERNET; PROVIDING ACCESS TO COMPUTER DATABASES; ELECTRONIC TRANSMISSION OF INSTANT MESSAGES AND DATA; PROVIDING MULTIPLE USER ACCESS TO PROPRIETARY COLLECTIONS OF INFORMATION BY MEANS OF GLOBAL COMPUTER INFORMATION NETWORKS (U.S. CLS. 100, 101 AND 104).

CLASS 41—EDUCATION AND ENTERTAINMENT

FOR ENTERTAINMENT AND EDUCATIONAL SERVICES, NAMELY, PROVIDING A WEBSITE FEATURING NON-DOWNLOADABLE AUDIO CLIPS, VIDEOS, PHOTOGRAPHS, PICTURES, TEXT AND OTHER MULTIMEDIA MATERIALS FEATURING MOTIVATIONAL AND EDUCATIONAL SPEAKERS IN THE FIELD OF SELF- AND PERSONAL IMPROVEMENT FOR MOTIVATIONAL AND INSPIRATIONAL PURPOSES; PROVIDING ONLINE JOURNALS, NAMELY, BLOGS FEATURING MOTIVATIONAL AND EDUCATIONAL SPEAKERS IN THE FIELD OF SELF- AND PERSONAL IMPROVEMENT; ONLINE DIGITAL VIDEO, AUDIO AND MULTIMEDIA PUBLISHING SERVICES (U.S. CLS. 100, 101 AND 107).

TARAH HARDY, EXAMINING ATTORNEY

SN 85-443,563. BEST DOCTORS, INC., BOSTON, MA. FILED 10-10-2011.

BEST DOCTORS

THE MARK CONSISTS OF STANDARD CHARACTERS WITHOUT CLAIM TO ANY PARTICULAR FONT, STYLE, SIZE, OR COLOR.

OWNER OF U.S. REG. NOS. 2,218,424, 3,297,547 AND OTHERS.

NO CLAIM IS MADE TO THE EXCLUSIVE RIGHT TO USE "DOCTORS", APART FROM THE MARK AS SHOWN. SEC. 2(F).

SN 85-443,554. BEST DOCTORS, INC., BOSTON, MA. FILED 10-10-2011.

I AM A BEST DOCTOR

THE MARK CONSISTS OF STANDARD CHARACTERS WITHOUT CLAIM TO ANY PARTICULAR FONT, STYLE, SIZE, OR COLOR.

OWNER OF U.S. REG. NOS. 2,218,424, 3,297,547 AND OTHERS.

CLASS 35—ADVERTISING AND BUSINESS

FOR PHYSICIAN AND HOSPITAL REFERRAL SERVICES AND MEDICAL REFERRAL SERVICES; MANAGEMENT AND COMPILATION OF A COMPUTERIZED DATABASE OF OUTSTANDING PHYSICIANS; PROVIDING AN ONLINE DIRECTORY INFORMATION SERVICE FEATURING INFORMATION ON OUTSTANDING PHYSICIANS AND HEALTHCARE PROVIDERS (U.S. CLS. 100, 101 AND 102).

CLASS 36—INSURANCE AND FINANCIAL

FOR CONSULTATION CONCERNING EMPLOYEE FINANCIAL BENEFITS PROGRAMS; CONSULTATION CONCERNING EMPLOYEE HEALTHCARE BENEFITS (U.S. CLS. 100, 101 AND 102).

CLASS 41—EDUCATION AND ENTERTAINMENT

FOR CONDUCTING A RECOGNITION PROGRAM BY WAY OF AWARDS FOR OUTSTANDING QUALITY IN THE PRACTICE OF MEDICINE (U.S. CLS. 100, 101 AND 107).

B. PARADEWELAI, EXAMINING ATTORNEY

CLASS 35—ADVERTISING AND BUSINESS

FOR REVIEW, ASSESSMENT AND MANAGEMENT OF CLAIMS TO OTHER PARTIES FOR SHORT- AND LONG-TERM DISABILITY BENEFITS; MANAGEMENT AND COMPILATION OF A COMPUTERIZED DATABASE OF OUTSTANDING PHYSICIANS; PROVIDING AN ON-LINE DIRECTORY INFORMATION SERVICE FEATURING INFORMATION ON OUTSTANDING PHYSICIANS AND HEALTHCARE PROVIDERS; PHYSICIAN AND HOSPITAL REFERRAL SERVICES AND MEDICAL REFERRAL SERVICES; ADMINISTRATION OF A DISCOUNT PROGRAM ENABLING PARTICIPANTS TO OBTAIN REDUCED PRICES ON HEALTH-CARE SERVICES AND HEALTH-RELATED INFORMATION FEATURING THE USE OF A CARD OR CERTIFICATE, NAMELY, USE OF A MEMBERSHIP CARD AND CERTIFICATES OF MEMBERSHIP TO OBTAIN SUCH DISCOUNTS (U.S. CLS. 100, 101 AND 102).

CLASS 36—INSURANCE AND FINANCIAL

FOR HEALTH INSURANCE UNDERWRITING AND ADMINISTRATION SERVICES; ADMINISTRATION OF HEALTH INSURANCE AND PREPAID HEALTHCARE PLANS; CONSULTATION CONCERNING EMPLOYEE FINANCIAL BENEFITS PROGRAMS; CONSULTATION CONCERNING EMPLOYEE HEALTHCARE BENEFITS (U.S. CLS. 100, 101 AND 102).

CLASS 41—EDUCATION AND ENTERTAINMENT

FOR CONDUCTING A RECOGNITION PROGRAM BY WAY OF AWARDS FOR OUTSTANDING QUALITY IN THE PRACTICE OF MEDICINE (U.S. CLS. 100, 101 AND 107).

B. PARADEWELAI, EXAMINING ATTORNEY

SN 85-443,636. KIWANIS CLUB OF LITTLE HAVANA, INC., MIAMI, FL. FILED 10-10-2011.

ART IN THE PARK

THE MARK CONSISTS OF STANDARD CHARACTERS WITHOUT CLAIM TO ANY PARTICULAR FONT, STYLE, SIZE, OR COLOR.

NO CLAIM IS MADE TO THE EXCLUSIVE RIGHT TO USE "ART", APART FROM THE MARK AS SHOWN.

CLASS 36—INSURANCE AND FINANCIAL

FOR CHARITABLE FUNDRAISING SERVICES BY MEANS OF MUSICAL CONCERTS (U.S. CLS. 100, 101 AND 102).

FIRST USE 10-4-2007; IN COMMERCE 10-4-2007.

CLASS 41—EDUCATION AND ENTERTAINMENT

FOR CONDUCTING ENTERTAINMENT EXHIBITIONS IN THE NATURE OF JAZZ AND FUNK CONCERTS; ENTERTAINMENT IN THE NATURE OF JAZZ AND FUNK CONCERTS WITH EXHIBITS OF ART, CRAFTS AND FINE JEWELRY; ENTERTAINMENT, NAMELY, LIVE MUSIC CONCERTS; ORGANIZATION OF EXHIBITIONS FOR CULTURAL OR EDUCATIONAL PURPOSES; ORGANIZING AND ARRANGING EXHIBITIONS FOR ENTERTAINMENT PURPOSES; ORGANIZING COMMUNITY FESTIVALS FEATURING PRIMARILY CONCERTS AND ALSO PROVIDING EXHIBITS OF ART, CRAFTS AND FINE JEWELRY (U.S. CLS. 100, 101 AND 107).

FIRST USE 10-4-2007; IN COMMERCE 10-4-2007.

LINDA M. KING, EXAMINING ATTORNEY

CLASS 20—FURNITURE AND ARTICLES NOT OTHERWISE CLASSIFIED

FOR PLASTIC FLAGS; PLASTIC BANNERS; FLAG-POLES AND PLASTIC FLAGS AND ACCESSORIES FOR FLAGS AND FLAGPOLES SOLD TOGETHER AS A UNIT, NAMELY, RODS, ROD SUPPORTS, COUPLERS, CONNECTIONS, PINS, BRACKETS AND POLE SUPPORTS (U.S. CLS. 2, 13, 22, 25, 32 AND 50).

CLASS 21—HOUSEWARES AND GLASS

FOR HOUSEWARES AND GLASS PRODUCTS, NAMELY, DRINKING GLASSES, CUPS, AND MUGS; RUBBER, PLASTIC, OR FOAM INSULATED BEVERAGE HOLDERS; PLASTIC WATER BOTTLES SOLD EMPTY; TRASH CANS (U.S. CLS. 2, 13, 23, 29, 30, 33, 40 AND 50).

CLASS 24—FABRICS

FOR FLAGS AND BANNERS MADE OF CLOTH; BEDDING, NAMELY, BED SHEETS, FITTED BED SHEET COVERS, BED FLAT SHEETS, PILLOW CASES AND DUVET COVERS (U.S. CLS. 42 AND 50).

CLASS 25—CLOTHING

FOR CLOTHING, NAMELY, T-SHIRTS, HATS, CAPS, SWEATSHIRTS, SWEATPANTS, SWEATSUITS, SHOES, PANTS, SHORTS, VESTS, JACKETS, FLEECE PULL-OVERS, VISORS, SWEATERS, TANK TOPS, SHIRTS, GOLF SHIRTS, WARM UP SUITS, BATHING SUITS, BATHING SUIT COVER-UPS, SKI SUITS, WET SUITS, SUITS, JEANS, PULLOVERS, BERETS, PAJAMAS, UNDERWEAR, SUSPENDERS, SOCKS, HALLOWEEN COSTUMES, APRONS, RAINWEAR, GLOVES, MITTENS, DRESSES, SKIRTS, JUMPSUITS, COATS, SPORT COATS, ROBES, WRIST BANDS, SWEAT BANDS, HEAD BANDS, PARKAS, SLIPPERS, AND BELTS (U.S. CLS. 22 AND 39).

CLASS 28—TOYS AND SPORTING GOODS

FOR TOYS AND SPORTING GOODS, NAMELY, ACTION FIGURES, MINIATURE CARS AND TRUCKS, TOY CARS, BOARD GAMES, ELECTRONIC DART GAMES AND ELECTRONIC GAMES FOR TEACHING CHILDREN, ELECTRONIC TOY VEHICLE RACING SETS AND TRACKS, MINIATURE TOY TROPHIES, PLUSH ANIMALS, POOL CUES, POOL CUE CASES, POOL CUE CHALK, PUZZLES, REMOTE CONTROL CARS, AIRPLANES AND BOATS, MINIATURE TOY HELMETS, RIDE ON PLASTIC CARS, WIND UP VEHICLES, WIND UP TOYS, ELECTRONIC TOY SLOT CARS AND TRACKS, BATH TOYS, CARD GAMES, TOY CASES IN THE NATURE OF CASES FOR TOY STRUCTURES AND TOY VEHICLES, CHESS BOARDS, CHECKER BOARDS, CHILDREN'S DRESS UP ACCESSORIES IN THE NATURE OF TOY HELMETS FOR PLAY, DART BOARDS, DARTS, DOG TOYS, ELECTRONIC TOY VEHICLES, INFLATABLE TOYS, KITES, PUNCHING TOYS, WATER TOYS, AND YO-YOS (U.S. CLS. 22, 23, 38 AND 50).

CLASS 41—EDUCATION AND ENTERTAINMENT

FOR ENTERTAINMENT SERVICES, NAMELY, PARTICIPATION IN PROFESSIONAL AUTOMOBILE RACES AND SPORTS CAR RACES, AND RELATED EXHIBITIONS; FAN CLUBS (U.S. CLS. 100, 101 AND 107).

JORDAN BAKER, EXAMINING ATTORNEY

SN 85-443,732. FURNITURE ROW RACING, LLC, DENVER, CO. FILED 10-10-2011.

FURNITURE ROW RACING

THE MARK CONSISTS OF STANDARD CHARACTERS WITHOUT CLAIM TO ANY PARTICULAR FONT, STYLE, SIZE, OR COLOR.

OWNER OF U.S. REG. NO. 3,530,238.

NO CLAIM IS MADE TO THE EXCLUSIVE RIGHT TO USE "RACING", APART FROM THE MARK AS SHOWN.

CLASS 6—METAL GOODS

FOR METAL GOODS, NAMELY, METAL KEY RINGS AND METAL LICENSE PLATES (U.S. CLS. 2, 12, 13, 14, 23, 25 AND 50).

CLASS 9—ELECTRICAL AND SCIENTIFIC APPARATUS

FOR SUNGLASSES; BRIEFCASES SPECIALLY ADAPTED FOR HOLDING LAPTOP COMPUTERS; MOUSE PADS (U.S. CLS. 21, 23, 26, 36 AND 38).

CLASS 14—JEWELRY

FOR JEWELRY; WALL CLOCKS (U.S. CLS. 2, 27, 28 AND 50).

CLASS 16—PAPER GOODS AND PRINTED MATTER

FOR PAPER PRODUCTS, NAMELY, TRADING CARDS, BUMPER STICKERS, POSTCARDS, DECALS, CALENDARS, WRAPPING PAPER, POSTERS, PAPER GIFT BAGS, STATIONERY, PAPER PENNANTS, STICKERS, PHOTOGRAPHS, COMIC BOOKS, BOOK COVERS, MEMO PADS, NOTEBOOKS, PLACEMATS, BANNERS, FLAGS, TRADING CARD ALBUMS, THREE RING BINDERS, PENCIL BOXES, PENCIL CASES, AND BROCHURES ABOUT PROFESSIONAL AUTOMOBILE AND SPORTS CAR RACES (U.S. CLS. 2, 5, 22, 23, 29, 37, 38 AND 50).

SN 85-443,804. TERRAGO TECHNOLOGIES, INC., ATLANTA, GA. FILED 10-10-2011.

PLACEGENIUS

THE MARK CONSISTS OF STANDARD CHARACTERS WITHOUT CLAIM TO ANY PARTICULAR FONT, STYLE, SIZE, OR COLOR.

CLASS 9—ELECTRICAL AND SCIENTIFIC APPARATUS

FOR COMPUTER SOFTWARE USED TO SEARCH, DISCOVER AND MANAGE TEXTUAL INFORMATION GEOGRAPHICALLY, BY LINKING UNSTRUCTURED CONTENT TO LOCATIONS (U.S. CLS. 21, 23, 26, 36 AND 38).

CLASS 42—SCIENTIFIC AND COMPUTER SERVICES

FOR PROVIDING TEMPORARY USE OF ON-LINE, NON-DOWNLOADABLE COMPUTER SOFTWARE USED TO SEARCH, DISCOVER AND MANAGE TEXTUAL INFORMATION GEOGRAPHICALLY, BY LINKING UNSTRUCTURED CONTENT TO LOCATIONS (U.S. CLS. 100 AND 101).

EDWARD NELSON, EXAMINING ATTORNEY

SN 85-443,810. ART APPRENTICE ONLINE, LLC, SALT LAKE CITY, UT. FILED 10-10-2011.



NO CLAIM IS MADE TO THE EXCLUSIVE RIGHT TO USE "ART" AND "ONLINE", APART FROM THE MARK AS SHOWN.

THE COLOR(S) BLACK, WHITE, GREY, LIGHT BLUE, AND DARK BLUE IS/ARE CLAIMED AS A FEATURE OF THE MARK.

THE MARK CONSISTS OF BLACK STYLIZED LETTERS "ART" UNDERLINED WITH A HORIZONTALLY-PLACED PAINT BRUSH THAT HAS A BLUE HANDLE AND GREY BRISTLES JOINED BY A GREY-AND-WHITE FERRULE. THE LETTERS "APPRENTICE" IN BLACK ARE PLACED UNDER THE PAINT BRUSH IN THE NEXT LINE. THE LETTERS "ONLINE" ARE ON THE THIRD ROW OF WRITING AND ARE BLACK. THE ENTIRE MARK IS ON A WHITE SQUARE BACKGROUND WITH A NARROW OUTLINE THAT CHANGES FROM LIGHT BLUE TO DARK BLUE.

CLASS 9—ELECTRICAL AND SCIENTIFIC APPARATUS

FOR DIGITAL MEDIA, NAMELY, PRE-RECORDED DVDS, DOWNLOADABLE AUDIO AND VIDEO RECORDINGS, AND CDS FEATURING AND PROMOTING ART EDUCATION; ELECTRONIC PUBLICATIONS, NAMELY, E-ZINES FEATURING ART INSTRUCTION AND EDUCATION RECORDED ON COMPUTER MEDIA (U.S. CLS. 21, 23, 26, 36 AND 38).

FIRST USE 10-1-2008; IN COMMERCE 10-1-2008.

CLASS 41—EDUCATION AND ENTERTAINMENT

FOR EDUCATION SERVICES, NAMELY, PROVIDING ON-LINE CLASSES AND INSTRUCTION IN THE FIELD OF ART (U.S. CLS. 100, 101 AND 107).

FIRST USE 10-1-2008; IN COMMERCE 10-1-2008.

BRENDAN REGAN, EXAMINING ATTORNEY

SN 85-443,898. PRESS GANEY ASSOCIATES, INC, INDIANA, IN. FILED 10-11-2011.

CLINICAL PERFORMER

THE MARK CONSISTS OF STANDARD CHARACTERS WITHOUT CLAIM TO ANY PARTICULAR FONT, STYLE, SIZE, OR COLOR.

NO CLAIM IS MADE TO THE EXCLUSIVE RIGHT TO USE "CLINICAL", APART FROM THE MARK AS SHOWN.

CLASS 35—ADVERTISING AND BUSINESS

FOR BUSINESS AND MANAGEMENT CONSULTING FOR HEALTHCARE PROVIDERS AND RELATED BUSINESSES, ANALYSIS RELATING TO THE BUSINESS MANAGEMENT OF HEALTH CARE FACILITIES (U.S. CLS. 100, 101 AND 102).

FIRST USE 10-25-2010; IN COMMERCE 10-25-2010.

CLASS 38—COMMUNICATION

FOR TELECOMMUNICATION SERVICES RELATING TO PROVIDING ONLINE ACCESS TO DATABASES; EMAIL NOTIFICATION ALERTS VIA THE INTERNET TO CLIENTS (U.S. CLS. 100, 101 AND 104).

FIRST USE 10-25-2010; IN COMMERCE 10-25-2010.

CLASS 42—SCIENTIFIC AND COMPUTER SERVICES

FOR INDUSTRIAL ANALYSIS AND RESEARCH SERVICES RELATING TO HEALTH CARE FACILITIES; PROVIDING DESIGN AND DEVELOPMENT OF SOFTWARE THROUGH WEB BASED TOOLS FOR THE PURPOSE OF FACILITATING IMPROVEMENT OF HOSPITALS; PROVIDING AN INTERACTIVE WEBSITE THAT ENABLES USERS TO ACCESS REPORTS REGARDING CLINICAL, OPERATIONAL, FINANCIAL, SATISFACTION AND QUALITY PERFORMANCE IN THE FIELD OF HEALTHCARE (U.S. CLS. 100 AND 101).

FIRST USE 10-25-2010; IN COMMERCE 10-25-2010.

CHRISTINA SOBRAL, EXAMINING ATTORNEY

SN 85-444,142. LIFEDOTS LLC, VALLEY COTTAGE, NY.
FILED 10-11-2011.

LIFEDOTS

THE MARK CONSISTS OF STANDARD CHARACTERS WITHOUT CLAIM TO ANY PARTICULAR FONT, STYLE, SIZE, OR COLOR.

CLASS 9—ELECTRICAL AND SCIENTIFIC APPARATUS

FOR DOWNLOADABLE COMPUTER PROGRAMS AND SOFTWARE FOR USE IN CONNECTION WITH INTERNET AND MOBILE BASED SOCIAL NETWORKING SERVICES AND CONTENT AGGREGATION (U.S. CLS. 21, 23, 26, 36 AND 38).

CLASS 38—COMMUNICATION

FOR COMMUNICATIONS BY COMPUTER TERMINALS; INTERNET AND ONLINE CHAT ROOMS; ELECTRONIC BULLETIN BOARD SERVICES; TRANSMISSION OF MESSAGES AND IMAGES AND CONTENT AIDED BY A COMPUTER (U.S. CLS. 100, 101 AND 104).

Laurie Kaufman, Examining Attorney

SN 85-444,150. MOHN, LOUISE, LONDON, UNITED KINGDOM, FILED 10-11-2011.



The logo for "Sweet Harmony" features the word "Sweet" in a large, elegant, cursive script font. Below it, the word "HARMONY" is written in a smaller, plain, all-caps, sans-serif font.

THE MARK CONSISTS OF THE WORDS "SWEET HARMONY", WITH THE WORD "SWEET" DISPLAYED IN CURSIVE LETTERING ABOVE THE WORD "HARMONY" IN PLAIN BLOCK LETTERS.

CLASS 9—ELECTRICAL AND SCIENTIFIC APPARATUS

FOR SOUND RECORDINGS FEATURING MUSIC; CINEMATOGRAPHIC, OPTICAL APPARATUS AND INSTRUMENTS, NAMELY, CINEMATOGRAPHIC CAMERAS AND PROJECTORS; APPARATUS FOR RECORDING, TRANSMISSION, REPRODUCTION OF SOUND OR IMAGES; MEDIA FOR RECORDING SOUND, IMAGES AND DATA, NAMELY, BLANK CDS, BLANK CD-ROMS, BLANK RECORDABLE DVDS, BLANK RECORDABLE DVD-ROMS, BLANK PHONOGRAPH RECORDS, BLANK FLOPPY DISKS, BLANK USB FLASH DRIVES, BLANK RECORDABLE AUDIO AND VIDEO DISCS AND CASSETTES; COMPUTERS AND COMPUTER PERIPHERAL DEVICES; HEADPHONES; DATA-PROCESSING APPARATUS, NAMELY, CENTRAL PROCESSING UNITS FOR PROCESSING INFORMATION, DATA, SOUND OR IMAGES; COMPUTER SOFTWARE FOR THE PRODUCTION OF MUSIC AND SOUND RECORDINGS; SOUND MIXERS; LOUSPEAKERS; RECORD PLAYERS; AMPLIFIERS; SOUND AND VIDEO EFFECTORS, NAMELY, ELECTRONIC SOUND MIXING, PROCESSING AND SYNTHESIZING APPARATUS; MICROPHONES AND MICROPHONE SOUND MIXERS; COMPUTER PERIPHERALS NAMELY, MEMORIES, DATA PROCESSORS; AUDIO RACKS, NAMELY, STEREO AMPLIFIER, RECEIVER AND TUNER RACKS, AMPLIFIER RACKS, SOUND MIXER UNIT RACKS AND DATA PROCESSOR RACKS; TELEVISIONS AND MONITORS (U.S. CLS. 21, 23, 26, 36 AND 38).

CLASS 16—PAPER GOODS AND PRINTED MATTER

FOR PAPER, CARDBOARD AND GOODS MADE FROM THESE MATERIALS, NOT INCLUDED IN OTHER CLASSES, NAMELY, INFORMATIONAL FLYERS IN RELATION TO PROMOTION OF NIGHT CLUB EVENTS AND DJ SERVICES, PRINTED ADVERTISEMENT BOARDS OF PAPER AND PRINTED ADVERTISEMENT BOARDS OF CARDBOARD, AND PAPER BANNERS; PRINTED MATTER, NAMELY, BOOKS, PAPER SIGNS, MANUALS AND MAGAZINES IN THE FIELD OF MUSIC PRODUCTION AND THE MUSIC INDUSTRY; BROCHURES IN THE FIELD OF MUSIC PRODUCTION AND THE MUSIC INDUSTRY; CALENDARS; BOOK BINDING MATERIAL; PHOTOGRAPHS; DRAWINGS; STICKERS; ADHESIVES FOR STATIONERY AND HOUSEHOLD PURPOSES; POSTERS; PENS, PENCILS, MARKERS; PEN CASES AND LABELS, NAMELY, ADHESIVE LABELS (U.S. CLS. 2, 5, 22, 23, 29, 37, 38 AND 50).

CLASS 25—CLOTHING

FOR ARTICLES OF CLOTHING, NAMELY, T-SHIRTS, SHIRTS, PANTS, JACKETS, SWEATSHIRTS; FOOTWEAR; HEADGEAR, NAMELY, HATS AND CAPS (U.S. CLS. 22 AND 39).

CLASS 41—EDUCATION AND ENTERTAINMENT

FOR MUSIC PRODUCTION SERVICES; ENTERTAINMENT SERVICES, NAMELY, DISC JOCKEY SERVICES FOR SPECIAL EVENTS; RADIO, AUDIO-VISUAL AND TELEVISED ENTERTAINMENT, NAMELY, A CONTINUING PROGRAM REGARDING MUSIC PRODUCTION AND LIVE MUSIC ACCESSIBLE BY RADIO, TELEVISION, SATELLITE, AUDIO, VIDEO AND COMPUTER NETWORKS; ARRANGING AND CONDUCTING OF EDUCATIONAL CONFERENCES IN THE MUSICAL FIELD; ORGANISATION OF EXHIBITIONS AND COMPETITIONS FOR CULTURAL, PLAY OR EDUCATIONAL PURPOSES IN THE MUSICAL FIELD; ORGANISATION AND PRODUCTION OF SHOWS, NAMELY, CULTURAL SHOWS, FASHION SHOWS, SHOWS FEATURING LIVE MUSICAL PERFORMANCES

AND NIGHT CLUB OPENINGS; ARRANGING AND CONDUCTING NIGHTCLUB PARTIES; PRESENTATION OF LIVE MUSICAL PERFORMANCES; DISCOTHEQUE SERVICES; ARRANGING FOR TICKET RESERVATIONS OF SEATS FOR SHOWS; MUSIC, FILM, TELEVISION OR RADIO RECORDING STUDIO SERVICES; VIDEO TAPE EDITING; PRODUCTION OF FILMS, RADIO OR TELEVISION BROADCASTS; RENTAL OF FILMS, MUSICAL RECORDINGS; RECORD LABEL SERVICES, NAMELY, MUSIC PRODUCTION AND PUBLISHING SERVICES, AND ORGANISING EVENTS FEATURING LIVE MUSICAL PERFORMANCES (U.S. CLS. 100, 101 AND 107).

CLASS 45—PERSONAL AND LEGAL SERVICES

FOR LICENSING OF INTELLECTUAL PROPERTY, NAMELY, MUSICAL AND LYRICAL WORKS; COPYRIGHT MANAGEMENT; PROVIDING ON-LINE INFORMATION IN THE FIELD OF INTELLECTUAL PROPERTY VIA A COMPUTER DATABASE, THE INTERNET OR ANY OTHER COMMUNICATIONS NETWORK; CREATING AND MAINTAINING WEBSITES FOR OTHERS (U.S. CLS. 100 AND 101).

JAY FLOWERS, EXAMINING ATTORNEY

SN 85-444,279. YADKIN VALLEY TELEPHONE MEMBERSHIP CORPORATION, YADKINVILLE, NC. FILED 10-11-2011.

YADTEL

THE MARK CONSISTS OF STANDARD CHARACTERS WITHOUT CLAIM TO ANY PARTICULAR FONT, STYLE, SIZE, OR COLOR.

CLASS 37—CONSTRUCTION AND REPAIR

FOR INSTALLATION, MAINTENANCE AND REPAIR OF COMPUTER HARDWARE AND COMPUTER NETWORKING HARDWARE (U.S. CLS. 100, 103 AND 106). FIRST USE 5-1-2004; IN COMMERCE 5-1-2004.

CLASS 41—EDUCATION AND ENTERTAINMENT

FOR PUBLISHING TELEPHONE DIRECTORIES (U.S. CLS. 100, 101 AND 107). FIRST USE 8-1-2002; IN COMMERCE 11-1-2002.

CLASS 42—SCIENTIFIC AND COMPUTER SERVICES

FOR DESIGN, DEVELOPMENT, INSTALLATION AND MAINTENANCE OF COMPUTER SOFTWARE; APPLICATION SERVICE PROVIDER, NAMELY, HOSTING COMPUTER SOFTWARE APPLICATIONS FOR OTHERS (U.S. CLS. 100 AND 101).

FIRST USE 1-1-1985; IN COMMERCE 11-1-1990.

KATHERINE CHANG, EXAMINING ATTORNEY

SN 85-444,164. LIFEDOTS LLC, VALLEY COTTAGE, NY. FILED 10-11-2011.



THE MARK CONSISTS OF THE WORD "LIFEDOTS" WITH AN EIGHT-DOT DESIGN DEPICTED TO THE LEFT OF THE WORDS, COMPRISED OF THREE VERTICALLY DEPICTED ROWS OF DOTS, WITH THREE DOTS IN THE LEFT-MOST ROW, TWO DOTS IN THE CENTER ROW, AND THREE DOTS IN THE RIGHT-MOST ROW CLOSEST IN PROXIMITY TO THE WORD "LIFEDOTS".

CLASS 9—ELECTRICAL AND SCIENTIFIC APPARATUS

FOR DOWNLOADABLE COMPUTER PROGRAMS AND SOFTWARE FOR USE IN CONNECTION WITH INTERNET AND MOBILE BASED SOCIAL NETWORKING SERVICES AND CONTENT AGGREGATION (U.S. CLS. 21, 23, 26, 36 AND 38).

CLASS 38—COMMUNICATION

FOR COMMUNICATIONS BY COMPUTER TERMINALS; INTERNET AND ONLINE CHAT ROOMS; ELECTRONIC BULLETIN BOARD SERVICES; TRANSMISSION OF MESSAGES AND IMAGES AND CONTENT AIDED BY A COMPUTER (U.S. CLS. 100, 101 AND 104).

LAURIE KAUFMAN, EXAMINING ATTORNEY

SN 85-444,399. EMBRACING EXCELLENCE, LLC, HIGHLAND, UT. FILED 10-11-2011.



OWNER OF U.S. REG. NOS. 3,556,541, 3,569,334 AND 3,693,511.

NO CLAIM IS MADE TO THE EXCLUSIVE RIGHT TO USE "ENTERPRISES", APART FROM THE MARK AS SHOWN.

THE COLOR(S) RED AND ORANGE IS/ARE CLAIMED AS A FEATURE OF THE MARK.

THE MARK CONSISTS OF A DESIGN OF SPIRAL STAIRS ON A RED CIRCLE OUTLINED IN ORANGE. THERE ARE FANCIFUL ORANGE CURLS EMANATING FROM THE CIRCLE AND AN ORANGE STAR OUTSIDE THE TOP RIGHT OF THE CIRCLE. THE STYLIZED WORDING "STEP IT UP" APPEARS IN RED TO THE RIGHT OF THE DESIGN, WITH THE STYLIZED ORANGE WORDING "ENTERPRISES" UNDERNEATH. BELOW ALL OF THE FOREGOING IS THE STYLIZED WORDING "THE ULTIMATE GUIDE TO", WHICH APPEARS IN ORANGE FOLLOWED BY "THE POWER OF THE POSSIBLE" IN RED. THE WHITE IS NOT PART OF THE MARK AND REPRESENTS BACKGROUND AREA.

CLASS 9—ELECTRICAL AND SCIENTIFIC APPARATUS

FOR PRERECORDED ELECTRONIC MEDIA, NAMELY, AUDIO AND VIDEO CASSETTES, CDS AND DVDS ALL FEATURING INFORMATION ON SELF-HELP, SELF-IMPROVEMENT, SELF-MOTIVATION, PERSONAL AND PROFESSIONAL EMPOWERMENT, LIFE COACHING, AND HUMAN POTENTIAL (U.S. CLS. 21, 23, 26, 36 AND 38).

SN 85-444,426. WORDNIK, INC., BURLINGAME, CA. FILED 10-11-2011.

NIKIO

THE MARK CONSISTS OF STANDARD CHARACTERS WITHOUT CLAIM TO ANY PARTICULAR FONT, STYLE, SIZE, OR COLOR.

CLASS 16—PAPER GOODS AND PRINTED MATTER

FOR PAPER AND PRINTED MATTER, NAMELY, A SERIES OF ARTICLES FOR PUBLICATION IN BOOKS, CATALOGS, GUIDES, HANDOUTS, MAGAZINES, MANUALS AND NEWSLETTERS ALL FEATURING INFORMATION ON SELF-HELP, SELF-IMPROVEMENT, SELF-MOTIVATION, PERSONAL AND PROFESSIONAL EMPOWERMENT, LIFE COACHING, AND HUMAN POTENTIAL, MANAGEMENT, MARKETING, MOTIVATION, NEGOTIATION AND SALES TRAINING; POSTERS; PRINTED EDUCATIONAL, INSTRUCTIONAL AND TEACHING MATERIALS ALL FEATURING INFORMATION ON SELF-HELP, SELF-IMPROVEMENT, SELF-MOTIVATION, PERSONAL AND PROFESSIONAL EMPOWERMENT, LIFE COACHING, AND HUMAN POTENTIAL; SERIES OF NON-FICTION BOOKS ALL FEATURING INFORMATION ON SELF-HELP, SELF-IMPROVEMENT, SELF-MOTIVATION, PERSONAL AND PROFESSIONAL EMPOWERMENT, LIFE COACHING, AND HUMAN POTENTIAL (U.S. CLS. 2, 5, 22, 23, 29, 37, 38 AND 50).

CLASS 35—ADVERTISING AND BUSINESS

FOR MARKETING SERVICES, NAMELY, CONDUCTING CONSUMER TRACKING BEHAVIOR RESEARCH AND CONSUMER TREND ANALYSIS (U.S. CLS. 100, 101 AND 102).

CLASS 42—SCIENTIFIC AND COMPUTER SERVICES

FOR PROVIDING ON-LINE NON-DOWNLOADABLE COMPUTER SOFTWARE THAT ANALYZES TEXT AND MAKES USER-RECOMMENDATIONS OF OTHER SIMILAR TEXTS BASED ON A COMPUTER ALGORITHM MATCHING REVIEW (U.S. CLS. 100 AND 101).
TARAH HARDY, EXAMINING ATTORNEY

SN 85-444,626. JUDI'S HOUSE, DENVER, CO. FILED 10-11-2011.

CLASS 35—ADVERTISING AND BUSINESS

FOR ARRANGING AND CONDUCTING BUSINESS CONFERENCES AND PROMOTIONAL MARKETING EVENT PLANNING; BUSINESS MARKETING AND BUSINESS MANAGEMENT CONSULTING SERVICES; RETAIL, WHOLESALE, AND CATALOG ORDERING SERVICES, VIA TELEPHONE AND ONLINE, FEATURING AUDIO AND VIDEO RECORDINGS AND BOOKS RELATING TO PERSONAL AND PROFESSIONAL EMPOWERMENT (U.S. CLS. 100, 101 AND 102).



NO CLAIM IS MADE TO THE EXCLUSIVE RIGHT TO USE "COMPREHENSIVE GRIEF CARE", APART FROM THE MARK AS SHOWN.

THE COLOR(S) RED, YELLOW, BLUE, ORANGE, GREEN, MAGENTA, BLACK AND WHITE IS/ARE CLAIMED AS A FEATURE OF THE MARK.

THE MARK CONSISTS OF THE INTERLINKING CAPITAL LETTERS "CGC" AND THE WORDS "COMPREHENSIVE GRIEF CARE". THE LETTERS AND WORDS ARE IN BLACK. THE LETTERS "CGC" ARE TO THE LEFT OF THE WORDS "COMPREHENSIVE GRIEF CARE" AND ARE INTERLINKED TO FORM A CURVACEOUS INVERTED TRIANGLE, WITH THE LETTERS "CG" FORMING THE INVERTED BASE OF THE TRIANGLE ABOVE THE SECOND LETTER "C". EACH OF THE LETTERS OVERLAY THREE OVERLAPPING CIRCLES OF PRIMARY COLORS COMPRISED OF RED (THE UPPER LETTER "C"), YELLOW ("G") AND BLUE (THE LOWER LETTER "C"), WHERE THE COLORS OVERLAP THEY FORM A COLOR WHEEL, SUCH THAT THE AREA WHERE RED AND YELLOW OVERLAP IS ORANGE, THE AREA WHERE RED AND BLUE OVERLAP IS MAGENTA, THE AREA WHERE YELLOW AND BLUE OVERLAP IS GREEN, AND THE AREA WHERE ALL PRIMARY COLORS OVERLAP IS WHITE. THE WORDS "COMPREHENSIVE GRIEF CARE" APPEAR TO THE RIGHT OF THE LETTERS "CGC", THE FIRST LETTER OF EACH WORD CAPITALIZED AND BOLD, WITH "COMPREHENSIVE" APPEARING ABOVE "GRIEF CARE" AND THE TWO WORD GROUPINGS LEFT-JUSTIFIED.

CLASS 41—EDUCATION AND ENTERTAINMENT

FOR EDUCATIONAL AND INSTRUCTIONAL SERVICES, NAMELY, CONDUCTING EDUCATIONAL CLASSES, CONFERENCES, SEMINARS AND WORKSHOPS ALL FEATURING INFORMATION ON SELF-HELP, SELF-IMPROVEMENT, SELF-MOTIVATION, PERSONAL AND PROFESSIONAL EMPOWERMENT, LIFE COACHING, AND HUMAN POTENTIAL AND DISTRIBUTING INSTRUCTIONAL MATERIALS IN CONNECTION THEREWITH; PROVIDING ON-LINE INFORMATION ABOUT LIFE COACHING IN THE FIELDS OF SELF-HELP, SELF IMPROVEMENTS, SELF MOTIVATION, AND PERSONAL AND PROFESSIONAL EMPOWERMENT; ENTERTAINMENT SERVICES, NAMELY, PROVIDING LIVE SPEAKING PERFORMANCES AND SPEAKING ENGAGEMENTS ALL FEATURING INFORMATION ON SELF-HELP, SELF-IMPROVEMENT, SELF-MOTIVATION, PERSONAL AND PROFESSIONAL EMPOWERMENT, LIFE COACHING, AND HUMAN POTENTIAL; PROVIDING BUSINESS TRAINING INFORMATION IN THE FIELD OF PROFESSIONAL EMPOWERMENT, NAMELY, IN THE FIELD OF BUSINESS LEADERSHIP DEVELOPMENT (U.S. CLS. 100, 101 AND 107).

ELLEN B. AWRICH, EXAMINING ATTORNEY

CLASS 41—EDUCATION AND ENTERTAINMENT

FOR EDUCATION SERVICES, NAMELY, PROVIDING ON-LINE CLASSES, SEMINARS, AND WORKSHOPS TO GRIEF CARE PROVIDERS AND CONSUMERS VIA A GLOBAL COMPUTER NETWORK IN THE FIELD OF GRIEF (U.S. CLS. 100, 101 AND 107).

CLASS 45—PERSONAL AND LEGAL SERVICES

FOR PROVIDING GRIEF INFORMATION TO CONSUMER AND PROVIDERS VIA AN ON-LINE COMPUTER NETWORK (U.S. CLS. 100 AND 101).

ESTHER A. BORSUK, EXAMINING ATTORNEY

SN 85-444,862. ZIFTIT, INC., SAN DIEGO, CA. FILED 10-11-2011.



The logo for Ziftit, featuring the word "ziftit" in a lowercase, sans-serif font.

THE MARK CONSISTS OF STANDARD CHARACTERS WITHOUT CLAIM TO ANY PARTICULAR FONT, STYLE, SIZE, OR COLOR.

CLASS 35—ADVERTISING AND BUSINESS

FOR COMPUTERIZED ON-LINE GIFT REGISTRY AND ORDERING SERVICE WHICH MATCHES THE GIFT RECIPIENT'S WANTS AND/OR NEEDS WITH THE GIFT GIVER'S MONETARY CONTRIBUTION TOWARDS THE GIFT; MERCHANDISING SERVICES FOR INDUCING THE PURCHASING PUBLIC TO BUY THE GOODS AND SERVICES OF OTHERS THROUGH A GIFT REGISTRY SERVICE; PROMOTIONAL SERVICES, NAMELY, PROMOTING THE GOODS AND SERVICES OF OTHERS BY MEANS OF PROVIDING ONLINE GIFT REGISTRY AND PURCHASE CLEARING SERVICES; DISSEMINATION OF ADVERTISING FOR OTHERS VIA AN ELECTRONIC COMMUNICATIONS NETWORK; PROMOTIONAL SERVICES, NAMELY, PROMOTING THE GOODS AND SERVICES OF OTHERS BY MEANS OF PROVIDING ONLINE GIFT CARDS; PROMOTING THE GOODS AND SERVICES OF OTHERS BY PROVIDING A WEBSITE FEATURING COUPONS, PRICE-COMPARISON INFORMATION, LINKS TO THE RETAIL WEBSITES OF OTHERS, AND DISCOUNT INFORMATION; PROMOTIONAL SERVICES, NAMELY PROMOTING THE GOODS AND SERVICES OF OTHERS BY MEANS OF PROVIDING ONLINE COUPONS (U.S. CLS. 100, 101 AND 102).

CLASS 36—INSURANCE AND FINANCIAL

FOR CLEARING AND RECONCILING FINANCIAL TRANSACTIONS VIA A GLOBAL COMPUTER NETWORK; FINANCIAL TRANSACTION SERVICES, NAMELY, PROVIDING SECURE COMMERCIAL TRANSACTIONS AND PAYMENT OPTIONS; PROVIDING FINANCIAL TRANSACTION SERVICES FOR ELECTRONIC FUNDS TRANSFER, CREDIT, DEBIT AND GIFT CARD TRANSACTIONS AND ELECTRONIC CHECK TRANSACTIONS VIA A GLOBAL COMPUTER NETWORK (U.S. CLS. 100, 101 AND 102).

CLASS 38—COMMUNICATION

FOR TRANSMISSIONS OF INVITATIONS, NOTIFICATIONS, DATA, ELECTRONIC MAIL, CALENDARS, ANNOUNCEMENTS AND GREETINGS VIA AN ELECTRONIC COMMUNICATIONS NETWORK; AUDIO AND VIDEO BROADCASTING SERVICES OVER THE INTERNET, NAMELY, UPLOADING, POSTING, SHOWING, DISPLAYING AND ELECTRONICALLY TRANSMITTING INFORMATION, AUDIO AND VIDEO CLIPS; PROVISION OF ON-LINE FORUMS FOR THE TRANSMISSION OF PHOTOGRAPHIC AND VIDEO IMAGES (U.S. CLS. 100, 101 AND 104).

CLASS 42—SCIENTIFIC AND COMPUTER SERVICES

FOR PREPARATION OF ELECTRONIC INVITATIONS; PROVIDING PARTY AND EVENTS PLANNING AND INVITATION INFORMATION PROVIDED BY USERS VIA AN ELECTRONICS COMMUNICATIONS NETWORK; COMPUTER SERVICES IN THE NATURE OF CUSTOMIZED WEB PAGES FEATURING USER-DEFINED OR SPECIFIC INFORMATION, PERSONAL PROFILES, AUDIO, VIDEO, PHOTOGRAPHIC IMAGES, TEXT, GRAPHICS AND DATA (U.S. CLS. 100 AND 101).

CLASS 45—PERSONAL AND LEGAL SERVICES

FOR ONLINE SOCIAL NETWORKING SERVICE WHICH ALLOWS USERS TO PROVIDE INFORMATION AND PURCHASE ADVICE TO THEIR NETWORK OF POTENTIAL GIFT GIVERS TO FACILITATE THE GIVING AND RECEIVING OF GIFTS (U.S. CLS. 100 AND 101).

LINDA MICKLEBURGH, EXAMINING ATTORNEY

SN 85-445,110. RH ET CIE, PARIS, FRANCE, FILED 10-12-2011.



OWNER OF ERPN CMNTY TM OFC REG. NO. 009008772, DATED 10-19-2010, EXPIRES 4-7-2020.

THE MARK CONSISTS OF THE WORDING "BORN HIV FREE" SHOWN UNDER TWO STYLIZED RIBBONS.

CLASS 35—ADVERTISING AND BUSINESS

FOR CONDUCTING ADVOCACY CAMPAIGNS, NAMELY, PROMOTIONAL CAMPAIGNS TO PROMOTE PUBLIC KNOWLEDGE AND AWARENESS OF THE NEED TO IMPROVE HEALTH AND WORLDWIDE DETECTION, PREVENTION AND TREATMENT, OF HIV/AIDS (U.S. CLS. 100, 101 AND 102).

CLASS 36—INSURANCE AND FINANCIAL

FOR CHARITABLE FUND RAISING FOR RESEARCH, FOR IMPROVEMENT OF HEALTH AND FOR WORLDWIDE DETECTION, PREVENTION AND TREATMENT FOR HIV/AIDS; PROVIDING FUNDING AND PROVIDING ASSISTANCE IN OBTAINING AND MAINTAINING FUNDING, NAMELY, PROVIDING FUNDRAISING ACTIVITIES AND FINANCIAL ASSISTANCE FOR PROGRAMS IN DEVELOPING NATIONS RELATING TO DETECTION, PREVENTION AND TREATMENT OF HIV/AIDS (U.S. CLS. 100, 101 AND 102).

CLASS 41—EDUCATION AND ENTERTAINMENT

FOR PROVIDING EDUCATIONAL SERVICES TO INCREASE KNOWLEDGE AND AWARENESS, IMPROVE HEALTH AND WORLDWIDE DETECTION, PREVENTION AND TREATMENT, OF HIV/AIDS, NAMELY, PROVIDING EDUCATIONAL CLASSES, WORKSHOPS AND SEMINARS CONCERNING HIV/AIDS TO INCREASE KNOWLEDGE AND AWARENESS, IMPROVE HEALTH AND WORLDWIDE DETECTION, PREVENTION AND TREATMENT, OF HIV/AIDS (U.S. CLS. 100, 101 AND 107).

ANDREA K. NADELMAN, EXAMINING ATTORNEY

SN 85-445.160. ADS HOLDING LLC, ABU DHABI, UNITED ARAB EMIR., FILED 10-12-2011.

ADS

THE MARK CONSISTS OF STANDARD CHARACTERS WITHOUT CLAIM TO ANY PARTICULAR FONT, STYLE, SIZE, OR COLOR.

PRIORITY CLAIMED UNDER SEC. 44(D) ON ERPN CMNTY TM OFC APPLICATION NO. 009916149, FILED 4-21-2011, REG. NO. 009916149, DATED 3-27-2012, EXPIRES 4-21-2021.

CLASS 35—ADVERTISING AND BUSINESS

FOR INVESTMENT MARKETING SERVICES; ECONOMIC FORECASTING AND ANALYSIS FOR BUSINESS PURPOSES, BUSINESS AND COMMERCIAL RESEARCH; THE COMPILATION OF DATABASES AND COMPUTER RECORDS IN THE FIELD OF COMMODITIES, SECURITIES, SHARES, FUTURES, STOCKS, BONDS, OPTIONS AND DERIVATIVES; RECORDING, REGISTERING, MAINTAINING RECORDS AND SETTLEMENT OF THE TRANSFER OF SHARES, FUTURES, STOCKS, BONDS, COMMODITIES, OPTIONS AND DERIVATIVES; BUSINESS INFORMATION SERVICES; ADVISORY SERVICES RELATING TO BUSINESS RISK MANAGEMENT; STATISTICAL INFORMATION SERVICES; PROVIDING BUSINESS AND MARKET RESEARCH SERVICES TO INDIVIDUAL AND INSTITUTIONAL FINANCIAL INVESTORS AND FINANCIAL PROFESSIONALS; PREPARATION AND COMPILATION OF REPORTS AND STATISTICAL INFORMATION RELATING TO PRICES OF FUTURES, ENERGY FUTURES, SHARES, OPTIONS, STOCKS, BONDS, COMMODITIES AND DERIVATIVES; AUTOMATED DATA PROCESSING, STORAGE, RETRIEVAL AND VERIFICATION; INFORMATION, CONSULTANCY AND ADVICE RELATING TO ALL THE AFORESAID (U.S. CLS. 100, 101 AND 102).

CLASS 36—INSURANCE AND FINANCIAL

FOR INVESTMENT ADVISORY SERVICES; FINANCIAL ADVICE AND CONSULTANCY SERVICES; FINANCIAL AND INVESTMENT SERVICES, NAMELY, MANAGEMENT AND BROKERAGE IN THE FIELDS OF STOCKS, BONDS, OPTIONS, COMMODITIES, FUTURES AND OTHER SECURITIES, AND THE INVESTMENT OF FUNDS FOR OTHERS; INVESTMENT ANALYSIS AND INVESTMENT BROKERAGE; PROVIDING INVESTMENT SYSTEMS, RISK ANALYTICS AND STRATEGIC ADVICE RELATING TO INVESTMENT OPPORTUNITIES AND DEVELOPMENT; CONSULTING SERVICES IN THE FIELD OF INVESTMENT OPPORTUNITIES, DEVELOPMENT AND MANAGEMENT; CONSULTING SERVICES RELATING TO THE ALLOCATION OF FINANCIAL RISK; STOCK EXCHANGE QUOTATIONS; OPERATION, PROVISION, ORGANIZATION, ADMINISTRATION AND SUPERVISION OF MARKETS AND EXCHANGES; OPERATION, PROVISION, ORGANIZATION, ADMINISTRATION AND SUPERVISION OF EXCHANGE MARKETS AND FINANCIAL MARKETS IN THE FIELD OF COMMODITIES AND FINANCIAL INSTRUMENTS; OPERATION, PROVISION, ORGANIZATION, ADMINISTRATION AND SUPERVISION OF EXCHANGE MARKETS AND FINANCIAL MARKETS FOR THE TRADING OF ENERGY FUTURES, SECURITIES, SHARES, FUTURES, STOCKS, BONDS, OPTIONS, COMMODITIES AND DERIVATIVES; FINANCIAL TRADING, CLEARING, SETTLEMENT AND TRANSACTION SERVICES; FINANCIAL INFORMATION MANAGEMENT AND ANALYSIS SERVICES; FINANCIAL ANALYSIS AND RESEARCH SERVICES; PREPARATION AND COMPILATION OF FINANCIAL REPORTS; FINANCIAL EXCHANGE QUOTATION AND LISTINGS SERVICES; SHARE PRICE INFORMATION SERVICES; TRADE REGISTRATION, NAMELY, REGISTRATION OF FOREIGN CURRENCY TRANSACTIONS, STOCKS OR COMMODITIES; TRADE MATCHING SERVICES, NAMELY, CONNECTING BUYERS AND SELLERS OF FINANCIAL ASSETS FOR FINANCIAL TRANSACTIONS; INFORMATION, CONSULTANCY AND ADVICE RELATING TO THE AFORESAID (U.S. CLS. 100, 101 AND 102).

CLASS 42—SCIENTIFIC AND COMPUTER SERVICES

FOR COMPUTER SERVICES RELATING TO FINANCE, INVESTMENT, BROKERAGE, SECURITIES AND/OR RISK MANAGEMENT, NAMELY, PROVIDING TEMPORARY USE OF ONLINE NON-DOWNLOADABLE COMPUTER SOFTWARE FOR USE BY OTHERS IN THE EVALUATION, ANALYSIS AND RISK ASSESSMENT OF FINANCIAL INSTRUMENTS; PROVIDING TEMPORARY USE OF ONLINE NON-DOWNLOADABLE SOFTWARE FOR USE IN FINANCIAL REPORTING, INVESTMENT MANAGEMENT AND FINANCIAL TRADING; PROVIDING COMPUTER SOFTWARE PLATFORMS FOR FINANCIAL SERVICE PROVIDERS, INVESTMENT CONSULTANTS AND FUND INTERMEDIARIES; DESIGN AND PREPARATION OF COMPUTER PROGRAMS FOR USE IN RELATION TO FINANCE, INVESTMENT AND GLOBAL STOCKS; INFORMATION, CONSULTANCY AND ADVICE RELATING TO THE AFORESAID (U.S. CLS. 100 AND 101).

MATTHEW KLINE, EXAMINING ATTORNEY

SN 85-445.269. JOHNSON & JOHNSON, NEW BRUNSWICK, NJ. FILED 10-12-2011.

HEXINOME

THE MARK CONSISTS OF STANDARD CHARACTERS WITHOUT CLAIM TO ANY PARTICULAR FONT, STYLE, SIZE, OR COLOR.

CLASS 3—COSMETICS AND CLEANING PREPARATIONS

FOR NON-MEDICATED SKIN CARE PREPARATIONS; COSMETICS; SUN SCREENS; FACIAL PRODUCTS, NAMELY, CLEANSERS, MOISTURIZERS, LOTIONS, CREAMS; BODY CARE PRODUCTS, NAMELY, CLEANSERS, MOISTURIZERS, LOTIONS, CREAMS; NON-MEDICATED INGREDIENTS SOLD AS INTEGRAL COMPONENTS OF NON-MEDICATED SKIN CARE PREPARATIONS, COSMETICS, SUN SCREENS, FACIAL AND BODY CLEANSERS, MOISTURIZERS, LOTIONS, CREAMS (U.S. CLS. 1, 4, 6, 50, 51 AND 52).

CLASS 5—PHARMACEUTICALS

FOR MEDICATED SKIN CARE PREPARATIONS; MEDICATED SUNSCREENS; MEDICATED FACIAL CARE PRODUCTS, NAMELY, CLEANSERS, MOISTURIZERS, LOTIONS, CREAMS; MEDICATED BODY CARE PRODUCTS, NAMELY, CLEANSERS, MOISTURIZERS, LOTIONS, CREAMS; MEDICATED INGREDIENTS SOLD AS INTEGRAL COMPONENTS OF MEDICATED SKIN CARE PREPARATIONS, MEDICATED COSMETICS, MEDICATED SUN SCREENS, MEDICATED FACIAL AND BODY CLEANSERS, MOISTURIZERS, LOTIONS, CREAMS (U.S. CLS. 6, 18, 44, 46, 51 AND 52).

CLASS 44—MEDICAL, BEAUTY AND AGRICULTURAL SERVICES

FOR PROVIDING INFORMATION IN THE FIELD OF BEAUTY CARE AND AGEING (U.S. CLS. 100 AND 101).
MICHAEL SOUDERS, EXAMINING ATTORNEY

SN 85-445,369. INGENHOVEN ARCHITECTS GBR, DUSSELDORF, FED REP GERMANY, FILED 10-12-2011.

INGENHOVEN

THE MARK CONSISTS OF STANDARD CHARACTERS WITHOUT CLAIM TO ANY PARTICULAR FONT, STYLE, SIZE, OR COLOR.

PRIORITY CLAIMED UNDER SEC. 44(D) ON ERPN CMNTY TM OFC APPLICATION NO. 010108173, FILED 7-8-2011, REG. NO. 010108173, DATED 12-27-2011, EXPIRES 7-8-2021.

CLASS 36—INSURANCE AND FINANCIAL

FOR REAL ESTATE AFFAIRS, NAMELY, REAL ESTATE AGENCIES, REAL ESTATE BROKERAGE, REAL ESTATE CONSULTATION; FINANCIAL CONSULTING SERVICES; MANAGEMENT OF LAND, NAMELY, MANAGEMENT OF BUILDINGS, REAL ESTATE MANAGEMENT; ADMINISTRATION AND MANAGEMENT OF BUILDINGS, BUILDING INSTALLATIONS, NAMELY, RENTAL PROPERTY MANAGEMENT AND COMMERCIAL PROPERTY MANAGEMENT (U.S. CLS. 100, 101 AND 102).

CLASS 37—CONSTRUCTION AND REPAIR

FOR BUILDING CONSTRUCTION; CONSTRUCTION MANAGEMENT SERVICES; PROVIDING TECHNICAL INFORMATION IN THE FIELD OF BUILDING CONSTRUCTION; TECHNICAL PLANNING, NAMELY, CONSTRUCTION PLANNING; PROVIDING FIRE PROTECTION EXPERTISE, NAMELY, FIRE ALARM INSTALLATION AND REPAIR (U.S. CLS. 100, 103 AND 106).

CLASS 42—SCIENTIFIC AND COMPUTER SERVICES

FOR SCIENTIFIC AND TECHNOLOGICAL SERVICES, NAMELY, SCIENTIFIC LABORATORY SERVICES, SCIENTIFIC RESEARCH, SCIENTIFIC ANALYSIS AND TESTING IN THE FIELD OF CONSTRUCTION AND ARCHITECTURE; PROVIDING SCIENTIFIC INFORMATION IN THE FIELDS OF ARCHITECTURE AND BUILDING CONSTRUCTION, INCLUDING BUILDING DRAFTING AND URBAN PLANNING; PROVIDING TECHNICAL INFORMATION IN THE FIELD OF ARCHITECTURE; ARCHITECTURE; ARCHITECTURAL CONSULTANCY; PROVIDING TECHNICAL EXPERTISE IN THE FIELD OF ENGINEERING AND ARCHITECTURE; INDUSTRIAL DESIGN; DESIGN SERVICES IN THE FIELD OF ARCHITECTURAL DESIGN; PRODUCT DEVELOPMENT SERVICES; TECHNICAL PLANNING, NAMELY, PLANNING AND DESIGN OF BUILDINGS AND INFRASTRUCTURE SYSTEMS FOR BUILDINGS; CONSTRUCTION DRAFTING; TECHNICAL DRAFTING; TECHNICAL PLANNING OF TECHNICAL INSTALLATIONS FOR BUILDINGS, NAMELY, PLANNING AND DESIGN OF TECHNICAL BUILDING INSTALLATIONS; CONSULTANCY, PHYSICS SERVICES, AND ENGINEERING SERVICES IN THE FIELD OF CONSTRUCTION PHYSICS, ARCHITECTURAL AND ROOM ACOUSTICS; CONSULTANCY AND ENGINEERING SERVICES IN THE FIELD OF FACADE DESIGN PLANNING; TECHNICAL DESIGN AND PLANNING OF DAYLIGHT AND ARTIFICIAL LIGHT IN BUILDINGS, STRUCTURAL INSTALLATIONS AND OUTDOOR INSTALLATIONS; CONSULTANCY, ENGINEERING, AND ARCHITECTURE SERVICES IN THE FIELD OF GREEN BUILDINGS, NAMELY, SUSTAINABLE, ECOLOGICAL AND ENERGY EFFICIENT PLANNING OF BUILDINGS AND TECHNICAL INSTALLATIONS; PHYSICAL INVESTIGATIONS AND SERVICES, NAMELY, AERODYNAMIC AND WIND-TUNNEL TESTING, RESEARCH, AND ANALYSIS; CONSTRUCTION DRAFTING, INCLUDING STRUCTURAL PLANNING AND PLANNING OF SPECIAL STRUCTURES; GEOLOGICAL SURVEY AND FOUNDATION SOIL SCIENTIFIC STUDIES AND REPORTS, IN PARTICULAR FOUNDATION SOIL REPORTS INTO THE BEARING CAPACITY OF THE FOUNDATION SOIL WHEN CONSTRUCTING BUILDINGS; TECHNICAL DESIGN AND PLANNING OF INSTALLATIONS FOR TRANSPORTING PERSONS AND ITEMS AND PIECES OF GOODS, SPECIFICALLY, LIFTS AND ESCALATORS; PROVIDING FIRE PROTECTION EXPERTISE, NAMELY, DESIGN AND INSPECTION OF FIRE ALARM, DETECTION, AND SUPPRESSION SYSTEMS; ARCHITECTURAL PLANNING, NAMELY, DESIGN AND DEVELOPMENT OF EFFICIENT, COMMUNICATION-ENHANCING OFFICE WORKPLACES, AND DESIGN, DEVELOPMENT AND ANALYSIS OF ROOM SCHEMES; TECHNICAL DRAFTING, PLANNING AND DESIGN OF DAYLIGHT AND ARTIFICIAL LIGHT IN BUILDINGS, STRUCTURAL INSTALLATIONS AND OUTDOOR INSTALLATIONS; INTERIOR ARCHITECTURAL SERVICES AND ARCHITECTURAL SERVICES, INCLUDING PLANNING SERVICES IN THE FIELD OF OUTDOOR INSTALLATIONS AND GREEN BUILDING; TECHNICAL DRAFTING, PLANNING AND DESIGN OF SECURITY TECHNOLOGY INSTALLATIONS IN BUILDINGS; TECHNICAL DESIGN AND PLANNING OF THE CONVERSION AND PRESERVATION OF LISTED BUILDINGS, LISTED STRUCTURAL INSTALLATIONS AND LISTED OUTDOOR INSTALLATIONS; TECHNICAL DRAFTING, PLANNING AND DESIGN OF ARTWORK PLACEMENT IN BUILDINGS AND STRUCTURAL INSTALLATIONS AND OUTDOOR INSTALLATIONS; TECHNICAL DRAFTING, PLANNING, AND DESIGN OF ANALOGUE AND DIGITAL COMMUNICATIONS SYSTEMS AND SIGNAGE; COMPUTER SOFTWARE DESIGN AND COMPUTER NETWORK DESIGN; DESIGN, MAINTENANCE AND UPDATING OF A TELECOMMUNICATIONS NETWORK SEARCH ENGINE; LANDSCAPE ARCHITECTURE, NAMELY, LANDSCAPE ARCHITECTURAL DESIGN (U.S. CLS. 100 AND 101).

CLASS 44—MEDICAL, BEAUTY AND AGRICULTURAL SERVICES

FOR LANDSCAPE ARCHITECTURE, NAMELY, LANDSCAPE DESIGN, LANDSCAPE GARDENING (U.S. CLS. 100 AND 101).

MARK SHINER, EXAMINING ATTORNEY

SN 85-445,384. INGENHOVEN ARCHITECTS GBR, DUSSELDORF, FED REP GERMANY, FILED 10-12-2011.

ingenhoven

PRIORITY CLAIMED UNDER SEC. 44(D) ON ERP N CMNTY TM OFC APPLICATION NO. 010109791, FILED 7-8-2011, REG. NO. 010109791, DATED 12-21-2011, EXPIRES 7-8-2021.

THE COLOR(S) GREY IS/ARE CLAIMED AS A FEATURE OF THE MARK.

THE MARK CONSISTS OF THE MARK "INGENHOVEN" IN LOWER CASE LETTERS IN THE COLOR GREY.

CLASS 36—INSURANCE AND FINANCIAL

FOR REAL ESTATE AFFAIRS, NAMELY, REAL ESTATE AGENCIES, REAL ESTATE BROKERAGE, REAL ESTATE CONSULTATION; FINANCIAL CONSULTING SERVICES; MANAGEMENT OF LAND, NAMELY, MANAGEMENT OF BUILDINGS, REAL ESTATE MANAGEMENT; ADMINISTRATION AND MANAGEMENT OF BUILDINGS, BUILDING INSTALLATIONS, NAMELY, RENTAL PROPERTY MANAGEMENT AND COMMERCIAL PROPERTY MANAGEMENT (U.S. CLS. 100, 101 AND 102).

CLASS 37—CONSTRUCTION AND REPAIR

FOR BUILDING CONSTRUCTION; CONSTRUCTION MANAGEMENT SERVICES; PROVIDING TECHNICAL INFORMATION IN THE FIELD OF BUILDING CONSTRUCTION; TECHNICAL PLANNING, NAMELY, CONSTRUCTION PLANNING; PROVIDING FIRE PROTECTION EXPERTISE, NAMELY, FIRE ALARM INSTALLATION AND REPAIR (U.S. CLS. 100, 103 AND 106).

CLASS 42—SCIENTIFIC AND COMPUTER SERVICES

FOR SCIENTIFIC AND TECHNOLOGICAL SERVICES, NAMELY, SCIENTIFIC LABORATORY SERVICES, SCIENTIFIC RESEARCH, SCIENTIFIC ANALYSIS AND TESTING IN THE FIELD OF CONSTRUCTION AND ARCHITECTURE; PROVIDING SCIENTIFIC INFORMATION IN THE FIELDS OF ARCHITECTURE AND BUILDING CONSTRUCTION, INCLUDING BUILDING DRAFTING AND URBAN PLANNING; PROVIDING TECHNICAL INFORMATION IN THE FIELD OF ARCHITECTURE; ARCHITECTURE; ARCHITECTURAL CONSULTANCY; PROVIDING TECHNICAL EXPERTISE IN THE FIELD OF ENGINEERING AND ARCHITECTURE; INDUSTRIAL DESIGN; DESIGN SERVICES IN THE FIELD OF ARCHITECTURAL DESIGN; PRODUCT DEVELOPMENT SERVICES; TECHNICAL PLANNING, NAMELY, PLANNING AND DESIGN OF BUILDINGS AND INFRASTRUCTURE SYSTEMS FOR BUILDINGS; CONSTRUCTION DRAFTING; TECHNICAL DRAFTING; TECHNICAL PLANNING OF TECHNICAL INSTALLATIONS FOR BUILDINGS, NAMELY, PLANNING AND DESIGN OF TECHNICAL BUILDING INSTALLATIONS; CONSULTANCY, PHYSICS SERVICES, AND ENGINEERING SERVICES IN THE FIELD OF CONSTRUCTION PHYSICS, ARCHITECTURAL AND ROOM ACOUSTICS; CONSULTANCY AND ENGINEERING SERVICES IN THE FIELD OF FACADE DESIGN PLANNING; TECHNICAL DESIGN AND PLANNING OF DAYLIGHT AND ARTIFICIAL LIGHT IN BUILDINGS, STRUCTURAL INSTALLATIONS AND OUTDOOR IN-

STALLATIONS; CONSULTANCY, ENGINEERING, AND ARCHITECTURE SERVICES IN THE FIELD OF GREEN BUILDINGS, NAMELY, SUSTAINABLE, ECOLOGICAL AND ENERGY EFFICIENT PLANNING OF BUILDINGS AND TECHNICAL INSTALLATIONS; PHYSICAL INVESTIGATIONS AND SERVICES, NAMELY, AERODYNAMIC AND WIND-TUNNEL TESTING, RESEARCH, AND ANALYSIS; CONSTRUCTION DRAFTING, INCLUDING STRUCTURAL PLANNING AND PLANNING OF SPECIAL STRUCTURES; GEOLOGICAL SURVEY AND FOUNDATION SOIL SCIENTIFIC STUDIES AND REPORTS, IN PARTICULAR FOUNDATION SOIL REPORTS INTO THE BEARING CAPACITY OF THE FOUNDATION SOIL WHEN CONSTRUCTING BUILDINGS; TECHNICAL DESIGN AND PLANNING OF INSTALLATIONS FOR TRANSPORTING PERSONS AND ITEMS AND PIECES OF GOODS, SPECIFICALLY, LIFTS AND ESCALATORS; PROVIDING FIRE PROTECTION EXPERTISE, NAMELY, DESIGN AND INSPECTION OF FIRE ALARM, DETECTION, AND SUPPRESSION SYSTEMS; ARCHITECTURAL PLANNING, NAMELY, DESIGN AND DEVELOPMENT OF EFFICIENT, COMMUNICATION-ENHANCING OFFICE WORKPLACES, AND DESIGN, DEVELOPMENT AND ANALYSIS OF ROOM SCHEMES; TECHNICAL DRAFTING, PLANNING AND DESIGN OF DAYLIGHT AND ARTIFICIAL LIGHT IN BUILDINGS, STRUCTURAL INSTALLATIONS AND OUTDOOR INSTALLATIONS; INTERIOR ARCHITECTURAL SERVICES AND ARCHITECTURAL SERVICES, INCLUDING PLANNING SERVICES IN THE FIELD OF OUTDOOR INSTALLATIONS AND GREEN BUILDING; TECHNICAL DRAFTING, PLANNING AND DESIGN OF SECURITY TECHNOLOGY INSTALLATIONS IN BUILDINGS; TECHNICAL DESIGN AND PLANNING OF THE CONVERSION AND PRESERVATION OF LISTED BUILDINGS, LISTED STRUCTURAL INSTALLATIONS AND LISTED OUTDOOR INSTALLATIONS; TECHNICAL DRAFTING, PLANNING AND DESIGN OF ARTWORK PLACEMENT IN BUILDINGS AND STRUCTURAL INSTALLATIONS AND OUTDOOR INSTALLATIONS; TECHNICAL DRAFTING, PLANNING, AND DESIGN OF ANALOGUE AND DIGITAL COMMUNICATIONS SYSTEMS AND SIGNAGE; COMPUTER SOFTWARE DESIGN AND COMPUTER NETWORK DESIGN; DESIGN, MAINTENANCE AND UPDATING OF A TELECOMMUNICATIONS NETWORK SEARCH ENGINE; LANDSCAPE ARCHITECTURE, NAMELY, LANDSCAPE ARCHITECTURAL DESIGN (U.S. CLS. 100 AND 101).

CLASS 44—MEDICAL, BEAUTY AND AGRICULTURAL SERVICES

FOR LANDSCAPE ARCHITECTURE, NAMELY, LANDSCAPE DESIGN, LANDSCAPE GARDENING (U.S. CLS. 100 AND 101).

MARK SHINER, EXAMINING ATTORNEY

SN 85-445,521. SAM MANUFACTURING, LLC, CINCINNATI, OH. FILED 10-12-2011.



THE COLOR(S) YELLOW, BLACK, BLUE, MAUVE, RED, ORANGE, WHITE, BROWN AND GREY IS/ARE CLAIMED AS A FEATURE OF THE MARK.

THE MARK CONSISTS OF THE WORDS "QUICKDRAW EXPRESS" INSIDE AN OVAL WITH TWO, WESTERN-STYLE SIX SHOOTER PISTOLS IN THE CENTER ABOVE

THREE HORSES IN SILHOUETTE, ON A DESERT BACKGROUND. THE WORDING "QUICK DRAW" IS OUTLINED IN BLACK. THE TOP OF THE LETTERS ARE BLACK, WITH THE BLACK FADING TO BLUE. THE WORDING "EXPRESS" IS OUTLINED IN BLACK, WITH THE TOP OF THE LETTERS IN BLACK, WITH THE BLACK FADING TO YELLOW. THE MIDDLE SILHOUETTE OF THE HORSE IN BLACK, AND THE OTHER TWO HORSES ARE BROWN. THE PISTOLS ARE BLACK WITH WHITE LINING AND A MAUVE HANDLE. RIGHT BELOW THE TWO PISTOLS, ON EITHER SIDE ARE TWO MISCELLANEOUS DESIGNS; ONE SMALL AND THE OTHER LARGE. THOSE DESIGNS ARE BLACK AND BROWN. ABOVE THE PISTOLS ON EITHER SIDE ARE TWO OTHER MISCELLANEOUS DESIGNS; ONE SMALL AND THE OTHER LARGE. THOSE DESIGNS ARE BLACK AND GREY. THE DESERT BACKGROUND CONTAINS A RED AND ORANGE MOUNTAIN WITH A BLUE SKY. THE AREA UNDER THE MOUNTAIN, TO THE BOTTOM OF THE DESERT SCENE IS YELLOW AND ORANGE. THE CLOUDS ARE GREY. THE OVAL IS OUTLINED WITH A YELLOW BAND. A THICK BLACK BAND OUTLINES THE YELLOW BAND. THE SAME BLACK BAND IS OUTLINED WITH ANOTHER YELLOW BAND.

CLASS 7—MACHINERY

FOR CIGARETTE FILLING MACHINES (U.S. CLS. 13, 19, 21, 23, 31, 34 AND 35).

CLASS 34—SMOKERS' ARTICLES

FOR TOBACCO; CIGARETTE TUBES (U.S. CLS. 2, 8, 9 AND 17).
INGA ERVIN, EXAMINING ATTORNEY

SN 85-445,767. FABULOUS FABRICATORS, LLC, DBA SOURCE ONE, PASSAIC, NJ. FILED 10-12-2011.

FLATCUT_

THE MARK CONSISTS OF STANDARD CHARACTERS WITHOUT CLAIM TO ANY PARTICULAR FONT, STYLE, SIZE, OR COLOR.

CLASS 37—CONSTRUCTION AND REPAIR

FOR INSTALLATION SERVICES IN THE FIELD OF ARTWORK, INDOOR AND OUTDOOR FURNITURE, ARCHITECTURAL STRUCTURES, NAMELY, ARCHITECTURAL METALWORK, DECKS, SKYLIGHTS, FACADES, WALLS AND FIXTURES, STORE DISPLAYS AND FIXTURES, AND OFFICE FIXTURES (U.S. CLS. 100, 103 AND 106).

CLASS 40—MATERIAL TREATMENT

FOR CUSTOM PRODUCTION, FABRICATION, ASSEMBLY AND FINISHING FOR OTHERS OF ARTWORK, SCULPTURES, INDOOR AND OUTDOOR FURNITURE, ARCHITECTURAL STRUCTURES, NAMELY, ARCHITECTURAL METALWORK, DECKS, SKYLIGHTS, FACADES, WALLS AND FIXTURES, STORE DISPLAYS AND FIXTURES, SIGNAGE, AND OFFICE FIXTURES; PROTOTYPE FABRICATION OF NEW PRODUCTS FOR OTHERS (U.S. CLS. 100, 103 AND 106).

CLASS 42—SCIENTIFIC AND COMPUTER SERVICES

FOR NEW PRODUCT DESIGN SERVICES; DESIGN AND PROJECT MANAGEMENT IN THE FIELD OF ARTWORK, INDOOR AND OUTDOOR FURNITURE, ARCHITECTURAL STRUCTURES, NAMELY, ARCHITECTURAL METALWORK, DECKS, SKYLIGHTS, FACADES, WALLS AND FIXTURES, STORE DISPLAYS AND FIXTURES, AND OFFICE FIXTURES (U.S. CLS. 100 AND 101).

THOMAS MANOR, EXAMINING ATTORNEY

SN 85-445,780. KRAMER, LARRY L., NAPLES, FL. FILED 10-12-2011.

WILD HARE

THE MARK CONSISTS OF STANDARD CHARACTERS WITHOUT CLAIM TO ANY PARTICULAR FONT, STYLE, SIZE, OR COLOR.

CLASS 13—FIREARMS

FOR SHOOTING ACCESSORIES, NAMELY, CARRYING BAGS SPECIALLY ADAPTED FOR GUNS, CARRYING POUCHES, NAMELY, CARTRIDGE POUCHES, AMMUNITION CARRIERS, NAMELY, AMMUNITION BAGS, GUN SLIPS, NAMELY, GUN AND RIFLE CASES, RANGE BAGS FOR CARRYING FIREARMS AND FIREARM ACCESSORIES; AND TOE PADS, NAMELY, GUNSTOCK RECOIL PADS (U.S. CLS. 2 AND 9).

CLASS 25—CLOTHING

FOR CLOTHING, NAMELY, JACKETS, VESTS, SHIRTS, PANTS, HATS, AND GLOVES (U.S. CLS. 22 AND 39).

JAMES LOVELACE, EXAMINING ATTORNEY

SN 85-446,065. DOCKERY FARMS, LLC, CLEVELAND, MS. FILED 10-12-2011.

Dockery Farms

THE MARK CONSISTS OF STANDARD CHARACTERS WITHOUT CLAIM TO ANY PARTICULAR FONT, STYLE, SIZE, OR COLOR.

NO CLAIM IS MADE TO THE EXCLUSIVE RIGHT TO USE "FARMS", APART FROM THE MARK AS SHOWN.

CLASS 9—ELECTRICAL AND SCIENTIFIC APPARATUS

FOR DECORATIVE REFRIGERATOR MAGNETS (U.S. CLS. 21, 23, 26, 36 AND 38).

FIRST USE 12-1-2010; IN COMMERCE 6-1-2011.

CLASS 16—PAPER GOODS AND PRINTED MATTER

FOR POSTERS (U.S. CLS. 2, 5, 22, 23, 29, 37, 38 AND 50).
FIRST USE 12-1-2010; IN COMMERCE 6-1-2011.

CLASS 21—HOUSEWARES AND GLASS

FOR COFFEE CUPS, TEA CUPS AND MUGS (U.S. CLS. 2, 13, 23, 29, 30, 33, 40 AND 50).
FIRST USE 12-1-2010; IN COMMERCE 6-1-2011.

CLASS 25—CLOTHING

FOR SHORT-SLEEVED OR LONG-SLEEVED T-SHIRTS (U.S. CLS. 22 AND 39).
FIRST USE 12-1-2010; IN COMMERCE 6-1-2011.

CLASS 41—EDUCATION AND ENTERTAINMENT

FOR EDUCATION SERVICES, NAMELY, PROVIDING CLASSES, SEMINARS AND WORKSHOPS IN THE FIELD OF MUSIC, HISTORY AND AGRICULTURE (U.S. CLS. 100, 101 AND 107).
FIRST USE 1-5-2008; IN COMMERCE 1-15-2008.
WILLIAM VERHOSEK, EXAMINING ATTORNEY

SN 85-446,662. ODD FUTURE, LLC, LOS ANGELES, CA.
FILED 10-13-2011.

GOLF WANG

THE MARK CONSISTS OF STANDARD CHARACTERS WITHOUT CLAIM TO ANY PARTICULAR FONT, STYLE, SIZE, OR COLOR.

NO CLAIM IS MADE TO THE EXCLUSIVE RIGHT TO USE "GOLF", APART FROM THE MARK AS SHOWN.

CLASS 16—PAPER GOODS AND PRINTED MATTER

FOR STICKERS; BOOKS FEATURING PHOTOGRAPHS AND INFORMATION IN THE FIELD OF ENTERTAINMENT (U.S. CLS. 2, 5, 22, 23, 29, 37, 38 AND 50).

CLASS 25—CLOTHING

FOR CLOTHING, NAMELY, SHIRTS AND SWEATSHIRTS (U.S. CLS. 22 AND 39).

CLASS 41—EDUCATION AND ENTERTAINMENT

FOR ENTERTAINMENT, NAMELY, LIVE MUSICAL CONCERTS, ARRANGING AND CONDUCTING CONCERTS AND MUSICAL EVENTS; PROVIDING A WEBSITE AND ONLINE PROFILE PAGES FEATURING NONDOWNLOADABLE RECORDED MUSIC, MUSICAL PERFORMANCES, MUSICAL VIDEOS, RELATED VIDEO CLIPS, PHOTOGRAPHS, ENTERTAINMENT INFORMATION ON MUSICAL ARTISTS AND THEIR RECORDINGS, ENTERTAINMENT INFORMATION ON A RECORD LABEL, AND LINKS TO MUSICAL ARTIST WEBSITES AND OTHER MUSIC EVENT AND MUSIC-ORIENTED WEBSITES; ENTERTAINMENT SERVICES, NAMELY, PERSONAL APPEARANCES BY PROFESSIONAL ENTERTAINERS (U.S. CLS. 100, 101 AND 107).
FIRST USE 9-28-2011; IN COMMERCE 9-28-2011.

LIEF MARTIN, EXAMINING ATTORNEY

SN 85-446,670. ODD FUTURE, LLC, LOS ANGELES, CA.
FILED 10-13-2011.

GOLF WANG

THE MARK CONSISTS OF STANDARD CHARACTERS WITHOUT CLAIM TO ANY PARTICULAR FONT, STYLE, SIZE, OR COLOR.

NO CLAIM IS MADE TO THE EXCLUSIVE RIGHT TO USE "GOLF", APART FROM THE MARK AS SHOWN.

CLASS 9—ELECTRICAL AND SCIENTIFIC APPARATUS

FOR MUSICAL SOUND RECORDINGS; DOWNLOADABLE MUSICAL SOUND RECORDINGS; AUDIOVISUAL RECORDINGS FEATURING MUSIC, MUSICAL PERFORMANCES; DOWNLOADABLE AUDIOVISUAL RECORDINGS FEATURING MUSIC AND MUSICAL PERFORMANCES; DOWNLOADABLE RINGTONES AND GRAPHICS VIA A GLOBAL COMPUTER NETWORK AND WIRELESS DEVICES; DOWNLOADABLE AUDIOVISUAL RECORDINGS IN THE FIELD OF SKITS, MUSIC VIDEOS, COMEDY, AND DRAMA; CDS AND DVDS FEATURING MUSIC, MUSICAL PERFORMANCES, SKITS, MUSIC VIDEOS, COMEDY, ANIMATED CARTOONS AND DRAMA; MOTION PICTURE FILMS ABOUT MUSIC, MUSIC VIDEOS, COMEDY AND DRAMA; MOTION PICTURE FILMS IN THE NATURE OF ANIMATED CARTOONS; MOTION PICTURE FILMS FEATURING SKITS, PRANKS, MUSIC, COMEDY AND DRAMA (U.S. CLS. 21, 23, 26, 36 AND 38).

CLASS 16—PAPER GOODS AND PRINTED MATTER

FOR POSTERS, POSTCARDS, PHOTOGRAPHS, SOUVENIR PROGRAMS CONCERNING MUSIC EVENTS, ARTISTS AND RECORDINGS; PRINTED AND PAPER ITEMS, NAMELY, STICKERS, CALENDARS, NOTECARDS, STATIONERY AND BOOKS IN THE FIELD OF MUSIC, COMEDY AND ENTERTAINMENT (U.S. CLS. 2, 5, 22, 23, 29, 37, 38 AND 50).

CLASS 25—CLOTHING

FOR CLOTHING, NAMELY, SHIRTS, PANTS, TOPS, BOTTOMS, JACKETS, JEANS, VESTS, BELTS, HEADWEAR, FOOTWEAR, UNDERWEAR, SWEATSHIRTS, COATS, TANK TOPS, SWEATPANTS, SHORTS, SKIRTS, DRESSES (U.S. CLS. 22 AND 39).

CLASS 35—ADVERTISING AND BUSINESS

FOR PROMOTING THE CONCERTS OF OTHERS; ONLINE RETAIL STORE SERVICES FEATURING MUSICAL SOUND RECORDINGS, AUDIOVISUAL RECORDINGS, CLOTHING, STICKERS, RINGTONES AND GRAPHICS, AND PROMOTIONAL MERCHANDISE OF A RECORD LABEL AND MUSICAL COLLECTIVE; BUSINESS MARKETING SERVICES (U.S. CLS. 100, 101 AND 102).

CLASS 41—EDUCATION AND ENTERTAINMENT

FOR ENTERTAINMENT IN THE NATURE OF ON-GOING TELEVISION SHOWS IN THE FIELD OF COMEDY, MUSIC AND DRAMA; ENTERTAINMENT IN THE NATURE OF ON-GOING REALITY-BASED TELEVISION SHOWS FEATURING SKITS, PRANKS, MUSIC AND COMEDY; ENTERTAINMENT IN THE NATURE OF ON-GOING TELEVISION SHOWS IN THE NATURE OF CARTOONS; PROVIDING ON-LINE BLOGS IN THE FIELD OF MUSIC AND ENTERTAINMENT (U.S. CLS. 100, 101 AND 107).

LIEF MARTIN, EXAMINING ATTORNEY



SN 85-447,099. VITAL ANIMAL HEALTH, LLC, COLORADO SPRINGS, CO. FILED 10-13-2011.

VITAL-BENZ

THE MARK CONSISTS OF STANDARD CHARACTERS WITHOUT CLAIM TO ANY PARTICULAR FONT, STYLE, SIZE, OR COLOR.

CLASS 3—COSMETICS AND CLEANING PREPARATIONS

FOR HAIR SHAMPOOS AND CONDITIONERS; BODY CLEANSERS (U.S. CLS. 1, 4, 6, 50, 51 AND 52).

CLASS 5—PHARMACEUTICALS

FOR PHARMACEUTICAL PRODUCTS, NAMELY, MEDICATED SHAMPOOS, SKIN CLEANSERS, BODY CLEANSERS, HAIR CLEANSERS, AND SKIN CONDITIONERS, BODY CONDITIONERS, AND HAIR CONDITIONERS; PHARMACEUTICAL PRODUCTS PREPARATIONS FOR SKIN CARE; FUNGAL MEDICATIONS (U.S. CLS. 6, 18, 44, 46, 51 AND 52).

ALICIA COLLINS, EXAMINING ATTORNEY



SN 85-447,216. MY OCEAN LIFE, LLC, ISLE OF PALMS, SC. FILED 10-13-2011.

VOG

THE MARK CONSISTS OF STANDARD CHARACTERS WITHOUT CLAIM TO ANY PARTICULAR FONT, STYLE, SIZE, OR COLOR.

CLASS 28—TOYS AND SPORTING GOODS

FOR BOARDS FOR BOARD SPORTS, NAMELY, SKATEBOARDS, SURFBOARDS, SNOWBOARDS, KITE BOARDS AND STAND-UP PADDLEBOARDS; BALANCE BOARDS FOR RECREATION AND BALANCE TRAINING (U.S. CLS. 22, 23, 38 AND 50).

CLASS 35—ADVERTISING AND BUSINESS

FOR RETAIL STORE SERVICES AND ON-LINE RETAIL STORE SERVICES FEATURING A WIDE VARIETY OF CONSUMER GOODS OF OTHERS (U.S. CLS. 100, 101 AND 102).

RUSS HERMAN, EXAMINING ATTORNEY



SN 85-447,219. MY OCEAN LIFE, LLC, ISLE OF PALMS, SC. FILED 10-13-2011.

VOG

THE MARK CONSISTS OF STANDARD CHARACTERS WITHOUT CLAIM TO ANY PARTICULAR FONT, STYLE, SIZE, OR COLOR.

CLASS 14—JEWELRY

FOR JEWELRY (U.S. CLS. 2, 27, 28 AND 50).

CLASS 16—PAPER GOODS AND PRINTED MATTER

FOR PRINTED MATTER, NAMELY, BOOKS DEALING WITH OCEAN-LIFESTYLE; PRINTS; POSTERS; ART PRINTS (U.S. CLS. 2, 5, 22, 23, 29, 37, 38 AND 50).

CLASS 25—CLOTHING

FOR CLOTHING, NAMELY, BEACH COVER-UPS, SURF WEAR, SWIMWEAR, WETSUITS, BOARD SHORTS, AND INFANT AND TODDLER ONE PIECE CLOTHING; HEADWEAR, AND FOOTWEAR; BELTS; SUN PROTECTIVE CLOTHING, NAMELY, BEACH COVER-UPS (U.S. CLS. 22 AND 39).

RUSS HERMAN, EXAMINING ATTORNEY



SN 85-447,284. THE IDEAL WORLD, SAN FRANCISCO, CA. FILED 10-13-2011.

THE IDEAL WORLD

THE MARK CONSISTS OF STANDARD CHARACTERS WITHOUT CLAIM TO ANY PARTICULAR FONT, STYLE, SIZE, OR COLOR.

CLASS 35—ADVERTISING AND BUSINESS

FOR PROMOTING PUBLIC AWARENESS OF THE NEED TO PREVENT, MANAGE, ADDRESS AND RESOLVE CONFLICTS; PROMOTING PUBLIC AWARENESS OF THE IMPORTANCE OF NEGOTIATION, CONFLICT RESOLUTION, COLLABORATIVE PROBLEM SOLVING, CHANGE INITIATIVES, AND GROWTH AND DEVELOPMENT OF PEOPLE, ORGANIZATIONS AND THEIR IDEAS, TO MANAGE AND ADDRESS COMPLEX CHALLENGES; PUBLIC POLICY RESEARCH SERVICES IN THE FIELDS OF NEGOTIATION, CONFLICT RESOLUTION, COLLABORATIVE PROBLEM SOLVING, CHANGE INITIATIVES, AND GROWTH AND DEVELOPMENT OF PEOPLE, ORGANIZATIONS AND THEIR IDEAS; BUSINESS CONSULTATION SERVICES FEATURING STRATEGIC GROWTH AND STRATEGY DEVELOPMENT AND IMPLEMENTATION FOR CORPORATIONS, ORGANIZATIONS AND MULTI-STAKEHOLDER ALLIANCES (U.S. CLS. 100, 101 AND 102).

FIRST USE 2-6-2010; IN COMMERCE 2-6-2010.

CLASS 41—EDUCATION AND ENTERTAINMENT

FOR RESEARCH IN THE FIELD OF EDUCATION; EDUCATIONAL SERVICES, NAMELY, DEVELOPING CURRICULUM FOR OTHERS AND CONDUCTING PROGRAMS, SEMINARS, TRAININGS, PEER TO PEER COACHING, PERSONAL COACHING AND GROUP COACHING IN THE FIELDS OF NEGOTIATION, CONFLICT RESOLUTION, COLLABORATIVE PROBLEM SOLVING, CHANGE INITIATIVES, AND GROWTH AND DEVELOPMENT OF PEOPLE, ORGANIZATIONS AND THEIR IDEAS, AND DISTRIBUTING COURSE MATERIALS IN CONNECTION THEREWITH; GROUP FACILITATION SERVICES, NAMELY, PROVIDING GROUP COACHING IN THE FIELDS OF NEGOTIATION, CONFLICT RESOLUTION, COLLABORATIVE PROBLEM SOLVING, CHANGE INITIATIVES, AND GROWTH AND DEVELOPMENT OF PEOPLE, ORGANIZATIONS AND THEIR IDEAS (U.S. CLS. 100, 101 AND 107).

FIRST USE 6-10-2010; IN COMMERCE 6-10-2010.

CLASS 45—PERSONAL AND LEGAL SERVICES

FOR MEDIATION OF DISPUTES, NAMELY, CONFLICT PREVENTION, NEGOTIATION, MANAGEMENT, AND RESOLUTION SERVICES, AND CONSULTING SERVICES PROVIDED IN CONNECTION THEREWITH (U.S. CLS. 100 AND 101).

FIRST USE 2-6-2010; IN COMMERCE 2-6-2010.
B. PARADEWELAI, EXAMINING ATTORNEY

SN 85-447,463. SUNFLOWER MEADOWS HERB FARM LLC, KANOSH, UT. FILED 10-14-2011.



NO CLAIM IS MADE TO THE EXCLUSIVE RIGHT TO USE "HERB FARM", APART FROM THE MARK AS SHOWN.

THE COLOR(S) BROWN AND YELLOW IS/ARE CLAIMED AS A FEATURE OF THE MARK.

THE MARK CONSISTS OF THE STYLIZED WORDING "HERB FARM" IN THE COLOR BROWN SET BELOW A DESIGN ELEMENT COMPRISED OF A DEPICTION OF A SUNFLOWER IN THE COLORS BROWN AND YELLOW, SUPERIMPOSED, IN PART, OVER A YELLOW CIRCLE; THE AREAS OF THE FLOWER SHOWN IN WHITE ARE NOT PART OF THE MARK, AND MERELY SHOW THE SURFACE UPON WHICH THE MARK IS AFFIXED.

CLASS 5—PHARMACEUTICALS

FOR HERBAL SUPPLEMENTS AND MEDICINAL HERBAL PREPARATIONS (U.S. CLS. 6, 18, 44, 46, 51 AND 52).

CLASS 30—STAPLE FOODS

FOR HERBAL TEA AND HERBAL FOOD BEVERAGES (U.S. CL. 46).

CLASS 32—LIGHT BEVERAGES

FOR HERBAL JUICES (U.S. CLS. 45, 46 AND 48).
WILLIAM BRECKENFELD, EXAMINING ATTORNEY

SN 85-447,621. TEAM UNICORN LLC, WEST HOLLYWOOD, CA. FILED 10-14-2011.



THE MARK CONSISTS OF A HEART SHAPE WITH A SHAPE RESEMBLING A UNICORN HORN COMING OUT OF THE TOP OF THE HEART SHAPE.

CLASS 16—PAPER GOODS AND PRINTED MATTER

FOR POSTERS; STICKERS; TEMPORARY TATTOOS (U.S. CLS. 2, 5, 22, 23, 29, 37, 38 AND 50).
FIRST USE 7-22-2011; IN COMMERCE 7-22-2011.

CLASS 25—CLOTHING

FOR T-SHIRTS (U.S. CLS. 22 AND 39).
FIRST USE 7-22-2011; IN COMMERCE 7-22-2011.

CLASS 26—FANCY GOODS

FOR NOVELTY BUTTONS (U.S. CLS. 37, 39, 40, 42 AND 50).
FIRST USE 7-22-2011; IN COMMERCE 7-22-2011.
DEIRDRE ROBERTSON, EXAMINING ATTORNEY

SN 85-447,697. THE B&F SYSTEM, INC., DALLAS, TX.
FILED 10-14-2011.

4 SQUARE

THE MARK CONSISTS OF STANDARD CHARACTERS WITHOUT CLAIM TO ANY PARTICULAR FONT, STYLE, SIZE, OR COLOR.

CLASS 8—HAND TOOLS

FOR HAND TOOLS FOR USE IN CUTTING FRUITS AND VEGETABLES, NAMELY, KNIVES, SHREDDERS, PEELERS, CORERS, AND SLICERS (U.S. CLS. 23, 28 AND 44).

CLASS 11—ENVIRONMENTAL CONTROL APPARATUS

FOR ELECTRIC ROASTERS (U.S. CLS. 13, 21, 23, 31 AND 34).

CLASS 21—HOUSEWARES AND GLASS

FOR COOKWARE, NAMELY, POTS, PANS, SKILLETS, GRIDDLES, STOCK POTS, ROASTING DISHES, AND NON-ELECTRIC GRATERS FOR CUTTING FRUITS AND VEGETABLES (U.S. CLS. 2, 13, 23, 29, 30, 33, 40 AND 50).

JORDAN BAKER, EXAMINING ATTORNEY

SN 85-447,705. THE B&F SYSTEM, INC., DALLAS, TX.
FILED 10-14-2011.



THE MARK CONSISTS OF A CHECKERED SQUARE PATTERN ABOVE THE STYLIZED WORDING "4 SQUARE", WITH THE "4" APPEARING IN BOLD. IMMEDIATELY BELOW THIS WORDING IS A THIN HORIZONTAL LINE. IMMEDIATELY BELOW THE LINE IS THE STYLIZED LITERAL ELEMENT ".HEALTH.SMART.FLAVOR.LIFETIME".

CLASS 8—HAND TOOLS

FOR HAND TOOLS FOR USE IN CUTTING FRUITS AND VEGETABLES, NAMELY, KNIVES, SHREDDERS, PEELERS, CORERS, AND SLICERS (U.S. CLS. 23, 28 AND 44).

CLASS 11—ENVIRONMENTAL CONTROL APPARATUS

FOR ELECTRIC ROASTERS (U.S. CLS. 13, 21, 23, 31 AND 34).

CLASS 21—HOUSEWARES AND GLASS

FOR COOKWARE, NAMELY, POTS, PANS, SKILLETS, GRIDDLES, STOCK POTS, ROASTING DISHES, AND NON-ELECTRIC GRATERS FOR CUTTING FRUITS AND VEGETABLES (U.S. CLS. 2, 13, 23, 29, 30, 33, 40 AND 50).

JORDAN BAKER, EXAMINING ATTORNEY

SN 85-447,850. XAVIER UNIVERSITY, CINCINNATI, OH.
FILED 10-14-2011.

American Dream Diversity Index

THE MARK CONSISTS OF STANDARD CHARACTERS WITHOUT CLAIM TO ANY PARTICULAR FONT, STYLE, SIZE, OR COLOR.

OWNER OF U.S. REG. NOS. 3,866,997, 3,869,901 AND 3,969,676.

NO CLAIM IS MADE TO THE EXCLUSIVE RIGHT TO USE "DIVERSITY INDEX", APART FROM THE MARK AS SHOWN.

CLASS 35—ADVERTISING AND BUSINESS

FOR ANALYSIS OF MARKET RESEARCH DATA AND STATISTICS; CONDUCTING MARKET SURVEYS; CONDUCTING PUBLIC OPINION POLLS; MARKET ANALYSIS; MARKET ANALYSIS AND RESEARCH SERVICES; MARKET REPORTS AND STUDIES; PUBLIC OPINION SURVEYS (U.S. CLS. 100, 101 AND 102).

FIRST USE 10-1-2011; IN COMMERCE 10-1-2011.

CLASS 41—EDUCATION AND ENTERTAINMENT

FOR ONLINE PUBLICATIONS IN THE NATURE OF RESEARCH REPORTS FEATURING INFORMATION AND TRENDS PERTAINING TO AMERICANS' ATTITUDES TOWARD THE ASSIMILATION OF DIFFERENCES IN ONE'S COMMUNITY (U.S. CLS. 100, 101 AND 107).

FIRST USE 10-1-2011; IN COMMERCE 10-1-2011.

NICHOLAS COLEMAN, EXAMINING ATTORNEY

SN 85-448,163. ZUREX PHARMA, INC., MADISON, WI.
FILED 10-14-2011.

ZUREX

THE MARK CONSISTS OF STANDARD CHARACTERS WITHOUT CLAIM TO ANY PARTICULAR FONT, STYLE, SIZE, OR COLOR.

CLASS 5—PHARMACEUTICALS

FOR (BASED ON USE IN COMMERCE) ANTISEPTIC PREPARATIONS; CHEMICAL PREPARATIONS FOR SANITARY PURPOSES (U.S. CLS. 6, 18, 44, 46, 51 AND 52).

FIRST USE 10-4-2011; IN COMMERCE 10-4-2011.

CLASS 7—MACHINERY

FOR (BASED ON INTENT TO USE) MIXING MACHINES FOR PROCESSING CHEMICALS AND PRODUCING CHEMICAL PREPARATIONS (U.S. CLS. 13, 19, 21, 23, 31, 34 AND 35).

CHRISTOPHER BUONGIORNO, EXAMINING ATTORNEY

SN 85-448,183. ZUREX PHARMAGRA, LLC, MADISON, WI. FILED 10-14-2011.

ZUREX PHARMAGRA

THE MARK CONSISTS OF STANDARD CHARACTERS WITHOUT CLAIM TO ANY PARTICULAR FONT, STYLE, SIZE, OR COLOR.

CLASS 5—PHARMACEUTICALS

FOR (BASED ON USE IN COMMERCE) ANTISEPTIC PREPARATIONS; CHEMICAL PREPARATIONS FOR SANITARY PURPOSES (U.S. CLS. 6, 18, 44, 46, 51 AND 52). FIRST USE 10-4-2011; IN COMMERCE 10-4-2011.

CLASS 7—MACHINERY

FOR (BASED ON INTENT TO USE) MIXING MACHINES FOR PROCESSING CHEMICALS AND PRODUCING CHEMICAL PREPARATIONS (U.S. CLS. 13, 19, 21, 23, 31, 34 AND 35).

CHRISTOPHER BUONGIORNO, EXAMINING ATTORNEY

SN 85-448,200. EVA CHUN CHOW, UNITED STATES CITIZEN, PARENT OF ASIA CHOW;, LOS ANGELES, CA. FILED 10-14-2011.

Asia Chow

THE MARK CONSISTS OF STANDARD CHARACTERS WITHOUT CLAIM TO ANY PARTICULAR FONT, STYLE, SIZE, OR COLOR.

THE NAME(S), PORTRAIT(S), AND/OR SIGNATURE(S) SHOWN IN THE MARK IDENTIFIES "ASIA CHOW", WHOSE CONSENT(S) TO REGISTER IS MADE OF RECORD.

CLASS 3—COSMETICS AND CLEANING PREPARATIONS

FOR PERFUME, COLOGNE, FRAGRANCES, COSMETICS, MAKEUP, NON-MEDICATED SKIN CARE PREPARATIONS, SUN SCREEN PREPARATIONS, NAIL CARE PREPARATIONS, HAIR CARE PREPARATIONS, SOAPS, SOAP POWDERS, BATH OILS AND POWDERS, AND BABY OILS AND POWDERS (U.S. CLS. 1, 4, 6, 50, 51 AND 52).

CLASS 25—CLOTHING

FOR CLOTHING, NAMELY, TOPS, BLOUSES, SHIRTS, PANTS, SHORTS, PANTSUITS, DRESSES, SKIRTS, JACKETS, COATS, PONCHOS, SWEATERS, SWEATSHIRTS, SWEATPANTS, LINGERIE, UNDERGARMENTS, SLEEPWEAR, ROBES, LOUNGEWEAR, SWIMWEAR, BEACH COVER-UPS, BELTS, GLOVES, SOCKS, STOCKINGS, SHAWLS, AND SCARVES; HEADWEAR; AND FOOTWEAR (U.S. CLS. 22 AND 39).

ANDREW RHIM, EXAMINING ATTORNEY

SN 85-448,277. MODERN CONSCIENCE INCORPORATED, FORMERLY MODERN CONSCIENCE, SEATTLE, WA. FILED 10-15-2011.

MODERN CONSCIENCE

THE MARK CONSISTS OF STANDARD CHARACTERS WITHOUT CLAIM TO ANY PARTICULAR FONT, STYLE, SIZE, OR COLOR.

NO CLAIM IS MADE TO THE EXCLUSIVE RIGHT TO USE "MODERN", APART FROM THE MARK AS SHOWN.

CLASS 20—FURNITURE AND ARTICLES NOT OTHERWISE CLASSIFIED

FOR FURNITURE FOR HOME AND OFFICE USE (U.S. CLS. 2, 13, 22, 25, 32 AND 50). FIRST USE 1-2-2004; IN COMMERCE 2-16-2008.

CLASS 35—ADVERTISING AND BUSINESS

FOR ONLINE RETAIL STORE SERVICES, RETAIL STORE SERVICES, AND MAIL ORDER SERVICES IN THE FIELDS OF FURNITURE, HOUSEWARES, AND ACCESSORIES RELATING THERETO (U.S. CLS. 100, 101 AND 102).

FIRST USE 1-2-2004; IN COMMERCE 2-16-2008.

CLASS 41—EDUCATION AND ENTERTAINMENT

FOR ONLINE NEWSLETTERS, BLOGS, AND NON-DOWNLOADABLE PUBLICATIONS IN THE NATURE OF ARTICLES, JOURNALS, AND PHOTOGRAPHY IN THE FIELDS OF FURNITURE, DESIGN, AND ARCHITECTURE (U.S. CLS. 100, 101 AND 107).

FIRST USE 1-2-2004; IN COMMERCE 2-16-2008.

ELI HELLMAN, EXAMINING ATTORNEY

SN 85-448,520. XAVIER UNIVERSITY, CINCINNATI, OH. FILED 10-17-2011.

**American Dream Well-Being
Index**

THE MARK CONSISTS OF STANDARD CHARACTERS WITHOUT CLAIM TO ANY PARTICULAR FONT, STYLE, SIZE, OR COLOR.

OWNER OF U.S. REG. NOS. 3,866,997, 3,869,901 AND 3,969,676.

NO CLAIM IS MADE TO THE EXCLUSIVE RIGHT TO USE "INDEX", APART FROM THE MARK AS SHOWN.

CLASS 35—ADVERTISING AND BUSINESS

FOR ANALYSIS OF MARKET RESEARCH DATA AND STATISTICS; CONDUCTING MARKET SURVEYS; CONDUCTING MARKETING STUDIES; CONDUCTING PUBLIC OPINION POLLS; MARKET ANALYSIS; MARKET ANALYSIS AND RESEARCH SERVICES; MARKET REPORTS AND STUDIES; PUBLIC OPINION SURVEYS (U.S. CLS. 100, 101 AND 102).

FIRST USE 10-1-2011; IN COMMERCE 10-1-2011.

CLASS 41—EDUCATION AND ENTERTAINMENT

FOR ONLINE PUBLICATIONS IN THE NATURE OF RESEARCH REPORTS FEATURING INFORMATION AND TRENDS IN AMERICANS' FEELINGS AND THOUGHTS TOWARDS THEIR LEVEL OF CONTENTMENT, HEALTH, AND PROSPERITY IN LIFE (U.S. CLS. 100, 101 AND 107).

FIRST USE 10-1-2011; IN COMMERCE 10-1-2011.
NICHOLAS COLEMAN, EXAMINING ATTORNEY

SN 85-448,720. INSURANCE LEADERSHIP NETWORK, INC., REDWOOD CITY, CA. FILED 10-17-2011.

ABD

THE MARK CONSISTS OF STANDARD CHARACTERS WITHOUT CLAIM TO ANY PARTICULAR FONT, STYLE, SIZE, OR COLOR.

CLASS 35—ADVERTISING AND BUSINESS

FOR BUSINESS RISK MANAGEMENT; HUMAN RESOURCE CONSULTING; HUMAN CAPITAL MANAGEMENT OUTSOURCING SERVICES (U.S. CLS. 100, 101 AND 102).

CLASS 36—INSURANCE AND FINANCIAL

FOR INSURANCE AGENCIES; PROCESSING, ADMINISTERING AND MANAGING EMPLOYEE BENEFIT PLANS CONCERNING INSURANCE AND FINANCE; INVESTMENT BROKERAGE SERVICES; FINANCIAL RISK MANAGEMENT SERVICES; FINANCIAL ADVISORY AND CONSULTANCY SERVICES (U.S. CLS. 100, 101 AND 102).

CHRISIE B. KING, EXAMINING ATTORNEY

SN 85-448,732. HERMAN, STEVEN M., BRIDGEPORT, CT. FILED 10-17-2011.

**RIGHT ANGLE FOOD AND
BEVERAGE COMPANY**

THE MARK CONSISTS OF STANDARD CHARACTERS WITHOUT CLAIM TO ANY PARTICULAR FONT, STYLE, SIZE, OR COLOR.

NO CLAIM IS MADE TO THE EXCLUSIVE RIGHT TO USE "FOOD AND BEVERAGE COMPANY", APART FROM THE MARK AS SHOWN.

CLASS 30—STAPLE FOODS

FOR CONDIMENT SAUCES AND SALAD DRESSINGS (U.S. CL. 46).

CLASS 32—LIGHT BEVERAGES

FOR PLAIN AND FLAVORED BOTTLED WATER (U.S. CLS. 45, 46 AND 48).
DANIEL CAPSHAW, EXAMINING ATTORNEY

SN 85-449,397. PATIENT FORWARD, LLC, DRIPPING SPRINGS, TX. FILED 10-18-2011.

Patient Forward

THE MARK CONSISTS OF STANDARD CHARACTERS WITHOUT CLAIM TO ANY PARTICULAR FONT, STYLE, SIZE, OR COLOR.

NO CLAIM IS MADE TO THE EXCLUSIVE RIGHT TO USE "PATIENT", APART FROM THE MARK AS SHOWN.

CLASS 9—ELECTRICAL AND SCIENTIFIC APPARATUS

FOR SOFTWARE FOR PROVIDING CONSUMERS ACCESS TO HEALTH CARE, WELLNESS CARE, HEALTH CARE PROFESSIONALS AND WELLNESS CARE PROFESSIONALS VIA COMPUTER, TELEPHONE OR OTHER ELECTRONIC MEANS (U.S. CLS. 21, 23, 26, 36 AND 38).

CLASS 42—SCIENTIFIC AND COMPUTER SERVICES

FOR PROVIDING ONLINE NON-DOWNLOADABLE SOFTWARE, NAMELY, SOFTWARE FOR PROVIDING CONSUMERS ACCESS TO HEALTH CARE, WELLNESS CARE, HEALTH CARE PROFESSIONALS AND WELLNESS CARE PROFESSIONALS VIA COMPUTER, TELEPHONE OR OTHER ELECTRONIC MEANS (U.S. CLS. 100 AND 101).

CLASS 44—MEDICAL, BEAUTY AND AGRICULTURAL SERVICES

FOR TELEMEDICINE SERVICES; CONSULTING SERVICES IN THE FIELD OF PROVIDING CONSUMERS ACCESS TO HEALTH CARE, WELLNESS CARE, HEALTH CARE PROFESSIONALS AND WELLNESS CARE PROFESSIONALS VIA COMPUTER, TELEPHONE OR OTHER ELECTRONIC MEANS (U.S. CLS. 100 AND 101).

DORITT L. CARROLL, EXAMINING ATTORNEY

SN 85-449,504. TON ART, LLC, SCARSDALE, NY. FILED 10-18-2011.

TŌN

THE MARK CONSISTS OF THE WORD "TON".

CLASS 16—PAPER GOODS AND PRINTED MATTER

FOR PRINTED PHOTOGRAPHS (U.S. CLS. 2, 5, 22, 23, 29, 37, 38 AND 50).

CLASS 20—FURNITURE AND ARTICLES NOT OTHERWISE CLASSIFIED

FOR SCULPTURES OF PLASTIC, WOOD AND PLASTER (U.S. CLS. 2, 13, 22, 25, 32 AND 50).
TRACY WHITTAKER-BROWN, EXAMINING ATTORNEY

CLASS 11—ENVIRONMENTAL CONTROL APPARATUS

FOR SINKS; TOILET BOWLS; BATH TUBS; WATER-CLOSETS TOILETS; SHOWERS; SHOWER CUBICLES; WASH-HAND BASINS AS PARTS OF SANITARY INSTALLATIONS; RADIATORS (U.S. CLS. 13, 21, 23, 31 AND 34).

CLASS 16—PAPER GOODS AND PRINTED MATTER

FOR ADHESIVE TAPES FOR STATIONERY; XUAN PAPER FOR CHINESE PAINTING AND CALLIGRAPHY; IMITATION LEATHER PAPER (U.S. CLS. 2, 5, 22, 23, 29, 37, 38 AND 50).

CLASS 17—RUBBER GOODS

FOR VINYL SHEETS USED IN THE MANUFACTURE OF APPLIANCES AND FURNITURE; PLASTIC RODS, BARS, AND SHEETS; LAMINATED BOARDS OF PLASTICS FOR USE IN MANUFACTURING; BOARDS AND PLATES OF PLASTICS FOR USE IN MANUFACTURING; PLASTIC FILM FOR COMMERCIAL AND INDUSTRIAL USE; PLASTIC FILM FOR USE IN THE MANUFACTURE OF APPLIANCES AND FURNITURE; RUBBER PIPES; RUBBER BARS AND RODS; RUBBER SHEETS; GUTTAPERCHA; NITRILE RUBBER; NITRILE BUTADIENE RUBBER; POLYSULFIDE RUBBER; UNPROCESSED LIQUID RUBBER; BALATA RUBBER; BUTYL RUBBER; FLUORO RUBBER; CRUDE RUBBER; STYRENE-BUTADIENE RUBBER; SYNTHETIC POLYBUTADIENE RUBBER; SILICONE RUBBER; ACRYLIC RUBBER; ETHYLENE VINYL ACETATE RUBBER; ETHYLENE PROPYLENE RUBBER; ETHYLENE PROPYLENE DIENE RUBBER; EPICHLOROHYDRIN RUBBER; MNA CRAFT RUBBER; HYDROCHLORIC ACIDIFIED RUBBER; CHLORINATED RUBBER; URETHANE RUBBER; ISOBUTYLENE-ISOPRENE RUBBER; RECLAIMED RUBBER; CHLORO SULFONATED POLYETHYLENE RUBBER; FOAM RUBBER; POLYBUTADIENE RUBBER; POLYOLEFIN SULFIDE RUBBER; POLYOLEFIN OXIDE RUBBER; POLY ISOPRENE RUBBER; POLY CHLOROPRENE RUBBER; POLY PENTAMER RUBBER; PROPYLENE OXIDE RUBBER; SULFIDE RUBBER; SOUNDPROOFING MATERIALS FOR BUILDINGS, NAMELY, SOUNDPROOF ENCLOSURE AND SOUND ABSORPTION PLATES; SYNTHETIC RESIN-FACED SHEETS; ELASTIC SEALANTS FOR BUILDINGS (U.S. CLS. 1, 5, 12, 13, 35 AND 50).

CLASS 18—LEATHER GOODS

FOR RAW SKINS; RAWHIDES; TANNED LEATHER; SPONGE LEATHER; ARTIFICIAL FUR; POLYURETHANE LEATHER (U.S. CLS. 1, 2, 3, 22 AND 41).

CLASS 19—NON-METALLIC BUILDING MATERIALS

FOR FIRECLAY; TEMPERED GLASS FOR BUILDING; PLYWOOD; ARTIFICIAL STONE; SYNTHETIC FLOORING MATERIALS; VINYL FLOORING; FLOOR PANELS NOT OF METAL; NON-METAL FLOOR TILES; NON-METAL FLOORS; PLASTIC TILES; CRYSTALLIZED GLASS FOR BUILDING; INSULATION GLASS FOR BUILDING; MODIFIED SHEET GLASS FOR BUILDING; LUMINOUS GLASS FOR BUILDING; RADIATION SHIELD GLASS FOR BUILDING; COMMON SHEET GLASS FOR BUILDING; COLORED SHEET GLASS FOR BUILDING; FIBER GLASS FOR BUILDING; DUPLEX GLASS FOR BUILDING; ULTRAVIOLET-RAY TRANSMITTING GLASS FOR BUILDING; DECORATIVE GLASS FOR BUILDING; INFRARED-RAY ABSORBING GLASS FOR BUILDING; INSULATING GLASS FOR BUILDING; ADHESIVE GLASS FOR BUILDING; COLORED GLASS FOR BUILDING; WINDOW GLASS FOR BUILDING; FOAM GLASS FOR BUILDING; LAMINATED FLAT GLASS FOR BUILDING; FIGURED PLATE GLASS FOR BUILDING; STAINED-GLASS WINDOWS; SAFETY GLASS FOR BUILDING PURPOSES; NON-METAL ROOFING TILES; NON-METAL PANTILES; RUBBER TILES; WOODEN TILES; VINYL TILES; ASPHALT TILES; GLASS ROOF-

SN 85-450,055, LG CORP., SEOUL, REPUBLIC OF KOREA,
FILED 10-18-2011.

LG Hausys

THE MARK CONSISTS OF STANDARD CHARACTERS WITHOUT CLAIM TO ANY PARTICULAR FONT, STYLE, SIZE, OR COLOR.

OWNER OF REPUBLIC OF KOREA REG. NO. 0030352,
DATED 2-11-2010, EXPIRES 2-11-2020.

OWNER OF U.S. REG. NOS. 2,959,403, 3,927,703 AND OTHERS.

CLASS 6—METAL GOODS

FOR SHEETS AND PLATES OF METAL; SHEET PILES OF METAL; FENCES OF METAL; ROOF COVERINGS OF METAL; WAINSCOTING OF METAL; WINDOWS OF METAL; WINDOW STOPS OF METAL; METAL WINDOW PULLEYS; GRATINGS OF METAL; WINDOW FRAME SYSTEM UNIT OF METAL; CEILINGS OF METAL; PARTITION UNITS OF METAL; CORNICES OF METAL; ROTARY WINDOW FASTENERS OF METAL; RUNNERS OF METAL FOR SLIDING DOORS; NON-AUTOMATIC METAL TURNSTILES; METAL GREENHOUSE FRAMES; ROOF FLASHING OF METAL; WINDOW RAILS OF METAL; WINDOW HANDLES OF METAL; MOLDINGS OF METAL FOR CORNICES; FLOORING TILES OF METAL; WALL TILES OF METAL; PREFABRICATED PLATFORMS OF METAL; FLOOR BOARDS OF METAL; SASHES OF ALUMINIUM; FLOOR TILES OF METAL; PREFABRICATED BUILDING ASSEMBLY KITS OF METAL; FRAMEWORK OF METAL FOR BUILDING; PILLARS OF METAL FOR BUILDINGS; PLASTER SIDING OF METAL FOR BUILDING; WALL LININGS OF METAL FOR BUILDING; REINFORCING MATERIALS OF METAL FOR BUILDING; BRACKETS OF METAL FOR BUILDING; BUILDING PANELS OF METAL; PORCHES OF METAL FOR BUILDING; CLADDING OF METAL FOR BUILDING; CHIMNEY POTS OF METAL; CASEMENT WINDOWS OF METAL; METAL SLIDING DOORS; CHIMNEYS OF METAL; CHIMNEY COWLS OF METAL; HANDRAILS OF METAL; BARS FOR METAL RAILINGS; OUTER DOORS OF METAL; DOOR PANELS OF METAL; DRAW HANDLES OF METAL; DOORS OF METAL; GATE STOPS OF METAL; DOOR KNOCKERS OF METAL; DOOR STOPS OF METAL; DOOR HANDLES OF METAL; DOOR CASES OF METAL; FLOORS OF METAL; WALL BOARDS OF METAL; WINDOW FRAMES OF METAL (U.S. CLS. 2, 12, 13, 14, 23, 25 AND 50).

ING TILES; GLASS BRICKS; GLASS TILES; CONCRETE TILES; RUBBER FLOORING AND RUBBER FLOOR TILES EXCLUSIVELY FOR BUILDING OR CONSTRUCTION; PREFABRICATED PLATFORMS, NOT OF METAL; PLASTER FOR EXCLUSIVE USE IN BUILDING OR CONSTRUCTION; LIME BUILDING MATERIALS; ALABASTER GLASS; THIN WOOD BOARDS; WOOD BOARDS FOR WORKS OF ART; TIMBER FOR PILLARS; TIMBER FOR GIRDERS; VENEER WOOD; SAWN TIMBER; WOOD BOARDS; FOOTING STONE; FRAMEWORK FOR BUILDING, NOT OF METAL; MOLDINGS FOR BUILDING, NOT OF METAL; PLASTER SIDING FOR BUILDING, NOT OF METAL; FLASHING FOR BUILDING, NOT OF METAL; WALL LININGS FOR BUILDING, NOT OF METAL; REINFORCING MATERIALS FOR BUILDING, NOT OF METAL; CARDBOARDS FOR BUILDING, NOT OF METAL, NAMELY, NON-METAL WALL PANELS; BUILDING PANELS, NOT OF METAL; PORCHES FOR BUILDING, NOT OF METAL; CLADDING FOR BUILDING, NOT OF METAL; CHIMNEY POTS, NOT OF METAL; CRASH BARRIERS FOR ROADS, NOT OF METAL; CONSTRUCTION ELEMENTS NOT MADE OF METAL, NAMELY, BRACES FOR TUNNELS; DUCKBOARDS, NOT OF METAL; LATTICEWORK, NOT OF METAL; STAIRCASES, NOT OF METAL; CHIMNEYS, NOT OF METAL; CHIMNEY COWLS, NOT OF METAL; NON-METAL HANDRAILS; OUTER DOORS, NOT OF METAL; DOOR PANELS, NOT OF METAL; BEAMS, NOT OF METAL; LATHS, NOT OF METAL; MANTLEPIECE, NOT OF METAL; NON-METAL GATES; DOOR CASINGS, NOT OF METAL; FLOORS, NOT OF METAL; SCAFFOLDING, NOT OF METAL; WALL PANELS, NOT OF METAL; WALL BOARDS, NOT OF METAL; NON-WOVEN TEXTILE SHEETS, WITH PILE TEXTURED SURFACES, MADE OF SYNTHETIC FIBERS FOR USE IN THE BUILDING INDUSTRY; CASEMENT WINDOWS, NOT OF METAL; NON-METAL SLIDING DOORS; SHINGLE, NOT OF METAL; ROOF FLASHING, NOT OF METAL; HIPPS FOR ROOFING, NOT OF METAL; WAINSCOTTING, NOT OF METAL; WINDOWS, NOT OF METAL; WINDOW RAILS, NOT OF METAL; LATTICE WORK, NOT OF METAL; WINDOW FRAMES, NOT OF METAL; WINDOW FRAME SYSTEM UNITS, NOT OF METAL; NON-METAL PARTITIONS IN THE NATURE OF WALL PANELS; CORNICES, NOT OF METAL; ROTARY WINDOW FASTENERS, NOT OF METAL; SHUTTERING FOR CONCRETE, NOT OF METAL; FOUNDRY MOLDS, NOT OF METAL; BRICKS (U.S. CLS. 1, 12, 33 AND 50).

CLASS 21—HOUSEWARES AND GLASS

FOR PHOTSENSITIVE SHEET GLASS, NOT FOR BUILDING; GLASS INCORPORATING FINE ELECTRICAL CONDUCTORS; MOSAICS OF GLASS, NOT FOR BUILDING; UNWORKED OR SEMI-WORKED OPTICAL GLASS, NOT FOR BUILDING; UNWORKED OR SEMI-WORKED LENSE GLASS, NOT FOR BUILDING; UNWORKED OR SEMI-WORKED ULTRAVIOLET-RAY TRANSMITTING GLASS, NOT FOR BUILDING; UNWORKED OR SEMI-WORKED INFRARED-RAY ABSORBING GLASS; NOT FOR BUILDING; MODIFIED SHEET GLASS, NOT FOR BUILDING; LUMINOUS GLASS, NOT FOR BUILDING; RADIATION SHIELD GLASS, NOT FOR BUILDING; COMMON SHEET GLASS, NOT FOR BUILDING; COLORED SHEET GLASS, NOT FOR BUILDING; DECORATIVE GLASS, NOT FOR BUILDING; LAMINATED FLAT GLASS, NOT FOR BUILDING; FIGURED PLATE GLASS, NOT FOR BUILDING; ENAMELLED GLASS; GLASS TUBES NOT FOR SCIENTIFIC PURPOSES; GLASS RODS; POWDERED GLASS FOR DECORATION, NOT FOR BUILDING (U.S. CLS. 2, 13, 23, 29, 30, 33, 40 AND 50).

CLASS 22—CORDAGE AND FIBERS

FOR TARPAULINS (U.S. CLS. 1, 2, 7, 19, 22, 42 AND 50).

CLASS 24—FABRICS

FOR VINYL CLOTH, NAMELY, VINYL TEXTILES FOR USE IN THE MANUFACTURE OF TABLECLOTHS; SYNTHETIC FIBER FABRICS; FIBERGLASS IN FABRIC FORM FOR TEXTILE USE (U.S. CLS. 42 AND 50).

CLASS 27—FLOOR COVERINGS

FOR BATH MATS; FLOOR COVERINGS, NAMELY, MATTINGS, PLASTIC MATS, MATS; NON-TEXTILE WALL HANGINGS; AUTOMOBILE CARPETS; NON-TEXTILE HANGING SCROLLS; ARTIFICIAL TURF; GYMNASIUM MATS; WALLPAPER; LINOLEUM SHEETS (U.S. CLS. 19, 20, 37, 42 AND 50).

CLASS 35—ADVERTISING AND BUSINESS

FOR SALES AGENCY OF CONSTRUCTION MATERIALS, INTERIOR PRODUCTS, WALLPAPER, TARPAULINS, LEATHER IMITATIONS AND ARTIFICIAL LEATHER, NAMELY, PROVIDING INDEPENDENT SALES REPRESENTATIVES; DEMONSTRATION OF GOODS (U.S. CLS. 100, 101 AND 102).

CLASS 37—CONSTRUCTION AND REPAIR

FOR FURNITURE RESTORATION; UPHOLSTERY REPAIR; UPHOLSTERING; KITCHEN EQUIPMENT INSTALLATION (U.S. CLS. 100, 103 AND 106).

CLASS 40—MATERIAL TREATMENT

FOR PROCESSING OF PLASTICS (U.S. CLS. 100, 103 AND 106).

CLASS 42—SCIENTIFIC AND COMPUTER SERVICES

FOR DESIGN OF INTERIOR DECOR; ARCHITECTURAL CONSULTATION; INTERIOR ARCHITECTURE SERVICES (U.S. CLS. 100 AND 101).

KRISTIN DAHLING, EXAMINING ATTORNEY

SN 85-450,085. OPTIMARE HOLDING GMBH, WILHELM-SHAVEN, FED REP GERMANY, FILED 10-18-2011.

E-LUX

THE MARK CONSISTS OF STANDARD CHARACTERS WITHOUT CLAIM TO ANY PARTICULAR FONT, STYLE, SIZE, OR COLOR.

CLASS 11—ENVIRONMENTAL CONTROL APPARATUS

FOR LAMPS FOR LABORATORY USE, NAMELY, ELECTRON-BEAM PUMP LAMPS THAT LIGHT IN THE UV AND VUV SPECTRAL RANGE NOT FOR MEDICAL USE (U.S. CLS. 13, 21, 23, 31 AND 34).

CLASS 40—MATERIAL TREATMENT

FOR TREATMENT OF MATERIALS, NAMELY, BACTERIAL REMOVAL TREATMENT OF BIOLOGICAL MATERIALS, TREATMENT OF MATERIALS BY LASER BEAM AND UV LIGHT, FOR THE COAGULATION OF BIOLOGICAL MATERIALS, ENGRAVING OF ARTICLES OF MANUFACTURE AND TREATMENT OF MATERIALS BY UV LIGHT FOR THE REMOVAL OF MATERIAL FROM ARTICLES OF MANUFACTURE TO EXPOSE AN UNDERLYING LAYER (U.S. CLS. 100, 103 AND 106).

CLASS 42—SCIENTIFIC AND COMPUTER SERVICES

FOR SCIENTIFIC RESEARCH (U.S. CLS. 100 AND 101).

SETH A. RAPPAPORT, EXAMINING ATTORNEY

SN 85-450,826. ANA MARTINS-VEGA, FORT LEE, NJ. FILED 10-19-2011.

SN 85-450,712. JACKRABBIT SPORTS, INC., NEW YORK, NY. FILED 10-19-2011.



THE MARK CONSISTS OF A REPRESENTATION OF A RABBIT.

CLASS 25—CLOTHING

FOR PERFORMANCE SPORTSWEAR FOR RUNNERS, CYCLISTS, TRIATHLETES, AND YOGA, NAMELY, SHIRTS, CAPS, SWEATSHIRTS, ARM WARMERS, PANTS, HEADBANDS, AND GLOVES (U.S. CLS. 22 AND 39).

FIRST USE 12-11-2003; IN COMMERCE 12-11-2003.

CLASS 35—ADVERTISING AND BUSINESS

FOR RETAIL DEPARTMENT STORE AND ON-LINE DEPARTMENT STORE SERVICES FEATURING PRODUCTS FOR RUNNING, CYCLING, SWIMMING, YOGA, HEALTH, WELLNESS, NUTRITION, SPORTS, AND PHYSICAL FITNESS (U.S. CLS. 100, 101 AND 102).

FIRST USE 12-11-2003; IN COMMERCE 12-11-2003.

CLASS 41—EDUCATION AND ENTERTAINMENT

FOR ORGANIZING AND CONDUCTING TRAINING PROGRAMS, CLASSES, SEMINARS, AND WORKSHOPS IN THE FIELDS OF RUNNING, CYCLING, SWIMMING, YOGA, NUTRITION, SPORTS, AND PHYSICAL FITNESS (U.S. CLS. 100, 101 AND 107).

FIRST USE 12-15-2003; IN COMMERCE 12-15-2003.
TEJBIR SINGH, EXAMINING ATTORNEY



NO CLAIM IS MADE TO THE EXCLUSIVE RIGHT TO USE "MUSICA" FOR CLASS 41 ONLY, APART FROM THE MARK AS SHOWN.

THE MARK CONSISTS OF AN OUTLINED CIRCLE AS CARRIER OF THE WORDS "PEACE LOVE MUSICA" IN STYLIZED FONT DISTRIBUTED EVENLY AROUND THE INSIDE OF THE CIRCLE. IN THE CENTER OF THE CIRCLE IS A LARGE STYLIZED AMPERSAND ("&").

THE ENGLISH TRANSLATION OF "MUSICA" IN THE MARK IS MUSIC.

CLASS 25—CLOTHING

FOR (BASED ON USE IN COMMERCE) HATS; SHIRTS; SWEATSHIRTS; TOPS (U.S. CLS. 22 AND 39).

FIRST USE 10-16-2011; IN COMMERCE 10-16-2011.

CLASS 41—EDUCATION AND ENTERTAINMENT

FOR (BASED ON INTENT TO USE) CONDUCTING ENTERTAINMENT EXHIBITIONS IN THE NATURE OF MUSIC FESTIVALS; ENTERTAINMENT, NAMELY, LIVE PERFORMANCES BY MUSICAL BANDS; PRESENTATION OF LIVE SHOW PERFORMANCES (U.S. CLS. 100, 101 AND 107).

SIMON TENG, EXAMINING ATTORNEY

SN 85-451,070. EAST COAST SEAFOOD, INC., DBA EAST COAST SEAFOOD, INC., LYNN, MA. FILED 10-19-2011.

East Coast Seafood

THE MARK CONSISTS OF STANDARD CHARACTERS WITHOUT CLAIM TO ANY PARTICULAR FONT, STYLE, SIZE, OR COLOR.

NO CLAIM IS MADE TO THE EXCLUSIVE RIGHT TO USE "SEAFOOD", APART FROM THE MARK AS SHOWN. SEC. 2(F).

CLASS 29—MEATS AND PROCESSED FOODS

FOR LOBSTERS (U.S. CL. 46).

FIRST USE 2-18-1981; IN COMMERCE 2-18-1981.

CLASS 31—NATURAL AGRICULTURAL PRODUCTS

FOR LOBSTERS; LOBSTERS, LIVE (U.S. CLS. 1 AND 46).
FIRST USE 2-18-1981; IN COMMERCE 2-18-1981.
JULIE WATSON, EXAMINING ATTORNEY

CLASS 16—PAPER GOODS AND PRINTED MATTER

FOR CHILDREN'S BOOKS (U.S. CLS. 2, 5, 22, 23, 29, 37, 38 AND 50).
FIRST USE 6-1-2011; IN COMMERCE 10-1-2011.
DAVID HOFFMAN, EXAMINING ATTORNEY

SN 85-451,357. XAVIER UNIVERSITY, CINCINNATI, OH.
FILED 10-19-2011.

American Dream Societal Index

THE MARK CONSISTS OF STANDARD CHARACTERS WITHOUT CLAIM TO ANY PARTICULAR FONT, STYLE, SIZE, OR COLOR.

OWNER OF U.S. REG. NOS. 3,866,997, 3,869,901 AND 3,969,676.

NO CLAIM IS MADE TO THE EXCLUSIVE RIGHT TO USE "SOCIETAL INDEX", APART FROM THE MARK AS SHOWN.

CLASS 35—ADVERTISING AND BUSINESS

FOR ANALYSIS OF MARKET RESEARCH DATA AND STATISTICS; CONDUCTING MARKET SURVEYS; CONDUCTING PUBLIC OPINION POLLS; MARKET ANALYSIS; MARKET ANALYSIS AND RESEARCH SERVICES; MARKET REPORTS AND STUDIES; PUBLIC OPINION SURVEYS (U.S. CLS. 100, 101 AND 102).

FIRST USE 10-1-2011; IN COMMERCE 10-1-2011.

CLASS 41—EDUCATION AND ENTERTAINMENT

FOR ONLINE PUBLICATIONS IN THE NATURE OF RESEARCH REPORTS FEATURING INFORMATION AND TRENDS PERTAINING TO THE EXTENT TO WHICH AMERICANS BELIEVE THE GOVERNMENT, BUSINESSES, AND PEOPLE ARE FAIR AND TRUSTWORTHY (U.S. CLS. 100, 101 AND 107).

FIRST USE 10-1-2011; IN COMMERCE 10-1-2011.

NICHOLAS COLEMAN, EXAMINING ATTORNEY

SN 85-451,735. LEANNE LEVETT, MAITLAND, FL. FILED 10-20-2011.

Sleep Angel Sleep

THE MARK CONSISTS OF STANDARD CHARACTERS WITHOUT CLAIM TO ANY PARTICULAR FONT, STYLE, SIZE, OR COLOR.

NO CLAIM IS MADE TO THE EXCLUSIVE RIGHT TO USE "SLEEP", APART FROM THE MARK AS SHOWN.

CLASS 9—ELECTRICAL AND SCIENTIFIC APPARATUS

FOR AUDIO RECORDINGS FEATURING SPOKEN WORD FOR PROMOTING SLEEP (U.S. CLS. 21, 23, 26, 36 AND 38).

FIRST USE 1-1-1998; IN COMMERCE 6-1-2009.

SN 85-451,750. XAVIER UNIVERSITY, CINCINNATI, OH.
FILED 10-20-2011.

American Dream Environmental Index

THE MARK CONSISTS OF STANDARD CHARACTERS WITHOUT CLAIM TO ANY PARTICULAR FONT, STYLE, SIZE, OR COLOR.

OWNER OF U.S. REG. NOS. 3,866,997, 3,869,901 AND 3,969,676.

NO CLAIM IS MADE TO THE EXCLUSIVE RIGHT TO USE "ENVIRONMENTAL INDEX", APART FROM THE MARK AS SHOWN.

CLASS 35—ADVERTISING AND BUSINESS

FOR ANALYSIS OF MARKET RESEARCH DATA AND STATISTICS; CONDUCTING MARKET SURVEYS; CONDUCTING PUBLIC OPINION POLLS; MARKET ANALYSIS; MARKET ANALYSIS AND RESEARCH SERVICES; PUBLIC OPINION SURVEYS (U.S. CLS. 100, 101 AND 102).

FIRST USE 10-1-2011; IN COMMERCE 10-1-2011.

CLASS 41—EDUCATION AND ENTERTAINMENT

FOR ONLINE PUBLICATIONS IN THE NATURE OF RESEARCH REPORTS FEATURING INFORMATION AND TRENDS PERTAINING TO THE AMOUNT OF POLLUTION IN THE AIR, FOOD, WATER, AND LAND THAT AMERICANS BELIEVE THEY ENCOUNTER ON A REGULAR BASIS (U.S. CLS. 100, 101 AND 107).

FIRST USE 10-1-2011; IN COMMERCE 10-1-2011.

NICHOLAS COLEMAN, EXAMINING ATTORNEY

SN 85-451,960. JOHNSON & JOHNSON, NEW BRUNSWICK, NJ. FILED 10-20-2011.

THE MARK CONSISTS OF STYLIZED WORD "HEXINOME".

CLASS 3—COSMETICS AND CLEANING PREPARATIONS

FOR NON-MEDICATED SKIN CARE PREPARATIONS; COSMETICS; SUN SCREENS; FACIAL PRODUCTS, NAMELY, CLEANSERS, MOISTURIZERS, LOTIONS, CREAMS; BODY CARE PRODUCTS, NAMELY, CLEANSERS, MOISTURIZERS, LOTIONS, CREAMS; NON-MEDICATED INGREDIENTS SOLD AS INTEGRAL COMPONENTS OF NON-MEDICATED SKIN CARE PREPARATIONS, COSMETICS, SUN SCREENS, FACIAL AND BODY CLEANSERS, MOISTURIZERS, LOTIONS, CREAMS (U.S. CLS. 1, 4, 6, 50, 51 AND 52).

CLASS 5—PHARMACEUTICALS

FOR MEDICATED SKIN CARE PREPARATIONS; MEDICATED SUNSCREENS; MEDICATED FACIAL CARE PRODUCTS, NAMELY, CLEANSERS, MOISTURIZERS, LOTIONS, CREAMS; MEDICATED BODY CARE PRODUCTS, NAMELY, CLEANSERS, MOISTURIZERS, LOTIONS, CREAMS; MEDICATED INGREDIENTS SOLD AS INTEGRAL COMPONENTS OF MEDICATED SKIN CARE PREPARATIONS, MEDICATED COSMETICS, MEDICATED SUN SCREENS, MEDICATED FACIAL AND BODY CLEANSERS, MOISTURIZERS, LOTIONS, CREAMS (U.S. CLS. 6, 18, 44, 46, 51 AND 52).

CLASS 44—MEDICAL, BEAUTY AND AGRICULTURAL SERVICES

FOR PROVIDING INFORMATION IN THE FIELD OF BEAUTY CARE AND AGEING (U.S. CLS. 100 AND 101).
MICHAEL SOUDERS, EXAMINING ATTORNEY

SN 85-452,216. INTERNATIONAL TRUST FOR MARKETING AND E-COMMERCE, AMMAN, JORDAN, FILED 10-20-2011.



OWNER OF JORDAN REG. NO. 77193, DATED 7-21-2005, EXPIRES 9-22-2014.

OWNER OF JORDAN REG. NO. 76390, DATED 7-21-2005, EXPIRES 8-24-2014.

THE MARK CONSISTS OF THE STYLIZED WORD E-POINTS.

CLASS 35—ADVERTISING AND BUSINESS

FOR MARKETING AND ADVERTISING SERVICES; ARRANGING AND CONDUCTING INCENTIVE REWARD PROGRAMS TO PROMOTE THE SALE OF CONSUMER GOODS OR SERVICES OF OTHERS; ADMINISTRATION OF A CONSUMER LOYALTY PROGRAM TO PROMOTE THE CONSUMER GOODS AND SERVICES OF OTHERS (U.S. CLS. 100, 101 AND 102).

CLASS 36—INSURANCE AND FINANCIAL

FOR LOYALTY PROGRAM PAYMENT PROCESSING SERVICES (U.S. CLS. 100, 101 AND 102).
DOUGLAS LEE, EXAMINING ATTORNEY

SN 85-452,316. CELLCO PARTNERSHIP, DBA VERIZON WIRELESS, BASKING RIDGE, NJ. FILED 10-20-2011.



THE MARK CONSISTS OF STANDARD CHARACTERS WITHOUT CLAIM TO ANY PARTICULAR FONT, STYLE, SIZE, OR COLOR.

CLASS 9—ELECTRICAL AND SCIENTIFIC APPARATUS

FOR TELECOMMUNICATIONS PRODUCTS, NAMELY, A SOFTWARE APPLICATION THAT ENABLES THE USER OF A PARENT DEVICE TO CHECK THE SPEED AT WHICH A CHILD DEVICE IS MOVING AND THAT IS CAPABLE OF SENDING AUTOMATIC ALERTS REGARDING THE SPEED AT WHICH A CHILD DEVICE IS MOVING (U.S. CLS. 21, 23, 26, 36 AND 38).

CLASS 38—COMMUNICATION

FOR TELECOMMUNICATIONS SERVICES, NAMELY, PROVIDING ELECTRONIC MESSAGE ALERTS VIA WIRELESS COMMUNICATIONS NETWORKS THAT ALERT USERS OF A PARENT DEVICE ABOUT THE SPEED AT WHICH A CHILD DEVICE IS MOVING (U.S. CLS. 100, 101 AND 104).
ROBERT STRUCK, EXAMINING ATTORNEY

SN 85-452,408. BAIN, BRAD, HEDLEY, BC, CANADA, AND BAIN, LANA, HEDLEY, BC, CANADA, FILED 10-20-2011.



THE MARK CONSISTS OF STANDARD CHARACTERS WITHOUT CLAIM TO ANY PARTICULAR FONT, STYLE, SIZE, OR COLOR.

NO CLAIM IS MADE TO THE EXCLUSIVE RIGHT TO USE "VINTAGE PATTERNS", APART FROM THE MARK AS SHOWN.

CLASS 9—ELECTRICAL AND SCIENTIFIC APPARATUS

FOR DOWNLOADABLE ELECTRONIC PUBLICATIONS IN THE NATURE OF NEWSLETTERS IN THE FIELD OF SEWING (U.S. CLS. 21, 23, 26, 36 AND 38).
FIRST USE 1-16-2005; IN COMMERCE 1-16-2005.

CLASS 16—PAPER GOODS AND PRINTED MATTER

FOR PRINTED PATTERNS FOR DRESSMAKING; PATTERNS FOR MAKING CLOTHES; CRAFT PATTERNS IN THE NATURE OF PRINTED PATTERNS FOR KNITTING, SEWING AND EMBROIDERY; PRINTED GIFT CERTIFICATES (U.S. CLS. 2, 5, 22, 23, 29, 37, 38 AND 50).
FIRST USE 1-16-2005; IN COMMERCE 1-16-2005.

CLASS 35—ADVERTISING AND BUSINESS

FOR ISSUING GIFT CERTIFICATES WHICH MAY THEN BE REDEEMED FOR GOODS; RETAIL STORE FEATURING SEWING PATTERNS, PATTERNS FOR MAKING CLOTHES, CRAFT PATTERNS AND GIFT CERTIFICATES (U.S. CLS. 100, 101 AND 102).

FIRST USE 1-16-2005; IN COMMERCE 1-16-2005.

CLASS 40—MATERIAL TREATMENT

FOR PROVIDING A WEBSITE FEATURING INFORMATION ABOUT SEWING (U.S. CLS. 100, 103 AND 106).

FIRST USE 1-16-2005; IN COMMERCE 1-16-2005.

KAREN BRACEY, EXAMINING ATTORNEY

SN 85-453,237. NCH CORPORATION, IRVING, TX. FILED 10-21-2011.

PARTSMASTER

THE MARK CONSISTS OF STANDARD CHARACTERS WITHOUT CLAIM TO ANY PARTICULAR FONT, STYLE, SIZE, OR COLOR.

OWNER OF U.S. REG. NO. 3,117,515.

CLASS 1—CHEMICALS

FOR ANTI-SPATTER CHEMICAL COMPOUNDS FOR WELDING, BRAZING AND SOLDERING; SOLDERING CHEMICALS; SOLDERING FLUX; CHEMICALS, NAMELY, COOLANT TYPE CUTTING FLUIDS FOR INDUSTRIAL METAL WORKING; SPECIFICALLY NOT INCLUDING GOODS SOLD OR DISTRIBUTED IN THE AFTERMARKET AUTO PARTS INDUSTRY, SUCH INDUSTRY SPECIFICALLY INCLUDING, BUT NOT LIMITED TO, RETAIL AND WHOLESALE AUTOMOTIVE PARTS STORES (U.S. CLS. 1, 5, 6, 10, 26 AND 46).

FIRST USE 10-31-2002; IN COMMERCE 10-31-2002.

CLASS 2—PAINTS

FOR SPRAY PENETRANTS FOR RELEASING RUSTED AND CORRODED PARTS, AND RELEASE COMPOUNDS FOR RELEASING RUSTED AND CORRODED PARTS; PROTECTIVE COATINGS FOR WIRE AND ELECTRICAL COMPONENTS; SPECIFICALLY NOT INCLUDING GOODS SOLD OR DISTRIBUTED IN THE AFTERMARKET AUTO PARTS INDUSTRY, SUCH INDUSTRY SPECIFICALLY INCLUDING, BUT NOT LIMITED TO, RETAIL AND WHOLESALE AUTOMOTIVE PARTS STORES (U.S. CLS. 6, 11 AND 16).

FIRST USE 10-31-2002; IN COMMERCE 10-31-2002.

CLASS 3—COSMETICS AND CLEANING PREPARATIONS

FOR ALL PURPOSE CLEANERS AND DEGREASING PREPARATIONS FOR WELDING, BONDING AND GENERAL CLEAN-UP; CLEANING PREPARATIONS FOR USE ON INDUSTRIAL MACHINERY, ELECTRICAL EQUIPMENT AND ELECTRONIC EQUIPMENT; CLEANERS AND POLISHES FOR GLASS AND HARD SURFACES, NAMELY, LAMINANTS, TILE, AND COUNTER TOPS; PAINT REMOVERS; WASHING AND CLEANING COMPOUNDS FOR METAL SURFACES; HAND CLEANERS, SPECIFICALLY NOT INCLUDING GOODS SOLD OR DISTRIBUTED IN THE AFTERMARKET AUTO PARTS INDUSTRY, SUCH INDUSTRY SPECIFICALLY INCLUDING, BUT NOT LIMITED TO, RETAIL AND WHOLESALE AUTOMOTIVE PARTS STORES (U.S. CLS. 1, 4, 6, 50, 51 AND 52).

FIRST USE 10-31-2002; IN COMMERCE 10-31-2002.

CLASS 6—METAL GOODS

FOR METAL FASTENERS, NAMELY, BOLTS, SCREWS, RIVETS, NUTS, LOCK WASHERS, WALL ANCHORS; PRE-MADE ASSORTMENT KITS USING TRAYS WHICH CONTAIN METAL FASTENERS, NAMELY, BOLTS, SCREWS, RIVETS, NUTS, LOCK WASHERS, WALL ANCHORS; WELDING EQUIPMENT, NAMELY, FLUX COATED METAL BRAZING AND WELDING RODS; SPECIFICALLY NOT INCLUDING GOODS SOLD OR DISTRIBUTED IN THE AFTERMARKET AUTO PARTS INDUSTRY, SUCH INDUSTRY SPECIFICALLY INCLUDING, BUT NOT LIMITED TO, RETAIL AND WHOLESALE AUTOMOTIVE PARTS STORES (U.S. CLS. 2, 12, 13, 14, 23, 25 AND 50).

FIRST USE 10-31-2002; IN COMMERCE 10-31-2002.

CLASS 9—ELECTRICAL AND SCIENTIFIC APPARATUS

FOR ELECTRICAL HARDWARE, NAMELY, WIRING, CONDUCTORS, AND TERMINAL CONNECTORS; SPECIFICALLY NOT INCLUDING GOODS SOLD OR DISTRIBUTED IN THE AFTERMARKET AUTO PARTS INDUSTRY, SUCH INDUSTRY SPECIFICALLY INCLUDING, BUT NOT LIMITED TO, RETAIL AND WHOLESALE AUTOMOTIVE PARTS STORES (U.S. CLS. 21, 23, 26, 36 AND 38).

FIRST USE 10-31-2002; IN COMMERCE 10-31-2002.

CLASS 17—RUBBER GOODS

FOR ELECTRICAL TAPE; POLYMER BASED PATCHING, FILLING AND SEALING COMPOUNDS FOR METAL, WOOD, COMPOSITION AND PLASTIC SURFACES; SEALING COMPOUNDS FOR PAVEMENT; SPECIFICALLY NOT INCLUDING GOODS SOLD OR DISTRIBUTED IN THE AFTERMARKET AUTO PARTS INDUSTRY, SUCH INDUSTRY SPECIFICALLY INCLUDING, BUT NOT LIMITED TO, RETAIL AND WHOLESALE AUTOMOTIVE PARTS STORES (U.S. CLS. 1, 5, 12, 13, 35 AND 50).

FIRST USE 10-31-2002; IN COMMERCE 10-31-2002.

KATHLEEN LORENZO, EXAMINING ATTORNEY

SN 85-453,701. GLOVER II, DONALD, LOS ANGELES, CA. FILED 10-21-2011.

CHILDISH GAMBINO

THE MARK CONSISTS OF STANDARD CHARACTERS WITHOUT CLAIM TO ANY PARTICULAR FONT, STYLE, SIZE, OR COLOR.

CLASS 9—ELECTRICAL AND SCIENTIFIC APPARATUS

FOR AUDIO AND VIDEO RECORDINGS FEATURING MUSIC AND ARTISTIC PERFORMANCES (U.S. CLS. 21, 23, 26, 36 AND 38).

FIRST USE 1-31-2010; IN COMMERCE 1-31-2010.

CLASS 14—JEWELRY

FOR JEWELRY (U.S. CLS. 2, 27, 28 AND 50).

CLASS 16—PAPER GOODS AND PRINTED MATTER

FOR CALENDARS; POSTERS; PRINTED PERIODICALS IN THE FIELD OF MUSIC (U.S. CLS. 2, 5, 22, 23, 29, 37, 38 AND 50).

FIRST USE 1-31-2010; IN COMMERCE 1-31-2010.

CLASS 25—CLOTHING

FOR CAPS; HOODED SWEATSHIRTS; KNIT SHIRTS; KNITTED CAPS; SHIRTS; SWEATSHIRTS; T-SHIRTS (U.S. CLS. 22 AND 39).
FIRST USE 1-31-2010; IN COMMERCE 1-31-2010.

CLASS 41—EDUCATION AND ENTERTAINMENT

FOR ENTERTAINMENT SERVICES IN THE NATURE OF LIVE MUSICAL PERFORMANCES; ENTERTAINMENT SERVICES, NAMELY, LIVE, TELEVISED AND MOVIE APPEARANCES BY A PROFESSIONAL ENTERTAINER (U.S. CLS. 100, 101 AND 107).
FIRST USE 1-31-2010; IN COMMERCE 1-31-2010.
LAURIE MAYES, EXAMINING ATTORNEY

SN 85-454,853. TMI HOSPITALITY, INC., FARGO, ND. FILED 10-24-2011.



THE COLOR(S) WHITE, GREEN AND BLUE IS/ARE CLAIMED AS A FEATURE OF THE MARK.
THE MARK CONSISTS OF THE REPRESENTATION OF THE LETTERS "TMI"; A CURVED BAND APPEARS AT THE TOP IN COLOR BLUE; A PARTIAL SQUARE IN THE COLOR BLUE IS LOCATED UNDERNEATH WITH A GREEN, VERTICAL RECTANGLE AND WHITE SQUARE LOCATED WHERE THE PARTIAL SQUARE AND RECTANGLE INTERSECT.

SN 85-453,716. SMITH & HOOK WINERY, INC., SOLEDAD, CA. FILED 10-21-2011.



NO CLAIM IS MADE TO THE EXCLUSIVE RIGHT TO USE "LIMITED PRODUCTION", APART FROM THE MARK AS SHOWN.
THE MARK CONSISTS OF THE IMAGE OF A SKULL COMPRISED OF A BICYCLE, VINES AND BICYCLE CHAIN LINKS AND PARTS. THE WORD "BONESHAKER" APPEARS IN THE TOP PORTION OF THE DESIGN AND THE WORDING "PRODUCED & BOTTLED IN LODI", "LIMITED PRODUCTION" AND "ZINFANDEL" APPEAR IN THE BOTTOM PORTION OF THE DESIGN.

CLASS 24—FABRICS

FOR HANDKERCHIEFS (U.S. CLS. 42 AND 50).

CLASS 25—CLOTHING

FOR CLOTHING, NAMELY, JACKETS, SHIRTS (U.S. CLS. 22 AND 39).
AHSEN KHAN, EXAMINING ATTORNEY

CLASS 35—ADVERTISING AND BUSINESS

FOR HOTEL AND MOTEL MANAGEMENT FOR OTHERS (U.S. CLS. 100, 101 AND 102).

CLASS 43—HOTEL AND RESTAURANT SERVICES

FOR HOTEL ACCOMMODATION SERVICES (U.S. CLS. 100 AND 101).
CHRISTOPHER BUONGIORNO, EXAMINING ATTORNEY

SN 85-454,876. TMI HOSPITALITY, INC., FARGO, ND. FILED 10-24-2011.

TMI HOSPITALITY

THE MARK CONSISTS OF STANDARD CHARACTERS WITHOUT CLAIM TO ANY PARTICULAR FONT, STYLE, SIZE, OR COLOR.
NO CLAIM IS MADE TO THE EXCLUSIVE RIGHT TO USE "HOSPITALITY", APART FROM THE MARK AS SHOWN.

CLASS 35—ADVERTISING AND BUSINESS

FOR HOTEL AND MOTEL MANAGEMENT FOR OTHERS (U.S. CLS. 100, 101 AND 102).

CLASS 43—HOTEL AND RESTAURANT SERVICES

FOR HOTEL ACCOMMODATION SERVICES (U.S. CLS. 100 AND 101).
CHRISTOPHER BUONGIORNO, EXAMINING ATTORNEY

SN 85-456,289. SNCC LEGACY PROJECT, INC., WASHINGTON, DC. FILED 10-26-2011.

SNCC

THE MARK CONSISTS OF STANDARD CHARACTERS WITHOUT CLAIM TO ANY PARTICULAR FONT, STYLE, SIZE, OR COLOR.

CLASS 35—ADVERTISING AND BUSINESS

FOR PUBLIC ADVOCACY SERVICES TO PROMOTE AWARENESS OF CIVIL RIGHTS, HUMAN RIGHTS, AND INTERNATIONAL STRUGGLES FOR LIBERATION AND PEACE (U.S. CLS. 100, 101 AND 102).
FIRST USE 4-15-2009; IN COMMERCE 4-15-2010.

CLASS 36—INSURANCE AND FINANCIAL

FOR CHARITABLE FUNDRAISING SERVICES, NAMELY, RAISING FUNDS TO PROMOTE CAUSES RELATED TO CIVIL RIGHTS, HUMAN RIGHTS, AND INTERNATIONAL STRUGGLES FOR LIBERATION AND PEACE (U.S. CLS. 100, 101 AND 102).
FIRST USE 4-15-2009; IN COMMERCE 4-15-2010.

CLASS 41—EDUCATION AND ENTERTAINMENT

FOR EDUCATION SERVICES, NAMELY, PROVIDING CLASSES, SEMINARS, CONFERENCES, WORKSHOPS, EXHIBITIONS, DISPLAYS, WEB SITES, AND INTERACTIVE EXHIBITS IN THE FIELD OF CIVIL RIGHTS, HUMAN RIGHTS, AND INTERNATIONAL STRUGGLES FOR LIBERATION AND PEACE (U.S. CLS. 100, 101 AND 107).
FIRST USE 4-15-2009; IN COMMERCE 4-15-2010.
GIANCARLO CASTRO, EXAMINING ATTORNEY

SN 85-456,527. WALGREEN CO., DEERFIELD, IL. FILED 10-26-2011.

LIVING SOLUTIONS

THE MARK CONSISTS OF STANDARD CHARACTERS WITHOUT CLAIM TO ANY PARTICULAR FONT, STYLE, SIZE, OR COLOR.
OWNER OF U.S. REG. NOS. 2,794,947, 3,710,088 AND 3,713,282.

CLASS 6—METAL GOODS

FOR BASKETS, NAMELY, BASKETS OF COMMON METALS; ADHESIVE HOOKS, NAMELY, METAL HOOKS; BOTTLE STOPPERS, NAMELY, METAL BOTTLE STOPPERS (U.S. CLS. 2, 12, 13, 14, 23, 25 AND 50).

CLASS 11—ENVIRONMENTAL CONTROL APPARATUS

FOR ELECTRIC COFFEE PERCOLATORS; ELECTRIC COFFEE WARMERS; HOT PLATES; SANDWICH MAKERS, NAMELY, ELECTRIC SANDWICH MAKERS; BLANKETS, NAMELY, ELECTRIC BLANKETS (U.S. CLS. 13, 21, 23, 31 AND 34).

CLASS 16—PAPER GOODS AND PRINTED MATTER

FOR SHELF LINER, NAMELY, SELF-ADHESIVE PLASTIC OR PAPER SHEETS FOR LINING SHELVES; COASTERS, NAMELY, COASTERS MADE OF PAPER; PLASTIC OR PAPER BAGS FOR HOUSEHOLD USE (U.S. CLS. 2, 5, 22, 23, 29, 37, 38 AND 50).

CLASS 20—FURNITURE AND ARTICLES NOT OTHERWISE CLASSIFIED

FOR INFLATABLE BEDDING, NAMELY, INFLATABLE BEDS FOR INDOOR AND OUTDOOR USE; BAG CLIPS, NAMELY, PLASTIC CLIPS FOR SEALING BAGS; HANGERS FOR CLOTHES; CLOSET ORGANIZER ACCESSORIES, NAMELY, SHOE RACKS, BELT RACKS, SHELVES, CLOTHES BARS AND SLIDING CLOTHING RAILS; MIRRORS; ADHESIVE HOOKS, NAMELY, NON-METAL HOOKS; LAWN FURNITURE; DECK CHAIRS; FOLDING CHAIRS; LOUNGE CHAIRS; BEACH CHAIRS; TABLES; WIND CHIMES; NON-METAL LANDSCAPE EDGING; SCULPTURES OF MOLDED PLASTIC; BOTTLE STOPPERS, NAMELY, NON-METALLIC BOTTLE STOPPERS; PILLOWS (U.S. CLS. 2, 13, 22, 25, 32 AND 50).

CLASS 21—HOUSEWARES AND GLASS

FOR COFFEE CUPS, COFFEE STIRRERS; KETTLES; HOT POTS; CORKSCREWS; BOTTLE OPENERS; BOTTLE STOPPERS, NAMELY, BOTTLE STOPPERS SPECIALLY ADAPTED FOR USE WITH WINE BOTTLES; SLOTTED TURNERS; SPATULAS; SCRAPERS; LADLES FOR KITCHEN USE; PASTA SERVING FORKS; BARBECUE UTENSILS, NAMELY, FORKS, TONGS AND TURNERS; COOKING UTENSILS, NAMELY, TONGS; NYLON KITCHEN TOOLS, NAMELY, POURING AND STRAINING SPOUTS; COOKING/KITCHEN UTENSIL CADDIES; BASKETS, NAMELY, BASKETS FOR DOMESTIC USE, NOT OF METAL; LINT ROLLERS; LINT BRUSHES; BEVERAGE GLASSWARE; CHARMS FOR ATTACHMENT TO BEVERAGE GLASSWARE FOR IDENTIFICATION PURPOSES; COLANDERS; CUTTING BOARDS; SALAD SPINNER/SERVERS; SCOOPS; ICE CREAM SCOOPS; COOKIE CUTTERS; SERVING WARE FOR SERVING FOOD AND DRINKS; SERVING TRAYS; CHARGER PLATES; TRIVETS; NAPKIN RINGS; BUFFET SERVERS, NAMELY, SERVING TRAYS, SERVING SPOONS AND SERVING FORKS; EGG HOLDERS, NAMELY, PLASTIC OR CERAMIC EGG HOLDERS FOR DOMESTIC USE; SALT AND PEPPER SHAKERS; SPOON RESTS; TOOTHPICK HOLDERS; COOKWARE, NAMELY, POTS AND PANS; BAKEWARE, NAMELY, COOKIE SHEETS, CAKE PANS, LOAF PANS, CUPCAKE PANS; COOKIE TINS; SHAPED TIN CONTAINERS SOLD EMPTY FOR DOMESTIC USE; CANDY BAGS SOLD EMPTY; CANDY DISHES; MUGS AND CUPS; SHOT GLASSES; DINNERWARE, NAMELY, PLATES, CUPS, SAUCERS AND BOWLS; DISH DRYING RACK; LUNCH BOXES; PLASTIC STORAGE CONTAINERS FOR HOUSEHOLD USE; CERAMIC STORAGE CANISTERS; PITCHERS; JARS OF GLASS OR PLASTIC; PORTABLE COOLERS; PARTY TUBS FOR COOLING BEVERAGES; REUSABLE PLASTIC ICE CUBES IN A VARIETY OF SHAPES; INDIVIDUAL INSULATED BEVERAGE CAN COOLERS, NAMELY, INSULATING SLEEVE HOLDERS FOR BEVERAGE CANS; JUGS; PORTABLE BEVERAGE DISPENSERS, NAMELY, DESKTOP WATER DISPENSERS; COASTERS, NAMELY, COASTERS NOT OF PAPER OR TABLE LINEN; JAR OPENERS; REUSABLE PLASTIC WATER BOTTLES SOLD EMPTY; REUSABLE STAINLESS STEEL WATER BOTTLES SOLD EMPTY; THERMAL INSULATED CONTAINERS FOR FOOD OR BEVERAGES; PLASTIC ICE POP FORMS; NON-ELECTRIC FOOD BLENDERS FOR HOUSEHOLD USE; IRONING BOARDS; IRONING BOARD COVERS; BIRD HOUSES; BIRD BATHS; LAWN SPRINKLERS; FLOWER POTS; CLAY POTS; HOSE NOZZLES; MOUSE TRAPS; INSECT TRAPS; BOOT BRUSHES; SHOE BRUSHES; LIQUID SOAP AND LOTION DISPENSERS SOLD EMPTY; STORAGE CONTAINERS MADE OF PLASTIC FOR HOUSEHOLD OR DOMESTIC USE; PLASTIC STRAWS, NAMELY, DRINKING STRAWS (U.S. CLS. 2, 13, 23, 29, 30, 33, 40 AND 50).

CLASS 22—CORDAGE AND FIBERS

FOR BAGS FOR THE STORAGE OF CLOTHING (U.S. CLS. 1, 2, 7, 19, 22, 42 AND 50).

CLASS 24—FABRICS

FOR TOWELS; DISH CLOTHS; POTHOLDERS; OVEN MITTS; BARBECUE MITTS; CLOTH NAPKINS; BLANKETS, NAMELY, BED BLANKETS AND BLANKET THROWS; TABLECLOTHS, NOT OF PAPER; PLACE-MATS, NOT OF PAPER; COASTERS, NAMELY, COASTERS OF TEXTILE (U.S. CLS. 42 AND 50).

CLASS 25—CLOTHING

FOR APRONS; AND INSULATED TRAINING SUITS (U.S. CLS. 22 AND 39).

CLASS 27—FLOOR COVERINGS

FOR RUGS (U.S. CLS. 19, 20, 37, 42 AND 50).

CLASS 28—TOYS AND SPORTING GOODS

FOR ARTIFICIAL CHRISTMAS TREES; PRE-LIT ARTIFICIAL CHRISTMAS TREES; ARTIFICIAL FIBER OPTIC CHRISTMAS TREES; YOGA MATS; JUMP ROPES; HAND GRIPS FOR SPORTING EQUIPMENT; AND HAND WEIGHTS (U.S. CLS. 22, 23, 38 AND 50).

CLASS 31—NATURAL AGRICULTURAL PRODUCTS

FOR GRASS SEED; PLANT SEEDS; FRUIT AND VEGETABLE SEEDS; FLOWER SEEDS AND BULBS (U.S. CLS. 1 AND 46).
GEORGE LORENZO, EXAMINING ATTORNEY

CLASS 9—ELECTRICAL AND SCIENTIFIC APPARATUS

FOR ELECTRONIC DEVICES FOR HAND HYGIENE COMPLIANCE SYSTEMS, NAMELY, REMOTE ELECTRONIC MONITORING STATIONS CONSISTING OF IDENTIFICATION SENSORS AND DISPLAY SCREENS FOR DETECTING AND DISPLAYING INFORMATION RELATING TO EDUCATION, SUPPLIES, EQUIPMENT, AND PEOPLE, NAMELY, HEALTHCARE WORKERS, PATIENTS, AND VISITORS; WIRED AND WIRELESS NETWORK DEVICES FOR HAND HYGIENE COMPLIANCE SYSTEMS, NAMELY, REMOTE ELECTRONIC MONITORING STATIONS CONSISTING OF IDENTIFICATION SENSORS, DISPLAY SCREENS, AND COMMUNICATIONS CIRCUITRY PROVIDING TWO-WAY COMMUNICATION OF INFORMATION INCLUDING IDENTITY INFORMATION AND CONTEXT-SPECIFIC INFORMATION; BOTH DEVICES FOR USE IN CONNECTION WITH MONITORING HEALTHCARE WORKERS VIA REMOTE ELECTRONIC MONITORING STATIONS TO PROVIDE INFORMATION FOR PURPOSES OF RECORDING COMPLIANCE LEVELS WITH HEALTHCARE FACILITY WORKFLOW PROCEDURES AND TRACKING VIA REMOTE ELECTRONIC MONITORING STATIONS TO PROVIDE OTHERS WITH REAL-TIME INFORMATION RELATING TO LOCATION OF PEOPLE, SUPPLIES, AND EQUIPMENT (U.S. CLS. 21, 23, 26, 36 AND 38).

CLASS 35—ADVERTISING AND BUSINESS

FOR BUSINESS SERVICES, NAMELY, OPERATION AND ADMINISTRATION OF HAND HYGIENE COMPLIANCE SYSTEMS PROVIDING TWO-WAY COMMUNICATION OF INFORMATION VIA REMOTE ELECTRONIC MONITORING STATIONS; BUSINESS ASSET MANAGEMENT CONSULTING SERVICES IN THE FIELD OF MONITORING HEALTHCARE WORKERS VIA REMOTE ELECTRONIC MONITORING STATIONS TO PROVIDE INFORMATION FOR PURPOSES OF RECORDING COMPLIANCE LEVELS WITH HEALTHCARE FACILITY WORKFLOW PROCEDURES (U.S. CLS. 100, 101 AND 102).
BRENDAN MCCAULEY, EXAMINING ATTORNEY

SN 85-457,451. ALCOHOLICS ANONYMOUS WORLD SERVICES, INC., NEW YORK, NY. FILED 10-27-2011.

SN 85-457,058. PROVENTIX SYSTEMS, INC., BIRMINGHAM, AL. FILED 10-26-2011.

TEAM ASSIST

THE MARK CONSISTS OF STANDARD CHARACTERS WITHOUT CLAIM TO ANY PARTICULAR FONT, STYLE, SIZE, OR COLOR.

A.A.W.S.

THE MARK CONSISTS OF STANDARD CHARACTERS WITHOUT CLAIM TO ANY PARTICULAR FONT, STYLE, SIZE, OR COLOR.

CLASS 9—ELECTRICAL AND SCIENTIFIC APPARATUS

FOR DOWNLOADABLE ELECTRONIC PUBLICATIONS IN THE NATURE OF ELECTRONIC BOOKS IN THE FIELDS OF ALCOHOLISM, ALCOHOL AND ADDICTION; COMPUTER SOFTWARE FOR USE IN CREATING AND ACCESSING SEARCHABLE DATABASES OF INFORMATION AND DATA FOR ELECTRONIC BOOKS; COMPUTER SOFTWARE FOR USE IN CREATING AND ACCESSING SEARCHABLE DATABASES OF INFORMATION AND DATA FOR ELECTRONIC BOOKS THAT MAY BE DOWNLOADED FROM A GLOBAL COMPUTER NETWORK (U.S. CLS. 21, 23, 26, 36 AND 38).

CLASS 35—ADVERTISING AND BUSINESS

FOR ON-LINE RETAIL STORE SERVICES FEATURING BOOKS, MAGAZINES, PAMPHLETS, NEWSLETTERS IN THE FIELDS OF ALCOHOLISM, ALCOHOL AND ADDICTION (U.S. CLS. 100, 101 AND 102).
TRACY FLETCHER, EXAMINING ATTORNEY

SN 85-457,843. FUNDACIÓN PARA LA INVESTIGACIÓN BIOMÉDICA DEL HOSPITAL UNIVERSITARIO LA PAZ, E-28046 MADRID, SPAIN, FILED 10-27-2011.

SN 85-457,648. J.R. SIMPLOT COMPANY, BOISE, ID. FILED 10-27-2011.

INFLUENCE THE ACRE

THE MARK CONSISTS OF STANDARD CHARACTERS WITHOUT CLAIM TO ANY PARTICULAR FONT, STYLE, SIZE, OR COLOR.

CLASS 42—SCIENTIFIC AND COMPUTER SERVICES

FOR TECHNOLOGICAL SERVICES TO AGRICULTURAL GROWERS AND PRODUCERS, NAMELY, MAPPING OF TOPOGRAPHY AND ACREAGE OF AGRICULTURAL FIELDS USING GLOBAL POSITIONING SYSTEMS AND GEOGRAPHIC INFORMATION SYSTEMS, AIRBORNE AND GROUND-BASED VISIBLE CAMERAS, AND IMAGING SPECTROMETERS, TO MEASURE AND ANALYZE PHYSICAL PROPERTIES RELEVANT TO CROP PRODUCTION, NAMELY, SOIL CONDITION ANALYSIS, FERTILITY ANALYSIS, CROP ANALYSIS, CROP YIELD ANALYSIS, CROP PRODUCTION ANALYSIS, IRRIGATION AND WATER FLOW ANALYSIS, AND FIELD ANALYSIS; TECHNOLOGICAL SERVICES IN THE FIELD OF AGRICULTURE, NAMELY, PERFORMING SOIL AND PLANT TISSUE SAMPLING FOR ANALYSIS PURPOSES; TECHNICAL AGRICULTURAL SERVICES, NAMELY, PROVIDING TECHNICAL INFORMATION TO AGRICULTURAL GROWERS AND PRODUCERS IN THE FIELD OF TESTING AND ANALYSIS OF SOIL CHARACTERISTICS, INCLUDING NUTRIENTS, FERTILITY, MOISTURE-HOLDING CAPACITY, TEXTURE, TOPOGRAPHY, AND ACREAGE, IN ORDER TO ASSIST AGRICULTURAL GROWERS AND PRODUCERS IN GROWING, MANAGING AND IMPROVING CROP PRODUCTION (U.S. CLS. 100 AND 101).

CLASS 44—MEDICAL, BEAUTY AND AGRICULTURAL SERVICES

FOR PROVIDING AGRICULTURAL ADVICE; AGRICULTURAL CONSULTING AND ADVISORY SERVICES TO AGRICULTURAL GROWERS AND PRODUCERS IN THE FIELD OF PLANTING, PLANT AND SEED NUTRITION, PLANT AND CROP HEALTH, CROP PROTECTION, FERTILITY MANAGEMENT, AND SOIL CONDITIONS; AGRICULTURAL ADVISORY AND CONSULTING SERVICES TO ASSIST AGRICULTURAL GROWERS AND PRODUCERS IN MANAGING AND IMPROVING THEIR CROPS (U.S. CLS. 100 AND 101).
AMY ALFIERI, EXAMINING ATTORNEY



PRIORITY CLAIMED UNDER SEC. 44(D) ON ERPN CMNTY TM OFC APPLICATION NO. 009969064, FILED 5-16-2011, REG. NO. 009969064, DATED 9-15-2011, EXPIRES 5-16-2021.

THE COLOR(S) ORANGE, BLUE AND WHITE IS/ARE CLAIMED AS A FEATURE OF THE MARK.

THE MARK CONSISTS OF TWO ROWS OF FOUR ORANGE SQUARES ABOVE A ROW OF THREE ORANGE SQUARES AND ONE BLUE CIRCLE ON WHITE BACKGROUND ABOVE A ROW OF FOUR ORANGE SQUARES ABOVE "ONCO" IN ORANGE AND "SEQ" IN BLUE. THE COLOR WHITE ALSO APPEARS AS BACKGROUND BETWEEN THE SIXTEEN SQUARES.

CLASS 9—ELECTRICAL AND SCIENTIFIC APPARATUS

FOR SCIENTIFIC APPARATUS AND INSTRUMENTS, NAMELY, MICROARRAY FOR GENETIC AND GENOMIC DATA; APPARATUS FOR RECORDING, TRANSMITTING, REPRODUCING SOUNDS OR IMAGES, NAMELY, SUPPORT FOR BIOLOGICAL INTENSITY IMAGES IN THE NATURE OF COMPUTER CHIPS WHICH CONTAIN BIOLOGICAL AND GENETIC INFORMATION ON PATIENTS, AND COMPUTERS WHICH PROCESS THESE COMPUTER CHIPS IN ORDER TO PROVIDE INFORMATION REGARDING DISEASES AND PREVENTATIVE TREATMENT (U.S. CLS. 21, 23, 26, 36 AND 38).

CLASS 42—SCIENTIFIC AND COMPUTER SERVICES

FOR SCIENTIFIC AND TECHNOLOGICAL SERVICES, AND RESEARCH AND DESIGN SERVICES RELATED THERETO, NAMELY, FOR THE DEVELOPMENT AND USE OF A MICROARRAY AND COMPUTER CHIP TOOL WHICH IS USED TO PROCESS AND PROVIDE INFORMATION ABOUT THE BIOLOGICAL AND GENETIC INFORMATION OF A PATIENT AS WELL AS DISEASES AND PREVENTATIVE TREATMENT (U.S. CLS. 100 AND 101).

WILLIAM VERHOSEK, EXAMINING ATTORNEY

SN 85-458,226. SALVATION, LLC, TUCSON, AZ. FILED 10-27-2011.

DON'T BLAME ME...BLAME JAMES

THE MARK CONSISTS OF STANDARD CHARACTERS WITHOUT CLAIM TO ANY PARTICULAR FONT, STYLE, SIZE, OR COLOR.

CLASS 16—PAPER GOODS AND PRINTED MATTER

FOR WINDOW STICKERS (U.S. CLS. 2, 5, 22, 23, 29, 37, 38 AND 50).

CLASS 25—CLOTHING

FOR T-SHIRTS (U.S. CLS. 22 AND 39), ELLEN BURNS, EXAMINING ATTORNEY

SN 85-460,143. DETTERBERG GROUP APS, DK-2620 ALBERTSLUND, DENMARK, FILED 10-31-2011.

INIMOVE DENMARK

THE MARK CONSISTS OF STANDARD CHARACTERS WITHOUT CLAIM TO ANY PARTICULAR FONT, STYLE, SIZE, OR COLOR.

NO CLAIM IS MADE TO THE EXCLUSIVE RIGHT TO USE "DENMARK", APART FROM THE MARK AS SHOWN.

CLASS 10—MEDICAL APPARATUS

FOR MANUALLY-OPERATED EXERCISE EQUIPMENT FOR PHYSICAL THERAPY PURPOSES (U.S. CLS. 26, 39 AND 44).

CLASS 28—TOYS AND SPORTING GOODS

FOR MANUALLY-OPERATED EXERCISE EQUIPMENT FOR PHYSICAL FITNESS PURPOSES (U.S. CLS. 22, 23, 38 AND 50).

JESSICA FATHY, EXAMINING ATTORNEY

SN 85-460,672. MOTIVATING GRAPHICS, LLC, FORT WORTH, TX. FILED 10-31-2011.

MOTIVATINGGRAPHICS INC.

THE MARK CONSISTS OF STANDARD CHARACTERS WITHOUT CLAIM TO ANY PARTICULAR FONT, STYLE, SIZE, OR COLOR.

NO CLAIM IS MADE TO THE EXCLUSIVE RIGHT TO USE "INC.", APART FROM THE MARK AS SHOWN.

CLASS 16—PAPER GOODS AND PRINTED MATTER

FOR PACKAGING MATERIALS, NAMELY, CARDBOARD AND PAPER PULP TRAYS AND CONTAINERS (U.S. CLS. 2, 5, 22, 23, 29, 37, 38 AND 50).

FIRST USE 1-1-1976; IN COMMERCE 1-1-1976.

CLASS 20—FURNITURE AND ARTICLES NOT OTHERWISE CLASSIFIED

FOR PACKAGING MATERIALS, NAMELY, CORRUGATED PLASTIC BOXES AND CONTAINER TRAYS, AND THERMOFORMED PLASTIC CONTAINERS (U.S. CLS. 2, 13, 22, 25, 32 AND 50).

FIRST USE 1-1-1976; IN COMMERCE 1-1-1976.

DEIRDRE ROBERTSON, EXAMINING ATTORNEY

SN 85-460,898. MY OCEAN LIFE, LLC, ISLE OF PALMS, SC. FILED 10-31-2011.

MY OCEAN LIFE

THE MARK CONSISTS OF STANDARD CHARACTERS WITHOUT CLAIM TO ANY PARTICULAR FONT, STYLE, SIZE, OR COLOR.

CLASS 16—PAPER GOODS AND PRINTED MATTER

FOR SERIES OF BOOKS IN THE FIELDS OF OCEAN-SPORTS LIFESTYLE (U.S. CLS. 2, 5, 22, 23, 29, 37, 38 AND 50).

CLASS 41—EDUCATION AND ENTERTAINMENT

FOR ENTERTAINMENT SERVICES, NAMELY, A CONTINUING VARIETY SHOW ON WATER SPORTS, TRAVEL AND AN OCEAN-SPORTS LIFESTYLE BROADCAST VIA TELEVISION OR THE INTERNET; ONLINE JOURNALS FEATURING BLOGS IN THE FIELDS OF OCEAN-SPORTS LIFESTYLE (U.S. CLS. 100, 101 AND 107).

RUSS HERMAN, EXAMINING ATTORNEY

SN 85-461,393. WKI HOLDING COMPANY, INC., ROSEMONT, IL. FILED 11-1-2011.

Belmont

THE MARK CONSISTS OF STANDARD CHARACTERS WITHOUT CLAIM TO ANY PARTICULAR FONT, STYLE, SIZE, OR COLOR.

CLASS 8—HAND TOOLS

FOR CUTLERY, NAMELY, CARVING KNIVES, CHEF'S KNIVES, UTILITY KNIVES, STEAK KNIVES, BREAD KNIVES, SANTOKU KNIVES, PARING KNIVES, AND PEELING KNIVES (U.S. CLS. 23, 28 AND 44).

CLASS 21—HOUSEWARES AND GLASS

FOR KNIFE STORAGE BLOCKS (U.S. CLS. 2, 13, 23, 29, 30, 33, 40 AND 50);
SHANNON TWOHIG, EXAMINING ATTORNEY

SN 85-461,841. TAPSENSE, INC., SAN FRANCISCO, CA.
FILED 11-1-2011.

SN 85-461,445. MICHAELS STORES PROCUREMENT COMPANY, INC., IRVING, TX. FILED 11-1-2011.

TAPSENSE

IMAGIN8

THE MARK CONSISTS OF STANDARD CHARACTERS WITHOUT CLAIM TO ANY PARTICULAR FONT, STYLE, SIZE, OR COLOR.

THE MARK CONSISTS OF STANDARD CHARACTERS WITHOUT CLAIM TO ANY PARTICULAR FONT, STYLE, SIZE, OR COLOR.

OWNER OF U.S. REG. NO. 3,544,161.

CLASS 35—ADVERTISING AND BUSINESS

FOR ADVERTISING AGENCY SERVICES; DISSEMINATION AND PLACEMENT OF ADVERTISING FOR OTHERS VIA ELECTRONIC AND OPTICAL COMMUNICATIONS NETWORKS; ADVERTISING SERVICES, NAMELY, TRACKING, ADMINISTERING, BILLING, AND REPORTING OF ONLINE, MOBILE, AND SOCIAL ADVERTISING; PROVIDING ADVERTISING DATA REPORTS, ADVERTISEMENT TARGETING, AND BUSINESS MANAGEMENT OF ELECTRONICALLY STORED ADVERTISING; MEDIA PLANNING FOR THIRD PARTIES, NAMELY, ADVISING THE CLIENT ON THE TIMES AND CHANNELS TO ADVERTISE; MEDIA BUYING FOR THIRD PARTIES, NAMELY, ADVISING THE CLIENT ON THE TIMES, AMOUNTS AND CHANNELS FOR PURCHASING ADVERTISING; EVALUATING SOCIAL MEDIA DATA AND INFORMATION FOR OTHERS FOR ADVERTISING AND MARKETING PURPOSES; CONSULTING SERVICES IN THE FIELDS OF BUSINESS, ADVERTISING AND MARKETING (U.S. CLS. 100, 101 AND 102).

CLASS 18—LEATHER GOODS

FOR PET CLOTHING (U.S. CLS. 1, 2, 3, 22 AND 41).

CLASS 25—CLOTHING

FOR BANDANAS; SHOES; SLIPPERS; GLOVES; WRIST WARMERS; SCARVES; HEADBANDS; NECK TIES; BABY CREEPERS; BABY BIBS NOT OF PAPER; SOCKS; SWEATSHIRTS; APRONS; SHORTS; PANTS (U.S. CLS. 22 AND 39).

TRACY CROSS, EXAMINING ATTORNEY

CLASS 38—COMMUNICATION

FOR ELECTRONIC MESSAGE AND DATA TRANSMISSION; ELECTRONIC, ELECTRIC, AND DIGITAL TRANSMISSION OF VOICE, DATA, IMAGES, SIGNALS, AND MESSAGES VIA COMPUTERS, MOBILE PHONES, TABLET COMPUTERS, WIRED AND WIRELESS COMMUNICATION DEVICES, AND OPTICAL AND ELECTRONIC COMMUNICATIONS NETWORKS; PROVIDING NEWS AND INFORMATION RELATING TO MOBILE PHONE COMMUNICATIONS AND COMMUNICATIONS VIA WIRED AND WIRELESS COMMUNICATION DEVICES (U.S. CLS. 100, 101 AND 104).

SN 85-461,725. PREFERRED GUEST, INC., STAMFORD, CT.
FILED 11-1-2011.

SPG LIFETIME

THE MARK CONSISTS OF STANDARD CHARACTERS WITHOUT CLAIM TO ANY PARTICULAR FONT, STYLE, SIZE, OR COLOR.

OWNER OF U.S. REG. NOS. 3,195,926, 3,528,063 AND OTHERS.

NO CLAIM IS MADE TO THE EXCLUSIVE RIGHT TO USE "LIFETIME", APART FROM THE MARK AS SHOWN.

CLASS 41—EDUCATION AND ENTERTAINMENT

FOR PROVIDING NEWS AND INFORMATION RELATING TO GAMES FOR MOBILE PHONES AND TABLETS (U.S. CLS. 100, 101 AND 107).

CLASS 35—ADVERTISING AND BUSINESS

FOR ADMINISTRATION OF CUSTOMER LOYALTY PROGRAMS IN THE HOTEL AND RESORT FIELDS, WHICH PROVIDE FREE OR DISCOUNTED HOTEL ROOMS, FOOD, BEVERAGE AND RECREATION CREDITS TO FREQUENT GUESTS AT PARTICIPATING HOTELS OR RESORTS THROUGH THE ISSUANCE AND PROCESSING OF LOYALTY POINTS TO FREQUENT GUESTS (U.S. CLS. 100, 101 AND 102).

CLASS 42—SCIENTIFIC AND COMPUTER SERVICES

FOR PROVIDING TEMPORARY USE OF NONDOWNLOADABLE COMPUTER SOFTWARE FOR USE IN POSTING, TRANSMITTING, RETRIEVING, RECEIVING, REVIEWING, ORGANIZING, SEARCHING AND MANAGING TEXT, AUDIO, MESSAGES, VISUAL AND MULTIMEDIA DATA AND CONTENT VIA COMPUTERS, MOBILE PHONES, TABLET COMPUTERS, WIRED AND WIRELESS COMMUNICATION DEVICES, AND OPTICAL AND ELECTRONIC COMMUNICATIONS NETWORKS; PROVIDING NEWS AND INFORMATION RELATING TO MOBILE PHONE TECHNOLOGY, MOBILE COMPUTING TECHNOLOGY, TABLET COMPUTING TECHNOLOGY, AND SOFTWARE APPLICATIONS FOR MOBILE PHONES AND TABLETS (U.S. CLS. 100 AND 101).

CLASS 43—HOTEL AND RESTAURANT SERVICES

FOR HOTEL SERVICES (U.S. CLS. 100 AND 101).
DAVID COLLIER, EXAMINING ATTORNEY

KATHERINE CHANG, EXAMINING ATTORNEY

SN 85-461,945. NEOLOGY, INC., POWAY, CA. FILED 11-1-2011.

WATCHPRO

THE MARK CONSISTS OF STANDARD CHARACTERS WITHOUT CLAIM TO ANY PARTICULAR FONT, STYLE, SIZE, OR COLOR.

CLASS 9—ELECTRICAL AND SCIENTIFIC APPARATUS

FOR COMPUTER SOFTWARE PLATFORMS FOR COMPUTER SYSTEMS INTEGRATION IN HETEROGENEOUS AND COMPLEX ENVIRONMENTS IN THE RADIO FREQUENCY IDENTIFICATION (RFID) FIELD (U.S. CLS. 21, 23, 26, 36 AND 38).

CLASS 42—SCIENTIFIC AND COMPUTER SERVICES

FOR COMPUTER SERVICES, NAMELY, COMPUTER SYSTEMS INTEGRATION SERVICES; INTEGRATION OF COMPUTER SOFTWARE INTO MULTIPLE SYSTEMS, NETWORKS, DEVICES, SUBSYSTEMS, MESSAGE PROCESSING; PLATFORM AS A SERVICE (PAAS) FEATURING COMPUTER SOFTWARE PLATFORMS FOR COMPUTER SYSTEMS INTEGRATION IN HETEROGENEOUS AND COMPLEX ENVIRONMENTS IN THE RADIO FREQUENCY IDENTIFICATION (RFID) FIELD (U.S. CLS. 100 AND 101).

BARBARA GAYNOR, EXAMINING ATTORNEY

SN 85-462,220. ALCOHOLICS ANONYMOUS WORLD SERVICES, INC., NEW YORK, NY. FILED 11-2-2011.

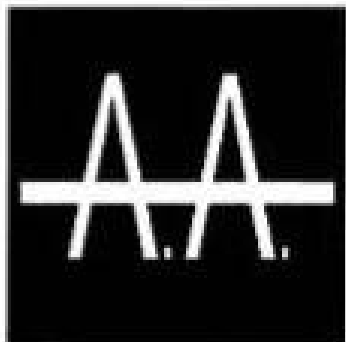

THE MARK CONSISTS OF THE STYLIZED LETTERS "AA", WITH A PERIOD AFTER EACH "A" AND A HORIZONTAL LINE CROSSING THROUGH THE DESIGN, CONNECTING THE LETTERS.

CLASS 9—ELECTRICAL AND SCIENTIFIC APPARATUS

FOR DOWNLOADABLE ELECTRONIC PUBLICATIONS IN THE NATURE OF ELECTRONIC BOOKS IN THE FIELDS OF ALCOHOLISM, ALCOHOL AND ADDICTION; COMPUTER SOFTWARE FOR USE IN CREATING AND ACCESSING SEARCHABLE DATABASES OF INFORMATION AND DATA FOR ELECTRONIC BOOKS; COMPUTER SOFTWARE FOR USE IN CREATING AND ACCESSING SEARCHABLE DATABASES OF INFORMATION AND DATA FOR ELECTRONIC BOOKS THAT MAY BE DOWNLOADED FROM A GLOBAL COMPUTER NETWORK (U.S. CLS. 21, 23, 26, 36 AND 38).

CLASS 35—ADVERTISING AND BUSINESS

FOR ON-LINE RETAIL STORE SERVICES FEATURING BOOKS, MAGAZINES, PAMPHLETS, NEWSLETTERS IN THE FIELDS OF ALCOHOLISM, ALCOHOL AND ADDICTION (U.S. CLS. 100, 101 AND 102).

TRACY FLETCHER, EXAMINING ATTORNEY

SN 85-462,222. VENGROFF WILLIAMS, INC., SARASOTA, FL. FILED 11-2-2011.



THE MARK CONSISTS OF A STYLIZED "V" AND "W" WITH THE WORDS "VENGROFF WILLIAMS" BELOW THE "VW". THE WORDS "VENGROFF" IS SITUATED ABOVE THE WORD "WILLIAMS".

CLASS 35—ADVERTISING AND BUSINESS

FOR THIRD PARTY CUSTOMER DISPUTE MANAGEMENT; THIRD PARTY ACCOUNTS RECEIVABLE SERVICES; RECONCILIATION OF ACCOUNTS ON BEHALF OF OTHERS (U.S. CLS. 100, 101 AND 102).

CLASS 36—INSURANCE AND FINANCIAL

FOR THIRD PARTY DEBT COLLECTIONS (U.S. CLS. 100, 101 AND 102).

ALICIA COLLINS, EXAMINING ATTORNEY

SN 85-462,251. TORAY KABUSHIKI KAISHA (TORAY INDUSTRIES, INC.), TOKYO, JAPAN, FILED 11-2-2011.

CASSIOPEIR

THE MARK CONSISTS OF STANDARD CHARACTERS WITHOUT CLAIM TO ANY PARTICULAR FONT, STYLE, SIZE, OR COLOR.

PRIORITY CLAIMED UNDER SEC. 44(D) ON JAPAN APPLICATION NO. 2011-063030, FILED 9-2-2011.

THE WORDING "CASSIOPEIR" HAS NO MEANING IN A FOREIGN LANGUAGE.

CLASS 5—PHARMACEUTICALS

FOR PHARMACEUTICAL PREPARATIONS AND SUBSTANCES FOR HUMAN USE, NAMELY, FOR THE TREATMENT OF KIDNEY DISEASE AND RENAL FAILURE (U.S. CLS. 6, 18, 44, 46, 51 AND 52).

CLASS 42—SCIENTIFIC AND COMPUTER SERVICES

FOR TESTING, INSPECTION AND RESEARCH OF PHARMACEUTICALS (U.S. CLS. 100 AND 101).
ALAIN LAPTER, EXAMINING ATTORNEY

CLASS 43—HOTEL AND RESTAURANT SERVICES

FOR HOTEL, BAR, RESTAURANT AND CATERING SERVICES (U.S. CLS. 100 AND 101).

CLASS 44—MEDICAL, BEAUTY AND AGRICULTURAL SERVICES

FOR HEALTH SPA SERVICES FOR HEALTH AND WELLNESS OF THE BODY AND SPIRIT, NAMELY, PROVIDING MASSAGE, FACIAL AND BODY TREATMENT SERVICES, COSMETIC BODY CARE SERVICES, NAMELY, MANICURES AND PEDICURES, BODY WAXING SERVICES; HAIR SALON SERVICES (U.S. CLS. 100 AND 101).

INGA ERVIN, EXAMINING ATTORNEY

SN 85-462,337. VENGROFF WILLIAMS, INC., SARASOTA, FL. FILED 11-2-2011.



THE MARK CONSISTS OF A STYLIZED "V" AND "W" WITH THE WORDS "VENGROFF WILLIAMS" TO THE RIGHT OF THE "VW". THE WORD "VENGROFF" IS SITUATED ABOVE THE WORD "WILLIAMS".

CLASS 35—ADVERTISING AND BUSINESS

FOR THIRD PARTY CUSTOMER DISPUTE MANAGEMENT; THIRD PARTY ACCOUNTS RECEIVABLE SERVICES; RECONCILIATION OF ACCOUNTS ON BEHALF OF OTHERS (U.S. CLS. 100, 101 AND 102).

CLASS 36—INSURANCE AND FINANCIAL

FOR THIRD PARTY DEBT COLLECTIONS (U.S. CLS. 100, 101 AND 102).
ALICIA COLLINS, EXAMINING ATTORNEY

SN 85-462,538. COSTA DORADA ASSOCIATES, LTD., MIAMI, FL. FILED 11-2-2011.



THE MARK CONSISTS OF THE WORD "THE" FOLLOWED BY A STYLIZED "Q" AND "C", THE "C" BEING THE FIRST LETTER IN "CLUB".

CLASS 41—EDUCATION AND ENTERTAINMENT

FOR DANCE CLUB SERVICES; NIGHT CLUB RESERVATION SERVICES, NAMELY, ARRANGING FOR ADMISSION TO NIGHT CLUBS AND NIGHT CLUB EVENTS; ARRANGING AND CONDUCTING NIGHT-CLUB ENTERTAINMENT EVENTS; DISC JOCKEY SERVICES (U.S. CLS. 100, 101 AND 107).

SN 85-464,388. BEHAVIORAL SCIENCES RESEARCH PRESS, INC., DALLAS, TX. FILED 11-4-2011.

PSYCHSCORE

THE MARK CONSISTS OF STANDARD CHARACTERS WITHOUT CLAIM TO ANY PARTICULAR FONT, STYLE, SIZE, OR COLOR.

OWNER OF U.S. REG. NO. 2,801,553.
SEC. 2(F).

CLASS 9—ELECTRICAL AND SCIENTIFIC APPARATUS

FOR PRERECORDED AUDIO AND VISUAL TAPES AND COMPUTER PROGRAMS CONTAINING EDUCATIONAL MATTER FOR TRAINING IN THE FIELD OF CAREER DEVELOPMENT (U.S. CLS. 21, 23, 26, 36 AND 38).

FIRST USE 8-22-2000; IN COMMERCE 8-22-2000.

CLASS 16—PAPER GOODS AND PRINTED MATTER

FOR PRINTED MATTER, NAMELY, QUESTIONNAIRES TO DETERMINE PSYCHOLOGICAL ATTRIBUTES FOR SUCCESSFUL CAREER DEVELOPMENT (U.S. CLS. 2, 5, 22, 23, 29, 37, 38 AND 50).

FIRST USE 8-22-2000; IN COMMERCE 8-22-2000.

CLASS 35—ADVERTISING AND BUSINESS

FOR TESTING TO DETERMINE EMPLOYMENT SKILLS IN THE FIELD OF CAREER DEVELOPMENT (U.S. CLS. 100, 101 AND 102).

FIRST USE 8-22-2000; IN COMMERCE 8-22-2000.

CLASS 41—EDUCATION AND ENTERTAINMENT

FOR EDUCATIONAL SERVICES, NAMELY, CONDUCTING CLASSES AND SEMINARS IN THE FIELD OF CAREER DEVELOPMENT (U.S. CLS. 100, 101 AND 107).

FIRST USE 8-22-2000; IN COMMERCE 8-22-2000.
MAUREEN DALL, EXAMINING ATTORNEY

SN 85-465,067. MCP INVESTMENT, LLC, NORCO, CA.
FILED 11-4-2011.

SN 85-465,561. THE TRAVEL CHANNEL, L.L.C., CHEVY
CHASE, MD. FILED 11-6-2011.

TRAVEL MOVES YOU



OWNER OF U.S. REG. NO. 1,800,657.
THE MARK CONSISTS OF "PRO CIRCUIT" IN BLOCK
LETTERING.

CLASS 12—VEHICLES

FOR HIGH PERFORMANCE MOTORCYCLE PARTS,
NAMELY, EXHAUST SYSTEMS COMPRISED OF MUF-
FLERS, EXHAUST PIPES, SILENCERS, SPARK ARRES-
TERS, AND SUSPENSION SYSTEMS COMPRISED OF
SHOCK ABSORBERS, SPRINGS AND SWAY BARS;
MOTORCYCLE PARTS, NAMELY, LAUNCH CON-
TROLS, THROTTLE TUBES, CLUTCH AND BRAKE
LEVERS, CLUTCH COVERS, BRAKE HOSE CLAMP,
CLUTCH PERCH, AXLE BLOCKS, BOLTS, SWIVEL PIPE
SPRINGS, CROSS BAR PADS, FOOT-PEGS, METAL
MOTORCYCLE STANDS (U.S. CLS. 19, 21, 23, 31, 35
AND 44).

FIRST USE 12-27-1996; IN COMMERCE 12-27-1996.

CLASS 16—PAPER GOODS AND PRINTED MATTER

FOR STICKERS AND MOTORCYCLE STICKER KITS
COMPRISED OF STICKERS (U.S. CLS. 2, 5, 22, 23, 29, 37,
38 AND 50).

FIRST USE 12-27-1996; IN COMMERCE 12-27-1996.

CLASS 18—LEATHER GOODS

FOR UMBRELLAS, ALL-PURPOSE SPORT BAGS,
DUFFEL BAGS AND BACKPACKS (U.S. CLS. 1, 2, 3, 22
AND 41).

FIRST USE 12-27-1996; IN COMMERCE 12-27-1996.

CLASS 20—FURNITURE AND ARTICLES NOT OTHERWISE CLASSIFIED

FOR PLASTIC BANNERS (U.S. CLS. 2, 13, 22, 25, 32
AND 50).

FIRST USE 12-27-1996; IN COMMERCE 12-27-1996.

CLASS 25—CLOTHING

FOR CLOTHING, NAMELY, T-SHIRTS, SWEAT-
SHIRTS, TANK TOPS, HATS, BEANIES, MOTORSPORTS
RACING JERSEYS, AND MOTORCYCLE RACING
PANTS (U.S. CLS. 22 AND 39).

FIRST USE 12-27-1996; IN COMMERCE 12-27-1996.

CLASS 37—CONSTRUCTION AND REPAIR

FOR MOTORCYCLE MODIFICATION SERVICES (U.S.
CLS. 100, 103 AND 106).

FIRST USE 12-27-1996; IN COMMERCE 12-27-1996.
WON TEAK OH, EXAMINING ATTORNEY

THE MARK CONSISTS OF STANDARD CHARACTERS
WITHOUT CLAIM TO ANY PARTICULAR FONT, STYLE,
SIZE, OR COLOR.

SEC. 2(F) AS TO "TRAVEL".

CLASS 38—COMMUNICATION

FOR BROADCAST SERVICES, NAMELY, TRANSMIS-
SION OF TELEVISION PROGRAMS VIA TELEVISION,
SATELLITE, WIRELESS, FIBER OPTICS, CABLE, AND A
GLOBAL COMPUTER NETWORK (U.S. CLS. 100, 101
AND 104).

CLASS 41—EDUCATION AND ENTERTAIN- MENT

FOR ENTERTAINMENT SERVICES IN THE NATURE
OF ONGOING TELEVISION PROGRAMS IN THE
FIELDS OF GENERAL HUMAN INTEREST, REALITY-
BASED PROGRAMMING, TRAVEL, EXPLORATION,
GEOGRAPHY, ECOLOGY, ARCHITECTURE, HISTORY,
FOOD AND DRINK, ART, ADVENTURE, SPORTS,
HISTORY, PARANORMAL ACTIVITY, LEISURE AND
LIFESTYLES, DISTRIBUTED THROUGH AUDIO AND
VIDEO MEDIA, NAMELY, TELEVISION, SATELLITE,
WIRELESS, FIBER OPTICS, CABLE, RADIO AND A
GLOBAL COMPUTER NETWORK; PROVIDING ENTER-
TAINMENT INFORMATION REGARDING TELEVISION
PROGRAMS VIA A GLOBAL COMPUTER NETWORK
AND MOBILE NETWORK (U.S. CLS. 100, 101 AND 107).

RONALD MCMORROW, EXAMINING ATTORNEY

SN 85-465,562. THE TRAVEL CHANNEL, L.L.C., CHEVY
CHASE, MD. FILED 11-6-2011.

TRAVEL CHANNEL MOVES YOU

THE MARK CONSISTS OF STANDARD CHARACTERS
WITHOUT CLAIM TO ANY PARTICULAR FONT, STYLE,
SIZE, OR COLOR.

OWNER OF U.S. REG. NOS. 1,982,443, 3,686,637 AND
OTHERS.

SEC. 2(F) AS TO "TRAVEL CHANNEL".

CLASS 38—COMMUNICATION

FOR BROADCAST SERVICES, NAMELY, TRANSMIS-
SION OF TELEVISION PROGRAMS VIA TELEVISION,
SATELLITE, WIRELESS, FIBER OPTICS, CABLE, AND A
GLOBAL COMPUTER NETWORK (U.S. CLS. 100, 101
AND 104).

CLASS 41—EDUCATION AND ENTERTAINMENT

FOR ENTERTAINMENT SERVICES IN THE NATURE OF ONGOING TELEVISION PROGRAMS IN THE FIELDS OF GENERAL HUMAN INTEREST, REALITY-BASED PROGRAMMING, TRAVEL, EXPLORATION, GEOGRAPHY, ECOLOGY, ARCHITECTURE, HISTORY, FOOD AND DRINK, ART, ADVENTURE, SPORTS, HISTORY, PARANORMAL ACTIVITY, LEISURE AND LIFESTYLES, DISTRIBUTED THROUGH AUDIO AND VIDEO MEDIA, NAMELY, TELEVISION, SATELLITE, WIRELESS, FIBER OPTICS, CABLE, RADIO AND A GLOBAL COMPUTER NETWORK; PROVIDING ENTERTAINMENT INFORMATION REGARDING TELEVISION PROGRAMS VIA A GLOBAL COMPUTER NETWORK AND MOBILE NETWORK (U.S. CLS. 100, 101 AND 107).

RONALD MCMORROW, EXAMINING ATTORNEY

SN 85-466,590. AGUILERA, CARLOS, MADERA, CA. FILED 11-7-2011.

CHANGIO

THE MARK CONSISTS OF STANDARD CHARACTERS WITHOUT CLAIM TO ANY PARTICULAR FONT, STYLE, SIZE, OR COLOR.

SN 85-465,652. LIGHTING SCIENCE GROUP CORPORATION, SATELLITE BEACH, FL. FILED 11-7-2011.



The logo for LightingScience features the word "LightingScience" in a sans-serif font. Above the letter "i" in "Science", there is a graphic element consisting of a series of small dots forming a partial arc, resembling a stylized light source or a portion of a circle.

OWNER OF U.S. REG. NOS. 3,121,689, 3,948,258 AND OTHERS.

NO CLAIM IS MADE TO THE EXCLUSIVE RIGHT TO USE "LIGHTING", APART FROM THE MARK AS SHOWN.

THE MARK CONSISTS OF THE WORDS "LIGHTING SCIENCE" WITH THE DOT OF THE "I" IN "SCIENCE" FORMED BY A SMALL CIRCLE AT THE END OF AN ARC OF SMALL CIRCLES FORMING A THREE-QUARTER CIRCLE.

CLASS 9—ELECTRICAL AND SCIENTIFIC APPARATUS

FOR MAGNETICALLY ENCODED CREDIT CARDS AND MAGNETICALLY ENCODED DEBIT CARDS (U.S. CLS. 21, 23, 26, 36 AND 38).

CLASS 16—PAPER GOODS AND PRINTED MATTER

FOR STICKERS, DECALS, CREDIT CARDS WITHOUT MAGNETIC ENCODING AND DEBIT CARDS WITHOUT MAGNETIC ENCODING (U.S. CLS. 2, 5, 22, 23, 29, 37, 38 AND 50).

RONALD AIKENS, EXAMINING ATTORNEY

SN 85-466,612. TIMELESS MEDIA GROUP, INC., EUGENE, OR. FILED 11-7-2011.

Timelessvideo

THE MARK CONSISTS OF STANDARD CHARACTERS WITHOUT CLAIM TO ANY PARTICULAR FONT, STYLE, SIZE, OR COLOR.

CLASS 11—ENVIRONMENTAL CONTROL APPARATUS

FOR LED (LIGHT EMITTING DIODE) LIGHT BULBS; ILLUMINATION SYSTEMS COMPRISED PRIMARILY OF LED LIGHT BULBS, LED LIGHT PODS, LED LAMPS, LED LAMPS AND THEIR FITTINGS, LED LIGHTING FIXTURES OR LED LUMINARIES, FOR USE IN ANY APPLICATION WHERE HIGHLY ENERGY EFFICIENT ILLUMINATION IS REQUIRED INCLUDING FOR USE IN DOMESTIC, CONSUMER, VEHICULAR, COMMERCIAL, MUNICIPAL, CIVIL AND MILITARY LIGHTING APPLICATIONS WHEREVER LOCATED INCLUDING TERRESTRIAL, INTERIOR, SUBTERRANEAN, UNDERWATER AND SPACE BASED ILLUMINATION SYSTEMS AND DEVICES; LED RETROFIT LAMPS, BULBS AND FIXTURES; LED-BASED OUTDOOR, STREET AND ROADWAY LIGHTS (U.S. CLS. 13, 21, 23, 31 AND 34).

FIRST USE 10-0-2008; IN COMMERCE 10-0-2008.

CLASS 41—EDUCATION AND ENTERTAINMENT

FOR EDUCATIONAL SERVICES, NAMELY, CLASSES, SEMINARS AND WORKSHOPS IN THE FIELD OF LIGHTING (U.S. CLS. 100, 101 AND 107).

FIRST USE 6-0-2009; IN COMMERCE 6-0-2009.

CLASS 42—SCIENTIFIC AND COMPUTER SERVICES

FOR DESIGN AND DEVELOPMENT OF CUSTOM LIGHTING DEVICES AND PROJECTS USING LIGHT EMITTING DIODES AS THE LIGHT SOURCE (U.S. CLS. 100 AND 101).

FIRST USE 6-0-2009; IN COMMERCE 6-0-2009.
JOHN WILKE, EXAMINING ATTORNEY

CLASS 9—ELECTRICAL AND SCIENTIFIC APPARATUS

FOR PRERECORDED CASSETTES, DVDS, AND PRE-RECORDED OPTICAL DISCS FEATURING MOTION PICTURES AND TELEVISION PROGRAMS (U.S. CLS. 21, 23, 26, 36 AND 38).

FIRST USE 8-23-2003; IN COMMERCE 8-23-2003.

CLASS 41—EDUCATION AND ENTERTAINMENT

FOR ENTERTAINMENT SERVICES, NAMELY, THE PRODUCTION AND DISTRIBUTION OF MOTION PICTURES AND TELEVISION PROGRAMS (U.S. CLS. 100, 101 AND 107).

FIRST USE 8-23-2003; IN COMMERCE 8-23-2003.
NAAKWAMA ANKRAH, EXAMINING ATTORNEY

SN 85-468,945. WHITE, JASON A., LOS ANGELES, CA. FILED 11-9-2011.

SN 85-469,049. PILEPRO, LLC, AUSTIN, TX. FILED 11-10-2011.



THE MARK CONSISTS OF THE WORDING "BALLOON HEAD FRED" NEXT TO THE DESIGN OF A SILHOUETTE OF A CARTOON BOY'S BODY PROUDLY HOLDING HIS BALLOON SHAPED HEAD (COMPLETE WITH PROTRUDING EARS) WHICH IS ATTACHED TO A STRING AWAY FROM HIS BODY.

CLASS 9—ELECTRICAL AND SCIENTIFIC APPARATUS

FOR AUDIO BOOKS IN THE NATURE OF NOVELS; DIGITAL BOOK READERS; DOWNLOADABLE MOTION PICTURES AND TELEVISION SHOWS ABOUT A FICTIONAL ANIMATED CHARACTER; MOTION PICTURE FILMS ABOUT A FICTIONAL ANIMATED CHARACTER; MOTION PICTURE FILMS AND FILMS FOR TELEVISION FEATURING CHILDREN'S ENTERTAINMENT; MOTION PICTURE FILMS FEATURING CHILDREN'S ENTERTAINMENT (U.S. CLS. 21, 23, 26, 36 AND 38).

CLASS 16—PAPER GOODS AND PRINTED MATTER

FOR CHILDREN'S BOOKS; CHILDREN'S INTERACTIVE EDUCATIONAL BOOKS; COLORING BOOKS; MANUSCRIPT BOOKS; PICTURE BOOKS; PRINTED MATERIALS, NAMELY, NOVELS AND SERIES OF FICTION BOOKS AND SHORT STORIES FEATURING SCENES AND CHARACTERS BASED ON VIDEO GAMES; SERIES OF FICTION WORKS, NAMELY, NOVELS AND BOOKS; TALKING CHILDREN'S BOOKS (U.S. CLS. 2, 5, 22, 23, 29, 37, 38 AND 50).

CLASS 35—ADVERTISING AND BUSINESS

FOR ON-LINE RETAIL STORE SERVICES FEATURING PHYSICAL AND VIRTUAL MERCHANDISE FOR USE BY MEMBERS OF AN ONLINE COMMUNITY IN CONNECTION WITH A DESIGNATED WEBSITE FEATURING FICTIONAL CHARACTERS (U.S. CLS. 100, 101 AND 102).

CLASS 41—EDUCATION AND ENTERTAINMENT

FOR MOTION PICTURE FILM PRODUCTION; PRODUCTION AND DISTRIBUTION OF INDEPENDENT MOTION PICTURES; PROVISION OF INFORMATION RELATING TO DISTRIBUTION OF TELEVISION SHOWS, MOTION PICTURE FILM AND RADIO SHOWS; PROVISION OF INFORMATION RELATING TO TELEVISION, MOTION PICTURE FILM, AUDIO AND RADIO PRODUCTION (U.S. CLS. 100, 101 AND 107).

CLASS 45—PERSONAL AND LEGAL SERVICES

FOR CARTOON CHARACTER LICENSING; LICENSING OF ADVERTISING SLOGANS AND CARTOON CHARACTERS (U.S. CLS. 100 AND 101).
ELIZABETH HUGHITT, EXAMINING ATTORNEY

DR. SHEETPILE

THE MARK CONSISTS OF STANDARD CHARACTERS WITHOUT CLAIM TO ANY PARTICULAR FONT, STYLE, SIZE, OR COLOR.

CLASS 36—INSURANCE AND FINANCIAL

FOR TECHNICAL SUPPORT SERVICES IN THE FIELD OF ASSISTING IN RESOLVING CONTRACTOR CLAIMS FOR THE CONSTRUCTION INDUSTRY IN THE FIELD OF SHEET PILING (U.S. CLS. 100, 101 AND 102).

FIRST USE 11-4-2011; IN COMMERCE 11-4-2011.

CLASS 37—CONSTRUCTION AND REPAIR

FOR TECHNICAL SUPPORT SERVICES, NAMELY, PROVIDING TECHNICAL ADVICE AND INFORMATION ON THE INSTALLATION OF SHEET PILING; TECHNICAL SUPPORT SERVICES, NAMELY, PROVIDING TECHNICAL ADVICE AND INFORMATION ON THE APPLICATION OF COATINGS FOR OTHERS, NAMELY, PROTECTIVE COATING (U.S. CLS. 100, 103 AND 106).

FIRST USE 11-4-2011; IN COMMERCE 11-4-2011.

CLASS 40—MATERIAL TREATMENT

FOR TECHNICAL SUPPORT SERVICES, NAMELY, PROVIDING TECHNICAL ADVICE AND INFORMATION RELATED TO THE MANUFACTURE OF SHEET PILES, PIPE PILES AND SHEET PILE CONNECTORS; TECHNICAL SUPPORT SERVICES, NAMELY, PROVIDING TECHNICAL ADVICE AND INFORMATION ON FIREPROOFING OF SHEET PILE PIPE, PIPE PILE AND KING PILE SYSTEMS FOR OTHERS (U.S. CLS. 100, 103 AND 106).

FIRST USE 11-4-2011; IN COMMERCE 11-4-2011.

CLASS 41—EDUCATION AND ENTERTAINMENT

FOR EDUCATIONAL SERVICES, NAMELY, CONDUCTING CLASSES, SEMINARS CONFERENCES, WORKSHOPS IN THE FIELD OF SHEET PILING AND DISTRIBUTION OF EDUCATIONAL MATERIALS IN CONNECTION THEREWITH; EDUCATIONAL SERVICES, NAMELY, PROVIDING ONLINE INSTRUCTION IN THE FIELD OF SHEET PILING VIA AN ONLINE WEBSITE; PROVIDING EDUCATIONAL DEMONSTRATIONS ON TECHNICAL ADVICE AND INFORMATION RELATED TO SHEET PILES, PIPE PILES AND KING PILE SYSTEMS FOR OTHERS (U.S. CLS. 100, 101 AND 107).

FIRST USE 11-4-2011; IN COMMERCE 11-4-2011.

CLASS 42—SCIENTIFIC AND COMPUTER SERVICES

FOR TECHNICAL SUPPORT SERVICES, NAMELY, PROVIDING TECHNICAL ADVICE AND INFORMATION IN THE DESIGN OF SHEET PILES, PIPE PILES AND KING PILE SYSTEMS FOR OTHERS; TECHNOLOGY SPECIFICATION, NAMELY, ANALYZING TECHNOLOGY REQUIREMENTS AND DEVELOPING RECOMMENDATIONS FOR SHEET PILES, PIPE PILES AND KING PILE SYSTEMS FOR OTHERS AND OTHER TECHNOLOGY NEEDED TO MEET THOSE REQUIREMENTS; TECHNICAL SUPPORT SERVICES, NAMELY, PROVIDING TECHNICAL CONSULTING ADVICE IN THE FIELD OF CONFIGURATION OF SHEET PILES, PIPE PILES, AND KING PILE SYSTEMS FOR OTHERS; TECHNICAL SUPPORT SERVICES, NAMELY, PROVIDING TECHNICAL ADVICE AND INFORMATION ON CONDUCTING FEASIBILITY STUDIES ON THE DURABILITY, STEEL GRADES, PRODUCT APPLICATION OF SHEET PILES, PIPE PILES AND KING PILE SYSTEMS; TECHNICAL SUPPORT SERVICES, NAMELY, PROVIDING TECHNICAL ADVICE AND INFORMATION ON SCIENTIFIC STUDIES AND RESEARCH IN THE FIELD OF SHEET PILES, PIPE PILES AND KING PILE SYSTEMS FOR OTHERS (U.S. CLS. 100 AND 101).

FIRST USE 11-4-2011; IN COMMERCE 11-4-2011.
LOURDES AYALA, EXAMINING ATTORNEY

SN 85-469,813. XENTRIS WIRELESS, LLC, ADDISON, IL.
FILED 11-10-2011.

soundology

THE MARK CONSISTS OF THE WORD "SOUNDOLOGY" IN STYLIZED, LOWERCASE LETTERING. THE SECOND "O" IS IN THE SHAPE OF A HEADSET, AND THE "G" IS COMPRISED OF A CIRCLE STACKED ON TOP OF AN INCOMPLETE CIRCLE.

CLASS 6—METAL GOODS

FOR METAL AUDIO SPEAKER MOUNTS (U.S. CLS. 2, 12, 13, 14, 23, 25 AND 50).

CLASS 9—ELECTRICAL AND SCIENTIFIC APPARATUS

FOR HEADSETS FOR MOBILE TELEPHONES, COMPUTERS, LAPTOPS, PORTABLE MEDIA PLAYERS, TABLET COMPUTERS AND PORTABLE AND HANDHELD DIGITAL ELECTRONIC DEVICES; AUDIO AND BASS SPEAKERS; WIRELESS HEADSETS FOR CELL PHONES, COMPUTERS, LAPTOPS, PORTABLE MEDIA PLAYERS, TABLET COMPUTERS AND PORTABLE AND HANDHELD DIGITAL ELECTRONIC DEVICES; WIRELESS SPEAKERS; ELECTRONIC MEDIA DOCKING STATIONS; AUDIO PERIPHERAL DEVICES FOR COMPUTERS; AUDIO CABLES; CORDED HEADSETS FOR CELL PHONES, COMPUTERS, LAPTOPS, PORTABLE MEDIA PLAYERS, TABLET COMPUTERS AND PORTABLE AND HANDHELD DIGITAL ELECTRONIC DEVICES; FM RADIO TRANSMITTERS; AUXILIARY AUDIO CABLES; SIGNAL SPLITTERS FOR HEADPHONES; HEADPHONE ADAPTERS; AUDIO/VIDEO CABLES; DESKTOP DOCKING STATIONS FOR CELL PHONES, COMPUTERS, LAPTOPS, PORTABLE MEDIA PLAYERS, TABLET COMPUTERS AND PORTABLE AND HANDHELD DIGITAL ELECTRONIC DEVICES; PORTABLE AUDIO SPEAKERS; AUDIO ADAPTERS (U.S. CLS. 21, 23, 26, 36 AND 38).

KATHERINE CHANG, EXAMINING ATTORNEY

SN 85-470,060. GHOBRIAL, MARY MONIR SHAFIK, DUBAI, UNITED ARAB EMIR., FILED 11-11-2011.



THE MARK CONSISTS OF THE WORDS "IN LOVE AGAIN" SURROUNDED BY A FLORAL DESIGN WITH A BIRD WITH HEARTS AS ITS TAIL ON THE UPPER LEFT HAND SECTION OF THE DESIGN AND ANOTHER BIRD WITH HEARTS AS ITS TAIL ON THE MIDDLE RIGHT SIDE OF THE DESIGN.

CLASS 25—CLOTHING

FOR DRESSES, LINGERIE, WEDDING GOWNS, EVENING DRESSES, EVENING SHOES (U.S. CLS. 22 AND 39).

CLASS 30—STAPLE FOODS

FOR CUPCAKES, BOXED CHOCOLATE/TRUFFLES, CANDY (U.S. CL. 46).

CLASS 35—ADVERTISING AND BUSINESS

FOR RETAIL STORE SERVICES AND WHOLESALE STORE SERVICES FEATURING CLOTHING, SHOES, ACCESSORIES, PACKAGED FOOD AND BEAUTY PRODUCTS (U.S. CLS. 100, 101 AND 102).

JAY FLOWERS, EXAMINING ATTORNEY

SN 85-470,485. XENTRIS WIRELESS, LLC, ADDISON, IL.
FILED 11-11-2011.

coverology

THE MARK CONSISTS OF THE WORD "COVEROLOGY" IN LOWERCASE, STYLIZED LETTERS. THE SECOND "O" IS FORMED BY AN INCOMPLETE CIRCLE WITH AN ARCH OVER THE OPEN SPACE, AND THE "G" IS COMPRISED OF A CIRCLE STACKED ON TOP OF AN INCOMPLETE CIRCLE.

CLASS 6—METAL GOODS

FOR METAL AUDIO SPEAKER MOUNTS (U.S. CLS. 2, 12, 13, 14, 23, 25 AND 50).

CLASS 9—ELECTRICAL AND SCIENTIFIC APPARATUS

FOR CELL PHONE COVERS; CLEAR PROTECTIVE COVERS SPECIALLY ADAPTED FOR PERSONAL ELECTRONIC DEVICES AND TABLET COMPUTERS; PROTECTIVE COVERS AND CASES FOR CELL PHONES, LAPTOPS, PORTABLE MEDIA PLAYERS, TABLET COMPUTERS AND PORTABLE AND HANDHELD ELECTRONIC DEVICES; CARRYING CASES FOR CELL PHONES, LAPTOPS, PORTABLE MEDIA PLAYERS, TABLET COMPUTERS, AND PORTABLE AND HANDHELD DIGITAL ELECTRONIC DEVICES; PROTECTIVE COVERS FOR ELECTRONIC READING DEVICES; TRAVEL BATTERY CHARGERS; POWER ADAPTERS FOR ELECTRONIC DEVICES USED IN VEHICLES; HEADSETS FOR COMPUTERS, MOBILE TELEPHONES, LAPTOPS, PORTABLE MEDIA PLAYERS, TABLET COMPUTERS AND PORTABLE AND HANDHELD DIGITAL ELECTRONIC DEVICES; FACE PLATES FOR MOBILE PHONES; ELECTRIC DATA CABLES; MOBILE TELEPHONE ACCESSORIES, NAMELY, BELT CLIPS; SPECIALTY HOLSTERS FOR CARRYING MOBILE PHONES AND PERSONAL DIGITAL ASSISTANTS; PHONE CORD KEEPERS, NAMELY, PLASTIC ROTATING ATTACHMENT AFFIXED TO A TELEPHONE OR OTHER ELECTRONIC CORD TO PREVENT TANGLING; GAMING CONTROL DEVICES, VIDEO GAME INTERACTIVE REMOTE CONTROL UNITS; CASES FOR MOBILE PHONES, TABLET COMPUTERS, AND PORTABLE AND HANDHELD DIGITAL ELECTRONIC DEVICES; POWER SLEEVE BATTERY CHARGING CASES; WIRELESS POWER SLEEVE BATTERY CHARGING CASES; BATTERY CHARGING CASES; SOLAR POWER SLEEVE BATTERY CHARGING CASES; ELECTRONIC DOCKING STATIONS; MOUNTS SPECIALLY ADAPTED FOR MOBILE DEVICES, NAMELY, MOBILE PHONES, TABLET COMPUTERS, AND PORTABLE AND HANDHELD DIGITAL ELECTRONIC DEVICES, USED IN VEHICLES (U.S. CLS. 21, 23, 26, 36 AND 38).

KATHERINE CHANG, EXAMINING ATTORNEY

SN 85-470,515. THE SIDWELL FRIENDS SCHOOL, WASHINGTON, DC. FILED 11-11-2011.



NO CLAIM IS MADE TO THE EXCLUSIVE RIGHT TO USE "FRIENDS SCHOOL", "FOUNDED 1883" AND "WASHINGTON, DC", APART FROM THE MARK AS SHOWN.

THE MARK CONSISTS OF THE WORDS "ELUCEAT OMNIBUS LUX" POSITIONED DIAGONALLY BETWEEN TWO OPEN BOOKS ON A CREST TOPPED WITH A LAMP OVER A BANNER CONTAINING THE WORDS "FOUNDED 1883" WITH THE ENTIRE DESIGN SURROUNDED BY THE WORDS "SIDWELL FRIENDS SCHOOL WASHINGTON, DC".

THE ENGLISH TRANSLATION OF "ELUCEAT OMNIBUS LUX" IN THE MARK IS LET THE LIGHT SHINE FORTH FROM EVERYONE.

CLASS 16—PAPER GOODS AND PRINTED MATTER

FOR DECALS, STICKERS, PENS, NOTEBOOKS AND BINDERS (U.S. CLS. 2, 5, 22, 23, 29, 37, 38 AND 50).
FIRST USE 0-0-1998; IN COMMERCE 0-0-1998.

CLASS 18—LEATHER GOODS

FOR TOTE BAGS (U.S. CLS. 1, 2, 3, 22 AND 41).
FIRST USE 0-0-1999; IN COMMERCE 0-0-1999.

CLASS 21—HOUSEWARES AND GLASS

FOR MUGS, DRINKING GLASSES (U.S. CLS. 2, 13, 23, 29, 30, 33, 40 AND 50).
FIRST USE 0-0-1998; IN COMMERCE 0-0-1998.

CLASS 25—CLOTHING

FOR CLOTHING, NAMELY, T-SHIRTS, SHIRTS, SWEATSHIRTS, TIES, INFANTWEAR AND CLOTH BIBS (U.S. CLS. 22 AND 39).
FIRST USE 0-0-1998; IN COMMERCE 0-0-1998.

CLASS 41—EDUCATION AND ENTERTAINMENT

FOR EDUCATIONAL SERVICES, NAMELY, A DAY SCHOOL PROVIDING COURSES OF INSTRUCTION AT THE PRE-KINDERGARTEN THROUGH GRADE TWELVE LEVEL; ENTERTAINMENT SERVICES IN THE NATURE OF CROSS-COUNTRY RUNNING, TRACK AND FIELD, FIELD HOCKEY, FOOTBALL, SOCCER, TENNIS, VOLLEYBALL, BASKETBALL, SQUASH, SWIMMING, WRESTLING, BASEBALL, SOFTBALL, CREW AND LACROSSE GAMES; ENTERTAINMENT SERVICES IN THE NATURE OF COMPETITIONS IN THE FIELD OF CROSS-COUNTRY RUNNING, TRACK AND FIELD, FIELD HOCKEY, FOOTBALL, SOCCER, TENNIS, VOLLEYBALL, BASKETBALL, SQUASH, SWIMMING, WRESTLING, BASEBALL, SOFTBALL, CREW AND LACROSSE; ARRANGING LIVE MUSICAL CONCERTS, PLAYS, AND DANCE PERFORMANCES; ENTERTAINMENT IN THE NATURE OF LIVE STAGE PERFORMANCES IN THE NATURE OF LECTURES IN THE FIELDS OF EDUCATION, PSYCHOLOGY, HEALTH, HUMAN DEVELOPMENT, LITERATURE, MODERN AND CLASSICAL LANGUAGES, FINE AND PERFORMING ARTS, SCIENCE, HISTORY, COMPUTER SCIENCE AND MATHEMATICS BY AN INDIVIDUAL; ART EXHIBITIONS; CONDUCTING WORKSHOPS IN EDUCATION, PSYCHOLOGY, HEALTH, HUMAN DEVELOPMENT, LITERATURE, MODERN AND CLASSICAL LANGUAGES, FINE AND PERFORMING ARTS, SCIENCE, HISTORY, COMPUTER SCIENCE AND MATHEMATICS; RECREATIONAL CAMPS, SPORT CAMPS AND TRAINING IN THE FIELD OF SPORTS, NAMELY, SPORTS CLINICS; CONDUCTING WORKSHOPS IN THE FIELD OF CRAFTS, CULTURAL AND COOKING; SUMMER CAMPS (U.S. CLS. 100, 101 AND 107).

FIRST USE 0-0-1997; IN COMMERCE 0-0-1997.

WON TEAK OH, EXAMINING ATTORNEY

SN 85-470,581. GIFTCRAFT LTD., BRAMPTON, ON, CANADA, FILED 11-11-2011.

CELEBRATIONS CREATING SMILES

THE MARK CONSISTS OF STANDARD CHARACTERS WITHOUT CLAIM TO ANY PARTICULAR FONT, STYLE, SIZE, OR COLOR.

CLASS 20—FURNITURE AND ARTICLES NOT OTHERWISE CLASSIFIED

FOR PICTURE FRAMES, WALL CROSSES, TRINKET BOXES AND FIGURINES ALL MADE OF PLASTIC (U.S. CLS. 2, 13, 22, 25, 32 AND 50).

CLASS 21—HOUSEWARES AND GLASS

FOR TABLE CROSSES MADE OF POLYRESIN; WALL CROSSES MADE OF POLYRESIN; NON-METAL COIN BANKS; MUGS; TRAVEL MUGS; TABLE DÉCOR, NAMELY, PLATES, BOWLS, TEAPOTS, SALT AND PEPPER SETS, CREAM AND SUGAR SETS, ALL MADE OF CERAMIC; PLATES; BELLS OF PORCELAIN, CERAMIC OR GLASS AND NOT OF METAL; FIGURINES OF PORCELAIN, CERAMIC OR GLASS; TRINKET BOXES MADE OF PORCELAIN, CERAMIC OR GLASS (U.S. CLS. 2, 13, 23, 29, 30, 33, 40 AND 50).

CLASS 28—TOYS AND SPORTING GOODS

FOR STUFFED TOYS AND PLUSH TOY FIGURINES (U.S. CLS. 22, 23, 38 AND 50).
SHARON MEIER, EXAMINING ATTORNEY

CLASS 9—ELECTRICAL AND SCIENTIFIC APPARATUS

FOR CELL PHONE BATTERY CHARGERS; CELL PHONE BATTERY CHARGERS FOR USE IN VEHICLES; PORTABLE CELL PHONE BATTERY CHARGERS; POWER ADAPTERS FOR COMPUTERS; POWER ADAPTERS FOR ELECTRONIC DEVICES USED IN VEHICLES; TRAVEL BATTERY CHARGERS; POWER SUPPLIES; POWER SUPPLY CONNECTOR CABLES AND ADAPTERS FOR USE WITH PORTABLE ELECTRONIC DEVICES; ELECTRIC DATA CABLES; ELECTRICAL CONNECTORS; ELECTRIC WIRES; ADAPTERS; MHL (MOBILE HIGH-DEFINITION LINK) ADAPTERS; MHL (MOBILE HIGH-DEFINITION LINK) CABLES; CASES FOR MOBILE PHONES, TABLET COMPUTERS, AND PORTABLE AND HANDHELD DIGITAL ELECTRONIC DEVICES; POWER SLEEVE BATTERY CHARGING CASES; WIRELESS POWER SLEEVE BATTERY CHARGING CASES; BATTERY CHARGING CASES; HIGH DEFINITION MULTIMEDIA INTERFACE CABLES; BATTERY CHARGERS; WIRELESS BATTERY CHARGERS; ELECTRONIC DOCKING STATIONS; ANTENNAS; ELECTRIC CABLES; RF ANTENNAS; RF CABLES; INTERFACES AND PERIPHERAL DEVICES FOR COMPUTERS; PORTABLE ENERGY CHARGERS, NAMELY, RECHARGEABLE BATTERIES INTEGRATED INTO A PROTECTIVE CASE WITH AN ELECTRICAL CONNECTOR FOR USE WITH MOBILE ELECTRONIC DEVICES, NAMELY, WIRELESS PHONES, TABLET COMPUTERS, AND PORTABLE AND HANDHELD DIGITAL ELECTRONIC DEVICES; MOUNTS SPECIALLY ADAPTED FOR MOBILE DEVICES, NAMELY, MOBILE PHONES, TABLET COMPUTERS, AND PORTABLE AND HANDHELD DIGITAL ELECTRONIC DEVICES, USED IN VEHICLES (U.S. CLS. 21, 23, 26, 36 AND 38).
KATHERINE CHANG, EXAMINING ATTORNEY

SN 85-471,387. MORRISON MANAGEMENT SPECIALISTS, INC., ATLANTA, GA. FILED 11-14-2011.

SN 85-470,603. XENTRIS WIRELESS, LLC, ADDISON, IL. FILED 11-11-2011.

TOUCHPOINT SUPPORT SERVICES

THE MARK CONSISTS OF STANDARD CHARACTERS WITHOUT CLAIM TO ANY PARTICULAR FONT, STYLE, SIZE, OR COLOR.

NO CLAIM IS MADE TO THE EXCLUSIVE RIGHT TO USE "SUPPORT SERVICES", APART FROM THE MARK AS SHOWN.



The logo for "powerology" features the word in a lowercase, sans-serif font. The letter "o" is stylized, containing a graphic of an electrical plug with a circle stacked on top of it, representing the "G" in "powerology".

THE MARK CONSISTS OF THE WORD "POWERLOGY" IN LOWERCASE, STYLIZED LETTERS. THE SECOND "O" INCLUDES A DESIGN OF AN ELECTRIC PLUG. THE "G" IS COMPRISED OF A CIRCLE STACKED ON TOP OF AN INCOMPLETE CIRCLE.

CLASS 6—METAL GOODS

FOR METAL AUDIO SPEAKER MOUNTS (U.S. CLS. 2, 12, 13, 14, 23, 25 AND 50).

CLASS 35—ADVERTISING AND BUSINESS

FOR MANAGEMENT AND OPERATION OF A BUSINESS FOR OTHERS, NAMELY, RESTAURANTS, CAFETERIAS, CAFES, AND SNACK BARS; INDUSTRIAL AND COMMERCIAL MANAGEMENT ASSISTANCE FOR HOSPITALS, EXTENDED CARE FACILITIES, NURSING HOMES, MEDICAL OFFICE BUILDINGS (U.S. CLS. 100, 101 AND 102).

CLASS 37—CONSTRUCTION AND REPAIR

FOR CONTRACT MANAGEMENT OF PLANT OPERATIONS, NAMELY, BUILDING MAINTENANCE SERVICES, LAUNDRY SERVICES FOR LINENS, JANITORIAL AND MAID SERVICES FOR HOSPITALS, EXTENDED CARE FACILITIES, NURSING HOMES, MEDICAL OFFICE BUILDINGS (U.S. CLS. 100, 103 AND 106).

CLASS 43—HOTEL AND RESTAURANT SERVICES

FOR CONTRACT FOOD SERVICES; FOOD PREPARATION SERVICES (U.S. CLS. 100 AND 101).

DANNEAN HETZEL, EXAMINING ATTORNEY

SN 85-471,445. PANASONIC CORPORATION, OSAKA, JAPAN, FILED 11-14-2011.

HEARING HUB

THE MARK CONSISTS OF STANDARD CHARACTERS WITHOUT CLAIM TO ANY PARTICULAR FONT, STYLE, SIZE, OR COLOR.

NO CLAIM IS MADE TO THE EXCLUSIVE RIGHT TO USE "HEARING", APART FROM THE MARK AS SHOWN.

CLASS 9—ELECTRICAL AND SCIENTIFIC APPARATUS

FOR REMOTE CONTROLS FOR USE WITH HEARING AIDS AND SOLD IN CONNECTION WITH HEARING AIDS, NAMELY, HANDHELD ELECTRONIC UNITS FOR ADJUSTING SOUND LEVELS IN HEARING AIDS; REMOTE CONTROLS FOR USE WITH HEARING AIDS AND SOLD IN CONNECTION WITH HEARING AIDS, NAMELY, HANDHELD ELECTRONIC UNITS FOR SWITCHING PRESET MODES FOR ENVIRONMENT ADAPTATIONS IN HEARING AIDS (U.S. CLS. 21, 23, 26, 36 AND 38).

CLASS 10—MEDICAL APPARATUS

FOR ELECTRICAL HEARING AIDS; COMMUNICATION DEVICES FOR USE WITH HEARING AIDS IN THE NATURE OF WIRELESS TRANSMITTERS AND RECEIVERS FOR CONNECTING HEARING AIDS TO OTHER ELECTRONIC COMMUNICATION DEVICES, SUCH AS TELEPHONES AND TELEVISION RECEIVERS (U.S. CLS. 26, 39 AND 44).

AMY ALFIERI, EXAMINING ATTORNEY

SN 85-472,466. PATIENT FORWARD, LLC, DRIPPING SPRINGS, TX. FILED 11-15-2011.

Wellness Cycle

THE MARK CONSISTS OF STANDARD CHARACTERS WITHOUT CLAIM TO ANY PARTICULAR FONT, STYLE, SIZE, OR COLOR.

NO CLAIM IS MADE TO THE EXCLUSIVE RIGHT TO USE "WELLNESS", APART FROM THE MARK AS SHOWN.

CLASS 42—SCIENTIFIC AND COMPUTER SERVICES

FOR PROVIDING ONLINE NON-DOWNLOADABLE SOFTWARE, NAMELY, SOFTWARE FOR PROVIDING CONSUMERS ACCESS TO HEALTH CARE, WELLNESS CARE, HEALTH CARE PROFESSIONALS AND WELLNESS CARE PROFESSIONALS VIA COMPUTER, TELEPHONE OR OTHER ELECTRONIC MEANS; PROVIDING ONLINE NON-DOWNLOADABLE SOFTWARE, NAMELY, SOFTWARE FOR PROVIDING CONSUMERS, HEALTH CARE PROFESSIONALS AND WELLNESS CARE PROFESSIONALS WITH A COMPREHENSIVE UNDERSTANDING OF A CONSUMER'S HEALTH AND WELLNESS (U.S. CLS. 100 AND 101).

CLASS 44—MEDICAL, BEAUTY AND AGRICULTURAL SERVICES

FOR TELEMEDICINE SERVICES; CONSULTING SERVICES IN THE FIELD OF PROVIDING CONSUMERS ACCESS TO HEALTH CARE, WELLNESS CARE, HEALTH CARE PROFESSIONALS AND WELLNESS CARE PROFESSIONALS VIA COMPUTER, TELEPHONE OR OTHER ELECTRONIC MEANS; CONSULTING SERVICES IN THE FIELD OF PROVIDING CONSUMERS, HEALTH CARE PROFESSIONALS AND WELLNESS CARE PROFESSIONALS WITH A COMPREHENSIVE UNDERSTANDING OF A CONSUMER'S HEALTH AND WELLNESS VIA COMPUTER, TELEPHONE OR OTHER ELECTRONIC MEANS (U.S. CLS. 100 AND 101).

DORITT L. CARROLL, EXAMINING ATTORNEY

SN 85-472,862. REGLOCHILL CORPORATION, ST. JOSEPH, MI. FILED 11-15-2011.



NO CLAIM IS MADE TO THE EXCLUSIVE RIGHT TO USE "ICE-RINKS", APART FROM THE MARK AS SHOWN. THE COLOR(S) BLACK, WHITE, ORANGE AND BLUE IS/ ARE CLAIMED AS A FEATURE OF THE MARK.

THE MARK CONSISTS OF A BLACK PENGUIN WITH A WHITE CHEST AND FACE WEARING ICE SKATES DRAWN TO APPEAR IN MOTION BY THREE HORIZONTAL LINES TO THE LEFT OF THE PENGUIN WITH THE WORDS "PENGUIN", IN ORANGE AND "ICE-RINKS" IN BLUE TO THE RIGHT OF THE PENGUIN.

CLASS 35—ADVERTISING AND BUSINESS

FOR RETAIL STORE SERVICES FEATURING ICE SKATING RINKS, MAIL ORDER SERVICES FEATURING ICE SKATING RINKS, AND ON-LINE RETAIL STORE SERVICES FEATURING ICE SKATING RINKS (U.S. CLS. 100, 101 AND 102).

FIRST USE 10-17-2011; IN COMMERCE 10-17-2011.

CLASS 41—EDUCATION AND ENTERTAINMENT

FOR RENTAL OF ICE SKATING RINKS (U.S. CLS. 100, 101 AND 107).

FIRST USE 10-17-2011; IN COMMERCE 10-17-2011.

JOHN DWYER, EXAMINING ATTORNEY

SN 85-474,602. YOO, DANIEL, AKA DANNY, KIMPO, KYUNGKIDO, REPUBLIC OF KOREA, FILED 11-16-2011.



NO CLAIM IS MADE TO THE EXCLUSIVE RIGHT TO USE "CHAKRA FOOD", APART FROM THE MARK AS SHOWN.

THE COLOR(S) BROWN, VIOLET, INDIGO, BLUE, GREEN, YELLOW, ORANGE, AND RED IS/ARE CLAIMED AS A FEATURE OF THE MARK.

THE MARK CONSISTS OF THE BROWN STYLIZED WORDING "CHAKRAFOOD" BELOW A PINE TREE COMPOSED OF BRUSH STROKES WITH A BROWN TRUNK, VIOLET ROUNDED TOP, AND STRAIGHT BRUSH STROKES ON THE LEFT AND RIGHT SIDES OF THE TRUNK OF INDIGO, BLUE, GREEN, YELLOW, ORANGE, AND RED IN DESCENDING ORDER FROM THE TOP, WHICH REPRESENT THE LEAVES OF THE TREE.

CLASS 5—PHARMACEUTICALS

FOR ANTI-DIABETIC PHARMACEUTICALS; ANTI-BACTERIAL PHARMACEUTICALS; BEE POLLEN FOR USE AS A DIETARY FOOD SUPPLEMENT; BISCUITS, BREAD, BREAD ROLLS, CAKES, CEREAL PRODUCTS, CONFECTIONERY, CRACKERS, NOODLES, FISH SAUCE, RELISH, SAUCES, CEREAL-BASED SNACK-FOODS AND PREPARED DIETARY ITEMS ALL OF WHICH ARE GLUTEN -FREE TO ACCOMMODATE SPECIAL MEDICAL AND HEALTH CONDITIONS; CALCIUM SUPPLEMENTS; DIETARY AND NUTRITIONAL SUPPLEMENTS; DIETARY AND NUTRITIONAL SUPPLEMENTS USED FOR WEIGHT LOSS; DIETARY BEVERAGE SUPPLEMENTS FOR HUMAN CONSUMPTION IN LIQUID AND DRY MIX FORM FOR THERAPEUTIC PURPOSES; DIETARY FOOD SUPPLEMENTS; DIETARY SUPPLEMENT FOR ELIMINATING TOXINS FROM THE INTESTINAL TRACT; DIETARY SUPPLEMENTAL DRINKS; DIETARY SUPPLEMENTAL DRINKS IN THE NATURE OF VITAMIN AND MINERAL BEVERAGES; DIETARY SUPPLEMENTS; DIETARY SUPPLEMENTS FOR CONTROLLING CHOLESTEROL; DIETARY SUPPLEMENTS FOR HUMAN CONSUMPTION; DIETARY SUPPLEMENTS FOR URINARY HEALTH; DIGESTIVES FOR PHARMACEUTICAL PURPOSES; ENZYME FOOD SUPPLEMENTS; FERMENTS FOR PHARMACEUTICAL PURPOSES; FISH, PICKLES, PRESERVED OLIVES AND DIETARY FOODS AND FOOD-ITEMS THAT ARE GLUTEN-FREE TO ACCOMMODATE SPECIAL MEDICAL AND HEALTH CONDITIONS; FOOD SUPPLEMENTS; FOOD SUPPLEMENTS, NAMELY, ANTI-OXIDANTS; GINSENG FOR MEDICINAL USE; HEALTH FOOD SUPPLEMENTS; HERB TEAS FOR MEDICINAL PURPOSES; HERBAL SUPPLEMENTS; HERBAL SUPPLEMENTS FOR SLEEPING PROBLEMS; HERBAL TEAS FOR MEDICINAL PURPOSES; HERBS FOR MEDICINAL PURPOSES; HOMEOPATHIC SUPPLEMENTS; MEDICINAL DRINKS; MEDICINAL HAIR GROWTH PREPARATIONS; MEDICINAL HERB EXTRACTS; MEDICINAL HERBAL EXTRACTS FOR MEDICAL PURPOSES; MEDICINAL HERBAL PREPARATIONS; MEDICINAL HERBS; MEDICINAL HERBS IN DRIED OR PRESERVED FORM; MEDICINAL PREPARATIONS FOR THE MOUTH TO BE APPLIED IN THE FORM OF DROPS, CAPSULES, TABLETS AND COMPRESSED TABLETS; MEDICINAL ROOTS; NUTRACEUTICALS FOR USE AS A DIETARY SUPPLEMENT; NUTRITIONAL AND DIETARY SUPPLEMENTS FORMED AND PACK-

AGED AS BARS; NUTRITIONAL SUPPLEMENT FOR ELIMINATING TOXINS FROM THE BODY; NUTRITIONAL SUPPLEMENT FOR ELIMINATING TOXINS FROM THE INTESTINAL TRACT; NUTRITIONAL SUPPLEMENTS; PHARMACEUTICAL PREPARATIONS FOR SKIN CARE; PHARMACEUTICAL PREPARATIONS, NAMELY, A BLOOD CLOTTING AID AND DELIVERY SYSTEM FOR USE IN HUMAN AND VETERINARY MEDICINE; PRESCRIPTION AND NON-PRESCRIPTION MEDICINES, NAMELY, PILLS, TABLETS, CAPSULES, CAPLETS, LIQUID DROPS, SACHETS AND PHARMACEUTICAL PREPARATIONS FOR THE TREATMENT OF CARDIOVASCULAR DISORDERS (U.S. CLS. 6, 18, 44, 46, 51 AND 52).

CLASS 45—PERSONAL AND LEGAL SERVICES

FOR PROVIDING SPIRITUAL RETREATS IN THE FIELDS OF TOGETHERNESS AND HOW TO BE BETTER MEN; RELIGIOUS AND SPIRITUAL SERVICES, NAMELY, PROVIDING GATHERINGS AND RETREATS TO DEVELOP AND ENHANCE THE SPIRITUAL LIVES OF INDIVIDUALS (U.S. CLS. 100 AND 101).

KRISTINA MORRIS, EXAMINING ATTORNEY

SN 85-475,260. LEE, CALVIN, DBA FISH OF FURY, SAN MATEO, CA. FILED 11-17-2011.

FISH OF FURY

THE MARK CONSISTS OF STANDARD CHARACTERS WITHOUT CLAIM TO ANY PARTICULAR FONT, STYLE, SIZE, OR COLOR.

CLASS 9—ELECTRICAL AND SCIENTIFIC APPARATUS

FOR DOWNLOADABLE ELECTRONIC PUBLICATIONS, NAMELY, ARTICLES, BOOKS AND STORIES IN THE FIELD OF A FICTIONAL SUPERHERO (U.S. CLS. 21, 23, 26, 36 AND 38).

CLASS 16—PAPER GOODS AND PRINTED MATTER

FOR PRINTED PUBLICATIONS, NAMELY, ARTICLES, BOOKS AND STORIES IN THE FIELD OF A FICTIONAL SUPERHERO (U.S. CLS. 2, 5, 22, 23, 29, 37, 38 AND 50).

JOHN HWANG, EXAMINING ATTORNEY

SN 85-475,714. ENT TECHNOLOGIES PTY LTD., HAWTHORN EAST, VIC, AUSTRALIA, FILED 11-17-2011.

FLOCRS

THE MARK CONSISTS OF STANDARD CHARACTERS WITHOUT CLAIM TO ANY PARTICULAR FONT, STYLE, SIZE, OR COLOR.

CLASS 5—PHARMACEUTICALS

FOR PHARMACEUTICAL PREPARATIONS FOR THE TREATMENT OF SINUS DISEASE IN HUMANS (U.S. CLS. 6, 18, 44, 46, 51 AND 52).

CLASS 10—MEDICAL APPARATUS

FOR MEDICAL APPARATUS AND INSTRUMENTS USED TO DELIVER PHARMACEUTICALS IN THE TREATMENT OF SINUS DISEASE IN HUMANS (U.S. CLS. 26, 39 AND 44).

MARILYN IZZI, EXAMINING ATTORNEY

SN 85-476,792. CERNER INNOVATION, INC., LENEXA, KS. FILED 11-18-2011.



OWNER OF U.S. REG. NOS. 1,458,174, 3,772,468 AND OTHERS.

THE COLOR(S) BLUE AND GREEN IS/ARE CLAIMED AS A FEATURE OF THE MARK.

THE MARK CONSISTS OF THE WORDING "CERNER" TO THE LEFT OF WHICH IS A PARTIALLY CLOSED BLUE CIRCULAR FORM WHEREIN THE LEFT BORDER OF THE CIRCLE DOES NOT CONNECT BUT RATHER CONVERGES INTO TWO CURVING GREEN PARALLEL LINES EXTENDING OUTSIDE OF THE CIRCULAR FORM TOWARDS THE WORDING.

CLASS 9—ELECTRICAL AND SCIENTIFIC APPARATUS

FOR COMPUTER SOFTWARE FOR USE IN THE HEALTHCARE FIELD, NAMELY SOFTWARE FOR MANAGING, STORING, ANALYZING, MAINTAINING, PROCESSING, STRUCTURING, REVIEWING, BUILDING, EDITING, DISTRIBUTING, COMMUNICATING, ORGANIZING, SHARING, REFERENCING, MONITORING AND INTEGRATING HEALTHCARE INFORMATION; COMPUTER SOFTWARE FOR AUTOMATING CLINICAL, FINANCIAL AND ADMINISTRATIVE HEALTHCARE PROCESSES AND CONDUCTING HEALTH RELATED TRANSACTIONS VIA COMPUTER AND COMMUNICATION NETWORKS (U.S. CLS. 21, 23, 26, 36 AND 38).

CLASS 42—SCIENTIFIC AND COMPUTER SERVICES

FOR PROVIDING ONLINE NON-DOWNLOADABLE COMPUTER SOFTWARE FOR USE IN THE HEALTHCARE FIELD, NAMELY, SOFTWARE FOR MANAGING, STORING, ANALYZING, MAINTAINING, PROCESSING, STRUCTURING, REVIEWING, BUILDING, EDITING, DISTRIBUTING, COMMUNICATING, ORGANIZING, SHARING, REFERENCING, MONITORING AND INTEGRATING HEALTHCARE INFORMATION; PROVIDING ONLINE NON-DOWNLOADABLE COMPUTER SOFTWARE FOR AUTOMATING CLINICAL, FINANCIAL AND ADMINISTRATIVE HEALTHCARE PROCESSES AND CONDUCTING HEALTH RELATED TRANSACTIONS VIA COMPUTER AND COMMUNICATION NETWORKS; DESIGN FOR OTHERS OF COMPUTER SOFTWARE FOR USE IN THE HEALTHCARE FIELD; IMPLEMENTATION, MAINTENANCE AND REPAIR OF COMPUTER SOFTWARE FOR USE IN THE HEALTHCARE FIELD; TECHNICAL SUPPORT SERVICES, NAMELY, TROUBLESHOOTING OF HEALTHCARE SOFTWARE VIA TELEPHONE, ELECTRONIC AND ON-SITE COMMUNICATION (U.S. CLS. 100 AND 101).

CLASS 44—MEDICAL, BEAUTY AND AGRICULTURAL SERVICES

FOR HEALTHCARE CONSULTATION SERVICES (U.S. CLS. 100 AND 101).

JAMES STEIN, EXAMINING ATTORNEY

SN 85-477,565. RITCHIE, CAROL A., CLARKSTON, MI. FILED 11-21-2011.



THE COLOR(S) PINK AND BLACK IS/ARE CLAIMED AS A FEATURE OF THE MARK.

THE MARK CONSISTS OF THE STYLIZED WORDS "AFTER PINK" IN PINK; SITTING ATOP THE "N" IN THE WORD "PINK" IS AN IMAGE OF A WOMAN WEARING A PINK EARRING AND PINK WRAP AROUND HER NECK.

CLASS 41—EDUCATION AND ENTERTAINMENT

FOR PROVIDING INTERNET BASED EDUCATION SERVICES IN THE NATURE OF PROGRAMS AND PRESENTATIONS TO ADDRESS THE PHYSICAL, PSYCHOLOGICAL AND SOCIAL ISSUES FOLLOWING BREAST CANCER AND BREAST CANCER TREATMENT (U.S. CLS. 100, 101 AND 107).

CLASS 45—PERSONAL AND LEGAL SERVICES

FOR ORGANIZING AND CONDUCTING SUPPORT GROUPS FOR WOMEN ADDRESSING THE EFFECTS OF BREAST CANCER AND BREAST CANCER TREATMENT; PROVIDING PERSONAL SUPPORT SERVICES TO ASSIST WOMEN WITH PHYSICAL, PSYCHOLOGICAL AND SOCIAL ISSUES FOLLOWING BREAST CANCER AND BREAST CANCER TREATMENT; PROVIDING INTERNET BASED INFORMATION SERVICES IN THE FIELD OF PROMOTING PERSONAL SUPPORT SERVICES TO ADDRESS THE PHYSICAL, PSYCHOLOGICAL AND SOCIAL ISSUES FOLLOWING BREAST CANCER AND BREAST CANCER TREATMENT (U.S. CLS. 100 AND 101).

SEAN CROWLEY, EXAMINING ATTORNEY

SN 85-477,991. ADDISON M. FISCHER, NAPLES, FL. FILED S.R. 11-21-2011; AM. P.R. 6-27-2012.

FOOD & THOUGHT

THE MARK CONSISTS OF STANDARD CHARACTERS WITHOUT CLAIM TO ANY PARTICULAR FONT, STYLE, SIZE, OR COLOR.

NO CLAIM IS MADE TO THE EXCLUSIVE RIGHT TO USE "FOOD", APART FROM THE MARK AS SHOWN.

CLASS 35—ADVERTISING AND BUSINESS

FOR RETAIL STORE SERVICES FEATURING GREEN AND ECO-FRIENDLY PRODUCTS IN THE NATURE OF ORGANIC FOODS AND SUPPLEMENTS (U.S. CLS. 100, 101 AND 102).

FIRST USE 2-22-2005; IN COMMERCE 2-22-2005.

CLASS 43—HOTEL AND RESTAURANT SERVICES

FOR FOOD PREPARATION SERVICES FEATURING ORGANIC MEALS (U.S. CLS. 100 AND 101).

FIRST USE 2-22-2005; IN COMMERCE 2-22-2005.

DAWN HAN, EXAMINING ATTORNEY

SN 85-478,185. ROLAND CORPORATION, SHIZUOKA, JAPAN, FILED 11-21-2011.

BOSS

THE MARK CONSISTS OF STANDARD CHARACTERS WITHOUT CLAIM TO ANY PARTICULAR FONT, STYLE, SIZE, OR COLOR.

OWNER OF U.S. REG. NOS. 1,150,998, 1,151,665 AND 1,468,044.

CLASS 9—ELECTRICAL AND SCIENTIFIC APPARATUS

FOR ANALOG OR DIGITAL EFFECTS PEDALS FOR VOCAL OR RECORDED SOUND; GRAPHIC EQUALIZERS; DIGITAL AUDIO RECORDERS; AUDIO PLAYERS AND RECORDERS WITH BUILT-IN GUITAR EFFECTS; ELECTRONIC METRONOMES (U.S. CLS. 21, 23, 26, 36 AND 38).

FIRST USE 0-0-1976; IN COMMERCE 0-0-1976.

CLASS 15—MUSICAL INSTRUMENTS

FOR ELECTRONIC SOUND EFFECTORS FOR MUSICAL INSTRUMENTS AND PARTS AND FITTINGS; ELECTRONIC RHYTHM MACHINES; TUNERS FOR USE WITH MUSICAL INSTRUMENTS; VOLUME PEDALS FOR MUSICAL INSTRUMENTS; FOOT SWITCHES FOR MUSICAL INSTRUMENTS, EFFECTORS OR RHYTHM MACHINES; PEDAL BOARDS FOR ELECTRONIC MUSICAL INSTRUMENT SOUND EFFECTORS; FITTED BAGS FOR ELECTRONIC MUSICAL INSTRUMENT SOUND EFFECTORS; ELECTRONIC MUSICAL INSTRUMENTS, NAMELY, MUSIC SYNTHESIZERS (U.S. CLS. 2, 21 AND 36).

FIRST USE 6-12-1976; IN COMMERCE 6-12-1976.

JEFFREY LOOK, EXAMINING ATTORNEY

SN 85-478,334. PERFECT WORLD EUROPE, B.V., 1101 BA AMSTERDAM, NETHERLANDS, FILED 11-21-2011.



OWNER OF U.S. REG. NO. 3,871,551.

THE COLOR(S) BLUE, DARK BLUE, GREY AND SILVER IS/ARE CLAIMED AS A FEATURE OF THE MARK.

THE MARK CONSISTS OF THE WORDS "WAR OF THE IMMORTALS" IN SILVER WITH GREY BORDERS; THE WORDS APPEAR WITHIN A SHIELD DESIGN CONTAINING POINTED BLADES STICKING OUTWARD; THE INTERIOR OF THE SHIELD IS BLUE BECOMING DARK BLUE TOWARD THE CORNERS OF THE SHIELD; THE POINTED BLADES BORDER FOR THE SHIELD IS SILVER.

CLASS 9—ELECTRICAL AND SCIENTIFIC APPARATUS

FOR COMPUTER APPLICATION DEVICES FOR MOBILE SOFTWARE FOR PLAYING ELECTRONIC GAMES (U.S. CLS. 21, 23, 26, 36 AND 38).

FIRST USE 11-9-2011; IN COMMERCE 11-9-2011.

CLASS 41—EDUCATION AND ENTERTAINMENT

FOR ENTERTAINMENT SERVICES, NAMELY, PROVIDING ON-LINE ELECTRONIC GAMES; ENTERTAINMENT SERVICES, NAMELY, PROVIDING ON-LINE ROLE PLAYING COMPUTER GAMES; ENTERTAINMENT SERVICES IN THE NATURE OF AN ON-LINE INTERACTIVE COMPUTER GAME PROVIDED BY MEANS OF A GLOBAL COMPUTER NETWORK (U.S. CLS. 100, 101 AND 107).

FIRST USE 11-9-2011; IN COMMERCE 11-9-2011.

HENRY S. ZAK, EXAMINING ATTORNEY

SN 85-479,289. UNITED RENTALS, INC., GREENWHICH, CT. FILED 11-22-2011.

READY WHEN YOU ARE

THE MARK CONSISTS OF STANDARD CHARACTERS WITHOUT CLAIM TO ANY PARTICULAR FONT, STYLE, SIZE, OR COLOR.

CLASS 35—ADVERTISING AND BUSINESS

FOR ON-LINE RETAIL STORE SERVICES FEATURING NEW AND USED CONSTRUCTION AND INDUSTRIAL EQUIPMENT (U.S. CLS. 100, 101 AND 102).

CLASS 37—CONSTRUCTION AND REPAIR

FOR ON-LINE RENTAL SERVICES FEATURING CONSTRUCTION EQUIPMENT; ON-LINE RENTAL SERVICES FEATURING CONSTRUCTION AND INDUSTRIAL EQUIPMENT IN THE NATURE OF CLEANING EQUIPMENT, EARTH MOVING EQUIPMENT, AIR COMPRESSORS, AIR TOOLS, COMPACTORS, CRANES FOR CONSTRUCTION PURPOSES, MOBILE LIGHT TOWERS FOR CONSTRUCTION PURPOSES, PLUMBING EQUIPMENT, POWER TOOLS, PRESSURE WASHERS, PUMPS FOR CONSTRUCTION PURPOSES, AND SURFACE PREPARATION EQUIPMENT (U.S. CLS. 100, 103 AND 106).

CLASS 39—TRANSPORTATION AND STORAGE

FOR ON-LINE RENTAL SERVICES FEATURING CONSTRUCTION AND INDUSTRIAL EQUIPMENT IN THE NATURE OF AERIAL LIFTS, FORKLIFTS, CRANES FOR LOADING AND UNLOADING PURPOSES, POWER DISTRIBUTION EQUIPMENT, TRAFFIC CONTROL EQUIPMENT, TRUCKS, TRAILERS, AND UTILITY VEHICLES (U.S. CLS. 100 AND 105).

CLASS 40—MATERIAL TREATMENT

FOR ON-LINE RENTAL SERVICES FEATURING CONSTRUCTION AND INDUSTRIAL EQUIPMENT IN THE NATURE OF SPACE COOLING UNITS, INDUSTRIAL AIR CONDITIONERS, MOBILE CHILLERS, GENERATORS, REMEDIATION AND WELDING EQUIPMENT (U.S. CLS. 100, 103 AND 106).

CLASS 42—SCIENTIFIC AND COMPUTER SERVICES

FOR ON-LINE RENTAL SERVICES FEATURING SURVEYING EQUIPMENT (U.S. CLS. 100 AND 101).

CLASS 44—MEDICAL, BEAUTY AND AGRICULTURAL SERVICES

FOR ON-LINE RENTAL SERVICES FEATURING CONSTRUCTION AND INDUSTRIAL EQUIPMENT IN THE NATURE OF LAWN AND LANDSCAPING EQUIPMENT (U.S. CLS. 100 AND 101).

CLASS 45—PERSONAL AND LEGAL SERVICES

FOR ON-LINE RENTAL SERVICES FEATURING TRENCH SAFETY CONSTRUCTION EQUIPMENT (U.S. CLS. 100 AND 101).
VIVIAN MICZNIK FIRST, EXAMINING ATTORNEY

CLASS 31—NATURAL AGRICULTURAL PRODUCTS

FOR PET FOOD; EDIBLE PET TREATS; EDIBLE DOG CHEWS (U.S. CLS. 1 AND 46).
ALICIA COLLINS, EXAMINING ATTORNEY

SN 85-480,282. HESS CORPORATION, NEW YORK, NY.
FILED 11-23-2011.



Small Business Services

SN 85-480,000. ONLY NATURAL PET STORE, LLC,
BOULDER, CO. FILED 11-23-2011.

OWNER OF U.S. REG. NOS. 836,173, 3,334,717 AND OTHERS.

NO CLAIM IS MADE TO THE EXCLUSIVE RIGHT TO USE "SMALL BUSINESS SERVICES", APART FROM THE MARK AS SHOWN.

THE MARK CONSISTS OF THE STYLIZED WORDING "HESS SMALL BUSINESS SERVICES" WITH THE WORD "HESS" WITHIN A RECTANGLE DESIGN.

I AND LOVE AND YOU

THE MARK CONSISTS OF STANDARD CHARACTERS WITHOUT CLAIM TO ANY PARTICULAR FONT, STYLE, SIZE, OR COLOR.

CLASS 3—COSMETICS AND CLEANING PREPARATIONS

FOR HOME DENTAL CARE PRODUCTS FOR DOGS AND CATS, NAMELY, HERBAL DENTAL SPRAY; PET SHAMPOO AND CONDITIONER; NON-MEDICATED GROOMING PREPARATIONS FOR DOGS AND CATS, NAMELY, TEAR STAIN REMOVERS; ESSENTIAL OILS FOR PETS (U.S. CLS. 1, 4, 6, 50, 51 AND 52).

CLASS 5—PHARMACEUTICALS

FOR DIETARY SUPPLEMENTS FOR PETS; DIETARY PET SUPPLEMENTS IN THE FORM OF PET TREATS; VITAMINS FOR PETS; MEDICINAL HERBAL PREPARATIONS FOR PETS; MEDICINAL HOMEOPATHIC PREPARATIONS AND MEDICINAL PREPARATIONS CONTAINING FLOWER ESSENCES FOR PETS FOR OVERALL HEALTH AND ENERGY AND STRESS RELIEF; HERBAL ANTI-ITCH AND SORE SKIN OINTMENT FOR PETS; FLEA AND TICK CONTROL PRODUCTS, NAMELY, POWDERS, SPRAYS, OILS, COLLARS, AND TAGS; EAR CARE PRODUCTS FOR DOGS AND CATS, NAMELY, MEDICINAL HERBAL PREPARATIONS FOR DISINFECTING; EYE CARE PRODUCTS FOR DOGS AND CATS, NAMELY, EYE WASHES (U.S. CLS. 6, 18, 44, 46, 51 AND 52).

CLASS 35—ADVERTISING AND BUSINESS

FOR MARKETING OF NATURAL GAS AND ELECTRICITY; BUSINESS CONSULTING IN THE FIELD OF ENVIRONMENTAL MANAGEMENT, NAMELY, ADVISING BUSINESSES ON ISSUES OF ENVIRONMENTAL IMPACT, CONSERVATION AND PRESERVATION; BUSINESS MANAGEMENT AND ADVISORY SERVICES; BUSINESS CONSULTING SERVICES REGARDING THE MANAGING, THE TIMING AND THE QUANTITIES OF ENERGY PURCHASES; PROVIDING BUSINESS AND CONSUMER INFORMATION ON ENERGY MARKETS AS WELL AS NATURAL GAS AND ELECTRICITY; RETAIL ENERGY PROVIDER SERVICES, NAMELY, PROVIDING A SERVICE THAT ALLOWS CUSTOMERS TO PURCHASE ENERGY, NAMELY, NATURAL GAS AND ELECTRICITY; ENERGY MANAGEMENT SERVICES, NAMELY, PROVIDING A SERVICE THAT ALLOWS CUSTOMERS TO PURCHASE ENERGY, NAMELY, ELECTRICITY AND NATURAL GAS AT A FIXED PRICE; ENERGY MANAGEMENT SERVICES, NAMELY, PROVIDING A SERVICE THAT ALLOWS CUSTOMERS TO PURCHASE ENERGY, NAMELY, ELECTRICITY AT MARKET RATES; ENERGY ASSESSMENT SERVICES FOR THE PURPOSE OF DETERMINING ENERGY EFFICIENCY OR USAGE MANAGEMENT; ENERGY USAGE MANAGEMENT; ENERGY USAGE MANAGEMENT INFORMATION SERVICES (U.S. CLS. 100, 101 AND 102).

FIRST USE 8-1-2011; IN COMMERCE 8-1-2011.

CLASS 39—TRANSPORTATION AND STORAGE

FOR ELECTRICITY DISTRIBUTION (U.S. CLS. 100 AND 105).

FIRST USE 8-1-2011; IN COMMERCE 8-1-2011.
BRIAN PINO, EXAMINING ATTORNEY

SN 85-480,298. CAESARS WORLD, INC., LAS VEGAS, NV.
FILED 11-23-2011.

Reign

THE MARK CONSISTS OF STANDARD CHARACTERS WITHOUT CLAIM TO ANY PARTICULAR FONT, STYLE, SIZE, OR COLOR.

CLASS 35—ADVERTISING AND BUSINESS

FOR BUSINESS MANAGEMENT OF HOTELS AND MOTELS AND OTHER TEMPORARY ACCOMMODATION INCLUDING SERVICED APARTMENTS AND APARTMENT HOTELS; PUBLIC RELATIONS SERVICES IN RELATION TO TEMPORARY ACCOMMODATION, INCLUDING HOTELS AND MOTELS, SERVICED APARTMENTS AND APARTMENT HOTELS; MARKETING OF TEMPORARY ACCOMMODATION INCLUDING HOTELS AND MOTELS, SERVICED APARTMENTS AND APARTMENT HOTELS INCLUDING THE ADVERTISING OF THE AFOREMENTIONED SERVICES VIA THE INTERNET AND OTHER GLOBAL COMPUTER NETWORKS (U.S. CLS. 100, 101 AND 102).

CLASS 43—HOTEL AND RESTAURANT SERVICES

FOR PROVIDING TEMPORARY HOUSING ACCOMMODATIONS; PROVIDING HOTEL AND TEMPORARY ACCOMMODATIONS RESERVATION SERVICES; HOTEL SERVICES; PROVIDING TEMPORARY HOUSING ACCOMMODATIONS IN THE NATURE OF BRANDED RESIDENCES, SERVICED APARTMENTS, AND RESIDENTIAL APARTMENTS; RESIDENTIAL HOTEL SERVICES; RESORT HOTEL SERVICES; RESTAURANT SERVICES; BAR AND LOUNGE SERVICES; PROVISION OF CONFERENCE, EXHIBITION AND MEETING FACILITIES (U.S. CLS. 100 AND 101).

ERIN FALK, EXAMINING ATTORNEY

SN 85-480,798. CONVENTION OF INDEPENDENT FINANCIAL ADVISORS - CIFA, GENEVA 3, SWITZERLAND, FILED 11-25-2011.



PRIORITY CLAIMED UNDER SEC. 44(D) ON SWITZERLAND APPLICATION NO. 56671/2011, FILED 6-3-2011, REG. NO. 621141, DATED 6-3-2011, EXPIRES 6-3-2021.

NO CLAIM IS MADE TO THE EXCLUSIVE RIGHT TO USE "CONVENTION OF INTERNATIONAL FINANCIAL ADVISORS" OR "A NON-PROFIT FOUNDATION", APART FROM THE MARK AS SHOWN.

THE COLOR(S) RED AND BLACK IS/ARE CLAIMED AS A FEATURE OF THE MARK.

THE MARK CONSISTS OF THE LETTERING "CIFA" APPEARING WITHIN RED BLOCKS WITH THE WORDING "CONVENTION OF INDEPENDENT FINANCIAL ADVISORS" APPEARING TO THE RIGHT OF THE BLOCKS IN RED AND THE WORDING "A NON-PROFIT FOUNDATION" APPEARING IN BLACK BELOW THE WORDING "CONVENTION OF INDEPENDENT FINANCIAL ADVISORS" AND ALSO TO THE RIGHT OF THE BLOCKS. THE COLOR WHITE IN THE MARK REPRESENTS BACKGROUND AND/OR TRANSPARENT AREAS AND IS NOT PART OF THE MARK.

CLASS 16—PAPER GOODS AND PRINTED MATTER

FOR MAGAZINES AND PERIODICALS IN THE FIELD OF FINANCIAL AFFAIRS (U.S. CLS. 2, 5, 22, 23, 29, 37, 38 AND 50).

CLASS 41—EDUCATION AND ENTERTAINMENT

FOR TRAINING AND TEACHING RELATING TO FINANCIAL AFFAIRS, ASSET MANAGEMENT, WEALTH MANAGEMENT, FUND MANAGEMENT; TRAINING AND TEACHING REGARDING LEGISLATION RELATING TO FINANCIAL AFFAIRS, ASSET MANAGEMENT, WEALTH MANAGEMENT, FUND MANAGEMENT; EDUCATIONAL SERVICES, NAMELY, SEMINARS, WORKSHOPS, CLASSES RELATING TO FINANCIAL AFFAIRS, ASSET MANAGEMENT, WEALTH MANAGEMENT, FUND MANAGEMENT; EDUCATIONAL SERVICES, NAMELY, SEMINARS, WORKSHOPS, CLASSES REGARDING LEGISLATION RELATING TO FINANCIAL AFFAIRS, ASSET MANAGEMENT, WEALTH MANAGEMENT, FUND MANAGEMENT (U.S. CLS. 100, 101 AND 107).

CLASS 45—PERSONAL AND LEGAL SERVICES

FOR LEGAL SERVICES IN THE FIELD OF FINANCIAL AFFAIRS (U.S. CLS. 100 AND 101).

MARK SHINER, EXAMINING ATTORNEY

SN 85-480,800. CONVENTION OF INDEPENDENT FINANCIAL ADVISORS - CIFA, GENEVA 3, SWITZERLAND, FILED 11-25-2011.



PRIORITY CLAIMED UNDER SEC. 44(D) ON SWITZERLAND APPLICATION NO. 56670/2011, FILED 6-3-2011, REG. NO. 621140, DATED 6-3-2011, EXPIRES 6-3-2021.

NO CLAIM IS MADE TO THE EXCLUSIVE RIGHT TO USE "CONVENTION OF INDEPENDENT FINANCIAL ADVISORS" OR "A NON-PROFIT FOUNDATION", APART FROM THE MARK AS SHOWN.

THE COLOR(S) RED AND BLACK IS/ARE CLAIMED AS A FEATURE OF THE MARK.

THE MARK CONSISTS OF THE LETTERING "CIFA" APPEARING WITHIN RED BLOCKS WITH THE WORDING "CONVENTION OF INDEPENDENT FINANCIAL ADVISORS" APPEARING TO THE RIGHT OF THE BLOCKS IN RED AND THE WORDING "A NON-PROFIT FOUNDATION" APPEARING IN BLACK BELOW THE WORDING "CONVENTION OF INDEPENDENT FINANCIAL ADVISORS" AND ALSO TO THE RIGHT OF THE BLOCKS. THE COLOR WHITE IN THE MARK REPRESENTS BACKGROUND AND/OR TRANSPARENT AREAS AND IS NOT PART OF THE MARK.

CLASS 16—PAPER GOODS AND PRINTED MATTER

FOR MAGAZINES AND PERIODICALS IN THE FIELD OF FINANCIAL AFFAIRS (U.S. CLS. 2, 5, 22, 23, 29, 37, 38 AND 50).

CLASS 41—EDUCATION AND ENTERTAINMENT

FOR TRAINING AND TEACHING RELATING TO FINANCIAL AFFAIRS, ASSET MANAGEMENT, WEALTH MANAGEMENT, FUND MANAGEMENT; TRAINING AND TEACHING REGARDING LEGISLATION RELATING TO FINANCIAL AFFAIRS, ASSET MANAGEMENT, WEALTH MANAGEMENT, FUND MANAGEMENT; EDUCATIONAL SERVICES, NAMELY, SEMINARS, WORKSHOPS, CLASSES RELATING TO FINANCIAL AFFAIRS, ASSET MANAGEMENT, WEALTH MANAGEMENT, FUND MANAGEMENT; EDUCATIONAL SERVICES, NAMELY, SEMINARS, WORKSHOPS, CLASSES REGARDING LEGISLATION RELATING TO FINANCIAL AFFAIRS, ASSET MANAGEMENT, WEALTH MANAGEMENT, FUND MANAGEMENT (U.S. CLS. 100, 101 AND 107).

CLASS 45—PERSONAL AND LEGAL SERVICES

FOR LEGAL SERVICES IN THE FIELD OF FINANCIAL AFFAIRS (U.S. CLS. 100 AND 101).
MARK SHINER, EXAMINING ATTORNEY

CLASS 35—ADVERTISING AND BUSINESS

FOR ALPHANUMERIC REGISTRY SERVICES, NAMELY, MAINTAINING A REGISTRY OF ALPHANUMERIC NAMES TO BE USED AS PERSONAL TELEPHONE NUMBERS; PROVIDING A WEBSITE FEATURING A REGISTRY OF ALPHANUMERIC NAMES TO BE USED AS PERSONAL TELEPHONE NUMBERS; BUSINESS SERVICES, NAMELY, TRACKING AND MONITORING OF CALLS FOR OTHERS IN RESPONSE TO ADVERTISING ADS; MANAGEMENT OF TELEPHONE CALL CENTERS FOR OTHERS; OPERATION OF TELEPHONE CALL CENTERS FOR OTHERS; PROVIDING A WEBSITE FEATURING ONLINE REGISTRATION SERVICES FOR ALPHANUMERIC NAMES TO BE USED AS PERSONAL TELEPHONE NUMBERS; SERVICES CONSISTING OF THE REGISTRATION, COLLECTION, TRANSCRIPTION, COMPILATION AND SYSTEMIZATION OF WRITTEN COMMUNICATIONS AND DATA; BUSINESS ADMINISTRATION AND MANAGEMENT; BUSINESS MANAGEMENT PLANNING; COMMERCIAL AND INDUSTRIAL MANAGEMENT ASSISTANCE; COMMERCIAL MANAGEMENT; COMPUTERIZED REGISTER MANAGEMENT; COMPUTERIZED DATABASE MANAGEMENT; DATABASE MANAGEMENT; FINANCIAL RECORD-KEEPING OF ALPHANUMERIC NAMES FOR REGULATORY COMPLIANCE PURPOSES; PROVIDING AN INTERNET-BASED DATABASE OF ALPHANUMERIC NAMES DESIGNED TO FACILITATE RECORDS OF ALPHANUMERIC NAMES TO BE USED AS PERSONAL TELEPHONE NUMBERS AS A MEANS OF TELEPHONE DIRECTORY; COMMERCIAL ADMINISTRATION OF THE LICENSING OF ALPHANUMERIC NAMES OF OTHERS TO BE USED AS PERSONAL TELEPHONE NUMBERS; TELEPHONE DIRECTORY INFORMATION; TELEPHONE DIRECTORY ASSISTANCE SERVICES (U.S. CLS. 100, 101 AND 102).

CLASS 38—COMMUNICATION

FOR DIGITAL NETWORK TELECOMMUNICATIONS SERVICES; DATA TRANSMISSION AND RECEPTION SERVICES VIA TELECOMMUNICATION MEANS; PROVIDING TELECOMMUNICATIONS CONNECTIONS TO THE INTERNET OR DATABASES; PROVIDING TELECOMMUNICATION CONNECTIVITY SERVICES FOR TRANSFER OF IMAGES, MESSAGES, AUDIO, VISUAL, AUDIOVISUAL AND MULTIMEDIA WORKS; PROVIDING THIRD PARTY USERS WITH ACCESS TO TELECOMMUNICATION INFRASTRUCTURE; TELECOMMUNICATION ACCESS SERVICES; TELECOMMUNICATION SERVICES, NAMELY, LOCAL AND LONG DISTANCE TRANSMISSION OF VOICE, DATA, GRAPHICS BY MEANS OF TELEPHONE, TELEGRAPHIC, CABLE, AND SATELLITE TRANSMISSIONS; TELECOMMUNICATION SERVICES, NAMELY, WIRELESS TELEPHONE SERVICES; TELECOMMUNICATION SERVICES IN THE NATURE OF PROVIDING TELEPHONE FEATURES, NAMELY, CALL WAITING, SPEED DIALING SERVICES, ALPHANUMERIC DIALING SERVICES, CALL IDENTIFICATION, CALL FORWARDING, AND MESSAGE WAITING; TELECOMMUNICATIONS CONSULTATION; TELECOMMUNICATIONS SERVICES, NAMELY, PERSONAL COMMUNICATION SERVICES; TELECOMMUNICATIONS SERVICES, NAMELY, WIRELESS TELEPHONY AND WIRELESS BROADBAND COMMUNICATIONS SERVICES FOR THE TRANSMISSION OF VOICE AND DATA; TRANSMISSION OF DATABASE INFORMATION VIA TELECOMMUNICATIONS NETWORKS; WIRELESS TELEPHONE TELECOMMUNICATIONS SERVICES, NAMELY, WIRELESS MOBILE TELEPHONE CALLING PLANS; TELECOMMUNICATION SERVICES, NAMELY, PROVIDING ADVANCED CALLING FEATURES, NAMELY, PROVIDING ACCESS TO DATABASES OF ALPHANUMERIC NAMES TO BE USED AS PERSONAL TELEPHONE NUMBERS; TELEPHONE CALL COMPLETION SERVICES FOR DIRECTORY ASSISTANCE CUSTOMERS; VOICE-ACTIVATED DIALING SERVICES; TRANSMISSION AND RECEPTION OF DATABASE INFORMATION VIA THE TELECOMMUNICATION NETWORK; COMMUNICATION SERVICES, NAMELY, PROVIDING ELECTRONIC TRANSMISSION OF INFORMATION STORED IN A DATABASE VIA INTERACTIVELY COMMUNICATING COMPUTER SYSTEMS; PBX DIALING SERVICES (U.S. CLS. 100, 101 AND 104).
STEVEN JACKSON, EXAMINING ATTORNEY

SN 85-481,068. NTTM (NAME TO TELEPHONE MAPPING) LIMITED, NICOSIA, CYPRUS, FILED 11-27-2011.



THE COLOR(S) BLACK AND PINK IS/ARE CLAIMED AS A FEATURE OF THE MARK.
THE MARK CONSISTS OF A DESIGN OF BLACK LEFT PARENTHESIS AND PINK COLON.

SN 85-481,427. THE NATIONAL TRUST (ENTERPRISES) LIMITED, SWINDON, UNITED KINGDOM, FILED 11-28-2011.

CLIVEDEN

THE MARK CONSISTS OF STANDARD CHARACTERS WITHOUT CLAIM TO ANY PARTICULAR FONT, STYLE, SIZE, OR COLOR.

OWNER OF UNITED KINGDOM REG. NO. 2601957, DATED 2-24-2012, EXPIRES 11-16-2021.

CLASS 30—STAPLE FOODS

FOR COFFEE, TEA, COCOA, SUGAR, RICE, TAPIOCA, SAGO, ARTIFICIAL COFFEE; FLOURS AND PREPARATIONS MADE FROM CEREALS, NAMELY, CEREALS FOR EATING AND CEREAL BASED SNACKS; BREAD, PASTRY AND CONFECTIONERY, NAMELY, COOKIES, AND CANDY; EDIBLE ICES; HONEY, TREACLE; YEAST, BAKING-POWDER; SALT; MUSTARD; VINEGAR, SAUCES AS CONDIMENTS; SPICES; ICE; SANDWICHES; PIZZAS, PIES, AND PASTA DISHES (U.S. CL. 46).

CLASS 43—HOTEL AND RESTAURANT SERVICES

FOR SERVICES FOR PROVIDING FOOD AND DRINK; PROVIDING TEMPORARY HOUSING ACCOMMODATIONS; RESTAURANT, BAR AND CATERING SERVICES; PROVISION OF HOLIDAY ACCOMMODATION, NAMELY, PROVISION OF TEMPORARY HOUSING ACCOMMODATIONS, BOOKING AND RESERVATION SERVICES FOR RESTAURANTS AND HOLIDAY TEMPORARY HOUSING ACCOMMODATION; RETIREMENT HOME SERVICES; PROVISION OF HOTEL ACCOMMODATION SERVICES (U.S. CLS. 100 AND 101).

RUDY R. SINGLETON, EXAMINING ATTORNEY

SN 85-481,594. YES GROUP, INC., NEW YORK, NY. FILED 11-28-2011.

THE MARK CONSISTS OF THE LETTERS "C" AND "G" SHOWN CONSECUTIVELY AND INTERSECTED BY A ZERO.

CLASS 9—ELECTRICAL AND SCIENTIFIC APPARATUS

FOR SPECTACLES, EYEGLASSES, SPORTS GOGGLES, SKI GOGGLES, SUNGLASSES, OPTICAL FRAMES AND MOTORCYCLE GOGGLES, AND LAPTOP CASES (U.S. CLS. 21, 23, 26, 36 AND 38).

CLASS 18—LEATHER GOODS

FOR HANDBAGS, TOTE BAGS, LUGGAGE, WALLETS, MAKE UP CASES SOLD EMPTY, BACKPACKS, SUITCASES, PET CARRIERS (U.S. CLS. 1, 2, 3, 22 AND 41).

MICHAEL WEBSTER, EXAMINING ATTORNEY

SN 85-482,133. RUNDU L. STAGGERS, ATLANTA, GA. FILED 11-28-2011.

RUNDU

THE MARK CONSISTS OF STANDARD CHARACTERS WITHOUT CLAIM TO ANY PARTICULAR FONT, STYLE, SIZE, OR COLOR.

THE NAME(S), PORTRAIT(S), AND/OR SIGNATURE(S) SHOWN IN THE MARK DOES NOT IDENTIFY A PARTICULAR LIVING INDIVIDUAL.

CLASS 9—ELECTRICAL AND SCIENTIFIC APPARATUS

FOR DIGITAL MEDIA, NAMELY PRE-RECORDED VIDEOCASSETTES, DVDS AND DOWNLOADABLE AUDIO AND VIDEO RECORDINGS FEATURING MEN (U.S. CLS. 21, 23, 26, 36 AND 38).

FIRST USE 9-1-1990; IN COMMERCE 1-1-1999.

CLASS 16—PAPER GOODS AND PRINTED MATTER

FOR CALENDARS AND PICTURE BOOKS FEATURING MEN (U.S. CLS. 2, 5, 22, 23, 29, 37, 38 AND 50).

FIRST USE 9-1-1990; IN COMMERCE 1-1-1991.

CLASS 35—ADVERTISING AND BUSINESS

FOR PROVIDING A WEBSITE WITH LINKS TO MERCHANDISE FEATURING PHOTOGRAPHY IMAGES OF MEN AND WOMEN, VIDEO RECORDINGS OF MEN, ARTICLES, FICTION AND FEATURE STORIES FOCUSING ON MEN FOR RETAIL PURPOSES (U.S. CLS. 100, 101 AND 102).

FIRST USE 9-1-1990; IN COMMERCE 9-1-1999.

CLASS 41—EDUCATION AND ENTERTAINMENT

FOR ENTERTAINMENT SERVICES, NAMELY, LIVE PERFORMANCE SHOWS FEATURING MEN; PROVIDING A WEBSITE FEATURING PHOTOGRAPHY IMAGES OF MEN AND WOMEN, VIDEO RECORDINGS OF MEN, ARTICLES, FICTION AND FEATURE STORIES FOCUSING ON MEN FOR ENTERTAINMENT PURPOSES (U.S. CLS. 100, 101 AND 107).

FIRST USE 9-1-1990; IN COMMERCE 1-1-1993.

ARETHA SOMERVILLE, EXAMINING ATTORNEY

SN 85-483,512. THE PIP VAULT LLC, PHOENIX, AZ. FILED 11-30-2011.



THE COLOR(S) WHITE, PANTONE BLUE 072C, BURGUNDY IS/ARE CLAIMED AS A FEATURE OF THE MARK.

THE MARK CONSISTS OF ON THE LEFT A FANCY SHIELD IN BURGUNDY AND WHITE, AND A LIGHT BULB INSIDE THE SHIELD WITH A SHIELD SHAPED FILAMENT AND A STYLIZED SQUIGGLE ALL IN PANTONE BLUE AND TO THE RIGHT THE WORD "TRAK-LIGHT" HAS A STYLIZED "T" AND "L" IN BURGUNDY AND A "RAK" AND "IGHT" IN PANTONE BLUE.

CLASS 35—ADVERTISING AND BUSINESS

FOR BUSINESS CONSULTATION IN THE FIELD OF ONLINE CONSULTING AND INFORMATION SERVICES IN THE FIELD OF MANAGING INTELLECTUAL PROPERTIES (U.S. CLS. 100, 101 AND 102).

FIRST USE 9-30-2011; IN COMMERCE 10-31-2011.

CLASS 45—PERSONAL AND LEGAL SERVICES

FOR LEGAL SERVICES, NAMELY, INTELLECTUAL PROPERTY CONSULTING SERVICES IN THE FIELD OF IDENTIFICATION, STRATEGY, ANALYTICS, AND INVENTION (U.S. CLS. 100 AND 101).

FIRST USE 9-30-2011; IN COMMERCE 10-31-2011.
BRIAN NEVILLE, EXAMINING ATTORNEY

CLASS 35—ADVERTISING AND BUSINESS

FOR BUSINESS AND MANAGEMENT RESEARCH AND CONSULTING SERVICES IN THE FIELD OF GOVERNMENT AGENCY MANAGEMENT AND LOGISTICS; PROCUREMENT CONSULTING, NAMELY, CONSULTING IN THE OUTSOURCING OF FACILITIES AND HUMAN CAPITAL MANAGEMENT SERVICES; BUSINESS SERVICES, NAMELY, FACILITIES MANAGEMENT OF TECHNICAL OPERATION; PROJECT MANAGEMENT SERVICES FOR OTHERS FOR BUSINESS PURPOSES IN THE FIELDS OF PUBLIC WORKS; HUMAN RESOURCE MANAGEMENT; ENGINEERING ECONOMICS AND COST ENGINEERING, NAMELY, COST ANALYSIS; HUMAN CAPITAL MANAGEMENT, OUTSOURCING SERVICES; BUSINESS INFORMATION MANAGEMENT; ORGANIZATIONAL IMPROVEMENT, NAMELY, BUSINESS EFFICIENCY EXPERT SERVICES; POLICY AND PROGRAM SUPPORT FOR GOVERNMENT AGENCIES, NAMELY, ANALYZING LOGISTICS AND OPERATIONS FOR COST EFFICIENCY POLICIES; CONDUCTING MARKET SURVEYS (U.S. CLS. 100, 101 AND 102).

CLASS 36—INSURANCE AND FINANCIAL

FOR FINANCIAL MANAGEMENT; FINANCIAL RESOURCE MANAGEMENT; ASSET ACQUISITION MANAGEMENT; EDUCATION AND FEDERAL GOVERNMENT RESEARCH GRANTS MANAGEMENT AND ISSUANCE; FINANCIAL INVESTMENT ANALYSIS; FINANCIAL ADVICE, NAMELY, BUDGET FORMULATION FOR OTHERS; FINANCIAL PLANNING AND PROCESS IMPROVEMENT; FINANCIAL SYSTEM MODERNIZATION PLANNING; REAL PROPERTY MANAGEMENT OF FEDERAL GOVERNMENT LAND AND FACILITIES (U.S. CLS. 100, 101 AND 102).

SN 85-485,358. LOGISTICS MANAGEMENT INSTITUTE, MCLEAN, VA. FILED 12-1-2011.

WE GET THE DETAILS RIGHT

THE MARK CONSISTS OF STANDARD CHARACTERS WITHOUT CLAIM TO ANY PARTICULAR FONT, STYLE, SIZE, OR COLOR.

CLASS 9—ELECTRICAL AND SCIENTIFIC APPARATUS

FOR COMPUTER SOFTWARE FOR USE IN STATISTICAL ANALYSIS; COMPUTER SOFTWARE FOR INVENTORY CONTROL AND MANAGEMENT, LOGISTICS MANAGEMENT, FLEET MANAGEMENT AND FLIGHT MISSION ASSESSMENT; MODELING AND SIMULATION SOFTWARE IN THE FIELDS OF MANAGEMENT, LOGISTICS, INVENTORY CONTROL, FLEET, FLIGHT MISSION AND AIRCRAFT MANAGEMENT, AND ORGANIZATIONAL DEVELOPMENT; INFORMATION TECHNOLOGY SOFTWARE, NAMELY, SOFTWARE FOR USE IN CONDUCTING CORRESPONDENCE COURSES; DATA REPOSITORY AND ANALYSIS SOFTWARE IN THE FIELDS OF COST AND TIME ANALYSIS (U.S. CLS. 21, 23, 26, 36 AND 38).

CLASS 41—EDUCATION AND ENTERTAINMENT

FOR EDUCATIONAL SERVICES, NAMELY, COURSES ON ACHIEVING ORGANIZATIONAL OBJECTIVES, USING COLLABORATIVE TECHNOLOGIES AND IMPROVING GOVERNMENT AGENCY MANAGEMENT; EMPLOYEE TRAINING IN THE FIELD OF ORGANIZATIONAL NETWORKS, INFORMATION TECHNOLOGY AND ENTERPRISE ARCHITECTURE; CERTIFICATION AND ACCREDITATION PROGRAMS, NAMELY, TRAINING IN THE FIELD OF MILITARY PROCUREMENT AND INVENTORY MANAGEMENT PRACTICES; EDUCATIONAL SERVICES, NAMELY, PROVIDING INTERNSHIPS AND APPRENTICESHIPS IN THE FIELD OF FEDERAL AGENCY MANAGEMENT; PUBLISHING AND ISSUING RESEARCH ARTICLES AND WHITE PAPERS IN THE FIELD OF LOGISTICS, ORGANIZATIONAL NETWORKS, FEDERAL DEFENSE OPERATIONS AND POLICIES, WEATHER, ASTRONOMY AND OTHER SCIENTIFIC DEVELOPMENTS RELATED TO MILITARY AND CIVIL DEFENSE OPERATIONS (U.S. CLS. 100, 101 AND 107).

CLASS 42—SCIENTIFIC AND COMPUTER SERVICES

FOR CONSULTING IN THE FIELDS OF COMPUTER ENTERPRISE ARCHITECTURE AND INFORMATION TECHNOLOGY; COMPUTER SERVICES, NAMELY, ON-SITE MANAGEMENT OF INFORMATION TECHNOLOGY (IT) SYSTEMS; SYSTEMS DEVELOPMENT; INFORMATION ASSURANCE AND CYBERSECURITY, NAMELY, DESIGN AND DEVELOPMENT OF ELECTRONIC DATA SECURITY SYSTEMS; RESEARCH AND DEVELOPMENT OF TECHNOLOGY IN THE FIELD OF GOVERNMENT MANAGEMENT; COMPUTER PROJECT MANAGEMENT SERVICES FOR PUBLIC WORKS (U.S. CLS. 100 AND 101).

DAVID TOOLEY, EXAMINING ATTORNEY

SN 85-486,633. BIANCHI 1770 S.R.L., CONEGLIANO (TV), ITALY, FILED 12-4-2011.

Innovators by design • Since 1770

PRIORITY CLAIMED UNDER SEC. 44(D) ON ERPN CMNTY TM OFC APPLICATION NO. 010315653, FILED 10-5-2011, REG. NO. 010315653, DATED 2-15-2012, EXPIRES 10-5-2021.

NO CLAIM IS MADE TO THE EXCLUSIVE RIGHT TO USE "SINCE 1770", APART FROM THE MARK AS SHOWN.

THE MARK CONSISTS OF THE WORDS "INNOVATORS BY DESIGN" AND "SINCE 1770" IN STYLIZED LETTERS SEPARATED BY A SMALL SQUARE.

CLASS 6—METAL GOODS

FOR METALS AND METAL ALLOYS; METAL BUILDING MATERIALS, NAMELY, BUILDING WALL FRAMING MADE PRIMARILY OF METAL; METAL BUILDING MATERIALS IN THE NATURE OF SOFFITS AND FASCIA; TRANSPORTABLE BUILDINGS OF METAL; MATERIALS OF METAL FOR RAILWAY TRACKS; NON-ELECTRIC CABLES AND WIRES OF COMMON METAL; IRONMONGERY AND SMALL ITEMS OF METAL HARDWARE, NAMELY, METAL KEYS AND KEYS BLANKS OF COMMON METALS AND THEIR ALLOYS FOR LOCKS AND AUTOMOBILES, AND METAL KEYS BLANKS; PIPES AND TUBES OF METAL; METAL SAFES; GOODS OF METAL NOT INCLUDED IN OTHER CLASSES, NAMELY, TRANSPONDER KEY BLANKS, KEY FOBS OF COMMON METAL, AND KEY BLANKS MADE PRIMARILY OF METAL AND ALSO CONSISTING OF PLASTIC; METAL ORES (U.S. CLS. 2, 12, 13, 14, 23, 25 AND 50).

CLASS 7—MACHINERY

FOR MACHINES, NAMELY, KEY CUTTING MACHINES, KEY MAKING MACHINES, KEY DUPLICATING MACHINES, AND CODE CUTTING KEY MACHINES; MACHINE TOOLS, NAMELY, METAL-WORKING MACHINE TOOLS, AND METAL LATHES; MOTORS AND ENGINES EXCEPT FOR LAND VEHICLES; MACHINE COUPLING AND TRANSMISSION COMPONENTS EXCEPT FOR LAND VEHICLES; AGRICULTURAL IMPLEMENTS OTHER THAN HAND-OPERATED, NAMELY, CULTIVATORS, HARVESTORS, AND DISK HARROWS; INCUBATOR FOR EGGS (U.S. CLS. 13, 19, 21, 23, 31, 34 AND 35).

CLASS 9—ELECTRICAL AND SCIENTIFIC APPARATUS

FOR SCIENTIFIC, NAUTICAL, SURVEYING, PHOTOGRAPHIC, CINEMATOGRAPHIC, OPTICAL, WEIGHING, MEASURING, SIGNALING, SUPERVISION IN THE NATURE OF CHECKING, LIFE-SAVING AND TEACHING APPARATUS AND INSTRUMENTS, NAMELY, TRANSPONDER KEYS, ELECTRONIC DEVICES FOR READING, ENCODING, AND PROGRAMMING TRANSPONDER KEYS, ELECTRONIC REMOTE KEYLESS ENTRY FOBS, TRANSPONDER KEY DETECTORS, COMPUTER SOFTWARE FOR DIAGNOSTIC AND CLONING TOOLS FOR KEY DUPLICATION, AND TRANSPONDER CIRCUIT CHIPS FOR USE IN KEYS FOR AUTOMOBILES; APPARATUS AND INSTRUMENTS FOR CONDUCTING, SWITCHING, TRANSFORMING, ACCUMULATING, REGULATING OR CONTROLLING ELECTRICITY, NAMELY, ELECTRICAL PLUGS AND SOCKETS, AND LIGHT SWITCHES; APPARATUS FOR RECORDING, TRANSMISSION OR REPRODUCTION OF SOUND OR IMAGES; BLANK MAGNETIC DATA CARRIERS AND BLANK MAGNETIC RECORDING DISCS; AUTOMATIC VENDING MACHINES AND MECHANISMS FOR COIN-OPERATED APPARATUS; AUTOMATIC DISTRIBUTION MACHINES, NAMELY, ELECTRICAL POWER DISTRIBUTION UNITS AND ELECTRICAL POWER DISTRIBUTION BLOCKS; CASH REGISTERS, CALCULATING MACHINES, DATA PROCESSING EQUIPMENT AND COMPUTERS; FIRE-EXTINGUISHING APPARATUS (U.S. CLS. 21, 23, 26, 36 AND 38).

CLASS 17—RUBBER GOODS

FOR RUBBER, GUTTA-PERCHA, ASBESTOS, MICA; GUM, NAMELY, RUBBER MATERIAL FOR RECAPPING TIRES; GOODS MADE FROM RUBBER, GUTTA-PERCHA, ASBESTOS AND MICA NOT INCLUDED IN OTHER CLASSES, NAMELY, RUBBER TUBES AND PIPES, ASBESTOS BOARDS AND ELECTRICAL INSULATING MICA PRODUCTS; EXTRUDED PLASTICS IN THE FORM OF BARS, BLOCKS, PELLETS AND SHEETS FOR USE IN MANUFACTURE; PACKING AND INSULATING MATERIALS; STOPPING MATERIALS, NAMELY, RUBBER STOPPERS FOR INDUSTRIAL PACKAGING CONTAINERS; FLEXIBLE PIPES NOT OF METAL (U.S. CLS. 1, 5, 12, 13, 35 AND 50).

COURTNEY ALVAREZ, EXAMINING ATTORNEY

SN 85-486,840. 1590475 ALBERTA LTD., CALGARY, ALBERTA, CANADA, FILED 12-5-2011.

WORKOUT PHONICS

THE MARK CONSISTS OF STANDARD CHARACTERS WITHOUT CLAIM TO ANY PARTICULAR FONT, STYLE, SIZE, OR COLOR.

NO CLAIM IS MADE TO THE EXCLUSIVE RIGHT TO USE "WORKOUT", APART FROM THE MARK AS SHOWN.

CLASS 16—PAPER GOODS AND PRINTED MATTER

FOR PRINTED INSTRUCTIONAL MATERIALS, NAMELY, EDUCATIONAL LEARNING CARDS THAT DEMONSTRATE TECHNIQUES IN THE FIELD OF PHYSICAL EXERCISE; STRETCHING CHARTS (U.S. CLS. 2, 5, 22, 23, 29, 37, 38 AND 50).

CLASS 28—TOYS AND SPORTING GOODS

FOR EXERCISE EQUIPMENT, NAMELY, STRENGTHENING EXERCISE BANDS (U.S. CLS. 22, 23, 38 AND 50).

JOHN KELLY, EXAMINING ATTORNEY

SN 85-486,907. AVG TECHNOLOGIES CZ, S.R.O, BRNO, CZECH REPUBLIC, FILED 12-5-2011.

BRINGING PEACE OF MIND TO OUR CONNECTED WORLD

THE MARK CONSISTS OF STANDARD CHARACTERS WITHOUT CLAIM TO ANY PARTICULAR FONT, STYLE, SIZE, OR COLOR.

CLASS 9—ELECTRICAL AND SCIENTIFIC APPARATUS

FOR COMPUTER SOFTWARE AND PROGRAMS FOR SECURITY PROTECTION, INCLUDING ANTI-VIRUS PROTECTION, IN THE FIELD OF COMPUTERS; ELECTRONIC, MAGNETIC AND OPTICAL MEDIA, NAMELY, CDS AND DVDS CONTAINING INFORMATION FOR SECURITY AND ANTI-VIRUS PROTECTION; DOWNLOADABLE ELECTRONIC MAGAZINES IN THE FIELD OF COMPUTERS; DOWNLOADABLE ELECTRONIC PUBLICATIONS, NAMELY MAGAZINES IN THE FIELD OF SECURITY AND ANTI-VIRUS PROTECTION IN THE FIELD OF COMPUTERS; MULTI-MEDIA SOFTWARE RECORDED ON CD-ROMS FEATURING INFORMATION ON SECURITY AND ANTI-VIRUS PROTECTION; PERSONAL COMPUTERS AND PORTABLE PERSONAL COMPUTERS AND PARTS, COMPLEMENTS AND ACCESSORIES THEREFOR, NAMELY COMPUTER PERIPHERALS (U.S. CLS. 21, 23, 26, 36 AND 38).

SN 85-488,227. TACTICAL COMMUNICATIONS GROUP, LLC, TEWKSBURY, MA. FILED 12-6-2011.



NO CLAIM IS MADE TO THE EXCLUSIVE RIGHT TO USE "TACTICAL COMMUNICATIONS GROUP, LLC", APART FROM THE MARK AS SHOWN.

THE MARK CONSISTS OF AN IMAGE OF A SATELLITE DISH WITH SOUND WAVES EMITTING FROM IT WITHIN A SQUARE. TO THE RIGHT OF THE IMAGE ARE THE LETTERS "TCG", WITH A LINE RUNNING UNDERNEATH THE IMAGE AND "TCG". THE WORDING "TACTICAL COMMUNICATIONS GROUP, LLC" APPEARS UNDERNEATH THE LINE.

CLASS 9—ELECTRICAL AND SCIENTIFIC APPARATUS

FOR COMPUTER HARDWARE AND SOFTWARE FOR USE IN MILITARY TESTING AND TRAINING EXERCISES (U.S. CLS. 21, 23, 26, 36 AND 38).

FIRST USE 1-18-2001; IN COMMERCE 4-17-2002.

CLASS 41—EDUCATION AND ENTERTAINMENT

FOR TRAINING FOR MILITARY AND/OR GOVERNMENTAL ENTITIES IN THE USE OF COMPUTER SOFTWARE (U.S. CLS. 100, 101 AND 107).

FIRST USE 1-18-2001; IN COMMERCE 4-17-2002.

CLASS 42—SCIENTIFIC AND COMPUTER SERVICES

FOR COMPUTER SERVICES, NAMELY, COMPUTER PROGRAMMING AND DESIGN AND DEVELOPMENT OF COMPUTER HARDWARE AND SOFTWARE; INTERNET SECURITY SERVICES, NAMELY, DEVELOPMENT OF SOFTWARE FOR INTERNET SECURITY; PROVIDING TEMPORARY USE OF ON-LINE NON-DOWNLOADABLE SOFTWARE APPLICATIONS FOR MONITORING SOCIAL NETWORKING SITES, PROVIDING A FILTERING MECHANISM ON INTERNET SEARCHES SEPARATING DESIRED RESULTS FROM UNWANTED AND INAPPROPRIATE WEBSITES, AND FOR PROVIDING A PARENTAL CONTROL FUNCTION ON OBSCENE AND INAPPROPRIATE WEBSITES; COMPUTER SERVICES, NAMELY, DOWNLOADING, INSTALLATION AND MAINTENANCE OF SECURITY SOFTWARE APPLICATIONS, SOFTWARE APPLICATIONS FOR SCREENING AND BLOCKING UNWANTED E-MAIL, AND SOFTWARE APPLICATIONS FOR PARENTAL CONTROLS OF INTERNET ACTIVITIES PROVIDED BY COMMUNICATION DEVICES, E-MAIL, AND ON-LINE VIA THE INTERNET; COMPUTER SERVICES, NAMELY, MONITORING, AND ANALYZING COMPUTER AND INTERNET USAGE FOR OTHERS, AND GENERATING REPORTS REGARDING SAME; COMPUTER CONSULTATION IN THE FIELD OF COMPUTER SECURITY; COMPUTER SERVICES, NAMELY, PROVIDING INFORMATION CONCERNING THE ENCRYPTION AND AUTHENTICATION OF ELECTRONIC DATA, NAMELY, AUTHENTICATION OF EMAIL AND DOCUMENTS; ENCRYPTION AND DECRYPTION OF DATA AND COMMUNICATIONS; PROVIDING INFORMATION IN THE FIELDS OF COMPUTER INTERNET SECURITY, PREVENTION OF COMPUTER THREATS, AND INFORMATION ABOUT COMPUTER HARDWARE AND SOFTWARE APPLICATIONS IN SECURITY, NAMELY, INFORMATION ABOUT ASSESSING COMPUTER SECURITY AND THREATS, AND DESIGN AND DEVELOPMENT OF COMPUTER SECURITY HARDWARE AND SOFTWARE APPLICATIONS (U.S. CLS. 100 AND 101).

JUHI KAVEESHVAR, EXAMINING ATTORNEY

CLASS 42—SCIENTIFIC AND COMPUTER SERVICES

FOR SOFTWARE DEVELOPMENT SERVICES FOR MILITARY AND/OR GOVERNMENTAL ENTITIES; COMPUTER SOFTWARE DESIGN FOR MILITARY AND/OR GOVERNMENTAL ENTITIES; MAINTENANCE OF COMPUTER SOFTWARE FOR MILITARY AND/OR GOVERNMENTAL ENTITIES; CUSTOMIZATION OF COMPUTER SOFTWARE FOR MILITARY AND/OR GOVERNMENTAL ENTITIES; TECHNICAL SUPPORT SERVICES, NAMELY, TROUBLESHOOTING OF COMPUTER SOFTWARE PROBLEMS FOR MILITARY AND/OR GOVERNMENTAL ENTITIES (U.S. CLS. 100 AND 101).

FIRST USE 1-18-2001; IN COMMERCE 4-17-2002.

TASHIA BUNCH, EXAMINING ATTORNEY

SN 85-489,305. RIGHTS CO., LTD., TOKYO, JAPAN, FILED 12-7-2011.

Palm Top Theater

THE MARK CONSISTS OF STANDARD CHARACTERS WITHOUT CLAIM TO ANY PARTICULAR FONT, STYLE, SIZE, OR COLOR.

PRIORITY CLAIMED UNDER SEC. 44(D) ON JAPAN APPLICATION NO. 2011-75374, FILED 10-20-2011.

OWNER OF JAPAN REG. NO. 5489543, DATED 4-27-2012, EXPIRES 4-27-2022.

CLASS 9—ELECTRICAL AND SCIENTIFIC APPARATUS

FOR THREE-DIMENSIONAL VIEWING APPARATUS USED BY ATTACHING THE APPARATUS TO SMARTPHONE AND TABLET PC SCREENS; COMPUTER GAME PROGRAMS; COMPUTER PERIPHERAL DEVICES; COMPUTER PROGRAMS FOR ENABLING USE OF THREE-DIMENSIONAL VIEWING APPARATUS WHICH ATTACHES TO SMARTPHONE AND TABLET PC SCREENS; RECORDED COMPUTER SOFTWARE FOR ENABLING USE OF THREE-DIMENSIONAL VIEWING APPARATUS WHICH ATTACHES TO SMARTPHONE AND TABLET PC SCREENS; VIDEO GAME MACHINES FOR USE WITH EXTERNAL DISPLAY SCREEN OR MONITOR; OPTICAL LANTERNS; PROJECTION SCREENS; VIDEO SCREENS; VIDEO AND COMPUTER GAME PROGRAMS FOR CONSUMER USE; ELECTRONIC CIRCUITS AND CD-ROMS RECORDED WITH PROGRAMS FOR HAND-HELD GAMES WITH LIQUID CRYSTAL DISPLAYS; COMPUTER SOFTWARE FOR ENABLING USE OF THREE-DIMENSIONAL VIEWING APPARATUS WHICH ATTACHES TO SMARTPHONE AND TABLET PC SCREENS, DOWNLOADABLE THROUGH COMPUTER NETWORK (U.S. CLS. 21, 23, 26, 36 AND 38).

CLASS 42—SCIENTIFIC AND COMPUTER SERVICES

FOR COMPUTER SOFTWARE DESIGN; GRAPHIC ARTS DESIGNING; INSTALLATION OF COMPUTER SOFTWARE; COMPUTER SERVICES, NAMELY, PROVIDING SEARCH ENGINES FOR OBTAINING DATA ON A GLOBAL COMPUTER NETWORK; RENTAL OF COMPUTER SOFTWARE; RENTAL OF COMPUTER PROGRAMS THROUGH COMMUNICATION LINE; PROVIDING TEMPORARY USE OF ON-LINE NON-DOWNLOADABLE SOFTWARE AND APPLICATIONS FOR ENABLING USE OF THREE-DIMENSIONAL VIEWING APPARATUS WHICH ATTACHES TO SMARTPHONE AND TABLET PC SCREENS; COMPUTER SOFTWARE DESIGN, COMPUTER PROGRAMMING, AND MAINTENANCE OF COMPUTER SOFTWARE (U.S. CLS. 100 AND 101).

DOMINIC J. FERRAIUOLO, EXAMINING ATTORNEY

SN 85-489,623. TORAYA CONFECTIONERY CO., LTD., TOKYO, JAPAN, FILED 12-7-2011.

TORAYA

OWNER OF U.S. REG. NOS. 1,933,489, 1,943,331 AND 1,944,447.

THE MARK CONSISTS OF THE WORD "TORAYA" IN STYLIZED FORM.

THE ENGLISH TRANSLATION OF "TORAYA" IN THE MARK IS "STORE OF THE TIGER".

CLASS 30—STAPLE FOODS

FOR BARS OF SWEET ADZUKI-BEAN JELLIED BEAN PASTE (YOHKAN); MIXES OF SWEET ADZUKI-BEAN JELLY; BEAN-JAM FILLED WAFERS (MONAKA); STEAMED BUNS STUFFED WITH SWEET BEAN-JAM FILLING (MANJU); DRIED SWEETS MADE FROM RICE FLOUR, SUGAR AND STARCH AND PRESSED INTO MOLDS (HIGASHI); FRUIT JELLY CANDY; DESSERT PUDDINGS; RICE CAKES; CAKES; PASTE MADE FROM RICE; CONFECTIONERY, NAMELY, PASTRIES, FROZEN CONFECTIONERY, FROZEN YOGHURT, CONFECTIONERY MADE OF SUGAR, PASTRY; BREAD; BUNS; SWEET RED DESSERT COULIS FLAVORED WITH ADZUKI-BEAN JELLIED BEAN PASTE AND CONTAINING ADZUKI-BEAN RICE CAKE (SHIRUKO) (U.S. CL. 46).

CLASS 43—HOTEL AND RESTAURANT SERVICES

FOR CAFÉ SERVICES; RESTAURANT AND CAFÉ SERVICES; CATERING SERVICES; COFFEE SHOPS; SNACK BAR SERVICES; TEA ROOMS FEATURING CONFECTIONERIES, FOOD AND BEVERAGES (U.S. CLS. 100 AND 101).

BARBARA A. GOLD, EXAMINING ATTORNEY

SN 85-489,661. YOBEL SCM COSTUME JEWELRY S.A., JESUS MARIA, LIMA, PERU, FILED 12-7-2011.

PRIORITY CLAIMED UNDER SEC. 44(D) ON PERU APPLICATION NO. 473940-2011, FILED 11-17-2011, REG. NO. 00070447, DATED 2-22-2011, EXPIRES 2-22-2022.

PRIORITY CLAIMED UNDER SEC. 44(D) ON PERU APPLICATION NO. 473941-2011, FILED 11-17-2011, REG. NO. 00184870, DATED 2-22-2012, EXPIRES 2-22-2022.

OWNER OF U.S. REG. NO. 3,820,952.

NO CLAIM IS MADE TO THE EXCLUSIVE RIGHT TO USE "JEWELRY", APART FROM THE MARK AS SHOWN.

THE MARK CONSISTS OF THE WORD "PARAISO" IN A STYLIZED FONT, ABOVE THE PHRASE "BY JEWELRY TALES" IN THE SAME STYLIZED FONT.

THE ENGLISH TRANSLATION OF "PARAISO" IN THE MARK IS PARADISE.

CLASS 14—JEWELRY

FOR JEWELRY MADE OF SILVER WITH SEMI-PRECIOUS STONES (U.S. CLS. 2, 27, 28 AND 50).

CLASS 42—SCIENTIFIC AND COMPUTER SERVICES

FOR JEWELRY DESIGN SERVICES (U.S. CLS. 100 AND 101).

WILLIAM JACKSON, EXAMINING ATTORNEY

SN 85-490,373. ACORN ENGINEERING COMPANY, DBA WHITEHALL MANUFACTURING, CITY OF INDUSTRY, CA. FILED 12-8-2011.

BestCare

THE MARK CONSISTS OF STANDARD CHARACTERS WITHOUT CLAIM TO ANY PARTICULAR FONT, STYLE, SIZE, OR COLOR.

CLASS 6—METAL GOODS

FOR ANTI-LIGATURE SUICIDE RESISTANT PRODUCTS, NAMELY, METAL TOWEL AND CLOTHING HOOKS (U.S. CLS. 2, 12, 13, 14, 23, 25 AND 50).

CLASS 11—ENVIRONMENTAL CONTROL APPARATUS

FOR ANTI-LIGATURE SUICIDE RESISTANT PRODUCTS, NAMELY, TOILETS AND URINALS, PUSH-BUTTON FLUSH VALVES, AND WATER FOUNTAIN BUBBLERS (U.S. CLS. 13, 21, 23, 31 AND 34).

CLASS 20—FURNITURE AND ARTICLES NOT OTHERWISE CLASSIFIED

FOR ANTI-LIGATURE SUICIDE RESISTANT PRODUCTS, NAMELY, FIRE EXTINGUISHER CABINETS, AND RECESSED SHELVES (U.S. CLS. 2, 13, 22, 25, 32 AND 50).

CLASS 21—HOUSEWARES AND GLASS

FOR ANTI-LIGATURE SUICIDE RESISTANT PRODUCTS, NAMELY, TOILET PAPER HOLDERS (U.S. CLS. 2, 13, 23, 29, 30, 33, 40 AND 50).
BARBARA GAYNOR, EXAMINING ATTORNEY

SN 85-490,533. NEW SPIN GOLF LLC, LIBERTYVILLE, IL. FILED 12-8-2011.



THE MARK CONSISTS OF THE STYLIZED REPRESENTATION OF THE LETTER "S" WITH A STYLIZED LINE EMANATING FROM THE TOP OF THE LETTER "S" IN A SWING PATTERN. THE WORD "SWINGSMART" IN SMALLER FONT IS REPRESENTED BELOW THE LETTER "S".

CLASS 9—ELECTRICAL AND SCIENTIFIC APPARATUS

FOR COMPUTER SOFTWARE FOR ANALYZING GOLF SWING PATTERN DATA (U.S. CLS. 21, 23, 26, 36 AND 38).

CLASS 28—TOYS AND SPORTING GOODS

FOR GOLF TRAINING AIDS, NAMELY, MOTION CAPTURE SENSORS FOR CAPTURING AND TRANSFERRING GOLF SWING PATTERN DATA TO A COMPUTER OR MOBILE DEVICE (U.S. CLS. 22, 23, 38 AND 50).
FLORENTINA BLANDU, EXAMINING ATTORNEY

SN 85-490,527. NEW SPIN GOLF LLC, LIBERTYVILLE, IL. FILED 12-8-2011.

SN 85-491,611. POWDR-WOODWARD PA LLC, PARK CITY, UT. FILED 12-9-2011.

SWINGSMART

WOODWARD FILMS

THE MARK CONSISTS OF STANDARD CHARACTERS WITHOUT CLAIM TO ANY PARTICULAR FONT, STYLE, SIZE, OR COLOR.

CLASS 9—ELECTRICAL AND SCIENTIFIC APPARATUS

FOR COMPUTER SOFTWARE FOR ANALYZING GOLF SWING PATTERN DATA (U.S. CLS. 21, 23, 26, 36 AND 38).

CLASS 28—TOYS AND SPORTING GOODS

FOR GOLF TRAINING AIDS, NAMELY, MOTION CAPTURE SENSORS FOR CAPTURING AND TRANSFERRING GOLF SWING PATTERN DATA TO A COMPUTER OR MOBILE DEVICE (U.S. CLS. 22, 23, 38 AND 50).
FLORENTINA BLANDU, EXAMINING ATTORNEY

THE MARK CONSISTS OF STANDARD CHARACTERS WITHOUT CLAIM TO ANY PARTICULAR FONT, STYLE, SIZE, OR COLOR.

OWNER OF U.S. REG. NOS. 2,522,557, 4,152,993 AND OTHERS.

NO CLAIM IS MADE TO THE EXCLUSIVE RIGHT TO USE "FILMS", APART FROM THE MARK AS SHOWN.
SEC. 2(F) AS TO "WOODWARD".

CLASS 9—ELECTRICAL AND SCIENTIFIC APPARATUS

FOR DOWNLOADABLE FILMS AND TELEVISION PROGRAMS FEATURING ACTION SPORTS, SKATEBOARDING, GYMNASTICS, INLINE SKATING, AND BMX FREESTYLE BICYCLING AND RACING (U.S. CLS. 21, 23, 26, 36 AND 38).

CLASS 41—EDUCATION AND ENTERTAINMENT

FOR ENTERTAINMENT SERVICES, NAMELY, PRODUCTION OF DOWNLOADABLE FILMS AND TELEVISION PROGRAMS FEATURING ACTION SPORTS, SKATEBOARDING, GYMNASTICS, INLINE SKATING, AND BMX FREESTYLE BICYCLING AND RACING (U.S. CLS. 100, 101 AND 107).
ELIZABETH HUGHITT, EXAMINING ATTORNEY

SN 85-491,644. BRUNSWICK-GOLDEN ISLES CHAMBER OF COMMERCE, INC., BRUNSWICK, GA. FILED 12-9-2011.



NO CLAIM IS MADE TO THE EXCLUSIVE RIGHT TO USE "GOLDEN ISLES GEORGIA", APART FROM THE MARK AS SHOWN.

THE MARK CONSISTS OF THE WORDS "GOLDEN ISLES GEORGIA" BELOW A LIVE OAK TREE SUBSTANTIALLY ENCLOSED WITHIN A GENERALLY OVAL SHAPE, WHEREIN THE BOTTOM OF THE OVAL SHAPE INCLUDES A WAVY LINE.

CLASS 39—TRANSPORTATION AND STORAGE

FOR TRAVEL INFORMATION SERVICES, NAMELY, PROVIDING INFORMATION TO TRAVELERS ON VACATION ACTIVITIES AND ATTRACTIONS (U.S. CLS. 100 AND 105).

FIRST USE 10-16-2011; IN COMMERCE 10-16-2011.

CLASS 43—HOTEL AND RESTAURANT SERVICES

FOR PROVIDING INFORMATION AND ADVICE ON HOTELS AND RESTAURANTS TO TOURISTS AND BUSINESS TRAVELERS (U.S. CLS. 100 AND 101).

FIRST USE 10-16-2011; IN COMMERCE 10-16-2011.
MARK T. MULLEN, EXAMINING ATTORNEY

SN 85-492,619. MANPOWER INC., MILWAUKEE, WI. FILED 12-12-2011.



THE COLOR(S) BLUE, LIGHT BLUE, GREEN, AND ORANGE IS/ARE CLAIMED AS A FEATURE OF THE MARK.

THE MARK CONSISTS OF FOUR COLORED PARALLEL OBLONGS ARRANGED IN THE COLOR ORDER, FROM LEFT TO RIGHT, BLUE, LIGHT BLUE, GREEN, AND ORANGE.

CLASS 9—ELECTRICAL AND SCIENTIFIC APPARATUS

FOR COMPUTER SOFTWARE FOR ASSESSING JOB AND BUSINESS SKILLS; COMPUTER SOFTWARE FOR USE IN JOB, BUSINESS, WORD PROCESSING, AND OFFICE AUTOMATION TRAINING; COMPUTER SOFTWARE FOR USE IN MANAGEMENT OF JOB APPLICANT DATA (U.S. CLS. 21, 23, 26, 36 AND 38).

CLASS 16—PAPER GOODS AND PRINTED MATTER

FOR PRINTED TESTING MATERIALS FOR USE IN ASSESSING JOB SKILLS; PRINTED INSTRUCTIONAL MATERIALS FOR USE IN JOB SKILL TRAINING; PRINTED INSTRUCTIONAL MATERIALS IN THE FIELD OF HUMAN RESOURCES; PRINTED TRAINING MANUALS FOR JOB SKILL TRAINING; PRINTED MONOGRAPHS, NEWSLETTERS AND BULLETINS, ALL IN THE FIELD OF HUMAN RESOURCES (U.S. CLS. 2, 5, 22, 23, 29, 37, 38 AND 50).

CLASS 35—ADVERTISING AND BUSINESS

FOR BUSINESS MANAGEMENT; BUSINESS ADMINISTRATION; OFFICE FUNCTIONS; EMPLOYMENT AGENCY SERVICES; TEMPORARY AND PERMANENT EMPLOYMENT AGENCY SERVICES; EMPLOYMENT RELATED SERVICES, NAMELY, PROVIDING JOB PLACEMENT, CAREER DEVELOPMENT, EMPLOYMENT RECRUITMENT, AND GENERAL EMPLOYMENT INFORMATION TO OTHERS; PERSONNEL MANAGEMENT SERVICES; HUMAN RESOURCES MANAGEMENT SERVICES; PROVIDING AND MANAGING CONTRACT PERSONNEL PROGRAMS; PERSONNEL MANAGEMENT AND CONSULTANCY SERVICES; EMPLOYMENT SERVICES, NAMELY, PROVIDING EMPLOYEE SKILLS SCREENING AND ASSESSMENT TOOLS VIA A WEBSITE ON A GLOBAL INFORMATION NETWORK; EMPLOYMENT COUNSELING SERVICES; CAREER MANAGEMENT CONSULTATION SERVICES; EMPLOYMENT OUTPLACEMENT SERVICES; PROFESSIONAL BUSINESS CONSULTANCY SERVICES; ACCOUNTING AND INTERNAL BUSINESS AUDIT SERVICES FOR OTHERS, BUSINESS INVESTIGATION SERVICES; BUSINESS ADVICE AND INFORMATION SERVICES; BUSINESS ORGANIZATION CONSULTANCY SERVICES; TAX PREPARATION AND CONSULTING SERVICES (U.S. CLS. 100, 101 AND 102).

CLASS 41—EDUCATION AND ENTERTAINMENT

FOR EDUCATIONAL AND TRAINING SERVICES, NAMELY, PROVIDING TRAINING IN BUSINESS AND JOB SKILLS AND OFFICE TECHNOLOGY; EDUCATION AND TRAINING SERVICES, NAMELY, PROVIDING CLASSES AND SEMINARS IN THE FIELD OF CAREER MANAGEMENT AND CAREER TRANSITION; PROVIDING TRAINING IN THE FIELD OF JOB SEARCHING, CAREER DEVELOPMENT, SELF MARKETING, INTERVIEW SKILLS AND RESEARCH WORKSHOPS; TRAINING SERVICES FOR PERSONNEL, NAMELY, PROVIDING ON-LINE COURSES OF STUDY IN THE FIELDS OF INFORMATION TECHNOLOGY, SOFTWARE USE, JOB AND BUSINESS SKILLS, CAREER COUNSELING SERVICES, CAREER MANAGEMENT SERVICES, OUTPLACEMENT SERVICES, AND CAREER TRANSITION SERVICES (U.S. CLS. 100, 101 AND 107).

CLASS 42—SCIENTIFIC AND COMPUTER SERVICES

FOR CONSULTING SERVICES IN THE FIELD OF COMPUTER NETWORKS; CONSULTING SERVICES IN THE FIELD OF COMPUTER HARDWARE AND SOFTWARE, COMPUTER STORAGE SYSTEMS AND COMPUTER SECURITY; COMPUTER PROGRAMMING CONSULTANCY; COMPUTER SECURITY CONSULTANCY; COMPUTER SECURITY CONSULTANCY IN THE FIELD OF SCANNING AND PENETRATION TESTING OF COMPUTERS AND NETWORKS TO ASSESS INFORMATION SECURITY VULNERABILITY; COMPUTER SOFTWARE CONSULTANCY; CONSULTING IN THE FIELD OF INFORMATION TECHNOLOGY; NON-DOWNLOADABLE COMPUTER SOFTWARE FOR ACCESSING, INPUTTING, STORING, PROCESSING AND RETRIEVING EMPLOYMENT AND CAREER RELATED INFORMATION; NON-DOWNLOADABLE SOFTWARE FOR EVALUATING JOB AND CAREER SKILLS (U.S. CLS. 100 AND 101).

MARGERY A. TIERNEY, EXAMINING ATTORNEY

SN 85-492,872. HUSH HUSH BROADCASTING, LLC,
WORTHINGTON, OH. FILED 12-12-2011.

THE EXPERIENCE CHANNEL

THE MARK CONSISTS OF STANDARD CHARACTERS WITHOUT CLAIM TO ANY PARTICULAR FONT, STYLE, SIZE, OR COLOR.

NO CLAIM IS MADE TO THE EXCLUSIVE RIGHT TO USE "CHANNEL", APART FROM THE MARK AS SHOWN.

CLASS 9—ELECTRICAL AND SCIENTIFIC APPARATUS

FOR DOWNLOADABLE VIDEO RECORDINGS FEATURING ADULT ENTERTAINMENT; DVDS FEATURING ADULT ENTERTAINMENT; DOWNLOADABLE ELECTRONIC PUBLICATIONS IN THE NATURE OF NEWSLETTERS IN THE FIELD OF ADULT ENTERTAINMENT; DOWNLOADABLE SOFTWARE IN THE NATURE OF MOBILE APPLICATIONS FOR VIEWING ADULT ENTERTAINMENT (U.S. CLS. 21, 23, 26, 36 AND 38).

CLASS 38—COMMUNICATION

FOR AUDIO AND VIDEO BROADCASTING SERVICES OVER THE INTERNET IN THE FIELD OF ADULT ENTERTAINMENT; STREAMING OF VIDEO MATERIAL ON THE INTERNET; VIDEO BROADCASTING SERVICES OVER THE INTERNET OR OTHER COMMUNICATIONS NETWORK, NAMELY, ELECTRONICALLY TRANSMITTING VIDEO CLIPS; WIRELESS COMMUNICATIONS SERVICES, NAMELY, TRANSMISSION OF GRAPHICS, VIDEOS AND TELEVISION PROGRAMS IN THE FIELD OF ADULT ENTERTAINMENT TO MOBILE TELEPHONES; VIDEO-ON-DEMAND TRANSMISSION SERVICES (U.S. CLS. 100, 101 AND 104).

CLASS 41—EDUCATION AND ENTERTAINMENT

FOR ENTERTAINMENT SERVICES, NAMELY, PROVIDING A WEBSITE FEATURING NON-DOWNLOADABLE ADULT-THEMED VIDEOS; PRODUCTION AND DISTRIBUTION OF TELEVISION PROGRAMS AND VIDEOS IN THE FIELD OF ADULT ENTERTAINMENT; FILM AND VIDEO PRODUCTION (U.S. CLS. 100, 101 AND 107).

KEVON CHISOLM, EXAMINING ATTORNEY

SN 85-492,891. HUSH HUSH BROADCASTING, LLC,
WORTHINGTON, OH. FILED 12-12-2011.

THE EXPERIENCE CHANNEL

THE MARK CONSISTS OF STANDARD CHARACTERS WITHOUT CLAIM TO ANY PARTICULAR FONT, STYLE, SIZE, OR COLOR.

CLASS 3—COSMETICS AND CLEANING PREPARATIONS

FOR BODY LOTIONS AND BODY OILS; MASSAGE LOTIONS AND MASSAGE OILS; SACHETS FOR PERFUMING LINEN; SCENTED LINEN SPRAYS; EDIBLE FLAVORED BODY PAINTS; EDIBLE FLAVORED BODY POWDERS; BATH AND SHOWER GELS; BUBBLE BATH; BATH OIL; BATH SALTS; BODY SCRUBS; ESSENTIAL OILS FOR AROMATHERAPY USE (U.S. CLS. 1, 4, 6, 50, 51 AND 52).

CLASS 10—MEDICAL APPARATUS

FOR ELECTRIC MASSAGE APPLIANCES, NAMELY, ELECTRIC VIBRATING MASSAGERS; MASSAGE APPARATUS; ELECTRIC MASSAGE APPARATUS FOR HOUSEHOLD USE; ELECTRIC AND NON-ELECTRIC MASSAGING APPARATUS FOR PERSONAL USE (U.S. CLS. 26, 39 AND 44).

KEVON CHISOLM, EXAMINING ATTORNEY

SN 85-492,916. HUSH HUSH BROADCASTING, LLC,
WORTHINGTON, OH. FILED 12-12-2011.

THE EXPERIENCE CHANNEL

THE MARK CONSISTS OF STANDARD CHARACTERS WITHOUT CLAIM TO ANY PARTICULAR FONT, STYLE, SIZE, OR COLOR.

CLASS 4—LUBRICANTS AND FUELS

FOR CANDLES; SCENTED CANDLES (U.S. CLS. 1, 6 AND 15).

CLASS 30—STAPLE FOODS

FOR CHOCOLATE AND CANDIES; GIFT BASKETS CONTAINING CANDY AND EDIBLE CANDY LINERIE (U.S. CL. 46).

CLASS 31—NATURAL AGRICULTURAL PRODUCTS

FOR FLOWERS AND CUT FLOWERS; LIVE FLOWERS ARRANGEMENTS; GIFT BASKETS CONTAINING FRESH FRUIT (U.S. CLS. 1 AND 46).

KEVON CHISOLM, EXAMINING ATTORNEY

SN 85-492,993. NEO GRAPHIC, INC., OSAKA-SHI, OSAKA-FU, JAPAN, FILED 12-12-2011.

GROWZE

THE MARK CONSISTS OF STANDARD CHARACTERS WITHOUT CLAIM TO ANY PARTICULAR FONT, STYLE, SIZE, OR COLOR.

PRIORITY CLAIMED UNDER SEC. 44(D) ON JAPAN APPLICATION NO. 2010-097839, FILED 6-17-2011, REG. NO. 5419616, DATED 12-16-2011, EXPIRES 6-16-2016.

CLASS 14—JEWELRY

FOR BRACELETS; COSTUME JEWELRY; HAIR JEWELRY IN THE NATURE OF JEWELRY FOR USE IN THE HAIR; JEWELRY WATCHES (U.S. CLS. 2, 27, 28 AND 50).

CLASS 18—LEATHER GOODS

FOR PURSES; UMBRELLAS (U.S. CLS. 1, 2, 3, 22 AND 41).

CLASS 25—CLOTHING

FOR DRESSES; JEANS; SHOES; SHORTS; SKIRTS; T-SHIRTS; TANK TOPS; WAIST BELTS (U.S. CLS. 22 AND 39).

WARREN L. OLANDRIA, EXAMINING ATTORNEY

SN 85-493,676. ARCHIBALD, SARAH L., FLORISSANT, MO.
FILED 12-13-2011.

SIT BACK CUSHION CAP

THE MARK CONSISTS OF STANDARD CHARACTERS WITHOUT CLAIM TO ANY PARTICULAR FONT, STYLE, SIZE, OR COLOR.

NO CLAIM IS MADE TO THE EXCLUSIVE RIGHT TO USE "CUSHION CAP", APART FROM THE MARK AS SHOWN.

CLASS 20—FURNITURE AND ARTICLES NOT OTHERWISE CLASSIFIED

FOR FITTED CHAIR COVERS; FITTED SEAT COVERS (U.S. CLS. 2, 13, 22, 25, 32 AND 50).

CLASS 24—FABRICS

FOR UNFITTED CHAIR COVERS NOT OF PAPER; UNFITTED SEAT COVERS NOT OF PAPER; CUSHION COVERS (U.S. CLS. 42 AND 50).

LINDA LAVACHE, EXAMINING ATTORNEY

SN 85-494,761. EDISONLEARNING, INC., NEW YORK, NY.
FILED 12-14-2011.

FIVE STRAND DESIGN

THE MARK CONSISTS OF STANDARD CHARACTERS WITHOUT CLAIM TO ANY PARTICULAR FONT, STYLE, SIZE, OR COLOR.

NO CLAIM IS MADE TO THE EXCLUSIVE RIGHT TO USE "DESIGN" FOR CLASS 41, APART FROM THE MARK AS SHOWN.

CLASS 35—ADVERTISING AND BUSINESS

FOR MANAGEMENT AND OPERATION OF PUBLIC SCHOOLS, CHARTER SCHOOLS AND SCHOOL DISTRICTS FOR OTHERS; CONSULTING FOR OTHERS IN THE OPERATION AND MANAGEMENT OF PUBLIC SCHOOLS, CHARTER SCHOOLS AND SCHOOL DISTRICTS IN THE FIELD OF ELEMENTARY, MIDDLE AND HIGH SCHOOL EDUCATION (U.S. CLS. 100, 101 AND 102).

CLASS 41—EDUCATION AND ENTERTAINMENT

FOR DEVELOPMENT AND DISSEMINATION OF EDUCATIONAL MATERIALS FOR OTHERS IN THE FIELD OF ELEMENTARY, MIDDLE AND HIGH SCHOOL EDUCATION; CURRICULUM DEVELOPMENT FOR OTHERS IN THE FIELD OF ELEMENTARY, MIDDLE AND HIGH SCHOOL EDUCATION; DEVELOPMENT AND DISSEMINATION OF EDUCATIONAL TEACHING ASSESSMENT MATERIALS FOR OTHERS IN THE FIELD OF ELEMENTARY, MIDDLE AND HIGH SCHOOL EDUCATION; EDUCATIONAL CONSULTING SERVICES PROVIDED TO OTHERS IN THE FIELDS OF ELEMENTARY, MIDDLE AND HIGH SCHOOL EDUCATION AND IMPROVING STUDENT LEARNING PERFORMANCE; EDUCATION SERVICES, NAMELY, PROVIDING AFTER-SCHOOL, WEEKEND AND SUMMER TUTORING IN THE FIELDS OF ELEMENTARY, MIDDLE AND HIGH SCHOOL EDUCATION; RECREATIONAL CAMPS, NAMELY, CONDUCTING AFTER-SCHOOL, WEEKEND AND SUMMER RECREATION CAMPS FOR ELEMENTARY, MIDDLE AND HIGH SCHOOL STUDENTS; DEVELOPMENT AND DISSEMINATION OF EDUCATIONAL MATERIALS FOR OTHERS IN THE NATURE OF RESEARCH-BASED STUDENT ACHIEVEMENT DIAGNOSTIC TOOLS IN THE FIELD OF ELEMENTARY, MIDDLE AND HIGH SCHOOL EDUCATION; PROVIDING SUPPLEMENTAL EDUCATIONAL SERVICES IN ACCORDANCE WITH THE NO CHILD LEFT BEHIND LAW, NAMELY, PROVIDING AFTER-SCHOOL, WEEKEND AND SUMMER TUTORING PROGRAMS FOR PUBLIC SCHOOL STUDENTS IN THE FIELDS OF ELEMENTARY, MIDDLE AND HIGH SCHOOL EDUCATION (U.S. CLS. 100, 101 AND 107).

ALAIN LAPTER, EXAMINING ATTORNEY

SN 85-495,043. GENERAL CIGAR CO., INC., GLEN ALLEN, VA. FILED 12-14-2011.

CONCERT

THE MARK CONSISTS OF STANDARD CHARACTERS WITHOUT CLAIM TO ANY PARTICULAR FONT, STYLE, SIZE, OR COLOR.

CLASS 16—PAPER GOODS AND PRINTED MATTER

FOR CIGAR BANDS (U.S. CLS. 2, 5, 22, 23, 29, 37, 38 AND 50).

CLASS 25—CLOTHING

FOR HATS; SHIRTS; JACKETS (U.S. CLS. 22 AND 39).

CLASS 34—SMOKERS' ARTICLES

FOR CIGARS, CIGAR ACCESSORIES, NAMELY, CIGAR BOXES, CIGAR CUTTERS, CIGAR CASES, NOT OF PRECIOUS METAL, HUMIDORS, CIGAR LIGHTERS AND ASHTRAYS (U.S. CLS. 2, 8, 9 AND 17).

BENJAMIN OKEKE, EXAMINING ATTORNEY

SN 85-495,177. NETRONIX CORPORATION, SOUTH BARRINGTON, IL. FILED 12-14-2011.



THE MARK CONSISTS OF THE WORDING "ESHOW" WITHIN STYLIZED LETTERING. SEC. 2(F).

CLASS 35—ADVERTISING AND BUSINESS

FOR ARRANGING AND CONDUCTING OF BUSINESS CONFERENCES, NAMELY, RESERVATION FOR EXHIBIT SPACE AND DOCUMENTATION SERVICES RELATED THERETO FOR OTHERS IN CONNECTION WITH CONFERENCES, CONVENTIONS AND TRADE SHOWS; ARRANGING AND CONDUCTING OF BUSINESS CONFERENCES, NAMELY, PREPARATION OF EXHIBITOR REPORTS, LEAD RETRIEVAL DOCUMENTATION AND REPORTS, SPEAKER MANAGEMENT, CALL CENTERS, DATA ENTRY, VIRTUAL FLOOR PLANS, EVENT DIRECTORIES, SESSION TRACKING AND EVALUATIONS, ALL FOR USE IN CONNECTION WITH CONFERENCES, CONVENTIONS AND TRADE SHOWS; AND TRADE SHOW, CONVENTION AND CONFERENCE MANAGEMENT SERVICES FOR OTHERS (U.S. CLS. 100, 101 AND 102).

FIRST USE 8-0-1998; IN COMMERCE 8-0-1998.

CLASS 42—SCIENTIFIC AND COMPUTER SERVICES

FOR EVENT WEBSITE DEVELOPMENT AND MAINTENANCE FOR TRADE SHOWS, CONFERENCES AND CONVENTIONS AND THEIR EXHIBITORS; CUSTOM DESIGN OF BADGES FOR TRADE SHOWS, CONVENTIONS AND CONFERENCES (U.S. CLS. 100 AND 101).

FIRST USE 8-0-1998; IN COMMERCE 8-0-1998.

CLASS 43—HOTEL AND RESTAURANT SERVICES

FOR ON-LINE AND IN-PERSON HOTEL RESERVATION SERVICES FOR ATTENDEES AND EXHIBITORS AT TRADE SHOWS, CONFERENCES AND CONVENTIONS (U.S. CLS. 100 AND 101).

FIRST USE 8-0-1998; IN COMMERCE 8-0-1998.

WARREN L. OLANDRIA, EXAMINING ATTORNEY

SN 85-495,186. WIDEPEN NETWORKS LLC, BLACKSBURG, VA. FILED 12-14-2011.



THE MARK CONSISTS OF STANDARD CHARACTERS WITHOUT CLAIM TO ANY PARTICULAR FONT, STYLE, SIZE, OR COLOR.

CLASS 37—CONSTRUCTION AND REPAIR

FOR TECHNICAL SUPPORT SERVICES IN THE NATURE OF REPAIR OF ELECTRONIC COMMUNICATIONS NETWORKS, NAMELY, TELECOMMUNICATIONS NETWORKS; TECHNICAL SUPPORT SERVICES IN THE NATURE OF TECHNICAL ADVICE RELATED TO THE INSTALLATION OF ELECTRONIC COMMUNICATIONS NETWORKS, NAMELY, TELECOMMUNICATIONS NETWORKS (U.S. CLS. 100, 103 AND 106).

FIRST USE 12-12-2011; IN COMMERCE 4-1-2012.

CLASS 42—SCIENTIFIC AND COMPUTER SERVICES

FOR PLANNING AND DEVELOPMENT AND TECHNICAL SUPPORT OF ELECTRONIC COMMUNICATIONS NETWORKS, NAMELY, TELECOMMUNICATIONS NETWORKS; TECHNICAL SUPPORT SERVICES, NAMELY, TROUBLESHOOTING IN THE NATURE OF DIAGNOSING PROBLEMS RELATED TO ELECTRONIC COMMUNICATIONS NETWORKS, NAMELY, TELECOMMUNICATIONS NETWORKS (U.S. CLS. 100 AND 101).

FIRST USE 12-12-2011; IN COMMERCE 4-1-2012.

RONALD DELGIZZI, EXAMINING ATTORNEY

SN 85-495,218. NETRONIX CORPORATION, SOUTH BARRINGTON, IL. FILED 12-14-2011.



THE MARK CONSISTS OF STANDARD CHARACTERS WITHOUT CLAIM TO ANY PARTICULAR FONT, STYLE, SIZE, OR COLOR.

CLASS 35—ADVERTISING AND BUSINESS

FOR ARRANGING AND CONDUCTING OF BUSINESS CONFERENCES, NAMELY, RESERVATION FOR EXHIBIT SPACE AND DOCUMENTATION SERVICES RELATED THERETO FOR OTHERS IN CONNECTION WITH CONFERENCES, CONVENTIONS AND TRADE SHOWS; ARRANGING AND CONDUCTING OF BUSINESS CONFERENCES, NAMELY, PREPARATION OF EXHIBITOR REPORTS, LEAD RETRIEVAL DOCUMENTATION AND REPORTS, SPEAKER MANAGEMENT, CALL CENTERS, DATA ENTRY, VIRTUAL FLOOR PLANS, EVENT DIRECTORIES, SESSION TRACKING AND EVALUATIONS, ALL FOR USE IN CONNECTION WITH CONFERENCES, CONVENTIONS AND TRADE SHOWS; AND TRADE SHOW, CONVENTION AND CONFERENCE MANAGEMENT SERVICES FOR OTHERS (U.S. CLS. 100, 101 AND 102).

CLASS 42—SCIENTIFIC AND COMPUTER SERVICES

FOR EVENT WEBSITE DEVELOPMENT AND MAINTENANCE FOR TRADE SHOWS, CONFERENCES AND CONVENTIONS AND THEIR EXHIBITORS; CUSTOM DESIGN OF BADGES FOR TRADE SHOWS, CONVENTIONS AND CONFERENCES (U.S. CLS. 100 AND 101).

CLASS 43—HOTEL AND RESTAURANT SERVICES

FOR ON-LINE AND IN-PERSON HOTEL RESERVATION SERVICES FOR ATTENDEES AND EXHIBITORS AT TRADE SHOWS, CONFERENCES AND CONVENTIONS (U.S. CLS. 100 AND 101).

WARREN L. OLANDRIA, EXAMINING ATTORNEY

SN 85-495,557. WIKILOC OUTDOOR, S.L., C/PIC DE PE-
GUERA, 15, SPAIN, FILED 12-14-2011.



THE COLOR(S) GREEN AND ORANGE IS/ARE
CLAIMED AS A FEATURE OF THE MARK.

THE MARK CONSISTS OF THE WORD "WIKILOC" IN
STYLIZED GREEN LETTERS; THE LETTER "O" IN "WIKI-
LOC" APPEARS TO BE AN EARTH GLOBE WITH A ROUTE
IN ORANGE.

CLASS 9—ELECTRICAL AND SCIENTIFIC APPARATUS

FOR GLOBAL POSITIONING SYSTEM (GPS), SATEL-
LITE NAVIGATIONAL SYSTEM, NAMELY, A GLOBAL
POSITIONING SYSTEM (GPS), GPS DATA LOGGER
FOR RECORDING TRIPS AND CLASSIFYING THEM
INTO DIFFERENT ACCOUNTS, GPS NAVIGATION
DEVICE; ELECTRONIC NAVIGATIONAL AND POSI-
TIONING APPARATUS AND INSTRUMENTS; COMPU-
TER SOFTWARE FOR THE DATABASING,
VISUALIZATION, MANIPULATION, VIRTUAL REALI-
TY IMMERSION AND INTEGRATION OF GEO-
GRAPHIC INFORMATION WITH ON-LINE MEMBER
COMMUNITIES; DOWNLOADABLE SOFTWARE APPLI-
CATION TO ALLOW USERS TO DISCOVER AND
SHARE OUTDOOR TRAILS VIA A GLOBAL COMPUTER
NETWORK IN AN EASY WAY; MOBILE TELEPHONE
APPLICATIONS SOFTWARE AND DOWNLOADABLE
MOBILE TELEPHONE APPLICATIONS SOFTWARE
FOR GLOBAL COMMUNICATIONS NETWORK DATA
TRANSMISSION USING GLOBAL NETWORK PHONE-
BOOK CAPABILITIES AND GLOBAL NETWORK FOR-
MATS FOR DATA TRANSMISSION, NAMELY,
TRANSMITTING AND SHARING DATA BETWEEN
ANY COMBINATION OF MOBILE, LAND-BASED OR
GLOBAL COMMUNICATIONS NETWORK COMMUNI-
CATIONS DEVICES; COMPUTER APPLICATION SOFT-
WARE FOR MOBILE PHONES, NAMELY, SOFTWARE
FOR USE IN DATABASING, VISUALIZATION, MANI-
PULATION, VIRTUAL REALITY IMMERSION AND IN-
TEGRATION OF GEOGRAPHIC INFORMATION WITH
ON-LINE MEMBER COMMUNITIES; COMPUTER AP-
PLICATION SOFTWARE FOR MOBILE PHONES TO
ALLOW USERS TO DISCOVER AND SHARE OUTDOOR
TRAILS VIA A GLOBAL COMPUTER NETWORK IN AN
EASY WAY (U.S. CLS. 21, 23, 26, 36 AND 38).

CLASS 38—COMMUNICATION

FOR TELECOMMUNICATIONS SERVICES, NAMELY,
MOBILE TELEPHONE COMMUNICATION; TELECOM-
MUNICATIONS PORTAL SERVICES, NAMELY, PRO-
VIDING INTERNET CHAT ROOMS FOR
TRANSMISSION OF MESSAGES AMONG COMPUTER
USERS CONCERNING GPS TRACKING; PROVIDING
ACCESS TO MOBILE TELECOMMUNICATION NET-
WORKS; COMMUNICATIONS CONSISTING OF PRO-
VIDING MULTIPLE USER ACCESS TO A GLOBAL
COMPUTER DATA NETWORK, BOTH INTERNET AND
INTRANET, FOR THE TRANSMISSION AND DISSEMI-
NATION OF ALL KINDS OF INFORMATION, IMAGES
OR SOUND; ELECTRONIC MAIL SERVICES; MESSAGE
SENDING, RECEIVING AND FORWARDING; PRO-
VIDING TELECOMMUNICATION ACCESS TO ELECTRO-
NIC COMMUNICATIONS NETWORKS FOR
COMMERCIAL TRANSACTIONS; TELEVISION, RADIO
AND INTERNET BROADCASTING SERVICES; TRAN-
SMISSION OF INFORMATION ON THE AFORESAID
NETWORKS, INCLUDING THE INTERNET; PROVISION
OF ACCESS TO AN ELECTRONIC ONLINE NETWORK
FOR INFORMATION RETRIEVAL; PROVIDING TELE-
COMMUNICATIONS CONNECTIONS TO THE INTER-
NET OR DATABASES; TELECOMMUNICATIONS
ROUTING AND JUNCTION SERVICES; TELECOMMU-
UNICATIONS GATEWAY SERVICES; ELECTRONIC BUL-
LETIN BOARD SERVICES; TELECOMMUNICATIONS,
NAMELY, COMMUNICATIONS BY OPTICAL FIBRE

NETWORKS; COMMUNICATIONS VIA COMPUTER
TERMINALS, BY DIGITAL TRANSMISSION OR BY
SATELLITE; COMPUTER AIDED TRANSMISSION OF
MESSAGES AND IMAGES; SATELLITE TRANSMISSION
SERVICES; INFORMATION ABOUT TELECOMMUNI-
CATIONS; PROVIDING TECHNICAL SUPPORT SER-
VICES REGARDING THE USAGE OF
COMMUNICATIONS EQUIPMENT; TRANSMISSION OF
SOUND, VIDEO AND INFORMATION FROM WEB
CAMS, VIDEO CAMERAS OR MOBILE PHONES, ALL
FEATURING LIVE OR RECORDED MATERIALS; WIRE-
LESS COMMUNICATIONS SERVICES, NAMELY,
TRANSMISSION OF VOICE, DATA AND IMAGES TO
MOBILE TELEPHONES (U.S. CLS. 100, 101 AND 104).

CLASS 39—TRANSPORTATION AND STO- RAGE

FOR GPS NAVIGATION SERVICES; PROVIDING A
WEB SITE AND WEB SITE LINKS TO GEOGRAPHIC
INFORMATION, MAP IMAGES, AND TRIP ROUTING;
INTERNET PORTAL SERVICES, NAMELY, PROVIDING
AN INTERNET WEBSITE PORTAL IN THE FIELD OF
TRAVEL (U.S. CLS. 100 AND 105).

REBECCA POVARCHUK, EXAMINING ATTORNEY

SN 85-495,800. KEVIN ALLEN PARTNERS LIMITED, LON-
DON, UNITED KINGDOM, FILED 12-15-2011.



THE MARK CONSISTS OF STANDARD CHARACTERS
WITHOUT CLAIM TO ANY PARTICULAR FONT, STYLE,
SIZE, OR COLOR.

PRIORITY CLAIMED UNDER SEC. 44(D) ON ERPN
CMNTY TM OFC APPLICATION NO. 10428779, FILED 11-
18-2011, REG. NO. 010428779, DATED 3-28-2012, EXPIRES 11-
18-2021.

THE NAME(S), PORTRAIT(S), AND/OR SIGNATURE(S)
SHOWN IN THE MARK DOES NOT IDENTIFY A PARTI-
CULAR LIVING INDIVIDUAL.

CLASS 16—PAPER GOODS AND PRINTED MATTER

FOR PRINTED MATTER AND PRINTED PUBLICA-
TIONS, NAMELY, SERIES OF BOOKS, MAGAZINES,
NEWSLETTERS, BROCHURES, JOURNALS, LEAFLETS
AND SEMINAR AND WORKSHOP NOTES IN THE
FIELD OF BUSINESS AND MARKETING (U.S. CLS. 2,
5, 22, 23, 29, 37, 38 AND 50).

CLASS 35—ADVERTISING AND BUSINESS

FOR BUSINESS CONSULTANCY AND ADVISORY
SERVICES; MARKETING AND PROMOTIONAL CON-
SULTANCY AND ADVISORY SERVICES (U.S. CLS. 100,
101 AND 102).

CLASS 38—COMMUNICATION

FOR VIDEO AND AUDIO BROADCASTING SER-
VICES; WEBCASTING SERVICES; STREAMING AUDIO,
VIDEO AND MULTIMEDIA CONTENT VIA THE INTER-
NET AND WIRELESS NETWORKS; ALL FEATURING
BUSINESS AND MARKETING ADVICE (U.S. CLS. 100,
101 AND 104).

CLASS 41—EDUCATION AND ENTERTAINMENT

FOR EDUCATIONAL SERVICES, NAMELY, CONDUCTING CLASSES, SEMINARS, WORKSHOPS, CONFERENCES AND TRAINING IN THE FIELD OF BUSINESS AND MARKETING (U.S. CLS. 100, 101 AND 107).

SHAILA SETTLES, EXAMINING ATTORNEY

SN 85-497,243. CALIFORNIA HOSPITAL PATIENT SAFETY ORGANIZATION, SACRAMENTO, CA. FILED 12-16-2011.

CHPSO CALIFORNIA HOSPITAL PATIENT SAFETY ORGANIZATION

THE MARK CONSISTS OF STANDARD CHARACTERS WITHOUT CLAIM TO ANY PARTICULAR FONT, STYLE, SIZE, OR COLOR.

NO CLAIM IS MADE TO THE EXCLUSIVE RIGHT TO USE "CALIFORNIA HOSPITAL PATIENT SAFETY ORGANIZATION", APART FROM THE MARK AS SHOWN.

CLASS 42—SCIENTIFIC AND COMPUTER SERVICES

FOR COLLECTING AND PROVIDING MEDICAL SCIENTIFIC INFORMATION THAT CAN BE USED BY HEALTH CARE PROVIDERS IN CONNECTION WITH THEIR PATIENT SAFETY RESPONSIBILITIES (U.S. CLS. 100 AND 101).

FIRST USE 2-25-2009; IN COMMERCE 2-25-2009.

CLASS 44—MEDICAL, BEAUTY AND AGRICULTURAL SERVICES

FOR PROVIDING AN INTERNET WEBSITE PORTAL FEATURING MEDICAL INFORMATION FOR HEALTH CARE PROVIDERS, NAMELY, MEDICAL INFORMATION AND COLLECTED DATA IN THE FIELD OF PATIENTS' HEALTH CARE SAFETY; PROVIDING AN INTERNET WEBSITE PORTAL TO HEALTH CARE PROVIDERS IN THE FIELD OF PATIENTS' HEALTH CARE SAFETY, NAMELY, FEATURING MEDICAL INFORMATION FOR USE BY HEALTH CARE PROVIDERS IN SATISFYING THEIR PATIENT SAFETY RESPONSIBILITIES; MEDICAL RESEARCH, NAMELY, COLLECTING MEDICAL INFORMATION FOR USE BY HEALTH CARE PROVIDERS IN THE FIELD OF PATIENTS' HEALTH CARE SAFETY (U.S. CLS. 100 AND 101).

FIRST USE 11-17-2008; IN COMMERCE 11-17-2008.
KEVIN CORWIN, EXAMINING ATTORNEY

SN 85-497,435. STRYKER CORPORATION, KALAMAZOO, MI. FILED 12-16-2011.

IRAIL

THE MARK CONSISTS OF STANDARD CHARACTERS WITHOUT CLAIM TO ANY PARTICULAR FONT, STYLE, SIZE, OR COLOR.

CLASS 10—MEDICAL APPARATUS

FOR INTEGRAL COMPONENT PART OF A PATIENT SUPPORT, NAMELY, A SIDE RAIL FOR A MEDICAL STRETCHER, A SIDE RAIL FOR A THERAPEUTIC MEDICAL BED, AND A SIDE RAIL FOR AN EMERGENCY MEDICAL COT (U.S. CLS. 26, 39 AND 44).

CLASS 20—FURNITURE AND ARTICLES NOT OTHERWISE CLASSIFIED

FOR INTEGRAL COMPONENT PART OF A PATIENT SUPPORT, NAMELY, A HOSPITAL BED SIDE RAIL (U.S. CLS. 2, 13, 22, 25, 32 AND 50).

ALYSSA STEEL, EXAMINING ATTORNEY

SN 85-497,466. STRYKER CORPORATION, KALAMAZOO, MI. FILED 12-16-2011.

COLOR THERAPY

THE MARK CONSISTS OF STANDARD CHARACTERS WITHOUT CLAIM TO ANY PARTICULAR FONT, STYLE, SIZE, OR COLOR.

CLASS 10—MEDICAL APPARATUS

FOR PATIENT SUPPORT, NAMELY, THERAPEUTIC MEDICAL BED, MEDICAL STRETCHER, AND EMERGENCY MEDICAL COT (U.S. CLS. 26, 39 AND 44).

CLASS 20—FURNITURE AND ARTICLES NOT OTHERWISE CLASSIFIED

FOR PATIENT SUPPORT, NAMELY, HOSPITAL BED (U.S. CLS. 2, 13, 22, 25, 32 AND 50).

ALYSSA STEEL, EXAMINING ATTORNEY

SN 85-497,485. TAROKO DOOR & WINDOW TECHNOLOGIES, INC., KAOHSIUNG, TAIWAN, FILED 12-16-2011.

TAROKO

THE MARK CONSISTS OF STANDARD CHARACTERS WITHOUT CLAIM TO ANY PARTICULAR FONT, STYLE, SIZE, OR COLOR.

CLASS 6—METAL GOODS

FOR BOLTS OF METAL; DOOR FITTINGS OF METAL; DOOR FRAMES OF METAL; DOOR STOPS OF METAL; DOORS OF METAL; DOOR CASINGS OF METAL; DOORS AND WINDOWS OF METAL; INSECT SCREENS OF METAL; FRAMEWORKS OF METAL; METAL LATCH BARS; METAL LATCHES; METAL REINFORCEMENT MATERIALS FOR BUILDING; METAL WINDOW CASEMENTS; METAL DOOR BOLTS; METAL HANDLES FOR DOORS, TOOLS AND FURNITURE; METAL HINGES; METAL JALOUSIES; METAL LATTICES; METAL RUNNERS FOR SLIDING DOORS; METAL SASH FASTENERS FOR WINDOWS; METAL WINDOW PULLEYS; METAL WINDOW SHUTTERS; WINDOW FRAMES OF METAL; WINDOW FITTINGS OF METAL (U.S. CLS. 2, 12, 13, 14, 23, 25 AND 50).

CLASS 19—NON-METALLIC BUILDING MATERIALS

FOR DOOR CASINGS, NOT OF METAL; DOOR FRAMES, NOT OF METAL; GLASS FOR BUILDING; INSECT SCREENS NOT OF METAL; INSULATING GLASS FOR WINDOWS FOR BUILDING PURPOSES; NON-METAL BUILDING MATERIALS, NAMELY, COMPOSITE PANELS COMPOSED PRIMARILY OF NON-METAL MATERIALS; NON-METAL CONSTRUCTION MATERIALS, NAMELY, NON-METAL EXTERIOR PANELS; NON-METAL DOOR PANELS; NON-METAL DOORS; NON-METAL FOLDING DOORS; NON-METAL GATES; NON-METAL JALOUSIES; NON-METAL LATTICES; NON-METAL LINTELS; NON-METAL WINDOW SCREENS; NON-METAL WINDOW CASEMENTS; NON-METAL WINDOW SHUTTERS; NON-METAL WINDOW SILLS; NON-METAL WINDOW FRAMES; NON-METAL WINDOWS; SAFETY GLASS FOR BUILDING PURPOSES; WINDOW GLASS (U.S. CLS. 1, 12, 33 AND 50).

CLASS 20—FURNITURE AND ARTICLES NOT OTHERWISE CLASSIFIED

FOR CURTAIN RAILS; CURTAIN RODS, ROLLERS AND HOOKS; INDOOR WINDOW BLINDS, SHADE, FURNITURE; NON-METAL DOOR FITTINGS; NON-METAL HANDLES FOR DOORS AND FURNITURE; NON-METAL LATCHES; NON-METAL PEGS; NON-METAL COTTER PINS; NON-METAL SCREWS; PULLEYS OF PLASTIC; SLATTED INDOOR BLINDS FOR WINDOWS; WINDOW FITTINGS, NOT OF METAL (U.S. CLS. 2, 13, 22, 25, 32 AND 50).

DOUGLAS LEE, EXAMINING ATTORNEY

SN 85-497,562. ANDREA SIEBERT, 8700-128 MONCARAPACHO, PORTUGAL, FILED 12-16-2011.

FLOS SALIS

THE MARK CONSISTS OF STANDARD CHARACTERS WITHOUT CLAIM TO ANY PARTICULAR FONT, STYLE, SIZE, OR COLOR.

OWNER OF ERPNTM CMNTY TM OFC REG. NO. 004163879, DATED 1-25-2006, EXPIRES 12-3-2014.

THE ENGLISH TRANSLATION OF "FLOS SALIS" IN THE MARK IS FROM A LATIN EXPRESSION MEANING FLOWER OF SALT.

CLASS 21—HOUSEWARES AND GLASS

FOR SALT CELLARS, SALT SHAKERS, TABLE SALT CONTAINERS; CONTAINERS FOR HOUSEHOLD OR KITCHEN USE; KITCHEN STORAGE CONTAINERS; TABLE AND SERVING VESSELS, NAMELY, DISPENSERS FOR SALT, PEPPER AND SPICES, AND SERVING PLATTERS (U.S. CLS. 2, 13, 23, 29, 30, 33, 40 AND 50).

CLASS 30—STAPLE FOODS

FOR SALT, SEA SALT, IN PARTICULAR NATURAL SEA SALT, HAND-HARVESTED SEA SALT, HERBAL SALTS, SPICE SALTS, SALT CONTAINERS FILLED WITH SALT (U.S. CL. 46).

MARY ROSSMAN, EXAMINING ATTORNEY

SN 85-497,768. READVENTURES, LLC, BEL AIR, MD. FILED 12-16-2011.

Funny Mix

THE MARK CONSISTS OF STANDARD CHARACTERS WITHOUT CLAIM TO ANY PARTICULAR FONT, STYLE, SIZE, OR COLOR.

CLASS 28—TOYS AND SPORTING GOODS

FOR EDUCATIONAL CARD GAMES (U.S. CLS. 22, 23, 38 AND 50).

CLASS 41—EDUCATION AND ENTERTAINMENT

FOR COMPUTER NETWORK BASED ENVIRONMENTS, NAMELY, PROVIDING A WEBSITE FEATURING ONLINE INSTRUCTION IN READING, PHONICS AND PHONEMIC AWARENESS (U.S. CLS. 100, 101 AND 107).

KATHERINE E. HALMEN, EXAMINING ATTORNEY

SN 85-498,948. POWDR-WOODWARD PA LLC, PARK CITY, UT. FILED 12-19-2011.

WOODWARD TV

THE MARK CONSISTS OF STANDARD CHARACTERS WITHOUT CLAIM TO ANY PARTICULAR FONT, STYLE, SIZE, OR COLOR.

OWNER OF U.S. REG. NOS. 2,522,557, 4,152,993 AND OTHERS.

NO CLAIM IS MADE TO THE EXCLUSIVE RIGHT TO USE "TV", APART FROM THE MARK AS SHOWN.

SEC. 2(F) AS TO "WOODWARD".

CLASS 9—ELECTRICAL AND SCIENTIFIC APPARATUS

FOR DOWNLOADABLE FILMS AND TELEVISION PROGRAMS FEATURING ACTION SPORTS, SKATEBOARDING, GYMNASTICS, INLINE SKATING, AND BMX FREESTYLE BICYCLING AND RACING (U.S. CLS. 21, 23, 26, 36 AND 38).

CLASS 41—EDUCATION AND ENTERTAINMENT

FOR ENTERTAINMENT SERVICES, NAMELY, PRODUCTION OF DOWNLOADABLE FILMS AND TELEVISION PROGRAMS FEATURING ACTION SPORTS, SKATEBOARDING, GYMNASTICS, INLINE SKATING, AND BMX FREESTYLE BICYCLING AND RACING (U.S. CLS. 100, 101 AND 107).

ELIZABETH HUGHITT, EXAMINING ATTORNEY

SN 85-501,884. STEUBER CORPORATION, LONG BEACH, CA. FILED 12-22-2011.

ALTA

THE MARK CONSISTS OF STANDARD CHARACTERS WITHOUT CLAIM TO ANY PARTICULAR FONT, STYLE, SIZE, OR COLOR.

OWNER OF U.S. REG. NOS. 2,219,628 AND 3,253,139.

SN 85-501,094. CARDIO CORE, LLC, LONG ISLAND CITY, NY. FILED 12-21-2011.

JCORE BODY-LITE

THE MARK CONSISTS OF STANDARD CHARACTERS WITHOUT CLAIM TO ANY PARTICULAR FONT, STYLE, SIZE, OR COLOR.

CLASS 5—PHARMACEUTICALS

FOR DIETARY AND NUTRITIONAL SUPPLEMENTS; MEAL REPLACEMENT DRINKS (U.S. CLS. 6, 18, 44, 46, 51 AND 52).

CLASS 32—LIGHT BEVERAGES

FOR SPORTS DRINKS; POWDERS FOR USE IN THE PREPARATION OF ISOTONIC SPORTS DRINKS AND SPORTS BEVERAGES (U.S. CLS. 45, 46 AND 48).

CAROLINE WOOD, EXAMINING ATTORNEY

CLASS 35—ADVERTISING AND BUSINESS

FOR DISTRIBUTORSHIP SERVICES IN THE FIELD OF COFFEE, COFFEE BREWING EQUIPMENT, BOTTLED DRINKING WATER, FIRST AID AND EMERGENCY EQUIPMENT, SAFETY EQUIPMENT, FOOD SEASONINGS, SNACK FOODS, SOUPS, PLATES, BOWLS, UTENSILS, PAPER TOWELS, TISSUES, NAPKINS, HAND SANITIZING PREPARATIONS, KITCHEN CLEANING PREPARATIONS AND CLEANING EQUIPMENT, COFFEE APPLIANCE CLEANING PREPARATIONS AND EQUIPMENT, FOOD STORAGE EQUIPMENT, AND EMERGENCY SUPPLY KITS FOR PETS AND HUMANS TO BUSINESSES AND OFFICES (U.S. CLS. 100, 101 AND 102).

FIRST USE 8-0-2011; IN COMMERCE 8-0-2011.

CLASS 39—TRANSPORTATION AND STORAGE

FOR DELIVERY OF BOTTLED WATER (U.S. CLS. 100 AND 105).

FIRST USE 8-0-2011; IN COMMERCE 8-0-2011.

CLASS 43—HOTEL AND RESTAURANT SERVICES

FOR RENTAL, LEASING AND LOANING OF FOOD SERVICE EQUIPMENT, NAMELY, EQUIPMENT RELATED TO COFFEE, SOUPS AND BOTTLED WATER TO BUSINESSES AND OFFICES; COFFEE SUPPLY; RENTAL OF DRINKING WATER DISPENSERS, COOLERS AND HOT AND COLD DISPENSING CONSOLES (U.S. CLS. 100 AND 101).

FIRST USE 8-0-2011. THE MARK WAS FIRST USED ANYWHERE IN A DIFFERENT FORM OTHER THAN THAT SOUGHT TO BE REGISTERED AT LEAST AS EARLY AS 04/01/1997; IN COMMERCE 8-0-2011. THE MARK WAS FIRST USED IN COMMERCE IN A DIFFERENT FORM OTHER THAN THAT SOUGHT TO BE REGISTERED AT LEAST AS EARLY AS 04/01/1997.

SUSAN RICHARDS, EXAMINING ATTORNEY

SN 85-501,159. CARDIO CORE, LLC, LONG ISLAND CITY, NY. FILED 12-21-2011.

JCORE ZERO-LITE

THE MARK CONSISTS OF STANDARD CHARACTERS WITHOUT CLAIM TO ANY PARTICULAR FONT, STYLE, SIZE, OR COLOR.

CLASS 5—PHARMACEUTICALS

FOR DIETARY AND NUTRITIONAL SUPPLEMENTS; MEAL REPLACEMENT DRINKS (U.S. CLS. 6, 18, 44, 46, 51 AND 52).

CLASS 32—LIGHT BEVERAGES

FOR SPORTS DRINKS; POWDERS FOR USE IN THE PREPARATION OF ISOTONIC SPORTS DRINKS AND SPORTS BEVERAGES (U.S. CLS. 45, 46 AND 48).

CAROLINE WOOD, EXAMINING ATTORNEY

SN 85-501,897. STEUBER CORPORATION, LONG BEACH, CA. FILED 12-22-2011.

FOODCRAFT

THE MARK CONSISTS OF STANDARD CHARACTERS WITHOUT CLAIM TO ANY PARTICULAR FONT, STYLE, SIZE, OR COLOR.

CLASS 35—ADVERTISING AND BUSINESS

FOR DISTRIBUTORSHIP SERVICES IN THE FIELD OF COFFEE, COFFEE BREWING EQUIPMENT, BOTTLED DRINKING WATER, FIRST AID AND EMERGENCY EQUIPMENT, SAFETY EQUIPMENT, FOOD SEASONINGS, SNACK FOODS, SOUPS, PLATES, BOWLS, UTENSILS, PAPER TOWELS, TISSUES, NAPKINS, HAND SANITIZING PREPARATIONS, KITCHEN CLEANING PREPARATIONS AND CLEANING EQUIPMENT, COFFEE APPLIANCE CLEANING PREPARATIONS AND EQUIPMENT, AND FOOD STORAGE EQUIPMENT TO BUSINESSES AND OFFICES (U.S. CLS. 100, 101 AND 102).

FIRST USE 0-0-1967; IN COMMERCE 0-0-1967.

CLASS 39—TRANSPORTATION AND STORAGE

FOR DELIVERY OF BOTTLED WATER (U.S. CLS. 100 AND 105).

FIRST USE 0-0-1967; IN COMMERCE 0-0-1967.

CLASS 43—HOTEL AND RESTAURANT SERVICES

FOR RENTAL, LEASING AND LOANING OF FOOD SERVICE EQUIPMENT, NAMELY, EQUIPMENT RELATED TO COFFEE, SOUPS AND BOTTLED WATER TO BUSINESSES AND OFFICES; COFFEE SUPPLY; RENTAL OF DRINKING WATER DISPENSERS, COOLERS AND HOT AND COLD DISPENSING CONSOLES (U.S. CLS. 100 AND 101).

FIRST USE 0-0-1967; IN COMMERCE 0-0-1967.
SUSAN RICHARDS, EXAMINING ATTORNEY

SN 85-501,940. STEUBER CORPORATION, LONG BEACH, CA. FILED 12-22-2011.

"THE ROAST OF THE TOWN"

THE MARK CONSISTS OF STANDARD CHARACTERS WITHOUT CLAIM TO ANY PARTICULAR FONT, STYLE, SIZE, OR COLOR.

CLASS 35—ADVERTISING AND BUSINESS

FOR DISTRIBUTORSHIP SERVICES IN THE FIELD OF COFFEE, COFFEE BREWING EQUIPMENT, BOTTLED DRINKING WATER, FIRST AID AND EMERGENCY EQUIPMENT, SAFETY EQUIPMENT, FOOD SEASONINGS, SNACK FOODS, SOUPS, PLATES, BOWLS, UTENSILS, PAPER TOWELS, TISSUES, NAPKINS, HAND SANITIZING PREPARATIONS, KITCHEN CLEANING PREPARATIONS AND CLEANING EQUIPMENT, COFFEE APPLIANCE CLEANING PREPARATIONS AND EQUIPMENT, AND FOOD STORAGE EQUIPMENT TO BUSINESSES AND OFFICES (U.S. CLS. 100, 101 AND 102).

FIRST USE 0-0-1983; IN COMMERCE 0-0-1983.

CLASS 39—TRANSPORTATION AND STORAGE

FOR DELIVERY OF BOTTLED WATER (U.S. CLS. 100 AND 105).

FIRST USE 0-0-1983; IN COMMERCE 0-0-1983.

CLASS 43—HOTEL AND RESTAURANT SERVICES

FOR RENTAL, LEASING AND LOANING OF FOOD SERVICE EQUIPMENT, NAMELY, EQUIPMENT RELATED TO COFFEE, SOUPS AND BOTTLED WATER TO BUSINESSES AND OFFICES; COFFEE SUPPLY; RENTAL OF DRINKING WATER DISPENSERS, COOLERS AND HOT AND COLD DISPENSING CONSOLES (U.S. CLS. 100 AND 101).

FIRST USE 0-0-1983; IN COMMERCE 0-0-1983.
SUSAN RICHARDS, EXAMINING ATTORNEY

SN 85-502,682. CARDIO CORE, LLC, LONG ISLAND CITY, NY. FILED 12-22-2011.

CHANGE YOUR LIFE, NOT YOUR LIFESTYLE

THE MARK CONSISTS OF STANDARD CHARACTERS WITHOUT CLAIM TO ANY PARTICULAR FONT, STYLE, SIZE, OR COLOR.

CLASS 5—PHARMACEUTICALS

FOR NUTRITIONAL SUPPLEMENTS (U.S. CLS. 6, 18, 44, 46, 51 AND 52).

CLASS 9—ELECTRICAL AND SCIENTIFIC APPARATUS

FOR DVDS FEATURING FITNESS PROGRAMS (U.S. CLS. 21, 23, 26, 36 AND 38).

CLASS 41—EDUCATION AND ENTERTAINMENT

FOR PHYSICAL FITNESS INSTRUCTION AND CONSULTATION (U.S. CLS. 100, 101 AND 107).
CAROLINE WOOD, EXAMINING ATTORNEY

SN 85-502,846. DEE GEE HOLDINGS, LLC, MELBOURNE, FL. FILED 12-23-2011.



OWNER OF U.S. REG. NO. 3,809,347.
NO CLAIM IS MADE TO THE EXCLUSIVE RIGHT TO USE "TECHNOLOGIES", APART FROM THE MARK AS SHOWN.

THE MARK CONSISTS OF THE WORDS "CRAIG" ABOVE "TECHNOLOGIES" SEPARATED BY A LINE CARRIED BY AN OFFSET "C" WHICH FADES FROM DARK TO LIGHT FROM RIGHT TO LEFT IN THREE WAVES.

CLASS 35—ADVERTISING AND BUSINESS

FOR BUSINESS AND MANAGEMENT SUPPORT SERVICES, NAMELY, PROVIDING HIGH LEVEL BUSINESS MANAGEMENT SERVICES, BUSINESS ANALYSIS SERVICES, NAMELY, BUSINESS ADVICE AND ANALYSIS OF MARKETS, AND BUSINESS PROCESS SUPPORT SERVICES, NAMELY, PROVIDING BUSINESS SUPPORT STAFF SERVICES (U.S. CLS. 100, 101 AND 102).
FIRST USE 2-1-2011; IN COMMERCE 2-1-2011.

CLASS 41—EDUCATION AND ENTERTAINMENT

FOR INSTRUCTIONAL TRAINING SERVICES IN THE FIELD OF ENGINEERING PLANT OPERATION USING MODELING AND SIMULATIONS (U.S. CLS. 100, 101 AND 107).
FIRST USE 2-1-2011; IN COMMERCE 2-1-2011.

CLASS 42—SCIENTIFIC AND COMPUTER SERVICES

FOR ENGINEERING SERVICES IN THE FIELD OF SYSTEMS, SOFTWARE, MECHANICAL, ELECTRICAL, NETWORK AND INFORMATION ASSURANCE; DATA ANALYSIS SUPPORT SERVICES, NAMELY, TECHNICAL SUPPORT, NAMELY, PROVIDING BACK-UP COMPUTER PROGRAMS AND FACILITIES; INFORMATION TECHNOLOGY CONSULTING SERVICES; AND COMPUTER MODELING SERVICES FOR OTHERS, NAMELY, COMPUTER SIMULATION TO DEVELOP TOOLS FOR TRAINING (U.S. CLS. 100 AND 101).
FIRST USE 2-1-2011; IN COMMERCE 2-1-2011.
JESSICA FATHY, EXAMINING ATTORNEY

SN 85-503,976. AMERICAN AXLE & MANUFACTURING, INC., DETROIT, MI. FILED 12-27-2011.

DELIVERING POWER

THE MARK CONSISTS OF STANDARD CHARACTERS WITHOUT CLAIM TO ANY PARTICULAR FONT, STYLE, SIZE, OR COLOR.

OWNER OF U.S. REG. NO. 2,787,658.
NO CLAIM IS MADE TO THE EXCLUSIVE RIGHT TO USE "POWER", APART FROM THE MARK AS SHOWN.

CLASS 35—ADVERTISING AND BUSINESS

FOR PROVIDING A WEB-BASED SYSTEM AND ONLINE PORTAL IN THE NATURE OF CONSUMER-TO-BUSINESS COMMERCE AND SUPPLIER-TO-BUSINESS COMMERCE FOR ORDERING AND PURCHASER INFORMATION SERVICES IN THE FIELD OF AUTOMOTIVE DRIVELINE SYSTEMS (U.S. CLS. 100, 101 AND 102).

CLASS 40—MATERIAL TREATMENT

FOR CUSTOM MANUFACTURE OF AUTOMOBILE PARTS TO THE ORDER AND SPECIFICATION OF OTHERS (U.S. CLS. 100, 103 AND 106).

CLASS 42—SCIENTIFIC AND COMPUTER SERVICES

FOR ENGINEERING SERVICES IN THE FIELD OF LAND VEHICLE PRODUCTION (U.S. CLS. 100 AND 101).
TINA MAI, EXAMINING ATTORNEY

SN 85-504,102. SQUARE ENIX LIMITED, WIMBLEDON, UNITED KINGDOM, FILED 12-27-2011.

CORESKILLS

THE MARK CONSISTS OF STANDARD CHARACTERS WITHOUT CLAIM TO ANY PARTICULAR FONT, STYLE, SIZE, OR COLOR.

PRIORITY CLAIMED UNDER SEC. 44(D) ON UNITED KINGDOM APPLICATION NO. 2603217, FILED 12-1-2011, REG. NO. 2603217, DATED 3-9-2012, EXPIRES 12-1-2021.

CLASS 9—ELECTRICAL AND SCIENTIFIC APPARATUS

FOR COMPUTER GAME SOFTWARE; COMPUTER GAMES RECORDED ON COMPUTER DISCS; VIDEO GAME SOFTWARE; VIDEO GAMES RECORDED ON COMPUTER DISCS; ELECTRONIC GAME SOFTWARE FOR MOBILE PHONES; COMPUTER GAME SOFTWARE SUPPLIED ON LINE BY MEANS OF MULTI-MEDIA ELECTRONIC BROADCAST OR NETWORK TRANSMISSION; DOWNLOADABLE ELECTRONIC PUBLICATIONS IN THE NATURE OF NEWSLETTERS AND MAGAZINES FEATURING ELECTRONIC GAMES, COMPUTER GAME STRATEGY GUIDES FEATURING INFORMATION ABOUT VIDEO, COMPUTER, AND ELECTRONIC GAMES PROVIDED BY MEANS OF MULTI-MEDIA ELECTRONIC BROADCAST OR NETWORK TRANSMISSION; COMPUTER DISCS, CD-ROMS, DVDS, TAPES AND CASSETTES FEATURING COMPUTER GAMES AND FEATURE MOTION PICTURE FILMS (U.S. CLS. 21, 23, 26, 36 AND 38).

CLASS 41—EDUCATION AND ENTERTAINMENT

FOR ENTERTAINMENT SERVICES, NAMELY, PROVIDING ONLINE COMPUTER GAMES; PROVIDING ONLINE COMPUTER GAMES BY MEANS OF AN INTERNET WEBSITE PORTAL (U.S. CLS. 100, 101 AND 107).

DAVID C. REIHNER, EXAMINING ATTORNEY

SN 85-506,498. HUNTER'S SPECIALTIES, INC., CEDAR RAPIDS, IA. FILED 12-30-2011.

THE STUFF OF LEGENDS

THE MARK CONSISTS OF STANDARD CHARACTERS WITHOUT CLAIM TO ANY PARTICULAR FONT, STYLE, SIZE, OR COLOR.

CLASS 16—PAPER GOODS AND PRINTED MATTER

FOR ITEMS FOR MOUNTING AND DISPLAYING OF ANTLERS AND ANIMALS, NAMELY, MOUNTING BOARDS (U.S. CLS. 2, 5, 22, 23, 29, 37, 38 AND 50).

CLASS 28—TOYS AND SPORTING GOODS

FOR HUNTING GEAR AND ACCESSORIES, NAMELY, WILD ANIMAL GAME CALLS, SCENTS, MUSKS AND HUNTING LURE, HUNTING SEATS, SHOOTING TARGETS, DEER URINE, FACE MASKS, HUNTING BLINDS, AND GUN SOCKS; SCENT ELIMINATION PRODUCTS, NAMELY, ODOR NEUTRALIZING PREPARATIONS FOR USE IN HUNTING; ARCHERY ACCESSORIES, NAMELY, BOW HOLDERS, CABLE LOCKS, TRAIL MARKERS, ACCESSORY HOOKS; HUNTERS' CAMOUFLAGE EQUIPMENT AND ACCESSORIES, NAMELY, MAKEUP, MAKEUP REMOVER, PAINT, TAPES, GUN COVERS, GLOVES, HEAD NETS, AND FACE NETS (U.S. CLS. 22, 23, 38 AND 50).
BRENDAN REGAN, EXAMINING ATTORNEY

SN 85-506,522. MY SCHOOL SWAP, LLC, AKA MY SCHOOL SWAP, GAINESVILLE, VA. FILED 12-30-2011.

My School Swap

THE MARK CONSISTS OF STANDARD CHARACTERS WITHOUT CLAIM TO ANY PARTICULAR FONT, STYLE, SIZE, OR COLOR.

CLASS 35—ADVERTISING AND BUSINESS

FOR ONLINE CLASSIFIED ADVERTISING SERVICES; PROVIDING CLASSIFIED ADVERTISEMENTS VIA THE INTERNET USING A WEB SITE WHERE SCHOOL EMPLOYEES, PARENTS AND THE COMMUNITY CAN POST CLASSIFIED ADS FOR THE PURPOSE OF FUNDRAISING FOR PRESCHOOL, ELEMENTARY AND SECONDARY SCHOOLS; PROVIDING ON-LINE SEARCHABLE COMPUTER DATABASE FEATURING ADVERTISING LISTINGS; ADVERTISING; ADVERTISING, NAMELY, PROMOTION RELATING TO REAL ESTATE AND PROMOTING THE SALE AND EXCHANGE OF ARTICLES, GOODS AND SERVICES OF OTHERS; PROVIDING AN ON-LINE SEARCHABLE DATABASE FEATURING EMPLOYMENT OPPORTUNITIES THROUGH THE TRANSMISSION OF ADVERTISING MATERIAL AND MESSAGES ON COMPUTER AND SOCIAL MEDIA NETWORKS; PROVIDING ADVERTISING OF SPECIAL EVENTS BY THIRD PARTIES (U.S. CLS. 100, 101 AND 102).
FIRST USE 9-30-2011; IN COMMERCE 12-27-2011.

CLASS 36—INSURANCE AND FINANCIAL

FOR CHARITABLE FUNDRAISING SERVICES; CHARITABLE SCHOOL FUNDRAISING SERVICES BY MEANS OF SHARING REVENUE FROM THE SALES OF ON-LINE CLASSIFIED ADVERTISING LISTINGS WITH PRESCHOOL, ELEMENTARY AND SECONDARY SCHOOLS BY PROVIDING A WEB SITE WHERE SCHOOL EMPLOYEES, PARENTS AND THE COMMUNITY CAN POST CLASSIFIED ADS FOR ITEMS FOR SALE OR EXCHANGE, GOODS AND SERVICES, NEWS AND ANNOUNCEMENTS, HOUSING, AND EMPLOYMENT OPPORTUNITIES; CHARITABLE FUNDRAISING SERVICES FEATURING AN ON-LINE SEARCHABLE COMPUTER DATABASE OF PRESCHOOL, ELEMENTARY AND SECONDARY SCHOOLS TO IDENTIFY FOR SHARING REVENUE AND ON-LINE SEARCHABLE DATABASES FEATURING CLASSIFIED ADVERTISING LISTINGS; PROVIDING INFORMATION IN THE FIELD OF CHARITABLE SCHOOL FUNDRAISING (U.S. CLS. 100, 101 AND 102).
FIRST USE 9-30-2011; IN COMMERCE 12-27-2011.
LESLIE RICHARDS, EXAMINING ATTORNEY

SN 85-507,798. HILLARD HEINTZE, LLC, CHICAGO, IL. FILED 1-3-2012.



**Advancing Excellence in
Policing and Public Safety**

NO CLAIM IS MADE TO THE EXCLUSIVE RIGHT TO USE "SENIOR LEADERSHIP COUNCIL", APART FROM THE MARK AS SHOWN.

THE NAME(S), PORTRAIT(S), AND/OR SIGNATURE(S) SHOWN IN THE MARK IDENTIFIES TERRY HILLARD AND ARNETTE HEINTZE, WHOSE CONSENT(S) TO REGISTER IS MADE OF RECORD.

THE MARK CONSISTS OF TWO CONCENTRIC CIRCLES WITH THREE ARROWS INSIDE THE CIRCLE POINTING UPWARD WITH THE WORDS "SENIOR LEADERSHIP COUNCIL" IN AN ARC ABOVE THE CIRCLE, AND THE WORDS "HILLARD HEINTZE" IN A RECTANGLE BELOW THE TRIANGLES, CUTTING THROUGH THE BOTTOM PART OF THE CIRCLE. THE WORDING "ADVANCING EXCELLENCE IN POLICING & PUBLIC SAFETY" APPEARS BELOW THE DESIGN ELEMENT.

CLASS 35—ADVERTISING AND BUSINESS

FOR BUSINESS SERVICES, NAMELY, FORMULATION OF BEST PRACTICES FOR POLICING AND PUBLIC SAFETY (U.S. CLS. 100, 101 AND 102).
FIRST USE 4-8-2010; IN COMMERCE 4-8-2010.

CLASS 45—PERSONAL AND LEGAL SERVICES

FOR CONSULTING SERVICES IN THE FIELD OF POLICE PROTECTION AND PUBLIC SAFETY (U.S. CLS. 100 AND 101).
FIRST USE 4-8-2010; IN COMMERCE 4-8-2010.
ELLEN PERKINS, EXAMINING ATTORNEY

SN 85-508,540. STEUBER CORPORATION, LONG BEACH, CA. FILED 1-4-2012.



OWNER OF U.S. REG. NOS. 2,219,628 AND 3,253,139.

THE MARK CONSISTS OF A DESIGN OF THREE FANCIFUL CURVES ABOVE THE STYLIZED TERM "ALTA".

CLASS 35—ADVERTISING AND BUSINESS

FOR DISTRIBUTORSHIP SERVICES IN THE FIELD OF COFFEE, COFFEE BREWING EQUIPMENT, BOTTLED DRINKING WATER, FIRST AID AND EMERGENCY EQUIPMENT, SAFETY EQUIPMENT, FOOD SEASONINGS, SNACK FOODS, SOUPS, PLATES, BOWLS, UTENSILS, PAPER TOWELS, TISSUES, NAPKINS, HAND SANITIZING PREPARATIONS, KITCHEN CLEANING PREPARATIONS AND CLEANING EQUIPMENT, COFFEE APPLIANCE CLEANING PREPARATIONS AND EQUIPMENT, FOOD STORAGE EQUIPMENT, AND EMERGENCY SUPPLY KITS FOR PETS AND HUMANS TO BUSINESSES AND OFFICES (U.S. CLS. 100, 101 AND 102).

FIRST USE 8-0-2011; IN COMMERCE 8-0-2011.

CLASS 39—TRANSPORTATION AND STORAGE

FOR DELIVERY OF BOTTLED WATER (U.S. CLS. 100 AND 105).

FIRST USE 8-0-2011; IN COMMERCE 8-0-2011.

CLASS 43—HOTEL AND RESTAURANT SERVICES

FOR RENTAL, LEASING AND LOANING OF FOOD SERVICE EQUIPMENT, NAMELY, EQUIPMENT RELATED TO COFFEE, SOUPS AND BOTTLED WATER TO BUSINESSES AND OFFICES; COFFEE SUPPLY; RENTAL OF DRINKING WATER DISPENSERS, COOLERS AND HOT AND COLD DISPENSING CONSOLES (U.S. CLS. 100 AND 101).

FIRST USE 8-0-2011, THE MARK WAS FIRST USED ANYWHERE IN A DIFFERENT FORM OTHER THAN THAT SOUGHT TO BE REGISTERED AT LEAST AS EARLY AS 04/01/1997; IN COMMERCE 8-0-2011, THE MARK WAS FIRST USED IN COMMERCE IN A DIFFERENT FORM OTHER THAN THAT SOUGHT TO BE REGISTERED AT LEAST AS EARLY AS 04/01/1997.

SUSAN RICHARDS, EXAMINING ATTORNEY

CLASS 35—ADVERTISING AND BUSINESS

FOR DISTRIBUTORSHIP SERVICES IN THE FIELD OF COFFEE, COFFEE BREWING EQUIPMENT, BOTTLED DRINKING WATER, FIRST AID AND EMERGENCY EQUIPMENT, SAFETY EQUIPMENT, FOOD SEASONINGS, SNACK FOODS, SOUPS, PLATES, BOWLS, UTENSILS, PAPER TOWELS, TISSUES, NAPKINS, HAND SANITIZING PREPARATIONS, KITCHEN CLEANING PREPARATIONS AND CLEANING EQUIPMENT, COFFEE APPLIANCE CLEANING PREPARATIONS AND EQUIPMENT, AND FOOD STORAGE EQUIPMENT TO BUSINESSES AND OFFICES (U.S. CLS. 100, 101 AND 102).

FIRST USE 0-0-1983; IN COMMERCE 0-0-1983.

CLASS 39—TRANSPORTATION AND STORAGE

FOR DELIVERY OF BOTTLED WATER (U.S. CLS. 100 AND 105).

FIRST USE 0-0-1983; IN COMMERCE 0-0-1983.

CLASS 43—HOTEL AND RESTAURANT SERVICES

FOR RENTAL, LEASING AND LOANING OF FOOD SERVICE EQUIPMENT, NAMELY, EQUIPMENT RELATED TO COFFEE, SOUPS AND BOTTLED WATER TO BUSINESSES AND OFFICES; COFFEE SUPPLY; RENTAL OF DRINKING WATER DISPENSERS, COOLERS AND HOT AND COLD DISPENSING CONSOLES (U.S. CLS. 100 AND 101).

FIRST USE 0-0-1983, THE MARK WAS FIRST USED ANYWHERE IN A DIFFERENT FORM OTHER THAN THAT SOUGHT TO BE REGISTERED AT LEAST AS EARLY AS 00/00/1967. ; IN COMMERCE 0-0-1983, THE MARK WAS FIRST USED IN COMMERCE IN A DIFFERENT FORM OTHER THAN THAT SOUGHT TO BE REGISTERED AT LEAST AS EARLY AS 00/00/1967..

SUSAN RICHARDS, EXAMINING ATTORNEY

SN 85-508,608. VETERINARIANS WITHOUT BORDERS, DAVIS, CA. FILED 1-4-2012.

VÉTÉRINAIRES SANS FRONTIÈRES

THE MARK CONSISTS OF STANDARD CHARACTERS WITHOUT CLAIM TO ANY PARTICULAR FONT, STYLE, SIZE, OR COLOR.

OWNER OF U.S. REG. NO. 3,722,063.

NO CLAIM IS MADE TO THE EXCLUSIVE RIGHT TO USE "VÉTÉRINAIRES", APART FROM THE MARK AS SHOWN.

THE ENGLISH TRANSLATION OF "VÉTÉRINAIRES SANS FRONTIÈRES" IN THE MARK IS "VETERINARIANS WITHOUT BORDERS".

CLASS 41—EDUCATION AND ENTERTAINMENT

FOR EDUCATION SERVICES, NAMELY, PROVIDING INSTRUCTION IN THE FIELD OF VETERINARY HEALTH (U.S. CLS. 100, 101 AND 107).

CLASS 44—MEDICAL, BEAUTY AND AGRICULTURAL SERVICES

FOR VETERINARY SERVICES; VETERINARY SPECIALTY SERVICES PROVIDING ADVANCED MEDICAL, DIAGNOSTIC OR SURGICAL SERVICES FOR ANIMALS (U.S. CLS. 100 AND 101).

GISELLE AGOSTO, EXAMINING ATTORNEY

SN 85-508,561. STEUBER CORPORATION, LONG BEACH, CA. FILED 1-4-2012.



NO CLAIM IS MADE TO THE EXCLUSIVE RIGHT TO USE "COFFEE & REFRESHMENT SERVICES", APART FROM THE MARK AS SHOWN.

THE MARK CONSISTS OF THE LETTER "F" IN AN OVAL DESIGN ABOVE THE STACKED TERMS "FOODCRAFT" AND "COFFEE & REFRESHMENT SERVICES".

SN 85-509,074. THIMESCH ENTERPRISES, LLC, DBA OUTLAW INNOVATIONS, KINGMAN, KS. FILED 1-5-2012.



THE MARK CONSISTS OF THE STYLIZED WORDS "OUTLAW INNOVATIONS" CURVING ABOUT A STYLIZED IMAGE OF AN OVAL WITH A LINE THROUGH THE MIDDLE.

CLASS 37—CONSTRUCTION AND REPAIR

FOR ANTI-RUST TREATMENT FOR VEHICLES OR OTHER METAL GOODS; APPLICATION OF COATINGS FOR OTHERS, NAMELY, APPLYING PAINT, POWDER COATING, PLATINGS, CERAMIC COATINGS, AND SPECIALTY FINISHES; METAL PREPARATION, NAMELY, APPLYING PROTECTIVE COATINGS TO METAL; MEDIA BLASTING, NAMELY, PREPARING METAL FOR FINISHING; APPLICATION OF PROTECTIVE COATINGS; APPLICATION OF PROTECTIVE COATINGS TO METAL GOODS; AUTOMOBILE CUSTOMIZATION AND REPAIR SERVICES, INCLUDING ALL TYPES OF MOTORIZED VEHICLES, NAMELY, TRUCKS, CARS, MOTORCYCLES, ALL TERRAIN VEHICLES, FOUR-WHEELERS, UTILITY VEHICLES, RECREATIONAL VEHICLES; GARAGE SERVICES, NAMELY, REPAIR OF AUTOMOBILE; RUST REMOVAL; RUST PROOFING; RESTORATION IN THE FIELD OF ON AND OFF-ROAD VEHICLES, ANTIQUES, VEHICLE AND TRAILER PARTS, APPLIANCES, COLLECTIBLES, AND A VARIETY OF ASSEMBLY PARTS; MOTORCYCLE CUSTOMIZATION SERVICE (U.S. CLS. 100, 103 AND 106).

FIRST USE 11-0-2003; IN COMMERCE 11-0-2003.

CLASS 40—MATERIAL TREATMENT

FOR ASSEMBLY OF PRODUCTS FOR OTHERS; CUSTOM CONSTRUCTION OF METAL GOODS; ELECTRO AND METAL COATING; ELECTROPLATING; METAL FABRICATION AND FINISHING SERVICES; METAL PLATING; METAL TREATING; PROTOTYPE FABRICATION OF NEW PRODUCTS FOR OTHERS; WELDING; GRINDING; ALUMINUM OXIDE BLASTING, WALNUT SHELL BLASTING, COAL SLAG BLASTING, GLASS BEAD BLASTING, CRUSHED GLASS BLASTING, PLASTIC BEAD BLASTING, SODA BLASTING, SAND BLASTING, AND DRY ICE BLASTING SERVICES; GLASS ETCHING; DRY ICE BLASTING SERVICES (U.S. CLS. 100, 103 AND 106).

FIRST USE 11-0-2003; IN COMMERCE 11-0-2003.
BRIDGETT SMITH, EXAMINING ATTORNEY

SN 85-510,400. VEREFINA, LLC, SANDY, UT. FILED 1-6-2012.

VEREFINA

THE MARK CONSISTS OF STANDARD CHARACTERS WITHOUT CLAIM TO ANY PARTICULAR FONT, STYLE, SIZE, OR COLOR.

CLASS 3—COSMETICS AND CLEANING PREPARATIONS

FOR BABY LOTION; BEAUTY GELS; BEAUTY SERUMS; BODY SCRUB; ESSENTIAL OILS; FACE AND BODY LOTIONS; FACIAL SCRUBS; FOOT SCRUBS; HAND SCRUBS; LIP BALM; MOISTURIZING PREPARATIONS FOR THE SKIN; NON-MEDICATED SKIN CARE PREPARATIONS; NON-MEDICATED SKIN CREAMS WITH ESSENTIAL OILS FOR USE IN AROMATHERAPY; REEDS AND SCENTED OILS SOLD AS A UNIT FOR USE IN ROOM SCENT DIFFUSERS; SKIN CARE PREPARATIONS, NAMELY, BODY BALM; SKIN CLEANSERS; SKIN SOAP; SKIN CREAMS AND LOTIONS; BEAUTY MASKS AND BEAUTY MILKS, COSMETICS, BODY AND BEAUTY CARE COSMETICS (U.S. CLS. 1, 4, 6, 50, 51 AND 52).

FIRST USE 10-20-2011; IN COMMERCE 10-20-2011.

CLASS 11—ENVIRONMENTAL CONTROL APPARATUS

FOR NON-ELECTRIC AIR DIFFUSERS COMPRISED OF A WICK IN A CONTAINER USED TO EMIT SCENT WHEN LIT SOLD WITHOUT SCENTED OIL (U.S. CLS. 13, 21, 23, 31 AND 34).

JOHN DWYER, EXAMINING ATTORNEY

SN 85-511,753. SPRINGFIELD, INC., GENESEO, IL. FILED 1-9-2012.

NOTICEABLY UNNOTICEABLE

THE MARK CONSISTS OF STANDARD CHARACTERS WITHOUT CLAIM TO ANY PARTICULAR FONT, STYLE, SIZE, OR COLOR.

CLASS 13—FIREARMS

FOR FIREARMS (U.S. CLS. 2 AND 9).

CLASS 25—CLOTHING

FOR CLOTHING, NAMELY, HATS, T-SHIRTS AND SWEATSHIRTS (U.S. CLS. 22 AND 39).

BRIAN PINO, EXAMINING ATTORNEY

SN 85-511,872. CERNER INNOVATION, INC., LENEXA, KS. FILED 1-9-2012.

CERNER HEALTH

THE MARK CONSISTS OF STANDARD CHARACTERS WITHOUT CLAIM TO ANY PARTICULAR FONT, STYLE, SIZE, OR COLOR.

OWNER OF U.S. REG. NOS. 1,458,174, 2,550,007 AND OTHERS.

NO CLAIM IS MADE TO THE EXCLUSIVE RIGHT TO USE "HEALTH", APART FROM THE MARK AS SHOWN.

CLASS 9—ELECTRICAL AND SCIENTIFIC APPARATUS

SN 85-513,094. D3 LED, LLC, UNION CITY, NJ. FILED 1-10-2012.

FOR COMPUTER SOFTWARE FOR MANAGING, STORING, ANALYZING, MAINTAINING, PROCESSING, STRUCTURING, REVIEWING, BUILDING, EDITING, DISTRIBUTING, COMMUNICATING, ORGANIZING, SHARING, REFERENCING, MONITORING AND INTEGRATING PATIENT MEDICAL, EDUCATIONAL, AND TRANSACTIONAL INFORMATION, FOR USE IN THE HEALTH CARE FIELD (U.S. CLS. 21, 23, 26, 36 AND 38).

CLASS 42—SCIENTIFIC AND COMPUTER SERVICES

FOR APPLICATION SERVICE PROVIDER (ASP) FEATURING SOFTWARE FOR MANAGING, STORING, ANALYZING, MAINTAINING, PROCESSING, STRUCTURING, REVIEWING, BUILDING, EDITING, DISTRIBUTING, COMMUNICATING, ORGANIZING, SHARING, REFERENCING, MONITORING AND INTEGRATING PATIENT MEDICAL, EDUCATIONAL, AND TRANSACTIONAL INFORMATION (U.S. CLS. 100 AND 101).

JAMES STEIN, EXAMINING ATTORNEY



SN 85-512,281. CLOUD B, INC., GARDENA, CA. FILED 1-9-2012.

OWNER OF U.S. REG. NOS. 3,365,320, 3,545,318 AND 3,548,365.

NO CLAIM IS MADE TO THE EXCLUSIVE RIGHT TO USE "DYNAMIC DIGITAL DISPLAYS", APART FROM THE MARK AS SHOWN.

THE COLOR(S) RED, GRAY AND WHITE IS/ARE CLAIMED AS A FEATURE OF THE MARK.

THE MARK CONSISTS OF THE WORDS "DYNAMIC DIGITAL DISPLAYS" IN THE COLOR WHITE WITHIN A GRAY RECTANGULAR BOX. A WHITE LINE EXTENDS VERTICALLY UPWARD FROM THE LETTER "I" IN "DYNAMIC" AND A WHITE LINE EXTENDS VERTICALLY DOWNWARD FROM THE LETTER "L" IN "DISPLAYS". THE TERM "D3" APPEARS IN THE COLORS RED AND WHITE, OFFSET FROM THE UPPER LEFT-HAND CORNER OF THE RECTANGULAR BOX.

SLUMBER SCENT

THE MARK CONSISTS OF STANDARD CHARACTERS WITHOUT CLAIM TO ANY PARTICULAR FONT, STYLE, SIZE, OR COLOR.

NO CLAIM IS MADE TO THE EXCLUSIVE RIGHT TO USE "SCENT", APART FROM THE MARK AS SHOWN.

CLASS 3—COSMETICS AND CLEANING PREPARATIONS

FOR AROMATIC PILLOWS CONTAINING POTPOURRI IN FABRIC CONTAINERS (U.S. CLS. 1, 4, 6, 50, 51 AND 52).

CLASS 28—TOYS AND SPORTING GOODS

FOR TOYS, NAMELY, PLUSH TOYS (U.S. CLS. 22, 23, 38 AND 50).
ZACHARY BELLO, EXAMINING ATTORNEY

CLASS 9—ELECTRICAL AND SCIENTIFIC APPARATUS

FOR LED DIGITAL DISPLAYS FOR COMMERCIAL USAGE, LED LUMINOUS SIGNS FOR COMMERCIAL USAGE, LED DISPLAYS FOR COMMERCIAL USAGE; LED DISPLAY MULTI-MEDIA OPERATING SYSTEMS FOR COMMERCIAL USE, NAMELY, MEDIA CONTENT PLAYER DEVICES THAT PLAY BOTH PRE-RECORDED AND LIVE VIDEO, STILLS, GRAPHICS, ANIMATION, AND OTHER DIGITAL IMAGERY, AND LED DISPLAY CONTROLLERS THAT PROCESS DIGITAL SIGNALS TO THE DISPLAY AND COMMUNICATE BI-DIRECTIONALLY WITH THE LED DISPLAY, ALLOWING FOR PIXEL LEVEL COLOR, BRIGHTNESS, AND LUMINANCE CONTROL AND DISPLAY PERFORMANCE DIAGNOSTICS (U.S. CLS. 21, 23, 26, 36 AND 38).

CLASS 42—SCIENTIFIC AND COMPUTER SERVICES

FOR ENGINEERING AND CONSULTING SERVICES RELATING TO THE DESIGN AND DEVELOPMENT OF LED DISPLAY SYSTEMS FOR COMMERCIAL USE; CUSTOM DEVELOPMENT OF SOFTWARE FOR OTHERS, NAMELY, LED DISPLAY SOFTWARE (U.S. CLS. 100 AND 101).
ANDREW RHIM, EXAMINING ATTORNEY

SN 85-513,484. HAJNASR, GEORGE, KINGSTON, MA.
FILED 1-10-2012.

**JEET KUNE DO: THE SYSTEM
WITHOUT A SYSTEM**

THE MARK CONSISTS OF STANDARD CHARACTERS WITHOUT CLAIM TO ANY PARTICULAR FONT, STYLE, SIZE, OR COLOR.

OWNER OF U.S. REG. NO. 2,946,415.

NO CLAIM IS MADE TO THE EXCLUSIVE RIGHT TO USE "JEET KUNE DO", APART FROM THE MARK AS SHOWN.

THE ENGLISH TRANSLATION OF "JEET KUNE DO" IN THE MARK IS "THE WAY OF THE INTERCEPTING FIST".

CLASS 16—PAPER GOODS AND PRINTED MATTER

FOR BOOKS IN THE FIELD OF MARTIAL ARTS, JEET KUNE DO (U.S. CLS. 2, 5, 22, 23, 29, 37, 38 AND 50).
FIRST USE 5-3-2005; IN COMMERCE 5-3-2005.

CLASS 41—EDUCATION AND ENTERTAINMENT

FOR PROVIDING A WEB SITE FEATURING NON-DOWNLOADABLE INSTRUCTIONAL VIDEOS IN THE FIELD OF MARTIAL ARTS; PROVIDING CLASSES, WORKSHOPS, SEMINARS AND CAMPS IN THE FIELDS OF FITNESS, EXERCISE, BOXING, KICK BOXING AND MIXED MARTIAL ARTS (U.S. CLS. 100, 101 AND 107).
CHRIS WELLS, EXAMINING ATTORNEY

SN 85-513,614. 4SEMO.COM, INC., MALDEN, MO. FILED 1-11-2012.



NO CLAIM IS MADE TO THE EXCLUSIVE RIGHT TO USE "STORM SHELTERS", APART FROM THE MARK AS SHOWN.

THE MARK CONSISTS OF A GREEK STYLE CROSS CONSISTING OF TWO LINES OR BARS PERPENDICULAR TO EACH OTHER. THE STYLIZED TEXT "LIFESAVER" SITS INSIDE THE HORIZONTAL PORTION OF THE CROSS WITH THE STYLIZED TEXT "STORM SHELTERS" JUST BELOW.

CLASS 19—NON-METALLIC BUILDING MATERIALS

FOR NON-METAL STORM SHELTERS (U.S. CLS. 1, 12, 33 AND 50).
FIRST USE 5-31-2005; IN COMMERCE 6-1-2005.

CLASS 35—ADVERTISING AND BUSINESS

FOR RETAIL STORE SERVICES FEATURING NON-METAL STORM SHELTERS AND ACCESSORIES (U.S. CLS. 100, 101 AND 102).

FIRST USE 5-31-2005; IN COMMERCE 6-1-2005.

CLASS 37—CONSTRUCTION AND REPAIR

FOR INSTALLATION OF IN-GROUND NON-METAL STORM SHELTERS AND ABOVE GROUND METAL SAFE ROOMS (U.S. CLS. 100, 103 AND 106).

FIRST USE 5-31-2005; IN COMMERCE 6-1-2005.

CHARISMA HAMPTON, EXAMINING ATTORNEY

SN 85-514,336. MONSTER ENERGY COMPANY, CORONA, CA. FILED 1-11-2012.

MONSTER ENERGY WHITE LIGHT

THE MARK CONSISTS OF STANDARD CHARACTERS WITHOUT CLAIM TO ANY PARTICULAR FONT, STYLE, SIZE, OR COLOR.

OWNER OF U.S. REG. NOS. 4,036,680 AND 4,036,681.

NO CLAIM IS MADE TO THE EXCLUSIVE RIGHT TO USE "ENERGY", APART FROM THE MARK AS SHOWN.

CLASS 5—PHARMACEUTICALS

FOR NUTRITIONAL SUPPLEMENTS (U.S. CLS. 6, 18, 44, 46, 51 AND 52).

CLASS 32—LIGHT BEVERAGES

FOR NON-ALCOHOLIC BEVERAGES, NAMELY, ENERGY DRINKS, ENERGY DRINKS FLAVORED WITH JUICE, ENERGY DRINKS FLAVORED WITH COFFEE, SPORTS DRINKS, ALL ENHANCED WITH VITAMINS, MINERALS, NUTRIENTS, PROTEINS, AMINO ACIDS, AND/OR HERBS, BUT EXCLUDING PERISHABLE BEVERAGE PRODUCTS THAT CONTAIN FRUIT JUICE OR SOY, WHETHER SUCH PRODUCTS ARE PASTEURIZED OR NOT (U.S. CLS. 45, 46 AND 48).

GEOFFREY FOSDICK, EXAMINING ATTORNEY

SN 85-515,509. MONSTER ENERGY COMPANY, CORONA, CA. FILED 1-12-2012.

MONSTER ENERGY BLAKOUT

THE MARK CONSISTS OF STANDARD CHARACTERS WITHOUT CLAIM TO ANY PARTICULAR FONT, STYLE, SIZE, OR COLOR.

OWNER OF U.S. REG. NOS. 4,036,680 AND 4,036,681.

NO CLAIM IS MADE TO THE EXCLUSIVE RIGHT TO USE "ENERGY", APART FROM THE MARK AS SHOWN.

CLASS 30—STAPLE FOODS

FOR READY TO DRINK COFFEE, ICED COFFEE AND COFFEE BASED BEVERAGES; READY TO DRINK FLAVORED COFFEE, ICED COFFEE AND COFFEE BASED BEVERAGES (U.S. CL. 46).

CLASS 32—LIGHT BEVERAGES

FOR NON-ALCOHOLIC BEVERAGES, NAMELY, ENERGY DRINKS, ENERGY DRINKS FLAVORED WITH JUICE, ENERGY DRINKS FLAVORED WITH COFFEE, SPORTS DRINKS, ALL ENHANCED WITH VITAMINS, MINERALS, NUTRIENTS, PROTEINS, AMINO ACIDS, AND/OR HERBS, BUT EXCLUDING PERISHABLE BEVERAGE PRODUCTS THAT CONTAIN FRUIT JUICE OR SOY, WHETHER SUCH PRODUCTS ARE PASTEURIZED OR NOT (U.S. CLS. 45, 46 AND 48).

GEOFFREY FOSDICK, EXAMINING ATTORNEY

SN 85-516,863. BRENNER, MICHAEL, BALTIMORE, MD.
FILED 1-15-2012.

Betamore

THE MARK CONSISTS OF STANDARD CHARACTERS WITHOUT CLAIM TO ANY PARTICULAR FONT, STYLE, SIZE, OR COLOR.

CLASS 35—ADVERTISING AND BUSINESS

FOR BUSINESS DEVELOPMENT SERVICES, NAMELY, PROVIDING STARTUP SUPPORT FOR BUSINESSES OF OTHERS; BUSINESS SERVICES, NAMELY, MATCHING POTENTIAL PRIVATE INVESTORS WITH ENTREPRENEURS NEEDING FUNDING; NEW BUSINESS VENTURE DEVELOPMENT AND FORMATION CONSULTING SERVICES; BUSINESS PLANNING; ASSISTANCE WITH BUSINESS MANAGEMENT AND PLANNING; PROVIDING BUSINESS DEVELOPMENT SERVICES, NAMELY, OFFERING ORGANIZATIONAL AND MANAGEMENT BUSINESS ADVICE FOR ENTREPRENEURS AND DESIGNERS; BUSINESS CONCEPT EVALUATION THROUGH MARKET FEASIBILITY STUDIES; ASSISTANCE WITH BUSINESS MANAGEMENT AND PLANNING; OPERATIONS MANAGEMENT; BUSINESS MANAGEMENT CONSULTING WITH RELATION TO STRATEGY, MARKETING, SALES, OPERATION, PRODUCT DESIGN PARTICULARLY SPECIALIZING IN THE USE OF ANALYTIC AND STATISTIC MODELS FOR THE UNDERSTANDING AND PREDICTING OF CONSUMERS, BUSINESS, MARKET TRENDS AND ACTIONS; BUSINESS ACQUISITION CONSULTATION; ECONOMIC FORECASTING AND ANALYSIS (U.S. CLS. 100, 101 AND 102).

SN 85-515,996. KAPLAN, FELISSA M., SIMI VALLEY, CA.
FILED 1-13-2012.



THE NAME "LISSI KAPLAN" IDENTIFIES A LIVING INDIVIDUAL WHOSE CONSENT IS OF RECORD.

THE MARK CONSISTS OF THE STYLIZED WORDING "LISSI KAPLAN" BENEATH THE DESIGN OF A VASE WITH FLOWERS.

CLASS 41—EDUCATION AND ENTERTAINMENT

FOR EDUCATIONAL SERVICES, NAMELY, PROVIDING COURSES IN THE FIELD OF ORGANIZATION OF BUSINESSES AND BUSINESS MANAGEMENT FOR ENTREPRENEURS AND BUSINESS DESIGNERS (U.S. CLS. 100, 101 AND 107).

CAROLINE WOOD, EXAMINING ATTORNEY

CLASS 16—PAPER GOODS AND PRINTED MATTER

FOR STATIONERY (U.S. CLS. 2, 5, 22, 23, 29, 37, 38 AND 50).

CLASS 21—HOUSEWARES AND GLASS

FOR VASES, CANDLESTICK HOLDERS, PLATES, DISHES, CUPS, MUGS, SAUCERS, PLATTERS, BEVERAGE GLASSWARE, SERVING TRAYS, SUGAR BOWLS, CREAMER PITCHERS, ALL OF THE AFOREMENTIONED GOODS BEING MADE OF PORCELAIN AND CERAMIC (U.S. CLS. 2, 13, 23, 29, 30, 33, 40 AND 50).

CLASS 24—FABRICS

FOR LINENS, NAMELY, HOUSEHOLD LINENS, BED AND TABLE LINENS, AND BATH LINENS (U.S. CLS. 2 AND 50).

CLASS 27—FLOOR COVERINGS

FOR WALLPAPER (U.S. CLS. 19, 20, 37, 42 AND 50).
ANTHONY RINKER, EXAMINING ATTORNEY

SN 85-516,983. THE FOSTER CORPORATION, DBA BIO-SERV, FRENCHTOWN, NJ. FILED 1-16-2012.

BIO-SERV

THE MARK CONSISTS OF STANDARD CHARACTERS WITHOUT CLAIM TO ANY PARTICULAR FONT, STYLE, SIZE, OR COLOR.

OWNER OF U.S. REG. NO. 1,570,610.

CLASS 6—METAL GOODS

FOR METAL LOCKS, CLIPS, LINKS, AND CHAINS FOR USE WITH CAGES FOR CAPTIVE, RESEARCH, AND BREEDING ANIMALS AND REPTILES (U.S. CLS. 2, 12, 13, 14, 23, 25 AND 50).

FIRST USE 7-0-1971; IN COMMERCE 7-0-1971.

CLASS 10—MEDICAL APPARATUS

FOR VETERINARY INSTRUMENTS AND ARTICLES, NAMELY, ORAL HYDRATION AND CONSUMABLE LIQUID DELIVERY DEVICES, SOLID FOOD DELIVERY DEVICES, AND SPECIAL FURNITURE PRODUCTS SPECIFICALLY ADAPTED FOR VETERINARY USE, FOR CAPTIVE, RESEARCH, AND BREEDING ANIMALS AND REPTILES (U.S. CLS. 26, 39 AND 44).

FIRST USE 7-0-1971; IN COMMERCE 7-0-1971.

CLASS 19—NON-METALLIC BUILDING MATERIALS

FOR NON-METALLIC ANIMAL SHELTERS AND ENRICHMENT DEVICES, NAMELY, ENVIRONMENT ENRICHMENT ANIMAL SHELTERS AND HUTS FOR CAPTIVE, RESEARCH, AND BREEDING ANIMALS AND REPTILES (U.S. CLS. 1, 12, 33 AND 50).

FIRST USE 7-0-1971; IN COMMERCE 7-0-1971.

CLASS 20—FURNITURE AND ARTICLES NOT OTHERWISE CLASSIFIED

FOR SCRATCHING BOARDS AND POSTS AND ENVIRONMENT ENRICHMENT NESTING SHEETS MADE OF WOOD PULP FOR ENCOURAGING NATURAL NEST BUILDING BEHAVIOR, MIRRORS, AND PADS MADE OF FABRIC FOR SCRATCHING, RESTING OR SLEEPING FOR CAPTIVE, RESEARCH, AND BREEDING ANIMALS AND REPTILES (U.S. CLS. 2, 13, 22, 25, 32 AND 50).

FIRST USE 7-0-1971; IN COMMERCE 7-0-1971.

CLASS 28—TOYS AND SPORTING GOODS

FOR ENVIRONMENT ENRICHMENT AND AMUSEMENT DEVICES, NAMELY, CHEW TOYS, GNAWING TOYS, BALLS, EXERCISE WHEELS, AND TRAPEZE EXERCISE DEVICES, FOR CAPTIVE, RESEARCH, AND BREEDING ANIMALS AND REPTILES (U.S. CLS. 22, 23, 38 AND 50).

FIRST USE 7-0-1971; IN COMMERCE 7-0-1971.

CLASS 31—NATURAL AGRICULTURAL PRODUCTS

FOR NUTRITIONAL PRODUCTS, NAMELY, FOODSTUFFS, HAY BALES, AND TREATS, FOR CAPTIVE, RESEARCH, AND BREEDING ANIMALS AND REPTILES (U.S. CLS. 1 AND 46).

FIRST USE 7-0-1971; IN COMMERCE 7-0-1971.

CLASS 44—MEDICAL, BEAUTY AND AGRICULTURAL SERVICES

FOR VETERINARY ADVICE AND ANALYSIS SERVICES, NAMELY, MEDICAL, NUTRITIONAL, HYGIENIC AND DIETETIC CONSULTATION SERVICES FOR CAPTIVE, RESEARCH, AND BREEDING ANIMALS AND REPTILES (U.S. CLS. 100 AND 101).

FIRST USE 7-0-1971; IN COMMERCE 7-0-1971.
DOUGLAS LEE, EXAMINING ATTORNEY

SN 85-518,203. REAL-TIME LEASING, LLC, BURNSVILLE, MN. FILED 1-17-2012.



NO CLAIM IS MADE TO THE EXCLUSIVE RIGHT TO USE "LEASING" OR "EXPERTS IN PROPERTY MANAGEMENT", APART FROM THE MARK AS SHOWN.

THE COLOR(S) BLUE, WHITE AND GOLD IS/ARE CLAIMED AS A FEATURE OF THE MARK.

THE MARK CONSISTS OF A LARGE WHITE CAPITAL "R" ON BLUE BACKGROUND. THE WHITE LETTER "R" IS BORDERED IN BLUE. EXTENDING FROM THE LOWER RIGHT END OF THE LETTER "R" ARE THE HANDS OF A CLOCK IN THE 1:20 POSITION, PARTIALLY SURROUNDED BY SEMI-CIRCULAR DOUBLE LINES INDICATING A CLOCK DESIGN. THE HANDS OF THE CLOCK AND THE SEMI-CIRCULAR LINES ARE IN THE COLOR GOLD. UNDER THE DESIGN, THE WORDS "REAL-TIME LEASING" APPEAR IN THE COLOR WHITE. ON THE LINE BELOW, THE WORDS "EXPERTS IN PROPERTY MANAGEMENT" APPEAR IN THE COLOR GOLD.

CLASS 36—INSURANCE AND FINANCIAL

FOR REAL ESTATE SERVICES, NAMELY, LEASING, BROKERAGE, AND MANAGEMENT OF RESIDENTIAL AND INVESTMENT PROPERTY (U.S. CLS. 100, 101 AND 102).

FIRST USE 10-26-2001; IN COMMERCE 10-26-2001.

CLASS 37—CONSTRUCTION AND REPAIR

FOR REAL ESTATE SERVICES, NAMELY, MAINTENANCE OF RESIDENTIAL AND INVESTMENT PROPERTY (U.S. CLS. 100, 103 AND 106).

FIRST USE 10-26-2001; IN COMMERCE 10-26-2001.

LINDA LAVACHE, EXAMINING ATTORNEY

SN 85-518,444. MACY'S MERCHANDISING GROUP, INC., NEW YORK, NY. FILED 1-17-2012.

IDEOLOGY

THE MARK CONSISTS OF STANDARD CHARACTERS WITHOUT CLAIM TO ANY PARTICULAR FONT, STYLE, SIZE, OR COLOR.

OWNER OF U.S. REG. NO. 2,916,715.

CLASS 21—HOUSEWARES AND GLASS

FOR PLASTIC WATER BOTTLES SOLD EMPTY (U.S. CLS. 2, 13, 23, 29, 30, 33, 40 AND 50).

CLASS 25—CLOTHING

FOR CLOTHING AND CLOTHING FOR ATHLETIC USE, NAMELY, ARM WARMERS, CAPS, CYCLING SHORTS, HEADBANDS, HEADWEAR, HOODED SWEATSHIRTS, JACKETS, JERSEYS, LEG WARMERS, LEGGINGS, PANTS, RUNNING SUITS, SHIRTS, SHORTS, SOCKS, SPORTS BRAS, SWEATBANDS, SWEATPANTS, SWEATSHIRTS, SWEATSUITS, T-SHIRTS, TANK TOPS, TOPS, TRACK SUITS, VISORS, WRIST BANDS, YOGA PANTS, YOGA SHIRTS (U.S. CLS. 22 AND 39).

CLASS 28—TOYS AND SPORTING GOODS

FOR YOGA MATS (U.S. CLS. 22, 23, 38 AND 50).
SIMON TENG, EXAMINING ATTORNEY

SN 85-518,454. MACY'S MERCHANDISING GROUP, INC.,
NEW YORK, NY. FILED 1-17-2012.



THE MARK CONSISTS OF A ROUND SOLID CIRCLE WITH TWO WAVE SHAPE LINES ABOVE IT.

CLASS 21—HOUSEWARES AND GLASS

FOR PLASTIC WATER BOTTLES SOLD EMPTY (U.S. CLS. 2, 13, 23, 29, 30, 33, 40 AND 50).

CLASS 25—CLOTHING

FOR CLOTHING AND CLOTHING FOR ATHLETIC USE, NAMELY, ARM WARMERS, CAPS, CYCLING SHORTS, HEADBANDS, HEADWEAR, HOODED SWEATSHIRTS, JACKETS, JERSEYS, LEG WARMERS, LEGGINGS, PANTS, RUNNING SUITS, SHIRTS, SHORTS, SOCKS, SPORTS BRAS, SWEATBANDS, SWEATPANTS, SWEATSHIRTS, SWEATSUITS, T-SHIRTS, TANK TOPS, TOPS, TRACK SUITS, VISORS, WRIST BANDS, YOGA PANTS, YOGA SHIRTS (U.S. CLS. 22 AND 39).

CLASS 28—TOYS AND SPORTING GOODS

FOR YOGA MATS (U.S. CLS. 22, 23, 38 AND 50).
SIMON TENG, EXAMINING ATTORNEY

SN 85-518,780. TRIA BEAUTY, INC., DUBLIN, CA. FILED 1-18-2012.

SEE BEAUTY IN A NEW LIGHT

THE MARK CONSISTS OF STANDARD CHARACTERS WITHOUT CLAIM TO ANY PARTICULAR FONT, STYLE, SIZE, OR COLOR.

CLASS 3—COSMETICS AND CLEANING PREPARATIONS

FOR NON-MEDICATED SKIN CARE PREPARATIONS, NAMELY, CREAMS, LOTIONS, GELS, TONERS, CLEANSERS AND PEELS; NON-MEDICATED ACNE TREATMENT PREPARATIONS (U.S. CLS. 1, 4, 6, 50, 51 AND 52).
FIRST USE 12-27-2011; IN COMMERCE 12-27-2011.

CLASS 8—HAND TOOLS

FOR HAND HELD BATTERY OPERATED AND ELECTRICAL DEVICES FOR PERSONAL USE FOR THE REMOVAL OF HAIR (U.S. CLS. 23, 28 AND 44).
FIRST USE 12-27-2011; IN COMMERCE 12-27-2011.

CLASS 10—MEDICAL APPARATUS

FOR PORTABLE HAND-OPERATED, BATTERY POWERED AND ELECTRICAL DEVICES FOR FACIAL REJUVENATION AND TONING, SKIN CARE, AND ELIMINATING ACNE (U.S. CLS. 26, 39 AND 44).
FIRST USE 12-27-2011; IN COMMERCE 12-27-2011.
DAVID COLLIER, EXAMINING ATTORNEY

SN 85-518,970. MARHOLD LLC, WAXAHACHIE, TX. FILED 1-18-2012.

MEASURING BUDDY

THE MARK CONSISTS OF STANDARD CHARACTERS WITHOUT CLAIM TO ANY PARTICULAR FONT, STYLE, SIZE, OR COLOR.

NO CLAIM IS MADE TO THE EXCLUSIVE RIGHT TO USE "MEASURING", APART FROM THE MARK AS SHOWN.

CLASS 8—HAND TOOLS

FOR DEVICES FOR HOLDING AND GRIPPING, NAMELY, DEVICES FOR HOLDING AND GRIPPING A FREE END OF A MEASURING TAPE OR A LINE (U.S. CLS. 23, 28 AND 44).

CLASS 9—ELECTRICAL AND SCIENTIFIC APPARATUS

FOR MEASURING DEVICES, NAMELY, DEVICES FOR ANGULAR MEASUREMENT BETWEEN A MEASURING TAPE OR A LINE AND A REFERENCE LINE (U.S. CLS. 21, 23, 26, 36 AND 38).

KATHLEEN LORENZO, EXAMINING ATTORNEY

SN 85-519,197. OMAHA STANDARD, INC., COUNCIL BLUFFS, IA. FILED 1-18-2012.

OMAHA STANDARD

THE MARK CONSISTS OF STANDARD CHARACTERS WITHOUT CLAIM TO ANY PARTICULAR FONT, STYLE, SIZE, OR COLOR.

NO CLAIM IS MADE TO THE EXCLUSIVE RIGHT TO USE "OMAHA", APART FROM THE MARK AS SHOWN.

SN 85-519,396. MARCOS AURELIO MUÑOZ TORRES, LEÓN, GUANAJUATO, MEXICO, FILED 1-18-2012.

CLASS 6—METAL GOODS

FOR METAL TOOLBOXES (U.S. CLS. 2, 12, 13, 14, 23, 25 AND 50).

CLASS 7—MACHINERY

FOR MECHANICAL LOADING AND UNLOADING MECHANISM, NAMELY, HOISTS, SCISSOR HOISTS; TELESCOPIC HYDRAULIC AND ELECTRIC CRANES; HYDRAULICALLY POWERED LIFTING PLATFORMS FOR ATTACHMENT TO REAR OF TRUCKS, WHICH CAN ALSO SERVE AS REAR GATE WHILE IN STORED POSITION (U.S. CLS. 13, 19, 21, 23, 31, 34 AND 35).

CLASS 12—VEHICLES

FOR TRUCK BODIES, NAMELY, MECHANIC TRUCK BODIES, SERVICE BODIES, LANDSCAPER BODIES, BADGER ALL-PURPOSE TRUCK BODIES, PLATFORM BODIES, GRAIN BODIES AND STAKE BODIES, GENERAL BODIES, AND LINE BODIES (U.S. CLS. 19, 21, 23, 31, 35 AND 44).

DEIRDRE ROBERTSON, EXAMINING ATTORNEY

LOBO SOLO

THE MARK CONSISTS OF STANDARD CHARACTERS WITHOUT CLAIM TO ANY PARTICULAR FONT, STYLE, SIZE, OR COLOR.

THE ENGLISH TRANSLATION OF THE WORD LOBO SOLO IN THE MARK IS LONE WOLF.

CLASS 25—CLOTHING

FOR CLOTHING, NAMELY, SHIRTS, T-SHIRTS, PANTS, SHORTS, AND SWEATSHIRTS; SHOES (U.S. CLS. 22 AND 39).

CLASS 35—ADVERTISING AND BUSINESS

FOR RETAIL STORE SERVICES FEATURING CLOTHING AND SHOES (U.S. CLS. 100, 101 AND 102).

KAPIL BHANOT, EXAMINING ATTORNEY

SN 85-519,287. NIHON KOHDEN AMERICA, FOOTHILL RANCH, CA. FILED 1-18-2012.

SN 85-519,791. ALLTECH, INC., NICHOLASVILLE, KY. FILED 1-19-2012.

NATURALLY IT TASTES BETTER, IT'S ALL NATURAL

QUALNOMICS

THE MARK CONSISTS OF STANDARD CHARACTERS WITHOUT CLAIM TO ANY PARTICULAR FONT, STYLE, SIZE, OR COLOR.

NO CLAIM IS MADE TO THE EXCLUSIVE RIGHT TO USE "IT'S ALL NATURAL", APART FROM THE MARK AS SHOWN.

THE MARK CONSISTS OF STANDARD CHARACTERS WITHOUT CLAIM TO ANY PARTICULAR FONT, STYLE, SIZE, OR COLOR.

CLASS 35—ADVERTISING AND BUSINESS

FOR PROVIDING ONLINE INFORMATION AND ENABLING THE ONLINE EXCHANGE OF INFORMATION PERTAINING TO THE MEDICAL FIELD, NAMELY, HOSPITAL ECONOMICS, PATIENT CARE ECONOMICS, AND REIMBURSEMENTS (U.S. CLS. 100, 101 AND 102).

CLASS 38—COMMUNICATION

FOR PROVIDING ON-LINE CHAT ROOMS AND BULLETIN BOARDS FOR USERS INTERESTED IN MEDICAL ISSUES (U.S. CLS. 100, 101 AND 104).

CLASS 44—MEDICAL, BEAUTY AND AGRICULTURAL SERVICES

FOR PROVIDING ONLINE INFORMATION AND ENABLING THE ONLINE EXCHANGE OF INFORMATION PERTAINING TO THE MEDICAL FIELD, NAMELY, PATIENT MONITORING, PATIENT SAFETY, AND MEDICAL HARM TO PATIENTS (U.S. CLS. 100 AND 101).

HENRY S. ZAK, EXAMINING ATTORNEY

CLASS 29—MEATS AND PROCESSED FOODS

FOR MEAT (U.S. CL. 46).

CLASS 31—NATURAL AGRICULTURAL PRODUCTS

FOR ANIMAL FOODSTUFFS (U.S. CLS. 1 AND 46).

KELLEY WELLS, EXAMINING ATTORNEY

SN 85-521,677. BOLD LEARNING SOLUTIONS, INC., DBA BRAINSCAPE, NEW YORK, NY. FILED 1-20-2012.

BRAINSCAPE

THE MARK CONSISTS OF STANDARD CHARACTERS WITHOUT CLAIM TO ANY PARTICULAR FONT, STYLE, SIZE, OR COLOR.

CLASS 9—ELECTRICAL AND SCIENTIFIC APPARATUS

FOR DOWNLOADABLE COMPUTER APPLICATION SOFTWARE, FOR MOBILE PHONES, PORTABLE MEDIA PLAYERS, HANDHELD COMPUTERS, AND LAPTOP COMPUTERS, FOR USE AS AN EDUCATIONAL STUDY AID (U.S. CLS. 21, 23, 26, 36 AND 38).

FIRST USE 8-1-2010; IN COMMERCE 8-1-2010.

CLASS 42—SCIENTIFIC AND COMPUTER SERVICES

FOR PROVIDING TEMPORARY USE OF NON-DOWNLOADABLE SOFTWARE FOR HELPING USERS LEARN EDUCATIONAL MATERIALS (U.S. CLS. 100 AND 101).

FIRST USE 8-1-2008; IN COMMERCE 8-1-2008.

WON TEAK OH, EXAMINING ATTORNEY

SN 85-522,915. HAA LIMITED, MIDDLESEX, UNITED KINGDOM, FILED 1-23-2012.



PRIORITY CLAIMED UNDER SEC. 44(D) ON UNITED KINGDOM APPLICATION NO. NOTYETASSIGN, FILED 1-19-2012.

NO CLAIM IS MADE TO THE EXCLUSIVE RIGHT TO USE "NAIL", APART FROM THE MARK AS SHOWN.

THE MARK CONSISTS OF THE STYLIZED WORDS NAIL SCIENCE INSIDE OF A BLACK RECTANGLE DESIGN.

CLASS 3—COSMETICS AND CLEANING PREPARATIONS

FOR PREPARATIONS FOR USE IN MANICURE, PEDICURE AND NAIL TREATMENTS; NAIL VARNISH REMOVER; NAIL BASE TREATMENT PREPARATIONS; CUTICLE TREATMENT PREPARATIONS; EXFOLIATORS; KERATIN EXFOLIATORS; HAND CREAM; PREPARATIONS FOR REINFORCING AND STRENGTHENING NAILS; NAIL POLISH, NAIL BASE COATS, NAIL TOP COATS; CUTICLE CREAM, CUTICLE LOTIONS, CUTICLE OIL; NAIL REVITALISING LOTIONS; EMERY BOARDS; EMERY CLOTH; FALSE NAILS, NAIL ENAMEL (U.S. CLS. 1, 4, 6, 50, 51 AND 52).

SN 85-522,351. GRUND & MOBIL VERWALTUNGS AG, ZUG, SWITZERLAND, FILED 1-23-2012.

**CLASS 5—PHARMACEUTICALS**

FOR MEDICATED FOOD SUPPLEMENTS; HEALTH FOOD SUPPLEMENTS; DIETARY SUPPLEMENTS, FOR MEDICAL USE; FOOD SUPPLEMENTS, PREDOMINANTLY OF VITAMINS, MINERALS OR TRACE ELEMENTS (U.S. CLS. 6, 18, 44, 46, 51 AND 52).

RON FAIRBANKS, EXAMINING ATTORNEY

THE COLOR(S) BLACK, WHITE AND RED IS/ARE CLAIMED AS A FEATURE OF THE MARK.

THE MARK CONSISTS OF A RED HEART IN FRONT OF THE WORD "WINE?" IN WHITE LETTERING, ALL SURROUNDED BY A BLACK RECTANGLE.

CLASS 21—HOUSEWARES AND GLASS

FOR BEVERAGE GLASSWARE FOR THE HOUSEHOLD, FOR KITCHEN AND FOR THE HOTEL AND RESTAURANT INDUSTRY; ARTIFICIAL OBJECTS AND DECORATIVE OBJECTS OF GLASS, NAMELY, DECANTERS WITH AND WITHOUT STOPPERS, CANDLE HOLDERS IN DIFFERENT SIZES, DECORATIVE PLATES, SCULPTURES, BUSTS, STATUES; COLOURED SHEET GLASS, NOT FOR BUILDING, BEVERAGE SHEET GLASS; PIECES OF CUT AND UNCUT CRYSTAL GLASS IN THE FORM OF SCULPTURES, FIGURINES, CRYSTAL DECANTERS WITH AND WITHOUT STOPPERS, CRYSTAL CANDLE HOLDERS OF DIFFERENT SIZES, CRYSTAL BOWLS OF DIFFERENT SIZES, CRYSTAL CHAMPAGNE COOLERS, CRYSTAL VASES, CRYSTAL DECORATIVE PLATES, HOLLOW GLASSWARE IN THE NATURE OF GOBLET, CUPS, DECANTERS, POTS, BOWLS AND VASES (U.S. CLS. 2, 13, 23, 29, 30, 33, 40 AND 50).

CLASS 43—HOTEL AND RESTAURANT SERVICES

FOR CATERING AND RESORT LODGING OF GUESTS (U.S. CLS. 100 AND 101).

TASHIA BUNCH, EXAMINING ATTORNEY

SN 85-522,990. FARIS, JOE, BEVERLY HILLS, MI. FILED 1-23-2012.



NO CLAIM IS MADE TO THE EXCLUSIVE RIGHT TO USE "FASHION IN DETROIT", APART FROM THE MARK AS SHOWN.

THE MARK CONSISTS OF THE WORDS "FASHION IN DETROIT" TO THE LEFT OF A SILHOUETTE OF A WOMAN.

CLASS 25—CLOTHING

FOR T-SHIRTS (U.S. CLS. 22 AND 39).

FIRST USE 10-1-2009; IN COMMERCE 10-1-2009.

CLASS 41—EDUCATION AND ENTERTAINMENT

FOR ORGANIZATION OF FASHION SHOWS FOR ENTERTAINMENT PURPOSES (U.S. CLS. 100, 101 AND 107).

FIRST USE 10-1-2009; IN COMMERCE 10-1-2009.
ANDREW LEASER, EXAMINING ATTORNEY

SN 85-525,436. GRACE MUSIC MANAGEMENT, INC., NEW YORK, NY. FILED 1-25-2012.

GRACE VALERIE

THE MARK CONSISTS OF STANDARD CHARACTERS WITHOUT CLAIM TO ANY PARTICULAR FONT, STYLE, SIZE, OR COLOR.

THE NAME "GRACE VALERIE" IDENTIFIES THE STAGE NAME OF KSENIA ORLOVA WHOSE CONSENT IS OF RECORD.

CLASS 9—ELECTRICAL AND SCIENTIFIC APPARATUS

FOR AUDIO AND VIDEO RECORDINGS FEATURING MUSIC AND ARTISTIC PERFORMANCES; DOWNLOADABLE MUSICAL SOUND RECORDINGS; MUSICAL SOUND RECORDINGS; SERIES OF MUSICAL SOUND RECORDINGS (U.S. CLS. 21, 23, 26, 36 AND 38).

CLASS 41—EDUCATION AND ENTERTAINMENT

FOR ENTERTAINMENT SERVICES IN THE NATURE OF LIVE MUSICAL PERFORMANCES; ENTERTAINMENT SERVICES, NAMELY, PERSONAL APPEARANCES BY A PERFORMING ARTIST; ENTERTAINMENT SERVICES, NAMELY, PROVIDING A WEB SITE FEATURING NON-DOWNLOADABLE MUSICAL PERFORMANCES, MUSICAL VIDEOS, RELATED FILM CLIPS, PHOTOGRAPHS, AND OTHER MULTIMEDIA MATERIALS FEATURING PERFORMING ARTIST; ENTERTAINMENT SERVICES, NAMELY, PROVIDING INFORMATION ABOUT A RECORDING ARTIST VIA AN ONLINE NETWORK (U.S. CLS. 100, 101 AND 107).

FIRST USE 5-18-2011; IN COMMERCE 9-17-2011.
DAWN FELDMAN, EXAMINING ATTORNEY

SN 85-525,484. NIKE, INC., BEAVERTON, OR 97005, OR. FILED 1-25-2012.



OWNER OF U.S. REG. NOS. 1,264,529, 2,024,437 AND OTHERS.

THE MARK CONSISTS OF THE PHRASE "THE CHANCE" AND A DESIGN OF A SHIELD FEATURING A SWOOSH.

CLASS 41—EDUCATION AND ENTERTAINMENT

FOR ORGANIZING AND CONDUCTING SPORTING EVENTS, COMPETITIONS AND TOURNAMENTS; ENCOURAGING AND DEVELOPING SPORTS TALENT BY ORGANIZING AND CONDUCTING ATHLETIC PROGRAMS AND ACTIVITIES; ENTERTAINMENT SERVICES, NAMELY, PRODUCING AND DISPLAYING A SERIES OF SHORT FILMS VIA THE INTERNET AND SOCIAL NETWORKS (U.S. CLS. 100, 101 AND 107).

CLASS 42—SCIENTIFIC AND COMPUTER SERVICES

FOR PROVIDING AN INTERACTIVE WEBSITE FEATURING TECHNOLOGY THAT ALLOW USERS TO MANAGE SOCIAL NETWORKS, ACCOUNTS, AND CONNECTIONS TO EXISTING AND EMERGING APPLICATIONS; DEVELOPING DATA FEEDS FORMATS FEATURING USER-DEFINED INFORMATION ALL IN THE FIELD OF SPORTS (U.S. CLS. 100 AND 101).

JAY FLOWERS, EXAMINING ATTORNEY

SN 85-526,774. CUNNINGHAM, GEORGE, WEST POINT, VA. FILED 1-27-2012.

CHANICO

THE MARK CONSISTS OF STANDARD CHARACTERS WITHOUT CLAIM TO ANY PARTICULAR FONT, STYLE, SIZE, OR COLOR.

CLASS 35—ADVERTISING AND BUSINESS

FOR BUSINESS RECORD MANAGEMENT; BUSINESS CONSULTATION IN THE FIELD OF INFORMATION GOVERNANCE, RECORD MANAGEMENT AND CORPORATE RISK MANAGEMENT AND REGULATORY COMPLIANCE RELATING THERETO (U.S. CLS. 100, 101 AND 102).

CLASS 42—SCIENTIFIC AND COMPUTER SERVICES

FOR INFORMATION GOVERNANCE IN THE NATURE OF DEVELOPING COMPUTER PROGRAMS AND SOFTWARE SYSTEMS FOR DOCUMENT MANAGEMENT, DATA PRESERVATION, SECURITY CLASSIFICATION AND DATA PRIVACY (U.S. CLS. 100 AND 101).

DOUGLAS LEE, EXAMINING ATTORNEY

SN 85-527,261. LINDA LASALA, CHICAGO, IL. FILED 1-27-2012.

The Psychology of Fashion

THE MARK CONSISTS OF STANDARD CHARACTERS WITHOUT CLAIM TO ANY PARTICULAR FONT, STYLE, SIZE, OR COLOR.

NO CLAIM IS MADE TO THE EXCLUSIVE RIGHT TO USE "FASHION", APART FROM THE MARK AS SHOWN.

CLASS 42—SCIENTIFIC AND COMPUTER SERVICES

FOR COMPUTER SERVICES, NAMELY, CREATING AN ON-LINE COMMUNITY FOR REGISTERED USERS TO PARTICIPATE IN DISCUSSIONS, GET FEEDBACK FROM THEIR PEERS, FORM VIRTUAL COMMUNITIES, AND ENGAGE IN SOCIAL NETWORKING SERVICES IN THE FIELD OF FASHION AND SHOPPING (U.S. CLS. 100 AND 101).

FIRST USE 5-1-2011; IN COMMERCE 5-1-2011.

CLASS 45—PERSONAL AND LEGAL SERVICES

FOR PROVIDING ONLINE FASHION QUESTIONS TO HELP USERS DETERMINE THE STYLE OF CLOTHING BEST SUITED TO THEIR INDIVIDUAL NEEDS AND PREFERENCES (U.S. CLS. 100 AND 101).

FIRST USE 5-1-2011; IN COMMERCE 5-1-2011.

PAM WILLIS, EXAMINING ATTORNEY

SN 85-527,422. UNITED STATES ANTI-DOPING AGENCY, COLORADO SPRINGS, CO. FILED 1-27-2012.

SUPPLEMENT 411

THE MARK CONSISTS OF STANDARD CHARACTERS WITHOUT CLAIM TO ANY PARTICULAR FONT, STYLE, SIZE, OR COLOR.

NO CLAIM IS MADE TO THE EXCLUSIVE RIGHT TO USE "SUPPLEMENT", APART FROM THE MARK AS SHOWN.

CLASS 41—EDUCATION AND ENTERTAINMENT

FOR EDUCATIONAL SERVICES, NAMELY, CONDUCTING CONFERENCES AND SYMPOSIA IN THE FIELD OF DIETARY SUPPLEMENTS AND DISTRIBUTION OF EDUCATIONAL MATERIALS IN CONNECTION THEREWITH (U.S. CLS. 100, 101 AND 107).

FIRST USE 9-1-2011; IN COMMERCE 9-1-2011.

CLASS 44—MEDICAL, BEAUTY AND AGRICULTURAL SERVICES

FOR DISSEMINATION OF EDUCATIONAL INFORMATION IN THE FIELD OF DIETARY SUPPLEMENTS; PROVIDING AN INTERNET WEBSITE PORTAL FEATURING EDUCATIONAL INFORMATION, NON-DOWNLOADABLE ARTICLES AND ELECTRONIC PUBLICATIONS, VIDEOS AND PRE-RECORDED ELECTRONIC AND DIGITAL MEDIA ABOUT DIETARY SUPPLEMENTS (U.S. CLS. 100 AND 101).

FIRST USE 9-1-2011; IN COMMERCE 9-1-2011.

KELLY TRUSILO, EXAMINING ATTORNEY

SN 85-527,426. UNITED STATES ANTI-DOPING AGENCY, COLORADO SPRINGS, CO. FILED 1-27-2012.

Supplement
411

NO CLAIM IS MADE TO THE EXCLUSIVE RIGHT TO USE "SUPPLEMENT", APART FROM THE MARK AS SHOWN.

THE MARK CONSISTS OF THE STYLIZED WORD "SUPPLEMENT" WITH THE STYLIZED NUMBERS "411" BELOW AND THE DESIGN OF A HARD CAPSULE BETWEEN THE "4" AND "1" AND THE SAME INVERTED HARD CAPSULE BETWEEN BOTH OF THE "1"'S.

CLASS 41—EDUCATION AND ENTERTAINMENT

FOR EDUCATIONAL SERVICES, NAMELY, CONDUCTING CONFERENCES AND SYMPOSIA IN THE FIELD OF DIETARY SUPPLEMENTS AND DISTRIBUTION OF EDUCATIONAL MATERIALS IN CONNECTION THEREWITH (U.S. CLS. 100, 101 AND 107).

FIRST USE 9-1-2011; IN COMMERCE 9-1-2011.

CLASS 44—MEDICAL, BEAUTY AND AGRICULTURAL SERVICES

FOR DISSEMINATION OF EDUCATIONAL INFORMATION IN THE FIELD OF DIETARY SUPPLEMENTS; PROVIDING AN INTERNET WEBSITE PORTAL FEATURING EDUCATIONAL INFORMATION, NON-DOWNLOADABLE ARTICLES AND ELECTRONIC PUBLICATIONS, VIDEOS AND PRE-RECORDED ELECTRONIC AND DIGITAL MEDIA ABOUT DIETARY SUPPLEMENTS (U.S. CLS. 100 AND 101).

FIRST USE 9-1-2011; IN COMMERCE 9-1-2011.

KELLY TRUSILO, EXAMINING ATTORNEY

SN 85-528,004. WI-NEXT S.R.L., RIVOLI CASCINE VICA TO, ITALY, FILED 1-29-2012.

 **WI-NEXT**

THE MARK CONSISTS OF THE TERM "WI-NEXT" NEXT TO A SHADED CIRCULAR DESIGN.

CLASS 9—ELECTRICAL AND SCIENTIFIC APPARATUS

FOR WIRELESS NETWORK ROUTERS; WIRELESS NETWORK ROUTERS WITH INPUT AND OUTPUT BOARD FOR CONNECTING SENSORS; ELECTRIC ACTUATORS; RADIO TRANSCEIVERS (U.S. CLS. 21, 23, 26, 36 AND 38).

CLASS 38—COMMUNICATION

FOR PUBLIC AND PRIVATE CONNECTIVITY SERVICES, NAMELY, PROVIDING TELECOMMUNICATIONS CONNECTIVITY TO THE INTERNET; ELECTRONIC DATA TRANSMISSION SERVICES FEATURING VIDEO SIGNALS AND TELEMETRY (U.S. CLS. 100, 101 AND 104).

AHSEN KHAN, EXAMINING ATTORNEY

SN 85-528,443. BROOKSHIRE BROTHERS, INC., LUFKIN, TX. FILED 1-30-2012.



OWNER OF U.S. REG. NOS. 2,921,695, 3,126,710 AND 3,172,215.

NO CLAIM IS MADE TO THE EXCLUSIVE RIGHT TO USE "FRESH", APART FROM THE MARK AS SHOWN.

THE MARK CONSISTS OF THE WORDS "FRESH HARVEST" WITH WHEAT STALKS EXTENDING OUT OF EACH "H".

SN 85-528,029. PUTU LLC, DOVER, DE. FILED 1-29-2012.

LOLO

THE MARK CONSISTS OF STANDARD CHARACTERS WITHOUT CLAIM TO ANY PARTICULAR FONT, STYLE, SIZE, OR COLOR.

THE WORDING "LOLO" HAS NO MEANING IN A FOREIGN LANGUAGE.

CLASS 9—ELECTRICAL AND SCIENTIFIC APPARATUS

FOR CARRYING BAGS AND CASES, NAMELY, LAPTOP CASES, COMPUTER TABLET COVERS AND BAGS, EYE GLASS CASES, AND CELL PHONE CASES (U.S. CLS. 21, 23, 26, 36 AND 38).

FIRST USE 1-6-2012; IN COMMERCE 1-6-2012.

CLASS 16—PAPER GOODS AND PRINTED MATTER

FOR PENCIL CASES, PASSPORT CASES AND GROCERY BAGS (U.S. CLS. 2, 5, 22, 23, 29, 37, 38 AND 50).

FIRST USE 1-6-2012; IN COMMERCE 1-6-2012.

CLASS 18—LEATHER GOODS

FOR ALL-PURPOSE CARRYING BAGS MADE OF MESH, CANVAS, VINYL, COATED CANVAS, NEOPRENE, NYLON AND STRAW, NAMELY, BEACH BAGS, SCHOOL BAGS, BOOK BAGS, WINE BOTTLE CARRIERS, BAGS AND POUCHES TO HOLD WET BATHING SUITS; COIN PURSES; COSMETIC CASES SOLD EMPTY; CREDIT CARD HOLDERS; TRAVEL BAGS, NAMELY, LUGGAGE; BUSINESS CARD HOLDERS IN THE NATURE OF CARD CASES; WRISTLET BAGS FOR HOLDING COINS AND IDENTIFICATION (U.S. CLS. 1, 2, 3, 22 AND 41).

FIRST USE 1-6-2012; IN COMMERCE 1-6-2012.
RICHARD WHITE, EXAMINING ATTORNEY

CLASS 29—MEATS AND PROCESSED FOODS

FOR CHEESE; EGGS; MILK; POTATO CHIPS; PROCESSED CHEESE (U.S. CL. 46).

CLASS 30—STAPLE FOODS

FOR BEVERAGES MADE OF TEA; CHEESE SAUCE; CORN CHIPS; FLOUR-BASED CHIPS; GRAIN-BASED CHIPS; TAMALES; TEA; TEA BAGS; TORTILLA CHIPS (U.S. CL. 46).

MICHELLE DUBOIS, EXAMINING ATTORNEY

SN 85-529,968. PRICING SOLUTIONS LTD., TORONTO, CANADA, FILED 1-31-2012.



NO CLAIM IS MADE TO THE EXCLUSIVE RIGHT TO USE "PRICING", APART FROM THE MARK AS SHOWN.

THE MARK CONSISTS OF TWO RINGS AND THE WORDS "PRICING SOLUTIONS".

SEC. 2(F) AS TO "PRICING SOLUTIONS".

CLASS 35—ADVERTISING AND BUSINESS

FOR BUSINESS CONSULTANCY SERVICES RELATING TO DEVELOPING PRICING STRATEGIES AND CONDUCTING RESEARCH FOR COMPANIES SELLING PRODUCTS AND/OR SERVICES; AND BUSINESS CONSULTING IN THE FIELD OF PRICING (U.S. CLS. 100, 101 AND 102).

FIRST USE 2-28-2006; IN COMMERCE 2-28-2006.

CLASS 41—EDUCATION AND ENTERTAINMENT

FOR BUSINESS TRAINING IN THE FIELD OF PRICING (U.S. CLS. 100, 101 AND 107).

FIRST USE 2-28-2006; IN COMMERCE 2-28-2006.
DORITT L. CARROLL, EXAMINING ATTORNEY

SN 85-530,696. ULTRA-IMAGING, LLC, CHAMPAIGN, IL.
FILED 2-1-2012.

SN 85-530,744. LIFEQB, INC., SCARSDALE, NY. FILED 2-1-2012.

AesthaDerm

CarePlanners

THE MARK CONSISTS OF STANDARD CHARACTERS WITHOUT CLAIM TO ANY PARTICULAR FONT, STYLE, SIZE, OR COLOR.

THE MARK CONSISTS OF STANDARD CHARACTERS WITHOUT CLAIM TO ANY PARTICULAR FONT, STYLE, SIZE, OR COLOR.

CLASS 3—COSMETICS AND CLEANING PREPARATIONS

FOR ANTI-AGING CREAM; UNDER EYE CREAM; CLEANSING CREAM; SKIN LIGHTENING CREAM; FACE CREAM AND HAND CREAM (U.S. CLS. 1, 4, 6, 50, 51 AND 52).

CLASS 35—ADVERTISING AND BUSINESS

FOR PROVIDING A WEBSITE FEATURING BUSINESS INFORMATION ABOUT HEALTH CARE PROVIDERS AND HEALTH CARE INSURERS (U.S. CLS. 100, 101 AND 102).

CLASS 10—MEDICAL APPARATUS

FOR HANDHELD BATTERY OPERATED ULTRASOUND AND LIGHT APPARATUS FOR THE SKIN (U.S. CLS. 26, 39 AND 44).
CAROLINE WOOD, EXAMINING ATTORNEY

CLASS 36—INSURANCE AND FINANCIAL

FOR PROVIDING A WEBSITE FEATURING INFORMATION ABOUT HEALTH CARE INSURANCE (U.S. CLS. 100, 101 AND 102).

CLASS 44—MEDICAL, BEAUTY AND AGRICULTURAL SERVICES

FOR PROVIDING A WEBSITE FEATURING INFORMATION ABOUT HEALTH CARE PROVIDER SERVICES (U.S. CLS. 100 AND 101).
KATHERINE CHANG, EXAMINING ATTORNEY

SN 85-530,716. ULTRA-IMAGING, LLC, CHAMPAIGN, IL.
FILED 2-1-2012.

SN 85-530,816. DECIBULLZ LLC, LOVELAND, CO. FILED 2-1-2012.

AesthaDerm Laboratories

DECIBULLZ

THE MARK CONSISTS OF STANDARD CHARACTERS WITHOUT CLAIM TO ANY PARTICULAR FONT, STYLE, SIZE, OR COLOR.

NO CLAIM IS MADE TO THE EXCLUSIVE RIGHT TO USE "LABORATORIES", APART FROM THE MARK AS SHOWN.

THE MARK CONSISTS OF STANDARD CHARACTERS WITHOUT CLAIM TO ANY PARTICULAR FONT, STYLE, SIZE, OR COLOR.

CLASS 3—COSMETICS AND CLEANING PREPARATIONS

FOR ANTI-AGING CREAM; UNDER EYE CREAM; CLEANSING CREAM; SKIN LIGHTENING CREAM; FACE CREAM AND HAND CREAM (U.S. CLS. 1, 4, 6, 50, 51 AND 52).

CLASS 9—ELECTRICAL AND SCIENTIFIC APPARATUS

FOR MOLDABLE EARBUDS; WIRELESS AUDIO COMMUNICATION HEADSETS (U.S. CLS. 21, 23, 26, 36 AND 38).

CLASS 10—MEDICAL APPARATUS

FOR HANDHELD BATTERY OPERATED ULTRASOUND AND LIGHT APPARATUS FOR THE SKIN (U.S. CLS. 26, 39 AND 44).
CAROLINE WOOD, EXAMINING ATTORNEY

CLASS 10—MEDICAL APPARATUS

FOR HEARING AIDS (U.S. CLS. 26, 39 AND 44).
JULIE WATSON, EXAMINING ATTORNEY

SN 85-530,965. GE HEALTHCARE BIO-SCIENCES AB, UPSALA, SWEDEN, FILED 2-1-2012.

SN 85-532,056. NTE ENERGY, LLC, ST. AUGUSTINE, FL. FILED 2-2-2012.

VETA

THE MARK CONSISTS OF STANDARD CHARACTERS WITHOUT CLAIM TO ANY PARTICULAR FONT, STYLE, SIZE, OR COLOR.

THE ENGLISH TRANSLATION OF "VETA" IN THE MARK IS TO KNOW, TO UNDERSTAND.

CLASS 1—CHEMICALS

FOR CHEMICAL REAGENTS FOR SCIENTIFIC, LABORATORY AND RESEARCH USE; ELECTROPHORESIS GELS FOR SCIENTIFIC, LABORATORY AND RESEARCH USE (U.S. CLS. 1, 5, 6, 10, 26 AND 46).

CLASS 9—ELECTRICAL AND SCIENTIFIC APPARATUS

FOR ELECTROPHORESIS APPARATUS NOT FOR MEDICAL PURPOSES; WESTERN BLOTTING APPARATUS NOT FOR MEDICAL PURPOSES FOR THE DETECTION AND ANALYSIS OF PROTEINS; COMPUTER SOFTWARE FOR USE IN ANALYZING PROTEINS IN THE FIELD OF ELECTROPHORESIS AND WESTERN BLOTTING (U.S. CLS. 21, 23, 26, 36 AND 38).

JOHN GARTNER, EXAMINING ATTORNEY

SN 85-530,969. GE HEALTHCARE BIO-SCIENCES AB, UPSALA, SWEDEN, FILED 2-1-2012.

SIKTA

THE MARK CONSISTS OF STANDARD CHARACTERS WITHOUT CLAIM TO ANY PARTICULAR FONT, STYLE, SIZE, OR COLOR.

THE ENGLISH TRANSLATION OF "SIKTA" IN THE MARK IS TO LOOK FORWARD.

CLASS 1—CHEMICALS

FOR CHEMICAL REAGENTS FOR SCIENTIFIC, LABORATORY AND RESEARCH USE; ELECTROPHORESIS GELS FOR SCIENTIFIC, LABORATORY AND RESEARCH USE (U.S. CLS. 1, 5, 6, 10, 26 AND 46).

CLASS 9—ELECTRICAL AND SCIENTIFIC APPARATUS

FOR ELECTROPHORESIS APPARATUS NOT FOR MEDICAL PURPOSES; WESTERN BLOTTING APPARATUS NOT FOR MEDICAL PURPOSES FOR THE DETECTION AND ANALYSIS OF PROTEINS; COMPUTER SOFTWARE FOR USE IN ANALYZING PROTEINS IN THE FIELD OF ELECTROPHORESIS AND WESTERN BLOTTING (U.S. CLS. 21, 23, 26, 36 AND 38).

JOHN GARTNER, EXAMINING ATTORNEY



Hybrid energy solutions for a sustainable future

NO CLAIM IS MADE TO THE EXCLUSIVE RIGHT TO USE "ENERGY LLC", APART FROM THE MARK AS SHOWN.

THE MARK CONSISTS OF A SQUARE CONTAINING THREE CIRCULAR RAYS TO THE LEFT OF THE WORDS "NTE ENERGY LLC", ALL ABOVE A STRAIGHT LINE AND BELOW THE STRAIGHT LINE ARE THE WORDS "HYBRID ENERGY SOLUTIONS FOR A SUSTAINABLE FUTURE".

CLASS 35—ADVERTISING AND BUSINESS

FOR BUSINESS MARKETING CONSULTATION IN THE FIELD OF ELECTRIC POWER GENERATION AND SALES, FUEL SUPPLY, POWER GENERATION SITE DEVELOPMENT, POWER GENERATION PROJECT OPERATION, HYBRID RENEWABLE ENERGY, HYBRID ENERGY TECHNOLOGY AND RELATED INFRASTRUCTURE (U.S. CLS. 100, 101 AND 102).

FIRST USE 5-26-2010; IN COMMERCE 9-0-2011.

CLASS 36—INSURANCE AND FINANCIAL

FOR FINANCIAL ADVISORY SERVICES IN THE NATURE OF FINANCIAL ADVICE AND CONSULTATION IN THE FIELDS OF ELECTRIC POWER GENERATION AND SALES, FUEL SUPPLY, POWER GENERATION SITE DEVELOPMENT, POWER GENERATION PROJECT OPERATION, HYBRID RENEWABLE ENERGY, HYBRID ENERGY TECHNOLOGY AND RELATED INFRASTRUCTURE (U.S. CLS. 100, 101 AND 102).

FIRST USE 5-26-2010; IN COMMERCE 9-0-2011.

CLASS 37—CONSTRUCTION AND REPAIR

FOR CONSULTING SERVICES AND PROJECT MANAGEMENT SERVICES IN THE FIELDS OF CONSTRUCTION OF ELECTRIC POWER GENERATION, HYBRID RENEWABLE ENERGY FACILITIES AND ENERGY GENERATION EQUIPMENT SUPPORT STRUCTURES (U.S. CLS. 100, 103 AND 106).

FIRST USE 5-26-2010; IN COMMERCE 9-0-2011.

CLASS 42—SCIENTIFIC AND COMPUTER SERVICES

FOR TECHNOLOGICAL PLANNING AND CONSULTING SERVICES IN THE FIELDS OF ELECTRIC POWER GENERATION, FUEL SUPPLY, POWER GENERATION SITE DEVELOPMENT AND DESIGN, OPERATION OF POWER GENERATION EQUIPMENT AND FACILITIES, HYBRID RENEWABLE ENERGY PROJECTS, AND DEVELOPMENT AND DESIGN OF RELATED INFRASTRUCTURE; CONSULTING SERVICES IN THE FIELD OF PROJECT DESIGN SERVICES FOR POWER GENERATION SITES, POWER GENERATION FUEL SUPPLY, HYBRID RENEWABLE ENERGY AND RELATED INFRASTRUCTURE (U.S. CLS. 100 AND 101).

FIRST USE 5-26-2010; IN COMMERCE 9-0-2011.

KIMBERLY PERRY, EXAMINING ATTORNEY

SN 85-532,640. ATIRMA COLLECTIONS, INC., ARTESIA, CA. FILED 2-2-2012.

ATIRMA

THE MARK CONSISTS OF STANDARD CHARACTERS WITHOUT CLAIM TO ANY PARTICULAR FONT, STYLE, SIZE, OR COLOR.

THE WORDING "ATIRMA" HAS NO MEANING IN A FOREIGN LANGUAGE.

CLASS 25—CLOTHING

FOR WOMEN'S CLOTHING, NAMELY, LEHENGAS CONSISTING OF LONG FLOWING SKIRTS, FITTED TOPS, AND SCARVES, SAREES, TOPS, SKIRTS, TUNICS AND SHAWLS; MEN'S CLOTHING, NAMELY, SHERWANIS WHICH ARE HEAVILY EMBROIDERED COATS WORN LIKE A SUIT JACKET WITH LOOSE PANTS, JODHPURIS WHICH CONSIST OF WESTERN CUT SUITS WITH TRADITIONAL INDIAN EMBROIDERY AND A NEHRU COLLAR, SHIRTS, AND TROUSERS, KURTAS WHICH CONSIST OF LOOSE, KNEE-LENGTH SHIRTS AND LIGHTWEIGHT DRAWSTRING TROUSERS, AND STOLEES; ETHNIC BRIDAL WEAR, NAMELY, INDIAN WEDDING GOWNS, VEILS, SCARVES, SHAWLS, TURBANS, AND SUITS (U.S. CLS. 22 AND 39).

FIRST USE 7-1-2006; IN COMMERCE 7-1-2006.

CLASS 35—ADVERTISING AND BUSINESS

FOR RETAIL CLOTHING BOUTIQUES AND CONSIGNMENT STORES FEATURING TRADITIONAL AND DESIGNER INDIAN DRESSES, CLOTHINGS, SUITS AND APPAREL (U.S. CLS. 100, 101 AND 102).

FIRST USE 10-1-2004; IN COMMERCE 10-1-2004.
GIANCARLO CASTRO, EXAMINING ATTORNEY

SN 85-532,729. SECURITIES AND COMMERCE INSTITUTE, LLC, MIAMI, FL. FILED 2-2-2012.



OWNER OF U.S. REG. NO. 4,126,692.

NO CLAIM IS MADE TO THE EXCLUSIVE RIGHT TO USE "ST BARTH BUSINESS SCHOOL" AND THE DESIGN OF THE PICTORIAL REPRESENTATION OF THE ISLAND OF ST. BARTHÉLEMY, APART FROM THE MARK AS SHOWN.

THE MARK CONSISTS OF A SQUARE DIVIDED INTO TWO SECTIONS, THE UPPER-HALF SECTION OF THE SQUARE CONSISTS OF A THREE VERTICAL SECTIONS, THE LEFT SECTION IS A SOLID BAND, THE CENTER SECTION IS A CIRCLE OF STARS, THE RIGHT SECTION IS A SOLID BAND, THE LOWER-HALF SECTION OF THE SQUARE CONSIST OF AN IMAGE OF AN ISLAND, TO THE RIGHT OF THE SQUARE ARE THE LITERAL ELEMENTS, "ST BARTH BUSINESS SCHOOL" UNDERLINED AND UNDERNEATH THE LITERAL ELEMENT, "WWW.SBHBUSINESS.COM".

CLASS 25—CLOTHING

FOR CLOTHING, NAMELY, T-SHIRTS, LONG SLEEVE PULLOVERS, POLO SHIRTS, SWEATERS, HOODED SWEATSHIRTS, JACKETS, COATS, PANTS, SHORTS, SHOES, AND HATS (U.S. CLS. 22 AND 39).

CLASS 41—EDUCATION AND ENTERTAINMENT

FOR EDUCATION SERVICES, NAMELY, ARRANGING AND CONDUCTING COURSES, ONLINE COURSES, SEMINARS, WEBINARS, AND WORKSHOPS FEATURING BUSINESS, INFORMATION TECHNOLOGY, AND HOSPITALITY; PROVIDING COURSES OF INSTRUCTION AND TRAINING AT THE COLLEGE AND UNIVERSITY LEVEL IN THE FIELD OF BUSINESS AND SUBJECTS RELATING TO BUSINESS, INFORMATION TECHNOLOGY, AND HOSPITALITY (U.S. CLS. 100, 101 AND 107).

FIRST USE 3-12-2011; IN COMMERCE 5-15-2011.
MARILYN IZZI, EXAMINING ATTORNEY

SN 85-533,538. EUREKA REALTY PARTNERS, INC., DBA CRAIG REALTY GROUP, NEWPORT BEACH, CA. FILED 2-3-2012.

CRAIG REALTY GROUP

THE MARK CONSISTS OF STANDARD CHARACTERS WITHOUT CLAIM TO ANY PARTICULAR FONT, STYLE, SIZE, OR COLOR.

NO CLAIM IS MADE TO THE EXCLUSIVE RIGHT TO USE "REALTY GROUP", APART FROM THE MARK AS SHOWN.

CLASS 35—ADVERTISING AND BUSINESS

FOR REAL ESTATE MARKETING SERVICES (U.S. CLS. 100, 101 AND 102).

FIRST USE 4-1-1997; IN COMMERCE 4-1-1997.

CLASS 36—INSURANCE AND FINANCIAL

FOR REAL ESTATE LEASING AND MANAGEMENT SERVICES (U.S. CLS. 100, 101 AND 102).

FIRST USE 4-1-1997; IN COMMERCE 4-1-1997.

CLASS 37—CONSTRUCTION AND REPAIR

FOR REAL ESTATE DEVELOPMENT (U.S. CLS. 100, 103 AND 106).

FIRST USE 1-1-1996; IN COMMERCE 1-1-1996.
JILL PRATER, EXAMINING ATTORNEY

SN 85-533,582. ECQUANT INC., GREENWICH, CT. FILED 2-3-2012.

BE FIRST

THE MARK CONSISTS OF STANDARD CHARACTERS WITHOUT CLAIM TO ANY PARTICULAR FONT, STYLE, SIZE, OR COLOR.

CLASS 35—ADVERTISING AND BUSINESS

FOR PROVIDING AN ON-LINE COMPUTER DATABASE FEATURING NEWS IN THE FIELD OF BUSINESS (U.S. CLS. 100, 101 AND 102).

CLASS 36—INSURANCE AND FINANCIAL

FOR PROVIDING AN ON-LINE COMPUTER DATABASE FEATURING NEWS IN THE FIELDS OF FINANCIAL MARKETS AND FINANCE (U.S. CLS. 100, 101 AND 102).

CLASS 41—EDUCATION AND ENTERTAINMENT

FOR PROVIDING AN INTERNET NEWS PORTAL FEATURING LINKS TO NEWS STORIES AND ARTICLES IN THE FIELD OF CURRENT EVENTS; PROVIDING AN ON-LINE COMPUTER DATABASE IN THE FIELD OF CURRENT EVENTS NEWS (U.S. CLS. 100, 101 AND 107).

CLASS 42—SCIENTIFIC AND COMPUTER SERVICES

FOR PROVIDING A WEBSITE FEATURING NON-DOWNLOADABLE SOFTWARE FOR ACCESSING AND DOWNLOADING NEWS ARTICLES; PROVIDING A WEB SITE FEATURING TECHNOLOGY WHICH ENABLES ACCESS, PURCHASE AND SALE OF NEWS INFORMATION AND ARTICLES; PROVIDING A WEBSITE FEATURING TECHNOLOGY WHICH ENABLES USERS TO ESTABLISH AND MANAGE ACCOUNTS FOR OFFERING AND SELLING NEWS ARTICLES AND INFORMATION; PROVIDING A WEBSITE FEATURING TECHNOLOGY WHICH CALCULATES A PRICE FOR NEWS INFORMATION; PROVIDING A WEBSITE FEATURING TECHNOLOGY WHICH PROCESSES AND ANALYZES REAL-TIME DATA (U.S. CLS. 100 AND 101).

NAAKWAMA ANKRAH, EXAMINING ATTORNEY

SN 85-533,876. TEKNOTHERM, INC., SEATTLE, WA. FILED 2-3-2012.



THE COLOR(S) DARK BLUE AND LIGHT BLUE IS/ARE CLAIMED AS A FEATURE OF THE MARK.

THE MARK CONSISTS OF AN OVERALL RECTANGULAR DESIGN OF A STYLIZED DARK BLUE SHIP ON THE LEFT, A LIGHT BLUE SKY ON THE RIGHT, AND TWO DARK BLUE WAVES UNDERNEATH THE SHIP AND SKY. THE WHITE BORDERS SEPARATING THE SHIP, SKY, AND WAVES ARE TRANSPARENT AREAS AND NOT PART OF THE MARK.

CLASS 11—ENVIRONMENTAL CONTROL APPARATUS

FOR REFRIGERATING MACHINES; REFRIGERATING MACHINES AND INSTALLATIONS; REFRIGERATION EQUIPMENT, NAMELY, FOOD AND BEVERAGE CHILLING UNITS (U.S. CLS. 13, 21, 23, 31 AND 34).
FIRST USE 6-1-2005; IN COMMERCE 6-1-2005.

CLASS 37—CONSTRUCTION AND REPAIR

FOR REFRIGERANT RECOVERY AND ABATEMENT SERVICES, NAMELY, REMOVAL OF REFRIGERANT FROM A SYSTEM AND PLACEMENT OF THE REFRIGERANT INTO A CONTAINER (U.S. CLS. 100, 103 AND 106).

FIRST USE 6-1-2005; IN COMMERCE 6-1-2005.

CLASS 40—MATERIAL TREATMENT

FOR REFRIGERANT RECLAMATION SERVICES; REFRIGERATION SERVICES, NAMELY, THE COOLING OF PRODUCE AND FOOD FOR PRESERVATION PURPOSES (U.S. CLS. 100, 103 AND 106).

FIRST USE 6-1-2005; IN COMMERCE 6-1-2005.

MICHAEL ENGEL, EXAMINING ATTORNEY

SN 85-533,952. WANG, SHAOting, ALPHARETTA, GA. AND WANG, XIJUAN, ALPHARETTA, GA. FILED 2-3-2012.



THE MARK CONSISTS OF DESIGN OF A BOY WEARING A CAP POSITIONED ABOVE THREE ASIAN CHARACTERS AND THE WORDING "YI WAN XIANG".

THE ENGLISH TRANSLATION OF FOREIGN CHARACTERS IN THE MARK IS ONE BOWL SMELLS GOOD.

THE NON-LATIN CHARACTERS IN THE MARK TRANSLITERATE TO "YI WAN XIANG" AND THIS MEANS ONE BOWL SMELLS GOOD IN ENGLISH.

CLASS 30—STAPLE FOODS

FOR NOODLES (U.S. CL. 46).

CLASS 43—HOTEL AND RESTAURANT SERVICES

FOR RESTAURANT SERVICES (U.S. CLS. 100 AND 101).

KAREN BRACEY, EXAMINING ATTORNEY

SN 85-534,901. CAMERON INTERNATIONAL CORPORATION, HOUSTON, TX. FILED 2-6-2012.

TST-CFU

THE MARK CONSISTS OF STANDARD CHARACTERS WITHOUT CLAIM TO ANY PARTICULAR FONT, STYLE, SIZE, OR COLOR.

CLASS 7—MACHINERY

FOR COMPACT FLOTATION UNIT FOR SEPARATION OF HYDROCARBONS FROM PRODUCED WATER, NAMELY, SEPARATING MACHINES (U.S. CLS. 13, 19, 21, 23, 31, 34 AND 35).

CLASS 11—ENVIRONMENTAL CONTROL APPARATUS

FOR COMPACT FLOTATION UNIT FOR SEPARATION OF HYDROCARBONS FROM PRODUCED WATER, NAMELY, SEPARATORS FOR CLEANING AND PURIFICATION OF PRODUCED WATER (U.S. CLS. 13, 21, 23, 31 AND 34).

APRIL ROACH, EXAMINING ATTORNEY

CLASS 3—COSMETICS AND CLEANING PREPARATIONS

FOR SOAP AND COSMETICS, NAMELY, SKIN, FACE AND BODY CREAMS AND CLEANSERS, SKIN FACE AND BODY LOTIONS AND BATH AND SHOWER GELS, SKIN EMOLLIENTS, NON-MEDICATED LIP BALMS, MASSAGE OILS, ESSENTIAL OILS FOR PERSONAL USE, SHAMPOO AND CONDITIONER, MILK BATHS, FLORAL WATER, MAKE-UP FOUNDATION FOR THE FACE, BLUSH, LIPSTICK, FACIAL TONERS AND SPLASHES, BODY SPRAY, NON-MEDICATED HERBAL EXTRACTS, NON-MEDICATED BODY POWDER, NON-MEDICATED BATH SALTS, BODY SCRUBS, NON-MEDICATED BATH SALTS IN SOLID FORM COMPOSED OF EFFERVESCENT MATERIALS, NON-MEDICATED SALVES, EYE SHADOW AND COSMETIC FACE POWDERS FOR SKIN AND EYES; LAUNDRY AND DISHWASHING SOAP AND CLEANSERS AND STAIN REMOVERS (U.S. CLS. 1, 4, 6, 50, 51 AND 52).

FIRST USE 2-15-2012; IN COMMERCE 2-15-2012.

CLASS 40—MATERIAL TREATMENT

FOR CUSTOM FORMULATION AND PRIVATE LABEL MANUFACTURE OF SKIN CARE PRODUCTS FOR OTHERS, NAMELY, BAR SOAPS, LIQUID SOAPS, BATH GELS, SKIN AND FACE CREAMS, SKIN AND BODY LOTIONS, FACIAL TONERS AND ASTRINGENTS, BATH AND BODY OILS, AFTERSHAVE LOTIONS, MAKE-UP, EYE SHADOWS, FOUNDATIONS, SKIN BRONZERS, HAIR STYLING GELS, SHAMPOO, FACE AND BODY MASKS, CONDITIONERS, BODY AND FACIAL GELS, ESSENTIAL OILS FOR PERSONAL USE, NON-MEDICATED LIP BALM, LIP GLOSS, LIP STICK, LIP SALVE, NON-MEDICATED SKIN BALMS AND SKIN SALVES, NON-MEDICATED BATH SALTS AND PERFUMES (U.S. CLS. 100, 103 AND 106).

FIRST USE 1-10-2012; IN COMMERCE 1-10-2012.

KATHY DE JONGE, EXAMINING ATTORNEY

SN 85-535,863. FIORAVANTI CUSTOM PRODUCTS, LLC, DBA ESSENTIAL WHOLESALE & LABS, PORTLAND, OR. FILED 2-7-2012.



OWNER OF U.S. REG. NOS. 3,079,348 AND 3,653,362. NO CLAIM IS MADE TO THE EXCLUSIVE RIGHT TO USE "WHOLESALE & LABS", APART FROM THE MARK AS SHOWN.

THE COLOR(S) FOREST GREEN, KELLY GREEN, CELERY GREEN, SAGE, YELLOW-GREEN, BLACK AND WHITE IS/ARE CLAIMED AS A FEATURE OF THE MARK.

THE MARK CONSISTS OF THE WORDING "ESSENTIAL WHOLESALE & LABS" IN BLACK ACCOMPANIED BY A GLOBE IN CELERY GREEN, YELLOW-GREEN AND WHITE DISPLAYING THE CONTINENTS OF THE EARTH IN WHITE WRAPPED IN THE CENTER OF A PLANT WITH FIVE LEAVES IN FOREST GREEN, KELLY GREEN, CELERY GREEN, YELLOW-GREEN AND SAGE.

SN 85-536,017. KIDS AGREE, INC., SAN DIEGO, CA. FILED 2-7-2012.

HUGO & PRIT

THE MARK CONSISTS OF STANDARD CHARACTERS WITHOUT CLAIM TO ANY PARTICULAR FONT, STYLE, SIZE, OR COLOR.

CLASS 9—ELECTRICAL AND SCIENTIFIC APPARATUS

FOR AUDIO AND VIDEO RECORDINGS FEATURING MUSIC AND ANIMATION; AUDIO AND VIDEO RECORDINGS FEATURING MOTION PICTURE FILM AND TELEVISION PROGRAMS IN THE NATURE OF CHILDREN'S ENTERTAINMENT AND FEATURING ANIMATION AND MUSIC; VIDEO GAME DISCS; VIDEO GAME SOFTWARE (U.S. CLS. 21, 23, 26, 36 AND 38).

CLASS 16—PAPER GOODS AND PRINTED MATTER

FOR PAPER GOODS AND PRINTED MATTER, NAMELY, NOTE PAPER; DECALS; SERIES OF FICTION BOOKS; GREETING CARDS; CARTOON PRINTS; CARTOON STRIPS; CHILDREN'S ACTIVITY BOOKS; CHILDREN'S BOOKS; CHILDREN'S INTERACTIVE EDUCATIONAL BOOKS; CHILDREN'S WALL STICKERS AND MURALS; CHILDREN'S ARTS AND CRAFTS PAPER KITS; COMICS; EDUCATIONAL AND LEARNING PUBLICATIONS, NAMELY, BOOKLETS AND FLASH CARDS ON A VARIETY OF EDUCATIONAL DISCIPLINES IN PRE-SCHOOL THROUGH EIGHTH GRADE; EDUCATIONAL PUBLICATIONS, NAMELY, EDUCATIONAL LEARNING CARDS, FLASH CARDS, ACTIVITY CARDS, WORKBOOKS, TEXTBOOKS, ACTIVITY BOOKS, STORY BOOKS, PUZZLE BOOKS, PRINTED PUZZLES, TEACHER GUIDES, MANUALS, POSTERS AND EDUCATIONAL BOOKLETS IN THE FIELD OF COGNITIVE LEARNING; STICKERS AND STICKER ALBUMS (U.S. CLS. 2, 5, 22, 23, 29, 37, 38 AND 50).

CLASS 25—CLOTHING

FOR CLOTHING, NAMELY, SHORTS; COATS; SOCKS; FOOTWEAR; CLOTHING BELTS; BANDANAS; SWEATERS; DRESSES; GLOVES; GYM SHORTS; NECKWEAR; PAJAMAS; PANTS; SHIRTS; SLACKS; UNDERCLOTHES; VESTS; WARM-UP SUITS; HEADWEAR; BATHROBES; BEACHWEAR; CHILDREN'S AND INFANT'S APPAREL, NAMELY, JUMPERS, OVERALL SLEEPWEAR, PAJAMAS, ROMPERS AND ONE-PIECE GARMENTS (U.S. CLS. 22 AND 39).

CLASS 28—TOYS AND SPORTING GOODS

FOR DOLLS AND ACCESSORIES THEREFOR; ACTION FIGURES AND ACCESSORIES THEREFOR; BOARD GAMES; CHILDREN'S EDUCATIONAL TOYS FOR DEVELOPING MOTOR SKILLS AND COGNITIVE SKILLS; EDUCATIONAL CARD GAMES; EDUCATIONAL TOYS FOR TEACHING MATH PRINCIPLES TO CHILDREN, NAMELY, MANIPULATIVE BLOCKS FOR DISPLAYING PATTERNS AND GROUPINGS; ELECTRONIC GAMES FOR THE TEACHING OF CHILDREN; ELECTRONIC LEARNING TOYS; JIGSAW PUZZLES; PARTY FAVORS IN THE NATURE OF SMALL TOYS; PAPER PARTY HATS; PIÑATAS; PLAYGROUND BALLS; PLUSH DOLLS; POSITIONABLE TOY FIGURES; PUZZLES; RUBBER CHARACTER TOYS; SAND TOYS; STUFFED AND PLUSH TOYS; TRADING CARD GAMES; TOYS, NAMELY, CHILDREN'S DRESS-UP ACCESSORIES (U.S. CLS. 22, 23, 38 AND 50).

KIMBERLY PARKS, EXAMINING ATTORNEY

SN 85-536,060. RELATIONAL SECURITY CORPORATION, DBA RSAM, SECAUCUS, NJ. FILED 2-7-2012.



OWNER OF U.S. REG. NO. 3,205,009.
THE COLOR(S) GREEN AND GREY IS/ARE CLAIMED AS A FEATURE OF THE MARK.
THE MARK CONSISTS OF TWO GREEN OPPOSING SEMI-CIRCLES ABOVE A GREY CARET WITH THE WORD "RSAM" TO THE RIGHT IN GREY WITH A GREEN BULLET AFTER THE LETTER "R".

CLASS 9—ELECTRICAL AND SCIENTIFIC APPARATUS

FOR COMPUTER SOFTWARE FOR RISK ASSESSMENT, RISK MANAGEMENT, AND REGULATORY COMPLIANCE (U.S. CLS. 21, 23, 26, 36 AND 38).
FIRST USE 2-1-2010; IN COMMERCE 2-1-2010.

CLASS 35—ADVERTISING AND BUSINESS

FOR BUSINESS AUDITING IN THE FIELDS OF INFORMATION TECHNOLOGY RISK ASSESSMENT AND RISK MANAGEMENT; BUSINESS CONSULTING SERVICES IN THE FIELD OF FORMULATING BEST PRACTICES FOR ASSESSING AND MANAGING RISK (U.S. CLS. 100, 101 AND 102).
FIRST USE 2-1-2010; IN COMMERCE 2-1-2010.

CLASS 42—SCIENTIFIC AND COMPUTER SERVICES

FOR COMPUTER SOFTWARE DEVELOPMENT (U.S. CLS. 100 AND 101).
FIRST USE 2-1-2010; IN COMMERCE 2-1-2010.
KAREN K. BUSH, EXAMINING ATTORNEY

SN 85-536,140. CENTRIS CONSULTING, INC., SCRANTON, PA. FILED 2-7-2012.

Worklynx

THE MARK CONSISTS OF STANDARD CHARACTERS WITHOUT CLAIM TO ANY PARTICULAR FONT, STYLE, SIZE, OR COLOR.

CLASS 9—ELECTRICAL AND SCIENTIFIC APPARATUS

FOR COMPUTER SOFTWARE FOR THE COLLECTION, EDITING, ORGANIZING, MODIFYING, BOOK MARKING, TRANSMISSION, STORAGE AND SHARING OF DATA AND INFORMATION IN THE FIELD OF MERGER INTEGRATIONS, ORGANIZATIONAL REALIGNMENTS AND DOWNSIZING (U.S. CLS. 21, 23, 26, 36 AND 38).

CLASS 35—ADVERTISING AND BUSINESS

FOR BUSINESS CONSULTING SERVICES IN THE FIELD OF MERGER INTEGRATIONS, ORGANIZATIONAL REALIGNMENTS AND DOWNSIZING (U.S. CLS. 100, 101 AND 102).
TARA PATE, EXAMINING ATTORNEY

SN 85-536,643. FREMANTLEMEDIA LIMITED, LONDON, UNITED KINGDOM, FILED 2-8-2012.

THROUGH THE KEYHOLE

THE MARK CONSISTS OF STANDARD CHARACTERS WITHOUT CLAIM TO ANY PARTICULAR FONT, STYLE, SIZE, OR COLOR.

OWNER OF ERPN CMNTY TM OFC REG. NO. 010217149,
DATED 12-8-2011, EXPIRES 8-24-2021.

CLASS 9—ELECTRICAL AND SCIENTIFIC APPARATUS

FOR CINEMATOGRAPHIC FILMS FEATURING MUSIC, SOUNDTRACKS, ARTISTIC PERFORMANCES, DOCUMENTARIES, DRAMAS, COMEDIES, AND ANIMATION; ANIMATED CARTOONS RECORDED ON VIDEO DISCS AND VIDEO TAPES; MAGNETIC RECORDINGS, NAMELY, VIDEO CASSETTES, PRE-RECORDED CD-ROM, PRE-RECORDED DVD, PRE-RECORDED HIGH DEFINITION VIDEO CASSETTES, PRE-RECORDED HD-DVD, PRE-RECORDED COMPUTER DISCS, AND PRE-RECORDED LASERDISCS FEATURING MUSIC, DOCUMENTARIES, DRAMAS, COMEDIES, ANIMATIONS, AND CARTOONS; OPTICAL RECORDINGS, NAMELY, VIDEO CASSETTES, PRE-RECORDED CD-ROM, PRE-RECORDED DVD, PRE-RECORDED HIGH DEFINITION VIDEO CASSETTES, PRE-RECORDED HD-DVD, PRE-RECORDED COMPUTER DISCS, AND PRE-RECORDED LASERDISCS FEATURING MUSIC, DOCUMENTARIES, DRAMAS, COMEDIES, ANIMATIONS, AND CARTOONS; MAGNETO-OPTICAL RECORDINGS, NAMELY, PRE-RECORDED DVDS AND COMPACT DISCS FEATURING MUSIC, DOCUMENTARIES, DRAMAS, ANIMATIONS, CARTOONS AND COMEDIES; SOLID-STATE RECORDINGS, NAMELY, PRE-RECORDED FLASH MEMORY CARDS FEATURING MUSIC, DOCUMENTARIES, DRAMAS, ANIMATIONS, CARTOONS AND COMEDIES; DOWNLOADABLE ELECTRONIC BOOKS AND PUBLICATIONS IN THE NATURE OF BOOKS AND MAGAZINES FEATURING MUSIC, DOCUMENTARIES, DRAMAS, COMEDIES, ANIMATIONS, AND CARTOONS; DOWNLOADABLE ELECTRONIC GAME PROGRAMS; INTERACTIVE GAME PROGRAMS; MULTIMEDIA DISCS AND DOWNLOADABLE PUBLICATIONS, NAMELY, ELECTRONIC BOOKS AND MAGAZINES FEATURING MUSIC, DOCUMENTARIES, DRAMAS, COMEDIES, ANIMATIONS, AND CARTOONS; COMPUTER SOFTWARE, NAMELY, GAMES AND VIDEO GAMES FOR USE IN CONNECTION WITH COMPUTERS, MOBILE COMPUTERS, MEDIA PLAYERS, CELLULAR PHONES, WIRELESS DEVICES AND PORTABLE AND HANDHELD DIGITAL ELECTRONIC DEVICES; COMPUTER APPLICATION SOFTWARE FOR MOBILE PHONES, PORTABLE COMPUTER DEVICES AND HANDHELD COMPUTERS FOR RETRIEVING FROM A NETWORK OR INTERNET BASED SERVER, PLAYING AND DISPLAYING MULTIMEDIA CONTENT, MOVIES, FILM CLIPS, MOVIE TRAILERS, NEWS ARTICLES, PHOTOGRAPHS, TELEVISION, MUSIC, VIDEOS, GAMES AND INFORMATION IN THE FIELD OF ENTERTAINMENT; AUDIO TAPES FEATURING MUSIC, SOUNDTRACKS, ARTISTIC PERFORMANCES, DOCUMENTARIES, DRAMAS, COMEDIES, AND ANIMATION; TAPE CASSETTES FEATURING MUSIC, SOUNDTRACKS, ARTISTIC PERFORMANCES, DOCUMENTARIES, DRAMAS, COMEDIES, AND ANIMATION; VIDEO TAPES FEATURING MUSIC, SOUNDTRACKS, ARTISTIC PERFORMANCES, DOCUMENTARIES, DRAMAS, COMEDIES, AND ANIMATION; LASER DISCS FEATURING MUSIC, SOUNDTRACKS, ARTISTIC PERFORMANCES, DOCUMENTARIES, DRAMAS, COMEDIES, AND ANIMATION; COMPACT DISCS-INTERACTIVE CD ROMS FEATURING MUSIC, SOUNDTRACKS, ARTISTIC PERFORMANCES, DOCUMENTARIES, DRAMAS, COMEDIES, AND ANIMATION; DIGITAL VIDEO DISCS FEATURING MUSIC, SOUNDTRACKS, ARTISTIC PERFORMANCES, DOCUMENTARIES, DRAMAS, COMEDIES, AND ANIMATION; TELEPHONES; MOBILE PHONES; BATTERY CHARGERS; BATTERY CHARGERS FOR MOBILE PHONES; DOWNLOADABLE MOBILE PHONE GAMES; KARAOKE MACHINES, NAMELY, KARAOKE PLAYERS; PARTS AND FITTINGS FOR ALL THE AFORESAID GOODS; DOWNLOADABLE DIGITAL GAMES, DOWNLOADABLE MOBILE PHONE GAMES; DVD GAMES, NAMELY, GAME PROGRAMS ON DVD (U.S. CLS. 21, 23, 26, 36 AND 38).

CLASS 41—EDUCATION AND ENTERTAINMENT

FOR ENTERTAINMENT SERVICES, NAMELY, PRODUCTION, PRESENTATION, SYNDICATION, AND RENTAL OF MATERIAL WITH A VISUAL AND/OR AUDIO ELEMENT IN THE FORM OF TELEVISION PROGRAMS, LIVE SHOWS, STAGE PLAYS, EXHIBITIONS, CONCERTS, COMPUTER GAMES, RADIO, CABLE, SATELLITE AND INTERNET PROGRAMS; ENTERTAINMENT SERVICES, NAMELY, IN THE NATURE OF AN ONGOING TELEVISION SERIES FEATURING DRAMA, COMEDY, ACTION, ADVENTURE AND ROMANCE; ENTERTAINMENT SERVICES, NAMELY, PROVIDING AN ON-LINE NON-DOWNLOADABLE COMPUTER GAME; ENTERTAINMENT SERVICES, NAMELY, PROVIDING ONLINE NON-DOWNLOADABLE DIGITIZED PRINT AND AUDIO-VISUAL INFORMATION IN THE FORM OF IMAGES, TEXT, ELECTRONIC DOCUMENTS AND GRAPHICS ABOUT A TELEVISION SERIES VIA A GLOBAL COMPUTER NETWORK; ENTERTAINMENT SERVICES IN THE NATURE OF AN AMUSEMENT PARK ATTRACTION, NAMELY, A THEMED AREA; PRODUCTION, PRESENTATION AND RENTAL OF TELEVISION AND RADIO PROGRAMMES AND OF FILMS AND SOUND AND VIDEO RECORDINGS; ORGANIZATION, PRODUCTION AND PRESENTATION OF COMPETITIONS, GAMES, QUIZZES RELATING TO MUSIC, DRAMA, FILM, ART, COMEDY, GENERAL KNOWLEDGE, GAMES, QUIZZES, INFORMATION, NEWS, TELEVISION AND RADIO PROGRAMS INCLUDING CHILDREN'S RADIO AND TELEVISION PROGRAMS, EVENTS, SPORT, HISTORY, FICTION, NON-FICTION TOPICS, SCIENCE AND TECHNOLOGY; ORGANIZATION, PRESENTATION AND PRODUCTION OF LIVE SHOWS, LIVE PERFORMANCES AND AUDIENCE PARTICIPATION EVENTS RELATING TO MUSIC, DRAMA, FILM, ART, COMEDY, GENERAL KNOWLEDGE, GAMES, QUIZZES, INFORMATION, NEWS, TELEVISION AND RADIO PROGRAMS INCLUDING CHILDREN'S RADIO AND TELEVISION PROGRAMS, EVENTS, SPORT, HISTORY, FICTION, NON-FICTION TOPICS, SCIENCE AND TECHNOLOGY; PROVISION OF ONLINE NON-DOWNLOADABLE GAMES VIA MOBILE AND COMPUTER NETWORKS; PROVISION OF ONLINE NON-DOWNLOADABLE INTERACTIVE VOICE RECOGNITION GAMES AND COMPETITIONS RELATING TO MUSIC, DRAMA, FILM, ART, COMEDY, GENERAL KNOWLEDGE, GAMES, QUIZZES, INFORMATION, NEWS, TELEVISION AND RADIO PROGRAMS INCLUDING CHILDREN'S RADIO AND TELEVISION PROGRAMS, EVENTS, SPORT, HISTORY, FICTION, NON-FICTION TOPICS, SCIENCE AND TECHNOLOGY; QUIZZES AND LOTTERIES PROVIDED ON-LINE; OPERATION OF LOTTERY AND GAMES OF CHANCE; PROVISION OF ONLINE NON-DOWNLOADABLE VIDEO CLIPS FEATURING MUSIC, SOUNDTRACKS, ARTISTIC PERFORMANCES, DOCUMENTARIES, DRAMAS, COMEDIES, AND ANIMATION VIA MOBILE AND COMPUTER NETWORKS FOR ENTERTAINMENT AND EDUCATIONAL PURPOSES (U.S. CLS. 100, 101 AND 107).

FRANK LATTUCA, EXAMINING ATTORNEY

SN 85-538,091. KTR CAPITAL PARTNERS, CONSHOHOCKEN, PA. FILED 2-9-2012.

KTR INDUSTRIAL FUND III LP

THE MARK CONSISTS OF STANDARD CHARACTERS WITHOUT CLAIM TO ANY PARTICULAR FONT, STYLE, SIZE, OR COLOR.

OWNER OF U.S. REG. NOS. 3,090,820 AND 3,582,909.
NO CLAIM IS MADE TO THE EXCLUSIVE RIGHT TO USE "INDUSTRIAL FUND III LP", APART FROM THE MARK AS SHOWN.

CLASS 36—INSURANCE AND FINANCIAL

FOR REAL ESTATE INVESTMENT AND FINANCIAL SERVICES, NAMELY, PROVIDING REAL ESTATE INVESTMENT TRUSTS, PRIVATE EQUITY FUNDS INVESTMENT AND VENTURE CAPITAL FUNDS INVESTMENT (U.S. CLS. 100, 101 AND 102).

CLASS 37—CONSTRUCTION AND REPAIR

FOR REAL ESTATE DEVELOPMENT (U.S. CLS. 100, 103 AND 106).
LESLEY LAMOTHE, EXAMINING ATTORNEY

SN 85-538,117. RESICOM CUSTOM PAINTING & MAINTENANCE, INC., LEMONT, IL. FILED 2-9-2012.

B.I.G. MEETING

THE MARK CONSISTS OF STANDARD CHARACTERS WITHOUT CLAIM TO ANY PARTICULAR FONT, STYLE, SIZE, OR COLOR.

NO CLAIM IS MADE TO THE EXCLUSIVE RIGHT TO USE "MEETING", APART FROM THE MARK AS SHOWN.

CLASS 35—ADVERTISING AND BUSINESS

FOR CONSULTING SERVICES RELATING TO PROVIDING ADVICE AND ASSISTANCE TO BUSINESS OWNERS REGARDING THE MORE EFFECTIVE OPERATION OF THEIR BUSINESS, EXECUTIVE TRAINING AND EXECUTIVE LEADERSHIP DEVELOPMENT; ORGANIZING AND CONDUCTING MEETINGS RELATING TO PROVIDING ADVICE AND ASSISTANCE TO BUSINESS OWNERS REGARDING THE MORE EFFECTIVE OPERATION OF THEIR BUSINESSES, EXECUTIVE TRAINING AND EXECUTIVE LEADERSHIP DEVELOPMENT (U.S. CLS. 100, 101 AND 102).

FIRST USE 11-16-2010; IN COMMERCE 11-16-2010.

CLASS 41—EDUCATION AND ENTERTAINMENT

FOR EDUCATIONAL SERVICES, NAMELY, EDUCATIONAL MEETINGS AND SEMINARS AND CLASSES IN WHICH TRAINING MODULES ARE USED TO INSTRUCT BUSINESSES REGARDING MORE EFFECTIVE OPERATION OF THEIR BUSINESSES, EXECUTIVE LEADERSHIP AND LEADERSHIP TRAINING (U.S. CLS. 100, 101 AND 107).

FIRST USE 11-16-2010; IN COMMERCE 11-16-2010.
HENRY S. ZAK, EXAMINING ATTORNEY

SN 85-538,462. THE MENTHOLATUM COMPANY, ORCHARD PARK, NY. FILED 2-9-2012.

OXY MAXIMUM ACTION

THE MARK CONSISTS OF STANDARD CHARACTERS WITHOUT CLAIM TO ANY PARTICULAR FONT, STYLE, SIZE, OR COLOR.

OWNER OF U.S. REG. NOS. 1,873,555, 3,532,521 AND OTHERS.

CLASS 3—COSMETICS AND CLEANING PREPARATIONS

FOR MEDICATED AND NON-MEDICATED SOAPS; NON-MEDICATED FACIAL SCRUBS, SKIN CLEANSERS, SKIN WASHES, PRE-MOISTENED COSMETIC WIPES, SHAVING CREAMS AND GELS, FACIAL CREAMS AND LOTIONS, SKIN MOISTURIZERS, SUNSCREEN CREAMS, ANTI-AGING CREAMS AND LOTIONS (U.S. CLS. 1, 4, 6, 50, 51 AND 52).

CLASS 5—PHARMACEUTICALS

FOR ACNE MEDICATIONS; MEDICATED FACIAL SCRUBS, SKIN CLEANSERS, AND SKIN WASHES; PRE-MOISTENED MEDICATED COSMETIC WIPES; MEDICATED SHAVING CREAMS AND GELS, FACIAL CREAMS AND LOTIONS, SKIN MOISTURIZERS, SUNSCREEN CREAMS, AND ANTI-AGING CREAMS AND LOTIONS; PRE-MOISTENED MEDICATED WIPES AND MEDICATED SKIN WASHES FOR THE TREATMENT OR PREVENTION OF ACNE OR PROBLEM SKIN CONDITIONS (U.S. CLS. 6, 18, 44, 46, 51 AND 52).

DAVID ELTON, EXAMINING ATTORNEY

SN 85-538,678. EELUSION GMBH, 10999 BERLIN, FED REP GERMANY, FILED 2-9-2012.

eevoo

THE MARK CONSISTS OF STANDARD CHARACTERS WITHOUT CLAIM TO ANY PARTICULAR FONT, STYLE, SIZE, OR COLOR.

PRIORITY CLAIMED UNDER SEC. 44(D) ON ERP CMNTY TM OFC APPLICATION NO. 010190651, FILED 8-11-2011, REG. NO. 010190651, DATED 2-2-2012, EXPIRES 8-11-2021.

THE WORDING "EEVOO" HAS NO MEANING IN A FOREIGN LANGUAGE.

CLASS 9—ELECTRICAL AND SCIENTIFIC APPARATUS

FOR COMPUTER GAME SOFTWARE ADAPTED FOR USE WITH VISUAL DISPLAY UNITS; COMPUTER GAME SOFTWARE DOWNLOADED VIA THE INTERNET; COMPUTER PROGRAMS FOR VIDEO GAMES, COMPUTER GAME PROGRAMS, DOWNLOADABLE COMPUTER GAME PROGRAMS (U.S. CLS. 21, 23, 26, 36 AND 38).

CLASS 35—ADVERTISING AND BUSINESS

FOR PROVIDING ADVERTISING, ADVERTISING SERVICES (U.S. CLS. 100, 101 AND 102).

CLASS 38—COMMUNICATION

FOR TELECOMMUNICATIONS BY MEANS OF PLATFORMS AND PORTALS ON THE INTERNET IN RELATION TO GAMES, NAMELY, ALLOWING GAME PLAYERS TO COMMUNICATE THROUGH THE INTERNET DURING GAMEPLAY (U.S. CLS. 100, 101 AND 104).

CLASS 41—EDUCATION AND ENTERTAINMENT

FOR PROVIDING ON-LINE COMPUTER GAMES; PROVIDING GAMES VIA THE INTERNET; PROVIDING NON-DOWNLOADABLE INTERNET GAMES; ELECTRONIC GAMES SERVICES PROVIDED FROM A COMPUTER DATABASE OR BY MEANS OF THE INTERNET; CONDUCTING ONLINE GAMES, ORGANISING OF GAMES (U.S. CLS. 100, 101 AND 107).

CLASS 45—PERSONAL AND LEGAL SERVICES

FOR GRANTING OF LICENSES, IN PARTICULAR RELATING TO COMPUTER GAMES AND VIDEO GAMES (U.S. CLS. 100 AND 101).

LINDA E. BLOHM, EXAMINING ATTORNEY

SN 85-539,669. ASAP WORLDWIDE, LLC, BEVERLY HILLS, CA. FILED 2-10-2012.

A\$AP WORLDWIDE

THE MARK CONSISTS OF STANDARD CHARACTERS WITHOUT CLAIM TO ANY PARTICULAR FONT, STYLE, SIZE, OR COLOR.

NO CLAIM IS MADE TO THE EXCLUSIVE RIGHT TO USE "WORLDWIDE", APART FROM THE MARK AS SHOWN.

CLASS 25—CLOTHING

FOR CLOTHING, NAMELY, CAPS, HATS, JACKETS, T-SHIRTS, TANK TOPS, SHIRTS, SWEAT SHIRTS, UNDERWEAR, PULLOVERS AND PANTS; ALL OF THE FOREGOING AS PROMOTIONAL ITEMS (U.S. CLS. 22 AND 39).

SN 85-539,111. IPT, LLC, DBA US SIGNS, HOUSTON, TX. FILED 2-10-2012.

US BRITE

CLASS 41—EDUCATION AND ENTERTAINMENT

FOR ENTERTAINMENT SERVICES IN THE NATURE OF LIVE MUSICAL PERFORMANCES; PROVIDING A WEBSITE FEATURING MUSICAL PERFORMANCE VIDEOS, MUSICAL MULTI-MEDIA MATERIALS, AND INFORMATION ON A MUSICAL PERFORMER; RECORDING STUDIO SERVICES FEATURING SOUND RECORDING AND VIDEO ENTERTAINMENT; PROVIDING LIVE CONCERTS; PRODUCTION OF MUSICAL PERFORMANCE, SHOWS AND CONCERTS (U.S. CLS. 100, 101 AND 107).

EMILY CHUO, EXAMINING ATTORNEY

SN 85-539,700. FINANCIAL PLANNING STANDARDS BOARD LTD., DENVER, CO. FILED 2-10-2012.

FINANCIAL PLANET

THE MARK CONSISTS OF STANDARD CHARACTERS WITHOUT CLAIM TO ANY PARTICULAR FONT, STYLE, SIZE, OR COLOR.

NO CLAIM IS MADE TO THE EXCLUSIVE RIGHT TO USE "US", APART FROM THE MARK AS SHOWN.

CLASS 35—ADVERTISING AND BUSINESS

FOR BUSINESS PROJECT MANAGEMENT SERVICES IN THE FIELD OF COMMERCIAL LIGHTING (U.S. CLS. 100, 101 AND 102).

CLASS 37—CONSTRUCTION AND REPAIR

FOR INSTALLATION, REMOVAL, REPAIR, AND MAINTENANCE OF ELECTRIC LIGHTING APPARATUS; INSTALLATION IN THE FIELD OF COMMERCIAL LIGHTING; CONSTRUCTION PROJECT MANAGEMENT SERVICES IN THE FIELD OF COMMERCIAL LIGHTING; RETROFITTING EXISTING LIGHTING WITH LED LUMINAIRES (U.S. CLS. 100, 103 AND 106).

CLASS 42—SCIENTIFIC AND COMPUTER SERVICES

FOR INSPECTION OF COMMERCIAL LIGHTING SYSTEMS; DESIGN PROJECT MANAGEMENT SERVICES IN THE FIELD OF COMMERCIAL LIGHTING (U.S. CLS. 100 AND 101).

KAREN BRACEY, EXAMINING ATTORNEY

THE MARK CONSISTS OF STANDARD CHARACTERS WITHOUT CLAIM TO ANY PARTICULAR FONT, STYLE, SIZE, OR COLOR.

NO CLAIM IS MADE TO THE EXCLUSIVE RIGHT TO USE "FINANCIAL", APART FROM THE MARK AS SHOWN.

CLASS 35—ADVERTISING AND BUSINESS

FOR FINANCIAL PLANNING ADVOCACY, NAMELY, PROMOTING THE PUBLIC AWARENESS OF THE IMPORTANCE OF FINANCIAL PLANNING (U.S. CLS. 100, 101 AND 102).

FIRST USE 10-31-2011; IN COMMERCE 10-31-2011.

CLASS 38—COMMUNICATION

FOR PROVIDING ON-LINE CHAT ROOMS AND ELECTRONIC BULLETIN BOARDS FOR TRANSMISSION OF MESSAGES AMONG USERS IN THE FIELD OF FINANCIAL PLANNING (U.S. CLS. 100, 101 AND 104).

FIRST USE 10-31-2011; IN COMMERCE 10-31-2011.

CLASS 41—EDUCATION AND ENTERTAINMENT

FOR PROVIDING A WEBSITE FEATURING BLOGS AND NON-DOWNLOADABLE PUBLICATIONS IN THE NATURE OF ARTICLES, PUBLICATIONS AND NEWS IN THE FIELD OF FINANCIAL PLANNING (U.S. CLS. 100, 101 AND 107).

FIRST USE 10-31-2011; IN COMMERCE 10-31-2011.
LUCY ARANT, EXAMINING ATTORNEY

SN 85-539,920. SEVENTH GENERATION, INC., BURLINGTON, VT. FILED 2-10-2012.

CARING TODAY FOR SEVEN GENERATIONS OF TOMORROWS.

THE MARK CONSISTS OF STANDARD CHARACTERS WITHOUT CLAIM TO ANY PARTICULAR FONT, STYLE, SIZE, OR COLOR.

SN 85-539,840. LAMBDA TAU OMEGA SORORITY, INC., UPPER MONTCLAIR, NJ. FILED 2-10-2012.

Lambda Tau Omega Sorority, Inc.

THE MARK CONSISTS OF STANDARD CHARACTERS WITHOUT CLAIM TO ANY PARTICULAR FONT, STYLE, SIZE, OR COLOR.

NO CLAIM IS MADE TO THE EXCLUSIVE RIGHT TO USE "INC." FOR INTERNATIONAL CLASS 025 AND "SORORITY, INC." FOR INTERNATIONAL CLASS 035, APART FROM THE MARK AS SHOWN.

CLASS 25—CLOTHING

FOR APPAREL FOR DANCERS, NAMELY, TEE SHIRTS, SWEATSHIRTS, PANTS, LEGGINGS, SHORTS AND JACKETS; ATHLETIC APPAREL, NAMELY, SHIRTS, PANTS, JACKETS, FOOTWEAR, HATS AND CAPS, ATHLETIC UNIFORMS; BODY SHIRTS; BOMBER JACKETS; BUTTON DOWN SHIRTS; COLLARED SHIRTS; DRESS SHIRTS; HATS; HEADBANDS FOR CLOTHING; HEADGEAR, NAMELY, HATS, CAPS, HEADBANDS, HOODS; HOODED SWEAT SHIRTS; HOODS; JACKETS; JERSEYS; JOGGING PANTS; LONG-SLEEVED SHIRTS; POLO SHIRTS; RUGBY SHIRTS; SHIRTS; SHIRTS AND SHORT-SLEEVED SHIRTS; SHIRTS FOR SUITS; SHORT-SLEEVED OR LONG-SLEEVED T-SHIRTS; SHORT-SLEEVED SHIRTS; SLEEVES WORN SEPARATE AND APART FROM BLOUSES, SHIRTS AND OTHER TOPS; SPORT SHIRTS; SPORTS CAPS AND HATS; SPORTS JACKETS; SPORTS JERSEYS; SPORTS SHIRTS; SPORTS SHIRTS WITH SHORT SLEEVES; SWEAT JACKETS; SWEAT PANTS; SWEAT SHIRTS; T-SHIRTS; T-SHIRTS FOR WOMEN; TEE SHIRTS; TURTLE NECK SHIRTS; WEARABLE GARMENTS AND CLOTHING, NAMELY, SHIRTS; WOMEN'S CLOTHING, NAMELY, SHIRTS, DRESSES, SKIRTS, BLOUSES; WOMEN'S HATS AND HOODS (U.S. CLS. 22 AND 39).

FIRST USE 10-9-1988; IN COMMERCE 10-9-1988.

CLASS 35—ADVERTISING AND BUSINESS

FOR ASSOCIATION SERVICES, NAMELY, ORGANIZING CHAPTERS OF A SORORITY AND PROMOTING THE INTERESTS OF MEMBERS THEREOF; ASSOCIATION SERVICES, NAMELY, PROMOTING THE INTERESTS OF MEMBERS OF A NATIONAL SORORITY (U.S. CLS. 100, 101 AND 102).

FIRST USE 10-9-1988; IN COMMERCE 10-9-1988.
DEIRDRE ROBERTSON, EXAMINING ATTORNEY

CLASS 2—PAINTS

FOR EXTERIOR PAINT; HOUSE PAINT; INTERIOR PAINT; PAINT PRIMERS; PAINT SEALERS; PAINT THINNERS; PAINTS (U.S. CLS. 6, 11 AND 16).

CLASS 3—COSMETICS AND CLEANING PREPARATIONS

FOR NON-MEDICATED SOAPS, SHOWER GELS, BUBBLE BATHS, BODY WASHES, SHAMPOOS, AND HAIR CONDITIONERS FOR INFANTS, CHILDREN AND ADULTS, NON-MEDICATED SKIN CARE PREPARATIONS; NON-MEDICATED DIAPER CRÈMES AND OINTMENTS; NON-MEDICATED SKIN LOTIONS, CRÈMES, OILS AND GELS FOR INFANTS, CHILDREN AND ADULTS; PRE-MOISTENED, NON-MEDICATED BABY WIPES; DISPOSABLE WIPES IMPREGNATED WITH CLEANSING COMPOUNDS FOR HOUSEHOLD CLEANING; FABRIC SOFTENER FOR LAUNDRY USE; DISHWASHER RINSE AID; BATH SOAP, TOILET SOAP, LAUNDRY BLEACH, LAUNDRY CLEANING PREPARATIONS, LAUNDRY STAIN REMOVAL PREPARATIONS; AUTOMATIC DISHWASHER DETERGENTS; DISH WASHING PREPARATIONS, GLASS CLEANING PREPARATIONS, TOILET CLEANING PREPARATIONS, ALL-PURPOSE CLEANING PREPARATIONS, HOUSEHOLD SURFACE CLEANING PREPARATIONS; HOUSEHOLD CLEANING PREPARATIONS FOR USE IN NURSERIES; GLASS CLEANING PREPARATIONS; TUB AND TILE CLEANING PREPARATIONS; SHOWER CLEANING PREPARATIONS; CARPET CLEANERS; CLEANERS FOR METAL HOUSEHOLD SURFACES; CLEANERS FOR CERAMIC HOUSEHOLD SURFACES; CLEANERS FOR STONE HOUSEHOLD SURFACES; PAINT, LACQUER AND VARNISH REMOVING COMPOSITIONS; GIFT BASKETS COMPOSED PRIMARILY OF NON-MEDICATED BATH PREPARATIONS AND COSMETIC PREPARATIONS FOR INFANTS AND CHILDREN; AFTER-SUN GELS; AFTER-SUN LOTIONS; COSMETIC SUN-PROTECTING PREPARATIONS; COSMETIC SUN-TANNING PREPARATIONS; COSMETIC SUNSCREEN PREPARATIONS; MOUTHWASH; NON-MEDICATED SUN CARE PREPARATIONS; SPF SUN BLOCK TOWELETTES; SUN BLOCK; SUN BLOCK PREPARATIONS; SUN-TANNING PREPARATIONS; TOOTHPASTE; WATERPROOF SUNSCREEN; AIR FRAGRANCING PREPARATIONS; CLOTHES DRYING PRODUCT, NAMELY, NON-METAL DRYER BALLS IMPREGNATED WITH FABRIC SOFTENER THAT ARE PLACED IN THE CLOTHES-DRYING MACHINE WITH THE CLOTHING TO ASSIST IN THE DRYING PROCESS (U.S. CLS. 1, 4, 6, 50, 51 AND 52).

CLASS 5—PHARMACEUTICALS

FOR ALL PURPOSE DISINFECTING AND DEODORIZING CLEANING PREPARATIONS; DISINFECTING AND DEODORIZING HOUSEHOLD SURFACE CLEANING PREPARATIONS; HOUSEHOLD DISINFECTING HOUSEHOLD CLEANING PREPARATIONS FOR USE IN NURSERIES; DISPOSABLE WIPES IMPREGNATED WITH DISINFECTING CHEMICALS OR COMPOUNDS FOR HOUSEHOLD USE; FEMININE HYGIENE PADS AND PANTY LINERS; TAMPONS; MEDICATED SOAPS, SHOWER GELS, BUBBLE BATHS, BODY WASHES, SHAMPOOS, AND HAIR CONDITIONERS FOR INFANTS, CHILDREN AND ADULTS, MEDICATED SKIN CARE PREPARATIONS FOR INFANTS, CHILDREN

AND ADULTS; MEDICATED DIAPER CREMES; DISINFECTING AND DEODORIZING HOUSEHOLD SURFACE CLEANING PREPARATIONS; PRE-MOISTENED MEDICATED DISPOSABLE BABY WIPES; DIAPER PAIL DEODORIZING COMPOUNDS; AIR DEODORIZING PREPARATIONS; ANTI-INSECT SPRAY; INSECT REPELLENT AGENTS; INSECT REPELLENTS; MEDICATED MOUTHWASH; MEDICATED SUN BLOCK; MEDICATED SUN CARE PREPARATIONS; MEDICATED SUNSCREEN; MEDICATED TOOTHPASTE; TOPICAL ANESTHETICS; TOPICAL DERMATOLOGICAL PREPARATIONS THAT TREAT INSECT BITES AND STINGS; BABIES' DIAPERS OF PAPER; DISPOSABLE BABY DIAPERS; CLOTH BABY DIAPERS; BABY DIAPER COVERS (U.S. CLS. 6, 18, 44, 46, 51 AND 52).

CLASS 16—PAPER GOODS AND PRINTED MATTER

FOR PAPER TOWELS, TOILET PAPER, FACIAL TISSUES, GROCERY BAGS, PAPER BAGS, PLASTIC TRASH BAGS, PAPER NAPKINS; DISPOSABLE CHILDREN'S TRAINING PANTS; NEWSLETTERS IN THE FIELD OF ENVIRONMENTAL AND SOCIAL INITIATIVES, IMPLICATIONS OF USE OF ENVIRONMENTALLY SENSITIVE PRODUCTS, EARTH-FRIENDLY CONSUMER STRATEGIES AND INITIATIVES AND ENVIRONMENTAL RESOURCES (U.S. CLS. 2, 5, 22, 23, 29, 37, 38 AND 50).

CLASS 20—FURNITURE AND ARTICLES NOT OTHERWISE CLASSIFIED

FOR CLOTHES DRYING PRODUCT, NAMELY, NON-METAL DRYER BALLS, SOLD EMPTY, THAT ARE PLACED IN THE CLOTHES-DRYING MACHINE WITH THE CLOTHING TO ASSIST IN THE DRYING PROCESS (U.S. CLS. 2, 13, 22, 25, 32 AND 50).

CLASS 21—HOUSEWARES AND GLASS

FOR BASKETS OF PLASTIC FOR HOUSEHOLD AND LAUNDRY USE, BASKETS OF NATURAL FIBERS FOR HOUSEHOLD AND LAUNDRY USE; LAUNDRY BINS FOR HOUSEHOLD USE; LAUNDRY HAMPERS FOR HOUSEHOLD USE; LAUNDRY SORTERS FOR HOUSEHOLD USE; LAUNDRY BASKETS NOT MADE OF METAL WITH AND WITHOUT LEGS; LAUNDRY BINS FOR HOUSEHOLD USE; CLOTHES PINS; LAUNDRY DRYING RACKS; COLLAPSIBLE LAUNDRY BINS FOR HOUSEHOLD USE; COLLAPSIBLE LAUNDRY HAMPERS AND BASKETS FOR HOUSEHOLD USE (U.S. CLS. 2, 13, 23, 29, 30, 33, 40 AND 50).

CLASS 22—CORDAGE AND FIBERS

FOR MESH LINGERIE BAGS FOR WASHING LINGERIE, HOSIERY AND DELICATE CLOTHING; CLOTH BAGS FOR LAUNDRY, NAMELY, LINGERIE AND DELICATE CLOTHING BAGS FOR WASHING LINGERIE AND DELICATE CLOTHING; LAUNDRY BAGS FOR HOUSEHOLD USE; LAUNDRY WASH BAGS; HANGING LAUNDRY BAGS FOR HOUSEHOLD USE (U.S. CLS. 1, 2, 7, 19, 22, 42 AND 50).

CLASS 24—FABRICS

FOR BABY BEDDING, NAMELY, SWADDLING BLANKETS, FITTED AND UNFITTED CRIB SHEETS, CRIB COVERLETS; CRIB BUMPERS, DIAPER CHANGING PAD COVERS NOT MADE OF PAPER (U.S. CLS. 42 AND 50).

CLASS 25—CLOTHING

FOR MEN'S, WOMEN'S, AND CHILDREN'S CLOTHING, NAMELY, SHIRTS, T-SHIRTS, BLOUSES, JACKETS, SWEATSHIRTS, SWEATPANTS, SHORTS; ALL IN ONE BABY SUITS; BABY BUNTINGS, BABY SHIRTS, INFANT AND TODDLER ONE-PIECE CLOTHING, ROMPERS, PANTS AND SWEATERS, BABY LAYETTES (U.S. CLS. 22 AND 39).

CLASS 35—ADVERTISING AND BUSINESS

FOR ON-LINE RETAIL STORE SERVICES FEATURING HOUSEHOLD CLEANING PRODUCTS, BABY CARE PRODUCTS, HOUSEHOLD TRASH DISPOSAL PRODUCTS, HOUSEHOLD PAPER GOODS, CLOTHING AND PERSONAL CARE PRODUCTS; PROVIDING ON-LINE EDUCATIONAL INFORMATION CONCERNING ENVIRONMENTAL AND SOCIAL INITIATIVES, NAMELY, PROMOTING ENVIRONMENTAL AWARENESS BY DETAILING IMPLICATIONS OF USE OF ENVIRONMENTALLY SENSITIVE PRODUCTS, EARTH-FRIENDLY CONSUMER STRATEGIES AND INITIATIVES AND ENVIRONMENTAL RESOURCES USED FOR POVERTY RELIEF, SOCIAL RESPONSIBILITY AND CONSERVATION; CHARITABLE SERVICES, NAMELY, PROVIDING ONLINE INFORMATION CONCERNING CHARITABLE PROGRAMS, NAMELY, ORGANIZING AND CONDUCTING VOLUNTEER PROGRAM AND COMMUNITY SERVICE PROJECTS (U.S. CLS. 100, 101 AND 102).

CLASS 38—COMMUNICATION

FOR PROVIDING ON-LINE FORUMS, CHAT-ROOMS AND MESSAGE BOARDS FOR TRANSMISSION OF MESSAGES AMONG COMPUTER USERS IN THE FIELD OF ENVIRONMENTAL AND SOCIAL INITIATIVES, IMPLICATIONS OF USE OF ENVIRONMENTALLY SENSITIVE PRODUCTS, EARTH-FRIENDLY CONSUMER STRATEGIES AND INITIATIVES AND ENVIRONMENTAL RESOURCES (U.S. CLS. 100, 101 AND 104).
TEJBIR SINGH, EXAMINING ATTORNEY

SN 85-540,763. SAMSUNG C&T CORPORATION, SEOCHO-GU, SEOUL, REPUBLIC OF KOREA, FILED 2-13-2012.

SAMSUNG LABGEO

THE MARK CONSISTS OF STANDARD CHARACTERS WITHOUT CLAIM TO ANY PARTICULAR FONT, STYLE, SIZE, OR COLOR.

CLASS 10—MEDICAL APPARATUS

FOR MRI DIAGNOSTIC APPARATUS; RADIOLOGICAL APPARATUS FOR DIAGNOSTIC AND MEDICAL PURPOSES; MEDICAL EQUIPMENT, NAMELY, COMPUTED TOMOGRAPHY (CT) APPARATUS; X-RAY CT SCANNERS; ULTRASONIC MEDICAL DIAGNOSTIC APPARATUS; PROBES FOR MEDICAL PURPOSES; APPARATUS FOR CLINICAL DIAGNOSIS; X-RAY APPARATUS FOR MEDICAL PURPOSES (U.S. CLS. 26, 39 AND 44).

CLASS 44—MEDICAL, BEAUTY AND AGRICULTURAL SERVICES

FOR MEDICAL CLINIC SERVICES; DENTISTRY; HOSPITALS; RENTAL OF MEDICAL APPARATUS AND INSTRUMENTS; TELEMEDICINE SERVICES; PHYSICAL THERAPY SERVICES; MEDICAL AND PHARMACEUTICAL CONSULTATION; MEDICAL IMAGING SERVICES, NAMELY, CONSULTING SERVICES IN THE FIELD OF USING AND OPERATING MEDICAL IMAGING APPARATUS (U.S. CLS. 100 AND 101).
JASON TURNER, EXAMINING ATTORNEY

SN 85-540,775. SAMSUNG C&T CORPORATION, SEOCHO-GU, SEOUL, REPUBLIC OF KOREA, FILED 2-13-2012.

SN 85-542,762. TERRA-PETRA, INCORPORATED, DBA EARTH MERCHANT, CLAREMONT, CA. FILED 2-14-2012.

SAMSUNG MRGEO

THE MARK CONSISTS OF STANDARD CHARACTERS WITHOUT CLAIM TO ANY PARTICULAR FONT, STYLE, SIZE, OR COLOR.

CLASS 10—MEDICAL APPARATUS

FOR MRI DIAGNOSTIC APPARATUS; RADIOLOGICAL APPARATUS FOR DIAGNOSTIC AND MEDICAL PURPOSES; MEDICAL EQUIPMENT, NAMELY, COMPUTED TOMOGRAPHY (CT) APPARATUS; X-RAY CT SCANNERS; ULTRASONIC MEDICAL DIAGNOSTIC APPARATUS; PROBES FOR MEDICAL PURPOSES; APPARATUS FOR CLINICAL DIAGNOSIS; X-RAY APPARATUS FOR MEDICAL PURPOSES (U.S. CLS. 26, 39 AND 44).

CLASS 44—MEDICAL, BEAUTY AND AGRICULTURAL SERVICES

FOR MEDICAL CLINIC SERVICES; DENTISTRY; HOSPITALS; RENTAL OF MEDICAL APPARATUS AND INSTRUMENTS; TELEMEDICINE SERVICES; PHYSICAL THERAPY SERVICES; MEDICAL AND PHARMACEUTICAL CONSULTATION; MEDICAL IMAGING SERVICES, NAMELY, CONSULTING SERVICES IN THE FIELD OF USING AND OPERATING MEDICAL IMAGING APPARATUS (U.S. CLS. 100 AND 101).

JASON TURNER, EXAMINING ATTORNEY

Earth Merchant

THE MARK CONSISTS OF STANDARD CHARACTERS WITHOUT CLAIM TO ANY PARTICULAR FONT, STYLE, SIZE, OR COLOR.

NO CLAIM IS MADE TO THE EXCLUSIVE RIGHT TO USE "MERCHANT", APART FROM THE MARK AS SHOWN.

CLASS 8—HAND TOOLS

FOR TABLE KNIVES, FORKS AND SPOONS (U.S. CLS. 23, 28 AND 44).

CLASS 21—HOUSEWARES AND GLASS

FOR DINNERWARE, NAMELY, CUPS, PLATES, BOWLS; SERVING FORKS, SERVING SPOONS (U.S. CLS. 2, 13, 23, 29, 30, 33, 40 AND 50).

ANTHONY RINKER, EXAMINING ATTORNEY

SN 85-542,825. GRILL CONCEPTS, INC., WOODLAND HILLS, CA. FILED 2-14-2012.

SN 85-542,244. J BRAND, LLC, ROHNERT PARK, CA. FILED 2-14-2012.



THE MARK CONSISTS OF AN ARROW BESIDE THE LETTER "J".

CLASS 16—PAPER GOODS AND PRINTED MATTER

FOR CORRUGATED CONTAINERS (U.S. CLS. 2, 5, 22, 23, 29, 37, 38 AND 50).
FIRST USE 7-0-2005; IN COMMERCE 7-0-2005.

CLASS 29—MEATS AND PROCESSED FOODS

FOR BEEF (U.S. CL. 46).
FIRST USE 7-0-2011; IN COMMERCE 7-0-2011.
CURTIS FRENCH, EXAMINING ATTORNEY

SIMPLY 600

THE MARK CONSISTS OF STANDARD CHARACTERS WITHOUT CLAIM TO ANY PARTICULAR FONT, STYLE, SIZE, OR COLOR.

NO CLAIM IS MADE TO THE EXCLUSIVE RIGHT TO USE "600", APART FROM THE MARK AS SHOWN.

CLASS 29—MEATS AND PROCESSED FOODS

FOR PREPARED ENTREES CONSISTING PRIMARILY OF MEAT, POULTRY, FISH, VEGETABLES, SEAFOOD, OR GARDEN SALADS, ON A CHANGING MENU FOR CONSUMPTION ON OR OFF THE PREMISES (U.S. CL. 46).

FIRST USE 11-29-2011; IN COMMERCE 11-29-2011.

CLASS 30—STAPLE FOODS

FOR PREPARED ENTREES CONSISTING PRIMARILY OF PROCESSED GRAINS OR PASTA; SANDWICHES, AND TACOS, ON A CHANGING MENU FOR CONSUMPTION ON OR OFF THE PREMISES (U.S. CL. 46).

FIRST USE 11-29-2011; IN COMMERCE 11-29-2011.
JOHN E. MICHOS, EXAMINING ATTORNEY

SN 85-542,970. ENGEL & VÖLKERS PRIVATE OFFICE LTD.,
LONDON, UNITED KINGDOM, FILED 2-15-2012.



THE MARK CONSISTS OF A DESIGN COMPRISING A
STYLIZED GREEK CROSS INSIDE A CIRCLE.

**CLASS 16—PAPER GOODS AND PRINTED
MATTER**

FOR PRINTED MATTER, NAMELY, BROCHURES,
EXPOSES IN THE FORM OF PAMPHLETS, REPORTS,
BROCHURES, INVESTMENT REPORTS AND MAILINGS
FEATURING FINANCIAL, COMMERCIAL AND IN-
VESTMENT INFORMATION FOR REAL ESTATE AND
WATER VEHICLES, NAMELY, NEW AND USED PLEA-
SURE CRAFTS, SHIPS, YACHTS AND BOATS (U.S. CLS.
2, 5, 22, 23, 29, 37, 38 AND 50).

CLASS 35—ADVERTISING AND BUSINESS

FOR FRANCHISE SERVICES AND SUPPORT SER-
VICES, NAMELY, OFFERING BUSINESS MANAGE-
MENT ASSISTANCE IN THE ESTABLISHMENT AND
OPERATION OF REAL ESTATE AGENCIES; FRAN-
CHISING, NAMELY, CONSULTATION AND ASSIS-
TANCE IN THE BUSINESS MANAGEMENT,
ORGANIZATION AND PROMOTION OF REAL ESTATE
AGENCIES; BUSINESS INTERMEDIARY SERVICES
FOR THE PURCHASE AND SALE, IMPORT AND
EXPORT OF APPARATUS FOR LOCOMOTION BY
WATER, INCLUDING NEW AND USED PLEASURE
CRAFTS, SHIPS, YACHTS AND BOATS, AS WELL AS
ARTICLES RELATED THERETO; PROVIDING COM-
MERCIAL INFORMATION AND ADVICE WITH RE-
GARD TO THE PURCHASE AND SALE OF NEW AND
USED SHIPS, YACHTS, BOATS AND PLEASURE
CRAFTS; BUSINESS MANAGEMENT AND OPERATION
ASSISTANCE TO YACHT, BOAT OR SHIP OWNERS
AND CHARTERERS; BUSINESS ADMINISTRATION AS-
SISTANCE, NAMELY, ADMINISTRATIVE SUPPORT
SERVICES IN THE FRAMEWORK OF THE PURCHASE
OF NEW AND USED SHIPS, YACHTS, BOATS AND
PLEASURE CRAFTS; ADMINISTRATIVE SUPPORT
SERVICES IN THE FRAMEWORK OF THE RENTAL
OF SHIPS, YACHTS, BOATS AND PLEASURE CRAFTS;
ADVERTISING, PROMOTION AND MARKETING IN
THE FIELD OF THE SALE AND PURCHASE OF REAL
ESTATE, PLEASURE CRAFTS, SHIPS, YACHTS AND
BOATS; BUSINESS MANAGEMENT SERVICES RELAT-
ING TO PLEASURE CRAFT, YACHT, SHIP AND BOAT
CHARTERS (U.S. CLS. 100, 101 AND 102).

CLASS 36—INSURANCE AND FINANCIAL

FOR REAL ESTATE SERVICES, NAMELY, REAL
ESTATE AGENCIES; REAL ESTATE BROKERAGE SER-
VICES; ASSESSMENT AND MANAGEMENT OF REAL
ESTATE; COMMERCIAL AND RESIDENTIAL REAL
ESTATE AGENCY SERVICES; EVALUATION OF REAL
PROPERTY; LAND ACQUISITION, NAMELY, REAL
ESTATE BROKERAGE; LEASING OF REAL ESTATE;
LEASING OF REAL PROPERTY; PROVIDING A DATA-
BASE OF RESIDENTIAL REAL ESTATE LISTINGS
WITHIN NEIGHBORHOODS AND COMMUNITIES SPE-
CIFICALLY IDENTIFIED BY USERS; PROVIDING IN-
FORMATION IN THE FIELD OF REAL ESTATE VIA
THE INTERNET; PROVIDING REAL ESTATE LISTINGS
AND REAL ESTATE INFORMATION VIA THE INTER-
NET; REAL ESTATE ACQUISITION SERVICES; REAL
ESTATE CONSULTANCY SERVICES; REAL ESTATE
INVESTMENT ADVICE; REAL ESTATE INVESTMENT
SERVICES IN THE NATURE OF PURCHASING AND
SELLING OF REAL ESTATE FOR OTHERS; REAL
ESTATE LISTING; REAL ESTATE LISTING SERVICES
FOR THE HOUSING RENTALS AND APARTMENT
RENTALS; REAL ESTATE MANAGEMENT; REAL ES-
TATE MANAGEMENT CONSULTATION; REAL ESTATE
MULTIPLE LISTING SERVICES; REAL ESTATE PRO-
CUREMENT FOR OTHERS; REAL ESTATE RENTAL
SERVICES, NAMELY, RENTAL OF RESIDENTIAL
HOUSING; INSURANCE ADVISORY, ARRANGEMENT
AND CONSULTANCY SERVICES FOR REAL ESTATE;
INVESTMENT ADVISORY AND CONSULTANCY SER-
VICES FOR NEW AND USED PLEASURE CRAFT,
YACHT, BOAT OR SHIP OWNERS AND CHARTERERS;
FINANCIAL ARRANGEMENT SERVICES, NAMELY,
ARRANGING OF LOANS, BROKERAGE FOR HIRE-
PURCHASE, HIRE-PURCHASE FINANCING SERVICES,
AND FINANCIAL MANAGEMENT OF PLEASURE
CRAFT, YACHT, BOAT, SHIP OPERATIONS FOR PLEA-
SURE CRAFT, YACHT, BOAT OR SHIP OWNERS AND
CHARTERERS; INSURANCE ADVISORY, ARRANGE-
MENT AND CONSULTANCY SERVICES FOR PLEA-
SURE CRAFT, YACHT, BOAT OR SHIP OWNERS AND
CHARTERERS; PLEASURE CRAFT, YACHT, SHIP, AND
BOAT BROKERAGE SERVICES, NAMELY, BROKER-
AGE SERVICES BETWEEN BUYERS, SELLERS AND
VENDORS FOR NEW AND USED PLEASURE CRAFTS,
YACHTS, SHIPS, AND BOATS (U.S. CLS. 100, 101 AND
102).

**CLASS 39—TRANSPORTATION AND STO-
RAGE**

FOR CHARTERING, RENTING AND LEASING OF
PLEASURE CRAFTS, YACHTS, BOATS AND SHIPS (U.S.
CLS. 100 AND 105).

MELISSA VALLILLO, EXAMINING ATTORNEY

SN 85-543,001. IRON PEDDLERS PARTS DIVISION, INC.,
MONROE, NC. FILED 2-15-2012.

THE IRONPEDDLERS

THE MARK CONSISTS OF STANDARD CHARACTERS
WITHOUT CLAIM TO ANY PARTICULAR FONT, STYLE,
SIZE, OR COLOR.

OWNER OF U.S. REG. NO. 1,337,170.

CLASS 35—ADVERTISING AND BUSINESS

FOR DISTRIBUTORSHIP SERVICES AND RESELLER DISTRIBUTORSHIP SERVICES, PROCUREMENTS, NAMELY, PURCHASING GOODS FOR OTHERS, ALL FEATURING VEHICLES, EQUIPMENT, MACHINERY, AND VARIOUS COMPONENTS AND PARTS FOR USE IN EARTH MOVING, EARTH CONDITIONING, MATERIAL HANDLING, CONSTRUCTION, MINING, PAVING, AGRICULTURE, AND FORESTRY (U.S. CLS. 100, 101 AND 102).

FIRST USE 1-3-1975; IN COMMERCE 1-3-1975.

CLASS 37—CONSTRUCTION AND REPAIR

FOR SERVICE, MAINTENANCE, REFURBISHMENT, REPAIR AND RENTAL OF SPECIALTY VEHICLES, EQUIPMENT, MACHINERY, AND VARIOUS COMPONENTS AND PARTS FOR USE IN EARTH MOVING, EARTH CONDITIONING, MATERIAL HANDLING, CONSTRUCTION, MINING, PAVING, AGRICULTURE, AND FORESTRY (U.S. CLS. 100, 103 AND 106).

FIRST USE 1-3-1975; IN COMMERCE 1-3-1975.

GISELLE AGOSTO, EXAMINING ATTORNEY

CLASS 36—INSURANCE AND FINANCIAL

FOR FINANCIAL ASSET MANAGEMENT; FINANCIAL INVESTMENT IN THE FIELD OF REAL ESTATE; INVESTMENT BANKING SERVICES; INVESTMENT MANAGEMENT; MANAGEMENT OF A CAPITAL INVESTMENT FUND; PRIVATE EQUITY FUND INVESTMENT SERVICES; REAL ESTATE INVESTMENT SERVICES; REAL ESTATE MANAGEMENT OF REAL ESTATE ASSETS (U.S. CLS. 100, 101 AND 102).

CLASS 42—SCIENTIFIC AND COMPUTER SERVICES

FOR AGRICULTURAL RESEARCH; AGRICULTURAL SERVICES, NAMELY, SOIL SAMPLING AND CROP OBSERVING FOR ANALYSIS PURPOSES; RESEARCH AND DEVELOPMENT IN THE FIELD OF AGRONOMY, FARMING, AND CROP YIELDS (U.S. CLS. 100 AND 101).

STEVEN PEREZ, EXAMINING ATTORNEY

SN 85-543,117. PACTIV LLC, LAKE FOREST, IL. FILED 2-15-2012.

SN 85-543,542. INTERNATIONAL FARMING CORPORATION, LLC, KINSTON, NC. FILED 2-15-2012.

CLEAN STOCK

THE MARK CONSISTS OF STANDARD CHARACTERS WITHOUT CLAIM TO ANY PARTICULAR FONT, STYLE, SIZE, OR COLOR.

CLASS 8—HAND TOOLS

FOR DISPOSABLE CUTLERY, NAMELY, FORKS, KNIVES AND SPOONS (U.S. CLS. 23, 28 AND 44).

CLASS 20—FURNITURE AND ARTICLES NOT OTHERWISE CLASSIFIED

FOR NON-METAL CUTLERY DISPENSERS NOT FOR HOUSEHOLD USE (U.S. CLS. 2, 13, 22, 25, 32 AND 50).

NICHOLAS COLEMAN, EXAMINING ATTORNEY

Top Producer Program

THE MARK CONSISTS OF STANDARD CHARACTERS WITHOUT CLAIM TO ANY PARTICULAR FONT, STYLE, SIZE, OR COLOR.

NO CLAIM IS MADE TO THE EXCLUSIVE RIGHT TO USE "PRODUCER PROGRAM", APART FROM THE MARK AS SHOWN.

SN 85-543,511. INTERNATIONAL FARMING CORPORATION, LLC, KINSTON, NC. FILED 2-15-2012.

CLASS 36—INSURANCE AND FINANCIAL

FOR FINANCIAL ASSET MANAGEMENT; FINANCIAL INVESTMENT IN THE FIELD OF REAL ESTATE; INVESTMENT BANKING SERVICES; INVESTMENT MANAGEMENT; MANAGEMENT OF A CAPITAL INVESTMENT FUND; PRIVATE EQUITY FUND INVESTMENT SERVICES; REAL ESTATE INVESTMENT SERVICES; REAL ESTATE MANAGEMENT OF REAL ESTATE ASSETS (U.S. CLS. 100, 101 AND 102).

CLASS 42—SCIENTIFIC AND COMPUTER SERVICES

FOR AGRICULTURAL RESEARCH; AGRICULTURAL SERVICES, NAMELY, SOIL SAMPLING AND CROP OBSERVING FOR ANALYSIS PURPOSES; RESEARCH AND DEVELOPMENT IN THE FIELD OF AGRONOMY, FARMING, AND CROP YIELDS (U.S. CLS. 100 AND 101).

STEVEN PEREZ, EXAMINING ATTORNEY

Top Trials

THE MARK CONSISTS OF STANDARD CHARACTERS WITHOUT CLAIM TO ANY PARTICULAR FONT, STYLE, SIZE, OR COLOR.

NO CLAIM IS MADE TO THE EXCLUSIVE RIGHT TO USE "TRIALS", APART FROM THE MARK AS SHOWN.

SN 85-543,716. VALERUS COMPRESSION SERVICES, LP,
HOUSTON, TX. FILED 2-15-2012.

VALERUS

THE MARK CONSISTS OF STANDARD CHARACTERS WITHOUT CLAIM TO ANY PARTICULAR FONT, STYLE, SIZE, OR COLOR.

OWNER OF U.S. REG. NO. 3,724,165.

CLASS 7—MACHINERY

FOR NATURAL GAS COMPRESSION EQUIPMENT, NAMELY, RECIPROCATING AND ROTARY COMPRESSORS FOR USE IN NATURAL GAS FIELDS; NATURAL GAS PROCESSING AND TREATMENT EQUIPMENT, NAMELY, PUMPS (U.S. CLS. 13, 19, 21, 23, 31, 34 AND 35).

FIRST USE 11-0-2002; IN COMMERCE 11-0-2002.

CLASS 11—ENVIRONMENTAL CONTROL APPARATUS

FOR NATURAL GAS PRODUCTION EQUIPMENT, NAMELY, GAS AND WATER FILTRATION AND SEPARATION DEVICES CONSISTING OF DEHYDRATORS, LINE HEATERS, GAS COOLERS AND LIQUID SEPARATORS AND CONTROL INSTRUMENTATION; NATURAL GAS PROCESSING AND TREATMENT EQUIPMENT, NAMELY, AMINE TREATING SYSTEMS FOR FILTERING A NATURAL GAS STREAM BY REMOVING CO₂ (CARBON DIOXIDE), H₂S (HYDROGEN SULFIDE) AND CONTAMINANTS, REFRIGERATION EQUIPMENT, AND CRYOGENIC EQUIPMENT FOR EXTRACTING LIQUIDS FROM A NATURAL GAS STREAM BY CHILLING THE NATURAL GAS; WATER AND HYDROCARBON DEW POINT CONTROL SYSTEMS COMPRISING A HEAT EXCHANGER, PRESSURE REDUCING VALVE AND COLD SEPARATOR FOR RECOVERING HYDROCARBON LIQUIDS FROM A NATURAL GAS STREAM TO PREPARE THE NATURAL GAS FOR PIPELINE DISTRIBUTION (U.S. CLS. 13, 21, 31 AND 34).

FIRST USE 11-0-2002; IN COMMERCE 11-0-2002.

CLASS 35—ADVERTISING AND BUSINESS

FOR DISTRIBUTORSHIP IN THE FIELD OF NATURAL GAS EQUIPMENT, MACHINERY AND PARTS; BUSINESS SERVICES, NAMELY, OPERATION OF NATURAL GAS COMPRESSION SYSTEMS AND EQUIPMENT USED IN PROCESSING AND TREATMENT OF NATURAL GAS FOR OTHERS (U.S. CLS. 100, 101 AND 102).

FIRST USE 11-0-2002; IN COMMERCE 11-0-2002.

CLASS 37—CONSTRUCTION AND REPAIR

FOR INSTALLATION, MAINTENANCE, REPAIR AND SERVICING OF COMPRESSION SYSTEMS AND EQUIPMENT FOR USE IN EXPLORING, MANUFACTURING, MAINTENANCE, MONITORING, PRODUCTION, TRANSMISSION AND PROCESSING OF NATURAL GAS; REFURBISHING SERVICES, NAMELY, REVAMPING, REENGINEERING AND REAPPLICATION OF NATURAL GAS COMPRESSION SYSTEMS, EQUIPMENT AND COMPONENTS; REBUILDING AND SERVICING OF NATURAL GAS COMPRESSION SYSTEMS AND EQUIPMENT (U.S. CLS. 100, 103 AND 106).

FIRST USE 11-0-2002; IN COMMERCE 11-0-2002.

CLASS 40—MATERIAL TREATMENT

FOR LEASING OF NATURAL GAS COMPRESSION SYSTEMS AND EQUIPMENT FOR USE IN EXPLORING, MANUFACTURING, MAINTENANCE, MONITORING, PRODUCTION, TRANSMISSION AND PROCESSING OF NATURAL GAS; CUSTOM MANUFACTURE AND FABRICATION OF NATURAL GAS COMPRESSION SYSTEMS AND EQUIPMENT, DESALINATION EQUIPMENT, AND GAS AND LIQUID STORAGE VESSELS FOR OTHERS; CUSTOM MANUFACTURING AND FABRICATING SERVICES RELATING TO NATURAL GAS COMPRESSION SYSTEMS FOR OTHERS; CUSTOM ASSEMBLY OF NATURAL GAS COMPRESSION SYSTEMS FOR OTHERS; CONSTRUCTION OF NATURAL GAS COMPRESSION SYSTEMS AND EQUIPMENT FOR OTHERS (U.S. CLS. 100, 103 AND 106).

FIRST USE 11-0-2002; IN COMMERCE 11-0-2002.

CLASS 42—SCIENTIFIC AND COMPUTER SERVICES

FOR ENGINEERING SERVICES FOR NATURAL GAS COMPRESSION SYSTEMS AND EQUIPMENT FOR USE IN THE PRODUCTION, TRANSMISSION, PROCESSING AND TREATING OF NATURAL GAS (U.S. CLS. 100 AND 101).

FIRST USE 11-0-2002; IN COMMERCE 11-0-2002.

BRIAN CALLAGHAN, EXAMINING ATTORNEY

SN 85-544,173. VALERUS COMPRESSION SERVICES, LP,
HOUSTON, TX. FILED 2-16-2012.



OWNER OF U.S. REG. NOS. 3,724,165 AND 3,724,166.
THE COLOR(S) BLUE AND BLACK IS/ARE CLAIMED AS A FEATURE OF THE MARK.

THE MARK CONSISTS OF THE LETTER "V" IN BLUE AND BELOW IT IS THE NAME "VALERUS" IN BLACK.

CLASS 7—MACHINERY

FOR NATURAL GAS COMPRESSION EQUIPMENT, NAMELY, RECIPROCATING AND ROTARY COMPRESSORS FOR USE IN NATURAL GAS FIELDS; NATURAL GAS PROCESSING AND TREATMENT EQUIPMENT, NAMELY, PUMPS (U.S. CLS. 13, 19, 21, 23, 31, 34 AND 35).

FIRST USE 11-4-2009; IN COMMERCE 12-4-2009.

CLASS 11—ENVIRONMENTAL CONTROL APPARATUS

FOR NATURAL GAS PRODUCTION EQUIPMENT, NAMELY, GAS AND WATER FILTRATION AND SEPARATION DEVICES CONSISTING OF DEHYDRATORS, LINE HEATERS, GAS COOLERS AND LIQUID SEPARATORS AND CONTROL INSTRUMENTATION; NATURAL GAS PROCESSING AND TREATMENT EQUIPMENT, NAMELY, AMINE TREATING SYSTEMS FOR FILTERING A NATURAL GAS STREAM BY REMOVING CO₂ (CARBON DIOXIDE), H₂S (HYDROGEN SULFIDE) AND CONTAMINANTS, REFRIGERATION EQUIPMENT, AND CRYOGENIC EQUIPMENT FOR EXTRACTING LIQUIDS FROM A NATURAL GAS STREAM BY CHILLING THE NATURAL GAS; WATER AND HYDROCARBON DEW POINT CONTROL SYSTEMS COMPRISING A HEAT EXCHANGER, PRESSURE REDUCING VALVE AND COLD SEPARATOR FOR RECOVERING HYDROCARBON LIQUIDS FROM A NATURAL GAS STREAM TO PREPARE THE NATURAL GAS FOR PIPELINE DISTRIBUTION (U.S. CLS. 13, 21, 23, 31 AND 34).

FIRST USE 11-4-2009; IN COMMERCE 12-4-2009.

CLASS 35—ADVERTISING AND BUSINESS

FOR DISTRIBUTORSHIP IN THE FIELD OF NATURAL GAS EQUIPMENT, MACHINERY AND PARTS; BUSINESS SERVICES, NAMELY, OPERATION OF NATURAL GAS COMPRESSION SYSTEMS AND EQUIPMENT USED IN PROCESSING AND TREATMENT OF NATURAL GAS FOR OTHERS (U.S. CLS. 100, 101 AND 102).

FIRST USE 11-4-2009; IN COMMERCE 12-4-2009.

CLASS 37—CONSTRUCTION AND REPAIR

FOR INSTALLATION, MAINTENANCE, REPAIR AND SERVICING OF COMPRESSION SYSTEMS AND EQUIPMENT FOR USE IN EXPLORING, MANUFACTURING, MAINTENANCE, MONITORING, PRODUCTION, TRANSMISSION AND PROCESSING OF NATURAL GAS; REFURBISHING SERVICES, NAMELY, REVAMPING, REENGINEERING AND REAPPLICATION OF NATURAL GAS COMPRESSION SYSTEMS, EQUIPMENT AND COMPONENTS; REBUILDING AND SERVICING OF NATURAL GAS COMPRESSION SYSTEMS AND EQUIPMENT (U.S. CLS. 100, 103 AND 106).

FIRST USE 11-4-2009; IN COMMERCE 12-4-2009.

CLASS 40—MATERIAL TREATMENT

FOR LEASING OF NATURAL GAS COMPRESSION SYSTEMS AND EQUIPMENT FOR USE IN EXPLORING, MANUFACTURING, MAINTENANCE, MONITORING, PRODUCTION, TRANSMISSION AND PROCESSING OF NATURAL GAS; CUSTOM MANUFACTURE AND FABRICATION OF NATURAL GAS COMPRESSION SYSTEMS AND EQUIPMENT, DESALINATION EQUIPMENT, AND GAS AND LIQUID STORAGE VESSELS FOR OTHERS; CUSTOM MANUFACTURING AND FABRICATING SERVICES RELATING TO NATURAL GAS COMPRESSION SYSTEMS FOR OTHERS; CUSTOM ASSEMBLY OF NATURAL GAS COMPRESSION SYSTEMS FOR OTHERS; CONSTRUCTION OF NATURAL GAS COMPRESSION SYSTEMS AND EQUIPMENT FOR OTHERS (U.S. CLS. 100, 103 AND 106).

FIRST USE 11-4-2009; IN COMMERCE 12-4-2009.

CLASS 42—SCIENTIFIC AND COMPUTER SERVICES

FOR ENGINEERING SERVICES FOR NATURAL GAS COMPRESSION SYSTEMS AND EQUIPMENT FOR USE IN THE PRODUCTION, TRANSMISSION, PROCESSING AND TREATING OF NATURAL GAS (U.S. CLS. 100 AND 101).

FIRST USE 11-4-2009; IN COMMERCE 12-4-2009.
BRIAN CALLAGHAN, EXAMINING ATTORNEY

SN 85-545,122. DATAPIPE, INC., JERSEY CITY, NJ. FILED 2-16-2012.

E STRATOSPHERE

THE MARK CONSISTS OF STANDARD CHARACTERS WITHOUT CLAIM TO ANY PARTICULAR FONT, STYLE, SIZE, OR COLOR.

NO CLAIM IS MADE TO THE EXCLUSIVE RIGHT TO USE "E", APART FROM THE MARK AS SHOWN.

CLASS 38—COMMUNICATION

FOR PROVIDING MULTIPLE USER ACCESS TO THE INTERNET IN THE FORM OF INTERNET BANDWIDTH DATA CONNECTION SERVICES; PROVIDING ON-DEMAND ACCESS TO DATA STORED VIRTUALLY ON OFF-SITE COMPUTER HARDWARE (U.S. CLS. 100, 101 AND 104).

CLASS 39—TRANSPORTATION AND STORAGE

FOR ELECTRONIC DATA STORAGE SERVICES, NAMELY, STORING ELECTRONIC DATA AT DATA CENTERS; ELECTRONIC DATA STORAGE; PROVIDING ON-DEMAND ELECTRONIC STORAGE OF DATA ON OFF-SITE COMPUTER HARDWARE (U.S. CLS. 100 AND 105).

CLASS 42—SCIENTIFIC AND COMPUTER SERVICES

FOR COMPUTER SERVICES IN THE NATURE OF PROVIDING AN INTEGRATED SUITE OF DATA AND COMPUTER RELATED SERVICES, NAMELY, PROVIDING COMPUTER SECURITY CONSULTING IN THE AREA OF DATA STORAGE, ONLINE SECURITY AND INFORMATION SECURITY VULNERABILITY; COMPUTER SERVICES IN THE NATURE OF MONITORING THE COMPUTER NETWORK SYSTEMS OF OTHERS FOR TECHNICAL PURPOSES; SECURITY MANAGEMENT SERVICES, NAMELY, COMPUTER CONSULTATION IN THE FIELD OF COMPUTER SECURITY; DISASTER RECOVERY SERVICES, NAMELY, COMPUTER DISASTER RECOVERY PLANNING AND RECOVERY OF COMPUTER DATA; SERVER MANAGEMENT SERVICES, NAMELY, HOSTING THE WEB SITES OF OTHERS ON A COMPUTER SERVER FOR A GLOBAL COMPUTER NETWORK; DATA BACKUP SERVICES, NAMELY, BACK-UP SERVICES FOR COMPUTER HARD DRIVE DATA; WEB SITE HOSTING SERVICES; COMPUTER SERVICES, NAMELY, REMOTE AND ON-SITE MANAGEMENT OF THE INFORMATION TECHNOLOGY CLOUD COMPUTING SYSTEMS OF OTHERS; CONSULTING SERVICES IN THE FIELD OF CLOUD COMPUTING, NAMELY, CONSULTING IN CONNECTION WITH CLOUD COMPUTING APPLICATIONS AND NETWORKS; TECHNICAL CONSULTING SERVICES IN THE FIELDS OF PUBLIC AND PRIVATE CLOUD COMPUTING, NAMELY, CONSULTING SERVICES IN THE FIELD OF DESIGN, SELECTION, IMPLEMENTATION AND USE OF COMPUTER HARDWARE AND SOFTWARE SYSTEMS FOR OTHERS; TECHNICAL SUPPORT SERVICES, NAMELY, MONITORING OF NETWORK SYSTEMS, SERVERS AND WEB AND DATABASE APPLICATIONS AND NOTIFICATION OF RELATED EVENTS AND ALERTS; PROVIDING ON-DEMAND TEMPORARY USE OF NON-DOWNLOADABLE COMPUTER SOFTWARE FOR DATA AND WORD PROCESSING; HOSTING THE SOFTWARE AND OTHER COMPUTER APPLICATIONS OF OTHERS ON A VIRTUAL PRIVATE AND PUBLIC SERVER; TECHNICAL SUPPORT SERVICES FOR HARDWARE, SOFTWARE AND OPERATING SYSTEMS IN THE NATURE OF MONITORING, DIAGNOSING AND PROBLEM RESOLUTION RELATED TO SOFTWARE APPLICATIONS; COMPUTER SERVICES, NAMELY, REMOTE AND ON-

SITE MANAGEMENT OF ELECTRONIC MESSAGING SYSTEMS OF OTHERS INCLUDING TROUBLESHOOTING, OPTIMIZING, PATCHING, HARDENING, STORAGE MANAGEMENT, MAILBOX MOVEMENT, INSTALLATION AND CONFIGURATION AND MIGRATION OF ELECTRONIC MESSAGES AND MESSAGE SYSTEMS, SUCH AS E-MAIL; COMPUTER SERVICES, NAMELY, PROVIDING MANAGED WEB HOSTING SERVICES, WEB SITE SECURITY SERVICES TO PREVENT UNAUTHORIZED ACCESS TO CLIENT WEB SITES AND DATABASES (U.S. CLS. 100 AND 101).

CLASS 45—PERSONAL AND LEGAL SERVICES

FOR COMPUTERIZED SECURITY SERVICES IN THE NATURE OF MONITORING THE COMPUTERS NETWORK SYSTEMS OF OTHERS FOR SECURITY PURPOSES (U.S. CLS. 100 AND 101).

VERNA BETH RIRIE, EXAMINING ATTORNEY

CLASS 42—SCIENTIFIC AND COMPUTER SERVICES

FOR COMPUTER SERVICES IN THE NATURE OF PROVIDING AN INTEGRATED SUITE OF DATA AND COMPUTER RELATED SERVICES, NAMELY, PROVIDING COMPUTER SECURITY CONSULTING IN THE AREA OF DATA STORAGE, ONLINE SECURITY AND INFORMATION SECURITY VULNERABILITY; COMPUTER SERVICES IN THE NATURE OF MONITORING THE COMPUTER NETWORK SYSTEMS OF OTHERS FOR TECHNICAL PURPOSES; SECURITY MANAGEMENT SERVICES, NAMELY, COMPUTER CONSULTATION IN THE FIELD OF COMPUTER SECURITY; DISASTER RECOVERY SERVICES, NAMELY, COMPUTER DISASTER RECOVERY PLANNING AND RECOVERY OF COMPUTER DATA; SERVER MANAGEMENT SERVICES, NAMELY, HOSTING THE WEB SITES OF OTHERS ON A COMPUTER SERVER FOR A GLOBAL COMPUTER NETWORK; DATA BACKUP SERVICES, NAMELY, BACK-UP SERVICES FOR COMPUTER HARD DRIVE DATA; WEB SITE HOSTING SERVICES; COMPUTER SERVICES, NAMELY, REMOTE AND ON-SITE MANAGEMENT OF THE INFORMATION TECHNOLOGY CLOUD COMPUTING SYSTEMS OF OTHERS; CONSULTING SERVICES IN THE FIELD OF CLOUD COMPUTING, NAMELY, CONSULTING IN CONNECTION WITH CLOUD COMPUTING APPLICATIONS AND NETWORKS; TECHNICAL CONSULTING SERVICES IN THE FIELDS OF PUBLIC AND PRIVATE CLOUD COMPUTING, NAMELY, CONSULTING SERVICES IN THE FIELD OF DESIGN, SELECTION, IMPLEMENTATION AND USE OF COMPUTER HARDWARE AND SOFTWARE SYSTEMS FOR OTHERS; TECHNICAL SUPPORT SERVICES, NAMELY, MONITORING OF NETWORK SYSTEMS, SERVERS AND WEB AND DATABASE APPLICATIONS AND NOTIFICATION OF RELATED EVENTS AND ALERTS; PROVIDING ON-DEMAND TEMPORARY USE OF NON-DOWNLOADABLE COMPUTER SOFTWARE FOR DATA AND WORD PROCESSING; HOSTING THE SOFTWARE AND OTHER COMPUTER APPLICATIONS OF OTHERS ON A VIRTUAL PRIVATE AND PUBLIC SERVER; TECHNICAL SUPPORT SERVICES FOR HARDWARE, SOFTWARE AND OPERATING SYSTEMS IN THE NATURE OF MONITORING, DIAGNOSING AND PROBLEM RESOLUTION RELATED TO SOFTWARE APPLICATIONS; COMPUTER SERVICES, NAMELY, REMOTE AND ON-SITE MANAGEMENT OF ELECTRONIC MESSAGING SYSTEMS OF OTHERS INCLUDING TROUBLESHOOTING, OPTIMIZING, PATCHING, HARDENING, STORAGE MANAGEMENT, MAILBOX MOVEMENT, INSTALLATION AND CONFIGURATION AND MIGRATION OF ELECTRONIC MESSAGES AND MESSAGE SYSTEMS, SUCH AS E-MAIL; COMPUTER SERVICES, NAMELY, PROVIDING MANAGED WEB HOSTING SERVICES, WEB SITE SECURITY SERVICES TO PREVENT UNAUTHORIZED ACCESS TO CLIENT WEB SITES AND DATABASES (U.S. CLS. 100 AND 101).

SN 85-545,169. DATAPIPE, INC., JERSEY CITY, NJ. FILED 2-16-2012.

V STRATOSPHERE

THE MARK CONSISTS OF STANDARD CHARACTERS WITHOUT CLAIM TO ANY PARTICULAR FONT, STYLE, SIZE, OR COLOR.

NO CLAIM IS MADE TO THE EXCLUSIVE RIGHT TO USE "V", APART FROM THE MARK AS SHOWN.

CLASS 38—COMMUNICATION

FOR PROVIDING MULTIPLE USER ACCESS TO THE INTERNET IN THE FORM OF INTERNET BANDWIDTH DATA CONNECTION SERVICES; PROVIDING ON-DEMAND ACCESS TO DATA STORED VIRTUALLY ON OFF-SITE COMPUTER HARDWARE (U.S. CLS. 100, 101 AND 104).

CLASS 39—TRANSPORTATION AND STORAGE

FOR ELECTRONIC DATA STORAGE SERVICES, NAMELY, STORING ELECTRONIC DATA AT DATA CENTERS; ELECTRONIC DATA STORAGE; PROVIDING ON-DEMAND ELECTRONIC STORAGE OF DATA ON OFF-SITE COMPUTER HARDWARE (U.S. CLS. 100 AND 105).

CLASS 45—PERSONAL AND LEGAL SERVICES

FOR COMPUTERIZED SECURITY SERVICES IN THE NATURE OF MONITORING THE COMPUTERS NETWORK SYSTEMS OF OTHERS FOR SECURITY PURPOSES (U.S. CLS. 100 AND 101).

VERNA BETH RIRIE, EXAMINING ATTORNEY

SN 85-547,113. SERVPRO INTELLECTUAL PROPERTY, INC., GALLATIN, TN. FILED 2-20-2012.



NO CLAIM IS MADE TO THE EXCLUSIVE RIGHT TO USE "EMERGENCY READY PROFILE", APART FROM THE MARK AS SHOWN.

THE MARK CONSISTS OF A SQUARE BOX WITH A CHECK MARK INSIDE TO THE IMMEDIATE LEFT OF THE STACKED WORDS "EMERGENCY READY PROFILE".

CLASS 37—CONSTRUCTION AND REPAIR

FOR SERVICES FOR BOTH INDOORS AND OUTDOORS RESTORATION OF COMMERCIAL AND RESIDENTIAL STRUCTURES AND/OR CONTENTS DAMAGED BY FIRE, WATER, AND WATER CATASTROPHES; CARPET, FURNITURE, AND DRAPERY CLEANING SERVICES (U.S. CLS. 100, 103 AND 106).

FIRST USE 7-0-2011; IN COMMERCE 7-0-2011.

CLASS 40—MATERIAL TREATMENT

FOR MOLD REMEDIATION SERVICES (U.S. CLS. 100, 103 AND 106).

FIRST USE 7-0-2011; IN COMMERCE 7-0-2011.

ANDREW RHIM, EXAMINING ATTORNEY

SN 85-547,184. MOMENTIS SYSTEMS INC., MONTREAL, QUEBEC, CANADA, FILED 2-20-2012.

MOMENTIS

THE MARK CONSISTS OF STANDARD CHARACTERS WITHOUT CLAIM TO ANY PARTICULAR FONT, STYLE, SIZE, OR COLOR.

CLASS 9—ELECTRICAL AND SCIENTIFIC APPARATUS

FOR COMPUTER SOFTWARE FOR WHOLESALERS, IMPORTERS, MANUFACTURERS AND SELF-SOURCING RETAILERS WHICH PERMITS AND ENABLES OVERSEAS SOURCING, ALERTS, CUSTOMER SERVICE, EDI, STYLE SPECIFICATIONS, COSTING, LOGISTICS, PRODUCTION PLANNING AND CONTROL, INVENTORY AND CREDIT MANAGEMENT, WAREHOUSING AND DISTRIBUTION, ALLOCATION, EXECUTIVE SUMMARIES AND ACCOUNTS RECEIVABLE; DOWNLOADABLE WEB-BASED INTERACTIVE COMPUTER SOFTWARE SOLUTION FOR WHOLESALERS, IMPORTERS, MANUFACTURERS AND SELF-SOURCING RETAILERS WHICH PERMITS AND ENABLES OVERSEAS SOURCING, ALERTS, CUSTOMER SERVICE, EDI, STYLE SPECIFICATIONS, COSTING, LOGISTICS, PRODUCTION PLANNING AND CONTROL, INVENTORY AND CREDIT MANAGEMENT, WAREHOUSING AND DISTRIBUTION, ALLOCATION, EXECUTIVE SUMMARIES AND ACCOUNTS RECEIVABLE (U.S. CLS. 21, 23, 26, 36 AND 38).

FIRST USE 1-0-1995; IN COMMERCE 1-0-1995.

CLASS 42—SCIENTIFIC AND COMPUTER SERVICES

FOR DEVELOPMENT, CUSTOMIZATION, HOSTING, CONSULTING, INSTALLATION AND INTEGRATION OF COMPUTER SOFTWARE FOR WHOLESALERS, IMPORTERS, MANUFACTURERS AND SELF-SOURCING RETAILERS; DEVELOPMENT, CUSTOMIZATION, HOSTING, CONSULTING, INSTALLATION AND INTEGRATION OF A WEB-BASED INTERACTIVE COMPUTER SOFTWARE FOR WHOLESALERS, IMPORTERS, MANUFACTURERS AND SELF-SOURCING RETAILERS (U.S. CLS. 100 AND 101).

FIRST USE 1-0-1995; IN COMMERCE 1-0-1995.

LINDA MICKLEBURGH, EXAMINING ATTORNEY

SN 85-547,803. FARRELL, WESLEY J., MIAMI, FL. FILED 2-21-2012.

BEER LIFE

THE MARK CONSISTS OF STANDARD CHARACTERS WITHOUT CLAIM TO ANY PARTICULAR FONT, STYLE, SIZE, OR COLOR.

NO CLAIM IS MADE TO THE EXCLUSIVE RIGHT TO USE "BEER", APART FROM THE MARK AS SHOWN.

CLASS 16—PAPER GOODS AND PRINTED MATTER

FOR BUMPER STICKERS; DECALS; DECORATIVE DECALS FOR VEHICLE WINDOWS; MAGAZINES FEATURING BEER, BEER GEAR, AND/OR BEER RELATED SUBJECT MATTER; STICKERS (U.S. CLS. 2, 5, 22, 23, 29, 37, 38 AND 50).

CLASS 21—HOUSEWARES AND GLASS

FOR BEER JUGS; BEER MUGS; DRINKING CUPS AND SAUCERS; DRINKING FLASKS; DRINKING FLASKS; DRINKING GLASSES; DRINKING GLASSES, NAMELY, TUMBLERS; DRINKING HORNS; DRINKING STEINS; FOAM DRINK HOLDERS; PILSNER DRINKING GLASSES; PORTABLE BEVERAGE COOLERS; PORTABLE COOLERS; PORTABLE COOLERS, NAMELY, PORTABLE BEVERAGE OR ICE COOLERS MOUNTED ON TELESCOPING WHEELED CADDIES (U.S. CLS. 2, 13, 23, 29, 30, 33, 40 AND 50).

CLASS 25—CLOTHING

FOR A-SHIRTS; ADULT NOVELTY GAG CLOTHING ITEM, NAMELY, SOCKS; ATHLETIC APPAREL, NAMELY, SHIRTS, PANTS, JACKETS, FOOTWEAR, HATS AND CAPS, ATHLETIC UNIFORMS; BABY TOPS; BASEBALL CAPS AND HATS; BOARD SHORTS; BODY SHIRTS; BOXER SHORTS; BUTTON DOWN SHIRTS; COLLARED SHIRTS; DRESS SHIRTS; GOLF PANTS, SHIRTS AND SKIRTS; GOLF SHORTS; GYM SHORTS; HATS; HATS FOR INFANTS, BABIES, TODDLERS AND CHILDREN; HEADBANDS FOR CLOTHING; HUNTING PANTS; INFANT AND TODDLER ONE PIECE CLOTHING; JACKETS; JERSEYS; JOGGING PANTS; MUSCLE TOPS; PANTS; PARTY HATS; POLO KNIT TOPS; RUGBY TOPS; SHIRTS AND SHORT-SLEEVED SHIRTS; SHORTS; SPORTS PANTS; SPORTS SHIRTS WITH SHORT SLEEVES; SWEAT PANTS; TANK TOPS; TANK-TOPS (U.S. CLS. 22 AND 39).

CLASS 35—ADVERTISING AND BUSINESS

FOR ON-LINE RETAIL STORE SERVICES FEATURING APPAREL, STICKERS, AND BEER RELATED MERCHANDISE AND GEAR (U.S. CLS. 100, 101 AND 102).

JOSETTE BEVERLY, EXAMINING ATTORNEY

SN 85-548,577. NEWMAN, TIFFANY, WASHINGTON, DC. AND NEWMAN, MICHAEL, WASHINGTON, DC. FILED 2-21-2012.

OUR MARRIAGE WAS ONCE
ILLEGAL, TOO!

THE MARK CONSISTS OF STANDARD CHARACTERS WITHOUT CLAIM TO ANY PARTICULAR FONT, STYLE, SIZE, OR COLOR.

CLASS 41—EDUCATION AND ENTERTAINMENT

FOR WEDDING PLANNING AND COORDINATION SERVICES (U.S. CLS. 100, 101 AND 107).
FIRST USE 10-0-2009; IN COMMERCE 10-0-2009.

CLASS 45—PERSONAL AND LEGAL SERVICES

FOR PROVIDING WEDDING OFFICIANT SERVICES (U.S. CLS. 100 AND 101).
FIRST USE 10-0-2009; IN COMMERCE 10-0-2009.
ROSELLE HERRERA, EXAMINING ATTORNEY

SN 85-548,732. ABC FINANCIAL SERVICES, INC., NORTH LITTLE ROCK, AR. FILED 2-21-2012.



OWNER OF U.S. REG. NO. 3,903,416.
THE COLOR(S) BLACK, WHITE, AND YELLOW IS/ARE CLAIMED AS A FEATURE OF THE MARK.

THE MARK CONSISTS OF A BLACK SQUARE THAT CONTAINS THE WORDING "MYICLUB" APPEARING ABOVE THE WORD "ONLINE" IN WHITE AND A STYLIZED RUNNING HUMAN FIGURE IN WHITE ABOVE THE WORDING, A YELLOW SWOOSH APPEARS BELOW THE RUNNING FIGURE.

CLASS 9—ELECTRICAL AND SCIENTIFIC APPARATUS

FOR DOWNLOADABLE SOFTWARE IN THE NATURE OF A MOBILE APPLICATION FOR MANAGEMENT OF FITNESS CLUB MEMBERSHIP SERVICES, INCLUDING SCHEDULING, CLASS ENROLLMENT AND PERSONAL TRAINING RESERVATIONS, BY THE FITNESS CLUB MEMBER ON A PORTABLE OR MOBILE DEVICE (U.S. CLS. 21, 23, 26, 36 AND 38).

CLASS 36—INSURANCE AND FINANCIAL

FOR FINANCIAL SERVICES FOR THE FITNESS INDUSTRY AND ITS CONSUMERS, NAMELY, PAYMENT TRANSACTION PROCESSING SERVICES FOR DUES PAID BY FITNESS CLUB MEMBERS, PROVIDING BANK ACCOUNT INFORMATION BY TELEPHONE, PROVIDING DEBIT CARD AND CREDIT CARD INFORMATION REGARDING MEMBER ACCOUNTS, AND FINANCIAL MANAGEMENT OF MEMBERSHIP ACCOUNTS (U.S. CLS. 100, 101 AND 102).
MICHAEL SOUDERS, EXAMINING ATTORNEY

SN 85-550,787. VERIFONE, INC., SAN JOSE, CA. FILED 2-23-2012.

SAIL

THE MARK CONSISTS OF STANDARD CHARACTERS WITHOUT CLAIM TO ANY PARTICULAR FONT, STYLE, SIZE, OR COLOR.

CLASS 9—ELECTRICAL AND SCIENTIFIC APPARATUS

FOR HARDWARE AND SOFTWARE FOR SECURE PROCESSING OF PAYMENTS ON MOBILE DEVICES, MOBILE PHONES, HANDHELD DEVICES, TABLETS, AND COMPUTERS, NAMELY, A MOBILE DEVICE, MOBILE PHONE, HANDHELD DEVICE, TABLET AND COMPUTER APPLICATION AND AN AUDIO JACK CARD READER (U.S. CLS. 21, 23, 26, 36 AND 38).

CLASS 35—ADVERTISING AND BUSINESS

FOR PROVIDING AN ON-LINE PORTAL THAT PROVIDES COMMERCIAL FINANCIAL TRANSACTION DATA, ACCOUNT MANAGEMENT, FINANCIAL REPORTING, ACCOUNTING FEATURES AND RELATED REFERENCE INFORMATION (U.S. CLS. 100, 101 AND 102).

CLASS 36—INSURANCE AND FINANCIAL

FOR PAYMENT PROCESSING SERVICES, NAMELY, PROVIDING SECURE PROCESSING OF PAYMENTS ON MOBILE DEVICES, MOBILE PHONES, HANDHELD DEVICES, TABLETS, AND COMPUTERS; PROVIDING SECURE ELECTRONIC PAYMENT ACCEPTANCE AND PROCESSING SERVICES VIA AN INTERNET PAYMENT GATEWAY TO MERCHANTS, RESTAURANTS, RETAIL STORES, COMMERCIAL PRODUCT AND SERVICE PROVIDERS, ONLINE MERCHANTS AND ONLINE COMMERCIAL PRODUCT AND SERVICE PROVIDERS; PAYMENT GATEWAY SERVICES NAMELY, AUTHORIZING AND PROCESSING SECURE, REAL-TIME PAYMENTS FOR OTHERS OVER A NETWORK CONNECTION; PROVIDING AN ONLINE PORTAL FOR FINANCIAL TRANSACTION SERVICES, NAMELY, PROVIDING SECURE COMMERCIAL TRANSACTIONS AND PAYMENT OPTIONS; PROVIDING FINANCIAL INFORMATION ABOUT DEPOSITS MADE TO A CREDIT OR BANK ACCOUNT (U.S. CLS. 100, 101 AND 102).

CLASS 42—SCIENTIFIC AND COMPUTER SERVICES

FOR PROVIDING A SECURE ELECTRONIC ONLINE SYSTEM FEATURING TECHNOLOGY WHICH ALLOWS THE REPORTING OF DEPOSITS (U.S. CLS. 100 AND 101).

ANDREA BUTLER, EXAMINING ATTORNEY

SN 85-551,022. ANDO MEDIA, LLC, SHERMAN OAKS, CA. FILED 2-23-2012.

Webcast Metrics

THE MARK CONSISTS OF STANDARD CHARACTERS WITHOUT CLAIM TO ANY PARTICULAR FONT, STYLE, SIZE, OR COLOR.

OWNER OF U.S. REG. NO. 3,061,368.
SEC. 2(F).

CLASS 9—ELECTRICAL AND SCIENTIFIC APPARATUS

FOR COMPUTER SOFTWARE FOR MEASURING THE NUMBER OF AUDIENCE MEMBERS AND DURATION OF STREAMING FOR INTERNET RADIO AND OTHER INTERNET STREAMING MEDIA (U.S. CLS. 21, 23, 26, 36 AND 38).

FIRST USE 7-0-2004; IN COMMERCE 7-0-2004.

CLASS 42—SCIENTIFIC AND COMPUTER SERVICES

FOR SOFTWARE AS A SERVICE (SAAS) SERVICES FEATURING SOFTWARE FOR MEASURING THE NUMBER OF AUDIENCE MEMBERS AND DURATION OF STREAMING FOR INTERNET RADIO AND OTHER INTERNET STREAMING MEDIA (U.S. CLS. 100 AND 101).

FIRST USE 7-0-2004; IN COMMERCE 7-0-2004.
TIMOTHY FINNEGAN, EXAMINING ATTORNEY

SN 85-551,433. INDIRA CESARINE, INC, NEW YORK, NY. FILED 2-23-2012.

NO CLAIM IS MADE TO THE EXCLUSIVE RIGHT TO USE "MAGAZINE", APART FROM THE MARK AS SHOWN. THE MARK CONSISTS OF THE WORDING "THE" AND "MAGAZINE" WRITTEN IN STANDARD LETTERS, AND THE WORD "UNTITLED" WRITTEN IN SMALL STARS.

CLASS 9—ELECTRICAL AND SCIENTIFIC APPARATUS

FOR ELECTRONIC PUBLICATIONS, NAMELY, DOWNLOADABLE GENERAL FEATURE MAGAZINES FEATURING MULTIMEDIA CONTENT IN THE FIELD OF CREATIVE AND PERFORMING ARTS, BEAUTY, FASHION TRENDS AND STYLES (U.S. CLS. 21, 23, 26, 36 AND 38).

FIRST USE 4-1-2010; IN COMMERCE 4-1-2010.

CLASS 16—PAPER GOODS AND PRINTED MATTER

FOR GENERAL FEATURE MAGAZINES IN THE FIELD OF CREATIVE AND PERFORMING ARTS, BEAUTY, FASHION TRENDS AND STYLES (U.S. CLS. 2, 5, 22, 23, 29, 37, 38 AND 50).

FIRST USE 4-1-2010; IN COMMERCE 3-1-2011.
JOHN KELLY, EXAMINING ATTORNEY

SN 85-551,506. SEAN MICHAEL ANDERSON APPAREL, LLC, DETROIT, MI. AND KWL APPAREL, LLC, NEW YORK, NY. FILED 2-23-2012.

Finally Famous

THE MARK CONSISTS OF STANDARD CHARACTERS WITHOUT CLAIM TO ANY PARTICULAR FONT, STYLE, SIZE, OR COLOR.

CLASS 18—LEATHER GOODS

FOR LEATHER CASES; OVERNIGHT CASES; TRAVEL CASES; ALL-PURPOSE SPORT BAGS; BACKPACKS; BOOK BAGS; WALLETS; HANDBAGS; BELT BAGS; HIP BAGS; TOTE BAGS; CARRY-ON BAGS; CLUTCH BAGS; COSMETIC BAGS SOLD EMPTY; DUFFEL BAGS; GARMENT BAGS FOR TRAVEL; SHOULDER BAGS; SLING BAGS; WAIST BAGS; WHEELED BAGS; BILL-FOLDS; COIN PURSES; CREDIT CARD CASES; POCKETBOOKS; MESSENGER BAGS (U.S. CLS. 1, 2, 3, 22 AND 41).

CLASS 25—CLOTHING

FOR MEN'S, WOMEN'S AND CHILDREN'S APPAREL, NAMELY, SHIRTS, TOPS, SLACKS, SWEATERS, T-SHIRTS, HOODED SWEATSHIRTS, SHORTS, SWIMWEAR, SUITS, SPORTS JACKETS, DRESS SHIRTS, DRESS SLACKS, TUXEDOS AND FORMAL DRESSES, COATS, RAINCOATS, JACKETS, UNDERWEAR, SLEEPWEAR, HEADWEAR, BELTS, HOSIERY, SCARVES, GLOVES, PANT SUITS, SKIRTS, BLOUSES, SUIT JACKETS, DRESSES, LINGERIE; FOOTWEAR (U.S. CLS. 22 AND 39).

ANGELA M. MICHELI, EXAMINING ATTORNEY

SN 85-552,419. NISH, VIENNA, VA. FILED 2-24-2012.

SOURCEAMERICA

THE MARK CONSISTS OF STANDARD CHARACTERS WITHOUT CLAIM TO ANY PARTICULAR FONT, STYLE, SIZE, OR COLOR.

CLASS 16—PAPER GOODS AND PRINTED MATTER

FOR PRINTED PUBLICATIONS, NAMELY, A MONTHLY MAGAZINE ABOUT PROGRAMS DESIGNED TO EMPLOY INDIVIDUALS WITH DISABILITIES (U.S. CLS. 2, 5, 22, 23, 29, 37, 38 AND 50).

CLASS 35—ADVERTISING AND BUSINESS

FOR POLITICAL CONSULTANCY; POLITICAL ACTION COMMITTEE, NAMELY, PROMOTING THE INTERESTS OF ORGANIZATIONS AND AGENCIES THAT EMPLOY PEOPLE WITH DISABILITIES; LOBBYING SERVICES, NAMELY, PROMOTING THE INTERESTS OF ORGANIZATIONS AND AGENCIES THAT EMPLOY PEOPLE WITH DISABILITIES IN THE FIELDS OF LEGISLATION AND REGULATION; BUSINESS CONSULTATION TO ORGANIZATIONS AND AGENCIES THAT EMPLOY PEOPLE WITH DISABILITIES IN THE FIELD OF LEGISLATIVE AND REGULATORY AFFAIRS; PUBLIC RELATIONS AND MARKETING SERVICES; EMPLOYMENT SERVICES, NAMELY, COORDINATION OF A PROGRAM TO HELP CREATE EMPLOYMENT OPPORTUNITIES FOR PEOPLE WITH DISABILITIES FIND EMPLOYMENT WITH NONPROFIT AGENCIES FILLING CONTRACTS FOR GOODS AND SERVICES FOR OTHERS; PROVIDING EMPLOYMENT INFORMATION ABOUT ORGANIZATIONS AND AGENCIES THAT EMPLOY INDIVIDUALS WITH DISABILITIES; PROMOTING PUBLIC AWARENESS OF THE IMPORTANCE OF PROVIDING EMPLOYMENT OPPORTUNITIES FOR INDIVIDUALS WITH DISABILITIES; PROMOTING THE SALE OF THE GOODS OF OTHERS, NAMELY, GOODS MANUFACTURED BY PEOPLE WITH DISABILITIES THROUGH ALL OF THE ABOVE, AND THROUGH ALL FORMS OF MARKETING AND COMMUNICATIONS, NAMELY, MASS MEDIA, DIRECT MARKETING, AND ONLINE THROUGH SOCIAL MEDIA AND WEBSITE PRESENCE, FOR THE PURPOSE OF PROMOTING THE EMPLOYMENT, STAFFING AND HIRING OF PEOPLE WITH DISABILITIES (U.S. CLS. 100, 101 AND 102).

CLASS 36—INSURANCE AND FINANCIAL

FOR PROVIDING GRANTS AND LOANS TO ORGANIZATIONS THAT TRAIN AND EMPLOY PEOPLE WITH DISABILITIES (U.S. CLS. 100, 101 AND 102).

CLASS 41—EDUCATION AND ENTERTAINMENT

FOR EDUCATIONAL SERVICES, NAMELY, TRAINING, COURSES AND SEMINARS FOR ORGANIZATIONS AND AGENCIES THAT EMPLOY PEOPLE WITH DISABILITIES TO INCREASE HIRING AND PRODUCTIVITY OF SUCH EMPLOYEES AND FOR SUCCESSFUL CONTRACT MANAGEMENT; EDUCATIONAL SERVICES, NAMELY, PROVIDING SPEAKERS WITH DISABILITIES TO SPEAK ABOUT THE IMPORTANCE OF PROGRAMS DESIGNED TO EMPLOY INDIVIDUALS WITH DISABILITIES; PROVIDING ON-LINE INFORMATION IN THE FIELD OF EMPLOYMENT TRAINING FOR INDIVIDUALS WITH DISABILITIES; ARRANGING AND CONDUCTING EDUCATIONAL CONFERENCES IN THE FIELD OF EMPLOYING INDIVIDUALS WITH DISABILITIES AND SUCCESSFUL CONTRACT MANAGEMENT, AND DISTRIBUTION OF TRAINING MATERIALS IN CONNECTION THEREWITH (U.S. CLS. 100, 101 AND 107).

TOBY BULLOFF, EXAMINING ATTORNEY

SN 85-554,533. SALADO SALES, INC., TEMPLE, TX. FILED 2-28-2012.



OWNER OF U.S. REG. NOS. 3,403,435 AND 3,980,942.
NO CLAIM IS MADE TO THE EXCLUSIVE RIGHT TO USE "FOODS", APART FROM THE MARK AS SHOWN.
THE MARK CONSISTS OF THE WORD "DOUBLE" OVER THE STYLIZED LETTER "S" WITH THE WORD "FOODS" BELOW IT, WITHIN AN OVAL, IMPOSED ON TOP OF A RIBBON SHAPE.

CLASS 29—MEATS AND PROCESSED FOODS

FOR POWDERED CREAMER, NAMELY, CREAMERS FOR BEVERAGES; FRUIT CHIPS, VEGETABLE CHIPS AND POTATO CHIPS; SNACK MIXES CONSISTING PRIMARILY OF PROCESSED FRUITS, SEEDS, NUTS AND/OR RAISINS; DAIRY PRODUCTS, EXCLUDING ICE-CREAM, ICE MILK AND FROZEN YOGURT; BEEF JERKY; FRENCH ONION DIP, CHEESE DIP AND BEAN DIP (U.S. CL. 46).

CLASS 30—STAPLE FOODS

FOR MAYONNAISE, MUSTARD, KETCHUP AND SALSA DIP; COOKIES, CRACKERS; POPCORN; SUGAR, SALT, PEPPER; BAGEL CHIPS, CORN CHIPS AND PITA CHIPS; SNACK MIXES CONSISTING PRIMARILY OF CRACKERS, PRETZELS AND/OR POPPED POPCORN (U.S. CL. 46).

CHRISTOPHER BUONGIORNO, EXAMINING ATTORNEY

SN 85-554,608. STAND FOR THE SILENT, INC., PERKINS, OK. FILED 2-28-2012.

SFTS

THE MARK CONSISTS OF STANDARD CHARACTERS WITHOUT CLAIM TO ANY PARTICULAR FONT, STYLE, SIZE, OR COLOR.

CLASS 35—ADVERTISING AND BUSINESS

FOR PROMOTING PUBLIC AWARENESS OF THE NEED FOR EDUCATION AND ENGAGEMENT IN PROGRAMS REGARDING BULLYING (U.S. CLS. 100, 101 AND 102).
FIRST USE 7-11-2010; IN COMMERCE 7-11-2010.

CLASS 36—INSURANCE AND FINANCIAL

FOR CHARITABLE FUNDRAISING SERVICES (U.S. CLS. 100, 101 AND 102).
FIRST USE 7-11-2010; IN COMMERCE 7-11-2010.

CLASS 41—EDUCATION AND ENTERTAINMENT

FOR EDUCATIONAL SERVICES, NAMELY, ORGANIZING AND CONDUCTING COMMUNITY RESPONSE AND EDUCATIONAL RESPONSE IN THE NATURE OF CLASSES, SEMINARS, WORKSHOPS, CONFERENCES AND SYMPOSIA IN THE FIELD OF THE PREVENTION OF BULLYING (U.S. CLS. 100, 101 AND 107).
FIRST USE 7-11-2010; IN COMMERCE 7-11-2010.
JASON BLAIR, EXAMINING ATTORNEY

SN 85-554,615. STAND FOR THE SILENT, INC., PERKINS, OK. FILED 2-28-2012.

STAND FOR THE SILENT

THE MARK CONSISTS OF STANDARD CHARACTERS WITHOUT CLAIM TO ANY PARTICULAR FONT, STYLE, SIZE, OR COLOR.

CLASS 35—ADVERTISING AND BUSINESS

FOR PROMOTING PUBLIC AWARENESS OF THE NEED FOR EDUCATION AND ENGAGEMENT IN PROGRAMS REGARDING BULLYING (U.S. CLS. 100, 101 AND 102).
FIRST USE 7-11-2010; IN COMMERCE 7-11-2010.

CLASS 36—INSURANCE AND FINANCIAL

FOR CHARITABLE FUNDRAISING SERVICES (U.S. CLS. 100, 101 AND 102).
FIRST USE 7-11-2010; IN COMMERCE 7-11-2010.

CLASS 41—EDUCATION AND ENTERTAINMENT

FOR EDUCATIONAL SERVICES, NAMELY, ORGANIZING AND CONDUCTING COMMUNITY RESPONSE AND EDUCATIONAL RESPONSE IN THE NATURE OF CLASSES, SEMINARS, WORKSHOPS, CONFERENCES AND SYMPOSIA IN THE FIELD OF THE PREVENTION OF BULLYING (U.S. CLS. 100, 101 AND 107).
FIRST USE 7-11-2010; IN COMMERCE 7-11-2010.
JASON BLAIR, EXAMINING ATTORNEY

SN 85-554,619. STAND FOR THE SILENT, INC., PERKINS, OK. FILED 2-28-2012.

I AM SOMEBODY

THE MARK CONSISTS OF STANDARD CHARACTERS WITHOUT CLAIM TO ANY PARTICULAR FONT, STYLE, SIZE, OR COLOR.

CLASS 35—ADVERTISING AND BUSINESS

FOR PROMOTING PUBLIC AWARENESS OF THE NEED FOR EDUCATION AND ENGAGEMENT IN PROGRAMS REGARDING BULLYING (U.S. CLS. 100, 101 AND 102).
FIRST USE 7-11-2010; IN COMMERCE 7-11-2010.

CLASS 36—INSURANCE AND FINANCIAL

FOR CHARITABLE FUNDRAISING SERVICES (U.S. CLS. 100, 101 AND 102).
FIRST USE 7-11-2010; IN COMMERCE 7-11-2010.

CLASS 41—EDUCATION AND ENTERTAINMENT

FOR EDUCATIONAL SERVICES, NAMELY, ORGANIZING AND CONDUCTING COMMUNITY RESPONSE AND EDUCATIONAL RESPONSE IN THE NATURE OF CLASSES, SEMINARS, WORKSHOPS, CONFERENCES AND SYMPOSIA IN THE FIELD OF THE PREVENTION OF BULLYING (U.S. CLS. 100, 101 AND 107).
FIRST USE 7-11-2010; IN COMMERCE 7-11-2010.
JASON BLAIR, EXAMINING ATTORNEY

SN 85-555,930. OAKSTONE PUBLISHING, LLC, DBA PERSONAL BEST, BIRMINGHAM, AL. FILED 2-29-2012.

BODY BULLETIN

THE MARK CONSISTS OF STANDARD CHARACTERS WITHOUT CLAIM TO ANY PARTICULAR FONT, STYLE, SIZE, OR COLOR.

OWNER OF U.S. REG. NO. 1,678,537.
NO CLAIM IS MADE TO THE EXCLUSIVE RIGHT TO USE "BULLETIN", APART FROM THE MARK AS SHOWN.

CLASS 9—ELECTRICAL AND SCIENTIFIC APPARATUS

FOR PROVIDING DOWNLOADABLE ELECTRONIC NEWSLETTERS IN THE FIELD OF HEALTH, WELLNESS, FITNESS AND NUTRITION (U.S. CLS. 21, 23, 26, 36 AND 38).

FIRST USE 11-30-2009; IN COMMERCE 11-30-2009.

CLASS 41—EDUCATION AND ENTERTAINMENT

FOR PROVIDING ONLINE ELECTRONIC NEWSLETTERS IN THE FIELD OF HEALTH, WELLNESS, FITNESS AND NUTRITION VIA E-MAIL; PROVIDING ONLINE PUBLICATIONS, NAMELY, NEWSLETTERS IN THE FIELD OF HEALTH, WELLNESS, FITNESS AND NUTRITION; PROVIDING AN ONGOING SERIES OF AUDIO AND VIDEO PROGRAMS IN THE FIELD OF HEALTH, WELLNESS, FITNESS AND NUTRITION VIA THE INTERNET (U.S. CLS. 100, 101 AND 107).

FIRST USE 11-30-2009; IN COMMERCE 11-30-2009.

TAMARA FRAZIER, EXAMINING ATTORNEY

SN 85-556,109. WALGREEN CO., DEERFIELD, IL. FILED 2-29-2012.



OWNER OF U.S. REG. NOS. 3,268,858, 3,722,729 AND 3,921,113.

THE MARK CONSISTS OF THE WORDS "PET SHOPPE" WITH A STYLIZED ANIMAL PAW PRINT IN PLACE OF THE LETTER "O".

CLASS 3—COSMETICS AND CLEANING PREPARATIONS

FOR NON-MEDICATED SHAMPOO AND CONDITIONER FOR PETS; DETANGLING SPRAY FOR PETS; PRE-MOISTENED CLEANSING WIPES FOR PETS; FRESHENING SPRAY FOR PETS (U.S. CLS. 1, 4, 6, 50, 51 AND 52).

CLASS 5—PHARMACEUTICALS

FOR VITAMINS FOR PETS; FLEA AND TICK ERADICATION PREPARATIONS FOR ANIMALS, NAMELY, FLEA AND TICK REPELLANT SPRAYS AND SHAMPOOS (U.S. CLS. 6, 18, 44, 46, 51 AND 52).

CLASS 8—HAND TOOLS

FOR NAIL CLIPPERS (U.S. CLS. 23, 28 AND 44).

CLASS 20—FURNITURE AND ARTICLES NOT OTHERWISE CLASSIFIED

FOR NON-METAL PORTABLE STAIRS FOR USE BY PETS FOR FURNITURE AND CARS; PORTABLE PET KENNELS AND CRATES (U.S. CLS. 2, 13, 22, 25, 32 AND 50).

CLASS 21—HOUSEWARES AND GLASS

FOR PET FEEDING AND DRINKING BOWLS AND DISHES; RACKS AND STANDS FOR ELEVATING PET FEEDING BOWLS AND DISHES; SCOOPS FOR THE DISPOSAL OF PET WASTE; PET GROOMING MITTS OF TEXTILE MATERIALS (U.S. CLS. 2, 13, 23, 29, 30, 33, 40 AND 50).

CLASS 24—FABRICS

FOR TOWELS; PET BLANKETS; BLANKET THROWS (U.S. CLS. 42 AND 50).

PRISCILLA MILTON, EXAMINING ATTORNEY

SN 85-556,125. SELECT JEWELRY INC., LONG ISLAND CITY, NY. FILED 2-29-2012.

6 LUCKY WISHES

THE MARK CONSISTS OF STANDARD CHARACTERS WITHOUT CLAIM TO ANY PARTICULAR FONT, STYLE, SIZE, OR COLOR.

OWNER OF U.S. REG. NO. 2,538,831.

CLASS 14—JEWELRY

FOR JEWELRY, NAMELY, WEDDING BANDS, RINGS, BRACELETS, PENDANTS, EARRINGS, NECKLACES, BROOCHES AND PINS (U.S. CLS. 2, 27, 28 AND 50).

CLASS 35—ADVERTISING AND BUSINESS

FOR RETAIL STORE SERVICES AND ON-LINE RETAIL STORE SERVICES FEATURING JEWELRY, RINGS, WATCHES, BRACELETS, PENDANTS, EARRINGS, NECKLACES, BROOCHES, PINS (U.S. CLS. 100, 101 AND 102).

CHARLES L. JENKINS, EXAMINING ATTORNEY

SN 85-556,375. WALGREEN CO., DEERFIELD, IL. FILED 2-29-2012.

PURE BY DESIGN

THE MARK CONSISTS OF STANDARD CHARACTERS WITHOUT CLAIM TO ANY PARTICULAR FONT, STYLE, SIZE, OR COLOR.

CLASS 5—PHARMACEUTICALS

FOR GAUZE; BANDAGES, NAMELY, ADHESIVE BANDAGES AND BANDAGES FOR DRESSINGS; MEDICAL ADHESIVE TAPE; TEST STRIPS FOR MEASURING BLOOD GLUCOSE LEVELS (U.S. CLS. 6, 18, 44, 46, 51 AND 52).

CLASS 10—MEDICAL APPARATUS

FOR MEDICAL GLOVES (U.S. CLS. 26, 39 AND 44).

CLASS 11—ENVIRONMENTAL CONTROL APPARATUS

FOR LIGHT BULBS (U.S. CLS. 13, 21, 23, 31 AND 34).

CLASS 21—HOUSEWARES AND GLASS

FOR PLASTIC CUPS; PAPER PLATES (U.S. CLS. 2, 13, 23, 29, 30, 33, 40 AND 50).

CLASS 28—TOYS AND SPORTING GOODS

FOR ATHLETIC TAPE (U.S. CLS. 22, 23, 38 AND 50).
PRISCILLA MILTON, EXAMINING ATTORNEY

SN 85-556,391. MEADWESTVACO CORPORATION, RICHMOND, VA. FILED 2-29-2012.

SMARTFARE

THE MARK CONSISTS OF STANDARD CHARACTERS WITHOUT CLAIM TO ANY PARTICULAR FONT, STYLE, SIZE, OR COLOR.

CLASS 16—PAPER GOODS AND PRINTED MATTER

FOR PACKAGING CONTAINERS COMPRISED OF PAPERBOARD FOR FOOD AND BEVERAGES (U.S. CLS. 2, 5, 22, 23, 29, 37, 38 AND 50).

CLASS 20—FURNITURE AND ARTICLES NOT OTHERWISE CLASSIFIED

FOR PACKAGING CONTAINERS COMPRISED OF PLASTIC FOR FOOD AND BEVERAGES (U.S. CLS. 2, 13, 22, 25, 32 AND 50).
MARLENE BELL, EXAMINING ATTORNEY

SN 85-556,963. THE OPEN FIELD NETWORK, LLC, LOS ANGELES, CA. FILED 2-29-2012.

THE OPEN FIELD

THE MARK CONSISTS OF STANDARD CHARACTERS WITHOUT CLAIM TO ANY PARTICULAR FONT, STYLE, SIZE, OR COLOR.

CLASS 38—COMMUNICATION

FOR CABLE TELEVISION BROADCASTING; BROADCASTING SERVICES, NAMELY, THE ELECTRONIC TRANSMISSION AND STREAMING OF AUDIO VISUAL CONTENT VIA THE INTERNET, BROADBAND SYSTEMS AND PORTABLE AND WIRELESS COMMUNICATION NETWORKS; PROVIDING ONLINE CHAT ROOMS AND BULLETIN BOARDS FOR ELECTRONIC TRANSMISSION OF MESSAGES AMONG USERS IN THE FIELD OF MOTION PICTURES, MUSIC, TELEVISION PROGRAMS, NEWS, SPORTS, GAMES, CULTURAL EVENTS AND ENTERTAINMENT RELATED PROGRAMS VIA COMPUTER AND OTHER COMMUNICATION NETWORKS (U.S. CLS. 100, 101 AND 104).

CLASS 41—EDUCATION AND ENTERTAINMENT

FOR TELEVISION AND ENTERTAINMENT SERVICES, NAMELY, THE PRODUCTION OF A BROAD SPECTRUM OF TELEVISION PROGRAMS AND MOTION PICTURES; ENTERTAINMENT IN THE FORM OF LIVE CONCERTS, TALENT CONTESTS, MUSIC AND TELEVISION AWARD EVENTS, SPORTS EVENTS, GAME EVENTS, EVENTS WITH SPEAKERS ON VARIOUS SOCIAL AND POLITICAL TOPICS; DANCE SHOWS, MUSIC SHOWS AND VIDEO AWARD SHOWS; COMEDY SHOWS, GAME SHOWS AND SPORTS EVENTS BEFORE LIVE AUDIENCES WHICH ARE BROADCAST LIVE OR TAPED FOR LATER BROADCAST; LIVE CONCERTS; TV NEWS SHOWS; ORGANIZING TALENT CONTESTS AND MUSIC AND TELEVISION AWARD EVENTS; EDUCATION AND ENTERTAINMENT SERVICES, NAMELY, PROVIDING INFORMATION IN THE FIELD OF MOTION PICTURES, MUSIC, TELEVISION PROGRAMS, ENTERTAINMENT NEWS, SPORTS, GAMES, CULTURAL EVENTS, AND ENTERTAINMENT RELATED CONTENT OVER THE INTERNET; ENTERTAINMENT SERVICES, NAMELY, PROVIDING A WEBSITE AND ONLINE DATABASE IN THE FIELD OF MOTION PICTURES, TELEVISION, MUSIC, ENTERTAINMENT NEWS, SPORTS, GAMES, CULTURAL EVENTS AND ENTERTAINMENT RELATED PROGRAMS; BOOK PUBLISHING; MAGAZINE PUBLISHING; PUBLISHING OF ONLINE CONTENT; ELECTRONIC PUBLISHING SERVICES, NAMELY, PUBLICATION OF TEXT AND GRAPHIC WORKS ON-LINE FEATURING GENERAL INTEREST CONTENT (U.S. CLS. 100, 101 AND 107).
LAURIE KAUFMAN, EXAMINING ATTORNEY

SN 85-557,459. GHADIR GHUZLAN LLC, BROOKLYN, NY. FILED 3-1-2012.

5L Swimwear

THE MARK CONSISTS OF STANDARD CHARACTERS WITHOUT CLAIM TO ANY PARTICULAR FONT, STYLE, SIZE, OR COLOR.

NO CLAIM IS MADE TO THE EXCLUSIVE RIGHT TO USE "SWIMWEAR", APART FROM THE MARK AS SHOWN.

CLASS 18—LEATHER GOODS

FOR BEACH BAGS (U.S. CLS. 1, 2, 3, 22 AND 41).

CLASS 25—CLOTHING

FOR SWIMWEAR (U.S. CLS. 22 AND 39).
TIMOTHY FINNEGAN, EXAMINING ATTORNEY

SN 85-557,747. PARK, EUN-KYUNG, SEOUL 121-895, REPUBLIC OF KOREA, FILED 3-1-2012.

天上天下

THE MARK CONSISTS OF KOREAN CHARACTERS MEANING "HEAVEN AND EARTH".

THE NON-LATIN CHARACTERS IN THE MARK TRANSLITERATE TO CHUNSANGCHUNHA AND THIS MEANS "HEAVEN AND EARTH" IN ENGLISH.

SN 85-558,868. QUICKPAY CORP., MENLO PARK, CA. FILED 3-2-2012.

CLASS 28—TOYS AND SPORTING GOODS

FOR MARIONETTES, DHARMA DOLLS WITHOUT EYES, TOY MANNEQUIN DOLLS, MASCOT DOLLS, STUFFED DOLLS, PUPPETS, TOY DOLLS, HEADGEAR FOR DOLLS, DOLL ROOMS, SHOES FOR DOLLS, DOLL FEEDING BOTTLES, CLOTHES FOR DOLLS, DOLL HOUSES, FURNITURE FOR DOLL HOUSES, DOLL BEDS, TRADITIONALLY DRESSED WESTERN DOLLS (U.S. CLS. 22, 23, 38 AND 50).

FREQUENT PARKER

CLASS 35—ADVERTISING AND BUSINESS

FOR DESIGN OF ADVERTISING MATERIALS FOR OTHERS; CREATING TRADEMARKS FOR OTHERS; BRAND DESIGN SERVICES IN THE NATURE OF BRAND IMAGERY CONSULTING SERVICES (U.S. CLS. 100, 101 AND 102).

THE MARK CONSISTS OF STANDARD CHARACTERS WITHOUT CLAIM TO ANY PARTICULAR FONT, STYLE, SIZE, OR COLOR.

NO CLAIM IS MADE TO THE EXCLUSIVE RIGHT TO USE "PARKER", APART FROM THE MARK AS SHOWN.

CLASS 42—SCIENTIFIC AND COMPUTER SERVICES

FOR GRAPHIC DESIGN SERVICES; GRAPHIC DESIGN SERVICES, NAMELY, CREATING GRAPHIC ELEMENTS OF CORPORATE LOGOS; DESIGN OF NEW PRODUCTS FOR OTHERS; PRODUCT DEVELOPMENT; DOLL CHARACTER DESIGN FOR OTHERS; PACKAGING DESIGN SERVICES; DRESS DESIGN SERVICES; CLOTHING DESIGN SERVICES; TEXTILE DESIGN SERVICES; FASHION DESIGN SERVICES; DOLL DESIGN SERVICES FOR OTHERS; STATIONERY DESIGN SERVICES IN THE NATURE OF LETTERHEAD DESIGN AND EXCLUDING STATIONERY PRINTING SERVICES; TOY DESIGN SERVICES FOR OTHERS (U.S. CLS. 100 AND 101).

KIMBERLY PARKS, EXAMINING ATTORNEY

CLASS 38—COMMUNICATION

FOR COMMUNICATION SERVICES REGARDING PARKING, NAMELY TRANSMISSION OF DATA, IMAGES AND GRAPHICS VIA WIRED OR WIRELESS NETWORKS TO COMPUTERS, MOBILE ELECTRONIC DEVICES, VEHICLE PHONES, NAVIGATION OR COMMUNICATION SYSTEMS (U.S. CLS. 100, 101 AND 104).

CLASS 42—SCIENTIFIC AND COMPUTER SERVICES

FOR APPLICATION SERVICE PROVIDER FEATURING SOFTWARE DOWNLOADABLE TO A MOBILE ELECTRONIC DEVICE FOR MANAGING AND PROCESSING END USER PARKING AND PAYMENT TRANSACTIONS (U.S. CLS. 100 AND 101).

INGA ERVIN, EXAMINING ATTORNEY

SN 85-558,302. WHITEWAVE SERVICES, INC., DALLAS, TX. FILED 3-2-2012.

SN 85-558,932. HEALTH TO HAPPINESS, INC., LARGO, FL. FILED 3-2-2012.

A TASTE FOR EVERYONE

The Swedish Diet Energy
Boost

THE MARK CONSISTS OF STANDARD CHARACTERS WITHOUT CLAIM TO ANY PARTICULAR FONT, STYLE, SIZE, OR COLOR.

THE MARK CONSISTS OF STANDARD CHARACTERS WITHOUT CLAIM TO ANY PARTICULAR FONT, STYLE, SIZE, OR COLOR.

OWNER OF U.S. REG. NO. 4,046,027.

NO CLAIM IS MADE TO THE EXCLUSIVE RIGHT TO USE "DIET" AND "ENERGY BOOST", APART FROM THE MARK AS SHOWN.

CLASS 29—MEATS AND PROCESSED FOODS

FOR SOY-BASED FOOD BEVERAGE USED AS A MILK SUBSTITUTE; SOY-BASED YOGURT; AND SOY-BASED CREAMERS (U.S. CL. 46).

CLASS 5—PHARMACEUTICALS

FOR LIQUID DIETARY VITAMIN SUPPLEMENT (U.S. CLS. 6, 18, 44, 46, 51 AND 52).

CLASS 32—LIGHT BEVERAGES

FOR ALMOND MILK BEVERAGE AND COCONUT MILK (U.S. CLS. 45, 46 AND 48).

DOMINIC J. FERRAIUOLO, EXAMINING ATTORNEY

CLASS 32—LIGHT BEVERAGES

FOR FRUIT JUICE CONTAINING VITAMINS AND MINERALS (U.S. CLS. 45, 46 AND 48).

LAURA KOVALSKY, EXAMINING ATTORNEY

SN 85-558,976. KOMATSU LTD., TOKYO, JAPAN, FILED 3-2-2012.



NO CLAIM IS MADE TO THE EXCLUSIVE RIGHT TO USE "REMAN", APART FROM THE MARK AS SHOWN. THE MARK CONSISTS OF THE WORDING "REMAN" WITH CURVED ARROWS ABOVE AND BELOW.

CLASS 7—MACHINERY

FOR CUTTER LOADERS, OIL WELL PUMPING MACHINES, ROCK DRILLS, WELL DRILLING MACHINES, DRILLING AND BORING MACHINES, TRUCK MILLS; EARTH MOVING EQUIPMENT, NAMELY, LOADERS, UNLOADERS, WHEEL LOADERS, GRADERS, SCRAPERS; TRUCK CRANES, POWER SHOVELS, DOZER SHOVELS BEING MACHINES, EARTH AUGERS, PILE DRIVERS, PILE EXTRACTORS, GROUTING PUMPS, BULLDOZERS, ROLLERS, NAMELY, ROAD ROLLER MACHINES; CONCRETE PLACING MACHINES, CONCRETE VIBRATORS, CONCRETE PAVING MACHINES, CONCRETE MIXERS, ASPHALT FINISHERS, ASPHALT MIXERS, DREDGING MACHINES, PIPE-LAYING MACHINES; CABLE CRANES, JIB CRANES, DERRICKS, OVERHEAD TRAVELLING CRANES, TOWER CRANES, BRIDGE CRANES, FLOATING CRANES, LOCOMOTIVE CRANES, PNEUMATIC CONVEYORS, HYDRAULIC CONVEYORS, SCREW CONVEYORS, CHAIN CONVEYORS, BUCKET ELEVATORS, BELT CONVEYORS, ROLLER CONVEYORS, WINCHES, WINDLASSES, CAPSTANS, HOISTS; CHAINSAWS; INTERNAL COMBUSTION ENGINES, STEAM ENGINES, JET ENGINES, AND TURBINES, NOT FOR LAND VEHICLES; WATER WHEELS, WINDMILLS; PUMPS, VACUUM PUMPS, BLOWERS, AND COMPRESSORS FOR MACHINES; CRUDE VEGETABLE FIBER PREPARATION MACHINES, FEED COMPRESSORS, FEED CUTTERS, FEED MIXERS, FEED MILLS; STARTERS, ALTERNATING CURRENT MOTORS AND DIRECT CURRENT MOTORS NOT FOR USE WITH LAND VEHICLES, ALTERNATING CURRENT GENERATORS, DIRECT CURRENT GENERATORS; VEHICLE WASHING MACHINES; WASTE COMPRESSORS AND WASTE CRUSHERS; MACHINE PARTS, NAMELY, SHAFTS, BEARINGS, SHAFT COUPLINGS, MECHANICAL POWER TRANSMISSIONS, SPRINGS, DAMPERS, AND VALVES; STANDS FOR HYDRAULIC JACKS (U.S. CLS. 13, 19, 21, 23, 31, 34 AND 35).

CLASS 12—VEHICLES

FOR SHIPS; AIRCRAFT; RAIL ROLLING STOCK; TRUCKS, AMBULANCES, RACING MOTOR CARS, CONCRETE MIXER TRUCKS, WATER SPRINKLER TRUCKS, PASSENGER CARS, AMPHIBIOUS VEHICLES, SNOWMOBILES, ARMoured CARS, DUMP TRUCKS, LIBRARY TRUCKS, TRACTORS, TRAILERS, TROLLEY BUSES, BUSES, FORKLIFT TRUCKS; PARTS AND ATTACHMENTS FOR THE AFOREMENTIONED LAND VEHICLES, NAMELY, AIR PUMPS, CLUTCHES, TUBES; TWO-WHEELED MOTOR CARS, BICYCLES; INTERNAL COMBUSTION ENGINES, STEAM ENGINES, JET ENGINES, AND TURBINES FOR LAND VEHICLES; MACHINE ELEMENTS FOR LAND VEHICLES, NAMELY, SHAFTS, SHAFT BEARINGS, SHAFT COUPLINGS, BEARINGS; MECHANICAL POWER TRANSMISSIONS FOR LAND VEHICLES; BUFFERS, NAMELY, PNEUMATIC SPRINGS, SPRING BUFFERS, SPRING OIL PRESSURE BUFFERS; PARTS FOR LAND VEHICLES SUSPENSIONS, NAMELY, SPRINGS, NAMELY, SPIRAL SPRINGS, LEAF SPRINGS, COIL SPRINGS; DAMPERS; ALTERNATING CURRENT MOTORS OR DIRECT CURRENT MOTORS FOR LAND VEHICLES; MECHANICAL PARKING APPARATUS, NAMELY, WINCH BRAKES, STEERING BRAKES, CLUTCH BRAKES AND DRUM BRAKES (U.S. CLS. 19, 21, 23, 31, 35 AND 44).
KIMBERLY FRYE, EXAMINING ATTORNEY

SN 85-559,009. RULEBASE LLC, DALLAS, TX. FILED 3-2-2012.

RULEBASE

THE MARK CONSISTS OF STANDARD CHARACTERS WITHOUT CLAIM TO ANY PARTICULAR FONT, STYLE, SIZE, OR COLOR.

CLASS 38—COMMUNICATION

FOR PROVIDING INTERNET ACCESS, NAMELY, PROVIDING ACCESS TO ONLINE LEGAL SERVICES AND AN ONLINE SEARCHABLE DATABASE PROVIDING ACCESS TO U.S. FEDERAL, STATE, AND LOCAL STATUTES, RULES AND REGULATIONS, AND U.S. STATUTORY AND FEDERAL AGENCY LAWS AND RULES (U.S. CLS. 100, 101 AND 104).

CLASS 45—PERSONAL AND LEGAL SERVICES

FOR LEGAL SERVICES AND ONLINE LEGAL SERVICES, INCLUDING AN ONLINE SEARCHABLE DATABASE PROVIDING ACCESS TO U.S. FEDERAL, STATE, AND LOCAL STATUTES, RULES AND REGULATIONS, AND U.S. STATUTORY AND FEDERAL AGENCY LAWS AND RULES; ANALYSIS OF CASE RATIONALE, VERDICTS AND SETTLEMENTS REFERENCING FEDERAL, STATE AND LOCAL RULES AND REGULATIONS (U.S. CLS. 100 AND 101).

ALLISON SCHRODY, EXAMINING ATTORNEY

SN 85-559,059. LANE BRYANT PURCHASING CORP., COLUMBUS, OH. FILED 3-2-2012.



OWNER OF U.S. REG. NOS. 1,211,680, 3,300,228 AND OTHERS.

THE MARK CONSISTS OF THE LETTERS "LB". THE LETTERS ARE CONNECTED AND SLIGHTLY LEANING TO THE LEFT. THE "B" RESEMBLES A HEART.

CLASS 14—JEWELRY

FOR JEWELRY, NAMELY, COSTUME JEWELRY, BRACELETS, EARRINGS, NECKLACES, PENDANTS, PINS, RINGS AND WATCHES, IMITATION JEWELRY AND JEWELRY OF PRECIOUS METAL AND STONES (U.S. CLS. 2, 27, 28 AND 50).

CLASS 25—CLOTHING

FOR WOMEN'S WEARING APPAREL, NAMELY, BATHROBES, BELTS, BLOUSES, BODY SHAPERS, BODY STOCKINGS, BODY SUITS, BOOTS, BRAS, CAMISOLES, COATS, CONTROL UNDERGARMENTS, DRESSES, FOOTWEAR, FOUNDATION GARMENTS, GLOVES, HEADWEAR, HOSIERY, JACKETS, JEANS, JOGGING SUITS, KNEE HIGHS, LEGGINGS, LEG WARMERS, LINGERIE, LOUNGEWEAR, MUFFLERS, NECKWEAR, NEGLIGEEES, NIGHTGOWNS, NIGHT SHIRTS, PAJAMAS, PANTIES, PANTS, PULLOVERS, RAINCOATS, ROMPERS, SASHES, SCARVES, SHAWLS, SHIRTS, SHORTS, SKIRTS, SKORTS, SLEEPWEAR, SLIPPERS, SLIPS, SOCKS, STOCKINGS, SUITS, SWEATERS, SWEATPANTS, SWEATSHIRTS, SWIMSUITS, TEDDIES, T-SHIRTS, TANK TOPS, TOPS, UNDERPANTS, UNDERWEAR, VESTS (U.S. CLS. 22 AND 39).

CLASS 35—ADVERTISING AND BUSINESS

FOR RETAIL STORE SERVICES FEATURING WOMEN'S WEARING APPAREL, ACCESSORIES, AND BEAUTY PRODUCTS; COMPUTERIZED ON-LINE RETAIL STORE SERVICES FEATURING WOMEN'S WEARING APPAREL, ACCESSORIES AND BEAUTY PRODUCTS (U.S. CLS. 100, 101 AND 102).

DOMINIC FATHY, EXAMINING ATTORNEY

SN 85-559,306. ENFORCE GUNS, LLC, DBA ENFORCE GUNS, FALLS CHURCH, VA. FILED 3-2-2012.

EnForce Guns

THE MARK CONSISTS OF STANDARD CHARACTERS WITHOUT CLAIM TO ANY PARTICULAR FONT, STYLE, SIZE, OR COLOR.

NO CLAIM IS MADE TO THE EXCLUSIVE RIGHT TO USE "GUNS", APART FROM THE MARK AS SHOWN.

CLASS 35—ADVERTISING AND BUSINESS

FOR RETAIL SPORTING GOODS STORES (U.S. CLS. 100, 101 AND 102).
FIRST USE 3-2-2012; IN COMMERCE 3-2-2012.

CLASS 41—EDUCATION AND ENTERTAINMENT

FOR GUN FIRING RANGES (U.S. CLS. 100, 101 AND 107).
FIRST USE 3-2-2012; IN COMMERCE 3-2-2012.
KRISTIN DAHLING, EXAMINING ATTORNEY

SN 85-560,635. MAKRI A.E., DBA MAKRI S.A., ATHENS, GREECE, FILED 3-5-2012.

MAKRI

THE MARK CONSISTS OF STANDARD CHARACTERS WITHOUT CLAIM TO ANY PARTICULAR FONT, STYLE, SIZE, OR COLOR.

OWNER OF U.S. REG. NO. 3,199,114.

CLASS 14—JEWELRY

FOR JEWELRY (U.S. CLS. 2, 27, 28 AND 50).
FIRST USE 3-0-1999; IN COMMERCE 3-0-1999.

CLASS 35—ADVERTISING AND BUSINESS

FOR ONLINE RETAIL STORE SERVICES FEATURING JEWELRY (U.S. CLS. 100, 101 AND 102).
JESSICA FATHY, EXAMINING ATTORNEY

SN 85-560,738. MAKRI A.E., DBA MAKRI S.A., ATHENS, GREECE, FILED 3-5-2012.

OWNER OF U.S. REG. NO. 3,199,114.
THE MARK CONSISTS OF THE WORD "MAKRI" DISPLAYED IN A STYLIZED MANNER.

CLASS 14—JEWELRY

FOR JEWELRY (U.S. CLS. 2, 27, 28 AND 50).
FIRST USE 0-0-2005; IN COMMERCE 0-0-2005.

CLASS 35—ADVERTISING AND BUSINESS

FOR ONLINE RETAIL STORE SERVICES FEATURING JEWELRY (U.S. CLS. 100, 101 AND 102).
JESSICA FATHY, EXAMINING ATTORNEY

SN 85-560,756. YELLOWBRIX, INC., ARLINGTON, VA.
FILED 3-5-2012.



THE MARK CONSISTS OF THE WORD "ISYNDICATE" AND A PARTIAL OVAL THAT BEGINS AT THE DOT IN THE "I" AND SCRIBES TO THE RIGHT ENCLOSING THE TOP OF THE WORD AND ENDS UNDER THE LETTER "E".

SEC. 2(F) ISYNDICATE HAS BECOME DISTINCTIVE OF THE GOODS/SERVICES THROUGH THE APPLICANT'S SUBSTANTIALLY EXCLUSIVE AND CONTINUOUS USE IN COMMERCE THAT THE U.S. CONGRESS MAY LAWFULLY REGULATE FOR AT LEAST THE FIVE YEARS IMMEDIATELY BEFORE THE DATE OF THIS STATEMENT.

CLASS 35—ADVERTISING AND BUSINESS

FOR ONLINE MEDIA MONITORING SERVICES, NAMELY, MONITORING ONLINE PUBLICATIONS, TELEVISION, RADIO AND OTHER MEDIA FOR CUSTOMER-SPECIFIED TOPICS, GATHERING RELEVANT CONTENT ON THOSE TOPICS, AND PROVIDING ANALYSIS OF THAT MEDIA CONTENT TO OTHERS FOR BUSINESS PURPOSES (U.S. CLS. 100, 101 AND 102).
FIRST USE 12-0-2000; IN COMMERCE 12-0-2000.

CLASS 41—EDUCATION AND ENTERTAINMENT

FOR NEWS AGENCY SERVICES, NAMELY, GATHERING AND DISSEMINATION OF NEWS REGARDING A WIDE VARIETY OF TOPICS OF GENERAL INTEREST VIA THE INTERNET (U.S. CLS. 100, 101 AND 107).
FIRST USE 12-0-2000; IN COMMERCE 12-0-2000.

CLASS 42—SCIENTIFIC AND COMPUTER SERVICES

FOR PROVIDING A WEBSITE FEATURING A MEDIA NEWS AGGREGATOR AND SEARCH ENGINE FOR INTERNET CONTENT (U.S. CLS. 100 AND 101).
FIRST USE 12-0-2000; IN COMMERCE 12-0-2000.
SUE LAWRENCE, EXAMINING ATTORNEY

SN 85-560,966. DETHRONE ROYALTY INC, BURLINGAME, CA. FILED 3-5-2012.

dethrone

THE MARK CONSISTS OF STANDARD CHARACTERS WITHOUT CLAIM TO ANY PARTICULAR FONT, STYLE, SIZE, OR COLOR.

OWNER OF U.S. REG. NO. 3,959,427.

CLASS 5—PHARMACEUTICALS

FOR DIETARY AND NUTRITIONAL SUPPLEMENTS; NUTRITIONAL AND DIETARY SUPPLEMENTS FORMED AND PACKAGED AS BARS; PROTEIN SUPPLEMENT SHAKES (U.S. CLS. 6, 18, 44, 46, 51 AND 52).

CLASS 32—LIGHT BEVERAGES

FOR CONCENTRATES AND POWDERS USED IN THE PREPARATION OF ENERGY DRINKS AND FRUIT-FLAVORED BEVERAGES; FRUIT-FLAVOURED BEVERAGES; ISOTONIC BEVERAGES; NON-ALCOHOLIC BEVERAGES, NAMELY, CARBONATED BEVERAGES; WATER BEVERAGES (U.S. CLS. 45, 46 AND 48).

ZACHARY CROMER, EXAMINING ATTORNEY

SN 85-561,450. SHULA'S STEAK HOUSES, LLLP, FORT LAUDERDALE, FL. FILED 3-6-2012.

SHULA'S HOTEL AND GOLF CLUB

THE MARK CONSISTS OF STANDARD CHARACTERS WITHOUT CLAIM TO ANY PARTICULAR FONT, STYLE, SIZE, OR COLOR.

OWNER OF U.S. REG. NOS. 3,179,580, 3,179,584 AND 4,076,559.

NO CLAIM IS MADE TO THE EXCLUSIVE RIGHT TO USE "HOTEL AND GOLF CLUB", APART FROM THE MARK AS SHOWN.

SEC. 2(F).

CLASS 41—EDUCATION AND ENTERTAINMENT

FOR GOLF CLUB SERVICES (U.S. CLS. 100, 101 AND 107).

FIRST USE 6-1-2005; IN COMMERCE 6-1-2005.

CLASS 43—HOTEL AND RESTAURANT SERVICES

FOR RESTAURANT AND HOTEL SERVICES (U.S. CLS. 100 AND 101).

FIRST USE 6-1-2005; IN COMMERCE 6-1-2005.

SHAUNIA CARLYLE, EXAMINING ATTORNEY

SN 85-561,949. TRAINING & E-TRACKING SOLUTIONS, LLC, HUNT VALLEY, MD. FILED 3-6-2012.



NO CLAIM IS MADE TO THE EXCLUSIVE RIGHT TO USE "TRAINING & ETRACKING SOLUTIONS", APART FROM THE MARK AS SHOWN.

THE COLOR(S) BLUE, GRAY AND LIGHT GREEN IS/ARE CLAIMED AS A FEATURE OF THE MARK.

THE MARK CONSISTS OF THE WORD "TRAINING," IN BLUE, FOLLOWED BY A BARE FOOTPRINT WITH THE SYMBOL "&" INSIDE OF THE PRINT, IN LIGHT GREEN, FOLLOWED BY THE WORD "ETRACKING," IN BLUE, ABOVE THE WORD "SOLUTIONS," IN GRAY.

CLASS 35—ADVERTISING AND BUSINESS

FOR DATA COMPILING AND ANALYZING FOR BUSINESS MANAGEMENT PURPOSES, NAMELY, COMPUTERIZED TRACKING OF EMPLOYEE EDUCATION AND TRAINING DATA (U.S. CLS. 100, 101 AND 102).

FIRST USE 11-1-2011; IN COMMERCE 11-1-2011.

CLASS 41—EDUCATION AND ENTERTAINMENT

FOR EDUCATIONAL SERVICES, NAMELY, PROVIDING ONLINE TRAINING FOR EMPLOYEES OF NON-PROFIT BUSINESSES AND SOCIAL SERVICE AGENCIES IN THE FIELD OF CAREER AND PROFESSIONAL DEVELOPMENT (U.S. CLS. 100, 101 AND 107).

FIRST USE 11-1-2011; IN COMMERCE 11-1-2011.
AISHA SALEM, EXAMINING ATTORNEY

SN 85-561,959. CAREXTEND, LLC, CHICAGO, IL. FILED 3-6-2012.

CAREXTEND

THE MARK CONSISTS OF STANDARD CHARACTERS WITHOUT CLAIM TO ANY PARTICULAR FONT, STYLE, SIZE, OR COLOR.

CLASS 35—ADVERTISING AND BUSINESS

FOR ADMINISTERING DISCOUNT HEALTHCARE MARKETPLACE PROGRAMS, NAMELY, NEGOTIATING CONTRACTS WITH PROVIDERS OF HEALTHCARE, MEDICAL, VISION AND DENTAL SERVICES, TO ENABLE PARTICIPANT MEMBERS TO OBTAIN DISCOUNTS ON THE PURCHASE OF HEALTHCARE, MEDICAL, VISION AND DENTAL PRODUCTS AND SERVICES THROUGH THE USE OF DISCOUNT MEMBERSHIP CARDS, DISCOUNT CARE VOUCHERS, DISCOUNT PROGRAMS FOR DEFINED TIME PERIODS, AND DISCOUNT SUBSCRIPTION SERVICES (U.S. CLS. 100, 101 AND 102).

CLASS 36—INSURANCE AND FINANCIAL

FOR INSURANCE SERVICES, NAMELY, PROVIDING INFORMATION AND UNDERWRITING SERVICES FOR HEALTH, LIFE, ACCIDENTAL DEATH AND DISABILITY AND DENTAL INSURANCE; FINANCIAL ADVICE AND CONSULTANCY SERVICES (U.S. CLS. 100, 101 AND 102).

SUSAN LESLIE DUBOIS, EXAMINING ATTORNEY

SN 85-562,419. ALICE + OLIVIA, LLC, NEW YORK, NY. FILED 3-7-2012.

ALICE + OLIVIA

THE MARK CONSISTS OF STANDARD CHARACTERS WITHOUT CLAIM TO ANY PARTICULAR FONT, STYLE, SIZE, OR COLOR.

OWNER OF U.S. REG. NOS. 3,787,870, 4,029,466 AND OTHERS.

CLASS 7—MACHINERY

FOR SMALL ELECTRIC KITCHEN APPLIANCES, NAMELY, ELECTRIC FOOD BLENDERS, ELECTRIC FOOD PROCESSORS, ELECTRIC MIXERS (U.S. CLS. 13, 19, 21, 23, 31, 34 AND 35).

CLASS 8—HAND TOOLS

FOR FLATWARE, NAMELY, KNIVES, FORKS AND SPOONS; KNIVES FOR FOOD PREPARATION AND COOKING; SERVING KNIVES; MANDOLINE SLICERS (U.S. CLS. 23, 28 AND 44).

CLASS 11—ENVIRONMENTAL CONTROL APPARATUS

FOR SMALL ELECTRIC KITCHEN APPLIANCES, NAMELY, ELECTRIC SLOW COOKERS, ELECTRIC COFFEE MAKERS, ELECTRIC PANINI MAKERS (U.S. CLS. 13, 21, 23, 31 AND 34).

CLASS 21—HOUSEWARES AND GLASS

FOR DINNERWARE, NAMELY, PLATES, SAUCERS, BOWLS, CUPS, SERVING PLATTERS, VASES, PITCHERS, CAKE SERVERS, SALAD BOWLS, AND SALT AND PEPPER SHAKERS; BEVERAGE GLASSWARE, NAMELY, STEMWARE, TUMBLERS IN THE NATURE OF DRINKING GLASSES, ICED TEA GLASSES, WINE GLASSES, WATER GLASSES, HI-BALL GLASSES, GOBLET, CHAMPAGNE GLASSES, LIQUEUR GLASSES, BRANDY GLASSES, CARAFES, ICE BUCKETS, DECANTERS; HOUSEHOLD UTENSILS, NAMELY, SPATULAS, WHISKS, LADLES, TONGS, MIXING SPOONS, SLOTTED SPOONS, SERVING SPOONS, COOKING FORKS, SERVING FORKS, SALAD HANDS, POTATO MASHER BLOCKS; COOKWARE, NAMELY, POTS, PANS, SAUCEPANS, SKILLETS, DOUBLE BOILERS, STEAMERS AND STEAMER BASKETS, NON-ELECTRIC GRIDDLES, DUTCH OVENS, POT LIDS, COOKING SIEVES AND SIFTERS AND COLANDERS; BAKEWARE, NAMELY, CAKE PANS, COOKIE SHEETS, MUFFIN AND CUPCAKE PANS, PIZZA PANS, PIZZA STONES AND CRISPERS; CORK SCREWS (U.S. CLS. 2, 13, 23, 29, 30, 33, 40 AND 50).

CLASS 24—FABRICS

FOR KITCHEN TEXTILES, NAMELY, KITCHEN TOWELS, TEXTILE SERVIETTES, TABLE NAPKINS OF TEXTILE, TEXTILE PLACE MATS, TABLE CLOTHS NOT MADE OF PAPER, FABRIC TABLE RUNNERS, TABLE LINENS (U.S. CLS. 42 AND 50).

MARY ROSSMAN, EXAMINING ATTORNEY

SN 85-562,897. DIVERSIFIED DYNAMICS CORP., MINNEAPOLIS, MN. FILED 3-7-2012.



THE COLOR(S) BLUE AND ORANGE IS/ARE CLAIMED AS A FEATURE OF THE MARK.

THE MARK CONSISTS OF A "SWOOSH" DESIGN HAVING A SHORT VERTICAL LINE AND A LONG HORIZONTAL LINE MEETING TOGETHER AT A RIGHT ANGLE; THE THIRD EDGE OF THE DESIGN FORMS AN ARC FROM THE VERTICAL LINE TO THE END OF THE HORIZONTAL LINE. THE MAJORITY OF THE DESIGN IS BLUE WITH A THIN BORDER OF ORANGE ON THE BOTTOM EDGE OF THE ARC.

SEC. 2(F).

CLASS 7—MACHINERY

FOR ELECTRIC PAINT APPLICATION SYSTEMS COMPRISED OF THE FOLLOWING, NAMELY, PAINT CAN-MOUNTABLE PUMPS WITH HOSE, ROLLER HANDLE AND ROLLER AND ELECTRIC PAINT OR STAIN SPRAYERS WITH RESERVOIR (U.S. CLS. 13, 19, 21, 23, 31, 34 AND 35).

FIRST USE 3-1-2002; IN COMMERCE 3-1-2002.

CLASS 11—ENVIRONMENTAL CONTROL APPARATUS

FOR HEAT GUNS FOR STRIPPING FINISHES AND FLOOR TILE (U.S. CLS. 13, 21, 23, 31 AND 34).

FIRST USE 3-1-2002; IN COMMERCE 3-1-2002.

CLASS 16—PAPER GOODS AND PRINTED MATTER

FOR HAND OPERATED PAINT OR STAIN APPLICATORS CONSISTING OF PAINT OR STAIN RESERVOIR OR TUBE WITH PAD OR ROLLER ATTACHMENTS (U.S. CLS. 2, 5, 22, 23, 29, 37, 38 AND 50).

FIRST USE 3-1-2002; IN COMMERCE 3-1-2002.

CLASS 17—RUBBER GOODS

FOR MASKING TAPE WITH APPLICATOR (U.S. CLS. 1, 5, 12, 13, 35 AND 50).

FIRST USE 3-1-2002; IN COMMERCE 3-1-2002.

MATTHEW GALAN, EXAMINING ATTORNEY

CLASS 45—PERSONAL AND LEGAL SERVICES

FOR REGULATORY COMPLIANCE CONSULTING IN THE FIELD OF HUMAN AND VETERINARY HEALTH AND SAFETY RELATED ISSUES IN THE NATURAL PRODUCTS AND PHARMACEUTICAL INDUSTRIES, NAMELY, IN THE FIELD OF NATURAL HEALTH PRODUCTS, DIETARY SUPPLEMENTS, FOODS, BEVERAGES, COSMETICS AND OTCS; PATENT AGENT SERVICES, NAMELY, MONITORING PATENTS; TRADEMARK WATCH SERVICES; REVIEWING STANDARDS AND PRACTICES TO ASSURE COMPLIANCE WITH U.S. FOOD AND DRUG ADMINISTRATION LAWS AND REGULATIONS AND HEALTH CANADA LAWS AND REGULATIONS FOR NATURAL HEALTH PRODUCTS, DIETARY SUPPLEMENTS, FOOD, BEVERAGES, COSMETICS AND OTCS (U.S. CLS. 100 AND 101).

FIRST USE 7-17-2008; IN COMMERCE 1-20-2010.
JENNIFER MARTIN, EXAMINING ATTORNEY

SN 85-564,085. HYDRASCAN LIMITED, TYNE AND WEAR, UNITED KINGDOM, FILED 3-8-2012.

TYPHOON

SN 85-563,320. DICENTRA, LLC, DAVIE, FL. FILED 3-7-2012.

dicentra

THE MARK CONSISTS OF STANDARD CHARACTERS WITHOUT CLAIM TO ANY PARTICULAR FONT, STYLE, SIZE, OR COLOR.

CLASS 41—EDUCATION AND ENTERTAINMENT

FOR EDUCATIONAL SERVICES, NAMELY, PRESENTATIONS AND SEMINARS AND INFORMATIONAL LECTURES TO INDUSTRY ON THE REQUIREMENTS OF GLOBAL REGULATORY AGENCIES, IN REGARD TO PHARMACEUTICAL PRODUCTS AND MEDICAL DEVICES, DEALING WITH REQUIREMENTS OF REGULATORY AGENCIES IN REGARD TO PHARMACEUTICAL PRODUCTS AND MEDICAL DEVICES; TRAINING AND EDUCATIONAL SUPPORT, NAMELY, PROVIDING TRAINING SERVICES FOR INDUSTRY MEMBERS WITH RESPECT TO HOW TO COMPLY WITH U.S. FOOD AND DRUG ADMINISTRATION REGULATIONS AND HEALTH CANADA REGULATIONS FOR NATURAL HEALTH PRODUCTS, DIETARY SUPPLEMENTS, FOOD, BEVERAGES, COSMETICS AND OTCS (U.S. CLS. 100, 101 AND 107).

FIRST USE 7-17-2008; IN COMMERCE 9-20-2011.

THE MARK CONSISTS OF STANDARD CHARACTERS WITHOUT CLAIM TO ANY PARTICULAR FONT, STYLE, SIZE, OR COLOR.

OWNER OF ERP CMNTY TM OFC REG. NO. 009357914, DATED 2-25-2011, EXPIRES 9-7-2020.

CLASS 7—MACHINERY

FOR APPARATUS, NAMELY, PIPE CLEANING AND CLEARING MACHINES FOR THE CLEANING OF PIPELINES; MACHINES FOR USE IN THE CLEANING OF PIPELINES; MACHINE TOOLS FOR USE IN REPAIRING PIPELINES; COMPONENT AND REPLACEMENT PARTS FOR ALL THE AFORESAID GOODS (U.S. CLS. 13, 19, 21, 23, 31, 34 AND 35).

CLASS 9—ELECTRICAL AND SCIENTIFIC APPARATUS

FOR PIPELINE INSPECTION APPARATUS IN THE NATURE OF ELECTRONIC INSTRUMENTS FOR USE IN REMOTE INSPECTION OF PIPELINES USING REMOTE VISUAL DEVICES; PIPELINE INSPECTION TOOLS FOR DETECTING DEFECTS, NAMELY, ULTRASONIC FLAW DETECTORS; PIPELINE INSPECTION TOOLS, NAMELY, COMPUTER HARDWARE, SOFTWARE, MODEMS AND COMMUNICATION CABLES FOR TRANSMITTING IMAGES OF PIPELINES; COMPONENT AND REPLACEMENT PARTS FOR ALL THE AFORESAID GOODS (U.S. CLS. 21, 23, 26, 36 AND 38).

CLASS 42—SCIENTIFIC AND COMPUTER SERVICES

FOR PIPELINE INSPECTION SERVICES; DESIGN OF MACHINES FOR PIPELINE INSPECTION (U.S. CLS. 100 AND 101).

ZACHARY BELLO, EXAMINING ATTORNEY

SN 85-564,298. WM. NEUMANN & CO. LLC, WILLIAMSBURG, VA. FILED 3-8-2012.

WM. NEUMANN & CO.

THE MARK CONSISTS OF STANDARD CHARACTERS WITHOUT CLAIM TO ANY PARTICULAR FONT, STYLE, SIZE, OR COLOR.

NO CLAIM IS MADE TO THE EXCLUSIVE RIGHT TO USE "& CO.", APART FROM THE MARK AS SHOWN.

THE NAME(S), PORTRAIT(S), AND/OR SIGNATURE(S) SHOWN IN THE MARK DOES NOT IDENTIFY A PARTICULAR LIVING INDIVIDUAL.

CLASS 3—COSMETICS AND CLEANING PREPARATIONS

FOR COLOGNES; BAR SOAP; LIQUID HAND SOAP; SHAMPOO; CONDITIONER; SHOWER BODY WASH; HAIR STYLING GEL; HAIR STYLING WAX; HAIR STYLING POMADE; AFTER-SHAVE SPLASH; AFTER-SHAVE GEL; AFTER-SHAVE LOTION; AFTER-SHAVE BALM; SHAVING CREAM; SHAVING SOAP; SHAVING GEL; PRE-SHAVE OIL; SHAVING OIL; HAND LOTION; BODY LOTION; NON-MEDICATED HERBAL BODY SALVE; SUNSCREEN CREAMS; FACIAL TONER; FACIAL CLEANSER; FACIAL MOISTURIZER; TOOTH-PASTE; NON-MEDICATED LIP BALM; NON-MEDICATED ACNE PREPARATIONS (U.S. CLS. 1, 4, 6, 50, 51 AND 52).

CLASS 21—HOUSEWARES AND GLASS

FOR SHAVING BRUSHES, SHAVING DISHES; SHAVING MUGS (U.S. CLS. 2, 13, 23, 29, 30, 33, 40 AND 50).
SOPHIA S. KIM, EXAMINING ATTORNEY

SN 85-564,309. WM. NEUMANN & CO. LLC, WILLIAMSBURG, VA. FILED 3-8-2012.



NO CLAIM IS MADE TO THE EXCLUSIVE RIGHT TO USE "& CO. VIRGINIA, USA FINE APOTHECARY FOR MEN", APART FROM THE MARK AS SHOWN.

THE NAME "WM. NEUMANN" DOES NOT IDENTIFY A LIVING INDIVIDUAL. THE LIKENESS (OR, "PORTRAIT") IN THE MARK DOES NOT IDENTIFY A LIVING INDIVIDUAL.

THE COLOR(S) BROWN, BLACK, GRAY AND WHITE / ARE CLAIMED AS A FEATURE OF THE MARK.

THE MARK CONSISTS OF THE STYLIZED WORDS "WM. NEUMANN & CO" IN BLACK, BROWN AND WHITE APPEARING ABOVE A MISCELLANEOUS DESIGN IN BLACK, BROWN AND WHITE WHICH IS SEPARATED BY A CIRCLE CONTAINING THE ARTISTIC RENDERING OF A YOUNG MAN IN BLACK, GRAY AND BROWN. THE STYLIZED WORDS "VIRGINIA USA" IN BLACK APPEAR TO THE LEFT OF THE CIRCLE. THE STYLIZED WORDS "FINE APOTHECARY FOR MEN" IN BLACK APPEAR TO THE RIGHT OF THE CIRCLE. TWO BROWN LINES APPEAR AT THE TOP AND BOTTOM OF THE AFOREMENTIONED TEXT AND DRAWING.

CLASS 3—COSMETICS AND CLEANING PREPARATIONS

FOR COLOGNES; BAR SOAP; LIQUID HAND SOAP; SHAMPOO; CONDITIONER; SHOWER BODY WASH; HAIR STYLING GEL; HAIR STYLING WAX; HAIR STYLING POMADE; AFTER-SHAVE SPLASH; AFTER-SHAVE GEL; AFTER-SHAVE LOTION; AFTER-SHAVE BALM; SHAVING CREAM; SHAVING SOAP; SHAVING GEL; PRE-SHAVE OIL; SHAVING OIL; HAND LOTION; BODY LOTION; NON-MEDICATED HERBAL BODY SALVE; SUNSCREEN CREAMS; FACIAL TONER; FACIAL CLEANSER; FACIAL MOISTURIZER; TOOTH-PASTE; NON-MEDICATED LIP BALM; NON-MEDICATED ACNE PREPARATIONS (U.S. CLS. 1, 4, 6, 50, 51 AND 52).

CLASS 21—HOUSEWARES AND GLASS

FOR SHAVING BRUSHES, SHAVING DISHES; SHAVING MUGS (U.S. CLS. 2, 13, 23, 29, 30, 33, 40 AND 50).
SOPHIA S. KIM, EXAMINING ATTORNEY

SN 85-564,365. TEXAS BEST SMOKEHOUSE, INC., WAXAHACHIE, TX. FILED 3-8-2012.



OWNER OF U.S. REG. NOS. 3,321,980 AND 3,321,981. SEC. 2(F) AS TO "TEXAS BEST SMOKEHOUSE".

CLASS 35—ADVERTISING AND BUSINESS

FOR RETAIL STORE SERVICES FEATURING GENERAL CONSUMER MERCHANDISE (U.S. CLS. 100, 101 AND 102).

FIRST USE 2-28-2007; IN COMMERCE 2-28-2007.

CLASS 43—HOTEL AND RESTAURANT SERVICES

FOR RESTAURANT AND CATERING SERVICES (U.S. CLS. 100 AND 101).

FIRST USE 2-28-2007; IN COMMERCE 2-28-2007.
MARK SPARACINO, EXAMINING ATTORNEY

SN 85-564,378. FARMIGEA S.P.A., I-56121 PISA, ITALY,
FILED 3-8-2012.

BLEFARETTE

THE MARK CONSISTS OF STANDARD CHARACTERS WITHOUT CLAIM TO ANY PARTICULAR FONT, STYLE, SIZE, OR COLOR.

OWNER OF ITALY REG. NO. 00719253, DATED 7-17-1997, RENEWED AS REG. NO. 0001141898, DATED 11-29-2005, EXPIRES 12-28-2015.

CLASS 3—COSMETICS AND CLEANING PREPARATIONS

FOR COSMETIC PRODUCTS, NAMELY, CLEANSING AND MOISTENING WIPES IMPREGNATED WITH A CLEANING PREPARATION FOR CLEANING THE EYELIDS AND EYELASHES (U.S. CLS. 1, 4, 6, 50, 51 AND 52).

CLASS 5—PHARMACEUTICALS

FOR PHARMACEUTICAL PRODUCTS, NAMELY, OPHTHALMIC PREPARATIONS, NAMELY, PRE-MOISTENED DISPOSABLE WIPES FOR DISINFECTING THE EYELIDS AND EYELASHES (U.S. CLS. 6, 18, 44, 46, 51 AND 52).

SOPHIA S. KIM, EXAMINING ATTORNEY

SN 85-564,596. MAZEPLAY, INC., DBA THE FARM SCENE, FIRTH, ID. FILED 3-8-2012.



THE COLOR(S) BURNT ORANGE, YELLOW-ORANGE, YELLOW, MEDIUM-ORANGE, LIGHT ROSE PINK, MEDIUM ROSE PINK, YELLOW, SIENNA BROWN, DARK BROWN, MEDIUM-BROWN, LIGHT-TAN, TAN, BLACK, LIGHT-SILVER, MEDIUM-SILVER, MEDIUM-GRAY, LIGHT-GRAY AND GRAY IS/ARE CLAIMED AS A FEATURE OF THE MARK.

THE MARK CONSISTS OF AN AMERICAN-STYLE RECTANGULAR SILVER LICENSE PLATE WITH A BLACK OUTLINE WHICH HAS DARKER AND LIGHTER SHADES OF ORANGE AND ROSE PINK CAMOUFLAGE IN THE BACKGROUND. THE SILVER LICENSE PLATE FEATURES TWO SILVER SCREW OR RIVET HEADS AND ALSO FEATURES TWO BLACK AND LIGHT SILVER BULLET HOLES APPEARING TO BE SHOT INTO THE LICENSE PLATE. THE WORD "FARM" IS FEATURED ON THE SILVER LICENSE PLATE AND APPEARS AS RAISED OR STAMPED LETTERING ON THE LICENSE PLATE. THE IMAGE UPON THE WORD "FARM" SHOWS MATURE CORN-STALKS IN SILHOUETTE AT DUSK IN SHADES OF BLACK AND MEDIUM-GRAY, AND LIGHT-SILVER. THE LETTERS OF THE WORD "FARM" IS OUTLINED IN SHADES OF BLACK, DARK-GRAY, DARK-SILVER, LIGHT-GRAY, AND LIGHT-SILVER. THE WORD "THE" APPEARS IN BLOCK TEXT IN THE UPPER LEFT QUADRANT OF THE IMAGE. THE WORD "THE" IS IN LIGHT-TAN. THE WORD "THE" APPEARS ON A ROUGH-HEWN PLANK OF WOOD WHICH SAID WOOD HAS A GRAIN

DESIGN APPEARING IN DARKER AND MEDIUM SHADES OF BROWN AND TAN. THE ROUGH-HEWN WOODEN PLANK IS ATTACHED IN THE UPPER LEFT-HAND CORNER TO THE SILVER LICENSE PLATE WITH TWO BLACK AND GRAY NAILS WHICH ARE SLIGHTLY BENT AND ALSO BY A THIRD NAIL OF WHICH ONLY THE GRAY NAIL-HEAD SHOWS. THE WORDS "SCENE INVESTIGATION" APPEAR ON A LONG AND NARROW RECTANGLE LOCATED IN THE BOTTOM THIRD OF THE IMAGE WHICH OBSCURES ONLY A SMALL AMOUNT OF THE LICENSE PLATE IMAGE IN THE LOWER-LEFT-HAND CORNER. THIS LONG AND NARROW RECTANGLE FEATURES THE COLORS OF BURNT ORANGE, YELLOW-ORANGE, MEDIUM ORANGE, TAN, AND YELLOW IN A PATTERN REMINISCENT OF CAMOUFLAGE. THE LONG AND NARROW RECTANGLE IS REMINISCENT OF TAPE USED BY POLICE TO MARK OF A CRIME SCENE. ACROSS THE MID-SECTION OF THE LONG AND NARROW RECTANGLE APPEAR THE WORDS "SCENE INVESTIGATION." THE WORDS "SCENE INVESTIGATION" APPEAR TO BE STENCILED THEREON IN BLACK BLOCK LETTERS. THE LONG AND NARROW RECTANGLE IS OUTLINED IN BLACK. THE LONG AND NARROW RECTANGLE APPEARS TO BE ATTACHED TO THE LICENSE PLATE BY A SINGLE SCREW OR RIVET WITH ONLY THE MEDIUM AND LIGHT-GRAY HEAD OF THE SCREW OR RIVET SHOWING .

CLASS 16—PAPER GOODS AND PRINTED MATTER

FOR CHILDREN'S ACTIVITY BOOKS; CHILDREN'S BOOKS; CHILDREN'S INTERACTIVE EDUCATIONAL BOOKS; CHILDREN'S STORYBOOKS (U.S. CLS. 2, 5, 22, 23, 29, 37, 38 AND 50).

CLASS 28—TOYS AND SPORTING GOODS

FOR GAME CARDS; OUTDOOR ACTIVITY GAME EQUIPMENT IN THE NATURE OF TANGIBLE ITEMS AND SIGNS TO BE HIDDEN, OFTEN IN MAZES (U.S. CLS. 22, 23, 38 AND 50).

FIRST USE 1-18-2010; IN COMMERCE 5-5-2011.
ANGELA DUONG, EXAMINING ATTORNEY

SN 85-564,949. MULTI-HEALTH SYSTEMS INC., TORONTO, ONTARIO, CANADA, FILED 3-9-2012.

CDI 2

THE MARK CONSISTS OF STANDARD CHARACTERS WITHOUT CLAIM TO ANY PARTICULAR FONT, STYLE, SIZE, OR COLOR.

PRIORITY CLAIMED UNDER SEC. 44(D) ON CANADA APPLICATION NO. 1561069, FILED 1-24-2012, REG. NO. TMA804615, DATED 8-17-2011, EXPIRES 8-17-2026.

CLASS 16—PAPER GOODS AND PRINTED MATTER

FOR A PSYCHOLOGICAL ASSESSMENT TOOL, NAMELY, PRINTED BOOKLETS, QUESTIONNAIRES, INTERVIEW FORMS, WORKBOOKS, SCORING FORMS, ANSWER KEYS, PROFILE SHEETS, REPORT FORMS AND MANUALS, ALL USED TO DETECT BEHAVIORAL DISORDERS AND AUTOMATICALLY GENERATE INTERPRETATION REPORTS AND TREATMENT MEASURES USING COMPUTER SOFTWARE AND WEB-BASED TECHNOLOGY (U.S. CLS. 2, 5, 22, 23, 29, 37, 38 AND 50).

FIRST USE 11-0-2010; IN COMMERCE 11-0-2010.

CLASS 41—EDUCATION AND ENTERTAINMENT

FOR EDUCATIONAL TRAINING WORKSHOPS, IN THE FIELD OF PSYCHOLOGICAL TESTING, AND DISTRIBUTION OF COURSE AND EDUCATIONAL MATERIALS IN CONNECTION THEREWITH, NAMELY, COMPUTER SOFTWARE AND PRINTED BOOKLETS, QUESTIONNAIRES, INTERVIEW FORMS, WORKBOOKS, SCORING FORMS, ANSWER KEYS, PROFILE SHEETS, REPORT FORMS AND MANUALS (U.S. CLS. 100, 101 AND 107).

CLASS 44—MEDICAL, BEAUTY AND AGRICULTURAL SERVICES

FOR PSYCHOLOGICAL TESTING AND CONSULTATION SERVICES (U.S. CLS. 100 AND 101).
WARREN L. OLANDRIA, EXAMINING ATTORNEY

CLASS 9—ELECTRICAL AND SCIENTIFIC APPARATUS

FOR DOWNLOADABLE GAME SOFTWARE DELIVERED VIA ELECTRONIC MEANS; DOWNLOADABLE GAME BOARD DEVELOPMENT SOFTWARE (U.S. CLS. 21, 23, 26, 36 AND 38).

CLASS 41—EDUCATION AND ENTERTAINMENT

FOR ENTERTAINMENT SERVICES IN THE NATURE OF ONLINE VIDEO AND COMPUTER GAMES AND GAME SOFTWARE THEREFOR; ENTERTAINMENT SERVICES IN THE NATURE OF ONLINE VIDEO AND COMPUTER GAME BOARD DEVELOPMENT TOOLS AND GAME DEVELOPMENT SOFTWARE THEREFOR; ENTERTAINMENT SERVICES IN THE NATURE OF A WEBSITE FEATURING INFORMATION ABOUT VIDEO AND COMPUTER GAMES (U.S. CLS. 100, 101 AND 107).
MICHAEL LITZAU, EXAMINING ATTORNEY

SN 85-565,107. LIFEGUARD LICENSING CORP., NEW YORK, NY. FILED 3-9-2012.

SN 85-565,674. ELITE GUDZ CORP., FARMINGDALE, NY. FILED 3-9-2012.

LIFEGUARD

GET OFF MY ISLAND

THE MARK CONSISTS OF STANDARD CHARACTERS WITHOUT CLAIM TO ANY PARTICULAR FONT, STYLE, SIZE, OR COLOR.
OWNER OF U.S. REG. NO. 2,831,050.

THE MARK CONSISTS OF STANDARD CHARACTERS WITHOUT CLAIM TO ANY PARTICULAR FONT, STYLE, SIZE, OR COLOR.

CLASS 9—ELECTRICAL AND SCIENTIFIC APPARATUS

FOR COUNTDOWN TIMER(S) AND ALARMS TO REMIND A PERSON TO TAKE OR GIVE A MEDICATION(S) AND/OR TO REMIND A PERSON TO DO A DAILY ROUTINE(S) INCORPORATED INTO A WRISTBAND; RADIATION, SUN, AND TANNING BOOTH EXPOSURE MONITORING DEVICE; DOSIMETER (U.S. CLS. 21, 23, 26, 36 AND 38).

CLASS 9—ELECTRICAL AND SCIENTIFIC APPARATUS

FOR DOWNLOADABLE GAME SOFTWARE DELIVERED VIA ELECTRONIC MEANS; DOWNLOADABLE GAME BOARD DEVELOPMENT SOFTWARE (U.S. CLS. 21, 23, 26, 36 AND 38).

CLASS 14—JEWELRY

FOR JEWELRY, NAMELY, BRACELETS, WRISTBANDS AND NECKLACES THAT ALSO PROVIDES NOTIFICATION TO THE WEARER OF A PENDING MEDICAL RELATED TASK; RUBBER OR SILICON WRISTBANDS IN THE NATURE OF A BRACELET (U.S. CLS. 2, 27, 28 AND 50).
TINA BROWN, EXAMINING ATTORNEY

CLASS 41—EDUCATION AND ENTERTAINMENT

FOR ENTERTAINMENT SERVICES IN THE NATURE OF ONLINE VIDEO AND COMPUTER GAMES AND GAME SOFTWARE THEREFOR; ENTERTAINMENT SERVICES IN THE NATURE OF ONLINE VIDEO AND COMPUTER GAME BOARD DEVELOPMENT TOOLS AND GAME DEVELOPMENT SOFTWARE THEREFOR; ENTERTAINMENT SERVICES IN THE NATURE OF A WEBSITE FEATURING INFORMATION ABOUT VIDEO AND COMPUTER GAMES (U.S. CLS. 100, 101 AND 107).
MICHAEL LITZAU, EXAMINING ATTORNEY

SN 85-565,651. ELITE GUDZ CORP., FARMINGDALE, NY. FILED 3-9-2012.

SN 85-566,259. SHANDALOVE, SCOT T, COSTA MESA, CA. AND CHOI, HENRY, LOS ANGELES, CA. FILED 3-11-2012.

GOMI

MODEVI

THE MARK CONSISTS OF STANDARD CHARACTERS WITHOUT CLAIM TO ANY PARTICULAR FONT, STYLE, SIZE, OR COLOR.

THE MARK CONSISTS OF STANDARD CHARACTERS WITHOUT CLAIM TO ANY PARTICULAR FONT, STYLE, SIZE, OR COLOR.

CLASS 18—LEATHER GOODS

FOR TRUNKS; TRAVELING TRUNKS; SUITCASES; TRAVELING BAGS; LUGGAGE; GARMENT BAGS FOR TRAVEL; HAT BOXES FOR TRAVEL NOT OF PAPER OR CARDBOARD; SHOE BAGS FOR TRAVEL; UMBRELLAS; ANIMAL CARRIERS; RUCKSACKS; HAVERSACKS; LEATHER AND TEXTILE SHOPPING BAGS; BEACH BAGS; HANDBAGS; VANITY CASES SOLD EMPTY; ATTACHE CASES; TOTE BAGS; TRAVEL SATCHELS; CLUTCH BAGS; BRIEFCASES; WALLETS; POCKET WALLETS; CREDIT CARD CASES AND HOLDERS; BUSINESS CARD CASES; KEY CASES; CHANGE PURSES; BRIEFCASE-TYPE PORTFOLIOS (U.S. CLS. 1, 2, 3, 22 AND 41).

CLASS 25—CLOTHING

FOR MEN'S, WOMEN'S, AND CHILDREN'S CLOTHING, NAMELY, T-SHIRTS, SWEATSHIRTS, SWEATPANTS, SWIM TRUNKS, WALKING SHORTS, PANTS, BELTS, JACKETS AND HATS (U.S. CLS. 22 AND 39).
CHRISTOPHER BUONGIORNO, EXAMINING ATTORNEY

CLASS 25—CLOTHING

FOR CLOTHING, NAMELY, TOPS, BOTTOMS, BLOUSES, SHIRTS, T-SHIRTS, COLLARED SHIRTS, GOLF SHIRTS, POLO SHIRTS, SPORT SHIRTS; SHORTS, PANTS, VESTS, APRONS, JACKETS, PULLOVERS, HOODED PULLOVERS, SWEATSHIRTS, HOODED SWEATSHIRTS, SWEATERS; ACTIVE WEAR CLOTHING, NAMELY, SHIRTS, T-SHIRTS, SPORT SHIRTS, SWEATSHIRTS, SWEATERS AND JUMPERS; HEADWEAR; HATS; CAPS; BEANIES; WRIST BANDS; HEADBANDS; SOCKS (U.S. CLS. 22 AND 39).

CLASS 42—SCIENTIFIC AND COMPUTER SERVICES

FOR PROVIDING A WEBSITE FEATURING TECHNOLOGY THAT ENABLES USERS TO POST AND SHARE STORIES ABOUT THEMSELVES (U.S. CLS. 100 AND 101).

Laurie Kaufman, Examining Attorney

SN 85-566,546. SIMON PROPERTY GROUP, L.P., INDIANAPOLIS, IN. FILED 3-12-2012.

SN 85-568,599. RUSSELL, SHAROLYN A, TAMPA, FL. FILED 3-13-2012.

SIMON STYLE SETTER

THE MARK CONSISTS OF STANDARD CHARACTERS WITHOUT CLAIM TO ANY PARTICULAR FONT, STYLE, SIZE, OR COLOR.

OWNER OF U.S. REG. NOS. 2,969,024, 3,273,205 AND OTHERS.

NO CLAIM IS MADE TO THE EXCLUSIVE RIGHT TO USE "STYLE", APART FROM THE MARK AS SHOWN.

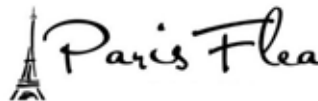
**CLASS 41—EDUCATION AND ENTERTAINMENT**

FOR PROVIDING ON-LINE JOURNALS, NAMELY, BLOGS IN THE FIELD OF FASHION STYLE AND FASHION TRENDS (U.S. CLS. 100, 101 AND 107).

CLASS 45—PERSONAL AND LEGAL SERVICES

FOR PROVIDING INFORMATION, NEWS, REVIEWS, STORIES AND COMMENTARY ABOUT FASHION STYLE AND FASHION TRENDS THROUGH SOCIAL MEDIA PLATFORMS, ELECTRONIC MAIL AND TEXTING (U.S. CLS. 100 AND 101).

Tina Brown, Examining Attorney

NO CLAIM IS MADE TO THE EXCLUSIVE RIGHT TO USE "PARIS FLEA", APART FROM THE MARK AS SHOWN.

THE MARK CONSISTS OF THE WORDS "PARIS FLEA" AND A STYLIZED DESIGN OF THE EIFFEL TOWER.

CLASS 3—COSMETICS AND CLEANING PREPARATIONS

FOR FURNITURE POLISH; FURNITURE POLISHES; LIPSTICK CASES (U.S. CLS. 1, 4, 6, 50, 51 AND 52).

CLASS 6—METAL GOODS

FOR CASINGS OF METAL; DOOR CASINGS OF METAL (U.S. CLS. 2, 12, 13, 14, 23, 25 AND 50).

CLASS 11—ENVIRONMENTAL CONTROL APPARATUS

FOR CHANDELIERS (U.S. CLS. 13, 21, 23, 31 AND 34).

CLASS 18—LEATHER GOODS

FOR LEATHER BOXES FOR STORING GREETING CARDS; LEATHER FOR FURNITURE (U.S. CLS. 1, 2, 3, 22 AND 41).

SN 85-566,855. DANA EDMONDS, JACKSONVILLE, FL. FILED 3-12-2012.

YES I DID

THE MARK CONSISTS OF STANDARD CHARACTERS WITHOUT CLAIM TO ANY PARTICULAR FONT, STYLE, SIZE, OR COLOR.

CLASS 20—FURNITURE AND ARTICLES NOT OTHERWISE CLASSIFIED

FOR BATHROOM FURNITURE; BEAN BAG BEDS; BED FRAMES; BED HEADBOARDS; BED PILLOWS; BED RAILS; BED RESTS; BEDROOM FURNITURE; BEDS; BEDS FOR HOUSEHOLD PETS; BEDS, MATTRESSES, PILLOWS AND BOLSTERS; BUFFETS; BUNK BEDS; CABINET DOORS FOR FURNITURE CABINETS; CABINET DRAWERS FOR FURNITURE CABINETS; CABINETS; CAST STONE HOUSEHOLD AND GARDEN FURNITURE; CERAMIC PULLS FOR CABINETS, DRAWERS AND FURNITURE; CHAIR BEDS; CUSHIONS; CUSTOM FURNITURE; DOORS FOR FURNITURE; ENTERTAINMENT CENTERS; FEATHER BEDS; FITTED FABRIC FURNITURE COVERS; FITTED FABRIC SLIPCOVERS FOR FURNITURE; FITTED FURNITURE COVER NOT OF FABRIC; FOLDING BEDS; FURNITURE; FURNITURE CHESTS; FURNITURE FOR HOUSE, OFFICE AND GARDEN; FURNITURE FRAMES; FURNITURE HARDWARE, NAMELY, DRAWER SLIDES; FURNITURE PARTS; FURNITURE PRIMARILY OF METAL, NAMELY, MIRRORS, BED FRAMES, DINING TABLES, COFFEE TABLES, END TABLES, DESKS, DISPLAY CASES, SHELVING, DOG GATES, AND BABY GATES; LIBRARY FURNITURE; LIVING ROOM FURNITURE; METAL FURNITURE; MIRRORS; SEATING FURNITURE; SOFA BEDS; STONE FURNITURE; TABLES; UPHOLSTERED FURNITURE; WOODEN BEDS (U.S. CLS. 2, 13, 22, 25, 32 AND 50).

CLASS 22—CORDAGE AND FIBERS

FOR FEATHERS FOR BEDDING (U.S. CLS. 1, 2, 7, 19, 22, 42 AND 50).

CLASS 24—FABRICS

FOR BED AND TABLE LINEN; BED AND TABLE LINEN, WALL HANGINGS OF TEXTILE; BED BLANKETS; BED CANOPIES; BED COVERS; BED LINEN; BED LINEN AND TABLE LINEN; BED PADS; BED SHEETS; BED SHEETS OF PAPER; BED SHEETS, FITTED BED SHEET COVERS, BED FLAT SHEETS, AND PILLOW CASES USED IN THE BEDDING, HEALTH CARE, HOME-HEALTH CARE AND NURSING HOME INDUSTRIES MADE OF BIODEGRADABLE FILM CREATED FROM RENEWABLE BIO-POLYMER RESOURCES; BED SKIRTS; BED SPREADS; BED THROWS; FITTED BED SHEETS; FITTED BED SHEETS FOR PETS; FLAT BED SHEETS; FURNISHING AND UPHOLSTERY FABRICS; PAPER BED COVERS; PILLOW-TOP, LOW-PROFILE BED SKIRTS; SILK BED BLANKETS; TABLE AND BED LINEN; UPHOLSTERY FABRICS (U.S. CLS. 42 AND 50).

CLASS 25—CLOTHING

FOR BED JACKETS (U.S. CLS. 22 AND 39).

CLASS 35—ADVERTISING AND BUSINESS

FOR FRANCHISING, NAMELY, OFFERING BUSINESS MANAGEMENT ASSISTANCE IN THE ESTABLISHMENT AND/OR OPERATION OF RETAIL DESIGN STORES; ON-LINE RETAIL GIFT SHOPS; ON-LINE RETAIL STORE SERVICES FEATURING A WIDE VARIETY OF CONSUMER GOODS OF OTHERS; ON-LINE RETAIL STORE SERVICES FEATURING HOME FURNISHINGS AND CUSTOM FURNITURE; RETAIL FURNITURE STORES; RETAIL MARKETS FEATURING HOME FURNISHINGS, INTERIOR DESIGN AND CUSTOM FURNISHINGS; WHOLESALE STORE SERVICES FEATURING LIGHTING, FLOOR COVERINGS, LINENS, BEDDING, UPHOLSTERY, WALL ART, FURNITURE, AND CASE GOODS IN THE NATURE OF FURNITURE (U.S. CLS. 100, 101 AND 102).

CLASS 40—MATERIAL TREATMENT

FOR CUSTOM FABRICATION AND PRODUCTION OF FURNITURE, LIGHTING AND ACCESSORIES; CUSTOM MANUFACTURE OF HOME FURNISHINGS; MANUFACTURE OF GENERAL PRODUCT LINES IN THE FIELD OF INTERIOR DESIGN TO THE ORDER AND SPECIFICATION OF OTHERS (U.S. CLS. 100, 103 AND 106).

CLASS 42—SCIENTIFIC AND COMPUTER SERVICES

FOR DESIGN OF HOME PAGES; DESIGN OF HOME PAGES AND WEB SITES; DESIGN OF HOME PAGES, COMPUTER SOFTWARE AND WEB SITES; FURNITURE DESIGN SERVICES; HOME STAGING CONSULTATION, NAMELY, TEMPORARY INTERIOR AND EXTERIOR HOME DECORATION CONSULTATION FOR THE PURPOSE OF MAKING HOMES MORE APPEALING TO PROSPECTIVE BUYERS; INTERIOR DESIGN SERVICES INCLUDING SPACE PLANNING, FURNITURE SELECTION, MATERIAL AND SURFACE SELECTION; INTERIOR DESIGN SERVICES, NAMELY, HOME FURNISHINGS (U.S. CLS. 100 AND 101).

KHANH LE, EXAMINING ATTORNEY

SN 85-568,824. DANIEL MECCA, TAMPA, FL. FILED 3-14-2012.

got I.F.?

THE MARK CONSISTS OF THE WORDING "GOT I.F.?".

CLASS 14—JEWELRY

FOR RUBBER OR SILICON WRISTBANDS IN THE NATURE OF A BRACELET (U.S. CLS. 2, 27, 28 AND 50).

CLASS 25—CLOTHING

FOR SPORTS CAPS AND HATS; T-SHIRTS (U.S. CLS. 22 AND 39).

LAURA KOVALSKY, EXAMINING ATTORNEY

SN 85-568,860. RECKITT BENCKISER LLC, PARSIPPANY, NJ. FILED 3-14-2012.

**CARIBBEAN LAGOON &
HIBISCUS FLOWER**

THE MARK CONSISTS OF STANDARD CHARACTERS WITHOUT CLAIM TO ANY PARTICULAR FONT, STYLE, SIZE, OR COLOR.

NO CLAIM IS MADE TO THE EXCLUSIVE RIGHT TO USE "HIBISCUS FLOWER", APART FROM THE MARK AS SHOWN.

CLASS 3—COSMETICS AND CLEANING PREPARATIONS

FOR PERFUMING PREPARATIONS FOR THE ATMOSPHERE, NAMELY, ROOM FRAGRANCES, ROOM PERFUME SPRAYS; POTPOURRI; ESSENTIAL OILS; AROMATIC ESSENTIAL OILS; ESSENTIAL OILS FOR HOUSEHOLD USE; ESSENTIAL OILS FOR USE IN THE MANUFACTURE OF SCENTED PRODUCTS; ESSENTIAL OILS FOR USE AS A COMPONENT OF ROOM PERFUME SPRAYS, SCENTED OILS AND AIR FRESHENERS; ESSENTIAL OILS USED TO PRODUCE AROMAS WHEN HEATED; ROOM PERFUME SPRAYS (U.S. CLS. 1, 4, 6, 50, 51 AND 52).

CLASS 5—PHARMACEUTICALS

FOR AIR PURIFYING PREPARATIONS; AIR DEODORIZING PREPARATIONS; HOUSEHOLD AND ROOM DEODORANTS; PREPARATIONS FOR NEUTRALIZING ODORS IN CARPETS, TEXTILES AND IN THE AIR (U.S. CLS. 6, 18, 44, 46, 51 AND 52).

CLASS 11—ENVIRONMENTAL CONTROL APPARATUS

FOR APPARATUS AND INSTRUMENTS, NAMELY, DISPENSING UNITS AND DIFFUSERS FOR ROOM FRAGRANCES, AIR FRESHENERS AND ROOM DEODORANTS, ALL FOR SCENTING, PURIFYING OR FRESHENING THE ATMOSPHERE; PARTS AND FITTINGS FOR ALL THE AFORESAID GOODS SOLD AS A UNIT THEREWITH (U.S. CLS. 13, 21, 23, 31 AND 34).
AMEEN IMAM, EXAMINING ATTORNEY

SN 85-568,879. NATHAN DUBROWSKI, TAMPA, FL. FILED 3-14-2012.

PROUD TO SUPPORT

THE MARK CONSISTS OF STANDARD CHARACTERS WITHOUT CLAIM TO ANY PARTICULAR FONT, STYLE, SIZE, OR COLOR.

CLASS 16—PAPER GOODS AND PRINTED MATTER

FOR BUMPER STICKERS; DECALS (U.S. CLS. 2, 5, 22, 23, 29, 37, 38 AND 50).

CLASS 21—HOUSEWARES AND GLASS

FOR MUGS (U.S. CLS. 2, 13, 23, 29, 30, 33, 40 AND 50).

CLASS 25—CLOTHING

FOR CLOTHING, NAMELY, T-SHIRTS (U.S. CLS. 22 AND 39).
BRENDAN MCCAULEY, EXAMINING ATTORNEY

SN 85-569,762. MARSHALL REINARDY, LLC, DBA CENTERX, MADISON, WI. FILED 3-14-2012.

CenterX

THE MARK CONSISTS OF STANDARD CHARACTERS WITHOUT CLAIM TO ANY PARTICULAR FONT, STYLE, SIZE, OR COLOR.

CLASS 9—ELECTRICAL AND SCIENTIFIC APPARATUS

FOR COMPUTER SOFTWARE FOR ACCESSING A GLOBAL COMPUTER NETWORK, NAMELY, COMMUNICATION SOFTWARE FOR PROVIDING ACCESS TO THE INTERNET, COMPUTER SOFTWARE FOR ACCESSING INFORMATION DIRECTORIES THAT MAY BE DOWNLOADED FROM THE GLOBAL COMPUTER NETWORK, COMPUTER SOFTWARE FOR CONTROLLING AND MANAGING ACCESS SERVER APPLICATIONS, AND COMPUTER SOFTWARE THAT PROVIDES WEB-BASED ACCESS TO APPLICATIONS AND SERVICES THROUGH A WEB OPERATING SYSTEM OR PORTAL INTERFACE; COMPUTER SOFTWARE USED FOR DOCUMENT MANAGEMENT AND ENTERING, STORING, SHARING, RETRIEVING, ANALYZING, INTEGRATING AND COMMUNICATING DATA AND INFORMATION, AND ACCOMPANYING INSTRUCTIONAL MANUALS SOLD AS A UNIT (U.S. CLS. 21, 23, 26, 36 AND 38).

FIRST USE 12-15-2009; IN COMMERCE 5-4-2010.

CLASS 38—COMMUNICATION

FOR COMMUNICATION SERVICES, NAMELY, ELECTRONIC TRANSMISSION OF DATA AND DOCUMENTS AMONG USERS OF COMPUTERS (U.S. CLS. 100, 101 AND 104).

FIRST USE 12-15-2009; IN COMMERCE 5-4-2010.

CLASS 42—SCIENTIFIC AND COMPUTER SERVICES

FOR COMPUTER SERVICES, NAMELY, CLOUD HOSTING PROVIDER SERVICES (U.S. CLS. 100 AND 101).

FIRST USE 12-15-2009; IN COMMERCE 5-4-2010.
JAY BESCH, EXAMINING ATTORNEY

SN 85-570,214. TW TRAINING NYC, LLC, NEW YORK, NY. FILED 3-15-2012.

A-List Body BootCamp

THE MARK CONSISTS OF STANDARD CHARACTERS WITHOUT CLAIM TO ANY PARTICULAR FONT, STYLE, SIZE, OR COLOR.

NO CLAIM IS MADE TO THE EXCLUSIVE RIGHT TO USE "BODY BOOTCAMP", APART FROM THE MARK AS SHOWN.

CLASS 9—ELECTRICAL AND SCIENTIFIC APPARATUS

FOR DOWNLOADABLE VIDEO RECORDINGS FEATURING EXERCISE ROUTINES WITH INSTRUCTION; DOWNLOADABLE VIDEO EXERCISE ROUTINES WITH INSTRUCTION VIA THE INTERNET AND WIRELESS DEVICES (U.S. CLS. 21, 23, 26, 36 AND 38).

CLASS 41—EDUCATION AND ENTERTAINMENT

FOR PHYSICAL FITNESS TRAINING OF INDIVIDUALS AND GROUPS; PHYSICAL FITNESS TRAINING SERVICES (U.S. CLS. 100, 101 AND 107).

FIRST USE 3-1-2012; IN COMMERCE 3-1-2012.
FLORENTINA BLANDU, EXAMINING ATTORNEY

SN 85-570,481. ROBIG, MIGUEL ARPA, CARACAS, VENEZUELA, FILED 3-15-2012.

YAMMING

THE MARK CONSISTS OF STANDARD CHARACTERS WITHOUT CLAIM TO ANY PARTICULAR FONT, STYLE, SIZE, OR COLOR.

THE WORDING "YAMMING" HAS NO MEANING IN A FOREIGN LANGUAGE.

CLASS 9—ELECTRICAL AND SCIENTIFIC APPARATUS

FOR COMPUTER APPLICATION SOFTWARE FOR MOBILE PHONES FOR ENTERTAINMENT, BUSINESS, AND PRODUCTIVITY, NAMELY, SOFTWARE THAT ALLOWS FOR THE CONSOLIDATION OF CONTACTS FROM SOCIAL NETWORKS, E-MAILS, INSTANT MESSAGING, SMS/TEXTS, AND PHONE CONTACT, WITH THE ABILITY OF THE USER TO COMMUNICATE WITH SUCH CONTACTS THROUGH A SINGLE APPLICATION (U.S. CLS. 21, 23, 26, 36 AND 38).

CLASS 42—SCIENTIFIC AND COMPUTER SERVICES

FOR COMPUTER SOFTWARE DESIGN; COMPUTER SOFTWARE DEVELOPMENT AND COMPUTER PROGRAMMING DEVELOPMENT FOR OTHERS; WEBSITE DESIGN AND DEVELOPMENT FOR OTHERS (U.S. CLS. 100 AND 101).

MARTHA FROMM, EXAMINING ATTORNEY

SN 85-572,127. MOSHAY, INC., VERNON, CA. FILED 3-16-2012.

A4 SPORT

THE MARK CONSISTS OF STANDARD CHARACTERS WITHOUT CLAIM TO ANY PARTICULAR FONT, STYLE, SIZE, OR COLOR.

OWNER OF U.S. REG. NOS. 3,189,978 AND 3,931,285.
NO CLAIM IS MADE TO THE EXCLUSIVE RIGHT TO USE "SPORT", APART FROM THE MARK AS SHOWN.

CLASS 18—LEATHER GOODS

FOR DUFFEL BAGS, ATHLETIC BAGS, BACKPACKS, KNAPSACKS, SHOULDER BAGS, OVERNIGHT BAGS, CARRY-ON BAGS AND LUGGAGE (U.S. CLS. 1, 2, 3, 22 AND 41).

CLASS 25—CLOTHING

FOR CLOTHING, NAMELY, SHORTS, TANK TOPS, SHIRTS, PANTS, SWEAT TOPS, JERSEYS, T-SHIRTS, SPORTS BRAS, SWEAT SHIRTS, SWEAT PANTS, SWEAT SUITS, FLEECE PULLOVERS, FLEECE PANTS, JEANS, OVERALLS, JUMPSUITS, SKIRTS, DRESSES, BLOUSES, SWEATERS, VESTS, SWIMWEAR, BATHING SUITS, COVER-UPS, SLEEPWEAR, PAJAMAS, ROBES, NIGHTGOWNS, LEOTARDS, LINGERIE, PANTIES, BRAS, BOXER SHORTS, UNDERWEAR, SCARVES, BELTS, SOCKS, STOCKINGS, TIGHTS, LEGGINGS, GLOVES; OUTERWEAR, NAMELY, JACKETS, WIND-RESISTANT JACKETS, WATER-RESISTANT JACKETS, COATS AND RAINCOATS; HEADGEAR, NAMELY, HATS, CAPS, HEADBANDS, VISORS AND BANDANAS; FOOTWEAR, NAMELY, SHOES, SLIPPERS, BOOTS, SANDALS, FLIP-FLOPS, AND ATHLETIC SHOES (U.S. CLS. 22 AND 39).
NICHOLAS COLEMAN, EXAMINING ATTORNEY

SN 85-573,010. CHILDREN'S MEMORIAL HOSPITAL, CHICAGO, IL. FILED 3-19-2012.

CHILDREN'S EXPRESSIONS

THE MARK CONSISTS OF STANDARD CHARACTERS WITHOUT CLAIM TO ANY PARTICULAR FONT, STYLE, SIZE, OR COLOR.

NO CLAIM IS MADE TO THE EXCLUSIVE RIGHT TO USE "CHILDREN'S", APART FROM THE MARK AS SHOWN.

CLASS 16—PAPER GOODS AND PRINTED MATTER

FOR PAPER AND PAPER ARTICLES, NAMELY, GREETING CARDS, POST CARDS, NOTE CARDS, STATIONERY, WRITING PADS, ENVELOPES, COLORING BOOKS; STICKERS, BOOKMARKS, POSTERS AND CALENDARS (U.S. CLS. 2, 5, 22, 23, 29, 37, 38 AND 50).

FIRST USE 11-30-2004; IN COMMERCE 11-30-2004.

CLASS 41—EDUCATION AND ENTERTAINMENT

FOR EDUCATIONAL AND ENTERTAINMENT SERVICES, NAMELY, PROVIDING ARTS AND CRAFTS INSTRUCTION FOR CHILDREN (U.S. CLS. 100, 101 AND 107).

FIRST USE 11-30-2004; IN COMMERCE 11-30-2004.
JAMES LOVELACE, EXAMINING ATTORNEY

SN 85-573,477. GUTHY-RENKER LLC, PALM DESERT, CA. FILED 3-19-2012.

PROACTIV MD

THE MARK CONSISTS OF STANDARD CHARACTERS WITHOUT CLAIM TO ANY PARTICULAR FONT, STYLE, SIZE, OR COLOR.

OWNER OF U.S. REG. NOS. 1,890,769, 2,574,142 AND OTHERS.

NO CLAIM IS MADE TO THE EXCLUSIVE RIGHT TO USE "MD", APART FROM THE MARK AS SHOWN.

CLASS 3—COSMETICS AND CLEANING PREPARATIONS

FOR SKIN AND BODY CARE PREPARATIONS, NAMELY, SKIN CLEANSERS, SKIN MOISTURIZERS, SKIN LOTIONS, SKIN SOAPS, SUN SCREEN PREPARATIONS, COSMETICS, NON-MEDICATED HAIR CARE PREPARATIONS, NAIL CARE PREPARATIONS, NON-MEDICATED SKIN CARE PREPARATIONS, COLONGES, PERFUMES AND TOOTH WHITENING PREPARATIONS (U.S. CLS. 1, 4, 6, 50, 51 AND 52).

CLASS 5—PHARMACEUTICALS

FOR ACNE TREATMENT PREPARATIONS, VITAMINS AND DIETARY SUPPLEMENTS FOR THE TREATMENT OR REDUCTION OF ACNE OR BLEMISHES (U.S. CLS. 6, 18, 44, 46, 51 AND 52).

CLASS 10—MEDICAL APPARATUS

FOR ELECTRONIC MEDICAL DEVICES FOR THE TREATMENT OF ACNE (U.S. CLS. 26, 39 AND 44). JOHN DWYER, EXAMINING ATTORNEY

CLASS 35—ADVERTISING AND BUSINESS

FOR RETAIL STORE SERVICES FEATURING BEVERAGE SYSTEMS AND BEVERAGE SYSTEM COMPONENTS, NAMELY, GAS EQUIPMENT, BEVERAGE COOLING EQUIPMENT, BEVERAGE DELIVERY EQUIPMENT, BEVERAGE SYSTEM MONITORING EQUIPMENT, AND GLASS WASHING EQUIPMENT; ONLINE RETAIL STORE SERVICES FEATURING BEVERAGE SYSTEMS AND BEVERAGE SYSTEM COMPONENTS, NAMELY, GAS EQUIPMENT, BEVERAGE COOLING EQUIPMENT, BEVERAGE DELIVERY EQUIPMENT, BEVERAGE SYSTEM MONITORING EQUIPMENT, AND GLASS WASHING EQUIPMENT; BUSINESS CONSULTING SERVICES IN THE FIELD OF BEVERAGE SYSTEMS USED IN RETAIL VENUES; BUSINESS CONSULTING SERVICES, NAMELY, CONSULTING SERVICES RELATING TO THE PURCHASE OF BEVERAGE SYSTEMS USED IN RETAIL VENUES (U.S. CLS. 100, 101 AND 102).

CLASS 37—CONSTRUCTION AND REPAIR

FOR REFRIGERATION SYSTEM MAINTENANCE AND REPAIR SERVICES; GAS SYSTEM MAINTENANCE AND REPAIR SERVICES; ICE MACHINE MAINTENANCE AND REPAIR SERVICES; BEVERAGE SYSTEM MAINTENANCE AND REPAIR SERVICES; BEVERAGE SYSTEM LINE CLEANING SERVICES; GLASS WASHING EQUIPMENT MAINTENANCE AND REPAIR SERVICES; INSTALLATION OF BEVERAGE SYSTEMS AND BEVERAGE SYSTEM COMPONENTS, NAMELY, GAS EQUIPMENT, BEVERAGE COOLING EQUIPMENT, BEVERAGE DELIVERY EQUIPMENT, BEVERAGE SYSTEM MONITORING EQUIPMENT, AND GLASS WASHING EQUIPMENT; RENTAL OF GLASS WASHING EQUIPMENT (U.S. CLS. 100, 103 AND 106).

CLASS 39—TRANSPORTATION AND STORAGE

FOR RENTAL OF REFRIGERATORS FOR COMMERCIAL USE, NAMELY, BEVERAGE COOLING EQUIPMENT; GAS SUPPLY AND DISTRIBUTION SERVICES; DELIVERY OF GAS BY TRUCK (U.S. CLS. 100 AND 105).

CLASS 43—HOTEL AND RESTAURANT SERVICES

FOR RENTAL OF DRINK DISPENSING MACHINES, NAMELY, BEVERAGE SYSTEMS AND BEVERAGE SYSTEM COMPONENTS (U.S. CLS. 100 AND 101). JOHN SCHUYLER YARD, EXAMINING ATTORNEY

SN 85-573,841. GREEN AIR SUPPLY, INC., TACOMA, WA. FILED 3-19-2012.

DRAUGHTWORKS

THE MARK CONSISTS OF STANDARD CHARACTERS WITHOUT CLAIM TO ANY PARTICULAR FONT, STYLE, SIZE, OR COLOR.

SN 85-573,850. GREEN AIR SUPPLY, INC., TACOMA, WA. FILED 3-19-2012.

FROM GAS TO GLASS

THE MARK CONSISTS OF STANDARD CHARACTERS WITHOUT CLAIM TO ANY PARTICULAR FONT, STYLE, SIZE, OR COLOR.

CLASS 35—ADVERTISING AND BUSINESS

FOR RETAIL STORE SERVICES FEATURING BEVERAGE SYSTEMS AND BEVERAGE SYSTEM COMPONENTS, NAMELY, GAS EQUIPMENT, BEVERAGE COOLING EQUIPMENT, BEVERAGE DELIVERY EQUIPMENT, BEVERAGE SYSTEM MONITORING EQUIPMENT, AND GLASS WASHING EQUIPMENT; ONLINE RETAIL STORE SERVICES FEATURING BEVERAGE SYSTEMS AND BEVERAGE SYSTEM COMPONENTS, NAMELY, GAS EQUIPMENT, BEVERAGE COOLING EQUIPMENT, BEVERAGE DELIVERY EQUIPMENT, BEVERAGE SYSTEM MONITORING EQUIPMENT, AND GLASS WASHING EQUIPMENT; BUSINESS CONSULTING SERVICES IN THE FIELD OF BEVERAGE SYSTEMS USED IN RETAIL VENUES; BUSINESS CONSULTING SERVICES, NAMELY, CONSULTING SERVICES RELATING TO THE PURCHASE OF BEVERAGE SYSTEMS USED IN RETAIL VENUES (U.S. CLS. 100, 101 AND 102).

CLASS 37—CONSTRUCTION AND REPAIR

FOR REFRIGERATION SYSTEM MAINTENANCE AND REPAIR SERVICES; GAS SYSTEM MAINTENANCE AND REPAIR SERVICES; ICE MACHINE MAINTENANCE AND REPAIR SERVICES; BEVERAGE SYSTEM MAINTENANCE AND REPAIR SERVICES; BEVERAGE SYSTEM LINE CLEANING SERVICES; GLASS WASHING EQUIPMENT MAINTENANCE AND REPAIR SERVICES; INSTALLATION OF BEVERAGE SYSTEMS AND BEVERAGE SYSTEM COMPONENTS, NAMELY, GAS EQUIPMENT, BEVERAGE COOLING EQUIPMENT, BEVERAGE DELIVERY EQUIPMENT, BEVERAGE SYSTEM MONITORING EQUIPMENT, AND GLASS WASHING EQUIPMENT; RENTAL OF GLASS WASHING EQUIPMENT (U.S. CLS. 100, 103 AND 106).

CLASS 39—TRANSPORTATION AND STORAGE

FOR RENTAL OF REFRIGERATORS FOR COMMERCIAL USE, NAMELY, BEVERAGE COOLING EQUIPMENT; GAS SUPPLY AND DISTRIBUTION SERVICES; DELIVERY OF GAS BY TRUCK (U.S. CLS. 100 AND 105).

CLASS 43—HOTEL AND RESTAURANT SERVICES

FOR RENTAL OF DRINK DISPENSING MACHINES, NAMELY, BEVERAGE SYSTEMS AND BEVERAGE SYSTEM COMPONENTS (U.S. CLS. 100 AND 101).
JOHN SCHUYLER YARD, EXAMINING ATTORNEY

SN 85-573,938. FLOWER GROUP OPERATING LP, JORDAN STATION, CANADA, FILED 3-19-2012.



NO CLAIM IS MADE TO THE EXCLUSIVE RIGHT TO USE "FLORAL GROUP", APART FROM THE MARK AS SHOWN.

THE MARK CONSISTS OF THE WORDS, "ONE FLORAL GROUP", WITH FLOWER PETALS AROUND THE "O" OF THE WORD "ONE".

CLASS 31—NATURAL AGRICULTURAL PRODUCTS

FOR CUT FLOWERS; LIVE PLANTS; AND NURSERY STOCK (U.S. CLS. 1 AND 46).

CLASS 35—ADVERTISING AND BUSINESS

FOR WHOLESALE DISTRIBUTORSHIP SERVICES IN THE FIELD OF HORTICULTURAL PRODUCTS, CUT FLOWERS, AND NURSERY STOCK; AND RETAIL STORE SERVICES IN THE FIELD OF HORTICULTURAL PRODUCTS (U.S. CLS. 100, 101 AND 102).
BARBARA A. GOLD, EXAMINING ATTORNEY

SN 85-574,322. KESWICK PINES, INC., WHITING, NJ. FILED 3-20-2012.



NO CLAIM IS MADE TO THE EXCLUSIVE RIGHT TO USE "FITNESS RECREATION EDUCATION SPIRITUALITY HEALTH", APART FROM THE MARK AS SHOWN.

THE COLOR(S) ORANGE AND BLUE IS/ARE CLAIMED AS A FEATURE OF THE MARK.

THE MARK CONSISTS OF A STYLIZED OPEN UMBRELLA CANOPY COLORED ORANGE BELOW WHICH APPEARS THE WORD "FRESH" WITH THE LETTERS ARRANGED HORIZONTALLY, EACH LETTER COLORED BLUE AND IN A DIFFERENT FONT OR SCRIPT, BENEATH WHICH APPEAR, HORIZONTALLY FROM LEFT TO RIGHT THE WORDS "FITNESS", "RECREATION", "EDUCATION", "SPIRITUALITY", AND "HEALTH" IN LOWER CASE LETTERS ALL COLORED ORANGE, EACH WORD SEPARATED FROM THE ADJACENT WORD OR WORDS BY A SHORT, VERTICAL ORANGE LINE SEGMENT, BENEATH WHICH APPEARS A STYLIZED UMBRELLA HANDLE CROOK, CURVED TO THE LEFT, COLORED ORANGE.

CLASS 43—HOTEL AND RESTAURANT SERVICES

FOR PROVIDING A RETIREMENT COMMUNITY FOR SENIOR ADULTS IN THE NATURE OF A RETIREMENT HOME; PROVIDING RETIREMENT, INDEPENDENT LIVING AND ASSISTED LIVING FACILITIES (U.S. CLS. 100 AND 101).

FIRST USE 2-29-2008; IN COMMERCE 2-29-2008.

CLASS 44—MEDICAL, BEAUTY AND AGRICULTURAL SERVICES

FOR PROVIDING A CONTINUING CARE RETIREMENT COMMUNITY THAT OFFERS SKILLED NURSING CARE, SPECIALIZED MEMORY AND ALZHEIMER'S CARE, SHORT TERM PHYSICAL REHABILITATION SERVICES AND LONG-TERM CARE FOR SENIOR ADULTS IN THE NATURE OF A NURSING HOME (U.S. CLS. 100 AND 101).

FIRST USE 2-29-2008; IN COMMERCE 2-29-2008.
HENRY S. ZAK, EXAMINING ATTORNEY

SN 85-574,487. SCHOTTEL GMBH, SPAY/RHEIN, FED REP GERMANY, FILED 3-20-2012.

S-COM

THE MARK CONSISTS OF STANDARD CHARACTERS WITHOUT CLAIM TO ANY PARTICULAR FONT, STYLE, SIZE, OR COLOR.

CLASS 9—ELECTRICAL AND SCIENTIFIC APPARATUS

FOR WATER VEHICLE CONDITION, OPERATION AND PERFORMANCE MONITORING AND CONTROL SYSTEMS COMPRISING COMPUTER SOFTWARE, COMPUTER HARDWARE, SENSORS, TRANSMITTERS, AND RECEIVERS ALL FOR USE IN CONNECTION WITH SHIP STEERING AND PROPULSION SYSTEMS; COMPUTER HARDWARE AND SOFTWARE FOR USE WITH WATER VEHICLE STEERING AND PROPULSION MONITORING AND CONTROL EQUIPMENT, FOR RECEIVING, STORING, PROCESSING, TRANSMITTING AND DISPLAYING DATA; COMPUTER HARDWARE AND SOFTWARE FOR ONBOARD OR REMOTELY MONITORING AND CONTROLLING THE CONDITION, OPERATION AND PERFORMANCE OF WATER VEHICLE STEERING AND PROPULSION SYSTEMS; FAULT RECORDERS AND MEMORY DEVICES FOR RECORDING AND STORING DATA RESULTING FROM MONITORING AND CONTROLLING THE CONDITION, OPERATION AND PERFORMANCE OF WATER VEHICLE STEERING AND PROPULSION SYSTEMS; ELECTRIC AND ELECTRONIC SENSORS FOR MEASURING DATA FOR MONITORING AND CONTROLLING THE CONDITION, OPERATION AND PERFORMANCE OF WATER VEHICLE STEERING AND PROPULSION SYSTEMS; ELECTRIC DATA RELAYS FOR SENSORS; VIBRATION SENSORS; ELECTRIC SENSORS; GAS SENSORS FOR MEASURING GAS CONCENTRATION; INDUSTRIAL CALIBRATION SENSORS; LIQUID LEVEL SENSORS; OPTICAL SENSORS; PHOTOELECTRIC SENSORS; PRESSURE SENSORS; PROXIMITY SENSORS; SENSORS FOR THE DETERMINATION OF TEMPERATURES, POSITIONS, DISTANCES, VELOCITY AND ACCELERATION; TIMING SENSORS; ULTRASONIC SENSORS; ALL AFOREMENTIONED SENSORS ESPECIALLY FOR INSTALLATION IN WATER VEHICLE STEERING AND PROPULSION SYSTEMS OR FOR MEASURING DATA FOR MONITORING AND CONTROLLING THE CONDITION, OPERATION AND PERFORMANCE OF WATER VEHICLE STEERING AND PROPULSION SYSTEMS; VEHICLE SAFETY EQUIPMENT, NAMELY, BACK-UP SENSORS AND CAMERAS; ENVIRONMENTAL MONITORING SYSTEM COMPRISING METERS AND SENSORS THAT MEASURE PRESSURE, HUMIDITY AND TEMPERATURE, AND INCLUDING ALARM AND REPORTING FUNCTIONS; NAUTICS SENSOR SYSTEMS, NAMELY, NAVIGATION SYSTEMS; NAVIGATION APPARATUS FOR WATER VEHICLES IN THE NATURE OF ON-BOARD COMPUTERS; NAUTICAL APPARATUS AND INSTRUMENTS, NAMELY, GLOBAL POSITIONING SYSTEMS, ELECTRONIC NAVIGATIONAL AND POSITIONING APPARATUS, RADAR APPARATUS, SONAR EQUIPMENT AND PARTS THEREOF, COORDINATE MEASURING MACHINES, ECHO SOUNDING DEVICES, DIRECTIONAL COMPASSES, DISTANCE MEASURING APPARATUS, ELECTRONIC TRANSMITTERS AND RECEIVERS FOR NAVIGATION AND POSITIONING, SOUND TRANSMITTING APPARATUS, OPTICAL TRANSMITTERS, OPTICAL RECEIVERS, MARINE COMPASSES, TELESCOPES, PERISCOPES, OCTANTS, SEXTANTS, ELECTRONIC MONITORS AND MONITOR MODULES FOR MONITORING ELECTRIC CURRENT AND ELECTRICAL SIGNALS (U.S. CLS. 21, 23, 26, 36 AND 38).

CLASS 37—CONSTRUCTION AND REPAIR

FOR INSTALLATION, MAINTENANCE AND REPAIR OF SYSTEMS AND APPARATUS FOR MONITORING AND CONTROLLING THE CONDITION, OPERATION AND PERFORMANCE OF WATER VEHICLE STEERING AND PROPULSION SYSTEMS (U.S. CLS. 100, 103 AND 106).

CLASS 42—SCIENTIFIC AND COMPUTER SERVICES

FOR DESIGN AND DEVELOPMENT OF SYSTEMS, SOFTWARE AND HARDWARE FOR MONITORING AND CONTROLLING THE CONDITION, OPERATION AND PERFORMANCE OF WATER VEHICLE STEERING AND PROPULSION SYSTEMS (U.S. CLS. 100 AND 101).
KIMBERLY FRYE, EXAMINING ATTORNEY

SN 85-574,798. CONSUMER CAPITAL PARTNERS LLC, DENVER, CO. FILED 3-20-2012.

EAT FOR GOOD

THE MARK CONSISTS OF STANDARD CHARACTERS WITHOUT CLAIM TO ANY PARTICULAR FONT, STYLE, SIZE, OR COLOR.

CLASS 36—INSURANCE AND FINANCIAL

FOR CHARITABLE FUNDRAISING SERVICES (U.S. CLS. 100, 101 AND 102).

CLASS 43—HOTEL AND RESTAURANT SERVICES

FOR CARRY-OUT RESTAURANTS; CATERING; RESTAURANT AND BAR SERVICES; SELF SERVICE RESTAURANTS (U.S. CLS. 100 AND 101).
LEIGH LOWRY, EXAMINING ATTORNEY

SN 85-574,843. BLUE BEE CIDER, LLC, RICHMOND, VA. FILED 3-20-2012.

BLUE BEE CIDER

THE MARK CONSISTS OF STANDARD CHARACTERS WITHOUT CLAIM TO ANY PARTICULAR FONT, STYLE, SIZE, OR COLOR.

NO CLAIM IS MADE TO THE EXCLUSIVE RIGHT TO USE "CIDER", APART FROM THE MARK AS SHOWN.

CLASS 32—LIGHT BEVERAGES

FOR APPLE JUICE BEVERAGES (U.S. CLS. 45, 46 AND 48).

CLASS 33—WINES AND SPIRITS

FOR HARD CIDER; HARD CIDER FORTIFIED WITH APPLE BRANDY (U.S. CLS. 47 AND 49).

ZACHARY CROMER, EXAMINING ATTORNEY

SN 85-575,082. FREEPOINT COMMODITIES LLC, STAMFORD, CT. FILED 3-20-2012.



OWNER OF U.S. REG. NO. 2,934,711.

NO CLAIM IS MADE TO THE EXCLUSIVE RIGHT TO USE "COMMODITIES", APART FROM THE MARK AS SHOWN.

THE MARK CONSISTS OF THE WORDS "FREEPOINT COMMODITIES" IN LOWER CASE LETTERS WITH THE WORD "COMMODITIES" BENEATH THE WORD "FREEPOINT", AND TO THE LEFT OF THESE WORDS, A DEPICTION OF A CIRCLE SHOWING WAVY LINES IN A LATTICE PATTERN.

CLASS 36—INSURANCE AND FINANCIAL

FOR FINANCIAL SERVICES, NAMELY, WHOLESALE TRADING OF PHYSICAL COMMODITIES; FINANCIAL RISK MANAGEMENT; FINANCIAL ASSET MANAGEMENT (U.S. CLS. 100, 101 AND 102).

FIRST USE 6-1-2011; IN COMMERCE 6-1-2011.

CLASS 39—TRANSPORTATION AND STORAGE

FOR STORAGE OF GOODS; CONSULTATION SERVICES RELATED TO DISTRIBUTION, TRANSMISSION AND STORAGE OF ENERGY RELATED PRODUCTS; ENERGY SUPPLY SERVICES FOR OTHERS FEATURING THE STORAGE OF ENERGY; TRANSMITTING, TRANSPORTING, STORING, AND DISTRIBUTING OF COMMODITIES; CONSULTATION SERVICES RELATED TO DISTRIBUTION, TRANSMISSION AND STORAGE OF COMMODITIES; UTILITY SERVICES, NAMELY, ELECTRICITY POWER GRID LOAD SHIFTING (U.S. CLS. 100 AND 105).

FIRST USE 6-1-2011; IN COMMERCE 6-1-2011.
INGA ERVIN, EXAMINING ATTORNEY

SN 85-575,128. SABER BUSINESS SOLUTIONS INC., DBA SABER BUSINESS SOLUTIONS INC., CHARLOTTE, NC. FILED 3-20-2012.

ezCloudAudit

THE MARK CONSISTS OF STANDARD CHARACTERS WITHOUT CLAIM TO ANY PARTICULAR FONT, STYLE, SIZE, OR COLOR.

CLASS 35—ADVERTISING AND BUSINESS

FOR ONLINE MEDIA MONITORING SERVICES USING COMPUTER SOFTWARE TO AUTOMATICALLY MONITOR INTERNET WEBSITES AND ONLINE PUBLICATIONS FOR CUSTOMER-SPECIFIED TOPICS, AND TO CAPTURE RELEVANT CONTENT ON THOSE TOPICS, PROVIDING DOCUMENTATION AND ANALYSIS OF THAT ONLINE CONTENT TO OTHERS FOR BUSINESS PURPOSES (U.S. CLS. 100, 101 AND 102).

FIRST USE 8-30-2011; IN COMMERCE 8-30-2011.

CLASS 42—SCIENTIFIC AND COMPUTER SERVICES

FOR SOFTWARE AS A SERVICE (SAAS) SERVICES FEATURING SOFTWARE FOR ALLOWING THE AUDIT OF COMPLETE VIEW OR ACCESS HISTORY OF A USER IN ANOTHER SOFTWARE APPLICATION ENVIRONMENT FOR DATABASE MANAGEMENT AND DATA TRACKING; SOFTWARE AS A SERVICE (SAAS) SERVICES, NAMELY, HOSTING SOFTWARE FOR USE BY OTHERS FOR USE INSIDE ANOTHER SOFTWARE APPLICATION ENVIRONMENT FOR ALLOWING THE AUDIT OF COMPLETE VIEW OR ACCESS HISTORY OF A USER FOR DATABASE MANAGEMENT AND DATA TRACKING (U.S. CLS. 100 AND 101).

FIRST USE 8-30-2011; IN COMMERCE 8-30-2011.

BENJAMIN OKEKE, EXAMINING ATTORNEY

SN 85-575,661. ELMER'S PRODUCTS, INC., WESTERVILLE, OH. FILED 3-21-2012.

X-ACTO
PRECISION INSTRUMENTS

OWNER OF U.S. REG. NOS. 1,361,485, 4,017,206 AND OTHERS.

NO CLAIM IS MADE TO THE EXCLUSIVE RIGHT TO USE "PRECISION INSTRUMENTS", APART FROM THE MARK AS SHOWN.

THE MARK CONSISTS OF THE WORD "X-ACTO" IN STYLIZED LETTERS. THE WORDS "PRECISION INSTRUMENTS" IN STYLIZED LETTERS APPEARS BELOW "X-ACTO".

CLASS 8—HAND TOOLS

FOR HAND TOOLS FOR HOBBIES, ARTS AND CRAFTS, NAMELY, COMPASS CUTTERS, BRAYERS, BURNISHERS, BLADE SAFETY CAPS, TWIST DRILLS AND CHUCKS AND BITS THEREFORE, C-CLAMPS, CHISELS, FILES AND FILE HANDLES SOLD AS A UNIT, GOUGES, HAMMERS, KNIVES, KNIFE BLADES, MAT CUTTERS, PLANES, PLIERS, RASPS, SANDING BLOCKS, SAWS, SCREWDRIVERS, SPOKE SHAVES, MAT BEVELING BLADES AND GUIDE TOOLS THEREFORE, MINIATURE OILERS WITH NEEDLEPOINT APPLICATORS, CORNER CLAMPS, METAL VISE GRIPS, TWEEZERS, SAWS AND HAND SAW BLADES, MITRE BOX AND DRILL BITS FOR HAND DRILLS; SCISSORS (U.S. CLS. 23, 28 AND 44).

FIRST USE 7-31-2004; IN COMMERCE 7-31-2004.

CLASS 16—PAPER GOODS AND PRINTED MATTER

FOR BATTERY POWERED PENCIL SHARPENERS, MANUALLY OPERATED PENCIL SHARPENERS, ELECTRIC PENCIL SHARPENERS, PAPER TRIMMERS, ELECTRIC STAPLERS, MANUAL STAPLERS, BULL-DOG CLIPS, PAPER HOLE PUNCHES, CUTTING MATS (U.S. CLS. 2, 5, 22, 23, 29, 37, 38 AND 50).

FIRST USE 7-31-2004; IN COMMERCE 7-31-2004.

ANTHONY RINKER, EXAMINING ATTORNEY

SN 85-575,950. VANS, INC., CYPRESS, CA. FILED 3-21-2012.

SN 85-575,698. CENTRAL SPRAYBOOTH INC., DBA CENTERLINE SPRAYBOOTH, AMITYVILLE, NY. FILED 3-21-2012.

WIND WIZARD



THE MARK CONSISTS OF STANDARD CHARACTERS WITHOUT CLAIM TO ANY PARTICULAR FONT, STYLE, SIZE, OR COLOR.

NO CLAIM IS MADE TO THE EXCLUSIVE RIGHT TO USE "WIND", APART FROM THE MARK AS SHOWN.

CLASS 7—MACHINERY

FOR POWER-OPERATED BLOWERS FOR DRYING PAINT (U.S. CLS. 13, 19, 21, 23, 31, 34 AND 35).

CLASS 11—ENVIRONMENTAL CONTROL APPARATUS

FOR INDUSTRIAL APPARATUS FOR DRYING AUTOMOBILE PAINT (U.S. CLS. 13, 21, 23, 31 AND 34).
CORY BOONE, EXAMINING ATTORNEY

OWNER OF U.S. REG. NOS. 1,353,939, 3,824,639 AND OTHERS.

THE MARK CONSISTS OF THE STYLIZED WORDING "LVNI" APPEARING OVER A HORIZONTAL LINE AND THE STYLIZED WORD "VANS".

CLASS 18—LEATHER GOODS

FOR BACKPACKS, MESSENGER BAGS, PURSES, ALL-PURPOSE CARRYING BAGS, TRAVEL BAGS, WALLETS AND HANDBAGS (U.S. CLS. 1, 2, 3, 22 AND 41).

CLASS 25—CLOTHING

FOR FOOTWEAR, CLOTHING AND HEADGEAR, NAMELY, T-SHIRTS, SHIRTS, SWEATSHIRTS, PANTS, SHORTS, DENIMS, SWEATER, JACKETS, BELTS, BOXERS, SOCKS, SCARVES, UNDERWEAR, SWIMWEAR, HATS, CAPS AND BEANIES (U.S. CLS. 22 AND 39).

CLASS 35—ADVERTISING AND BUSINESS

FOR RETAIL STORE SERVICES AND ON-LINE RETAIL STORE SERVICES FEATURING CLOTHING, FOOTWEAR AND ACCESSORIES (U.S. CLS. 100, 101 AND 102).

KEVIN DINALLO, EXAMINING ATTORNEY

SN 85-575,733. CENTRAL SPRAYBOOTH INC., DBA CENTERLINE SPRAYBOOTH, AMITYVILLE, NY. FILED 3-21-2012.



NO CLAIM IS MADE TO THE EXCLUSIVE RIGHT TO USE "WIND", APART FROM THE MARK AS SHOWN.

THE MARK CONSISTS OF THE WORDING "WIND WIZARD" AND DESIGNS. ABOVE THE WORDING, THERE IS A DESIGN OF A WIZARD'S HAT WITH STARS AND MOONS ON IT. THREE CURVED LINES EMERGE FROM EACH SIDE OF THE BOTTOM OF THE HAT. THERE ARE FOUR LINES RESEMBLING SPRAY NOZZLES BRACKETING THE LEFT AND RIGHT OF THE WORDING.

CLASS 7—MACHINERY

FOR POWER OPERATED BLOWERS FOR DRYING PAINT (U.S. CLS. 13, 19, 21, 23, 31, 34 AND 35).

CLASS 11—ENVIRONMENTAL CONTROL APPARATUS

FOR INDUSTRIAL APPARATUS FOR DRYING AUTOMOBILE PAINT (U.S. CLS. 13, 21, 23, 31 AND 34).
CORY BOONE, EXAMINING ATTORNEY

SN 85-577,552. CISCO TECHNOLOGY, INC., SAN JOSE, CA. FILED 3-22-2012.

CISCO CONNECTED JUSTICE

THE MARK CONSISTS OF STANDARD CHARACTERS WITHOUT CLAIM TO ANY PARTICULAR FONT, STYLE, SIZE, OR COLOR.

PRIORITY CLAIMED UNDER SEC. 44(D) ON SWITZERLAND APPLICATION NO. 53364/2012, FILED 3-21-2012.

OWNER OF U.S. REG. NOS. 3,759,451, 3,978,294 AND 4,035,428.

NO CLAIM IS MADE TO THE EXCLUSIVE RIGHT TO USE "JUSTICE", APART FROM THE MARK AS SHOWN.

CLASS 9—ELECTRICAL AND SCIENTIFIC APPARATUS

FOR APPARATUS FOR RECORDING, TRANSMISSION OR REPRODUCTION OF SOUND OR IMAGES; COMPUTERS; COMPUTER HARDWARE; COMPUTER HARDWARE AND SOFTWARE FOR INTERCONNECTING, MANAGING, SECURING AND OPERATING LOCAL AND WIDE AREA NETWORKS AND TELEPHONY SYSTEMS; TELEPHONES, TELEPHONE HEADSETS; COMPUTER SOFTWARE AND HARDWARE FOR NETWORK SECURITY, EMAIL AND WEB SECURITY, SECURE ACCESS CONTROL, USER IDENTIFICATION, ENCRYPTION AND SECURITY MANAGEMENT; MESSAGING AND NETWORK SECURITY APPLIANCES COMPRISING COMPUTER HARDWARE AND SOFTWARE FOR DETECTING, BLOCKING AND REMOVING COMPUTER VIRUSES AND THREATS, ENCRYPTING AND AUTHENTICATING DATA, PREVENTING DATA LOSS, RECOVERING DATA, SECURING NETWORKS, AND DETECTING, FILTERING, ANALYZING, MANAGING AND BLOCKING ELECTRONIC COMMUNICATIONS; COMPUTER SOFTWARE FOR SECURING MOBILE DEVICES; COMPUTER HARDWARE CONTAINING NETWORK SECURITY FUNCTIONALITY, INCLUDING FIREWALLS; DATA ENCRYPTION, AND/OR INTEROPERABILITY WITH NETWORK SECURITY PROTOCOLS; COMPUTERS; HANDHELD COMPUTERS; WIRELESS COMMUNICATIONS DEVICES, NAMELY, WIRELESS HARDWARE AND SOFTWARE FOR THE TRANSMISSION OF VOICE, DATA, AUDIO, AND VIDEO; CONSUMER ELECTRONICS, NAMELY, HARDWARE AND SOFTWARE FOR THE TRANSMISSION OF VOICE, DATA, AUDIO, AND/OR VIDEO; COMPUTER PERIPHERALS; HEADPHONES; SOFTWARE FOR RECORDING, TRANSMITTING, STORING, MANAGING, VIEWING AND SECURING INFORMATION, DATA, DOCUMENTS, VOICE, VIDEO AND IMAGES OVER COMPUTER NETWORKS; AUDIO AND VIDEO CONFERENCING SOFTWARE; WEB CONFERENCING SOFTWARE; SOFTWARE FOR SEARCHING AND LOCATING PEOPLE; COMPUTER SOFTWARE FOR CONNECTING INDIVIDUALS, INFORMATION, APPLICATIONS, COMMUNICATIONS TOOLS AND AUDIO, VIDEO, AND MULTIMEDIA CONTENT ACROSS COMPUTER NETWORKS; TELECOMMUNICATIONS SOFTWARE FOR SENDING AND RECEIVING TEXT AND VIDEO MESSAGES; COMPUTER SOFTWARE THAT FACILITATES COLLABORATION AMONG INDIVIDUALS AND ORGANIZATIONS; SOFTWARE THAT FACILITATES VIDEO AND VOICE COMMUNICATIONS BETWEEN PARTIES; COMPUTER TELEPHONY SOFTWARE; COMPUTER NETWORK MANAGEMENT SOFTWARE; COMPUTER SOFTWARE FOR SHARING COMPUTER SCREENS, DESKTOPS, DATA, ELECTRONIC DOCUMENTS AND APPLICATIONS; DIGITAL IMAGING SOFTWARE; CAMERAS; COMPUTER SOFTWARE FOR UPLOADING, POSTING, DISPLAYING, EDITING, ORGANIZING, TRANSMITTING, SHARING AND TAGGING VIDEO, IMAGES, AUDIO AND CONTENT; SOFTWARE FOR ACCESSING THE INTERNET AND COMPUTER NETWORKS; COMPUTER SOFTWARE THAT PROVIDES AN INFRASTRUCTURE FOR COLLABORATIVE SERVICES AND AN INTEGRATED ENVIRONMENT FOR SOFTWARE APPLICATIONS; NETWORK SOFTWARE TO CONNECT COMPUTER NETWORK USERS WITH KNOWLEDGE RESOURCES AND INFORMATION RESIDENT ON THE NETWORK; COMPUTER SOFTWARE USED TO FACILITATE THE EXCHANGE OF INFORMATION VIA A GLOBAL COMPUTER NETWORK OR THE INTERNET FEATURING BRAINSTORMING TOOLS, CATEGORIZATION TOOLS, PRESENCE MANAGEMENT, INSTANT MESSAGING AND COLLABORATION TOOLS, DOCUMENT MANAGEMENT AND APPLICATION INTEGRATION; COMPUTER HARDWARE FOR TELECOMMUNICATIONS; COMPUTER HARDWARE AND SOFTWARE FOR INTERCONNECTING, INTEGRATING, SECURING, MANAGING, MONITORING, AND OPERATING VIDEO CONFERENCING SYSTEMS; COMPUTER HARDWARE AND SOFTWARE FOR ENABLING MULTI-LOCATION VIDEO CONFERENCING; COMPUTER HARDWARE AND SOFTWARE FOR PROCESSING AUDIO AND VIDEO; VIDEO AND AUDIO CONFERENCING SYSTEMS COMPRISED OF FURNITURE, ENDPOINT DEVICES, POWER AND ETHERNET PORTS, IP PHONES, CAMERAS, DISPLAYS, LIGHTING, SPEAKERS, MICROPHONES, AND PROJECTORS (U.S. CLS. 21, 23, 26, 36 AND 38).

CLASS 37—CONSTRUCTION AND REPAIR

FOR INSTALLATION OF COMPUTER SYSTEMS, CONFERENCING SYSTEMS, COMMUNICATION NETWORKS AND COMPUTER NETWORKS; TECHNICAL SUPPORT SERVICES, NAMELY, TROUBLESHOOTING IN THE NATURE OF REPAIR OF COMPUTER NETWORK HARDWARE AND VIDEO CONFERENCING SYSTEM HARDWARE (U.S. CLS. 100, 103 AND 106).

CLASS 38—COMMUNICATION

FOR WEB CONFERENCING SERVICES; AUDIO CONFERENCING SERVICES; TELECONFERENCING SERVICES; VIDEO CONFERENCING SERVICES; INSTANT MESSAGING; ELECTRONIC MAIL AND VOICE OVER INTERNET PROTOCOL (VOIP) COMMUNICATION SERVICES; INTERNET TELEPHONY SERVICES; BROADCASTING PROGRAMS VIA COMPUTER NETWORKS; ELECTRONIC VOICE MESSAGING, NAMELY, THE RECORDING AND SUBSEQUENT TRANSMISSION OF VOICE MESSAGES BY TELEPHONE AND EMAIL; TRANSMISSION OF VOICE, AUDIO, VISUAL IMAGES AND DATA BY TELECOMMUNICATIONS NETWORKS, WIRELESS COMMUNICATION NETWORKS, THE INTERNET, INFORMATION SERVICES NETWORKS AND DATA NETWORKS; PROVIDING ACCESS AND CONNECTIONS TO THE INTERNET, COMPUTER NETWORKS, COMPUTER DATABASES AND APPLICATIONS; STREAMING OF AUDIO, DATA, VIDEO, AND IMAGES ON THE INTERNET; PROVIDING ONLINE INFORMATION IN THE FIELD OF TELECOMMUNICATIONS AND TELEPHONY SYSTEMS (U.S. CLS. 100, 101 AND 104).

CLASS 42—SCIENTIFIC AND COMPUTER SERVICES

FOR DESIGN AND DEVELOPMENT OF COMPUTER HARDWARE AND SOFTWARE; UPDATING OF COMPUTER SOFTWARE; TECHNICAL SUPPORT SERVICES, NAMELY, TROUBLESHOOTING IN THE NATURE OF DIAGNOSING PROBLEMS WITH COMPUTER NETWORKS AND VIDEO CONFERENCING SYSTEMS; COMPUTER SERVICES, NAMELY, NETWORK AND VIDEO CONFERENCING SOLUTION MANAGEMENT IN THE NATURE OF TROUBLESHOOTING IN THE NATURE OF DIAGNOSING AND REPAIRING SOFTWARE PROBLEMS; TECHNICAL SUPPORT, NAMELY, MONITORING OF NETWORKING AND VIDEO CONFERENCING SYSTEMS; MONITORING THE COMPUTER SYSTEMS OF OTHERS FOR TECHNICAL PURPOSES AND PROVIDING BACK-UP COMPUTER PROGRAMS AND FACILITIES; COMPUTER HARDWARE AND SOFTWARE DESIGN; COMPUTER DATA RECOVERY; COMPUTER PROGRAMMING FOR OTHERS; COMPUTER NETWORK CONFIGURATION SERVICES; PROVIDING TEMPORARY USE OF ONLINE NON-DOWNLOADABLE SOFTWARE TO ENABLE UPLOADING, POSTING, SHOWING, DISPLAYING, EDITING, AND TRANSMITTING IMAGES, VIDEO AND AUDIOVISUAL WORKS; APPLICATION SERVICE PROVIDER (ASP) SERVICES FEATURING SOFTWARE FOR USE IN WEB-BASED CONFERENCING, AUDIO CONFERENCING, ELECTRONIC MESSAGING, DOCUMENT COLLABORATION, VIDEO CONFERENCING, AND VOICE AND CALL PROCESSING; PROVIDING TEMPORARY USE OF ONLINE NON-DOWNLOADABLE SOFTWARE FOR FACILITATING THE INTEROPERABILITY OF MULTIPLE SOFTWARE APPLICATIONS; APPLICATION SERVICE PROVIDER (ASP), NAMELY, HOSTING THE SOFTWARE APPLICATIONS OF OTHERS; APPLICATION SERVICE PROVIDER (ASP) FEATURING SOFTWARE FOR UPLOADING, POSTING, DISPLAYING, EDITING, ORGANIZING, TRANSMITTING, SHARING AND TAGGING VIDEO, IMAGES, AUDIO AND MULTIMEDIA CONTENT; APPLICATION SERVICE PROVIDER (ASP) FEATURING SOFTWARE FOR RECORDING, TRANSMITTING AND VIEWING INFORMATION, PRESENTATIONS, DATA, DOCUMENTS, VOICE, VIDEO, AND IMAGES OVER COMPUTER NETWORKS (U.S. CLS. 100 AND 101).

KATHERINE CHANG, EXAMINING ATTORNEY

SN 85-577,582. SUMMERWINDS GARDEN CENTERS, INC.,
BOISE, ID. FILED 3-22-2012.

SN 85-578,127. HILLPOINT CAPITAL, LLC, NEW YORK, NY.
FILED 3-23-2012.

SUMMERWINDS

THE MARK CONSISTS OF STANDARD CHARACTERS WITHOUT CLAIM TO ANY PARTICULAR FONT, STYLE, SIZE, OR COLOR.

OWNER OF U.S. REG. NOS. 2,439,377 AND 2,568,028.

CLASS 35—ADVERTISING AND BUSINESS

FOR RETAIL STORE SERVICES FEATURING EQUIPMENT AND SUPPLIES FOR LAWN, GARDEN, AND PLANT CARE (U.S. CLS. 100, 101 AND 102).

FIRST USE 3-31-2000; IN COMMERCE 3-31-2000.

CLASS 44—MEDICAL, BEAUTY AND AGRICULTURAL SERVICES

FOR PLANT AND TREE NURSERIES (U.S. CLS. 100 AND 101).

FIRST USE 3-31-2000; IN COMMERCE 3-31-2000.
SHAUNIA CARLYLE, EXAMINING ATTORNEY

SN 85-577,932. HIMALAYAN INTERNATIONAL INSTITUTE OF YOGA SCIENCE AND PHILOSOPHY OF THE USA, HONESDALE, PA. FILED 3-23-2012.

SAGE PROGRAM: YOUR POWERFUL LIFE

THE MARK CONSISTS OF STANDARD CHARACTERS WITHOUT CLAIM TO ANY PARTICULAR FONT, STYLE, SIZE, OR COLOR.

NO CLAIM IS MADE TO THE EXCLUSIVE RIGHT TO USE "PROGRAM", APART FROM THE MARK AS SHOWN.

CLASS 9—ELECTRICAL AND SCIENTIFIC APPARATUS

FOR PRE-RECORDED AUDIO AND VIDEO CDS AND DVDS ALL THE FOREGOING FEATURING INFORMATION AND EDUCATIONAL PROGRAMS IN THE FIELDS OF YOGA, TANTRA, MEDITATION AND AYURVEDA (U.S. CLS. 21, 23, 26, 36 AND 38).

CLASS 38—COMMUNICATION

FOR ELECTRONIC TRANSMISSION AND STREAMING OF ONLINE ON-DEMAND MEDIA FEATURING INFORMATION AND EDUCATIONAL PROGRAMS REGARDING THE PHILOSOPHY AND PRACTICAL APPLICATION OF YOGA, TANTRA, MEDITATION AND AYURVEDA (U.S. CLS. 100, 101 AND 104).

CLASS 41—EDUCATION AND ENTERTAINMENT

FOR EDUCATIONAL SERVICES, NAMELY, CONDUCTING SEMINARS AND CLASSES OF INSTRUCTION ALL IN THE FIELDS OF YOGA, TANTRA, MEDITATION AND AYURVEDA (U.S. CLS. 100, 101 AND 107).

BERYL GARDNER, EXAMINING ATTORNEY

openproperty

THE MARK CONSISTS OF STANDARD CHARACTERS WITHOUT CLAIM TO ANY PARTICULAR FONT, STYLE, SIZE, OR COLOR.

CLASS 35—ADVERTISING AND BUSINESS

FOR PROVIDING SERVICES TO TENANTS AND LANDLORDS, NAMELY, GATHERING, RECORDING, MONITORING, SCORING, RATING AND MANAGING DATA; PROVIDING ADVERTISING OPPORTUNITIES; PROVIDING A WEBSITE THROUGH WHICH PROPERTY ISSUERS CAN REVIEW PROSPECTIVE TENANTS' LETTERS OF RECOMMENDATION; AND INVOICING SERVICES (U.S. CLS. 100, 101 AND 102).

CLASS 36—INSURANCE AND FINANCIAL

FOR REAL ESTATE LISTING SERVICES FOR HOUSING RENTALS AND APARTMENT RENTALS; REAL ESTATE LISTING SERVICES FOR HOUSING RENTALS AND APARTMENT RENTALS, NAMELY, SCREENING AND BOOKING RENTAL APPOINTMENTS; ELECTRONIC FUND TRANSFERS; PROVIDING SERVICES THAT FACILITATE PROPERTY MANAGEMENT, NAMELY, EVALUATION OF REAL PROPERTY; AND PROVIDING LETTERS OF CREDIT (U.S. CLS. 100, 101 AND 102).

WILLIAM JACKSON, EXAMINING ATTORNEY

SN 85-578,849. WORK LOSS DATA INSTITUTE, LLC, ENCINITAS, CA. FILED 3-23-2012.



Work Loss Data Institute

"The Evidence-Based Guideline Company"

NO CLAIM IS MADE TO THE EXCLUSIVE RIGHT TO USE "WORK LOSS DATA INSTITUTE THE EVIDENCE-BASED GUIDELINE COMPANY", APART FROM THE MARK AS SHOWN.

THE MARK CONSISTS OF THE WORDING "THE-EVIDENCE BASED GUIDELINE COMPANY" BELOW THE WORDING "WORK LOSS DATA INSTITUTE," WHICH IN TURN IS BELOW TWO SOLID SQUARES ("R SQUARES") ORIENTATED ON THE SAME HORIZONTAL PLANE AND SEPARATED BY A DISTANCE EQUIVALENT TO THE LENGTH OF THE SIDE OF THE SQUARES. THE LEFT R SQUARE ("R1") HAS TWO SLIGHTLY-SMALLER, SOLID SQUARES ("S SQUARES") THAT ARE TANGENT TO THE TOP SIDE OF R1. THE LOWER-RIGHT CORNER OF ONE OF THE S SQUARES ("S1") IS TANGENT TO THE TOP-LEFT CORNER OF R1. THE LOWER-LEFT CORNER OF THE OTHER S SQUARE ("S2") IS TANGENT TO THE TOP-RIGHT CORNER OF R1. IN ADDITION, THERE ARE TWO EVEN SMALLER, SOLID SQUARES ("T SQUARES") THAT ARE TANGENT TO THE TOP SIDES OF THE S SQUARES. THE LOWER-RIGHT CORNER OF ONE OF THE T SQUARES ("T1") IS TANGENT TO THE TOP-LEFT

CORNER OF S1. THE LOWER-LEFT CORNER OF THE OTHER T SQUARE ("T2") IS TANGENT TO THE TOP-RIGHT CORNER OF S2. THE RIGHT R SQUARE ("R2") HAS ONE SOLID SQUARE ("S3") THAT IS THE SAME SIZE AS THE S SQUARES OF WHICH THE LOWER-LEFT CORNER IS TANGENT TO THE TOP-RIGHT CORNER OF R2. FINALLY, THERE IS ONE SMALLER, SOLID SQUARE ("T3") THAT IS THE SAME SIZE AS THE T SQUARES OF WHICH THE LOWER-LEFT CORNER IS TANGENT TO THE TOP-RIGHT CORNER OF S3.

SN 85-578,926. UUMYFIND, INC., MARYSVILLE, WA. FILED 3-23-2012.

CITYSHOTZ

CLASS 16—PAPER GOODS AND PRINTED MATTER

FOR A SERIES OF BOOKS AND WRITTEN ARTICLES IN THE FIELD OF MEDICAL TREATMENT AND DISABILITY DURATION GUIDELINES; A SERIES OF BOOKS, WRITTEN ARTICLES, HANDOUTS AND WORKSHEETS IN THE FIELD OF WORKERS COMPENSATION, MEDICAL TREATMENT AND DISABILITY DURATION GUIDELINES; BOOKS IN THE FIELD OF MEDICAL TREATMENT AND DISABILITY DURATION GUIDELINES; PRINTED CERTIFICATES; PRINTED EDUCATIONAL MATERIALS IN THE FIELD OF WORKERS COMPENSATION, MEDICAL TREATMENT AND DISABILITY DURATION GUIDELINES; PRINTED MATERIALS, NAMELY, WRITTEN ARTICLES IN THE FIELD OF WORKERS COMPENSATION, MEDICAL TREATMENT AND DISABILITY DURATION GUIDELINES; PUBLICATIONS, NAMELY, BOOKS AND HANDOUTS IN THE FIELDS OF WORKERS COMPENSATION, MEDICAL TREATMENT AND DISABILITY DURATION GUIDELINES; REFERENCE BOOKS IN THE FIELD OF MEDICAL TREATMENT AND DISABILITY DURATION GUIDELINES; RESEARCH REPORTS FEATURING STUDIES ON WORKERS COMPENSATION, MEDICAL TREATMENT AND DISABILITY DURATION GUIDELINES; RESOURCE BOOKS IN THE FIELD OF MEDICAL TREATMENT AND DISABILITY DURATION GUIDELINES; SERIES OF NON-FICTION BOOKS IN THE FIELD OF MEDICAL TREATMENT AND DISABILITY DURATION GUIDELINES (U.S. CLS. 2, 5, 22, 23, 29, 37, 38 AND 50).

FIRST USE 1-1-2007; IN COMMERCE 1-1-2007.

THE MARK CONSISTS OF STANDARD CHARACTERS WITHOUT CLAIM TO ANY PARTICULAR FONT, STYLE, SIZE, OR COLOR.

CLASS 38—COMMUNICATION

FOR ELECTRONIC TRANSMISSION OF PHOTOS AND IMAGES, NAMELY, THE COMPUTER AIDED, ELECTRIC, DIGITAL, CELLULAR, WIRELESS, MOBILE PHONE, AND TELEVISION INFORMATION DISTRIBUTION TECHNOLOGY USED FOR THE TRANSMISSION OF IMAGES AND PHOTOS TO THE PUBLIC (U.S. CLS. 100, 101 AND 104).

CLASS 42—SCIENTIFIC AND COMPUTER SERVICES

FOR PROVIDING A WEB SITE THAT GIVES COMPUTER USERS THE ABILITY TO UPLOAD, EXCHANGE AND SHARE PHOTOS AND IMAGES VIA THE INTERNET, MOBILE, DIGITAL, WIRELESS, CELLULAR, AND TELEVISION TECHNOLOGY FOR PUBLIC AND BUSINESS EDUCATION AND ENTERTAINMENT (U.S. CLS. 100 AND 101).

DAVID TAYLOR, EXAMINING ATTORNEY

SN 85-579,216. A.B. SCHARF AND COMPANY LTD., PLANTATION, FL. FILED 3-24-2012.

CLASS 42—SCIENTIFIC AND COMPUTER SERVICES

FOR DATABASE DEVELOPMENT SERVICES; MEDICAL AND SCIENTIFIC RESEARCH IN THE FIELD OF MEDICAL TREATMENT AND DISABILITY DURATION GUIDELINES; PROVIDING A MEMBERS-ONLY WEB SITE FEATURING TECHNOLOGY WHICH PROVIDES MEMBERS WITH THE ABILITY TO FIND TIME OUT OF WORK INFORMATION AS IT RELATES TO MEDICAL TREATMENT; PROVIDING A WEB SITE FEATURING TECHNOLOGY ENABLING PHYSICIANS TO ACCESS RESOURCES IN CLINICAL MEDICINE; PROVIDING A WEB SITE FEATURING TECHNOLOGY THAT ENABLES USERS TO FIND TIME OUT OF WORK INFORMATION AS IT RELATES TO MEDICAL TREATMENT; PROVIDING A WEB SITE FEATURING TEMPORARY USE OF NON-DOWNLOADABLE SOFTWARE FOR MEDICAL TREATMENT AND DISABILITY DURATION GUIDELINES; PROVIDING A WEBSITE FEATURING INFORMATION ABOUT INVESTIGATIONAL MEDICAL DEVICES, DIAGNOSTIC AND DRUGS; PROVIDING AN ON-LINE SEARCHABLE DATABASE IN THE FIELD OF MEDICAL TREATMENT AND DISABILITY DURATION GUIDELINES FOR SCIENTIFIC RESEARCH PURPOSES; PROVIDING MEDICAL AND SCIENTIFIC RESEARCH INFORMATION IN THE FIELD OF CLINICAL TRIALS; PROVIDING MEDICAL AND SCIENTIFIC RESEARCH INFORMATION IN THE FIELD OF PHARMACEUTICALS AND CLINICAL TRIALS (U.S. CLS. 100 AND 101).

FIRST USE 1-1-2007; IN COMMERCE 1-1-2007.

JILL PRATER, EXAMINING ATTORNEY

Newdies

THE MARK CONSISTS OF STANDARD CHARACTERS WITHOUT CLAIM TO ANY PARTICULAR FONT, STYLE, SIZE, OR COLOR.

CLASS 9—ELECTRICAL AND SCIENTIFIC APPARATUS

FOR DIGITAL MUSIC DOWNLOADABLE FROM THE INTERNET; DOWNLOADABLE MUSIC FILES; DOWNLOADABLE MUSICAL SOUND RECORDINGS; DOWNLOADABLE VIDEO RECORDINGS FEATURING INFORMATION ABOUT MUSICIANS, MUSICAL PERFORMANCES, MUSIC VIDEOS AND MUSIC; DOWNLOADABLE PRE-RECORDED MUSICAL PERFORMANCES, MUSIC VIDEOS AND MUSIC VIA THE INTERNET AND WIRELESS DEVICES (U.S. CLS. 21, 23, 26, 36 AND 38).

FIRST USE 3-9-2012; IN COMMERCE 3-9-2012.

CLASS 38—COMMUNICATION

FOR AUDIO AND VIDEO BROADCASTING SERVICES OVER THE INTERNET; BROADCASTING OF VIDEO AND AUDIO PROGRAMMING OVER THE INTERNET; BROADCASTING SERVICES AND PROVISION OF TELECOMMUNICATION ACCESS TO VIDEO AND AUDIO CONTENT PROVIDED VIA A VIDEO-ON-DEMAND SERVICE VIA THE INTERNET; INTERNET RADIO BROADCASTING SERVICES; INTERNET RADIO SERVICES, NAMELY, TRANSMISSION OF AUDIO MATERIAL VIA THE INTERNET; STREAMING OF AUDIO MATERIAL ON THE INTERNET; STREAMING OF VIDEO MATERIAL ON THE INTERNET; STREAMING OF AUDIO, VIDEO AND AUDIOVISUAL MATERIAL ON THE INTERNET; TELECOMMUNICATION SERVICES, NAMELY, TRANSMISSION OF VOICE, DATA, GRAPHICS, IMAGES, AUDIO AND VIDEO BY MEANS OF TELECOMMUNICATIONS NETWORKS, WIRELESS COMMUNICATION NETWORKS, AND THE INTERNET; TRANSMISSION AND DISTRIBUTION OF DATA OR AUDIO VISUAL IMAGES VIA A GLOBAL COMPUTER NETWORK OR THE INTERNET (U.S. CLS. 100, 101 AND 104).

FIRST USE 3-9-2012; IN COMMERCE 3-9-2012.
NELSON SNYDER, EXAMINING ATTORNEY

SN 85-579,243. ULG HOLDINGS LIMITED, TORTOLA, BR.VIRGIN ISLANDS, FILED 3-25-2012.



THE COLOR(S) RED AND GRAY IS/ARE CLAIMED AS A FEATURE OF THE MARK.

THE MARK CONSISTS OF THE WORDING "UNITED CELLARS" IN THE COLOR GRAY WITH A ROUNDED STYLIZED LETTER "U" IN THE COLOR RED PLACED TO THE LEFT OF THE WORDING.

CLASS 35—ADVERTISING AND BUSINESS

FOR ONLINE RETAIL STORE OUTLET FEATURING WINE; WHOLESALE DISTRIBUTORSHIP SERVICES FEATURING WINE; ADVERTISING; MARKETING (U.S. CLS. 100, 101 AND 102).

CLASS 41—EDUCATION AND ENTERTAINMENT

FOR ORGANIZATION OF SEMINARS AND WORKSHOPS IN RELATION TO WINE; PUBLISHING SERVICES FOR OTHERS (U.S. CLS. 100, 101 AND 107).
LESLEY LAMOTHE, EXAMINING ATTORNEY

SN 85-580,235. BETTER BABY LLC, STATELINE, NV. FILED 3-26-2012.



THE MARK CONSISTS OF STANDARD CHARACTERS WITHOUT CLAIM TO ANY PARTICULAR FONT, STYLE, SIZE, OR COLOR.

CLASS 9—ELECTRICAL AND SCIENTIFIC APPARATUS

FOR COMPUTER SOFTWARE FOR BRAIN TRAINING EXERCISES AND INCREASING INTELLIGENCE (U.S. CLS. 21, 23, 26, 36 AND 38).

FIRST USE 11-1-2011; IN COMMERCE 11-1-2011.

CLASS 30—STAPLE FOODS

FOR CHOCOLATE; COFFEE; SALT; VANILLA (U.S. CL. 46).

FIRST USE 11-1-2011; IN COMMERCE 11-1-2011.
MIAH ROSENBERG, EXAMINING ATTORNEY

SN 85-580,236. THE SURFN MONKEY LLC, SAN DIEGO, CA. FILED 3-26-2012.



NO CLAIM IS MADE TO THE EXCLUSIVE RIGHT TO USE "SURF", APART FROM THE MARK AS SHOWN.

THE MARK CONSISTS OF THE STYLIZED TEXT "SURF MONKEY" WHERE THE LETTER "O" IS REPRESENTED BY A STYLIZED MONKEY HEAD.

CLASS 12—VEHICLES

FOR BICYCLES (U.S. CLS. 19, 21, 23, 31, 35 AND 44).
FIRST USE 1-1-2012; IN COMMERCE 1-1-2012.

CLASS 25—CLOTHING

FOR SPORTSWEAR, NAMELY, T-SHIRTS, HATS, SWEATSHIRTS, DRESS SHIRTS, SHORTS, AND SURF TRUNKS (U.S. CLS. 22 AND 39).

FIRST USE 1-1-2012; IN COMMERCE 1-1-2012.
MICHELE SWAIN, EXAMINING ATTORNEY

SN 85-582,152. TYMETRIX, INC., HARTFORD, CT. FILED 3-28-2012.



THE MARK CONSISTS OF STANDARD CHARACTERS WITHOUT CLAIM TO ANY PARTICULAR FONT, STYLE, SIZE, OR COLOR.

CLASS 35—ADVERTISING AND BUSINESS

FOR PROVIDING BUSINESS MANAGEMENT SERVICES FOR LAW FIRMS AND LAW DEPARTMENTS, NAMELY, PROVIDING BILLING ANALYTICS; PROVIDING AN ANALYSIS OF PRICING AND STAFFING FOR LAW FIRMS AND LAW DEPARTMENTS (U.S. CLS. 100, 101 AND 102).

FIRST USE 9-1-2011; IN COMMERCE 9-1-2011.

CLASS 42—SCIENTIFIC AND COMPUTER SERVICES

FOR PROVIDING ON-LINE, NON-DOWNLOADABLE, INTERNET-BASED SOFTWARE APPLICATION THAT TRACKS, ANALYZES, AND STORES BILLING DATA AND INFORMATION; PROVIDING NON-DOWNLOADABLE ONLINE BILLING SOFTWARE THAT TRACKS BUDGET PERFORMANCE FOR LEGAL SERVICES; PROVIDING NON-DOWNLOADABLE ONLINE FINANCIAL SOFTWARE THAT ANALYZES LEGAL EXPENDITURES; APPLICATION SERVICES PROVIDER FEATURING SOFTWARE FOR PROVIDING AN ONLINE DATABASE IN THE FIELD OF FINANCIAL TRANSACTION PROCESSING TO UPLOAD TRANSACTIONAL DATA, PROVIDE STATISTICAL ANALYSIS, AND PRODUCE REPORTS (U.S. CLS. 100 AND 101).

FIRST USE 9-1-2011; IN COMMERCE 9-1-2011.

DOUGLAS LEE, EXAMINING ATTORNEY

SN 85-583,146. DR. ING. H.C. F. PORSCHE AKTIENGESELLSCHAFT, STUTTGART-ZUFFENHAUSEN, FED REP GERMANY, FILED 3-29-2012.



SN 85-582,412. THE SUN PRODUCTS CORPORATION, WILTON, CT. FILED 3-28-2012.

SNUG

THE MARK CONSISTS OF STANDARD CHARACTERS WITHOUT CLAIM TO ANY PARTICULAR FONT, STYLE, SIZE, OR COLOR.

CLASS 35—ADVERTISING AND BUSINESS

FOR SOCIAL ACTION CAMPAIGN TO PROMOTE PUBLIC AWARENESS OF EMOTIONAL UPLIFTMENT AND OPTIMISM THROUGH THE DISPLAY OF PHYSICAL AFFECTION RENDERED ACROSS TRADITIONAL AND SOCIAL MEDIA PLATFORMS AND THROUGH GRASS ROOTS EFFORTS; PUBLIC AWARENESS CAMPAIGN TO PROMOTE EMOTIONAL UPLIFTMENT AND OPTIMISM THROUGH THE DISPLAY OF PHYSICAL AFFECTION RENDERED ACROSS TRADITIONAL AND SOCIAL MEDIA PLATFORMS AND THROUGH GRASS ROOTS EFFORTS; COMMUNITY OUTREACH PROGRAM TO PROMOTE PUBLIC AWARENESS OF EMOTIONAL UPLIFTMENT AND OPTIMISM THROUGH THE DISPLAY OF PHYSICAL AFFECTION RENDERED ACROSS TRADITIONAL AND SOCIAL MEDIA PLATFORMS AND THROUGH GRASS ROOTS EFFORTS (U.S. CLS. 100, 101 AND 102).

CLASS 38—COMMUNICATION

FOR DELIVERY OF GREETINGS AND VIRTUAL DISPLAYS OF PHYSICAL AFFECTION TO OTHERS VIA ELECTRONIC MAIL (U.S. CLS. 100, 101 AND 104).

CLASS 42—SCIENTIFIC AND COMPUTER SERVICES

FOR PROVIDING AN ONLINE NON-DOWNLOADABLE COMPUTER PROGRAM FOR THE CREATION AND DELIVERY OF ELECTRONIC GREETINGS AND VIRTUAL DISPLAYS OF PHYSICAL AFFECTION (U.S. CLS. 100 AND 101).

PRISCILLA MILTON, EXAMINING ATTORNEY

OWNER OF U.S. REG. NOS. 618,932, 1,008,642 AND OTHERS.

NO CLAIM IS MADE TO THE EXCLUSIVE RIGHT TO USE "PERFORMANCE", APART FROM THE MARK AS SHOWN.

THE COLOR(S) GREY, WHITE AND BLACK IS/ARE CLAIMED AS A FEATURE OF THE MARK.

THE MARK CONSISTS OF A SHIELD DESIGN. THE EXTERIOR BORDER OF THE SHIELD DESIGN AND THE INTERIOR SHIELD DESIGN ARE GREY. THE INTERIOR SHIELD IS SURROUNDED BY WHITE. THE WORDS "INTELLIGENT PERFORMANCE" ARE BLACK.

CLASS 12—VEHICLES

FOR AUTOMOBILES AND STRUCTURAL PARTS THEREOF (U.S. CLS. 19, 21, 23, 31, 35 AND 44).

CLASS 37—CONSTRUCTION AND REPAIR

FOR CONSTRUCTION AND REPAIR, NAMELY, REPAIR AND MAINTENANCE OF AUTOMOBILES; AUTOMOBILE CUSTOMIZATION SERVICES NAMELY, TUNING OF STANDARD CARS TO SPORT AND RACING CARS (U.S. CLS. 100, 103 AND 106).

CLASS 41—EDUCATION AND ENTERTAINMENT

FOR SPORTS AND CULTURAL ACTIVITIES NAMELY, ARRANGING AND CONDUCTING OF FESTIVALS, TOURNAMENTS, EXHIBITIONS AND COMPETITIONS THAT CELEBRATE AND FEATURE AUTOMOBILE RACES, AUTOMOBILE RALLIES AND CELEBRITY DRIVERS (U.S. CLS. 100, 101 AND 107).

CLASS 42—SCIENTIFIC AND COMPUTER SERVICES

FOR TECHNOLOGY RESEARCH FOR OTHERS IN THE FIELD OF VEHICLE AND ENGINE MANUFACTURING; TECHNOLOGICAL CONSULTATION SERVICES IN THE FIELD OF VEHICLE AND ENGINE MANUFACTURING; INDUSTRIAL RESEARCH SERVICES IN THE FIELD OF VEHICLE AND ENGINE MANUFACTURING; DESIGN AND DEVELOPMENT OF COMPUTER HARDWARE AND SOFTWARE (U.S. CLS. 100 AND 101).

ROBIN MITTLER, EXAMINING ATTORNEY

SN 85-583,233. SIMON PROPERTY GROUP, L.P., INDIANA-POLIS, IN. FILED 3-29-2012.

SN 85-583,789. UDECX, LLC, BEAVERCREEK, OH. FILED 3-29-2012.

SIMON
STYLE
SETTER

OWNER OF U.S. REG. NOS. 2,969,024, 3,273,205 AND OTHERS.

NO CLAIM IS MADE TO THE EXCLUSIVE RIGHT TO USE "STYLE", APART FROM THE MARK AS SHOWN.

THE MARK CONSISTS OF WORDING "SIMON STYLE SETTER" IN STYLIZED FONT WHERE THE WORDING "SIMON" APPEARS CENTERED ABOVE THE LETTERS "TY" IN THE WORD "STYLE" AND THE WORD "SETTER" APPEARS CENTERED BELOW THE LETTERS "TYLE" IN THE WORD "STYLE".

CLASS 41—EDUCATION AND ENTERTAINMENT

FOR PROVIDING ON-LINE JOURNALS, NAMELY, BLOGS IN THE FIELD OF FASHION STYLE AND FASHION TRENDS (U.S. CLS. 100, 101 AND 107).

CLASS 45—PERSONAL AND LEGAL SERVICES

FOR PROVIDING INFORMATION, NEWS, REVIEWS, STORIES AND COMMENTARY ABOUT FASHION STYLE AND FASHION TRENDS THROUGH SOCIAL MEDIA PLATFORMS, ELECTRONIC MAIL AND TEXTING (U.S. CLS. 100 AND 101).

TINA BROWN, EXAMINING ATTORNEY

SN 85-583,356. LUVIN YU COLLECTIBLES, LLC, LAS VEGAS, NV. FILED 3-29-2012.

Luvin Yu Collectibles

THE MARK CONSISTS OF STANDARD CHARACTERS WITHOUT CLAIM TO ANY PARTICULAR FONT, STYLE, SIZE, OR COLOR.

NO CLAIM IS MADE TO THE EXCLUSIVE RIGHT TO USE "COLLECTIBLES", APART FROM THE MARK AS SHOWN.

CLASS 20—FURNITURE AND ARTICLES NOT OTHERWISE CLASSIFIED

FOR FIGURINES OF PLASTIC (U.S. CLS. 2, 13, 22, 25, 32 AND 50).

CLASS 28—TOYS AND SPORTING GOODS

FOR ACTION FIGURE TOYS; COLLECTABLE TOY FIGURES; FANTASY CHARACTER TOYS; MODELED PLASTIC TOY FIGURINES; MOLDED TOY FIGURES; PLASTIC CHARACTER TOYS; TOY FIGURES (U.S. CLS. 22, 23, 38 AND 50).

EMILY CARLSEN, EXAMINING ATTORNEY

UDECX

THE MARK CONSISTS OF STANDARD CHARACTERS WITHOUT CLAIM TO ANY PARTICULAR FONT, STYLE, SIZE, OR COLOR.

CLASS 16—PAPER GOODS AND PRINTED MATTER

FOR MAGAZINE, FLYERS AND OTHER PRINTED EDUCATIONAL MATERIALS ALL CONTAINING IDEAS FOR DECKING/PATIO AND RAILING PRODUCTS (U.S. CLS. 2, 5, 22, 23, 29, 37, 38 AND 50).

CLASS 19—NON-METALLIC BUILDING MATERIALS

FOR NON METALLIC BUILDING MATERIALS, NAMELY, THERMOPLASTIC OR COMPOSITE BUILDING MATERIALS FOR MODULAR DECKING/PATIO AND RAILING PRODUCTS (U.S. CLS. 1, 12, 33 AND 50).

CLASS 20—FURNITURE AND ARTICLES NOT OTHERWISE CLASSIFIED

FOR OUTDOOR LIVING FURNITURE COMPOSED OF THERMOPLASTIC OR COMPOSITE BUILDING MATERIALS FOR PORTABLE USE (U.S. CLS. 2, 13, 22, 25, 32 AND 50).

BRENDAN REGAN, EXAMINING ATTORNEY

SN 85-583,827. TEATRO CHICAGO, LLC, SONOMA, CA. FILED 3-29-2012.

ZAZOU

THE MARK CONSISTS OF STANDARD CHARACTERS WITHOUT CLAIM TO ANY PARTICULAR FONT, STYLE, SIZE, OR COLOR.

THE WORDING "ZAZOU" HAS NO MEANING IN A FOREIGN LANGUAGE.

CLASS 35—ADVERTISING AND BUSINESS

FOR PROVIDING FACILITIES FOR BUSINESS MEETINGS AND BUSINESS CONFERENCES (U.S. CLS. 100, 101 AND 102).

CLASS 41—EDUCATION AND ENTERTAINMENT

FOR ENTERTAINMENT SERVICES IN THE NATURE OF PRESENTATION OF THEATRICAL SHOWS, MUSICAL SHOWS, CONCERTS, AND LIVE ENTERTAINMENT SHOWS AND PERFORMANCES BY ACTORS, COMEDIANS, MAGICIANS, VOCALISTS, MUSICIANS, DANCERS AND OTHER PERFORMING ARTISTS; ARRANGING AND CONDUCTING NIGHTCLUB AND LATE NIGHT ENTERTAINMENT EVENTS; CABARETS; PROVIDING FACILITIES FOR SHOWS, LIVE PERFORMANCES, SPECIAL EVENTS, MUSIC EVENTS, AND EDUCATIONAL TRAINING (U.S. CLS. 100, 101 AND 107).

KIMBERLY PERRY, EXAMINING ATTORNEY

SN 85-583,840. UDECX, LLC, BEAVERCREEK, OH. FILED 3-29-2012.

simple outdoor living

THE MARK CONSISTS OF STANDARD CHARACTERS WITHOUT CLAIM TO ANY PARTICULAR FONT, STYLE, SIZE, OR COLOR.

NO CLAIM IS MADE TO THE EXCLUSIVE RIGHT TO USE "OUTDOOR", APART FROM THE MARK AS SHOWN.

CLASS 16—PAPER GOODS AND PRINTED MATTER

FOR MAGAZINE, FLYERS AND OTHER PRINTED EDUCATIONAL MATERIALS, ALL CONTAINING IDEAS FOR DECKING/PATIO AND RAILING PRODUCTS (U.S. CLS. 2, 5, 22, 23, 29, 37, 38 AND 50).

CLASS 19—NON-METALLIC BUILDING MATERIALS

FOR NON METALLIC BUILDING MATERIALS, NAMELY, THERMOPLASTIC OR COMPOSITE BUILDING MATERIALS FOR MODULAR DECKING/PATIO AND RAILING PRODUCTS (U.S. CLS. 1, 12, 33 AND 50).

CLASS 20—FURNITURE AND ARTICLES NOT OTHERWISE CLASSIFIED

FOR OUTDOOR LIVING FURNITURE COMPOSED OF THERMOPLASTIC OR COMPOSITE BUILDING MATERIALS FOR PORTABLE USE (U.S. CLS. 2, 13, 22, 25, 32 AND 50).

BRENDAN REGAN, EXAMINING ATTORNEY

SN 85-583,968. IMPERIAL CLINICAL RESEARCH SERVICES, GRAND RAPIDS, MI. FILED 3-29-2012.

Clinicalingua

THE MARK CONSISTS OF STANDARD CHARACTERS WITHOUT CLAIM TO ANY PARTICULAR FONT, STYLE, SIZE, OR COLOR.

THE WORDING "CLINICALINGUA" HAS NO MEANING IN A FOREIGN LANGUAGE.

CLASS 35—ADVERTISING AND BUSINESS

FOR PROJECT MANAGEMENT SERVICES FOR OTHERS IN THE FIELD OF LANGUAGE TRANSLATION, CUSTOM WRITING, TEXT ADAPTATION, INTERPRETATION, DOCUMENT DEVELOPMENT, PROTOCOL DEVELOPMENT, EDITING, PROOFREADING; BUSINESS MANAGEMENT SERVICES FOR OTHERS IN THE FIELD OF LANGUAGE TRANSLATION, CUSTOM WRITING, TEXT ADAPTATION, INTERPRETATION, DOCUMENT DEVELOPMENT, PROTOCOL DEVELOPMENT, EDITING, PROOFREADING; BUSINESS MANAGEMENT SERVICES FOR OTHERS IN THE FIELDS OF CUSTOM DESIGN OF CLINICAL STUDY MATERIALS AND TRANSLATION OF CLINICAL STUDY MATERIALS (U.S. CLS. 100, 101 AND 102).

CLASS 41—EDUCATION AND ENTERTAINMENT

FOR TRANSLATION SERVICES; CUSTOM WRITING OF CLINICAL STUDY MATERIALS, LANGUAGE INTERPRETATION, WRITTEN TEXT EDITING, AND PROOF READING FOR OTHERS (U.S. CLS. 100, 101 AND 107).

KIMBERLY PARKS, EXAMINING ATTORNEY

SN 85-584,008. SPORTIF U.S.A., INC., SPARKS, NV. FILED 3-29-2012.

Aventura Clothing

THE MARK CONSISTS OF STANDARD CHARACTERS WITHOUT CLAIM TO ANY PARTICULAR FONT, STYLE, SIZE, OR COLOR.

NO CLAIM IS MADE TO THE EXCLUSIVE RIGHT TO USE "CLOTHING", APART FROM THE MARK AS SHOWN.

THE ENGLISH TRANSLATION OF "AVENTURA" IN THE MARK IS "ADVENTURE".

CLASS 18—LEATHER GOODS

FOR BAGS, NAMELY, BACKPACKS, BOOK BAGS, SPORTS BAGS, BUM BAGS, WALLETS, PURSES, HANDBAGS, BEACH BAGS, DRAWSTRING BAGS, MESSENGER BAGS, SLING BAGS, TOTE BAGS, AND TRAVEL BAGS (U.S. CLS. 1, 2, 3, 22 AND 41).

FIRST USE 4-9-2007; IN COMMERCE 4-9-2007.

CLASS 25—CLOTHING

FOR CLOTHING, NAMELY, BELTS, HATS, CAPS, BEANIES, GLOVES, MITTENS, SCARVES, UNDERWEAR, TIGHTS, LEGGINGS, SWIMWEAR, SHORTS, SKIRTS, DRESSES, CAPRIS, PANTS, TANK TOPS, SWEATERS, FLEECE TOPS, LONG AND SHORT SLEEVE SHIRTS, PONCHOS, JACKETS, COATS, VESTS, AND PARKAS (U.S. CLS. 22 AND 39).

FIRST USE 4-1-2005; IN COMMERCE 4-1-2005.

WON TEAK OH, EXAMINING ATTORNEY

SN 85-584,012. SPORTIF U.S.A., INC., SPARKS, NV. FILED 3-29-2012.

SN 85-584,490. SAINT JOSEPH MISSIONS, DBA WE ARE ONE BODY, LATROBE, PA. FILED 3-30-2012.

Aventura

WAOB

THE MARK CONSISTS OF STANDARD CHARACTERS WITHOUT CLAIM TO ANY PARTICULAR FONT, STYLE, SIZE, OR COLOR.

THE MARK CONSISTS OF STANDARD CHARACTERS WITHOUT CLAIM TO ANY PARTICULAR FONT, STYLE, SIZE, OR COLOR.

THE ENGLISH TRANSLATION OF "AVENTURA" IN THE MARK IS "ADVENTURE".

CLASS 38—COMMUNICATION

CLASS 18—LEATHER GOODS

FOR BROADCASTING OF RADIO PROGRAMMES; BROADCASTING OF RELIGIOUS RADIO PROGRAMS; BROADCASTING PROGRAMS VIA A GLOBAL COMPUTER NETWORK; INTERNET RADIO SERVICES, NAMELY, TRANSMISSION OF AUDIO MATERIAL VIA THE INTERNET; RADIO BROADCASTING; RADIO PROGRAM BROADCASTING (U.S. CLS. 100, 101 AND 104).

FOR BAGS, NAMELY, BACKPACKS, BOOK BAGS, SPORTS BAGS, BUM BAGS, WALLETS, PURSES, HANDBAGS, BEACH BAGS, DRAWSTRING BAGS, MESSENGER BAGS, SLING BAGS, TOTE BAGS, AND TRAVEL BAGS (U.S. CLS. 1, 2, 3, 22 AND 41).

FIRST USE 4-9-2007; IN COMMERCE 4-9-2007.

FIRST USE 3-19-2010; IN COMMERCE 3-19-2010.

CLASS 25—CLOTHING

CLASS 41—EDUCATION AND ENTERTAINMENT

FOR CLOTHING, NAMELY, BELTS, HATS, CAPS, BEANIES, GLOVES, MITTENS, SCARVES, UNDERWEAR, TIGHTS, LEGGINGS, SWIMWEAR, SHORTS, SKIRTS, DRESSES, CAPRIS, PANTS, TANK TOPS, SWEATERS, FLEECE TOPS, LONG AND SHORT SLEEVE SHIRTS, PONCHOS, JACKETS, COATS, VESTS, AND PARKAS (U.S. CLS. 22 AND 39).

FIRST USE 4-1-2005; IN COMMERCE 4-1-2005.
WON TEAK OH, EXAMINING ATTORNEY

FOR PRODUCTION AND DISTRIBUTION OF RADIO PROGRAMMES; PRODUCTION OF RADIO PROGRAMS (U.S. CLS. 100, 101 AND 107).

FIRST USE 3-19-2010; IN COMMERCE 3-19-2010.
ELLEN B. AWRICH, EXAMINING ATTORNEY

SN 85-584,440. JUTEC BIEGESYSTEME GMBH, LIMBURG, FED REP GERMANY, FILED 3-30-2012.

SN 85-584,553. CARD LIMITED CORP., LEHI, UT. FILED 3-30-2012.

YouCad



THE MARK CONSISTS OF STANDARD CHARACTERS WITHOUT CLAIM TO ANY PARTICULAR FONT, STYLE, SIZE, OR COLOR.

THE MARK CONSISTS OF A STYLIZED LETTER "B" IN WHICH THE NEGATIVE SPACE INSIDE THE LETTER APPEARS AS TWO RECTANGLES DIVIDED HORIZONTALLY BY A STRIPE, TO CREATE THE IMAGE OF A MAGNETICALLY STRIPED DEBIT CARD.

CLASS 12—VEHICLES

CLASS 9—ELECTRICAL AND SCIENTIFIC APPARATUS

FOR GOLF COURSE-SPECIFIC VEHICLES WITH AND WITHOUT MOTOR DRIVES, ELECTRIC GOLF CADDIES, MOTORIZED GOLF CARTS (U.S. CLS. 19, 21, 23, 31, 35 AND 44).

FOR MAGNETICALLY ENCODED DEBIT CARDS (U.S. CLS. 21, 23, 26, 36 AND 38).

FIRST USE 3-15-2012; IN COMMERCE 3-15-2012.

CLASS 28—TOYS AND SPORTING GOODS

CLASS 36—INSURANCE AND FINANCIAL

FOR NON-ELECTRIC GOLF CADDIES, NON-MOTORIZED GOLF CARTS (U.S. CLS. 22, 23, 38 AND 50).

FOR DEBIT CARD SERVICES (U.S. CLS. 100, 101 AND 102).

FIRST USE 6-1-2012; IN COMMERCE 6-1-2012.
KAREN K. BUSH, EXAMINING ATTORNEY

SN 85-584,756. INFINISOURCE, INC., COLDWATER, MI. FILED 3-30-2012.



OWNER OF U.S. REG. NOS. 3,774,505, 3,809,840 AND OTHERS.

THE MARK CONSISTS OF THE WORD "INFINISOURCE", WITH NINE CIRCLES GRADUATING FROM LIGHT TO DARK AND APPEARING HORIZONTALLY ABOVE THE "INFINI" PORTION.

CLASS 35—ADVERTISING AND BUSINESS

FOR COST MANAGEMENT FOR THE HEALTH CARE BENEFIT PLANS OF OTHERS; TRACKING AND MONITORING INSURANCE COMPLIANCE; FINANCIAL RECORD-KEEPING FOR REGULATORY COMPLIANCE PURPOSES; PAYROLL ADMINISTRATION AND MANAGEMENT SERVICES; BUSINESS ADVISORY SERVICES IN THE FIELD OF COBRA COMPLIANCE; TAX FILING SERVICES (U.S. CLS. 100, 101 AND 102).

FIRST USE 2-1-2012; IN COMMERCE 2-1-2012.

CLASS 36—INSURANCE AND FINANCIAL

FOR PAYROLL TAX DEBITING SERVICES; PROCESSING, ADMINISTERING AND MANAGING EMPLOYEE BENEFIT PLANS CONCERNING INSURANCE AND FINANCE; ADVISORY SERVICES IN THE FIELD OF EMPLOYEE BENEFITS FOR GROUP HEALTHCARE; ADMINISTRATION OF EMPLOYEE BENEFIT PLANS CONCERNING INSURANCE UNDER COBRA (U.S. CLS. 100, 101 AND 102).

FIRST USE 2-1-2012; IN COMMERCE 2-1-2012.

CLASS 41—EDUCATION AND ENTERTAINMENT

FOR EDUCATIONAL SERVICES, NAMELY, CONDUCTING SEMINARS AND WEBINARS IN THE FIELDS OF EMPLOYEE BENEFITS ADMINISTRATION, COBRA COMPLIANCE AND ADMINISTRATION, HUMAN RESOURCES, EMPLOYEE RECRUITING AND RETENTION, AND HUMAN CAPITAL AND HUMAN TALENT MANAGEMENT AND DISTRIBUTION OF COURSE MATERIAL IN CONNECTION THEREWITH (U.S. CLS. 100, 101 AND 107).

FIRST USE 2-1-2012; IN COMMERCE 2-1-2012.

CLASS 42—SCIENTIFIC AND COMPUTER SERVICES

FOR APPLICATION SERVICE PROVIDER, NAMELY, MANAGING, DEVELOPING, AND MAINTAINING APPLICATIONS AND SOFTWARE FOR OTHERS IN THE FIELDS OF EMPLOYEE BENEFITS ADMINISTRATION, PAYROLL, HUMAN RESOURCES, EMPLOYEE RECRUITING AND RETENTION, AND HUMAN CAPITAL AND TALENT MANAGEMENT; PROVIDING TEMPORARY USE OF ON-LINE NON-DOWNLOADABLE COMPUTER SOFTWARE FOR USE IN EMPLOYEE-RELATED BENEFITS SERVICES, NAMELY, FOR USE IN PAYROLL ADMINISTRATION, HUMAN RESOURCES, PAYROLL TAX CALCULATION, TAX REGULATION, EMPLOYEE BENEFITS MANAGEMENT, ENROLLMENT, AND ADMINISTRATION, CONSOLIDATED BILLING AND FOR DETERMINING BENEFITS ELIGIBILITY; PROVIDING TEMPORARY USE OF NON-DOWNLOADABLE COMPUTER SOFTWARE FOR SECURING COMPANY DATA AND PROVIDING SECURE ACCESS TO COMPANY DATA, NAMELY, COMPANY PAYROLL DATA, TAX DATA AND EMPLOYEE DATA (U.S. CLS. 100 AND 101).

FIRST USE 2-1-2012; IN COMMERCE 2-1-2012.

CLASS 45—PERSONAL AND LEGAL SERVICES

FOR REGULATORY COMPLIANCE CONSULTING IN THE FIELDS OF EMPLOYEE BENEFITS ADMINISTRATION, COBRA COMPLIANCE AND ADMINISTRATION, PAYROLL, HUMAN RESOURCES, EMPLOYEE RECRUITING AND RETENTION, AND HUMAN CAPITAL AND TALENT MANAGEMENT; TRACKING AND MONITORING REGULATORY REQUIREMENTS IN THE FIELD OF COBRA BENEFITS FOR REGULATORY COMPLIANCE PURPOSES; PROVIDING INFORMATION IN THE FIELD OF COMPLIANCE WITH COBRA REGULATIONS (U.S. CLS. 100 AND 101).

FIRST USE 2-1-2012; IN COMMERCE 2-1-2012.

MATTHEW PAPPAS, EXAMINING ATTORNEY

SN 85-585,030. GAS SOUTH, LLC, ATLANTA, GA. FILED 3-30-2012.

BEST VALUE FOR YOUR ENERGY DOLLAR

THE MARK CONSISTS OF STANDARD CHARACTERS WITHOUT CLAIM TO ANY PARTICULAR FONT, STYLE, SIZE, OR COLOR.

CLASS 35—ADVERTISING AND BUSINESS

FOR UTILITY BILL MANAGEMENT SERVICES, NAMELY, TRACKING, REPORTING, ANALYZING AND DELIVERING ENERGY INFORMATION IN THE FORM OF UTILITY BILLS AND UTILITY METER DATA RATE SCHEDULES; APPOINTMENT SCHEDULING FOR DELIVERY OF ENERGY FOR OTHERS; PROMOTION AND MARKETING SERVICES AND PROVIDING CONSUMER INFORMATION ALL IN THE FIELD OF ENERGY (U.S. CLS. 100, 101 AND 102).

CLASS 39—TRANSPORTATION AND STORAGE

FOR TRANSPORTATION AND DELIVERY OF ENERGY, NATURAL GAS, LIQUID HYDROCARBONS, AND GAS CONDENSATE; PUBLIC UTILITY AND ENERGY RELATED SERVICES, NAMELY, TRANSMISSION THROUGH PIPELINES, DISTRIBUTION, TRANSPORTATION, AND STORAGE OF GAS AND ENERGY FOR AND TO INDUSTRIAL, COMMERCIAL, GOVERNMENTAL, AND RESIDENTIAL CUSTOMERS (U.S. CLS. 100 AND 105).

KEVON CHISOLM, EXAMINING ATTORNEY

SN 85-585,190. FINANCIAL FRUITCAKES, INC., NAPLES, FL. FILED 3-30-2012.

FINANCIAL FUNDAMENTALS

THE MARK CONSISTS OF STANDARD CHARACTERS WITHOUT CLAIM TO ANY PARTICULAR FONT, STYLE, SIZE, OR COLOR.

NO CLAIM IS MADE TO THE EXCLUSIVE RIGHT TO USE "FINANCIAL", APART FROM THE MARK AS SHOWN.

CLASS 9—ELECTRICAL AND SCIENTIFIC APPARATUS

FOR COMPUTER APPLICATION SOFTWARE FOR MOBILE PHONES, NAMELY, SOFTWARE FOR TEACHING FINANCIAL RESPONSIBILITY TO YOUNG ADULTS (U.S. CLS. 21, 23, 26, 36 AND 38).

CLASS 41—EDUCATION AND ENTERTAINMENT

FOR ENTERTAINMENT SERVICES, NAMELY, AN ON-GOING SERIES FEATURING TEACHING FINANCIAL RESPONSIBILITY TO YOUNG ADULTS PROVIDED THROUGH CABLE TELEVISION, WEBCASTS, AND RADIO BROADCASTS; ENTERTAINMENT SERVICES, NAMELY, PROVIDING ON-GOING WEBISODES FEATURING TEACHING FINANCIAL RESPONSIBILITY TO YOUNG ADULTS VIA A GLOBAL COMPUTER NETWORK; EDUCATION SERVICES, NAMELY, PROVIDING SEMINARS, LECTURES AND PRESENTATIONS FEATURING TEACHING FINANCIAL RESPONSIBILITY TO YOUNG ADULTS (U.S. CLS. 100, 101 AND 107).

JEFFREY LOOK, EXAMINING ATTORNEY

SN 85-585,222. HER VIEW, LLC, OSSINING, NY. FILED 3-30-2012.

HER VIEW

THE MARK CONSISTS OF STANDARD CHARACTERS WITHOUT CLAIM TO ANY PARTICULAR FONT, STYLE, SIZE, OR COLOR.

CLASS 18—LEATHER GOODS

FOR CLUTCHES; HANDBAGS; TOTE BAGS (U.S. CLS. 1, 2, 3, 22 AND 41).

CLASS 35—ADVERTISING AND BUSINESS

FOR ON-LINE RETAIL STORE SERVICES FEATURING HANDBAGS, WOMEN'S ACCESSORIES, JEWELRY, BELTS, HATS, WALLETS, TOTE BAGS, CLUTCHES, SATCHELS, HOBO BAGS, T-SHIRTS, SCARVES AND GLOVES (U.S. CLS. 100, 101 AND 102).

ALICE BENMAMAN, EXAMINING ATTORNEY

SN 85-585,510. RICE FIELD CORPORATION, CITY OF INDUSTRY, CA. FILED 3-30-2012.

ENDURA

THE MARK CONSISTS OF STANDARD CHARACTERS WITHOUT CLAIM TO ANY PARTICULAR FONT, STYLE, SIZE, OR COLOR.

CLASS 29—MEATS AND PROCESSED FOODS

FOR DAIRY AND MILK PRODUCTS, EXCLUDING ICE CREAM, ICE MILK AND FROZEN YOGURT (U.S. CL. 46).

CLASS 30—STAPLE FOODS

FOR COFFEE AND TEA; DAIRY AND MILK PRODUCTS, NAMELY, ICE CREAM, ICE MILK AND FROZEN YOGURT (U.S. CL. 46).

DOMINIC J. FERRAIUOLO, EXAMINING ATTORNEY

SN 85-585,581. VON YURT, JOANNA, SANTA BARBARA, CA. AND VON YURT, JAN MARCO, SANTA BARBARA, CA. FILED 3-30-2012.

SWANLING

THE MARK CONSISTS OF STANDARD CHARACTERS WITHOUT CLAIM TO ANY PARTICULAR FONT, STYLE, SIZE, OR COLOR.

CLASS 24—FABRICS

FOR BEDDING, NAMELY, SHEETS, BLANKETS; BABY BEDDING, NAMELY, BUNDLE BAGS, SWADDLING BLANKETS, CRIB BUMPERS, FITTED CRIB SHEETS, CRIB SHEETS, CRIB SKIRTS, CRIB BLANKETS, AND DIAPER CHANGING PAD COVERS NOT OF PAPER; BABY BLANKETS, BED LINEN; BED BLANKETS; BED SHEETS; BED PADS; CRIB PADS; BED THROWS; SLEEPING BAGS IN THE NATURE OF SHEETING; CHILDREN'S BLANKETS (U.S. CLS. 42 AND 50).

CLASS 25—CLOTHING

FOR CLOTHING, NAMELY, BABY BOTTOMS AND BABY TOPS; BABY BUNTING; JUMPERS; LAYETTES; NIGHTGOWNS; PAJAMAS; AND SLEEPWEAR; INFANT WEARABLE BED PADS; INFANT WEARABLE BED SHEETS; INFANT WEARABLE BLANKETS; INFANT WEARABLE CRIB SHEETS; AND WEARABLE BLANKETS IN THE NATURE OF BLANKETS WITH SLEEVES (U.S. CLS. 22 AND 39).

CLASS 28—TOYS AND SPORTING GOODS

FOR CHILDREN'S MULTIPLE ACTIVITY TOYS; PLUSH TOYS AND DOLLS; STUFFED TOYS AND DOLLS; CRIB TOYS; CRIB MOBILES; INFANT TOYS; RIDE-ON TOYS; TOY ANIMALS; AND TEETHING TOYS (U.S. CLS. 22, 23, 38 AND 50).

MATTHEW MCDOWELL, EXAMINING ATTORNEY

SN 85-585,587. IMI INNOVATIONS, INC., NAPERVILLE, IL.
FILED 3-30-2012.

SN 85-585,614. HECSA, LLC, NORTH PALM BEACH, FL.
FILED 3-30-2012.

GLOBLAPP

THE MARK CONSISTS OF STANDARD CHARACTERS WITHOUT CLAIM TO ANY PARTICULAR FONT, STYLE, SIZE, OR COLOR.

CLASS 9—ELECTRICAL AND SCIENTIFIC APPARATUS

FOR COMPUTER SOFTWARE FOR ALLOWING SIMULTANEOUS OPERATION OF MULTIPLE USER INPUT DEVICES (U.S. CLS. 21, 23, 26, 36 AND 38).

CLASS 42—SCIENTIFIC AND COMPUTER SERVICES

FOR PROVIDING ON-LINE NON-DOWNLOADABLE SOFTWARE FOR ALLOWING SIMULTANEOUS OPERATION OF MULTIPLE USER INPUT DEVICES (U.S. CLS. 100 AND 101).

KEVEN MITTLER, EXAMINING ATTORNEY

SN 85-585,589. VON YURT, JOANNA, SANTA BARBARA, CA. AND VON YURT, JAN MARCO, SANTA BARBARA, CA. FILED 3-30-2012.

SLUMBER SHEET

THE MARK CONSISTS OF STANDARD CHARACTERS WITHOUT CLAIM TO ANY PARTICULAR FONT, STYLE, SIZE, OR COLOR.

NO CLAIM IS MADE TO THE EXCLUSIVE RIGHT TO USE "SHEET", APART FROM THE MARK AS SHOWN.

CLASS 24—FABRICS

FOR BEDDING, NAMELY, SHEETS, BLANKETS; BABY BEDDING, NAMELY, BUNDLE BAGS, SWADDLING BLANKETS, CRIB BUMPERS, FITTED CRIB SHEETS, CRIB SHEETS, CRIB SKIRTS, CRIB BLANKETS, AND DIAPER CHANGING PAD COVERS NOT OF PAPER; BABY BLANKETS, BED LINEN; BED BLANKETS; BED SHEETS; BED PADS; CRIB PADS; BED THROWS; SLEEPING BAGS IN THE NATURE OF SHEETING; CHILDREN'S BLANKETS (U.S. CLS. 42 AND 50).

CLASS 25—CLOTHING

FOR CLOTHING, NAMELY, BABY BOTTOMS AND BABY TOPS; BABY BUNTING; JUMPERS; LAYETTES; NIGHTGOWNS; PAJAMAS; AND SLEEPWEAR; INFANT WEARABLE BED PADS; INFANT WEARABLE BED SHEETS; INFANT WEARABLE BLANKETS; INFANT WEARABLE CRIB SHEETS; AND WEARABLE BLANKETS IN THE NATURE OF BLANKETS WITH SLEEVES (U.S. CLS. 22 AND 39).

MATTHEW MCDOWELL, EXAMINING ATTORNEY



THE MARK CONSISTS OF A CHEVRON DESIGN TO THE LEFT OF THE WORDING "HECSA".

CLASS 16—PAPER GOODS AND PRINTED MATTER

FOR ADHESIVE NOTE PADS; NOTEPADS; SKETCH BOOKS; SKETCH PADS; STICKERS (U.S. CLS. 2, 5, 22, 23, 29, 37, 38 AND 50).

CLASS 25—CLOTHING

FOR LONG-SLEEVED SHIRTS; POLO SHIRTS; SHIRTS; SHORT-SLEEVED SHIRTS; SWEAT SHIRTS; T-SHIRTS; TANK TOPS (U.S. CLS. 22 AND 39).

WON TEAK OH, EXAMINING ATTORNEY

SN 85-586,047. INSERRA JR., CARL, RAMSEY, NJ. FILED 4-2-2012.

BREW CIRCUS

THE MARK CONSISTS OF STANDARD CHARACTERS WITHOUT CLAIM TO ANY PARTICULAR FONT, STYLE, SIZE, OR COLOR.

NO CLAIM IS MADE TO THE EXCLUSIVE RIGHT TO USE "BREW", APART FROM THE MARK AS SHOWN.

CLASS 32—LIGHT BEVERAGES

FOR BEER (U.S. CLS. 45, 46 AND 48).

CLASS 43—HOTEL AND RESTAURANT SERVICES

FOR RESTAURANT AND CAFE SERVICES; CATERING SERVICES; BREWERY RESTAURANT AND SEASONAL KITCHEN, NAMELY, PROVISION OF FOOD AND BEVERAGES (U.S. CLS. 100 AND 101).

LINDA POWELL, EXAMINING ATTORNEY

SN 85-586,135. ARTHUR WILLIAMS INDUSTRIES LLC,
CINCINNATI, OH. FILED 4-2-2012.

SN 85-586,363. DILEMMA X, LLC, DBA DILEMMA X,
ATLANTA, GA. FILED 4-2-2012.

ArthurWilliams Industries

THE MARK CONSISTS OF STANDARD CHARACTERS WITHOUT CLAIM TO ANY PARTICULAR FONT, STYLE, SIZE, OR COLOR.

OWNER OF U.S. REG. NO. 3,368,073.

NO CLAIM IS MADE TO THE EXCLUSIVE RIGHT TO USE "INDUSTRIES", APART FROM THE MARK AS SHOWN.

THE NAME(S), PORTRAIT(S), AND/OR SIGNATURE(S) SHOWN IN THE MARK DOES NOT IDENTIFY A PARTICULAR LIVING INDIVIDUAL.

CLASS 35—ADVERTISING AND BUSINESS

FOR BUSINESS MANAGEMENT SERVICES RELATING TO THE PROCUREMENT, TRANSPORT, INVENTORY AND SALE OF BUSINESS SUPPLIES, JANITORIAL SUPPLIES AND OFFICE SUPPLIES (U.S. CLS. 100, 101 AND 102).

FIRST USE 6-30-2011; IN COMMERCE 6-30-2011.

CLASS 42—SCIENTIFIC AND COMPUTER SERVICES

FOR PROVIDING TEMPORARY USE OF ON-LINE NON-DOWNLOADABLE SOFTWARE TO INPUT, STORE, MANAGE, TRACK, ANALYZE, DISPLAY AND REPORT DATA IN THE FIELDS OF PROCUREMENT, TRANSPORTING, INVENTORY AND SALES OF JANITORIAL SUPPLIES, OFFICE SUPPLIES AND BUSINESS PRODUCTS; AND PROVIDING TEMPORARY USE OF ON-LINE NON-DOWNLOADABLE SOFTWARE TO FACILITATE ORDERING JANITORIAL SUPPLIES, OFFICE SUPPLIES AND BUSINESS PRODUCTS (U.S. CLS. 100 AND 101).

FIRST USE 6-30-2011; IN COMMERCE 6-30-2011.
ANNE FARRELL, EXAMINING ATTORNEY

SN 85-586,313. MOY, JAMES J., JR., DBA JIM JIM'S WATER-ICE, AUSTIN, TX. FILED 4-2-2012.

JIM-JIM'S WATER-ICE

THE MARK CONSISTS OF STANDARD CHARACTERS WITHOUT CLAIM TO ANY PARTICULAR FONT, STYLE, SIZE, OR COLOR.

OWNER OF U.S. REG. NO. 2,980,935.

NO CLAIM IS MADE TO THE EXCLUSIVE RIGHT TO USE "WATER ICE", APART FROM THE MARK AS SHOWN.

CLASS 35—ADVERTISING AND BUSINESS

FOR RETAIL STORE SERVICES FEATURING ITALIAN ICES (U.S. CLS. 100, 101 AND 102).

FIRST USE 6-22-1994; IN COMMERCE 6-22-1994.

CLASS 43—HOTEL AND RESTAURANT SERVICES

FOR CATERING SERVICES (U.S. CLS. 100 AND 101).

FIRST USE 6-22-1994; IN COMMERCE 6-22-1994.
JOSETTE BEVERLY, EXAMINING ATTORNEY

Dilemma X

THE MARK CONSISTS OF STANDARD CHARACTERS WITHOUT CLAIM TO ANY PARTICULAR FONT, STYLE, SIZE, OR COLOR.

OWNER OF U.S. REG. NO. 4,117,699.

CLASS 9—ELECTRICAL AND SCIENTIFIC APPARATUS

FOR AUDIO AND VIDEO RECORDINGS FEATURING MUSIC, POLITICS, NEWS, CULTURAL (U.S. CLS. 21, 23, 26, 36 AND 38).

FIRST USE 4-1-2011; IN COMMERCE 4-1-2011.

CLASS 35—ADVERTISING AND BUSINESS

FOR BUSINESS RESEARCH CONSULTATION; DEMOGRAPHIC CONSULTATION AND STUDIES (U.S. CLS. 100, 101 AND 102).

FIRST USE 4-1-2011; IN COMMERCE 4-1-2011.

JOSETTE BEVERLY, EXAMINING ATTORNEY

SN 85-586,656. BLUEKAI, INC., BELLEVUE, WA. FILED 4-2-2012.

FASTRAMP

THE MARK CONSISTS OF STANDARD CHARACTERS WITHOUT CLAIM TO ANY PARTICULAR FONT, STYLE, SIZE, OR COLOR.

CLASS 9—ELECTRICAL AND SCIENTIFIC APPARATUS

FOR COMPUTER SOFTWARE FOR MANAGING EFFICIENT DATA FLOWS (U.S. CLS. 21, 23, 26, 36 AND 38).

CLASS 39—TRANSPORTATION AND STORAGE

FOR COMPUTER SERVICES, NAMELY, PROVIDING ELECTRONIC CENTRALIZED DATA STORAGE FOR OTHERS (U.S. CLS. 100 AND 105).

ANDREW LEASER, EXAMINING ATTORNEY

SN 85-586,816. BOONE, THOMAS A., DBA BOONE INTERACTIVE, CARRALES, NM. FILED 4-2-2012.

BOONE INTERACTIVE

THE MARK CONSISTS OF STANDARD CHARACTERS WITHOUT CLAIM TO ANY PARTICULAR FONT, STYLE, SIZE, OR COLOR.

NO CLAIM IS MADE TO THE EXCLUSIVE RIGHT TO USE "INTERACTIVE", APART FROM THE MARK AS SHOWN.

SEC. 2(F).

CLASS 42—SCIENTIFIC AND COMPUTER SERVICES

FOR TECHNOLOGICAL CONSULTATION SERVICES PROVIDED TO MANUFACTURERS IN THE FIELDS OF PHARMACEUTICALS, BIOTECHNOLOGY, AND MEDICAL DEVICES REGARDING PROCESS AUTOMATION, COMPUTER SOFTWARE, VALIDATION SYSTEMS, AND PRODUCT QUALITY CONTROL (U.S. CLS. 100 AND 101).

FIRST USE 4-1-1995; IN COMMERCE 4-1-1995.

CLASS 45—PERSONAL AND LEGAL SERVICES

FOR LEGAL CONSULTATION SERVICES PROVIDED TO MANUFACTURERS IN THE FIELDS OF PHARMACEUTICALS, BIOTECHNOLOGY, AND MEDICAL DEVICES, REGARDING GOVERNMENTAL REGULATORY LAWS AND GOVERNMENT REGULATORY PRACTICES (U.S. CLS. 100 AND 101).

FIRST USE 4-1-1995; IN COMMERCE 4-1-1995.

DANIEL S. STRINGER, EXAMINING ATTORNEY

SN 85-587,037. SABER BUSINESS SOLUTIONS INC., DBA SABER BUSINESS SOLUTIONS INC., CHARLOTTE, NC. FILED 4-2-2012.

SABER SOLUTIONS

THE MARK CONSISTS OF STANDARD CHARACTERS WITHOUT CLAIM TO ANY PARTICULAR FONT, STYLE, SIZE, OR COLOR.

NO CLAIM IS MADE TO THE EXCLUSIVE RIGHT TO USE "SOLUTIONS", APART FROM THE MARK AS SHOWN.

CLASS 9—ELECTRICAL AND SCIENTIFIC APPARATUS

FOR COMPUTER SOFTWARE DEVELOPMENT TOOLS; COMPUTER SOFTWARE FOR ADMINISTRATION OF COMPUTER LOCAL AREA NETWORKS; COMPUTER SOFTWARE FOR APPLICATION AND DATABASE INTEGRATION; COMPUTER SOFTWARE FOR COMPUTER SYSTEM AND APPLICATION DEVELOPMENT, DEPLOYMENT AND MANAGEMENT; COMPUTER SOFTWARE FOR THE COLLECTION, EDITING, ORGANIZING, MODIFYING, BOOK MARKING, TRANSMISSION, STORAGE AND SHARING OF DATA AND INFORMATION; COMPUTER SOFTWARE FOR THE DATABASING, VISUALIZATION, MANIPULATION, VIRTUAL REALITY IMMERSION AND INTEGRATION OF GEOGRAPHIC INFORMATION WITH ON-LINE MEMBER COMMUNITIES; COMPUTER SOFTWARE FOR THE FIELD OF WAREHOUSING AND DISTRIBUTION, TO MANAGE TRANSACTIONAL DATA, PROVIDE STATISTICAL ANALYSIS, AND PRODUCE NOTIFICATIONS AND REPORTS; COMPUTER SOFTWARE FOR USE IN CUSTOMER RELATIONSHIP MANAGEMENT (CRM); COMPUTER SOFTWARE FOR USE IN THE SAFEGUARDING OF DIGITAL FILES, INCLUDING AUDIO, VIDEO, TEXT, BINARY, STILL IMAGES, GRAPHICS AND MULTIMEDIA FILES; COMPUTER SOFTWARE PLATFORMS FOR DESIGNING, INSTALLING, AND EXECUTING USER/SERVER PROGRAMS FOR INTEGRATING FINANCIAL, MANUFACTURING, SALES, DISTRIBUTION FUNCTIONS AND FOR MANAGING CUSTOMER RELATIONS, AND HUMAN CAPITAL MANAGEMENT, DIGITAL MARKETING, INTERACTIVE MEETING SOFTWARE; COMPUTER SOFTWARE THAT PROVIDES REAL-TIME, INTEGRATED BUSINESS MANAGEMENT INTELLIGENCE BY COMBINING INFORMATION FROM VARIOUS DATABASES AND PRESENTING IT IN AN EASY-TO-UNDERSTAND USER INTERFACE; COMPUTER SOFTWARE THAT PROVIDES WEB-BASED ACCESS TO APPLICATIONS AND SERVICES THROUGH A WEB OPERATING SYSTEM OR PORTAL INTERFACE; COMPUTER SOFTWARE TO AUTOMATE DATA WAREHOUSING; COMPUTER SOFTWARE TO MONITOR AND CONTROL FACTORY MANUFACTURING PROCESSES; DATABASE MANAGEMENT SOFTWARE FOR USER/SERVER PROGRAMS FOR INTEGRATING FINANCIAL, MANUFACTURING, SALES, DISTRIBUTION FUNCTIONS AND FOR MANAGING CUSTOMER RELATIONS, AND HUMAN CAPITAL MANAGEMENT, DIGITAL MARKETING, INTERACTIVE MEETING SOFTWARE; DOWNLOADABLE ELECTRONIC DATA FILES AND DATABASES, NAMELY, BUSINESS AND TAX FORMS, FOR USE WITH COMPUTER SOFTWARE; FACTORY AUTOMATION SOFTWARE, NAMELY, SOFTWARE TO INTEGRATE MANUFACTURING MACHINE OPERATIONS, TRACK PROBLEMS AND GENERATE PRODUCTION REPORTS; INDUSTRIAL PROCESS CONTROL SOFTWARE; SOFTWARE FOR MONITORING AND CONTROLLING COMMUNICATION BETWEEN COMPUTERS AND AUTOMATED MACHINE SYSTEMS; TAX MANAGEMENT DATA COLLECTION SOFTWARE (U.S. CLS. 21, 23, 26, 36 AND 38).

FIRST USE 8-5-2009; IN COMMERCE 8-5-2009.

CLASS 35—ADVERTISING AND BUSINESS

FOR ONLINE MEDIA MONITORING SERVICES USING COMPUTER SOFTWARE TO AUTOMATICALLY MONITOR INTERNET WEBSITES AND ONLINE PUBLICATIONS FOR CUSTOMER-SPECIFIED TOPICS AND TO CAPTURE RELEVANT CONTENT ON THOSE TOPICS, AND PROVIDING DOCUMENTATION AND ANALYSIS OF THAT ONLINE CONTENT TO OTHERS FOR BUSINESS PURPOSES; OUTSOURCING IN THE FIELD OF SALES AND MARKETING OF COMPUTER SOFTWARE (U.S. CLS. 100, 101 AND 102).

FIRST USE 8-5-2009; IN COMMERCE 8-5-2009.

CLASS 37—CONSTRUCTION AND REPAIR

FOR TECHNICAL SUPPORT SERVICES, NAMELY, TECHNICAL ADVICE RELATED TO THE REPAIR OF, INSTALLATION, AND MAINTENANCE OF COMPUTER SYSTEMS AND NETWORK HARDWARE (U.S. CLS. 100, 103 AND 106).

FIRST USE 8-5-2009; IN COMMERCE 8-5-2009.

CLASS 38—COMMUNICATION

FOR INTERNET SERVICES, NAMELY, PROVIDING MULTIPLE-USER ACCESS TO INFORMATION ON THE INTERNET CONCERNING THE DEVELOPMENT AND GENERATION OF COMPUTER SOFTWARE FOR USE IN BUSINESSES AS WELL AS THE FUNCTIONS AND APPLICATION OF SUCH BUSINESS SOFTWARE (U.S. CLS. 100, 101 AND 104).

FIRST USE 8-5-2009; IN COMMERCE 8-5-2009.

CLASS 41—EDUCATION AND ENTERTAINMENT

FOR PROVIDING A WEBSITE FEATURING RESOURCES, NAMELY, NON-DOWNLOADABLE PUBLICATIONS IN THE NATURE OF E-ZINES AND NEWSLETTERS FOR USE WITH TRAINING, COURSES, WORKSHOPS, SEMINARS IN THE FIELD OF COMPUTER SYSTEMS, SOFTWARE DEVELOPMENT AND USE, BUSINESS AND BUSINESS OPERATIONS AND ALSO FEATURING NON-DOWNLOADABLE SOFTWARE FOR STORAGE OF DATA GENERATED BY BUSINESS ACTIVITY, FINANCE, DISTRIBUTION, MARKETING AND CUSTOMER RELATIONS, SALES DATA, AND HUMAN CAPITAL MANAGEMENT (U.S. CLS. 100, 101 AND 107).

FIRST USE 8-5-2009; IN COMMERCE 8-5-2009.

CLASS 42—SCIENTIFIC AND COMPUTER SERVICES

FOR TECHNICAL SUPPORT SERVICES, NAMELY, TECHNICAL ADVICE RELATED TO THE REPAIR OF INSTALLATION AND MAINTENANCE OF COMPUTER NETWORK SOFTWARE (U.S. CLS. 100 AND 101).

FIRST USE 8-5-2009; IN COMMERCE 8-5-2009.
BENJAMIN OKEKE, EXAMINING ATTORNEY

SN 85-587,229. LIBERTY HARDWARE MFG. CORP., WINSTON-SALEM, NC. FILED 4-3-2012.

HOMEGROWN HARDWARE

THE MARK CONSISTS OF STANDARD CHARACTERS WITHOUT CLAIM TO ANY PARTICULAR FONT, STYLE, SIZE, OR COLOR.

NO CLAIM IS MADE TO THE EXCLUSIVE RIGHT TO USE "HARDWARE", APART FROM THE MARK AS SHOWN.

CLASS 6—METAL GOODS

FOR METAL CABINET HARDWARE, NAMELY, KNOBS AND PULLS, HOOKS AND HOOK RAILS AND WALL PLATES (U.S. CLS. 2, 12, 13, 14, 23, 25 AND 50).

CLASS 20—FURNITURE AND ARTICLES NOT OTHERWISE CLASSIFIED

FOR NON-METAL CABINET HARDWARE, NAMELY, KNOBS AND PULLS, HOOKS AND HOOK RAILS, WALL PLATES, ROBE HOOKS AND SHELVING (U.S. CLS. 2, 13, 22, 25, 32 AND 50).

BRENDAN REGAN, EXAMINING ATTORNEY

SN 85-587,242. HARTFORD FIRE INSURANCE COMPANY, HARTFORD, CT. FILED 4-3-2012.

GroupRePlus

THE MARK CONSISTS OF STANDARD CHARACTERS WITHOUT CLAIM TO ANY PARTICULAR FONT, STYLE, SIZE, OR COLOR.

CLASS 36—INSURANCE AND FINANCIAL

FOR INSURANCE SERVICES, NAMELY, INSURANCE UNDERWRITING, ACTUARIAL, AND CLAIMS ADMINISTRATION IN THE AREAS OF SHORT TERM DISABILITY, LONG TERM DISABILITY, LIFE, AND ACCIDENTAL DEATH AND DISMEMBERMENT INSURANCE; INSURANCE BROKERAGE SERVICES (U.S. CLS. 100, 101 AND 102).

FIRST USE 12-31-2007; IN COMMERCE 12-31-2007.

CLASS 41—EDUCATION AND ENTERTAINMENT

FOR TRAINING IN THE FIELD OF INSURANCE UNDERWRITING, ACTUARIAL, AND CLAIMS MANAGEMENT IN THE AREAS OF SHORT TERM DISABILITY, LONG TERM DISABILITY, LIFE, AND ACCIDENTAL DEATH AND DISMEMBERMENT INSURANCE (U.S. CLS. 100, 101 AND 107).

FIRST USE 12-31-2007; IN COMMERCE 12-31-2007.
KARANENDRA S. CHHINA, EXAMINING ATTORNEY

SN 85-587,503. GROBET FILE COMPANY OF AMERICA, INC., WINNETKA, IL. FILED 4-3-2012.

CERAMIT

THE MARK CONSISTS OF STANDARD CHARACTERS WITHOUT CLAIM TO ANY PARTICULAR FONT, STYLE, SIZE, OR COLOR.

CLASS 1—CHEMICALS

FOR CATALYST REFILLS CONTAINING CATALYSTS FOR CURING ENAMELS BY OXIDATION FOR USE IN THE MANUFACTURE OF JEWELRY (U.S. CLS. 1, 5, 6, 10, 26 AND 46).

FIRST USE 0-0-1978; IN COMMERCE 0-0-1978.

CLASS 2—PAINTS

FOR CERAMIC AND CERAMIC-LIKE GLAZES IN THE NATURE OF A LIQUID COLORANT COATING; THINNERS FOR COLORS (U.S. CLS. 6, 11 AND 16).

FIRST USE 0-0-1978; IN COMMERCE 0-0-1978.
DAWN HAN, EXAMINING ATTORNEY

SN 85-587,603. SEIB, EVE A, DUNWOODY, GA. FILED 4-3-2012.

Sweet Tweets Ice Cream

THE MARK CONSISTS OF STANDARD CHARACTERS WITHOUT CLAIM TO ANY PARTICULAR FONT, STYLE, SIZE, OR COLOR.

NO CLAIM IS MADE TO THE EXCLUSIVE RIGHT TO USE "ICE CREAM", APART FROM THE MARK AS SHOWN.

CLASS 30—STAPLE FOODS

FOR ICE CREAM; ICE CREAM DESSERTS; ICE CREAM DRINKS; ICE CREAM FLOATS; ICE CREAMS (U.S. CL. 46).

CLASS 35—ADVERTISING AND BUSINESS

FOR RETAIL STORE SERVICES FEATURING ICE CREAM FOR CONSUMPTION OFF THE PREMISES (U.S. CLS. 100, 101 AND 102).

CLASS 43—HOTEL AND RESTAURANT SERVICES

FOR ICE CREAM PARLORS; PROVIDING OF FOOD AND DRINK VIA A MOBILE TRUCK (U.S. CLS. 100 AND 101).

KEVIN CORWIN, EXAMINING ATTORNEY

SN 85-587,679. NATIONAL OILWELL VARCO, L.P., HOUSTON, TX. FILED 4-3-2012.

NOVAPPS

THE MARK CONSISTS OF STANDARD CHARACTERS WITHOUT CLAIM TO ANY PARTICULAR FONT, STYLE, SIZE, OR COLOR.

CLASS 35—ADVERTISING AND BUSINESS

FOR RETAIL STORE SERVICES FEATURING COMPUTER SOFTWARE PROVIDED VIA THE INTERNET AND OTHER COMPUTER AND ELECTRONIC COMMUNICATION NETWORKS; RETAIL STORE SERVICES FEATURING COMPUTER SOFTWARE (U.S. CLS. 100, 101 AND 102).

CLASS 38—COMMUNICATION

FOR ELECTRONIC TRANSMISSION OF DATA VIA THE INTERNET, GLOBAL COMPUTER NETWORKS, WIRELESS NETWORKS AND ELECTRONIC COMMUNICATION NETWORKS; PROVIDING USER ACCESS TO GLOBAL COMPUTER NETWORKS, WIRELESS NETWORKS AND ELECTRONIC COMMUNICATIONS NETWORKS FOR TRANSMISSION OR RECEIPT OF DATA (U.S. CLS. 100, 101 AND 104).

CLASS 42—SCIENTIFIC AND COMPUTER SERVICES

FOR MAINTENANCE, REPAIR AND UPDATING OF COMPUTER SOFTWARE USED IN THE FIELDS OF OIL AND GAS EXPLORATION AND PRODUCTION; PROVIDING A WEBSITE FEATURING TECHNICAL INFORMATION RELATING TO COMPUTER SOFTWARE USED IN THE FIELDS OF OIL AND GAS EXPLORATION AND PRODUCTION; TECHNICAL SUPPORT SERVICES, NAMELY, TROUBLESHOOTING IN THE NATURE OF DIAGNOSING AND REPAIRING COMPUTER SOFTWARE PROBLEMS FOR COMPUTER SOFTWARE USED IN THE FIELDS OF OIL AND GAS EXPLORATION AND PRODUCTION; PROVIDING TEMPORARY USE OF NON-DOWNLOADABLE COMPUTER SOFTWARE TO ENABLE USERS TO PROGRAM, ORGANIZE AND ACCESS THIRD-PARTY COMPUTER SOFTWARE PROGRAMS USED IN THE FIELDS OF OIL AND GAS EXPLORATION AND PRODUCTION; INTERNET SERVICES, NAMELY, CREATING COMPUTER NETWORK BASED INDEXES OF INFORMATION, WEBSITES, AND RESOURCES AVAILABLE ON GLOBAL COMPUTER NETWORKS FOR OTHERS; PROVIDING TECHNICAL INFORMATION UPDATES OF COMPUTER SOFTWARE USED IN THE FIELDS OF OIL AND GAS EXPLORATION AND PRODUCTION; COMPUTER SOFTWARE CONSULTATION; CONSULTATION SERVICES IN THE FIELDS OF SELECTION, TESTING, IMPLEMENTATION AND USE OF COMPUTER HARDWARE AND SOFTWARE SYSTEMS FOR OTHERS; PROVIDING ONLINE TECHNICAL COMPUTER SOFTWARE INFORMATION IN THE FIELDS OF OIL AND GAS EXPLORATION AND PRODUCTION; REMOTE MONITORING SERVICES WHICH TRACKS APPLICATION SOFTWARE PERFORMANCE, PERFORMS PERIODIC MAINTENANCE AND PROVIDES REPORTS AND ALERTS CONCERNING SUCH PERFORMANCES, THE AFOREMENTIONED FOR SOFTWARE IN THE FIELDS OF OIL AND GAS EXPLORATION AND PRODUCTION; AND REMOTE TECHNICAL SUPPORT SERVICES, NAMELY, TROUBLESHOOTING IN THE NATURE OF DIAGNOSING COMPUTER HARDWARE AND SOFTWARE PROBLEMS IN THE FIELDS OF OIL AND GAS EXPLORATION AND PRODUCTION (U.S. CLS. 100 AND 101).

ELI HELLMAN, EXAMINING ATTORNEY

SN 85-587,852. DSH MGMT SYSTEMS, LLC, CHANTILLY, VA. FILED 4-3-2012.

NAVEOS

THE MARK CONSISTS OF STANDARD CHARACTERS WITHOUT CLAIM TO ANY PARTICULAR FONT, STYLE, SIZE, OR COLOR.

CLASS 9—ELECTRICAL AND SCIENTIFIC APPARATUS

FOR COMPUTER SOFTWARE FOR DATA PROCESSING, DATA MANAGEMENT, AND MANAGEMENT OF REVENUE STREAMS IN THE FIELD OF HEALTHCARE REIMBURSEMENT CLAIMS BY HEALTHCARE PROVIDERS (U.S. CLS. 21, 23, 26, 36 AND 38).

CLASS 35—ADVERTISING AND BUSINESS

FOR DATA PROCESSING, DATA MANAGEMENT, BUSINESS CONSULTING, AND MANAGEMENT OF REVENUE STREAMS IN THE NATURE OF FINANCIAL RECORDS MANAGEMENT, IN THE FIELD OF HEALTHCARE REIMBURSEMENT CLAIMS BY HEALTHCARE PROVIDERS; COMPUTER AND INTERNET-BASED DATA PROCESSING IN THE FIELD OF HEALTHCARE REIMBURSEMENT CLAIMS BY HEALTHCARE PROVIDERS (U.S. CLS. 100, 101 AND 102).

SN 85-587,901. WOLSKY, JAMES, COLLEGEVILLE, PA. FILED 4-3-2012.

BEACON BOX

THE MARK CONSISTS OF STANDARD CHARACTERS WITHOUT CLAIM TO ANY PARTICULAR FONT, STYLE, SIZE, OR COLOR.

CLASS 42—SCIENTIFIC AND COMPUTER SERVICES

FOR TECHNICAL SUPPORT SERVICES, NAMELY, TROUBLESHOOTING OF COMPUTER SOFTWARE PROBLEMS IN THE FIELD IN THE FIELD OF HEALTHCARE REIMBURSEMENT CLAIMS BY HEALTHCARE PROVIDERS (U.S. CLS. 100 AND 101).
SHANNON TWOHIG, EXAMINING ATTORNEY

CLASS 35—ADVERTISING AND BUSINESS

FOR EMPLOYMENT STAFFING AND EMPLOYMENT STAFFING AUGMENTATION SERVICES; EMPLOYMENT STAFFING AND EMPLOYMENT STAFFING AUGMENTATION SERVICES FOR OTHERS DIRECTED TO THE SOFTWARE, SOFTWARE DEVELOPMENT, SOFTWARE ENGINEERING AND IT NEEDS OF OTHERS (U.S. CLS. 100, 101 AND 102).

SN 85-587,881. STUFFED CUPCAKES, LLC, NUTLEY, NJ. FILED 4-3-2012.

Jarets Stuffed Cupcakes

CLASS 42—SCIENTIFIC AND COMPUTER SERVICES

FOR CUSTOM DESIGN AND DEVELOPMENT OF COMPUTER SOFTWARE AND COMPUTER HARDWARE SYSTEMS; CUSTOM DESIGN AND DEVELOPMENT OF COMPUTER SOFTWARE FOR USE ON SMART PHONES AND MOBILE DEVICES; CUSTOM DESIGN AND DEVELOPMENT OF COMPUTER SOFTWARE FOR DIGITAL FILE AND CONTENT CONVERSION, MODIFICATION AND TRANSFER OVER A NETWORK; CUSTOM DESIGN AND DEVELOPMENT OF COMPUTER SOFTWARE FOR VIDEO, AUDIO AND IMAGE FILE AND CONTENT CONVERSION, MODIFICATION AND TRANSFER OVER A NETWORK; CONSULTING SERVICES IN THE FIELD OF DESIGN, SELECTION, IMPLEMENTATION AND USE OF COMPUTER SOFTWARE AND COMPUTER HARDWARE SYSTEMS; E-COMMERCE SOFTWARE DESIGN AND DEVELOPMENT; COMPUTER AND SOFTWARE PROJECT MANAGEMENT SERVICES; SOFTWARE TESTING AND QUALITY ASSURANCE SERVICES (U.S. CLS. 100 AND 101).

MARK SPARACINO, EXAMINING ATTORNEY

THE MARK CONSISTS OF STANDARD CHARACTERS WITHOUT CLAIM TO ANY PARTICULAR FONT, STYLE, SIZE, OR COLOR.

OWNER OF U.S. REG. NOS. 3,792,979 AND 3,843,491.
NO CLAIM IS MADE TO THE EXCLUSIVE RIGHT TO USE "STUFFED CUPCAKES", APART FROM THE MARK AS SHOWN.

CLASS 29—MEATS AND PROCESSED FOODS

FOR MILK SHAKES (U.S. CL. 46).

SN 85-587,906. STUFFED CUPCAKES, LLC, NUTLEY, NJ. FILED 4-3-2012.

CLASS 30—STAPLE FOODS

FOR BAKED GOODS, NAMELY, CUPCAKES, CAKES, SMALL LAYER CAKES, COOKIES, BLONDIES, BROWNIES, DANISH, BREADS, MUFFINS, CAKES FOR INDIVIDUAL CONSUMPTION MOUNTED ON STICKS, CAKE POPS, SMALL LAYERED CAKES FOR INDIVIDUAL CONSUMPTION, WHOOPIE PIES, PIES, CHEESECAKES, TARTS, PASTRIES, DONUTS; AND CHOCOLATES, CHOCOLATE DIPPED FRUITS, CHOCOLATE DIPPED COOKIES AND BROWNIES, CHOCOLATE DIPPED CHEESECAKES; AND ICE CREAM, CANDY, HOT CHOCOLATE, COFFEE, DESSERT MOUSSES, CUSTARDS AND PUDDINGS (U.S. CL. 46).

Jarets Bakery

THE MARK CONSISTS OF STANDARD CHARACTERS WITHOUT CLAIM TO ANY PARTICULAR FONT, STYLE, SIZE, OR COLOR.

NO CLAIM IS MADE TO THE EXCLUSIVE RIGHT TO USE "BAKERY", APART FROM THE MARK AS SHOWN.

CLASS 32—LIGHT BEVERAGES

FOR FRESH LEMONADES, FRUIT DRINKS AND SMOOTHIES (U.S. CLS. 45, 46 AND 48).
GRETCHEN ULRICH, EXAMINING ATTORNEY

CLASS 29—MEATS AND PROCESSED FOODS

FOR MILK SHAKES (U.S. CL. 46).

CLASS 30—STAPLE FOODS

FOR BAKED GOODS, NAMELY, CUPCAKES, CAKES, SMALL LAYER CAKES, COOKIES, BLONDIES, BROWNIES, DANISH, BREADS, MUFFINS, CAKES FOR INDIVIDUAL CONSUMPTION MOUNTED ON STICKS, CAKE POPS, SMALL LAYERED CAKES FOR INDIVIDUAL CONSUMPTION, WHOOPIE PIES, PIES, CHEESECAKES, TARTS, PASTRIES, DONUTS; AND CHOCOLATES, CHOCOLATE DIPPED FRUITS, CHOCOLATE DIPPED COOKIES AND BROWNIES, CHOCOLATE DIPPED CHEESECAKES; AND ICE CREAM, CANDY, HOT CHOCOLATE, COFFEE, DESSERT MOUSSES, CUSTARDS AND PUDDINGS (U.S. CL. 46).

CLASS 32—LIGHT BEVERAGES

FOR FRESH LEMONADES, FRUIT DRINKS AND SMOOTHIES (U.S. CLS. 45, 46 AND 48).
GRETCHEN ULRICH, EXAMINING ATTORNEY

SN 85-588,551. 1105 MEDIA, INC., CHATSWORTH, CA.
FILED 4-4-2012.



OWNER OF U.S. REG. NOS. 2,984,802, 3,004,240 AND OTHERS.

THE COLOR(S) CYAN, MAGENTA, YELLOW AND BLACK IS/ARE CLAIMED AS A FEATURE OF THE MARK. THE MARK CONSISTS OF THE WORD "RECHARGER" IN A STYLIZED BLACK FONT. POSITIONED BELOW THE ENDING LETTERS "E" AND "R" ARE, ALIGNED IN A ROW LEFT TO RIGHT, A CYAN CIRCLE, A MAGENTA CIRCLE, A YELLOW CIRCLE AND A BLACK CIRCLE.

SN 85-587,991. AMER.COM CORP., MISSISSAUGA, ONTARIO, CANADA, FILED 4-3-2012.



OWNER OF U.S. REG. NO. 2,441,987.
NO CLAIM IS MADE TO THE EXCLUSIVE RIGHT TO USE "NETWORKS", APART FROM THE MARK AS SHOWN.

THE MARK CONSISTS OF A STYLIZED PARTIAL "A" DESIGN WITHIN A PARTIAL CIRCLE TO THE LEFT OF THE TERMS "AMER", "NETWORKS" AND "LET'S CONNECT".

CLASS 9—ELECTRICAL AND SCIENTIFIC APPARATUS

FOR COMPUTER HARDWARE AND SOFTWARE USED FOR THE DIGITAL TRANSMISSION OF DATA; COMPUTER HARDWARE USED FOR STORAGE OF DIGITAL DATA; COMPUTER PERIPHERAL DEVICES; COMPUTER NETWORK INTERFACE DEVICES; COMPUTER NETWORK SWITCHES, COMPUTER NETWORK WIRELESS DEVICES, COMPUTER NETWORK STORAGE DEVICES (U.S. CLS. 21, 23, 26, 36 AND 38).
FIRST USE 4-7-2011; IN COMMERCE 4-7-2011.

CLASS 42—SCIENTIFIC AND COMPUTER SERVICES

FOR CLOUD COMPUTING FEATURING SOFTWARE FOR USE IN THE MANAGEMENT OF NETWORK DEVICES, NAMELY, TO PERMIT USERS TO OBTAIN INFORMATION IN THE FORM OF A COMPUTERIZED REPORT ON HOW THEIR COMPUTER NETWORK DEVICES ARE PERFORMING AND TO ALLOW NETWORK USERS TO CONTROL, CONFIGURE AND UPDATE THEIR CONNECTED DEVICES VIA THE CLOUD; CLOUD COMPUTING FEATURING SOFTWARE FOR USE IN THE DIGITAL TRANSMISSION OF DATA; PROVIDING VIRTUAL COMPUTER SYSTEMS AND VIRTUAL COMPUTER ENVIRONMENTS, THE FOREGOING PROVIDED THROUGH CLOUD COMPUTING (U.S. CLS. 100 AND 101).

FIRST USE 4-7-2011; IN COMMERCE 4-7-2011.
JAMES GRIFFIN, EXAMINING ATTORNEY

CLASS 9—ELECTRICAL AND SCIENTIFIC APPARATUS

FOR DOWNLOADABLE ELECTRONIC PUBLICATIONS, NAMELY, MAGAZINES, NEWSLETTERS, REPORTS, BULLETINS, AND COMMUNIQUE RELATING TO THE OFFICE PRODUCTS RECYCLING INDUSTRY (U.S. CLS. 21, 23, 26, 36 AND 38).
FIRST USE 8-0-2006; IN COMMERCE 8-0-2006.

CLASS 16—PAPER GOODS AND PRINTED MATTER

FOR PRINTED PUBLICATIONS, NAMELY, MAGAZINES RELATING TO THE OFFICE PRODUCTS RECYCLING INDUSTRY (U.S. CLS. 2, 5, 22, 23, 29, 37, 38 AND 50).

FIRST USE 8-0-2006; IN COMMERCE 8-0-2006.

CLASS 41—EDUCATION AND ENTERTAINMENT

FOR EDUCATIONAL SERVICES, NAMELY, CONDUCTING SEMINARS AND CONFERENCES, INCLUDING BY ELECTRONIC MEANS, IN THE FIELD OF INFORMATION TECHNOLOGY (U.S. CLS. 100, 101 AND 107).

FIRST USE 8-0-2006; IN COMMERCE 8-0-2006.

BRENDAN REGAN, EXAMINING ATTORNEY

SN 85-588,595. SUPER RESTORATION HOLDINGS INC., DORAL, FL. FILED 4-4-2012.

SUPER RESTORATION

THE MARK CONSISTS OF STANDARD CHARACTERS WITHOUT CLAIM TO ANY PARTICULAR FONT, STYLE, SIZE, OR COLOR.

NO CLAIM IS MADE TO THE EXCLUSIVE RIGHT TO USE "RESTORATION", APART FROM THE MARK AS SHOWN.

SEC. 2(F).

CLASS 37—CONSTRUCTION AND REPAIR

FOR CLEANING OF CARPET, FURNITURE AND DRAPERY; RESTORATION IN THE FIELD OF RESTORATION OF BUILDING STRUCTURES, FURNITURE, CARPET, AND DRAPERY DAMAGED BY FIRE WATER AND OTHER CATASTROPHES; RESTORATION SERVICES IN THE FIELD OF WATER, SMOKE AND FIRE DAMAGE (U.S. CLS. 100, 103 AND 106).
FIRST USE 5-7-1997; IN COMMERCE 5-7-1997.

CLASS 40—MATERIAL TREATMENT

FOR MOLD REMEDIATION SERVICES (U.S. CLS. 100, 103 AND 106).
FIRST USE 5-7-1997; IN COMMERCE 5-7-1997.
GIANCARLO CASTRO, EXAMINING ATTORNEY

SN 85-588,754. TWO BROADS DESIGN L.L.C., SPARKS, NV.
FILED 4-4-2012.

Two Broads Design

THE MARK CONSISTS OF STANDARD CHARACTERS WITHOUT CLAIM TO ANY PARTICULAR FONT, STYLE, SIZE, OR COLOR.
NO CLAIM IS MADE TO THE EXCLUSIVE RIGHT TO USE "DESIGN", APART FROM THE MARK AS SHOWN.

CLASS 20—FURNITURE AND ARTICLES NOT OTHERWISE CLASSIFIED

FOR CLOTHES HANGERS (U.S. CLS. 2, 13, 22, 25, 32 AND 50).
FIRST USE 4-15-2011; IN COMMERCE 4-15-2011.

CLASS 35—ADVERTISING AND BUSINESS

FOR ONLINE RETAIL STORE SERVICES IN THE FIELDS OF CLOTHES HANGERS, BOXES, CAKE TOPPERS, BAGS, HANGTAGS, JARS, BIRD CAGES, CHALK BOARDS, AND JEWELRY (U.S. CLS. 100, 101 AND 102).
FIRST USE 11-9-2010; IN COMMERCE 11-9-2010.
DAVID I, EXAMINING ATTORNEY

SN 85-588,806. JOHNSON & JOHNSON, NEW BRUNSWICK, NJ. FILED 4-4-2012.

ASP INFECTIONOIDS

THE MARK CONSISTS OF STANDARD CHARACTERS WITHOUT CLAIM TO ANY PARTICULAR FONT, STYLE, SIZE, OR COLOR.

CLASS 9—ELECTRICAL AND SCIENTIFIC APPARATUS

FOR COMPUTER EDUCATIONAL GAME SOFTWARE FOR USE ON MOBILE AND CELLULAR PHONES REGARDING INFECTION PREVENTION AND HOSPITAL ASSOCIATED INFECTIONS (U.S. CLS. 21, 23, 26, 36 AND 38).

CLASS 41—EDUCATION AND ENTERTAINMENT

FOR ENTERTAINMENT SERVICES, NAMELY, PROVIDING TEMPORARY USE OF NON-DOWNLOADABLE EDUCATIONAL COMPUTER GAMES REGARDING INFECTION PREVENTION AND HOSPITAL ASSOCIATED INFECTIONS (U.S. CLS. 100, 101 AND 107).
TEJBIR SINGH, EXAMINING ATTORNEY

SN 85-588,885. AMERICAN TEXTILE COMPANY, DUQUESNE, PA. FILED 4-4-2012.

AllerEase Select

THE MARK CONSISTS OF STANDARD CHARACTERS WITHOUT CLAIM TO ANY PARTICULAR FONT, STYLE, SIZE, OR COLOR.
OWNER OF U.S. REG. NOS. 2,080,165, 3,319,027 AND OTHERS.
NO CLAIM IS MADE TO THE EXCLUSIVE RIGHT TO USE "SELECT", APART FROM THE MARK AS SHOWN.

CLASS 20—FURNITURE AND ARTICLES NOT OTHERWISE CLASSIFIED

FOR PILLOWS (U.S. CLS. 2, 13, 22, 25, 32 AND 50).

CLASS 24—FABRICS

FOR MATTRESS PADS, MATTRESS PROTECTORS IN THE NATURE OF MATTRESS COVERS, PILLOW PROTECTORS IN THE NATURE OF PILLOW COVERS, DUVETS AND COMFORTERS (U.S. CLS. 42 AND 50).
DAVID I, EXAMINING ATTORNEY

SN 85-589,287. NEWSRING CHURCH, INC., ANDERSON, SC. FILED 4-4-2012.

THE MARK CONSISTS OF THE WORD "FUSE" WITH SEVEN CIRCLES EMANATING FROM THE LEFT OF THE TEXT AND ARCING OVER THE LETTER "F" WITH EACH CIRCLE BECOMING LARGER IN SIZE.

CLASS 9—ELECTRICAL AND SCIENTIFIC APPARATUS

FOR DIGITAL MEDIA, NAMELY, CDS, DVDS, DOWNLOADABLE AUDIO AND VIDEO RECORDINGS FEATURING YOUTH MINISTRY, YOUTH DEVELOPMENT, SPIRITUAL GROWTH AND CHRISTIAN LIFESTYLES; DOWNLOADABLE PODCASTS IN THE FIELD OF YOUTH MINISTRY, YOUTH DEVELOPMENT, SPIRITUAL GROWTH AND CHRISTIAN LIFESTYLES; DOWNLOADABLE WEBCASTS IN THE FIELD OF YOUTH MINISTRY, YOUTH DEVELOPMENT, SPIRITUAL GROWTH AND CHRISTIAN LIFESTYLES (U.S. CLS. 21, 23, 26, 36 AND 38).
FIRST USE 3-1-2007; IN COMMERCE 3-1-2007.

CLASS 16—PAPER GOODS AND PRINTED MATTER

FOR PRINTED MATTER, NAMELY, PAPER SIGNS, BOOKS, MANUALS, CURRICULUM, NEWSLETTERS, INFORMATIONAL CARDS AND BROCHURES IN THE FIELD OF YOUTH MINISTRY, YOUTH DEVELOPMENT, SPIRITUAL GROWTH AND CHRISTIAN LIFESTYLES (U.S. CLS. 2, 5, 22, 23, 29, 37, 38 AND 50).
FIRST USE 3-1-2007; IN COMMERCE 3-1-2007.

CLASS 45—PERSONAL AND LEGAL SERVICES

FOR CHRISTIAN MINISTRY SERVICES; ON-LINE SOCIAL NETWORKING SERVICES (U.S. CLS. 100 AND 101).

FIRST USE 3-1-2007; IN COMMERCE 3-1-2007.
MIAH ROSENBERG, EXAMINING ATTORNEY

SN 85-589,509. WINE RACKS AMERICA, INC., NORTH SALT LAKE, UT. FILED 4-4-2012.

WINE RACKS AMERICA

THE MARK CONSISTS OF STANDARD CHARACTERS WITHOUT CLAIM TO ANY PARTICULAR FONT, STYLE, SIZE, OR COLOR.

NO CLAIM IS MADE TO THE EXCLUSIVE RIGHT TO USE "WINE RACKS", APART FROM THE MARK AS SHOWN.

SEC. 2(F).

CLASS 20—FURNITURE AND ARTICLES NOT OTHERWISE CLASSIFIED

FOR WINE RACKS (U.S. CLS. 2, 13, 22, 25, 32 AND 50).
FIRST USE 11-4-2003; IN COMMERCE 11-4-2003.

SN 85-589,475. JONES, STEPHEN, TAMPA, FL. FILED 4-4-2012.

CLASS 35—ADVERTISING AND BUSINESS

FOR ONLINE RETAIL STORE SERVICES FEATURING WINE RACKS, WINE CELLAR KITS, WINE CABINETS, WINE CELLAR DOORS, WINE COOLING UNITS, WINE RACK ACCESSORIES, WINE BOTTLE TAGS, AND THERMOMETERS FOR USE IN WINE CELLARS (U.S. CLS. 100, 101 AND 102).

FIRST USE 11-4-2003; IN COMMERCE 11-4-2003.

ALYSSA STEEL, EXAMINING ATTORNEY



NO CLAIM IS MADE TO THE EXCLUSIVE RIGHT TO USE "LVC" AND "NET", APART FROM THE MARK AS SHOWN.

THE MARK CONSISTS OF AN ARROW EMERGING FROM A NARROW POINT BENEATH THE LETTERS "LVCNET" AND BECOMING WIDER AS IT SWEEPS COMET-LIKE AROUND THE LEFT END OF THE LETTERS AND CONTINUES ON ABOVE THE LETTERS, AND WITH AN IDENTICAL ARROW MOVING IN THE OPPOSITE DIRECTION EMERGING FROM A NARROW POINT ABOVE THE LETTERS AND BECOMING WIDER AS IT SWEEPS COMET-LIKE DOWN AND AROUND THE RIGHT SIDE OF THE LETTERS, CONTINUING TO A POINT UNDER THE LETTERS, ALL ON A RECTANGLE BACKGROUND.

SN 85-589,569. DOUBLE DRIVE MEDICAL, INC., TACOMA, WA. FILED 4-4-2012.

DOUBLE DRIVE MEDICAL

THE MARK CONSISTS OF STANDARD CHARACTERS WITHOUT CLAIM TO ANY PARTICULAR FONT, STYLE, SIZE, OR COLOR.

NO CLAIM IS MADE TO THE EXCLUSIVE RIGHT TO USE "MEDICAL", APART FROM THE MARK AS SHOWN.

CLASS 9—ELECTRICAL AND SCIENTIFIC APPARATUS

FOR COMPUTER SOFTWARE FOR TESTING THE INTEROPERABILITY AND ADHERENCE TO INDUSTRY STANDARDS OF COMPUTER SOFTWARE APPLICATIONS (U.S. CLS. 21, 23, 26, 36 AND 38).

CLASS 35—ADVERTISING AND BUSINESS

FOR PROMOTING THE AWARENESS OF STANDARDIZED PROTOCOLS FOR INTERCONNECTING LIVE, VIRTUAL AND CONSTRUCTIVE (LVC) DISTRIBUTED MODELING AND SIMULATION APPLICATIONS (U.S. CLS. 100, 101 AND 102).

CLASS 8—HAND TOOLS

FOR HAND TOOLS, NAMELY, SCREWDRIVERS; HAND TOOLS, NAMELY, TORQUE MULTIPLIERS (U.S. CLS. 23, 28 AND 44).

CLASS 42—SCIENTIFIC AND COMPUTER SERVICES

FOR TESTING OF COMPUTER SOFTWARE OF OTHERS TO ASSURE COMPLIANCE WITH INDUSTRY STANDARDS (U.S. CLS. 100 AND 101).
TEJBIR SINGH, EXAMINING ATTORNEY

CLASS 10—MEDICAL APPARATUS

FOR MEDICAL APPARATUS AND INSTRUMENTS FOR USE IN SURGERY; MEDICAL INSTRUMENTS, NAMELY, ORTHOPEDIC APPARATUS AND INSTRUMENTS; SURGICAL APPARATUS AND INSTRUMENTS FOR USE IN ORTHOPEDIC SURGERY; SURGICAL INSTRUMENTS AND APPARATUS; SURGICAL INSTRUMENTS, NAMELY, DRIVERS (U.S. CLS. 26, 39 AND 44).

TINA L. SNAPP, EXAMINING ATTORNEY

SN 85-589,831. SGA DESIGN GROUP, P.C., TULSA, OK.
FILED 4-5-2012.



THE MARK CONSISTS OF THE LETTERS "S" AND "G".

CLASS 35—ADVERTISING AND BUSINESS

FOR BUSINESS ADVISORY AND BUSINESS PROJECT MANAGEMENT SERVICES FOR OTHERS IN THE FIELD OF ARCHITECTURAL AND URBAN PLANNING DESIGN (U.S. CLS. 100, 101 AND 102).
FIRST USE 1-31-2012; IN COMMERCE 1-31-2012.

CLASS 37—CONSTRUCTION AND REPAIR

FOR CONSULTATION IN THE FIELD OF BUILDING CONSTRUCTION AND RENOVATION; CONSTRUCTION PROJECT MANAGEMENT (U.S. CLS. 100, 103 AND 106).
FIRST USE 1-31-2012; IN COMMERCE 1-31-2012.

CLASS 42—SCIENTIFIC AND COMPUTER SERVICES

FOR ARCHITECTURAL AND ENGINEERING SERVICES; DESIGN AND DEVELOPMENT OF INTEGRATED BUILDING SYSTEMS; TECHNICAL CONSULTING SERVICES IN THE FIELD OF ARCHITECTURE AND ENGINEERING; ARCHITECTURAL RESEARCH; COMPUTER MODELING SERVICES, NAMELY, DEVELOPMENT OF PROTOTYPES FOR BUILDING DESIGN; ARCHITECTURAL FORENSIC ANALYSIS AND DESIGN (U.S. CLS. 100 AND 101).
FIRST USE 1-31-2012; IN COMMERCE 1-31-2012.
JENNIFER RICHARDSON, EXAMINING ATTORNEY

SN 85-589,842. SGA DESIGN GROUP, P.C., TULSA, OK.
FILED 4-5-2012.



THE MARK CONSISTS OF STANDARD CHARACTERS WITHOUT CLAIM TO ANY PARTICULAR FONT, STYLE, SIZE, OR COLOR.

CLASS 35—ADVERTISING AND BUSINESS

FOR BUSINESS ADVISORY AND BUSINESS PROJECT MANAGEMENT SERVICES FOR OTHERS IN THE FIELD OF ARCHITECTURAL AND URBAN PLANNING DESIGN (U.S. CLS. 100, 101 AND 102).
FIRST USE 1-31-2012; IN COMMERCE 1-31-2012.

CLASS 37—CONSTRUCTION AND REPAIR

FOR CONSULTATION IN THE FIELD OF BUILDING CONSTRUCTION AND RENOVATION; CONSTRUCTION PROJECT MANAGEMENT (U.S. CLS. 100, 103 AND 106).
FIRST USE 1-31-2012; IN COMMERCE 1-31-2012.

CLASS 42—SCIENTIFIC AND COMPUTER SERVICES

FOR ARCHITECTURAL AND ENGINEERING SERVICES; DESIGN AND DEVELOPMENT OF INTEGRATED BUILDING SYSTEMS; TECHNICAL CONSULTING SERVICES IN THE FIELD OF ARCHITECTURE AND ENGINEERING; ARCHITECTURAL RESEARCH; COMPUTER MODELING SERVICES, NAMELY, DEVELOPMENT OF PROTOTYPES FOR BUILDING DESIGN; ARCHITECTURAL FORENSIC ANALYSIS AND DESIGN (U.S. CLS. 100 AND 101).
FIRST USE 1-31-2012; IN COMMERCE 1-31-2012.
JENNIFER RICHARDSON, EXAMINING ATTORNEY

SN 85-589,882. FAMILYMART CO., LTD., TOSHIMA-KU, TOKYO, JAPAN, FILED 4-5-2012.



OWNER OF U.S. REG. NO. 3,075,009.
THE MARK CONSISTS OF A CIRCLE WITH A HAPPY FACE FOUND ON THE UPPER PORTION OF THE CIRCLE, INTERPOSED WITH A STAR ON THE LOWER RIGHT OF THE CIRCLE. A HAPPY FACE IS CENTERED INSIDE THE STAR.

CLASS 35—ADVERTISING AND BUSINESS

FOR PROFESSIONAL BUSINESS CONSULTATION; MARKETING RESEARCH; BUSINESS INFORMATION, NAMELY, SUPPLYING COMMERCIAL SALES INFORMATION; BUSINESS AUDITING, NAMELY, CERTIFIED AUDITS OF FINANCIAL STATEMENTS; CERTIFIED INCOME TAX PREPARATION; RETAIL STORE SERVICES FEATURING FOOD, DRINKS, FRESH FOODS, JAPANESE BOX LUNCHES, READY-MADE FOODS, DETERGENT, SANITARY GOODS, CLOTHING, TOWELS, STATIONERY, SKIN-CARE PRODUCTS, COSMETICS, TOILETRIES, MAGAZINES, COMICS, BOOKS, CLOTHING ACCESSORIES, MEDICAL GOODS, NAMELY, SANITARY MASKS, GAUZE, ADHESIVE PLASTER, ADHESIVE BANDAGES, CLEANING AND PRESERVATION SOLUTIONS FOR CONTACT LENS, DIETETIC PREPARATIONS FOR MEDICAL SUPPLEMENT; BUSINESS MANAGEMENT OF RETAIL STORES; RETAIL CONVENIENCE STORE SERVICES; BUSINESS MANAGEMENT OF CONVENIENCE STORES AND CONVENIENCE STORE FRANCHISES; PROMOTING THE SALE OF GOODS AND SERVICES OF OTHERS THROUGH THE DISTRIBUTION OF PRINTED MATERIAL AND PROMOTIONAL CONTESTS (U.S. CLS. 100, 101 AND 102).

CLASS 43—HOTEL AND RESTAURANT SERVICES

FOR RESTAURANT SERVICES, NAMELY, PROVIDING OF FOOD (U.S. CLS. 100 AND 101).
COLLEEN DOMBROW, EXAMINING ATTORNEY

SN 85-589,894. ADAMS, ROBERT J., PLANT CITY, FL.
FILED 4-5-2012.

BLOODY PALMETTO

THE MARK CONSISTS OF STANDARD CHARACTERS WITHOUT CLAIM TO ANY PARTICULAR FONT, STYLE, SIZE, OR COLOR.

CLASS 16—PAPER GOODS AND PRINTED MATTER

FOR BUMPER STICKERS, DECALS (U.S. CLS. 2, 5, 22, 23, 29, 37, 38 AND 50).

CLASS 25—CLOTHING

FOR SHIRTS, HATS, JACKETS, SWEATSHIRTS, HOODED SWEATSHIRTS, BANDANAS (U.S. CLS. 22 AND 39).

CLASS 35—ADVERTISING AND BUSINESS

FOR RETAIL STORE SERVICES FEATURING CLOTHING, BUMPER STICKERS, AND DECALS (U.S. CLS. 100, 101 AND 102).
CHRISTOPHER LAW, EXAMINING ATTORNEY

SN 85-590,132. HUBLER, LILLIAN I., DBA TIME TO SIGN, INC, INDIALANTIC, FL. FILED 4-5-2012.

TIME TO SIGN

THE MARK CONSISTS OF STANDARD CHARACTERS WITHOUT CLAIM TO ANY PARTICULAR FONT, STYLE, SIZE, OR COLOR.

CLASS 16—PAPER GOODS AND PRINTED MATTER

FOR EDUCATIONAL PAPER GOODS, NAMELY, TRAINING MANUALS, BOOKS, BROCHURES AND ACTIVITY GUIDES, LABELING, PRINTED STORIES WITH INSTRUCTIONS IN SIGN LANGUAGE, FLASH CARDS, BUMPER STICKERS, ALL IN CONNECTION WITH TEACHING SIGN LANGUAGE USING MUSIC, GAMES, AND STORIES TO CHILDREN AND ADULTS (U.S. CLS. 2, 5, 22, 23, 29, 37, 38 AND 50).

FIRST USE 8-5-2001; IN COMMERCE 8-5-2001.

CLASS 41—EDUCATION AND ENTERTAINMENT

FOR EDUCATIONAL SERVICES, NAMELY, WORKSHOPS, CLASSES, AND PROGRAMS TEACHING SIGN LANGUAGE TO ADULTS AND CHILDREN WITH MUSIC, GAMES, AND STORIES; TRAINING INSTRUCTORS AND CONSULTANTS HOW TO TEACH SIGN LANGUAGE TO ADULTS AND CHILDREN (U.S. CLS. 100, 101 AND 107).

FIRST USE 8-5-2001; IN COMMERCE 8-5-2001.
SUNG IN, EXAMINING ATTORNEY

SN 85-590,136. BLURRED WHISPER, LLC, PALO ALTO, CA.
FILED 4-5-2012.

BLURRED WHISPER

THE MARK CONSISTS OF STANDARD CHARACTERS WITHOUT CLAIM TO ANY PARTICULAR FONT, STYLE, SIZE, OR COLOR.

CLASS 35—ADVERTISING AND BUSINESS

FOR ADVERTISING; MARKETING; MARKET RESEARCH; BRAND MANAGEMENT; CORPORATE IDENTITY CONSULTING; ONLINE BUSINESS RESEARCH SERVICES THAT ALLOW USERS TO SHARE OPINIONS WITH A MARKETING RESEARCH COMPANY RELATED TO EVERYDAY CONSUMER PRODUCTS AND SERVICES; CONSUMER RESEARCH (U.S. CLS. 100, 101 AND 102).

FIRST USE 1-1-2002; IN COMMERCE 1-1-2002.

CLASS 41—EDUCATION AND ENTERTAINMENT

FOR DIGITAL VIDEO, PRINT, AUDIO, AND MULTIMEDIA PUBLISHING SERVICES; FILM, VIDEO, GAME, AND TV PRODUCTION; ENTERTAINMENT SERVICES, NAMELY, PROVIDING ADVICE AND INFORMATION FOR MUSIC, VIDEO AND FILM CONCEPT AND SCRIPT DEVELOPMENT STORY AND SCRIPT WRITING; MUSIC COMPOSITION AND PRODUCTION; MUSIC PUBLISHING; MULTIMEDIA PUBLISHING OF BOOKS, MAGAZINES, JOURNALS, SOFTWARE, GAMES, MUSIC, AND ELECTRONIC PUBLICATIONS (U.S. CLS. 100, 101 AND 107).

FIRST USE 1-1-2002; IN COMMERCE 1-1-2002.

CLASS 42—SCIENTIFIC AND COMPUTER SERVICES

FOR CONSULTING IN THE FIELD OF VISUAL, GRAPHIC AND PUBLICATION DESIGN; VISUAL DESIGN SERVICES IN THE NATURE OF DESIGNING VISUAL ELEMENTS FOR ON-LINE, BROADCAST, PRINT, OUTDOOR AND OTHER COMMUNICATION MEDIA; GRAPHIC DESIGN; COMMERCIAL ART DESIGN; CONSULTING IN THE FIELDS OF COMMERCIAL ART DESIGN AND GRAPHIC DESIGN; SOFTWARE AND PRODUCT DESIGN AND DEVELOPMENT; MOBILE AND WEB APP DESIGN AND DEVELOPMENT; SOFTWARE DESIGN PROCESS CONSULTING; EBOOK DESIGN AND DEVELOPMENT; WEB PUBLISHING, NAMELY, CREATING A WEBSITE AND UPLOADING IT ONTO AN INTERNET SERVER; VIDEO GAME DEVELOPMENT SERVICES (U.S. CLS. 100 AND 101).

FIRST USE 1-1-2002; IN COMMERCE 1-1-2002.
JOHN HWANG, EXAMINING ATTORNEY

SN 85-590,176. OLD MAN RIVER PUBLISHING, LLC,
LAFAYETTE, LA. FILED 4-5-2012.

SN 85-590,221. EUROCHANNEL INC., MIAMI BEACH, FL.
FILED 4-5-2012.

Old Man River Publishing

THE MARK CONSISTS OF STANDARD CHARACTERS WITHOUT CLAIM TO ANY PARTICULAR FONT, STYLE, SIZE, OR COLOR.

NO CLAIM IS MADE TO THE EXCLUSIVE RIGHT TO USE "PUBLISHING", APART FROM THE MARK AS SHOWN.

CLASS 16—PAPER GOODS AND PRINTED MATTER

FOR BOOKS IN THE FIELD OF BUSINESS; PRINTED MATTER, NAMELY, PAPER SIGNS, BOOKS, MANUALS, CURRICULUM, NEWSLETTERS, INFORMATIONAL CARDS AND BROCHURES IN THE FIELD OF ORGANIZATIONAL DEVELOPMENT (U.S. CLS. 2, 5, 22, 23, 29, 37, 38 AND 50).

CLASS 41—EDUCATION AND ENTERTAINMENT

FOR BOOK PUBLISHING; PUBLICATION OF BOOKS (U.S. CLS. 100, 101 AND 107).

COLLEEN MULCRONE, EXAMINING ATTORNEY

SN 85-590,203. ALLIED MARKETING GROUP, INC., DAL-
LAS, TX. FILED 4-5-2012.

NIRVANA

THE MARK CONSISTS OF STANDARD CHARACTERS WITHOUT CLAIM TO ANY PARTICULAR FONT, STYLE, SIZE, OR COLOR.

CLASS 20—FURNITURE AND ARTICLES NOT OTHERWISE CLASSIFIED

FOR MATTRESSES, PILLOWS, MATTRESS TOPPERS AND INFLATABLE GUEST BEDS (U.S. CLS. 2, 13, 22, 25, 32 AND 50).

CLASS 24—FABRICS

FOR BEDDING SOLD TOGETHER IN A BAG, NAMELY, COMFORTERS, BED SKIRTS, SHAMS, SHEETS AND PILLOWCASES ALL SOLD TOGETHER AS A UNIT; COMFORTERS AND SHEETS (U.S. CLS. 42 AND 50).

DANIEL CAPSHAW, EXAMINING ATTORNEY

EUROCHANNEL

THE MARK CONSISTS OF STANDARD CHARACTERS WITHOUT CLAIM TO ANY PARTICULAR FONT, STYLE, SIZE, OR COLOR.

SEC. 2(F).

CLASS 38—COMMUNICATION

FOR BROADCAST OF CABLE TELEVISION PROGRAMMES; BROADCASTING OF RADIO AND TELEVISION PROGRAMMES; BROADCASTING OF VIDEO AND AUDIO PROGRAMMING OVER THE INTERNET; CABLE TELEVISION BROADCASTING SERVICES; ELECTRONIC TRANSMISSION AND STREAMING OF DIGITAL MEDIA CONTENT FOR OTHERS VIA GLOBAL AND LOCAL COMPUTER NETWORKS; ELECTRONIC TRANSMISSION OF VOICE, DATA AND IMAGES BY TELEVISION AND VIDEO BROADCASTING; WEBCASTING SERVICES (U.S. CLS. 100, 101 AND 104).

FIRST USE 2-10-2002; IN COMMERCE 2-10-2002.

CLASS 41—EDUCATION AND ENTERTAINMENT

FOR CABLE TELEVISION PROGRAMMING; DISTRIBUTION OF MOTION PICTURE FILMS; DISTRIBUTION OF TELEVISION PROGRAMMING TO CABLE TELEVISION SYSTEMS; EDUCATIONAL AND ENTERTAINMENT SERVICES, NAMELY, A CONTINUING PROGRAM ABOUT ARTS, SPORTS, MUSIC, AND CULTURE ACCESSIBLE BY RADIO, TELEVISION, SATELLITE, AUDIO, VIDEO AND COMPUTER NETWORKS; ENTERTAINMENT SERVICES, NAMELY, DISPLAYING A SERIES OF FILMS; ENTERTAINMENT SERVICES, NAMELY, PROVIDING WEBCASTS IN THE FIELD OF ENTERTAINMENT, SPORTS, AND CULTURE; FILM AND VIDEO FILM PRODUCTION; ORGANIZATION OF EXHIBITIONS FOR CULTURAL OR EDUCATIONAL PURPOSES; ORGANIZING COMMUNITY SPORTING AND CULTURAL EVENTS; ORGANIZING CULTURAL AND ARTS EVENTS; PRODUCTION OF CABLE TELEVISION PROGRAMS; PRODUCTION OF FILMS; PROVIDING AN INTERNET WEBSITE PORTAL IN THE FIELD OF ENTERTAINMENT, CULTURAL AND SPORTING EVENTS; PROVIDING INFORMATION RELATING TO THE ORGANIZING OF EDUCATIONAL, CULTURAL, SPORTING, OR ENTERTAINMENT EXHIBITIONS; PROVISION OF NON-DOWNLOADABLE FILMS AND TELEVISION PROGRAMMES VIA A VIDEO-ON-DEMAND SERVICE; TRAINING SERVICES IN THE FIELD OF ACTING, MOVIES, FILMS, AND BROADCASTING (U.S. CLS. 100, 101 AND 107).

FIRST USE 2-10-2002; IN COMMERCE 2-10-2002.

MARILYN IZZI, EXAMINING ATTORNEY

SN 85-590,248. THE SPEARMINT RHINO COMPANIES
WORLDWIDE, INC., NORCO, CA. FILED 4-5-2012.

DAMES N GAMES

THE MARK CONSISTS OF STANDARD CHARACTERS WITHOUT CLAIM TO ANY PARTICULAR FONT, STYLE, SIZE, OR COLOR.

CLASS 9—ELECTRICAL AND SCIENTIFIC APPARATUS

FOR MOTION PICTURE FILMS FEATURING ADULT ENTERTAINMENT; VIDEO TAPES FEATURING ADULT ENTERTAINMENT; DVDS FEATURING ADULT ENTERTAINMENT; VIDEO AND COMPUTER GAME PROGRAMS; VIDEO GAME DISCS; VIDEO GAME CARTRIDGES; VIDEO GAME SOFTWARE; COMPUTER GAME DISCS; COMPUTER GAME CARTRIDGES; COMPUTER GAME SOFTWARE (U.S. CLS. 21, 23, 26, 36 AND 38).

CLASS 16—PAPER GOODS AND PRINTED MATTER

FOR PAPER NAPKINS (U.S. CLS. 2, 5, 22, 23, 29, 37, 38 AND 50).

CLASS 25—CLOTHING

FOR T-SHIRTS; HATS; PANTIES; G-STRINGS; BRASIERES; CORSETS; GOLF SHIRTS; JACKETS; VESTS; CAPS (U.S. CLS. 22 AND 39).

CLASS 28—TOYS AND SPORTING GOODS

FOR ARCADE-TYPE ELECTRONIC VIDEO GAMES; COIN-OPERATED VIDEO GAMES (U.S. CLS. 22, 23, 38 AND 50).

CLASS 41—EDUCATION AND ENTERTAINMENT

FOR ENTERTAINMENT SERVICES, NAMELY, ADULT CABARETS; ARRANGING AND CONDUCTING NIGHTCLUB ENTERTAINMENT EVENTS; ENTERTAINMENT SERVICES, NAMELY, PROVIDING LIVE DANCE PERFORMANCES; EXOTIC DANCING SERVICES; PROVIDING ONLINE VIDEO GAMES (U.S. CLS. 100, 101 AND 107).

CLASS 43—HOTEL AND RESTAURANT SERVICES

FOR RESTAURANT AND BAR SERVICES; PREPARATION OF FOOD AND BEVERAGES; SERVING FOOD AND DRINKS (U.S. CLS. 100 AND 101).
CORY BOONE, EXAMINING ATTORNEY

SN 85-590,253. INJIXO, INC., RATINGEN, FED REP GERMANY, FILED 4-5-2012.



OWNER OF U.S. REG. NO. 3,650,370.
NO CLAIM IS MADE TO THE EXCLUSIVE RIGHT TO USE "THE CALL CENTER SCHOOL", APART FROM THE MARK AS SHOWN.
THE MARK CONSISTS OF THE WORDING "THE CALL CENTER SCHOOL" TO THE RIGHT OF DESIGNS. THE DESIGNS FEATURE A STYLIZED LETTER "C" FORMING PART OF A CIRCLE.

CLASS 9—ELECTRICAL AND SCIENTIFIC APPARATUS

FOR PRERECORDED VIDEO AND AUDIO TAPES FEATURING INSTRUCTIONAL, EDUCATIONAL AND TEACHING MATERIALS IN THE FIELD OF TELEPHONE CALL CENTERS (U.S. CLS. 21, 23, 26, 36 AND 38).

CLASS 16—PAPER GOODS AND PRINTED MATTER

FOR PRINTED INSTRUCTIONAL, EDUCATIONAL AND TEACHING MATERIALS IN THE FIELD OF TELEPHONE CALL CENTERS (U.S. CLS. 2, 5, 22, 23, 29, 37, 38 AND 50).

CLASS 41—EDUCATION AND ENTERTAINMENT

FOR EDUCATIONAL SERVICES, NAMELY, PROVIDING TRAINING OF OTHERS IN THE USE OF TELECOMMUNICATIONS PRODUCTS, NAMELY, TELEPHONE CALL CENTERS, AND PROVIDING SEMINARS, WORKSHOPS, CONFERENCES, AND CLASSES IN THE FIELD OF TELEPHONE CALL CENTERS PROVIDED THROUGH PUBLIC SEMINARS OR PRIVATE ON-SITE PROGRAMS AND VIA THE INTERNET (U.S. CLS. 100, 101 AND 107).
CORY BOONE, EXAMINING ATTORNEY

SN 85-590,339. G-III LEATHER FASHIONS, INC., NEW YORK, NY. FILED 4-5-2012.

ANDREW MARC

THE MARK CONSISTS OF STANDARD CHARACTERS WITHOUT CLAIM TO ANY PARTICULAR FONT, STYLE, SIZE, OR COLOR.

OWNER OF U.S. REG. NOS. 1,221,846, 3,971,650 AND OTHERS.

THE NAME(S), PORTRAIT(S), AND/OR SIGNATURE(S) SHOWN IN THE MARK IDENTIFIES "ANDREW MARC", WHOSE CONSENT(S) TO REGISTER IS MADE OF RECORD.

CLASS 3—COSMETICS AND CLEANING PREPARATIONS

FOR FRAGRANCE, PERFUMES, COLOGNE, AND NON-MEDICATED TOILETRIES (U.S. CLS. 1, 4, 6, 50, 51 AND 52).

CLASS 18—LEATHER GOODS

FOR SMALL LEATHER GOODS, NAMELY, LEATHER AGENDA CASES (U.S. CLS. 1, 2, 3, 22 AND 41).

CLASS 25—CLOTHING

FOR CLOTHING, NAMELY, OUTERWEAR, NAMELY, PONCHOS; SPORTSWEAR, NAMELY, BLOUSES, CARDIGANS, JACKETS, BLAZERS, SPORT COATS, SLACKS, SHORTS, SWEATERS; UNDERWEAR, HOSIERY, HEADWEAR, NECKWEAR, SCARVES AND GLOVES (U.S. CLS. 22 AND 39).

CLASS 35—ADVERTISING AND BUSINESS

FOR RETAIL STORE SERVICES FEATURING FRAGRANCES, COLOGNE, NON-MEDICATED TOILETRIES, VALISES, WALLETS, CREDIT CARD CASES, SMALL LEATHER GOODS, LEATHER AGENDA CASES, ALL PURPOSE SPORTS BAGS, FOOTWEAR, SHOES AND BOOTS (U.S. CLS. 100, 101 AND 102).

LUCY ARANT, EXAMINING ATTORNEY

SN 85-590,384. OLD MAN RIVER PUBLISHING, LLC, LAFAYETTE, LA. FILED 4-5-2012.



NO CLAIM IS MADE TO THE EXCLUSIVE RIGHT TO USE "PUBLISHING", APART FROM THE MARK AS SHOWN.

THE COLOR(S) DARK BLUE AND WHITE IS/ARE CLAIMED AS A FEATURE OF THE MARK.

THE MARK CONSISTS OF A DARK BLUE RECTANGLE WITH THREE WHITE CURVED LINES CROSSING THROUGH WITH THE WORDS "OLD MAN RIVER" IN DARK BLUE ABOVE THE WORD "PUBLISHING" IN DARK BLUE.

CLASS 16—PAPER GOODS AND PRINTED MATTER

FOR BOOKS IN THE FIELD OF BUSINESS; PRINTED MATTER, NAMELY, PAPER SIGNS, BOOKS, MANUALS, CURRICULUM, NEWSLETTERS, INFORMATIONAL CARDS AND BROCHURES IN THE FIELD OF ORGANIZATIONAL DEVELOPMENT (U.S. CLS. 2, 5, 22, 23, 29, 37, 38 AND 50).

CLASS 41—EDUCATION AND ENTERTAINMENT

FOR BOOK PUBLISHING; PUBLICATION OF BOOKS (U.S. CLS. 100, 101 AND 107).

COLLEEN MULCRONE, EXAMINING ATTORNEY

SN 85-590,431. CURRY, NATHANIEL, WOBURN, MA. FILED 4-5-2012.



THE NAME(S), PORTRAIT(S), AND/OR SIGNATURE(S) SHOWN IN THE MARK IDENTIFIES NATHANIEL CURRY, WHOSE CONSENT(S) TO REGISTER IS MADE OF RECORD.

THE MARK CONSISTS OF THE WORDS GOD'S WARRIOR IN STYLIZED FORM WITH THE W STYLIZED TO RESEMBLE SWORDS, THE DOT OVER THE "I" RESEMBLING A FLAME DEPICTED AS FINGERS AND THE "O" REPRESENTING A SHIELD. THE COLOR WHITE IN THE DRAWING REPRESENTS TRANSPARENT AREAS AND IS NOT PART OF THE MARK.

CLASS 16—PAPER GOODS AND PRINTED MATTER

FOR GRAPHIC NOVELS (U.S. CLS. 2, 5, 22, 23, 29, 37, 38 AND 50).

CLASS 41—EDUCATION AND ENTERTAINMENT

FOR ENTERTAINMENT IN THE NATURE OF VISUAL AND AUDIO PERFORMANCES BY MUSIC ARTIST, GOD'S WARRIOR (U.S. CLS. 100, 101 AND 107).

CARYN GLASSER, EXAMINING ATTORNEY

SN 85-590,595. QUINONES, EFRAIN, FREDERICKSBURG, VA. FILED 4-5-2012.

SAINT DIABLO

THE MARK CONSISTS OF STANDARD CHARACTERS WITHOUT CLAIM TO ANY PARTICULAR FONT, STYLE, SIZE, OR COLOR.

THE ENGLISH TRANSLATION OF "DIABLO" IN THE MARK IS "DEVIL".

CLASS 9—ELECTRICAL AND SCIENTIFIC APPARATUS

FOR US 021 023 026 036 038. G AND S: PHONOGRAPH RECORDS FEATURING MUSICAL SOUND RECORDINGS AND PERFORMANCES; AUDIO CASSETTES FEATURING MUSICAL SOUND RECORDINGS AND PERFORMANCES; COMPACT DISCS FEATURING MUSICAL SOUND RECORDINGS AND PERFORMANCES; DIGITAL MEDIA, NAMELY, PRE-RECORDED VIDEO CASSETTES, DIGITAL VIDEO DISCS, DIGITAL VERSATILE DISCS, DOWNLOADABLE AUDIO AND VIDEO RECORDINGS, DVDS, AND HIGH DEFINITION DIGITAL DISKS FEATURING MUSICAL SOUND RECORDINGS AND PERFORMANCES; LASER DISCS FEATURING MUSICAL SOUND RECORDINGS AND PERFORMANCES (U.S. CLS. 21, 23, 26, 36 AND 38).

FIRST USE 12-15-1993; IN COMMERCE 6-1-2008.

CLASS 41—EDUCATION AND ENTERTAINMENT

FOR US 100 101 107. G AND S: ENTERTAINMENT, NAMELY, LIVE PERFORMANCES BY A MUSICAL BAND (U.S. CLS. 100, 101 AND 107).

FIRST USE 12-15-1993; IN COMMERCE 2-6-2009. FRANK LATTUCA, EXAMINING ATTORNEY

SN 85-590,660. AFFINION BENEFITS GROUP, LLC, FRANKLIN, TN. FILED 4-5-2012.



THE MARK CONSISTS OF THE TERM "VERI-" ABOVE THE WORD SWIPE. THE TERM "VERI-" IS PARTIALLY HIDDEN BY THE "SWIPE".

CLASS 9—ELECTRICAL AND SCIENTIFIC APPARATUS

FOR MOBILE TRANSACTION MONITORING SOFTWARE FOR USE IN FRAUD MONITORING, AND AUTHENTICATING IDENTITY IN FINANCIAL TRANSACTIONS, AND SECURITY AND FRAUD DETECTION; DOWNLOADABLE COMPUTER SOFTWARE FOR USE IN FRAUD MONITORING, FINANCIAL TRANSACTION AUTHORIZATION AND AUTHENTICATION, AND SECURITY AND FRAUD DETECTION; COMPUTER SOFTWARE APPLICATIONS FOR MOBILE DEVICES FOR FRAUD MONITORING AND SECURITY AND FRAUD PREVENTION AND DETECTION (U.S. CLS. 21, 23, 26, 36 AND 38).

CLASS 42—SCIENTIFIC AND COMPUTER SERVICES

FOR PROVIDING TEMPORARY USE OF NON-DOWNLOADABLE SOFTWARE VIA A WEB-SITE FOR USE IN FRAUD MONITORING, FINANCIAL TRANSACTION AUTHORIZATION AND AUTHENTICATION, AND SECURITY AND FRAUD PREVENTION AND IN ALERTING CUSTOMERS TO POSSIBLE FRAUDULENT ACTIVITY THROUGH THEIR CREDIT OR DEBIT CARDS (U.S. CLS. 100 AND 101).

CLASS 45—PERSONAL AND LEGAL SERVICES

FOR PROVIDING INFORMATION IN THE FIELD OF FRAUD MONITORING, AND IDENTITY AUTHENTICATION AND SECURITY AND FRAUD PREVENTION; CONSULTING SERVICES RELATED TO IDENTITY AUTHENTICATION AND SECURITY AND FRAUD PREVENTION (U.S. CLS. 100 AND 101).
AMY HELLA, EXAMINING ATTORNEY

SN 85-590,826. VENEVISION MOBILE LLC, CORAL GABLES, FL. FILED 4-6-2012.



THE MARK CONSISTS OF STANDARD CHARACTERS WITHOUT CLAIM TO ANY PARTICULAR FONT, STYLE, SIZE, OR COLOR.

CLASS 9—ELECTRICAL AND SCIENTIFIC APPARATUS

FOR DOWNLOADABLE SOFTWARE IN THE NATURE OF A MOBILE APPLICATION FOR ENTERTAINMENT PURPOSES RELATED TO SPORTS, ALLOWING USERS TO SHARE FORECASTS FOR SPORTING EVENTS AND TO INTERACT WITH INFORMATION REGARDING LIVE SPORTING EVENTS; COMPUTER APPLICATION SOFTWARE FOR MOBILE PHONES, WEB BROWSERS OR COMPUTERS, NAMELY, SOFTWARE FOR POSTING COMMENTS AND FORECASTS ON LIVE AND FUTURE SPORTING EVENTS (U.S. CLS. 21, 23, 26, 36 AND 38).

CLASS 42—SCIENTIFIC AND COMPUTER SERVICES

FOR PROVIDING AN INTERACTIVE WEB SITE FEATURING TEMPORARY USE OF NON-DOWNLOADABLE SOFTWARE THAT ENABLES USERS TO POST FORECASTS RELATING TO SPORTING EVENTS AND EARN POINTS AND DIGITAL REWARDS FOR COUPONS, REBATES, DISCOUNTS OR SPECIAL OFFERINGS ON GOODS AND SERVICES PROVIDED BY OTHERS (U.S. CLS. 100 AND 101).
SANDRA BUJA, EXAMINING ATTORNEY

SN 85-590,837. WOODVILLE INDUSTRIES, LLC, BRANCHPORT, NY. FILED 4-6-2012.



THE MARK CONSISTS OF STANDARD CHARACTERS WITHOUT CLAIM TO ANY PARTICULAR FONT, STYLE, SIZE, OR COLOR.

CLASS 25—CLOTHING

FOR T-SHIRTS; HATS (U.S. CLS. 22 AND 39).

CLASS 28—TOYS AND SPORTING GOODS

FOR WAKESURFING BOARDS; WAKESKATE BOARDS; KITE BOARDS (U.S. CLS. 22, 23, 38 AND 50).
BARBARA RUTLAND, EXAMINING ATTORNEY

SN 85-590,842. VENEVISION MOBILE LLC, CORAL GABLES, FL. FILED 4-6-2012.



THE MARK CONSISTS OF THE STYLIZED WORDING "WALL" AND "CUP" WITH THE DESIGN OF A SOCCER BALL LOCATED IN THE MIDDLE OF THE TWO WORDS.

CLASS 9—ELECTRICAL AND SCIENTIFIC APPARATUS

FOR DOWNLOADABLE SOFTWARE IN THE NATURE OF A MOBILE APPLICATION FOR ENTERTAINMENT PURPOSES RELATED TO SPORTS, ALLOWING USERS TO SHARE FORECASTS FOR SPORTING EVENTS AND TO INTERACT WITH INFORMATION REGARDING LIVE SPORTING EVENTS; COMPUTER APPLICATION SOFTWARE FOR MOBILE PHONES, WEB BROWSERS OR COMPUTERS, NAMELY, SOFTWARE FOR POSTING COMMENTS AND FORECASTS ON LIVE AND FUTURE SPORTING EVENTS (U.S. CLS. 21, 23, 26, 36 AND 38).

CLASS 42—SCIENTIFIC AND COMPUTER SERVICES

FOR PROVIDING AN INTERACTIVE WEB SITE FEATURING TEMPORARY USE OF NON-DOWNLOADABLE SOFTWARE THAT ENABLES USERS TO POST FORECASTS RELATING TO SPORTING EVENTS AND EARN POINTS AND DIGITAL REWARDS FOR COUPONS, REBATES, DISCOUNTS OR SPECIAL OFFERINGS ON GOODS AND SERVICES PROVIDED BY OTHERS (U.S. CLS. 100 AND 101).

SANDRA BUJA, EXAMINING ATTORNEY

SN 85-590,887. CAROLINAS HEALTHCARE FOUNDATION, CHARLOTTE, NC. FILED 4-6-2012.

KEEP POUNDING

THE MARK CONSISTS OF STANDARD CHARACTERS WITHOUT CLAIM TO ANY PARTICULAR FONT, STYLE, SIZE, OR COLOR.

OWNER OF U.S. REG. NO. 3,484,403.

CLASS 16—PAPER GOODS AND PRINTED MATTER

FOR PAPER GOODS AND PRINTED MATERIAL, NAMELY, PAMPHLETS, BROCHURES, BOOKS, AND SOUVENIR PROGRAMS IN THE FIELDS OF SPORTS, HEALTHCARE, MEDICAL RESEARCH, FUNDRAISING, CHARITABLE ACTIVITIES, AND CHARITABLE EVENTS; TRADING CARDS, ADHESIVE BACKED STICKERS AND DECALS; CALENDARS, UNMOUNTED PHOTOGRAPHS, AND POSTERS (U.S. CLS. 2, 5, 22, 23, 29, 37, 38 AND 50).

CLASS 21—HOUSEWARES AND GLASS

FOR BEVERAGE GLASSWARE, MUGS, INSULATING SLEEVE HOLDERS FOR BEVERAGE CANS, INSULATED BAGS FOR FOOD OR BEVERAGE FOR DOMESTIC USE, AND WATER BOTTLES SOLD EMPTY (U.S. CLS. 2, 13, 23, 29, 30, 33, 40 AND 50).

CLASS 24—FABRICS

FOR FABRIC FLAGS AND PENNANTS; TOWELS (U.S. CLS. 42 AND 50).

CLASS 25—CLOTHING

FOR CLOTHING, NAMELY, SHIRTS, TANK TOPS, JERSEYS, TURTLENECKS, BOTTOMS, SHORTS, SKIRTS, DRESSES, PANTS, SHOES, COATS, UNDERWEAR, HATS, SCARVES, BELTS, SOCKS, HOSIERY, SLEEP WEAR, SWIM WEAR, SUITS, SWEAT SHIRTS AND SWEAT PANTS, WIND SUITS, WARM-UP SUITS, SWEATERS, JACKETS, PARKAS, WRISTBANDS, GLOVES, AND APRONS; HEADWEAR, AND FOOTWEAR; WRISTBANDS (U.S. CLS. 22 AND 39).

CLASS 28—TOYS AND SPORTING GOODS

FOR TOYS AND SPORTING GOODS, NAMELY, MINIATURE BALLS AND BATS FOR SPORTS, MINIATURE AUTOMOBILES, AND PLUSH DOLLS AND TOYS (U.S. CLS. 22, 23, 38 AND 50).

JAMES GRIFFIN, EXAMINING ATTORNEY

SN 85-590,875. NURAXI LLC, BERKELEY, CA. FILED 4-6-2012.

NURAXI

THE MARK CONSISTS OF STANDARD CHARACTERS WITHOUT CLAIM TO ANY PARTICULAR FONT, STYLE, SIZE, OR COLOR.

CLASS 4—LUBRICANTS AND FUELS

FOR SCENTED CANDLES (U.S. CLS. 1, 6 AND 15).

CLASS 18—LEATHER GOODS

FOR HANDBAGS, TOTE BAGS, SHOULDER BAGS, BEACH BAGS, AND CARRY-ON BAGS (U.S. CLS. 1, 2, 3, 22 AND 41).

CLASS 24—FABRICS

FOR BABY BLANKETS (U.S. CLS. 42 AND 50).

CLASS 25—CLOTHING

FOR SCARVES AND SHAWLS (U.S. CLS. 22 AND 39).

CLASS 35—ADVERTISING AND BUSINESS

FOR RETAIL STORE AND ONLINE RETAIL STORE SERVICES FEATURING HOME AND FASHION ACCESSORIES, NAMELY, BLANKETS, BABY BLANKETS, CANDLES, SCARVES, SHAWLS, AND HANDBAGS (U.S. CLS. 100, 101 AND 102).

FIRST USE 9-15-2010; IN COMMERCE 11-5-2011.
WON TEAK OH, EXAMINING ATTORNEY

SN 85-590,995. CRUZ BAY PUBLISHING, INC., EL SEGUNDO, CA. FILED 4-6-2012.

ADVENTURES DENVER

THE MARK CONSISTS OF STANDARD CHARACTERS WITHOUT CLAIM TO ANY PARTICULAR FONT, STYLE, SIZE, OR COLOR.

NO CLAIM IS MADE TO THE EXCLUSIVE RIGHT TO USE "DENVER", APART FROM THE MARK AS SHOWN.

SN 85-591,026. THE MUSTACHE OPEN ENTERPRISES LLC, SCOTTSDALE, AZ. FILED 4-6-2012.

CLASS 35—ADVERTISING AND BUSINESS

FOR ORGANIZING AND CONDUCTING CAMPING EXHIBITIONS IN THE NATURE OF TRADE SHOWS FEATURING RECREATIONAL EQUIPMENT AND SUPPLIES (U.S. CLS. 100, 101 AND 102).

CLASS 41—EDUCATION AND ENTERTAINMENT

FOR ORGANIZING AND CONDUCTING RECREATIONAL EVENTS, NAMELY, HIKING, CLIMBING, KAYAKING, CAMPING, NATURE TRAILS, OUTDOOR COOKING, AND PHOTOGRAPHY; ORGANIZING AND CONDUCTING SEMINARS, CLINICS AND WORKSHOPS IN THE FIELDS OF HIKING, CLIMBING, KAYAKING, CAMPING, NATURE TRAILS, OUTDOOR COOKING, AND PHOTOGRAPHY (U.S. CLS. 100, 101 AND 107).

WILLIAM BRECKENFELD, EXAMINING ATTORNEY

THE MUSTACHE OPEN

THE MARK CONSISTS OF STANDARD CHARACTERS WITHOUT CLAIM TO ANY PARTICULAR FONT, STYLE, SIZE, OR COLOR.

NO CLAIM IS MADE TO THE EXCLUSIVE RIGHT TO USE "OPEN", APART FROM THE MARK AS SHOWN.

SN 85-591,021. B2B WEB VENTURES, LLC, DALLAS, TX. FILED 4-6-2012.

CLASS 25—CLOTHING

FOR T-SHIRTS (U.S. CLS. 22 AND 39).
FIRST USE 6-30-1999; IN COMMERCE 6-30-1999.

CLASS 41—EDUCATION AND ENTERTAINMENT

FOR ENTERTAINMENT IN THE NATURE OF GOLF TOURNAMENTS (U.S. CLS. 100, 101 AND 107).
FIRST USE 6-30-1999; IN COMMERCE 6-30-1999.
DAVID COLLIER, EXAMINING ATTORNEY

BEAUTIMARK

THE MARK CONSISTS OF STANDARD CHARACTERS WITHOUT CLAIM TO ANY PARTICULAR FONT, STYLE, SIZE, OR COLOR.

CLASS 3—COSMETICS AND CLEANING PREPARATIONS

FOR HAIR CARE PRODUCTS, NAMELY, SHAMPOOS, CONDITIONERS, SHAPING CREME, AND HAIRSPRAY (U.S. CLS. 1, 4, 6, 50, 51 AND 52).

FIRST USE 10-31-2007; IN COMMERCE 10-31-2007.

SN 85-591,108. AFFIRMA CONSULTING, LLC, BELLEVUE, WA. FILED 4-6-2012.

CLASS 20—FURNITURE AND ARTICLES NOT OTHERWISE CLASSIFIED

FOR WIG STANDS, NAMELY, NON-METAL STANDS FOR WIG DISPLAY AND STORAGE (U.S. CLS. 2, 13, 22, 25, 32 AND 50).

FIRST USE 10-31-2007; IN COMMERCE 10-31-2007.

CLASS 21—HOUSEWARES AND GLASS

FOR HAIR COMBS; HAND-OPERATED ATOMIZERS FOR WIGS, FOR HOUSEHOLD USE (U.S. CLS. 2, 13, 23, 29, 30, 33, 40 AND 50).

FIRST USE 10-31-2007; IN COMMERCE 10-31-2007.

Affirma

CLASS 26—FANCY GOODS

FOR HAIR ACCESSORIES, NAMELY, HAIR EXTENSION CLIPS, WIG CAPS, WIG LINERS, AND WIG BANDS (U.S. CLS. 37, 39, 40, 42 AND 50).

FIRST USE 10-31-2007; IN COMMERCE 10-31-2007.
ELISSA GARBER KON, EXAMINING ATTORNEY

THE MARK CONSISTS OF STANDARD CHARACTERS WITHOUT CLAIM TO ANY PARTICULAR FONT, STYLE, SIZE, OR COLOR.

CLASS 35—ADVERTISING AND BUSINESS

FOR EMPLOYMENT STAFFING SERVICES, NAMELY, FILLING THE TEMPORARY AND PERMANENT STAFFING NEEDS OF BUSINESSES FOR TECHNICAL, ENGINEERING, MANAGEMENT, FINANCE AND ADMINISTRATIVE EMPLOYEES; BUSINESS CONSULTING IN THE FIELDS OF ENTERPRISE ANALYSIS, NEEDS IDENTIFICATION, BUSINESS INTELLIGENCE ANALYTICS AND SOLUTIONS, PROCESS IMPROVEMENTS, SYSTEMS ASSESSMENT, DATA WAREHOUSING, DATA ANALYSIS AND REPORTING, STRATEGIC PLANNING, BUSINESS PLAN DEVELOPMENT, PROJECT MANAGEMENT, BRAND POSITIONING, CUSTOMER AND USER EXPERIENCE ENHANCEMENT, PROFITABILITY IMPROVEMENT, OPERATIONS SUPPORT, TECHNOLOGY SUPPORT, DATA AND INFORMATION MANAGEMENT, STAFFING NEEDS AND AUGMENTATION; TECHNICAL CONSULTING SERVICES IN THE FIELD OF DOCUMENT MANAGEMENT; BUSINESS CONSULTING SERVICES, NAMELY, PROVIDING ASSISTANCE IN DEVELOPMENT OF BUSINESS STRATEGIES AND CREATIVE IDEATION; BUSINESS MONITORING AND CONSULTING SERVICES, NAMELY, TRACKING WEB SITES AND APPLICATIONS OF OTHERS TO PROVIDE STRATEGY, INSIGHT, MARKETING, SALES, OPERATION, PRODUCT DESIGN, PARTICULARLY SPECIALIZING IN THE USE OF ANALYTIC AND STATISTIC MODELS FOR THE UNDERSTANDING AND PREDICTING OF CONSUMERS, BUSINESSES, AND MARKET TRENDS AND ACTIONS; ADVERTISING SERVICES, NAMELY, CREATING CORPORATE AND BRAND IDENTITY FOR OTHERS AND CREATING CORPORATE LOGOS FOR OTHERS; MARKET RESEARCH; CREATIVE MARKETING DESIGN SERVICES (U.S. CLS. 100, 101 AND 102).
FIRST USE 9-30-2003; IN COMMERCE 9-30-2003.

CLASS 42—SCIENTIFIC AND COMPUTER SERVICES

FOR TECHNICAL CONSULTING SERVICES IN THE FIELDS OF DATA CENTER ARCHITECTURE, PUBLIC AND PRIVATE CLOUD COMPUTING TECHNOLOGY SOLUTIONS, MOBILE DEVICE SOFTWARE APPLICATIONS, EVALUATION AND IMPLEMENTATION OF INTERNET TECHNOLOGY AND SERVICES, INTRANET AND EXTRANET SOLUTIONS, SYSTEM INTEGRATIONS, PORTAL USABILITY AND PORTAL DESIGN, DEVELOPMENT OF CUSTOM COMPUTER SOFTWARE APPLICATIONS FOR USE ON CLIENT SERVERS AND/OR COMMERCIALLY AVAILABLE GLOBAL WEB-BASED PLATFORMS; CREATION, DESIGN, DEVELOPMENT AND MAINTENANCE OF WEB SITES FOR THIRD PARTIES; WEBSITE USER INTERFACE DESIGN; CREATION AND DESIGN OF BUSINESS INFOGRAPHICS; WEBSITE AUDITS, NAMELY, CONSULTING IN THE AREA OF WEBSITE CONTENT (U.S. CLS. 100 AND 101).
FIRST USE 9-30-2003; IN COMMERCE 9-30-2003.
CATHERINE ROEHL, EXAMINING ATTORNEY

SN 85-591,244. SPRAGUE OPERATING RESOURCES LLC, PORTSMOUTH, NH. FILED 4-6-2012.

SPRAGUE RESOURCES

THE MARK CONSISTS OF STANDARD CHARACTERS WITHOUT CLAIM TO ANY PARTICULAR FONT, STYLE, SIZE, OR COLOR.
OWNER OF U.S. REG. NO. 911,441.
NO CLAIM IS MADE TO THE EXCLUSIVE RIGHT TO USE "RESOURCES", APART FROM THE MARK AS SHOWN.

CLASS 4—LUBRICANTS AND FUELS

FOR DIESEL FUEL; FUEL OIL; NATURAL GAS (U.S. CLS. 1, 6 AND 15).

CLASS 35—ADVERTISING AND BUSINESS

FOR BUSINESS RISK ASSESSMENT SERVICES; ENERGY MANAGEMENT SERVICES, NAMELY, PROVIDING A SERVICE THAT ALLOWS CUSTOMERS TO PURCHASE ENERGY, NAMELY, ELECTRICITY, NATURAL GAS AND RENEWABLE ENERGY, AT A FIXED PRICE (U.S. CLS. 100, 101 AND 102).

CLASS 39—TRANSPORTATION AND STORAGE

FOR TRANSPORTATION AND STORAGE OF FUELS (U.S. CLS. 100 AND 105).
KERI CANTONE, EXAMINING ATTORNEY

SN 85-591,259. GOFF, ROBERT K., GIG HARBOR, WA. FILED 4-6-2012.

LOVE DOES

THE MARK CONSISTS OF STANDARD CHARACTERS WITHOUT CLAIM TO ANY PARTICULAR FONT, STYLE, SIZE, OR COLOR.

CLASS 9—ELECTRICAL AND SCIENTIFIC APPARATUS

FOR COMPACT DISCS FEATURING MUSIC; DIGITAL DOWNLOADABLE MUSIC FILES; PRERECORDED VIDEO DISCS ON THE SUBJECT OF PEOPLE WHO HAVE DONE ACTS OF LOVE, CHARITY OR SERVICE TO OTHERS (U.S. CLS. 21, 23, 26, 36 AND 38).

CLASS 21—HOUSEWARES AND GLASS

FOR CUPS AND MUGS (U.S. CLS. 2, 13, 23, 29, 30, 33, 40 AND 50).

CLASS 25—CLOTHING

FOR CLOTHING, NAMELY, T-SHIRTS, JACKETS, CAPS, SWEATSHIRTS (U.S. CLS. 22 AND 39).

CLASS 41—EDUCATION AND ENTERTAINMENT

FOR EDUCATIONAL SERVICES, NAMELY, SEMINARS IN THE FIELD OF ACTS OF LOVE, CHARITY OR SERVICE TO OTHERS (U.S. CLS. 100, 101 AND 107).
ASMAT KHAN, EXAMINING ATTORNEY

SN 85-591,265. SPRAGUE OPERATING RESOURCES LLC, PORTSMOUTH, NH. FILED 4-6-2012.

SN 85-591,336. THE BASKETBALL MARKETING COMPANY, INC., ALISO VIEJO, CA. FILED 4-6-2012.

SPRAGUE SOLUTIONS

THE MARK CONSISTS OF STANDARD CHARACTERS WITHOUT CLAIM TO ANY PARTICULAR FONT, STYLE, SIZE, OR COLOR.

OWNER OF U.S. REG. NO. 911,441.

NO CLAIM IS MADE TO THE EXCLUSIVE RIGHT TO USE "SOLUTIONS", APART FROM THE MARK AS SHOWN.

CLASS 4—LUBRICANTS AND FUELS

FOR DIESEL FUEL; FUEL OIL; NATURAL GAS (U.S. CLS. 1, 6 AND 15).

CLASS 35—ADVERTISING AND BUSINESS

FOR BUSINESS RISK ASSESSMENT SERVICES; ENERGY MANAGEMENT SERVICES, NAMELY, PROVIDING A SERVICE THAT ALLOWS CUSTOMERS TO PURCHASE ENERGY, NAMELY, ELECTRICITY, NATURAL GAS AND RENEWABLE ENERGY, AT A FIXED PRICE (U.S. CLS. 100, 101 AND 102).

CLASS 39—TRANSPORTATION AND STORAGE

FOR TRANSPORTATION AND STORAGE OF FUELS (U.S. CLS. 100 AND 105).
KERI CANTONE, EXAMINING ATTORNEY

SN 85-591,307. LABORGAMING, LLC, GOODYEAR, AZ. FILED 4-6-2012.

LaborGaming

THE MARK CONSISTS OF STANDARD CHARACTERS WITHOUT CLAIM TO ANY PARTICULAR FONT, STYLE, SIZE, OR COLOR.

CLASS 35—ADVERTISING AND BUSINESS

FOR CONSULTING SERVICES IN THE FIELD OF HUMAN RESOURCES DEVELOPMENT, NAMELY, UTILIZING TECHNOLOGY FOR THE PROMOTION OF EMPLOYEE RETENTION, CAREER GROWTH AND INCREASED PRODUCTIVITY FOR EMPLOYEES AND EMPLOYERS (U.S. CLS. 100, 101 AND 102).
FIRST USE 5-0-2011; IN COMMERCE 5-0-2011.

CLASS 41—EDUCATION AND ENTERTAINMENT

FOR ENTERTAINMENT SERVICES, NAMELY, PROVIDING ONLINE GAMES THAT HELP INCREASE WORKPLACE PRODUCTIVITY (U.S. CLS. 100, 101 AND 107).

FIRST USE 5-0-2011; IN COMMERCE 5-0-2011.
ELLEN BURNS, EXAMINING ATTORNEY



OWNER OF U.S. REG. NOS. 4,105,807 AND 4,105,808.
THE MARK CONSISTS OF STYLIZED LETTER "A" WITH THE NUMBER "1" SUPERIMPOSED OVER THE RIGHT HAND VERTICAL LINE OF THE "A".

CLASS 9—ELECTRICAL AND SCIENTIFIC APPARATUS

FOR EYEGLASSES; EYEWEAR; SUNGLASSES (U.S. CLS. 21, 23, 26, 36 AND 38).

CLASS 18—LEATHER GOODS

FOR SPORT BAGS (U.S. CLS. 1, 2, 3, 22 AND 41).
WON TEAK OH, EXAMINING ATTORNEY

SN 85-591,356. THE BASKETBALL MARKETING COMPANY, INC., ALISO VIEJO, CA. FILED 4-6-2012.



OWNER OF U.S. REG. NOS. 4,105,807 AND 4,105,808.
THE MARK CONSISTS OF STYLIZED LETTER "A" WITH THE NUMBER "1" SUPERIMPOSED OVER THE RIGHT HAND VERTICAL LINE OF THE "A" WITHIN A RECTANGLE WITH CURVED CORNERS.

CLASS 9—ELECTRICAL AND SCIENTIFIC APPARATUS

FOR EYEGLASSES; EYEWEAR; SUNGLASSES (U.S. CLS. 21, 23, 26, 36 AND 38).

CLASS 18—LEATHER GOODS

FOR SPORT BAGS (U.S. CLS. 1, 2, 3, 22 AND 41).
WON TEAK OH, EXAMINING ATTORNEY

SN 85-591,400. ABBETT, SCOTT, SAN DIEGO, CA. FILED 4-6-2012.

SN 85-591,802. LUCAS, ERIC, MINNETONKA, MN. FILED 4-7-2012.



THE MARK CONSISTS OF THE WORDING "A NICE BODY" AT THE TOP WITH A MUSCULAR ARM BELOW IT, THE WORDING "HARDBODY SUCCESS" IS WRITTEN IN BIG BOLD FONT TO THE RIGHT OF THE DESIGN OF THE ARM, AND THE WORDING " ... COULD BE EASIER THAN YOU THINK" BELOW THE WORD "SUCCESS".

CLASS 5—PHARMACEUTICALS

FOR DIETARY SUPPLEMENTS; NUTRITIONAL SUPPLEMENTS (U.S. CLS. 6, 18, 44, 46, 51 AND 52).

CLASS 41—EDUCATION AND ENTERTAINMENT

FOR PROVIDING A WEB SITE FEATURING INFORMATION ON EXERCISE AND FITNESS (U.S. CLS. 100, 101 AND 107).

FIRST USE 9-15-2009; IN COMMERCE 10-20-2009.
JANET LEE, EXAMINING ATTORNEY

LIFT THEM UP

THE MARK CONSISTS OF STANDARD CHARACTERS WITHOUT CLAIM TO ANY PARTICULAR FONT, STYLE, SIZE, OR COLOR.

CLASS 16—PAPER GOODS AND PRINTED MATTER

FOR SCHOOL SUPPLY KITS CONTAINING VARIOUS COMBINATIONS OF SELECTED SCHOOL SUPPLIES, NAMELY, WRITING INSTRUMENTS, PENS, PENCILS, MECHANICAL PENCILS, ERASERS, MARKERS, CRAYONS, HIGHLIGHTER PENS, FOLDERS, NOTEBOOKS, PAPER, PROTRACTORS, PAPER CLIPS, PENCIL SHARPENERS, WRITING GRIPS, GLUE AND BOOK MARKS; PRINTED SIGNS; PAPER BANNERS (U.S. CLS. 2, 5, 22, 23, 29, 37, 38 AND 50).

SN 85-591,630. POORE, DALLAS SHANE, SANTEE, CA. FILED 4-6-2012.



NO CLAIM IS MADE TO THE EXCLUSIVE RIGHT TO USE "PROJECT", APART FROM THE MARK AS SHOWN. THE STIPPLING IS FOR SHADING PURPOSES ONLY.

THE MARK CONSISTS OF A DRAWING OF A NON-BRANDED SLR CAMERA WITH A HEART IN PLACE OF THE LENS. THE STYLIZED TEXT "BENEVOLENCE" IS WRITTEN IN CURSIVE SCRIPT UNDERNEATH THE CAMERA AND THE HEART. ABOVE THE FIRST "E" IN "BENEVOLENCE" IS THE STYLIZED TEXT "THE". BELOW THE "NC" IN "BENEVOLENCE" IS THE STYLIZED TEXT "PROJECT".

CLASS 35—ADVERTISING AND BUSINESS

FOR RETAIL STORE SERVICES FEATURING FINE ART PRINTS (U.S. CLS. 100, 101 AND 102).

CLASS 41—EDUCATION AND ENTERTAINMENT

FOR PHOTOGRAPHY SERVICES (U.S. CLS. 100, 101 AND 107).

CAITLIN WATTS-FITZGERALD, EXAMINING ATTORNEY

CLASS 18—LEATHER GOODS

FOR BACKPACKS, BOOK BAGS, SPORTS BAGS, BUM BAGS, WALLETS AND HANDBAGS (U.S. CLS. 1, 2, 3, 22 AND 41).

CLASS 20—FURNITURE AND ARTICLES NOT OTHERWISE CLASSIFIED

FOR PLASTIC AND VINYL BANNERS (U.S. CLS. 2, 13, 22, 25, 32 AND 50).

CLASS 25—CLOTHING

FOR CLOTHING, NAMELY, PANTS, T-SHIRTS, SWEATERS, AND SHORTS (U.S. CLS. 22 AND 39).

CLASS 35—ADVERTISING AND BUSINESS

FOR ASSOCIATION SERVICES, NAMELY, PROMOTING THE EDUCATIONAL AND ECONOMIC INTERESTS OF INDIVIDUALS AND COMMUNITIES BY ORGANIZING AND CONDUCTING VOLUNTEER PROGRAMS AND COMMUNITY SERVICE PROJECTS; CATALOG AND ONLINE RETAIL STORE SERVICES FEATURING COMMEMORATIVE PRODUCTS FOR USE IN CHARITABLE FUNDRAISING CAMPAIGNS; CONSULTING IN THE FIELD OF BRAND PROMOTION OF THE GOODS AND SERVICES OF OTHERS; CONSULTING IN THE FIELD OF CAREER PROMOTION, NAMELY, PROVIDING CAREER INFORMATION (U.S. CLS. 100, 101 AND 102).

CLASS 36—INSURANCE AND FINANCIAL

FOR ELEEMOSYNARY SERVICES, NAMELY, CHARITABLE FUNDRAISING; CHARITABLE FUNDRAISING SERVICES BY MEANS OF A CELEBRITY SPONSORED AND ATTENDED ENTERTAINMENT EVENT; COLLEGE CONSULTING SERVICES, NAMELY, ASSISTING STUDENTS IN APPLYING FOR SCHOLARSHIPS AND FINANCIAL AID (U.S. CLS. 100, 101 AND 102).

CLASS 41—EDUCATION AND ENTERTAINMENT

FOR EDUCATION SERVICES, NAMELY, PROVIDING TRAINING AND EDUCATIONAL PROGRAMS IN THE FIELDS OF SECONDARY AND POST-SECONDARY EDUCATION; EDUCATIONAL SERVICES, NAMELY, PROVIDING TUTORING, WORKSHOPS AND COACHING TO HELP STUDENTS ACHIEVE EDUCATIONAL SUCCESS AND FINANCIAL STABILITY, NAMELY, ACADEMIC ENRICHMENT PROGRAMS IN THE FIELD(S) OF MATH, SCIENCE, CIVICS, HISTORY, AND ECONOMICS (U.S. CLS. 100, 101 AND 107).

JESSICA A. POWERS, EXAMINING ATTORNEY

SN 85-592,146. URBAN TRI GEAR, LLC, WESTMONT, IL. FILED 4-9-2012.

URBAN TRI GEAR

THE MARK CONSISTS OF STANDARD CHARACTERS WITHOUT CLAIM TO ANY PARTICULAR FONT, STYLE, SIZE, OR COLOR.

NO CLAIM IS MADE TO THE EXCLUSIVE RIGHT TO USE "TRI GEAR", APART FROM THE MARK AS SHOWN.

CLASS 21—HOUSEWARES AND GLASS

FOR PLASTIC WATER BOTTLES SOLD EMPTY; SPORTS BOTTLES SOLD EMPTY; SQUEEZE BOTTLE SOLD EMPTY; REUSABLE STAINLESS STEEL WATER BOTTLES SOLD EMPTY (U.S. CLS. 2, 13, 23, 29, 30, 33, 40 AND 50).

CLASS 25—CLOTHING

FOR CLOTHING, NAMELY, SOCKS, CYCLING JERSEYS, CYCLING SHIRTS, CYCLING SHORTS, WETSUITS, TRIATHLON SUITS, RACE NUMBER BELTS THAT HOLD A PAPER NUMBER ON THE RACE PARTICIPANT'S FRONT OR BACK DURING COMPETITION, SWIM SUITS, SWIM CAPS, RUNNING SHIRTS, RUNNING SHORTS, TRIATHLON SHIRTS, TRIATHLON SHORTS, T-SHIRTS (U.S. CLS. 22 AND 39).

FIRST USE 6-0-2008; IN COMMERCE 6-0-2008.

CLASS 35—ADVERTISING AND BUSINESS

FOR ON-LINE RETAIL STORE SERVICES FEATURING SPORTING GOODS; RETAIL STORE SERVICES FEATURING SPORTING GOODS (U.S. CLS. 100, 101 AND 102).

FIRST USE 3-1-2005; IN COMMERCE 3-1-2005.

ZACHARY CROMER, EXAMINING ATTORNEY

SN 85-592,164. MIBA MEDICAL, INC., SAN JOSE, CA. FILED 4-9-2012.

MIBA

THE MARK CONSISTS OF STANDARD CHARACTERS WITHOUT CLAIM TO ANY PARTICULAR FONT, STYLE, SIZE, OR COLOR.

CLASS 10—MEDICAL APPARATUS

FOR ARTIFICIAL BREAST IMPLANTS; BEAUTY AND COSMETIC STERILIZING POUCHES; BONE IMPLANTS COMPOSED OF ARTIFICIAL MATERIALS; COSMETIC APPARATUS, NAMELY, SOFT PLASTIC FACIAL ADHESIVE FILM FOR TEMPORARY WRINKLE REMOVAL OR REDUCTION; IMPLANTABLE SCAFFOLDS COMPRISING ARTIFICIAL MATERIALS FOR MAINTAINING TISSUE CONTOUR; IMPLANTS COMPRISING NATURAL, NON-LIVING MATERIALS; IMPLANTS CONSISTING OF ARTIFICIAL MATERIALS; MEDICAL DEVICES FOR NONSURGICAL COSMETIC TREATMENTS; MEDICAL IMPLANTS OF ARTIFICIAL MATERIAL IN PARTICULAR FOR ANCHORING JOINT CAPSULE COMPONENTS AND LIGAMENT TENDON STRUCTURES; MEDICAL, SURGICAL AND ORTHOPAEDIC IMPLANTS MADE OF ARTIFICIAL MATERIALS; ORTHOPEDIC JOINT IMPLANTS; OSSEOINTEGRATED IMPLANTS MADE OF ARTIFICIAL MATTER; OSSEOUS IMPLANTS; SURGICAL IMPLANTS AND MESH MADE OF SYNTHETIC MATERIALS FOR USE IN SOFT TISSUE REPAIR OR THE RECONSTRUCTION OF SOFT TISSUE DEFICIENCIES; SURGICAL IMPLANTS COMPRISING ARTIFICIAL MATERIAL; SURGICAL IMPLANTS COMPRISING ARTIFICIAL MATERIAL AND ASSOCIATED SURGICAL INSTRUMENT SETS (U.S. CLS. 26, 39 AND 44).

CLASS 44—MEDICAL, BEAUTY AND AGRICULTURAL SERVICES

FOR BEAUTY ANALYSIS TO DETERMINE COSMETICS THAT ARE BEST SUITED TO PARTICULAR INDIVIDUALS; BEAUTY CONSULTATION SERVICES IN THE SELECTION AND USE OF COSMETICS, FRAGRANCES, BEAUTY AIDS, PERSONAL CARE PRODUCTS, AND BATH, BODY AND BEAUTY PRODUCTS; BEAUTY SPA SERVICES, NAMELY, COSMETIC BODY CARE; COSMETIC ANALYSIS; COSMETIC AND PLASTIC SURGERY; COSMETIC AND PLASTIC SURGERY, NAMELY, A MINIMALLY INVASIVE FACE/NECK LIFT DONE UNDER LOCAL ANESTHESIA; COSMETIC BODY CARE SERVICES; COSMETIC BODY CARE SERVICES IN THE NATURE OF BODY WRAPS; COSMETIC DENTISTRY; COSMETIC FACE CARE SERVICES; COSMETIC SKIN CARE SERVICES; COSMETIC SURGERY SERVICES; FACIAL TREATMENT SERVICES, NAMELY, COSMETIC PEELS; HEALTH SPA SERVICES FOR HEALTH AND WELLNESS OF THE BODY AND SPIRIT, NAMELY, PROVIDING MASSAGE, FACIAL AND BODY TREATMENT SERVICES, COSMETIC BODY CARE SERVICES; HEALTH SPA SERVICES, NAMELY, COSMETIC BODY CARE SERVICES; MEDICAL SPA SERVICES, NAMELY, MINIMALLY AND NON-INVASIVE COSMETIC AND BODY FITNESS THERAPIES; NON-INVASIVE COSMETIC MEDICAL PROCEDURES; PROVIDE A WEBSITE FEATURING INFORMATION ABOUT HOLISTIC COSMETIC AND PLASTIC SURGERY PRACTICE (U.S. CLS. 100 AND 101).

TRICIA SONNEBORN, EXAMINING ATTORNEY

SN 85-592,169. FERGUSON, DESMOND, LANSING, MI.
FILED 4-9-2012.



THE MARK CONSISTS OF A STYLIZED LETTER "M" AND "B" FORMING AN OVAL.

CLASS 18—LEATHER GOODS

FOR BACKPACKS; BAGS AND HOLDALLS FOR SPORTS CLOTHING; SPORTS BAGS; DUFFEL BAGS; GENERAL PURPOSE BAGS FOR CARRYING CLOTHING AND SPORTS EQUIPMENT (U.S. CLS. 1, 2, 3, 22 AND 41).

FIRST USE 5-1-2005; IN COMMERCE 5-1-2005.

CLASS 25—CLOTHING

FOR DRESS, EXERCISE AND ATHLETIC CLOTHING AND ACCESSORIES FOR MEN AND WOMEN, NAMELY, DRESS PANTS, SUITS AND SHIRTS, T-SHIRTS, CASUAL SHIRTS, SWEAT SUITS, JERSEYS, UNIFORMS, JEANS, SHORTS, HATS, HEADBANDS, WRISTBANDS, JACKETS, SOCKS, SHORTS, SWIM-SUITS, SWIM TRUNKS, WORKOUT PANTS, WARM-UP SHIRTS AND SUITS, COVER-UPS, SPORT SHIRTS; TRACK UNIFORMS, FOOTBALL UNIFORMS, BASEBALL UNIFORMS, VOLLEYBALL UNIFORMS, SOCCER UNIFORMS, VELOUR JUMPSUITS, AND SHOES (U.S. CLS. 22 AND 39).

FIRST USE 5-1-2005; IN COMMERCE 5-1-2005.
STEVEN R. FINE, EXAMINING ATTORNEY

SN 85-592,461. AUBURN THEOLOGICAL SEMINARY, NEW YORK, NY. FILED 4-9-2012.

GROUNDSWELL

THE MARK CONSISTS OF STANDARD CHARACTERS WITHOUT CLAIM TO ANY PARTICULAR FONT, STYLE, SIZE, OR COLOR.

CLASS 35—ADVERTISING AND BUSINESS

FOR PROMOTING AWARENESS OF THE NEED FOR SOCIAL JUSTICE, CIVILITY, COMPASSION, COURAGE, MULTIFAITH COOPERATION, AND MUTUAL UNDERSTANDING AMONG DISTINCT RELIGIOUS COMMUNITIES; CHARITABLE SERVICES, NAMELY, ORGANIZING AND DEVELOPING CAMPAIGNS IN THE FIELD OF SOCIAL ACTION AND JUSTICE (U.S. CLS. 100, 101 AND 102).

FIRST USE 1-15-2011; IN COMMERCE 1-15-2011.

CLASS 45—PERSONAL AND LEGAL SERVICES

FOR PROVIDING INFORMATION CONCERNING CAUSES AND EVENTS IN THE FIELDS OF SOCIAL ACTION AND JUSTICE AND MULTIFAITH COOPERATION (U.S. CLS. 100 AND 101).

FIRST USE 1-15-2011; IN COMMERCE 1-15-2011.
ELIZABETH HUGHITT, EXAMINING ATTORNEY

SN 85-592,462. SAF-T-PAK INC., EDMONTON, CANADA,
FILED 4-9-2012.

SAF-T-PAK

THE MARK CONSISTS OF STANDARD CHARACTERS WITHOUT CLAIM TO ANY PARTICULAR FONT, STYLE, SIZE, OR COLOR.

OWNER OF U.S. REG. NOS. 1,646,037, 2,568,943 AND OTHERS.

CLASS 11—ENVIRONMENTAL CONTROL APPARATUS

FOR GEL PACKS FOR MAINTAINING HOT, COLD, AND WARM TEMPERATURES IN FOOD, BEVERAGES, PHARMACEUTICALS, DIAGNOSTIC AND INFECTIOUS SPECIMENS, REAGENTS USED IN TESTING EQUIPMENT, AND MANUFACTURED TISSUE (U.S. CLS. 13, 21, 23, 31 AND 34).

FIRST USE 12-14-2005; IN COMMERCE 12-14-2005.

CLASS 16—PAPER GOODS AND PRINTED MATTER

FOR PLASTIC BUBBLE PACKS FOR WRAPPING OR PACKAGING; PLASTIC BUBBLE POUCH CONTAINER FOR TRANSPORTING MEDICAL SPECIMENS (U.S. CLS. 2, 5, 22, 23, 29, 37, 38 AND 50).

FIRST USE 4-29-1991; IN COMMERCE 4-29-1991.

CLASS 20—FURNITURE AND ARTICLES NOT OTHERWISE CLASSIFIED

FOR SHIPPING AND SHORT-TERM STORAGE CONTAINERS MADE PREDOMINANTLY OF PLASTIC AND OTHER NONMETALLIC MATERIALS FOR CONTAMINATED, DANGEROUS OR INFECTIOUS SUBSTANCES (U.S. CLS. 2, 13, 22, 25, 32 AND 50).

FIRST USE 8-10-1988; IN COMMERCE 8-10-1988.
ELIZABETH HUGHITT, EXAMINING ATTORNEY

SN 85-592,522. BAGGALLINI, INC., PICKERINGTON, OH.
FILED 4-9-2012.

BAGGALLINI

THE MARK CONSISTS OF STANDARD CHARACTERS WITHOUT CLAIM TO ANY PARTICULAR FONT, STYLE, SIZE, OR COLOR.

OWNER OF U.S. REG. NOS. 2,736,830 AND 3,970,285.

CLASS 9—ELECTRICAL AND SCIENTIFIC APPARATUS

FOR CARRYING CASES, BAGS AND PROTECTIVE COVERS FOR MOBILE PHONES, MOBILE DEVICES, ELECTRONIC READING DEVICES, PORTABLE MEDIA PLAYERS, COMPUTERS, COMPUTER PERIPHERALS, ELECTRONIC GAMES, AND PORTABLE AND HAND-HELD DIGITAL AND ELECTRONIC DEVICES AND ACCESSORIES (U.S. CLS. 21, 23, 26, 36 AND 38).

CLASS 18—LEATHER GOODS

FOR TRAVEL BAGS, TOTE BAGS, HANDBAGS, PURSES, CARRY-ALL BAGS, SPORT BAGS, SCHOOL BAGS, SATCHELS, BRIEFCASES, FANNY PACKS, BACKPACKS, TRAVEL CASES, COSMETIC BAGS AND CASES SOLD EMPTY, TOILETRY BAGS AND CASES SOLD EMPTY, JEWELRY POUCHES, KIT BAGS, WALLET, LUGGAGE, LUGGAGE TAGS (U.S. CLS. 1, 2, 3, 22 AND 41).

AMY KELLY, EXAMINING ATTORNEY

CLASS 41—EDUCATION AND ENTERTAINMENT

FOR ENTERTAINMENT, NAMELY, A CONTINUING COOKING SHOW AND COOKING INSTRUCTION SHOW BROADCAST OVER TELEVISION, INTERNET, AND RADIO; EDUCATIONAL DEMONSTRATIONS IN THE FIELD OF COOKING; PRESENTATION OF LIVE COOKING SHOW PERFORMANCES (U.S. CLS. 100, 101 AND 107).

FIRST USE 9-1-2001; IN COMMERCE 9-1-2001.

CLASS 43—HOTEL AND RESTAURANT SERVICES

FOR RESTAURANT AND CATERING SERVICES; RESTAURANT SERVICES; RESTAURANT SERVICES, INCLUDING SIT-DOWN SERVICE OF FOOD AND TAKE-OUT RESTAURANT SERVICES (U.S. CLS. 100 AND 101).

FIRST USE 9-1-2001; IN COMMERCE 9-1-2001.

JIM RINGLE, EXAMINING ATTORNEY

SN 85-592,611. LISA FINE/CAROLINA IRVING CORP., NEW YORK, NY. FILED 4-9-2012.



THE MARK CONSISTS OF AN OVAL OF SMALL DOTS SURROUNDING A SOLID OVAL SURROUNDING TWO HANDS, EACH WITH A CIRCLE OF DOTS ON THE PALM, AROUND THE WORDS "IRVING & FINE".

CLASS 18—LEATHER GOODS

FOR HANDBAGS; TOTE BAGS (U.S. CLS. 1, 2, 3, 22 AND 41).

CLASS 25—CLOTHING

FOR HATS; JEANS; SANDALS; SHORTS; T-SHIRTS; TOPS (U.S. CLS. 22 AND 39).

DAVID COLLIER, EXAMINING ATTORNEY

SN 85-592,692. EVEREST, MARK A., HARRISBURG, PA. FILED 4-9-2012.

GAMEPLAN FOR AGING

THE MARK CONSISTS OF STANDARD CHARACTERS WITHOUT CLAIM TO ANY PARTICULAR FONT, STYLE, SIZE, OR COLOR.

OWNER OF U.S. REG. NO. 2,968,578.

CLASS 9—ELECTRICAL AND SCIENTIFIC APPARATUS

FOR PRERECORDED COMPACT DISCS AND PRERECORDED DVDS FEATURING PERSONAL IMPROVEMENT, EXERCISE PROGRAMS AND NUTRITION ADVICE (U.S. CLS. 21, 23, 26, 36 AND 38).

CLASS 16—PAPER GOODS AND PRINTED MATTER

FOR PRINTED PUBLICATIONS AND MATERIALS, NAMELY, BOOKS, MAGAZINES, PAMPHLETS, BROCHURES, BULLETINS AND NEWSLETTERS, CALENDARS, WORKBOOKS, RECIPE CARDS AND FOOD CHARTS IN THE FIELD OF HEALTH, NUTRITION, WEIGHT LOSS, WEIGHT CONTROL, COOKING AND RECIPES AND SELF-IMPROVEMENT THROUGH THE ADOPTION OF HEALTHY LIFESTYLES (U.S. CLS. 2, 5, 22, 23, 29, 37, 38 AND 50).

SN 85-592,654. CAFARELLI, JAMES G., CANTON, MA. FILED 4-9-2012.

Rustic Kitchen

THE MARK CONSISTS OF STANDARD CHARACTERS WITHOUT CLAIM TO ANY PARTICULAR FONT, STYLE, SIZE, OR COLOR.

NO CLAIM IS MADE TO THE EXCLUSIVE RIGHT TO USE "KITCHEN", APART FROM THE MARK AS SHOWN.

CLASS 41—EDUCATION AND ENTERTAINMENT

FOR PROVIDING INFORMATION ONLINE RELATING TO FITNESS, EXERCISE, AND OUTDOOR RECREATION; EDUCATIONAL SERVICES, NAMELY, CONDUCTING SEMINARS, CLASSES AND GROUP INSTRUCTION IN THE FIELD OF NUTRITION, DIETARY MANAGEMENT AND WEIGHT REDUCTION; ENTERTAINMENT SERVICES, NAMELY, THE PRODUCTION OF AUDIO/VISUAL PROGRAMS CONSISTING OF NUTRITIONAL AND DIETARY INFORMATION, INTERVIEWS AND RECIPES (U.S. CLS. 100, 101 AND 107).

ALEX KEAM, EXAMINING ATTORNEY

SN 85-592,880. ZANNELLI, GERARD S., YONKERS, NY.
FILED 4-9-2012.

SN 85-593,132. HOT TODDY DESIGN LLC, WENHAM, MA.
FILED 4-10-2012.

AbbyApps

THE MARK CONSISTS OF STANDARD CHARACTERS WITHOUT CLAIM TO ANY PARTICULAR FONT, STYLE, SIZE, OR COLOR.

CLASS 9—ELECTRICAL AND SCIENTIFIC APPARATUS

FOR COMPUTER SOFTWARE FOR COMPUTER SYSTEM AND APPLICATION DEVELOPMENT, DEPLOYMENT AND MANAGEMENT FOR MOBILE PHONES AND DESKTOP COMPUTERS (U.S. CLS. 21, 23, 26, 36 AND 38).

CLASS 41—EDUCATION AND ENTERTAINMENT

FOR IT TRAINING SERVICES; TRAINING SERVICES IN THE FIELD OF DESIGNING AND USING COMPUTER SOFTWARE (U.S. CLS. 100, 101 AND 107).
BARNEY CHARLON, EXAMINING ATTORNEY



NO CLAIM IS MADE TO THE EXCLUSIVE RIGHT TO USE "DESIGN", APART FROM THE MARK AS SHOWN.

THE MARK CONSISTS OF A PORTRAIT OF A WOMAN WITH A RAISED LEFT HAND, ENCIRCLED IN AN OVAL, WITH THE WORDS "HOT TODDY" DESIGN UNDERNEATH.

CLASS 18—LEATHER GOODS

FOR TOTE BAGS, PURSES, HIP BAGS; COSMETIC CASES SOLD EMPTY; JEWELRY ROLLS FOR TRAVEL; GENERAL PURPOSE BAGS FOR CARRYING YOGA AND DANCE EQUIPMENT (U.S. CLS. 1, 2, 3, 22 AND 41).

CLASS 25—CLOTHING

FOR WRAPS; FINGERLESS GLOVES (U.S. CLS. 22 AND 39).

CLASS 28—TOYS AND SPORTING GOODS

FOR MEDITATION CUSHIONS, YOGA MATS, SAVASANA YOGA BLANKETS; BAGS, SPECIALLY ADAPTED FOR CARRYING YOGA MATS (U.S. CLS. 22, 23, 38 AND 50).

KELLEY WELLS, EXAMINING ATTORNEY

SN 85-593,128. DENNIS ROY TEXTER, NEW SMYRNA BEACH, FL. FILED 4-10-2012.

TOPLESS HOOKER

THE MARK CONSISTS OF STANDARD CHARACTERS WITHOUT CLAIM TO ANY PARTICULAR FONT, STYLE, SIZE, OR COLOR.

CLASS 16—PAPER GOODS AND PRINTED MATTER

FOR STICKERS (U.S. CLS. 2, 5, 22, 23, 29, 37, 38 AND 50).
FIRST USE 5-31-2011; IN COMMERCE 3-16-2012.

CLASS 25—CLOTHING

FOR CLOTHING, NAMELY, SHIRTS, PANTS, T-SHIRTS, PANTIES, HOODED SWEATSHIRTS, WOMEN'S TOPS, VISORS, HATS, JACKETS, CAPS (U.S. CLS. 22 AND 39).

FIRST USE 5-31-2011; IN COMMERCE 3-16-2012.
COLLEEN MULCRONE, EXAMINING ATTORNEY

SN 85-593,357. GLOBUS MEDICAL, INC., AUDUBON, PA.
FILED 4-10-2012.



GLOBUS MEDICAL

OWNER OF U.S. REG. NOS. 2,991,142 AND 2,991,143.
NO CLAIM IS MADE TO THE EXCLUSIVE RIGHT TO USE "MEDICAL", APART FROM THE MARK AS SHOWN.

THE MARK CONSISTS OF A GLOBE DESIGN FEATURING MERIDIANS AND PARALLELS. LOCATED TO THE LEFT OF THE GLOBE ARE TWO SHADED POLYGON SHAPED SWOOSHES. THE TEXT "GLOBUS MEDICAL" IS CENTERED BENEATH THE GLOBE AND SWOOSHES.

CLASS 10—MEDICAL APPARATUS

FOR MEDICAL DEVICES FOR TREATING SPINAL PATHOLOGIES AND CONDITIONS FOR USE IN SPINAL SURGERY PERFORMED BY SPINAL SURGEONS; SPINAL IMPLANTS COMPOSED OF ARTIFICIAL MATERIALS AND SURGICAL INSTRUMENTS FOR USE IN SPINAL PROCEDURES PERFORMED BY SPINAL SURGEONS (U.S. CLS. 26, 39 AND 44).
FIRST USE 6-1-2010; IN COMMERCE 6-1-2010.

SN 85-593,527. GOLDBERG, ELLIOTT, SCARSDALE, NY.
FILED 4-10-2012.

Val-U TUBING

THE MARK CONSISTS OF STANDARD CHARACTERS WITHOUT CLAIM TO ANY PARTICULAR FONT, STYLE, SIZE, OR COLOR.

NO CLAIM IS MADE TO THE EXCLUSIVE RIGHT TO USE "TUBING", APART FROM THE MARK AS SHOWN.

CLASS 41—EDUCATION AND ENTERTAINMENT

FOR EDUCATIONAL SERVICES, NAMELY, CONDUCTING SEMINARS AND WORKSHOPS IN THE FIELD OF SPINAL SURGERY, RESEARCH AND PRODUCT DEVELOPMENT (U.S. CLS. 100, 101 AND 107).
FIRST USE 1-7-2010; IN COMMERCE 1-7-2010.

CLASS 42—SCIENTIFIC AND COMPUTER SERVICES

FOR MEDICAL RESEARCH IN THE FIELD OF ORTHOPEDIC SURGERY; PRODUCT RESEARCH AND DEVELOPMENT IN THE FIELD OF ORTHOPEDIC SURGERY; RESEARCH AND DEVELOPMENT OF TECHNOLOGY IN THE FIELD OF SPINAL PRODUCTS (U.S. CLS. 100 AND 101).
FIRST USE 9-14-2009; IN COMMERCE 12-6-2009.
BRIAN CALLAGHAN, EXAMINING ATTORNEY

CLASS 10—MEDICAL APPARATUS

FOR REHABILITATIVE AND PHYSICAL THERAPY DEVICES, NAMELY, MANUALLY OPERATED RESISTIVE EXERCISE BAND COMPRISED OF TUBING AND ACCESSORIES THEREFOR; REHABILITATIVE AND PHYSICAL THERAPY KITS CONSISTING OF MANUALLY OPERATED RESISTIVE EXERCISE BAND COMPRISED OF TUBING AND HAND GRIPS, HAND PUTTY AND ACCESSORIES THEREFOR (U.S. CLS. 26, 39 AND 44).

CLASS 28—TOYS AND SPORTING GOODS

FOR EXERCISE DEVICES, NAMELY, MANUALLY OPERATED RESISTIVE EXERCISE BAND COMPRISED OF TUBING AND ACCESSORIES THEREFOR (U.S. CLS. 22, 23, 38 AND 50).
AMY C. KEAN, EXAMINING ATTORNEY

SN 85-593,499. GOLDBERG, ELLIOTT, SCARSDALE, NY.
FILED 4-10-2012.

SN 85-593,599. XERCISE LAB, LLC, PALO ALTO, CA. FILED
4-10-2012.

Val-U BAND

THE MARK CONSISTS OF STANDARD CHARACTERS WITHOUT CLAIM TO ANY PARTICULAR FONT, STYLE, SIZE, OR COLOR.

NO CLAIM IS MADE TO THE EXCLUSIVE RIGHT TO USE "BAND", APART FROM THE MARK AS SHOWN.

CLASS 10—MEDICAL APPARATUS

FOR REHABILITATIVE AND PHYSICAL THERAPY DEVICES, NAMELY, MANUALLY OPERATED RESISTIVE EXERCISE BAND AND ACCESSORIES THEREFOR; REHABILITATIVE AND PHYSICAL THERAPY KITS CONSISTING OF MANUALLY OPERATED RESISTIVE EXERCISE BAND AND HAND GRIPS, HAND PUTTY, AND ACCESSORIES THEREFOR (U.S. CLS. 26, 39 AND 44).

CLASS 28—TOYS AND SPORTING GOODS

FOR EXERCISE DEVICES, NAMELY, MANUALLY OPERATED RESISTIVE EXERCISE BAND AND ACCESSORIES THEREFOR (U.S. CLS. 22, 23, 38 AND 50).
AMY C. KEAN, EXAMINING ATTORNEY



THE MARK CONSISTS OF AN "X" WHEREIN ONE LINE FORMING THE "X" IS CROSSED WITH AN UPSIDE-DOWN EXCLAMATION POINT.

CLASS 3—COSMETICS AND CLEANING PREPARATIONS

FOR (BASED ON INTENT TO USE) COSMETIC PREPARATIONS FOR SKIN CARE (U.S. CLS. 1, 4, 6, 50, 51 AND 52).

CLASS 18—LEATHER GOODS

FOR (BASED ON INTENT TO USE) GYM BAGS, BACKPACKS, TOTE BAGS (U.S. CLS. 1, 2, 3, 22 AND 41).

CLASS 21—HOUSEWARES AND GLASS

FOR (BASED ON INTENT TO USE) REUSABLE WATER BOTTLES SOLD EMPTY (U.S. CLS. 2, 13, 23, 29, 30, 33, 40 AND 50).

CLASS 25—CLOTHING

FOR (BASED ON INTENT TO USE) MEN'S, WOMEN'S AND KID'S FITNESS CLOTHING, NAMELY, SHIRTS, PANTS, JACKETS, FOOTWEAR, HATS, CAPS, T-SHIRTS, SHORTS, SWEATPANTS, YOGA PANTS, SOCKS, WRIST BANDS, HEADBANDS (U.S. CLS. 22 AND 39).

CLASS 32—LIGHT BEVERAGES

FOR (BASED ON INTENT TO USE) WATER BEVERAGES, ENERGY DRINKS, SPORTS DRINKS (U.S. CLS. 45, 46 AND 48).

CLASS 41—EDUCATION AND ENTERTAINMENT

FOR (BASED ON USE IN COMMERCE) EDUCATION SERVICES, NAMELY, PROVIDING CHOREOGRAPHED GROUP FITNESS PROGRAMS FOR CHILDREN AND ADULTS IN THE FIELD OF PHYSICAL FITNESS; ENTERTAINMENT SERVICES IN THE NATURE OF CHOREOGRAPHED GROUP FITNESS PERFORMANCES; HEALTH CLUB SERVICES, NAMELY, PROVIDING INSTRUCTION AND EQUIPMENT IN THE FIELD OF PHYSICAL EXERCISE; PERSONAL TRAINING SERVICES, NAMELY, STRENGTH AND CONDITIONING TRAINING; PHYSICAL FITNESS CONSULTATION; PHYSICAL FITNESS INSTRUCTION (U.S. CLS. 100, 101 AND 107).

FIRST USE 4-2-2012; IN COMMERCE 4-2-2012.
COLLEEN MULCRONE, EXAMINING ATTORNEY

SN 85-593,775. DIDDY RIESE COOKIES, INC., LOS ANGELES, CA. FILED 4-10-2012.

The CrumbleCream Cookie Co.

THE MARK CONSISTS OF STANDARD CHARACTERS WITHOUT CLAIM TO ANY PARTICULAR FONT, STYLE, SIZE, OR COLOR.

NO CLAIM IS MADE TO THE EXCLUSIVE RIGHT TO USE "COOKIE CO.", APART FROM THE MARK AS SHOWN.

CLASS 30—STAPLE FOODS

FOR BAKERY PRODUCTS, ICE CREAM, ICE CREAM SANDWICHES, ICE CREAM CONES, ICE CREAM CUPS, AND ICE CREAM CAKES (U.S. CL. 46).

CLASS 43—HOTEL AND RESTAURANT SERVICES

FOR RESTAURANT SERVICES (U.S. CLS. 100 AND 101).

RONALD AIKENS, EXAMINING ATTORNEY

SN 85-593,925. AMEREX GROUP, LLC, NEW YORK, NY. FILED 4-10-2012.

SNOW TUNZ

THE MARK CONSISTS OF STANDARD CHARACTERS WITHOUT CLAIM TO ANY PARTICULAR FONT, STYLE, SIZE, OR COLOR.

CLASS 9—ELECTRICAL AND SCIENTIFIC APPARATUS

FOR AUDIO HEADPHONES (U.S. CLS. 21, 23, 26, 36 AND 38).

CLASS 25—CLOTHING

FOR CLOTHING WITH BUILT-IN WASHABLE AUDIO HEADPHONES, NAMELY, JACKETS (U.S. CLS. 22 AND 39).

ALYSSA STEEL, EXAMINING ATTORNEY

SN 85-593,977. BROADVISION, INC., REDWOOD CITY, CA. FILED 4-10-2012.

clearvale

THE MARK CONSISTS OF "CLEARVALE" WITH A LONG SWOOSH ABOVE THE MARK.

CLASS 38—COMMUNICATION

FOR TELECOMMUNICATIONS SERVICES, NAMELY, ENABLING USERS TO ELECTRONICALLY TRANSMIT MESSAGES, TEXT, MULTIMEDIA CONTENT, VIDEOS, AUDIO, AND IMAGES VIA A GLOBAL COMPUTER NETWORK; PROVIDING ONLINE COMMUNICATIONS LINKS WHICH TRANSFER WEBSITE USERS TO OTHER WEBSITES; PROVIDING ONLINE FORUMS, CHAT ROOMS AND ELECTRONIC BULLETIN BOARDS FOR TRANSMISSION OF MESSAGES AMONG USERS; PROVIDING ACCESS TO COMPUTER, ELECTRONIC AND ONLINE DATABASES; AUDIO AND VIDEO BROADCASTING SERVICES OVER THE INTERNET, NAMELY, POSTING, DISPLAYING AND ELECTRONICALLY TRANSMITTING DATA, AUDIO AND VIDEO INFORMATION (U.S. CLS. 100, 101 AND 104).

FIRST USE 9-0-2009; IN COMMERCE 9-0-2009.

CLASS 41—EDUCATION AND ENTERTAINMENT

FOR PROVIDING A WEBSITE FEATURING BLOGS IN THE FIELD OF CUSTOMER RELATIONSHIPS, MARKETING, AND BUSINESS NETWORKING (U.S. CLS. 100, 101 AND 107).

FIRST USE 9-0-2009; IN COMMERCE 9-0-2009.

CLASS 42—SCIENTIFIC AND COMPUTER SERVICES

FOR APPLICATION SERVICE PROVIDER, NAMELY, HOSTING WEB-BASED COMPUTER SOFTWARE FOR ESTABLISHING, ORGANIZING AND MANAGING COMMUNICATIONS AND RELATIONSHIPS WITH CUSTOMERS, SUPPLIERS, PARTNERS, AND EMPLOYEES; CLOUD-BASED SOFTWARE SERVICE THAT PROVIDES NON-DOWNLOADABLE SOFTWARE THAT HELPS BUSINESSES ESTABLISH, MAINTAIN AND MANAGE COMMUNICATIONS AND RELATIONSHIPS WITH EMPLOYEES, CUSTOMERS AND PARTNERS (U.S. CLS. 100 AND 101).

FIRST USE 9-0-2009; IN COMMERCE 9-0-2009.

CLASS 45—PERSONAL AND LEGAL SERVICES

FOR CLOUD-BASED ENTERPRISE SOCIAL NETWORKING SERVICES THAT HELP BUSINESSES ENGAGE WITH EMPLOYEES, CUSTOMERS AND PARTNERS (U.S. CLS. 100 AND 101).

FIRST USE 9-0-2009; IN COMMERCE 9-0-2009.

DOMINIC FATHY, EXAMINING ATTORNEY

CLASS 42—SCIENTIFIC AND COMPUTER SERVICES

FOR APPLICATION SERVICE PROVIDER, NAMELY, HOSTING WEB-BASED COMPUTER SOFTWARE FOR ESTABLISHING, ORGANIZING AND MANAGING COMMUNICATIONS AND RELATIONSHIPS WITH CUSTOMERS, SUPPLIERS, PARTNERS, AND EMPLOYEES; CLOUD-BASED SOFTWARE SERVICE THAT PROVIDES NON-DOWNLOADABLE SOFTWARE THAT HELPS BUSINESSES ESTABLISH, MAINTAIN AND MANAGE COMMUNICATIONS AND RELATIONSHIPS WITH EMPLOYEES, CUSTOMERS AND PARTNERS (U.S. CLS. 100 AND 101).

FIRST USE 9-0-2009; IN COMMERCE 9-0-2009.

CLASS 45—PERSONAL AND LEGAL SERVICES

FOR CLOUD-BASED ENTERPRISE SOCIAL NETWORKING SERVICES THAT HELP BUSINESSES ENGAGE WITH EMPLOYEES, CUSTOMERS AND PARTNERS (U.S. CLS. 100 AND 101).

FIRST USE 9-0-2009; IN COMMERCE 9-0-2009.

DOMINIC FATHY, EXAMINING ATTORNEY

SN 85-593,984. BROADVISION, INC., REDWOOD CITY, CA. FILED 4-10-2012.

CLEARVALE

THE MARK CONSISTS OF STANDARD CHARACTERS WITHOUT CLAIM TO ANY PARTICULAR FONT, STYLE, SIZE, OR COLOR.

CLASS 38—COMMUNICATION

FOR TELECOMMUNICATIONS SERVICES, NAMELY, ENABLING USERS TO ELECTRONICALLY TRANSMIT MESSAGES, TEXT, MULTIMEDIA CONTENT, VIDEOS, AUDIO, AND IMAGES VIA A GLOBAL COMPUTER NETWORK; PROVIDING ONLINE COMMUNICATIONS LINKS WHICH TRANSFER WEBSITE USERS TO OTHER WEBSITES; PROVIDING ONLINE FORUMS, CHAT ROOMS AND ELECTRONIC BULLETIN BOARDS FOR TRANSMISSION OF MESSAGES AMONG USERS; PROVIDING ACCESS TO COMPUTER, ELECTRONIC AND ONLINE DATABASES; AUDIO AND VIDEO BROADCASTING SERVICES OVER THE INTERNET, NAMELY, POSTING, DISPLAYING AND ELECTRONICALLY TRANSMITTING DATA, AUDIO AND VIDEO INFORMATION (U.S. CLS. 100, 101 AND 104).

FIRST USE 9-0-2009; IN COMMERCE 9-0-2009.

CLASS 41—EDUCATION AND ENTERTAINMENT

FOR PROVIDING A WEBSITE FEATURING BLOGS IN THE FIELD OF CUSTOMER RELATIONSHIPS, MARKETING, AND BUSINESS NETWORKING (U.S. CLS. 100, 101 AND 107).

FIRST USE 9-0-2009; IN COMMERCE 9-0-2009.

SN 85-594,010. RGH ENTERTAINMENT, LLC, WOODLAND HILLS, CA. FILED 4-10-2012.



NO CLAIM IS MADE TO THE EXCLUSIVE RIGHT TO USE "ENTERTAINMENT", APART FROM THE MARK AS SHOWN.

THE MARK CONSISTS OF A FLAG DESIGN WITH THE STYLIZED WORDING "RGH ENTERTAINMENT" BELOW THE DESIGN.

CLASS 9—ELECTRICAL AND SCIENTIFIC APPARATUS

FOR COMPUTER SOFTWARE FOR THE COLLECTION, EDITING, ORGANIZING, MODIFYING, BOOK MARKING, TRANSMISSION, STORAGE AND SHARING OF DATA AND INFORMATION; COMPUTER ENTERTAINMENT GAME SOFTWARE; DOWNLOADABLE GAME SOFTWARE AND DOWNLOADABLE COMPUTER GAME PROGRAMS VIA A GLOBAL COMPUTER NETWORK AND WIRELESS MOBILE DEVICES (U.S. CLS. 21, 23, 26, 36 AND 38).

CLASS 16—PAPER GOODS AND PRINTED MATTER

FOR PRINTED MATTER, NAMELY, BOOKS, MAGAZINES, NEWSLETTERS AND GUIDES IN THE FIELD OF ENTERTAINMENT AND COMPUTER GAMES; PRINTED MATTER, NAMELY, COMPUTER GAME INSTRUCTION MANUALS; POSTERS (U.S. CLS. 2, 5, 22, 23, 29, 37, 38 AND 50).

CLASS 25—CLOTHING

FOR CLOTHING, NAMELY, SHIRTS, PANTS, SHORTS, JACKETS, SOCKS, BELTS, TOPS AND BOTTOMS; FOOTWEAR; HEADGEAR, NAMELY, CAPS, HATS AND VISORS (U.S. CLS. 22 AND 39).

CLASS 28—TOYS AND SPORTING GOODS

FOR TOYS AND GAMES, NAMELY, HAND-HELD UNITS FOR PLAYING ELECTRONIC GAMES AND VIDEO GAMES OTHER THAN THOSE ADAPTED FOR USE WITH AN EXTERNAL DISPLAY SCREEN OR MONITOR, HAND-HELD ELECTRONIC GAMES ADAPTED FOR USE WITH TELEVISION RECEIVERS ONLY, HAND-HELD GAMES WITH LIQUID CRYSTAL DISPLAYS, HAND-HELD UNITS FOR PLAYING ELECTRONIC GAMES FOR USE WITH EXTERNAL DISPLAY SCREEN OR MONITOR, LCD GAME MACHINES, HAND HELD JOY STICK UNITS FOR PLAYING VIDEO GAMES AND GAMING HEADSETS ADAPTED FOR USE IN PLAYING VIDEO GAMES; ACTION FIGURES (U.S. CLS. 22, 23, 38 AND 50).

CLASS 35—ADVERTISING AND BUSINESS

FOR PRODUCTION AND DISTRIBUTION OF RADIO AND TELEVISION COMMERCIALS (U.S. CLS. 100, 101 AND 102).

CLASS 41—EDUCATION AND ENTERTAINMENT

FOR ENTERTAINMENT SERVICES, NAMELY, PROVIDING ONLINE COMPUTER, VIDEO AND ELECTRONIC GAMES; ENTERTAINMENT SERVICES IN THE NATURE OF ON-GOING TELEVISION PROGRAMS IN THE FIELD OF CHILDREN'S ENTERTAINMENT; PROVIDING INFORMATION RELATING TO CHILDREN'S ENTERTAINMENT; ENTERTAINMENT SERVICES IN THE NATURE OF DEVELOPMENT, CREATION, PRODUCTION AND POST-PRODUCTION SERVICES OF MULTIMEDIA ENTERTAINMENT CONTENT; MULTIMEDIA ENTERTAINMENT SERVICES IN THE NATURE OF DEVELOPMENT, PRODUCTION AND POST-PRODUCTION SERVICES IN THE FIELDS OF VIDEO AND FILMS; ENTERTAINMENT SERVICES, NAMELY, MULTIMEDIA PRODUCTION SERVICES; ENTERTAINMENT IN THE NATURE OF ON-GOING TELEVISION PROGRAMS IN THE FIELD OF ANIMATION, ACTION, ADVENTURE, COMEDY AND DRAMA; ENTERTAINMENT SERVICES, NAMELY, PROVIDING ON-GOING WEBISODES FEATURING ANIMATION, ACTION, ADVENTURE, COMEDY AND DRAMA VIA A GLOBAL COMPUTER NETWORK; AMUSEMENT PARK AND THEME PARK SERVICES; BOOK PUBLISHING; PRODUCTION AND DISTRIBUTION OF MOTION PICTURES AND TELEVISION PROGRAMS; PRODUCTION OF VIDEO AND COMPUTER GAME SOFTWARE; MULTIMEDIA ENTERTAINMENT SOFTWARE PRODUCTION SERVICES; CORPORATE VIDEO PRODUCTION SERVICES; PROVIDING NON-DOWNLOADABLE FILMS, MOVIES AND TELEVISION PROGRAMS VIA A VIDEO-ON-DEMAND SERVICE; PROVIDING A WEBSITE FEATURING ENTERTAINMENT INFORMATION; ENTERTAINMENT INFORMATION PROVIDED TO MOBILE DEVICES; PRODUCTION AND DISTRIBUTION OF MOTION PICTURES AND TELEVISION PROGRAMS FEATURING ANIMATION; ANIMATION PRODUCTION SERVICES; SPECIAL EFFECTS ANIMATION SERVICES FOR FILM AND VIDEO; PROVIDING INFORMATION IN THE FIELD OF ENTERTAINMENT, FEATURING ANIMATION RENDERED BY MEANS OF A GLOBAL COMPUTER NETWORK (U.S. CLS. 100, 101 AND 107).

CLASS 42—SCIENTIFIC AND COMPUTER SERVICES

FOR PRODUCT DEVELOPMENT IN THE FIELD OF THEME PARK RIDES (U.S. CLS. 100 AND 101).
DAVID YONTEF, EXAMINING ATTORNEY

SN 85-594,155. W. VAN DE LAGEWEG HOLDING B.V., 9025 BR BEARS, NETHERLANDS, FILED 4-11-2012.

VDL

THE MARK CONSISTS OF STANDARD CHARACTERS WITHOUT CLAIM TO ANY PARTICULAR FONT, STYLE, SIZE, OR COLOR.

OWNER OF ERPN CMNTY TM OFC REG. NO. 003703154, DATED 7-28-2005, EXPIRES 3-11-2014.

CLASS 31—NATURAL AGRICULTURAL PRODUCTS

FOR LIVE ANIMALS, NAMELY, HORSES (U.S. CLS. 1 AND 46).

FIRST USE 6-1-1996; IN COMMERCE 6-1-2000.

CLASS 35—ADVERTISING AND BUSINESS

FOR ONLINE RETAIL STORE SERVICES FEATURING HORSES AND HORSE SPERM; ORGANIZATION OF PROMOTIONAL CAMPAIGNS AND ACTIVITIES IN THE FIELD OF HORSES, NAMELY, ADVERTISING AND PROMOTIONAL SERVICES (U.S. CLS. 100, 101 AND 102).

FIRST USE 6-1-1996; IN COMMERCE 6-1-2000.

CLASS 44—MEDICAL, BEAUTY AND AGRICULTURAL SERVICES

FOR BREEDING AND STUD SERVICES FOR HORSES (U.S. CLS. 100 AND 101).

FIRST USE 6-1-1996; IN COMMERCE 6-1-2000.

MARK SHINER, EXAMINING ATTORNEY

SN 85-594,240. SOUTHERN MARYLAND ELECTRIC COOPERATIVE, INC., HUGHESVILLE, MD. FILED 4-11-2012.

GETTING SMARTER TOGETHER

THE MARK CONSISTS OF STANDARD CHARACTERS WITHOUT CLAIM TO ANY PARTICULAR FONT, STYLE, SIZE, OR COLOR.

CLASS 35—ADVERTISING AND BUSINESS

FOR UTILITY BILL MANAGEMENT SERVICES, NAMELY, TRACKING, REPORTING, ANALYZING AND DELIVERING ENERGY INFORMATION IN THE FORM OF UTILITY BILLS AND UTILITY METER DATA RATE SCHEDULES (U.S. CLS. 100, 101 AND 102).

CLASS 37—CONSTRUCTION AND REPAIR

FOR REPAIR AND INSTALLATION SERVICES, NAMELY, THE INSTALLATION OF SMART METERS FOR TRACKING AND MONITORING ENERGY USAGE (U.S. CLS. 100, 103 AND 106).

CLASS 42—SCIENTIFIC AND COMPUTER SERVICES

FOR SMART METER READING AND DATA ANALYSIS OF PUBLIC UTILITIES (U.S. CLS. 100 AND 101).
REBECCA SMITH, EXAMINING ATTORNEY

SN 85-594,289. VIGLINK, INC., SAN FRANCISCO, CA.
FILED 4-11-2012.

LINKWEAVER

THE MARK CONSISTS OF STANDARD CHARACTERS WITHOUT CLAIM TO ANY PARTICULAR FONT, STYLE, SIZE, OR COLOR.

CLASS 9—ELECTRICAL AND SCIENTIFIC APPARATUS

FOR COMPUTER SOFTWARE UTILIZING SEMANTIC ALGORITHMS AND OTHER TECHNIQUES FOR ANALYZING INDIVIDUAL PAGES WITHIN WEBSITES TO IDENTIFY REFERENCES IN THE WEBPAGE CONTENT TO PRODUCTS, PRODUCT NAMES, PRODUCT CATEGORIES, MERCHANTS AND BRANDS, AND CONVERTING THE TEXT TO A LINK, OR INSERTING A LINK INTO THE CONTENT (U.S. CLS. 21, 23, 26, 36 AND 38).

CLASS 35—ADVERTISING AND BUSINESS

FOR ADVERTISING, MARKETING AND PROMOTION SERVICES; ON-LINE ADVERTISING AND MARKETING SERVICES PROMOTING THE GOODS AND SERVICES OF OTHERS BY PROVIDING HYPERLINKS ON THE WEBSITES OF BLOGGERS AND ONLINE PUBLISHERS TO THE WEBSITES OF OTHERS, NAMELY, MEMBERS OF AN AFFILIATE MARKETING NETWORK; ONLINE AFFILIATE MARKETING SERVICES, NAMELY, ENABLING WEBSITES TO ADVERTISE PRODUCTS AND SERVICES OF ADVERTISING PARTNERS, AND MANAGING AND TRACKING USE, DELIVERY AND EFFECTIVENESS OF ADVERTISEMENTS (U.S. CLS. 100, 101 AND 102).

CLASS 42—SCIENTIFIC AND COMPUTER SERVICES

FOR APPLICATION SERVICE PROVIDER (ASP) FEATURING SOFTWARE FOR ANALYZING WEB PAGES WITHIN WEBSITES TO FIND REFERENCES IN THE WEBPAGE CONTENT TO PRODUCTS, PRODUCT NAMES, PRODUCT CATEGORIES, MERCHANTS, BRANDS, WEBSITES, ADVERTISERS, AND OTHER ADVERTISING RELATED CONTENT AND CONVERTING THE TEXT TO LINKS, OR INSERTING NEW LINKS INTO THE WEB PAGE, GIVING THE WEBSITE READER THE ABILITY TO CLICK TO REACH A NEW WEBSITE OR WEBPAGE DESTINATION RELATING TO THE CONTENT IN THE WEB PAGE FOR THE PURPOSE OF MONETIZING WEBSITE CONTENT AND GENERATING REVENUE FOR WEBSITE PUBLISHERS; APPLICATION SERVICE PROVIDER FEATURING APPLICATION PROGRAMMING INTERFACE (API) SOFTWARE FOR ALLOWING DATA RETRIEVAL, UPLOAD, ACCESS AND MANAGEMENT; APPLICATION SERVICE PROVIDER (ASP) FEATURING SOFTWARE FOR USE IN AUTOMATICALLY INSERTING AFFILIATE MARKETING LINKS TO ADVERTISERS IN THE FIELD OF AFFILIATE MARKETING; PROVIDING TEMPORARY USE OF A WEB-BASED SOFTWARE APPLICATION FOR TRACKING AND ANALYZING OUTBOUND WEBSITE TRAFFIC, CALCULATING REVENUES GENERATED FROM PURCHASES RESULTING FROM OUTBOUND WEBSITE TRAFFIC, AND PROVIDING REPORTS IN CONNEC-

TION THEREWITH IN THE FIELD OF AFFILIATE MARKETING; COMPUTER SERVICE, NAMELY, ACTING AS AN APPLICATION SERVICE PROVIDER IN THE FIELDS OF INFORMATION AND KNOWLEDGE MANAGEMENT TO HOST COMPUTER APPLICATION SOFTWARE FOR THE PURPOSE OF AUTOMATICALLY GENERATING AFFILIATE MARKETING LINKS FROM EXISTING DIRECT LINKS TO ADVERTISERS; APPLICATION SERVICE PROVIDER (ASP) FEATURING SOFTWARE FOR USE IN TRACKING AND ANALYZING ADVERTISING LINK INSERTION INTO WEBSITE CONTENT, CALCULATING REVENUES GENERATED FROM PURCHASES RESULTING FROM OUTBOUND WEBSITE TRAFFIC DRIVEN BY INSERTED LINKS, AND PROVIDING REPORTS IN CONNECTION THEREWITH, USING A DASHBOARD FORMAT; COMPUTER SERVICE, NAMELY, ACTING AS AN APPLICATION SERVICE PROVIDER IN THE FIELDS OF INFORMATION AND KNOWLEDGE MANAGEMENT TO HOST COMPUTER APPLICATION SOFTWARE FOR THE PURPOSE OF AUTOMATICALLY INSERTING AFFILIATE MARKETING LINKS INTO WEBSITE CONTENT (U.S. CLS. 100 AND 101).

MICHAEL WEBSTER, EXAMINING ATTORNEY

SN 85-594,323. TASK VALUE MANAGEMENT, LLC, DETROIT, MI. FILED 4-11-2012.



NO CLAIM IS MADE TO THE EXCLUSIVE RIGHT TO USE "SOLUTIONS", APART FROM THE MARK AS SHOWN.

THE MARK CONSISTS OF A CIRCLE AND TWO CURVED BANDS POSITIONED AT THE TOP AND BOTTOM OF THE CIRCLE AND CURVING TO THE RIGHT. A SPACE SEPARATES EACH BAND FROM THE CIRCLE. TO THE LEFT OF THE CIRCLE AND THE BANDS ARE THE LETTERS "TVM" ALL IN UPPER CASE IN STYLIZED FONT. TO THE RIGHT OF THE CIRCLE AND THE BANDS ARE THE WORD "SOLUTIONS" IN TITLE CASE LETTERS IN STYLIZED FONT.

CLASS 35—ADVERTISING AND BUSINESS

FOR BILLING (U.S. CLS. 100, 101 AND 102).

CLASS 45—PERSONAL AND LEGAL SERVICES

FOR LEGAL SERVICES (U.S. CLS. 100 AND 101).
BRENDAN REGAN, EXAMINING ATTORNEY

SN 85-594,337. STRATEGYCORPS, LLC, BRENTWOOD, TN.
FILED 4-11-2012.

CHECKING ZONE

THE MARK CONSISTS OF STANDARD CHARACTERS WITHOUT CLAIM TO ANY PARTICULAR FONT, STYLE, SIZE, OR COLOR.

NO CLAIM IS MADE TO THE EXCLUSIVE RIGHT TO USE "CHECKING", APART FROM THE MARK AS SHOWN.

CLASS 35—ADVERTISING AND BUSINESS

FOR ARRANGING AND ADMINISTRATING CUSTOMER INCENTIVE REWARD AND BENEFIT PROGRAMS TO PROMOTE THE OFFERING AND SALE OF CHECKING ACCOUNTS; PROVIDING PROMOTIONAL MARKETING SERVICES TO FINANCIAL INSTITUTIONS (U.S. CLS. 100, 101 AND 102).

CLASS 36—INSURANCE AND FINANCIAL

FOR FINANCIAL SERVICES, NAMELY, PROVIDING FINANCIAL CONSULTING TO FINANCIAL INSTITUTIONS TO INCREASE PROFITABILITY (U.S. CLS. 100, 101 AND 102).

CLASS 41—EDUCATION AND ENTERTAINMENT

FOR SALES TRAINING SERVICES FOR FINANCIAL INSTITUTION PERSONNEL AND DISTRIBUTING TRAINING MANUALS IN CONNECTION THEREWITH (U.S. CLS. 100, 101 AND 107).

JANICE L. MCMORROW, EXAMINING ATTORNEY

SN 85-594,463. AGFEED INDUSTRIES, INC., GRAND JUNCTION, CO. FILED 4-11-2012.



NO CLAIM IS MADE TO THE EXCLUSIVE RIGHT TO USE "INDUSTRIES, INC.", APART FROM THE MARK AS SHOWN.

THE MARK CONSISTS OF THE WORDS "AGFEED INDUSTRIES, INC." BELOW A PYRAMID COMPRISED OF THREE LAYERS.

CLASS 31—NATURAL AGRICULTURAL PRODUCTS

FOR LIVE HOGS (U.S. CLS. 1 AND 46).
FIRST USE 7-0-2010; IN COMMERCE 7-0-2010.

CLASS 44—MEDICAL, BEAUTY AND AGRICULTURAL SERVICES

FOR HOG BREEDING; HOG FARMS (U.S. CLS. 100 AND 101).
FIRST USE 7-0-2010; IN COMMERCE 7-0-2010.
ESTHER BELENKER, EXAMINING ATTORNEY

SN 85-594,446. UNITED STATES TENNIS ASSOCIATION INCORPORATED, WHITE PLAINS, NY. FILED 4-11-2012.



NO CLAIM IS MADE TO THE EXCLUSIVE RIGHT TO USE "TENNIS", APART FROM THE MARK AS SHOWN.

THE MARK CONSISTS OF THE WORDING "TENNIS PLAY DAYS" IN STYLIZED LETTERING, IN WHICH THE FINAL "Y" IS REPRESENTED BY A DESIGN OF A TENNIS PLAYER SERVING THE BALL.

CLASS 35—ADVERTISING AND BUSINESS

FOR PROMOTING PUBLIC INTEREST IN THE SPORT OF TENNIS AMONG CHILDREN (U.S. CLS. 100, 101 AND 102).

FIRST USE 6-1-2011; IN COMMERCE 6-1-2011.

CLASS 41—EDUCATION AND ENTERTAINMENT

FOR TEACHING CHILDREN THE SPORT OF TENNIS AND CONDUCTING TENNIS TOURNAMENTS, CONTESTS, CLINICS AND WORKSHOPS AMONG CHILDREN (U.S. CLS. 100, 101 AND 107).

FIRST USE 6-1-2011; IN COMMERCE 6-1-2011.
AMY KELLY, EXAMINING ATTORNEY

SN 85-594,483. UNITED BRIDGE PARTNERS, L.P., FOSTER CITY, CA. FILED 4-11-2012.

UNITED BRIDGE PARTNERS

THE MARK CONSISTS OF STANDARD CHARACTERS WITHOUT CLAIM TO ANY PARTICULAR FONT, STYLE, SIZE, OR COLOR.

NO CLAIM IS MADE TO THE EXCLUSIVE RIGHT TO USE "BRIDGE PARTNERS", APART FROM THE MARK AS SHOWN.

CLASS 35—ADVERTISING AND BUSINESS

FOR OPERATION OF TOLL BRIDGES AND TOLL ROADS FOR OTHERS (U.S. CLS. 100, 101 AND 102).

CLASS 37—CONSTRUCTION AND REPAIR

FOR CONSTRUCTION OF TOLL BRIDGES AND TOLL ROADS; CONSULTING SERVICES FOR THE CONSTRUCTION OF TOLL BRIDGES AND TOLL ROADS (U.S. CLS. 100, 103 AND 106).

BARBARA GAYNOR, EXAMINING ATTORNEY

SN 85-594,485. UNITED BRIDGE PARTNERS, L.P., FOSTER CITY, CA. FILED 4-11-2012.

UNITED BRIDGE

THE MARK CONSISTS OF STANDARD CHARACTERS WITHOUT CLAIM TO ANY PARTICULAR FONT, STYLE, SIZE, OR COLOR.

NO CLAIM IS MADE TO THE EXCLUSIVE RIGHT TO USE "BRIDGE", APART FROM THE MARK AS SHOWN.

CLASS 35—ADVERTISING AND BUSINESS

FOR OPERATION OF TOLL BRIDGES AND TOLL ROADS FOR OTHERS (U.S. CLS. 100, 101 AND 102).

CLASS 37—CONSTRUCTION AND REPAIR

FOR CONSTRUCTION OF TOLL BRIDGES AND TOLL ROADS; CONSULTING SERVICES FOR THE CONSTRUCTION OF TOLL BRIDGES AND TOLL ROADS (U.S. CLS. 100, 103 AND 106).

BARBARA GAYNOR, EXAMINING ATTORNEY

SN 85-594,566. THE GRILLIN' GUYS, BELDING, MI. FILED 4-11-2012.



NO CLAIM IS MADE TO THE EXCLUSIVE RIGHT TO USE "GRILLING", APART FROM THE MARK AS SHOWN.

THE MARK CONSISTS OF THREE CIRCLES, AND, MORE PARTICULARLY, AN OUTER CIRCLE, A CIRCULAR MIDDLE BANNER AND AN INNER CIRCLE. THE OUTER CIRCLE IS A LINE CIRCLE DEFINING GENERALLY AN OUTER PERIMETER OF THE MARK. SPACED INWARDLY FROM THE OUTER CIRCLE, THE CIRCULAR MIDDLE BANNER COMPRISES A BAND WITH THE WORDING "THE GRILLIN' GUYS" DISPOSED THEREON. SPECIFICALLY, THE TERM "THE" APPEARS IN A HORIZONTAL MANNER ON THE MIDDLE LEFT OF THE CIRCULAR MIDDLE BANNER, AND THE TERMS "GRILLIN'" AND "GUYS" APPEAR IN ARCULATE FORM AT THE TOP AND BOTTOM OF THE CIRCULAR MIDDLE BANNER RESPECTIVELY. THE INNER CIRCLE COMPRISES A CIRCUMFERENTIAL OUTLINE WITH STAR-LIKE SPOKE IMAGES EMANATING FROM THE CENTER OF THE INNER CIRCLE. THE MARK FURTHER COMPRISES, FROM LEFT TO RIGHT, AN IMAGE OF A CARTOON CHICKEN BODY, A CARTOON COW HEAD, AND A CARTOON PIG HEAD, WHEREIN THE IMAGES ARE SUPERIMPOSED OVER THE THREE CIRCLES.

CLASS 35—ADVERTISING AND BUSINESS

FOR ON-LINE RETAIL STORE SERVICES FEATURING OUTDOOR COOKING EQUIPMENT SUCH AS OUTDOOR GRILLS AND ACCESSORIES THEREFOR; APRONS, CLOTHING, TOWELS, CLEANERS, SAUCES, RUBS, MARINADES, SEASONINGS, CHARCOAL, SMOKING CHIPS AND PELLETS, AND GRILLING UTENSILS; CONDUCTING TRADE SHOWS IN THE FIELD OF GRILLING AND OUTDOOR COOKING; TEMPORARY RETAIL STORES SET UP ON-SITE AT CONSUMER LOCATIONS TO PROVIDE SHOPPING FACILITIES FOR THE PUBLIC TO PURCHASE OUTDOOR COOKING EQUIPMENT AND ACCESSORIES THEREFOR; DEMONSTRATION OF GOODS; MARKETING SERVICES FOR OTHERS, NAMELY, CONDUCTING PROMOTIONAL EVENTS RELATED TO FOOD, GRILLING AND OUTDOOR COOKING TECHNIQUES; AND ON-LINE RETAIL STORE SERVICES FEATURING A WIDE VARIETY OF CONSUMER GOODS OF OTHERS (U.S. CLS. 100, 101 AND 102).

CLASS 41—EDUCATION AND ENTERTAINMENT

FOR EDUCATIONAL AND ENTERTAINMENT SERVICES, NAMELY, A CONTINUING PROGRAM ABOUT GRILLING AND OUTDOOR COOKING TECHNIQUES ACCESSIBLE BY RADIO, TELEVISION, SATELLITE, AUDIO, VIDEO AND COMPUTER NETWORKS; ENTERTAINMENT IN THE NATURE OF ON-SITE LIVE PERFORMANCES OF COOKING DEMONSTRATIONS RELATED TO FOOD, GRILLING AND OUTDOOR COOKING TECHNIQUES; CONDUCTING ENTERTAINMENT EXHIBITIONS IN THE NATURE OF COOKING DEMONSTRATIONS; PROVIDING EDUCATIONAL DEMONSTRATIONS; EDUCATIONAL SERVICES, NAMELY, CONDUCTING COOKING CLASSES IN THE FIELD OF GRILLING AND OUTDOOR COOKING TECHNIQUES; PROVIDING A WEBSITE FEATURING ENTERTAINMENT INFORMATION, NEWS, AND FEATURES ON EVENTS SUCH AS FAIRS, FESTIVALS AND COMMUNITY EVENTS, RELATING TO GRILLING AND OUTDOOR COOKING TECHNIQUES; AND CONDUCTING ONLINE EDUCATIONAL PROGRAMS, EXHIBITS AND DISPLAYS IN THE FIELD OF GRILLING AND OUTDOOR COOKING TECHNIQUES (U.S. CLS. 100, 101 AND 107).

MATTHEW GALAN, EXAMINING ATTORNEY

SN 85-594,605. AMERICAN MEADOWS INC., WILLISTON, VT. FILED 4-11-2012.

WHERE CONFIDENCE GROWS

THE MARK CONSISTS OF STANDARD CHARACTERS WITHOUT CLAIM TO ANY PARTICULAR FONT, STYLE, SIZE, OR COLOR.

CLASS 31—NATURAL AGRICULTURAL PRODUCTS

FOR FLOWER SEEDS; HERB SEEDS FOR PLANTING; VEGETABLE SEEDS FOR PLANTING; BULBS FOR HORTICULTURAL PURPOSES; LIVE PLANTS (U.S. CLS. 1 AND 46).

FIRST USE 3-21-2011; IN COMMERCE 3-21-2011.

CLASS 35—ADVERTISING AND BUSINESS

FOR ON-LINE RETAIL STORE SERVICES FEATURING BULBS FOR HORTICULTURAL PURPOSES, FLOWER SEEDS, HERB SEEDS FOR PLANTING, VEGETABLE SEEDS FOR PLANTING AND LIVE PLANTS; MAIL ORDER CATALOG SERVICES FEATURING BULBS FOR HORTICULTURAL PURPOSES, FLOWER SEEDS, HERB SEEDS FOR PLANTING, VEGETABLE SEEDS FOR PLANTING, AND LIVE PLANTS (U.S. CLS. 100, 101 AND 102).

FIRST USE 12-31-2010; IN COMMERCE 12-31-2010.
KAREN BRACEY, EXAMINING ATTORNEY

SN 85-594,815. SUNRUN INC., SAN FRANCISCO, CA. FILED 4-11-2012.



THE MARK CONSISTS OF AN ABSTRACT DESIGN OF A STREET GRID WITH BUILDINGS REPRESENTED BY VARIOUS SIZED SQUARES AND RECTANGLES.

SN 85-594,679. CLASSIC BICYCLE RACING LLC, DENVER, CO. FILED 4-11-2012.



OWNER OF U.S. REG. NO. 4,180,349.
THE COLOR(S) GRAY, BLUE, RED AND WHITE IS/ARE CLAIMED AS A FEATURE OF THE MARK.

THE MARK CONSISTS OF A BLUE AND RED MOUNTAIN MOTIF BEHIND THE WHITE IMAGE OF A CYCLIST. THERE APPEARS A WHITE DIAGONAL LINE UNDERNEATH THE CYCLIST SEPARATING THE BLUE ON THE LEFT AND THE RED ON THE RIGHT. THE ENTIRE IMAGE IS SURROUNDED BY A WHITE AND GRAY LINED BORDER.

CLASS 25—CLOTHING

FOR CLOTHING, NAMELY, SOCKS, SHOE COVERS FOR USE WHEN WEARING SHOES, LEG WARMERS, KNEE WARMERS, SHORTS, CYCLING SHORTS, UNDERWEAR, TIGHTS, KNICKERS, PANTS, WARM UP PANTS, SHIRTS, SKIRTS, PULLOVERS, JACKETS, VESTS, RAINWEAR, CYCLING JERSEYS, SPORTS BRAS, CROP TOPS, TANK TOPS, TOPS, ARM WARMERS, GLOVES, SPLIT-FINGERED GLOVES, BICYCLING GLOVES, BALACLAVAS, CAPS, VISORS, HATS, HEADBANDS, AND BASELAYERS, NAMELY, UNDERCLOTHES, TOPS, BOTTOMS AND UNDERWEAR (U.S. CLS. 22 AND 39).

CLASS 41—EDUCATION AND ENTERTAINMENT

FOR ARRANGING, ORGANIZING, OPERATING AND CONDUCTING CYCLING RACES (U.S. CLS. 100, 101 AND 107).
COURTNEY ALVAREZ, EXAMINING ATTORNEY

CLASS 7—MACHINERY

FOR APPARATUS AND INSTALLATIONS FOR GENERATING SOLAR ELECTRICITY, NAMELY, SOLAR-POWERED ELECTRICITY GENERATORS (U.S. CLS. 13, 19, 21, 23, 31, 34 AND 35).

CLASS 35—ADVERTISING AND BUSINESS

FOR MANAGEMENT RELATING TO THE USAGE OF SOLAR ELECTRICITY, NAMELY, PROVIDING RENEWABLE ENERGY SOLUTIONS TO CUSTOMERS AND ASSISTING IN THE MANAGEMENT OF ENERGY PRICES AND SUSTAINABILITY INITIATIVES FOR THE PURPOSES OF MANAGING ENERGY USAGE; CONSULTATION IN THE FIELD OF SOLAR ENERGY USAGE MANAGEMENT; DISTRIBUTION AND SUPPLY OF ENERGY DEVICES AND ALTERNATIVE ENERGY SOURCES, NAMELY, RETAIL STORE FEATURING ALTERNATIVE ENERGY GOODS (U.S. CLS. 100, 101 AND 102).

CLASS 36—INSURANCE AND FINANCIAL

FOR ENERGY BROKERAGE SERVICES, NAMELY, BROKERING ELECTRICITY GENERATED FROM RENEWABLE RESOURCES TO RESIDENTIAL AND COMMERCIAL CUSTOMERS THROUGH THE BUNDLING OF RENEWABLE ENERGY CREDITS WITH SUPPLIED SOLAR ELECTRICITY (U.S. CLS. 100, 101 AND 102).

CLASS 37—CONSTRUCTION AND REPAIR

FOR MAINTAINING AND SERVICING ENERGY DEVICES AND RENEWABLE ENERGY SYSTEMS, NAMELY, MAINTENANCE AND SERVICING OF RENEWABLE ENERGY EQUIPMENT AND INSTALLATIONS (U.S. CLS. 100, 103 AND 106).

CLASS 38—COMMUNICATION

FOR PROVIDING AN ONLINE FORUM FOR TRANSMISSION OF MESSAGES AMONG COMPUTER USERS FEATURING CONSUMER QUESTIONS, ANSWERS, AND INFORMATION ABOUT ENERGY INSTALLATIONS IN A HOUSEHOLD ENVIRONMENT (U.S. CLS. 100, 101 AND 104).

CLASS 39—TRANSPORTATION AND STORAGE

FOR DISTRIBUTION AND SUPPLY OF ENERGY DEVICES AND ALTERNATIVE ENERGY SOURCES, NAMELY, DISTRIBUTION AND TRANSMISSION OF ELECTRICITY FROM ALTERNATIVE ENERGY SOURCES; CONSULTATION RELATING TO THE DISTRIBUTION AND SUPPLY OF ENERGY DEVICES AND ALTERNATIVE ENERGY SOURCES, NAMELY, CONSULTATION IN THE FIELD OF DISTRIBUTION AND TRANSMISSION OF ELECTRICITY FROM ALTERNATIVE ENERGY SOURCES (U.S. CLS. 100 AND 105).

CLASS 40—MATERIAL TREATMENT

FOR OPERATING ENERGY DEVICES AND RENEWABLE ENERGY SYSTEMS, NAMELY, ENERGY GENERATION FROM RENEWABLE SOURCES; CONSULTATION IN THE FIELD OF GENERATION OF ENERGY FOR ALTERNATIVE SOURCES (U.S. CLS. 100, 103 AND 106).

CLASS 41—EDUCATION AND ENTERTAINMENT

FOR PROVIDING AN IN-PERSON EDUCATIONAL FORUM FOR CONSUMER QUESTIONS, ANSWERS, AND INFORMATION ABOUT ENERGY INSTALLATIONS IN A HOUSEHOLD ENVIRONMENT (U.S. CLS. 100, 101 AND 107).

KEVIN DINALLO, EXAMINING ATTORNEY

CLASS 38—COMMUNICATION

FOR PROVIDING AN ONLINE FORUM FOR TRANSMISSION OF MESSAGES AMONG COMPUTER USERS FEATURING CONSUMER QUESTIONS, ANSWERS, AND INFORMATION ABOUT ENERGY INSTALLATIONS IN A HOUSEHOLD ENVIRONMENT (U.S. CLS. 100, 101 AND 104).

CLASS 39—TRANSPORTATION AND STORAGE

FOR DISTRIBUTION AND SUPPLY OF ENERGY DEVICES AND ALTERNATIVE ENERGY SOURCES, NAMELY, DISTRIBUTION AND TRANSMISSION OF ELECTRICITY FROM ALTERNATIVE ENERGY SOURCES; CONSULTATION RELATING TO THE DISTRIBUTION AND SUPPLY OF ENERGY DEVICES AND ALTERNATIVE ENERGY SOURCES, NAMELY, CONSULTATION IN THE FIELD OF DISTRIBUTION AND TRANSMISSION OF ELECTRICITY FROM ALTERNATIVE ENERGY SOURCES (U.S. CLS. 100 AND 105).

SN 85-594,817. SUNRUN INC., SAN FRANCISCO, CA. FILED 4-11-2012.

OWNER OF U.S. REG. NOS. 3,479,236, 3,530,740 AND OTHERS.

THE MARK CONSISTS OF THE WORD "SUNRUN" IN STYLIZED LETTERS.

CLASS 7—MACHINERY

FOR APPARATUS AND INSTALLATIONS FOR GENERATING SOLAR ELECTRICITY, NAMELY, SOLAR-POWERED ELECTRICITY GENERATORS (U.S. CLS. 13, 19, 21, 23, 31, 34 AND 35).

CLASS 35—ADVERTISING AND BUSINESS

FOR MANAGEMENT RELATING TO THE USAGE OF SOLAR ELECTRICITY, NAMELY, PROVIDING RENEWABLE ENERGY SOLUTIONS TO CUSTOMERS AND ASSISTING IN THE MANAGEMENT OF ENERGY PRICES AND SUSTAINABILITY INITIATIVES FOR THE PURPOSES OF MANAGING ENERGY USAGE; CONSULTATION IN THE FIELD OF SOLAR ENERGY USAGE MANAGEMENT; DISTRIBUTION AND SUPPLY OF ENERGY DEVICES AND ALTERNATIVE ENERGY SOURCES, NAMELY, RETAIL STORE FEATURING ALTERNATIVE ENERGY GOODS (U.S. CLS. 100, 101 AND 102).

CLASS 36—INSURANCE AND FINANCIAL

FOR ENERGY BROKERAGE SERVICES, NAMELY, BROKERING ELECTRICITY GENERATED FROM RENEWABLE RESOURCES TO RESIDENTIAL AND COMMERCIAL CUSTOMERS THROUGH THE BUNDLING OF RENEWABLE ENERGY CREDITS WITH SUPPLIED SOLAR ELECTRICITY (U.S. CLS. 100, 101 AND 102).

CLASS 37—CONSTRUCTION AND REPAIR

FOR MAINTAINING AND SERVICING ENERGY DEVICES AND RENEWABLE ENERGY SYSTEMS, NAMELY, MAINTENANCE AND SERVICING OF RENEWABLE ENERGY EQUIPMENT AND INSTALLATIONS (U.S. CLS. 100, 103 AND 106).

CLASS 40—MATERIAL TREATMENT

FOR OPERATING ENERGY DEVICES AND RENEWABLE ENERGY SYSTEMS, NAMELY, ENERGY GENERATION FROM RENEWABLE SOURCES; CONSULTATION IN THE FIELD OF GENERATION OF ENERGY FOR ALTERNATIVE SOURCES (U.S. CLS. 100, 103 AND 106).

CLASS 41—EDUCATION AND ENTERTAINMENT

FOR PROVIDING AN IN-PERSON EDUCATIONAL FORUM FOR CONSUMER QUESTIONS, ANSWERS, AND INFORMATION ABOUT ENERGY INSTALLATIONS IN A HOUSEHOLD ENVIRONMENT (U.S. CLS. 100, 101 AND 107).

KEVIN DINALLO, EXAMINING ATTORNEY

SN 85-594,856. ALEXANDER KLEIN, WERNAU, FED REP GERMANY, FILED 4-11-2012.

OWNER OF ERPN CMNTY TM OFC REG. NO. 010337251, DATED 2-28-2012, EXPIRES 2-28-2022.

THE COLOR(S) GRAY, RED, AND BLACK IS/ARE CLAIMED AS A FEATURE OF THE MARK.

THE MARK CONSISTS OF NINE RED VERTICAL LINES, INCREASING IN WIDTH, FOLLOWED BY THE WORDING, "LIFTCORE" WITH THE TERM, "LIFT" IN BLACK, WITH A RED DOT ON THE "I" IN "LIFT" AND WITH THE TERM, "CORE" IN RED, WITH A GRAY HORIZONTAL BAR ABOVE AND BELOW THE VERTICAL LINES AND WORDING. THE COLOR WHITE REPRESENTS TRANSPARENT AREAS AND IS NOT PART OF THE MARK.

CLASS 7—MACHINERY

FOR ELEVATORS; HOISTS; LIFTING INSTALLATIONS FOR THE TRANSPORT OF PERSONS AND GOODS; STAIR LIFTS (U.S. CLS. 13, 19, 21, 23, 31, 34 AND 35).

CLASS 9—ELECTRICAL AND SCIENTIFIC APPARATUS

FOR ACCESS CONTROL AND ALARM MONITORING SYSTEMS; CABLES, ELECTRIC; CIRCUIT BOARDS; CONNECTION CABLES; ELECTRIC CABLES AND WIRES; ELECTRIC CABLES, WIRES, CONDUCTORS AND CONNECTION FITTINGS THEREFOR; ELECTRIC CONTROL PANELS; ELECTRIC SWITCHES; ELECTRICAL SWITCHES; ELECTRONIC CONTROLLER TO MANAGE THE POWER, MOVEMENT AND FUNCTIONS OF AN ELEVATOR; ELEVATOR PERFORMANCE MONITORING SYSTEM, NAMELY, EMBEDDED SOFTWARE IN CONTROLLERS FOR MONITORING ELEVATOR FUNCTIONS; HARNESSES FOR HOLDING ELECTRONIC DEVICES, NAMELY, ELECTRIC CABLES; POWER SWITCHES; PRESSURE SWITCHES AND SENSORS FOR MONITORING, CONTROLLING, AND SWITCHING HYDRAULIC OR PNEUMATIC SYSTEMS (U.S. CLS. 21, 23, 26, 36 AND 38).

ODESSA BIBBINS, EXAMINING ATTORNEY

CLASS 3—COSMETICS AND CLEANING PREPARATIONS

FOR AFTER-SUN LOTIONS; ALCOHOL FOR CLEANING PURPOSES; ALL PURPOSE CLEANING PREPARATIONS; ALMOND MILK FOR COSMETIC PURPOSES; ANTI-BACTERIAL SOAP; AROMATIC PREPARATIONS, NAMELY, BODY CARE PRODUCTS, NAMELY, BODY LOTION, SHOWER GEL, CUTICLE CREAM, SHAMPOO, CONDITIONER, NON-MEDICATED LIP BALM, SOAP, BODY POLISH, BODY AND FOOT SCRUB AND NON-MEDICATED FOOT CREAM; BABY BUBBLE BATH; BABY HAIR CONDITIONER; BABY HAND SOAP; BABY LOTION; BABY OIL; BABY OILS; BABY POWDER; BABY POWDERS; BABY SHAMPOO; BABY WIPES; BATH AND SHOWER GELS AND SALTS NOT FOR MEDICAL PURPOSES; BLEACHING PREPARATIONS FOR LAUNDRY USE; CLEANING PREPARATIONS; COLOGNES, PERFUMES AND COSMETICS; COSMETIC SUNSCREEN PREPARATIONS; COTTON WOOL BALLS FOR COSMETIC USE; DENTIFRICE; DEODORANT FOR PERSONAL USE; SHAMPOOS FOR BABIES; SOAPS FOR BODY CARE; TALCUM POWDER; WIPES IMPREGNATED WITH A CLEANING PREPARATION; WIPES IMPREGNATED WITH A SKIN CLEANSER (U.S. CLS. 1, 4, 6, 50, 51 AND 52).

CLASS 10—MEDICAL APPARATUS

FOR BABY BOTTLE NIPPLES; BABY BOTTLE THAT PLAYS SOUNDS USING WIRELESS TECHNOLOGY; BABY BOTTLES; BABY NURSERS; BREAST MILK STORAGE BOTTLES; BREAST PUMPS; COOLING APPARATUS USED FOR MEDICAL AND SURGICAL EQUIPMENT USED DURING MEDICAL AND SURGICAL PROCEDURES; DISPOSABLE BABY BOTTLE LINERS; FITTED BABY BOTTLE COVERS AND SLEEVES MADE FROM TEXTILES AND/OR WOVEN FABRIC; GLOVES FOR MEDICAL PURPOSES; GOODS OF METAL FOR MEDICAL USE, NAMELY, SCREWS, PLATES, PINS AND PIVOTS; HUMIDIFICATION APPARATUS FOR MEDICAL PURPOSES; ICE BAGS FOR MEDICAL PURPOSES; INCONTINENCE SHEETS; INHALERS FOR THERAPEUTIC USE; INJECTION DEVICE FOR PHARMACEUTICALS; KNIVES FOR SURGICAL PURPOSES; MAGNETS FOR MEDICAL PURPOSES; MASKS FOR USE BY MEDICAL PERSONNEL; MEDICAL APPARATUS AND INSTRUMENTS FOR USE IN SURGERY; MEDICAL FLUID INJECTORS; MEDICAL GLOVES; MEDICAL SCISSORS; NEEDLES FOR MEDICAL PURPOSES; NEONATAL PRODUCTS, NAMELY, ENTERAL SAFETY SYSTEM COMPRISING ORAL DISPENSERS, ORAL EXTENSION TUBES AND ENTERAL FEEDING TUBES, ORAL SYRINGES AND CONTAINERS FOR BREAST MILK OR FORMULA SOLD AS A UNIT; NON-MEDICATED COMPRESSES; OXYGEN INHALATORS; PACIFIERS FOR BABIES; PEDIATRIC BREATHING MASKS FOR MEDICAL PURPOSES; SURGICAL AND MEDICAL APPARATUS AND INSTRUMENTS FOR USE IN GENERAL SURGERY; TEATS; THERMOMETERS FOR MEDICAL PURPOSES (U.S. CLS. 26, 39 AND 44).

CLASS 12—VEHICLES

FOR BABY CARRIAGES; BABY CARRIAGES; BABY STROLLERS; BRAKE SYSTEMS FOR VEHICLES; CANOPIES FOR BABY STROLLERS; CHAIR LIFTS; CHILD CARRYING TRAILERS FOR USE IN TRANSPORTING CHILDREN WHILE HIKING, JOGGING, WALKING, SKIING, SNOW SHOEING OR SKATING; CHILD RESTRAINTS FOR VEHICLE SEATS; CHILD SAFETY HARNESSES FOR VEHICLE SEATS; CHILDREN'S CAR SEATS; CHILDREN'S SAFETY SEATS FOR CARS; CHILDREN'S SAFETY SEATS FOR VEHICLES; COVERS FOR BABY STROLLERS; COVERS FOR CHILDREN'S CAR SEATS; PRAMS; PUSH CHAIRS; RUBBER BABY BUGGY BUMPERS; SAFETY BELTS FOR VEHICLES FOR MOTOR CARS; SAFETY PADS FOR BICYCLES; SAFETY SEATS FOR CHILDREN FOR MOTOR CARS; SAFETY SEATS FOR INFANTS AND CHILDREN FOR VEHICLES; SEAT BELTS FOR USE IN VEHICLES; SEAT SAFETY HARNESSES FOR MOTOR CARS; SMALL WAGONS FOR CHILDREN; TIRES FOR CHILDREN'S BICYCLES; TRICYCLES; UMBRELLAS TO BE AFFIXED TO BABY STROLLER (U.S. CLS. 19, 21, 23, 31, 35 AND 44).

SN 85-595,016. ISAM ECONOMIC COMPANY LTD., RIYADH, SAUDI ARABIA, FILED 4-11-2012.



THE COLOR(S) RED, BLACK, WHITE, BLUE, PINK, YELLOW, DARK PINK, PEACH, AND DARK PEACH IS/ ARE CLAIMED AS A FEATURE OF THE MARK.

THE MARK CONSISTS OF A STYLIZED DEPICTION OF A YOUNG FEMALE CHILD WITH RED HAIR AND PINK BOW IN HER HAIR, AND WITH PEACH SKIN SHOWN IN THE FACE, EARS, AND HANDS, WITH DARK PEACH COLOR FOR SHADING. SHE HAS BLACK AND WHITE EYES WITH THREE RED DOTS UNDER EACH EYE REPRESENTING FRECKLES, A MOUTH IN THE SHAPE OF AN UPSIDE-DOWN TRIANGLE WITH DARK PINK ON TOP AND PINK ON THE BOTTOM, WITH THE LETTERS "KI" IN BLUE ON THE FRONT OF HER PINK PAJAMAS. THE PAJAMAS HAVE TWO YELLOW BUTTONS ON THE FRONT.

CLASS 21—HOUSEWARES AND GLASS

FOR BABY BATHTUBS; BAKEWARE; BASINS; BASKETS FOR DOMESTIC USE, NOT OF METAL; BASTING SPOONS; BATH SPONGES; BATHROOM FITTINGS, NAMELY, DISPENSING UNITS FOR HOUSEHOLD PURPOSES FOR DISPENSING HYGIENIC WIPES AND LOTIONS, NOT FOR MEDICAL PURPOSES; BEVERAGEWARE; BOTTLE OPENERS; BOTTLES FOR PHARMACEUTICALS SOLD EMPTY; BOTTLES, SOLD EMPTY; BOWLS; BOXES FOR DISPENSING PAPER TOWELS; BROOMS; BRUSHES FOR WASHING UP; BUTLERS' TRAYS; CAKE SERVERS; CANDLE HOLDERS; CASSEROLES; CERAMIC FIGURINES; CERAMIC TISSUE BOX COVERS; CHEESE BOARD AND KNIFE SET; CHEESE COVERS; CLEANING BRUSHES FOR HOUSEHOLD USE; CLEANING SPONGES; CLEANING, DUSTING AND POLISHING CLOTHS; CLOTHES DRYING HANGERS SPECIALLY DESIGNED FOR SPECIALTY CLOTHING; COFFEE CUPS, TEA CUPS AND MUGS; COFFEE SERVERS; COLANDERS FOR HOUSEHOLD USE; COMBS; CONFECTIONERS' DECORATING BAGS; CONTAINERS FOR HOUSEHOLD USE; CONTAINERS FOR ICE; COOKERY MOLDS; COOKING POTS; COOKING POTS AND PANS; COOKING STEAMERS; COOKWARE, NAMELY, POTS AND PANS; COTTON BALL DISPENSERS; COTTON BALLS; COUNTERTOP HOLDERS FOR PAPER TOWELS; CREAM AND SUGAR SET; CROCKERY, NAMELY, POTS, DISHES, DRINKING CUPS AND SAUCERS, BOWLS, SERVING BOWLS AND TRAYS; CUPS AND MUGS; DECORATIVE PLATES; DISHES AND PLATES; DISPENSERS FOR CELLULOSE WIPES FOR HOUSEHOLD USE; DISPENSERS FOR CLEANING AND DISINFECTING SOLUTIONS; DISPENSERS FOR FACIAL TISSUES; DISPENSERS FOR LIQUID SOAP; DISPENSERS FOR PAPER TOWELS; EGG CUPS; EMPTY SPRAY BOTTLES; FABRIC AND TEXTILE PARTY FAVOR BOXES SOLD EMPTY; FACIAL CLEANSING SPONGES; FLOWER BASKETS; FLOWER BOWLS; FRUIT BOWLS; FURNITURE DUSTERS; GLASS BEVERAGEWARE; GLASS JARS; GLOVES FOR HOUSEHOLD PURPOSES; HAIR BRUSHES; HAIR COMBS; HAIR, NAIL AND TOOTH BRUSHES; HOLDERS FOR FLOWERS AND PLANTS; HOLDERS FOR TOILET PAPER; HOUSEHOLD CONTAINERS OF PRECIOUS METAL; HOUSEHOLD GLOVES FOR GENERAL USE; ICE BUCKETS; ICE CREAM SCOOPS; INCENSE BURNERS; JUGS; KITCHEN CONTAINERS; KITCHEN UTENSIL, NAMELY, NON-METAL FLEXIBLE LID DESIGNED FOR DRAINING OR PRESSING LIQUIDS FROM A FOOD CAN; LAUNDRY BASKETS; LUNCH BOXES MADE OF PLASTIC; MAKE-UP BRUSHES; MANUAL TOOTHBRUSHES; NAPKIN DISPENSERS FOR HOUSEHOLD USE; NON-ELECTRIC EGG BEATERS; NON-ELECTRIC FOOD MIXERS; NON-ELECTRIC FRUIT SQUEEZERS; NON-ELECTRIC JUICERS; NON-ELECTRIC MEAT GRINDERS; ORAL CARE KIT COMPRISING TOOTHBRUSHES AND FLOSS; ORNAMENTS OF PORCELAIN; PAPER AND PLASTIC CUPS; PICNIC BASKETS SOLD EMPTY; PILL BOXES FOR PERSONAL USE; PLANT BASKETS; PLASTIC BAG HOLDERS FOR HOUSEHOLD USE; PLASTIC BATHTUBS FOR CHILDREN; PLASTIC CUPS; PORTABLE BEVERAGE COOLERS; PORTABLE BEVERAGE DISPENSERS; PORTABLE COOKING KITS FOR OUTDOOR USE; PORTABLE COOLERS; PORTABLE ICE CHESTS FOR FOOD AND BEVERAGES; SALAD BOWLS; SERVIETTE HOLDERS; SERVIETTE RINGS; SERVING DISHES; SHOE BRUSHES; SOAP DISPENSERS; SOAP HOLDERS AND BOXES; SOUVENIR PLATES; SPONGES FOR HOUSEHOLD PURPOSES; SPORTS BOTTLES SOLD EMPTY; SUGAR BASINS; TART SCOOPS; TEA BALLS; TEA INFUSERS; TEA POTS; TEA SERVICES; TOILET BRUSHES; TOILET PAPER DISPENSERS; TOILETRY SPONGES; TOOTH BRUSHES; VINEGAR CRUETS; WASHING BRUSHES; WATERING CANS; WINE OPENERS; WORKS OF ART MADE OF GLASS; WORKS OF ART MADE OF PORCELAIN (U.S. CLS. 2, 13, 23, 29, 30, 33, 40 AND 50).

CLASS 25—CLOTHING

FOR A-SHIRTS; ANORAK; AQUA SHOES; ATHLETIC FOOTWEAR; ATHLETIC SHOES; ATHLETIC UNIFORMS; BABIES' PANTS; BABY BIBS NOT OF PAPER; BABY BODYSUITS; BABY BOTTOMS; BABY BUNTING; BABY LAYETTES FOR CLOTHING; BABY TOPS; BATH SLIPPERS; BATHING CAPS; BATHING COSTUMES FOR WOMEN; BATHING SUITS; BATHROBES; BEACH FOOTWEAR; BEACHWEAR; BED JACKETS; BELTS; BERMUDA SHORTS; BLAZERS; BLOUSES; BOAS; BOOTS; BRAS; BUTTON DOWN SHIRTS; CAMISOLES; CAMP SHIRTS; CANVAS SHOES; CAP VISORS; CAPS; CARDIGANS; CHEMISETTES; CHILDREN'S AND INFANT'S APPAREL, NAMELY, JUMPERS, OVERALL SLEEPWEAR, PAJAMAS, ROMPERS AND ONE-PIECE GARMENTS; CHILDREN'S AND INFANTS' CLOTH BIBS; CHILDREN'S HEADWEAR; CLOTHING, NAMELY, MATERNITY BANDS; COATS; DRESSES; FOULARDS; GABERDINES; GLOVES; GOWNS; GYMNAS TIC SHOES; HATS; HATS FOR INFANTS, BABIES, TODDLERS AND CHILDREN; HEAD WEAR; HOODS; HOUSECOATS; INFANT AND TODDLER ONE PIECE CLOTHING; INFANT SLEEPERS; INFANT WEAR; INFANT WEARABLE BLANKETS; INFANTS' SHOES AND BOOTS; INFANTS' TROUSERS; JACKETS; JEANS; JERSEYS; LADIES' UNDERWEAR; LEOTARDS AND TIGHTS FOR WOMEN, MEN AND CHILDREN OF NYLON, COTTON OR OTHER TEXTILE FIBERS; LINGERIE; MATERNITY BRAS; MATERNITY CLOTHING, NAMELY, SHIRTS, PANTS, SHORTS, SKIRTS, DRESSES; MATERNITY LEGGINGS, NAMELY, LEGGINGS FEATURING BUILT-IN MATERNITY BANDS; MATERNITY LINGERIE; MATERNITY SLEEPWEAR; MEN'S AND WOMEN'S JACKETS, COATS, TROUSERS, VESTS; MEN'S SOCKS; MEN'S SUITS; MEN'S UNDERWEAR; NIGHTWEAR; ONE PIECE GARMENT FOR INFANTS AND TODDLERS; ONE-PIECE GARMENTS FOR CHILDREN; PANTIES; PANTS; PARKAS; RAIN JACKETS; SANDALS AND BEACH SHOES; SHIRTS; SHOES; SHORTS; SKIRTS; SWEATERS; SWIM WEAR; SWIMMING CAPS; T-SHIRTS; TROUSERS; UNDERCLOTHES (U.S. CLS. 22 AND 39).

CLASS 28—TOYS AND SPORTING GOODS

FOR AMUSEMENT MACHINES, NAMELY, HAND-HELD ELECTRONIC GAME UNITS ADAPTED FOR USE WITH AN EXTERNAL DISPLAY SCREEN OR MONITOR; APPARATUS FOR PLAYING CHESS, NAMELY, CHESS TIMERS; ARTICLES OF CLOTHING FOR TOYS; ARTIFICIAL CHRISTMAS GARLANDS; ARTIFICIAL CHRISTMAS TREES; AUDIO AND VISUAL HEADSETS FOR USE IN PLAYING VIDEO GAMES; BABY MULTIPLE ACTIVITY TOYS; BABY RATTLES; BABY RATTLES INCORPORATING TEETHING RINGS; BABY SWINGS; BALLOONS; BALLS FOR GAMES; BASKET BALLS; BATH TOYS; BEACH BALLS; BOARD GAMES; BODY BOARDS; BOOMERANGS; BUBBLE MAKING WAND AND SOLUTION SETS; BUILDING GAMES; CARD GAMES; CARNIVAL MASKS; CAT TOYS; CHESS GAMES; CHILDREN'S DRESS UP ACCESSORIES, NAMELY, TOY HELMETS FOR PLAY; CHILDREN'S MULTIPLE ACTIVITY TABLES; CHILDREN'S MULTIPLE ACTIVITY TOYS; CHILDREN'S MULTIPLE ACTIVITY TOYS SOLD AS A UNIT WITH PRINTED BOOKS; CHILDREN'S PLAY COSMETICS; CHILDREN'S TOY BICYCLES OTHER THAN FOR TRANSPORT; CHILDREN'S WIRE CONSTRUCTION AND ART ACTIVITY TOYS; CHRISTMAS TREE ORNAMENTS AND DECORATIONS; CHRISTMAS TREES OF SYNTHETIC MATERIAL; CONSTRUCTION TOYS; DOG TOYS; DOLLS AND ACCESSORIES THEREFOR; EDUCATIONAL CARD GAMES; EDUCATIONAL TOYS FOR TEACHING MUSIC PRINCIPLES TO CHILDREN, NAMELY, HAND-HELD MUSIC NOTATION SYMBOLS AND MUSIC RELATED FIGURES, SUCH AS INDIVIDUAL HAND-HELD PIANO KEYS; FACE PLATES FOR VIDEO GAME CONSOLES FOR USE WITH EXTERNAL MONITORS; FANTASY CHARACTER TOYS; FLOATS FOR BATHING AND SWIMMING; FOOT BALLS; GAME CARDS; HAND PUPPETS; INFANT DEVELOPMENT TOYS; INFANT TOYS; INFLATABLE BATH TOYS; MARIONETTES; MARTIAL ARTS TRAINING EQUIPMENT; MUSICAL TOYS; PET TOYS; PLAY HOUSES AND TOY ACCESSORIES THEREFOR; PLAY MOTOR CARS; PLAY SWIMMING POOLS; PROMOTIONAL GAME CARDS; PROMOTIONAL GAME MATERIALS;

PUPPETS; PUZZLE GAMES; REMOTE CONTROL TOYS, NAMELY, CARS, RACE CARS, AIRPLANES, BOATS; SPORTBALLS; TALKING TOYS; TOY ACTION FIGURES AND ACCESSORIES THEREFOR; TOY BOATS; TOY BUILDING BLOCKS CAPABLE OF INTERCONNECTION; TOY CARS; TOY FIGURES; TOY MODEL CARS; TOY PIANOS; TOY ROBOTS; TOY TOOLS; TOY TRAINS AND PARTS AND ACCESSORIES THEREFOR; TOY VEHICLE TRACK SETS AND ROADWAYS AND ACCESSORIES THEREFOR; TOY VEHICLES; TOY WATCHES; TOYS DESIGNED TO BE ATTACHED TO CAR SEATS, STROLLER, CRIBS, HIGH CHAIRS (U.S. CLS. 22, 23, 38 AND 50).

SUSAN BILLHEIMER, EXAMINING ATTORNEY

SN 85-595,033. ISAM ECONOMIC COMPANY LTD., RIYADH, SAUDI ARABIA, FILED 4-11-2012.



THE COLOR(S) PINK, DARK PINK, PURPLE, YELLOW, ORANGE AND WHITE IS/ARE CLAIMED AS A FEATURE OF THE MARK.

THE MARK CONSISTS OF A STYLIZED DEPICTION OF A BIRD WITH PINK AND WHITE FEATHERS WITH DARK PINK SHADOWING, A WHITE FACE, ONE DARK PINK LINE UNDER EACH EYE, YELLOW AND ORANGE BEAK, PINK TONGUE, DARK PINK MOUTH, PURPLE AND WHITE EYES, YELLOW FEET, WITH THE LETTER "MI" IN PINK LETTERS ON ITS WHITE BREAST.

CLASS 3—COSMETICS AND CLEANING PREPARATIONS

FOR AFTER-SUN LOTIONS; ALCOHOL FOR CLEANING PURPOSES; ALL PURPOSE CLEANING PREPARATIONS; ALMOND MILK FOR COSMETIC PURPOSES; ANTI-BACTERIAL SOAP; AROMATIC PREPARATIONS, NAMELY, BODY CARE PRODUCTS, NAMELY, BODY LOTION, SHOWER GEL, CUTICLE CREAM, SHAMPOO, CONDITIONER, NON-MEDICATED LIP BALM, SOAP, BODY POLISH, BODY AND FOOT SCRUB AND NON-MEDICATED FOOT CREAM; BABY BUBBLE BATH; BABY HAIR CONDITIONER; BABY HAND SOAP; BABY LOTION; BABY OIL; BABY OILS; BABY POWDER; BABY POWDERS; BABY SHAMPOO; BABY WIPES; BATH AND SHOWER GELS AND SALTS NOT FOR MEDICAL PURPOSES; BLEACHING PREPARATIONS FOR LAUNDRY USE; CLEANING PREPARATIONS; COLOGNES, PERFUMES AND COSMETICS; COSMETIC SUNSCREEN PREPARATIONS; COTTON WOOL BALLS FOR COSMETIC USE; DENTIFRICE; DEODORANT FOR PERSONAL USE; SHAMPOOS FOR BABIES; SOAPS FOR BODY CARE; TALCUM POWDER; WIPES IMPREGNATED WITH A CLEANING PREPARATION; WIPES IMPREGNATED WITH A SKIN CLEANSER (U.S. CLS. 1, 4, 6, 50, 51 AND 52).

CLASS 10—MEDICAL APPARATUS

FOR BABY BOTTLE NIPPLES; BABY BOTTLE THAT PLAYS SOUNDS USING WIRELESS TECHNOLOGY; BABY BOTTLES; BABY NURSERS; BREAST MILK STORAGE BOTTLES; BREAST PUMPS; COOLING APPARATUS USED FOR MEDICAL AND SURGICAL EQUIPMENT USED DURING MEDICAL AND SURGICAL PROCEDURES; DISPOSABLE BABY BOTTLE LINERS; FITTED BABY BOTTLE COVERS AND SLEEVES MADE FROM TEXTILES AND/OR WOVEN FABRIC; GLOVES FOR MEDICAL PURPOSES; GOODS OF METAL FOR MEDICAL USE, NAMELY, SCREWS, PLATES, PINS AND PIVOTS; HUMIDIFICATION APPARATUS FOR MEDICAL PURPOSES; ICE BAGS FOR MEDICAL PURPOSES; INCONTINENCE SHEETS; INHALERS FOR THERAPEUTIC USE; INJECTION DEVICE FOR PHARMACEUTICALS; KNIVES FOR SURGICAL PURPOSES; MAGNETS FOR MEDICAL PURPOSES; MASKS FOR USE BY MEDICAL PERSONNEL; MEDICAL APPARATUS AND INSTRUMENTS FOR USE IN SURGERY; MEDICAL FLUID INJECTORS; MEDICAL GLOVES; MEDICAL SCISSORS; NEEDLES FOR MEDICAL PURPOSES; NEONATAL PRODUCTS, NAMELY, ENTERAL SAFETY SYSTEM COMPRISING ORAL DISPENSERS, ORAL EXTENSION TUBES AND ENTERAL FEEDING TUBES, ORAL SYRINGES AND CONTAINERS FOR BREAST MILK OR FORMULA SOLD AS A UNIT; NON-MEDICATED COMPRESSES; OXYGEN INHALATORS; PACIFIERS FOR BABIES; PEDIATRIC BREATHING MASKS FOR MEDICAL PURPOSES; SURGICAL AND MEDICAL APPARATUS AND INSTRUMENTS FOR USE IN GENERAL SURGERY; TEATS; THERMOMETERS FOR MEDICAL PURPOSES (U.S. CLS. 26, 39 AND 44).

CLASS 12—VEHICLES

FOR BABY CARRIAGES; BABY CARRIAGES; BABY STROLLERS; BRAKE SYSTEMS FOR VEHICLES; CANOPIES FOR BABY STROLLERS; CHAIR LIFTS; CHILD CARRYING TRAILERS FOR USE IN TRANSPORTING CHILDREN WHILE HIKING, JOGGING, WALKING, SKIING, SNOW SHOEING OR SKATING; CHILD RESTRAINTS FOR VEHICLE SEATS; CHILD SAFETY HARNESSSES FOR VEHICLE SEATS; CHILDREN'S CAR SEATS; CHILDREN'S SAFETY SEATS FOR CARS; CHILDREN'S SAFETY SEATS FOR VEHICLES; COVERS FOR BABY STROLLERS; COVERS FOR CHILDREN'S CAR SEATS; PRAMS; PUSH CHAIRS; RUBBER BABY BUGGY BUMPERS; SAFETY BELTS FOR VEHICLES FOR MOTOR CARS; SAFETY PADS FOR BICYCLES; SAFETY SEATS FOR CHILDREN FOR MOTOR CARS; SAFETY SEATS FOR INFANTS AND CHILDREN FOR VEHICLES; SEAT BELTS FOR USE IN VEHICLES; SEAT SAFETY HARNESSSES FOR MOTOR CARS; SMALL WAGONS FOR CHILDREN; TIRES FOR CHILDREN'S BICYCLES; TRICYCLES; UMBRELLAS TO BE AFFIXED TO BABY STROLLER (U.S. CLS. 19, 21, 23, 31, 35 AND 44).

CLASS 21—HOUSEWARES AND GLASS

FOR BABY BATHTUBS; BAKEWARE; BASINS; BASKETS FOR DOMESTIC USE, NOT OF METAL; BASTING SPOONS; BATH SPONGES; BATHROOM FITTINGS, NAMELY, DISPENSING UNITS FOR HOUSEHOLD PURPOSES FOR DISPENSING HYGIENIC WIPES AND LOTIONS, NOT FOR MEDICAL PURPOSES; BEVERAGEWARE; BOTTLE OPENERS; BOTTLES FOR PHARMACEUTICALS SOLD EMPTY; BOTTLES, SOLD EMPTY; BOWLS; BOXES FOR DISPENSING PAPER TOWELS; BROOMS; BRUSHES FOR WASHING UP; BUTLERS' TRAYS; CAKE SERVERS; CANDLE HOLDERS; CASSEROLES; CERAMIC FIGURINES; CERAMIC TISSUE BOX COVERS; CHEESE BOARD AND KNIFE SET; CHEESE COVERS; CLEANING BRUSHES FOR HOUSEHOLD USE; CLEANING SPONGES; CLEANING, DUSTING AND POLISHING CLOTHS; CLOTHES DRYING HANGERS SPECIALLY DESIGNED FOR SPECIALTY CLOTHING; COFFEE CUPS, TEA CUPS AND MUGS; COFFEE SERVERS; COLANDERS FOR HOUSEHOLD USE; COMBS; CONFECTIONERS' DECORATING BAGS; CONTAINERS FOR HOUSEHOLD USE; CONTAINERS FOR ICE; COOKERY MOLDS; COOKING POTS; COOKING POTS AND PANS; COOKING STEAMERS; COOKWARE, NAMELY, POTS AND PANS; COTTON BALL DISPENSERS; COT-

TON BALLS; COUNTERTOP HOLDERS FOR PAPER TOWELS; CREAM AND SUGAR SET; CROCKERY, NAMELY, POTS, DISHES, DRINKING CUPS AND SAUCERS, BOWLS, SERVING BOWLS AND TRAYS; CUPS AND MUGS; DECORATIVE PLATES; DISHES AND PLATES; DISPENSERS FOR CELLULOSE WIPES FOR HOUSEHOLD USE; DISPENSERS FOR CLEANING AND DISINFECTING SOLUTIONS; DISPENSERS FOR FACIAL TISSUES; DISPENSERS FOR LIQUID SOAP; DISPENSERS FOR PAPER TOWELS; EGG CUPS; EMPTY SPRAY BOTTLES; FABRIC AND TEXTILE PARTY FAVOR BOXES SOLD EMPTY; FACIAL CLEANSING SPONGES; FLOWER BASKETS; FLOWER BOWLS; FRUIT BOWLS; FURNITURE DUSTERS; GLASS BEVERAGEWARE; GLASS JARS; GLOVES FOR HOUSEHOLD PURPOSES; HAIR BRUSHES; HAIR COMBS; HAIR, NAIL AND TOOTH BRUSHES; HOLDERS FOR FLOWERS AND PLANTS; HOLDERS FOR TOILET PAPER; HOUSEHOLD CONTAINERS OF PRECIOUS METAL; HOUSEHOLD GLOVES FOR GENERAL USE; ICE BUCKETS; ICE CREAM SCOOPS; INCENSE BURNERS; JUGS; KITCHEN CONTAINERS; KITCHEN UTENSIL, NAMELY, NON-METAL FLEXIBLE LID DESIGNED FOR DRAINING OR PRESSING LIQUIDS FROM A FOOD CAN; LAUNDRY BASKETS; LUNCH BOXES MADE OF PLASTIC; MAKE-UP BRUSHES; MANUAL TOOTHBRUSHES; NAPKIN DISPENSERS FOR HOUSEHOLD USE; NON-ELECTRIC EGG BEATERS; NON-ELECTRIC FOOD MIXERS; NON-ELECTRIC FRUIT SQUEEZERS; NON-ELECTRIC JUICERS; NON-ELECTRIC MEAT GRINDERS; ORAL CARE KIT COMPRISING TOOTHBRUSHES AND FLOSS; ORNAMENTS OF PORCELAIN; PAPER AND PLASTIC CUPS; PICNIC BASKETS SOLD EMPTY; PILL BOXES FOR PERSONAL USE; PLANT BASKETS; PLASTIC BAG HOLDERS FOR HOUSEHOLD USE; PLASTIC BATH-TUBS FOR CHILDREN; PLASTIC CUPS; PORTABLE BEVERAGE COOLERS; PORTABLE BEVERAGE DISPENSERS; PORTABLE COOKING KITS FOR OUTDOOR USE; PORTABLE COOLERS; PORTABLE ICE CHESTS FOR FOOD AND BEVERAGES; SALAD BOWLS; SERVIETTE HOLDERS; SERVIETTE RINGS; SERVING DISHES; SHOE BRUSHES; SOAP DISPENSERS; SOAP HOLDERS AND BOXES; SOUVENIR PLATES; SPONGES FOR HOUSEHOLD PURPOSES; SPORTS BOTTLES SOLD EMPTY; SUGAR BASINS; TART SCOOPS; TEA BALLS; TEA INFUSERS; TEA POTS; TEA SERVICES; TOILET BRUSHES; TOILET PAPER DISPENSERS; TOILETRY SPONGES; TOOTH BRUSHES; VINEGAR CRUETS; WASHING BRUSHES; WATERING CANS; WINE OPENERS; WORKS OF ART MADE OF GLASS; WORKS OF ART MADE OF PORCELAIN (U.S. CLS. 2, 13, 23, 29, 30, 33, 40 AND 50).

CLASS 25—CLOTHING

FOR A-SHIRTS; ANORAK; AQUA SHOES; ATHLETIC FOOTWEAR; ATHLETIC SHOES; ATHLETIC UNIFORMS; BABIES' PANTS; BABY BIBS NOT OF PAPER; BABY BODYSUITS; BABY BOTTOMS; BABY BUNTING; BABY LAYETTES FOR CLOTHING; BABY TOPS; BATH SLIPPERS; BATHING CAPS; BATHING COSTUMES FOR WOMEN; BATHING SUITS; BATHROBES; BEACH FOOTWEAR; BEACHWEAR; BED JACKETS; BELTS; BERMUDA SHORTS; BLAZERS; BLOUSES; BOAS; BOOTS; BRAS; BUTTON DOWN SHIRTS; CAMISOLES; CAMP SHIRTS; CANVAS SHOES; CAP VISORS; CAPS; CARDIGANS; CHEMISETTES; CHILDREN'S AND INFANT'S APPAREL, NAMELY, JUMPERS, OVERALL SLEEPWEAR, PAJAMAS, ROMPERS AND ONE-PIECE GARMENTS; CHILDREN'S AND INFANTS' CLOTH BIBS; CHILDREN'S HEADWEAR; CLOTHING, NAMELY, MATERNITY BANDS; COATS; DRESSES; FOULARDS; GABERDINES; GLOVES; GOWNS; GYM-NASTIC SHOES; HATS; HATS FOR INFANTS, BABIES, TODDLERS AND CHILDREN; HEAD WEAR; HOODS; HOUSECOATS; INFANT AND TODDLER ONE PIECE CLOTHING; INFANT SLEEPERS; INFANT WEAR; INFANT WEARABLE BLANKETS; INFANTS' SHOES AND BOOTS; INFANTS' TROUSERS; JACKETS; JEANS; JERSEYS; LADIES' UNDERWEAR; LEOTARDS AND TIGHTS FOR WOMEN, MEN AND CHILDREN OF NYLON, COTTON OR OTHER TEXTILE FIBERS; LINGERIE; MATERNITY BRAS; MATERNITY CLOTHING, NAMELY, SHIRTS, PANTS, SHORTS, SKIRTS, DRESSES;

MATERNITY LEGGINGS, NAMELY, LEGGINGS FEATURING BUILT-IN MATERNITY BANDS; MATERNITY LINGERIE; MATERNITY SLEEPWEAR; MEN'S AND WOMEN'S JACKETS, COATS, TROUSERS, VESTS; MEN'S SOCKS; MEN'S SUITS; MEN'S UNDERWEAR; NIGHTWEAR; ONE PIECE GARMENT FOR INFANTS AND TODDLERS; ONE-PIECE GARMENTS FOR CHILDREN; PANTIES; PANTS; PARKAS; RAIN JACKETS; SANDALS AND BEACH SHOES; SHIRTS; SHOES; SHORTS; SKIRTS; SWEATERS; SWIM WEAR; SWIMMING CAPS; T-SHIRTS; TROUSERS; UNDERCLOTHES (U.S. CLS. 22 AND 39).

CLASS 28—TOYS AND SPORTING GOODS

FOR AMUSEMENT MACHINES, NAMELY, HAND-HELD ELECTRONIC GAME UNITS ADAPTED FOR USE WITH AN EXTERNAL DISPLAY SCREEN OR MONITOR; APPARATUS FOR PLAYING CHESS, NAMELY, CHESS TIMERS; ARTICLES OF CLOTHING FOR TOYS; ARTIFICIAL CHRISTMAS GARLANDS; ARTIFICIAL CHRISTMAS TREES; AUDIO AND VISUAL HEADSETS FOR USE IN PLAYING VIDEO GAMES; BABY MULTIPLE ACTIVITY TOYS; BABY RATTLES; BABY RATTLES INCORPORATING TEETHING RINGS; BABY SWINGS; BALLOONS; BALLS FOR GAMES; BASKET BALLS; BATH TOYS; BEACH BALLS; BOARD GAMES; BODY BOARDS; BOOMERANGS; BUBBLE MAKING WAND AND SOLUTION SETS; BUILDING GAMES; CARD GAMES; CARNIVAL MASKS; CAT TOYS; CHESS GAMES; CHILDREN'S DRESS UP ACCESSORIES, NAMELY, TOY HELMETS FOR PLAY; CHILDREN'S MULTIPLE ACTIVITY TABLES; CHILDREN'S MULTIPLE ACTIVITY TOYS; CHILDREN'S MULTIPLE ACTIVITY TOYS SOLD AS A UNIT WITH PRINTED BOOKS; CHILDREN'S PLAY COSMETICS; CHILDREN'S TOY BICYCLES OTHER THAN FOR TRANSPORT; CHILDREN'S WIRE CONSTRUCTION AND ART ACTIVITY TOYS; CHRISTMAS TREE ORNAMENTS AND DECORATIONS; CHRISTMAS TREES OF SYNTHETIC MATERIAL; CONSTRUCTION TOYS; DOG TOYS; DOLLS AND ACCESSORIES THEREFOR; EDUCATIONAL CARD GAMES; EDUCATIONAL TOYS FOR TEACHING MUSIC PRINCIPLES TO CHILDREN, NAMELY, HAND-HELD MUSIC NOTATION SYMBOLS AND MUSIC RELATED FIGURES, SUCH AS INDIVIDUAL HAND-HELD PIANO KEYS; FACE PLATES FOR VIDEO GAME CONSOLES FOR USE WITH EXTERNAL MONITORS; FANTASY CHARACTER TOYS; FLOATS FOR BATHING AND SWIMMING; FOOT BALLS; GAME CARDS; HAND PUPPETS; INFANT DEVELOPMENT TOYS; INFANT TOYS; INFLATABLE BATH TOYS; MARIONETTES; MARTIAL ARTS TRAINING EQUIPMENT; MUSICAL TOYS; PET TOYS; PLAY HOUSES AND TOY ACCESSORIES THEREFOR; PLAY MOTOR CARS; PLAY SWIMMING POOLS; PROMOTIONAL GAME CARDS; PROMOTIONAL GAME MATERIALS; PUPPETS; PUZZLE GAMES; REMOTE CONTROL TOYS, NAMELY, CARS, RACE CARS, AIRPLANES, BOATS; SPORTBALLS; TALKING TOYS; TOY ACTION FIGURES AND ACCESSORIES THEREFOR; TOY BOATS; TOY BUILDING BLOCKS CAPABLE OF INTERCONNECTION; TOY CARS; TOY FIGURES; TOY MODEL CARS; TOY PIANOS; TOY ROBOTS; TOY TOOLS; TOY TRAINS AND PARTS AND ACCESSORIES THEREFOR; TOY VEHICLE TRACK SETS AND ROADWAYS AND ACCESSORIES THEREFOR; TOY VEHICLES; TOY WATCHES; TOYS DESIGNED TO BE ATTACHED TO CAR SEATS, STROLLER, CRIBS, HIGH CHAIRS (U.S. CLS. 22, 23, 38 AND 50).

SUSAN BILLHEIMER, EXAMINING ATTORNEY

SN 85-595,036. RAPID AIR LLC, PEWAUKEE, WI. FILED 4-11-2012.



The logo for RapidAir SYSTEMS features the word "RapidAir" in a large, bold, sans-serif font. The "AIR" portion of "RapidAir" is stylized with three horizontal wavy lines passing through it. Below "RapidAir", the word "SYSTEMS" is written in a smaller, all-caps, sans-serif font.

OWNER OF U.S. REG. NO. 3,468,661.
NO CLAIM IS MADE TO THE EXCLUSIVE RIGHT TO USE "SYSTEMS", APART FROM THE MARK AS SHOWN.
THE MARK CONSISTS OF THE WORD "RAPIDAIR" WITH A WAVE PATTERN THROUGH THE "AIR" PORTION; OVER THE WORD "SYSTEMS".

CLASS 7—MACHINERY

FOR PNEUMATIC PUMPS FOR INFLATABLE BEDS (U.S. CLS. 13, 19, 21, 23, 31, 34 AND 35).

CLASS 20—FURNITURE AND ARTICLES NOT OTHERWISE CLASSIFIED

FOR INFLATABLE BED KITS CONSISTING PRIMARILY OF AN INFLATABLE BED AIR CHAMBER, A PNEUMATIC PUMP, AND HAND-HELD WIRED PENDANTS USED FOR CONTROLLING THE OPERATION OF PUMPS (U.S. CLS. 2, 13, 22, 25, 32 AND 50).
ELLEN B. AWRICH, EXAMINING ATTORNEY

SN 85-595,043. ISAM ECONOMIC COMPANY LTD., RIYADH, SAUDI ARABIA, FILED 4-11-2012.



THE COLOR(S) DARK BLUE, BLUE, LIGHT BLUE, PURPLE, WHITE, DARK PINK, PINK AND GREEN IS/ARE CLAIMED AS A FEATURE OF THE MARK.

THE MARK CONSISTS OF A STYLIZED DEPICTION OF A BLUE OCTOPUS WITH DARK BLUE HEART DESIGNS ON ITS HEAD, AND LIGHT BLUE HIGHLIGHTING ON ITS HEAD AND FEET, WITH PURPLE AND WHITE EYES, A MOUTH IN THE SHAPE OF AN UPSIDE-DOWN TRIANGLE WITH DARK PINK ON TOP AND PINK ON THE BOTTOM, AND A GREEN TANK TOP ON WHICH APPEAR THE LETTERS "MO" IN PURPLE. A THIN PURPLE LINE REPRESENTING SHADOWING APPEARS UNDERNEATH THE OCTOPUS.

CLASS 3—COSMETICS AND CLEANING PREPARATIONS

FOR AFTER-SUN LOTIONS; ALCOHOL FOR CLEANING PURPOSES; ALL PURPOSE CLEANING PREPARATIONS; ALMOND MILK FOR COSMETIC PURPOSES; ANTI-BACTERIAL SOAP; AROMATIC PREPARATIONS, NAMELY, BODY CARE PRODUCTS, NAMELY, BODY LOTION, SHOWER GEL, CUTICLE CREAM, SHAMPOO, CONDITIONER, NON-MEDICATED LIP BALM, SOAP, BODY POLISH, BODY AND FOOT SCRUB AND NON-MEDICATED FOOT CREAM; BABY BUBBLE BATH; BABY HAIR CONDITIONER; BABY HAND SOAP; BABY LOTION; BABY OIL; BABY OILS; BABY POWDER; BABY POWDERS; BABY SHAMPOO; BABY WIPES; BATH AND SHOWER GELS AND SALTS NOT FOR MEDICAL PURPOSES; BLEACHING PREPARATIONS FOR LAUNDRY USE; CLEANING PREPARATIONS; COLOGNES, PERFUMES AND COSMETICS; COSMETIC SUNSCREEN PREPARATIONS; COTTON WOOL BALLS FOR COSMETIC USE; DENTIFRICE; DEODORANT FOR PERSONAL USE; SHAMPOOS FOR BABIES; SOAPS FOR BODY CARE; TALCUM POWDER; WIPES IMPREGNATED WITH A CLEANING PREPARATION; WIPES IMPREGNATED WITH A SKIN CLEANSER (U.S. CLS. 1, 4, 6, 50, 51 AND 52).

CLASS 10—MEDICAL APPARATUS

FOR BABY BOTTLE NIPPLES; BABY BOTTLE THAT PLAYS SOUNDS USING WIRELESS TECHNOLOGY; BABY BOTTLES; BABY NURSERS; BREAST MILK STORAGE BOTTLES; BREAST PUMPS; COOLING APPARATUS USED FOR MEDICAL AND SURGICAL EQUIPMENT USED DURING MEDICAL AND SURGICAL PROCEDURES; DISPOSABLE BABY BOTTLE LINERS; FITTED BABY BOTTLE COVERS AND SLEEVES MADE FROM TEXTILES AND/OR WOVEN FABRIC; GLOVES FOR MEDICAL PURPOSES; GOODS OF METAL FOR MEDICAL USE, NAMELY, SCREWS, PLATES, PINS AND PIVOTS; HUMIDIFICATION APPARATUS FOR MEDICAL PURPOSES; ICE BAGS FOR MEDICAL PURPOSES; INCONTINENCE SHEETS; INHALERS FOR THERAPEUTIC USE; INJECTION DEVICE FOR PHARMACEUTICALS; KNIVES FOR SURGICAL PURPOSES; MAGNETS FOR MEDICAL PURPOSES; MASKS FOR USE BY MEDICAL PERSONNEL; MEDICAL APPARATUS AND INSTRUMENTS FOR USE IN SURGERY; MEDICAL FLUID INJECTORS; MEDICAL GLOVES; MEDICAL SCISSORS; NEEDLES FOR MEDICAL PURPOSES; NEONATAL PRODUCTS, NAMELY, ENTERAL SAFETY SYSTEM COMPRISING ORAL DISPENSERS, ORAL EXTENSION TUBES AND ENTERAL FEEDING TUBES, ORAL SYRINGES AND CONTAINERS FOR BREAST MILK OR FORMULA SOLD AS A UNIT; NON-MEDICATED COMPRESSES; OXYGEN INHALATORS; PACIFIERS FOR BABIES; PEDIATRIC BREATHING MASKS FOR MEDICAL PURPOSES; SURGICAL AND MEDICAL APPARATUS AND INSTRUMENTS FOR USE IN GENERAL SURGERY; TATS; THERMOMETERS FOR MEDICAL PURPOSES (U.S. CLS. 26, 39 AND 44).

CLASS 12—VEHICLES

FOR BABY CARRIAGES; BABY CARRIAGES; BABY STROLLERS; BRAKE SYSTEMS FOR VEHICLES; CANOPIES FOR BABY STROLLERS; CHAIR LIFTS; CHILD CARRYING TRAILERS FOR USE IN TRANSPORTING CHILDREN WHILE HIKING, JOGGING, WALKING, SKIING, SNOW SHOEING OR SKATING; CHILD RESTRAINTS FOR VEHICLE SEATS; CHILD SAFETY HARNESSES FOR VEHICLE SEATS; CHILDREN'S CAR SEATS; CHILDREN'S SAFETY SEATS FOR CARS; CHILDREN'S SAFETY SEATS FOR VEHICLES; COVERS FOR BABY STROLLERS; COVERS FOR CHILDREN'S CAR SEATS; PRAMS; PUSH CHAIRS; RUBBER BABY BUGGY BUMPERS; SAFETY BELTS FOR VEHICLES FOR MOTOR CARS; SAFETY PADS FOR BICYCLES; SAFETY SEATS FOR CHILDREN FOR MOTOR CARS; SAFETY SEATS FOR INFANTS AND CHILDREN FOR VEHICLES; SEAT BELTS FOR USE IN VEHICLES; SEAT SAFETY HARNESSES FOR MOTOR CARS; SMALL WAGONS FOR CHILDREN; TIRES FOR CHILDREN'S BICYCLES; TRICYCLES; UMBRELLAS TO BE AFFIXED TO BABY STROLLER (U.S. CLS. 19, 21, 23, 31, 35 AND 44).

CLASS 21—HOUSEWARES AND GLASS

FOR BABY BATHTUBS; BAKEWARE; BASINS; BASKETS FOR DOMESTIC USE, NOT OF METAL; BASTING SPOONS; BATH SPONGES; BATHROOM FITTINGS, NAMELY, DISPENSING UNITS FOR HOUSEHOLD PURPOSES FOR DISPENSING HYGIENIC WIPES AND LOTIONS, NOT FOR MEDICAL PURPOSES; BEVERAGEWARE; BOTTLE OPENERS; BOTTLES FOR PHARMACEUTICALS SOLD EMPTY; BOTTLES, SOLD EMPTY; BOWLS; BOXES FOR DISPENSING PAPER TOWELS; BROOMS; BRUSHES FOR WASHING UP; BUTLERS' TRAYS; CAKE SERVERS; CANDLE HOLDERS; CASSEROLES; CERAMIC FIGURINES; CERAMIC TISSUE BOX COVERS; CHEESE BOARD AND KNIFE SET; CHEESE COVERS; CLEANING BRUSHES FOR HOUSEHOLD USE; CLEANING SPONGES; CLEANING, DUSTING AND POLISHING CLOTHS; CLOTHES DRYING HANGERS SPECIALLY DESIGNED FOR SPECIALTY CLOTHING; COFFEE CUPS, TEA CUPS AND MUGS; COFFEE SERVERS; COLANDERS FOR HOUSEHOLD USE; COMBS; CONFECTIONERS' DECORATING BAGS; CONTAINERS FOR HOUSEHOLD USE; CONTAINERS FOR ICE; COOKERY MOLDS; COOKING POTS; COOKING POTS AND PANS; COOKING STEAMERS; COOKWARE, NAMELY, POTS AND PANS; COTTON BALL DISPENSERS; COTTON BALLS; COUNTERTOP HOLDERS FOR PAPER TOWELS; CREAM AND SUGAR SET; CROCKERY, NAMELY, POTS, DISHES, DRINKING CUPS AND SAUCERS, BOWLS, SERVING BOWLS AND TRAYS; CUPS AND MUGS; DECORATIVE PLATES; DISHES AND PLATES; DISPENSERS FOR CELLULOSE WIPES FOR HOUSEHOLD USE; DISPENSERS FOR CLEANING AND DISINFECTING SOLUTIONS; DISPENSERS FOR FACIAL TISSUES; DISPENSERS FOR LIQUID SOAP; DISPENSERS FOR PAPER TOWELS; EGG CUPS; EMPTY SPRAY BOTTLES; FABRIC AND TEXTILE PARTY FAVOR BOXES SOLD EMPTY; FACIAL CLEANSING SPONGES; FLOWER BASKETS; FLOWER BOWLS; FRUIT BOWLS; FURNITURE DUSTERS; GLASS BEVERAGEWARE; GLASS JARS; GLOVES FOR HOUSEHOLD PURPOSES; HAIR BRUSHES; HAIR COMBS; HAIR, NAIL AND TOOTH BRUSHES; HOLDERS FOR FLOWERS AND PLANTS; HOLDERS FOR TOILET PAPER; HOUSEHOLD CONTAINERS OF PRECIOUS METAL; HOUSEHOLD GLOVES FOR GENERAL USE; ICE BUCKETS; ICE CREAM SCOOPS; INCENSE BURNERS; JUGS; KITCHEN CONTAINERS; KITCHEN UTENSIL, NAMELY, NON-METAL FLEXIBLE LID DESIGNED FOR DRAINING OR PRESSING LIQUIDS FROM A FOOD CAN; LAUNDRY BASKETS; LUNCH BOXES MADE OF PLASTIC; MAKE-UP BRUSHES; MANUAL TOOTHBRUSHES; NAPKIN DISPENSERS FOR HOUSEHOLD USE; NON-ELECTRIC EGG BEATERS; NON-ELECTRIC FOOD MIXERS; NON-ELECTRIC FRUIT SQUEEZERS; NON-ELECTRIC JUICERS; NON-ELECTRIC MEAT GRINDERS; ORAL CARE KIT COMPRISING TOOTHBRUSHES AND FLOSS; ORNAMENTS OF PORCELAIN; PAPER AND PLASTIC CUPS; PICNIC BASKETS SOLD EMPTY; PILL BOXES FOR PERSONAL USE; PLANT BASKETS; PLASTIC BAG HOLDERS FOR HOUSEHOLD USE; PLASTIC BATHTUBS FOR CHILDREN; PLASTIC CUPS; PORTABLE BEVERAGE COOLERS; PORTABLE BEVERAGE DISPENSERS; PORTABLE COOKING KITS FOR OUTDOOR USE; PORTABLE COOLERS; PORTABLE ICE CHESTS FOR FOOD AND BEVERAGES; SALAD BOWLS; SERVIETTE HOLDERS; SERVIETTE RINGS; SERVING DISHES; SHOE BRUSHES; SOAP DISPENSERS; SOAP HOLDERS AND BOXES; SOUVENIR PLATES; SPONGES FOR HOUSEHOLD PURPOSES; SPORTS BOTTLES SOLD EMPTY; SUGAR BASINS; TART SCOOPS; TEA BALLS; TEA INFUSERS; TEA POTS; TEA SERVICES; TOILET BRUSHES; TOILET PAPER DISPENSERS; TOILETRY SPONGES; TOOTH BRUSHES; VINEGAR CRUETS; WASHING BRUSHES; WATERING CANS; WINE OPENERS; WORKS OF ART MADE OF GLASS; WORKS OF ART MADE OF PORCELAIN (U.S. CLS. 2, 13, 23, 29, 30, 33, 40 AND 50).

CLASS 25—CLOTHING

FOR A-SHIRTS; ANORAK; AQUA SHOES; ATHLETIC FOOTWEAR; ATHLETIC SHOES; ATHLETIC UNIFORMS; BABIES' PANTS; BABY BIBS NOT OF PAPER; BABY BODYSUITS; BABY BOTTOMS; BABY BUNTING; BABY LAYETTES FOR CLOTHING; BABY TOPS; BATH SLIPPERS; BATHING CAPS; BATHING COSTUMES FOR WOMEN; BATHING SUITS; BATHROBES; BEACH FOOTWEAR; BEACHWEAR; BED JACKETS; BELTS; BERMUDA SHORTS; BLAZERS; BLOUSES; BOAS; BOOTS; BRAS; BUTTON DOWN SHIRTS; CAMISOLES; CAMP SHIRTS; CANVAS SHOES; CAP VISORS; CAPS; CARDIGANS; CHEMISETTES; CHILDREN'S AND INFANT'S APPAREL, NAMELY, JUMPERS, OVERALL SLEEPWEAR, PAJAMAS, ROMPERS AND ONE-PIECE GARMENTS; CHILDREN'S AND INFANTS' CLOTH BIBS; CHILDREN'S HEADWEAR; CLOTHING, NAMELY, MATERNITY BANDS; COATS; DRESSES; FOULARDS; GABERDINES; GLOVES; GOWNS; GYMNAS TIC SHOES; HATS; HATS FOR INFANTS, BABIES, TODDLERS AND CHILDREN; HEAD WEAR; HOODS; HOUSECOATS; INFANT AND TODDLER ONE PIECE CLOTHING; INFANT SLEEPERS; INFANT WEAR; INFANT WEARABLE BLANKETS; INFANTS' SHOES AND BOOTS; INFANTS' TROUSERS; JACKETS; JEANS; JERSEYS; LADIES' UNDERWEAR; LEOTARDS AND TIGHTS FOR WOMEN, MEN AND CHILDREN OF NYLON, COTTON OR OTHER TEXTILE FIBERS; LINGERIE; MATERNITY BRAS; MATERNITY CLOTHING, NAMELY, SHIRTS, PANTS, SHORTS, SKIRTS, DRESSES; MATERNITY LEGGINGS, NAMELY, LEGGINGS FEATURING BUILT-IN MATERNITY BANDS; MATERNITY LINGERIE; MATERNITY SLEEPWEAR; MEN'S AND WOMEN'S JACKETS, COATS, TROUSERS, VESTS; MEN'S SOCKS; MEN'S SUITS; MEN'S UNDERWEAR; NIGHTWEAR; ONE PIECE GARMENT FOR INFANTS AND TODDLERS; ONE-PIECE GARMENTS FOR CHILDREN; PANTIES; PANTS; PARKAS; RAIN JACKETS; SANDALS AND BEACH SHOES; SHIRTS; SHOES; SHORTS; SKIRTS; SWEATERS; SWIM WEAR; SWIMMING CAPS; T-SHIRTS; TROUSERS; UNDERCLOTHES (U.S. CLS. 22 AND 39).

CLASS 28—TOYS AND SPORTING GOODS

FOR AMUSEMENT MACHINES, NAMELY, HAND-HELD ELECTRONIC GAME UNITS ADAPTED FOR USE WITH AN EXTERNAL DISPLAY SCREEN OR MONITOR; APPARATUS FOR PLAYING CHESS, NAMELY, CHESS TIMERS; ARTICLES OF CLOTHING FOR TOYS; ARTIFICIAL CHRISTMAS GARLANDS; ARTIFICIAL CHRISTMAS TREES; AUDIO AND VISUAL HEADSETS FOR USE IN PLAYING VIDEO GAMES; BABY MULTIPLE ACTIVITY TOYS; BABY RATTLES; BABY RATTLES INCORPORATING TEETHING RINGS; BABY SWINGS; BALLOONS; BALLS FOR GAMES; BASKET BALLS; BATH TOYS; BEACH BALLS; BOARD GAMES; BODY BOARDS; BOOMERANGS; BUBBLE MAKING WAND AND SOLUTION SETS; BUILDING GAMES; CARD GAMES; CARNIVAL MASKS; CAT TOYS; CHESS GAMES; CHILDREN'S DRESS UP ACCESSORIES, NAMELY, TOY HELMETS FOR PLAY; CHILDREN'S MULTIPLE ACTIVITY TABLES; CHILDREN'S MULTIPLE ACTIVITY TOYS; CHILDREN'S MULTIPLE ACTIVITY TOYS SOLD AS A UNIT WITH PRINTED BOOKS; CHILDREN'S PLAY COSMETICS; CHILDREN'S TOY BICYCLES OTHER THAN FOR TRANSPORT; CHILDREN'S WIRE CONSTRUCTION AND ART ACTIVITY TOYS; CHRISTMAS TREE ORNAMENTS AND DECORATIONS; CHRISTMAS TREES OF SYNTHETIC MATERIAL; CONSTRUCTION TOYS; DOG TOYS; DOLLS AND ACCESSORIES THEREFOR; EDUCATIONAL CARD GAMES; EDUCATIONAL TOYS FOR TEACHING MUSIC PRINCIPLES TO CHILDREN, NAMELY, HAND-HELD MUSIC NOTATION SYMBOLS AND MUSIC RELATED FIGURES, SUCH AS INDIVIDUAL HAND-HELD PIANO KEYS; FACE PLATES FOR VIDEO GAME CONSOLES FOR USE WITH EXTERNAL MONITORS; FANTASY CHARACTER TOYS; FLOATS FOR BATHING AND SWIMMING; FOOT BALLS; GAME CARDS; HAND PUPPETS; INFANT DEVELOPMENT TOYS; INFANT TOYS; INFLATABLE BATH TOYS; MARIONETTES; MARTIAL ARTS TRAINING EQUIPMENT; MUSICAL TOYS; PET TOYS; PLAY HOUSES AND TOY ACCESSORIES THEREFOR; PLAY MOTOR CARS; PLAY SWIMMING POOLS; PROMOTIONAL GAME CARDS; PROMOTIONAL GAME MATERIALS;

PUPPETS; PUZZLE GAMES; REMOTE CONTROL TOYS, NAMELY, CARS, RACE CARS, AIRPLANES, BOATS; SPORTBALLS; TALKING TOYS; TOY ACTION FIGURES AND ACCESSORIES THEREFOR; TOY BOATS; TOY BUILDING BLOCKS CAPABLE OF INTERCONNECTION; TOY CARS; TOY FIGURES; TOY MODEL CARS; TOY PIANOS; TOY ROBOTS; TOY TOOLS; TOY TRAINS AND PARTS AND ACCESSORIES THEREFOR; TOY VEHICLE TRACK SETS AND ROADWAYS AND ACCESSORIES THEREFOR; TOY VEHICLES; TOY WATCHES; TOYS DESIGNED TO BE ATTACHED TO CAR SEATS, STROLLER, CRIBS, HIGH CHAIRS (U.S. CLS. 22, 23, 38 AND 50).

SUSAN BILLHEIMER, EXAMINING ATTORNEY

SN 85-595,182. MOULIN ROUGE S.A., BRUSSELS, BELGIUM, FILED 4-11-2012.

Moulin Rouge

THE MARK CONSISTS OF STANDARD CHARACTERS WITHOUT CLAIM TO ANY PARTICULAR FONT, STYLE, SIZE, OR COLOR.

OWNER OF U.S. REG. NOS. 2,667,568, 2,852,285 AND OTHERS.

THE ENGLISH TRANSLATION OF "MOULIN ROUGE" IN THE MARK IS RED WINDMILL.

CLASS 21—HOUSEWARES AND GLASS

FOR WINE BUCKETS (U.S. CLS. 2, 13, 23, 29, 30, 33, 40 AND 50).

CLASS 28—TOYS AND SPORTING GOODS

FOR LOTTERY TICKETS (U.S. CLS. 22, 23, 38 AND 50).
SEAN CROWLEY, EXAMINING ATTORNEY

SN 85-595,198. GEVO, INC., ENGLEWOOD, CO. FILED 4-11-2012.

POWERED BY GEVO

THE MARK CONSISTS OF STANDARD CHARACTERS WITHOUT CLAIM TO ANY PARTICULAR FONT, STYLE, SIZE, OR COLOR.

OWNER OF U.S. REG. NOS. 3,948,330, 3,999,250 AND OTHERS.

CLASS 1—CHEMICALS

FOR RENEWABLE CHEMICALS FOR USE IN INDUSTRY (U.S. CLS. 1, 5, 6, 10, 26 AND 46).

CLASS 4—LUBRICANTS AND FUELS

FOR BIOFUELS (U.S. CLS. 1, 6 AND 15).

CLASS 40—MATERIAL TREATMENT

FOR CHEMICAL PROCESSING AND PRODUCTION, NAMELY, PROCESSING AND PRODUCING BIOFUELS AND RENEWABLE CHEMICALS FOR OTHERS (U.S. CLS. 100, 103 AND 106).

CLASS 42—SCIENTIFIC AND COMPUTER SERVICES

FOR RESEARCH AND DEVELOPMENT, AND SCIENTIFIC ADVICE IN THE FIELD OF RENEWABLE ENERGY, NAMELY, BIOFUELS AND RENEWABLE CHEMICALS; TECHNICAL DESIGN ADVICE PERTAINING TO THE RETROFITTING OF ETHANOL PROCESSING PLANTS (U.S. CLS. 100 AND 101).

CATHERINE ROEHL, EXAMINING ATTORNEY

SN 85-595,464. KRATECH INC, PORT CHARLOTTE, FL. FILED 4-11-2012.

OUTWILD

THE MARK CONSISTS OF STANDARD CHARACTERS WITHOUT CLAIM TO ANY PARTICULAR FONT, STYLE, SIZE, OR COLOR.

CLASS 38—COMMUNICATION

FOR BROADCASTING SERVICES, NAMELY, AUDIO AND VIDEO BROADCASTING (U.S. CLS. 100, 101 AND 104).

CLASS 41—EDUCATION AND ENTERTAINMENT

FOR ENTERTAINMENT SERVICES, NAMELY, ONLINE TELEVISION AND TELEVISION PROGRAMMING SERVICES; ENTERTAINMENT IN THE NATURE OF ONGOING VIDEO AND AUDIO PROGRAMS IN THE FIELD OF NEWS, VARIETY AND EDUCATIONAL PROGRAMS ABOUT NATURE AND OUTDOOR ACTIVITIES, ACCESSIBLE BY RADIO, TELEVISION, SATELLITE, AUDIO, VIDEO AND COMPUTER NETWORKS (U.S. CLS. 100, 101 AND 107).

LYNDSEY KUYKENDALL, EXAMINING ATTORNEY

SN 85-595,497. H. FOX & CO., INC., BROOKLYN, NY. FILED 4-11-2012.

U-BET

THE MARK CONSISTS OF STANDARD CHARACTERS WITHOUT CLAIM TO ANY PARTICULAR FONT, STYLE, SIZE, OR COLOR.

OWNER OF U.S. REG. NOS. 1,568,653 AND 3,718,455.

CLASS 30—STAPLE FOODS

FOR FLAVORED SYRUPS FOR USE AS TOPPINGS ON ICE CREAM (U.S. CL. 46).

FIRST USE 4-27-1942; IN COMMERCE 4-27-1942.

CLASS 32—LIGHT BEVERAGES

FOR FLAVORED SYRUPS FOR USE IN THE PREPARATION OF SOFT DRINKS (U.S. CLS. 45, 46 AND 48). FIRST USE 4-27-1942; IN COMMERCE 4-27-1942. ANDREA K. NADELMAN, EXAMINING ATTORNEY

SN 85-595,517. LEVION, LLC, DBA LEVION, PARADISE VALLEY, AZ. FILED 4-11-2012.

Levion

THE MARK CONSISTS OF STANDARD CHARACTERS WITHOUT CLAIM TO ANY PARTICULAR FONT, STYLE, SIZE, OR COLOR.

CLASS 9—ELECTRICAL AND SCIENTIFIC APPARATUS

FOR COMPUTER SOFTWARE AND HARDWARE FOR USE IN TRANSACTION PROCESSING, ACCOUNTING, RECEIPT PRINTING, CUSTOMER RELATIONSHIP MANAGEMENT, INVENTORY MANAGEMENT AND OPERATIONS MANAGEMENT, ALL IN THE FIELD OF POINT OF SALE TRANSACTIONS AND RETAIL MANAGEMENT, AND USER MANUALS SOLD AS A UNIT THEREWITH; CASH REGISTERS; COMPUTER PRINTERS; POINT OF SALE PRINTERS AND TERMINALS; CREDIT CARD AND DEBIT CARD READERS AND SCANNERS; BAR CODE READERS AND SCANNERS; CREDIT CARD AND TRANSACTION PROCESSING TERMINALS AND COMPUTER HARDWARE; COMPUTER SOFTWARE FOR USE IN CUSTOMER RELATIONSHIP MANAGEMENT (CRM) (U.S. CLS. 21, 23, 26, 36 AND 38).

FIRST USE 6-4-2010; IN COMMERCE 6-4-2010.

CLASS 42—SCIENTIFIC AND COMPUTER SERVICES

FOR CONSULTING SERVICES IN THE FIELD OF SOFTWARE AS A SERVICE (SAAS); SOFTWARE AS A SERVICE (SAAS) SERVICES FEATURING SOFTWARE FOR CALCULATING AND CHARGING SALES TAX AND CREATING REPORTS TO PAY SALES TAX TO APPROPRIATE TAX AGENCIES; SOFTWARE AS A SERVICE (SAAS) SERVICES FEATURING SOFTWARE FOR CREDIT CARD INVOICING AND CREDIT CARD PAYMENT PROCESSING; SOFTWARE AS A SERVICE (SAAS) SERVICES FEATURING SOFTWARE FOR ONLINE BANKING; SOFTWARE AS A SERVICE (SAAS) SERVICES FEATURING SOFTWARE FOR CONTROLLING ACCESS TO FINANCIAL INFORMATION VIA ELECTRONIC PERMISSION SETTINGS; SOFTWARE AS A SERVICE (SAAS) SERVICES FEATURING SOFTWARE TO CREATE, CUSTOMIZE, PRINT, EXPORT, AND E-MAIL PURCHASE ORDERS; SOFTWARE AS A SERVICE (SAAS) SERVICES FEATURING SOFTWARE FOR TRACKING INCOME, EXPENSES, SALES, AND PROFITABILITY BY BUSINESS LOCATION, DEPARTMENT, TYPE OF BUSINESS, OR OTHER USER SET FIELD; SOFTWARE AS A SERVICE (SAAS) SERVICES FEATURING SOFTWARE TO TRACK TIME WORKED BY EMPLOYEES AND SUBCONTRACTORS; SOFTWARE AS A SERVICE (SAAS) SERVICES FEATURING SOFTWARE FOR ACCOUNTING, BOOKKEEPING, TRANSACTION PROCESSING, TRANSACTION MANAGEMENT, TAX PREPARATION AND PLANNING, BUSINESS PROCESS MANAGEMENT, AND FINANCIAL PLANNING; SOFTWARE AS A SERVICE (SAAS) SERVICES FEATURING SOFTWARE TO CREATE, CUSTOMIZE, AND MANAGE INVOICES; SOFTWARE AS A SERVICE (SAAS) SERVICES FEATURING SOFTWARE TO CREATE AND MANAGE BUDGETS; SOFTWARE AS A SERVICE (SAAS) SERVICES FEATURING SOFTWARE TO CREATE PRICE QUOTE ESTI-

MATES AND TRANSFER PRICE QUOTE ESTIMATES TO INVOICES; SOFTWARE AS A SERVICE (SAAS) SERVICES FEATURING SOFTWARE TO AUTOMATE CREATION OF INVOICES; SOFTWARE AS A SERVICE (SAAS) SERVICES FEATURING SOFTWARE TO CREATE, CUSTOMIZE, PRINT, EXPORT, AND E-MAIL FINANCIAL REPORTS, BUSINESS REPORTS, BALANCE SHEETS, PROFIT AND LOSS STATEMENTS, CASH FLOW STATEMENTS, AND TAXABLE SALES REPORTS; SOFTWARE AS A SERVICE (SAAS) SERVICES FEATURING SOFTWARE TO CREATE, PRINT, AND TRACK CHECKS AND PURCHASE ORDERS; SOFTWARE AS A SERVICE (SAAS) SERVICES FEATURING SOFTWARE TO TRACK SALES, EXPENSES, AND PAYMENTS; SOFTWARE AS A SERVICE (SAAS) SERVICES FEATURING SOFTWARE TO ANALYZE THE FINANCIAL STATUS OF BUSINESSES AND INDUSTRIES; SOFTWARE AS A SERVICE (SAAS) SERVICES FEATURING SOFTWARE TO MANAGE CUSTOMER LISTS, EMAIL AND PRINT SALES FORMS, AND TRACK RUNNING BALANCES; SOFTWARE AS A SERVICE (SAAS) SERVICES FEATURING SOFTWARE FOR INVENTORY MANAGEMENT AND CUSTOMER RELATIONSHIP MANAGEMENT; SOFTWARE AS A SERVICE (SAAS) SERVICES FEATURING SOFTWARE FOR ADMINISTERING EMPLOYEE PAYROLL; SOFTWARE AS A SERVICE (SAAS) SERVICES FEATURING SOFTWARE TO IMPORT CONTACTS AND FINANCIAL DATA FROM OTHER ELECTRONIC SERVICES AND SOFTWARE; SOFTWARE AS A SERVICE (SAAS) SERVICES FEATURING SOFTWARE FOR DATABASE MANAGEMENT, DATA AGGREGATION, DATA REPORTING, AND DATA TRANSMISSION; SOFTWARE AS A SERVICE (SAAS) SERVICES FEATURING SOFTWARE FOR ONLINE BACKUP OF ELECTRONIC FILES; PROVIDING TEMPORARY USE OF ONLINE NON-DOWNLOADABLE SOFTWARE TO CALCULATE AND CHARGE SALES TAX AND TO CREATE REPORTS TO PAY SALES TAX TO APPROPRIATE TAX AGENCIES; PROVIDING TEMPORARY USE OF ONLINE NON-DOWNLOADABLE SOFTWARE FOR CREDIT CARD INVOICING AND CREDIT CARD PAYMENT PROCESSING; SOFTWARE AS A SERVICE (SAAS) SERVICES FEATURING SOFTWARE FOR ONLINE BANKING; PROVIDING TEMPORARY USE OF ONLINE NON-DOWNLOADABLE SOFTWARE FOR CONTROLLING ACCESS TO FINANCIAL INFORMATION VIA ELECTRONIC PERMISSION SETTINGS; PROVIDING TEMPORARY USE OF ONLINE NON-DOWNLOADABLE SOFTWARE TO CREATE, CUSTOMIZE, PRINT, EXPORT, AND E-MAIL PURCHASE ORDERS; PROVIDING TEMPORARY USE OF ONLINE NON-DOWNLOADABLE SOFTWARE FOR TRACKING INCOME, EXPENSES, SALES, AND PROFITABILITY BY BUSINESS LOCATION, DEPARTMENT, TYPE OF BUSINESS, OR OTHER USER SET FIELD; PROVIDING TEMPORARY USE OF ONLINE NON-DOWNLOADABLE SOFTWARE TO TRACK TIME WORKED BY EMPLOYEES AND SUBCONTRACTORS; PROVIDING TEMPORARY USE OF ONLINE NON-DOWNLOADABLE COMPUTER SOFTWARE FOR ACCOUNTING, BOOKKEEPING, TRANSACTION PROCESSING, TRANSACTION MANAGEMENT, TAX PREPARATION AND PLANNING, BUSINESS PROCESS MANAGEMENT, AND FINANCIAL PLANNING; PROVIDING TEMPORARY USE OF ONLINE NON-DOWNLOADABLE COMPUTER SOFTWARE TO CREATE, CUSTOMIZE, AND MANAGE INVOICES; PROVIDING TEMPORARY USE OF ONLINE NON-DOWNLOADABLE COMPUTER SOFTWARE TO CREATE AND MANAGE BUDGETS; PROVIDING TEMPORARY USE OF ONLINE NON-DOWNLOADABLE COMPUTER SOFTWARE TO CREATE PRICE QUOTE ESTIMATES AND TRANSFER PRICE QUOTE ESTIMATES TO INVOICES; PROVIDING TEMPORARY USE OF ONLINE NON-DOWNLOADABLE COMPUTER SOFTWARE TO AUTOMATE CREATION OF INVOICES; PROVIDING TEMPORARY USE OF ONLINE NON-DOWNLOADABLE COMPUTER SOFTWARE TO CREATE, CUSTOMIZE, PRINT, EXPORT, AND E-MAIL FINANCIAL REPORTS, BUSINESS REPORTS, BALANCE SHEETS, PROFIT AND LOSS STATEMENTS, CASH FLOW STATEMENTS, AND TAXABLE SALES REPORTS; PROVIDING TEMPORARY USE OF ONLINE NON-DOWNLOADABLE COMPUTER SOFTWARE TO CREATE, PRINT, AND TRACK CHECKS AND PURCHASE ORDERS; PROVIDING TEMPORARY USE OF ONLINE NON-DOWNLOADABLE COMPUTER SOFTWARE TO TRACK SALES, EXPENSES, AND PAYMENTS; PROVIDING TEMPORARY USE OF ONLINE NON-DOWNLOADABLE COMPUTER SOFTWARE TO

ANALYZE THE FINANCIAL STATUS OF BUSINESSES AND INDUSTRIES; PROVIDING TEMPORARY USE OF ONLINE NON-DOWNLOADABLE COMPUTER SOFTWARE TO MANAGE CUSTOMER LISTS, EMAIL AND PRINT SALES FORMS, AND TRACK RUNNING BALANCES; PROVIDING TEMPORARY USE OF ONLINE NON-DOWNLOADABLE COMPUTER SOFTWARE FOR INVENTORY MANAGEMENT AND CUSTOMER RELATIONSHIP MANAGEMENT; PROVIDING TEMPORARY USE OF ONLINE NON-DOWNLOADABLE COMPUTER SOFTWARE FOR ADMINISTERING EMPLOYEE PAYROLL; PROVIDING TEMPORARY USE OF ONLINE NON-DOWNLOADABLE COMPUTER SOFTWARE TO IMPORT CONTACTS AND FINANCIAL DATA FROM OTHER ELECTRONIC SERVICES AND SOFTWARE; PROVIDING TEMPORARY USE OF ONLINE NON-DOWNLOADABLE COMPUTER SOFTWARE FOR DATABASE MANAGEMENT, DATA AGGREGATION, DATA REPORTING, AND DATA TRANSMISSION; PROVIDING TEMPORARY USE OF ONLINE NON-DOWNLOADABLE COMPUTER SOFTWARE FOR ONLINE BACKUP OF ELECTRONIC FILES; TECHNICAL SUPPORT SERVICES, NAMELY, HELP DESK SERVICES; TECHNICAL SUPPORT SERVICES, NAMELY, TROUBLESHOOTING OF COMPUTER SOFTWARE PROBLEMS, WEB SITES, AND ONLINE SERVICES; DATA HOSTING SERVICES (U.S. CLS. 100 AND 101).

FIRST USE 6-4-2010; IN COMMERCE 6-4-2010.
MORGAN WYNNE, EXAMINING ATTORNEY

SN 85-595,626. XENON LAMP STORE, HOLLYWOOD, FL.
FILED 4-12-2012.



SN 85-595,622. BELKNAP WHITE GROUP, INC., WEST GREENWICH, RI. FILED 4-12-2012.

BELLA CERA

THE MARK CONSISTS OF STANDARD CHARACTERS WITHOUT CLAIM TO ANY PARTICULAR FONT, STYLE, SIZE, OR COLOR.

OWNER OF U.S. REG. NO. 3,943,561.
THE ENGLISH TRANSLATION OF "BELLA CERA" IN THE MARK IS BEAUTIFUL WAX.

CLASS 19—NON-METALLIC BUILDING MATERIALS

FOR (BASED ON INTENT TO USE) VINYL FLOORING (U.S. CLS. 1, 12, 33 AND 50).

CLASS 27—FLOOR COVERINGS

FOR (BASED ON USE IN COMMERCE) CARPETING; CARPETS; (BASED ON INTENT TO USE) VINYL FLOOR COVERINGS (U.S. CLS. 19, 20, 37, 42 AND 50).
FIRST USE 9-0-2010; IN COMMERCE 10-6-2010.
DAVID H. STINE, EXAMINING ATTORNEY

NO CLAIM IS MADE TO THE EXCLUSIVE RIGHT TO USE "XENON LAMP STORE" AND "54" AND "131.2932", APART FROM THE MARK AS SHOWN.

THE COLOR(S) BLACK AND GREEN IS/ARE CLAIMED AS A FEATURE OF THE MARK.

THE MARK CONSISTS OF THE GREEN WORDING "XENON LAMP STORE" AND A STYLIZED REPRESENTATION OF A BLACK PERIODIC TABLE BOX WITH THE GREEN ELEMENT LOCATION OF "54" ABOVE THE LETTERS "XE" AND THE GREEN ELEMENT WEIGHT "131.2932" BELOW THE LETTERS "XE".

CLASS 9—ELECTRICAL AND SCIENTIFIC APPARATUS

FOR BALLASTS FOR GAS DISCHARGE LAMPS (U.S. CLS. 21, 23, 26, 36 AND 38).

CLASS 10—MEDICAL APPARATUS

FOR DENTAL OPERATING LAMPS; LIGHT EMITTING DEVICES, NAMELY, LAMPS AND LED DEVICES FOR TREATMENT OF A VARIETY OF SKIN CONDITIONS; MEDICAL OPERATING LAMPS; MERCURY ARC LAMP UNITS FOR THERAPEUTIC PURPOSES; SURGICAL LAMPS; SURGICAL OPERATING LAMPS; ULTRAVIOLET LAMPS FOR MEDICAL PURPOSES; UV LAMPS FOR MEDICAL APPLICATIONS; VETERINARY OPERATING LAMPS (U.S. CLS. 26, 39 AND 44).

CLASS 11—ENVIRONMENTAL CONTROL APPARATUS

FOR ARC LAMPS; DISCHARGE LAMPS AND THEIR FITTINGS; LAMP BULBS; MERCURY LAMPS; ULTRAVIOLET LAMPS NOT FOR MEDICAL PURPOSES; ULTRAVIOLET RAY LAMPS, NOT FOR MEDICAL PURPOSES; UV HALOGEN METAL VAPOUR LAMPS (U.S. CLS. 13, 21, 23, 31 AND 34).
TRACY FLETCHER, EXAMINING ATTORNEY

SN 85-595,642. THE STATE AGRICULTURAL AND MECHANICAL SOCIETY OF SOUTH CAROLINA, DBA THE SOUTH CAROLINA STATE FAIR, COLUMBIA, SC. FILED 4-12-2012.

SN 85-595,720. MOGAME INC, NEW YORK, NY. FILED 4-12-2012.



THE COLOR(S) RED, YELLOW, GREEN, WHITE AND BROWN IS/ARE CLAIMED AS A FEATURE OF THE MARK.

THE MARK CONSISTS OF A HORIZONTAL YELLOW EAR OF CORN OPPOSITE A HORIZONTAL BROWN CORNDOG. THE CORNDOG HAS A SWIRL OF YELLOW MUSTARD WITH WHITE HIGHLIGHTS RUNNING ALONG ITS LENGTH. THE CORNDOG AND EAR OF CORN ARE EMERGING FROM GREEN CORN HUSKS AS IF FRESHLY HARVESTED. ABOVE THE IMAGE ARE THE WORDS: "FROM FIELD". BELOW THE IMAGE ARE THE WORDS: "TO FAIR". ALL WORDS ARE WRITTEN IN RED. THE ENTIRE GRAPHIC AND WORDS ARE SURROUNDED BY TWO RED HORIZONTAL PARENTHESIS

CLASS 35—ADVERTISING AND BUSINESS

FOR CONSULTATION RELATING TO TRADE FAIRS; ORGANISATION OF EXHIBITIONS AND TRADE FAIRS FOR BUSINESS AND PROMOTIONAL PURPOSES; ORGANIZATION OF EVENTS, EXHIBITIONS, FAIRS AND SHOWS FOR COMMERCIAL, PROMOTIONAL AND ADVERTISING PURPOSES (U.S. CLS. 100, 101 AND 102).
FIRST USE 1-1-2012; IN COMMERCE 1-1-2012.

CLASS 41—EDUCATION AND ENTERTAINMENT

FOR ENTERTAINMENT SERVICES, NAMELY, CONDUCTING FAIRS (U.S. CLS. 100, 101 AND 107).
FIRST USE 1-1-2012; IN COMMERCE 1-1-2012.

CLASS 43—HOTEL AND RESTAURANT SERVICES

FOR PROVIDING FACILITIES FOR FAIRS AND EXHIBITIONS (U.S. CLS. 100 AND 101).
FIRST USE 1-1-2012; IN COMMERCE 1-1-2012.
THOMAS MANOR, EXAMINING ATTORNEY

N.Y.C.



www.piccolocafe.us

IMPORTED FROM ITALY

PICCOLOCAFE

SINCE
1938

NO CLAIM IS MADE TO THE EXCLUSIVE RIGHT TO USE "N.Y.C." "IMPORTED FROM ITALY" AND "SINCE 1938", APART FROM THE MARK AS SHOWN.

THE MARK CONSISTS OF THE STYLIZED TEXT "N.Y.C." ABOVE A COFFEE BEAN. BELOW THE COFFEE ARE THE FOLLOWING STYLIZED PHRASES, EACH STACKED UPON THE NEXT: "WWW.PICCOLOCAFE.US", "IMPORTED FROM ITALY", "PICCOLO CAFE", "SINCE", AND "1938".

CLASS 35—ADVERTISING AND BUSINESS

FOR ON-LINE RETAIL STORE SERVICES FEATURING COFFEE AND COFFEE-RELATED PRODUCTS; RETAIL STORE SERVICES FEATURING COFFEE AND COFFEE-RELATED PRODUCTS (U.S. CLS. 100, 101 AND 102).
FIRST USE 5-0-2009; IN COMMERCE 10-0-2009.

CLASS 43—HOTEL AND RESTAURANT SERVICES

FOR CATERING SERVICES; COFFEE SHOPS; RESTAURANT AND CAFE SERVICES (U.S. CLS. 100 AND 101).
FIRST USE 5-0-2009; IN COMMERCE 10-0-2009.
FRANK LATTUCA, EXAMINING ATTORNEY

SN 85-595,846. GRUPO BIMBO, S.A. B. DE C.V., MEXICO CITY, MEXICO, FILED 4-12-2012.

THINGS THAT MAKE YOU GO BOOM

THE MARK CONSISTS OF STANDARD CHARACTERS WITHOUT CLAIM TO ANY PARTICULAR FONT, STYLE, SIZE, OR COLOR.

CLASS 29—MEATS AND PROCESSED FOODS

FOR POTATO CHIPS AND PROCESSED PEANUTS (U.S. CL. 46).

CLASS 30—STAPLE FOODS

FOR FRIED CORN SNACKS, CORN-BASED SNACK FOODS, FRIED CORN FLOUR SNACKS, FRIED WHEAT FLOUR SNACKS, PUFFED WHEAT SNACKS (U.S. CL. 46).
DAWN FELDMAN, EXAMINING ATTORNEY

SN 85-595,899. BIOMED REALTY TRUST, INC., SAN DIEGO, CA. FILED 4-12-2012.

BIOMED REALTY TRUST

THE MARK CONSISTS OF STANDARD CHARACTERS WITHOUT CLAIM TO ANY PARTICULAR FONT, STYLE, SIZE, OR COLOR.

OWNER OF U.S. REG. NOS. 2,996,195, 3,086,831 AND 4,097,891.

NO CLAIM IS MADE TO THE EXCLUSIVE RIGHT TO USE "REALTY TRUST", APART FROM THE MARK AS SHOWN.

SEC. 2(F).

CLASS 36—INSURANCE AND FINANCIAL

FOR REAL ESTATE ACQUISITION, LEASING, AND MANAGEMENT SERVICES; REAL ESTATE INVESTMENT SERVICES; REAL ESTATE INVESTMENT TRUST SERVICES (U.S. CLS. 100, 101 AND 102).

FIRST USE 7-11-2005; IN COMMERCE 7-11-2005.

CLASS 37—CONSTRUCTION AND REPAIR

FOR REAL ESTATE DEVELOPMENT (U.S. CLS. 100, 103 AND 106).

FIRST USE 7-11-2005; IN COMMERCE 7-11-2005.

SCOTT OSICK, EXAMINING ATTORNEY

SN 85-596,002. MCCC SPORTSWEAR, INC., LOVELAND, OH. FILED 4-12-2012.

FIGHT IT WITH SPARKLE

THE MARK CONSISTS OF STANDARD CHARACTERS WITHOUT CLAIM TO ANY PARTICULAR FONT, STYLE, SIZE, OR COLOR.

CLASS 14—JEWELRY

FOR LAPEL PINS, BRACELETS, NECKLACES (U.S. CLS. 2, 27, 28 AND 50).

CLASS 16—PAPER GOODS AND PRINTED MATTER

FOR STATIONERY, CALENDARS, GREETING CARDS (U.S. CLS. 2, 5, 22, 23, 29, 37, 38 AND 50).

CLASS 18—LEATHER GOODS

FOR HANDBAGS, PURSES, TOTE BAGS (U.S. CLS. 1, 2, 3, 22 AND 41).

CLASS 21—HOUSEWARES AND GLASS

FOR WATER BOTTLES SOLD EMPTY, DRINKING CUPS, INSULATED DRINKING CUPS AND TUMBLERS (U.S. CLS. 2, 13, 23, 29, 30, 33, 40 AND 50).

CLASS 22—CORDAGE AND FIBERS

FOR LANYARDS FOR HOLDING EYEWEAR, BADGES AND KEYS (U.S. CLS. 1, 2, 7, 19, 22, 42 AND 50).

CLASS 25—CLOTHING

FOR WOMEN'S, MEN'S, AND CHILDREN'S APPAREL, NAMELY, T-SHIRTS, SWEATSHIRTS, DRESS SHIRTS, POLO-STYLE SHIRTS, SHORTS, PANTS, WIND RESISTANT JACKETS, SOCKS, SLIPPERS, SLEEPWEAR, BOXER SHORTS, HATS, VISORS, BASEBALL CAPS, BEANIES, GLOVES, WRIST BANDS, AND FLEECE TOPS, VESTS, BOTTOMS AND JACKETS; FOOTWEAR, NAMELY, SHOES, SANDALS, AND FLIP-FLOPS; WRIST BANDS (U.S. CLS. 22 AND 39).

CHRISTINE MARTIN, EXAMINING ATTORNEY

SN 85-596,049. PLATINUM AUTO SERVICE, INC., SOUTH YARMOUTH, MA. FILED 4-12-2012.



NO CLAIM IS MADE TO THE EXCLUSIVE RIGHT TO USE "AUTO SERVICE INC", APART FROM THE MARK AS SHOWN.

THE MARK CONSISTS OF THE WORD "PLATINUM" IN A STYLIZED FONT WHICH APPEARS ABOVE THE ITALICIZED WORDS "AUTO SERVICE INC" INSIDE AN OVAL WITHIN AN INCOMPLETE OVAL.

SEC. 2(F).

CLASS 35—ADVERTISING AND BUSINESS

FOR AUTOMOBILE DEALERSHIP FEATURING USED VEHICLES AND RETAIL STORE SERVICES IN THE FIELD OF AUTOMOTIVE PARTS AND EQUIPMENT, CAR CARE PRODUCTS, AND TOOLS FOR SERVICING AND REPAIRING VEHICLES AND EQUIPMENT (U.S. CLS. 100, 101 AND 102).

FIRST USE 12-1-2004; IN COMMERCE 12-1-2004.

CLASS 37—CONSTRUCTION AND REPAIR

FOR AUTOMOBILE SERVICE, REPAIR, AND MAINTENANCE INCLUDING BUT NOT LIMITED TO OIL CHANGES, INSPECTIONS, TIRE ROTATION, BRAKE REPAIR, AND REPLACING PARTS (U.S. CLS. 100, 103 AND 106).

FIRST USE 12-1-2004; IN COMMERCE 12-1-2004.

NAKWAMA ANKRAH, EXAMINING ATTORNEY

SN 85-596,517. SANS PAREIL, INC., CORAL SPRINGS, FL. FILED 4-12-2012.

Henri Vétu

THE MARK CONSISTS OF STANDARD CHARACTERS WITHOUT CLAIM TO ANY PARTICULAR FONT, STYLE, SIZE, OR COLOR.

THE NAME(S), PORTRAIT(S), AND/OR SIGNATURE(S) SHOWN IN THE MARK DOES NOT IDENTIFY A PARTICULAR LIVING INDIVIDUAL.

THE ENGLISH TRANSLATION OF THE WORD "VÉTU" IN THE MARK IS DRESSED.

CLASS 9—ELECTRICAL AND SCIENTIFIC APPARATUS

FOR EYEGLASS CASES; EYEGLASSES; EYEWEAR, NAMELY, CLIP-ON EYEGLASSES; FRAMES FOR GLASSES AND PINCE-NEZ; READING EYEGLASSES; SUNGLASSES (U.S. CLS. 21, 23, 26, 36 AND 38).

CLASS 18—LEATHER GOODS

FOR ATTACHE CASES; HANDBAGS; LUGGAGE; POCKETBOOKS; PURSES; WALLETS (U.S. CLS. 1, 2, 3, 22 AND 41).

CHARISMA HAMPTON, EXAMINING ATTORNEY

SN 85-596,838. SMITH, JAMES, TOLUCA LAKE, CA. FILED 4-13-2012.

FIBS

THE MARK CONSISTS OF STANDARD CHARACTERS WITHOUT CLAIM TO ANY PARTICULAR FONT, STYLE, SIZE, OR COLOR.

CLASS 16—PAPER GOODS AND PRINTED MATTER

FOR PAPER AND GOODS MADE FROM PAPER, NAMELY, COMIC BOOKS, PICTORIAL PRINTS, CARTOON PRINTS, GREETING CARDS, AND CALENDARS (U.S. CLS. 2, 5, 22, 23, 29, 37, 38 AND 50).

CLASS 25—CLOTHING

FOR CLOTHING, NAMELY, CAPS, SHIRTS, JACKETS, UNDERWEAR, FOOTWEAR, HEADWEAR, TOPS, BOTTOMS, PANTS (U.S. CLS. 22 AND 39).

CLASS 41—EDUCATION AND ENTERTAINMENT

FOR ENTERTAINMENT SERVICES, NAMELY, DIGITAL MOTION PICTURE SCREEN CARTOON SERIES FEATURING MOTION COMICS, CARTOONS, LIVE ACTION, COMEDY, AND DRAMA; PRODUCTION AND DISTRIBUTION OF MOTION PICTURES; MOTION PICTURE FILM PRODUCTION (U.S. CLS. 100, 101 AND 107).

MICHAEL ENGEL, EXAMINING ATTORNEY

SN 85-597,050. CONNECTIVITY DATA SYSTEMS LLC, NEW YORK, NY. FILED 4-13-2012.

RELSCI

THE MARK CONSISTS OF STANDARD CHARACTERS WITHOUT CLAIM TO ANY PARTICULAR FONT, STYLE, SIZE, OR COLOR.

CLASS 9—ELECTRICAL AND SCIENTIFIC APPARATUS

FOR COMPUTER SOFTWARE FOR CREATING, MANAGING, AND SEARCHING PROFILE INFORMATION, FOR PURPOSES OF PROFESSIONAL, BUSINESS AND CAREER NETWORKING; COMPUTER SOFTWARE FOR THE COLLECTION, EDITING, ORGANIZING, MODIFYING, BOOKMARKING, TRANSMISSION, STORAGE AND SHARING OF DATA AND INFORMATION IN THE FIELDS OF BUSINESS, PROFESSIONAL, BUSINESS AND CAREER NETWORKING, SOCIAL NETWORKING, EMPLOYMENT, CAREERS AND RECRUITING (U.S. CLS. 21, 23, 26, 36 AND 38).

CLASS 35—ADVERTISING AND BUSINESS

FOR PROFESSIONAL, BUSINESS AND CAREER NETWORKING SERVICES; PROFESSIONAL, BUSINESS AND CAREER NETWORKING VIA SOCIAL MEDIA; PROVIDING PROFESSIONAL AND CAREER NETWORKING AND EMPLOYMENT RECRUITING INFORMATION VIA ELECTRONIC AND OPTICAL COMMUNICATIONS NETWORKS; PROVIDING SEARCHABLE DATABASES FEATURING PROFESSIONAL, BUSINESS AND CAREER NETWORKING AND CAREER DEVELOPMENT INFORMATION VIA ELECTRONIC AND OPTICAL COMMUNICATIONS NETWORKS; INFORMATION SERVICES RELATED TO BUSINESS MATTERS; BUSINESS KNOWLEDGE MANAGEMENT SERVICES; PREPARING BUSINESS REPORTS; BUSINESS INFORMATION RESEARCH AND REPORTING SERVICES; BUSINESS INFORMATION RESEARCH AND REPORTING SERVICES FOR PROFESSIONAL AND CAREER NETWORKING PURPOSES (U.S. CLS. 100, 101 AND 102).

CLASS 42—SCIENTIFIC AND COMPUTER SERVICES

FOR PROVIDING TEMPORARY USE OF NONDOWNLOADABLE COMPUTER SOFTWARE FOR CREATING, MANAGING, CONNECTING AND SEARCHING PROFILE INFORMATION, FOR PURPOSES OF PROFESSIONAL, BUSINESS AND CAREER NETWORKING; PROVIDING TEMPORARY USE OF NONDOWNLOADABLE COMPUTER SOFTWARE FOR THE COLLECTION, EDITING, ORGANIZING, MODIFYING, BOOKMARKING, TRANSMISSION, STORAGE AND SHARING OF DATA AND INFORMATION IN THE FIELDS OF BUSINESS, PROFESSIONAL, BUSINESS AND CAREER NETWORKING, SOCIAL NETWORKING, EMPLOYMENT, CAREERS AND RECRUITING; COMPUTER SERVICES, NAMELY, CREATING A COMMUNITY VIA ELECTRONIC AND OPTICAL COMMUNICATIONS NETWORKS FOR REGISTERED USERS TO ORGANIZE GROUPS, SHARE INFORMATION AND RESOURCES, AND ENGAGE IN SOCIAL, BUSINESS AND COMMUNITY NETWORKING; PROVIDING TEMPORARY USE OF NONDOWNLOADABLE COMPUTER SOFTWARE FOR ALLOWING WEB SITE USERS TO COMMUNICATE INFORMATION OF GENERAL INTEREST FOR PURPOSES OF SOCIAL, BUSINESS AND COMMUNITY NETWORKING, MARKETING, RECRUITMENT AND EMPLOYMENT; PROVIDING TEMPORARY USE OF NONDOWNLOADABLE COMPUTER SOFTWARE ENABLING USERS TO SEARCH, LOCATE AND COMMUNICATE WITH OTHERS VIA ELECTRONIC COMMUNICATIONS NET-

WORKS TO NETWORK; COMPUTER SERVICES IN THE NATURE OF CUSTOMIZED WEB PAGES FEATURING PERSONAL PROFILES AND IMAGES; PROVIDING TEMPORARY USE OF NONDOWNLOADABLE COMPUTER SOFTWARE FOR USE IN COLLECTING, MANAGING AND EXCHANGING BUSINESS INFORMATION AND CONTACT DATA ACROSS MULTIPLE INDUSTRY FIELDS AND FOR USE IN MAPPING OF BUSINESS ORGANIZATIONS, BUSINESS RESEARCH, AND TO FACILITATE COMMUNICATIONS BETWEEN BUSINESS PROFESSIONALS; PROVIDING TEMPORARY USE OF NONDOWNLOADABLE COMPUTER SOFTWARE FOR ALLOWING USERS TO ACCESS INFORMATION AND GENERATE REPORTS FOR USE IN CONSULTING AND COMMUNICATE WITH EXECUTIVES, BUSINESS CONTACTS AND BUSINESSES; PROVIDING TEMPORARY USE OF NONDOWNLOADABLE COMPUTER SOFTWARE IN THE FIELD OF KNOWLEDGE MANAGEMENT FOR USE IN MANAGING PROFESSIONAL, BUSINESS AND CAREER NETWORKING (U.S. CLS. 100 AND 101).

CLASS 45—PERSONAL AND LEGAL SERVICES

FOR ONLINE SOCIAL NETWORKING SERVICES (U.S. CLS. 100 AND 101).
GISELLE AGOSTO, EXAMINING ATTORNEY

SN 85-597,061. CONNECTIVITY DATA SYSTEMS LLC, NEW YORK, NY. FILED 4-13-2012.

RELATIONSHIP SCIENCE

THE MARK CONSISTS OF STANDARD CHARACTERS WITHOUT CLAIM TO ANY PARTICULAR FONT, STYLE, SIZE, OR COLOR.

CLASS 9—ELECTRICAL AND SCIENTIFIC APPARATUS

FOR COMPUTER SOFTWARE FOR CREATING, MANAGING, AND SEARCHING PROFILE INFORMATION, FOR PURPOSES OF PROFESSIONAL, BUSINESS AND CAREER NETWORKING; COMPUTER SOFTWARE FOR THE COLLECTION, EDITING, ORGANIZING, MODIFYING, BOOKMARKING, TRANSMISSION, STORAGE AND SHARING OF DATA AND INFORMATION IN THE FIELDS OF BUSINESS, PROFESSIONAL, BUSINESS AND CAREER NETWORKING, SOCIAL NETWORKING, EMPLOYMENT, CAREERS AND RECRUITING (U.S. CLS. 21, 23, 26, 36 AND 38).

CLASS 35—ADVERTISING AND BUSINESS

FOR PROFESSIONAL, BUSINESS AND CAREER NETWORKING SERVICES; PROFESSIONAL, BUSINESS AND CAREER NETWORKING VIA SOCIAL MEDIA; PROVIDING PROFESSIONAL AND CAREER NETWORKING AND EMPLOYMENT RECRUITING INFORMATION VIA ELECTRONIC AND OPTICAL COMMUNICATIONS NETWORKS; PROVIDING SEARCHABLE DATABASES FEATURING PROFESSIONAL, BUSINESS AND CAREER NETWORKING AND CAREER DEVELOPMENT INFORMATION VIA ELECTRONIC AND OPTICAL COMMUNICATIONS NETWORKS; INFORMATION SERVICES RELATED TO BUSINESS MATTERS; BUSINESS KNOWLEDGE MANAGEMENT SERVICES; PREPARING BUSINESS REPORTS; BUSINESS INFORMATION RESEARCH AND REPORTING SERVICES; BUSINESS INFORMATION RESEARCH AND REPORTING SERVICES FOR PROFESSIONAL AND CAREER NETWORKING PURPOSES (U.S. CLS. 100, 101 AND 102).

CLASS 42—SCIENTIFIC AND COMPUTER SERVICES

FOR PROVIDING TEMPORARY USE OF NON DOWNLOADABLE COMPUTER SOFTWARE FOR CREATING, MANAGING, CONNECTING AND SEARCHING PROFILE INFORMATION, FOR PURPOSES OF PROFESSIONAL, BUSINESS AND CAREER NETWORKING; PROVIDING TEMPORARY USE OF NON DOWNLOADABLE COMPUTER SOFTWARE FOR THE COLLECTION, EDITING, ORGANIZING, MODIFYING, BOOKMARKING, TRANSMISSION, STORAGE AND SHARING OF DATA AND INFORMATION IN THE FIELDS OF BUSINESS, PROFESSIONAL, BUSINESS AND CAREER NETWORKING, SOCIAL NETWORKING, EMPLOYMENT, CAREERS AND RECRUITING; COMPUTER SERVICES, NAMELY, CREATING A COMMUNITY VIA ELECTRONIC AND OPTICAL COMMUNICATIONS NETWORKS FOR REGISTERED USERS TO ORGANIZE GROUPS, SHARE INFORMATION AND RESOURCES, AND ENGAGE IN SOCIAL, BUSINESS AND COMMUNITY NETWORKING; PROVIDING TEMPORARY USE OF NON DOWNLOADABLE COMPUTER SOFTWARE FOR ALLOWING WEB SITE USERS TO COMMUNICATE INFORMATION OF GENERAL INTEREST FOR PURPOSES OF SOCIAL, BUSINESS AND COMMUNITY NETWORKING, MARKETING, RECRUITMENT AND EMPLOYMENT; PROVIDING TEMPORARY USE OF NON DOWNLOADABLE COMPUTER SOFTWARE ENABLING USERS TO SEARCH, LOCATE AND COMMUNICATE WITH OTHERS VIA ELECTRONIC COMMUNICATIONS NETWORKS TO NETWORK; COMPUTER SERVICES IN THE NATURE OF CUSTOMIZED WEB PAGES FEATURING PERSONAL PROFILES AND IMAGES; PROVIDING TEMPORARY USE OF NON DOWNLOADABLE COMPUTER SOFTWARE FOR USE IN COLLECTING, MANAGING AND EXCHANGING BUSINESS INFORMATION AND CONTACT DATA ACROSS MULTIPLE INDUSTRY FIELDS AND FOR USE IN MAPPING OF BUSINESS ORGANIZATIONS, BUSINESS RESEARCH, AND TO FACILITATE COMMUNICATIONS BETWEEN BUSINESS PROFESSIONALS; PROVIDING TEMPORARY USE OF NON DOWNLOADABLE COMPUTER SOFTWARE FOR ALLOWING USERS TO ACCESS INFORMATION AND GENERATE REPORTS FOR USE IN CONSULTING AND COMMUNICATE WITH EXECUTIVES, BUSINESS CONTACTS AND BUSINESSES; PROVIDING TEMPORARY USE OF NON DOWNLOADABLE COMPUTER SOFTWARE IN THE FIELD OF KNOWLEDGE MANAGEMENT FOR USE IN MANAGING PROFESSIONAL, BUSINESS AND CAREER NETWORKING (U.S. CLS. 100 AND 101).

CLASS 45—PERSONAL AND LEGAL SERVICES

FOR ONLINE SOCIAL NETWORKING SERVICES (U.S. CLS. 100 AND 101).
GISELLE AGOSTO, EXAMINING ATTORNEY

SN 85-597,127. MASSEY, TAYLOR, ENCINITAS, CA. FILED 4-13-2012.

GOLF PUNK

THE MARK CONSISTS OF STANDARD CHARACTERS WITHOUT CLAIM TO ANY PARTICULAR FONT, STYLE, SIZE, OR COLOR.

NO CLAIM IS MADE TO THE EXCLUSIVE RIGHT TO USE "GOLF", APART FROM THE MARK AS SHOWN.

CLASS 9—ELECTRICAL AND SCIENTIFIC APPARATUS

FOR ELECTRONIC PUBLICATIONS, NAMELY, E-ZINES FEATURING GOLF AND MEN'S LIFESTYLES RECORDED ON COMPUTER MEDIA (U.S. CLS. 21, 23, 26, 36 AND 38).

CLASS 16—PAPER GOODS AND PRINTED MATTER

FOR MAGAZINES FEATURING GOLF AND MEN'S LIFESTYLES (U.S. CLS. 2, 5, 22, 23, 29, 37, 38 AND 50).

CLASS 41—EDUCATION AND ENTERTAINMENT

FOR PROVIDING A WEBSITE FEATURING NON-DOWNLOADABLE PUBLICATIONS IN THE NATURE OF MAGAZINES AND ARTICLES IN THE FIELD OF GOLF AND MEN'S LIFESTYLES (U.S. CLS. 100, 101 AND 107).

LYNDSEY KUYKENDALL, EXAMINING ATTORNEY

SN 85-597,317. WCTV NETWORK, LLC, RIVERWOODS, IL. FILED 4-13-2012.

RED TEETH ROCK

THE MARK CONSISTS OF STANDARD CHARACTERS WITHOUT CLAIM TO ANY PARTICULAR FONT, STYLE, SIZE, OR COLOR.

NO CLAIM IS MADE TO THE EXCLUSIVE RIGHT TO USE "RED", APART FROM THE MARK AS SHOWN.

CLASS 16—PAPER GOODS AND PRINTED MATTER

FOR PUBLICATIONS, NAMELY, BOOKS, MAGAZINES, BROCHURES AND PAMPHLETS IN THE FIELD OF WINES, BEERS, SPIRITS, LIQUORS, LIQUEURS AND ALCOHOLIC BEVERAGES (U.S. CLS. 2, 5, 22, 23, 29, 37, 38 AND 50).

CLASS 25—CLOTHING

FOR CLOTHING, NAMELY, SHIRTS, T-SHIRTS AND HATS (U.S. CLS. 22 AND 39).

CLASS 35—ADVERTISING AND BUSINESS

FOR ARRANGING AND CONDUCTING SPECIAL EVENTS FOR BUSINESS PURPOSES; ARRANGING AND CONDUCTING SPECIAL EVENTS FOR COMMERCIAL, PROMOTIONAL OR ADVERTISING PURPOSES; PROMOTING WINES, BEERS, SPIRITS, LIQUORS, LIQUEURS AND ALCOHOLIC BEVERAGES OF OTHERS; PROVIDING CONSUMER INFORMATION IN THE FIELD OF WINES, BEERS, SPIRITS, LIQUORS, LIQUEURS AND ALCOHOLIC BEVERAGES (U.S. CLS. 100, 101 AND 102).

CLASS 41—EDUCATION AND ENTERTAINMENT

FOR ENTERTAINMENT, NAMELY, PRODUCTION OF A CONTINUING AND ONGOING NEWS AND INFORMATIONAL TELEVISION SHOW CONCERNING WINES, BEERS, SPIRITS, LIQUORS, LIQUEURS AND ALCOHOLIC BEVERAGES FOR BROADCAST OVER THE INTERNET AND TELEVISION; ARRANGING AND CONDUCTING SPECIAL EVENTS FOR SOCIAL ENTERTAINMENT PURPOSES; EDUCATION SERVICES, NAMELY, PROVIDING CLASSES, SEMINARS AND WORKSHOPS IN THE FIELD OF WINES, BEERS, SPIRITS, LIQUORS, LIQUEURS AND ALCOHOLIC BEVERAGES (U.S. CLS. 100, 101 AND 107).

DAVID YONTEF, EXAMINING ATTORNEY

SN 85-597,310. TDINDUSTRIES, INC., DALLAS, TX. FILED 4-13-2012.



OWNER OF U.S. REG. NO. 2,597,607.
THE COLOR(S) DARK BLUE IS/ARE CLAIMED AS A FEATURE OF THE MARK.

THE MARK CONSISTS OF THE TERM "TDINDUSTRIES" IN DARK BLUE STYLIZED FONT BELOW A STYLIZED DESIGN OF THREE PEOPLE WITH INTERLOCKING ARMS ALL SHOWN IN DARK BLUE.

CLASS 37—CONSTRUCTION AND REPAIR

FOR INSTALLATION, MAINTENANCE AND REPAIR OF HEATING, AIR CONDITIONING, PLUMBING, REFRIGERATION, AND BUILDING AUTOMATION EQUIPMENT (U.S. CLS. 100, 103 AND 106).

FIRST USE 1-31-2010; IN COMMERCE 1-31-2010.

CLASS 42—SCIENTIFIC AND COMPUTER SERVICES

FOR DESIGN OF HEATING, AIR CONDITIONING, PLUMBING, REFRIGERATION, AND BUILDING AUTOMATION SYSTEMS (U.S. CLS. 100 AND 101).

FIRST USE 1-31-2010; IN COMMERCE 1-31-2010.
DAVID YONTEF, EXAMINING ATTORNEY

SN 85-597,657. ALLERGAN, INC., IRVINE, CA. FILED 4-13-2012.

OPTOMETRY JUMPSTART AND DESIGN

THE MARK CONSISTS OF STANDARD CHARACTERS WITHOUT CLAIM TO ANY PARTICULAR FONT, STYLE, SIZE, OR COLOR.

OWNER OF U.S. REG. NO. 3,874,883.

NO CLAIM IS MADE TO THE EXCLUSIVE RIGHT TO USE "OPTOMETRY", APART FROM THE MARK AS SHOWN.

CLASS 16—PAPER GOODS AND PRINTED MATTER

FOR PRINTED PAMPHLETS, BROCHURES, MANUALS, LEAFLETS, FLYERS, AND INFORMATIONAL SHEETS AND NEWSLETTERS IN THE FIELD OF EYE CARE (U.S. CLS. 2, 5, 22, 23, 29, 37, 38 AND 50).

CLASS 35—ADVERTISING AND BUSINESS

FOR DISTRIBUTION OF SAMPLES FOR TRIAL PURPOSES IN THE FIELD OF EYE CARE (U.S. CLS. 100, 101 AND 102).

CLASS 44—MEDICAL, BEAUTY AND AGRICULTURAL SERVICES

FOR PROVIDING MEDICAL INFORMATION TO OPTOMETRISTS IN THE FIELD OF EYE CARE (U.S. CLS. 100 AND 101).

WARREN L. OLANDRIA, EXAMINING ATTORNEY

SN 85-597,725. RONALDO DESIGNER JEWELRY, INC., LACONIA, IN. FILED 4-13-2012.

THE RONALDO COLLECTION

THE MARK CONSISTS OF STANDARD CHARACTERS WITHOUT CLAIM TO ANY PARTICULAR FONT, STYLE, SIZE, OR COLOR.

NO CLAIM IS MADE TO THE EXCLUSIVE RIGHT TO USE "COLLECTION", APART FROM THE MARK AS SHOWN.

CLASS 3—COSMETICS AND CLEANING PREPARATIONS

FOR SOLUTION FOR CLEANING JEWELRY (U.S. CLS. 1, 4, 6, 50, 51 AND 52).

FIRST USE 11-25-2011; IN COMMERCE 11-25-2011.

CLASS 14—JEWELRY

FOR JEWELRY (U.S. CLS. 2, 27, 28 AND 50). FIRST USE 4-16-1999; IN COMMERCE 4-16-1999. ROSELLE HERRERA, EXAMINING ATTORNEY

SN 85-597,992. HARO, ROBERT B., CARDIFF, CA. FILED 4-13-2012.

BORN FROM BMX

THE MARK CONSISTS OF STANDARD CHARACTERS WITHOUT CLAIM TO ANY PARTICULAR FONT, STYLE, SIZE, OR COLOR.

CLASS 12—VEHICLES

FOR BICYCLES, RACING BICYCLES, MOUNTAIN BICYCLES AND BICYCLE PARTS AND COMPONENTS, NAMELY, FRAMES, HANDLEBARS, HANDLEBAR GRIPS, GEAR WHEELS, DRIVE CHAINS, DISK WHEELS, BAR STEMS, SPROCKETS, BICYCLE PEDALS, BICYCLE SEATS, SEAT POSTS AND SADDLES; BICYCLE WHEELS, RIMS AND STRUCTURAL PARTS THEREFORE, INNER TUBES FOR BICYCLES, RIMS AND SPOKES FOR BICYCLE WHEELS, TIRES FOR BICYCLES; SAFETY PADS FOR BICYCLES; CARRIER BAGS SPECIALLY ADAPTED FOR USE ON BICYCLES (U.S. CLS. 19, 21, 23, 31, 35 AND 44).

CLASS 18—LEATHER GOODS

FOR BAGS, NAMELY, ALL-PURPOSE CARRYING BAGS, ATHLETIC BAGS, GENERAL PURPOSE BAGS FOR TRAVEL, WAIST BAGS, GYM BAGS; BACK PACKS, DUFFLE BAGS, SPORTS BAGS, TRAVEL BAGS, WALLET, AND LUGGAGE (U.S. CLS. 1, 2, 3, 22 AND 41).

CLASS 25—CLOTHING

FOR CLOTHING, NAMELY, T-SHIRTS, SHIRTS, TOPS, SWEAT SHIRTS, SWEAT PANTS, HOODED JACKETS, GLOVES, HATS, CAPS, JACKETS, HEADBANDS; CLOTHING FOR ATHLETIC USE, NAMELY, PADDED SHIRTS, PANTS AND SHORTS, TIGHTS, VESTS, CYCLING PANTS, CYCLING JERSEYS, CYCLING SHORTS, CYCLING SHOES AND CYCLING GLOVES (U.S. CLS. 22 AND 39).

ROBIN CHOSID, EXAMINING ATTORNEY

SN 85-598,090. DYNAMICS INC., CHESWICK, PA. FILED 4-14-2012.

EXPERIENCE MANAGER

THE MARK CONSISTS OF STANDARD CHARACTERS WITHOUT CLAIM TO ANY PARTICULAR FONT, STYLE, SIZE, OR COLOR.

NO CLAIM IS MADE TO THE EXCLUSIVE RIGHT TO USE "MANAGER", APART FROM THE MARK AS SHOWN.

CLASS 9—ELECTRICAL AND SCIENTIFIC APPARATUS

FOR COMPUTER APPLICATION SOFTWARE FOR COMPUTING DEVICES, NAMELY, SOFTWARE FOR USERS TO ASSOCIATE APPLICATIONS PROVIDED BY VARIOUS ENTITIES TO MAGNETIC, VIRTUAL AND ELECTRONIC CARDS AND/OR BUTTONS ON MAGNETIC, VIRTUAL AND ELECTRONIC CARDS TO ALLOW THE USER TO GAIN THE BENEFIT OF FEATURES PROVIDED BY THE APPLICATIONS; SOFTWARE FOR THE OPERATIONAL MANAGEMENT OF PORTABLE MAGNETIC AND ELECTRONIC CARDS (U.S. CLS. 21, 23, 26, 36 AND 38).

CLASS 35—ADVERTISING AND BUSINESS

FOR ADMINISTRATION OF A PROGRAM FOR ENABLING PARTICIPANTS TO OBTAIN DISCOUNTS ON PRODUCTS AND SERVICES; ADVERTISING SERVICES, NAMELY, COST-PER-ACTION ON-LINE ADVERTISING; ADVERTISING, MARKETING, AND PROMOTING THE GOODS AND SERVICES OF OTHERS VIA AN APPLICATION, BY PROVIDING INFORMATION ABOUT SUCH GOODS AND SERVICES PROVIDERS, HYPERTEXT LINKS TO THE WEBSITES OF SUCH GOODS AND SERVICES PROVIDERS, AND ADMINISTERING A PROGRAM ALLOWING PARTICIPANTS TO ASSOCIATE PAYMENT METHODS TO FEATURES PROVIDED BY SUCH GOODS AND SERVICES PROVIDERS; CONTESTS AND INCENTIVE AWARD PROGRAMS TO PROMOTE THE SALE OF PRODUCTS AND SERVICES OF OTHERS; DEVELOPING AND MANAGING THE CHARITABLE GIVING PROGRAMS OF OTHERS; PROMOTING THE CHARITABLE SERVICES OF OTHERS, NAMELY, PROVIDING INDIVIDUALS WITH INFORMATION ABOUT VARIOUS CHARITIES FOR THE PURPOSE OF MAKING DONATIONS TO CHARITIES; PROMOTING THE SALE OF CREDIT CARD ACCOUNTS THROUGH THE ADMINISTRATION OF INCENTIVE AWARD PROGRAMS; PROMOTIONAL SERVICES, NAMELY, PROMOTING THE CHARITIES OF OTHERS (U.S. CLS. 100, 101 AND 102).

CLASS 36—INSURANCE AND FINANCIAL

FOR ARRANGING AND PROVISION OF CREDIT, LOANS, INSURANCE, CURRENCY EXCHANGE AND TRAVELLERS CHEQUES; CREDIT CARD AND PAYMENT CARD SERVICES; CREDIT CARD TRANSACTION PROCESSING SERVICES (U.S. CLS. 100, 101 AND 102).

CLASS 41—EDUCATION AND ENTERTAINMENT

FOR ENTERTAINMENT SERVICES, NAMELY, CONTEST AND INCENTIVE AWARD PROGRAMS DESIGNED TO REWARD PROGRAM PARTICIPANTS WHO USE PAYMENT CARDS OR DEVICES; ENTERTAINMENT SERVICES, NAMELY, PROVIDING AN ON-LINE COMPUTER GAME; ENTERTAINMENT SERVICES, NAMELY, PROVIDING AN ON-LINE VIRTUAL ENVIRONMENT FOR TRADING VIRTUAL SPORTS TRADING CARDS AND TOKENS; SWEEPSTAKE SERVICES PROVIDED OVER A GLOBAL COMPUTER NETWORK (U.S. CLS. 100, 101 AND 107).

CLASS 42—SCIENTIFIC AND COMPUTER SERVICES

FOR APPLICATION SERVICE PROVIDER (ASP) FEATURING SOFTWARE FOR USE IN ASSOCIATING APPLICATIONS PROVIDED BY VARIOUS ENTITIES TO MAGNETIC, VIRTUAL AND ELECTRONIC CARDS AND/OR BUTTONS ON MAGNETIC, VIRTUAL AND ELECTRONIC CARDS TO ALLOW THE USER TO GAIN THE BENEFIT OF FEATURES PROVIDED BY THE APPLICATIONS; APPLICATION SERVICE PROVIDER (ASP), NAMELY, HOSTING COMPUTER SOFTWARE APPLICATIONS OF OTHERS; COMPUTER SERVICES, NAMELY, CREATING AN ON-LINE VIRTUAL ENVIRONMENT FOR OBTAINING AND/OR TRADING COLLECTIBLES; SOFTWARE AS A SERVICE (SAAS) SERVICES FEATURING SOFTWARE FOR USERS TO ASSOCIATE APPLICATIONS PROVIDED BY ENTITIES TO MAGNETIC, VIRTUAL AND ELECTRONIC CARDS AND/OR BUTTONS ON MAGNETIC, VIRTUAL AND ELECTRONIC CARDS TO ALLOW THE USER TO GAIN THE BENEFIT OF FEATURES PROVIDED BY THE APPLICATIONS (U.S. CLS. 100 AND 101).

DAVID MURRAY, EXAMINING ATTORNEY

SN 85-598,110. KIBBLEWHITE PRECISION MACHINING, INC., PACIFICA, CA. FILED 4-14-2012.

KIBBLEWHITE

THE MARK CONSISTS OF STANDARD CHARACTERS WITHOUT CLAIM TO ANY PARTICULAR FONT, STYLE, SIZE, OR COLOR.
SEC. 2(F).

CLASS 7—MACHINERY

FOR INTERNAL COMBUSTION ENGINE PARTS, NAMELY, VALVES, VALVE GUIDES, VALVE SPRINGS, VALVE SPRING RETAINERS, BUSHINGS, CYLINDER STUDS, CLUTCH SPRINGS, VALVE SEATS, VALVE SEALS, VALVE BASE WASHERS, VALVE SPRING TAPPETS, KEEPERS AND SHIMS (U.S. CLS. 13, 19, 21, 23, 31, 34 AND 35).

FIRST USE 1-15-1989; IN COMMERCE 1-15-1989.

CLASS 40—MATERIAL TREATMENT

FOR MACHINE SHOP SERVICES, NAMELY, MACHINING PARTS FOR OTHERS (U.S. CLS. 100, 103 AND 106).

FIRST USE 1-15-1989; IN COMMERCE 1-15-1989.

CLASS 42—SCIENTIFIC AND COMPUTER SERVICES

FOR ENGINEERING, TESTING AND PRODUCT DEVELOPMENT SERVICES IN THE FIELD OF INTERNAL COMBUSTION ENGINE PARTS, NAMELY, VALVES, VALVE SEATS, VALVE GUIDES, VALVE SEALS, VALVE SPRINGS, VALVE BASE WASHERS, VALVE SPRING TAPPETS, RETAINERS, KEEPERS AND SHIMS (U.S. CLS. 100 AND 101).

FIRST USE 1-15-1989; IN COMMERCE 1-15-1989.

MIDGE BUTLER, EXAMINING ATTORNEY

SN 85-598,114. KIBBLEWHITE PRECISION MACHINING, INC., PACIFICA, CA. FILED 4-14-2012.



NO CLAIM IS MADE TO THE EXCLUSIVE RIGHT TO USE "PRECISION MACHINING INC. MANUFACTURER OF VALVETRAIN COMPONENTS", APART FROM THE MARK AS SHOWN.

THE COLOR(S) YELLOW, BLACK AND RED IS/ARE CLAIMED AS A FEATURE OF THE MARK.

THE MARK CONSISTS OF THE WORDS "KIBBLEWHITE PRECISION MACHINING INC. MANUFACTURER OF VALVETRAIN COMPONENTS" IN BLACK STYLIZED LETTERING ON A YELLOW OVAL BACKGROUND WITH A FANCIFUL DESIGN OF A LEAPING PANTHER IN BLACK OUTLINE AND BLACK SHADOWING AND THE YELLOW BACKGROUND IS BORDERED BY A THIN BLACK BORDER SURROUNDED BY AN IRREGULAR RED BORDER SURROUNDED BY AN IRREGULAR BLACK BORDER.

CLASS 7—MACHINERY

FOR INTERNAL COMBUSTION ENGINE PARTS, NAMELY, VALVES, VALVE GUIDES, VALVE SPRINGS, VALVE SPRING RETAINERS, BUSHINGS, CYLINDER STUDS, CLUTCH SPRINGS, VALVE SEATS, VALVE SEALS, VALVE BASE WASHERS, VALVE SPRING TAPPETS, KEEPERS AND SHIMS (U.S. CLS. 13, 19, 21, 23, 31, 34 AND 35).

FIRST USE 1-15-1989; IN COMMERCE 1-15-1989.

CLASS 40—MATERIAL TREATMENT

FOR MACHINE SHOP SERVICES, NAMELY, MACHINING PARTS FOR OTHERS (U.S. CLS. 100, 103 AND 106).

FIRST USE 1-15-1989; IN COMMERCE 1-15-1989.

CLASS 42—SCIENTIFIC AND COMPUTER SERVICES

FOR ENGINEERING, TESTING AND PRODUCT DEVELOPMENT SERVICES IN THE FIELD OF INTERNAL COMBUSTION ENGINE PARTS, NAMELY, VALVES, VALVE SEATS, VALVE GUIDES, VALVE SEALS, VALVE SPRINGS, VALVE BASE WASHERS, VALVE SPRING TAPPETS, RETAINERS, KEEPERS AND SHIMS (U.S. CLS. 100 AND 101).

FIRST USE 1-15-1989; IN COMMERCE 1-15-1989.

MIDGE BUTLER, EXAMINING ATTORNEY

CLASS 25—CLOTHING

FOR ATHLETIC APPAREL, NAMELY, SHIRTS, PANTS, JACKETS, FOOTWEAR, HATS AND CAPS, ATHLETIC UNIFORMS; BASEBALL CAPS AND HATS; CHEF'S HATS; FUR HATS; HAT BANDS; HATS; HATS FOR INFANTS, BABIES, TODDLERS AND CHILDREN; HEADGEAR, NAMELY, HATS; LEATHER HATS; PAPER HATS FOR USE AS CLOTHING ITEMS; PARTY HATS; PERSPIRATION ABSORBENT STRAP TO BE USED IN THE BILL OF A HAT; RACE NUMBER BELTS THAT HOLD A PAPER NUMBER ON THE RACE PARTICIPANT'S FRONT OR BACK DURING COMPETITION; RAIN HATS; SCIENTIFIC AND TECHNOLOGICAL APPAREL, NAMELY, SHIRTS, PANTS, JACKETS, FOOTWEAR, HATS AND CAPS, UNIFORMS; SEDGE HATS (SUGE-GASA); SHORT-SLEEVED OR LONG-SLEEVED T-SHIRTS; SMALL HATS; SPORTS CAPS AND HATS; T-SHIRTS; TOBOGGAN HATS, PANTS AND CAPS; WOMEN'S HATS AND HOODS; WOOLLY HATS (U.S. CLS. 22 AND 39).

CLASS 28—TOYS AND SPORTING GOODS

FOR ARCADE RACING GAME MACHINES; MODEL RACING CAR BODIES; REMOTE CONTROL TOYS, NAMELY, RC CARS (U.S. CLS. 22, 23, 38 AND 50).

KERI CANTONE, EXAMINING ATTORNEY

SN 85-598,205. NEXUS SOFTWARE LLC, CONCORD, OH.
FILED 4-15-2012.

SN 85-598,161. WHITE KNUCKLE MARKETING, INC., DBA WHITE KNUCKLE MARKETING, INC., SIMI VALLEY, CA. FILED 4-14-2012.



NO CLAIM IS MADE TO THE EXCLUSIVE RIGHT TO USE "RACING", APART FROM THE MARK AS SHOWN.

THE COLOR(S) ORANGE, WHITE, AND BLACK IS/ARE CLAIMED AS A FEATURE OF THE MARK.

THE MARK CONSISTS OF THE STYLIZED WORDING "UP TEAM UP RACING." THE "U" IN "UP" IS COMPRISED OF AN ARROW. THE WORD "UP" IS IN BLACK, WITH WHITE OUTLINING. THE WHITE OUTLINING IS THEN OUTLINED IN ORANGE. BELOW "UP" IS THE WORDING "TEAM UP" IN WHITE WITH BLACK OUTLINING. THE BLACK OUTLINE IS THEN OUTLINED IN ORANGE. BELOW THAT IS THE WORD "RACING" IN ORANGE.

NEXUS EVOLUTION

THE MARK CONSISTS OF STANDARD CHARACTERS WITHOUT CLAIM TO ANY PARTICULAR FONT, STYLE, SIZE, OR COLOR.

CLASS 9—ELECTRICAL AND SCIENTIFIC APPARATUS

FOR COMPUTER SOFTWARE AND FIRMWARE FOR BANKING AND FINANCIAL INSTITUTION DEVICE CONTROLS; COMPUTER SOFTWARE FOR BANKING AND FINANCIAL INSTITUTION DEVICE CONTROLS THAT MAY BE DOWNLOADED FROM A GLOBAL COMPUTER NETWORK; COMPUTER SOFTWARE FOR ENCRYPTION; COMPUTER SOFTWARE FOR PROVIDING AN ON-LINE DATABASE IN THE FIELD OF TRANSACTION PROCESSING TO UPLOAD TRANSACTIONAL DATA, PROVIDE STATISTICAL ANALYSIS, AND PRODUCE NOTIFICATIONS AND REPORTS; AND COMPUTER SOFTWARE PLATFORMS FOR BANKING AND FINANCIAL INSTITUTION DEVICE CONTROLS (U.S. CLS. 21, 23, 26, 36 AND 38).

CLASS 42—SCIENTIFIC AND COMPUTER SERVICES

FOR COMPUTER SERVICES, NAMELY, REMOTE AND ON-SITE MANAGEMENT OF BANKING AND FINANCIAL INSTITUTION SOFTWARE DEVICE CONTROLS OF OTHERS; DESIGN, DEVELOPMENT, INSTALLATION AND MAINTENANCE OF COMPUTER SOFTWARE; AND DEVELOPING CUSTOMIZED SOFTWARE IN THE FIELD OF BANK AND FINANCIAL INSTITUTION CONTROLS FOR OTHERS (U.S. CLS. 100 AND 101).

MARGERY A. TIERNEY, EXAMINING ATTORNEY

SN 85-598,354. MISSION MEASUREMENT LLC, CHICAGO, IL. FILED 4-16-2012.

SN 85-598,677. MICHAEL & SUSAN DELL FOUNDATION, AUSTIN, TX. FILED 4-16-2012.

STUDENTGPS

SOCIAL VALUE DRIVERS

THE MARK CONSISTS OF STANDARD CHARACTERS WITHOUT CLAIM TO ANY PARTICULAR FONT, STYLE, SIZE, OR COLOR.

NO CLAIM IS MADE TO THE EXCLUSIVE RIGHT TO USE "VALUE DRIVERS", APART FROM THE MARK AS SHOWN.

CLASS 35—ADVERTISING AND BUSINESS

FOR BUSINESS CONSULTING SERVICE THAT PROVIDES TRANSFORMATIONAL STRATEGIES TO COMPANIES WISHING TO MOVE TOWARDS SUSTAINABILITY AND SOCIALLY RESPONSIBLE BUSINESS PRACTICES, PROVIDED MAINLY TO THE CONSUMER PRODUCTS INDUSTRY; CONDUCTING BUSINESS RESEARCH AND SURVEYS (U.S. CLS. 100, 101 AND 102).

CLASS 36—INSURANCE AND FINANCIAL

FOR PROVIDING INFORMATION AND RESEARCH IN THE FIELD OF FINANCE AND FINANCIAL INVESTMENTS (U.S. CLS. 100, 101 AND 102).
VIVIAN MICZNIK FIRST, EXAMINING ATTORNEY

THE MARK CONSISTS OF STANDARD CHARACTERS WITHOUT CLAIM TO ANY PARTICULAR FONT, STYLE, SIZE, OR COLOR.

CLASS 9—ELECTRICAL AND SCIENTIFIC APPARATUS

FOR COMPUTER SOFTWARE FOR USE IN THE EDUCATIONAL INDUSTRY FOR INFORMATION COLLECTION AND REPORTING OF STUDENT ACADEMIC AND PERSONAL HISTORY (U.S. CLS. 21, 23, 26, 36 AND 38).

CLASS 42—SCIENTIFIC AND COMPUTER SERVICES

FOR PROVIDING ON-LINE NON-DOWNLOADABLE SOFTWARE FOR USE IN THE EDUCATIONAL INDUSTRY FOR INFORMATION COLLECTION AND REPORTING OF STUDENT ACADEMIC AND PERSONAL HISTORY; SOFTWARE DESIGN AND DEVELOPMENT (U.S. CLS. 100 AND 101).
EDWARD NELSON, EXAMINING ATTORNEY

SN 85-598,705. BRAND MARKETING INC., MANHATTAN BEACH, CA. FILED 4-16-2012.

SN 85-598,416. PADDOCK, MATTHEW, ELKHORN, WI. AND HAYES, RYAN, DARIEN, WI. FILED 4-16-2012.

Recall Santa

THE MARK CONSISTS OF STANDARD CHARACTERS WITHOUT CLAIM TO ANY PARTICULAR FONT, STYLE, SIZE, OR COLOR.

CLASS 16—PAPER GOODS AND PRINTED MATTER

FOR BUMPER STICKERS; PRINTED PAPER SIGNS (U.S. CLS. 2, 5, 22, 23, 29, 37, 38 AND 50).

CLASS 25—CLOTHING

FOR HATS; T-SHIRTS (U.S. CLS. 22 AND 39).
RAUL CORDOVA, EXAMINING ATTORNEY

JOZU

THE MARK CONSISTS OF STANDARD CHARACTERS WITHOUT CLAIM TO ANY PARTICULAR FONT, STYLE, SIZE, OR COLOR.

THE WORDING "JOZU" HAS NO MEANING IN A FOREIGN LANGUAGE.

CLASS 9—ELECTRICAL AND SCIENTIFIC APPARATUS

FOR EYEWEAR, NAMELY, SUNGLASSES, EYEGLASSES AND OPHTHALMIC FRAMES AND CASES THEREFOR; EYEWEAR, NAMELY, SUNGLASSES; FRAMES FOR SPECTACLES AND SUNGLASSES; SUNGLASS CHAINS AND CORDS; SUNGLASSES; SUNGLASSES AND SPECTACLES (U.S. CLS. 21, 23, 26, 36 AND 38).

CLASS 14—JEWELRY

FOR CASES FOR CLOCK AND WATCH-MAKING; CASES FOR WATCHES AND CLOCKS; CHRONOGRAPHS AS WATCHES; CHRONOGRAPHS FOR USE AS WATCHES; CHRONOMETRIC INSTRUMENTS AND WATCH MOVEMENTS; CLOCK AND WATCH HANDS; CLOCKS AND WATCHES; DIALS FOR CLOCK-AND-WATCH-MAKING; DIVING WATCHES; DRESS WATCHES; INEXPENSIVE NON-JEWELRY WATCHES; JEWELLERY AND WATCHES; JEWELLERY, CLOCKS AND WATCHES; JEWELRY WATCHES; SPORTS WATCHES; STOP WATCHES; WATCH BANDS (U.S. CLS. 2, 27, 28 AND 50).

CLASS 18—LEATHER GOODS

FOR BACKPACKS, BOOK BAGS, SPORTS BAGS, BUM BAGS, WALLETS AND HANDBAGS; EVENING HANDBAGS; FASHION HANDBAGS; HANDBAGS; HANDBAGS FOR LADIES; HANDBAGS, PURSES AND WALLETS; LEATHER HANDBAGS (U.S. CLS. 1, 2, 3, 22 AND 41).

KEVIN DINALLO, EXAMINING ATTORNEY

CLASS 16—PAPER GOODS AND PRINTED MATTER

FOR BOOKS, NEWSLETTERS, AND INFORMATIONAL PAMPHLETS ALL IN THE FIELD OF PEDIATRIC LITERACY; BOOKMARKS; NOTECARDS (U.S. CLS. 2, 5, 22, 23, 29, 37, 38 AND 50).

CLASS 18—LEATHER GOODS

FOR TOTE BAGS (U.S. CLS. 1, 2, 3, 22 AND 41).

CLASS 25—CLOTHING

FOR CLOTHING, NAMELY SHIRTS AND HATS (U.S. CLS. 22 AND 39).

CLASS 35—ADVERTISING AND BUSINESS

FOR PROMOTING PUBLIC AWARENESS OF THE NEED FOR PEDIATRIC LITERACY (U.S. CLS. 100, 101 AND 102).

CLASS 41—EDUCATION AND ENTERTAINMENT

FOR EDUCATIONAL SERVICES, NAMELY, CONDUCTING TRAINING SESSIONS FOR PEDIATRICIANS, PARENTS, AND VOLUNTEERS IN THE FIELD OF PEDIATRIC LITERACY AS PART OF A PRIMARY CARE EARLY LITERACY PROGRAM AND DISTRIBUTING TRAINING AND LITERACY MATERIALS IN CONNECTION THEREWITH; ON-LINE TRAINING SERVICES IN THE FIELD OF PEDIATRIC LITERACY; ON-LINE EDUCATIONAL SERVICES, NAMELY, CONDUCTING CLASSES, SEMINARS, AND WORKSHOPS IN THE FIELD OF PEDIATRIC LITERACY; PROVIDING INFORMATION VIA THE INTERNET IN THE FIELD OF PEDIATRIC LITERACY (U.S. CLS. 100, 101 AND 107).

BRIAN PINO, EXAMINING ATTORNEY

STUDENTGPS HUB

THE MARK CONSISTS OF STANDARD CHARACTERS WITHOUT CLAIM TO ANY PARTICULAR FONT, STYLE, SIZE, OR COLOR.

NO CLAIM IS MADE TO THE EXCLUSIVE RIGHT TO USE "HUB", APART FROM THE MARK AS SHOWN.

CLASS 9—ELECTRICAL AND SCIENTIFIC APPARATUS

FOR COMPUTER SOFTWARE FOR USE IN THE EDUCATIONAL INDUSTRY FOR INFORMATION COLLECTION AND REPORTING OF STUDENT ACADEMIC AND PERSONAL HISTORY (U.S. CLS. 21, 23, 26, 36 AND 38).

CLASS 42—SCIENTIFIC AND COMPUTER SERVICES

FOR PROVIDING ON-LINE NON-DOWNLOADABLE SOFTWARE FOR USE IN THE EDUCATIONAL INDUSTRY FOR INFORMATION COLLECTION AND REPORTING OF STUDENT ACADEMIC AND PERSONAL HISTORY; SOFTWARE DESIGN AND DEVELOPMENT (U.S. CLS. 100 AND 101).

EDWARD NELSON, EXAMINING ATTORNEY

SN 85-598,732. MICHAEL & SUSAN DELL FOUNDATION, AUSTIN, TX. FILED 4-16-2012.

MY STUDENTGPS

THE MARK CONSISTS OF STANDARD CHARACTERS WITHOUT CLAIM TO ANY PARTICULAR FONT, STYLE, SIZE, OR COLOR.

CLASS 9—ELECTRICAL AND SCIENTIFIC APPARATUS

FOR COMPUTER SOFTWARE FOR USE IN THE EDUCATIONAL INDUSTRY FOR INFORMATION COLLECTION AND REPORTING OF STUDENT ACADEMIC AND PERSONAL HISTORY (U.S. CLS. 21, 23, 26, 36 AND 38).

CLASS 42—SCIENTIFIC AND COMPUTER SERVICES

FOR PROVIDING ON-LINE NON-DOWNLOADABLE SOFTWARE FOR USE IN THE EDUCATIONAL INDUSTRY FOR INFORMATION COLLECTION AND REPORTING OF STUDENT ACADEMIC AND PERSONAL HISTORY; SOFTWARE DESIGN AND DEVELOPMENT (U.S. CLS. 100 AND 101).

EDWARD NELSON, EXAMINING ATTORNEY

SN 85-598,709. REACH OUT AND READ NATIONAL CENTER, BOSTON, MA. FILED 4-16-2012.

WHERE GREAT STORIES BEGIN

THE MARK CONSISTS OF STANDARD CHARACTERS WITHOUT CLAIM TO ANY PARTICULAR FONT, STYLE, SIZE, OR COLOR.

CLASS 9—ELECTRICAL AND SCIENTIFIC APPARATUS

FOR REFRIGERATOR AND DECORATIVE MAGNETS; VIDEO TAPES FEATURING PEDIATRIC LITERACY TRAINING PROGRAMS AND SERVICES AND PEDIATRIC LITERACY INFORMATION PROGRAMS (U.S. CLS. 21, 23, 26, 36 AND 38).

SN 85-598,736. SOCIAL ENTERPRISES, LLC, BROOKLYN, NY. FILED 4-16-2012.

TASTE ME DO GOOD

THE MARK CONSISTS OF STANDARD CHARACTERS WITHOUT CLAIM TO ANY PARTICULAR FONT, STYLE, SIZE, OR COLOR.

CLASS 29—MEATS AND PROCESSED FOODS

FOR EDIBLE OILS; FROZEN FRUITS; PROCESSED VEGETABLES AND FRUITS (U.S. CL. 46).

CLASS 30—STAPLE FOODS

FOR CHOCOLATE; COFFEE; HONEY (U.S. CL. 46).

CLASS 31—NATURAL AGRICULTURAL PRODUCTS

FOR FRESH FRUIT AND VEGETABLES (U.S. CLS. 1 AND 46).
SEAN CROWLEY, EXAMINING ATTORNEY

SN 85-598,772. VISION RT LIMITED, LONDON, UNITED KINGDOM, FILED 4-16-2012.

ALIGNRT

THE MARK CONSISTS OF STANDARD CHARACTERS WITHOUT CLAIM TO ANY PARTICULAR FONT, STYLE, SIZE, OR COLOR.

CLASS 9—ELECTRICAL AND SCIENTIFIC APPARATUS

FOR COMPUTER HARDWARE AND SOFTWARE FOR MEDICAL IMAGING APPARATUS; COMPUTER HARDWARE AND SOFTWARE, FOR USE WITH MEDICAL PATIENT MONITORING APPARATUS, FOR RECEIVING, PROCESSING, TRANSMITTING AND DISPLAYING DATA AND IMAGES; SOFTWARE FOR MEDICAL IMAGING EQUIPMENT, NAMELY, FOR INTERPRETING POSITION AND MOVEMENT INFORMATION FROM PATIENT IMAGES AND IMPROVING RADIO-THERAPY TARGETING; ALL OF THE FOREGOING EXPRESSLY EXCLUDING GOODS IN THE DENTAL AND ORTHODONTIC FIELDS (U.S. CLS. 21, 23, 26, 36 AND 38).

FIRST USE 1-0-2006; IN COMMERCE 1-0-2006.

CLASS 10—MEDICAL APPARATUS

FOR MEDICAL APPARATUS FOR USE IN RADIO-THERAPY APPLICATIONS; MEDICAL APPARATUS FOR USE IN IMAGE GUIDED THERAPY; SCANNERS FOR MEDICAL USE; MEDICAL APPARATUS FOR MONITORING PATIENT POSITION; MEDICAL APPARATUS FOR MONITORING PATIENT MOVEMENT; MEDICAL APPARATUS FOR POSITIONING PATIENTS; DEVICES USED FOR MONITORING PATIENT POSITION AND MOVEMENT DURING PREPARATION FOR RADIOTHERAPY; DEVICES USED FOR MONITORING PATIENT POSITION AND MOVEMENT DURING RADIOTHERAPY; DEVICES USED FOR MONITORING PATIENT POSITION AND MOVEMENT DURING IMAGE GUIDED THERAPY; PARTS AND FITTINGS FOR ALL THE AFORESAID GOODS; ALL OF THE FOREGOING EXPRESSLY EXCLUDING GOODS IN THE DENTAL AND ORTHODONTIC FIELDS (U.S. CLS. 26, 39 AND 44).

FIRST USE 1-0-2006; IN COMMERCE 1-0-2006.
KIMBERLY FRYE, EXAMINING ATTORNEY

SN 85-598,778. DAVID CHANG, LLC, NEW YORK, NY. FILED 4-16-2012.

FUKUMOMO

THE MARK CONSISTS OF STANDARD CHARACTERS WITHOUT CLAIM TO ANY PARTICULAR FONT, STYLE, SIZE, OR COLOR.

OWNER OF U.S. REG. NOS. 3,241,296, 3,364,565 AND 3,768,197.

THE ENGLISH TRANSLATION OF FUKU IN THE MARK IS HAPPY OR LUCKY, AND THE ENGLISH TRANSLATION OF "MOMO" IN THE MARK IS "PEACH".

CLASS 29—MEATS AND PROCESSED FOODS

FOR PICKLED VEGETABLES IN SOY SAUCE, SOY-BEAN PASTE OR VINEGAR; PICKLES; PROCESSED VEGETABLES AND FRUITS; SOUP CONCENTRATES; SOUP MIXES; PREPARED OR PACKAGED MEALS CONSISTING PRIMARILY OF MEAT, FISH, POULTRY OR VEGETABLES (U.S. CL. 46).

CLASS 30—STAPLE FOODS

FOR ASIAN NOODLES; BARBECUE SAUCE; CAKE MIXES; CHILI SAUCE; COOKIE MIXES; DIPPING SAUCES; FLAVOURED VINEGAR; HOT SAUCE; ICE CREAM MIXES; INSTANT SOBA NOODLES; INSTANT UDON NOODLES; KETCHUP; MIXES FOR BAKERY GOODS; MUSTARD; NOODLES; NOODLES AND SAUCE MIXES COMBINED IN UNITARY PACKAGES; NOODLES AND SEASONING MIXES COMBINED IN UNITARY PACKAGES; NOODLES, SAUCE, AND TOPPING COMBINED IN UNITARY PACKAGES; PASTA; READY-MADE SAUCES; RICE; SOY SAUCE; SPICE BLENDS; SPICE RUBS; SPICES; TERIYAKI SAUCE; VINEGAR (U.S. CL. 46).

ANGELA M. MICHELI, EXAMINING ATTORNEY

SN 85-598,811. MABE, DANIEL J, WOODLAND HILLS, CA.
FILED 4-16-2012.

SN 85-598,823. VISION RT LIMITED, LONDON, UNITED
KINGDOM, FILED 4-16-2012.

Green Zone

THE MARK CONSISTS OF STANDARD CHARACTERS WITHOUT CLAIM TO ANY PARTICULAR FONT, STYLE, SIZE, OR COLOR.

NO CLAIM IS MADE TO THE EXCLUSIVE RIGHT TO USE "GREEN", APART FROM THE MARK AS SHOWN.

CLASS 41—EDUCATION AND ENTERTAINMENT

FOR GARDENS FOR PUBLIC ADMISSION (U.S. CLS. 100, 101 AND 107).

FIRST USE 1-15-2011; IN COMMERCE 1-15-2011.

CLASS 44—MEDICAL, BEAUTY AND AGRICULTURAL SERVICES

FOR LANDSCAPE DESIGN; LANDSCAPE GARDENING; LANDSCAPE GARDENING DESIGN FOR OTHERS; PROVIDING INFORMATION ABOUT DROUGHT TOLERANT LANDSCAPE DESIGN AND INSTALLATION (U.S. CLS. 100 AND 101).

FIRST USE 1-15-2011; IN COMMERCE 1-15-2011.

JIM RINGLE, EXAMINING ATTORNEY

SN 85-598,818. BEST OF EVERYTHING OF SOUTHWEST FLORIDA, INC., NAPLES, FL. FILED 4-16-2012.

SIMPLY THE BEST

THE MARK CONSISTS OF STANDARD CHARACTERS WITHOUT CLAIM TO ANY PARTICULAR FONT, STYLE, SIZE, OR COLOR.

OWNER OF U.S. REG. NOS. 3,722,800, 3,954,030 AND OTHERS.

CLASS 14—JEWELRY

FOR JEWELRY; STERLING SILVER JEWELRY, BRACELETS, NECKLACES, PINS BEING JEWELRY, RINGS BEING JEWELRY, WATCHES (U.S. CLS. 2, 27, 28 AND 50).

FIRST USE 10-1-2007; IN COMMERCE 10-1-2007.

CLASS 35—ADVERTISING AND BUSINESS

FOR RETAIL JEWELRY STORE SERVICES, RETAIL STERLING SILVER JEWELRY STORE SERVICES AND RETAIL GIFT STORE SERVICES FEATURING JEWELRY, BRACELETS, NECKLACES, RINGS, PINS, WATCHES, GIFT ITEMS, GIFT CARDS, STUFFED ANIMALS, SCARVES, HAIR ACCESSORIES, SUNGLASSES, HANDBAGS, BELTS AND OTHER FASHION ACCESSORIES (U.S. CLS. 100, 101 AND 102).

FIRST USE 10-1-2007; IN COMMERCE 10-1-2007.

DEZMONA MIZELLE, EXAMINING ATTORNEY

GATECT

THE MARK CONSISTS OF STANDARD CHARACTERS WITHOUT CLAIM TO ANY PARTICULAR FONT, STYLE, SIZE, OR COLOR.

CLASS 9—ELECTRICAL AND SCIENTIFIC APPARATUS

FOR COMPUTER HARDWARE AND SOFTWARE FOR MEDICAL IMAGING APPARATUS; COMPUTER HARDWARE AND SOFTWARE, FOR USE WITH MEDICAL PATIENT MONITORING APPARATUS, FOR RECEIVING, PROCESSING, TRANSMITTING AND DISPLAYING DATA AND IMAGES; SOFTWARE FOR MEDICAL IMAGING EQUIPMENT, NAMELY, FOR INTERPRETING POSITION, RESPIRATORY AND MOVEMENT INFORMATION FROM PATIENT IMAGES AND IMPROVING RADIOTHERAPY TARGETING (U.S. CLS. 21, 23, 26, 36 AND 38).

FIRST USE 10-0-2007; IN COMMERCE 10-0-2007.

CLASS 10—MEDICAL APPARATUS

FOR MEDICAL APPARATUS FOR USE IN RADIOTHERAPY APPLICATIONS; MEDICAL APPARATUS FOR USE IN IMAGE GUIDED THERAPY; SCANNERS FOR MEDICAL USE; MEDICAL APPARATUS FOR MONITORING PATIENT POSITION; MEDICAL APPARATUS FOR MONITORING PATIENT BREATHING; MEDICAL APPARATUS FOR MONITORING PATIENT MOVEMENT; DEVICES USED FOR MONITORING PATIENT POSITION, BREATHING AND MOVEMENT DURING PREPARATION FOR RADIOTHERAPY; DEVICES USED FOR MONITORING PATIENT POSITION, BREATHING AND MOVEMENT DURING PREPARATION FOR IMAGE GUIDED THERAPY; PARTS AND FITTINGS FOR ALL THE AFORESAID GOODS (U.S. CLS. 26, 39 AND 44).

FIRST USE 10-0-2007; IN COMMERCE 10-0-2007.

KIMBERLY FRYE, EXAMINING ATTORNEY

SN 85-598,842. VISION RT LIMITED, LONDON, UNITED KINGDOM, FILED 4-16-2012.

GATERT

THE MARK CONSISTS OF STANDARD CHARACTERS WITHOUT CLAIM TO ANY PARTICULAR FONT, STYLE, SIZE, OR COLOR.

CLASS 9—ELECTRICAL AND SCIENTIFIC APPARATUS

FOR COMPUTER HARDWARE AND SOFTWARE FOR MEDICAL IMAGING APPARATUS; COMPUTER HARDWARE AND SOFTWARE, FOR USE WITH MEDICAL PATIENT MONITORING APPARATUS, FOR RECEIVING, PROCESSING, TRANSMITTING AND DISPLAYING DATA AND IMAGES; SOFTWARE FOR MEDICAL IMAGING EQUIPMENT, NAMELY, FOR INTERPRETING POSITION, RESPIRATORY AND MOVEMENT INFORMATION FROM PATIENT IMAGES AND IMPROVING RADIOTHERAPY TARGETING (U.S. CLS. 21, 23, 26, 36 AND 38).

FIRST USE 10-0-2007; IN COMMERCE 10-0-2007.

CLASS 10—MEDICAL APPARATUS

FOR MEDICAL APPARATUS FOR USE IN RADIOTHERAPY APPLICATIONS; MEDICAL APPARATUS FOR USE IN IMAGE GUIDED THERAPY; SCANNERS FOR MEDICAL USE; MEDICAL APPARATUS FOR MONITORING PATIENT POSITION; MEDICAL APPARATUS FOR MONITORING PATIENT BREATHING; MEDICAL APPARATUS FOR MONITORING PATIENT MOVEMENT; DEVICES USED FOR MONITORING PATIENT POSITION, BREATHING AND MOVEMENT DURING PREPARATION FOR RADIOTHERAPY; DEVICES USED FOR MONITORING PATIENT POSITION, BREATHING AND MOVEMENT DURING RADIOTHERAPY; DEVICES USED FOR MONITORING PATIENT POSITION, BREATHING AND MOVEMENT DURING IMAGE GUIDED THERAPY; PARTS AND FITTINGS FOR ALL THE AFORESAID GOODS (U.S. CLS. 26, 39 AND 44).

FIRST USE 10-0-2007; IN COMMERCE 10-0-2007.

KIMBERLY FRYE, EXAMINING ATTORNEY

SN 85-598,947. MICHAEL & SUSAN DELL FOUNDATION, AUSTIN, TX. FILED 4-16-2012.

MY STUDENTGPS HUB

THE MARK CONSISTS OF STANDARD CHARACTERS WITHOUT CLAIM TO ANY PARTICULAR FONT, STYLE, SIZE, OR COLOR.

NO CLAIM IS MADE TO THE EXCLUSIVE RIGHT TO USE "HUB", APART FROM THE MARK AS SHOWN.

CLASS 9—ELECTRICAL AND SCIENTIFIC APPARATUS

FOR COMPUTER SOFTWARE FOR USE IN THE EDUCATIONAL INDUSTRY FOR INFORMATION COLLECTION AND REPORTING OF STUDENT ACADEMIC AND PERSONAL HISTORY (U.S. CLS. 21, 23, 26, 36 AND 38).

CLASS 42—SCIENTIFIC AND COMPUTER SERVICES

FOR PROVIDING ON-LINE NON-DOWNLOADABLE SOFTWARE FOR USE IN THE EDUCATIONAL INDUSTRY FOR INFORMATION COLLECTION AND REPORTING OF STUDENT ACADEMIC AND PERSONAL HISTORY; SOFTWARE DESIGN AND DEVELOPMENT (U.S. CLS. 100 AND 101).

EDWARD NELSON, EXAMINING ATTORNEY

SN 85-598,878. CELESTRON ACQUISITION LLC, TORRANCE, CA. FILED 4-16-2012.

FIRECEL

THE MARK CONSISTS OF STANDARD CHARACTERS WITHOUT CLAIM TO ANY PARTICULAR FONT, STYLE, SIZE, OR COLOR.

CLASS 9—ELECTRICAL AND SCIENTIFIC APPARATUS

FOR CELL PHONE BATTERY CHARGERS (U.S. CLS. 21, 23, 26, 36 AND 38).

CLASS 11—ENVIRONMENTAL CONTROL APPARATUS

FOR ELECTRONIC HAND WARMERS; FLASH-LIGHTS (U.S. CLS. 13, 21, 23, 31 AND 34).

WILLIAM ROSSMAN, EXAMINING ATTORNEY

SN 85-598,951. LOG CABIN HOMES LTD., ROCKY MOUNT, NC. FILED 4-16-2012.

THE FIRST NAME IN LOG HOMES

THE MARK CONSISTS OF STANDARD CHARACTERS WITHOUT CLAIM TO ANY PARTICULAR FONT, STYLE, SIZE, OR COLOR.

NO CLAIM IS MADE TO THE EXCLUSIVE RIGHT TO USE "LOG HOMES", APART FROM THE MARK AS SHOWN.

CLASS 19—NON-METALLIC BUILDING MATERIALS

FOR PRE-FABRICATED HOMES; NON-METAL BUILDING MATERIALS, NAMELY, PREFABRICATED PANELLIZED HOMES, MODULAR HOMES, AND MOBILE HOMES; WOOD SIDING; WOOD LOGS FOR LOG HOMES (U.S. CLS. 1, 12, 33 AND 50).

CLASS 35—ADVERTISING AND BUSINESS

FOR RETAIL OUTLETS FEATURING KITS FOR CONSTRUCTING BUILDINGS, ESPECIALLY, HOUSES (U.S. CLS. 100, 101 AND 102).

CLASS 42—SCIENTIFIC AND COMPUTER SERVICES

FOR ARCHITECTURAL DESIGN OF BUILDINGS, ESPECIALLY HOUSES, FOR OTHERS (U.S. CLS. 100 AND 101).

MARGERY A. TIERNEY, EXAMINING ATTORNEY

SN 85-598,994. GOLDSTEIN, SAMUEL A., WEST CHESTER, PA. FILED 4-16-2012.

Latinas Reprise

THE MARK CONSISTS OF STANDARD CHARACTERS WITHOUT CLAIM TO ANY PARTICULAR FONT, STYLE, SIZE, OR COLOR.

NO CLAIM IS MADE TO THE EXCLUSIVE RIGHT TO USE "LATINAS", APART FROM THE MARK AS SHOWN.

THE ENGLISH TRANSLATION OF "LATINAS" IN THE MARK IS WOMEN OR GIRLS OF LATIN DESCENT.

CLASS 14—JEWELRY

FOR JEWELRY, NAMELY, NECKLACES, BRACELETS, EARRINGS, BROACHES, ANKLETS, TIARAS, RINGS, AND WATCHES; LEATHER WATCHBANDS (U.S. CLS. 2, 27, 28 AND 50).

CLASS 18—LEATHER GOODS

FOR LEATHER GOODS, NAMELY, HANDBAGS, POUCHES, BRIEFCASES, AND LUGGAGE (U.S. CLS. 1, 2, 3, 22 AND 41).

CLASS 25—CLOTHING

FOR CLOTHING, NAMELY, DRESSES, SKIRTS, BLOUSES, SWIMSUITS, JEANS, SLACKS, PANTS, LINGERIE, HATS, SWEATERS, COATS, AND JACKETS; FOOTWEAR, NAMELY, SHOES, SLIPPERS, SNEAKERS, BOOTS, THONGS, AND SANDALS; LEATHER BELTS (U.S. CLS. 22 AND 39).

JANICE L. MCMORROW, EXAMINING ATTORNEY

SN 85-599,125. ACCLIVUS CORPORATION, DALLAS, TX. FILED 4-16-2012.

UPSOLVING

THE MARK CONSISTS OF STANDARD CHARACTERS WITHOUT CLAIM TO ANY PARTICULAR FONT, STYLE, SIZE, OR COLOR.

CLASS 16—PAPER GOODS AND PRINTED MATTER

FOR PRINTED MATERIALS, NAMELY, WORKBOOKS, WALL CHARTS AND SKILL GUIDES FOR USE IN WORKSHOPS, LECTURES, COURSE SYMPOSIA, WEBINARS, E-LEARNING, WEB-BASED LEARNING, AND CONFERENCES USED FOR INSTRUCTIONAL AND TEACHING PURPOSES IN THE FIELD OF BUSINESS MANAGEMENT, SALES AND SERVICE COMMUNICATION AND BUILDING RELATIONSHIPS WITH CUSTOMERS (U.S. CLS. 2, 5, 22, 23, 29, 37, 38 AND 50).
FIRST USE 5-31-2006; IN COMMERCE 5-31-2006.

CLASS 41—EDUCATION AND ENTERTAINMENT

FOR EDUCATIONAL SERVICES, NAMELY, CONDUCTING WORKSHOPS, LECTURES, COURSE SYMPOSIA, NON-DOWNLOADABLE WEBINARS, ONLINE EDUCATIONAL CLASSES, AND CONFERENCES IN THE FIELD OF BUSINESS MANAGEMENT, SALES COMMUNICATION AND BUILDING RELATIONSHIPS WITH CUSTOMERS, AND DISTRIBUTING COURSE MATERIALS IN CONNECTION THEREWITH (U.S. CLS. 100, 101 AND 107).

TEJBIR SINGH, EXAMINING ATTORNEY

SN 85-599,129. TONAGO INC., LAS VEGAS, NV. FILED 4-16-2012.

DE CHEMIN

THE MARK CONSISTS OF STANDARD CHARACTERS WITHOUT CLAIM TO ANY PARTICULAR FONT, STYLE, SIZE, OR COLOR.

THE ENGLISH TRANSLATION OF THE FOREIGN WORDING "DE CHEMIN" IS "THE PATH".

CLASS 3—COSMETICS AND CLEANING PREPARATIONS

FOR PERFUME (U.S. CLS. 1, 4, 6, 50, 51 AND 52).

CLASS 25—CLOTHING

FOR DENIMS; JEANS; PANTS (U.S. CLS. 22 AND 39).
GIANCARLO CASTRO, EXAMINING ATTORNEY

SN 85-599,143. MICHIGAN HEALTH INFORMATION NETWORK SHARED SERVICES, AKA MIHIN, EAST LANSING, MI. FILED 4-16-2012.

HISC

THE MARK CONSISTS OF STANDARD CHARACTERS WITHOUT CLAIM TO ANY PARTICULAR FONT, STYLE, SIZE, OR COLOR.

CLASS 35—ADVERTISING AND BUSINESS

FOR ELECTRONIC DATA COLLECTION AND DATA SUBMISSION SERVICES FOR BUSINESS PURPOSES IN THE FIELDS OF MEDICINE AND HEALTHCARE; MANAGED CARE SERVICES, NAMELY, ELECTRONIC PROCESSING OF HEALTH CARE INFORMATION (U.S. CLS. 100, 101 AND 102).

CLASS 44—MEDICAL, BEAUTY AND AGRICULTURAL SERVICES

FOR INTERNET-BASED HEALTH CARE INFORMATION SERVICES (U.S. CLS. 100 AND 101).
STEVEN PEREZ, EXAMINING ATTORNEY

SN 85-599,173. TONAGO INC., LAS VEGAS, NV. FILED 4-16-2012.

de CHEMIN

THE ENGLISH TRANSLATION OF THE FOREIGN WORDING "DE CHEMIN" IS "THE PATH".

CLASS 3—COSMETICS AND CLEANING PREPARATIONS

FOR PERFUME (U.S. CLS. 1, 4, 6, 50, 51 AND 52).

CLASS 25—CLOTHING

FOR DENIMS; JEANS; PANTS (U.S. CLS. 22 AND 39).
GIANCARLO CASTRO, EXAMINING ATTORNEY

SN 85-599,465. DAWSON, JAMES P., TAMPA, FL. FILED 4-17-2012.



NO CLAIM IS MADE TO THE EXCLUSIVE RIGHT TO USE "ATHLETIC TESTING", APART FROM THE MARK AS SHOWN.

THE COLOR(S) RED AND BLACK IS/ARE CLAIMED AS A FEATURE OF THE MARK.

THE MARK CONSISTS OF THE STYLIZED WORDS "UNIVERSAL ATHLETIC TESTING" APPEARING IN RED AT THE TOP AND BOTTOM OF THE DESIGN. A RED LINE APPEARS BELOW THE WORDS "UNIVERSAL ATHLETIC" AND ABOVE THE WORD "TESTING". IN BETWEEN THE RED LINES IS THE ARTISTIC RENDERING OF A HUMAN BEING IN RED AND A WEIGHT BENCH IN BLACK. THE WEIGHT BENCH AND HUMAN BEING ARE DRAWN TO FORM THE INITIALS "UAT".

CLASS 41—EDUCATION AND ENTERTAINMENT

FOR RATING SERVICES, NAMELY, RATING OF ATHLETES BY ASSIGNING A NUMERIC VALUE TO VARIOUS ATHLETIC TESTS AND COMBINING THE TEST RESULTS INTO A SINGLE NUMBER THAT MEASURES AN ATHLETE'S OVERALL ATHLETICISM (U.S. CLS. 100, 101 AND 107).

CLASS 42—SCIENTIFIC AND COMPUTER SERVICES

FOR PROVIDING A WEB SITE FEATURING ON-LINE NON-DOWNLOADABLE SOFTWARE TO TRACK RESULTS OF ATHLETIC TESTS COMPLETED BY ATHLETES, ANALYZE THE RESULTS OF THE ATHLETIC TESTS COMPLETED BY ATHLETES AND PROVIDE REPORTS ON THE OVERALL ATHLETICISM OF AN ATHLETE (U.S. CLS. 100 AND 101).

TINA MAI, EXAMINING ATTORNEY

SN 85-599,582. PRECISION PERFORMANCE MARKETING, INC., TAMPA, FL. FILED 4-17-2012.



THE MARK CONSISTS OF A STYLIZED IMAGE OF A BUTTERFLY.

CLASS 25—CLOTHING

FOR ATHLETIC APPAREL, NAMELY, SHIRTS, PANTS, JACKETS, FOOTWEAR, HATS AND CAPS; ATHLETIC UNIFORMS; BELTS; BRAS; CAPRIS; SHORTS; SWIM WEAR; TENNIS WEAR; WOMEN'S CLOTHING, NAMELY, SHIRTS, DRESSES, SKIRTS, BLOUSES (U.S. CLS. 22 AND 39).

FIRST USE 9-1-2008; IN COMMERCE 9-1-2008.

CLASS 35—ADVERTISING AND BUSINESS

FOR ON-LINE RETAIL STORE SERVICES FEATURING BRAZILIAN STYLE PANTS, CAPRIS, SHORTS, TOPS, BRAS, DRESSES, JACKETS, SWIM WEAR, TENNIS WEAR, HAND BAGS, DUFFEL BAGS, BELTS, JEWELRY, HATS AND HEADBANDS (U.S. CLS. 100, 101 AND 102).

FIRST USE 5-18-2008; IN COMMERCE 5-18-2008.

BRIDGETT SMITH, EXAMINING ATTORNEY

SN 85-599,683. BROOKLYN NAVY YARD DEVELOPMENT CORP., BROOKLYN, NY. FILED 4-17-2012.



OWNER OF U.S. REG. NOS. 3,185,950 AND 3,205,064.

NO CLAIM IS MADE TO THE EXCLUSIVE RIGHT TO USE "BROOKLYN" AND "CENTER", APART FROM THE MARK AS SHOWN.

THE MARK CONSISTS OF A DESIGN IN THE SHAPE OF A RECTANGULAR ADMISSION TICKET WITH BLOCK CAPITAL LETTERS AND NUMBERS "BLDG 92" ON THE TOP PORTION OF THE TICKET AND IN SMALLER SIZE CAPITAL LETTERS THE WORDS "BROOKLYN NAVY YARD CENTER" ON THE BOTTOM PORTION OF THE TICKET.

CLASS 35—ADVERTISING AND BUSINESS

FOR ART AND PICTORIAL GALLERY; RETAIL STORE SERVICES IN THE FIELD OF HISTORICAL SOUVENIRS, REPLICAS OF HISTORICAL ARTIFACTS AND HISTORICAL LITERATURE AND BOOKS (U.S. CLS. 100, 101 AND 102).

FIRST USE 11-11-2011; IN COMMERCE 11-11-2011.

CLASS 41—EDUCATION AND ENTERTAINMENT

FOR MUSEUM SERVICES, NAMELY, OPERATION OF MUSEUM FACILITY FOR THE PUBLIC, HISTORICAL MUSEUM, ART AND PICTORIAL MUSEUM; GUIDED TOURS OF AN HISTORICAL SITE; CONDUCTING CULTURAL OR EDUCATIONAL EXHIBITIONS AND INTERACTIVE EXHIBITS AND DISPLAYS IN THE FIELDS OF HISTORY, ARCHITECTURE AND NEIGHBORHOOD GROWTH AND DEVELOPMENT (U.S. CLS. 100, 101 AND 107).

FIRST USE 11-11-2011; IN COMMERCE 11-11-2011.

CLASS 43—HOTEL AND RESTAURANT SERVICES

FOR PROVIDING COMMUNITY CENTERS FOR SOCIAL GATHERINGS AND MEETINGS (U.S. CLS. 100 AND 101).

FIRST USE 11-11-2011; IN COMMERCE 11-11-2011.

MICHAEL WEBSTER, EXAMINING ATTORNEY

SN 85-599,687. CORTINA, EUSTAQUIO, VAIL, CO. FILED 4-17-2012.

PANZA

THE MARK CONSISTS OF STANDARD CHARACTERS WITHOUT CLAIM TO ANY PARTICULAR FONT, STYLE, SIZE, OR COLOR.

THE ENGLISH TRANSLATION OF PANZA IN THE MARK IS BELLY.

CLASS 9—ELECTRICAL AND SCIENTIFIC APPARATUS

FOR COMPUTER GAME PROGRAMMES DOWNLOADABLE VIA THE INTERNET; COMPUTER GAME PROGRAMS; COMPUTER GAME SOFTWARE; COMPUTER GAME SOFTWARE FOR USE ON MOBILE AND CELLULAR PHONES; ELECTRONIC GAME PROGRAMS; ELECTRONIC GAME SOFTWARE FOR CELLULAR TELEPHONES; ELECTRONIC GAME SOFTWARE FOR HANDHELD ELECTRONIC DEVICES; ELECTRONIC GAME SOFTWARE FOR WIRELESS DEVICES; GAME SOFTWARE; VIDEO GAME SOFTWARE (U.S. CLS. 21, 23, 26, 36 AND 38).

CLASS 28—TOYS AND SPORTING GOODS

FOR CARD GAMES; EDUCATIONAL CARD GAMES (U.S. CLS. 22, 23, 38 AND 50).

MICHAEL WEBSTER, EXAMINING ATTORNEY

SN 85-599,787. HARTMANN USA, INC., ROCK HILL, SC. FILED 4-17-2012.

DIGNITY

THE MARK CONSISTS OF STANDARD CHARACTERS WITHOUT CLAIM TO ANY PARTICULAR FONT, STYLE, SIZE, OR COLOR.

OWNER OF U.S. REG. NOS. 2,140,842, 2,912,466 AND OTHERS.

CLASS 5—PHARMACEUTICALS

FOR DISPOSABLE INCONTINENCE UNDERWEAR, REUSABLE INCONTINENCE UNDERWEAR, ADULT INCONTINENCE DIAPERS, ABSORBENT INCONTINENCE LINERS AND INSERTS FOR UNDERWEAR, INCONTINENCE BRIEFS, DISPOSABLE SANITARY BODY WIPES (U.S. CLS. 6, 18, 44, 46, 51 AND 52).

FIRST USE 0-0-2007; IN COMMERCE 0-0-2007.

CLASS 10—MEDICAL APPARATUS

FOR BED AND FURNITURE INCONTINENCE UNDERPADS, BED SHEETING WITH AN INCONTINENCE BARRIER (U.S. CLS. 26, 39 AND 44).

FIRST USE 0-0-2007; IN COMMERCE 0-0-2007.

CLASS 16—PAPER GOODS AND PRINTED MATTER

FOR ADULT BIBS MADE OF PAPER (U.S. CLS. 2, 5, 22, 23, 29, 37, 38 AND 50).

FIRST USE 0-0-2007; IN COMMERCE 0-0-2007.

SANDRA BUJA, EXAMINING ATTORNEY

SN 85-599,800. BETHEL INTERNATIONAL, INC., FAYETTEVILLE, NC. FILED 4-17-2012.

SANDOL

THE MARK CONSISTS OF STANDARD CHARACTERS WITHOUT CLAIM TO ANY PARTICULAR FONT, STYLE, SIZE, OR COLOR.

OWNER OF U.S. REG. NO. 3,153,835.

CLASS 14—JEWELRY

FOR JEWELRY, NAMELY, WATCHES, EARRINGS, BRACELETS, NECKLACES, AND PENDANTS (U.S. CLS. 2, 27, 28 AND 50).

FIRST USE 7-1-2005; IN COMMERCE 7-1-2005.

CLASS 25—CLOTHING

FOR APPAREL, NAMELY, SCARVES AND BELTS (U.S. CLS. 22 AND 39).

FIRST USE 7-1-2005; IN COMMERCE 7-1-2005.

SIMON TENG, EXAMINING ATTORNEY

SN 85-599,927. AMEREQUIP CORPORATION, KIEL, WI.
FILED 4-17-2012.

AMEREQUIP

THE MARK CONSISTS OF STANDARD CHARACTERS WITHOUT CLAIM TO ANY PARTICULAR FONT, STYLE, SIZE, OR COLOR.

CLASS 7—MACHINERY

FOR AGRICULTURAL MACHINES, NAMELY, TRACTOR TOWED OR MOUNTED MOWER DECKS, MATERIAL COLLECTORS AND SWEEPERS, FRONT END LOADERS, BOX BLADES, SNOW BLOWERS, SNOW PLOW BLADES, TILLERS, AND CULTIVATORS (U.S. CLS. 13, 19, 21, 23, 31, 34 AND 35).

CLASS 40—MATERIAL TREATMENT

FOR CONTRACT MANUFACTURING IN THE FIELDS OF AGRICULTURAL IMPLEMENTS, CONSTRUCTION EQUIPMENT, AND TURF CARE EQUIPMENT (U.S. CLS. 100, 103 AND 106).

RICHARD WHITE, EXAMINING ATTORNEY

SN 85-600,090. WISDOMGATE, INC., HARRINGTON PARK, NJ. FILED 4-17-2012.

WISDOMGATE

THE MARK CONSISTS OF STANDARD CHARACTERS WITHOUT CLAIM TO ANY PARTICULAR FONT, STYLE, SIZE, OR COLOR.

CLASS 16—PAPER GOODS AND PRINTED MATTER

FOR ADDRESS BOOKS; ART PRINTS; BLANK JOURNALS; BLANK WRITING JOURNALS; BOOKMARKS; BUMPER STICKERS; CALENDARS; CHECKBOOK COVERS; CLIP BOARDS; CUSTOM PAINTINGS; DAY PLANNERS; DECALS; DECORATIVE DECALS FOR VEHICLE WINDOWS; DESKTOP PLANNERS; ENVELOPES FOR STATIONERY USE; FRAMED PAINTINGS; GREETING CARDS; GROCERY BAGS; HOLDERS FOR NOTEPADS; LETTER HOLDERS; LETTER-OPENERS; LETTERHEAD PAPER; MAGNETIC BUMPER STICKERS; MONEY CLIPS; NOTE PAD HOLDERS; NOTEBOOKS; PAINTINGS; PAPER CLIP HOLDERS; PAPER CLIPS; PAPER STATIONERY WITH INSPIRATIONAL MESSAGES IMPRINTED THEREON; PAPER WEIGHTS; PASSPORT COVERS; PENS; PLACE MATS OF PAPER; POSTERS; RUBBER STAMPS; STATIONERY; STATIONERY WRITING PAPER AND ENVELOPES; STICKERS; WORKS OF ART MADE OF PAPER (U.S. CLS. 2, 5, 22, 23, 29, 37, 38 AND 50).

CLASS 18—LEATHER GOODS

FOR BRIEFCASES; DIAPER BAGS; DUFFEL BAGS; LUGGAGE; LUGGAGE TAGS; TOILETRY BAGS SOLD EMPTY; TOTE BAGS; UMBRELLAS; WALLETS (U.S. CLS. 1, 2, 3, 22 AND 41).

CLASS 21—HOUSEWARES AND GLASS

FOR BOWLS; CANDLE HOLDERS; COASTERS, NOT OF PAPER AND OTHER THAN TABLE LINEN; COOKIE JARS; DRINKING GLASSES; MUGS; PIGGY BANKS; PITCHERS; PLATES; SERVING PLATTERS; SERVING TRAYS; VASES (U.S. CLS. 2, 13, 23, 29, 30, 33, 40 AND 50).

CLASS 25—CLOTHING

FOR CAPS; DRESS SHIRTS; FLEECE BOTTOMS; FLEECE PULLOVERS; FLEECE TOPS; GLOVES; HATS; HEAD SWEATBANDS; HEAD WEAR; JACKETS; NIGHT SHIRTS; PAJAMAS; POLO SHIRTS; ROBES; SCARVES; SCRUBS NOT FOR MEDICAL PURPOSES; SHIRTS; SHORTS; SLIPPERS; SWEAT SHIRTS; SWEATERS; T-SHIRTS; TANK TOPS; TIES; VISORS; WRIST BANDS (U.S. CLS. 22 AND 39).

JEANIE LEE, EXAMINING ATTORNEY

SN 85-600,205. RED ACE, LLC, BOULDER, CO. FILED 4-17-2012.

RED ACE

THE MARK CONSISTS OF STANDARD CHARACTERS WITHOUT CLAIM TO ANY PARTICULAR FONT, STYLE, SIZE, OR COLOR.

CLASS 5—PHARMACEUTICALS

FOR DIETARY SUPPLEMENTS FOR ENHANCED ATHLETIC PERFORMANCE AND CIRCULATORY HEALTH (U.S. CLS. 6, 18, 44, 46, 51 AND 52).

CLASS 32—LIGHT BEVERAGES

FOR NON-ALCOHOLIC BEVERAGES, NAMELY, ENERGY SHOTS AND ENERGY DRINKS (U.S. CLS. 45, 46 AND 48).

TIMOTHY O. SCHIMPF, EXAMINING ATTORNEY

SN 85-600,334. SIGNATURE CONCEPTS, INC., MINNETONKA, MN. FILED 4-17-2012.

SIGNATURE CONCEPTS

THE MARK CONSISTS OF STANDARD CHARACTERS WITHOUT CLAIM TO ANY PARTICULAR FONT, STYLE, SIZE, OR COLOR.

CLASS 25—CLOTHING

FOR CLOTHING, NAMELY LONG SLEEVE T-SHIRTS, SHORT SLEEVE T-SHIRTS, CREW NECK SWEATSHIRTS, HOODED SWEATSHIRTS, LACED HOODED SWEATSHIRTS, FULL ZIP SWEATSHIRTS, QUARTER ZIP SWEATSHIRTS, SWEAT PANTS (U.S. CLS. 22 AND 39).

FIRST USE 1-1-2010; IN COMMERCE 1-1-2010.

CLASS 40—MATERIAL TREATMENT

FOR EMBROIDERY SERVICES, SCREEN PRINTING, DIGITAL PRINTING, TACKLE TWILL SERVICES (U.S. CLS. 100, 103 AND 106).

FIRST USE 1-1-1989; IN COMMERCE 1-1-1989.
LYNDSEY KUYKENDALL, EXAMINING ATTORNEY

SN 85-600,358. HARBOUR RIDGE YACHT & COUNTRY CLUB, PALM CITY, FL. FILED 4-17-2012.



NO CLAIM IS MADE TO THE EXCLUSIVE RIGHT TO USE "YACHT & COUNTRY CLUB", APART FROM THE MARK AS SHOWN.

THE COLOR(S) ORANGE AND WHITE IS/ARE CLAIMED AS A FEATURE OF THE MARK.

THE MARK CONSISTS OF A WHITE EAGLE SILHOUETTE ABOVE THE WHITE WORDING "HARBOUR RIDGE YACHT & COUNTRY CLUB", ALL APPEARING ON AN ORANGE RECTANGULAR BACKGROUND.

CLASS 35—ADVERTISING AND BUSINESS

FOR ADVERTISING OF COMMERCIAL OR RESIDENTIAL REAL ESTATE (U.S. CLS. 100, 101 AND 102).
FIRST USE 2-28-2011; IN COMMERCE 2-28-2011.

CLASS 41—EDUCATION AND ENTERTAINMENT

FOR GOLF CLUB SERVICES; GOLF COURSES; GOLF INSTRUCTION (U.S. CLS. 100, 101 AND 107).
FIRST USE 2-28-2011; IN COMMERCE 2-28-2011.
KIMBERLY FRYE, EXAMINING ATTORNEY

SN 85-600,359. SERGIO J. LOYA, DBA GUADALUPE CANYON HOT SPRINGS, LOS ANGELES, CA. FILED 4-17-2012.



NO CLAIM IS MADE TO THE EXCLUSIVE RIGHT TO USE "HOT SPRINGS", APART FROM THE MARK AS SHOWN.

THE MARK CONSISTS OF THE WORD GUADALUPE IN STYLIZED SCRIPT FONT ABOVE THE STYLIZED WORD CANYON. BELOW THE WORD CANYON ARE THE STYLIZED WORDS HOT SPRINGS. THE WORDS ARE INSIDE AN OVAL OUTLINED CARRIER WITH ORNAMENTAL FRAMEWORK ON BOTH SIDES. INSIDE THE OVAL, BEHIND THE WORDS, IS A DRAWING OF A TROPICAL SCENE WITH A BAREFOOT CAMPER IN A TENT.

CLASS 25—CLOTHING

FOR T-SHIRTS (U.S. CLS. 22 AND 39).
FIRST USE 11-0-2001; IN COMMERCE 11-0-2001.

CLASS 43—HOTEL AND RESTAURANT SERVICES

FOR PROVIDING CAMPGROUND FACILITIES (U.S. CLS. 100 AND 101).
FIRST USE 11-0-2001; IN COMMERCE 11-0-2001.
KIMBERLY FRYE, EXAMINING ATTORNEY

SN 85-600,656. BENEFITALIGN LLC, REDMOND, WA. FILED 4-17-2012.

BENEFITALIGN

THE MARK CONSISTS OF STANDARD CHARACTERS WITHOUT CLAIM TO ANY PARTICULAR FONT, STYLE, SIZE, OR COLOR.

CLASS 35—ADVERTISING AND BUSINESS

FOR BUSINESS ASSISTANCE SERVICES, NAMELY, ASSISTING HEALTH INSURANCE ORGANIZATIONS, HEALTHCARE FACILITIES, COMMUNITY ORGANIZATIONS, GOVERNMENTS, BROKERS AND EMPLOYERS WITH CONSUMER MARKETING, CUSTOMER ENGAGEMENT INCLUDING SIGN-UP, FOLLOW-UP AND ON-GOING CUSTOMER SERVICES TO IMPROVE CUSTOMER SATISFACTION THROUGH BUSINESS APPLICATIONS, BUSINESS PROCESS MANAGEMENT AND DATA AND INFRASTRUCTURE MANAGEMENT; BUSINESS CONSULTING SERVICES NAMELY, TO HEALTH INSURANCE ORGANIZATIONS, HEALTHCARE FACILITIES, COMMUNITY ORGANIZATIONS, GOVERNMENTS, BROKERS AND EMPLOYERS RELATED TO INFORMATION MANAGEMENT, BUSINESS INTELLIGENCE, ANALYTICS, HEALTHCARE REFORM AND REGULATIONS, HEALTH INSURANCE EXCHANGES (HIX) AND OTHER AREAS WITH REGARD TO MEMBER ENGAGEMENT AND INDUSTRY TRENDS (U.S. CLS. 100, 101 AND 102).

FIRST USE 4-17-2012; IN COMMERCE 4-17-2012.

CLASS 42—SCIENTIFIC AND COMPUTER SERVICES

FOR BUSINESS APPLICATIONS SERVICE PROVIDER FEATURING ONLINE AND MOBILE BUSINESS PROCESS AUTOMATION SOFTWARE APPLICATIONS FOR USE IN CONSUMER MARKETING, MEMBER AND EMPLOYER GROUP INSTALLATION AND ENROLLMENT, MEMBER SERVICES, SALES FORCE AUTOMATION, CUSTOMER RELATIONSHIP MANAGEMENT, ON-LINE BILL PRESENTMENT AND PAYMENT, BUSINESS MANAGEMENT, CUSTOMER SUPPORT, AND OFFICE AND BUSINESS PRODUCTIVITY (U.S. CLS. 100 AND 101).

FIRST USE 4-17-2012; IN COMMERCE 4-17-2012.
DAVID I, EXAMINING ATTORNEY

SN 85-600,773. RECKITT BENCKISER LLC, PARSIPPANY, NJ. FILED 4-18-2012.

COOL VANILLA & ORCHIDS

THE MARK CONSISTS OF STANDARD CHARACTERS WITHOUT CLAIM TO ANY PARTICULAR FONT, STYLE, SIZE, OR COLOR.

NO CLAIM IS MADE TO THE EXCLUSIVE RIGHT TO USE "VANILLA & ORCHIDS", APART FROM THE MARK AS SHOWN.

CLASS 3—COSMETICS AND CLEANING PREPARATIONS

FOR PERFUMING PREPARATIONS FOR THE ATMOSPHERE, NAMELY, ROOM FRAGRANCES, ROOM PERFUME SPRAYS; POTPOURRI; ESSENTIAL OILS; AROMATIC ESSENTIAL OILS; ESSENTIAL OILS FOR HOUSEHOLD USE; ESSENTIAL OILS FOR USE IN THE MANUFACTURE OF SCENTED PRODUCTS; ESSENTIAL OILS FOR USE AS A COMPONENT OF ROOM PERFUME SPRAYS, SCENTED OILS AND AIR FRESHENERS; ESSENTIAL OILS USED TO PRODUCE AROMAS WHEN HEATED; ROOM PERFUME SPRAYS (U.S. CLS. 1, 4, 6, 50, 51 AND 52).

CLASS 5—PHARMACEUTICALS

FOR AIR PURIFYING PREPARATIONS; AIR DEODORIZING PREPARATIONS; HOUSEHOLD AND ROOM DEODORANTS; PREPARATIONS FOR NEUTRALIZING ODORS IN CARPETS, TEXTILES AND IN THE AIR (U.S. CLS. 6, 18, 44, 46, 51 AND 52).

CLASS 11—ENVIRONMENTAL CONTROL APPARATUS

FOR APPARATUS AND INSTRUMENTS, NAMELY, DISPENSING UNITS AND DIFFUSERS FOR ROOM FRAGRANCES, AIR FRESHENERS AND ROOM DEODORANTS, ALL FOR SCENTING, PURIFYING OR FRESHENING THE ATMOSPHERE; PARTS AND FITTINGS FOR ALL THE AFORESAID GOODS SOLD AS A UNIT THEREWITH (U.S. CLS. 13, 21, 23, 31 AND 34).
AMEEN IMAM, EXAMINING ATTORNEY

SN 85-600,802. ASSETPOINT, LLC, GREENVILLE, SC. FILED 4-18-2012.



OWNER OF U.S. REG. NOS. 2,857,629, 3,533,959 AND OTHERS.

THE MARK CONSISTS OF OVAL WITH CURVED ARROW GOING AROUND OVAL ABOVE THE TEXT TABWARE.

CLASS 9—ELECTRICAL AND SCIENTIFIC APPARATUS

FOR COMPUTER SOFTWARE FOR ENTERPRISE ASSET MANAGEMENT SYSTEM, NAMELY, ADMINISTRATION, MANAGEMENT AND ANALYSIS OF FACILITIES, PLANT ASSETS, EQUIPMENT, MAINTENANCE, PERSONAL, INVENTORY, INSPECTIONS, REQUISITIONS, PURCHASING, WORK ORDERS, WAREHOUSING, RESOURCES, INVOICING, SCHEDULES, SUPPLIER CATALOGS, SUPPLIER BIDS, EVENT TRACKING, SECURITY, AND PROCEDURES (U.S. CLS. 21, 23, 26, 36 AND 38).

FIRST USE 12-31-1995; IN COMMERCE 12-31-1995.

CLASS 42—SCIENTIFIC AND COMPUTER SERVICES

FOR APPLICATION SERVICE PROVIDER (ASP) FEATURING SOFTWARE FOR USE ENTERPRISE ASSET MANAGEMENT SYSTEM, NAMELY, ADMINISTRATION, MANAGEMENT AND ANALYSIS OF FACILITIES, PLANT ASSETS, EQUIPMENT, MAINTENANCE, PERSONAL, INVENTORY, INSPECTIONS, REQUISITIONS, PURCHASING, WORK ORDERS, WAREHOUSING, RESOURCES, INVOICING, SCHEDULES, SUPPLIER CATALOGS, SUPPLIER BIDS, EVENT TRACKING, SECURITY, AND PROCEDURES (U.S. CLS. 100 AND 101).

FIRST USE 12-31-1995; IN COMMERCE 12-31-1995.

TINA L. SNAPP, EXAMINING ATTORNEY

SN 85-600,803. ASSETPOINT, LLC, GREENVILLE, SC. FILED 4-18-2012.

TABWARE

THE MARK CONSISTS OF STANDARD CHARACTERS WITHOUT CLAIM TO ANY PARTICULAR FONT, STYLE, SIZE, OR COLOR.

OWNER OF U.S. REG. NOS. 2,857,629, 3,533,959 AND OTHERS.

CLASS 9—ELECTRICAL AND SCIENTIFIC APPARATUS

FOR COMPUTER SOFTWARE FOR ENTERPRISE ASSET MANAGEMENT SYSTEM, NAMELY, ADMINISTRATION, MANAGEMENT AND ANALYSIS OF FACILITIES, PLANT ASSETS, EQUIPMENT, MAINTENANCE, PERSONAL, INVENTORY, INSPECTIONS, REQUISITIONS, PURCHASING, WORK ORDERS, WAREHOUSING, RESOURCES, INVOICING, SCHEDULES, SUPPLIER CATALOGS, SUPPLIER BIDS, EVENT TRACKING, SECURITY, AND PROCEDURES (U.S. CLS. 21, 23, 26, 36 AND 38).

FIRST USE 12-31-1995; IN COMMERCE 12-31-1995.

CLASS 42—SCIENTIFIC AND COMPUTER SERVICES

FOR APPLICATION SERVICE PROVIDER (ASP) FEATURING SOFTWARE FOR USE ENTERPRISE ASSET MANAGEMENT SYSTEM, NAMELY, ADMINISTRATION, MANAGEMENT AND ANALYSIS OF FACILITIES, PLANT ASSETS, EQUIPMENT, MAINTENANCE, PERSONAL, INVENTORY, INSPECTIONS, REQUISITIONS, PURCHASING, WORK ORDERS, WAREHOUSING, RESOURCES, INVOICING, SCHEDULES, SUPPLIER CATALOGS, SUPPLIER BIDS, EVENT TRACKING, SECURITY, AND PROCEDURES (U.S. CLS. 100 AND 101).

FIRST USE 12-31-1995; IN COMMERCE 12-31-1995.

TINA L. SNAPP, EXAMINING ATTORNEY

SN 85-600,871. SIRIUSDECISIONS, INC., WILTON, CT.
FILED 4-18-2012.

SN 85-600,906. KENTUCKY EQUINE RESEARCH, VER-
SAILLES, KY. FILED 4-18-2012.

SIRIUSDECISIONS

THE MARK CONSISTS OF STANDARD CHARACTERS
WITHOUT CLAIM TO ANY PARTICULAR FONT, STYLE,
SIZE, OR COLOR.

CLASS 35—ADVERTISING AND BUSINESS

FOR RESEARCH AND ANALYSIS SERVICES IN THE
FIELD OF BUSINESS-TO-BUSINESS SALES AND MAR-
KETING; CONSULTING IN THE FIELD OF SALES AND
MARKETING (U.S. CLS. 100, 101 AND 102).

FIRST USE 11-30-2005; IN COMMERCE 11-30-2005.

CLASS 41—EDUCATION AND ENTERTAIN- MENT

FOR TRAINING COURSES IN THE FIELD OF BUSI-
NESS-TO-BUSINESS SALES AND MARKETING; AR-
RANGING AND CONDUCTING BUSINESS SEMINARS,
WORKSHOPS AND CONFERENCES IN THE FIELD OF
BUSINESS-TO-BUSINESS SALES AND MARKETING
(U.S. CLS. 100, 101 AND 107).

FIRST USE 9-30-2008; IN COMMERCE 9-30-2008.
WENDY JUN, EXAMINING ATTORNEY

SN 85-600,902. CROSSROADS PUBLISHING HOUSE, DRE-
WRYVILLE, VA. FILED 4-18-2012.

Read. Relax. Repeat.

THE MARK CONSISTS OF STANDARD CHARACTERS
WITHOUT CLAIM TO ANY PARTICULAR FONT, STYLE,
SIZE, OR COLOR.

NO CLAIM IS MADE TO THE EXCLUSIVE RIGHT TO
USE "READ" FOR INTERNATIONAL CLASS 16, APART
FROM THE MARK AS SHOWN.

CLASS 16—PAPER GOODS AND PRINTED MATTER

FOR BOOK MARKS; NOVELS (U.S. CLS. 2, 5, 22, 23, 29,
37, 38 AND 50).

FIRST USE 7-1-2011; IN COMMERCE 7-1-2011.

CLASS 18—LEATHER GOODS

FOR TOTE BAGS (U.S. CLS. 1, 2, 3, 22 AND 41).
FIRST USE 7-1-2011; IN COMMERCE 7-1-2011.
NICHOLAS COLEMAN, EXAMINING ATTORNEY

World class nutrition, world class results.

THE MARK CONSISTS OF STANDARD CHARACTERS
WITHOUT CLAIM TO ANY PARTICULAR FONT, STYLE,
SIZE, OR COLOR.

CLASS 5—PHARMACEUTICALS

FOR FEED SUPPLEMENTS FOR HORSES; NUTRI-
TIONAL SUPPLEMENTS FOR HORSES (U.S. CLS. 6, 18,
44, 46, 51 AND 52).

CLASS 31—NATURAL AGRICULTURAL PRO- DUCTS

FOR HORSE FEED (U.S. CLS. 1 AND 46).

CLASS 42—SCIENTIFIC AND COMPUTER SERVICES

FOR RESEARCH AND DEVELOPMENT AND CON-
SULTATION RELATED THERETO IN THE FIELD OF
HORSE NUTRITION AND EXERCISE PHYSIOLOGY;
SCIENTIFIC AND TECHNOLOGICAL SERVICES,
NAMELY, SCIENTIFIC RESEARCH AND SCIENTIFIC
RESEARCH CONSULTING IN THE FIELD OF HORSE
NUTRITION AND EXERCISE PHYSIOLOGY (U.S. CLS.
100 AND 101).

FIRST USE 3-1-2008; IN COMMERCE 3-1-2008.
DAVID YONTEF, EXAMINING ATTORNEY

SN 85-600,953. HMS MFG. CO., TROY, MI. FILED 4-18-2012.

P O E T

THE MARK CONSISTS OF STANDARD CHARACTERS
WITHOUT CLAIM TO ANY PARTICULAR FONT, STYLE,
SIZE, OR COLOR.

CLASS 20—FURNITURE AND ARTICLES NOT OTHERWISE CLASSIFIED

FOR CLOSET ACCESSORIES, NAMELY, BELT
RACKS; CLOSET ACCESSORIES, NAMELY, CLOTHES
BARS; CLOSET ACCESSORIES, NAMELY, SHOE
RACKS; CLOSET ACCESSORIES, NAMELY, SLIDING
CLOTHES RAILS; CLOTHES HANGERS; CLOTHES
HANGERS HAVING SLIDING ARMS FOR USE WITH
SHIRTS, SWEATERS OR TURTLENECKS BY PLACE-
MENT THROUGH THE NECK HOLE; CLOTHES RODS;
DRAWER ORGANIZERS; HANGERS FOR CLOTHES;
HIGH DENSITY MOBILE FILING AND STORAGE
SHELVING; NON-METAL FABRIC HANGING ORGANI-
ZER; NON-METAL FABRIC STORAGE BIN ORGANI-
ZER; NONMETAL AND NON-PAPER CONTAINERS
FOR STORAGE OR TRANSPORT; PLASTIC CRATES;
SHELVES FOR STORAGE; STORAGE RACKS (U.S. CLS.
2, 13, 22, 25, 32 AND 50).

FIRST USE 2-7-2012; IN COMMERCE 2-7-2012.

CLASS 21—HOUSEWARES AND GLASS

FOR BASKETS FOR DOMESTIC USE, NOT OF METAL; BASKETS OF CORK; CLOTHES DRYING HANGERS; CLOTHES DRYING HANGERS SPECIALLY DESIGNED FOR SPECIALTY CLOTHING; CLOTHES DRYING RACKS; COLLAPSIBLE FABRIC STORAGE CONTAINER FOR DOMESTIC USE; COLLAPSIBLE STORAGE CONTAINERS FOR DOMESTIC USE; GENERAL PURPOSE STORAGE BINS FOR HOUSEHOLD USE; LAUNDRY BASKETS; LAUNDRY BINS FOR DOMESTIC OR HOUSEHOLD USE; LAUNDRY HAMPERS FOR DOMESTIC OR HOUSEHOLD USE; LAUNDRY SORTERS FOR HOUSEHOLD USE; PLASTIC STORAGE CONTAINERS FOR DOMESTIC USE; PLASTIC STORAGE CONTAINERS FOR HOUSEHOLD OR DOMESTIC USE; PLASTIC STORAGE CONTAINERS FOR HOUSEHOLD USE; WASTE BASKETS (U.S. CLS. 2, 13, 23, 29, 30, 33, 40 AND 50).

FIRST USE 2-7-2012; IN COMMERCE 2-7-2012.
SCOTT OSCLICK, EXAMINING ATTORNEY

SN 85-601,331. BIG SPOON ROASTERS, LLC, DURHAM, NC.
FILED 4-18-2012.



NO CLAIM IS MADE TO THE EXCLUSIVE RIGHT TO USE "HANDCRAFTED NUT BUTTERS" AND "DURHAM, NC" AND "ROASTERS", APART FROM THE MARK AS SHOWN.

THE MARK CONSISTS OF A CIRCLE COMPRISED OF A THICK OUTER LINE AND A THIN INNER LINE WITH THE CURVING WORDS "HANDCRAFTED NUT BUTTERS" IN A STYLIZED FORM DISPLACED INSIDE AND AT THE TOP OF THE CIRCLE, THE STYLIZED WORDS "DURHAM, NC" DISPLACED THEREBELOW, THE STYLIZED WORDS "BIG SPOON" DISPLACED THEREBELOW, THE STYLIZED WORD "ROASTERS" DISPLACED THEREBELOW, A DRAWING OF A SPOON DISPLACED THEREBELOW, AND THE CURVING WORD "BIGSPOONROASTERS.COM" IN A STYLIZED FORM DISPLACED INSIDE AND AT THE BOTTOM OF THE CIRCLE.

SN 85-601,277. BIG SPOON ROASTERS, LLC, DURHAM, NC.
FILED 4-18-2012.

BIG SPOON ROASTERS**CLASS 29—MEATS AND PROCESSED FOODS**

FOR PEANUT BUTTER BASED SNACK FOODS; PEANUT BUTTER BASED ENERGY BARS NOT FOR USE AS A MEAL REPLACEMENT (U.S. CL. 46).

CLASS 30—STAPLE FOODS

FOR PEANUT BUTTER AND NUT BUTTER BASED BAKERY GOODS AND DESSERT ITEMS (U.S. CL. 46).
EVIN L. KOZAK, EXAMINING ATTORNEY

SN 85-601,520. ACADEMY, LTD., KATY, TX. FILED 4-18-2012.

DURA-PROOF

THE MARK CONSISTS OF STANDARD CHARACTERS WITHOUT CLAIM TO ANY PARTICULAR FONT, STYLE, SIZE, OR COLOR.

NO CLAIM IS MADE TO THE EXCLUSIVE RIGHT TO USE "ROASTERS", APART FROM THE MARK AS SHOWN.

THE MARK CONSISTS OF STANDARD CHARACTERS WITHOUT CLAIM TO ANY PARTICULAR FONT, STYLE, SIZE, OR COLOR.

CLASS 29—MEATS AND PROCESSED FOODS

FOR PEANUT BUTTER BASED SNACK FOODS; PEANUT BUTTER BASED ENERGY BARS NOT FOR USE AS A MEAL REPLACEMENT (U.S. CL. 46).

CLASS 18—LEATHER GOODS

FOR HUNTING BAGS; BACK PACKS (U.S. CLS. 1, 2, 3, 22 AND 41).

CLASS 30—STAPLE FOODS

FOR PEANUT BUTTER AND NUT BUTTER BASED BAKERY GOODS AND DESSERT ITEMS (U.S. CL. 46).
EVIN L. KOZAK, EXAMINING ATTORNEY

CLASS 25—CLOTHING

FOR CLOTHING, NAMELY, JACKETS, PANTS, BIB OVERALLS, COVERALLS, GLOVES, BEANIES AND BALACLAVAS; FOOTWEAR (U.S. CLS. 22 AND 39).
CHARISMA HAMPTON, EXAMINING ATTORNEY

SN 85-601,527. HOAG FAMILY FOUNDATION, ATHERTON, CA. FILED 4-18-2012.

PART THE CLOUD

THE MARK CONSISTS OF STANDARD CHARACTERS WITHOUT CLAIM TO ANY PARTICULAR FONT, STYLE, SIZE, OR COLOR.

CLASS 35—ADVERTISING AND BUSINESS

FOR CHARITABLE SERVICES, NAMELY, PROMOTING ALZHEIMER'S AWARENESS (U.S. CLS. 100, 101 AND 102).

FIRST USE 10-19-2011; IN COMMERCE 1-31-2012.

CLASS 36—INSURANCE AND FINANCIAL

FOR CHARITABLE FUNDRAISING SERVICES, NAMELY, PROVIDING FUNDRAISING ACTIVITIES TO SUPPORT ALZHEIMER'S RESEARCH (U.S. CLS. 100, 101 AND 102).

FIRST USE 10-19-2011; IN COMMERCE 1-31-2012.
JULIE GUTTADAURO, EXAMINING ATTORNEY

CLASS 28—TOYS AND SPORTING GOODS

FOR TOYS FOR INFANTS; PLUSH TOYS; BABY RATTLE TOYS, PLUSH AND PLASTIC; MOBILES, NAMELY, CRIB MOBILES, MUSICAL MOBILES AND TOY MOBILES; PLAY GYM FOR INFANTS; CHILDREN'S SOOTHING PROJECTORS THAT PLAY MUSIC AND PROJECT IMAGES; CHILDREN'S MULTIPLE ACTIVITY TOYS; NESTING AND STACKING TOYS; TOY SHAPE SORTERS; TOYS FOR FILLING AND SPILLING, NAMELY, SHOVELS, TOY ANIMALS, BALLS AND TOY PLUSH ANIMALS; CHILDREN'S POUNDING BENCHES; FOAM TOYS; SOFT TOY BLOCKS; CRIB TOYS AND CRIB ACTIVITY CENTERS; PLAY MATS, NAMELY, PLAY MATS CONTAINING INFANT TOYS; TOY SOOTHERS THAT ATTACH TO A CRIB WHICH PLAY CALMING MUSIC; RIDE-ON TOYS; PLASTIC SHAPE TOYS; TOYS ATTACHABLE TO CAR SEATS, STROLLERS, CRIBS AND HIGH CHAIRS; TOY VEHICLES, PLAY SETS AND ACCESSORIES THEREFOR; TOY ANIMALS; BABY MULTIPLE ACTIVITY TOYS; TOY BUILDING BLOCKS; BATH TOYS, INCLUDING BATH MULTIPLE ACTIVITY TOYS; PUSH AND PULL TOYS; MUSICAL TOYS; PLASTIC CHARACTER TOYS (U.S. CLS. 22, 23, 38 AND 50).

WILLIAM VERHOSEK, EXAMINING ATTORNEY

SN 85-601,861. CERAGEM INTERNATIONAL, INC., LOS ANGELES, CA. FILED 4-18-2012.

SN 85-601,605. GEOFFREY, LLC, WAYNE, NJ. FILED 4-18-2012.



NO CLAIM IS MADE TO THE EXCLUSIVE RIGHT TO USE "BABY", APART FROM THE MARK AS SHOWN.

THE MARK CONSISTS OF A TEDDY BEAR ABOVE THE WORDS "BABY INSPIRE" WHICH IS ON AN OBLONG HANGING OBJECT HAVING ATTACHED ON A STRING ARE THREE STARS, A ROCKET, THE MOON, AND A PLANET, ALL HAVING SMILEY FACES.

CLASS 10—MEDICAL APPARATUS

FOR TEETHERS FOR BABIES (U.S. CLS. 26, 39 AND 44).

CLASS 24—FABRICS

FOR TEETHING BLANKETS (U.S. CLS. 42 AND 50).

Sectional Body Mass Index

THE MARK CONSISTS OF STANDARD CHARACTERS WITHOUT CLAIM TO ANY PARTICULAR FONT, STYLE, SIZE, OR COLOR.

NO CLAIM IS MADE TO THE EXCLUSIVE RIGHT TO USE "BODY MASS INDEX", APART FROM THE MARK AS SHOWN.

CLASS 9—ELECTRICAL AND SCIENTIFIC APPARATUS

FOR BEDDING DIAGNOSTIC SYSTEM COMPRISED OF TV SCREENS, COMPUTER, COMPUTER SOFTWARE, PRINTER, MATTRESSES, BOX-SPRINGS, SENSOR PADS, AIR-CONTROLLER SYSTEM, HOSES AND CABLES, SOLD OR UTILIZED AS A UNIT TO ANALYZE AND EVALUATE INDIVIDUALS AND PROVIDE CUSTOMIZED MATTRESS FITTING LEVEL (U.S. CLS. 21, 23, 26, 36 AND 38).

CLASS 20—FURNITURE AND ARTICLES NOT OTHERWISE CLASSIFIED

FOR MATTRESSES AND BOX SPRINGS (U.S. CLS. 2, 13, 22, 25, 32 AND 50).

JOHN HWANG, EXAMINING ATTORNEY

SN 85-602,001. CERAGEM INTERNATIONAL, INC., LOS ANGELES, CA. FILED 4-18-2012.



THE COLOR(S) GREEN AND WHITE IS/ARE CLAIMED AS A FEATURE OF THE MARK.

THE MARK CONSISTS OF THE ABSTRACT DIAMOND SHAPED DESIGN COMPRISED OF FOUR GREEN DIAMOND SHAPES AND A WHITE CIRCLE FOLLOWED BY "CELLUPEDIC" IN GREEN STYLIZED LETTERING ALL SET AGAINST A WHITE BACKGROUND.

CLASS 20—FURNITURE AND ARTICLES NOT OTHERWISE CLASSIFIED

FOR BED FRAMES; BED HEADBOARDS; BED PILLOWS; BED RAILS; BED RESTS; BEDS; BEDS, MATTRESSES, PILLOWS AND BOLSTERS; MATTRESS COMPONENT, NAMELY, ELASTIC GEL MATERIAL LOCATED IN THE TOP UPHOLSTERY LAYER OF MATTRESSES SOLD AS AN INTEGRAL COMPONENT OF THE MATTRESSES; MATTRESS CUSHIONS; MATTRESS FOUNDATIONS; MATTRESS TOPPERS; MATTRESSES; MATTRESSES AND PILLOWS (U.S. CLS. 2, 13, 22, 25, 32 AND 50).

CLASS 35—ADVERTISING AND BUSINESS

FOR ON-LINE RETAIL STORE SERVICES FEATURING BEDS, MATTRESSES, ADJUSTABLE BEDS, BED FRAMES, MATTRESS FOUNDATIONS, FURNITURE, AND RELATED ACCESSORIES, NAMELY, PILLOWS, SHEETS AND BLANKETS.; RETAIL SHOPS FEATURING BEDS, MATTRESSES, ADJUSTABLE BEDS, BED FRAMES, MATTRESS FOUNDATIONS, FURNITURE, AND RELATED ACCESSORIES, NAMELY, PILLOWS, SHEETS AND BLANKETS (U.S. CLS. 100, 101 AND 102).
JOHN HWANG, EXAMINING ATTORNEY

SN 85-602,007. CERAGEM INTERNATIONAL, INC., LOS ANGELES, CA. FILED 4-18-2012.



THE COLOR(S) GREEN AND WHITE IS/ARE CLAIMED AS A FEATURE OF THE MARK.

THE MARK CONSISTS OF THE ABSTRACT DIAMOND SHAPED DESIGN COMPRISED OF FOUR GREEN DIAMOND SHAPES AND A WHITE CIRCLE FOLLOWED BY "CELLUPEDIC" IN GREEN STYLIZED LETTERING ALL SET AGAINST A WHITE BACKGROUND.

CLASS 20—FURNITURE AND ARTICLES NOT OTHERWISE CLASSIFIED

FOR BED FRAMES; BED HEADBOARDS; BED PILLOWS; BED RAILS; BED RESTS; BEDS; BEDS, MATTRESSES, PILLOWS AND BOLSTERS; MATTRESS COMPONENT, NAMELY, ELASTIC GEL MATERIAL LOCATED IN THE TOP UPHOLSTERY LAYER OF MATTRESSES SOLD AS AN INTEGRAL COMPONENT OF THE MATTRESSES; MATTRESS CUSHIONS; MATTRESS FOUNDATIONS; MATTRESS TOPPERS; MATTRESSES; MATTRESSES AND PILLOWS (U.S. CLS. 2, 13, 22, 25, 32 AND 50).

CLASS 35—ADVERTISING AND BUSINESS

FOR ON-LINE RETAIL STORE SERVICES FEATURING BEDS, MATTRESSES, ADJUSTABLE BEDS, BED FRAME, MATTRESS FOUNDATIONS, FURNITURE, AND RELATED ACCESSORIES, NAMELY, PILLOWS, SHEETS AND BLANKETS.; RETAIL STORE SERVICES FEATURING BEDS, MATTRESSES, ADJUSTABLE BEDS, BED FRAMES, MATTRESS FOUNDATIONS, FURNITURE, AND RELATED ACCESSORIES, NAMELY, PILLOWS, SHEETS AND BLANKETS (U.S. CLS. 100, 101 AND 102).

JOHN HWANG, EXAMINING ATTORNEY

SN 85-602,155. KENTUCKY EQUINE RESEARCH, VERMONT, KY. FILED 4-19-2012.

KER Sport Horse Nutrition

THE MARK CONSISTS OF STANDARD CHARACTERS WITHOUT CLAIM TO ANY PARTICULAR FONT, STYLE, SIZE, OR COLOR.

OWNER OF U.S. REG. NOS. 3,374,326 AND 3,847,735.
NO CLAIM IS MADE TO THE EXCLUSIVE RIGHT TO USE "SPORT HORSE NUTRITION", APART FROM THE MARK AS SHOWN.

CLASS 31—NATURAL AGRICULTURAL PRODUCTS

FOR HORSE FEED (U.S. CLS. 1 AND 46).

CLASS 42—SCIENTIFIC AND COMPUTER SERVICES

FOR RESEARCH AND DEVELOPMENT AND CONSULTATION RELATED THERETO IN THE FIELD OF HORSE NUTRITION AND EXERCISE PHYSIOLOGY; SCIENTIFIC AND TECHNOLOGICAL SERVICES, NAMELY, SCIENTIFIC RESEARCH AND SCIENTIFIC RESEARCH CONSULTING IN THE FIELD OF HORSE NUTRITION AND EXERCISE PHYSIOLOGY (U.S. CLS. 100 AND 101).

DAVID YONTEF, EXAMINING ATTORNEY

SN 85-602,170. NARVAEZ, GARY, NEW YORK, NY. FILED 4-19-2012.

SN 85-602,309. TOWNSEND, RICHARD, IRVING, TX. FILED 4-19-2012.

2Patrias

THE MARK CONSISTS OF STANDARD CHARACTERS WITHOUT CLAIM TO ANY PARTICULAR FONT, STYLE, SIZE, OR COLOR.

THE ENGLISH TRANSLATION OF "2 PATRIAS" IN THE MARK IS "2 HOMELANDS".

CLASS 41—EDUCATION AND ENTERTAINMENT

FOR PROVIDING CURRENT EVENT NEWS VIA A GLOBAL COMPUTER NETWORK (U.S. CLS. 100, 101 AND 107).

CLASS 42—SCIENTIFIC AND COMPUTER SERVICES

FOR PROVIDING A WEBSITE FEATURING TECHNOLOGY THAT ENABLES USERS TO UPLOAD AND SHARE PHOTOS, VIDEOS, AND ARTICLES, AND ENGAGE IN SOCIAL NETWORKING (U.S. CLS. 100 AND 101).
DAVID TOOLEY, EXAMINING ATTORNEY

SN 85-602,219. AMERICAN COLLEGE OF PHYSICIANS, INC., PHILADELPHIA, PA. FILED 4-19-2012.



OWNER OF U.S. REG. NOS. 1,647,797, 3,633,949 AND OTHERS.

THE MARK CONSISTS OF THE WORDS "ACP JOURNALWISE" WITH AN OWL SITTING ON THE BOTTOM LINE OF THE "E".

CLASS 38—COMMUNICATION

FOR ELECTRONIC MAIL SERVICES, NAMELY, PROVIDING E-MAIL ALERTS FEATURING INFORMATION ON MEDICAL TOPICS (U.S. CLS. 100, 101 AND 104).

CLASS 44—MEDICAL, BEAUTY AND AGRICULTURAL SERVICES

FOR PROVIDING AN ONLINE COMPUTER DATABASE FEATURING ARCHIVAL MEDICAL INFORMATION (U.S. CLS. 100 AND 101).
KELLEY WELLS, EXAMINING ATTORNEY

ZenScorpio

THE MARK CONSISTS OF STANDARD CHARACTERS WITHOUT CLAIM TO ANY PARTICULAR FONT, STYLE, SIZE, OR COLOR.

CLASS 9—ELECTRICAL AND SCIENTIFIC APPARATUS

FOR AUDIO AND VIDEO RECORDINGS FEATURING MUSIC (U.S. CLS. 21, 23, 26, 36 AND 38).

CLASS 41—EDUCATION AND ENTERTAINMENT

FOR ENTERTAINMENT, NAMELY, LIVE PERFORMANCES BY A MUSICAL BAND (U.S. CLS. 100, 101 AND 107).
LINDA E. BLOHM, EXAMINING ATTORNEY

SN 85-602,341. 5TH PLANET GAMES, INC., ROSEVILLE, CA. FILED 4-19-2012.

LEGACY OF HEROES

THE MARK CONSISTS OF STANDARD CHARACTERS WITHOUT CLAIM TO ANY PARTICULAR FONT, STYLE, SIZE, OR COLOR.

CLASS 9—ELECTRICAL AND SCIENTIFIC APPARATUS

FOR DOWNLOADABLE VIDEO GAME SOFTWARE FOR USE ON WIRELESS DEVICES; COMPUTER GAME SOFTWARE DOWNLOADABLE FROM A GLOBAL COMPUTER NETWORK (U.S. CLS. 21, 23, 26, 36 AND 38).

CLASS 41—EDUCATION AND ENTERTAINMENT

FOR ENTERTAINMENT SERVICES, NAMELY, PROVIDING TEMPORARY USE OF NON-DOWNLOADABLE VIDEO GAMES; ENTERTAINMENT SERVICES, NAMELY, PROVIDING ONLINE, NON-DOWNLOADABLE VIRTUAL ARMOR, WEAPONS, HEROES, MOUNTS, MAGIC, LEGIONS, TROOPS, CONSUMABLE GOODS, STATISTIC-ENHANCING ITEMS, LAND, AND CURRENCY, FOR USE IN VIRTUAL ENVIRONMENTS CREATED FOR ENTERTAINMENT PURPOSES; PROVIDING AN INTERNET WEBSITE PORTAL IN THE FIELD OF COMPUTER GAMES AND GAMING; ENTERTAINMENT SERVICES, NAMELY, PROVIDING VIRTUAL ENVIRONMENTS IN WHICH USERS CAN INTERACT THROUGH SOCIAL GAMES FOR RECREATIONAL, LEISURE, OR ENTERTAINMENT PURPOSES (U.S. CLS. 100, 101 AND 107).

CLASS 42—SCIENTIFIC AND COMPUTER SERVICES

FOR COMPUTER SERVICES, NAMELY, CREATING AN ONLINE COMMUNITY FOR REGISTERED USERS TO PARTICIPATE IN COMPETITIONS, SHOWCASE THEIR SKILLS, GET FEEDBACK FROM THEIR PEERS, FORM VIRTUAL COMMUNITIES, ENGAGE IN SOCIAL NETWORKING, AND IMPROVE THEIR TALENT; PROVIDING A WEBSITE FEATURING ON-LINE NON-DOWNLOADABLE SOFTWARE TOOLS FOR USE IN ACCESSING, PLAYING, AND TRACKING PERFORMANCE OF COMPUTER GAMES (U.S. CLS. 100 AND 101).

JESSICA A. POWERS, EXAMINING ATTORNEY

SN 85-602,351. ZOOBY'S LLC, BUFFALO GROVE, IL. FILED 4-19-2012.

WEIRDABLES

THE MARK CONSISTS OF STANDARD CHARACTERS WITHOUT CLAIM TO ANY PARTICULAR FONT, STYLE, SIZE, OR COLOR.

CLASS 9—ELECTRICAL AND SCIENTIFIC APPARATUS

FOR COMPUTER GAME SOFTWARE FOR USE ON MOBILE AND CELLULAR PHONES, HANDHELD COMPUTERS, AND TABLET COMPUTERS (U.S. CLS. 21, 23, 26, 36 AND 38).

CLASS 28—TOYS AND SPORTING GOODS

FOR TOYS, GAMES AND PLAYTHINGS, NAMELY, BOARD GAMES, PLUSH TOYS, ACTION FIGURES AND ACCESSORIES THEREFOR (U.S. CLS. 22, 23, 38 AND 50).

CLASS 41—EDUCATION AND ENTERTAINMENT

FOR ENTERTAINMENT SERVICES IN THE NATURE OF ON-LINE INTERACTIVE COMPUTER GAMES PROVIDED VIA THE INTERNET (U.S. CLS. 100, 101 AND 107).

JESSICA A. POWERS, EXAMINING ATTORNEY

SN 85-602,427. SHALOM, JOSEPH, BROOKLYN, NY. FILED 4-19-2012.

RIDICULOUS REQUESTS

THE MARK CONSISTS OF STANDARD CHARACTERS WITHOUT CLAIM TO ANY PARTICULAR FONT, STYLE, SIZE, OR COLOR.

CLASS 9—ELECTRICAL AND SCIENTIFIC APPARATUS

FOR COMPUTER APPLICATION SOFTWARE FOR MOBILE PHONES, PORTABLE MEDIA PLAYERS, HANDHELD COMPUTERS, NAMELY, SOFTWARE FOR THE ORDERING OF CONCIERGE AND SIMILAR SERVICES (U.S. CLS. 21, 23, 26, 36 AND 38).

CLASS 45—PERSONAL AND LEGAL SERVICES

FOR PERSONAL CONCIERGE SERVICES FOR OTHERS COMPRISING MAKING REQUESTED PERSONAL ARRANGEMENTS AND RESERVATIONS, RUNNING ERRANDS AND PROVIDING CUSTOMER SPECIFIC INFORMATION TO MEET INDIVIDUAL NEEDS, ALL RENDERED IN BUSINESS ESTABLISHMENTS, OFFICE BUILDINGS, HOTELS, RESIDENTIAL COMPLEXES AND HOMES (U.S. CLS. 100 AND 101).

CATHERINE ROEHL, EXAMINING ATTORNEY

SN 85-602,627. BERNARD BUBMAN, LOS ANGELES, CA. AND NOAH BUBMAN, LOS ANGELES, CA. AND DAVID HAKIMIAN, LOS ANGELES, CA. FILED 4-19-2012.

URTHBAR

THE MARK CONSISTS OF STANDARD CHARACTERS WITHOUT CLAIM TO ANY PARTICULAR FONT, STYLE, SIZE, OR COLOR.

OWNER OF U.S. REG. NOS. 3,725,420, 4,041,728 AND OTHERS.

CLASS 5—PHARMACEUTICALS

FOR DIETARY AND NUTRITIONAL SUPPLEMENTS; HERBAL SUPPLEMENTS; HERBS FOR MEDICINAL PURPOSES; LIQUID NUTRITIONAL SUPPLEMENT; MEDICINAL HERBAL PREPARATIONS; POWDERED NUTRITIONAL SUPPLEMENT DRINK MIX; PROTEIN SUPPLEMENTS (U.S. CLS. 6, 18, 44, 46, 51 AND 52).

CLASS 43—HOTEL AND RESTAURANT SERVICES

FOR PREPARATION OF FOOD AND BEVERAGES; PROVIDING OF FOOD AND DRINK; RESTAURANT AND CAFE SERVICES; RESTAURANT SERVICES, INCLUDING SIT-DOWN SERVICE OF FOOD AND TAKE-OUT RESTAURANT SERVICES; RESTAURANT SERVICES, NAMELY, PROVIDING OF FOOD AND BEVERAGES FOR CONSUMPTION ON AND OFF THE PREMISES; SERVING FOOD AND DRINKS (U.S. CLS. 100 AND 101).

CLASS 44—MEDICAL, BEAUTY AND AGRICULTURAL SERVICES

FOR COUNSELING SERVICES IN THE FIELDS OF HEALTH, NUTRITION AND LIFESTYLE WELLNESS; DIETARY AND NUTRITIONAL GUIDANCE; FOOD NUTRITION CONSULTATION; PROVIDING ASSISTANCE, FITNESS EVALUATION AND CONSULTATION TO CORPORATE CLIENTS TO HELP THEIR EMPLOYEES MAKE HEALTH, WELLNESS AND NUTRITIONAL CHANGES IN THEIR DAILY LIVING TO IMPROVE HEALTH; PROVIDING INFORMATION ABOUT DIETARY SUPPLEMENTS AND NUTRITION; PROVIDING WEIGHT LOSS PROGRAM SERVICES (U.S. CLS. 100 AND 101).

KATHLEEN M. VANSTON, EXAMINING ATTORNEY

SN 85-602,690. QUALNETICS CORPORATION, BELLINGHAM, WA. FILED 4-19-2012.

Road-iQ

THE MARK CONSISTS OF STANDARD CHARACTERS WITHOUT CLAIM TO ANY PARTICULAR FONT, STYLE, SIZE, OR COLOR.

CLASS 9—ELECTRICAL AND SCIENTIFIC APPARATUS

FOR TELEMATICS APPARATUS, NAMELY, WIRELESS INTERNET DEVICES WHICH PROVIDE TELE-MATIC SERVICES AND HAVE A CELLULAR PHONE FUNCTION (U.S. CLS. 21, 23, 26, 36 AND 38).
FIRST USE 2-7-2012; IN COMMERCE 3-22-2012.

CLASS 45—PERSONAL AND LEGAL SERVICES

FOR VEHICLE AND DRIVER TELEMATIC SERVICES IN THE NATURE OF PROVIDING INFORMATION CONCERNING SAFETY RISKS ON DRIVER BEHAVIOR TO CONSUMERS AND AUTOMOBILE INSURANCE COMPANIES (U.S. CLS. 100 AND 101).
FIRST USE 2-7-2012; IN COMMERCE 3-22-2012.
JOHN E. MICHOS, EXAMINING ATTORNEY

SN 85-602,736. LIN KEY, LLC, BALTIMORE, MD. FILED 4-19-2012.



THE MARK CONSISTS OF AN APPLE WITH STICK FIGURE APPENDAGES-THE APPLE STEM IS SUBSTITUTED WITH A STICK FIGURED NECK CONNECTING ABOVE THE APPLE AT THE TOP TO A ROUND CIRCLED SHAPED HEAD SPECKLED WITH SEVEN (7) STARS ON THE FACE AND A GRADUATION CAP WITH A HANGING TASSEL ON TOP OF THE HEAD-THE BOTTOM OF THE STICK FIGURED NECK CONNECTS TO THE APPLE WITH A STRIPED TRIANGLE SHAPED CHEST BANNER CENTERED ON THE FRONT OF THE APPLE WITH A LARGE "T" CENTERED WITHIN THE TRIANGLE AND WITH THE VERTICAL SPELLING OF THE ACRONYM "TARTOY" THAT IS POSITIONED FROM TOP TO BOTTOM WITH THE SINGLE POINT OF THE TRIANGLE DOWN AND THE DOUBLE POINTS UP AT SHOULDER LEVEL OF THE APPLE-AT THE LEFT AND RIGHT SIDES OF THE APPLE

ARE TWO (2) STICK FIGURED ARMS AND TWO (2) SMALL STRIPED TRIANGLES FOR HANDS AND AT THE BOTTOM OF THE APPLE ARE TWO (2) STICK FIGURED LEGS WITH TWO (2) SMALL STRIPED SQUARES AS THE FEET. ABOVE THE LOGO DESIGN, IN A CRESCENT-SHAPED CONFIGURATION, IS THE ACRONYM SPELLING OUT "T.A.R.T.O.Y.". BENEATH THE LOGO DESIGN IN A U-SHAPED CONFIGURATION, IS THE SPELLED-OUT MEANING OF THE ABOVE ACRONYM "TEACHING ACADEMICS RHYMINGLY TO OUR YOUTH".

CLASS 20—FURNITURE AND ARTICLES NOT OTHERWISE CLASSIFIED

FOR PLASTIC KEY CHAINS (U.S. CLS. 2, 13, 22, 25, 32 AND 50).
FIRST USE 11-0-2011; IN COMMERCE 11-0-2011.

CLASS 25—CLOTHING

FOR CAPS; T-SHIRTS (U.S. CLS. 22 AND 39).
FIRST USE 11-0-2011; IN COMMERCE 11-0-2011.
SAMUEL E. SHARPER JR., EXAMINING ATTORNEY

SN 85-602,767. HARBOUR RIDGE YACHT & COUNTRY CLUB INC., PALM CITY, FL. FILED 4-19-2012.

HARBOUR RIDGE

THE MARK CONSISTS OF STANDARD CHARACTERS WITHOUT CLAIM TO ANY PARTICULAR FONT, STYLE, SIZE, OR COLOR.

CLASS 25—CLOTHING

FOR GOLF CAPS; GOLF PANTS, SHIRTS AND SKIRTS; GOLF SHIRTS (U.S. CLS. 22 AND 39).
FIRST USE 10-31-2011; IN COMMERCE 10-31-2011.

CLASS 35—ADVERTISING AND BUSINESS

FOR ADVERTISING OF COMMERCIAL OR RESIDENTIAL REAL ESTATE (U.S. CLS. 100, 101 AND 102).
FIRST USE 2-28-2011; IN COMMERCE 2-28-2011.

CLASS 41—EDUCATION AND ENTERTAINMENT

FOR GOLF CLUB SERVICES; GOLF COURSES; GOLF INSTRUCTION (U.S. CLS. 100, 101 AND 107).
FIRST USE 2-28-2011; IN COMMERCE 2-28-2011.
LYNDSEY KUYKENDALL, EXAMINING ATTORNEY

SN 85-602,772. WORD OF FAITH INTERNATIONAL CHRISTIAN CENTER, SOUTHFIELD, MI. FILED 4-19-2012.

REAL GOD. REAL FAITH. REAL ANSWERS.

THE MARK CONSISTS OF STANDARD CHARACTERS WITHOUT CLAIM TO ANY PARTICULAR FONT, STYLE, SIZE, OR COLOR.

CLASS 16—PAPER GOODS AND PRINTED MATTER

FOR PRINTED INFORMATIONAL PUBLICATIONS AND EDUCATIONAL MATERIAL COVERING RELIGIOUS TOPICS, NAMELY, BULLETINS, BOOKLETS, PAMPHLETS, AND NEWSLETTERS (U.S. CLS. 2, 5, 22, 23, 29, 37, 38 AND 50).

CLASS 25—CLOTHING

FOR CLOTHING, NAMELY, SHORTS, PANTS, JACKETS, SWEATERS, SWEATSHIRTS, T-SHIRTS, HEADBANDS, WRISTBANDS, HATS AND CAPS (U.S. CLS. 22 AND 39).

CLASS 45—PERSONAL AND LEGAL SERVICES

FOR EVANGELICAL AND MINISTERIAL SERVICES IN THE NATURE OF CONDUCTING CHURCH SERVICES AND PROMOTING CHRISTIAN BELIEFS THROUGH A RELIGIOUS ORGANIZATION; RELIGIOUS SERVICES, NAMELY, MINISTERIAL SERVICES, EVANGELICAL SERVICES, PREACHING SERVICES, CONDUCTING RELIGIOUS SERVICES, AND PERSONAL RELIGIOUS COUNSELING (U.S. CLS. 100 AND 101).

STEVEN R. FINE, EXAMINING ATTORNEY

SN 85-602,860. GILCHRIST, JODY, ATMORE, AL. FILED 4-19-2012.

bayed life

THE MARK CONSISTS OF STANDARD CHARACTERS WITHOUT CLAIM TO ANY PARTICULAR FONT, STYLE, SIZE, OR COLOR.

CLASS 16—PAPER GOODS AND PRINTED MATTER

FOR BUMPER STICKERS; DECALS; STICKERS (U.S. CLS. 2, 5, 22, 23, 29, 37, 38 AND 50).

CLASS 25—CLOTHING

FOR HATS; JACKETS; LONG-SLEEVED SHIRTS; SHIRTS; SHORT-SLEEVED SHIRTS; T-SHIRTS (U.S. CLS. 22 AND 39).

RONALD MCMORROW, EXAMINING ATTORNEY

SN 85-602,855. AUTHENTIDATE HOLDING CORP., BERKELEY HEIGHTS, NJ. FILED 4-19-2012.

InscribeMD

THE MARK CONSISTS OF STANDARD CHARACTERS WITHOUT CLAIM TO ANY PARTICULAR FONT, STYLE, SIZE, OR COLOR.

CLASS 42—SCIENTIFIC AND COMPUTER SERVICES

FOR PROVIDING TEMPORARY USE OF ON-LINE NONDOWNLOADABLE SOFTWARE AND APPLICATIONS FOR COLLECTING AND MANAGING PATIENT VITAL SIGNS AND CHRONIC ILLNESS INFORMATION, AND MONITORING OF DATA INDICATIVE OF THE HEALTH OR CONDITION OF AN INDIVIDUAL OR GROUP OF INDIVIDUALS (U.S. CLS. 100 AND 101).

CLASS 44—MEDICAL, BEAUTY AND AGRICULTURAL SERVICES

FOR PROVIDING REMOTE IN-HOME TELEHEALTH PATIENT MONITORING SERVICES TO COLLECT AND MANAGE VITAL SIGNS AND CHRONIC ILLNESS INFORMATION; PROVIDING REMOTE MONITORING OF DATA INDICATIVE OF THE HEALTH OR CONDITION OF AN INDIVIDUAL OR GROUP OF INDIVIDUALS; PROVIDING AN INTERNET WEB SITE FOR MEDICAL PROFESSIONALS AND MEDICAL PATIENTS FEATURING IN-HOME TELEHEALTH PATIENT MONITORING SERVICES TO COLLECT AND MANAGE VITAL SIGNS AND CHRONIC ILLNESS INFORMATION (U.S. CLS. 100 AND 101).

MARK RADEMACHER, EXAMINING ATTORNEY

SN 85-602,899. REID WINICK, D.D.S., NEW YORK, NY. FILED 4-19-2012.

WE KNEW THERE HAD TO BE A
BETTER WAY. SO WE CREATED
ONE

THE MARK CONSISTS OF STANDARD CHARACTERS WITHOUT CLAIM TO ANY PARTICULAR FONT, STYLE, SIZE, OR COLOR.

CLASS 16—PAPER GOODS AND PRINTED MATTER

FOR PRINTED MATERIALS, NAMELY, WRITTEN ARTICLES IN THE FIELD OF DENTISTRY (U.S. CLS. 2, 5, 22, 23, 29, 37, 38 AND 50).

CLASS 44—MEDICAL, BEAUTY AND AGRICULTURAL SERVICES

FOR DENTISTRY (U.S. CLS. 100 AND 101).
DAVID YONTEF, EXAMINING ATTORNEY

SN 85-603,059. AUTHENTIDATE HOLDING CORP., BERKELEY HEIGHTS, NJ. FILED 4-19-2012.

InscribeMD

THE MARK CONSISTS OF STANDARD CHARACTERS WITHOUT CLAIM TO ANY PARTICULAR FONT, STYLE, SIZE, OR COLOR.

CLASS 9—ELECTRICAL AND SCIENTIFIC APPARATUS

FOR COMPUTER HARDWARE AND SOFTWARE AND TELECOMMUNICATIONS HARDWARE AND SOFTWARE FOR IN-HOME TELEHEALTH PATIENT MONITORING SYSTEM THAT COLLECTS AND MANAGES VITAL SIGNS AND CHRONIC ILLNESS INFORMATION (U.S. CLS. 21, 23, 26, 36 AND 38).

CLASS 10—MEDICAL APPARATUS

FOR MEDICAL APPARATUS FOR IN-HOME TELEHEALTH PATIENT MONITORING SYSTEM THAT COLLECTS AND MANAGES VITAL SIGNS AND CHRONIC ILLNESS INFORMATION (U.S. CLS. 26, 39 AND 44).
MARK RADEMACHER, EXAMINING ATTORNEY

CLASS 21—HOUSEWARES AND GLASS

FOR APPLICATOR STICKS FOR APPLYING MAKE-UP; COMBS; DENTAL FLOSS; EXFOLIATING PADS; FACIAL BUFFING PADS; HAIR BRUSHES; MAKE-UP BRUSHES; PERSONAL DISPENSERS FOR PILLS OR CAPSULES FOR DOMESTIC USE; PILL BOXES FOR PERSONAL USE; POLISHING CLOTHS; POWDER PUFFS; SOAP BOXES; TEETH WHITENING TRAYS SOLD EMPTY; TOOTHBRUSH HOLDERS; TOOTHBRUSHES (U.S. CLS. 2, 13, 23, 29, 30, 33, 40 AND 50).
FIRST USE 6-0-2004; IN COMMERCE 6-0-2004.

CLASS 28—TOYS AND SPORTING GOODS

FOR ATHLETIC TAPE (U.S. CLS. 22, 23, 38 AND 50).
FIRST USE 6-0-2004; IN COMMERCE 6-0-2004.
BRIDGETT SMITH, EXAMINING ATTORNEY

SN 85-603,381. AHOLD LICENSING SARL, GENEVA, SWITZERLAND, FILED 4-20-2012.

SN 85-603,382. AHOLD LICENSING SARL, GENEVA, SWITZERLAND, FILED 4-20-2012.

CAREONE

THE MARK CONSISTS OF STANDARD CHARACTERS WITHOUT CLAIM TO ANY PARTICULAR FONT, STYLE, SIZE, OR COLOR.
OWNER OF U.S. REG. NO. 3,926,907.

CLASS 8—HAND TOOLS

FOR CALLUS CUTTERS; EYELASH CURLERS; HAIR CUTTING SCISSORS; NAIL BUFFERS; NAIL FILES (U.S. CLS. 23, 28 AND 44).
FIRST USE 11-0-2004; IN COMMERCE 11-0-2004.

CLASS 10—MEDICAL APPARATUS

FOR DROPPER BOTTLES FOR ADMINISTERING MEDICATION, SOLD EMPTY; EXTERNAL NASAL DILATORS; FINGER GUARDS FOR MEDICAL PURPOSES; MEDICAL SYRINGES; MOUTH GUARDS FOR MEDICAL PURPOSES; NASAL ASPIRATORS; PILL AND TABLET CUTTERS AND CRUSHERS; SANITARY MASKS FOR MEDICAL PURPOSES; SPLINTS; SUPPORT BANDAGES; THERAPEUTIC HOT AND COLD THERAPY PACKS (U.S. CLS. 26, 39 AND 44).
FIRST USE 2-0-2005; IN COMMERCE 2-0-2005.

CLASS 16—PAPER GOODS AND PRINTED MATTER

FOR COSMETIC PENCIL SHARPENERS (U.S. CLS. 2, 5, 22, 23, 29, 37, 38 AND 50).
FIRST USE 6-0-2008; IN COMMERCE 6-0-2008.

CLASS 20—FURNITURE AND ARTICLES NOT OTHERWISE CLASSIFIED

FOR MIRRORS; PERSONAL COMPACT MIRRORS (U.S. CLS. 2, 13, 22, 25, 32 AND 50).
FIRST USE 6-0-2008; IN COMMERCE 6-0-2008.

CAREONE

THE MARK CONSISTS OF STANDARD CHARACTERS WITHOUT CLAIM TO ANY PARTICULAR FONT, STYLE, SIZE, OR COLOR.
OWNER OF U.S. REG. NO. 3,926,907.

CLASS 3—COSMETICS AND CLEANING PREPARATIONS

FOR AFTERSHAVE PREPARATIONS; DENTURE CLEANING PREPARATIONS; EMERY BOARDS; FOOT POWDER; HAIR GEL; LIP BALM; MAKE-UP REMOVER; NON-MEDICATED DOUCHES; NON-MEDICATED FEMINE HYGIENE WASH; PETROLEUM JELLY FOR COSMETIC PURPOSES; PRE-MOISTENED COSMETIC WIPES; TOOTH WHITENING PREPARATIONS (U.S. CLS. 1, 4, 6, 50, 51 AND 52).
FIRST USE 11-0-2004; IN COMMERCE 11-0-2004.

CLASS 5—PHARMACEUTICALS

FOR ANTACIDS; BUNION PADS; CONTACT LENS SOLUTIONS; CORN PADS; DIARRHEA MEDICATION; EYE PATCHES FOR MEDICAL PURPOSES; IODINE; MEDICAL ADHESIVE TAPE; MEDICATED DERMATOLOGICAL PREPARATIONS AND SUBSTANCES; MEDICATED LIP BALM; MEDICATED OILS CONTAINING MINERALS; MEDICATED OINTMENTS FOR TREATING DERMATOLOGICAL CONDITIONS; MOLESKIN FOR MEDICAL PURPOSES; MOTION SICKNESS TREATMENT PREPARATIONS; NUTRITIONAL SUPPLEMENT IN THE NATURE OF A NUTRIENT-DENSE, PROTEIN-BASED DRINK MIX; PHARMACEUTICAL PREPARATIONS FOR THE TREATMENT OF ACID REFLUX, GAS, AND INSOMNIA; SMOKING CESSATION PREPARATIONS; STYPTIC PENCILS; SUPPOSITORIES; WART REMOVING PREPARATIONS (U.S. CLS. 6, 18, 44, 46, 51 AND 52).
FIRST USE 5-0-2004; IN COMMERCE 5-0-2004.
BRIDGETT SMITH, EXAMINING ATTORNEY

SN 85-603,406. SMALLWOOD, ABDUR RAHIM-JAMAL, LYNDHURST, NJ. FILED 4-20-2012.

TINA L. SNAPP, EXAMINING ATTORNEY

SWURVEY

THE MARK CONSISTS OF STANDARD CHARACTERS WITHOUT CLAIM TO ANY PARTICULAR FONT, STYLE, SIZE, OR COLOR.

CLASS 9—ELECTRICAL AND SCIENTIFIC APPARATUS

FOR AUDIO AND VIDEO RECORDINGS FEATURING MUSIC AND ARTISTIC PERFORMANCES (U.S. CLS. 21, 23, 26, 36 AND 38).

CLASS 25—CLOTHING

FOR SHORT-SLEEVED OR LONG-SLEEVED T-SHIRTS (U.S. CLS. 22 AND 39).
EDWARD FENNESSY, EXAMINING ATTORNEY

SN 85-603,443. MITCHELL COMMUNICATIONS GROUP, INC., FAYETTEVILLE, AR. FILED 4-20-2012.

ENJOY THE RIDE

THE MARK CONSISTS OF STANDARD CHARACTERS WITHOUT CLAIM TO ANY PARTICULAR FONT, STYLE, SIZE, OR COLOR.

CLASS 35—ADVERTISING AND BUSINESS

FOR PUBLIC RELATIONS SERVICES; BUSINESS STRATEGIC PLANNING IN THE FIELD OF MEDIA RELATIONS; BUSINESS STRATEGIC PLANNING CONSULTATION SERVICES IN THE FIELD OF REPUTATION MANAGEMENT, CRISIS MANAGEMENT, CRISIS COMMUNICATIONS, CORPORATE COMMUNICATIONS, CORPORATE SOCIAL RESPONSIBILITY, AND EMPLOYEE COMMUNICATIONS; BUSINESS MARKETING CONSULTING IN THE FIELD OF CONSUMER RELATIONS, PRODUCT PROMOTION, BRAND DEVELOPMENT, POSITIONING AND MANAGEMENT, AND CONTENT CREATION (U.S. CLS. 100, 101 AND 102).
FIRST USE 10-1-2010; IN COMMERCE 10-1-2010.

CLASS 42—SCIENTIFIC AND COMPUTER SERVICES

FOR DESIGN AND DEVELOPMENT OF COMPUTER SOFTWARE PLATFORMS FOR SOCIAL MEDIA; COMPUTER SERVICES, NAMELY, DESIGNING AND IMPLEMENTING WEBSITES FOR USE AS SOCIAL MEDIA; COMPUTER SERVICES, NAMELY, CREATING AN ON-LINE COMMUNITY FOR REGISTERED USERS TO PARTICIPATE IN DISCUSSIONS, GET FEEDBACK FROM THEIR PEERS, FORM VIRTUAL COMMUNITIES, AND ENGAGE IN SOCIAL NETWORKING SERVICES IN THE FIELD OF ADVERTISING, PUBLIC RELATIONS AND MARKETING; PROVIDING A WEBSITE FEATURING BLOGS IN THE FIELD OF PUBLIC RELATIONS AND STRATEGIC MARKETING COMMUNICATIONS (U.S. CLS. 100 AND 101).
FIRST USE 10-1-2010; IN COMMERCE 10-1-2010.

SN 85-603,454. MITCHELL COMMUNICATIONS GROUP, INC., FAYETTEVILLE, AR. FILED 4-20-2012.

LOOKING THROUGH THE TURN

THE MARK CONSISTS OF STANDARD CHARACTERS WITHOUT CLAIM TO ANY PARTICULAR FONT, STYLE, SIZE, OR COLOR.

CLASS 35—ADVERTISING AND BUSINESS

FOR PUBLIC RELATIONS SERVICES; BUSINESS STRATEGIC PLANNING IN THE FIELD OF MEDIA RELATIONS; BUSINESS STRATEGIC PLANNING CONSULTATION SERVICES IN THE FIELD OF REPUTATION MANAGEMENT, CRISIS MANAGEMENT, CRISIS COMMUNICATIONS, CORPORATE COMMUNICATIONS, CORPORATE SOCIAL RESPONSIBILITY, AND EMPLOYEE COMMUNICATIONS; BUSINESS MARKETING CONSULTING IN THE FIELD OF CONSUMER RELATIONS, PRODUCT PROMOTION, BRAND DEVELOPMENT, POSITIONING AND MANAGEMENT, AND CONTENT CREATION (U.S. CLS. 100, 101 AND 102).
FIRST USE 5-21-2009; IN COMMERCE 5-21-2009.

CLASS 42—SCIENTIFIC AND COMPUTER SERVICES

FOR DESIGN AND DEVELOPMENT OF COMPUTER SOFTWARE PLATFORMS FOR SOCIAL MEDIA; COMPUTER SERVICES, NAMELY, DESIGNING AND IMPLEMENTING WEBSITES FOR OTHERS FOR USE AS SOCIAL MEDIA; COMPUTER SERVICES, NAMELY, CREATING AN ON-LINE COMMUNITY FOR REGISTERED USERS TO PARTICIPATE IN DISCUSSIONS, GET FEEDBACK FROM THEIR PEERS, FORM VIRTUAL COMMUNITIES, AND ENGAGE IN SOCIAL NETWORKING SERVICES IN THE FIELD OF ADVERTISING, PUBLIC RELATIONS AND MARKETING; PROVIDING A WEBSITE FEATURING BLOGS IN THE FIELD OF PUBLIC RELATIONS AND STRATEGIC MARKETING COMMUNICATIONS (U.S. CLS. 100 AND 101).
FIRST USE 5-21-2009; IN COMMERCE 5-21-2009.

TINA L. SNAPP, EXAMINING ATTORNEY

SN 85-603,518. WEARKSTATT LTD., BROOKLYN, NY. FILED 4-20-2012.

Jon Ashe

THE MARK CONSISTS OF STANDARD CHARACTERS WITHOUT CLAIM TO ANY PARTICULAR FONT, STYLE, SIZE, OR COLOR.

THE NAME(S), PORTRAIT(S), AND/OR SIGNATURE(S) SHOWN IN THE MARK DOES NOT IDENTIFY A PARTICULAR LIVING INDIVIDUAL.

CLASS 25—CLOTHING

FOR BELTS; DRESS SUITS; GLOVES; HATS; MEN'S SUITS; PANTS; SCARVES; SHIRTS; SHOES; SWEATERS; TIES; VESTS (U.S. CLS. 22 AND 39).

FIRST USE 11-0-2010; IN COMMERCE 11-0-2010.

CLASS 35—ADVERTISING AND BUSINESS

FOR ON-LINE RETAIL STORE SERVICES FEATURING APPAREL AND ACCESSORIES; RETAIL STORE SERVICES FEATURING APPAREL AND ACCESSORIES (U.S. CLS. 100, 101 AND 102).

FIRST USE 11-0-2010; IN COMMERCE 11-0-2010.
DANIEL S. STRINGER, EXAMINING ATTORNEY

SN 85-603,573. SINGLETON, FRANKIE GREGORY, NAVARRE, FL. AND SINGLETON, PATRICIA ANN, NAVARRE, FL. FILED 4-20-2012.

RUSTY GRITS

THE MARK CONSISTS OF STANDARD CHARACTERS WITHOUT CLAIM TO ANY PARTICULAR FONT, STYLE, SIZE, OR COLOR.

CLASS 9—ELECTRICAL AND SCIENTIFIC APPARATUS

FOR DIGITAL MATERIALS, NAMELY, CDS, DVDS, DOWNLOADABLE AUDIO FILES, VINYL RECORDS FEATURING ROCK AND ROLL MUSIC (U.S. CLS. 21, 23, 26, 36 AND 38).

FIRST USE 1-1-2009; IN COMMERCE 1-1-2009.

CLASS 41—EDUCATION AND ENTERTAINMENT

FOR ENTERTAINMENT IN THE NATURE OF VISUAL AND AUDIO PERFORMANCES BY MUSICAL BAND (U.S. CLS. 100, 101 AND 107).

FIRST USE 1-1-2009; IN COMMERCE 1-1-2009.
EMILY CARLSEN, EXAMINING ATTORNEY

SN 85-603,716. E-REWARDS, INC., PLANO, TX. FILED 4-20-2012.

RESEARCH ROCKET

THE MARK CONSISTS OF STANDARD CHARACTERS WITHOUT CLAIM TO ANY PARTICULAR FONT, STYLE, SIZE, OR COLOR.

NO CLAIM IS MADE TO THE EXCLUSIVE RIGHT TO USE "RESEARCH", APART FROM THE MARK AS SHOWN.

CLASS 35—ADVERTISING AND BUSINESS

FOR BUSINESS AND MARKET RESEARCH SERVICES; BUSINESS INFORMATION SERVICES, NAMELY, DATA COLLECTION AND SAMPLING; CONDUCTING, PROCESSING AND ANALYZING BUSINESS, MARKET RESEARCH AND PUBLIC OPINION RESEARCH SURVEYS; CONSULTING SERVICES IN THE FIELD OF BUSINESS, MARKET RESEARCH AND PUBLIC OPINION RESEARCH SURVEYS (U.S. CLS. 100, 101 AND 102).

CLASS 42—SCIENTIFIC AND COMPUTER SERVICES

FOR SAAS FEATURING SOFTWARE FOR DESIGNING, CONDUCTING AND MANAGING ONLINE, OFF-LINE AND MOBILE SURVEYS, POLLS AND OTHER FEEDBACK AND DATA COLLECTION ACTIVITIES; SAAS FEATURING SOFTWARE FOR THE ADMINISTRATION, DISTRIBUTION, COLLECTION, REPORTING, ANALYSIS AND PRESENTATION OF RESPONDENTS' FEEDBACK AND OTHER INFORMATION GATHERED; PAAS FEATURING COMPUTER SOFTWARE PLATFORMS ENABLING PANEL INTEGRATED RESEARCH TOOLS; PAAS FEATURING COMPUTER SOFTWARE PLATFORMS ENABLING CUSTOMERS TO CONDUCT MARKET RESEARCH ON A SELF-SERVE BASIS, THE ABILITY TO CUSTOMIZE SURVEYS AND THE ABILITY TO CUSTOMIZE THE PANEL OF SURVEY RESPONDENTS (U.S. CLS. 100 AND 101).

DAVID MURRAY, EXAMINING ATTORNEY

SN 85-603,746. RUIZ PRODUCTIONS, LLC, LAS VEGAS, NV. FILED 4-20-2012.



THE COLOR(S) BROWN, GREEN, LIGHT YELLOW, DARK YELLOW AND WHITE IS/ARE CLAIMED AS A FEATURE OF THE MARK.

THE MARK CONSISTS OF A STYLIZED FIGURE OF A BROWN MAN WITH ARMS RAISED, STANDING ON A GREEN TEARDROP SHAPE, A SECOND LIGHT YELLOW AND DARK YELLOW TEARDROP SHAPE OVER THE HEAD OF THE MAN CONTAINING A WHITE SUN DESIGN ON THE RIGHT SIDE OF THE TEARDROP.

CLASS 18—LEATHER GOODS

FOR TOTE BAGS (U.S. CLS. 1, 2, 3, 22 AND 41).

CLASS 21—HOUSEWARES AND GLASS

FOR ORNAMENTS OF PORCELAIN, CUTTING BOARDS, COASTERS NOT OF PAPER AND NOT BEING TABLE LINEN, ALUMINUM WATER BOTTLES SOLD EMPTY, REUSABLE STAINLESS STEEL WATER BOTTLES SOLD EMPTY, MUGS, DRINKING STEINS, PORTABLE BEVERAGE COOLERS (U.S. CLS. 2, 13, 23, 29, 30, 33, 40 AND 50).

CLASS 25—CLOTHING

FOR APRONS; BASEBALL CAPS; CAMISOLES; SHIRTS; SPORTS JERSEYS; SWEAT SHIRTS; T-SHIRTS; TANK TOPS (U.S. CLS. 22 AND 39).
KHANH LE, EXAMINING ATTORNEY

SN 85-603,843. DENNY, ROBERT J., SCOTTSDALE, AZ.
FILED 4-20-2012.

IMPACKS

THE MARK CONSISTS OF STANDARD CHARACTERS WITHOUT CLAIM TO ANY PARTICULAR FONT, STYLE, SIZE, OR COLOR.

SN 85-603,785. BRIGHTWAY INSURANCE, INC., JACKSONVILLE, FL. FILED 4-20-2012.

CLASS 18—LEATHER GOODS

FOR BACKPACKS (U.S. CLS. 1, 2, 3, 22 AND 41).

CLASS 25—CLOTHING

FOR CAPS; JACKETS; SHIRTS; SOCKS; T-SHIRTS (U.S. CLS. 22 AND 39).

CLASS 41—EDUCATION AND ENTERTAINMENT

FOR EDUCATIONAL SERVICES, NAMELY, CONDUCTING CLASSES, INTERACTIVE ON-LINE WORKSHOPS, AND COMMUNITY TRAINING COURSES IN THE FIELDS OF LIFE SKILLS, PERSONAL SAFETY AND DISTRIBUTION OF TRAINING MATERIALS IN CONNECTION THEREWITH (U.S. CLS. 100, 101 AND 107).

JIM RINGLE, EXAMINING ATTORNEY



OWNER OF U.S. REG. NOS. 4,023,007 AND 4,029,015.
NO CLAIM IS MADE TO THE EXCLUSIVE RIGHT TO USE "INSURANCE", APART FROM THE MARK AS SHOWN.

THE COLOR(S) BLUE IS/ARE CLAIMED AS A FEATURE OF THE MARK.

THE MARK CONSISTS OF THE WORD "BRIGHTWAY" OVER THE WORD "INSURANCE". BOTH IN A BLUE FONT. THE DOT OF THE "I" IN "BRIGHTWAY" IS A BLUE SUNBURST AND THERE IS A BLUE LINE IN BETWEEN "BRIGHTWAY" AND "INSURANCE" WHICH IS INTERRUPTED BY THE LETTER "G" IN "BRIGHTWAY".

SN 85-603,898. MEDIA GENESIS, INCORPORATED, TROY, MI. FILED 4-20-2012.

Media Genesis

THE MARK CONSISTS OF STANDARD CHARACTERS WITHOUT CLAIM TO ANY PARTICULAR FONT, STYLE, SIZE, OR COLOR.

NO CLAIM IS MADE TO THE EXCLUSIVE RIGHT TO USE "MEDIA", APART FROM THE MARK AS SHOWN.

CLASS 35—ADVERTISING AND BUSINESS

FOR FRANCHISE SERVICES, NAMELY, OFFERING BUSINESS MANAGEMENT ASSISTANCE IN THE ESTABLISHMENT AND OPERATION OF INSURANCE AGENCIES, NAMELY, ASSISTANCE IN THE ESTABLISHMENT AND OPERATION OF PERSONNEL AND BUSINESS TRAINING TECHNIQUES, SALES TECHNIQUES, MARKETING AND ADVERTISING TECHNIQUES, RECORD-KEEPING AND ACCOUNTING METHODS PERTAINING TO THE BUSINESS OF VARIOUS PERSONAL LINES AND COMMERCIAL LINES INSURANCE PRODUCTS INCLUDING, HOME, AUTO, LIFE, COMMERCIAL PROPERTY AND CASUALTY, AND WORKERS' COMPENSATION INSURANCE PRODUCTS (U.S. CLS. 100, 101 AND 102).

FIRST USE 5-11-2007; IN COMMERCE 3-14-2011.

CLASS 35—ADVERTISING AND BUSINESS

FOR ADVERTISING AND MARKETING SERVICES PROVIDED BY MEANS OF INDIRECT METHODS OF MARKETING COMMUNICATIONS, NAMELY, SOCIAL MEDIA, SEARCH ENGINE MARKETING, INQUIRY MARKETING, INTERNET MARKETING, MOBILE MARKETING, BLOGGING AND OTHER FORMS OF PASSIVE, SHARABLE OR VIRAL COMMUNICATIONS CHANNELS; CONSULTING SERVICES IN THE FIELD OF INTERNET MARKETING; ONLINE MEDIA MONITORING SERVICES USING COMPUTER SOFTWARE TO AUTOMATICALLY MONITOR INTERNET WEBSITES AND ONLINE PUBLICATIONS FOR CUSTOMER-SPECIFIED TOPICS AND TO CAPTURE RELEVANT CONTENT ON THOSE TOPICS, AND PROVIDING DOCUMENTATION AND ANALYSIS OF THAT ONLINE CONTENT TO OTHERS FOR BUSINESS PURPOSES; PRODUCING PROMOTIONAL VIDEOTAPES, VIDEO DISCS, AND AUDIO VISUAL RECORDINGS; PROMOTING, ADVERTISING AND MARKETING ON-LINE WEB SITES OF OTHERS (U.S. CLS. 100, 101 AND 102).

FIRST USE 4-3-1996; IN COMMERCE 4-3-1996.

CLASS 36—INSURANCE AND FINANCIAL

FOR INSURANCE ADMINISTRATION IN THE FIELD OF HOME, AUTO, LIFE, COMMERCIAL PROPERTY AND CASUALTY AND WORKERS' COMPENSATION INSURANCE PRODUCTS; INSURANCE AGENCY AND BROKERAGE; INSURANCE CONSULTATION; INSURANCE PREMIUM RATE COMPUTING; PROVIDING INFORMATION REGARDING POLICY RATES FOR ALL TYPES OF INSURANCE AND ELECTRONIC PROCESSING OF INSURANCE CLAIMS AND PAYMENT DATA OVER A WEB BASED COMPUTER NETWORK (U.S. CLS. 100, 101 AND 102).

FIRST USE 5-11-2007; IN COMMERCE 6-27-2011.

SANDRA BUJA, EXAMINING ATTORNEY

CLASS 42—SCIENTIFIC AND COMPUTER SERVICES

FOR COMPUTER SERVICES, NAMELY, INTERACTIVE HOSTING SERVICES WHICH ALLOW THE USER TO PUBLISH AND SHARE THEIR OWN CONTENT AND IMAGES ON-LINE; COMPUTER SERVICES, NAMELY, MONITORING, TESTING, ANALYZING, AND REPORTING ON THE INTERNET TRAFFIC CONTROL AND CONTENT CONTROL OF THE WEB SITES OF OTHERS; COMPUTER SERVICES, NAMELY, REMOTE MANAGEMENT OF THE INFORMATION TECHNOLOGY (IT) SYSTEMS OF OTHERS; COMPUTER SERVICES, NAMELY, SEARCH ENGINE OPTIMIZATION; COMPUTER SOFTWARE DEVELOPMENT AND COMPUTER PROGRAMMING DEVELOPMENT FOR OTHERS; COMPUTER SOFTWARE DEVELOPMENT IN THE FIELD OF MOBILE APPLICATIONS; PLANNING, DESIGN, DEVELOPMENT, MAINTENANCE AND OPTIMIZATION OF ONLINE WEBSITES FOR THIRD PARTIES; PROVIDING A WEB SITE FEATURING TECHNOLOGY THAT ENABLES INTERNET USERS TO CREATE, BOOKMARK, ANNOTATE, AND PUBLICLY SHARE DATA; PROVIDING TEMPORARY USE OF ON-LINE NON-DOWNLOADABLE SOFTWARE AND APPLICATIONS FOR E-LEARNING; VISUAL DESIGN SERVICES IN THE NATURE OF DESIGNING VISUAL ELEMENTS FOR ON-LINE, BROADCAST, PRINT, OUTDOOR AND OTHER COMMUNICATION MEDIA (U.S. CLS. 100 AND 101).

FIRST USE 4-3-1996; IN COMMERCE 4-3-1996.
KATHERINE CHANG, EXAMINING ATTORNEY

CLASS 42—SCIENTIFIC AND COMPUTER SERVICES

FOR COMPUTER SERVICES, NAMELY, INTERACTIVE HOSTING SERVICES WHICH ALLOW THE USER TO PUBLISH AND SHARE THEIR OWN CONTENT AND IMAGES ON-LINE; COMPUTER SERVICES, NAMELY, MONITORING, TESTING, ANALYZING, AND REPORTING ON THE INTERNET TRAFFIC CONTROL AND CONTENT CONTROL OF THE WEB SITES OF OTHERS; COMPUTER SERVICES, NAMELY, REMOTE MANAGEMENT OF THE INFORMATION TECHNOLOGY (IT) SYSTEMS OF OTHERS; COMPUTER SERVICES, NAMELY, SEARCH ENGINE OPTIMIZATION; COMPUTER SOFTWARE DEVELOPMENT AND COMPUTER PROGRAMMING DEVELOPMENT FOR OTHERS; COMPUTER SOFTWARE DEVELOPMENT IN THE FIELD OF MOBILE APPLICATIONS; PLANNING, DESIGN, DEVELOPMENT, MAINTENANCE AND OPTIMIZATION OF ONLINE WEBSITES FOR THIRD PARTIES; PROVIDING A WEB SITE FEATURING TECHNOLOGY THAT ENABLES INTERNET USERS TO CREATE, BOOKMARK, ANNOTATE, AND PUBLICLY SHARE DATA; PROVIDING TEMPORARY USE OF ON-LINE NON-DOWNLOADABLE SOFTWARE AND APPLICATIONS FOR E-LEARNING; VISUAL DESIGN SERVICES IN THE NATURE OF DESIGNING VISUAL ELEMENTS FOR ON-LINE, BROADCAST, PRINT, OUTDOOR AND OTHER COMMUNICATION MEDIA (U.S. CLS. 100 AND 101).

FIRST USE 4-3-1996; IN COMMERCE 4-3-1996.
KATHERINE CHANG, EXAMINING ATTORNEY

SN 85-604,003. MEDIA GENESIS, INCORPORATED, TROY, MI. FILED 4-20-2012.



NO CLAIM IS MADE TO THE EXCLUSIVE RIGHT TO USE "MEDIA", APART FROM THE MARK AS SHOWN.

CLASS 35—ADVERTISING AND BUSINESS

FOR ADVERTISING AND MARKETING SERVICES PROVIDED BY MEANS OF INDIRECT METHODS OF MARKETING COMMUNICATIONS, NAMELY, SOCIAL MEDIA, SEARCH ENGINE MARKETING, INQUIRY MARKETING, INTERNET MARKETING, MOBILE MARKETING, BLOGGING AND OTHER FORMS OF PASSIVE, SHARABLE OR VIRAL COMMUNICATIONS CHANNELS; CONSULTING SERVICES IN THE FIELD OF INTERNET MARKETING; ONLINE MEDIA MONITORING SERVICES USING COMPUTER SOFTWARE TO AUTOMATICALLY MONITOR INTERNET WEBSITES AND ONLINE PUBLICATIONS FOR CUSTOMER-SPECIFIED TOPICS AND TO CAPTURE RELEVANT CONTENT ON THOSE TOPICS, AND PROVIDING DOCUMENTATION AND ANALYSIS OF THAT ONLINE CONTENT TO OTHERS FOR BUSINESS PURPOSES; PRODUCING PROMOTIONAL VIDEOTAPES, VIDEO DISCS, AND AUDIO VISUAL RECORDINGS; PROMOTING, ADVERTISING AND MARKETING ONLINE WEB SITES OF OTHERS (U.S. CLS. 100, 101 AND 102).

FIRST USE 4-3-1996; IN COMMERCE 4-3-1996.

SN 85-604,116. 54 BELOW LLC, NEW YORK, NY. FILED 4-20-2012.



THE MARK CONSISTS OF STANDARD CHARACTERS WITHOUT CLAIM TO ANY PARTICULAR FONT, STYLE, SIZE, OR COLOR.

CLASS 41—EDUCATION AND ENTERTAINMENT

FOR ENTERTAINMENT SERVICES IN THE NATURE OF LIVE THEATRE, CABARET AND MUSICAL PERFORMANCES; ARRANGING AND CONDUCTING NIGHTCLUB ENTERTAINMENT EVENTS; BOOKING OF SEATS FOR SHOWS FOR THEATRE, CABARET AND MUSICAL PERFORMANCES (U.S. CLS. 100, 101 AND 107).

CLASS 43—HOTEL AND RESTAURANT SERVICES

FOR RESTAURANT, BAR AND CAFE SERVICES (U.S. CLS. 100 AND 101).

GEORGE LORENZO, EXAMINING ATTORNEY

SN 85-604,128. 54 BELOW LLC, NEW YORK, NY. FILED 4-20-2012.

SN 85-604,324. ACUPATH LABORATORIES, INC., PLAINVIEW, NY. FILED 4-20-2012.

54
BELOW

THE MARK CONSISTS OF THE NUMBER "54" ABOVE THE WORD "BELOW".

CLASS 41—EDUCATION AND ENTERTAINMENT

FOR ENTERTAINMENT SERVICES IN THE NATURE OF LIVE THEATRE, CABARET AND MUSICAL PERFORMANCES; ARRANGING AND CONDUCTING NIGHTCLUB ENTERTAINMENT EVENTS; BOOKING OF SEATS FOR SHOWS FOR THEATRE, CABARET AND MUSICAL PERFORMANCES (U.S. CLS. 100, 101 AND 107).

CLASS 43—HOTEL AND RESTAURANT SERVICES

FOR RESTAURANT, BAR AND CAFE SERVICES (U.S. CLS. 100 AND 101).
GEORGE LORENZO, EXAMINING ATTORNEY

SN 85-604,292. UNK & WIL, INC., NEW YORK CITY, NY. FILED 4-20-2012.

Unk & Wil

THE MARK CONSISTS OF STANDARD CHARACTERS WITHOUT CLAIM TO ANY PARTICULAR FONT, STYLE, SIZE, OR COLOR.

CLASS 18—LEATHER GOODS

FOR HANDBAGS (U.S. CLS. 1, 2, 3, 22 AND 41).

CLASS 25—CLOTHING

FOR COATS; DRESSES; PANTS; SHIRTS; SHORTS; SKIRTS; T-SHIRTS (U.S. CLS. 22 AND 39).

CLASS 26—FANCY GOODS

FOR HAIR BANDS (U.S. CLS. 37, 39, 40, 42 AND 50).
ESTHER A. BORSUK, EXAMINING ATTORNEY

ACUPROBE

THE MARK CONSISTS OF STANDARD CHARACTERS WITHOUT CLAIM TO ANY PARTICULAR FONT, STYLE, SIZE, OR COLOR.

CLASS 42—SCIENTIFIC AND COMPUTER SERVICES

FOR SCIENTIFIC TESTING AND RESEARCH SERVICES IN THE FIELD OF HUMAN DISEASE AND HUMAN MEDICAL CONDITIONS; PROVIDING MEDICAL RESEARCH SERVICES IN THE FIELD OF CANCER; PROVIDING CLINICAL SCIENTIFIC TESTING SERVICES AND MEDICAL RESEARCH AND TESTING IN THE FIELD OF HUMAN DISEASE AND HUMAN MEDICAL CONDITIONS (U.S. CLS. 100 AND 101).
FIRST USE 7-21-2011; IN COMMERCE 7-21-2011.

CLASS 44—MEDICAL, BEAUTY AND AGRICULTURAL SERVICES

FOR MEDICAL TESTING FOR DIAGNOSTIC OR TREATMENT PURPOSES; CANCER SCREENING SERVICES; MEDICAL TESTING OF TISSUE SAMPLES; MEDICAL TESTING SERVICES USING HYBRIDIZATION PROBES (U.S. CLS. 100 AND 101).

FIRST USE 7-21-2011; IN COMMERCE 7-21-2011.
ALAIN LAPTEY, EXAMINING ATTORNEY

SN 85-604,476. VAULTED BRANDS, INC, LAKE ZURICH, IL. FILED 4-20-2012.

ICONTROL

THE MARK CONSISTS OF STANDARD CHARACTERS WITHOUT CLAIM TO ANY PARTICULAR FONT, STYLE, SIZE, OR COLOR.

CLASS 9—ELECTRICAL AND SCIENTIFIC APPARATUS

FOR TELECOMMUNICATIONS HARDWARE AND SOFTWARE FOR REMOTELY MONITORING AND CONTROLLING BATTERY-OPERATED AND ELECTRIC HOUSEHOLD SUMP PUMPS AND SEWAGE PUMPS VIA THE INTERNET (U.S. CLS. 21, 23, 26, 36 AND 38).
FIRST USE 4-22-2011; IN COMMERCE 8-1-2011.

CLASS 42—SCIENTIFIC AND COMPUTER SERVICES

FOR INTERNET BASED MONITORING AND CONTROL SERVICES RELATING TO BATTERY-OPERATED AND ELECTRIC HOUSEHOLD SUMP PUMPS AND SEWAGE PUMPS (U.S. CLS. 100 AND 101).
CHARLES L. JENKINS, EXAMINING ATTORNEY

SN 85-604,484. DIAL GLOBAL, INC., NEW YORK, NY.
FILED 4-20-2012.

SN 85-604,528. SKYLITE SNOWBALLS, BERKELEY, CA.
FILED 4-21-2012.

DEFINING GREAT

THE MARK CONSISTS OF STANDARD CHARACTERS WITHOUT CLAIM TO ANY PARTICULAR FONT, STYLE, SIZE, OR COLOR.

CLASS 35—ADVERTISING AND BUSINESS

FOR PRODUCTION OF ADVERTISING AND PROMOTIONAL MATERIALS (U.S. CLS. 100, 101 AND 102).

CLASS 41—EDUCATION AND ENTERTAINMENT

FOR PRODUCTION AND DISTRIBUTION OF RADIO PROGRAMS; RADIO ENTERTAINMENT PRODUCTION; RADIO PROGRAM SYNDICATION (U.S. CLS. 100, 101 AND 107).

NATALIE POLZER, EXAMINING ATTORNEY

SN 85-604,525. THE POOCH PITT, LLC, DBA THE POOCH PITT, BRIDGEVILLE, PA. FILED 4-20-2012.



THE COLOR(S) BLACK, BLUE, GOLD, GRAY IS/ARE CLAIMED AS A FEATURE OF THE MARK.

THE MARK CONSISTS OF THE WORDS "THE POOCH PITT." THE WORD "THE" IS BLACK WITH NO CAPITALIZED LETTERS. THE WORD "POOCH" IS BLUE WITH THE "P" CAPITALIZED. THE FIRST THREE LETTERS OF THE WORD "PITT" ARE BLACK AND THE LAST LETTER "T" IS BLUE. THE "P" IN PITT IS CAPITALIZED. THE WORDS HAVE A REFLECTION BELOW THEM IN A FADING GREYSCALE COLOR. THE IMAGE IS A BLACK DOG, WITH A BLUE COLLAR, STANDING WITH HIND LEGS ON THE "O'S" OF THE WORD "POOCH," AND FRONT LEGS STANDING ON THE "C" OF THE WORD "POOCH." THE DOT ABOVE THE "I" IN THE WORD "PITT" IS DEPICTED AS A BALL BOUNCING OFF THE "I" TOWARDS THE DOG'S MOUTH. THE MOTION OF THE BALL IS DEPICTED WITH A GOLD SWOOSH, WHICH IS A V-SHAPE.

CLASS 43—HOTEL AND RESTAURANT SERVICES

FOR KENNEL SERVICES, NAMELY, BOARDING FOR PETS (U.S. CLS. 100 AND 101).
FIRST USE 12-20-2011; IN COMMERCE 2-11-2012.

CLASS 44—MEDICAL, BEAUTY AND AGRICULTURAL SERVICES

FOR DOG GROOMING SERVICES (U.S. CLS. 100 AND 101).
FIRST USE 12-20-2011; IN COMMERCE 2-11-2012.
SANJEEV VOHRA, EXAMINING ATTORNEY

Skylite Snowballs

THE MARK CONSISTS OF STANDARD CHARACTERS WITHOUT CLAIM TO ANY PARTICULAR FONT, STYLE, SIZE, OR COLOR.

NO CLAIM IS MADE TO THE EXCLUSIVE RIGHT TO USE "SNOWBALLS", APART FROM THE MARK AS SHOWN.

CLASS 30—STAPLE FOODS

FOR FROZEN CONFECTIONS; SHAVED ICE CONFECTIONS (U.S. CL. 46).
FIRST USE 9-1-2010; IN COMMERCE 9-1-2010.

CLASS 35—ADVERTISING AND BUSINESS

FOR MOBILE VENDING IN THE FIELD OF FROZEN CONFECTIONS AND SHAVED ICE CONFECTIONS KNOWN AS SNOWBALLS (U.S. CLS. 100, 101 AND 102).
FIRST USE 9-1-2010; IN COMMERCE 9-1-2010.
SUSAN LESLIE DUBOIS, EXAMINING ATTORNEY

SN 85-604,611. CUSTOM LEATHERCRAFT MANUFACTURING CO., INC., SOUTH GATE, CA. FILED 4-21-2012.

WILD RIVER

THE MARK CONSISTS OF STANDARD CHARACTERS WITHOUT CLAIM TO ANY PARTICULAR FONT, STYLE, SIZE, OR COLOR.

CLASS 8—HAND TOOLS

FOR TOOL AND ACCESSORY APRONS, TOOL AND ACCESSORY BELTS, TOOL AND ACCESSORY HOLDERS, TOTES, TOOL AND ACCESSORY SUSPENDERS, TOOL AND ACCESSORY HOLDERS SHAPED AS SUSPENDERS, TOOL AND ACCESSORY POUCHES FOR ATTACHMENT TO BELTS, WEATHER RESISTANT APRONS FOR CARRYING TOOLS AND ACCESSORIES, WEATHER RESISTANT UTILITY BELTS FOR CARRYING TOOLS AND ACCESSORIES, WEATHER RESISTANT SUSPENDERS FOR HOLDING UTILITY TOOL AND ACCESSORY BELTS, WEATHER RESISTANT TOOL AND ACCESSORY HOLDING POUCHES FOR ATTACHMENT TO UTILITY TOOL AND ACCESSORY BELTS (U.S. CLS. 23, 28 AND 44).

CLASS 9—ELECTRICAL AND SCIENTIFIC APPARATUS

FOR SUPPORT BELTS FOR WORKERS TO SUPPORT BACK AND LUMBAR REGION; PROTECTIVE WORK GLOVES; NON-DISPOSABLE PROTECTIVE AND SAFETY APPAREL FOR PROTECTING AGAINST BODILY HARM AND FOR PROVIDING ADDED VISIBILITY, NAMELY, HATS, CAPS, VISORS, GLOVES, MITTENS, BELTS, SHIRTS, VESTS, JACKETS, COATS, JUMPSUITS, PANTS AND WORKER'S KNEEPADS AND LIGHTED KNEEPADS (U.S. CLS. 21, 23, 26, 36 AND 38).

CLASS 18—LEATHER GOODS

FOR TOOL AND ACCESSORY BAGS SOLD EMPTY, SOFT-SIDED TOOL AND ACCESSORY BAGS SOLD EMPTY, WEATHER RESISTANT TOOL AND ACCESSORY BAGS AND TOOL CARRYING BAGS, ALL SOLD EMPTY; BACK PACKS, GENERAL PURPOSE BAGS FOR HOLDING CAMPING EQUIPMENT, TRAVEL BAGS, AND SPORT BAGS, ALL SOLD EMPTY; LIGHTED UTILITY BAGS SOLD EMPTY; UTILITY BAGS WITH INTEGRATED SPEAKERS SOLD EMPTY; LIGHTED SOFT-SIDED TOOL AND ACCESSORY BAGS SOLD EMPTY; LIGHTED BACK PACKS, LIGHTED GENERAL PURPOSE BAGS FOR HOLDING CAMPING EQUIPMENT, LIGHTED TRAVEL BAGS, AND LIGHTED SPORT BAGS ALL SOLD EMPTY (U.S. CLS. 1, 2, 3, 22 AND 41).

CLASS 21—HOUSEWARES AND GLASS

FOR HOUSEHOLD GLOVES FOR GENERAL USE, ACCESSORY AND TOOL BUCKET ORGANIZER, NAMELY, AN ORGANIZER SPECIALLY ADAPTED FOR AFFIXATION TO A BUCKET FOR HOLDING ACCESSORIES AND TOOLS; PORTABLE COOLERS (U.S. CLS. 2, 13, 23, 29, 30, 33, 40 AND 50).

CLASS 25—CLOTHING

FOR WEATHER RESISTANT CLOTHING, NAMELY, WIND AND WATER RESISTANT SHIRTS, VESTS, JACKETS, PANTS, HATS, CAPS, VISORS, AND GLOVES; RAIN SUITS, PONCHOS, WADERS, GLOVES, MITTENS, FISHING AND HUNTING VESTS, AND SAFETY-COLORED VESTS, PARKAS, COATS, JACKETS, SHIRTS, HATS, VESTS, RAINWEAR, AND COVERALLS, BOOTS, SHOES, HATS, CAPS, SUITS, COATS, JACKETS, PANTS, SOCKS AND UNDERWEAR, SWEATSHIRTS, AND T-SHIRTS (U.S. CLS. 22 AND 39).

CLASS 28—TOYS AND SPORTING GOODS

FOR FISHING REEL BAGS, FISHING TACKLE BAGS, CLIMBING EQUIPMENT BAGS, ALL SOLD EMPTY; LIGHTED FISHING EQUIPMENT BAGS, LIGHTED CLIMBING EQUIPMENT BAGS, ALL SOLD EMPTY (U.S. CLS. 22, 23, 38 AND 50).
JAMES A. RAUEN, EXAMINING ATTORNEY

SN 85-604,666. BAIT INC, DBA BAIT, DIAMOND BAR, CA. FILED 4-22-2012.

BAIT

THE MARK CONSISTS OF STANDARD CHARACTERS WITHOUT CLAIM TO ANY PARTICULAR FONT, STYLE, SIZE, OR COLOR.

CLASS 9—ELECTRICAL AND SCIENTIFIC APPARATUS

FOR BAGS AND CASES SPECIALLY ADAPTED FOR HOLDING OR CARRYING PORTABLE TELEPHONES AND TELEPHONE EQUIPMENT AND ACCESSORIES (U.S. CLS. 21, 23, 26, 36 AND 38).

CLASS 18—LEATHER GOODS

FOR BACKPACKS (U.S. CLS. 1, 2, 3, 22 AND 41).

CLASS 25—CLOTHING

FOR TEE SHIRTS (U.S. CLS. 22 AND 39).
JAY FLOWERS, EXAMINING ATTORNEY

SN 85-604,707. DE GUZMAN, ANTON CARLO, HOUSTON, TX. AND OVIEDO, DANIEL, HOUSTON, TX. FILED 4-22-2012.

Devil Killing Moth

THE MARK CONSISTS OF STANDARD CHARACTERS WITHOUT CLAIM TO ANY PARTICULAR FONT, STYLE, SIZE, OR COLOR.

CLASS 9—ELECTRICAL AND SCIENTIFIC APPARATUS

FOR DIGITAL MATERIALS, NAMELY, CDS, DVDS, DOWNLOADABLE AUDIO FILES FEATURING MUSIC (U.S. CLS. 21, 23, 26, 36 AND 38).
FIRST USE 5-12-2008; IN COMMERCE 8-8-2009.

CLASS 41—EDUCATION AND ENTERTAINMENT

FOR ENTERTAINMENT SERVICES IN THE NATURE OF LIVE MUSICAL PERFORMANCES (U.S. CLS. 100, 101 AND 107).
FIRST USE 5-12-2008; IN COMMERCE 8-8-2009.
DAVID C. REIHNER, EXAMINING ATTORNEY

SN 85-604,778. AFTERISK INC., COVINA, CA. FILED 4-22-2012.

Sketch Guess

THE MARK CONSISTS OF STANDARD CHARACTERS WITHOUT CLAIM TO ANY PARTICULAR FONT, STYLE, SIZE, OR COLOR.

CLASS 9—ELECTRICAL AND SCIENTIFIC APPARATUS

FOR DOWNLOADABLE COMPUTER GAME SOFTWARE FOR USE ON WIRELESS DEVICES AND COMPUTERS (U.S. CLS. 21, 23, 26, 36 AND 38).

CLASS 41—EDUCATION AND ENTERTAINMENT

FOR ENTERTAINMENT SERVICES, NAMELY, PROVIDING ON-LINE COMPUTER GAMES (U.S. CLS. 100, 101 AND 107).
ALYSSA STEEL, EXAMINING ATTORNEY

SN 85-605,089. ROSTOMIAN, ASHOT, GLENDALE, CA. AND ROSTOMYAN, ANITA, GLENDALE, CA. FILED 4-23-2012.

SN 85-605,153. SPLUNK INC., SAN FRANCISCO, CA. FILED 4-23-2012.



THE MARK CONSISTS OF A STYLIZED "B" INSIDE THE OUTLINE OF A DONUT AND A LEAF ON THE LEFT OF THE DONUT SHAPE.

CLASS 16—PAPER GOODS AND PRINTED MATTER

FOR BOXES, CARTONS, STORAGE CONTAINERS, AND PACKAGING CONTAINERS MADE OF PAPER OR CARDBOARD; PAPER FOR WRAPPING AND PACKAGING; PAPER BAGS; PAPER LABELS; PLASTIC BAGS FOR PACKAGING; TISSUE PAPER (U.S. CLS. 2, 5, 22, 23, 29, 37, 38 AND 50).

CLASS 20—FURNITURE AND ARTICLES NOT OTHERWISE CLASSIFIED

FOR PACKAGING CONTAINERS OF PLASTIC (U.S. CLS. 2, 13, 22, 25, 32 AND 50).
AHSEN KHAN, EXAMINING ATTORNEY

SN 85-605,147. CHAPIN MANUFACTURING, INC., BATAVIA, NY. FILED 4-23-2012.

HUNTING NATION

THE MARK CONSISTS OF STANDARD CHARACTERS WITHOUT CLAIM TO ANY PARTICULAR FONT, STYLE, SIZE, OR COLOR.

CLASS 7—MACHINERY

FOR POWER-OPERATED SPRAYERS, MECHANICAL SPREADERS FOR SEED AND DRY LAWN CHEMICALS, AND BROADCAST SEEDERS MOUNTABLE ON ATVS OR TOWED AS AGRICULTURAL IMPLEMENTS (U.S. CLS. 13, 19, 21, 23, 31, 34 AND 35).

CLASS 8—HAND TOOLS

FOR HAND OPERATED SPRAYERS FOR APPLYING LIQUID HERBICIDES, FERTILIZERS, OR INSECTICIDES FOR HOME, LAWN, GARDEN, FARM, FIELD, MARINE, OR PEST CONTROL USE, AND HAND OPERATED SPREADERS FOR SEED AND DRY LAWN CHEMICALS (U.S. CLS. 23, 28 AND 44).
LUCY ARANT, EXAMINING ATTORNEY

DATA WITH DESTINY

THE MARK CONSISTS OF STANDARD CHARACTERS WITHOUT CLAIM TO ANY PARTICULAR FONT, STYLE, SIZE, OR COLOR.

CLASS 9—ELECTRICAL AND SCIENTIFIC APPARATUS

FOR COMPUTER HARDWARE; COMPUTER SERVER OPERATING SOFTWARE; COMPUTER SEARCH ENGINE SOFTWARE; AND INSTRUCTIONAL MANUALS SOLD AS A UNIT THEREWITH (U.S. CLS. 21, 23, 26, 36 AND 38).

CLASS 16—PAPER GOODS AND PRINTED MATTER

FOR PRINTED MATTER, NAMELY, MANUALS, WHITE PAPERS, MAGAZINES, NEWSLETTERS AND USER GUIDES IN THE FIELD OF INFORMATION TECHNOLOGY (U.S. CLS. 2, 5, 22, 23, 29, 37, 38 AND 50).

CLASS 35—ADVERTISING AND BUSINESS

FOR BUSINESS CONSULTING SERVICES IN THE FIELD OF INFORMATION TECHNOLOGY (U.S. CLS. 100, 101 AND 102).

CLASS 38—COMMUNICATION

FOR PROVIDING MULTIPLE USER ACCESS TO GLOBAL COMPUTER NETWORKS FOR THE TRANSFER AND DISSEMINATION OF A WIDE RANGE OF INFORMATION, PROVIDING ON-LINE ELECTRONIC BULLETIN BOARDS FOR TRANSMISSION OF MESSAGES AMONG COMPUTER USERS IN THE FIELDS OF COMPUTER OPERATION AND NETWORKING AND INFORMATION TECHNOLOGY (U.S. CLS. 100, 101 AND 104).

CLASS 41—EDUCATION AND ENTERTAINMENT

FOR EDUCATIONAL SERVICES, NAMELY, PROVIDING TRAINING, TUTORING, CLASSES AND SEMINARS IN THE FIELD OF COMPUTERS, COMPUTER SOFTWARE AND COMPUTER NETWORKS AND THE DEVELOPMENT AND OPERATION OF COMPUTING NETWORKS AND DISTRIBUTION OF COURSE MATERIALS IN CONNECTION THEREWITH (U.S. CLS. 100, 101 AND 107).

CLASS 42—SCIENTIFIC AND COMPUTER SERVICES

FOR PROVIDING ON-LINE NON-DOWNLOADABLE SOFTWARE FOR INDEXING AND MAKING SEARCHABLE DATA FROM ANY APPLICATION, SERVER OR NETWORK DEVICE; CONSULTING SERVICES IN THE FIELD OF INFORMATION TECHNOLOGY; TECHNICAL CONSULTING SERVICES IN THE FIELD EVALUATION AND IMPLEMENTATION OF INFORMATION TECHNOLOGY AND SERVICES; TECHNICAL SUPPORT SERVICES, NAMELY, REMOTE AND ON-SITE INFRASTRUCTURE MANAGEMENT SERVICES FOR MONITORING, ADMINISTRATION AND MANAGEMENT OF PUBLIC AND PRIVATE COMPUTER APPLICATION SYSTEMS (U.S. CLS. 100 AND 101).
PAM WILLIS, EXAMINING ATTORNEY

SN 85-605,488. GOOGLE INC., MOUNTAIN VIEW, CA.
FILED 4-23-2012.



THE COLOR(S) GREEN, YELLOW, AND BLUE IS/ARE CLAIMED AS A FEATURE OF THE MARK.

THE MARK CONSISTS OF A TRIANGULAR DESIGN, NAMELY WITH A GREEN LEFT LEG, A YELLOW RIGHT LEG AND A BLUE BOTTOM LEG.

CLASS 39—TRANSPORTATION AND STORAGE

FOR STORAGE OF ELECTRONIC MEDIA, NAMELY, USER-GENERATED DOCUMENTS, SPREADSHEETS, DRAWINGS, IMAGES, AUDIO FILES, VIDEO FILES, AND SCANNED DOCUMENTS (U.S. CLS. 100 AND 105).

CLASS 42—SCIENTIFIC AND COMPUTER SERVICES

FOR CLOUD COMPUTING FEATURING SOFTWARE FOR USE IN CREATING TEXT DOCUMENTS, SPREADSHEETS, TABLES, AND WEBSITES; APPLICATION SERVICE PROVIDER (ASP), NAMELY, HOSTING COMPUTER SOFTWARE APPLICATIONS OF OTHERS; APPLICATION SERVICE PROVIDER (ASP) FEATURING SOFTWARE FOR USE IN CREATING TEXT DOCUMENTS, SPREADSHEETS, TABLES, AND WEBSITES; COMPUTER SERVICES, NAMELY, INTEGRATION OF PRIVATE AND PUBLIC CLOUD COMPUTING ENVIRONMENTS; COMPUTER SERVICES, NAMELY, CLOUD HOSTING PROVIDER SERVICES; PROVIDING VIRTUAL COMPUTER SYSTEMS AND VIRTUAL COMPUTER ENVIRONMENTS THROUGH CLOUD COMPUTING; TECHNICAL SUPPORT SERVICES, NAMELY, TROUBLESHOOTING OF COMPUTER SOFTWARE PROBLEMS IN THE FIELD OF CLOUD COMPUTING; APPLICATION SERVICE PROVIDER, NAMELY, HOSTING AND MAINTENANCE OF COLLABORATIVE WEBSITES CREATED BY OTHERS USING NON-DOWNLOADABLE SOFTWARE (U.S. CLS. 100 AND 101).

INGA ERVIN, EXAMINING ATTORNEY

SN 85-605,554. EL MUNDO FEO, INC., NEW YORK, NY.
FILED 4-23-2012.

EL MUNDO FEO

THE MARK CONSISTS OF STANDARD CHARACTERS WITHOUT CLAIM TO ANY PARTICULAR FONT, STYLE, SIZE, OR COLOR.

THE ENGLISH TRANSLATION OF "EL MUNDO FEO" IN THE MARK IS "THE UGLY WORLD".

CLASS 24—FABRICS

FOR COTTON BASE MIXED FABRICS; COTTON FABRIC; CURTAIN FABRIC; DENIM FABRIC; ELASTIC FABRICS FOR CLOTHING; FABRIC FLAGS; FABRIC TABLE RUNNERS; FABRIC TABLE TOPPERS; FABRICS FOR TEXTILE USE; FABRICS THAT MAY OR MAY NOT HAVE PRINTED PATTERNS AND DESIGNS THEREON FOR USE IN TEXTILE APPLICATIONS, NAMELY, THE MANUFACTURE OF APPAREL, UPHOLSTERY, SIGNAGE, FLAGS, BANNERS AND WALL-PAPER; FURNISHING AND UPHOLSTERY FABRICS; HAND-TOWELS MADE OF TEXTILE FABRICS; INTERIOR DECORATION FABRICS; KNITTED FABRIC; LINEN; NATURAL AND SYNTHETIC FABRICS AND TEXTILES, NAMELY, COTTON, SILK, POLYESTER AND NYLON FABRICS; SILK FABRIC FOR PRINTING PATTERNS; TEXTILE FABRICS FOR HOME AND COMMERCIAL INTERIORS; TEXTILE FABRICS FOR THE MANUFACTURE OF CLOTHING; TEXTILE FABRICS FOR USE IN MAKING CLOTHING AND HOUSEHOLD FURNISHINGS; TEXTILE FABRICS FOR USE IN THE MANUFACTURE OF GARMENTS, BAGS, JACKETS, GLOVES, AND APPAREL; UPHOLSTERY FABRICS (U.S. CLS. 42 AND 50).

FIRST USE 7-31-2010; IN COMMERCE 12-1-2011.

CLASS 25—CLOTHING

FOR T-SHIRTS (U.S. CLS. 22 AND 39).
FIRST USE 7-31-2010; IN COMMERCE 7-31-2010.
BRIAN CALLAGHAN, EXAMINING ATTORNEY

SN 85-605,705. THE CONRAD FOUNDATION, IRVINE, CA.
FILED 4-23-2012.

GEEK IS CHIC

THE MARK CONSISTS OF STANDARD CHARACTERS WITHOUT CLAIM TO ANY PARTICULAR FONT, STYLE, SIZE, OR COLOR.

CLASS 25—CLOTHING

FOR CLOTHING, NAMELY, SHIRTS, T-SHIRTS, SWEATSHIRTS (U.S. CLS. 22 AND 39).

CLASS 41—EDUCATION AND ENTERTAINMENT

FOR EDUCATIONAL SERVICES, NAMELY, DEVELOPING CURRICULUM IN THE FIELD OF SCIENCE; EDUCATIONAL SERVICES, NAMELY, CONDUCTING CLASSES, MEETINGS, CONFERENCES, COMPETITIONS AND WORKSHOPS IN THE FIELD OF SCIENCE (U.S. CLS. 100, 101 AND 107).

KAREN K. BUSH, EXAMINING ATTORNEY

SN 85-605,872. POW GAMES, LLC, TRUCKEE, CA. FILED 4-23-2012.

SEASIDE HIDEAWAY

THE MARK CONSISTS OF STANDARD CHARACTERS WITHOUT CLAIM TO ANY PARTICULAR FONT, STYLE, SIZE, OR COLOR.

CLASS 9—ELECTRICAL AND SCIENTIFIC APPARATUS

FOR COMPUTER GAME PROGRAMS; COMPUTER GAME SOFTWARE; COMPUTER SOFTWARE FOR USE IN ENABLING POSTING, UPLOADING, SHARING, AND OTHERWISE PROVIDING INTERACTIVE ENTERTAINMENT MEDIA, ELECTRONIC GAMING AND SOCIAL NETWORKING; COMPUTER SOFTWARE PLATFORMS FOR GAMING AND SOCIAL NETWORKING; ELECTRONIC GAME PROGRAMS; INTERACTIVE GAME PROGRAMS; INTERACTIVE GAME SOFTWARE; INTERACTIVE VIDEO GAME PROGRAMS (U.S. CLS. 21, 23, 26, 36 AND 38).

CLASS 41—EDUCATION AND ENTERTAINMENT

FOR ELECTRONIC GAMES SERVICES PROVIDED BY MEANS OF THE INTERNET; ENTERTAINMENT SERVICES, NAMELY, PROVIDING ON-LINE COMPUTER GAMES; ENTERTAINMENT SERVICES, NAMELY, PROVIDING ONLINE ELECTRONIC GAMES; ENTERTAINMENT SERVICES, NAMELY, PROVIDING TEMPORARY USE OF NON-DOWNLOADABLE COMPUTER GAMES; ENTERTAINMENT SERVICES, NAMELY, PROVIDING TEMPORARY USE OF NON-DOWNLOADABLE INTERACTIVE GAMES; ENTERTAINMENT SERVICES, NAMELY, PROVIDING VIRTUAL ENVIRONMENTS IN WHICH USERS CAN INTERACT FOR RECREATIONAL, LEISURE OR ENTERTAINMENT PURPOSES (U.S. CLS. 100, 101 AND 107).

KERI CANTONE, EXAMINING ATTORNEY

SN 85-605,959. JADS INTERNATIONAL, LLC, LUTHERVILLE, MD. FILED 4-23-2012.



NO CLAIM IS MADE TO THE EXCLUSIVE RIGHT TO USE "INTERNATIONAL", APART FROM THE MARK AS SHOWN.

THE COLOR(S) TURQUOISE, WHITE AND BLACK IS/ARE CLAIMED AS A FEATURE OF THE MARK.

THE MARK CONSISTS OF A CIRCLE IN TURQUOISE AND WHITE. INSIDE THE CIRCLE APPEARS THE ARTISTIC RENDERING OF A HUMAN HEAD IN BLACK. BENEATH THE HUMAN HEAD ARE THE STYLIZED WORDS "JADS" IN BLACK AND "INTERNATIONAL" IN WHITE.

CLASS 3—COSMETICS AND CLEANING PREPARATIONS

FOR PERFUMES; COLOGNES; SCENT DIFFUSERS, NAMELY, REEDS AND SCENTED OIL SOLD AS A UNIT FOR USE IN ROOM SCENT DIFFUSERS; DEODORANTS FOR HUMAN BEINGS; PET FRAGRANCES (U.S. CLS. 1, 4, 6, 50, 51 AND 52).

CLASS 4—LUBRICANTS AND FUELS

FOR CANDLES (U.S. CLS. 1, 6 AND 15).
KEVIN DINALLO, EXAMINING ATTORNEY

SN 85-606,436. HEWLETT-PACKARD DEVELOPMENT COMPANY, L.P., HOUSTON, TX. FILED 4-24-2012.

CONNECTED: PROTECTED

THE MARK CONSISTS OF STANDARD CHARACTERS WITHOUT CLAIM TO ANY PARTICULAR FONT, STYLE, SIZE, OR COLOR.

CLASS 9—ELECTRICAL AND SCIENTIFIC APPARATUS

FOR COMPUTER SOFTWARE FOR DATA BACKUP, SYNCHRONIZATION AND MIGRATION; COMPUTER STORAGE DEVICES, NAMELY, HIGH-SPEED STORAGE SUBSYSTEMS FOR STORAGE AND BACKUP OF ELECTRONIC DATA EITHER LOCALLY OR VIA A TELECOMMUNICATIONS NETWORK (U.S. CLS. 21, 23, 26, 36 AND 38).

CLASS 42—SCIENTIFIC AND COMPUTER SERVICES

FOR SOFTWARE AS A SERVICE (SAAS) FEATURING SOFTWARE FOR DATA BACKUP, SYNCHRONIZATION AND MIGRATION; CLOUD COMPUTING SERVICES FEATURING SOFTWARE FOR DATA BACKUP, SYNCHRONIZATION AND MIGRATION; DATA MIGRATION SERVICES; REMOTE COMPUTER BACKUP SERVICES; REMOTE ONLINE BACKUP OF COMPUTER DATA; COMPUTER SERVICES, NAMELY, CLOUD HOSTING PROVIDER SERVICES; CONSULTING SERVICES IN THE FIELD OF CLOUD COMPUTING; COMPUTER SERVICES, NAMELY, INTEGRATION OF PRIVATE AND PUBLIC CLOUD COMPUTING ENVIRONMENTS; PROVIDING VIRTUAL COMPUTER SYSTEMS AND VIRTUAL COMPUTER ENVIRONMENTS THROUGH CLOUD COMPUTING (U.S. CLS. 100 AND 101).

JANICE KIM, EXAMINING ATTORNEY

SN 85-607,067. KIM, SO HEE, INCHEON, REPUBLIC OF KOREA, FILED 4-24-2012.

SN 85-607,133. ANTIOCH MISSIONARY BAPTIST CHURCH OF CAROL CITY, INC., MIAMI, FL. FILED 4-24-2012.

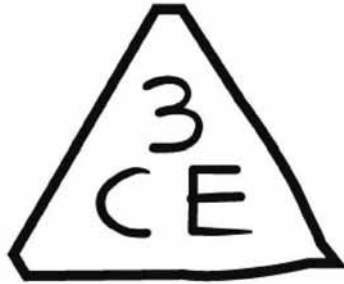

THE MARK CONSISTS OF NUMBER "3" AND LETTERS "CE" ENCLOSED IN A TRIANGULAR IMAGE.

CLASS 3—COSMETICS AND CLEANING PREPARATIONS

FOR BEAUTY CREAMS; COSMETIC PREPARATIONS FOR BATH AND SHOWER; COSMETIC PREPARATIONS FOR SKIN CARE; COTTON WOOL FOR COSMETIC PURPOSES; EYE SHADOWS; LIPSTICKS; NAIL POLISH; PERFUMES; SHAMPOOS; SUN-TANNING PREPARATIONS (U.S. CLS. 1, 4, 6, 50, 51 AND 52).

CLASS 18—LEATHER GOODS

FOR CLOTHING FOR DOMESTIC PETS; CREDIT CARD CASES; DOCUMENT CASES; EVENING HANDBAGS; LEATHER AND IMITATION LEATHER BAGS; LEATHER HANDBAGS; PURSES; TOILETRY BAGS SOLD EMPTY; TRAVELING BAGS; UMBRELLAS (U.S. CLS. 1, 2, 3, 22 AND 41).

CLASS 25—CLOTHING

FOR ATHLETIC FOOTWEAR; BATHING SUITS; BELTS; BRAS; CAPS; JEANS; JUMPERS; LEGGINGS; T-SHIRTS; WOMEN'S SHOES (U.S. CLS. 22 AND 39).

CLASS 35—ADVERTISING AND BUSINESS

FOR DISTRIBUTORSHIP SERVICES IN THE FIELD OF CLOTHES, BAGS, COSMETICS, FOOTWEAR, SPECTACLES, SUNGLASSES AND CAPS; ON-LINE RETAIL STORE SERVICES FEATURING A WIDE VARIETY OF CONSUMER GOODS OF OTHERS; ON-LINE WHOLESALE STORE SERVICES FEATURING A WIDE VARIETY OF CONSUMER GOODS OF OTHERS; ONLINE RETAIL SERVICES THROUGH DIRECT SOLICITATION BY DISTRIBUTORS DIRECTED TO END-USERS FEATURING CLOTHES, BAGS, COSMETICS, FOOTWEAR, SPECTACLES, SUNGLASSES AN CAPS; RETAIL STORE SERVICES FEATURING A WIDE VARIETY OF CONSUMER GOODS OF OTHERS; WHOLESALE STORE SERVICES FEATURING A WIDE VARIETY OF CONSUMER GOODS OF OTHERS (U.S. CLS. 100, 101 AND 102).

SANJEEV VOHRA, EXAMINING ATTORNEY



OWNER OF U.S. REG. NOS. 3,009,135 AND 3,009,136. THE MARK CONSISTS OF A DOWNWARD POINTED TRIANGLE BEHIND THE LETTER "A" IN STYLIZED FONT AND A DRAWING OF A DOVE. THE DOVE IS INCORPORATED INTO THE LETTER "A" IN THAT IT'S WING FORMS THE CROSS SECTION.

CLASS 21—HOUSEWARES AND GLASS

FOR CUPS AND MUGS (U.S. CLS. 2, 13, 23, 29, 30, 33, 40 AND 50).
FIRST USE 9-0-2002; IN COMMERCE 9-0-2002.

CLASS 24—FABRICS

FOR CLOTH FLAGS; GOLF TOWELS (U.S. CLS. 42 AND 50).
FIRST USE 8-16-2003; IN COMMERCE 8-16-2003.
IRA J. GOODSaid, EXAMINING ATTORNEY

SN 85-607,268. CHINA JADE CORPORATION, CHRISTIANSTED ST.CROIX, US VIRGIN ISLANDS, FILED 4-24-2012.

I Slept On A Virgin Island

THE MARK CONSISTS OF STANDARD CHARACTERS WITHOUT CLAIM TO ANY PARTICULAR FONT, STYLE, SIZE, OR COLOR.

CLASS 25—CLOTHING

FOR CAPS; T-SHIRTS (U.S. CLS. 22 AND 39).

CLASS 35—ADVERTISING AND BUSINESS

FOR PROMOTING RECREATION AND TOURISM IN THE VIRGIN ISLANDS (U.S. CLS. 100, 101 AND 102).
MARY CRAWFORD, EXAMINING ATTORNEY

SN 85-607,706. GRUPO BIMBO, S.A. B. DE C.V., MEXICO CITY, MEXICO, FILED 4-25-2012.

FACE THE INTENSITY

THE MARK CONSISTS OF STANDARD CHARACTERS WITHOUT CLAIM TO ANY PARTICULAR FONT, STYLE, SIZE, OR COLOR.

CLASS 29—MEATS AND PROCESSED FOODS

FOR POTATO CHIPS AND PROCESSED PEANUTS (U.S. CL. 46).

CLASS 30—STAPLE FOODS

FOR FRIED CORN SNACKS, CORN-BASED SNACK FOODS, FRIED CORN FLOUR SNACKS, FRIED WHEAT FLOUR SNACKS, PUFFED WHEAT SNACKS (U.S. CL. 46).

DAWN FELDMAN, EXAMINING ATTORNEY

SN 85-607,783. MAYTAG PROPERTIES, LLC, ST. JOSEPH, MI. FILED 4-25-2012.

Cool Core

THE MARK CONSISTS OF STANDARD CHARACTERS WITHOUT CLAIM TO ANY PARTICULAR FONT, STYLE, SIZE, OR COLOR.

NO CLAIM IS MADE TO THE EXCLUSIVE RIGHT TO USE "COOL", APART FROM THE MARK AS SHOWN.

CLASS 7—MACHINERY

FOR COMPRESSORS FOR REFRIGERATORS (U.S. CLS. 13, 19, 21, 23, 31, 34 AND 35).

CLASS 11—ENVIRONMENTAL CONTROL APPARATUS

FOR REFRIGERATORS (U.S. CLS. 13, 21, 23, 31 AND 34).

JORDAN BAKER, EXAMINING ATTORNEY

SN 85-607,812. DIAL GLOBAL, INC., NEW YORK, NY. FILED 4-25-2012.

DEFINING GREAT RADIO

THE MARK CONSISTS OF STANDARD CHARACTERS WITHOUT CLAIM TO ANY PARTICULAR FONT, STYLE, SIZE, OR COLOR.

CLASS 35—ADVERTISING AND BUSINESS

FOR PRODUCTION OF ADVERTISING AND PROMOTIONAL MATERIALS (U.S. CLS. 100, 101 AND 102).

CLASS 41—EDUCATION AND ENTERTAINMENT

FOR PRODUCTION AND DISTRIBUTION OF RADIO PROGRAMS; RADIO ENTERTAINMENT PRODUCTION; RADIO PROGRAM SYNDICATION (U.S. CLS. 100, 101 AND 107).

NATALIE POLZER, EXAMINING ATTORNEY

SN 85-607,853. DIAL GLOBAL, INC., NEW YORK, NY. FILED 4-25-2012.

DEFINING GREAT SPORTS

THE MARK CONSISTS OF STANDARD CHARACTERS WITHOUT CLAIM TO ANY PARTICULAR FONT, STYLE, SIZE, OR COLOR.

CLASS 35—ADVERTISING AND BUSINESS

FOR PRODUCTION OF ADVERTISING AND PROMOTIONAL MATERIALS (U.S. CLS. 100, 101 AND 102).

CLASS 41—EDUCATION AND ENTERTAINMENT

FOR PRODUCTION AND DISTRIBUTION OF RADIO PROGRAMS; RADIO ENTERTAINMENT PRODUCTION; RADIO PROGRAM SYNDICATION (U.S. CLS. 100, 101 AND 107).

NATALIE POLZER, EXAMINING ATTORNEY

SN 85-607,870. DIAL GLOBAL, INC., NEW YORK, NY. FILED 4-25-2012.

DEFINING GREAT MEDIA

THE MARK CONSISTS OF STANDARD CHARACTERS WITHOUT CLAIM TO ANY PARTICULAR FONT, STYLE, SIZE, OR COLOR.

CLASS 35—ADVERTISING AND BUSINESS

FOR PRODUCTION OF ADVERTISING AND PROMOTIONAL MATERIALS (U.S. CLS. 100, 101 AND 102).

CLASS 41—EDUCATION AND ENTERTAINMENT

FOR PRODUCTION AND DISTRIBUTION OF RADIO PROGRAMS; RADIO ENTERTAINMENT PRODUCTION; RADIO PROGRAM SYNDICATION (U.S. CLS. 100, 101 AND 107).

NATALIE POLZER, EXAMINING ATTORNEY

SN 85-608,049. SIRIUSDECISIONS, INC., WILTON, CT.
FILED 4-25-2012.

SN 85-610,531. WORD OF FAITH INTERNATIONAL CHRIS-
TIAN CENTER, SOUTHFIELD, MI. FILED 4-27-2012.

SIRIUSDECISIONS

THE MARK CONSISTS OF STANDARD CHARACTERS WITHOUT CLAIM TO ANY PARTICULAR FONT, STYLE, SIZE, OR COLOR.

CLASS 9—ELECTRICAL AND SCIENTIFIC APPARATUS

FOR DOWNLOADABLE ELECTRONIC NEWSLETTERS IN THE FIELD OF BUSINESS-TO-BUSINESS SALES AND MARKETING (U.S. CLS. 21, 23, 26, 36 AND 38).

FIRST USE 7-31-2003; IN COMMERCE 7-31-2003.

CLASS 16—PAPER GOODS AND PRINTED MATTER

FOR RESEARCH BRIEFS IN THE FIELD OF BUSINESS-TO-BUSINESS SALES AND MARKETING (U.S. CLS. 2, 5, 22, 23, 29, 37, 38 AND 50).

FIRST USE 7-31-2003; IN COMMERCE 7-31-2003.

WENDY JUN, EXAMINING ATTORNEY

SN 85-609,476. JOHNSON & JOHNSON, NEW BRUNSWICK, NJ. FILED 4-26-2012.

BE.FEEL.LIVE.

THE MARK CONSISTS OF STANDARD CHARACTERS WITHOUT CLAIM TO ANY PARTICULAR FONT, STYLE, SIZE, OR COLOR.

CLASS 16—PAPER GOODS AND PRINTED MATTER

FOR PRINTED PUBLICATIONS, NAMELY, BOOKS, MAGAZINES, PAMPHLETS, BOOKLETS AND BROCHURES IN THE FIELD OF HEALTH AND WELLNESS (U.S. CLS. 2, 5, 22, 23, 29, 37, 38 AND 50).

CLASS 44—MEDICAL, BEAUTY AND AGRICULTURAL SERVICES

FOR PROVIDING A WEBSITE FEATURING INFORMATION IN THE FIELD OF HEALTH AND WELLNESS; PROVIDING EDUCATIONAL INFORMATION IN THE FIELD OF HEALTH AND WELLNESS (U.S. CLS. 100 AND 101).

TEJBIR SINGH, EXAMINING ATTORNEY

FAITH4LIFE

THE MARK CONSISTS OF STANDARD CHARACTERS WITHOUT CLAIM TO ANY PARTICULAR FONT, STYLE, SIZE, OR COLOR.

CLASS 16—PAPER GOODS AND PRINTED MATTER

FOR PRINTED INFORMATIONAL PUBLICATIONS AND EDUCATIONAL MATERIAL COVERING RELIGIOUS TOPICS, NAMELY, BULLETINS, BOOKLETS, PAMPHLETS, AND NEWSLETTERS (U.S. CLS. 2, 5, 22, 23, 29, 37, 38 AND 50).

CLASS 45—PERSONAL AND LEGAL SERVICES

FOR EVANGELICAL AND MINISTERIAL SERVICES IN THE NATURE OF CONDUCTING CHURCH SERVICES AND PROMOTING CHRISTIAN BELIEFS THROUGH A RELIGIOUS ORGANIZATION; RELIGIOUS SERVICES, NAMELY, MINISTERIAL SERVICES, EVANGELICAL SERVICES, PREACHING SERVICES, CONDUCTING RELIGIOUS SERVICES, AND PERSONAL RELIGIOUS COUNSELING (U.S. CLS. 100 AND 101).

STEVEN R. FINE, EXAMINING ATTORNEY

SN 85-611,100. BRANDON MCCARTNEY, OAKLAND, CA. FILED 4-28-2012.

Lil B

THE MARK CONSISTS OF STANDARD CHARACTERS WITHOUT CLAIM TO ANY PARTICULAR FONT, STYLE, SIZE, OR COLOR.

OWNER OF U.S. REG. NO. 3,721,092.

"LIL B" IDENTIFIES THE STAGE NAME OF BRANDON MCCARTNEY, A LIVING INDIVIDUAL WHOSE CONSENT IS OF RECORD.

CLASS 9—ELECTRICAL AND SCIENTIFIC APPARATUS

FOR AUDIO AND VIDEO RECORDINGS FEATURING MUSIC AND ARTISTIC PERFORMANCES; AUDIO AND VIDEO RECORDINGS FEATURING MUSIC; AUDIO RECORDINGS FEATURING MUSIC; COMPACT DISCS FEATURING MUSIC; DIGITAL MATERIALS, NAMELY, CDS AND DOWNLOADABLE AUDIO FILES FEATURING MUSIC; DIGITAL MEDIA, NAMELY, CDS AND DOWNLOADABLE AUDIO FILES FEATURING MUSIC; DOWNLOADABLE MP3 FILES AND MP3 RECORDINGS FEATURING MUSIC; DOWNLOADABLE MUSICAL SOUND RECORDINGS; MUSICAL RECORDINGS; MUSICAL SOUND RECORDINGS; MUSICAL VIDEO RECORDINGS; VISUAL AND AUDIO RECORDINGS FEATURING MUSIC (U.S. CLS. 21, 23, 26, 36 AND 38).

FIRST USE 1-1-2005; IN COMMERCE 1-1-2005.

CLASS 16—PAPER GOODS AND PRINTED MATTER

FOR ART PRINTS; POSTERS (U.S. CLS. 2, 5, 22, 23, 29, 37, 38 AND 50).
FIRST USE 1-1-2005; IN COMMERCE 1-1-2005.

CLASS 25—CLOTHING

FOR T-SHIRTS FOR ADULTS, CHILDREN, WOMEN, AND MEN (U.S. CLS. 22 AND 39).
FIRST USE 1-1-2005; IN COMMERCE 1-1-2005.
HEATHER THOMPSON, EXAMINING ATTORNEY

SN 85-611,200. FRANKLIN, KEN, VICKSBURG, MI. FILED 4-28-2012.

Plunder!

THE MARK CONSISTS OF STANDARD CHARACTERS WITHOUT CLAIM TO ANY PARTICULAR FONT, STYLE, SIZE, OR COLOR.

CLASS 9—ELECTRICAL AND SCIENTIFIC APPARATUS

FOR COMPUTER GAME SOFTWARE FOR PERSONAL COMPUTERS AND HOME VIDEO GAME CONSOLES; COMPUTER GAME SOFTWARE FOR USE ON MOBILE AND CELLULAR PHONES (U.S. CLS. 21, 23, 26, 36 AND 38).
FIRST USE 7-1-1990; IN COMMERCE 7-1-1990.

CLASS 28—TOYS AND SPORTING GOODS

FOR BOARD GAMES (U.S. CLS. 22, 23, 38 AND 50).
FIRST USE 7-1-1990; IN COMMERCE 7-1-1990.
DAVID H. STINE, EXAMINING ATTORNEY

SN 85-611,690. EXHIBITUS, INC., TUCKER, GA. FILED 4-30-2012.



THE MARK CONSISTS OF THE WORD "EXHIBITUS" UNDERNEATH A GEOMETRIC SOLID IN THE SHAPE OF A QUARTERED SPHERE FORMED BY TWO (2) ROUNDED "M" ARCHES CONNECTED AT THEIR BASE.

CLASS 40—MATERIAL TREATMENT

FOR CUSTOM FABRICATION OF THREE-DIMENSIONAL MARKETING ENVIRONMENTS FOR OTHERS IN THE NATURE OF TRADE SHOW AND CONVENTION EXHIBITS, KIOSKS, MUSEUM DISPLAYS, CORPORATE ENTRANCES AND INTERIORS, MOBILE EXHIBITS AND VEHICLES, SHOW ROOMS, CORPORATE PRESENTATIONS, AND OTHER VENUES (U.S. CLS. 100, 103 AND 106).
FIRST USE 1-1-2006; IN COMMERCE 1-1-2006.

CLASS 42—SCIENTIFIC AND COMPUTER SERVICES

FOR CUSTOM DESIGN OF THREE-DIMENSIONAL MARKETING ENVIRONMENTS FOR OTHERS IN THE NATURE OF TRADE SHOW AND CONVENTION EXHIBITS, KIOSKS, MUSEUM DISPLAYS, CORPORATE ENTRANCES AND INTERIORS, MOBILE EXHIBITS AND VEHICLES, SHOW ROOMS, CORPORATE PRESENTATIONS, AND OTHER VENUES (U.S. CLS. 100 AND 101).
FIRST USE 1-1-2006; IN COMMERCE 1-1-2006.
JEANIE LEE, EXAMINING ATTORNEY

SN 85-612,892. SUPERVALU INC., EDEN PRAIRIE, MN. FILED 5-1-2012.

SEASONAL ESSENTIALS

THE MARK CONSISTS OF STANDARD CHARACTERS WITHOUT CLAIM TO ANY PARTICULAR FONT, STYLE, SIZE, OR COLOR.
NO CLAIM IS MADE TO THE EXCLUSIVE RIGHT TO USE "SEASONAL", APART FROM THE MARK AS SHOWN.

CLASS 6—METAL GOODS

FOR METAL GAZEBOS; METAL PICTURE HANGERS (U.S. CLS. 2, 12, 13, 14, 23, 25 AND 50).

CLASS 8—HAND TOOLS

FOR HAND TOOLS FOR USE IN CARVING OR DECORATING PUMPKINS, FRUITS AND VEGETABLES, NAMELY, KNIVES, SAWS, SCOOPS, CHISELS AND DRILLS; GARDENING TOOLS, NAMELY, WEEDING FORKS, SPADES AND HOES; PLASTIC CUTLERY, NAMELY, KNIVES, FORKS AND SPOONS (U.S. CLS. 23, 28 AND 44).

CLASS 11—ENVIRONMENTAL CONTROL APPARATUS

FOR BATTERY OPERATED ELECTRIC CANDLES; FIRE TABLES; LIGHTED PARTY-THEMED DECORATIONS, NAMELY, ELECTRIC LIGHT DECORATIVE STRINGS (U.S. CLS. 13, 21, 23, 31 AND 34).

CLASS 16—PAPER GOODS AND PRINTED MATTER

FOR PAPER GIFT WRAP AND BAGS; PAPER GIFT WRAP BOWS AND RIBBON; TISSUE PAPER; PAPER NAPKINS; PAPER TOWELS; GREETING CARDS; NOTE PADS; TATTOO STICKERS, NAMELY, TEMPORARY TATTOOS AND REMOVABLE TATTOOS; PLASTIC FOOD STORAGE BAGS FOR HOUSEHOLD USE; PHOTO ALBUMS; ERASERS (U.S. CLS. 2, 5, 22, 23, 29, 37, 38 AND 50).

CLASS 18—LEATHER GOODS

FOR PATIO UMBRELLAS; REUSABLE SHOPPING BAGS (U.S. CLS. 1, 2, 3, 22 AND 41).

CLASS 20—FURNITURE AND ARTICLES NOT OTHERWISE CLASSIFIED

FOR WIND CHIMES; PATIO FURNITURE; HOLIDAY ORNAMENTS, NAMELY, PLASTIC EASTER EGGS; VINYL APPLIQUES FOR ATTACHMENT TO WINDOWS; PICTURE FRAMES; DECORATIVE PILLOWS; FIGURINES OF WOOD; PLASTIC CONTAINERS FOR FOOD STORAGE FOR THE FOOD INDUSTRY (U.S. CLS. 2, 13, 22, 25, 32 AND 50).

CLASS 21—HOUSEWARES AND GLASS

FOR SERVING TRAYS; BUCKETS; WOODEN BASKETS; PAPER PLATES; SERVING BOWLS; BIRD HOUSES; PLASTIC CUPS; FLOWER POTS; FLY SWATERS; LAWN SPRINKLERS; WATERING CANS; GRILL ACCESSORIES, NAMELY, SKEWERS, TONGS, SPATULAS, BRUSHES, GRILLING WIRE BASKETS; PLASTIC WATER BOTTLES SOLD EMPTY; PAILS (U.S. CLS. 2, 13, 23, 29, 30, 33, 40 AND 50).

CLASS 24—FABRICS

FOR KITCHEN TOWELS; BLANKET THROWS; BED SHEETS; INTERIOR DECORATIVE FABRICS; FABRIC TABLE RUNNERS (U.S. CLS. 42 AND 50).

CLASS 25—CLOTHING

FOR HATS AND HEADBANDS; SLEEP PANTS; SLIPPERS AND SOCKS; COSTUMES FOR CHILDREN'S DRESS UP PLAY; FLEECE BOTTOMS AND TOPS; FOOTWEAR, NAMELY, FLIP FLOPS AND SANDALS; BOXER SHORTS (U.S. CLS. 22 AND 39).

CLASS 26—FANCY GOODS

FOR ARTIFICIAL WREATHS (U.S. CLS. 37, 39, 40, 42 AND 50).

CLASS 28—TOYS AND SPORTING GOODS

FOR CHRISTMAS TREE ORNAMENTS AND DECORATIONS; HANGERS FOR CHRISTMAS TREE ORNAMENTS; STUFFED TOYS; CHRISTMAS STOCKINGS; DOLLS; ARTIFICIAL CHRISTMAS TREES; CHRISTMAS TREE SKIRTS; TOY AND NOVELTY FACE MASKS; CONFETTI; BOARD GAMES (U.S. CLS. 22, 23, 38 AND 50).

WARREN L. OLANDRIA, EXAMINING ATTORNEY

SN 85-615,011. DAIMLER AG, STUTTGART, FED REP GERMANY, FILED 5-2-2012.

for-us

THE MARK CONSISTS OF STANDARD CHARACTERS WITHOUT CLAIM TO ANY PARTICULAR FONT, STYLE, SIZE, OR COLOR.

PRIORITY CLAIMED UNDER SEC. 44(D) ON FED REP GERMANY APPLICATION NO. 302011061211, FILED 11-11-2011, REG. NO. 302011061211, DATED 2-20-2012, EXPIRES 11-30-2021.

CLASS 12—VEHICLES

FOR AUTOMOBILES AND THEIR STRUCTURAL PARTS (U.S. CLS. 19, 21, 23, 31, 35 AND 44).

CLASS 28—TOYS AND SPORTING GOODS

FOR TOY MODEL VEHICLES (U.S. CLS. 22, 23, 38 AND 50).

CAITLIN WATTS-FITZGERALD, EXAMINING ATTORNEY

SN 85-615,618. THE PROCTER & GAMBLE COMPANY, CINCINNATI, OH. FILED 5-3-2012.

MIX. MATCH. WOW. REPEAT.
PLAY YOUR WAY TO
PERFECTION.

THE MARK CONSISTS OF STANDARD CHARACTERS WITHOUT CLAIM TO ANY PARTICULAR FONT, STYLE, SIZE, OR COLOR.

CLASS 3—COSMETICS AND CLEANING PREPARATIONS

FOR NON-MEDICATED SKIN CARE PREPARATIONS AND COSMETICS (U.S. CLS. 1, 4, 6, 50, 51 AND 52).

CLASS 21—HOUSEWARES AND GLASS

FOR BATTERY OPERATED FACIAL BRUSH USED TO CLEAN THE SKIN (U.S. CLS. 2, 13, 23, 29, 30, 33, 40 AND 50).

VERNA BETH RIRIE, EXAMINING ATTORNEY

SN 85-615,953. WORD OF FAITH INTERNATIONAL CHRISTIAN CENTER, SOUTHFIELD, MI. FILED 5-3-2012.

12 OPS

THE MARK CONSISTS OF STANDARD CHARACTERS WITHOUT CLAIM TO ANY PARTICULAR FONT, STYLE, SIZE, OR COLOR.

CLASS 25—CLOTHING

FOR CLOTHING, NAMELY, SHORTS, PANTS, JACKETS, SWEATERS, SWEATSHIRTS, T-SHIRTS, HEADBANDS, WRISTBANDS, HATS AND CAPS (U.S. CLS. 22 AND 39).

CLASS 45—PERSONAL AND LEGAL SERVICES

FOR EVANGELICAL AND MINISTERIAL SERVICES IN THE NATURE OF CONDUCTING CHURCH SERVICES AND PROMOTING CHRISTIAN BELIEFS THROUGH A RELIGIOUS ORGANIZATION; RELIGIOUS SERVICES, NAMELY, MINISTERIAL SERVICES, EVANGELICAL SERVICES, PREACHING SERVICES, CONDUCTING RELIGIOUS SERVICES, AND PERSONAL RELIGIOUS COUNSELING (U.S. CLS. 100 AND 101).

STEVEN R. FINE, EXAMINING ATTORNEY

SN 85-619,721. LEVIN, ALAN, CABIN JOHN, MD. FILED 5-8-2012.

SN 85-618,046. ASPEN SKIING COMPANY, ASPEN, CO. FILED 5-7-2012.

D&E

THE MARK CONSISTS OF STANDARD CHARACTERS WITHOUT CLAIM TO ANY PARTICULAR FONT, STYLE, SIZE, OR COLOR.

CLASS 35—ADVERTISING AND BUSINESS

FOR RETAIL SPORTING GOODS STORES (U.S. CLS. 100, 101 AND 102).
FIRST USE 10-5-1993; IN COMMERCE 10-5-1993.

CLASS 41—EDUCATION AND ENTERTAINMENT

FOR RENTAL OF SKI AND SNOWBOARD EQUIPMENT (U.S. CLS. 100, 101 AND 107).
FIRST USE 10-5-1993; IN COMMERCE 10-5-1993.
JEFF DEFORD, EXAMINING ATTORNEY

SN 85-619,370. BOARD OF GOVERNORS OF THE COLORADO STATE UNIVERSITY SYSTEM, ACTING BY AND THROUGH COLORADO STATE UNIVERSITY, DENVER, CO. FILED 5-8-2012.

Colorado State University

THE MARK CONSISTS OF STANDARD CHARACTERS WITHOUT CLAIM TO ANY PARTICULAR FONT, STYLE, SIZE, OR COLOR.

OWNER OF U.S. REG. NOS. 1,492,718, 2,039,973 AND OTHERS.

NO CLAIM IS MADE TO THE EXCLUSIVE RIGHT TO USE "STATE UNIVERSITY", APART FROM THE MARK AS SHOWN.

SEC. 2(F).

CLASS 25—CLOTHING

FOR CLOTHING, NAMELY, T-SHIRTS, POLO SHIRTS, SWEATPANTS AND SWEATSHIRTS (U.S. CLS. 22 AND 39).

FIRST USE 5-31-1957; IN COMMERCE 5-31-1957.

CLASS 41—EDUCATION AND ENTERTAINMENT

FOR EDUCATIONAL SERVICES, NAMELY, PROVIDING COURSES OF INSTRUCTION AT THE UNIVERSITY LEVEL AND EDUCATIONAL RESEARCH; AND ENTERTAINMENT IN THE NATURE OF ARRANGING AND CONDUCTING COLLEGIATE ATHLETIC EVENTS, AND MUSIC CONCERTS, PLAYS AND CULTURAL EVENTS (U.S. CLS. 100, 101 AND 107).

FIRST USE 5-31-1957; IN COMMERCE 5-31-1957.
SHAILA SETTLES, EXAMINING ATTORNEY**CAPTAIN
VIDEO**

NO CLAIM IS MADE TO THE EXCLUSIVE RIGHT TO USE "VIDEO", APART FROM THE MARK AS SHOWN.

THE NAME(S), PORTRAIT(S), AND/OR SIGNATURE(S) SHOWN IN THE MARK DOES NOT IDENTIFY A PARTICULAR LIVING INDIVIDUAL.

THE MARK CONSISTS OF THE STYLIZED WORDS "CAPTAIN VIDEO." THE LETTERS IN THE WORDS LOOK LIKE LIGHTNING BOLTS.

CLASS 38—COMMUNICATION

FOR COMMUNICATION SERVICES, NAMELY, TRANSMISSION OF VOICE, AUDIO, VISUAL IMAGES AND DATA BY TELECOMMUNICATIONS NETWORKS, WIRELESS COMMUNICATION NETWORKS, THE INTERNET, INFORMATION SERVICES NETWORKS AND DATA NETWORKS; RADIO AND TELEVISION BROADCASTING SERVICES (U.S. CLS. 100, 101 AND 104).

CLASS 41—EDUCATION AND ENTERTAINMENT

FOR ENTERTAINMENT IN THE NATURE OF ONGOING TELEVISION PROGRAMS IN THE FIELD OF SCIENCE FICTION; PRODUCTION AND DISTRIBUTION OF TELEVISION SHOWS AND MOVIES (U.S. CLS. 100, 101 AND 107).

GENE MACIOL, EXAMINING ATTORNEY

SN 85-620,911. AW CHANG CORPORATION, COMPTON, CA. FILED 5-9-2012.

CALABRUM

THE MARK CONSISTS OF STANDARD CHARACTERS WITHOUT CLAIM TO ANY PARTICULAR FONT, STYLE, SIZE, OR COLOR.

CLASS 25—CLOTHING

FOR WEARABLE GARMENTS AND CLOTHING, NAMELY, SHIRTS (U.S. CLS. 22 AND 39).

CLASS 35—ADVERTISING AND BUSINESS

FOR RETAIL CLOTHING BOUTIQUES (U.S. CLS. 100, 101 AND 102).

CAROLINE WOOD, EXAMINING ATTORNEY

SN 85-620,927. AW CHANG CORPORATION, COMPTON, CA. FILED 5-9-2012.

SN 85-624,753. COVENANT MULTI-FAMILY OFFICES, LLC, SAN ANTONIO, TX. FILED 5-14-2012.

SIRCO

THE MARK CONSISTS OF STANDARD CHARACTERS WITHOUT CLAIM TO ANY PARTICULAR FONT, STYLE, SIZE, OR COLOR.

CLASS 25—CLOTHING

FOR WEARABLE GARMENTS AND CLOTHING, NAMELY, SHIRTS (U.S. CLS. 22 AND 39).

CLASS 35—ADVERTISING AND BUSINESS

FOR RETAIL CLOTHING BOUTIQUES (U.S. CLS. 100, 101 AND 102).

CAROLINE WOOD, EXAMINING ATTORNEY

SN 85-622,464. SCHEMER, ROBERT, JACKSONVILLE, FL. FILED 5-11-2012.



THE MARK CONSISTS OF THE LITERAL ELEMENTS "SAIKHEL" WRITTEN IN STYLIZED FORM WHEREIN A STAR HAS BEEN PLACED OVER THE LETTER "I" AS SHOWN IN THE MARK.

THE ENGLISH TRANSLATION OF THE WORD "SAIKHEL" IN THE MARK IS "COMMON SENSE".

CLASS 3—COSMETICS AND CLEANING PREPARATIONS

FOR HAND SOAPS; LIQUID SOAPS; COLOGNE; PERFUME; DEODORANTS FOR PERSONAL USE; NON-MEDICATED TOILETRIES (U.S. CLS. 1, 4, 6, 50, 51 AND 52).

CLASS 25—CLOTHING

FOR CLOTHING, NAMELY, TOPS, BOTTOMS, T-SHIRTS, SWEATSHIRTS, HATS, SHORTS, SKIRTS, DRESSES, PANTS, SWIMWEAR, BEACHWEAR, JACKETS, COATS, GLOVES, SOCKS, SHOES, AND UNDERWEAR (U.S. CLS. 22 AND 39).

AISHA SALEM, EXAMINING ATTORNEY

LIFEDECK

THE MARK CONSISTS OF STANDARD CHARACTERS WITHOUT CLAIM TO ANY PARTICULAR FONT, STYLE, SIZE, OR COLOR.

CLASS 9—ELECTRICAL AND SCIENTIFIC APPARATUS

FOR DOWNLOADABLE ELECTRONIC DOCUMENTS IN THE FIELDS OF WEALTH MANAGEMENT, FINANCIAL PLANNING, ESTATE PLANNING, GIFT PLANNING, RETIREMENT PLANNING, INVESTMENT MANAGEMENT, RISK MANAGEMENT, ASSET MANAGEMENT, FAMILY GOVERNANCE AND EDUCATION, COMMUNITY INVOLVEMENT, AND PHILANTHROPY; COMPUTER SOFTWARE FOR ADDRESSING QUESTIONS AND CONSIDERATIONS IN THE FIELDS OF WEALTH MANAGEMENT, FINANCIAL PLANNING, ESTATE PLANNING, GIFT PLANNING, RETIREMENT PLANNING, INVESTMENT MANAGEMENT, RISK MANAGEMENT, ASSET MANAGEMENT, FAMILY GOVERNANCE AND EDUCATION, COMMUNITY INVOLVEMENT, AND PHILANTHROPY; DOWNLOADABLE COMPUTER SOFTWARE FOR ADDRESSING QUESTIONS AND CONSIDERATIONS IN THE FIELDS OF WEALTH MANAGEMENT, FINANCIAL PLANNING, ESTATE PLANNING, GIFT PLANNING, RETIREMENT PLANNING, INVESTMENT MANAGEMENT, RISK MANAGEMENT, ASSET MANAGEMENT, FAMILY GOVERNANCE AND EDUCATION, COMMUNITY INVOLVEMENT, AND PHILANTHROPY; DOWNLOADABLE SOFTWARE IN THE NATURE OF A MOBILE APPLICATION FOR ADDRESSING QUESTIONS AND CONSIDERATIONS IN THE FIELDS OF WEALTH MANAGEMENT, FINANCIAL PLANNING, ESTATE PLANNING, GIFT PLANNING, RETIREMENT PLANNING, INVESTMENT MANAGEMENT, RISK MANAGEMENT, ASSET MANAGEMENT, FAMILY GOVERNANCE AND EDUCATION, COMMUNITY INVOLVEMENT, AND PHILANTHROPY (U.S. CLS. 21, 23, 26, 36 AND 38).

CLASS 16—PAPER GOODS AND PRINTED MATTER

FOR PRINTED INFORMATIONAL MATERIALS IN THE FIELDS OF WEALTH MANAGEMENT, FINANCIAL PLANNING, ESTATE PLANNING, GIFT PLANNING, RETIREMENT PLANNING, INVESTMENT MANAGEMENT, RISK MANAGEMENT, ASSET MANAGEMENT, FAMILY GOVERNANCE AND EDUCATION, COMMUNITY INVOLVEMENT, AND PHILANTHROPY (U.S. CLS. 2, 5, 22, 23, 29, 37, 38 AND 50).

ALLISON SCHRODY, EXAMINING ATTORNEY

SN 85-625,980. CSC BRANDS LP, CAMDEN, NJ. FILED 5-15-2012.

SOUPERISTA

THE MARK CONSISTS OF STANDARD CHARACTERS WITHOUT CLAIM TO ANY PARTICULAR FONT, STYLE, SIZE, OR COLOR.

CLASS 7—MACHINERY

FOR FOOD AND BEVERAGE DISPENSERS, NAMELY, TABLE TOP MIXING AND VENDING MACHINES (U.S. CLS. 13, 19, 21, 23, 31, 34 AND 35).

CLASS 11—ENVIRONMENTAL CONTROL APPARATUS

FOR TEMPERATURE-CONTROLLED FOOD AND BEVERAGE DISPENSERS (U.S. CLS. 13, 21, 23, 31 AND 34).

CLASS 29—MEATS AND PROCESSED FOODS

FOR SOUPS (U.S. CL. 46).
LEIGH CAROLINE CASE, EXAMINING ATTORNEY

SN 85-626,648. CSC BRANDS LP, CAMDEN, NJ. FILED 5-16-2012.

CAMPBELL'S SOUPERISTA

THE MARK CONSISTS OF STANDARD CHARACTERS WITHOUT CLAIM TO ANY PARTICULAR FONT, STYLE, SIZE, OR COLOR.

OWNER OF U.S. REG. NOS. 48,461, 804,371 AND OTHERS.

CLASS 7—MACHINERY

FOR FOOD AND BEVERAGE DISPENSERS, NAMELY, TABLE TOP MIXING AND VENDING MACHINES (U.S. CLS. 13, 19, 21, 23, 31, 34 AND 35).

CLASS 11—ENVIRONMENTAL CONTROL APPARATUS

FOR TEMPERATURE-CONTROLLED FOOD AND BEVERAGE DISPENSERS (U.S. CLS. 13, 21, 23, 31 AND 34).

CLASS 29—MEATS AND PROCESSED FOODS

FOR SOUPS (U.S. CL. 46).
LEIGH CAROLINE CASE, EXAMINING ATTORNEY

SN 85-629,371. CHS INC., INVER GROVE HEIGHTS, MN. FILED 5-18-2012.

DISTILLER'S PRO

THE MARK CONSISTS OF STANDARD CHARACTERS WITHOUT CLAIM TO ANY PARTICULAR FONT, STYLE, SIZE, OR COLOR.

CLASS 5—PHARMACEUTICALS

FOR FEED SUPPLEMENTS FOR ANIMALS (U.S. CLS. 6, 18, 44, 46, 51 AND 52).
FIRST USE 0-0-2004; IN COMMERCE 0-0-2004.

CLASS 31—NATURAL AGRICULTURAL PRODUCTS

FOR ANIMAL FEED (U.S. CLS. 1 AND 46).
FIRST USE 0-0-2004; IN COMMERCE 0-0-2004.
PAUL E. FAHRENKOPF, EXAMINING ATTORNEY

SN 85-629,862. SEARS BRANDS, LLC, HOFFMAN ESTATES, IL. FILED 5-18-2012.

**SERVING YOUR COMMUNITY
YOUR WAY**

THE MARK CONSISTS OF STANDARD CHARACTERS WITHOUT CLAIM TO ANY PARTICULAR FONT, STYLE, SIZE, OR COLOR.

CLASS 35—ADVERTISING AND BUSINESS

FOR CHARITABLE SERVICES, NAMELY, ORGANIZING AND CONDUCTING VOLUNTEER PROGRAMS AND COMMUNITY SERVICE PROJECTS (U.S. CLS. 100, 101 AND 102).

CLASS 36—INSURANCE AND FINANCIAL

FOR CHARITABLE FUNDRAISING SERVICES BY MEANS OF COORDINATING THE PROCUREMENT OF MONETARY DONATIONS AND THE DISTRIBUTION OF RETAIL GIFT CARDS TO GROUPS OR INDIVIDUALS IN NEED (U.S. CLS. 100, 101 AND 102).

JUHI KAVEESHVAR, EXAMINING ATTORNEY

SN 85-630,964. CHURCH & DWIGHT CO., INC., PRINCETON, NJ. FILED 5-21-2012.

XTRA

THE MARK CONSISTS OF STANDARD CHARACTERS WITHOUT CLAIM TO ANY PARTICULAR FONT, STYLE, SIZE, OR COLOR.

OWNER OF U.S. REG. NOS. 1,637,328, 2,726,860 AND 2,877,617.

CLASS 4—LUBRICANTS AND FUELS

FOR CANDLES, PERFUMED CANDLES, SCENTED CANDLES, TALLOW CANDLES, CANDLE TORCHES (U.S. CLS. 1, 6 AND 15).

CLASS 5—PHARMACEUTICALS

FOR AIR DEODORIZERS FOR AUTOMOTIVE, HOUSEHOLD, COMMERCIAL AND INSTITUTIONAL USE; AIR DEODORIZER FRAGRANCE REFILLS FOR AUTOMOTIVE, HOUSEHOLD, COMMERCIAL AND INSTITUTIONAL USE; CARPET DEODORIZERS AND ODOR ELIMINATORS; AIR AND ROOM DEODORIZERS; DEODORIZERS FOR HOUSEHOLD PET LITTER BOXES; DEODORIZERS FOR GARBAGE DISPOSALS AND OTHER KITCHEN APPLIANCES (U.S. CLS. 6, 18, 44, 46, 51 AND 52).

CLASS 11—ENVIRONMENTAL CONTROL APPARATUS

FOR AIR FRESHENING, AIR PURIFICATION, AIR DEODORIZING AND FRAGRANCE DISPENSING UNITS FOR AUTOMOTIVE, HOUSEHOLD, COMMERCIAL AND INSTITUTIONAL USE, CONSISTING OF AN ELECTRICALLY POWERED FAN, AN AIR FILTER, AND A REPLACEABLE AIR FRESHENING FRAGRANCE CARTRIDGE; ELECTRIC DISPENSERS FOR AIR FRESHENERS AND DEODORIZERS TO BE PLUGGED INTO WALL OUTLETS; PORTABLE ELECTRIC FANS; HUMIDIFIERS FOR HOUSEHOLD, INDUSTRIAL AND COMMERCIAL PURPOSES; AIR PURIFIERS FOR AUTOMOTIVE, HOUSEHOLD, INDUSTRIAL AND COMMERCIAL PURPOSES; AIR CLEANERS FOR AUTOMOTIVE, HOUSEHOLD, COMMERCIAL AND INSTITUTIONAL USE; FILTERS FOR HUMIDIFIERS; AIR FILTERS FOR AIR CONDITIONING UNITS; AIR FILTERS FOR HVAC UNITS; AIR FILTER MACHINES FOR AUTOMOTIVE, HOUSEHOLD, COMMERCIAL AND INSTITUTIONAL USE AND REPLACEMENT FILTERS FOR SUCH AIR FILTER MACHINES; WATER FILTERS FOR DOMESTIC, INDUSTRIAL AND COMMERCIAL PURPOSES (U.S. CLS. 13, 21, 23, 31 AND 34).

JOHN HWANG, EXAMINING ATTORNEY

CLASS 9—ELECTRICAL AND SCIENTIFIC APPARATUS

FOR AUDIO AND VIDEO RECORDINGS FEATURING MATERIALS IN THE FIELDS OF RELIGION, SPIRITUALITY, ETHICS, CULTURAL ISSUES, AND SOCIAL ISSUES; CHILDREN'S EDUCATIONAL SOFTWARE; DIGITAL MEDIA, NAMELY, PRE-RECORDED VIDEO CASSETTES, DIGITAL VIDEO DISCS, DIGITAL VERSATILE DISCS, DOWNLOADABLE AUDIO AND VIDEO RECORDINGS, DVDS, AND HIGH DEFINITION DIGITAL DISCS FEATURING MATERIALS IN THE FIELDS OF RELIGION, SPIRITUALITY, ETHICS, CULTURAL ISSUES, AND SOCIAL ISSUES; EDUCATIONAL SOFTWARE FEATURING INSTRUCTION IN THE FIELDS OF RELIGION, SPIRITUALITY, ETHICS, CULTURAL ISSUES, AND SOCIAL ISSUES; ELECTRONIC PUBLICATIONS, NAMELY, BOOKS, BROCHURES, MANUALS, PAMPHLETS, MAGAZINES, NEWSPAPERS, NEWSLETTERS, BOOKLETS, COMPUTER PROGRAM MANUALS, AND BULLETINS FEATURING MATERIALS IN THE FIELDS OF RELIGION, SPIRITUALITY, ETHICS, CULTURAL ISSUES, AND SOCIAL ISSUES RECORDED ON COMPUTER MEDIA; INTERACTIVE MULTIMEDIA COMPUTER PROGRAM FOR GAMES AND STUDY MATERIALS IN THE FIELDS OF RELIGION, SPIRITUALITY, ETHICS, CULTURAL ISSUES, AND SOCIAL ISSUES (U.S. CLS. 21, 23, 26, 36 AND 38).

CLASS 16—PAPER GOODS AND PRINTED MATTER

FOR ART PICTURES; BOOKLETS IN THE FIELD OF RELIGION, SPIRITUALITY, ETHICS, CULTURAL ISSUES, AND SOCIAL ISSUES; BOOKS IN THE FIELD OF RELIGION, SPIRITUALITY, ETHICS, CULTURAL ISSUES, AND SOCIAL ISSUES; BROCHURES ABOUT RELIGION, SPIRITUALITY, ETHICS, CULTURAL ISSUES, AND SOCIAL ISSUES; BULLETINS CONCERNING RELIGION, SPIRITUALITY, ETHICS, CULTURAL ISSUES, AND SOCIAL ISSUES; CHILDREN'S BOOKS; COMPUTER PROGRAM MANUALS FOR SOFTWARE IN THE FIELDS OF RELIGION, SPIRITUALITY, ETHICS, CULTURAL ISSUES, AND SOCIAL ISSUES; EDUCATIONAL PUBLICATIONS, NAMELY, TRAINING MANUALS IN THE FIELD OF RELIGION, SPIRITUALITY, ETHICS, CULTURAL ISSUES, AND SOCIAL ISSUES; MAGAZINES IN THE FIELD OF RELIGION, SPIRITUALITY, ETHICS, CULTURAL ISSUES, AND SOCIAL ISSUES; MANUALS IN THE FIELD OF RELIGION, SPIRITUALITY, ETHICS, CULTURAL ISSUES, AND SOCIAL ISSUES; NEWSLETTERS IN THE FIELD OF RELIGION, SPIRITUALITY, ETHICS, CULTURAL ISSUES, AND SOCIAL ISSUES; NEWSPAPERS IN THE FIELD OF RELIGION, SPIRITUALITY, ETHICS, CULTURAL ISSUES, AND SOCIAL ISSUES; PAMPHLETS IN THE FIELD OF RELIGION, SPIRITUALITY, ETHICS, CULTURAL ISSUES, AND SOCIAL ISSUES; PRINTED INSTRUCTIONAL, EDUCATIONAL, AND TEACHING MATERIALS IN THE FIELD OF RELIGION, SPIRITUALITY, ETHICS, CULTURAL ISSUES, AND SOCIAL ISSUES; PRINTED LECTURES; PRINTED LESSONS ON THE FIELDS OF RELIGION, SPIRITUALITY, ETHICS, CULTURAL ISSUES, AND SOCIAL ISSUES; PRINTED SEMINAR NOTES; PRINTED TEACHING MATERIALS IN THE FIELD OF RELIGION, SPIRITUALITY, ETHICS, CULTURAL ISSUES, AND SOCIAL ISSUES; PRINTED VISUALS IN THE NATURE OF INFORMATION GRAPHICS, PROMOTIONAL MATERIAL, AND RELIGIOUS BOOKS (U.S. CLS. 2, 5, 22, 23, 29, 37, 38 AND 50).

SN 85-632,809. AWANA CLUBS INTERNATIONAL, STREAMWOOD, IL. FILED 5-23-2012.



THE MARK CONSISTS OF A STYLIZED LETTER "K" WHERE THE VERTICAL LINE OF THE LETTER IS AN EXCLAMATION POINT ON A GEOMETRIC CARRIER HAVING FIVE SIDES.

CLASS 25—CLOTHING

FOR TOPS (U.S. CLS. 22 AND 39).

CLASS 28—TOYS AND SPORTING GOODS

FOR BAGS SPECIALLY ADAPTED FOR SPORTS EQUIPMENT; SPORT BALLS (U.S. CLS. 22, 23, 38 AND 50).

CLASS 41—EDUCATION AND ENTERTAINMENT

FOR ARRANGING OF SEMINARS; ARRANGING PROFESSIONAL WORKSHOP AND TRAINING COURSES; CONDUCTING EDUCATIONAL EXHIBITIONS IN THE NATURE OF EXHIBITIONS IN THE FIELDS OF RELIGION, SPIRITUALITY, ETHICS, CULTURAL ISSUES, AND SOCIAL ISSUES; EDUCATIONAL AND ENTERTAINMENT SERVICES, NAMELY, PROVIDING MOTIVATIONAL AND EDUCATIONAL SPEAKERS; EDUCATIONAL SERVICES, NAMELY, CONDUCTING PROGRAMS, CLASSES, LECTURES, SEMINARS, CONFERENCES, AND WORKSHOPS IN THE FIELD OF RELIGION, SPIRITUALITY, ETHICS, CULTURAL ISSUES, AND SOCIAL ISSUES AND DISTRIBUTION OF TRAINING MATERIAL IN CONNECTION THEREWITH; EDUCATIONAL SERVICES, NAMELY, DEVELOPING, ARRANGING, AND CONDUCTING EDUCATIONAL CONFERENCES AND PROGRAMS AND PROVIDING COURSES OF INSTRUCTION IN THE FIELD OF RELIGION, SPIRITUALITY, ETHICS, CULTURAL ISSUES, AND SOCIAL ISSUES; EDUCATIONAL SERVICES, NAMELY, PROVIDING COURSES OF INSTRUCTION AT THE PRE-SCHOOL, ELEMENTARY, SECONDARY, AND HIGH SCHOOL LEVEL AND DISTRIBUTION OF COURSE MATERIAL IN CONNECTION THEREWITH; ENTERTAINMENT IN THE NATURE OF LIVE PERFORMANCES BY LECTURERS IN THE FIELDS OF RELIGION, SPIRITUALITY, ETHICS, CULTURAL ISSUES, AND SOCIAL ISSUES; ORGANIZATION OF EXHIBITIONS FOR CULTURAL OR EDUCATIONAL PURPOSES; PROVIDING EDUCATIONAL DEMONSTRATIONS; PROVIDING FACILITIES FOR MOVIES, SHOWS, PLAYS, MUSIC OR EDUCATIONAL TRAINING; RELIGIOUS INSTRUCTION SERVICES; TEACHING IN THE FIELD OF RELIGION, SPIRITUALITY, ETHICS, CULTURAL ISSUES, AND SOCIAL ISSUES; WORKSHOPS AND SEMINARS IN THE FIELD OF RELIGION, SPIRITUALITY, ETHICS, CULTURAL ISSUES, AND SOCIAL ISSUES (U.S. CLS. 100, 101 AND 107).

DOMINIC FATHY, EXAMINING ATTORNEY

CLASS 6—METAL GOODS

FOR METAL UNIVERSAL MOUNTS COMPRISING A BASE, ARMS WITH SOCKETS, BALLS, BOLTS AND TIGHTENERS, TO BE USED WITH A VARIETY OF CUSTOM COMPONENTS TO MOUNT A WIDE VARIETY OF ITEMS, NAMELY, ELECTRONIC DEVICES AND SPORTING EQUIPMENT; PARTS FOR THE AFOREMENTIONED GOODS, NAMELY, DOUBLE-SOCKET METAL MOUNT ARMS (U.S. CLS. 2, 12, 13, 14, 23, 25 AND 50).

FIRST USE 0-0-1992; IN COMMERCE 0-0-1992.

CLASS 12—VEHICLES

FOR MOUNTS FOR ELECTRONIC DEVICES AND SPORTING EQUIPMENT SPECIALLY ADAPTED FOR USE IN VEHICLES (U.S. CLS. 19, 21, 23, 31, 35 AND 44).

FIRST USE 0-0-1992; IN COMMERCE 0-0-1992.
ELIZABETH KAJUBI, EXAMINING ATTORNEY

SN 85-633,466. TERRAIN MERCHANDISING LLC, PHILADELPHIA, PA. FILED 5-23-2012.

BOTANICULTURE

THE MARK CONSISTS OF STANDARD CHARACTERS WITHOUT CLAIM TO ANY PARTICULAR FONT, STYLE, SIZE, OR COLOR.

CLASS 3—COSMETICS AND CLEANING PREPARATIONS

FOR EYESHADOW, FOUNDATION, CONCEALER, BLUSH, LIPSTICK, LIP GLOSS, EYELINER, UNDER EYE LOTION, BODY LOTION, SKIN MOISTURIZER, HAND SOAP, HAND WASH, SHAMPOO, CONDITIONER, HAIR MOUSSE, HAIRSPRAY, HAIR GEL, POMADE, LEAVE-IN CONDITIONER, MOISTURIZING TREATMENTS FOR THE SKIN AND FACE, FACIAL WASHES, FACIAL MASQUES, BODY LOTION, BODY SCRUB, BATH SALTS, COSMETIC SALVES, NON-MEDICATED SERUMS FOR USE ON THE SKIN, FACIAL CLEANSERS, FACIAL TONERS, LIP MOISTURIZERS, HAND CREAM, SCENTED ROOM SPRAY, AIR FRAGRANCING PREPARATIONS, INCENSE, LAUNDRY DETERGENT, ESSENTIAL OILS FOR AROMATHERAPY, PERSONAL USE AND FOOD FLAVORINGS (U.S. CLS. 1, 4, 6, 50, 51 AND 52).

CLASS 4—LUBRICANTS AND FUELS

FOR CANDLES (U.S. CLS. 1, 6 AND 15).

CLASS 5—PHARMACEUTICALS

FOR MEDICINAL HERBAL PREPARATIONS; AIR DEODORIZING PREPARATIONS (U.S. CLS. 6, 18, 44, 46, 51 AND 52).

CLASS 6—METAL GOODS

FOR GARDEN STAKES, TOMATO CAGES, TRELLISES, ARBORS, ARCHES, PLANT SUPPORTS, TREE CAGES, VEGETABLE SUPPORTS, HAND OPERATED GARDEN HOSE REELS, KEY CHAINS, PLANT STAKES ALL MADE OF METAL (U.S. CLS. 2, 12, 13, 14, 23, 25 AND 50).

SN 85-632,977. NATIONAL PRODUCTS, INC., SEATTLE, WA. FILED 5-23-2012.

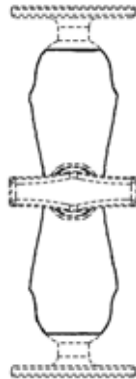

THE MARK CONSISTS OF A THREE-DIMENSIONAL CONFIGURATION OF A DOUBLE-SOCKET MOUNT ARM THAT IS TAPERED IN THE MIDDLE LIKE AN HOURGLASS. THE DOTTED LINES OUTLINING THE ENDS OF THE MOUNT AND THE ADJUSTMENT KNOB INDICATE PLACEMENT OF THE MARK ON THE GOODS AND ARE NOT PART OF THE MARK.

SEC. 2(F).

CLASS 8—HAND TOOLS

FOR TROWELS, SPADES, HOES, SHOVELS, WEEDERS, UTILITY KNIVES, SPOONS, KITCHEN SHEARS (U.S. CLS. 23, 28 AND 44).

CLASS 9—ELECTRICAL AND SCIENTIFIC APPARATUS

FOR MEASURING SPOONS, MEASURING CUPS (U.S. CLS. 21, 23, 26, 36 AND 38).

CLASS 14—JEWELRY

FOR JEWELRY (U.S. CLS. 2, 27, 28 AND 50).

CLASS 17—RUBBER GOODS

FOR GARDEN HOSES (U.S. CLS. 1, 5, 12, 13, 35 AND 50).

CLASS 18—LEATHER GOODS

FOR HANDBAGS, PURSES, TOTE BAGS, OVERNIGHT BAGS, LUGGAGE BAGS, WALLET, CHANGE PURSES, LEATHER KEY CHAINS, POUCHES FOR HOLDING MAKE-UP, KEYS, AND OTHER PERSONAL ITEMS (U.S. CLS. 1, 2, 3, 22 AND 41).

CLASS 19—NON-METALLIC BUILDING MATERIALS

FOR TOMATO CAGE STRUCTURES, TRELLISES, ARBORS, ARCHES, STRUCTURES FOR SUPPORTING PLANTS, TREE CAGE STRUCTURES, STRUCTURES FOR SUPPORTING VEGETABLES, ALL MADE OF PLASTIC OR WOOD (U.S. CLS. 1, 12, 33 AND 50).

CLASS 20—FURNITURE AND ARTICLES NOT OTHERWISE CLASSIFIED

FOR NON-METAL GARDEN STAKES, NON-METAL AND NON-LEATHER KEY CHAINS, OUTDOOR FURNITURE, INDOOR FURNITURE, GARDEN FURNITURE, NON-METAL PLANT STAKES (U.S. CLS. 2, 13, 22, 25, 32 AND 50).

CLASS 21—HOUSEWARES AND GLASS

FOR PLANT CONTAINERS, PLANTERS FOR FLOWERS AND PLANTS, GARDENING GLOVES, WATERING CANS, DISHES, SERVING PLATTERS, BOWLS, MUGS, SERVINGWARE FOR SERVING FOOD AND DRINK, SMALL DISHES, CUTTING BOARDS (U.S. CLS. 2, 13, 23, 29, 30, 33, 40 AND 50).

CLASS 24—FABRICS

FOR BED BLANKETS, TOWELS (U.S. CLS. 42 AND 50).

CLASS 25—CLOTHING

FOR TOPS, SWEATERS, JACKETS, BOTTOMS, SLEEPWEAR, SCARVES (U.S. CLS. 22 AND 39).

CLASS 27—FLOOR COVERINGS

FOR RUGS (U.S. CLS. 19, 20, 37, 42 AND 50).

CLASS 29—MEATS AND PROCESSED FOODS

FOR OLIVE OIL, COOKING OIL, JAMS, FRUIT PRESERVES (U.S. CL. 46).

CLASS 30—STAPLE FOODS

FOR DRIED HERBS, VINEGARS, SAUCES, TEA, HONEY, FOOD SEASONINGS, FLAVORING SYRUP (U.S. CL. 46).

CLASS 31—NATURAL AGRICULTURAL PRODUCTS

FOR GRASS, PLANT AND FLOWER SEEDS; LIVE PLANTS, FRESH HERBS (U.S. CLS. 1 AND 46).

CLASS 32—LIGHT BEVERAGES

FOR SOFT DRINKS, NON-ALCOHOLIC BEVERAGES WITH TEA FLAVOR, NON-ALCOHOLIC BEVERAGES CONTAINING FRUIT JUICES, NON-ALCOHOLIC BEVERAGES, NAMELY CARBONATED BEVERAGES, FRUIT-FLAVORED BEVERAGES (U.S. CLS. 45, 46 AND 48).

WILLIAM JACKSON, EXAMINING ATTORNEY

SN 85-634,291. AKZO NOBEL COATINGS INTERNATIONAL B.V., ARNHEM, NETHERLANDS, FILED 5-24-2012.

SIMPLE ACROSS THE BOARD

THE MARK CONSISTS OF STANDARD CHARACTERS WITHOUT CLAIM TO ANY PARTICULAR FONT, STYLE, SIZE, OR COLOR.

CLASS 2—PAINTS

FOR COATINGS IN THE NATURE OF INTERIOR AND EXTERIOR WOOD FINISHES; PRIMERS FOR PREPARING SURFACES TO BE PAINTED IN THE NATURE OF SURFACE PREPARATIONS (U.S. CLS. 6, 11 AND 16).

CLASS 3—COSMETICS AND CLEANING PREPARATIONS

FOR SURFACE PREPARATIONS FOR WOOD SURFACES TO BE PAINTED OR STAINED IN THE NATURE OF SURFACE CLEANERS AND PAINT AND STAIN STRIPPERS (U.S. CLS. 1, 4, 6, 50, 51 AND 52).

MAYUR VAGHANI, EXAMINING ATTORNEY

SN 85-635,706. HARO, ROBERT B., CARDIFF, CA. FILED 5-25-2012.

SN 85-637,799. NETAPP, INC., SUNNYVALE, CA. FILED 5-29-2012.

STORAGEGRID



THE MARK CONSISTS OF LEFT FACING BOOMERANG SHAPED DESIGN WITH A STYLIZED "R" TO THE RIGHT OF IT.

CLASS 12—VEHICLES

FOR BICYCLES, RACING BICYCLES, MOUNTAIN BICYCLES AND BICYCLE PARTS AND COMPONENTS, NAMELY, FRAMES, HANDLEBARS, HANDLEBAR GRIPS, GEAR WHEELS, DRIVE CHAINS, DISK WHEELS, BAR STEMS, SPROCKETS, BICYCLE PEDALS, BICYCLE SEATS, SEAT POSTS AND SADDLES; BICYCLE WHEELS, RIMS AND STRUCTURAL PARTS THEREFORE, INNER TUBES FOR BICYCLES, RIMS AND SPOKES FOR BICYCLE WHEELS, TIRES FOR BICYCLES; SAFETY PADS FOR BICYCLES; CARRIER BAGS SPECIALLY ADAPTED FOR USE ON BICYCLES (U.S. CLS. 19, 21, 23, 31, 35 AND 44).

CLASS 18—LEATHER GOODS

FOR BAGS, NAMELY, ALL-PURPOSE CARRYING BAGS, ATHLETIC BAGS, GENERAL PURPOSE BAGS FOR TRAVEL, WAIST BAGS, GYM BAGS, BACK PACKS, DUFFLE BAGS, SPORTS BAGS, TRAVEL BAGS, WALLETS, LUGGAGE, ORGANIZER BAGS AND BRIEFCASES, AND PARTS AND ACCESSORIES FOR ALL OF THE FOREGOING BAGS AND PACKS, NAMELY, WAIST STRAPS, SHOULDER STRAPS, STORAGE BAGS, RAIN COVERS AND CARGO POCKETS, NAMELY, POUCHES FOR ATTACHMENT TO THE FOREGOING BAGS AND PACKS (U.S. CLS. 1, 2, 3, 22 AND 41).

CLASS 25—CLOTHING

FOR CLOTHING, NAMELY, T-SHIRTS, SHIRTS, TOPS, SWEAT SHIRTS, SWEAT PANTS, HOODED JACKETS, GLOVES, HATS, CAPS, JACKETS, HEADBANDS; CLOTHING FOR ATHLETIC USE, NAMELY, PADDED SHIRTS, PANTS AND SHORTS, TIGHTS, VESTS, CYCLING PANTS, CYCLING JERSEYS, CYCLING SHORTS, CYCLING SHOES AND CYCLING GLOVES (U.S. CLS. 22 AND 39).

ROBIN CHOSID, EXAMINING ATTORNEY

THE MARK CONSISTS OF STANDARD CHARACTERS WITHOUT CLAIM TO ANY PARTICULAR FONT, STYLE, SIZE, OR COLOR.

OWNER OF U.S. REG. NO. 3,115,736.

CLASS 9—ELECTRICAL AND SCIENTIFIC APPARATUS

FOR COMPUTER SOFTWARE FOR OPTIMIZING STORAGE OF AND ACCESS TO DATA, IMAGES AND RECORDS (U.S. CLS. 21, 23, 26, 36 AND 38).

FIRST USE 12-31-2005; IN COMMERCE 12-31-2005.

CLASS 42—SCIENTIFIC AND COMPUTER SERVICES

FOR TECHNICAL SUPPORT SERVICES, NAMELY TROUBLESHOOTING AND CUSTOMIZATION OF COMPUTER STORAGE SOFTWARE (U.S. CLS. 100 AND 101).

FIRST USE 12-31-2005; IN COMMERCE 12-31-2005.

KATHLEEN LORENZO, EXAMINING ATTORNEY

SN 85-639,069. RUBICON GROUP HOLDING LIMITED, ROAD TOWN, TORTOLA, BR.VIRGIN ISLANDS, FILED 5-30-2012.

TRSA

THE MARK CONSISTS OF STANDARD CHARACTERS WITHOUT CLAIM TO ANY PARTICULAR FONT, STYLE, SIZE, OR COLOR.

CLASS 41—EDUCATION AND ENTERTAINMENT

FOR AMUSEMENT PARK AND THEME PARK SERVICES; AMUSEMENT PARKS; ENTERTAINMENT SERVICES IN THE NATURE OF AN AMUSEMENT PARK ATTRACTION, NAMELY, A THEMED AREA; ENTERTAINMENT SERVICES IN THE NATURE OF AN AMUSEMENT PARK SHOW; ENTERTAINMENT SERVICES, NAMELY, ARRANGING AND CONDUCTING SPECIAL EVENTS AT AN AMUSEMENT PARK (U.S. CLS. 100, 101 AND 107).

CLASS 43—HOTEL AND RESTAURANT SERVICES

FOR BAR SERVICES; HOTEL SERVICES; RESORT HOTEL SERVICES; RESTAURANT AND CAFE SERVICES; RESTAURANT SERVICES (U.S. CLS. 100 AND 101).

TRACY FLETCHER, EXAMINING ATTORNEY

SN 85-639,881. INTELLIGENT NUTRIENTS, LLC, MINNEAPOLIS, MN. FILED 5-31-2012.

Intellimune

THE MARK CONSISTS OF STANDARD CHARACTERS WITHOUT CLAIM TO ANY PARTICULAR FONT, STYLE, SIZE, OR COLOR.

OWNER OF U.S. REG. NO. 3,513,941.

CLASS 3—COSMETICS AND CLEANING PREPARATIONS

FOR HAIR CARE PRODUCTS, NAMELY, SHAMPOOS, CONDITIONERS, SPRAY AND SCULPTING GELS, HAIR COLOR, AND WAVING LOTIONS; SKIN CARE PRODUCTS, NAMELY, MOISTURIZERS, TONERS, SKIN CLEANING CREAMS, BODY AND FACIAL LOTIONS AND GELS, SKIN MASKS AND ASTRINGENTS FOR COSMETIC PURPOSES; COSMETICS, NAMELY, LIPSTICK, EYE SHADOW, FOUNDATION, BLUSH, FACE POWDER, CONCEALER, EYE PENCILS, LIP PENCILS AND MASCARA; PERSONAL CARE PRODUCTS, NAMELY, BODY AND BATH GELS, FRAGRANCES, BODY AND BATH OILS AND BODY LOTIONS, SKIN CREAMS, SKIN LOTIONS, SKIN EMOLLIENTS, MOISTURIZING COSMETIC OILS AND SKIN LOTIONS, PERFUMES AND COLOGNES; AND HOUSEHOLD CLEANING PRODUCTS, NAMELY, ALL-PURPOSE CLEANERS, CLEANERS FOR USE ON DISHES, CLEANERS FOR USE ON FABRIC, AND CLEANERS FOR USE ON FLOORS, WALLS, WINDOWS; INCENSE; AND AROMATIC OILS AND SCENTED OILS THAT ARE USED AND/OR DISTRIBUTED INTO THE AIR THROUGH THE USE OF AROMATHERAPY UNITS AND AIR DIFFUSERS; ROOM AIR FRAGRANCING PREPARATIONS (U.S. CLS. 1, 4, 6, 50, 51 AND 52).

CLASS 4—LUBRICANTS AND FUELS

FOR CANDLES (U.S. CLS. 1, 6 AND 15).

CLASS 5—PHARMACEUTICALS

FOR PERSONAL LUBRICANTS; DISINFECTANT TOILET BOWL CLEANERS; ROOM AIR DEODORIZING PREPARATIONS (U.S. CLS. 6, 18, 44, 46, 51 AND 52).

ANDREA K. NADELMAN, EXAMINING ATTORNEY

SN 85-640,754. HEIFER PROJECT INTERNATIONAL, LITTLE ROCK, AR. FILED 6-1-2012.

good food makes good work

THE MARK CONSISTS OF STANDARD CHARACTERS WITHOUT CLAIM TO ANY PARTICULAR FONT, STYLE, SIZE, OR COLOR.

CLASS 36—INSURANCE AND FINANCIAL

FOR CHARITABLE FUNDRAISING SERVICES (U.S. CLS. 100, 101 AND 102).

CLASS 41—EDUCATION AND ENTERTAINMENT

FOR EDUCATIONAL SERVICES, NAMELY CONDUCTING CLASS, SEMINARS AND LECTURES RELATED TO SUSTAINABLE AGRICULTURE, ANIMAL HUSBANDRY AND ENVIRONMENTAL PROTECTION (U.S. CLS. 100, 101 AND 107).

AMY C. KEAN, EXAMINING ATTORNEY

SN 85-643,643. MARTHA GRAHAM CENTER OF CONTEMPORARY DANCE, NEW YORK, NY. FILED 6-5-2012.

MARTHA GRAHAM DANCE COMPANY

THE MARK CONSISTS OF STANDARD CHARACTERS WITHOUT CLAIM TO ANY PARTICULAR FONT, STYLE, SIZE, OR COLOR.

NO CLAIM IS MADE TO THE EXCLUSIVE RIGHT TO USE "DANCE COMPANY", APART FROM THE MARK AS SHOWN.

THE NAME(S), PORTRAIT(S), AND/OR SIGNATURE(S) SHOWN IN THE MARK DOES NOT IDENTIFY A PARTICULAR LIVING INDIVIDUAL.

CLASS 18—LEATHER GOODS

FOR TOTE BAGS (U.S. CLS. 1, 2, 3, 22 AND 41).
FIRST USE 12-31-2003; IN COMMERCE 12-31-2003.

CLASS 25—CLOTHING

FOR T-SHIRTS, SWEATPANTS AND SWEATSHIRTS (U.S. CLS. 22 AND 39).
FIRST USE 12-31-2003; IN COMMERCE 12-31-2003.

CLASS 41—EDUCATION AND ENTERTAINMENT

FOR ENTERTAINMENT SERVICES IN THE NATURE OF DANCE PERFORMANCES (U.S. CLS. 100, 101 AND 107).

FIRST USE 12-31-1970; IN COMMERCE 12-31-1970.
COLLEEN MULCRONE, EXAMINING ATTORNEY

SN 85-644,490. REAL MADRID CLUB DE FUTBOL, MADRID, SPAIN, FILED 6-6-2012.



THE COLOR(S) GOLD, RED AND BLUE IS/ARE CLAIMED AS A FEATURE OF THE MARK.

THE MARK CONSISTS OF GOLD LETTERS "M", "C", AND "F" OUTLINED IN BLUE WITHIN A GOLD CIRCLE OUTLINED IN BLUE OVERLAPPING A BLUE DIAGONAL BAND WITH A RED, BLUE AND GOLD CROWN ON TOP.

CLASS 16—PAPER GOODS AND PRINTED MATTER

FOR STATIONERY; STATIONERY SETS CONSISTING PRIMARILY OF STATIONERY, PENS OR PENCILS, RULERS, SCISSORS AND STATIONERY COVERS OR STATIONERY CONTAINERS IN THE NATURE OF CARDBOARD BOXES; BINDERS; CALENDARS; POSTERS; BOOKS IN THE FIELD OF FOOTBALL AND BASKETBALL; COMMEMORATIVE BOOKS FEATURING FOOTBALL AND BASKETBALL INFORMATION, FOOTBALL AND BASKETBALL TEAMS, TEAM INFORMATION, SEASON INFORMATION, LEAGUE INFORMATION, HISTORY RELATED INFORMATION; REFERENCE BOOKS IN THE FIELD OF FOOTBALL AND BASKETBALL; AUTOGRAPH BOOKS; MEMORANDUM BOOKS; PICTURE BOOKS; MAGAZINES IN THE FIELD OF FOOTBALL AND BASKETBALL; PRINTED MATERIALS, NAMELY, JOURNALS FEATURING FOOTBALL AND BASKETBALL INFORMATION, FOOTBALL AND BASKETBALL TEAMS, TEAM INFORMATION, SEASON INFORMATION, LEAGUE INFORMATION, HISTORY RELATED INFORMATION; BLANK JOURNALS; BLANK JOURNAL BOOKS; BLANK WRITING JOURNALS; PERSONALIZED WRITING JOURNALS; CUSTOMIZABLE JOURNAL BOOKS; BANNERS AND FLAGS OF PAPER (U.S. CLS. 2, 5, 22, 23, 29, 37, 38 AND 50).

FIRST USE 1-1-2012; IN COMMERCE 1-1-2012.

CLASS 18—LEATHER GOODS

FOR UMBRELLAS; ALL-PURPOSE CARRYING BAGS; DRAWSTRING BAGS; SHOE BAGS FOR TRAVEL; HANDBAGS; ATTACHE CASES; BANDS OF LEATHER; BRIEFCASES; GARMENT BAGS FOR TRAVEL; KEY CASES; SPORT BAGS; GENERAL PURPOSE SPORT TROLLEY BAGS; LEATHER AND IMITATION LEATHER SPORT BAGS AND GENERAL PURPOSE TROLLEY BAGS; LEATHER BAGS AND HANDBAGS; SUITCASES; WALLET; CREDIT CARD CASES AND HOLDERS; LEATHER BINDERS FOR TRAVEL PURPOSES; LEATHER LEADS; LEATHER LEASHES; LEATHER STRAPS; PURSES AND LEATHER PURSES; LEATHER POUCHES (U.S. CLS. 1, 2, 3, 22 AND 41).

FIRST USE 1-1-2012; IN COMMERCE 1-1-2012.

CLASS 21—HOUSEWARES AND GLASS

FOR PLATES, BOWLS, MUGS, CUPS AND DISHES; BEVERAGE GLASSWARE; BUSTS OF GLASS AND CERAMIC; CANDLESTICKS; DECORATIVE CENTERPIECES OF GLASS AND CERAMIC; DRINKING GLASSES; FIGURES, FIGURINES, ORNAMENTS AND SCULPTURES OF GLASS AND CERAMIC; GLASS BEVERAGEWARE; WINE GLASSES; GLASS STOPPERS; SHOT GLASSES; STAMPED GLASS; WORKS OF ART OF GLASS; DECORATIVE GLASS; GLASS AND CERAMIC VASES, DRINKING VESSELS, BOWLS, PLATES AND COOKING POTS; MOSAIC ART TILES MADE OF GLASS AND CERAMIC (U.S. CLS. 2, 13, 23, 29, 30, 33, 40 AND 50).

FIRST USE 1-1-2012; IN COMMERCE 1-1-2012.

CLASS 24—FABRICS

FOR BANNERS AND FLAGS OF TEXTILE, CLOTH AND FABRIC; BED CLOTHES, NAMELY, BED SHEETS, BED BLANKETS, BED LINEN; BED SPREADS; BED BLANKETS; BED SHEETS; BED COVERS; MATTRESS COVERS; BLANKETS, NAMELY, BED BLANKETS, LAP BLANKETS, CHILDREN'S BLANKETS; PILLOW SHAMS, COVERS AND CASES; QUILTS; QUILT COVERS; QUILTS OF TEXTILE; COVERS FOR CUSHIONS (U.S. CLS. 42 AND 50).

FIRST USE 1-1-2012; IN COMMERCE 1-1-2012.

CLASS 28—TOYS AND SPORTING GOODS

FOR BASKETBALLS; FOOTBALLS; BALLS FOR SPORTS; BAGS AND CASES SPECIALLY ADAPTED FOR SPORTS EQUIPMENT; SPORTS TRAINING APPARATUS FOR IMPROVING FOOT SKILLS IN FOOTBALL, BASKETBALL SHOOTING AND DRIBBLING SKILLS AND FOOTBALL AND BASKETBALL AGILITY AND SPEED; SHIN PADS FOR ATHLETIC USE; SAFETY PADDING FOR FOOTBALL AND BASKETBALL; GOLF BALLS, GOLF TEES, GOLF CLUB HEADS, GOLF BALL MARKERS, DIVOT REPAIR TOOL FOR GOLFERS, GOLF BAG TAGS AND GOLF KITS CONSISTING PRIMARILY OF GOLF BALLS, GOLF TEES, GOLF CLUB HEADS, GOLF BALL MARKERS, DIVOT REPAIR TOOL FOR GOLFERS AND GOLF BAG TAGS; SPORT ACCESSORY KITS CONSISTING PRIMARILY OF A FOOTBALL, CONES, PUMPS AND NEEDLES FOR PUMPS ESPECIALLY ADAPTED FOR USE WITH BALLS FOR GAMES AND REUSABLE PLASTIC OR STAINLESS STEEL WATER BOTTLES SOLD EMPTY; STUFFED DOLLS AND ANIMALS AND PLUSH TOYS (U.S. CLS. 22, 23, 38 AND 50).

FIRST USE 1-1-2012; IN COMMERCE 1-1-2012.

ANDREA K. NADELMAN, EXAMINING ATTORNEY

SN 85-645,932. BOLTHOUSE JUICE PRODUCTS, LLC, BAKERSFIELD, CA. FILED 6-7-2012.

PROTEIN PLUS

THE MARK CONSISTS OF STANDARD CHARACTERS WITHOUT CLAIM TO ANY PARTICULAR FONT, STYLE, SIZE, OR COLOR.

OWNER OF U.S. REG. NOS. 3,130,549 AND 3,287,016.

NO CLAIM IS MADE TO THE EXCLUSIVE RIGHT TO USE "PROTEIN", APART FROM THE MARK AS SHOWN.

CLASS 30—STAPLE FOODS

FOR COFFEE AND ESPRESSO BASED BEVERAGES IN A VARIETY OF FLAVORS CONTAINING PROTEIN (U.S. CL. 46).

CLASS 32—LIGHT BEVERAGES

FOR SOY OR WHEY PROTEIN BASED BEVERAGES IN A VARIETY OF FLAVORS NOT USED AS A MILK SUBSTITUTE; FRUIT AND VEGETABLE JUICES CONTAINING PROTEIN; BLENDED FRUIT AND VEGETABLE JUICES IN A VARIETY OF FLAVORS CONTAINING PROTEIN AND IN THE NATURE OF SMOOTHIES CONTAINING PROTEIN (U.S. CLS. 45, 46 AND 48).

ROBIN MITTLER, EXAMINING ATTORNEY

SN 85-646,234. BELLIN HOLDING GMBH, ETTENHEIM 77955, FED REP GERMANY, FILED 6-7-2012.

BELLIN

THE MARK CONSISTS OF STANDARD CHARACTERS WITHOUT CLAIM TO ANY PARTICULAR FONT, STYLE, SIZE, OR COLOR.

CLASS 9—ELECTRICAL AND SCIENTIFIC APPARATUS

FOR COMPUTER SOFTWARE FOR USE IN THE FIELD OF CORPORATE TREASURY MANAGEMENT (U.S. CLS. 21, 23, 26, 36 AND 38).

FIRST USE 12-31-1998; IN COMMERCE 1-1-2004.

CLASS 36—INSURANCE AND FINANCIAL

FOR CONSULTING SERVICES IN THE FIELD OF CORPORATE TREASURY MANAGEMENT; FINANCIAL SERVICES, NAMELY, CORPORATE TREASURY MANAGEMENT SERVICES (U.S. CLS. 100, 101 AND 102).

FIRST USE 12-31-1998; IN COMMERCE 1-1-2004.
DAVID MURRAY, EXAMINING ATTORNEY

SN 85-654,071. SIRIUSDECISIONS, INC., WILTON, CT.
FILED 6-18-2012.

SIRIUS EVENTS

THE MARK CONSISTS OF STANDARD CHARACTERS WITHOUT CLAIM TO ANY PARTICULAR FONT, STYLE, SIZE, OR COLOR.

NO CLAIM IS MADE TO THE EXCLUSIVE RIGHT TO USE "EVENTS", APART FROM THE MARK AS SHOWN.

CLASS 9—ELECTRICAL AND SCIENTIFIC APPARATUS

FOR DOWNLOADABLE WEBCASTS IN THE FIELD OF SALES AND MARKETING (U.S. CLS. 21, 23, 26, 36 AND 38).

CLASS 35—ADVERTISING AND BUSINESS

FOR PROVIDING IN-PERSON BUSINESS FORUMS IN THE FIELDS OF SALES AND MARKETING (U.S. CLS. 100, 101 AND 102).

CLASS 41—EDUCATION AND ENTERTAINMENT

FOR ORGANIZATION OF ON-LINE AND IN-PERSON STUDY GROUPS IN THE FIELDS OF SALES AND MARKETING, FOR EDUCATIONAL PURPOSES (U.S. CLS. 100, 101 AND 107).

WENDY JUN, EXAMINING ATTORNEY

SN 85-656,402. DAVID CHANG, LLC, NEW YORK, NY.
FILED 6-20-2012.

LUCKY PEACH

THE MARK CONSISTS OF STANDARD CHARACTERS WITHOUT CLAIM TO ANY PARTICULAR FONT, STYLE, SIZE, OR COLOR.

OWNER OF U.S. REG. NO. 4,098,985.

CLASS 29—MEATS AND PROCESSED FOODS

FOR PREPARED ENTREES CONSISTING PRIMARILY OF MEAT, FISH, POULTRY OR VEGETABLES; PREPARED MEALS CONSISTING PRIMARILY OF MEAT, FISH, POULTRY OR VEGETABLES (U.S. CL. 46).

CLASS 30—STAPLE FOODS

FOR NOODLES, SAUCE, DEHYDRATED VEGETABLES, AND TOPPING COMBINED IN UNITARY PACKAGES; SAUCE MIXES; SAUCES; SPICE BLENDS; SPICES; PREPARED ENTREES CONSISTING PRIMARILY OF PASTA OR RICE; PREPARED MEALS CONSISTING PRIMARILY OF PASTA OR RICE (U.S. CL. 46).

CLASS 43—HOTEL AND RESTAURANT SERVICES

FOR BAR SERVICES; RESTAURANT SERVICES, INCLUDING SIT-DOWN SERVICE OF FOOD AND TAKE-OUT RESTAURANT SERVICES (U.S. CLS. 100 AND 101).
ANGELA M. MICHELI, EXAMINING ATTORNEY

SN 85-657,120. PIREL INC., BOUCHERVILLE, QUEBEC, CANADA, FILED 6-20-2012.

PIREL

THE MARK CONSISTS OF STANDARD CHARACTERS WITHOUT CLAIM TO ANY PARTICULAR FONT, STYLE, SIZE, OR COLOR.

CLASS 9—ELECTRICAL AND SCIENTIFIC APPARATUS

FOR COMPUTER SOFTWARE USED FOR ENTERPRISE CONTENT MANAGEMENT, NAMELY TO CREATE, MANAGE, DISTRIBUTE, PUBLISH, EXTRACT AND SEARCH COMPANY INFORMATION OF ALL TYPES, SUCH AS DIGITAL DATA, ELECTRONIC DOCUMENTS, IMAGES, OFFICE FILES, APPLICATION FILES, WEB CONTENT, REPORTS, FORMS, PHOTOS, AUDIO AND VIDEO FILES AND ALSO OFFERING SOLUTIONS SUCH AS INTEGRATED ARCHIVING AND DOCUMENT RETRIEVAL SYSTEMS, IMAGING, WORKFLOW AND COLLABORATION (U.S. CLS. 21, 23, 26, 36 AND 38).

FIRST USE 0-0-1995; IN COMMERCE 0-0-1995.

CLASS 42—SCIENTIFIC AND COMPUTER SERVICES

FOR INFORMATION TECHNOLOGY CONSULTING, SUPPORT AND HOSTING SERVICES, NAMELY THE DEVELOPMENT AND INSTALLATION OF COMPUTER PROGRAMS FOR OTHERS TO USE FOR ENTERPRISE CONTENT MANAGEMENT, NAMELY TO CREATE, MANAGE, DISTRIBUTE, PUBLISH, EXTRACT AND SEARCH COMPANY INFORMATION OF ALL TYPES, SUCH AS DIGITAL DATA, ELECTRONIC DOCUMENTS, IMAGES, OFFICE FILES, APPLICATION FILES, WEB CONTENT, REPORTS, FORMS, PHOTOS, AUDIO AND VIDEO FILES, ALSO OFFERING SOLUTIONS SUCH AS INTEGRATED ARCHIVING AND DOCUMENT RETRIEVAL SYSTEMS, IMAGING, WORKFLOW AND COLLABORATION (U.S. CLS. 100 AND 101).

FIRST USE 0-0-1995; IN COMMERCE 0-0-1995.
AMY C. KEAN, EXAMINING ATTORNEY

SN 85-657,926. BDSRCO, INC., WILMINGTON, DE. FILED 6-21-2012.

STYLE & HOME

THE MARK CONSISTS OF STANDARD CHARACTERS WITHOUT CLAIM TO ANY PARTICULAR FONT, STYLE, SIZE, OR COLOR.

NO CLAIM IS MADE TO THE EXCLUSIVE RIGHT TO USE "HOME", APART FROM THE MARK AS SHOWN.

CLASS 4—LUBRICANTS AND FUELS

FOR CANDLES (U.S. CLS. 1, 6 AND 15).

CLASS 6—METAL GOODS

FOR GARDEN DECOR ITEMS, NAMELY, NON-LUMINOUS AND NON-MECHANICAL DECORATIVE METAL SIGNS, METAL GARDEN STAKES, STATUES OF NON-PRECIOUS METAL AND METAL STEPPING STONES; HOLIDAY OR SEASONAL DECORATIONS AND DÉCOR MADE OF METAL DIE CUT FORMS HAVING HOLIDAY OR SEASONAL THEMED SHAPES AND ICONS (U.S. CLS. 2, 12, 13, 14, 23, 25 AND 50).

CLASS 11—ENVIRONMENTAL CONTROL APPARATUS

FOR SOLAR LIGHT FIXTURES, NAMELY, INDOOR AND OUTDOOR SOLAR POWERED LIGHTING UNITS AND FIXTURES (U.S. CLS. 13, 21, 23, 31 AND 34).

CLASS 16—PAPER GOODS AND PRINTED MATTER

FOR FRAMED ART PRINTS (U.S. CLS. 2, 5, 22, 23, 29, 37, 38 AND 50).

CLASS 19—NON-METALLIC BUILDING MATERIALS

FOR GARDEN DÉCOR ITEMS, NAMELY, WOOD STEPPING STONES (U.S. CLS. 1, 12, 33 AND 50).

CLASS 20—FURNITURE AND ARTICLES NOT OTHERWISE CLASSIFIED

FOR GARDEN DECOR ITEMS, NAMELY, NON-LUMINOUS, NON-MECHANICAL DECORATIVE WOOD SIGNS, WOOD GARDEN STAKES, STATUES OF WOOD; HOLIDAY OR SEASONAL DECORATIONS AND DÉCOR MADE OF WOOD DIE CUT FORMS HAVING HOLIDAY OR SEASONAL THEMED SHAPES AND ICONS; GARDEN DECOR ITEMS, NAMELY, NON-LUMINOUS, NON-MECHANICAL DECORATIVE POLYRESIN SIGNS, POLYRESIN GARDEN STAKES, STATUES OF POLYRESIN AND POLYRESIN STEPPING STONES; HOLIDAY OR SEASONAL DECORATIONS AND DÉCOR MADE OF POLYRESIN DIE CUT FORMS HAVING HOLIDAY OR SEASONAL THEMED SHAPES AND ICONS; PATIO FURNITURE; PICTURE FRAMES (U.S. CLS. 2, 13, 22, 25, 32 AND 50).

CLASS 21—HOUSEWARES AND GLASS

FOR CANDLE HOLDERS NOT OF PRECIOUS METAL (U.S. CLS. 2, 13, 23, 29, 30, 33, 40 AND 50).

CLASS 24—FABRICS

FOR BED LINENS; TABLE LINENS; KITCHEN LINENS; TROWS (U.S. CLS. 42 AND 50).

CLASS 27—FLOOR COVERINGS

FOR RUGS; BATH MATS (U.S. CLS. 19, 20, 37, 42 AND 50).

MATTHEW EINSTEIN, EXAMINING ATTORNEY

SN 85-681,288. THE ALPEN HOUSE LIMITED, AURORA, ONTARIO, CANADA, FILED 7-19-2012.

ADENA GOURMET

THE MARK CONSISTS OF STANDARD CHARACTERS WITHOUT CLAIM TO ANY PARTICULAR FONT, STYLE, SIZE, OR COLOR.

NO CLAIM IS MADE TO THE EXCLUSIVE RIGHT TO USE "GOURMET", APART FROM THE MARK AS SHOWN.

CLASS 35—ADVERTISING AND BUSINESS

FOR BUTCHER SHOPS; RETAIL STORE SERVICES FEATURING GOURMET FOOD (U.S. CLS. 100, 101 AND 102).

CLASS 43—HOTEL AND RESTAURANT SERVICES

FOR RESTAURANT SERVICES (U.S. CLS. 100 AND 101).

JIM RINGLE, EXAMINING ATTORNEY

SN 85-681,303. THE ALPEN HOUSE LIMITED, AURORA, ONTARIO, CANADA, FILED 7-19-2012.

ADENA GOURMET AND GRILL

THE MARK CONSISTS OF STANDARD CHARACTERS WITHOUT CLAIM TO ANY PARTICULAR FONT, STYLE, SIZE, OR COLOR.

NO CLAIM IS MADE TO THE EXCLUSIVE RIGHT TO USE "GOURMET AND GRILL", APART FROM THE MARK AS SHOWN.

CLASS 35—ADVERTISING AND BUSINESS

FOR BUTCHER SHOPS; RETAIL STORE SERVICES FEATURING GOURMET FOOD (U.S. CLS. 100, 101 AND 102).

CLASS 43—HOTEL AND RESTAURANT SERVICES

FOR RESTAURANT SERVICES (U.S. CLS. 100 AND 101).

JIM RINGLE, EXAMINING ATTORNEY

SN 85-681,866. WISDOMGATE, INC., HARRINGTON PARK, NJ. FILED 7-19-2012.

SN 85-682,093. RAINBOW DISPOSAL CO., INC., DBA RAINBOW ENVIRONMENTAL SERVICES, HUNTINGTON BEACH, CA. FILED 7-19-2012.



THE MARK CONSISTS OF AN OWL WITHIN AN OVAL BORDER; A RIBBON LOCATED BELOW THE OWL BEARING A "WISDOMGATE" TERM; AND A KEY ON A STRING LOCATED AROUND THE OWL'S NECK.

CLASS 16—PAPER GOODS AND PRINTED MATTER

FOR ADDRESS BOOKS; ART PRINTS; BLANK JOURNALS; BLANK WRITING JOURNALS; BOOKMARKS; BUMPER STICKERS; CALENDARS; CHECKBOOK COVERS; CLIP BOARDS; CUSTOM PAINTINGS; DAY PLANNERS; DECALS; DECORATIVE DECALS FOR VEHICLE WINDOWS; DESKTOP PLANNERS; ENVELOPES FOR STATIONERY USE; FRAMED PAINTINGS; GREETING CARDS; GROCERY BAGS; HOLDERS FOR NOTEPADS; LETTER HOLDERS; LETTER-OPENERS; LETTERHEAD PAPER; MAGNETIC BUMPER STICKERS; MONEY CLIPS; NOTE PAD HOLDERS; NOTEBOOKS; PAINTINGS; PAPER CLIP HOLDERS; PAPER CLIPS; PAPER STATIONERY WITH INSPIRATIONAL MESSAGES IMPRINTED THEREON; PAPER WEIGHTS; PASSPORT COVERS; PENS; PLACE MATS OF PAPER; POSTERS; RUBBER STAMPS; STATIONERY; STATIONERY WRITING PAPER AND ENVELOPES; STICKERS; WORKS OF ART MADE OF PAPER (U.S. CLS. 2, 5, 22, 23, 29, 37, 38 AND 50).

CLASS 18—LEATHER GOODS

FOR BRIEFCASES; DIAPER BAGS; DUFFEL BAGS; LUGGAGE; LUGGAGE TAGS; TOILETRY BAGS SOLD EMPTY; TOTE BAGS; UMBRELLAS; WALLETS (U.S. CLS. 1, 2, 3, 22 AND 41).

CLASS 21—HOUSEWARES AND GLASS

FOR BOWLS; CANDLE HOLDERS; COASTERS, NOT OF PAPER AND OTHER THAN TABLE LINEN; COOKIE JARS; DRINKING GLASSES; MUGS; PIGGY BANKS; PITCHERS; PLATES; SERVING PLATTERS; SERVING TRAYS; VASES (U.S. CLS. 2, 13, 23, 29, 30, 33, 40 AND 50).

CLASS 25—CLOTHING

FOR CAPS; DRESS SHIRTS; FLEECE BOTTOMS; FLEECE PULLOVERS; FLEECE TOPS; GLOVES; HATS; HEAD SWEATBANDS; HEAD WEAR; JACKETS; NIGHT SHIRTS; PAJAMAS; POLO SHIRTS; ROBES; SCARVES; SCRUBS NOT FOR MEDICAL PURPOSES; SHIRTS; SHORTS; SLIPPERS; SWEAT SHIRTS; SWEATERS; T-SHIRTS; TANK TOPS; TIES; VISORS; WRIST BANDS (U.S. CLS. 22 AND 39).

JEANIE LEE, EXAMINING ATTORNEY

PROVIDING GREENER POSSIBILITIES

THE MARK CONSISTS OF STANDARD CHARACTERS WITHOUT CLAIM TO ANY PARTICULAR FONT, STYLE, SIZE, OR COLOR.

CLASS 39—TRANSPORTATION AND STORAGE

FOR GARBAGE COLLECTION (U.S. CLS. 100 AND 105).
FIRST USE 3-1-2012; IN COMMERCE 3-1-2012.

CLASS 40—MATERIAL TREATMENT

FOR RECYCLING OF WASTE AND TRASH (U.S. CLS. 100, 103 AND 106).
FIRST USE 3-1-2012; IN COMMERCE 3-1-2012.
DAVID C. REIHNER, EXAMINING ATTORNEY

SN 85-976,065. LOANDEPOT.COM, LLC, IRVINE, CA. FILED 2-23-2011.

EQUITY FREEDOM

THE MARK CONSISTS OF STANDARD CHARACTERS WITHOUT CLAIM TO ANY PARTICULAR FONT, STYLE, SIZE, OR COLOR.

OWNER OF U.S. REG. NO. 3,654,651.
NO CLAIM IS MADE TO THE EXCLUSIVE RIGHT TO USE "EQUITY", APART FROM THE MARK AS SHOWN.

CLASS 35—ADVERTISING AND BUSINESS

FOR MATCHING BORROWERS WITH POTENTIAL LENDERS IN THE FIELD OF CONSUMER AND MORTGAGE LENDING; PROVIDING STATISTICAL INFORMATION AND INDEXES OF MORTGAGES, INTERESTS, AND PRICES FOR OTHERS; BUSINESS ADVICE AND INFORMATION RELATING TO LOANS, FINANCE AND CAPITAL; AND BUSINESS MANAGEMENT AND CONSULTATION AND MARKET RESEARCH (U.S. CLS. 100, 101 AND 102).

CLASS 36—INSURANCE AND FINANCIAL

FOR ARRANGING OF LOANS; CREDIT AND LOAN SERVICES; HOME EQUITY LOANS; FINANCIAL SERVICES, NAMELY, MONEY LENDING, LOAN PROCESSING, LOAN SERVICING; CONSUMER AND COMMERCIAL LENDING SERVICES; MORTGAGE LENDING, PLANNING AND REFINANCING; WHOLESALE LENDING SERVICES; REAL ESTATE AND HOME EQUITY LENDING SERVICES; ELECTRONIC LOAN ORIGINATION SERVICES; FINANCIAL SERVICES, NAMELY, PROVIDING EVERYDAY PERSONAL FINANCIAL INFORMATION AND ADVISORY SERVICES VIA A GLOBAL COMPUTER NETWORK; CREDIT CONSULTATION; FINANCIAL ADVICE AND CONSULTANCY SERVICES; PROVIDING A WEB SITE FEATURING PERSONAL FINANCIAL INFORMATION AND FINANCIAL ADVICE; PROVIDING EDUCATIONAL INFORMATION AND CONSULTATION REGARDING EVERYDAY FINANCIAL MATTERS VIA A GLOBAL COMPUTER NETWORK; AND FINANCING AND LOAN SERVICES AND CONSULTING; PROVIDING A WEB SITE FEATURING INFORMATION FOR CONSUMERS IN THE FIELD OF MONEY LENDING, LOAN PROCESSING, AND LOAN SERVICING (U.S. CLS. 100, 101 AND 102).

CLASS 38—COMMUNICATION

FOR ELECTRONIC DELIVERY OF LOAN DOCUMENTS; TELECOMMUNICATION SERVICES, NAMELY, PROVIDING E-MAIL NOTIFICATION ALERTS VIA THE INTERNET REGARDING FINANCIAL ADVICE; PROVIDING ON-LINE COMMUNICATIONS LINKS WHICH TRANSFER THE WEB SITE USER TO OTHER LOCAL AND GLOBAL WEB PAGES (U.S. CLS. 100, 101 AND 104).

CLASS 41—EDUCATION AND ENTERTAINMENT

FOR PROVIDING ON-LINE DOCUMENTS FOR APPLICATIONS CONCERNING LOANS; AND ONLINE ELECTRONIC PUBLISHING OF TEXT AND GRAPHIC FEATURING INFORMATION REGARDING FINANCIAL AND BUSINESS INFORMATION; AND EDUCATIONAL AND ENTERTAINMENT SERVICES, NAMELY, COURSES, SEMINARS, CLASSES, CONFERENCES, AND WORKSHOPS IN THE FIELD OF MONEY LENDING, LOAN PROCESSING, AND LOAN SERVICING (U.S. CLS. 100, 101 AND 107).

CLASS 45—PERSONAL AND LEGAL SERVICES

FOR PREPARING AND ORGANIZING LOAN CLOSING DOCUMENTS; AND CLOSING SERVICES FOR MORTGAGE LOANS (U.S. CLS. 100 AND 101).
KAREN K. BUSH, EXAMINING ATTORNEY

SN 85-977,141. S A S SAFETY CORP., LONG BEACH, CA.
FILED 11-9-2009.

SAS

THE MARK CONSISTS OF STANDARD CHARACTERS WITHOUT CLAIM TO ANY PARTICULAR FONT, STYLE, SIZE, OR COLOR.

CLASS 5—PHARMACEUTICALS

FOR EYE WASHES; FIRST AID KITS, PANDEMIC AND FLU PREVENTION KITS CONTAINING HAND SANITIZER GEL, ANTI-BACTERIAL HAND WIPES, RESPIRATORS IN THE NATURE OF SANITARY MASKS AND NITRILE GLOVES USED FOR GERM PREVENTION (U.S. CLS. 6, 18, 44, 46, 51 AND 52).

FIRST USE 0-0-1995; IN COMMERCE 0-0-1995.

CLASS 10—MEDICAL APPARATUS

FOR MEDICAL EXAMINATION GLOVES; RESPIRATORS FOR ARTIFICIAL RESPIRATION (U.S. CLS. 26, 39 AND 44).

FIRST USE 0-0-1995; IN COMMERCE 0-0-1995.

CLASS 11—ENVIRONMENTAL CONTROL APPARATUS

FOR PORTABLE EMERGENCY EYE WASH STATIONS FOR INDUSTRIAL, COMMERCIAL AND INSTITUTIONAL USE (U.S. CLS. 13, 21, 23, 31 AND 34).

FIRST USE 0-0-1995; IN COMMERCE 0-0-1995.

CLASS 21—HOUSEWARES AND GLASS

FOR DISPOSABLE LATEX, NITRILE AND VINYL GLOVES FOR GENERAL USE (U.S. CLS. 2, 13, 23, 29, 30, 33, 40 AND 50).

FIRST USE 0-0-1995; IN COMMERCE 0-0-1995.

CLASS 22—CORDAGE AND FIBERS

FOR EYEWEAR LANYARDS FOR HOLDING SAFETY GLASSES AND GOGGLES (U.S. CLS. 1, 2, 7, 19, 22, 42 AND 50).

FIRST USE 0-0-1995; IN COMMERCE 0-0-1995.
LINDA ESTRADA, EXAMINING ATTORNEY

SN 85-977,220. ARTHUR ALEXAKIS, PASADENA, CA.
FILED 12-19-2011.

SUMMERLAND

THE MARK CONSISTS OF STANDARD CHARACTERS WITHOUT CLAIM TO ANY PARTICULAR FONT, STYLE, SIZE, OR COLOR.

CLASS 9—ELECTRICAL AND SCIENTIFIC APPARATUS

FOR MUSICAL SOUND RECORDINGS AND VIDEO RECORDINGS RELATING TO MUSIC (U.S. CLS. 21, 23, 26, 36 AND 38).

CLASS 16—PAPER GOODS AND PRINTED MATTER

FOR SOUVENIR POSTERS, STICKERS, BUMPER STICKERS, DECALS AND CONCERT SOUVENIR PROGRAMS, ALL IN ASSOCIATION WITH A MUSICAL PERFORMER OR GROUP (U.S. CLS. 2, 5, 22, 23, 29, 37, 38 AND 50).

CLASS 41—EDUCATION AND ENTERTAINMENT

JUDITH HELFMAN, EXAMINING ATTORNEY

FOR ENTERTAINMENT SERVICES, NAMELY, ORGANIZING AND CONDUCTING MUSIC CONCERTS AND MUSIC FESTIVALS, LIVE PERFORMANCES FEATURING MUSIC, PROVIDING A WEBSITE FEATURING NON-DOWNLOADABLE MUSICAL PERFORMANCES, MUSICAL VIDEOS, PHOTOGRAPHS AND OTHER MULTIMEDIA MATERIALS AND INFORMATION REGARDING A MUSICAL ARTIST OR ARTISTS (U.S. CLS. 100, 101 AND 107).

* * * * *

SECTION 2.— INTERNATIONAL CLASSIFICATION

The short titles associated below with the international class numbers are terms designed merely for quick identification and are not an official part of the international classification. The full names of international classes are given in section 6.1 of the trademark rules of practice.

The designation "U.S. Cl." appearing in this section refers to the U.S. class in effect prior to Sep. 1, 1973 rather than the international class which applies to applications filed on or after that date. For adoption of international classification see notice in the OFFICIAL GAZETTE of Jun. 26, 1973 (911 O.G. TM 210).

Application in one class

CLASS 1—CHEMICALS

SN 79-105,238. BIOGRUND GMBH, FED REP GERMANY, FILED 10-20-2011.

CompactCel

THE MARK CONSISTS OF STANDARD CHARACTERS WITHOUT CLAIM TO ANY PARTICULAR FONT, STYLE, SIZE, OR COLOR.

OWNER OF INTERNATIONAL REGISTRATION 1097252 DATED 10-20-2011, EXPIRES 10-20-2021.

FOR CHEMICALS USED IN INDUSTRY AND SCIENCE, IN PARTICULAR AUXILIARY AGENTS FOR TABLETTING PHARMACEUTICAL PREPARATIONS AND CONFECTIONERY (U.S. CLS. 1, 5, 6, 10, 26 AND 46).

SHANNON TWOHIG, EXAMINING ATTORNEY

SN 79-108,183. TECHNO POLYMER COMPANY LIMITED, TOKYO, JAPAN, FILED 12-12-2011.

HUSHLLOY

THE MARK CONSISTS OF STANDARD CHARACTERS WITHOUT CLAIM TO ANY PARTICULAR FONT, STYLE, SIZE, OR COLOR.

PRIORITY DATE OF 9-28-2011 IS CLAIMED.

OWNER OF INTERNATIONAL REGISTRATION 1104341 DATED 12-12-2011, EXPIRES 12-12-2021.

THE WORDING "HUSHLLOY" HAS NO MEANING IN A FOREIGN LANGUAGE.

FOR UNPROCESSED PLASTICS, NAMELY, THERMOPLASTIC UNPROCESSED SYNTHETIC RESIN PELLETS (U.S. CLS. 1, 5, 6, 10, 26 AND 46).

CHARISMA HAMPTON, EXAMINING ATTORNEY

SN 79-109,067. DIC CORPORATION, JAPAN, FILED 1-24-2012.

WATERSOL

THE MARK CONSISTS OF STANDARD CHARACTERS WITHOUT CLAIM TO ANY PARTICULAR FONT, STYLE, SIZE, OR COLOR.

OWNER OF INTERNATIONAL REGISTRATION 1070242 DATED 2-22-2011, EXPIRES 2-22-2021.

FOR UNPROCESSED SYNTHETIC RESINS; UNPROCESSED PLASTICS; INDUSTRIAL CHEMICALS (U.S. CLS. 1, 5, 6, 10, 26 AND 46).

KRISTINA MORRIS, EXAMINING ATTORNEY

CLASS 1—(Continued).

SN 79-109,069. DIC CORPORATION, TOKYO 174-8520, JAPAN, FILED 1-24-2012.

ACRYDIC

THE MARK CONSISTS OF STANDARD CHARACTERS WITHOUT CLAIM TO ANY PARTICULAR FONT, STYLE, SIZE, OR COLOR.

OWNER OF INTERNATIONAL REGISTRATION 1088389 DATED 7-29-2011, EXPIRES 7-29-2021.

FOR UNPROCESSED SYNTHETIC RESINS; UNPROCESSED PLASTICS; INDUSTRIAL CHEMICALS (U.S. CLS. 1, 5, 6, 10, 26 AND 46).

KRISTINA MORRIS, EXAMINING ATTORNEY

SN 79-112,771. CISBIO BIOASSAYS, FRANCE, FILED 4-18-2012.

INOVIEW

THE MARK CONSISTS OF STANDARD CHARACTERS WITHOUT CLAIM TO ANY PARTICULAR FONT, STYLE, SIZE, OR COLOR.

PRIORITY DATE OF 1-24-2012 IS CLAIMED.

OWNER OF INTERNATIONAL REGISTRATION 1115526 DATED 4-18-2012, EXPIRES 4-18-2022.

FOR CHEMICALS FOR USE IN RESEARCH, INDUSTRY AND MANUFACTURING; REAGENTS FOR DETECTING BIOMOLECULES OR BIOMOLECULAR INTERACTIONS IN CONNECTION WITH LIFE SCIENCE RESEARCH; REAGENTS FOR DETECTING BIOMOLECULES OR BIOMOLECULAR INTERACTIONS IN CONNECTION WITH LIFE SCIENCE RESEARCH, FOR IN VITRO USE; FLUORESCENT REAGENTS FOR MEASURING BIOMOLECULES OR BIOMOLECULAR INTERACTIONS IN CONNECTION WITH LIFE SCIENCE RESEARCH, FOR IN VITRO USE (U.S. CLS. 1, 5, 6, 10, 26 AND 46).

SHANNON TWOHIG, EXAMINING ATTORNEY

CLASS 1—(Continued).

SN 79-113,476. MASSIMO POLLIO, ARENZANO (GE), ITALY, AND IMAGRO S.P.A., GENOVA (GE), ITALY, FILED 3-22-2012.



PRIORITY DATE OF 1-20-2012 IS CLAIMED.
OWNER OF INTERNATIONAL REGISTRATION 1117611
DATED 3-22-2012, EXPIRES 3-22-2022.

THE MARK CONSISTS OF THE WORDING "POLHI" IN STYLIZED HANCOCKPARKBOLDLASER FONT SUBJECT TO A TORSION FROM THE BACK TO THE FRONT IN THE HORIZONTAL AXIS AND TOWARDS THE TOP CENTER IN THE VERTICAL AXIS WITH THE LETTERS APPEARING TO INCREASE IN SIZE FROM LEFT TO RIGHT THE MARK WILL BE USED IN ALL COLORS AND COMBINATIONS OF COLORS.

THE WORDING "POLHI" HAS NO MEANING IN A FOREIGN LANGUAGE.

FOR UNPROCESSED ARTIFICIAL RESINS; UNPROCESSED PLASTICS (U.S. CLS. 1, 5, 6, 10, 26 AND 46).
SUZANNE BLANE, EXAMINING ATTORNEY

SN 85-266,062. AALTO SCIENTIFIC, LTD., CARLSBAD, CA.
FILED 3-14-2011.

AUDIT MICROCONTROLS

THE MARK CONSISTS OF STANDARD CHARACTERS WITHOUT CLAIM TO ANY PARTICULAR FONT, STYLE, SIZE, OR COLOR.

FOR IN VITRO DIAGNOSTIC PRODUCTS, NAMELY, SERA CONSISTING OF PLASMA FOR CONTROL AND CALIBRATION OF INSTRUMENTS AND REAGENTS COMPRISING PROTEINS, ENZYMES, ISO-ENZYMES, ANTIBODIES AND CHEMICAL COMPOUNDS (U.S. CLS. 1, 5, 6, 10, 26 AND 46).

FIRST USE 9-0-2003; IN COMMERCE 9-0-2003.
GIANCARLO CASTRO, EXAMINING ATTORNEY

SN 85-343,671. BIOCOGENT, INC., STONY BROOK, NY.
FILED 6-10-2011.

PLEIOTANICALS

THE MARK CONSISTS OF STANDARD CHARACTERS WITHOUT CLAIM TO ANY PARTICULAR FONT, STYLE, SIZE, OR COLOR.

FOR ACTIVE BOTANICAL MOLECULES IN THE NATURE OF EXTRACTS FOR USE IN THE MANUFACTURE OF COSMETICS AND PERSONAL CARE PRODUCTS (U.S. CLS. 1, 5, 6, 10, 26 AND 46).

FIRST USE 6-2-2011; IN COMMERCE 6-2-2011.
NELSON SNYDER, EXAMINING ATTORNEY

CLASS 1—(Continued).

SN 85-372,967. ROCK HOLDINGS PTY. LTD., CLARENDON S.A. 5157, AUSTRALIA, FILED 7-15-2011.

ROCK RESINATOR

THE MARK CONSISTS OF STANDARD CHARACTERS WITHOUT CLAIM TO ANY PARTICULAR FONT, STYLE, SIZE, OR COLOR.

OWNER OF U.S. REG. NO. 4,160,251.

SEC. 2(F) AS TO "ROCK".

FOR FERTILIZER FOR SOIL AND POTTING SOIL; SOIL ADDITIVES (U.S. CLS. 1, 5, 6, 10, 26 AND 46).

FIRST USE 11-1-1995; IN COMMERCE 11-2-2010.
DANNEAN HETZEL, EXAMINING ATTORNEY

SN 85-381,301. AMIRAN TECHNOLOGIES, LLC, OAK CREEK, WI. FILED 7-26-2011.



NO CLAIM IS MADE TO THE EXCLUSIVE RIGHT TO USE "AG", APART FROM THE MARK AS SHOWN.

THE COLOR(S) GREEN, BLACK IS/ARE CLAIMED AS A FEATURE OF THE MARK.

THE MARK CONSISTS OF THE WORDS "AG", IN GREEN, AND THE WORD "CONVERSIONS", IN BLACK. THERE ARE GREEN AND BLACK LEAVES THAT MAKE UP A PLANT IN THE MARK.

FOR ARTIFICIAL PLANT-CULTIVATION SOIL; COMPLEX FERTILIZER; COMPOST; FERTILISER FOR SOIL AND POTTING SOIL; FERTILISERS FOR SOIL AND POTTING SOIL; FERTILIZERS; FERTILIZERS AND MANURES; FERTILIZERS FOR AGRICULTURAL USE; FERTILIZERS FOR DOMESTIC USE; FERTILIZING PREPARATIONS; NUTRITIVE ADDITIVE TO ENHANCE THE BIOLOGICAL ACTIVITY OF WATER, SOIL, SEEDS AND PLANTS FOR PURPOSES OF FERTILIZATION AND BIOREMEDIATION OF POLLUTANTS; PEAT; PLANTING SOIL; POTTING COMPOST; POTTING SOIL (U.S. CLS. 1, 5, 6, 10, 26 AND 46).

JESSICA FATHY, EXAMINING ATTORNEY

CLASS 1—(Continued).

SN 85-395,935. LEGENE BIOSCIENCES CORP., SAN DIEGO, CA. FILED 8-11-2011.

"Solutions - Start to Finish"

THE MARK CONSISTS OF STANDARD CHARACTERS WITHOUT CLAIM TO ANY PARTICULAR FONT, STYLE, SIZE, OR COLOR.

FOR ASSAYS AND REAGENTS FOR USE IN GENETIC RESEARCH; BIOCHEMICAL REAGENTS COMMONLY KNOWN AS PROBES, FOR DETECTING AND ANALYZING MOLECULES IN PROTEIN OR NUCLEOTIDE ARRAYS; BIOCHEMICAL REAGENTS USED FOR NON-MEDICAL PURPOSES; CHEMICAL REAGENTS FOR NON-MEDICAL PURPOSES; CHEMICAL REAGENTS FOR NON-MEDICAL PURPOSES, NAMELY, FOR USE IN EVALUATING ENZYMES; CHEMICAL REAGENTS, OTHER THAN FOR MEDICAL OR VETERINARY PURPOSE; CHEMICAL SOLUTIONS AND PREPARATIONS CONSISTING OF PRE-MIXED REACTANTS AND REAGENTS FOR SCIENTIFIC AND RESEARCH USE IN CONNECTION WITH AMPLIFICATION, ANALYSIS OR LABELING OF NUCLEIC ACID; DIAGNOSTIC KITS CONSISTING PRIMARILY OF MONOCLONAL ANTIBODIES, BUFFERS, AND REAGENTS TO MONITOR TOXICITY OF DRUGS; DIAGNOSTIC PREPARATIONS FOR SCIENTIFIC OR RESEARCH USE; DIAGNOSTIC REAGENTS AND PREPARATIONS, EXCEPT FOR MEDICAL OR VETERINARY USE; DIAGNOSTIC REAGENTS FOR CLINICAL OR MEDICAL LABORATORY USE; DIAGNOSTIC REAGENTS FOR IN VITRO USE IN BIOCHEMISTRY, CLINICAL CHEMISTRY AND MICROBIOLOGY; DIAGNOSTIC REAGENTS FOR SCIENTIFIC OR RESEARCH USE; GENETIC IDENTITY TESTS COMPRISED OF REAGENTS; IMMUNOHISTOCHEMISTRY DETECTION KITS CONSISTING OF MOUSE SECONDARY REAGENTS, DAB CHROMOGENS, DAB BUFFERS, PEROXIDASE BLOCKING REAGENT, AND HEMATOXYLIN, FOR ANATOMIC PATHOLOGY PURPOSES IN THE MEDICAL DIAGNOSTICS INDUSTRY; LABORATORY CHEMICALS, NAMELY, AN ANTIBODY REAGENT USED FOR THE DETECTION OF ANTIGENS IN CELL AND TISSUE ANALYSIS FOR IN VITRO DIAGNOSTIC USE; NUCLEIC ACID ISOLATION AND PURIFICATION KIT CONSISTING PRIMARILY OF REAGENTS AND MAGNETIC BEADS FOR SCIENTIFIC RESEARCH PURPOSES; NUCLEIC ACID SEQUENCES AND CHEMICAL REAGENTS FOR OTHER THAN MEDICAL AND VETERINARY PURPOSES; PATERNITY IDENTITY TESTS COMPRISED OF REAGENTS; REAGENT BEARING TEST STRIPS FOR TESTING SWIMMING POOL WATER; REAGENT FOR CHEMICAL ANALYSES; REAGENT KITS COMPRISING GENERIC DNA CIRCLE, DNA PRIMERS, POLYMERASE AND BUFFERS FOR USE IN BIOTECHNOLOGY FIELDS; REAGENTS AND SUBSTRATES, NAMELY, CHEMICAL COMPOUNDS FOR USE IN PATTERNING AT NANO SCALE OR NEAR NANO SCALE; REAGENTS FOR RESEARCH PURPOSES; REAGENTS FOR SCIENTIFIC OR MEDICAL RESEARCH USE; REAGENTS FOR TESTING THE STERILITY OF MEDICAL EQUIPMENT; REAGENTS FOR TESTING THE STERILITY OF PHARMACEUTICALS AND INJECTABLE SOLUTIONS; REAGENTS FOR USE IN SCIENTIFIC APPARATUS FOR CHEMICAL OR BIOLOGICAL ANALYSIS; REAGENTS USED FOR ANALYTICAL MOISTURE DETERMINATIONS (U.S. CLS. 1, 5, 6, 10, 26 AND 46).

FIRST USE 12-26-2010; IN COMMERCE 8-6-2011.
ROSELLE HERRERA, EXAMINING ATTORNEY

CLASS 1—(Continued).

SN 85-438,955. PRESTONE PRODUCTS CORPORATION, DANBURY, CT. FILED 10-4-2011.

SUMMER PERFORMANCE

THE MARK CONSISTS OF STANDARD CHARACTERS WITHOUT CLAIM TO ANY PARTICULAR FONT, STYLE, SIZE, OR COLOR.

NO CLAIM IS MADE TO THE EXCLUSIVE RIGHT TO USE "SUMMER", APART FROM THE MARK AS SHOWN. FOR CHEMICAL ENGINE TREATMENTS AND ADDITIVES FOR DIESEL FUELS (U.S. CLS. 1, 5, 6, 10, 26 AND 46).

CAROLYN CATALDO, EXAMINING ATTORNEY

SN 85-439,672. AGAROSE UNLIMITED, INC., GAINESVILLE, FL. FILED 10-5-2011.

PS 1200

THE MARK CONSISTS OF STANDARD CHARACTERS WITHOUT CLAIM TO ANY PARTICULAR FONT, STYLE, SIZE, OR COLOR.

FOR REAGENTS FOR SCIENTIFIC RESEARCH; CHEMICALS, NAMELY, SUBSTRATES, GELLING AGENTS AND MATRICES FOR USE IN SCIENTIFIC RESEARCH (U.S. CLS. 1, 5, 6, 10, 26 AND 46).

FIRST USE 9-30-2007; IN COMMERCE 9-30-2007.
CHRISTOPHER SIDOTI, EXAMINING ATTORNEY

SN 85-441,673. FOAMSHIELD, INC., EASTANOLLEE, GA. FILED 10-7-2011.

FOAM SHIELD

THE MARK CONSISTS OF STANDARD CHARACTERS WITHOUT CLAIM TO ANY PARTICULAR FONT, STYLE, SIZE, OR COLOR.

NO CLAIM IS MADE TO THE EXCLUSIVE RIGHT TO USE "FOAM", APART FROM THE MARK AS SHOWN. FOR INDUSTRIAL ADHESIVES FOR USE IN COATING TO REMOVE PARTICULATE MATTER (U.S. CLS. 1, 5, 6, 10, 26 AND 46).

FIRST USE 1-15-2011; IN COMMERCE 1-15-2011.
BERYL GARDNER, EXAMINING ATTORNEY

CLASS 1—(Continued).

SN 85-445,578. MMP, INC., SOUTH PLAINFIELD, NJ. FILED 10-12-2011.

Active Solutions

THE MARK CONSISTS OF STANDARD CHARACTERS WITHOUT CLAIM TO ANY PARTICULAR FONT, STYLE, SIZE, OR COLOR.

NO CLAIM IS MADE TO THE EXCLUSIVE RIGHT TO USE "SOLUTIONS", APART FROM THE MARK AS SHOWN.

FOR CHEMICALS FOR USE IN THE MANUFACTURE OF COSMETIC AND PERSONAL CARE PRODUCTS (U.S. CLS. 1, 5, 6, 10, 26 AND 46).

FIRST USE 10-11-2011; IN COMMERCE 10-11-2011.
ALICE BENMAMAN, EXAMINING ATTORNEY

SN 85-450,077. ECOLOGIQ, LLC, TROY, MI. FILED 10-18-2011.

BALLACLEAN

THE MARK CONSISTS OF STANDARD CHARACTERS WITHOUT CLAIM TO ANY PARTICULAR FONT, STYLE, SIZE, OR COLOR.

FOR CHEMICAL ADDITIVES FOR WATER TREATMENT (U.S. CLS. 1, 5, 6, 10, 26 AND 46).

SETH A. RAPPAPORT, EXAMINING ATTORNEY

SN 85-456,678. TOPCO HOLDINGS, INC., SKOKIE, IL. FILED 10-26-2011.

FOOD CLUB

THE MARK CONSISTS OF STANDARD CHARACTERS WITHOUT CLAIM TO ANY PARTICULAR FONT, STYLE, SIZE, OR COLOR.

OWNER OF U.S. REG. NOS. 650,608, 1,610,724 AND OTHERS.

NO CLAIM IS MADE TO THE EXCLUSIVE RIGHT TO USE "FOOD", APART FROM THE MARK AS SHOWN.

FOR GRANULAR ARTIFICIAL SWEETENERS (U.S. CLS. 1, 5, 6, 10, 26 AND 46).

FIRST USE 6-0-1995; IN COMMERCE 6-0-1995.
KAREN BRACEY, EXAMINING ATTORNEY

CLASS 1—(Continued).

SN 85-526,130. ADVANCED ANALYTICAL TESTING SERVICE, INC., ONTARIO, CA. FILED 1-26-2012.



THE COLOR(S) BLACK, WHITE, AND BLUE IS/ARE CLAIMED AS A FEATURE OF THE MARK.

THE MARK CONSISTS OF THE WORDING "A.A.T.S." IN BLACK AND WHITE. A THIN, BLUE HORIZONTAL LINE APPEARS ABOVE THE WORDING. A THICKER BLUE HORIZONTAL LINE APPEARS BELOW THE WORDING. THE WORDING "AUTHENTIC/ACCURATE/THOROUGH/SWIFT" APPEARS IN WHITE ON TOP OF THE THICKER BLUE LINE.

FOR CHEMICAL TEST KITS FOR TESTING HERBAL PRODUCTS, PHARMACEUTICALS, DIETARY SUPPLEMENTS, AND COSMETICS FOR LABORATORY OR RESEARCH USE (U.S. CLS. 1, 5, 6, 10, 26 AND 46).

SETH A. RAPPAPORT, EXAMINING ATTORNEY

SN 85-572,063. AGRICARE INCORPORATED, DBA AGRICARE INC., AMITY, OR. FILED 3-16-2012.

SILICA SHIELD

THE MARK CONSISTS OF STANDARD CHARACTERS WITHOUT CLAIM TO ANY PARTICULAR FONT, STYLE, SIZE, OR COLOR.

NO CLAIM IS MADE TO THE EXCLUSIVE RIGHT TO USE "SILICA", APART FROM THE MARK AS SHOWN.

FOR FERTILIZERS; FERTILIZERS FOR AGRICULTURAL USE; FERTILIZERS FOR DOMESTIC USE; FERTILIZING PREPARATIONS; HUMIC ACID SOLD AS AN INGREDIENT OF FERTILIZER AND SOIL CONDITIONING PREPARATIONS; MIXED FERTILIZERS; NON-CHEMICAL BIO-FERTILIZERS (U.S. CLS. 1, 5, 6, 10, 26 AND 46).

FIRST USE 5-28-1999; IN COMMERCE 5-28-1999.
LUCY ARANT, EXAMINING ATTORNEY

CLASS 1—(Continued).

SN 85-572,151. HUMBOLDT NUTRIENTS LLC, EUREKA, CA. FILED 3-16-2012.



NO CLAIM IS MADE TO THE EXCLUSIVE RIGHT TO USE "HUMBOLDT" AND "EARTH" A PREMIUM ALL-NATURAL AMENDED SOIL MIX" AND "NUTRIENT SOILS", APART FROM THE MARK AS SHOWN.

THE COLOR(S) BLACK, WHITE, BROWN, GREEN, GRAY, AND TAN IS/ARE CLAIMED AS A FEATURE OF THE MARK.

THE MARK CONSISTS OF STYLIZED CAPITAL TAN LETTERS WHICH SPELL THE WORDS "HUMBOLDT EARTH" POSITIONED AT THE TOP OF, AND PARTIALLY SUPERIMPOSED OVER, A CONCAVE CORNERED RECTANGULAR BROWN AND TAN BORDERED IMAGE, AND STYLIZED CAPITAL TAN LETTERS SPELLING "HUMBOLDT NUTRIENTS SOILS" POSITIONED AT THE BOTTOM OF SUCH IMAGE ON A BROWN BACKGROUND BANNER WITH A TAN FLOWER TO THE LEFT OF THE WORDS "HUMBOLDT NUTRIENTS", AND THE FLOWER SUPERIMPOSED OVER THE SILHOUETTE OF THREE CONIFER TREES WITH A TAN SKY BACKGROUND, WITH THE IMAGE BEING A TREE AND ROOTS IN BROWN, GREEN AND TAN, SUPERIMPOSED OVER ROLLING EARTH AND A SUN BOTH IN BROWN, GREEN AND TAN WITH THE STYLIZED WORDS "A PREMIUM ALL-NATURAL AMENDED SOIL MIX", WITH ALL OF THE FOREGOING SUPERIMPOSED OVER A CAMOUFLAGE DESIGN BACKGROUND IN BLACK, WHITE, BROWN, GREEN, GRAY AND TAN.

FOR GROWING MEDIA FOR PLANTS; PLANT NUTRITION PREPARATIONS; PLANTING SOIL; POTTING SOIL (U.S. CLS. 1, 5, 6, 10, 26 AND 46).

FIRST USE 10-1-2011; IN COMMERCE 10-1-2011.
PAM WILLIS, EXAMINING ATTORNEY

SN 85-575,652. GREENBLENDZ, INC., AUBURN HILLS, MI. FILED 3-21-2012.

NuBalm

THE MARK CONSISTS OF STANDARD CHARACTERS WITHOUT CLAIM TO ANY PARTICULAR FONT, STYLE, SIZE, OR COLOR.

FOR CHEMICALS FOR PRESERVATION OF BIOLOGICAL TISSUE (U.S. CLS. 1, 5, 6, 10, 26 AND 46).

KATHLEEN KOLACZ, EXAMINING ATTORNEY

CLASS 1—(Continued).

SN 85-582,692. FUSION 360, INC., TURLOCK, CA. FILED 3-28-2012.

EVENMORE CLASSIC LEAF

THE MARK CONSISTS OF STANDARD CHARACTERS WITHOUT CLAIM TO ANY PARTICULAR FONT, STYLE, SIZE, OR COLOR.

NO CLAIM IS MADE TO THE EXCLUSIVE RIGHT TO USE "LEAF", APART FROM THE MARK AS SHOWN.

FOR FERTILIZERS; PLANT FOODS; CHEMICALS FOR USE IN AGRICULTURE AND INDUSTRY, NAMELY, MICROBIAL NUTRIENT COMPOSITIONS, MICROBIAL COMPOSITIONS, BIOREMEDIATION COMPOSITIONS, MINERAL FERTILIZING PREPARATIONS, AND PLANT NUTRIENT COMPOSITIONS (U.S. CLS. 1, 5, 6, 10, 26 AND 46).

ROBERT C. CLARK JR., EXAMINING ATTORNEY

SN 85-582,697. FUSION 360, INC., TURLOCK, CA. FILED 3-28-2012.

EVENMORE CLASSIC SOIL

THE MARK CONSISTS OF STANDARD CHARACTERS WITHOUT CLAIM TO ANY PARTICULAR FONT, STYLE, SIZE, OR COLOR.

NO CLAIM IS MADE TO THE EXCLUSIVE RIGHT TO USE "SOIL", APART FROM THE MARK AS SHOWN.

FOR FERTILIZERS; PLANT FOODS; CHEMICALS FOR USE IN AGRICULTURE AND INDUSTRY, NAMELY, MICROBIAL NUTRIENT COMPOSITIONS, MICROBIAL COMPOSITIONS, BIOREMEDIATION COMPOSITIONS, MINERAL FERTILIZING PREPARATIONS, AND PLANT NUTRIENT COMPOSITIONS (U.S. CLS. 1, 5, 6, 10, 26 AND 46).

ROBERT C. CLARK JR., EXAMINING ATTORNEY

SN 85-582,708. FUSION 360, INC., TURLOCK, CA. FILED 3-28-2012.

FUSION 360 FOLIAR FG 31-HR

THE MARK CONSISTS OF STANDARD CHARACTERS WITHOUT CLAIM TO ANY PARTICULAR FONT, STYLE, SIZE, OR COLOR.

NO CLAIM IS MADE TO THE EXCLUSIVE RIGHT TO USE "FOLIAR", APART FROM THE MARK AS SHOWN.

FOR FERTILIZERS; PLANT FOODS; CHEMICALS FOR USE IN AGRICULTURE AND INDUSTRY, NAMELY, MICROBIAL NUTRIENT COMPOSITIONS, MICROBIAL COMPOSITIONS, BIOREMEDIATION COMPOSITIONS, MINERAL FERTILIZING PREPARATIONS, AND PLANT NUTRIENT COMPOSITIONS (U.S. CLS. 1, 5, 6, 10, 26 AND 46).

ROBERT C. CLARK JR., EXAMINING ATTORNEY

CLASS 1—(Continued).

SN 85-583,982. NANOCO TECHNOLOGIES LTD., MANCHESTER, UNITED KINGDOM, FILED 3-29-2012.

CFQD

THE MARK CONSISTS OF STANDARD CHARACTERS WITHOUT CLAIM TO ANY PARTICULAR FONT, STYLE, SIZE, OR COLOR.

FOR SEMICONDUCTOR NANOPARTICLES FOR USE IN COMMERCIAL APPLICATIONS (U.S. CLS. 1, 5, 6, 10, 26 AND 46).

DOUGLAS LEE, EXAMINING ATTORNEY

SN 85-584,456. PERSTORP FRANCE, SAINT PRIEST, FRANCE, FILED 3-30-2012.

ALPUR

THE MARK CONSISTS OF STANDARD CHARACTERS WITHOUT CLAIM TO ANY PARTICULAR FONT, STYLE, SIZE, OR COLOR.

THE WORDING "ALPUR" HAS NO MEANING IN A FOREIGN LANGUAGE.

FOR INDUSTRIAL CHEMICALS; INDUSTRIAL CHEMICALS USED IN THE MANUFACTURE OF PAINTS, VARNISHES, LACQUER, ADHESIVES, RESINS, PACKING, STUFFING AND INSULATING MATERIALS (U.S. CLS. 1, 5, 6, 10, 26 AND 46).

ALYSSA STEEL, EXAMINING ATTORNEY

SN 85-585,121. PREMIER CHEMICAL, LLC, CALUMET, OK, FILED 3-30-2012.



NO CLAIM IS MADE TO THE EXCLUSIVE RIGHT TO USE "CHEMICAL", APART FROM THE MARK AS SHOWN.

THE MARK CONSISTS OF THE STYLIZED IMAGE OF AN OIL RIG. TO THE LEFT OF THE OIL RIG IS THE WORD "PREMIER" AND TO THE RIGHT OF THE OIL RIG IS THE WORD "CHEMICAL".

FOR CHEMICALS, NAMELY, ADDITIVES FOR TREATMENT OF RAW OIL AND GASOLINE (U.S. CLS. 1, 5, 6, 10, 26 AND 46).

FIRST USE 6-0-2009; IN COMMERCE 6-0-2009.
IRA J. GOODSAD, EXAMINING ATTORNEY

CLASS 1—(Continued).

SN 85-590,913. TANDY LEATHER FACTORY, INC., FT. WORTH, TX. FILED 4-6-2012.

CRAFTSMAN

THE MARK CONSISTS OF STANDARD CHARACTERS WITHOUT CLAIM TO ANY PARTICULAR FONT, STYLE, SIZE, OR COLOR.

FOR CONTACT CEMENTS; CONTACT ADHESIVES FOR USE IN LEATHER CRAFTS; ADHESIVE CEMENTS FOR HOBBYISTS; RUBBER CEMENTS FOR HOBBYISTS (U.S. CLS. 1, 5, 6, 10, 26 AND 46).

FIRST USE 8-0-1953; IN COMMERCE 8-0-1953.
KEVEN MITTLER, EXAMINING ATTORNEY

SN 85-591,557. ESSENTIAL WATER SOLUTIONS INC., STORY CITY, IA. FILED 4-6-2012.

OXY BLAST

THE MARK CONSISTS OF STANDARD CHARACTERS WITHOUT CLAIM TO ANY PARTICULAR FONT, STYLE, SIZE, OR COLOR.

OWNER OF U.S. REG. NO. 3,322,594.

FOR CHEMICAL ADDITIVES, NAMELY, HYDROGEN PEROXIDE FOR USE IN AGRICULTURE AND RESIDENTIAL INDUSTRIES AS A WATER ADDITIVE FOR HUMAN AND ANIMAL HEALTH, WATER PURIFICATION, AND WELL WATER QUALITY (U.S. CLS. 1, 5, 6, 10, 26 AND 46).

FIRST USE 6-16-2005; IN COMMERCE 6-16-2005.

ANDREA K. NADELMAN, EXAMINING ATTORNEY

SN 85-592,628. MICROBEAD ENERGY DEVELOPMENT CO., LIMITED, CENTRAL, HONG KONG, FILED 4-9-2012.



NO CLAIM IS MADE TO THE EXCLUSIVE RIGHT TO USE "MICROBEAD", APART FROM THE MARK AS SHOWN.

THE COLOR(S) BLUE IS/ARE CLAIMED AS A FEATURE OF THE MARK.

THE MARK CONSISTS OF THE WORD "MICROBEAD" IN BLUE COLOR WITH AN IMAGE OF A MOLECULE OVER THE "I" IN BLUE COLOR.

FOR PROPPANT FOR USE IN OIL WELL AND GAS WELL FOR HYDRAULIC FRACTURING OPERATIONS (U.S. CLS. 1, 5, 6, 10, 26 AND 46).

FIRST USE 1-1-2012; IN COMMERCE 1-1-2012.

MARGERY A. TIERNEY, EXAMINING ATTORNEY

CLASS 1—(Continued).

SN 85-595,821. CELL BIOLOGICS, INC., CHICAGO, IL.
FILED 4-12-2012.



NO CLAIM IS MADE TO THE EXCLUSIVE RIGHT TO USE "CELL", APART FROM THE MARK AS SHOWN.

THE MARK CONSISTS OF THE STYLIZED WORDING "CELL" WHEREIN THE LETTER "C" IS CAPITALIZED AND NOT ITALICIZED, AND THE LETTERS "ELL" ARE CAPITALIZED AND ITALICIZED. THE WORDING "CELL" IS SUPERIMPOSED ON A STYLIZED DNA DOUBLE-HELIX, WITH THE DNA DOUBLE-HELIX HAVING A HORIZONTAL ORIENTATION.

FOR CELL GROWTH MEDIA FOR GROWING CELLS FOR USE IN SCIENTIFIC RESEARCH; CELLS FOR SCIENTIFIC, LABORATORY OR MEDICAL RESEARCH (U.S. CLS. 1, 5, 6, 10, 26 AND 46).

MICHAEL TANNER, EXAMINING ATTORNEY

CLASS 1—(Continued).

SN 85-600,042. TJ TECHNOLOGIES, INC., BUFFALO, SD.
FILED 4-17-2012.

QuickRoots

THE MARK CONSISTS OF STANDARD CHARACTERS WITHOUT CLAIM TO ANY PARTICULAR FONT, STYLE, SIZE, OR COLOR.

OWNER OF U.S. REG. NO. 3,211,228.

FOR INOCULANT FOR USE WITH AGRICULTURAL SEEDS, PLANTS OR MIXTURES OF SOIL MEDIA TO ENHANCE PLANT GROWTH AND INCREASE PLANT YIELD (U.S. CLS. 1, 5, 6, 10, 26 AND 46).

FIRST USE 12-11-2006; IN COMMERCE 12-11-2006.

WILLIAM VERHOSEK, EXAMINING ATTORNEY

SN 85-597,122. COOPERATIVE PRODUCERS, INC., HASTINGS, NE. FILED 4-13-2012.

Bean Armor

THE MARK CONSISTS OF STANDARD CHARACTERS WITHOUT CLAIM TO ANY PARTICULAR FONT, STYLE, SIZE, OR COLOR.

NO CLAIM IS MADE TO THE EXCLUSIVE RIGHT TO USE "BEAN", APART FROM THE MARK AS SHOWN.

FOR CHEMICAL PREPARATIONS FOR USE IN AGRICULTURE, HORTICULTURE AND FORESTRY, NAMELY, CHEMICAL PREPARATIONS FOR THE TREATMENT OF SEEDS; SEED COATING APPLIED TO CORN, SOYBEANS, WHEAT AND ALFALFA SEEDS TO IMPROVE STANDS, SEEDLING HEALTH AND YIELD (U.S. CLS. 1, 5, 6, 10, 26 AND 46).

FIRST USE 4-9-2012; IN COMMERCE 4-9-2012.

JEANIE LEE, EXAMINING ATTORNEY

SN 85-601,518. COLONIA CONSULTING, LLC, PARADISE VALLEY, AZ. FILED 4-18-2012.

ENVIRONITE

THE MARK CONSISTS OF STANDARD CHARACTERS WITHOUT CLAIM TO ANY PARTICULAR FONT, STYLE, SIZE, OR COLOR.

FOR FERTILIZERS; PLANT FOOD (U.S. CLS. 1, 5, 6, 10, 26 AND 46).

SUSAN RICHARDS, EXAMINING ATTORNEY

SN 85-599,282. E-YEAR CORPORATION, TAIPEI CITY, TAIWAN, FILED 4-16-2012.

DIAMOND

THE MARK CONSISTS OF STANDARD CHARACTERS WITHOUT CLAIM TO ANY PARTICULAR FONT, STYLE, SIZE, OR COLOR.

FOR BLUEPRINT PAPER; PHOTOGRAPHIC PAPER; PHOTSENSITIVE PAPER; UNEXPOSED CAMERA FILM; UNEXPOSED CINEMATOGRAPHIC FILM; UNEXPOSED PHOTOGRAPHIC FILM (U.S. CLS. 1, 5, 6, 10, 26 AND 46).

KIMBERLY PARKS, EXAMINING ATTORNEY

SN 85-602,112. FUZION PRODUCTS LLC, INDIANAPOLIS, IN. FILED 4-19-2012.

FUZION ENGINEERED ADHESIVES

THE MARK CONSISTS OF STANDARD CHARACTERS WITHOUT CLAIM TO ANY PARTICULAR FONT, STYLE, SIZE, OR COLOR.

OWNER OF U.S. REG. NO. 3,929,663.

NO CLAIM IS MADE TO THE EXCLUSIVE RIGHT TO USE "ENGINEERED ADHESIVES", APART FROM THE MARK AS SHOWN.

FOR ADHESIVES FOR INDUSTRIAL USE (U.S. CLS. 1, 5, 6, 10, 26 AND 46).

FIRST USE 6-8-2012; IN COMMERCE 6-8-2012.

ANTHONY RINKER, EXAMINING ATTORNEY

CLASS 1—(Continued).

SN 85-602,655. WATCO USA, INC., VERNON HILLS, IL. FILED 4-19-2012.

CEMTETCH

THE MARK CONSISTS OF STANDARD CHARACTERS WITHOUT CLAIM TO ANY PARTICULAR FONT, STYLE, SIZE, OR COLOR.
FOR ETCHING SOLUTION FOR CONCRETE FLOORS (U.S. CLS. 1, 5, 6, 10, 26 AND 46).
FIRST USE 9-16-2011; IN COMMERCE 9-16-2011.
JOHN E. MICHOS, EXAMINING ATTORNEY

SN 85-604,918. CHEMTURA CORPORATION, MIDDLEBURY, CT. FILED 4-23-2012.

Emerald Innovation

THE MARK CONSISTS OF STANDARD CHARACTERS WITHOUT CLAIM TO ANY PARTICULAR FONT, STYLE, SIZE, OR COLOR.
FOR FIRE RETARDANT CHEMICALS (U.S. CLS. 1, 5, 6, 10, 26 AND 46).
CHRISTINA SOBRAL, EXAMINING ATTORNEY

SN 85-604,931. CHEMTURA CORPORATION, MIDDLEBURY, CT. FILED 4-23-2012.

Emerald Innovation

THE COLOR(S) GREEN AND BLUE IS/ARE CLAIMED AS A FEATURE OF THE MARK.
THE MARK CONSISTS OF THE WORD "EMERALD" IN THE COLOR GREEN AND THE WORD "INNOVATION" IN THE COLOR BLUE.
FOR FIRE RETARDANT CHEMICALS (U.S. CLS. 1, 5, 6, 10, 26 AND 46).
CHRISTINA SOBRAL, EXAMINING ATTORNEY

CLASS 1—(Continued).

SN 85-604,938. CHEMTURA CORPORATION, MIDDLEBURY, CT. FILED 4-23-2012.

Emerald Innovation

THE COLOR(S) GREEN AND BLUE IS/ARE CLAIMED AS A FEATURE OF THE MARK.
THE MARK CONSISTS OF THE WORD "EMERALD" IN THE COLOR GREEN AND THE WORD "INNOVATION" IN THE COLOR BLUE.
FOR FIRE RETARDANT CHEMICALS (U.S. CLS. 1, 5, 6, 10, 26 AND 46).
CHRISTINA SOBRAL, EXAMINING ATTORNEY

SN 85-671,647. AMCOL INTERNATIONAL CORPORATION, HOFFMAN ESTATES, IL. FILED 7-9-2012.

CHAREX

THE MARK CONSISTS OF STANDARD CHARACTERS WITHOUT CLAIM TO ANY PARTICULAR FONT, STYLE, SIZE, OR COLOR.
FOR FIRE RETARDANT CHEMICAL ADDITIVES FOR USE IN PLASTICS, RUBBERS AND COATINGS (U.S. CLS. 1, 5, 6, 10, 26 AND 46).
C. DIONNE CLYBURN, EXAMINING ATTORNEY

CLASS 2—PAINTS

SN 79-106,477. BIOGRUND GMBH, FED REP GERMANY, FILED 10-24-2011.

TopMill

THE MARK CONSISTS OF STANDARD CHARACTERS WITHOUT CLAIM TO ANY PARTICULAR FONT, STYLE, SIZE, OR COLOR.
OWNER OF INTERNATIONAL REGISTRATION 1099909 DATED 10-24-2011, EXPIRES 10-24-2021.
FOR COLORANTS, IN PARTICULAR DRY MILLING OF PIGMENTS AND CARRIERS, IN PARTICULAR FOR DYEING TABLETS, PELLETS, POWDER MIXTURES, GRANULES, COATING PREPARATIONS, PASTES, DRY COMPOUNDS, SUSPENSIONS, GELS OR CREAMS (U.S. CLS. 6, 11 AND 16).
SHANNON TWOHIG, EXAMINING ATTORNEY

CLASS 2—(Continued).

SN 85-554,985. ENVIRONMENTAL TECHNOLOGY INC.,
FIELDS LANDING, CA. FILED 2-28-2012.

Envirotex Jewelry Resin

THE MARK CONSISTS OF STANDARD CHARACTERS WITHOUT CLAIM TO ANY PARTICULAR FONT, STYLE, SIZE, OR COLOR.

OWNER OF U.S. REG. NO. 2,991,351.

NO CLAIM IS MADE TO THE EXCLUSIVE RIGHT TO USE "JEWELRY RESIN", APART FROM THE MARK AS SHOWN.

FOR COATINGS IN THE NATURE OF A CLEAR PLASTIC FINISH FOR USE WITH JEWELRY INCLUDING WOOD, METAL AND GLASS (U.S. CLS. 6, 11 AND 16).

FIRST USE 11-1-2011; IN COMMERCE 12-7-2011.
SOPHIA S. KIM, EXAMINING ATTORNEY

SN 85-563,617. TSRC CORPORATION, TAIPEI CITY, TAIWAN, FILED 3-8-2012.



OWNER OF TAIWAN REG. NO. 797206, DATED 3-1-1998, EXPIRES 2-28-2018.

THE MARK CONSISTS OF A SOLID SQUARE AND FOUR CHECK MARKS. THE FOUR CHECK MARKS CONTINUALLY FLIP 90 DEGREES COUNTER CLOCKWISE WITH TWO SOLID CHECK MARKS APART FROM THE SQUARE AND THE OTHER TWO CHECK MARKS OVER THE SQUARE THAT EXTEND BEYOND THE BORDERS OF THE SQUARE.

FOR SYNTHETIC RUBBER PAINT, SYNTHETIC RESIN PAINT, WATERPROOF PAINT, HEAT-RESISTANT PAINT (U.S. CLS. 6, 11 AND 16).

AHSEN KHAN, EXAMINING ATTORNEY

CLASS 2—(Continued).

SN 85-584,985. ASTER GRAPHICS, INC., LA MIRADA, CA. FILED 3-30-2012.

THE MARK CONSISTS OF THE STYLIZED WORD "ASTER" WITH TWO SQUARES APPEARING AT THE TOP LEFT OF LETTER "A". THE LOWER SQUARE CONNECTS TO LETTER "A" WITH ITS RIGHT BOTTOM CORNER AND CONNECTS TO THE OTHER SMALLER SQUARE WITH ITS RIGHT TOP CORNER.

FOR FILLED TONER CARTRIDGES THAT ARE COMPATIBLE WITH LASER PRINTERS, INKJET PRINTERS, AND LABEL PRINTERS (U.S. CLS. 6, 11 AND 16).
FIRST USE 3-15-2011; IN COMMERCE 3-15-2011.
ALYSSA STEEL, EXAMINING ATTORNEY

SN 85-596,889. ELEMENTIS SPECIALTIES, INC., HIGHTSTOWN, NJ. FILED 4-13-2012.

TINT-AYD

THE MARK CONSISTS OF STANDARD CHARACTERS WITHOUT CLAIM TO ANY PARTICULAR FONT, STYLE, SIZE, OR COLOR.

FOR COLORED ADDITIVES FOR PAINTS AND LACQUERS, EITHER IN LIQUID OR SOLID FORM, NAMELY, COLOR PIGMENT DISPERSIONS FOR COLORING, TONING OR SHADING OF PAINTS AND LACQUERS (U.S. CLS. 6, 11 AND 16).

FIRST USE 1-31-1955; IN COMMERCE 1-31-1955.
MICHAEL WIENER, EXAMINING ATTORNEY

SN 85-597,806. AMERICOATS, FRANKLIN PARK, IL. FILED 4-13-2012.

AmeriGard

THE MARK CONSISTS OF STANDARD CHARACTERS WITHOUT CLAIM TO ANY PARTICULAR FONT, STYLE, SIZE, OR COLOR.

FOR POWDER PAINTS USED TO COAT VARIOUS FERROUS AND NON-FERROUS SUBSTRATES, FOR MANUFACTURERS WHO HAVE SPECIAL APPLICATION EQUIPMENT TO APPLY IT ON (U.S. CLS. 6, 11 AND 16).

ARETHA SOMERVILLE, EXAMINING ATTORNEY

CLASS 2—(Continued).

SN 85-602,397. EVIL TATTOO SUPPLY & MFG. CORP., SYOSSET, NY. FILED 4-19-2012.

Ink Shooterz

THE MARK CONSISTS OF STANDARD CHARACTERS WITHOUT CLAIM TO ANY PARTICULAR FONT, STYLE, SIZE, OR COLOR.

NO CLAIM IS MADE TO THE EXCLUSIVE RIGHT TO USE "INK", APART FROM THE MARK AS SHOWN.

FOR TATTOO COLORS; TATTOO INKS; TATTOOING INK (U.S. CLS. 6, 11 AND 16).

TINA MAI, EXAMINING ATTORNEY

CLASS 3—COSMETICS AND CLEANING PREPARATIONS

SN 76-710,858. POTTINGER, CLAUDETTE, HAVERHILL, FL. FILED 3-9-2012.

ALOEVERALIZE

THE MARK CONSISTS OF STANDARD CHARACTERS WITHOUT CLAIM TO ANY PARTICULAR FONT, STYLE, SIZE, OR COLOR.

FOR HAIR CARE TREATMENT, NAMELY, NON-MEDICATED HAIR TREATMENT PREPARATIONS FOR COSMETIC PURPOSES, NON-MEDICATED HAIR CARE PREPARATIONS, HAIR CARE PREPARATIONS, HAIR CARE CREAMS, AND HAIR CARE LOTIONS (U.S. CLS. 1, 4, 6, 50, 51 AND 52).

JEANIE LEE, EXAMINING ATTORNEY

SN 76-711,310. JASON & JEAN PRODUCTS INC., CORONA, NY. FILED 4-23-2012.

20 SEC

THE MARK CONSISTS OF STANDARD CHARACTERS WITHOUT CLAIM TO ANY PARTICULAR FONT, STYLE, SIZE, OR COLOR.

FOR HAIR SHAMPOO, HAIR CONDITIONER, HAIR SPRAY, ADHESIVE FOR AFFIXING FALSE HAIR (U.S. CLS. 1, 4, 6, 50, 51 AND 52).

TEJBIR SINGH, EXAMINING ATTORNEY

CLASS 3—(Continued).

SN 79-103,714. NOELLE O'CONNOR, IRELAND, FILED 9-16-2011.

OILARGANIC

THE MARK CONSISTS OF STANDARD CHARACTERS WITHOUT CLAIM TO ANY PARTICULAR FONT, STYLE, SIZE, OR COLOR.

PRIORITY DATE OF 3-24-2011 IS CLAIMED.

OWNER OF INTERNATIONAL REGISTRATION 1093696 DATED 9-16-2011, EXPIRES 9-16-2021.

FOR ESSENTIAL OILS, COSMETIC OILS, SKIN CARE OILS, DERMATOLOGICAL PREPARATIONS AND SUBSTANCES IN THE NATURE OF NON-MEDICATED OILS (U.S. CLS. 1, 4, 6, 50, 51 AND 52).

APRIL ROACH, EXAMINING ATTORNEY

SN 79-104,978. BORIS BARTEL, FED REP GERMANY, FILED 10-18-2011.

Mangasun

THE MARK CONSISTS OF STANDARD CHARACTERS WITHOUT CLAIM TO ANY PARTICULAR FONT, STYLE, SIZE, OR COLOR.

OWNER OF INTERNATIONAL REGISTRATION 1096634 DATED 10-18-2011, EXPIRES 10-18-2021.

FOR COSMETICS, COSMETICS AND SUN COSMETICS FOR NATURAL SUNSHINE AND ARTIFICIAL SUN, ESPECIALLY SOLARIUMS AND SUN BEDS, NAMELY, SUN-TANNING PREPARATIONS COSMETICS, COSMETIC SUN OILS, COSMETIC PREPARATIONS WITH SELF-TANNER, COSMETIC PREPARATIONS TO ENHANCE THE PROCESS OF TANNING, COSMETIC PREPARATIONS FOR USE UNDER THE ARTIFICIAL SUN (U.S. CLS. 1, 4, 6, 50, 51 AND 52).

ANDREA BUTLER, EXAMINING ATTORNEY

SN 79-105,869. MARCUS ASAM, FED REP GERMANY, AND MIRJAM ASAM, FED REP GERMANY, FILED 10-18-2011.

M. Asam

THE MARK CONSISTS OF STANDARD CHARACTERS WITHOUT CLAIM TO ANY PARTICULAR FONT, STYLE, SIZE, OR COLOR.

OWNER OF INTERNATIONAL REGISTRATION 1008027 DATED 5-25-2009, EXPIRES 5-25-2019.

OWNER OF U.S. REG. NO. 3,004,565.

FOR SOAPS FOR PERSONAL USE, SOAPS FOR HOUSEHOLD USE, PERFUMERY, ESSENTIAL OILS, COSMETICS, HAIR LOTIONS, BLEACHING PREPARATIONS AND OTHER SUBSTANCES FOR LAUNDRY USE, NAMELY, LAUNDRY DETERGENT AND DISHWASHING DETERGENT FOR HOUSEHOLD USE (U.S. CLS. 1, 4, 6, 50, 51 AND 52).

KRISTINA MORRIS, EXAMINING ATTORNEY

CLASS 3—(Continued).

SN 79-108,187. BORIS BARTEL, 47877 WILLICH, FED REP GERMANY, FILED 11-28-2011.



PRIORITY DATE OF 9-1-2011 IS CLAIMED.
 OWNER OF INTERNATIONAL REGISTRATION 1104352 DATED 11-28-2011, EXPIRES 11-28-2021.
 THE WORDING "HYPHEE" HAS NO MEANING IN A FOREIGN LANGUAGE.
 FOR SOAPS; PERFUMERY, ETHEREAL OILS, COSMETICS, HAIR LOTIONS; DENTIFRICES; MAKE-UP REMOVING PREPARATIONS; COSMETICS PREPARATIONS FOR BATHS; SUN-TANNING PREPARATIONS COSMETICS; LOTIONS FOR COSMETIC PURPOSES; OILS FOR CLEANING PURPOSES; COSMETIC SUNSCREEN PREPARATIONS AND SUN COSMETICS FOR NATURAL SUN, NAMELY, COSMETIC SUN OILS, COSMETIC PREPARATIONS WITH SELF- TANNER, COSMETIC PREPARATIONS TO ENHANCE THE PROCESS OF TANNING; SUNSCREENS AND SUN COSMETICS FOR ARTIFICIAL SUN, ESPECIALLY SOLARIA AND SUN BEDS, NAMELY, COSMETIC SUN OILS, COSMETIC PREPARATION FOR USE UNDER THE ARTIFICIAL SUN, COSMETIC PREPARATIONS WITH SELF- TANNER, COSMETIC PREPARATIONS TO ENHANCE THE PROCESS OF TANNING (U.S. CLS. 1, 4, 6, 50, 51 AND 52).
 ANDREA BUTLER, EXAMINING ATTORNEY

SN 79-111,259. BEIJING ZHENYANLISHE COMMERCE TRADE CO., LTD., BEIJING, CHINA, FILED 1-31-2012.



OWNER OF INTERNATIONAL REGISTRATION 1111853 DATED 1-31-2012, EXPIRES 1-31-2022.
 THE MARK CONSISTS OF THE STYLIZED LETTER-NUMBER COMBINATION "PF79" WITH A "+" SYMBOL ABOVE AND TO THE RIGHT OF THE LETTER "F".
 FOR COSMETICS; LIPSTICKS; EYEBROW PENCILS; EYE SHADOWS; COSMETIC ROUGES; MAKE-UP PREPARATIONS FOR THE SKIN; PERFUMED POWDER FOR COSMETIC PURPOSES; MASCARAS; SHAMPOOS; PERFUMES (U.S. CLS. 1, 4, 6, 50, 51 AND 52).
 WILLIAM P. SHANAHAN, EXAMINING ATTORNEY

CLASS 3—(Continued).

SN 79-111,391. TONINO LAMBORGHINI S.R.L., MODENA (MO), ITALY, FILED 8-5-2011.



OWNER OF INTERNATIONAL REGISTRATION 0806231 DATED 4-22-2003, EXPIRES 4-22-2013.
 THE NAME(S), PORTRAIT(S), AND/OR SIGNATURE(S) SHOWN IN THE MARK IDENTIFIES "TONINO LAMBORGHINI", WHOSE CONSENT(S) TO REGISTER IS MADE OF RECORD.
 THE MARK CONSISTS OF STYLIZED DESIGN DEPICTING A BULL IN A FIGHTING POSE INSIDE A BADGE, AND UNDERNEATH THE TERM "TONINO LAMBORGHINI" IN CURSIVE TYPE.
 FOR BODY LOTION, SHOWER GEL, AFTER SHAVE LOTION, AFTER SHAVE BALM, DEODORANT STICK FOR PERSONAL USE, COLOGNE, LAVENDER WATER, ESSENTIAL OILS FOR FOOD FLAVOURING, COSMETIC PREPARATIONS, DEODORANT SOAPS, DEODORANTS FOR PERSONAL USE, ESSENTIAL OILS FOR AROMATHERAPY USE, PERFUMES, SHAMPOOS, TALCUM POWDER, COSMETICS, NAMELY, BEAUTY MASKS, FACE POWDER, LIPSTICKS, FACIAL CREAM, COSMETIC PREPARATIONS FOR THE BATH, NAMELY, BATH OIL; SUN CARE PRODUCTS, NAMELY, SUN BLOCK, SUN SCREEN, SUNTAN OIL, COSMETIC SUNTAN LOTION, AFTER SUN MOISTURIZING LOTION; SKIN TONIC; COSMETIC PREPARATIONS FOR SLIMMING PURPOSES, MOISTURIZING CREAMS, ANTI-AGING CREAMS, CREAMS FOR CELLULITE REDUCTION, BODY CLEANSING MILK, BODY MOISTURIZING MILK, BODY MOISTURIZING SERUM, ANTI-WRINKLE SERUM, FACE SERUM, EYE SERUM FOR FIRMS THE SKIN AROUND THE EYES, SKIN MOISTURIZING GEL, HERBED DISTILLATE BODY SPRAY USED AS A FRAGRANCE, DEPILATORY PREPARATIONS, DEPILATORY CREAMS (U.S. CLS. 1, 4, 6, 50, 51 AND 52).
 INGA ERVIN, EXAMINING ATTORNEY

SN 79-113,980. NEOVIX, FRANCE, FILED 4-18-2012.



THE MARK CONSISTS OF STANDARD CHARACTERS WITHOUT CLAIM TO ANY PARTICULAR FONT, STYLE, SIZE, OR COLOR.
 OWNER OF INTERNATIONAL REGISTRATION 1119034 DATED 4-18-2012, EXPIRES 4-18-2022.
 FOR PERFUMES, ESSENTIAL OILS, COSMETICS, HAIR LOTIONS; DENTIFRICES; DEPILATORY PREPARATIONS; MAKE-UP REMOVING PREPARATIONS; CREAMS FOR LEATHER (U.S. CLS. 1, 4, 6, 50, 51 AND 52).
 LINDA LAVACHE, EXAMINING ATTORNEY

CLASS 3—(Continued).

SN 85-074,305. JEJU HI-TECH INDUSTRY DEVELOPMENT INSTITUTE, JEJU-CITY, JEJU-DO, REPUBLIC OF KOREA, FILED 6-29-2010.

REOROM
레오롬

OWNER OF REPUBLIC OF KOREA REG. NO. 40-0695705, DATED 1-29-2007, EXPIRES 1-29-2017.

THE MARK CONSISTS OF THE WORD "REOROM" AND THE KOREAN LETTERING FOR "REOREM."

THE TERM "REOROM" HAS NO MEANING IN ENGLISH OR IN A FOREIGN LANGUAGE.

THE NON-LATIN CHARACTERS IN THE MARK TRANSLITERATE TO "REOROM."

FOR SKIN LOTION, EYE SHADOW, FACIAL CREAMS, BODY LOTIONS, CLEANSING CREAMS, LIPSTICKS, MAKE-UP PREPARATIONS, BALMS FOR COSMETIC PURPOSES, NAMELY, PERFUMED OIL FOR COSMETICS; SOLID COSMETIC POWDER FOR COMPACTS, MAKE-UP POWDER, FOUNDATION CREAM, NON-MEDICATED LIP CARE PREPARATIONS, NAMELY, LIP BRIGHTENERS; MASCARA, EYEBROW PENCILS, COSMETIC PENCILS, EYELINER, CHEEK COLORS, NAMELY, BLUSH; NAIL ENAMEL FOR MANICURE (U.S. CLS. 1, 4, 6, 50, 51 AND 52).

LINDSEY RUBIN, EXAMINING ATTORNEY

CLASS 3—(Continued).

SN 85-260,475. WAGNER, LEAH, VANCOUVER, CANADA, FILED 3-8-2011.

ROYAL HORSE BITBALM

THE MARK CONSISTS OF STANDARD CHARACTERS WITHOUT CLAIM TO ANY PARTICULAR FONT, STYLE, SIZE, OR COLOR.

NO CLAIM IS MADE TO THE EXCLUSIVE RIGHT TO USE "HORSE BITBALM", APART FROM THE MARK AS SHOWN.

FOR LUBRICATING AND MOISTURIZING LIP BALM FOR HORSE LIPS (U.S. CLS. 1, 4, 6, 50, 51 AND 52).

FIRST USE 2-14-2011; IN COMMERCE 2-14-2011.

INGA ERVIN, EXAMINING ATTORNEY

SN 85-108,177. STELLA MCCARTNEY LIMITED, LONDON, UNITED KINGDOM, FILED 8-16-2010.

L.I.L.Y
STELLA/McCARTNEY

OWNER OF U.S. REG. NOS. 2,953,202, 3,069,625 AND OTHERS.

NO CLAIM IS MADE TO THE EXCLUSIVE RIGHT TO USE "LILY", APART FROM THE MARK AS SHOWN.

THE STIPPLING IS A FEATURE OF THE MARK AND DOES NOT INDICATE COLOR.

THE NAME "STELLA MCCARTNEY" IDENTIFIES A LIVING INDIVIDUAL WHOSE CONSENT IS OF RECORD.

FOR PERFUME; EAU DE TOILETTE; GELS AND SALTS FOR THE BATH AND THE SHOWER NOT FOR MEDICAL PURPOSE; TOILET SOAPS; BODY DEODORANTS; COSMETICS, NAMELY, CREAMS, MILKS, LOTIONS, GELS AND POWDERS FOR THE FACE, THE BODY AND THE HANDS; MAKEUP PREPARATIONS; SHAMPOOS; ESSENTIAL OILS FOR PERSONAL USE (U.S. CLS. 1, 4, 6, 50, 51 AND 52).

MARY CRAWFORD, EXAMINING ATTORNEY

SN 85-294,368. INNOVAGE, LLC, FOOTHILL RANCH, CA, FILED 4-13-2011.

MAKEOVER ESSENTIALS

THE MARK CONSISTS OF STANDARD CHARACTERS WITHOUT CLAIM TO ANY PARTICULAR FONT, STYLE, SIZE, OR COLOR.

NO CLAIM IS MADE TO THE EXCLUSIVE RIGHT TO USE "MAKEOVER", APART FROM THE MARK AS SHOWN.

FOR COSMETICS; COSMETIC PREPARATIONS; MAKE-UP; MAKE-UP PREPARATIONS; AND MAKE-UP KITS COMPRISED OF ANY COMBINATION OF LIP LINER, LIP GLOSS, BLUSH, SKIN BRONZER, EYE SHADOW, EYE PENCIL, MASCARA, APPLICATOR BRUSHES AND FACIAL SPONGES (U.S. CLS. 1, 4, 6, 50, 51 AND 52).

RUSS HERMAN, EXAMINING ATTORNEY

CLASS 3—(Continued).

SN 85-332,361. ARACADIA GROUP BRANDS LIMITED, LONDON, UNITED KINGDOM, FILED 5-27-2011.

TOPMAN

THE MARK CONSISTS OF STANDARD CHARACTERS WITHOUT CLAIM TO ANY PARTICULAR FONT, STYLE, SIZE, OR COLOR.

OWNER OF ERP N CMNTY TM OFC REG. NO. 7482235, DATED 7-29-2009, EXPIRES 12-19-2018.

OWNER OF U.S. REG. NOS. 3,492,560, 3,499,038 AND OTHERS.

FOR CLEANING, POLISHING, SCOURING, AND GENERAL PURPOSE ABRASIVE PREPARATIONS; HAIR, SKIN, AND NAIL CARE PRODUCTS, NAMELY, NON-MEDICATED PREPARATIONS FOR THE APPLICATION TO, CLEANSING, CONDITIONING, AND CARE OF HAIR, SCALP, SKIN, AND NAILS; SOAPS; PERFUMES; PERFUMERY, NAMELY, FRAGRANCES, COLOGNES, EAU DE COLOGNE, AND TOILET WATERS; COSMETICS, NAMELY, MAKE-UP PREPARATIONS, MAKE-UP, CONCEALERS FOR SPOTS AND BLEMISHES, FOUNDATION MAKE-UP BASE, FACE POWDER, MASCARA, EYEBROW PENCILS, EYE SHADOW, LIQUID EYELINER, BLUSHERS, EYELINER PENCILS, SKIN BRONZERS, NON-MEDICATED PROTECTIVE LOTIONS IN THE NATURE OF SKIN LOTION AND NON-MEDICATED SKIN CREAMS, NON-MEDICATED EYE CARE PREPARATIONS IN THE NATURE OF EYE GELS, EYE CREAM, AND GEL EYE MASKS, LIPSTICKS, NAIL VARNISHES, AND NAIL VARNISH REMOVERS; COSMETICS, NAMELY, COSMETIC HERBAL AND MASSAGE OILS; NON-MEDICATED TOILETRIES; ESSENTIAL OILS; BEAUTY PRODUCTS, NAMELY, BEAUTY CREAMS, BEAUTY GELS, BEAUTY LOTIONS, BEAUTY MASKS, BEAUTY MILKS, AND NON-MEDICATED PREPARATIONS FOR CARE OF THE FACE, FEET, BODY, SCALP, NAILS, AND HAIR; HAIR CARE PRODUCTS, NAMELY, HAIR CARE PREPARATIONS AND HAIR CARE CREAMS; HAIR CARE LOTIONS; HAIR SPRAYS AND HAIR GELS; BEAUTY PREPARATIONS FOR USE IN THE BATH OR SHOWER, NAMELY, BATH BEADS, BATH FIZZIES, BATH FOAMS, BATH LOTION, BATH GELS; TOILETRIES, NAMELY, BATH AND SHOWER OILS, GELS, CREAMS, AND FOAMS, FACE AND BODY MASKS; FACE AND BODY SCRUBS; SKIN CARE PRODUCTS, NAMELY, COSMETIC PREPARATIONS FOR SKIN CARE AND COSMETIC PRODUCTS IN THE FORM OF AEROSOLS FOR SKIN CARE, FACIAL WASHES; SKIN CLEANSERS AND NON-MEDICATED SKIN HYDRATORS; SKIN TONERS; SKIN MOISTURIZERS; NON-MEDICATED BLEMISH CREAMS AND NON-MEDICATED BLEMISH GELS; DEODORANTS, NAMELY, BODY DEODORANTS, DEODORANT SOAP, AND DEODORANTS FOR BODY CARE; DEODORANTS FOR PERSONAL USE; ANTIPERSPIRANTS; MEN'S GROOMING PRODUCTS, NAMELY, NON-MEDICATED PREPARATIONS FOR CARE OF THE FACE, FEET, BODY, SCALP, NAILS, AND HAIR AND NON-MEDICATED DEPILATORY AND SKIN EXFOLIATING PREPARATIONS; BEAUTY PRODUCTS IN THE NATURE OF PREPARATIONS FOR USE BEFORE SHAVING AND AFTER SHAVING, NAMELY, AFTER-SHAVE, PRE-SHAVE CREAMS, SHAVING SOAP, LOTION, AND SHAVING SPRITZ IN THE NATURE OF A MOISTURIZING SOLUTION FOR SHAVING; SHAVING SOAPS; SKIN CARE PRODUCTS, NAMELY, SHAVING CREAMS, SHAVING GELS, SHAVING LOTIONS, SHAVING OILS, AFTER-SHAVE PREPARATIONS, AND PRE-SHAVE PREPARATIONS; BEAUTY PRODUCTS, NAMELY, TALCUM POWDERS, AND BODY POWDER; DENTIFRICES; AND DENTIFRICES IN THE NATURE OF TOOTHPASTES (U.S. CLS. 1, 4, 6, 50, 51 AND 52).

ANDREA K. NADELMAN, EXAMINING ATTORNEY

CLASS 3—(Continued).

SN 85-370,647. ELMAR HOHNHEISSER, HAMBURG, FED REP GERMANY, FILED 7-13-2011.

QUEEN OF SHEABA

THE MARK CONSISTS OF STANDARD CHARACTERS WITHOUT CLAIM TO ANY PARTICULAR FONT, STYLE, SIZE, OR COLOR.

PRIORITY CLAIMED UNDER SEC. 44(D) ON FED REP GERMANY APPLICATION NO. 302011014327, FILED 2-28-2011, REG. NO. 302011014327, DATED 4-1-2011, EXPIRES 2-28-2021.

FOR COSMETICS (U.S. CLS. 1, 4, 6, 50, 51 AND 52).
KELLY BOULTON, EXAMINING ATTORNEY

SN 85-372,016. NINE NATURALS, LLC, NEW YORK, NY, FILED 7-14-2011.

Nine Naturals

THE MARK CONSISTS OF STANDARD CHARACTERS WITHOUT CLAIM TO ANY PARTICULAR FONT, STYLE, SIZE, OR COLOR.

NO CLAIM IS MADE TO THE EXCLUSIVE RIGHT TO USE "NATURALS", APART FROM THE MARK AS SHOWN. FOR NATURAL BEAUTY CARE PRODUCTS, NAMELY, NON-MEDICATED, NATURAL HAIR AND SKIN CARE PREPARATIONS (U.S. CLS. 1, 4, 6, 50, 51 AND 52).

FIRST USE 9-15-2008; IN COMMERCE 9-15-2008.
MARTHA FROMM, EXAMINING ATTORNEY

SN 85-372,018. NINE NATURALS, LLC, NEW YORK, NY, FILED 7-14-2011.

9 Naturals

THE MARK CONSISTS OF STANDARD CHARACTERS WITHOUT CLAIM TO ANY PARTICULAR FONT, STYLE, SIZE, OR COLOR.

NO CLAIM IS MADE TO THE EXCLUSIVE RIGHT TO USE "NATURALS", APART FROM THE MARK AS SHOWN.

FOR NATURAL BEAUTY CARE PRODUCTS, NAMELY, NON-MEDICATED, NATURAL HAIR AND SKIN CARE PREPARATIONS (U.S. CLS. 1, 4, 6, 50, 51 AND 52).

MARTHA FROMM, EXAMINING ATTORNEY

CLASS 3—(Continued).

SN 85-383,523. THE PROCTER & GAMBLE COMPANY, CINCINNATI, OH. FILED 7-28-2011.

GET READY TO POP YOUR
LAUNDRY

THE MARK CONSISTS OF STANDARD CHARACTERS WITHOUT CLAIM TO ANY PARTICULAR FONT, STYLE, SIZE, OR COLOR.

OWNER OF SWITZERLAND REG. NO. 611451, DATED 2-7-2011, EXPIRES 1-30-2021.

FOR LAUNDRY STAIN REMOVERS, LAUNDRY DETERGENTS (U.S. CLS. 1, 4, 6, 50, 51 AND 52); SUSAN RICHARDS, EXAMINING ATTORNEY

CLASS 3—(Continued).

SN 85-397,894. LE BLANC, INC., TAMPA, FL. FILED 8-15-2011.



OWNER OF U.S. REG. NOS. 1,413,907 AND 2,000,576. NO CLAIM IS MADE TO THE EXCLUSIVE RIGHT TO USE "WASH" AND "SINCE 1985" AND "A FINE SPECIALTY CLEANSER", APART FROM THE MARK AS SHOWN.

THE MARK CONSISTS OF THE TEXT "LE BLANC" SUPERIMPOSED OVER A FLEUR-DE-LIS AND THE WORDS "LINEN WASH" ABOVE THE WORDS "A FINE SPECIALTY CLEANSER" ALL WITHIN A SQUARE HAVING A SHADED HORIZONTAL BAR ACROSS THE TOP.

THE ENGLISH TRANSLATION OF "LE BLANC" IN THE MARK IS "THE WHITE".

SEC. 2(F) AS TO "LINEN". FOR CONCENTRATED CLEANING FLUID SUITABLE FOR USE IN COLD WATER FOR THE PURPOSE OF CLEANING WASHABLE FABRICS, ESPECIALLY FINE LINENS AND HARD SURFACES (U.S. CLS. 1, 4, 6, 50, 51 AND 52).

FIRST USE 7-10-1985; IN COMMERCE 7-10-1985. JOHN WILKE, EXAMINING ATTORNEY

SN 85-401,083. AYURDEVAS NATURAL PRODUCTS LLC, MIAMI BEACH, FL. FILED 8-18-2011.

Deva's Natural Life
Essentials

THE MARK CONSISTS OF STANDARD CHARACTERS WITHOUT CLAIM TO ANY PARTICULAR FONT, STYLE, SIZE, OR COLOR.

NO CLAIM IS MADE TO THE EXCLUSIVE RIGHT TO USE "NATURAL" AND "ESSENTIALS", APART FROM THE MARK AS SHOWN.

FOR AFTER SHAVE LOTIONS; AFTER SUN CREAMS; AFTER-SHAVE; ANTI-AGING CLEANSER; ANTI-AGING CREAM; ANTI-AGING MOISTURIZER; ANTI-AGING TONER; ANTI-BACTERIAL SOAP; ANTI-WRINKLE CREAM; AROMATIC BODY CARE PRODUCTS, NAMELY, BODY LOTION, SHOWER GEL, CUTICLE CREAM, SHAMPOO, CONDITIONER, NON-MEDICATED LIP BALM, SOAP, BODY POLISH, BODY AND FOOT SCRUB AND NON-MEDICATED FOOT CREAM; AROMATIC ESSENTIAL OILS; AROMATIC OILS; BABY LOTION; BABY OIL; BABY OILS; BABY SHAMPOO; BATH AND SHOWER GELS AND SALTS NOT FOR MEDICAL PURPOSES; BATH GEL; BATH GELS; BATH OIL; BATH OILS; BATH OILS AND BATH SALTS; BATH SOAPS IN LIQUID, SOLID OR GEL FORM; BEAUTY CREAMS; BEAUTY CREAMS FOR BODY CARE; BEAUTY GELS; BEAUTY LOTIONS; BEAUTY MASKS; BEAUTY SOAP; BERGAMOT OIL; BODY CREAM; BODY CREAM SOAP; BODY CREAMS; BODY DEODORANTS; BODY GLITTER; BODY LOTION; BODY LOTIONS; BODY MASK CREAM; BODY MASK LOTION; BODY OIL; BODY OILS; BODY POWDER; BODY SCRUB; BODY SPLASH; BODY SPRAY USED AS A PERSONAL

SN 85-390,482. 12 ANGELS, LLC, FORT LAUDERDALE, FL. FILED 8-5-2011.

COAL

THE MARK CONSISTS OF STANDARD CHARACTERS WITHOUT CLAIM TO ANY PARTICULAR FONT, STYLE, SIZE, OR COLOR.

FOR BLUSH; BODY WASH; COSMETICS; MAKE-UP REMOVER; MOISTURIZING PREPARATIONS FOR THE SKIN (U.S. CLS. 1, 4, 6, 50, 51 AND 52).

JILL PRATER, EXAMINING ATTORNEY

CLASS 3—(Continued).

DEODORANT AND AS FRAGRANCE; BODY SPRAYS; BODY SPRAYS, NAMELY, WATER IN ATOMIZED CONTAINERS USED TO PRODUCE A COOLING EFFECT; BODY WASH; COLOGNE; COLOGNE WATER; COLOGNES, PERFUMES AND COSMETICS; COSMETIC BATH SALTS; COSMETIC CREAMS; COSMETIC CREAMS FOR SKIN CARE; COSMETIC HAND CREAMS; COSMETIC MASKS; COSMETIC MILKS; COSMETIC NOURISHING CREAMS; COSMETIC OILS; COSMETIC OILS FOR THE EPIDERMIS; COSMETIC OLIVE OIL FOR THE FACE AND BODY; COSMETIC PENCILS; COSMETIC PREPARATIONS; COSMETIC PREPARATIONS AGAINST SUNBURN; COSMETIC SUN MILK LOTIONS; COSMETICS AND MAKE-UP; COSMETICS, NAMELY, LIP PRIMER; COSMETICS, NAMELY, LIP REPAIRERS; CREAM SOAPS; CUTICLE CONDITIONERS; CUTICLE CREAM; DEODORANTS AND ANTIPERSPIRANTS FOR PERSONAL USE; EAU DE COLOGNE; EAU DE COLOGNES; EAU DE PARFUM; EAU DE PERFUME; EAU DE TOILETTE; EAU DE TOILETTE AND EAU DE COLOGNE; EAU-DE-COLOGNE; EAU-DE-TOILETTE; ESSENTIAL OILS; ESSENTIAL OILS FOR AROMATHERAPY USE; ESSENTIAL OILS FOR PERSONAL USE; ESSENTIAL OILS FOR USE IN AROMATHERAPY; EXFOLIANT CREAMS; EYE CREAM; EYE LINER; EYE MAKE-UP; EYE PENCILS; EYE SHADOWS; EYEBROW COLORS; EYEBROW COSMETICS; EYELINER; EYELINER PENCILS; EYELINERS; EYES MAKE-UP; EYES PENCILS; EYESHADOW; EYESHADOWS; FACE AND BODY LOTIONS; FACE CREAMS; FACE POWDER; FOUNDATION; FOUNDATION MAKE-UP; FOUNDATIONS; HAIR CONDITIONER; HAIR CONDITIONERS; HAIR CREAMS; HAIR LOTION; HAIR LOTIONS; HAIR SPRAYS AND HAIR GELS; HAND CLEANING PREPARATIONS; HAND CREAM; HAND CREAMS; HAND LOTIONS; LIP BALM; LIP BALM; LIP CREAM; LIP GLOSS; LIP GLOSS PALATTE; LIP LINER; LIPSTICK; LIPSTICKS; LIQUID BATH SOAPS; LIQUID SOAP; LIQUID SOAPS; LOTIONS FOR COSMETIC PURPOSES; LOTIONS FOR FACE AND BODY CARE; MAKE-UP; MAKE-UP FOUNDATIONS; MAKE-UP PENCILS; MAKE-UP POWDER; MAKE-UP REMOVER; MASCARA; MASCARAS; MASSAGE CREAMS; MASSAGE LOTIONS; MASSAGE OIL; MASSAGE OILS; MASSAGE WAXES; MOISTURIZING CREAMS; NAIL ENAMEL; NAIL ENAMELS; NAIL POLISH; NAIL POLISH BASE COAT; NATURAL ESSENTIAL OILS; NATURAL MINERAL MAKE-UP; NIGHT CREAM; NON-MEDICATED ACNE TREATMENT PREPARATIONS; NON-MEDICATED ANTI-AGING SERUM; NON-MEDICATED DIAPER RASH CREAM; NON-MEDICATED DIAPER RASH OINTMENTS AND LOTIONS; NON-MEDICATED FACIAL AND EYE SERUM CONTAINING ANTIOXIDANTS; NON-MEDICATED FEMINE HYGIENE WASH; NON-MEDICATED FOOT LOTIONS; NON-MEDICATED HAIR SERUMS; PERSONAL DEODORANTS; SCENTED BODY LOTIONS AND CREAMS; SCENTED BODY SPRAY; SHAMPOOS; SHAMPOOS FOR BABIES; SHOWER GEL; SKIN CONDITIONERS; SKIN CREAM; SKIN CREAMS; SKIN SOAP; SOAPS FOR BODY CARE; SUN CARE LOTIONS (U.S. CLS. 1, 4, 6, 50, 51 AND 52).

KEVIN CORWIN, EXAMINING ATTORNEY

CLASS 3—(Continued).

SN 85-422,014. LITTLE MISS FUZZY HEAD, LLC, OAK PARK, IL. FILED 9-14-2011.

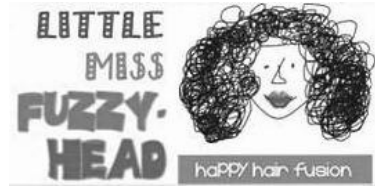

NO CLAIM IS MADE TO THE EXCLUSIVE RIGHT TO USE "HAIR", APART FROM THE MARK AS SHOWN.

FOR HAIR LOTIONS; HAIR WAVING PREPARATIONS; HAIR STYLING PREPARATIONS; HAIR MOISTURIZERS (U.S. CLS. 1, 4, 6, 50, 51 AND 52).

FIRST USE 9-18-2010; IN COMMERCE 9-18-2010.
LEIGH LOWRY, EXAMINING ATTORNEY

SN 85-424,241. BRENNAN, CHRISTINA, DBA SKIN2ITION SKIN CARE COMPANY, ALBANY, NY. AND BERBEN, GERILYNN KANE, DBA SKIN2ITION SKIN CARE COMPANY, ALBANY, NY. FILED 9-16-2011.



NO CLAIM IS MADE TO THE EXCLUSIVE RIGHT TO USE "NATURAL SKIN CARE WITH ORGANIC INGREDIENTS", APART FROM THE MARK AS SHOWN.

THE COLOR(S) BLACK, GREEN, WHITE AND GRAY IS/ARE CLAIMED AS A FEATURE OF THE MARK.

THE MARK CONSISTS OF A GREEN TREE WHICH COMPRISES GREEN LEAVES WITH A WHITE CENTER DISPOSED ABOUT THE BRANCHES; THE WORDS "PURELY PRETTY BY" IN BLACK LETTERS SUPERIMPOSED OVER THE RIGHT PORTION OF THE GREEN TREE; THE WORD "SKIN2ITION" WITH THE NUMERAL "2" IN GRAY LOCATED BENEATH THE WORD "PRETTY" WITH THE TERMINUS OF THE LETTER "Y" FORMING THE "DOT" FOR THE LETTER "I" IN THE WORD; AND THE WORDS "NATURAL SKIN CARE WITH ORGANIC INGREDIENTS" IN BLACK LETTERS READING FROM LEFT TO RIGHT AND LOCATED UNDER THE OTHER ELEMENTS OF THE MARK.

FOR ORGANIC NON-MEDICATED SKIN CARE PREPARATIONS, NAMELY, CLEANSERS, TONERS, FRESHENERS, MOISTURIZERS, REFINISHING PREPARATIONS AND EXFOLIATORS, OXYGEN SKIN BOOSTING PREPARATIONS, EYE CREAMS, EYE GELS, SUNSCREENS, ANTI-AGING CREAMS AND SERUMS, REVITALIZING AND REPAIR CREAMS AND SERUMS, SKIN ANTIOXIDANTS, SKIN BLEMISH CONTROL LOTIONS AND CREAMS, NIGHT CREAMS, AND HYDRATING MISTS (U.S. CLS. 1, 4, 6, 50, 51 AND 52).

FIRST USE 1-2-2011; IN COMMERCE 3-18-2011.
CAROLINE WOOD, EXAMINING ATTORNEY

CLASS 3—(Continued).

SN 85-425,073. CHUCKLES, INC., MANCHESTER, NH. FILED 9-16-2011.

ALL-NUTRIENT

THE MARK CONSISTS OF STANDARD CHARACTERS WITHOUT CLAIM TO ANY PARTICULAR FONT, STYLE, SIZE, OR COLOR.

OWNER OF U.S. REG. NO. 1,680,915.

FOR HAIR COLOR CREAM, LIQUID HAIR COLOR, BLEACH AND PEROXIDES FOR HAIR, HAIR STRAIGHTENERS, HAIR SMOOTHERS, HAIR MOUSSE, HAIR GEL, HAIR SPRAY, HAIR COLOR DEVELOPER, HAIR COLORANTS AND HAIR DE-COLORANT PRODUCTS, COLOR SHAMPOOS AND CONDITIONERS, HAIR CARE PRODUCTS, NAMELY, HAIR CARE PREPARATIONS, HAIR STYLING PRODUCTS, NAMELY, HAIR STYLING PREPARATIONS, PERMANENT WAVE PRODUCTS, NAMELY, PERMANENT WAVE PREPARATIONS, NON-MEDICATED HAIR BALMS, HAIR FIXATIVES, HAIR STYLING GELS, HAIR SPRAYS AND HAIR GELS, HAIR PROTEIN SPRAY, NON-MEDICATED HAIR TREATMENTS FOR COSMETIC PURPOSES, NON-MEDICATED HAIR PROTEIN RECONSTRUCTIVE TREATMENTS FOR COSMETIC PURPOSES, HAIR CLARIFYING PRODUCTS, NAMELY, HAIR CLARIFYING PREPARATIONS, HAIRCARE PREPARATIONS, NAMELY, PREPARATIONS THAT PROTECT HAIR COLOR; HAIRCARE PREPARATIONS, NAMELY, PREPARATIONS THAT PROTECT HAIR PERMANENTS, HAIR SHINE PRODUCTS, NAMELY, HAIR SHINE PREPARATIONS, NON-MEDICATED HAIR OIL TREATMENTS FOR COSMETIC PURPOSES, NON-MEDICATED HAIR AND SCALP TREATMENTS FOR COSMETIC PURPOSES, HAND AND BODY LOTIONS, NON-MEDICATED SKIN BALMS, SKIN EXFOLIATORS, BATH AND SHOWER LOTIONS, ESSENTIAL OILS (U.S. CLS. 1, 4, 6, 50, 51 AND 52).

FIRST USE 12-31-1994; IN COMMERCE 12-31-1994.

MARK SPARACINO, EXAMINING ATTORNEY

CLASS 3—(Continued).

SN 85-425,460. TRAIL RIDGE PARTNERS LLC, DBA BAY-BERRY NATURALS, STAMFORD, CT. FILED 9-18-2011.

**bayberry
NATURALS**

THE MARK CONSISTS OF STANDARD CHARACTERS WITHOUT CLAIM TO ANY PARTICULAR FONT, STYLE, SIZE, OR COLOR.

NO CLAIM IS MADE TO THE EXCLUSIVE RIGHT TO USE "NATURALS", APART FROM THE MARK AS SHOWN.

FOR 3-IN-1 ORGANIC SOAP BARS FOR USE AS SOAP, SHAMPOO AND CONDITIONER; AROMATIC BODY CARE PRODUCTS, NAMELY, BODY LOTION, SHOWER GEL, CUTICLE CREAM, SHAMPOO, CONDITIONER, NON-MEDICATED LIP BALM, SOAP, BODY POLISH, BODY AND FOOT SCRUB AND NON-MEDICATED FOOT CREAM; BABY LOTION; BABY SHAMPOO; BAR SOAP; BATH AND SHOWER GELS AND SALTS NOT FOR MEDICAL PURPOSES; BATH CRYSTALS; BATH LOTION; BATH OILS AND BATH SALTS; BATH SOAPS; BATH SOAPS IN LIQUID, SOLID OR GEL FORM; BEAUTY CREAMS; BEAUTY CREAMS FOR BODY CARE; BEAUTY GELS; BEAUTY LOTIONS; BEAUTY MILKS; BEAUTY SERUMS; BEAUTY SOAP; BODY AND BEAUTY CARE COSMETICS; BODY LOTIONS; FACE AND BODY BEAUTY CREAMS; FACE AND BODY LOTIONS; FRAGRANCED FACIAL MOISTURIZER; HAIR SHAMPOOS AND CONDITIONERS; HAND SOAPS; LIQUID SOAP; LIQUID SOAPS FOR HANDS, FACE AND BODY; MOISTURIZING CREAMS; NATURAL COCOA BUTTER BASED PERSONAL CARE PRODUCTS, NAMELY, BODY LOTION, SHOWER GEL, SOAP, BODY POLISH, BODY AND FOOT SCRUB AND NON-MEDICATED SKIN CREAMS; NATURAL SOAP BARS; ORGANIC SOAP BARS; SHAMPOOS FOR BABIES; SKIN MOISTURIZER; SOAPS FOR BODY CARE (U.S. CLS. 1, 4, 6, 50, 51 AND 52).

FIRST USE 11-1-2009; IN COMMERCE 3-19-2010.

DAWN HAN, EXAMINING ATTORNEY

SN 85-428,763. DOUBT, ELIZABETH, DALLAS, TX. FILED 9-21-2011.

**SO GOOD FOR YOU, IT'S A
REMEDY - NOT A CHORE!**

THE MARK CONSISTS OF STANDARD CHARACTERS WITHOUT CLAIM TO ANY PARTICULAR FONT, STYLE, SIZE, OR COLOR.

FOR NON-MEDICATED SKIN CARE PREPARATIONS, NAMELY, CLEANERS (U.S. CLS. 1, 4, 6, 50, 51 AND 52).

TRICIA SONNEBORN, EXAMINING ATTORNEY

CLASS 3—(Continued).

SN 85-432,253. KENNETH GRAND, SANTA BARBARA, CA. FILED 9-26-2011.

TRULY NATURAL FRAGRANCE

THE MARK CONSISTS OF STANDARD CHARACTERS WITHOUT CLAIM TO ANY PARTICULAR FONT, STYLE, SIZE, OR COLOR.

NO CLAIM IS MADE TO THE EXCLUSIVE RIGHT TO USE "NATURAL FRAGRANCE", APART FROM THE MARK AS SHOWN.

FOR COSMETIC CREAMS FOR SKIN CARE; FRAGRANCES; SOAPS FOR BODY CARE (U.S. CLS. 1, 4, 6, 50, 51 AND 52).

LAKEISHA LEWIS, EXAMINING ATTORNEY

CLASS 3—(Continued).

SN 85-441,747. BIO-SURGE, INC., AMARILLO, TX. FILED 10-7-2011.

BIO-SURGE M1

THE MARK CONSISTS OF STANDARD CHARACTERS WITHOUT CLAIM TO ANY PARTICULAR FONT, STYLE, SIZE, OR COLOR.

FOR DEGREASING PREPARATIONS NOT USED IN MANUFACTURING PROCESSES FOR USE ON DRIED PETROCHEMICAL RESIDUE (U.S. CLS. 1, 4, 6, 50, 51 AND 52).

EDWARD FENNESSY, EXAMINING ATTORNEY

SN 85-442,947. DIAMAR CLOTHING LLC, MIRAMAR, FL. FILED 10-9-2011.

CLINICFACE

SN 85-435,636. BIJOUX INDISCRETS, S.L., BARCELONA, SPAIN, FILED 9-29-2011.



NO CLAIM IS MADE TO THE EXCLUSIVE RIGHT TO USE "COSMETIQUES", APART FROM THE MARK AS SHOWN.

THE MARK CONSISTS OF THE WORDS "BIJOUX COSMETIQUES" IN STYLIZED LETTERS WITH A CIRCLE APPEARING OVER THE LETTER "J".

THE ENGLISH TRANSLATION OF "BIJOUX COSMETIQUES" IN THE MARK IS "JEWELRY" AND "COSMETICS".

FOR ESSENTIAL OILS; OILS FOR COSMETIC PURPOSES; MAKE-UP POWDER; MASSAGE GEL FOR COSMETIC PURPOSES; PERFUMES; AROMATIC OILS (U.S. CLS. 1, 4, 6, 50, 51 AND 52).

MARILYN IZZI, EXAMINING ATTORNEY

THE MARK CONSISTS OF STANDARD CHARACTERS WITHOUT CLAIM TO ANY PARTICULAR FONT, STYLE, SIZE, OR COLOR.

FOR AROMATIC BODY CARE PRODUCTS, NAMELY, BODY LOTION, CUTICLE CREAM, NON-MEDICATED LIP BALM, SOAP, BODY POLISH, BODY AND FOOT SCRUB AND NON-MEDICATED FOOT CREAM; BEAUTY CREAMS FOR BODY CARE; BODY AND BEAUTY CARE COSMETICS; COSMETIC CREAMS FOR SKIN CARE; COSMETIC FACIAL BLOTTER PAPERS; COSMETIC PREPARATIONS FOR BODY CARE; COSMETIC PREPARATIONS FOR SKIN CARE; COSMETIC PRODUCTS IN THE FORM OF AEROSOLS FOR SKIN CARE; DEODORANTS FOR BODY CARE; FACIAL BEAUTY MASKS; FACIAL CLEANING PREPARATION, NAMELY, SALICYLIC ACNE CLEANSER NOT FOR MEDICAL PURPOSES; FACIAL CLEANSERS; FACIAL CLEANSING GRAINS; FACIAL CLEANSING MILK; FACIAL CONCEALER; FACIAL CREAM; FACIAL LOTION; FACIAL MAKE-UP; FACIAL MASKS; FACIAL MOISTURIZER WITH SPF; FACIAL SCRUBS; FACIAL WASHES; FRAGRANCED FACE CARE PREPARATIONS, NAMELY, FACIAL CLEANSERS AND FACIAL MOISTURIZERS; FRAGRANCED FACIAL MOISTURIZER; FRAGRANCED SKIN CARE PREPARATIONS, NAMELY, SKIN CLEANSERS AND SKIN MOISTURIZERS; NON-MEDICATED SKIN CARE CREAMS AND LOTIONS; NON-MEDICATED SKIN CARE PREPARATIONS; NON-MEDICATED SKIN CARE PREPARATIONS, NAMELY, CREAMS, LOTIONS, GELS, TONERS, CLEANERS AND PEELS; NON-MEDICATED SUN CARE PREPARATIONS; SEAWATER-BASED SKIN CARE PREPARATIONS FOR SKIN RENEWAL; SKIN CARE PREPARATION, NAMELY, BODY POLISH; SKIN CARE PREPARATIONS, NAMELY, CHEMICAL PEELS FOR SKIN; SKIN CARE PREPARATIONS, NAMELY, FRUIT ACID PEELS FOR SKIN; SKIN CARE PREPARATIONS, NAMELY, SKIN PEELS; SKIN CARE PRODUCTS, NAMELY, NON-MEDICATED SKIN SERUM; WRINKLE REMOVING SKIN CARE PREPARATIONS; WRINKLE-MINIMIZING COSMETIC PREPARATIONS FOR TOPICAL FACIAL USE (U.S. CLS. 1, 4, 6, 50, 51 AND 52).

TARAH HARDY, EXAMINING ATTORNEY

CLASS 3—(Continued).

SN 85-443,152. MARY KAY INC., ADDISON, TX. FILED 10-10-2011.

MARY KAY ONE WOMAN ONE
DREAM

THE MARK CONSISTS OF STANDARD CHARACTERS WITHOUT CLAIM TO ANY PARTICULAR FONT, STYLE, SIZE, OR COLOR.

OWNER OF U.S. REG. NOS. 817,516, 1,070,841 AND 1,215,807.

THE NAME(S), PORTRAIT(S), AND/OR SIGNATURE(S) SHOWN IN THE MARK DOES NOT IDENTIFY A PARTICULAR LIVING INDIVIDUAL.

FOR COSMETICS; FRAGRANCES FOR PERSONAL USE; PERFUMES, COLOGNES, EAU DE TOILET; NON-MEDICATED SKIN CARE PREPARATIONS (U.S. CLS. 1, 4, 6, 50, 51 AND 52).

DEBORAH LOBO, EXAMINING ATTORNEY

SN 85-443,952. MARY KAY INC., ADDISON, TX. FILED 10-11-2011.

MARY KAY ONE WOMAN CAN

THE MARK CONSISTS OF STANDARD CHARACTERS WITHOUT CLAIM TO ANY PARTICULAR FONT, STYLE, SIZE, OR COLOR.

OWNER OF U.S. REG. NOS. 817,516, 1,070,841 AND 1,215,807.

THE NAME(S), PORTRAIT(S), AND/OR SIGNATURE(S) SHOWN IN THE MARK DOES NOT IDENTIFY A PARTICULAR LIVING INDIVIDUAL.

FOR COSMETICS; FRAGRANCES FOR PERSONAL USE; PERFUMES, COLOGNES, EAU DE TOILET; NON-MEDICATED SKIN CARE PREPARATIONS (U.S. CLS. 1, 4, 6, 50, 51 AND 52).

DEBORAH LOBO, EXAMINING ATTORNEY

SN 85-444,057. SASI HOLDINGS PTY LTD, ENGLISHTOWN, NJ. FILED 10-11-2011.

POWER BASE

THE MARK CONSISTS OF STANDARD CHARACTERS WITHOUT CLAIM TO ANY PARTICULAR FONT, STYLE, SIZE, OR COLOR.

FOR NON-MEDICATED HAIR STRENGTHENING TREATMENT LOTION (U.S. CLS. 1, 4, 6, 50, 51 AND 52).

ODESSA BIBBINS, EXAMINING ATTORNEY

CLASS 3—(Continued).

SN 85-445,240. LA MER TECHNOLOGY, INC., NEW YORK, NY. FILED 10-12-2011.

CREME SOYEUSE DE LA MER

THE MARK CONSISTS OF STANDARD CHARACTERS WITHOUT CLAIM TO ANY PARTICULAR FONT, STYLE, SIZE, OR COLOR.

OWNER OF U.S. REG. NOS. 1,245,722, 2,751,557 AND OTHERS.

NO CLAIM IS MADE TO THE EXCLUSIVE RIGHT TO USE "CREME", APART FROM THE MARK AS SHOWN.

THE ENGLISH TRANSLATION OF "CREME SOYEUSE DE LA MER" IN THE MARK IS "SILKY CREAM OF THE SEA".

FOR BODY AND BEAUTY CARE COSMETICS; NON-MEDICATED SKIN CARE PREPARATIONS; NON-MEDICATED SUN CARE PREPARATIONS; NON-MEDICATED TOILETRIES (U.S. CLS. 1, 4, 6, 50, 51 AND 52).

JAMES STEIN, EXAMINING ATTORNEY

SN 85-446,189. LAURICE EL BADRY RAHME, LTD., DBA LAURICE & CO., NEW YORK, NY. FILED 10-13-2011.

SUTTON PLACE

THE MARK CONSISTS OF STANDARD CHARACTERS WITHOUT CLAIM TO ANY PARTICULAR FONT, STYLE, SIZE, OR COLOR.

FOR FRAGRANCES FOR PERSONAL USE, NAMELY, PERFUME, COLOGNES; AFTER BATH SPLASHES, BODY SPRAYS, SHOWER GELS, SOAPS, BODY LOTIONS, MASSAGE OILS, COSMETICS; NON-MEDICATED SKIN CARE PREPARATIONS, NAMELY, BODY CREAMS, SKIN LOTIONS, SKIN CLEANSERS, SKIN CREAMS, SKIN EXFOLIATES, SKIN MOISTURIZERS AND SKIN TONERS; MAKEUP, LIPSTICK, FOUNDATION POWDERS, EYE SHADOW, NAIL POLISH, MASCARA AND EYE PENCILS (U.S. CLS. 1, 4, 6, 50, 51 AND 52).

DAVID H. STINE, EXAMINING ATTORNEY

SN 85-446,209. NISSAN JIDOSHA KABUSHIKI KAISHA, TA NISSAN MOTOR CO., LTD., YOKOHAMA-SHI, KANAGAWA, JAPAN, FILED 10-13-2011.



FOR COSMETICS, PERFUME, EAU DE COLOGNE (U.S. CLS. 1, 4, 6, 50, 51 AND 52).

SETH A. RAPPAPORT, EXAMINING ATTORNEY

CLASS 3—(Continued).

SN 85-447,905. DAI ENTERPRISES LLC, BEVERLY HILLS, CA. FILED 10-14-2011.

TAYA BEAUTY

THE MARK CONSISTS OF STANDARD CHARACTERS WITHOUT CLAIM TO ANY PARTICULAR FONT, STYLE, SIZE, OR COLOR.

OWNER OF U.S. REG. NO. 3,860,651.

NO CLAIM IS MADE TO THE EXCLUSIVE RIGHT TO USE "BEAUTY", APART FROM THE MARK AS SHOWN.

FOR HAIR CARE PRODUCTS, NAMELY, SHAMPOO, CONDITIONERS, HAIR SPRAY, STYLING GELS, AND MOUSSE; NON-MEDICATED SKIN CARE PREPARATIONS, NAMELY, LOTIONS, GELS, AND CREAMS FOR THE FACE AND BODY (U.S. CLS. 1, 4, 6, 50, 51 AND 52).

FIRST USE 2-9-2011; IN COMMERCE 2-9-2011.

APRIL ROACH, EXAMINING ATTORNEY

CLASS 3—(Continued).

SN 85-451,589. TRI-COASTAL DESIGN GROUP, INC., WHARTON, NJ. FILED 10-19-2011.

CRISP APPLE

THE MARK CONSISTS OF STANDARD CHARACTERS WITHOUT CLAIM TO ANY PARTICULAR FONT, STYLE, SIZE, OR COLOR.

NO CLAIM IS MADE TO THE EXCLUSIVE RIGHT TO USE "APPLE", APART FROM THE MARK AS SHOWN.

FOR BATH GEL; BATH SALTS; BATH SOAPS; BODY CREAM; BODY LOTIONS; BODY OIL; BODY SCRUB; BODY SPRAYS; BUBBLE BATH; DUSTING POWDER; FOOT SCRUBS; LIP BALM; LIP GLOSS; LIQUID SOAP; NAIL POLISH; REEDS AND SCENTED OILS SOLD AS A UNIT FOR USE IN ROOM SCENT DIFFUSERS (U.S. CLS. 1, 4, 6, 50, 51 AND 52).

ROBERT C. CLARK JR., EXAMINING ATTORNEY

SN 85-457,850. COTY GERMANY GMBH, MAINZ, FED REP GERMANY, FILED 10-27-2011.

SIN IS MY TWIN

THE MARK CONSISTS OF STANDARD CHARACTERS WITHOUT CLAIM TO ANY PARTICULAR FONT, STYLE, SIZE, OR COLOR.

OWNER OF ERP CMNTY TM OFC REG. NO. 010143221, DATED 12-1-2011, EXPIRES 7-22-2021.

FOR SOAPS, PERFUMERY, ESSENTIAL OILS, COSMETICS, HAIR LOTIONS (U.S. CLS. 1, 4, 6, 50, 51 AND 52).

KELLY TRUSILO, EXAMINING ATTORNEY

SN 85-451,580. TRI-COASTAL DESIGN GROUP, INC., WHARTON, NJ. FILED 10-19-2011.

GEAR UP AND GO GRAPE

SN 85-458,817. GLO SCIENCE, INC., NEW YORK, NY. FILED 10-28-2011.

EVERYDAY GLO

THE MARK CONSISTS OF STANDARD CHARACTERS WITHOUT CLAIM TO ANY PARTICULAR FONT, STYLE, SIZE, OR COLOR.

NO CLAIM IS MADE TO THE EXCLUSIVE RIGHT TO USE "GRAPE", APART FROM THE MARK AS SHOWN.

FOR BATH GEL; BATH SALTS; BATH SOAPS; BODY CREAM; BODY LOTION; BODY OIL; BODY SCRUB; BODY SPRAYS; DUSTING POWDER; FOOT SCRUBS; LIP BALM; LIP GLOSS; LIQUID SOAP; NAIL POLISH; REEDS AND SCENTED OILS SOLD AS A UNIT FOR USE IN ROOM SCENT DIFFUSERS (U.S. CLS. 1, 4, 6, 50, 51 AND 52).

FIRST USE 5-20-2011; IN COMMERCE 5-20-2011.

ROBERT C. CLARK JR., EXAMINING ATTORNEY

THE MARK CONSISTS OF STANDARD CHARACTERS WITHOUT CLAIM TO ANY PARTICULAR FONT, STYLE, SIZE, OR COLOR.

NO CLAIM IS MADE TO THE EXCLUSIVE RIGHT TO USE "GLO", APART FROM THE MARK AS SHOWN.

FOR TOOTHPASTE, MOUTHWASHES, NON-MEDICATED MOUTH RINSES AND SPRAYS, TOOTH WHITENING PREPARATIONS, GELS, CREAMS AND PASTES, NON-MEDICATED DENTAL RINSE (U.S. CLS. 1, 4, 6, 50, 51 AND 52).

SHANNON TWOHIG, EXAMINING ATTORNEY

CLASS 3—(Continued).

SN 85-466,033. MSD CONSUMER CARE, INC., MEMPHIS, TN. FILED 11-7-2011.

WET 'N CLEAR

THE MARK CONSISTS OF STANDARD CHARACTERS WITHOUT CLAIM TO ANY PARTICULAR FONT, STYLE, SIZE, OR COLOR.

NO CLAIM IS MADE TO THE EXCLUSIVE RIGHT TO USE "CLEAR", APART FROM THE MARK AS SHOWN.

FOR NON-MEDICATED SUN CARE PREPARATIONS; SUN BLOCK PREPARATIONS; SUN SCREEN PREPARATIONS; SUN-TANNING PREPARATIONS (U.S. CLS. 1, 4, 6, 50, 51 AND 52).

KHANH LE, EXAMINING ATTORNEY

CLASS 3—(Continued).

SN 85-473,216. LANCOME PARFUMS ET BEAUTE & CIE, PARIS, FRANCE, FILED 11-15-2011.

LA VIE EST BELLE

THE MARK CONSISTS OF STANDARD CHARACTERS WITHOUT CLAIM TO ANY PARTICULAR FONT, STYLE, SIZE, OR COLOR.

PRIORITY CLAIMED UNDER SEC. 44(D) ON FRANCE APPLICATION NO. 113833636, FILED 5-23-2011, REG. NO. 113833636, DATED 5-23-2011, EXPIRES 5-23-2021.

THE ENGLISH TRANSLATION OF "LA VIE EST BELLE" IN THE MARK IS "LIFE IS BEAUTIFUL".

FOR PERFUME, EAU DE TOILETTE; GELS AND SALTS FOR THE BATH AND THE SHOWER NOT FOR MEDICAL PURPOSE; TOILET SOAPS, BODY DEODORANTS; COSMETICS, NAMELY, CREAMS, MILKS, LOTIONS, GELS AND POWDERS FOR THE FACE, THE BODY AND THE HANDS; NON-MEDICATED SUN CARE PREPARATIONS; MAKEUP PREPARATIONS, NAMELY, MASCARA, EYE-LINER, EYE-SHADOW, EYEBROW PENCIL, LIPSTICKS, NAIL POLISH, BLUSH, FOUNDATION CREAMS AND POWDERS; SHAMPOOS; HAIR CARE AND HAIR STYLING PREPARATIONS, NAMELY, GELS, SPRAYS, MOUSSES AND BALMS FOR HAIR STYLING AND HAIR CARE; HAIR LACQUERS; HAIR COLOURING AND HAIR DECOLORANT PREPARATIONS; PERMANENT WAVING AND CURLING PREPARATIONS; ESSENTIAL OILS FOR PERSONAL USE (U.S. CLS. 1, 4, 6, 50, 51 AND 52).

SUE LAWRENCE, EXAMINING ATTORNEY

SN 85-467,575. QUATRE, LLC, SAN CLEMENTE, CA. FILED 11-8-2011.

EX ANIMO

THE MARK CONSISTS OF STANDARD CHARACTERS WITHOUT CLAIM TO ANY PARTICULAR FONT, STYLE, SIZE, OR COLOR.

THE WORDING "EX ANIMO" HAS NO MEANING IN A FOREIGN LANGUAGE.

FOR HAND CREAM, BODY AND FOOT SCRUB, BODY WASH FOR HUMANS, SHOWER GEL, COLOGNE, AFTERSHAVE, NON MEDICATED LIP BALM, BODY POWDER, SCENTED ROOM SPRAYS; REEDS AND SCENTED OILS SOLD AS A UNIT FOR USE IN ROOM SCENT DIFFUSERS (U.S. CLS. 1, 4, 6, 50, 51 AND 52).

FLORENTINA BLANDU, EXAMINING ATTORNEY

SN 85-474,791. LAURUS CREATIVE PERFUMES, L.L.C., HACIENDA HEIGHTS, CA. FILED 11-16-2011.

Heart of Mine

THE MARK CONSISTS OF STANDARD CHARACTERS WITHOUT CLAIM TO ANY PARTICULAR FONT, STYLE, SIZE, OR COLOR.

FOR 3-IN-1 ORGANIC SOAP BARS FOR USE AS SOAP, SHAMPOO AND CONDITIONER; COLOGNES, PERFUMES AND COSMETICS; COSMETICS IN GENERAL, INCLUDING PERFUMES; EAU DE PERFUME; HAIR RINSES; HAIR SHAMPOO; HAIR SHAMPOOS AND CONDITIONERS; NAIL CARE KITS COMPRISING NAIL POLISH; NAIL POLISH; NAIL POLISH REMOVER; NAIL POLISH REMOVERS; PERFUME; PERFUME OILS FOR THE MANUFACTURE OF COSMETIC PREPARATIONS; PERFUMES; PERFUMES AND COLOGNES; PERFUMES AND TOILET WATERS; PERFUMES, AFTERSHAVES AND COLOGNES; PERFUMES, EAU DE COLOGNES AND AFTERSHAVES; SHAMPOO-CONDITIONERS; SHAMPOOS (U.S. CLS. 1, 4, 6, 50, 51 AND 52).

MARY CRAWFORD, EXAMINING ATTORNEY

CLASS 3—(Continued).

SN 85-474,834. LAURUS CREATIVE PERFUMES, L.L.C.,
HACIENDA HEIGHTS, CA. FILED 11-17-2011.

Heart of Joy

THE MARK CONSISTS OF STANDARD CHARACTERS WITHOUT CLAIM TO ANY PARTICULAR FONT, STYLE, SIZE, OR COLOR.

FOR 3-IN-1 HAIR SHAMPOOS; BODY AND BEAUTY CARE COSMETICS; BODY LOTIONS; COLOGNES, PERFUMES AND COSMETICS; COSMETIC PREPARATIONS FOR BODY CARE; COSMETICS; COSMETICS IN GENERAL, INCLUDING PERFUMES; EAU DE PERFUME; HAIR RINSES; HAIR SHAMPOO; HAIR SHAMPOOS AND CONDITIONERS; LOTIONS FOR COSMETIC PURPOSES; LOTIONS FOR FACE AND BODY CARE; NAIL CARE KITS COMPRISING NAIL POLISH; NAIL POLISH; NAIL POLISH REMOVER; NAIL POLISH REMOVERS; NON-MEDICATED SKIN CARE CREAMS AND LOTIONS; NON-MEDICATED SKIN CARE PREPARATION, NAMELY, BODY MIST; PERFUME; PERFUME OILS FOR THE MANUFACTURE OF COSMETIC PREPARATIONS; PERFUMES; PERFUMES AND COLOGNES; PERFUMES AND TOILET WATERS; PERFUMES, AFTERSHAVES AND COLOGNES; PERFUMES, EAU DE COLOGNES AND AFTERSHAVES; SCENTED BODY LOTIONS AND CREAMS; SCENTED BODY SPRAY; SHAMPOO-CONDITIONERS; SHAMPOOS (U.S. CLS. 1, 4, 6, 50, 51 AND 52).

MARY CRAWFORD, EXAMINING ATTORNEY

CLASS 3—(Continued).

SN 85-478,489. LAURUS CREATIVE PERFUMES, L.L.C.,
HACIENDA HEIGHTS, CA. FILED 11-22-2011.

His Excellency

THE MARK CONSISTS OF STANDARD CHARACTERS WITHOUT CLAIM TO ANY PARTICULAR FONT, STYLE, SIZE, OR COLOR.

FOR 3-IN-1 HAIR SHAMPOOS; BEAUTY CREAMS FOR BODY CARE; BEAUTY LOTIONS; BODY AND BEAUTY CARE COSMETICS; BODY LOTION; BODY SPRAYS; COLOGNES, PERFUMES AND COSMETICS; COSMETIC PREPARATIONS; COSMETIC PREPARATIONS FOR BATH AND SHOWER; COSMETIC PREPARATIONS FOR BODY CARE; COSMETIC PREPARATIONS FOR SKIN CARE; COSMETIC PREPARATIONS, NAMELY, FIRING LOTIONS; COSMETICS AND COSMETIC PREPARATIONS; COSMETICS IN GENERAL, INCLUDING PERFUMES; EAU DE PERFUME; HAIR SHAMPOO; HAIR SHAMPOOS AND CONDITIONERS; LOTIONS FOR COSMETIC PURPOSES; LOTIONS FOR FACE AND BODY CARE; NAIL CARE KITS COMPRISING NAIL POLISH; NAIL POLISH; NAIL POLISH REMOVER; NAIL POLISH REMOVERS; NON-MEDICATED SKIN CARE PREPARATION, NAMELY, BODY MIST; PERFUME; PERFUME OILS FOR THE MANUFACTURE OF COSMETIC PREPARATIONS; PERFUMES; PERFUMES AND COLOGNES; PERFUMES AND TOILET WATERS; PERFUMES, AFTERSHAVES AND COLOGNES; PERFUMES, EAU DE COLOGNES AND AFTERSHAVES; SCENTED BODY LOTIONS AND CREAMS; SCENTED BODY SPRAY; SHAMPOO-CONDITIONERS; SHAMPOOS (U.S. CLS. 1, 4, 6, 50, 51 AND 52).

MARY CRAWFORD, EXAMINING ATTORNEY

SN 85-477,480. JOHNSON & JOHNSON, NEW BRUNSWICK,
NJ. FILED 11-21-2011.

REMBRANDT DEEPLY WHITE

THE MARK CONSISTS OF STANDARD CHARACTERS WITHOUT CLAIM TO ANY PARTICULAR FONT, STYLE, SIZE, OR COLOR.

OWNER OF U.S. REG. NOS. 1,423,544, 4,088,529 AND OTHERS.

NO CLAIM IS MADE TO THE EXCLUSIVE RIGHT TO USE "WHITE", APART FROM THE MARK AS SHOWN.

FOR COSMETIC TOOTH WHITENING APPLICATORS, NAMELY, PENS AND WANDS, SOLD CONTAINING TOOTH WHITENING PREPARATIONS (U.S. CLS. 1, 4, 6, 50, 51 AND 52).

NICHOLAS ALTREE, EXAMINING ATTORNEY

CLASS 3—(Continued).

SN 85-478,491. LAURUS CREATIVE PERFUMES, L.L.C.,
HACIENDA HEIGHTS, CA. FILED 11-22-2011.

CLASS 3—(Continued).

SN 85-486,681. LAURUS CREATIVE PERFUMES, L.L.C.,
HACIENDA HEIGHTS, CA. FILED 12-4-2011.

Her Excellency

Majestic Grace

THE MARK CONSISTS OF STANDARD CHARACTERS WITHOUT CLAIM TO ANY PARTICULAR FONT, STYLE, SIZE, OR COLOR.

FOR 3-IN-1 HAIR SHAMPOOS; BODY AND BEAUTY CARE COSMETICS; BODY LOTION; BODY SPRAYS; COLOGNES, PERFUMES AND COSMETICS; COSMETIC PREPARATIONS; COSMETIC PREPARATIONS FOR BODY CARE; COSMETIC PREPARATIONS FOR SKIN CARE; COSMETICS; COSMETICS IN GENERAL, INCLUDING PERFUMES; EAU DE PERFUME; HAIR RINSES; HAIR SHAMPOO; HAIR SHAMPOOS AND CONDITIONERS; LIQUID SOAPS FOR HANDS, FACE AND BODY; LOTIONS FOR COSMETIC PURPOSES; LOTIONS FOR FACE AND BODY CARE; NAIL CARE KITS COMPRISING NAIL POLISH; NAIL POLISH; NAIL POLISH REMOVER; NAIL POLISH REMOVERS; NON-MEDICATED SKIN CARE PREPARATION, NAMELY, BODY MIST; PERFUME; PERFUME OILS FOR THE MANUFACTURE OF COSMETIC PREPARATIONS; PERFUMES; PERFUMES AND COLOGNES; PERFUMES AND TOILET WATERS; PERFUMES, AFTERSHAVES AND COLOGNES; PERFUMES, EAU DE COLOGNES AND AFTERSHAVES; POLISHING PREPARATIONS; POLISHING, SCOURING AND ABRASIVE PREPARATIONS; SCENTED BODY LOTIONS AND CREAMS; SCENTED BODY SPRAY; SHAMPOOS; SHINING PREPARATIONS; SKIN AND BODY TOPICAL LOTIONS, CREAMS AND OILS FOR COSMETIC USE (U.S. CLS. 1, 4, 6, 50, 51 AND 52).

MARY CRAWFORD, EXAMINING ATTORNEY

THE MARK CONSISTS OF STANDARD CHARACTERS WITHOUT CLAIM TO ANY PARTICULAR FONT, STYLE, SIZE, OR COLOR.

FOR 3-IN-1 HAIR SHAMPOOS; BODY AND BEAUTY CARE COSMETICS; BODY LOTION; BODY SPRAYS; COLOGNES, PERFUMES AND COSMETICS; COSMETIC CREAMS; COSMETIC PREPARATIONS; COSMETIC PREPARATIONS FOR BODY CARE; COSMETIC PREPARATIONS FOR SKIN CARE; COSMETIC PREPARATIONS, NAMELY, FIRING LOTIONS; COSMETICS AND COSMETIC PREPARATIONS; COSMETICS IN GENERAL, INCLUDING PERFUMES; EAU DE PERFUME; FACE AND BODY BEAUTY CREAMS; FACE AND BODY CREAMS; FACE AND BODY LOTIONS; HAIR RINSES; HAIR SHAMPOO; HAIR SHAMPOOS AND CONDITIONERS; LOTIONS FOR COSMETIC PURPOSES; LOTIONS FOR FACE AND BODY CARE; NAIL CARE KITS COMPRISING NAIL POLISH; NAIL CARE PREPARATIONS; NAIL POLISH; NAIL POLISH REMOVER; NAIL POLISH REMOVERS; NON-MEDICATED SKIN CARE PREPARATION, NAMELY, BODY MIST; NON-MEDICATED STIMULATING LOTIONS FOR THE SKIN; PERFUME; PERFUME OILS FOR THE MANUFACTURE OF COSMETIC PREPARATIONS; PERFUMES; PERFUMES AND COLOGNES; PERFUMES AND TOILET WATERS; PERFUMES, AFTERSHAVES AND COLOGNES; PERFUMES, EAU DE COLOGNES AND AFTERSHAVES; SCENTED BODY LOTIONS AND CREAMS; SCENTED BODY SPRAY; SHAMPOO-CONDITIONERS; SHAMPOOS (U.S. CLS. 1, 4, 6, 50, 51 AND 52).

MARY CRAWFORD, EXAMINING ATTORNEY

SN 85-490,910. LANCOME PARFUMS ET BEAUTE & CIE,
PARIS, FRANCE, FILED 12-8-2011.

COLOR DESIGN INFINITE

THE MARK CONSISTS OF STANDARD CHARACTERS WITHOUT CLAIM TO ANY PARTICULAR FONT, STYLE, SIZE, OR COLOR.

OWNER OF U.S. REG. NO. 3,173,417.
NO CLAIM IS MADE TO THE EXCLUSIVE RIGHT TO USE "COLOR", APART FROM THE MARK AS SHOWN.
FOR EYE-SHADOWS (U.S. CLS. 1, 4, 6, 50, 51 AND 52).
SUE LAWRENCE, EXAMINING ATTORNEY

CLASS 3—(Continued).

SN 85-493,284. KEMON S.P.A., SAN GIUSTINO, PERUGIA, ITALY, FILED 12-12-2011.

COLORINGreen

PRIORITY CLAIMED UNDER SEC. 44(D) ON ERPN CMNTY TM OFC APPLICATION NO. 010458115, FILED 11-30-2011, REG. NO. 010458115, DATED 4-24-2012, EXPIRES 11-30-2021.

THE MARK CONSISTS OF THE WORD "COLORINGREEN" WITH A STYLIZED DESIGN TO REPRESENT THE LETTER "R".

FOR SHAMPOO, HAIR COLORING PRODUCTS, NAMELY, HAIR DYES; HAIR COLORING PREPARATIONS; HAIRCARE PREPARATIONS, HAIR PACKS, NAMELY, HAIR MASKS, HAIR GELS, HAIR FRIC-TIONS, NAMELY, HAIR CONDITIONERS, HAIR LOTIONS, HAIR LACQUERS, NON-MEDICATED HAIR BALMS (U.S. CLS. 1, 4, 6, 50, 51 AND 52).

DAVID MURRAY, EXAMINING ATTORNEY

SN 85-493,786. PLYMOUTH DIRECT, INC., MONTGOMERY-VILLE, PA. AND NATURES PILLOWS, INC., TREVOSÉ, PA. FILED 12-13-2011.

CODE YELLOW

THE MARK CONSISTS OF STANDARD CHARACTERS WITHOUT CLAIM TO ANY PARTICULAR FONT, STYLE, SIZE, OR COLOR.

FOR STAIN REMOVERS; STAIN AND ODOR REMOVER KIT COMPRISED OF A STAIN AND ODOR REMOVER AND A PORTABLE BATTERY OPERATED FLUORESCENT BLACK LIGHT FOR DETECTING STAINS (U.S. CLS. 1, 4, 6, 50, 51 AND 52).

CAROLINE WOOD, EXAMINING ATTORNEY

SN 85-495,036. SHISEIDO COMPANY, LIMITED, TOKYO 104-0061, JAPAN, FILED 12-14-2011.

ENERGETICEL TECHNOLOGY

THE MARK CONSISTS OF STANDARD CHARACTERS WITHOUT CLAIM TO ANY PARTICULAR FONT, STYLE, SIZE, OR COLOR.

NO CLAIM IS MADE TO THE EXCLUSIVE RIGHT TO USE "TECHNOLOGY", APART FROM THE MARK AS SHOWN.

FOR NON-MEDICATED SKIN CARE PREPARATIONS (U.S. CLS. 1, 4, 6, 50, 51 AND 52).

KATHRYN COWARD, EXAMINING ATTORNEY

CLASS 3—(Continued).

SN 85-511,114. KWDZ MANUFACTURING, LLC, LOS ANGELES, CA. FILED 1-7-2012.

BEAUTEES

THE MARK CONSISTS OF STANDARD CHARACTERS WITHOUT CLAIM TO ANY PARTICULAR FONT, STYLE, SIZE, OR COLOR.

OWNER OF U.S. REG. NO. 3,852,987.

FOR COSMETICS (U.S. CLS. 1, 4, 6, 50, 51 AND 52).

ROBERT STRUCK, EXAMINING ATTORNEY

SN 85-519,698. IVY BELLA COSMETICS CORP., COUNTY OF NEW CASTLE, DE. FILED 1-18-2012.



Ivy' Bella

THE NAME "IVY BELLA" DOES NOT IDENTIFY A LIVING INDIVIDUAL.

THE MARK CONSISTS OF A SQUARE DESIGN WITH A CURVED LINE INSIDE ABOVE THE STYLIZED WORDS "IVY' BELLA".

FOR BEAUTY MASKS; CAKES OF TOILET SOAP; COSMETIC PREPARATIONS FOR BATH AND SHOWER; COSMETIC PREPARATIONS FOR SKIN CARE; COSMETIC PREPARATIONS FOR SLIMMING PURPOSES; COSMETICS; ESSENTIAL OILS; EYEBROW COSMETICS; HAIR LOTIONS; LIPSTICKS (U.S. CLS. 1, 4, 6, 50, 51 AND 52).

BRIAN NEVILLE, EXAMINING ATTORNEY

CLASS 3—(Continued).

SN 85-522,403. NOMIKI GLYNATSIS COUTURE PTY LTD, KENMORE QLD, AUSTRALIA, FILED 1-23-2012.



PRIORITY CLAIMED UNDER SEC. 44(D) ON AUSTRALIA APPLICATION NO. 1456132, FILED 10-31-2011, REG. NO. 1456132, DATED 5-31-2012, EXPIRES 10-31-2021.

THE MARK CONSISTS OF THE CAPITAL LETTER "N" HAVING A SERIES OF JEWELS HANGING FROM THE UPPER LEFT PORTION OF THE LETTER, AND JEWELRY SURROUNDING THE LETTER.

FOR NON-MEDICATED PERFUMERY PREPARATIONS; PERFUME; PERFUMED ARTICLES, NAMELY, EAU DE PERFUME, PERFUMED OILS, PERFUMED CREAMS, PERFUMED PASTE, PERFUMED POWDER; PERFUMES; PERFUMED SOAPS; COSMETIC CREAMS; NON-MEDICATED CLEANSING PREPARATIONS FOR PERSONAL BODY AND FACE USE; EAU DE COLOGNE; PERFUMED TOILET WATERS; PERFUME WATER (U.S. CLS. 1, 4, 6, 50, 51 AND 52).

SOPHIA S. KIM, EXAMINING ATTORNEY

SN 85-524,878. LANCOME PARFUMS ET BEAUTE & CIE, PARIS, FRANCE, FILED 1-25-2012.

**RENERGIE LIFT
MULTI-ACTION**

OWNER OF U.S. REG. NOS. 1,739,355, 3,495,138 AND 3,834,171.

THE MARK CONSISTS OF "RENERGIE LIFT MULTI-ACTION" IN STYLIZED FORM.

FOR COSMETICS, NAMELY, CREAMS, GELS, MILKS, POWDERS AND LOTIONS FOR THE FACE, BODY AND HANDS (U.S. CLS. 1, 4, 6, 50, 51 AND 52).

JORDAN BAKER, EXAMINING ATTORNEY

CLASS 3—(Continued).

SN 85-530,351. LITTLE BUSY BODIES, LLC, CINCINNATI, OH. FILED 1-31-2012.

SNEEZERS

THE MARK CONSISTS OF STANDARD CHARACTERS WITHOUT CLAIM TO ANY PARTICULAR FONT, STYLE, SIZE, OR COLOR.

FOR DISPOSABLE NASAL WIPES IMPREGNATED WITH SALINE; DISPOSABLE WIPES IMPREGNATED WITH SALINE FOR PERSONAL HYGIENE; PRE-MOISTENED COSMETIC WIPES; SCENT-INFUSED PRE-MOISTENED COSMETIC WIPES; MOISTURIZING DISPOSABLE WIPES IMPREGNATED WITH CLEANSING CHEMICALS OR COMPOUNDS FOR PERSONAL HYGIENE (U.S. CLS. 1, 4, 6, 50, 51 AND 52).

ESTHER BELENKER, EXAMINING ATTORNEY

SN 85-531,144. ECO HOLDINGS, LLC, HOLLYWOOD, FL. FILED 2-1-2012.

GREEN CONCEPTS

THE MARK CONSISTS OF STANDARD CHARACTERS WITHOUT CLAIM TO ANY PARTICULAR FONT, STYLE, SIZE, OR COLOR.

OWNER OF U.S. REG. NO. 3,061,340.

SEC. 2(F).

FOR ALL PURPOSE CLEANERS; DEGREASERS, NAMELY, DEGREASING PREPARATIONS NOT USED IN MANUFACTURING PROCESSES FOR GENERAL HOUSEHOLD AND OFFICE CLEANING (U.S. CLS. 1, 4, 6, 50, 51 AND 52).

FIRST USE 12-10-2004; IN COMMERCE 1-12-2005.

PAUL E. FAHRENKOPF, EXAMINING ATTORNEY

CLASS 3—(Continued).

SN 85-543,129. DR ORGANIC LTD, SWANSEA, UNITED KINGDOM, FILED 2-15-2012.



PRIORITY CLAIMED UNDER SEC. 44(D) ON UNITED KINGDOM APPLICATION NO. 2592022, FILED 8-18-2011. THE COLOR(S) GREEN IS/ARE CLAIMED AS A FEATURE OF THE MARK.

THE MARK CONSISTS OF A GREEN LEAF WITH A CUTOUT OF A CROSS.

FOR NON-MEDICATED BATH OILS; HAIR CARE PREPARATIONS; NON-MEDICATED SKIN-CARE PREPARATIONS; NON-MEDICATED SKIN LOTIONS; SERUMS AND EMOLLIENTS FOR COSMETIC APPLICATION TO THE SKIN; COSMETIC PREPARATIONS FOR APPLICATION TO THE FINGER NAILS; CUTICLE OIL; AFTER-SUN LOTIONS (U.S. CLS. 1, 4, 50, 51 AND 52).

FIRST USE 4-30-2009; IN COMMERCE 2-29-2012. NICHOLAS COLEMAN, EXAMINING ATTORNEY

CLASS 3—(Continued).

SN 85-559,786. MADE IN THE USA MARKETING, LLC, DORAL, FL. FILED 3-5-2012.

Q'Viva!

THE MARK CONSISTS OF STANDARD CHARACTERS WITHOUT CLAIM TO ANY PARTICULAR FONT, STYLE, SIZE, OR COLOR.

THE ENGLISH TRANSLATION OF "Q'VIVA" IN THE MARK IS HOW ALIVE.

FOR COLOGNES, PERFUMES AND COSMETICS (U.S. CLS. 1, 4, 6, 50, 51 AND 52).

CIMMERIAN COLEMAN, EXAMINING ATTORNEY

SN 85-561,048. ORANGE A PEEL PRODUCT PTY LTD, BRISBANE, AUSTRALIA, FILED 3-6-2012.

ORANGE A PEEL

SN 85-548,871. EGLOBAL BEAUTE, INC., CITY OF INDUSTRY, CA. FILED 2-21-2012.

MO CLINICAL

THE MARK CONSISTS OF STANDARD CHARACTERS WITHOUT CLAIM TO ANY PARTICULAR FONT, STYLE, SIZE, OR COLOR.

NO CLAIM IS MADE TO THE EXCLUSIVE RIGHT TO USE "CLINICAL", APART FROM THE MARK AS SHOWN.

FOR SKIN CARE PRODUCTS, NAMELY, LOTIONS, CLEANSERS AND CREAMS; ESSENTIAL OILS FOR USE IN AROMATHERAPY; ESSENTIAL OILS; BODY CARE PRODUCTS, NAMELY, LOTIONS, CLEANSERS AND CREAMS; HAIR SHAMPOO; COSMETICS (U.S. CLS. 1, 4, 6, 50, 51 AND 52).

KERI CANTONE, EXAMINING ATTORNEY

THE MARK CONSISTS OF STANDARD CHARACTERS WITHOUT CLAIM TO ANY PARTICULAR FONT, STYLE, SIZE, OR COLOR.

NO CLAIM IS MADE TO THE EXCLUSIVE RIGHT TO USE "ORANGE", APART FROM THE MARK AS SHOWN.

FOR MULTI-PURPOSE CLEANING AND DEGREASING PREPARATIONS; LAUNDRY STAIN REMOVING PREPARATIONS; BATHROOM CLEANING PREPARATIONS; TOILET CLEANING PREPARATIONS; OVEN AND BBQ CLEANING PREPARATIONS; RINSE AGENTS FOR DISHWASHING MACHINES; WINDOW CLEANING PREPARATIONS; BOAT CLEANING PREPARATIONS; DISHWASHING DETERGENT; LAUNDRY DETERGENT; HAND WASHING SOAPS; FLOOR CLEANING PREPARATIONS; UPHOLSTERY CLEANING PREPARATIONS; JEWELRY CLEANING PREPARATIONS; ENGINE DEGREASING PREPARATIONS AND EXHAUST RANGE HOOD DEGREASING PREPARATIONS (U.S. CLS. 1, 4, 6, 50, 51 AND 52).

NORA BUCHANAN WILL, EXAMINING ATTORNEY

CLASS 3—(Continued).

SN 85-561,049. ORANGE A PEEL PRODUCT PTY LTD, BRISBANE, AUSTRALIA, FILED 3-6-2012.



NO CLAIM IS MADE TO THE EXCLUSIVE RIGHT TO USE "ORANGE" AND "PRODUCTS", APART FROM THE MARK AS SHOWN.

THE MARK CONSISTS OF THE LITERAL ELEMENTS "ORANGE A PEEL PRODUCTS" WRITTEN IN STYLIZED FORM WHEREIN THE WORDS "A PEEL" WITH A STYLIZED UNDERLINE ARE WRITTEN BENEATH THE WORD "ORANGE" AND THE WORD "PRODUCTS" IS WRITTEN BENEATH THE STYLIZED UNDERLINE AND ALL THIS LITERAL ELEMENTS ARE PLACED IN FRONT OF AN HALF PEELED ORANGE AS SHOWN IN THE MARK.

FOR MULTI-PURPOSE CLEANING AND DEGREASING PREPARATIONS; LAUNDRY STAIN REMOVING PREPARATIONS; BATHROOM CLEANING PREPARATIONS; TOILET CLEANING PREPARATIONS; OVEN AND BBQ CLEANING PREPARATIONS; RINSE AGENTS FOR DISHWASHING MACHINES; WINDOW CLEANING PREPARATIONS; BOAT CLEANING PREPARATIONS; DISHWASHING DETERGENT; LAUNDRY DETERGENT; HAND WASHING SOAPS; FLOOR CLEANING PREPARATIONS; UPHOLSTERY CLEANING PREPARATIONS; JEWELRY CLEANING PREPARATIONS; ENGINE DEGREASING PREPARATIONS AND EXHAUST RANGE HOOD DEGREASING PREPARATIONS (U.S. CLS. 1, 4, 6, 50, 51 AND 52).

NORA BUCHANAN WILL, EXAMINING ATTORNEY

SN 85-563,949. XANIA LABS, INC., LONG ISLAND CITY, NY. FILED 3-8-2012.

PROFOUND HAIR

THE MARK CONSISTS OF STANDARD CHARACTERS WITHOUT CLAIM TO ANY PARTICULAR FONT, STYLE, SIZE, OR COLOR.

OWNER OF U.S. REG. NOS. 2,851,782, 3,169,044 AND 3,917,529.

NO CLAIM IS MADE TO THE EXCLUSIVE RIGHT TO USE "HAIR", APART FROM THE MARK AS SHOWN.

FOR HAIR CARE PREPARATIONS (U.S. CLS. 1, 4, 6, 50, 51 AND 52).

SKYE YOUNG, EXAMINING ATTORNEY

CLASS 3—(Continued).

SN 85-564,339. WM. NEUMANN & CO. LLC, WILLIAMSBURG, VA. FILED 3-8-2012.



NO CLAIM IS MADE TO THE EXCLUSIVE RIGHT TO USE "1911", APART FROM THE MARK AS SHOWN.

THE MARK CONSISTS OF A RECTANGLE WITH THE ARTISTIC RENDERING OF A GUN FORMING EACH CORNER OF THE RECTANGLE. THE STYLIZED NUMBER "1911" APPEARS IN THE MIDDLE OF THE RECTANGLE. ON EITHER SIDE OF THE NUMBER "1911" IS A CIRCLE DRAWN INSIDE A LARGER CIRCLE.

FOR COLOGNES; BAR SOAP; LIQUID HAND SOAP; SHAMPOO; CONDITIONER; SHOWER BODY WASH; HAIR STYLING GEL; HAIR STYLING WAX; HAIR STYLING POMADE; AFTER-SHAVE SPLASH; AFTER-SHAVE GEL; AFTER-SHAVE LOTION; AFTER-SHAVE BALM; SHAVING CREAM; SHAVING SOAP; SHAVING GEL; PRE-SHAVE OIL; SHAVING OIL; HAND LOTION; BODY LOTION; NON-MEDICATED HERBAL BODY SALVE; SUNSCREEN CREAMS; FACIAL TONER; FACIAL CLEANSER; FACIAL MOISTURIZER; TOOTHPASTE; NON-MEDICATED LIP BALM; NON-MEDICATED ACNE PREPARATIONS (U.S. CLS. 1, 4, 6, 50, 51 AND 52).

SOPHIA S. KIM, EXAMINING ATTORNEY

SN 85-564,355. WM. NEUMANN & CO. LLC, WILLIAMSBURG, VA. FILED 3-8-2012.

SIGNATURE 1907

THE MARK CONSISTS OF STANDARD CHARACTERS WITHOUT CLAIM TO ANY PARTICULAR FONT, STYLE, SIZE, OR COLOR.

NO CLAIM IS MADE TO THE EXCLUSIVE RIGHT TO USE "1907", APART FROM THE MARK AS SHOWN.

FOR COLOGNES; BAR SOAP; LIQUID HAND SOAP; SHAMPOO; CONDITIONER; SHOWER BODY WASH; HAIR STYLING GEL; HAIR STYLING WAX; HAIR STYLING POMADE; AFTER-SHAVE SPLASH; AFTER-SHAVE GEL; AFTER-SHAVE LOTION; AFTER-SHAVE BALM; SHAVING CREAM; SHAVING SOAP; SHAVING GEL; PRE-SHAVE OIL; SHAVING OIL; HAND LOTION; BODY LOTION; NON-MEDICATED HERBAL BODY SALVE; SUNSCREEN CREAMS; FACIAL TONER; FACIAL CLEANSER; FACIAL MOISTURIZER; TOOTHPASTE; NON-MEDICATED LIP BALM; NON-MEDICATED ACNE PREPARATIONS (U.S. CLS. 1, 4, 6, 50, 51 AND 52).

SOPHIA S. KIM, EXAMINING ATTORNEY

CLASS 3—(Continued).

SN 85-570,356. WM. NEUMANN & CO. LLC, WILLIAMSBURG, VA. FILED 3-15-2012.

HEARTWOOD

THE MARK CONSISTS OF STANDARD CHARACTERS WITHOUT CLAIM TO ANY PARTICULAR FONT, STYLE, SIZE, OR COLOR.

FOR COLOGNES; BAR SOAP; LIQUID HAND SOAP; SHAMPOO; CONDITIONER; SHOWER BODY WASH; HAIR STYLING GEL; HAIR STYLING WAX; HAIR STYLING POMADE; AFTER-SHAVE SPLASH; AFTER-SHAVE GEL; AFTER-SHAVE LOTION; AFTER-SHAVE BALM; SHAVING CREAM; SHAVING SOAP; SHAVING GEL; PRE-SHAVE OIL; SHAVING OIL; HAND LOTION; BODY LOTION; NON-MEDICATED HERBAL BODY SALVE; SUNSCREEN CREAMS; FACIAL TONER; FACIAL CLEANSER; FACIAL MOISTURIZER; TOOTHPASTE; NON-MEDICATED LIP BALM; NON-MEDICATED ACNE PREPARATIONS (U.S. CLS. 1, 4, 6, 50, 51 AND 52).

SOPHIA S. KIM, EXAMINING ATTORNEY

CLASS 3—(Continued).

SN 85-577,782. L'OREAL USA CREATIVE, INC., NEW YORK, NY. FILED 3-23-2012.

SATIN VOLUMIZER

THE MARK CONSISTS OF STANDARD CHARACTERS WITHOUT CLAIM TO ANY PARTICULAR FONT, STYLE, SIZE, OR COLOR.

NO CLAIM IS MADE TO THE EXCLUSIVE RIGHT TO USE "VOLUMIZER", APART FROM THE MARK AS SHOWN.

FOR HAIR STYLING PREPARATION (U.S. CLS. 1, 4, 6, 50, 51 AND 52).

JERI J. FICKES, EXAMINING ATTORNEY

SN 85-573,332. AUSTRALIAN GOLD, LLC, INDIANAPOLIS, IN. FILED 3-19-2012.

DESIGNER BY DESIGNER

THE MARK CONSISTS OF STANDARD CHARACTERS WITHOUT CLAIM TO ANY PARTICULAR FONT, STYLE, SIZE, OR COLOR.

FOR INDOOR AND OUTDOOR NON-MEDICATED SKIN TANNING PREPARATIONS (U.S. CLS. 1, 4, 6, 50, 51 AND 52).

JEANIE LEE, EXAMINING ATTORNEY

SN 85-578,715. WISCONSIN NOTE INVESTORS, LLC, DALLAS, TX. FILED 3-23-2012.



SN 85-575,331. MANA PRODUCTS, INC., LONG ISLAND CITY, NY. FILED 3-21-2012.

BIOBROWX3

THE MARK CONSISTS OF STANDARD CHARACTERS WITHOUT CLAIM TO ANY PARTICULAR FONT, STYLE, SIZE, OR COLOR.

FOR COSMETICS (U.S. CLS. 1, 4, 6, 50, 51 AND 52).

FIRST USE 4-30-2011; IN COMMERCE 4-30-2011.

HELENE LIWINSKI, EXAMINING ATTORNEY

NO CLAIM IS MADE TO THE EXCLUSIVE RIGHT TO USE "WIPES", APART FROM THE MARK AS SHOWN.

THE COLOR(S) RED, WHITE, AND BLACK IS/ARE CLAIMED AS A FEATURE OF THE MARK.

THE MARK CONSISTS OF THE WORDING "GRAB N' SCRUB" IN WHITE SMALL CAPITAL LETTERS, OVER THE WORD "WIPES" IN WHITE CAPITAL LETTERS, WITH THE FIRST LINE OF THE LETTER "W" EXTENDING UP AND IN FRONT OF THE "G" IN GRAB AND THE VERTICAL LINE OF THE LETTER "P" EXTENDING LOWER THAN THE REST OF THE LETTERS IN "WIPES," ALL ON A BLACK BACKGROUND LINED IN RED.

FOR WET TOWELS IN THE NATURE OF DISPOSABLE WIPES COMPRISED OF SUBSTRATES IMPREGNATED WITH PRIMARILY CLEANING CHEMICALS FOR HOUSEHOLD, INDUSTRIAL, AUTOMOTIVE, AND COMMERCIAL USE (U.S. CLS. 1, 4, 6, 50, 51 AND 52).

NELSON SNYDER, EXAMINING ATTORNEY

CLASS 3—(Continued).

SN 85-580,674. MUIRHEAD, ROXANNE, BRONX, NY. FILED 3-27-2012.



NO CLAIM IS MADE TO THE EXCLUSIVE RIGHT TO USE "BODY ORGANIKS", APART FROM THE MARK AS SHOWN.

THE MARK CONSISTS OF THE STYLIZED WORDING "BODY ORGANIKS", THE DESIGN OF A HALF CIRCLE CONTAINING THE DESIGN OF TWO LEAVES ABOVE THE WORDING "BODY ORGANIKS" AND THE DESIGN OF A RECTANGLE BELOW THE HALF CIRCLE.

FOR AROMATIC AND ORGANIC BODY CARE PRODUCTS, NAMELY, BODY LOTION, SHOWER GEL, CUTICLE CREAM, SHAMPOO, CONDITIONER, NON-MEDICATED LIP BALM, SOAP, BODY POLISH, BODY AND FOOT SCRUB AND NON-MEDICATED FOOT CREAM (U.S. CLS. 1, 4, 6, 50, 51 AND 52).

FIRST USE 0-0-2009; IN COMMERCE 0-0-2009. IRA J. GOODSaid, EXAMINING ATTORNEY

CLASS 3—(Continued).

SN 85-584,355. BUSHMICH, EUGENIA, NORTH PORT, FL. FILED 3-30-2012.

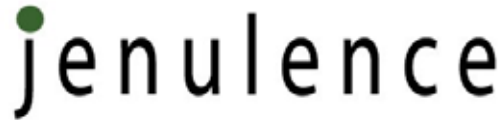

THE COLOR(S) BLACK AND GREEN IS/ARE CLAIMED AS A FEATURE OF THE MARK.

THE MARK CONSISTS OF THE WORD "JENULENCE" WRITTEN IN LOWERCASE BLACK LETTERS WITH THE DOT ABOVE THE "J" WRITTEN IN GREEN.

THE WORDING "JENULENCE" HAS NO MEANING IN A FOREIGN LANGUAGE.

FOR BEAUTY SERUMS; BLUSH; BODY GLITTER; BODY LOTIONS; BODY POWDER; CONCEALERS; EYE SHADOWS; FACIAL CLEANSERS; FACIAL CREAM; FACIAL MASKS; FACIAL SCRUBS; FOOT POWDER; FOUNDATION; HAIR DRESSINGS FOR MEN; LIP BALM; NATURAL MINERAL MAKE-UP; NON-MEDICATED SKIN CARE PREPARATION, NAMELY, BODY MIST; OILS FOR COSMETIC PURPOSES; SKIN BRONZER; TONERS (U.S. CLS. 1, 4, 6, 50, 51 AND 52).

FIRST USE 12-0-2007; IN COMMERCE 12-0-2007. GEORGE LORENZO, EXAMINING ATTORNEY

SN 85-581,648. YUMMY SUDS, MELBOURNE BEACH, FL. FILED 3-27-2012.



THE MARK CONSISTS OF STANDARD CHARACTERS WITHOUT CLAIM TO ANY PARTICULAR FONT, STYLE, SIZE, OR COLOR.

OWNER OF U.S. REG. NO. 3,824,406. FOR AROMATIC BODY CARE PRODUCTS, NAMELY, BODY LOTION, SHOWER GEL, CUTICLE CREAM, SHAMPOO, CONDITIONER, NON-MEDICATED LIP BALM, SOAP, BODY POLISH, BODY AND FOOT SCRUB AND NON-MEDICATED FOOT CREAM; BODY AND BEAUTY CARE COSMETICS (U.S. CLS. 1, 4, 6, 50, 51 AND 52).

FIRST USE 9-1-2011; IN COMMERCE 9-1-2011. PAUL E. FAHRENKOPF, EXAMINING ATTORNEY

SN 85-584,725. BURWELL INDUSTRIES, INC., CENTENNIAL, CO. FILED 3-30-2012.



THE MARK CONSISTS OF A RECTANGLE CONTAINING ONE VERTICAL LINE AND THREE HORIZONTAL LINES WITH THE WORDING "APOTHEKE:M" ABOVE THE TOP HORIZONTAL LINE AND TO THE RIGHT OF THE VERTICAL LINE.

THE ENGLISH TRANSLATION OF "APOTHEKE" IN THE MARK IS "PHARMACY".

FOR SHOWER GEL, BODY LOTION, BODY CLEANSER, BODY SCRUB, BODY SPRAY, FOAMING SOAP, BODY CREAM, BATH GEL, BATH TONIC, BODY POLISH (U.S. CLS. 1, 4, 6, 50, 51 AND 52).

FIRST USE 3-15-2012; IN COMMERCE 3-15-2012. DAVID ELTON, EXAMINING ATTORNEY

CLASS 3—(Continued).

SN 85-584,731. BURWELL INDUSTRIES, INC., CENTENNIAL, CO. FILED 3-30-2012.

APOTHEKE:M

THE MARK CONSISTS OF STANDARD CHARACTERS WITHOUT CLAIM TO ANY PARTICULAR FONT, STYLE, SIZE, OR COLOR.

THE ENGLISH TRANSLATION OF "APOTHEKE" IN THE MARK IS "PHARMACY".

FOR SHOWER GEL, BODY LOTION, BODY CLEANSER, BODY SCRUB, BODY SPRAY, FOAMING SOAP, BODY CREAM, BATH GEL, BATH TONIC, BODY POLISH (U.S. CLS. 1, 4, 6, 50, 51 AND 52).

FIRST USE 3-15-2012; IN COMMERCE 3-15-2012.
DAVID ELTON, EXAMINING ATTORNEY

SN 85-585,068. XANIA LABS, INC., LONG ISLAND CITY, NY. FILED 3-30-2012.

STYLE EDIT

THE MARK CONSISTS OF STANDARD CHARACTERS WITHOUT CLAIM TO ANY PARTICULAR FONT, STYLE, SIZE, OR COLOR.

NO CLAIM IS MADE TO THE EXCLUSIVE RIGHT TO USE "STYLE", APART FROM THE MARK AS SHOWN.

FOR COSMETICS, NON-MEDICATED SKIN CARE PREPARATIONS, HAIR CARE PREPARATIONS (U.S. CLS. 1, 4, 6, 50, 51 AND 52).

SKYE YOUNG, EXAMINING ATTORNEY

SN 85-586,766. MANNA KADAR BEAUTY, INC., LAGUNA NIGUEL, CA. FILED 4-2-2012.

MANNA KADAR

THE MARK CONSISTS OF STANDARD CHARACTERS WITHOUT CLAIM TO ANY PARTICULAR FONT, STYLE, SIZE, OR COLOR.

THE NAME(S), PORTRAIT(S), AND/OR SIGNATURE(S) SHOWN IN THE MARK IDENTIFIES "MANNA KADAR", WHOSE CONSENT(S) TO REGISTER IS MADE OF RECORD.

FOR COSMETICS; LIPSTICKS, LIP GLOSS, BLUSHES, FOUNDATION MAKE-UP, CONCEALERS, LIP PRIMERS, EYE SHADOWS, FACE POWDER, AND EYELINERS; SELF TANNING LOTION (U.S. CLS. 1, 4, 6, 50, 51 AND 52).

JASON BLAIR, EXAMINING ATTORNEY

CLASS 3—(Continued).

SN 85-587,112. SPINSTER SISTERS COMPANY, AKA SPINSTER SISTERS SOAP, GOLDEN, CO. FILED 4-2-2012.



NO CLAIM IS MADE TO THE EXCLUSIVE RIGHT TO USE "CO ALL NATURAL HANDCRAFTED", APART FROM THE MARK AS SHOWN.

THE MARK CONSISTS OF "SPINSTER SISTERS CO" AND "ALL NATURAL" AND "HANDCRAFTED". THE FIRST LETTER "S" IN THE WORD "SPINSTER" IS STYLIZED WITH DIAGONAL LINES AND AN INTERTWINING VINE.

FOR 3-IN-1 ORGANIC SOAP BARS FOR USE AS SOAP, SHAMPOO AND CONDITIONER; AGE RETARDANT LOTION; ANTI-BACTERIAL SOAP; AROMATIC BODY CARE PRODUCTS, NAMELY, BODY LOTION, SHOWER GEL, CUTICLE CREAM, SHAMPOO, CONDITIONER, NON-MEDICATED LIP BALM, SOAP, BODY POLISH, BODY AND FOOT SCRUB AND NON-MEDICATED FOOT CREAM; BABY HAND SOAP; BAR SOAP; BATH AND SHOWER GELS AND SALTS NOT FOR MEDICAL PURPOSES; BATH OILS AND BATH SALTS; BATH SALTS; BATH SOAPS; BEAUTY SOAP; BODY AND BEAUTY CARE COSMETICS; BODY BUTTER; BODY CREAM; BODY CREAM SOAP; BODY LOTION; COSMETIC BATH SALTS; COSMETIC SOAPS; CREAM SOAPS; FACE AND BODY LOTIONS; LIP BALM; MINERAL SALT IN THE NATURE OF BATH SALTS NOT FOR MEDICAL PURPOSES (U.S. CLS. 1, 4, 6, 50, 51 AND 52).

FIRST USE 1-1-2010; IN COMMERCE 1-1-2010.

VIVIAN MICZNIK FIRST, EXAMINING ATTORNEY

SN 85-588,115. JAFRA COSMETICS INTERNATIONAL, INC., WESTLAKE VILLAGE, CA. FILED 4-3-2012.

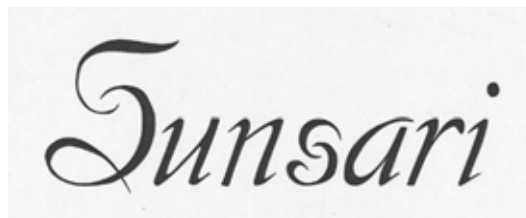

THE MARK CONSISTS OF THE WORD "SUNSARI" IN STYLIZED LETTERS.

THE WORDING "SUNSARI" HAS NO MEANING IN A FOREIGN LANGUAGE.

FOR FRAGRANCES; EAU DE TOILETTE; BODY CARE PRODUCTS, NAMELY, BODY POWDER; BODY LOTIONS; SHOWER GELS; AND PERSONAL DEODORANTS (U.S. CLS. 1, 4, 6, 50, 51 AND 52).

ALICE BENMAMAN, EXAMINING ATTORNEY

CLASS 3—(Continued).

SN 85-589,949. L'OREAL, PARIS, FRANCE, FILED 4-5-2012.

MESS MAKER

THE MARK CONSISTS OF STANDARD CHARACTERS WITHOUT CLAIM TO ANY PARTICULAR FONT, STYLE, SIZE, OR COLOR.

OWNER OF U.S. REG. NO. 3,670,899.
FOR HAIR STYLING PREPARATIONS (U.S. CLS. 1, 4, 6, 50, 51 AND 52).
EDWARD NELSON, EXAMINING ATTORNEY

SN 85-590,183. NORTHERN LABS, INC., MANITOWOC, WI.
FILED 4-5-2012.

CLEAN SHOT

THE MARK CONSISTS OF STANDARD CHARACTERS WITHOUT CLAIM TO ANY PARTICULAR FONT, STYLE, SIZE, OR COLOR.

OWNER OF U.S. REG. NO. 2,514,516.
NO CLAIM IS MADE TO THE EXCLUSIVE RIGHT TO USE "CLEAN", APART FROM THE MARK AS SHOWN.
FOR BLEACHING PREPARATIONS FOR LAUNDRY USE; DISHWASHING DETERGENTS; LAUNDRY DETERGENT; STAIN REMOVERS (U.S. CLS. 1, 4, 6, 50, 51 AND 52).
TINA L. SNAPP, EXAMINING ATTORNEY

SN 85-592,685. DANNY FIRST, INC., LOS ANGELES, CA.
FILED 4-9-2012.

La La Land

THE MARK CONSISTS OF STANDARD CHARACTERS WITHOUT CLAIM TO ANY PARTICULAR FONT, STYLE, SIZE, OR COLOR.

OWNER OF U.S. REG. NO. 3,515,693.
FOR COLOGNE; PERFUME (U.S. CLS. 1, 4, 6, 50, 51 AND 52).
ALEX KEAM, EXAMINING ATTORNEY

CLASS 3—(Continued).

SN 85-593,073. JENNIFER BIRMINGHAM LEE, LOS ANGELES, CA. FILED 4-10-2012.

**Parlour
By: Jenn Birmingham Lee**

THE MARK CONSISTS OF STANDARD CHARACTERS WITHOUT CLAIM TO ANY PARTICULAR FONT, STYLE, SIZE, OR COLOR.

"JENN BIRMINGHAM LEE" IDENTIFIES A LIVING INDIVIDUAL WHOSE CONSENT IS OF RECORD.
FOR NAIL POLISH; NAIL POLISH BASE COAT; NAIL POLISH REMOVER; NAIL POLISH TOP COAT (U.S. CLS. 1, 4, 6, 50, 51 AND 52).
PAUL E. FAHRENKOPF, EXAMINING ATTORNEY

SN 85-593,976. DALLAS SKIN INSTITUTE, DBA DALLAS SKIN INSTITUTE, DALLAS, TX. FILED 4-10-2012.

Ooh La Lash

THE MARK CONSISTS OF STANDARD CHARACTERS WITHOUT CLAIM TO ANY PARTICULAR FONT, STYLE, SIZE, OR COLOR.

FOR COSMETIC PREPARATIONS FOR EYE LASHES (U.S. CLS. 1, 4, 6, 50, 51 AND 52).
FIRST USE 1-21-2012; IN COMMERCE 1-21-2012.
MEREDITH MARESCA, EXAMINING ATTORNEY

SN 85-594,680. LJ LAROCCA, INC, STUDIO CITY, CA. FILED 4-11-2012.

OrganiKai

THE MARK CONSISTS OF STANDARD CHARACTERS WITHOUT CLAIM TO ANY PARTICULAR FONT, STYLE, SIZE, OR COLOR.

FOR COSMETICS AND MAKE-UP MADE IN WHOLE OR SUBSTANTIAL PART OF ORGANIC INGREDIENTS (U.S. CLS. 1, 4, 6, 50, 51 AND 52).
FIRST USE 4-3-2012; IN COMMERCE 4-10-2012.
JIM RINGLE, EXAMINING ATTORNEY

CLASS 3—(Continued).

SN 85-595,763. GUIETTE, DEBORAH E, WESTON, WI, WI. FILED 4-12-2012.

You're A Good Dog!

THE MARK CONSISTS OF STANDARD CHARACTERS WITHOUT CLAIM TO ANY PARTICULAR FONT, STYLE, SIZE, OR COLOR.

FOR NON-MEDICATED GROOMING PREPARATIONS FOR DOGS, NAMELY, EAR CLEANER AND FRESHENER (U.S. CLS. 1, 4, 6, 50, 51 AND 52).

FIRST USE 1-1-2004; IN COMMERCE 3-1-2008.

KIMBERLY PARKS, EXAMINING ATTORNEY

SN 85-595,844. NEUMA RESEARCH, AKA NEUMA, CARSON, CA. FILED 4-12-2012.

neuMoisture

THE MARK CONSISTS OF STANDARD CHARACTERS WITHOUT CLAIM TO ANY PARTICULAR FONT, STYLE, SIZE, OR COLOR.

THE ENGLISH TRANSLATION OF "NEU" IN THE MARK IS "NEW".

FOR (BASED ON USE IN COMMERCE) HAIR CARE PRODUCTS, NAMELY, HAIR CARE PREPARATIONS, HAIR SHAMPOO, HAIR CLEANING PREPARATIONS, HAIR CONDITIONERS, HAIR RINSES, HAIR CREME, HAIR GEL, AND HAIR STYLING PREPARATIONS; BODY CARE PRODUCTS, NAMELY, BODY CLEANSING SOAP AND GEL, BODY CREAMS AND LOTIONS, SKIN MOISTURIZER, NON-MEDICATED FOOT CREAM, NON-MEDICATED FOOT LOTIONS, HAND CREAMS AND LOTIONS; BATH PRODUCTS, NAMELY, BATH AND SHOWER GELS, BATH AND SHOWER WASHES, BATH AND SHOWER FOAMS; ESSENTIAL OILS FOR USE IN THE MANUFACTURE OF SCENTED PRODUCTS.; (BASED ON INTENT TO USE) BODY CARE PRODUCTS, NAMELY, MOISTURIZING CREAMS; SKIN CARE PRODUCTS, NAMELY, FACIAL CLEANSERS, UNDER EYE CREAMS, FACIAL CREAMS, FACIAL LOTION, FACIAL TONER, FACIAL EMULSIONS, FACIAL MASKS, ANTI-WRINKLE CREAM, ANTI-AGING CREAM, FACIAL WASH, FACIAL SCRUB, FACIAL EXFOLIANT, FACIAL MOISTURIZER, FACIAL MOISTURIZER WITH SUN PROTECTION FACTOR, EYE CREAM, UNDER EYE GELS, MASKS AND ASTRINGENTS FOR COSMETIC PURPOSES; FACIAL COSMETICS, NAMELY, LIP CREAM, LIP BALM, LIP BALM WITH SUN PROTECTION FACTOR, LIP STICK, LIP GLOSS; BODY SCRUB EXFOLIANT, SKIN TONER, SKIN MOISTURIZER WITH SUN PROTECTION FACTOR, SELF TANNING LOTION, SUN SCREEN PREPARATIONS, PERSONAL DEODORANTS AND ANTIPERSPIRANTS, MASSAGE OILS; BATH PRODUCTS, NAMELY, BUBBLE BATHS, MILK BATHS, NON-MEDICATED BATH SALTS, BATH OILS, BODY OILS, BATH CRYSTALS, BATH PEARLS, BATH POWDER, SHAVING CREAM, SHAVING GEL, PRE-SHAVING PREPARATIONS, AFTER-SHAVE LOTIONS AND BALM, TOILET WATER, TALCUM POWDER AND SKIN SOAP; COSMETICS; SCENTED PRODUCTS, NAMELY, PERFUMES, COLOGNE, ESSENTIAL OILS FOR PERSONAL USE (U.S. CLS. 1, 4, 6, 50, 51 AND 52).

FIRST USE 3-3-2012; IN COMMERCE 3-3-2012.

ERIN FALK, EXAMINING ATTORNEY

CLASS 3—(Continued).

SN 85-595,929. RITA HAZAN, NEW YORK, NY. FILED 4-12-2012.

RITA HAZAN ROOT CONCEALER

THE MARK CONSISTS OF STANDARD CHARACTERS WITHOUT CLAIM TO ANY PARTICULAR FONT, STYLE, SIZE, OR COLOR.

OWNER OF U.S. REG. NOS. 2,969,668 AND 3,572,935.

NO CLAIM IS MADE TO THE EXCLUSIVE RIGHT TO USE "ROOT CONCEALER", APART FROM THE MARK AS SHOWN.

THE NAME "RITA HAZAN" IDENTIFIES A LIVING INDIVIDUAL WHOSE CONSENT IS OF RECORD.

FOR HAIR DYE (U.S. CLS. 1, 4, 6, 50, 51 AND 52).

JENNY PARK, EXAMINING ATTORNEY

SN 85-596,191. AG GLOBAL PRODUCTS, LLC, LOS ANGELES, CA. FILED 4-12-2012.

HAIR VEIL

THE MARK CONSISTS OF STANDARD CHARACTERS WITHOUT CLAIM TO ANY PARTICULAR FONT, STYLE, SIZE, OR COLOR.

NO CLAIM IS MADE TO THE EXCLUSIVE RIGHT TO USE "HAIR", APART FROM THE MARK AS SHOWN.

FOR HAIR CARE PREPARATIONS; HAIR POWDER; HAIR CONDITIONER; HAIR STYLING PREPARATIONS; SHAMPOOS (U.S. CLS. 1, 4, 6, 50, 51 AND 52).

ALAIN LAPTEK, EXAMINING ATTORNEY

SN 85-596,262. HUESTON, MARK, JACKSONVILLE, FL. FILED 4-12-2012.

X Cream

THE MARK CONSISTS OF STANDARD CHARACTERS WITHOUT CLAIM TO ANY PARTICULAR FONT, STYLE, SIZE, OR COLOR.

NO CLAIM IS MADE TO THE EXCLUSIVE RIGHT TO USE "CREAM", APART FROM THE MARK AS SHOWN.

FOR BODY CREAM (U.S. CLS. 1, 4, 6, 50, 51 AND 52).

FIRST USE 5-5-2005; IN COMMERCE 5-5-2005.

RICHARD WHITE, EXAMINING ATTORNEY

CLASS 3—(Continued).

SN 85-596,406. JON RICHARD, WINSTON-SALEM, NC.
FILED 4-12-2012.

CLASS 3—(Continued).

SN 85-596,879. SYSCO CORPORATION, HOUSTON, TX.
FILED 4-13-2012.

LENSLIQKER

THE MARK CONSISTS OF STANDARD CHARACTERS WITHOUT CLAIM TO ANY PARTICULAR FONT, STYLE, SIZE, OR COLOR.

FOR LENS CLEANERS FOR OPTICAL LENSES, COMPUTER SCREENS, COMPACT DISKS, TABLETS, SMARTPHONES, NAUTICAL GAUGES, SKI GOGGLES; LENS CLEANING KITS COMPRISED OF CLEANING FLUID AND A CLEANING CLOTH; AND IMPREGNATED CLEANING CLOTHS (U.S. CLS. 1, 4, 6, 50, 51 AND 52).

JOSETTE BEVERLY, EXAMINING ATTORNEY



SN 85-596,706. ARTWOHL, BRITTANY E, DBA BRITT'S
BALMS, SCOTTSDALE, AZ. FILED 4-12-2012.

Britt's Balms

THE MARK CONSISTS OF STANDARD CHARACTERS WITHOUT CLAIM TO ANY PARTICULAR FONT, STYLE, SIZE, OR COLOR.

NO CLAIM IS MADE TO THE EXCLUSIVE RIGHT TO USE "BALMS", APART FROM THE MARK AS SHOWN.

FOR NON-MEDICATED BALMS FOR USE ON SKIN, LIPS, AND NAILS; POMADES FOR HAIR (U.S. CLS. 1, 4, 6, 50, 51 AND 52).

FIRST USE 12-20-2011; IN COMMERCE 4-10-2012.
EDWARD NELSON, EXAMINING ATTORNEY

NO CLAIM IS MADE TO THE EXCLUSIVE RIGHT TO USE "QA", APART FROM THE MARK AS SHOWN.

THE MARK CONSISTS OF THESE STYLIZED LETTERS "Q" AND "A" WITH A LEAF DESIGN AS THE STEM ON THE "Q" AND THE BAR ACROSS THE LETTER "A".

FOR FLOOR CARE PREPARATIONS, NAMELY, FLOOR FINISH, FINISH REMOVER, AND SEALANT; HAND SOAP; FURNITURE POLISH, AMMONIA FOR CLEANING PURPOSES, LAUNDRY BLEACH; DISHWASHER SOAP, AND CLEANING PREPARATIONS FOR USE ON FABRICS, AND IN FOOD PREPARATION, SERVICE, AND STORAGE AREAS; AND FABRIC SOFTENERS; SKIN CREAM WITH CONDITIONER; BODY SHAMPOO; HAND DETERGENT, DISHWATER RINSE AIDS; FLOOR CLEANING PREPARATIONS; SKIN CREAM WITH ALOE; ALL PURPOSE CLEANING AND DEGREASING PREPARATIONS FOR USE IN THE FOOD SERVICE INDUSTRY; LAUNDRY DETERGENT; DISPOSABLE WIPES IMPREGNATED WITH CLEANING COMPOUNDS FOR USE IN PERSONAL HYGIENE; WINDOW CLEANER; DRAIN OPENER; PERSONAL CARE AMENITIES, NAMELY, SHAMPOO, SOAP, HAND AND BODY LOTION, HAIR CONDITIONER, MOUTH WASH, TOOTH PASTE, BATH GEL; ALL PURPOSE CLEANING PREPARATIONS; NAIL CARE PREPARATIONS (U.S. CLS. 1, 4, 6, 50, 51 AND 52).

TINA MAI, EXAMINING ATTORNEY

CLASS 3—(Continued).

SN 85-597,259. DR FRESH INC., BUENA PARK, CA. FILED 4-13-2012.

**THE BEST THINGS IN LIFE ARE FREE
AND NEXT TO BEST, IS FOR \$1
DOLLAR!**

THE MARK CONSISTS OF STANDARD CHARACTERS WITHOUT CLAIM TO ANY PARTICULAR FONT, STYLE, SIZE, OR COLOR.

FOR ANTI-CAVITY MOUTHWASHES; BREATH FRESHENER; BREATH FRESHENER, NAMELY, BETEL NUT POWDER; BREATH FRESHENER, NAMELY, KATHA; BREATH FRESHENER, NAMELY, MUKHWAS; BREATH FRESHENER, NAMELY, PAN MASALA; BREATH FRESHENER, NAMELY, SCENTED SUPARI; BREATH FRESHENING CONFECTIONARY, NAMELY, DISSOLVABLE BREATH STRIPS, BREATH MINTS, CANDY AND GUM; BREATH FRESHENING SPRAYS; BREATH FRESHENING STRIPS; BREATH MINTS FOR USE AS A BREATH FRESHENER; COSMETIC PREPARATIONS FOR THE CARE OF MOUTH AND TEETH; DENTIFRICES AND MOUTHWASHES; HOME DENTAL CARE PRODUCTS FOR DOGS AND CATS, NAMELY, TOOTHPASTE; MOUTHWASH; MOUTHWASHES; NON-MEDICATED BREATH FRESHENING STRIPS; NON-MEDICATED MOUTHWASH AND GARGLE; NON-MEDICATED MOUTHWASHES; SKIN WHITENING PREPARATIONS; TEETH CLEANING LOTIONS; TEETH WHITENING KIT; TEETH WHITENING STRIPS IMPREGNATED WITH TEETH WHITENING PREPARATIONS; TOOTH WHITENERS FOR COSMETIC PURPOSES COMPRISED OF NEUTRAL SODIUM FLUORIDE SUSTAINED RELEASE GEL; TOOTH WHITENING CREAMS; TOOTH WHITENING GELS; TOOTH WHITENING PASTES; TOOTH WHITENING PREPARATIONS; TOOTHPASTE; TOOTHPASTE AND MOUTHWASHES; TOOTHPASTES (U.S. CLS. 1, 4, 6, 50, 51 AND 52).

FIRST USE 2-9-2011; IN COMMERCE 2-9-2011.
CYNTHIA TRIPI, EXAMINING ATTORNEY

SN 85-597,658. BIRMINGHAM LEE, JENNIFER, DBA PETITE PARLOUR BY JENN BIRMINGHAM LEE, LOS ANGELES, CA. FILED 4-13-2012.

**Petite Parlour
By Jenn Birmingham Lee**

THE MARK CONSISTS OF STANDARD CHARACTERS WITHOUT CLAIM TO ANY PARTICULAR FONT, STYLE, SIZE, OR COLOR.

THE NAME "JENN BIRMINGHAM LEE" IDENTIFIES A LIVING INDIVIDUAL WHOSE CONSENT IS OF RECORD. FOR NAIL POLISH (U.S. CLS. 1, 4, 6, 50, 51 AND 52).
TRACY FLETCHER, EXAMINING ATTORNEY

CLASS 3—(Continued).

SN 85-599,035. MELALEUCA, INC., IDAHO FALLS, ID. FILED 4-16-2012.

**CLARITY CLEAR SKIN
ESSENTIALS**

THE MARK CONSISTS OF STANDARD CHARACTERS WITHOUT CLAIM TO ANY PARTICULAR FONT, STYLE, SIZE, OR COLOR.

NO CLAIM IS MADE TO THE EXCLUSIVE RIGHT TO USE "CLEAR SKIN", APART FROM THE MARK AS SHOWN.

FOR FACIAL WASHES; NON-MEDICATED SKIN CARE PREPARATIONS; SKIN CLEANSERS; SKIN MOISTURIZER (U.S. CLS. 1, 4, 6, 50, 51 AND 52).
GRETCHEN ULRICH, EXAMINING ATTORNEY

SN 85-599,277. BURTS BEES, INC, DURHAM, NC. FILED 4-16-2012.

RED RUBY GROOVY

THE MARK CONSISTS OF STANDARD CHARACTERS WITHOUT CLAIM TO ANY PARTICULAR FONT, STYLE, SIZE, OR COLOR.

FOR FRAGRANCE AS AN INTEGRAL COMPONENT OF PERSONAL CARE PRODUCTS, NAMELY, BODY LOTIONS; HAIR SHAMPOOS AND CONDITIONERS; HAND CREAMS (U.S. CLS. 1, 4, 6, 50, 51 AND 52).
JASON BLAIR, EXAMINING ATTORNEY

SN 85-599,686. SUESCUN, ENRIQUE, MIAMI, FL. FILED 4-17-2012.

BOSOM MAX

THE MARK CONSISTS OF STANDARD CHARACTERS WITHOUT CLAIM TO ANY PARTICULAR FONT, STYLE, SIZE, OR COLOR.

NO CLAIM IS MADE TO THE EXCLUSIVE RIGHT TO USE "BOSOM", APART FROM THE MARK AS SHOWN.

FOR COSMETIC CREAMS FOR SKIN CARE; NON-MEDICATED SKIN CARE PREPARATIONS, NAMELY, TONING CREAMS FOR FIRING, SCULPTING, AND ENHANCING THE BODY (U.S. CLS. 1, 4, 6, 50, 51 AND 52).

FIRST USE 1-0-2001; IN COMMERCE 1-0-2001.
MICHAEL WEBSTER, EXAMINING ATTORNEY

CLASS 3—(Continued).

SN 85-599,740. SPECIALTY CONCEPTS, INC., BOCA RATON, FL. FILED 4-17-2012.

Tooth Stars

THE MARK CONSISTS OF STANDARD CHARACTERS WITHOUT CLAIM TO ANY PARTICULAR FONT, STYLE, SIZE, OR COLOR.

NO CLAIM IS MADE TO THE EXCLUSIVE RIGHT TO USE "TOOTH", APART FROM THE MARK AS SHOWN.

FOR TOOTHPASTES (U.S. CLS. 1, 4, 6, 50, 51 AND 52).

FIRST USE 11-1-2011; IN COMMERCE 11-1-2011.

KELLEY WELLS, EXAMINING ATTORNEY

SN 85-600,175. PROCTER & GAMBLE COMPANY, THE, CINCINNATI, OH. FILED 4-17-2012.

GLAMOROUS WHITE

THE MARK CONSISTS OF STANDARD CHARACTERS WITHOUT CLAIM TO ANY PARTICULAR FONT, STYLE, SIZE, OR COLOR.

NO CLAIM IS MADE TO THE EXCLUSIVE RIGHT TO USE "WHITE", APART FROM THE MARK AS SHOWN.

FOR TOOTHPASTE (U.S. CLS. 1, 4, 6, 50, 51 AND 52).

FIRST USE 3-5-2012; IN COMMERCE 3-5-2012.

VERNA BETH RIRIE, EXAMINING ATTORNEY

SN 85-600,243. L'OREAL USA CREATIVE, INC., NEW YORK, NY. FILED 4-17-2012.

SATIN VOLUME

THE MARK CONSISTS OF STANDARD CHARACTERS WITHOUT CLAIM TO ANY PARTICULAR FONT, STYLE, SIZE, OR COLOR.

NO CLAIM IS MADE TO THE EXCLUSIVE RIGHT TO USE "VOLUME", APART FROM THE MARK AS SHOWN.

FOR HAIR CARE PREPARATIONS AND HAIR STYLING PREPARATIONS (U.S. CLS. 1, 4, 6, 50, 51 AND 52).

JERI J. FICKES, EXAMINING ATTORNEY

CLASS 3—(Continued).

SN 85-600,530. RAMOS, RENDA, MILLBRAE, CA. FILED 4-17-2012.

SKINDUSTRY

THE MARK CONSISTS OF STANDARD CHARACTERS WITHOUT CLAIM TO ANY PARTICULAR FONT, STYLE, SIZE, OR COLOR.

FOR FACIAL CLEANSERS; MAKE-UP PENCILS; MAKE-UP; HAIR WAX; WAX FOR REMOVING BODY HAIR (U.S. CLS. 1, 4, 6, 50, 51 AND 52).

HOWARD SMIGA, EXAMINING ATTORNEY

SN 85-600,736. D, BIG BAD, YPSILAANTI, MI. FILED 4-18-2012.

BBD ADDICTED

THE MARK CONSISTS OF STANDARD CHARACTERS WITHOUT CLAIM TO ANY PARTICULAR FONT, STYLE, SIZE, OR COLOR.

FOR COSMETICS; HAIR CARE PREPARATIONS; NON-MEDICATED SKIN CARE PREPARATIONS (U.S. CLS. 1, 4, 6, 50, 51 AND 52).

ZACHARY CROMER, EXAMINING ATTORNEY

SN 85-600,833. SEXY HAIR CONCEPTS, LLC, CHATSWORTH, CA. FILED 4-18-2012.

SMOOTH SEXY HAIR

THE MARK CONSISTS OF STANDARD CHARACTERS WITHOUT CLAIM TO ANY PARTICULAR FONT, STYLE, SIZE, OR COLOR.

OWNER OF U.S. REG. NOS. 2,553,996, 3,247,541 AND OTHERS.

NO CLAIM IS MADE TO THE EXCLUSIVE RIGHT TO USE "SMOOTH" AND "HAIR", APART FROM THE MARK AS SHOWN.

FOR HAIR CARE PRODUCTS, NAMELY, HAIR SHAMPOOS, HAIR CONDITIONERS, HAIR MOUSSES, HAIR SPRAYS, HAIR GELS, HAIR GEL FOAMS, HAIR CREAMS, HAIR WAXES, HAIR DETANGLERS, HAIR BALMS, HAIR GLOSSES, HAIR POMADES AND HAIR TONICS (U.S. CLS. 1, 4, 6, 50, 51 AND 52).

APRIL HESIK, EXAMINING ATTORNEY

CLASS 3—(Continued).

SN 85-600,845. SEXY HAIR CONCEPTS, LLC, CHATSWORTH, CA. FILED 4-18-2012.

HOT SEXY HAIR

THE MARK CONSISTS OF STANDARD CHARACTERS WITHOUT CLAIM TO ANY PARTICULAR FONT, STYLE, SIZE, OR COLOR.

OWNER OF U.S. REG. NOS. 2,553,996, 3,247,541 AND OTHERS.

NO CLAIM IS MADE TO THE EXCLUSIVE RIGHT TO USE "HAIR", APART FROM THE MARK AS SHOWN.

FOR HAIR CARE PRODUCTS, NAMELY, HAIR SHAMPOOS, HAIR CONDITIONERS, HAIR MOUSSES, HAIR SPRAYS, HAIR GELS, HAIR GEL FOAMS, HAIR CREAMS, HAIR WAXES, HAIR DETANGLERS, HAIR BALMS, HAIR GLOSSES, HAIR POMADES AND HAIR TONICS (U.S. CLS. 1, 4, 6, 50, 51 AND 52).

APRIL HESIK, EXAMINING ATTORNEY

SN 85-601,515. MY MIRACLE HAIR SECRETS INC., WESTON, FL. FILED 4-18-2012.

MY MIRACLE BLOW DRY SECRET!

THE MARK CONSISTS OF STANDARD CHARACTERS WITHOUT CLAIM TO ANY PARTICULAR FONT, STYLE, SIZE, OR COLOR.

FOR SHAMPOO, CONDITIONER, LEAVE-IN CONDITIONER, LEAVE-IN GEL (U.S. CLS. 1, 4, 6, 50, 51 AND 52).

JESSICA A. POWERS, EXAMINING ATTORNEY

SN 85-601,787. JASIBO, LLC, LAS VEGAS, NV. FILED 4-18-2012.

PROWHITENER EXPRESS

THE MARK CONSISTS OF STANDARD CHARACTERS WITHOUT CLAIM TO ANY PARTICULAR FONT, STYLE, SIZE, OR COLOR.

FOR MOUTHWASH; TEETH WHITENING KIT; TOOTH BLEACHING PREPARATIONS; TOOTH POLISHES; TOOTH WHITENING CREAMS; TOOTH WHITENING GELS; TOOTH WHITENING PASTES; TOOTH WHITENING PREPARATIONS; TOOTHPASTE (U.S. CLS. 1, 4, 6, 50, 51 AND 52).

JUHI KAVEESHVAR, EXAMINING ATTORNEY

CLASS 3—(Continued).

SN 85-602,118. CODI N CODI, INC., COLLEGE POINT, NY. FILED 4-19-2012.

CODI

THE MARK CONSISTS OF STANDARD CHARACTERS WITHOUT CLAIM TO ANY PARTICULAR FONT, STYLE, SIZE, OR COLOR.

FOR BODY LOTION; LOTIONS FOR COSMETIC PURPOSES (U.S. CLS. 1, 4, 6, 50, 51 AND 52).

FIRST USE 3-31-2012; IN COMMERCE 3-31-2012.

BRENDAN MCCAULEY, EXAMINING ATTORNEY

SN 85-602,439. BUZZAGOGO, LLC, NOTTINGHAM, NH. FILED 4-19-2012.

Boo Boo Bee Gone

THE MARK CONSISTS OF STANDARD CHARACTERS WITHOUT CLAIM TO ANY PARTICULAR FONT, STYLE, SIZE, OR COLOR.

FOR NON-MEDICATED HERBAL BODY CARE PRODUCTS, NAMELY, BODY OILS, SALVES, AND LIP BALMS (U.S. CLS. 1, 4, 6, 50, 51 AND 52).

FIRST USE 3-15-2012; IN COMMERCE 4-15-2012.

CHARLES L. JENKINS, EXAMINING ATTORNEY

SN 85-602,477. L'OREAL USA CREATIVE, INC., NEW YORK, NY. FILED 4-19-2012.

DREAM SURF

THE MARK CONSISTS OF STANDARD CHARACTERS WITHOUT CLAIM TO ANY PARTICULAR FONT, STYLE, SIZE, OR COLOR.

OWNER OF U.S. REG. NOS. 3,199,836, 3,696,688 AND OTHERS.

FOR SELF TANNING PREPARATIONS AND SKIN BRONZERS (U.S. CLS. 1, 4, 6, 50, 51 AND 52).

ALYSSA STEEL, EXAMINING ATTORNEY

CLASS 3—(Continued).

SN 85-602,649. PACIFICA, INC., PORTLAND, OR. FILED 4-19-2012.

HAIRVANA

THE MARK CONSISTS OF STANDARD CHARACTERS WITHOUT CLAIM TO ANY PARTICULAR FONT, STYLE, SIZE, OR COLOR.

FOR HAIR SHAMPOOS AND CONDITIONERS (U.S. CLS. 1, 4, 6, 50, 51 AND 52).

FIRST USE 3-10-2012; IN COMMERCE 3-10-2012.
ZACHARY BELLO, EXAMINING ATTORNEY

SN 85-602,681. WATCO USA, INC., VERNON HILLS, IL. FILED 4-19-2012.

CONCROFF

THE MARK CONSISTS OF STANDARD CHARACTERS WITHOUT CLAIM TO ANY PARTICULAR FONT, STYLE, SIZE, OR COLOR.

FOR EMULSIFYING PREPARATIONS FOR REMOVING OIL AND GREASE FROM FLOORS AND MACHINERY (U.S. CLS. 1, 4, 6, 50, 51 AND 52).

FIRST USE 9-28-2011; IN COMMERCE 9-28-2011.
JOHN E. MICHOS, EXAMINING ATTORNEY

SN 85-602,706. PARFUMS DE COEUR, LTD., STAMFORD, CT. FILED 4-19-2012.

You! Me! Dancing!

THE MARK CONSISTS OF STANDARD CHARACTERS WITHOUT CLAIM TO ANY PARTICULAR FONT, STYLE, SIZE, OR COLOR.

FOR MEN'S AND WOMEN'S FRAGRANCES, NAMELY, PERFUME, COLOGNE, TOILET WATER; SCENTED BODY SPRAYS; PERSONAL DEODORANTS; SHOWER GELS; BODY LOTIONS; BODY POWDERS; SOAPS (U.S. CLS. 1, 4, 6, 50, 51 AND 52).

COLLEEN MULCRONE, EXAMINING ATTORNEY

CLASS 3—(Continued).

SN 85-603,006. THE LIBMAN COMPANY, ARCOLA, IL. FILED 4-19-2012.



OWNER OF U.S. REG. NOS. 1,739,891 AND 2,986,576.
THE MARK CONSISTS OF THE WORD "LIBMAN" UNDERLINED BY A CURVED BAND.

FOR CLEANING PREPARATIONS; CLEANING PREPARATIONS FOR HOUSEHOLD PURPOSES; CLEANING PREPARATIONS FOR CLEANING SURFACES; CLEANER FOR USE ON FLOORS; CLEANER FOR USE ON WINDOWS (U.S. CLS. 1, 4, 6, 50, 51 AND 52).

KRISTINA MORRIS, EXAMINING ATTORNEY

SN 85-603,267. AMARANTHUS LLC, RALEIGH, NC. FILED 4-19-2012.



THE MARK CONSISTS OF A SILHOUETTE OF A "HUMAN BEING" SITTING ON FOLDED LEGS (YOGA MEDITATION POSITION) WITH THE WORDED TEXT "HARMONIOUS" WRITTEN IN AN ARCHING SHAPE ON THE TOP SECTION OF THE SILHOUETTE AND THE WORDED TEXT "BALANCE" WRITTEN IN A CATENARY SHAPE (U-LIKE SHAPE OR INVERTED ARCHING SHAPE) AT THE BOTTOM SECTION OF THE SAME SILHOUETTE.

FOR COSMETICS (U.S. CLS. 1, 4, 6, 50, 51 AND 52).
FIRST USE 4-27-2011; IN COMMERCE 3-15-2012.
THOMAS MANOR, EXAMINING ATTORNEY

SN 85-604,325. SAUNDERS, PAULINE, LOS ANGELES, CA. FILED 4-20-2012.

Let It Block

THE MARK CONSISTS OF STANDARD CHARACTERS WITHOUT CLAIM TO ANY PARTICULAR FONT, STYLE, SIZE, OR COLOR.

FOR SUN SCREEN PREPARATIONS (U.S. CLS. 1, 4, 6, 50, 51 AND 52).

JULIE WATSON, EXAMINING ATTORNEY

CLASS 3—(Continued).

SN 85-604,579. NATURAL HEALTH NETWORK, LLC, BREA, CA. FILED 4-21-2012.

BELLAGENIX

THE MARK CONSISTS OF STANDARD CHARACTERS WITHOUT CLAIM TO ANY PARTICULAR FONT, STYLE, SIZE, OR COLOR.

FOR ANTI-WRINKLE CREAM; ANTI-WRINKLE CREAMS; BEAUTY CREAMS; COSMETIC CREAMS; COSMETIC CREAMS FOR SKIN CARE; COSMETIC PREPARATIONS; COSMETIC PREPARATIONS FOR SKIN RENEWAL; FACE CREAMS; FACE CREAMS FOR COSMETIC USE; FACIAL CREAM; FACIAL CREAMS; MOISTURIZING CREAMS; NON-MEDICATED SKIN CARE PREPARATIONS, NAMELY, CREAMS, LOTIONS, GELS, TONERS, CLEANERS AND PEELS; NON-MEDICATED SKIN CREAMS (U.S. CLS. 1, 4, 6, 50, 51 AND 52).

JORDAN BAKER, EXAMINING ATTORNEY

CLASS 3—(Continued).

SN 85-604,765. ZETINO, MARTA R., DBA ILLUSION CREATIONS, VAN NUYS, CA. FILED 4-22-2012.



NO CLAIM IS MADE TO THE EXCLUSIVE RIGHT TO USE "FOR ACNE", APART FROM THE MARK AS SHOWN. THE COLOR(S) WHITE, PINK, GREEN, BLUE-GREEN AND BLACK IS/ARE CLAIMED AS A FEATURE OF THE MARK.

THE MARK CONSISTS OF A BLACK RECTANGLE ENCLOSING PINK AND WHITE FLOWERS OVER A BACKGROUND CONSISTING OF GREEN AND BLUE-GREEN SHADING IN THE OUTER EDGES BORDERING THE BLACK RECTANGLE WITH THE WORDS "MARCHITOL FOR ACNE" WRITTEN IN BLACK CAPITAL LETTERS PLACED OVER THE IMAGE.

THE WORDING "MARCHITOL" HAS NO MEANING IN A FOREIGN LANGUAGE.

FOR NON-MEDICATED ACNE TREATMENT PREPARATIONS (U.S. CLS. 1, 4, 6, 50, 51 AND 52).

FIRST USE 4-14-2012; IN COMMERCE 4-15-2012.

JEFFREY LOOK, EXAMINING ATTORNEY

SN 85-604,728. KHOSROW AMERI, LOS ANGELES, CA. FILED 4-22-2012.

Lookology

THE MARK CONSISTS OF STANDARD CHARACTERS WITHOUT CLAIM TO ANY PARTICULAR FONT, STYLE, SIZE, OR COLOR.

FOR BODY AND BEAUTY CARE COSMETICS; COSMETIC CREAMS FOR SKIN CARE; COSMETIC PREPARATIONS FOR BODY CARE; COSMETIC PREPARATIONS FOR SKIN CARE; COSMETIC PREPARATIONS FOR SKIN RENEWAL (U.S. CLS. 1, 4, 6, 50, 51 AND 52).

CHRISTINE MARTIN, EXAMINING ATTORNEY

SN 85-605,023. LAURICE EL BADRY RAHME LTD., DBA LAURICE & CO., NEW YORK, NY. FILED 4-23-2012.

LITTLE INDIA

THE MARK CONSISTS OF STANDARD CHARACTERS WITHOUT CLAIM TO ANY PARTICULAR FONT, STYLE, SIZE, OR COLOR.

FOR FRAGRANCES FOR PERSONAL USE, NAMELY PERFUMES, COLOGNES, AFTER BATH SPLASHES, BODY SPRAYS, SHOWER GELS, SOAPS, BODY LOTIONS, MASSAGE OILS, COSMETICS, NAMELY, NON-MEDICATED SKIN CARE PREPARATIONS, MAKEUP, LIPSTICK, FOUNDATION POWDER, EYESHADOW, NAIL POLISH, MASCARA AND EYE PENCIL (U.S. CLS. 1, 4, 6, 50, 51 AND 52).

JOHN WILKE, EXAMINING ATTORNEY

CLASS 3—(Continued).

SN 85-605,275. CHURCH & DWIGHT CO., INC., PRINCETON, NJ. FILED 4-23-2012.

EXTREME POWER CRYSTALS

THE MARK CONSISTS OF STANDARD CHARACTERS WITHOUT CLAIM TO ANY PARTICULAR FONT, STYLE, SIZE, OR COLOR.

NO CLAIM IS MADE TO THE EXCLUSIVE RIGHT TO USE "CRYSTALS", APART FROM THE MARK AS SHOWN.

FOR AUTOMATIC DISHWASHING DETERGENTS AND AUTOMATIC DISHWASHING DETERGENT BOOSTERS (U.S. CLS. 1, 4, 6, 50, 51 AND 52).

JOHN HWANG, EXAMINING ATTORNEY

SN 85-605,366. ALAMODEUS, LLC, DBA CAPISTRANO SOAP COMPANY, SAN ANTONIO, TX. FILED 4-23-2012.

ACEQUIA

THE MARK CONSISTS OF THE WORD "ACEQUIA" IN ALL CAPITAL LETTERS WITH A WAVE UNDER THE LETTERS "UIA".

FOR AROMATIC BODY CARE PRODUCTS, NAMELY, BODY LOTION, SHOWER GEL, CUTICLE CREAM, SHAMPOO, CONDITIONER, NON-MEDICATED LIP BALM, SOAP, BODY POLISH, BODY AND FOOT SCRUB AND NON-MEDICATED FOOT CREAM (U.S. CLS. 1, 4, 6, 50, 51 AND 52).

FIRST USE 5-19-2011; IN COMMERCE 6-1-2011.

LINDA M. KING, EXAMINING ATTORNEY

SN 85-605,676. FLEMING, KAREN TANLER, CARLSBAD, CA. FILED 4-23-2012.

As You Were

THE MARK CONSISTS OF STANDARD CHARACTERS WITHOUT CLAIM TO ANY PARTICULAR FONT, STYLE, SIZE, OR COLOR.

FOR COSMETICS, NAMELY, FACE AND BODY OIL (U.S. CLS. 1, 4, 6, 50, 51 AND 52).

FIRST USE 1-1-2012; IN COMMERCE 1-1-2012.

LINDA ESTRADA, EXAMINING ATTORNEY

CLASS 3—(Continued).

SN 85-605,755. KITTRICH CORPORATION, LA MIRADA, CA. FILED 4-23-2012.



THE MARK CONSISTS OF A STYLIZED BUMBLE BEE HAVING A PAIR OF WINGS. THE BODY IS COMPOSED OF A HEAD, THORAX AND ABDOMEN. THE HEAD HAS EXTENDING ANTENNAE AND ONE OVAL SHAPED EYE. THE THORAX HAS ONE LEG AND THE ABDOMEN HAS A SINGLE PAIR OF LEGS. THE THORAX AND ABDOMEN HAVE A COMBINED TOTAL OF FIVE STRIPES OF VARYING PROPORTIONS.

FOR BABY LOTION; BABY OILS; BABY POWDER; BABY SHAMPOO; BABY WIPES; BATH LOTION; BATH SOAPS; FACE AND BODY LOTIONS; HAIR CONDITIONERS FOR BABIES; HAIR SHAMPOOS AND CONDITIONERS; HAND LOTIONS; LIQUID SOAPS FOR HANDS, FACE AND BODY; SKIN CLEANSING LOTION; SUN CARE LOTIONS (U.S. CLS. 1, 4, 6, 50, 51 AND 52).

INGA ERVIN, EXAMINING ATTORNEY

SN 85-605,854. KITTRICH CORPORATION, LA MIRADA, CA. FILED 4-23-2012.



THE MARK CONSISTS OF A STYLIZED FLYING ANT HAVING A PAIR OF WINGS. THE BODY IS COMPOSED OF A HEAD, A THORAX AND AN ABDOMEN. THE HEAD HAS EXTENDING ANTENNAE, ONE CIRCULAR EYE AND A SMILE. THE THORAX HAS ONE PAIR OF LEGS. THE ABDOMEN HAS ONE VENTRAL STRIPE WITH ONE PAIR OF LEGS.

FOR BABY LOTION; BABY OILS; BABY POWDER; BABY SHAMPOO; BABY WIPES; BATH LOTION; BATH SOAPS; FACE AND BODY LOTIONS; HAIR CONDITIONERS FOR BABIES; HAIR SHAMPOOS AND CONDITIONERS; HAND LOTIONS; LIQUID SOAPS FOR HANDS, FACE AND BODY; SKIN CLEANSING LOTION; SUN CARE LOTIONS (U.S. CLS. 1, 4, 6, 50, 51 AND 52).

INGA ERVIN, EXAMINING ATTORNEY

CLASS 3—(Continued).

SN 85-606,119. THE PROCTER & GAMBLE COMPANY, CINCINNATI, OH. FILED 4-24-2012.

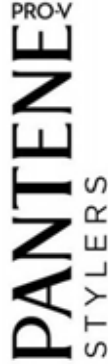

OWNER OF U.S. REG. NOS. 1,005,694, 3,851,628 AND OTHERS.

NO CLAIM IS MADE TO THE EXCLUSIVE RIGHT TO USE "STYLERS", APART FROM THE MARK AS SHOWN.

THE MARK CONSISTS OF "PANTENE PRO-V STYLERS" WITH "PANTENE" AND "STYLERS" APPEARING VERTICALLY AND "PRO-V" POSITIONED HORIZONTALLY ACROSS THE "E" OF "PANTENE".

FOR HAIR CARE PREPARATIONS (U.S. CLS. 1, 4, 6, 50, 51 AND 52).

VERNA BETH RIRIE, EXAMINING ATTORNEY

SN 85-606,559. KITTRICH CORPORATION, LA MIRADA, CA. FILED 4-24-2012.

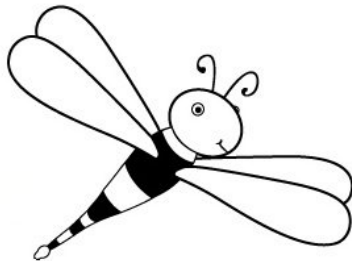

THE MARK CONSISTS OF A STYLIZED DRAGONFLY HAVING TWO PAIRS OF UNEMBELLISHED WINGS. THE BODY IS COMPOSED OF A HEAD AND AN ADJOINING ELONGATED BODY WITH A PROTUBERANT TAIL. THE HEAD HAS EXTENDING ANTENNAE, A PARTIAL SMILE AND A PAIR OF CIRCULAR EYES OF WHICH ONE IS ALMOST FULLY OBSCURED. THE ELONGATED BODY HAS A PATTERN OF FOUR STRIPES OF DIMINISHING PROPORTIONS.

FOR BABY LOTION; BABY OILS; BABY POWDER; BABY SHAMPOO; BABY WIPES; BATH LOTION; BATH SOAPS; FACE AND BODY LOTIONS; HAIR CONDITIONERS FOR BABIES; HAIR SHAMPOOS AND CONDITIONERS; HAND LOTIONS; LIQUID SOAPS FOR HANDS, FACE AND BODY; SKIN CLEANSING LOTION; SUN CARE LOTIONS (U.S. CLS. 1, 4, 6, 50, 51 AND 52).

INGA ERVIN, EXAMINING ATTORNEY

CLASS 3—(Continued).

SN 85-606,790. KITTRICH CORPORATION, LA MIRADA, CA. FILED 4-24-2012.



THE MARK CONSISTS OF STYLIZED SNAIL HAVING A DORSAL SHELL AND A VENTRAL MUSCULAR FOOT. THE SHELL HAS TWO CONCENTRIC TEARDROPS. THE HEAD OF THE SNAIL EXTENDS UPWARD FROM THE MUSCULAR FOOT, AND HAS TWO PROJECTING OMMATOPHORES. THE HEAD FURTHER HAS TWO CIRCULAR SHAPED EYES AND A SMILE.

FOR BABY LOTION; BABY OILS; BABY POWDER; BABY SHAMPOO; BABY WIPES; BATH LOTION; BATH SOAPS; FACE AND BODY LOTIONS; HAIR CONDITIONERS FOR BABIES; HAIR SHAMPOOS AND CONDITIONERS; HAND LOTIONS; LIQUID SOAPS FOR HANDS AND FACE; SKIN CLEANSING LOTION; SUN CARE LOTIONS (U.S. CLS. 1, 4, 6, 50, 51 AND 52).

INGA ERVIN, EXAMINING ATTORNEY

SN 85-606,855. KITTRICH CORPORATION, LA MIRADA, CA. FILED 4-24-2012.



THE MARK CONSISTS OF A STYLIZED BUTTERFLY

CLASS 3—(Continued).

HAVING TWO ORNAMENTAL FOREWINGS AND ONE UNEMBELLISHED HINDWING. THE LEFT FOREWING HAS ONE HEART WITH TWO PARTIALLY OBSCURED CIRCULAR DOTS. THE RIGHT FOREWING HAS ONE HEART AND FIVE CIRCULAR DOTS. THE BODY IS COMPOSED OF A HEAD, THORAX AND ABDOMEN. THE HEAD HAS EXTENDING ANTENNAE, TWO CIRCULAR EYES AND A SMILE. THE THORAX HAS ONE PAIR OF LEGS, AND THE ADJOINING ABDOMEN HAS TWO PAIRS OF LEGS.

FOR BABY BUBBLE BATH; BABY LOTION; BABY OILS; BABY POWDER; BABY SHAMPOO; BABY WIPES; BATH LOTION; BATH SOAPS; FACE AND BODY LOTIONS; HAIR CONDITIONERS FOR BABIES; HAIR SHAMPOOS AND CONDITIONERS; HAND LOTIONS; LIQUID SOAPS FOR HANDS, FACE AND BODY; SKIN CLEANSING LOTION; SUN CARE LOTIONS (U.S. CLS. 1, 4, 6, 50, 51 AND 52).

INGA ERVIN, EXAMINING ATTORNEY

CLASS 3—(Continued).

HAVING A PAIR OF EMBELLISHED ELYTRA IN A PARTIALLY OPEN POSITION. THE INTERIOR FACE OF THE FURTHERMOST ELYTRA HAS ONE LARGE PARTIALLY OBSCURED OVAL AND ONE SMALLER OVAL. THE EXTERIOR FACE OF THE FULLY VISIBLE ELYTRA HAS TWO LARGE OVALS AND TWO SMALLER CIRCLES. THE BODY IS COMPOSED OF A HEAD AND AN ADJOINING ABDOMEN. THE HEAD HAS EXTENDING ANTENNAE, ONE OVAL SHAPED EYE AND A SMILE. THE ABDOMEN HAS TWO PAIRS OF LEGS.

FOR BABY HAIR CONDITIONER; BABY LOTION; BABY OILS; BABY POWDER; BABY SHAMPOO; BABY WIPES; BATH LOTION; BATH SOAPS; FACE AND BODY LOTIONS; HAIR SHAMPOOS AND CONDITIONERS; HAND LOTIONS; LIQUID SOAPS FOR HANDS, FACE AND BODY; SKIN CLEANSING LOTION; SUN CARE LOTIONS (U.S. CLS. 1, 4, 6, 50, 51 AND 52).

INGA ERVIN, EXAMINING ATTORNEY

SN 85-606,924. L'OREAL USA CREATIVE, INC., NEW YORK, NY. FILED 4-24-2012.

SN 85-606,976. KITTRICH CORPORATION, LA MIRADA, CA. FILED 4-24-2012.

DEEPREBUILD

THE MARK CONSISTS OF STANDARD CHARACTERS WITHOUT CLAIM TO ANY PARTICULAR FONT, STYLE, SIZE, OR COLOR.

FOR HAIR CARE PREPARATIONS (U.S. CLS. 1, 4, 6, 50, 51 AND 52).

ALYSSA STEEL, EXAMINING ATTORNEY



SN 85-606,929. KITTRICH CORPORATION, LA MIRADA, CA. FILED 4-24-2012.

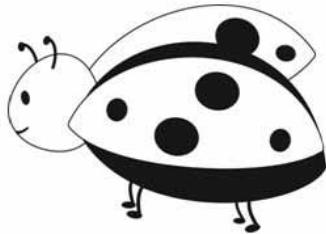

THE MARK CONSISTS OF A STYLIZED FIREFLY HAVING A PAIR OF UNEMBELLISHED WINGS. THE BODY IS COMPOSED OF A HEAD AND AN ADJOINING ABDOMEN. THE HEAD HAS EXTENDING ANTENNAE, TWO CIRCULAR EYES AND A SMILE. THE ABDOMEN HAS ONE LARGE STRIPE, TOGETHER WITH A SERIES OF FIVE RADIANT OVALS TO CONVEY THE EMISSION OF LIGHT.

FOR BABY LOTION; BABY OILS; BABY POWDER; BABY SHAMPOO; BABY WIPES; BATH LOTION; BATH SOAPS; FACE AND BODY LOTIONS; HAIR CONDITIONERS FOR BABIES; HAIR SHAMPOOS AND CONDITIONERS; HAND LOTIONS; LIQUID SOAPS FOR HANDS, FACE AND BODY; NON-MEDICATED DIAPER RASH CREAM; NON-MEDICATED DIAPER RASH OINTMENTS AND LOTIONS; SKIN CLEANSING LOTION; SUN CARE LOTIONS (U.S. CLS. 1, 4, 6, 50, 51 AND 52).

INGA ERVIN, EXAMINING ATTORNEY

THE MARK CONSISTS OF A STYLIZED LADY BUG

CLASS 3—(Continued).

SN 85-607,013. KITTRICH CORPORATION, LA MIRADA, CA. FILED 4-24-2012.

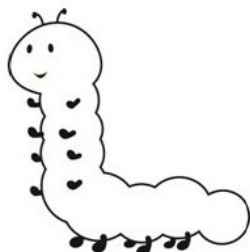

THE MARK CONSISTS OF A STYLIZED CATERPILLAR IN A STANDING UPRIGHT POSITION. THE CATERPILLAR HAS SEVEN BODY SEGMENTS, WITH SEVEN PAIRS OF LEGS, AND ONE HEAD WITH EXTENDING ANTENNAE. THE HEAD HAS TWO OVAL SHAPED EYES AND A SMILE.

FOR BABY LOTION; BABY OILS; BABY POWDER; BABY SHAMPOO; BABY WIPES; BATH LOTION; BATH SOAPS; FACE AND BODY LOTIONS; HAIR CONDITIONERS FOR BABIES; HAIR SHAMPOOS AND CONDITIONERS; HAND LOTIONS; LIQUID SOAPS FOR HANDS, FACE AND BODY; SKIN CLEANSING LOTION; SUN CARE LOTIONS (U.S. CLS. 1, 4, 6, 50, 51 AND 52).
INGA ERVIN, EXAMINING ATTORNEY

SN 85-607,041. KITTRICH CORPORATION, LA MIRADA, CA. FILED 4-24-2012.

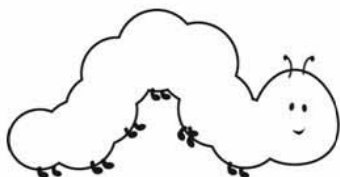

THE MARK CONSISTS OF A STYLIZED CATERPILLAR ORIENTED IN A LATERAL POSITION HAVING A RAISED MIDSECTION. THE CATERPILLAR HAS EIGHT BODY SEGMENTS, WITH SIX PAIRS OF LEGS, AND ONE HEAD WITH EXTENDING ANTENNAE. THE HEAD HAS TWO OVAL SHAPED EYES AND A SMILE.

FOR BABY LOTION; BABY OILS; BABY POWDER; BABY SHAMPOO; BABY WIPES; BATH LOTION; BATH SOAPS; FACE AND BODY LOTIONS; HAIR CONDITIONERS FOR BABIES; HAIR SHAMPOOS AND CONDITIONERS; HAND LOTIONS; LIQUID SOAPS FOR HANDS, FACE AND BODY; SKIN CLEANSING LOTION; SUN BLOCK; SUN CARE LOTIONS; SUN CREAMS; SUN SCREEN PREPARATIONS (U.S. CLS. 1, 4, 6, 50, 51 AND 52).
INGA ERVIN, EXAMINING ATTORNEY

CLASS 3—(Continued).

SN 85-609,566. L'OREAL USA CREATIVE, INC., NEW YORK, NY. FILED 4-26-2012.

WAVE CUSTOMIZER

THE MARK CONSISTS OF STANDARD CHARACTERS WITHOUT CLAIM TO ANY PARTICULAR FONT, STYLE, SIZE, OR COLOR.

NO CLAIM IS MADE TO THE EXCLUSIVE RIGHT TO USE "WAVE", APART FROM THE MARK AS SHOWN.

FOR HAIR WAVING AND HAIR CURLING PREPARATIONS (U.S. CLS. 1, 4, 6, 50, 51 AND 52).
ALYSSA STEEL, EXAMINING ATTORNEY

SN 85-610,774. L'OREAL USA CREATIVE, INC., NEW YORK, NY. FILED 4-27-2012.

FLASH LIFT

THE MARK CONSISTS OF STANDARD CHARACTERS WITHOUT CLAIM TO ANY PARTICULAR FONT, STYLE, SIZE, OR COLOR.

FOR HAIR LIGHTENERS FOR USE IN PROFESSIONAL SALONS (U.S. CLS. 1, 4, 6, 50, 51 AND 52).

ALYSSA STEEL, EXAMINING ATTORNEY

SN 85-611,925. TARGET BRANDS, INC., MINNEAPOLIS, MN. FILED 4-30-2012.

UP & UP

THE MARK CONSISTS OF STANDARD CHARACTERS WITHOUT CLAIM TO ANY PARTICULAR FONT, STYLE, SIZE, OR COLOR.

OWNER OF U.S. REG. NOS. 3,786,202, 4,042,813 AND OTHERS.

FOR WAX FOR HAIR REMOVAL; DEPILATORIES; EMERY BOARDS (U.S. CLS. 1, 4, 6, 50, 51 AND 52).

JEAN IM, EXAMINING ATTORNEY

CLASS 3—(Continued).

SN 85-611,932. TARGET BRANDS, INC., MINNEAPOLIS, MN. FILED 4-30-2012.



OWNER OF U.S. REG. NOS. 3,786,202, 4,042,813 AND OTHERS.

THE MARK CONSISTS OF AN ARROW DESIGN POINTING AT A 45 DEGREE DIAGONAL, UP AND TO THE RIGHT, WITH THE WORDS "UP & UP" INSIDE THE ARROW.

FOR WAX FOR HAIR REMOVAL; DEPILATORIES; EMERY BOARDS (U.S. CLS. 1, 4, 6, 50, 51 AND 52).
JEAN IM, EXAMINING ATTORNEY

SN 85-612,306. ATHLETA, INC., PETALUMA, CA. FILED 4-30-2012.

ATHLETA

THE MARK CONSISTS OF STANDARD CHARACTERS WITHOUT CLAIM TO ANY PARTICULAR FONT, STYLE, SIZE, OR COLOR.

OWNER OF U.S. REG. NOS. 2,427,769, 3,931,195 AND OTHERS.

FOR COSMETICS; BODY AND BEAUTY CARE COSMETICS; FRAGRANCES AND PERFUMERY; BATH AND BODY OILS; SOAPS FOR PERSONAL USE; SKIN LOTIONS; NON-MEDICATED BATH PREPARATIONS; ROOM FRAGRANCES; FRAGRANCE EMITTING WICKS FOR ROOM FRAGRANCE; POTPOURRI; HAIR CARE PREPARATIONS; NON-MEDICATED SKIN CARE PREPARATIONS; NON-MEDICATED SUN CARE PREPARATIONS (U.S. CLS. 1, 4, 6, 50, 51 AND 52).
AMY HELLA, EXAMINING ATTORNEY

CLASS 3—(Continued).

SN 85-613,717. MALCOLM CHRISTINE, SANTA FE, NM. FILED 5-1-2012.

PROPHETISIMA

THE MARK CONSISTS OF STANDARD CHARACTERS WITHOUT CLAIM TO ANY PARTICULAR FONT, STYLE, SIZE, OR COLOR.

FOR AROMATIC ESSENTIAL OILS; BATH AND SHOWER GELS AND SALTS NOT FOR MEDICAL PURPOSES; BATH OILS AND BATH SALTS; BEAUTY CREAMS FOR BODY CARE; BODY AND BEAUTY CARE COSMETICS; BODY LOTION; BODY LOTIONS; BODY OIL; BODY SPLASH; BODY SPRAY USED AS A PERSONAL DEODORANT AND AS FRAGRANCE; COLOGNES, PERFUMES AND COSMETICS; EAU DE PERFUME; ESSENTIAL OILS; ESSENTIAL OILS FOR AROMATHERAPY USE; ESSENTIAL OILS FOR PERSONAL USE; ESSENTIAL OILS FOR USE IN AROMATHERAPY; ESSENTIAL OILS FOR USE IN THE MANUFACTURE OF SCENTED PRODUCTS; FACE AND BODY BEAUTY CREAMS; FACIAL CREAM; FRAGRANCED FACIAL MOISTURIZER; LIQUID PERFUMES; LOTIONS FOR FACE AND BODY CARE; MASSAGE OIL; NATURAL ESSENTIAL OILS; NON-MEDICATED SKIN CREAMS WITH ESSENTIAL OILS FOR USE IN AROMATHERAPY; OILS FOR PERFUMES AND SCENTS; PERFUME; PERFUME OILS; PERFUME OILS FOR THE MANUFACTURE OF COSMETIC PREPARATIONS; PERFUMED POWDER; PERFUMES AND COLOGNES; PERFUMES AND TOILET WATERS; PERFUMES IN SOLID FORM; PERFUMES, AFTERSHAVES AND COLOGNES; SKIN MOISTURIZER (U.S. CLS. 1, 4, 6, 50, 51 AND 52).

FIRST USE 9-1-1994; IN COMMERCE 8-1-1995.

KIMBERLY PARKS, EXAMINING ATTORNEY

SN 85-614,133. LAURICE EL BADRY RAHME LTD., DBA LAURICE & CO., NEW YORK, NY. FILED 5-2-2012.

BOND NO. 9 ELLIS ISLAND

THE MARK CONSISTS OF STANDARD CHARACTERS WITHOUT CLAIM TO ANY PARTICULAR FONT, STYLE, SIZE, OR COLOR.

OWNER OF U.S. REG. NOS. 3,604,512, 4,110,647 AND OTHERS.

FOR FRAGRANCES FOR PERSONAL USE, NAMELY PERFUMES AND COLOGNES; AFTER BATH BODY SPLASHES, BODY SPRAYS, SHOWER GELS, SOAPS, BODY LOTIONS, MASSAGE OILS; COSMETICS, NAMELY, NON-MEDICATED SKIN CARE PREPARATIONS; MAKEUP, LIPSTICK, FOUNDATION, FACE POWDER, EYESHADOW, NAIL POLISH, MASCARA AND EYE PENCILS (U.S. CLS. 1, 4, 6, 50, 51 AND 52).
JOHN WILKE, EXAMINING ATTORNEY

CLASS 3—(Continued).

SN 85-614,238. L'OREAL USA CREATIVE, INC., NEW YORK, NY. FILED 5-2-2012.



OWNER OF U.S. REG. NOS. 2,496,231, 3,412,244 AND OTHERS.

NO CLAIM IS MADE TO THE EXCLUSIVE RIGHT TO USE "ADVANCED", APART FROM THE MARK AS SHOWN.

THE MARK CONSISTS OF THE WORDS "BIOLAGE ADVANCED" AND A THREE SQUARE AND LEAF DESIGN.

FOR HAIR CARE PREPARATIONS, HAIR STYLING PREPARATIONS, AND NON-MEDICATED HAIR TREATMENT PREPARATIONS (U.S. CLS. 1, 4, 6, 50, 51 AND 52).

ALYSSA STEEL, EXAMINING ATTORNEY

CLASS 3—(Continued).

SN 85-615,511. TANDY LEATHER FACTORY, INC., FT. WORTH, TX. FILED 5-3-2012.



OWNER OF U.S. REG. NO. 3,125,301.

THE NAME(S), PORTRAIT(S), AND/OR SIGNATURE(S) SHOWN IN THE MARK DOES NOT IDENTIFY A PARTICULAR LIVING INDIVIDUAL.

THE MARK CONSISTS OF THE WORDS "DR. JACKSON'S" IN A RIBBON BANNER, CENTERED ABOVE WHICH IS A PICTURE OF A MAN'S HEAD CONTAINED IN A PARTIAL OVAL.

FOR LEATHER CLEANING PREPARATIONS; PRESERVATIVE CREAMS FOR LEATHER (U.S. CLS. 1, 4, 6, 50, 51 AND 52).

FIRST USE 12-1-1981; IN COMMERCE 12-1-1981.

CARYN GLASSER, EXAMINING ATTORNEY

SN 85-615,296. L'OREAL USA CREATIVE, INC., NEW YORK, NY. FILED 5-3-2012.

**HEAT-PROTECTIVE SILK
STRAIGHTENING CREAM**

THE MARK CONSISTS OF STANDARD CHARACTERS WITHOUT CLAIM TO ANY PARTICULAR FONT, STYLE, SIZE, OR COLOR.

OWNER OF U.S. REG. NO. 3,223,523.

NO CLAIM IS MADE TO THE EXCLUSIVE RIGHT TO USE "STRAIGHTENING CREAM", APART FROM THE MARK AS SHOWN.

SEC. 2(F).

FOR SILK-BASED HAIR STYLING PREPARATION (U.S. CLS. 1, 4, 6, 50, 51 AND 52).

FIRST USE 5-0-2005; IN COMMERCE 6-1-2005.

ALYSSA STEEL, EXAMINING ATTORNEY

SN 85-620,360. L'OREAL, PARIS, FRANCE, FILED 5-9-2012.

**L'OREAL PARIS ADVANCED
HAIRCARE**

THE MARK CONSISTS OF STANDARD CHARACTERS WITHOUT CLAIM TO ANY PARTICULAR FONT, STYLE, SIZE, OR COLOR.

OWNER OF U.S. REG. NOS. 661,746, 4,110,823 AND OTHERS.

NO CLAIM IS MADE TO THE EXCLUSIVE RIGHT TO USE "PARIS ADVANCED HAIRCARE", APART FROM THE MARK AS SHOWN.

FOR HAIR CARE PREPARATIONS, HAIR STYLING PREPARATIONS AND NON-MEDICATED HAIR TREATMENT PREPARATIONS (U.S. CLS. 1, 4, 6, 50, 51 AND 52).

EDWARD NELSON, EXAMINING ATTORNEY

CLASS 3—(Continued).

SN 85-622,461. SCHEMER, ROBERT, JACKSONVILLE, FL.
FILED 5-11-2012.

SAIKHEL

THE MARK CONSISTS OF STANDARD CHARACTERS WITHOUT CLAIM TO ANY PARTICULAR FONT, STYLE, SIZE, OR COLOR.

THE ENGLISH TRANSLATION OF THE WORD "SAIKHEL" IN THE MARK IS "COMMON SENSE".

FOR HAND SOAPS; LIQUID SOAPS; COLOGNE; PERFUME; DEODORANTS FOR PERSONAL USE; NON-MEDICATED TOILETRIES (U.S. CLS. 1, 4, 6, 50, 51 AND 52).

AISHA SALEM, EXAMINING ATTORNEY

SN 85-622,761. SHEAR EXPRESS, INC., THE VILLAGES, FL.
FILED 5-11-2012.

PureTenaj

THE MARK CONSISTS OF STANDARD CHARACTERS WITHOUT CLAIM TO ANY PARTICULAR FONT, STYLE, SIZE, OR COLOR.

FOR COSMETIC PREPARATIONS FOR SKIN CARE; HAIR CARE PREPARATIONS; NAIL CARE PREPARATIONS; NAIL POLISH; SKIN AND BODY TOPICAL LOTIONS, CREAMS AND OILS FOR COSMETIC USE (U.S. CLS. 1, 4, 6, 50, 51 AND 52).

DOMINIC FATHY, EXAMINING ATTORNEY

SN 85-622,784. SHEAR EXPRESS, INC., THE VILLAGES, FL.
FILED 5-11-2012.

ProTenaj

THE MARK CONSISTS OF STANDARD CHARACTERS WITHOUT CLAIM TO ANY PARTICULAR FONT, STYLE, SIZE, OR COLOR.

FOR COSMETIC PREPARATIONS FOR SKIN CARE; HAIR CARE PREPARATIONS; NAIL CARE PREPARATIONS; NAIL POLISH; SKIN AND BODY TOPICAL LOTIONS, CREAMS AND OILS FOR COSMETIC USE (U.S. CLS. 1, 4, 6, 50, 51 AND 52).

DOMINIC FATHY, EXAMINING ATTORNEY

CLASS 3—(Continued).

SN 85-623,290. NATURES IMAGE HAIR PRODUCTS, INC.,
JUPITER, FL. FILED 5-11-2012.

LIVE TWISTED

THE MARK CONSISTS OF STANDARD CHARACTERS WITHOUT CLAIM TO ANY PARTICULAR FONT, STYLE, SIZE, OR COLOR.

FOR HAIR CARE PRODUCTS, NAMELY HAIR CARE PREPARATIONS (U.S. CLS. 1, 4, 6, 50, 51 AND 52).

AISHA SALEM, EXAMINING ATTORNEY

SN 85-624,494. THE PROCTER & GAMBLE COMPANY,
CINCINNATI, OH. FILED 5-14-2012.

PROUD KEEPER OF OUR COUNTRY'S COLORS

THE MARK CONSISTS OF STANDARD CHARACTERS WITHOUT CLAIM TO ANY PARTICULAR FONT, STYLE, SIZE, OR COLOR.

FOR LAUNDRY DETERGENTS (U.S. CLS. 1, 4, 6, 50, 51 AND 52).

FIRST USE 2-6-2012; IN COMMERCE 2-6-2012.

KIMBERLY PARKS, EXAMINING ATTORNEY

SN 85-633,784. RETAIL ROYALTY COMPANY, LAS VEGAS,
NV. FILED 5-24-2012.

— AE —
LEGEND

OWNER OF U.S. REG. NOS. 2,930,147, 3,574,196 AND 3,878,197.

THE MARK CONSISTS OF THE PHRASE "-AE-" ABOVE THE WORD "LEGEND" ALL ABOVE A FLYING EAGLE. THE ENTIRE MARK HAS A DISTRESSED APPEARANCE.

FOR BODY SPRAYS; COLOGNE (U.S. CLS. 1, 4, 6, 50, 51 AND 52).

ZHALEH DELANEY, EXAMINING ATTORNEY

CLASS 3—(Continued).

SN 85-633,785. RETAIL ROYALTY COMPANY, LAS VEGAS, NV. FILED 5-24-2012.

OWNER OF U.S. REG. NOS. 2,930,147, 3,574,196 AND 4,144,299.

THE MARK CONSISTS OF THE PHRASE "-AE-" ABOVE THE STYLIZED AND UNDERSCORED WORD "ME". FOR FRAGRANCES (U.S. CLS. 1, 4, 6, 50, 51 AND 52). ZHALEH DELANEY, EXAMINING ATTORNEY

SN 85-636,991. GEORGIA-PACIFIC CONSUMER PRODUCTS LP, ATLANTA, GA. FILED 5-29-2012.

PACIFIC CITRUS

THE MARK CONSISTS OF STANDARD CHARACTERS WITHOUT CLAIM TO ANY PARTICULAR FONT, STYLE, SIZE, OR COLOR.

OWNER OF U.S. REG. NO. 4,071,293.
NO CLAIM IS MADE TO THE EXCLUSIVE RIGHT TO USE "CITRUS", APART FROM THE MARK AS SHOWN.
FOR AIR FRAGRANCING PREPARATIONS (U.S. CLS. 1, 4, 6, 50, 51 AND 52).
HANNO RITTNER, EXAMINING ATTORNEY

SN 85-636,992. GEORGIA-PACIFIC CONSUMER PRODUCTS LP, ATLANTA, GA. FILED 5-29-2012.

PACIFIC CITRUS

THE MARK CONSISTS OF STANDARD CHARACTERS WITHOUT CLAIM TO ANY PARTICULAR FONT, STYLE, SIZE, OR COLOR.

OWNER OF U.S. REG. NO. 4,071,293.
NO CLAIM IS MADE TO THE EXCLUSIVE RIGHT TO USE "CITRUS", APART FROM THE MARK AS SHOWN.
FOR BODY LOTION; BODY WASH; HAND LOTIONS; SHAMPOOS (U.S. CLS. 1, 4, 6, 50, 51 AND 52).
HANNO RITTNER, EXAMINING ATTORNEY

CLASS 3—(Continued).

SN 85-640,747. I AM OTHER ENTERTAINMENT, LLC, NEW YORK, NY. FILED 6-1-2012.

I AM OTHER

THE MARK CONSISTS OF STANDARD CHARACTERS WITHOUT CLAIM TO ANY PARTICULAR FONT, STYLE, SIZE, OR COLOR.

FOR COSMETICS; FACIAL MAKEUP, CONCEALERS, BLUSHERS, FACIAL POWDERS, FOUNDATION MAKEUP, EYE MAKEUP, EYE PENCILS, EYEBROW PENCILS, MASCARA, FALSE EYELASHES, FACE AND BODY GLITTER, COSMETIC COMPACTS, COSMETIC PENCILS, LIPSTICK, LIPSTICK CASES, LIPSTICK HOLDERS, LIP GLOSS, LIP POMADES, LIP PENCILS, MAKEUP REMOVERS, MAKEUP APPLICATORS IN THE NATURE OF COTTON SWABS FOR COSMETIC PURPOSES, EYE CREAMS, FACIAL CLEANSERS, TONERS, FACIAL EXFOLIANTS AND SCRUBS, FACIAL CREAMS, FACIAL MOISTURIZERS, FACIAL LOTIONS AND NON-MEDICATED FACIAL TREATMENTS IN THE NATURE OF FACIAL EMULSIONS, WRINKLE REMOVING SKIN CARE PREPARATIONS, NAIL POLISHES, NAIL POLISH BASE COAT, NAIL POLISH TOP COAT, NAIL STRENGTHENERS, NAIL HARDENERS, NAIL POLISH REMOVERS, NAIL CREAMS, CUTICLE REMOVING PREPARATIONS, NAIL TIPS, AND NAIL BUFFING PREPARATIONS; BEAUTY MILKS, SKIN MOISTURIZERS AND SKIN MOISTURIZER MASKS, SKIN CONDITIONERS, HAND CREAMS, MASSAGE OILS, ESSENTIAL OILS FOR PERSONAL USE, TALCUM POWDER, PERFUMED POWDERS, BATH BEADS, BATH CRYSTALS, BATH FOAM, BATH GELS, BATH OILS, BATH POWDERS, BATH SALTS, FACE WASH, SKIN CLEANSERS, SKIN HIGHLIGHTER, BODY SCRUBS, BODY FRAGRANCES, FRAGRANCES FOR PERSONAL USE, BODY AND HAND LOTIONS, BODY GELS, SHOWER GELS, BODY OILS, BODY POWDERS, BODY EXFOLIANTS, BODY MASKS, BODY MASK CREAMS AND LOTIONS, SHAVING PREPARATIONS, AFTER SHAVE LOTIONS, SHAVING BALM, SHAVING CREAM, SHAVING GEL, SKIN ABRASIVE PREPARATIONS, NON-MEDICATED SKIN CREAMS AND SKIN LOTIONS FOR RELIEVING RAZOR BURNS, NON-MEDICATED LIP CARE PREPARATIONS, LIP CREAM, SUNSCREEN PREPARATIONS, SUNTANNING PREPARATIONS AND AFTER-SUN LOTIONS; COSMETIC SUN-PROTECTING PREPARATIONS; SUN TAN OILS; SELF-TANNING PREPARATIONS, NAMELY, SELF TANNING MILK AND CREAM, ACCELERATED TANNING CREAM, SELF-TANNING LOTIONS, GELS AND SPRAYS; NON-MEDICATED OINTMENTS FOR THE TREATMENT OF SUNBURNS; NON-MEDICATED TOILETRIES; PERFUME, PERFUME OILS, COLOGNE, EAU DE TOILETTE, EAU DE PERFUME, EAU DE COLOGNE AND TOILETTE WATER; TOOTHPASTE, DEODORANT AND ANTIPERSPIRANT; COSMETIC SOAPS, PERFUMED SOAPS, LIQUID SOAPS, HAND, FACIAL AND BATH SOAPS, DEODORANT SOAPS, SHAVING SOAPS, SOAP POWDER, TOILET SOAPS, SOAPS FOR BODY CARE, AND SOAPS FOR PERSONAL USE; COSMETIC PADS, PRE-MOISTENED COSMETIC WIPES, PRE-MOISTENED COSMETIC TISSUES AND TOWELETTES; COTTON STICKS FOR COSMETIC PURPOSES; ALL PURPOSE COTTON SWABS FOR PERSONAL USE AND COSMETIC PURPOSES; NON-MEDICATED TOPICAL SKIN CREAMS, GELS, TONERS, AND LOTIONS; TOPICAL SKIN SPRAYS FOR COSMETIC PURPOSES; AROMATHERAPY CREAMS, LOTIONS AND OILS; HAIR CARE PRODUCTS, NAMELY, SHAMPOOS, CONDITIONERS, MOUSSE, GELS, FROSTS, CREAMS, RINSES, SPRAYS, HAIR COLOR, HAIR WAVING LOTION, PERMANENT WAVE PREPARATIONS, HAIR LIGHTENERS, HAIR DYES, HAIR EMOLLIENTS, HAIR MASCARA, HAIR POMADES, HAIR COLOR REMOVERS, HAIR RELAXING PREPARATIONS, HAIR STYLING PREPARATIONS, HAIR REMOVING CREAM, AND HAIR CARE PREPARATIONS; ASTRINGENTS FOR COSMETIC PURPOSES;

CLASS 3—(Continued).

BABY WIPES; DISPOSABLE WIPES IMPREGNATED WITH CHEMICALS OR COMPOUNDS FOR PERSONAL HYGIENE AND HOUSEHOLD USE; INCENSE; ROOM FRAGRANCES; FRAGRANCE EMITTING WICKS FOR ROOM FRAGRANCES; SACHETS; SACHET-LIKE EYE PILLOWS CONTAINING FRAGRANCES; SCENTED CERAMIC STONES; SCENTED LINEN SPRAYS AND SCENTED ROOM SPRAYS; SCENTED OILS USED TO PRODUCE AROMAS WHEN HEATED; SCENTED PINE CONES; POTPOURRI; AROMATHERAPY PILLOWS COMPRISING POTPOURRI IN FABRIC CONTAINERS (U.S. CLS. 1, 4, 6, 50, 51 AND 52).

DAVID MURRAY, EXAMINING ATTORNEY

CLASS 3—(Continued).

SN 85-645,871. PRODUCTOS FAMILIA S.A., MEDELLIN, ANTIOQUIA, COLOMBIA, FILED 6-7-2012.



THE COLOR(S) GREEN, BLUE, YELLOW, ORANGE, AND WHITE IS/ARE CLAIMED AS A FEATURE OF THE MARK.

THE MARK CONSISTS OF FOUR CONCENTRIC CIRCLES WITH LEAVES AND FLOWERS INSIDE THE CIRCLES. THE OUTERMOST CIRCLE AND THE PLANT LEAVES ARE GREEN, THE OUTER MIDDLE CIRCLE IS BLUE, THE INNER MIDDLE CIRCLE IS ORANGE, AND THE INNERMOST CIRCLE AND THE FLOWERS' CENTERS ARE YELLOW, AND THE FLOWER PETALS ARE WHITE.

FOR BABY LOTION; BATH LOTION; BATHING LOTIONS; BEAUTY LOTIONS; COSMETIC PREPARATIONS FOR BATH AND SHOWER; COSMETICS; DEODORANT FOR PERSONAL USE; DEPILATORY PREPARATIONS; ESSENTIAL OILS; FACE AND BODY LOTIONS; FACIAL LOTION; HAIR LOTIONS; MAKE UP REMOVING PREPARATIONS; MAKE-UP REMOVER; MAKE-UP REMOVING LOTIONS; MASSAGE LOTIONS; NAIL CARE PREPARATIONS; NAIL POLISH REMOVER; PERFUMES; PRE-MOISTENED COSMETIC TOWEL-ETTES; SKIN LOTIONS; SOAPS FOR BODY CARE; SOAPS FOR HOUSEHOLD USE; SOAPS FOR PERSONAL USE; SOAPS FOR TOILET PURPOSES; TISSUES IMPREGNATED WITH COSMETIC LOTIONS (U.S. CLS. 1, 4, 6, 50, 51 AND 52).

SANJEEV VOHRA, EXAMINING ATTORNEY

SN 85-645,857. PRODUCTOS FAMILIA S.A., MEDELLIN, ANTIOQUIA, COLOMBIA, FILED 6-7-2012.



THE COLOR(S) LIGHT BLUE, BLUE AND WHITE IS/ARE CLAIMED AS A FEATURE OF THE MARK.

THE MARK CONSISTS OF BLUE CIRCLE WITH A BLUE WATER DROP WITH A LIGHT BLUE INTERIOR IN THE MIDDLE OF THE CIRCLE AGAINST A WHITE BACKGROUND

FOR BABY LOTION; BATH LOTION; BATHING LOTIONS; BEAUTY LOTIONS; COSMETIC PREPARATIONS FOR BATH AND SHOWER; COSMETICS; DEODORANT FOR PERSONAL USE; DEPILATORY PREPARATIONS; ESSENTIAL OILS; FACE AND BODY LOTIONS; FACIAL LOTION; HAIR LOTIONS; MAKE UP REMOVING PREPARATIONS; MAKE-UP REMOVER; MAKE-UP REMOVING LOTIONS; MASSAGE LOTIONS; NAIL CARE PREPARATIONS; NAIL POLISH REMOVER; PERFUMES; PRE-MOISTENED COSMETIC TOWEL-ETTES; SKIN LOTIONS; SOAPS FOR BODY CARE; SOAPS FOR HOUSEHOLD USE; SOAPS FOR PERSONAL USE; SOAPS FOR TOILET PURPOSES; TISSUES IMPREGNATED WITH COSMETIC LOTIONS (U.S. CLS. 1, 4, 6, 50, 51 AND 52).

SANJEEV VOHRA, EXAMINING ATTORNEY

SN 85-648,132. IMADULATION INTERNATIONAL, LP, DBA ONEHEART AROMATHERAPY, DALLAS, TX. FILED 6-11-2012.

SLUGS BUGS

THE MARK CONSISTS OF STANDARD CHARACTERS WITHOUT CLAIM TO ANY PARTICULAR FONT, STYLE, SIZE, OR COLOR.

FOR ESSENTIAL OILS FOR USE IN AROMATHERAPY (U.S. CLS. 1, 4, 6, 50, 51 AND 52).

FIRST USE 6-1-2012; IN COMMERCE 6-1-2012.

ALYSSA STEEL, EXAMINING ATTORNEY

CLASS 3—(Continued).

SN 85-653,643. BUTTER LONDON LLC, SEATTLE, WA.
FILED 6-15-2012.

**BE BRITISH. BE COLOUR.
BESPOKE.**

THE MARK CONSISTS OF STANDARD CHARACTERS WITHOUT CLAIM TO ANY PARTICULAR FONT, STYLE, SIZE, OR COLOR.

FOR NAIL POLISH; NAIL POLISH BASE COAT; NAIL POLISH TOP COAT; CUTICLE CONDITIONERS AND OILS; CUTICLE REMOVING PREPARATIONS; NAIL POLISH REMOVER; NAIL CARE PREPARATIONS; NAIL STRENGTHENERS AND TREATMENTS, NAMELY, NON-MEDICATED NAIL PREPARATIONS FOR PROMOTING NAIL GROWTH; NON-MEDICATED FOOT CARE PREPARATIONS AND CONDITIONERS; BODY AND HAND LOTIONS; PACKAGES IN THE FORM OF NAIL CARE KITS COMPRISED OF NAIL POLISH, NAIL POLISH BASE COAT, NAIL POLISH TOP COAT, CUTICLE CONDITIONERS AND OILS, CUTICLE REMOVING PREPARATIONS, NAIL POLISH REMOVER, NAIL CARE PREPARATIONS, NAIL STRENGTHENERS AND TREATMENTS, NAMELY, NON-MEDICATED NAIL PREPARATIONS FOR PROMOTING GROWTH, NON-MEDICATED FOOT CARE PREPARATIONS AND CONDITIONS, OR BODY AND HAND LOTIONS; LIPSTICKS, LIP GLOSSES, LIP LINERS, LIP GLOSS PALETTES, LIP BALMS AND TREATMENTS IN THE NATURE OF NON-MEDICATED LIP CARE PREPARATIONS; EYE SHADOWS, EYE SHADOW PALETTES, EYE LINING PENCILS, LIQUID EYE LINERS, EYE MAKEUP, MASCARA, EYEBROW PENCILS; BLUSHERS; MULTI-USE COLORED CREAMS, NAMELY, COSMETIC COLORED CREAMS FOR SKIN APPLICATION; POWDERS AND GELS FOR FACIAL USE (U.S. CLS. 1, 4, 6, 50, 51 AND 52).

DOMINIC J. FERRAIUOLO, EXAMINING ATTORNEY

CLASS 3—(Continued).

SN 85-653,646. BUTTER LONDON LLC, SEATTLE, WA.
FILED 6-15-2012.

**WE BELIEVE IN ROCK &
ROLL. GREAT BRITAIN. AND
FASHION.**

THE MARK CONSISTS OF STANDARD CHARACTERS WITHOUT CLAIM TO ANY PARTICULAR FONT, STYLE, SIZE, OR COLOR.

FOR NAIL POLISH; NAIL POLISH BASE COAT; NAIL POLISH TOP COAT; CUTICLE CONDITIONERS AND OILS; CUTICLE REMOVING PREPARATIONS; NAIL POLISH REMOVER; NAIL CARE PREPARATIONS; NAIL STRENGTHENERS AND TREATMENTS, NAMELY, NON-MEDICATED NAIL PREPARATIONS FOR PROMOTING NAIL GROWTH; NON-MEDICATED FOOT CARE PREPARATIONS AND CONDITIONERS; BODY AND HAND LOTIONS; PACKAGES IN THE FORM OF NAIL CARE KITS COMPRISED OF NAIL POLISH, NAIL POLISH BASE COAT, NAIL POLISH TOP COAT, CUTICLE CONDITIONERS AND OILS, CUTICLE REMOVING PREPARATIONS, NAIL POLISH REMOVER, NAIL CARE PREPARATIONS, NAIL STRENGTHENERS AND TREATMENTS, NAMELY, NON-MEDICATED NAIL PREPARATIONS FOR PROMOTING GROWTH, NON-MEDICATED FOOT CARE PREPARATIONS AND CONDITIONS, OR BODY AND HAND LOTIONS; LIPSTICKS, LIP GLOSSES, LIP LINERS, LIP GLOSS PALETTES, LIP BALMS AND TREATMENTS IN THE NATURE OF NON-MEDICATED LIP CARE PREPARATIONS; EYE SHADOWS, EYE SHADOW PALETTES, EYE LINING PENCILS, LIQUID EYE LINERS, EYE MAKEUP, MASCARA, EYEBROW PENCILS; BLUSHERS; MULTI-USE COLORED CREAMS, NAMELY, COSMETIC COLORED CREAMS FOR SKIN APPLICATION; POWDERS AND GELS FOR FACIAL USE (U.S. CLS. 1, 4, 6, 50, 51 AND 52).

DOMINIC J. FERRAIUOLO, EXAMINING ATTORNEY

SN 85-653,657. BUTTER LONDON LLC, SEATTLE, WA.
FILED 6-15-2012.

HANDBAG HOLIDAY

THE MARK CONSISTS OF STANDARD CHARACTERS WITHOUT CLAIM TO ANY PARTICULAR FONT, STYLE, SIZE, OR COLOR.

FOR CUTICLE CONDITIONERS AND OILS; CUTICLE REMOVING PREPARATIONS; NAIL CARE PREPARATIONS (U.S. CLS. 1, 4, 6, 50, 51 AND 52).

DOMINIC J. FERRAIUOLO, EXAMINING ATTORNEY

CLASS 3—(Continued).

SN 85-655,283. THE LIBMAN COMPANY, ARCOLA, IL.
FILED 6-19-2012.



THE MARK CONSISTS OF THE WORD "LIBMAN" SURROUNDED BY AN OVAL WITH FIVE TRIANGLES EXUDING FROM THE "I".

FOR CLEANING PREPARATIONS; CLEANING PREPARATIONS FOR HOUSEHOLD PURPOSES; CLEANING PREPARATIONS FOR CLEANING SURFACES; CLEANER FOR USE ON FLOORS; CLEANER FOR USE ON WINDOWS (U.S. CLS. 1, 4, 6, 50, 51 AND 52).

KRISTINA MORRIS, EXAMINING ATTORNEY

SN 85-656,366. PBIGROUP, INC., DALLAS, TX. FILED 6-20-2012.

The Secret is in the Seed

THE MARK CONSISTS OF STANDARD CHARACTERS WITHOUT CLAIM TO ANY PARTICULAR FONT, STYLE, SIZE, OR COLOR.

FOR INDOOR AND OUTDOOR TANNING PRODUCTS, NAMELY, NON-MEDICATED TAN DARKENING LOTIONS AND SKIN MOISTURIZERS (U.S. CLS. 1, 4, 6, 50, 51 AND 52).

MICHAEL KEATING, EXAMINING ATTORNEY

SN 85-659,359. THE GILLETTE COMPANY, BOSTON, MA.
FILED 6-22-2012.

GILLETTE FUSION

THE MARK CONSISTS OF STANDARD CHARACTERS WITHOUT CLAIM TO ANY PARTICULAR FONT, STYLE, SIZE, OR COLOR.

OWNER OF U.S. REG. NOS. 3,518,242, 3,850,836 AND 4,122,236.

FOR AFTER SHAVE SPLASHES, LOTIONS, BALMS, AND GELS; PRE-SHAVE FACIAL WASHES AND SCRUBS; SKIN MOISTURIZERS (U.S. CLS. 1, 4, 6, 50, 51 AND 52).

JANICE KIM, EXAMINING ATTORNEY

CLASS 3—(Continued).

SN 85-663,462. D, BIG BAD, YPSILANTI, MI. FILED 6-27-2012.

BBD NATURAL ADDICTION

THE MARK CONSISTS OF STANDARD CHARACTERS WITHOUT CLAIM TO ANY PARTICULAR FONT, STYLE, SIZE, OR COLOR.

FOR COSMETICS; HAIR CARE PREPARATIONS; NON-MEDICATED SKIN CARE PREPARATIONS; HAIR SHAMPOOS AND CONDITIONERS; HAIR SPRAY AND GEL; HAIR STYLING MOUSSE (U.S. CLS. 1, 4, 6, 50, 51 AND 52).

ZACHARY CROMER, EXAMINING ATTORNEY

SN 85-664,121. PARFUMS DE COEUR, LTD., DARIEN, CT.
FILED 6-28-2012.

I WANT YOUR BOD

THE MARK CONSISTS OF STANDARD CHARACTERS WITHOUT CLAIM TO ANY PARTICULAR FONT, STYLE, SIZE, OR COLOR.

OWNER OF U.S. REG. NOS. 2,398,731 AND 2,571,581.
FOR MEN'S FRAGRANCES, NAMELY, SCENTED BODY SPRAYS AND PERSONAL DEODORANTS (U.S. CLS. 1, 4, 6, 50, 51 AND 52).

FIRST USE 1-27-2000; IN COMMERCE 1-27-2000.

COLLEEN MULCRONE, EXAMINING ATTORNEY

SN 85-664,124. PARFUMS DE COEUR, LTD., DARIEN, CT.
FILED 6-28-2012.

AVIANCE

THE MARK CONSISTS OF STANDARD CHARACTERS WITHOUT CLAIM TO ANY PARTICULAR FONT, STYLE, SIZE, OR COLOR.

FOR WOMEN'S FRAGRANCES, NAMELY, COLOGNE (U.S. CLS. 1, 4, 6, 50, 51 AND 52).

FIRST USE 8-8-1974; IN COMMERCE 8-8-1974.

COLLEEN MULCRONE, EXAMINING ATTORNEY

CLASS 3—(Continued).

SN 85-666,772. THE PROCTER & GAMBLE COMPANY, CINCINNATI, OH. FILED 7-2-2012.

PANTENE PRO-V EXPERT COLLECTION

THE MARK CONSISTS OF STANDARD CHARACTERS WITHOUT CLAIM TO ANY PARTICULAR FONT, STYLE, SIZE, OR COLOR.
 OWNER OF U.S. REG. NOS. 3,131,092, 3,851,628 AND OTHERS.
 NO CLAIM IS MADE TO THE EXCLUSIVE RIGHT TO USE "EXPERT COLLECTION", APART FROM THE MARK AS SHOWN.
 FOR HAIR CARE PREPARATIONS (U.S. CLS. 1, 4, 6, 50, 51 AND 52).
 VERNA BETH RIRIE, EXAMINING ATTORNEY

SN 85-679,903. LAURICE EL BADRY RAHME LTD., DBA LAURICE & CO., NEW YORK, NY. FILED 7-18-2012.

SHELTER ISLAND

THE MARK CONSISTS OF STANDARD CHARACTERS WITHOUT CLAIM TO ANY PARTICULAR FONT, STYLE, SIZE, OR COLOR.
 FOR FRAGRANCES FOR PERSONAL USE, NAMELY PERFUMES AND COLOGNES; AFTER BATH SPLASHES, BODY SPRAYS, SHOWER GELS, SOAPS, BODY LOTIONS, MASSAGE OILS; COSMETICS, NAMELY, NON-MEDICATED SKIN CARE PREPARATIONS; MAKE UP SKIN CARE PREPARATIONS; MAKE-UP; LIPSTICK, FOUNDATION, FACE POWDER, EYESHADOW, NAIL POLISH, MASCARA AND EYE PENCILS (U.S. CLS. 1, 4, 6, 50, 51 AND 52).
 JOHN WILKE, EXAMINING ATTORNEY

CLASS 4—LUBRICANTS AND FUELS

SN 85-433,822. CASTROL LIMITED, SWINDON, WILTSHIRE, UNITED KINGDOM, FILED 9-28-2011.

TITANIUM FLUID STRENGTH TECHNOLOGY

THE MARK CONSISTS OF STANDARD CHARACTERS WITHOUT CLAIM TO ANY PARTICULAR FONT, STYLE, SIZE, OR COLOR.
 OWNER OF ERPN CMNTY TM OFC REG. NO. 009787532, DATED 7-14-2011, EXPIRES 3-4-2021.
 NO CLAIM IS MADE TO THE EXCLUSIVE RIGHT TO USE "TITANIUM FLUID" AND "TECHNOLOGY", APART FROM THE MARK AS SHOWN.
 FOR AUTOMOTIVE LUBRICANTS; LUBRICATING OILS FOR MOTOR VEHICLES; NON-CHEMICAL ADDITIVES FOR FUELS AND LUBRICANTS; GEAR OILS; TRANSMISSION OILS (U.S. CLS. 1, 6 AND 15).
 KATHERINE E. HALMEN, EXAMINING ATTORNEY

SN 85-438,389. ENGINE UP INTERNATIONAL LLC, WILMINGTON, DE. FILED 10-4-2011.

Engine Up

THE MARK CONSISTS OF STANDARD CHARACTERS WITHOUT CLAIM TO ANY PARTICULAR FONT, STYLE, SIZE, OR COLOR.
 NO CLAIM IS MADE TO THE EXCLUSIVE RIGHT TO USE "ENGINE", APART FROM THE MARK AS SHOWN.
 FOR LUBRICANT PRODUCTS, NAMELY, ENGINE OIL, NON-CHEMICAL ADDITIVES FOR ENGINE OILS, MOTOR FUEL AND MOTOR VEHICLE LUBRICANTS (U.S. CLS. 1, 6 AND 15).
 ANDREW RHIM, EXAMINING ATTORNEY

SN 85-451,803. GREENTREE, LLC, FINLEY, ND. FILED 10-20-2011.



NO CLAIM IS MADE TO THE EXCLUSIVE RIGHT TO USE "SKEETER LOG", APART FROM THE MARK AS SHOWN.
 THE MARK CONSISTS OF THE TERM "SKEETERLOG" IN BLOCK LETTERING UNDERNEATH A STYLIZED MOSQUITO DESIGN.
 FOR FIRE LOGS (U.S. CLS. 1, 6 AND 15).
 DANIEL BRODY, EXAMINING ATTORNEY

CLASS 4—(Continued).

SN 85-480,154. TOPCO HOLDINGS, INC., SKOKIE, IL. FILED 11-23-2011.

QUICK STICKS

THE MARK CONSISTS OF STANDARD CHARACTERS WITHOUT CLAIM TO ANY PARTICULAR FONT, STYLE, SIZE, OR COLOR.

NO CLAIM IS MADE TO THE EXCLUSIVE RIGHT TO USE "STICKS", APART FROM THE MARK AS SHOWN.

FOR FIRE STARTERS FOR FIREPLACES, GRILLS AND CAMPFIRES (U.S. CLS. 1, 6 AND 15).

KAREN BRACEY, EXAMINING ATTORNEY

SN 85-594,808. GOLDEN LUBRICANTS LLC, PHOENIX, AZ. FILED 4-11-2012.

MorGas

THE MARK CONSISTS OF STANDARD CHARACTERS WITHOUT CLAIM TO ANY PARTICULAR FONT, STYLE, SIZE, OR COLOR.

FOR ALL PURPOSE PENETRATING OIL; AUTOMOTIVE ENGINE OILS; BASE OILS; CRUDE OIL; CRUDE OILS; CUTTING OIL FOR INDUSTRIAL METAL WORKING; CUTTING OILS; DIESEL OIL; ENGINE OILS; FUEL FROM CRUDE OIL; FUEL OIL; GEAR OILS; HYDRAULIC OILS; INDUSTRIAL OILS; LUBRICATING OIL FOR MOTOR VEHICLE ENGINES; LUBRICATING OILS; LUBRICATING OILS AND GREASES; MINERAL LUBRICATING OILS; MINERAL OIL FOR USE IN THE MANUFACTURE OF METAL CUTTING FLUIDS; MINERAL OILS AND GREASES FOR INDUSTRIAL PURPOSES; MOTOR FUEL; MOTOR OIL; MOTOR OILS; NON-CHEMICAL ADDITIVES FOR ENGINE OILS; NON-CHEMICAL ADDITIVES FOR OILS AND FUELS; NON-CHEMICAL ENGINE TREATMENTS AND ADDITIVES FOR ENGINE OILS, GASOLINE AND DIESEL FUELS, TRANSMISSION FLUIDS AND COOLING SYSTEMS; NON-CHEMICAL MOTOR OIL ADDITIVES; NON-MINERAL OILS AND GREASES FOR INDUSTRIAL PURPOSES; PENETRATING OIL; RACING OIL; SYNTHETIC GEAR OIL; TRANSMISSION OILS; TWO CYCLE ENGINE OIL (U.S. CLS. 1, 6 AND 15).

CAITLIN WATTS-FITZGERALD, EXAMINING ATTORNEY

CLASS 4—(Continued).

SN 85-602,045. TIPLER, CARSON, NEENAH, WI. FILED 4-19-2012.

SCREWEZE

THE MARK CONSISTS OF STANDARD CHARACTERS WITHOUT CLAIM TO ANY PARTICULAR FONT, STYLE, SIZE, OR COLOR.

FOR ALL PURPOSE LUBRICANT FOR SCREWS (U.S. CLS. 1, 6 AND 15).

FIRST USE 11-17-2009; IN COMMERCE 4-4-2012.

ANDREA K. NADELMAN, EXAMINING ATTORNEY

SN 85-602,531. WINDSTREAM TECHNOLOGIES, INC., MANHATTAN BEACH, CA. FILED 4-19-2012.

SolarMill

THE MARK CONSISTS OF STANDARD CHARACTERS WITHOUT CLAIM TO ANY PARTICULAR FONT, STYLE, SIZE, OR COLOR.

FOR RENEWABLE ENERGY, NAMELY, SOLAR ENERGY, WIND ENERGY AND GEOTHERMAL ENERGY (U.S. CLS. 1, 6 AND 15).

DOMINIC J. FERRAIUOLO, EXAMINING ATTORNEY

CLASS 5—PHARMACEUTICALS

SN 76-711,262. F3 NUTRITION, LLC, DEERFIELD BEACH, FL. FILED 4-18-2012.

REBELLION

FOR DIETARY AND NUTRITIONAL SUPPLEMENTS (U.S. CLS. 6, 18, 44, 46, 51 AND 52).

FRANK LATTUCA, EXAMINING ATTORNEY

CLASS 5—(Continued).

SN 76-711,281. CONTROL SOLUTIONS, INC., PASADENA, TX. FILED 4-19-2012.

FAHRENHEIT

THE MARK CONSISTS OF STANDARD CHARACTERS WITHOUT CLAIM TO ANY PARTICULAR FONT, STYLE, SIZE, OR COLOR.

FOR HERBICIDES FOR PROFESSIONAL AND COMMERCIAL USE (U.S. CLS. 6, 18, 44, 46, 51 AND 52).
NICHOLAS COLEMAN, EXAMINING ATTORNEY

SN 76-711,282. CONTROL SOLUTIONS, INC., PASADENA, TX. FILED 4-19-2012.

D-FENSE

THE MARK CONSISTS OF STANDARD CHARACTERS WITHOUT CLAIM TO ANY PARTICULAR FONT, STYLE, SIZE, OR COLOR.

FOR INSECTICIDES FOR PROFESSIONAL USE (U.S. CLS. 6, 18, 44, 46, 51 AND 52).
FIRST USE 3-30-2011; IN COMMERCE 4-12-2011.
NICHOLAS COLEMAN, EXAMINING ATTORNEY

SN 76-711,821. CONTROL SOLUTIONS, INC., PASADENA, TX. FILED 6-25-2012.

FLEE

THE MARK CONSISTS OF STANDARD CHARACTERS WITHOUT CLAIM TO ANY PARTICULAR FONT, STYLE, SIZE, OR COLOR.

FOR INSECTICIDE AND INSECT REPELLENT SPRAYS FOR DOGS AND CATS (U.S. CLS. 6, 18, 44, 46, 51 AND 52).
NICHOLAS COLEMAN, EXAMINING ATTORNEY

CLASS 5—(Continued).

SN 77-836,120. BARILLAS HOLDINGS, LLC., MIAMI, FL. FILED 9-28-2009.

GERMA 9 JARABES

THE MARK CONSISTS OF STANDARD CHARACTERS WITHOUT CLAIM TO ANY PARTICULAR FONT, STYLE, SIZE, OR COLOR.

NO CLAIM IS MADE TO THE EXCLUSIVE RIGHT TO USE "JARABES", APART FROM THE MARK AS SHOWN.

THE ENGLISH TRANSLATION OF "JARABES" IN THE MARK IS "SYRUPS".

FOR DIETARY SUPPLEMENTS (U.S. CLS. 6, 18, 44, 46, 51 AND 52).

FIRST USE 12-1-2008; IN COMMERCE 12-1-2008.

CAROLYN CATALDO, EXAMINING ATTORNEY

SN 77-969,452. PACELINE PRODUCTS, PLEASANT VALLEY, MO. FILED 3-26-2010.

Bod'e Arm'r

THE MARK CONSISTS OF STANDARD CHARACTERS WITHOUT CLAIM TO ANY PARTICULAR FONT, STYLE, SIZE, OR COLOR.

FOR SKIN LUBRICANTS FOR ATHLETES TO PREVENT SKIN CHAFFING (U.S. CLS. 6, 18, 44, 46, 51 AND 52).

DAVID ELTON, EXAMINING ATTORNEY

SN 79-105,535. DEBREGEAS ET ASSOCIES PHARMA, PARIS, FRANCE, FILED 9-8-2011.

D&A PHARMA

THE MARK CONSISTS OF STANDARD CHARACTERS WITHOUT CLAIM TO ANY PARTICULAR FONT, STYLE, SIZE, OR COLOR.

OWNER OF INTERNATIONAL REGISTRATION 1097676 DATED 9-8-2011, EXPIRES 9-8-2021.

NO CLAIM IS MADE TO THE EXCLUSIVE RIGHT TO USE "PHARMA", APART FROM THE MARK AS SHOWN.

FOR PHARMACEUTICAL PREPARATIONS, NAMELY, PHARMACEUTICAL PREPARATIONS FOR THE TREATMENT OF NEUROLOGICAL, PSYCHIATRIC, ADDICTIVE, SLEEP, CARDIOVASCULAR, RESPIRATORY, DIGESTIVE, NEPHRO-UROLOGICAL, ENDOCRINE DISEASES AND DISORDERS AND PHARMACEUTICAL PREPARATIONS FOR THE TREATMENT OF PAIN, NAMELY, ALGOLOGY; SANITARY PREPARATIONS FOR MEDICAL PURPOSES, DIETETIC SUBSTANCES ADAPTED FOR MEDICAL USE; FOOD SUPPLEMENTS FOR MEDICAL PURPOSES; MATERIAL FOR DENTAL FILLINGS AND DENTAL IMPRESSIONS; DIAGNOSTIC PREPARATIONS FOR MEDICAL AND VETERINARY PURPOSES; PLASTERS, MATERIALS FOR DRESSINGS; ALL PURPOSE DISINFECTANTS; FUNGICIDES; ALL THESE GOODS PERTAINING TO THE PHARMACEUTICAL SECTOR (U.S. CLS. 6, 18, 44, 46, 51 AND 52).

SUZANNE BLANE, EXAMINING ATTORNEY

CLASS 5—(Continued).

SN 79-107,396. SEEGENE, INC., REPUBLIC OF KOREA, FILED 10-11-2011.



PRIORITY DATE OF 4-14-2011 IS CLAIMED.
OWNER OF INTERNATIONAL REGISTRATION 1102252 DATED 10-11-2011, EXPIRES 10-11-2021.

THE COLOR(S) BLACK, RED IS/ARE CLAIMED AS A FEATURE OF THE MARK.

THE LINE OF CIRCLE IS IN BLACK; THE TWO RINGS IN THE CIRCLE ARE IN RED; THE WORD "SEEGENE" IS IN BLACK.

THE MARK CONSISTS OF THE BLACK WORD "SEEGENE" TO THE RIGHT OF A BLACK CIRCLE THAT CONTAINS A RED DNA HELIX.

FOR DIAGNOSTIC TEST KITS NAMELY, KITS CONSISTING PRIMARILY OF DIAGNOSTIC REAGENTS FOR MEDICAL PURPOSES; DIAGNOSTIC PREPARATION FOR MEDICAL PURPOSES; DIAGNOSTIC REAGENTS FOR MEDICAL LABORATORY OR CLINICAL PURPOSES; DIAGNOSTIC REAGENTS FOR MEDICAL USE; CHEMICAL REAGENTS FOR MEDICAL PURPOSES; DIAGNOSTIC REAGENTS FOR MEDICAL USE, USED FOR THE DIAGNOSIS OF GENETIC DISEASE AND CANCER; DIAGNOSTIC TEST KITS CONSISTING PRIMARILY OF DIAGNOSTIC REAGENTS FOR MEDICAL USE USED FOR THE DIAGNOSIS OF GENETIC DISEASE AND CANCER; DIAGNOSTIC PREPARATIONS FOR MEDICAL USE; DIAGNOSTIC KITS CONSISTING PRIMARILY OF DIAGNOSTIC REAGENTS FOR THE DETECTION OF VIRAL INFECTION; DIAGNOSTIC KITS CONSISTING PRIMARILY OF DIAGNOSTIC REAGENTS FOR THE DETECTION OF MICROORGANIC INFECTION; DIAGNOSTIC KITS CONSISTING PRIMARILY OF DIAGNOSTIC REAGENTS FOR THE DETECTION OF SYMPTOM ARISING FROM VIRAL OR MICROORGANIC INFECTION (U.S. CLS. 6, 18, 44, 46, 51 AND 52).

AHSEN KHAN, EXAMINING ATTORNEY

SN 79-108,127. BIOIBERICA, S.A., SPAIN, FILED 12-22-2011.

ENTERO-CHRONIC

THE MARK CONSISTS OF STANDARD CHARACTERS WITHOUT CLAIM TO ANY PARTICULAR FONT, STYLE, SIZE, OR COLOR.

OWNER OF INTERNATIONAL REGISTRATION 1104205 DATED 12-22-2011, EXPIRES 12-22-2021.

FOR VETERINARY PREPARATIONS, NAMELY, NUTRITIONAL SUPPLEMENTS FOR ANIMAL FEED (U.S. CLS. 6, 18, 44, 46, 51 AND 52).

WENDY GOODMAN, EXAMINING ATTORNEY

CLASS 5—(Continued).

SN 79-108,631. YIXING JIANGSHAN BIO-TECH CO.,LTD., CHINA, FILED 12-13-2011.



鑫 磊

OWNER OF INTERNATIONAL REGISTRATION 1105394 DATED 12-13-2011, EXPIRES 12-13-2021.

THE MARK CONSISTS OF THE LETTER "L" WITHIN A STYLIZED "X" IN A SHADED SQUARE UNDERNEATH WHICH ARE TWO CHINESE CHARACTERS.

THE SEPARATE CHINESE TERMS "XIN" AND "LEI" MEAN "PROSPER" AND "BUILD," COMBINED TOGETHER, THIS MARK HAS NO SPECIFIC MEANING.

THE TRANSLITERATION OF THE NON-LATIN CHARACTERS IN THE MARK IS "XIN LEI".

FOR VITAMIN PREPARATIONS; MEDICINE PREPARATIONS, NAMELY, ANTIALLERGIC MEDICINES; YEAST FOR PHARMACEUTICAL PURPOSES; BULK PHARMACEUTICAL CHEMICALS, NAMELY, CHEMICAL PREPARATIONS FOR PHARMACEUTICAL PURPOSES, NAMELY, FOR TREATING SCURVY; AMINO ACID FOR MEDICAL PURPOSES; CHEMICAL PREPARATION FOR PHARMACEUTICAL PURPOSES, NAMELY, FOR TREATING OR PREVENTING SCURVY (U.S. CLS. 6, 18, 44, 46, 51 AND 52).

SUE LAWRENCE, EXAMINING ATTORNEY

SN 79-110,056. BIOALLIANCE PHARMA, PARIS, FRANCE, FILED 12-16-2011.

VALIDIVE

THE MARK CONSISTS OF STANDARD CHARACTERS WITHOUT CLAIM TO ANY PARTICULAR FONT, STYLE, SIZE, OR COLOR.

PRIORITY DATE OF 7-28-2011 IS CLAIMED.

OWNER OF INTERNATIONAL REGISTRATION 1109304 DATED 12-16-2011, EXPIRES 12-16-2021.

THE WORDING "VALIDIVE" HAS NO MEANING IN A FOREIGN LANGUAGE.

FOR BIO-ADHESIVE PHARMACEUTICAL PREPARATIONS WITH SLOW-RELEASE OF AN ANTI-INFLAMMATORY AGENT USED FOR TREATING INFLAMMATORY DISEASES AND MUCITIS (U.S. CLS. 6, 18, 44, 46, 51 AND 52).

AMY KELLY, EXAMINING ATTORNEY

CLASS 5—(Continued).

SN 79-110,057. BIOALLIANCE PHARMA, PARIS, FRANCE, FILED 12-16-2011.

COTILIX

THE MARK CONSISTS OF STANDARD CHARACTERS WITHOUT CLAIM TO ANY PARTICULAR FONT, STYLE, SIZE, OR COLOR.

PRIORITY DATE OF 7-28-2011 IS CLAIMED.

OWNER OF INTERNATIONAL REGISTRATION 1109305 DATED 12-16-2011, EXPIRES 12-16-2021.

THE WORDING "COTILIX" HAS NO MEANING IN A FOREIGN LANGUAGE.

FOR BIO-ADHESIVE PHARMACEUTICAL PREPARATIONS WITH SLOW-RELEASE OF AN ANTI-INFLAMMATORY AGENT USED FOR TREATING INFLAMMATORY DISEASES AND MUCITIS (U.S. CLS. 6, 18, 44, 46, 51 AND 52).

AMY KELLY, EXAMINING ATTORNEY

SN 79-110,058. BIOALLIANCE PHARMA, PARIS, FRANCE, FILED 12-16-2011.

CLONIDOL

THE MARK CONSISTS OF STANDARD CHARACTERS WITHOUT CLAIM TO ANY PARTICULAR FONT, STYLE, SIZE, OR COLOR.

PRIORITY DATE OF 7-28-2011 IS CLAIMED.

OWNER OF INTERNATIONAL REGISTRATION 1109306 DATED 12-16-2011, EXPIRES 12-16-2021.

THE WORDING "CLONIDOL" HAS NO MEANING IN A FOREIGN LANGUAGE.

FOR BIO-ADHESIVE PHARMACEUTICAL PREPARATIONS WITH SLOW-RELEASE OF AN ANTI-INFLAMMATORY AGENT USED FOR TREATING INFLAMMATORY DISEASES AND MUCITIS (U.S. CLS. 6, 18, 44, 46, 51 AND 52).

AMY KELLY, EXAMINING ATTORNEY

SN 79-110,059. BIOALLIANCE PHARMA, PARIS, FRANCE, FILED 12-16-2011.

BAXEFYN

THE MARK CONSISTS OF STANDARD CHARACTERS WITHOUT CLAIM TO ANY PARTICULAR FONT, STYLE, SIZE, OR COLOR.

PRIORITY DATE OF 7-28-2011 IS CLAIMED.

OWNER OF INTERNATIONAL REGISTRATION 1109307 DATED 12-16-2011, EXPIRES 12-16-2021.

THE WORDING "BAXEFYN" HAS NO MEANING IN A FOREIGN LANGUAGE.

FOR BIO-ADHESIVE PHARMACEUTICAL PREPARATIONS WITH SLOW-RELEASE OF AN ANTI-INFLAMMATORY AGENT USED FOR TREATING INFLAMMATORY DISEASES AND MUCITIS (U.S. CLS. 6, 18, 44, 46, 51 AND 52).

AMY KELLY, EXAMINING ATTORNEY

CLASS 5—(Continued).

SN 79-111,548. GREEN AID RELIEF PTY LTD, MAIDSTONE VIC 3012, AUSTRALIA, FILED 1-13-2012.



OWNER OF INTERNATIONAL REGISTRATION 1112581 DATED 1-13-2012, EXPIRES 1-13-2022.

THE COLOR(S) GREEN, WHITE AND BLACK IS/ARE CLAIMED AS A FEATURE OF THE MARK.

THE MARK CONSISTS OF THE WORDING "GREEN AID" WITH A CROSS INSIDE OF A SQUARE SEPARATING THE TWO TERMS ALL DEPICTED IN THE COLOR GREEN WITH THE INSIDE OF THE SQUARE DEPICTED IN THE COLOR WHITE AND THE WORDING "MAKING LIFE BETTER." UNDERNEATH DEPICTED IN THE COLOR BLACK.

FOR ADHESIVE STERILE WOUND DRESSING STRIPS; ADHESIVE STERILE WOUND DRESSINGS (U.S. CLS. 6, 18, 44, 46, 51 AND 52).

BRIDGETT SMITH, EXAMINING ATTORNEY

SN 79-113,299. BOEHRINGER INGELHEIM INTERNATIONAL GMBH, FED REP GERMANY, FILED 4-4-2012.

FEVEOS

THE MARK CONSISTS OF STANDARD CHARACTERS WITHOUT CLAIM TO ANY PARTICULAR FONT, STYLE, SIZE, OR COLOR.

PRIORITY DATE OF 11-7-2011 IS CLAIMED.

OWNER OF INTERNATIONAL REGISTRATION 1117060 DATED 4-4-2012, EXPIRES 4-4-2022.

FOR PHARMACEUTICAL PREPARATIONS, NAMELY, PHARMACEUTICAL PREPARATIONS FOR THE TREATMENT OF DISEASES AND DISORDERS OF THE ALIMENTARY TRACT AND METABOLISM, BLOOD AND BLOOD FORMING ORGANS; PHARMACEUTICAL PREPARATIONS FOR THE TREATMENT OF DISEASES AND DISORDERS OF THE CARDIOVASCULAR SYSTEM, MUSCULOSKELETAL SYSTEM, CENTRAL NERVOUS SYSTEM, PERIPHERAL NERVOUS SYSTEM, GENITOURINARY SYSTEM AND RESPIRATORY SYSTEM; PHARMACEUTICAL PREPARATIONS FOR THE TREATMENT OF DERMATOLOGICAL, HORMONAL, INFECTIOUS, VIRAL AND ONCOLOGICAL DISEASES AND DISORDERS (U.S. CLS. 6, 18, 44, 46, 51 AND 52).

LIEF MARTIN, EXAMINING ATTORNEY

CLASS 5—(Continued).

SN 79-113,300. BOEHRINGER INGELHEIM INTERNATIONAL GMBH, FED REP GERMANY, FILED 4-4-2012.

AKALINX

THE MARK CONSISTS OF STANDARD CHARACTERS WITHOUT CLAIM TO ANY PARTICULAR FONT, STYLE, SIZE, OR COLOR.

PRIORITY DATE OF 11-7-2011 IS CLAIMED.
OWNER OF INTERNATIONAL REGISTRATION 1117061 DATED 4-4-2012, EXPIRES 4-4-2022.

FOR PHARMACEUTICAL PREPARATIONS, NAMELY, PHARMACEUTICAL PREPARATIONS FOR THE TREATMENT OF DISEASES AND DISORDERS OF THE ALIMENTARY TRACT AND METABOLISM, BLOOD AND BLOOD FORMING ORGANS; PHARMACEUTICAL PREPARATIONS FOR THE TREATMENT OF DISEASES AND DISORDERS OF THE CARDIOVASCULAR SYSTEM, MUSCULOSKELETAL SYSTEM, CENTRAL NERVOUS SYSTEM, PERIPHERAL NERVOUS SYSTEM, GENITOURINARY SYSTEM AND RESPIRATORY SYSTEM; PHARMACEUTICAL PREPARATIONS FOR THE TREATMENT OF DERMATOLOGICAL, HORMONAL, INFECTIOUS, VIRAL AND ONCOLOGICAL DISEASES AND DISORDERS (U.S. CLS. 6, 18, 44, 46, 51 AND 52).

LIEF MARTIN, EXAMINING ATTORNEY

CLASS 5—(Continued).

SN 79-113,302. BOEHRINGER INGELHEIM INTERNATIONAL GMBH, FED REP GERMANY, FILED 4-4-2012.

AKARTEF

THE MARK CONSISTS OF STANDARD CHARACTERS WITHOUT CLAIM TO ANY PARTICULAR FONT, STYLE, SIZE, OR COLOR.

PRIORITY DATE OF 11-7-2011 IS CLAIMED.
OWNER OF INTERNATIONAL REGISTRATION 1117064 DATED 4-4-2012, EXPIRES 4-4-2022.

FOR PHARMACEUTICAL PREPARATIONS, NAMELY, PHARMACEUTICAL PREPARATIONS FOR THE TREATMENT OF DISEASES AND DISORDERS OF THE ALIMENTARY TRACT AND METABOLISM, BLOOD AND BLOOD FORMING ORGANS; PHARMACEUTICAL PREPARATIONS FOR THE TREATMENT OF DISEASES AND DISORDERS OF THE CARDIOVASCULAR SYSTEM, MUSCULOSKELETAL SYSTEM, CENTRAL NERVOUS SYSTEM, PERIPHERAL NERVOUS SYSTEM, GENITOURINARY SYSTEM AND RESPIRATORY SYSTEM; PHARMACEUTICAL PREPARATIONS FOR THE TREATMENT OF DERMATOLOGICAL, HORMONAL, INFECTIOUS, VIRAL AND ONCOLOGICAL DISEASES AND DISORDERS (U.S. CLS. 6, 18, 44, 46, 51 AND 52).

LIEF MARTIN, EXAMINING ATTORNEY

SN 79-113,301. BOEHRINGER INGELHEIM INTERNATIONAL GMBH, FED REP GERMANY, FILED 4-4-2012.

ISTORATEF

THE MARK CONSISTS OF STANDARD CHARACTERS WITHOUT CLAIM TO ANY PARTICULAR FONT, STYLE, SIZE, OR COLOR.

PRIORITY DATE OF 10-26-2011 IS CLAIMED.
OWNER OF INTERNATIONAL REGISTRATION 1117062 DATED 4-4-2012, EXPIRES 4-4-2022.

FOR PHARMACEUTICAL PREPARATIONS, NAMELY, PHARMACEUTICAL PREPARATIONS FOR THE TREATMENT OF DISEASES AND DISORDERS OF THE ALIMENTARY TRACT AND METABOLISM, BLOOD AND BLOOD FORMING ORGANS; PHARMACEUTICAL PREPARATIONS FOR THE TREATMENT OF DISEASES AND DISORDERS OF THE CARDIOVASCULAR SYSTEM, MUSCULOSKELETAL SYSTEM, CENTRAL NERVOUS SYSTEM, PERIPHERAL NERVOUS SYSTEM, GENITOURINARY SYSTEM AND RESPIRATORY SYSTEM; PHARMACEUTICAL PREPARATIONS FOR THE TREATMENT OF DERMATOLOGICAL, HORMONAL, INFECTIOUS, VIRAL AND ONCOLOGICAL DISEASES AND DISORDERS (U.S. CLS. 6, 18, 44, 46, 51 AND 52).

LIEF MARTIN, EXAMINING ATTORNEY

SN 79-113,303. BOEHRINGER INGELHEIM INTERNATIONAL GMBH, FED REP GERMANY, FILED 4-4-2012.

FEVIO

THE MARK CONSISTS OF STANDARD CHARACTERS WITHOUT CLAIM TO ANY PARTICULAR FONT, STYLE, SIZE, OR COLOR.

PRIORITY DATE OF 11-7-2011 IS CLAIMED.
OWNER OF INTERNATIONAL REGISTRATION 1117065 DATED 4-4-2012, EXPIRES 4-4-2022.

FOR PHARMACEUTICAL PREPARATIONS, NAMELY, PHARMACEUTICAL PREPARATIONS FOR THE TREATMENT OF DISEASES AND DISORDERS OF THE ALIMENTARY TRACT AND METABOLISM, BLOOD AND BLOOD FORMING ORGANS; PHARMACEUTICAL PREPARATIONS FOR THE TREATMENT OF DISEASES AND DISORDERS OF THE CARDIOVASCULAR SYSTEM, MUSCULOSKELETAL SYSTEM, CENTRAL NERVOUS SYSTEM, PERIPHERAL NERVOUS SYSTEM, GENITOURINARY SYSTEM AND RESPIRATORY SYSTEM; PHARMACEUTICAL PREPARATIONS FOR THE TREATMENT OF DERMATOLOGICAL, HORMONAL, INFECTIOUS, VIRAL AND ONCOLOGICAL DISEASES AND DISORDERS (U.S. CLS. 6, 18, 44, 46, 51 AND 52).

LIEF MARTIN, EXAMINING ATTORNEY

CLASS 5—(Continued).

SN 79-114,518. BOEHRINGER INGELHEIM INTERNATIONAL GMBH, FED REP GERMANY, FILED 6-13-2012.

ODEQUOS

THE MARK CONSISTS OF STANDARD CHARACTERS WITHOUT CLAIM TO ANY PARTICULAR FONT, STYLE, SIZE, OR COLOR.

OWNER OF INTERNATIONAL REGISTRATION 1120279 DATED 6-13-2012, EXPIRES 6-13-2022.

FOR PHARMACEUTICAL PREPARATIONS, NAMELY, PHARMACEUTICAL PREPARATIONS FOR THE TREATMENT OF DISEASES AND DISORDERS OF THE ALIMENTARY TRACT AND METABOLISM, AND BLOOD AND BLOOD FORMING ORGANS; PHARMACEUTICAL PREPARATIONS FOR THE TREATMENT OF DISEASES AND DISORDERS OF THE CARDIOVASCULAR SYSTEM, MUSCULOSKELETAL SYSTEM, CENTRAL NERVOUS SYSTEM, PERIPHERAL NERVOUS SYSTEM, GENITOURINARY SYSTEM AND RESPIRATORY SYSTEM; AND PHARMACEUTICAL PREPARATIONS FOR THE TREATMENT OF DERMATOLOGICAL, HORMONAL, INFECTIOUS, VIRAL AND ONCOLOGICAL DISEASES AND DISORDERS (U.S. CLS. 6, 18, 44, 46, 51 AND 52).

KIMBERLY PARKS, EXAMINING ATTORNEY

CLASS 5—(Continued).

SN 79-114,654. BOEHRINGER INGELHEIM INTERNATIONAL GMBH, FED REP GERMANY, FILED 4-25-2012.

COSPIAQ

THE MARK CONSISTS OF STANDARD CHARACTERS WITHOUT CLAIM TO ANY PARTICULAR FONT, STYLE, SIZE, OR COLOR.

PRIORITY DATE OF 10-25-2011 IS CLAIMED.

OWNER OF INTERNATIONAL REGISTRATION 1120766 DATED 4-25-2012, EXPIRES 4-25-2022.

FOR PHARMACEUTICAL PREPARATIONS, NAMELY, PHARMACEUTICAL PREPARATIONS FOR THE TREATMENT OF DISEASES AND DISORDERS OF THE ALIMENTARY TRACT AND METABOLISM, AND BLOOD AND BLOOD FORMING ORGANS; PHARMACEUTICAL PREPARATIONS FOR THE TREATMENT OF DISEASES AND DISORDERS OF THE CARDIOVASCULAR SYSTEM, MUSCULOSKELETAL SYSTEM, CENTRAL NERVOUS SYSTEM, PERIPHERAL NERVOUS SYSTEM, GENITOURINARY SYSTEM AND RESPIRATORY SYSTEM; AND PHARMACEUTICAL PREPARATIONS FOR THE TREATMENT OF DERMATOLOGICAL, HORMONAL, INFECTIOUS, VIRAL AND ONCOLOGICAL DISEASES AND DISORDERS (U.S. CLS. 6, 18, 44, 46, 51 AND 52).

KIMBERLY PARKS, EXAMINING ATTORNEY

SN 79-114,557. BOEHRINGER INGELHEIM INTERNATIONAL GMBH, FED REP GERMANY, FILED 6-13-2012.

OFEV

THE MARK CONSISTS OF STANDARD CHARACTERS WITHOUT CLAIM TO ANY PARTICULAR FONT, STYLE, SIZE, OR COLOR.

OWNER OF INTERNATIONAL REGISTRATION 1120388 DATED 6-13-2012, EXPIRES 6-13-2022.

FOR PHARMACEUTICAL PREPARATIONS, NAMELY, PHARMACEUTICAL PREPARATIONS FOR THE TREATMENT OF DISEASES AND DISORDERS OF THE ALIMENTARY TRACT AND METABOLISM, AND BLOOD AND BLOOD FORMING ORGANS; PHARMACEUTICAL PREPARATIONS FOR THE TREATMENT OF DISEASES AND DISORDERS OF THE CARDIOVASCULAR SYSTEM, MUSCULOSKELETAL SYSTEM, CENTRAL NERVOUS SYSTEM, PERIPHERAL NERVOUS SYSTEM, GENITOURINARY SYSTEM AND RESPIRATORY SYSTEM; AND PHARMACEUTICAL PREPARATIONS FOR THE TREATMENT OF DERMATOLOGICAL, HORMONAL, INFECTIOUS, VIRAL AND ONCOLOGICAL DISEASES AND DISORDERS (U.S. CLS. 6, 18, 44, 46, 51 AND 52).

KIMBERLY PARKS, EXAMINING ATTORNEY

SN 85-098,206. TINA GIANESINI, NEW YORK, NY. FILED 8-2-2010.

SENT-O

THE MARK CONSISTS OF STANDARD CHARACTERS WITHOUT CLAIM TO ANY PARTICULAR FONT, STYLE, SIZE, OR COLOR.

FOR AIR FRESHENER (U.S. CLS. 6, 18, 44, 46, 51 AND 52).

CORY BOONE, EXAMINING ATTORNEY

CLASS 5—(Continued).

SN 85-108,643. NEKUTLI SA DE CV, CUQUÍO, JALISCO, MEXICO, FILED 8-16-2010.



PRO·BIO

PRIORITY CLAIMED UNDER SEC. 44(D) ON MEXICO APPLICATION NO. R20152238, FILED 7-8-2010.

NO CLAIM IS MADE TO THE EXCLUSIVE RIGHT TO USE "SUPPLEMENTS" AND "PRO-BIO", APART FROM THE MARK AS SHOWN.

THE MARK CONSISTS OF A STYLIZED DESIGN OF AN AGAVE PLANT OVER THE TERM "VIVENTE SUPPLEMENTS" ALL ABOVE AND TO THE LEFT OF THE TERMS "PRO-BIO".

THE ENGLISH TRANSLATION OF "VIVENTE" IN THE MARK IS "LIVING".

FOR PROBIOTIC FOOD SUPPLEMENTS (U.S. CLS. 6, 18, 44, 46, 51 AND 52).

JANICE L. MCMORROW, EXAMINING ATTORNEY

SN 85-146,557. GARMON CORPORATION, TEMECULA, CA, FILED 10-6-2010.

AT EASE

THE MARK CONSISTS OF STANDARD CHARACTERS WITHOUT CLAIM TO ANY PARTICULAR FONT, STYLE, SIZE, OR COLOR.

FOR VETERINARY PREPARATIONS FOR PETS, NAMELY, HERBAL-BASED NON-AEROSOL SPRAY FOR USE IN CALMING ANIMALS WHEN SPRAYED ONTO SURFACES OR INTO THE AIR (U.S. CLS. 6, 18, 44, 46, 51 AND 52).

FIRST USE 4-30-2005; IN COMMERCE 4-30-2005.
CHRISTINA SOBRAL, EXAMINING ATTORNEY

CLASS 5—(Continued).

SN 85-180,298. ARLEN, MICHAEL W., DBA ARLEN NUTRACEUTICALS, LOS ANGELES, CA. FILED 11-18-2010.

Instant Newtrition

THE MARK CONSISTS OF STANDARD CHARACTERS WITHOUT CLAIM TO ANY PARTICULAR FONT, STYLE, SIZE, OR COLOR.

FOR POWDERED MIXES IN THE NATURE OF POWDERED NUTRITIONAL SUPPLEMENT MIX (U.S. CLS. 6, 18, 44, 46, 51 AND 52).

SUZANNE BLANE, EXAMINING ATTORNEY

SN 85-203,173. MISSION PHARMACAL COMPANY, SAN ANTONIO, TX. FILED 12-21-2010.

MUSCLE MAGIC

THE MARK CONSISTS OF STANDARD CHARACTERS WITHOUT CLAIM TO ANY PARTICULAR FONT, STYLE, SIZE, OR COLOR.

NO CLAIM IS MADE TO THE EXCLUSIVE RIGHT TO USE "MUSCLE", APART FROM THE MARK AS SHOWN.

FOR ANALGESIC BALM (U.S. CLS. 6, 18, 44, 46, 51 AND 52).

DOMINICK J. SALEMI, EXAMINING ATTORNEY

SN 85-241,431. RIVERO, EDUARDO, MIAMI, FL. FILED 2-14-2011.



THE MARK CONSISTS OF THE WORD "CHIROGESIC" ABOVE A DESIGN OF THE BACK OF THE UPPER BODY OF A HUMAN SHOWING THE MUSCULATURE AND WHERE THE RIGHT ARM IS RAISED AND RIGHT HAND IS HELD BEHIND THE FIGURE'S HEAD.

FOR ANALGESIC AND MUSCLE RELAXANT PHARMACEUTICAL PREPARATIONS; ANALGESICS; TOPICAL ANALGESICS (U.S. CLS. 6, 18, 44, 46, 51 AND 52).

FIRST USE 9-11-1991; IN COMMERCE 9-11-1991.
CHRIS WELLS, EXAMINING ATTORNEY

CLASS 5—(Continued).

SN 85-247,561. CAIRNS, BRIAN, NEW YORK, NY. FILED 2-21-2011.

LIBRE

THE MARK CONSISTS OF STANDARD CHARACTERS WITHOUT CLAIM TO ANY PARTICULAR FONT, STYLE, SIZE, OR COLOR.

THE ENGLISH TRANSLATION OF "LIBRE" IN THE MARK IS "FREE".

FOR DIETARY SUPPLEMENTS; DIETARY AND NUTRITIONAL SUPPLEMENTS USED FOR WEIGHT LOSS (U.S. CLS. 6, 18, 44, 46, 51 AND 52).

RUDY R. SINGLETON, EXAMINING ATTORNEY

CLASS 5—(Continued).

SN 85-287,553. GREENCOAT LIMITED, MONMOUTH, UNITED KINGDOM, FILED 4-6-2011.

NAF + Naturalintex

OWNER OF U.S. REG. NO. 2,553,560.

THE MARK CONSISTS OF THE CAPITAL LETTERS "NAF" FOLLOWED BY A PLUS SIGN, WHEREIN THE CENTER OF THE PLUS SIGN INCLUDES THE NECK AND HEAD OF A HORSE, AFTER THE PLUS SIGN IS THE WORD "NATURALINTEX".

SEC. 2(F) AS TO "NAF".

FOR MEDICATED SKIN OINTMENTS, CREAMS AND LOTIONS, ANTIBACTERIAL SPRAYS, BODY AND FOOT WASHES FOR VETERINARY USE; ALL PURPOSE DISINFECTANTS, ARNICA GEL FOR HEALING STRAINS, SPRAINS AND BRUISES; ALOE VERA SPRAY FOR WOUND HEALING; MSM (METHYL SULPHONYL METHANE) OINTMENT FOR REDUCING PAIN AND INFLAMMATION; ANTIBACTERIAL AND ANTISEPTIC CREAMS; POUltICES; BANDAGES FOR WOUNDS AND MEDICAL DRESSINGS; COTTON WOOL FOR MEDICAL PURPOSES; AND FIRST AID KITS (U.S. CLS. 6, 18, 44, 46, 51 AND 52).

SALLY SHIH, EXAMINING ATTORNEY

SN 85-288,294. THE NEST COLLECTIVE, INC., EMERYVILLE, CA. FILED 4-6-2011.

JUST

THE MARK CONSISTS OF STANDARD CHARACTERS WITHOUT CLAIM TO ANY PARTICULAR FONT, STYLE, SIZE, OR COLOR.

FOR FOOD FOR BABIES, NAMELY, ORGANIC FRUIT PUREES (U.S. CLS. 6, 18, 44, 46, 51 AND 52).

FIRST USE 12-1-2009; IN COMMERCE 12-1-2009.

MICHELE SWAIN, EXAMINING ATTORNEY

SN 85-250,467. BRAIN PHARMA, LLC, DAVIE, FL. FILED 2-24-2011.



THE MARK CONSISTS OF A LOWERCASE "B" AND "P" ENCLOSED IN A CIRCULAR SHAPE. THERE IS A LOWERCASE "I" LOCATED OUTSIDE THE CIRCLE SHAPE.

FOR DIETARY AND NUTRITIONAL SUPPLEMENTS; DIETARY AND NUTRITIONAL SUPPLEMENTS FOR HUMAN CONSUMPTION; DIETARY AND NUTRITIONAL SUPPLEMENTS FOR HUMAN CONSUMPTION, NAMELY, PROTEIN SUPPLEMENTS FOR MUSCLE GROWTH AND RECOVERY; DIETARY SUPPLEMENTS FOR HUMAN CONSUMPTION SOLD VIA INTERNET COMMERCE AND SPORTS NUTRITION SPECIALTY STORES (U.S. CLS. 6, 18, 44, 46, 51 AND 52).

FIRST USE 1-28-2009; IN COMMERCE 1-28-2009.

LINDA LAVACHE, EXAMINING ATTORNEY

SN 85-288,301. THE NEST COLLECTIVE, INC., EMERYVILLE, CA. FILED 4-6-2011.

JUST

THE MARK CONSISTS OF STANDARD CHARACTERS WITHOUT CLAIM TO ANY PARTICULAR FONT, STYLE, SIZE, OR COLOR.

FOR FOOD FOR BABIES, NAMELY, ORGANIC VEGETABLE PUREES (U.S. CLS. 6, 18, 44, 46, 51 AND 52).

MICHELE SWAIN, EXAMINING ATTORNEY

CLASS 5—(Continued).

SN 85-301,388. VIIV HEALTHCARE COMPANY, WILMINGTON, DE. FILED 4-21-2011.

VIVADO

THE MARK CONSISTS OF STANDARD CHARACTERS WITHOUT CLAIM TO ANY PARTICULAR FONT, STYLE, SIZE, OR COLOR.

FOR PHARMACEUTICAL PREPARATIONS AND SUBSTANCES FOR THE TREATMENT OF INFECTIOUS DISEASES; VACCINES; PHARMACEUTICAL PREPARATIONS AND SUBSTANCES FOR THE TREATMENT OF VIRAL DISEASES AND DISORDERS; INHALERS FILLED WITH PHARMACEUTICAL PREPARATIONS FOR THE TREATMENT AND ALLEVIATION OF INFECTIOUS DISEASES AND VIRAL DISEASES AND DISORDERS (U.S. CLS. 6, 18, 44, 46, 51 AND 52).

SHARON MEIER, EXAMINING ATTORNEY

SN 85-335,147. FRANCO PAVIA INTERNATIONAL LLC, MIAMI, FL. FILED 6-1-2011.



THE COLOR(S) RED, BLACK, YELLOW, GRAY, BEIGE IS/ARE CLAIMED AS A FEATURE OF THE MARK.

THE MARK CONSISTS OF THE WORDS "CRAVING CRUSHER" IN RED TRANSPARED OVER A YELLOW EXPLOSION DESIGN OUTLINED IN BLACK, WITH A BEIGE FIST OUTLINED IN BLACK GRASPING A TEST TUBE THAT IS GRAY ON ONE END AND YELLOW ON THE OTHER.

FOR APPETITE SUPPRESSANT IN THE FORM OF A LIQUID SERVED IN A TEST TUBE CONTAINER (U.S. CLS. 6, 18, 44, 46, 51 AND 52).

LINDA POWELL, EXAMINING ATTORNEY

CLASS 5—(Continued).

SN 85-425,300. ARGO NATURAL HEALTH LABS INC, CHULA VISTA, CA. FILED 9-17-2011.

TECHNOVIAL

THE MARK CONSISTS OF STANDARD CHARACTERS WITHOUT CLAIM TO ANY PARTICULAR FONT, STYLE, SIZE, OR COLOR.

FOR VITAMIN AND MINERAL SUPPLEMENTS; DIETARY AND NUTRITIONAL SUPPLEMENTS (U.S. CLS. 6, 18, 44, 46, 51 AND 52).

FIRST USE 1-7-2009; IN COMMERCE 2-2-2009.

MARK RADEMACHER, EXAMINING ATTORNEY

SN 85-431,276. XU, WEI, SOUTH EL MONTE, CA. FILED 9-24-2011.



THE COLOR(S) BLUE AND SILVER IS/ARE CLAIMED AS A FEATURE OF THE MARK.

THE MARK CONSISTS OF THE WORDS "ULTRA ELEMENT" IN SILVER WITHIN A BLUE, OVAL SHAPE. THE OVAL SHAPE IS BORDERED IN SILVER.

FOR COD LIVER OIL; DIETARY AND NUTRITIONAL SUPPLEMENTS CONTAINING FISH OIL; MIXED VITAMIN PREPARATIONS; MULTI-VITAMIN PREPARATIONS; NUTRITIONAL SUPPLEMENT IN THE NATURE OF A NUTRIENT-DENSE, PROTEIN-BASED DRINK MIX; PROTEIN SUPPLEMENTS; VITAMIN AND MINERAL SUPPLEMENTS; VITAMIN SUPPLEMENTS; VITAMINS (U.S. CLS. 6, 18, 44, 46, 51 AND 52).

FIRST USE 9-6-2011; IN COMMERCE 9-6-2011.

KIMBERLY FRYE, EXAMINING ATTORNEY

SN 85-431,958. HALSCION, INC., SUWANEE, GA. FILED 9-26-2011.

CELOTRES

THE MARK CONSISTS OF STANDARD CHARACTERS WITHOUT CLAIM TO ANY PARTICULAR FONT, STYLE, SIZE, OR COLOR.

FOR HYDROGEL SCAFFOLD CONSISTING OF BIO-COMPATIBLE MATERIALS USED TO IMPROVE AND/OR PREVENT SCAR FORMATION (U.S. CLS. 6, 18, 44, 46, 51 AND 52).

GIANCARLO CASTRO, EXAMINING ATTORNEY

CLASS 5—(Continued).

SN 85-437,211. UPSHER-SMITH LABORATORIES, INC.,
MAPLE GROVE, MN. FILED 10-1-2011.

BREKSEZE

THE MARK CONSISTS OF STANDARD CHARACTERS WITHOUT CLAIM TO ANY PARTICULAR FONT, STYLE, SIZE, OR COLOR.

THE WORD "BREKSEZE" HAS NO MEANING IN A FOREIGN LANGUAGE.

FOR PHARMACEUTICAL PREPARATIONS FOR THE TREATMENT OF CENTRAL NERVOUS SYSTEM DISORDERS (U.S. CLS. 6, 18, 44, 46, 51 AND 52).

PAUL MORENO, EXAMINING ATTORNEY

CLASS 5—(Continued).

SN 85-446,141. JENNIFER ELK, DBA CRC SUPPLEMENTS,
INC., NEW YORK, NY. FILED 10-13-2011.

Slim without Stim

THE MARK CONSISTS OF STANDARD CHARACTERS WITHOUT CLAIM TO ANY PARTICULAR FONT, STYLE, SIZE, OR COLOR.

FOR DIETARY AND NUTRITIONAL SUPPLEMENTS USED FOR WEIGHT LOSS (U.S. CLS. 6, 18, 44, 46, 51 AND 52).

FIRST USE 2-1-2011; IN COMMERCE 4-15-2011.

MICHAEL ENGEL, EXAMINING ATTORNEY

SN 85-437,260. SPARTA BEVERAGE LLC, LOS ANGELES,
CA. FILED 10-2-2011.



OWNER OF U.S. REG. NOS. 3,730,440 AND 3,987,579.
NO CLAIM IS MADE TO THE EXCLUSIVE RIGHT TO USE "ENERGEIA", APART FROM THE MARK AS SHOWN.
THE COLOR(S) GOLD IS/ARE CLAIMED AS A FEATURE OF THE MARK.

THE MARK CONSISTS OF A GOLD GLADIATOR OR SPARTAN SOLDIER'S HELMET WITH A CHARACTERISTIC CREST, THE WORDING "SPARTA ENERGEIA" IN GOLD LETTERS, THE CAPITAL LETTER SIGMA OF THE GREEK ALPHABET FORMS THE "S" IN "SPARTA", TWO GOLD LETTER CAPITAL LETTER SIGMAS FACING EACH OTHER APPEAR BENEATH THE WORDING. THE DARK COLOR OF THE CREST IS INCIDENTAL AND IS NOT CLAIMED AS A FEATURE OF THE MARK.

THE ENGLISH TRANSLATION OF "ENERGEIA" IN THE MARK IS "ENERGY".

FOR DIETARY AND NUTRITIONAL SUPPLEMENTS; DIETARY DRINK MIX FOR USE AS A MEAL REPLACEMENT; DIETARY SUPPLEMENTAL DRINKS; ENERGY BOOSTING BARS FOR USE AS A MEAL SUBSTITUTE; FOOD SUPPLEMENTS; LIQUID PROTEIN SUPPLEMENTS; MEAL REPLACEMENT DRINKS; MINERAL, VITAMIN, OR NUTRITIONALLY ENHANCED WATER; NUTRITIONAL AND DIETARY SUPPLEMENTS FORMED AND PACKAGED AS BARS; NUTRITIONAL SUPPLEMENT IN THE NATURE OF A NUTRIENT-DENSE, PROTEIN-BASED DRINK MIX; NUTRITIONAL SUPPLEMENTS FOR BOOSTING ENERGY; NUTRITIONALLY FORTIFIED BEVERAGES; NUTRITIONALLY FORTIFIED WATER; POWDERED NUTRITIONAL SUPPLEMENT DRINK MIX AND CONCENTRATE; VITAMIN FORTIFIED BEVERAGES (U.S. CLS. 6, 18, 44, 46, 51 AND 52).

RONALD MCMORROW, EXAMINING ATTORNEY

SN 85-456,711. GAMMA ENTERPRISES, LLC, WEST BABY-
LON, NY. FILED 10-26-2011.

GAMMA GAMERS

THE MARK CONSISTS OF STANDARD CHARACTERS WITHOUT CLAIM TO ANY PARTICULAR FONT, STYLE, SIZE, OR COLOR.

OWNER OF U.S. REG. NO. 3,424,078.

NO CLAIM IS MADE TO THE EXCLUSIVE RIGHT TO USE "GAMERS", APART FROM THE MARK AS SHOWN.

FOR DIETARY AND NUTRITIONAL SUPPLEMENTS; DIETARY AND NUTRITIONAL BODYBUILDING SUPPLEMENTS; MEAL REPLACEMENT BARS; MEAL REPLACEMENT DRINKS; MEAL REPLACEMENT POWDERS; MEAL REPLACEMENT SHAKES; MEAL REPLACEMENT SNACKS; NUTRITIONAL DRINK MIX FOR USE AS A MEAL REPLACEMENT; NUTRITIONAL DRINKS USED FOR MEAL REPLACEMENT; NUTRITIONAL ENERGY BARS FOR USE AS A MEAL SUBSTITUTE; NUTRITIONAL FOOD BARS FOR USE AS A MEAL REPLACEMENT (U.S. CLS. 6, 18, 44, 46, 51 AND 52).

SETH A. RAPPAPORT, EXAMINING ATTORNEY

SN 85-457,443. RICECO LLC, MEMPHIS, TN. FILED 10-27-
2011.

RICESOLO

THE MARK CONSISTS OF STANDARD CHARACTERS WITHOUT CLAIM TO ANY PARTICULAR FONT, STYLE, SIZE, OR COLOR.

FOR HERBICIDES, INSECTICIDES, PESTICIDES, AND FUNGICIDES (U.S. CLS. 6, 18, 44, 46, 51 AND 52).

DOMINIC J. FERRAIUOLO, EXAMINING ATTORNEY

CLASS 5—(Continued).

SN 85-457,538. RICECO LLC, MEMPHIS, TN. FILED 10-27-2011.

RICEEX

THE MARK CONSISTS OF STANDARD CHARACTERS WITHOUT CLAIM TO ANY PARTICULAR FONT, STYLE, SIZE, OR COLOR.

FOR HERBICIDES, INSECTICIDES, PESTICIDES, AND FUNGICIDES (U.S. CLS. 6, 18, 44, 46, 51 AND 52).

DOMINIC J. FERRAIUOLO, EXAMINING ATTORNEY

SN 85-458,440. ARLEN, MICHAEL W., DBA ARLEN NUTRACEUTICALS, LOS ANGELES, CA. FILED 10-27-2011.

Add Flavor & NewTriton To
Your Meals!

THE MARK CONSISTS OF STANDARD CHARACTERS WITHOUT CLAIM TO ANY PARTICULAR FONT, STYLE, SIZE, OR COLOR.

NO CLAIM IS MADE TO THE EXCLUSIVE RIGHT TO USE "NUTRITION", APART FROM THE MARK AS SHOWN.

FOR POWDERED MIXES IN THE NATURE OF POWDERED NUTRITIONAL SUPPLEMENT MIX (U.S. CLS. 6, 18, 44, 46, 51 AND 52).

MARC LEIPZIG, EXAMINING ATTORNEY

SN 85-458,611. BOEHRINGER INGELHEIM PHARMACEUTICALS, INC., RIDGEFIELD, CT. FILED 10-28-2011.

ZANTAC EFFERDOSE

THE MARK CONSISTS OF STANDARD CHARACTERS WITHOUT CLAIM TO ANY PARTICULAR FONT, STYLE, SIZE, OR COLOR.

OWNER OF U.S. REG. NOS. 1,220,525, 3,666,759 AND OTHERS.

FOR PHARMACEUTICAL PREPARATIONS AND SUBSTANCES, NAMELY, PHARMACEUTICAL PREPARATIONS FOR THE TREATMENT AND/OR ALLEVIATION OF ULCERS AND GASTROINTESTINAL DISORDERS (U.S. CLS. 6, 18, 44, 46, 51 AND 52).

JULIE VEPPUMTHARA, EXAMINING ATTORNEY

CLASS 5—(Continued).

SN 85-461,197. FRANKLIN EVERETT, NEWPORT, RI. FILED 11-1-2011.

THRIVE FROZEN NUTRITION

THE MARK CONSISTS OF STANDARD CHARACTERS WITHOUT CLAIM TO ANY PARTICULAR FONT, STYLE, SIZE, OR COLOR.

NO CLAIM IS MADE TO THE EXCLUSIVE RIGHT TO USE "FROZEN NUTRITION", APART FROM THE MARK AS SHOWN.

FOR FROZEN NUTRITIONAL SUPPLEMENTS (U.S. CLS. 6, 18, 44, 46, 51 AND 52).

DAVID MURRAY, EXAMINING ATTORNEY

SN 85-465,412. NATROL, INC., CHATSWORTH, CA. FILED 11-5-2011.

MoodON

THE MARK CONSISTS OF STANDARD CHARACTERS WITHOUT CLAIM TO ANY PARTICULAR FONT, STYLE, SIZE, OR COLOR.

OWNER OF U.S. REG. NO. 3,596,181.
FOR DIETARY AND NUTRITIONAL SUPPLEMENTS (U.S. CLS. 6, 18, 44, 46, 51 AND 52).

BARBARA GAYNOR, EXAMINING ATTORNEY

SN 85-465,418. NATROL, INC., CHATSWORTH, CA. FILED 11-5-2011.

BMI Women

THE MARK CONSISTS OF STANDARD CHARACTERS WITHOUT CLAIM TO ANY PARTICULAR FONT, STYLE, SIZE, OR COLOR.

NO CLAIM IS MADE TO THE EXCLUSIVE RIGHT TO USE "WOMEN", APART FROM THE MARK AS SHOWN.

FOR DIETARY AND NUTRITIONAL SUPPLEMENTS (U.S. CLS. 6, 18, 44, 46, 51 AND 52).

BARBARA GAYNOR, EXAMINING ATTORNEY

CLASS 5—(Continued).

SN 85-465,421. NATROL, INC., CHATSWORTH, CA. FILED 11-5-2011.

BMI MenZ

THE MARK CONSISTS OF STANDARD CHARACTERS WITHOUT CLAIM TO ANY PARTICULAR FONT, STYLE, SIZE, OR COLOR.

NO CLAIM IS MADE TO THE EXCLUSIVE RIGHT TO USE "MEN'S", APART FROM THE MARK AS SHOWN.

FOR DIETARY AND NUTRITIONAL SUPPLEMENTS (U.S. CLS. 6, 18, 44, 46, 51 AND 52).

BARBARA GAYNOR, EXAMINING ATTORNEY

CLASS 5—(Continued).

SN 85-467,892. LABORATOIRES EXPANSCIENCE, 92400 COURBEVOIE, FRANCE, FILED 11-9-2011.

ASU Expanscience

THE MARK CONSISTS OF STANDARD CHARACTERS WITHOUT CLAIM TO ANY PARTICULAR FONT, STYLE, SIZE, OR COLOR.

OWNER OF U.S. REG. NOS. 2,264,084 AND 3,067,352.

NO CLAIM IS MADE TO THE EXCLUSIVE RIGHT TO USE ASU, APART FROM THE MARK AS SHOWN.

FOR AVOCADO AND SOYA OIL PHARMACEUTICAL EXTRACTS FOR USE AS AN ACTIVE PRINCIPAL IN THE COMPOSITION OF PHARMACEUTICALS OR NUTRACEUTICALS (U.S. CLS. 6, 18, 44, 46, 51 AND 52).

ALAIN LAPTER, EXAMINING ATTORNEY

SN 85-469,034. LIFEHEALTH SCIENCE, LLC, CLEVELAND, OH. FILED 11-10-2011.

SN 85-467,877. LIFEHEALTH SCIENCE, LLC, CLEVELAND, OH. FILED 11-9-2011.

ZNATURAL



THE MARK CONSISTS OF STANDARD CHARACTERS WITHOUT CLAIM TO ANY PARTICULAR FONT, STYLE, SIZE, OR COLOR.

FOR DIETARY AND NUTRITIONAL SUPPLEMENTS, ALL CONTAINING NATURAL INGREDIENTS (U.S. CLS. 6, 18, 44, 46, 51 AND 52).

FIRST USE 7-7-2010; IN COMMERCE 7-7-2010.

KATHERINE CHANG, EXAMINING ATTORNEY

SN 85-476,284. OCUSOFT, INC., ROSENBERG, TX. FILED 11-18-2011.

RETAINÉ CMC

NO CLAIM IS MADE TO THE EXCLUSIVE RIGHT TO USE "NATURAL", APART FROM THE MARK AS SHOWN. THE COLOR(S) GREEN, WHITE AND BLACK IS/ARE CLAIMED AS A FEATURE OF THE MARK.

THE MARK CONSISTS OF A LARGE LETTER "Z" IN WHITE APPEARING ABOVE THE WORD "NATURAL" IN BLACK. ALL OF THE FOREGOING APPEARS ON A SQUARE IN SHADES OF GREEN AND HAVING A THREE-DIMENSIONAL APPEARANCE.

FOR DIETARY AND NUTRITIONAL SUPPLEMENTS, ALL CONTAINING NATURAL INGREDIENTS (U.S. CLS. 6, 18, 44, 46, 51 AND 52).

FIRST USE 7-7-2010; IN COMMERCE 7-7-2010.

KATHERINE CHANG, EXAMINING ATTORNEY

THE MARK CONSISTS OF STANDARD CHARACTERS WITHOUT CLAIM TO ANY PARTICULAR FONT, STYLE, SIZE, OR COLOR.

OWNER OF U.S. REG. NO. 3,858,143.

NO CLAIM IS MADE TO THE EXCLUSIVE RIGHT TO USE "CMC", APART FROM THE MARK AS SHOWN.

FOR LUBRICANT EYE DROPS CONTAINING CMC (CARBOXYMETHYLCELLULOSE) (U.S. CLS. 6, 18, 44, 46, 51 AND 52).

JESSICA FATHY, EXAMINING ATTORNEY

CLASS 5—(Continued).

SN 85-476,290. OCUSOFT, INC., ROSENBERG, TX. FILED 11-18-2011.

RETAINED MGD

THE MARK CONSISTS OF STANDARD CHARACTERS WITHOUT CLAIM TO ANY PARTICULAR FONT, STYLE, SIZE, OR COLOR.

OWNER OF U.S. REG. NO. 3,858,143.

NO CLAIM IS MADE TO THE EXCLUSIVE RIGHT TO USE "MGD", APART FROM THE MARK AS SHOWN.

FOR LUBRICANT EYE DROPS FOR THE TREATMENT OF MGD OR MEIBOMIAN GLAND DYSFUNCTION (U.S. CLS. 6, 18, 44, 46, 51 AND 52).

JESSICA FATHY, EXAMINING ATTORNEY

CLASS 5—(Continued).

SN 85-493,984. BIA SPORT, INC., MANHATTAN BEACH, CA. FILED 12-13-2011.

BIA

THE MARK CONSISTS OF STANDARD CHARACTERS WITHOUT CLAIM TO ANY PARTICULAR FONT, STYLE, SIZE, OR COLOR.

FOR DIETARY AND NUTRITIONAL SUPPLEMENTS FOR ENDURANCE SPORTS; NUTRITIONAL AND DIETARY SUPPLEMENTS FORMED AND PACKAGED AS BARS; NUTRITIONAL SUPPLEMENTAL ENERGY BARS; PERFORMANCE NUTRITIONAL SUPPLEMENTS (U.S. CLS. 6, 18, 44, 46, 51 AND 52).

ANNE E. GUSTASON, EXAMINING ATTORNEY

SN 85-477,320. HUMAN HEALTH INSTITUTE LLC, DBA HUMAN HEALTH INSTITUTE, MIAMI, FL. FILED 11-20-2011.



NO CLAIM IS MADE TO THE EXCLUSIVE RIGHT TO USE "DIET", APART FROM THE MARK AS SHOWN.

THE NAME(S), PORTRAIT(S), AND/OR SIGNATURE(S) SHOWN IN THE MARK DOES NOT IDENTIFY A PARTICULAR LIVING INDIVIDUAL.

THE COLOR(S) RED, BLACK, AND WHITE IS/ARE CLAIMED AS A FEATURE OF THE MARK.

THE MARK CONSISTS OF THE FOLLOWING: THE WORD FOR "PORN" IN RED WITHIN A RECTANGLE SHADED BLACK, WITH THE LAST "O" IN "PORN" CUT OFF. NEXT TO THE WORD "PORN" ARE A MAN AND WOMAN IN RED OUTLINED IN BLACK, STANDING AND KISSING, WITHIN A RECTANGLE SHADED IN VARIOUS COLORS OF RED. BELOW THE IMAGE OF THE EMBRACING COUPLE AND BELOW THE WORD "PORN", IS THE STYLIZED WORD "DIET" IN WHITE.

FOR DIETARY AND NUTRITIONAL SUPPLEMENTS (U.S. CLS. 6, 18, 44, 46, 51 AND 52).

FIRST USE 6-17-2011. THE MARK WAS FIRST USED ANYWHERE IN A DIFFERENT FORM OTHER THAN THAT SOUGHT TO BE REGISTERED AT LEAST AS EARLY AS 06/17/2011; IN COMMERCE 6-17-2011, THE MARK WAS FIRST USED IN COMMERCE IN A DIFFERENT FORM OTHER THAN THAT SOUGHT TO BE REGISTERED AT LEAST AS EARLY AS 06/17/2011.

STEVEN JACKSON, EXAMINING ATTORNEY

SN 85-495,404. CELGENE CORPORATION, SUMMIT, NJ. FILED 12-14-2011.

IMLOVID

THE MARK CONSISTS OF STANDARD CHARACTERS WITHOUT CLAIM TO ANY PARTICULAR FONT, STYLE, SIZE, OR COLOR.

PRIORITY CLAIMED UNDER SEC. 44(D) ON SWITZERLAND APPLICATION NO. 63907/2011, FILED 12-12-2011, REG. NO. 628504, DATED 12-12-2011, EXPIRES 12-12-2021.

OWNER OF U.S. REG. NOS. 3,988,920 AND 4,045,529.

FOR PHARMACEUTICAL PREPARATIONS, NAMELY, CYTOKINE INHIBITORY DRUGS; PHARMACEUTICAL PREPARATIONS THAT MODULATE THE IMMUNE SYSTEM; PHARMACEUTICAL PREPARATIONS FOR THE TREATMENT OF CERTAIN CANCER AND BLOOD DISEASES (U.S. CLS. 6, 18, 44, 46, 51 AND 52).

BARBARA GAYNOR, EXAMINING ATTORNEY

CLASS 5—(Continued).

SN 85-495,426. CELGENE CORPORATION, SUMMIT, NJ. FILED 12-14-2011.

IMLOVYD

THE MARK CONSISTS OF STANDARD CHARACTERS WITHOUT CLAIM TO ANY PARTICULAR FONT, STYLE, SIZE, OR COLOR.

PRIORITY CLAIMED UNDER SEC. 44(D) ON SWITZERLAND APPLICATION NO. 63906/2011, FILED 12-12-2011, REG. NO. 628503, DATED 12-12-2011, EXPIRES 12-12-2021.

OWNER OF U.S. REG. NOS. 3,988,920 AND 4,045,529. FOR PHARMACEUTICAL PREPARATIONS, NAMELY, CYTOKINE INHIBITORY DRUGS; PHARMACEUTICAL PREPARATIONS THAT MODULATE THE IMMUNE SYSTEM; PHARMACEUTICAL PREPARATIONS FOR THE TREATMENT OF CERTAIN CANCER AND BLOOD DISEASES (U.S. CLS. 6, 18, 44, 46, 51 AND 52).

BARBARA GAYNOR, EXAMINING ATTORNEY

CLASS 5—(Continued).

SN 85-499,421. YOLI, INC., SALT LAKE CITY, UT. FILED 12-20-2011.



OWNER OF U.S. REG. NOS. 3,710,363 AND 3,817,729. NO CLAIM IS MADE TO THE EXCLUSIVE RIGHT TO USE "COMPANY", APART FROM THE MARK AS SHOWN.

THE MARK CONSISTS OF THE STYLIZED WORDING "YOLI THE BETTER BODY COMPANY", WITH THE "Y" IN "YOLI" CONSISTING IN PART OF A PLANT LEAF, AND THE DOT OVER THE LETTER "I" CONSISTING OF A DROP OF WATER.

FOR NUTRITIONAL AND DIETARY SUPPLEMENTS, NAMELY, WEIGHT LOSS SUPPLEMENTS OFFERED AS PART OF A WEIGHT MANAGEMENT SYSTEM, NUTRITIONAL AND DIETARY SUPPLEMENTS, NAMELY, WEIGHT LOSS SHAKE MIX AND PH BALANCER OFFERED AS PART OF A WEIGHT MANAGEMENT SYSTEM, NUTRITIONAL AND DIETARY SUPPLEMENTS, NAMELY, WEIGHT LOSS SHAKE MIX, PH BALANCER, AND DIETARY AND NUTRITIONAL SUPPLEMENT HEALTH DRINKS OFFERED AS PART OF A WEIGHT MANAGEMENT SYSTEM (U.S. CLS. 6, 18, 44, 46, 51 AND 52).

JEAN IM, EXAMINING ATTORNEY

SN 85-499,420. YOLI, INC., SALT LAKE CITY, UT. FILED 12-20-2011.

SN 85-502,121. NOVARTIS AG, BASEL, SWITZERLAND, FILED 12-22-2011.



FTY

OWNER OF U.S. REG. NOS. 3,710,363 AND 3,817,729. NO CLAIM IS MADE TO THE EXCLUSIVE RIGHT TO USE "SYSTEM", APART FROM THE MARK AS SHOWN.

THE MARK CONSISTS OF THE STYLIZED WORDING "YOLI BETTER BODY SYSTEM", WITH THE STYLIZED IMAGE OF A PERSON LOCATED BETWEEN THE WORDS "BETTER" AND "BODY".

FOR DIETARY AND NUTRITIONAL SUPPLEMENTS OFFERED IN MULTIPLE PACKAGES THROUGH A WEIGHT MANAGEMENT PROGRAM FOR CONSUMPTION IN CONJUNCTION WITH OTHER FOODS (U.S. CLS. 6, 18, 44, 46, 51 AND 52).

JEAN IM, EXAMINING ATTORNEY

THE MARK CONSISTS OF STANDARD CHARACTERS WITHOUT CLAIM TO ANY PARTICULAR FONT, STYLE, SIZE, OR COLOR.

PRIORITY CLAIMED UNDER SEC. 44(D) ON SWITZERLAND APPLICATION NO. 64535, FILED 12-22-2011, REG. NO. 628733, DATED 12-22-2011, EXPIRES 12-22-2021.

FOR PHARMACEUTICAL PREPARATIONS ACTING ON THE CENTRAL NERVOUS SYSTEM (U.S. CLS. 6, 18, 44, 46, 51 AND 52).

FIRST USE 10-7-2010; IN COMMERCE 10-7-2010.

SANJEEV VOHRA, EXAMINING ATTORNEY

CLASS 5—(Continued).

SN 85-513,760. HEALTH SPOT, LLC, AVON, IN. FILED 1-11-2012.

HEALTH SPOT

THE MARK CONSISTS OF STANDARD CHARACTERS WITHOUT CLAIM TO ANY PARTICULAR FONT, STYLE, SIZE, OR COLOR.

NO CLAIM IS MADE TO THE EXCLUSIVE RIGHT TO USE "HEALTH", APART FROM THE MARK AS SHOWN, FOR DIETARY AND NUTRITIONAL SUPPLEMENTS (U.S. CLS. 6, 18, 44, 46, 51 AND 52).

FIRST USE 5-1-1993; IN COMMERCE 5-1-1993.
RENEE MCCRAY, EXAMINING ATTORNEY

CLASS 5—(Continued).

SN 85-531,504. LONZA AG (LONZA LTD.), VISP, SWITZERLAND, FILED 2-1-2012.



THE MARK CONSISTS OF A STANDING PENGUIN WEARING A HAT STANDING TO THE RIGHT OF "ALO" AND ABOVE "MUNE", TRAILED BY FOUR FOOTPRINTS, FOR DIETARY SUPPLEMENTS AND PREPARATIONS FOR TREATING COLDS (U.S. CLS. 6, 18, 44, 46, 51 AND 52).

BRIAN NEVILLE, EXAMINING ATTORNEY

SN 85-523,937. BRAKE, JEFFREY L, PHOENIX, AZ. FILED 1-24-2012.

2DazeDeal

THE MARK CONSISTS OF STANDARD CHARACTERS WITHOUT CLAIM TO ANY PARTICULAR FONT, STYLE, SIZE, OR COLOR.

FOR DIETARY AND NUTRITIONAL SUPPLEMENTS (U.S. CLS. 6, 18, 44, 46, 51 AND 52).

FIRST USE 10-29-2009; IN COMMERCE 11-10-2009.
RON FAIRBANKS, EXAMINING ATTORNEY

SN 85-532,363. BRISTOL-MYERS SQUIBB COMPANY, NEW YORK, NY. FILED 2-2-2012.

BIFORXI

THE MARK CONSISTS OF STANDARD CHARACTERS WITHOUT CLAIM TO ANY PARTICULAR FONT, STYLE, SIZE, OR COLOR.

FOR PHARMACEUTICAL PREPARATIONS FOR HUMAN USE FOR THE TREATMENT OR PREVENTION OF METABOLIC DISORDERS, NAMELY, DIABETES, OBESITY, HYPERLIPIDEMIA, INSULIN RESISTANCE, METABOLIC SYNDROME (U.S. CLS. 6, 18, 44, 46, 51 AND 52).

ZACHARY BELLO, EXAMINING ATTORNEY

SN 85-524,040. SMARTHEALTH, INC., PHOENIX, WI. FILED 1-24-2012.

PATCH PROTECT

THE MARK CONSISTS OF STANDARD CHARACTERS WITHOUT CLAIM TO ANY PARTICULAR FONT, STYLE, SIZE, OR COLOR.

NO CLAIM IS MADE TO THE EXCLUSIVE RIGHT TO USE "PATCH", APART FROM THE MARK AS SHOWN,

FOR POLYURETHANE OVER TAPE USED TO COVER ALLERGY PATCH TESTS ON THE SKIN (U.S. CLS. 6, 18, 44, 46, 51 AND 52).

NAAKWAMA ANKRAH, EXAMINING ATTORNEY

SN 85-533,360. KITESTRING LLC, LYNCHBURG, VA. FILED 2-3-2012.

nanoseptic

THE MARK CONSISTS OF STANDARD CHARACTERS WITHOUT CLAIM TO ANY PARTICULAR FONT, STYLE, SIZE, OR COLOR.

FOR ALL PURPOSE DISINFECTANTS FOR KILLING PATHOGENS, NAMELY, ANTI-MICROBIAL, ANTI-VIRAL, ANTI-FUNGAL, ANTI-BACTERIAL COATINGS AND SOLUTIONS FOR USE ON SUBSTRATE MATERIALS THAT CAN RECEIVE PHYSICAL INDICIA (U.S. CLS. 6, 18, 44, 46, 51 AND 52).

GIANCARLO CASTRO, EXAMINING ATTORNEY

CLASS 5—(Continued).

SN 85-546,993. LEY & SON LLC, ENCINITAS, CA. FILED 2-20-2012.

CLASS 5—(Continued).

SN 85-560,316. OSMOSIS SKINCARE NZ LIMITED, AUCKLAND, NEW ZEALAND, FILED 3-5-2012.



CALMESTRA

PRIORITY CLAIMED UNDER SEC. 44(D) ON NEW ZEALAND APPLICATION NO. 849628, FILED 9-11-2011.

OWNER OF NEW ZEALAND REG. NO. 849628, DATED 9-21-2011, EXPIRES 3-21-2018.

NO CLAIM IS MADE TO THE EXCLUSIVE RIGHT TO USE "YELLOW", APART FROM THE MARK AS SHOWN.

THE MARK CONSISTS OF THE WORD "YELLOW" IN CAPITAL LETTERS, WHICH IS OVER A SCHEMATIC ILLUSTRATION OF A DIAMOND CONTAINING THE CAPITAL LETTERS "YD", WHICH IS OVER THE WORD "DIAMONDS" IN STYLIZED SCRIPT.

FOR DIETARY SUPPLEMENTS (U.S. CLS. 6, 18, 44, 46, 51 AND 52).

SCOTT BIBB, EXAMINING ATTORNEY

THE MARK CONSISTS OF STANDARD CHARACTERS WITHOUT CLAIM TO ANY PARTICULAR FONT, STYLE, SIZE, OR COLOR.

FOR DIETARY AND NUTRITIONAL SUPPLEMENTS; DIETARY AND NUTRITIONAL SUPPLEMENTS CONTAINING CYNANCHUM WILFORDII, PHLOMIS UMBROSA, ANGELICA GIGAS NAKAI; DIETARY AND NUTRITIONAL SUPPLEMENTS USED FOR WEIGHT LOSS; DIETARY SUPPLEMENT BEVERAGE FOR NATURAL RELIEF FOR FEMININE HORMONAL IMBALANCE AND MENOPAUSAL SYMPTOMS; DIETARY SUPPLEMENTAL DRINKS; DIETARY SUPPLEMENTAL DRINKS IN THE NATURE OF VITAMIN AND MINERAL BEVERAGES; DIETARY SUPPLEMENTS; DIETARY SUPPLEMENTS ALSO CONTAINING CYNANCHUM WILFORDII, PHLOMIS UMBROSA, ANGELICA GIGAS NAKAI; DIETARY SUPPLEMENTS FOR HUMAN CONSUMPTION; DIETARY SUPPLEMENTS FOR NATURAL RELIEF FOR FEMININE HORMONAL IMBALANCE AND MENOPAUSAL SYMPTOMS; NUTRACEUTICALS FOR USE AS A DIETARY SUPPLEMENT; NUTRACEUTICALS FOR USE AS A DIETARY SUPPLEMENT FOR NATURAL RELIEF FOR FEMININE HORMONAL IMBALANCE AND MENOPAUSAL SYMPTOMS; NUTRITIONAL SUPPLEMENTS; NUTRITIONAL SUPPLEMENTS FOR NATURAL RELIEF FOR FEMININE HORMONAL IMBALANCE AND MENOPAUSAL SYMPTOMS; NUTRITIONAL SUPPLEMENTS IN THE FORM OF CAPSULES, TABLETS, CAPLETS, POWDER, SYRUPS, GUMMIES AND GELS; NUTRITIONAL SUPPLEMENTS IN THE NATURE OF NUTRITIONALLY FORTIFIED SOFT CHEWS (U.S. CLS. 6, 18, 44, 46, 51 AND 52).

FIRST USE 12-20-2011; IN COMMERCE 1-23-2012.

ELIZABETH KAJUBI, EXAMINING ATTORNEY

SN 85-562,629. TICK TOCK NATURALS LLC, JERSEY CITY, NJ. FILED 3-7-2012.

TICK TOCK naturals

THE MARK CONSISTS OF STANDARD CHARACTERS WITHOUT CLAIM TO ANY PARTICULAR FONT, STYLE, SIZE, OR COLOR.

NO CLAIM IS MADE TO THE EXCLUSIVE RIGHT TO USE "NATURALS", APART FROM THE MARK AS SHOWN.

FOR INSECT REPELLENT AGENTS; INSECT REPELLENTS; INSECT REPELLENTS CONTAINING ESSENTIAL OILS, AROMATIC OILS, AND SCENTED OILS (U.S. CLS. 6, 18, 44, 46, 51 AND 52).

FIRST USE 2-13-2012; IN COMMERCE 2-13-2012.

NICHOLAS COLEMAN, EXAMINING ATTORNEY

CLASS 5—(Continued).

SN 85-565,313. JENNIFER BARTELS, HAMMOND, LA. FILED 3-9-2012.

Good Stuff

THE MARK CONSISTS OF STANDARD CHARACTERS WITHOUT CLAIM TO ANY PARTICULAR FONT, STYLE, SIZE, OR COLOR.

FOR VETERINARY PREPARATIONS FOR ITCHING, PRESSURE WOUNDS, SKIN CONDITIONS (U.S. CLS. 6, 18, 44, 46, 51 AND 52).

WARREN L. OLANDRIA, EXAMINING ATTORNEY

SN 85-567,370. COOPERS TUF E NUF, RHOME, TX. FILED 3-12-2012.

TUF·E·NUF
HEALTHY ENERGY JUICE

NO CLAIM IS MADE TO THE EXCLUSIVE RIGHT TO USE "HEALTHY ENERGY JUICE", APART FROM THE MARK AS SHOWN.

THE STIPPLING IS FOR SHADING PURPOSES ONLY.

THE MARK CONSISTS OF A STYLIZED LETTER "E" IN THE TEXT "TUF - E - NUF" WITH A SPUR ATTACHED TO BACK SIDE ON THE BOTTOM OF THE "E", AND THE TEXT "HEALTHY ENERGY JUICE" BELOW.

FOR DIETARY FOOD SUPPLEMENTS (U.S. CLS. 6, 18, 44, 46, 51 AND 52).

FIRST USE 12-1-2011; IN COMMERCE 12-1-2011.
MARK SPARACINO, EXAMINING ATTORNEY

SN 85-567,601. UNIVERA, INC., SEATTLE, WA. FILED 3-13-2012.

PROTEIN QUOTIENT

THE MARK CONSISTS OF STANDARD CHARACTERS WITHOUT CLAIM TO ANY PARTICULAR FONT, STYLE, SIZE, OR COLOR.

NO CLAIM IS MADE TO THE EXCLUSIVE RIGHT TO USE "PROTEIN", APART FROM THE MARK AS SHOWN.

FOR DIETARY SUPPLEMENT DRINK MIXES CONTAINING PROTEIN, NAMELY, DIETARY DRINK MIX FOR USE AS A MEAL REPLACEMENT (U.S. CLS. 6, 18, 44, 46, 51 AND 52).

KIMBERLY PARKS, EXAMINING ATTORNEY

CLASS 5—(Continued).

SN 85-568,093. MERIDIAN BIOSCIENCE, INC., CINCINNATI, OH. FILED 3-13-2012.

PARA-PANEL

THE MARK CONSISTS OF STANDARD CHARACTERS WITHOUT CLAIM TO ANY PARTICULAR FONT, STYLE, SIZE, OR COLOR.

FOR BIOLOGICAL TISSUE CULTURES FOR MEDICAL PURPOSES, NAMELY, FOR PERFORMANCE ASSESSMENT AND QUALITY CONTROL; BACTERIAL AND BACTERIOLOGICAL PREPARATIONS OF INFECTIOUS DISEASES FOR MEDICAL OR VETERINARY PURPOSES, NAMELY, FOR PERFORMANCE ASSESSMENT AND QUALITY CONTROL (U.S. CLS. 6, 18, 44, 46, 51 AND 52).

WILLIAM BRECKENFELD, EXAMINING ATTORNEY

SN 85-568,098. MERIDIAN BIOSCIENCE, INC., CINCINNATI, OH. FILED 3-13-2012.

BACTQUAL

THE MARK CONSISTS OF STANDARD CHARACTERS WITHOUT CLAIM TO ANY PARTICULAR FONT, STYLE, SIZE, OR COLOR.

FOR BIOLOGICAL TISSUE CULTURES FOR MEDICAL PURPOSES, NAMELY, FOR PERFORMANCE ASSESSMENT AND QUALITY CONTROL; BACTERIAL AND BACTERIOLOGICAL PREPARATIONS OF INFECTIOUS DISEASES FOR MEDICAL OR VETERINARY PURPOSES, NAMELY, FOR PERFORMANCE ASSESSMENT AND QUALITY CONTROL (U.S. CLS. 6, 18, 44, 46, 51 AND 52).

WILLIAM BRECKENFELD, EXAMINING ATTORNEY

SN 85-568,100. MERIDIAN BIOSCIENCE, INC., CINCINNATI, OH. FILED 3-13-2012.

PARAQUAL

THE MARK CONSISTS OF STANDARD CHARACTERS WITHOUT CLAIM TO ANY PARTICULAR FONT, STYLE, SIZE, OR COLOR.

FOR BIOLOGICAL TISSUE CULTURES FOR MEDICAL PURPOSES, NAMELY, FOR PERFORMANCE ASSESSMENT AND QUALITY CONTROL; BACTERIAL AND BACTERIOLOGICAL PREPARATIONS OF INFECTIOUS DISEASES FOR MEDICAL OR VETERINARY PURPOSES, NAMELY, FOR PERFORMANCE ASSESSMENT AND QUALITY CONTROL (U.S. CLS. 6, 18, 44, 46, 51 AND 52).

WILLIAM BRECKENFELD, EXAMINING ATTORNEY

CLASS 5—(Continued).

SN 85-569,401. RUTHIE HARPER, AUSTIN, TX. FILED 3-14-2012.

SKINSHIFT

THE MARK CONSISTS OF STANDARD CHARACTERS WITHOUT CLAIM TO ANY PARTICULAR FONT, STYLE, SIZE, OR COLOR.

FOR DIETARY AND NUTRITIONAL SUPPLEMENTS; PREPARATIONS FOR DETECTING GENETIC PREDISPOSITIONS FOR SKINCARE PURPOSES (U.S. CLS. 6, 18, 44, 46, 51 AND 52).

FIRST USE 7-25-2007; IN COMMERCE 7-25-2007.
NAPOLEON SHARMA, EXAMINING ATTORNEY

SN 85-572,015. KEVCO INTELLECTUAL PROPERTIES LLC, BLUFFDALE, UT. FILED 3-16-2012.

YOU ARE BADDASS

THE MARK CONSISTS OF STANDARD CHARACTERS WITHOUT CLAIM TO ANY PARTICULAR FONT, STYLE, SIZE, OR COLOR.

FOR DIETARY AND NUTRITIONAL SUPPLEMENTS; DIETARY AND NUTRITIONAL SUPPLEMENTS FOR SPORTS NUTRITION AND FOR ENDURANCE AND ATHLETIC SPORTS, DIETARY AND NUTRITION SUPPLEMENTS FOR WEIGHT MANAGEMENT; DIETARY AND NUTRITIONAL SUPPLEMENTS INCLUDING PROTEIN, CREATINE, GLYCEROL, FOLIC ACID, CARBOHYDRATES, VITAMINS, MINERALS, AMINO ACIDS, AND/OR TESTOSTERONE (U.S. CLS. 6, 18, 44, 46, 51 AND 52).

FIRST USE 3-1-2012; IN COMMERCE 3-1-2012.
NICHOLAS COLEMAN, EXAMINING ATTORNEY

SN 85-574,944. LANTEV DISTRIBUTING CORP., BROOKLYN, NY. FILED 3-20-2012.

WEIGH-IN

THE MARK CONSISTS OF STANDARD CHARACTERS WITHOUT CLAIM TO ANY PARTICULAR FONT, STYLE, SIZE, OR COLOR.

FOR PROTEIN POWDER SUPPLEMENTS; VITAMINS; VITAMIN SUPPLEMENTS; MINERAL SUPPLEMENTS; MULTI-VITAMIN PREPARATIONS; DIETARY SUPPLEMENTS; NUTRITIONAL SUPPLEMENTS; HERBAL SUPPLEMENTS (U.S. CLS. 6, 18, 44, 46, 51 AND 52).

WILLIAM VERHOSEK, EXAMINING ATTORNEY

CLASS 5—(Continued).

SN 85-580,744. DUTTON, DOUG, AUBREY, TX. AND DUTTON, LAURIE ANN, AUBREY, TX. FILED 3-27-2012.



NO CLAIM IS MADE TO THE EXCLUSIVE RIGHT TO USE "STERILE", APART FROM THE MARK AS SHOWN.

THE COLOR(S) WHITE, GRAY, BLACK, GREEN, BLUE, RED AND ORANGE IS/ARE CLAIMED AS A FEATURE OF THE MARK.

THE MARK CONSISTS OF THE WORDING "STERILE DOCTOR" INSIDE OF AN OVAL WITH A DESIGN CONSISTING OF NINE CIRCLES BETWEEN THE WORD STERILE AND THE WORD DOCTOR. THE COLOR WHITE APPEARS IN THE WORDING "STERILE DOCTOR" AND THE INNER PERIMETER OF THE OVAL AND IN THE CENTERS OF THE NINE CIRCLES. THE COLOR GRAY APPEARS IN THE OVAL. THE COLOR BLACK APPEARS IN THE OUTER PERIMETER OF THE OVAL AND THE OUTLINES OF THE LETTERS OF THE WORDS "STERILE DOCTOR". THE COLOR GREEN APPEARS IN FOUR OF THE CIRCLES COMPRISING PART OF THE NINE CIRCLE DESIGN. THE COLOR BLUE APPEARS IN ONE OF THE CIRCLES COMPRISING THE NINE CIRCLE DESIGN. THE COLOR RED APPEARS IN THREE OF THE CIRCLES COMPRISING THE NINE CIRCLE DESIGN, AND THE COLOR ORANGE APPEARS IN THE LARGEST OF THE CIRCLES COMPRISING THE NINE CIRCLE DESIGN.

FOR (BASED ON USE IN COMMERCE) LIQUID ANTIMICROBIAL SOLUTION THAT CAN BE APPLIED TO ANY SURFACE AND ACTS TO INHIBIT MOLD, MILDEW, BACTERIA, VIRUSES AND FUNGI; MOLD INHIBITING PRODUCTS, NAMELY SILANE QUATERNARY AMMONIUM SALT; ANTIMICROBIAL PREPARATIONS FOR KILLING AND INHIBITING THE GROWTH OF MOLD; ANTIMICROBIAL PREPARATION FOR MOLD PREVENTION; CLEANING AND DISINFECTING PREPARATIONS USED FOR STERILIZING, DISINFECTING, SANITIZING, MOLD KILLING AND INHIBITING THE GROWTH OF MOLD ON SURFACES; ECO-FRIENDLY ANTIMICROBIAL PREPARATIONS IN THE NATURE OF COATINGS, SPRAYS, AND LAUNDRY DETERGENT ADDITIVES (BASED ON INTENT TO USE) DISPOSABLE SANITIZING WIPES AND HAND SANITIZER LIQUID AND HAND SANITIZER GEL; ANTISEPTIC WIPES; ANTISEPTICS; DISPOSABLE WIPES IMPREGNATED WITH DISINFECTING CHEMICALS OR COMPOUNDS THEREFOR FOR USE IN HOSPITALS, CLINICS, MEDICAL OFFICES, MEDICAL FACILITIES, PATIENT CARE FACILITIES, BATHROOMS, RESTAURANTS, AND FOOD PREPARATION FACILITIES; DISPOSABLE WIPES IMPREGNATED WITH DISINFECTING CHEMICALS OR COMPOUNDS THEREFOR FOR USE ON HANDS OR SKIN, OR ON SOLID SURFACES, NAMELY, FURNITURE, WHEELCHAIRS, SHOPPING CARTS, REST ROOM FIXTURES AND COUNTERS, TOILET SEATS, DOOR-KNOBS, SINKS, RESTAURANT TABLES, SEATING, BOOSTER SEATS, HIGH CHAIRS, MENUS, CASH REGISTERS, TELEPHONES, AND FOOD PREPARATION AND KITCHEN EQUIPMENT AND TOOLS, GYM EQUIPMENT; SANITIZING WIPES; ALL PURPOSE DISINFECTANT SPRAY FOR SANITIZING AND CLEANING SURFACES; DISINFECTANT SPRAYS FOR KILLING AND INHIBITING THE GROWTH OF MOLD ON SURFACES (U.S. CLS. 6, 18, 44, 46, 51 AND 52).

FIRST USE 3-16-2012; IN COMMERCE 3-16-2012.
FRANK LATTUCA, EXAMINING ATTORNEY

CLASS 5—(Continued).

SN 85-583,854. HAELAN PRODUCTS, INC., WOODINVILLE, WA. FILED 3-29-2012.

ESTRO MGR

THE MARK CONSISTS OF STANDARD CHARACTERS WITHOUT CLAIM TO ANY PARTICULAR FONT, STYLE, SIZE, OR COLOR.

FOR DIETETIC FOODS PREPARED FROM FERMENTED SOYBEANS, NAMELY, A SOYBEAN BEVERAGE, ADAPTED FOR MEDICAL USE FOR THE TOXIC SIDE EFFECTS OF CHEMOTHERAPY SUCH AS FATIGUE, PROTEIN CALORIE MALNUTRITION, CACHEXIA, ANOREXIA, MALNUTRITION, MALABSORPTION, NAUSEA (U.S. CLS. 6, 18, 44, 46, 51 AND 52).

KAPIL BHANOT, EXAMINING ATTORNEY

SN 85-584,347. ZETINO, MARTA R., DBA ILLUSION CREATIONS, VAN NUYS, CA. FILED 3-30-2012.



THE COLOR(S) BLACK, GREEN, DARK GREEN, LIGHT GREEN AND BROWN IS/ARE CLAIMED AS A FEATURE OF THE MARK.

THE MARK CONSISTS OF A BLACK OVAL ENCLOSING THE WORD "NACICRECE". THE WORD "NACICRECE" HAS A CAPITAL "N" AND A CAPITAL "C". THE WORD "NACICRECE" IS SEPARATED BETWEEN THE LETTER "I" AND THE LETTER "C" BY A TREE WITH LIGHT GREEN AND DARK GREEN FOLIAGE, THREE BROWN BRANCHES, A BROWN TRUNK, AND BROWN ROOTS. EIGHT GREEN LEAVES ARE PLACED UNDER THE WORD "NACICRECE".

THE WORDING "NACICRECE" HAS NO MEANING IN A FOREIGN LANGUAGE.

FOR HAIR GROWTH STIMULANTS (U.S. CLS. 6, 18, 44, 46, 51 AND 52).

FIRST USE 3-24-2012; IN COMMERCE 3-24-2012.

JEFFREY LOOK, EXAMINING ATTORNEY

CLASS 5—(Continued).

SN 85-584,370. VITAMIN BOAT CORP., LAWRENCEVILLE, GA. FILED 3-30-2012.

AVAILYN

THE MARK CONSISTS OF STANDARD CHARACTERS WITHOUT CLAIM TO ANY PARTICULAR FONT, STYLE, SIZE, OR COLOR.

FOR DIETARY SUPPLEMENTS (U.S. CLS. 6, 18, 44, 46, 51 AND 52).

FIRST USE 3-1-2012; IN COMMERCE 3-1-2012.

AHSEN KHAN, EXAMINING ATTORNEY

SN 85-588,509. NATURAL ORGANICS, INC., MELVILLE, NY. FILED 4-4-2012.

ETERNAL LEAN

THE MARK CONSISTS OF STANDARD CHARACTERS WITHOUT CLAIM TO ANY PARTICULAR FONT, STYLE, SIZE, OR COLOR.

NO CLAIM IS MADE TO THE EXCLUSIVE RIGHT TO USE "LEAN", APART FROM THE MARK AS SHOWN.

FOR NUTRITIONAL SUPPLEMENTS (U.S. CLS. 6, 18, 44, 46, 51 AND 52).

ZACHARY BELLO, EXAMINING ATTORNEY

SN 85-589,805. AGE-LESS MEDICINE, LLC, TAMPA, FL. FILED 4-5-2012.

DR. LINDA'S AGE-LESS

THE MARK CONSISTS OF STANDARD CHARACTERS WITHOUT CLAIM TO ANY PARTICULAR FONT, STYLE, SIZE, OR COLOR.

THE NAME "DR. LINDA" IDENTIFIES A LIVING INDIVIDUAL WHOSE CONSENT IS OF RECORD.

FOR NUTRITIONAL SUPPLEMENTS; DIETARY SUPPLEMENTS; VITAMIN SUPPLEMENTS; MINERAL SUPPLEMENTS; HERBAL SUPPLEMENTS; NUTRITIONAL SUPPLEMENT DRINK MIXES, PUDDINGS AND SHAKES; DIETARY SUPPLEMENT DRINK MIXES, PUDDINGS AND SHAKES; VITAMIN FORTIFIED BEVERAGES; NUTRITIONAL AND DIETARY SUPPLEMENTS IN THE FORM OF FOOD BARS; VITAMINS AND MINERALS FORMED AND PACKAGED AS BARS (U.S. CLS. 6, 18, 44, 46, 51 AND 52).

FIRST USE 11-30-2008; IN COMMERCE 5-31-2009.

STEVEN R. FINE, EXAMINING ATTORNEY

CLASS 5—(Continued).

SN 85-590,539. CUDDLE BUNS, APPLE VALLEY, CA. FILED 4-5-2012.



THE MARK CONSISTS OF THE WORDS "CUDDLE BUNS" SURROUNDED BY AN UPSIDE DOWN HEART AND ACCOMPANIED BY 3 SMALL HEARTS.

FOR BABIES' DIAPERS OF PAPER; DIAPERS FOR INCONTINENCE (U.S. CLS. 6, 18, 44, 46, 51 AND 52).

FIRST USE 12-12-2011; IN COMMERCE 5-26-2012.

DORITT L. CARROLL, EXAMINING ATTORNEY

SN 85-591,278. QUALITY CONCEPTS, LLC, DBA PRESCRIBED FOR LIFE PFORLIFE.COM, FREDERICKSBURG, TX. FILED 4-6-2012.

THE FAT ERADICATOR

THE MARK CONSISTS OF STANDARD CHARACTERS WITHOUT CLAIM TO ANY PARTICULAR FONT, STYLE, SIZE, OR COLOR.

NO CLAIM IS MADE TO THE EXCLUSIVE RIGHT TO USE "FAT", APART FROM THE MARK AS SHOWN.

FOR DIETING PILLS AND POWDER PREPARATIONS TO PROMOTE FAT BURNING (U.S. CLS. 6, 18, 44, 46, 51 AND 52).

FIRST USE 12-4-2008; IN COMMERCE 12-4-2008.

NAKIA HENRY, EXAMINING ATTORNEY

SN 85-592,483. ENTEGRION, INC., RESEARCH TRIANGLE PARK, NC. FILED 4-9-2012.

RESUSIX

THE MARK CONSISTS OF STANDARD CHARACTERS WITHOUT CLAIM TO ANY PARTICULAR FONT, STYLE, SIZE, OR COLOR.

FOR DEHYDRATED, PATHOGEN INACTIVATED HUMAN PLASMA-BASED THERAPEUTIC AGENT FOR USE IN RESUSCITATION (U.S. CLS. 6, 18, 44, 46, 51 AND 52).

KAPIL BHANOT, EXAMINING ATTORNEY

CLASS 5—(Continued).

SN 85-593,972. KINGFISHER MEDIA, LLC, MURRAY, UT. FILED 4-10-2012.

BOOST WHAT MATTERS

THE MARK CONSISTS OF STANDARD CHARACTERS WITHOUT CLAIM TO ANY PARTICULAR FONT, STYLE, SIZE, OR COLOR.

FOR DIETARY SUPPLEMENTS; VITAMIN AND MINERAL SUPPLEMENTS; DIETARY SUPPLEMENTS FOR MUSCLE, BONE AND JOINT RECOVERY AND PAIN RELIEF; DIETARY SUPPLEMENTS FOR MUSCLE GROWTH; DIETARY SUPPLEMENTS FOR SUPPRESSING APPETITES, WEIGHT CONTROL AND BODY FAT BURNING; DIETARY SUPPLEMENTS FOR BOOSTING ENERGY; DIETARY SUPPLEMENTS FOR BOOSTING COGNITIVE AND MENTAL ACUITY; DIETARY SUPPLEMENTS FOR INCREASING TESTOSTERONE LEVELS; DIETARY SUPPLEMENTS FOR INCREASING LIBIDO AND SEXUAL VITALITY; DIETARY SUPPLEMENTS FOR THYROID HEALTH; TOPICAL PREPARATIONS, NAMELY, SPRAYS, GELS AND CREAMS FOR ENHANCING MUSCLE, BONE AND JOINT RECOVERY; TOPICAL PREPARATIONS FOR PAIN RELIEF (U.S. CLS. 6, 18, 44, 46, 51 AND 52).

DAVID YONTEF, EXAMINING ATTORNEY

SN 85-594,339. IGUANA-RID, LLC, DEERFIELD BEACH, FL. FILED 4-11-2012.

BED BUG ADIOS

THE MARK CONSISTS OF STANDARD CHARACTERS WITHOUT CLAIM TO ANY PARTICULAR FONT, STYLE, SIZE, OR COLOR.

NO CLAIM IS MADE TO THE EXCLUSIVE RIGHT TO USE "BED BUG", APART FROM THE MARK AS SHOWN.

FOR ANIMAL, INSECT AND REPTILE REPELLANTS (U.S. CLS. 6, 18, 44, 46, 51 AND 52).

JANICE L. MCMORROW, EXAMINING ATTORNEY

SN 85-594,592. BIO-SOLUTIONS CORP, SAN ANTONIO, TX. FILED 4-11-2012.

Type 2 Defense

THE MARK CONSISTS OF STANDARD CHARACTERS WITHOUT CLAIM TO ANY PARTICULAR FONT, STYLE, SIZE, OR COLOR.

NO CLAIM IS MADE TO THE EXCLUSIVE RIGHT TO USE "TYPE 2", APART FROM THE MARK AS SHOWN.

FOR DIETARY AND NUTRITIONAL SUPPLEMENTS TO HELP METABOLIZE BLOOD GLUCOSE (U.S. CLS. 6, 18, 44, 46, 51 AND 52).

ELISSA GARBER KON, EXAMINING ATTORNEY

CLASS 5—(Continued).

SN 85-595,471. DHINGRA, AMIT, CHICAGO HEIGHTS, IL.
FILED 4-11-2012.

BareHerbs
HEALTHY. MADE EASY.

NO CLAIM IS MADE TO THE EXCLUSIVE RIGHT TO USE "HERBS", APART FROM THE MARK AS SHOWN. THE MARK CONSISTS OF A PICTURE OF A STRIP ABOVE THE LETTERS "E" IN THE TEXT, "BARE" AND "H" IN THE TEXT "HERBS", AND THE TEXT "HEALTHY. MADE EASY." BELOW.

FOR DIETARY SUPPLEMENTS CONTAINING HERBS (U.S. CLS. 6, 18, 44, 46, 51 AND 52).
DOMINICK J. SALEMI, EXAMINING ATTORNEY

SN 85-595,474. THERALOGIX LLC, ROCKVILLE, MD.
FILED 4-11-2012.

PROCERV HP

THE MARK CONSISTS OF STANDARD CHARACTERS WITHOUT CLAIM TO ANY PARTICULAR FONT, STYLE, SIZE, OR COLOR.

NO CLAIM IS MADE TO THE EXCLUSIVE RIGHT TO USE "HP", APART FROM THE MARK AS SHOWN.

FOR NUTRITIONAL SUPPLEMENTS (U.S. CLS. 6, 18, 44, 46, 51 AND 52).

FIRST USE 3-29-2012; IN COMMERCE 3-29-2012.
DOMINICK J. SALEMI, EXAMINING ATTORNEY

SN 85-595,921. GSC PRODUCTS, LLC, SCHENECTADY, NY.
FILED 4-12-2012.

Sinus Plumber

THE MARK CONSISTS OF STANDARD CHARACTERS WITHOUT CLAIM TO ANY PARTICULAR FONT, STYLE, SIZE, OR COLOR.

NO CLAIM IS MADE TO THE EXCLUSIVE RIGHT TO USE "SINUS", APART FROM THE MARK AS SHOWN.

FOR DECONGESTANT NASAL SPRAYS (U.S. CLS. 6, 18, 44, 46, 51 AND 52).

FIRST USE 1-1-2009; IN COMMERCE 4-1-2012.
JIM RINGLE, EXAMINING ATTORNEY

CLASS 5—(Continued).

SN 85-596,178. PRINCIPLE BUSINESS ENTERPRISES, INC.,
DUNBRIDGE, OH. FILED 4-12-2012.

TopLiner

THE MARK CONSISTS OF STANDARD CHARACTERS WITHOUT CLAIM TO ANY PARTICULAR FONT, STYLE, SIZE, OR COLOR.

SEC. 2(F).
FOR INCONTINENCE PADS (U.S. CLS. 6, 18, 44, 46, 51 AND 52).

FIRST USE 0-0-2001; IN COMMERCE 0-0-2001.
NORA BUCHANAN WILL, EXAMINING ATTORNEY

SN 85-596,343. TATALOU SCIENCE, LLC, SALT LAKE CITY,
UT. FILED 4-12-2012.

TATALOU

THE MARK CONSISTS OF STANDARD CHARACTERS WITHOUT CLAIM TO ANY PARTICULAR FONT, STYLE, SIZE, OR COLOR.

THE WORDING "TATALOU" HAS NO MEANING IN A FOREIGN LANGUAGE.

FOR DIETARY AND NUTRITIONAL SUPPLEMENTS; DIETARY AND NUTRITIONAL SUPPLEMENTS DESIGNED FOR WOMEN; DIETARY AND NUTRITIONAL SUPPLEMENTS USED FOR WEIGHT LOSS; AND DIETARY AND NUTRITIONAL SUPPLEMENTS FOR SUPPORTING, RESTORING AND IMPROVING COGNITIVE FUNCTION (U.S. CLS. 6, 18, 44, 46, 51 AND 52).

FIRST USE 2-17-2012; IN COMMERCE 2-17-2012.
GILBERT SWIFT, EXAMINING ATTORNEY

SN 85-596,382. B&A NATURAL SOLUTIONS LLC., OREM,
UT. FILED 4-12-2012.

Hemroid Harry

THE MARK CONSISTS OF STANDARD CHARACTERS WITHOUT CLAIM TO ANY PARTICULAR FONT, STYLE, SIZE, OR COLOR.

NO CLAIM IS MADE TO THE EXCLUSIVE RIGHT TO USE "HEMORRHOID", APART FROM THE MARK AS SHOWN.

FOR HERBAL SUPPLEMENTS FOR TREATING HEMORRHOIDS (U.S. CLS. 6, 18, 44, 46, 51 AND 52).

FIRST USE 2-1-2008; IN COMMERCE 2-1-2008.
JOSETTE BEVERLY, EXAMINING ATTORNEY

CLASS 5—(Continued).

SN 85-596,459. WOODBOLT DISTRIBUTION, LLC, BRYAN, TX. FILED 4-12-2012.

Cellucor Daily Essentials

THE MARK CONSISTS OF STANDARD CHARACTERS WITHOUT CLAIM TO ANY PARTICULAR FONT, STYLE, SIZE, OR COLOR.

OWNER OF U.S. REG. NOS. 4,075,985 AND 4,076,246.

NO CLAIM IS MADE TO THE EXCLUSIVE RIGHT TO USE "DAILY ESSENTIALS", APART FROM THE MARK AS SHOWN.

FOR DIETARY SUPPLEMENTS (U.S. CLS. 6, 18, 44, 46, 51 AND 52).

EMILY CARLSEN, EXAMINING ATTORNEY

CLASS 5—(Continued).

SN 85-597,419. STILES, TERRI L., MURRIETA, CA. FILED 4-13-2012.

KOLLA2-XS

THE MARK CONSISTS OF STANDARD CHARACTERS WITHOUT CLAIM TO ANY PARTICULAR FONT, STYLE, SIZE, OR COLOR.

OWNER OF U.S. REG. NO. 2,693,894.

FOR DIETARY FOOD SUPPLEMENTS (U.S. CLS. 6, 18, 44, 46, 51 AND 52).

FIRST USE 11-2-2011; IN COMMERCE 11-2-2011.

BRENDAN REGAN, EXAMINING ATTORNEY

SN 85-596,505. WOODBOLT DISTRIBUTION, LLC, BRYAN, TX. FILED 4-12-2012.

Cellucor Essentials

THE MARK CONSISTS OF STANDARD CHARACTERS WITHOUT CLAIM TO ANY PARTICULAR FONT, STYLE, SIZE, OR COLOR.

OWNER OF U.S. REG. NOS. 4,075,985 AND 4,076,246.

NO CLAIM IS MADE TO THE EXCLUSIVE RIGHT TO USE "ESSENTIALS", APART FROM THE MARK AS SHOWN.

FOR DIETARY SUPPLEMENTS (U.S. CLS. 6, 18, 44, 46, 51 AND 52).

EMILY CARLSEN, EXAMINING ATTORNEY

SN 85-598,283. CUSTOM NUTRICEUTICAL LABORATORIES, LLC, FARMERS BRANCH, TX. FILED 4-15-2012.

NITRO2GRANIT

THE MARK CONSISTS OF STANDARD CHARACTERS WITHOUT CLAIM TO ANY PARTICULAR FONT, STYLE, SIZE, OR COLOR.

FOR DIETARY AND NUTRITIONAL SUPPLEMENTS (U.S. CLS. 6, 18, 44, 46, 51 AND 52).

HENRY S. ZAK, EXAMINING ATTORNEY

SN 85-597,146. NUTRITION & FITNESS, INC., FAYETTEVILLE, NC. FILED 4-13-2012.

CARDIO NO

THE MARK CONSISTS OF STANDARD CHARACTERS WITHOUT CLAIM TO ANY PARTICULAR FONT, STYLE, SIZE, OR COLOR.

NO CLAIM IS MADE TO THE EXCLUSIVE RIGHT TO USE "CARDIO", APART FROM THE MARK AS SHOWN.

FOR DIETARY SUPPLEMENTS (U.S. CLS. 6, 18, 44, 46, 51 AND 52).

EMILY CHUO, EXAMINING ATTORNEY

SN 85-598,944. PORTASCIENCE, INC., MOORESTOWN, NJ. FILED 4-16-2012.

PORTABHB

THE MARK CONSISTS OF STANDARD CHARACTERS WITHOUT CLAIM TO ANY PARTICULAR FONT, STYLE, SIZE, OR COLOR.

FOR DIAGNOSTIC KIT COMPRISED OF TEST STRIPS AND RESULT CHARTS FOR USE IN DETECTING SUBCLINICAL KETOSIS IN ANIMAL BODY FLUIDS, SOLD AS A UNIT (U.S. CLS. 6, 18, 44, 46, 51 AND 52).

FIRST USE 6-29-2007; IN COMMERCE 9-29-2009.

COURTNEY ALVAREZ, EXAMINING ATTORNEY

CLASS 5—(Continued).

SN 85-599,040. MELALEUCA, INC., IDAHO FALLS, ID. FILED 4-16-2012.

CLARITY CLEAR SKIN ESSENTIALS

THE MARK CONSISTS OF STANDARD CHARACTERS WITHOUT CLAIM TO ANY PARTICULAR FONT, STYLE, SIZE, OR COLOR.

NO CLAIM IS MADE TO THE EXCLUSIVE RIGHT TO USE "CLEAR SKIN", APART FROM THE MARK AS SHOWN.

FOR ACNE TREATMENT PREPARATIONS; ASTRINGENTS FOR MEDICINAL PURPOSES; MEDICATED SKIN CARE PREPARATIONS (U.S. CLS. 6, 18, 44, 46, 51 AND 52).

GRETCHEN ULRICH, EXAMINING ATTORNEY

SN 85-599,528. BIOMARIN PHARMACEUTICAL, INC., NOVATO, CA. FILED 4-17-2012.

OSQUIO

THE MARK CONSISTS OF STANDARD CHARACTERS WITHOUT CLAIM TO ANY PARTICULAR FONT, STYLE, SIZE, OR COLOR.

FOR PHARMACEUTICAL PREPARATIONS FOR THE TREATMENT OF GENETIC DISEASES AND DISORDERS; PHARMACEUTICAL PREPARATIONS FOR USE IN ENZYME THERAPY (U.S. CLS. 6, 18, 44, 46, 51 AND 52).

DOUGLAS LEE, EXAMINING ATTORNEY

SN 85-599,529. BIOMARIN PHARMACEUTICAL, INC., NOVATO, CA. FILED 4-17-2012.

KONDROZYME

THE MARK CONSISTS OF STANDARD CHARACTERS WITHOUT CLAIM TO ANY PARTICULAR FONT, STYLE, SIZE, OR COLOR.

FOR PHARMACEUTICAL PREPARATIONS FOR THE TREATMENT OF GENETIC DISEASES AND DISORDERS; PHARMACEUTICAL PREPARATIONS FOR USE IN ENZYME THERAPY (U.S. CLS. 6, 18, 44, 46, 51 AND 52).

DOUGLAS LEE, EXAMINING ATTORNEY

CLASS 5—(Continued).

SN 85-599,935. TSI GROUP LIMITED, CENTRAL HONG KONG, HONG KONG, FILED 4-17-2012.



OWNER OF U.S. REG. NOS. 2,644,173 AND 3,471,597. THE COLOR(S) DARK TEAL, TEAL, LIGHT TEAL, GOLD AND WHITE IS/ARE CLAIMED AS A FEATURE OF THE MARK.

THE MARK CONSISTS OF THE LETTERS "TSI" IN DARK TEAL UNDERNEATH THREE CONCENTRIC OVALS COLORED DARK TEAL, TEAL, AND LIGHT TEAL (FROM OUTSIDE IN), THE TOP OF THE OUTER OVAL HAVING A CIRCULAR NOTCH, WITH A GOLD CIRCLE IN THE MIDDLE OF THE OVALS ON A WHITE BACKGROUND.

FOR DIETARY AND NUTRITIONAL SUPPLEMENTS (U.S. CLS. 6, 18, 44, 46, 51 AND 52).

GEOFFREY FOSDICK, EXAMINING ATTORNEY

SN 85-600,238. ABBOTT PRODUCTS GMBH, HANNOVER D-30173, FED REP GERMANY, FILED 4-17-2012.



THE COLOR(S) BLUE AND WHITE IS/ARE CLAIMED AS A FEATURE OF THE MARK.

THE MARK CONSISTS OF FIVE BLUE SPHERES THAT HAVE WHITE SHADOWING AND ARE IN VARIOUS SIZES AND WHICH FLOW THROUGH THREE BLUE OVAL RINGS WITH WHITE SHADING; THE RINGS ARE SEPARATED BY WHITE AND BY A SIMILAR DISTANCE.

FOR PHARMACEUTICAL PREPARATIONS FOR THE PREVENTION AND TREATMENT OF GASTROINTESTINAL CONDITIONS (U.S. CLS. 6, 18, 44, 46, 51 AND 52).

SEAN CROWLEY, EXAMINING ATTORNEY

CLASS 5—(Continued).

SN 85-600,245. MATE HIDVEGI, BUDAPEST, HUNGARY, FILED 4-17-2012.

HIDVEGI

THE MARK CONSISTS OF STANDARD CHARACTERS WITHOUT CLAIM TO ANY PARTICULAR FONT, STYLE, SIZE, OR COLOR.

OWNER OF ERPN CMNTY TM OFC REG. NO. 008625551, DATED 4-5-2010, EXPIRES 10-20-2019.

FOR PHARMACEUTICAL AND VETERINARY PREPARATIONS FOR USE AS IMMUNO-THERAPEUTIC, IMMUNO-STIMULANTS, ANTICANCER DRUGS AND ANTICANCER THERAPEUTIC AGENTS; SANITARY PREPARATIONS FOR USE ON HUMANS, ANIMALS AND FOR HOSPITAL USE, NAMELY, ALCOHOL FOR TOPICAL USE, ANTI-INFECTIVES, ANTISEPTICS, ANTIPARASITICS, ASTRINGENTS FOR MEDICAL PURPOSES, DISINFECTANTS FOR MEDICAL INSTRUMENTS, ALL PURPOSE DISINFECTANTS, DISINFECTING HANDWASH, IODINE, MEDICATED PRE-MOISTENED WIPES, GENERAL PURPOSE GERMICIDES, AND SANITIZERS FOR HOUSEHOLD AND HOSPITAL USE; DIETARY AND NUTRITIONAL SUPPLEMENTS (U.S. CLS. 6, 18, 44, 46, 51 AND 52).

EMILY CARLSEN, EXAMINING ATTORNEY

SN 85-601,030. EP MINERALS, LLC, RENO, NV. FILED 4-18-2012.

DTERRA

THE MARK CONSISTS OF STANDARD CHARACTERS WITHOUT CLAIM TO ANY PARTICULAR FONT, STYLE, SIZE, OR COLOR.

FOR NATURAL INSECTICIDES FOR AGRICULTURAL AND DOMESTIC USE; ANIMAL FEED ADDITIVES FOR ANTI-CAKING AND FLOW CONTROL (U.S. CLS. 6, 18, 44, 46, 51 AND 52).

MICHAEL WIENER, EXAMINING ATTORNEY

SN 85-601,275. STEM CENTRX, INC., SOUTH SAN FRANCISCO, CA. FILED 4-18-2012.

STEM CENTRX

THE MARK CONSISTS OF STANDARD CHARACTERS WITHOUT CLAIM TO ANY PARTICULAR FONT, STYLE, SIZE, OR COLOR.

FOR MEDICINAL PREPARATIONS FOR USE IN ONCOLOGY (U.S. CLS. 6, 18, 44, 46, 51 AND 52).

BARBARA RUTLAND, EXAMINING ATTORNEY

CLASS 5—(Continued).

SN 85-601,288. STEM CENTRX, INC., SOUTH SAN FRANCISCO, CA. FILED 4-18-2012.

STEMCENTRX

THE MARK CONSISTS OF STANDARD CHARACTERS WITHOUT CLAIM TO ANY PARTICULAR FONT, STYLE, SIZE, OR COLOR.

FOR MEDICINAL PREPARATIONS FOR USE IN ONCOLOGY (U.S. CLS. 6, 18, 44, 46, 51 AND 52).

BARBARA RUTLAND, EXAMINING ATTORNEY

SN 85-601,741. NATURE'S APPEAL MANUFACTURING CORPORATION, ADDISON, IL. FILED 4-18-2012.

ATTACK STINK SNIPER

THE MARK CONSISTS OF STANDARD CHARACTERS WITHOUT CLAIM TO ANY PARTICULAR FONT, STYLE, SIZE, OR COLOR.

OWNER OF U.S. REG. NO. 4,175,516.

NO CLAIM IS MADE TO THE EXCLUSIVE RIGHT TO USE "STINK", APART FROM THE MARK AS SHOWN.

FOR AIR DEODORIZER (U.S. CLS. 6, 18, 44, 46, 51 AND 52).

FIRST USE 7-19-2012; IN COMMERCE 7-19-2012.

ZACHARY BELLO, EXAMINING ATTORNEY

SN 85-602,019. GIANT SPORTS PRODUCTS LLC, BRICK, NJ. FILED 4-18-2012.

EVERY SPORT DRINK

THE MARK CONSISTS OF STANDARD CHARACTERS WITHOUT CLAIM TO ANY PARTICULAR FONT, STYLE, SIZE, OR COLOR.

NO CLAIM IS MADE TO THE EXCLUSIVE RIGHT TO USE "SPORT DRINK", APART FROM THE MARK AS SHOWN.

FOR DIETARY SUPPLEMENT BEVERAGE FOR INCREASING ATHLETIC PERFORMANCE; POWDERED FRUIT-FLAVORED DIETARY SUPPLEMENT DRINK MIX; POWDERED NUTRITIONAL SUPPLEMENT DRINK MIX (U.S. CLS. 6, 18, 44, 46, 51 AND 52).

JORDAN BAKER, EXAMINING ATTORNEY

CLASS 5—(Continued).

SN 85-602,020. GIANT SPORTS PRODUCTS LLC, BRICK, NJ. FILED 4-18-2012.

TOTAL SPORTS DRINK

THE MARK CONSISTS OF STANDARD CHARACTERS WITHOUT CLAIM TO ANY PARTICULAR FONT, STYLE, SIZE, OR COLOR.

NO CLAIM IS MADE TO THE EXCLUSIVE RIGHT TO USE "SPORTS DRINK", APART FROM THE MARK AS SHOWN.

FOR DIETARY SUPPLEMENT BEVERAGE FOR INCREASING ATHLETIC PERFORMANCE; POWDERED FRUIT-FLAVORED DIETARY SUPPLEMENT DRINK MIX; POWDERED NUTRITIONAL SUPPLEMENT DRINK MIX (U.S. CLS. 6, 18, 44, 46, 51 AND 52).

JORDAN BAKER, EXAMINING ATTORNEY

SN 85-602,378. MY GOODNESS,LLC, ERWIN, TN. FILED 4-19-2012.

Citro-Ban

THE MARK CONSISTS OF STANDARD CHARACTERS WITHOUT CLAIM TO ANY PARTICULAR FONT, STYLE, SIZE, OR COLOR.

FOR INSECT REPELLENT AGENTS; INSECT REPELLENTS (U.S. CLS. 6, 18, 44, 46, 51 AND 52).

FIRST USE 4-1-2012; IN COMMERCE 4-1-2012.

DAVID HOFFMAN, EXAMINING ATTORNEY

SN 85-602,428. WANZHU LI, LOS ANGELES, CA. FILED 4-19-2012.



NO CLAIM IS MADE TO THE EXCLUSIVE RIGHT TO USE "ORGANIC", APART FROM THE MARK AS SHOWN. THE COLOR(S) ORANGE, GREEN, BLACK AND WHITE IS/ARE CLAIMED AS A FEATURE OF THE MARK.

THE MARK CONSISTS OF THE WORD "ORGANIC" IN BLACK IN AN ORANGE FRUIT IN ORANGE IN THE LETTER "O" AND A GREEN AND WHITE LEAF IN THE LETTER "R".

FOR ORGANIC FOOD FOR INFANTS; ORGANIC INFANT FORMULA (U.S. CLS. 6, 18, 44, 46, 51 AND 52). FIRST USE 9-10-2011; IN COMMERCE 9-10-2011.

KAPIL BHANOT, EXAMINING ATTORNEY

CLASS 5—(Continued).

SN 85-602,450. 4D LLC., DBA 4D LLC, NEW ORLEANS, LA. FILED 4-19-2012.

4dat

THE MARK CONSISTS OF STANDARD CHARACTERS WITHOUT CLAIM TO ANY PARTICULAR FONT, STYLE, SIZE, OR COLOR.

FOR DIETARY BEVERAGE SUPPLEMENTS FOR HUMAN CONSUMPTION IN LIQUID AND DRY MIX FORM FOR THERAPEUTIC PURPOSES; DIETARY SUPPLEMENTAL DRINKS; DIETARY SUPPLEMENTAL DRINKS IN THE NATURE OF VITAMIN AND MINERAL BEVERAGES; FOOD SUPPLEMENTS, NAMELY, ANTI-OXIDANTS; LIQUID NUTRITIONAL SUPPLEMENT; POWDERED NUTRITIONAL SUPPLEMENT DRINK MIX; VITAMIN AND MINERAL SUPPLEMENTS; VITAMIN SUPPLEMENT IN TABLET FORM FOR USE IN MAKING AN EFFERVESCENT BEVERAGE WHEN ADDED TO WATER; VITAMIN SUPPLEMENTS (U.S. CLS. 6, 18, 44, 46, 51 AND 52).

JAY FLOWERS, EXAMINING ATTORNEY

SN 85-602,927. CATLIN, GEORGE, AUSTIN, TX. FILED S.R. 4-19-2012; AM. P.R. 8-8-2012.

Withdrawal-Ease

THE MARK CONSISTS OF STANDARD CHARACTERS WITHOUT CLAIM TO ANY PARTICULAR FONT, STYLE, SIZE, OR COLOR.

FOR VITAMIN AND HERBAL SUPPLEMENT FOR THE ALLEVIATION OF OPIATE WITHDRAWAL (U.S. CLS. 6, 18, 44, 46, 51 AND 52).

FIRST USE 1-15-2009; IN COMMERCE 1-15-2009.

WENDY JUN, EXAMINING ATTORNEY

SN 85-603,502. WILLIAM C. CUMMINGS, LONG BEACH, CA. FILED 4-20-2012.

Hollywood Hangovers

THE MARK CONSISTS OF STANDARD CHARACTERS WITHOUT CLAIM TO ANY PARTICULAR FONT, STYLE, SIZE, OR COLOR.

NO CLAIM IS MADE TO THE EXCLUSIVE RIGHT TO USE "HANGOVERS", APART FROM THE MARK AS SHOWN.

FOR INTRAVENOUS FLUIDS USED FOR REHYDRATION, NUTRITION AND THE DELIVERY OF PHARMACEUTICAL PREPARATIONS (U.S. CLS. 6, 18, 44, 46, 51 AND 52).

IRA J. GOODSaid, EXAMINING ATTORNEY

CLASS 5—(Continued).

SN 85-604,016. WARD, PAULA MARIE L., RINGOES, NJ. FILED 4-20-2012.



NO CLAIM IS MADE TO THE EXCLUSIVE RIGHT TO USE "BEST", APART FROM THE MARK AS SHOWN.

THE MARK CONSISTS OF A CIRCULARLY LINED CIRCLE WITH RECTANGULARLY LINED BAR RUNNING HORIZONTALLY THROUGH THE CIRCULAR IMAGE, APPROXIMATELY DISSECTING THE CIRCLE IN HALF; CONTAINS A FIGURE IN THE UPPER SECTION HOLDING TOOLS WITH FAN RAYS OF ALTERNATING SHADE IN THE BACKGROUND; THE BRAND NAME "BRIGHTMAN'S BEST" IS INSCRIBED IN THE CENTER OF THE BAR; THE PHRASE "BEST FROM THE GROUND UP" IS INSCRIBED IN THE LOWER SECTION OF THE CIRCLE INTERIOR ON A SHADE BACKGROUND. THE GRAY IN THE MARK IS FOR SHADING PURPOSES ONLY AND DOES NOT INDICATE COLOR.

FOR HERBICIDES, INSECTICIDES, PESTICIDES AND FUNGICIDES FOR HOME, GARDEN AND LAWN USE AND FOR PROFESSIONAL USE (U.S. CLS. 6, 18, 44, 46, 51 AND 52).

FIRST USE 4-4-2012; IN COMMERCE 4-4-2012.

KATHLEEN M. VANSTON, EXAMINING ATTORNEY

SN 85-604,083. INSMED INCORPORATED, MONMOUTH JUNCTION, NJ. FILED 4-20-2012.

VONCERA

THE MARK CONSISTS OF STANDARD CHARACTERS WITHOUT CLAIM TO ANY PARTICULAR FONT, STYLE, SIZE, OR COLOR.

FOR PHARMACEUTICAL PREPARATIONS FOR THE TREATMENT OF RESPIRATORY DISEASES AND DISORDERS (U.S. CLS. 6, 18, 44, 46, 51 AND 52).

AHSEN KHAN, EXAMINING ATTORNEY

CLASS 5—(Continued).

SN 85-604,091. INSMED INCORPORATED, MONMOUTH JUNCTION, NJ. FILED 4-20-2012.

LONSPIRA

THE MARK CONSISTS OF STANDARD CHARACTERS WITHOUT CLAIM TO ANY PARTICULAR FONT, STYLE, SIZE, OR COLOR.

FOR PHARMACEUTICAL PREPARATIONS FOR THE TREATMENT OF RESPIRATORY DISEASES AND DISORDERS (U.S. CLS. 6, 18, 44, 46, 51 AND 52).

AHSEN KHAN, EXAMINING ATTORNEY

SN 85-604,172. CUREMARK, LLC, RYE, NY. FILED 4-20-2012.

LUMENENZ

THE MARK CONSISTS OF STANDARD CHARACTERS WITHOUT CLAIM TO ANY PARTICULAR FONT, STYLE, SIZE, OR COLOR.

OWNER OF U.S. REG. NO. 4,080,370.

FOR PHARMACEUTICAL PREPARATIONS FOR THE TREATMENT OF PERVASIVE DEVELOPMENT DISORDERS, DYSAUTONOMIAS, TOPICAL INFECTIONS, WOUNDS, ALOPECIA, CELIAC DISEASE AND INFLUENZA; PHARMACEUTICAL PREPARATIONS FOR THE TREATMENT OF MICROBIAL INFECTIONS, INCLUDING BACTERIAL, VIRAL AND PRION DISEASES; PHARMACEUTICAL PREPARATIONS FOR THE TREATMENT OF CYSTIC FIBROSIS, PANCREATIC DYSFUNCTION AND RELATED DISORDERS; PHARMACEUTICAL PREPARATIONS FOR THE TREATMENT OF NEUROPSYCHIATRIC AND MENTAL HEALTH DISORDERS (U.S. CLS. 6, 18, 44, 46, 51 AND 52).

AHSEN KHAN, EXAMINING ATTORNEY

SN 85-604,674. DREMU SALES, INC., AVENTURA, FL. FILED 4-22-2012.

Fireplay

THE MARK CONSISTS OF STANDARD CHARACTERS WITHOUT CLAIM TO ANY PARTICULAR FONT, STYLE, SIZE, OR COLOR.

FOR GELS FOR USE AS PERSONAL LUBRICANT; PERSONAL LUBRICANTS; PERSONAL SEXUAL LUBRICANTS; SEXUAL STIMULANT GELS; SILICONE-BASED PERSONAL LUBRICANTS; TOPICAL PREPARATIONS, NAMELY, GELS, CREAMS AND OILS FOR ENHANCING SEXUAL AROUSAL; WATER-BASED PERSONAL LUBRICANTS (U.S. CLS. 6, 18, 44, 46, 51 AND 52).

FIRST USE 1-1-2004; IN COMMERCE 1-1-2004.

THOMAS MANOR, EXAMINING ATTORNEY

CLASS 5—(Continued).

SN 85-604,874. TEVA WOMEN'S HEALTH, INC., WOOD-CLIFF LAKE, NJ. FILED 4-23-2012.

BITHENA

THE MARK CONSISTS OF STANDARD CHARACTERS WITHOUT CLAIM TO ANY PARTICULAR FONT, STYLE, SIZE, OR COLOR.

FOR PHARMACEUTICALS, NAMELY, A VAGINAL CREAM FOR THE TREATMENT OF SYMPTOMS ASSOCIATED WITH MENOPAUSE; PHARMACEUTICALS, NAMELY, A VAGINAL GEL FOR THE TREATMENT OF SYMPTOMS ASSOCIATED WITH MENOPAUSE (U.S. CLS. 6, 18, 44, 46, 51 AND 52).

MARY CRAWFORD, EXAMINING ATTORNEY

SN 85-605,076. NUTRAVALUE, LLC, YORBA LINDA, CA. FILED 4-23-2012.

NUTRAVALUE

THE MARK CONSISTS OF STANDARD CHARACTERS WITHOUT CLAIM TO ANY PARTICULAR FONT, STYLE, SIZE, OR COLOR.

FOR DIETARY AND NUTRITIONAL SUPPLEMENTS (U.S. CLS. 6, 18, 44, 46, 51 AND 52).

FIRST USE 6-0-2010; IN COMMERCE 6-0-2010.
JOHN WILKE, EXAMINING ATTORNEY

SN 85-605,111. BANNER PHARMACAPS INC., HIGH POINT, NC. FILED 4-23-2012.

ECOCAPS

THE MARK CONSISTS OF STANDARD CHARACTERS WITHOUT CLAIM TO ANY PARTICULAR FONT, STYLE, SIZE, OR COLOR.

FOR FILM FORMING COMPOSITIONS SOLD AS AN INTEGRAL COMPONENT OF CAPSULES, CAPLETS, TABLETS AND ENCAPSULATED LIQUID AND SEMI-SOLID PHARMACEUTICAL AND NUTRITIONAL PRODUCTS, NAMELY, ANALGESICS, ANTITUSSIVES, ANTI-INFLAMMATORIES, ANTIPYRETICS, ANTIHISTAMINES, DECONGESTANTS, VITAMINS AND DIETARY SUPPLEMENTS (U.S. CLS. 6, 18, 44, 46, 51 AND 52).

TOBY BULLOFF, EXAMINING ATTORNEY

CLASS 5—(Continued).

SN 85-605,185. COMPLETE NUTRITION IP, LLC, OMAHA, NE. FILED 4-23-2012.

ISO-Z5

THE MARK CONSISTS OF STANDARD CHARACTERS WITHOUT CLAIM TO ANY PARTICULAR FONT, STYLE, SIZE, OR COLOR.

FOR DIETARY AND NUTRITIONAL SUPPLEMENTS (U.S. CLS. 6, 18, 44, 46, 51 AND 52).

ALLISON SCHRODY, EXAMINING ATTORNEY

SN 85-605,453. THE PROCTER & GAMBLE COMPANY, CINCINNATI, OH. FILED 4-23-2012.

NEED SLEEP?

THE MARK CONSISTS OF STANDARD CHARACTERS WITHOUT CLAIM TO ANY PARTICULAR FONT, STYLE, SIZE, OR COLOR.

FOR SLEEP-AID PREPARATIONS (U.S. CLS. 6, 18, 44, 46, 51 AND 52).

VERNA BETH RIRIE, EXAMINING ATTORNEY

SN 85-605,614. AMERICAN CUSTOM COMPOUNDING PHARMACY, DBA AMERICAN CUSTOM COMPOUNDING PHARMACY, DALLAS, TX. FILED 4-23-2012.

LipoGenix

THE MARK CONSISTS OF STANDARD CHARACTERS WITHOUT CLAIM TO ANY PARTICULAR FONT, STYLE, SIZE, OR COLOR.

FOR DRUG DELIVERY AGENTS CONSISTING OF COMPOUNDS THAT FACILITATE DELIVERY OF A WIDE RANGE OF PHARMACEUTICALS; DRUG DELIVERY AGENTS IN THE FORM OF CAPSULES THAT PROVIDE CONTROLLED RELEASE OF THE ACTIVE INGREDIENTS FOR A WIDE VARIETY OF PHARMACEUTICALS; DRUG DELIVERY AGENTS IN THE FORM OF POWDERS THAT PROVIDE CONTROLLED RELEASE OF THE ACTIVE INGREDIENTS FOR A WIDE VARIETY OF PHARMACEUTICALS; DRUG DELIVERY AGENTS IN THE FORM OF TABLETS THAT PROVIDE CONTROLLED RELEASE OF THE ACTIVE INGREDIENTS FOR A WIDE VARIETY OF PHARMACEUTICALS; PHARMACEUTICAL PREPARATIONS, NAMELY, A DRUG DELIVERY SYSTEM COMPRISING POLYMER-BASED ORAL TABLETS FOR THE CONTINUOUS RELEASE OF A WIDE VARIETY OF THERAPEUTIC AGENTS (U.S. CLS. 6, 18, 44, 46, 51 AND 52).

SUNG IN, EXAMINING ATTORNEY

CLASS 5—(Continued).

SN 85-605,717. SHARK BRANDING CORP., NEW YORK, NY. FILED 4-23-2012.

CLASS 5—(Continued).

SN 85-605,767. PUGET SOUND DRUG CORPORATION, DBA KEY COMPOUNDING PHARMACY, FEDERAL WAY, WA. FILED 4-23-2012.

THE MOGULS GROUP

Just for you.

THE MARK CONSISTS OF STANDARD CHARACTERS WITHOUT CLAIM TO ANY PARTICULAR FONT, STYLE, SIZE, OR COLOR.

NO CLAIM IS MADE TO THE EXCLUSIVE RIGHT TO USE "GROUP", APART FROM THE MARK AS SHOWN.

FOR DIETARY AND NUTRITIONAL SUPPLEMENTS; DIETARY SUPPLEMENTAL DRINKS; DIETARY SUPPLEMENTAL DRINKS IN THE NATURE OF VITAMIN AND MINERAL BEVERAGES; NUTRITIONAL AND DIETARY SUPPLEMENTS FORMED AND PACKAGED AS BARS; NUTRITIONAL SUPPLEMENT IN THE NATURE OF A NUTRIENT-DENSE, PROTEIN-BASED DRINK MIX; NUTRITIONAL SUPPLEMENT SHAKES; NUTRITIONAL SUPPLEMENTS (U.S. CLS. 6, 18, 44, 46, 51 AND 52).

KERI CANTONE, EXAMINING ATTORNEY

THE MARK CONSISTS OF STANDARD CHARACTERS WITHOUT CLAIM TO ANY PARTICULAR FONT, STYLE, SIZE, OR COLOR.

FOR DENTAL COMPOUNDS USED IN ENDODONTIC PROCEDURES; DENTAL RESTORATION COMPOUNDS; DENTAL RESTORATION COMPOUNDS, NAMELY, DUAL CORE CEMENT; DRUG DELIVERY AGENTS IN THE FORM OF CAPSULES THAT PROVIDE CONTROLLED RELEASE OF THE ACTIVE INGREDIENTS FOR A WIDE VARIETY OF PHARMACEUTICALS; DRUG DELIVERY AGENTS IN THE FORM OF POWDERS THAT PROVIDE CONTROLLED RELEASE OF THE ACTIVE INGREDIENTS FOR A WIDE VARIETY OF PHARMACEUTICALS; DRUG DELIVERY AGENTS IN THE FORM OF TABLETS THAT PROVIDE CONTROLLED RELEASE OF THE ACTIVE INGREDIENTS FOR A WIDE VARIETY OF PHARMACEUTICALS; DRUG TESTING KITS COMPRISED OF MEDICAL DIAGNOSTIC REAGENTS AND ASSAYS FOR TESTING BODY FLUIDS; PHARMACEUTICAL PREPARATIONS, NAMELY, A DRUG DELIVERY SYSTEM COMPRISING POLYMER-BASED ORAL TABLETS FOR THE CONTINUOUS RELEASE OF A WIDE VARIETY OF THERAPEUTIC AGENTS; VETERINARY PHARMACEUTICAL COMPOUNDS FOR EQUINE USE TO TREAT CONDITIONS OF THE LEG, HOOF, EAR, NOSE AND THROAT (U.S. CLS. 6, 18, 44, 46, 51 AND 52).

FIRST USE 10-9-2011; IN COMMERCE 10-21-2011.

KRISTINA MORRIS, EXAMINING ATTORNEY

SN 85-605,738. ZAJAC, ROBERT A., SAN ANTONIO, TX. FILED 4-23-2012.

SN 85-605,822. ILUMI SCIENCES INC., MCLEAN, VA. FILED 4-23-2012.

Not So Diff

iLumi

THE MARK CONSISTS OF STANDARD CHARACTERS WITHOUT CLAIM TO ANY PARTICULAR FONT, STYLE, SIZE, OR COLOR.

FOR DIETARY FOOD SUPPLEMENTS (U.S. CLS. 6, 18, 44, 46, 51 AND 52).

MICHAEL KEATING, EXAMINING ATTORNEY

THE MARK CONSISTS OF STANDARD CHARACTERS WITHOUT CLAIM TO ANY PARTICULAR FONT, STYLE, SIZE, OR COLOR.

FOR COMPOSITE MATERIALS FOR DENTAL AND DENTAL TECHNICAL PURPOSES; DENTAL CEMENTS; DENTAL COMPOSITE MATERIALS (U.S. CLS. 6, 18, 44, 46, 51 AND 52).

PATRICIA EVANKO, EXAMINING ATTORNEY

CLASS 5—(Continued).

SN 85-605,835. ALLFROMTHE4TH LLC, SARASOTA, FL. FILED 4-23-2012.

AllFromThe4th

THE MARK CONSISTS OF STANDARD CHARACTERS WITHOUT CLAIM TO ANY PARTICULAR FONT, STYLE, SIZE, OR COLOR.

FOR DIETARY AND NUTRITIONAL SUPPLEMENTS; MINERAL, VITAMIN, OR NUTRITIONALLY ENHANCED WATER (U.S. CLS. 6, 18, 44, 46, 51 AND 52).

JEFF DEFORD, EXAMINING ATTORNEY

SN 85-605,924. VI NUTRITION, INC., AMERICAN FORK, UT. FILED 4-23-2012.



NUTRITION

NO CLAIM IS MADE TO THE EXCLUSIVE RIGHT TO USE "NUTRITION", APART FROM THE MARK AS SHOWN.

THE MARK CONSISTS OF A CIRCLE CONTAINING THE ROMAN NUMERALS "VI" WITH A LINE APPEARING ABOVE THE "VI". BELOW THE AFOREMENTIONED IS THE STYLIZED WORD "NUTRITION".

FOR DIETARY AND NUTRITIONAL SUPPLEMENTS (U.S. CLS. 6, 18, 44, 46, 51 AND 52).

FIRST USE 0-0-2011; IN COMMERCE 0-0-2011.

IRA J. GOODSAY, EXAMINING ATTORNEY

SN 85-605,927. FUTREXONLINE, INC, NORTH PALM BEACH, FL. FILED 4-23-2012.

Dynamic Fuel

THE MARK CONSISTS OF STANDARD CHARACTERS WITHOUT CLAIM TO ANY PARTICULAR FONT, STYLE, SIZE, OR COLOR.

FOR NUTRITIONAL SUPPLEMENTS; NUTRITIONAL SUPPLEMENTS IN THE FORM OF NUTRACEUTICAL POWDER, LIQUID, PILL, CAPSULE AND SUBLINGUAL FORM (U.S. CLS. 6, 18, 44, 46, 51 AND 52).

MATTHEW KLINE, EXAMINING ATTORNEY

CLASS 5—(Continued).

SN 85-607,157. BAD DRAGON ENTERPRISES, INC., PHOENIX, AZ. FILED 4-24-2012.



THE MARK CONSISTS OF AN ANTHROPOMORPHIC SCALED DRAGON INSIDE A CIRCLE WITH SEVERAL SPIKES ON HIS BACK, CLAWS, A LARGE HORN THAT PROTRUDES FROM HIS SKULL, AND A LARGE TAIL, AND THE TEXT "BAD DRAGON" ACROSS THE BOTTOM.

FOR PERSONAL LUBRICANTS (U.S. CLS. 6, 18, 44, 46, 51 AND 52).

FIRST USE 12-12-2007; IN COMMERCE 12-12-2007.

FRANK LATTUCA, EXAMINING ATTORNEY

SN 85-607,166. QORE SYSTEMS, LLC, TEMPE, AZ. FILED 4-24-2012.

QORE-24

THE MARK CONSISTS OF STANDARD CHARACTERS WITHOUT CLAIM TO ANY PARTICULAR FONT, STYLE, SIZE, OR COLOR.

FOR ANTIMICROBIAL COATINGS TO TREAT THE GROWTH OF MOLD, MILDEW, BACTERIA AND FUNGUS ON VARIOUS SURFACES; ANTIMICROBIALS FOR DERMATOLOGIC USE (U.S. CLS. 6, 18, 44, 46, 51 AND 52).

FIRST USE 10-1-2011; IN COMMERCE 12-1-2011.

RONALD AIKENS, EXAMINING ATTORNEY

CLASS 5—(Continued).

SN 85-607,183. QORE SYSTEMS, LLC, TEMPE, AZ. FILED 4-24-2012.

CLEAN-IQ

THE MARK CONSISTS OF STANDARD CHARACTERS WITHOUT CLAIM TO ANY PARTICULAR FONT, STYLE, SIZE, OR COLOR.

FOR ANTIMICROBIAL COATINGS TO TREAT THE GROWTH OF MOLD, MILDEW, BACTERIA AND FUNGUS ON VARIOUS SURFACES (U.S. CLS. 6, 18, 44, 46, 51 AND 52).

FIRST USE 10-1-2011; IN COMMERCE 12-1-2011.
RONALD AIKENS, EXAMINING ATTORNEY

SN 85-608,811. NUTRITION & FITNESS, INC., FAYETTEVILLE, NC. FILED 4-26-2012.

CARDIO DEFENDER

THE MARK CONSISTS OF STANDARD CHARACTERS WITHOUT CLAIM TO ANY PARTICULAR FONT, STYLE, SIZE, OR COLOR.

NO CLAIM IS MADE TO THE EXCLUSIVE RIGHT TO USE "CARDIO", APART FROM THE MARK AS SHOWN.

FOR DIETARY SUPPLEMENTS (U.S. CLS. 6, 18, 44, 46, 51 AND 52).

EMILY CHUO, EXAMINING ATTORNEY

SN 85-609,042. ILUMI SCIENCES INC., MCLEAN, VA. FILED 4-26-2012.

Lumi

THE MARK CONSISTS OF STANDARD CHARACTERS WITHOUT CLAIM TO ANY PARTICULAR FONT, STYLE, SIZE, OR COLOR.

FOR COMPOSITE MATERIALS FOR DENTAL AND DENTAL TECHNICAL PURPOSES; DENTAL CEMENTS; DENTAL COMPOSITE MATERIALS (U.S. CLS. 6, 18, 44, 46, 51 AND 52).

PATRICIA EVANKO, EXAMINING ATTORNEY

CLASS 5—(Continued).

SN 85-611,940. TARGET BRANDS, INC., MINNEAPOLIS, MN. FILED 4-30-2012.

UP & UP

THE MARK CONSISTS OF STANDARD CHARACTERS WITHOUT CLAIM TO ANY PARTICULAR FONT, STYLE, SIZE, OR COLOR.

OWNER OF U.S. REG. NOS. 3,786,202, 4,029,541 AND OTHERS.

FOR BABY FOOD; DISPOSABLE INCONTINENCE UNDERGARMENTS, BRIEFS, PROTECTIVE UNDERWEAR, ABSORBENT SHIELDS AND PADS; ADULT DIAPERS; MEDICATED HAIR CARE PREPARATIONS FOR HAIR GROWTH; DANDRUFF SHAMPOO; TEST STRIPS FOR MONITORING GLUCOSE LEVELS; CORN AND CALLUS PADS (U.S. CLS. 6, 18, 44, 46, 51 AND 52).

FIRST USE 4-0-2009; IN COMMERCE 4-0-2009.

JEAN IM, EXAMINING ATTORNEY

SN 85-611,966. TARGET BRANDS, INC., MINNEAPOLIS, MN. FILED 4-30-2012.



OWNER OF U.S. REG. NOS. 3,765,423, 4,042,816 AND OTHERS.

THE MARK CONSISTS OF AN ARROW DESIGN POINTING AT A 45 DEGREE DIAGONAL, UP AND TO THE RIGHT, WITH THE WORDS "UP & UP" INSIDE THE ARROW.

FOR BABY FOOD; DISPOSABLE INCONTINENCE UNDERGARMENTS, BRIEFS, PROTECTIVE UNDERWEAR, ABSORBENT SHIELDS AND PADS; ADULT DIAPERS; MEDICATED HAIR CARE PREPARATIONS FOR HAIR GROWTH; DANDRUFF SHAMPOO; TEST STRIPS FOR MONITORING GLUCOSE LEVELS; CORN AND CALLUS PADS (U.S. CLS. 6, 18, 44, 46, 51 AND 52).

FIRST USE 4-0-2009; IN COMMERCE 4-0-2009.

JEAN IM, EXAMINING ATTORNEY

CLASS 5—(Continued).

SN 85-614,066. BEACHBODY, LLC, SANTA MONICA, CA. FILED 5-2-2012.

NU BODY

THE MARK CONSISTS OF STANDARD CHARACTERS WITHOUT CLAIM TO ANY PARTICULAR FONT, STYLE, SIZE, OR COLOR.

FOR DIETARY, VITAMIN AND MINERAL SUPPLEMENTS; MEAL REPLACEMENT BARS, NAMELY, NUTRITIONAL MEAL REPLACEMENT BARS ADAPTED FOR MEDICAL USE FOR INDIVIDUALS UNDERGOING MEDICAL TREATMENTS, CHOCOLATE-BASED MEAL REPLACEMENT BARS FOR MEDICAL PURPOSES, FRUIT-BASED MEAL REPLACEMENT BARS FOR TREATING VITAMIN B12 DEFICIENCY THAT CAUSES FATIGUE; POWDERED NUTRITIONAL SUPPLEMENT DRINK MIX (U.S. CLS. 6, 18, 44, 46, 51 AND 52).

EMILY CHUO, EXAMINING ATTORNEY

CLASS 5—(Continued).

SN 85-621,800. BEACHBODY, LLC, SANTA MONICA, CA. FILED 5-10-2012.

E&E ENERGY AND ENDURANCE

THE MARK CONSISTS OF STANDARD CHARACTERS WITHOUT CLAIM TO ANY PARTICULAR FONT, STYLE, SIZE, OR COLOR.

NO CLAIM IS MADE TO THE EXCLUSIVE RIGHT TO USE "ENERGY AND ENDURANCE", APART FROM THE MARK AS SHOWN.

FOR DIETARY SUPPLEMENTS DRINKS; CHOCOLATE-BASED MEAL REPLACEMENT SHAKES FOR WEIGHT LOSS PURPOSES; MEAL REPLACEMENT BARS, NAMELY, NUTRITIONAL MEAL REPLACEMENT BARS ADAPTED FOR MEDICAL USE FOR INDIVIDUALS UNDERGOING MEDICAL TREATMENTS, CHOCOLATE-BASED MEAL REPLACEMENT BARS FOR MEDICAL PURPOSES, FRUIT-BASED MEAL REPLACEMENT BARS FOR TREATING VITAMIN B12 DEFICIENCY THAT CAUSES FATIGUE (U.S. CLS. 6, 18, 44, 46, 51 AND 52).

FIRST USE 1-10-2012; IN COMMERCE 1-10-2012.

EMILY CHUO, EXAMINING ATTORNEY

SN 85-622,095. NSE PRODUCTS, INC., PROVO, UT. FILED 5-10-2012.

AGELOC ALPHA

THE MARK CONSISTS OF STANDARD CHARACTERS WITHOUT CLAIM TO ANY PARTICULAR FONT, STYLE, SIZE, OR COLOR.

FOR DIETARY AND NUTRITIONAL SUPPLEMENTS; HERBAL SUPPLEMENTS; NUTRITIONAL SUPPLEMENTS; VITAMIN AND MINERAL SUPPLEMENTS; VITAMIN SUPPLEMENTS (U.S. CLS. 6, 18, 44, 46, 51 AND 52).

TRACY FLETCHER, EXAMINING ATTORNEY

SN 85-615,209. WEIDER GLOBAL NUTRITION, LLC, SALT LAKE CITY, UT. FILED 5-3-2012.

DICFIT

THE MARK CONSISTS OF STANDARD CHARACTERS WITHOUT CLAIM TO ANY PARTICULAR FONT, STYLE, SIZE, OR COLOR.

FOR DIETARY AND NUTRITIONAL SUPPLEMENTS; DIETARY SUPPLEMENTAL DRINKS; DIETARY SUPPLEMENTS; LIQUID NUTRITIONAL SUPPLEMENT; NUTRITIONAL SUPPLEMENTS (U.S. CLS. 6, 18, 44, 46, 51 AND 52).

MATTHEW GALAN, EXAMINING ATTORNEY

SN 85-623,531. NATROL, INC., CHATSWORTH, CA. FILED 5-11-2012.

THIN NOW

THE MARK CONSISTS OF STANDARD CHARACTERS WITHOUT CLAIM TO ANY PARTICULAR FONT, STYLE, SIZE, OR COLOR.

FOR DIETARY SUPPLEMENTS (U.S. CLS. 6, 18, 44, 46, 51 AND 52).

CURTIS FRENCH, EXAMINING ATTORNEY

CLASS 5—(Continued).

SN 85-631,646. THE PROCTER & GAMBLE COMPANY, CINCINNATI, OH. FILED 5-22-2012.



NO CLAIM IS MADE TO THE EXCLUSIVE RIGHT TO USE "HOLD", "SEAL", OR "COMFORT", APART FROM THE MARK AS SHOWN.

THE MARK CONSISTS OF THREE, GRADIENT SHADED, CURVING ARROWS OVERLAP TO FORM A CIRCLE. THE CENTER OF THE CIRCLE IS SOLID AND EACH OF THE ARROWS CONTAINS ONE OF THE WORDS "HOLD", "SEAL", "COMFORT".

FOR DENTURE ADHESIVES (U.S. CLS. 6, 18, 44, 46, 51 AND 52).

VERNA BETH RIRIE, EXAMINING ATTORNEY

SN 85-636,994. GEORGIA-PACIFIC CONSUMER PRODUCTS LP, ATLANTA, GA. FILED 5-29-2012.

PACIFIC CITRUS

THE MARK CONSISTS OF STANDARD CHARACTERS WITHOUT CLAIM TO ANY PARTICULAR FONT, STYLE, SIZE, OR COLOR.

OWNER OF U.S. REG. NO. 4,071,293.

NO CLAIM IS MADE TO THE EXCLUSIVE RIGHT TO USE "CITRUS", APART FROM THE MARK AS SHOWN.

FOR HAND-SANITIZING PREPARATIONS (U.S. CLS. 6, 18, 44, 46, 51 AND 52).

HANNO RITTNER, EXAMINING ATTORNEY

SN 85-645,218. CENTURY NATIONWIDE ENTERPRISES INC, OLIVEHURST, CA. FILED 6-6-2012.

CROWNED EAGLE

THE MARK CONSISTS OF STANDARD CHARACTERS WITHOUT CLAIM TO ANY PARTICULAR FONT, STYLE, SIZE, OR COLOR.

FOR POWDERED MILK FOR BABIES (U.S. CLS. 6, 18, 44, 46, 51 AND 52).

MARK SHINER, EXAMINING ATTORNEY

CLASS 5—(Continued).

SN 85-649,223. TEVA WOMEN'S HEALTH, INC., WOODCLIFF LAKE, NJ. FILED 6-12-2012.

GITERA

THE MARK CONSISTS OF STANDARD CHARACTERS WITHOUT CLAIM TO ANY PARTICULAR FONT, STYLE, SIZE, OR COLOR.

FOR PHARMACEUTICALS, NAMELY, CONTRACEPTIVES, ORAL CONTRACEPTIVES, HORMONE REPLACEMENT THERAPIES, AND HORMONAL AGENTS FOR TREATING DISORDERS AND CONDITIONS RELATED TO WOMEN'S HEALTH (U.S. CLS. 6, 18, 44, 46, 51 AND 52).

MARY CRAWFORD, EXAMINING ATTORNEY

SN 85-653,461. CHEMTURA CORPORATION, MIDDLEBURY, CT. FILED 6-15-2012.

DOUBLETAKE

THE MARK CONSISTS OF STANDARD CHARACTERS WITHOUT CLAIM TO ANY PARTICULAR FONT, STYLE, SIZE, OR COLOR.

FOR INSECTICIDES FOR USE IN AGRICULTURE (U.S. CLS. 6, 18, 44, 46, 51 AND 52).

CHRISTINA SOBRAL, EXAMINING ATTORNEY

SN 85-653,470. CHEMTURA CORPORATION, MIDDLEBURY, CT. FILED 6-15-2012.

ANNIHILATE

THE MARK CONSISTS OF STANDARD CHARACTERS WITHOUT CLAIM TO ANY PARTICULAR FONT, STYLE, SIZE, OR COLOR.

FOR INSECTICIDES FOR USE IN AGRICULTURE (U.S. CLS. 6, 18, 44, 46, 51 AND 52).

CHRISTINA SOBRAL, EXAMINING ATTORNEY

CLASS 5—(Continued).

SN 85-655,210. COMPLETE NUTRITION IP, LLC, OMAHA, NE. FILED 6-19-2012.

PRIME DRIVE

THE MARK CONSISTS OF STANDARD CHARACTERS WITHOUT CLAIM TO ANY PARTICULAR FONT, STYLE, SIZE, OR COLOR.

FOR DIETARY AND NUTRITIONAL SUPPLEMENTS (U.S. CLS. 6, 18, 44, 46, 51 AND 52).

ALLISON SCHRODY, EXAMINING ATTORNEY

SN 85-655,263. COMPLETE NUTRITION IP, LLC, OMAHA, NE. FILED 6-19-2012.

SEN-FRX

THE MARK CONSISTS OF STANDARD CHARACTERS WITHOUT CLAIM TO ANY PARTICULAR FONT, STYLE, SIZE, OR COLOR.

FOR DIETARY AND NUTRITIONAL SUPPLEMENTS (U.S. CLS. 6, 18, 44, 46, 51 AND 52).

ALLISON SCHRODY, EXAMINING ATTORNEY

SN 85-655,317. COMPLETE NUTRITION IP, LLC, OMAHA, NE. FILED 6-19-2012.

3PLENISH

THE MARK CONSISTS OF STANDARD CHARACTERS WITHOUT CLAIM TO ANY PARTICULAR FONT, STYLE, SIZE, OR COLOR.

FOR DIETARY AND NUTRITIONAL SUPPLEMENTS (U.S. CLS. 6, 18, 44, 46, 51 AND 52).

FIRST USE 5-1-2012; IN COMMERCE 5-1-2012.

ALLISON SCHRODY, EXAMINING ATTORNEY

CLASS 5—(Continued).

SN 85-668,102. BANNER PHARMACAPS INC., HIGH POINT, NC. FILED 7-3-2012.

SOLVATROL

THE MARK CONSISTS OF STANDARD CHARACTERS WITHOUT CLAIM TO ANY PARTICULAR FONT, STYLE, SIZE, OR COLOR.

FOR SOLUBLE COMPOSITIONS IN THE NATURE OF A DRUG RELEASE SYSTEM SOLD AS AN INTEGRAL COMPONENT OF ENCAPSULATED LIQUID AND SEMI-SOLID NUTRITIONAL AND PHARMACEUTICAL PREPARATIONS, NAMELY, ANALGESICS, ANTI-INFECTIVES, ANTIHISTAMINES, ANTI-PSYCHOTICS, ANTI-DEPRESSANTS, ANTACIDS, ANTI-VIRALS, ANTI-FUNGALS, ANTI-MICROBIALS, ANTI-TUSSIVES, DECONGESTANTS, IMMUNOSUPPRESSANTS, MALE AND FEMALE HORMONES, GASTROINTESTINALS, CARDIOVASCULARS, AND PREPARATIONS FOR TREATING DISEASES AND DISORDERS OF THE CENTRAL NERVOUS SYSTEM, HIV/AIDS, OBESITY, HIGH CHOLESTEROL, AND OSTEOPOROSIS (U.S. CLS. 6, 18, 44, 46, 51 AND 52).

TOBY BULLOFF, EXAMINING ATTORNEY

SN 85-673,200. WINDMILL HEALTH PRODUCTS LLC, WEST CALDWELL, NJ. FILED 7-10-2012.

TESTONOX

THE MARK CONSISTS OF STANDARD CHARACTERS WITHOUT CLAIM TO ANY PARTICULAR FONT, STYLE, SIZE, OR COLOR.

FOR DIETARY AND NUTRITIONAL SUPPLEMENTS (U.S. CLS. 6, 18, 44, 46, 51 AND 52).

KELLY BOULTON, EXAMINING ATTORNEY

SN 85-673,208. WINDMILL HEALTH PRODUCTS, LLC, WEST CALDWELL, NJ. FILED 7-10-2012.

TESTANOX

THE MARK CONSISTS OF STANDARD CHARACTERS WITHOUT CLAIM TO ANY PARTICULAR FONT, STYLE, SIZE, OR COLOR.

FOR DIETARY AND NUTRITIONAL SUPPLEMENTS (U.S. CLS. 6, 18, 44, 46, 51 AND 52).

KELLY BOULTON, EXAMINING ATTORNEY

CLASS 5—(Continued).

SN 85-679,120. MISSION PHARMACAL COMPANY, SAN ANTONIO, TX. FILED 7-17-2012.

**DIAPER RASH PROBLEM?
SOLVED.**

THE MARK CONSISTS OF STANDARD CHARACTERS WITHOUT CLAIM TO ANY PARTICULAR FONT, STYLE, SIZE, OR COLOR.

FOR PHARMACEUTICAL OINTMENT USED FOR THE PREVENTION AND TREATMENT OF RASH (U.S. CLS. 6, 18, 44, 46, 51 AND 52).

FIRST USE 6-1-2012; IN COMMERCE 6-1-2012.
EMILY CARLSEN, EXAMINING ATTORNEY

SN 85-684,350. INSITE VISION INCORPORATED, ALAMEDA, CA. FILED 7-23-2012.

BROMDEX

THE MARK CONSISTS OF STANDARD CHARACTERS WITHOUT CLAIM TO ANY PARTICULAR FONT, STYLE, SIZE, OR COLOR.

FOR EYE DROPS; PHARMACEUTICAL PREPARATIONS AND SUBSTANCES USED FOR THE TREATMENT OF INFLAMMATION AND PAIN IN THE EYE; AND PHARMACEUTICAL PREPARATIONS AND SUBSTANCES FOR USE IN THE PREVENTION OR TREATMENT OF DISEASES OR DISORDERS OF THE EYE (U.S. CLS. 6, 18, 44, 46, 51 AND 52).

MIDGE BUTLER, EXAMINING ATTORNEY

CLASS 6—METAL GOODS

SN 79-105,676. SCHOLTES FAMILY HOLDINGS PTY LTD, AUSTRALIA, FILED 10-20-2011.

Hexies

THE MARK CONSISTS OF STANDARD CHARACTERS WITHOUT CLAIM TO ANY PARTICULAR FONT, STYLE, SIZE, OR COLOR.

PRIORITY DATE OF 9-14-2011 IS CLAIMED.

OWNER OF INTERNATIONAL REGISTRATION 1098087 DATED 10-20-2011, EXPIRES 10-20-2021.

FOR METAL BUILDING MATERIALS, NAMELY, PRE-FABRICATED METAL SHEETS FOR SHED WALLS AND ROOFS AND FOR METAL RAISED GARDEN BEDS; METAL STRUCTURES, NAMELY, METAL SHEDS AND METAL RAISED GARDEN BEDS; FRAMES OF METAL, NAMELY, METAL FRAMES FOR METAL SHEDS AND METAL RAISED GARDEN BEDS; METAL ENCLOSURES, NAMELY, METAL RAISED GARDEN BEDS; METAL BUILDING COMPONENTS, NAMELY, PREFABRICATED METAL WALL AND ROOF PANELS AND METAL JOINERY FITTINGS FOR METAL SHEDS AND METAL RAISED GARDEN BEDS; GARDEN BED FRAMES OF METAL AND PRIMARILY OF METAL SPECIALLY DESIGNED FOR METAL GARDEN BEDS; METAL COMPONENTS SPECIALLY DESIGNED FOR METAL GARDEN BEDS, NAMELY, METAL FRAMES, METAL WALL PANELS AND METAL JOINERY FITTINGS; METAL GARDEN BEDS; METAL GARDEN BEDS IN KIT FORM, NAMELY, KITS FOR MAKING METAL GARDEN BEDS; RAISED GARDEN BEDS OF METAL; MODULAR GARDEN BEDS OF METAL; STRUCTURAL METAL COMPONENTS SPECIALLY DESIGNED FOR METAL GARDEN BEDS; METAL WALL, FLOOR AND ROOF PANELS; METAL PARTITIONS; METAL JOINERY FITTINGS; ACCESSORIES, PARTS AND FITTINGS FOR THE AFORESAID GOODS IN THIS CLASS, NAMELY, METAL SCREWS, METAL JOINERY FITTINGS, METAL BOLTS AND METAL BARS (U.S. CLS. 2, 12, 13, 14, 23, 25 AND 50).

JAMES MACFARLANE, EXAMINING ATTORNEY

SN 79-109,689. GROWERMETAL S.R.L., ITALY, FILED 1-26-2012.

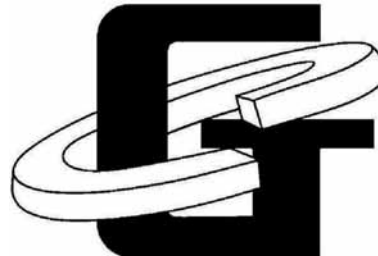

OWNER OF INTERNATIONAL REGISTRATION 1108148 DATED 1-26-2012, EXPIRES 1-26-2022.

THE MARK CONSISTS OF THE LETTER "G" WITH A SINGLE SPLIT LOCK WASHER AROUND IT.

FOR WASHERS MADE OF STEEL, CARBON STEEL, STAINLESS STEEL, BRONZE, ALUMINIUM, COPPER AND CORROSION-RESISTANT ALLOYS OF NICKEL AND CHROMIUM (U.S. CLS. 2, 12, 13, 14, 23, 25 AND 50).

RAMONA ORTIGA, EXAMINING ATTORNEY

CLASS 6—(Continued).

SN 85-346,024. NISSEI CO., LTD., YAMANASHI, JAPAN,
FILED 6-14-2011.

PERFECT LOCK BOLT

THE MARK CONSISTS OF STANDARD CHARACTERS
WITHOUT CLAIM TO ANY PARTICULAR FONT, STYLE,
SIZE, OR COLOR.

OWNER OF U.S. REG. NO. 4,089,977.

NO CLAIM IS MADE TO THE EXCLUSIVE RIGHT TO
USE "LOCK BOLT", APART FROM THE MARK AS SHOWN.
FOR METAL HARDWARE, NAMELY, BOLTS, NUTS,
AND BOLT-NUT COMBINATIONS (U.S. CLS. 2, 12, 13,
14, 23, 25 AND 50).

FIRST USE 6-1-2010; IN COMMERCE 6-1-2010.

REBECCA EISINGER, EXAMINING ATTORNEY

SN 85-410,214. AMERICAN UTILITY METALS LLC, BATON
ROUGE, LA. FILED 8-30-2011.



OWNER OF U.S. REG. NO. 3,242,953.
NO CLAIM IS MADE TO THE EXCLUSIVE RIGHT TO
USE "INTERNATIONAL", APART FROM THE MARK AS
SHOWN.

THE MARK CONSISTS OF THE LETTER "C" ON A
SHIELD ABOVE THE WORDS "CROMGARD INTERNA-
TIONAL".

FOR COMMON METALS AND THEIR ALLOYS,
NAMELY, STAINLESS STEEL IN SHEET, SLAB AND
COIL FORM (U.S. CLS. 2, 12, 13, 14, 23, 25 AND 50).

MARTHA SANTOMARTINO, EXAMINING ATTORNEY

SN 85-424,386. PILEPRO, LLC, AUSTIN, TX. FILED 9-16-2011.

ORIGAMI STEEL

THE MARK CONSISTS OF STANDARD CHARACTERS
WITHOUT CLAIM TO ANY PARTICULAR FONT, STYLE,
SIZE, OR COLOR.

NO CLAIM IS MADE TO THE EXCLUSIVE RIGHT TO
USE "STEEL", APART FROM THE MARK AS SHOWN.

FOR METAL SHEET PILES, METAL SHEET PILE
SECTIONS, AND METAL SHEET PILE CONNECTORS
FOR JOINING METAL SHEET PILES (U.S. CLS. 2, 12, 13,
14, 23, 25 AND 50).

LOURDES AYALA, EXAMINING ATTORNEY

CLASS 6—(Continued).

SN 85-427,615. WILLIAMS, JASON ALDINE, NASHVILLE,
TN. FILED 9-20-2011.

Jason Aldean

THE MARK CONSISTS OF STANDARD CHARACTERS
WITHOUT CLAIM TO ANY PARTICULAR FONT, STYLE,
SIZE, OR COLOR.

THE NAME(S), PORTRAIT(S), AND/OR SIGNATURE(S)
SHOWN IN THE MARK IDENTIFIES JASON ALDINE
WILLIAMS, P/K/A "JASON ALDEAN", WHOSE CON-
SENT(S) TO REGISTER IS MADE OF RECORD.

FOR METAL LICENSE PLATES (U.S. CLS. 2, 12, 13, 14,
23, 25 AND 50).

FIRST USE 7-1-1993; IN COMMERCE 7-1-1993.

AMY ALFIERI, EXAMINING ATTORNEY

SN 85-438,658. COSMIC ANT, LLC, LA JOLLA, CA. FILED 10-
4-2011.

COLLECTABELLS

THE MARK CONSISTS OF STANDARD CHARACTERS
WITHOUT CLAIM TO ANY PARTICULAR FONT, STYLE,
SIZE, OR COLOR.

FOR METAL BELLS (U.S. CLS. 2, 12, 13, 14, 23, 25 AND
50).

FIRST USE 3-7-2011; IN COMMERCE 3-7-2011.

GENE MACIOL, EXAMINING ATTORNEY

SN 85-444,281. ODOM CONSTRUCTION SYSTEMS, INC.,
KNOXVILLE, TN. FILED 10-11-2011.

OCSSTEEL

THE MARK CONSISTS OF STANDARD CHARACTERS
WITHOUT CLAIM TO ANY PARTICULAR FONT, STYLE,
SIZE, OR COLOR.

FOR METAL FRAMING MATERIALS, NAMELY,
WALL PANELS, FLOOR PANELS, ROOF TRUSSES,
METAL STUDS AND TRACK (U.S. CLS. 2, 12, 13, 14,
23, 25 AND 50).

LEIGH CAROLINE CASE, EXAMINING ATTORNEY

CLASS 6—(Continued).

SN 85-493,670. DJF CO., LTD., BUSAN, REPUBLIC OF KOREA, FILED 12-13-2011.



THE MARK CONSISTS OF A SPHERE WITH DIAGONAL PARALLEL LINES AND THE LETTERS "D", "J" AND "F" APPEAR TO THE RIGHT OF THE SPHERE.

FOR FLANGES OF METAL; METAL IN THE FORM OF SHEETS AND PLATES FOR FURTHER MANUFACTURE (U.S. CLS. 2, 12, 13, 14, 23, 25 AND 50).

ELISSA GARBER KON, EXAMINING ATTORNEY

SN 85-515,326. DAVIS, DON, COLORADO SPRINGS, CO. FILED 1-12-2012.



NO CLAIM IS MADE TO THE EXCLUSIVE RIGHT TO USE "ROOF", APART FROM THE MARK AS SHOWN.

THE MARK CONSISTS OF THE LITERAL ELEMENTS "ROOF ANGEL" WHEREIN THERE IS AN IMAGE OF LADDER WITH WINGS ABOVE WHICH THERE IS RING AND AT THE BOTTOM OF LADDER THERE IS PLACED CLOUD WITH WORDS "ROOF ANGEL" AS SHOWN IN THE MARK.

FOR METAL STABILIZERS FOR LADDERS (U.S. CLS. 2, 12, 13, 14, 23, 25 AND 50).

JANICE KIM, EXAMINING ATTORNEY

CLASS 6—(Continued).

SN 85-548,039. JODAN (AUST) PTY LTD., CLOVELLY PARK SA, AUSTRALIA, FILED 2-21-2012.

AQUAMATE

THE MARK CONSISTS OF STANDARD CHARACTERS WITHOUT CLAIM TO ANY PARTICULAR FONT, STYLE, SIZE, OR COLOR.

OWNER OF AUSTRALIA REG. NO. 1305692, DATED 5-6-2010. EXPIRES 6-29-2019.

FOR METAL WATER TANKS (U.S. CLS. 2, 12, 13, 14, 23, 25 AND 50).

ARETHA SOMERVILLE, EXAMINING ATTORNEY

SN 85-592,862. PRYOR PRODUCTS, OCEANSIDE, CA. FILED 4-9-2012.

CENTER G

THE MARK CONSISTS OF STANDARD CHARACTERS WITHOUT CLAIM TO ANY PARTICULAR FONT, STYLE, SIZE, OR COLOR.

FOR METAL STANDS FOR SUPPORTING A LOAD (U.S. CLS. 2, 12, 13, 14, 23, 25 AND 50).

FIRST USE 5-22-2012; IN COMMERCE 5-22-2012.

JAY FLOWERS, EXAMINING ATTORNEY

SN 85-598,499. THE GATES CORPORATION, DENVER, CO. FILED 4-16-2012.

ILOK

THE MARK CONSISTS OF STANDARD CHARACTERS WITHOUT CLAIM TO ANY PARTICULAR FONT, STYLE, SIZE, OR COLOR.

FOR METAL HOSE COUPLINGS FOR USE WITH HYDRAULIC HOSE AND HYDRAULIC HOSE ASSEMBLIES (U.S. CLS. 2, 12, 13, 14, 23, 25 AND 50).

MICHAEL ENGEL, EXAMINING ATTORNEY

CLASS 6—(Continued).

SN 85-600,190. BIRD-B-GONE, INC., MISSION VIEJO, CA.
FILED 4-17-2012.

ENVIRO SPIKE

THE MARK CONSISTS OF STANDARD CHARACTERS WITHOUT CLAIM TO ANY PARTICULAR FONT, STYLE, SIZE, OR COLOR.

NO CLAIM IS MADE TO THE EXCLUSIVE RIGHT TO USE "SPIKE", APART FROM THE MARK AS SHOWN.

FOR BIRD DETERRENT DEVICES, NAMELY, DEVICES HAVING A PLURALITY OF METAL SPIKES FOR PREVENTING BIRDS FROM LANDING AND PERCHING (U.S. CLS. 2, 12, 13, 14, 23, 25 AND 50).

CHRISTINA SOBRAL, EXAMINING ATTORNEY

SN 85-602,138. JEANETTE PARKER HEARN, CAPE GIRARDEAU, MO. FILED 4-19-2012.

IDENTIFY ME ID

THE MARK CONSISTS OF STANDARD CHARACTERS WITHOUT CLAIM TO ANY PARTICULAR FONT, STYLE, SIZE, OR COLOR.

NO CLAIM IS MADE TO THE EXCLUSIVE RIGHT TO USE "IDENTIFY" AND "ID", APART FROM THE MARK AS SHOWN.

FOR METAL IDENTIFICATION BRACELETS (U.S. CLS. 2, 12, 13, 14, 23, 25 AND 50).

LINDA M. KING, EXAMINING ATTORNEY

SN 85-602,238. PREMIUM PROTECTIVE COATINGS LLC, DBA PREMIUM PROTECTIVE COATINGS, PALMYRA, PA. FILED 4-19-2012.

PERMANENT POST

THE MARK CONSISTS OF STANDARD CHARACTERS WITHOUT CLAIM TO ANY PARTICULAR FONT, STYLE, SIZE, OR COLOR.

NO CLAIM IS MADE TO THE EXCLUSIVE RIGHT TO USE "POST", APART FROM THE MARK AS SHOWN.

FOR METAL POSTS EXCLUDING MARKER POSTS FOR IDENTIFYING UNDERGROUND UTILITY LINES (U.S. CLS. 2, 12, 13, 14, 23, 25 AND 50).

JOHN HWANG, EXAMINING ATTORNEY

CLASS 6—(Continued).

SN 85-603,483. ULTRA-TEC CORPORATION, CARSON CITY, NV. FILED 4-20-2012.

PUSH-LOCK

THE MARK CONSISTS OF STANDARD CHARACTERS WITHOUT CLAIM TO ANY PARTICULAR FONT, STYLE, SIZE, OR COLOR.

FOR METAL FASTENING AND TENSIONING DEVICES, NAMELY OF RAILINGS, GUARDRAILS, HANDRAILS AND FENCING, NAMELY NUTS, BOLTS, EYES AND TUBES CONTAINING LOCKING DEVICES (U.S. CLS. 2, 12, 13, 14, 23, 25 AND 50).

FIRST USE 9-6-2006; IN COMMERCE 9-6-2006.

JOHN HWANG, EXAMINING ATTORNEY

SN 85-603,486. ULTRA-TEC CORPORATION, CARSON CITY, NV. FILED 4-20-2012.

PULL-LOCK

THE MARK CONSISTS OF STANDARD CHARACTERS WITHOUT CLAIM TO ANY PARTICULAR FONT, STYLE, SIZE, OR COLOR.

FOR METAL FASTENING AND TENSIONING DEVICES, NAMELY OF RAILINGS, GUARDRAILS, HANDRAILS AND FENCING, NAMELY NUTS, BOLTS, EYES AND TUBES CONTAINING LOCKING DEVICES (U.S. CLS. 2, 12, 13, 14, 23, 25 AND 50).

FIRST USE 9-6-2006; IN COMMERCE 9-6-2006.

JOHN HWANG, EXAMINING ATTORNEY

CLASS 7—MACHINERY

SN 76-709,319. TOMAHAWK MANUFACTURING INC., SHEBOYGAN, WI. FILED 10-5-2011.

FOT

THE MARK CONSISTS OF STANDARD CHARACTERS WITHOUT CLAIM TO ANY PARTICULAR FONT, STYLE, SIZE, OR COLOR.

FOR FOOD PROCESSING MACHINES FOR ACHIEVING BETTER MEAT QUALITY, NAMELY, MACHINES FOR MOLDING, STACKING, SCORING, AND ROLLING OF MEAT PRODUCTS, AND MACHINES FOR GRINDING MEAT PRODUCTS AND PARTS THEREOF (U.S. CLS. 13, 19, 21, 23, 31, 34 AND 35).

TRACY FLETCHER, EXAMINING ATTORNEY

SN 76-710,870. L & B MANUFACTURING, INC., BROWNSDALE, MN. FILED 3-12-2012.

ROWBASKET

THE MARK CONSISTS OF STANDARD CHARACTERS WITHOUT CLAIM TO ANY PARTICULAR FONT, STYLE, SIZE, OR COLOR.

FOR AGRICULTURE IMPLEMENTS, NAMELY, GROUND CONDITIONING DEVICES IN THE FORM OF ROLLING BASKET HARROW DEVICES THAT ARE GENERALLY IN THE SHAPE OF OPEN, ROUND CAGE-LIKE STRUCTURES FOR CONDITIONING SOIL PRIOR TO PLANTING (U.S. CLS. 13, 19, 21, 23, 31, 34 AND 35).

FIRST USE 8-12-2010; IN COMMERCE 4-25-2011.
DAVID HOFFMAN, EXAMINING ATTORNEY

CLASS 7—(Continued).

SN 79-103,091. EUROBOTS GMBH, FED REP GERMANY, FILED 6-10-2011.

EUROBOTS

THE MARK CONSISTS OF STANDARD CHARACTERS WITHOUT CLAIM TO ANY PARTICULAR FONT, STYLE, SIZE, OR COLOR.

PRIORITY DATE OF 12-23-2010 IS CLAIMED.

OWNER OF INTERNATIONAL REGISTRATION 1092171 DATED 6-10-2011, EXPIRES 6-10-2021.

FOR PARTS OF STEAM CLEANING MACHINES, NAMELY, STEAM TRAPS; ELECTRIC WAX POLISHING MACHINES FOR HOUSEHOLD AND INDUSTRIAL FLOORS; IRONING MACHINES, NAMELY, ELECTRIC CLOTHING PRESSING MACHINES FOR COMMERCIAL DRY CLEANING AND LAUNDRY PURPOSES INCLUDING SHIRT PRESS, COLLAR AND CUFF PRESS, UTILITY PRESS, LEGGER PRESS, DRAPERY PRESS, PANTS TOPPER, MUSHROOM TOPPER AND PUFF IRON; CLEANING APPARATUS UTILIZING STEAM, NAMELY, STEAM CLEANING MACHINES; ELECTRICALLY OPERATED BRUSHES BEING PARTS OF MACHINES; ELECTRIC SHOE POLISHERS; ELECTRIC FOOD PROCESSORS; DUST REMOVING INSTALLATIONS FOR CLEANING, NAMELY, VACUUM CLEANERS FOR REMOVING DUST; HIGH-PRESSURE CLEANERS, NAMELY, HIGH PRESSURE WASHING MACHINES, HIGH PRESSURE SURFACE AND WALL CLEANING MACHINES; LIFTING APPARATUS, NAMELY, LIFTING INSTALLATIONS FOR THE TRANSPORT OF PERSONS AND GOODS; ELECTRIC KITCHEN MACHINES, NAMELY, FOR CHOPPING, GRATING, MINCING, GRINDING, MILLING, PRESSING, CUTTING, MIXING, KNEADING, SLICING, EMULSIFYING, LIQUEFYING, BEATING OR PEELING FOOD; CENTRIFUGES, FOOD PROCESSORS, ELECTRIC CAN-OPENERS; POWER-OPERATED MOWING AND REAPING MACHINES; EDIBLE PASTE MAKING MACHINES; GARBAGE DISPOSALS; MACHINES, NAMELY, LAWNMOWERS; ELECTRIC MACHINES AND APPARATUS FOR CLEANING, NAMELY, FLOOR CLEANING ROBOTS, DISH WASHING MACHINES, DRY-CLEANING MACHINES, SHOE CLEANING MACHINES, CARPET CLEANING MACHINES, FLOOR CLEANING MACHINES, CAR CLEANING MACHINES, WINDOW CLEANING MACHINES, CLOTHES WASHING MACHINES; ROBOTS, NAMELY, INDUSTRIAL ROBOTS, INDUSTRIAL SEWING ROBOTS, ROBOTS FOR CLEANING WINDOWS, MOWING LAWNS AND CLEANING SNOW; ELECTRIC MACHINES AND APPARATUS FOR CARPET SHAMPOOING; RINSING MACHINES, NAMELY, CLOTHES RINSING MACHINES, BOTTLE RINSING MACHINES; DUST EXHAUSTING INSTALLATIONS FOR CLEANING PURPOSES, NAMELY, DUST SEPARATORS BEING PNEUMATIC CLEANING DEVICES FOR USE IN BLOWING DUST OFF PARTS, WORKSTATIONS OR WHEREVER NECESSARY; VACUUM CLEANERS; SELF-PROPELLED ROAD SWEEPING MACHINES; ELECTROMECHANICAL BEVERAGE PREPARATION MACHINES, NAMELY, BEVERAGE BLENDERS (U.S. CLS. 13, 19, 21, 23, 31, 34 AND 35).
APRIL ROACH, EXAMINING ATTORNEY

CLASS 7—(Continued).

SN 79-106,779. MINIPAN S.R.L., ITALY, FILED 10-13-2011.

MULTIPAN

THE MARK CONSISTS OF STANDARD CHARACTERS WITHOUT CLAIM TO ANY PARTICULAR FONT, STYLE, SIZE, OR COLOR.

PRIORITY DATE OF 4-20-2011 IS CLAIMED.

OWNER OF INTERNATIONAL REGISTRATION 1100705 DATED 10-13-2011, EXPIRES 10-13-2021.

OWNER OF U.S. REG. NO. 4,027,664.

FOR AUTOMATIC MACHINES FOR BAKERY AND CONFECTIONERY, NAMELY, MACHINES FOR PROCESSING DOUGH AND PASTES, MACHINES FOR FORMING BISCUITS AND COOKIES, MACHINES FOR FORMING BREAD, BREADSTICKS AND BREAD SNACKS, MACHINES FOR EXTRUDING AND WIRE CUTTING BISCUITS, COOKIES AND BREAD SNACKS, MACHINES FOR FILLING BISCUITS AND COOKIES, MACHINES FOR DEPOSITING CREAMS, JAMS, SUGAR AND TOPPINGS UPON BISCUITS AND COOKIES, MACHINES FOR PLACING BISCUITS, COOKIES, BREAD AND BREAD SNACKS UPON TRAYS; LOADERS AND CONVEYORS BEING INTEGRATED WITH MACHINES FOR PROCESSING BAKERY AND CONFECTIONERY PRODUCTS; AUTOMATIC MOULDING MACHINES, NAMELY, MACHINES FOR CREATING SHAPES OF BISCUITS, COOKIES, BREAD, BREADSTICKS AND BREAD SNACKS; AUTOMATIC REFINING BAKERY MACHINES, NAMELY, MACHINES FOR THE LAMINATION OF FLAT BREADS, CRACKERS, BREADSTICKS AND BREAD SNACKS, MACHINES FOR DEPOSITING SPICES, SALT, SUGAR, SESAME, POPPY SEEDS AND TOPPINGS UPON BREAD, BREADSTICKS AND BREAD SNACKS; MACHINES IN THE NATURE OF MECHANICAL SYRINGES FOR FORMING BISCUITS (U.S. CLS. 13, 19, 21, 23, 31, 34 AND 35).

CHARLOTTE CORWIN, EXAMINING ATTORNEY

CLASS 7—(Continued).

SN 79-107,338. OLIVOTTO GLASS TECHNOLOGIES S.P.A., ITALY, FILED 12-7-2011.

OLIVOTTO GLASS TECHNOLOGIES

PRIORITY DATE OF 9-21-2011 IS CLAIMED.

OWNER OF INTERNATIONAL REGISTRATION 1102103 DATED 12-7-2011, EXPIRES 12-7-2021.

NO CLAIM IS MADE TO THE EXCLUSIVE RIGHT TO USE "GLASS TECHNOLOGIES", APART FROM THE MARK AS SHOWN.

FOR MACHINES FOR WORKING GLASS; MACHINES FOR THE PRODUCTION OF GLASS ARTICLES; MACHINES FOR THE PRODUCTION OF GLASS BY MEANS OF BLOWING; GLASS GRINDING MACHINES; GLASS CUTTING MACHINES; MECHANICAL AND HYDRAULIC PRESSES FOR PROCESSING OF GLASS (U.S. CLS. 13, 19, 21, 23, 31, 34 AND 35).

TRACY WHITTAKER-BROWN, EXAMINING ATTORNEY

SN 79-107,645. COMEXI GROUP INDUSTRIES, S.A.U, RIUDELLOTS DE LA SELVA, SPAIN, FILED 7-27-2011.

COMEXI

THE MARK CONSISTS OF STANDARD CHARACTERS WITHOUT CLAIM TO ANY PARTICULAR FONT, STYLE, SIZE, OR COLOR.

PRIORITY DATE OF 6-15-2011 IS CLAIMED.

OWNER OF INTERNATIONAL REGISTRATION 1102883 DATED 7-27-2011, EXPIRES 7-27-2021.

OWNER OF U.S. REG. NO. 2,891,115.

THE WORDING "COMEXI" HAS NO MEANING IN A FOREIGN LANGUAGE.

FOR ROTARY PRINTING MACHINES; AUTOMATIC ELECTRIC WELDING MACHINES; MACHINE PARTS AND FITTINGS THEREOF NOT INCLUDED IN OTHER CLASSES, NAMELY, BEARINGS, BLADES, ROLLER BEARINGS; METAL WORKING MACHINES, NAMELY, CUTTERS AND CUTTERS-REWINDERS FOR SLITTING PLASTIC, FILMS PAPERS, CELLULOSE FILMS, LAMINATES, SUPPORTED AND UNSUPPORTED ALUMINUM FOIL, AND SIMILAR MATERIALS; VULCANIZING PRESSES FOR PLASTIC, PLASTIC FILMS, PAPERS, CELLULOSE FILMS, LAMINATES AND ALUMINUM FOIL; INDUSTRIAL LAMINATION MACHINES FOR LAMINATION OF PAPERS; CLICHE FIXING MACHINES FOR SEALING, PACKAGING, CONVERTING AND PRINTING; FLEXOGRAPHIC PRINTING AND CONVERTING PRESSES; COLOR IMPRESSION FLEXOGRAPHIC PRINTING AND CONVERTING PRESSES; MACHINES FOR GRAPHIC ART, PAPER AND CARDBOARD HANDLING, NAMELY, PRINTING PRESSES AND PRINTING MACHINES, PACKAGING MACHINES, PRINT CONVERTING MACHINES AND CARTON SEALING MACHINES (U.S. CLS. 13, 19, 21, 23, 31, 34 AND 35).

NATALIE POLZER, EXAMINING ATTORNEY

SN 79-107,231. DANTEX GRAPHICS LIMITED, UNITED KINGDOM, FILED 11-28-2011.

AQUAFLEX ECO

THE MARK CONSISTS OF STANDARD CHARACTERS WITHOUT CLAIM TO ANY PARTICULAR FONT, STYLE, SIZE, OR COLOR.

PRIORITY DATE OF 6-29-2011 IS CLAIMED.

OWNER OF INTERNATIONAL REGISTRATION 1101794 DATED 11-28-2011, EXPIRES 11-28-2021.

OWNER OF U.S. REG. NO. 1,753,600.

FOR PRINTING MACHINES; PRINTING PLATES; APPARATUS FOR MAKING PRINTING PLATES, NAMELY, PLATE PRINTING MACHINES; FLEXOGRAPHIC PRINTING PLATES; LITHOGRAPHIC PRINTING PLATES; WATER WASH PRINTING PLATES; LETTERPRESS PRINTING PLATES; MACHINES FOR THE DEVELOPING OF SENSITIZED PRINTING PLATES; MACHINES FOR PROCESSING PRINTING PLATES; MACHINES FOR MAKING PRINTING PLATES; PRINTING MACHINES FOR HANDLING, TRANSPORTING AND MOUNTING PRINTING PLATES; APPARATUS FOR PRINTING, NAMELY, PRINTING PRESSES; MACHINES FOR USE IN THE PRINTING INDUSTRY, NAMELY, INDUSTRIAL PRINTING MACHINES; PARTS AND FITTINGS FOR THE AFORESAID GOODS (U.S. CLS. 13, 19, 21, 23, 31, 34 AND 35).

AHSEN KHAN, EXAMINING ATTORNEY

CLASS 7—(Continued).

SN 79-108,159. TEEPACK SPEZIALMASCHINEN GMBH & CO. KG, 40667 MEERBUSCH, FED REP GERMANY, FILED 11-3-2011.

PERFECTA 

PRIORITY DATE OF 5-5-2011 IS CLAIMED.
 OWNER OF INTERNATIONAL REGISTRATION 1104288 DATED 11-3-2011, EXPIRES 11-3-2021.
 OWNER OF U.S. REG. NO. 3,505,457.
 THE MARK CONSISTS OF THE STYLIZED WORDING "PERFECTA" AND DESIGN OF A TEABAG.
 FOR TEA FILLING AND PACKAGING MACHINES AND PARTS THEREOF (U.S. CLS. 13, 19, 21, 23, 31, 34 AND 35).
 GENE MACIOL, EXAMINING ATTORNEY

SN 79-108,181. TEEPACK SPEZIALMASCHINEN GMBH & CO. KG, 40667 MEERBUSCH, FED REP GERMANY, FILED 11-3-2011.

ZENOBI 

PRIORITY DATE OF 5-5-2011 IS CLAIMED.
 OWNER OF INTERNATIONAL REGISTRATION 1104338 DATED 11-3-2011, EXPIRES 11-3-2021.
 OWNER OF U.S. REG. NO. 3,318,759.
 THE MARK CONSISTS OF THE STYLIZED WORDING "ZENOBI" AND DESIGN OF A BAG.
 FOR FILLING MACHINES, PACKING MACHINES AND PARTS THEREOF (U.S. CLS. 13, 19, 21, 23, 31, 34 AND 35).
 GENE MACIOL, EXAMINING ATTORNEY

CLASS 7—(Continued).

SN 79-108,424. MILLUTENSIL S.R.L., I-20124 MILANO, ITALY, FILED 8-4-2011.



PRIORITY DATE OF 6-24-2011 IS CLAIMED.
 OWNER OF INTERNATIONAL REGISTRATION 1104954 DATED 8-4-2011, EXPIRES 8-4-2021.
 THE MARK CONSISTS OF THE TERM "MILLUTENSIL" IN SPECIAL SCRIPT COMBINED WITH THE LETTER "M" POSITIONED INTO A CIRCULAR PROFILE.
 FOR PRESSES, NAMELY, HYDRAULIC PRESSES; DIE AND MOULD SPOTTING PRESSES, NAMELY, TRY-OUT PRESSES; DIE-SPLITTERS, NAMELY, DIE-STAMPING MACHINES; MATERIAL HANDLING MACHINES, NAMELY, STACKERS; METAL WORKING MACHINES, NAMELY, DECOILERS, STRAIGHTENERS, ROLL FEEDS, POWER-OPERATED SHEARS; LIFTING TROLLEYS, NAMELY, HYDRAULIC LIFT TABLES; METAL WORKING MACHINES, NAMELY, FELT LUBRICATORS FOR SHEET METAL; METAL WORKING MACHINES, NAMELY, LUBRICATORS WITH BRUSH ROLLER FOR SHEET METAL; METAL WORKING MACHINES, NAMELY, SPRAY LUBRICATORS FOR SHEET METAL; CONVEYOR LINES; PUNCHING SYSTEMS, NAMELY, PUNCHING PRESSES FOR METAL WORKING; METAL WORKING MACHINES, NAMELY, CUTTING LINES FOR SHEET METAL; METAL WORKING MACHINES, NAMELY, CUT-TO-LENGTH LINES FOR SHEET METAL; METAL WORKING MACHINES, NAMELY, SLITTING LINES FOR SHEET METAL; METAL WORKING MACHINES, NAMELY, FEEDING LINES FOR SHEET METAL (U.S. CLS. 13, 19, 21, 23, 31, 34 AND 35).
 MARK SHINER, EXAMINING ATTORNEY

SN 85-317,119. BONELL MANUFACTURING COMPANY, RIVERDALE, IL. FILED 5-10-2011.



THE COLOR(S) DARK BLUE, ORANGE, BLACK IS/ARE CLAIMED AS A FEATURE OF THE MARK.
 THE MARK CONSISTS OF AN ORANGE DIAMOND WITH A DARK BLUE CAPITAL "B" IN THE CENTER FORMED WITH TWO CIRCLES INSIDE THE LETTER "B" AND WITH A SMALLER BLACK CAPITAL "M" TO THE LEFT OF THE "B" INSIDE THE DIAMOND AND A SMALLER BLACK CAPITAL "C" TO THE RIGHT OF THE "B" INSIDE THE DIAMOND.
 FOR MACHINERY PARTS, NAMELY, INDUSTRIAL ROLLS AND ROLLERS FOR USE IN STEEL MILLS, ALUMINUM AND NON-FERROUS MILLS, PAPER MILLS, AND THE LIKE TO FLATTEN METAL AND PAPER, FEED METAL AND PAPER (U.S. CLS. 13, 19, 21, 23, 31, 34 AND 35).
 FIRST USE 6-19-1967; IN COMMERCE 6-19-1967.
 REBECCA GILBERT, EXAMINING ATTORNEY

CLASS 7—(Continued).

SN 85-318,720. TENNANT COMPANY, MINNEAPOLIS, MN. FILED 5-11-2011.



OWNER OF U.S. REG. NOS. 3,901,861 AND 3,948,801. NO CLAIM IS MADE TO THE EXCLUSIVE RIGHT TO USE "H2O" OR "TECHNOLOGY", APART FROM THE MARK AS SHOWN.

THE MARK CONSISTS OF THE LETTERS "EC H2O" WITH A SUBSCRIPT "2" AND A DOUBLE SWIRL DESIGN AROUND THE "EC" BUT NOT CONNECTED AND STOPPING BEFORE THE UPPER AND LOWER SIDES OF THE "H2O" WITH THE WORDS "AN ORBIO TECHNOLOGY" UNDERNEATH THE "H2O".

FOR CLEANING MACHINES THAT ELECTRICALLY ACTIVATE WATER FOR THE PURPOSE OF CLEANING, SANITIZING AND DISINFECTING SURFACES (U.S. CLS. 13, 19, 21, 23, 31, 34 AND 35).

FIRST USE 9-30-2010; IN COMMERCE 9-30-2010. JESSICA A. POWERS, EXAMINING ATTORNEY

SN 85-328,938. CHARLES AUSTEN PUMPS LIMITED, BY-FLEET, SURREY, UNITED KINGDOM, FILED 5-24-2011.

ENVIR-O

THE MARK CONSISTS OF STANDARD CHARACTERS WITHOUT CLAIM TO ANY PARTICULAR FONT, STYLE, SIZE, OR COLOR.

FOR PUMPS FOR USE IN SEWAGE TREATMENT SYSTEMS; PUMPS FOR USE IN AQUATIC SYSTEMS; PUMPS FOR USE IN HYDROPHONIC SYSTEMS; COMPRESSORS, NAMELY, COMPRESSORS FOR USE IN SEWAGE TREATMENT SYSTEMS, COMPRESSORS FOR USE IN AQUATIC SYSTEMS, AND COMPRESSORS FOR USE IN HYDROPHONIC SYSTEMS, BUT NOT INCLUDING COMPRESSORS FOR AIR CONDITIONERS; ENGINES AND MOTORS, NONE BEING FOR LAND VEHICLES; AND PARTS AND FITTINGS FOR THE AFORESAID GOODS (U.S. CLS. 13, 19, 21, 23, 31, 34 AND 35).

SUSAN RICHARDS, EXAMINING ATTORNEY

CLASS 7—(Continued).

SN 85-370,050. PREMIER PALLET SYSTEMS LIMITED, NORFOLK, UNITED KINGDOM, FILED 7-13-2011.



PRIORITY CLAIMED UNDER SEC. 44(D) ON UNITED KINGDOM APPLICATION NO. 2584509, FILED 6-14-2011.

OWNER OF UNITED KINGDOM REG. NO. 2584509, DATED 9-16-2011, EXPIRES 6-14-2021.

THE COLOR(S) BLACK AND BLUE IS/ARE CLAIMED AS A FEATURE OF THE MARK.

THE MARK CONSISTS OF THE WORD "PREMIER" WITH THE SECOND "E" BACKWARDS, IN BLACK BENEATH AN ARROW IN THE SHAPE OF AN ARCH IN BLUE.

FOR MACHINES AND MACHINE TOOLS ALL FOR MATERIALS HANDLING AND TRANSPORT; PALLET HANDLING MACHINERY AND EQUIPMENT; PALLET INVERTERS; PALLET CHANGERS; PALLETLESS LOADING AND HANDLING MACHINES; PARTS AND FITTINGS FOR ALL THE AFORESAID GOODS (U.S. CLS. 13, 19, 21, 23, 31, 34 AND 35).

MARK T. MULLEN, EXAMINING ATTORNEY

SN 85-370,920. GREENMAN MACHINERY COMPANY, SHUNYI DIST., BEIJING, CHINA, FILED 7-13-2011.

GREENMAN

THE MARK CONSISTS OF "GREENMAN".

FOR AC GENERATORS; AERATORS; AGRICULTURAL IMPLEMENTS, NAMELY, SEED DRILLS; AGRICULTURAL MACHINERY AND ATTACHMENTS THEREFORE, NAMELY, ROTARY MOWERS, BOX SCRAPERS, AND THREE-POINT ATTACHMENTS; AGRICULTURAL MACHINERY, NAMELY, TILLERS; AGRICULTURAL MACHINES, NAMELY, CULTIPACKERS; AGRICULTURAL MACHINES, NAMELY, CULTIVATORS, HARVESTORS, DISK HARROWS, SEEDERS; AGRICULTURAL SEED PLANTING MACHINE; AGRICULTURAL SEED PLANTING MACHINES, NAMELY, SOWERS; AIR COMPRESSORS; AIR FILTERS FOR MECHANICAL PURPOSES; AIR FILTERS FOR VEHICLE MOTORS AND ENGINES; AIR POWERED TOOLS, NAMELY, DRILLS, SCREWDRIVERS, RIVET HAMMERS, SAWS; AXLES FOR MACHINES; BLADES FOR POWER SAWS; BRAKE LININGS FOR MACHINES; BRAKES FOR INDUSTRIAL MACHINES; BRAKES FOR MACHINES; BROACHES; BROACHING MACHINES; BRUSHES BEING PARTS OF MOTORS, GENERATORS AND DYNAMOS; CAM SHAFTS; CARBURETORS; CHAIN SAWS; CHAINS FOR CHAIN SAWS; CHAINSAWS; CLUTCHES FOR MACHINES; COUPLINGS FOR MACHINES; CRANK SHAFTS FOR MACHINES, MOTORS AND ENGINES; CRANKCASES FOR MACHINES, MOTORS AND ENGINES; CYLINDER HEADS FOR ENGINES; CYLINDERS FOR MOTORS AND ENGINES; DC GENERATORS; DIESEL ENGINES NOT FOR LAND VEHICLES; DIESEL-ENGINE HEATING PLUGS; DIRECT CURRENT MOTORS; EARTH AUGERS; EARTH COMPACTING MACHINES; EARTH MOVING MACHINES; EARTH MOVING MACHINES, NAMELY, BACKHOES; EARTH MOVING MACHINES, NAMELY, EXCAVATORS; EARTH MOVING MACHINES, NAMELY, GRADERS; EARTH MOVING MACHINES, NAMELY, LOADERS; EARTH MOVING MACHINES, NAMELY, SCARIFIERS; EARTH MOVING MACHINES, NAMELY, SCRAPERS; ELECTRIC CHAIN SAWS; ELEC-

CLASS 7—(Continued).

TRIC GENERATORS; ELECTRIC LAWN TRIMMERS; ELECTRIC LAWNMOWERS; ELECTRIC STARTER MOTORS; ENGINE BEARINGS; ENGINE CAMSHAFTS; ENGINE EXHAUST TIPS; ENGINE MUFFLERS; ENGINE RODS; FUEL FILTERS; GASKETS FOR INTERNAL COMBUSTION ENGINES; GASOLINE ENGINES NOT FOR LAND VEHICLES; HYDRAULIC CONTROLS FOR MACHINES, MOTORS AND ENGINES; HYDRAULIC PUMPS; HYDRAULIC VALVE ACTUATORS; IMPACT WRENCHES. INTERNAL COMBUSTION ENGINE PARTS, NAMELY, HEADS; INTERNAL COMBUSTION ENGINE PARTS, NAMELY, PISTON RINGS; INTERNAL COMBUSTION ENGINE PARTS, NAMELY, PISTONS; LAWN AND GARDEN STRING TRIMMER SPOOLS; LAWN AND GARDEN TILLING MACHINES; LAWN MOWERS; LAWNMOWERS; MACHINE COUPLING AND BELTING EXCEPT FOR LAND VEHICLES; MACHINE COUPLINGS AND TRANSMISSION COMPONENTS EXCEPT FOR LAND VEHICLES; MACHINE FLYWHEELS; MACHINE PARTS, NAMELY, BEARING HOUSINGS; MACHINE PARTS, NAMELY, BEARING INSERTS; MACHINE PARTS, NAMELY, BEARINGS; MACHINE PARTS, NAMELY, NOZZLES WHICH ARE PARTS OF POWER-OPERATED SPRAYERS; MACHINE PARTS, NAMELY, ROLLER BEARINGS; MACHINES FOR CLEANING SURFACES USING HIGH PRESSURE WATER; MECHANICAL LAWN MOWERS; MECHANICAL SPREADERS FOR SEED AND DRY LAWN CHEMICALS; METAL VALVES USED IN CLEANING MACHINES FOR GAS TURBINE AND COMBUSTION ENGINES; MULTI-PURPOSE HIGH PRESSURE WASHERS; OIL FILTERS; PNEUMATIC GREASE GUNS; POSITIVE DISPLACEMENT PUMPS; POWER BLOWERS FOR LAWN DEBRIS; POWER LAWN AND GARDEN TOOLS, NAMELY, CHIPPERS; POWER LAWN AND GARDEN TOOLS, NAMELY, SHREDDERS; POWER OPERATED BLOWERS; POWER OPERATED JACKS; POWER OPERATED LAWN AND GARDEN STRING TRIMMERS; POWER OPERATED LAWN AND GARDEN TOOLS, NAMELY, CULTIVATORS; POWER OPERATED TOOLS, NAMELY, LAWN AND GARDEN EDGERS; POWER TRANSMISSION BELTS FOR MACHINES; POWER TRANSMISSION BELTS FOR MACHINES, MOTORS AND ENGINES USED IN INDUSTRIAL APPLICATIONS; POWER TRANSMISSIONS AND GEARING FOR MACHINES; POWER-OPERATED GARDEN HOSE REELS; POWER-OPERATED GRASS/WEED TRIMMERS; POWER-OPERATED GRINDING WHEELS; POWER-OPERATED LAWN AERATORS; POWER-OPERATED LAWN AND GARDEN TILLERS; POWER-OPERATED LAWN EDGERS; POWER-OPERATED SPRAY EQUIPMENT FOR APPLYING THERMOPLASTIC ROAD MARKING PAINTS; POWER-OPERATED SPRAYERS; PRESSURE SWITCHES AND SENSORS FOR MONITORING, CONTROLLING, AND SWITCHING HYDRAULIC OR PNEUMATIC SYSTEMS BEING SOLD AS A UNIT WITH MANUFACTURING MACHINES. PUMP CONTROL VALVES; PUMP DIAPHRAGMS; PUMP IMPELLERS; PUMPS AND COMPRESSORS AS PARTS OF MACHINES, MOTORS AND ENGINES; PUMPS AS PARTS OF MACHINES, MOTORS AND ENGINES; PUMPS FOR COOLING ENGINES; RADIATORS FOR MOTORS AND ENGINES; RADIATORS FOR MOTORS AND ENGINES; RECHARGEABLE HEDGE CUTTERS; RIDING LAWN MOWERS; ROTARY BRUSHES FOR MACHINES; ROTARY GRINDING MACHINES; ROTARY PUMPS; SERVO-VALVES; SHAFT COUPLINGS FOR MACHINES; SHAFT COUPLINGS, NOT FOR LAND VEHICLES; SHOCK ABSORBERS FOR MACHINES; SILT PUMPS; SKID-STEER LOADERS; SPARK PLUG IGNITION WIRES; SPARK PLUGS; STARTERS FOR MOTORS AND ENGINES; SUBMERSIBLE PUMPS; SUCTION PUMPS; SUMP PUMPS; TIMING BELTS FOR MACHINES, MOTORS AND ENGINES USED IN USED IN INDUSTRIAL APPLICATIONS; TOOL GRINDING MACHINES; TRACTOR TOWED AGRICULTURAL IMPLEMENTS, NAMELY, BROADCAST SEEDERS; TRACTOR TOWED AGRICULTURAL IMPLEMENTS, NAMELY, DISC HARROWS; TRACTOR TOWED AGRICULTURAL IMPLEMENTS, NAMELY, FERTILIZER DISTRIBUTORS; TRACTOR TOWED AGRICULTURAL IMPLEMENTS, NAMELY, HARROWS; TRACTOR TOWED AGRICULTURAL IMPLEMENTS, NAMELY, HARVESTERS; TRACTOR TOWED AGRICULTURAL IMPLEMENTS, NAMELY, HAY BALERS; TRACTOR TOWED

CLASS 7—(Continued).

AGRICULTURAL IMPLEMENTS, NAMELY, HAY RAKES; TRACTOR TOWED AGRICULTURAL IMPLEMENTS, NAMELY, MANURE SPREADERS; TRACTOR TOWED AGRICULTURAL IMPLEMENTS, NAMELY, MOWERS; TRACTOR TOWED AGRICULTURAL IMPLEMENTS, NAMELY, PLOWS; TRACTOR TOWED AGRICULTURAL IMPLEMENTS, NAMELY, REAPERS; TRACTOR TOWED AGRICULTURAL IMPLEMENTS, NAMELY, ROLLERS; TRACTOR-TOWED FERTILIZER APPLICATORS; TRACTOR-TOWED HARROWS; TRANSMISSION GEARS FOR MACHINES; TRENCH CUTTERS (U.S. CLS. 13, 19, 21, 23, 31, 34 AND 35).
PATRICIA EVANKO, EXAMINING ATTORNEY

SN 85-403,873. INTRADIN (SHANGHAI) MACHINERY CO. LTD., SHANGHAI, CHINA, FILED 8-22-2011.



The logo for RiteLube features the word "Rite" in a bold, red, sans-serif font, followed by "Lube" in a bold, black, sans-serif font. The letters are closely spaced and have a slight shadow effect.

THE COLOR(S) RED AND BLACK IS/ARE CLAIMED AS A FEATURE OF THE MARK.

THE MARK CONSISTS OF THE WORDING "RITELUBE" APPEARING IN STYLIZED FORM WITH THE TERM "RITE" APPEARING IN THE COLOR RED AND THE TERM "LUBE" APPEARING IN THE COLOR BLACK.

FOR POWER-OPERATED VEHICLE LUBRICATION, REPAIR AND MAINTENANCE EQUIPMENT, NAMELY, PUMPS FOR PUMPING OIL, DISPENSERS FOR DISPENSING OIL, PUMPS FOR PUMPING GREASE, GREASE GUNS FOR DISPENSING GREASE, OIL DRAINERS, OIL CHANGERS, BRAKE AND CLUTCH BLEEDING MACHINES, AND PARTS THEREFOR, NAMELY, VALVES FOR CONTROLLING THE DISPENSING OF OIL, METERS FOR MEASURING THE QUANTITY OF OIL BEING DISPENSED, AND AIR PRESSURE REGULATORS; POWER-OPERATED OIL DISTRIBUTION EQUIPMENT, NAMELY, PUMPS FOR PUMPING OIL, DISPENSERS FOR DISPENSING OIL, AND PARTS THEREFOR, NAMELY, VALVES FOR CONTROLLING THE DISPENSING OF OIL, METERS FOR MEASURING THE QUANTITY OF OIL BEING DISPENSED, AND AIR PRESSURE REGULATORS; ELECTRIC OIL PUMPS, AND PARTS THEREFOR, NAMELY, VALVES FOR CONTROLLING THE DISPENSING OF OIL, METERS FOR MEASURING THE QUANTITY OF OIL BEING DISPENSED, AND AIR PRESSURE REGULATORS; POWER-OPERATED GREASE DISTRIBUTION EQUIPMENT, NAMELY, PUMPS FOR PUMPING GREASE, GREASE GUNS FOR DISPENSING GREASE, AND STRUCTURAL REPLACEMENT PARTS RELATING TO THE FOREGOING GREASE DISTRIBUTION EQUIPMENT; POWER-OPERATED PUMPS FOR PUMPING GREASE, POWER-OPERATED GUNS FOR DISPENSING GREASE; POWER-OPERATED WASTE OIL EQUIPMENT, NAMELY, OIL DRAINERS AND OIL CHANGERS; POWER-OPERATED PRESSURE SPRAYERS; VEHICLE SERVICE EQUIPMENT, NAMELY, BRAKE AND CLUTCH BLEEDING MACHINES (U.S. CLS. 13, 19, 21, 23, 31, 34 AND 35).
DARRYL SPRUILL, EXAMINING ATTORNEY

CLASS 7—(Continued).

SN 85-416,333. SUNSTAR CO., LTD., INCHEON, REPUBLIC OF KOREA, FILED 9-7-2011.



THE COLOR(S) RED IS/ARE CLAIMED AS A FEATURE OF THE MARK.

THE MARK CONSISTS OF THE LETTERS "SWF" IN UPPERCASE FORMAT AND COLOR RED.

FOR HOTFIX SETTING MACHINE FOR TEXTILE IN THE NATURE OF RHINESTONE, SEQUIN AND OTHER EMBELLISHMENT APPLICATOR MACHINE; HOTFIX SETTING MACHINE FOR CLOTHING IN THE NATURE OF RHINESTONE, SEQUIN AND OTHER EMBELLISHMENT APPLICATOR MACHINE; HOTFIX MOTIF SETTING MACHINE FOR CLOTHING IN THE NATURE OF RHINESTONE, SEQUIN AND OTHER EMBELLISHMENT APPLICATOR MACHINE; SPANGLE MOTIF SETTING MACHINE IN THE NATURE OF RHINESTONE, SEQUIN AND OTHER EMBELLISHMENT APPLICATOR MACHINE; HOTFIX BONDING MACHINE FOR CLOTHING IN THE NATURE OF RHINESTONE, SEQUIN AND OTHER EMBELLISHMENT APPLICATOR MACHINE; AUTOMATIC PASTE JEWELLERY SETTING MACHINE IN THE NATURE OF RHINESTONE, SEQUIN AND OTHER EMBELLISHMENT APPLICATOR MACHINE; JEWELLERY SETTING MACHINE FOR CLOTHING IN THE NATURE OF RHINESTONE, SEQUIN AND OTHER EMBELLISHMENT APPLICATOR MACHINE; JEWELLERY ABSORBING MACHINE FOR CLOTHING IN THE NATURE OF RHINESTONE, SEQUIN AND OTHER EMBELLISHMENT APPLICATOR MACHINE (U.S. CLS. 13, 19, 21, 23, 31, 34 AND 35).

SOPHIA S. KIM, EXAMINING ATTORNEY

CLASS 7—(Continued).

SN 85-416,458. SUNSTAR CO., LTD., INCHEON, REPUBLIC OF KOREA, FILED 9-7-2011.



OWNER OF U.S. REG. NO. 2,489,903.

THE COLOR(S) RED IS/ARE CLAIMED AS A FEATURE OF THE MARK.

THE MARK CONSISTS OF THE WORD "SUNSTAR" IN UPPERCASE FORMAT AND COLOR RED.

FOR HOTFIX SETTING MACHINE FOR TEXTILE IN THE NATURE OF RHINESTONE, SEQUIN AND OTHER EMBELLISHMENT APPLICATOR MACHINE; HOTFIX SETTING MACHINE FOR CLOTHING IN THE NATURE OF RHINESTONE, SEQUIN AND OTHER EMBELLISHMENT APPLICATOR MACHINE; HOTFIX MOTIF SETTING MACHINE FOR CLOTHING IN THE NATURE OF RHINESTONE, SEQUIN AND OTHER EMBELLISHMENT APPLICATOR MACHINE; SPANGLE MOTIF SETTING MACHINE IN THE NATURE OF RHINESTONE, SEQUIN AND OTHER EMBELLISHMENT APPLICATOR MACHINE; HOTFIX BONDING MACHINE FOR CLOTHING IN THE NATURE OF RHINESTONE, SEQUIN AND OTHER EMBELLISHMENT APPLICATOR MACHINE; AUTOMATIC PASTE JEWELLERY SETTING MACHINE IN THE NATURE OF RHINESTONE, SEQUIN AND OTHER EMBELLISHMENT APPLICATOR MACHINE; JEWELLERY SETTING MACHINE FOR CLOTHING IN THE NATURE OF RHINESTONE, SEQUIN AND OTHER EMBELLISHMENT APPLICATOR MACHINE; JEWELLERY ABSORBING MACHINE FOR CLOTHING IN THE NATURE OF RHINESTONE, SEQUIN AND OTHER EMBELLISHMENT APPLICATOR MACHINE (U.S. CLS. 13, 19, 21, 23, 31, 34 AND 35).

SOPHIA S. KIM, EXAMINING ATTORNEY

SN 85-422,948. INTEVAC, INC., SANTA CLARA, CA. FILED 9-14-2011.

INTEVAC ENERGi

THE MARK CONSISTS OF STANDARD CHARACTERS WITHOUT CLAIM TO ANY PARTICULAR FONT, STYLE, SIZE, OR COLOR.

FOR MACHINES AND MACHINE TOOLS FOR MAKING SOLAR CELLS; MACHINERY, NAMELY, ION IMPLANTATION EQUIPMENT USED IN THE MANUFACTURE OF SOLAR CELLS; MACHINERY, NAMELY, SOLAR CELLS HANDLING EQUIPMENT USED IN THE MANUFACTURE OF SOLAR CELLS; VACUUM PLASMA CHAMBER ASSEMBLIES AND SUBASSEMBLIES FOR SURFACE PROCESSING OF SUBSTRATE FABRICATING MACHINES USED IN THE MANUFACTURE OF SOLAR CELLS (U.S. CLS. 13, 19, 21, 23, 31, 34 AND 35).

BARBARA A. GOLD, EXAMINING ATTORNEY

CLASS 7—(Continued).

SN 85-423,301. IN DEMAND MARKETING LLC, SAN MARCOS, CA. FILED 9-15-2011.

PERFECT FRIES

THE MARK CONSISTS OF STANDARD CHARACTERS WITHOUT CLAIM TO ANY PARTICULAR FONT, STYLE, SIZE, OR COLOR.

NO CLAIM IS MADE TO THE EXCLUSIVE RIGHT TO USE "FRIES", APART FROM THE MARK AS SHOWN.

FOR MACHINES FOR CUTTING AND COOKING POTATOES INTO FRENCH FRIES (U.S. CLS. 13, 19, 21, 23, 31, 34 AND 35).

FRANK LATTUCA, EXAMINING ATTORNEY

SN 85-425,510. DAVID A. JONES, ALBUQUERQUE, NM. FILED 9-18-2011.

WOMBAT

THE MARK CONSISTS OF STANDARD CHARACTERS WITHOUT CLAIM TO ANY PARTICULAR FONT, STYLE, SIZE, OR COLOR.

FOR EARTH MOVING MACHINES, NAMELY, BACKHOE LOADERS; SKID STEER LOADERS; COMPACT WHEEL LOADERS; WHEEL LOADERS; INTEGRATED TOOL CARRIERS; TELESCOPIC HANDLERS; TRACK LOADERS; WHEEL TRACTOR SCRAPERS; TRACK-TYPE TRACTORS; WHEEL DOZERS; MOTOR GRADERS; SOIL COMPACTORS; COLD PLANERS; ROAD RECLAIMERS; ASPHALT PAVERS; VIBRATORY COMPACTORS; MARINE ENGINES; INDUSTRIAL ENGINES (U.S. CLS. 13, 19, 21, 23, 31, 34 AND 35).

MICHAEL WIENER, EXAMINING ATTORNEY

SN 85-442,419. MBF S.P.A., VERONELLA (VI), ITALY, FILED 10-7-2011.

SUPERBLOC

THE MARK CONSISTS OF STANDARD CHARACTERS WITHOUT CLAIM TO ANY PARTICULAR FONT, STYLE, SIZE, OR COLOR.

FOR COMPUTER CONTROLLED MACHINES FOR THE RINSING, BOTTLING AND LABELING OF LIQUIDS; BOTTLING MACHINES (U.S. CLS. 13, 19, 21, 23, 31, 34 AND 35).

DOMINIC J. FERRAIUOLO, EXAMINING ATTORNEY

CLASS 7—(Continued).

SN 85-444,800. CLEANLOGIX LLC, VALENCIA, CA. FILED 10-11-2011.

CPU

THE MARK CONSISTS OF STANDARD CHARACTERS WITHOUT CLAIM TO ANY PARTICULAR FONT, STYLE, SIZE, OR COLOR.

FOR MACHINES EMPLOYING CARBON DIOXIDE FOR PRECISION CLEANING OF SURFACES AND TREATMENT OF SURFACES; MACHINES EMPLOYING CARBON DIOXIDE FOR LUBRICATION OF MACHINES AND TOOLS (U.S. CLS. 13, 19, 21, 23, 31, 34 AND 35).

FIRST USE 2-15-2011; IN COMMERCE 10-3-2011.

ANDREW LEASER, EXAMINING ATTORNEY

SN 85-446,118. ILLINOIS TOOL WORKS INC., GLENVIEW, IL. FILED 10-12-2011.

CLEARDRIVE

THE MARK CONSISTS OF STANDARD CHARACTERS WITHOUT CLAIM TO ANY PARTICULAR FONT, STYLE, SIZE, OR COLOR.

OWNER OF U.S. REG. NO. 3,794,355.

FOR TOOLING FOR METAL FASTENERS, NAMELY, MACHINE PARTS IN THE NATURE OF MOLDS FOR USE IN THE MANUFACTURE OF METAL FASTENERS AND IN FORMING THE HEADS OF METAL FASTENERS (U.S. CLS. 13, 19, 21, 23, 31, 34 AND 35).

NANCY CLARKE, EXAMINING ATTORNEY

SN 85-448,201. ZUREX PHARMAGRA, LLC, MADISON, WI. FILED 10-14-2011.

ECALOGIX

THE MARK CONSISTS OF STANDARD CHARACTERS WITHOUT CLAIM TO ANY PARTICULAR FONT, STYLE, SIZE, OR COLOR.

FOR MIXING MACHINES FOR PROCESSING CHEMICALS AND PRODUCING CHEMICAL PREPARATIONS (U.S. CLS. 13, 19, 21, 23, 31, 34 AND 35).

CHRISTOPHER BUONGIORNO, EXAMINING ATTORNEY

CLASS 7—(Continued).

SN 85-491,803. MUNCIE POWER PRODUCTS, INC., MUNCIE, IN. FILED 12-9-2011.

ADVANTAGE +

THE MARK CONSISTS OF STANDARD CHARACTERS WITHOUT CLAIM TO ANY PARTICULAR FONT, STYLE, SIZE, OR COLOR.

FOR HYDRAULIC CONTROL SYSTEMS COMPRISED OF HYDRAULIC PUMPS, MOTORS, VALVES, SWITCHES, SENSORS, ELECTRONIC CONTROLS, CYLINDERS, ACCUMULATORS, AUDIBLE AND VISUAL WARNING DEVICES, NAMELY, ALARMS AND LIGHTS, THERMAL CONTROLS AND VEHICLE LIGHTING FOR VEHICLE-MOUNTED AUXILIARY POWER EQUIPMENT IN THE NATURE OF SNOW PLOWS, SALT SPREADERS AND DUMPS (U.S. CLS. 13, 19, 21, 23, 31, 34 AND 35).

ANGELA DUONG, EXAMINING ATTORNEY

SN 85-500,080. THE BLACK & DECKER CORPORATION, TOWSON, MD. FILED 12-20-2011.



THE MARK CONSISTS OF THE WORD "GYRO" IN DECORATIVE BOLD FONT WITH CURVED DIRECTIONAL ARROWS AT THE BEGINNING AND END OF THE WORD.

FOR POWER TOOLS, NAMELY, DRILLS, DRILL/DRIVERS, SCREWDRIVERS AND WRENCHES (U.S. CLS. 13, 19, 21, 23, 31, 34 AND 35).

MARK RADEMÄCHER, EXAMINING ATTORNEY

SN 85-500,196. DISCOVERY COMMUNICATIONS, LLC, SILVER SPRING, MD. FILED 12-20-2011.

KITCHEN BOSS

THE MARK CONSISTS OF STANDARD CHARACTERS WITHOUT CLAIM TO ANY PARTICULAR FONT, STYLE, SIZE, OR COLOR.

NO CLAIM IS MADE TO THE EXCLUSIVE RIGHT TO USE "KITCHEN", APART FROM THE MARK AS SHOWN.

FOR ELECTRIC FOOD BLENDERS, ELECTRIC FOOD PROCESSORS, ELECTRIC MIXERS (U.S. CLS. 13, 19, 21, 23, 31, 34 AND 35).

MICHELE SWAIN, EXAMINING ATTORNEY

CLASS 7—(Continued).

SN 85-504,289. MOPO, INC., BERKELEY, CA. FILED 12-27-2011.

MOPO

THE MARK CONSISTS OF STANDARD CHARACTERS WITHOUT CLAIM TO ANY PARTICULAR FONT, STYLE, SIZE, OR COLOR.

FOR PORTABLE ELECTRICITY GENERATORS (U.S. CLS. 13, 19, 21, 23, 31, 34 AND 35).

FIRST USE 12-31-2011; IN COMMERCE 12-31-2011.

AHSEN KHAN, EXAMINING ATTORNEY

SN 85-521,685. INROCK DRILLING SYSTEMS, INC., HOUSTON, TX. FILED 1-20-2012.

XTM - EXTREME MOTOR

THE MARK CONSISTS OF STANDARD CHARACTERS WITHOUT CLAIM TO ANY PARTICULAR FONT, STYLE, SIZE, OR COLOR.

OWNER OF U.S. REG. NO. 3,321,772.

NO CLAIM IS MADE TO THE EXCLUSIVE RIGHT TO USE "MOTOR", APART FROM THE MARK AS SHOWN.

FOR DRILLING EQUIPMENT, NAMELY, DOWN-HOLE MUD MOTORS (U.S. CLS. 13, 19, 21, 23, 31, 34 AND 35).

MICHAEL LITZAU, EXAMINING ATTORNEY

CLASS 7—(Continued).

SN 85-546,293. WITTMANN BATTENFELD GMBH, KOTTINGBRUNN, AUSTRIA, FILED 2-17-2012.

CELLMOULD

THE MARK CONSISTS OF STANDARD CHARACTERS WITHOUT CLAIM TO ANY PARTICULAR FONT, STYLE, SIZE, OR COLOR.

FOR PLASTIC PROCESSING MACHINES, NAMELY, PLASTIC INJECTION MOLDING MACHINES, EXTRUSION MOULDING MACHINES, BLOW MOLDING MACHINES, BLOWN FILM MOLDING MACHINES, FILM EXTRUSION MACHINES, FILM CASTING MACHINES, CONTINUOUS METAL CASING MACHINES; MACHINES USED FOR PRODUCTION OF PLASTIC PARTS WITH A COMPACT SKIN AND A FOAMED CORE; POLYURETHANE FOAMING MACHINES, AND PARTS THEREFOR FOR ALL THE ABOVE MENTIONED MACHINES; MACHINE PARTS, NAMELY, MOLDS USED FOR INSERTION IN THE ABOVE MENTIONED MACHINES; PERIPHERAL EQUIPMENT FOR ALL THE ABOVE MENTIONED MACHINES, NAMELY, APPARATUS FOR INTRODUCTION OF GAS OR BLOWING AGENTS; PLASTIC MOLDINGS AS PARTS OF ALL THE AFOREMENTIONED MACHINES USED IN THE PRODUCTION OF THESE MACHINES (U.S. CLS. 13, 19, 21, 23, 31, 34 AND 35).

ODESSA BIBBINS, EXAMINING ATTORNEY

SN 85-556,008. PB'S ENTERPRISES, INC., RICHARSON, TX. FILED 2-29-2012.

LEAVES NO MORE

THE MARK CONSISTS OF STANDARD CHARACTERS WITHOUT CLAIM TO ANY PARTICULAR FONT, STYLE, SIZE, OR COLOR.

NO CLAIM IS MADE TO THE EXCLUSIVE RIGHT TO USE "LEAVES", APART FROM THE MARK AS SHOWN.

FOR AUTOMATED PORTABLE FLOATING SWIMMING POOL DEBRIS REMOVAL DEVICE (U.S. CLS. 13, 19, 21, 23, 31, 34 AND 35).

HOWARD B. LEVINE, EXAMINING ATTORNEY

CLASS 7—(Continued).

SN 85-557,431. LEMAR INDUSTRIES, DES MOINES, IA. FILED 3-1-2012.

MAVERIK

THE MARK CONSISTS OF STANDARD CHARACTERS WITHOUT CLAIM TO ANY PARTICULAR FONT, STYLE, SIZE, OR COLOR.

FOR AGRICULTURAL IMPLEMENTS, NAMELY, COMMERCIAL GRAIN SWEEP, GRAIN TRANSPORTING AUGER (U.S. CLS. 13, 19, 21, 23, 31, 34 AND 35).

FIRST USE 2-16-2012; IN COMMERCE 2-16-2012.
APRIL HESIK, EXAMINING ATTORNEY

SN 85-557,976. LEMAR INDUSTRIES, DES MOINES, IA. FILED 3-1-2012.

The image shows the word "MAVERIKHTF" in a large, bold, sans-serif font. Below it, the phrase "SINGLE PASS, SWEEP TWICE." is written in a smaller, all-caps, sans-serif font. The text is slightly blurred, suggesting motion or a specific perspective.

NO CLAIM IS MADE TO THE EXCLUSIVE RIGHT TO USE "SINGLE PASS, SWEEP TWICE.", APART FROM THE MARK AS SHOWN.

THE MARK CONSISTS OF THE LITERAL ELEMENTS "MAVERIKHTF SINGLE PASS, SWEEP TWICE." WHEREIN THE WORDS "MAVERIKHTF" IS WRITTEN AND TO THE BELOW THE WORDS "SINGLE PASS, SWEEP TWICE." ARE WRITTEN AS SHOWN IN THE MARK.

FOR AGRICULTURAL IMPLEMENTS, NAMELY, COMMERCIAL GRAIN SWEEP, GRAIN TRANSPORTING AUGER (U.S. CLS. 13, 19, 21, 23, 31, 34 AND 35).

FIRST USE 2-16-2012; IN COMMERCE 2-16-2012.
APRIL HESIK, EXAMINING ATTORNEY

SN 85-573,150. MERRITT, ROBERT J., WILMINGTON, NC. AND MERRITT, RUTH M., WILMINGTON, NC. FILED 3-19-2012.

PHOENIX

THE MARK CONSISTS OF STANDARD CHARACTERS WITHOUT CLAIM TO ANY PARTICULAR FONT, STYLE, SIZE, OR COLOR.

FOR AERATION TINES FOR TURF EQUIPMENT (U.S. CLS. 13, 19, 21, 23, 31, 34 AND 35).

FIRST USE 1-31-2012; IN COMMERCE 1-31-2012.
TARAH HARDY, EXAMINING ATTORNEY

CLASS 7—(Continued).

SN 85-576,159. BANDSAW USA INC., CAROL STREAM, IL.
FILED 3-21-2012.



NO CLAIM IS MADE TO THE EXCLUSIVE RIGHT TO USE "BAND SAW USA" AND "SAWING SOLUTIONS", APART FROM THE MARK AS SHOWN.

THE MARK CONSISTS OF A CIRCLE WITH A BORDER AROUND IT. IN THE CENTER OF THE CIRCLE IS A VERTICAL BANDSAW IMAGE AGAINST A STYLIZED AMERICAN FLAG BACKGROUND. A HALF CIRCLE OF STARS BORDER THE INSIDE OF THE TOP OF THE CIRCLE. A SWOOSH CROSSES THE CIRCLE. TO THE RIGHT OF THE CIRCLE IS THE STYLIZED TEXT "BANDSAW USA" ABOVE A HORIZONTAL LINE. BELOW THE LINE IS THE STYLIZED TEXT "SAWING SOLUTIONS". ANOTHER SWOOSH WRAPS AROUND THE RIGHT SIDE OF THE TEXT AND ARCHES ACROSS THE TOP. WITHIN THE RIGHT SIDE OF THE SWOOSH IS A CLUSTER OF SEVEN STARS OF VARIOUS SIZES.

FOR BAND SAWS (U.S. CLS. 13, 19, 21, 23, 31, 34 AND 35).

FIRST USE 11-1-2010; IN COMMERCE 11-1-2010.
COLLEEN KEARNEY, EXAMINING ATTORNEY

SN 85-577,404. SENCI POWER USA INC, ONTARIO, CA.
FILED 3-22-2012.

NO CLAIM IS MADE TO THE EXCLUSIVE RIGHT TO USE "POWER", APART FROM THE MARK AS SHOWN.

THE MARK CONSIST OF THE STYLIZED WORDING "AI POWER", WITH THE LETTERS "AI", SHOWN WITH THE LETTER "I" INSIDE THE LETTER "A", TO THE LEFT OF THE TERM "POWER".

FOR ELECTRIC GENERATORS WITH GASOLINE OR PROPANE ENGINES; MULTI-PURPOSE HIGH PRESSURE WASHERS AND WATER PUMPS FOR USE WITH GASOLINE ENGINES; WATER TREATMENT EQUIPMENT, NAMELY, PUMPS FOR USE IN DRAINAGE AND IRRIGATION SYSTEMS; SNOW BLOWERS; LAWN MOWERS; AND GASOLINE ENGINES NOT FOR ON-ROAD VEHICLES; ALTERNATORS (U.S. CLS. 13, 19, 21, 23, 31, 34 AND 35).

LINDA M. KING, EXAMINING ATTORNEY

CLASS 7—(Continued).

SN 85-578,888. IP HOLDINGS, LLC., VANCOUVER, WA.
FILED 3-23-2012.

Air Force Pro

THE MARK CONSISTS OF STANDARD CHARACTERS WITHOUT CLAIM TO ANY PARTICULAR FONT, STYLE, SIZE, OR COLOR.

NO CLAIM IS MADE TO THE EXCLUSIVE RIGHT TO USE "AIR" AND "PRO", APART FROM THE MARK AS SHOWN.

FOR AQUARIUM PUMPS; ELECTRIC PUMPS FOR HYDROPONIC SYSTEMS (U.S. CLS. 13, 19, 21, 23, 31, 34 AND 35).

COURTNEY ALVAREZ, EXAMINING ATTORNEY

SN 85-580,417. INFINITEX CORPORATION, CLARENCE, NY. FILED 3-26-2012.

SPLITTER

THE MARK CONSISTS OF STANDARD CHARACTERS WITHOUT CLAIM TO ANY PARTICULAR FONT, STYLE, SIZE, OR COLOR.

SEC. 2(F).

FOR SEPARATING AND FILTERING MACHINES FOR USE IN SEPARATING FLUIDS SUCH AS OIL FROM WATER FOR INDUSTRIAL AND COMMERCIAL USE (U.S. CLS. 13, 19, 21, 23, 31, 34 AND 35).

FIRST USE 4-22-1990; IN COMMERCE 4-22-1990.
ANNE FARRELL, EXAMINING ATTORNEY

SN 85-581,721. MULTIRAD THERMAL- SYS (WUHAN) CO., LTD, WUHAN, HUBEI PROVINCE, CHINA, FILED 3-28-2012.

THE MARK CONSISTS OF WAVE DEVICE WITH STYLIZED WORD "MULTI-RAD" ON THE BOTTOM.

THE WORDING "MULTI-RAD" HAS NO MEANING IN A FOREIGN LANGUAGE.

FOR COOLING RADIATORS FOR MOTORS AND ENGINES; HEAT EXCHANGERS BEING PARTS OF MACHINES; RADIATORS FOR MOTORS AND ENGINES; RADIATORS FOR VEHICLES (U.S. CLS. 13, 19, 21, 23, 31, 34 AND 35).

FIRST USE 12-23-2011; IN COMMERCE 12-23-2011.

TEJBIR SINGH, EXAMINING ATTORNEY

CLASS 7—(Continued).

SN 85-592,688. ELECTROLUX HOME PRODUCTS, INC., CHARLOTTE, NC. FILED 4-9-2012.

SAHARA DRY

THE MARK CONSISTS OF STANDARD CHARACTERS WITHOUT CLAIM TO ANY PARTICULAR FONT, STYLE, SIZE, OR COLOR.

NO CLAIM IS MADE TO THE EXCLUSIVE RIGHT TO USE "DRY", APART FROM THE MARK AS SHOWN.

FOR FEATURE OF DISHWASHERS, NAMELY, A CYCLE THAT CONTROLS DRYING, SOLD AS AN INTEGRAL COMPONENT OF A DISHWASHER (U.S. CLS. 13, 19, 21, 23, 31, 34 AND 35).

JUHI KAVEESHVAR, EXAMINING ATTORNEY

SN 85-593,142. TYCO VALVES & CONTROLS B.V., THE NETHERLANDS, NETHERLANDS, FILED 4-10-2012.

HOVAP

THE MARK CONSISTS OF STANDARD CHARACTERS WITHOUT CLAIM TO ANY PARTICULAR FONT, STYLE, SIZE, OR COLOR.

FOR MACHINE PARTS, NAMELY, PNEUMATIC PROCESS VALVES USED AS PART OF MECHANICAL CONDUCTING EQUIPMENT IN THE FOODSTUFFS, STIMULANTS, BEVERAGE AND CHEMICAL INDUSTRIES (U.S. CLS. 13, 19, 21, 23, 31, 34 AND 35).

FIRST USE 3-31-2005; IN COMMERCE 3-31-2005.
JULIE WATSON, EXAMINING ATTORNEY

SN 85-594,085. KEYME, LLC, SANTA ROSA, CA. FILED 4-10-2012.

KEYME

THE MARK CONSISTS OF STANDARD CHARACTERS WITHOUT CLAIM TO ANY PARTICULAR FONT, STYLE, SIZE, OR COLOR.

FOR KEY VENDING MACHINE FOR MAKING KEYS (U.S. CLS. 13, 19, 21, 23, 31, 34 AND 35).

JENNIFER MARTIN, EXAMINING ATTORNEY

CLASS 7—(Continued).

SN 85-594,099. KEYME, LLC, SANTA ROSA, CA. FILED 4-10-2012.



THE MARK CONSISTS OF A CIRCLE DESIGN WITH A KEY POSITIONED INSIDE THE CIRCLE AND THE WORD "KEYME" APPEARING TO THE RIGHT OF THE DESIGN. FOR KEY VENDING MACHINE FOR MAKING KEYS (U.S. CLS. 13, 19, 21, 23, 31, 34 AND 35).

JENNIFER MARTIN, EXAMINING ATTORNEY

SN 85-596,269. AUGUSTUS, PAT ANN, HOLLYWOOD, FL. AND BUCHANAN, REBECCA LYNN, TALLAHASSEE, FL. FILED 4-12-2012.

THE Original BOBBIN KNOBBINS

THE MARK CONSISTS OF STANDARD CHARACTERS WITHOUT CLAIM TO ANY PARTICULAR FONT, STYLE, SIZE, OR COLOR.

NO CLAIM IS MADE TO THE EXCLUSIVE RIGHT TO USE "THE ORIGINAL BOBBIN", APART FROM THE MARK AS SHOWN.

FOR ACCESSORIES FOR SEWING MACHINE BOBBINS, NAMELY, HORSESHOE-SHAPED FOAM HOLDERS THAT GO AROUND BOBBINS WHICH ARE FILLED WITH THREAD SO THAT THE THREAD WILL NOT UNRAVEL (U.S. CLS. 13, 19, 21, 23, 31, 34 AND 35).

FIRST USE 3-12-2012; IN COMMERCE 3-12-2012.

JAMES GRIFFIN, EXAMINING ATTORNEY

SN 85-596,315. INFUSION BRANDS, INC., CLEARWATER, FL. FILED 4-12-2012.

DESTROYER

THE MARK CONSISTS OF STANDARD CHARACTERS WITHOUT CLAIM TO ANY PARTICULAR FONT, STYLE, SIZE, OR COLOR.

FOR POWER TOOLS, NAMELY, POWER SAWS, POWER DRILLS, POWER-DRIVEN SCREWDRIVERS, POWER SANDERS, POWER GRINDERS, POWER MULTI-TOOL COMPRISING AN OSCILLATING BASE THAT INCLUDES A SANDER, SCRAPER OR CUTTING TOOL, POWER HOLE SAW, POWER RECIPROCATING SAW (U.S. CLS. 13, 19, 21, 23, 31, 34 AND 35).

APRIL HESIK, EXAMINING ATTORNEY

CLASS 7—(Continued).

SN 85-596,430. TECHKO MAID, INC., IRVINE, CA. FILED 4-12-2012.

Super Maid

THE MARK CONSISTS OF STANDARD CHARACTERS WITHOUT CLAIM TO ANY PARTICULAR FONT, STYLE, SIZE, OR COLOR.

OWNER OF U.S. REG. NO. 4,060,587.

FOR DUST FILTERS AND BAGS FOR VACUUM CLEANERS; ELECTRIC FLOOR POLISHING MACHINES AND APPARATUS; ELECTRIC VACUUM CLEANERS; ELECTRIC VACUUM CLEANERS AND THEIR COMPONENTS; FLOOR BUFFERS; FLOOR CLEANING MACHINES; FLOOR POLISHERS; FLOOR POLISHING MACHINES; FLOOR SCRUBBING MACHINES; FLOOR WASHING MACHINES; PADS FOR FLOOR POLISHING MACHINES; ROBOTIC VACUUM CLEANERS (U.S. CLS. 13, 19, 21, 23, 31, 34 AND 35).

FIRST USE 3-23-2012; IN COMMERCE 3-23-2012.

JAMES LOVELACE, EXAMINING ATTORNEY

SN 85-596,545. TECHKO MAID, INC., IRVINE, CA. FILED 4-12-2012.

Smart Maid

THE MARK CONSISTS OF STANDARD CHARACTERS WITHOUT CLAIM TO ANY PARTICULAR FONT, STYLE, SIZE, OR COLOR.

OWNER OF U.S. REG. NO. 4,060,587.

NO CLAIM IS MADE TO THE EXCLUSIVE RIGHT TO USE "SMART", APART FROM THE MARK AS SHOWN.

FOR DUST FILTERS AND BAGS FOR VACUUM CLEANERS; ELECTRIC FLOOR POLISHING MACHINES AND APPARATUS; ELECTRIC VACUUM CLEANERS; ELECTRIC VACUUM CLEANERS AND THEIR COMPONENTS; FLOOR BUFFERS; FLOOR CLEANING MACHINES; FLOOR POLISHERS; FLOOR POLISHING MACHINES; FLOOR SCRUBBING MACHINES; FLOOR WASHING MACHINES; PADS FOR FLOOR POLISHING MACHINES; ROBOTIC VACUUM CLEANERS (U.S. CLS. 13, 19, 21, 23, 31, 34 AND 35).

FIRST USE 10-3-2011; IN COMMERCE 10-3-2011.

JAMES LOVELACE, EXAMINING ATTORNEY

CLASS 7—(Continued).

SN 85-597,226. EBSCO INDUSTRIES, INC., BIRMINGHAM, AL. FILED 4-13-2012.

WINGSCAPES AUTOFEEDER

THE MARK CONSISTS OF STANDARD CHARACTERS WITHOUT CLAIM TO ANY PARTICULAR FONT, STYLE, SIZE, OR COLOR.

OWNER OF U.S. REG. NO. 3,369,908.

NO CLAIM IS MADE TO THE EXCLUSIVE RIGHT TO USE "AUTOFEEDER", APART FROM THE MARK AS SHOWN.

FOR MECHANIZED FEEDERS FOR WILDLIFE (U.S. CLS. 13, 19, 21, 23, 31, 34 AND 35).

COLLEEN DOMBROW, EXAMINING ATTORNEY

SN 85-597,505. POWER TECH STAPLE & NAIL, INC., ALHAMBRA, CA. FILED 4-13-2012.

GREXUSA

THE MARK CONSISTS OF STANDARD CHARACTERS WITHOUT CLAIM TO ANY PARTICULAR FONT, STYLE, SIZE, OR COLOR.

OWNER OF U.S. REG. NOS. 2,644,525 AND 3,075,434.

FOR POWER TOOLS, NAMELY, STAPLERS AND NAILERS FOR CONSTRUCTION AND INDUSTRIAL USE; AIR BRUSHES FOR APPLYING COLORING AND THE LIKE; AIR BRUSHES FOR DRAWINGS, IN CLASS 7 (U.S. CLS. 13, 19, 21, 23, 31, 34 AND 35) (U.S. CLS. 13, 19, 21, 23, 31, 34 AND 35).

LUCY ARANT, EXAMINING ATTORNEY

SN 85-597,528. POWER TECH STAPLE & NAIL, INC., ALHAMBRA, CA. FILED 4-13-2012.

GREXCO

THE MARK CONSISTS OF STANDARD CHARACTERS WITHOUT CLAIM TO ANY PARTICULAR FONT, STYLE, SIZE, OR COLOR.

OWNER OF U.S. REG. NOS. 2,644,525 AND 3,075,434.

FOR POWER TOOLS, NAMELY, STAPLERS AND NAILERS FOR CONSTRUCTION AND INDUSTRIAL USE; AIR BRUSHES FOR APPLYING COLORING AND THE LIKE; AIR BRUSHES FOR DRAWINGS, IN CLASS 7 (U.S. CLS. 13, 19, 21, 23, 31, 34 AND 35) (U.S. CLS. 13, 19, 21, 23, 31, 34 AND 35).

LUCY ARANT, EXAMINING ATTORNEY

CLASS 7—(Continued).

SN 85-597,821. INPRO/SEAL LLC, ROCK ISLAND, IL. FILED 4-13-2012.

Air Mizer

THE MARK CONSISTS OF STANDARD CHARACTERS WITHOUT CLAIM TO ANY PARTICULAR FONT, STYLE, SIZE, OR COLOR.

OWNER OF U.S. REG. NOS. 2,556,382 AND 3,755,782. NO CLAIM IS MADE TO THE EXCLUSIVE RIGHT TO USE "AIR", APART FROM THE MARK AS SHOWN. FOR BEARINGS, AS PARTS OF MACHINES; MACHINE PARTS, NAMELY, BEARINGS AND BUSHINGS; BEARING ISOLATORS FOR INDUSTRIAL MACHINES (U.S. CLS. 13, 19, 21, 23, 31, 34 AND 35). FIRST USE 7-11-1998; IN COMMERCE 7-11-1998. MAUREEN DALL, EXAMINING ATTORNEY

CLASS 7—(Continued).

SN 85-597,899. PANDA MACHINE TOOLS, INC., DBA HANKOOK AMERICA CORP., WEST CHICAGO, IL. FILED 4-13-2012.

HANKOOK

THE MARK CONSISTS OF STANDARD CHARACTERS WITHOUT CLAIM TO ANY PARTICULAR FONT, STYLE, SIZE, OR COLOR.

FOR BORING MACHINES; LATHES; MACHINE TOOLS, NAMELY, POWERED MACHINES FOR CUTTING OR SHAPING OR FINISHING METALS OR OTHER MATERIALS; MACHINES AND MACHINE TOOLS FOR THE CUTTING AND FORMING OF MATERIALS; METAL WORKING MACHINES; METAL WORKING MACHINES, NAMELY, MACHINING CENTERS; METALWORKING MACHINE TOOLS; METALWORKING MACHINES, NAMELY, MACHINING CENTERS; MILLING MACHINES; NUMERICALLY CONTROLLED MACHINES AND MACHINE TOOLS USED FOR MACHINING PARTS (U.S. CLS. 13, 19, 21, 23, 31, 34 AND 35). FIRST USE 9-15-1969; IN COMMERCE 12-21-2004. MAUREEN DALL, EXAMINING ATTORNEY

SN 85-603,669. COOK, BRYAN C., BRIGHTON, CO. FILED 4-20-2012.



THE MARK CONSISTS OF STYLIZED WORD "GAUNTLET" WITH THE "G" AND THE TRAILING "T" EACH ELONGATED VERTICALLY AND HORIZONTALLY ELONGATED AT THE TOP SUCH THAT THE REST OF THE LETTERS ARE SUBSTANTIALLY ENCLOSED, AND WITH A GRAPHICAL REPRESENTATION OF A POWER-DRILL HEAD ADJACENT TO THE "G".

FOR AIR POWERED TOOLS, NAMELY, DRILLS, DRILL HAMMERS, IMPACT WRENCHES, AND SCREWDRIVERS; AIR-OPERATED POWER TOOLS, NAMELY, DRILLS, DRILL HAMMERS, IMPACT WRENCHES, AND SCREWDRIVERS; BITS FOR POWER DRILLS; CENTERING DRILLING BITS BEING PARTS OF MACHINES; CHUCKS FOR POWER DRILLS; DRILL CHUCKS FOR POWER DRILLS; ELECTRIC DRILLS; ELECTRIC HAND-HELD DRILLS; ELECTRICAL DRILLS; EXTENSIONS FOR POWER DRILL BITS; EXTENSIONS FOR POWER TOOLS; PNEUMATIC DRILLS; POWER DRILL ACCESSORIES, NAMELY, NON-ELECTRICAL ADAPTERS FOR USE IN JOINING EXTENSIONS AND POWER DRILL BITS; POWER DRILL BIT EXTENSIONS; POWER DRILL BITS; POWER DRILLS; POWER OPERATED TOOLS, NAMELY, DRILL HAMMERS; POWER TOOLS, NAMELY, HAMMER DRILLS; POWER TOOLS, NAMELY, DRILLS, DRILL HAMMERS, IMPACT WRENCHES, AND SCREWDRIVERS; POWER-DRIVEN WRENCHES; POWER-OPERATED RIVET GUNS; POWER-OPERATED SCREWDRIVERS (U.S. CLS. 13, 19, 21, 23, 31, 34 AND 35). KARANENDRA S. CHHINA, EXAMINING ATTORNEY

SN 85-597,872. INPRO/SEAL LLC, ROCK ISLAND, IA. FILED 4-13-2012.

Inpro/Seal

THE MARK CONSISTS OF STANDARD CHARACTERS WITHOUT CLAIM TO ANY PARTICULAR FONT, STYLE, SIZE, OR COLOR.

OWNER OF U.S. REG. NO. 2,445,624. FOR MACHINE PARTS, NAMELY, BEARING SEALS; BEARINGS, AS PARTS OF MACHINES; MACHINE PARTS, NAMELY, BEARINGS AND BUSHINGS; BEARING ISOLATORS FOR INDUSTRIAL MACHINES (U.S. CLS. 13, 19, 21, 23, 31, 34 AND 35). FIRST USE 6-1-1967; IN COMMERCE 6-1-1967. MAUREEN DALL, EXAMINING ATTORNEY

CLASS 7—(Continued).

SN 85-603,692. COOK, BRYAN C., BRIGHTON, CO. FILED 4-20-2012.



THE MARK CONSISTS OF STYLIZED WORD "GAUNTLET" WITH THE "G" AND THE TRAILING "T" EACH ELONGATED VERTICALLY AND HORIZONTALLY ELONGATED AT THE TOP SUCH THAT THE REST OF THE LETTERS ARE SUBSTANTIALLY ENCLOSED, WITH A GRAPHICAL REPRESENTATION OF A POWER-DRILL HEAD ADJACENT TO THE "G", AND WITH THE WORDS "ONE FOR ALL" BRACKETED BY THE LOWER PART OF THE ELONGATED "G" AND "T".

FOR AIR POWERED TOOLS, NAMELY, DRILLS, DRILL HAMMERS, IMPACT WRENCHES, AND SCREWDRIVERS; AIR-OPERATED POWER TOOLS, NAMELY, DRILLS, DRILL HAMMERS, IMPACT WRENCHES, AND SCREWDRIVERS; BITS FOR POWER DRILLS; CENTERING DRILLING BITS BEING PARTS OF MACHINES; CHUCKS FOR POWER DRILLS; DRILL CHUCKS FOR POWER DRILLS; ELECTRIC DRILLS; ELECTRIC HAND-HELD DRILLS; ELECTRICAL DRILLS; EXTENSIONS FOR POWER DRILL BITS; EXTENSIONS FOR POWER TOOLS; PNEUMATIC DRILLS; POWER DRILL ACCESSORIES, NAMELY, NON-ELECTRICAL ADAPTERS FOR USE IN JOINING EXTENSIONS AND POWER DRILL BITS; POWER DRILL BIT EXTENSIONS; POWER DRILL BITS; POWER DRILLS; POWER OPERATED TOOLS, NAMELY, DRILL HAMMERS; POWER TOOLS, NAMELY, HAMMER DRILLS; POWER TOOLS, NAMELY, DRILLS, DRILL HAMMERS, IMPACT WRENCHES, AND SCREWDRIVERS; POWER-DRIVEN WRENCHES; POWER-OPERATED RIVET GUNS; POWER-OPERATED SCREWDRIVERS (U.S. CLS. 13, 19, 21, 23, 31, 34 AND 35).

KARANENDRA S. CHHINA, EXAMINING ATTORNEY

SN 85-605,523. SHOP VAC CORPORATION, WILLIAMSPORT, PA. FILED 4-23-2012.

KVAC

THE MARK CONSISTS OF STANDARD CHARACTERS WITHOUT CLAIM TO ANY PARTICULAR FONT, STYLE, SIZE, OR COLOR.

FOR FLOOR CLEANING MACHINES; VACUUM CLEANERS (U.S. CLS. 13, 19, 21, 23, 31, 34 AND 35).

LINDA ESTRADA, EXAMINING ATTORNEY

CLASS 7—(Continued).

SN 85-605,985. RIMROCK AUTOMATION INC., FORT COLLINS, CO. FILED 4-23-2012.

SMARTDOCK

THE MARK CONSISTS OF STANDARD CHARACTERS WITHOUT CLAIM TO ANY PARTICULAR FONT, STYLE, SIZE, OR COLOR.

FOR CLAMPS FOR USE IN THE PRECISION CLAMPING OF WORK PIECES (U.S. CLS. 13, 19, 21, 23, 31, 34 AND 35).

LUCY ARANT, EXAMINING ATTORNEY

SN 85-614,472. TYCO VALVES & CONTROLS B.V., NETHERLANDS, NETHERLANDS, FILED 5-2-2012.

VARIOFLOW

THE MARK CONSISTS OF STANDARD CHARACTERS WITHOUT CLAIM TO ANY PARTICULAR FONT, STYLE, SIZE, OR COLOR.

FOR MACHINE PARTS, PNEUMATIC PROCESS VALVES USED AS PART OF MECHANICAL CONDUCTING EQUIPMENT IN THE FOODSTUFFS, STIMULANTS, BEVERAGE AND CHEMICAL INDUSTRIES (U.S. CLS. 13, 19, 21, 23, 31, 34 AND 35).

FIRST USE 5-31-2005; IN COMMERCE 5-31-2005.

JULIE WATSON, EXAMINING ATTORNEY

SN 85-615,301. INFUSION BRANDS, INC., CLEARWATER, FL. FILED 5-3-2012.

DESTRUCT WITH A PURPOSE

THE MARK CONSISTS OF STANDARD CHARACTERS WITHOUT CLAIM TO ANY PARTICULAR FONT, STYLE, SIZE, OR COLOR.

FOR POWER TOOLS, NAMELY, POWER SAWS, POWER DRILLS, POWER-DRIVEN SCREWDRIVERS, POWER SANDERS, POWER GRINDERS, POWER MULTI-TOOL COMPRISING AN OSCILLATING BASE THAT INCLUDES A SANDER, SCRAPER OR CUTTING TOOL, POWER HOLE SAW, POWER RECIPROCATING SAW (U.S. CLS. 13, 19, 21, 23, 31, 34 AND 35).

APRIL HESIK, EXAMINING ATTORNEY

CLASS 7—(Continued).

SN 85-629,013. ELECTROLUX HOME PRODUCTS, INC.,
CHARLOTTE, NC. FILED 5-18-2012.

FRIGIDAIRE

THE MARK CONSISTS OF STANDARD CHARACTERS
WITHOUT CLAIM TO ANY PARTICULAR FONT, STYLE,
SIZE, OR COLOR.

OWNER OF U.S. REG. NOS. 364,709, 616,196 AND
OTHERS.

FOR GENERATORS, NAMELY, GAS OPERATED
POWER GENERATORS, AND SNOW BLOWERS (U.S.
CLS. 13, 19, 21, 23, 31, 34 AND 35).

JUHI KAVEESHVAR, EXAMINING ATTORNEY

SN 85-629,020. ELECTROLUX HOME PRODUCTS, INC.,
CHARLOTTE, NC. FILED 5-18-2012.

KELVINATOR

THE MARK CONSISTS OF STANDARD CHARACTERS
WITHOUT CLAIM TO ANY PARTICULAR FONT, STYLE,
SIZE, OR COLOR.

OWNER OF U.S. REG. NOS. 142,652, 783,552 AND
3,352,834.

FOR GENERATORS, NAMELY, GAS OPERATED
POWER GENERATORS, AND SNOW BLOWERS (U.S.
CLS. 13, 19, 21, 23, 31, 34 AND 35).

JUHI KAVEESHVAR, EXAMINING ATTORNEY

SN 85-645,731. THE BLACK & DECKER CORPORATION,
TOWSON, MD. FILED 6-7-2012.

2-N-1

THE MARK CONSISTS OF STANDARD CHARACTERS
WITHOUT CLAIM TO ANY PARTICULAR FONT, STYLE,
SIZE, OR COLOR.

FOR PNEUMATIC NAILERS (U.S. CLS. 13, 19, 21, 23,
31, 34 AND 35).

LINDA E. BLOHM, EXAMINING ATTORNEY

CLASS 7—(Continued).

SN 85-673,633. THE BLACK & DECKER CORPORATION,
TOWSON, MD. FILED 7-11-2012.

Steam-Mop

NO CLAIM IS MADE TO THE EXCLUSIVE RIGHT TO
USE "STEAM-MOP", APART FROM THE MARK AS
SHOWN.

THE MARK CONSISTS OF THE WORDS "STEAM-MOP"
FOLLOWED BY A BURST OF STEAM.

FOR STEAM CLEANING MACHINES IN THE NATURE
OF STEAM MOPS (U.S. CLS. 13, 19, 21, 23, 31, 34
AND 35).

FIRST USE 1-31-2011; IN COMMERCE 1-31-2011.

LINDA E. BLOHM, EXAMINING ATTORNEY

CLASS 8—HAND TOOLS

SN 76-710,520. GAUGLER, DONALD, NEW YORK, NY.
FILED 2-3-2012.

D* /NY

THE MARK CONSISTS OF STANDARD CHARACTERS
WITHOUT CLAIM TO ANY PARTICULAR FONT, STYLE,
SIZE, OR COLOR.

FOR RAZORS (U.S. CLS. 23, 28 AND 44).

INGA ERVIN, EXAMINING ATTORNEY

CLASS 8—(Continued).

SN 85-290,520. MADI, LLC, GREENVILLE, SC. FILED 4-8-2011.



NO CLAIM IS MADE TO THE EXCLUSIVE RIGHT TO USE "DE VINER", APART FROM THE MARK AS SHOWN. THE COLOR(S) BLACK AND GREEN IS/ARE CLAIMED AS A FEATURE OF THE MARK.

THE MARK CONSISTS OF THE STYLIZED WORDING "DE" FOLLOWED BY THE GRAPHIC REPRESENTATION OF A TOOL FOLLOWED BY THE STYLIZED WORDING "VINER". THE WORDING AND THE GRAPHIC DESIGN ELEMENT OF THE MARK BOTH APPEAR IN GREEN AND ARE BOTH OUTLINED IN BLACK.

FOR HAND TOOL, NAMELY, HOOK ATTACHMENT FOR NON-CONDUCTIVE TOOL HANDLES, FOR USE IN REMOVING VEGETATION LOCATED ON OR AROUND ELECTRICAL POWER LINES (U.S. CLS. 23, 28 AND 44). FIRST USE 1-31-2011; IN COMMERCE 1-31-2011. ALICE BENMAMAN, EXAMINING ATTORNEY

SN 85-331,625. APEX BRANDS, INC., APEX, NC. FILED 5-26-2011.

ARMSTRONG

THE MARK CONSISTS OF STANDARD CHARACTERS WITHOUT CLAIM TO ANY PARTICULAR FONT, STYLE, SIZE, OR COLOR.

OWNER OF U.S. REG. NOS. 243,601, 652,375 AND OTHERS. SEC. 2(F).

FOR MANUALLY OPERATED HAND TOOLS, NAMELY, NUT DRIVERS, SCREW EXTRACTORS, HEX KEY WRENCHES, CLAMPS, PRY BARS, HAND SOCKETS AND ACCESSORIES, NAMELY, HAND SOCKET WRENCHES; ROLL-UP VINYL CONTAINER FOR HAND TOOLS (U.S. CLS. 23, 28 AND 44).

FIRST USE 0-0-1892; IN COMMERCE 0-0-1892. ALEX KEAM, EXAMINING ATTORNEY

CLASS 8—(Continued).

SN 85-337,017. SUMMIT ENTERTAINMENT, LLC, SANTA MONICA, CA. FILED 6-3-2011.

TWILIGHT BRIDAL

THE MARK CONSISTS OF STANDARD CHARACTERS WITHOUT CLAIM TO ANY PARTICULAR FONT, STYLE, SIZE, OR COLOR.

OWNER OF U.S. REG. NOS. 3,867,985, 3,944,718 AND OTHERS.

NO CLAIM IS MADE TO THE EXCLUSIVE RIGHT TO USE "BRIDAL", APART FROM THE MARK AS SHOWN.

FOR FLATWARE, NAMELY, KNIVES, FORKS, AND SPOONS; AND SERVING KNIVES (U.S. CLS. 23, 28 AND 44).

ASMAT KHAN, EXAMINING ATTORNEY

SN 85-350,550. FOREVER CO., LTD., SAITAMA-KEN, JAPAN, FILED 6-20-2011.

CRYSTAL TITAN

THE MARK CONSISTS OF STANDARD CHARACTERS WITHOUT CLAIM TO ANY PARTICULAR FONT, STYLE, SIZE, OR COLOR.

OWNER OF U.S. REG. NOS. 2,880,412 AND 3,007,900.

FOR KITCHEN KNIVES; KITCHEN AND GARDENING SCISSORS; CHEF KNIVES (U.S. CLS. 23, 28 AND 44). CIMMERIAN COLEMAN, EXAMINING ATTORNEY

SN 85-367,811. GILLETTE COMPANY, THE, BOSTON, MA. FILED 7-11-2011.

MACH3 HD

THE MARK CONSISTS OF STANDARD CHARACTERS WITHOUT CLAIM TO ANY PARTICULAR FONT, STYLE, SIZE, OR COLOR.

OWNER OF U.S. REG. NOS. 2,599,189 AND 3,215,049.

NO CLAIM IS MADE TO THE EXCLUSIVE RIGHT TO USE "HD", APART FROM THE MARK AS SHOWN.

FOR RAZORS AND RAZOR BLADES; DISPENSERS, CASSETTES, HOLDERS, AND CARTRIDGES, ALL CONTAINING RAZOR BLADES; AND STRUCTURAL PARTS THEREFOR (U.S. CLS. 23, 28 AND 44).

COLLEEN DOMBROW, EXAMINING ATTORNEY

CLASS 8—(Continued).

SN 85-442,474. GHILONI, JOSHUA, POYNETTE, WI. FILED 10-7-2011.

Wap O Melon

THE MARK CONSISTS OF STANDARD CHARACTERS WITHOUT CLAIM TO ANY PARTICULAR FONT, STYLE, SIZE, OR COLOR.

NO CLAIM IS MADE TO THE EXCLUSIVE RIGHT TO USE "MELON", APART FROM THE MARK AS SHOWN.

FOR FRUIT AND VEGETABLE CORER INCORPORATING A FUNNEL (U.S. CLS. 23, 28 AND 44).

DOMINIC J. FERRAIUOLO, EXAMINING ATTORNEY

CLASS 8—(Continued).

SN 85-554,736. FROST CUTLERY COMPANY LLC, OOLTEWAH, TN. FILED 2-28-2012.

JACK FROST

THE MARK CONSISTS OF STANDARD CHARACTERS WITHOUT CLAIM TO ANY PARTICULAR FONT, STYLE, SIZE, OR COLOR.

OWNER OF U.S. REG. NOS. 1,218,915, 3,594,434 AND OTHERS.

FOR KNIVES (U.S. CLS. 23, 28 AND 44).

RONALD DELGIZZI, EXAMINING ATTORNEY

SN 85-500,237. DISCOVERY COMMUNICATIONS, LLC, SILVER SPRING, MD. FILED 12-20-2011.

KITCHEN BOSS

THE MARK CONSISTS OF STANDARD CHARACTERS WITHOUT CLAIM TO ANY PARTICULAR FONT, STYLE, SIZE, OR COLOR.

NO CLAIM IS MADE TO THE EXCLUSIVE RIGHT TO USE "KITCHEN", APART FROM THE MARK AS SHOWN.

FOR HAND-OPERATED FOOD PROCESSORS, HAND OPERATED FOOD DICERS, HAND OPERATED KITCHEN APPLIANCE FOR DICING, MINCING, SLICING AND CHOPPING FOOD, ZESTERS (U.S. CLS. 23, 28 AND 44).

MICHELE SWAIN, EXAMINING ATTORNEY

SN 85-560,005. KACZOR, DAWN B., GROVELAND, MA. AND KACZOR, JOSEPH J., SALEM, NH. AND KACZOR, CAROL A., SALEM, NH. FILED 3-5-2012.



THE MARK CONSISTS OF STYLIZED LETTERS "STINGER" IN AN ARC PATTERN. THE WORDING "STINGER" IN BLACK. STYLIZED LETTER "T" IN "STINGER" AS PART OF THE BEE DESIGN ELEMENT. STYLIZED "T" BEE ELEMENT IN BLACK AND WHITE.

FOR HAND TOOLS, NAMELY, LAWN AERATORS (U.S. CLS. 23, 28 AND 44).

FIRST USE 1-1-2012; IN COMMERCE 1-1-2012.

CHERYL CLAYTON, EXAMINING ATTORNEY

SN 85-505,759. RMJ TACTICAL, LLC, CHATTANOOGA, TN. FILED 12-29-2011.



NO CLAIM IS MADE TO THE EXCLUSIVE RIGHT TO USE "TACTICAL", APART FROM THE MARK AS SHOWN.

THE MARK CONSISTS OF TWO CROSSED SPIKE TOMAHAWKS WITH A SKULL LOCATED IN THE CENTER, AND "RMJ TACTICAL" BELOW THE DESIGN. THE BLACK BEHIND THE MARK MERELY REPRESENTS BACKGROUND, AND IS NOT CLAIMED AS A PART OF THE MARK.

FOR AXES (U.S. CLS. 23, 28 AND 44).

FIRST USE 2-15-2007; IN COMMERCE 2-15-2007.

TINA BROWN, EXAMINING ATTORNEY

SN 85-590,915. PAUN, MIHAI, NORTH OLMSTED, OH. FILED 4-6-2012.

HANDY SQUIRREL

THE MARK CONSISTS OF STANDARD CHARACTERS WITHOUT CLAIM TO ANY PARTICULAR FONT, STYLE, SIZE, OR COLOR.

FOR HOLDERS SPECIALLY ADAPTED FOR HOLDING PAINT CANS AND TOOLS FOR USE WITH LADDERS OR LIFTING EQUIPMENT (U.S. CLS. 23, 28 AND 44).

KEVEN MITTLER, EXAMINING ATTORNEY

CLASS 8—(Continued).

SN 85-595,854. ROMAR/MEC, LLC, HOUSTON, TX. FILED 4-12-2012.

MAG PRY

THE MARK CONSISTS OF STANDARD CHARACTERS WITHOUT CLAIM TO ANY PARTICULAR FONT, STYLE, SIZE, OR COLOR.

NO CLAIM IS MADE TO THE EXCLUSIVE RIGHT TO USE PRY, APART FROM THE MARK AS SHOWN.

FOR HAND TOOLS FOR WELDING AND FABRICATION, NAMELY, MAGNETIC PRY BARS, FOR STEEL PLATE AND SHEET METAL ALIGNMENT (U.S. CLS. 23, 28 AND 44).

FIRST USE 10-0-2007; IN COMMERCE 10-0-2008.
JOHN HWANG, EXAMINING ATTORNEY

SN 85-602,774. ONE WORLD ACCESS, LLC, LINCOLNSHIRE, IL. FILED 4-19-2012.

One World

THE MARK CONSISTS OF STANDARD CHARACTERS WITHOUT CLAIM TO ANY PARTICULAR FONT, STYLE, SIZE, OR COLOR.

FOR GARDENING SHEARS AND SCISSORS; GARDENING TOOLS, NAMELY, TROWELS, WEEDERS, CULTIVATORS, PRUNERS, LOPPERS, BULB PLANTERS, WEEDERS, SAWS, SHOVELS, HOES; GARDENING TROWELS; LAWN AND GARDEN TOOLS, NAMELY, CULTIVATORS (U.S. CLS. 23, 28 AND 44).

FIRST USE 1-1-1999; IN COMMERCE 1-1-2007.
AISHA SALEM, EXAMINING ATTORNEY

SN 85-604,551. LESCHE, GEORGE, AKA PREDATOR TOOLS, BRIDGETON, NJ. FILED 4-21-2012.

PredatorTools

THE MARK CONSISTS OF STANDARD CHARACTERS WITHOUT CLAIM TO ANY PARTICULAR FONT, STYLE, SIZE, OR COLOR.

FOR DRAW TAPE REELS; DRAW WIRES; EXTENSION BARS FOR HAND TOOLS; EXTENSIONS FOR HAND TOOLS; FIREPLACE BELLOWES; GARDENING TOOLS, NAMELY, A MANUALLY OPERATED TOOL FOR INJECTING SOLID FERTILIZER SPIKES INTO THE SOIL; HAND POWERED TOOL USED TO SEAL PLASTIC BAGS WITH ADHESIVE TAPE; HAND TOOL FOR PICKING UP AND MOVING POTTED PLANTS; HAND TOOL, NAMELY, RIGID AND ROD HAND BENDERS FOR USE ON PIPES AND CONDUITS; HAND TOOL, NAMELY, TELESCOPIC ANGLE SET TOOL FOR EMT FOR USE ON PIPES AND CONDUITS; HAND TOOLS FOR DECANTING LIQUIDS; HAND TOOLS FOR PUTTING A FINISH ON CONCRETE, NAMELY,

CLASS 8—(Continued).

CONCRETE BRUSHES AND COMBS; HAND TOOLS FOR REPAIR AND MAINTENANCE OF BICYCLES; HAND TOOLS FOR USE IN CARVING OR DECORATING PUMPKINS, MINI-PUMPKINS, GOURDS, AND OTHER FRUITS AND VEGETABLES, NAMELY, KNIVES, SAWS, SCOOPS, CHISELS AND DRILLS; HAND TOOLS FOR USE WITH BURNING CAMPFIRES AND PREVIOUSLY BURNT CAMPFIRES, NAMELY, FIRE POKERS TO MOVE BURNING LOGS AND PREVIOUSLY BURNT LOGS, TONGS TO PICK UP BURNING LOGS AND PREVIOUSLY BURNT LOGS; HAND TOOLS, NAMELY, AUGERS; HAND TOOLS, NAMELY, AUTOMOBILE SHEET METAL DENT REPAIR TOOL; HAND TOOLS, NAMELY, AWLS; HAND TOOLS, NAMELY, BAR CUTTERS; HAND TOOLS, NAMELY, BOLT CUTTERS; HAND TOOLS, NAMELY, BRASSWORKER SPATULAS FOR STIRRING HOT METAL; HAND TOOLS, NAMELY, BULB PLANTERS; HAND TOOLS, NAMELY, BUSHING DRIVERS; HAND TOOLS, NAMELY, CHALK LINE REELS; HAND TOOLS, NAMELY, CLAMPS; HAND TOOLS, NAMELY, CONCRETE MOVERS; HAND TOOLS, NAMELY, CRIMP WRENCH SETS; HAND TOOLS, NAMELY, CRIMP WRENCHES; HAND TOOLS, NAMELY, CRIMPING IRONS; HAND TOOLS, NAMELY, CUTTER BARS; HAND TOOLS, NAMELY, DICING BLADES, SLITTING BLADES, OPTICALLY TRANSPARENT BLADES, OPTICALLY TRANSMITTING BLADES; HAND TOOLS, NAMELY, DIE CHASERS; HAND TOOLS, NAMELY, DIE WRENCHES; HAND TOOLS, NAMELY, DIES; HAND TOOLS, NAMELY, DITCH BANK BLADES; HAND TOOLS, NAMELY, DRILLS; HAND TOOLS, NAMELY, EDGERS FOR GROUT, MORTAR OR CEMENT; HAND TOOLS, NAMELY, ENGRAVERS; HAND TOOLS, NAMELY, EXPANDERS; HAND TOOLS, NAMELY, FARRIERS' KNIVES; HAND TOOLS, NAMELY, FILES; HAND TOOLS, NAMELY, FLARING TOOLS; HAND TOOLS, NAMELY, FLAT FINISHER BOXES; HAND TOOLS, NAMELY, FLOATS FOR GROUT, MORTAR OR CEMENT; HAND TOOLS, NAMELY, FOUNDRY LADLES; HAND TOOLS, NAMELY, FRUIT PICKERS; HAND TOOLS, NAMELY, FULLERS; HAND TOOLS, NAMELY, GOUGES; HAND TOOLS, NAMELY, GRAFTING TOOLS; HAND TOOLS, NAMELY, GRASS HOOKS; HAND TOOLS, NAMELY, GRASS WHIPS; HAND TOOLS, NAMELY, GRAVING TOOLS; HAND TOOLS, NAMELY, GROOVERS FOR GROUT, MORTAR OR CEMENT; HAND TOOLS, NAMELY, GROOVING TOOLS; HAND TOOLS, NAMELY, HAMMERS; HAND TOOLS, NAMELY, HAND BENDERS FOR USE ON PIPES AND CONDUITS; HAND TOOLS, NAMELY, HAND JACKS; HAND TOOLS, NAMELY, HAND SEAMERS; HAND TOOLS, NAMELY, HAND TOOLS FOR SKIMMING WALL REPAIRS IN SMALL OR TIGHT AREAS WITH JOINT COMPOUND, PUTTY, OR SMOOTHING VINYL LETTERING; HAND TOOLS, NAMELY, HAND-OPERATED DEVICE TO AID WITH TYING AND UNTYING KNOTS; HAND TOOLS, NAMELY, HAND-OPERATED PUMPS; HAND TOOLS, NAMELY, HAND-OPERATED REACHING DEVICES FOR PICKING UP AND REMOVING TRASH, LITTER AND OBJECTS; HAND TOOLS, NAMELY, HATCHETS; HAND TOOLS, NAMELY, HEX KEYS WRENCHES; HAND TOOLS, NAMELY, ICE PICKS; HAND TOOLS, NAMELY, KNEE KICKERS; HAND TOOLS, NAMELY, KNIFE SHARPENERS; HAND TOOLS, NAMELY, LAWN AERATORS; HAND TOOLS, NAMELY, LEVERS; HAND TOOLS, NAMELY, LOPPERS; HAND TOOLS, NAMELY, MANUALLY-OPERATED GRINDING WHEELS; HAND TOOLS, NAMELY, MANUALLY-OPERATED GRINDSTONES; HAND TOOLS, NAMELY, MANUALLY-OPERATED GUIDES FOR KNIVES AND/OR SAWS; HAND TOOLS, NAMELY, MANUALLY-OPERATED SHARPENING WHEELS; HAND TOOLS, NAMELY, MAULS; HAND TOOLS, NAMELY, MILLING CUTTERS; HAND TOOLS, NAMELY, MITER BOXES; HAND TOOLS, NAMELY, MITRE BOXES; HAND TOOLS, NAMELY, NAIL SETS; HAND TOOLS, NAMELY, NIPPERS; HAND TOOLS, NAMELY, NUT DRIVERS; HAND TOOLS, NAMELY, PAINT SCRAPERS; HAND TOOLS, NAMELY, PAINT TRIM GUIDES; HAND TOOLS, NAMELY, PICKS; HAND TOOLS, NAMELY, PIKES; HAND TOOLS, NAMELY, PINCERS; HAND TOOLS, NAMELY, PLANERS; HAND TOOLS, NAMELY, PLANES; HAND TOOLS, NAMELY, PLIERS SETS; HAND TOOLS, NAMELY, POST HOLE DIGGERS; HAND TOOLS, NAMELY, PRIMING IRONS; HAND TOOLS, NAMELY,

CLASS 8—(Continued).

PRUNERS; HAND TOOLS, NAMELY, PRUNING SAWS; HAND TOOLS, NAMELY, PULLERS AND SPLITTERS; HAND TOOLS, NAMELY, PUNCHES; HAND TOOLS, NAMELY, PUTTY KNIVES; HAND TOOLS, NAMELY, RAMMERS; HAND TOOLS, NAMELY, RASPS; HAND TOOLS, NAMELY, RATCHET WRENCHES; HAND TOOLS, NAMELY, REAMERS; HAND TOOLS, NAMELY, RIPPING BARS; HAND TOOLS, NAMELY, RIVETERS; HAND TOOLS, NAMELY, ROLLERS AND BRUSHES FOR APPLYING ADHESIVES; HAND TOOLS, NAMELY, SANDING SPONGES; HAND TOOLS, NAMELY, SAWS; HAND TOOLS, NAMELY, SCRAPERS; HAND TOOLS, NAMELY, SCREW EXTRACTORS; HAND TOOLS, NAMELY, SCREWDRIVERS; HAND TOOLS, NAMELY, SCYTHE RINGS; HAND TOOLS, NAMELY, SCYTHE STONES; HAND TOOLS, NAMELY, SHEET METAL SHRINKING AND STRETCHING DEVICE; HAND TOOLS, NAMELY, SOCKET SETS; HAND TOOLS, NAMELY, SOCKET WRENCHES; HAND TOOLS, NAMELY, SOD LIFTERS; HAND TOOLS, NAMELY, SPATULAS; HAND TOOLS, NAMELY, SPOKESHAVES; HAND TOOLS, NAMELY, SQUARES; HAND TOOLS, NAMELY, STAMPING-OUT TOOLS; HAND TOOLS, NAMELY, STAMPS; HAND TOOLS, NAMELY, STRETCHERS FOR WIRE AND METAL BANDS; HAND TOOLS, NAMELY, SURFBOARD WAX REMOVAL TOOL; HAND TOOLS, NAMELY, TAMPERS; HAND TOOLS, NAMELY, TAP AND DIE SETS; HAND TOOLS, NAMELY, TAPS; HAND TOOLS, NAMELY, TILE CUTTERS; HAND TOOLS, NAMELY, TONGS; HAND TOOLS, NAMELY, TOOLS FOR PLACING A ROPE OR OTHER FLEXIBLE MEMBER THROUGH AN EYE OR AROUND A TARGET OBJECT; HAND TOOLS, NAMELY, TORQUE MULTIPLIERS; HAND TOOLS, NAMELY, TRANSPLANTERS; HAND TOOLS, NAMELY, VICES; HAND TOOLS, NAMELY, WEDGES; HAND TOOLS, NAMELY, WEED CUTTERS; HAND TOOLS, NAMELY, WEED DIGGERS; HAND TOOLS, NAMELY, WIRE CUTTERS; HAND TOOLS, NAMELY, WIRE NIPPERS; HAND TOOLS, NAMELY, WIRE STRIPPERS; HAND TOOLS, NAMELY, WRECKING BARS, STRIPPING BARS, SMALL BARS AND NAIL PULLERS, SAN ANGELO BARS, TAMPER BARS, WEDGE POINT BARS, PITCH POINT BARS; HAND TOOLS, NAMELY, WRENCHES; HAND-OPERATED AUTOMOTIVE REPAIR TOOLS, NAMELY, BALL JOINT SEPARATORS; HAND-OPERATED AUTOMOTIVE REPAIR TOOLS, NAMELY, BRAKE CYLINDER HONES; HAND-OPERATED AUTOMOTIVE REPAIR TOOLS, NAMELY, BRAKE PAD SPREADERS; HAND-OPERATED AUTOMOTIVE REPAIR TOOLS, NAMELY, BRAKE SPRING REMOVERS; HAND-OPERATED AUTOMOTIVE REPAIR TOOLS, NAMELY, DISC BRAKE PISTON CUBES; HAND-OPERATED AUTOMOTIVE REPAIR TOOLS, NAMELY, DRUM BRAKE ADJUSTING TOOLS; HAND-OPERATED AUTOMOTIVE REPAIR TOOLS, NAMELY, ENGINE CYLINDER HONES; HAND-OPERATED AUTOMOTIVE REPAIR TOOLS, NAMELY, MAGNETIC PICK-UP TOOLS; HAND-OPERATED AUTOMOTIVE REPAIR TOOLS, NAMELY, RING COMPRESSORS; HAND-OPERATED AUTOMOTIVE REPAIR TOOLS, NAMELY, VALVE HOLDERS; HAND-OPERATED AUTOMOTIVE REPAIR TOOLS, NAMELY, VALVE SPRING COMPRESSORS; HAND-OPERATED AUTOMOTIVE REPAIR TOOLS, NAMELY, VALVE SPRING DEPRESSORS; HAND-OPERATED CUTTING TOOLS; HAND-OPERATED CUTTING TOOLS, NAMELY, BOX CUTTERS; HAND-OPERATED CUTTING TOOLS, NAMELY, SAFETY CUTTERS; HAND-OPERATED DISARMING TOOLS FOR IMPROVISED EXPLOSIVE DEVICES (IED); HAND-OPERATED RIVETING TOOLS; HAND-OPERATED SCRAPING TOOL FOR CLEANING CLEATS FOR ATTACHMENT TO SPORTS SHOES; HAND-OPERATED SHARPENING TOOLS AND INSTRUMENTS; HAND-OPERATED TOOL TO AID IN SKINNING AN ANIMAL, NAMELY, A TOOL HAVING A BLADE AND HOOK TO ASSIST IN SKINNING AN ANIMAL; HAND-OPERATED TOOLS, NAMELY, CHISELS; HAND-POWERED TOOL USED TO CLOSE RESEALABLE BAGS USED WITH VACUUM SEALERS; HAND-TOOLS, NAMELY, WIRE CRIMPERS; KNIVES; LAWN AND GARDEN TOOLS, NAMELY, CULTIVATORS; MANUALLY OPERATED HAND TOOL FOR CRUSHING PIPES; MANUALLY OPERATED SHOP TOOLS FOR WORK ON MOTORCYCLES, NAMELY, CHAIN BREAKER TOOL, CHAIN RIVETING TOOL, CHAIN PRESS TOOL, CHAIN ALIGNMENT TOOL, CARBURETOR TUNING TOOL, CARBURETOR TUN-

CLASS 8—(Continued).

ING GAUGE SET, TIRE IRONS, TAPPET ADJUSTMENT TOOLS, VALVE SHIM TOOLS, TAPPET FEELER GAUGE, CARBURETOR JET WRENCHES, CLUTCH HOLDING TOOL, PISTON PIN REMOVING TOOL, SPRING REMOVING TOOL, TIMING COVER WRENCH, OIL FILTER WRENCH, SHOCK ABSORBER WRENCH, AXLE WRENCH, FLY WHEEL PULLER TOOL, CLUTCH PULLER TOOL AND MAGNETO FLYWHEEL PULLER TOOL; MANUALLY-OPERATED SPECIALIZED TOOL FOR THE PURPOSE OF PUSHING A MARINE BUSHING OUT OF THE STRUT; NON-POWERED LAWN AND TURF EDGING TOOL FOR ATTACHMENT TO UNIVERSAL UTILITY VEHICLES; RATCHET HAND TOOL FOR THE INSTALLATION AND REMOVAL OF ALPINE SKI AND SNOWBOARD RACING GATES; ROLL-UP FABRIC CONTAINER FOR HAND TOOLS; SCULPTING TOOLS, NAMELY, LOOPS; TOOL BELTS; TOOL HOLDERS; TOOL POUCHES FOR ATTACHMENT TO TOOL BELTS; WIRE STRIPPERS (U.S. CLS. 23, 28 AND 44).

FIRST USE 1-31-2008; IN COMMERCE 1-31-2008.
ALEXANDER L. POWERS, EXAMINING ATTORNEY

SN 85-611,990. TARGET BRANDS, INC., MINNEAPOLIS, MN. FILED 4-30-2012.

UP & UP

THE MARK CONSISTS OF STANDARD CHARACTERS WITHOUT CLAIM TO ANY PARTICULAR FONT, STYLE, SIZE, OR COLOR.

OWNER OF U.S. REG. NOS. 3,786,202, 4,029,541 AND OTHERS.

FOR MANICURE IMPLEMENTS, NAMELY, NAIL FILES, NAIL CLIPPERS, NAIL BUFFERS, CUTICLE PUSHERS, TWEEZERS, NAIL AND CUTICLE SCISSORS; PEDICURE IMPLEMENTS, NAMELY, NAIL FILES, NAIL CLIPPERS, NAIL BUFFERS, CUTICLE PUSHERS, TWEEZERS, NAIL AND CUTICLE SCISSORS (U.S. CLS. 23, 28 AND 44).

JEAN IM, EXAMINING ATTORNEY

SN 85-612,015. TARGET BRANDS, INC., MINNEAPOLIS, MN. FILED 4-30-2012.

UP & UP

THE MARK CONSISTS OF STANDARD CHARACTERS WITHOUT CLAIM TO ANY PARTICULAR FONT, STYLE, SIZE, OR COLOR.

OWNER OF U.S. REG. NOS. 3,786,202, 4,029,541 AND OTHERS.

FOR SHAVERS, NAMELY, CORN AND CALLUS REMOVERS; FOOT CARE IMPLEMENTS, NAMELY, FOOT FILES (U.S. CLS. 23, 28 AND 44).

FIRST USE 3-0-2010; IN COMMERCE 3-0-2010.
JEAN IM, EXAMINING ATTORNEY

CLASS 8—(Continued).

SN 85-612,024. TARGET BRANDS, INC., MINNEAPOLIS, MN. FILED 4-30-2012.



OWNER OF U.S. REG. NOS. 3,786,202, 4,029,541 AND OTHERS.

THE MARK CONSISTS OF AN ARROW DESIGN POINTING AT A 45 DEGREE DIAGONAL, UP AND TO THE RIGHT, WITH THE WORDS "UP & UP" INSIDE THE ARROW.

FOR SHAVERS, NAMELY, CORN AND CALLUS REMOVERS; FOOT CARE IMPLEMENTS, NAMELY, FOOT FILES (U.S. CLS. 23, 28 AND 44).

FIRST USE 3-0-2010; IN COMMERCE 3-0-2010.
JEAN IM, EXAMINING ATTORNEY

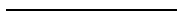

SN 85-612,033. TARGET BRANDS, INC., MINNEAPOLIS, MN. FILED 4-30-2012.



OWNER OF U.S. REG. NOS. 3,786,202, 4,029,541 AND OTHERS.

THE MARK CONSISTS OF AN ARROW DESIGN POINTING AT A 45 DEGREE DIAGONAL, UP AND TO THE RIGHT, WITH THE WORDS "UP & UP" INSIDE THE ARROW.

FOR MANICURE IMPLEMENTS, NAMELY, NAIL FILES, NAIL CLIPPERS, NAIL BUFFERS, CUTICLE PUSHERS, TWEEZERS, NAIL AND CUTICLE SCISSORS; PEDICURE IMPLEMENTS, NAMELY, NAIL FILES, NAIL CLIPPERS, NAIL BUFFERS, CUTICLE PUSHERS, TWEEZERS, NAIL AND CUTICLE SCISSORS (U.S. CLS. 23, 28 AND 44).

JEAN IM, EXAMINING ATTORNEY

CLASS 8—(Continued).

SN 85-618,491. TUSCAN LEVELING, INC., FAIRFIELD, IA. FILED 5-7-2012.

TUSCAN

THE MARK CONSISTS OF STANDARD CHARACTERS WITHOUT CLAIM TO ANY PARTICULAR FONT, STYLE, SIZE, OR COLOR.

OWNER OF U.S. REG. NO. 3,807,938.

FOR HAND TOOLS, NAMELY, TILE LEVELERS FOR INSERTION BETWEEN ADJACENT FLOORING TILES AND FLOORING MODULES MADE OF BOTH MAN-MADE AND NATURAL MATERIALS (U.S. CLS. 23, 28 AND 44).

CHRISTINA SOBRAL, EXAMINING ATTORNEY



SN 85-622,730. IDEAL INDUSTRIES, INC., SYCAMORE, IL. FILED 5-11-2012.

PREPPRO

THE MARK CONSISTS OF STANDARD CHARACTERS WITHOUT CLAIM TO ANY PARTICULAR FONT, STYLE, SIZE, OR COLOR.

FOR HAND TOOLS, NAMELY, WIRE STRIPPERS (U.S. CLS. 23, 28 AND 44).

CAROLYN CATALDO, EXAMINING ATTORNEY



SN 85-640,789. IDEAL INDUSTRIES, INC., SYCAMORE, IL. FILED 6-1-2012.

LINEARX

THE MARK CONSISTS OF STANDARD CHARACTERS WITHOUT CLAIM TO ANY PARTICULAR FONT, STYLE, SIZE, OR COLOR.

FOR HAND TOOLS FOR CABLE CONNECTORS, NAMELY, COMPRESSION TOOLS FOR USE IN ATTACHING CONNECTORS TO WIRES AND CABLES (U.S. CLS. 23, 28 AND 44).

FIRST USE 8-31-2011; IN COMMERCE 8-31-2011.

CAROLYN CATALDO, EXAMINING ATTORNEY

CLASS 8—(Continued).

SN 85-642,750. TUSCAN LEVELING, INC., CEDAR RAPIDS, IA. FILED 6-4-2012.

TUSCAN ELS

THE MARK CONSISTS OF STANDARD CHARACTERS WITHOUT CLAIM TO ANY PARTICULAR FONT, STYLE, SIZE, OR COLOR.

OWNER OF U.S. REG. NO. 3,807,938.
FOR HAND TOOLS, NAMELY, TILE LEVELERS FOR INSERTION BETWEEN ADJACENT FLOORING TILES AND FLOORING MODULES MADE OF BOTH MAN-MADE AND NATURAL MATERIALS (U.S. CLS. 23, 28 AND 44).

CHRISTINA SOBRAL, EXAMINING ATTORNEY

CLASS 9—ELECTRICAL AND SCIENTIFIC APPARATUS

SN 76-686,245. MALICO INC., YANG MEI, TAOYUAN COUNTY, TAIWAN, FILED 1-28-2008.

TALON

FOR HEAT SINKS FOR USE IN CENTRAL PROCESSING UNITS, HEAT SINKS FOR USE IN COMPUTERS, COOLERS FOR USE IN ELECTRONIC COMPONENTS, COOLING FANS FOR USE WITH COMPUTER PERIPHERALS, INTERNAL COOLING FANS FOR COMPUTERS, COOLERS FOR USE IN COMPUTER INTERFACE CARDS (U.S. CLS. 21, 23, 26, 36 AND 38).

SEAN CROWLEY, EXAMINING ATTORNEY

SN 85-684,794. WKI HOLDING COMPANY, INC., ROSEMONT, IL. FILED 7-23-2012.

ProHold

THE MARK CONSISTS OF STANDARD CHARACTERS WITHOUT CLAIM TO ANY PARTICULAR FONT, STYLE, SIZE, OR COLOR.

FOR CUTLERY, NAMELY, CHEF'S KNIVES, SLICING KNIVES, CARVING KNIVES, SANTOKU KNIVES, UTILITY KNIVES, PARING KNIVES, STEAK KNIVES, PEELING KNIVES, VEGETABLE KNIVES, AND FRUIT KNIVES; KNIFE SHARPENERS AND SHEARS (U.S. CLS. 23, 28 AND 44).

KRISTIN DAHLING, EXAMINING ATTORNEY

SN 76-710,002. GENX INTERNATIONAL, INC., GUILFORD, CT. FILED 12-15-2011.

GPS

THE MARK CONSISTS OF STANDARD CHARACTERS WITHOUT CLAIM TO ANY PARTICULAR FONT, STYLE, SIZE, OR COLOR.

OWNER OF U.S. REG. NOS. 3,431,257 AND 3,694,502.
FOR IN VITRO FERTILIZATION LABORATORY LABWARE, NAMELY, EMBRYO AND OOCYTE CULTURING PETRI DISHES USED FOR EMBRYO AND OOCYTE CULTURING IN VITRO FERTILIZATION PROCEDURE LABORATORIES (U.S. CLS. 21, 23, 26, 36 AND 38).

KATHLEEN KOLACZ, EXAMINING ATTORNEY

SN 85-684,795. WKI HOLDING COMPANY, INC., ROSEMONT, IL. FILED 7-23-2012.

ProControl

THE MARK CONSISTS OF STANDARD CHARACTERS WITHOUT CLAIM TO ANY PARTICULAR FONT, STYLE, SIZE, OR COLOR.

FOR CUTLERY, NAMELY, CHEF'S KNIVES, SLICING KNIVES, CARVING KNIVES, SANTOKU KNIVES, UTILITY KNIVES, PARING KNIVES, STEAK KNIVES, PEELING KNIVES, VEGETABLE KNIVES, AND FRUIT KNIVES; KNIFE SHARPENERS AND SHEARS (U.S. CLS. 23, 28 AND 44).

KRISTIN DAHLING, EXAMINING ATTORNEY

SN 76-711,258. DCBA, INC., ATLANTA, GA. FILED 4-18-2012.

PDITRAX

THE MARK CONSISTS OF STANDARD CHARACTERS WITHOUT CLAIM TO ANY PARTICULAR FONT, STYLE, SIZE, OR COLOR.

FOR COMPUTER SOFTWARE FOR TRACKING, REPORTING, AND CLINICAL DOCUMENTATION OF DATA IN THE FIELD OF CHILDREN'S HOSPITAL AND HEALTHCARE SERVICES (U.S. CLS. 21, 23, 26, 36 AND 38).

FRANK LATTUCA, EXAMINING ATTORNEY

CLASS 9—(Continued).

SN 77-474,242. HEATHER BROOKE TAYLOR, EL CERRITO, CA. FILED 5-14-2008.



NO CLAIM IS MADE TO THE EXCLUSIVE RIGHT TO USE "RACING", APART FROM THE MARK AS SHOWN.

THE MARK CONSISTS OF A DESIGN FEATURING THE FACE OF A BLACK CAT FLANKED BY CHECKERED FLAGS AND SURROUNDED BY THE WORDS "BLACK CAT RACING".

FOR UNDERWEAR FOR PROTECTION AGAINST ACCIDENTS, IRRADIATION, AND FIRE (U.S. CLS. 21, 23, 26, 36 AND 38).

LEIGH CAROLINE CASE, EXAMINING ATTORNEY

SN 77-541,426. TEIXEIRA FILHO, FABIO LOPES, SAO PAULO, BRAZIL, FILED 8-7-2008.

iCooking

THE MARK CONSISTS OF STANDARD CHARACTERS WITHOUT CLAIM TO ANY PARTICULAR FONT, STYLE, SIZE, OR COLOR.

FOR COMPUTER SOFTWARE AND HARDWARE FOR INTERNET-ENABLED MULTIMEDIA COOKING SYSTEM (U.S. CLS. 21, 23, 26, 36 AND 38).

MATTHEW KLINE, EXAMINING ATTORNEY

SN 77-667,941. PIPS TECHNOLOGY INC., KNOXVILLE, TN. FILED 2-11-2009.

SPEEDSPIKE

THE MARK CONSISTS OF STANDARD CHARACTERS WITHOUT CLAIM TO ANY PARTICULAR FONT, STYLE, SIZE, OR COLOR.

OWNER OF ERPN CMNTY TM OFC REG. NO. 008160509, DATED 7-10-2009, EXPIRES 7-10-2019.

FOR INFRARED CAMERA SYSTEM, COMPRISING AN INFRARED CAMERA AND COMPUTER SOFTWARE TO CAPTURE AND ANALYZE MOTOR VEHICLE LICENSE PLATE INFORMATION (U.S. CLS. 21, 23, 26, 36 AND 38).

DORITT L. CARROLL, EXAMINING ATTORNEY

CLASS 9—(Continued).

SN 77-694,358. BOSS PACKAGING INC., CALGARY, ALBERTA, CANADA, FILED 3-18-2009.

BOSSPAC

THE MARK CONSISTS OF STANDARD CHARACTERS WITHOUT CLAIM TO ANY PARTICULAR FONT, STYLE, SIZE, OR COLOR.

PRIORITY CLAIMED UNDER SEC. 44(D) ON CANADA APPLICATION NO. 1430881, FILED 3-12-2009, REG. NO. 820478, DATED 3-22-2012, EXPIRES 3-22-2027.

FOR AUTOMATIC PUMP CONTROLLER USED IN PLANT AUTOMATION AND OIL AND GAS SITES AND FACILITIES; WIRELESS THERMAL AND VIBRATION SENSORS USED FOR MONITORING AND CONTROL OF ENGINES AND EQUIPMENT; CHEMICAL INJECTION FLOW METER; DIVIDER BLOCK LUBRICATION SENSORS; BURNER CONTROL INSTRUMENTS FOR OIL TANKS AND TUBS; WEB BASED DOWNLOADABLE REMOTE MONITORING SOFTWARE FOR OIL AND GAS OPERATORS (U.S. CLS. 21, 23, 26, 36 AND 38).

JOHN E. MICHOS, EXAMINING ATTORNEY

SN 77-793,310. ENECSYS LIMITED, CAMBRIDGE, CAMBRIDGESH, UNITED KINGDOM, FILED 7-30-2009.

ENECSYS

THE MARK CONSISTS OF STANDARD CHARACTERS WITHOUT CLAIM TO ANY PARTICULAR FONT, STYLE, SIZE, OR COLOR.

PRIORITY CLAIMED UNDER SEC. 44(D) ON ERPN CMNTY TM OFC APPLICATION NO. 8366981, FILED 6-16-2009.

FOR APPARATUS, DEVICES AND SYSTEMS FOR CONVERTING ENERGY, SOLAR ENERGY OR RENEWABLE ENERGY INTO MAINS POWER, NAMELY, INVERTERS AND PARTS THEREFOR; APPARATUS, DEVICES AND SYSTEMS FOR SYNCHRONIZING THE CONVERSION OF ENERGY, SOLAR ENERGY OR RENEWABLE ENERGY INTO MAINS POWER, NAMELY, INVERTERS AND PARTS THEREFOR (U.S. CLS. 21, 23, 26, 36 AND 38).

LOURDES AYALA, EXAMINING ATTORNEY

CLASS 9—(Continued).

SN 77-867,284. NETWORK CRITICAL SOLUTIONS LIMITED, CAVERSHAM, BERKSHIRE, UNITED KINGDOM, FILED 11-6-2009.

CLASS 9—(Continued).

SN 77-889,017. T R CONTROLS INCORPORATED, LONDON, ONTARIO, CANADA, FILED 12-8-2009.



PRIORITY CLAIMED UNDER SEC. 44(D) ON CANADA APPLICATION NO. 1441027, FILED 6-10-2009, REG. NO. TMA815945, DATED 1-23-2012, EXPIRES 1-23-2027.

THE MARK CONSISTS OF THE WORD "SENSEABLE" IN CAPITAL LETTERS WITH A LINE EMANATING FROM THE SECOND LETTER "E" AND SERVING AS AN UNDERLINE FOR THE WORD "ABLE" IN "SENSEABLE". THE WORD "ABLE" IS ELEVATED ABOVE THE WORD "SENSE". ALL OF THIS IS SUPERIMPOSED ON A RECTANGULAR BACKGROUND.

FOR ABSOLUTE AND INCREMENTAL ROTARY ENCODERS, CABLE RETRACTORS, PROXIMITY SENSORS, COLOR SENSORS FOR TRUE COLOR DETECTION, COLOR CHANGE DETECTION, AND COLOR QUALITY DETECTION, LINEAR TRANSDUCERS FOR MAGNETOSTRICTIVE MEASURING, PHOTOELECTRIC SENSORS, LABEL SENSORS FOR THE DETECTION OF A VARIETY OF LABELS, AND COMPONENT PARTS FOR USE WITH THE AFORESAID WARES CONSISTING OF ELECTRONIC CABLES, ELECTRICAL POWER CONNECTORS AND MOUNTING HARDWARE FOR USE WITH THE AFORESAID WARES, NAMELY, NUTS AND BOLTS, HARDWARE SCREWS, AND MOUNTING CLAMPS (U.S. CLS. 21, 23, 26, 36 AND 38).
SHAILA SETTLES, EXAMINING ATTORNEY

PRIORITY CLAIMED UNDER SEC. 44(D) ON ERPN CMNTY TM OFC APPLICATION NO. 008650525, FILED 10-29-2009, REG. NO. 008650525, DATED 5-3-2010, EXPIRES 10-29-2019.

NO CLAIM IS MADE TO THE EXCLUSIVE RIGHT TO USE "NETWORK", APART FROM THE MARK AS SHOWN. THE COLOR(S) LIGHT BLUE AND DARK BLUE IS/ARE CLAIMED AS A FEATURE OF THE MARK.

THE MARK CONSISTS OF THE WORDING "NETWORK CRITICAL" IN DARK BLUE TO THE RIGHT OF A DESIGN. THE DESIGN CONSISTS OF A CIRCLE SEPARATED IN THE MIDDLE BY A ZIG-ZAG BREAK REPRESENTING A PULSE WAVE LINE. THE PORTION OF THE CIRCLE ABOVE THE LINE IS LIGHT BLUE, WHILE THE LOWER PORTION IS DARK BLUE.

FOR COMPUTER HARDWARE AND SOFTWARE FOR USE IN NETWORK MONITORING, DATA MONITORING, DATA SECURITY AND DATA TRACKING; COMPUTER HARDWARE AND SOFTWARE FOR INTEGRATING INTRUSION DETECTION, ANALYZERS, PROBES, SNIFFERS, COMPLIANCE, INTRUSION PREVENTION, VOIP MONITORING, DATA LEAKAGE PREVENTION, CONTENT FILTERING AND LAWFUL INTERCEPTION TOOLS INTO COMPUTER NETWORKS AND NETWORK INFRASTRUCTURE; PARTS AND FITTINGS FOR ALL THE AFORESAID GOODS (U.S. CLS. 21, 23, 26, 36 AND 38).
CORY BOONE, EXAMINING ATTORNEY

SN 77-900,115. TOSHIBA AMERICA INFORMATION SYSTEMS, INC., IRVINE, CA. FILED 12-23-2009.

BLADE

THE MARK CONSISTS OF STANDARD CHARACTERS WITHOUT CLAIM TO ANY PARTICULAR FONT, STYLE, SIZE, OR COLOR.
FOR TELEVISIONS (U.S. CLS. 21, 23, 26, 36 AND 38).
DAVID YONTEF, EXAMINING ATTORNEY

CLASS 9—(Continued).

SN 77-920,342. TOUCH-TO-GO TECHNOLOGIES INC., CALGARY, ALBERTA, CANADA, FILED 1-26-2010.



PRIORITY CLAIMED UNDER SEC. 44(D) ON CANADA APPLICATION NO. 1461605, FILED 12-4-2009, REG. NO. TMA797312, DATED 5-11-2011, EXPIRES 5-11-2026.

NO CLAIM IS MADE TO THE EXCLUSIVE RIGHT TO USE "TOUCH" AND "TECHNOLOGIES", APART FROM THE MARK AS SHOWN.

THE MARK CONSISTS OF THE WORDING "TOUCH TO GO TECHNOLOGIES" APPEARING TO THE RIGHT OF A DESIGN OF AN EXTENDED INDEX FINGER WITH LINES RADIATING FROM IT ALONGSIDE THREE FOLDED FINGERS ALL CONTAINED INSIDE A RECTANGLE WITH CURVE CORNERS.

FOR TOUCH SCREEN SYSTEMS COMPRISED OF TOUCH SCREEN USER INTERFACE, CENTRAL PROCESSING UNITS, ELECTRONIC CONTROLLER TO MANAGE THE POWER, MOVEMENT AND FUNCTIONS OF AN ELEVATOR, COMPUTER SERIAL PORTS, KEYPADS AND COMPUTER OPERATING SOFTWARE (U.S. CLS. 21, 23, 26, 36 AND 38).

SAMUEL E. SHARPER JR., EXAMINING ATTORNEY

SN 77-943,135. INTELLIGENT MECHATRONICS SYSTEMS, INC., WATERLOO, ONTARIO, CANADA, FILED 2-23-2010.

XTOP

THE MARK CONSISTS OF STANDARD CHARACTERS WITHOUT CLAIM TO ANY PARTICULAR FONT, STYLE, SIZE, OR COLOR.

PRIORITY CLAIMED UNDER SEC. 44(D) ON CANADA APPLICATION NO. 1469951, FILED 2-18-2010, REG. NO. TMA824725, DATED 5-24-2012, EXPIRES 5-24-2027.

FOR COMPUTER HARDWARE AND SOFTWARE USED TO ENABLE REAL-TIME BIDIRECTIONAL ACCESS BETWEEN MOBILE DEVICES AND ALTERNATE HUMAN-MACHINE INTERFACES, NAMELY, LAPTOPS, PCS, AND EMBEDDED INTERFACES, PROVIDING ACCESS TO MANIPULATE BOTH LOCAL AND REMOTE APPLICATIONS AND INFORMATION INCLUDING SMS, EMAIL, INSTANT MESSAGING, TELEPHONY, CALENDAR, INTERNET ACCESS, LEVERAGING THE STRENGTHS OF ALTERNATE HUMAN-MACHINE INCLUDING A FULL-SIZE KEYBOARD, SCREEN AND SUPPORTING ENVIRONMENT (U.S. CLS. 21, 23, 26, 36 AND 38).

LINDA ORNDORFF, EXAMINING ATTORNEY

CLASS 9—(Continued).

SN 79-101,004. NXP B.V., NETHERLANDS, FILED 12-22-2010.



PRIORITY DATE OF 7-9-2010 IS CLAIMED. OWNER OF INTERNATIONAL REGISTRATION 1086650 DATED 12-22-2010, EXPIRES 12-22-2020.

OWNER OF U.S. REG. NOS. 3,564,790, 3,564,793 AND 3,567,823.

THE MARK CONSISTS OF THE LETTERS "NXP" IN STYLIZED FORM IN WHICH THE "X" FORMS PART OF THE OTHER LETTERS AND APPEARS TO STAND OUT IN FRONT OF THEM.

FOR INTEGRATED CIRCUIT MODULES; PRINTED CIRCUIT BOARDS; INTEGRATED CIRCUITS; COMPUTER CHIPS; DIODES; TRANSISTORS; SEMICONDUCTORS; SEMICONDUCTOR POWER ELEMENTS; ELECTRICAL CONDUCTORS, NAMELY, TRIACS; THYRISTORS; AMPLIFIERS; ELECTROACOUSTIC DEVICES AND APPARATUS, NAMELY, SPEAKERS, MICROPHONES, AND EARPHONES; INTERFACES FOR COMPUTERS; ELECTRONIC DISPLAY INTERFACES; DATA CONVERTERS, NAMELY, ANALOG TO DIGITAL CONVERTERS, DIGITAL TO ANALOG CONVERTERS, AND MULTIPLEXERS; DATA PROCESSORS FOR SCANNING, READING, STORING, AND INTERPRETING ELECTRONIC DATA; SIGNAL PROCESSORS; MICROCONTROLLERS; ELECTRONIC SENSORS, NAMELY, POSITION SENSORS, SPEED SENSORS, TEMPERATURE SENSORS, PRESSURE SENSORS, AND LIGHT SENSORS; SOFTWARE FOR ENHANCING THE AUDIOVISUAL CAPABILITIES OF MOBILE DEVICES AND PERSONAL COMPUTERS; OPERATING SYSTEM SOFTWARE FOR USE WITH INTEGRATED CIRCUITS; OPERATING SOFTWARE FOR INTERFACING INTEGRATED CIRCUITS TO OTHER SOFTWARE AND OTHER INTEGRATED CIRCUITS; DIGITAL RIGHTS MANAGEMENT SOFTWARE; SOFTWARE DEVELOPMENT TOOLS; COMPUTER HARDWARE FOR TESTING ALL OF THE AFORESAID (U.S. CLS. 21, 23, 26, 36 AND 38).

CORY BOONE, EXAMINING ATTORNEY

SN 79-103,663. WENZHOU MAXGE ELECTRIC CO., LTD., CHINA, FILED 8-15-2011.



OWNER OF INTERNATIONAL REGISTRATION 1093557 DATED 8-15-2011, EXPIRES 8-15-2021.

THE WORDING "MAXGE" HAS NO MEANING IN A FOREIGN LANGUAGE.

FOR TIME RECORDING APPARATUS; FACSIMILE MACHINES; WEIGHING APPARATUS AND INSTRUMENTS; SLIDE CALIPERS; WARNING LIGHT; VIDEO TELEPHONES; CABINETS FOR LOUDSPEAKERS; ELECTRIC WIRES; CAMERAS; KILO-WATT-HOUR-METER; SCIENTIFIC AND TECHNICAL APPARATUS, NAMELY, OPTICAL MIRRORS; CIRCUIT BREAKERS; INTEGRATED CIRCUITS; ELECTRICAL PLUGS AND SOCKETS; ELECTRIC RELAYS; ELECTRICAL DISTRIBUTION BOXES; LIGHTNING ARRESTERS; GALVANIZING MACHINES; FIRE EXTINGUISHERS; GALVANIC BATTERIES; SPECTACLES; VIDEO DISKS AND VIDEO TAPES WITH RECORDED ANIMATED CARTOONS; ELECTRIC DOOR OPENERS (U.S. CLS. 21, 23, 26, 36 AND 38).

ANDREW LEASER, EXAMINING ATTORNEY

CLASS 9—(Continued).

SN 79-105,498. I-CUBED KENKYUSHO KABUSHIKI KAISHA; (I-CUBED RESEARCH CENTER INC.), KANAGAWA, JAPAN, FILED 9-27-2011.



OWNER OF INTERNATIONAL REGISTRATION 1097584 DATED 9-27-2011, EXPIRES 9-27-2021.

THE COLOR(S) BLACK, RED, GREEN AND BLUE IS/ARE CLAIMED AS A FEATURE OF THE MARK.

THE FIRST HORIZONTAL LINE ON THE RIGHT-HAND SIDE OF THE MARK IS IN COLOR RED; THE SECOND HORIZONTAL LINE ON THE RIGHT-HAND SIDE OF THE MARK IS IN COLOR GREEN; THE THIRD HORIZONTAL LINE ON THE RIGHT-HAND SIDE OF THE MARK IS IN COLOR BLUE; ALL OTHER PARTS EXCEPT THE AFOREMENTIONED HORIZONTAL LINES ARE IN COLOR BLACK.

THE MARK CONSISTS OF A STYLIZED "I3"; THE FIRST HORIZONTAL LINE ON THE RIGHT-HAND SIDE OF THE MARK IS IN THE COLOR RED; THE SECOND HORIZONTAL LINE ON THE RIGHT-HAND SIDE OF THE MARK IS IN THE COLOR GREEN; THE THIRD HORIZONTAL LINE ON THE RIGHT-HAND SIDE OF THE MARK IS IN THE COLOR BLUE; ALL OTHER PORTIONS OF THE MARK ARE IN THE COLOR BLACK.

FOR AUDIO AND VIDEO RECEIVERS; TELEVISION SETS; TELEVISION APPARATUS FOR PROJECTING PURPOSES; VIDEO RECORDERS; CAMCORDERS; DVD PLAYERS; TRANSMITTERS OF ELECTRONIC SIGNALS; TELEVISION TELEPHONE APPARATUS; INTERCOMMUNICATION APPARATUS, NAMELY, INTERCOMS; ELECTRO-DYNAMIC APPARATUS FOR THE REMOTE CONTROL OF SIGNALS; ELECTRON TUBES; SEMICONDUCTOR ELECTRONIC ELEMENTS; SEMICONDUCTORS; PRINTED CIRCUITS; INTEGRATED CIRCUITS; CHIPS WITH INTEGRATED CIRCUITS; PHOTOGRAPHY, MOVIE AND VIDEO CAMERAS; CINEMATOGRAPHIC CAMERAS; PROJECTION TRANSPARENCY APPARATUS; OPTICAL APPARATUS AND INSTRUMENTS, NAMELY, TELESCOPES, BINOCULARS, BINOCULAR TELESCOPES, MICROSCOPES, LENSES, PRISMS, REFLECTING MIRRORS; APPARATUS FOR GAMES ADAPTED FOR USE WITH AN EXTERNAL DISPLAY SCREEN OR MONITOR; ELECTRONIC CIRCUITS AND CD-ROMS RECORDED WITH PROGRAMS FOR HAND-HELD GAMES WITH LIQUID CRYSTAL DISPLAYS; EXPOSED CINEMATOGRAPHIC FILMS; EXPOSED SLIDE FILMS; SLIDE FILM MOUNTS; DOWNLOADABLE IMAGE FILES CONTAINING VIDEO CONTENT STREAMING OVER THE INTERNET; RECORDED VIDEO DISCS AND VIDEO TAPES FEATURING MOVIES, MUSIC VIDEOS AND BACKGROUND VIDEOS (U.S. CLS. 21, 23, 26, 36 AND 38).

FLORENTINA BLANDU, EXAMINING ATTORNEY

CLASS 9—(Continued).

SN 79-105,748. DANTAX RADIO A/S, DENMARK, FILED 10-6-2011.

Raidho

THE MARK CONSISTS OF STANDARD CHARACTERS WITHOUT CLAIM TO ANY PARTICULAR FONT, STYLE, SIZE, OR COLOR.

PRIORITY DATE OF 4-8-2011 IS CLAIMED. OWNER OF INTERNATIONAL REGISTRATION 1098324 DATED 10-6-2011, EXPIRES 10-6-2021.

THE WORDING "RAIDHO" HAS NO MEANING IN A FOREIGN LANGUAGE.

FOR APPARATUS FOR RECORDING, TRANSMISSION AND REPRODUCTION OF SOUND OR IMAGES, INCLUDING LOUDSPEAKERS, LOUDSPEAKERS FOR VEHICLES, RADIOS, AMPLIFIERS, RECORD PLAYERS, TAPE RECORDERS, TELEVISION SETS, AND CD PLAYERS (U.S. CLS. 21, 23, 26, 36 AND 38).

STEVEN PEREZ, EXAMINING ATTORNEY

SN 79-106,560. LAP GMBH LASER APPLIKATIONEN, FED REP GERMANY, FILED 11-18-2011.

CARINAsim

THE MARK CONSISTS OF STANDARD CHARACTERS WITHOUT CLAIM TO ANY PARTICULAR FONT, STYLE, SIZE, OR COLOR.

PRIORITY DATE OF 5-18-2011 IS CLAIMED. OWNER OF INTERNATIONAL REGISTRATION 1100156 DATED 11-18-2011, EXPIRES 11-18-2021.

FOR COMPUTER HARDWARE AND OPERATING SOFTWARE, DATABASE MANAGEMENT SOFTWARE AND DATA STORAGE SOFTWARE FOR LASERS, LASER MEASURING DEVICES AND OPTOELECTRONIC MEASURING DEVICES; COMPUTER MONITORS; DATA PROCESSING EQUIPMENT; ELECTRONIC DATA MEDIA, NAMELY, BLANK MAGNETIC DATA CARRIERS, BLANK OPTICAL DATA CARRIERS AND BLANK TAPE DATA CARRIERS; COMPUTER APPLICATION OPERATING SOFTWARE AND COMPUTER HARDWARE FOR A CLIENT SERVER MODEL FOR USE WITH LASERS, LASER MEASURING DEVICES AND OPTOELECTRONIC MEASURING DEVICES; COMPUTER APPLICATION SOFTWARE AND COMPUTER HARDWARE FOR DATA STORAGE OF LASERS, LASER MEASURING DEVICES AND OPTOELECTRONIC MEASURING DEVICES; COMPUTER APPLICATION SOFTWARE AND COMPUTER HARDWARE FOR DATABASE MANAGEMENT; COMPUTER NETWORK INTERFACE DEVICES, COMPUTER OPERATING SOFTWARE, DATABASE MANAGEMENT SOFTWARE AND DATA STORAGE SOFTWARE FOR COMPUTER NETWORK INTERFACE DEVICES (U.S. CLS. 21, 23, 26, 36 AND 38).

CHRISTOPHER BUONGIORNO, EXAMINING ATTORNEY

CLASS 9—(Continued).

SN 79-106,948. BANTZ, MICHAEL, DENMARK, FILED 11-2-2011.

MIBASafe

THE MARK CONSISTS OF STANDARD CHARACTERS WITHOUT CLAIM TO ANY PARTICULAR FONT, STYLE, SIZE, OR COLOR.

OWNER OF INTERNATIONAL REGISTRATION 1101022 DATED 11-2-2011, EXPIRES 11-2-2021.

THE WORDING "MIBASAFE" HAS NO MEANING IN A FOREIGN LANGUAGE.

FOR ELECTRONIC BURGLAR ALARMS AND THEFT PREVENTION INSTALLATIONS, NAMELY, SECURITY DEVICES THAT ACTIVATE VESSELS THAT SECURE VALUABLES WITH A GLUE OR FOAM WHEN THEFT IS ATTEMPTED (U.S. CLS. 21, 23, 26, 36 AND 38).

JEFF DEFORD, EXAMINING ATTORNEY

SN 79-107,650. ION BEAM APPLICATIONS S.A. EN ABRÉGÉ IBA, B-1348 LOUVAIN-LA-NEUVE, BELGIUM, FILED 11-22-2011.

RDI

THE MARK CONSISTS OF STANDARD CHARACTERS WITHOUT CLAIM TO ANY PARTICULAR FONT, STYLE, SIZE, OR COLOR.

PRIORITY DATE OF 8-22-2011 IS CLAIMED.

OWNER OF INTERNATIONAL REGISTRATION 1102893 DATED 11-22-2011, EXPIRES 11-22-2021.

FOR CHARGED PARTICLE ACCELERATORS (U.S. CLS. 21, 23, 26, 36 AND 38).

LANA PHAM, EXAMINING ATTORNEY

SN 79-107,680. AMAZONEN-WERKE H. DREYER GMBH & CO. KG, FED REP GERMANY, FILED 12-12-2011.

ACURA

THE MARK CONSISTS OF STANDARD CHARACTERS WITHOUT CLAIM TO ANY PARTICULAR FONT, STYLE, SIZE, OR COLOR.

PRIORITY DATE OF 6-17-2011 IS CLAIMED.

OWNER OF INTERNATIONAL REGISTRATION 1102968 DATED 12-12-2011, EXPIRES 12-12-2021.

THE WORDING "ACURA" HAS NO MEANING IN A FOREIGN LANGUAGE.

FOR COMPUTER SOFTWARE FOR COMPILATION OF PLANT PROTECTIVE CHEMICAL COMPOUNDS AND SPRAY AGENT MIXTURES FOR AGRICULTURAL AND CROP PROTECTION SPRAYERS (U.S. CLS. 21, 23, 26, 36 AND 38).

CHARISMA HAMPTON, EXAMINING ATTORNEY

CLASS 9—(Continued).

SN 79-109,470. QUANTIFOIL INSTRUMENTS GMBH, FED REP GERMANY, FILED 10-7-2011.

BioShake

THE MARK CONSISTS OF STANDARD CHARACTERS WITHOUT CLAIM TO ANY PARTICULAR FONT, STYLE, SIZE, OR COLOR.

PRIORITY DATE OF 6-22-2011 IS CLAIMED.

OWNER OF INTERNATIONAL REGISTRATION 1107637 DATED 10-7-2011, EXPIRES 10-7-2021.

FOR LABORATORY APPARATUS FOR THE TREATMENT, CONVERSION AND PROCESSING OF LIQUID SAMPLES, NAMELY, APPARATUS FOR THE DOSING, REFILLING, MIXING, TEMPERATURE CONTROL, CONCENTRATING, HOMOGENIZING AND FILTERING OF SUBSTANCES AND REAGENTS; LABORATORY ARTICLES, NAMELY, DISPOSABLE LABORATORY ARTICLES IN THE NATURE OF DISPOSABLE LATEX GLOVES FOR LABORATORY USES, CUVETTES, PIPETTES, PIPETTE TIPS, TEST TUBES, STORAGE TUBES, MICROTITER PLATES; LABORATORY WORKSTATION SYSTEMS, NAMELY, WORKSTATIONS CONSISTING OF COMPUTER CONTROLLED ROBOTS AND LABORATORY MIXERS FOR THE AUTOMATIC TREATMENT, CONVERSION AND PROCESSING OF LIQUID SAMPLES AND REAGENTS; COMPUTER HARDWARE AND COMPUTER SOFTWARE FOR THE CONTROL AND OPERATION OF LABORATORY ROBOTS AND LABORATORY MIXERS FOR THE AUTOMATIC TREATMENT, CONVERSION AND PROCESSING OF LIQUID SAMPLES AND REAGENTS (U.S. CLS. 21, 23, 26, 36 AND 38).

JAMES MACFARLANE, EXAMINING ATTORNEY

SN 79-111,851. HIRSCHMANN AUTOMOTIVE GMBH, RANKWEIL, AUSTRIA, FILED 8-16-2011.

EasyConn

PRIORITY DATE OF 2-21-2011 IS CLAIMED.

OWNER OF INTERNATIONAL REGISTRATION 1113320 DATED 8-16-2011, EXPIRES 8-16-2021.

FOR ELECTRIC AND ELECTRONIC CONTACT AND CONNECTION ELEMENTS, ELECTRIC PIN AND SOCKET CONNECTORS, ELECTRIC AND RECEPTACLE CONNECTORS, APPLIED IN CABLE ASSEMBLIES AND ELECTRIC WIRE HARNESSSES; ALL AFORESAID GOODS FOR THE AUTOMOTIVE INDUSTRY (U.S. CLS. 21, 23, 26, 36 AND 38).

KRISTINA MORRIS, EXAMINING ATTORNEY

CLASS 9—(Continued).

SN 79-111,989. MCQ S.R.L., ITALY, FILED 12-5-2011.



PRIORITY DATE OF 6-7-2011 IS CLAIMED.
OWNER OF INTERNATIONAL REGISTRATION 1113614
DATED 12-5-2011, EXPIRES 12-5-2021.
THE COLOR(S) WHITE AND BLUE IS/ARE CLAIMED AS
A FEATURE OF THE MARK.

THE MARK CONSISTS OF A DESIGN FORMED BY THE
STYLIZED MERGING OF THE LETTERS "MCQ" APPEAR-
ING IN BLUE SURROUNDED BY A BLUE SQUARE
APPEARING NEXT TO THE STYLIZED LETTERS "MCQ"
APPEARING IN BLUE SURROUNDED BY A BLUE REC-
TANGLE, ALL APPEARING AGAINST A WHITE BACK-
GROUND.

FOR GAS MIXERS FOR LABORATORY USE; AUTO-
MATIC LIQUID-FLOW CONTROL MACHINES AND
INSTRUMENTS; ELECTRONIC TEST INSTRUMENT
AND ASSOCIATED SOFTWARE FOR USE IN LEAK,
FLOW AND FUNCTIONAL TESTING; FLOW METERS;
FLOW REGULATORS FOR LABORATORY USE; FLOW
SWITCHES FOR MONITORING AND CONTROLLING
THE FLOW OF GASES OR LIQUIDS; CELL CULTURE
APPARATUS FOR LABORATORY USE, NAMELY, GAS
MIXER; APPARATUS FOR TESTING GAS, LIQUIDS
AND SOLIDS; GAS METERS; GAS TESTING INSTRU-
MENTS; TECHNICAL MEASURING, TESTING AND
CHECKING APPARATUS AND INSTRUMENTS FOR
MEASURING, TESTING AND CHECKING THE TEM-
PERATURE, PRESSURE, QUANTITY AND CONCENT-
RATION OF GAS AND LIQUIDS; AUTOMATIC
FLUID-COMPOSITION CONTROL MACHINES AND IN-
STRUMENTS; SCIENTIFIC APPARATUS AND INSTRU-
MENTS, NAMELY, FLUID HANDLING DEVICE USED
FOR DISPOSABLE BIOPROCESSING APPLICATIONS
AND PARTS AND FITTINGS THEREFOR (U.S. CLS. 21,
23, 26, 36 AND 38).

CHRISTINE MARTIN, EXAMINING ATTORNEY

SN 79-112,553. NANTONG HENGHUI GLOVES CO., LTD.,
CHINA, FILED 1-9-2012.

HANVO

PRIORITY DATE OF 8-10-2011 IS CLAIMED.
OWNER OF INTERNATIONAL REGISTRATION 1115028
DATED 1-9-2012, EXPIRES 1-9-2022.
THE WORDING "HANVO" HAS NO MEANING IN A
FOREIGN LANGUAGE.

FOR PROTECTION DEVICES FOR PERSONAL USE
AGAINST ACCIDENTS, NAMELY, INSULATED CLOTH-
ING FOR PROTECTION AGAINST ACCIDENT OR IN-
JURY; CLOTHING FOR PROTECTION AGAINST
ACCIDENTS, IRRADIATION AND FIRE; ANTI-GLARE
GLASSES; PROTECTIVE HELMETS; RESPIRATORY
MASKS, OTHER THAN FOR ARTIFICIAL RESPIRA-
TION AND NOT FOR MEDICAL PURPOSES; GLOVES
FOR PROTECTION AGAINST ACCIDENTS; PROTEC-
TIVE MASKS NOT FOR MEDICAL PURPOSES; SHOES
FOR PROTECTION AGAINST ACCIDENTS, IRRADIA-
TION AND FIRE; EAR PLUGS FOR DIVERS; CLOTH-
ING FOR PROTECTION AGAINST FIRE (U.S. CLS. 21,
23, 26, 36 AND 38).

ANNE MADDEN, EXAMINING ATTORNEY

CLASS 9—(Continued).SN 79-113,211. DANIEL DOMBROWE, FED REP GERMANY,
FILED 12-21-2011.

Weekender

THE MARK CONSISTS OF STANDARD CHARACTERS
WITHOUT CLAIM TO ANY PARTICULAR FONT, STYLE,
SIZE, OR COLOR.

OWNER OF INTERNATIONAL REGISTRATION 1116800
DATED 12-21-2011, EXPIRES 12-21-2021.

FOR COMPACT DISCS (CDS) FEATURING MUSIC;
SOUND CARRIERS, EXCEPT MAGNETIC DATA CAR-
RIERS, NAMELY, PHONOGRAPH RECORDS FEATUR-
ING MUSIC; RECORDING DISCS, NAMELY, BLANK
OPTICAL DATA CARRIERS, MOTION PICTURE FILMS
FEATURING CONCERTS AND CULTURAL EVENTS
AND EXPOSED CAMERA FILMS (U.S. CLS. 21, 23, 26,
36 AND 38).

RAMONA ORTIGA, EXAMINING ATTORNEY

SN 79-113,380. DPA MICROPHONES A/S, DK-3450 ALLER-
ØD, DENMARK, FILED 1-5-2012.

d:igital

PRIORITY DATE OF 9-28-2011 IS CLAIMED.
OWNER OF INTERNATIONAL REGISTRATION 1117343
DATED 1-5-2012, EXPIRES 1-5-2022.

NO CLAIM IS MADE TO THE EXCLUSIVE RIGHT TO
USE "DIGITAL", APART FROM THE MARK AS SHOWN.

THE MARK CONSISTS OF THE WORD "DIGITAL" WITH
A COLON APPEARING IN THE PLACE OF THE FIRST "I".

FOR MICROPHONES, MICROPHONE GRIDS AND
NOSE CONES, MICROPHONE WIND-SCREENS, MICRO-
PHONE HOLDERS, MICROPHONE STANDS, MICRO-
PHONE CABLES, MICROPHONE CONNECTORS AND
ADAPTERS, MICROPHONE BOOMS, MICROPHONE
AMPLIFIERS, MICROPHONE POWER SUPPLIES AND
MICROPHONE CALIBRATORS (U.S. CLS. 21, 23, 26, 36
AND 38).

CHRISTINE MARTIN, EXAMINING ATTORNEY

CLASS 9—(Continued).

SN 79-113,688. TRANSMODE SYSTEMS AB, SWEDEN,
FILED 2-20-2012.

MAKING LIGHT MAKING SENSE

THE MARK CONSISTS OF STANDARD CHARACTERS WITHOUT CLAIM TO ANY PARTICULAR FONT, STYLE, SIZE, OR COLOR.

PRIORITY DATE OF 10-20-2011 IS CLAIMED.
OWNER OF INTERNATIONAL REGISTRATION 1118266
DATED 2-20-2012, EXPIRES 2-20-2022.

FOR ELECTRIC, ELECTRONIC AND/OR OPTICAL APPARATUSES AND INSTRUMENTS IN THE FORM OF APPARATUSES AND INSTRUMENTS FOR TELECOMMUNICATION AND COMMUNICATION BY COMPUTER, NAMELY, COMPUTER HARDWARE FOR TELECOMMUNICATIONS, ELECTRIC CAPACITORS, AND ELECTRIC RESISTORS; FIBER OPTICAL APPARATUSES AND INSTRUMENTS, NAMELY, FIBER OPTIC CABLES AND FIBER OPTIC LIGHT AND IMAGE CONDUITS; APPARATUSES AND INSTRUMENTS FOR CONTROL SYSTEMS IN TELECOMMUNICATION AND COMMUNICATION BY COMPUTER, NAMELY, CARRIER-CLASS WAVELENGTH-DIVISION MULTIPLEXING, COARSE WAVELENGTH-DIVISION MULTIPLEXING AND DENSE WAVELENGTH-DIVISION MULTIPLEXING NETWORKS; APPARATUSES AND INSTRUMENTS FOR SUPPLYING POWER TO SAID APPARATUSES AND INSTRUMENTS, NAMELY, ELECTRICAL POWER SUPPLIES AND UNINTERRUPTIBLE ELECTRICAL POWER SUPPLIES; TELECOMMUNICATIONS COMPUTER PROGRAMS FOR USE IN TRAFFIC OPERATION, NETWORK MANAGEMENT AND NETWORK SURVEILLANCE; COMPUTER PROGRAMS FOR OPTICAL NETWORKING FOR TRANSPORT OF DATA, VOICE AND VIDEO IN THE FIELDS OF TELECOMMUNICATIONS AND COMMUNICATIONS BY COMPUTER (U.S. CLS. 21, 23, 26, 36 AND 38).
KRISTIN CARLSON, EXAMINING ATTORNEY

SN 85-050,378. LG ELECTRONICS INC., SEOUL, REPUBLIC OF KOREA, FILED 5-28-2010.

**PED Plasma Evolution
Display**

THE MARK CONSISTS OF STANDARD CHARACTERS WITHOUT CLAIM TO ANY PARTICULAR FONT, STYLE, SIZE, OR COLOR.

PRIORITY CLAIMED UNDER SEC. 44(D) ON REPUBLIC OF KOREA APPLICATION NO. 40-2010-0026, FILED 5-19-2010, REG. NO. 0902648, DATED 1-25-2012, EXPIRES 1-25-2022.

NO CLAIM IS MADE TO THE EXCLUSIVE RIGHT TO USE "PLASMA" OR "DISPLAY", APART FROM THE MARK AS SHOWN.

FOR TELEVISION RECEIVERS (U.S. CLS. 21, 23, 26, 36 AND 38).

ANDREW RHIM, EXAMINING ATTORNEY

CLASS 9—(Continued).

SN 85-084,226. CADUCEUS SYSTEMS, LLC, AUSTIN, TX,
FILED 7-14-2010.

Caduceus MMIS

THE MARK CONSISTS OF STANDARD CHARACTERS WITHOUT CLAIM TO ANY PARTICULAR FONT, STYLE, SIZE, OR COLOR.

NO CLAIM IS MADE TO THE EXCLUSIVE RIGHT TO USE "MMIS", APART FROM THE MARK AS SHOWN.

FOR COMPUTER APPLICATION SOFTWARE DOWNLOADABLE VIA THE INTERNET FOR MATERIAL MANAGEMENT, NAMELY, COMPUTER SOFTWARE FOR TRACKING THE INVENTORY OF MEDICAL MATERIALS (U.S. CLS. 21, 23, 26, 36 AND 38).

FIRST USE 1-1-2006; IN COMMERCE 1-1-2006.
BERYL GARDNER, EXAMINING ATTORNEY

SN 85-108,591. OPTICASET INC., QUEBEC, CANADA, FILED 8-16-2010.

TOXIC

THE MARK CONSISTS OF STANDARD CHARACTERS WITHOUT CLAIM TO ANY PARTICULAR FONT, STYLE, SIZE, OR COLOR.

FOR EYEWEAR; SUNGLASSES (U.S. CLS. 21, 23, 26, 36 AND 38).

FIRST USE 1-0-2007; IN COMMERCE 1-0-2007.
MICHAEL TANNER, EXAMINING ATTORNEY

SN 85-153,839. NOSS, DAVID R., DALTON GARDENS, ID,
FILED 10-15-2010.

Avatar

THE MARK CONSISTS OF STANDARD CHARACTERS WITHOUT CLAIM TO ANY PARTICULAR FONT, STYLE, SIZE, OR COLOR.

OWNER OF U.S. REG. NO. 3,005,921.
FOR AMPLIFIERS; CABINETS FOR LOUDSPEAKERS; LOUDSPEAKERS; SOUND EQUALIZERS AND CROSSOVERS (U.S. CLS. 21, 23, 26, 36 AND 38).

FIRST USE 2-2-1993; IN COMMERCE 2-2-1993.
JANICE KIM, EXAMINING ATTORNEY

CLASS 9—(Continued).

SN 85-187,566. ZYNGA INC., SAN FRANCISCO, CA. FILED 11-30-2010.

ZYNGA WITH FRIENDS

THE MARK CONSISTS OF STANDARD CHARACTERS WITHOUT CLAIM TO ANY PARTICULAR FONT, STYLE, SIZE, OR COLOR.

OWNER OF U.S. REG. NOS. 3,685,749 AND 3,861,862.
 FOR COMPUTER SOFTWARE PLATFORMS FOR SOCIAL NETWORKING; DOWNLOADABLE COMPUTER SOFTWARE PLATFORMS FOR SOCIAL NETWORKING THAT MAY BE ACCESSED VIA THE INTERNET, COMPUTERS AND WIRELESS DEVICES; COMPUTER SOFTWARE TO ENABLE UPLOADING, POSTING, SHOWING, DISPLAYING, TAGGING, BLOGGING, SHARING OR OTHERWISE PROVIDING ELECTRONIC MEDIA OR INFORMATION IN THE FIELDS OF VIRTUAL COMMUNITIES, ENTERTAINMENT, AND GENERAL INTEREST VIA THE INTERNET OR OTHER COMMUNICATIONS NETWORKS WITH THIRD PARTIES; MAGNETIC CODED GIFT CARDS (U.S. CLS. 21, 23, 26, 36 AND 38).

KATHERINE CHANG, EXAMINING ATTORNEY

CLASS 9—(Continued).

SN 85-200,673. BTI SYSTEMS INC., OTTAWA, ONTARIO, CANADA, FILED 12-17-2010.

proNX

THE MARK CONSISTS OF STANDARD CHARACTERS WITHOUT CLAIM TO ANY PARTICULAR FONT, STYLE, SIZE, OR COLOR.

PRIORITY CLAIMED UNDER SEC. 44(D) ON CANADA APPLICATION NO. 1507164, FILED 12-2-2010, REG. NO. TMA827,787, DATED 7-10-2012, EXPIRES 7-10-2027.

FOR COMPUTER SOFTWARE FOR MANAGEMENT OF OPTICAL COMMUNICATIONS EQUIPMENT (U.S. CLS. 21, 23, 26, 36 AND 38).

TRACY FLETCHER, EXAMINING ATTORNEY

SN 85-217,933. CALIBER EUROPE B.V., 4261 GA WIJK EN AALBUR, NETHERLANDS, FILED 1-14-2011.

CALIBER

THE MARK CONSISTS OF STANDARD CHARACTERS WITHOUT CLAIM TO ANY PARTICULAR FONT, STYLE, SIZE, OR COLOR.

FOR AUDIO EQUIPMENT FOR VEHICLES, NAMELY, LOUD SPEAKERS FOR AUTOMOTIVE AUDIO SYSTEMS; AUDIO EQUIPMENT FOR VEHICLES, NAMELY, STEREOs, SPEAKERS, AMPLIFIERS, EQUALIZERS, CROSSOVERS AND SPEAKER HOUSINGS; AUDIO EQUIPMENT FOR VEHICLES, NAMELY, SUBWOOFERS; BATTERIES AND BATTERY CHARGERS; CABLES, ELECTRIC; CAPACITORS; CONVERTERS; DVD PLAYERS; HEADPHONES; POWER ADAPTERS; RADIO RECEIVERS (U.S. CLS. 21, 23, 26, 36 AND 38).

DAVID H. STINE, EXAMINING ATTORNEY

SN 85-194,611. CELLCO PARTNERSHIP, DBA VERIZON WIRELESS, BASKING RIDGE, NJ. FILED 12-9-2010.

INVENTION

THE MARK CONSISTS OF STANDARD CHARACTERS WITHOUT CLAIM TO ANY PARTICULAR FONT, STYLE, SIZE, OR COLOR.

FOR WIRELESS TELECOMMUNICATIONS DEVICE FEATURING TRANSMISSION OF VOICE, DATA, IMAGE AND VIDEO, INCLUDING VOICE, TEXT, PICTURE AND VIDEO MESSAGING, INTERNET ACCESS, ACCESS TO NAVIGATION AND DIRECTIONAL SERVICE OVER THE AIR, THE ABILITY TO DOWNLOAD MUSIC, VIDEOS AND APPLICATIONS OVER THE AIR, AND WHICH HAS A MUSIC PLAYER AND A STILL IMAGE AND VIDEO CAMERA (U.S. CLS. 21, 23, 26, 36 AND 38).

HENRY S. ZAK, EXAMINING ATTORNEY

SN 85-230,510. PECK, KEVIN A, DBA GOOD NATURE GARDEN SUPPLY, SACRAMENTO, CA. FILED 1-31-2011.

PRODIGY

THE MARK CONSISTS OF STANDARD CHARACTERS WITHOUT CLAIM TO ANY PARTICULAR FONT, STYLE, SIZE, OR COLOR.

FOR LIGHTING BALLASTS (U.S. CLS. 21, 23, 26, 36 AND 38).

FIRST USE 10-9-2010; IN COMMERCE 10-9-2010.
 ELLEN PERKINS, EXAMINING ATTORNEY

CLASS 9—(Continued).

SN 85-261,696. MINNESOTA WIRE & CABLE CO., DBA MINNESOTA WIRE, ST. PAUL, MN. FILED 3-9-2011.

I STEALTH

THE MARK CONSISTS OF STANDARD CHARACTERS WITHOUT CLAIM TO ANY PARTICULAR FONT, STYLE, SIZE, OR COLOR.

FOR ELECTRICAL APPARATUS, NAMELY, NON-METALLIC ELECTRICAL CONDUCTORS AND SHIELDS USING CARBON NANOTUBE CONSTRUCTION (U.S. CLS. 21, 23, 26, 36 AND 38).

FIRST USE 2-1-2011; IN COMMERCE 2-2-2011.
JENNIFER DIXON, EXAMINING ATTORNEY

SN 85-264,810. SANMINA-SCI CORPORATION, SAN JOSE, CA. FILED 3-11-2011.

SANMINA

THE MARK CONSISTS OF STANDARD CHARACTERS WITHOUT CLAIM TO ANY PARTICULAR FONT, STYLE, SIZE, OR COLOR.

OWNER OF U.S. REG. NOS. 2,722,488, 2,948,708 AND OTHERS.

FOR COMPUTER HARDWARE; ELECTRONIC STORAGE DEVICES, NAMELY, MEMORY MEDIA FOR STORING INFORMATION AND DATA; ELECTRONIC MEMORY DEVICES, NAMELY, MEMORY MEDIA FOR STORING INFORMATION AND DATA; CIRCUIT BOARDS; COMPUTERS; COMPUTER PERIPHERALS; COMPUTER KEYBOARDS; COMPUTER MODEMS; COMPUTER SERVERS; COMPUTER MEMORY; COMPUTER MEMORY, NAMELY, COMPUTER MEMORY CARDS, MODULES, CHIPS AND FLASH MEMORY CARDS; COMPUTER MEMORY PACKAGES COMPRISED OF NOT AND FLASH MEMORY DEVICES AND INTERFACE CONTROLLER, PRINTED CIRCUIT BOARD, FIRMWARE USED TO ENABLE MEMORY CHIPS TO FUNCTION WITH LOGIC AND SOLID STATE DRIVE CONTROLLERS, AND SUPPORTING PASSIVE COMPONENTS; COMPUTER MEMORY, NAMELY, DIGITAL MEMORY DEVICES, NAMELY, SOLID STATE DRIVE DEVICES USED TO STORE DATA; COMPUTER DISK DRIVES; BLANK FLASH DRIVES; SOLID-STATE DRIVES; BACKUP DRIVES FOR COMPUTERS; COMPUTER HARDWARE, NAMELY, COMPUTER SERVERS; COMPUTER STORAGE DEVICES, NAMELY, CONFIGURABLE DATA STORAGE SYSTEMS COMPRISED OF RAID (REDUNDANT ARRAY OF INDEPENDENT DISKS), SAS (SERIAL ATTACHED SCSI), SATA (SERIAL ATA) AND/OR JBOD (JUST A BUNCH OF DISKS) HARD DRIVE BACKUP SYSTEMS AND CONTROLLERS; COMPUTER STORAGE DEVICES, NAMELY, COMPUTER BACKUP AND STORAGE SYSTEMS WITH MULTIPLE REMOVABLE DATA STORAGE CARTRIDGES; COMPUTER STORAGE DEVICES, NAMELY, HIGH-SPEED STORAGE SUBSYSTEMS FOR STORAGE AND BACKUP OF ELECTRONIC DATA EITHER LOCALLY OR VIA A TELECOMMUNICATIONS NETWORK; COMPUTER SOFTWARE, NAMELY, SOFTWARE FOR OPERATION OF COMPUTER SERVERS, CONFIGURABLE DATA STORAGE SYSTEMS COMPRISED OF RAID (REDUNDANT ARRAY OF INDEPENDENT DISKS), SAS (SERIAL ATTACHED SCSI), SATA (SERIAL ATA) AND JBOD (JUST A BUNCH OF DISKS) HARD DRIVE BACKUP SYSTEMS AND CONTROLLERS, COMPUTER BACKUP

CLASS 9—(Continued).

AND STORAGE SYSTEMS WITH MULTIPLE REMOVABLE DATA STORAGE CARTRIDGES, AND HIGH-SPEED STORAGE SUBSYSTEMS FOR STORAGE AND BACKUP OF ELECTRONIC DATA EITHER LOCALLY OR VIA A TELECOMMUNICATIONS NETWORK AND STRUCTURAL PARTS AND STRUCTURAL COMPONENTS FOR ALL OF THE FOREGOING; HARD DISK DRIVES; REMOVABLE HARD DRIVE BASED COMPUTER BACKUP SYSTEMS; STORAGE NETWORK ACCESS SERVER HARDWARE; RACKS, CABINETS AND ENCLOSURES FOR HOUSING ELECTRICAL AND ELECTRONIC EQUIPMENT, NAMELY, SEVERERS, WIRELESS BASE STATIONS, RELAYS AND SWITCHES; ELECTRICAL CABLING, PRINTED CIRCUIT BOARD SUBSTRATES IN THE NATURE OF FR-4 (FLAME RETARDANT) WOVEN GLASS AND EPOXY, LOW DK/DF (DIELECTRIC CONSTANT/DISSIPATION FACTOR) MODIFIED EPOXY (CYNATE ESTER AND POLYPHENYLENE BLENDED), BT (BISMALEIMIDE TRIAZINE) RESIN, POLYIMIDE RESIN, PTFE (POLYTETRAFLUOROETHYLENE) RESIN, LCP (LIQUID CRYSTAL POLYMER) RESIN, AND HYDROCARBON RESIN; PRINTED CIRCUIT BOARDS, BACK PLANE PANELS WITH ELECTRICAL CONNECTORS AND CABLING MOUNTED THEREON USED FOR COMPUTING, STORAGE, TELECOMMUNICATIONS, DATA COMMUNICATIONS, AND INDUSTRIAL, MULTIMEDIA, DEFENSE, AEROSPACE, MEDICAL, AND AUTOMOTIVE INDUSTRY APPLICATIONS; ELECTRONIC COMPONENTS, NAMELY, DUAL IN-LINE MEMORY MODULES (DIMMS), RANDOM ACCESS MEMORY (RAM) CARDS, AND PACKAGES FOR STACKING MEMORY DIE, NAMELY, NAND FLASH MEMORY DEVICES AND RAM DEVICES ALONG WITH CUSTOM PRINTED CIRCUIT BOARDS ASSEMBLED TO CREATE A PACKAGE THAT PROVIDES DOUBLE DENSITY MEMORY IN THE SAME FOOTPRINT; COMPONENT PARTS FOR ALL OF THE FOREGOING, NAMELY, COMPUTER CHIPS, REMOVABLE CARD FORM FACTOR DEVICES, AND CUSTOMER FORM FACTOR CARDS, SOLID STATE DRIVE MODULES, COMPUTER MEMORY, MAIN COMPUTER MEMORY AND SOLID STATE DRIVE PACKAGES AND OTHER REPLACEMENT PARTS; COMPUTER OPERATING SOFTWARE, DRIVERS SOFTWARE FOR SENDING MESSAGES AND DATA BETWEEN SOFTWARE AND HARDWARE, AND CONTROLLERS IN THE NATURE OF COMPUTER CHIPS, ALL OF THE FOREGOING USED IN CONNECTION WITH COMPUTER MAIN MEMORY AND SOLID STATE DRIVE DATA STORAGE DEVICES; ELECTRONIC COMMUNICATION SYSTEMS COMPRISED OF COMPUTER HARDWARE AND SOFTWARE FOR THE TRANSMISSION OF DATA BETWEEN RADIO AND COMMUNICATIONS SYSTEMS, PARTICULARLY, AIRCRAFT INTERCOMMUNICATIONS SYSTEMS, TACTICAL OPERATIONS CENTER INTERCOMMUNICATIONS SYSTEMS, AND GROUND VEHICLE INTERCOMMUNICATIONS SYSTEMS WITH ANALOG AND DIGITAL AUDIO AND DIGITAL DATA DISTRIBUTION; DIGITAL AUDIO FIRMWARE AND HARDWARE USED IN THE FIELDS OF DEFENSE AND AEROSPACE IN CONNECTION WITH AIRCRAFT AND GROUND VEHICLE INTERCOMMUNICATION SYSTEMS THAT PLACE AUDIO SOURCES IN 3 DIMENSIONAL SPACE; VOICE COMMAND AND CONTROL EQUIPMENT AND SYSTEMS THAT OPERATE AS STAND ALONE OR AS CIRCUIT CARD ASSEMBLIES AND THAT USE VOICE AND COMMAND RECOGNITION SOFTWARE TO CONTROL COMMUNICATION AND DISPLAY FUNCTIONS IN AIRCRAFT COCKPIT AND GROUND VEHICLES; COMPUTER FIRMWARE USED TO FACILITATE DIGITAL AUDIO PROCESSING AND DISTRIBUTION, CONTROL FUNCTIONS AND DATA CONCENTRATION FUNCTIONS WITHIN AEROSPACE AND AVIONIC COMMUNICATIONS SYSTEMS AND INSTRUMENTATION SYSTEMS; TELECOMMUNICATIONS AND DATA NETWORKING HARDWARE, NAMELY, DEVICES FOR TRANSPORTING AND AGGREGATING VOICE, DATA, AND VIDEO COMMUNICATIONS ACROSS MULTIPLE NETWORK INFRASTRUCTURES AND COMMUNICATIONS PROTOCOLS; RADIO AND LAND-LINE TELECOMMUNICATIONS SYSTEMS COMPRISED OF CENTRAL SWITCHING UNITS AND COMMUNICATIONS ASSETS, NAMELY, LINE REPLACEABLE UNITS, CREW ACCESS UNITS AND DESKTOP CREW ACCESS UNIT STAND ASSEMBLIES FOR NETWORKING MULTIPLE RADIO

CLASS 9—(Continued).

TRANSMITTERS/RECEIVERS AND LAND-LINE TELEPHONES FOR TACTICAL MILITARY COMMAND AND CONTROL APPLICATIONS, AND ASSOCIATED COMPUTER HARDWARE, PRINTED CIRCUIT BOARDS, AND SOFTWARE FOR FACILITATING COMMUNICATIONS BETWEEN ALL COMMUNICATIONS ASSETS CONNECTED WITHIN THE SYSTEM; RAPID RESPONSE INTERCOMMUNICATIONS AND COMMUNICATIONS SYSTEM PRIMARILY COMPRISED OF CENTRAL ELECTRICAL SWITCHING UNITS AND CREW ACCESSIBLE ELECTRIC JUNCTION BOXES, COMPUTER HARDWARE, AND TELECOMMUNICATION SOFTWARE USED TO ENABLE NETWORKING MULTIPLE RADIO TRANSMITTERS/RECEIVERS, LAND-LINE TELEPHONES, CELL PHONES, VOIP, WIRELESS, AND OTHER COMMUNICATIONS MEDIA FOR TACTICAL MILITARY OPERATIONS, COMMAND AND CONTROL SITUATIONS, AND FIRST RESPONDER EMERGENCY AND NATURAL DISASTER EVENTS; COMPUTER HARDWARE; BROADBAND WIRELESS EQUIPMENT, NAMELY, TELECOMMUNICATIONS BASE STATION EQUIPMENT FOR CELLULAR, WIRELESS, VOIP, RADIO, LANDLINE AND FIXED NETWORKING AND COMMUNICATIONS APPLICATIONS; TELECOMMUNICATIONS EQUIPMENT, NAMELY, COMPUTER ROUTERS, RADIO ROUTERS, VOIP ROUTERS, TELEPHONE CHANNEL BANKS USED FOR VOICE AND DATA TRANSMISSION, LAPTOP COMPUTERS, AND COMPUTER TELECOMMUNICATIONS SOFTWARE FOR VOICE AND DATA TRANSMISSION, ALL FOR TACTICAL MILITARY OPERATIONS, COMMAND AND CONTROL APPLICATIONS, AND FIRST RESPONDER EMERGENCY AND NATURAL DISASTER EVENTS; AIRCRAFT TEST EQUIPMENT, NAMELY, FLIGHT TEST INSTRUMENTATION AND HOUSINGS THEREFOR; MILITARY AND AEROSPACE HARDWARE, COMPONENT PARTS THEREFOR AND SOFTWARE, NAMELY, MISSION COMPUTERS AND REAL TIME MISSION CONTROL SOFTWARE, WEAPONS PROCESSORS AND REAL TIME WEAPONS CONTROL SOFTWARE USED FOR MILITARY AIRCRAFT, DATA ACQUISITION AND CONCENTRATION UNITS AND ACQUISITION AND DISTRIBUTION SOFTWARE USED FOR MILITARY AIRCRAFT, POWER SUPPLIES USED IN DEFENSE AND AEROSPACE PRODUCTS, CONTROL SYSTEMS, AND HOUSING AND SUPPORT STRUCTURES IMPLEMENTING ELECTRONICS SYSTEM ENCLOSURES USED FOR DEFENSE AND AEROSPACE PRODUCTS THEREFOR MADE OF METAL, PLASTICS AND FIBERGLASS; FIBER OPTIC DATA LINKS, FIBER OPTIC CABLE PACKS AND DISPENSERS, AND FIBER OPTIC TETHERS USED FOR, AMONG OTHER THINGS, UNDERSEA REMOTELY PILOTED VEHICLES AND TORPEDO DATA LINK; FIBER OPTIC EXPANDED BEAM CONNECTORS USED FOR MILITARY FIBER OPTIC AND COMMERCIAL APPLICATIONS AND OPTICAL ALIGNMENT EQUIPMENT USED IN THE MANUFACTURE OF EXPANDED BEAM CONNECTORS; AIRCRAFT DATA COUPLERS AND OPTICAL MEDIA COUPLERS USED FOR DATA COMMUNICATIONS BUSES ON AIRCRAFT; RADIATION DETECTION DEVICES AND TECHNOLOGY, NAMELY, HAND HELD RADIATION DETECTORS AND LARGE SCALE RADIATION DETECTORS, RADIATION DETECTORS WITH WIRELESS COMMUNICATION; WIRELESS VOICE AND DATA COMMUNICATIONS EQUIPMENT AND SYSTEMS, NAMELY, SECURE AND NON-SECURE WIRELESS INTERCOMMUNICATIONS SYSTEM COMPRISING MOBILE TRANSCEIVERS AND BASE STATIONS USED TO FACILITATE COMMUNICATIONS BETWEEN MOBILE TRANSCEIVERS AND OTHER COMMUNICATIONS EQUIPMENT (U.S. CLS. 21, 23, 26, 36 AND 38).

SHAILA SETTLES, EXAMINING ATTORNEY

CLASS 9—(Continued).

SN 85-264,903. SANMINA-SCI CORPORATION, SAN JOSE, CA. FILED 3-11-2011.

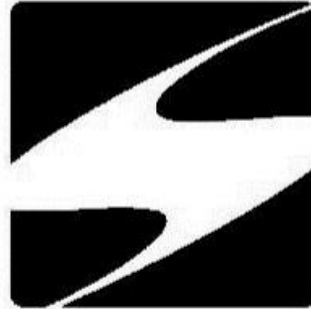

OWNER OF U.S. REG. NOS. 2,087,241 AND 2,722,489.
THE MARK CONSISTS OF A STYLIZED "S" CONTAINED WITHIN A SQUARE.

FOR COMPUTER HARDWARE; ELECTRONIC STORAGE DEVICES, NAMELY, MEMORY MEDIA FOR STORING INFORMATION AND DATA; ELECTRONIC MEMORY DEVICES, NAMELY, MEMORY MEDIA FOR STORING INFORMATION AND DATA; CIRCUIT BOARDS; COMPUTERS; COMPUTER PERIPHERALS; COMPUTER KEYBOARDS; COMPUTER MODEMS; COMPUTER SERVERS; COMPUTER MEMORY; COMPUTER MEMORY, NAMELY, COMPUTER MEMORY CARDS, MODULES, CHIPS AND FLASH MEMORY CARDS; COMPUTER MEMORY PACKAGES COMPRISED OF NOT AND FLASH MEMORY DEVICES AND INTERFACE CONTROLLER, PRINTED CIRCUIT BOARD, FIRMWARE USED TO ENABLE MEMORY CHIPS TO FUNCTION WITH LOGIC AND SOLID STATE DRIVE CONTROLLERS, AND SUPPORTING PASSIVE COMPONENTS; COMPUTER MEMORY, NAMELY, DIGITAL MEMORY DEVICES, NAMELY, SOLID STATE DRIVE DEVICES USED TO STORE DATA; COMPUTER DISK DRIVES; BLANK FLASH DRIVES; SOLID-STATE DRIVES; BACKUP DRIVES FOR COMPUTERS; COMPUTER HARDWARE, NAMELY, COMPUTER SERVERS; COMPUTER STORAGE DEVICES, NAMELY, CONFIGURABLE DATA STORAGE SYSTEMS COMPRISED OF RAID (REDUNDANT ARRAY OF INDEPENDENT DISKS), SAS (SERIAL ATTACHED SCSI), SATA (SERIAL ATA) AND/OR JBOD (JUST A BUNCH OF DISKS) HARD DRIVE BACKUP SYSTEMS AND CONTROLLERS; COMPUTER STORAGE DEVICES, NAMELY, COMPUTER BACKUP AND STORAGE SYSTEMS WITH MULTIPLE REMOVABLE DATA STORAGE CARTRIDGES; COMPUTER STORAGE DEVICES, NAMELY, HIGH-SPEED STORAGE SUBSYSTEMS FOR STORAGE AND BACKUP OF ELECTRONIC DATA EITHER LOCALLY OR VIA A TELECOMMUNICATIONS NETWORK; COMPUTER SOFTWARE, NAMELY, SOFTWARE FOR OPERATION OF COMPUTER SERVERS, CONFIGURABLE DATA STORAGE SYSTEMS COMPRISED OF RAID (REDUNDANT ARRAY OF INDEPENDENT DISKS), SAS (SERIAL ATTACHED SCSI), SATA (SERIAL ATA) AND JBOD (JUST A BUNCH OF DISKS) HARD DRIVE BACKUP SYSTEMS AND CONTROLLERS, COMPUTER BACKUP AND STORAGE SYSTEMS WITH MULTIPLE REMOVABLE DATA STORAGE CARTRIDGES, AND HIGH-SPEED STORAGE SUBSYSTEMS FOR STORAGE AND BACKUP OF ELECTRONIC DATA EITHER LOCALLY OR VIA A TELECOMMUNICATIONS NETWORK AND STRUCTURAL PARTS AND STRUCTURAL COMPONENTS FOR ALL OF THE FOREGOING; HARD DISK DRIVES; REMOVABLE HARD DRIVE BASED COMPUTER BACKUP SYSTEMS; STORAGE NETWORK ACCESS SERVER HARDWARE; RACKS, CABINETS AND ENCLOSURES FOR HOUSING ELECTRICAL AND ELECTRONIC EQUIPMENT, NAMELY, SEVERS, WIRELESS BASE STATIONS, RELAYS AND SWITCHES; ELECTRICAL CABLING, PRINTED CIRCUIT BOARD SUBSTRATES IN THE NATURE OF FR-4 (FLAME RETARDANT) WOVEN GLASS AND EPOXY, LOW DK/DF (DIELECTRIC CONSTANT/DISSIPATION FACTOR)

CLASS 9—(Continued).

MODIFIED EPOXY (CYNATE ESTER AND POLYPHENYLENE BLENDED), BT (BISMALEIMIDE TRIAZINE) RESIN, POLYIMIDE RESIN, PTFE (POLYTETRAFLUOROETHYLENE) RESIN, LCP (LIQUID CRYSTAL POLYMER) RESIN, AND HYDROCARBON RESIN; PRINTED CIRCUIT BOARDS, BACK PLANE PANELS WITH ELECTRICAL CONNECTORS AND CABLING MOUNTED THEREON USED FOR COMPUTING, STORAGE, TELECOMMUNICATIONS, DATA COMMUNICATIONS, AND INDUSTRIAL, MULTIMEDIA, DEFENSE, AEROSPACE, MEDICAL, AND AUTOMOTIVE INDUSTRY APPLICATIONS; ELECTRONIC COMPONENTS, NAMELY, DUAL IN-LINE MEMORY MODULES (DIMMS), RANDOM ACCESS MEMORY (RAM) CARDS, AND PACKAGES FOR STACKING MEMORY DIE, NAMELY, NAND FLASH MEMORY DEVICES AND RAM DEVICES ALONG WITH CUSTOM PRINTED CIRCUIT BOARDS ASSEMBLED TO CREATE A PACKAGE THAT PROVIDES DOUBLE DENSITY MEMORY IN THE SAME FOOTPRINT; COMPONENT PARTS FOR ALL OF THE FOREGOING, NAMELY, COMPUTER CHIPS, REMOVABLE CARD FORM FACTOR DEVICES, AND CUSTOMER FORM FACTOR CARDS, SOLID STATE DRIVE MODULES, COMPUTER MEMORY, MAIN COMPUTER MEMORY AND SOLID STATE DRIVE PACKAGES AND OTHER REPLACEMENT PARTS; COMPUTER OPERATING SOFTWARE, DRIVERS SOFTWARE FOR SENDING MESSAGES AND DATA BETWEEN SOFTWARE AND HARDWARE, AND CONTROLLERS IN THE NATURE OF COMPUTER CHIPS, ALL OF THE FOREGOING USED IN CONNECTION WITH COMPUTER MAIN MEMORY AND SOLID STATE DRIVE DATA STORAGE DEVICES; ELECTRONIC COMMUNICATION SYSTEMS COMPRISED OF COMPUTER HARDWARE AND SOFTWARE FOR THE TRANSMISSION OF DATA BETWEEN RADIO AND COMMUNICATIONS SYSTEMS, PARTICULARLY, AIRCRAFT INTERCOMMUNICATIONS SYSTEMS, TACTICAL OPERATIONS CENTER INTERCOMMUNICATIONS SYSTEMS, AND GROUND VEHICLE INTERCOMMUNICATIONS SYSTEMS WITH ANALOG AND DIGITAL AUDIO AND DIGITAL DATA DISTRIBUTION; DIGITAL AUDIO FIRMWARE AND HARDWARE USED IN THE FIELDS OF DEFENSE AND AEROSPACE IN CONNECTION WITH AIRCRAFT AND GROUND VEHICLE INTERCOMMUNICATION SYSTEMS THAT PLACE AUDIO SOURCES IN 3 DIMENSIONAL SPACE; VOICE COMMAND AND CONTROL EQUIPMENT AND SYSTEMS THAT OPERATE AS STAND ALONE OR AS CIRCUIT CARD ASSEMBLIES AND THAT USE VOICE AND COMMAND RECOGNITION SOFTWARE TO CONTROL COMMUNICATION AND DISPLAY FUNCTIONS IN AIRCRAFT COCKPIT AND GROUND VEHICLES; COMPUTER FIRMWARE USED TO FACILITATE DIGITAL AUDIO PROCESSING AND DISTRIBUTION, CONTROL FUNCTIONS AND DATA CONCENTRATION FUNCTIONS WITHIN AEROSPACE AND AVIONIC COMMUNICATIONS SYSTEMS AND INSTRUMENTATION SYSTEMS; TELECOMMUNICATIONS AND DATA NETWORKING HARDWARE, NAMELY, DEVICES FOR TRANSPORTING AND AGGREGATING VOICE, DATA, AND VIDEO COMMUNICATIONS ACROSS MULTIPLE NETWORK INFRASTRUCTURES AND COMMUNICATIONS PROTOCOLS; RADIO AND LAND-LINE TELECOMMUNICATIONS SYSTEMS COMPRISED OF CENTRAL SWITCHING UNITS AND COMMUNICATIONS ASSETS, NAMELY, LINE REPLACEABLE UNITS, CREW ACCESS UNITS AND DESKTOP CREW ACCESS UNIT STAND ASSEMBLIES FOR NETWORKING MULTIPLE RADIO TRANSMITTERS/RECEIVERS AND LAND-LINE TELEPHONES FOR TACTICAL MILITARY COMMAND AND CONTROL APPLICATIONS, AND ASSOCIATED COMPUTER HARDWARE, PRINTED CIRCUIT BOARDS, AND SOFTWARE FOR FACILITATING COMMUNICATIONS BETWEEN ALL COMMUNICATIONS ASSETS CONNECTED WITHIN THE SYSTEM; RAPID RESPONSE INTERCOMMUNICATIONS AND COMMUNICATIONS SYSTEM PRIMARILY COMPRISED OF CENTRAL ELECTRICAL SWITCHING UNITS AND CREW ACCESSIBLE ELECTRIC JUNCTION BOXES, COMPUTER HARDWARE, AND TELECOMMUNICATION SOFTWARE USED TO ENABLE NETWORKING MULTIPLE RADIO TRANSMITTERS/RECEIVERS, LAND-LINE TELEPHONES, CELL PHONES, VOIP, WIRELESS, AND OTHER COMMUNICATIONS MEDIA FOR TACTICAL MILITARY OPERATIONS, COMMAND

CLASS 9—(Continued).

AND CONTROL SITUATIONS, AND FIRST RESPONDER EMERGENCY AND NATURAL DISASTER EVENTS; COMPUTER HARDWARE; BROADBAND WIRELESS EQUIPMENT, NAMELY, TELECOMMUNICATIONS BASE STATION EQUIPMENT FOR CELLULAR, WIRELESS, VOIP, RADIO, LANDLINE AND FIXED NETWORKING AND COMMUNICATIONS APPLICATIONS; TELECOMMUNICATIONS EQUIPMENT, NAMELY, COMPUTER ROUTERS, RADIO ROUTERS, VOIP ROUTERS, TELEPHONE CHANNEL BANKS USED FOR VOICE AND DATA TRANSMISSION, LAPTOP COMPUTERS, AND COMPUTER TELECOMMUNICATIONS SOFTWARE FOR VOICE AND DATA TRANSMISSION, ALL FOR TACTICAL MILITARY OPERATIONS, COMMAND AND CONTROL APPLICATIONS, AND FIRST RESPONDER EMERGENCY AND NATURAL DISASTER EVENTS; AIRCRAFT TEST EQUIPMENT, NAMELY, FLIGHT TEST INSTRUMENTATION AND HOUSINGS THEREFOR; MILITARY AND AEROSPACE HARDWARE, COMPONENT PARTS THEREFOR AND SOFTWARE, NAMELY, MISSION COMPUTERS AND REAL TIME MISSION CONTROL SOFTWARE, WEAPONS PROCESSORS AND REAL TIME WEAPONS CONTROL SOFTWARE USED FOR MILITARY AIRCRAFT, DATA ACQUISITION AND CONCENTRATION UNITS AND ACQUISITION AND DISTRIBUTION SOFTWARE USED FOR MILITARY AIRCRAFT, POWER SUPPLIES USED IN DEFENSE AND AEROSPACE PRODUCTS, CONTROL SYSTEMS, AND HOUSING AND SUPPORT STRUCTURES IMPLEMENTING ELECTRONICS SYSTEM ENCLOSURES USED FOR DEFENSE AND AEROSPACE PRODUCTS THEREFOR MADE OF METAL, PLASTICS AND FIBERGLASS; FIBER OPTIC DATA LINKS, FIBER OPTIC CABLE PACKS AND DISPENSERS, AND FIBER OPTIC TETHERS USED FOR, AMONG OTHER THINGS, UNDERSEA REMOTELY PILOTED VEHICLES AND TORPEDO DATA LINK; FIBER OPTIC EXPANDED BEAM CONNECTORS USED FOR MILITARY FIBER OPTIC AND COMMERCIAL APPLICATIONS AND OPTICAL ALIGNMENT EQUIPMENT USED IN THE MANUFACTURE OF EXPANDED BEAM CONNECTORS; AIRCRAFT DATA COUPLERS AND OPTICAL MEDIA COUPLERS USED FOR DATA COMMUNICATIONS BUSES ON AIRCRAFT; RADIATION DETECTION DEVICES AND TECHNOLOGY, NAMELY, HAND HELD RADIATION DETECTORS AND LARGE SCALE RADIATION DETECTORS, RADIATION DETECTORS WITH WIRELESS COMMUNICATION; WIRELESS VOICE AND DATA COMMUNICATIONS EQUIPMENT AND SYSTEMS, NAMELY, SECURE AND NON-SECURE WIRELESS INTERCOMMUNICATIONS SYSTEM COMPRISING MOBILE TRANSCEIVERS AND BASE STATIONS USED TO FACILITATE COMMUNICATIONS BETWEEN MOBILE TRANSCEIVERS AND OTHER COMMUNICATIONS EQUIPMENT (U.S. CLS. 21, 23, 26, 36 AND 38).

SHAILA SETTLES, EXAMINING ATTORNEY

CLASS 9—(Continued).

SN 85-264,946. SANMINA-SCI CORPORATION, SAN JOSE, CA. FILED 3-11-2011.

HADCO

THE MARK CONSISTS OF STANDARD CHARACTERS WITHOUT CLAIM TO ANY PARTICULAR FONT, STYLE, SIZE, OR COLOR.

FOR COMPUTER HARDWARE; ELECTRONIC STORAGE DEVICES, NAMELY, MEMORY MEDIA FOR STORING INFORMATION AND DATA; ELECTRONIC MEMORY DEVICES, NAMELY, MEMORY MEDIA FOR STORING INFORMATION AND DATA; CIRCUIT BOARDS; COMPUTERS; COMPUTER PERIPHERALS; COMPUTER KEYBOARDS; COMPUTER MODEMS; COMPUTER SERVERS; COMPUTER MEMORY; COMPUTER MEMORY, NAMELY, COMPUTER MEMORY CARDS, MODULES, CHIPS AND FLASH MEMORY CARDS; COMPUTER MEMORY PACKAGES COMPRISED OF NOT AND FLASH MEMORY DEVICES AND INTERFACE CONTROLLER, PRINTED CIRCUIT BOARD, FIRMWARE USED TO ENABLE MEMORY CHIPS TO FUNCTION WITH LOGIC AND SOLID STATE DRIVE CONTROLLERS, AND SUPPORTING PASSIVE COMPONENTS; COMPUTER MEMORY, NAMELY, DIGITAL MEMORY DEVICES, NAMELY, SOLID STATE DRIVE DEVICES USED TO STORE DATA; COMPUTER DISK DRIVES; BLANK FLASH DRIVES; SOLID-STATE DRIVES; BACKUP DRIVES FOR COMPUTERS; COMPUTER HARDWARE, NAMELY, COMPUTER SERVERS; COMPUTER STORAGE DEVICES, NAMELY, CONFIGURABLE DATA STORAGE SYSTEMS COMPRISED OF RAID (REDUNDANT ARRAY OF INDEPENDENT DISKS), SAS (SERIAL ATTACHED SCSI), SATA (SERIAL ATA) AND/OR JBOD (JUST A BUNCH OF DISKS) HARD DRIVE BACKUP SYSTEMS AND CONTROLLERS; COMPUTER STORAGE DEVICES, NAMELY, COMPUTER BACKUP AND STORAGE SYSTEMS WITH MULTIPLE REMOVABLE DATA STORAGE CARTRIDGES; COMPUTER STORAGE DEVICES, NAMELY, HIGH-SPEED STORAGE SUBSYSTEMS FOR STORAGE AND BACKUP OF ELECTRONIC DATA EITHER LOCALLY OR VIA A TELECOMMUNICATIONS NETWORK; COMPUTER SOFTWARE, NAMELY, SOFTWARE FOR OPERATION OF COMPUTER SERVERS, CONFIGURABLE DATA STORAGE SYSTEMS COMPRISED OF RAID (REDUNDANT ARRAY OF INDEPENDENT DISKS), SAS (SERIAL ATTACHED SCSI), SATA (SERIAL ATA) AND JBOD (JUST A BUNCH OF DISKS) HARD DRIVE BACKUP SYSTEMS AND CONTROLLERS, COMPUTER BACKUP AND STORAGE SYSTEMS WITH MULTIPLE REMOVABLE DATA STORAGE CARTRIDGES, AND HIGH-SPEED STORAGE SUBSYSTEMS FOR STORAGE AND BACKUP OF ELECTRONIC DATA EITHER LOCALLY OR VIA A TELECOMMUNICATIONS NETWORK AND STRUCTURAL PARTS AND STRUCTURAL COMPONENTS FOR ALL OF THE FOREGOING; HARD DISK DRIVES; REMOVABLE HARD DRIVE BASED COMPUTER BACKUP SYSTEMS; STORAGE NETWORK ACCESS SERVER HARDWARE; RACKS, CABINETS AND ENCLOSURES FOR HOUSING ELECTRICAL AND ELECTRONIC EQUIPMENT, NAMELY, SEVERS, WIRELESS BASE STATIONS, RELAYS AND SWITCHES; ELECTRICAL CABLING, PRINTED CIRCUIT BOARD SUBSTRATES IN THE NATURE OF FR-4 (FLAME RETARDANT) WOVEN GLASS AND EPOXY, LOW DK/DF (DIELECTRIC CONSTANT/DISSIPATION FACTOR) MODIFIED EPOXY (CYNATE ESTER AND POLYPHENYLENE BLENDED), BT (BISMALEIMIDE TRIAZINE) RESIN, POLYIMIDE RESIN, PTFE (POLYTETRAFLUOROETHYLENE) RESIN, LCP (LIQUID CRYSTAL POLYMER) RESIN, AND HYDROCARBON RESIN; PRINTED CIRCUIT BOARDS, BACK PLANE PANELS WITH ELECTRICAL CONNECTORS AND CABLING MOUNTED THEREON USED FOR COMPUTING, STORAGE, TELECOMMUNICATIONS, DATA COMMUNICATIONS, AND INDUSTRIAL, MULTIMEDIA, DEFENSE, AEROSPACE, MEDICAL, AND AUTOMOTIVE INDUSTRY APPLICATIONS; ELECTRONIC COM-

CLASS 9—(Continued).

PONENTS, NAMELY, DUAL IN-LINE MEMORY MODULES (DIMMS), RANDOM ACCESS MEMORY (RAM) CARDS, AND PACKAGES FOR STACKING MEMORY DIE, NAMELY, NAND FLASH MEMORY DEVICES AND RAM DEVICES ALONG WITH CUSTOM PRINTED CIRCUIT BOARDS ASSEMBLED TO CREATE A PACKAGE THAT PROVIDES DOUBLE DENSITY MEMORY IN THE SAME FOOTPRINT; COMPONENT PARTS FOR ALL OF THE FOREGOING, NAMELY, COMPUTER CHIPS, REMOVABLE CARD FORM FACTOR DEVICES, AND CUSTOMER FORM FACTOR CARDS, SOLID STATE DRIVE MODULES, COMPUTER MEMORY, MAIN COMPUTER MEMORY AND SOLID STATE DRIVE PACKAGES AND OTHER REPLACEMENT PARTS; COMPUTER OPERATING SOFTWARE, DRIVERS SOFTWARE FOR SENDING MESSAGES AND DATA BETWEEN SOFTWARE AND HARDWARE, AND CONTROLLERS IN THE NATURE OF COMPUTER CHIPS, ALL OF THE FOREGOING USED IN CONNECTION WITH COMPUTER MAIN MEMORY AND SOLID STATE DRIVE DATA STORAGE DEVICES; ELECTRONIC COMMUNICATION SYSTEMS COMPRISED OF COMPUTER HARDWARE AND SOFTWARE FOR THE TRANSMISSION OF DATA BETWEEN RADIO AND COMMUNICATIONS SYSTEMS, PARTICULARLY, AIRCRAFT INTERCOMMUNICATIONS SYSTEMS, TACTICAL OPERATIONS CENTER INTERCOMMUNICATIONS SYSTEMS, AND GROUND VEHICLE INTERCOMMUNICATIONS SYSTEMS WITH ANALOG AND DIGITAL AUDIO AND DIGITAL DATA DISTRIBUTION; DIGITAL AUDIO FIRMWARE AND HARDWARE USED IN THE FIELDS OF DEFENSE AND AEROSPACE IN CONNECTION WITH AIRCRAFT AND GROUND VEHICLE INTERCOMMUNICATION SYSTEMS THAT PLACE AUDIO SOURCES IN 3 DIMENSIONAL SPACE; VOICE COMMAND AND CONTROL EQUIPMENT AND SYSTEMS THAT OPERATE AS STAND ALONE OR AS CIRCUIT CARD ASSEMBLIES AND THAT USE VOICE AND COMMAND RECOGNITION SOFTWARE TO CONTROL COMMUNICATION AND DISPLAY FUNCTIONS IN AIRCRAFT COCKPIT AND GROUND VEHICLES; COMPUTER FIRMWARE USED TO FACILITATE DIGITAL AUDIO PROCESSING AND DISTRIBUTION, CONTROL FUNCTIONS AND DATA CONCENTRATION FUNCTIONS WITHIN AEROSPACE AND AVIONIC COMMUNICATIONS SYSTEMS AND INSTRUMENTATION SYSTEMS; TELECOMMUNICATIONS AND DATA NETWORKING HARDWARE, NAMELY, DEVICES FOR TRANSPORTING AND AGGREGATING VOICE, DATA, AND VIDEO COMMUNICATIONS ACROSS MULTIPLE NETWORK INFRASTRUCTURES AND COMMUNICATIONS PROTOCOLS; RADIO AND LAND-LINE TELECOMMUNICATIONS SYSTEMS COMPRISED OF CENTRAL SWITCHING UNITS AND COMMUNICATIONS ASSETS, NAMELY, LINE REPLACEABLE UNITS, CREW ACCESS UNITS AND DESKTOP CREW ACCESS UNIT STAND ASSEMBLIES FOR NETWORKING MULTIPLE RADIO TRANSMITTERS/RECEIVERS AND LAND-LINE TELEPHONES FOR TACTICAL MILITARY COMMAND AND CONTROL APPLICATIONS, AND ASSOCIATED COMPUTER HARDWARE, PRINTED CIRCUIT BOARDS, AND SOFTWARE FOR FACILITATING COMMUNICATIONS BETWEEN ALL COMMUNICATIONS ASSETS CONNECTED WITHIN THE SYSTEM; RAPID RESPONSE INTERCOMMUNICATIONS AND COMMUNICATIONS SYSTEM PRIMARILY COMPRISED OF CENTRAL ELECTRICAL SWITCHING UNITS AND CREW ACCESSIBLE ELECTRIC JUNCTION BOXES, COMPUTER HARDWARE, AND TELECOMMUNICATION SOFTWARE USED TO ENABLE NETWORKING MULTIPLE RADIO TRANSMITTERS/RECEIVERS, LAND-LINE TELEPHONES, CELL PHONES, VOIP, WIRELESS, AND OTHER COMMUNICATIONS MEDIA FOR TACTICAL MILITARY OPERATIONS, COMMAND AND CONTROL SITUATIONS, AND FIRST RESPONDER EMERGENCY AND NATURAL DISASTER EVENTS; COMPUTER HARDWARE; BROADBAND WIRELESS EQUIPMENT, NAMELY, TELECOMMUNICATIONS BASE STATION EQUIPMENT FOR CELLULAR, WIRELESS, VOIP, RADIO, LANDLINE AND FIXED NETWORKING AND COMMUNICATIONS APPLICATIONS; TELECOMMUNICATIONS EQUIPMENT, NAMELY, COMPUTER ROUTERS, RADIO ROUTERS, VOIP ROUTERS, TELEPHONE CHANNEL BANKS USED FOR VOICE AND DATA TRANSMISSION, LAPTOP COMPUTERS, AND COMPUTER TELECOMMUNICA-

CLASS 9—(Continued).

TIONS SOFTWARE FOR VOICE AND DATA TRANSMISSION, ALL FOR TACTICAL MILITARY OPERATIONS, COMMAND AND CONTROL APPLICATIONS, AND FIRST RESPONDER EMERGENCY AND NATURAL DISASTER EVENTS; AIRCRAFT TEST EQUIPMENT, NAMELY, FLIGHT TEST INSTRUMENTATION AND HOUSINGS THEREFOR; MILITARY AND AEROSPACE HARDWARE, COMPONENT PARTS THEREFOR AND SOFTWARE, NAMELY, MISSION COMPUTERS AND REAL TIME MISSION CONTROL SOFTWARE, WEAPONS PROCESSORS AND REAL TIME WEAPONS CONTROL SOFTWARE USED FOR MILITARY AIRCRAFT, DATA ACQUISITION AND CONCENTRATION UNITS AND ACQUISITION AND DISTRIBUTION SOFTWARE USED FOR MILITARY AIRCRAFT, POWER SUPPLIES USED IN DEFENSE AND AEROSPACE PRODUCTS, CONTROL SYSTEMS, AND HOUSING AND SUPPORT STRUCTURES IMPLEMENTING ELECTRONICS SYSTEM ENCLOSURES USED FOR DEFENSE AND AEROSPACE PRODUCTS THEREFOR MADE OF METAL, PLASTICS AND FIBERGLASS; FIBER OPTIC DATA LINKS, FIBER OPTIC CABLE PACKS AND DISPENSERS, AND FIBER OPTIC TETHERS USED FOR, AMONG OTHER THINGS, UNDERSEA REMOTELY PILOTED VEHICLES AND TORPEDO DATA LINK; FIBER OPTIC EXPANDED BEAM CONNECTORS USED FOR MILITARY FIBER OPTIC AND COMMERCIAL APPLICATIONS AND OPTICAL ALIGNMENT EQUIPMENT USED IN THE MANUFACTURE OF EXPANDED BEAM CONNECTORS; AIRCRAFT DATA COUPLERS AND OPTICAL MEDIA COUPLERS USED FOR DATA COMMUNICATIONS BUSES ON AIRCRAFT; RADIATION DETECTION DEVICES AND TECHNOLOGY, NAMELY, HAND HELD RADIATION DETECTORS AND LARGE SCALE RADIATION DETECTORS, RADIATION DETECTORS WITH WIRELESS COMMUNICATION; WIRELESS VOICE AND DATA COMMUNICATIONS EQUIPMENT AND SYSTEMS, NAMELY, SECURE AND NON-SECURE WIRELESS INTERCOMMUNICATIONS SYSTEM COMPRISING MOBILE TRANSCIEVERS AND BASE STATIONS USED TO FACILITATE COMMUNICATIONS BETWEEN MOBILE TRANSCIEVERS AND OTHER COMMUNICATIONS EQUIPMENT (U.S. CLS. 21, 23, 26, 36 AND 38).

WILLIAM BRECKENFELD, EXAMINING ATTORNEY

SN 85-264,989. SANMINA-SCI CORPORATION, SAN JOSE, CA. FILED 3-11-2011.

WHAT WE MAKE, MAKES A DIFFERENCE.

THE MARK CONSISTS OF STANDARD CHARACTERS WITHOUT CLAIM TO ANY PARTICULAR FONT, STYLE, SIZE, OR COLOR.

FOR COMPUTER HARDWARE; ELECTRONIC STORAGE DEVICES, NAMELY, MEMORY MEDIA FOR STORING INFORMATION AND DATA; ELECTRONIC MEMORY DEVICES, NAMELY, MEMORY MEDIA FOR STORING INFORMATION AND DATA; CIRCUIT BOARDS; COMPUTERS; COMPUTER PERIPHERALS; COMPUTER KEYBOARDS; COMPUTER MODEMS; COMPUTER SERVERS; COMPUTER MEMORY; COMPUTER MEMORY, NAMELY, COMPUTER MEMORY CARDS, MODULES, CHIPS AND FLASH MEMORY CARDS; COMPUTER MEMORY PACKAGES COMPRISED OF NOT AND FLASH MEMORY DEVICES AND INTERFACE CONTROLLER, PRINTED CIRCUIT BOARD, FIRMWARE USED TO ENABLE MEMORY CHIPS TO FUNCTION WITH LOGIC AND SOLID STATE DRIVE CONTROLLERS, AND SUPPORTING PASSIVE COMPONENTS; COMPUTER MEMORY, NAMELY, DIGITAL MEMORY DEVICES, NAMELY, SOLID STATE DRIVE DEVICES USED TO STORE DATA; COMPUTER DISK DRIVES; BLANK FLASH DRIVES; SOLID-STATE DRIVES; BACKUP DRIVES FOR COMPUTERS; COMPU-

CLASS 9—(Continued).

TER HARDWARE, NAMELY, COMPUTER SERVERS; COMPUTER STORAGE DEVICES, NAMELY, CONFIGURABLE DATA STORAGE SYSTEMS COMPRISED OF RAID (REDUNDANT ARRAY OF INDEPENDENT DISKS), SAS (SERIAL ATTACHED SCSI), SATA (SERIAL ATA) AND/OR JBOD (JUST A BUNCH OF DISKS) HARD DRIVE BACKUP SYSTEMS AND CONTROLLERS; COMPUTER STORAGE DEVICES, NAMELY, COMPUTER BACKUP AND STORAGE SYSTEMS WITH MULTIPLE REMOVABLE DATA STORAGE CARTRIDGES; COMPUTER STORAGE DEVICES, NAMELY, HIGH-SPEED STORAGE SUBSYSTEMS FOR STORAGE AND BACKUP OF ELECTRONIC DATA EITHER LOCALLY OR VIA A TELECOMMUNICATIONS NETWORK; COMPUTER SOFTWARE, NAMELY, SOFTWARE FOR OPERATION OF COMPUTER SERVERS, CONFIGURABLE DATA STORAGE SYSTEMS COMPRISED OF RAID (REDUNDANT ARRAY OF INDEPENDENT DISKS), SAS (SERIAL ATTACHED SCSI), SATA (SERIAL ATA) AND JBOD (JUST A BUNCH OF DISKS) HARD DRIVE BACKUP SYSTEMS AND CONTROLLERS, COMPUTER BACKUP AND STORAGE SYSTEMS WITH MULTIPLE REMOVABLE DATA STORAGE CARTRIDGES, AND HIGH-SPEED STORAGE SUBSYSTEMS FOR STORAGE AND BACKUP OF ELECTRONIC DATA EITHER LOCALLY OR VIA A TELECOMMUNICATIONS NETWORK AND STRUCTURAL PARTS AND STRUCTURAL COMPONENTS FOR ALL OF THE FOREGOING; HARD DISK DRIVES; REMOVABLE HARD DRIVE BASED COMPUTER BACKUP SYSTEMS; STORAGE NETWORK ACCESS SERVER HARDWARE; RACKS, CABINETS AND ENCLOSURES FOR HOUSING ELECTRICAL AND ELECTRONIC EQUIPMENT, NAMELY, SEVERS, WIRELESS BASE STATIONS, RELAYS AND SWITCHES; ELECTRICAL CABLING, PRINTED CIRCUIT BOARD SUBSTRATES IN THE NATURE OF FR-4 (FLAME RETARDANT) WOVEN GLASS AND EPOXY, LOW DK/DF (DIELECTRIC CONSTANT/DISSIPATION FACTOR) MODIFIED EPOXY (CYNATE ESTER AND POLYPHENYLENE BLENDED), BT (BISMALEIMIDE TRIAZINE) RESIN, POLYIMIDE RESIN, PTFE (POLYTETRAFLUOROETHYLENE) RESIN, LCP (LIQUID CRYSTAL POLYMER) RESIN, AND HYDROCARBON RESIN; PRINTED CIRCUIT BOARDS, BACK PLANE PANELS WITH ELECTRICAL CONNECTORS AND CABLING MOUNTED THEREON USED FOR COMPUTING, STORAGE, TELECOMMUNICATIONS, DATA COMMUNICATIONS, AND INDUSTRIAL, MULTIMEDIA, DEFENSE, AEROSPACE, MEDICAL, AND AUTOMOTIVE INDUSTRY APPLICATIONS; ELECTRONIC COMPONENTS, NAMELY, DUAL IN-LINE MEMORY MODULES (DIMMS), RANDOM ACCESS MEMORY (RAM) CARDS, AND PACKAGES FOR STACKING MEMORY DIE, NAMELY, NAND FLASH MEMORY DEVICES AND RAM DEVICES ALONG WITH CUSTOM PRINTED CIRCUIT BOARDS ASSEMBLED TO CREATE A PACKAGE THAT PROVIDES DOUBLE DENSITY MEMORY IN THE SAME FOOTPRINT; COMPONENT PARTS FOR ALL OF THE FOREGOING, NAMELY, COMPUTER CHIPS, REMOVABLE CARD FORM FACTOR DEVICES, AND CUSTOMER FORM FACTOR CARDS, SOLID STATE DRIVE MODULES, COMPUTER MEMORY, MAIN COMPUTER MEMORY AND SOLID STATE DRIVE PACKAGES AND OTHER REPLACEMENT PARTS; COMPUTER OPERATING SOFTWARE, DRIVERS SOFTWARE FOR SENDING MESSAGES AND DATA BETWEEN SOFTWARE AND HARDWARE, AND CONTROLLERS IN THE NATURE OF COMPUTER CHIPS, ALL OF THE FOREGOING USED IN CONNECTION WITH COMPUTER MAIN MEMORY AND SOLID STATE DRIVE DATA STORAGE DEVICES; ELECTRONIC COMMUNICATION SYSTEMS COMPRISED OF COMPUTER HARDWARE AND SOFTWARE FOR THE TRANSMISSION OF DATA BETWEEN RADIO AND COMMUNICATIONS SYSTEMS, PARTICULARLY, AIRCRAFT INTERCOMMUNICATIONS SYSTEMS, TACTICAL OPERATIONS CENTER INTERCOMMUNICATIONS SYSTEMS, AND GROUND VEHICLE INTERCOMMUNICATIONS SYSTEMS WITH ANALOG AND DIGITAL AUDIO AND DIGITAL DATA DISTRIBUTION; DIGITAL AUDIO FIRMWARE AND HARDWARE USED IN THE FIELDS OF DEFENSE AND AEROSPACE IN CONNECTION WITH AIRCRAFT AND GROUND VEHICLE INTERCOMMUNICATION SYSTEMS THAT PLACE AUDIO SOURCES IN 3 DIMENSIONAL SPACE; VOICE COMMAND AND CONTROL EQUIPMENT AND SYSTEMS THAT OPERATE AS

CLASS 9—(Continued).

STAND ALONE OR AS CIRCUIT CARD ASSEMBLIES AND THAT USE VOICE AND COMMAND RECOGNITION SOFTWARE TO CONTROL COMMUNICATION AND DISPLAY FUNCTIONS IN AIRCRAFT COCKPIT AND GROUND VEHICLES; COMPUTER FIRMWARE USED TO FACILITATE DIGITAL AUDIO PROCESSING AND DISTRIBUTION, CONTROL FUNCTIONS AND DATA CONCENTRATION FUNCTIONS WITHIN AEROSPACE AND AVIONIC COMMUNICATIONS SYSTEMS AND INSTRUMENTATION SYSTEMS; TELECOMMUNICATIONS AND DATA NETWORKING HARDWARE, NAMELY, DEVICES FOR TRANSPORTING AND AGGREGATING VOICE, DATA, AND VIDEO COMMUNICATIONS ACROSS MULTIPLE NETWORK INFRASTRUCTURES AND COMMUNICATIONS PROTOCOLS; RADIO AND LAND-LINE TELECOMMUNICATIONS SYSTEMS COMPRISED OF CENTRAL SWITCHING UNITS AND COMMUNICATIONS ASSETS, NAMELY, LINE REPLACEABLE UNITS, CREW ACCESS UNITS AND DESKTOP CREW ACCESS UNIT STAND ASSEMBLIES FOR NETWORKING MULTIPLE RADIO TRANSMITTERS/RECEIVERS AND LAND-LINE TELEPHONES FOR TACTICAL MILITARY COMMAND AND CONTROL APPLICATIONS, AND ASSOCIATED COMPUTER HARDWARE, PRINTED CIRCUIT BOARDS, AND SOFTWARE FOR FACILITATING COMMUNICATIONS BETWEEN ALL COMMUNICATIONS ASSETS CONNECTED WITHIN THE SYSTEM; RAPID RESPONSE INTERCOMMUNICATIONS AND COMMUNICATIONS SYSTEM PRIMARILY COMPRISED OF CENTRAL ELECTRICAL SWITCHING UNITS AND CREW ACCESSIBLE ELECTRIC JUNCTION BOXES, COMPUTER HARDWARE, AND TELECOMMUNICATION SOFTWARE USED TO ENABLE NETWORKING MULTIPLE RADIO TRANSMITTERS/RECEIVERS, LAND-LINE TELEPHONES, CELL PHONES, VOIP, WIRELESS, AND OTHER COMMUNICATIONS MEDIA FOR TACTICAL MILITARY OPERATIONS, COMMAND AND CONTROL SITUATIONS, AND FIRST RESPONDER EMERGENCY AND NATURAL DISASTER EVENTS; COMPUTER HARDWARE; BROADBAND WIRELESS EQUIPMENT, NAMELY, TELECOMMUNICATIONS BASE STATION EQUIPMENT FOR CELLULAR, WIRELESS, VOIP, RADIO, LANDLINE AND FIXED NETWORKING AND COMMUNICATIONS APPLICATIONS; TELECOMMUNICATIONS EQUIPMENT, NAMELY, COMPUTER ROUTERS, RADIO ROUTERS, VOIP ROUTERS, TELEPHONE CHANNEL BANKS USED FOR VOICE AND DATA TRANSMISSION, LAPTOP COMPUTERS, AND COMPUTER TELECOMMUNICATIONS SOFTWARE FOR VOICE AND DATA TRANSMISSION, ALL FOR TACTICAL MILITARY OPERATIONS, COMMAND AND CONTROL APPLICATIONS, AND FIRST RESPONDER EMERGENCY AND NATURAL DISASTER EVENTS; AIRCRAFT TEST EQUIPMENT, NAMELY, FLIGHT TEST INSTRUMENTATION AND HOUSINGS THEREFOR; MILITARY AND AEROSPACE HARDWARE, COMPONENT PARTS THEREFOR AND SOFTWARE, NAMELY, MISSION COMPUTERS AND REAL TIME MISSION CONTROL SOFTWARE, WEAPONS PROCESSORS AND REAL TIME WEAPONS CONTROL SOFTWARE USED FOR MILITARY AIRCRAFT, DATA ACQUISITION AND CONCENTRATION UNITS AND ACQUISITION AND DISTRIBUTION SOFTWARE USED FOR MILITARY AIRCRAFT, POWER SUPPLIES USED IN DEFENSE AND AEROSPACE PRODUCTS, CONTROL SYSTEMS, AND HOUSING AND SUPPORT STRUCTURES IMPLEMENTING ELECTRONICS SYSTEM ENCLOSURES USED FOR DEFENSE AND AEROSPACE PRODUCTS THEREFOR MADE OF METAL, PLASTICS AND FIBERGLASS; FIBER OPTIC DATA LINKS, FIBER OPTIC CABLE PACKS AND DISPENSERS, AND FIBER OPTIC TETHERS USED FOR, AMONG OTHER THINGS, UNDERSEA REMOTELY PILOTED VEHICLES AND TORPEDO DATA LINK; FIBER OPTIC EXPANDED BEAM CONNECTORS USED FOR MILITARY FIBER OPTIC AND COMMERCIAL APPLICATIONS AND OPTICAL ALIGNMENT EQUIPMENT USED IN THE MANUFACTURE OF EXPANDED BEAM CONNECTORS; AIRCRAFT DATA COUPLERS AND OPTICAL MEDIA COUPLERS USED FOR DATA COMMUNICATIONS BUSES ON AIRCRAFT; RADIATION DETECTION DE-

CLASS 9—(Continued).

VICES AND TECHNOLOGY, NAMELY, HAND HELD RADIATION DETECTORS AND LARGE SCALE RADIATION DETECTORS, RADIATION DETECTORS WITH WIRELESS COMMUNICATION; WIRELESS VOICE AND DATA COMMUNICATIONS EQUIPMENT AND SYSTEMS, NAMELY, SECURE AND NON-SECURE WIRELESS INTERCOMMUNICATIONS SYSTEM COMPRISED MOBILE TRANSCEIVERS AND BASE STATIONS USED TO FACILITATE COMMUNICATIONS BETWEEN MOBILE TRANSCEIVERS AND OTHER COMMUNICATIONS EQUIPMENT (U.S. CLS. 21, 23, 26, 36 AND 38).

WILLIAM BRECKENFELD, EXAMINING ATTORNEY

SN 85-265,024. SANMINA-SCI CORPORATION, SAN JOSE, CA. FILED 3-11-2011.

YOUR VISION, ACCOMPLISHED.

THE MARK CONSISTS OF STANDARD CHARACTERS WITHOUT CLAIM TO ANY PARTICULAR FONT, STYLE, SIZE, OR COLOR.

FOR COMPUTER HARDWARE; ELECTRONIC STORAGE DEVICES, NAMELY, MEMORY MEDIA FOR STORING INFORMATION AND DATA; ELECTRONIC MEMORY DEVICES, NAMELY, MEMORY MEDIA FOR STORING INFORMATION AND DATA; CIRCUIT BOARDS; COMPUTERS; COMPUTER PERIPHERALS; COMPUTER KEYBOARDS; COMPUTER MODEMS; COMPUTER SERVERS; COMPUTER MEMORY; COMPUTER MEMORY, NAMELY, COMPUTER MEMORY CARDS, MODULES, CHIPS AND FLASH MEMORY CARDS; COMPUTER MEMORY PACKAGES COMPRISED OF NOT AND FLASH MEMORY DEVICES AND INTERFACE CONTROLLER, PRINTED CIRCUIT BOARD, FIRMWARE USED TO ENABLE MEMORY CHIPS TO FUNCTION WITH LOGIC AND SOLID STATE DRIVE CONTROLLERS, AND SUPPORTING PASSIVE COMPONENTS; COMPUTER MEMORY, NAMELY, DIGITAL MEMORY DEVICES, NAMELY, SOLID STATE DRIVE DEVICES USED TO STORE DATA; COMPUTER DISK DRIVES; BLANK FLASH DRIVES; SOLID-STATE DRIVES; BACKUP DRIVES FOR COMPUTERS; COMPUTER HARDWARE, NAMELY, COMPUTER SERVERS; COMPUTER STORAGE DEVICES, NAMELY, CONFIGURABLE DATA STORAGE SYSTEMS COMPRISED OF RAID (REDUNDANT ARRAY OF INDEPENDENT DISKS), SAS (SERIAL ATTACHED SCSI), SATA (SERIAL ATA) AND/OR JBOD (JUST A BUNCH OF DISKS) HARD DRIVE BACKUP SYSTEMS AND CONTROLLERS; COMPUTER STORAGE DEVICES, NAMELY, COMPUTER BACKUP AND STORAGE SYSTEMS WITH MULTIPLE REMOVABLE DATA STORAGE CARTRIDGES; COMPUTER STORAGE DEVICES, NAMELY, HIGH-SPEED STORAGE SUBSYSTEMS FOR STORAGE AND BACKUP OF ELECTRONIC DATA EITHER LOCALLY OR VIA A TELECOMMUNICATIONS NETWORK; COMPUTER SOFTWARE, NAMELY, SOFTWARE FOR OPERATION OF COMPUTER SERVERS, CONFIGURABLE DATA STORAGE SYSTEMS COMPRISED OF RAID (REDUNDANT ARRAY OF INDEPENDENT DISKS), SAS (SERIAL ATTACHED SCSI), SATA (SERIAL ATA) AND JBOD (JUST A BUNCH OF DISKS) HARD DRIVE BACKUP SYSTEMS AND CONTROLLERS, COMPUTER BACKUP AND STORAGE SYSTEMS WITH MULTIPLE REMOVABLE DATA STORAGE CARTRIDGES, AND HIGH-SPEED STORAGE SUBSYSTEMS FOR STORAGE AND BACKUP OF ELECTRONIC DATA EITHER LOCALLY OR VIA A TELECOMMUNICATIONS NETWORK AND STRUCTURAL PARTS AND STRUCTURAL COMPONENTS FOR ALL OF THE FOREGOING; HARD DISK DRIVES; REMOVABLE HARD DRIVE BASED COMPUTER BACKUP SYSTEMS; STORAGE NETWORK ACCESS SERVER HARDWARE; RACKS, CABINETS AND ENCLOSURES FOR HOUSING ELECTRICAL AND ELEC-

CLASS 9—(Continued).

TRONIC EQUIPMENT, NAMELY, SEVERS, WIRELESS BASE STATIONS, RELAYS AND SWITCHES; ELECTRICAL CABLING, PRINTED CIRCUIT BOARD SUBSTRATES IN THE NATURE OF FR-4 (FLAME RETARDANT) WOVEN GLASS AND EPOXY, LOW DK/DF (DIELECTRIC CONSTANT/DISSIPATION FACTOR) MODIFIED EPOXY (CYNATE ESTER AND POLYPHENYLENE BLENDED), BT (BISMALEIMIDE TRIAZINE) RESIN, POLYIMIDE RESIN, PTFE (POLYTETRAFLUOROETHYLENE) RESIN, LCP (LIQUID CRYSTAL POLYMER) RESIN, AND HYDROCARBON RESIN; PRINTED CIRCUIT BOARDS, BACK PLANE PANELS WITH ELECTRICAL CONNECTORS AND CABLING MOUNTED THEREON USED FOR COMPUTING, STORAGE, TELECOMMUNICATIONS, DATA COMMUNICATIONS, AND INDUSTRIAL, MULTIMEDIA, DEFENSE, AEROSPACE, MEDICAL, AND AUTOMOTIVE INDUSTRY APPLICATIONS; ELECTRONIC COMPONENTS, NAMELY, DUAL IN-LINE MEMORY MODULES (DIMMS), RANDOM ACCESS MEMORY (RAM) CARDS, AND PACKAGES FOR STACKING MEMORY DIE, NAMELY, NAND FLASH MEMORY DEVICES AND RAM DEVICES ALONG WITH CUSTOM PRINTED CIRCUIT BOARDS ASSEMBLED TO CREATE A PACKAGE THAT PROVIDES DOUBLE DENSITY MEMORY IN THE SAME FOOTPRINT; COMPONENT PARTS FOR ALL OF THE FOREGOING, NAMELY, COMPUTER CHIPS, REMOVABLE CARD FORM FACTOR DEVICES, AND CUSTOMER FORM FACTOR CARDS, SOLID STATE DRIVE MODULES, COMPUTER MEMORY, MAIN COMPUTER MEMORY AND SOLID STATE DRIVE PACKAGES AND OTHER REPLACEMENT PARTS; COMPUTER OPERATING SOFTWARE, DRIVERS SOFTWARE FOR SENDING MESSAGES AND DATA BETWEEN SOFTWARE AND HARDWARE, AND CONTROLLERS IN THE NATURE OF COMPUTER CHIPS, ALL OF THE FOREGOING USED IN CONNECTION WITH COMPUTER MAIN MEMORY AND SOLID STATE DRIVE DATA STORAGE DEVICES; ELECTRONIC COMMUNICATION SYSTEMS COMPRISED OF COMPUTER HARDWARE AND SOFTWARE FOR THE TRANSMISSION OF DATA BETWEEN RADIO AND COMMUNICATIONS SYSTEMS, PARTICULARLY, AIRCRAFT INTERCOMMUNICATIONS SYSTEMS, TACTICAL OPERATIONS CENTER INTERCOMMUNICATIONS SYSTEMS, AND GROUND VEHICLE INTERCOMMUNICATIONS SYSTEMS WITH ANALOG AND DIGITAL AUDIO AND DIGITAL DATA DISTRIBUTION; DIGITAL AUDIO FIRMWARE AND HARDWARE USED IN THE FIELDS OF DEFENSE AND AEROSPACE IN CONNECTION WITH AIRCRAFT AND GROUND VEHICLE INTERCOMMUNICATION SYSTEMS THAT PLACE AUDIO SOURCES IN 3 DIMENSIONAL SPACE; VOICE COMMAND AND CONTROL EQUIPMENT AND SYSTEMS THAT OPERATE AS STAND ALONE OR AS CIRCUIT CARD ASSEMBLIES AND THAT USE VOICE AND COMMAND RECOGNITION SOFTWARE TO CONTROL COMMUNICATION AND DISPLAY FUNCTIONS IN AIRCRAFT COCKPIT AND GROUND VEHICLES; COMPUTER FIRMWARE USED TO FACILITATE DIGITAL AUDIO PROCESSING AND DISTRIBUTION, CONTROL FUNCTIONS AND DATA CONCENTRATION FUNCTIONS WITHIN AEROSPACE AND AVIONIC COMMUNICATIONS SYSTEMS AND INSTRUMENTATION SYSTEMS; TELECOMMUNICATIONS AND DATA NETWORKING HARDWARE, NAMELY, DEVICES FOR TRANSPORTING AND AGGREGATING VOICE, DATA, AND VIDEO COMMUNICATIONS ACROSS MULTIPLE NETWORK INFRASTRUCTURES AND COMMUNICATIONS PROTOCOLS; RADIO AND LAND-LINE TELECOMMUNICATIONS SYSTEMS COMPRISED OF CENTRAL SWITCHING UNITS AND COMMUNICATIONS ASSETS, NAMELY, LINE REPLACEABLE UNITS, CREW ACCESS UNITS AND DESKTOP CREW ACCESS UNIT STAND ASSEMBLIES FOR NETWORKING MULTIPLE RADIO TRANSMITTERS/RECEIVERS AND LAND-LINE TELEPHONES FOR TACTICAL MILITARY COMMAND AND CONTROL APPLICATIONS, AND ASSOCIATED COMPUTER HARDWARE, PRINTED CIRCUIT BOARDS, AND SOFTWARE FOR FACILITATING COMMUNICATIONS BETWEEN ALL COMMUNICATIONS ASSETS CONNECTED WITHIN THE SYSTEM; RAPID RESPONSE INTERCOMMUNICATIONS AND COMMUNICATIONS SYSTEM PRIMARILY COMPRISED OF CENTRAL ELECTRICAL SWITCHING UNITS AND CREW ACCESSIBLE ELECTRIC JUNCTION BOXES,

CLASS 9—(Continued).

COMPUTER HARDWARE, AND TELECOMMUNICATION SOFTWARE USED TO ENABLE NETWORKING MULTIPLE RADIO TRANSMITTERS/RECEIVERS, LAND-LINE TELEPHONES, CELL PHONES, VOIP, WIRELESS, AND OTHER COMMUNICATIONS MEDIA FOR TACTICAL MILITARY OPERATIONS, COMMAND AND CONTROL SITUATIONS, AND FIRST RESPONDER EMERGENCY AND NATURAL DISASTER EVENTS; COMPUTER HARDWARE; BROADBAND WIRELESS EQUIPMENT, NAMELY, TELECOMMUNICATIONS BASE STATION EQUIPMENT FOR CELLULAR, WIRELESS, VOIP, RADIO, LANDLINE AND FIXED NETWORKING AND COMMUNICATIONS APPLICATIONS; TELECOMMUNICATIONS EQUIPMENT, NAMELY, COMPUTER ROUTERS, RADIO ROUTERS, VOIP ROUTERS, TELEPHONE CHANNEL BANKS USED FOR VOICE AND DATA TRANSMISSION, LAPTOP COMPUTERS, AND COMPUTER TELECOMMUNICATIONS SOFTWARE FOR VOICE AND DATA TRANSMISSION, ALL FOR TACTICAL MILITARY OPERATIONS, COMMAND AND CONTROL APPLICATIONS, AND FIRST RESPONDER EMERGENCY AND NATURAL DISASTER EVENTS; AIRCRAFT TEST EQUIPMENT, NAMELY, FLIGHT TEST INSTRUMENTATION AND HOUSINGS THEREFOR; MILITARY AND AEROSPACE HARDWARE, COMPONENT PARTS THEREFOR AND SOFTWARE, NAMELY, MISSION COMPUTERS AND REAL TIME MISSION CONTROL SOFTWARE, WEAPONS PROCESSORS AND REAL TIME WEAPONS CONTROL SOFTWARE USED FOR MILITARY AIRCRAFT, DATA ACQUISITION AND CONCENTRATION UNITS AND ACQUISITION AND DISTRIBUTION SOFTWARE USED FOR MILITARY AIRCRAFT, POWER SUPPLIES USED IN DEFENSE AND AEROSPACE PRODUCTS, CONTROL SYSTEMS, AND HOUSING AND SUPPORT STRUCTURES IMPLEMENTING ELECTRONICS SYSTEM ENCLOSURES USED FOR DEFENSE AND AEROSPACE PRODUCTS THEREFOR MADE OF METAL, PLASTICS AND FIBERGLASS; FIBER OPTIC DATA LINKS, FIBER OPTIC CABLE PACKS AND DISPENSERS, AND FIBER OPTIC TETHERS USED FOR, AMONG OTHER THINGS, UNDERSEA REMOTELY PILOTED VEHICLES AND TORPEDO DATA LINK; FIBER OPTIC EXPANDED BEAM CONNECTORS USED FOR MILITARY FIBER OPTIC AND COMMERCIAL APPLICATIONS AND OPTICAL ALIGNMENT EQUIPMENT USED IN THE MANUFACTURE OF EXPANDED BEAM CONNECTORS; AIRCRAFT DATA COUPLERS AND OPTICAL MEDIA COUPLERS USED FOR DATA COMMUNICATIONS BUSES ON AIRCRAFT; RADIATION DETECTION DEVICES AND TECHNOLOGY, NAMELY, HAND HELD RADIATION DETECTORS AND LARGE SCALE RADIATION DETECTORS, RADIATION DETECTORS WITH WIRELESS COMMUNICATION; WIRELESS VOICE AND DATA COMMUNICATIONS EQUIPMENT AND SYSTEMS, NAMELY, SECURE AND NON-SECURE WIRELESS INTERCOMMUNICATIONS SYSTEM COMPRISING MOBILE TRANSCEIVERS AND BASE STATIONS USED TO FACILITATE COMMUNICATIONS BETWEEN MOBILE TRANSCEIVERS AND OTHER COMMUNICATIONS EQUIPMENT (U.S. CLS. 21, 23, 26, 36 AND 38).

WILLIAM BRECKENFELD, EXAMINING ATTORNEY

CLASS 9—(Continued).

SN 85-266,099. AALTO SCIENTIFIC, LTD., CARLSBAD, CA. FILED 3-14-2011.

AUDIT

THE MARK CONSISTS OF STANDARD CHARACTERS WITHOUT CLAIM TO ANY PARTICULAR FONT, STYLE, SIZE, OR COLOR.

FOR CALIBRATION DEVICES PRELOADED WITH THE CALIBRATION AND QUALITY CONTROL MATERIALS, NAMELY, PIPETTES, PIPETTE TIPS, TUBES, AND VIALS FOR LABORATORY USE AND FOR USE TO CALIBRATE INSTRUMENTS AND REAGENTS (U.S. CLS. 21, 23, 26, 36 AND 38).

FIRST USE 5-6-1999; IN COMMERCE 5-6-1999.
GIANCARLO CASTRO, EXAMINING ATTORNEY

SN 85-274,521. SENKO ADVANCED COMPONENTS, INC., MARLBOROUGH, MA. FILED 3-23-2011.



**XP
FIT PLUS**

OWNER OF U.S. REG. NO. 4,107,830.

THE MARK CONSISTS OF THE WORDS "XP FIT PLUS". "XP" IS SHOWN IN A LOGO FORMAT WITH AN ARROW DESIGN EXTENDING FROM THE "P" BEHIND THE "X". "FIT PLUS" IS SHOWN IN FULL CAPITAL LETTERS BELOW THE "XP" DESIGN.

FOR FIBER OPTIC FIELD INSTALLABLE CONNECTORS; FIBER OPTIC CONNECTOR INSTALLATION KITS COMPRISED OF FIBER OPTIC CONNECTORS AND INSTALLATION TOOLS (U.S. CLS. 21, 23, 26, 36 AND 38).

GRETCHEN ULRICH, EXAMINING ATTORNEY

CLASS 9—(Continued).

SN 85-281,267. TRAINING FOR TRANSFORMATION, INC., SILVER SPRING, MD. FILED 3-30-2011.

TRAINING FOR TRANSFORMATION

THE MARK CONSISTS OF STANDARD CHARACTERS WITHOUT CLAIM TO ANY PARTICULAR FONT, STYLE, SIZE, OR COLOR.

FOR AUDIO AND VISUAL FILES IN ANALOG OR DIGITAL FORMATS, NAMELY, PRE-RECORDED CDS, DVDS, PRE-RECORDED OPTICAL DISCS, SECURE DIGITAL MEMORY CARD, FLASH DRIVES, AND DOWNLOADABLE AUDIO AND VIDEO FILES, DOWNLOADABLE PHOTOGRAPHS AND VISUAL IMAGES, ALL IN THE FIELDS OF SEXUAL ABUSE, SEXUAL IMMORALITY, SEXUAL ADDICTIONS, AND A CHRISTIAN AND BIBLICAL PERSPECTIVE ON HEALTHY SEXUALITY; DOWNLOADABLE ELECTRONIC PUBLICATIONS IN THE NATURE OF ABSTRACTS OF ARTICLES, FACT SHEETS, ARTICLES, BIBLIOGRAPHIES, BOOKS, BROCHURES, PAMPHLETS, MAGAZINES, CURRICULA, PROGRAM GUIDEBOOKS, MEETING NOTES AND HANDOUTS, NEWSLETTERS, REPORTS, STUDY GUIDES, AND DIRECTORIES OF ORGANIZATIONS, RESOURCES, WEBSITES, AND COUNSELORS, ALL IN THE FIELDS OF SEXUAL ABUSE, SEXUAL IMMORALITY, SEXUAL ADDICTIONS, AND A CHRISTIAN AND BIBLICAL PERSPECTIVE ON HEALTHY SEXUALITY (U.S. CLS. 21, 23, 26, 36 AND 38).

ANTHONY RINKER, EXAMINING ATTORNEY

SN 85-298,138. KEYMED (MEDICAL & INDUSTRIAL EQUIPMENT) LIMITED, ESSEX, UNITED KINGDOM, FILED 4-18-2011.

i-FOCUS

THE MARK CONSISTS OF STANDARD CHARACTERS WITHOUT CLAIM TO ANY PARTICULAR FONT, STYLE, SIZE, OR COLOR.

PRIORITY CLAIMED UNDER SEC. 44(D) ON ERPNTY TM OFC APPLICATION NO. 009671041, FILED 1-19-2011.

FOR HIGH SPEED VIDEO CAMERAS; ON-BOARD VIDEO CAMERA OPERATING SOFTWARE; SOFTWARE FOR THE REMOTE CONTROL AND OPERATION OF VIDEO CAMERAS; SOFTWARE FOR THE EDITING, VIEWING AND MANIPULATION OF VIDEOS AND IMAGES (U.S. CLS. 21, 23, 26, 36 AND 38).

FIRST USE 8-15-2008; IN COMMERCE 8-15-2008.
SETH A. RAPPAPORT, EXAMINING ATTORNEY

CLASS 9—(Continued).

SN 85-307,195. LG CORP., SEOUL 150-721, REPUBLIC OF KOREA, FILED 4-28-2011.



PRIORITY CLAIMED UNDER SEC. 44(D) ON REPUBLIC OF KOREA APPLICATION NO. 402011001474, FILED 3-23-2011, REG. NO. 0910788, DATED 3-16-2012, EXPIRES 3-16-2022.

OWNER OF U.S. REG. NOS. 2,334,058, 3,931,784 AND OTHERS.

THE MARK CONSISTS OF THE LETTERS "LG" TO THE LEFT OF WHICH IS A SHADED CIRCLE CONTAINING A GEOMETRIC DESIGN THAT LOOKS LIKE A FACE WITH ONE EYE.

FOR THREE DIMENSIONAL EYEGLASSES FOR TELEVISION RECEIVERS; THEATRE GLASSES; SPECTACLE FRAMES MADE OF METAL AND OF SYNTHETIC MATERIAL; MONOCULAR FRAMES; READING EYEGLASSES; UN-MOUNTED SPECTACLE FRAMES; DUST-PROOF EYEGLASSES; ANTI-GLARE EYEGLASSES; CORRECTIVE EYEGLASSES; EYEGLASSES; PROTECTIVE EYEGLASSES; PROTECTIVE EYE PIECES; HUNTING BINOCULARS; EYEGLASSES WITH A HANDLE; SWIM GOGGLES; SKI GOGGLES; GOGGLES FOR SPORTS; BINOCULARS; SPECTACLES; CASES FOR SPECTACLES AND SUNGLASSES; SPECTACLE GLASSES; EYEGLASS CHAINS; SIDE GUARDS FOR EYEGLASSES; EYEGLASS CORDS; CHAINS FOR SPECTACLES; EYEGLASS CASES; EYEGLASS FRAMES; FRAMES FOR SPECTACLES AND SUNGLASSES; FRAMES FOR EYEGLASSES AND PINCE-NEZ; SPECTACLE HOLDERS; CHILDREN'S EYE GLASSES; GLACIER EYEGLASSES; MONOCLES; ANTI-DAZZLE SPECTACLES; PINCE-NEZ; PINCE-NEZ CHAINS; PINCE-NEZ CORDS; PINCE-NEZ CASES; PINCE-NEZ MOUNTINGS; POLARIZING SPECTACLES; FIELD-GLASSES (U.S. CLS. 21, 23, 26, 36 AND 38).

KELLY TRUSILO, EXAMINING ATTORNEY

CLASS 9—(Continued).

SN 85-308,942. TWENTIETH CENTURY FOX FILM CORPORATION, LOS ANGELES, CA. FILED 4-29-2011.

AMERICAN HORROR STORY

THE MARK CONSISTS OF STANDARD CHARACTERS WITHOUT CLAIM TO ANY PARTICULAR FONT, STYLE, SIZE, OR COLOR.

SEC. 2(F).

FOR PRE-RECORDED DVDS FEATURING DRAMA; PRE-RECORDED CDS FEATURING DRAMA AND MUSICAL PERFORMANCES; DOWNLOADABLE AUDIO AND VIDEO RECORDINGS FEATURING DRAMA; DOWNLOADABLE TELEVISION SHOWS AND VIDEO RECORDINGS FEATURING DRAMA; DOWNLOADABLE RING TONES, RING BACKS, GRAPHICS, WALL-PAPER, GAMES AND MUSIC VIA A GLOBAL COMPUTER NETWORK AND WIRELESS DEVICES; COMPUTER SCREEN SAVER SOFTWARE; COMPUTER GAME AND VIDEO GAME SOFTWARE; MOUSEPADS; DECORATIVE MAGNETS (U.S. CLS. 21, 23, 26, 36 AND 38).

FIRST USE 10-5-2011; IN COMMERCE 10-5-2011.

JULIE WATSON, EXAMINING ATTORNEY

SN 85-313,000. JOHNSON & JOHNSON, NEW BRUNSWICK, NJ. FILED 5-5-2011.

AMERICAN JOY

THE MARK CONSISTS OF STANDARD CHARACTERS WITHOUT CLAIM TO ANY PARTICULAR FONT, STYLE, SIZE, OR COLOR.

NO CLAIM IS MADE TO THE EXCLUSIVE RIGHT TO USE "AMERICAN", APART FROM THE MARK AS SHOWN. FOR DOCUMENTARY FILMS ABOUT PARENTHOOD (U.S. CLS. 21, 23, 26, 36 AND 38).

ALICE BENMAMAN, EXAMINING ATTORNEY

SN 85-316,503. ALERT GPS HOLDINGS, CORP., SOUTH JORDAN, UT. FILED 5-10-2011.

GOLDEN ALERT GPS

THE MARK CONSISTS OF STANDARD CHARACTERS WITHOUT CLAIM TO ANY PARTICULAR FONT, STYLE, SIZE, OR COLOR.

NO CLAIM IS MADE TO THE EXCLUSIVE RIGHT TO USE "ALERT GPS", APART FROM THE MARK AS SHOWN.

FOR ELECTRONIC DEVICES FOR LOCATING AND TRACKING PEOPLE, PETS, AND OBJECTS PROGRAMMED TO USE GLOBAL POSITIONING SYSTEMS (GPS) AND/OR CELLULAR COMMUNICATIONS AND/OR WIRELESS NETWORK DATA (U.S. CLS. 21, 23, 26, 36 AND 38).

KATHLEEN LORENZO, EXAMINING ATTORNEY

CLASS 9—(Continued).

SN 85-317,207. INTUICOM, INCORPORATED, BOULDER, CO. FILED 5-10-2011.

RTK Bridge

THE MARK CONSISTS OF STANDARD CHARACTERS WITHOUT CLAIM TO ANY PARTICULAR FONT, STYLE, SIZE, OR COLOR.

SEC. 2(F).

FOR BROADBAND WIRELESS EQUIPMENT, NAMELY, TELECOMMUNICATIONS BASE STATION EQUIPMENT FOR CELLULAR AND FIXED NETWORKING AND COMMUNICATIONS APPLICATIONS; DIGITAL CELLULAR PHONES; ELECTRONIC DEVICES USED TO LOCATE LOST ARTICLES EMPLOYING THE GLOBAL POSITIONING SYSTEM OR CELLULAR COMMUNICATION NETWORKS; EXTERNAL MODEMS; INTERNAL MODEMS; MODEMS (U.S. CLS. 21, 23, 26, 36 AND 38).

FIRST USE 4-22-2007; IN COMMERCE 4-30-2007.
ESTHER BELENKER, EXAMINING ATTORNEY

SN 85-328,827. CARDINAL LOGISTICS MANAGEMENT CORPORATION, CONCORD, NC. FILED 5-24-2011.

CARDINAL HOSTED LOGISTICS

THE MARK CONSISTS OF STANDARD CHARACTERS WITHOUT CLAIM TO ANY PARTICULAR FONT, STYLE, SIZE, OR COLOR.

NO CLAIM IS MADE TO THE EXCLUSIVE RIGHT TO USE "LOGISTICS", APART FROM THE MARK AS SHOWN.

FOR HANDHELD PERSONAL COMPUTERS FOR LOGISTICS MANAGEMENT, ORDER MANAGEMENT, SUPPLY CHAIN MANAGEMENT, TRANSPORTATION, WAREHOUSING, STORAGE AND DELIVERY OF FREIGHT; HANDHELD PERSONAL COMPUTERS FOR LOGISTICS MANAGEMENT CONTAINING RADIO FREQUENCY IDENTIFICATION TAG READERS AND SCANNERS; HANDHELD PERSONAL COMPUTERS FOR LOGISTICS MANAGEMENT FEATURING STATUS UPDATES, ELECTRONIC SIGNATURE CAPTURE, EXCEPTION CODE LOGGING, GPS AND CELL PHONE COMMUNICATION CAPABILITY (U.S. CLS. 21, 23, 26, 36 AND 38).

JEFFERY COWARD, EXAMINING ATTORNEY

CLASS 9—(Continued).

SN 85-344,698. DISNEY ENTERPRISES, INC., BURBANK, CA. FILED 6-13-2011.

WRECK-IT RALPH

THE MARK CONSISTS OF STANDARD CHARACTERS WITHOUT CLAIM TO ANY PARTICULAR FONT, STYLE, SIZE, OR COLOR.

FOR APPARATUS FOR RECORDING, TRANSMISSION OR REPRODUCTION OF SOUND OR IMAGES; PRE-RECORDED OPTICAL AND MAGNETO-OPTICAL DISCS, CDS AND DVDS; AUDIO BOOKS FEATURING FICTION; AUDIO BOOKS FEATURING NON-FICTION; AUDIO RECORDINGS FEATURING MUSIC, STORIES, DRAMATIC PERFORMANCES, NON-DRAMATIC PERFORMANCES, LEARNING ACTIVITIES FOR CHILDREN, AND GAMES; DOWNLOADABLE RINGTONES AND SOUND RECORDINGS FEATURING MUSIC AND OTHER SOUNDS, ALL FOR WIRELESS COMMUNICATIONS DEVICES; AUDIO AND VISUAL RECORDINGS FEATURING LIVE-ACTION ENTERTAINMENT, ANIMATED ENTERTAINMENT, MUSIC, STORIES, AND GAMES FOR CHILDREN; MUSICAL RECORDINGS; VIDEO GAME SOFTWARE; COMPUTER GAME SOFTWARE; COMPUTER SOFTWARE FEATURING LEARNING ACTIVITIES FOR CHILDREN; CHIPS CONTAINING MUSICAL RECORDINGS; COMPUTER HARDWARE AND PERIPHERAL DEVICES; MOUSE PADS; WRIST AND ARM RESTS FOR USE WITH COMPUTERS; CALCULATORS; ELECTRICAL AND OPTICAL CABLES; ELECTRONIC PERSONAL ORGANIZERS; PERSONAL DIGITAL ASSISTANTS; CAMCORDERS; CAMERAS; DIGITAL CAMERAS; OPTICAL AND MAGNETO-OPTICAL DISC PLAYERS AND RECORDERS FOR AUDIO, VIDEO AND COMPUTER DATA; RADIOS; TELEVISION SETS; VIDEO GAME MACHINES FOR USE WITH TELEVISIONS; AUDIO SPEAKERS; HEADPHONES; EARPHONES; WALKIE-TALKIES; PAGERS; TELEPHONES; VIDEOPHONES; HEAD SETS FOR CELLULAR TELEPHONES; ADAPTERS FOR CELLULAR TELEPHONES; BATTERIES FOR CELLULAR TELEPHONES; CELLULAR TELEPHONE CASES; FACE PLATES FOR CELLULAR TELEPHONES; EYEGLASSES; SUNGLASSES; EYEGLASS AND SUNGLASS CASES; BINOCULARS; DECORATIVE MAGNETS; GRADUATED RULERS (U.S. CLS. 21, 23, 26, 36 AND 38).

RON FAIRBANKS, EXAMINING ATTORNEY

SN 85-345,014. JEFFERS, ROBERT E., LOS ANGELES, CA. FILED 6-13-2011.

BOSUE RECORDZ

THE MARK CONSISTS OF STANDARD CHARACTERS WITHOUT CLAIM TO ANY PARTICULAR FONT, STYLE, SIZE, OR COLOR.

NO CLAIM IS MADE TO THE EXCLUSIVE RIGHT TO USE "RECORDS", APART FROM THE MARK AS SHOWN.

FOR MUSICAL SOUND RECORDINGS (U.S. CLS. 21, 23, 26, 36 AND 38).

WILLIAM P. SHANAHAN, EXAMINING ATTORNEY

CLASS 9—(Continued).

SN 85-361,439. ETHEL J. POULOS & JOHN C. LAGADINOS, CANTON, MA. FILED 7-1-2011.

MAGCAP ENGINEERING

THE MARK CONSISTS OF STANDARD CHARACTERS WITHOUT CLAIM TO ANY PARTICULAR FONT, STYLE, SIZE, OR COLOR.

FOR POWER TRANSFORMERS FOR AMPLIFICATION; STEP DOWN TRANSFORMERS; STEP UP TRANSFORMERS; TRANSFORMERS (U.S. CLS. 21, 23, 26, 36 AND 38).

FIRST USE 10-1-1972; IN COMMERCE 10-1-1972.
EMILY CARLSEN, EXAMINING ATTORNEY

SN 85-371,074. MEETERMATE LLC, SOUTH MIAMI, FL. FILED 7-14-2011.

MEETER

THE MARK CONSISTS OF STANDARD CHARACTERS WITHOUT CLAIM TO ANY PARTICULAR FONT, STYLE, SIZE, OR COLOR.

FOR COMPUTER SOFTWARE FOR ENABLING A USER TO DEFINE COMPLEX QUERIES IDENTIFYING PARAMETERS ASSOCIATED WITH ANY OF OBJECTS, PLACES OR OTHER USERS AND HAVE THE RESULTS DELINEATED GRAPHICALLY BASED ON PROXIMITY TO THE USER'S CURRENT LOCATION (U.S. CLS. 21, 23, 26, 36 AND 38).

TASHIA BUNCH, EXAMINING ATTORNEY

SN 85-376,254. DONIS, JEFFRIE, SOUTHLINGTON, CT. FILED 7-20-2011.

VIPER POWER SYSTEMS

THE MARK CONSISTS OF STANDARD CHARACTERS WITHOUT CLAIM TO ANY PARTICULAR FONT, STYLE, SIZE, OR COLOR.

NO CLAIM IS MADE TO THE EXCLUSIVE RIGHT TO USE "POWER SYSTEMS", APART FROM THE MARK AS SHOWN.

FOR ELECTRIC DC/AC POWER CONVERSION EQUIPMENT, NAMELY, ELECTRIC DC/AC POWER CONVERTERS; ELECTRIC POWER CONVERTERS; ELECTRONIC CONTROLLERS FOR USE IN DETERMINING AT LEAST ONE OF A PLURALITY OF POWER SOURCES FOR USE IN A SYSTEM; POWER ADAPTERS; POWER CONTROLLERS; DC/AC POWER CONVERTERS AND RENEWABLE ENERGY SYSTEMS COMPRISED OF RECHARGEABLE ELECTRIC BATTERIES (U.S. CLS. 21, 23, 26, 36 AND 38).

ANDREW LEASER, EXAMINING ATTORNEY

CLASS 9—(Continued).

SN 85-381,822. WHITE SQUARE MEDIA, FORT LAUDERDALE, FL. FILED 7-26-2011.

ME

THE MARK CONSISTS OF STANDARD CHARACTERS WITHOUT CLAIM TO ANY PARTICULAR FONT, STYLE, SIZE, OR COLOR.

OWNER OF U.S. REG. NO. 4,025,999.

FOR COMPUTER APPLICATION SOFTWARE FOR MOBILE PHONES, PORTABLE MEDIA PLAYERS, HANDHELD COMPUTERS, DESKTOP COMPUTERS, PORTABLE COMPUTERS, WIRELESS INTELLIGENT DEVICES, VIDEO GAME CONSOLES, TELEVISION SETS, IPTV, INTERNET SET-TOP BOXES, SELF-SERVICE KIOSKS, NAMELY, SOFTWARE FOR PURCHASING GOODS AND SERVICES THROUGH DIGITAL PHOTOS AND STATIC AND MOTION VIDEO OVER ELECTRONIC COMMUNICATIONS NETWORKS, AND DATA RETRIEVAL RELATED TO VIDEO OBJECTS FROM LOCAL SOURCE DATABASES, OR DATABASES LOCATED OVER ELECTRONIC COMMUNICATIONS NETWORKS, AND STATISTICAL DATA GATHERING SOFTWARE FOR TRACKING CONSUMER PURCHASING AND CONSUMER INFORMATION RETRIEVAL PATTERNS BASED ON ACTIVITY WITHIN THE CONSUMERS INTERACTION WITH THE VIDEO MEDIA SOFTWARE (U.S. CLS. 21, 23, 26, 36 AND 38).

FIRST USE 2-1-2011; IN COMMERCE 3-1-2011.

SHAUNIA CARLYLE, EXAMINING ATTORNEY

SN 85-396,638. ASSISTIVWARE B.V., AMSTERDAM, NETHERLANDS, FILED 8-12-2011.

ASSISTIVWARE

THE MARK CONSISTS OF STANDARD CHARACTERS WITHOUT CLAIM TO ANY PARTICULAR FONT, STYLE, SIZE, OR COLOR.

SEC. 2(F).

FOR SOFTWARE SUPPORTING USERS WITH SPEECH, COMMUNICATION, READING, WRITING, PHYSICAL, AND VISION DIFFICULTIES FOR EDUCATIONAL AND ASSISTIVE TECHNOLOGY PURPOSES (U.S. CLS. 21, 23, 26, 36 AND 38).

FIRST USE 3-28-2002; IN COMMERCE 8-6-2002.

NAKIA HENRY, EXAMINING ATTORNEY

CLASS 9—(Continued).

SN 85-398,324. HELL'S KITCHEN, INC, MINNEAPOLIS, MN. FILED 8-15-2011.

Damn Good Food

THE MARK CONSISTS OF STANDARD CHARACTERS WITHOUT CLAIM TO ANY PARTICULAR FONT, STYLE, SIZE, OR COLOR.

NO CLAIM IS MADE TO THE EXCLUSIVE RIGHT TO USE "GOOD FOOD", APART FROM THE MARK AS SHOWN.

FOR MOTION PICTURE FILMS ABOUT COOKING AND RESTAURANTS (U.S. CLS. 21, 23, 26, 36 AND 38).
KATHY DE JONGE, EXAMINING ATTORNEY

SN 85-409,882. NINE COLLECTIVE, LLC, WEATHERFORD, OK. FILED 8-29-2011.

FIELDBOOK

THE MARK CONSISTS OF STANDARD CHARACTERS WITHOUT CLAIM TO ANY PARTICULAR FONT, STYLE, SIZE, OR COLOR.

FOR SOFTWARE FOR MANAGING OILFIELD OR MINERAL BUSINESS OPERATION, NAMELY, SOFTWARE TO COLLECT, VIEW AND ANALYZE BUSINESS OPERATIONS AND FINANCIAL DATA ASSOCIATED WITH LEASING SERVICES; PLANNING SOFTWARE FOR MANAGING MINERAL LEASING SERVICES, NAMELY, SOFTWARE TO COLLECT, VIEW AND ANALYZE BUSINESS OPERATIONS AND FINANCIAL DATA ASSOCIATED WITH LEASING SERVICES (U.S. CLS. 21, 23, 26, 36 AND 38).

FIRST USE 8-31-2010; IN COMMERCE 8-31-2010.
JOHN SCHUYLER YARD, EXAMINING ATTORNEY

SN 85-409,896. NINE COLLECTIVE, LLC, WEATHERFORD, OK. FILED 8-29-2011.

Fieldbook 

NO CLAIM IS MADE TO THE EXCLUSIVE RIGHT TO USE "ERP", APART FROM THE MARK AS SHOWN.

THE MARK CONSISTS OF THE WORD "FIELDBOOK" FOLLOWED BY A DROPLET CONTAINING THE LETTERS "ERP".

FOR SOFTWARE FOR MANAGING OILFIELD OR MINERAL BUSINESS OPERATIONS, NAMELY, SOFTWARE TO COLLECT, VIEW AND ANALYZE BUSINESS OPERATIONS AND FINANCIAL DATA ASSOCIATED WITH LEASING SERVICES; PLANNING SOFTWARE FOR MANAGING MINERAL LEASING SERVICES, NAMELY, SOFTWARE TO COLLECT, VIEW AND ANALYZE BUSINESS OPERATIONS AND FINANCIAL DATA ASSOCIATED WITH LEASING SERVICES (U.S. CLS. 21, 23, 26, 36 AND 38).

FIRST USE 8-31-2010; IN COMMERCE 8-31-2010.
JOHN SCHUYLER YARD, EXAMINING ATTORNEY

CLASS 9—(Continued).

SN 85-414,618. LEGRAND HOME SYSTEMS, INC., MIDDLETOWN, PA. FILED 9-2-2011.

INFUSION

THE MARK CONSISTS OF STANDARD CHARACTERS WITHOUT CLAIM TO ANY PARTICULAR FONT, STYLE, SIZE, OR COLOR.

OWNER OF U.S. REG. NO. 3,881,731.

FOR ELECTRICAL AND ELECTRONIC DEVICES IN THE FIELD OF BUILDING AUTOMATION SYSTEMS, NAMELY, WIRELESS AND WIRED ELECTRONIC CONTROLLERS, COMPUTER KEYPADS AND MODEMS TO MONITOR AND CONTROL THE FUNCTIONING OF AUDIOVISUAL EQUIPMENT, LIGHTING EQUIPMENT, WATER SYSTEMS, WINDOW TREATMENTS AND THERMOSTATS, ALL FOR RESIDENTIAL, LODGING, RETAIL, AND OFFICE BUILDINGS; AND COMPUTER PROGRAMS FOR USE IN MONITORING AND CONTROLLING BUILDING AUTOMATION SYSTEMS FOR RESIDENTIAL, LODGING, RETAIL, AND OFFICE BUILDINGS (U.S. CLS. 21, 23, 26, 36 AND 38).

FIRST USE 9-30-2005; IN COMMERCE 9-30-2005.

DAWN HAN, EXAMINING ATTORNEY

SN 85-415,680. GLOBALFOUNDRIES INC., GRAND CAYMAN, CAYMAN ISLANDS, FILED 9-6-2011.

BCDLITE

THE MARK CONSISTS OF STANDARD CHARACTERS WITHOUT CLAIM TO ANY PARTICULAR FONT, STYLE, SIZE, OR COLOR.

FOR SEMICONDUCTORS, PROCESSED SEMI-CONDUCTOR WAFERS, AND INTEGRATED CIRCUITS (U.S. CLS. 21, 23, 26, 36 AND 38).

MARY ROSSMAN, EXAMINING ATTORNEY

CLASS 9—(Continued).

SN 85-418,335. RUNCORE INNOVATION TECHNOLOGY CO., LTD., CHANGSHA, HUNAN, CHINA, FILED 9-9-2011.



OWNER OF CHINA REG. NO. 6270418, DATED 3-28-2010, EXPIRES 3-27-2020.

THE MARK CONSISTS OF TWO CHINESE CHARACTERS.

THE NON-LATIN CHARACTERS IN THE MARK TRANSLITERATE TO "YUAN KE" AND THIS MEANS "ORIGINATE FROM TECHNOLOGY" IN ENGLISH.

FOR COMPUTER MEMORIES; COMPUTER PROGRAMS FOR DATABASE MANAGEMENT, SPREADSHEET, AND WORD PROCESSING; COMPUTER PERIPHERAL DEVICES; COMPUTER SOFTWARE FOR DATABASE MANAGEMENT, SPREADSHEET, AND WORD PROCESSING; INTEGRATED CIRCUIT CARDS; BLANK SMART CARDS; ENCODED SMART CARDS CONTAINING PROGRAMMING FOR DATABASE MANAGEMENT, SPREADSHEET, AND WORD PROCESSING; PRINTED CIRCUITS; INTEGRATED CIRCUITS; ELECTRONIC CHIPS FOR THE MANUFACTURER OF INTEGRATED CIRCUITS (U.S. CLS. 21, 23, 26, 36 AND 38).
WARREN L. OLANDRIA, EXAMINING ATTORNEY

SN 85-418,547. MORGAN COLLECTION, INC., MOUNT VERNON, NY. FILED 9-9-2011.



THE MARK CONSISTS OF STANDARD CHARACTERS WITHOUT CLAIM TO ANY PARTICULAR FONT, STYLE, SIZE, OR COLOR.

FOR MOBILE PHONES, CELLULAR PHONES, INTERNET PHONES (U.S. CLS. 21, 23, 26, 36 AND 38).

MAUREEN DALL, EXAMINING ATTORNEY

CLASS 9—(Continued).

SN 85-419,742. AGNOVI CORPORATION, OTTAWA, ONTARIO, CANADA, FILED 9-11-2011.



THE MARK CONSISTS OF STANDARD CHARACTERS WITHOUT CLAIM TO ANY PARTICULAR FONT, STYLE, SIZE, OR COLOR.

OWNER OF CANADA REG. NO. TMA782746, DATED 11-18-2010, EXPIRES 11-18-2025.

NO CLAIM IS MADE TO THE EXCLUSIVE RIGHT TO USE "TRACK ENTITIES", APART FROM THE MARK AS SHOWN.

FOR SOFTWARE FOR ENTITY TRACKING, NAMELY, FOR TRACKING THE BEHAVIOR, RELATIONSHIPS AND LOCATION OF PEOPLE, ORGANIZATIONS, ADDRESSES, TELEPHONE COMMUNICATION, ELECTRONIC ADDRESSES, ACCOUNTS SUCH AS BANK ACCOUNTS AND CREDIT CARDS, VEHICLES, AIRCRAFT AND VESSELS (U.S. CLS. 21, 23, 26, 36 AND 38).

GISELLE AGOSTO, EXAMINING ATTORNEY

SN 85-420,762. HUGHES NETWORK SYSTEMS LLC, GERMANTOWN, MD. FILED 9-12-2011.



THE MARK CONSISTS OF STANDARD CHARACTERS WITHOUT CLAIM TO ANY PARTICULAR FONT, STYLE, SIZE, OR COLOR.

OWNER OF U.S. REG. NOS. 1,288,713, 3,093,477 AND OTHERS.

FOR COMPUTER SOFTWARE FOR TELECOMMUNICATIONS APPLICATIONS AND HARDWARE, NAMELY, COMPUTER SOFTWARE FOR MANAGING, CONTROLLING AND ACCESSING TELECOMMUNICATIONS AND DATA COMMUNICATIONS NETWORKS, SATELLITE COMMUNICATIONS, NEXT GENERATION NETWORKS, INTELLIGENT NETWORKS, NETWORK MANAGEMENT, INTERNET AND E-COMMERCE BASED SYSTEMS FOR USE BY TELECOMMUNICATION PROVIDERS AND DATA COMMUNICATIONS EQUIPMENT MANUFACTURERS, SYSTEMS INTEGRATORS AND COMMUNICATION SERVICE PROVIDERS; COMPUTER SOFTWARE FOR TELECOMMUNICATIONS SERVICES, NAMELY, THE TRANSMISSION OF AUDIO, VOICE, VIDEO, DATA AND INFORMATION VIA SATELLITE, TELEPHONE AND COMPUTER; CLOUD COMPUTING SOFTWARE, NAMELY, CLOUD COMPUTING SOFTWARE FOR USE IN THE MONITORING AND MANAGEMENT OF WEB APPLICATIONS,

CLASS 9—(Continued).

DATABASES, OPERATING SYSTEMS, NETWORK DATA STORAGE, DATA WAREHOUSING AND DATABASE OPTIMIZATION; COMPUTER SOFTWARE PLATFORM FOR CLOUD COMPUTING NETWORKS AND APPLICATIONS FOR CLOUD COMPUTING NETWORK AND APPLICATIONS, DATABASES, OPERATING SYSTEMS, NETWORK DATA STORAGE, DATA WAREHOUSING; COMPUTER SOFTWARE FOR STORAGE AND DELIVERY OF TEXT, AUDIO, VISUAL, SOFTWARE AND MEDIA CONTENT; COMPUTER SOFTWARE FOR HOSTING, MANAGING, DEVELOPING AND MAINTAINING APPLICATIONS, CONTENT, SOFTWARE, WEBSITES AND DATABASES; NONDOWNLOADABLE AND DOWNLOADABLE SOFTWARE FOR MANAGING COMPUTER APPLICATIONS, OPERATING SYSTEMS AND DATABASES; COMPUTER SOFTWARE FOR PROVIDING ACCESS TO A GLOBAL COMMUNICATIONS NETWORK OR OTHER COMPUTER OR COMMUNICATIONS NETWORKS; COMPUTER OPERATING SYSTEM SOFTWARE FOR USE IN DATABASE MANAGEMENT (U.S. CLS. 21, 23, 26, 36 AND 38).

KATHERINE STOIDES, EXAMINING ATTORNEY

SN 85-421,558. LINDSAY CORPORATION, OMAHA, NE. FILED 9-13-2011.



OWNER OF U.S. REG. NOS. 1,011,462 AND 3,024,033.
THE MARK CONSISTS OF A FILLED CIRCLE CONTAINING THREE CURVED LINES WHICH GRADUALLY INCREASE IN SIZE FROM THE TOP OF THE CIRCLE TO THE BOTTOM OF THE CIRCLE. THIS APPEARS TO THE LEFT OF THE STYLIZED WORDINGS "GROWSMART" AND "BY LINDSAY".

FOR ELECTRONIC AND COMPUTER INSTRUMENTS CONSISTING PRIMARILY OF COMPUTER HARDWARE, RECEIVERS OF ELECTRONIC SIGNALS, TRANSMITTERS, COMPUTER SOFTWARE AND ELECTRONIC SENSORS FOR THE TRANSMISSION OF DATA AND FOR USE IN DETERMINING, MAPPING AND TRACKING GEOGRAPHIC LOCATIONS AND EVALUATING IRRIGATION NEEDS, ALL FOR MONITORING WEATHER, WATER FLOW, WATER PRESSURE AND SOIL MOISTURE CONDITIONS AND FOR THE OPERATION OF IRRIGATION EQUIPMENT THAT FEATURES ELECTRONIC SOIL MOISTURE SENSORS, CHEMICAL INJECTORS FOR FERTILIZERS, PEST AND FUNGICIDE CONTROL, MICRO-CLIMATE STATIONS, WIRELESS PUMP TELEMETRY AND CONTROLS FOR VARIABLE RATE IRRIGATION (U.S. CLS. 21, 23, 26, 36 AND 38).

DAWN HAN, EXAMINING ATTORNEY

CLASS 9—(Continued).

SN 85-422,520. COMMVAULT SYSTEMS, INC., OCEANPORT, NJ. FILED 9-14-2011.

UNIFIED DATA MANAGEMENT

THE MARK CONSISTS OF STANDARD CHARACTERS WITHOUT CLAIM TO ANY PARTICULAR FONT, STYLE, SIZE, OR COLOR.

OWNER OF U.S. REG. NO. 2,999,321.

NO CLAIM IS MADE TO THE EXCLUSIVE RIGHT TO USE "DATA MANAGEMENT", APART FROM THE MARK AS SHOWN.

SEC. 2(F).

FOR COMPUTER SOFTWARE FOR DATA AND STORAGE MANAGEMENT, NAMELY, TO BACK-UP, RETRIEVE, RECOVER, REPLICATE, MIGRATE, ARCHIVE AND MANAGE RESOURCES (U.S. CLS. 21, 23, 26, 36 AND 38).

FIRST USE 4-1-2004; IN COMMERCE 4-1-2004.

TASHIA BUNCH, EXAMINING ATTORNEY

SN 85-422,649. JUNGLE TECH, LLC, SAN ANTONIO, TX. FILED 9-14-2011.

cattura

THE MARK CONSISTS OF STANDARD CHARACTERS WITHOUT CLAIM TO ANY PARTICULAR FONT, STYLE, SIZE, OR COLOR.

THE ENGLISH TRANSLATION OF THE WORD "CATTURA" IN THE MARK IS "TO CAPTURE".

FOR COMPUTER HARDWARE AND COMPUTER SOFTWARE FOR RECORDING AND PLAYBACK OF EDUCATIONAL LECTURES AND MEETINGS (U.S. CLS. 21, 23, 26, 36 AND 38).

FIRST USE 1-0-2008; IN COMMERCE 1-0-2008.

DAWN FELDMAN, EXAMINING ATTORNEY

SN 85-424,072. MYHEALTHTEAMS, INC., SAN FRANCISCO, CA. FILED 9-15-2011.

MYAUTISMTEAM

THE MARK CONSISTS OF STANDARD CHARACTERS WITHOUT CLAIM TO ANY PARTICULAR FONT, STYLE, SIZE, OR COLOR.

FOR COMPUTER APPLICATION SOFTWARE IN THE NATURE OF MOBILE APPLICATIONS FOR MOBILE AND WIRELESS DEVICES FOR PROVIDING INFORMATION AND RESOURCES RELATED TO AUTISM (U.S. CLS. 21, 23, 26, 36 AND 38).

DAVID TAYLOR, EXAMINING ATTORNEY

CLASS 9—(Continued).

SN 85-424,496. BLANCHARD, DANIEL LAWRENCE, SANTA MONICA, CA. FILED 9-16-2011.



THE COLOR(S) VIOLET, INDIGO, BLUE, GREEN, YELLOW, AND ORANGE IS/ARE CLAIMED AS A FEATURE OF THE MARK.

THE MARK CONSISTS OF LOTUS FLOWER WITH VIOLET, INDIGO, AND BLUE AT THE TOP STEMS, GREEN AND YELLOW IN THE BOTTOM STEMS, ORANGE AND YELLOW IN THE LEAVES AT THE BOTTOM. "PEACEFUL VIBES" TEXT AS INDIGO.

FOR AUDIO AND VIDEO RECORDINGS FEATURING MUSIC AND ARTISTIC PERFORMANCES; AUDIO RECORDINGS FEATURING HEALTH TIPS, WISDOM, SELF-IMPROVEMENT; CHILDREN'S EDUCATIONAL MUSIC CDS AND DVDS; COMPACT DISCS FEATURING MUSIC AND SPOKEN WORD IN THE FORM OF POETRY (U.S. CLS. 21, 23, 26, 36 AND 38).

FIRST USE 9-7-2011; IN COMMERCE 9-7-2011.
ANDREW LEASER, EXAMINING ATTORNEY

SN 85-425,681. COMPLETE CONSENT, LLC, SAVANNAH, GA. FILED 9-19-2011.

COMPLETE CONSENT

THE MARK CONSISTS OF STANDARD CHARACTERS WITHOUT CLAIM TO ANY PARTICULAR FONT, STYLE, SIZE, OR COLOR.

NO CLAIM IS MADE TO THE EXCLUSIVE RIGHT TO USE "CONSENT", APART FROM THE MARK AS SHOWN.

FOR SOFTWARE FOR USE IN OBTAINING AUTHORIZATION FROM PATIENTS IN THE CONTEXT OF MEDICAL RECORDS AND PROCEDURES; SOFTWARE FOR USE IN FACILITATING TRANSACTION ORDER ENTRY, ORDER DIRECTING AND ORDER CONFIRMATION SERVICES TO CUSTOMERS IN THE FIELD OF PHARMACEUTICALS; SOFTWARE FOR USE IN PROVIDING MEDICAL INFORMATION (U.S. CLS. 21, 23, 26, 36 AND 38).

NAAKWAMA ANKRAH, EXAMINING ATTORNEY

CLASS 9—(Continued).

SN 85-427,183. POSITRON ACCESS SOLUTIONS INC., NEWPORT BEACH, CA. FILED 9-20-2011.

FLEXSTREAM

THE MARK CONSISTS OF STANDARD CHARACTERS WITHOUT CLAIM TO ANY PARTICULAR FONT, STYLE, SIZE, OR COLOR.

FOR COMPUTER HARDWARE FOR DISTRIBUTION, MANIPULATION AND RETRIEVAL OF DATA; COMPUTER HARDWARE FOR INTERCONNECTION OF LOCAL NETWORKS; WIRED AND WIRELESS ETHERNET AND DSL INTERNET NETWORKING DEVICES, NAMELY, BONDED COPPER ETHERNET PLATFORMS AND FIBER OPTIC NETWORKING DEVICES (U.S. CLS. 21, 23, 26, 36 AND 38).

SANJEEV VOHRA, EXAMINING ATTORNEY

SN 85-429,235. AIRTIME MEDIA, INC., SAN FRANCISCO, CA. FILED 9-22-2011.

AIRTIME

THE MARK CONSISTS OF STANDARD CHARACTERS WITHOUT CLAIM TO ANY PARTICULAR FONT, STYLE, SIZE, OR COLOR.

FOR COMPUTER SOFTWARE FOR PROVIDING ACCESS TO AND ALLOWING COMMUNICATION WITHIN INTERNET CHATROOMS; COMPUTER SOFTWARE FOR VIDEO CONFERENCING; COMPUTER SOFTWARE FOR WEB CONFERENCING; COMPUTER SOFTWARE FOR PROVIDING INTEGRATED COMMUNICATION WITH COMPUTERIZED GLOBAL NETWORKS; COMPUTER SOFTWARE FOR VIDEO TELEPHONY; COMPUTER SOFTWARE FOR THE TRANSMISSION OF VOICE, DATA AND IMAGES BETWEEN FIXED OR REMOTE STATIONS AND DEVICES (U.S. CLS. 21, 23, 26, 36 AND 38).

JEFF DEFORD, EXAMINING ATTORNEY

SN 85-430,570. INTERNATIONAL FELLOWSHIP OF CHRISTIANS & JEWS, INC., CHICAGO, IL. FILED 9-23-2011.

ISAIAH 58

THE MARK CONSISTS OF STANDARD CHARACTERS WITHOUT CLAIM TO ANY PARTICULAR FONT, STYLE, SIZE, OR COLOR.

FOR PRE-RECORDED DVDS ABOUT ISSUES RELATED TO JEWISH FAITH AND TRADITIONS, JEWISH-CHRISTIAN RELATIONS, AND THE POLITICAL, ECONOMIC, SOCIAL, AND SPIRITUAL NEEDS OF JEWS IN THE FORMER SOVIET UNION (U.S. CLS. 21, 23, 26, 36 AND 38).

FIRST USE 1-1-2005; IN COMMERCE 1-1-2005.
DEBORAH LOBO, EXAMINING ATTORNEY

CLASS 9—(Continued).

SN 85-430,730. INTERNATIONAL FELLOWSHIP OF CHRISTIANS & JEWS, INC., CHICAGO, IL. FILED 9-23-2011.

ON WINGS OF EAGLES

THE MARK CONSISTS OF STANDARD CHARACTERS WITHOUT CLAIM TO ANY PARTICULAR FONT, STYLE, SIZE, OR COLOR.

OWNER OF U.S. REG. NO. 2,345,479.

FOR PRE-RECORDED DVDS ABOUT ISSUES RELATED TO JEWISH FAITH AND TRADITIONS, JEWISH-CHRISTIAN RELATIONS, AND THE POLITICAL, ECONOMIC, SOCIAL, AND SPIRITUAL NEEDS OF JEWS FROM THE FORMER SOVIET UNION, ISRAEL, THE PEOPLE OF ISRAEL, AND JEWISH PEOPLE AROUND THE WORLD (U.S. CLS. 21, 23, 26, 36 AND 38).

FIRST USE 2-1-2005; IN COMMERCE 2-1-2005.
DEBORAH LOBO, EXAMINING ATTORNEY

SN 85-431,061. JOHNSON CONTROLS TECHNOLOGY COMPANY, HOLLAND, MI. FILED 9-23-2011.



OWNER OF U.S. REG. NOS. 1,706,318 AND 2,905,282.
THE COLOR(S) RED, BLACK, WHITE IS/ARE CLAIMED AS A FEATURE OF THE MARK.

THE MARK CONSISTS OF THE WORD "OPTIMA" IN WHITE AND OUTLINED IN BLACK WITH WHITE LINES SEPARATING EACH LETTER. BENEATH THE WORD "OPTIMA" APPEARS A RED BAR OUTLINED IN WHITE. ALL OF THE FOREGOING IS FOUND WITHIN A BLACK RHOMBOID-SHAPED CARRIER.

FOR BATTERIES AND BATTERY CHARGERS (U.S. CLS. 21, 23, 26, 36 AND 38).

LAURIE MAYES, EXAMINING ATTORNEY

CLASS 9—(Continued).

SN 85-431,964. ZBB ENERGY CORPORATION, MENOMONEE FALLS, WI. FILED 9-26-2011.



OWNER OF U.S. REG. NO. 3,547,402.

NO CLAIM IS MADE TO THE EXCLUSIVE RIGHT TO USE "ENERGY CORPORATION", APART FROM THE MARK AS SHOWN.

THE COLOR(S) GREEN, YELLOW, AND BLUE IS/ARE CLAIMED AS A FEATURE OF THE MARK.

THE MARK CONSISTS OF THE FOLLOWING: A THREE PRONGED SWIRL DESIGN CONSISTING OF THE COLORS GREEN, BLUE, AND YELLOW WITH THE WORDING "ZBB ENERGY CORPORATION" TO THE RIGHT OF THE DESIGN. "ZBB" IS IN BLUE AND "ENERGY CORPORATION" IS IN GREEN.

FOR BATTERIES, AND BATTERY SYSTEMS COMPRISING BATTERIES, BUS BARS, CABLES, POWER CONVERTING EQUIPMENT, NAMELY, DC TO AC CONVERTERS, AND CONTROLS FOR ALL OF THE ABOVE, FOR LARGE SCALE APPLICATIONS INCLUDING INDUSTRIAL AND UTILITY APPLICATIONS (U.S. CLS. 21, 23, 26, 36 AND 38).

CURTIS FRENCH, EXAMINING ATTORNEY

SN 85-432,149. HANSON, JERRY JAY, DBA FOR THE LOVE OF GOD RECORDS, OLYMPIA, WA. FILED 9-26-2011.

For The Love Of God Records

THE MARK CONSISTS OF STANDARD CHARACTERS WITHOUT CLAIM TO ANY PARTICULAR FONT, STYLE, SIZE, OR COLOR.

NO CLAIM IS MADE TO THE EXCLUSIVE RIGHT TO USE "RECORDS", APART FROM THE MARK AS SHOWN.

FOR AUDIO AND VIDEO RECORDINGS FEATURING MUSIC AND ARTISTIC PERFORMANCES (U.S. CLS. 21, 23, 26, 36 AND 38).

FIRST USE 0-0-2009; IN COMMERCE 0-0-2009.

DAWN HAN, EXAMINING ATTORNEY

CLASS 9—(Continued).

SN 85-432,223. SIERRA INSTRUMENTS, INC., MONTEREY, CA. FILED 9-26-2011.



THE MARK CONSISTS OF THE LETTER "S" INSIDE OF A SQUARE.

FOR FLUID FLOW MEASUREMENT AND AUTOMOTIVE TEST SYSTEMS COMPRISED PRIMARILY OF FLOW METERS, FLOW CONTROLLERS, ENGINE AND VEHICLE TEST COMPONENTS (U.S. CLS. 21, 23, 26, 36 AND 38).

FIRST USE 1-0-2009; IN COMMERCE 1-0-2009.
NAKIA HENRY, EXAMINING ATTORNEY

CLASS 9—(Continued).

SN 85-436,024. REDCLOUD, INC., RESTON, VA. FILED 9-30-2011.

REDCLOUD

THE MARK CONSISTS OF STANDARD CHARACTERS WITHOUT CLAIM TO ANY PARTICULAR FONT, STYLE, SIZE, OR COLOR.

FOR ENCODED ELECTRONIC INTEGRATED CIRCUIT CARD AND CHIP CARD READING DEVICES, NAMELY, SMART CARD READERS, COMPUTER TERMINALS FOR READING SMART CARDS, RADIO FREQUENCY IDENTIFICATION READERS, AND BIOMETRIC READERS FOR MONITORING SECURITY ACCESS, IDENTIFICATION, INVENTORY, OR PHYSICAL STATE; ENCODED ELECTRONIC INTEGRATED CIRCUIT CARDS AND CHIP CARDS CONTAINING PROGRAMMING FOR USE IN CONTROLLING AND MONITORING SECURITY ACCESS, IDENTIFICATION, INVENTORY AND PHYSICAL STATE; COMPUTER SOFTWARE FOR PHYSICAL AND LOGICAL IDENTITY AND ACCESS MANAGEMENT, OPERATING VIDEO SURVEILLANCE AND INTRUSION ALARMS, MANAGING VISITOR CONTROLS, AND SITUATIONAL AWARENESS-EVENT MONITORING; COMPUTER SOFTWARE FOR CONTROLLING AND MONITORING PHYSICAL AND LOGICAL ACCESS TO PHYSICAL FACILITIES FOR SECURITY PURPOSES (U.S. CLS. 21, 23, 26, 36 AND 38).

KAREN BRACEY, EXAMINING ATTORNEY

SN 85-436,960. FASTCAP, LLC, BELLINGHAM, WA. FILED 9-30-2011.

IDANGLE

THE MARK CONSISTS OF STANDARD CHARACTERS WITHOUT CLAIM TO ANY PARTICULAR FONT, STYLE, SIZE, OR COLOR.

FOR ACCESSORIES FOR PORTABLE ELECTRONIC DEVICES, NAMELY, CASES, HEADSETS AND STRAPS FOR USE WITH SMARTPHONES, MOBILE PHONES, PORTABLE MUSIC PLAYERS AND PERSONAL DIGITAL ASSISTANTS; CASES, STRAPS AND HEADSETS FOR PORTABLE ELECTRONIC DEVICES, NAMELY, SMARTPHONES, MOBILE PHONES, PORTABLE MUSIC PLAYERS AND PERSONAL DIGITAL ASSISTANTS; INTEGRATED CASE, STRAP, AND HEADSET FOR PORTABLE ELECTRONIC DEVICES, NAMELY, SMARTPHONES, MOBILE PHONES, PORTABLE MUSIC PLAYERS AND PERSONAL DIGITAL ASSISTANTS (U.S. CLS. 21, 23, 26, 36 AND 38).

FIRST USE 1-31-2010; IN COMMERCE 1-31-2010.
AMY C. KEAN, EXAMINING ATTORNEY

SN 85-434,921. HOPI, DBA HOPI, ROSHEIM, FRANCE, FILED 9-29-2011.

eRosetta

THE MARK CONSISTS OF STANDARD CHARACTERS WITHOUT CLAIM TO ANY PARTICULAR FONT, STYLE, SIZE, OR COLOR.

FOR COMPUTER SOFTWARE FOR USE IN AGGREGATING MEDICAL INFORMATION DATA FROM DISPARATE COMPUTER SYSTEMS AND OPERATING SYSTEMS (U.S. CLS. 21, 23, 26, 36 AND 38).

CURTIS FRENCH, EXAMINING ATTORNEY

CLASS 9—(Continued).

SN 85-437,642. ECLINICALWORKS, LLC, WESTBOROUGH, MA. FILED 10-3-2011.

ECLINICALWORKS SCRIBE

THE MARK CONSISTS OF STANDARD CHARACTERS WITHOUT CLAIM TO ANY PARTICULAR FONT, STYLE, SIZE, OR COLOR.

OWNER OF U.S. REG. NOS. 2,729,199 AND 4,014,335. NO CLAIM IS MADE TO THE EXCLUSIVE RIGHT TO USE "SCRIBE", APART FROM THE MARK AS SHOWN.

FOR COMPUTER SOFTWARE FOR TRANSLATING, ORGANIZING, CONTROLLING AND MANAGING PATIENT MEDICAL INFORMATION (U.S. CLS. 21, 23, 26, 36 AND 38).

PATRICIA EVANKO, EXAMINING ATTORNEY

CLASS 9—(Continued).

SN 85-438,830. MIDAS SAFETY, INC., TORONTO, ONTARIO, CANADA, FILED 10-4-2011.



NO CLAIM IS MADE TO THE EXCLUSIVE RIGHT TO USE "TECHNOLOGY", APART FROM THE MARK AS SHOWN.

THE MARK CONSISTS OF THE STYLIZED LETTERS "HPT" INSIDE A DROP OUTLINE ABOVE THE STYLIZED WORDS "HYDROPELLENT TECHNOLOGY".

FOR PROTECTIVE GLOVES FOR INDUSTRIAL USE (U.S. CLS. 21, 23, 26, 36 AND 38).

FIRST USE 5-31-2004; IN COMMERCE 6-30-2004. NATALIE POLZER, EXAMINING ATTORNEY

SN 85-438,401. ALIANET, S.L., 28016 MADRID, SPAIN, FILED 10-4-2011.



PRIORITY CLAIMED UNDER SEC. 44(D) ON ERP N CMNTY TM OFC APPLICATION NO. 010302891, FILED 9-29-2011, REG. NO. 010302891, DATED 3-5-2012, EXPIRES 3-5-2022.

THE COLOR(S) BLACK, BLUE, ORANGE, SILVER AND WHITE IS/ARE CLAIMED AS A FEATURE OF THE MARK.

THE MARK CONSISTS OF FIVE ORANGE CUBES, A BLACK AND SILVER CALLIGRAPHY PEN, A PEN SCRIBBLE IN BLACK AND THE WORDING "BDOC SIGN". "BDOC" IS IN BLACK LETTERS WITH WHITE SHADOWING OF THE LETTERS "B","D". "SIGN" IS IN BLUE LETTERS.

FOR COMPUTER HARDWARE; COMPUTER GRAPHICS AND OPERATING SOFTWARE (U.S. CLS. 21, 23, 26, 36 AND 38).

IRA J. GOODSaid, EXAMINING ATTORNEY

SN 85-439,112. RANLIFE, INC., SALT LAKE CITY, UT, FILED 10-4-2011.



SN 85-438,790. MIDAS SAFETY, INC., TORONTO, ONTARIO, CANADA, FILED 10-4-2011.

HPT

THE MARK CONSISTS OF STANDARD CHARACTERS WITHOUT CLAIM TO ANY PARTICULAR FONT, STYLE, SIZE, OR COLOR.

FOR PROTECTIVE GLOVES FOR INDUSTRIAL USE (U.S. CLS. 21, 23, 26, 36 AND 38).

FIRST USE 5-31-2004; IN COMMERCE 6-30-2004. NATALIE POLZER, EXAMINING ATTORNEY

OWNER OF U.S. REG. NO. 3,674,422.

THE MARK CONSISTS OF A SHADOWED RUNNING HUMAN FIGURE.

FOR COMPUTER SOFTWARE FOR USE IN CLIENT DATABASE MANAGEMENT IN THE FIELD OF MORTGAGES AND REAL ESTATE (U.S. CLS. 21, 23, 26, 36 AND 38).

LUCY ARANT, EXAMINING ATTORNEY

CLASS 9—(Continued).

SN 85-440,092. TYLER STERBENTZ, YUCCA VALLEY, CA. FILED 10-5-2011.

DUST DONUT

THE MARK CONSISTS OF STANDARD CHARACTERS WITHOUT CLAIM TO ANY PARTICULAR FONT, STYLE, SIZE, OR COLOR.

NO CLAIM IS MADE TO THE EXCLUSIVE RIGHT TO USE "DUST", APART FROM THE MARK AS SHOWN.

FOR BAGS FOR CAMERAS AND PHOTOGRAPHIC EQUIPMENT; CAMERA CASES; CAMERA CLOSURES; CAMERA FILTERS; CAMERA FLASHES; CAMERA HOODS; CAMERA MOUNTS AND SUPPORTS; CAMERA TRIPODS; CAMERAS; CAMERAS SHUTTERS; ENVIRONMENTAL ENCLOSURES, NAMELY, STRUCTURES SPECIALLY ADAPTED TO HOLD AND PROTECT CAMERAS FROM OUTDOOR ELEMENTS AND TAMPERING; FITTED PLASTIC FILMS KNOWN AS SKINS FOR COVERING AND PROTECTING ELECTRONIC APPARATUS, NAMELY, CAMERAS AND CAMERA LENS TO CREATE A SEAL TO KEEP DIRT, DUST, AND SAND OUT; CAMERA SEALS; FITTED PLASTIC FILMS KNOWN AS SKINS FOR COVERING AND PROVIDING A SCRATCH PROOF BARRIER OR PROTECTION FOR ELECTRONIC DEVICES, NAMELY, MP3 PLAYERS, MOBILE TELEPHONES, SMART TELEPHONES, DIGITAL CAMERAS, GLOBAL POSITIONING SYSTEMS AND PERSONAL DIGITAL ASSISTANTS; FLASH LAMPS; LENS FILTERS; LENS HOODS; LENSES FOR CAMERAS; NAUTICAL AND PHOTOGRAPHIC APPARATUS AND INSTRUMENTS, NAMELY, UNDERWATER HOUSINGS FOR CAMERAS, UNDERWATER ENCLOSURES FOR CAMERAS AND UNDERWATER ENCLOSURES FOR PHOTOGRAPHIC LENSES; SHUTTERS; TRIPODS FOR CAMERAS (U.S. CLS. 21, 23, 26, 36 AND 38).

ANNE E. GUSTASON, EXAMINING ATTORNEY

SN 85-440,500. SANDHILL AUDIO SYSTEMS, LLC, LODI, WI. FILED 10-6-2011.

SANDHILL AUDIO SYSTEMS

THE MARK CONSISTS OF STANDARD CHARACTERS WITHOUT CLAIM TO ANY PARTICULAR FONT, STYLE, SIZE, OR COLOR.

NO CLAIM IS MADE TO THE EXCLUSIVE RIGHT TO USE "AUDIO SYSTEMS", APART FROM THE MARK AS SHOWN.

FOR AUDIO SYSTEMS COMPRISED OF AUDIO AMPLIFIERS, AUDIO AND BASS SPEAKERS, AUDIO MIXERS, CD PLAYERS, MICROPHONES, AND RADIO RECEIVERS (U.S. CLS. 21, 23, 26, 36 AND 38).

KATHERINE CHANG, EXAMINING ATTORNEY

CLASS 9—(Continued).

SN 85-440,524. SANDHILL AUDIO SYSTEMS, LLC, LODI, WI. FILED 10-6-2011.

OPEN YOUR WINDOWS TO THE WORLD...ALL YEAR 'ROUND

THE MARK CONSISTS OF STANDARD CHARACTERS WITHOUT CLAIM TO ANY PARTICULAR FONT, STYLE, SIZE, OR COLOR.

FOR AUDIO SYSTEMS COMPRISED OF AUDIO AMPLIFIERS, AUDIO AND BASS SPEAKERS, AUDIO MIXERS, CD PLAYERS, MICROPHONES AND RADIO RECEIVERS (U.S. CLS. 21, 23, 26, 36 AND 38).

KATHERINE CHANG, EXAMINING ATTORNEY

SN 85-441,000. MOVILWAY IP, S.À.R.L., LUXEMBOURG, LUXEMBOURG, FILED 10-6-2011.

movilway

THE MARK CONSISTS OF THE WORD "MOVILWAY" IN DISTINCTIVE FONT.

THE ENGLISH TRANSLATION OF "MOVIL" IN THE MARK IS "MOBILE". THE WORDING "MOVILWAY" HAS NO MEANING IN A FOREIGN LANGUAGE.

FOR BLANK MAGNETIC DATA CARRIERS, BLANK RECORDING DISCS; BLANK COMPACT DISCS, DVDS AND BLANK DIGITAL STORAGE MEDIA; MECHANISMS FOR COIN-OPERATED APPARATUS; CASH REGISTERS, CALCULATING MACHINES, DATA PROCESSING EQUIPMENT, COMPUTERS; COMPUTER SOFTWARE FOR IMPORTING, PRODUCING, DISPLAYING, SENDING, QUERYING, STORING PROCESSING, EDITING, RETRIEVING, ANONYMIZING, ENCRYPTING, MASKING, PRINTING, READING, MANIPULATING, CONVERTING, ENCODING, ACCESSING, VIEWING, DELIVERING, AND DISTRIBUTING DIGITAL AND VIDEO IMAGES, DATA, AND INFORMATION NAMELY DEALING WITH PERSONAL, FINANCIAL, EDUCATIONAL, INSURANCE, MARKETING, AND LEGAL INFORMATION; FIRE-EXTINGUISHING APPARATUS; MOBILE PHONES; MAGNETIC IDENTIFYING CARDS, AND MODEMS (U.S. CLS. 21, 23, 26, 36 AND 38).

ANNE MADDEN, EXAMINING ATTORNEY

CLASS 9—(Continued).

SN 85-441,362. ZEKTOR INCORPORATED, DBA ZEKTOR, POWAY, CA. FILED 10-6-2011.

Clarity HD

THE MARK CONSISTS OF STANDARD CHARACTERS WITHOUT CLAIM TO ANY PARTICULAR FONT, STYLE, SIZE, OR COLOR.

NO CLAIM IS MADE TO THE EXCLUSIVE RIGHT TO USE "HD", APART FROM THE MARK AS SHOWN.

FOR ELECTRONIC EQUIPMENT, NAMELY, TRANSFORMERS, BALUNS, CABLES USED IN CONNECTION WITH COMPUTERS, COMPUTER PERIPHERAL DEVICES, TELEVISIONS, AUDIO-VIDEO EQUIPMENT, CLOSED-CIRCUIT TV EQUIPMENT AND TELECOMMUNICATION EQUIPMENT; ELECTRONIC INTERCONNECTERS FOR AUDIO AND VIDEO SIGNALS; ELECTRONIC SCALERS FOR AUDIO AND VIDEO SIGNALS; VIDEO TRANSMISSION APPARATUS (U.S. CLS. 21, 23, 26, 36 AND 38).

FIRST USE 9-1-2010; IN COMMERCE 9-1-2010.
SANI KHOURI, EXAMINING ATTORNEY

CLASS 9—(Continued).

SN 85-441,985. NERO AG, KARLSBAD-ITTERSBAACH, FED REP GERMANY, FILED 10-7-2011.

KWIK PIX

THE MARK CONSISTS OF STANDARD CHARACTERS WITHOUT CLAIM TO ANY PARTICULAR FONT, STYLE, SIZE, OR COLOR.

NO CLAIM IS MADE TO THE EXCLUSIVE RIGHT TO USE "PIX", APART FROM THE MARK AS SHOWN.

FOR END USER SOFTWARE FOR PROCESSING AND EDITING PICTURE DATA, FOR UPLOADING PICTURE DATA TO THE INTERNET IN ORDER TO CREATE PHOTO BOOKS, GREETING CARDS, CALENDARS, POSTERS AND IN ORDER TO APPLY DIGITAL PICTURES TO IMPRINTABLE SURFACES LIKE COFFEE MUGS, T-SHIRTS AND OTHER MATERIAL (U.S. CLS. 21, 23, 26, 36 AND 38).

ELI HELLMAN, EXAMINING ATTORNEY

SN 85-441,781. CONVERSOCIAL (UK) LIMITED, LONDON, UNITED KINGDOM, FILED 10-7-2011.

CONVERSOCIAL

THE MARK CONSISTS OF STANDARD CHARACTERS WITHOUT CLAIM TO ANY PARTICULAR FONT, STYLE, SIZE, OR COLOR.

OWNER OF ERPN CMNTY TM OFC REG. NO. 010256691, DATED 2-23-2012, EXPIRES 2-23-2022.

FOR COMPUTER SOFTWARE AND SOFTWARE APPLICATIONS INCLUDING SOFTWARE APPLICATIONS FOR MOBILE DEVICES, SUCH AS SMART PHONES AND TABLETS, INCLUDING SOFTWARE AND SOFTWARE APPLICATIONS RELATING TO TELECOMMUNICATIONS, ELECTRONIC AND ONLINE COMMUNICATIONS, CUSTOMER RELATIONSHIP MANAGEMENT, CUSTOMER SERVICES AND SUPPORT, MARKETING, CUSTOMER ANALYTICS AND AGGREGATION OF CUSTOMER DATA AND SOCIAL MEDIA AND SOCIAL NETWORKING, CALL CENTRE SERVICES, TEAM WORKFLOW, MANAGEMENT, TRACKING AND AUDITING OF CUSTOMER SERVICE STAFF AND THEIR PERFORMANCE, STAFF DIRECTORIES, CORPORATE SOCIAL NETWORKING, BUDGETING, ADVERTISING, SOCIAL NETWORKING AND SOCIAL MEDIA, NAMELY, FOR USE IN DATABASE MANAGEMENT AND CUSTOMER RELATIONSHIP MANAGEMENT; SOFTWARE FOR HOSTING SOCIAL MEDIA AND SOCIAL NETWORKING PLATFORMS (U.S. CLS. 21, 23, 26, 36 AND 38).

DAVID TOOLEY, EXAMINING ATTORNEY

SN 85-441,986. ETG SYSTEMS, INC., AURORA, CO. FILED 10-7-2011.



THE MARK CONSISTS OF A RECTANGULAR BOX REPRESENTING A BUILDING, LETTERING "BLACKB", AND AN ILLUSTRATION OF A BEE.

FOR ELECTRONIC DEVICES, NAMELY, INTEGRATED INTRUSION, ACCESS, CLOSED CIRCUIT TELEVISION WITH VIDEO MONITORING, AND AUTOMATION SYSTEM COMPRISED OF COMPUTER CENTRAL PROCESSING UNITS, COMPUTER SOFTWARE, AND COMPUTER STORAGE FOR MONITORING AND CONTROLLING MOTION DETECTORS, VIDEO CAMERAS, LIGHTS, DOORS, WINDOWS, AND CLIMATE CONTROL DEVICES FOR BUILDINGS AND PROPERTIES (U.S. CLS. 21, 23, 26, 36 AND 38).

EMILY CHUO, EXAMINING ATTORNEY

CLASS 9—(Continued).

SN 85-441,987. PARTICLE MEASURING SYSTEMS, INC., BOULDER, CO. FILED 10-7-2011.

BIOLAZ

THE MARK CONSISTS OF STANDARD CHARACTERS WITHOUT CLAIM TO ANY PARTICULAR FONT, STYLE, SIZE, OR COLOR.

FOR PARTICLE DETECTORS FOR DETECTING AIRBORNE PARTICLES; BIOLOGICAL DETECTORS FOR DETECTING AIRBORNE BIOLOGICAL ORGANISMS; INSTRUMENTATION, NAMELY PARTICLE DETECTORS FOR DETECTING, COUNTING OR SIZING OF CONTAMINANT PARTICLES AND BIOLOGICAL ORGANISMS, INCLUDING AIRBORNE BIOLOGICAL PARTICLES AND INERT PARTICLES; REAL-TIME PARTICLE MONITORS FOR AIRBORNE CONTAMINANTS AND BIOLOGICS, INCLUDING REAL-TIME INERT PARTICLE MONITORS AND REAL-TIME BIOLOGICAL MONITORS (U.S. CLS. 21, 23, 26, 36 AND 38).
LEIGH CAROLINE CASE, EXAMINING ATTORNEY

SN 85-442,007. ETG SYSTEMS, INC., AURORA, CO. FILED 10-7-2011.

BlackB

THE MARK CONSISTS OF STANDARD CHARACTERS WITHOUT CLAIM TO ANY PARTICULAR FONT, STYLE, SIZE, OR COLOR.

FOR ELECTRONIC DEVICES, NAMELY, INTEGRATED INTRUSION, ACCESS, CLOSED CIRCUIT TELEVISION WITH VIDEO MONITORING, AND AUTOMATION SYSTEM COMPRISED OF COMPUTER CENTRAL PROCESSING UNITS, COMPUTER SOFTWARE, AND COMPUTER STORAGE FOR MONITORING AND CONTROLLING MOTION DETECTORS, VIDEO CAMERAS, LIGHTS, DOORS, WINDOWS, AND CLIMATE CONTROL DEVICES FOR BUILDINGS AND PROPERTIES (U.S. CLS. 21, 23, 26, 36 AND 38).
EMILY CHUO, EXAMINING ATTORNEY

CLASS 9—(Continued).

SN 85-442,734. NAMCO BANDAI GAMES INC., SHINAGAWA-KU TOKYO, JAPAN, FILED 10-7-2011.

TANK BATTALION BLITZ

THE MARK CONSISTS OF STANDARD CHARACTERS WITHOUT CLAIM TO ANY PARTICULAR FONT, STYLE, SIZE, OR COLOR.

OWNER OF U.S. REG. NO. 3,583,710.

NO CLAIM IS MADE TO THE EXCLUSIVE RIGHT TO USE "TANK", APART FROM THE MARK AS SHOWN.

FOR COMPUTER GAME PROGRAMS; COMPUTER GAME PROGRAMS, CARTRIDGES, AND CASSETTES; COMPUTER GAME SOFTWARE; DOWNLOADABLE COMPUTER GAME PROGRAMS; DOWNLOADABLE COMPUTER GAME SOFTWARE VIA A GLOBAL COMPUTER NETWORK AND WIRELESS DEVICES; VIDEO GAME CARTRIDGES; VIDEO GAME DISCS; VIDEO GAME SOFTWARE (U.S. CLS. 21, 23, 26, 36 AND 38).

CAROLINE WOOD, EXAMINING ATTORNEY

SN 85-443,598. PRO FIT OPTIX, AKA PROFIT OPTIX, IRVING, TX. FILED 10-10-2011.

Genius

THE MARK CONSISTS OF STANDARD CHARACTERS WITHOUT CLAIM TO ANY PARTICULAR FONT, STYLE, SIZE, OR COLOR.

FOR ANTI-GLARE SPECTACLES; ANTIREFLECTION COATED EYEGLASSES; EYEGGLASS FRAMES; EYEGGLASS LENSES; EYEGLASSES; EYEWEAR, NAMELY, SUNGLASSES, EYEGLASSES AND OPHTHALMIC FRAMES AND CASES THEREFOR; FRAMES FOR SPECTACLES; FRAMES FOR SPECTACLES AND SUNGLASSES; POLARIZING SPECTACLES; PROTECTIVE EYEGLASSES; PROTECTIVE SPECTACLES; READING EYEGLASSES; SPECTACLE FRAMES; SPECTACLE FRAMES MADE OF METAL AND OF SYNTHETIC MATERIAL; SPECTACLE FRAMES MADE OF METAL OR A COMBINATION OF METAL AND PLASTICS; SPECTACLE GLASSES; SPECTACLE LENSES; SPECTACLES; SPECTACLES AND SUNGLASSES (U.S. CLS. 21, 23, 26, 36 AND 38).
DEZMONA MIZELLE, EXAMINING ATTORNEY

CLASS 9—(Continued).

SN 85-444,125. HEWLETT-PACKARD DEVELOPMENT COMPANY, L.P., HOUSTON, TX. FILED 10-11-2011.

DIRECTFLOW

THE MARK CONSISTS OF STANDARD CHARACTERS WITHOUT CLAIM TO ANY PARTICULAR FONT, STYLE, SIZE, OR COLOR.

FOR COMPUTER HARDWARE; COMPUTER PERIPHERALS; BATTERIES (U.S. CLS. 21, 23, 26, 36 AND 38).
KELLY TRUSILO, EXAMINING ATTORNEY

SN 85-444,948. HOLLY B. HOLDINGS LLC, COLUMBUS, OH. FILED 10-11-2011.

GETTING PERSONAL

THE MARK CONSISTS OF STANDARD CHARACTERS WITHOUT CLAIM TO ANY PARTICULAR FONT, STYLE, SIZE, OR COLOR.

FOR COMPUTER APPLICATION SOFTWARE, NAMELY, SOFTWARE FOR CREATING AND SENDING GREETING CARDS ACCESSED THROUGH WIRELESS DEVICES OR ON A GLOBAL COMPUTER NETWORK (U.S. CLS. 21, 23, 26, 36 AND 38).
TRACY FLETCHER, EXAMINING ATTORNEY

CLASS 9—(Continued).

SN 85-445,038. GENERAL IMAGING COMPANY, GARDENA, CA. FILED 10-12-2011.

ipico 

THE COLOR(S) BLACK, RED, BLUE, GREEN AND WHITE IS/ARE CLAIMED AS A FEATURE OF THE MARK.

THE MARK CONSISTS OF THE LITERAL ELEMENT "IPICO" IN BLACK TEXT AND SEVERAL RECTANGULAR PATTERNS, APPEARING IN THE COLORS RED, GREEN, BLUE AND WHITE. THE WHITE SQUARE DESIGN IN THE CENTER OF THE VARIOUS RECTANGULAR COLOR DESIGNS DESCRIBED ABOVE IS WHITE.

FOR CAMERAS; CINEMATOGRAPHIC PROJECTORS; DIGITAL CAMERAS; DIGITAL VIDEO CAMERAS; LENSES FOR CAMERAS; LIQUID CRYSTAL DISPLAY (LCD) PROJECTORS; MOVIE PROJECTORS; MULTIMEDIA PROJECTORS; PHOTOGRAPHIC PROJECTORS; PICTURE PROJECTORS; PROJECTORS PARTICULARLY PROJECTORS FOR THE ENTERTAINMENT INDUSTRY; SELF-ACTING FOCUSING PROJECTORS; SLIDE PROJECTORS; VIDEO PROJECTORS (U.S. CLS. 21, 23, 26, 36 AND 38).

C. DIONNE CLYBURN, EXAMINING ATTORNEY

SN 85-446,930. METHODE ELECTRONICS, INC., CHICAGO, IL. FILED 10-13-2011.

THE FIRST SWITCH THAT WILL
OUTLAST THE PUMP

THE MARK CONSISTS OF STANDARD CHARACTERS WITHOUT CLAIM TO ANY PARTICULAR FONT, STYLE, SIZE, OR COLOR.

FOR ELECTRICAL SWITCHES FOR CONTROLLING FLUID PUMPS (U.S. CLS. 21, 23, 26, 36 AND 38).
MARK SPARACINO, EXAMINING ATTORNEY

CLASS 9—(Continued).

SN 85-447,676. INFOSIL, INC., EL DORADO HILLS, CA. FILED 10-14-2011.

INFOSIL

THE MARK CONSISTS OF STANDARD CHARACTERS WITHOUT CLAIM TO ANY PARTICULAR FONT, STYLE, SIZE, OR COLOR.

FOR DOWNLOADABLE SOFTWARE IN THE NATURE OF A MOBILE APPLICATION FOR INTERACTIVE VIDEO GAMES AND READING ELECTRONIC PUBLICATIONS; ELECTRONIC PUBLICATIONS, NAMELY, ELECTRONIC BOOKS FEATURING FICTION AND NON-FICTION NOVELS AND SELF-HELP BOOKS RECORDED ON COMPUTER MEDIA (U.S. CLS. 21, 23, 26, 36 AND 38).

FIRST USE 10-13-2011; IN COMMERCE 10-13-2011.
JENNY PARK, EXAMINING ATTORNEY

SN 85-448,221. KHRISTOV INC., LAKE FOREST, CA. FILED 10-14-2011.

BOOMZ AUDIO

THE MARK CONSISTS OF STANDARD CHARACTERS WITHOUT CLAIM TO ANY PARTICULAR FONT, STYLE, SIZE, OR COLOR.

NO CLAIM IS MADE TO THE EXCLUSIVE RIGHT TO USE "AUDIO", APART FROM THE MARK AS SHOWN.

FOR MINI-PORTABLE AUDIO SPEAKERS; USB AND SD CARD SUPPORTED ELECTRONIC AUDIO DEVICES, NAMELY, LOUD SPEAKERS; CARRYING CASES AND PROTECTIVE CASES SPECIALLY ADAPTED FOR USE WITH AUDIO SPEAKERS AND LOUD SPEAKERS (U.S. CLS. 21, 23, 26, 36 AND 38).

WILLIAM VERHOSEK, EXAMINING ATTORNEY

CLASS 9—(Continued).

SN 85-448,332. BEST PC FIXIT, INC., CHICO, CA. FILED 10-15-2011.

HOME TECHNICIAN TECH TALK

THE MARK CONSISTS OF STANDARD CHARACTERS WITHOUT CLAIM TO ANY PARTICULAR FONT, STYLE, SIZE, OR COLOR.

NO CLAIM IS MADE TO THE EXCLUSIVE RIGHT TO USE "TECHNICIAN TECH", APART FROM THE MARK AS SHOWN.

FOR COMPUTER HARDWARE AND COMPUTER SOFTWARE PROGRAMS FOR THE INTEGRATION OF TEXT, AUDIO, GRAPHICS, STILL IMAGES AND MOVING PICTURES INTO AN INTERACTIVE DELIVERY FOR MULTIMEDIA APPLICATIONS; COMPUTER SOFTWARE FOR ACCESSING INFORMATION DIRECTORIES THAT MAY BE DOWNLOADED FROM THE GLOBAL COMPUTER NETWORK; COMPUTER SOFTWARE FOR CREATING SEARCHABLE DATABASES OF INFORMATION AND DATA; COMPUTER SOFTWARE FOR USE IN THE ENCRYPTION AND DECRYPTION OF DIGITAL FILES, INCLUDING AUDIO, VIDEO, TEXT, BINARY, STILL IMAGES, GRAPHICS AND MULTIMEDIA FILES; COMPUTER SOFTWARE FOR USE IN THE SAFEGUARDING OF DIGITAL FILES, INCLUDING AUDIO, VIDEO, TEXT, BINARY, STILL IMAGES, GRAPHICS AND MULTIMEDIA FILES; COMPUTER SOFTWARE, NAMELY, DOWNLOADABLE SOFTWARE FOR COMPUTER DIAGNOSTICS, REPAIR AND UPGRADES THAT MAY BE DOWNLOADED FROM A GLOBAL COMPUTER NETWORK; COMPUTER SOFTWARE PLATFORMS CONSISTING OF DOWNLOADABLE SOFTWARE FOR COMPUTER DIAGNOSTICS, REPAIR AND UPGRADES; COMPUTER SOFTWARE THAT PROVIDES REAL-TIME, INTEGRATED BUSINESS MANAGEMENT INTELLIGENCE BY COMBINING INFORMATION FROM VARIOUS DATABASES AND PRESENTING IT IN AN EASY-TO-UNDERSTAND USER INTERFACE; COMPUTER SOFTWARE THAT PROVIDES WEB-BASED ACCESS TO APPLICATIONS AND SERVICES THROUGH A WEB OPERATING SYSTEM OR PORTAL INTERFACE; COMPUTER SOFTWARE TO MAINTAIN AND OPERATE COMPUTER SYSTEM; ELECTRONIC SOFTWARE UPDATES, NAMELY, DOWNLOADABLE COMPUTER SOFTWARE AND ASSOCIATED DATA FILES FOR UPDATING COMPUTER SOFTWARE IN THE FIELDS OF COMPUTER DIAGNOSTICS, REPAIR AND UPGRADES, PROVIDED VIA COMPUTER AND COMMUNICATION NETWORKS; OPERATING AND USER INSTRUCTIONS STORED IN DIGITAL FORM FOR COMPUTERS AND COMPUTER SOFTWARE, IN PARTICULAR ON FLOPPY DISKS OR CD-ROM; OPTICAL COMMUNICATIONS SYSTEMS COMPRISED OF OPTICAL AND ELECTRONIC HARDWARE AND COMPUTER SOFTWARE FOR THE TRANSMISSION OF DATA BETWEEN TWO POINTS (U.S. CLS. 21, 23, 26, 36 AND 38).

NATALIE POLZER, EXAMINING ATTORNEY

CLASS 9—(Continued).

SN 85-448,486. AIRVISION LASER PROTECTION SYSTEMS CORP., AIRDRIE, CANADA, FILED 10-17-2011.

AirVision Certified

THE MARK CONSISTS OF STANDARD CHARACTERS WITHOUT CLAIM TO ANY PARTICULAR FONT, STYLE, SIZE, OR COLOR.

NO CLAIM IS MADE TO THE EXCLUSIVE RIGHT TO USE "CERTIFIED", APART FROM THE MARK AS SHOWN.

FOR LASER DIODES; LASER POINTERS; RED LED LASER POINTING DEVICES THAT CONTAIN A SUBTLE ENERGY FIELD; SUPER LUMINESCENT LASER DIODES (U.S. CLS. 21, 23, 26, 36 AND 38).

JENNY PARK, EXAMINING ATTORNEY

CLASS 9—(Continued).

SN 85-451,794. HOWARD, SIDNEY, TROY, MI. FILED 10-20-2011.



THE MARK CONSISTS OF A CARTOON CHARACTER DESIGN WITH "POWER PUPPY" WRITTEN ON THE CHARACTER'S SHIRT SURROUNDING A SMILING STAR DESIGN. THE CHARACTER IS WEARING SHORTS, SOCKS, SHIRT, CAPE AND GLOVES, AND HAS ITS RIGHT HAND UP AND LEFT HAND DOWN. THE CHARACTER HAS WINGS, AND A HALO OVER ITS HEAD.

FOR ELECTRONIC DOWNLOADABLE PUBLICATIONS, NAMELY, A SERIES OF GRAPHIC NOVELS IN THE FIELD OF COMICS (U.S. CLS. 21, 23, 26, 36 AND 38).

TEJBIR SINGH, EXAMINING ATTORNEY

SN 85-452,626. SONY CORPORATION, TOKYO, JAPAN, FILED 10-20-2011.

SN 85-451,658. SKYLINE DISPLAYS, INC., EAGAN, MN. FILED 10-20-2011.

SKYLINE



THE MARK CONSISTS OF TWO OVERLAPPING CIRCLES, OF DIFFERENT SIZES, EACH WITH A LIGHT PORTION; THE SMALLER OVERLAPPING CIRCLE'S LIGHT PORTION IS IN THE DARK PORTION OF THE LARGER CIRCLE.

FOR USER INTERFACES FOR ELECTRONIC DEVICES; PERSONAL COMPUTERS; HANDHELD COMPUTERS; PERSONAL DIGITAL ASSISTANTS; MOBILE PHONES; SMART PHONES; TELEVISIONS; TOUCH PANELS; LIQUID CRYSTAL DISPLAYS (U.S. CLS. 21, 23, 26, 36 AND 38).

SUSAN STIGLITZ, EXAMINING ATTORNEY

THE MARK CONSISTS OF STANDARD CHARACTERS WITHOUT CLAIM TO ANY PARTICULAR FONT, STYLE, SIZE, OR COLOR.

OWNER OF U.S. REG. NO. 1,976,698.

FOR STANDS AND MOUNTING DEVICES FOR HOLDING COMPUTER MONITORS (U.S. CLS. 21, 23, 26, 36 AND 38).

FIRST USE 4-28-2011; IN COMMERCE 4-28-2011.

HOWARD B. LEVINE, EXAMINING ATTORNEY

CLASS 9—(Continued).

SN 85-452,710. TAIWAN TELEVISION ENTERPRISE, LTD.,
TAIPEI, TAIWAN, FILED 10-20-2011.



OWNER OF U.S. REG. NO. 1,867,489.
NO CLAIM IS MADE TO THE EXCLUSIVE RIGHT TO
USE "TAIWAN TELEVISION AND THE NON-LATIN CHAR-
ACTERS THAT MEAN TAIWAN TELEVISION", APART
FROM THE MARK AS SHOWN.

THE MARK CONSISTS OF THE DESIGN OF A TRIAN-
GLE INSIDE AN OVAL WITH CHINESE CHARACTERS
LOCATED TO THE RIGHT OF THE DESIGN.

THE ENGLISH TRANSLATION OF THE CHINESE CHAR-
ACTERS IN THE MARK IS TAIWAN TELEVISION.

THE NON-LATIN CHARACTERS IN THE MARK TRANS-
LITERATE TO TAI SHIH AND THIS MEANS TAIWAN
TELEVISION IN ENGLISH.

FOR DOWNLOADABLE TELEVISION PROGRAMS
VIA THE INTERNET AND WIRELESS DEVICES; PRE-
RECORDED CDS, VIDEO TAPES, LASER DISKS AND
DVDS FEATURING TELEVISION PROGRAMS (U.S.
CLS. 21, 23, 26, 36 AND 38).

FIRST USE 11-4-2007; IN COMMERCE 11-4-2007.
LESLEY LAMOTHE, EXAMINING ATTORNEY

SN 85-452,827. VIKARAN SOLUTIONS, LLC, FORMERLY
PARADOX TECHNOLOGY SOLUTIONS, LLC, LISLE, IL.
FILED 10-21-2011.

VIKARAN BILLINGEXPERT

THE MARK CONSISTS OF STANDARD CHARACTERS
WITHOUT CLAIM TO ANY PARTICULAR FONT, STYLE,
SIZE, OR COLOR.

FOR COMPUTER SOFTWARE, NAMELY, ENTER-
PRISE CLASS SOFTWARE FOR THE INSURANCE IN-
DUSTRY FOR MANAGING BILLING AND PREMIUM
AUDIT PROCESSING (U.S. CLS. 21, 23, 26, 36 AND 38).

DOUGLAS LEE, EXAMINING ATTORNEY

CLASS 9—(Continued).

SN 85-452,834. SASSO, ANTHONY, COCONUT CREEK, FL.
FILED 10-21-2011.

Bubble Cash

THE MARK CONSISTS OF STANDARD CHARACTERS
WITHOUT CLAIM TO ANY PARTICULAR FONT, STYLE,
SIZE, OR COLOR.

NO CLAIM IS MADE TO THE EXCLUSIVE RIGHT TO
USE "CASH", APART FROM THE MARK AS SHOWN.

FOR COMPUTER APPLICATION SOFTWARE FOR
MOBILE PHONES, NAMELY, SOFTWARE TO ENABLE
AUTHORIZED COMPANIES TO SEND TARGETED
COUPON BASED ADVERTISING DIRECTLY TO THE
TOP LAYER OF THE MOBILE PHONE TOUCH SCREEN
(U.S. CLS. 21, 23, 26, 36 AND 38).

STEVEN JACKSON, EXAMINING ATTORNEY

SN 85-452,875. VIKARAN SOLUTIONS, LLC, FORMERLY
PARADOX TECHNOLOGY SOLUTIONS, LLC, LISLE, IL.
FILED 10-21-2011.

VIKARAN QUOTEEXPERT

THE MARK CONSISTS OF STANDARD CHARACTERS
WITHOUT CLAIM TO ANY PARTICULAR FONT, STYLE,
SIZE, OR COLOR.

FOR COMPUTER SOFTWARE, NAMELY, ENTER-
PRISE CLASS SOFTWARE FOR THE INSURANCE IN-
DUSTRY FOR USE IN PROVIDING ONLINE QUICK
QUOTE AND FULL APPLICATION QUOTES AND ANA-
LYSIS OF INSURANCE PREMIUM PRICING (U.S. CLS.
21, 23, 26, 36 AND 38).

DOUGLAS LEE, EXAMINING ATTORNEY

SN 85-452,879. VIKARAN SOLUTIONS, LLC, FORMERLY
PARADOX TECHNOLOGY SOLUTIONS, LLC, LISLE, IL.
FILED 10-21-2011.

VIKARAN INSURANCEEXPERT

THE MARK CONSISTS OF STANDARD CHARACTERS
WITHOUT CLAIM TO ANY PARTICULAR FONT, STYLE,
SIZE, OR COLOR.

FOR COMPUTER SOFTWARE, NAMELY, ENTER-
PRISE CLASS SOFTWARE FOR THE INSURANCE IN-
DUSTRY FOR USE IN APPLICATIONS PROCESSING,
UNDERWRITING, POLICY ADMINISTRATION, AC-
COUNTING, BILLING AND CLAIMS PROCESSING
(U.S. CLS. 21, 23, 26, 36 AND 38).

DOUGLAS LEE, EXAMINING ATTORNEY

CLASS 9—(Continued).

SN 85-452,883. VIKARAN SOLUTIONS, LLC, FORMERLY PARADOX TECHNOLOGY SOLUTIONS, LLC, LISLE, IL. FILED 10-21-2011.

VIKARAN CLAIMSEXPERT

THE MARK CONSISTS OF STANDARD CHARACTERS WITHOUT CLAIM TO ANY PARTICULAR FONT, STYLE, SIZE, OR COLOR.

FOR COMPUTER SOFTWARE, NAMELY, ENTERPRISE CLASS SOFTWARE FOR THE INSURANCE INDUSTRY FOR THE PROCESSING, MANAGEMENT AND ADMINISTRATION OF INSURANCE CLAIMS (U.S. CLS. 21, 23, 26, 36 AND 38).

DOUGLAS LEE, EXAMINING ATTORNEY

SN 85-452,886. VIKARAN SOLUTIONS, LLC, FORMERLY PARADOX TECHNOLOGY SOLUTIONS, LLC, LISLE, IL. FILED 10-21-2011.

VIKARAN WORKERSCOMPEXP

THE MARK CONSISTS OF STANDARD CHARACTERS WITHOUT CLAIM TO ANY PARTICULAR FONT, STYLE, SIZE, OR COLOR.

FOR COMPUTER SOFTWARE, NAMELY, ENTERPRISE CLASS SOFTWARE FOR THE INSURANCE INDUSTRY FOR USE IN APPLICATIONS PROCESSING, UNDERWRITING, POLICY ADMINISTRATION, ACCOUNTING, BILLING AND CLAIMS PROCESSING FOR WORKERS COMPENSATION (U.S. CLS. 21, 23, 26, 36 AND 38).

DOUGLAS LEE, EXAMINING ATTORNEY

SN 85-452,974. VIKARAN SOLUTIONS, LLC, FORMERLY PARADOX TECHNOLOGY SOLUTIONS, LLC, LISLE, IL. FILED 10-21-2011.

VIKARAN

THE MARK CONSISTS OF STANDARD CHARACTERS WITHOUT CLAIM TO ANY PARTICULAR FONT, STYLE, SIZE, OR COLOR.

FOR COMPUTER SOFTWARE, NAMELY, ENTERPRISE CLASS SOFTWARE FOR THE INSURANCE INDUSTRY FOR THE PROCESSING, MANAGEMENT AND ADMINISTRATION OF INSURANCE POLICIES, BILLING AND CLAIMS (U.S. CLS. 21, 23, 26, 36 AND 38).

DOUGLAS LEE, EXAMINING ATTORNEY

CLASS 9—(Continued).

SN 85-452,979. VIKARAN SOLUTIONS, LLC, FORMERLY PARADOX TECHNOLOGY SOLUTIONS, LLC, LISLE, IL. FILED 10-21-2011.

VIKARAN POLICYEXPERT

THE MARK CONSISTS OF STANDARD CHARACTERS WITHOUT CLAIM TO ANY PARTICULAR FONT, STYLE, SIZE, OR COLOR.

FOR COMPUTER SOFTWARE, NAMELY, ENTERPRISE CLASS SOFTWARE FOR THE INSURANCE INDUSTRY FOR USE IN UNDERWRITING, POLICY PROCESSING AND ADMINISTRATION (U.S. CLS. 21, 23, 26, 36 AND 38).

DOUGLAS LEE, EXAMINING ATTORNEY

SN 85-454,842. FREMANTLE MEDIA NORTH AMERICA, INC., BURBANK, CA. FILED 10-24-2011.

THE BIG BLUFF

THE MARK CONSISTS OF STANDARD CHARACTERS WITHOUT CLAIM TO ANY PARTICULAR FONT, STYLE, SIZE, OR COLOR.

FOR CAMERA CASES; CAMERAS; CASES FOR ELECTRONIC DIARIES; CASES FOR MOBILE PHONES; CASES FOR POCKET CALCULATORS; CD CASES; CD PLAYERS; CELLULAR PHONE ACCESSORY CHARMS; COMPUTER GAME SOFTWARE; DECORATIVE MAGNETS; DOWNLOADABLE COMPUTER GAME PROGRAMS; DOWNLOADABLE COMPUTER GRAPHICS; DOWNLOADABLE IMAGE FILE CONTAINING artwork, TEXT, AUDIO, VIDEO, GAMES AND INTERNET WEB LINKS RELATING TO A REALITY-BASED GAME SHOW; ELECTRONIC DIARIES; ELECTRONIC DAY PLANNERS; ELECTRONIC GAME SOFTWARE AND APPLICATIONS FOR MOBILE DEVICES AND TELEPHONES; EYEGLASSES; FITTED PLASTIC FILMS KNOWN AS SKINS FOR COVERING AND PROVIDING A SCRATCH PROOF BARRIER OR PROTECTION FOR ELECTRONIC DEVICES, NAMELY, MP3 PLAYERS, MOBILE TELEPHONES, SMART TELEPHONES, DIGITAL CAMERAS, GLOBAL POSITIONING SYSTEMS AND PERSONAL DIGITAL ASSISTANTS; GAMING MACHINES, NAMELY, SLOT MACHINES AND VIDEO LOTTERY TERMINALS; GAMING MACHINES, NAMELY, DEVICES WHICH ACCEPT A WAGER; HEADSETS FOR MOBILE TELEPHONES; HOLDERS FOR MAGNETICALLY ENCODED GIFT CARDS; MAGNETICALLY ENCODED DEBIT CARDS; INTERACTIVE VIDEO GAME PROGRAMS; MAGNETIC CODED GIFT CARDS; MOBILE TELEPHONES; MP3 PLAYERS; PERSONAL DIGITAL ASSISTANTS (PDA); POCKET CALCULATORS; PRE-PAID TELEPHONE CALLING CARDS, MAGNETICALLY ENCODED; PRE-RECORDED ELECTRONIC AND DIGITAL MEDIA FEATURING A REALITY-BASED GAME SHOW; RADIOS; SUNGLASSES; VIDEO GAME INTERACTIVE CONTROL FLOOR PADS OR MATS; VIDEO GAME INTERACTIVE HAND HELD REMOTE CONTROLS FOR PLAYING ELECTRONIC GAMES; VIDEO GAME MACHINES FOR USE WITH EXTERNAL DISPLAY SCREEN OR MONITOR; VIDEO GAME SOFTWARE; ELECTRIC HAIR APPLIANCES,

CLASS 9—(Continued).

NAMELY, BRAIDERS, WRAPPERS, IRONS, CRIMPERS, CURLERS, CURLING IRONS, ROLLERS, STRAIGHTENERS; BATTERY-OPERATED HAIR APPLIANCES, NAMELY, BRAIDERS, WRAPPERS, IRONS, CRIMPERS, CURLERS, CURLING IRONS, ROLLERS, STRAIGHTENERS; COMPUTER SOFTWARE FOR CREATING, RECORDING, EDITING AND TRANSMITTING AUDIOVISUAL MATERIAL; PRINTERS; PICTURE PROJECTORS; DIGITAL PHOTO FRAMES FOR DISPLAYING DIGITAL PHOTOS; ELECTRONIC AUDIO TAPE RECORDER; DIGITAL AUDIO TAPE PLAYER AND RECORDER; PRE-RECORDED AUDIO AND VIDEO MEDIA FEATURING REALITY-BASED GAME SHOWS; KARAOKE PLAYER AND AUDIO AND VIDEO RECORDER; DOWNLOADABLE ELECTRONIC NEWSLETTERS IN THE FIELD OF REALITY-BASED GAME SHOWS; DOWNLOADABLE ELECTRONIC PUBLICATIONS IN THE NATURE OF MAGAZINES OR BOOKS IN THE FIELD OF REALITY-BASED GAME SHOWS; HOLDERS FOR MAGNETICALLY ENCODED GIFT CARDS (U.S. CLS. 21, 23, 26, 36 AND 38).

TINA MAI, EXAMINING ATTORNEY

CLASS 9—(Continued).

SN 85-459,819. APPLION MOBILE, PALO ALTO, CA. FILED 10-30-2011.

SN 85-455,317. JUNGLE TECH, LLC, SAN ANTONIO, TX. FILED 10-25-2011.

CaptureCast

THE MARK CONSISTS OF STANDARD CHARACTERS WITHOUT CLAIM TO ANY PARTICULAR FONT, STYLE, SIZE, OR COLOR.

FOR COMPUTER HARDWARE AND COMPUTER SOFTWARE FOR RECORDING AND PLAYBACK OF EDUCATIONAL LECTURES AND MEETINGS (U.S. CLS. 21, 23, 26, 36 AND 38).

CIMMERIAN COLEMAN, EXAMINING ATTORNEY

Applion Mobile

SN 85-457,590. ONLINE DATA SYSTEMS, INC, DBA XPERIA, ALLENTOWN, PA. FILED 10-27-2011.

Comprehensiv

THE MARK CONSISTS OF STANDARD CHARACTERS WITHOUT CLAIM TO ANY PARTICULAR FONT, STYLE, SIZE, OR COLOR.

FOR COMPUTER SOFTWARE FOR ENTERPRISE RESOURCE PLANNING INCLUDING ACCOUNTING, GENERAL LEDGER, ACCOUNTS PAYABLE, ACCOUNTS RECEIVABLE, PAYROLL AND CREDIT MANAGEMENT, PRODUCTION AND INVENTORY MANAGEMENT AND CONTROL, WAREHOUSE AND DISTRIBUTION MANAGEMENT, PROCUREMENT INCLUDING REQUISITION PURCHASE ORDERS AND TRACKING OR ORDER FULFILLMENT AND CUSTOMER SERVICE (U.S. CLS. 21, 23, 26, 36 AND 38).

JOHN HWANG, EXAMINING ATTORNEY

THE MARK CONSISTS OF STANDARD CHARACTERS WITHOUT CLAIM TO ANY PARTICULAR FONT, STYLE, SIZE, OR COLOR.

FOR COMPUTER PROGRAMS FOR CONNECTING REMOTELY TO COMPUTERS OR COMPUTER NETWORKS; COMPUTER PROGRAMS FOR SEARCHING REMOTELY FOR CONTENT ON COMPUTERS AND COMPUTER NETWORKS; COMPUTER PROGRAMS FOR THE ENABLING OF ACCESS OR ENTRANCE CONTROL; COMPUTER PROGRAMS FOR MONITORING MEDICAL DATA AND CONTROLLING HOME AUTOMATION AND ENERGY SYSTEMS COMPRISED OF SENSOR NETWORKS THAT UPLOAD DATA TO SERVERS (U.S. CLS. 21, 23, 26, 36 AND 38).

FIRST USE 7-1-2011; IN COMMERCE 9-6-2011.

KAREN BRACEY, EXAMINING ATTORNEY

CLASS 9—(Continued).

SN 85-464,511. TOP VICTORY INVESTMENTS, TSIM SHA TSUI, KOWLOON, HONG KONG, FILED 11-4-2011.

CLASS 9—(Continued).

SN 85-467,834. GAMELION STUDIOS, DBA GAMELION, SZCZECIN, POLAND, FILED 11-9-2011.

Monster Shooter

MeeU

THE MARK CONSISTS OF STANDARD CHARACTERS WITHOUT CLAIM TO ANY PARTICULAR FONT, STYLE, SIZE, OR COLOR.

FOR COMPUTER GAME PROGRAMS, COMPUTER GAME SOFTWARE, COMPUTER GAME SOFTWARE DOWNLOADABLE FROM A GLOBAL COMPUTER NETWORK, COMPUTER GAME SOFTWARE FOR PERSONAL COMPUTERS AND HOME VIDEO GAME CONSOLES, COMPUTER GAME SOFTWARE FOR USE ON MOBILE AND CELLULAR PHONES, DOWNLOADABLE COMPUTER GAME PROGRAMS, DOWNLOADABLE COMPUTER GAME SOFTWARE VIA A GLOBAL COMPUTER NETWORK AND WIRELESS DEVICES, ELECTRONIC GAME SOFTWARE, ELECTRONIC GAME SOFTWARE FOR CELLULAR TELEPHONES, ELECTRONIC GAME SOFTWARE FOR HANDHELD ELECTRONIC DEVICES, GAME SOFTWARE, AND INTERACTIVE GAME SOFTWARE (U.S. CLS. 21, 23, 26, 36 AND 38).

DAVID C. REIHNER, EXAMINING ATTORNEY

THE MARK CONSISTS OF THE WORD "MEEU" IN A STYLIZED FORMAT WITH A CAPITAL LETTER "M", TWO LOWER CASE LETTER "E'S, AND A CAPITAL LETTER "U".

FOR COMPUTER MONITORS; PLASMA TELEVISIONS; TELEVISION SETS; LIQUID CRYSTAL DISPLAY TELEVISIONS; COMPUTER LIQUID CRYSTAL DISPLAYS; LIQUID CRYSTAL DISPLAYS; COMPUTERS; IMAGE SCANNERS; DATA STORAGE PROCESSORS; OPTICAL AND CHIP CARD DATA READERS; COMPUTER KEYBOARDS; COMPUTER CARRYING CASES; NOTEBOOK COMPUTERS; COMPUTER MICE; INTERFACE CARDS FOR COMPUTERS; SET-TOP BOXES; COMPUTER MAIN-BOARDS; NETWORK SERVERS; COMPUTER TERMINALS; COMPUTER PRINTERS; PERSONAL COMPUTERS; PRINTED CIRCUIT BOARDS; FLOPPY DISCS FOR RECORDING COMPUTER PROGRAMS FOR USE IN DATA BASE MANAGEMENT AND WORD PROCESSING; COMPACT DISCS FOR RECORDING COMPUTER PROGRAMS FOR USE IN DATA MANAGEMENT AND WORD PROCESSING PROGRAMS; HAND-HELD COMPUTERS; PORTABLE COMPUTERS; COMPUTER PROGRAMS FOR USE IN DATA BASE MANAGEMENT AND WORD PROCESSING; LIGHT PENS; BLANK MAGNETIC DISCS; HAND-HELD ELECTRONIC TRANSLATORS; ELECTRONIC NOTEBOOK COMPUTERS FOR KEEPING BUSINESS AND PERSONAL INFORMATION RECORDED ON COMPUTER MEDIA; ELECTRONIC PUBLICATIONS, NAMELY, BOOKS FEATURING COMPUTERS, GLOBAL COMMUNICATIONS NETWORK RESOURCES, ENTERTAINMENT, NEWS, TRAVELING, FOOD, SCIENCES, ARTS, STORIES, AND/OR LITERATURE RECORDED ON COMPUTER MEDIA AND PERSONAL DIGITAL ASSISTANTS; ELECTRONIC PUBLICATIONS, NAMELY, DICTIONARIES OF THE ENGLISH LANGUAGE RECORDED ON COMPUTER MEDIA (U.S. CLS. 21, 23, 26, 36 AND 38).

TINA MAI, EXAMINING ATTORNEY

SN 85-468,168. INCIPIO TECHNOLOGIES, INC., IRVINE, CA. FILED 11-9-2011.

Effers

THE MARK CONSISTS OF STANDARD CHARACTERS WITHOUT CLAIM TO ANY PARTICULAR FONT, STYLE, SIZE, OR COLOR.

FOR EARPHONES; HEADPHONES; DEVICES FOR HANDS-FREE USE OF MOBILE PHONES; DIGITAL AUDIO PLAYERS; DIGITAL PHONES; LAPTOPS; COMPUTERS; MP3 PLAYERS; PORTABLE LISTENING DEVICES, NAMELY, MP3 PLAYERS; PORTABLE MEDIA PLAYERS (U.S. CLS. 21, 23, 26, 36 AND 38).

INGRID C. EULIN, EXAMINING ATTORNEY

CLASS 9—(Continued).

SN 85-472,031. TYY-BB, LLC, NEW YORK, NY. FILED 11-14-2011.

OPERA GIRL

THE MARK CONSISTS OF STANDARD CHARACTERS WITHOUT CLAIM TO ANY PARTICULAR FONT, STYLE, SIZE, OR COLOR.

FOR VIDEO GAMES, NAMELY, VIDEO GAME PROGRAMS, VIDEO GAME CARTRIDGES, AND VIDEO GAME DISCS; COMPUTER SOFTWARE AND HARDWARE FOR PLAYING AND OPERATING ELECTRONIC GAMES; ELECTRONIC EQUIPMENT, NAMELY, COMPUTERS, ACCESSORIES FOR COMPUTERS, NAMELY, COMPUTER MOUSE, USB HUBS; FITTED SKINS AND SPECIALLY ADAPTED CASES FOR COVERING AND PROTECTING CELL PHONES, SMART PHONES, PERSONAL DATA ASSISTANTS AND MP3 PLAYERS; AUDIO EQUIPMENT, NAMELY, EARPHONES, EARBUDS; ACCESSORIES FOR COMPUTERS, NAMELY, COMPUTER CARRYING CASES, PRINTERS; CAMERAS, ACCESSORIES FOR CAMERAS, NAMELY, CASES, STRAPS, AND BAGS; CELL PHONES AND SMART PHONES; TELEVISIONS, AUDIO EQUIPMENT, NAMELY, RADIOS, STEREO RECEIVERS, STEREO TUNERS, AUDIO SPEAKERS; PERSONAL DATA ASSISTANTS, MP3 PLAYERS; PORTABLE DVD PLAYERS (U.S. CLS. 21, 23, 26, 36 AND 38).

B. PARADEWELAI, EXAMINING ATTORNEY

SN 85-472,332. ACI COMMUNICATIONS, INC., KENT, WA. FILED 11-14-2011.

DSIM

THE MARK CONSISTS OF STANDARD CHARACTERS WITHOUT CLAIM TO ANY PARTICULAR FONT, STYLE, SIZE, OR COLOR.

FOR THERMALLY COMPENSATED CATV GAIN CONTROL APPARATUS AND FIRMWARE SOLD AS A UNIT (U.S. CLS. 21, 23, 26, 36 AND 38).

MARK T. MULLEN, EXAMINING ATTORNEY

CLASS 9—(Continued).

SN 85-473,171. ZOLL L.L.C., DBA LETHAL PROTECTION, NEW LOTHROP, MI. FILED 11-15-2011.

Life-Phorm

THE MARK CONSISTS OF STANDARD CHARACTERS WITHOUT CLAIM TO ANY PARTICULAR FONT, STYLE, SIZE, OR COLOR.

FOR MOBILE ELECTRONIC ACCESSORY, NAMELY, AN ADJUSTABLE MECHANICAL POSITIONING DEVICE/MOUNTING SYSTEM APPARATUS SPECIALLY DESIGNED FOR HOLDING TABLET COMPUTERS, PORTABLE ELECTRONIC DEVICES, CAMERAS, VIDEO CAMERAS, MOBILE PHONES AND PORTABLE GAMING DEVICES AND TEMPORARILY AFFIXING THEM TO OR POSITIONING THEM ON OTHER ITEMS (U.S. CLS. 21, 23, 26, 36 AND 38).

FIRST USE 10-20-2011; IN COMMERCE 10-31-2011.

LUCY ARANT, EXAMINING ATTORNEY

SN 85-476,551. ARMORWORKS ENTERPRISES, LLC, CHANDLER, AZ. FILED 11-18-2011.

4D

THE MARK CONSISTS OF STANDARD CHARACTERS WITHOUT CLAIM TO ANY PARTICULAR FONT, STYLE, SIZE, OR COLOR.

FOR PROTECTIVE BALLISTIC RESISTANT FABRICS SOLD AS AN INTEGRAL COMPONENT OF HARD AND SOFT ARMOR (U.S. CLS. 21, 23, 26, 36 AND 38).

ERIN FALK, EXAMINING ATTORNEY

SN 85-477,049. CENTRAL RECOVERY HOLDINGS, LLC, LAS VEGAS, NV. FILED 11-18-2011.

CENTRAL RECOVERY PRESS

THE MARK CONSISTS OF STANDARD CHARACTERS WITHOUT CLAIM TO ANY PARTICULAR FONT, STYLE, SIZE, OR COLOR.

NO CLAIM IS MADE TO THE EXCLUSIVE RIGHT TO USE "RECOVERY PRESS", APART FROM THE MARK AS SHOWN.

FOR DOWNLOADABLE ELECTRONIC PUBLICATIONS IN THE NATURE OF NEWSLETTERS AND EDUCATIONAL SUPPORT MATERIALS IN THE FIELDS OF CHEMICAL DEPENDENCY, ADDICTION TREATMENT, PAIN MANAGEMENT, COUNSELING AND OTHER MEDICAL REHABILITATION SERVICES (U.S. CLS. 21, 23, 26, 36 AND 38).

FIRST USE 11-1-2010; IN COMMERCE 11-1-2010.

ROBERT C. CLARK JR., EXAMINING ATTORNEY

CLASS 9—(Continued).

SN 85-478,202. CENTRAL RECOVERY HOLDINGS, LLC,
LAS VEGAS, NV. FILED 11-21-2011.

CRP

THE MARK CONSISTS OF STANDARD CHARACTERS WITHOUT CLAIM TO ANY PARTICULAR FONT, STYLE, SIZE, OR COLOR.

FOR DOWNLOADABLE ELECTRONIC PUBLICATIONS IN THE NATURE OF NEWSLETTERS AND EDUCATIONAL SUPPORT MATERIALS IN THE FIELDS OF CHEMICAL DEPENDENCY, ADDICTION TREATMENT, PAIN MANAGEMENT, COUNSELING AND OTHER MEDICAL REHABILITATION SERVICES (U.S. CLS. 21, 23, 26, 36 AND 38).

FIRST USE 11-1-2010; IN COMMERCE 11-1-2010.
ROBERT C. CLARK JR., EXAMINING ATTORNEY

CLASS 9—(Continued).

SN 85-479,970. STREAMBASE SYSTEMS, INC., LEXINGTON,
MA. FILED 11-23-2011.

STREAMBASE LIVEVIEW

THE MARK CONSISTS OF STANDARD CHARACTERS WITHOUT CLAIM TO ANY PARTICULAR FONT, STYLE, SIZE, OR COLOR.

OWNER OF U.S. REG. NO. 3,096,450.

NO CLAIM IS MADE TO THE EXCLUSIVE RIGHT TO USE "LIVEVIEW", APART FROM THE MARK AS SHOWN.

FOR COMPUTER SOFTWARE FOR PROCESSING AND ANALYZING REAL-TIME DATA (U.S. CLS. 21, 23, 26, 36 AND 38).

FIRST USE 11-14-2011; IN COMMERCE 11-14-2011.
BILL DAWE, EXAMINING ATTORNEY

SN 85-479,250. GS YUASA INTERNATIONAL LTD., KYOTO,
JAPAN, FILED 11-22-2011.

YU POWER

THE MARK CONSISTS OF STANDARD CHARACTERS WITHOUT CLAIM TO ANY PARTICULAR FONT, STYLE, SIZE, OR COLOR.

NO CLAIM IS MADE TO THE EXCLUSIVE RIGHT TO USE "POWER", APART FROM THE MARK AS SHOWN.

FOR BATTERIES AND ELECTRICAL CELLS (U.S. CLS. 21, 23, 26, 36 AND 38).

DOMINIC J. FERRAIUOLO, EXAMINING ATTORNEY

SN 85-481,178. SHENZHEN EXCELSECU DATA TECHNOLOGY CO., LTD., NANSHAN, SHENZHEN, CHINA, FILED 11-28-2011.

excelsecu

THE MARK CONSISTS OF STANDARD CHARACTERS WITHOUT CLAIM TO ANY PARTICULAR FONT, STYLE, SIZE, OR COLOR.

FOR COMPUTER MEMORIES; RECORDED COMPUTER PROGRAMS FOR VERIFYING IDENTITY OF NET USERS AND EXCHANGING DATA; PRE-RECORDED FLASH DRIVES FOR ENCRYPTION OF COMPUTER SOFTWARE AND DATA; ENCODED INTEGRATED CIRCUIT CARDS FOR VERIFYING IDENTITY OF NET USERS AND EXCHANGING DATA; COMPUTER HARDWARE AND PERIPHERAL DEVICES AND COMPUTER SOFTWARE FOR VERIFYING IDENTITY OF NET USERS AND EXCHANGING DATA; SMART CARD READER; APPARATUS FOR ENCRYPTION, DECRYPTION AND STORAGE OF DATA, NAMELY, ELECTRONIC ENCRYPTION UNITS; ENCODED INTEGRATED CIRCUITS CHIPS AND INTEGRATED CIRCUITS FOR VERIFYING IDENTITY OF NET USERS AND EXCHANGING DATA; ENCODED ELECTRONIC CHIP FOR VERIFYING IDENTITY OF NET USERS AND EXCHANGING DATA; APPARATUS FOR VERIFYING IDENTITY OF VISITORS, NAMELY, ENTRY/EXIT SECURITY PORTAL COMPRISED OF ELECTRONIC MACHINES AND PASSAGEWAY EQUIPPED WITH BIOMETRIC DEVICES FOR IDENTIFICATION VERIFICATION AND DETECTION; FINGERPRINT IDENTIFICATION SYSTEM COMPRISING BIOMETRIC FINGERPRINT DOOR LOCK, COMPUTERIZED TIME CLOCK WITH FINGERPRINT RECOGNITION, FINGERPRINT IMAGERS AND FINGERPRINT SCANNERS; RADIO FREQUENCY IDENTIFICATION TAG READERS (U.S. CLS. 21, 23, 26, 36 AND 38).

SOPHIA S. KIM, EXAMINING ATTORNEY

SN 85-479,517. LANTRONIX, INC., IRVINE, CA. FILED 11-22-2011.

XPRINTSERVER

THE MARK CONSISTS OF STANDARD CHARACTERS WITHOUT CLAIM TO ANY PARTICULAR FONT, STYLE, SIZE, OR COLOR.

FOR ELECTRONIC DEVICE, NAMELY, A NETWORK CONNECTED PERIPHERAL FOR RECEIVING DATA WIRELESSLY FROM MOBILE DEVICES TO ENABLE PRINTING DIRECTLY FROM MOBILE DEVICES TO REMOTE PRINTERS (U.S. CLS. 21, 23, 26, 36 AND 38).

WILLIAM VERHOSEK, EXAMINING ATTORNEY

CLASS 9—(Continued).

SN 85-482,191. PRECISION ENTERPRISE LTD., HONG KONG, HONG KONG, FILED 11-29-2011.



THE MARK CONSISTS OF THE WORDS "PRO USER" REPRESENTED IN STYLIZED FONT AND A DESIGN CONSISTING OF A SERIES OF PARALLEL HORIZONTAL SOLID BARS, A DIAGONAL LINE, AND IRREGULAR GEOMETRIC SHAPES WHEREIN THE TERM "PRO" IS LOCATED ON ONE OF THE GEOMETRIC SHAPES ABOVE AND SLIGHTLY TO THE LEFT OF THE TERM "USER" WHICH IS LOCATED ON A SECOND GEOMETRIC SHAPE BELOW AND SLIGHTLY TO THE RIGHT OF THE TERM "USER".

FOR APPARATUS FOR RECORDING, TRANSMITTING AND REPRODUCING SOUND AND IMAGES; AUDIO AND VIDEO RECORDINGS FEATURING STATIC AND OBJECTS MOVING TOWARDS VEHICLES; AUTOMOTIVE, INDUSTRIAL, CONSTRUCTION, LOCOMOTIVE, AVIATION, NAVIGATION AND MARINE SAFETY-WARNING LIGHTS, NAMELY, STROBES, ROTATING LIGHTS AND BAR LIGHTS; BABY MONITORS; BATTERY CHARGERS; BATTERY JUMP STARTERS; BATTERY MONITORS; BATTERY PERFORMANCE MONITORS; BURGLAR ALARMS; CAR VIDEO RECORDERS; CHARGERS FOR BATTERIES; CHARGERS FOR ELECTRIC BATTERIES; DC/AC POWER CONVERTERS; DEVICES FOR HANDS-FREE USE OF MOBILE PHONES; DEVICES FOR WIRELESS RADIO TRANSMISSION; ELECTRIC NAVIGATIONAL INSTRUMENTS; ELECTRIC WARNING LIGHTS; ELECTRICAL AND ELECTRONIC BURGLAR ALARMS; ELECTRONIC APPARATUS, NAMELY, MOTION DETECTORS; ELECTRONIC DEVICES, NAMELY, ENERGY METERS FOR TRACKING AND MONITORING ENERGY USAGE; FM MODULATORS; GLOBAL POSITIONING SYSTEM (GPS); SECURITY CONTROL PANELS AND MOTION DETECTORS; SENSORS AND DETECTOR UNITS FOR USE IN CONTROLLING THE ACTUATION AND OPERATION OF AUTOMOTIVE SAFETY APPARATUS AND EQUIPMENT; ULTRASONIC DETECTORS FOR MEASURING DISTANCES BETWEEN PARKED CARS WHILE PARKING; VEHICLE SAFETY EQUIPMENT, NAMELY, BACKUP SENSORS AND CAMERAS; VEHICLE SAFETY EQUIPMENT, NAMELY, AN ON-BOARD VEHICULAR SURVEILLANCE SYSTEM COMPRISED OF CAMERAS AND MONITORS FOR EXPOSING AND ELIMINATING THE BLIND SPOTS ON BOTH SIDES OF THE VEHICLE; VEHICLE TRACKING DEVICES COMPRISED OF CELLULAR RADIO MODULES, COMPUTER SOFTWARE AND COMPUTER HARDWARE, SENSORS, TRANSMITTERS, RECEIVERS AND GLOBAL POSITIONING SATELLITE RECEIVERS, ALL FOR USE IN CONNECTION WITH VEHICLE TRACKING, VEHICLE MONITORING AND ANTI-THEFT VEHICLE ALARMS (U.S. CLS. 21, 23, 26, 36 AND 38).

RONALD DELGIZZI, EXAMINING ATTORNEY

CLASS 9—(Continued).

SN 85-485,224. STEC, INC., SANTA ANA, CA. FILED 12-1-2011.

ACCELERATE ACCESS TO DATA

THE MARK CONSISTS OF STANDARD CHARACTERS WITHOUT CLAIM TO ANY PARTICULAR FONT, STYLE, SIZE, OR COLOR.

FOR COMPUTER HARDWARE; SOLID-STATE DRIVE (SSD); COMPUTER STORAGE SYSTEMS CONSISTING OF COMPUTER MEMORIES, COMPUTER MEMORY HARDWARE, COMPUTER SOFTWARE AND HARDWARE FOR USE IN DATA STORAGE, COMPUTER STORAGE DEVICES IN THE NATURE OF BLANK FLASH DRIVES, COMPUTER STORAGE DEVICES IN THE NATURE OF HIGH-SPEED STORAGE SUBSYSTEMS FOR STORAGE AND BACKUP OF ELECTRONIC DATA EITHER LOCALLY OR VIA A TELECOMMUNICATIONS NETWORK, DYNAMIC RANDOM ACCESS MEMORY (DRAM), ELECTRONIC MEMORIES, EXTERNAL COMPUTER HARD DRIVES, FLASH MEMORY CARDS, MEMORIES FOR DATA PROCESSING EQUIPMENT, MEMORIES FOR USE WITH COMPUTERS, MEMORY BOARDS, MEMORY CARDS, MEMORY EXPANSION MODULES, AND REMOVABLE HARD DRIVE BASED COMPUTER BACKUP SYSTEMS; COMPUTER STORAGE ARRAYS SYSTEMS CONSISTING OF BLANK ELECTRONIC STORAGE MEDIA, BLANK DATA STORAGE DRIVES, BLANK DATA STORAGE CARDS, BLANK DATA STORAGE CHIPS, AND DATA STORAGE ARRAYS IN THE NATURE OF COMPUTER HARDWARE; NETWORK ATTACHED STORAGE IN THE NATURE OF HIGH-SPEED STORAGE SUBSYSTEMS FOR STORAGE AND BACKUP OF ELECTRONIC DATA VIA A TELECOMMUNICATIONS NETWORK; COMPUTER STORAGE AREA NETWORKS CONSISTING OF COMPUTER HARDWARE AND COMPUTER SOFTWARE FOR OPERATING SOLID-STATE DRIVES AND COMPUTER STORAGE SUB-SYSTEMS; COMMUNICATIONS SWITCHES IN THE NATURE OF COMPUTER NETWORK SWITCHES; NETWORK ROUTERS; APPLIANCES AND STORAGE APPLIANCES, NAMELY, COMPUTER HARDWARE; EXTERNAL COMPUTER HARD DRIVES; COMPUTER SOFTWARE FOR OPERATING SOLID-STATE DRIVES AND COMPUTER STORAGE SUB-SYSTEMS; NON-VOLATILE MEMORY BASED STORAGE IN THE NATURE OF BLANK ELECTRONIC STORAGE MEDIA; MEMORY SYSTEMS CONSISTING OF FLASH MEMORY CARDS, MEMORIES FOR DATA PROCESSING EQUIPMENT, MEMORIES FOR USE WITH COMPUTERS, MEMORY BOARDS, MEMORY CARDS, MEMORY EXPANSION MODULES, REMOVABLE HARD DRIVE BASED COMPUTER BACKUP SYSTEMS; COMPUTER EXPANSION BOARDS; ETHERNET ADAPTER; BLANK HARD DRIVES FOR COMPUTERS, SERVERS, AND STORAGE SYSTEMS; FLASH MEMORY CARDS; MEMORY CARDS; RAM (RANDOM ACCESS MEMORY) CARDS; COMPUTER STORAGE DEVICES, NAMELY, BLANK FLASH DRIVES; COMPUTER MEMORY HARDWARE; INTEGRATED CIRCUITS, NAMELY, APPLICATION-SPECIFIC INTEGRATED CIRCUITS (ASICS) (U.S. CLS. 21, 23, 26, 36 AND 38).

BRIAN PINO, EXAMINING ATTORNEY

CLASS 9—(Continued).

SN 85-488,120. VIRTUOSO, LTD., FORT WORTH, TX. FILED 12-6-2011.

VIRTUOSO TRAVELER

THE MARK CONSISTS OF STANDARD CHARACTERS WITHOUT CLAIM TO ANY PARTICULAR FONT, STYLE, SIZE, OR COLOR.

OWNER OF U.S. REG. NOS. 3,095,926, 3,884,601 AND OTHERS.

NO CLAIM IS MADE TO THE EXCLUSIVE RIGHT TO USE "TRAVELER", APART FROM THE MARK AS SHOWN.

FOR DOWNLOADABLE ELECTRONIC PUBLICATIONS IN THE NATURE OF MAGAZINES IN THE FIELD OF TRAVEL (U.S. CLS. 21, 23, 26, 36 AND 38).

JULIE WATSON, EXAMINING ATTORNEY

CLASS 9—(Continued).

SN 85-494,711. QUANTEL LIMITED, NEWBURY, BERKSHIRE, UNITED KINGDOM, FILED 12-14-2011.

QUANTEL

THE MARK CONSISTS OF STANDARD CHARACTERS WITHOUT CLAIM TO ANY PARTICULAR FONT, STYLE, SIZE, OR COLOR.

OWNER OF U.S. REG. NOS. 1,206,705, 3,550,028 AND OTHERS.

FOR ELECTRICAL AND ELECTRONIC APPARATUS AND INSTRUMENTS, NAMELY, COMPUTER HARDWARE AND INTEGRATED PROPRIETARY COMPUTER HARDWARE AND SOFTWARE FOR RECEIVING, RECORDING, MONITORING, STORING, CONVERTING, EDITING, COMPOSITING, PROCESSING, MIXING, MANIPULATING, COLOUR CORRECTING, REPRODUCING AND TRANSMITTING IMAGES AND/OR IMAGE SIGNALS AND AUDIO SIGNALS FOR THE INTERNET, TELEVISION, CINEMATOGRAPHY AND THE GRAPHICS ARTS; COMPUTER PROGRAMS AND COMPUTER SOFTWARE FOR RECEIVING, RECORDING, MONITORING, STORING, CONVERTING, EDITING, COMPOSITING, PROCESSING, MIXING, MANIPULATING, COLOUR CORRECTING, REPRODUCING AND TRANSMITTING IMAGES AND IMAGE SIGNALS AND AUDIO SIGNALS FOR THE INTERNET, TELEVISION, CINEMATOGRAPHY AND THE GRAPHICS ARTS (U.S. CLS. 21, 23, 26, 36 AND 38).

BRENDAN MCCAULEY, EXAMINING ATTORNEY

SN 85-492,701. SOUNDBRUSH RECORDS LLC, BROOKLYN, NY. FILED 12-12-2011.

SOUNDBRUSH RECORDS

THE MARK CONSISTS OF STANDARD CHARACTERS WITHOUT CLAIM TO ANY PARTICULAR FONT, STYLE, SIZE, OR COLOR.

NO CLAIM IS MADE TO THE EXCLUSIVE RIGHT TO USE "RECORDS", APART FROM THE MARK AS SHOWN.

FOR PRE-RECORDED COMPACT DISKS, PHONOGRAPH RECORDS, AND AUDIO CASSETTES, ALL FEATURING MUSIC (U.S. CLS. 21, 23, 26, 36 AND 38).

FIRST USE 8-17-2003; IN COMMERCE 8-17-2003.

COURTNEY ALVAREZ, EXAMINING ATTORNEY

SN 85-494,730. POINTS OF LIFE, LLC, WALNUT CREEK, CA. FILED 12-14-2011.

THAT'S EDUTAINMENT!

THE MARK CONSISTS OF STANDARD CHARACTERS WITHOUT CLAIM TO ANY PARTICULAR FONT, STYLE, SIZE, OR COLOR.

NO CLAIM IS MADE TO THE EXCLUSIVE RIGHT TO USE "EDUTAINMENT", APART FROM THE MARK AS SHOWN.

FOR DOWNLOADABLE ELECTRONIC NEWSLETTERS DELIVERED BY E-MAIL IN THE FIELD OF TEACHING FAMILIES TO PLAN FOR LIFE'S STAGES; DOWNLOADABLE ELECTRONIC NEWSLETTERS IN THE FIELD OF TEACHING FAMILIES TO PLAN FOR LIFE'S STAGES (U.S. CLS. 21, 23, 26, 36 AND 38).

FIRST USE 10-24-2011; IN COMMERCE 10-24-2011.

SOPHIA S. KIM, EXAMINING ATTORNEY

CLASS 9—(Continued).

SN 85-494,763. SFERLE, SIMONA M., DALLAS, OR. FILED 12-14-2011.



NO CLAIM IS MADE TO THE EXCLUSIVE RIGHT TO USE "EYE SUN SHIELDS" AND "RAY BLOCKERS", APART FROM THE MARK AS SHOWN.

THE MARK CONSISTS OF A STYLIZED SUN ABOVE THE STYLIZED TEXT "MY EYESUNSHIELDS". THE LETTERS "M" THROUGH "D" ARE UNDERLINED. BELOW THIS LINE IS THE STYLIZED TEXT "RAY BLOCKERS".

FOR DISPOSABLE PROTECTIVE EYE SHIELDS TO AID IN BLOCKING LIGHT RAYS (U.S. CLS. 21, 23, 26, 36 AND 38).

BARNEY CHARLON, EXAMINING ATTORNEY

SN 85-495,736. SONO PLOT, INC., MIDDLETON, WI. FILED 12-14-2011.



THE COLOR(S) BLACK, BLUE, GRAY, CHARCOAL GRAY, PINK, TAN, WHITE, AND YELLOW IS/ARE CLAIMED AS A FEATURE OF THE MARK.

THE MARK CONSISTS OF A YELLOW PENCIL WITH BLACK AND WHITE BANDS, A PINK ERASER, AND A TAN PORTION WITH A CHARCOAL GRAY TIP PLACED AGAINST A BLUE SURFACE WITH WHITE LINES AND A WHITE AND GRAY BORDER.

FOR COMPUTER SOFTWARE FOR COMPUTER AIDED DESIGN (U.S. CLS. 21, 23, 26, 36 AND 38).

FIRST USE 8-8-2011; IN COMMERCE 8-8-2011.

DEBORAH LOBO, EXAMINING ATTORNEY

CLASS 9—(Continued).

SN 85-510,519. CERNER INNOVATION, INC., LENEXA, KS. FILED 1-6-2012.

CERNER DATA HIVE

THE MARK CONSISTS OF STANDARD CHARACTERS WITHOUT CLAIM TO ANY PARTICULAR FONT, STYLE, SIZE, OR COLOR.

OWNER OF U.S. REG. NOS. 1,458,174, 2,550,007 AND OTHERS.

FOR COMPUTER SOFTWARE FOR USE IN THE HEALTHCARE FIELD, NAMELY, SOFTWARE FOR MANAGING, STORING, ANALYZING, MAINTAINING, PROCESSING, STRUCTURING, REVIEWING, BUILDING, EDITING, DISTRIBUTING, COMMUNICATING, ORGANIZING, SHARING, REFERENCING, MONITORING AND INTEGRATING HEALTHCARE INFORMATION; COMPUTER SOFTWARE FOR AUTOMATING CLINICAL, FINANCIAL AND ADMINISTRATIVE HEALTHCARE PROCESSES (U.S. CLS. 21, 23, 26, 36 AND 38).

JAMES STEIN, EXAMINING ATTORNEY

SN 85-510,525. CERNER INNOVATION, INC., LENEXA, KS. FILED 1-6-2012.

RESEARCH-ABLE EHR

THE MARK CONSISTS OF STANDARD CHARACTERS WITHOUT CLAIM TO ANY PARTICULAR FONT, STYLE, SIZE, OR COLOR.

NO CLAIM IS MADE TO THE EXCLUSIVE RIGHT TO USE "EHR", APART FROM THE MARK AS SHOWN.

FOR COMPUTER SOFTWARE FOR USE IN THE HEALTHCARE FIELD, NAMELY, SOFTWARE FOR MANAGING, STORING, ANALYZING, MAINTAINING, PROCESSING, STRUCTURING, REVIEWING, BUILDING, EDITING, DISTRIBUTING, COMMUNICATING, ORGANIZING, SHARING, REFERENCING, MONITORING AND INTEGRATING HEALTHCARE INFORMATION; COMPUTER SOFTWARE FOR AUTOMATING CLINICAL, FINANCIAL AND ADMINISTRATIVE HEALTHCARE PROCESSES (U.S. CLS. 21, 23, 26, 36 AND 38).

JAMES STEIN, EXAMINING ATTORNEY

CLASS 9—(Continued).

SN 85-511,302. DIEBOLD, INCORPORATED, NORTH CANTON, OH. FILED 1-8-2012.

AGILIS

THE MARK CONSISTS OF STANDARD CHARACTERS WITHOUT CLAIM TO ANY PARTICULAR FONT, STYLE, SIZE, OR COLOR.

OWNER OF U.S. REG. NOS. 2,770,359, 3,175,959 AND OTHERS.

THE WORDING "AGILIS" HAS NO MEANING IN A FOREIGN LANGUAGE.

FOR AUTOMATED TRANSACTION MACHINES, AUTOMATED BANKING MACHINES, AUTOMATED TELLER MACHINES; SOFTWARE USED TO SUPPLY INFORMATION TO OR COLLECT INFORMATION FROM AUTOMATIC TELLER MACHINES FOR PURPOSES NOT RELATED TO THE OPERATION OF THE COMMUNICATIONS NETWORK; COMPUTER SOFTWARE, NAMELY, SOFTWARE THAT FACILITATES SECURE FINANCIAL ACCOUNT BALANCE INQUIRES, THE TRANSFER OF MONEY BETWEEN FINANCIAL FUNDS, PAYMENTS TO INDIVIDUALS, THE PAYMENT OF BILLS, ALERTS TO CUSTOMERS CONCERNING FINANCIAL ACCOUNT BALANCES, ALERTS TO CUSTOMERS CONCERNING DEBIT CARD OR CREDIT CARD PURCHASES, SECURITY AUTHORIZATIONS FOR USE OF FINANCIAL ACCOUNTS, DEBIT CARDS OR CREDIT CARDS, THE MANAGEMENT OF FINANCIAL ACCOUNTS, THE PURCHASING OF TICKETS USING MOBILE DEVICES; COMPUTER SOFTWARE THAT ENABLES FINANCIAL INSTITUTIONS TO INTEGRATE THE DELIVERY OF SERVICES TO CUSTOMERS BY MOBILE DEVICES, BRANCH FINANCIAL INSTITUTIONS, WORLDWIDE WEB PORTALS, CALL CENTERS, TELLERS, KIOSKS, AND AUTOMATED TELLER MACHINES (U.S. CLS. 21, 23, 26, 36 AND 38).

FIRST USE 7-31-2002; IN COMMERCE 9-30-2002.
DAVID C. REIHNER, EXAMINING ATTORNEY

SN 85-513,393. SOUNDBRUSH RECORDS LLC, BROOKLYN, NY. FILED 1-10-2012.

SOUNDBRUSH RECORDS

THE MARK CONSISTS OF STANDARD CHARACTERS WITHOUT CLAIM TO ANY PARTICULAR FONT, STYLE, SIZE, OR COLOR.

NO CLAIM IS MADE TO THE EXCLUSIVE RIGHT TO USE "RECORDS", APART FROM THE MARK AS SHOWN.

FOR PRERECORDED VIDEO DISKS, AUDIO-VISUAL RECORDINGS, NAMELY, VIDEO TAPES, VIDEO CASSETTES, MP3S, AND DVDS ALL FEATURING MUSICAL PERFORMANCES; DOWNLOADABLE VIDEO RECORDINGS FEATURING MUSICAL PERFORMANCES (U.S. CLS. 21, 23, 26, 36 AND 38).

COURTNEY ALVAREZ, EXAMINING ATTORNEY

CLASS 9—(Continued).

SN 85-514,934. HADDAD, CHARLES, CARROLL, NE. FILED 1-12-2012.

TOUCHNTAN

THE MARK CONSISTS OF STANDARD CHARACTERS WITHOUT CLAIM TO ANY PARTICULAR FONT, STYLE, SIZE, OR COLOR.

FOR COMPUTER SOFTWARE FOR USE IN PROVISION OF TANNING SERVICES THAT ALLOW CUSTOMERS TO ACCESS THEIR TANNING ACCOUNTS IN ORDER TO SELECT A TANNING PACKAGE, MANAGE THEIR ALLOTTED TIME, MANAGE THEIR PURCHASED TANNING PLANS, AND CHOOSE A TANNING BED WITHOUT STAFF ASSISTANCE (U.S. CLS. 21, 23, 26, 36 AND 38).

FRANK LATTUCA, EXAMINING ATTORNEY

SN 85-521,712. SKYHAWKE TECHNOLOGIES, LLC, RIDGE-LAND, MS. FILED 1-20-2012.

MyClub IQ

THE MARK CONSISTS OF STANDARD CHARACTERS WITHOUT CLAIM TO ANY PARTICULAR FONT, STYLE, SIZE, OR COLOR.

FOR COMPUTER SOFTWARE FOR USE IN CONNECTION WITH GOLF SWING OR GOLF BALL MONITORS, TO ANALYZE GOLF SWING DATA AND PROVIDE RECOMMENDATIONS FOR GOLF CLUBS, GOLF CLUB COMPONENTS, OR GOLF CLUB FITTING, AS WELL AS PROVIDING DATA AND INFORMATION FOR USE AND ANALYSIS BY GOLF COACHES (U.S. CLS. 21, 23, 26, 36 AND 38).

DEBORAH LOBO, EXAMINING ATTORNEY

SN 85-524,869. THOMSON BROADCAST LLC, SOUTHWICK, MA. FILED 1-25-2012.

COMARK COMMUNICATIONS CORP.

THE MARK CONSISTS OF STANDARD CHARACTERS WITHOUT CLAIM TO ANY PARTICULAR FONT, STYLE, SIZE, OR COLOR.

NO CLAIM IS MADE TO THE EXCLUSIVE RIGHT TO USE "COMMUNICATIONS CORP.", APART FROM THE MARK AS SHOWN.

FOR TELEVISION TRANSMITTERS AND TRANSMISSION EQUIPMENT (U.S. CLS. 21, 23, 26, 36 AND 38).

AMY HELLA, EXAMINING ATTORNEY

CLASS 9—(Continued).

SN 85-525,949. HARDY WAY LLC, NEW YORK, NY. FILED 1-26-2012.

ED BY ED HARDY

THE MARK CONSISTS OF STANDARD CHARACTERS WITHOUT CLAIM TO ANY PARTICULAR FONT, STYLE, SIZE, OR COLOR.

OWNER OF U.S. REG. NOS. 3,632,302, 3,655,472 AND OTHERS.

THE NAME(S), PORTRAIT(S), AND/OR SIGNATURE(S) SHOWN IN THE MARK IDENTIFIES DON "ED HARDY", WHOSE CONSENT(S) TO REGISTER IS MADE OF RECORD.

FOR EYEWEAR, NAMELY, SUNGLASSES, EYEGLASSES, EYEGLASS FRAMES AND CASES, AND ACCESSORIES THEREFOR, NAMELY CHAINS, STRAPS AND CORDS (U.S. CLS. 21, 23, 26, 36 AND 38).

SUE LAWRENCE, EXAMINING ATTORNEY

SN 85-526,270. 346 STANLEY, LLC, CINCINNATI, OH. FILED 1-26-2012.

AKSCENTZ THE CASE THAT MAKES SCENTS

THE MARK CONSISTS OF STANDARD CHARACTERS WITHOUT CLAIM TO ANY PARTICULAR FONT, STYLE, SIZE, OR COLOR.

FOR AROMA-EMITTING CASES FOR ELECTRONIC DEVICES INCLUDING, BUT NOT LIMITED TO, CELL PHONES AND SMARTPHONES (U.S. CLS. 21, 23, 26, 36 AND 38).

TINA L. SNAPP, EXAMINING ATTORNEY

SN 85-527,415. CERNER INNOVATION, INC., LENEXA, KS. FILED 1-27-2012.



THE COLOR(S) BLUE, BROWN, RED, YELLOW, ORANGE, AND BLACK IS/ARE CLAIMED AS A FEATURE OF THE MARK.

THE MARK CONSISTS OF A STYLIZED DRAWING: FROM LEFT TO RIGHT A SERIES OF OUTLINED BLACK

CLASS 9—(Continued).

PROFILES BEGINNING WITH A DEPICTION OF A PRIMATE AND EVOLVING TO A DEPICTION OF A HEALTHY UPRIGHT HUMAN BEING, CONTINUING WITH A DEPICTION OF AN UNHEALTHY HUMAN BEING, AND FINISHING WITH THE DEPICTION OF THE HEALTHY UPRIGHT HUMAN BEING, OVERLAYING A RANDOMIZED WAVEFORM SERIES OF VARIABLE AMPLITUDE LINES GENERALLY ORIENTED HORIZONTALLY AS WELL AS A RANDOM ARRAY OF DOTS IN THE COLORS BLUE, BROWN, YELLOW, ORANGE, RED, AND BLACK.

FOR COMPUTER HARDWARE AND SOFTWARE FOR MANAGING, INPUTTING, STORING, ANALYZING, MAINTAINING, PROCESSING, STRUCTURING, REVIEWING, BUILDING, EDITING, DISTRIBUTING, COMMUNICATING, ORGANIZING, SHARING, REFERENCING, MONITORING, INTEGRATING AND OUTPUTTING PERSONAL HEALTH, EXERCISE, FITNESS OR ATHLETIC INFORMATION (U.S. CLS. 21, 23, 26, 36 AND 38).

JAMES STEIN, EXAMINING ATTORNEY

SN 85-527,931. MARTIN, ANTHONY D, BROOKLYN, NY. FILED 1-28-2012.

Voxio

THE MARK CONSISTS OF STANDARD CHARACTERS WITHOUT CLAIM TO ANY PARTICULAR FONT, STYLE, SIZE, OR COLOR.

FOR COMPUTER SOFTWARE THAT PROVIDES WEB-BASED ACCESS TO APPLICATIONS AND SERVICES THROUGH A WEB OPERATING SYSTEM OR PORTAL INTERFACE (U.S. CLS. 21, 23, 26, 36 AND 38).

FIRST USE 10-21-2011; IN COMMERCE 10-21-2011.

GIANCARLO CASTRO, EXAMINING ATTORNEY

SN 85-528,012. WI-NEXT S.R.L., RIVOLI CASCINE VICA TO, ITALY, FILED 1-29-2012.



THE MARK CONSISTS OF THE TRADEMARK TERM "NAAW" AND, TO THE RIGHT THEREOF, A DOUBLE PARENTHETICAL-LIKE DESIGN WITH A SOLID CIRCLE BETWEEN THE PARENTHETICALS.

FOR WIRELESS NETWORK ROUTERS; WIRELESS NETWORK ROUTERS WITH INPUT AND OUTPUT BOARD FOR CONNECTING SENSORS; ELECTRIC ACTUATORS; RADIO TRANSCEIVERS (U.S. CLS. 21, 23, 26, 36 AND 38).

AHSEN KHAN, EXAMINING ATTORNEY

CLASS 9—(Continued).

SN 85-530,514. PURDON ASSOCIATES LLC, SPRINGFIELD, VA. FILED 2-1-2012.

CELEVOX

THE MARK CONSISTS OF STANDARD CHARACTERS WITHOUT CLAIM TO ANY PARTICULAR FONT, STYLE, SIZE, OR COLOR.

FOR DOWNLOADABLE MP3 FILES AND MP3 RECORDINGS FEATURING RECORDINGS BY CELEBRITY IMPERSONATORS OF QUOTES, AD LIBS, POSITIVE AFFIRMATIONS, STATEMENTS, JOKES, REMINDERS AND COMPLIMENTS; MULTIMEDIA SOFTWARE RECORDED ON CD-ROM FEATURING RECORDINGS BY CELEBRITY IMPERSONATORS OF QUOTES, AD LIBS, POSITIVE AFFIRMATIONS, STATEMENTS, JOKES, REMINDERS AND COMPLIMENTS (U.S. CLS. 21, 23, 26, 36 AND 38).

LINDA M. KING, EXAMINING ATTORNEY

CLASS 9—(Continued).

SN 85-534,863. SENSORMATIC ELECTRONICS, LLC, BOCA RATON, FL. FILED 2-6-2012.

TRUEVUE

THE MARK CONSISTS OF STANDARD CHARACTERS WITHOUT CLAIM TO ANY PARTICULAR FONT, STYLE, SIZE, OR COLOR.

OWNER OF U.S. REG. NO. 3,684,501.

FOR SOFTWARE FOR GATHERING INTELLIGENCE RELATED TO INVENTORY AND ASSET MANAGEMENT, ANTI-SHOPLIFTING AND LOSS PREVENTION, DEVICE HEALTH MONITORING, CONSUMER TRAFFIC AND SHOPPER BEHAVIOR, OPERATIONAL COMPLIANCE, POINT-OF-SALE TRANSACTION ANALYSIS, VIDEO ENABLED APPLICATIONS AND STORE EXECUTION FUNCTIONS; ANALYTICS AND REPORTING SOFTWARE FOR INVENTORY AND ASSET MANAGEMENT, ANTI-SHOPLIFTING AND LOSS PREVENTION, DEVICE HEALTH MONITORING, CONSUMER TRAFFIC AND SHOPPER BEHAVIOR, POINT-OF-SALE TRANSACTION ANALYSIS, VIDEO ENABLED APPLICATIONS AND STORE EXECUTION FUNCTIONS (U.S. CLS. 21, 23, 26, 36 AND 38).

BRIAN PINO, EXAMINING ATTORNEY

SN 85-533,684. YELLOWSTONE BRANDS, LLC, SOMERVILLE, NJ. FILED 2-3-2012.



OWNER OF U.S. REG. NOS. 1,324,683, 2,816,472 AND 3,999,222.

THE MARK CONSISTS OF THE LETTERS "CB" JOINED TOGETHER IN A BOLD ITALIC FONT.

FOR EYEGLASSES, SUNGLASSES, SKI GLASSES AND SKI GOGGLES (U.S. CLS. 21, 23, 26, 36 AND 38).

MARILYN IZZI, EXAMINING ATTORNEY

SN 85-535,176. MERIDIAN KNOWLEDGE SOLUTIONS, LLC, HERNDON, VA. FILED 2-6-2012.

MERIDIAN ANYWHERE

THE MARK CONSISTS OF STANDARD CHARACTERS WITHOUT CLAIM TO ANY PARTICULAR FONT, STYLE, SIZE, OR COLOR.

OWNER OF U.S. REG. NO. 2,905,384.

NO CLAIM IS MADE TO THE EXCLUSIVE RIGHT TO USE "ANYWHERE", APART FROM THE MARK AS SHOWN.

FOR DOWNLOADABLE COMPUTER SOFTWARE FOR USE IN MANAGING ONLINE EDUCATION, TRAINING, AND LEARNING MANAGEMENT SYSTEMS (U.S. CLS. 21, 23, 26, 36 AND 38).

FIRST USE 11-30-2006; IN COMMERCE 11-30-2006.

JANICE L. MCMORROW, EXAMINING ATTORNEY

CLASS 9—(Continued).

SN 85-537,217. BARTINGTON INSTRUMENTS LIMITED, WITNEY OXFORDSHIRE, UNITED KINGDOM, FILED 2-8-2012.

SPACEMAG

THE MARK CONSISTS OF STANDARD CHARACTERS WITHOUT CLAIM TO ANY PARTICULAR FONT, STYLE, SIZE, OR COLOR.

PRIORITY CLAIMED UNDER SEC. 44(D) ON UNITED KINGDOM APPLICATION NO. 2607673, FILED 1-20-2012, REG. NO. 2607673, DATED 4-27-2012, EXPIRES 1-20-2022.

FOR MAGNETOMETERS; MAGNETIC FIELD SENSORS FOR USE IN AEROSPACE APPLICATIONS; REPLACEMENT PARTS AND REPLACEMENT FITTINGS THEREFOR (U.S. CLS. 21, 23, 26, 36 AND 38).

HANNO RITTNER, EXAMINING ATTORNEY

SN 85-537,379. CINECORE LLC, BURBANK, CA. FILED 2-8-2012.

Cinecore

THE MARK CONSISTS OF STANDARD CHARACTERS WITHOUT CLAIM TO ANY PARTICULAR FONT, STYLE, SIZE, OR COLOR.

FOR COMPUTER SOFTWARE FOR MANAGING, COORDINATING AND UPDATING CAST AND CREW MEMBERS INVOLVED IN THE PRODUCTION OF FILMS AND TELEVISION PROGRAMS (U.S. CLS. 21, 23, 26, 36 AND 38).

JOHN KELLY, EXAMINING ATTORNEY

CLASS 9—(Continued).

SN 85-545,224. NXP B.V., EINDHOVEN, NETHERLANDS, FILED 2-16-2012.

SMARTLX

THE MARK CONSISTS OF STANDARD CHARACTERS WITHOUT CLAIM TO ANY PARTICULAR FONT, STYLE, SIZE, OR COLOR.

PRIORITY CLAIMED UNDER SEC. 44(D) ON UNITED KINGDOM APPLICATION NO. 2591942, FILED 8-19-2011.

OWNER OF U.S. REG. NO. 3,627,115.

FOR ELECTRONIC AND ELECTROTECHNICAL MODULES CONTAINING SEMICONDUCTORS FOR USE IN RFID (RADIO FREQUENCY IDENTIFICATION) AND NFC (NEAR FIELD COMMUNICATIONS) APPLICATIONS; ELECTRONIC AND ELECTROTECHNICAL MODULES CONTAINING INTEGRATED CIRCUITS FOR USE IN RFID (RADIO FREQUENCY IDENTIFICATION) AND NFC (NEAR FIELD COMMUNICATIONS) APPLICATIONS; ELECTRONIC AND ELECTROTECHNICAL MODULES CONTAINING MICROPROCESSOR CHIPS FOR USE IN RFID (RADIO FREQUENCY IDENTIFICATION) AND NFC (NEAR FIELD COMMUNICATIONS) APPLICATIONS; COMPUTER HARDWARE AND SOFTWARE FOR CREATING, PROGRAMMING, CONTROLLING, ENCODING, SCANNING, READING AND INTERPRETING RFID AND NFC CHIPS AND TAGS; USER INTERFACES FOR ELECTRONIC DEVICES; INTEGRATED CIRCUITS; COMPUTER CHIPS; SEMICONDUCTORS; BLANK SMART CARDS; ENCODED SMART CARDS CONTAINING PROGRAMMING USED FOR SECURITY PURPOSES FOR IDENTIFICATION, FOR LOGISTIC CONTROL, FOR AUTOMATIC BILLING AND AUTOMATED CONDUCTING OF FINANCIAL TRANSACTIONS, FOR DETECTING COUNTERFEIT PRODUCTS AND FOR ACCESS CONTROL; AND ELECTRONIC CONTROLLERS FOR SMART CARDS (U.S. CLS. 21, 23, 26, 36 AND 38).

DEIRDRE ROBERTSON, EXAMINING ATTORNEY

SN 85-545,246. DROID-ROBOTICS INC., SANTA CLARA, CA. FILED 2-16-2012.

Droid-Robotics Inc.

THE MARK CONSISTS OF STANDARD CHARACTERS WITHOUT CLAIM TO ANY PARTICULAR FONT, STYLE, SIZE, OR COLOR.

NO CLAIM IS MADE TO THE EXCLUSIVE RIGHT TO USE "INC.", APART FROM THE MARK AS SHOWN.

FOR COMPUTER SOFTWARE FOR CONTROLLING OF ROBOTIC SYSTEMS; MANIPULATORS FOR THE REMOTE OPERATION OF ROBOTIC ARMS; ROBOTIC ARMS FOR LABORATORY PURPOSES; ROBOTIC EXOSKELETON SUITS WORN BY HUMANS FOR THE PURPOSE OF ENHANCING THE STRENGTH AND ENDURANCE OF THE PERSON WEARING THE SUIT (U.S. CLS. 21, 23, 26, 36 AND 38).

FRED CARL, EXAMINING ATTORNEY

CLASS 9—(Continued).

SN 85-547,192. MOMENTIS SYSTEMS INC., MONTREAL, QUEBEC, CANADA, FILED 2-20-2012.

MOMENTIS FASHION SYSTEM

THE MARK CONSISTS OF STANDARD CHARACTERS WITHOUT CLAIM TO ANY PARTICULAR FONT, STYLE, SIZE, OR COLOR.

NO CLAIM IS MADE TO THE EXCLUSIVE RIGHT TO USE "FASHION SYSTEM", APART FROM THE MARK AS SHOWN.

FOR COMPUTER SOFTWARE FOR WHOLESALERS, IMPORTERS, MANUFACTURERS AND SELF-SOURCING RETAILERS WHICH PERMITS AND ENABLES OVERSEAS SOURCING, ALERTS, CUSTOMER SERVICE, EDI, STYLE SPECIFICATIONS, COSTING, LOGISTICS, PRODUCTION PLANNING AND CONTROL, INVENTORY AND CREDIT MANAGEMENT, WAREHOUSING AND DISTRIBUTION, ALLOCATION, EXECUTIVE SUMMARIES AND ACCOUNTS RECEIVABLE; DOWNLOADABLE WEB-BASED INTERACTIVE COMPUTER SOFTWARE SOLUTION FOR WHOLESALERS, IMPORTERS, MANUFACTURERS AND SELF-SOURCING RETAILERS WHICH PERMITS AND ENABLES OVERSEAS SOURCING, ALERTS, CUSTOMER SERVICE, EDI, STYLE SPECIFICATIONS, COSTING, LOGISTICS, PRODUCTION PLANNING AND CONTROL, INVENTORY AND CREDIT MANAGEMENT, WAREHOUSING AND DISTRIBUTION, ALLOCATION, EXECUTIVE SUMMARIES AND ACCOUNTS RECEIVABLE (U.S. CLS. 21, 23, 26, 36 AND 38).

FIRST USE 1-0-1995; IN COMMERCE 1-0-1995.

LINDA MICKLEBURGH, EXAMINING ATTORNEY

SN 85-547,948. UNISVR GLOBAL INFORMATION TECHNOLOGY CORP., HSINCHU, 300, TAIWAN, FILED 2-21-2012.

UniArgus Network of Device Platform

THE MARK CONSISTS OF STANDARD CHARACTERS WITHOUT CLAIM TO ANY PARTICULAR FONT, STYLE, SIZE, OR COLOR.

OWNER OF U.S. REG. NOS. 3,905,665, 3,905,666 AND 3,905,835.

NO CLAIM IS MADE TO THE EXCLUSIVE RIGHT TO USE "NETWORK" AND "DEVICE PLATFORM", APART FROM THE MARK AS SHOWN.

FOR NETWORK SERVER; INTERNET SERVERS; RECORDED COMPUTER SOFTWARE FOR USE IN INTERNET PROTOCOL SURVEILLANCE SYSTEMS CONSISTING OF COMPUTERS, INTERNET PROTOCOL CAMERAS, INTERNET SERVERS AND COMPUTER HARDWARE CONNECTED TO THE NETWORK; COMPUTER SOFTWARE TO ENABLE CAMERA SURVEILLANCE THAT IS VIEWABLE REMOTELY; REMOTE MONITORING EQUIPMENT, NAMELY, COMPUTER HARDWARE AND SOFTWARE FOR USE IN REMOTELY MONITORING EQUIPMENT; SYSTEM INTEGRATION PLATFORM, NAMELY, COMPUTER SOFTWARE FOR INTEGRATING COMPUTER HARDWARE, COMPUTER PERIPHERAL DEVICES, INTERNET PROTOCOL CAMERAS AND INTERNET SERVERS (U.S. CLS. 21, 23, 26, 36 AND 38).

DAVID TAYLOR, EXAMINING ATTORNEY

CLASS 9—(Continued).

SN 85-553,094. BLACK SEA INTERNATIONAL LLP, SKOKIE, IL. FILED 2-27-2012.



THE COLOR(S) NAVY BLUE, YELLOW AND BEIGE IS/ ARE CLAIMED AS A FEATURE OF THE MARK.

THE MARK CONSISTS OF A YELLOW MONOGRAM OUTLINED WITH NAVY BLUE AND WITH THE LETTER "B" IN NAVY BLUE IN THE CENTER; A NAVY BLUE LINE CROSSES THE BOTTOM LEFT PART OF THE MONOGRAM; THE MONOGRAM HAS A BEIGE SHADOW REFLECTING DOWN AND TO THE RIGHT; UNDER THE MONOGRAM A NAVY BLUE TEXT READS "SEA SHIELD"; THE WHOLE IMAGE LOOKS LIKE A SHIELD WITH THE LETTER "B" ON IT AND THE TEXT UNDERNEATH.

FOR CELL PHONE CASES; DEVICES FOR HANDS-FREE USE OF MOBILE PHONES; EAR PHONES; EARPHONE ACCESSORIES, NAMELY, EARPHONE CUSHIONS, EARPHONE PADS, CORD MANAGEMENT SYSTEMS, EARPHONE CASES, AND EARPHONE EXTENSION CORDS; HANDS FREE DEVICES FOR MOBILE-PHONES; HANDS FREE KITS FOR PHONES; HEAD-CLIP CELL PHONE HOLDERS; HEADSETS FOR CELLULAR OR MOBILE PHONES (U.S. CLS. 21, 23, 26, 36 AND 38).

CHRISTINA SOBRAL, EXAMINING ATTORNEY

SN 85-553,560. FENIEX INDUSTRIES INC., AUSTIN, TX. FILED 2-27-2012.

AVATAR

THE MARK CONSISTS OF STANDARD CHARACTERS WITHOUT CLAIM TO ANY PARTICULAR FONT, STYLE, SIZE, OR COLOR.

FOR EMERGENCY AND SAFETY SIGNAL LIGHTING FOR POLICE, FIRE, CONSTRUCTION, EMERGENCY MEDICAL SERVICES, TOW TRUCKS AND SECURITY VEHICLES, NAMELY, BEACON LIGHTS, STROBE LIGHTS, SAFETY LIGHTS, LED LIGHTS, FLASHING COLORED LIGHTS, LIGHT BARS AND TRAFFIC DIRECTIONAL LIGHT BARS (U.S. CLS. 21, 23, 26, 36 AND 38).

FRED CARL, EXAMINING ATTORNEY

CLASS 9—(Continued).

SN 85-554,392. POWER-CELL, LLC, DBA ZEUS BATTERY PRODUCTS AND POWER CELL BATTERY PRODUCTS, BLOOMINGDALE, IL. FILED 2-28-2012.

Power Your World

THE MARK CONSISTS OF STANDARD CHARACTERS WITHOUT CLAIM TO ANY PARTICULAR FONT, STYLE, SIZE, OR COLOR.

FOR ELECTRIC STORAGE BATTERIES; ELECTRICAL CELLS AND BATTERIES; ELECTRICAL STORAGE BATTERIES; LITHIUM ION BATTERIES; LITHIUM IRON PHOSPHATE BATTERIES; LITHIUM PHOSPHATE BATTERIES; MOBILE TELEPHONE BATTERIES; NICKEL-CADMIIUM STORAGE BATTERIES; RECHARGEABLE ELECTRIC BATTERIES; RENEWABLE BATTERY SYSTEM TO PROVIDE BACKUP POWER (U.S. CLS. 21, 23, 26, 36 AND 38).

FIRST USE 1-1-2011; IN COMMERCE 1-1-2011.
NANCY CLARKE, EXAMINING ATTORNEY

CLASS 9—(Continued).

SN 85-556,915. L-3 SERVICES, INC., SAN DIEGO, CA. FILED 2-29-2012.

NEXTGEN GPS

THE MARK CONSISTS OF STANDARD CHARACTERS WITHOUT CLAIM TO ANY PARTICULAR FONT, STYLE, SIZE, OR COLOR.

NO CLAIM IS MADE TO THE EXCLUSIVE RIGHT TO USE "GPS", APART FROM THE MARK AS SHOWN.

FOR GLOBAL POSITIONING SYSTEM (GPS) COMPRISED OF COMPUTERS, COMPUTER SOFTWARE, TRANSMITTERS, RECEIVERS, AND NETWORK INTERFACE DEVICES; SATELLITE NAVIGATIONAL SYSTEM, NAMELY, A GLOBAL POSITIONING SYSTEM (GPS); COMPUTER SOFTWARE PLATFORMS FOR INTEGRATION WITH GLOBAL POSITIONING SYSTEM (GPS); GPS SOFTWARE IN THE NATURE OF NAVIGATION, LOCATION, TRACKING, MAPPING AND TIMING SOFTWARE (U.S. CLS. 21, 23, 26, 36 AND 38).

RONALD MCMORROW, EXAMINING ATTORNEY

SN 85-556,108. TAFIQ'S PHYSIQUES, LOS ANGELES, CA. FILED 2-29-2012.



THE COLOR(S) BLACK AND RED IS/ARE CLAIMED AS A FEATURE OF THE MARK.

THE MARK CONSISTS OF A BLACK LETTER "T", A RED LETTER "X", AND A BLACK LETTER "T".

FOR DIGITAL MEDIA, NAMELY, PRE-RECORDED DVDS, DOWNLOADABLE AUDIO AND VIDEO RECORDINGS, AND CDS FEATURING AND PROMOTING EXERCISE, FITNESS, NUTRITION AND HEALTHY LIFESTYLE INFORMATION AND INSTRUCTION (U.S. CLS. 21, 23, 26, 36 AND 38).

KATHLEEN M. VANSTON, EXAMINING ATTORNEY

SN 85-557,232. LOOK WHO'S SMILING, LLC, EAST PROVIDENCE, RI. FILED 3-1-2012.

LOOK WHO'S SMILING

THE MARK CONSISTS OF STANDARD CHARACTERS WITHOUT CLAIM TO ANY PARTICULAR FONT, STYLE, SIZE, OR COLOR.

FOR COMPUTER SOFTWARE AND HARDWARE FOR CREATING A VISUAL DISPLAY OF DENTISTRY RESULTS PERTAINING TO THE TEETH OF INDIVIDUALS (U.S. CLS. 21, 23, 26, 36 AND 38).

FIRST USE 3-1-2012; IN COMMERCE 3-1-2012.
EDWARD NELSON, EXAMINING ATTORNEY

CLASS 9—(Continued).

SN 85-558,029. MIRKIN, EUGENE A, SAN FRANCISCO, CA.
FILED 3-1-2012.

Bobik

THE MARK CONSISTS OF STANDARD CHARACTERS WITHOUT CLAIM TO ANY PARTICULAR FONT, STYLE, SIZE, OR COLOR.

THE ENGLISH TRANSLATION OF "BOBIK" IN THE MARK IS "STREET DOG".

FOR COMMUNICATION SOFTWARE FOR PROVIDING ACCESS TO THE INTERNET; COMPUTER SEARCH ENGINE SOFTWARE; COMPUTER SOFTWARE FOR ACCESSING INFORMATION DIRECTORIES THAT MAY BE DOWNLOADED FROM THE GLOBAL COMPUTER NETWORK; COMPUTER SOFTWARE FOR CREATING SEARCHABLE DATABASES OF INFORMATION AND DATA; COMPUTER SOFTWARE FOR THE COLLECTION, EDITING, ORGANIZING, MODIFYING, BOOK MARKING, TRANSMISSION, STORAGE AND SHARING OF DATA AND INFORMATION; COMPUTER SOFTWARE PLATFORMS FOR DATA COLLECTION, COMPUTATION, AND TRANSFORMATION; COMPUTER SOFTWARE THAT PROVIDES WEB-BASED ACCESS TO APPLICATIONS AND SERVICES THROUGH A WEB OPERATING SYSTEM OR PORTAL INTERFACE (U.S. CLS. 21, 23, 26, 36 AND 38).

LINDA MICKLEBURGH, EXAMINING ATTORNEY

SN 85-558,218. CODE ORGANA LLC, POTTSTOWN, PA.
FILED 3-2-2012.

ToonCamera

THE MARK CONSISTS OF STANDARD CHARACTERS WITHOUT CLAIM TO ANY PARTICULAR FONT, STYLE, SIZE, OR COLOR.

FOR DOWNLOADABLE COMPUTER SOFTWARE APPLICATIONS FOR EDITING AND APPLYING SPECIAL EFFECTS TO DIGITAL IMAGES (U.S. CLS. 21, 23, 26, 36 AND 38).

FIRST USE 9-28-2010; IN COMMERCE 9-28-2010.
KIMBERLY PARKS, EXAMINING ATTORNEY

CLASS 9—(Continued).

SN 85-559,364. SONDPDEX CORPORATION OF AMERICA,
MONMOUTH JCT., NJ. FILED 3-3-2012.

The logo for TUNES2GO features the word "TUNES" in a bold, sans-serif font. The letter "T" has a downward-pointing arrow integrated into its base. The number "2" is smaller and positioned between "TUNES" and "GO". The word "GO" is in the same bold, sans-serif font as "TUNES".

THE MARK CONSISTS OF THE LETTERS "T", "U", "N", "E", "S", NUMERICAL NUMBER "2" AND LETTERS "G", "O". THERE IS AN ARROW UNDER THE LETTER "T". THE LETTERS "N" AND "G" GO DOWN TO MAKE THE MARK NOT AT THE SAME HORIZONTAL LINE, WHICH INDICATES THE TUNE OF MUSIC.

FOR AUDIO AMPLIFIERS; AUDIO EQUIPMENT FOR VEHICLES, NAMELY, LOUD SPEAKERS FOR AUTOMOTIVE AUDIO SYSTEMS; AUDIO EQUIPMENT FOR VEHICLES, NAMELY, STEREOS, SPEAKERS, AMPLIFIERS, EQUALIZERS, CROSSOVERS AND SPEAKER HOUSINGS; AUDIO EQUIPMENT FOR VEHICLES, NAMELY, SUBWOOFERS; AUDIO HEADPHONES; AUDIO SPEAKER ENCLOSURES; AUDIO SPEAKERS; BASS SPEAKERS; CASES FOR MUSIC, AUDIO AND RELATED ELECTRONIC EQUIPMENT, NAMELY, CASES FOR AUDIO TUNERS, AUDIO RECEIVERS, AMPLIFIERS, TAPE PLAYERS, COMPACT DISC PLAYERS, MP3 CONTROLLERS/PLAYERS, AUDIO MIXERS, AUDIO SPEAKERS IN THE NATURE OF MUSIC STUDIO MONITORS, MICROPHONES, AUDIO SPEAKERS, COMPACT DISCS, AUDIO TAPES, PORTABLE COMPUTERS, ANTENNAS, PHONOGRAPHIC RECORD PLAYERS, AUDIO RECORDING EQUIPMENT, AND THE CABLES ASSOCIATED WITH ALL OF THE FOREGOING EQUIPMENT; DIGITAL AUDIO AND VIDEO RECORDERS AND PLAYERS; ELECTRIC AUDIO PLAYBACK UNITS WITH LIGHTS AND SPEAKERS; FM MODULATORS; PORTABLE VIBRATION SPEAKERS; SPEAKER MICROPHONES; WIRELESS INDOOR AND OUTDOOR SPEAKERS (U.S. CLS. 21, 23, 26, 36 AND 38).
FIRST USE 4-8-2010; IN COMMERCE 4-8-2010.
ESTHER BELENKER, EXAMINING ATTORNEY

SN 85-559,824. HERAEUS ELECTRO-NITE INTERNATIONAL N.V., 3530 HOUTHALEN, BELGIUM, FILED 3-5-2012.

FiberCartridge

THE MARK CONSISTS OF STANDARD CHARACTERS WITHOUT CLAIM TO ANY PARTICULAR FONT, STYLE, SIZE, OR COLOR.

PRIORITY CLAIMED UNDER SEC. 44(D) ON ERPN CMNTY TM OFC APPLICATION NO. EU010390631, FILED 11-4-2011, REG. NO. 010390631, DATED 3-1-2012, EXPIRES 11-4-2021.

OWNER OF U.S. REG. NOS. 3,934,205 AND 3,934,207.
FOR MEASURING DEVICES AND SENSORS FOR MEASURING IN MOLTEN MASS, IN PARTICULAR IN MOLTEN METAL AND MOLTEN CRYOLITE; IN PARTICULAR FOR MEASURING TEMPERATURE (U.S. CLS. 21, 23, 26, 36 AND 38).

SHAILA SETTLES, EXAMINING ATTORNEY

CLASS 9—(Continued).

SN 85-560,612. THE GILBERTSON GROUP, COATESVILLE, PA. FILED 3-5-2012.

VeraPass

THE MARK CONSISTS OF STANDARD CHARACTERS WITHOUT CLAIM TO ANY PARTICULAR FONT, STYLE, SIZE, OR COLOR.

FOR COMPUTER HARDWARE AND SOFTWARE SYSTEMS FOR OPERATING AN ELECTRONIC LOCKING SYSTEM WITHIN COMMERCIAL AND FINANCIAL INSTITUTIONS; COMPUTER SOFTWARE FOR CONTROLLING SELF-SERVICE TERMINALS; FACILITIES MANAGEMENT SOFTWARE, NAMELY, SOFTWARE TO CONTROL BUILDING ENVIRONMENT, ACCESS AND SECURITY SYSTEMS; INTERACTIVE COMPUTER KIOSKS COMPRISING COMPUTERS, COMPUTER HARDWARE, COMPUTER PERIPHERALS, AND COMPUTER OPERATING SOFTWARE, FOR USE IN OPERATING AN ELECTRONIC LOCKING SYSTEM WITHIN COMMERCIAL AND FINANCIAL INSTITUTIONS (U.S. CLS. 21, 23, 26, 36 AND 38).

FIRST USE 7-27-2011; IN COMMERCE 8-1-2011.
DAVID HOFFMAN, EXAMINING ATTORNEY

CLASS 9—(Continued).

SN 85-561,887. ROCKTON SOFTWARE, INC., SANDPOINT, ID. FILED 3-6-2012.



THE MARK CONSISTS OF BOX SURROUNDING LETTER "R".

FOR COMPUTER SOFTWARE FOR IMPROVING CUSTOMER RELATIONSHIP MANAGEMENT (CRM) AND ENTERPRISE RESOURCE PLANNING (ERP), AUTOMATED DATA SEARCH, DATA MANAGEMENT AND AUDITING, REPORT MANAGEMENT, COMPLEX PRICING STRUCTURES, BUSINESS PROCESSES, AND FINANCIAL MANAGEMENT (U.S. CLS. 21, 23, 26, 36 AND 38).

FIRST USE 2-12-2010; IN COMMERCE 2-12-2010.
KATHY DE JONGE, EXAMINING ATTORNEY

SN 85-562,126. WARRIOR INDUSTRIES LLC, HEWITT, MN. FILED 3-6-2012.



SN 85-561,449. PARAGON VISION SCIENCES, INC., MESA, AZ. FILED 3-6-2012.

ICD

THE MARK CONSISTS OF STANDARD CHARACTERS WITHOUT CLAIM TO ANY PARTICULAR FONT, STYLE, SIZE, OR COLOR.

FOR CONTACT LENSES AND CONTACT LENS BLANKS AND BUTTONS (U.S. CLS. 21, 23, 26, 36 AND 38).

SHAUNIA CARLYLE, EXAMINING ATTORNEY

OWNER OF U.S. REG. NO. 4,018,604.

THE MARK CONSISTS OF THE LETTER "M" IS A "SWORD" FOLLOWED BY THE STYLIZED LETTER "A", STYLIZED LETTER "L", STYLIZED LETTER "I", STYLIZED LETTER "C", AND STYLIZED LETTER "E" TO SPELL OUT "MALICE".

FOR DIGITAL MATERIALS, NAMELY, MP3 FEATURING A MUSIC GROUP OR BAND; DIGITAL MEDIA, NAMELY, PRE-RECORDED DVDS, DOWNLOADABLE AUDIO AND VIDEO RECORDINGS, AND CDS FEATURING AND PROMOTING A MUSICAL GROUP OR BAND; DIGITAL MEDIA, NAMELY, CDS, AND DVDS FEATURING A MUSICAL GROUP OR BAND (U.S. CLS. 21, 23, 26, 36 AND 38).

FIRST USE 5-1-2009; IN COMMERCE 9-18-2010.
B. PARADEWELAI, EXAMINING ATTORNEY

CLASS 9—(Continued).

SN 85-562,761. BOUKLI-HACENE, MOUNIR, DBA QWERTY LOOK, ATLANTA, GA. FILED 3-7-2012.

Qwerty Look

THE MARK CONSISTS OF STANDARD CHARACTERS WITHOUT CLAIM TO ANY PARTICULAR FONT, STYLE, SIZE, OR COLOR.

FOR EYEWEAR (U.S. CLS. 21, 23, 26, 36 AND 38).
CYNTHIA TRIPI, EXAMINING ATTORNEY

SN 85-562,810. CUTHBERT, MELINDA, TIBURON, CA. FILED 3-7-2012.

I VITALITY LINKS

THE MARK CONSISTS OF STANDARD CHARACTERS WITHOUT CLAIM TO ANY PARTICULAR FONT, STYLE, SIZE, OR COLOR.

NO CLAIM IS MADE TO THE EXCLUSIVE RIGHT TO USE "I" AND "LINKS", APART FROM THE MARK AS SHOWN.

FOR COMPUTER APPLICATION SOFTWARE, NAMELY, SOFTWARE THAT WILL CAPTURE DATA FROM BACK-END DATABASES, TOGETHER WITH REAL TIME DATA FROM DEVICES VIA SENSOR AND COMMUNICATION AND COMPUTERIZED DEVICES AND USER GENERATED DATA IN THE COURSE OF INDIVIDUAL AND GROUP INTERACTION IN ORDER TO PROVIDE USERS WITH THE ABILITY TO MANAGE THEIR HEALTH, PREDICT DIFFICULTIES AND SECURE RESOURCES AND PROVIDES SUPPORT FOR PEOPLE WITH THEIR HEALTHCARE DECISIONS, HEALTH HABITS AND RECOVERY, AND CAN MAKE REFERRALS TO MEDICAL PERSONNEL, AGENCIES, PRODUCTS, AND OTHERS WITH A DISORDER AND USES ALGORITHMS TO PERSONALIZE HEALTH CARE INFORMATION; COMPUTER APPLICATION SOFTWARE, NAMELY, SOFTWARE THAT WILL CAPTURE DATA FROM BACK-END DATABASES, TOGETHER WITH REAL TIME DATA FROM DEVICES VIA SENSOR AND COMMUNICATION AND COMPUTERIZED DEVICES AND USER GENERATED DATA IN THE COURSE OF INDIVIDUAL AND GROUP INTERACTION IN ORDER TO PROVIDE USERS WITH THE ABILITY TO SET AND MANAGE OBJECTIVES, TRACKING PROGRESS ON OBJECTIVES AND PROVIDING RESOURCES THROUGH LINKS, SPECIAL OFFERS, AND ACCESS TO A COMMUNITY OF ADVICE AND SUPPORT (U.S. CLS. 21, 23, 26, 36 AND 38).

PAM WILLIS, EXAMINING ATTORNEY

CLASS 9—(Continued).

SN 85-562,892. PODZIBA, SUSAN, BROOKLINE, MA. FILED 3-7-2012.

CIVIC FUSION

THE MARK CONSISTS OF STANDARD CHARACTERS WITHOUT CLAIM TO ANY PARTICULAR FONT, STYLE, SIZE, OR COLOR.

NO CLAIM IS MADE TO THE EXCLUSIVE RIGHT TO USE "CIVIC", APART FROM THE MARK AS SHOWN.

FOR DOWNLOADABLE AUDIO FILES, MULTIMEDIA FILES, TEXT FILES, WRITTEN DOCUMENTS, AUDIO MATERIALS AND VIDEO MATERIALS FEATURING INFORMATION IN THE FIELDS OF PUBLIC POLICY AND MEDIATION (U.S. CLS. 21, 23, 26, 36 AND 38).
SCOTT BIBB, EXAMINING ATTORNEY

SN 85-564,867. FENIEX INDUSTRIES INC., AUSTIN, TX. FILED 3-9-2012.

PYTHON

THE MARK CONSISTS OF STANDARD CHARACTERS WITHOUT CLAIM TO ANY PARTICULAR FONT, STYLE, SIZE, OR COLOR.

FOR EMERGENCY AND SAFETY SIGNAL LIGHTING FOR POLICE, FIRE, CONSTRUCTION, EMERGENCY MEDICAL SERVICES, TOW TRUCKS AND SECURITY VEHICLES, NAMELY, BEACON LIGHTS, STROBE LIGHTS, SAFETY LIGHTS, LED LIGHTS, FLASHING COLORED LIGHTS, LIGHT BARS AND TRAFFIC DIRECTIONAL LIGHT BARS; EMERGENCY VEHICLE SIGNAL LIGHTING, NAMELY, WARNING LIGHTS, WRECKER LIGHTS, SECURITY LIGHTS, GRILLE SURFACE LIGHTS, POLICE LIGHTS AND TRAFFIC ADVISOR LIGHTS (U.S. CLS. 21, 23, 26, 36 AND 38).

FIRST USE 11-0-2010; IN COMMERCE 11-0-2010.

FRED CARL, EXAMINING ATTORNEY

CLASS 9—(Continued).

SN 85-564,873. FENIEX INDUSTRIES INC., AUSTIN, TX.
FILED 3-9-2012.

CYCLOPS

THE MARK CONSISTS OF STANDARD CHARACTERS WITHOUT CLAIM TO ANY PARTICULAR FONT, STYLE, SIZE, OR COLOR.

FOR EMERGENCY AND SAFETY SIGNAL LIGHTING FOR POLICE, FIRE, CONSTRUCTION, EMERGENCY MEDICAL SERVICES, TOW TRUCKS AND SECURITY VEHICLES, NAMELY, BEACON LIGHTS, STROBE LIGHTS, SAFETY LIGHTS, LED LIGHTS, FLASHING COLORED LIGHTS, LIGHT BARS AND TRAFFIC DIRECTIONAL LIGHT BARS; EMERGENCY VEHICLE SIGNAL LIGHTING, NAMELY, WARNING LIGHTS, WRECKER LIGHTS, SECURITY LIGHTS, POLICE LIGHTS AND TRAFFIC ADVISOR LIGHTS (U.S. CLS. 21, 23, 26, 36 AND 38).

FIRST USE 3-0-2011; IN COMMERCE 3-0-2011.
FRED CARL, EXAMINING ATTORNEY

CLASS 9—(Continued).

SN 85-565,497. INTERWEAVE PRESS, LLC, LOVELAND, CO.
FILED 3-9-2012.

EntreKnits

THE MARK CONSISTS OF STANDARD CHARACTERS WITHOUT CLAIM TO ANY PARTICULAR FONT, STYLE, SIZE, OR COLOR.

FOR DOWNLOADABLE ELECTRONIC PUBLICATIONS IN THE NATURE OF MAGAZINE FEATURING UNIQUE TIPS AND TECHNIQUES FOR ENTRELAC, MITERED AND MODULAR KNITTING WITH FUN PATTERNS, INNOVATIVE AND EDUCATIONAL TUTORIALS, INSPIRATIONAL VIDEOS AND UP-CLOSE IMAGE GALLERIES IN THE FIELD OF ARTS AND CRAFTS (U.S. CLS. 21, 23, 26, 36 AND 38).

FIRST USE 6-9-2011; IN COMMERCE 6-9-2011.
ANNE FARRELL, EXAMINING ATTORNEY

SN 85-565,486. INTERWEAVE PRESS, LLC, LOVELAND, CO.
FILED 3-9-2012.

Colorways

THE MARK CONSISTS OF STANDARD CHARACTERS WITHOUT CLAIM TO ANY PARTICULAR FONT, STYLE, SIZE, OR COLOR.

FOR DOWNLOADABLE ELECTRONIC PUBLICATIONS IN THE NATURE OF MAGAZINES FEATURING THE EXPLORATION OF THE ART, CRAFT, SCIENCE, CULTURE AND TRADITIONS OF COLOR IN TEXTILES OF ALL KINDS IN THE FIELD OF ARTS AND CRAFTS (U.S. CLS. 21, 23, 26, 36 AND 38).

FIRST USE 6-7-2011; IN COMMERCE 6-7-2011.
ANNE FARRELL, EXAMINING ATTORNEY

SN 85-565,509. INTERWEAVE PRESS, LLC, LOVELAND, CO.
FILED 3-9-2012.

LiveWire

THE MARK CONSISTS OF STANDARD CHARACTERS WITHOUT CLAIM TO ANY PARTICULAR FONT, STYLE, SIZE, OR COLOR.

FOR DOWNLOADABLE ELECTRONIC PUBLICATIONS IN THE NATURE OF MAGAZINE FEATURING ARTICLES, PROJECTS AND INFORMATION ABOUT MAKING WIRE JEWELRY IN THE FIELD OF ARTS AND CRAFTS (U.S. CLS. 21, 23, 26, 36 AND 38).

FIRST USE 7-18-2011; IN COMMERCE 7-18-2011.
ANNE FARRELL, EXAMINING ATTORNEY

CLASS 9—(Continued).

SN 85-567,125. BRIGDEN, GRANT, DBA HALFYBIRTHDAY, TORONTO, CANADA, FILED 3-12-2012.

halfybirthday

THE MARK CONSISTS OF STANDARD CHARACTERS WITHOUT CLAIM TO ANY PARTICULAR FONT, STYLE, SIZE, OR COLOR.

OWNER OF CANADA REG. NO. 1508449, DATED 3-9-2012, EXPIRES 3-9-2027.

FOR COMPUTER APPLICATION SOFTWARE FOR MOBILE PHONES, NAMELY, SOFTWARE FOR DETERMINING THE DATE OF A PERSONS HALF BIRTHDAY, THE MIDWAY POINT IN THE YEAR FROM THEIR ACTUAL BIRTH DATE; COMPUTER PROGRAMS FOR USING THE INTERNET AND THE WORLD WIDE WEB; COMPUTER SOFTWARE, NAMELY, SOFTWARE DEVELOPMENT TOOLS FOR THE CREATION OF MOBILE INTERNET APPLICATIONS AND CLIENT INTERFACES; CONSUMER COUPONS DOWNLOADED FROM A GLOBAL COMPUTER NETWORK (U.S. CLS. 21, 23, 26, 36 AND 38).

WILLIAM P. SHANAHAN, EXAMINING ATTORNEY

SN 85-567,180. GLOBAL CELLULAR, INC., ALPHARETTA, GA. FILED 3-12-2012.

TEGMEN

THE MARK CONSISTS OF STANDARD CHARACTERS WITHOUT CLAIM TO ANY PARTICULAR FONT, STYLE, SIZE, OR COLOR.

FOR CASES AND COVERS FOR WIRELESS DEVICES, NAMELY, PROTECTIVE COVERS AND CASES FOR CELL PHONES, LAPTOPS, PORTABLE MEDIA PLAYERS, TABLET COMPUTERS, ELECTRONIC READING DEVICES, AND PDAS (U.S. CLS. 21, 23, 26, 36 AND 38).

SCOTT BIBB, EXAMINING ATTORNEY

SN 85-567,251. GLOBAL CELLULAR, INC., ALPHARETTA, GA. FILED 3-12-2012.

TRILOGY

THE MARK CONSISTS OF STANDARD CHARACTERS WITHOUT CLAIM TO ANY PARTICULAR FONT, STYLE, SIZE, OR COLOR.

FOR CASES AND COVERS FOR WIRELESS DEVICES, NAMELY, PROTECTIVE COVERS AND CASES FOR CELL PHONES, LAPTOPS, PORTABLE MEDIA PLAYERS, TABLET COMPUTERS, ELECTRONIC READING DEVICES, AND PDAS (U.S. CLS. 21, 23, 26, 36 AND 38).

SCOTT BIBB, EXAMINING ATTORNEY

CLASS 9—(Continued).

SN 85-567,264. GLOBAL CELLULAR, INC., ALPHARETTA, GA. FILED 3-12-2012.

SHELL SHOCK

THE MARK CONSISTS OF STANDARD CHARACTERS WITHOUT CLAIM TO ANY PARTICULAR FONT, STYLE, SIZE, OR COLOR.

FOR CASES AND COVERS FOR WIRELESS DEVICES, NAMELY, PROTECTIVE COVERS AND CASES FOR CELL PHONES, LAPTOPS, PORTABLE MEDIA PLAYERS, TABLET COMPUTERS, ELECTRONIC READING DEVICES, AND PDAS (U.S. CLS. 21, 23, 26, 36 AND 38).

SCOTT BIBB, EXAMINING ATTORNEY

SN 85-569,468. PREVALENT NETWORKS, LLC, WARREN, NJ. FILED 3-14-2012.



NO CLAIM IS MADE TO THE EXCLUSIVE RIGHT TO USE "POLICY PORTAL", APART FROM THE MARK AS SHOWN.

THE COLOR(S) BLUE, TEAL, WHITE AND BLACK IS/ ARE CLAIMED AS A FEATURE OF THE MARK.

THE MARK CONSISTS OF A STYLIZED CIRCLE CONTAINING A STYLIZED LETTER P, AND A PIECE OF PAPER IN THE BOTTOM RIGHT HAND CORNER OF THE CIRCLE WITH A FOLDED EDGE. THE WORD "PREVALENT" APPEARS TO THE RIGHT OF THE CIRCLE ABOVE THE WORDS "POLICY PORTAL".

FOR COMPUTER SOFTWARE FOR MANAGING A COMPLIANCE REGULATING DATABASE (U.S. CLS. 21, 23, 26, 36 AND 38).

FIRST USE 9-0-2011; IN COMMERCE 9-0-2011.

SHAILA SETTLES, EXAMINING ATTORNEY

CLASS 9—(Continued).

SN 85-569,529. JANT, LLC, GREENSBORO, NC. FILED 3-14-2012.

jant

THE MARK CONSISTS OF STANDARD CHARACTERS WITHOUT CLAIM TO ANY PARTICULAR FONT, STYLE, SIZE, OR COLOR.

FOR AUDIO AND VIDEO RECORDINGS FEATURING MUSIC AND ARTISTIC PERFORMANCES; AUDIO AND VIDEO RECORDINGS FEATURING MUSIC AND VISUAL EFFECTS; AUDIO RECORDINGS FEATURING MUSIC; AUDIO TAPES FEATURING MUSIC; COMPACT DISCS FEATURING MUSIC; DIGITAL MUSIC DOWNLOADABLE FROM THE INTERNET; DOWNLOADABLE MP3 FILES AND MP3 RECORDINGS FEATURING MUSIC; DOWNLOADABLE MUSICAL SOUND RECORDINGS; MUSICAL RECORDINGS; MUSICAL SOUND RECORDINGS; OPTICAL COMPACT DISCS FEATURING AUDIO AND VISUAL ENTERTAINMENT; SOUND RECORDINGS FEATURING MUSIC; VISUAL AND AUDIO RECORDINGS FEATURING MUSIC AND MUSIC VIDEOS; CASES FOR MUSIC, AUDIO AND RELATED ELECTRONIC EQUIPMENT, NAMELY, CASES FOR AUDIO TUNERS, AUDIO RECEIVERS, AMPLIFIERS, TAPE PLAYERS, COMPACT DISC PLAYERS, MP3 CONTROLLERS/PLAYERS, AUDIO MIXERS, AUDIO SPEAKERS IN THE NATURE OF MUSIC STUDIO MONITORS, MICROPHONES, AUDIO SPEAKERS, COMPACT DISCS, AUDIO TAPES, PORTABLE COMPUTERS, ANTENNAS, PHONOGRAPHIC RECORD PLAYERS, AUDIO RECORDING EQUIPMENT, AND THE CABLES ASSOCIATED WITH ALL OF THE FOREGOING EQUIPMENT; DIGITAL MEDIA, NAMELY, PRE-RECORDED DVDS, DOWNLOADABLE AUDIO AND VIDEO RECORDINGS, AND CDS FEATURING AND PROMOTING MUSIC AND MUSIC VIDEOS; DIGITAL MEDIA, NAMELY, PRE-RECORDED VIDEO CASSETTES, DIGITAL VIDEO DISCS, DIGITAL VERSATILE DISCS, DOWNLOADABLE AUDIO AND VIDEO RECORDINGS, DVDS, AND HIGH DEFINITION DIGITAL DISCS FEATURING AUDIO OR VISUAL ENTERTAINMENT; DOWNLOADABLE VIDEO RECORDINGS FEATURING MUSIC AND MUSIC VIDEOS; MUSICAL VIDEO RECORDINGS; VIDEO RECORDINGS FEATURING MUSIC AND MUSIC VIDEOS (U.S. CLS. 21, 23, 26, 36 AND 38).

FIRST USE 10-1-2009; IN COMMERCE 11-21-2010.

MATTHEW MCDOWELL, EXAMINING ATTORNEY

CLASS 9—(Continued).

SN 85-569,712. AMERICAN PRODUCTS, LLC, STRAFFORD, MO. FILED 3-14-2012.



THE COLOR(S) RED, WHITE, AND BLUE IS/ARE CLAIMED AS A FEATURE OF THE MARK.

THE MARK CONSISTS OF RIGHT TO LEFT - A 5 FINGERED RED WAVE GOING INTO A BLUE STAR WITH THE WORD "THE" STACKED ON TOP OF THE WORD "PATRIOT" IN BLUE LOCATED TO THE RIGHT OF THE STAR, ALL WITH A WHITE BACKGROUND.

FOR OUTSIDE METAL CABINETS USED IN THE WIRELESS AND WIRED TELECOMMUNICATIONS INDUSTRY, NAMELY, METAL CLOSURES SPECIFICALLY ADAPTED TO PROTECT SENSITIVE TELECOMMUNICATION EQUIPMENT IN OUTDOOR ENVIRONMENTS (U.S. CLS. 21, 23, 26, 36 AND 38).

FIRST USE 2-20-2012; IN COMMERCE 2-20-2012.
SOPHIA S. KIM, EXAMINING ATTORNEY

SN 85-570,686. WEBSTER FINANCIAL CORPORATION, WATERBURY, CT. FILED 3-15-2012.

WEBSTER

THE MARK CONSISTS OF STANDARD CHARACTERS WITHOUT CLAIM TO ANY PARTICULAR FONT, STYLE, SIZE, OR COLOR.

FOR CALCULATORS; COUNTERFEIT MONEY DETECTION LIGHT TO BE USED IN RETAIL STORES AND BANKS (U.S. CLS. 21, 23, 26, 36 AND 38).

DANIEL CAPSHAW, EXAMINING ATTORNEY

SN 85-570,733. NATIONAL PRESORT, INC., FORT WORTH, TX. FILED 3-15-2012.

OPTE

THE MARK CONSISTS OF STANDARD CHARACTERS WITHOUT CLAIM TO ANY PARTICULAR FONT, STYLE, SIZE, OR COLOR.

FOR COMPUTER SOFTWARE FOR USE IN OPTIMIZING THE PLANNING, OPERATION, AND MONITORING OF DOCUMENT SORTING MACHINES (U.S. CLS. 21, 23, 26, 36 AND 38).

NORA BUCHANAN WILL, EXAMINING ATTORNEY

CLASS 9—(Continued).

SN 85-571,632. ANKER TECH CORPORATION, NEWARK, DE. FILED 3-16-2012.

USPEED

THE MARK CONSISTS OF STANDARD CHARACTERS WITHOUT CLAIM TO ANY PARTICULAR FONT, STYLE, SIZE, OR COLOR.

FOR COMPUTER HARDWARE AND PERIPHERALS; CONSUMER ELECTRONIC PRODUCTS IN THE NATURE OF ELECTRONIC MEMORY CARD READERS, COMPUTER NETWORKS ADAPTERS, SWITCHES, ROUTERS AND HUBS, WIRELESS NETWORK EXTENDERS, WIRELESS NETWORK REPEATERS, PERIPHERAL COMPONENT INTERFACE (PCI) HARDWARE; AUDIO RECEIVERS, ELECTRICAL AUDIO AND SPEAKER CABLES AND CONNECTORS; ELECTRIC POWER CONVERTERS AND POWER INVERTERS; HOME AND OFFICE AUTOMATION SYSTEMS COMPRISING WIRELESS AND WIRED CONTROLLERS, CONTROLLED DEVICES, AND SOFTWARE FOR LIGHTING, HVAC, SECURITY, SAFETY AND OTHER HOME AND OFFICE MONITORING AND CONTROL APPLICATIONS; USB (UNIVERSAL SERIAL BUS) HARDWARE; USB CABLES, USB HUBS, USB DRIVES (U.S. CLS. 21, 23, 26, 36 AND 38).

FIRST USE 11-1-2011; IN COMMERCE 11-1-2011.
MARILYN IZZI, EXAMINING ATTORNEY

CLASS 9—(Continued).

SN 85-575,083. SABER BUSINESS SOLUTIONS INC., DBA SABER BUSINESS SOLUTIONS INC., CHARLOTTE, NC. FILED 3-20-2012.

MAP EVERYTHING WITH MAP ANYTHING

THE MARK CONSISTS OF STANDARD CHARACTERS WITHOUT CLAIM TO ANY PARTICULAR FONT, STYLE, SIZE, OR COLOR.

FOR COMPUTER APPLICATION SOFTWARE FOR GEO-LOCATING AND ANALYSIS OF DATA, NAMELY, SOFTWARE FOR USE IN DATABASE MANAGEMENT AND DATA TRACKING; COMPUTER E-COMMERCE SOFTWARE TO ALLOW USERS TO PERFORM ELECTRONIC BUSINESS TRANSACTIONS VIA A GLOBAL COMPUTER NETWORK; COMPUTER SOFTWARE FOR APPLICATION AND DATABASE INTEGRATION; COMPUTER SOFTWARE THAT PROVIDES REAL-TIME, INTEGRATED BUSINESS MANAGEMENT INTELLIGENCE BY COMBINING INFORMATION FROM VARIOUS DATABASES AND PRESENTING IT IN AN EASY-TO-UNDERSTAND USER INTERFACE (U.S. CLS. 21, 23, 26, 36 AND 38).

FIRST USE 11-30-2009; IN COMMERCE 11-30-2009.
BENJAMIN OKEKE, EXAMINING ATTORNEY

SN 85-572,214. PRECISION DYNAMICS CORPORATION, SAN FERNANDO, CA. FILED 3-16-2012.

PDC

THE MARK CONSISTS OF STANDARD CHARACTERS WITHOUT CLAIM TO ANY PARTICULAR FONT, STYLE, SIZE, OR COLOR.

OWNER OF U.S. REG. NOS. 2,945,641, 2,988,514 AND 3,043,931.

FOR FLEXIBLE WRISTBANDS CONTAINING ENCODED ELECTRONIC CHIPS AND/OR EMBEDDED RFID TECHNOLOGY FOR USE IN REVENUE CONTROL, ADMISSIONS CONTROL, CROWD CONTROL, INCARCERATION CONTROL AND TRACKING AND IDENTIFICATION IN HOSPITALS OR OTHER SIMILAR HEALTHCARE AND HOSPITALITY APPLICATIONS; INTERACTIVE COMPUTER KIOSKS COMPRISING COMPUTERS, COMPUTER HARDWARE, COMPUTER PERIPHERALS, AND COMPUTER OPERATING SOFTWARE, FOR USE IN ELECTRONIC IDENTIFICATION (U.S. CLS. 21, 23, 26, 36 AND 38).

FIRST USE 1-1-2002; IN COMMERCE 1-1-2002.
EDWARD FENNESSY, EXAMINING ATTORNEY

SN 85-575,532. SELECTHEALTH, INC., MURRAY, UT. FILED 3-21-2012.

PROVIDER INSIGHT

THE MARK CONSISTS OF STANDARD CHARACTERS WITHOUT CLAIM TO ANY PARTICULAR FONT, STYLE, SIZE, OR COLOR.

NO CLAIM IS MADE TO THE EXCLUSIVE RIGHT TO USE "PROVIDER", APART FROM THE MARK AS SHOWN, FOR DOWNLOADABLE ELECTRONIC NEWSLETTERS IN THE FIELD OF HEALTHCARE INSURANCE PLANS (U.S. CLS. 21, 23, 26, 36 AND 38).

FIRST USE 11-30-2003; IN COMMERCE 11-30-2003.
DEBORAH LOBO, EXAMINING ATTORNEY

CLASS 9—(Continued).

SN 85-575,562. SELECTHEALTH, INC., MURRAY, UT.
FILED 3-21-2012.

PHARMACY & THERAPEUTICS

THE MARK CONSISTS OF STANDARD CHARACTERS
WITHOUT CLAIM TO ANY PARTICULAR FONT, STYLE,
SIZE, OR COLOR.

SEC. 2(F).

FOR DOWNLOADABLE ELECTRONIC NEWSLET-
TERS IN THE FIELD OF PRESCRIPTION AND OVER-
THE-COUNTER PHARMACEUTICALS (U.S. CLS. 21, 23,
26, 36 AND 38).

FIRST USE 3-31-2006; IN COMMERCE 3-31-2006.
DEBORAH LOBO, EXAMINING ATTORNEY

CLASS 9—(Continued).

SN 85-577,330. FILENE'S BASEMENT, LLC, SEACAUCUS,
NJ. FILED 3-22-2012.

STANLEY B. BY STANLEY
BLACKER

THE MARK CONSISTS OF STANDARD CHARACTERS
WITHOUT CLAIM TO ANY PARTICULAR FONT, STYLE,
SIZE, OR COLOR.

OWNER OF U.S. REG. NOS. 1,379,293, 2,862,769 AND
3,557,293.

THE NAME(S), PORTRAIT(S), AND/OR SIGNATURE(S)
SHOWN IN THE MARK DOES NOT IDENTIFY A PARTI-
CULAR LIVING INDIVIDUAL.

FOR EYEGLASSES; SUNGLASSES; EYEGLASS CASES
(U.S. CLS. 21, 23, 26, 36 AND 38).

KAREN BRACEY, EXAMINING ATTORNEY

SN 85-577,734. AGHA, SALMA, BAKERSFIELD, CA. FILED
3-23-2012.

IPORTASOLAR

THE MARK CONSISTS OF STANDARD CHARACTERS
WITHOUT CLAIM TO ANY PARTICULAR FONT, STYLE,
SIZE, OR COLOR.

FOR SOLAR BATTERIES; SOLAR PANELS FOR PRO-
DUCTION OF ELECTRICITY; SOLAR RECHARGING
BATTERY PACK FOR DIGITAL CAMERAS, MOBILE
PHONES, TOYS, LAPTOPS AND PORTABLE ELECTRO-
NIC DEVICES; PORTABLE RESIDENTIAL AND COM-
MERCIAL ELECTRICAL POWER DISTRIBUTION
UNITS (U.S. CLS. 21, 23, 26, 36 AND 38).

KRISTINA MORRIS, EXAMINING ATTORNEY

SN 85-576,620. RELIANCE COMMUNICATIONS, LLC,
HAUPPAUGE, NY. FILED 3-22-2012.



NO CLAIM IS MADE TO THE EXCLUSIVE RIGHT TO
USE "AIRTYME", APART FROM THE MARK AS SHOWN.

THE COLOR(S) BLACK, GRAY, YELLOW, BROWN,
ORANGE, LIGHT GREEN, RED, PURPLE AND BLUE IS/
ARE CLAIMED AS A FEATURE OF THE MARK.

THE MARK CONSISTS OF THE WORDS "AIRTYME"
AND "PICASSO" WHERE THE WORD "AIRTYME" IS IN A
STYLIZED, VARYING GRAYSCALE FONT SITUATED
ABOVE THE WORD "PICASSO" IN A STYLIZED, ARTISTIC
BUBBLE FONT WHERE THE LETTERS CONTAIN THE
COLORS BLACK, GRAY, YELLOW, BROWN, ORANGE,
LIGHT GREEN, RED, PURPLE AND BLUE IN A TILED
FASHION.

FOR MOBILE PHONES, SMARTPHONES, CELLULAR
PHONES, PORTABLE COMPUTERS, AND PERSONAL
DIGITAL ASSISTANTS AND WIRELESS HANDHELD
DIGITAL ELECTRONIC DEVICES FOR COMMUNICAT-
ING, RECORDING, ORGANIZING, TRANSMITTING,
MANIPULATING, STORING, AND REVIEWING TEXT,
DATA, IMAGE AND AUDIO FILES (U.S. CLS. 21, 23, 26,
36 AND 38).

RONALD MCMORROW, EXAMINING ATTORNEY

SN 85-579,309. BOCBEE HOLDINGS LTD., VICTORIA BC,
CANADA, FILED 3-25-2012.

VAMP

THE MARK CONSISTS OF STANDARD CHARACTERS
WITHOUT CLAIM TO ANY PARTICULAR FONT, STYLE,
SIZE, OR COLOR.

FOR COMPUTER GAME SOFTWARE; COMPUTER
SOFTWARE AND HARDWARE FOR A SERVER CON-
NECTED TO A GLOBAL COMPUTER NETWORK FOR
USE IN CREATING AND MANAGING THE VIRTUAL
ASSETS IN A COMPUTER GAME; COMPUTER SOFT-
WARE PLATFORMS FOR CROSS-GAME AND CROSS-
PLATFORM VIRTUAL ASSET CREATION AND MAN-
AGEMENT; COMPUTER SOFTWARE, NAMELY, GAME
ENGINE SOFTWARE FOR VIDEO GAME DEVELOP-
MENT AND OPERATION; VIRTUAL REALITY SOFT-
WARE FOR THE CREATION AND MANAGEMENT OF
VIRTUAL ASSETS IN COMPUTER GAMES (U.S. CLS. 21,
23, 26, 36 AND 38).

SHANNON TWOHIG, EXAMINING ATTORNEY

CLASS 9—(Continued).

SN 85-579,729. RENZONE, JOHN, MISSISSAUGA, ONTARIO, CANADA, FILED 3-26-2012.

TREAD TRACKER

THE MARK CONSISTS OF STANDARD CHARACTERS WITHOUT CLAIM TO ANY PARTICULAR FONT, STYLE, SIZE, OR COLOR.

NO CLAIM IS MADE TO THE EXCLUSIVE RIGHT TO USE "TREAD", APART FROM THE MARK AS SHOWN.

FOR GAUGES FOR MEASURING VEHICLE TIRE WEAR (U.S. CLS. 21, 23, 26, 36 AND 38).

SUZANNE BLANE, EXAMINING ATTORNEY

SN 85-580,269. WEBB, WILEY, MALIBU, CA. FILED 3-26-2012.

Wiley Webb

THE MARK CONSISTS OF STANDARD CHARACTERS WITHOUT CLAIM TO ANY PARTICULAR FONT, STYLE, SIZE, OR COLOR.

THE NAME "WILEY WEBB" IDENTIFIES A LIVING INDIVIDUAL WHOSE CONSENT IS OF RECORD.

FOR DIGITAL MATERIALS, NAMELY, CDS FEATURING MUSIC (U.S. CLS. 21, 23, 26, 36 AND 38).

TASHIA BUNCH, EXAMINING ATTORNEY

SN 85-581,203. DIGITAL ALLY, INC., OVERLAND PARK, KS. FILED 3-27-2012.

VUCOMMAND

THE MARK CONSISTS OF STANDARD CHARACTERS WITHOUT CLAIM TO ANY PARTICULAR FONT, STYLE, SIZE, OR COLOR.

FOR SOFTWARE FOR THE PURPOSE OF RECORDING, COLLECTING, DOWNLOADING, MANAGING, AND ANALYZING VIDEO, AUDIO, AND OTHER CASE EVIDENCE IN THE FIELD OF LAW ENFORCEMENT (U.S. CLS. 21, 23, 26, 36 AND 38).

CATHERINE ROEHL, EXAMINING ATTORNEY

CLASS 9—(Continued).

SN 85-581,585. SMUGMUG, INC., MOUNTAIN VIEW, CA. FILED 3-27-2012.



THE COLOR(S) YELLOW, GREEN, BLUE, TURQUOISE, PINK, GRAY, WHITE, BLACK AND PURPLE IS/ARE CLAIMED AS A FEATURE OF THE MARK.

THE MARK CONSISTS OF A STYLIZED DEPICTION OF A DIGITAL CAMERA LENS AND SHUTTER. THE LENS AND SHUTTER IS COMPRISED OF MULTIPLE CONCENTRIC CIRCLES IN VARYING SHADES OF GREEN, YELLOW, BLUE, TURQUOISE, PINK, PURPLE, WHITE, GRAY AND BLACK. FOUR SHAPES RESEMBLING HALF CIRCLES ARE SUPERIMPOSED OVER THE CONCENTRIC CIRCLES AND ARE PRESENTED IN VARYING SHADES OF GREEN, YELLOW, BLUE, PINK, PURPLE, WHITE, GRAY AND BLACK. A GRAY SHAPE RESEMBLING A TEAR DROP THAT IS OUTLINED IN WHITE IS SITUATED AROUND THE LENS AND SHUTTER. AN "A" PRESENTED IN STYLIZED BLACK FONT THAT IS OUTLINED IN WHITE SITS AT THE TOP OF THE TEARDROP. A TRIANGLE DESIGN COMPRISED OF ALTERNATING BARS OF DARK GRAY AND WHITE FLANK THE "A" ON EACH SIDE. THE TEAR DROP AND LENS ELEMENTS ARE SUPERIMPOSED OVER A BLACK SQUARE WITH ROUNDED CORNERS THAT FADES FROM BLACK TO GRAY AT THE TOP AND BOTTOM. THE MARK IN ITS ENTIRETY APPEARS ON A TRANSPARENT BACKGROUND.

FOR DOWNLOADABLE COMPUTER SOFTWARE FOR MODIFYING AND TRANSMITTING PHOTOGRAPHS (U.S. CLS. 21, 23, 26, 36 AND 38).

FIRST USE 2-29-2012; IN COMMERCE 2-29-2012.

GRETCHEN ULRICH, EXAMINING ATTORNEY

SN 85-582,523. DIGITALLBIZ.COM, LLC, AKA EASYMANA-GE.ME, LLC, ROCHESTER HILLS, MI. FILED 3-28-2012.

ReadyRide

THE MARK CONSISTS OF STANDARD CHARACTERS WITHOUT CLAIM TO ANY PARTICULAR FONT, STYLE, SIZE, OR COLOR.

FOR COMPUTER APPLICATION SOFTWARE FOR MOBILE PHONES, NAMELY, MOBILE DEVICE APPLICATIONS; COMPUTER APPLICATION SOFTWARE FOR MOBILE PHONES, TABLETS, AND OTHER MOBILE DEVICES, NAMELY, SOFTWARE FOR CUSTOMER APPLICATION FOR TAXI CAB SERVICES (U.S. CLS. 21, 23, 26, 36 AND 38).

FIRST USE 2-20-2012; IN COMMERCE 2-20-2012.

PAUL E. FAHRENKOPF, EXAMINING ATTORNEY

CLASS 9—(Continued).

SN 85-583,204. GLOBAL CELLULAR, INC., ALPHARETTA, GA. FILED 3-29-2012.

SHUX

THE MARK CONSISTS OF STANDARD CHARACTERS WITHOUT CLAIM TO ANY PARTICULAR FONT, STYLE, SIZE, OR COLOR.

FOR CASES AND COVERS FOR WIRELESS DEVICES, NAMELY, PROTECTIVE COVERS AND CASES FOR CELL PHONES, LAPTOPS, PORTABLE MEDIA PLAYERS, TABLET COMPUTERS, ELECTRONIC READING DEVICES, AND PDAS (U.S. CLS. 21, 23, 26, 36 AND 38).

SCOTT BIBB, EXAMINING ATTORNEY

CLASS 9—(Continued).

SN 85-584,341. CREATIVE DISTRIBUTION AUTOMATION CO., LTD., BEIJING, CHINA, FILED 3-30-2012.



THE MARK CONSISTS OF AN OVAL WITH THE WORD "ESCOUT" IN IT.

FOR FLASHING SAFETY LIGHTS; MECHANICAL SIGNS; ELECTRO-DYNAMIC APPARATUS FOR THE REMOTE CONTROL OF SIGNALS; LIGHTNING ARRESTERS; ALARM INSTALLATIONS AND ALARMS; FAULTED CIRCUIT INDICATORS; DIAGNOSTIC APPARATUS FOR TESTING ELECTRICITY POWER GRIDS; ELECTRIC INSTALLATIONS FOR THE REMOTE CONTROL OF INDUSTRIAL OPERATIONS (U.S. CLS. 21, 23, 26, 36 AND 38).

FIRST USE 9-1-2010; IN COMMERCE 8-1-2011.

JEFFREY LOOK, EXAMINING ATTORNEY

SN 85-584,340. LIN, ZHONG JIAN, OZONE PARK, NY. FILED 3-30-2012.

P&G

Peace Grace

THE MARK CONSISTS OF STANDARD CHARACTERS WITHOUT CLAIM TO ANY PARTICULAR FONT, STYLE, SIZE, OR COLOR.

OWNER OF U.S. REG. NO. 4,084,092.
FOR EYEWEAR; EYEWEAR ACCESSORIES, NAMELY, STRAPS, NECK CORDS AND HEAD STRAPS WHICH RESTRAIN EYEWEAR FROM MOVEMENT ON A WEARER; EYEWEAR CASES; EYEWEAR RETAINERS; EYEWEAR, NAMELY, SUNGLASSES, EYEGLASSES AND OPHTHALMIC FRAMES AND CASES THEREFOR; NOSE GUARDS WHICH CAN BE WORN BY ATTACHMENT TO EYEWEAR SUCH AS SUNGLASSES AND SKI GOGGLES; PROTECTIVE EYEWEAR; PROTECTIVE EYEWEAR AND COMPONENT PARTS THEREOF; SAFETY EYEWEAR; SPORTS EYEWEAR (U.S. CLS. 21, 23, 26, 36 AND 38).

FIRST USE 8-7-2008; IN COMMERCE 8-7-2008.

JEFFREY LOOK, EXAMINING ATTORNEY

SN 85-585,001. ALESIS, L.P., CUMBERLAND, RI. FILED 3-30-2012.

GUITAR IO

THE MARK CONSISTS OF STANDARD CHARACTERS WITHOUT CLAIM TO ANY PARTICULAR FONT, STYLE, SIZE, OR COLOR.

NO CLAIM IS MADE TO THE EXCLUSIVE RIGHT TO USE "GUITAR", APART FROM THE MARK AS SHOWN.

FOR DOCKING STATIONS FOR COMPUTERS, TABLETS AND SMARTPHONES THAT CONTAIN AN INTERFACE SPECIFICALLY FOR GUITARS (U.S. CLS. 21, 23, 26, 36 AND 38).

GIANCARLO CASTRO, EXAMINING ATTORNEY

CLASS 9—(Continued).

SN 85-585,048. FIFO WIRELESS, INC., MIAMI, FL. FILED 3-30-2012.



OWNER OF U.S. REG. NO. 3,384,486.
THE MARK CONSISTS OF A DEPICTION OF A MOON ON TOP OF A TRIANGLE, THE WORD "FIFO" IN STYLIZED FORM BELOW.

FOR AUDIO SPEAKERS; BATTERY CHARGERS; CASES FOR MOBILE PHONES; DEVICES FOR HANDS-FREE USE OF MOBILE PHONES; RADIO TRANSMITTERS; SIGNAL SPLITTERS FOR ELECTRONIC APPARATUS; SPECIALTY HOLSTER FOR CARRYING CELLULAR PHONES, PAGERS, AND/OR PERSONAL DIGITAL ASSISTANTS (U.S. CLS. 21, 23, 26, 36 AND 38).
FIRST USE 3-29-2012; IN COMMERCE 3-29-2012.
DAVID COLLIER, EXAMINING ATTORNEY

CLASS 9—(Continued).

SN 85-585,171. ICACHE, INC., CAMBRIDGE, MA. FILED 3-30-2012.



SN 85-585,141. ICACHE, INC., CAMBRIDGE, MA. FILED 3-30-2012.

GEODE

THE MARK CONSISTS OF STANDARD CHARACTERS WITHOUT CLAIM TO ANY PARTICULAR FONT, STYLE, SIZE, OR COLOR.

FOR CELL PHONE COVERS; CARD READERS FOR MAGNETICALLY ENCODED CARDS; BLANK SMART CARDS; CARDS WITH INTEGRATED CIRCUITS; COMPUTER CARD ADAPTERS; ELECTRONIC AND MAGNETIC ID CARDS FOR USE IN CONNECTION WITH PAYMENT FOR SERVICES; BIOMETRIC IDENTIFICATION APPARATUS; DEVICES FOR CELLULAR PHONES IN THE NATURE OF A CELL PHONE COVER FEATURING A BIOMETRIC IDENTIFICATION APPARATUS, A DISPLAY FOR PRESENTING BAR CODES, AN APPARATUS FOR STORING INFORMATION ON MAGNETICALLY ENCODED CARDS AND AN APPARATUS FOR STORING INFORMATION ON SMART CARDS ALL INCORPORATED THEREIN AS A SINGLE UNIT; COMPUTER HARDWARE AND SOFTWARE SOLD AS A UNIT FOR STORING INFORMATION RELATED TO CREDIT CARDS, LOYALTY CARDS, GIFT CARDS, MEMBERSHIP CARDS, FINANCIAL INFORMATION, IDENTIFICATION INFORMATION AND PERSONAL INFORMATION AND FOR RETRIEVING AND PRESENTING THE INFORMATION UPON REQUEST (U.S. CLS. 21, 23, 26, 36 AND 38).

JEFFREY LOOK, EXAMINING ATTORNEY

THE MARK CONSISTS OF THE STYLIZED LETTER "G" WITHIN A PARTIALLY SHADED OVAL.

FOR CELL PHONE COVERS; CARD READERS FOR MAGNETICALLY ENCODED CARDS; BLANK SMART CARDS; CARDS WITH INTEGRATED CIRCUITS; COMPUTER CARD ADAPTERS; ELECTRONIC AND MAGNETIC ID CARDS FOR USE IN CONNECTION WITH PAYMENT FOR SERVICES; BIOMETRIC IDENTIFICATION APPARATUS; DEVICES FOR CELLULAR PHONES IN THE NATURE OF A CELL PHONE COVER FEATURING A BIOMETRIC IDENTIFICATION APPARATUS, A DISPLAY FOR PRESENTING BAR CODES, AN APPARATUS FOR STORING INFORMATION ON MAGNETICALLY ENCODED CARDS AND AN APPARATUS FOR STORING INFORMATION ON SMART CARDS ALL INCORPORATED THEREIN AS A SINGLE UNIT; COMPUTER HARDWARE AND SOFTWARE SOLD AS A UNIT FOR STORING INFORMATION RELATED TO CREDIT CARDS, LOYALTY CARDS, GIFT CARDS, MEMBERSHIP CARDS, FINANCIAL INFORMATION, IDENTIFICATION INFORMATION AND PERSONAL INFORMATION AND FOR RETRIEVING AND PRESENTING THE INFORMATION UPON REQUEST (U.S. CLS. 21, 23, 26, 36 AND 38).

JEFFREY LOOK, EXAMINING ATTORNEY

CLASS 9—(Continued).

SN 85-585,188. ICACHE, INC., CAMBRIDGE, MA. FILED 3-30-2012.



THE MARK CONSISTS OF THE LITERAL TERM "GEODE", DISPLAYED BELOW A STYLIZED LETTER "G" CONTAINED WITHIN A PARTIALLY SHADED OVAL.

FOR CELL PHONE COVERS; CARD READERS FOR MAGNETICALLY ENCODED CARDS; BLANK SMART CARDS; CARDS WITH INTEGRATED CIRCUITS; COMPUTER CARD ADAPTERS; ELECTRONIC AND MAGNETIC ID CARDS FOR USE IN CONNECTION WITH PAYMENT FOR SERVICES; BIOMETRIC IDENTIFICATION APPARATUS; DEVICES FOR CELLULAR PHONES IN THE NATURE OF A CELL PHONE COVER FEATURING A BIOMETRIC IDENTIFICATION APPARATUS, A DISPLAY FOR PRESENTING BAR CODES, AN APPARATUS FOR STORING INFORMATION ON MAGNETICALLY ENCODED CARDS AND AN APPARATUS FOR STORING INFORMATION ON SMART CARDS ALL INCORPORATED THEREIN AS A SINGLE UNIT; COMPUTER HARDWARE AND SOFTWARE SOLD AS A UNIT FOR STORING INFORMATION RELATED TO CREDIT CARDS, LOYALTY CARDS, GIFT CARDS, MEMBERSHIP CARDS, FINANCIAL INFORMATION, IDENTIFICATION INFORMATION AND PERSONAL INFORMATION AND FOR RETRIEVING AND PRESENTING THE INFORMATION UPON REQUEST (U.S. CLS. 21, 23, 26, 36 AND 38).

JEFFREY LOOK, EXAMINING ATTORNEY

CLASS 9—(Continued).

SN 85-585,553. NATIONAL PRODUCTS, INC., SEATTLE, WA. FILED 3-30-2012.

AQUA BOX

THE MARK CONSISTS OF STANDARD CHARACTERS WITHOUT CLAIM TO ANY PARTICULAR FONT, STYLE, SIZE, OR COLOR.

NO CLAIM IS MADE TO THE EXCLUSIVE RIGHT TO USE "BOX", APART FROM THE MARK AS SHOWN.

FOR PROTECTIVE CARRYING CASES FOR CELL PHONES, GPS NAVIGATION DEVICES, PERSONAL DIGITAL ASSISTANTS, MP3 PLAYERS, COMPUTERS AND OTHER HANDHELD DIGITAL ELECTRONIC DEVICES; PROTECTIVE CASES SPECIALLY ADAPTED FOR USE WITH HANDHELD DIGITAL ELECTRONIC DEVICES, DESIGNED FOR ATTACHMENT TO VEHICLES, SUCH AS MOTORCYCLES, BICYCLES, ALL-TERRAIN VEHICLES, BOATS OR PERSONAL WATERCRAFT (U.S. CLS. 21, 23, 26, 36 AND 38).

FIRST USE 0-0-2006; IN COMMERCE 0-0-2006.

ELIZABETH KAJUBI, EXAMINING ATTORNEY

SN 85-585,507. FIBERJEN TELCOM LLC, NORTH ARLINGTON, NJ. FILED 3-30-2012.

E-Z Route Horizontal Cable Management

THE MARK CONSISTS OF STANDARD CHARACTERS WITHOUT CLAIM TO ANY PARTICULAR FONT, STYLE, SIZE, OR COLOR.

NO CLAIM IS MADE TO THE EXCLUSIVE RIGHT TO USE "HORIZONTAL CABLE", APART FROM THE MARK AS SHOWN.

FOR METAL BAR SPECIALLY ADAPTED TO PROTECT TELECOMMUNICATIONS AND NETWORKING EQUIPMENT AS WELL AS FIBER OPTIC CABLES (U.S. CLS. 21, 23, 26, 36 AND 38).

FIRST USE 8-2-2011; IN COMMERCE 12-13-2011.

DOMINIC J. FERRAIUOLO, EXAMINING ATTORNEY



NO CLAIM IS MADE TO THE EXCLUSIVE RIGHT TO USE "RAID", APART FROM THE MARK AS SHOWN.

THE MARK CONSISTS OF THE LETTER "M" IN A SHADED BOX NEXT TO THE WORD "RAID".

FOR COMPUTER SOFTWARE FOR USE IN ELECTRONIC STORAGE AND MANAGEMENT OF DATA, NAMELY, SELF CONTAINED REDUNDANT ARRAY OF INDEPENDENT DISKS (RAID) DATA STORAGE SUBSYSTEMS SPECIFICALLY DIRECTED TO THE ENTERTAINMENT AND MEDIA INDUSTRIES (U.S. CLS. 21, 23, 26, 36 AND 38).

FIRST USE 9-0-2011; IN COMMERCE 1-0-2012.

AISHA SALEM, EXAMINING ATTORNEY

CLASS 9—(Continued).

SN 85-585,598. ACTIVE STORAGE, INC., TORRANCE, CA. FILED 3-30-2012.



NO CLAIM IS MADE TO THE EXCLUSIVE RIGHT TO USE "MEDIA", APART FROM THE MARK AS SHOWN.
THE MARK CONSISTS OF THE LETTER "M" IN A SHADED BOX WITH THE WORD "MEDIA" BELOW IT.
FOR COMPUTER STORAGE SOFTWARE PLATFORMS FOR CREATION, DISTRIBUTION, ARCHIVE MANAGEMENT AND INTEGRATION OF DATA INTO AN INTERACTIVE DELIVERY FOR MULTIMEDIA APPLICATIONS (U.S. CLS. 21, 23, 26, 36 AND 38).
FIRST USE 9-0-2011; IN COMMERCE 1-0-2012.
AISHA SALEM, EXAMINING ATTORNEY

CLASS 9—(Continued).

SN 85-585,715. PISCITELLI, MICHAEL, GLENDALE HEIGHTS, IL. FILED 3-31-2012.

KUSH-CASES

THE MARK CONSISTS OF STANDARD CHARACTERS WITHOUT CLAIM TO ANY PARTICULAR FONT, STYLE, SIZE, OR COLOR.
FOR PROTECTIVE COVERS AND CASES FOR PORTABLE ELECTRONIC MOBILE DEVICES, NAMELY, MOBILE PHONES, E-READERS, TABLET COMPUTERS, AND DIGITAL MUSIC PLAYERS (U.S. CLS. 21, 23, 26, 36 AND 38).
DEIRDRE ROBERTSON, EXAMINING ATTORNEY

SN 85-585,751. ISAM TECHNOLOGIES CORPORATION, MIAMI, FL. FILED 3-31-2012.

SN 85-585,603. ACTIVE STORAGE, INC., TORRANCE, CA. FILED 3-30-2012.



NO CLAIM IS MADE TO THE EXCLUSIVE RIGHT TO USE "SAN", APART FROM THE MARK AS SHOWN.
THE MARK CONSISTS OF THE LETTER "M" IN A SHADED BOX NEXT TO THE LETTERS "SAN".
FOR COMPUTER SOFTWARE AND HARDWARE FOR USE IN NETWORK STORAGE MANAGEMENT FOR LARGE SCALE MEDIA APPLICATIONS (U.S. CLS. 21, 23, 26, 36 AND 38).
AISHA SALEM, EXAMINING ATTORNEY



THE MARK CONSISTS OF A STYLIZED SILHOUETTE OF A DOG FACING FORWARD AND SITTING ON A BLACK CIRCLE WHICH CONTAINS THE WORD "I-SAM".
FOR COMPUTER SOFTWARE FOR UNIVERSITIES, SCHOOLS, TEACHERS, STUDENTS AND OTHERS IN ALL CURRICULUM AREAS TO ALLOW FOR SEARCHING, SHARING, LEARNING, TEACHING, POSTING, COMMUNICATING, CONNECTING, AND COLLABORATING FOR CLASSES, TESTS, ACADEMIC PROJECTS AND PAPERS (U.S. CLS. 21, 23, 26, 36 AND 38).
DAWN FELDMAN, EXAMINING ATTORNEY

CLASS 9—(Continued).

SN 85-588,050. AYEHU SOFTWARE TECHNOLOGIES, LTD.,
TEL AVIV, ISRAEL, FILED 4-3-2012.

EYESHARE

THE MARK CONSISTS OF STANDARD CHARACTERS WITHOUT CLAIM TO ANY PARTICULAR FONT, STYLE, SIZE, OR COLOR.

FOR OPERATING SOFTWARE FOR PROCESS AUTOMATION FOR INFORMATION TECHNOLOGY DEPARTMENTS (U.S. CLS. 21, 23, 26, 36 AND 38).

FIRST USE 0-0-2010; IN COMMERCE 0-0-2010.
RAUL CORDOVA, EXAMINING ATTORNEY

SN 85-588,479. FULL SAIL, LLC, WINTER PARK, FL. FILED
4-4-2012.

FULL SAIL LABS

THE MARK CONSISTS OF STANDARD CHARACTERS WITHOUT CLAIM TO ANY PARTICULAR FONT, STYLE, SIZE, OR COLOR.

OWNER OF U.S. REG. NOS. 2,025,339, 2,996,883 AND OTHERS.

NO CLAIM IS MADE TO THE EXCLUSIVE RIGHT TO USE "LABS", APART FROM THE MARK AS SHOWN.

FOR PRERECORDED DIGITAL VIDEO DISCS, MOTION PICTURE FILMS, MULTIMEDIA COMPUTER SOFTWARE RECORDED ON CD-ROMS, COMPUTER DISCS AND DOWNLOADABLE VIDEO RECORDINGS, ALL FEATURING ENTERTAINMENT IN THE NATURE OF MOTION PICTURES FEATURING DRAMA, COMEDY, ACTION, HORROR, CHILDREN'S SUBJECTS AND DOCUMENTARIES IN ANIMATED AND LIVE-ACTION FORM, MUSIC VIDEOS, ANIMATED CARTOONS, MUSICAL PERFORMANCES AND DRAMAS; INTERACTIVE VIDEO GAME PROGRAMS; VIDEO GAME DISCS; VIDEO GAME SOFTWARE; COMPUTER SOFTWARE FOR USE BY TEACHERS, EDUCATORS AND ADMINISTRATION PROFESSIONALS IN THE FIELD OF EDUCATION IN CONNECTION WITH THE DESIGN AND DEVELOPMENT OF EDUCATIONAL PROGRAMS, CLASSES AND CURRICULA; PRERECORDED VIDEO TAPES, MOTION PICTURE FILMS, MULTIMEDIA COMPUTER SOFTWARE RECORDED ON CD-ROMS, COMPUTER DISCS AND DOWNLOADABLE VIDEO RECORDINGS AND COMPUTER SOFTWARE, ALL FEATURING INSTRUCTION IN THE OPERATION AND DEVELOPMENT OF COMPUTER GAMES AND DIGITAL MEDIA EQUIPMENT, COMPUTER SOFTWARE DEVELOPMENT, COMPUTER GAME AND DIGITAL MEDIA DEVELOPMENT AND IN THE FIELDS OF ART, MUSIC PRODUCTION, VIDEO PRODUCTION, AUDIO PRODUCTION, COMPUTER DESIGN, TELEVISION PROGRAMMING AND PRODUCTION, FILM PRODUCTION, COMPUTER ANIMATION, VIDEO AND COMPUTER GAME DESIGN, WEB DESIGN, TEACHER AND INSTRUCTOR CREDENTIALING, GRAPHIC DESIGN, INTERNET MARKETING, MEDIA DESIGN, CREATIVE WRITING, JOURNALISM, LIVE EVENT PRODUCTION, AND ENTERTAINMENT BUSINESS, NAMELY, MARKETING, PROMOTION, FUND-RAISING, ACCOUNTING AND ADVERTISING FOR INDEPENDENT ARTISTS, FILM MAKERS AND RECORDING ARTISTS. DOWNLOADABLE COMPUTER SOFTWARE, PRERECORDED VIDEO RECORDINGS, AND ELECTRONIC PUBLICATIONS IN THE NATURE OF TEXT-

CLASS 9—(Continued).

BOOKS AND WORKBOOKS FEATURING PRE-RECORDED COURSES OF INSTRUCTION, SEMINARS, CONFERENCES AND WORKSHOPS, ALL IN THE FIELDS OF ART, MUSIC PRODUCTION, VIDEO PRODUCTION, AUDIO PRODUCTION, COMPUTER DESIGN, TELEVISION PROGRAMMING AND PRODUCTION, FILM PRODUCTION, COMPUTER ANIMATION, VIDEO AND COMPUTER GAME DESIGN, WEB DESIGN, TEACHER AND INSTRUCTOR CREDENTIALING, GRAPHIC DESIGN, INTERNET MARKETING, MEDIA DESIGN, CREATIVE WRITING, JOURNALISM, LIVE EVENT PRODUCTION AND ENTERTAINMENT BUSINESS, NAMELY, ENTERTAINMENT MARKETING, PROMOTION, FUND-RAISING, ACCOUNTING AND ADVERTISING FOR INDEPENDENT ARTISTS, FILM MAKERS AND RECORDING ARTISTS; DOWNLOADABLE ELECTRONIC PUBLICATIONS, NAMELY, TEXTBOOKS, WORKBOOKS, TEACHING GUIDES, INSTRUCTIONAL MANUALS, CATALOGS, PHOTOGRAPHS, NEWSPAPERS, NEWSLETTERS AND MAGAZINES IN THE FIELDS OF ART, MUSIC PRODUCTION, VIDEO PRODUCTION, AUDIO PRODUCTION, COMPUTER DESIGN, TELEVISION PROGRAMMING AND PRODUCTION, FILM PRODUCTION, COMPUTER ANIMATION, VIDEO AND COMPUTER GAME DESIGN, WEB DESIGN, TEACHER AND INSTRUCTOR CREDENTIALING, GRAPHIC DESIGN, INTERNET MARKETING, MEDIA DESIGN, CREATIVE WRITING, JOURNALISM, LIVE EVENT PRODUCTION AND ENTERTAINMENT BUSINESS, NAMELY, ENTERTAINMENT MARKETING, PROMOTION, FUND-RAISING, ACCOUNTING AND ADVERTISING FOR INDEPENDENT ARTISTS, FILM MAKERS AND RECORDING ARTISTS; COMPUTER HARDWARE INCLUDING BLANK FLASH DRIVES AND PERSONAL AUDIO/VIDEO DEVICES, NAMELY, PORTABLE AND HANDHELD DIGITAL ELECTRONIC DEVICES FOR RECORDING, ORGANIZING, TRANSMITTING, MANIPULATING, AND REVIEWING TEXT, DATA, IMAGE AND AUDIO FILES; CD PLAYERS, MP3 PLAYERS, AND PORTABLE DVD PLAYERS (U.S. CLS. 21, 23, 26, 36 AND 38).

KIM MONINGHOFF, EXAMINING ATTORNEY

SN 85-588,531. WATERS TECHNOLOGIES CORPORATION,
WILMINGTON, DE. FILED 4-4-2012.

XTERRA

THE MARK CONSISTS OF STANDARD CHARACTERS WITHOUT CLAIM TO ANY PARTICULAR FONT, STYLE, SIZE, OR COLOR.

FOR DEVICES AND MATERIALS FOR USE IN LIQUID CHROMATOGRAPHY, NAMELY, CHROMATOGRAPHY EXTRACTION CARTRIDGES, PLATES, AND COLUMNS (U.S. CLS. 21, 23, 26, 36 AND 38).

FIRST USE 7-8-1999; IN COMMERCE 7-8-1999.

GIANCARLO CASTRO, EXAMINING ATTORNEY

CLASS 9—(Continued).

SN 85-589,104. JOHNSON, CLIFTON L., DBA IWEST ENTERTAINMENT, BROWNS VALLEY, CA. AND GLENN, LARRY E., DBA IWEST ENTERTAINMENT, ANTIOCH, CA. FILED 4-4-2012.



NO CLAIM IS MADE TO THE EXCLUSIVE RIGHT TO USE "ENTERTAINMENT", APART FROM THE MARK AS SHOWN.

THE MARK CONSISTS OF THE FOLLOWING WORDING "IWEST ENTERTAINMENT."

FOR AUDIO AND VIDEO RECORDINGS FEATURING MUSIC AND ARTISTIC PERFORMANCES; CHILDREN'S EDUCATIONAL MUSIC CDS AND DVDS; CHILDREN'S VIDEO TAPES; COMPUTER GAME SOFTWARE FOR PERSONAL COMPUTERS AND HOME VIDEO GAME CONSOLES; COMPUTER GAME SOFTWARE FOR USE WITH PERSONAL COMPUTERS, HOME VIDEO GAME CONSOLES USED WITH TELEVISIONS AND ARCADE-BASED VIDEO GAME CONSOLES; COMPUTER PROGRAMS FOR EDITING IMAGES, SOUND AND VIDEO; COMPUTER PROGRAMS FOR VIDEO AND COMPUTER GAMES; COMPUTER SOFTWARE FEATURING MUSICAL SOUND RECORDINGS AND MUSICAL VIDEO RECORDINGS; DIGITAL MATERIALS, NAMELY, DIGITAL, DVDS, DOWNLOADABLE FILES FEATURING MUSIC, MUSIC VIDEOS; DIGITAL MEDIA, NAMELY, PRE-RECORDED DVDS, DOWNLOADABLE AUDIO AND VIDEO RECORDINGS, AND CDS FEATURING AND PROMOTING MUSIC, MUSIC VIDEOS; DIGITAL MEDIA, NAMELY, PRE-RECORDED VIDEO CASSETTES, DIGITAL VIDEO DISCS, DIGITAL VERSATILE DISCS, DOWNLOADABLE AUDIO AND VIDEO RECORDINGS, DVDS, AND HIGH DEFINITION DIGITAL DISCS FEATURING MUSIC VIDEOS; DIGITAL MEDIA, NAMELY, CDS, DVDS, DOWNLOADABLE AUDIO AND VIDEO FILES FEATURING MUSIC, MUSIC VIDEOS; DOWNLOADABLE MP3 FILES AND MP3 RECORDINGS FEATURING MUSIC; DOWNLOADABLE MP3 FILES, MP3 RECORDINGS, ON-LINE DISCUSSION BOARDS, WEBCASTS, WEBINARS AND PODCASTS FEATURING MUSIC, AUDIO BOOKS IN THE FIELD OF MUSIC ENTERTAINMENT, AND NEWS BROADCASTS; DOWNLOADABLE MUSICAL SOUND RECORDINGS; DOWNLOADABLE VIDEO RECORDINGS FEATURING MUSIC VIDEOS (U.S. CLS. 21, 23, 26, 36 AND 38).

LOURDES AYALA, EXAMINING ATTORNEY

SN 85-589,601. JEON, ALEX SEUNG, TORONTO ONTARIO, CANADA, FILED 4-4-2012.



THE MARK CONSISTS OF STANDARD CHARACTERS WITHOUT CLAIM TO ANY PARTICULAR FONT, STYLE, SIZE, OR COLOR.

FOR COMPUTER APPLICATION SOFTWARE FOR MOBILE PHONES, NAMELY, EDUCATION SOFTWARE FOR ASSISTING STUDENTS WITH SPEECH TRAINING; COMPUTER APPLICATION SOFTWARE FOR HANDHELD DEVICES, NAMELY, EDUCATION SOFTWARE FOR ASSISTING STUDENTS WITH SPEECH TRAINING (U.S. CLS. 21, 23, 26, 36 AND 38).

FIRST USE 2-17-2012; IN COMMERCE 5-7-2012.
TAMARA FRAZIER, EXAMINING ATTORNEY

CLASS 9—(Continued).

SN 85-589,889. SILVER CREATION INTERNATIONAL LTD, TSIM SHA TSUI, HONG KONG, FILED 4-5-2012.



THE MARK CONSISTS OF STANDARD CHARACTERS WITHOUT CLAIM TO ANY PARTICULAR FONT, STYLE, SIZE, OR COLOR.

FOR MOUNTING DEVICES FOR WIRELESS DIGITAL ELECTRONIC DEVICES; CASES FOR WIRELESS DIGITAL ELECTRONIC DEVICES (U.S. CLS. 21, 23, 26, 36 AND 38).

SHAILA SETTLES, EXAMINING ATTORNEY

SN 85-589,910. FOLLOWILL MUSIC, INC., NASHVILLE, TN, FILED 4-5-2012.

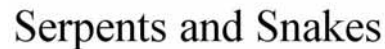

THE MARK CONSISTS OF STANDARD CHARACTERS WITHOUT CLAIM TO ANY PARTICULAR FONT, STYLE, SIZE, OR COLOR.

FOR DIGITAL MEDIA, NAMELY, PRE-RECORDED DVDS, DOWNLOADABLE AUDIO AND VIDEO RECORDINGS, AND CDS FEATURING AND PROMOTING AUDIO AND AUDIO-VISUAL RECORDINGS IN THE FIELD OF MUSIC AND MUSICAL PERFORMANCES; DIGITAL MEDIA, NAMELY, PRE-RECORDED VIDEO CASSETTES, DIGITAL VIDEO DISCS, DIGITAL VERSATILE DISCS, DOWNLOADABLE AUDIO AND VIDEO RECORDINGS, DVDS, AND HIGH DEFINITION DIGITAL DISCS FEATURING AUDIO AND AUDIO-VISUAL RECORDINGS IN THE FIELD OF MUSIC AND MUSICAL PERFORMANCES; DOWNLOADABLE MP3 FILES AND MP3 RECORDINGS FEATURING AUDIO AND AUDIO-VISUAL RECORDINGS IN THE FIELD OF MUSIC AND MUSICAL PERFORMANCES; DOWNLOADABLE MUSICAL SOUND RECORDINGS; DOWNLOADABLE VIDEO RECORDINGS FEATURING MUSICAL ARTISTS; MUSICAL RECORDINGS; MUSICAL SOUND RECORDINGS; MUSICAL VIDEO RECORDINGS; PHONOGRAPH RECORDS FEATURING MUSIC; PRE-RECORDED CDS FEATURING AUDIO RECORDINGS IN THE FIELD OF MUSIC AND MUSICAL PERFORMANCES; PRE-RECORDED CDS, VIDEO TAPES, LASER DISKS AND DVDS FEATURING AUDIO AND AUDIO-VISUAL RECORDINGS IN THE FIELD OF MUSIC AND MUSICAL PERFORMANCES; PRE-RECORDED DIGITAL MEDIA FEATURING AUDIO AND AUDIO-VISUAL RECORDINGS IN THE FIELD OF MUSIC AND MUSICAL PERFORMANCES; PRE-RECORDED DIGITAL VIDEO DISCS FEATURING AUDIO-VISUAL RECORDINGS; PRE-RECORDED DVDS FEATURING AUDIO AND AUDIO-VISUAL RECORDINGS IN THE FIELD OF MUSIC AND MUSICAL PERFORMANCES; PRE-RECORDED VIDEO DISCS, VIDEO RECORDING AND VIDEO TAPES FEATURING AUDIO-VISUAL RECORDINGS IN THE FIELD OF MUSIC AND MUSICAL PERFORMANCES (U.S. CLS. 21, 23, 26, 36 AND 38).

JANICE L. MCMORROW, EXAMINING ATTORNEY

CLASS 9—(Continued).

SN 85-591,406. THE EXECUTOR OF THE OTIS REDDING ESTATE, LOS ANGELES, CA. FILED 4-6-2012.

THE KING OF SOUL

THE MARK CONSISTS OF STANDARD CHARACTERS WITHOUT CLAIM TO ANY PARTICULAR FONT, STYLE, SIZE, OR COLOR.

THE NAME "THE KING OF SOUL" WAS THE NICK-NAME OF OTIS REDDING WHO IS NOT A LIVING INDIVIDUAL.

FOR COMPACT DISCS AND DVDS FEATURING MUSIC; MUSICAL SOUND RECORDINGS; DOWNLOADABLE RINGTONES FOR CELLULAR PHONES; DOWNLOADABLE MUSIC, AUDIO, AND VIDEO FILES FEATURING MUSIC; SUNGLASSES; DECORATIVE MAGNETS; DOWNLOADABLE ELECTRONIC GAME PROGRAMS; ELECTRONIC GAME PROGRAMS; ELECTRONIC GAME SOFTWARE FOR CELLULAR PHONES; ELECTRONIC GAME SOFTWARE FOR HANDHELD ELECTRONIC DEVICES; COMPUTER GAME PROGRAMS, CARTRIDGES, AND DISCS; COMPUTER GAME SOFTWARE; VIDEO GAME PROGRAMS, CARTRIDGES, AND DISCS; VIDEO GAME SOFTWARE; DIGITAL TRADING CARDS IN THE NATURE OF MULTIMEDIA SOFTWARE RECORDED ON MAGNETIC MEDIA FEATURING ANIMATED CHARACTERS; MICROPHONES; CD PLAYERS, MP3 PLAYERS, RADIOS; SMART PHONES; ELECTRONIC LEARNING SYSTEMS COMPRISED PRIMARILY OF COMPUTER HARDWARE AND SOFTWARE FOR CHILDREN'S EDUCATIONAL PURPOSES AND COMPUTER CARTRIDGES THEREFOR; MULTIMEDIA SOFTWARE RECORDED ON CD-ROMS FEATURING GAMES; APPARATUS FOR RECORDING, TRANSMISSION OR REPRODUCTION OF SOUND OR IMAGES; CALCULATORS; MOUSE PADS; PRE-PAID TELEPHONE CALLING CARDS MAGNETICALLY ENCODED; SOUND RECORDINGS FEATURING MUSIC; AUDIO BOOKS IN THE NATURE OF NOVELS; DIGITAL BOOK READERS (U.S. CLS. 21, 23, 26, 36 AND 38).

CATHERINE ROEHL, EXAMINING ATTORNEY

SN 85-592,019. TACTEC APPLIED OPTOELECTRONICS, LLC, HENDERSON, NV. FILED 4-8-2012.



THE MARK CONSISTS OF THE WORD "TAO" WRITTEN VERTICALLY, WHERE EACH OF THE LETTERS APPEARS INSIDE A SEPARATE SQUARE AND WHERE THE LETTER "A" IS FORMED BY AN INVERTED LETTER "V"

FOR LIGHT EMITTING DIODE (LED) DISPLAYS; LIGHT EMITTING DIODES (LEDS) (U.S. CLS. 21, 23, 26, 36 AND 38).

LINDA LAVACHE, EXAMINING ATTORNEY

CLASS 9—(Continued).

SN 85-592,982. INNERAPPS, LLC., PERRYSBURG, OH. FILED 4-9-2012.



NO CLAIM IS MADE TO THE EXCLUSIVE RIGHT TO USE "IDENTITY SYNCHRONIZER", APART FROM THE MARK AS SHOWN.

THE MARK CONSISTS OF A CIRCULAR ARROW WITH A CRESCENT SHAPED CENTER AND THE TEXT "IDENTITY SYNCHRONIZER" ON THE RIGHT, WITH "IDENTITY" ON TOP AND IN LARGER TEXT, AND "SYNCHRONIZER" BELOW.

FOR COMPUTER SOFTWARE FOR USE IN IDENTITY ACCESS AND MANAGEMENT (U.S. CLS. 21, 23, 26, 36 AND 38).

FIRST USE 12-6-2007; IN COMMERCE 8-6-2008.

TINA L. SNAPP, EXAMINING ATTORNEY

SN 85-593,139. HOT TODDY DESIGN LLC, WENHAM, MA. FILED 4-10-2012.



NO CLAIM IS MADE TO THE EXCLUSIVE RIGHT TO USE "DESIGN", APART FROM THE MARK AS SHOWN.

THE MARK CONSISTS OF A PORTRAIT OF A WOMAN WITH A RAISED LEFT HAND, ENCIRCLED IN AN OVAL, WITH THE WORDS "HOT TODDY" DESIGN UNDERNEATH.

FOR CARRYING CASES SPECIALLY ADAPTED FOR USE WITH HANDHELD DIGITAL ELECTRONIC DEVICES (U.S. CLS. 21, 23, 26, 36 AND 38).

KELLEY WELLS, EXAMINING ATTORNEY

CLASS 9—(Continued).

SN 85-593,260. RICHARD JOSEPH ABEL MURILLO, DBA AUTOCHROME, SOMERVILLE, MA. FILED 4-10-2012.

Autochrome

THE MARK CONSISTS OF STANDARD CHARACTERS WITHOUT CLAIM TO ANY PARTICULAR FONT, STYLE, SIZE, OR COLOR.

FOR DOWNLOADABLE DIGITAL MATERIALS, NAMELY, PRE-RECORDED CDS, DVDS AND MUSIC VIDEOS IN AUDIO FILE FORMAT FEATURING THE MUSIC OF THE BAND AUTOCHROME (U.S. CLS. 21, 23, 26, 36 AND 38).

FIRST USE 3-1-2007; IN COMMERCE 3-10-2012.
EVIN L. KOZAK, EXAMINING ATTORNEY

SN 85-593,756. CHECKPOINT FLUIDIC SYSTEMS INTERNATIONAL, LTD., MANDEVILLE, LA. FILED 4-10-2012.

INTELLIJECT

THE MARK CONSISTS OF STANDARD CHARACTERS WITHOUT CLAIM TO ANY PARTICULAR FONT, STYLE, SIZE, OR COLOR.

FOR CONTROL SYSTEMS COMPRISING COMPUTER HARDWARE, OPERATING SOFTWARE, AND SENSORS FOR FLOW, BATTERY VOLTAGE, PANEL VOLTAGE, AMPERAGE, TEMPERATURE AND PRESSURE FOR USE WITH POSITIVE DISPLACEMENT PUMPS USED TO DOSE OR INJECT CHEMICALS, INCLUDING PERFORMANCE-ENHANCEMENT CHEMICALS (PECS), FOR USE IN HYDROCARBON PRODUCTION, TRANSPORTATION, REFINING, AND OTHER INDUSTRIAL APPLICATIONS (U.S. CLS. 21, 23, 26, 36 AND 38).

KATHY DE JONGE, EXAMINING ATTORNEY

SN 85-593,815. CHECKPOINT FLUIDIC SYSTEMS INTERNATIONAL, LTD., MANDEVILLE, LA. FILED 4-10-2012.

ICARUS

THE MARK CONSISTS OF STANDARD CHARACTERS WITHOUT CLAIM TO ANY PARTICULAR FONT, STYLE, SIZE, OR COLOR.

FOR CONTROL SYSTEMS COMPRISING COMPUTER HARDWARE, OPERATING SOFTWARE, AND SENSORS FOR FLOW, BATTERY VOLTAGE, PANEL VOLTAGE, AMPERAGE, TEMPERATURE AND PRESSURE FOR USE WITH POSITIVE DISPLACEMENT PUMPS USED TO DOSE OR INJECT CHEMICALS, INCLUDING PERFORMANCE-ENHANCEMENT CHEMICALS (PECS), FOR USE IN HYDROCARBON PRODUCTION, TRANSPORTATION, REFINING, AND OTHER INDUSTRIAL APPLICATIONS (U.S. CLS. 21, 23, 26, 36 AND 38).

KATHY DE JONGE, EXAMINING ATTORNEY

CLASS 9—(Continued).

SN 85-593,841. CATALYST ON-LINE, AKA CATALYST ON-LINE, NEWTON, MA. FILED 4-10-2012.

Asset Optimization Platform

THE MARK CONSISTS OF STANDARD CHARACTERS WITHOUT CLAIM TO ANY PARTICULAR FONT, STYLE, SIZE, OR COLOR.

NO CLAIM IS MADE TO THE EXCLUSIVE RIGHT TO USE ASSET AND PLATFORM, APART FROM THE MARK AS SHOWN.

FOR COMPUTER SOFTWARE FOR PROVIDING AN ON-LINE DATABASE IN THE FIELD OF TRANSACTION PROCESSING TO UPLOAD TRANSACTIONAL DATA, PROVIDE STATISTICAL ANALYSIS, AND PRODUCE NOTIFICATIONS AND REPORTS (U.S. CLS. 21, 23, 26, 36 AND 38).

MATTHEW KLINE, EXAMINING ATTORNEY

SN 85-593,967. DOUBLELOOP, INC., RICHARDSON, TX. FILED 4-10-2012.



THE COLOR(S) GREEN AND BLACK IS/ARE CLAIMED AS A FEATURE OF THE MARK.

THE MARK CONSISTS OF THE GREEN LETTERS "DOUBLEL" NEXT TO A BLACK INFINITY SYMBOL NEXT TO A GREEN LETTER "P".

FOR COMPUTER APPLICATION SOFTWARE FOR MOBILE PHONES, NAMELY, EDUCATIONAL SOFTWARE IN THE FIELD OF MATHEMATICS AND SCIENCE; COMPUTER APPLICATION SOFTWARE FOR MOBILE PHONES, PORTABLE COMPUTERS, AND HANDHELD COMPUTERS, NAMELY, EDUCATION SOFTWARE IN THE FIELD OF MATHEMATICS AND SCIENCE AND GAMING SOFTWARE; COMPUTER APPLICATION SOFTWARE FOR MOBILE PHONES, NAMELY, SOFTWARE FEATURING ENTERTAINING MATHEMATICS LESSONS; DOWNLOADABLE SOFTWARE IN THE NATURE OF A MOBILE APPLICATION FOR USE IN EDUCATION IN THE FIELD OF MATHEMATICS AND SCIENCE (U.S. CLS. 21, 23, 26, 36 AND 38).

MATTHEW KLINE, EXAMINING ATTORNEY

SN 85-594,196. FEHRING, ROBERT, PATCHOGUE, NY. FILED 4-11-2012.



THE MARK CONSISTS OF THE WORDING "EZ TEXT-TIPS" IN STYLIZED LETTERS.

FOR RUBBER FINGER TIPS TO ENHANCE PHONE TEXTING ACCURACY (U.S. CLS. 21, 23, 26, 36 AND 38).

IRA J. GOODSAY, EXAMINING ATTORNEY

CLASS 9—(Continued).

SN 85-594,243. FINDMYTAP LLC, WHITE PLAINS, NY. FILED 4-11-2012.

Findmytap

THE MARK CONSISTS OF STANDARD CHARACTERS WITHOUT CLAIM TO ANY PARTICULAR FONT, STYLE, SIZE, OR COLOR.

FOR COMPUTER APPLICATION SOFTWARE FOR MOBILE PHONES, NAMELY, SOFTWARE FOR DISPLAYING AND SHARING A USER'S LOCATION, FINDING, LOCATING, AND INTERACTING WITH OTHER USERS, AND LOCATING A USER'S FAVORITE BAR AND/OR BEER (U.S. CLS. 21, 23, 26, 36 AND 38).

FIRST USE 1-1-2012; IN COMMERCE 1-1-2012.
JULIE WATSON, EXAMINING ATTORNEY

SN 85-594,704. BEGINNER TRIATHLETE, LLC, AKRON, OH. FILED 4-11-2012.

Beginner Triathlete

THE MARK CONSISTS OF STANDARD CHARACTERS WITHOUT CLAIM TO ANY PARTICULAR FONT, STYLE, SIZE, OR COLOR.

SEC. 2(F).
FOR DOWNLOADABLE TRAINING PROGRAMS, GUIDES, PLANS, AND TRAINING LOGS IN THE FIELD OF TRIATHLONS AND TRIATHLON TRAINING (U.S. CLS. 21, 23, 26, 36 AND 38).

FIRST USE 6-13-2003; IN COMMERCE 6-13-2003.
TRACY FLETCHER, EXAMINING ATTORNEY

SN 85-594,768. REID, DONALD J., SMITHTOWN, NY. FILED 4-11-2012.

E-Z CHANGE

THE MARK CONSISTS OF STANDARD CHARACTERS WITHOUT CLAIM TO ANY PARTICULAR FONT, STYLE, SIZE, OR COLOR.

FOR TELEVISIONS (U.S. CLS. 21, 23, 26, 36 AND 38).
BRENDAN MCCAULEY, EXAMINING ATTORNEY

CLASS 9—(Continued).

SN 85-594,824. COMMUNITYCENTRIC, LLC, SHELBY, NC. FILED 4-11-2012.

DATUMSUITE

THE MARK CONSISTS OF STANDARD CHARACTERS WITHOUT CLAIM TO ANY PARTICULAR FONT, STYLE, SIZE, OR COLOR.

FOR COMPUTER SOFTWARE FOR CONVERTING COMPUTER FILES IN ANY FORMAT TO ANOTHER FORMAT (U.S. CLS. 21, 23, 26, 36 AND 38).

FIRST USE 3-28-2012; IN COMMERCE 3-28-2012.
DAWN FELDMAN, EXAMINING ATTORNEY

SN 85-594,841. PATTERSON, JOHN, M, DBA ZOMBIELENS, MARIETTA, GA. FILED 4-11-2012.

ZOMBIE LENS

THE MARK CONSISTS OF STANDARD CHARACTERS WITHOUT CLAIM TO ANY PARTICULAR FONT, STYLE, SIZE, OR COLOR.

OWNER OF U.S. REG. NO. 3,939,194.
NO CLAIM IS MADE TO THE EXCLUSIVE RIGHT TO USE "LENS", APART FROM THE MARK AS SHOWN.
FOR CONTACT LENSES (U.S. CLS. 21, 23, 26, 36 AND 38).

FIRST USE 12-15-2010; IN COMMERCE 12-15-2010.
LINDA M. KING, EXAMINING ATTORNEY

SN 85-595,023. CARVED, LLC, ELKHART, IN. FILED 4-11-2012.

CARVED

NO CLAIM IS MADE TO THE EXCLUSIVE RIGHT TO USE "CARVED". APART FROM THE MARK AS SHOWN.

THE MARK CONSISTS OF A STYLIZED "C", A STYLIZED "A", STYLIZED "R", STYLIZED "V", STYLIZED "E", AND A STYLIZED "D", AND THE LETTERS IN THE LOGO HAVE SHARP POINTS AND EDGES.

FOR CASES MADE OF WOOD SPECIALLY FITTED FOR MOBILE PHONES AND TABLET COMPUTERS; FITTED WOOD FILMS KNOWN AS SKINS FOR COVERING AND PROTECTING ELECTRONIC APPARATUS, NAMELY, MOBILE PHONES AND TABLET COMPUTERS (U.S. CLS. 21, 23, 26, 36 AND 38).

FIRST USE 9-1-2011; IN COMMERCE 12-9-2011.
JEFFREY LOOK, EXAMINING ATTORNEY

CLASS 9—(Continued).

SN 85-595,185. LOTZ, JEFFREY PAUL, AYR, ONTARIO, CANADA, FILED 4-11-2012.

Deep Trekker

THE MARK CONSISTS OF STANDARD CHARACTERS WITHOUT CLAIM TO ANY PARTICULAR FONT, STYLE, SIZE, OR COLOR.

NO CLAIM IS MADE TO THE EXCLUSIVE RIGHT TO USE "DEEP", APART FROM THE MARK AS SHOWN.

FOR NAUTICAL AND PHOTOGRAPHIC APPARATUS AND INSTRUMENTS, NAMELY, UNDERWATER HOUSINGS FOR CAMERAS, UNDERWATER ENCLOSURES FOR CAMERAS AND UNDERWATER ENCLOSURES FOR PHOTOGRAPHIC LENSES; REMOTELY-CONTROLLED SUB-AQUATIC VIDEO CAMERA CONTAINING A TV CAMERA, TRANSMITTER, RECEIVER AND MICROPHONE TO RECORD, DETECT, MEASURE, SURVEY AND LOCATE OBJECTS UNDERWATER; UNDERWATER CAMERAS (U.S. CLS. 21, 23, 26, 36 AND 38).

FIRST USE 12-1-2009; IN COMMERCE 4-18-2011.
SETH A. RAPPAPORT, EXAMINING ATTORNEY

SN 85-595,372. MIHEALTH GLOBAL SYSTEMS INC., NORTH BAY, CANADA, FILED 4-11-2012.



SECURE INSTANT ACCESS

NO CLAIM IS MADE TO THE EXCLUSIVE RIGHT TO USE "SECURE INSTANT ACCESS", APART FROM THE MARK AS SHOWN.

THE MARK CONSISTS OF THE WORDS "SECURE INSTANT ACCESS" SITUATED TO THE LEFT OF A DESIGN, WHEREIN THE DESIGN HAS AN OVERALL GENERAL IMPRESSION OF A STICK-FIGURE HUMAN BEING CIRCUMSCRIBED WITHIN A SQUARE HAVING ROUNDED CORNERS, THE HUMAN BEING HAVING ARMS CONNECTED BY A TORSO TO JOINED LEGS, THE TORSO BEING SEPARATED FROM AND CENTERED BENEATH A CIRCLE REPRESENTING THE HEAD OF THE STICK-FIGURE HUMAN BEING, WHEREIN THE TORSO IS MADE UP OF A CENTER SQUARE HAVING VOID PROJECTING FROM THE TOP SIDE THEREOF, THE VOID IN THE CENTER SQUARE BEING AN UPSIDE DOWN TRIANGLE, THE CENTER SQUARE HAVING A PROJECTING SQUARE THAT PROJECTS FROM EACH OF THE THREE OTHER SIDES OF THE CENTER SQUARE, WHEREIN EACH OF THE PROJECTING SQUARES HAS AN OUTWARDLY ROUNDED SIDE PROJECTING FROM A SIDE THEREOF THAT IS OPPOSITE THE SIDE OF THE CENTER SQUARE FROM WHICH THE PROJECTING SQUARE PROJECTS, AND WHEREIN THE TOP SIDE OF THE CENTER SQUARE IS CENTERED BELOW AND SEPARATED FROM THE CIRCLE.

FOR DOWNLOADABLE SOFTWARE IN THE NATURE OF A MOBILE APPLICATION FOR USE BY A PATIENT OR ITS AGENT TO HAVE SECURE WIRELESS AND ONLINE ACCESS TO THE PATIENT'S MEDICAL RECORDS AND TO CONDUCT SECURE INTERACTIVE WIRELESS AND ONLINE PATIENT-HEALTHCARE PROVIDER COMMUNICATIONS OF OR RELATING TO THE PATIENT'S MEDICAL RECORDS (U.S. CLS. 21, 23, 26, 36 AND 38).

BRENDAN REGAN, EXAMINING ATTORNEY

CLASS 9—(Continued).

SN 85-595,377. MIHEALTH GLOBAL SYSTEMS INC., NORTH BAY, CANADA, FILED 4-11-2012.



SECURE INSTANT ACCESS

NO CLAIM IS MADE TO THE EXCLUSIVE RIGHT TO USE "SECURE INSTANT ACCESS", APART FROM THE MARK AS SHOWN.

THE MARK CONSISTS OF THE WORDS "SECURE INSTANT ACCESS" SITUATED TO THE LEFT OF A DESIGN, WHEREIN THE DESIGN HAS AN OVERALL GENERAL IMPRESSION OF A STICK-FIGURE HUMAN BEING CIRCUMSCRIBED WITHIN A SQUARE HAVING ROUNDED CORNERS, THE HUMAN BEING HAVING ARMS CONNECTED BY A TORSO TO JOINED LEGS, THE TORSO BEING SEPARATED FROM AND CENTERED BENEATH A CIRCLE REPRESENTING THE HEAD OF THE STICK-FIGURE HUMAN BEING, WHEREIN THE TORSO IS MADE UP OF A CENTER SQUARE HAVING VOID PROJECTING FROM THE TOP SIDE THEREOF, THE VOID IN THE CENTER SQUARE BEING AN UPSIDE DOWN TRIANGLE, THE CENTER SQUARE HAVING A PROJECTING SQUARE THAT PROJECTS FROM EACH OF THE THREE OTHER SIDES OF THE CENTER SQUARE, WHEREIN EACH OF THE PROJECTING SQUARES HAS AN OUTWARDLY ROUNDED SIDE PROJECTING FROM A SIDE THEREOF THAT IS OPPOSITE THE SIDE OF THE CENTER SQUARE FROM WHICH THE PROJECTING SQUARE PROJECTS, WHEREIN THE TOP SIDE OF THE CENTER SQUARE IS CENTERED BELOW AND SEPARATED FROM THE CIRCLE, AND WHEREIN THE WORD "VIEW" IS CENTERED BETWEEN PARALLEL LINES AND SUPERIMPOSED OVER PORTIONS OF THE JOINED LEGS AND LEFT ARM.

FOR DOWNLOADABLE SOFTWARE IN THE NATURE OF A MOBILE APPLICATION FOR USE BY A PATIENT OR ITS AGENT TO HAVE SECURE WIRELESS AND ONLINE ACCESS TO THE PATIENT'S MEDICAL RECORDS AND TO CONDUCT SECURE INTERACTIVE WIRELESS AND ONLINE PATIENT-HEALTHCARE PROVIDER COMMUNICATIONS OF OR RELATING TO THE PATIENT'S MEDICAL RECORDS (U.S. CLS. 21, 23, 26, 36 AND 38).

BRENDAN REGAN, EXAMINING ATTORNEY

SN 85-595,901. EDM INTERNATIONAL, INC., FORT COLLINS, CO. FILED 4-12-2012.

Span Sentry

THE MARK CONSISTS OF STANDARD CHARACTERS WITHOUT CLAIM TO ANY PARTICULAR FONT, STYLE, SIZE, OR COLOR.

NO CLAIM IS MADE TO THE EXCLUSIVE RIGHT TO USE "SPAN", APART FROM THE MARK AS SHOWN.

FOR ELECTRICAL CONDUCTIVITY MONITOR FOR MONITORING CONDUCTOR AMPACITY IN OVER-HEAD TRANSMISSION LINES (U.S. CLS. 21, 23, 26, 36 AND 38).

JIM RINGLE, EXAMINING ATTORNEY

CLASS 9—(Continued).

SN 85-595,925. ALTAVITAS INC., SUNNYVALE, CA. FILED 4-12-2012.

BABY ZOE

THE MARK CONSISTS OF STANDARD CHARACTERS WITHOUT CLAIM TO ANY PARTICULAR FONT, STYLE, SIZE, OR COLOR.

THE NAME IN THE MARK DOES NOT IDENTIFY A LIVING INDIVIDUAL.

FOR COMPUTER APPLICATION SOFTWARE FOR MOBILE PHONES, MOBILE DEVICES, AND HANDHELD COMPUTERS, NAMELY, SOFTWARE FOR USE IN TRACKING, MANAGING, SHARING AND STORING DATA RELATED TO HEALTH, DAILY ACTIVITIES AND CHILD CARE (U.S. CLS. 21, 23, 26, 36 AND 38).

FIRST USE 1-30-2012; IN COMMERCE 1-30-2012.

REBECCA SMITH, EXAMINING ATTORNEY

SN 85-596,196. ITENNIS MAGAZINE, INC., PASADENA, CA. FILED 4-12-2012.

iTennis Magazine

THE MARK CONSISTS OF STANDARD CHARACTERS WITHOUT CLAIM TO ANY PARTICULAR FONT, STYLE, SIZE, OR COLOR.

NO CLAIM IS MADE TO THE EXCLUSIVE RIGHT TO USE "MAGAZINE", APART FROM THE MARK AS SHOWN.

FOR COMPUTER APPLICATION SOFTWARE FOR MOBILE PHONES, SMARTPHONES, TABLETS, LAPTOPS, AND HANDHELD COMPUTERS, NAMELY, SOFTWARE FOR VIEWING DIGITAL MAGAZINES; DOWNLOADABLE SOFTWARE IN THE NATURE OF A MOBILE APPLICATION FOR VIEWING DIGITAL MAGAZINES (U.S. CLS. 21, 23, 26, 36 AND 38).

TASHIA BUNCH, EXAMINING ATTORNEY

CLASS 9—(Continued).

SN 85-596,279. NESTOR ORESTES TORRES LEON, SAN YSIDRO, CA. FILED 4-12-2012.



THE MARK CONSISTS OF THE WORDS "CELL CENTER" OUTLINED IN STYLIZED FORM WITH THE LETTERS "ELL" IN CELL AND THE LETTERS "ENTER" IN CENTER HAVING TWO HORIZONTALLY SPACED APART LINES.

FOR CARRYING CASES FOR CELL PHONES; CARRYING CASES FOR ELECTRONIC EQUIPMENT, NAMELY, CELLULAR TELEPHONES AND PERSONAL ELECTRONIC DEVICES; CELL PHONE BATTERY CHARGERS; CELL PHONE CASES; CELL PHONE COVERS; CLEAR PROTECTIVE COVERS SPECIALLY ADAPTED FOR PERSONAL ELECTRONIC DEVICES; HEADSETS FOR CELLULAR OR MOBILE PHONES; WIRELESS CELLULAR PHONE HEADSETS (U.S. CLS. 21, 23, 26, 36 AND 38).

FIRST USE 4-30-1999; IN COMMERCE 1-10-2012.

MARTHA FROMM, EXAMINING ATTORNEY

SN 85-596,632. KATCHITEK CORPORATION, LAS VEGAS, NV. FILED 4-12-2012.



OWNER OF U.S. REG. NO. 3,326,618.

THE MARK CONSISTS OF A CIRCLE AROUND THE FIRST LETTER "K" IN THE STYLIZED WORD "KATCHITEK".

FOR COMPUTER SOFTWARE AND HARDWARE FOR OPERATING SYSTEMS AND FOR USE IN OFFICE DATABASE MANAGEMENT (U.S. CLS. 21, 23, 26, 36 AND 38).

BRENDAN MCCAULEY, EXAMINING ATTORNEY

CLASS 9—(Continued).

SN 85-596,651. KATCHITEK CORPORATION, LAS VEGAS, NV. FILED 4-12-2012.

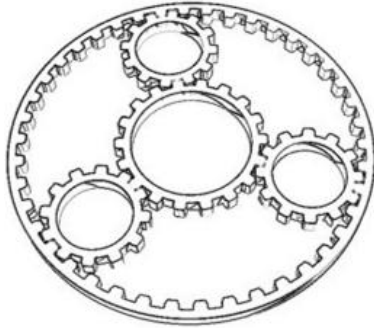

THE MARK CONSISTS OF A DEPICTION OF A GEAR WITH THREE SMALL CIRCLE GEARS EQUIDISTANT FROM EACH OTHER THAT CONNECT TO A CIRCLE GEAR WITHIN THE BIG CIRCLE GEAR.

FOR COMPUTER SOFTWARE FOR ADMINISTRATION OF COMPUTER NETWORKS; COMPUTER SOFTWARE FOR CONFIGURING, MONITORING, AND MAINTAINING COMPUTERS (U.S. CLS. 21, 23, 26, 36 AND 38).

BRENDAN MCCAULEY, EXAMINING ATTORNEY

CLASS 9—(Continued).

SN 85-596,783. SHENZHEN SUNSHINE CIRCUITS TECHNOLOGY CO., LTD., BAOAN, SHENZHEN, CHINA, FILED 4-12-2012.



THE MARK CONSISTS OF AN INCOMPLETE CIRCLE DESIGN WITH THREE WAVY OPENINGS, AND THE WORD "SONNENSCHN" BELOW THE DESIGN.

THE ENGLISH TRANSLATION OF THE WORD "SONNENSCHN" IN THE MARK IS SUNSHINE.

THE NON-LATIN CHARACTERS IN THE MARK TRANSLITERATE TO "SONNENSCHN" AND THIS MEANS SUNSHINE IN ENGLISH.

FOR INTEGRATED CIRCUITS; PRINTED CIRCUIT BOARDS; PRINTED CIRCUITS (U.S. CLS. 21, 23, 26, 36 AND 38).

AMY ALFIERI, EXAMINING ATTORNEY

SN 85-596,834. JAIN, KALPIT, DBA WAGMOB, REDMOND, WA. FILED 4-13-2012.

SN 85-596,773. GOAL ZERO LLC, BLUFFDALE, UT. FILED 4-12-2012.

Simple 'n Easy

GOAL ZERO SWITCH

THE MARK CONSISTS OF STANDARD CHARACTERS WITHOUT CLAIM TO ANY PARTICULAR FONT, STYLE, SIZE, OR COLOR.

NO CLAIM IS MADE TO THE EXCLUSIVE RIGHT TO USE "SWITCH", APART FROM THE MARK AS SHOWN.

FOR BATTERIES, BATTERY CHARGERS (U.S. CLS. 21, 23, 26, 36 AND 38).

JENNIFER RICHARDSON, EXAMINING ATTORNEY

THE MARK CONSISTS OF STANDARD CHARACTERS WITHOUT CLAIM TO ANY PARTICULAR FONT, STYLE, SIZE, OR COLOR.

FOR COMPUTER APPLICATION SOFTWARE FOR MOBILE PHONES NAMELY EDUCATIONAL SOFTWARE THAT PROVIDES TUTORIALS, QUIZZES AND FLASHCARDS IN MATH, SCIENCE AND LANGUAGES. COMPUTER APPLICATION SOFTWARE FOR TABLET COMPUTERS NAMELY EDUCATIONAL SOFTWARE THAT PROVIDES TUTORIALS, QUIZZES AND FLASHCARDS IN MATH, SCIENCE AND LANGUAGES (U.S. CLS. 21, 23, 26, 36 AND 38).

FIRST USE 4-13-2012; IN COMMERCE 4-13-2012.

BRIDGETT SMITH, EXAMINING ATTORNEY

CLASS 9—(Continued).

SN 85-596,954. FOOD DAT, INC., DBA FOOD DAT NATION, NEW ORLEANS, LA. FILED 4-13-2012.

FOOD DAT NATION

THE MARK CONSISTS OF STANDARD CHARACTERS WITHOUT CLAIM TO ANY PARTICULAR FONT, STYLE, SIZE, OR COLOR.

NO CLAIM IS MADE TO THE EXCLUSIVE RIGHT TO USE "FOOD", APART FROM THE MARK AS SHOWN.

FOR AD SERVER, NAMELY, A COMPUTER SERVER FOR STORING ADVERTISEMENTS AND DELIVERING ADVERTISEMENTS TO WEBSITES (U.S. CLS. 21, 23, 26, 36 AND 38).

MICHAEL WIENER, EXAMINING ATTORNEY

SN 85-597,002. CELECTEST, INC., HOUSTON, TX. FILED 4-13-2012.

CELECTEST

THE MARK CONSISTS OF STANDARD CHARACTERS WITHOUT CLAIM TO ANY PARTICULAR FONT, STYLE, SIZE, OR COLOR.

FOR COMPUTER SOFTWARE FOR AUTOMATIC TESTING OF ELECTRONIC ASSEMBLIES; COMPUTER SOFTWARE, NAMELY, SPREADSHEET CONTROL OF INSTRUMENTS ALLOWING THE SPREADSHEET TO OBTAIN MEASUREMENTS DIRECTLY FROM THESE INSTRUMENTS IN REAL TIME, PROVIDING DIRECT INTERFACE BETWEEN THE SPREADSHEET SOFTWARE ENVIRONMENT AND A VARIETY OF TEST INSTRUMENTS FOR AUTOMATIC CONTROL OF THE CONTROL AND MEASUREMENT FUNCTIONS, AND USING ADVANCED COMPUTATION AND DISPLAY CAPABILITIES TO SIMPLIFY USER INTERFACE AND DISPLAY MEASUREMENTS IN REAL TIME (U.S. CLS. 21, 23, 26, 36 AND 38).

KHANH LE, EXAMINING ATTORNEY

SN 85-597,074. AIRCRAFT OWNERS AND PILOTS ASSOCIATION, FREDERICK, MD. FILED 4-13-2012.

FlyQ

THE MARK CONSISTS OF STANDARD CHARACTERS WITHOUT CLAIM TO ANY PARTICULAR FONT, STYLE, SIZE, OR COLOR.

FOR COMPUTER APPLICATION SOFTWARE FOR COMPUTERS, WEBSITES, AND MOBILE DEVICES, NAMELY, SOFTWARE FOR AIRCRAFT OPERATIONS, NAMELY, FLIGHT PLANNING AND LOGGING, NAVIGATION, WEATHER, MAPS, AIRPORT INFORMATION, AND AIRCRAFT LOGGING (U.S. CLS. 21, 23, 26, 36 AND 38).

DAVID MURRAY, EXAMINING ATTORNEY

CLASS 9—(Continued).

SN 85-597,092. AIRCRAFT OWNERS AND PILOTS ASSOCIATION, FREDERICK, MD. FILED 4-13-2012.

FlyQ

THE MARK CONSISTS OF THE TERM "FLYQ" WITH A CURVED LINE STARTING TO THE LEFT OF THE "F" AND ENDING UNDER THE "Q".

FOR COMPUTER APPLICATION SOFTWARE FOR COMPUTERS, WEBSITES, AND MOBILE DEVICES, NAMELY, SOFTWARE FOR AIRCRAFT OPERATIONS, NAMELY, FLIGHT PLANNING AND LOGGING, NAVIGATION, WEATHER, MAPS, AIRPORT INFORMATION, AND AIRCRAFT LOGGING (U.S. CLS. 21, 23, 26, 36 AND 38).

DAVID MURRAY, EXAMINING ATTORNEY

SN 85-597,113. CELECTEST, INC., HOUSTON, TX. FILED 4-13-2012.

CELECLINK

THE MARK CONSISTS OF STANDARD CHARACTERS WITHOUT CLAIM TO ANY PARTICULAR FONT, STYLE, SIZE, OR COLOR.

FOR COMPUTER SOFTWARE FOR AUTOMATIC TESTING OF ELECTRONIC ASSEMBLIES; COMPUTER SOFTWARE, NAMELY, SPREADSHEET CONTROL OF INSTRUMENTS ALLOWING THE SPREADSHEET TO OBTAIN MEASUREMENTS DIRECTLY FROM THESE INSTRUMENTS IN REAL TIME, PROVIDING DIRECT INTERFACE BETWEEN THE SPREADSHEET SOFTWARE ENVIRONMENT AND A VARIETY OF TEST INSTRUMENTS FOR AUTOMATIC CONTROL OF THE CONTROL AND MEASUREMENT FUNCTIONS, AND USING ADVANCED COMPUTATION AND DISPLAY CAPABILITIES TO SIMPLIFY USER INTERFACE AND DISPLAY MEASUREMENTS IN REAL TIME (U.S. CLS. 21, 23, 26, 36 AND 38).

KHANH LE, EXAMINING ATTORNEY

SN 85-597,135. TEAM WENDY, LLC, CLEVELAND, OH. FILED 4-13-2012.

TEAM WENDY

THE MARK CONSISTS OF STANDARD CHARACTERS WITHOUT CLAIM TO ANY PARTICULAR FONT, STYLE, SIZE, OR COLOR.

FOR HEAD PROTECTION DEVICES, NAMELY, A PADDED IMPACT LINER AND RETENTION DEVICE FOR USE IN BALLISTIC, CRASH AND SPORT HELMETS (U.S. CLS. 21, 23, 26, 36 AND 38).

FIRST USE 3-1-1999; IN COMMERCE 3-1-1999.

LYNDSEY KUYKENDALL, EXAMINING ATTORNEY

CLASS 9—(Continued).

SN 85-597,148. COMPANY L. STEVEN, DBA TAMEBULL GHZ, BOYNTON BEACH, FL. FILED 4-13-2012.



OWNER OF U.S. REG. NO. 3,570,683.
 NO CLAIM IS MADE TO THE EXCLUSIVE RIGHT TO USE "GHZ", APART FROM THE MARK AS SHOWN.
 THE COLOR(S) RED, BLACK, WHITE AND GREEN IS/ARE CLAIMED AS A FEATURE OF THE MARK.
 THE MARK CONSISTS OF THE WORDING "TAMEBULL" IN RED, APPEARING ABOVE AN UPSIDE DOWN TRIANGLE IN RED WITH A WHITE BORDER, AND A SMALLER GREEN TRIANGLE INSIDE. THE WORDING "GHZ" IS IN WHITE BENEATH THE TRIANGLE, ALL AGAINST A BLACK BACKGROUND.
 FOR CELLULAR PHONE DETECTORS (U.S. CLS. 21, 23, 26, 36 AND 38).
 EMILY CHUO, EXAMINING ATTORNEY

SN 85-597,250. WINDWARD MARK INTERACTIVE, LLC, NEW YORK, NY. FILED 4-13-2012.

The Alliance Engine

THE MARK CONSISTS OF STANDARD CHARACTERS WITHOUT CLAIM TO ANY PARTICULAR FONT, STYLE, SIZE, OR COLOR.
 NO CLAIM IS MADE TO THE EXCLUSIVE RIGHT TO USE "ENGINE", APART FROM THE MARK AS SHOWN.
 FOR COMPUTER GAME SOFTWARE; COMPUTER GRAPHICS SOFTWARE; COMPUTER SOFTWARE DEVELOPMENT TOOLS; COMPUTER SOFTWARE FOR APPLICATION AND DATABASE INTEGRATION (U.S. CLS. 21, 23, 26, 36 AND 38).
 REBECCA SMITH, EXAMINING ATTORNEY

CLASS 9—(Continued).

SN 85-597,256. TEN STUDIO HILL, INC., BRIARCLIFF MANOR, NY. FILED 4-13-2012.



THE COLOR(S) BLACK, WHITE, AND RED IS/ARE CLAIMED AS A FEATURE OF THE MARK.
 THE MARK CONSISTS OF THE STYLIZED TEXT "HEARTUG". THE LETTERS "HEARTUG" ARE BLACK AND HAVE BLACK SQUIGGLY LINES EMANATING FROM THEM, REPRESENTING ENERGY. THE LETTER "G" IS WHITE AND IS IN THE SHAPE OF A SPIRAL. BEHIND THE LETTERS "TUG" IS A RED HEART.
 FOR COMPUTER APPLICATION SOFTWARE FOR MOBILE PHONES, PORTABLE MEDIA PLAYERS AND HANDHELD COMPUTERS, NAMELY, COMMUNICATION SOFTWARE FOR CONNECTING COMPUTER NETWORK USERS (U.S. CLS. 21, 23, 26, 36 AND 38).
 KATHY DE JONGE, EXAMINING ATTORNEY

SN 85-597,363. ENCHROMA INC., BERKELEY, CA. FILED 4-13-2012.



THE COLOR(S) GREEN, YELLOW, BLUE, RED AND GREY IS/ARE CLAIMED AS A FEATURE OF THE MARK.
 THE MARK CONSISTS OF FOUR LARGER CIRCLES WITH TWO CIRCLES ON TOP AND TWO CIRCLES ON THE BOTTOM. THE UPPER LEFT CIRCLE IS GREEN, THE UPPER RIGHT CIRCLE IS YELLOW, THE LOWER LEFT CIRCLE IS BLUE AND THE LOWER RIGHT CIRCLE IS RED. IN THE CENTER OF THE CIRCLES IS A SMALL GRAY CIRCLE.
 FOR SUNGLASSES; LENSES, NAMELY, CONTACT, SUNGLASS AND EYEGLASS LENSES; AND GLASSES, NAMELY, EYE GLASSES (U.S. CLS. 21, 23, 26, 36 AND 38).
 INGRID C. EULIN, EXAMINING ATTORNEY

CLASS 9—(Continued).

SN 85-597,535. SORTIAMO LLC, DBA CHOICE MEDICAL ALERT, WEST JORDAN, UT. FILED 4-13-2012.



NO CLAIM IS MADE TO THE EXCLUSIVE RIGHT TO USE "MEDICAL ALERT", APART FROM THE MARK AS SHOWN.

THE COLOR(S) BLUE, NAVY BLUE AND GREY IS/ARE CLAIMED AS A FEATURE OF THE MARK.

THE MARK CONSISTS OF THE STYLIZED TEXT "CHOICE" IN NAVY BLUE ABOVE THE WORDING "MEDICAL ALERT" IN GREY WITH AN ASTERISK IN NAVY BLUE AS THE DOT ON THE "I" IN "CHOICE" WITH LIGHT WAVES COMING AWAY THEREFROM FROM BOTH SIDES OF THE "I".

FOR ELECTRONIC EMERGENCY MEDICAL ALARMS (U.S. CLS. 21, 23, 26, 36 AND 38).

NAAKWAMA ANKRAH, EXAMINING ATTORNEY

SN 85-597,562. CABLE DESIGN SYSTEMS, INC., NEW YORK, NY. FILED 4-13-2012.



FOR CARRYING CASES FOR CELL PHONES; CELL PHONE BACKPLATES; CELL PHONE CASES; CELL PHONE COVERS; CELL PHONE STRAPS; MOBILE PHONE STRAPS; STRAPS FOR MOBILE PHONES (U.S. CLS. 21, 23, 26, 36 AND 38).

RONALD MCMORROW, EXAMINING ATTORNEY

CLASS 9—(Continued).

SN 85-597,782. LOADOUT TECHNOLOGIES, LLC, WEST LAFAYETTE, IN. FILED 4-13-2012.

YELLOW BOX

THE MARK CONSISTS OF STANDARD CHARACTERS WITHOUT CLAIM TO ANY PARTICULAR FONT, STYLE, SIZE, OR COLOR.

NO CLAIM IS MADE TO THE EXCLUSIVE RIGHT TO USE "BOX", APART FROM THE MARK AS SHOWN.

FOR COMPUTER SOFTWARE AND HARDWARE FOR AGRICULTURAL AND INDUSTRIAL PROCESS MONITORING AND CONTROL (U.S. CLS. 21, 23, 26, 36 AND 38).

FIRST USE 2-28-2012; IN COMMERCE 2-28-2012.
EMILY CHUO, EXAMINING ATTORNEY

SN 85-597,867. XPRO LED LLC, WILMINGTON, DE. FILED 4-13-2012.



THE MARK CONSISTS OF THE LETTERS "XPRO" WITH EACH LETTER MADE OF SMALL CIRCLES.

FOR ELECTRONIC LED SIGNS; LED AND HID LIGHT CONTROLS; LIGHT EMITTING DIODE (LED) DISPLAYS; LIGHT EMITTING DIODES (LEDS) (U.S. CLS. 21, 23, 26, 36 AND 38).

CHRISIE B. KING, EXAMINING ATTORNEY

SN 85-597,914. HEYALDA CORPORATION, DBA HEYALDA CORPORATION, CHICAGO, IL. FILED 4-13-2012.

HEYALDA

THE MARK CONSISTS OF STANDARD CHARACTERS WITHOUT CLAIM TO ANY PARTICULAR FONT, STYLE, SIZE, OR COLOR.

FOR COMPUTER APPLICATION SOFTWARE FOR PORTABLE MOBILE DEVICES SUCH AS TABLET COMPUTERS AND SMART PHONES, NAMELY, SOFTWARE FOR RETAIL CONSUMERS TO VIEW AND INTERACT WITH MULTIMEDIA CONTENT; COMPUTER GAME SOFTWARE FOR USE ON MOBILE AND CELLULAR PHONES; VIDEO GAME SOFTWARE (U.S. CLS. 21, 23, 26, 36 AND 38).

FIRST USE 10-6-2009; IN COMMERCE 10-6-2009.
ALAIN LAPTER, EXAMINING ATTORNEY

CLASS 9—(Continued).

SN 85-598,159. DEUXANE, WESTPORT, CT. FILED 4-14-2012.



NO CLAIM IS MADE TO THE EXCLUSIVE RIGHT TO USE "LACQUER", APART FROM THE MARK AS SHOWN.

THE MARK CONSISTS OF THE STYLIZED WORDING "SOCIETY OF LACQUER" WITH RAYS OF LIGHT EMANATING FROM BEHIND THE "L".

FOR COMPUTER APPLICATION SOFTWARE FOR MOBILE PHONES, PORTABLE MEDIA PLAYERS, HANDHELD COMPUTERS, AND COMPUTERS, NAMELY, SOFTWARE FOR UPLOADING, MANIPULATING, CATEGORIZING, SAVING, TRANSMITTING AND DOWNLOADING IMAGES AND TEXT IN THE FIELD OF NAIL CARE AND NAIL GROOMING PRODUCTS (U.S. CLS. 21, 23, 26, 36 AND 38).

HOWARD B. LEVINE, EXAMINING ATTORNEY

SN 85-598,170. BRONX MOST WANTED ENTERTAINMENT, LLC, GLENDALE, NY. FILED 4-14-2012.



NO CLAIM IS MADE TO THE EXCLUSIVE RIGHT TO USE "BRONX", APART FROM THE MARK AS SHOWN.

THE MARK CONSISTS OF A CIRCLE AND THE OUTER EDGE OF THE CIRCLE IS ENCRUSTED WITH DIAMOND-LIKE STONES AT THE TOP CENTER OF THE CIRCLE IS A FIST, WITHIN THE CENTER CIRCLE ARE THE LETTERS "B M W" AND AT THE TOP OF THE "M" THERE IS A DIAMOND-LIKE STONE AND UNDER THE LETTERS "BMW" IN CIRCULAR MOTION ARE THE WRITTEN WORDS "BRONX MOST WANTED".

FOR AUDIO AND VIDEO RECORDINGS FEATURING MUSIC AND ARTISTIC PERFORMANCES; AUDIO RECORDINGS FEATURING MUSIC; AUDIO TAPES FEATURING MUSIC; COMPACT DISCS FEATURING MUSIC; DIGITAL MATERIALS, NAMELY, CDS, DVDS, DOWNLOADABLE AUDIO FILES FEATURING MUSIC; DIGITAL MEDIA, NAMELY, CDS, DVDS, DOWNLOADABLE AUDIO FILES FEATURING MUSIC; DIGITAL MUSIC DOWNLOADABLE FROM THE INTERNET; DOWNLOADABLE MP3 FILES, MP3 RECORDINGS, ON-LINE DISCUSSION BOARDS, WEBCASTS, WEBINARS AND PODCASTS FEATURING MUSIC, AUDIO BOOKS IN THE FIELD OF MUSIC, AND NEWS BROADCASTS; DOWNLOADABLE MUSIC FILES; VIDEO RECORDINGS FEATURING MUSIC; VISUAL RECORDINGS AND AUDIOVISUAL RECORDINGS FEATURING MUSIC AND ANIMATION (U.S. CLS. 21, 23, 26, 36 AND 38).

FIRST USE 8-16-2010; IN COMMERCE 5-28-2011.

MARK T. MULLEN, EXAMINING ATTORNEY

CLASS 9—(Continued).

SN 85-598,221. ARMY ANTS MOBILE APPLICATION, HOUSTON, TX. FILED 4-15-2012.

Fire Ants

THE MARK CONSISTS OF STANDARD CHARACTERS WITHOUT CLAIM TO ANY PARTICULAR FONT, STYLE, SIZE, OR COLOR.

FOR COMPUTER APPLICATION SOFTWARE FOR MOBILE PHONES, NAMELY, SOFTWARE FOR GAMES; COMPUTER GAME SOFTWARE (U.S. CLS. 21, 23, 26, 36 AND 38).

DAVID I. EXAMINING ATTORNEY

SN 85-598,234. ROOM CANDY GAMES LLC, AKA ROOM CANDY GAMES, BREA, CA. FILED 4-15-2012.

Room Candy Games

THE MARK CONSISTS OF STANDARD CHARACTERS WITHOUT CLAIM TO ANY PARTICULAR FONT, STYLE, SIZE, OR COLOR.

NO CLAIM IS MADE TO THE EXCLUSIVE RIGHT TO USE GAMES, APART FROM THE MARK AS SHOWN.

FOR COMPUTER GAME SOFTWARE; COMPUTER GAME SOFTWARE FOR USE ON MOBILE AND CELLULAR PHONES; COMPUTER GAME SOFTWARE FOR USE WITH PERSONAL COMPUTERS, HOME VIDEO GAME CONSOLES USED WITH TELEVISIONS AND ARCADE-BASED VIDEO GAME CONSOLES (U.S. CLS. 21, 23, 26, 36 AND 38).

FIRST USE 1-1-2009; IN COMMERCE 1-1-2009.

DOMINICK J. SALEMI, EXAMINING ATTORNEY

SN 85-598,266. ALSAGHAYER, HAYTHAM, RIYADH, SAUDI ARABIA, FILED 4-15-2012.

WIFIZER

THE MARK CONSISTS OF STANDARD CHARACTERS WITHOUT CLAIM TO ANY PARTICULAR FONT, STYLE, SIZE, OR COLOR.

FOR DOWNLOADABLE SOFTWARE FOR TURNING DEVICES INTO FILE SHARING SERVERS AND FOR THE COLLECTION, EDITING, ORGANIZING, MODIFYING, TRANSMISSION, STORAGE AND SHARING OF DATA AND INFORMATION; DOWNLOADABLE COMPUTER SOFTWARE WHICH ENABLES DIGITAL MEDIA STREAMING AND DISCOVERY OF OTHER DEVICES ON A COMPUTER NETWORK (U.S. CLS. 21, 23, 26, 36 AND 38).

FIRST USE 3-0-2012; IN COMMERCE 3-0-2012.

IRA J. GOODSaid, EXAMINING ATTORNEY

CLASS 9—(Continued).

SN 85-598,406. BIOVEST INTERNATIONAL, INC., TAMPA, FL. FILED 4-16-2012.

Autovax

THE MARK CONSISTS OF STANDARD CHARACTERS WITHOUT CLAIM TO ANY PARTICULAR FONT, STYLE, SIZE, OR COLOR.

OWNER OF U.S. REG. NO. 4,066,185.

FOR SCIENTIFIC INSTRUMENTS AND SYSTEMS, NAMELY, FULLY ENCLOSED AUTOMATED INSTRUMENTS CONSISTING OF A CONTROL UNIT, NAMELY, COMPUTER HARDWARE, SOFTWARE, PUMPS, AND OTHER RELATED COMPONENT PARTS THEREFORE SOLD AS A UNIT, AND A DISPOSABLE CULTUREWARE UNIT CONSISTING OF BIOREACTORS, TUBING AND OTHER RELATED COMPONENT PARTS THEREFORE SOLD AS A UNIT WITH SAID CONTROL UNIT AND/OR SEPARATELY, ALL FOR USE IN CONNECTION WITH CELL CULTURE AND THE DEVELOPMENT, PRODUCTION, AND PURIFICATION OF VIRUS AND VIRAL VACCINES (U.S. CLS. 21, 23, 26, 36 AND 38).

AMY ALFIERI, EXAMINING ATTORNEY

SN 85-598,470. DAKOTA AUDIO INC, BISMARCK, ND. FILED 4-16-2012.

DAKOTA AUDIO

THE MARK CONSISTS OF STANDARD CHARACTERS WITHOUT CLAIM TO ANY PARTICULAR FONT, STYLE, SIZE, OR COLOR.

NO CLAIM IS MADE TO THE EXCLUSIVE RIGHT TO USE "AUDIO", APART FROM THE MARK AS SHOWN. SEC. 2(F).

FOR AUDIO ELECTRONIC COMPONENTS, NAMELY, SURROUND SOUND SYSTEMS; AUDIO SPEAKERS (U.S. CLS. 21, 23, 26, 36 AND 38).

FIRST USE 1-15-1994; IN COMMERCE 1-15-1994.
MICHAEL SOUDERS, EXAMINING ATTORNEY

CLASS 9—(Continued).

SN 85-598,491. DAKOTA AUDIO INC, BISMARCK, ND. FILED 4-16-2012.

DAKOTA SPEAKERS

THE MARK CONSISTS OF STANDARD CHARACTERS WITHOUT CLAIM TO ANY PARTICULAR FONT, STYLE, SIZE, OR COLOR.

NO CLAIM IS MADE TO THE EXCLUSIVE RIGHT TO USE "SPEAKERS", APART FROM THE MARK AS SHOWN. SEC. 2(F).

FOR AUDIO ELECTRONIC COMPONENTS, NAMELY, SURROUND SOUND SYSTEMS; AUDIO SPEAKERS (U.S. CLS. 21, 23, 26, 36 AND 38).

FIRST USE 1-15-1994; IN COMMERCE 1-15-1994.
MICHAEL SOUDERS, EXAMINING ATTORNEY

SN 85-598,621. MATTEL, INC., EL SEGUNDO, CA. FILED 4-16-2012.

CITY OF FRIGHTS

THE MARK CONSISTS OF STANDARD CHARACTERS WITHOUT CLAIM TO ANY PARTICULAR FONT, STYLE, SIZE, OR COLOR.

FOR MOTION PICTURE FILMS AND FILMS FOR TELEVISION FEATURING CHILDREN'S ENTERTAINMENT (U.S. CLS. 21, 23, 26, 36 AND 38).

DOMINIC FATHY, EXAMINING ATTORNEY

SN 85-599,311. OPENPATH PRODUCTS LLC, ANNAPOLIS, MD. FILED 4-16-2012.

CURRENCY 2 GO

THE MARK CONSISTS OF STANDARD CHARACTERS WITHOUT CLAIM TO ANY PARTICULAR FONT, STYLE, SIZE, OR COLOR.

NO CLAIM IS MADE TO THE EXCLUSIVE RIGHT TO USE "CURRENCY", APART FROM THE MARK AS SHOWN.

FOR COMPUTER APPLICATION SOFTWARE FOR MOBILE PHONES, NAMELY, SOFTWARE FOR CONVERTING MONETARY UNITS BASED ON CURRENT EXCHANGE RATES (U.S. CLS. 21, 23, 26, 36 AND 38).

SALLY SHIH, EXAMINING ATTORNEY

CLASS 9—(Continued).

SN 85-599,313. OPENPATH PRODUCTS LLC, ANNAPOLIS, MD. FILED 4-16-2012.

DISTANCE 2 GO

THE MARK CONSISTS OF STANDARD CHARACTERS WITHOUT CLAIM TO ANY PARTICULAR FONT, STYLE, SIZE, OR COLOR.

NO CLAIM IS MADE TO THE EXCLUSIVE RIGHT TO USE "DISTANCE", APART FROM THE MARK AS SHOWN.

FOR COMPUTER APPLICATION SOFTWARE FOR MOBILE PHONES, NAMELY, SOFTWARE FOR CALCULATING DISTANCE AND PROVIDING A DIRECT ROUTE FROM MULTIPLE POINTS ON A MAP (U.S. CLS. 21, 23, 26, 36 AND 38).

SALLY SHIH, EXAMINING ATTORNEY

SN 85-599,316. OPENPATH PRODUCTS LLC, ANNAPOLIS, MD. FILED 4-16-2012.

MEASUREMENTS 2 GO

THE MARK CONSISTS OF STANDARD CHARACTERS WITHOUT CLAIM TO ANY PARTICULAR FONT, STYLE, SIZE, OR COLOR.

NO CLAIM IS MADE TO THE EXCLUSIVE RIGHT TO USE "MEASUREMENTS", APART FROM THE MARK AS SHOWN.

FOR COMPUTER APPLICATION SOFTWARE FOR MOBILE PHONES, NAMELY, SOFTWARE FOR CONVERTING UNITS BETWEEN DIFFERENT MEASUREMENT TYPES (U.S. CLS. 21, 23, 26, 36 AND 38).

SALLY SHIH, EXAMINING ATTORNEY

SN 85-599,456. DIGITAL LIFE TECHNOLOGIES LLC, BALA CYNWYD, PA. FILED 4-17-2012.

GO NOW

THE MARK CONSISTS OF STANDARD CHARACTERS WITHOUT CLAIM TO ANY PARTICULAR FONT, STYLE, SIZE, OR COLOR.

FOR REPROGRAMMABLE MAGNETIC STRIPE UNIVERSAL CARD USED IN CONNECTION WITH A MOBILE DEVICE (U.S. CLS. 21, 23, 26, 36 AND 38).

STEVEN JACKSON, EXAMINING ATTORNEY

CLASS 9—(Continued).

SN 85-599,958. SHAT-R-SHIELD, INC., SALISBURY, NC. FILED 4-17-2012.



The logo for 'protect-r-shield' features the word 'protect' in a lowercase, sans-serif font, followed by a stylized gear icon with a dot in the center, then the word 'r-shield' in a lowercase, sans-serif font. The 'r' is smaller and positioned between 'protect' and 'shield'.

OWNER OF U.S. REG. NO. 3,957,384.

THE MARK CONSISTS OF THE WORDS PROTECT-R-SHIELD WRITTEN IN STYLIZED LETTERS WITH THE "O" BEING A GRAPHICAL ELEMENT DESIGNED AS A COG GEAR WITH DOTS.

FOR CIRCUIT BOARDS; LED CIRCUIT BOARDS (U.S. CLS. 21, 23, 26, 36 AND 38).

FIRST USE 1-27-2012; IN COMMERCE 1-27-2012.

VERNA BETH RIRIE, EXAMINING ATTORNEY

SN 85-599,980. TEXAS INSTRUMENTS INCORPORATED, DALLAS, TX. FILED 4-17-2012.

DLP PICO ARCADE

THE MARK CONSISTS OF STANDARD CHARACTERS WITHOUT CLAIM TO ANY PARTICULAR FONT, STYLE, SIZE, OR COLOR.

OWNER OF U.S. REG. NOS. 2,070,572, 3,818,895 AND OTHERS.

NO CLAIM IS MADE TO THE EXCLUSIVE RIGHT TO USE "ARCADE", APART FROM THE MARK AS SHOWN.

FOR GAMING SYSTEM, COMPRISING A MOVIE PROJECTOR COMPRISING MICRO MIRRORS, MOBILE PHONE WITH GAMING SOFTWARE, AND A GAMING CONTROLLER; MOVIE PROJECTORS COMPRISING MICRO MIRRORS; MOBILE PHONES WITH GAMING SOFTWARE; GAMING CONTROLLERS (U.S. CLS. 21, 23, 26, 36 AND 38).

SHANNON TWOHIG, EXAMINING ATTORNEY

CLASS 9—(Continued).

SN 85-600,071. TEXAS INSTRUMENTS INCORPORATED, DALLAS, TX. FILED 4-17-2012.

PICO ARCADE

THE MARK CONSISTS OF STANDARD CHARACTERS WITHOUT CLAIM TO ANY PARTICULAR FONT, STYLE, SIZE, OR COLOR.

OWNER OF U.S. REG. NO. 3,818,895.

NO CLAIM IS MADE TO THE EXCLUSIVE RIGHT TO USE "ARCADE", APART FROM THE MARK AS SHOWN.

FOR GAMING SYSTEM, COMPRISING A MOVIE PROJECTOR COMPRISING MICRO MIRRORS, MOBILE PHONE WITH GAMING SOFTWARE, AND A GAMING CONTROLLER; MOVIE PROJECTORS COMPRISING MICRO MIRRORS; MOBILE PHONES WITH GAMING SOFTWARE; GAMING CONTROLLERS (U.S. CLS. 21, 23, 26, 36 AND 38).

SHANNON TWOHIG, EXAMINING ATTORNEY

SN 85-600,269. EYE-D, LLC, SIOUX FALLS, SD. FILED 4-17-2012.

BlinkSpot

THE MARK CONSISTS OF STANDARD CHARACTERS WITHOUT CLAIM TO ANY PARTICULAR FONT, STYLE, SIZE, OR COLOR.

FOR SYSTEM COMPRISED OF COMPUTER HARDWARE AND SOFTWARE PROGRAMS AND DATABASE MANAGEMENT SOFTWARE FOR TRACKING AND MONITORING THE LOCATION, STATUS AND/OR ENTRY OF INDIVIDUALS; SYSTEM COMPRISED OF COMPUTER HARDWARE, COMPUTER SOFTWARE PROGRAMS AND DATABASE MANAGEMENT SOFTWARE FOR TRIGGERING AUTOMATED NOTIFICATION ALERTS AND REPORTS AS TO THE LOCATION, STATUS AND/OR AUTHORIZATION OF INDIVIDUALS (U.S. CLS. 21, 23, 26, 36 AND 38).

MEREDITH MARESCA, EXAMINING ATTORNEY

SN 85-600,315. OPSIVE, LLC, RALEIGH, NC. FILED 4-17-2012.

War Evolved

THE MARK CONSISTS OF STANDARD CHARACTERS WITHOUT CLAIM TO ANY PARTICULAR FONT, STYLE, SIZE, OR COLOR.

NO CLAIM IS MADE TO THE EXCLUSIVE RIGHT TO USE "WAR", APART FROM THE MARK AS SHOWN.

FOR COMPUTER GAME SOFTWARE FOR USE ON MOBILE AND CELLULAR PHONES (U.S. CLS. 21, 23, 26, 36 AND 38).

FIRST USE 11-25-2009; IN COMMERCE 11-25-2009.

AHSEN KHAN, EXAMINING ATTORNEY

CLASS 9—(Continued).

SN 85-600,721. CETON CORP., KIRKLAND, WA. FILED 4-18-2012.

INFINITV

THE MARK CONSISTS OF STANDARD CHARACTERS WITHOUT CLAIM TO ANY PARTICULAR FONT, STYLE, SIZE, OR COLOR.

FOR DIGITAL VIDEO PRODUCTS FOR THE PERSONAL COMPUTERS, NAMELY, DIGITAL VIDEO RECORDERS; COMPUTER HARDWARE AND PERIPHERAL DEVICES (U.S. CLS. 21, 23, 26, 36 AND 38).

FIRST USE 3-1-2010; IN COMMERCE 3-1-2010.

MEREDITH MARESCA, EXAMINING ATTORNEY

SN 85-601,157. IDEAL INDUSTRIES, INC., SYCAMORE, IL. FILED 4-18-2012.

SECURITEST

THE MARK CONSISTS OF STANDARD CHARACTERS WITHOUT CLAIM TO ANY PARTICULAR FONT, STYLE, SIZE, OR COLOR.

FOR TESTERS FOR CLOSED CIRCUIT TELEVISION (CCTV) CAMERAS; PTZ (PAN, TILT, ZOOM) ANALYZER, VIDEO GENERATOR AND PROGRAMMER FOR CCTV CAMERAS; TESTERS FOR DIGITAL CCTV CAMERAS THAT CAN PROGRAM THE CAMERAS AND PROVIDE PTZ CONTROL VIA A WEB INTERFACE; TESTERS FOR DIGITAL CCTV CAMERAS THAT CAN PASS POE (POWER OVER ETHERNET) FROM A NETWORK, THROUGH THE TESTER, TO THE CAMERA OR CAN PROVIDE POE TO THE CAMERA FROM THE TESTER'S INTERNAL BATTERY; TESTERS FOR DIGITAL CCTV CAMERAS THAT CAN ANALYZE THE VIDEO STREAMS OF MULTIPLE CAMERAS AND PROVIDE STATISTICS ABOUT THOSE STREAMS; DIGITAL MULTIMETERS; TWISTED PAIR CABLE TESTERS (U.S. CLS. 21, 23, 26, 36 AND 38).

FIRST USE 4-30-2007; IN COMMERCE 4-30-2007.

CAROLYN CATALDO, EXAMINING ATTORNEY

SN 85-601,264. ICON HEALTH & FITNESS, INC., LOGAN, UT. FILED 4-18-2012.

BOOTY FIRM

THE MARK CONSISTS OF STANDARD CHARACTERS WITHOUT CLAIM TO ANY PARTICULAR FONT, STYLE, SIZE, OR COLOR.

FOR DIGITAL MATERIALS, NAMELY, DVDS AND DOWNLOADABLE FILES FEATURING EXERCISE PROGRAMS, WORKOUTS, VIDEOS AND MATERIALS (U.S. CLS. 21, 23, 26, 36 AND 38).

FIRST USE 4-17-2012; IN COMMERCE 4-17-2012.

TINA L. SNAPP, EXAMINING ATTORNEY

CLASS 9—(Continued).

SN 85-601,330. KUNKEN, JOSHUA M, DBA SOHO SCIENTIFIC, SAN DIEGO, CA. FILED 4-18-2012.

MatPad

THE MARK CONSISTS OF STANDARD CHARACTERS WITHOUT CLAIM TO ANY PARTICULAR FONT, STYLE, SIZE, OR COLOR.

FOR COMPUTER SOFTWARE FOR CREATING SEARCHABLE DATABASES OF INFORMATION AND DATA (U.S. CLS. 21, 23, 26, 36 AND 38).

FIRST USE 3-12-2012; IN COMMERCE 3-12-2012.
ESTHER BELENKER, EXAMINING ATTORNEY

SN 85-601,404. GREENE COUNTY MEDICAL SOCIETY ALLIANCE, SPRINGFIELD, MO. FILED 4-18-2012.

Pills Are Not A Party

THE MARK CONSISTS OF STANDARD CHARACTERS WITHOUT CLAIM TO ANY PARTICULAR FONT, STYLE, SIZE, OR COLOR.

FOR DIGITAL MEDIA, NAMELY, DVDS FEATURING INFORMATION ON THE DELETERIOUS EFFECTS FROM THE ABUSE OF PRESCRIPTION AND OVER-THE-COUNTER MEDICATIONS (U.S. CLS. 21, 23, 26, 36 AND 38).

JEAN IM, EXAMINING ATTORNEY

SN 85-601,478. AMEDISYS, INC., BATON ROUGE, LA. FILED 4-18-2012.

APOC

THE MARK CONSISTS OF STANDARD CHARACTERS WITHOUT CLAIM TO ANY PARTICULAR FONT, STYLE, SIZE, OR COLOR.

FOR COMPUTER APPLICATION SOFTWARE FOR MOBILE PHONES, HANDHELD COMPUTERS, SMART PHONES, TABLET COMPUTERS, LAPTOPS AND OTHER END-USER DEVICES, NAMELY SOFTWARE APPLICATION FOR THE COLLECTION, SECURE TRANSMISSION AND STORAGE OF PATIENT EXAMINATION AND ASSESSMENT INFORMATION (U.S. CLS. 21, 23, 26, 36 AND 38).

STEVEN R. FINE, EXAMINING ATTORNEY

CLASS 9—(Continued).

SN 85-601,609. TELESOURCE SERVICES, LLC, PONTIAC, MI. FILED 4-18-2012.

HYBRID TECHNOLOGY DEPOT

THE MARK CONSISTS OF STANDARD CHARACTERS WITHOUT CLAIM TO ANY PARTICULAR FONT, STYLE, SIZE, OR COLOR.

NO CLAIM IS MADE TO THE EXCLUSIVE RIGHT TO USE "HYBRID TECHNOLOGY", APART FROM THE MARK AS SHOWN.

FOR BATTERIES FOR VEHICLES; SPEEDOMETERS FOR VEHICLES; NAVIGATION APPARATUS FOR VEHICLES IN THE NATURE OF ONBOARD COMPUTERS; ONBOARD DIAGNOSTIC COMPUTERS FOR VEHICLES (U.S. CLS. 21, 23, 26, 36 AND 38).

IRA J. GOODSaid, EXAMINING ATTORNEY

SN 85-601,739. WEISS, BOB, NEW YORK, NY. FILED 4-18-2012.

Hate Button

THE MARK CONSISTS OF STANDARD CHARACTERS WITHOUT CLAIM TO ANY PARTICULAR FONT, STYLE, SIZE, OR COLOR.

NO CLAIM IS MADE TO THE EXCLUSIVE RIGHT TO USE "BUTTON", APART FROM THE MARK AS SHOWN.

FOR COMPUTER SOFTWARE DEVELOPMENT TOOLS; COMPUTER SOFTWARE FOR USE AS AN APPLICATION PROGRAMMING INTERFACE (API); APPLICATION PROGRAMMING INTERFACE (API) FOR COMPUTER SOFTWARE WHICH FACILITATES ONLINE SERVICES FOR SOCIAL NETWORKING, BUILDING SOCIAL NETWORKING APPLICATIONS AND FOR ALLOWING DATA RETRIEVAL, UPLOAD, DOWNLOAD, ACCESS AND MANAGEMENT; COMPUTER SOFTWARE TO ENABLE UPLOADING, DOWNLOADING, ACCESSING, POSTING, DISPLAYING, TAGGING, BLOGGING, STREAMING, LINKING, SHARING OR OTHERWISE PROVIDING ELECTRONIC MEDIA OR INFORMATION VIA COMPUTER AND COMMUNICATION NETWORKS (U.S. CLS. 21, 23, 26, 36 AND 38).

TARAH HARDY, EXAMINING ATTORNEY

CLASS 9—(Continued).

SN 85-601,749. WEISS, BOB, NEW YORK, NY. FILED 4-18-2012.

Great Button

THE MARK CONSISTS OF STANDARD CHARACTERS WITHOUT CLAIM TO ANY PARTICULAR FONT, STYLE, SIZE, OR COLOR.

NO CLAIM IS MADE TO THE EXCLUSIVE RIGHT TO USE "BUTTON", APART FROM THE MARK AS SHOWN.

FOR COMPUTER SOFTWARE DEVELOPMENT TOOLS; COMPUTER SOFTWARE FOR USE AS AN APPLICATION PROGRAMMING INTERFACE (API); APPLICATION PROGRAMMING INTERFACE (API) FOR COMPUTER SOFTWARE WHICH FACILITATES ONLINE SERVICES FOR SOCIAL NETWORKING; BUILDING SOCIAL NETWORKING APPLICATIONS AND FOR ALLOWING DATA RETRIEVAL, UPLOAD, DOWNLOAD, ACCESS AND MANAGEMENT; COMPUTER SOFTWARE TO ENABLE UPLOADING, DOWNLOADING, ACCESSING, POSTING, DISPLAYING, TAGGING, BLOGGING, STREAMING, LINKING, SHARING OR OTHERWISE PROVIDING ELECTRONIC MEDIA OR INFORMATION VIA COMPUTER AND COMMUNICATION NETWORKS (U.S. CLS. 21, 23, 26, 36 AND 38).

TARAH HARDY, EXAMINING ATTORNEY

SN 85-601,754. LOVE IN MOTION NOVELTIES LLC, OCEANSIDE, NY. FILED 4-18-2012.

Sexometer

THE MARK CONSISTS OF STANDARD CHARACTERS WITHOUT CLAIM TO ANY PARTICULAR FONT, STYLE, SIZE, OR COLOR.

FOR PEDOMETERS (U.S. CLS. 21, 23, 26, 36 AND 38).
MATTHEW GALAN, EXAMINING ATTORNEY

CLASS 9—(Continued).

SN 85-601,755. WEISS, BOB, NEW YORK, NY. FILED 4-18-2012.

Cringe Button

THE MARK CONSISTS OF STANDARD CHARACTERS WITHOUT CLAIM TO ANY PARTICULAR FONT, STYLE, SIZE, OR COLOR.

NO CLAIM IS MADE TO THE EXCLUSIVE RIGHT TO USE "BUTTON", APART FROM THE MARK AS SHOWN.

FOR COMPUTER SOFTWARE DEVELOPMENT TOOLS; COMPUTER SOFTWARE FOR USE AS AN APPLICATION PROGRAMMING INTERFACE (API); APPLICATION PROGRAMMING INTERFACE (API) FOR COMPUTER SOFTWARE WHICH FACILITATES ONLINE SERVICES FOR SOCIAL NETWORKING; BUILDING SOCIAL NETWORKING APPLICATIONS AND FOR ALLOWING DATA RETRIEVAL, UPLOAD, DOWNLOAD, ACCESS AND MANAGEMENT; COMPUTER SOFTWARE TO ENABLE UPLOADING, DOWNLOADING, ACCESSING, POSTING, DISPLAYING, TAGGING, BLOGGING, STREAMING, LINKING, SHARING OR OTHERWISE PROVIDING ELECTRONIC MEDIA OR INFORMATION VIA COMPUTER AND COMMUNICATION NETWORKS (U.S. CLS. 21, 23, 26, 36 AND 38).

TARAH HARDY, EXAMINING ATTORNEY

SN 85-601,765. WEISS, BOB, NEW YORK, NY. FILED 4-18-2012.

Love Button

THE MARK CONSISTS OF STANDARD CHARACTERS WITHOUT CLAIM TO ANY PARTICULAR FONT, STYLE, SIZE, OR COLOR.

NO CLAIM IS MADE TO THE EXCLUSIVE RIGHT TO USE "BUTTON", APART FROM THE MARK AS SHOWN.

FOR COMPUTER SOFTWARE DEVELOPMENT TOOLS; COMPUTER SOFTWARE FOR USE AS AN APPLICATION PROGRAMMING INTERFACE (API); APPLICATION PROGRAMMING INTERFACE (API) FOR COMPUTER SOFTWARE WHICH FACILITATES ONLINE SERVICES FOR SOCIAL NETWORKING; BUILDING SOCIAL NETWORKING APPLICATIONS AND FOR ALLOWING DATA RETRIEVAL, UPLOAD, DOWNLOAD, ACCESS AND MANAGEMENT; COMPUTER SOFTWARE TO ENABLE UPLOADING, DOWNLOADING, ACCESSING, POSTING, DISPLAYING, TAGGING, BLOGGING, STREAMING, LINKING, SHARING OR OTHERWISE PROVIDING ELECTRONIC MEDIA OR INFORMATION VIA COMPUTER AND COMMUNICATION NETWORKS (U.S. CLS. 21, 23, 26, 36 AND 38).

TARAH HARDY, EXAMINING ATTORNEY

CLASS 9—(Continued).

SN 85-601,943. FLEXERA SOFTWARE LLC, SCHAUMBURG, IL. FILED 4-18-2012.

ADMINSTUDIO

THE MARK CONSISTS OF STANDARD CHARACTERS WITHOUT CLAIM TO ANY PARTICULAR FONT, STYLE, SIZE, OR COLOR.

OWNER OF U.S. REG. NO. 2,568,465.

FOR COMPUTER SOFTWARE WHICH REPACKAGES THIRD-PARTY DEVELOPED SOFTWARE, FIRMWARE, AND DATA INTO AN INSTALLABLE OR DEPLOYABLE FORM; COMPUTER SOFTWARE WHICH PACKAGES USER DEVELOPED SOFTWARE, FIRMWARE, AND DATA INTO AN INSTALLABLE OR DEPLOYABLE FORM; COMPUTER SOFTWARE WHICH DETERMINES THE COMPATIBILITY BETWEEN SOFTWARE AND FIRMWARE AND OTHER SOFTWARE AND FIRMWARE; COMPUTER SOFTWARE WHICH DETERMINES THE OPTIMAL RUNTIME ENVIRONMENT FOR SOFTWARE AND FIRMWARE; COMPUTER SOFTWARE WHICH MONITORS, REPORTS, AND OPTIMIZES RESPONSE TIME OF SOFTWARE AND FIRMWARE (U.S. CLS. 21, 23, 26, 36 AND 38).

JOHN E. MICHOS, EXAMINING ATTORNEY

CLASS 9—(Continued).

SN 85-602,090. GLOBAL ENGINEERING SECURITY SYSTEMS, INC., HIALEAH, FL. FILED 4-19-2012.



NO CLAIM IS MADE TO THE EXCLUSIVE RIGHT TO USE "TECHNOLOGIES", APART FROM THE MARK AS SHOWN.

THE MARK CONSISTS OF A FANCIFUL REPRESENTATION OF A GLOBAL AXIS TO THE LEFT OF THE WORD GESS IN CAPITAL LETTERS OVER "TECHNOLOGIES" IN SMALLER CAPITAL LETTERS.

FOR ACOUSTIC COUPLERS; ADAPTER PLUGS; ADAPTER RINGS FOR ATTACHING OBJECTIVES ON CAMERAS; AMPLIFIERS; APPARATUS FOR BROADCASTING, RECORDING, TRANSMISSION OR REPRODUCTION OF SOUND OR IMAGES; APPARATUS FOR RECORDING AND REPRODUCTION OF SOUND, IMAGES OR DATA; AUDIO CABLES; AUDIO PROCESSING EQUIPMENT, NAMELY, LIMITERS AND COMPRESSORS; AUDIO RECORDERS; AUTOMATED SELF CONTAINED ELECTRONIC SURVEILLANCE DEVICES THAT CAN BE DEPLOYED TO GATHER EVIDENCE OR INTELLIGENCE IN REMOTE LOCATIONS; BATTERY CABLES; BELLOWS; BUILDING SECURITY SYSTEMS COMPRISING SOFTWARE AND HARDWARE FOR PROVIDING PICTURE, VIDEO, ALARM STATUS, BUILDING PLANS, AND OTHER INFORMATION TO A REMOTE STATION; CABLE AND WIRING PLATES IN THE NATURE OF PROTECTIVE SHEATHS FOR ELECTRICAL CABLE AND WIRING; CABLE CONNECTORS; CABLES AND FIBRES FOR THE TRANSMISSION OF SOUNDS AND IMAGES; CABLES FOR ELECTRICAL AND OPTICAL SIGNAL TRANSMISSION SYSTEMS; CABLES FOR ELECTRICAL OR OPTICAL SIGNAL TRANSMISSION; CABLES, ELECTRIC; CAMERA CASES; CAMERA CLOSURES; CAMERA HARDWARE SYSTEMS FOR IP (INTERNET PROTOCOL) VIDEO SURVEILLANCE; CAMERA MOUNTS AND SUPPORTS; CAMERAS; CLOSED CIRCUIT TV SYSTEMS FOR SECURITY AND SURVEILLANCE, NAMELY, CAMERAS, SWITCHERS, MONITORS, MICROPHONES, AND RECORDERS; COAXIAL CABLES; COMBINATION VIDEO PLAYERS AND RECORDERS; COMPONENT VIDEO CABLES; COMPUTER CAMERAS; COMPUTER KEYBOARD CONTROLLERS; CONNECTING ELECTRICAL CABLES; CONNECTION CABLES; CONNECTORS FOR ELECTRONIC CIRCUITS; CONVERSION LENSES FOR CAMERAS; CONVERTERS; CONVERTERS FOR ELECTRIC PLUGS; DAY AND NIGHT VISION SYSTEMS PRIMARILY COMPRISING DAY AND NIGHT SENSORS, DAY AND NIGHT CAMERAS, POWER SOURCES, COMMUNICATION MEANS, MONITORS AND OPERATING SOFTWARE; DC/AC POWER CONVERTERS; DIGITAL AUDIO AND VIDEO RECORDERS AND PLAYERS; DIGITAL CAMERAS; DIGITAL CAMERAS FOR INDUSTRIAL USE; DIGITAL PHOTO IMAGE CONVERTERS; DIGITAL VIDEO CAMERAS; DISTRIBUTION BOXES FOR ELECTRICAL POWER; DVD RECORDERS; DVD RECORDING APPARATUS; DVR CARDS; ELECTRIC AND ELECTRONIC VIDEO SURVEILLANCE INSTALLATIONS; ELECTRIC CABLES AND WIRES; ELECTRIC CONNECTIONS AND CONNECTORS; ELECTRIC CONNECTORS; ELECTRIC CORDS; ELECTRIC FUSE BOXES; ELECTRIC PLUGS; ELECTRIC POWER CONVERTERS; ELECTRIC SENSORS; ELECTRIC SWITCH HOUSINGS; ELECTRICAL AND ELECTRONIC CONNECTORS; ELECTRICAL CONNECTION BOXES; ELECTRICAL CONNECTOR HOUSINGS; ELECTRICAL DISTRIBUTION BOXES; ELECTRICAL PLUG DEVICE ENABLING CONNECTION AND DISCONNECTION OF POWER AND/OR CONTROL CABLES; ELECTRICAL

SN 85-601,997. JUPISOFT, LLC, JUPITER, FL. FILED 4-18-2012.



THE MARK CONSISTS OF A STYLIZED LETTER "J", ALONG WITH THE STYLIZED TEXT "JUPISOFT" UNDERNEATH IT.

FOR COMPUTER SOFTWARE THAT PROVIDES WEB-BASED ACCESS TO APPLICATIONS AND SERVICES THROUGH A WEB OPERATING SYSTEM OR PORTAL INTERFACE (U.S. CLS. 21, 23, 26, 36 AND 38).

STEVEN PEREZ, EXAMINING ATTORNEY

CLASS 9—(Continued).

PLUGS AND SOCKETS; ELECTRICAL POWER CONNECTORS; ELECTRICAL POWER DEVICES, NAMELY, MULTIMEDIA OUTLETS; ELECTRICAL POWER DEVICES, NAMELY, TAPS; ELECTRICAL POWER DISTRIBUTION BLOCKS; ELECTRICAL POWER DISTRIBUTION UNITS; ELECTRICAL POWER EXTENSION CORDS; ELECTRONIC CONTROLLERS FOR USE WITH POWER CONVERTERS; ELECTRONIC EQUIPMENT, NAMELY, TRANSFORMERS, BALUNS, CABLES USED IN CONNECTION WITH COMPUTERS, COMPUTER PERIPHERAL DEVICES, TELEVISIONS, AUDIO-VIDEO EQUIPMENT, CLOSED-CIRCUIT TV EQUIPMENT AND TELECOMMUNICATION EQUIPMENT; ELECTRONIC VIDEO SURVEILLANCE PRODUCTS, NAMELY, ELECTRONIC COMPONENTS OF SECURITY SYSTEMS; FACILITIES MANAGEMENT SOFTWARE, NAMELY, SOFTWARE TO CONTROL BUILDING ENVIRONMENT, ACCESS AND SECURITY SYSTEMS; FIRE AND SMOKE DETECTORS; FREQUENCY CONVERTERS; INFRARED CAMERAS; INTEGRATED CIRCUITS, INTEGRATED CIRCUIT CHIPS, AND INTEGRATED CIRCUIT MODULES FOR DIGITAL VIDEO COMPRESSION AND DECOMPRESSION; IP (INTERNET PROTOCOL) CAMERAS; IP (INTERNET PROTOCOL) SPEED DOME CAMERAS; IRIS RECOGNITION SECURITY DEVICES; JUNCTION BOXES; KEYBOARDS; LCD MONITORS FOR SECURITY PURPOSES; LENSES FOR CAMERAS; METAL DEPOSITORY HOUSING SOLD EMPTY THAT IS SPECIALLY ADAPTED TO CONTAIN PHOTOGRAPHIC AND COMPUTER COMPONENTS; MICROPHONES; MOTION SENSITIVE SECURITY LIGHTS; MOUNTING DEVICES FOR CAMERAS AND MONITORS; MOUNTING DEVICES FOR MONITORS; MOUNTING DEVICES FOR PHOTOGRAPHIC EQUIPMENT; MULTIPLE PURPOSE CAMERAS; PLUG ADAPTORS; PLUG CONNECTORS; PLUG-IN CONNECTORS; PORTABLE VIDEO CAMERAS WITH BUILT-IN VIDEOCASSETTE RECORDERS; POWER ACCESS PORT FOR USE WITH ELECTRICAL CONTROL PANELS FOR CONNECTING MULTIPLE DATA AND ELECTRICAL DEVICES; POWER ADAPTERS; POWER ADAPTERS FOR COMPUTERS; POWER AMPLIFIERS; POWER CABLES; POWER CONNECTORS; POWER CONTROLLERS; POWER DISTRIBUTING BOXES; POWER INVERTERS; POWER SUPPLIES; POWER SUPPLY CONNECTORS AND ADAPTORS FOR USE WITH PORTABLE ELECTRONIC DEVICES; POWER TRANSFORMERS FOR AMPLIFICATION; POWER WIRES; SAFETY SENSORS, NAMELY, CARBON MONOXIDE DETECTORS, SMOKE DETECTORS, AND COMBINATION CARBON MONOXIDE AND SMOKE DETECTORS; SCANNERS; SECURITY CONTROL PANELS AND MOTION DETECTORS; SIGNAL SPLITTERS FOR ELECTRONIC APPARATUS; TELEVISION AND VIDEO CONVERTERS; TOOL MEASURING INSTRUMENTS; VIDEO CAMERAS; WIRELESS COMMUNICATION DEVICES FOR TRANSMITTING IMAGES TAKEN BY A CAMERA (U.S. CLS. 21, 23, 26, 36 AND 38).

REBECCA GILBERT, EXAMINING ATTORNEY

CLASS 9—(Continued).

SN 85-602,151. TELESOURCE SERVICES, LLC, PONTIAC, MI. FILED 4-19-2012.

HYBRID BATTERY DEPOT

THE MARK CONSISTS OF STANDARD CHARACTERS WITHOUT CLAIM TO ANY PARTICULAR FONT, STYLE, SIZE, OR COLOR.

NO CLAIM IS MADE TO THE EXCLUSIVE RIGHT TO USE "HYBRID BATTERY", APART FROM THE MARK AS SHOWN.

FOR BATTERIES FOR VEHICLES; SPEEDOMETERS FOR VEHICLES; NAVIGATION APPARATUS FOR VEHICLES IN THE NATURE OF ONBOARD COMPUTERS; ONBOARD DIAGNOSTIC COMPUTERS FOR VEHICLES (U.S. CLS. 21, 23, 26, 36 AND 38).

FIRST USE 10-27-2011; IN COMMERCE 12-9-2011.

IRA J. GOODSaid, EXAMINING ATTORNEY

SN 85-602,163. DURACELL POWERMAT, LLC, BETHEL, CT. FILED 4-19-2012.

NEVER BE POWERLESS

THE MARK CONSISTS OF STANDARD CHARACTERS WITHOUT CLAIM TO ANY PARTICULAR FONT, STYLE, SIZE, OR COLOR.

FOR BATTERIES, BATTERY CHARGERS AND PARTS THEREFORE (U.S. CLS. 21, 23, 26, 36 AND 38).

KRISTIN DAHLING, EXAMINING ATTORNEY

SN 85-602,180. TRT INTERNATIONAL TRADING CORP., LOS ANGELES, CA. FILED 4-19-2012.

iBastek

THE MARK CONSISTS OF STANDARD CHARACTERS WITHOUT CLAIM TO ANY PARTICULAR FONT, STYLE, SIZE, OR COLOR.

FOR AUDIO SPEAKERS; PROTECTIVE COVERS AND CASES FOR CELL PHONES, LAPTOPS AND PORTABLE MEDIA PLAYERS (U.S. CLS. 21, 23, 26, 36 AND 38).

SETH A. RAPPAPORT, EXAMINING ATTORNEY

CLASS 9—(Continued).

SN 85-602,187. DC SHOES, INC., HUNTINGTON BEACH, CA. FILED 4-19-2012.



OWNER OF U.S. REG. NOS. 2,317,622, 3,040,219 AND OTHERS.

THE MARK CONSISTS OF "DC" AND A 7-POINTED STAR.

FOR CELL PHONE CASES, CELL PHONE COVERS, CELL PHONE HOLDERS (U.S. CLS. 21, 23, 26, 36 AND 38).

TOBY BULLOFF, EXAMINING ATTORNEY

CLASS 9—(Continued).

SN 85-602,422. MEDAMORPHIS LLC, DENVER, CO. FILED 4-19-2012.

MEDATOMY

THE MARK CONSISTS OF STANDARD CHARACTERS WITHOUT CLAIM TO ANY PARTICULAR FONT, STYLE, SIZE, OR COLOR.

FOR MEDICAL SOFTWARE USED TO CREATE MODELS OF BODY PARTS AND TO TEACH MEDICAL PROCEDURES TO DOCTORS (U.S. CLS. 21, 23, 26, 36 AND 38).

JENNIFER RICHARDSON, EXAMINING ATTORNEY

SN 85-602,349. MELLOW MILITIA, LLC, DELRAY BEACH, FL. FILED 4-19-2012.

SHUTTERSTAR

SN 85-602,469. MELLOW MILITIA, LLC, DELRAY BEACH, FL. FILED 4-19-2012.

THE MARK CONSISTS OF STANDARD CHARACTERS WITHOUT CLAIM TO ANY PARTICULAR FONT, STYLE, SIZE, OR COLOR.

FOR COMPUTER APPLICATION SOFTWARE FOR MOBILE PHONES, NAMELY, SOFTWARE FOR SHARING PHOTOGRAPHS AND OTHER DIGITAL IMAGES (U.S. CLS. 21, 23, 26, 36 AND 38).

JAY FLOWERS, EXAMINING ATTORNEY



SN 85-602,419. WRIGHT EXPRESS CORPORATION, SOUTH PORTLAND, ME. FILED 4-19-2012.

OCTANE

THE MARK CONSISTS OF STANDARD CHARACTERS WITHOUT CLAIM TO ANY PARTICULAR FONT, STYLE, SIZE, OR COLOR.

FOR COMPUTER APPLICATION SOFTWARE FOR MOBILE PHONES AND HANDHELD DEVICES, NAMELY, SOFTWARE FOR IDENTIFYING AUTOMOBILE FUEL LOCATIONS AND FUEL PRICES, AND PROVIDING MAPPING AND NAVIGATION FUNCTIONALITY (U.S. CLS. 21, 23, 26, 36 AND 38).

FIRST USE 3-1-2012; IN COMMERCE 3-1-2012. KAPIL BHANOT, EXAMINING ATTORNEY

THE MARK CONSISTS OF A CONCENTRIC STAR DESIGN WITH A SMALLER STAR DESIGN INSIDE ANOTHER LARGER STAR DESIGN, SURROUNDED BY TRIANGLE-LIKE SHAPES THAT FORM A CIRCLE AROUND THE CONCENTRIC STARS.

FOR COMPUTER APPLICATION SOFTWARE FOR MOBILE PHONES, NAMELY, SOFTWARE FOR SHARING PHOTOGRAPHS AND OTHER DIGITAL MATERIALS (U.S. CLS. 21, 23, 26, 36 AND 38).

JAY FLOWERS, EXAMINING ATTORNEY

CLASS 9—(Continued).

SN 85-602,503. GREENSTACK, INC., SEBASTOPOL, CA. FILED 4-19-2012.

GREENSTACK

THE MARK CONSISTS OF STANDARD CHARACTERS WITHOUT CLAIM TO ANY PARTICULAR FONT, STYLE, SIZE, OR COLOR.

FOR COMPUTER SOFTWARE AND MOBILE SOFTWARE APPLICATIONS THAT ALLOW USERS TO KEEP TRACK OF THE BENEFITS OF THIRD-PARTY MEMBERSHIPS AND RECEIVE ASSOCIATED DISCOUNTS AND PERKS AND COMBINE THOSE DISCOUNTS AND PERKS IN ORDER TO INCREASE SAVINGS; COMPUTER SOFTWARE AND MOBILE SOFTWARE APPLICATIONS THAT PINPOINT GEOLOCATION OF DISCOUNTS, PERKS, AND BENEFITS BASED ON EXISTING MEMBERSHIPS AND MEMBERSHIPS PROPOSED THROUGH AUTOMATIC AND SOCIAL INTEREST MATCHING; COMPUTER SOFTWARE TOOL TO RECOMMEND SAVINGS OPPORTUNITIES INCLUDING NEW OR REPLACEMENT CREDIT CARDS (U.S. CLS. 21, 23, 26, 36 AND 38).

DOMINIC J. FERRAIUOLO, EXAMINING ATTORNEY

CLASS 9—(Continued).

SN 85-602,537. WRIGHT EXPRESS CORPORATION, SOUTH PORTLAND, ME. FILED 4-19-2012.



THE MARK CONSISTS OF FOUR STACKED LIQUID DROP SHAPES ABOVE THE WORD OCTANE.

FOR COMPUTER APPLICATION SOFTWARE FOR MOBILE PHONES AND HANDHELD DEVICES, NAMELY, SOFTWARE FOR IDENTIFYING AUTOMOBILE FUEL LOCATIONS AND FUEL PRICES, AND PROVIDING MAPPING AND NAVIGATION FUNCTIONALITY (U.S. CLS. 21, 23, 26, 36 AND 38).

FIRST USE 3-1-2012; IN COMMERCE 3-1-2012.
KAPIL BHANOT, EXAMINING ATTORNEY

SN 85-602,519. PURE STORAGE, INC., MOUNTAIN VIEW, CA. FILED 4-19-2012.

PURESTORAGE

THE MARK CONSISTS OF STANDARD CHARACTERS WITHOUT CLAIM TO ANY PARTICULAR FONT, STYLE, SIZE, OR COLOR.

FOR FLASH MEMORY ARRAY (U.S. CLS. 21, 23, 26, 36 AND 38).

FIRST USE 8-1-2011; IN COMMERCE 8-1-2011.

DOMINIC J. FERRAIUOLO, EXAMINING ATTORNEY

SN 85-602,582. HEWLETT-PACKARD DEVELOPMENT COMPANY, L.P., HOUSTON, TX. FILED 4-19-2012.

ENVY X OVER

THE MARK CONSISTS OF STANDARD CHARACTERS WITHOUT CLAIM TO ANY PARTICULAR FONT, STYLE, SIZE, OR COLOR.

OWNER OF U.S. REG. NO. 3,641,673.

FOR COMPUTERS; PERSONAL COMPUTERS; LAPTOP COMPUTERS; NOTEBOOK COMPUTERS; TABLET COMPUTERS; DESKTOP COMPUTERS; COMPUTER HARDWARE; COMPUTER PERIPHERALS (U.S. CLS. 21, 23, 26, 36 AND 38).

CAROLYN CATALDO, EXAMINING ATTORNEY

CLASS 9—(Continued).

SN 85-602,593. WRIGHT EXPRESS CORPORATION, SOUTH PORTLAND, ME. FILED 4-19-2012.



THE MARK CONSISTS OF A SQUARE WITH ROUNDED CORNERS. INSIDE THE SQUARE IS A DESIGN OF FOUR STACKED LIQUID DROP SHAPES.

FOR COMPUTER APPLICATION SOFTWARE FOR MOBILE PHONES AND HANDHELD DEVICES, NAMELY, SOFTWARE FOR IDENTIFYING AUTOMOBILE FUEL LOCATIONS AND FUEL PRICES, AND PROVIDING MAPPING AND NAVIGATION FUNCTIONALITY (U.S. CLS. 21, 23, 26, 36 AND 38).

FIRST USE 3-1-2012; IN COMMERCE 3-1-2012.
KAPIL BHANOT, EXAMINING ATTORNEY

CLASS 9—(Continued).

SN 85-602,674. HI-TECH TRANSPORT ELECTRONICS, INC., EUGENE, OR. FILED 4-19-2012.

Binmaxx

THE MARK CONSISTS OF STANDARD CHARACTERS WITHOUT CLAIM TO ANY PARTICULAR FONT, STYLE, SIZE, OR COLOR.

FOR ELECTRONIC COMMUNICATIONS SYSTEMS COMPRISED OF COMPUTER HARDWARE AND SOFTWARE FOR THE TRANSMISSION OF DATA BETWEEN TWO POINTS (U.S. CLS. 21, 23, 26, 36 AND 38).

ROBIN CHOSID, EXAMINING ATTORNEY

SN 85-602,693. HEWLETT-PACKARD DEVELOPMENT COMPANY, L.P., HOUSTON, TX. FILED 4-19-2012.

ENVY BLADE

THE MARK CONSISTS OF STANDARD CHARACTERS WITHOUT CLAIM TO ANY PARTICULAR FONT, STYLE, SIZE, OR COLOR.

OWNER OF U.S. REG. NO. 3,641,673.
FOR COMPUTERS; PERSONAL COMPUTERS; LAPTOP COMPUTERS; NOTEBOOK COMPUTERS; TABLET COMPUTERS; DESKTOP COMPUTERS; COMPUTER HARDWARE; COMPUTER PERIPHERALS (U.S. CLS. 21, 23, 26, 36 AND 38).

CAROLYN CATALDO, EXAMINING ATTORNEY

SN 85-602,660. HEWLETT-PACKARD DEVELOPMENT COMPANY, L.P., HOUSTON, TX. FILED 4-19-2012.

ENVY X2

THE MARK CONSISTS OF STANDARD CHARACTERS WITHOUT CLAIM TO ANY PARTICULAR FONT, STYLE, SIZE, OR COLOR.

OWNER OF U.S. REG. NO. 3,641,673.
FOR COMPUTERS; PERSONAL COMPUTERS; LAPTOP COMPUTERS; NOTEBOOK COMPUTERS; TABLET COMPUTERS; DESKTOP COMPUTERS; COMPUTER HARDWARE; COMPUTER PERIPHERALS (U.S. CLS. 21, 23, 26, 36 AND 38).

CAROLYN CATALDO, EXAMINING ATTORNEY

SN 85-602,708. HEWLETT-PACKARD DEVELOPMENT COMPANY, L.P., HOUSTON, TX. FILED 4-19-2012.

HP ENVY BLAZE

THE MARK CONSISTS OF STANDARD CHARACTERS WITHOUT CLAIM TO ANY PARTICULAR FONT, STYLE, SIZE, OR COLOR.

OWNER OF U.S. REG. NO. 3,641,673.
FOR COMPUTERS; PERSONAL COMPUTERS; LAPTOP COMPUTERS; NOTEBOOK COMPUTERS; TABLET COMPUTERS; DESKTOP COMPUTERS; COMPUTER HARDWARE; COMPUTER PERIPHERALS (U.S. CLS. 21, 23, 26, 36 AND 38).

CAROLYN CATALDO, EXAMINING ATTORNEY

CLASS 9—(Continued).

SN 85-602,721. HEWLETT-PACKARD DEVELOPMENT COMPANY, L.P., HOUSTON, TX. FILED 4-19-2012.

HP ENVY RAY

THE MARK CONSISTS OF STANDARD CHARACTERS WITHOUT CLAIM TO ANY PARTICULAR FONT, STYLE, SIZE, OR COLOR.

OWNER OF U.S. REG. NO. 3,641,673.
FOR COMPUTERS; PERSONAL COMPUTERS; LAPTOP COMPUTERS; NOTEBOOK COMPUTERS; TABLET COMPUTERS; DESKTOP COMPUTERS; COMPUTER HARDWARE; COMPUTER PERIPHERALS (U.S. CLS. 21, 23, 26, 36 AND 38).
CAROLYN CATALDO, EXAMINING ATTORNEY

SN 85-602,735. HEWLETT-PACKARD DEVELOPMENT COMPANY, L.P., HOUSTON, TX. FILED 4-19-2012.

SPECTRE ONE

THE MARK CONSISTS OF STANDARD CHARACTERS WITHOUT CLAIM TO ANY PARTICULAR FONT, STYLE, SIZE, OR COLOR.

FOR COMPUTERS; PERSONAL COMPUTERS; LAPTOP COMPUTERS; NOTEBOOK COMPUTERS; TABLET COMPUTERS; DESKTOP COMPUTERS; COMPUTER HARDWARE; COMPUTER PERIPHERALS (U.S. CLS. 21, 23, 26, 36 AND 38).
JANICE KIM, EXAMINING ATTORNEY

SN 85-602,739. VERINT SYSTEMS CANADA, INC., QUEBEC, CANADA, FILED 4-19-2012.

SMARTSIGHT

THE MARK CONSISTS OF STANDARD CHARACTERS WITHOUT CLAIM TO ANY PARTICULAR FONT, STYLE, SIZE, OR COLOR.

OWNER OF U.S. REG. NO. 2,601,199.
FOR COMPUTER HARDWARE, NAMELY, ENCODERS, AUDIO AND VIDEO DECODERS, DIGITAL TRANSMITTERS, COMPUTER NETWORK BRIDGES, WIRELESS ACCESS POINT DEVICES, AND WIRELESS NETWORK REPEATERS FOR USE IN THE FIELD OF SURVEILLANCE (U.S. CLS. 21, 23, 26, 36 AND 38).
SAMUEL E. SHARPER JR., EXAMINING ATTORNEY

CLASS 9—(Continued).

SN 85-602,862. BLIZZARD LIGHTING, LLC, WAUKESHA, WI. FILED 4-19-2012.

wiCICLE

THE MARK CONSISTS OF STANDARD CHARACTERS WITHOUT CLAIM TO ANY PARTICULAR FONT, STYLE, SIZE, OR COLOR.

FOR LIGHTING CONTROLS (U.S. CLS. 21, 23, 26, 36 AND 38).
FIRST USE 1-3-2011; IN COMMERCE 1-20-2011.
RONALD MCMORROW, EXAMINING ATTORNEY

SN 85-603,099. MIPS LTD, REHOVOT, ISRAEL, FILED 4-19-2012.



THE COLOR(S) WHITE AND PINK IS/ARE CLAIMED AS A FEATURE OF THE MARK.

THE MARK CONSISTS OF THE STYLIZED TERM "FIT" IN WHITE FONT ENCASED IN A PINK BOX.

FOR COMPUTER APPLICATION SOFTWARE FOR WEBSITES OF APPAREL AND SHOE RETAILERS, MOBILE PHONES, MOBILE COMPUTERS TABLETS, AND SIMILAR DEVICES, NAMELY, SOFTWARE FOR PREDICTING USERS' RIGHT SIZE AND FITTING OF GARMENTS PROVIDING STYLING ADVICE AND ENABLING AND IMPROVING APPAREL ITEMS COMMERCE (ONLINE AND IN PHYSICAL STORES) (U.S. CLS. 21, 23, 26, 36 AND 38).
FIRST USE 11-25-2011; IN COMMERCE 11-25-2011.
KYLE PEETE, EXAMINING ATTORNEY

SN 85-603,240. ELLISON, TERRENCE JAMES, ROCHESTER, PA. FILED 4-19-2012.

Holla 5-9!

THE MARK CONSISTS OF STANDARD CHARACTERS WITHOUT CLAIM TO ANY PARTICULAR FONT, STYLE, SIZE, OR COLOR.

FOR AUDIO RECORDINGS FEATURING MUSIC (U.S. CLS. 21, 23, 26, 36 AND 38).
FIRST USE 7-20-2001; IN COMMERCE 1-24-2012.
ALAIN LAPTER, EXAMINING ATTORNEY

CLASS 9—(Continued).

SN 85-603,361. PATEL, ARUN, QUEEN CREEK, AZ. FILED 4-20-2012.

WOOLER

THE MARK CONSISTS OF STANDARD CHARACTERS WITHOUT CLAIM TO ANY PARTICULAR FONT, STYLE, SIZE, OR COLOR.

FOR COMPUTER SOFTWARE, NAMELY, A COLLABORATION AND KNOWLEDGE MANAGEMENT TOOL (U.S. CLS. 21, 23, 26, 36 AND 38).

FIRST USE 2-8-2009; IN COMMERCE 4-10-2009.

TRACY WHITTAKER-BROWN, EXAMINING ATTORNEY

SN 85-603,384. ALTICOR INC., ADA, MI. FILED 4-20-2012.

BODYKEY

THE MARK CONSISTS OF STANDARD CHARACTERS WITHOUT CLAIM TO ANY PARTICULAR FONT, STYLE, SIZE, OR COLOR.

PRIORITY CLAIMED UNDER SEC. 44(D) ON MEXICO APPLICATION NO. 1237906, FILED 12-16-2011.

FOR COMPUTER HARDWARE, SOFTWARE AND PERIPHERAL DEVICES FOR USE IN A WEIGHT MANAGEMENT PROGRAM, NAMELY, FOOD DIARY TRACKING, ACTIVITY PLANNER, MENU PLANNER, CALORIE TRACKER, RECIPE CALCULATOR AND RESULT TRACKING SOFTWARE; DIGITAL MATERIALS, NAMELY, CDS, DVDS, DOWNLOADABLE FILES FEATURING INFORMATION ON WEIGHT LOSS, WEIGHT MANAGEMENT, NUTRITION AND EXERCISE; COMPUTER APPLICATION SOFTWARE FOR MOBILE PHONES, NAMELY, SOFTWARE FOR USE IN WEIGHT MANAGEMENT; ELECTRONIC DIARIES (U.S. CLS. 21, 23, 26, 36 AND 38).

MIAH ROSENBERG, EXAMINING ATTORNEY

CLASS 9—(Continued).

SN 85-603,681. ENTERPRISING APPS, LLC, BENTON, KY. FILED 4-20-2012.



THE MARK CONSISTS OF THE SILHOUETTE OF A HOWLING WOLF'S HEAD WITH THE WIRELESS ICON ABOVE THE WOLF'S MOUTH.

FOR DOWNLOADABLE SOFTWARE APPLICATIONS FOR MOBILE DEVICES WHICH PERMIT USERS TO LOCATE, IDENTIFY, SURVEY AND DETERMINE THE STRENGTH OF OPEN, WIRED EQUIVALENT PRIVACY (WEP), AD HOC AND SECURE NETWORKS (U.S. CLS. 21, 23, 26, 36 AND 38).

FIRST USE 8-13-2011; IN COMMERCE 8-13-2011.

ROBERT STRUCK, EXAMINING ATTORNEY

SN 85-603,702. CANADA PIPELINE ACCESSORIES COMPANY, LTD., S.E. CALGARY, ALBERTA, CANADA, FILED 4-20-2012.

TBR

THE MARK CONSISTS OF STANDARD CHARACTERS WITHOUT CLAIM TO ANY PARTICULAR FONT, STYLE, SIZE, OR COLOR.

FOR FLOW CONDITIONERS, NAMELY, DEVICES FOR REGULATING FLUID FLOW IN PRESSURIZED PIPELINES (U.S. CLS. 21, 23, 26, 36 AND 38).

FIRST USE 0-0-2003; IN COMMERCE 0-0-2003.

MARK RADEMACHER, EXAMINING ATTORNEY

CLASS 9—(Continued).

SN 85-603,748. CHERRYCOM, INC., SAN FRANCISCO, CA. FILED 4-20-2012.

CHERRY

THE MARK CONSISTS OF STANDARD CHARACTERS WITHOUT CLAIM TO ANY PARTICULAR FONT, STYLE, SIZE, OR COLOR.

FOR DOWNLOADABLE SOFTWARE FOR MOBILE COMPUTER AND SMART PHONE DEVICES THAT ENABLES THE LOCATION OF A MOTOR VEHICLE TO BE SENT TO AN ONLINE SERVICE THAT DISPATCHES PERSONNEL TO WASH AND DETAIL THE MOTOR VEHICLE AT THAT LOCATION (U.S. CLS. 21, 23, 26, 36 AND 38).

FIRST USE 11-8-2011; IN COMMERCE 11-8-2011.
MIDGE BUTLER, EXAMINING ATTORNEY

SN 85-603,750. THE FONT BUREAU INC., BOSTON, MA. FILED 4-20-2012.

SAVANNA SCRIPT

THE MARK CONSISTS OF STANDARD CHARACTERS WITHOUT CLAIM TO ANY PARTICULAR FONT, STYLE, SIZE, OR COLOR.

NO CLAIM IS MADE TO THE EXCLUSIVE RIGHT TO USE "SCRIPT", APART FROM THE MARK AS SHOWN.

FOR PRINTING FONTS THAT CAN BE DOWNLOADED PROVIDED BY MEANS OF ELECTRONIC TRANSMISSION; TYPEFACE FONTS RECORDED ON MAGNETIC MEDIA (U.S. CLS. 21, 23, 26, 36 AND 38).

FIRST USE 4-19-2012; IN COMMERCE 4-19-2012.
SUSAN LESLIE DUBOIS, EXAMINING ATTORNEY

SN 85-603,751. CANADA PIPELINE ACCESSORIES COMPANY, LTD., S.E. CALGARY, ALBERTA, CANADA, FILED 4-20-2012.

FTBR

THE MARK CONSISTS OF STANDARD CHARACTERS WITHOUT CLAIM TO ANY PARTICULAR FONT, STYLE, SIZE, OR COLOR.

FOR FLOW CONDITIONERS, NAMELY, DEVICES FOR REGULATING FLUID FLOW IN PRESSURIZED PIPELINES (U.S. CLS. 21, 23, 26, 36 AND 38).

FIRST USE 0-0-2011; IN COMMERCE 0-0-2011.
MARK RADEMACHER, EXAMINING ATTORNEY

CLASS 9—(Continued).

SN 85-603,870. HEWLETT-PACKARD DEVELOPMENT COMPANY, L.P., HOUSTON, TX. FILED 4-20-2012.

AERABOOK

THE MARK CONSISTS OF STANDARD CHARACTERS WITHOUT CLAIM TO ANY PARTICULAR FONT, STYLE, SIZE, OR COLOR.

FOR COMPUTERS; PERSONAL COMPUTERS; LAPTOP COMPUTERS; NOTEBOOK COMPUTERS; TABLET COMPUTERS; DESKTOP COMPUTERS; COMPUTER HARDWARE; COMPUTER PERIPHERALS (U.S. CLS. 21, 23, 26, 36 AND 38).

JANICE KIM, EXAMINING ATTORNEY

SN 85-603,892. CANDI CONTROLS, INC., LAFAYETTE, CA. FILED 4-20-2012.

POWERTOOLS

THE MARK CONSISTS OF STANDARD CHARACTERS WITHOUT CLAIM TO ANY PARTICULAR FONT, STYLE, SIZE, OR COLOR.

FOR SOFTWARE APPLICATIONS FOR ENERGY MANAGEMENT BY CONSUMERS (U.S. CLS. 21, 23, 26, 36 AND 38).

FIRST USE 8-30-2011; IN COMMERCE 9-15-2011.
ROBERT STRUCK, EXAMINING ATTORNEY

SN 85-603,902. BLOOM INSURANCE AGENCY, LLC, BLOOMINGTON, IN. FILED 4-20-2012.



THE MARK CONSISTS OF THE FIGURE OF A MAN WEARING A SUIT STANDING IN FRONT OF THE WORD ASCEND WHICH APPEARS WITH A STYLIZED A.

FOR DOWNLOADABLE SOFTWARE IN THE NATURE OF A MOBILE APPLICATION FOR FACILITATING, TRACKING AND MONITORING INSURANCE SALES BY AGENTS FOR REGULATORY COMPLIANCE AND QUALITY PURPOSES (U.S. CLS. 21, 23, 26, 36 AND 38).

CHRISTINA SOBRAL, EXAMINING ATTORNEY

CLASS 9—(Continued).

SN 85-604,316. 2 FUNGUYS, LLC, PHOENIX, AZ. FILED 4-20-2012.

MORAL DILEMMA

THE MARK CONSISTS OF STANDARD CHARACTERS WITHOUT CLAIM TO ANY PARTICULAR FONT, STYLE, SIZE, OR COLOR.

FOR DOWNLOADABLE SOFTWARE IN THE NATURE OF A MOBILE APPLICATION FOR PLAYING A GAME (U.S. CLS. 21, 23, 26, 36 AND 38).

VIVIAN MICZNIK FIRST, EXAMINING ATTORNEY

SN 85-604,359. RUBICON GROUP HOLDING LIMITED, AMMAN, JORDAN, FILED 4-20-2012.

MAGENTA PIPELINE

THE MARK CONSISTS OF STANDARD CHARACTERS WITHOUT CLAIM TO ANY PARTICULAR FONT, STYLE, SIZE, OR COLOR.

FOR COMPUTER SOFTWARE FOR ASSET AND WORKFLOW MANAGEMENT; DOWNLOADABLE COMPUTER SOFTWARE FOR ASSET AND WORKFLOW MANAGEMENT; DOWNLOADABLE SOFTWARE FOR ASSET AND WORKFLOW MANAGEMENT (U.S. CLS. 21, 23, 26, 36 AND 38).

TRACY FLETCHER, EXAMINING ATTORNEY

SN 85-604,378. WEISS, BOB, NEW YORK, NY. FILED 4-20-2012.

Hate

THE MARK CONSISTS OF STANDARD CHARACTERS WITHOUT CLAIM TO ANY PARTICULAR FONT, STYLE, SIZE, OR COLOR.

FOR COMPUTER SOFTWARE DEVELOPMENT TOOLS; COMPUTER SOFTWARE FOR USE AS AN APPLICATION PROGRAMMING INTERFACE (API); APPLICATION PROGRAMMING INTERFACE (API) FOR COMPUTER SOFTWARE WHICH FACILITATES ONLINE SERVICES FOR SOCIAL NETWORKING, BUILDING SOCIAL NETWORKING APPLICATIONS AND FOR ALLOWING DATA RETRIEVAL, UPLOAD, DOWNLOAD, ACCESS AND MANAGEMENT; COMPUTER SOFTWARE TO ENABLE UPLOADING, DOWNLOADING, ACCESSING, POSTING, DISPLAYING, TAGGING, BLOGGING, STREAMING, LINKING, SHARING OR OTHERWISE PROVIDING ELECTRONIC MEDIA OR INFORMATION VIA COMPUTER AND COMMUNICATION NETWORKS (U.S. CLS. 21, 23, 26, 36 AND 38).

ALYSSA STEEL, EXAMINING ATTORNEY

CLASS 9—(Continued).

SN 85-604,448. WEISS, BOB, NEW YORK, NY. FILED 4-20-2012.

Cringe

THE MARK CONSISTS OF STANDARD CHARACTERS WITHOUT CLAIM TO ANY PARTICULAR FONT, STYLE, SIZE, OR COLOR.

FOR COMPUTER SOFTWARE DEVELOPMENT TOOLS; COMPUTER SOFTWARE FOR USE AS AN APPLICATION PROGRAMMING INTERFACE (API); APPLICATION PROGRAMMING INTERFACE (API) FOR COMPUTER SOFTWARE WHICH FACILITATES ONLINE SERVICES FOR SOCIAL NETWORKING, BUILDING SOCIAL NETWORKING APPLICATIONS AND FOR ALLOWING DATA RETRIEVAL, UPLOAD, DOWNLOAD, ACCESS AND MANAGEMENT; COMPUTER SOFTWARE TO ENABLE UPLOADING, DOWNLOADING, ACCESSING, POSTING, DISPLAYING, TAGGING, BLOGGING, STREAMING, LINKING, SHARING OR OTHERWISE PROVIDING ELECTRONIC MEDIA OR INFORMATION VIA COMPUTER AND COMMUNICATION NETWORKS (U.S. CLS. 21, 23, 26, 36 AND 38).

ALYSSA STEEL, EXAMINING ATTORNEY

SN 85-604,492. AARON SOLOMON, ASHEVILLE, NC. AND ROBERT BRINKER, GREELEY, CO. FILED 4-20-2012.

Re Vera

THE MARK CONSISTS OF STANDARD CHARACTERS WITHOUT CLAIM TO ANY PARTICULAR FONT, STYLE, SIZE, OR COLOR.

THE ENGLISH TRANSLATION OF RE VERA IN THE MARK IS 'IN TRUTH' OR 'IN FACT'.

FOR COMPACT DISCS FEATURING MUSIC (U.S. CLS. 21, 23, 26, 36 AND 38).

KELLEY WELLS, EXAMINING ATTORNEY

CLASS 9—(Continued).

SN 85-604,505. REMI COLLECTIONS LLC, HONOLULU, HI. FILED 4-20-2012.



THE MARK CONSISTS OF THE STYLIZED TEXT "BM" WITH A HALO OVER THE LETTER "B".

FOR CARRYING CASES FOR ELECTRONIC EQUIPMENT, NAMELY, EREADERS, TABLET COMPUTERS, LAPTOPS, CELL PHONES, MP3 PLAYERS, HANDHELD VIDEO GAME DEVICES, COMPUTERS, AND HANDHELD ELECTRONIC DEVICES (U.S. CLS. 21, 23, 26, 36 AND 38).

FIRST USE 6-9-2009; IN COMMERCE 4-1-2011.
KELLEY WELLS, EXAMINING ATTORNEY

SN 85-604,552. DING, CHIH-SHUN, AUSTIN, TX. FILED 4-21-2012.



THE MARK CONSISTS OF STANDARD CHARACTERS WITHOUT CLAIM TO ANY PARTICULAR FONT, STYLE, SIZE, OR COLOR.

FOR AUDIO AMPLIFIERS; AUDIO SPEAKERS (U.S. CLS. 21, 23, 26, 36 AND 38).

ALEXANDER L. POWERS, EXAMINING ATTORNEY

SN 85-604,594. WEBUCATOR, INC., JAMESVILLE, NY. FILED 4-21-2012.

WORDS WITH SKILL

THE MARK CONSISTS OF STANDARD CHARACTERS WITHOUT CLAIM TO ANY PARTICULAR FONT, STYLE, SIZE, OR COLOR.

FOR ELECTRONIC GAME SOFTWARE; ELECTRONIC GAME SOFTWARE FOR CELLULAR TELEPHONES; ELECTRONIC GAME SOFTWARE FOR HANDHELD ELECTRONIC DEVICES; ELECTRONIC GAME SOFTWARE FOR WIRELESS DEVICES (U.S. CLS. 21, 23, 26, 36 AND 38).

ALYSSA STEEL, EXAMINING ATTORNEY

CLASS 9—(Continued).

SN 85-604,667. 8LIKES INC, SAMMAMISH, WA. FILED 4-22-2012.



THE MARK CONSISTS OF STANDARD CHARACTERS WITHOUT CLAIM TO ANY PARTICULAR FONT, STYLE, SIZE, OR COLOR.

FOR CARRYING CASES FOR ELECTRONIC EQUIPMENT, NAMELY, TABLETS, NOTEBOOK COMPUTERS, LAPTOP COMPUTERS, MP3 PLAYERS, DIGITAL CAMERAS, PDA AND HANDHELD PDAS, MOBILE PHONES AND COMPUTERS (U.S. CLS. 21, 23, 26, 36 AND 38).

FIRST USE 10-24-2011; IN COMMERCE 10-24-2011.
JAY FLOWERS, EXAMINING ATTORNEY

SN 85-604,704. TILDEN APPS, OAKLAND, CA. FILED 4-22-2012.



THE MARK CONSISTS OF STANDARD CHARACTERS WITHOUT CLAIM TO ANY PARTICULAR FONT, STYLE, SIZE, OR COLOR.

FOR COMPUTER APPLICATION SOFTWARE FOR MOBILE PHONES AND HANDHELD COMPUTERS, NAMELY, SOFTWARE FOR DETERMINING A CENTRAL MEETING PLACE BETWEEN FRIENDS (U.S. CLS. 21, 23, 26, 36 AND 38).

FIRST USE 8-25-2011; IN COMMERCE 4-17-2012.

MARK RADEMACHER, EXAMINING ATTORNEY

CLASS 9—(Continued).

SN 85-604,722. GRACE DIGITAL, INC., SAN DIEGO, CA.
FILED 4-22-2012.

ECOXGEAR

THE MARK CONSISTS OF STANDARD CHARACTERS WITHOUT CLAIM TO ANY PARTICULAR FONT, STYLE, SIZE, OR COLOR.

FOR AUDIO SPEAKER ENCLOSURES; AUDIO SPEAKERS; CARRYING CASES, HOLDERS, PROTECTIVE CASES AND STANDS FEATURING POWER SUPPLY CONNECTORS, ADAPTORS, SPEAKERS AND BATTERY CHARGING DEVICES, SPECIALLY ADAPTED FOR USE WITH HANDHELD DIGITAL ELECTRONIC DEVICES; CASES FOR MUSIC, AUDIO AND RELATED ELECTRONIC EQUIPMENT, NAMELY, CASES FOR AUDIO TUNERS, AUDIO RECEIVERS, AMPLIFIERS, TAPE PLAYERS, COMPACT DISC PLAYERS, MP3 CONTROLLERS/PLAYERS, AUDIO MIXERS, AUDIO SPEAKERS IN THE NATURE OF MUSIC STUDIO MONITORS, MICROPHONES, AUDIO SPEAKERS, COMPACT DISCS, AUDIO TAPES, PORTABLE COMPUTERS, ANTENNAS, PHONOGRAPHIC RECORD PLAYERS, AUDIO RECORDING EQUIPMENT, AND THE CABLES ASSOCIATED WITH ALL OF THE FOREGOING EQUIPMENT; SPEAKER ENCLOSURES (U.S. CLS. 21, 23, 26, 36 AND 38).

FIRST USE 3-1-2012; IN COMMERCE 3-5-2012.
INGRID C. EULIN, EXAMINING ATTORNEY

SN 85-604,725. RAMARAO GARIKAPATI, KENNER, LA.
FILED 4-22-2012.

HealthTone

THE MARK CONSISTS OF STANDARD CHARACTERS WITHOUT CLAIM TO ANY PARTICULAR FONT, STYLE, SIZE, OR COLOR.

FOR COMPUTER SOFTWARE FOR CONTROLLING AND MANAGING PATIENT MEDICAL INFORMATION (U.S. CLS. 21, 23, 26, 36 AND 38).

KATHERINE M. DUBRAY, EXAMINING ATTORNEY

CLASS 9—(Continued).

SN 85-604,826. BOXWAVE CORPORATION, BELLEVUE, WA.
FILED 4-22-2012.

EVERTOUCH

THE MARK CONSISTS OF STANDARD CHARACTERS WITHOUT CLAIM TO ANY PARTICULAR FONT, STYLE, SIZE, OR COLOR.

FOR STYLUS FOR COMPUTERS AND HANDHELD ELECTRONIC DEVICES, NAMELY, CELLULAR PHONES, MOBILE PHONES, SMART PHONES, TOUCHSCREEN TABLETS, TOUCHSCREEN MONITORS, TOUCHSCREEN COMPUTERS, TOUCHSCREEN DEVICES, PERSONAL DIGITAL ASSISTANTS, E-READERS, TABLET COMPUTERS, CAMERAS, GLOBAL POSITIONING SYSTEMS, AND GAMES (U.S. CLS. 21, 23, 26, 36 AND 38).

FIRST USE 4-10-2012; IN COMMERCE 4-10-2012.
JACLYN KIDWELL WALKER, EXAMINING ATTORNEY

SN 85-605,217. SOLID SUGAR, INC., AKA GAMAGO,
GAMA-GO, SAN FRANCISCO, CA. FILED 4-23-2012.

FAUX TAIL

THE MARK CONSISTS OF STANDARD CHARACTERS WITHOUT CLAIM TO ANY PARTICULAR FONT, STYLE, SIZE, OR COLOR.

FOR DECORATIVE ORNAMENTS FOR CELLULAR TELEPHONES (U.S. CLS. 21, 23, 26, 36 AND 38).

MARK SPARACINO, EXAMINING ATTORNEY

SN 85-605,220. CRESTRON ELECTRONICS, INC., ROCK-
LEIGH, NJ. FILED 4-23-2012.

Integrated By Design

THE MARK CONSISTS OF STANDARD CHARACTERS WITHOUT CLAIM TO ANY PARTICULAR FONT, STYLE, SIZE, OR COLOR.

FOR ELECTRONIC CONTROL PROCESSORS AND REMOTE CONTROLS FOR MULTIMEDIA DEVICES, HOME THEATER SYSTEMS, AND AUTOMATION SYSTEMS FOR LIGHTING, AUDIO/VIDEO, ENVIRONMENTAL CONTROL SYSTEMS, HVAC, SECURITY, COMPUTERS, APPLIANCES, WATER, AND SHADES; COMPUTER SOFTWARE FOR CONTROLLING AND MONITORING MULTIMEDIA DEVICES, HOME THEATER SYSTEMS, AND AUTOMATION SYSTEMS FOR LIGHTING, AUDIO/VIDEO, ENVIRONMENTAL CONTROL SYSTEMS, HVAC, SECURITY, COMPUTERS, APPLIANCES, WATER, AND SHADES (U.S. CLS. 21, 23, 26, 36 AND 38).

WENDY JUN, EXAMINING ATTORNEY

CLASS 9—(Continued).

SN 85-605,372. BOLLYDOLL, LLC, LOS ANGELES, CA. FILED 4-23-2012.

BOLLYDOLL

THE MARK CONSISTS OF STANDARD CHARACTERS WITHOUT CLAIM TO ANY PARTICULAR FONT, STYLE, SIZE, OR COLOR.

FOR DOWNLOADABLE MUSICAL SOUND RECORDINGS; DOWNLOADABLE ELECTRONIC PUBLICATIONS, NAMELY GRAPHIC AND ANIMATED NOVELS; DIGITAL MEDIA, NAMELY, CDS, DVDS, DOWNLOADABLE AUDIO FILES, DOWNLOADABLE VIDEO FILES, AND DOWNLOADABLE MULTIMEDIA FILES, FEATURING MUSIC, STORIES, LIVE ACTION, GRAPHIC ART, AND ANIMATED ENTERTAINMENT; COMPUTER APPLICATION SOFTWARE FOR MOBILE PHONES, PORTABLE MEDIA PLAYERS, COMPUTERS, NOTEBOOK COMPUTERS, AND HANDHELD COMPUTERS THAT PROVIDES ACCESS TO AUDIO, VIDEO AND MULTIMEDIA FILES FEATURING MUSIC, STORIES, LIVE ACTION, GRAPHIC ART, AND/OR ANIMATED ENTERTAINMENT; DOWNLOADABLE SOFTWARE IN THE NATURE OF A MOBILE APPLICATIONS FOR COMMUNICATIONS DEVICES THAT PROVIDE ACCESS TO AUDIO, VIDEO AND MULTIMEDIA FILES FEATURING MUSIC, STORIES, LIVE ACTION, GRAPHIC ART, AND/OR ANIMATED ENTERTAINMENT (U.S. CLS. 21, 23, 26, 36 AND 38).

LINDA M. KING, EXAMINING ATTORNEY

SN 85-605,383. JOHN WARE RESEARCH GROUP, INC., DBA JOHN WARE RESEARCH GROUP, INC., WORCESTER, MA. FILED 4-23-2012.

ASLX

THE MARK CONSISTS OF STANDARD CHARACTERS WITHOUT CLAIM TO ANY PARTICULAR FONT, STYLE, SIZE, OR COLOR.

FOR PROGRAMMABLE LOGIC CONTROLLER (PLC) (U.S. CLS. 21, 23, 26, 36 AND 38).

IRA J. GOODSID, EXAMINING ATTORNEY

CLASS 9—(Continued).

SN 85-605,464. ILC DOVER IP, INC., FREDERICA, DE. FILED 4-23-2012.

SCAPE

THE MARK CONSISTS OF STANDARD CHARACTERS WITHOUT CLAIM TO ANY PARTICULAR FONT, STYLE, SIZE, OR COLOR.

FOR CHEMICAL RESPIRATORS FOR USE IN CHEMICAL, BIOLOGICAL AND RADIOLOGICAL PROTECTION; PROTECTIVE RESPIRATORS FOR USE IN SMOKE, FIRE AND CARBON MONOXIDE PROTECTION (U.S. CLS. 21, 23, 26, 36 AND 38).

FIRST USE 1-20-2003; IN COMMERCE 1-20-2003.

KYLE PEETE, EXAMINING ATTORNEY

SN 85-605,609. KYOCERA COMMUNICATIONS, INC., SAN DIEGO, CA. FILED 4-23-2012.

SCOUT

THE MARK CONSISTS OF STANDARD CHARACTERS WITHOUT CLAIM TO ANY PARTICULAR FONT, STYLE, SIZE, OR COLOR.

FOR CELL PHONES; CELLULAR PHONES; MOBILE PHONES (U.S. CLS. 21, 23, 26, 36 AND 38).

SUNG IN, EXAMINING ATTORNEY

SN 85-605,645. OPZI INC., SAN FRANCISCO, CA. FILED 4-23-2012.

Slotorama

THE MARK CONSISTS OF STANDARD CHARACTERS WITHOUT CLAIM TO ANY PARTICULAR FONT, STYLE, SIZE, OR COLOR.

FOR COMPUTER GAME PROGRAMMES DOWNLOADABLE VIA THE INTERNET; COMPUTER GAME SOFTWARE; COMPUTER GAME SOFTWARE DOWNLOADABLE FROM A GLOBAL COMPUTER NETWORK; COMPUTER GAME SOFTWARE FOR GAMING MACHINES INCLUDING SLOT MACHINES OR VIDEO LOTTERY TERMINALS; COMPUTER GAME SOFTWARE FOR USE ON MOBILE AND CELLULAR PHONES; COMPUTER SOFTWARE PLATFORMS FOR SOCIAL NETWORKING; DOWNLOADABLE COMPUTER GAME SOFTWARE VIA A GLOBAL COMPUTER NETWORK AND WIRELESS DEVICES; DOWNLOADABLE GAME PROGRAMS AND COMPUTER SOFTWARE PLATFORMS FOR SOCIAL NETWORKING THAT MAY BE ACCESSED VIA THE INTERNET AND WIRELESS DEVICES; ELECTRONIC GAME SOFTWARE FOR WIRELESS DEVICES; INTERACTIVE VIDEO GAME PROGRAMS (U.S. CLS. 21, 23, 26, 36 AND 38).

FIRST USE 1-15-2012; IN COMMERCE 1-15-2012.

SUNG IN, EXAMINING ATTORNEY

CLASS 9—(Continued).

SN 85-605,760. JONES, TYCHICUS, MEMPHIS, TN. FILED 4-23-2012.

MYHOT16

THE MARK CONSISTS OF STANDARD CHARACTERS WITHOUT CLAIM TO ANY PARTICULAR FONT, STYLE, SIZE, OR COLOR.

FOR COMPUTER APPLICATION SOFTWARE FOR MOBILE PHONES, PORTABLE MEDIA PLAYERS, HANDHELD COMPUTERS, TABLET COMPUTERS, NAMELY, SOFTWARE FOR PLAYING KEYBOARDS, GUITARS, DRUMS, DIGITAL MEDIA AND RECORDING DIGITAL MEDIA AS WELL COMPOSING OR WRITING SHEET MUSIC (U.S. CLS. 21, 23, 26, 36 AND 38).

APRIL HESIK, EXAMINING ATTORNEY

CLASS 9—(Continued).

SN 85-605,816. BLAZING TOURS, INC., SAN FRANCISCO, CA. FILED 4-23-2012.

BLAZING TOURS

THE MARK CONSISTS OF STANDARD CHARACTERS WITHOUT CLAIM TO ANY PARTICULAR FONT, STYLE, SIZE, OR COLOR.

NO CLAIM IS MADE TO THE EXCLUSIVE RIGHT TO USE "TOURS", APART FROM THE MARK AS SHOWN.

FOR COMPUTER APPLICATION SOFTWARE FOR MOBILE PHONES, PORTABLE MEDIA PLAYERS, PORTABLE AND DESKTOP COMPUTERS, NAMELY, SOFTWARE FOR CREATING AND SHARING PROFESSIONAL VIDEO TOURS OF REAL ESTATE AND SMALL BUSINESS LOCATIONS (U.S. CLS. 21, 23, 26, 36 AND 38).

FIRST USE 7-28-2012; IN COMMERCE 7-28-2012.

AMEEN IMAM, EXAMINING ATTORNEY

SN 85-605,778. SYNCOMM TECHNOLOGY CORPORATION, HSINCHU CITY, TAIWAN, FILED 4-23-2012.



THE MARK CONSISTS OF THE STYLIZED WORD EZWA. FOR COMPUTER PERIPHERAL DEVICES; COMPUTER MOUSE; COMPUTER MOUSE IN THE NATURE OF A TRACKPAD; COMPUTER MOUSE, NAMELY, TRACKBALLS; COMPUTER MOUSE, NAMELY, TOUCHPADS; ANTENNAS; TRANSMITTERS OF ELECTRONIC SIGNALS; REMOTE CONTROLS FOR TELEVISION OR COMPUTERS; LOUDSPEAKERS; MICROPHONES; SOUND TRANSMITTING APPARATUS; HORNS FOR LOUDSPEAKERS; PERSONAL STEREO; HEADPHONES; AUDIOVISUAL RECEIVERS; INTEGRATED CIRCUITS; ELECTRONIC ANTI-THEFT SYSTEM COMPRISED OF A BAR CODE SCANNER THAT ALLOWS MANUFACTURERS TO TEMPORARILY DISABLE ELECTRONIC GOODS DURING THE MANUFACTURING PROCESS AND ALLOWS RETAILERS TO ENABLE SUCH GOODS UPON RECEIVING THE PURCHASE PRICE FOR THE GOODS; THEFT ALARMS; WIRELESS DIGITAL ELECTRONIC APPARATUS TO SECURE AND PROTECT DATA AND IMAGES ON ALL FORMS OF WIRELESS EQUIPMENT INCLUDING MOBILE TELECOMMUNICATIONS EQUIPMENT USING AN AUTOMATIC SYNCHRONIZATION PROCESS AND ALARM NOTIFICATION OF THE LOSS OR THEFT OF THE WIRELESS EQUIPMENT INCLUDING MOBILE TELECOMMUNICATIONS EQUIPMENT; ELECTRIC DOOR BELLS (U.S. CLS. 21, 23, 26, 36 AND 38).

THEODORE MCBRIDE, EXAMINING ATTORNEY

SN 85-606,041. FOSHAN HUAQUAN ELECTRICAL LIGHTING CO. LTD, GUANGDONG PROVINCE, CHINA, FILED 4-24-2012.



THE MARK CONSISTS OF STANDARD CHARACTERS WITHOUT CLAIM TO ANY PARTICULAR FONT, STYLE, SIZE, OR COLOR.

FOR BATTERIES AND BATTERY CHARGERS; BATTERIES FOR LIGHTING; CAPACITORS; CURRENT TRANSFORMERS; DISTRIBUTION BOXES FOR ELECTRICAL POWER; DISTRIBUTION TRANSFORMERS; ELECTRIC IGNITERS USED IN CONNECTION WITH BALLASTS TO START DISCHARGE LAMPS; ELECTRIC LIGHT DIMMERS; ELECTRIC LIGHT SWITCHES; ELECTRIC TRANSFORMERS; ELECTRIC WARNING LIGHT SYSTEMS; ELECTRIC WARNING LIGHTS; ELECTRICAL DISTRIBUTION BOXES; ELECTRICAL LIGHTS FOR USE IN PROFESSIONAL QUALITY PHOTOGRAPHY; ELECTRICAL TRANSFORMERS; ELECTROMAGNETIC COILS; EMERGENCY WARNING LIGHTS; INTEGRATED CIRCUIT MODULES; INTERNAL COOLING FANS FOR COMPUTERS; JUMP START CABLES; LED AND HID LIGHT CONTROLS; LIGHTING BALLASTS; MEMORY EXPANSION MODULES; MICROPHONES FOR COMMUNICATION DEVICES; POWER TRANSFORMERS FOR AMPLIFICATION; SOLAR BATTERIES; STEP DOWN TRANSFORMERS; TRANSFORMERS (U.S. CLS. 21, 23, 26, 36 AND 38).

FIRST USE 12-1-2004; IN COMMERCE 12-8-2006.

LINDA MICKLEBURGH, EXAMINING ATTORNEY

CLASS 9—(Continued).

SN 85-606,723. FITNESS ON REQUEST, INC., MAPLE GROVE, MN. FILED 4-24-2012.



NO CLAIM IS MADE TO THE EXCLUSIVE RIGHT TO USE "FITNESS", APART FROM THE MARK AS SHOWN.

THE COLOR(S) GREEN AND GRAY IS/ARE CLAIMED AS A FEATURE OF THE MARK.

THE MARK CONSISTS OF A DESIGN OF A HAND, THE COLOR GRAY, PRESSING A BUTTON, THE COLOR OF GREEN, NEXT TO THE WORDS "FITNESS", THE COLOR OF GREEN, ON TOP OF THE WORDS "ON REQUEST", THE COLOR OF GRAY.

FOR INTERACTIVE COMPUTER KIOSKS COMPRISING HARDWARE, SOFTWARE, AND PROJECTION SYSTEMS, FOR USE IN PROVIDING FITNESS CLASSES; SOFTWARE FOR MANAGING GROUP FITNESS CLASSES (U.S. CLS. 21, 23, 26, 36 AND 38).

BARBARA GAYNOR, EXAMINING ATTORNEY

SN 85-606,826. SWIVEL VISION, CORONA, CA. FILED 4-24-2012.



THE MARK CONSISTS OF THE LETTER "S" INCORPORATED INTO THE LETTER "V".

FOR SPORT GOGGLES FOR USE IN ALL SPORTS (U.S. CLS. 21, 23, 26, 36 AND 38).

ALEXANDER L. POWERS, EXAMINING ATTORNEY

CLASS 9—(Continued).

SN 85-606,996. SEEDBAR LLC, BURLINGAME, CA. FILED 4-24-2012.

LURV

THE MARK CONSISTS OF STANDARD CHARACTERS WITHOUT CLAIM TO ANY PARTICULAR FONT, STYLE, SIZE, OR COLOR.

FOR DOWNLOADABLE COMPUTER SOFTWARE FOR ENABLING THE TRANSMISSION OF PHOTOGRAPHS (U.S. CLS. 21, 23, 26, 36 AND 38).

MAUREEN DALL, EXAMINING ATTORNEY

SN 85-607,058. AUTOTRONIC CONTROLS CORPORATION, EL PASO, TX. FILED 4-24-2012.

SMARTWIRE

THE MARK CONSISTS OF STANDARD CHARACTERS WITHOUT CLAIM TO ANY PARTICULAR FONT, STYLE, SIZE, OR COLOR.

FOR ELECTRONICS AND COMPUTER HARDWARE AND SOFTWARE USED TO CONTROL POWER IN AUTOMOBILE WIRING; NAMELY, A PROGRAMMABLE POWER CONTROL MODULE CONSISTING OF THE MODULE, RELATED COMPUTER SOFTWARE, MANUAL SWITCHING PANEL, WIRING HARNESS, USB CABLE AND INSTRUCTIONAL MANUALS FOR USE THEREWITH, SOLD AS A UNIT (U.S. CLS. 21, 23, 26, 36 AND 38).

FIRST USE 12-3-2010; IN COMMERCE 12-3-2010.
KATINA MISTER, EXAMINING ATTORNEY

SN 85-607,219. 4 S TECHNOLOGIES, LLC., MOUNTAINSIDE, NJ. FILED 4-24-2012.

DEBBIE

THE MARK CONSISTS OF STANDARD CHARACTERS WITHOUT CLAIM TO ANY PARTICULAR FONT, STYLE, SIZE, OR COLOR.

FOR COMPUTER PROGRAMS AND SOFTWARE FOR THE AUTOMATED GATHERING, LOGICAL EDITING, RECOGNITION, FORMATTING, STORAGE AND TRANSMISSION OF DATA AND INFORMATION TO AND FROM COMPUTERS, WEB PORTALS, OR COMPUTER NETWORKS (U.S. CLS. 21, 23, 26, 36 AND 38).

FIRST USE 4-22-2009; IN COMMERCE 4-22-2009.
JULIE WATSON, EXAMINING ATTORNEY

CLASS 9—(Continued).

SN 85-608,088. SIRIUSDECISIONS, INC., WILTON, CT. FILED 4-25-2012.

SIRIUSPERSPECTIVES

THE MARK CONSISTS OF STANDARD CHARACTERS WITHOUT CLAIM TO ANY PARTICULAR FONT, STYLE, SIZE, OR COLOR.

FOR DOWNLOADABLE ELECTRONIC NEWSLETTERS IN THE FIELD OF BUSINESS-TO-BUSINESS SALES AND MARKETING (U.S. CLS. 21, 23, 26, 36 AND 38).

FIRST USE 4-25-2012; IN COMMERCE 4-25-2012.
WENDY JUN, EXAMINING ATTORNEY

CLASS 9—(Continued).

SN 85-610,143. PANASONIC CORPORATION, OSAKA, JAPAN, FILED 4-27-2012.



NO CLAIM IS MADE TO THE EXCLUSIVE RIGHT TO USE "1ST MIRRORLESS SINCE 2008" AND "1ST DIGITAL SINGLE LENS MIRRORLESS", APART FROM THE MARK AS SHOWN.

THE MARK CONSISTS OF A DESIGN OF THE NUMERAL "1" CONTAINING THE WORDING "SINCE 2008 ST MIRRORLESS" WITH THE WORDING "1ST DIGITAL SINGLE LENS MIRRORLESS" APPEARING NEXT TO THE NUMERAL "1".

FOR DIGITAL CAMERAS (U.S. CLS. 21, 23, 26, 36 AND 38).
ALICIA COLLINS, EXAMINING ATTORNEY

SN 85-608,533. ZENIMAX MEDIA INC., ROCKVILLE, MD. FILED 4-25-2012.

REVENGE SOLVES EVERYTHING

THE MARK CONSISTS OF STANDARD CHARACTERS WITHOUT CLAIM TO ANY PARTICULAR FONT, STYLE, SIZE, OR COLOR.

FOR COMPUTER GAME SOFTWARE FOR USE WITH COMPUTERS AND VIDEO GAME CONSOLES; DOWNLOADABLE COMPUTER GAME SOFTWARE OFFERED VIA THE INTERNET AND WIRELESS DEVICES; COMPUTER GAME SOFTWARE FOR USE WITH ON-LINE INTERACTIVE GAMES (U.S. CLS. 21, 23, 26, 36 AND 38).
ROBERT STRUCK, EXAMINING ATTORNEY

SN 85-612,042. TARGET BRANDS, INC., MINNEAPOLIS, MN. FILED 4-30-2012.

UP & UP

THE MARK CONSISTS OF STANDARD CHARACTERS WITHOUT CLAIM TO ANY PARTICULAR FONT, STYLE, SIZE, OR COLOR.

OWNER OF U.S. REG. NOS. 4,023,535, 4,042,814 AND OTHERS.

FOR MAGNETS FOR USE WITH MEMO BOARDS AND REFRIGERATORS; MAGNIFYING GLASSES (U.S. CLS. 21, 23, 26, 36 AND 38).

FIRST USE 3-0-2011; IN COMMERCE 3-0-2011.
JEAN IM, EXAMINING ATTORNEY

CLASS 9—(Continued).

SN 85-612,053. TARGET BRANDS, INC., MINNEAPOLIS, MN. FILED 4-30-2012.



OWNER OF U.S. REG. NOS. 4,023,535, 4,042,814 AND OTHERS.

THE MARK CONSISTS OF AN ARROW DESIGN POINTING AT A 45 DEGREE DIAGONAL, UP AND TO THE RIGHT, WITH THE WORDS UP & UP INSIDE THE ARROW.

FOR MAGNETS FOR USE WITH MEMO BOARDS AND REFRIGERATORS; MAGNIFYING GLASSES (U.S. CLS. 21, 23, 26, 36 AND 38).

FIRST USE 3-0-2011; IN COMMERCE 3-0-2011.
JEAN IM, EXAMINING ATTORNEY

SN 85-614,632. ZENIMAX MEDIA INC., ROCKVILLE, MD. FILED 5-2-2012.



THE MARK CONSISTS OF A THREE HEADED CREATURE SWALLOWING ITS OWN TAILS CREATING A CIRCLE.

FOR COMPUTER GAME SOFTWARE FOR USE WITH COMPUTERS AND VIDEO GAME CONSOLES; DOWNLOADABLE COMPUTER GAME SOFTWARE OFFERED VIA THE INTERNET AND WIRELESS DEVICES; COMPUTER GAME SOFTWARE FOR USE WITH ON-LINE INTERACTIVE GAMES (U.S. CLS. 21, 23, 26, 36 AND 38).
ROBERT STRUCK, EXAMINING ATTORNEY

CLASS 9—(Continued).

SN 85-616,071. HEWLETT-PACKARD DEVELOPMENT COMPANY, L.P., HOUSTON, TX. FILED 5-3-2012.

ELITEBOOK SWIVIA

THE MARK CONSISTS OF STANDARD CHARACTERS WITHOUT CLAIM TO ANY PARTICULAR FONT, STYLE, SIZE, OR COLOR.

FOR COMPUTERS; PERSONAL COMPUTERS; LAPTOP COMPUTERS; NOTEBOOK COMPUTERS; TABLET COMPUTERS; DESKTOP COMPUTERS; COMPUTER HARDWARE; COMPUTER PERIPHERALS (U.S. CLS. 21, 23, 26, 36 AND 38).

JANICE KIM, EXAMINING ATTORNEY

SN 85-616,089. HEWLETT-PACKARD DEVELOPMENT COMPANY, L.P., HOUSTON, TX. FILED 5-3-2012.

ELITEBOOK SWIVEL

THE MARK CONSISTS OF STANDARD CHARACTERS WITHOUT CLAIM TO ANY PARTICULAR FONT, STYLE, SIZE, OR COLOR.

FOR COMPUTERS; PERSONAL COMPUTERS; LAPTOP COMPUTERS; NOTEBOOK COMPUTERS; TABLET COMPUTERS; DESKTOP COMPUTERS; COMPUTER HARDWARE; COMPUTER PERIPHERALS (U.S. CLS. 21, 23, 26, 36 AND 38).

JANICE KIM, EXAMINING ATTORNEY

SN 85-616,100. HEWLETT-PACKARD DEVELOPMENT COMPANY, L.P., HOUSTON, TX. FILED 5-3-2012.

ELITEBOOK ENFOLD

THE MARK CONSISTS OF STANDARD CHARACTERS WITHOUT CLAIM TO ANY PARTICULAR FONT, STYLE, SIZE, OR COLOR.

FOR COMPUTERS; PERSONAL COMPUTERS; LAPTOP COMPUTERS; NOTEBOOK COMPUTERS; TABLET COMPUTERS; DESKTOP COMPUTERS; COMPUTER HARDWARE; COMPUTER PERIPHERALS (U.S. CLS. 21, 23, 26, 36 AND 38).

JANICE KIM, EXAMINING ATTORNEY

CLASS 9—(Continued).

SN 85-616,255. AUTOTRONIC CONTROLS CORPORATION,
EL PASO, TX. FILED 5-3-2012.



THE COLOR(S) YELLOW, BLACK AND WHITE. IS/ARE CLAIMED AS A FEATURE OF THE MARK.

THE MARK CONSISTS OF THE WORD ELEMENTS "SMART" RENDERED IN A YELLOW STYLIZED FONT WITH A BLACK OUTLINE AND "WIRE" RENDERED IN A WHITE STYLIZED FONT WITH A BLACK OUTLINE.

FOR ELECTRONICS AND COMPUTER HARDWARE AND SOFTWARE USED TO CONTROL POWER IN AUTOMOBILE WIRING; NAMELY, A PROGRAMMABLE POWER CONTROL MODULE CONSISTING OF THE MODULE, RELATED COMPUTER SOFTWARE, MANUAL SWITCHING PANEL, WIRING HARNESS, USB CABLE AND INSTRUCTIONAL MANUALS FOR USE THEREWITH, SOLD AS A UNIT (U.S. CLS. 21, 23, 26, 36 AND 38).

FIRST USE 12-3-2010; IN COMMERCE 12-3-2010.
KATINA MISTER, EXAMINING ATTORNEY

SN 85-626,511. KATCHITEK CORPORATION, LAS VEGAS,
NV. FILED 5-16-2012.

SKATE

THE MARK CONSISTS OF STANDARD CHARACTERS WITHOUT CLAIM TO ANY PARTICULAR FONT, STYLE, SIZE, OR COLOR.

FOR COMPILER SOFTWARE; COMPUTER HARDWARE; COMPUTER OPERATING SOFTWARE; COMPUTER SOFTWARE DEVELOPMENT TOOLS (U.S. CLS. 21, 23, 26, 36 AND 38).

BRENDAN MCCAULEY, EXAMINING ATTORNEY

SN 85-626,512. KATCHITEK CORPORATION, LAS VEGAS,
NV. FILED 5-16-2012.

SCHEMACS

THE MARK CONSISTS OF STANDARD CHARACTERS WITHOUT CLAIM TO ANY PARTICULAR FONT, STYLE, SIZE, OR COLOR.

FOR COMPILER SOFTWARE; COMPUTER SOFTWARE DEVELOPMENT TOOLS (U.S. CLS. 21, 23, 26, 36 AND 38).

BRENDAN MCCAULEY, EXAMINING ATTORNEY

CLASS 9—(Continued).

SN 85-626,516. KATCHITEK CORPORATION, LAS VEGAS,
NV. FILED 5-16-2012.



THE MARK CONSISTS OF THE GREEK SYMBOL LAMBDA WITHIN A CIRCLE.

FOR COMPILER SOFTWARE; COMPUTER SOFTWARE DEVELOPMENT TOOLS (U.S. CLS. 21, 23, 26, 36 AND 38).

BRENDAN MCCAULEY, EXAMINING ATTORNEY

SN 85-627,536. COOL LUMENS, INC., DBA COOL LUMENS,
SANTA CRUZ, CA. FILED 5-16-2012.

SmartDim

THE MARK CONSISTS OF STANDARD CHARACTERS WITHOUT CLAIM TO ANY PARTICULAR FONT, STYLE, SIZE, OR COLOR.

FOR LIGHTING CONTROL SOFTWARE FOR USE IN COMMERCIAL AND INDUSTRIAL FACILITIES (U.S. CLS. 21, 23, 26, 36 AND 38).

TASNEEM HUSSAIN, EXAMINING ATTORNEY

SN 85-630,462. LIPOSCIENCE, INC., RALEIGH, NC. FILED 5-21-2012.

VALET

THE MARK CONSISTS OF STANDARD CHARACTERS WITHOUT CLAIM TO ANY PARTICULAR FONT, STYLE, SIZE, OR COLOR.

FOR COMPUTER INTERFACE SUPPORTING COMMUNICATION BETWEEN LABORATORY EQUIPMENT AND A SERVICE CENTER WHICH FACILITATES THE PROCESSING OF DATA FOR REMOTE ANALYSIS, QUALITY CONTROL, BILLING, CONSUMABLES, AND REMOTE DIAGNOSTICS (U.S. CLS. 21, 23, 26, 36 AND 38).

MARK SHINER, EXAMINING ATTORNEY

CLASS 9—(Continued).

SN 85-631,549. KORE, LLC, ELON, NC. FILED 5-22-2012.

Buck Cashidy

THE MARK CONSISTS OF STANDARD CHARACTERS WITHOUT CLAIM TO ANY PARTICULAR FONT, STYLE, SIZE, OR COLOR.

FOR COMPUTER GAME SOFTWARE (U.S. CLS. 21, 23, 26, 36 AND 38).

DAVID H. STINE, EXAMINING ATTORNEY

SN 85-631,565. KORE, LLC, ELON, NC. FILED 5-22-2012.

Crown of Cleopatra

THE MARK CONSISTS OF STANDARD CHARACTERS WITHOUT CLAIM TO ANY PARTICULAR FONT, STYLE, SIZE, OR COLOR.

FOR COMPUTER GAME SOFTWARE (U.S. CLS. 21, 23, 26, 36 AND 38).

DAVID H. STINE, EXAMINING ATTORNEY

SN 85-631,598. KORE, LLC, ELON, NC. FILED 5-22-2012.

Master FoSho & the Dragon Pearl

THE MARK CONSISTS OF STANDARD CHARACTERS WITHOUT CLAIM TO ANY PARTICULAR FONT, STYLE, SIZE, OR COLOR.

FOR COMPUTER GAME SOFTWARE (U.S. CLS. 21, 23, 26, 36 AND 38).

DAVID H. STINE, EXAMINING ATTORNEY

SN 85-631,837. KORE, LLC, ELON, NC. FILED 5-22-2012.

Mausoleum Madness

THE MARK CONSISTS OF STANDARD CHARACTERS WITHOUT CLAIM TO ANY PARTICULAR FONT, STYLE, SIZE, OR COLOR.

FOR COMPUTER GAME SOFTWARE (U.S. CLS. 21, 23, 26, 36 AND 38).

DAVID H. STINE, EXAMINING ATTORNEY

CLASS 9—(Continued).

SN 85-631,868. KORE, LLC, ELON, NC. FILED 5-22-2012.

The Knight of Chance

THE MARK CONSISTS OF STANDARD CHARACTERS WITHOUT CLAIM TO ANY PARTICULAR FONT, STYLE, SIZE, OR COLOR.

FOR COMPUTER GAME SOFTWARE (U.S. CLS. 21, 23, 26, 36 AND 38).

DAVID H. STINE, EXAMINING ATTORNEY

SN 85-631,900. DIGIACOMO, ROBERT, DBA DATA BY DESIGN, LAKE RONKONKOMA, NY. FILED 5-22-2012.

THE FAT FINGER

THE MARK CONSISTS OF STANDARD CHARACTERS WITHOUT CLAIM TO ANY PARTICULAR FONT, STYLE, SIZE, OR COLOR.

FOR COMPUTER APPLICATION SOFTWARE FOR MOBILE PHONES, NAMELY, SOFTWARE FOR CHILDREN AND THE DISABLED FOR ASSISTING IN THE ENTRY OF LETTERS AND NUMBERS WHEN TYPING ON A VIRTUAL KEYBOARD (U.S. CLS. 21, 23, 26, 36 AND 38).

FIRST USE 2-1-2012; IN COMMERCE 3-1-2012.

ANN E. SAPPENFIELD, EXAMINING ATTORNEY

SN 85-631,987. KORE, LLC, ELON, NC. FILED 5-22-2012.

Moe Money

THE MARK CONSISTS OF STANDARD CHARACTERS WITHOUT CLAIM TO ANY PARTICULAR FONT, STYLE, SIZE, OR COLOR.

FOR COMPUTER GAME SOFTWARE (U.S. CLS. 21, 23, 26, 36 AND 38).

DAVID H. STINE, EXAMINING ATTORNEY

CLASS 9—(Continued).

SN 85-635,926. CATONA, GARY, LOS ANGELES, CA. FILED 5-25-2012.

VOICE BUILDER

THE MARK CONSISTS OF STANDARD CHARACTERS WITHOUT CLAIM TO ANY PARTICULAR FONT, STYLE, SIZE, OR COLOR.

NO CLAIM IS MADE TO THE EXCLUSIVE RIGHT TO USE "VOICE", APART FROM THE MARK AS SHOWN.

FOR EDUCATIONAL SOFTWARE FEATURING INSTRUCTION FOR SINGING AND SPEAKING VOICES WITH EXERCISES AND DEMONSTRATIONS FOR INCREASING VOCAL POWER, RESONANCE, RANGE, FLEXIBILITY AND ENDURANCE (U.S. CLS. 21, 23, 26, 36 AND 38).

MARY ROSSMAN, EXAMINING ATTORNEY

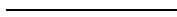

SN 85-638,687. SONY COMPUTER ENTERTAINMENT AMERICA LLC, FOSTER CITY, CA. FILED 5-30-2012.

THE CON

THE MARK CONSISTS OF STANDARD CHARACTERS WITHOUT CLAIM TO ANY PARTICULAR FONT, STYLE, SIZE, OR COLOR.

FOR COMPUTER GAME SOFTWARE; VIDEO GAME SOFTWARE (U.S. CLS. 21, 23, 26, 36 AND 38).

FIRST USE 10-17-2005; IN COMMERCE 10-17-2005.
ELIZABETH HUGHITT, EXAMINING ATTORNEY



SN 85-644,654. SONY COMPUTER ENTERTAINMENT AMERICA LLC, FOSTER CITY, CA. FILED 6-6-2012.

THE SHOOT

THE MARK CONSISTS OF STANDARD CHARACTERS WITHOUT CLAIM TO ANY PARTICULAR FONT, STYLE, SIZE, OR COLOR.

FOR COMPUTER GAME SOFTWARE; VIDEO GAME SOFTWARE (U.S. CLS. 21, 23, 26, 36 AND 38).

FIRST USE 10-19-2010; IN COMMERCE 10-19-2010.
ELIZABETH HUGHITT, EXAMINING ATTORNEY

CLASS 9—(Continued).

SN 85-656,034. COACH SERVICES, INC., NEW YORK, NY. FILED 6-19-2012.



OWNER OF U.S. REG. NO. 3,441,671.
NO CLAIM IS MADE TO THE EXCLUSIVE RIGHT TO USE "LEATHERWARE" AND "EST. 1941", APART FROM THE MARK AS SHOWN.

THE MARK CONSISTS OF AN IMAGE OF A HORSE DRAWN CARRIAGE WITH THE WORDS "COACH LEATHERWARE" IN A LOZENGE DESIGN AND THE WORDS "EST. 1941".

FOR PROTECTIVE COVERS AND CASES FOR CELL PHONES, LAPTOPS AND PORTABLE MEDIA PLAYERS (U.S. CLS. 21, 23, 26, 36 AND 38).

RENEE MCCRAY, EXAMINING ATTORNEY



SN 85-656,171. SONY COMPUTER ENTERTAINMENT AMERICA LLC, FOSTER CITY, CA. FILED 6-19-2012.



NO CLAIM IS MADE TO THE EXCLUSIVE RIGHT TO USE "SAN DIEGO STUDIO", APART FROM THE MARK AS SHOWN.

THE MARK CONSISTS OF A WAVE DESIGN FORMING THE HIGHLY STYLIZED LETTERS "SD" WITH THE WORDS "SAN DIEGO" ABOVE AND THE WORD "STUDIO" BELOW.

FOR COMPUTER GAME SOFTWARE; VIDEO GAME SOFTWARE (U.S. CLS. 21, 23, 26, 36 AND 38).

FIRST USE 5-19-2010; IN COMMERCE 5-19-2010.
ELIZABETH HUGHITT, EXAMINING ATTORNEY

CLASS 9—(Continued).

SN 85-656,657. CRESTRON ELECTRONICS, INC., ROCK-LEIGH, NJ. FILED 6-20-2012.

Crestron Fusion

THE MARK CONSISTS OF STANDARD CHARACTERS WITHOUT CLAIM TO ANY PARTICULAR FONT, STYLE, SIZE, OR COLOR.

FOR COMPUTER SOFTWARE FOR CONTROLLING AND MONITORING AUDIO-VISUAL EQUIPMENT, ENVIRONMENTAL CONTROL SYSTEMS, HOME THEATER, HOME AUTOMATION SYSTEMS, LIGHTING SYSTEMS, AND RESIDENTIAL SECURITY SYSTEMS (U.S. CLS. 21, 23, 26, 36 AND 38).

WENDY JUN, EXAMINING ATTORNEY

CLASS 9—(Continued).

SN 85-664,004. KYOCERA COMMUNICATIONS, INC., SAN DIEGO, CA. FILED 6-28-2012.

LAGUNA

THE MARK CONSISTS OF STANDARD CHARACTERS WITHOUT CLAIM TO ANY PARTICULAR FONT, STYLE, SIZE, OR COLOR.

THE ENGLISH TRANSLATION OF LAGUNA IN THE MARK IS LAGOON.

FOR CELL PHONES; CELLULAR PHONES; MOBILE PHONES (U.S. CLS. 21, 23, 26, 36 AND 38).

SUNG IN, EXAMINING ATTORNEY

SN 85-657,226. SONY COMPUTER ENTERTAINMENT AMERICA LLC, FOSTER CITY, CA. FILED 6-20-2012.

TWISTED METAL: BLACK

THE MARK CONSISTS OF STANDARD CHARACTERS WITHOUT CLAIM TO ANY PARTICULAR FONT, STYLE, SIZE, OR COLOR.

OWNER OF U.S. REG. NOS. 2,753,882 AND 3,149,183. FOR COMPUTER GAME SOFTWARE; VIDEO GAME SOFTWARE (U.S. CLS. 21, 23, 26, 36 AND 38).

FIRST USE 6-19-2001; IN COMMERCE 6-19-2001.

ELIZABETH HUGHITT, EXAMINING ATTORNEY

SN 85-664,006. KYOCERA COMMUNICATIONS, INC., SAN DIEGO, CA. FILED 6-28-2012.

PISMO

THE MARK CONSISTS OF STANDARD CHARACTERS WITHOUT CLAIM TO ANY PARTICULAR FONT, STYLE, SIZE, OR COLOR.

THE ENGLISH TRANSLATION OF PISMO IN THE MARK IS WRITING.

FOR CELL PHONES; CELLULAR PHONES; MOBILE PHONES (U.S. CLS. 21, 23, 26, 36 AND 38).

SUNG IN, EXAMINING ATTORNEY

SN 85-659,371. CRESTRON ELECTRONICS, INC., ROCK-LEIGH, NJ. FILED 6-22-2012.

FUSION RV

THE MARK CONSISTS OF STANDARD CHARACTERS WITHOUT CLAIM TO ANY PARTICULAR FONT, STYLE, SIZE, OR COLOR.

FOR COMPUTER SOFTWARE FOR THE CENTRALIZED CONTROL, MONITORING, MANAGEMENT AND SCHEDULING OF CONFERENCE ROOMS, CLASSROOMS, LECTURE HALLS, AND PRESENTATION AND VIDEO CONFERENCE EQUIPMENT; COMPUTER SOFTWARE FOR RECORDING, PROCESSING, AND DISTRIBUTING PRESENTATIONS AND LECTURES (U.S. CLS. 21, 23, 26, 36 AND 38).

FIRST USE 4-5-2011; IN COMMERCE 4-5-2011.

WENDY JUN, EXAMINING ATTORNEY

SN 85-664,604. HEALTH LEVEL SEVEN INTERNATIONAL, INC., DBA HEALTH LEVEL SEVEN INTERNATIONAL, ANN ARBOR, MI. FILED 6-28-2012.

FHIR

THE MARK CONSISTS OF STANDARD CHARACTERS WITHOUT CLAIM TO ANY PARTICULAR FONT, STYLE, SIZE, OR COLOR.

FOR ELECTRONIC EXCHANGE OF HEALTHCARE DOCUMENTS AND INFORMATION (U.S. CLS. 21, 23, 26, 36 AND 38).

FIRST USE 5-4-2012; IN COMMERCE 5-4-2012.

EDWARD NELSON, EXAMINING ATTORNEY

CLASS 9—(Continued).

SN 85-666,058. MITEK SYSTEMS, INC., SAN DIEGO, CA. FILED 6-29-2012.

MITEK MOBILE

THE MARK CONSISTS OF STANDARD CHARACTERS WITHOUT CLAIM TO ANY PARTICULAR FONT, STYLE, SIZE, OR COLOR.

OWNER OF U.S. REG. NOS. 2,379,045 AND 2,379,046. NO CLAIM IS MADE TO THE EXCLUSIVE RIGHT TO USE "MOBILE", APART FROM THE MARK AS SHOWN.

FOR COMPUTER SOFTWARE FOR DOCUMENT IMAGING, INTELLIGENT CHARACTER AND IMAGE RECOGNITION, AND DOCUMENT ANALYSIS; AND INSTRUCTIONAL BOOKS AND MANUALS SOLD THEREWITH (U.S. CLS. 21, 23, 26, 36 AND 38).

ANDREA HACK, EXAMINING ATTORNEY

SN 85-674,011. UNILUV MARKETING, INC., SAN DIEGO, CA. FILED 7-11-2012.

BIVO

THE MARK CONSISTS OF STANDARD CHARACTERS WITHOUT CLAIM TO ANY PARTICULAR FONT, STYLE, SIZE, OR COLOR.

FOR AUDIO SPEAKERS; CELL PHONE COVERS; EAR BUDS; ELECTRONIC BOOK READER COVERS; HEADPHONES; PROTECTIVE COVERS AND CASES FOR CELL PHONES, LAPTOPS AND PORTABLE MEDIA PLAYERS; PROTECTIVE COVERS AND CASES FOR TABLET COMPUTERS; PROTECTIVE COVERS FOR ELECTRONIC READING DEVICES (U.S. CLS. 21, 23, 26, 36 AND 38).

LINDA M. KING, EXAMINING ATTORNEY

SN 85-682,702. SOLID SUGAR, INC., AKA GAMAGO, GAMA-GO, SAN FRANCISCO, CA. FILED 7-20-2012.

PHONEY

THE MARK CONSISTS OF STANDARD CHARACTERS WITHOUT CLAIM TO ANY PARTICULAR FONT, STYLE, SIZE, OR COLOR.

FOR DECORATIVE ORNAMENTS FOR CELLULAR TELEPHONES (U.S. CLS. 21, 23, 26, 36 AND 38).

MARK SPARACINO, EXAMINING ATTORNEY

CLASS 10—MEDICAL APPARATUS

SN 78-815,012. MEDRAD, INC., INDIANOLA, PA. FILED 2-15-2006.

IMAXEON AVIDIA

THE MARK CONSISTS OF STANDARD CHARACTERS WITHOUT CLAIM TO ANY PARTICULAR FONT, STYLE, SIZE, OR COLOR.

PRIORITY CLAIMED UNDER SEC. 44(D) ON AUSTRALIA APPLICATION NO. 1075466, FILED 9-13-2005.

OWNER OF U.S. REG. NO. 2,804,689.

FOR MEDICAL INJECTORS AND INJECTOR SYSTEMS FOR DIAGNOSTIC AND THERAPEUTIC PROCEDURES, NAMELY, MEDICAL SYRINGES, DISPOSABLE MEDICAL SYRINGES, AND MEDICAL INJECTORS USED TO DELIVER CONTRAST MEDIA TO PATIENTS FOR MAGNETIC RESONANCE IMAGING, CONTRAST RADIOGRAPHY, ANGIOGRAPHY, COMPUTED TOMOGRAPHY, ULTRASOUND PROCEDURES AND OTHER DIAGNOSTIC IMAGING PROCEDURES. (U.S. CLS. 26, 39 AND 44).

RICHARD WHITE, EXAMINING ATTORNEY

SN 79-103,221. Q CORE MEDICAL LTD., ISRAEL, FILED 8-24-2011.

SAPPHIRE

THE MARK CONSISTS OF STANDARD CHARACTERS WITHOUT CLAIM TO ANY PARTICULAR FONT, STYLE, SIZE, OR COLOR.

PRIORITY DATE OF 3-3-2011 IS CLAIMED.

OWNER OF INTERNATIONAL REGISTRATION 1092464 DATED 8-24-2011, EXPIRES 8-24-2021.

FOR INFUSION PUMPS FOR DELIVERY OF MEDICATION AND NUTRITIONAL INFUSIONS INTO PATIENTS, IN HOSPITAL OR AMBULATORY SETTING; INFUSION PUMPS; TUBE SETS AND RELATED ACCESSORIES FOR DELIVERY OF MEDICATION AND NUTRITION TO PATIENTS, NAMELY, INFUSION BOLUS HANDLE, INFUSION PUMPS CRADLES, INFUSION LOCK BOXES (U.S. CLS. 26, 39 AND 44).

APRIL ROACH, EXAMINING ATTORNEY

CLASS 10—(Continued).

SN 79-103,360. MEDIN MEDICAL INNOVATIONS GMBH, FED REP GERMANY, FILED 8-30-2011.

Medin

THE MARK CONSISTS OF STANDARD CHARACTERS WITHOUT CLAIM TO ANY PARTICULAR FONT, STYLE, SIZE, OR COLOR.

PRIORITY DATE OF 3-1-2011 IS CLAIMED.

OWNER OF INTERNATIONAL REGISTRATION 1092896 DATED 8-30-2011, EXPIRES 8-30-2021.

THE WORDING "MEDIN" HAS NO MEANING IN A FOREIGN LANGUAGE.

FOR RESPIRATORY MASKS FOR MEDICAL PURPOSES FOR USE ON INFANTS, BABIES AND NEWBORN BABIES (U.S. CLS. 26, 39 AND 44).

NANCY CLARKE, EXAMINING ATTORNEY

CLASS 10—(Continued).

SN 79-103,827. BMC MEDICAL CO., LTD., BEIJING, CHINA, FILED 9-27-2011.

BPAP

OWNER OF INTERNATIONAL REGISTRATION 1093941 DATED 9-27-2011, EXPIRES 9-27-2021.

FOR MEDICAL DEVICES FOR THE TREATING, SCREENING, MONITORING AND DIAGNOSING RESPIRATORY DISORDERS AND SLEEP APNEA AND SNORING; MEDICAL HUMIDIFIERS AND THEIR STRUCTURAL PARTS, NAMELY, WATER TUBS, AIR TUBES; MEDICAL RESPIRATORY MASKS, NAMELY, NASAL MASKS, FULL FACE MASKS, ORO-NASAL MASKS AND NASAL PILLOWS; CUSHIONS FOR MEDICAL RESPIRATORY MASKS; HEADGEAR FOR MEDICAL RESPIRATORY MASKS; SPHYGMOMANOMETERS; SPHYGMOTENSIOMETERS; RESPIRATORS FOR ARTIFICIAL RESPIRATION; VENTILATORS; MEDICAL CONTINUOUS POSITIVE AIRWAY PRESSURE DEVICES; MEDICAL AUTOMATIC POSITIVE AIRWAY PRESSURE DEVICES; ANESTHETIC MASKS; INHALERS FOR MEDICAL PURPOSES, SOLD EMPTY (U.S. CLS. 26, 39 AND 44).

FRANK LATTUCA, EXAMINING ATTORNEY

SN 79-103,826. BMC MEDICAL CO., LTD., BEIJING, CHINA, FILED 9-27-2011.

iCode

OWNER OF INTERNATIONAL REGISTRATION 1093940 DATED 9-27-2011, EXPIRES 9-27-2021.

FOR MEDICAL DEVICES FOR THE TREATING, SCREENING, MONITORING AND DIAGNOSING RESPIRATORY DISORDERS AND SLEEP APNEA AND SNORING; MEDICAL HUMIDIFIERS AND THEIR STRUCTURAL PARTS, NAMELY, WATER TUBS, AIR TUBES; MEDICAL RESPIRATORY MASKS, NAMELY, NASAL MASKS, FULL FACE MASKS, ORO-NASAL MASKS AND NASAL PILLOWS; CUSHIONS FOR MEDICAL RESPIRATORY MASKS; HEADGEAR FOR MEDICAL RESPIRATORY MASKS; SPHYGMOMANOMETERS; SPHYGMOTENSIOMETERS; RESPIRATORS FOR ARTIFICIAL RESPIRATION; VENTILATORS; MEDICAL CONTINUOUS POSITIVE AIRWAY PRESSURE DEVICES; MEDICAL AUTOMATIC POSITIVE AIRWAY PRESSURE DEVICES; ANESTHETIC MASKS; INHALERS FOR MEDICAL PURPOSES, SOLD EMPTY (U.S. CLS. 26, 39 AND 44).

FRANK LATTUCA, EXAMINING ATTORNEY

SN 79-106,665. BMC MEDICAL CO., LTD., CHINA, FILED 11-24-2011.

PolyWatch

OWNER OF INTERNATIONAL REGISTRATION 1100435 DATED 11-24-2011, EXPIRES 11-24-2021.

THE MARK CONSISTS OF THE WORDING "POLYWATCH" IN STYLIZED FONT.

FOR MEDICAL DEVICES FOR THE TREATING, SCREENING, MONITORING AND DIAGNOSING RESPIRATORY DISORDERS AND SLEEP APNEA AND SNORING; MEDICAL HUMIDIFIERS AND THEIR STRUCTURAL PARTS, NAMELY, WATER TUBS, AIR TUBES; MEDICAL RESPIRATORY MASKS, NAMELY, NASAL MASKS, FULL FACE MASKS, ORO-NASAL MASKS AND NASAL PILLOWS; CUSHIONS FOR MEDICAL RESPIRATORY MASKS; HEADGEAR FOR MEDICAL RESPIRATORY MASKS; SPHYGMOMANOMETERS; SPHYGMOTENSIOMETERS; RESPIRATORS FOR ARTIFICIAL RESPIRATION; VENTILATORS; MEDICAL CONTINUOUS POSITIVE AIRWAY PRESSURE DEVICES; MEDICAL AUTOMATIC POSITIVE AIRWAY PRESSURE DEVICES; ANESTHETIC MASKS; INHALERS FOR MEDICAL PURPOSES, SOLD EMPTY (U.S. CLS. 26, 39 AND 44).

SUZANNE BLANE, EXAMINING ATTORNEY

CLASS 10—(Continued).

SN 79-106,669. BMC MEDICAL CO., LTD., BEIJING, CHINA,
FILED 11-24-2011.

PolyCare

OWNER OF INTERNATIONAL REGISTRATION 1100440
DATED 11-24-2011, EXPIRES 11-24-2021.

THE MARK CONSISTS OF THE WORDING "POLY-CARE"
IN STYLIZED FONT.

FOR MEDICAL DEVICES FOR THE TREATING,
SCREENING, MONITORING AND DIAGNOSING RE-
SPIRATORY DISORDERS AND SLEEP APNEA AND
SNORING; MEDICAL HUMIDIFIERS AND THEIR
STRUCTURAL PARTS, NAMELY, WATER TUBS, AIR
TUBES; MEDICAL RESPIRATORY MASKS, NAMELY,
NASAL MASKS, FULL FACE MASKS, ORO-NASAL
MASKS AND NASAL PILLOWS; CUSHIONS FOR MED-
ICAL RESPIRATORY MASKS; HEADGEAR FOR MEDI-
C A L R E S P I R A T O R Y M A S K S ;
SPHYGMOMANOMETERS; SPHYGMOTENSIOMETERS;
RESPIRATORS FOR ARTIFICIAL RESPIRATION; VEN-
TILATORS; MEDICAL CONTINUOUS POSITIVE AIR-
WAY PRESSURE DEVICES; MEDICAL AUTOMATIC
POSITIVE AIRWAY PRESSURE DEVICES; ANESTHETIC
MASKS; INHALERS FOR MEDICAL PURPOSES, SOLD
EMPTY (U.S. CLS. 26, 39 AND 44).
SUZANNE BLANE, EXAMINING ATTORNEY

SN 79-106,670. BMC MEDICAL CO., LTD., BEIJING, CHINA,
FILED 11-24-2011.

Fealite

OWNER OF INTERNATIONAL REGISTRATION 1100441
DATED 11-24-2011, EXPIRES 11-24-2021.

THE MARK CONSISTS OF THE WORDING "FEALITE"
IN STYLIZED FONT.

THE WORD(S) "FEALITE" HAS NO MEANING IN A
FOREIGN LANGUAGE.

FOR MEDICAL DEVICES FOR THE TREATING,
SCREENING, MONITORING AND DIAGNOSING RE-
SPIRATORY DISORDERS AND SLEEP APNEA AND
SNORING; MEDICAL HUMIDIFIERS AND THEIR
STRUCTURAL PARTS, NAMELY, WATER TUBS, AIR
TUBES; MEDICAL RESPIRATORY MASKS, NAMELY,
NASAL MASKS, FULL FACE MASKS, ORO-NASAL
MASKS AND NASAL PILLOWS; CUSHIONS FOR MED-
ICAL RESPIRATORY MASKS; HEADGEAR FOR MEDI-
C A L R E S P I R A T O R Y M A S K S ;
SPHYGMOMANOMETERS; SPHYGMOTENSIOMETERS;
RESPIRATORS FOR ARTIFICIAL RESPIRATION; VEN-
TILATORS; MEDICAL CONTINUOUS POSITIVE AIR-
WAY PRESSURE DEVICES; MEDICAL AUTOMATIC
POSITIVE AIRWAY PRESSURE DEVICES; ANESTHETIC
MASKS; INHALERS FOR MEDICAL PURPOSES, SOLD
EMPTY (U.S. CLS. 26, 39 AND 44).
SUZANNE BLANE, EXAMINING ATTORNEY

CLASS 10—(Continued).

SN 79-107,714. RAUMEDIC AG, FED REP GERMANY,
FILED 11-24-2011.

Neurovent

THE MARK CONSISTS OF STANDARD CHARACTERS
WITHOUT CLAIM TO ANY PARTICULAR FONT, STYLE,
SIZE, OR COLOR.

OWNER OF INTERNATIONAL REGISTRATION 1103049
DATED 11-24-2011, EXPIRES 11-24-2021.

FOR MEDICAL APPARATUS FOR THERAPEUTIC
PURPOSES, NAMELY, MEDICAL AND SURGICAL CA-
TETERS, MEDICAL APPARATUS AND INSTRU-
MENTS FOR TREATING BRAIN TUMOURS, MEDICAL
APPARATUS AND INSTRUMENTS FOR USE IN NEU-
RORADIOLOGY, NEUROLOGY AND NEURO-ANES-
THETICS, MEDICAL DEVICES TO TREAT
INTRAVASCULAR SITES; ELECTROMEDICAL APPA-
RATUS, NAMELY, ELECTRODES FOR MEDICAL USE,
ELECTROMAGNETIC DRUG DELIVERY APPARATUS
FOR MEDICAL USE, ELECTROMAGNETIC MEDICAL
DIAGNOSTIC IMAGING APPARATUS AND PARTS
THEREOF; MEDICAL MEASURING AND CONTROL
APPARATUS, NAMELY, CATHETERS, IN PARTICULAR
FOR MEASURING INTRACRANIAL PRESSURE (U.S.
CLS. 26, 39 AND 44).

JAY BESCH, EXAMINING ATTORNEY

SN 79-112,922. PROTIP SAS, FRANCE, FILED 4-23-2012.

ENTegral

THE MARK CONSISTS OF STANDARD CHARACTERS
WITHOUT CLAIM TO ANY PARTICULAR FONT, STYLE,
SIZE, OR COLOR.

PRIORITY DATE OF 11-4-2011 IS CLAIMED.

OWNER OF INTERNATIONAL REGISTRATION 1115933
DATED 4-23-2012, EXPIRES 4-23-2022.

FOR IMPLANTS FOR THE LARYNX; PROSTHESES
FOR LARYNXES; ARTIFICIAL LARYNXES (U.S. CLS.
26, 39 AND 44).

EDWARD FENNESSY, EXAMINING ATTORNEY

SN 85-135,926. ROY A. MEALS, MD, INC, LOS ANGELES,
CA. FILED 9-22-2010.

Freehand DEX Brace

THE MARK CONSISTS OF STANDARD CHARACTERS
WITHOUT CLAIM TO ANY PARTICULAR FONT, STYLE,
SIZE, OR COLOR.

OWNER OF U.S. REG. NOS. 3,687,366 AND 3,687,367.

NO CLAIM IS MADE TO THE EXCLUSIVE RIGHT TO
USE "BRACE", APART FROM THE MARK AS SHOWN.

FOR BRACES FOR LIMBS AND JOINTS, FOR MEDI-
CAL USE; MEDICAL BRACES FOR ELBOW; ORTHOPE-
DIC APPARATUS AND INSTRUMENTS FOR
DIAGNOSTIC AND THERAPEUTIC USE; ORTHOPEDIC
BRACES; SPLINTS (U.S. CLS. 26, 39 AND 44).

FIRST USE 8-18-2009; IN COMMERCE 9-16-2010.

KATHERINE E. HALMEN, EXAMINING ATTORNEY

CLASS 10—(Continued).

SN 85-182,907. SEQUENT MEDICAL INC., ALISO VIEJO, CA. FILED 11-22-2010.

SEQUENT MEDICAL

THE MARK CONSISTS OF STANDARD CHARACTERS WITHOUT CLAIM TO ANY PARTICULAR FONT, STYLE, SIZE, OR COLOR.

OWNER OF U.S. REG. NO. 3,459,624.

NO CLAIM IS MADE TO THE EXCLUSIVE RIGHT TO USE "MEDICAL", APART FROM THE MARK AS SHOWN.

FOR DEVICES FOR VASCULAR THERAPY, NAMELY, CATHETERS, IMPLANTS CONSISTING OF ARTIFICIAL MATERIALS, AND IMPLANT DELIVERY SYSTEMS CONSISTING PRIMARILY OF INTRAVASCULAR MEDICAL IMPLANTS FOR USE IN TREATING VASCULAR DEFECTS (U.S. CLS. 26, 39 AND 44).

MARC LEIPZIG, EXAMINING ATTORNEY

SN 85-225,577. SEVEN SEAS DISTRIBUTION AND MANUFACTURING LLC, WILMINGTON, DE. FILED 1-25-2011.

X-Force Stimulator

THE MARK CONSISTS OF STANDARD CHARACTERS WITHOUT CLAIM TO ANY PARTICULAR FONT, STYLE, SIZE, OR COLOR.

NO CLAIM IS MADE TO THE EXCLUSIVE RIGHT TO USE "STIMULATOR", APART FROM THE MARK AS SHOWN.

FOR ELECTROMEDICAL REHABILITATIVE AND PAIN MANAGEMENT PRODUCTS FOR CLINICAL AND HOME USE, NAMELY, ELECTRICAL NERVE AND MUSCLE STIMULATORS, ULTRASONIC STIMULATORS, MAGNET THERAPY STIMULATORS, AND LASER THERAPY STIMULATORS (U.S. CLS. 26, 39 AND 44).

RONALD DELGIZZI, EXAMINING ATTORNEY

CLASS 10—(Continued).

SN 85-376,921. HITACHI MEDICAL CORPORATION, TOKYO, JAPAN, FILED 7-21-2011.

Trillium Oval

THE MARK CONSISTS OF STANDARD CHARACTERS WITHOUT CLAIM TO ANY PARTICULAR FONT, STYLE, SIZE, OR COLOR.

PRIORITY CLAIMED UNDER SEC. 44(D) ON JAPAN APPLICATION NO. 2011-045540, FILED 6-30-2011, REG. NO. 5461550, DATED 1-6-2012, EXPIRES 1-6-2022.

NO CLAIM IS MADE TO THE EXCLUSIVE RIGHT TO USE "OVAL", APART FROM THE MARK AS SHOWN.

FOR MEDICAL DIAGNOSTIC APPARATUS, NAMELY, MAGNETIC RESONANCE IMAGING APPARATUS FOR MEDICAL USE, AND PARTS AND FITTINGS THEREFOR (U.S. CLS. 26, 39 AND 44).

WENDY GOODMAN, EXAMINING ATTORNEY

SN 85-431,900. EZEKIEL, MICHAEL, HOLLYWOOD, FL. FILED 9-26-2011.

STAY SAFE. SAVE MONEY.

THE MARK CONSISTS OF STANDARD CHARACTERS WITHOUT CLAIM TO ANY PARTICULAR FONT, STYLE, SIZE, OR COLOR.

FOR LATEX MEDICAL GLOVES; MEDICAL GLOVES; NITRILE GLOVES FOR MEDICAL USE SOLD TO THE MEDICAL FIELD (U.S. CLS. 26, 39 AND 44).

FIRST USE 1-1-2008; IN COMMERCE 1-1-2008.

DARRYL SPRUILL, EXAMINING ATTORNEY

SN 85-438,109. BEARD, JOHN, LAFAYETTE, CA. FILED 10-3-2011.

Monitor Mask

THE MARK CONSISTS OF STANDARD CHARACTERS WITHOUT CLAIM TO ANY PARTICULAR FONT, STYLE, SIZE, OR COLOR.

NO CLAIM IS MADE TO THE EXCLUSIVE RIGHT TO USE "MASK", APART FROM THE MARK AS SHOWN.

FOR OXYGEN MASKS FOR MEDICAL USE (U.S. CLS. 26, 39 AND 44).

FRED CARL, EXAMINING ATTORNEY

CLASS 10—(Continued).

SN 85-449,982. FAMILY KABUSHIKI KAISHA, DBA FAMILY CO., LTD., OSAKA, JAPAN, FILED 10-18-2011.

INADA

THE MARK CONSISTS OF THE STYLIZED WORD "INADA".

SEC. 2(F).

FOR MASSAGE APPARATUS; ELECTRIC MASSAGE APPARATUS; ELECTRIC MASSAGE CHAIRS FOR HOUSEHOLD USE; ELECTRIC MASSAGE CHAIRS FOR MEDICAL USE; PHYSICAL BODY REHABILITATION APPARATUS FOR MEDICAL PURPOSES; ESTHETIC MASSAGE APPARATUS (U.S. CLS. 26, 39 AND 44).

FIRST USE 4-0-2001; IN COMMERCE 6-0-2001.

ALICE BENMAMAN, EXAMINING ATTORNEY

SN 85-465,213. SYNGEN INC., SACRAMENTO, CA. FILED 11-4-2011.

SYNGEN

THE MARK CONSISTS OF STANDARD CHARACTERS WITHOUT CLAIM TO ANY PARTICULAR FONT, STYLE, SIZE, OR COLOR.

FOR MEDICAL APPARATUS AND INSTRUMENT FOR MEDICAL, CLINICAL, MEDICAL DIAGNOSTIC, AND THERAPEUTIC USES, NAMELY, APPARATUS FOR PURIFYING CERTAIN CELL POPULATIONS IN A BLOOD, BONE MARROW OR ADIPOSE TISSUE SAMPLE (U.S. CLS. 26, 39 AND 44).

DOMINICK J. SALEMI, EXAMINING ATTORNEY

CLASS 10—(Continued).

SN 85-493,352. ISONEA LIMITED, ARMADALE, VICTORIA, AUSTRALIA, FILED 12-12-2011.

WHEEZOGRAM

THE MARK CONSISTS OF STANDARD CHARACTERS WITHOUT CLAIM TO ANY PARTICULAR FONT, STYLE, SIZE, OR COLOR.

FOR MEDICAL DEVICE FOR MONITORING, DISPLAYING AND DIAGNOSING RESPIRATION AND THE PULMONARY SYSTEM TO DETERMINE PARAMETERS ASSOCIATED WITH THEIR STATE OF HEALTH BY SENSING, RECORDING AND ANALYZING ACOUSTIC SIGNALS EMITTED THEREFROM AND USING THESE PARAMETERS TO INFER THE STATE OF HEALTH OF THE PULMONARY SYSTEM AND RESPIRATION RELATING TO THEIR FUNCTIONS, ABNORMALITIES, CONDITIONS AND DISEASES (U.S. CLS. 26, 39 AND 44).

FIRST USE 12-31-1999; IN COMMERCE 12-31-1999.

AHSEN KHAN, EXAMINING ATTORNEY

SN 85-495,160. BROWNMED, INC., SPIRIT LAKE, IA. FILED 12-14-2011.

BROWNMED

THE MARK CONSISTS OF STANDARD CHARACTERS WITHOUT CLAIM TO ANY PARTICULAR FONT, STYLE, SIZE, OR COLOR.

FOR ORTHOPEDIC DEVICES, NAMELY, ORTHOPEDIC SUPPORT BANDAGES, ORTHOPEDIC SLEEVES, CASTS AND GLOVES FOR TREATMENT AND PREVENTION OF REPETITIVE STRAIN INJURIES, ANKLE STABILIZER WALKING SPLINTS, AND SOFT-SIDED ORTHOPEDIC BRACES (U.S. CLS. 26, 39 AND 44).

MARY ROSSMAN, EXAMINING ATTORNEY

SN 85-497,421. CODAN HOLDING GMBH, LENSACHN, FED REP GERMANY, FILED 12-16-2011.

CONTRELLE

THE MARK CONSISTS OF STANDARD CHARACTERS WITHOUT CLAIM TO ANY PARTICULAR FONT, STYLE, SIZE, OR COLOR.

OWNER OF DENMARK REG. NO. VR199503545, DATED 6-6-1995, EXPIRES 6-9-2015.

FOR MEDICAL APPARATUS, NAMELY, BLADDER SUPPORTS AND URETHRAL CLOSURES IN THE NATURE OF PLUGS AND COVERS FOR USE IN THE INCONTINENCE CONTROL; CATHETER FLUSHING DEVICE COMPRISING SYRINGE, FEMALE LUER LOCK, CLAMP AND CONNECTOR (U.S. CLS. 26, 39 AND 44).

MATTHEW MCDOWELL, EXAMINING ATTORNEY

CLASS 10—(Continued).

SN 85-504,834. KIMBERLY-CLARK WORLDWIDE, INC.,
NEENAH, WI. FILED 12-28-2011.

KIMPACK

THE MARK CONSISTS OF STANDARD CHARACTERS
WITHOUT CLAIM TO ANY PARTICULAR FONT, STYLE,
SIZE, OR COLOR.

OWNER OF U.S. REG. NOS. 554,685, 3,755,090 AND
OTHERS.

FOR SURGICAL KITS COMPRISING SINGLE-USE
SURGICAL DEVICES AND INSTRUMENTS, SURGICAL
DRAPES AND SURGICAL GOWNS (U.S. CLS. 26, 39
AND 44).

TASNEEM HUSSAIN, EXAMINING ATTORNEY

CLASS 10—(Continued).

SN 85-507,734. PIPELINE BIOMEDICAL HOLDINGS, INC.,
CEDAR KNOLLS, NJ. FILED 1-3-2012.

PST

THE MARK CONSISTS OF STANDARD CHARACTERS
WITHOUT CLAIM TO ANY PARTICULAR FONT, STYLE,
SIZE, OR COLOR.

FOR MEDICAL, SURGICAL AND ORTHOPAEDIC
IMPLANTS MADE OF ARTIFICIAL MATERIALS;
ORTHOPEDIC JOINT IMPLANTS; BONE IMPLANTS
COMPOSED OF ARTIFICIAL MATERIALS; MEDICAL
IMPLANTS OF ARTIFICIAL MATERIAL IN PARTICU-
LAR FOR ANCHORING JOINT CAPSULE COMPO-
NENTS AND LIGAMENT TENDON STRUCTURES;
COTYLOID IMPLANTS MADE OF ARTIFICIAL MATE-
RIALS; SPINAL IMPLANTS COMPOSED OF ARTIFI-
CIAL MATERIAL; BONE SCREWS; PROSTHETIC AND
FILLING MATERIALS, NAMELY, ARTIFICIAL MATE-
RIALS FOR USE IN THE REPLACEMENT OF BONES;
SUBSTITUTES FOR BONES, CARTILAGE, LIGAMENTS
AND TENDONS; BONE SUBSTITUTES FOR SURGICAL
USE (U.S. CLS. 26, 39 AND 44).

JOHN HWANG, EXAMINING ATTORNEY

SN 85-506,188. SYNERON BEAUTY INC., CAMBRIDGE,
ONTARIO, CANADA, FILED 12-30-2011.

TANDA CLEAR +

THE MARK CONSISTS OF STANDARD CHARACTERS
WITHOUT CLAIM TO ANY PARTICULAR FONT, STYLE,
SIZE, OR COLOR.

OWNER OF U.S. REG. NO. 3,694,648.

NO CLAIM IS MADE TO THE EXCLUSIVE RIGHT TO
USE "CLEAR", APART FROM THE MARK AS SHOWN.

FOR MEDICAL AESTHETIC HAND-HELD DEVICE
USING BLUE LIGHT ENERGY FOR THERAPEUTIC
AND AESTHETIC SKIN TREATMENTS (U.S. CLS. 26,
39 AND 44).

FIRST USE 9-15-2011; IN COMMERCE 9-15-2011.

ANGELA DUONG, EXAMINING ATTORNEY

SN 85-521,461. OPERATING ROOM SAFETY ENTERPRISES,
LLC, BERWYN, PA. FILED 1-20-2012.

OpenFrame

THE MARK CONSISTS OF STANDARD CHARACTERS
WITHOUT CLAIM TO ANY PARTICULAR FONT, STYLE,
SIZE, OR COLOR.

FOR MEDICAL EQUIPMENT, NAMELY, PADS FOR
SUPPORTING A PATIENT IN A PRONE POSITION
DURING SPINAL SURGERY (U.S. CLS. 26, 39 AND 44).

TAMARA FRAZIER, EXAMINING ATTORNEY

CLASS 10—(Continued).

SN 85-521,970. GUPTA, SANJAY, TUSTIN, CA. FILED 1-21-2012.

SANTAMEDICAL

THE MARK CONSISTS OF STANDARD CHARACTERS WITHOUT CLAIM TO ANY PARTICULAR FONT, STYLE, SIZE, OR COLOR.

FOR ARTERIAL BLOOD PRESSURE MEASURING APPARATUS; BLOOD PRESSURE MONITOR; STETHOSCOPES; PORTABLE MEDICAL ULTRASOUND APPARATUS; OTOSCOPE; OPHTHALMOSCOPE; TENS UNIT, NAMELY, ELECTROTHERAPY DEVICES FOR PROVIDING TRANSCUTANEOUS ELECTRICAL NERVE STIMULATION, INFRARED HEAT AND COMPRESSION; TENS ELECTRODES, NAMELY, MEDICAL ELECTRODES FOR USE IN TRANSCUTANEOUS ELECTRICAL NERVE STIMULATION; THERMOMETERS FOR MEDICAL PURPOSES; FETAL DOPPLER APPARATUS FOR MEDICAL PURPOSES (U.S. CLS. 26, 39 AND 44).

FIRST USE 1-2-2008; IN COMMERCE 1-2-2008.
JAMES LOVELACE, EXAMINING ATTORNEY

SN 85-524,731. OPERATING ROOM SAFETY ENTERPRISES, LLC, BERWYN, PA. FILED 1-25-2012.

FlexFrame

THE MARK CONSISTS OF STANDARD CHARACTERS WITHOUT CLAIM TO ANY PARTICULAR FONT, STYLE, SIZE, OR COLOR.

FOR MEDICAL EQUIPMENT, NAMELY, PADS FOR SUPPORTING A PATIENT IN A PRONE POSITION DURING SPINAL SURGERY (U.S. CLS. 26, 39 AND 44).
TAMARA FRAZIER, EXAMINING ATTORNEY

SN 85-556,873. SUPERDIMENSION, LTD., HERZLIYA, ISRAEL, FILED 2-29-2012.

SUPERLOCK COBRA

THE MARK CONSISTS OF STANDARD CHARACTERS WITHOUT CLAIM TO ANY PARTICULAR FONT, STYLE, SIZE, OR COLOR.

OWNER OF U.S. REG. NO. 4,053,823.
FOR MEDICAL DEVICES, NAMELY, FIDUCIAL MARKER IMPLANTS COMPRISED OF ARTIFICIAL MATERIALS (U.S. CLS. 26, 39 AND 44).
WILLIAM VERHOSEK, EXAMINING ATTORNEY

CLASS 10—(Continued).

SN 85-561,228. ARNO FRIEDRICHS GMBH & CO. KG, MAINLEUS, FED REP GERMANY, FILED 3-6-2012.



THE MARK CONSISTS THE WORD "SWELL" IN BLOCK LETTERS WITH A BORDER, INSIDE A RECTANGLE DIVIDED BY A WAVY HORIZONTAL LINE THAT DIVIDES THE RECTANGLE INTO TWO PARTS, WITH THE TOP PART LIGHTER THAN THE DARKER BOTTOM PART.

FOR AIR MATTRESSES FOR MEDICAL PURPOSES; BEDS FOR SPECIALIZED MEDICAL PURPOSES, NAMELY, FOR USE BY BEDRIDDEN PATIENTS FOR PROPHYLAXIS AND THERAPY OF DECUBITUS AND FOR USE BY BURN PATIENTS; DENTAL DRILLS (U.S. CLS. 26, 39 AND 44).

JOHN SCHUYLER YARD, EXAMINING ATTORNEY

SN 85-565,060. NOSTRUM PHARMACEUTICALS, LLC, NEW BRUNSWICK, NJ. FILED 3-9-2012.

InspiraMask

THE MARK CONSISTS OF STANDARD CHARACTERS WITHOUT CLAIM TO ANY PARTICULAR FONT, STYLE, SIZE, OR COLOR.

FOR MEDICAL APPARATUS FOR FACILITATING THE INHALATION OF PHARMACEUTICAL PREPARATIONS (U.S. CLS. 26, 39 AND 44).

KATHERINE STOIDES, EXAMINING ATTORNEY

SN 85-571,258. HEALTHTRONICS, INC., CHADDS FORD, PA. FILED 3-16-2012.

SimplifID

THE MARK CONSISTS OF A CAPITAL LETTER "S" AND LOWERCASE LETTERS "IMPLIF" AND CAPITAL ENDING LETTERS "ID".

FOR BIOPSY COLLECTION KITS COMPRISING OF FORMALIN JARS, BIOHAZARD BAGS, TEST REQUISITIONS, CASSETTES AND MAILING PACKAGE AND LABEL, ALL FOR MEDICAL USE (U.S. CLS. 26, 39 AND 44).

FIRST USE 6-1-2010; IN COMMERCE 6-1-2010.
STEVEN JACKSON, EXAMINING ATTORNEY

CLASS 10—(Continued).

SN 85-571,273. HEALTHTRONICS, INC., CHADDS FORD, PA. FILED 3-16-2012.

SIMPLIFID

THE MARK CONSISTS OF STANDARD CHARACTERS WITHOUT CLAIM TO ANY PARTICULAR FONT, STYLE, SIZE, OR COLOR.

FOR BIOPSY COLLECTION KITS COMPRISING OF FORMALIN JARS, BIOHAZARD BAGS, TEST REQUISITIONS, CASSETTES AND MAILING PACKAGE AND LABEL, ALL FOR MEDICAL USE (U.S. CLS. 26, 39 AND 44).

FIRST USE 6-1-2010; IN COMMERCE 6-1-2010.
STEVEN JACKSON, EXAMINING ATTORNEY

SN 85-575,784. BROWNMED, INC., SPIRIT LAKE, IA. FILED 3-21-2012.



THE MARK CONSISTS OF TWO OPPOSITE-FACING INTERSECTING TRIANGLES WITH ROUNDED EDGES, WITH THE WORD "BROWNMED" TO THE RIGHT OF THE TRIANGLES.

FOR ORTHOPEDIC DEVICES, NAMELY, ORTHOPEDIC SUPPORT BANDAGES, ORTHOPEDIC SLEEVES, CASTS AND GLOVES FOR TREATMENT AND PREVENTION OF REPETITIVE STRAIN INJURIES, ANKLE STABILIZER WALKING SPLINTS, AND SOFT-SIDED ORTHOPEDIC BRACES (U.S. CLS. 26, 39 AND 44).

FIRST USE 1-24-2012; IN COMMERCE 1-24-2012.
MARY ROSSMAN, EXAMINING ATTORNEY

SN 85-575,801. BROWNMED, INC., SPIRIT LAKE, IA. FILED 3-21-2012.



THE MARK CONSISTS OF TWO OPPOSITE-FACING INTERSECTING TRIANGLES WITH ROUNDED EDGES, WITH THE WORD "BROWNMED" TO THE RIGHT OF THE TRIANGLES AND THE WORDS "IMPROVING LIFE IS OUR PASSION" IN A SMALLER FONT UNDERNEATH OF THE WORD "BROWNMED".

FOR ORTHOPEDIC DEVICES, NAMELY, ORTHOPEDIC SUPPORT BANDAGES, ORTHOPEDIC SLEEVES, CASTS AND GLOVES FOR TREATMENT AND PREVENTION OF REPETITIVE STRAIN INJURIES, ANKLE STABILIZER WALKING SPLINTS, AND SOFT-SIDED ORTHOPEDIC BRACES (U.S. CLS. 26, 39 AND 44).

FIRST USE 1-24-2012; IN COMMERCE 1-24-2012.
MARY ROSSMAN, EXAMINING ATTORNEY

CLASS 10—(Continued).

SN 85-575,822. BROWNMED, INC., SPIRIT LAKE, IA. FILED 3-21-2012.



THE COLOR(S) BLACK, BLUE, AND LIGHT BLUE IS/ ARE CLAIMED AS A FEATURE OF THE MARK.

THE MARK CONSISTS OF TWO OPPOSITE-FACING INTERSECTING LIGHT BLUE TRIANGLES WITH ROUNDED EDGES, THE TRIANGLES BEING DARK BLUE WHERE THEY INTERSECT, WITH THE WORD "BROWNMED" TO THE RIGHT OF THE TRIANGLES, "BROWN" BEING BLACK IN COLOR AND "MED" BEING LIGHT BLUE IN COLOR.

FOR ORTHOPEDIC DEVICES, NAMELY, ORTHOPEDIC SUPPORT BANDAGES, ORTHOPEDIC SLEEVES, CASTS AND GLOVES FOR TREATMENT AND PREVENTION OF REPETITIVE STRAIN INJURIES, ANKLE STABILIZER WALKING SPLINTS, AND SOFT-SIDED ORTHOPEDIC BRACES (U.S. CLS. 26, 39 AND 44).

FIRST USE 1-24-2012; IN COMMERCE 1-24-2012.
MARY ROSSMAN, EXAMINING ATTORNEY

SN 85-576,315. SENSORY UNIVERSITY LLC, BUFORD, GA. FILED 3-21-2012.

TACTILE TIGER

THE MARK CONSISTS OF STANDARD CHARACTERS WITHOUT CLAIM TO ANY PARTICULAR FONT, STYLE, SIZE, OR COLOR.

NO CLAIM IS MADE TO THE EXCLUSIVE RIGHT TO USE "TACTILE", APART FROM THE MARK AS SHOWN.

FOR ORAL STIMULATION DEVICE, NAMELY, HAND-HELD MULTI-TEXTURE APPARATUS DESIGNED TO PROVIDE SENSORY FEEDBACK AS A TEMPORARY REMEDY FOR FIDGETING AND TO LESSEN THE DESTRUCTIVE NATURE OF ORAL GRINDING IN CHILDREN SEEKING SENSORY INPUT (U.S. CLS. 26, 39 AND 44).

FIRST USE 6-11-2011; IN COMMERCE 6-11-2011.
RONALD AIKENS, EXAMINING ATTORNEY

CLASS 10—(Continued).

SN 85-591,907. METRIC MEDICAL DEVICES, INC., HELOTES, TX. FILED 4-7-2012.

Metric Medical Devices

THE MARK CONSISTS OF STANDARD CHARACTERS WITHOUT CLAIM TO ANY PARTICULAR FONT, STYLE, SIZE, OR COLOR.

NO CLAIM IS MADE TO THE EXCLUSIVE RIGHT TO USE "MEDICAL DEVICES", APART FROM THE MARK AS SHOWN.

FOR FIXATION IMPLANTS COMPRISED OF ARTIFICIAL MATERIAL; MEDICAL AND SURGICAL APPARATUS AND INSTRUMENTS, NAMELY, ORTHOPEDIC FIXATION DEVICE USED IN ORTHOPEDIC TRANSPLANT AND/OR IMPLANT SURGERY; MEDICAL, SURGICAL AND ORTHOPAEDIC IMPLANTS MADE OF ARTIFICIAL MATERIALS (U.S. CLS. 26, 39 AND 44).
JESSICA A. POWERS, EXAMINING ATTORNEY

CLASS 10—(Continued).

SN 85-598,651. EHOB, INC., INDIANAPOLIS, IN. FILED 4-16-2012.

FOOT WAFFLE CUSTOM

THE MARK CONSISTS OF STANDARD CHARACTERS WITHOUT CLAIM TO ANY PARTICULAR FONT, STYLE, SIZE, OR COLOR.

OWNER OF U.S. REG. NOS. 1,668,406, 2,185,464 AND 3,389,513.

NO CLAIM IS MADE TO THE EXCLUSIVE RIGHT TO USE "FOOT" AND "CUSTOM", APART FROM THE MARK AS SHOWN.

SEC. 2(F) AS TO WAFFLE.
FOR ORTHOTICS FOR ANKLES TO PREVENT, TREAT AND CORRECT FOOT DROP, PLANTAR FLEXION CONTRACTURE, PLANTAR FASCIITIS AND CONTRACTURES; AND TO PREVENT PRESSURE ULCERS IN PATIENTS WHO ARE HOSPITALIZED, IN NURSING HOMES, OR IN HOME CARE (U.S. CLS. 26, 39 AND 44).
APRIL ROACH, EXAMINING ATTORNEY

SN 85-598,996. MEDTRONIC CRYOCATH LP, POINTE CLAIRE, CANADA, FILED 4-16-2012.

EVENCOOL

THE MARK CONSISTS OF STANDARD CHARACTERS WITHOUT CLAIM TO ANY PARTICULAR FONT, STYLE, SIZE, OR COLOR.

FOR SURGICAL APPARATUS AND INSTRUMENTS, NAMELY, CRYOSURGICAL BALLOON CATHETERS; COMPONENT FEATURE OF CRYOSURGICAL BALLOON CATHETERS, NAMELY, COOLANT DELIVERY ARRAY (U.S. CLS. 26, 39 AND 44).
JANICE L. MCMORROW, EXAMINING ATTORNEY

SN 85-595,639. SOF CONCEPTS, INC., NEW YORK, NY. FILED 4-12-2012.

RAPID DEPLOYMENT TOURNIQUET

THE MARK CONSISTS OF STANDARD CHARACTERS WITHOUT CLAIM TO ANY PARTICULAR FONT, STYLE, SIZE, OR COLOR.

NO CLAIM IS MADE TO THE EXCLUSIVE RIGHT TO USE "TOURNIQUET", APART FROM THE MARK AS SHOWN.

FOR MEDICAL DEVICES FOR USE IN CANNULATION, TO STEM THE FLOW OF TRAUMATIC BLEEDING, CONSTRICTING OR COMPRESSING THE FLOW OF BLOOD, NAMELY, TOURNIQUETS; ONE-HANDED TOURNIQUET MEDICAL DEVICE (U.S. CLS. 26, 39 AND 44).
THOMAS MANOR, EXAMINING ATTORNEY

SN 85-599,399. K & Y CORPORATION, LACEY, WA. FILED 4-16-2012.

SIMS

THE MARK CONSISTS OF STANDARD CHARACTERS WITHOUT CLAIM TO ANY PARTICULAR FONT, STYLE, SIZE, OR COLOR.

FOR MEDICAL APPARATUS FOR ADMINISTERING FLUIDS (U.S. CLS. 26, 39 AND 44).
AMY HELLA, EXAMINING ATTORNEY

CLASS 10—(Continued).

SN 85-599,512. AERIE PHARMACEUTICALS, INC., RESEARCH TRIANGLE PARK, NC. FILED 4-17-2012.

EYE-D

THE MARK CONSISTS OF STANDARD CHARACTERS WITHOUT CLAIM TO ANY PARTICULAR FONT, STYLE, SIZE, OR COLOR.

FOR OCULAR IMPLANT PROVIDING SUSTAINED RELEASE OF THERAPEUTIC AGENTS (U.S. CLS. 26, 39 AND 44).

DAVID YONTEF, EXAMINING ATTORNEY

SN 85-599,865. VM POSITIONING, INC, SAN ANTONIO, TX. FILED 4-17-2012.

The NOTCH

THE MARK CONSISTS OF STANDARD CHARACTERS WITHOUT CLAIM TO ANY PARTICULAR FONT, STYLE, SIZE, OR COLOR.

FOR FOAM POSITIONING PADS FOR MEDICAL AND PHYSICAL THERAPY USE (U.S. CLS. 26, 39 AND 44).

FIRST USE 8-4-2011; IN COMMERCE 3-6-2012.

CIMMERIAN COLEMAN, EXAMINING ATTORNEY

SN 85-602,475. MOLDEX-METRIC, INC., CULVER CITY, CA. FILED 4-19-2012.

GLIDE

THE MARK CONSISTS OF STANDARD CHARACTERS WITHOUT CLAIM TO ANY PARTICULAR FONT, STYLE, SIZE, OR COLOR.

FOR EAR PLUGS FOR NOISE REDUCTION (U.S. CLS. 26, 39 AND 44).

TEJBIR SINGH, EXAMINING ATTORNEY

CLASS 10—(Continued).

SN 85-602,599. MIRIAM B. MULLEN, ST. PETERSBURG, FL. FILED 4-19-2012.

Nutri-Soothe

THE MARK CONSISTS OF STANDARD CHARACTERS WITHOUT CLAIM TO ANY PARTICULAR FONT, STYLE, SIZE, OR COLOR.

FOR NIPPLES FOR BABY BOTTLES (U.S. CLS. 26, 39 AND 44).

FIRST USE 6-15-2011; IN COMMERCE 6-15-2011.

ANDREA K. NADELMAN, EXAMINING ATTORNEY

SN 85-602,861. CLINICAL INNOVATIONS, LLC, MURRAY, UT. FILED 4-19-2012.

C-SNORKEL

THE MARK CONSISTS OF STANDARD CHARACTERS WITHOUT CLAIM TO ANY PARTICULAR FONT, STYLE, SIZE, OR COLOR.

FOR DISPOSABLE MEDICAL APPARATUS, NAMELY, A VACUUM RELEASE FOR USE IN OBSTETRICS (U.S. CLS. 26, 39 AND 44).

FIRST USE 3-19-2012; IN COMMERCE 3-19-2012.

RONALD MCMORROW, EXAMINING ATTORNEY

SN 85-602,974. HAYS, GREGORY, ONSTED, MI. FILED 4-19-2012.

VITAL GLOVE

THE MARK CONSISTS OF STANDARD CHARACTERS WITHOUT CLAIM TO ANY PARTICULAR FONT, STYLE, SIZE, OR COLOR.

NO CLAIM IS MADE TO THE EXCLUSIVE RIGHT TO USE "GLOVE", APART FROM THE MARK AS SHOWN.

FOR GLOVES FOR MEDICAL PURPOSES; GLOVES FOR MEDICAL USE; GLOVES FOR USE IN HOSPITALS; MEDICAL DEVICES FOR MONITORING OXYMETORY, GAS ANALYSIS, VITAL SIGNS, BLOOD PROPERTIES AND RESPIRATORY EVENTS; MEDICAL DEVICES FOR MONITORING VITAL SIGNS, BLOOD PROPERTIES AND RESPIRATORY EVENTS; MEDICAL EXAMINATION GLOVES; MEDICAL GLOVES; PULSE RATE MONITORS; RESPIRATION MONITORS (U.S. CLS. 26, 39 AND 44).

JESSICA A. POWERS, EXAMINING ATTORNEY

CLASS 10—(Continued).

SN 85-603,036. RETROVASCULAR, INC., PLEASANTON, CA. FILED 4-19-2012.

CARTA

THE MARK CONSISTS OF STANDARD CHARACTERS WITHOUT CLAIM TO ANY PARTICULAR FONT, STYLE, SIZE, OR COLOR.

FOR CATHETERS; CATHETERS AND PARTS AND FITTINGS THEREFOR; INTRACARDIAC CATHETER; MEDICAL AND SURGICAL CATHETERS; MEDICAL APPARATUS AND INSTRUMENTS FOR TREATING CARDIOVASCULAR DISEASE; MEDICAL APPARATUS, NAMELY, MARKING PENS FOR USE IN SURGICAL PROCEDURES; MEDICAL DEVICE FOR ACCESSING SUBCUTANEOUS STRUCTURES OF THE HUMAN BODY FOR THE PURPOSE OF ADMINISTERING MEDICAL TREATMENT; MEDICAL DEVICE FOR PERCUTANEOUS INTRALUMINAL EMPLACEMENT OF CORONARY BYPASS GRAFTS; MEDICAL DEVICES AND APPARATUS, NAMELY, MEDICAL GUIDEWIRES AND PARTS AND FITTINGS THEREFOR; MEDICAL DEVICES TO TREAT INTRAVASCULAR SITES; MEDICAL DEVICES, NAMELY, SURGICAL DEVICES THAT FACILITATE THE IDENTIFICATION, SEPARATION OR ABLATION OF BIOLOGIC TISSUES; MEDICAL ELECTRODES; MEDICAL GUIDEWIRES; MEDICAL GUIDEWIRES AND PARTS AND FITTINGS THEREFOR (U.S. CLS. 26, 39 AND 44).

GIANCARLO CASTRO, EXAMINING ATTORNEY

SN 85-603,271. INFINITUDE CLOTHING, SCOTTSDALE, AZ. FILED 4-19-2012.

Infinitude Clothing

THE MARK CONSISTS OF STANDARD CHARACTERS WITHOUT CLAIM TO ANY PARTICULAR FONT, STYLE, SIZE, OR COLOR.

NO CLAIM IS MADE TO THE EXCLUSIVE RIGHT TO USE "CLOTHING", APART FROM THE MARK AS SHOWN. FOR MEDICAL WEARING APPAREL, NAMELY, SCRUB PANTS; MEDICAL WEARING APPAREL, NAMELY, SCRUB TOPS (U.S. CLS. 26, 39 AND 44).

ROBERT STRUCK, EXAMINING ATTORNEY

CLASS 10—(Continued).

SN 85-603,557. TACTICAL MEDICAL SOLUTIONS, INC., ANDERSON, SC. FILED 4-20-2012.

TEVAH

THE MARK CONSISTS OF STANDARD CHARACTERS WITHOUT CLAIM TO ANY PARTICULAR FONT, STYLE, SIZE, OR COLOR.

FOR PATIENT LITTERS IN THE NATURE OF STRETCHERS (U.S. CLS. 26, 39 AND 44).

ODESSA BIBBINS, EXAMINING ATTORNEY

SN 85-604,599. MATWAVE TECHNOLOGIES INC., FARMERS BRANCH, TX. FILED 4-21-2012.



Matwave

THE MARK CONSISTS OF THE WORD "MATWAVE" WITH 2 STYLIZED LETTERS "M" AND "W" CROSSINGLY FIT INTO EACH OTHER ABOVE THE WORD.

FOR DENTAL INSTRUMENTS, NAMELY, ORAL IRRIGATORS (U.S. CLS. 26, 39 AND 44).

FIRST USE 0-0-2011; IN COMMERCE 0-0-2011.

NICHOLAS COLEMAN, EXAMINING ATTORNEY

SN 85-605,724. ORTHO DEVELOPMENT CORPORATION, DRAPER, UT. FILED 4-23-2012.

MODE

THE MARK CONSISTS OF STANDARD CHARACTERS WITHOUT CLAIM TO ANY PARTICULAR FONT, STYLE, SIZE, OR COLOR.

FOR ORTHOPEDIC IMPLANTS, NAMELY RECONSTRUCTION PROSTHESES, RADIUS PROSTHESES, FIBULA PROSTHESES, TIBIA PROSTHESES, STRAIGHT PLATES AND SCREWS TO REPAIR FRACTURES (U.S. CLS. 26, 39 AND 44).

FIRST USE 12-21-2011; IN COMMERCE 12-21-2011.

RICHARD WHITE, EXAMINING ATTORNEY

CLASS 10—(Continued).

SN 85-607,135. RASSMAN, JANET, STUDIO CITY, CA.
FILED 4-24-2012.

Medicomb

THE MARK CONSISTS OF STANDARD CHARACTERS WITHOUT CLAIM TO ANY PARTICULAR FONT, STYLE, SIZE, OR COLOR.

FOR MEDICAL APPARATUS FOR INTRODUCING PHARMACEUTICAL PREPARATIONS INTO THE HUMAN BODY (U.S. CLS. 26, 39 AND 44).

DORITT L. CARROLL, EXAMINING ATTORNEY

SN 85-607,141. RASSMAN, JANET, STUDIO CITY, CA.
FILED 4-24-2012.

Minoxicomb

THE MARK CONSISTS OF STANDARD CHARACTERS WITHOUT CLAIM TO ANY PARTICULAR FONT, STYLE, SIZE, OR COLOR.

FOR MEDICAL APPARATUS FOR INTRODUCING PHARMACEUTICAL PREPARATIONS INTO THE HUMAN BODY (U.S. CLS. 26, 39 AND 44).

DORITT L. CARROLL, EXAMINING ATTORNEY

SN 85-612,064. TARGET BRANDS, INC., MINNEAPOLIS,
MN. FILED 4-30-2012.



OWNER OF U.S. REG. NOS. 3,765,423, 4,029,541 AND OTHERS.

THE MARK CONSISTS OF AN ARROW DESIGN POINTING AT A 45 DEGREE DIAGONAL, UP AND TO THE RIGHT, WITH THE WORDS UP & UP INSIDE THE ARROW.

FOR DEVICES FOR MONITORING BLOOD GLUCOSE FOR MEDICAL PURPOSES; PILL OR TABLET CUTTERS; ORTHOTIC INSERTS FOR FOOTWEAR (U.S. CLS. 26, 39 AND 44).

FIRST USE 0-0-2009; IN COMMERCE 0-0-2009.
JEAN IM, EXAMINING ATTORNEY

CLASS 10—(Continued).

SN 85-612,191. TARGET BRANDS, INC., MINNEAPOLIS,
MN. FILED 4-30-2012.

UP & UP

THE MARK CONSISTS OF STANDARD CHARACTERS WITHOUT CLAIM TO ANY PARTICULAR FONT, STYLE, SIZE, OR COLOR.

OWNER OF U.S. REG. NOS. 3,765,423, 4,029,541 AND OTHERS.

FOR DEVICES FOR MONITORING BLOOD GLUCOSE FOR MEDICAL PURPOSES; PILL OR TABLET CUTTERS; ORTHOTIC INSERTS FOR FOOTWEAR (U.S. CLS. 26, 39 AND 44).

FIRST USE 0-0-2009; IN COMMERCE 0-0-2009.
JEAN IM, EXAMINING ATTORNEY

SN 85-627,165. SALVIN DENTAL SPECIALTIES, INC.,
CHARLOTTE, NC. FILED 5-16-2012.

SALVINOSS-COLLAGEN

THE MARK CONSISTS OF STANDARD CHARACTERS WITHOUT CLAIM TO ANY PARTICULAR FONT, STYLE, SIZE, OR COLOR.

NO CLAIM IS MADE TO THE EXCLUSIVE RIGHT TO USE "COLLAGEN", APART FROM THE MARK AS SHOWN.

FOR SYNTHETIC BONE GRAFTING MATERIAL EMBEDDED INTO A COLLAGEN MEMBRANE (U.S. CLS. 26, 39 AND 44).

MORGAN WYNNE, EXAMINING ATTORNEY

SN 85-632,799. BIO-REFERENCE LABORATORIES, INC.,
ELMWOOD PARK, NJ. FILED 5-23-2012.

GENSOFT

THE MARK CONSISTS OF STANDARD CHARACTERS WITHOUT CLAIM TO ANY PARTICULAR FONT, STYLE, SIZE, OR COLOR.

FOR CERVIX BRUSHES (U.S. CLS. 26, 39 AND 44).
KELLY TRUSILO, EXAMINING ATTORNEY

CLASS 10—(Continued).

SN 85-647,200. OPERATING ROOM SAFETY ENTERPRISES, LLC, AKA OR SAFETY, BERWYN, PA. FILED 6-8-2012.



NO CLAIM IS MADE TO THE EXCLUSIVE RIGHT TO USE "FLEX FRAME", APART FROM THE MARK AS SHOWN.

THE MARK CONSISTS OF AN ARCH CENTERED AND ABOVE THE WORDING "FLEXFRAME".

FOR RADIOLUCENT-CHEST SUPPORT FOR SUPPORTING A PATIENT IN A PRONE POSITION; PORTABLE-SURGICAL EQUIPMENT, NAMELY, A TORSO-SUPPORT DEVICE FOR SUPPORTING AND ADJUSTING THE POSITION OF A PATIENT DURING POSTIOR SURGERY (U.S. CLS. 26, 39 AND 44).

TAMARA FRAZIER, EXAMINING ATTORNEY

SN 85-667,866. OLYMPUS MEDICAL SYSTEMS CORP., TOKYO, JAPAN, FILED 7-3-2012.

OPTERA

THE MARK CONSISTS OF STANDARD CHARACTERS WITHOUT CLAIM TO ANY PARTICULAR FONT, STYLE, SIZE, OR COLOR.

FOR MEDICAL ENDOSCOPES; LIGHT SOURCES FOR MEDICAL ENDOSCOPES; VIDEO PROCESSORS FOR MEDICAL ENDOSCOPES (U.S. CLS. 26, 39 AND 44).

KERI CANTONE, EXAMINING ATTORNEY

SN 85-674,354. GLOBUS MEDICAL, INC, AUDUBON, PA. FILED 7-11-2012.

Xpedit

THE MARK CONSISTS OF STANDARD CHARACTERS WITHOUT CLAIM TO ANY PARTICULAR FONT, STYLE, SIZE, OR COLOR.

FOR IMPLANT MATERIAL FOR USE IN ORTHOPEDIC SURGERY COMPRISING SYNTHETIC MATERIALS (U.S. CLS. 26, 39 AND 44).

BRIAN CALLAGHAN, EXAMINING ATTORNEY

CLASS 10—(Continued).

SN 85-682,858. CONTOURMED, INC., LITTLE ROCK, AR. FILED 7-20-2012.

ContourMed

THE MARK CONSISTS OF STANDARD CHARACTERS WITHOUT CLAIM TO ANY PARTICULAR FONT, STYLE, SIZE, OR COLOR.

FOR BREAST PROSTHESES (U.S. CLS. 26, 39 AND 44). FIRST USE 9-1-1998; IN COMMERCE 9-1-1998.

KATHERINE M. DUBRAY, EXAMINING ATTORNEY

CLASS 11—ENVIRONMENTAL CONTROL APPARATUS

SN 78-532,507. SUNDANCE SPAS, INC., CHINO, CA. FILED 12-14-2004.

IMPERIAL SPAS

THE MARK CONSISTS OF STANDARD CHARACTERS WITHOUT CLAIM TO ANY PARTICULAR FONT, STYLE, SIZE, OR COLOR.

NO CLAIM IS MADE TO THE EXCLUSIVE RIGHT TO USE "SPAS", APART FROM THE MARK AS SHOWN.

FOR SPAS IN THE NATURE OF HEATED POOLS (U.S. CLS. 13, 21, 23, 31 AND 34).

FIRST USE 3-1-1997; IN COMMERCE 4-15-1997.

WARREN L. OLANDRIA, EXAMINING ATTORNEY

SN 79-104,526. ENGHARD,FLORIAN, SULZBACH, FED REP GERMANY, FILED 9-30-2011.

HAPPY NIGHT SET

THE MARK CONSISTS OF STANDARD CHARACTERS WITHOUT CLAIM TO ANY PARTICULAR FONT, STYLE, SIZE, OR COLOR.

PRIORITY DATE OF 4-5-2011 IS CLAIMED.

OWNER OF INTERNATIONAL REGISTRATION 1095673 DATED 9-30-2011, EXPIRES 9-30-2021.

NO CLAIM IS MADE TO THE EXCLUSIVE RIGHT TO USE "SET", APART FROM THE MARK AS SHOWN.

FOR ELECTRIC HEATING APPARATUS, NAMELY, WARMING APPARATUS FOR BABY BOTTLES (U.S. CLS. 13, 21, 23, 31 AND 34).

AISHA SALEM, EXAMINING ATTORNEY

CLASS 11—(Continued).

SN 79-106,044. XIAMEN PENGCHUANG TRADE CO., LTD., CHINA, FILED 11-16-2011.



OWNER OF INTERNATIONAL REGISTRATION 1098912 DATED 11-16-2011, EXPIRES 11-16-2021.

FOR LIGHT BULBS; ELECTRIC LIGHT BULBS; ELECTRIC LAMPS; LAMPS; LANTERNS FOR LIGHTING; LIGHTING APPARATUS, NAMELY, LIGHTING INSTALLATIONS; ELECTRIC CHINESE LANTERNS; LUMINOUS TUBES FOR LIGHTING; ELECTRIC LIGHTS FOR CHRISTMAS TREES; SEARCHLIGHTS (U.S. CLS. 13, 21, 23, 31 AND 34).

LESLIE RICHARDS, EXAMINING ATTORNEY

SN 79-108,656. BOE TECHNOLOGY GROUP CO., LTD., 100016 BEIJING, CHINA, FILED 11-10-2011.



PRIORITY DATE OF 8-19-2011 IS CLAIMED.

OWNER OF INTERNATIONAL REGISTRATION 1105448 DATED 11-10-2011, EXPIRES 11-10-2021.

OWNER OF U.S. REG. NOS. 3,226,977 AND 3,226,978.

THE MARK CONSISTS OF THE WORDING "BOE" IN STYLIZED LETTERING.

FOR LAMPS; INCANDESCENT BURNERS; LIGHT BULBS; LUMINOUS TUBES FOR LIGHTING; STAGE ELECTRIC OR LED LUMINAIRES; ELECTRIC DISCHARGE TUBES FOR LIGHTING; LIGHTING INSTALLATIONS FOR AIR VEHICLES; LIGHTING APPARATUS, NAMELY, LIGHTING INSTALLATIONS FOR AIRCRAFT; LIGHTING APPARATUS, NAMELY, LIGHTING INSTALLATIONS; ELECTRIC LAMPS; DAY-LIGHT FLUORESCENT LAMP TUBES; ELECTRIC POCKET TORCHES FOR LIGHTING; CEILING LIGHTS; LABORATORY LIGHTS; ULTRAVIOLET RAY LAMPS, NOT FOR MEDICAL PURPOSES; SAFETY LAMPS; FAIRY LIGHTS FOR FESTIVE DECORATION; MINERS' LAMPS; LUMINOUS DOORPLATE SIGNS; SEARCHLIGHTS; ELECTRIC TORCHES FOR LIGHTING; STREET LAMPS; AQUARIUM LIGHTS; DIVING LIGHTS; LIGHTS FOR VEHICLES; LIGHTING APPARATUS FOR VEHICLES; SOLAR COLLECTORS FOR HEATING; LED (LIGHT EMITTING DIODE) LAMPS; LED (LIGHT EMITTING DIODE) LIGHT BULBS; LED (LIGHT EMITTING DIODE) ILLUMINATING LAMPS; LED (LIGHT EMITTING DIODE) LIGHTING FIXTURES; LED (LIGHT EMITTING DIODE) LIGHTING APPARATUS, NAMELY, LIGHTING INSTALLATIONS; OLED (ORGANIC LIGHT-EMITTING DIODE) LAMPS; OLED (ORGANIC LIGHT-EMITTING DIODE) LIGHT BULBS; OLED (ORGANIC LIGHT-EMITTING DIODE) ILLUMINATING LAMPS; OLED (ORGANIC LIGHT-EMITTING DIODE) LIGHTING FIXTURES; OLED (LIGHT EMITTING DIODE) LIGHTING APPARATUS, NAMELY, LIGHTING INSTALLATIONS; ILLUMINATING LAMPS; ELECTRIC AND LED ILLUMINATORS; PLANAR COLD CATHODE FLUORESCENT LAMPS (U.S. CLS. 13, 21, 23, 31 AND 34).

AMY C. KEAN, EXAMINING ATTORNEY

CLASS 11—(Continued).

SN 85-291,288. TACO, INC., CRANSTON, RI. FILED 4-11-2011.



THE MARK CONSISTS OF STANDARD CHARACTERS WITHOUT CLAIM TO ANY PARTICULAR FONT, STYLE, SIZE, OR COLOR.

NO CLAIM IS MADE TO THE EXCLUSIVE RIGHT TO USE "BARRIER", APART FROM THE MARK AS SHOWN.

FOR FILTERS FOR FLUIDS; FOR USE IN CIRCULATION PUMPS (U.S. CLS. 13, 21, 23, 31 AND 34).

TIMOTHY FINNEGAN, EXAMINING ATTORNEY

SN 85-413,467. WANGS ALLIANCE, DBA WAC LIGHTING, GARDEN CITY, NY. FILED 9-1-2011.



THE MARK CONSISTS OF STANDARD CHARACTERS WITHOUT CLAIM TO ANY PARTICULAR FONT, STYLE, SIZE, OR COLOR.

THE ENGLISH TRANSLATION OF "GAIA" IN THE MARK IS "EARTH".

FOR ELECTRIC LIGHTING FIXTURES; LED (LIGHT EMITTING DIODE) LIGHTING FIXTURES; LED (LIGHT EMITTING DIODES) LIGHTING FIXTURES FOR USE IN DISPLAY, COMMERCIAL, INDUSTRIAL, RESIDENTIAL, AND ARCHITECTURAL ACCENT LIGHTING APPLICATIONS; LIGHTING FIXTURES (U.S. CLS. 13, 21, 23, 31 AND 34).

DAVID TAYLOR, EXAMINING ATTORNEY

SN 85-420,214. HYDRO-LOGIC PURIFICATION SYSTEMS, INC., SANTA CRUZ, CA. FILED 9-12-2011.



THE MARK CONSISTS OF STANDARD CHARACTERS WITHOUT CLAIM TO ANY PARTICULAR FONT, STYLE, SIZE, OR COLOR.

FOR WATER FILTERING, PURIFICATION AND CONDITIONING DEVICES, FOR RESIDENTIAL AND LIGHT COMMERCIAL USE (U.S. CLS. 13, 21, 23, 31 AND 34).

LESLIE RICHARDS, EXAMINING ATTORNEY

CLASS 11—(Continued).

SN 85-422,027. OH BIO-FILTER, LLC, EDGEWOOD, NM. FILED 9-14-2011.



ODORHOG

THE COLOR(S) GRAY, RED, YELLOW, WHITE, GREEN AND BLACK IS/ARE CLAIMED AS A FEATURE OF THE MARK.

THE MARK CONSISTS OF THE WORDS "ODORHOG", "ODOR" AND "HOG" WHEREIN THE WORD "ODORHOG" IS WRITTEN IN BLACK COLOR BELOW THE IMAGE OF FACE OF A PIG IN RED COLOR AND OUTLINED IN BLACK, WITH EYE COLORED IN YELLOW, BLACK AND WHITE AND EAR COLORED IN YELLOW AND RED AND OUTLINED IN BLACK, WITH WHITE TEETH OUTLINED IN BLACK, WITH A RED TONGUE, AND THE WORD "ODOR" IS ARISING OUT OF ITS MOUTH IN GRAY AND YELLOW COLOR DEPICTING BAD ODOR WAVES AROUND IT IN GREEN COLOR AND THE WORD "HOG" WRITTEN IN BLACK COLOR OVER THE YELLOW AND BLACK COLLAR OF THE PIG AS SHOWN IN THE MARK, ALL OUTLINED IN BLACK.

FOR FILTERING UNITS, NAMELY, FILTER UNITS MADE PRIMARILY OF ACTIVATED CARBON USED FOR THE PURPOSE OF REMOVING ODOR FROM PLUMBING VENT PIPES; AIR FILTERS FOR DOMESTIC AND INDUSTRIAL USE (U.S. CLS. 13, 21, 23, 31 AND 34).

SCOTT BIBB, EXAMINING ATTORNEY

SN 85-436,378. LG ELECTRONICS INC., SEOUL 150-721, REPUBLIC OF KOREA, FILED 9-30-2011.

Moist Balance Crisper

THE MARK CONSISTS OF STANDARD CHARACTERS WITHOUT CLAIM TO ANY PARTICULAR FONT, STYLE, SIZE, OR COLOR.

PRIORITY CLAIMED UNDER SEC. 44(D) ON REPUBLIC OF KOREA APPLICATION NO. 40-2011-0046, FILED 8-26-2011.

OWNER OF ERPN CMNTY TM OFC REG. NO. 010308245, DATED 3-6-2012, EXPIRES 3-6-2022.

NO CLAIM IS MADE TO THE EXCLUSIVE RIGHT TO USE "CRISPER", APART FROM THE MARK AS SHOWN.

FOR ELECTRIC REFRIGERATORS FOR HOUSEHOLD PURPOSES; WINE COOLERS FOR HOUSEHOLD PURPOSES, NAMELY, REFRIGERATED CABINETS CONTAINING RACKS FOR WINE BOTTLES AND STORAGE SHELVES; ELECTRIC FREEZERS (U.S. CLS. 13, 21, 23, 31 AND 34).

CHRISTOPHER LAW, EXAMINING ATTORNEY

CLASS 11—(Continued).

SN 85-439,271. ARROWHEAD BRASS & PLUMBING, LLC, LOS ANGELES, CA. FILED 10-4-2011.

QuickTurn

THE MARK CONSISTS OF STANDARD CHARACTERS WITHOUT CLAIM TO ANY PARTICULAR FONT, STYLE, SIZE, OR COLOR.

FOR PLUMBING FITTINGS, NAMELY, VALVES (U.S. CLS. 13, 21, 23, 31 AND 34).

FIRST USE 11-30-2011; IN COMMERCE 11-30-2011.

ANDREA BUTLER, EXAMINING ATTORNEY

SN 85-441,556. BRIGHTWAVE DESIGN GROUP, LLC, CITY OF INDUSTRY, CA. FILED 10-7-2011.

BRIGHTWAVE DESIGN GROUP

THE MARK CONSISTS OF STANDARD CHARACTERS WITHOUT CLAIM TO ANY PARTICULAR FONT, STYLE, SIZE, OR COLOR.

NO CLAIM IS MADE TO THE EXCLUSIVE RIGHT TO USE "DESIGN GROUP", APART FROM THE MARK AS SHOWN.

FOR ELECTRICALLY-POWERED LIGHTING FIXTURES USING LIGHT-EMITTING DIODES (U.S. CLS. 13, 21, 23, 31 AND 34).

KATHY DE JONGE, EXAMINING ATTORNEY

SN 85-453,536. AMAX LIGHTING, INC., SANTA FE SPRINGS, CA. FILED 10-21-2011.

UVF861

THE MARK CONSISTS OF STANDARD CHARACTERS WITHOUT CLAIM TO ANY PARTICULAR FONT, STYLE, SIZE, OR COLOR.

FOR LIGHTING FIXTURES, LIGHT BULBS, AND INTERNAL LIGHTING IN THE NATURE OF LIGHTING TRACKS AND LIGHTING TUBES (U.S. CLS. 13, 21, 23, 31 AND 34).

FIRST USE 3-20-2008; IN COMMERCE 3-20-2008.

NELSON SNYDER, EXAMINING ATTORNEY

CLASS 11—(Continued).

SN 85-455,552. RATIONAL AG, 86899 LANDSBERG/LECH, FED REP GERMANY, FILED 10-25-2011.

HDC

THE MARK CONSISTS OF STANDARD CHARACTERS WITHOUT CLAIM TO ANY PARTICULAR FONT, STYLE, SIZE, OR COLOR.

PRIORITY CLAIMED UNDER SEC. 44(D) ON FED REP GERMANY APPLICATION NO. 302011047864, FILED 8-31-2011, REG. NO. 302011047864, DATED 9-14-2011, EXPIRES 8-31-2021.

FOR COOKING AND STEAM GENERATING APPARATUS FOR THE TREATMENT AND PREPARATION OF FOOD IN COMMERCIAL KITCHENS, NAMELY, ELECTRIC FOOD COOKERS, ELECTRIC FOOD STEAMERS, AND COOKING OVENS, ALL FOR COMMERCIAL USE AND SOLD AS A UNIT; GAS FOOD COOKERS, GAS FOOD STEAMERS, AND COOKING OVENS, ALL FOR COMMERCIAL USE AND SOLD AS A UNIT; AND STRUCTURAL PARTS THEREFOR (U.S. CLS. 13, 21, 23, 31 AND 34).

BARBARA A. GOLD, EXAMINING ATTORNEY

SN 85-455,621. RATIONAL AG, 86899 LANDSBERG/LECH, FED REP GERMANY, FILED 10-25-2011.



PRIORITY CLAIMED UNDER SEC. 44(D) ON FED REP GERMANY APPLICATION NO. 302011047867, FILED 8-31-2011, REG. NO. 302011047867, DATED 9-14-2011, EXPIRES 8-31-2021.

THE COLOR(S) GRAY, LIGHT BLUE, DARK BLUE, LIGHT RED AND DARK RED IS/ARE CLAIMED AS A FEATURE OF THE MARK.

THE MARK CONSISTS OF THE LETTERS "HDC" IN STYLIZED FORM WITH THE UPPER HALF OF THE "H" AND "C" APPEARING IN LIGHT BLUE AND THE BOTTOM HALF IN DARK BLUE, AND THE TOP HALF OF THE LETTER "D" APPEARING IN LIGHT RED AND THE BOTTOM HALF APPEARING IN DARK RED, ABOVE THE UNITARY TERM, "HIDENSITYCONTROL", IN GRAY.

FOR COOKING AND STEAM GENERATING APPARATUS FOR THE TREATMENT AND PREPARATION OF FOOD IN COMMERCIAL KITCHENS, NAMELY, ELECTRIC FOOD COOKERS, ELECTRIC FOOD STEAMERS, AND COOKING OVENS, ALL FOR COMMERCIAL USE AND SOLD AS A UNIT; GAS FOOD COOKERS, GAS FOOD STEAMERS, AND COOKING OVENS, ALL FOR COMMERCIAL USE AND SOLD AS A UNIT; AND STRUCTURAL PARTS THEREFOR (U.S. CLS. 13, 21, 23, 31 AND 34).

BARBARA A. GOLD, EXAMINING ATTORNEY

CLASS 11—(Continued).

SN 85-461,224. FEDERAL-MOGUL PRODUCTS, INC., SOUTHFIELD, MI. FILED 11-1-2011.

NOVALENS

THE MARK CONSISTS OF STANDARD CHARACTERS WITHOUT CLAIM TO ANY PARTICULAR FONT, STYLE, SIZE, OR COLOR.

FOR LIGHTS FOR VEHICLES; LIGHTS FOR RAIL, AEROSPACE, AND MARINE VEHICLES; READING LAMPS; OFFICE LAMPS (U.S. CLS. 13, 21, 23, 31 AND 34).

KATHLEEN M. VANSTON, EXAMINING ATTORNEY

SN 85-468,547. SIEMENS INDUSTRY, INC., ALPHARETTA, GA. FILED 11-9-2011.

CLEARLOGX

THE MARK CONSISTS OF STANDARD CHARACTERS WITHOUT CLAIM TO ANY PARTICULAR FONT, STYLE, SIZE, OR COLOR.

FOR WATER TREATMENT AND PURIFICATION EQUIPMENT, NAMELY, CHEMICAL FEED UNITS FOR TREATING AND PURIFYING DRINKING WATER (U.S. CLS. 13, 21, 23, 31 AND 34).

JEFFERY COWARD, EXAMINING ATTORNEY

SN 85-475,372. CORONA CORPORATION, SANJO, NIIGATA, JAPAN, FILED 11-17-2011.

CORONA

THE MARK CONSISTS OF STANDARD CHARACTERS WITHOUT CLAIM TO ANY PARTICULAR FONT, STYLE, SIZE, OR COLOR.

OWNER OF JAPAN REG. NO. 2313586, DATED 6-28-1991, EXPIRES 6-28-2021.

OWNER OF U.S. REG. NOS. 1,177,969 AND 1,177,970. FOR OIL STOVES (U.S. CLS. 13, 21, 23, 31 AND 34).

WENDY JUN, EXAMINING ATTORNEY

CLASS 11—(Continued).

SN 85-507,020. FERGUSON ENTERPRISES, INC., NEWPORT NEWS, VA. FILED 1-1-2012.

NICOSIA

THE MARK CONSISTS OF STANDARD CHARACTERS WITHOUT CLAIM TO ANY PARTICULAR FONT, STYLE, SIZE, OR COLOR.

FOR PLUMBING FIXTURES, NAMELY, BATH TUB JETS, WHIRLPOOL BATHS, BATH INSTALLATIONS; FAUCET SPRAYERS; BIDETS; DRAIN STRUCTURES FOR USE IN SPAS, STEAM ROOMS AND BATHS; SITZ BATHS; SPOUTS FOR AFFIXING ON WALLS FOR BATHS, BASINS, BIDETS; SHOWERS, SHOWER HEADS, HAND HELD SHOWER HEADS, HAND SHOWERS, HAND HELD SHOWERS, SHOWER SPRAYERS, SHOWER HEAD SPRAYERS, SHOWER MIXERS, SHOWER AND BATH CUBICLES, SHOWER BASES, SHOWER CONTROL FITTINGS, NAMELY, ESCUTCHEONS, SHOWER DOORS, SHOWER ENCLOSURES, SHOWER FAUCET EXTENSIONS, SHOWER PANELS, SHOWER SURROUNDS, SHOWER TRAYS, SHOWER TUBS; ELECTRIC TOWEL WARMERS, INDOOR ELECTRIC LIGHTING FIXTURES AND CEILING FANS AND STAINLESS STEEL SINK BOTTOM GRIDS SPECIALLY ADAPTED AND SHAPED FOR USE IN SINKS (U.S. CLS. 13, 21, 23, 31 AND 34).

ASMAT KHAN, EXAMINING ATTORNEY

SN 85-516,261. PHOENIX MOBILE AIR, INC., CARROLLTON, TX. FILED 1-13-2012.



NO CLAIM IS MADE TO THE EXCLUSIVE RIGHT TO USE "MOBILE AIR", APART FROM THE MARK AS SHOWN.

THE COLOR(S) BLUE AND BLACK IS/ARE CLAIMED AS A FEATURE OF THE MARK.

THE MARK CONSISTS OF THE STYLIZED WORDS "PHOENIX MOBILE AIR" IN BLACK APPEARING ABOVE THE ARTISTIC RENDERING OF A PHOENIX IN BLUE AND BLACK.

FOR AUTOMOTIVE AIR CONDITIONERS; AUTOMOTIVE AIR CONDITIONER PARTS, NAMELY, BLOWER ASSEMBLIES, BLOWER MOTORS, CABIN AIR FILTERS, CONDENSERS, CONDENSER FANS, EVAPORATORS, EXPANSION DEVICES, FITTINGS, HEATER CONTROL VALVES, HOSES, HOSE ASSEMBLIES, IDLER ASSEMBLIES, ACCUMULATORS AND DRIERS, AND VACUUM CONTROL VALVES (U.S. CLS. 13, 21, 23, 31 AND 34).

FIRST USE 0-0-2010; IN COMMERCE 0-0-2010.
TINA L. SNAPP, EXAMINING ATTORNEY

CLASS 11—(Continued).

SN 85-535,772. THE ICE BOX COMPANY, INC., SUNSET BEACH, NC. FILED 2-7-2012.

E-Z ICE BAGGER

THE MARK CONSISTS OF STANDARD CHARACTERS WITHOUT CLAIM TO ANY PARTICULAR FONT, STYLE, SIZE, OR COLOR.

NO CLAIM IS MADE TO THE EXCLUSIVE RIGHT TO USE "ICE BAGGER", APART FROM THE MARK AS SHOWN.

FOR ICE MACHINE AND APPARATUS (U.S. CLS. 13, 21, 23, 31 AND 34).

FIRST USE 4-26-1986; IN COMMERCE 4-26-1986.

JULIE VEPPUMTHARA, EXAMINING ATTORNEY

SN 85-576,939. PENTAIR FILTRATION SOLUTIONS, LLC, BROOKFIELD, WI. FILED 3-22-2012.

ENDURANCE

THE MARK CONSISTS OF STANDARD CHARACTERS WITHOUT CLAIM TO ANY PARTICULAR FONT, STYLE, SIZE, OR COLOR.

FOR WATER FILTRATION AND PURIFICATION APPARATUS FOR USE IN COMMERCIAL AND FOOD SERVICE OPERATIONS (U.S. CLS. 13, 21, 23, 31 AND 34).
PRISCILLA MILTON, EXAMINING ATTORNEY

SN 85-581,726. MULTIRAD THERMAL-SYS (WUHAN) CO., LTD, WUHAN, HUBEI PROVINCE, CHINA, FILED 3-28-2012.



THE MARK CONSISTS OF WAVE DEVICE WITH STYLIZED WORD "MULTI-RAD" ON THE BOTTOM.

THE WORDING "MULTI-RAD" HAS NO MEANING IN A FOREIGN LANGUAGE.

FOR AIR CONDITIONING INSTALLATIONS; CENTRAL HEATING RADIATORS; FIREPLACE INSERTS, NAMELY, HEAT EXCHANGERS; GAS CONDENSERS, OTHER THAN PARTS OF MACHINES; HEAT EXCHANGERS; HEAT EXCHANGERS NOT BEING PARTS OF MACHINES; RADIATORS; STEAM RADIATORS FOR HEATING BUILDINGS; ULTRA-VIOLET RADIATORS NOT FOR MOTORS AND ENGINES (U.S. CLS. 13, 21, 23, 31 AND 34).

FIRST USE 12-23-2011; IN COMMERCE 12-23-2011.
TEJBIR SINGH, EXAMINING ATTORNEY

CLASS 11—(Continued).

SN 85-583,110. INGENUITY, LLC, WATERLOO, IA. FILED 3-29-2012.

Reflect Rock

THE MARK CONSISTS OF STANDARD CHARACTERS WITHOUT CLAIM TO ANY PARTICULAR FONT, STYLE, SIZE, OR COLOR.

NO CLAIM IS MADE TO THE EXCLUSIVE RIGHT TO USE "ROCK", APART FROM THE MARK AS SHOWN.

FOR RADIANT HEAT TRANSFER PLATE THAT PREVENTS THE RADIANT HEAT TRANSFER IN STRUCTURAL BUILDING ASSEMBLIES (U.S. CLS. 13, 21, 23, 31 AND 34).

FIRST USE 4-1-2011; IN COMMERCE 4-1-2011.
INGA ERVIN, EXAMINING ATTORNEY

CLASS 11—(Continued).

SN 85-587,218. SOUVENIRWINE.COM, INC., SOUTH SAN FRANCISCO, CA. FILED 4-3-2012.

WineSafe

THE MARK CONSISTS OF STANDARD CHARACTERS WITHOUT CLAIM TO ANY PARTICULAR FONT, STYLE, SIZE, OR COLOR.

FOR SECURE AND TEMPERATURE CONTROLLED PACKAGING MATERIALS FOR SHIPPING WINE, NAMELY, FREEZERS AND SHIPPING CONTAINERS (U.S. CLS. 13, 21, 23, 31 AND 34).

ZACHARY BELLO, EXAMINING ATTORNEY

SN 85-583,127. INGENUITY, LLC, WATERLOO, IA. FILED 3-29-2012.

Attic Reflect

THE MARK CONSISTS OF STANDARD CHARACTERS WITHOUT CLAIM TO ANY PARTICULAR FONT, STYLE, SIZE, OR COLOR.

NO CLAIM IS MADE TO THE EXCLUSIVE RIGHT TO USE "ATTIC", APART FROM THE MARK AS SHOWN.

FOR RADIANT HEAT TRANSFER PLATE THAT PREVENTS THE RADIANT HEAT TRANSFER IN STRUCTURAL BUILDING ASSEMBLIES (U.S. CLS. 13, 21, 23, 31 AND 34).

FIRST USE 7-1-2011; IN COMMERCE 7-1-2011.
INGA ERVIN, EXAMINING ATTORNEY

SN 85-593,156. V-TECH ENGINEERING, INC., BLUFFTON, IN. FILED 4-10-2012.

VENO

THE MARK CONSISTS OF STANDARD CHARACTERS WITHOUT CLAIM TO ANY PARTICULAR FONT, STYLE, SIZE, OR COLOR.

FOR INDUSTRIAL OVENS AND DRYERS USED FOR BAKING, HEATING, DRYING AND/OR CURING (U.S. CLS. 13, 21, 23, 31 AND 34).

JEFF DEFORD, EXAMINING ATTORNEY

SN 85-587,116. G-MAR INCORPORATED, MUNDELEIN, IL. FILED 4-2-2012.

CYCLES AVER

THE MARK CONSISTS OF STANDARD CHARACTERS WITHOUT CLAIM TO ANY PARTICULAR FONT, STYLE, SIZE, OR COLOR.

FOR REFRIGERATION EQUIPMENT NAMELY, AN AUTOMATIC TEMPERATURE REGULATOR THAT SAVES ELECTRICITY AND REDUCES DEMAND CYCLES OF THE REFRIGERATION COMPRESSORS AND FANS (U.S. CLS. 13, 21, 23, 31 AND 34).

FIRST USE 1-1-2012; IN COMMERCE 1-1-2012.
ANTHONY RINKER, EXAMINING ATTORNEY

SN 85-593,206. GARDEN GREEN ECOSOLUTIONS, LLC, MOUNT PROSPECT, IL. FILED 4-10-2012.

TURBO RAIN

THE MARK CONSISTS OF STANDARD CHARACTERS WITHOUT CLAIM TO ANY PARTICULAR FONT, STYLE, SIZE, OR COLOR.

FOR AGRICULTURAL IRRIGATION UNIT (U.S. CLS. 13, 21, 23, 31 AND 34).

FIRST USE 4-4-2011; IN COMMERCE 4-4-2011.
MIDGE BUTLER, EXAMINING ATTORNEY

CLASS 11—(Continued).

SN 85-593,219. MEDWASTE HOLDINGS, L.C., LONGVIEW, TX. FILED 4-10-2012.

Accelewaste

THE MARK CONSISTS OF STANDARD CHARACTERS WITHOUT CLAIM TO ANY PARTICULAR FONT, STYLE, SIZE, OR COLOR.

FOR WASTE PROCESSING MACHINES FOR THE CLEANING AND PURIFICATION OF BIO-HAZARDOUS FLUIDS IN HOSPITALS, SURGERY CENTERS, AND BLOOD BANKS (U.S. CLS. 13, 21, 23, 31 AND 34).

FIRST USE 5-13-2008; IN COMMERCE 5-13-2008.
TIMOTHY O. SCHIMPF, EXAMINING ATTORNEY

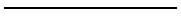

SN 85-596,445. BEMIS MANUFACTURING COMPANY, SHEBOYGAN FALLS, WI. FILED 4-12-2012.

**classic
colors**

NO CLAIM IS MADE TO THE EXCLUSIVE RIGHT TO USE "COLORS", APART FROM THE MARK AS SHOWN.

THE MARK CONSISTS OF A SWOOSH OVER THE WORD "CLASSIC" WHICH IS OVER THE WORD "COLORS".

FOR TOILET SEATS (U.S. CLS. 13, 21, 23, 31 AND 34).
JEAN IM, EXAMINING ATTORNEY



SN 85-597,325. RAB LIGHTING INC., NORTHVALE, NJ. FILED 4-13-2012.

LBEACON

THE MARK CONSISTS OF STANDARD CHARACTERS WITHOUT CLAIM TO ANY PARTICULAR FONT, STYLE, SIZE, OR COLOR.

OWNER OF U.S. REG. NOS. 3,920,752 AND 3,920,753.
FOR ELECTRIC LIGHTING FIXTURES; LED (LIGHT EMITTING DIODE) LIGHTING FIXTURES; LIGHTING FIXTURES (U.S. CLS. 13, 21, 23, 31 AND 34).
BARBARA BROWN, EXAMINING ATTORNEY

CLASS 11—(Continued).

SN 85-597,412. RAB LIGHTING INC., NORTHVALE, NJ. FILED 4-13-2012.

BAYLED

THE MARK CONSISTS OF STANDARD CHARACTERS WITHOUT CLAIM TO ANY PARTICULAR FONT, STYLE, SIZE, OR COLOR.

OWNER OF U.S. REG. NOS. 3,952,071 AND 4,045,983.
FOR ELECTRIC LIGHTING FIXTURES; LED (LIGHT EMITTING DIODE) LIGHTING FIXTURES; LIGHTING FIXTURES (U.S. CLS. 13, 21, 23, 31 AND 34).
BARBARA BROWN, EXAMINING ATTORNEY

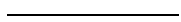

SN 85-598,033. MAPLE LIGHTING INC., MILLBRAE, CA. FILED 4-14-2012.

MARSLG

THE MARK CONSISTS OF STANDARD CHARACTERS WITHOUT CLAIM TO ANY PARTICULAR FONT, STYLE, SIZE, OR COLOR.

FOR LEDS (LIGHT EMITTING DIODES); LED LIGHTING FIXTURES; LED LIGHTS; LED LIGHT BULBS; LED LIGHTING SYSTEMS, NAMELY, LED MODULES, LED UNDERWATER LIGHTS; LED LANDSCAPE LIGHTS; LED LIGHTS FOR STRINGS, FLOWERS, BRANCHES AND OTHER ORNAMENTAL DECORATIONS; LED LUMINAIRES; LED PLANT GROW LIGHTS, LED LIGHT APPARATUS FOR USE IN DISPLAY, COMMERCIAL, INDUSTRIAL, RESIDENTIAL, AND ARCHITECTURAL ACCENT LIGHTING APPLICATIONS; FLEXIBLE LED STRIPS; RIGID LED STRIPS; UV ULTRA VIOLET LIGHTING FIXTURES AND BULBS (U.S. CLS. 13, 21, 23, 31 AND 34).
JORDAN BAKER, EXAMINING ATTORNEY

CLASS 11—(Continued).

SN 85-598,034. MAPLE LIGHTING INC., MILLBRAE, CA.
FILED 4-14-2012.

MAPLE LIGHTING

THE MARK CONSISTS OF STANDARD CHARACTERS WITHOUT CLAIM TO ANY PARTICULAR FONT, STYLE, SIZE, OR COLOR.

NO CLAIM IS MADE TO THE EXCLUSIVE RIGHT TO USE "LIGHTING", APART FROM THE MARK AS SHOWN. FOR LEDS (LIGHT EMITTING DIODES); LED LIGHTING FIXTURES; LED LIGHTS; LED LIGHT BULBS; LED LIGHTING SYSTEMS, NAMELY, LED MODULES, LED UNDERWATER LIGHTS; LED LANDSCAPE LIGHTS; LED LIGHTS FOR STRINGS, FLOWERS, BRANCHES AND OTHER ORNAMENTAL DECORATIONS; LED LUMINAIRES; LED PLANT GROW LIGHTS, LED LIGHT APPARATUS FOR USE IN DISPLAY, COMMERCIAL, INDUSTRIAL, RESIDENTIAL, AND ARCHITECTURAL ACCENT LIGHTING APPLICATIONS; FLEXIBLE LED STRIPS; RIGID LED STRIPS; UV ULTRA VIOLET LIGHTING FIXTURES AND BULBS (U.S. CLS. 13, 21, 23, 31 AND 34).

JORDAN BAKER, EXAMINING ATTORNEY

SN 85-598,134. CRAIG INDUSTRIES, INC., DBA U.S. COOLER, QUINCY, IL. FILED 4-14-2012.

Brew Cave

THE MARK CONSISTS OF STANDARD CHARACTERS WITHOUT CLAIM TO ANY PARTICULAR FONT, STYLE, SIZE, OR COLOR.

NO CLAIM IS MADE TO THE EXCLUSIVE RIGHT TO USE "BREW", APART FROM THE MARK AS SHOWN. FOR WALK-IN COOLERS (U.S. CLS. 13, 21, 23, 31 AND 34).

FIRST USE 2-8-2010; IN COMMERCE 2-8-2010.
NATALIE POLZER, EXAMINING ATTORNEY

SN 85-598,694. RAB LIGHTING INC., NORTHVALE, NJ.
FILED 4-16-2012.

LBOX

THE MARK CONSISTS OF STANDARD CHARACTERS WITHOUT CLAIM TO ANY PARTICULAR FONT, STYLE, SIZE, OR COLOR.

OWNER OF U.S. REG. NOS. 3,507,990, 3,920,753 AND OTHERS.

FOR LED DEMONSTRATION LIGHT FIXTURE (U.S. CLS. 13, 21, 23, 31 AND 34).

BARBARA BROWN, EXAMINING ATTORNEY

CLASS 11—(Continued).

SN 85-600,134. SHAT-R-SHIELD, INC., SALISBURY, NC.
FILED 4-17-2012.

ULTRA-SHIELD

THE MARK CONSISTS OF STANDARD CHARACTERS WITHOUT CLAIM TO ANY PARTICULAR FONT, STYLE, SIZE, OR COLOR.

FOR LED LIGHT BULBS AND LAMPS (U.S. CLS. 13, 21, 23, 31 AND 34).

VERNA BETH RIRIE, EXAMINING ATTORNEY

SN 85-600,177. SHAT-R-SHIELD, INC., SALISBURY, NC.
FILED 4-17-2012.

MULTI-SHIELD

THE MARK CONSISTS OF STANDARD CHARACTERS WITHOUT CLAIM TO ANY PARTICULAR FONT, STYLE, SIZE, OR COLOR.

FOR COMPACT FLUORESCENT LIGHT BULBS AND LAMPS (U.S. CLS. 13, 21, 23, 31 AND 34).

VERNA BETH RIRIE, EXAMINING ATTORNEY

SN 85-601,074. THE BIG GREEN EGG, INC., ATLANTA, GA.
FILED 4-18-2012.

PREPARE TO GET HUNGRY

THE MARK CONSISTS OF STANDARD CHARACTERS WITHOUT CLAIM TO ANY PARTICULAR FONT, STYLE, SIZE, OR COLOR.

FOR BARBECUE SMOKERS AND GRILLS (U.S. CLS. 13, 21, 23, 31 AND 34).

FIRST USE 3-0-2012; IN COMMERCE 3-0-2012.
BRENDAN REGAN, EXAMINING ATTORNEY

CLASS 11—(Continued).

SN 85-601,465. RAB LIGHTING INC., NORTHVALE, NJ. FILED 4-18-2012.

MDLED

THE MARK CONSISTS OF STANDARD CHARACTERS WITHOUT CLAIM TO ANY PARTICULAR FONT, STYLE, SIZE, OR COLOR.

FOR ELECTRIC LIGHTING FIXTURES; LED (LIGHT EMITTING DIODE) LIGHTING FIXTURES; LIGHTING FIXTURES (U.S. CLS. 13, 21, 23, 31 AND 34).

BARBARA BROWN, EXAMINING ATTORNEY

SN 85-602,366. VAPORPENZ LLC, FREMONT, CA. FILED 4-19-2012.

VaporPenz

THE MARK CONSISTS OF STANDARD CHARACTERS WITHOUT CLAIM TO ANY PARTICULAR FONT, STYLE, SIZE, OR COLOR.

FOR ELECTRICALLY POWERED HANDHELD VAPORIZERS FOR VAPORIZING VAPORIZABLE CONSTITUENTS OF HERBAL AND PLANT MATTER FOR CREATING AN AROMA (U.S. CLS. 13, 21, 23, 31 AND 34).

FIRST USE 10-1-2011; IN COMMERCE 12-1-2011.
JEFFREY LOOK, EXAMINING ATTORNEY

SN 85-602,556. JST PERFORMANCE, INC., DBA RIGID INDUSTRIES, MESA, AZ. FILED 4-19-2012.

DUALLY

THE MARK CONSISTS OF STANDARD CHARACTERS WITHOUT CLAIM TO ANY PARTICULAR FONT, STYLE, SIZE, OR COLOR.

FOR LIGHT BARS FOR VEHICLES, NAMELY, LAND BASED VEHICLES (U.S. CLS. 13, 21, 23, 31 AND 34).

FIRST USE 11-30-2009; IN COMMERCE 11-30-2009.
BRENDAN REGAN, EXAMINING ATTORNEY

CLASS 11—(Continued).

SN 85-602,560. JST PERFORMANCE, INC., DBA RIGID INDUSTRIES, MESA, AZ. FILED 4-19-2012.

Dually D²

THE MARK CONSISTS OF THE WORD "DUALLY" FOLLOWED BY A CAPITAL "D" RAISED TO THE POWER OF "2".

FOR LIGHT BARS FOR VEHICLES, NAMELY, LAND BASED VEHICLES (U.S. CLS. 13, 21, 23, 31 AND 34).

FIRST USE 11-30-2010; IN COMMERCE 11-30-2010.

BRENDAN REGAN, EXAMINING ATTORNEY

SN 85-602,566. JST PERFORMANCE, INC., DBA RIGID INDUSTRIES, MESA, AZ. FILED 4-19-2012.

SR-Series

THE MARK CONSISTS OF STANDARD CHARACTERS WITHOUT CLAIM TO ANY PARTICULAR FONT, STYLE, SIZE, OR COLOR.

FOR LIGHT BARS FOR VEHICLES, NAMELY, LAND BASED VEHICLES (U.S. CLS. 13, 21, 23, 31 AND 34).

FIRST USE 11-30-2010; IN COMMERCE 11-30-2010.

BRENDAN REGAN, EXAMINING ATTORNEY

SN 85-602,648. NATURE'S APPEAL MANUFACTURING CORPORATION, ADDISON, IL. FILED 4-19-2012.

NATURE'S APPEAL AIR BURST

THE MARK CONSISTS OF STANDARD CHARACTERS WITHOUT CLAIM TO ANY PARTICULAR FONT, STYLE, SIZE, OR COLOR.

OWNER OF U.S. REG. NO. 3,889,650.

NO CLAIM IS MADE TO THE EXCLUSIVE RIGHT TO USE "AIR", APART FROM THE MARK AS SHOWN.

FOR ELECTRIC AIR DEODORIZERS (U.S. CLS. 13, 21, 23, 31 AND 34).

FIRST USE 7-19-2012; IN COMMERCE 7-19-2012.

ZACHARY BELLO, EXAMINING ATTORNEY

CLASS 11—(Continued).

SN 85-603,974. RAB LIGHTING INC., NORTHVALE, NJ. FILED 4-20-2012.

WPMLD

THE MARK CONSISTS OF STANDARD CHARACTERS WITHOUT CLAIM TO ANY PARTICULAR FONT, STYLE, SIZE, OR COLOR.

OWNER OF U.S. REG. NO. 3,843,323.
FOR ELECTRIC LIGHTING FIXTURES; LED (LIGHT EMITTING DIODE) LIGHTING FIXTURES; LIGHTING FIXTURES (U.S. CLS. 13, 21, 23, 31 AND 34).
SANJEEV VOHRA, EXAMINING ATTORNEY

SN 85-604,121. GUANGDONG HOLATZ PLUMBING FITTINGS INDUSTRY CO., LIMITED, KAIPING, GUANGDONG, CHINA, FILED 4-20-2012.

Holatz

THE NAME(S), PORTRAIT(S), AND/OR SIGNATURE(S) SHOWN IN THE MARK DOES NOT IDENTIFY A PARTICULAR LIVING INDIVIDUAL.

THE MARK CONSISTS OF THE TERM "HOLATZ" IN STYLIZED FONT.

THE WORDING HOLATZ HAS NO MEANING IN A FOREIGN LANGUAGE.

FOR BATHS, BATHTUBS, WHIRLPOOL BATHS AND BATH INSTALLATIONS; BATHTUBS; DISINFECTANT DISPENSERS FOR TOILETS; EXTRACTOR HOODS FOR KITCHENS; GAS BURNERS; PIPES BEING PARTS OF SANITARY FACILITIES; SAUNA BATH INSTALLATIONS; TAPS; TOILET BOWLS; WATER HEATERS (U.S. CLS. 13, 21, 23, 31 AND 34).

FIRST USE 4-8-2012; IN COMMERCE 4-8-2012.
TIMOTHY FINNEGAN, EXAMINING ATTORNEY

CLASS 11—(Continued).

SN 85-604,225. GLOBAL AIR, INC., MIAMI GARDENS, FL. FILED 4-20-2012.

GA

THE MARK CONSISTS OF THE STYLIZED TEXT "GA" IN WHICH THE LETTER "A" IS FORMED BY AN UPSIDE DOWN V SHAPE ABOVE A TRIANGLE.

FOR AIR CONDITIONERS FOR VEHICLES; AIR FILTERS FOR AIR CONDITIONERS IN VEHICLE PASSENGER COMPARTMENTS; CLIMATE CONTROL SYSTEM FOR VEHICLES CONSISTING OF EVAPORATOR CORE, CONDENSER CORE, RECEIVER DRIER, COMPRESSOR, HOSE ASSEMBLY, PRESSURE CYCLING SWITCH, THERMOSTAT, EXPANSION VALVES, CONTROL VALVES, FITTINGS IN THE NATURE OF HOSE FITTINGS THAT CONNECT THE HOSE TO OTHER PARTS OF THE AIR CONDITIONING SYSTEM, HOSE FERRULES, ADAPTER HOUSINGS, COMPRESSOR SEAL KITS AND COMPRESSOR GASKET KITS, BLOWER MOTOR, COMPRESSOR CLUTCH BEARINGS, COMPRESSOR CLUTCHES, AND ORIFICE TUBES; PARTS FOR HEATING AND AIR CONDITIONING SYSTEMS, NAMELY, HEATER CORES AND GAS COOLERS FOR VEHICLES (U.S. CLS. 13, 21, 23, 31 AND 34).

FIRST USE 4-3-2001; IN COMMERCE 4-3-2001.
TASNEEM HUSSAIN, EXAMINING ATTORNEY

SN 85-604,264. COOL LUMENS, INC., DBA COOL LUMENS, SANTA CRUZ, CA. FILED 4-20-2012.

Cold HighBay

THE MARK CONSISTS OF STANDARD CHARACTERS WITHOUT CLAIM TO ANY PARTICULAR FONT, STYLE, SIZE, OR COLOR.

NO CLAIM IS MADE TO THE EXCLUSIVE RIGHT TO USE "HIGH BAY", APART FROM THE MARK AS SHOWN.

FOR LED (LIGHT EMITTING DIODES) LIGHTING FIXTURES FOR USE IN DISPLAY, COMMERCIAL, INDUSTRIAL, RESIDENTIAL, AND ARCHITECTURAL ACCENT LIGHTING APPLICATIONS (U.S. CLS. 13, 23, 31 AND 34).

TASNEEM HUSSAIN, EXAMINING ATTORNEY

CLASS 11—(Continued).

SN 85-605,210. ARCIERI, DAWN, HOUSTON, TX. FILED 4-23-2012.

Morsel Maker

THE MARK CONSISTS OF STANDARD CHARACTERS WITHOUT CLAIM TO ANY PARTICULAR FONT, STYLE, SIZE, OR COLOR.

FOR ELECTRIC KITCHEN COOKING APPLIANCES, NAMELY, ELECTRIC GRILLS, OVENS, AND DEEP FRYERS (U.S. CLS. 13, 21, 23, 31 AND 34).

CHRISTOPHER BUONGIORNO, EXAMINING ATTORNEY

CLASS 11—(Continued).

SN 85-605,421. THE B & F SYSTEM, INC., DALLAS, TX. FILED 4-23-2012.

4 SQUARE

THE MARK CONSISTS OF STANDARD CHARACTERS WITHOUT CLAIM TO ANY PARTICULAR FONT, STYLE, SIZE, OR COLOR.

FOR AIR FILTERS FOR DOMESTIC USE; AIR FILTERS FOR INDUSTRIAL INSTALLATIONS; WATER FILTERS; FILTERS FOR DRINKING WATER (U.S. CLS. 13, 21, 23, 31 AND 34).

JOHN WILKE, EXAMINING ATTORNEY

SN 85-605,310. TOPSEAT INTERNATIONAL, INC., PLANO, TX. FILED 4-23-2012.

MAYFRESH

THE MARK CONSISTS OF STANDARD CHARACTERS WITHOUT CLAIM TO ANY PARTICULAR FONT, STYLE, SIZE, OR COLOR.

FOR TOILET SEATS (U.S. CLS. 13, 21, 23, 31 AND 34). AMEEN IMAM, EXAMINING ATTORNEY

SN 85-605,581. AUDIE NORR, DALLAS, TX. FILED 4-23-2012.

SN 85-605,416. THE B & F SYSTEM, INC., DALLAS, TX. FILED 4-23-2012.



THE MARK CONSISTS OF A CHECKERED SQUARE PATTERN ABOVE THE STYLIZED WORDING "4 SQUARE HEALTH SMART FLAVOR LIFETIME".

FOR AIR FILTERS FOR DOMESTIC USE; AIR FILTERS FOR INDUSTRIAL INSTALLATIONS; WATER FILTERS; FILTERS FOR DRINKING WATER (U.S. CLS. 13, 21, 23, 31 AND 34).

JOHN WILKE, EXAMINING ATTORNEY

RoboShower

THE MARK CONSISTS OF STANDARD CHARACTERS WITHOUT CLAIM TO ANY PARTICULAR FONT, STYLE, SIZE, OR COLOR.

FOR SHOWER HEADS (U.S. CLS. 13, 21, 23, 31 AND 34).

DORITT L. CARROLL, EXAMINING ATTORNEY

CLASS 11—(Continued).

SN 85-606,051. FOSHAN HUAQUAN ELECTRICAL LIGHTING CO. LTD, GUANGDONG PROVINCE, CHINA, FILED 4-24-2012.

Watran

THE MARK CONSISTS OF STANDARD CHARACTERS WITHOUT CLAIM TO ANY PARTICULAR FONT, STYLE, SIZE, OR COLOR.

FOR BICYCLE LAMPS; ELECTRIC BULBS; ELECTRIC LAMPS; FLASHLIGHTS; HEADLIGHTS FOR VEHICLES; LAMP BASES; LAMP BULBS; LED (LIGHT EMITTING DIODE) LIGHTING FIXTURES; LED (LIGHT EMITTING DIODES) LIGHTING FIXTURES FOR USE IN DISPLAY, COMMERCIAL, INDUSTRIAL, RESIDENTIAL, AND ARCHITECTURAL ACCENT LIGHTING APPLICATIONS; LED AND HID LIGHT FIXTURES; LED LANDSCAPE LIGHTS; LED LIGHT APPARATUS THAT CLIPS ON TO A HANDBAG, USED TO ILLUMINATE A HANDBAG; LED LIGHT ASSEMBLIES FOR STREET LIGHTS, SIGNS, COMMERCIAL LIGHTING, AUTOMOBILES, BUILDINGS, AND OTHER ARCHITECTURAL USES; LED LIGHT BULBS; LED LIGHT ENGINES; LED LIGHT MACHINES; LED LIGHTING FIXTURES FOR INDOOR AND OUTDOOR LIGHTING APPLICATIONS; LED LIGHTING SYSTEMS, NAMELY, LED MODULES, POWER SUPPLIES, AND WIRING; LED LIGHTS FOR LIGHTING PURPOSES INCORPORATED INTO KEY CHAINS, SMALL TOYS OR OTHER SIMILAR PERSONAL ITEMS; LED LUMINAIRES; LED UNDERWATER LIGHTS; LIGHT BULBS; LIGHT EMITTING DIODE (LED) PLANT GROW LIGHT; LIGHT EMITTING DIODES (LEDS) INCORPORATED INTO METALLIC AND ADHESIVE PLASTIC REFLECTOR FILM FOR ILLUMINATING TRANSPARENT BALLOONS AND SIMILAR PRODUCTS; LIGHTING APPARATUS FOR VEHICLES; LIGHTS FOR VEHICLES; LUMINAIRES, USING LIGHT EMITTING DIODES (LEDS) AS A LIGHT SOURCE, FOR STREET OR ROADWAY LIGHTING; SAFETY LAMPS FOR UNDERGROUND USE; SEARCHLIGHTS; VEHICLE DYNAMO LAMPS (U.S. CLS. 13, 21, 23, 31 AND 34).

FIRST USE 12-1-2004; IN COMMERCE 12-8-2006.
LINDA MICKLEBURGH, EXAMINING ATTORNEY

SN 85-607,172. CHARCOAL COMPANION INCORPORATED, DBA THE COMPANION GROUP, EMERYVILLE, CA, FILED 4-24-2012.

PORTABLE PIZZERIA

THE MARK CONSISTS OF STANDARD CHARACTERS WITHOUT CLAIM TO ANY PARTICULAR FONT, STYLE, SIZE, OR COLOR.

FOR PIZZA OVENS (U.S. CLS. 13, 21, 23, 31 AND 34).
TOBY BULLOFF, EXAMINING ATTORNEY

CLASS 11—(Continued).

SN 85-612,069. TARGET BRANDS, INC., MINNEAPOLIS, MN. FILED 4-30-2012.

UP & UP

THE MARK CONSISTS OF STANDARD CHARACTERS WITHOUT CLAIM TO ANY PARTICULAR FONT, STYLE, SIZE, OR COLOR.

OWNER OF U.S. REG. NOS. 4,013,298, 4,029,541 AND OTHERS.

FOR DRINKING WATER FILTERS (U.S. CLS. 13, 21, 23, 31 AND 34).

FIRST USE 10-0-2011; IN COMMERCE 10-0-2011.
JEAN IM, EXAMINING ATTORNEY

SN 85-612,082. TARGET BRANDS, INC., MINNEAPOLIS, MN. FILED 4-30-2012.



OWNER OF U.S. REG. NOS. 4,013,298, 4,029,541 AND OTHERS.

THE MARK CONSISTS OF AN ARROW DESIGN POINTING AT A 45 DEGREE DIAGONAL, UP AND TO THE RIGHT, WITH THE WORDS "UP & UP" INSIDE THE ARROW.

FOR DRINKING WATER FILTERS (U.S. CLS. 13, 21, 23, 31 AND 34).

FIRST USE 10-0-2011; IN COMMERCE 10-0-2011.
JEAN IM, EXAMINING ATTORNEY

SN 85-612,088. TARGET BRANDS, INC., MINNEAPOLIS, MN. FILED 4-30-2012.

UP & UP

THE MARK CONSISTS OF STANDARD CHARACTERS WITHOUT CLAIM TO ANY PARTICULAR FONT, STYLE, SIZE, OR COLOR.

OWNER OF U.S. REG. NOS. 4,013,298, 4,029,541 AND OTHERS.

FOR LIGHT BULBS (U.S. CLS. 13, 21, 23, 31 AND 34).
JEAN IM, EXAMINING ATTORNEY

CLASS 11—(Continued).

SN 85-612,097. TARGET BRANDS, INC., MINNEAPOLIS, MN. FILED 4-30-2012.



OWNER OF U.S. REG. NOS. 4,013,298, 4,029,541 AND OTHERS.

THE MARK CONSISTS OF AN ARROW DESIGN POINTING AT A 45 DEGREE DIAGONAL, UP AND TO THE RIGHT, WITH THE WORDS "UP & UP" INSIDE THE ARROW.

FOR LIGHT BULBS (U.S. CLS. 13, 21, 23, 31 AND 34).
JEAN IM, EXAMINING ATTORNEY

CLASS 11—(Continued).

PLUMBING FITTINGS, NAMELY, SHOWER CONTROL VALVES; PLUMBING FITTINGS, NAMELY, SINK STRAINERS; PLUMBING FITTINGS, NAMELY, SPOUTS; PLUMBING FITTINGS, NAMELY, TRAPS; PLUMBING FITTINGS, NAMELY, TUB CONTROL VALVES; PLUMBING FITTINGS, NAMELY, VALVES; PLUMBING FIXTURES, NAMELY, SHOWER MIXERS; PLUMBING FIXTURES, NAMELY, SHOWER SPRAYERS; PLUMBING FIXTURES, NAMELY, SINK SPRAYERS; PLUMBING FIXTURES, NAMELY, SINK TRAPS; PLUMBING SUPPLIES, NAMELY, SINK STRAINERS; SHOWER FAUCET EXTENSIONS; SINGLE LEVER FIXTURES FOR LAVATORIES AND SINKS; SINK DRAINER SYSTEM COMPRISED OF A DRAIN TRAY, SINK MOUNT, KICK STAND AND ROD; SINK PEDESTALS; SINKS; SINKS INTEGRATED INTO COUNTERTOPS OR COUNTERTOPS; STAINLESS STEEL BOTTOM GRIDS SPECIALLY ADAPTED AND SHAPED FOR USE IN SINKS; STRAINERS FOR PLUMBING DRAINS; TAP WATER FAUCETS; TAPS; WATER FAUCET SPOUT (U.S. CLS. 13, 21, 23, 31 AND 34).

FIRST USE 1-1-2007; IN COMMERCE 1-1-2007.
BARNEY CHARLON, EXAMINING ATTORNEY

SN 85-637,130. PRIZER-PAINTER STOVE WORKS, INC., READING, PA. FILED 5-29-2012.

UNLEASH YOUR INNER CHEF

THE MARK CONSISTS OF STANDARD CHARACTERS WITHOUT CLAIM TO ANY PARTICULAR FONT, STYLE, SIZE, OR COLOR.

FOR GAS COOKING APPLIANCES, NAMELY RANGES AND RANGE HOODS, OVENS, STOVES AND COOKTOPS FOR COMMERCIAL OR RESIDENTIAL USE (U.S. CLS. 13, 21, 23, 31 AND 34).

LEIGH CAROLINE CASE, EXAMINING ATTORNEY

SN 85-616,890. LAERA, VITO, FORT LAUDERDALE, FL. FILED 5-4-2012.

linea vianco

THE MARK CONSISTS OF STANDARD CHARACTERS WITHOUT CLAIM TO ANY PARTICULAR FONT, STYLE, SIZE, OR COLOR.

OWNER OF U.S. REG. NO. 3,588,180.

NO CLAIM IS MADE TO THE EXCLUSIVE RIGHT TO USE "LINEA", APART FROM THE MARK AS SHOWN.

THE ENGLISH TRANSLATION OF "LINEA" IN THE MARK IS LINE, WHICH MEANS MERCHANDISE OR SERVICES OF A SIMILAR OR A RELATED NATURE. THE WORDING "VIANCO" HAS NO MEANING IN A FOREIGN LANGUAGE.

FOR FAUCET AERATORS; FAUCET HANDLES; FAUCET SPRAYERS; FAUCETS; FLEXIBLE PIPES BEING PARTS OF BASIN PLUMBING INSTALLATIONS; FLEXIBLE PIPES BEING PARTS OF BATH PLUMBING INSTALLATIONS; FLEXIBLE PIPES BEING PARTS OF SHOWER PLUMBING INSTALLATIONS; FLEXIBLE PIPES BEING PARTS OF SINK PLUMBING INSTALLATIONS; HEAT SINKS FOR USE IN HEATING, COOLING AND VENTILATING APPARATUS; KITCHEN SINK SPRAYERS; KITCHEN SINKS; MANUALLY-OPERATED PLUMBING VALVES; MIXER FAUCETS FOR WATER PIPES; PLUMBING FITTINGS, NAMELY, AERATORS FOR FAUCETS; PLUMBING FITTINGS, NAMELY, DRAINS; PLUMBING FITTINGS, NAMELY, FAUCET FILTERS; PLUMBING FITTINGS, NAMELY, FRESH WATER FILLS FOR RECREATIONAL VEHICLES;

SN 85-655,971. CHARCOAL COMPANION INCORPORATED, DBA THE COMPANION GROUP, EMERYVILLE, CA. FILED 6-19-2012.

THE BIG CHEESE

THE MARK CONSISTS OF STANDARD CHARACTERS WITHOUT CLAIM TO ANY PARTICULAR FONT, STYLE, SIZE, OR COLOR.

FOR PIZZA OVENS (U.S. CLS. 13, 21, 23, 31 AND 34).
TOBY BULLOFF, EXAMINING ATTORNEY

CLASS 11—(Continued).

SN 85-656,553. CRESTRON ELECTRONICS, INC., ROCK-LEIGH, NJ. FILED 6-20-2012.

Ecomist

THE MARK CONSISTS OF STANDARD CHARACTERS WITHOUT CLAIM TO ANY PARTICULAR FONT, STYLE, SIZE, OR COLOR.
FOR HUMIDIFIERS (U.S. CLS. 13, 21, 23, 31 AND 34).
WENDY JUN, EXAMINING ATTORNEY

SN 85-677,998. OWENS CORNING INTELLECTUAL CAPITAL, LLC, TOLEDO, OH. FILED 7-16-2012.

VENTSURE

THE MARK CONSISTS OF STANDARD CHARACTERS WITHOUT CLAIM TO ANY PARTICULAR FONT, STYLE, SIZE, OR COLOR.
OWNER OF U.S. REG. NO. 2,013,195.
FOR VENTILATING EXHAUST FANS (U.S. CLS. 13, 21, 23, 31 AND 34).
DAVID TOOLEY, EXAMINING ATTORNEY

SN 85-977,274. UNIVERSAL SCIENTIFIC INDUSTRIAL CO., LTD., NAN-TOU HSIEN, CHINA, FILED 7-2-2010.

HSiP

THE MARK CONSISTS OF STANDARD CHARACTERS WITHOUT CLAIM TO ANY PARTICULAR FONT, STYLE, SIZE, OR COLOR.
FOR LIGHTS FOR VEHICLES; LIGHTING APPARATUS FOR VEHICLES; VEHICLE DYNAMO LAMPS (U.S. CLS. 13, 21, 23, 31 AND 34).
KHANH LE, EXAMINING ATTORNEY

CLASS 12—VEHICLES

SN 79-103,418. MOTONAUTICA F.LLI RANIERI SRL, ITALY, FILED 9-23-2011.

RANIERI INTERNATIONAL

THE MARK CONSISTS OF STANDARD CHARACTERS WITHOUT CLAIM TO ANY PARTICULAR FONT, STYLE, SIZE, OR COLOR.

OWNER OF INTERNATIONAL REGISTRATION 1093019 DATED 9-23-2011, EXPIRES 9-23-2021.

NO CLAIM IS MADE TO THE EXCLUSIVE RIGHT TO USE "INTERNATIONAL", APART FROM THE MARK AS SHOWN.

SEC. 2(F).
FOR BOATS;BOAT ACCESSORIES, NAMELY, PLANING HULLS; SAIL BOATS (U.S. CLS. 19, 21, 23, 31, 35 AND 44).

LOURDES AYALA, EXAMINING ATTORNEY

SN 79-106,068. GILETTA S.P.A., ITALY, FILED 9-21-2011.



PRIORITY DATE OF 5-24-2011 IS CLAIMED.

OWNER OF INTERNATIONAL REGISTRATION 1098983 DATED 9-21-2011, EXPIRES 9-21-2021.

THE COLOR(S) GREY, LIGHT BLUE AND ORANGE IS/ARE CLAIMED AS A FEATURE OF THE MARK.

THE MARK CONSISTS OF THE WORD "UNIQA" SHOWN LARGELY IN GREY, BUT WITH THE "Q" SHOWN IN LIGHT BLUE WITH AN ORANGE CIRCLE AT ITS BOTTOM.

FOR VEHICLES, NAMELY, TRUCKS EQUIPPED TO SPREAD SALT AND SAND ON ROADS IN WINTER; VEHICLES, NAMELY, TRUCKS FOR SNOW SWEEPING AND PLOWING; TRUCKS EQUIPPED FOR SPRAYING DE-ICING SOLUTION; STREET SWEEPING TRUCKS AND COMPONENT PARTS THEREOF; TRUCKS EQUIPPED FOR CLEANING STREETS AND BUILDINGS AND COMPONENT PARTS THEREOF; TRANSPORT TROLLEYS FOR CLEANING MATERIALS AND CLEANING EQUIPMENT; TRUCKS FOR THE TRANSPORT OF GOODS AND EQUIPMENT; GARBAGE TRUCKS; FORK LIFT TRUCKS; WINTER ROAD MAINTENANCE TRUCKS FOR PLOWING SNOW AND SPREADING SALT OR SAND; TRUCKS EQUIPPED WITH DEVICES FOR DE-ICING SURFACES AND OBJECTS (U.S. CLS. 19, 21, 23, 31, 35 AND 44).

FRED CARL, EXAMINING ATTORNEY

CLASS 12—(Continued).

SN 79-106,153. XGM GROUP CO., LTD., CHINA, FILED 10-31-2011.

CLASS 12—(Continued).

SN 79-106,162. MBI CO., LTD., CHUNGBUK, REPUBLIC OF KOREA, FILED 6-3-2011.



PRIORITY DATE OF 12-7-2010 IS CLAIMED.
OWNER OF INTERNATIONAL REGISTRATION 1099260 DATED 6-3-2011, EXPIRES 6-3-2021.

THE COLOR(S) BLACK AND RED IS/ARE CLAIMED AS A FEATURE OF THE MARK.

THE IMAGE OF THREE OVAL CIRCLES WHICH ARE PARTIALLY OVERLAPPED TOGETHER IS IN RED, ONE SMALL CIRCLE ABOVE THE THIRD OVAL CIRCLE IS IN RED, THE LETTERS "MBI" ARE IN BLACK.

FOR WHEELCHAIRS; TANDEM BICYCLES; MOPEDS; MOUNTAIN BICYCLES; TOURING BICYCLES; DELIVERY BICYCLES; BICYCLES; INNER TUBES FOR BICYCLES; BICYCLE RIMS; WHEELS FOR BICYCLES; BICYCLE SPOKES; DIRECTION INDICATORS FOR BICYCLES; BELLS FOR BICYCLES; BICYCLE SADDLES; LUGGAGE CARRIERS FOR BICYCLES; BICYCLE STANDS; BICYCLE SADDLE COVERS; CHAIN GUARDS FOR BICYCLES; BICYCLE CHAINS; BICYCLE PUMPS; BICYCLE PEDALS; BICYCLE FRAMES; BICYCLE HANDLE BARS; RACING BICYCLES; BICYCLE TIRES; TUBELESS TIRES FOR BICYCLES AND MOTORCYCLES; INNER TUBES FOR BICYCLES AND MOTORCYCLES; TIRES FOR BICYCLES AND MOTORCYCLES; GEARS FOR BICYCLES AND MOTORCYCLES; CRANKS FOR BICYCLES AND MOTORCYCLES; MOTORS FOR MOTORCYCLES; HANDLEBARS FOR TWO-WHEELED MOTOR VEHICLES AND BICYCLES; MUDGUARDS FOR TWO-WHEELED MOTOR VEHICLES AND BICYCLES; SADDLE COVERS FOR BICYCLES AND MOTORCYCLES; SADDLES FOR BICYCLES AND MOTORCYCLES; WHEEL HUBS FOR TWO-WHEELED MOTOR VEHICLES AND BICYCLES; TRANSMISSIONS FOR LAND VEHICLES; GEARS FOR LAND VEHICLES; GEAR BOXES FOR LAND VEHICLES; GEAR BOXES FOR MOTOR CARS; REDUCTION GEARS FOR LAND VEHICLES; REVERSING GEARS FOR LAND VEHICLES; MOTORS FOR ELECTRIC BICYCLES; CHANGE-SPEED GEARS FOR ELECTRIC BICYCLES; MOTORS FOR ELECTRIC SCOOTERS; CHANGE-SPEED GEARS FOR ELECTRIC SCOOTERS (U.S. CLS. 19, 21, 23, 31, 35 AND 44).

OWNER OF INTERNATIONAL REGISTRATION 1099234 DATED 10-31-2011, EXPIRES 10-31-2021.

THE MARK CONSISTS OF A STYLED LETTER "E" WITH DIAMOND SHAPE AND THE DIAMOND SHAPE WITHIN A RECTANGLE DESIGN .

FOR AUTOMOBILES; AUTOMOBILE BUMPERS; SUSPENSION SHOCK ABSORBERS FOR VEHICLES; SHOCK ABSORBING SPRINGS FOR VEHICLES; MOTORCYCLES; BRAKE SEGMENTS FOR VEHICLES (U.S. CLS. 19, 21, 23, 31, 35 AND 44).

CURTIS FRENCH, EXAMINING ATTORNEY

ALEXANDER L. POWERS, EXAMINING ATTORNEY

CLASS 12—(Continued).

SN 79-107,010. BRIDGESTONE CORPORATION, JAPAN, FILED 10-25-2011.



PRIORITY DATE OF 5-13-2011 IS CLAIMED.
 OWNER OF INTERNATIONAL REGISTRATION 1101200 DATED 10-25-2011, EXPIRES 10-25-2021.
 OWNER OF U.S. REG. NO. 3,509,024.
 THE COLOR(S) BLACK, GOLDEN YELLOW, YELLOW AND LIGHT ORANGE IS/ARE CLAIMED AS A FEATURE OF THE MARK.
 THE MARK CONSISTS OF THE WORDING "3LC" IN GOLDEN YELLOW BELOW A CURVED MULTI-COLORED ARC. THE LEFT SIDE AND RIGHT SIDE OF THE ARC ARE YELLOW AND THE MIDDLE OF THE ARC IS LIGHT ORANGE. ALL OF THE FOREGOING ELEMENTS APPEAR INSIDE A BLACK SQUARE.
 FOR TIRES FOR TWO-WHEELED MOTOR VEHICLES; INNER TUBES FOR TWO-WHEELED MOTOR VEHICLES (U.S. CLS. 19, 21, 23, 31, 35 AND 44).
 LINDA LAVACHE, EXAMINING ATTORNEY

CLASS 12—(Continued).

SN 79-107,503. BRIDGESTONE CORPORATION, JAPAN, FILED 10-25-2011.



PRIORITY DATE OF 5-13-2011 IS CLAIMED.
 OWNER OF INTERNATIONAL REGISTRATION 1102464 DATED 10-25-2011, EXPIRES 10-25-2021.
 OWNER OF U.S. REG. NO. 3,509,025.
 THE COLOR(S) BLACK, GOLDEN YELLOW, YELLOW, LIGHT ORANGE AND RED IS/ARE CLAIMED AS A FEATURE OF THE MARK.
 THE MARK CONSISTS OF THE WORDING "5LC" IN GOLDEN YELLOW BELOW A CURVED MULTICOLORED ARC. THE OUTER LEFT SIDE AND OUTER RIGHT SIDE OF THE ARC ARE YELLOW, THE INNER LEFT SIDE AND INNER RIGHT SIDE OF THE ARC ARE LIGHT ORANGE, AND THE MIDDLE OF THE ARC IS RED. ALL OF THE FOREGOING ELEMENTS APPEAR INSIDE A BLACK SQUARE.
 FOR TIRES FOR TWO-WHEELED MOTOR VEHICLES; INNER TUBES FOR TWO-WHEELED MOTOR VEHICLES (U.S. CLS. 19, 21, 23, 31, 35 AND 44).
 LINDA LAVACHE, EXAMINING ATTORNEY

SN 79-108,777. HOOK MARINE AB, SWEDEN, FILED 11-30-2011.

HOOK&MOOR

THE MARK CONSISTS OF STANDARD CHARACTERS WITHOUT CLAIM TO ANY PARTICULAR FONT, STYLE, SIZE, OR COLOR.
 PRIORITY DATE OF 5-31-2011 IS CLAIMED.
 OWNER OF INTERNATIONAL REGISTRATION 1105739 DATED 11-30-2011, EXPIRES 11-30-2021.
 FOR HOOKS FOR BOATS (U.S. CLS. 19, 21, 23, 31, 35 AND 44).
 NICHOLAS COLEMAN, EXAMINING ATTORNEY

SN 79-108,969. QIANJIANG-KEEWAY (EURÓPA); IPARI ÉS KERESKEDELMI ZRT., HUNGARY, FILED 10-19-2011.



OWNER OF INTERNATIONAL REGISTRATION 1106310 DATED 10-19-2011, EXPIRES 10-19-2021.
 THE COLOR(S) SILVER, RED, BLACK, GREEN, AND WHITE IS/ARE CLAIMED AS A FEATURE OF THE MARK.
 THE MARK CONSISTS OF THE LITERAL ELEMENTS "G

CLASS 12—(Continued).

GOCCIA" IN STYLIZED LETTERING AND DESIGN, WITH SHADING CREATING A THREE-DIMENSIONAL EFFECT. THE LETTER "G" APPEARS IMBEDDED AT THE CENTER OF A SILVER TRIANGULAR-SHAPED CARRIER DESIGN THAT APPEARS TO REPRESENT A SHIELD THAT POINTS DOWNWARD AND HAS A RED LINE BORDERING ITS EXTERIOR. THE LETTERS "GO" IN THE WORD "GOCCIA" APPEAR IN GREEN AND THE REMAINING LETTERS APPEAR IN WHITE, WITH ALL LETTERS OUTLINED IN BLACK.

THE ENGLISH TRANSLATION OF THE ITALIAN WORDING "GOCCIA" IS DROP.

FOR VEHICLES BY LAND, SPECIFICALLY, ELECTRIC BICYCLES, MOTORIZED SCOOTERS, AND SPARE PARTS OF THESE, SPECIFICALLY, STRUCTURAL PARTS THEREFOR, HANDLE BARS, WHEEL RIMS, AND BRAKE CABLES (U.S. CLS. 19, 21, 23, 31, 35 AND 44).

JUDITH HELFMAN, EXAMINING ATTORNEY

SN 79-110,680. KOWA TMSUK COMPANY, LTD., FUKUOKA-KEN, JAPAN, FILED 1-20-2012.



PRIORITY DATE OF 10-14-2011 IS CLAIMED.
OWNER OF INTERNATIONAL REGISTRATION 1110749 DATED 1-20-2012, EXPIRES 1-20-2022.

THE MARK CONSISTS OF A STYLIZED SHIELD INSIDE OF WHICH ARE A LEFT SHADED PORTION CONTAINING A "K" AND A RIGHT PORTION CONTAINING A "T", THE SIDES ARE SEPARATED BY A STYLIZED ZIG-ZAG LINE IN THE MIDDLE OF THE SHIELD.

FOR AUTOMOBILES, MOTORIZED GOLF CARTS (U.S. CLS. 19, 21, 23, 31, 35 AND 44).

SCOTT BIBB, EXAMINING ATTORNEY

CLASS 12—(Continued).

SN 79-112,191. BEIQI FOTON MOTOR CO., LTD., 102206 BEIJING, CHINA, FILED 3-30-2012.



OWNER OF INTERNATIONAL REGISTRATION 0995631 DATED 2-18-2009, EXPIRES 2-18-2019.

THE MARK CONSISTS OF A DESIGN OF TWO CONCENTRIC OVALS WITH TWO CURVED BARS INSIDE THE INNER OVAL.

FOR ROLLING STOCK FOR RAILWAYS; AUTOMOBILES; MOTORCYCLES; BICYCLES; CABLE CARS; TROLLEYS; PRAMS, NAMELY, BABY CARRIAGES; OMNIBUSES; AIRPLANES; SHIPS (U.S. CLS. 19, 21, 23, 31, 35 AND 44).

ROBERT STRUCK, EXAMINING ATTORNEY

SN 79-112,804. LA REVOLTA DISSENY DE MOBILITAT, S. L., SPAIN, FILED 4-19-2012.

TRAQPOD

THE MARK CONSISTS OF STANDARD CHARACTERS WITHOUT CLAIM TO ANY PARTICULAR FONT, STYLE, SIZE, OR COLOR.

PRIORITY DATE OF 11-23-2011 IS CLAIMED.

OWNER OF INTERNATIONAL REGISTRATION 1115624 DATED 4-19-2012, EXPIRES 4-19-2022.

FOR ELECTRONICALLY MOTORIZED SKATEBOARDS (U.S. CLS. 19, 21, 23, 31, 35 AND 44).

AISHA SALEM, EXAMINING ATTORNEY

SN 85-246,999. X-RAK, LLC, THERMOPOLIS, WY. FILED 2-19-2011.



THE MARK CONSISTS OF THE STYLIZED WORD "XRAK" WITH "X" AND "RAK" SEPARATED BY A DRAWING OF ANTLERS.

FOR AUTOMOTIVE AFTERMARKET PARTS, NAMELY, TRUCK BED EXTENDER AND STORAGE BOX; AUTOMOTIVE CARGO RACK (U.S. CLS. 19, 21, 23, 31, 35 AND 44).

FIRST USE 4-13-2010; IN COMMERCE 4-13-2010.

SUNG IN, EXAMINING ATTORNEY

CLASS 12—(Continued).

SN 85-306,542. LET'S GO AERO, TA LGAHC, COLORADO SPRINGS, CO. FILED 4-27-2011.

GearSpace

THE MARK CONSISTS OF STANDARD CHARACTERS WITHOUT CLAIM TO ANY PARTICULAR FONT, STYLE, SIZE, OR COLOR.

FOR AUTOMOTIVE CARGO RACK; CARGO CARRIER FOR VEHICLES; CARGO STORAGE BINS ESPECIALLY ADAPTED TO BE USED WITH CARS, TRUCKS OR SUV'S; AUTOMOTIVE CARRIER PARTS, NAMELY, AUTOMOTIVE CARGO DECK AND CARGO PLATFORM; AUTOMOTIVE CARGO RACK FOR ATTACHMENT TO A VEHICLE (U.S. CLS. 19, 21, 23, 31, 35 AND 44).

FIRST USE 6-1-2004; IN COMMERCE 6-1-2004.
ELLEN B. AWRICH, EXAMINING ATTORNEY

CLASS 12—(Continued).

SN 85-366,469. AD MOTORS CO., LTD., SEOUL, REPUBLIC OF KOREA, FILED 7-8-2011.



NO CLAIM IS MADE TO THE EXCLUSIVE RIGHT TO USE "MOTORS", APART FROM THE MARK AS SHOWN. THE COLOR(S) BLUE AND SILVER IS/ARE CLAIMED AS A FEATURE OF THE MARK.

THE MARK CONSISTS OF SILVER CIRCLE WITH BLUE BORDER, AND BLUE COLOR INSIDE SILVER CIRCLE WITH DIVIDED DOMED SILVER CIRCLE TO LEFT AND RIGHT SIDE; THE CIRCLE IS FOLLOWED BY CAPITAL LETTERS OF "AD MOTORS" IN BLUE.

FOR ELECTRIC VEHICLES, NAMELY, ELECTRIC AUTOMOBILES (U.S. CLS. 19, 21, 23, 31, 35 AND 44).

FIRST USE 1-18-2010; IN COMMERCE 1-18-2010.
WILLIAM JACKSON, EXAMINING ATTORNEY

SN 85-404,794. THULE IP AB, MALMO, SWEDEN, FILED 8-23-2011.

SN 85-306,552. LET'S GO AERO, TA LGAHC, COLORADO SPRINGS, CO. FILED 4-27-2011.



TwinTube

THE MARK CONSISTS OF STANDARD CHARACTERS WITHOUT CLAIM TO ANY PARTICULAR FONT, STYLE, SIZE, OR COLOR.

SEC. 2(F).
FOR AUTOMOTIVE TRAILER HITCH RACK PARTS, NAMELY, HITCH RECEIVER MOUNTING PLATFORM, STRUCTURAL BASE FOR HITCH-RECEIVER PLATFORM, AND HITCH-RECEIVER STRUCTURAL BASE FOR MOUNTABLE ACCESSORIES; AUTOMOTIVE CARGO RACK PARTS, NAMELY, CARGO MOUNTING STRUCTURAL BASE AND TELESCOPING BASE FOR HITCH MOUNTING SYSTEM; TELESCOPING AUTOMOTIVE CARGO RACK AND PARTS THEREFOR, NAMELY, TELESCOPING CARGO MOUNTING PLATFORM AND BASE FRAME FOR CARGO, ALL FOR USE WITH VEHICLES (U.S. CLS. 19, 21, 23, 31, 35 AND 44).

FIRST USE 1-6-2002; IN COMMERCE 1-6-2002.
ELLEN B. AWRICH, EXAMINING ATTORNEY

OWNER OF U.S. REG. NOS. 2,460,950, 2,460,951 AND 2,788,504.

THE MARK CONSISTS OF THE STYLIZED LETTERS "UWS" APPEARING TO THE RIGHT OF THE DEPICTION OF A FISH.

FOR TRUCK AND TRUCK BED ACCESSORIES, NAMELY, TOOL BOXES, TOOL STORAGE BOXES AND TANKS FOR STORING LIQUID ALL SPECIFICALLY DESIGNED AND ADAPTED TO FIT IN AND BE MOUNTED TO THE BED OF A TRUCK; CARGO STORAGE BINS SPECIFICALLY DESIGNED AND ADAPTED TO FIT IN TRUCKS OR SUV'S; TRUCK BED STORAGE ORGANIZERS; CARGO CARRIERS FOR VEHICLES; HITCH MOUNTED CARGO CARRIERS FOR VEHICLES; LADDER RACKS IN THE NATURE OF LADDER MOUNTS SPECIFICALLY DESIGNED AND ADAPTED TO FIT IN THE BED OF A TRUCK; SIDE RAIL AND TAILGATE PROTECTORS, NAMELY, FITTED LINERS FOR PROTECTING THE SIDE RAILS AND TAILGATES OF TRUCKS AND SUV'S; STEP TREADS AND STEP BARS FOR VEHICLES, NAMELY, NERF BARS FOR VEHICLES, AND STEPS FOR ATTACHMENT TO LAND VEHICLES; AUTOMOTIVE AFTERMARKET PARTS, NAMELY, TRUCK BED EXTENDER AND STORAGE BOX, TRUCK HEADACHE RACKS, AND STRUCTURAL PARTS AND FITTINGS THEREFOR (U.S. CLS. 19, 21, 23, 31, 35 AND 44).

MICHAEL TANNER, EXAMINING ATTORNEY

CLASS 12—(Continued).

SN 85-417,365. THULE IP AB, MALMO, SWEDEN, FILED 9-8-2011.

UWS

THE MARK CONSISTS OF STANDARD CHARACTERS WITHOUT CLAIM TO ANY PARTICULAR FONT, STYLE, SIZE, OR COLOR.

OWNER OF U.S. REG. NOS. 2,460,950 AND 2,788,504.

FOR TRUCK AND TRUCK BED ACCESSORIES, NAMELY, TOOL BOXES, DOG STORAGE BOXES AND TANKS FOR STORING LIQUID ALL SPECIFICALLY DESIGNED AND ADAPTED TO FIT IN AND BE MOUNTED TO THE BED OF A TRUCK; CARGO STORAGE BINS SPECIFICALLY DESIGNED AND ADAPTED TO FIT IN TRUCKS OR SUVs; TRUCK BED STORAGE ORGANIZERS; CARGO CARRIERS FOR VEHICLES; HITCH MOUNTED CARGO CARRIERS FOR VEHICLES; LADDER RACKS IN THE NATURE OF LADDER MOUNTS SPECIFICALLY DESIGNED AND ADAPTED TO FIT IN THE BED OF A TRUCK; SIDE RAIL AND TAILGATE PROTECTORS, NAMELY, FITTED LINERS FOR PROTECTING THE SIDE RAILS AND TAILGATES OF TRUCKS AND SUVs; STEP TREADS AND STEP BARS FOR VEHICLES, NAMELY, NERF BARS FOR VEHICLES, AND STEPS FOR ATTACHMENT TO LAND VEHICLES; AUTOMOTIVE AFTERMARKET PARTS, NAMELY, TRUCK BED EXTENDER AND STORAGE BOX, TRUCK HEADACHE RACKS, AND STRUCTURAL PARTS AND FITTINGS THEREFOR (U.S. CLS. 19, 21, 23, 31, 35 AND 44).

MICHAEL TANNER, EXAMINING ATTORNEY

CLASS 12—(Continued).

SN 85-432,684. CITY CYCLE IP, LLC, VENICE, FL. FILED 9-27-2011.

CITY CYCLE TOURS

THE MARK CONSISTS OF STANDARD CHARACTERS WITHOUT CLAIM TO ANY PARTICULAR FONT, STYLE, SIZE, OR COLOR.

NO CLAIM IS MADE TO THE EXCLUSIVE RIGHT TO USE "CYCLE", APART FROM THE MARK AS SHOWN.

FOR MULTI-PASSENGER, PEDAL-POWERED VEHICLE WITH FOUR WHEELS (U.S. CLS. 19, 21, 23, 31, 35 AND 44).

FIRST USE 1-7-2011; IN COMMERCE 1-7-2011.

JASON BLAIR, EXAMINING ATTORNEY

SN 85-431,041. COMPOSITE SOLUTIONS, INC., JUNCTION CITY, OR. FILED 9-23-2011.

SEAMLESS SLIDES

THE MARK CONSISTS OF STANDARD CHARACTERS WITHOUT CLAIM TO ANY PARTICULAR FONT, STYLE, SIZE, OR COLOR.

NO CLAIM IS MADE TO THE EXCLUSIVE RIGHT TO USE "SLIDES", APART FROM THE MARK AS SHOWN.

FOR EXPANDABLE AND RETRACTABLE ROOM ASSEMBLIES COMPRISED OF FIVE-SIDED UNITS COMPRISING A FLOOR, A CEILING, AND THREE VERTICAL WALLS MADE OF FIBERGLASS OUTER SHELL AND A PLURALITY OF INTERIOR PANELS SECURED TO THE INNER SURFACES OF THE SHELL SPECIALLY ADAPTED FOR RECREATIONAL VEHICLES AND TRAILERS (U.S. CLS. 19, 21, 23, 31, 35 AND 44).

DAVID I, EXAMINING ATTORNEY

SN 85-433,265. INNOVA GROUP, INC., DBA INNOVA, BURLINGTON, WA. FILED 9-27-2011.

INNOVA

THE MARK CONSISTS OF LETTERS SPELLING "INNOVA" USING UNIQUELY DESIGNED FONTS.

FOR INFLATABLE BOATS (U.S. CLS. 19, 21, 23, 31, 35 AND 44).

FIRST USE 8-20-2002; IN COMMERCE 8-20-2002.

TRACY CROSS, EXAMINING ATTORNEY

CLASS 12—(Continued).

SN 85-436,920. ENERGY CONTROL LIMITED, TORTOLA, BR. VIRGIN ISLANDS, FILED 9-30-2011.



THE COLOR(S) SILVER AND GOLD IS/ARE CLAIMED AS A FEATURE OF THE MARK.

THE MARK CONSISTS OF A CIRCLE WITH TWO HALVES REMINISCENT OF THE YIN/YANG SYMBOL. THE TOP HALF IS SILVER AND THE BOTTOM HALF IS GOLD.

FOR AUTOMOBILE BODIES; AUTOMOBILES; BICYCLES; CARS; CARGO CARRIERS FOR VEHICLES; ELECTRIC VEHICLES, NAMELY, SIDE CARS; MOTOR CARS FOR TRANSPORT ON LAND; BUSES; MOTORCYCLES; TRUCKS; MOTORS FOR LAND VEHICLES; MOTORIZED GOLF CARTS; MOTORIZED WHEELCHAIRS FOR THE DISABLED AND THOSE WITH MOBILITY DIFFICULTIES (U.S. CLS. 19, 21, 23, 31, 35 AND 44).

MARILYN IZZI, EXAMINING ATTORNEY

SN 85-442,151. KLEMA FLORIDA INTERNATIONAL, L.L.C., MIAMI, FL. FILED 10-7-2011.

KLEMA

THE MARK CONSISTS OF STANDARD CHARACTERS WITHOUT CLAIM TO ANY PARTICULAR FONT, STYLE, SIZE, OR COLOR.

THE WORDING "KLEMA" HAS NO MEANING IN A FOREIGN LANGUAGE.

FOR ANTI-THEFT ALARMS FOR VEHICLES; ANTI-THEFT AUTOMOTIVE ALARMS; ANTI-THEFT DEVICES FOR MOTOR CARS; MOTOR VEHICLE ALARM SYSTEMS (U.S. CLS. 19, 21, 23, 31, 35 AND 44).

FIRST USE 6-19-2007; IN COMMERCE 12-20-2007.

BILL DAWE, EXAMINING ATTORNEY

CLASS 12—(Continued).

SN 85-451,179. HAWKER BEECHCRAFT CORPORATION, WICHITA, KS. FILED 10-19-2011.

GENUINE HAWKER

THE MARK CONSISTS OF STANDARD CHARACTERS WITHOUT CLAIM TO ANY PARTICULAR FONT, STYLE, SIZE, OR COLOR.

OWNER OF U.S. REG. NOS. 1,984,927, 3,775,829 AND OTHERS.

NO CLAIM IS MADE TO THE EXCLUSIVE RIGHT TO USE "GENUINE", APART FROM THE MARK AS SHOWN, FOR STRUCTURAL PARTS FOR AIRCRAFT; STRUCTURAL PARTS FOR AIRCRAFT, NAMELY, WINGLETS FOR AIRCRAFT (U.S. CLS. 19, 21, 23, 31, 35 AND 44).

SANJEEV VOHRA, EXAMINING ATTORNEY

SN 85-457,636. OH BABY CHIC LLC, ATLANTA, GA. FILED 10-27-2011.



ohbabychic

THE COLOR(S) BLACK, WHITE, SILVER IS/ARE CLAIMED AS A FEATURE OF THE MARK.

THE MARK CONSISTS OF BLACK OVAL WITH WHITE LETTERS "B" AND "C" OVERLAPPING INSIDE OF A WHITE LETTER "O" AND BLACK BACKGROUND. THE WORDING "OHBABY" IN SILVER AND "CHIC" IN BLACK, FOR INFANT CAR SEAT COVERS (U.S. CLS. 19, 21, 23, 31, 35 AND 44).

FIRST USE 10-1-2011; IN COMMERCE 10-1-2011.

LUCY ARANT, EXAMINING ATTORNEY

CLASS 12—(Continued).

SN 85-476,615. CAMPAGNOLO S.R.L., VINCENZA, ITALY, FILED 11-18-2011.



PRIORITY CLAIMED UNDER SEC. 44(D) ON ITALY APPLICATION NO. MI2011C01081, FILED 11-4-2011, REG. NO. 1491519, DATED 5-17-2012, EXPIRES 11-4-2021.

THE MARK CONSISTS OF THE NUMBER ELEVEN INSIDE A RECTANGULAR BOX, THE OUTLINE OF A HORIZONTAL BOX IS OVERLAID ON THE IMAGE.

FOR BICYCLES; STRUCTURAL PARTS OF BICYCLES, NAMELY, BICYCLE FRAMES, TUBES AND CONNECTORS FOR BICYCLE FRAMES, BICYCLE WHEELS, RIMS AND SPOKES FOR BICYCLE WHEELS, PEDALS, HUB QUICK RELEASE DEVICES AND HUBS COMPRISING SAID DEVICES, REAR DERAILLEURS, FRONT DERAILLEURS, CRANK ARMS, GEAR WHEELS AND GEAR WHEEL ASSEMBLIES, CRANK ARMS WITH GEAR WHEELS, SPROCKETS, SPROCKET ASSEMBLIES, FREE WHEELS, MECHANIC AND ELECTRONIC DRIVE AND CONTROL MEANS FOR FRONT DERAILLEURS OR REAR DERAILLEURS, BRAKES, BRAKE PADS, DISK BRAKES, CABLE GUIDES, KNOBS AND CONTROL LEVERS, SEAT POSTS AND SEATS, SHAFTS AND BEARINGS FOR CRANK ARMS AND FOR PEDALS, HEAD SETS FOR STEERING ASSEMBLIES, AND BEARINGS AND BUSHINGS THEREOF, FRONT AND REAR FORKS, BRAKE CABLES FOR BICYCLES, FASTENING CLAMPS, BOTTOM BRACKETS, BOTTOM BRACKET ASSEMBLIES, HANDLEBAR CONNECTIONS AND HANDLEBARS, FORKS AND SUSPENSION FORKS, BICYCLE STANDS, TIRES, TUBULAR TIRES, INNER TUBES, CLINCHER TIRES, RIM TAPES FOR TUBELESS TIRES, BICYCLE PUMPS AND SUPPORTS FOR PUMP, TRANSMISSION CHAINS FOR LAND VEHICLES, NAMELY, BICYCLE TRANSMISSION CHAINS; ALL OF THE AFOREMENTIONED GOODS BEING FOR BICYCLES (U.S. CLS. 19, 21, 23, 31, 35 AND 44).

EMILY CHUO, EXAMINING ATTORNEY

SN 85-477,601. APEXWAY PRODUCTS CORPORATION, TAICHUNG, TAIWAN, FILED 11-21-2011.



THE COLOR(S) RED AND BLACK IS/ARE CLAIMED AS A FEATURE OF THE MARK.

THE MARK CONSISTS OF: THE CHARACTERS FORMING THE WORD "APEX" IN RED, FOLLOWED BY ZIGZAG TIRE THREAD PATTERNS IN BLACK TO THE RIGHT OF THE CHARACTERS "APEX".

FOR SOLID TIRES FOR USE WITH FORKLIFTS, EARTHMOVING VEHICLES AND OTHER INDUSTRIAL GRADE VEHICLES, SOLD TO CONSTRUCTION AND OTHER INDUSTRIAL BUSINESSES (U.S. CLS. 19, 21, 23, 31, 35 AND 44).

FIRST USE 4-1-2010; IN COMMERCE 4-1-2010.

HENRY S. ZAK, EXAMINING ATTORNEY

CLASS 12—(Continued).

SN 85-479,772. AUDI AG, INGOLSTADT, FED REP GERMANY, FILED 11-23-2011.

CYLINDER ON DEMAND

THE MARK CONSISTS OF STANDARD CHARACTERS WITHOUT CLAIM TO ANY PARTICULAR FONT, STYLE, SIZE, OR COLOR.

NO CLAIM IS MADE TO THE EXCLUSIVE RIGHT TO USE "CYLINDER", APART FROM THE MARK AS SHOWN.

FOR AUTOMOBILES AND THEIR STRUCTURAL PARTS (U.S. CLS. 19, 21, 23, 31, 35 AND 44).

AMY KELLY, EXAMINING ATTORNEY

SN 85-513,854. NIVEL PARTS AND MANUFACTURING COMPANY, LLC, JACKSONVILLE, FL. FILED 1-11-2012.

TAMPA G

THE MARK CONSISTS OF STANDARD CHARACTERS WITHOUT CLAIM TO ANY PARTICULAR FONT, STYLE, SIZE, OR COLOR.

NO CLAIM IS MADE TO THE EXCLUSIVE RIGHT TO USE "TAMPA", APART FROM THE MARK AS SHOWN.

FOR AFTERMARKET ACCESSORIES FOR GAS, ELECTRIC, AND HYBRID POWERED MOTORIZED GOLF CARTS, LAND VEHICLES, AND ALL-TERRAIN VEHICLES, NAMELY, CANOPIES AND FITTED COVERS FOR MOTORIZED GOLF CARTS, LAND VEHICLES AND ALL-TERRAIN VEHICLES; CARGO CONTAINERS SPECIALLY DESIGNED AND ADAPTED FOR MOTORIZED GOLF CARTS, LAND VEHICLES, AND ALL-TERRAIN VEHICLES; ENCLOSURES IN THE NATURE OF PROTECTIVE FITTED COVERS FOR GAS, ELECTRIC, AND HYBRID POWERED MOTORIZED GOLF CARTS, LAND VEHICLES, AND ALL-TERRAIN VEHICLES; AND CLUB PROTECTORS IN THE NATURE OF GOLF CART CLUB CANOPIES (U.S. CLS. 19, 21, 23, 31, 35 AND 44).

BARBARA BROWN, EXAMINING ATTORNEY

CLASS 12—(Continued).

SN 85-513,861. NIVEL PARTS AND MANUFACTURING COMPANY, LLC, JACKSONVILLE, FL. FILED 1-11-2012.

JAKE'S LIFT KITS

THE MARK CONSISTS OF STANDARD CHARACTERS WITHOUT CLAIM TO ANY PARTICULAR FONT, STYLE, SIZE, OR COLOR.

OWNER OF U.S. REG. NO. 3,694,746.

NO CLAIM IS MADE TO THE EXCLUSIVE RIGHT TO USE "LIFT KITS", APART FROM THE MARK AS SHOWN.

FOR LIFT KITS SPECIALLY DESIGNED AND ADAPTED FOR GAS, ELECTRIC, AND HYBRID POWERED MOTORIZED GOLF CARTS, LAND VEHICLES, AND ALL-TERRAIN VEHICLES CONSISTING OF SUSPENSION HARDWARE, NAMELY, SHOCK ABSORBERS AND LEAF SPRINGS (U.S. CLS. 19, 21, 23, 31, 35 AND 44).

BARBARA BROWN, EXAMINING ATTORNEY

CLASS 12—(Continued).

SN 85-554,970. MARINE ACQUISITION CORP., NEW YORK, NY. FILED 2-28-2012.

DETWILER

THE MARK CONSISTS OF STANDARD CHARACTERS WITHOUT CLAIM TO ANY PARTICULAR FONT, STYLE, SIZE, OR COLOR.

SEC. 2(F).

FOR BOAT PARTS, NAMELY, HYDRAULIC JACK PLATES AND OUTBOARD ENGINE STABILIZER CLIPS (U.S. CLS. 19, 21, 23, 31, 35 AND 44).

FIRST USE 12-0-2000; IN COMMERCE 12-0-2000.

AISHA SALEM, EXAMINING ATTORNEY

SN 85-591,911. KRYPTIC SPORTS LLC, ALBUQUERQUE, NM. FILED 4-7-2012.

KRYPTIC PRO SCOOTERS

THE MARK CONSISTS OF STANDARD CHARACTERS WITHOUT CLAIM TO ANY PARTICULAR FONT, STYLE, SIZE, OR COLOR.

NO CLAIM IS MADE TO THE EXCLUSIVE RIGHT TO USE "PRO SCOOTERS", APART FROM THE MARK AS SHOWN.

FOR SCOOTERS AND STRUCTURAL PARTS FOR SCOOTERS (U.S. CLS. 19, 21, 23, 31, 35 AND 44).

FIRST USE 3-31-2011; IN COMMERCE 6-30-2011.

MEREDITH MARESCA, EXAMINING ATTORNEY

SN 85-513,865. NIVEL PARTS AND MANUFACTURING COMPANY, LLC, JACKSONVILLE, FL. FILED 1-11-2012.

JAKE'S

THE MARK CONSISTS OF STANDARD CHARACTERS WITHOUT CLAIM TO ANY PARTICULAR FONT, STYLE, SIZE, OR COLOR.

OWNER OF U.S. REG. NO. 3,694,746.

FOR GAS, ELECTRIC, AND HYBRID POWERED MOTORIZED GOLF CARTS, LAND VEHICLES, AND ALL-TERRAIN VEHICLES; AFTERMARKET PARTS FOR GAS, ELECTRIC, AND HYBRID POWERED GOLF CARTS, NAMELY, LIFT KITS SPECIALLY DESIGNED AND ADAPTED FOR GAS, ELECTRIC, AND HYBRID POWERED MOTORIZED GOLF CARTS, LAND VEHICLES, AND ALL-TERRAIN VEHICLES CONSISTING OF SUSPENSION HARDWARE, NAMELY, SHOCK ABSORBERS AND LEAF SPRINGS; BOLT-ON OFF-ROAD ACCESSORIES, NAMELY, BRUSH MUD GUARDS, NERF BARS, AND BUMPERS SPECIALLY DESIGNED AND ADAPTED FOR GAS, ELECTRIC, AND HYBRID POWERED MOTORIZED GOLF CARTS, LAND VEHICLES, AND ALL-TERRAIN VEHICLES (U.S. CLS. 19, 21, 23, 31, 35 AND 44).

BARBARA BROWN, EXAMINING ATTORNEY

SN 85-594,217. ROBINSON, LOWELL KIM, FRUITLAND PARK, FL. FILED 4-11-2012.

FLYBOARD

THE MARK CONSISTS OF STANDARD CHARACTERS WITHOUT CLAIM TO ANY PARTICULAR FONT, STYLE, SIZE, OR COLOR.

FOR PERSONAL WATERCRAFT, NAMELY, WATER-JET PROPULSION DRIVEN HARNESSSES (U.S. CLS. 19, 21, 23, 31, 35 AND 44).

IRA J. GOODSaid, EXAMINING ATTORNEY

CLASS 12—(Continued).

SN 85-594,875. DANNAR, GARY, GREENVILLE, SC. FILED 4-11-2012.

MOBILE POWER STATION

THE MARK CONSISTS OF STANDARD CHARACTERS WITHOUT CLAIM TO ANY PARTICULAR FONT, STYLE, SIZE, OR COLOR.

NO CLAIM IS MADE TO THE EXCLUSIVE RIGHT TO USE "MOBILE", APART FROM THE MARK AS SHOWN.

FOR TRACTORS TO WHICH THE FOLLOWING IMPLEMENTS MAY BE ATTACHED—MOWERS, SNOW BLOWERS, SWEEPERS, GRAPPLE BUCKETS AND BLADES FOR MOVING EARTH AND LOOSE OBJECTS, EARTH AUGERS, HYDRAULIC BUCKETS, CHAIN SAWS, CRIMPERS, SHEARS, IMPACT WRENCHES, WATER PUMPS, ASPHALT PLANERS, TREE STUMP GRINDERS, COMPACTORS, BEACH RAKES, HERBICIDE SPRAYERS, CULTIVATORS, PLOWS, TRENCHERS, EARTH BORERS, PRUNERS, AND CLIPPERS (U.S. CLS. 19, 21, 23, 31, 35 AND 44).

DAVID MURRAY, EXAMINING ATTORNEY

SN 85-596,853. GOTOBIKE CARBON COMPOSITE TECHNOLOGY COMPANY LIMITED, HONG KONG, HONG KONG, FILED 4-13-2012.

Winspace

THE MARK CONSISTS OF THE STYLIZED WORDING "Winspace".

FOR BICYCLES; CYCLE HANDLE BARS; BICYCLE RIMS; BICYCLE SADDLES; BICYCLE FRAMES; WHEELS FOR BICYCLES, CYCLES; CRANKS FOR CYCLES; CYCLE HUBS; SADDLES FOR BICYCLES, CYCLES OR MOTORCYCLES; WHEELCHAIRS (U.S. CLS. 19, 21, 23, 31, 35 AND 44).

FIRST USE 2-20-2012; IN COMMERCE 2-20-2012.

JIM RINGLE, EXAMINING ATTORNEY

CLASS 12—(Continued).

SN 85-596,991. BRYAN, LISA, SOUTHLAKE, TX. FILED 4-13-2012.

Seatbelt Soothies

THE MARK CONSISTS OF STANDARD CHARACTERS WITHOUT CLAIM TO ANY PARTICULAR FONT, STYLE, SIZE, OR COLOR.

NO CLAIM IS MADE TO THE EXCLUSIVE RIGHT TO USE "SEATBELT", APART FROM THE MARK AS SHOWN.

FOR FITTED FABRIC COVERS FOR VEHICLE SEAT BELTS TO PROTECT THE NECK FROM CHAFING (U.S. CLS. 19, 21, 23, 31, 35 AND 44).

MICHAEL SOUDERS, EXAMINING ATTORNEY

SN 85-597,224. AMERICAN PACIFIC INDUSTRIES, INC., VALENCIA, CA. FILED 4-13-2012.

PEGASUS MINOS

THE MARK CONSISTS OF STANDARD CHARACTERS WITHOUT CLAIM TO ANY PARTICULAR FONT, STYLE, SIZE, OR COLOR.

OWNER OF U.S. REG. NO. 3,283,529.

FOR TIRES FOR AUTOMOTIVE VEHICLES (U.S. CLS. 19, 21, 23, 31, 35 AND 44).

TOBY BULLOFF, EXAMINING ATTORNEY

SN 85-599,054. FIAT GROUP AUTOMOBILES S.P.A., TORINO, ITALY, FILED 4-16-2012.

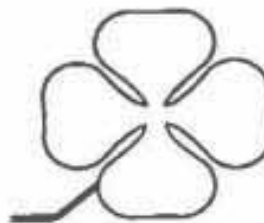

OWNER OF ITALY REG. NO. 1057196, DATED 7-23-2007, EXPIRES 11-30-2013.

THE MARK CONSISTS OF FOUR-LEAVED SHAMROCK DESIGN.

FOR AUTOMOBILES AND STRUCTURAL PARTS THEREFOR (U.S. CLS. 19, 21, 23, 31, 35 AND 44).

REBECCA SMITH, EXAMINING ATTORNEY

CLASS 12—(Continued).

SN 85-599,085. MAURICE SPORTING GOODS, INC., NORTHBROOK, IL. FILED 4-16-2012.

CHARTER MARINE ACCESSORIES

THE MARK CONSISTS OF STANDARD CHARACTERS WITHOUT CLAIM TO ANY PARTICULAR FONT, STYLE, SIZE, OR COLOR.

NO CLAIM IS MADE TO THE EXCLUSIVE RIGHT TO USE "MARINE ACCESSORIES", APART FROM THE MARK AS SHOWN.

FOR CARTOP CANOE AND KAYAK CARRIER KITS; KAYAK EQUIPMENT, NAMELY, KAYAK PADDLE LEASHES, KAYAK TROLLING MOTOR MOUNTS; KAYAK PADDLES (U.S. CLS. 19, 21, 23, 31, 35 AND 44).
LAURIE KAUFMAN, EXAMINING ATTORNEY

CLASS 12—(Continued).

SN 85-600,087. BONE MOUNTAIN MOTOR GEAR, LLC, KANSAS CITY, MO. FILED 4-17-2012.



THE MARK CONSISTS OF CONCENTRIC CIRCLES WITH CROSSED BONES IN THE CENTER OF THE CIRCLES.

FOR LUGGAGE SPECIALLY ADAPTED FOR USE ON MOTORCYCLES; ORGANIZER POUCH SPECIALLY ADAPTED FOR USE ON THE BACKS OF SEATS OF MOTORCYCLES (U.S. CLS. 19, 21, 23, 31, 35 AND 44).
FIRST USE 3-2-2012; IN COMMERCE 3-2-2012.
MEREDITH MARESCA, EXAMINING ATTORNEY

SN 85-599,991. BONE MOUNTAIN MOTOR GEAR, LLC, KANSAS CITY, MO. FILED 4-17-2012.

THE BONE

THE MARK CONSISTS OF STANDARD CHARACTERS WITHOUT CLAIM TO ANY PARTICULAR FONT, STYLE, SIZE, OR COLOR.

FOR LUGGAGE SPECIALLY ADAPTED FOR USE ON MOTORCYCLES; ORGANIZER POUCH SPECIALLY ADAPTED FOR USE ON THE BACKS OF SEATS OF MOTORCYCLES (U.S. CLS. 19, 21, 23, 31, 35 AND 44).
FIRST USE 3-2-2012; IN COMMERCE 3-2-2012.
MEREDITH MARESCA, EXAMINING ATTORNEY

SN 85-600,148. FIAT GROUP AUTOMOBILES S.P.A., TORINO, ITALY, FILED 4-17-2012.

CROSSWAGON

THE MARK CONSISTS OF STANDARD CHARACTERS WITHOUT CLAIM TO ANY PARTICULAR FONT, STYLE, SIZE, OR COLOR.

OWNER OF ITALY REG. NO. 927668, DATED 4-30-2004, EXPIRES 12-24-2013.

FOR MOTOR VEHICLES, NAMELY, AUTOMOBILES; BODYWORKS, NAMELY, AUTOMOBILE BODIES; WINDSHIELD WIPERS, SHOCK ABSORBERS, WHEEL RIMS, ORNAMENTAL HUB CAPS, SAFETY BELTS, ROOF RACKS, TIRES, SEATS, ENGINES, GAS TANKS, SEAT COVERS, AND WHEEL COVERS, ALL FOR LAND VEHICLES (U.S. CLS. 19, 21, 23, 31, 35 AND 44).
REBECCA SMITH, EXAMINING ATTORNEY

CLASS 12—(Continued).

SN 85-600,266. FIAT GROUP AUTOMOBILES S.P.A., TORINO, ITALY, FILED 4-17-2012.

ALFA CROSSWAGON

THE MARK CONSISTS OF STANDARD CHARACTERS WITHOUT CLAIM TO ANY PARTICULAR FONT, STYLE, SIZE, OR COLOR.

OWNER OF ITALY REG. NO. 927667, DATED 4-30-2004, EXPIRES 12-24-2013.

OWNER OF U.S. REG. NOS. 3,881,983, 4,107,413 AND OTHERS.

FOR MOTOR VEHICLES, NAMELY, AUTOMOBILES; BODYWORKS, NAMELY, AUTOMOBILE BODIES; WINDSHIELD WIPERS, SHOCK ABSORBERS, WHEEL RIMS, ORNAMENTAL HUB CAPS, SAFETY BELTS, ROOF RACKS, TIRES, SEATS, ENGINES, GAS TANKS, SEAT COVERS, AND WHEEL COVERS, ALL FOR LAND VEHICLES (U.S. CLS. 19, 21, 23, 31, 35 AND 44).

REBECCA SMITH, EXAMINING ATTORNEY

SN 85-602,107. AIR GALAXY ROAD TECHNOLOGIES, LLC, PARKLAND, FL. FILED 4-19-2012.

AIR GALAXY ROAD

THE MARK CONSISTS OF STANDARD CHARACTERS WITHOUT CLAIM TO ANY PARTICULAR FONT, STYLE, SIZE, OR COLOR.

FOR AUTOMOBILES AND STRUCTURAL PARTS THEREFOR (U.S. CLS. 19, 21, 23, 31, 35 AND 44).

MICHAEL SOUDERS, EXAMINING ATTORNEY

SN 85-602,682. ROLL N BABI3, LLC, ROWLETT, TX. FILED 4-19-2012.

ROLL N BABI3

THE MARK CONSISTS OF STANDARD CHARACTERS WITHOUT CLAIM TO ANY PARTICULAR FONT, STYLE, SIZE, OR COLOR.

FOR BABY STROLLERS; STROLLERS; SAFETY SEATS FOR INFANTS AND CHILDREN FOR VEHICLES, NAMELY SAFETY SEATS CONVERTIBLE FOR USE AS A STROLLER; SAFETY CAR SEATS FOR CHILDREN, INFANTS, AND TODDLERS (U.S. CLS. 19, 21, 23, 31, 35 AND 44).

JOHN E. MICHOS, EXAMINING ATTORNEY

CLASS 12—(Continued).

SN 85-602,801. TURNER, LAURENCE D, VACAVILLE, CA. FILED 4-19-2012.

HITCHHAT

THE MARK CONSISTS OF STANDARD CHARACTERS WITHOUT CLAIM TO ANY PARTICULAR FONT, STYLE, SIZE, OR COLOR.

FOR TRAILER HITCH BALL COVERS (U.S. CLS. 19, 21, 23, 31, 35 AND 44).

ANNE E. GUSTASON, EXAMINING ATTORNEY

SN 85-603,459. MALIBU BOATS, LLC, MERCED, CA. FILED 4-20-2012.



THE MARK CONSISTS OF TWO HALVES OF A CIRCLE ON TOP AND BOTTOM WITH FOUR HORIZONTAL LINES OF VARYING LENGTH AND WIDTH IN BETWEEN THE HALVES TO THE LEFT AND THE LETTER M IN BETWEEN IN THE HALVES ON THE RIGHT.

FOR BOATS (U.S. CLS. 19, 21, 23, 31, 35 AND 44).

TINA L. SNAPP, EXAMINING ATTORNEY

SN 85-603,494. D. TERRY GREENFIELD, FAIRHOPE,, AL. FILED 4-20-2012.

SEAFLIGHT

THE MARK CONSISTS OF STANDARD CHARACTERS WITHOUT CLAIM TO ANY PARTICULAR FONT, STYLE, SIZE, OR COLOR.

FOR BOATS (U.S. CLS. 19, 21, 23, 31, 35 AND 44).

STEVEN R. FINE, EXAMINING ATTORNEY

CLASS 12—(Continued).

SN 85-603,844. FAIRWAY GOLF CAR CORP., MEDFORD, NY. FILED 4-20-2012.

PIT-CREWZER

THE MARK CONSISTS OF STANDARD CHARACTERS WITHOUT CLAIM TO ANY PARTICULAR FONT, STYLE, SIZE, OR COLOR.

FOR ELECTRIC GOLF CADDIES; MOTORIZED GOLF CARTS (U.S. CLS. 19, 21, 23, 31, 35 AND 44).
FIRST USE 3-1-2012; IN COMMERCE 3-1-2012.
JIM RINGLE, EXAMINING ATTORNEY

CLASS 12—(Continued).

SN 85-605,091. MOTORAMBAR, INC., SAN JUAN, PUERTO RICO, FILED 4-23-2012.

LUJO A OTRO NIVEL

THE MARK CONSISTS OF STANDARD CHARACTERS WITHOUT CLAIM TO ANY PARTICULAR FONT, STYLE, SIZE, OR COLOR.

THE ENGLISH TRANSLATION OF "LUJO A OTRO NIVEL" IN THE MARK IS "LUXURY TO ANOTHER LEVEL".

FOR MOTOR VEHICLES, NAMELY, AUTOMOBILES, TRUCKS, VANS, SPORT UTILITY VEHICLES AND STRUCTURAL PARTS THEREFOR (U.S. CLS. 19, 21, 23, 31, 35 AND 44).
AHSEN KHAN, EXAMINING ATTORNEY

SN 85-604,092. ACTIVE CONTROLS LLC, SEWELL, NJ. FILED 4-20-2012.

ReJoy

THE MARK CONSISTS OF STANDARD CHARACTERS WITHOUT CLAIM TO ANY PARTICULAR FONT, STYLE, SIZE, OR COLOR.

FOR STEERING UNITS FOR LAND VEHICLES AND PARTS THEREOF (U.S. CLS. 19, 21, 23, 31, 35 AND 44).
AHSEN KHAN, EXAMINING ATTORNEY

SN 85-605,323. FLEETWOOD RV, INC., DECATUR, IN. FILED 4-23-2012.

AMERICAN REVOLUTION

THE MARK CONSISTS OF STANDARD CHARACTERS WITHOUT CLAIM TO ANY PARTICULAR FONT, STYLE, SIZE, OR COLOR.

OWNER OF U.S. REG. NOS. 2,715,631 AND 4,127,857.
FOR RECREATIONAL VEHICLES, NAMELY, MOTOR HOMES (U.S. CLS. 19, 21, 23, 31, 35 AND 44).
FIRST USE 11-30-2010; IN COMMERCE 11-30-2010.
MAUREEN DALL, EXAMINING ATTORNEY

SN 85-604,567. CURLESS, CRAIG, INDIANAPOLIS, IN. FILED 4-21-2012.

DaSaddle

THE MARK CONSISTS OF STANDARD CHARACTERS WITHOUT CLAIM TO ANY PARTICULAR FONT, STYLE, SIZE, OR COLOR.

FOR BICYCLE SADDLES; BICYCLE SEATS (U.S. CLS. 19, 21, 23, 31, 35 AND 44).
SETH A. RAPPAPORT, EXAMINING ATTORNEY

SN 85-605,487. LANCE CALEEN, HAINES CITY, FL. AND LILLIAN CALEEN, HAINES CITY, FL. FILED 4-23-2012.

ROLL-A-LADDER

THE MARK CONSISTS OF STANDARD CHARACTERS WITHOUT CLAIM TO ANY PARTICULAR FONT, STYLE, SIZE, OR COLOR.

FOR WHEELED LADDER ATTACHMENTS, NAMELY, ATTACHMENTS HAVING NON-MOTORIZED WHEELS DESIGNED FOR THE BOTTOM PORTION OF LADDER LEGS AND USED FOR MOVING AND MANIPULATING LADDER PLACEMENT (U.S. CLS. 19, 21, 23, 31, 35 AND 44).

MIDGE BUTLER, EXAMINING ATTORNEY

CLASS 12—(Continued).

SN 85-605,855. WOHO BIKE ACCESSORY CORP., TAIPEI CITY, TAIWAN, FILED 4-23-2012.



THE MARK CONSISTS OF THE STYLIZED WORDING "WOHO".

FOR LAND VEHICLES, NAMELY, BICYCLES, NAMELY, ELECTRIC BICYCLES AND NON-ELECTRIC BICYCLES, AND PARTS AND ACCESSORIES THEREOF, NAMELY, PANNIER BAGS FOR BICYCLES, SHOPPING BASKETS ADAPTED FOR BICYCLES, BICYCLE FENDERS, BICYCLE BELLS, BICYCLE BRAKES, BICYCLE CHAINS, BICYCLE FRAMES, BICYCLE HANDLE BARS, BICYCLE HANDLE BAR GRIPS, BICYCLE SADDLES, BICYCLE TIRES, BICYCLE CHANGE-SPEED GEARS, BICYCLE PEDALS AND VEHICLE LUGGAGE RACKS ADAPTED FOR BICYCLES (U.S. CLS. 19, 21, 23, 31, 35 AND 44).

FIRST USE 7-1-2009; IN COMMERCE 7-1-2009.
JORDAN BAKER, EXAMINING ATTORNEY

CLASS 12—(Continued).

SN 85-623,288. BRIDGESTONE CORPORATION, TOKYO, JAPAN, FILED 5-11-2012.

BATTLAX RACING R10 EVO

THE MARK CONSISTS OF STANDARD CHARACTERS WITHOUT CLAIM TO ANY PARTICULAR FONT, STYLE, SIZE, OR COLOR.

OWNER OF U.S. REG. NO. 1,656,197.

NO CLAIM IS MADE TO THE EXCLUSIVE RIGHT TO USE "RACING", APART FROM THE MARK AS SHOWN.

FOR TIRES; TIRES OF TWO-WHEELED MOTOR VEHICLES OR BICYCLES (U.S. CLS. 19, 21, 23, 31, 35 AND 44).

SANI KHOURI, EXAMINING ATTORNEY

SN 85-624,390. SPECIALIZED BICYCLE COMPONENTS, INC., MORGAN HILL, CA. FILED 5-14-2012.



OWNER OF U.S. REG. NOS. 1,709,918, 3,957,466 AND OTHERS.

THE MARK CONSISTS OF THE LETTER "S" FOLLOWED BY A DASH AND THEN THE WORD "WORKS" ALL IN A STYLIZED FONT.

FOR BICYCLES AND BICYCLE FRAMES (U.S. CLS. 19, 21, 23, 31, 35 AND 44).

FIRST USE 7-31-2001; IN COMMERCE 7-31-2001.

IRA J. GOODSAD, EXAMINING ATTORNEY

SN 85-610,693. FIAT GROUP AUTOMOBILES S.P.A., TORINO, ITALY, FILED 4-27-2012.



THE MARK CONSISTS OF STANDARD CHARACTERS WITHOUT CLAIM TO ANY PARTICULAR FONT, STYLE, SIZE, OR COLOR.

OWNER OF ITALY REG. NO. 926763, DATED 3-26-2004, EXPIRES 9-30-2013.

OWNER OF U.S. REG. NOS. 3,927,317, 4,123,672 AND OTHERS.

NO CLAIM IS MADE TO THE EXCLUSIVE RIGHT TO USE "GT", APART FROM THE MARK AS SHOWN.

FOR MOTOR VEHICLES, BODYWORKS, WIND-SCREEN WIPERS, SHOCK ABSORBERS, WHEEL RIMS, ORNAMENTAL HUB CAPS, SAFETY BELTS, ROOF RACKS, TYRES, WHEELS, DOORS, SEATS, ENGINES AND TANKS FOR MOTOR VEHICLES (U.S. CLS. 19, 21, 23, 31, 35 AND 44).

REBECCA SMITH, EXAMINING ATTORNEY

SN 85-634,833. EMBRAER S.A., SAN JOSE DOS CAMPOS SP, BRAZIL, FILED 5-24-2012.



THE MARK CONSISTS OF STANDARD CHARACTERS WITHOUT CLAIM TO ANY PARTICULAR FONT, STYLE, SIZE, OR COLOR.

FOR AIRCRAFT, NAMELY AIRPLANES AND STRUCTURAL PARTS THEREOF (U.S. CLS. 19, 21, 23, 31, 35 AND 44).

ANGELA M. MICHELI, EXAMINING ATTORNEY

CLASS 12—(Continued).

SN 85-644,305. BRIDGESTONE CORPORATION, TOKYO, JAPAN, FILED 6-6-2012.

ECOPIA H/L 422 PLUS

THE MARK CONSISTS OF STANDARD CHARACTERS WITHOUT CLAIM TO ANY PARTICULAR FONT, STYLE, SIZE, OR COLOR.

OWNER OF U.S. REG. NOS. 3,060,405, 3,557,891 AND 3,790,969.

FOR TIRES (U.S. CLS. 19, 21, 23, 31, 35 AND 44).
SANI KHOURI, EXAMINING ATTORNEY

CLASS 13—(Continued).

SN 85-151,833. PLASTIC INDUSTRIES, ATHENS, TN. FILED 10-13-2010.

CarbonKnight

THE MARK CONSISTS OF STANDARD CHARACTERS WITHOUT CLAIM TO ANY PARTICULAR FONT, STYLE, SIZE, OR COLOR.

OWNER OF U.S. REG. NOS. 1,947,037, 3,381,829 AND OTHERS.

FOR MUZZLE-LOADING FIREARMS (U.S. CLS. 2 AND 9).

FIRST USE 12-0-2010; IN COMMERCE 12-0-2010.
ELIZABETH KAJUBI, EXAMINING ATTORNEY

CLASS 13—FIREARMS

SN 77-631,684. IMPERIAL MANUFACTURING GROUP, INC., RICHIBUCTO, CANADA, FILED 12-11-2008.

FLAME-MAGIK

THE MARK CONSISTS OF STANDARD CHARACTERS WITHOUT CLAIM TO ANY PARTICULAR FONT, STYLE, SIZE, OR COLOR.

PRIORITY CLAIMED UNDER SEC. 44(D) ON CANADA APPLICATION NO. 1,399,081, FILED 6-11-2008, REG. NO. TMA814,000, DATED 12-14-2011, EXPIRES 12-14-2026.

FOR FIRE IGNITERS, NAMELY, FIRE CRYSTALS (U.S. CLS. 2 AND 9).

ANNE E. GUSTASON, EXAMINING ATTORNEY

SN 85-511,630. SLIDE FIRE SOLUTIONS, LP, MORAN, TX. FILED 1-9-2012.

SSAK-47

THE MARK CONSISTS OF STANDARD CHARACTERS WITHOUT CLAIM TO ANY PARTICULAR FONT, STYLE, SIZE, OR COLOR.

FOR GUN STOCKS, NAMELY, RECIPROCATING STOCK PERMITTING CONTROLLED RAPID FIRING OF FIREARMS (U.S. CLS. 2 AND 9).

JAY BESCH, EXAMINING ATTORNEY

SN 79-112,236. CLOSED JOINT STOCK COMPANY "BARNAUL CARTRIDGE PLANT", RU-656002 ALTAI TERRITORY, RUSSIAN FED., FILED 11-17-2011.



OWNER OF INTERNATIONAL REGISTRATION 1114197 DATED 11-17-2011, EXPIRES 11-17-2021.

THE MARK CONSISTS OF CYRILLIC CHARACTERS THAT TRANSLITERATE TO "BE PE ZE" AND FORM A BULLET.

THE NON-LATIN CHARACTERS IN THE MARK TRANSLITERATE TO "BE PE ZE" AND THIS MEANS "BPZ" IN ENGLISH.

FOR GUN CARTRIDGES; CARTRIDGE CASES; AMMUNITION FOR FIREARMS (U.S. CLS. 2 AND 9).

ROBERT STRUCK, EXAMINING ATTORNEY

SN 85-593,564. DEFINITIVE ARMS LLC, ST. PETERSBURG, FL. FILED 4-10-2012.

Definitive Arms

THE MARK CONSISTS OF STANDARD CHARACTERS WITHOUT CLAIM TO ANY PARTICULAR FONT, STYLE, SIZE, OR COLOR.

NO CLAIM IS MADE TO THE EXCLUSIVE RIGHT TO USE "ARMS", APART FROM THE MARK AS SHOWN.

FOR FIREARMS (U.S. CLS. 2 AND 9).

FIRST USE 9-9-2010; IN COMMERCE 1-1-2011.

SEAN CROWLEY, EXAMINING ATTORNEY

CLASS 13—(Continued).

SN 85-598,556. SMITH & WESSON CORP., SPRINGFIELD, MA. FILED 4-16-2012.



NO CLAIM IS MADE TO THE EXCLUSIVE RIGHT TO USE "COMPONENTS", APART FROM THE MARK AS SHOWN.

FOR FIREARMS AND COMPONENT PARTS THEREOF (U.S. CLS. 2 AND 9).

FIRST USE 1-20-2012; IN COMMERCE 1-20-2012.
KIMBERLY FRYE, EXAMINING ATTORNEY

SN 85-604,929. SMITH & WESSON CORP., SPRINGFIELD, MA. FILED 4-23-2012.



OWNER OF U.S. REG. NOS. 3,207,677, 4,184,281 AND OTHERS.

NO CLAIM IS MADE TO THE EXCLUSIVE RIGHT TO USE "BOLT-ACTION PLATFORM" AND "INTERCHANGEABLE BARRELS, STOCKS, COMPONENTS", APART FROM THE MARK AS SHOWN.

THE MARK CONSISTS OF "DIMENSION" ABOVE THE WORDS "BOLT-ACTION PLATFORM", ALONG WITH A PICTURE OF A RIFLE IN A SHIELD ALONG WITH THE WORDS "INTERCHANGEABLE BARRELS, STOCKS, COMPONENTS" AND AN INTERLOCKING 'T' AND 'C' IN A CIRCLE.

FOR FIREARMS AND COMPONENT PARTS THEREOF (U.S. CLS. 2 AND 9).

FIRST USE 1-20-2012; IN COMMERCE 1-20-2012.
KIMBERLY FRYE, EXAMINING ATTORNEY

CLASS 14—JEWELRY

SN 76-711,283. DEMARCO JEWELRY, INC., LOS ANGELES, CA. FILED 4-19-2012.



THE COLORS GOLD AND PINK ARE CLAIMED AS A FEATURE OF THE MARK.

THE MARK CONSISTS OF A RAISED GOLD STYLIZED LETTER "D" BESIDE A RAISED GOLD CIRCLE CONTAINING A PINK GEMSTONE ALL WITHIN A RAISED GOLD OVAL BORDER.

FOR JEWELRY (U.S. CLS. 2, 27, 28 AND 50).
FIRST USE 5-1-2011; IN COMMERCE 7-19-2011.

JOHN WILKE, EXAMINING ATTORNEY

SN 79-102,302. YASUHARA YOSHIO, TOKYO, JAPAN, FILED 8-19-2011.

COLLAR SUSPENDER

THE MARK CONSISTS OF STANDARD CHARACTERS WITHOUT CLAIM TO ANY PARTICULAR FONT, STYLE, SIZE, OR COLOR.

PRIORITY DATE OF 2-21-2011 IS CLAIMED.

OWNER OF INTERNATIONAL REGISTRATION 1090030 DATED 8-19-2011, EXPIRES 8-19-2021.

NO CLAIM IS MADE TO THE EXCLUSIVE RIGHT TO USE "COLLAR", APART FROM THE MARK AS SHOWN.

FOR ORNAMENTS, NAMELY, ORNAMENTS FOR COLLAR IN THE NATURE OF JEWELRY (U.S. CLS. 2, 27, 28 AND 50).

CARYN GLASSER, EXAMINING ATTORNEY

CLASS 14—(Continued).

SN 79-108,871. VINCENT PLOMB, CH-2926 BONCOURT, SWITZERLAND, FILED 12-13-2011.



PRIORITY DATE OF 6-14-2011 IS CLAIMED.
OWNER OF INTERNATIONAL REGISTRATION 1105989 DATED 12-13-2011, EXPIRES 12-13-2021.

FOR PRECIOUS METALS AND THEIR ALLOYS AND GOODS IN PRECIOUS METALS OR COATED THEREWITH, NAMELY, JEWELRY, PRECIOUS STONES, TIMEPIECES AND CHRONOMETRIC INSTRUMENTS, WATCHES, MECHANICAL WATCHES, CHRONOGRAPHS AS WATCHES, CHRONOGRAPHS FOR USE AS WATCHES, CHRONOGRAPHS FOR USE AS TIMEPIECES, CHRONOMETERS, CLOCK HANDS, WATCH CASES, CLOCK DIALS, WATCH DIALS, DIALS FOR CLOCK AND WATCH MAKING, WATCH BANDS, MOVEMENTS FOR CLOCKS AND WATCHES, PRESENTATION CASES FOR TIMEPIECES, CASES FOR TIMEPIECES, AND BUCKLE BRACELETS; JEWELRY, PRECIOUS STONES; HOROLOGICAL AND CHRONOMETRIC INSTRUMENTS; TIMEPIECES; WATCHES, WRISTWATCHES, MECHANICAL WATCHES, CHRONOGRAPHS FOR USE AS WATCHES, CHRONOMETERS, CLOCK HANDS, WATCH CASES, CLOCK AND WATCH DIALS, WATCH STRAPS, WATCH BANDS, WATCH SPRINGS, MOVEMENTS FOR CLOCKS AND WATCHES, CLOCK AND WATCH-MAKING PARTS, NAMELY, BARRELS, WATCH CHAINS, WATCH GLASSES; CASES FOR WATCHES, CASES FOR CLOCK- AND WATCH-MAKING, CASES FOR TIMEPIECES (U.S. CLS. 2, 27, 28 AND 50).

SUE LAWRENCE, EXAMINING ATTORNEY

SN 79-111,120. NANA FINK, BASEL, SWITZERLAND, FILED 1-16-2012.



NANA FINK

OWNER OF INTERNATIONAL REGISTRATION 1111651 DATED 1-16-2012, EXPIRES 1-16-2022.

THE NAME(S), PORTRAIT(S), AND/OR SIGNATURE(S) SHOWN IN THE MARK IDENTIFIES NADINE FINK, WHOSE CONSENT(S) TO REGISTER IS MADE OF RECORD.

THE MARK CONSISTS OF A DESIGN OF A RING WITH LION HEADS AT EACH END OF THE RING; UNDERNEATH THE RING APPEARS THE ELEMENTS "NANA FINK".

FOR PRECIOUS METALS AND THEIR ALLOYS; JEWELRY OF PRECIOUS METALS AND PLATED WITH PRECIOUS METALS, NAMELY, BRACELETS, RINGS, BANGLES, PENDANTS, NECKLACES, EARRINGS, AND CUFFLINKS; JEWELRY, PRECIOUS STONES; HOROLOGICAL AND CHRONOMETRIC INSTRUMENTS; KEY RINGS OF PRECIOUS METALS (U.S. CLS. 2, 27, 28 AND 50).

CHRISTOPHER BUONGIORNO, EXAMINING ATTORNEY

CLASS 14—(Continued).

SN 79-111,759. CHRISTIAN DIOR COUTURE, FRANCE, FILED 2-24-2012.

ROSE DIOR BAGATELLE

THE MARK CONSISTS OF STANDARD CHARACTERS WITHOUT CLAIM TO ANY PARTICULAR FONT, STYLE, SIZE, OR COLOR.

PRIORITY DATE OF 11-30-2011 IS CLAIMED.

OWNER OF INTERNATIONAL REGISTRATION 1113075 DATED 2-24-2012, EXPIRES 2-24-2022.

THE NAME "ROSE DIOR" DOES NOT IDENTIFY A LIVING INDIVIDUAL.

FOR JEWELRY; PRECIOUS AND SEMI-PRECIOUS STONES AND IMITATIONS THEREOF, TIMEPIECES AND CHRONOMETRIC INSTRUMENTS; COLLECTIBLE COINS; NON-MONETARY COINS; WORKS OF ART OF PRECIOUS METAL; JEWELRY CASES; BOXES OF PRECIOUS METAL; WATCH CASES, BANDS, CHAINS, SPRINGS OR GLASSES; KEY RINGS OF PRECIOUS METAL; STATUES AND FIGURINES OF PRECIOUS METAL; CASES AND PRESENTATION CASES FOR TIMEPIECES; MEDALS; TRINKETS, NAMELY, RINGS; BUCKLES OF PRECIOUS METAL FOR WATCHSTRAPS (U.S. CLS. 2, 27, 28 AND 50).

WILLIAM BRECKENFELD, EXAMINING ATTORNEY

SN 79-111,825. CHRISTIAN DIOR COUTURE, FRANCE, FILED 2-24-2012.

ROSE DIOR PRE CATELAN

THE MARK CONSISTS OF STANDARD CHARACTERS WITHOUT CLAIM TO ANY PARTICULAR FONT, STYLE, SIZE, OR COLOR.

PRIORITY DATE OF 11-30-2011 IS CLAIMED.

OWNER OF INTERNATIONAL REGISTRATION 1113235 DATED 2-24-2012, EXPIRES 2-24-2022.

FOR JEWELRY; PRECIOUS AND SEMI-PRECIOUS STONES AND IMITATIONS THEREOF, TIMEPIECES AND CHRONOMETRIC INSTRUMENTS; COLLECTIBLE COINS; NON-MONETARY COINS; WORKS OF ART OF PRECIOUS METAL; JEWELRY CASES; BOXES OF PRECIOUS METAL; WATCH CASES, BANDS, CHAINS, SPRINGS OR GLASSES; KEY RINGS OF PRECIOUS METAL; STATUES AND FIGURINES OF PRECIOUS METAL; CASES AND PRESENTATION CASES FOR TIMEPIECES; MEDALS; TRINKETS, NAMELY, RINGS; BUCKLES OF PRECIOUS METAL FOR WATCH STRAPS (U.S. CLS. 2, 27, 28 AND 50).

WILLIAM BRECKENFELD, EXAMINING ATTORNEY

SN 79-112,404. MANUFACTURE ROGER DUBUIS SA, SWITZERLAND, FILED 4-19-2012.

THE INCREDIBLE PLAYER

THE MARK CONSISTS OF STANDARD CHARACTERS WITHOUT CLAIM TO ANY PARTICULAR FONT, STYLE, SIZE, OR COLOR.

PRIORITY DATE OF 11-3-2011 IS CLAIMED.

OWNER OF INTERNATIONAL REGISTRATION 1114700 DATED 4-19-2012, EXPIRES 4-19-2022.

FOR CUFF LINKS, TIE CLIPS, RINGS, BRACELETS, EARRINGS, NECKLACES, BROOCHES, KEY RINGS OF PRECIOUS METALS, WATCHES, CHRONOMETERS, CLOCKS; WATCH BANDS, BOXES OF PRECIOUS METAL FOR WATCHES AND JEWELRY, ALARM CLOCKS (U.S. CLS. 2, 27, 28 AND 50).

SANI KHOURI, EXAMINING ATTORNEY

CLASS 14—(Continued).

SN 79-112,405. MANUFACTURE ROGER DUBUIS SA, CH-1217 MEYRIN, SWITZERLAND, FILED 4-19-2012.

THE INCREDIBLE WARRIOR

THE MARK CONSISTS OF STANDARD CHARACTERS WITHOUT CLAIM TO ANY PARTICULAR FONT, STYLE, SIZE, OR COLOR.

PRIORITY DATE OF 11-3-2011 IS CLAIMED.

OWNER OF INTERNATIONAL REGISTRATION 1114701 DATED 4-19-2012, EXPIRES 4-19-2022.

FOR CUFF LINKS, TIE CLIPS, RINGS, BRACELETS, EARRINGS, NECKLACES, BROOCHES, KEY RINGS OF PRECIOUS METALS, WATCHES, CHRONOMETERS, CLOCKS; WATCH BANDS, BOXES OF PRECIOUS METAL FOR WATCHES AND JEWELRY, ALARM CLOCKS (U.S. CLS. 2, 27, 28 AND 50).

SANI KHOURI, EXAMINING ATTORNEY

SN 79-112,406. MANUFACTURE ROGER DUBUIS SA, CH-1217 MEYRIN, SWITZERLAND, FILED 4-19-2012.

THE INCREDIBLE DIVA

THE MARK CONSISTS OF STANDARD CHARACTERS WITHOUT CLAIM TO ANY PARTICULAR FONT, STYLE, SIZE, OR COLOR.

PRIORITY DATE OF 11-3-2011 IS CLAIMED.

OWNER OF INTERNATIONAL REGISTRATION 1114702 DATED 4-19-2012, EXPIRES 4-19-2022.

FOR CUFF LINKS, TIE CLIPS, RINGS, BRACELETS, EARRINGS, NECKLACES, BROOCHES, KEY RINGS OF PRECIOUS METALS, WATCHES, CHRONOMETERS, CLOCKS; WATCH BANDS, BOXES OF PRECIOUS METAL FOR WATCHES AND JEWELRY, ALARM CLOCKS (U.S. CLS. 2, 27, 28 AND 50).

SANI KHOURI, EXAMINING ATTORNEY

SN 79-113,197. XIAMEN NEWSTEP IMP. & EXP. CO., LTD., XIAMEN, CHINA, FILED 3-13-2012.

**NEWSTEP
2001**

OWNER OF INTERNATIONAL REGISTRATION 1116737 DATED 3-13-2012, EXPIRES 3-13-2022.

NO CLAIM IS MADE TO THE EXCLUSIVE RIGHT TO USE "2001", APART FROM THE MARK AS SHOWN.

THE MARK CONSISTS OF THE STYLIZED LETTERING "N", "E", "W", "S", "T", "E", "P" "2001".

FOR CLOCKS; WRISTWATCHES; DIALS FOR CLOCK AND WATCH MAKING; ELECTRIC CLOCKS AND WATCHES; ALARM CLOCKS; CLOCKWORKS; WATCHES; ATOMIC CLOCKS; STOPWATCHES (U.S. CLS. 2, 27, 28 AND 50).

JOSETTE BEVERLY, EXAMINING ATTORNEY

CLASS 14—(Continued).

SN 85-424,116. KYLIE JENNER, INC., WOODLAND HILLS, CA. FILED 9-15-2011.

KYLIE JENNER

THE MARK CONSISTS OF STANDARD CHARACTERS WITHOUT CLAIM TO ANY PARTICULAR FONT, STYLE, SIZE, OR COLOR.

THE NAME(S), PORTRAIT(S), AND/OR SIGNATURE(S) SHOWN IN THE MARK IDENTIFIES "KYLIE JENNER", WHOSE CONSENT(S) TO REGISTER IS MADE OF RECORD.

FOR CLOCKS; JEWELRY; WATCHES (U.S. CLS. 2, 27, 28 AND 50).

PRISCILLA MILTON, EXAMINING ATTORNEY

SN 85-440,331. WYCOFF, CHRISTOPHER D., FRISCO, TX. FILED 10-5-2011.

NEXGEN BANDZ

THE MARK CONSISTS OF STANDARD CHARACTERS WITHOUT CLAIM TO ANY PARTICULAR FONT, STYLE, SIZE, OR COLOR.

NO CLAIM IS MADE TO THE EXCLUSIVE RIGHT TO USE "BANDS", APART FROM THE MARK AS SHOWN.

FOR BRACELETS; RUBBER OR SILICON WRISTBANDS IN THE NATURE OF A BRACELET (U.S. CLS. 2, 27, 28 AND 50).

FIRST USE 8-1-2012; IN COMMERCE 8-1-2012.

SUZANNE BLANE, EXAMINING ATTORNEY

SN 85-440,624. PIXIE STUFF, L.L.C., ST. LOUIS, MO. FILED 10-6-2011.

SAY "NOPE" TO SMOKE

THE MARK CONSISTS OF STANDARD CHARACTERS WITHOUT CLAIM TO ANY PARTICULAR FONT, STYLE, SIZE, OR COLOR.

FOR JEWELRY; RUBBER OR SILICON WRISTBANDS IN THE NATURE OF A BRACELET (U.S. CLS. 2, 27, 28 AND 50).

FIRST USE 9-6-2011; IN COMMERCE 10-6-2011.

LINDA POWELL, EXAMINING ATTORNEY

CLASS 14—(Continued).

SN 85-443,763. AMORO HOLDINGS LTD., BRIDGETOWN, BARBADOS, FILED 10-10-2011.



OWNER OF U.S. REG. NO. 2,901,686.
NO CLAIM IS MADE TO THE EXCLUSIVE RIGHT TO USE "FINE JEWELRY", APART FROM THE MARK AS SHOWN.

THE MARK CONSISTS OF A STYLIZED DESIGN OF TWO HEARTS TO THE LEFT OF THE WORDS "AMORO FINE JEWELRY".

FOR JEWELRY (U.S. CLS. 2, 27, 28 AND 50).
FIRST USE 8-1-2011; IN COMMERCE 8-1-2011.
BRENDAN REGAN, EXAMINING ATTORNEY

SN 85-443,794. AMORO HOLDINGS LTD., BRIDGETOWN, BARBADOS, FILED 10-10-2011.

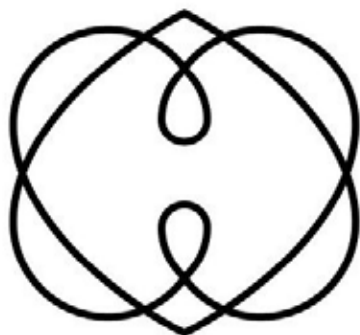

THE MARK CONSISTS OF A STYLIZED DESIGN OF TWO HEARTS.

FOR JEWELRY (U.S. CLS. 2, 27, 28 AND 50).
FIRST USE 8-1-2011; IN COMMERCE 8-1-2011.
BRENDAN REGAN, EXAMINING ATTORNEY

SN 85-449,306. AMORO HOLDINGS LTD., BRIDGETOWN, BARBADOS, FILED 10-17-2011.



OWNER OF U.S. REG. NO. 2,901,686.
THE MARK CONSISTS OF A STYLIZED DESIGN OF TWO HEARTS TO THE LEFT OF THE WORDS "YESTERDAY. TODAY. AMORO".

FOR JEWELRY (U.S. CLS. 2, 27, 28 AND 50).
FIRST USE 8-1-2011; IN COMMERCE 8-1-2011.
BRENDAN REGAN, EXAMINING ATTORNEY

CLASS 14—(Continued).

SN 85-450,927. BAMA RAGS, INC., CHARLOTTESVILLE, VA, FILED 10-19-2011.

DAVE MATTHEWS BAND

THE MARK CONSISTS OF STANDARD CHARACTERS WITHOUT CLAIM TO ANY PARTICULAR FONT, STYLE, SIZE, OR COLOR.

OWNER OF U.S. REG. NOS. 1,865,013, 2,260,276 AND OTHERS.

THE NAME(S), PORTRAIT(S), AND/OR SIGNATURE(S) SHOWN IN THE MARK IDENTIFIES "DAVID J. MATTHEWS", WHOSE CONSENT(S) TO REGISTER IS MADE OF RECORD.

FOR JEWELRY; KEY CHAINS OF PRECIOUS METAL; WORKS OF ART OF PRECIOUS METAL (U.S. CLS. 2, 27, 28 AND 50).

FIRST USE 5-30-2001; IN COMMERCE 5-30-2001.
WON TEAK OH, EXAMINING ATTORNEY

SN 85-459,948. PRIME GROWTH ASSETS LIMITED, ROAD TOWN, TORTOLA, BR. VIRGIN ISLANDS, FILED 10-31-2011.

ENZO

THE MARK CONSISTS OF STANDARD CHARACTERS WITHOUT CLAIM TO ANY PARTICULAR FONT, STYLE, SIZE, OR COLOR.

OWNER OF U.S. REG. NOS. 3,726,282 AND 3,729,320.
THE WORDING "ENZO" HAS NO MEANING IN A FOREIGN LANGUAGE.

FOR CLOCKS AND WATCHES; DIAMONDS; HAT ORNAMENTS OF PRECIOUS METAL; HOROLOGICAL AND CHRONOMETRIC INSTRUMENTS AND PARTS THEREOF; JEWELRY; PRECIOUS GEMSTONES; PRECIOUS METALS; PRECIOUS METALS AND ALLOYS THEREOF; PRECIOUS STONES; SEMI-PRECIOUS GEMSTONES; SHOE ORNAMENTS OF PRECIOUS METAL (U.S. CLS. 2, 27, 28 AND 50).

LINDA MICKLEBURGH, EXAMINING ATTORNEY

SN 85-464,917. RENAISSANCE JEWELRY NEW YORK, INC., NEW YORK, NY, FILED 11-4-2011.

AURELLE

THE MARK CONSISTS OF STANDARD CHARACTERS WITHOUT CLAIM TO ANY PARTICULAR FONT, STYLE, SIZE, OR COLOR.

FOR JEWELRY (U.S. CLS. 2, 27, 28 AND 50).
SANI KHOURI, EXAMINING ATTORNEY

CLASS 14—(Continued).

SN 85-482,223. SALVATORE FERRAGAMO S.P.A., FLORENCE, ITALY, FILED 11-29-2011.

**SALVATORE FERRAGAMO
RENAISSANCE**

THE MARK CONSISTS OF STANDARD CHARACTERS WITHOUT CLAIM TO ANY PARTICULAR FONT, STYLE, SIZE, OR COLOR.

OWNER OF U.S. REG. NOS. 1,016,032, 2,859,772 AND OTHERS.

THE NAME(S), PORTRAIT(S), AND/OR SIGNATURE(S) SHOWN IN THE MARK DOES NOT IDENTIFY A PARTICULAR LIVING INDIVIDUAL.

FOR CLOCKS, WATCHES, DIVING WATCHES, POCKET WATCHES, WRISTWATCHES, WATCH BANDS AND STRAPS, WATCH CHAINS, WATCH CASES, CHRONOGRAPHS FOR USE AS TIMEPIECES AND FOR USE AS WATCHES, CHRONOMETERS (U.S. CLS. 2, 27, 28 AND 50).

MARK SPARACINO, EXAMINING ATTORNEY

CLASS 14—(Continued).

SN 85-506,008. RADO UHREN AG (RADO WATCH CO. LTD) (MONTRES RADO SA), 2543 LENGNAU, SWITZERLAND, FILED 12-29-2011.

RADO R-ONE

THE MARK CONSISTS OF STANDARD CHARACTERS WITHOUT CLAIM TO ANY PARTICULAR FONT, STYLE, SIZE, OR COLOR.

PRIORITY CLAIMED UNDER SEC. 44(D) ON SWITZERLAND APPLICATION NO. 63162/2011, FILED 11-24-2011, REG. NO. 623280, DATED 12-1-2011, EXPIRES 11-24-2021.

OWNER OF U.S. REG. NOS. 788,733, 1,729,207 AND OTHERS.

FOR JEWELRY; HOROLOGICAL AND CHRONOMETRIC INSTRUMENTS, NAMELY, WATCHES AND CHRONOMETERS (U.S. CLS. 2, 27, 28 AND 50).

ANDREW LEASER, EXAMINING ATTORNEY

SN 85-516,857. LISA WELCH DESIGNS, LLC, DAYTON, OH. FILED 1-15-2012.

SN 85-499,477. SALVATORE FERRAGAMO S.P.A., FLORENCE, ITALY, FILED 12-20-2011.

**GANCINO SOIREE SALVATORE
FERRAGAMO**

THE MARK CONSISTS OF STANDARD CHARACTERS WITHOUT CLAIM TO ANY PARTICULAR FONT, STYLE, SIZE, OR COLOR.

OWNER OF U.S. REG. NOS. 2,220,530, 3,631,593 AND OTHERS.

THE NAME(S), PORTRAIT(S), AND/OR SIGNATURE(S) SHOWN IN THE MARK DOES NOT IDENTIFY A PARTICULAR LIVING INDIVIDUAL.

THE ENGLISH TRANSLATION OF "GANCINO" IN THE MARK IS "LITTLE HOOK".

FOR CLOCKS, WATCHES, DIVING WATCHES, POCKET WATCHES, WRISTWATCHES, WATCH BANDS AND STRAPS, WATCH CHAINS, WATCH CASES, CHRONOGRAPHS FOR USE AS TIMEPIECES AND FOR USE AS WATCHES, CHRONOMETERS (U.S. CLS. 2, 27, 28 AND 50).

MARK SPARACINO, EXAMINING ATTORNEY



THE COLOR(S) RED, BLACK AND WHITE IS/ARE CLAIMED AS A FEATURE OF THE MARK.

THE MARK CONSISTS OF CIRCULAR MARK WITH A RED OUTLINE. BLACK FILLS THE MIDDLE. A WHITE HORSESHOE SITS ON TOP OF THE BLACK FILL-IN AND A WHITE DOG PAW SITS WITHIN THE HORSESHOE.

FOR PET JEWELRY (U.S. CLS. 2, 27, 28 AND 50).

FIRST USE 12-1-2010; IN COMMERCE 12-1-2010.

CAROLINE WOOD, EXAMINING ATTORNEY

CLASS 14—(Continued).

SN 85-542,381. HARRY WINSTON INC., NEW YORK, NY.
FILED 2-14-2012.

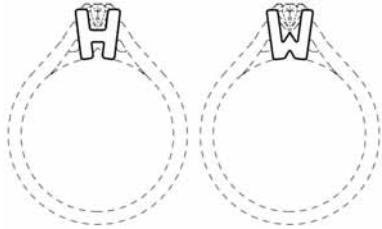

OWNER OF U.S. REG. NOS. 1,747,040 AND 1,929,448.
THE MARK CONSISTS OF THREE-DIMENSIONAL CONFIGURATIONS OF THE LETTERS "H" AND "W", WHICH RESPECTIVELY ARE PLACED ON OPPOSITE SIDES OF A THREE-DIMENSIONAL RING; ONLY THE LETTERS "H" AND "W", DEPICTED IN SOLID LINES, CONSTITUTE THE MARK; THE REST OF THE RING, DEPICTED IN BROKEN LINES, IS NOT PART OF THE MARK AND SERVES ONLY TO SHOW THE POSITION OF THE MARK.

SEC. 2(F).
FOR JEWELRY, NAMELY, RINGS (U.S. CLS. 2, 27, 28 AND 50).

FIRST USE 1-1-2007; IN COMMERCE 1-1-2007.
JUHI KAVEESHVAR, EXAMINING ATTORNEY

CLASS 14—(Continued).

SN 85-555,577. MICHAEL BARIN, STUDIO CITY, CA. FILED
S.R. 2-28-2012; AM. P.R. 7-30-2012.

MICHAEL BARIN

THE MARK CONSISTS OF STANDARD CHARACTERS WITHOUT CLAIM TO ANY PARTICULAR FONT, STYLE, SIZE, OR COLOR.

THE NAME "MICHAEL BARIN" IDENTIFIES A LIVING INDIVIDUAL WHOSE CONSENT IS OF RECORD, FOR JEWELLERY AND PRECIOUS STONES; RINGS (U.S. CLS. 2, 27, 28 AND 50).

FIRST USE 12-1-1997; IN COMMERCE 12-1-1997.
PAM WILLIS, EXAMINING ATTORNEY

SN 85-564,445. PATEL, KESHA, DBA OLIVIER CRI, NORTH HOLLYWOOD, CA. FILED 3-8-2012.

Olivier Cri

THE MARK CONSISTS OF STANDARD CHARACTERS WITHOUT CLAIM TO ANY PARTICULAR FONT, STYLE, SIZE, OR COLOR.

THE NAME(S), PORTRAIT(S), AND/OR SIGNATURE(S) SHOWN IN THE MARK DOES NOT IDENTIFY A PARTICULAR LIVING INDIVIDUAL.

THE ENGLISH TRANSLATION OF "CRI" IN THE MARK IS "CRY".

FOR BODY JEWELRY; BRACELETS; BRACELETS AND JEWELRY FEATURING ELECTRONIC CHIPS FOR ATTRACTING ENERGY TO THE BODY WHEREIN THE ELECTRONIC CHIPS INCREASE IN POWER IN THE PRESENCE OF ELECTROMAGNETIC FIELDS, FOR THE PURPOSE OF RE-BALANCING THE HUMAN ENERGY FIELD; BROACHES; BRONZE JEWELRY; BROOCHES; CAMEOS; CHARMS; CHARMS FOR COLLAR JEWELRY AND BRACELET; COSTUME JEWELRY; DIAMOND JEWELRY; GEMSTONE JEWELRY; GOLD THREAD JEWELRY; HAIR JEWELRY IN THE NATURE OF JEWELRY FOR USE IN THE HAIR; IDENTIFICATION BRACELETS; INEXPENSIVE NON-JEWELRY WATCHES; IVORY JEWELRY; JEWELRY; JEWELRY AND IMITATION JEWELRY; JEWELRY BROOCHES; JEWELRY CHAINS; JEWELRY FINDINGS; JEWELRY FOR ATTACHMENT TO CLOTHING; JEWELRY FOR THE HEAD; JEWELRY IN THE NATURE OF ARMBANDS; JEWELRY PINS FOR USE ON HATS; JEWELRY WATCHES; JEWELRY, NAMELY, ANKLETS; JEWELRY, NAMELY, ARM CUFFS; JEWELRY, NAMELY, CROSSES; JEWELRY, NAMELY, DOG TAGS FOR WEAR BY HUMANS FOR DECORATIVE PURPOSES; JEWELRY, NAMELY, MAGNETIC NECKLACES; JEWELRY, NAMELY, MAGNETIC PENDANTS; JEWELRY, NAMELY, STONE PENDANTS; LAPEL PINS; PET JEWELRY; PINS BEING JEWELRY; PLASTIC BRACELETS IN THE NATURE OF JEWELRY; RINGS; RINGS BEING JEWELRY; STAINLESS STEEL JEWELRY BRACELETS; WATCHES AND JEWELRY; WOMEN'S JEWELRY (U.S. CLS. 2, 27, 28 AND 50).

FIRST USE 2-10-2011; IN COMMERCE 2-20-2011.
CYNTHIA TRIPI, EXAMINING ATTORNEY

SN 85-551,464. NEWBURYPORT KNOT PARTNERS, DBA NEWBURYPORT KNOT CO., NEWBURYPORT, MA.
FILED 2-23-2012.



NO CLAIM IS MADE TO THE EXCLUSIVE RIGHT TO USE "NEWBURYPORT" AND "CO.", APART FROM THE MARK AS SHOWN.

THE MARK CONSISTS OF AN ANCHOR ENCOMPASSED BY A NAUTICAL ROPE IN THE SHAPE OF A KNOT. BELOW THE ANCHOR APPEARS THE WORDING "NEWBURYPORT KNOT CO." IN STYLIZED FONT.

FOR JEWELRY (U.S. CLS. 2, 27, 28 AND 50).
JULIE WATSON, EXAMINING ATTORNEY

CLASS 14—(Continued).

SN 85-577,324. FILENE'S BASEMENT, LLC, SEACAUCUS, NJ. FILED 3-22-2012.

STANLEY B. BY STANLEY
BLACKER

THE MARK CONSISTS OF STANDARD CHARACTERS WITHOUT CLAIM TO ANY PARTICULAR FONT, STYLE, SIZE, OR COLOR.

OWNER OF U.S. REG. NOS. 1,379,293, 2,862,769 AND 3,557,293.

THE NAME(S), PORTRAIT(S), AND/OR SIGNATURE(S) SHOWN IN THE MARK DOES NOT IDENTIFY A PARTICULAR LIVING INDIVIDUAL.

FOR WATCHES; JEWELRY (U.S. CLS. 2, 27, 28 AND 50).

KAREN BRACEY, EXAMINING ATTORNEY

SN 85-582,794. SILVIA, KAREN, J, GREENE, RI. FILED 3-28-2012.

Chinawear by Karen J

THE MARK CONSISTS OF STANDARD CHARACTERS WITHOUT CLAIM TO ANY PARTICULAR FONT, STYLE, SIZE, OR COLOR.

THE NAME "KAREN J" IDENTIFIES A LIVING INDIVIDUAL WHOSE CONSENT IS OF RECORD.

FOR BRACELETS; BROOCHES; COSTUME JEWELRY (U.S. CLS. 2, 27, 28 AND 50).

FIRST USE 1-1-2012; IN COMMERCE 1-1-2012.

TRACY WHITTAKER-BROWN, EXAMINING ATTORNEY

CLASS 14—(Continued).

SN 85-586,031. HONGKONG TOP JEWELRY INTERNATIONAL GROUP INVESTMENT LIMITED, TST, KL., HONG KONG, FILED 4-2-2012.



宝 | 至 | 尊
BUZZON 1974

NO CLAIM IS MADE TO THE EXCLUSIVE RIGHT TO USE "1974", APART FROM THE MARK AS SHOWN.

THE MARK CONSISTS OF A SQUARE DESIGN WITH CURVED ANGLES AND A CHINESE CHARACTER WHICH TRANSLITERATE INTO ZUN INSIDE, THREE CHINESE CHARACTERS WHICH TRANSLITERATE INTO BAO; ZHI; ZUN BELOW THE SQUARE DESIGN, TWO VERTICAL LINES IN BETWEEN OF THE THREE CHINESE CHARACTERS, AND THE STYLIZED WORDS "BUZZON 1974" AT THE BOTTOM.

THE WORDING "BUZZON" HAS NO MEANING IN A FOREIGN LANGUAGE.

THE NON-LATIN CHARACTERS IN THE MARK TRANSLITERATE TO "BAO; ZHI; ZUN" AND THIS MEANS "TREASURE; UNTIL; RESPECT" IN ENGLISH.

FOR AGATE AND SARDONYX; ALLOYS OF PRECIOUS METAL; BOXES OF PRECIOUS METAL; CLOCKS; JADE; ORNAMENTS OF PRECIOUS METAL IN THE NATURE OF JEWELRY; PRECIOUS STONES; STATUETTES OF PRECIOUS METAL AND THEIR ALLOYS; WORKS OF ART OF PRECIOUS METAL; WRISTWATCHES (U.S. CLS. 2, 27, 28 AND 50).

ESTHER A. BORSUK, EXAMINING ATTORNEY

SN 85-592,831. ASTRAL HOLDINGS, INC., SEATTLE, WA. FILED 4-9-2012.

MIRRAGIO

THE MARK CONSISTS OF STANDARD CHARACTERS WITHOUT CLAIM TO ANY PARTICULAR FONT, STYLE, SIZE, OR COLOR.

FOR JEWELRY (U.S. CLS. 2, 27, 28 AND 50).

WON TEAK OH, EXAMINING ATTORNEY

CLASS 14—(Continued).

SN 85-592,938. SAMANTHA'S CHARMS, LLC, DBA SAMANTHA'S CHARMS, WABAN, MA. FILED 4-9-2012.

Samantha's Charms

THE MARK CONSISTS OF STANDARD CHARACTERS WITHOUT CLAIM TO ANY PARTICULAR FONT, STYLE, SIZE, OR COLOR.

NO CLAIM IS MADE TO THE EXCLUSIVE RIGHT TO USE "CHARMS", APART FROM THE MARK AS SHOWN.

FOR JEWELRY (U.S. CLS. 2, 27, 28 AND 50).

FIRST USE 8-1-2011; IN COMMERCE 9-1-2011.

JAMES A. RAUEN, EXAMINING ATTORNEY

SN 85-595,046. VS COLLECTIVE, LLC, BROOKLYN, NY. FILED 4-11-2012.

Venessa Arizaga

THE MARK CONSISTS OF STANDARD CHARACTERS WITHOUT CLAIM TO ANY PARTICULAR FONT, STYLE, SIZE, OR COLOR.

THE NAME(S), PORTRAIT(S), AND/OR SIGNATURE(S) SHOWN IN THE MARK IDENTIFIES "VENESSA ARIZAGA", WHOSE CONSENT(S) TO REGISTER IS MADE OF RECORD.

FOR BRACELETS; BROOCHES; EARRINGS; NECKLACES; RINGS (U.S. CLS. 2, 27, 28 AND 50).

FIRST USE 2-28-2010; IN COMMERCE 2-28-2010.

JENNIFER WILLISTON, EXAMINING ATTORNEY

CLASS 14—(Continued).

SN 85-595,527. NOBLE, WESTLEY G., RANCHO CUCAMONGA, CA. FILED 4-11-2012.

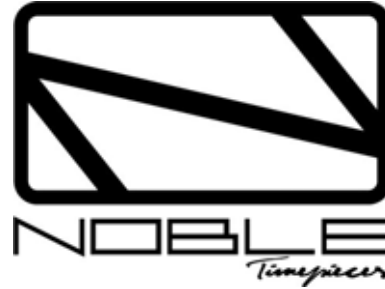

NO CLAIM IS MADE TO THE EXCLUSIVE RIGHT TO USE "TIMEPIECES", APART FROM THE MARK AS SHOWN.

THE MARK CONSISTS OF A BOLD ITALICIZED LETTER "N" TILTED IN A FORTY-FIVE DEGREE ANGLE COUNTER-CLOCKWISE INSIDE A RECTANGULAR BORDER THAT TOUCHES THE LETTER "N" AT FOUR POINTS. THE LETTERING DIRECTLY BELOW THE MARK STATES, "NOBLE", IN AN UPPER-CASE BLOCK LETTER FONT AND, "TIMEPIECES" IN A STYLIZED CURSIVE FONT TO THE LOWER RIGHT CORNER OF "NOBLE" DIRECTLY UNDER THE LETTERS "L" AND "E".

FOR DRESS WATCHES; MECHANICAL AND AUTOMATIC WATCHES; WATCH BANDS AND STRAPS; WATCH BOXES; WATCH FACES; WATCH STRAPS MADE OF METAL OR LEATHER OR PLASTIC; WATCHES; WATCHES MADE OF PRECIOUS METALS OR COATED THEREWITH; WRIST WATCHES (U.S. CLS. 2, 27, 28 AND 50).

MORGAN WYNN, EXAMINING ATTORNEY

SN 85-596,588. ATHLETA, INC., PETALUMA, CA. FILED 4-12-2012.

ATHLETA

THE MARK CONSISTS OF STANDARD CHARACTERS WITHOUT CLAIM TO ANY PARTICULAR FONT, STYLE, SIZE, OR COLOR.

OWNER OF U.S. REG. NOS. 2,427,769, 3,931,195 AND OTHERS.

FOR JEWELRY (U.S. CLS. 2, 27, 28 AND 50).

AMY HELLA, EXAMINING ATTORNEY

CLASS 14—(Continued).

SN 85-597,334. RALLY BANDZ LLC, SOUTHLAKE, TX. FILED 4-13-2012.

RallyBandz

THE MARK CONSISTS OF STANDARD CHARACTERS WITHOUT CLAIM TO ANY PARTICULAR FONT, STYLE, SIZE, OR COLOR.
FOR NYLON BRACELETS (U.S. CLS. 2, 27, 28 AND 50).
FIRST USE 10-1-2010; IN COMMERCE 8-1-2011.
TIMOTHY FINNEGAN, EXAMINING ATTORNEY

CLASS 14—(Continued).

SN 85-598,997. LEE, DAISY, SAN GABRIEL, CA. FILED 4-16-2012.

Jade World

THE MARK CONSISTS OF STANDARD CHARACTERS WITHOUT CLAIM TO ANY PARTICULAR FONT, STYLE, SIZE, OR COLOR.
NO CLAIM IS MADE TO THE EXCLUSIVE RIGHT TO USE "JADE", APART FROM THE MARK AS SHOWN.
FOR JADE (U.S. CLS. 2, 27, 28 AND 50).
JANICE L. MCMORROW, EXAMINING ATTORNEY

SN 85-598,094. RUSHWEAR LLC, DBA CREATE CONNECT JEWELRY, MADISON, WI. FILED 4-14-2012.

You're too special to look
like anyone else

THE MARK CONSISTS OF STANDARD CHARACTERS WITHOUT CLAIM TO ANY PARTICULAR FONT, STYLE, SIZE, OR COLOR.
FOR COSTUME JEWELRY (U.S. CLS. 2, 27, 28 AND 50).
FIRST USE 4-1-2010; IN COMMERCE 4-1-2010.
HENRY S. ZAK, EXAMINING ATTORNEY

SN 85-599,284. BOOMKACK WORLD WIDE, INC., LOS ANGELES, CA. FILED 4-16-2012.

BOOMKACK

THE MARK CONSISTS OF STANDARD CHARACTERS WITHOUT CLAIM TO ANY PARTICULAR FONT, STYLE, SIZE, OR COLOR.
FOR JEWELRY (U.S. CLS. 2, 27, 28 AND 50).
RONALD DELGIZZI, EXAMINING ATTORNEY

SN 85-598,968. LEE, DAISY, SAN GABRIEL, CA. FILED 4-16-2012.

Jade International

THE MARK CONSISTS OF STANDARD CHARACTERS WITHOUT CLAIM TO ANY PARTICULAR FONT, STYLE, SIZE, OR COLOR.
NO CLAIM IS MADE TO THE EXCLUSIVE RIGHT TO USE "JADE", APART FROM THE MARK AS SHOWN.
FOR JADE (U.S. CLS. 2, 27, 28 AND 50).
JANICE L. MCMORROW, EXAMINING ATTORNEY

SN 85-599,478. KING'S OF NEW CASTLE INC., NEW CASTLE, PA. FILED 4-17-2012.

BRIGHT-VALUE

THE MARK CONSISTS OF STANDARD CHARACTERS WITHOUT CLAIM TO ANY PARTICULAR FONT, STYLE, SIZE, OR COLOR.
FOR JEWELRY (U.S. CLS. 2, 27, 28 AND 50).
FIRST USE 4-9-2012; IN COMMERCE 4-9-2012.
WANDA KAY PRICE, EXAMINING ATTORNEY

CLASS 14—(Continued).

SN 85-600,752. ARNER, FRANZ, MENDOCINO, CA. FILED 4-18-2012.

FRANZIO ARNETTI

THE MARK CONSISTS OF STANDARD CHARACTERS WITHOUT CLAIM TO ANY PARTICULAR FONT, STYLE, SIZE, OR COLOR.

THE NAME(S), PORTRAIT(S), AND/OR SIGNATURE(S) SHOWN IN THE MARK DOES NOT IDENTIFY A PARTICULAR LIVING INDIVIDUAL.

FOR JEWELRY (U.S. CLS. 2, 27, 28 AND 50).
MATTHEW PAPPAS, EXAMINING ATTORNEY

SN 85-601,056. SAVALIA GROUP, LLC, NEW YORK, NY. FILED 4-18-2012.

COLORBLOOM

THE MARK CONSISTS OF STANDARD CHARACTERS WITHOUT CLAIM TO ANY PARTICULAR FONT, STYLE, SIZE, OR COLOR.

FOR ANKLE BRACELETS; BANGLE BRACELETS; BANGLES; BRACELETS; BRACELETS OF PRECIOUS METAL; BRONZE JEWELRY; BROOCHES; CASES FOR WATCHES AND CLOCKS; CHARMS; CHOKERS; CLIP EARRINGS; CLOCKS AND WATCHES; COSTUME JEWELRY; CUFFLINKS; CUT DIAMONDS; DIAMOND JEWELRY; DIAMONDS; DRESS WATCHES; EARRINGS; GEMSTONE JEWELRY; GEMSTONES; GOLD; JEWELRY; JEWELRY BOXES; JEWELRY CASES; JEWELRY CHAINS; JEWELRY FINDINGS; JEWELRY FOR ATTACHMENT TO CLOTHING; JEWELRY FOR THE HEAD; JEWELRY IN THE NATURE OF ARMBANDS; JEWELRY ORGANIZERS; JEWELRY PINS FOR USE ON HATS; JEWELRY RING HOLDERS; JEWELRY TO BE AFFIXED TO BIKINIS; JEWELRY WATCHES; LAPEL PINS; LEATHER JEWELRY AND ACCESSORY BOXES; NECK CHAINS; NECKLACES; ORNAMENTAL LAPEL PINS; PENDANTS; PET JEWELRY; PLASTIC BRACELETS IN THE NATURE OF JEWELRY; POCKET WATCHES; RINGS; STOPWATCHES; TIARAS; WATCH BOXES; WATCH BRACELETS; WATCH FACES; WATCH BANDS; WATCHES AND CLOCKS; WEDDING BANDS; WRIST WATCHES (U.S. CLS. 2, 27, 28 AND 50).
FIRST USE 1-2-2012; IN COMMERCE 1-2-2012.

STEVEN R. FINE, EXAMINING ATTORNEY

CLASS 14—(Continued).

SN 85-602,354. ARNETT, TONYA, ALBION, MI. FILED 4-19-2012.

CanSur-vive To Thrive

THE MARK CONSISTS OF STANDARD CHARACTERS WITHOUT CLAIM TO ANY PARTICULAR FONT, STYLE, SIZE, OR COLOR.

FOR JEWELRY (U.S. CLS. 2, 27, 28 AND 50).
JESSICA A. POWERS, EXAMINING ATTORNEY

SN 85-603,400. JPI LIMITED, HUNGHOM, KOWLOON, HONG KONG, FILED 4-20-2012.

personagirl

OWNER OF U.S. REG. NOS. 4,022,576 AND 4,059,056.

THE MARK CONSISTS OF THE WORDS "PERSONA-GIRL" WITH A FLOWER IN THE CENTER OF THE "O".

FOR BRACELETS OF PRECIOUS METAL; CHARMS; CHARMS IN PRECIOUS METALS OR COATED THEREWITH; JEWELLERY AND PRECIOUS STONES; NECKLACES; PRECIOUS AND SEMI-PRECIOUS CRYSTAL STONES AND BEADS FOR USE IN JEWELRY (U.S. CLS. 2, 27, 28 AND 50).

NAKWAMA ANKRAH, EXAMINING ATTORNEY

SN 85-603,409. JPI LIMITED, HUNGHOM, KOWLOON, HONG KONG, FILED 4-20-2012.

PERSONAGIRL

THE MARK CONSISTS OF STANDARD CHARACTERS WITHOUT CLAIM TO ANY PARTICULAR FONT, STYLE, SIZE, OR COLOR.

OWNER OF U.S. REG. NOS. 4,022,576 AND 4,059,056.

FOR BRACELETS OF PRECIOUS METAL; CHARMS; CHARMS IN PRECIOUS METALS OR COATED THEREWITH; JEWELLERY AND PRECIOUS STONES; NECKLACES; PRECIOUS AND SEMI-PRECIOUS CRYSTAL STONES AND BEADS FOR USE IN JEWELRY (U.S. CLS. 2, 27, 28 AND 50).

NAKWAMA ANKRAH, EXAMINING ATTORNEY

CLASS 14—(Continued).

SN 85-603,612. ABADI, JOSEPH, BROOKLYN, NY. FILED 4-20-2012.



THE MARK CONSISTS OF AN ABSTRACT SET OF LINES THAT MAKE A SHIELD. WITHIN THE SHIELD THERE IS A SEPARATE SET OF LINES THAT FORM THE PROFILE FIGURE OF A LYNX. THE LYNX'S HEAD COMES OUT OF THE SHIELD A LITTLE.

FOR BRACELETS; CUFFLINKS; EARRINGS; JEWELRY; NECKLACES; RINGS; TIE PINS; TIMEPIECES; WATCHES (U.S. CLS. 2, 27, 28 AND 50).
JOHN HWANG, EXAMINING ATTORNEY

SN 85-603,895. RONALDO DESIGNER JEWELRY, INC., LACONIA, IN. FILED 4-20-2012.

**"THE POWER OF PRAYER"
BRACELET**

THE MARK CONSISTS OF STANDARD CHARACTERS WITHOUT CLAIM TO ANY PARTICULAR FONT, STYLE, SIZE, OR COLOR.

NO CLAIM IS MADE TO THE EXCLUSIVE RIGHT TO USE "BRACELET", APART FROM THE MARK AS SHOWN. FOR JEWELRY (U.S. CLS. 2, 27, 28 AND 50).
FIRST USE 8-1-1995; IN COMMERCE 8-1-1995.
ROSELLE HERRERA, EXAMINING ATTORNEY

SN 85-604,187. TRIFLESPHERE LLC, LAFAYETTE, CO. FILED 4-20-2012.

TRIFLESPHERE

THE MARK CONSISTS OF STANDARD CHARACTERS WITHOUT CLAIM TO ANY PARTICULAR FONT, STYLE, SIZE, OR COLOR.

FOR JEWELRY (U.S. CLS. 2, 27, 28 AND 50).
FIRST USE 11-6-2011; IN COMMERCE 4-17-2012.
INGRID C. EULIN, EXAMINING ATTORNEY

CLASS 14—(Continued).

SN 85-604,370. SPAULDING, ROY, SUN CITY, AZ. FILED 4-20-2012.

EARRINGS WITH AN ATTITUDE

THE MARK CONSISTS OF STANDARD CHARACTERS WITHOUT CLAIM TO ANY PARTICULAR FONT, STYLE, SIZE, OR COLOR.

FOR JEWELRY; EARRINGS; PRECIOUS METALS, THEIR ALLOYS AND GOODS IN PRECIOUS METALS OR COATED THEREWITH, NAMELY, STERLING SILVER WIRE SOLDERED INTO EARRINGS MAKING WORDS (U.S. CLS. 2, 27, 28 AND 50).
FONG HSU, EXAMINING ATTORNEY

SN 85-604,706. BODIE GROUP INC., LAKE OSWEGO, OR. FILED 4-22-2012.

CHICKIELOU

THE MARK CONSISTS OF STANDARD CHARACTERS WITHOUT CLAIM TO ANY PARTICULAR FONT, STYLE, SIZE, OR COLOR.

FOR JEWELRY, SPECIFICALLY HANDMADE JEWELRY USING PLASTICS, GLASS AND SEMIPRECIOUS STONE BEADING, STERLING SILVER AND SEMI-PRECIOUS METALS (U.S. CLS. 2, 27, 28 AND 50).

FIRST USE 1-18-2011; IN COMMERCE 1-18-2011.
HELENE LIWINSKI, EXAMINING ATTORNEY

SN 85-604,858. CHADWELL, NATALIE W., DBA E.4.U DESIGNS, INC., SOUTH HOLLAND, IL. FILED 4-23-2012.

e.4.u

THE MARK CONSISTS OF STANDARD CHARACTERS WITHOUT CLAIM TO ANY PARTICULAR FONT, STYLE, SIZE, OR COLOR.

FOR JEWELRY; WOMEN'S JEWELRY (U.S. CLS. 2, 27, 28 AND 50).

FIRST USE 5-1-2002; IN COMMERCE 5-1-2002.
GINA HAYES, EXAMINING ATTORNEY

CLASS 14—(Continued).

SN 85-605,158. THE BAZAR GROUP, INC., EAST PROVIDENCE, RI. FILED 4-23-2012.

IMPERIAL LACE

THE MARK CONSISTS OF STANDARD CHARACTERS WITHOUT CLAIM TO ANY PARTICULAR FONT, STYLE, SIZE, OR COLOR.

OWNER OF U.S. REG. NO. 500,280.
FOR JEWELRY (U.S. CLS. 2, 27, 28 AND 50).
FIRST USE 6-1-2012; IN COMMERCE 6-1-2012.
PAM WILLIS, EXAMINING ATTORNEY

SN 85-605,313. PINK POMELO, WASHINGTON, DC. FILED 4-23-2012.

PINK POMELO

THE MARK CONSISTS OF STANDARD CHARACTERS WITHOUT CLAIM TO ANY PARTICULAR FONT, STYLE, SIZE, OR COLOR.

FOR (BASED ON USE IN COMMERCE) BODY JEWELRY; BRACELETS; BRACELETS; BRACELETS OF PRECIOUS METAL; BRONZE JEWELRY; COSTUME JEWELRY; EARRINGS; JEWELRY; JEWELRY AND IMITATION JEWELRY; JEWELRY CHAINS; NECKLACES; WOMEN'S JEWELRY(BASED ON INTENT TO USE) CUFFLINKS; RINGS; RINGS BEING JEWELRY; WEDDING RINGS (U.S. CLS. 2, 27, 28 AND 50).
FIRST USE 1-31-2011; IN COMMERCE 1-31-2011.
FONG HSU, EXAMINING ATTORNEY

SN 85-606,749. FIRST JEWELRY LIMITED, TORONTO, ONTARIO, CANADA, FILED 4-24-2012.

FIRST

THE MARK CONSISTS OF STANDARD CHARACTERS WITHOUT CLAIM TO ANY PARTICULAR FONT, STYLE, SIZE, OR COLOR.

FOR JEWELRY (U.S. CLS. 2, 27, 28 AND 50).
FIRST USE 6-1-2009; IN COMMERCE 6-1-2009.
JOHN HWANG, EXAMINING ATTORNEY

CLASS 14—(Continued).

SN 85-613,714. ASTRAL HOLDINGS, INC., SEATTLE, WA. FILED 5-1-2012.

IVY MY BRIDE

THE MARK CONSISTS OF STANDARD CHARACTERS WITHOUT CLAIM TO ANY PARTICULAR FONT, STYLE, SIZE, OR COLOR.

NO CLAIM IS MADE TO THE EXCLUSIVE RIGHT TO USE "BRIDE", APART FROM THE MARK AS SHOWN.
FOR JEWELRY (U.S. CLS. 2, 27, 28 AND 50).
WON TEAK OH, EXAMINING ATTORNEY

SN 85-640,758. I AM OTHER ENTERTAINMENT, LLC, NEW YORK, NY. FILED 6-1-2012.

I AM OTHER

THE MARK CONSISTS OF STANDARD CHARACTERS WITHOUT CLAIM TO ANY PARTICULAR FONT, STYLE, SIZE, OR COLOR.

FOR JEWELRY; JEWELRY FINDINGS; GEMSTONE AND PRECIOUS STONES; SEMI-PRECIOUS STONES; PEARLS; OPALS; PLATINUM AND ITS ALLOYS; PRECIOUS METALS; CHARMS, CHOKERS, AND PENDANTS; LAPEL PINS; ORNAMENTAL LAPEL PINS; PINS BEING JEWELRY; BODY-PIERCING RINGS AND STUDS; EAR STUDS; EAR CLIPS; TIE PINS; TIE CLIPS; TIE BARS; TIE TACKS; TIE FASTENERS; BOLO TIES WITH PRECIOUS METAL TIPS; CUFF-LINKS; SHIRT STUDS; BADGES OF PRECIOUS METAL; COSTUME JEWELRY; JEWELRY CHAINS; JEWELRY PINS FOR USE ON HATS; HAT ORNAMENTS OF PRECIOUS METAL; HOLIDAY ORNAMENTS OF PRECIOUS METAL; JEWELRY BOXES AND CASES; KEY HOLDERS OF PRECIOUS METALS; KEY CHAINS OF PRECIOUS METAL; WATCHES; WATCH BRACELETS; WATCH ACCESSORIES, NAMELY, PARTS FOR WATCHES; WRISTWATCHES; POCKET WATCHES; STOP WATCHES; WATCH STRAPS AND BANDS; WATCH CHAINS AND FOBS; WATCH CASES; WATCH BOXES; CLOCKS; ALARM CLOCKS; CLOCKS INCORPORATING RADIOS; WALL CLOCKS; TIMEPIECES; BOXES FOR TIMEPIECES; FIGURINES, SCULPTURES, BUSTS, FIGURES, STATUES, AND STATUETTES, ALL OF THE FOREGOING OF PRECIOUS METAL (U.S. CLS. 2, 27, 28 AND 50).
DAVID MURRAY, EXAMINING ATTORNEY

CLASS 14—(Continued).

SN 85-690,933. BOLLYDOLL, LLC, LOS ANGELES, CA. FILED 7-31-2012.

BOLLYDOLL

THE MARK CONSISTS OF STANDARD CHARACTERS WITHOUT CLAIM TO ANY PARTICULAR FONT, STYLE, SIZE, OR COLOR.

OWNER OF U.S. REG. NOS. 4,162,503 AND 4,165,937. FOR JEWELRY (U.S. CLS. 2, 27, 28 AND 50). LINDA M. KING, EXAMINING ATTORNEY

CLASS 15—(Continued).

SN 79-104,257. YAMAHA CORPORATION, JAPAN, FILED 9-22-2011.

T o u r C u s t o m

THE MARK CONSISTS OF STANDARD CHARACTERS WITHOUT CLAIM TO ANY PARTICULAR FONT, STYLE, SIZE, OR COLOR.

OWNER OF INTERNATIONAL REGISTRATION 1095042 DATED 9-22-2011, EXPIRES 9-22-2021.

OWNER OF U.S. REG. NO. 3,268,894. NO CLAIM IS MADE TO THE EXCLUSIVE RIGHT TO USE "CUSTOM", APART FROM THE MARK AS SHOWN.

FOR TUNING APPARATUS FOR MUSICAL INSTRUMENTS; MUSICAL INSTRUMENTS; CYMBALS; DRUMS BEING MUSICAL INSTRUMENTS; DRUMS SETS BEING MUSICAL INSTRUMENTS; DRUMSTICKS; MUSICAL PERFORMANCE AUXILIARIES, NAMELY, SHEET MUSIC STANDS AND CONDUCTORS' BATONS; TUNING FORKS (U.S. CLS. 2, 21 AND 36).

MYRIAH HABEEB, EXAMINING ATTORNEY

SN 85-449,169. PHILLIP JARRELL, CUTHBERT, GA. FILED 10-17-2011.

JARRELL

CLASS 15—MUSICAL INSTRUMENTS

SN 76-711,098. YAMAHA CORPORATION, SHIZUOKA, JAPAN, FILED 4-2-2012.

 **INFOSOUND**

THE MARK CONSISTS OF STANDARD CHARACTERS WITHOUT CLAIM TO ANY PARTICULAR FONT, STYLE, SIZE, OR COLOR.

SEC. 2(F).

FOR GUITARS AND BASS GUITARS, TUNERS FOR MUSICAL INSTRUMENTS, MUSICAL INSTRUMENT ACCESSORIES, NAMELY, CASES, STRAPS AND STANDS (U.S. CLS. 2, 21 AND 36).

FIRST USE 1-0-2010; IN COMMERCE 1-0-2010. KELLEY WELLS, EXAMINING ATTORNEY

SN 85-585,195. ALESIS, L.P., CUMBERLAND, RI. FILED 3-30-2012.

PRO X KICK PEDAL

THE MARK CONSISTS OF STANDARD CHARACTERS WITHOUT CLAIM TO ANY PARTICULAR FONT, STYLE, SIZE, OR COLOR.

NO CLAIM IS MADE TO THE EXCLUSIVE RIGHT TO USE "KICK PEDAL", APART FROM THE MARK AS SHOWN.

FOR BASS DRUM PEDAL (U.S. CLS. 2, 21 AND 36). CHARISMA HAMPTON, EXAMINING ATTORNEY

THE MARK CONSISTS OF THE WORDING "INFOSOUND" ADJACENT TO THE DESIGN OF AN AUDIO SPEAKER.

FOR MUSICAL INSTRUMENTS; ACOUSTIC MUSICAL INSTRUMENTS; ELECTRONIC MUSICAL INSTRUMENTS; ELECTRONIC MUSICAL KEYBOARDS; ELECTRONIC MUSICAL KEYBOARDS WITH RHYTHM AND TUNING TRAINING FUNCTIONS SPECIFICALLY DESIGNED FOR WIND BANDS, ORCHESTRAS, ENSEMBLES AND CHORUSES; ELECTRONIC PIANOS; ELECTRONIC ORGANS; ELECTRONIC MUSIC SYNTHESIZERS; ELECTRONIC DRUMS; ELECTRONIC PERCUSSION INSTRUMENTS; ELECTRONIC MUSIC STRINGED INSTRUMENTS; ELECTRIC MUSICAL INSTRUMENTS; ELECTRIC GUITARS; ELECTRIC PIANOS; WIND MUSICAL INSTRUMENTS; PERCUSSION MUSICAL INSTRUMENTS; STRINGED MUSICAL INSTRUMENTS; MUSICAL KEYBOARDS (U.S. CLS. 2, 21 AND 36).

KAREN BRACEY, EXAMINING ATTORNEY

CLASS 15—(Continued).

SN 85-592,579. DALE WEBB, SHEFFIELD, MA. FILED 4-9-2012.

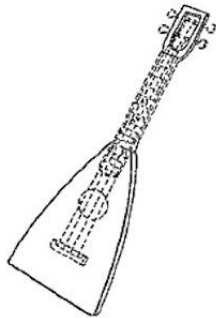

OWNER OF U.S. REG. NO. 2,560,536.
THE MARK CONSISTS OF A CONFIGURATION OF A UKULELE HAVING A TAPERED, GENERALLY TRIANGULAR-SHAPED BODY WITH A FLAT BASE, AND AN OPEN HEADSTOCK. THE UKULELE NECK, STRINGS, BRIDGE, SOUNDHOLE AND TUNING PEGS SHOWN IN DOTTED LINES ARE NOT PART OF THE MARK AND SERVE ONLY TO SHOW THE POSITION OF THE MARK ON THE GOODS.

SEC. 2(F).

FOR UKULELES (U.S. CLS. 2, 21 AND 36).
FIRST USE 1-0-1999; IN COMMERCE 5-0-1999.
STEVEN PEREZ, EXAMINING ATTORNEY

CLASS 15—(Continued).

SN 85-599,164. KESTER, JAMES B., DBA JK INNOVATIONS, GARDEN GROVE, CA. FILED 4-16-2012.



THE MARK IS COMPRISED OF THE ATTACHED LETTERS "JK" IN CALLIGRAPHY STYLE LETTERING, THE TOP OF THE DESIGN RESEMBLES A GUITAR NECK AND A GUITAR BRIDGE APPEARS WITHIN THE ENCLOSED PORTION THE J.

FOR PLECTRUMS (U.S. CLS. 2, 21 AND 36).

RONALD MCMORROW, EXAMINING ATTORNEY

SN 85-596,484. CHRISTOPHER ARTHUR MITCHELL, STATESBORO, GA. FILED 4-12-2012.

Pladd Dot Music

THE MARK CONSISTS OF STANDARD CHARACTERS WITHOUT CLAIM TO ANY PARTICULAR FONT, STYLE, SIZE, OR COLOR.

NO CLAIM IS MADE TO THE EXCLUSIVE RIGHT TO USE "DOT MUSIC", APART FROM THE MARK AS SHOWN.
FOR MUSICAL INSTRUMENTS, NAMELY, GUITARS AND BASS GUITARS; STRINGS FOR MUSICAL INSTRUMENTS (U.S. CLS. 2, 21 AND 36).

FIRST USE 0-0-1999; IN COMMERCE 0-0-1999.
KATHY DE JONGE, EXAMINING ATTORNEY

SN 85-602,393. STITCH N. GENIUS, INC., BEVERLY HILLS, CA. FILED 4-19-2012.

HANGPANS

THE MARK CONSISTS OF STANDARD CHARACTERS WITHOUT CLAIM TO ANY PARTICULAR FONT, STYLE, SIZE, OR COLOR.

FOR MUSICAL INSTRUMENTS (U.S. CLS. 2, 21 AND 36).

TINA MAI, EXAMINING ATTORNEY

CLASS 16—PAPER GOODS AND PRINTED MATTER

SN 77-272,912. CLEAR IMAGE INC, DBA IMPACT IMAGES, EL DORADO HILLS, CA. FILED 9-6-2007.

clearbags

THE MARK CONSISTS OF STANDARD CHARACTERS WITHOUT CLAIM TO ANY PARTICULAR FONT, STYLE, SIZE, OR COLOR.

SEC. 2(F).
FOR PAPER BAGS FOR MERCHANDISE PACKAGING (U.S. CLS. 2, 5, 22, 23, 29, 37, 38 AND 50).
FIRST USE 1-1-1996; IN COMMERCE 1-1-1996.
HENRY S. ZAK, EXAMINING ATTORNEY

CLASS 16—(Continued).

SN 79-108,026. J.S. STAEDTLER GMBH & CO. KG, 90427 NÜRNBERG, FED REP GERMANY, FILED 2-24-2011.



SN 79-102,364. ARJOWIGGINS PALALDA, FRANCE, FILED 7-13-2011.

STERIMED

THE MARK CONSISTS OF STANDARD CHARACTERS WITHOUT CLAIM TO ANY PARTICULAR FONT, STYLE, SIZE, OR COLOR.

PRIORITY DATE OF 7-11-2011 IS CLAIMED.
OWNER OF INTERNATIONAL REGISTRATION 1090193 DATED 7-13-2011, EXPIRES 7-13-2021.
FOR PAPER; CARDBOARD; PAPER AND CARDBOARD FOR PACKAGING; SHEETS OF PLASTIC MATERIALS FOR PACKAGING, NAMELY, PLASTIC FOILS, PLASTIC WRAPS, PLASTIC BAGS FOR PACKAGING (U.S. CLS. 2, 5, 22, 23, 29, 37, 38 AND 50).
WARREN L. OLANDRIA, EXAMINING ATTORNEY

OWNER OF INTERNATIONAL REGISTRATION 0689668 DATED 2-4-1998, EXPIRES 2-4-2018.

OWNER OF U.S. REG. NO. 697,131.
THE COLOR(S) RED, YELLOW, GREEN, LIGHT BLUE, DARK BLUE, AND VIOLET IS/ARE CLAIMED AS A FEATURE OF THE MARK.

THE MARK CONSISTS OF THE FOLLOWING: THE WORDING "NORIS CLUB" WITH A TRIANGLE DOTTING THE "I" IN THE WORD "NORIS". THE WORD "NORIS" IS OUTLINED IN DARK BLUE WITH THE "N" IN RED, THE "O" IN YELLOW, THE "R" IN GREEN, THE "I" WITH THE TRIANGLE DOTTING THE "I" IN LIGHT BLUE AND THE "S" IN VIOLET. THE WORD "CLUB" APPEARS BELOW THE WORD "NORIS" IN DARK BLUE.

FOR PAPER, NAMELY WRITING AND DRAWING PAPER, COLORING BOOKS, NOTE BOOKS, CALENDARS; PHOTOGRAPHS; WRITING, DRAWING, PAINTING AND MODELING GOODS, NAMELY BLACKLEAD AND COLORED PENCILS, DRAWING PENCILS, MECHANICAL PENCILS, FIBRE-TIP PENS, COLORED PENS, BALLPOINT PENS, FINE LINE WRITING INSTRUMENTS, MARKERS, PENS, ERASERS, PENCIL SHARPENERS, PAINT BOXES AND BRUSHES, CRAYONS, FINGER PAINTS, GEL CRAYONS, OIL PASTELS, CHALKS, WAX CRAYONS, MODELING CLAY, MODELING DOUGH IN THE NATURE OF MODELING CLAY, CUTTERS FOR MODELING CLAY, NAMELY MOLDS FOR MODELING CLAY; ADHESIVES FOR STATIONERY OR HOUSEHOLD PURPOSES, NAMELY GLUE STICKS FOR STATIONERY OR HOUSEHOLD PURPOSES; ARTISTS MATERIALS, NAMELY PAINT BOXES; PAINT BRUSHES; TRAYS FOR PAINTING AND MODELING GOODS, NAMELY DRAWING TRAYS, PAINTING TRAYS, MODELING TRAYS; PLASTIC BOX FOR WRITING INSTRUMENTS, NAMELY BLACKLEAD AND COLORED PENCILS, DRAWING PENCILS, MECHANICAL PENCILS, FIBRE-TIP PENS, COLORED PENS, BALLPOINT PENS, FINE LINE WRITING INSTRUMENTS, MARKERS, PENS, ERASERS, PENCIL SHARPENERS; PLASTIC MATERIALS FOR PACKAGING OF WRITING, DRAWING, PAINTING AND MODELING GOODS, NAMELY, PLASTIC BAGS FOR PACKAGING (U.S. CLS. 2, 5, 22, 23, 29, 37, 38 AND 50).
JENNIFER WILLISTON, EXAMINING ATTORNEY

SN 79-104,772. DECLICMEDIA, FRANCE, FILED 6-14-2011.

Instapost

PRIORITY DATE OF 5-25-2011 IS CLAIMED.
OWNER OF INTERNATIONAL REGISTRATION 1096124 DATED 6-14-2011, EXPIRES 6-14-2021.
THE MARK CONSISTS OF "INSTAPOST" IN STYLIZED TEXT.

FOR PERSONALIZED AND NON-PERSONALIZED POSTCARDS; PERSONALIZED AND NON-PERSONALIZED GIFTS, NAMELY, CANVAS FOR PAINTING, ALUMINUM PRINTS, WOODEN PRINTS, POSTERS; PERSONALIZED PHOTO PRINTS (U.S. CLS. 2, 5, 22, 23, 29, 37, 38 AND 50).
SHANNON TWOHIG, EXAMINING ATTORNEY

CLASS 16—(Continued).

SN 85-069,637. DISNEY ONLINE STUDIOS CANADA INC., VANCOUVER, CANADA, FILED 6-23-2010.

CADENCE

THE MARK CONSISTS OF STANDARD CHARACTERS WITHOUT CLAIM TO ANY PARTICULAR FONT, STYLE, SIZE, OR COLOR.

FOR ADDRESS BOOKS; ALMANACS; APPLIQUÉS IN THE FORM OF DECALS; APPOINTMENT BOOKS; ART PRINTS; ARTS AND CRAFT PAINT KITS; AUTOGRAPH BOOKS; BABY BOOKS; BALL POINT PENS; BASEBALL CARDS; BINDERS; BOOKENDS; BOOKMARKS; A SERIES OF FICTION BOOKS; BOOKS, MAGAZINES, NEWSLETTERS, NEWSPAPERS, AND PERIODICALS FEATURING CHILDREN'S STORIES, GAMES, AND ACTIVITIES; BUMPER STICKERS; CALENDARS; CARTOON STRIPS; CHRISTMAS CARDS; CHALK; COASTERS MADE OF PAPER; COIN ALBUMS; COLORING BOOKS; COLORED PENCILS; COMIC BOOKS; COMIC STRIPS; COUPON BOOKS; DECALS; DECORATIVE PAPER CENTERPIECES; DIARIES; DISPOSABLE DIAPERS FOR BABIES MADE OF PAPER; DRAWING RULERS; ENVELOPES; ERASERS; FELT PENS; FLASH CARDS; PAPER GIFT CARDS; GLOBES; GUEST BOOKS; MAPS; MEMO PADS; MODELING CLAY; NOTE PAPER; NOTEBOOKS; NOTEBOOK PAPER; PAINTINGS; PAPER FLAGS; PAPER PARTY FAVORS; PAPER CAKE DECORATIONS; PAPER PARTY DECORATIONS; PAPER NAPKINS; PAPERWEIGHTS; PAPER PENNANTS; PAPER PLACE MATS; PAPER TABLE CLOTHS; PEN AND PENCIL HOLDERS; PENCILS; PENCIL SHARPENERS; PEN AND PENCIL CASES AND BOXES; PENS; PHOTOGRAPH ALBUMS; PHOTOGRAPHS; PHOTO-ENGRAVINGS; PICTORIAL PRINTS; PICTURE BOOKS; PORTRAITS; POSTCARDS; POSTERS; PRINTED AWARDS; PRINTED CERTIFICATES; PRINTED INVITATIONS; PRINTED MENUS; RECIPE BOOKS; RUBBER STAMPS; SCORE CARDS; STAMP ALBUMS; STATIONERY; STAPLERS; STICKERS; TRADING CARDS; UNGRADUATED RULERS; WRITING PAPER (U.S. CLS. 2, 5, 22, 23, 29, 37, 38 AND 50).

ELIZABETH KAJUBI, EXAMINING ATTORNEY

SN 85-114,903. DRAPE CREATIVE, INC., LEAWOOD, KS. FILED 8-24-2010.

bottlecap cards
(Go ahead, open it!)

NO CLAIM IS MADE TO THE EXCLUSIVE RIGHT TO USE "CARDS", APART FROM THE MARK AS SHOWN.

THE MARK CONSISTS OF THE WORDS "BOTTLECAP CARDS" WITH A DEPICTION OF A BOUNCING (AS SHOWN BY DOTTED LINES) BOTTLECAP BETWEEN THE TWO WORDS, WITH THE WORDS "(GO AHEAD, OPEN IT!)" BELOW.

FOR GREETING CARDS (U.S. CLS. 2, 5, 22, 23, 29, 37, 38 AND 50).

MARLENE BELL, EXAMINING ATTORNEY

CLASS 16—(Continued).

SN 85-236,506. MOMMYMADE, LLC, CENTENNIAL, CO. FILED 2-8-2011.

MOMMY MADE

THE MARK CONSISTS OF STANDARD CHARACTERS WITHOUT CLAIM TO ANY PARTICULAR FONT, STYLE, SIZE, OR COLOR.

FOR PRINTED MATERIALS, NAMELY, PAMPHLETS AND BROCHURES ABOUT EDUCATION AND ENTERTAINMENT FOR BABIES, TODDLERS, AND PRESCHOOLERS AND NOT BEING ADVERTISING PAMPHLETS OR BROCHURES, CALENDARS, BLANK JOURNALS, GREETING CARDS AND POSTCARDS FOR ADULTS; PRINTED DEVELOPMENTAL MEDIA IN THE FORM OF INTERACTIVE EDUCATIONAL BOOKS FOR BABIES AND TODDLERS (U.S. CLS. 2, 5, 22, 23, 29, 37, 38 AND 50).

TRACY WHITTAKER-BROWN, EXAMINING ATTORNEY

SN 85-290,443. SOURCE INTERLINK MAGAZINES, LLC, EL SEGUNDO, CA. FILED 4-8-2011.

AUDIO VIDEO INTERIORS

THE MARK CONSISTS OF STANDARD CHARACTERS WITHOUT CLAIM TO ANY PARTICULAR FONT, STYLE, SIZE, OR COLOR.

OWNER OF U.S. REG. NO. 1,617,578.

SEC. 2(F).

FOR MAGAZINES FEATURING ELECTRONICS AND HOME DÉCOR (U.S. CLS. 2, 5, 22, 23, 29, 37, 38 AND 50).

SUNG IN, EXAMINING ATTORNEY

SN 85-308,609. G.P. ENTERPRISES, LLC, SANTA MONICA, CA. FILED 4-29-2011.

ROY ORBISON

THE MARK CONSISTS OF STANDARD CHARACTERS WITHOUT CLAIM TO ANY PARTICULAR FONT, STYLE, SIZE, OR COLOR.

THE NAME(S), PORTRAIT(S), AND/OR SIGNATURE(S) SHOWN IN THE MARK DOES NOT IDENTIFY A PARTICULAR LIVING INDIVIDUAL.

FOR STATIONERY; PRINTED MATTER, NAMELY, STICKERS, POSTERS, POST CARDS, CALENDARS, NOTEPADS, BOOKS AND MAGAZINES IN THE FIELD OF MUSIC AND ENTERTAINMENT; BOOKMARKS; PENS AND PENCILS (U.S. CLS. 2, 5, 22, 23, 29, 37, 38 AND 50).

RAMONA ORTIGA, EXAMINING ATTORNEY

CLASS 16—(Continued).

SN 85-391,226. EPIC PRODUCTS INC., SANTA ANA, CA. FILED 8-5-2011.

ST. NICK'S WINE LODGE

THE MARK CONSISTS OF STANDARD CHARACTERS WITHOUT CLAIM TO ANY PARTICULAR FONT, STYLE, SIZE, OR COLOR.

FOR GIFT BAGS; PAPER NAPKINS; DISPOSABLE NAPKINS (U.S. CLS. 2, 5, 22, 23, 29, 37, 38 AND 50).
DORITT L. CARROLL, EXAMINING ATTORNEY

SN 85-392,787. ROSS, KAREN G., LOS ANGELES, CA. FILED 8-8-2011.

MY BREASTS TALKING!

THE MARK CONSISTS OF STANDARD CHARACTERS WITHOUT CLAIM TO ANY PARTICULAR FONT, STYLE, SIZE, OR COLOR.

FOR PAPER GOODS AND PRINTED MATTER, NAMELY, PRINTED GREETING CARDS WITH ELECTRONIC INFORMATION STORED THEREIN, GREETING CARDS, STICKERS, GIFT WRAPPING PAPER, PAPER GIFT BAGS, PAPER GIFT TAGS, PAPER RIBBONS FOR GIFT WRAPPING, PAPER BOWS FOR GIFT WRAPPING, PAPERWEIGHTS, DESK BASKETS FOR DESK ACCESSORIES, DESK CALENDARS, DESK PADS, DESK CALENDAR PADS, DESK SETS, DESK STANDS AND HOLDERS FOR PENS, PENCILS AND INK, DESK TOP ORGANIZERS, DESK TOP PLANNERS, WALL CALENDARS, STUDENT DAILY PLANNERS, LOCKER CALENDARS, STICKER BOOKS, PAPER NAPKINS, PAPER TABLE COVERS, NAMELY, TABLE CLOTHS OF PAPER AND TABLE LINENS AT PAPER, PRINTED PAPER INVITATIONS, PAPER PARTY HATS, PAPER TREAT BAGS, DECORATIVE PAPER CENTERPIECES, PAPER BANNERS, PRINTED PAPER HANGTAGS; DISPLAYS IN THE NATURE OF PAPER BANNERS, PRINTED PAPER DOOR SIGNS, NOTE PAPER, NAMELY, PARTY SIGN-IN SHEETS, NOTE CARDS, NAMELY, THANK YOU NOTES, PAPER CAKE DECORATIONS, PAPER BOARDS, NAMELY, PRINTED CAKE DECORATING BOARDS, PAPER BAKERY BOXES, LITHOGRAPHS, MINIATURE ART PRINTS, PAPER WALL HANGINGS, NAMELY, PAPER WALL SCROLLS, TRADING CARDS, TRADING CARD BINDERS, CHILDREN'S BOOKS, ARTS AND CRAFTS PAINT KITS, SCHOOL SUPPLIES, NAMELY, PENCILS, PENS, GLUE, PENCIL SHARPENERS, ERASERS AND DESKTOP ORGANIZERS, PAPER TRANSPARENCIES, NAMELY, TRANSPARENT CELLO PAPER WITH CHARACTER ART, MEMORANDUM BOARDS, HEAT TRANSFER PAPER, ART ACTIVITY DESK SETS IN THE

CLASS 16—(Continued).

NATURE OF PAINTING SETS FOR CHILDREN, DECORATIVE PAPER, NAMELY, TISSUE PAPER, STATIONERY PRODUCTS, NAMELY, STATIONERY BOXES, STATIONERY FOLDERS, STATIONERY WRITING PAPER AND ENVELOPES, STATIONERY-TYPE PORTFOLIOS, PRINTED BLANK JOURNALS, NAMELY, DIARIES, PHOTOGRAPH ALBUMS, PENCILS, PENS, DRAWING PAPER, POSTERS, WALL DECORATIONS, NAMELY, PAPER PARTY DECORATIONS FAR THE WALL; NAIL AND SKIN STICKERS, CHILDREN'S ACTIVITY BOOKS, CHILDREN STORY BOOKS, NAMELY, STICKER PUZZLE ACTIVITY BOOKS, ART DOODLE KITS COMPRISED OF COLORING BOOKS, CRAYONS, COLORING PENCILS, BLANK PAPER, RUBBER STAMPS AND MARKERS, PRINTED GUIDES FOR COMPUTER VIDEO GAMES, PAPER BEVERAGE NAPKINS, PAPER COASTERS; INSPIRATIONAL, SELF-HELP AND HOW TO BOOKS ALL IN THE FIELD OF ART AND PERSONAL DEVELOPMENT; SCRAPBOOKS; STICKERS, STAMP PAD SET (U.S. CLS. 2, 5, 22, 23, 29, 37, 38 AND 50).

TRACY FLETCHER, EXAMINING ATTORNEY

SN 85-406,757. JOSEPH & EDNA JOSEPHSON INSTITUTE OF ETHICS, LOS ANGELES, CA. FILED 8-25-2011.

CHARACTER COUNTS! SCHOOL AGENDAS

THE MARK CONSISTS OF STANDARD CHARACTERS WITHOUT CLAIM TO ANY PARTICULAR FONT, STYLE, SIZE, OR COLOR.

OWNER OF U.S. REG. NOS. 3,047,280, 3,533,310 AND OTHERS.

NO CLAIM IS MADE TO THE EXCLUSIVE RIGHT TO USE "SCHOOL AGENDAS", APART FROM THE MARK AS SHOWN.

FOR DAY PLANNERS (U.S. CLS. 2, 5, 22, 23, 29, 37, 38 AND 50).

FIRST USE 0-0-2000; IN COMMERCE 0-0-2000.

JEFF DEFORD, EXAMINING ATTORNEY

SN 85-414,054. QUARK DISTRIBUTION, INC., NEW YORK, NY. FILED 9-2-2011.

STINK SACK

THE MARK CONSISTS OF STANDARD CHARACTERS WITHOUT CLAIM TO ANY PARTICULAR FONT, STYLE, SIZE, OR COLOR.

PRIORITY CLAIMED UNDER SEC. 44(D) ON CANADA APPLICATION NO. 1517421, FILED 3-2-2011.

NO CLAIM IS MADE TO THE EXCLUSIVE RIGHT TO USE "SACK", APART FROM THE MARK AS SHOWN.

FOR PLASTIC ODOR-PROOF RESEALABLE GENERAL PURPOSE BAGS (U.S. CLS. 2, 5, 22, 23, 29, 37, 38 AND 50).

FIRST USE 6-17-2010; IN COMMERCE 9-3-2010.

ELLEN BURNS, EXAMINING ATTORNEY

CLASS 16—(Continued).

SN 85-419,195. PETEDGE, INC., BEVERLY, MA. FILED 9-9-2011.

CLEAN GO PET

THE MARK CONSISTS OF STANDARD CHARACTERS WITHOUT CLAIM TO ANY PARTICULAR FONT, STYLE, SIZE, OR COLOR.

NO CLAIM IS MADE TO THE EXCLUSIVE RIGHT TO USE "CLEAN" AND "PET", APART FROM THE MARK AS SHOWN.

FOR DISPOSABLE HOUSEBREAKING PADS FOR PETS; DISPOSABLE PET DIAPERS; PLASTIC BAGS FOR DISPOSING OF PET WASTE (U.S. CLS. 2, 5, 22, 23, 29, 37, 38 AND 50).

FIRST USE 2-25-2003; IN COMMERCE 2-25-2003.
MICHELLE DUBOIS, EXAMINING ATTORNEY

CLASS 16—(Continued).

SN 85-444,380. WINGATE PACKAGING, INC., BLUE ASH, OH. FILED 10-11-2011.

WINGATE PACKAGING, INC.

THE MARK CONSISTS OF STANDARD CHARACTERS WITHOUT CLAIM TO ANY PARTICULAR FONT, STYLE, SIZE, OR COLOR.

NO CLAIM IS MADE TO THE EXCLUSIVE RIGHT TO USE "PACKAGING, INC.", APART FROM THE MARK AS SHOWN.

SEC. 2(F).

FOR PRINTED AND CONVERTED PACKAGING CONTAINERS COMPRISED PRIMARILY OF PAPERBOARD AND ALSO INCLUDING POLY SUBSTRATES, NAMELY, PAPERBOARD BOXES; PRINTED PACKAGING MATERIALS MADE PRIMARILY OF PAPERBOARD AND ALSO INCLUDING POLY SUBSTRATES (U.S. CLS. 2, 5, 22, 23, 29, 37, 38 AND 50).

FIRST USE 12-31-1987; IN COMMERCE 12-31-1987.
AMY KERTGATE, EXAMINING ATTORNEY

SN 85-435,438. MARKETPLAN, INC., TOLEDO, OH. FILED 9-29-2011.



OWNER OF U.S. REG. NO. 3,151,294.
THE MARK CONSISTS OF THE WORDS "LOOK UP" AND AN ARROW CONTAINED WITHIN A CIRCLE.

FOR BUMPER STICKERS; CASES SPECIALLY ADAPTED FOR HOLDING AND CARRYING BOOKS AND BIBLES; BOOK AND BIBLE COVERS; WINDOW CLINGS; WINDOW DECALS; BOOKMARKS; STATIONERY; GREETING CARDS; POSTERS; GIFT BAGS OF PAPER AND FABRIC; AND GIFT WRAP OF PAPER, METAL, AND PLASTIC (U.S. CLS. 2, 5, 22, 23, 29, 37, 38 AND 50).

MARY ROSSMAN, EXAMINING ATTORNEY

SN 85-448,166. SCHWARTZ, MAURI, SAN FRANCISCO, CA. FILED 10-14-2011.

Career Insiders

THE MARK CONSISTS OF STANDARD CHARACTERS WITHOUT CLAIM TO ANY PARTICULAR FONT, STYLE, SIZE, OR COLOR.

OWNER OF U.S. REG. NO. 3,241,000.

NO CLAIM IS MADE TO THE EXCLUSIVE RIGHT TO USE "CAREER", APART FROM THE MARK AS SHOWN.

FOR PUBLICATIONS, NAMELY, BOOKS, WORKBOOKS, HAND-OUTS, NEWSLETTERS, BROCHURES, AND ARTICLES IN THE FIELDS OF CAREER SERVICES, EXCLUDING MAGAZINE AND NEWSPAPER COLUMNS AND ARTICLES (U.S. CLS. 2, 5, 22, 23, 29, 37, 38 AND 50).

FIRST USE 8-1-2004; IN COMMERCE 8-1-2004.
APRIL HESIK, EXAMINING ATTORNEY

CLASS 16—(Continued).

SN 85-454,219. PHARMD PRESS, LLC, MINNEAPOLIS, MN. FILED 10-24-2011.

PHARMD PRESS

THE MARK CONSISTS OF STANDARD CHARACTERS WITHOUT CLAIM TO ANY PARTICULAR FONT, STYLE, SIZE, OR COLOR.

NO CLAIM IS MADE TO THE EXCLUSIVE RIGHT TO USE "PRESS", APART FROM THE MARK AS SHOWN.

FOR PERIODICAL BOOKLETS, PAMPHLETS AND JOURNALS IN THE FIELD OF PHARMACEUTICAL EDUCATION AND TRAINING (U.S. CLS. 2, 5, 22, 23, 29, 37, 38 AND 50).

FIRST USE 8-3-2011; IN COMMERCE 8-3-2011.
STEVEN PEREZ, EXAMINING ATTORNEY

CLASS 16—(Continued).

SN 85-454,560. FUNDUCATE, LLC, LIBERTY TOWNSHIP, OH. FILED 10-24-2011.

THE FUNBUNCH

THE MARK CONSISTS OF STANDARD CHARACTERS WITHOUT CLAIM TO ANY PARTICULAR FONT, STYLE, SIZE, OR COLOR.

FOR BOOKS IN THE FIELD OF EDUCATION FOR CHILDREN, NAMELY, READING, ART, CULTURE, AND SINGING; CHILDREN'S BOOKS; CHILDREN'S INTERACTIVE EDUCATIONAL BOOKS; COLORING BOOKS; FLASH CARDS (U.S. CLS. 2, 5, 22, 23, 29, 37, 38 AND 50).

FIRST USE 1-29-2002; IN COMMERCE 1-29-2002.
DORITT L. CARROLL, EXAMINING ATTORNEY

SN 85-466,962. PERSONAL LIBERTY MEDIA GROUP, LLC, HANCEVILLE, AL. FILED 11-8-2011.

THE BOB LIVINGSTON LETTER

THE MARK CONSISTS OF STANDARD CHARACTERS WITHOUT CLAIM TO ANY PARTICULAR FONT, STYLE, SIZE, OR COLOR.

NO CLAIM IS MADE TO THE EXCLUSIVE RIGHT TO USE "LETTER", APART FROM THE MARK AS SHOWN.

"BOB LIVINGSTON" IDENTIFIES A PEN NAME OF DON LOWERY, A LIVING INDIVIDUAL WHOSE CONSENT IS OF RECORD.

FOR NEWSLETTERS IN THE FIELD OF CURRENT EVENTS, ECONOMICS, POLITICS, WEALTH MANAGEMENT AND PERSONAL HEALTH (U.S. CLS. 2, 5, 22, 23, 29, 37, 38 AND 50).

FIRST USE 1-0-1995; IN COMMERCE 1-0-1995.
JAMES MACFARLANE, EXAMINING ATTORNEY

SN 85-454,507. FREMANTLE MEDIA NORTH AMERICA, INC., BURBANK, CA. FILED 10-24-2011.

THE BIG BLUFF

THE MARK CONSISTS OF STANDARD CHARACTERS WITHOUT CLAIM TO ANY PARTICULAR FONT, STYLE, SIZE, OR COLOR.

FOR POSTERS, CALENDARS, NOTEBOOKS, BINDERS, DAILY PERSONAL ORGANIZERS, MEMOPADS, STICKERS, COMIC BOOKS, WRITING PAPER, ENVELOPES, GREETING CARDS, PAPER COASTERS, PAPER MATS, NEWSPAPERS FOR GENERAL CIRCULATION, BOOKS AND MAGAZINES IN THE FIELD OF A REALITY-BASED GAME SHOW SERIES, NEWSLETTERS IN THE FIELD OF A REALITY-BASED GAME SHOW SERIES, PHOTOGRAPHS, POSTCARDS, TRADING CARDS, CARDBOARD STAND-UP CUTOUTS FEATURING PHOTOGRAPHS OR ARTWORK, PREPAID PHONE DEBIT CARDS WITHOUT MAGNETIC CODING, TRADING CARD MILK BOTTLE CAPS, AND CUSTOMIZED PERSONAL BANK CHECKS, PAPER PARTY DECORATIONS, PAPER PARTY BAGS, PAPER PARTY FAVORS, PAPER CAKE DECORATIONS (U.S. CLS. 2, 5, 22, 23, 29, 37, 38 AND 50).

TINA MAI, EXAMINING ATTORNEY

SN 85-468,482. MICHAELS STORES PROCUREMENT COMPANY, INC., IRVING, TX. FILED 11-9-2011.

IMAGIN8

THE MARK CONSISTS OF STANDARD CHARACTERS WITHOUT CLAIM TO ANY PARTICULAR FONT, STYLE, SIZE, OR COLOR.

OWNER OF U.S. REG. NO. 3,544,161.

FOR PAINT APPLICATORS IN THE NATURE OF SPONGES (U.S. CLS. 2, 5, 22, 23, 29, 37, 38 AND 50).

TRACY CROSS, EXAMINING ATTORNEY

CLASS 16—(Continued).

SN 85-468,494. MICHAELS STORES PROCUREMENT COMPANY, INC., IRVING, TX. FILED 11-9-2011.

IMAGIN8

THE MARK CONSISTS OF STANDARD CHARACTERS WITHOUT CLAIM TO ANY PARTICULAR FONT, STYLE, SIZE, OR COLOR.

OWNER OF U.S. REG. NO. 3,544,161.
FOR FABRIC MARKERS; CARDBOARD T-SHIRT FORM; RUBBER BANDS; FABRIC GLUE FOR HOUSEHOLD USE; STENCILS; IRON-ON TRANSFERS; IRON-ON HEAT TRANSFER PAPER; TEMPORARY TATTOOS; PAINT BRUSHES (U.S. CLS. 2, 5, 22, 23, 29, 37, 38 AND 50).

TRACY CROSS, EXAMINING ATTORNEY

SN 85-475,985. TEAM SIZZLE FILMS, INC., BALTIMORE, MD. FILED 11-17-2011.

T-SIZZLE

THE MARK CONSISTS OF STANDARD CHARACTERS WITHOUT CLAIM TO ANY PARTICULAR FONT, STYLE, SIZE, OR COLOR.

THE NAME(S), PORTRAIT(S), AND/OR SIGNATURE(S) SHOWN IN THE MARK IDENTIFIES "TERRELL RAYMONN SUGGS", WHOSE CONSENT(S) TO REGISTER IS MADE OF RECORD.

FOR PAPER GOODS, NAMELY, ART PRINTS, POSTERS, UNMOUNTED AND MOUNTED PHOTOGRAPHS, NOTEBOOKS, AND SPORTS TRADING CARDS (U.S. CLS. 2, 5, 22, 23, 29, 37, 38 AND 50).

JUDITH HELFMAN, EXAMINING ATTORNEY

SN 85-477,036. CENTRAL RECOVERY HOLDINGS, LLC, LAS VEGAS, NV. FILED 11-18-2011.

CENTRAL RECOVERY PRESS

THE MARK CONSISTS OF STANDARD CHARACTERS WITHOUT CLAIM TO ANY PARTICULAR FONT, STYLE, SIZE, OR COLOR.

NO CLAIM IS MADE TO THE EXCLUSIVE RIGHT TO USE "RECOVERY PRESS", APART FROM THE MARK AS SHOWN.

FOR PUBLICATIONS, NAMELY, TEXTS, BOOKS, JOURNALS AND OTHER PRINTED MATTER IN THE FIELDS OF CHEMICAL DEPENDENCY, ADDICTION TREATMENT, PAIN MANAGEMENT, COUNSELING AND OTHER MEDICAL REHABILITATION SERVICES (U.S. CLS. 2, 5, 22, 23, 29, 37, 38 AND 50).

FIRST USE 6-1-2008; IN COMMERCE 6-1-2008.

ROBERT C. CLARK JR., EXAMINING ATTORNEY

CLASS 16—(Continued).

SN 85-484,939. HOOKED NATION, INC., VERO BEACH, FL. FILED 12-1-2011.

CARPE DIEM

THE MARK CONSISTS OF STANDARD CHARACTERS WITHOUT CLAIM TO ANY PARTICULAR FONT, STYLE, SIZE, OR COLOR.

OWNER OF U.S. REG. NOS. 3,954,924 AND 3,955,101.
THE ENGLISH TRANSLATION OF "CARPE DIEM" IN THE MARK IS "SEIZE THE DAY".

FOR BUMPER STICKERS; DECALS (U.S. CLS. 2, 5, 22, 23, 29, 37, 38 AND 50).

FIRST USE 9-1-2011; IN COMMERCE 9-1-2011.

CHRISTOPHER SIDOTI, EXAMINING ATTORNEY

SN 85-487,006. THE WILTED FLOWER CARD CO. LLC, PURCHASE, NY. FILED 12-5-2011.



NO CLAIM IS MADE TO THE EXCLUSIVE RIGHT TO USE "CARD CO." AND "CARDS", APART FROM THE MARK AS SHOWN.

THE MARK CONSISTS OF THE DESIGN OF A WILTED FLOWER WITH THE WORDS "THE WILTED FLOWER CARD CO." APPEARING ABOVE THE DESIGN, AND THE WORDS "CARDS FOR THE DISGRUNTLED" APPEARING BELOW.

FOR GREETING CARDS (U.S. CLS. 2, 5, 22, 23, 29, 37, 38 AND 50).

CHRISTOPHER SIDOTI, EXAMINING ATTORNEY

CLASS 16—(Continued).

SN 85-488,140. VIRTUOSO, LTD., FORT WORTH, TX. FILED 12-6-2011.

VIRTUOSO TRAVELER

THE MARK CONSISTS OF STANDARD CHARACTERS WITHOUT CLAIM TO ANY PARTICULAR FONT, STYLE, SIZE, OR COLOR.

OWNER OF U.S. REG. NOS. 3,095,926, 3,884,601 AND OTHERS.

NO CLAIM IS MADE TO THE EXCLUSIVE RIGHT TO USE "TRAVELER", APART FROM THE MARK AS SHOWN.

FOR PRINTED PUBLICATIONS, NAMELY, MAGAZINES IN THE FIELD OF TRAVEL (U.S. CLS. 2, 5, 22, 23, 29, 37, 38 AND 50).

JULIE WATSON, EXAMINING ATTORNEY

CLASS 16—(Continued).

SN 85-521,156. FUNDRAISING FOR A CAUSE, INC., TAMPA, FL. FILED 1-20-2012.



SN 85-505,597. CHECKPOINT SYSTEMS, INC., PHILADELPHIA, PA. FILED 12-29-2011.

AMP

THE MARK CONSISTS OF STANDARD CHARACTERS WITHOUT CLAIM TO ANY PARTICULAR FONT, STYLE, SIZE, OR COLOR.

FOR SYSTEM FOR ORGANIZING SECURITY CONTAINERS AND DEVICES, COMPRISED OF ORGANIZATIONAL POSTERS, STICKERS AND PLACARDS HAVING AN INDICIA PRINTED THEREON (U.S. CLS. 2, 5, 22, 23, 29, 37, 38 AND 50).

BILL DAWE, EXAMINING ATTORNEY

THE MARK CONSISTS OF THE WORDING "TOGETHER WE CAN MAKE A DIFFERENCE" ENCIRCLING THREE FANCIFUL STICK FIGURE DESIGNS.

FOR GREETING CARDS; DECALS; STICKERS (U.S. CLS. 2, 5, 22, 23, 29, 37, 38 AND 50).

FIRST USE 1-31-2008; IN COMMERCE 1-31-2008.

RUSS HERMAN, EXAMINING ATTORNEY

SN 85-513,400. SOUNDBRUSH RECORDS LLC, BROOKLYN, NY. FILED 1-10-2012.

SOUNDBRUSH RECORDS

THE MARK CONSISTS OF STANDARD CHARACTERS WITHOUT CLAIM TO ANY PARTICULAR FONT, STYLE, SIZE, OR COLOR.

NO CLAIM IS MADE TO THE EXCLUSIVE RIGHT TO USE "RECORDS", APART FROM THE MARK AS SHOWN.

FOR A SERIES OF BOOKS IN THE FIELD OF MUSIC (U.S. CLS. 2, 5, 22, 23, 29, 37, 38 AND 50).

COURTNEY ALVAREZ, EXAMINING ATTORNEY

SN 85-521,334. FILSINGER & COMPANY, LTD., NEW YORK, NY. FILED 1-20-2012.

NEIGHBORS

THE MARK CONSISTS OF STANDARD CHARACTERS WITHOUT CLAIM TO ANY PARTICULAR FONT, STYLE, SIZE, OR COLOR.

FOR CHILDREN'S BOOKS, PRINTS, POST CARDS, COLORING BOOKS (U.S. CLS. 2, 5, 22, 23, 29, 37, 38 AND 50).

KIM SAITO, EXAMINING ATTORNEY

CLASS 16—(Continued).

SN 85-524,352. CENTRAL RECOVERY HOLDINGS, LLC, LAS VEGAS, NV. FILED 1-24-2012.



NO CLAIM IS MADE TO THE EXCLUSIVE RIGHT TO USE "RECOVERY PRESS", APART FROM THE MARK AS SHOWN.

THE MARK CONSISTS OF THE TEXT "CRP" CENTERED ABOVE THE TEXT "CENTRAL RECOVERY PRESS" WITH AN EIGHT POINT STAR CENTERED INSIDE THE "C" OF THE TEXT "CRP".

FOR PUBLICATIONS, NAMELY, TEXTS, BOOKS, JOURNALS AND OTHER PRINTED MATTER IN THE FIELDS OF CHEMICAL DEPENDENCY, ADDICTION TREATMENT, PAIN MANAGEMENT, COUNSELING AND OTHER MEDICAL REHABILITATION SERVICES (U.S. CLS. 2, 5, 22, 23, 29, 37, 38 AND 50).

FIRST USE 6-27-2011; IN COMMERCE 6-27-2011.

ROBERT C. CLARK JR., EXAMINING ATTORNEY

CLASS 16—(Continued).

SN 85-531,507. PAUL FRANK INDUSTRIES LLC, LOS ANGELES, CA. FILED 2-1-2012.

SMALL PAUL

THE MARK CONSISTS OF STANDARD CHARACTERS WITHOUT CLAIM TO ANY PARTICULAR FONT, STYLE, SIZE, OR COLOR.

OWNER OF U.S. REG. NO. 3,614,027.

FOR WRITING PAPER; STATIONERY; PAPER PARTY DECORATIONS; DECORATIVE PAPER CENTERPIECES; PAPER NAPKINS; PAPER PARTY BAGS; PAPER TABLE CLOTHS; POSTERS; PRINTED CERTIFICATES; CHILDREN'S ACTIVITY BOOKS; BINDERS; ENVELOPES; PRINTED INVITATIONS; MEMO PADS; NOTEBOOKS; COLORING BOOKS; BOOKS FEATURING STORIES FOR CHILDREN; PENS AND PENCILS; PEN AND PENCIL BOXES AND CASES; ERASERS; MARKERS; CRAYONS; GREETING CARDS AND STICKERS (U.S. CLS. 2, 5, 22, 23, 29, 37, 38 AND 50).

MARTHA FROMM, EXAMINING ATTORNEY

SN 85-538,083. LITTLE ANGELS, LLC, NEW YORK, NY. FILED 2-9-2012.



SN 85-527,481. BALLIN, DIMA, BRIGHTON, MA. FILED 1-27-2012.

DIABOLIQUE

THE MARK CONSISTS OF THE TERMS "DIABOLIQUE" IN STYLIZED FONT.

THE ENGLISH TRANSLATION OF "DIABOLIQUE" IN THE MARK IS "DIABOLIC".

FOR MAGAZINES IN THE FIELD OF HORROR CINEMA, LITERATURE, HISTORY AND ART (U.S. CLS. 2, 5, 22, 23, 29, 37, 38 AND 50).

FIRST USE 11-0-2010; IN COMMERCE 11-0-2010.

ELIZABETH KAJUBI, EXAMINING ATTORNEY

THE MARK CONSISTS OF DEPICTIONS OF EIGHT ANGELS WITH HALOS AND WINGS AND TWO CHILDREN ALL WITHIN A CLOUD.

FOR PRINTED MATTER, NAMELY, NOTE PAPER AND LOOSE LEAF PAPER, BOOKS IN THE FIELD OF CHILDREN'S STORIES, DECALS, BUMPER STICKERS, CHILDREN'S WALL STICKERS AND MURALS; TRADING CARDS, GREETING CARDS, NOTE CARDS, POSTERS, FOLDERS, CALENDARS, STATIONERY WRITING PAPER AND ENVELOPES, ARTS AND CRAFT PAINT KITS, ACTIVITY BOOKS; BOARD BOOKS; PICTURE BOOKS; NOVELTY BOOKS IN THE FIELDS OF CHILDREN'S STORIES; COLORING BOOKS; NOTEBOOKS; BLANK JOURNALS; BOOKMARKS; CRAFT BOOKS; SCHOOL SUPPLIES, NAMELY, PENCIL, PENS, PEN AND PENCIL CASES AND HOLDERS, ERASERS, PENCIL SHARPENERS, HIGHLIGHTS MARKERS, MARKERS, AND DRAWING RULERS; GIFT WRAPPING PAPER; PAPER PARTY DECORATIONS; PARTY PAPER BAGS; PAPER PLACEMATS (U.S. CLS. 2, 5, 22, 23, 29, 37, 38 AND 50).

ELIZABETH KAJUBI, EXAMINING ATTORNEY

CLASS 16—(Continued).

SN 85-542,793. THE UNLIMITED US, DBA VENETIAN BEAD SHOP, SUNNYVALE, CA. FILED 2-14-2012.



THE COLOR(S) RED, DARK BLUE, ORANGE, AQUA, FUCHSIA, GREEN, BLUE, PINK IS/ARE CLAIMED AS A FEATURE OF THE MARK.

THE MARK CONSISTS OF LETTERS OF A WORD REPRESENTED BY A DIFFERENT COLOR, IN ORDER, THEY ARE AS FOLLOWS: RED "C", DARK BLUE "R", ORANGE "E", AQUA "A", FUCHSIA "T", GREEN "I", BLUE "V", PINK "O" WITH THE LETTER "I" APPEARING WITH AN ACUTE ACCENT TO INDICATE ITS PRONUNCIATION. THE ENGLISH TRANSLATION OF "CREATIVO" IN THE MARK IS "CREATIVE".

FOR ARTS AND CRAFT CLAY KITS; MODELING COMPOUNDS (U.S. CLS. 2, 5, 22, 23, 29, 37, 38 AND 50). FIRST USE 2-12-2012; IN COMMERCE 2-12-2012. JENNIFER MARTIN, EXAMINING ATTORNEY

CLASS 16—(Continued).

SN 85-545,157. PHANCO, JOHN, JACKSONVILLE, FL. FILED 2-16-2012.



THE COLOR(S) BLACK AND WHITE IS/ARE CLAIMED AS A FEATURE OF THE MARK.

THE MARK CONSISTS OF A SKULL IN THE MIDDLE WITH BANDANA WITH STARS COVERING THE FACE, CROSSED RIFLES BELOW IT AND IN SPECIALIZED FONT "RECOIL" ON THE LEFT SIDE AND "NATION" ON THE RIGHT SIDE, WITH THE WORDING AND DESIGN ELEMENTS IN WHITE AND BLACK COLOR, ALL ON A BLACK RECTANGLE BACKGROUND.

FOR STICKERS (U.S. CLS. 2, 5, 22, 23, 29, 37, 38 AND 50). TEJBIR SINGH, EXAMINING ATTORNEY

SN 85-550,067. BARBOUR, LYSA A, LARCHMONT, NY. AND SHINN, MICHAEL J, LARCHMONT, NY. FILED 2-22-2012.

Blue Diamond Development

THE MARK CONSISTS OF STANDARD CHARACTERS WITHOUT CLAIM TO ANY PARTICULAR FONT, STYLE, SIZE, OR COLOR.

NO CLAIM IS MADE TO THE EXCLUSIVE RIGHT TO USE "DEVELOPMENT", APART FROM THE MARK AS SHOWN.

FOR PLANS FOR BUILDING CONSTRUCTION, BUSINESS DEVELOPMENT (U.S. CLS. 2, 5, 22, 23, 29, 37, 38 AND 50).

FLORENTINA BLANDU, EXAMINING ATTORNEY

SN 85-543,694. TRANSFORMATIONAL WISDOM, LLC, TUCSON, AZ. FILED 2-15-2012.



Susan Sophia James

SN 85-551,150. MICHAEL L. KLASSEN, CEDAR FALLS, IA. FILED 2-23-2012.

Billion-Dollar Hippy

THE MARK CONSISTS OF STANDARD CHARACTERS WITHOUT CLAIM TO ANY PARTICULAR FONT, STYLE, SIZE, OR COLOR.

FOR BOOK IN THE FIELD OF BUSINESS AND BUSINESS HISTORY, AND ADVICE AND SELF-HELP (U.S. CLS. 2, 5, 22, 23, 29, 37, 38 AND 50).

TRACY WHITTAKER-BROWN, EXAMINING ATTORNEY

THE NAME "SUSAN SOPHIA JAMES" IDENTIFIES THE PSEUDONYM OF "SUSAN ELLEN HEGEMEYER", A LIVING INDIVIDUAL WHOSE CONSENT IS OF RECORD.

THE MARK CONSISTS OF A SHADED CIRCLE FEATURING A SQUARED BOX TURNED ON ITS SIDE TO LOOK LIKE A DIAMOND. THE DIAMOND FEATURES A DARK TRISKELION. THE ENTIRE DESIGN MARK IS ON THE LEFT OF THE WORDS, "SUSAN SOPHIA JAMES".

FOR NON-FICTION BOOKS ON ENERGY MEDICINE AND MEDITATION (U.S. CLS. 2, 5, 22, 23, 29, 37, 38 AND 50).

FIRST USE 1-15-2011; IN COMMERCE 8-11-2011. HOWARD SMIGA, EXAMINING ATTORNEY

CLASS 16—(Continued).

SN 85-554,768. SHOPZOOEY, INC., LAKE MARY, FL. FILED 2-28-2012.



THE MARK CONSISTS OF THE WORDING "WWW.SHOPZUI.COM" COMBINED WITH A PEACE SIGN, A HEART, AND A SMILEY FACE ON A SHOPPING BAG. FOR BUMPER STICKERS (U.S. CLS. 2, 5, 22, 23, 29, 37, 38 AND 50).
KIM MONINGHOFF, EXAMINING ATTORNEY

SN 85-554,779. SHOPZOOEY, INC., LAKE MARY, FL. FILED 2-28-2012.



THE MARK CONSISTS OF THE WORDING "WWW.SHOPZUI.COM" COMBINED WITH A FLAME, A CRACKED HEART, AND A SMILEY FACE ON A SHOPPING BAG. FOR BUMPER STICKERS (U.S. CLS. 2, 5, 22, 23, 29, 37, 38 AND 50).
KIM MONINGHOFF, EXAMINING ATTORNEY

SN 85-559,186. INSIDER NEWSPAPERS, INC., COVINGTON, GA. FILED 3-2-2012.



NO CLAIM IS MADE TO THE EXCLUSIVE RIGHT TO USE "HVAC & REFRIGERATION", APART FROM THE MARK AS SHOWN.
THE COLOR(S) BLUE, BLACK AND RED IS/ARE CLAIMED AS A FEATURE OF THE MARK.
THE MARK CONSISTS OF "HVAC & REFRIGERATION INSIDER" THE WORD "HVAC" IS IN ALL CAPS THE WORDS "& REFRIGERATION" HAS A CAPITAL "R" AND "INSIDER" HAS A CAPITAL "I" THE WORD "HVAC" IS IN BLUE THE WORDS "& REFRIGERATION" ARE IN BLACK AND THE WORD "INSIDER" IS IN RED INSIDE AN ANGLED DOUBLE LINED BOX WITH THE OUTSIDE LINE DARKER THAN THE INSIDE LINE AGAINST THE LETTERS "HVAC".
FOR TRADE JOURNALS IN THE FIELD OF THE HEATING VENTILATING AIRCONDITIONING AND REFRIGERATION TRADE (U.S. CLS. 2, 5, 22, 23, 29, 37, 38 AND 50).
FIRST USE 1-0-1991; IN COMMERCE 2-6-1991.
SUSAN LESLIE DUBOIS, EXAMINING ATTORNEY

CLASS 16—(Continued).

SN 85-561,040. DEREK EDGINGTON PRODUCTIONS LLC, PLEASANTON, CA. FILED 3-6-2012.

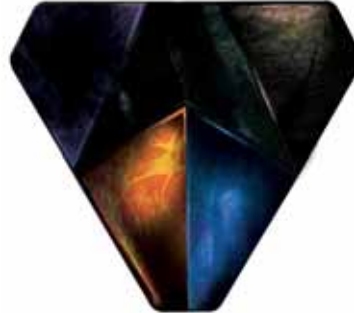

THE COLOR(S) BLACK, PURPLE, GREEN, BLUE, BROWN, PINK, YELLOW AND ORANGE IS/ARE CLAIMED AS A FEATURE OF THE MARK.
THE MARK CONSISTS OF AN AMULET DESIGN IN THE COLORS BLACK, PURPLE, GREEN, BLUE, BROWN, PINK, YELLOW AND ORANGE.
FOR SERIES OF FICTION BOOKS; SERIES OF FICTION WORKS, NAMELY, NOVELS AND BOOKS (U.S. CLS. 2, 5, 22, 23, 29, 37, 38 AND 50).
FIRST USE 1-0-2012; IN COMMERCE 1-0-2012.
ANDREW LEASER, EXAMINING ATTORNEY

SN 85-564,051. E Z CALL TELECOM INC., BONITA, CA. FILED 3-8-2012.

CHICHARITO

THE MARK CONSISTS OF STANDARD CHARACTERS WITHOUT CLAIM TO ANY PARTICULAR FONT, STYLE, SIZE, OR COLOR.
THE ENGLISH TRANSLATION OF THE WORD "CHICHARITO" IN THE MARK IS "LITTLE GREEN PEA".
FOR TELEPHONE CALLING CARDS, NOT MAGNETICALLY ENCODED (U.S. CLS. 2, 5, 22, 23, 29, 37, 38 AND 50).
JACQUELINE A. LAVINE, EXAMINING ATTORNEY

SN 85-564,998. SARAH BANKS, ORLANDO, FL. AND MICHAEL BANKS, ORLANDO, FL. FILED 3-9-2012.

SUGAR FUELED

THE MARK CONSISTS OF STANDARD CHARACTERS WITHOUT CLAIM TO ANY PARTICULAR FONT, STYLE, SIZE, OR COLOR.
FOR GRAPHIC ART REPRODUCTIONS, PRINT ART, AND ADHESIVE PAPER STICKERS (U.S. CLS. 2, 5, 22, 23, 29, 37, 38 AND 50).
FIRST USE 6-5-2011; IN COMMERCE 6-11-2011.
JOHN KELLY, EXAMINING ATTORNEY

CLASS 16—(Continued).

SN 85-566,740. IMAGE AWARENESS CENTER, INC., NORTH LAKEWOOD, WA. FILED 3-12-2012.

COLORS MADE EASY

THE MARK CONSISTS OF STANDARD CHARACTERS WITHOUT CLAIM TO ANY PARTICULAR FONT, STYLE, SIZE, OR COLOR.

NO CLAIM IS MADE TO THE EXCLUSIVE RIGHT TO USE "COLORS", APART FROM THE MARK AS SHOWN.

FOR COLOR ANALYSIS KITS FOR WARDROBE AND COSMETIC PURPOSES COMPRISED OF PRINTED COLOR CHARTS, PRINTED COLOR CARDS, PRINTED INSTRUCTION CARDS, MIRROR, CAPE AND CARRYING CASE; PRINTED MATERIAL IN THE NATURE OF COLOR SAMPLES FOR CONDUCTING COLOR ANALYSIS FOR WARDROBE AND COSMETIC PURPOSES; PRINTED COLOR CHARTS, PRINTED COLOR SWATCH CARDS, PRINTED COLOR CARDS AND COLLECTION OF PRINTED COLOR CARDS ALL FOR CONDUCTING COLOR ANALYSIS FOR WARDROBE AND COSMETIC PURPOSES (U.S. CLS. 2, 5, 22, 23, 29, 37, 38 AND 50).

FIRST USE 11-4-2001; IN COMMERCE 11-4-2001.
DANIEL CAPSHAW, EXAMINING ATTORNEY

SN 85-567,864. ZAN MAGAZINE INC., HOUSTON, TX. FILED 3-13-2012.

zan

THE MARK CONSISTS OF THE WORD "ZAN". FOR GENERAL FEATURE MAGAZINES (U.S. CLS. 2, 5, 22, 23, 29, 37, 38 AND 50).

FIRST USE 11-1-2011; IN COMMERCE 11-1-2011.
KRISTIN DAHLING, EXAMINING ATTORNEY

SN 85-571,030. ALLDREDGE, SHERMAN, PORTLAND, OR. FILED 3-15-2012.

iPresent Box

THE MARK CONSISTS OF STANDARD CHARACTERS WITHOUT CLAIM TO ANY PARTICULAR FONT, STYLE, SIZE, OR COLOR.

NO CLAIM IS MADE TO THE EXCLUSIVE RIGHT TO USE "BOX", APART FROM THE MARK AS SHOWN.

FOR BOXES, CONTAINERS, AND CARTONS OF PAPERBOARD OR CARDBOARD FOR COMMERCIAL OR INDUSTRIAL PACKAGING (U.S. CLS. 2, 5, 22, 23, 29, 37, 38 AND 50).

FIRST USE 12-1-2011; IN COMMERCE 12-16-2011.
LINDA MICKLEBURGH, EXAMINING ATTORNEY

CLASS 16—(Continued).

SN 85-571,719. REAL MADRID CLUB DE FUTBOL, MADRID, SPAIN, FILED 3-16-2012.



Realmadrid

THE COLOR(S) GOLD, RED AND BLUE IS/ARE CLAIMED AS A FEATURE OF THE MARK.

THE MARK CONSISTS OF GOLD LETTERS "M", "C", AND "F" OUTLINED IN BLUE WITHIN A GOLD CIRCLE OUTLINED IN BLUE OVERLAPPING A BLUE DIAGONAL BAND WITH A RED, BLUE AND GOLD CROWN ON TOP, AND THE WORDING "REALMADRID" IN BLUE BENEATH THE CIRCLE.

FOR STATIONERY; POSTERS; POST CARDS; CALENDARS (U.S. CLS. 2, 5, 22, 23, 29, 37, 38 AND 50).

FIRST USE 12-31-2008; IN COMMERCE 12-31-2008.
ANDREA K. NADELMAN, EXAMINING ATTORNEY

CLASS 16—(Continued).

SN 85-572,223. RKO PICTURES, LOS ANGELES, CA. FILED 3-16-2012.



OWNER OF U.S. REG. NOS. 2,628,024, 3,318,872 AND OTHERS.

NO CLAIM IS MADE TO THE EXCLUSIVE RIGHT TO USE "STAGE", APART FROM THE MARK AS SHOWN.

THE MARK CONSISTS OF AN UPSIDE-DOWN STYLIZED TRIANGLE AND A LIGHTNING BOLT THAT RUNS DOWN THE MIDDLE OF THE TRIANGLE. THE WORD "STAGE" APPEARS INSIDE THE TRIANGLE AND IS INTERSECTED BY THE LIGHTNING BOLT WHILE "RKO", WITH SPACE IN BETWEEN EACH LETTER, RESTS ON THE BASE OF THE TRIANGLE.

FOR PAPER OR CARDBOARD ARTICLES AND PRINTED MATTER, NAMELY, CARDBOARD, STATIONERY, MOUNTED AND UNMOUNTED PHOTOGRAPHS, BOOKS IN THE FIELD OF PERFORMING ARTS; NEWSPAPERS FOR GENERAL CIRCULATION, GENERAL FEATURE MAGAZINES, COMIC BOOKS, CALENDARS, NOTEBOOKS, MEMO PADS, PENS, PENCILS, WRITING INSTRUMENTS, MARKERS, HIGHLIGHTERS, FOLDERS, PAPER CLIPS, STICKERS, ERASERS, PENCIL SHARPENERS, PENCIL CASES, STAPLERS, WRITING PAPER, ENVELOPES, PAPER WEIGHTS, PAPER COASTERS, PAPER MATS, DRAWING RULERS, POSTCARDS AND TRADING CARDS, POSTERS; PAPER PARTY GOODS, NAMELY, PAPER PARTY BAGS, PAPER PARTY DECORATIONS, PAPER PARTY FAVORS, PARTY GOODIE BAGS OF PAPER OR PLASTIC, PARTY ORNAMENTS OF PAPER AND PAPER NAPKINS (U.S. CLS. 2, 5, 22, 23, 29, 37, 38 AND 50).

LYNDSSEY KUYKENDALL, EXAMINING ATTORNEY

SN 85-573,533. LAURA ANN HART, ACWORTH, GA. FILED 3-19-2012.

QUICKIE COUPONS

THE MARK CONSISTS OF STANDARD CHARACTERS WITHOUT CLAIM TO ANY PARTICULAR FONT, STYLE, SIZE, OR COLOR.

OWNER OF U.S. REG. NO. 3,932,708.

NO CLAIM IS MADE TO THE EXCLUSIVE RIGHT TO USE "COUPONS", APART FROM THE MARK AS SHOWN. FOR COUPON BOOKS (U.S. CLS. 2, 5, 22, 23, 29, 37, 38 AND 50).

FIRST USE 1-27-2009; IN COMMERCE 7-0-2009.

KATHLEEN M. VANSTON, EXAMINING ATTORNEY

CLASS 16—(Continued).

SN 85-578,336. ISLAND P.I. LLC, WAUKESHA, WI. FILED 3-23-2012.



THE MARK CONSISTS OF THE WORDS "ISLAND DESTINATION POINT" AND LETTERS "PI". THE WORDS ARE PRESENTED IN A STYLIZED FONT. THE LETTERS "PI" ARE REPRESENTED IN A LARGER FONT THAN THE WORD "ISLAND". BELOW THE WORD "ISLAND" ARE THE WORDS "DESTINATION POINT" IN A RECTANGULAR SHADED SHAPE. THE RECTANGLE IS IN CONNECTION WITH THE LETTER "P".

FOR PRINTED GUIDES FOR TRAVEL (U.S. CLS. 2, 5, 22, 23, 29, 37, 38 AND 50).

NAKIA HENRY, EXAMINING ATTORNEY

SN 85-582,408. SICPA HOLDING SA, 1008 PRILLY, SWITZERLAND, FILED 3-28-2012.

SICPA

OWNER OF SWITZERLAND REG. NO. 1,065,060, DATED 11-1-2010, EXPIRES 11-1-2020.

OWNER OF U.S. REG. NOS. 1,565,337, 4,085,797 AND OTHERS.

THE MARK CONSISTS OF THE WORD "SICPA" IN STYLIZED FORM.

FOR PRINTED MATTER, PAPER, CARDBOARD AND GOODS MADE OF THESE MATERIALS, NAMELY, PRINTED BANKNOTES, PRINTED TICKETS, PAPER LABELS, PAPER BANDEROLES, AND PRINTED FINANCIAL, FIDUCIARY AND FISCAL DOCUMENTS; STATIONERY; PAPER AND CARDBOARD AND PLASTIC SHEETS FOR PACKAGING COMPRISING SECURITY ELEMENTS; BOOKBINDING MATERIAL; PHOTOGRAPHS; ADHESIVES FOR STATIONERY OR HOUSEHOLD PURPOSES; PRINTED INSTRUCTIONAL AND TEACHING MATERIAL IN THE FIELD OF SECURITY PRINTING INDUSTRY; PRINTING TYPES; PRINTING BLOCKS (U.S. CLS. 2, 5, 22, 23, 29, 37, 38 AND 50).

NANCY CLARKE, EXAMINING ATTORNEY

CLASS 16—(Continued).

SN 85-584,810. SEXY FOR LIFE, LLC, SARASOTA, FL. FILED 3-30-2012.

NDD NUTRIENT DEFICIENCY
DISORDER

THE MARK CONSISTS OF STANDARD CHARACTERS WITHOUT CLAIM TO ANY PARTICULAR FONT, STYLE, SIZE, OR COLOR.

NO CLAIM IS MADE TO THE EXCLUSIVE RIGHT TO USE "NUTRIENT DEFICIENCY DISORDER", APART FROM THE MARK AS SHOWN.

FOR A SERIES OF BOOKS AND WRITTEN ARTICLES IN THE FIELD OF FITNESS, HEALTH, WEIGHT LOSS AND NUTRITION (U.S. CLS. 2, 5, 22, 23, 29, 37, 38 AND 50).

BARBARA RUTLAND, EXAMINING ATTORNEY

CLASS 16—(Continued).

SN 85-590,877. TOOHEY, LISA, FAIR HAVEN, NJ. FILED 4-6-2012.



NO CLAIM IS MADE TO THE EXCLUSIVE RIGHT TO USE "COLORING", APART FROM THE MARK AS SHOWN.

THE MARK CONSISTS OF A STYLIZED IMAGE OF A GLOBE DRAWN IN CRAYON, WITH A CRAYON AT THE BASE OF THE GLOBE. AROUND THE LEFT AND TOP OF THE GLOBE IS THE STYLIZED TEXT "COLORING OUR WORLD.NET". A DASHED LINE CONNECTS THE BEGINNING AND END OF THIS PHRASE BY WRAPPING AROUND THE GLOBE.

FOR COLORING BOOKS (U.S. CLS. 2, 5, 22, 23, 29, 37, 38 AND 50).

WON TEAK OH, EXAMINING ATTORNEY

SN 85-591,410. THE EXECUTOR OF THE OTIS REDDING ESTATE, A GEORGIA ESTATE, COMPRISING ZELMA REDDING, A UNITED STATES CITIZEN., LOS ANGELES, CA. FILED 4-6-2012.

THE KING OF SOUL

THE MARK CONSISTS OF STANDARD CHARACTERS WITHOUT CLAIM TO ANY PARTICULAR FONT, STYLE, SIZE, OR COLOR.

THE NAME "THE KING OF SOUL" WAS THE NICK-NAME OF "OTIS REDDING" WHO IS NOT A LIVING INDIVIDUAL.

FOR PAPER GOODS, NAMELY, STATIONERY, NOTEPADS, NOTEBOOKS, BINDERS, PENCILS, PENS, NOTECARDS, PHOTO ALBUMS; COLLECTOR ALBUMS FOR PHOTOGRAPHS, STAMPS AND COINS; FOLDERS; BLANK JOURNALS; PERSONALIZED WRITING JOURNALS; CALENDARS; PENCIL CASES; PAPERWEIGHTS; POSTERS; POSTCARDS; STICKERS; COLORING AND ACTIVITY BOOKS AND CHILDREN'S COLORING PAGES MADE OF PAPER; GREETING CARDS; CARDBOARD STANDEES; TRADING CARDS; LETTER OPENERS; PARTY GOODS MADE OF PAPER, NAMELY, WRAPPING PAPER, BAGS, FAVORS, DECORATIONS, TABLE COVERS AND SIGNS; BOOKENDS; TEMPORARY TATTOOS; LIMITED EDITION ART PRINTS ON CANVAS AND GICLEE; LITHOGRAPHIC PRINTS; POSTAGE STAMPS; MONEY CLIPS; PLACEMATS MADE OF PAPER; COMIC BOOKS, PICTURE BOOKS, STORY BOOKS AND NOVELS; STICKER BOOKS; WALL DECORATIONS, NAMELY, POSTERS AND PAINTINGS; TOY TATTOO SETS (U.S. CLS. 2, 5, 22, 23, 29, 37, 38 AND 50).

CATHERINE ROEHL, EXAMINING ATTORNEY

SN 85-589,597. JESSICA LABRIOLA, GATES, NY. FILED 4-4-2012.

s before f and d, if after
3

THE MARK CONSISTS OF STANDARD CHARACTERS WITHOUT CLAIM TO ANY PARTICULAR FONT, STYLE, SIZE, OR COLOR.

FOR PRINTED INSTRUCTIONAL, EDUCATIONAL, AND TEACHING MATERIALS IN THE FIELD OF CHEMISTRY AND ALL SCIENCES (U.S. CLS. 2, 5, 22, 23, 29, 37, 38 AND 50).

TAMARA FRAZIER, EXAMINING ATTORNEY

CLASS 16—(Continued).

SN 85-591,859. BOUND TO ORGANIZE, LLC, GREENVALE, CA. FILED 4-7-2012.



THE COLOR(S) BLACK, GREY, RED, ORANGE, GREEN, BLUE AND PURPLE IS/ARE CLAIMED AS A FEATURE OF THE MARK.

THE MARK CONSISTS OF THE LETTERS "BTO" IN BLACK SUPERIMPOSED OVER AN IMAGE OF A 3-RING BINDER IN GREY, WITH 5 COLORED TABS IN RED, ORANGE, GREEN, BLUE AND PURPLE ON THE RIGHT SIDE OF THE BINDER.

FOR A SERIES OF BOOKS, WRITTEN ARTICLES, HANDOUTS AND WORKSHEETS IN THE FIELD OF ORGANIZATION (U.S. CLS. 2, 5, 22, 23, 29, 37, 38 AND 50).

RENEE MCCRAY, EXAMINING ATTORNEY

CLASS 16—(Continued).

SN 85-592,065. HOME ELDERCARE WORLDWIDE, LLC, DBA YOU CAN AGE AT HOME, MALIBU, CA. FILED 4-8-2012.



THE COLOR(S) BLUE, YELLOW-GOLD AND WHITE IS/ARE CLAIMED AS A FEATURE OF THE MARK.

THE MARK CONSISTS OF THE WORDING "YOU CAN" IN YELLOW-GOLD, THE WORDING "AGE AT HOME" IN BLUE WITH A BLUE HOUSE WITH FOUR WHITE SQUARES REPRESENTING A WINDOW AND ONE BLUE AND ONE YELLOW-GOLD HUMAN FIGURE WRAPPED AROUND THE LEFT SIDE OF THE HOUSE, CREATING THE ROOF.

FOR EDUCATIONAL KITS SOLD AS A UNIT IN THE FIELD OF FAMILY CARE GIVING/HEALTHCARE/NURSING CONSISTING PRIMARILY OF EDUCATIONAL BOOKS AND ALSO INCLUDING DVDS AND T-SHIRTS (U.S. CLS. 2, 5, 22, 23, 29, 37, 38 AND 50).

FIRST USE 9-1-2011; IN COMMERCE 9-1-2011.

WILLIAM JACKSON, EXAMINING ATTORNEY

SN 85-592,154. LEWIS, GEORGE J., LOS ANGELES, CA. FILED 4-9-2012.

SN 85-591,943. POP DECORS CORPORATION, AKA POP DECORS, FORT MYERS, FL. FILED 4-7-2012.

Pop Decors

YEAH RIGHT!
U.S. GRATING CARD CO.

THE MARK CONSISTS OF STANDARD CHARACTERS WITHOUT CLAIM TO ANY PARTICULAR FONT, STYLE, SIZE, OR COLOR.

NO CLAIM IS MADE TO THE EXCLUSIVE RIGHT TO USE "DECORS", APART FROM THE MARK AS SHOWN.

FOR DECALS (U.S. CLS. 2, 5, 22, 23, 29, 37, 38 AND 50). FIRST USE 6-19-2010; IN COMMERCE 9-8-2010.

JOHN DWYER, EXAMINING ATTORNEY

NO CLAIM IS MADE TO THE EXCLUSIVE RIGHT TO USE "U.S." AND "CARD CO.", APART FROM THE MARK AS SHOWN.

THE MARK CONSISTS OF THE STYLIZED TEXT "YEAH RIGHT!" ABOVE THE STYLIZED TEXT "U.S. GRATING CARD CO.". BELOW THIS LINE OF TEXT IS AN IRREGULAR LINE.

FOR GREETING CARDS (U.S. CLS. 2, 5, 22, 23, 29, 37, 38 AND 50).

DEBORAH LOBO, EXAMINING ATTORNEY

CLASS 16—(Continued).

SN 85-592,345. PRIMA MARKETTING INC, CHINO, CA. FILED 4-9-2012.

Prima Marketing Inc.

THE MARK CONSISTS OF STANDARD CHARACTERS WITHOUT CLAIM TO ANY PARTICULAR FONT, STYLE, SIZE, OR COLOR.

OWNER OF U.S. REG. NOS. 4,001,857 AND 4,008,917. NO CLAIM IS MADE TO THE EXCLUSIVE RIGHT TO USE "MARKETING INC.", APART FROM THE MARK AS SHOWN.

FOR SCRAPBOOK ALBUMS; SCRAPBOOK PAGES; SCRAPBOOKS (U.S. CLS. 2, 5, 22, 23, 29, 37, 38 AND 50). FIRST USE 0-0-2006; IN COMMERCE 0-0-2006. CHRISIE B. KING, EXAMINING ATTORNEY

CLASS 16—(Continued).

SN 85-593,178. DMC COMMUNICATIONS LLC, BRAY-BURG, NJ. FILED 4-10-2012.

CURRENT INSIGHTS

THE MARK CONSISTS OF STANDARD CHARACTERS WITHOUT CLAIM TO ANY PARTICULAR FONT, STYLE, SIZE, OR COLOR.

FOR PUBLICATIONS, NAMELY, NEWSLETTERS, MAGAZINES AND HAND-OUTS IN THE FIELDS OF ANAPHYLAXIS (U.S. CLS. 2, 5, 22, 23, 29, 37, 38 AND 50). SIMON TENG, EXAMINING ATTORNEY

SN 85-593,414. LEA, SAM, IRVINE, CA. FILED 4-10-2012.

eco Pop Artist Sam Lea

THE MARK CONSISTS OF STANDARD CHARACTERS WITHOUT CLAIM TO ANY PARTICULAR FONT, STYLE, SIZE, OR COLOR.

NO CLAIM IS MADE TO THE EXCLUSIVE RIGHT TO USE "ECO POP ARTIST", APART FROM THE MARK AS SHOWN.

THE NAME(S), PORTRAIT(S), AND/OR SIGNATURE(S) SHOWN IN THE MARK IDENTIFIES "SAM LEA", WHOSE CONSENT(S) TO REGISTER IS MADE OF RECORD.

FOR ART PRINTS ON CANVAS; PRINTED ART REPRODUCTIONS (U.S. CLS. 2, 5, 22, 23, 29, 37, 38 AND 50).

DAVID C. REIHNER, EXAMINING ATTORNEY

SN 85-594,810. STRINGS OF SCRIPTURE, LLC, DES PERES, MO. FILED 4-11-2012.

STRINGS OF SCRIPTURE

THE MARK CONSISTS OF STANDARD CHARACTERS WITHOUT CLAIM TO ANY PARTICULAR FONT, STYLE, SIZE, OR COLOR.

NO CLAIM IS MADE TO THE EXCLUSIVE RIGHT TO USE "SCRIPTURE", APART FROM THE MARK AS SHOWN.

FOR BOOKS WITH A COMPILED ARRANGEMENT OF VERSES TAKEN FROM COMMONLY ACCEPTED VERSIONS OF THE BIBLE AND SCROLLS WITH BIBLICAL TEXT (U.S. CLS. 2, 5, 22, 23, 29, 37, 38 AND 50). MIDGE BUTLER, EXAMINING ATTORNEY

SN 85-592,801. SALON PROFESSIONAL SERVICES, INC., BELMAR, NJ. FILED 4-9-2012.



THE MARK CONSISTS OF A DESIGN OF A WOMEN LOOKING FORWARD WITH HER BODY FACING TO THE SIDE WITH LONG FLOWING HAIR, THE DESIGN OF THE WOMAN CONSISTS OF BLACK WAVY HAIR, BLACK EYE LASHES, BLACK BORDER AROUND THE EYES, BLACK EYES, BLACK BORDER AROUND THE FACE, BLACK BORDER AROUND THE HAND, BLACK BORDER AROUND THE ARM, BLACK BORDER AROUND THE BODY, BLACK BORDER AROUND THE BACK, WHITE INTERIOR OF FACE, WHITE INTERIOR OF EYES, WHITE IN BETWEEN THE BLACK WAVES OF THE WAVY HAIR, WHITE ARM, WHITE HAND, WHITE BODY, WHITE BACK AND RED LIPS.

FOR PRINTED STORIES IN ILLUSTRATED FORM (U.S. CLS. 2, 5, 22, 23, 29, 37, 38 AND 50).

CHRISTINA SOBRAL, EXAMINING ATTORNEY

CLASS 16—(Continued).

SN 85-595,435. MCCLARIN, DEIRDRE A., BOLINGBROOK, IL. FILED 4-11-2012.

Optional Optimism

THE MARK CONSISTS OF STANDARD CHARACTERS WITHOUT CLAIM TO ANY PARTICULAR FONT, STYLE, SIZE, OR COLOR.

FOR BOOKMARKS; BOOKS IN THE FIELD OF POETRY, INSPIRATION, MOTIVATION, AND SELF-HELP; CALENDARS; POST CARDS; SOCIAL NOTE CARDS (U.S. CLS. 2, 5, 22, 23, 29, 37, 38 AND 50).

MARY ROSSMAN, EXAMINING ATTORNEY

SN 85-595,438. MCCLARIN, DEIRDRE A., BOLINGBROOK, IL. FILED 4-11-2012.

It's all in how you look at it

THE MARK CONSISTS OF STANDARD CHARACTERS WITHOUT CLAIM TO ANY PARTICULAR FONT, STYLE, SIZE, OR COLOR.

FOR BOOKMARKS; BOOKS IN THE FIELD OF POETRY, INSPIRATION, MOTIVATION, AND SELF-HELP; CALENDARS; POST CARDS; SOCIAL NOTE CARDS (U.S. CLS. 2, 5, 22, 23, 29, 37, 38 AND 50).

MARY ROSSMAN, EXAMINING ATTORNEY

SN 85-595,459. MARK STEPHENS J, NEW ORLEANS, LA. FILED 4-11-2012.

Rag Bag

THE MARK CONSISTS OF STANDARD CHARACTERS WITHOUT CLAIM TO ANY PARTICULAR FONT, STYLE, SIZE, OR COLOR.

NO CLAIM IS MADE TO THE EXCLUSIVE RIGHT TO USE "BAG", APART FROM THE MARK AS SHOWN.

FOR RUBBISH BAGS IN THE FORM OF BIODEGRADABLE PLASTIC MITTENS FOR REMOVAL AND DISPOSAL OF SOILED TAMPONS (U.S. CLS. 2, 5, 22, 23, 29, 37, 38 AND 50).

JAY BESCH, EXAMINING ATTORNEY

CLASS 16—(Continued).

SN 85-596,023. PANINI AMERICA, INC., IRVING, TX. FILED 4-12-2012.

NATIONAL TREASURES

THE MARK CONSISTS OF STANDARD CHARACTERS WITHOUT CLAIM TO ANY PARTICULAR FONT, STYLE, SIZE, OR COLOR.

OWNER OF U.S. REG. NO. 2,934,576.

FOR SPORTS TRADING CARDS (U.S. CLS. 2, 5, 22, 23, 29, 37, 38 AND 50).

FIRST USE 12-0-2010; IN COMMERCE 12-0-2010.

WILLIAM JACKSON, EXAMINING ATTORNEY

SN 85-596,915. PATRICIA JOHNSON, GRAND BLANC, MI. FILED 4-13-2012.

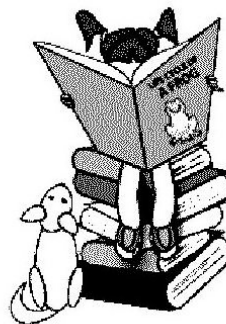

THE MARK CONSISTS OF A PIG-TAIL HAIED GIRL SEATED ON A PILE OF LARGE BOOKS READING AN OPENED BOOK TITLED "LIFE CYCLE OF A FROG" WITH A UPWARD LOOKING DOG SEATED ON THE GROUND TO THE LEFT OF THE GIRL.

FOR BOOKS IN THE FIELD OF BEGINNING LITERACY DEVELOPMENT FOR CHILDREN; CHILDREN'S BOOKS; EDUCATIONAL BOOKS FEATURING BOTH FICTIONAL AND NON-FICTIONAL CONTENT FOCUSING ON PHONOLOGICAL AWARENESS AND THE ALPHABETIC PRINCIPLE FOR BEGINNING READERS; PRINTED INSTRUCTIONAL, EDUCATIONAL, AND TEACHING MATERIALS IN THE FIELD OF SUPPORTING TEACHERS IN CONDUCTING GUIDED READING GROUPS FOR STUDENTS FROM PRE-SCHOOL THROUGH THE BEGINNING OF FIRST GRADE (U.S. CLS. 2, 5, 22, 23, 29, 37, 38 AND 50).

FIRST USE 1-31-2009; IN COMMERCE 1-31-2009.

CAROLINE WOOD, EXAMINING ATTORNEY

CLASS 16—(Continued).

SN 85-597,160. RICHARDSON COMPANY, PHILADELPHIA, PA. FILED 4-13-2012.

CYBER SERVICE TIPS

THE MARK CONSISTS OF STANDARD CHARACTERS WITHOUT CLAIM TO ANY PARTICULAR FONT, STYLE, SIZE, OR COLOR.

SEC. 2(F).

FOR PRINTED NEWSLETTERS, EDUCATIONAL MATERIALS, AND PERIODICALS ALL IN THE FIELD OF SALES AND SALES TECHNIQUES (U.S. CLS. 2, 5, 22, 23, 29, 37, 38 AND 50).

FIRST USE 1-1-2003; IN COMMERCE 1-1-2003.
EMILY CHUO, EXAMINING ATTORNEY

SN 85-598,969. VANCAUWENBERGH, STEVEN, OKLAHOMA CITY, OK. FILED 4-16-2012.

Savvy Landlord

THE MARK CONSISTS OF STANDARD CHARACTERS WITHOUT CLAIM TO ANY PARTICULAR FONT, STYLE, SIZE, OR COLOR.

NO CLAIM IS MADE TO THE EXCLUSIVE RIGHT TO USE "LANDLORD", APART FROM THE MARK AS SHOWN.

FOR BOOKS IN THE FIELD OF REAL ESTATE (U.S. CLS. 2, 5, 22, 23, 29, 37, 38 AND 50).

FIRST USE 1-3-2012; IN COMMERCE 1-3-2012.
JIM RINGLE, EXAMINING ATTORNEY

SN 85-599,280. CONNECTED PARTNERS, LLC, SANTA BARBARA, CA. FILED 4-16-2012.

HOOK-A-BRUSH

THE MARK CONSISTS OF STANDARD CHARACTERS WITHOUT CLAIM TO ANY PARTICULAR FONT, STYLE, SIZE, OR COLOR.

FOR TOOL HOLDERS, NAMELY, CLIPS THAT ALLOW PAINT BRUSHES TO BE SUSPENDED FROM THE PERIMETER OF CONTAINERS, SUCH AS PAINT CANS, BUCKETS, JARS OR TRAYS (U.S. CLS. 2, 5, 22, 23, 29, 37, 38 AND 50).

JASON BLAIR, EXAMINING ATTORNEY

CLASS 16—(Continued).

SN 85-599,827. CHARTPAK, INC., MELVILLE, NY. FILED 4-17-2012.

MAGIC FX

THE MARK CONSISTS OF STANDARD CHARACTERS WITHOUT CLAIM TO ANY PARTICULAR FONT, STYLE, SIZE, OR COLOR.

FOR PENCILS (U.S. CLS. 2, 5, 22, 23, 29, 37, 38 AND 50).
FIRST USE 3-0-2001; IN COMMERCE 3-0-2001.
ALLISON HOLTZ, EXAMINING ATTORNEY

SN 85-600,119. DAYSPRING CARDS, INC., SILOAM SPRINGS, AR. FILED 4-17-2012.

BIBLE TAILS

THE MARK CONSISTS OF STANDARD CHARACTERS WITHOUT CLAIM TO ANY PARTICULAR FONT, STYLE, SIZE, OR COLOR.

NO CLAIM IS MADE TO THE EXCLUSIVE RIGHT TO USE "BIBLE", APART FROM THE MARK AS SHOWN.

FOR CALENDARS; GREETING CARDS (U.S. CLS. 2, 5, 22, 23, 29, 37, 38 AND 50).

FIRST USE 6-30-2008; IN COMMERCE 6-30-2008.
BARBARA BROWN, EXAMINING ATTORNEY

SN 85-600,258. CLARK PRODUCTIONS LTD., INC., LITTLE ROCK, AR. FILED 4-17-2012.

CHILDREN OF THE 21ST CENTURY

THE MARK CONSISTS OF STANDARD CHARACTERS WITHOUT CLAIM TO ANY PARTICULAR FONT, STYLE, SIZE, OR COLOR.

FOR BOOKLETS IN THE FIELD OF MUSIC AND CULTURAL DIVERSITY EDUCATION (U.S. CLS. 2, 5, 22, 23, 29, 37, 38 AND 50).

FIRST USE 7-1-1987; IN COMMERCE 12-1-1987.
JENNY PARK, EXAMINING ATTORNEY

CLASS 16—(Continued).

SN 85-600,918. GRANT, RONALD, PHOENIXVILLE, PA. FILED 4-18-2012.

BENJAMIN BREADMAN

THE MARK CONSISTS OF STANDARD CHARACTERS WITHOUT CLAIM TO ANY PARTICULAR FONT, STYLE, SIZE, OR COLOR.

FOR CARTOON PRINTS; CARTOON STRIPS; COMIC BOOKS; COMIC MAGAZINES; COMIC STRIPS; COMIC STRIPS APPEARING IN NEWSPAPERS AND MAGAZINES; COMICS; NEWSPAPER CARTOONS; NEWSPAPER COMIC STRIPS (U.S. CLS. 2, 5, 22, 23, 29, 37, 38 AND 50).

MATTHEW PAPPAS, EXAMINING ATTORNEY

SN 85-600,943. BERLOW, ALICE, BOSTON, MA. AND BERLOW, SAM, BOSTON, MA. FILED 4-18-2012.

GLEAN

THE MARK CONSISTS OF STANDARD CHARACTERS WITHOUT CLAIM TO ANY PARTICULAR FONT, STYLE, SIZE, OR COLOR.

FOR MAGAZINES FEATURING STORIES, ARTICLES, NEWS, INFORMATION AND ADVICE RELATING TO LOCALLY AND SUSTAINABLY SOURCED ORGANIC FOOD AND NUTRITION, HEALTHY COOKING, EATING AND LIFESTYLE (U.S. CLS. 2, 5, 22, 23, 29, 37, 38 AND 50).

SHAUNIA CARLYLE, EXAMINING ATTORNEY

SN 85-601,355. BECKETT MEDIA, LLC, DALLAS, TX. FILED 4-18-2012.

WELL STYLED HOME

THE MARK CONSISTS OF STANDARD CHARACTERS WITHOUT CLAIM TO ANY PARTICULAR FONT, STYLE, SIZE, OR COLOR.

NO CLAIM IS MADE TO THE EXCLUSIVE RIGHT TO USE "HOME", APART FROM THE MARK AS SHOWN.

FOR MAGAZINES IN THE FIELDS OF HOME DÉCOR, DECORATING AND INTERIOR DESIGN, NOTABLE DESIGNERS AND RETAILERS, ARCHITECTURE, HOME IMPROVEMENT, LIFESTYLE, LANDSCAPING AND GARDENING, ENTERTAINING, TRAVEL, ART, FOOD, BEVERAGES, AND RECIPES (U.S. CLS. 2, 5, 22, 23, 29, 37, 38 AND 50).

CHRISTOPHER LAW, EXAMINING ATTORNEY

CLASS 16—(Continued).

SN 85-601,476. WORD OF FAITH INTERNATIONAL CHRISTIAN CENTER, SOUTHFIELD, MI. FILED 4-18-2012.



NO CLAIM IS MADE TO THE EXCLUSIVE RIGHT TO USE "CHURCH", APART FROM THE MARK AS SHOWN.

THE MARK CONSISTS OF A CIRCLE WITH A LOWER CASE "F" IN THE MIDDLE AND THE WORDS "FAITH4-LIFE CHURCH" BELOW.

FOR PRINTED INFORMATIONAL PUBLICATIONS AND EDUCATIONAL MATERIAL COVERING RELIGIOUS TOPICS, NAMELY, BULLETINS, BOOKLETS, PAMPHLETS, AND NEWSLETTERS (U.S. CLS. 2, 5, 22, 23, 29, 37, 38 AND 50).

STEVEN R. FINE, EXAMINING ATTORNEY

SN 85-602,182. ESSELTE CORPORATION, MELVILLE, NY. FILED 4-19-2012.

HANDWRITTEN TO HANDHELD

THE MARK CONSISTS OF STANDARD CHARACTERS WITHOUT CLAIM TO ANY PARTICULAR FONT, STYLE, SIZE, OR COLOR.

FOR WRITING PADS; NOTEBOOKS; EASEL PADS; FLIP CHARTS; AND INDEX CARDS (U.S. CLS. 2, 5, 22, 23, 29, 37, 38 AND 50).

SETH A. RAPPAPORT, EXAMINING ATTORNEY

SN 85-602,248. THE BLACK & DECKER CORPORATION, TOWSON, MD. FILED 4-19-2012.

STOP TAPING. START PAINTING.

THE MARK CONSISTS OF STANDARD CHARACTERS WITHOUT CLAIM TO ANY PARTICULAR FONT, STYLE, SIZE, OR COLOR.

FOR PAINT APPLICATORS (U.S. CLS. 2, 5, 22, 23, 29, 37, 38 AND 50).

LINDA E. BLOHM, EXAMINING ATTORNEY

CLASS 16—(Continued).

SN 85-602,257. THE BLACK & DECKER CORPORATION, TOWSON, MD. FILED 4-19-2012.

ESCAPE THE TAPE

THE MARK CONSISTS OF STANDARD CHARACTERS WITHOUT CLAIM TO ANY PARTICULAR FONT, STYLE, SIZE, OR COLOR.
FOR PAINT APPLICATORS (U.S. CLS. 2, 5, 22, 23, 29, 37, 38 AND 50).
LINDA E. BLOHM, EXAMINING ATTORNEY

SN 85-602,401. POETS OF GOD, INC., PHILADELPHIA, PA. FILED 4-19-2012.

Poets of God

THE MARK CONSISTS OF STANDARD CHARACTERS WITHOUT CLAIM TO ANY PARTICULAR FONT, STYLE, SIZE, OR COLOR.
FOR BOOKS IN THE FIELD OF RELIGION (U.S. CLS. 2, 5, 22, 23, 29, 37, 38 AND 50).
KATHERINE CHANG, EXAMINING ATTORNEY

SN 85-602,689. NIEHUES, MATTHIAS, HICKORY, NC. FILED 4-19-2012.

311

THE MARK CONSISTS OF STANDARD CHARACTERS WITHOUT CLAIM TO ANY PARTICULAR FONT, STYLE, SIZE, OR COLOR.
FOR WEIGHT LOSS PROGRAM KITS CONSISTING PRIMARILY OF PRINTED BOOK ON WEIGHT LOSS AND DIETING, AND ALSO INCLUDING VITAMIN SUPPLEMENTS AND HORMONES (U.S. CLS. 2, 5, 22, 23, 29, 37, 38 AND 50).
JOHN E. MICHOS, EXAMINING ATTORNEY

CLASS 16—(Continued).

SN 85-603,184. H. CO. COMPUTER PRODUCTS, DBA FINESTRA ART, IRVINE, CA. FILED 4-19-2012.



The logo for Finestra Art features the word "Finestra" in a bold, lowercase, sans-serif font, with a small five-pointed star above the letter "i". The word "Art" is in a larger, bold, uppercase, sans-serif font to the right of "Finestra".

THE MARK CONSISTS OF STYLIZED WORDS, LETTERS OR NUMBERS FORMING THE CONJOINED WORDS, "FINESTRA ART" WITH 3 CONCENTRIC FIVE POINT STARS USED TO REPRESENT THE DOT OVER THE "I" IN THE WORD "FINESTRA".
THE ENGLISH TRANSLATION OF "FINESTRA" IN THE MARK IS "WINDOW".
FOR COMPUTER PAPER; DIGITAL PRINTING PAPER; PAPER FOR PRINTING PHOTOGRAPHS; PAPER FOR USE IN MAKING SIGNS; PAPER FOR USE IN THE GRAPHIC ARTS INDUSTRY (U.S. CLS. 2, 5, 22, 23, 29, 37, 38 AND 50).
FIRST USE 3-28-2012; IN COMMERCE 3-28-2012.
DAWN FELDMAN, EXAMINING ATTORNEY

SN 85-603,341. INSTANTBOOK PRINTING COMPANY LIMITED, CHAI WAN,, HONG KONG, FILED 4-20-2012.



The logo for iMAGENATOR features a lowercase letter "i" inside a square frame, with a solid black dot above it. To the right of this frame, the word "MAGENATOR" is written in a bold, uppercase, sans-serif font.

THE MARK CONSISTS OF THE WORDING "IMAGENATOR", WHEREIN THE VERTICAL LINE OF THE LETTER "I" IS INSIDE A SQUARE AND THE DOT OF THE LETTER "I" IS ABOVE THE SQUARE.
THE WORDING IMAGENATOR HAS NO MEANING IN A FOREIGN LANGUAGE.
FOR ART AND PHOTOGRAPH PORTFOLIO CASES; BOXES, CARTONS, STORAGE CONTAINERS, AND PACKAGING CONTAINERS MADE OF PAPER OR CARDBOARD; BRAG BOOKS; MEMORY BOOKS; MINI PHOTO ALBUMS; MOUNTED AND UNMOUNTED PHOTOGRAPHS; NON-METAL PHOTO STORAGE BOXES; PHOTO MOUNTING CORNERS; PHOTO STORAGE BOXES; PHOTO STORAGE BOXES OF METAL; PHOTO-ENGRAVINGS; PHOTOGRAPH ALBUMS; PHOTOGRAPH STANDS; PHOTOGRAPHIC CROPPERS; PLASTIC PAGES FOR HOLDING PHOTOGRAPHS (U.S. CLS. 2, 5, 22, 23, 29, 37, 38 AND 50).
FIRST USE 2-20-2012; IN COMMERCE 2-20-2012.
TRICIA SONNEBORN, EXAMINING ATTORNEY

CLASS 16—(Continued).

SN 85-603,351. INSTANTBOOK PRINTING COMPANY LIMITED, CHAI WAN., HONG KONG, FILED 4-20-2012.

Imagenator

THE MARK CONSISTS OF STANDARD CHARACTERS WITHOUT CLAIM TO ANY PARTICULAR FONT, STYLE, SIZE, OR COLOR.

THE WORDING IMAGENATOR HAS NO MEANING IN A FOREIGN LANGUAGE.

FOR ART AND PHOTOGRAPH PORTFOLIO CASES; BOXES, CARTONS, STORAGE CONTAINERS, AND PACKAGING CONTAINERS MADE OF PAPER OR CARDBOARD; BRAG BOOKS; MEMORY BOOKS; MINI PHOTO ALBUMS; MOUNTED AND UNMOUNTED PHOTOGRAPHS; NON-METAL PHOTO STORAGE BOXES; PHOTO MOUNTING CORNERS; PHOTO STORAGE BOXES; PHOTO STORAGE BOXES OF METAL; PHOTO-ENGRAVINGS; PHOTOGRAPH ALBUMS; PHOTOGRAPH STANDS; PHOTOGRAPHIC CROPPERS; PLASTIC PAGES FOR HOLDING PHOTOGRAPHS (U.S. CLS. 2, 5, 22, 23, 29, 37, 38 AND 50).

FIRST USE 2-20-2012; IN COMMERCE 2-20-2012.
TRICIA SONNEBORN, EXAMINING ATTORNEY

SN 85-603,734. SYMONDS, CATHERINE A., WESTLAKE VILLAGE, CA. FILED 4-20-2012.



THE MARK CONSISTS OF THREE CROCUS FLOWERS RESTING IN A STYLIZED U SHAPE AND WORDS "CROCUS CREATIONS".

SEC. 2(F).

FOR BLANK CARDS; BLANK NOTE CARDS; CARDS BEARING UNIVERSAL GREETINGS; CHRISTMAS CARDS; CORRESPONDENCE CARDS; GREETING CARDS; HOLIDAY CARDS; MOTIVATIONAL CARDS; NOTE CARDS; NOTE CARDS FEATURING CALLIGRAPHY, PRESSED FLOWERS AND/OR IMAGES OF PRESSED FLOWERS; OCCASION CARDS; PICTURE CARDS; SOCIAL NOTE CARDS (U.S. CLS. 2, 5, 22, 23, 29, 37, 38 AND 50).

DAVID C. REIHNER, EXAMINING ATTORNEY

CLASS 16—(Continued).

SN 85-604,087. CURRINGTON, WILLIAM M., NASHVILLE, TN. FILED 4-20-2012.

BEER IS GOOD

THE MARK CONSISTS OF STANDARD CHARACTERS WITHOUT CLAIM TO ANY PARTICULAR FONT, STYLE, SIZE, OR COLOR.

FOR DECALS; STICKERS; STATIONERY (U.S. CLS. 2, 5, 22, 23, 29, 37, 38 AND 50).

AHSEN KHAN, EXAMINING ATTORNEY

SN 85-604,284. DATAQUICK INFORMATION SYSTEMS, INC., SAN DIEGO, CA. FILED 4-20-2012.

APPRAISALQ

THE MARK CONSISTS OF STANDARD CHARACTERS WITHOUT CLAIM TO ANY PARTICULAR FONT, STYLE, SIZE, OR COLOR.

FOR PRINTED REPORTS FEATURING REAL ESTATE AND PROPERTY INFORMATION (U.S. CLS. 2, 5, 22, 23, 29, 37, 38 AND 50).

FIRST USE 11-11-2011; IN COMMERCE 1-15-2012.

BRENDAN MCCAULEY, EXAMINING ATTORNEY

SN 85-604,299. TESS, GREG, CEDARBURG, WI. FILED 4-20-2012.

Cheddarburg

THE MARK CONSISTS OF STANDARD CHARACTERS WITHOUT CLAIM TO ANY PARTICULAR FONT, STYLE, SIZE, OR COLOR.

FOR GRAPHIC NOVELS (U.S. CLS. 2, 5, 22, 23, 29, 37, 38 AND 50).

STEVEN JACKSON, EXAMINING ATTORNEY

CLASS 16—(Continued).

SN 85-604,715. CONNELLY, AGATHA, HOLLIS, NH. FILED 4-22-2012.

My Friends the Saints

THE MARK CONSISTS OF STANDARD CHARACTERS WITHOUT CLAIM TO ANY PARTICULAR FONT, STYLE, SIZE, OR COLOR.

FOR BOOKS IN THE FIELD OF RELIGION; CHILDREN'S BOOKS (U.S. CLS. 2, 5, 22, 23, 29, 37, 38 AND 50).
INGRID C. EULIN, EXAMINING ATTORNEY

SN 85-605,259. SIMPLY CLEAN AUTOMOTIVE GROUP LLC, MAITLAND, FL. FILED 4-23-2012.

Simply Clean

THE MARK CONSISTS OF THE STYLIZED WORDING SIMPLY CLEAN.

FOR BUMPER STICKERS; STICKERS (U.S. CLS. 2, 5, 22, 23, 29, 37, 38 AND 50).

FIRST USE 1-10-2010; IN COMMERCE 1-10-2010.
ELISSA GARBER KON, EXAMINING ATTORNEY

SN 85-605,539. COUNTRY LIFE OUTFITTERS INC., PANAMA CITY, FL. FILED 4-23-2012.

Country Life Outfitters

THE MARK CONSISTS OF STANDARD CHARACTERS WITHOUT CLAIM TO ANY PARTICULAR FONT, STYLE, SIZE, OR COLOR.

OWNER OF U.S. REG. NO. 4,069,655.
NO CLAIM IS MADE TO THE EXCLUSIVE RIGHT TO USE "OUTFITTERS", APART FROM THE MARK AS SHOWN.

FOR DECORATIVE DECALS FOR VEHICLE WINDOWS (U.S. CLS. 2, 5, 22, 23, 29, 37, 38 AND 50).
FIRST USE 3-10-2009; IN COMMERCE 3-10-2009.
KRISTIN DAHLING, EXAMINING ATTORNEY

CLASS 16—(Continued).

SN 85-605,630. THE INSPIRED PENCIL, LLC, VIRGINIA BEACH, VA. FILED 4-23-2012.

The Inspired Pencil

THE MARK CONSISTS OF STANDARD CHARACTERS WITHOUT CLAIM TO ANY PARTICULAR FONT, STYLE, SIZE, OR COLOR.

FOR SERIES OF EDUCATIONAL FICTION AND REFERENCE BOOKS FOR CHILDREN, WITH INTERACTIVE COMPONENTS (U.S. CLS. 2, 5, 22, 23, 29, 37, 38 AND 50).

FRANK LATTUCA, EXAMINING ATTORNEY

SN 85-605,826. MAEROV, JEFFREY, NEWPORT COAST, CA. FILED 4-23-2012.

Boca Buddies

THE MARK CONSISTS OF STANDARD CHARACTERS WITHOUT CLAIM TO ANY PARTICULAR FONT, STYLE, SIZE, OR COLOR.

FOR CHILDREN'S BOOKS (U.S. CLS. 2, 5, 22, 23, 29, 37, 38 AND 50).

DAVID HOFFMAN, EXAMINING ATTORNEY

SN 85-606,686. CHARTPAK, INC., MELVILLE, NY. FILED 4-24-2012.

BLACK DIAMOND

THE MARK CONSISTS OF STANDARD CHARACTERS WITHOUT CLAIM TO ANY PARTICULAR FONT, STYLE, SIZE, OR COLOR.

FOR ARTIST'S PAINT BRUSHES (U.S. CLS. 2, 5, 22, 23, 29, 37, 38 AND 50).

ALLISON HOLTZ, EXAMINING ATTORNEY

CLASS 16—(Continued).

SN 85-612,124. TARGET BRANDS, INC., MINNEAPOLIS, MN. FILED 4-30-2012.

UP & UP

THE MARK CONSISTS OF STANDARD CHARACTERS WITHOUT CLAIM TO ANY PARTICULAR FONT, STYLE, SIZE, OR COLOR.

OWNER OF U.S. REG. NOS. 4,023,535, 4,042,814 AND OTHERS.

FOR PAPER HOLE PUNCHES; DESKTOP ORGANIZERS; BINDER CLIPS; RUBBER ERASERS; LEAD REFILLS FOR MECHANICAL PENCILS; CLIP BOARDS; DISPOSABLE LAWN AND LEAF BAGS; ENVELOPES (U.S. CLS. 2, 5, 22, 23, 29, 37, 38 AND 50).

FIRST USE 3-0-2011; IN COMMERCE 3-0-2011.

JEAN IM, EXAMINING ATTORNEY

SN 85-612,175. TARGET BRANDS, INC., MINNEAPOLIS, MN. FILED 4-30-2012.



OWNER OF U.S. REG. NOS. 4,023,535, 4,042,814 AND OTHERS.

THE MARK CONSISTS OF AN ARROW DESIGN POINTING AT A 45 DEGREE DIAGONAL, UP AND TO THE RIGHT, WITH THE WORDS "UP & UP" INSIDE THE ARROW.

FOR PAPER HOLE PUNCHES; DESKTOP ORGANIZERS; BINDER CLIPS; RUBBER ERASERS; LEAD REFILLS FOR MECHANICAL PENCILS; CLIP BOARDS; DISPOSABLE LAWN AND LEAF BAGS (U.S. CLS. 2, 5, 22, 23, 29, 37, 38 AND 50).

FIRST USE 3-0-2011; IN COMMERCE 3-0-2011.

JEAN IM, EXAMINING ATTORNEY

CLASS 16—(Continued).

SN 85-613,716. DATAQUICK INFORMATION SYSTEMS, INC., SAN DIEGO, CA. FILED 5-1-2012.

PORTFOLIOQ

THE MARK CONSISTS OF STANDARD CHARACTERS WITHOUT CLAIM TO ANY PARTICULAR FONT, STYLE, SIZE, OR COLOR.

FOR PRINTED REPORTS FEATURING REAL ESTATE AND REAL PROPERTY LIEN RISK INFORMATION (U.S. CLS. 2, 5, 22, 23, 29, 37, 38 AND 50).

FIRST USE 3-12-2012; IN COMMERCE 3-19-2012.

BRENDAN MCCAULEY, EXAMINING ATTORNEY

SN 85-614,603. ZENIMAX MEDIA INC., ROCKVILLE, MD. FILED 5-2-2012.



THE MARK CONSISTS OF A THREE HEADED CREATURE SWALLOWING ITS OWN TAILS CREATING A CIRCLE.

FOR COMPUTER AND VIDEO GAME USER INSTRUCTION MANUALS; MAGAZINES, BOOKS, AND PAMPHLETS CONCERNING VIDEO GAMES; COMPUTER AND VIDEO GAME STRATEGY GUIDE BOOKS AND MAGAZINES; TRADING CARDS, MAPS, POSTERS, ADVERTISEMENT BOARDS OF PAPER OR CARDBOARD, ART PRINTS (U.S. CLS. 2, 5, 22, 23, 29, 37, 38 AND 50).

ROBERT STRUCK, EXAMINING ATTORNEY

SN 85-617,324. DIXIE CONSUMER PRODUCTS LLC, ATLANTA, GA. FILED 5-4-2012.

HANDI-SIZE

THE MARK CONSISTS OF STANDARD CHARACTERS WITHOUT CLAIM TO ANY PARTICULAR FONT, STYLE, SIZE, OR COLOR.

FOR PAPER PAN LINERS (U.S. CLS. 2, 5, 22, 23, 29, 37, 38 AND 50).

FIRST USE 4-30-2008; IN COMMERCE 4-30-2008.

JANET LEE, EXAMINING ATTORNEY

CLASS 16—(Continued).

SN 85-639,316. AKZO NOBEL COATINGS INTERNATIONAL B.V., ARNHEM, NETHERLANDS, FILED 5-31-2012.

THE DUO

THE MARK CONSISTS OF STANDARD CHARACTERS WITHOUT CLAIM TO ANY PARTICULAR FONT, STYLE, SIZE, OR COLOR.

FOR PAINT ROLLER HANDLES (U.S. CLS. 2, 5, 22, 23, 29, 37, 38 AND 50).

FIRST USE 11-1-1998; IN COMMERCE 11-1-1998.
MAYUR VAGHANI, EXAMINING ATTORNEY

SN 85-639,332. AKZO NOBEL COATINGS INTERNATIONAL B.V., ARNHEM, NETHERLANDS, FILED 5-31-2012.



THE MARKS CONSISTS OF THE WORDING "THE DUO" WITH THE WORD "THE" ABOVE "DUO"

FOR PAINT ROLLER HANDLES (U.S. CLS. 2, 5, 22, 23, 29, 37, 38 AND 50).

FIRST USE 0-0-1999; IN COMMERCE 0-0-1999.
MAYUR VAGHANI, EXAMINING ATTORNEY

SN 85-643,420. PANINI AMERICA, INC., IRVING, TX. FILED 6-5-2012.

RATED ROOKIE

THE MARK CONSISTS OF STANDARD CHARACTERS WITHOUT CLAIM TO ANY PARTICULAR FONT, STYLE, SIZE, OR COLOR.

NO CLAIM IS MADE TO THE EXCLUSIVE RIGHT TO USE "ROOKIE", APART FROM THE MARK AS SHOWN.

FOR SPORTS TRADING CARDS (U.S. CLS. 2, 5, 22, 23, 29, 37, 38 AND 50).

FIRST USE 0-0-2010; IN COMMERCE 0-0-2010.
WILLIAM JACKSON, EXAMINING ATTORNEY

CLASS 16—(Continued).

SN 85-643,426. PANINI AMERICA, INC., IRVING, TX. FILED 6-5-2012.



NO CLAIM IS MADE TO THE EXCLUSIVE RIGHT TO USE "ROOKIE", APART FROM THE MARK AS SHOWN.

THE MARK CONSISTS OF THE WORDS "RATED ROOKIE" IN A STYLIZED FORMAT.

FOR SPORTS TRADING CARDS (U.S. CLS. 2, 5, 22, 23, 29, 37, 38 AND 50).

FIRST USE 0-0-2010; IN COMMERCE 0-0-2010.
WILLIAM JACKSON, EXAMINING ATTORNEY

CLASS 17—RUBBER GOODS

SN 76-710,291. NEW ENGLAND BRAIDING COMPANY, INC., MANCHESTER, NH. FILED 1-17-2012.



NO CLAIM IS MADE TO THE EXCLUSIVE RIGHT TO USE "PACKING", APART FROM THE MARK AS SHOWN.

THE MARK CONSISTS OF THE WORDS "ANTI-KEYSTONE PACKING" INSIDE THE DESIGN OF A REPRESENTATION OF A SHAFT ABOUT WHICH IS SHOWN A REPRESENTATION OF PACKING WOUND AROUND THE SHAFT.

FOR MECHANICAL COMPRESSION PACKING MANUFACTURED FROM YARN OR FILTER AND OPTIONALLY CONTAINING IMPREGNANTS OR LUBRICANTS, WIRE REINFORCEMENT, OR ELASTOMERIC AXIAL WARP FILL USED TO SEAL OR PACK PUMPS, VALVES, ROTARY SHAFTS, AND RECIPROCATING SHAFTS FOR USE IN A WIDE VARIETY OF INDUSTRIES (U.S. CLS. 1, 5, 12, 13, 35 AND 50).

FIRST USE 3-5-1991; IN COMMERCE 3-5-1991.
MICHAEL WEBSTER, EXAMINING ATTORNEY

CLASS 17—(Continued).

SN 79-103,565. TRELLEBORG OFFSHORE UK LTD, UNITED KINGDOM, FILED 9-2-2011.

URADUCT

THE MARK CONSISTS OF STANDARD CHARACTERS WITHOUT CLAIM TO ANY PARTICULAR FONT, STYLE, SIZE, OR COLOR.

OWNER OF INTERNATIONAL REGISTRATION 1093301 DATED 9-2-2011, EXPIRES 9-2-2021.

FOR NON-METALLIC PROTECTIVE COVERS FOR CABLES, PIPES, UMBILICALS, WIRES AND ROPES; NON-METALLIC PROTECTIVE DUCTING FOR CABLES, PIPES, UMBILICALS, WIRES AND ROPES (U.S. CLS. 1, 5, 12, 13, 35 AND 50).

SHAILA SETTLES, EXAMINING ATTORNEY

SN 85-128,724. ELIZONDO CARLOS GERARDO, DBA EX-SEC S.A. DE C.V., SAN PEDRO GARZA GARCIA, MEXICO, FILED 9-14-2010.

CONCEPTA

THE MARK CONSISTS OF STANDARD CHARACTERS WITHOUT CLAIM TO ANY PARTICULAR FONT, STYLE, SIZE, OR COLOR.

OWNER OF MEXICO REG. NO. 1230739, DATED 7-29-2011, EXPIRES 3-10-2021.

THE ENGLISH TRANSLATION OF "CONCEPTA" IN THE MARK IS "CONCEPT".

FOR SEMI-PROCESSED PLASTICS; SEMI-WORKED SYNTHETIC PLASTIC AND SYNTHETIC RESINS AS SEMI-FINISHED PRODUCTS IN FORM OF PELLETS, RODS, FOILS, FOAMS, FIBERS, FILMS AND SHEETS; TINTED, LAMINATED AND REFLECTIVE PLASTIC FILMS FOR USE IN HOME OR AUTO WINDOWS (U.S. CLS. 1, 5, 12, 13, 35 AND 50).

JOHN E. MICHOS, EXAMINING ATTORNEY

SN 85-380,561. CHAN, LAM ANDIE, TA DRIPRO INTERNATIONAL COMPANY, KOWLOON, HONG KONG, FILED 7-26-2011.

DRiPRO

OWNER OF HONG KONG REG. NO. 300952867, DATED 9-12-2007, EXPIRES 9-11-2017.

THE COLOR(S) BLACK, RED IS/ARE CLAIMED AS A FEATURE OF THE MARK.

THE MARK CONSISTS OF THE WORD "DRIPRO" IN BLACK STYLIZED FONT WITH RED ROUND CORNER SPOTS ON THE UPPER LEFT OF "D", "R", "P", "R" AND RED DOT ABOVE OF "I".

FOR WATERPROOF PACKINGS FOR ELECTRONIC DEVICES (U.S. CLS. 1, 5, 12, 13, 35 AND 50).

NAKIA HENRY, EXAMINING ATTORNEY

CLASS 17—(Continued).

SN 85-423,944. GARDNER ASPHALT CORPORATION, TAMPA, FL. FILED 9-15-2011.

INCREDIBLE

THE MARK CONSISTS OF STANDARD CHARACTERS WITHOUT CLAIM TO ANY PARTICULAR FONT, STYLE, SIZE, OR COLOR.

FOR ADHESIVE SEALANTS FOR USE IN ROOFING; ACRYLIC-BASED SEALANTS AND ADHESIVES; RESIN-BASED SEALANTS FOR USE ON ROOFS, WALLS AND PAVEMENTS; SILICONE-BASED SEALANTS AND ADHESIVES; URETHANE-BASED SEALANTS AND ADHESIVES FOR CONSTRUCTION PARTICULARLY FOR USE IN GLAZING, SIDING AND TRIM; SEALANTS FOR BUILDINGS (U.S. CLS. 1, 5, 12, 13, 35 AND 50).

TARA PATE, EXAMINING ATTORNEY

SN 85-454,811. JAS ENTERPRISES, INC., VANCOUVER, WA. FILED 10-24-2011.

T-Foil

THE MARK CONSISTS OF STANDARD CHARACTERS WITHOUT CLAIM TO ANY PARTICULAR FONT, STYLE, SIZE, OR COLOR.

FOR PLASTIC SHEETING USED IN THE CONSTRUCTION INDUSTRY AS A VAPOR BARRIER; POLYPROPYLENE FOIL OTHER THAN FOR PACKING (U.S. CLS. 1, 5, 12, 13, 35 AND 50).

FIRST USE 7-1-2011; IN COMMERCE 7-1-2011.

DAWN FELDMAN, EXAMINING ATTORNEY

SN 85-466,486. THOMAS R. ROSSI, NEWPORT BEACH, CA. FILED 11-7-2011.

OILINATOR

THE MARK CONSISTS OF STANDARD CHARACTERS WITHOUT CLAIM TO ANY PARTICULAR FONT, STYLE, SIZE, OR COLOR.

FOR ABSORBENT PADS COMPRISED OF CLOTH TEXTILES FOR CONTAINING AND ABSORBING OIL, CHEMICAL SPILLS (U.S. CLS. 1, 5, 12, 13, 35 AND 50).

FIRST USE 10-26-2011; IN COMMERCE 10-26-2011.

DEZMONA MIZELLE, EXAMINING ATTORNEY

CLASS 17—(Continued).

SN 85-479,589. XENE CORPORATION, WILMINGTON, DE.
FILED 11-22-2011.

XENECORE

THE MARK CONSISTS OF STANDARD CHARACTERS WITHOUT CLAIM TO ANY PARTICULAR FONT, STYLE, SIZE, OR COLOR.

FOR SUBSTANTIALLY RIGID SEMI-WORKED COMPOSITE STRUCTURAL MEMBERS COMPRISED OF GRAPHITE FIBERS, SYNTHETIC RESIN AND FOAM PLASTIC IN THE FORM OF SEMI-FINISHED PRODUCTS IN THE FORM OF FRAMES FOR USE IN COMBINATION WITH OTHER STRUCTURAL MEMBERS TO MAKE FINISHED USABLE IMPLEMENTS; SUBSTANTIALLY RIGID COMPOSITE MEMBERS FORMED UNDER CHEMICALLY CREATED PRESSURE IN A SUBSTANTIALLY CLOSED MOLD AND COMPRISED OF GRAPHITE FIBERS, SYNTHETIC RESINS AND FOAM PLASTIC AS SEMI-FINISHED PRODUCTS IN THE FORM OF FRAMES FOR USE IN COMBINATION WITH OTHER STRUCTURAL MEMBERS TO MAKE FINISHED USEABLE IMPLEMENTS (U.S. CLS. 1, 5, 12, 13, 35 AND 50).

FIRST USE 7-0-2010; IN COMMERCE 7-0-2010.
JAMES LOVELACE, EXAMINING ATTORNEY

SN 85-500,863. FRONTIER PAPER & PACKAGING INCORPORATED, PLAINFIELD, IN. FILED 12-21-2011.

PALLET SHIELD

THE MARK CONSISTS OF STANDARD CHARACTERS WITHOUT CLAIM TO ANY PARTICULAR FONT, STYLE, SIZE, OR COLOR.

NO CLAIM IS MADE TO THE EXCLUSIVE RIGHT TO USE "PALLET", APART FROM THE MARK AS SHOWN.

FOR THERMAL INSULATION COVERS FOR STORAGE OR TRANSPORTATION OF GOODS, NAMELY, THERMAL INSULATING COVERS AND THERMAL INSULATED PALLET COVERS (U.S. CLS. 1, 5, 12, 13, 35 AND 50).

JOHN SCHUYLER YARD, EXAMINING ATTORNEY

CLASS 17—(Continued).

SN 85-523,560. DYNASOL ELASTOMEROS, S.A. DE C.V.,
ALTAMIRA, TAMAULIPAS, MEXICO, FILED 1-24-2012.



OWNER OF U.S. REG. NO. 1,066,517.

THE MARK CONSISTS OF THE STYLIZED TERM "SOLPRENE" WHEREIN THE LEFT SIDE OF THE LETTER "S" IS CUT OUT WITH EIGHT DIAGONAL LINES.

THE WORDING "SOLPRENE" HAS NO MEANING IN A FOREIGN LANGUAGE.

FOR RUBBER, SYNTHETIC RUBBER AND RUBBER SUBSTITUTES, NAMELY, SILICONE RUBBER AND RUBBER DERIVATIVES (U.S. CLS. 1, 5, 12, 13, 35 AND 50).

MYRIAH HABEEB, EXAMINING ATTORNEY

SN 85-548,398. FLODYNAMIX, LLC, AKA NUGENERATION TECHNOLOGIES, EMERYVILLE, CA. FILED 2-21-2012.



THE COLOR(S) BLUE AND GREEN IS/ARE CLAIMED AS A FEATURE OF THE MARK.

THE MARK CONSISTS OF THE WORD "KRATOS" WRITTEN IN ALL UPPERCASE LETTERS AND IS ONE WORD. "KRATOS" IS WRITTEN IN SOLID BLUE LETTERS. TO THE LEFT OF THE WORD "KRATOS" IS A STYLIZED CIRCULAR DESIGN OF A 3-DIMENSIONAL O. THE OUTER EDGE OF THE O IS IN BLUE AND THE INNER EDGE IS IN GREEN.

FOR NON-METAL GASKETS FOR VACUUM PUMPS, REACTOR VESSELS, COMPRESSORS, ENGINES, SPECIAL PROCESSING EQUIPMENT, VACUUM FURNACES, HATCH COVERS, LARGE PROCESS AND PIPELINE VALVES, FITTINGS, BEARINGS, AUTOCLAVES, FLANGES, DRILLING EQUIPMENT, HEAT EXCHANGERS AND HVAC EQUIPMENT; SEALING PLUGS MADE PRIMARILY FROM RUBBER (U.S. CLS. 1, 5, 12, 13, 35 AND 50).

FIRST USE 1-1-2012; IN COMMERCE 1-18-2012.
DAWN FELDMAN, EXAMINING ATTORNEY

SN 85-602,289. IP HOLDINGS, LLC, VANCOUVER, WA.
FILED 4-19-2012.



OWNER OF U.S. REG. NO. 4,144,315.

NO CLAIM IS MADE TO THE EXCLUSIVE RIGHT TO USE "HYDRO", APART FROM THE MARK AS SHOWN.

THE COLOR(S) WHITE, NAVY BLUE, CERULEAN BLUE, AND GREEN IS/ARE CLAIMED AS A FEATURE OF THE MARK.

THE MARK CONSISTS OF THE WORDS "HYDRO FLOW" IN A STYLIZED FONT WITH A NAVY BLUE CIRCLE IN BETWEEN "HYDRO" AND "FLOW", THE NAVY BLUE

CLASS 17—(Continued).

CIRCLE HAVING THREE GREEN LEAVES EXTENDING FROM ITS TOP WITH A WHITE SWIRL EXTENDING DOWNWARD THROUGH ITS MIDDLE AND A NAVY BLUE DISC BELOW WITH PARTIAL CONCENTRIC RIPLE RINGS OF CERULEAN BLUE AND THEN NAVY BLUE EXTENDING RADially OUTWARD FROM THE NAVY BLUE DISC, THE WORD "HYDRO" IN SOLID COLOR NAVY BLUE WITH THE "O" HAVING A FANCIFUL SHAPE OF A RAIN DROP AND THE WORD "FLOW" IN TWO TONE WITH A CERULEAN BLUE SOLID COLOR AND NAVY BLUE SHADOWING WITH THE "O" HAVING A FANCIFUL SHAPE OF A RAIN DROP.

FOR HOSES MADE OF RUBBER OR PLASTIC FOR INDOOR GARDENING (U.S. CLS. 1, 5, 12, 13, 35 AND 50).

FIRST USE 3-7-2012; IN COMMERCE 3-7-2012.
PAUL E. FAHRENKOPF, EXAMINING ATTORNEY

CLASS 17—(Continued).

SN 85-665,912. SEALED AIR CORPORATION (US), ELMWOOD PARK, NJ. FILED 6-29-2012.

NEXMARK

SN 85-605,393. TONY LITTLE, ST. PETERSBURG, FL. FILED 4-23-2012.

SNUGGLE FOAM

THE MARK CONSISTS OF STANDARD CHARACTERS WITHOUT CLAIM TO ANY PARTICULAR FONT, STYLE, SIZE, OR COLOR.

FOR PLASTIC FLEXIBLE PACKAGING FILMS FOR COMMERCIAL AND INDUSTRIAL USE (U.S. CLS. 1, 5, 12, 13, 35 AND 50).

ODESSA BIBBINS, EXAMINING ATTORNEY

THE MARK CONSISTS OF STANDARD CHARACTERS WITHOUT CLAIM TO ANY PARTICULAR FONT, STYLE, SIZE, OR COLOR.

NO CLAIM IS MADE TO THE EXCLUSIVE RIGHT TO USE "FOAM", APART FROM THE MARK AS SHOWN.

FOR SUPPORTIVE FOAM FOR USE IN THE MANUFACTURE OF FOOTWEAR, BEDDING, PILLOWS, AND OTHER PRODUCTS (U.S. CLS. 1, 5, 12, 13, 35 AND 50).

THOMAS MANOR, EXAMINING ATTORNEY

CLASS 18—LEATHER GOODS

SN 79-114,606. EOM, SE YOUNG, REPUBLIC OF KOREA, FILED 3-22-2012.

ALIFEDESIGN

SN 85-613,016. THE GATES CORPORATION, DENVER, CO. FILED 5-1-2012.

POWERCLEAN

THE MARK CONSISTS OF STANDARD CHARACTERS WITHOUT CLAIM TO ANY PARTICULAR FONT, STYLE, SIZE, OR COLOR.

SEC. 2(F).
FOR NON-METALLIC HOSES (U.S. CLS. 1, 5, 12, 13, 35 AND 50).

FIRST USE 12-31-1985; IN COMMERCE 12-31-1985.
MICHAEL ENGEL, EXAMINING ATTORNEY

THE MARK CONSISTS OF STANDARD CHARACTERS WITHOUT CLAIM TO ANY PARTICULAR FONT, STYLE, SIZE, OR COLOR.

OWNER OF INTERNATIONAL REGISTRATION 1120611 DATED 3-22-2012. EXPIRES 3-22-2022.

FOR TRAVELLING BAGS; TRAVELLING TRUNKS; PURSES; CREDIT CARD CASES OF LEATHER; BACKPACKS; LUGGAGE TAGS OF LEATHER (U.S. CLS. 1, 2, 3, 22 AND 41).

ROBIN MITTLER, EXAMINING ATTORNEY

CLASS 18—(Continued).

SN 85-124,520. 413 SPORTS AND ENTERTAINMENT, GLENDALE, AZ. FILED 9-7-2010.



THE MARK CONSISTS OF THE STYLIZED NUMBERS AND WORDS "413" WITH "FOURONETHREE" WITH A BACKWARDS "N" IN "ONE" BELOW THE NUMBERS AND "SPORTSANDENTERTAINMENT" BELOW "FOURONETHREE".

FOR ALL-PURPOSE ATHLETIC BAGS; ATHLETIC BAGS; BABY BACKPACKS; BACKPACKS; BACKPACKS WITH ROLLING WHEELS; BACKPACKS, BOOK BAGS, SPORTS BAGS, BUM BAGS, WALLET AND HANDBAGS; CARRIERS FOR SUITS, SHIRTS AND DRESSES; MILITARY DUFFLE BAGS, GARMENT BAGS FOR TRAVEL, TOTE BAGS, SHOULDER BAGS AND BACKPACKS; PROTECTIVE FITTED LINERS FOR BACKPACKS AND LUGGAGE; SACK PACKS, NAMELY, DRAWSTRING BAGS USED AS BACKPACKS; SCHOOL-CHILDREN'S BACKPACKS; SMALL BACKPACKS; TOTE BAGS; WHEELED TOTE BAGS (U.S. CLS. 1, 2, 3, 22 AND 41).

ANNE FARRELL, EXAMINING ATTORNEY

CLASS 18—(Continued).

SN 85-314,587. CHEHEBAR, ALFRED, NEW YORK, NY. FILED 5-6-2011.

Genius Pack

THE MARK CONSISTS OF STANDARD CHARACTERS WITHOUT CLAIM TO ANY PARTICULAR FONT, STYLE, SIZE, OR COLOR.

NO CLAIM IS MADE TO THE EXCLUSIVE RIGHT TO USE "PACK", APART FROM THE MARK AS SHOWN.

FOR BACKPACKS; LUGGAGE; TOILETRY CASES SOLD EMPTY; TOTE BAGS (U.S. CLS. 1, 2, 3, 22 AND 41). SIMON TENG, EXAMINING ATTORNEY

SN 85-377,627. PERFECTION MIGHTY INDUSTRIAL CO., LTD., TAICHUNG CITY, TAIWAN, FILED 7-21-2011.



NO CLAIM IS MADE TO THE EXCLUSIVE RIGHT TO USE "REACTION TPU", APART FROM THE MARK AS SHOWN.

THE MARK CONSISTS OF TWO CONCENTRIC CIRCLES WITH "REACTION TPU" WRITTEN ON THE LOWER EDGE OF THE OUTER CIRCLE AND A VERTICAL BAR AND TWO LEAF-LIKE ELEMENTS AROUND THE VERTICAL BAR, ONE ON EACH SIDE, INSIDE THE INNER CIRCLE.

FOR LEATHER, IMITATION LEATHER AND FURS SOLD IN BULK, LEATHER GOODS—NAMELY, HANDBAGS, WALLET, TRAVEL BAGS, LUGGAGE, BUSINESS AND CREDIT CARD CASES, BRIEF CASE TYPE PORTFOLIOS, ATTACHE CASES, CHANGE PURSES, SUITCASES, TOTE BAGS, MAKEUP BAGS SOLD EMPTY, VANITY CASES SOLD EMPTY, GARMENT BAGS, AND SHOE BAGS FOR TRAVEL (U.S. CLS. 1, 2, 3, 22 AND 41).

JULIE WATSON, EXAMINING ATTORNEY

SN 85-283,198. EPI-ESSENTIALS, LLC, WAYNE, NJ. FILED 3-31-2011.



THE COLOR(S) BLUE, WHITE AND BLACK IS/ARE CLAIMED AS A FEATURE OF THE MARK.

THE MARK CONSISTS OF A LIGHT BLUE STYLIZED HANDBAG WITH UPSTANDING HANDLE; WITH A WHITE SIX POINT STAR IN THE MIDDLE OF THE BODY OF THE HANDBAG; ALL OF THIS IS OVER A BLACK BACKGROUND.

FOR HANDBAGS (U.S. CLS. 1, 2, 3, 22 AND 41). BENJAMIN OKEKE, EXAMINING ATTORNEY

CLASS 18—(Continued).

SN 85-441,869. GO SPUR 1 APPAREL LLC, GREELEY, CO. FILED 10-7-2011.



THE MARK CONSISTS OF THE CAPITAL LETTER "G" ADJACENT TO THE NUMBER "1" FROM WHICH A SHANK EXTENDS DOWNWARD BETWEEN THE TWO LITERAL ELEMENTS AND SUPPORTS A STAR-SHAPED ROWEL.

FOR TACK FOR HORSES AND CATTLE, NAMELY, HALTERS, LEADS, HEADSTALLS, BREASTCOLLARS, AND REINS (U.S. CLS. 1, 2, 3, 22 AND 41).

FIRST USE 6-30-2008; IN COMMERCE 6-30-2008.
BRENDAN MCCAULEY, EXAMINING ATTORNEY

SN 85-448,302. FUSION ONE GLOBAL LLC, GOLETA, CA. FILED 10-15-2011.

Amazing Case

THE MARK CONSISTS OF STANDARD CHARACTERS WITHOUT CLAIM TO ANY PARTICULAR FONT, STYLE, SIZE, OR COLOR.

NO CLAIM IS MADE TO THE EXCLUSIVE RIGHT TO USE "CASE", APART FROM THE MARK AS SHOWN.

FOR BAGS AND CASES IN THE NATURE OF LUGGAGE, BRIEFCASES, BAGS, CASES, SLEEVES AND PACKS ASSOCIATED WITH HOLDING AND CARRYING LAPTOPS, TABLETS, MOBILE DEVICES AND SMART PHONES (U.S. CLS. 1, 2, 3, 22 AND 41).

FIRST USE 2-1-2012; IN COMMERCE 2-1-2012.
JEFF DEFORD, EXAMINING ATTORNEY

CLASS 18—(Continued).

SN 85-449,179. MOD HOG, INC., PASADENA, CA. FILED 10-17-2011.

CUORE & PELLE

THE MARK CONSISTS OF STANDARD CHARACTERS WITHOUT CLAIM TO ANY PARTICULAR FONT, STYLE, SIZE, OR COLOR.

NO CLAIM IS MADE TO THE EXCLUSIVE RIGHT TO USE "PELLE", APART FROM THE MARK AS SHOWN.

THE ENGLISH TRANSLATION OF "CUORE" AND "PELLE" IN THE MARK IS "HEART" AND "LEATHER".

FOR BAGS AND HOLDALLS FOR SPORTS CLOTHING; BAGS FOR CARRYING BABIES' ACCESSORIES; BEACH BAGS; BELT BAGS AND HIP BAGS; BOOK BAGS; CARRY-ALL BAGS; CHANGE PURSES; CLUTCH BAGS; CLUTCHES; COIN PURSES; COSMETIC BAGS SOLD EMPTY; DIAPER BAGS; FLIGHT BAGS; GARMENT BAGS FOR TRAVEL; GYM BAGS; HANDBAGS, PURSES AND WALLETS; LEATHER PURSES (U.S. CLS. 1, 2, 3, 22 AND 41).

FIRST USE 10-18-2011; IN COMMERCE 10-18-2011.
DANNEAN HETZEL, EXAMINING ATTORNEY

SN 85-470,133. COUTURE PLANET, INC., LYNN, MA. FILED 11-11-2011.

COUTUREPLANET

THE MARK CONSISTS OF STANDARD CHARACTERS WITHOUT CLAIM TO ANY PARTICULAR FONT, STYLE, SIZE, OR COLOR.

FOR FASHION BAGS, NAMELY, HANDBAGS, TOTE BAGS, CLUTCHES, POCKETBOOKS, WALLETS (U.S. CLS. 1, 2, 3, 22 AND 41).

FIRST USE 12-22-2008; IN COMMERCE 12-22-2008.
ALYSSA STEEL, EXAMINING ATTORNEY

SN 85-475,097. TEAM SIZZLE FILMS, INC., BALTIMORE, MD. FILED 11-17-2011.

T-SIZZLE

THE MARK CONSISTS OF STANDARD CHARACTERS WITHOUT CLAIM TO ANY PARTICULAR FONT, STYLE, SIZE, OR COLOR.

THE NAME(S), PORTRAIT(S), AND/OR SIGNATURE(S) SHOWN IN THE MARK IDENTIFIES "TERRELL RAYMONN SUGGS", WHOSE CONSENT(S) TO REGISTER IS MADE OF RECORD.

FOR BACKPACKS; DUFFEL BAGS; SACK PACKS, NAMELY, DRAWSTRING BAGS USED AS BACKPACKS; SPORT BAGS; TRAVEL BAGS (U.S. CLS. 1, 2, 3, 22 AND 41).

JUDITH HELFMAN, EXAMINING ATTORNEY

CLASS 18—(Continued).

SN 85-541,270. RHOADES, VERNON F., FAIRFAX, MO.
FILED 2-13-2012.

TURKEY TOTER

THE MARK CONSISTS OF STANDARD CHARACTERS WITHOUT CLAIM TO ANY PARTICULAR FONT, STYLE, SIZE, OR COLOR.

NO CLAIM IS MADE TO THE EXCLUSIVE RIGHT TO USE "TURKEY", APART FROM THE MARK AS SHOWN.

FOR ANIMAL GAME BAGS (U.S. CLS. 1, 2, 3, 22 AND 41).

RUDY R. SINGLETON, EXAMINING ATTORNEY

SN 85-556,154. GENAL STRAP, INC., DBA VOGUESTRAP,
LONG ISLAND CITY, NY. FILED 2-29-2012.

ISABEL GRAYSON

THE MARK CONSISTS OF STANDARD CHARACTERS WITHOUT CLAIM TO ANY PARTICULAR FONT, STYLE, SIZE, OR COLOR.

THE NAME(S), PORTRAIT(S), AND/OR SIGNATURE(S) SHOWN IN THE MARK DOES NOT IDENTIFY A PARTICULAR LIVING INDIVIDUAL.

FOR BAGS, NAMELY, TOTE BAGS, HANDBAGS, TRAVEL TOTE BAGS, SATCHELS (U.S. CLS. 1, 2, 3, 22 AND 41).

CHRISTINE MARTIN, EXAMINING ATTORNEY

SN 85-558,968. CHARLES-JORDAN INVESTMENTS LLC,
RUMSON, NJ. FILED 3-2-2012.

SUTLERSAC

THE MARK CONSISTS OF STANDARD CHARACTERS WITHOUT CLAIM TO ANY PARTICULAR FONT, STYLE, SIZE, OR COLOR.

FOR HANDBAGS, CARRIERS FOR PERSONAL ITEMS, NAMELY, WALLET, CASH, IDENTIFICATION CARDS, CREDIT CARDS, CHECKBOOK, KEYS, BOOKS, ELECTRONIC READERS, MAGAZINES, NEWSPAPERS, CAMERA, SUNSCREEN, COSMETICS, EYEWEAR, WATER BOTTLE, HAT, VISOR, SNACK FOOD, BEVERAGES, TELEPHONE, TABLET COMPUTER, MP3 CONTROLLERS/PLAYERS, EARPHONES, TOWELS, AND TEXTILE POUCHES (U.S. CLS. 1, 2, 3, 22 AND 41).

GIANCARLO CASTRO, EXAMINING ATTORNEY

CLASS 18—(Continued).

SN 85-559,118. KVP INTERNATIONAL INC., DBA THE GRALEN COMPANY, IRWINDALE, CA. FILED 3-2-2012.

**lift 'em up mobility
harness**

THE MARK CONSISTS OF STANDARD CHARACTERS WITHOUT CLAIM TO ANY PARTICULAR FONT, STYLE, SIZE, OR COLOR.

NO CLAIM IS MADE TO THE EXCLUSIVE RIGHT TO USE "MOBILITY HARNESS", APART FROM THE MARK AS SHOWN.

FOR ANIMAL HARNESES (U.S. CLS. 1, 2, 3, 22 AND 41).

SIMON TENG, EXAMINING ATTORNEY

SN 85-566,692. TESORIERO, ANTHONY, PORT ST. LUCIE,
FL. FILED 3-12-2012.



NO CLAIM IS MADE TO THE EXCLUSIVE RIGHT TO USE "GEAR", APART FROM THE MARK AS SHOWN.

THE MARK CONSISTS OF A SKULL DESIGN WITH A BONE BELOW IT. THE WORDING "ZHT GEAR" APPEARS BELOW THE SKULL AND BONE DESIGN IN A STYLIZED FONT. THE SHADED SQUARE AREA APPEARING IN THE MARK REPRESENTS BACKGROUND, AND IS NOT CLAIMED AS A FEATURE OF THE MARK.

FOR BACKPACK STRAPS; BACKPACKS; FANNY PACKS; MILITARY DUFFLE BAGS, GARMENT BAGS FOR TRAVEL, TOTE BAGS, SHOULDER BAGS AND BACKPACKS; POUCHES AND BAGS SOLD EMPTY FOR ATTACHMENT TO BACKPACKS; POUCHES MADE OUT OF CLOTH; POUCHES OF TEXTILE; PROTECTIVE FITTED LINERS FOR BACKPACKS AND LUGGAGE (U.S. CLS. 1, 2, 3, 22 AND 41).

ALLISON SCHRODY, EXAMINING ATTORNEY

CLASS 18—(Continued).

SN 85-577,323. FILENE'S BASEMENT, LLC, SEACAUCUS, NJ. FILED 3-22-2012.

STANLEY B. BY STANLEY
BLACKER

THE MARK CONSISTS OF STANDARD CHARACTERS WITHOUT CLAIM TO ANY PARTICULAR FONT, STYLE, SIZE, OR COLOR.

OWNER OF U.S. REG. NOS. 1,379,293, 2,862,769 AND 3,557,293.

THE NAME(S), PORTRAIT(S), AND/OR SIGNATURE(S) SHOWN IN THE MARK DOES NOT IDENTIFY A PARTICULAR LIVING INDIVIDUAL.

FOR GOODS MADE OF LEATHER, NAMELY, WALLETS, BRIEFCASE-TYPE PORTFOLIOS, KEY CHAINS, AND HANDBAGS, AND GOODS NOT MADE OF LEATHER, NAMELY, UMBRELLAS AND TOTE BAGS (U.S. CLS. 1, 2, 3, 22 AND 41).

KAREN BRACEY, EXAMINING ATTORNEY

SN 85-585,949. ANTHONY L. HINTON, AKA MCBEAN-HINTON LLP, JERSEY CITY, NJ. FILED 4-1-2012.



THE COLOR(S) BLACK AND GREEN IS/ARE CLAIMED AS A FEATURE OF THE MARK.

THE MARK CONSISTS OF THE STYLIZED WORDING "PAVÓY" APPEARING BETWEEN THE DEPICTION OF A CURVED HANDLE AND THE BOTTOM OF A BAG. THE COLOR BLACK APPEARS IN THE WORDING "PAVOY". THE COLOR GREEN APPEARS ON THE DEPICTION OF THE CURVED HANDLE AND THE BOTTOM OF THE BAG.

THE WORDING "PAVOY" HAS NO MEANING IN A FOREIGN LANGUAGE.

FOR BACKPACKS, BOOK BAGS, SPORTS BAGS, BUM BAGS, WALLETS AND HANDBAGS; STRAPS FOR HANDBAGS (U.S. CLS. 1, 2, 3, 22 AND 41).

MICHAEL TANNER, EXAMINING ATTORNEY

CLASS 18—(Continued).

SN 85-588,480. RODARTE, LLC, PASADENA, CA. FILED 4-4-2012.

RODARTE

THE MARK CONSISTS OF STANDARD CHARACTERS WITHOUT CLAIM TO ANY PARTICULAR FONT, STYLE, SIZE, OR COLOR.

OWNER OF U.S. REG. NOS. 3,600,929, 3,975,621 AND OTHERS.

SEC. 2(F).

FOR LUGGAGE (U.S. CLS. 1, 2, 3, 22 AND 41).

HANNO RITTNER, EXAMINING ATTORNEY

SN 85-594,564. OCHSNER, DAMIAN B., ST. LOUIS, MO. FILED 4-11-2012.

K9STRONG

THE COLOR(S) YELLOW, AND BLACK IS/ARE CLAIMED AS A FEATURE OF THE MARK.

THE MARK CONSISTS OF A BLACK BACKGROUND WITH THE STYLIZED TEXT "K9STRONG" IN YELLOW.

FOR DOG COLLARS (U.S. CLS. 1, 2, 3, 22 AND 41).

MATTHEW GALAN, EXAMINING ATTORNEY

SN 85-597,017. JL & M DESIGNS, INC, LOS ANGELES, CA. FILED 4-13-2012.

Perry Mackin

THE NAME "PERRY MACKIN" DOES NOT IDENTIFY A LIVING INDIVIDUAL.

THE MARK CONSISTS OF THE STYLIZED WORDS "PERRY MACKIN".

FOR DIAPER BAGS (U.S. CLS. 1, 2, 3, 22 AND 41).

FIRST USE 6-1-2011; IN COMMERCE 6-1-2011.

HANNO RITTNER, EXAMINING ATTORNEY

CLASS 18—(Continued).

SN 85-597,666. SUD DE SUR, LOS ANGELES, CA. FILED 4-13-2012.

Sud de Sur

THE MARK CONSISTS OF STANDARD CHARACTERS WITHOUT CLAIM TO ANY PARTICULAR FONT, STYLE, SIZE, OR COLOR.
 THE ENGLISH TRANSLATION OF "SUD DE" IS "SOUTH OF".
 FOR FASHION HANDBAGS (U.S. CLS. 1, 2, 3, 22 AND 41).
 FIRST USE 7-1-2011; IN COMMERCE 9-1-2011.
 DAVID MURRAY, EXAMINING ATTORNEY

CLASS 18—(Continued).

SN 85-602,141. C.H.J. WATSON, INC., DBA WATSON AIR-LOCK, WASHINGTON, PA. FILED 4-19-2012.

Go Do What You Do

THE MARK CONSISTS OF STANDARD CHARACTERS WITHOUT CLAIM TO ANY PARTICULAR FONT, STYLE, SIZE, OR COLOR.
 FOR LUGGAGE (U.S. CLS. 1, 2, 3, 22 AND 41).
 LEIGH CAROLINE CASE, EXAMINING ATTORNEY

SN 85-600,151. C & C LEATHERS, LLC, DENVER, CO. FILED 4-17-2012.

COFI

THE MARK CONSISTS OF STANDARD CHARACTERS WITHOUT CLAIM TO ANY PARTICULAR FONT, STYLE, SIZE, OR COLOR.
 FOR CARRYING CASES FOR LAPTOP COMPUTERS, TABLET COMPUTERS AND ELECTRONIC BOOK READERS (U.S. CLS. 1, 2, 3, 22 AND 41).
 IRA J. GOODSAD, EXAMINING ATTORNEY

SN 85-603,156. FOZZY DOG, LLC, BOISE, ID. FILED 4-19-2012.



THE COLOR(S) BLACK AND WHITE IS/ARE CLAIMED AS A FEATURE OF THE MARK.
 THE MARK CONSISTS OF A STYLIZED LOGO DESIGN DEPICTING A SIDE-VIEW IMAGE OF A DOG'S HEAD SHOWN IN SILHOUETTE IN WHITE ON A BLACK BACKGROUND.
 FOR DOG LEASHES (U.S. CLS. 1, 2, 3, 22 AND 41).
 FIRST USE 4-25-2011; IN COMMERCE 4-25-2011.
 LINDA POWELL, EXAMINING ATTORNEY

SN 85-602,058. PERKINS GROUP PROPERTIES-CHINA, LLC, BELLEVUE, WA. FILED 4-19-2012.

ZBX

THE MARK CONSISTS OF STANDARD CHARACTERS WITHOUT CLAIM TO ANY PARTICULAR FONT, STYLE, SIZE, OR COLOR.
 FOR LEATHER AND NON-LEATHER LUGGAGE, TRAVEL BAGS, BEACH BAGS, TOTE BAGS, ATHLETIC BAGS, TOTE BAGS, MESSENGER BAGS, KNAPSACKS, GENERAL PURPOSE CARRY-ON BAGS, WALLETS, CHANGE PURSES, PURSES AND HANDBAGS, FANNY PACKS, AND BACKPACKS (U.S. CLS. 1, 2, 3, 22 AND 41).
 CHRISIE B. KING, EXAMINING ATTORNEY

SN 85-603,161. FOZZY DOG, LLC, BOISE, ID. FILED 4-19-2012.

PICK UP WHERE YOUR DOG LEFT OFF

THE MARK CONSISTS OF STANDARD CHARACTERS WITHOUT CLAIM TO ANY PARTICULAR FONT, STYLE, SIZE, OR COLOR.
 FOR DOG LEASHES (U.S. CLS. 1, 2, 3, 22 AND 41).
 LINDA POWELL, EXAMINING ATTORNEY

CLASS 18—(Continued).

SN 85-603,434. ROLLAGUARD SECURITY, LLC, LAKE PARK, FL. FILED 4-20-2012.

INTELLI-TRACKER

THE MARK CONSISTS OF STANDARD CHARACTERS WITHOUT CLAIM TO ANY PARTICULAR FONT, STYLE, SIZE, OR COLOR.

FOR SECURE PORTABLE TRAVEL BAGS, CONTAINERS AND CASES, NAMELY, BUSINESS CASES, CARRYING CASES, TRUNKS, BRIEFCASES, SUITCASES, ALL FOR HOLDING DOCUMENTS AND OTHER VALUABLES WHILE TRAVELING AND FITTED WITH ANTI-THEFT AND TRACKING DEVICES (U.S. CLS. 1, 2, 3, 22 AND 41).

THOMAS MANOR, EXAMINING ATTORNEY

SN 85-604,000. COACHMAN, LANCE, ATLANTA, GA. FILED 4-20-2012.

TRINITY

THE MARK CONSISTS OF STANDARD CHARACTERS WITHOUT CLAIM TO ANY PARTICULAR FONT, STYLE, SIZE, OR COLOR.

FOR LEATHER HANDBAGS (U.S. CLS. 1, 2, 3, 22 AND 41).

FIRST USE 3-0-2012; IN COMMERCE 3-0-2012.
DAVID HOFFMAN, EXAMINING ATTORNEY

CLASS 18—(Continued).

SN 85-637,699. UNDEFEATED, INC., LOS ANGELES, CA. FILED 5-29-2012.

UNDFTD

THE MARK CONSISTS OF STANDARD CHARACTERS WITHOUT CLAIM TO ANY PARTICULAR FONT, STYLE, SIZE, OR COLOR.

OWNER OF U.S. REG. NOS. 3,367,018, 3,525,867 AND OTHERS.

FOR ALL PURPOSE SPORT BAGS; ALL PURPOSE ATHLETIC BAGS; ANIMAL CARRIERS; ATTACHE CASES; BACKPACKS; BAGS FOR UMBRELLAS; BEACH BAGS; BEACH UMBRELLAS; BELT BAGS; BILLFOLDS; BOOK BAGS; BRIEFCASES; BRIEFCASE TYPE PORTFOLIOS; BUSINESS CARD CASES; BUSINESS CASES; CARRYALLS; CATALOG CASES; CHANGE PURSES; CLUTCH BAGS; CLUTCH PURSES; COIN PURSES; COSMETIC BAGS SOLD EMPTY; COSMETIC CASES SOLD EMPTY; CREDIT CARD CASES; DAY PACKS; DOCUMENT CASES; DRAWSTRING POUCHES; DUFFEL BAGS; EVENING HANDBAGS; FANNY PACKS; FELT POUCHES; GARMENT BAGS FOR TRAVEL; HANDBAGS; KEY CASES; LEATHER AND IMITATION LEATHER BAGS; SUIT CASES; LUGGAGE; WALLETS; LEATHER SHOPPING BAGS; LEATHER STRAPS; LUGGAGE TAGS; PURSES; SHAVING BAGS SOLD EMPTY; SHOE BAGS FOR TRAVEL; SHOULDER BAGS; SPORTS BAGS; TOILETRY CASES SOLD EMPTY; TOTE BAGS; VANITY CASES SOLD EMPTY; WALKING STICKS; WAIST PACKS; WINE TOTE BAGS WITH HANDLES FOR CARRYING OR HOLDING WINE; UMBRELLAS (U.S. CLS. 1, 2, 3, 22 AND 41).

KIMBERLY PARKS, EXAMINING ATTORNEY

SN 85-640,776. I AM OTHER ENTERTAINMENT, LLC, NEW YORK, NY. FILED 6-1-2012.

I AM OTHER

THE MARK CONSISTS OF STANDARD CHARACTERS WITHOUT CLAIM TO ANY PARTICULAR FONT, STYLE, SIZE, OR COLOR.

FOR ALL-PURPOSE SPORTS AND ATHLETIC BAGS; BEACH, BOOK, CARRY-ON, DUFFEL, GYM, LEATHER SHOPPING, SHOULDER, TOTE AND TRAVEL BAGS; FANNY PACKS AND WAIST PACKS; BACKPACKS; KNAPSACKS; PURSES; GARMENT BAGS FOR TRAVEL; SATCHELS; LUGGAGE; LUGGAGE TAGS; TRUNKS; SUITCASES; COSMETIC CASES AND BAGS SOLD EMPTY; TOILETRY AND VANITY CASES SOLD EMPTY; TOOL BAGS SOLD EMPTY; ATTACHE CASES; BRIEFCASES; BRIEFCASE-TYPE PORTFOLIOS; DOCUMENT CASES; MEN'S CLUTCHES; BUSINESS CASES; BUSINESS CARD CASES; CALLING AND CREDIT CARD CASES; KEY CASES; LEATHER KEY CHAINS; WALLETS; BANKNOTE HOLDERS; BILLFOLDS; UMBRELLAS (U.S. CLS. 1, 2, 3, 22 AND 41).

DAVID MURRAY, EXAMINING ATTORNEY

CLASS 18—(Continued).

SN 85-658,399. HOT TOPIC MERCHANDISING, INC., CITY OF INDUSTRY, CA. FILED 6-21-2012.

LOVESICK

THE MARK CONSISTS OF STANDARD CHARACTERS WITHOUT CLAIM TO ANY PARTICULAR FONT, STYLE, SIZE, OR COLOR.

OWNER OF U.S. REG. NO. 4,169,027.

FOR ALL PURPOSE SPORT BAGS; ALL-PURPOSE ATHLETIC BAGS; ALL-PURPOSE CARRYING BAGS; BACKPACKS, BOOK BAGS, SPORTS BAGS, BUM BAGS, WALLETS AND HANDBAGS; BELT BAGS AND HIP BAGS; BOOK BAGS; CANVAS SHOPPING BAGS; CARRY-ALL BAGS; CARRY-ON BAGS; CHALK BAGS; CLUTCH BAGS; COSMETIC BAGS SOLD EMPTY; DRAWSTRING BAGS; DUFFEL BAGS; EVENING BAGS; GARMENT BAGS FOR TRAVEL; HIP BAGS; HOBO BAGS; LEATHER AND IMITATION LEATHER SPORT BAGS AND GENERAL PURPOSE TROLLEY BAGS; MAKE-UP BAGS SOLD EMPTY; MESSENGER BAGS; MILITARY DUFFLE BAGS, GARMENT BAGS FOR TRAVEL, TOTE BAGS, SHOULDER BAGS AND BACKPACKS; OVERNIGHT BAGS; SCHOOL BAGS; SCHOOL BOOK BAGS; SHOULDER BAGS; TOTE BAGS (U.S. CLS. 1, 2, 3, 22 AND 41).

MAYUR VAGHANI, EXAMINING ATTORNEY

CLASS 19—(Continued).

SN 79-105,746. NAN'AN GUANG TAI XIANG STONE CO., LTD, FUJIAN PROVINCE, CHINA, FILED 10-31-2011.

**CLASS 19—NON-METALLIC BUILDING MATERIALS**

SN 76-709,238. ARLENE STAINED GLASS & DOOR CO., L.P., HOUSTON, TX. FILED 9-29-2011.

ARLENE

THE MARK CONSISTS OF STANDARD CHARACTERS WITHOUT CLAIM TO ANY PARTICULAR FONT, STYLE, SIZE, OR COLOR.

FOR NON-METAL DOORS (U.S. CLS. 1, 12, 33 AND 50).

FIRST USE 1-1-2010; IN COMMERCE 10-1-2010.

IRA J. GOODSAD, EXAMINING ATTORNEY

OWNER OF INTERNATIONAL REGISTRATION 1098322 DATED 10-31-2011, EXPIRES 10-31-2021.

NO CLAIM IS MADE TO THE EXCLUSIVE RIGHT TO USE THE NON-LATIN CHARACTERS THAT TRANSLITERATE TO "SHI" AND "STONE", APART FROM THE MARK AS SHOWN.

THE MARK CONSISTS OF A HIGHLY STYLIZED LETTER "G" DESIGN COMPRISED OF THREE GEOMETRIC SHAPES, CHINESE CHARACTERS THAT TRANSLITERATE TO GUANG TAI XIANG GANG SHI AND THE WORDING "GUANG TAI XIANG STONE".

THE ENGLISH TRANSLATION OF THE FOREIGN WORD(S) IN THE MARK IS THE FIRST CHINESE CHARACTER MEANS "WIDE" IN ENGLISH, THE SECOND CHARACTER MEANS "SAFE AND TRANQUIL" IN ENGLISH, THE THIRD CHARACTER MEANS "AUSPICIOUS" IN ENGLISH, THE FOURTH CHARACTER MEANS "MOUND" IN ENGLISH, AND THE FIFTH CHARACTER MEANS "STONE" IN ENGLISH; THE FIVE CHINESE CHARACTERS PUT TOGETHER HAVE NO MEANING.

THE TRANSLITERATION OF THE NON-LATIN CHARACTERS IN THE MARK IS: "GUANG TAI XIANG GANG SHI".

FOR ARTIFICIAL STONE; SLATE; MARBLE; GRANITE; BUILDING STONE; RUBBLE, NAMELY, BLOCK STONE; BRICKS; CERAMIC TILE; FLOOR TILES, NOT OF METAL; BUILDING MATERIALS, NOT OF METAL, NAMELY, WALL, HARDWOOD, DECKING, WOOD, PARTICLE BOARDS (U.S. CLS. 1, 12, 33 AND 50).

CURTIS FRENCH, EXAMINING ATTORNEY

CLASS 19—(Continued).

SN 79-107,779. KYUNG-EUN TEXTILE INDUSTRIAL CO.,LTD, BUSAN, REPUBLIC OF KOREA, FILED 12-20-2011.



PRIORITY DATE OF 7-28-2011 IS CLAIMED.
OWNER OF INTERNATIONAL REGISTRATION 1103203 DATED 12-20-2011, EXPIRES 12-20-2021.

NO CLAIM IS MADE TO THE EXCLUSIVE RIGHT TO USE "CASA", APART FROM THE MARK AS SHOWN.
THE COLOR(S) BLACK, ORANGE IS/ARE CLAIMED AS A FEATURE OF THE MARK.

THE MARK CONSISTS OF THE WORDING "CASA INILE" IN ORANGE UNDERNEATH FIVE HORIZONTAL ORANGE BANDS IN VARYING LENGTHS AND ALL OF WHICH ARE CONTAINED INSIDE A BLACK RECTANGLE CARRIER WITH ROUNDED CORNERS.

THE ENGLISH TRANSLATION OF "CASA" IN THE MARK IS "HOUSE".

FOR BUILDING PANELS, NOT OF METAL, NAMELY, NON-METAL WALL PANELS, NON-METAL FLOOR PANELS; BUILDING MATERIALS, NOT OF METAL, NAMELY, SOFFITS, FASCIA; CEILING PANELS, NOT OF METAL; CLADDING, NOT OF METAL, FOR BUILDING; PARQUET FLOORING; ARCHITECTURAL MOLDINGS, NOT OF METAL, FOR BUILDING; NON-METAL PANTILES; TILES, NOT OF METAL, FOR BUILDING (U.S. CLS. 1, 12, 33 AND 50).

ANDREW LEASER, EXAMINING ATTORNEY

CLASS 19—(Continued).

SN 85-366,832. HOLDING SOPREMA, STRASBOURG, FRANCE, FILED 7-8-2011.

RESISTOR PLUS

THE MARK CONSISTS OF STANDARD CHARACTERS WITHOUT CLAIM TO ANY PARTICULAR FONT, STYLE, SIZE, OR COLOR.

PRIORITY CLAIMED UNDER SEC. 44(D) ON CANADA APPLICATION NO. 1532159, FILED 6-17-2011, REG. NO. TMA824843, DATED 5-28-2012, EXPIRES 5-28-2027.

FOR ROOFING UNDERLAYMENT, NAMELY, A SYNTHETIC, WATER REPELLENT, HIGH STRENGTH ROOF UNDERLAYMENT MEMBRANE MADE OF POLYOLEFIN FOR USE IN PROTECTING THE DECKING AND ROOF ATTIC FROM MOISTURE INTRUSION (U.S. CLS. 1, 12, 33 AND 50).

FIRST USE 9-6-2006; IN COMMERCE 7-10-2010.

AMY KERTGATE, EXAMINING ATTORNEY

SN 79-108,063. GI.GAR SRL, I-60022 CASTELFIDARDO (AN), ITALY, FILED 8-11-2011.

OWNER OF INTERNATIONAL REGISTRATION 1104001 DATED 8-11-2011, EXPIRES 8-11-2021.

FOR NON-METAL DOORS, NON-METAL FRAMES FOR WINDOWS AND DOORS (U.S. CLS. 1, 12, 33 AND 50).

KIMBERLY FRYE, EXAMINING ATTORNEY

SN 85-366,889. HOLDING SOPREMA, STRASBOURG, FRANCE, FILED 7-8-2011.

RESISTOR

THE MARK CONSISTS OF STANDARD CHARACTERS WITHOUT CLAIM TO ANY PARTICULAR FONT, STYLE, SIZE, OR COLOR.

PRIORITY CLAIMED UNDER SEC. 44(D) ON CANADA APPLICATION NO. 1532156, FILED 6-17-2011, REG. NO. TMA824841, DATED 5-28-2012, EXPIRES 5-28-2027.

FOR ROOFING UNDERLAYMENT, NAMELY, A SYNTHETIC UNDERLAYMENT MADE FROM A WATER-PROOF, SLIP RESISTANT, HIGH STRENGTH NON-WOVEN POLYPROPYLENE FIBER AND POLYMER MATERIAL USED TO PROTECT THE DECKING AND ROOF ATTIC FROM MOISTURE INTRUSION (U.S. CLS. 1, 12, 33 AND 50).

FIRST USE 1-26-2010; IN COMMERCE 2-8-2011.

AMY KERTGATE, EXAMINING ATTORNEY

SN 79-114,067. KOWA COMPANY LTD., JAPAN, FILED 3-23-2012.

OWNER OF INTERNATIONAL REGISTRATION 1119259 DATED 3-23-2012, EXPIRES 3-23-2022.

THE MARK CONSISTS OF THE STYLIZED WORDING "KOWA" INSIDE AN OVAL.

FOR CERAMIC TILES (U.S. CLS. 1, 12, 33 AND 50).

TOBY BULLOFF, EXAMINING ATTORNEY

CLASS 19—(Continued).

SN 85-367,798. HOLDING SOPREMA, STRASBOURG, FRANCE, FILED 7-11-2011.



PRIORITY CLAIMED UNDER SEC. 44(D) ON CANADA APPLICATION NO. 1532215, FILED 6-17-2011, REG. NO. TMA824842, DATED 5-28-2012, EXPIRES 5-28-2027.

THE MARK CONSISTS OF THE STYLIZED WORD "RESISTOR" WITH THE LETTER "O" FORMED BY A UNIVERSAL PROHIBITION SYMBOL CONTAINING THE STYLIZED DEPICTION OF A WATER DROP. THE TOP OF THE WATER DROP EXTENDS OUTSIDE THE PROHIBITION SYMBOL.

FOR ROOFING UNDERLAYMENT, NAMELY, A SYNTHETIC UNDERLAYMENT MADE FROM A WATER-PROOF, SLIP RESISTANT, HIGH STRENGTH NON WOVEN POLYPROPYLENE FIBER AND POLYMER MATERIAL USED TO PROTECT THE DECKING AND ROOF ATTIC FROM MOISTURE INTRUSION (U.S. CLS. 1, 12, 33 AND 50).

FIRST USE 1-26-2010; IN COMMERCE 2-8-2011.
AMY KERTGATE, EXAMINING ATTORNEY

CLASS 19—(Continued).

SN 85-369,558. EZ ON VINYL, LLC, SHELLEY, ID. FILED 7-12-2011.

EZ ON

THE MARK CONSISTS OF STANDARD CHARACTERS WITHOUT CLAIM TO ANY PARTICULAR FONT, STYLE, SIZE, OR COLOR.

FOR FENCING PROTECTION PRODUCTS, NAMELY, VINYL EXTENDER INSULATORS (U.S. CLS. 1, 12, 33 AND 50).

NAAKWAMA ANKRAH, EXAMINING ATTORNEY

SN 85-416,169. GARDNER ASPHALT CORPORATION, TAMPA, FL. FILED 9-7-2011.

INCREDIBLE

SN 85-367,866. HOLDING SOPREMA, STRASBOURG, FRANCE, FILED 7-11-2011.



THE MARK CONSISTS OF STANDARD CHARACTERS WITHOUT CLAIM TO ANY PARTICULAR FONT, STYLE, SIZE, OR COLOR.

FOR NON-METALLIC BUILDING FLASHING AND SEAM TAPES USED FOR CONSTRUCTION AND BUILDING (U.S. CLS. 1, 12, 33 AND 50).

TARA PATE, EXAMINING ATTORNEY

SN 85-416,171. GARDNER ASPHALT CORPORATION, TAMPA, FL. FILED 9-7-2011.

PRIORITY CLAIMED UNDER SEC. 44(D) ON CANADA APPLICATION NO. 1532216, FILED 6-17-2011, REG. NO. TMA824844, DATED 5-28-2012, EXPIRES 5-28-2027.

THE MARK CONSISTS OF THE STYLIZED WORD "RESISTOR PLUS" WITH THE LETTER "O" IN "RESISTOR" FORMED BY A UNIVERSAL PROHIBITION SYMBOL CONTAINING THE STYLIZED DEPICTION OF A WATER DROP. THE TOP OF THE WATER DROP EXTENDS OUTSIDE THE PROHIBITION SYMBOL. THE STYLIZED WORD "PLUS" APPEARS BELOW THE LETTERS "T", "O" AND "R" IN "RESISTOR" WITH A CURVED LINE APPEARING UNDERNEATH IT.

FOR ROOFING UNDERLAYMENT, NAMELY, A SYNTHETIC, WATER REPELLENT, HIGH STRENGTH ROOF UNDERLAYMENT MEMBRANE MADE OF POLYOLEFIN FOR USE IN PROTECTING THE DECKING AND ROOF ATTIC FROM MOISTURE INTRUSION (U.S. CLS. 1, 12, 33 AND 50).

FIRST USE 9-6-2006; IN COMMERCE 7-10-2010.
AMY KERTGATE, EXAMINING ATTORNEY

NANO-SHIELD

THE MARK CONSISTS OF STANDARD CHARACTERS WITHOUT CLAIM TO ANY PARTICULAR FONT, STYLE, SIZE, OR COLOR.

FOR NON-METALLIC BUILDING FLASHING AND SEAM TAPES USED FOR CONSTRUCTION AND BUILDING (U.S. CLS. 1, 12, 33 AND 50).

TARA PATE, EXAMINING ATTORNEY

CLASS 19—(Continued).

SN 85-438,049. GLEN RAVEN, INC., GLEN RAVEN, NC. FILED 10-3-2011.

SLEEVE-IT

THE MARK CONSISTS OF STANDARD CHARACTERS WITHOUT CLAIM TO ANY PARTICULAR FONT, STYLE, SIZE, OR COLOR.

FOR COMBINATION PLASTIC AND STEEL FENCE COMPONENT IN THE NATURE OF A SLEEVE FOR USE WITH RETAINING WALLS (U.S. CLS. 1, 12, 33 AND 50). FIRST USE 4-0-2005; IN COMMERCE 10-0-2005. MICHELE SWAIN, EXAMINING ATTORNEY

CLASS 19—(Continued).

SN 85-449,104. CONCRETE & MORTAR PACKAGING LLC, MILFORD, MA. FILED 10-17-2011.

VITA CRETE

THE MARK CONSISTS OF STANDARD CHARACTERS WITHOUT CLAIM TO ANY PARTICULAR FONT, STYLE, SIZE, OR COLOR.

FOR CEMENT MIXES (U.S. CLS. 1, 12, 33 AND 50). FIRST USE 12-10-1958; IN COMMERCE 12-10-1958. FRED CARL, EXAMINING ATTORNEY

SN 85-443,775. PALM HARBOR VILLAGES, INC., DBA NATIONWIDE HOMES, PHOENIX, AZ. FILED 10-10-2011.



NO CLAIM IS MADE TO THE EXCLUSIVE RIGHT TO USE "ECO COTTAGES", APART FROM THE MARK AS SHOWN.

THE COLOR(S) GREEN AND BLUE IS/ARE CLAIMED AS A FEATURE OF THE MARK.

THE MARK CONSISTS OF A LEAF IN DARK GREEN FADING TO LIGHTER SHADES OF GREEN POINTING UPWARD AT A FORTY-FIVE DEGREE ANGLE TO THE LEFT OF THE WORD "ECO" IN GREEN AND THE WORD "COTTAGES" IN DARK BLUE BENEATH THE WORD "ECO". THE LETTER "E" IN "ECO" AND THE LETTER "C" IN "COTTAGES" INTERLOCK.

FOR MODULAR HOMES; PREFABRICATED HOUSES (U.S. CLS. 1, 12, 33 AND 50).

FIRST USE 1-19-2010; IN COMMERCE 1-19-2010. STEVEN JACKSON, EXAMINING ATTORNEY

SN 85-454,854. PEPPERS, DEBORAH SHERRILL, ALAMO, CA. FILED 10-24-2011.

True 10

THE MARK CONSISTS OF STANDARD CHARACTERS WITHOUT CLAIM TO ANY PARTICULAR FONT, STYLE, SIZE, OR COLOR.

FOR PREFABRICATED AND MANUFACTURED HOMES IN THE NATURE OF ENERGY EFFICIENT AND ECOLOGICALLY SUSTAINABLE RESIDENTIAL AND OFFICE BUILDING STRUCTURES, NAMELY, HOUSES, APARTMENTS, CONDOMINIUMS, SENIOR BUILDINGS, RETAIL BUILDINGS, AND OFFICE BUILDINGS (U.S. CLS. 1, 12, 33 AND 50).

ZACHARY BELLO, EXAMINING ATTORNEY

SN 85-445,604. CROSSVILLE, INC., CROSSVILLE, TN. FILED 10-12-2011.

BUENOS AIRES MOOD

THE MARK CONSISTS OF STANDARD CHARACTERS WITHOUT CLAIM TO ANY PARTICULAR FONT, STYLE, SIZE, OR COLOR.

NO CLAIM IS MADE TO THE EXCLUSIVE RIGHT TO USE "BUENOS AIRES", APART FROM THE MARK AS SHOWN.

FOR NON-METAL TILES (U.S. CLS. 1, 12, 33 AND 50). FIRST USE 12-5-2005; IN COMMERCE 9-15-2006. SANDRA BUJA, EXAMINING ATTORNEY

SN 85-477,772. AGT PRODUCTS (IP) INC., MISSISSAUGA, ONTARIO, CANADA, FILED 11-21-2011.

DON'T TRAP MOISTURE! LET IT DRY

THE MARK CONSISTS OF STANDARD CHARACTERS WITHOUT CLAIM TO ANY PARTICULAR FONT, STYLE, SIZE, OR COLOR.

FOR FLOORING PRODUCTS, NAMELY, HARDWOOD FLOORING, AND SUB-FLOORING PRODUCTS, NAMELY, TONGUE AND GROOVE WOOD COMPOSITE PANELS WITH A PLASTIC BASE FOR USE IN BASEMENT SUB-FLOOR APPLICATIONS TO RESIST MOISTURE (U.S. CLS. 1, 12, 33 AND 50).

DANIEL CAPSHAW, EXAMINING ATTORNEY

CLASS 19—(Continued).

SN 85-482,781. DUCTCAP PRODUCTS, INC., WILLMAR, MN. FILED 11-29-2011.

DUCTCAP

THE MARK CONSISTS OF STANDARD CHARACTERS WITHOUT CLAIM TO ANY PARTICULAR FONT, STYLE, SIZE, OR COLOR.

OWNER OF U.S. REG. NO. 2,892,099.
SEC. 2(F).
FOR NON-METAL VENT COVER FOR HVAC DUCTS (U.S. CLS. 1, 12, 33 AND 50).
FIRST USE 11-15-2002; IN COMMERCE 3-19-2003.
APRIL HESIK, EXAMINING ATTORNEY

SN 85-548,190. PENTAL GRANITE AND MARBLE, INC., SEATTLE, WA. FILED 2-21-2012.



THE MARK CONSISTS OF INTERSECTING LOWER CASE LETTERS "P" AND "Q".

FOR QUARTZ; BUILDING MATERIALS, NAMELY, QUARTZ MATERIAL USED IN THE MANUFACTURE OF COUNTERTOPS, BATHROOM VANITIES, BAR TOPS, AND TUB SURROUNDS; QUARTZ FLOORING; QUARTZ FLOOR TILES (U.S. CLS. 1, 12, 33 AND 50).
PAULA MAHONEY, EXAMINING ATTORNEY

SN 85-548,200. PENTAL GRANITE AND MARBLE, INC., SEATTLE, WA. FILED 2-21-2012.

PENTALQUARTZ

THE MARK CONSISTS OF STANDARD CHARACTERS WITHOUT CLAIM TO ANY PARTICULAR FONT, STYLE, SIZE, OR COLOR.

FOR QUARTZ; BUILDING MATERIALS, NAMELY, QUARTZ MATERIAL USED IN THE MANUFACTURE OF COUNTERTOPS, BATHROOM VANITIES, BAR TOPS, AND TUB SURROUNDS; QUARTZ FLOORING; QUARTZ FLOOR TILES (U.S. CLS. 1, 12, 33 AND 50).
PAULA MAHONEY, EXAMINING ATTORNEY

CLASS 19—(Continued).

SN 85-549,095. FELDMAN, JEAN H., HUTTO, TX. FILED 2-22-2012.

FROMS

THE MARK CONSISTS OF STANDARD CHARACTERS WITHOUT CLAIM TO ANY PARTICULAR FONT, STYLE, SIZE, OR COLOR.

FOR COLLECTABLE ROCK SCULPTURES REPRESENTED AS HUMAN FIGURES (U.S. CLS. 1, 12, 33 AND 50).
JOHN E. MICHOS, EXAMINING ATTORNEY

SN 85-549,521. THOMAS P. WHALEY, PIERCY, CA. FILED 2-22-2012.

FERREX

THE MARK CONSISTS OF STANDARD CHARACTERS WITHOUT CLAIM TO ANY PARTICULAR FONT, STYLE, SIZE, OR COLOR.

FOR BUILDING SECTIONS, NAMELY, PANELS, WALL FORMS AND ROOF FORMS COMPOSED OF FERRO-CEMENT (U.S. CLS. 1, 12, 33 AND 50).
CIMMERIAN COLEMAN, EXAMINING ATTORNEY

SN 85-554,321. CLASSIC MARBLE COMPANY PRIVATE LIMITED, MUMBAI, MAHARASHTRA, INDIA, FILED 2-28-2012.

KALINGASTONE

THE MARK CONSISTS OF STANDARD CHARACTERS WITHOUT CLAIM TO ANY PARTICULAR FONT, STYLE, SIZE, OR COLOR.

THE ENGLISH TRANSLATION OF "KALINGA" IN THE MARK IS "BIRD".

FOR ARTIFICIAL STONE; COBBLES AND BOULDERS; CONSTRUCTION MATERIALS, NAMELY, UNDERLAYS OF AGGLOMERATED CORK; DECORATIVE CENTERPIECES OF, NAMELY, STONE; GLAZED CERAMIC TILES; GRANITE; MARBLE; MONUMENTS OF MARBLE; MONUMENTS OF, NAMELY, STONE; MOSAIC ART TILES MADE OF MARBLE; MOSAICS MADE OF NATURAL STONE AND STONE TILE; NATURAL STONE AND STONE TILE; NON-METAL TILES; PAVEMENT TILES; PAVING BLOCKS; PAVING STONE; PAVING TILES; QUARTZ; STATUES OF MARBLE; STONE SCULPTURES; SYNTHETIC FLOORING MATERIALS OR WALL-CLADDINGS; TILES AND PAVING SLABS, NOT OF METAL; TILES OF CERAMIC FOR WALL, FLOOR OR CEILING (U.S. CLS. 1, 12, 33 AND 50).

GRETCHEN ULRICH, EXAMINING ATTORNEY

CLASS 19—(Continued).

SN 85-563,596. TSRC CORPORATION, TAIPEI CITY, TAIWAN, FILED 3-8-2012.



OWNER OF TAIWAN REG. NO. 778759, DATED 10-1-1997, EXPIRES 9-30-2017.

THE MARK CONSISTS OF A SOLID SQUARE AND FOUR CHECK MARKS. THE FOUR CHECK MARKS CONTINUALLY FLIP 90 DEGREES COUNTER CLOCKWISE WITH TWO SOLID CHECK MARKS APART FROM THE SQUARE AND THE OTHER TWO CHECK MARKS OVER THE SQUARE THAT EXTEND BEYOND THE BORDERS OF THE SQUARE.

FOR RUBBER STORAGE SHEDS USED TO STORE GREASE SHIELDS; RUBBER SUPPORT PADS FOR USE IN THE CONSTRUCTION OF BRIDGE BEARINGS; RUBBER FLOOR BRICKS (U.S. CLS. 1, 12, 33 AND 50).
AHSEN KHAN, EXAMINING ATTORNEY

SN 85-584,506. J. SONIC SERVICES INC., SAINT-LAURENT, QUEBEC, CANADA, FILED 3-30-2012.

GOLDEN SELECT

THE MARK CONSISTS OF STANDARD CHARACTERS WITHOUT CLAIM TO ANY PARTICULAR FONT, STYLE, SIZE, OR COLOR.

OWNER OF U.S. REG. NO. 3,150,603.
FOR NON-METAL FLOOR AND WALL TILES (U.S. CLS. 1, 12, 33 AND 50).
FIRST USE 12-31-2011; IN COMMERCE 12-31-2011.
KIMBERLY FRYE, EXAMINING ATTORNEY

CLASS 19—(Continued).

SN 85-591,684. B&M NOBLE CO., SAN DIEGO, CA. FILED 4-6-2012.

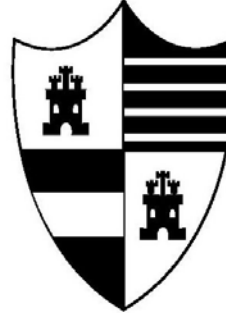

THE MARK CONSISTS OF A SHIELD DIVIDED INTO 4 QUADRANTS; A BLOCK CASTLE IS LOCATED IN THE CENTER OF THE TOP LEFT AND BOTTOM RIGHT QUADRANT; NINE ALTERNATE HORIZONTAL BARS FILL THE TOP RIGHT QUADRANT; 3 ALTERNATE HORIZONTAL BARS FILL THE BOTTOM LEFT QUADRANT.

FOR HARDWOOD FLOORING (U.S. CLS. 1, 12, 33 AND 50).

ERIN FALK, EXAMINING ATTORNEY

SN 85-591,702. B&M NOBLE CO., SAN DIEGO, CA. FILED 4-6-2012.

HERITAGE TIMBER COLLECTION

THE MARK CONSISTS OF STANDARD CHARACTERS WITHOUT CLAIM TO ANY PARTICULAR FONT, STYLE, SIZE, OR COLOR.

NO CLAIM IS MADE TO THE EXCLUSIVE RIGHT TO USE "TIMBER COLLECTION", APART FROM THE MARK AS SHOWN.

FOR HARDWOOD FLOORING (U.S. CLS. 1, 12, 33 AND 50).

ERIN FALK, EXAMINING ATTORNEY

SN 85-591,710. B&M NOBLE CO., SAN DIEGO, CA. FILED 4-6-2012.

VINTAGE REMAINS

THE MARK CONSISTS OF STANDARD CHARACTERS WITHOUT CLAIM TO ANY PARTICULAR FONT, STYLE, SIZE, OR COLOR.

NO CLAIM IS MADE TO THE EXCLUSIVE RIGHT TO USE "VINTAGE", APART FROM THE MARK AS SHOWN.

FOR HARD WOOD FLOORING (U.S. CLS. 1, 12, 33 AND 50).

ERIN FALK, EXAMINING ATTORNEY

CLASS 19—(Continued).

SN 85-592,875. CARLISLE WIDE PLANK FLOORS, INC., STODDARD, NH. FILED 4-9-2012.



OWNER OF U.S. REG. NOS. 3,042,503, 3,753,736 AND OTHERS.

NO CLAIM IS MADE TO THE EXCLUSIVE RIGHT TO USE "WIDE PLANK FLOORS", APART FROM THE MARK AS SHOWN.

THE COLOR(S) GREEN, BLACK AND WHITE IS/ARE CLAIMED AS A FEATURE OF THE MARK.

THE MARK CONSISTS OF THE LETTERS "C" AND "W" ON TOP OF THE LETTERS "P" AND "F" IN WHITE INSIDE A GREEN SQUARE WITH THE WORD "CARLISLE" IN BLACK ADJACENT TO THE SQUARE AND ON TOP OF THE WORDS "WIDE PLANK FLOORS" IN GREEN.

FOR WOOD FLOORING; WOOD STAIR COMPONENTS, NAMELY, STAIRS TREADS, RISERS AND NOSING; WOOD PANELING; WOOD BEAMS; WOOD FLOOR VENT COVERS FOR HVAC DUCTS (U.S. CLS. 1, 12, 33 AND 50).

FIRST USE 1-0-2012; IN COMMERCE 1-0-2012.
AMY ALFIERI, EXAMINING ATTORNEY

CLASS 19—(Continued).

SN 85-598,691. PERCOA USA, LLC, EDEN PRAIRIE, MN. FILED 4-16-2012.



THE MARK CONSISTS OF A DIAGONALLY POSITIONED SHADED IMAGE OF A FROG FACING THE UPPER LEFT CORNER DISPLAYING THREE LEGS WITH THREE TOES ON EACH FOOT.

FOR CONCRETE: CONCRETE BUILDING MATERIALS, NAMELY, PRECAST PERVIOUS SLABS, TILES AND PAVERS; PAVER TILES; PAVING TILES; SLABS OF PRECAST PERVIOUS CONCRETE (U.S. CLS. 1, 12, 33 AND 50).

FIRST USE 3-31-2012; IN COMMERCE 3-31-2012.
KATHERINE M. DUBRAY, EXAMINING ATTORNEY

SN 85-602,106. OWENS CORNING INTELLECTUAL CAPITAL, LLC, TOLEDO, OH. FILED 4-19-2012.

SN 85-598,664. PERCOA USA, LLC, EDEN PRAIRIE, MN. FILED 4-16-2012.

Clean water is a global responsibility



THE MARK CONSISTS OF STANDARD CHARACTERS WITHOUT CLAIM TO ANY PARTICULAR FONT, STYLE, SIZE, OR COLOR.

FOR CONCRETE: CONCRETE BUILDING MATERIALS, NAMELY, PRECAST PERVIOUS SLABS, TILES AND PAVERS; PAVER TILES; PAVING TILES; SLABS OF PRECAST PERVIOUS CONCRETE (U.S. CLS. 1, 12, 33 AND 50).

FIRST USE 3-31-2012; IN COMMERCE 3-31-2012.
KATHERINE M. DUBRAY, EXAMINING ATTORNEY

THE MARK CONSISTS OF A LIGHTNING BOLT. FOR NON-METAL ROOFING SHINGLES (U.S. CLS. 1, 12, 33 AND 50).

FIRST USE 2-1-2012; IN COMMERCE 2-1-2012.
DAVID TOOLEY, EXAMINING ATTORNEY

CLASS 19—(Continued).

SN 85-602,563. WATCO USA, INC., VERNON HILLS, IL.
FILED 4-19-2012.

CONCREX

THE MARK CONSISTS OF STANDARD CHARACTERS
WITHOUT CLAIM TO ANY PARTICULAR FONT, STYLE,
SIZE, OR COLOR.

FOR FLOOR PATCHING MATERIALS, NAMELY,
CONCRETE SEALERS (U.S. CLS. 1, 12, 33 AND 50).

FIRST USE 9-8-2011; IN COMMERCE 9-8-2011.
JOHN E. MICHOS, EXAMINING ATTORNEY

SN 85-602,595. WATCO USA, INC., VERNON HILLS, IL.
FILED 4-19-2012.

FLOWPATCH

THE MARK CONSISTS OF STANDARD CHARACTERS
WITHOUT CLAIM TO ANY PARTICULAR FONT, STYLE,
SIZE, OR COLOR.

FOR FLOOR PATCHING MATERIALS, NAMELY,
CONCRETE SEALERS (U.S. CLS. 1, 12, 33 AND 50).

FIRST USE 9-12-2011; IN COMMERCE 9-12-2011.
JOHN E. MICHOS, EXAMINING ATTORNEY

SN 85-611,072. PERGO (EUROPE) AB, TRELLEBORG, SWE-
DEN, FILED 4-27-2012.

WEARPRO

THE MARK CONSISTS OF STANDARD CHARACTERS
WITHOUT CLAIM TO ANY PARTICULAR FONT, STYLE,
SIZE, OR COLOR.

FOR FLOORING, NAMELY, LUXURY VINYL TILES,
WOOD, THERMOSETTING LAMINATE, THERMOSETTING
LAMINATE BONDED TO A BASE OF PARTICLE
BOARD OR FIBERBOARD AND PARTICLE BOARD OR
FIBERBOARD PROVIDED WITH A DECORATIVE SUR-
FACE OR COATING (U.S. CLS. 1, 12, 33 AND 50).

JAMES LOVELACE, EXAMINING ATTORNEY

CLASS 19—(Continued).

SN 85-624,009. OWENS CORNING INTELLECTUAL CAPI-
TAL, LLC, TOLEDO, OH. FILED 5-14-2012.



TRUDEFINITION
DURATION STORM

OWNER OF U.S. REG. NOS. 3,450,051 AND 4,075,227.
THE MARK CONSISTS OF "TRUDEFINITION DURA-
TION STORM" WITH LIGHTNING BOLT.

FOR NON-METAL ROOFING SHINGLES (U.S. CLS. 1,
12, 33 AND 50).

FIRST USE 2-1-2012; IN COMMERCE 2-1-2012.
DAVID TOOLEY, EXAMINING ATTORNEY

SN 85-630,813. OWENS CORNING INTELLECTUAL CAPI-
TAL, LLC, TOLEDO, OH. FILED 5-21-2012.

SKYWAY

THE MARK CONSISTS OF STANDARD CHARACTERS
WITHOUT CLAIM TO ANY PARTICULAR FONT, STYLE,
SIZE, OR COLOR.

FOR NON-METAL CEILING PANELS (U.S. CLS. 1, 12,
33 AND 50).

DAVID TOOLEY, EXAMINING ATTORNEY

SN 85-649,244. KEYSTONE RETAINING WALL SYSTEMS
LLC, EDINA, MN. FILED 6-12-2012.

LINDURA

THE MARK CONSISTS OF STANDARD CHARACTERS
WITHOUT CLAIM TO ANY PARTICULAR FONT, STYLE,
SIZE, OR COLOR.

THE ENGLISH TRANSLATION OF THE WORD "LINDURA"
IN THE MARK IS "PRETTINESS".

FOR MODULAR CONCRETE BLOCKS USED TO
CONSTRUCT EARTH RETAINING WALLS; MODULAR
CONCRETE BLOCKS USED IN LANDSCAPING APPLI-
CATIONS; CONCRETE BLOCKS USED IN LANDSCAPING
APPLICATIONS; PAVING BLOCKS; PAVING
STONES; PATIO STONES; CONCRETE EDGING
BLOCKS (U.S. CLS. 1, 12, 33 AND 50).

KAREN SEVERSON, EXAMINING ATTORNEY

CLASS 20—FURNITURE AND ARTICLES NOT OTHERWISE CLASSIFIED

SN 76-709,548. GLOBE COMPOSITE SOLUTIONS, LTD., DALLAS, TX. FILED 10-26-2011.

TUFF-TOTE

THE MARK CONSISTS OF STANDARD CHARACTERS WITHOUT CLAIM TO ANY PARTICULAR FONT, STYLE, SIZE, OR COLOR.

FOR COMMERCIAL PACKAGING MATERIALS, NAMELY, COMPOSITE PLASTIC TRAY FOR CARRYING AND DELIVERING PARCELS, NONMETAL AND NON-PAPER CONTAINERS FOR STORAGE OR TRANSPORT (U.S. CLS. 2, 13, 22, 25, 32 AND 50).

FIRST USE 6-28-2005; IN COMMERCE 6-28-2005.
ROSELLE HERRERA, EXAMINING ATTORNEY

CLASS 20—(Continued).

SN 77-674,621. SARAH NEHAMEN, LOS ANGELES, CA. FILED 2-20-2009.



THE MARK CONSISTS OF A STYLIZED EYE DISPLAYING A FANCIFUL PANTY LINE SHAPE WITHIN THE CORNEA, ACCOMPANIED BY THE FANCIFUL TERM "PEEKA-BU".

FOR MIRRORS FOR PERSONAL USE; SHAVING MIRRORS (U.S. CLS. 2, 13, 22, 25, 32 AND 50).
SHAUNIA CARLYLE, EXAMINING ATTORNEY

SN 76-710,353. HARPERS HOLLOW, LLC, LONG GROVE, IL. FILED 1-24-2012.



THE MARK COMPRISES A ZOMBIE MASTIFF DOG CHAINED TO A STAKE HAVING A SKULL ON TOP. A PARTIAL HUMAN ARM HOLDING MAIL LIES ON A FIELD OF GRASS NEXT TO WHERE THE MASTIFF DOG SITS. HUMAN SKULLS ARE LOCATED AT THE CORNERS OF THE GRASS.

FOR STATUETTES AND FIGURINES MADE OF PLASTIC (U.S. CLS. 2, 13, 22, 25, 32 AND 50).

SHANNON TWOHIG, EXAMINING ATTORNEY

SN 79-103,180. ETRO S.P.A., I-20135 MILANO, ITALY, FILED 7-12-2011.

ETRO

THE MARK CONSISTS OF STANDARD CHARACTERS WITHOUT CLAIM TO ANY PARTICULAR FONT, STYLE, SIZE, OR COLOR.

OWNER OF INTERNATIONAL REGISTRATION 0915140 DATED 11-23-2006, EXPIRES 11-23-2016.

OWNER OF U.S. REG. NOS. 3,882,762 AND 3,936,782.

FOR FURNITURE, MIRRORS, PICTURE FRAMES; GOODS, NOT INCLUDED IN OTHER CLASSES, OF WOOD, CORK, REED, CANE, WICKER, HORN, BONE, IVORY, WHALEBONE, SHELL, AMBER, MOTHER-OF-PEARL, MEERSCHAUM AND SUBSTITUTES FOR ALL THESE MATERIALS, OR OF PLASTICS, NAMELY, DECORATIVE CENTERPIECES, UMBRELLA STANDS, PILLOWS AND DECORATIVE PILLOWS, WOOD BOXES (U.S. CLS. 2, 13, 22, 25, 32 AND 50).

WILLIAM BRECKENFELD, EXAMINING ATTORNEY

CLASS 20—(Continued).

SN 79-104,601. DIAM BOUCHAGE, FRANCE, FILED 10-3-2011.



PRIORITY DATE OF 5-31-2011 IS CLAIMED.
OWNER OF INTERNATIONAL REGISTRATION 1095904
DATED 10-3-2011, EXPIRES 10-3-2021.

THE MARK CONSISTS OF THE STYLIZED WORDING
"MYTIK DIAM" APPEARING BETWEEN TWO CURVED
LINES WITH TAPERED ENDS. THE STYLIZED WORD
"TRADITION" APPEARS BELOW "MYTIK DIAM".
THE WORDING "MYTIK DIAM" HAS NO MEANING IN
A FOREIGN LANGUAGE.

FOR CORKS (U.S. CLS. 2, 13, 22, 25, 32 AND 50).
AMY KERTGATE, EXAMINING ATTORNEY

CLASS 20—(Continued).

SN 79-104,603. DIAM BOUCHAGE, FRANCE, FILED 10-3-2011.



PRIORITY DATE OF 5-31-2011 IS CLAIMED.
OWNER OF INTERNATIONAL REGISTRATION 1095906
DATED 10-3-2011, EXPIRES 10-3-2021.

NO CLAIM IS MADE TO THE EXCLUSIVE RIGHT TO
USE "GRANDS CRUS", APART FROM THE MARK AS
SHOWN.

THE MARK CONSISTS OF THE STYLIZED WORD
"DIAM" APPEARING BETWEEN TWO CURVED LINES
WITH TAPERED ENDS. THE STYLIZED WORDING
"GRANDS CRUS" APPEARS BELOW "DIAM".

THE ENGLISH TRANSLATION OF "GRANDS CRUS" IN
THE MARK IS "GREAT WINE".
FOR CORKS (U.S. CLS. 2, 13, 22, 25, 32 AND 50).
AMY KERTGATE, EXAMINING ATTORNEY

SN 79-104,602. DIAM BOUCHAGE, FRANCE, FILED 10-3-2011.



PRIORITY DATE OF 5-31-2011 IS CLAIMED.
OWNER OF INTERNATIONAL REGISTRATION 1095905
DATED 10-3-2011, EXPIRES 10-3-2021.

THE MARK CONSISTS OF THE STYLIZED WORD
"DIAM" APPEARING BETWEEN TWO CURVED LINES
WITH TAPERED ENDS. THE STYLIZED WORD "TRADI-
TION" APPEARS BELOW "DIAM".

THE WORDING "DIAM" HAS NO MEANING IN A
FOREIGN LANGUAGE.
FOR CORKS (U.S. CLS. 2, 13, 22, 25, 32 AND 50).
AMY KERTGATE, EXAMINING ATTORNEY

SN 79-104,971. PREMIERE BABY LIMITED, EAST SUSSEX BN21 2HR, UNITED KINGDOM, FILED 10-11-2011.

THE MARK CONSISTS OF STANDARD CHARACTERS
WITHOUT CLAIM TO ANY PARTICULAR FONT, STYLE,
SIZE, OR COLOR.

OWNER OF INTERNATIONAL REGISTRATION 1096606
DATED 10-11-2011, EXPIRES 10-11-2021.

FOR MOSES BASKETS, NAMELY, BASSINETS OF
PLASTIC, RUBBER, SYNTHETIC RUBBER, WICKER
OR SYNTHETIC WICKER, BABY CRIBS, COTS, BABY
TRAVEL CARRIERS, NAMELY, CARRY COTS (U.S.
CLS. 2, 13, 22, 25, 32 AND 50).

SANDRA BUJA, EXAMINING ATTORNEY

CLASS 20—(Continued).

SN 79-106,348. MYMITO GMBH, FED REP GERMANY, FILED 8-5-2011.

CUBIT

THE MARK CONSISTS OF STANDARD CHARACTERS WITHOUT CLAIM TO ANY PARTICULAR FONT, STYLE, SIZE, OR COLOR.

OWNER OF INTERNATIONAL REGISTRATION 0990351 DATED 8-8-2008, EXPIRES 8-8-2018.

FOR FURNITURE, MIRRORS, PICTURE FRAMES; SHELVES AND SHELVING SYSTEMS CONSISTING PRIMARILY OF RESIDENTIAL SHELVING UNITS AND COMPONENT PARTS THEREOF, NAMELY, SHELVES AND BRACKETS SOLD AS A UNIT; SHELF MODULES AS PARTS OR ACCESSORIES OF THE AFOREMENTIONED GOODS NOT INCLUDED IN OTHER CLASSES; DECORATIVE CENTERPIECES AND FIGURINES OF WOOD, CORK, REED, CANE, WICKER, HORN, BONE, IVORY, WHALEBONE, SHELL, AMBER, MOTHER-OF-PEARL, MEERSCHAUM, AND SUBSTITUTES FOR ALL THESE MATERIALS, OR OF PLASTICS (U.S. CLS. 2, 13, 22, 25, 32 AND 50).

WARREN L. OLANDRIA, EXAMINING ATTORNEY

CLASS 20—(Continued).

SN 79-112,601. ANHUI LONGHUA BAMBOO PRODUCT CO., LTD., ANHUI PROVINCE, CHINA, FILED 3-26-2012.



OWNER OF INTERNATIONAL REGISTRATION 1115173 DATED 3-26-2012, EXPIRES 3-26-2022.

NO CLAIM IS MADE TO THE EXCLUSIVE RIGHT TO USE THE NON-LATIN CHARACTERS THAT TRANSLITERATE TO "ZHU", APART FROM THE MARK AS SHOWN.

THE ENGLISH TRANSLATION OF THE FOREIGN WORD IN THE MARK IS THE FIRST CHINESE CHARACTER WHOSE TRANSLITERATION IS "ZHU" MEANS "BAMBOO"; THE SECOND CHINESE CHARACTER WHOSE TRANSLITERATION IS "DIAN" MEANS "ALLUSION".

THE TRANSLITERATION OF THE NON-LATIN CHARACTERS IN THE MARK IS "ZHU DIAN".

FOR FURNITURE; SIDEBOARDS; OFFICE FURNITURE; CHAIRS; DESKS; TABLES; BEDS; CASKS OF WOOD FOR DECANTING WINE; SOFAS; ALL THE FOREGOING MADE FROM BAMBOO; BAMBOO PLAITED GOODS, NAMELY, BLINDS, DRAPES EXCLUDING HATS, MATS AND CUSHIONS; ART CRAFTS OF BAMBOO AND WOOD, NAMELY, ORNAMENTS, FIGURINES (U.S. CLS. 2, 13, 22, 25, 32 AND 50).

WILLIAM VERHOSEK, EXAMINING ATTORNEY

SN 79-107,440. LAMMHULTS MÖBEL AB, SWEDEN, FILED 10-4-2011.

Lammhults

THE MARK CONSISTS OF STANDARD CHARACTERS WITHOUT CLAIM TO ANY PARTICULAR FONT, STYLE, SIZE, OR COLOR.

OWNER OF INTERNATIONAL REGISTRATION 1028354 DATED 11-5-2009, EXPIRES 11-5-2019.

FOR FURNITURE; MIRRORS; COAT RACKS AND MAGAZINE RACKS OF WOOD, CORK, CANE AND SUBSTITUTES FOR ALL OF THOSE MATERIALS, OR PLASTICS (U.S. CLS. 2, 13, 22, 25, 32 AND 50).

EDWARD FENNESSY, EXAMINING ATTORNEY

SN 79-113,196. HUGLOCK, SIA, LV-1006 RIGA, LATVIA, FILED 2-24-2012.



PRIORITY DATE OF 2-23-2012 IS CLAIMED. OWNER OF INTERNATIONAL REGISTRATION 1116735 DATED 2-24-2012, EXPIRES 2-24-2022.

THE MARK CONSISTS OF THE LETTER "H" AND THE WORDING "HUGLOCK".

FOR FURNITURE FITTINGS, NOT OF METAL; FURNITURE, NAMELY, FREE-STANDING NON-METAL PANEL UNITS FOR EXHIBITIONS, DISPLAYS AND PARTITIONING (U.S. CLS. 2, 13, 22, 25, 32 AND 50).

RAMONA ORTIGA, EXAMINING ATTORNEY

CLASS 20—(Continued).

SN 85-429,545. LUX PRAYER PAD, LLC, OMAHA, NE. FILED 9-22-2011.

LUX PRAYER PAD

THE MARK CONSISTS OF STANDARD CHARACTERS WITHOUT CLAIM TO ANY PARTICULAR FONT, STYLE, SIZE, OR COLOR.

NO CLAIM IS MADE TO THE EXCLUSIVE RIGHT TO USE "PRAYER PAD", APART FROM THE MARK AS SHOWN.

FOR CUSHIONS FOR KNEELING (U.S. CLS. 2, 13, 22, 25, 32 AND 50).

LAKEISHA LEWIS, EXAMINING ATTORNEY

CLASS 20—(Continued).

SN 85-442,261. TREVOR PAUL CLARKE, WEST SUSSEX, UNITED KINGDOM, AND BEVERLEY SUSAN CLARKE, WEST SUSSEX, UNITED KINGDOM, FILED 10-7-2011.

WRISTPULL

THE MARK CONSISTS OF STANDARD CHARACTERS WITHOUT CLAIM TO ANY PARTICULAR FONT, STYLE, SIZE, OR COLOR.

FOR NON-METALLIC DOOR HANDLES (U.S. CLS. 2, 13, 22, 25, 32 AND 50).

ANDREA K. NADELMAN, EXAMINING ATTORNEY

SN 85-455,931. CLASSIC BRANDS, LLC, JESSUP, MD. FILED 10-25-2011.

VALUEPEDIC

THE MARK CONSISTS OF STANDARD CHARACTERS WITHOUT CLAIM TO ANY PARTICULAR FONT, STYLE, SIZE, OR COLOR.

FOR MATTRESSES, PILLOWS, BED WEDGE PILLOWS, MATTRESS TOPPERS, BEDS, AND BED FRAMES; MATTRESSES, PILLOWS, BED WEDGE PILLOWS AND MATTRESS TOPPERS, MADE OF POLYURETHANE FOAM (U.S. CLS. 2, 13, 22, 25, 32 AND 50).

TASNEEM HUSSAIN, EXAMINING ATTORNEY

SN 85-442,073. KILIM MOBILYA KANEPE SANAYI VE TICARET A.S., KAYSERI, TURKEY, FILED 10-7-2011.



SN 85-459,762. DELGUIDICE, ROBERT, VISTA, CA. FILED 10-29-2011.

SALON FACTORY

NO CLAIM IS MADE TO THE EXCLUSIVE RIGHT TO USE "FURNITURE", APART FROM THE MARK AS SHOWN.

THE COLOR(S) WHITE, LIGHT GREEN AND DARK GREEN IS/ARE CLAIMED AS A FEATURE OF THE MARK.

THE MARK CONSISTS OF A RECTANGLE WITH ROUNDED CORNERS SHADED IN LIGHT GREEN AND THE TEXT "KILIM" IN WHITE AND ATTACHED TO A SMALLER RECTANGLE WITH ROUNDED CORNERS SHADED IN DARK GREEN AND THE TEXT "FURNITURE" IN WHITE.

SEC. 2(F).

FOR FURNITURE, NAMELY, SOFAS, SOFA SETS, SOFA BEDS, SITTING GROUPS, ARMCHAIRS, KNOCK DOWN FURNITURE AND MATTRESSES AND FUTONS (U.S. CLS. 2, 13, 22, 25, 32 AND 50).

FIRST USE 2-22-2006; IN COMMERCE 2-22-2006.

JANICE L. MCMORROW, EXAMINING ATTORNEY

THE MARK CONSISTS OF STANDARD CHARACTERS WITHOUT CLAIM TO ANY PARTICULAR FONT, STYLE, SIZE, OR COLOR.

NO CLAIM IS MADE TO THE EXCLUSIVE RIGHT TO USE "SALON", APART FROM THE MARK AS SHOWN.

FOR FURNITURE AND RELATED STRUCTURAL PARTS DESIGNED FOR USE IN BEAUTY SALONS (U.S. CLS. 2, 13, 22, 25, 32 AND 50).

FIRST USE 11-1-2000; IN COMMERCE 11-1-2000.

HENRY S. ZAK, EXAMINING ATTORNEY

CLASS 20—(Continued).

SN 85-477,218. SORDO GALARZA, JOSÉ IGNACIO, DBA CHURUATA ART, ARLINGTON HEIGHTS, IL. FILED 11-20-2011.

Churuata Art

THE MARK CONSISTS OF STANDARD CHARACTERS WITHOUT CLAIM TO ANY PARTICULAR FONT, STYLE, SIZE, OR COLOR.

NO CLAIM IS MADE TO THE EXCLUSIVE RIGHT TO USE "ART", APART FROM THE MARK AS SHOWN.

THE ENGLISH TRANSLATION OF "CHURUATA" IN THE MARK IS "GAZEBO".

FOR DECORATIVE BOXES MADE OF WOOD; FIGURINES OF WOOD; ORNAMENTS OF WOOD; WOOD BARRELS; WOOD BOXES; WOOD CARVINGS; WORKS OF ART MADE OF WOOD; WORKS OF ART OF WOOD, WAX, PLASTER OR PLASTIC; WORKS OF ART OF WOOD (U.S. CLS. 2, 13, 22, 25, 32 AND 50).

FIRST USE 7-1-2011; IN COMMERCE 7-1-2011.

STEVEN R. FINE, EXAMINING ATTORNEY

SN 85-510,453. VENDOR DEVELOPMENT GROUP, INC., MINNEAPOLIS, MN. FILED 1-6-2012.

ESTATE DESIGN

THE MARK CONSISTS OF STANDARD CHARACTERS WITHOUT CLAIM TO ANY PARTICULAR FONT, STYLE, SIZE, OR COLOR.

NO CLAIM IS MADE TO THE EXCLUSIVE RIGHT TO USE "DESIGN", APART FROM THE MARK AS SHOWN.

FOR INDOOR FURNITURE, PATIO FURNITURE AND PATIO FURNITURE PILLOWS (U.S. CLS. 2, 13, 22, 25, 32 AND 50).

SARA BENJAMIN, EXAMINING ATTORNEY

SN 85-511,377. BENNETT TERRY R, SANTA CLARITA, CA. FILED 1-9-2012.



THE MARK CONSISTS OF "QUAKE" WRITTEN ABOVE "PROOF" WITH A RICHTER SEISMOGRAM BETWEEN THE TWO WORDS.

FOR NON-METAL FASTENERS, NAMELY, FASTENERS FOR SECURING OFFICE, HOME AND LAB FURNITURE, APPLIANCES, ELECTRONIC EQUIPMENT AND OTHER BUSINESS AND HOME FURNISHINGS (U.S. CLS. 2, 13, 22, 25, 32 AND 50).

FIRST USE 0-0-1996; IN COMMERCE 0-0-1996.

DEIRDRE ROBERTSON, EXAMINING ATTORNEY

CLASS 20—(Continued).

SN 85-547,779. ANDRE AEKINS, ASBURY PARK, NJ. FILED 2-21-2012.



NO CLAIM IS MADE TO THE EXCLUSIVE RIGHT TO USE "TIE STORAGE", APART FROM THE MARK AS SHOWN.

THE MARK CONSISTS OF THE WORDING "TIECUBBIE" WITH THE PICTURE OF A FULLY TIED NECKTIE (COMPLETE WITH THE PORTION THAT USUALLY SITS AROUND THE WEARER'S NECK) IN THE PLACE OF THE "I" AND A SQUARE BOX (WITH A SINGLE ROLLED NECKTIE INSIDE) IN THE PLACE OF THE LOWER PORTION OF EACH OF THE "B" LETTERS WITH A SINGLE BOLD LINE UNDERNEATH THE FULL LENGTH OF THE WORD "TIECUBBIE". THE NEXT LINE HAS THE WORDING "YOUR TIE STORAGE SOLUTION" IN CAPITAL LETTERS WITH A SINGLE LINE (APPROXIMATELY 1/4 THE SIZE OF THE FIRST LINE) UNDERNEATH THE FULL LENGTH OF THE WORDS "YOUR TIE STORAGE SOLUTION".

FOR FURNITURE; FURNITURE MADE FROM WOOD OR SUBSTITUTES FOR WOOD; FURNITURE, NAMELY, WALL UNITS; TIE RACKS (U.S. CLS. 2, 13, 22, 25, 32 AND 50).

WILLIAM BRECKENFELD, EXAMINING ATTORNEY

SN 85-551,467. DALIAN HOFFEN BIO-TECHNIQUE CO., LTD., DALIAN, LIAONING PROV., CHINA, FILED 2-23-2012.



THE MARK CONSISTS OF THE WORDING "HOFFEN" WITH TWO HALF CIRCLES FORMING THE LETTER "O".

THE ENGLISH TRANSLATION OF "HOFFEN" IN THE MARK IS "HOPE".

FOR STUFFED ANIMALS; ANIMAL CLAWS; ANIMAL HORNS; CORAL; STUFFED ANIMALS, NAMELY, STUFFED BIRDS; YELLOW AMBER; MANNEQUINS; COWRY SHELLS; COWRIE SHELLS; SEA SHELLS; WHALEBONE (U.S. CLS. 2, 13, 22, 25, 32 AND 50).

FIRST USE 8-18-2005; IN COMMERCE 8-18-2005.

JOHN KELLY, EXAMINING ATTORNEY

CLASS 20—(Continued).

SN 85-565,644. EE&P, INC, ELMWOOD PARK, NJ. FILED 3-9-2012.

ARMADI ART

THE MARK CONSISTS OF STANDARD CHARACTERS WITHOUT CLAIM TO ANY PARTICULAR FONT, STYLE, SIZE, OR COLOR.

THE NAME(S), PORTRAIT(S), AND/OR SIGNATURE(S) SHOWN IN THE MARK DOES NOT IDENTIFY A PARTICULAR LIVING INDIVIDUAL.

FOR BATHROOM VANITIES (U.S. CLS. 2, 13, 22, 25, 32 AND 50).

NAAKWAMA ANKRAH, EXAMINING ATTORNEY

SN 85-582,071. PAT GREENLEE BUILDERS, LLC, MURCHISON, TX. FILED 3-28-2012.

Scorpion Composite Plugs

THE MARK CONSISTS OF STANDARD CHARACTERS WITHOUT CLAIM TO ANY PARTICULAR FONT, STYLE, SIZE, OR COLOR.

NO CLAIM IS MADE TO THE EXCLUSIVE RIGHT TO USE "COMPOSITE PLUGS", APART FROM THE MARK AS SHOWN.

FOR OIL AND GAS WELL EQUIPMENT, NAMELY, PLASTIC DOWNHOLE, DRILLABLE PLUGS, AND BRIDGE PLUGS USED TO BLOCK OR CONTROL THE FLOW OF FLUIDS IN OIL AND GAS WELLS (U.S. CLS. 2, 13, 22, 25, 32 AND 50).

FIRST USE 12-16-2011; IN COMMERCE 12-16-2011.

DEIRDRE ROBERTSON, EXAMINING ATTORNEY

SN 85-585,451. P.S. PIBBS, INC., FLUSHING, NY. FILED 3-30-2012.

SALON EXPRESS

THE MARK CONSISTS OF STANDARD CHARACTERS WITHOUT CLAIM TO ANY PARTICULAR FONT, STYLE, SIZE, OR COLOR.

NO CLAIM IS MADE TO THE EXCLUSIVE RIGHT TO USE "SALON", APART FROM THE MARK AS SHOWN.

FOR ARMCHAIRS; CABINETS; CABINETS FOR DISPLAY PURPOSES; CHAIRS; DISPLAY CASES; FOOT STOOLS; FURNITURE; MIRRORS; STOOLS (U.S. CLS. 2, 13, 22, 25, 32 AND 50).

WILLIAM ROSSMAN, EXAMINING ATTORNEY

CLASS 20—(Continued).

SN 85-591,525. B&M NOBLE CO., SAN DIEGO, CA. FILED 4-6-2012.

DUCHATEAU

THE MARK CONSISTS OF STANDARD CHARACTERS WITHOUT CLAIM TO ANY PARTICULAR FONT, STYLE, SIZE, OR COLOR.

OWNER OF U.S. REG. NO. 3,616,735.

THE ENGLISH TRANSLATION OF "DUCHATEAU" IN THE MARK IS "CASTLE".

FOR FURNITURE (U.S. CLS. 2, 13, 22, 25, 32 AND 50).

ERIN FALK, EXAMINING ATTORNEY

SN 85-591,688. B&M NOBLE CO., SAN DIEGO, CA. FILED 4-6-2012.

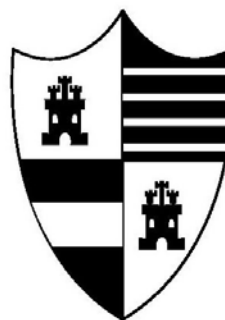

THE MARK CONSISTS OF A SHIELD DIVIDED INTO 4 QUADRANTS; A BLOCK CASTLE IS LOCATED IN THE CENTER OF THE TOP LEFT AND BOTTOM RIGHT QUADRANT; NINE ALTERNATE HORIZONTAL BARS FILL THE TOP RIGHT QUADRANT; 3 ALTERNATE HORIZONTAL BARS FILL THE BOTTOM LEFT QUADRANT.

FOR FURNITURE (U.S. CLS. 2, 13, 22, 25, 32 AND 50).

ERIN FALK, EXAMINING ATTORNEY

SN 85-592,356. KING KOIL LICENSING COMPANY, INC., CHICAGO, IL. FILED 4-9-2012.

COMFORT SOLUTIONS TOTAL

THE MARK CONSISTS OF STANDARD CHARACTERS WITHOUT CLAIM TO ANY PARTICULAR FONT, STYLE, SIZE, OR COLOR.

OWNER OF U.S. REG. NOS. 3,006,161, 3,986,571 AND OTHERS.

NO CLAIM IS MADE TO THE EXCLUSIVE RIGHT TO USE "COMFORT", APART FROM THE MARK AS SHOWN.

FOR BEDS; BOX SPRINGS; MATTRESSES (U.S. CLS. 2, 13, 22, 25, 32 AND 50).

DAVID ELTON, EXAMINING ATTORNEY

CLASS 20—(Continued).

SN 85-592,840. SMERICAN, SPENCER S., PHOENIXVILLE, PA. FILED 4-9-2012.

KaiAlina Designs

THE MARK CONSISTS OF STANDARD CHARACTERS WITHOUT CLAIM TO ANY PARTICULAR FONT, STYLE, SIZE, OR COLOR.

NO CLAIM IS MADE TO THE EXCLUSIVE RIGHT TO USE "DESIGNS", APART FROM THE MARK AS SHOWN.

FOR FURNITURE, NAMELY, DISPLAY UNITS; SHELVING (U.S. CLS. 2, 13, 22, 25, 32 AND 50).

JAY BESCH, EXAMINING ATTORNEY

SN 85-593,399. WEREVER PRODUCTS, INC., TAMPA, FL. FILED 4-10-2012.

SOLEIC

THE MARK CONSISTS OF STANDARD CHARACTERS WITHOUT CLAIM TO ANY PARTICULAR FONT, STYLE, SIZE, OR COLOR.

THE WORDING "SOLEIC" HAS NO MEANING IN A FOREIGN LANGUAGE.

FOR CABINETS; KITCHEN CABINETS; KITCHEN-TYPE CABINETS FOR OUTDOOR USE (U.S. CLS. 2, 13, 22, 25, 32 AND 50).

FIRST USE 0-0-2008; IN COMMERCE 0-0-2008.
ANGELA DUONG, EXAMINING ATTORNEY

SN 85-594,547. MYERS INDUSTRIES, INC., AKRON, OH. FILED 4-11-2012.

SLOPE-IT

THE MARK CONSISTS OF STANDARD CHARACTERS WITHOUT CLAIM TO ANY PARTICULAR FONT, STYLE, SIZE, OR COLOR.

FOR PLASTIC BIN INSERTS MADE OF PLASTIC FOR CREATING A SLOPE (U.S. CLS. 2, 13, 22, 25, 32 AND 50).
MAYUR VAGHANI, EXAMINING ATTORNEY

CLASS 20—(Continued).

SN 85-595,542. TEANN FRANTZ, DES MOINES, IA. FILED 4-12-2012.



THE COLOR(S) YELLOW, MAGENTA, GREEN, BLUE, PURPLE, BROWN, BLACK, WHITE, LIGHT PINK, GRAY, AND RED IS/ARE CLAIMED AS A FEATURE OF THE MARK.

THE MARK CONSISTS OF THE WORDING "PJPALS" WHEREIN THE FIRST "P" AND THE "J" ARE IN GREEN, AND THE "PALS" IS IN BLUE. ALL THE LETTERS ARE OUTLINED IN YELLOW AND MAGENTA AND APPEAR ACROSS A YELLOW BAR THAT ITSELF APPEARS OVER A PURPLE OVAL OUTLINED IN MAGENTA. A BROWN, BLACK, AND WHITE PUPPY'S FACE APPEARS IN THE FIRST "P". A YELLOW, WHITE, BLACK, AND MAGENTA CAT'S FACE APPEARS AS THE DOT OVER THE "J". A GRAY, LIGHT PINK, BLACK, AND WHITE BUNNY'S FACE APPEARS IN THE SECOND "P", AND A WHITE, RED, GREEN, AND BLACK CLOWN FACE APPEARS IN THE "A"

FOR NOVELTY PILLOWS (U.S. CLS. 2, 13, 22, 25, 32 AND 50).

ANDREA HACK, EXAMINING ATTORNEY

SN 85-596,813. TOMAR, STEPHEN, LOS ANGELES, CA. AND LAMPERT, STUART, LOS ANGELES, CA. FILED 4-13-2012.

STLUX

THE MARK CONSISTS OF STANDARD CHARACTERS WITHOUT CLAIM TO ANY PARTICULAR FONT, STYLE, SIZE, OR COLOR.

FOR ACCENT PILLOWS; ARMCHAIRS; ARMOIRES; BATH PILLOWS; BATHROOM FURNITURE; BATHROOM VANITIES; BEAUTY SALON FURNITURE, NAMELY, STYLING STATIONS; BED FRAMES; BED HEADBOARDS; BED PILLOWS; BED RAILS; BED RESTS; BEDROOM FURNITURE; BEDS; BEDS, MATTRESSES, PILLOWS AND BOLSTERS; BEDSIDE TABLES; BENCHES; BOLSTERS; BOOK STANDS; BOOKCASES; BOOKSHELVES; BREAKFRONTS; BUFFETS; BUNK BEDS; CABINET DOORS FOR FURNITURE CABINETS; CABINET DRAWERS FOR FURNITURE CABINETS; CABINETS; CABINETS FOR DISPLAY PURPOSES; CABINETWORK; CHAIR BEDS; CHAIR CUSHIONS; CHAIR MATS IN THE NATURE OF A PILLOW OR SEAT LINER; CHAIRS; CHAISE LOUNGES; CHESTS OF DRAWERS; CLOSET ACCESSORIES, NAMELY, SHOE RACKS; CLOSET ACCESSORIES, NAMELY, SLIDING CLOTHES RAILS; COAT RACKS; COAT STANDS; COATSTANDS; COMPUTER FURNITURE; CONSOLE TABLES; COTS; COUCHES; CREDENZAS; CUPBOARDS; CUSHIONS; CUSHIONS; CUSTOM FURNITURE; DECK CHAIRS; DESKS; DINING CHAIRS; DINING ROOM TABLES; DINING TABLES; DINNER WAGONS; DIRECTOR'S CHAIRS; DISPLAY CASES; DISPLAY STANDS; DISPLAY TABLES; DIVANS; DOORS FOR FURNITURE; DRAWER PULLS OF GLASS, PORCELAIN OR EARTHENWARE; DRAWER PULLS OF PLASTIC OR WOOD, CORK, REED, CANE, WICKER, HORN, BONE, IVORY, WHALEBONE, SHELL, AMBER, MOTHER-OF-PEARL, MEERSCHAUM AND SUBSTITUTES FOR ALL THESE MATERIALS; DRAWERS; DRAWERS AND DIVIDERS THEREFOR; DRESSERS; DRESSING TABLES; DROP-

CLASS 20—(Continued).

LEAF TABLES; EASY-CHAIRS; END TABLES; ENTERTAINMENT CENTERS; ETAGERE; EXTENDIBLE SOFAS; FABRIC SOLD AS AN INTEGRAL COMPONENT OF FINISHED FURNITURE; FOOTSTOOLS; FURNITURE; FURNITURE CHESTS; FURNITURE FOR DISPLAYING GOODS; FURNITURE FOR HOUSE, OFFICE AND GARDEN; FURNITURE MADE FROM STEEL TUBING; FURNITURE MADE FROM WOOD OR SUBSTITUTES FOR WOOD; FURNITURE OF METAL; FURNITURE PRIMARILY OF METAL, NAMELY, MIRRORS, BED FRAMES, DINING TABLES, COFFEE TABLES, END TABLES, DESKS, DISPLAY CASES, SHELVING, DOG GATES, AND BABY GATES; FURNITURE, MIRRORS, PICTURE FRAMES; FURNITURE, NAMELY, DISPLAY UNITS; FURNITURE, NAMELY, DRESSERS; FURNITURE, NAMELY, POUFS; FURNITURE, NAMELY, SALES AND DISPLAY COUNTERS; FURNITURE, NAMELY, SHOWCASES; FURNITURE, NAMELY, WALL UNITS; FURNITURE, NAMELY, WARDROBES; GLASS PULLS; HAT RACKS; HAT STANDS; HUTCHES; INTERIOR TEXTILE WINDOW BLINDS; INTERIOR WINDOW COVERINGS, NAMELY, VERTICAL AND HORIZONTAL LOUVERS; KITCHEN CABINETS; KITCHEN FURNITURE, NAMELY, READY TO ASSEMBLE MOBILE KITCHEN ISLANDS; KITCHEN-TYPE CABINETS FOR OUTDOOR USE; LAWN FURNITURE; LIBRARY FURNITURE; LIVING ROOM FURNITURE; LOUNGE CHAIRS; LOVE SEATS; MAGAZINE RACKS; MATTRESS FOUNDATIONS; METAL FURNITURE; MIRROR FRAMES; MIRRORS; MOSAIC TABLES; NIGHT TABLES; NIGHTSTANDS; NON-METAL TRESTLES FOR SUPPORTING TABLES; OCCASIONAL TABLES; OFFICE ARMCHAIRS; OFFICE CHAIRS; OFFICE DESKS; OFFICE FURNITURE; OFFICE SEATS; OFFICE TABLES; OTTOMAN SEATS; OTTOMANS; OUTDOOR FURNITURE; PATIO FURNITURE; PEDESTALS; PICTURE FRAMES; PICTURE FRAMES; PICTURE FRAMES OF PRECIOUS METAL; PICTURE FRAMES WITH PLUSH DECORATIVE OUTER SURFACE; PILLOWS; PLANT RACKS; PLANT STANDS; POINT OF PURCHASE DISPLAYS; PORCH SWINGS; RECLINERS; RECLINING ARMCHAIRS; RECLINING CHAIRS; RESIDENTIAL AND COMMERCIAL FURNITURE; RESIDENTIAL AND COMMERCIAL WROUGHT IRON FURNITURE; RESIDENTIAL SHELVING UNITS AND COMPONENT PARTS THEREOF, NAMELY, SHELVES AND BRACKETS SOLD AS A UNIT; ROCKING CHAIRS; ROOM DIVIDERS; SCREENS; SEAT CUSHIONS; SEATING FURNITURE; SEATS; SERVING TROLLEYS; SETTEES; SHELVES; SHELVES FOR BOOKS; SHELVES FOR STORAGE; SHELVING; SHOE CABINETS; SHOE RACKS; SIDEBOARDS; SLANTED SHELVES; SLEEPER SOFAS; SOFA BEDS; SOFAS; STANDING DESKS; STONE FURNITURE; STOOLS; TABLE TOPS; TABLES; TEA CARTS; TEA TABLES; TEA TROLLEYS; TELEVISION STANDS; THREE-MIRROR DRESSING TABLES; TOWEL CLOSETS; TOY BOXES; TRESTLE TABLES; UPHOLSTERED FURNITURE; WINDOW SHADES; WOOD CHOPPING BLOCK TABLES; WOODEN BEDS; WOODEN DISPLAY STANDS; WORKTOPS; WRITING DESKS (U.S. CLS. 2, 13, 22, 25, 32 AND 50).

KEVEN MITTLER, EXAMINING ATTORNEY

CLASS 20—(Continued).

SN 85-596,881. SYSCO CORPORATION, HOUSTON, TX. FILED 4-13-2012.



NO CLAIM IS MADE TO THE EXCLUSIVE RIGHT TO USE "QA", APART FROM THE MARK AS SHOWN.

THE MARK CONSISTS OF THESE STYLIZED LETTERS "Q" AND "A" WITH A LEAF DESIGN AS THE STEM ON THE "Q" AND THE BAR ACROSS THE LETTER "A".

FOR PLASTIC BOXES; DRINKING STRAWS; WIRE SHELVES; PLATE RACKS; DISPLAY RACKS FOR CUPS; PILLOWS; MATTRESSES (U.S. CLS. 2, 13, 22, 25, 32 AND 50).

TINA MAI, EXAMINING ATTORNEY

SN 85-597,525. SASKOWSKI, DALE, DAVENPORT, IA. FILED 4-13-2012.

NOTABI

THE MARK CONSISTS OF STANDARD CHARACTERS WITHOUT CLAIM TO ANY PARTICULAR FONT, STYLE, SIZE, OR COLOR.

THE WORDING "NOTABI" HAS NO MEANING IN A FOREIGN LANGUAGE.

FOR NON-METAL FASTENERS COMPRISED OF ELASTICS, WEBBING, VINYL FOAM PADS, AND RUBBER-COATED METAL CLIPS FOR HOLDING BED SHEETS AND LINENS IN PLACE, SOLD TOGETHER AS A UNIT (U.S. CLS. 2, 13, 22, 25, 32 AND 50).

KATHY DE JONGE, EXAMINING ATTORNEY

SN 85-597,840. FASTENATION, INC., CLIFTON, NJ. FILED 4-13-2012.

FASTENwrite

OWNER OF U.S. REG. NOS. 3,348,401, 3,401,844 AND 3,401,845.

THE MARK CONSISTS OF THE WORD "FASTENWRITE" WHEREIN "FASTEN" IS CAPITAL LETTERS AND "WRITE" IS SMALL LETTERS.

FOR NON-METAL HOOK AND LOOP FASTENERS WHICH CAN BE WRITTEN ON (U.S. CLS. 2, 13, 22, 25, 32 AND 50).

TARAH HARDY, EXAMINING ATTORNEY

CLASS 20—(Continued).

SN 85-597,880. FASTENATION, INC., CLIFTON, NJ. FILED 4-13-2012.

FASTENwrite

OWNER OF U.S. REG. NOS. 3,348,401, 3,401,844 AND 3,401,845.

THE COLOR(S) RED AND BLACK IS/ARE CLAIMED AS A FEATURE OF THE MARK.

THE MARK CONSISTS OF THE WORD "FASTENWRITE" WHEREIN "FASTEN" IS RED CAPITAL LETTERS AND "WRITE" IS BLACK SMALL LETTERS.

FOR NON-METAL HOOK AND LOOP FASTENERS WHICH CAN BE WRITTEN ON (U.S. CLS. 2, 13, 22, 25, 32 AND 50).

TARAH HARDY, EXAMINING ATTORNEY

CLASS 20—(Continued).

SN 85-599,434. NINGBO AURA OUTDOOR PRODUCTS CO., LTD, NINGBO, CHINA, FILED 4-17-2012.



NO CLAIM IS MADE TO THE EXCLUSIVE RIGHT TO USE "OUTDOOR", APART FROM THE MARK AS SHOWN.

THE MARK CONSISTS OF A CIRCLE IMPRINTED WITH STYLIZED LATIN WORDING OF "AURA" IN THE MIDDLE AND "OUTDOOR" BENEATH WITH AN ABSTRACT REPRESENTATION OF SUN AND BEACH RIGHT ABOVE "AURA".

THE WORDING AURA HAS NO MEANING IN A FOREIGN LANGUAGE.

FOR BEACH CHAIRS; CHAIRS; DECK CHAIRS; HAMMOCK STANDS; HARDWARE, NAMELY, NON-METAL BRACKETS FOR GENERAL USE; PORCH SWINGS; ROCKING CHAIRS (U.S. CLS. 2, 13, 22, 25, 32 AND 50).

EMILY CARLSEN, EXAMINING ATTORNEY

SN 85-599,947. THE CHAMBERLAIN GROUP, INC., ELMHUST, IL. FILED 4-17-2012.

LIFTMASTER

THE MARK CONSISTS OF STANDARD CHARACTERS WITHOUT CLAIM TO ANY PARTICULAR FONT, STYLE, SIZE, OR COLOR.

OWNER OF U.S. REG. NOS. 863,447 AND 2,724,638.

FOR BENCHES; BOOKSHELVES; CABINETWORK; CHAIRS; CHESTS OF DRAWERS; CURTAIN RODS; DRAWER ORGANIZERS; FILING CABINETS; FURNITURE; HOSE HANGERS NOT OF METAL; LOCKERS; METAL SHELVING; NONMETAL AND NON-PAPER CONTAINERS FOR STORAGE OR TRANSPORT; NON-METAL BINS; NON-METAL HANGERS FOR ELECTRICAL CORDS; NON-METAL HOOKS; NON-METAL STEP LADDERS; NON-METAL STEP STOOLS; NON-METAL TOOL BOXES; PEG BOARDS MADE OF PLASTIC; PLASTIC BOXES; SHELVES; STOOLS; STORAGE RACKS; TOOL AND TOOL ACCESSORY BOXES NOT MADE OF METAL SOLD EMPTY AND PARTS AND FITTINGS THEREFOR; TOOL AND TOOL ACCESSORY TRAYS NOT MADE OF METAL SOLD EMPTY AND PARTS AND FITTINGS THEREFOR; TOWEL RACKS; WALL-MOUNTED TOOL RACKS; WORK SURFACES; WORKBENCHES (U.S. CLS. 2, 13, 22, 25, 32 AND 50).

JEANIE LEE, EXAMINING ATTORNEY

SN 85-598,410. DESIGNS BY DIMICHAELS, RONKONKOMA, NY. FILED 4-16-2012.

Muun Chair

NO CLAIM IS MADE TO THE EXCLUSIVE RIGHT TO USE "CHAIR", APART FROM THE MARK AS SHOWN.

THE MARK CONSISTS OF THE STYLIZED TEXT "MUUN CHAIR".

THE WORDING "MUUN" HAS NO MEANING IN A FOREIGN LANGUAGE.

FOR CHAIRS (U.S. CLS. 2, 13, 22, 25, 32 AND 50).

ALAIN LAPTER, EXAMINING ATTORNEY

CLASS 20—(Continued).

SN 85-600,095. SECURITY PAKS INTERNATIONAL, LLC, INDIANAPOLIS, IN. FILED 4-17-2012.

RHINO

THE MARK CONSISTS OF STANDARD CHARACTERS WITHOUT CLAIM TO ANY PARTICULAR FONT, STYLE, SIZE, OR COLOR.

FOR NON-METAL PALLETS; NON-METAL FORK LIFT SLEEVES FOR HANDLING OR TRANSPORTING OF GOODS (U.S. CLS. 2, 13, 22, 25, 32 AND 50).
MATTHEW KLINE, EXAMINING ATTORNEY

CLASS 20—(Continued).

SN 85-602,358. DORMA DOOR CONTROLS, INC., REAMSTOWN, PA. FILED 4-19-2012.

FUSION

THE MARK CONSISTS OF STANDARD CHARACTERS WITHOUT CLAIM TO ANY PARTICULAR FONT, STYLE, SIZE, OR COLOR.

FOR MOVEABLE WALL PARTITIONS, PARTITION PANELS FOR OFFICE AND WORK SPACES, OFFICE AND WORK SPACE DIVIDERS AND ROUTING SYSTEMS FOR SAME, SOLD AS A UNIT, COMPRISED OF TRACKS, CABLES, DIVIDING PANELS, PARTITION PANELS, AND COMPONENT PARTS THEREOF (U.S. CLS. 2, 13, 22, 25, 32 AND 50).

JASON BLAIR, EXAMINING ATTORNEY

SN 85-600,115. FLOCAST, LLC, DBA BERGERON HEALTH CARE, DOLGEVILLE, NY. FILED 4-17-2012.



OWNER OF U.S. REG. NO. 3,309,889.
THE MARK CONSISTS OF A DESIGN OF A HIGH CHAIR IN A SQUARE FOLLOWED BY THE STYLIZED WORD "KEEKAROO".

FOR CHAIRS, HIGH CHAIRS (U.S. CLS. 2, 13, 22, 25, 32 AND 50).

FIRST USE 4-4-2012; IN COMMERCE 4-4-2012.
BARBARA BROWN, EXAMINING ATTORNEY

SN 85-602,949. JOOVY HOLDING CO., DALLAS, TX. FILED 4-19-2012.

MoonRoom

SN 85-600,427. BF GATEMATE INC., TUCKAHOE, NY. FILED 4-17-2012.

Gate Mate

THE MARK CONSISTS OF STANDARD CHARACTERS WITHOUT CLAIM TO ANY PARTICULAR FONT, STYLE, SIZE, OR COLOR.

FOR NON-METAL TOOL BOXES CUSTOM DESIGNED FOR THE STORAGE OF ITEMS USED FOR TAILGATING EVENTS, NAMELY GRILLING AND COOKING UTENSILS, EATING UTENSILS, DINNERWARE, CONDIMENTS, SEASONINGS, FOOD AND BEVERAGES (U.S. CLS. 2, 13, 22, 25, 32 AND 50).

VERNA BETH RIRIE, EXAMINING ATTORNEY

THE MARK CONSISTS OF STANDARD CHARACTERS WITHOUT CLAIM TO ANY PARTICULAR FONT, STYLE, SIZE, OR COLOR.

FOR MATS FOR INFANT PLAYPENS; PLAYPENS; PLAYPENS FOR BABIES (U.S. CLS. 2, 13, 22, 25, 32 AND 50).

ANGELA DUONG, EXAMINING ATTORNEY

CLASS 20—(Continued).

SN 85-603,097. JENNIFER BRANCH, DBA ONE PACK, LOS ANGELES, CA. FILED 4-19-2012.



NO CLAIM IS MADE TO THE EXCLUSIVE RIGHT TO USE "DOG" AND "BED", APART FROM THE MARK AS SHOWN.

THE MARK CONSISTS OF A SOLID OVAL CARRIER WITH A LINE INSIDE THE OUTSIDE EDGE. CENTERED INSIDE THE CARRIER ARE THE WORDS ONE PACK IN UPPERCASE STYLIZED FONT BELOW A LINE. ABOVE THE LINE IS A PAW PRINT. BELOW THE WORDS ONE PACK ARE THE STYLIZED WORDS GIVE A DOG A BED.

FOR BEDS FOR HOUSEHOLD PETS; PET FURNITURE (U.S. CLS. 2, 13, 22, 25, 32 AND 50).
FIRST USE 2-0-2012; IN COMMERCE 2-0-2012.
KYLE PEETE, EXAMINING ATTORNEY

SN 85-604,336. WORKMAN, NATHAN, CINCINNATI, OH. FILED 4-20-2012.



THE MARK CONSISTS OF A STYLIZED CAT SHAPE WITH THE TAIL CREATING A CIRCLE. BELOW THERE IS THE STYLIZED TEXT "CATTINO".

FOR CAT SCRATCHING POSTS (U.S. CLS. 2, 13, 22, 25, 32 AND 50).
DAVID ELTON, EXAMINING ATTORNEY

SN 85-605,429. BICOR PROCESSING CORP., BROOKLYN, NY. FILED 4-23-2012.

A SPACE FOR YOUR FACE

THE MARK CONSISTS OF STANDARD CHARACTERS WITHOUT CLAIM TO ANY PARTICULAR FONT, STYLE, SIZE, OR COLOR.

FOR PILLOWS (U.S. CLS. 2, 13, 22, 25, 32 AND 50).
JOHN WILKE, EXAMINING ATTORNEY

CLASS 20—(Continued).

SN 85-605,754. A&A GLOBAL IMPORTS, INC., LOS ANGELES, CA. FILED 4-23-2012.



THE MARK CONSISTS OF STANDARD CHARACTERS WITHOUT CLAIM TO ANY PARTICULAR FONT, STYLE, SIZE, OR COLOR.

FOR PLASTIC MEDICATION CONTAINERS FOR COMMERCIAL USE (U.S. CLS. 2, 13, 22, 25, 32 AND 50).
FIRST USE 12-29-2011; IN COMMERCE 2-10-2012.
MICHAEL SOUDERS, EXAMINING ATTORNEY

SN 85-606,755. KING KOIL LICENSING COMPANY, INC., WILLOWBROOK, IL. FILED 4-24-2012.

NATURAL RESPONSE LUXURY

THE MARK CONSISTS OF STANDARD CHARACTERS WITHOUT CLAIM TO ANY PARTICULAR FONT, STYLE, SIZE, OR COLOR.

OWNER OF U.S. REG. NOS. 2,222,660 AND 2,882,608.
NO CLAIM IS MADE TO THE EXCLUSIVE RIGHT TO USE "LUXURY", APART FROM THE MARK AS SHOWN.
FOR BEDS; BOX SPRINGS; MATTRESSES (U.S. CLS. 2, 13, 22, 25, 32 AND 50).
DAVID ELTON, EXAMINING ATTORNEY

SN 85-607,003. PS FURNITURE, INC., DBA PS FURNITURE, MILWAUKEE, WI. FILED 4-24-2012.



THE MARK CONSISTS OF STANDARD CHARACTERS WITHOUT CLAIM TO ANY PARTICULAR FONT, STYLE, SIZE, OR COLOR.

FOR LIGHTWEIGHT KNOCKDOWN RECEPTION TABLES (U.S. CLS. 2, 13, 22, 25, 32 AND 50).
FIRST USE 6-28-2010; IN COMMERCE 6-28-2010.
ANTHONY RINKER, EXAMINING ATTORNEY

CLASS 20—(Continued).

SN 85-607,641. KITTRICH CORPORATION, LA MIRADA, CA. FILED 4-25-2012.

Sure-Hang

THE MARK CONSISTS OF STANDARD CHARACTERS WITHOUT CLAIM TO ANY PARTICULAR FONT, STYLE, SIZE, OR COLOR.

FOR CLOSET ACCESSORIES, NAMELY, SLIDING CLOTHES RAILS (U.S. CLS. 2, 13, 22, 25, 32 AND 50).
INGA ERVIN, EXAMINING ATTORNEY

SN 85-610,691. SEALY TECHNOLOGY LLC, TRINITY, NC. FILED 4-27-2012.

SEALY KIDS WE SUPPORT YOUR
FUTURE

THE MARK CONSISTS OF STANDARD CHARACTERS WITHOUT CLAIM TO ANY PARTICULAR FONT, STYLE, SIZE, OR COLOR.

OWNER OF U.S. REG. NOS. 677,335, 2,615,632 AND OTHERS.

FOR MATTRESS FOUNDATIONS; MATTRESSES (U.S. CLS. 2, 13, 22, 25, 32 AND 50).

FIRST USE 3-0-1998; IN COMMERCE 3-0-1998.
BILL DAWE, EXAMINING ATTORNEY

SN 85-610,819. FLEET WHOLESALE SUPPLY CO., INC., APPLETON, WI. FILED 4-27-2012.

LEGION INDUSTRIAL TOOLS

THE MARK CONSISTS OF STANDARD CHARACTERS WITHOUT CLAIM TO ANY PARTICULAR FONT, STYLE, SIZE, OR COLOR.

NO CLAIM IS MADE TO THE EXCLUSIVE RIGHT TO USE "INDUSTRIAL TOOLS", APART FROM THE MARK AS SHOWN.

FOR NON-METAL TOOL BOXES (U.S. CLS. 2, 13, 22, 25, 32 AND 50).

JAMES STEIN, EXAMINING ATTORNEY

CLASS 20—(Continued).

SN 85-612,293. TARGET BRANDS, INC., MINNEAPOLIS, MN. FILED 4-30-2012.

UP & UP

THE MARK CONSISTS OF STANDARD CHARACTERS WITHOUT CLAIM TO ANY PARTICULAR FONT, STYLE, SIZE, OR COLOR.

OWNER OF U.S. REG. NOS. 3,794,935, 4,042,813 AND OTHERS.

FOR PERSONAL COMPACT MIRRORS (U.S. CLS. 2, 13, 22, 25, 32 AND 50).

FIRST USE 3-0-2011; IN COMMERCE 3-0-2011.
JEAN IM, EXAMINING ATTORNEY

SN 85-612,302. TARGET BRANDS, INC., MINNEAPOLIS, MN. FILED 4-30-2012.



OWNER OF U.S. REG. NOS. 3,794,935, 4,042,813 AND OTHERS.

THE MARK CONSISTS OF AN ARROW DESIGN POINTING AT A 45 DEGREE DIAGONAL, UP AND TO THE RIGHT, WITH THE WORDS "UP & UP" INSIDE THE ARROW.

FOR PERSONAL COMPACT MIRRORS (U.S. CLS. 2, 13, 22, 25, 32 AND 50).

FIRST USE 3-0-2011; IN COMMERCE 3-0-2011.
JEAN IM, EXAMINING ATTORNEY

SN 85-625,441. AMINI INNOVATION CORP., PICO RIVERA, CA. FILED 5-15-2012.

VICTORIA PALACE

THE MARK CONSISTS OF STANDARD CHARACTERS WITHOUT CLAIM TO ANY PARTICULAR FONT, STYLE, SIZE, OR COLOR.

FOR FURNITURE (U.S. CLS. 2, 13, 22, 25, 32 AND 50).
MATTHEW GALAN, EXAMINING ATTORNEY

CLASS 20—(Continued).

SN 85-625,446. AMINI INNOVATION CORP., PICO RIVERA, CA. FILED 5-15-2012.

AFTER EIGHT

THE MARK CONSISTS OF STANDARD CHARACTERS WITHOUT CLAIM TO ANY PARTICULAR FONT, STYLE, SIZE, OR COLOR.
FOR FURNITURE (U.S. CLS. 2, 13, 22, 25, 32 AND 50).
MATTHEW GALAN, EXAMINING ATTORNEY

SN 85-628,123. THE BLACK & DECKER CORPORATION, TOWSON, MD. FILED 5-17-2012.

TSTAK

THE MARK CONSISTS OF STANDARD CHARACTERS WITHOUT CLAIM TO ANY PARTICULAR FONT, STYLE, SIZE, OR COLOR.
FOR TOOL AND TOOL ACCESSORY BOXES NOT MADE OF METAL SOLD EMPTY AND PARTS AND FITTINGS THEREFOR (U.S. CLS. 2, 13, 22, 25, 32 AND 50).
LINDA E. BLOHM, EXAMINING ATTORNEY

SN 85-638,145. KING KOIL LICENSING COMPANY, INC., WILLOWBROOK, IL. FILED 5-30-2012.

BOOST FOAM FROM COMFORT SOLUTIONS

THE MARK CONSISTS OF STANDARD CHARACTERS WITHOUT CLAIM TO ANY PARTICULAR FONT, STYLE, SIZE, OR COLOR.
OWNER OF U.S. REG. NOS. 3,006,161, 3,986,571 AND OTHERS.
NO CLAIM IS MADE TO THE EXCLUSIVE RIGHT TO USE "FOAM", APART FROM THE MARK AS SHOWN.
FOR BEDS; BOX SPRINGS; MATTRESSES (U.S. CLS. 2, 13, 22, 25, 32 AND 50).
DAVID ELTON, EXAMINING ATTORNEY

CLASS 20—(Continued).

SN 85-649,804. KING KOIL LICENSING COMPANY, INC., WILLOWBROOK, IL. FILED 6-12-2012.

EXTENDED SLEEP

THE MARK CONSISTS OF STANDARD CHARACTERS WITHOUT CLAIM TO ANY PARTICULAR FONT, STYLE, SIZE, OR COLOR.
NO CLAIM IS MADE TO THE EXCLUSIVE RIGHT TO USE "SLEEP", APART FROM THE MARK AS SHOWN.
FOR BEDS; BOX SPRINGS; MATTRESSES (U.S. CLS. 2, 13, 22, 25, 32 AND 50).
DAVID ELTON, EXAMINING ATTORNEY

SN 85-656,765. SEALY TECHNOLOGY LLC, TRINITY, NC. FILED 6-20-2012.

SEALY POSTUREPEDIC

THE MARK CONSISTS OF STANDARD CHARACTERS WITHOUT CLAIM TO ANY PARTICULAR FONT, STYLE, SIZE, OR COLOR.
OWNER OF U.S. REG. NOS. 677,335, 2,647,002 AND OTHERS.
FOR BEDS FOR HOUSEHOLD PETS (U.S. CLS. 2, 13, 22, 25, 32 AND 50).
BILL DAWE, EXAMINING ATTORNEY

SN 85-660,793. RAYMOND KAHOUD, ORMOND BEACH, FL. AND JOSEPH FISCELLA, WEST ISLIP, NY. FILED 6-25-2012.



THE MARK CONSISTS OF A DOVE FLYING UP AND RIGHT FROM A BOWL.
FOR WOODEN SCULPTURES (U.S. CLS. 2, 13, 22, 25, 32 AND 50).
FIRST USE 4-9-2012; IN COMMERCE 4-9-2012.
TRACY WHITTAKER-BROWN, EXAMINING ATTORNEY

CLASS 20—(Continued).

SN 85-660,853. RAYMOND KAHOU, ORMOND BEACH, FL. AND JOSEPH FISCELLA, WEST ISLIP, NY. FILED 6-25-2012.

CLASS 21—HOUSEWARES AND GLASS

SN 76-709,506. BAILEY, DARBY, CLEVELAND, OH. FILED 10-25-2011.

It's In God's Hands Now



THE MARK CONSISTS OF STANDARD CHARACTERS WITHOUT CLAIM TO ANY PARTICULAR FONT, STYLE, SIZE, OR COLOR.

FOR WOODEN SCULPTURES (U.S. CLS. 2, 13, 22, 25, 32 AND 50).

FIRST USE 4-9-2012; IN COMMERCE 4-9-2012.
TRACY WHITTAKER-BROWN, EXAMINING ATTORNEY

THE MARK CONSISTS OF THE STYLIZED TERM "DARBY" ABOVE A STYLIZED "D" WHICH INCORPORATES THE OTHER LETTERS "A", "R", "B", AND "Y".

FOR SCULPTURES OF CHINA, EARTHENWARE, NAMELY, EARTHENWARE MUGS, DISHES, SERVING DISHES, AND DECORATIVE ACCESSORIES, NAMELY, VASES (U.S. CLS. 2, 13, 23, 29, 30, 33, 40 AND 50).

FIRST USE 5-23-1973; IN COMMERCE 3-17-2000.
KAREN K. BUSH, EXAMINING ATTORNEY

SN 85-678,104. KING KOIL LICENSING COMPANY, INC., WILLOWBROOK, IL. FILED 7-16-2012.

SN 76-710,396. KATHRYNE DEANE PECK, LITTLE ROCK, AR. FILED 1-31-2012.

GELRESPONSE LATEX FROM
COMFORT SOLUTIONS

PORTIONSIZEMATTERS

THE MARK CONSISTS OF STANDARD CHARACTERS WITHOUT CLAIM TO ANY PARTICULAR FONT, STYLE, SIZE, OR COLOR.

OWNER OF U.S. REG. NOS. 3,006,161, 3,986,571 AND OTHERS.

NO CLAIM IS MADE TO THE EXCLUSIVE RIGHT TO USE "LATEX", APART FROM THE MARK AS SHOWN.

FOR BEDS; BOX SPRINGS; MATTRESSES (U.S. CLS. 2, 13, 22, 25, 32 AND 50).

DAVID ELTON, EXAMINING ATTORNEY

THE MARK CONSISTS OF STANDARD CHARACTERS WITHOUT CLAIM TO ANY PARTICULAR FONT, STYLE, SIZE, OR COLOR.

FOR PLASTIC PLATES (U.S. CLS. 2, 13, 23, 29, 30, 33, 40 AND 50).

FIRST USE 11-1-2011; IN COMMERCE 11-1-2011.
CAROLYN CATALDO, EXAMINING ATTORNEY

CLASS 21—(Continued).

SN 79-096,787. KONINKLIJKE PHILIPS ELECTRONICS N.V., EINDHOVEN NL-5621, NETHERLANDS, FILED 4-11-2011.

AIR FLOSS

THE MARK CONSISTS OF STANDARD CHARACTERS WITHOUT CLAIM TO ANY PARTICULAR FONT, STYLE, SIZE, OR COLOR.

OWNER OF INTERNATIONAL REGISTRATION 1075424 DATED 4-11-2011, EXPIRES 4-11-2021.

NO CLAIM IS MADE TO THE EXCLUSIVE RIGHT TO USE "AIR" FOR "APPARATUS FOR CLEANING TEETH AND GUMS, NAMELY, APPARATUS WHICH USE WATER AND AIR FOR DENTAL CARE FOR HOME USE" AND "FLOSS" FOR "FLOSSING INSTRUMENTS FOR DENTAL CARE, NAMELY, DENTAL FLOSS, DENTAL FLOSSERS", APART FROM THE MARK AS SHOWN.

FOR ELECTRIC TOOTHBRUSHES AND DENTURE BRUSHES AND STRUCTURAL PARTS THEREFOR; APPARATUS FOR CLEANING TEETH AND GUMS USING HIGH PRESSURE WATER FOR HOME USE; APPARATUS FOR CLEANING TEETH AND GUMS, NAMELY, APPARATUS WHICH USE WATER AND AIR FOR DENTAL CARE FOR HOME USE; FLOSSING INSTRUMENTS FOR DENTAL CARE, NAMELY, DENTAL FLOSS, DENTAL FLOSSERS (U.S. CLS. 2, 13, 23, 29, 30, 33, 40 AND 50).

MATTHEW EINSTEIN, EXAMINING ATTORNEY

CLASS 21—(Continued).

SN 79-103,669. DURALEX INTERNATIONAL, F-45380 LA CHAPELLE SAINT MESMIN, FRANCE, FILED 8-25-2011.

VERECO

THE MARK CONSISTS OF STANDARD CHARACTERS WITHOUT CLAIM TO ANY PARTICULAR FONT, STYLE, SIZE, OR COLOR.

OWNER OF INTERNATIONAL REGISTRATION 1093572 DATED 8-25-2011, EXPIRES 8-25-2021.

THE ENGLISH TRANSLATION OF THE WORD "VERECO" IN THE MARK IS "CROSS-EYED".

FOR HOUSEHOLD OR KITCHEN UTENSILS, NAMELY, GRATERS, SIEVES; CONTAINERS FOR HOUSEHOLD OR KITCHEN USE NOT OF PRECIOUS METAL; COMBS; SPONGES FOR HOUSEHOLD PURPOSES; BRUSHES EXCEPT PAINTBRUSHES, NAMELY, BRUSHES FOR PIPES, CLOTHES BRUSHES, BRUSHES TO DO THE WASHING UP; MATERIAL FOR BRUSH-MAKING; STEEL WOOL; UNWORKED OR SEMI-WORKED GLASS EXCEPT BUILDING GLASS; GLASSWARE, PORCELAIN AND EARTHENWARE, NAMELY, BEVERAGE GLASSWARE, EARTHENWARE MUGS, BOWLS, PLATES, DISHES, TUMBLERS, MUGS, SAUCERS, GOBLETS; OBJECTS MADE OF TEMPERED GLASS FOR CULINARY USE, NAMELY, BAKEWARE, PLATES, DISHES, BOWLS, TUMBLERS, MUGS, SAUCERS, GOBLETS; PLATES, CUPS OF ALL KINDS, COOKING POT SETS, BOWLS, BUTTER DISHES, BOXES OF GLASS; BOXES FOR SWEETMEATS, BOTTLES SOLD EMPTY, JUGS, COFFEE SERVICES, TEA SERVICES, NON-ELECTRIC COFFEE POTS, NON-ELECTRIC TEA POTS, VASES; TABLEWARE, NAMELY, CANDLESTICKS, BEVERAGE GLASSWARE, EARTHENWARE MUGS, BOWLS, PLATES, DRINKING GLASSES, DISHES, TUMBLERS, MUGS, SAUCERS, GOBLETS; SAUCERS, DRINKING GLASSES, DRINKING VESSELS, DECANTERS, JUGS, CANDLESTICKS, NON-ELECTRIC CANDELABRAS, COOKERY MOLDS; NON-ELECTRIC COOKING UTENSILS, NAMELY, SIEVES; COASTERS FOR DECANTERS NOT OF PAPER AND NOT BEING TABLE LINEN; BOTTLES SOLD EMPTY; FLASKS, DRINKING GLASSES, NAMELY, TUMBLERS; ICE PAILS, ICE BUCKETS, DISHES, TRAYS FOR HOUSEHOLD USE, SALAD BOWLS, SOUP BOWLS, SAUCE BOATS, RAMEKINS, SIDE DISHES (U.S. CLS. 2, 13, 23, 29, 30, 33, 40 AND 50).

ELI HELLMAN, EXAMINING ATTORNEY

SN 79-108,916. NOEB CO.,LTD., REPUBLIC OF KOREA, FILED 12-21-2011.



OWNER OF INTERNATIONAL REGISTRATION 1106174 DATED 12-21-2011, EXPIRES 12-21-2021.

THE COLOR(S) NEON GREEN IS/ARE CLAIMED AS A FEATURE OF THE MARK.

THE MARK CONSISTS OF THE WORDING "NEOB" SUPERIMPOSED OVER A RECTANGULAR NEON GREEN BACKGROUND. THE COLOR WHITE REPRESENTS BACKGROUND AND IS NOT PART OF THE MARK.

FOR FLOSS FOR DENTAL PURPOSES; NON-ELECTRIC TOOTHBRUSHES; MANUAL TOOTHBRUSHES; WATER APPARATUS FOR CLEANING TEETH AND GUMS FOR HOME USE; TOOTHBRUSHES; TOOTHBRUSH CASES (U.S. CLS. 2, 13, 23, 29, 30, 33, 40 AND 50).

DAVID HOFFMAN, EXAMINING ATTORNEY

CLASS 21—(Continued).

SN 79-110,244. JIAXING JEHONN; CLEANING PRODUCTS CO., LTD., ZHEJIANG PROVINCE, CHINA, FILED 1-3-2012.



OWNER OF INTERNATIONAL REGISTRATION 1109537 DATED 1-3-2012, EXPIRES 1-3-2022.

THE MARK CONSISTS OF THE ENGLISH WORDING "JEHOONN" IN AN ELLIPSE IN WHITE WITH A RECTANGLE IN BLACK AS A BACKGROUND.

THE WORDING "JEHOONN" HAS NO MEANING IN A FOREIGN LANGUAGE.

FOR MOPS; CLEANING APPARATUS USED IN CLEANING OF WINDOW AND DOOR GLASS, NAMELY, WINDOW CLEANERS IN THE NATURE OF A COMBINATION SQUEEGEE AND SCRUBBER; CARPET SWEEPERS; BROOMS; CLEANING UTENSILS, NAMELY, CLEANING BRUSHES FOR HOUSEHOLD USE, METAL WOOL FOR CLEANING; RAGS FOR CLEANING; HAND-OPERATED CLEANING INSTRUMENTS, NAMELY, HAND OPERATED, NON-ELECTRIC POOL CLEANING PUMP IN A STICK-LIKE SHAPE WHICH A USER CAN MANIPULATE TO COLLECT DEBRIS FROM A SPA OR POOL THROUGH A SIMPLE PUMPING ACTION THAT CREATES SUCTION; SPONGES FOR HOUSEHOLD PURPOSES; BUCKETS; BRUSHES FOR FOOTWEAR, PARQUET FLOORS, BRUSHES FOR WASHING UP (U.S. CLS. 2, 13, 23, 29, 30, 33, 40 AND 50).

MYRIAH HABEEB, EXAMINING ATTORNEY

SN 85-323,118. WINSON, JULIE, AUSTIN, TX. AND WINSON, CHARLES, AUSTIN, TX. FILED 5-17-2011.

BELLA BISQUE

THE MARK CONSISTS OF STANDARD CHARACTERS WITHOUT CLAIM TO ANY PARTICULAR FONT, STYLE, SIZE, OR COLOR.

NO CLAIM IS MADE TO THE EXCLUSIVE RIGHT TO USE "BISQUE", APART FROM THE MARK AS SHOWN.

THE ENGLISH TRANSLATION OF "BELLA" IN THE MARK IS "BEAUTIFUL".

FOR FINISHED AND UNFINISHED FUNCTIONAL CERAMIC DINNERWARE AND ACCESSORIES, NAMELY, IMPORTED AND DOMESTIC BISQUE AND BISQUE WARE CONSISTING OF PLATES, SAUCERS, CUPS, MUGS, BOWLS, SERVING DISHES, TEAPOTS NOT OF PRECIOUS METAL, PITCHERS, SERVING PLATTERS, SALT AND PEPPER SHAKERS, VASES, FLOWER POTS, PLANTERS FOR FLOWERS AND PLANTS, COOKIE JARS, CREAMER AND SUGAR SETS, COASTERS, TRINKET BOXES, CANISTER SETS, CERAMIC DRAWER KNOBS, CANDLE HOLDERS NOT OF PRECIOUS METAL, PET FEEDING DISHES, GOBLETS, NON-METAL PIGGY BANKS, COOLERS FOR WINE, UTENSIL HOLDERS, TRIVETS, BUTTER DISHES, AND NAPKIN HOLDERS (U.S. CLS. 2, 13, 23, 29, 30, 33, 40 AND 50).

FIRST USE 12-27-2001; IN COMMERCE 12-27-2001.
LAKEISHA LEWIS, EXAMINING ATTORNEY

CLASS 21—(Continued).

SN 85-337,021. SUMMIT ENTERTAINMENT, LLC, SANTA MONICA, CA. FILED 6-3-2011.

TWILIGHT BRIDAL

THE MARK CONSISTS OF STANDARD CHARACTERS WITHOUT CLAIM TO ANY PARTICULAR FONT, STYLE, SIZE, OR COLOR.

OWNER OF U.S. REG. NOS. 3,867,985, 3,944,718 AND OTHERS.

NO CLAIM IS MADE TO THE EXCLUSIVE RIGHT TO USE "BRIDAL", APART FROM THE MARK AS SHOWN.

FOR PLATES; COMMEMORATIVE PLATES; DRINKING GLASSES; CANDLESTICKS; NON-ELECTRIC CANDLABRAS; NAPKIN RINGS; SALT AND PEPPER SHAKERS; VASES; AND ORNAMENTAL GLASS SPHERES (U.S. CLS. 2, 13, 23, 29, 30, 33, 40 AND 50).

ASMAT KHAN, EXAMINING ATTORNEY

SN 85-345,768. FUNDAMETAL DESIGNS INC., PORT COQUITLAM, BC, CANADA, FILED 6-14-2011.

PORTION PAL

THE MARK CONSISTS OF STANDARD CHARACTERS WITHOUT CLAIM TO ANY PARTICULAR FONT, STYLE, SIZE, OR COLOR.

NO CLAIM IS MADE TO THE EXCLUSIVE RIGHT TO USE "PORTION", APART FROM THE MARK AS SHOWN.

FOR HAND-OPERATED PUMP DISPENSERS THAT DISPENSE PRESET PORTIONS OF CONDIMENTS, PASTES, CREAMS AND GELS, FOR USE IN COMMERCIAL FOOD PREPARATION AND NOT FOR MEDICAL USE OR FOR USE IN DIETING (U.S. CLS. 2, 13, 23, 29, 30, 33, 40 AND 50).

KATHLEEN M. VANSTON, EXAMINING ATTORNEY

SN 85-427,870. SHOWERLINE PRODUCTS, LLC, WESTERVILLE, OH. FILED 9-21-2011.

SHOWERLINE

THE MARK CONSISTS OF STANDARD CHARACTERS WITHOUT CLAIM TO ANY PARTICULAR FONT, STYLE, SIZE, OR COLOR.

FOR SHOWER CADDIES (U.S. CLS. 2, 13, 23, 29, 30, 33, 40 AND 50).

FIRST USE 6-15-2011; IN COMMERCE 7-16-2011.

VIVIAN MICZNIK FIRST, EXAMINING ATTORNEY

CLASS 21—(Continued).

SN 85-435,253. P & A INTERNATIONAL, LLC, HOPE MILLS, NC. FILED 9-29-2011.

REBURST

THE MARK CONSISTS OF STANDARD CHARACTERS WITHOUT CLAIM TO ANY PARTICULAR FONT, STYLE, SIZE, OR COLOR.

FOR BEVERAGE CONTAINERS, NAMELY, BOTTLES SOLD EMPTY HAVING A COMPARTMENT FOR CONTAINING LIQUID AND A COMPARTMENT FOR CONTAINING SOLID MATERIAL TO BE MIXED WITH THE LIQUID (U.S. CLS. 2, 13, 23, 29, 30, 33, 40 AND 50).
WILLIAM VERHOSEK, EXAMINING ATTORNEY

SN 85-436,545. CLEANTOOLS, INC., WESTMONT, IL. FILED 9-30-2011.

DASH GEAR

THE MARK CONSISTS OF STANDARD CHARACTERS WITHOUT CLAIM TO ANY PARTICULAR FONT, STYLE, SIZE, OR COLOR.

OWNER OF U.S. REG. NO. 3,080,937.
NO CLAIM IS MADE TO THE EXCLUSIVE RIGHT TO USE "GEAR", APART FROM THE MARK AS SHOWN. SEC. 2(F).
FOR WIPING CLOTHS (U.S. CLS. 2, 13, 23, 29, 30, 33, 40 AND 50).
FIRST USE 4-29-2004; IN COMMERCE 4-29-2004.
EMILY CARLSEN, EXAMINING ATTORNEY

SN 85-438,852. ALUMINIO ROHMER, C. POR A., SANTO DOMINGO, DOMINICAN REP, FILED 10-4-2011.



FOR POTS; PANS; NON-ELECTRIC COFFEE MAKERS; DOUBLE BOILERS; DUTCH OVENS; EGG POACHERS; NON-ELECTRIC DEEP FRENCH FRYERS; SKILLETS; GRIDDLES; KETTLES; COOKING STEAMERS; NON-ELECTRIC PRESSURE COOKERS; CAKE MOLDS; CASSEROLES; MUGS; BOWLS; SERVING TRAYS; CANTEENS; SERVING SPOONS; SERVING FORKS; SERVING LADLES; DRINKING GLASSES; PLATES; SOUP BOWLS; COOKING STRAINERS AND SPAGHETTI STRAINERS; AND COLANDERS (U.S. CLS. 2, 13, 23, 29, 30, 33, 40 AND 50).
SIMON TENG, EXAMINING ATTORNEY

CLASS 21—(Continued).

SN 85-443,673. PRIME PRODUCTS, INC., DBA PRIME PRODUCTS, INC., SCHULENBURG, TX. FILED 10-10-2011.

Bolero Tumbler

THE MARK CONSISTS OF STANDARD CHARACTERS WITHOUT CLAIM TO ANY PARTICULAR FONT, STYLE, SIZE, OR COLOR.

NO CLAIM IS MADE TO THE EXCLUSIVE RIGHT TO USE "TUMBLER", APART FROM THE MARK AS SHOWN. FOR DRINKING GLASSES, NAMELY, TUMBLERS (U.S. CLS. 2, 13, 23, 29, 30, 33, 40 AND 50).
FIRST USE 9-6-2011; IN COMMERCE 9-26-2011.
TASNEEM HUSSAIN, EXAMINING ATTORNEY

SN 85-473,318. ENGHARD, FLORIAN, SULZBACH, FED REP GERMANY, FILED 11-15-2011.



THE MARK CONSISTS OF FIVE PROGRESSIVELY SMALLER CIRCLES, WHICH ARE ALTERNATELY DARK AND LIGHT, OVERLAID ON ONE ANOTHER, GIVING THE IMPRESSION OF A CONVERGING SPIRAL.

FOR DRINKING BOTTLES SOLD EMPTY; DRINKING CUPS; MIXING CUPS AND PARTS THEREOF; BEVERAGE SHAKERS AND PARTS THEREOF; NON-ELECTRIC MANUALLY-OPERATED BEVERAGE AND FOOD SHAKING CUPS AND PARTS THEREOF; BOTTLES AND CUPS SOLD EMPTY FOR STORING, MIXING, BLENDING, SHAKING, DISPENSING AND SERVING BEVERAGES, FOODS, AND FOOD AND BEVERAGE INGREDIENTS, AND PARTS OF SAID BOTTLES AND CUPS FOR DOMESTIC PURPOSES (U.S. CLS. 2, 13, 23, 29, 30, 33, 40 AND 50).
AISHA SALEM, EXAMINING ATTORNEY

CLASS 21—(Continued).

SN 85-475,124. TEAM SIZZLE FILMS, INC., BALTIMORE, MD. FILED 11-17-2011.

T-SIZZLE

THE MARK CONSISTS OF STANDARD CHARACTERS WITHOUT CLAIM TO ANY PARTICULAR FONT, STYLE, SIZE, OR COLOR.

THE NAME(S), PORTRAIT(S), AND/OR SIGNATURE(S) SHOWN IN THE MARK IDENTIFIES "TERRELL RAYMONN SUGGS", WHOSE CONSENT(S) TO REGISTER IS MADE OF RECORD.

FOR CUPS AND MUGS (U.S. CLS. 2, 13, 23, 29, 30, 33, 40 AND 50).

JUDITH HELFMAN, EXAMINING ATTORNEY

SN 85-491,901. FARHAN KHAN, DBA ARTISTIC CREATIONS, SANFORD, FL. FILED 12-9-2011.

FESTA

THE MARK CONSISTS OF STANDARD CHARACTERS WITHOUT CLAIM TO ANY PARTICULAR FONT, STYLE, SIZE, OR COLOR.

FOR BOTTLE STOPPERS SPECIALLY ADAPTED FOR USE WITH WINE BOTTLES; COOLERS FOR WINE; COOLING BUCKETS FOR WINE; VACUUM BOTTLE STOPPERS SPECIALLY ADAPTED FOR USE WITH WINE BOTTLES; VACUUM PUMPS FOR WINE BOTTLES; WINE BOTTLE CRADLES; WINE BOTTLE VESTS SPECIALLY ADAPTED FOR DECORATING WINE BOTTLES; WINE DRIP COLLARS SPECIALLY ADAPTED FOR USE AROUND THE TOP OF WINE BOTTLES TO STOP DRIPS; WINE GLASSES; WINE OPENERS; WINE POURERS; WINE STRAINERS (U.S. CLS. 2, 13, 23, 29, 30, 33, 40 AND 50).

ANDREW LEASER, EXAMINING ATTORNEY

SN 85-503,588. 5 STAR PERFORMANCE PRODUCTS, INC., DBA 5 STAR PERFORMANCE PRODUCTS FREAK, MELBOURNE BEACH FL, FL. FILED 12-24-2011.

STASH MASTER

THE MARK CONSISTS OF STANDARD CHARACTERS WITHOUT CLAIM TO ANY PARTICULAR FONT, STYLE, SIZE, OR COLOR.

FOR PLASTIC ALL PURPOSE CONTAINERS FEATURING COMPARTMENTS FOR CARRYING, HIDING, STOWING, OR KEEPING SEPARATE EITHER GOODS OR LIQUIDS, FOR DOMESTIC USE (U.S. CLS. 2, 13, 23, 29, 30, 33, 40 AND 50).

KATHRYN COWARD, EXAMINING ATTORNEY

CLASS 21—(Continued).

SN 85-511,739. HAPPY ANIMALS, LLC, MINNEAPOLIS, MN. FILED 1-9-2012.

MY VOICE

THE MARK CONSISTS OF STANDARD CHARACTERS WITHOUT CLAIM TO ANY PARTICULAR FONT, STYLE, SIZE, OR COLOR.

FOR REUSABLE STAINLESS STEEL WATER BOTTLES SOLD EMPTY, PET FEEDING AND DRINKING BOWLS (U.S. CLS. 2, 13, 23, 29, 30, 33, 40 AND 50).

JULIE GUTTADAURO, EXAMINING ATTORNEY

SN 85-531,529. PAUL FRANK INDUSTRIES LLC, LOS ANGELES, CA. FILED 2-1-2012.

SMALL PAUL

THE MARK CONSISTS OF STANDARD CHARACTERS WITHOUT CLAIM TO ANY PARTICULAR FONT, STYLE, SIZE, OR COLOR.

OWNER OF U.S. REG. NO. 3,614,027.

FOR DINNERWARE, NAMELY, PLATES AND PAPER CUPS; BEVERAGE GLASSWARE, MUGS, BOWLS, PLATES, GLASSES IN THE NATURE OF TUMBLERS, COOKIE JARS, WASTEPAPER BASKETS, PLASTIC BUCKETS, SHOWER CADDIES, CAKE MOLDS, CAKE SERVERS, THERMAL INSULATED CONTAINERS FOR FOOD OR BEVERAGES; COOKIE CUTTERS, PLASTIC WATER BOTTLES SOLD EMPTY, HAIR BRUSHES, TOOTHBRUSHES, SOAP CONTAINERS, LUNCH BOXES (U.S. CLS. 2, 13, 23, 29, 30, 33, 40 AND 50).

MARTHA FROMM, EXAMINING ATTORNEY

CLASS 21—(Continued).

SN 85-554,557. SINO-SING INTERNATIONAL CORP. USA, KINNELON, NJ. FILED 2-28-2012.



NO CLAIM IS MADE TO THE EXCLUSIVE RIGHT TO USE "SINO" AND "WARE", APART FROM THE MARK AS SHOWN.

THE MARK CONSISTS OF THE WORDS "SINO SING WARE" WITHIN AN OVAL HAVING TWO CURVED LINES EXTENDING FROM EACH END. THE CURVE ON THE LEFT EXTENDS OVER THE TOP OF THE OVAL, WHILE THE CURVE ON THE RIGHT EXTENDS UNDER THE BOTTOM OF THE OVAL.

THE WORDING "SINO SING" HAS NO MEANING IN A FOREIGN LANGUAGE.

FOR MUG, CUPS, BOTTLES SOLD EMPTY, AND OTHER DRINK WARE IN THE NATURE OF DRINKING VESSELS (U.S. CLS. 2, 13, 23, 29, 30, 33, 40 AND 50).

FIRST USE 9-17-2010; IN COMMERCE 9-17-2010.
HEATHER THOMPSON, EXAMINING ATTORNEY

SN 85-557,013. SMASH ENTERPRISES PTY LTD, VICTORIA 3132, AUSTRALIA, FILED 2-29-2012.

FOOD MOVERS

THE MARK CONSISTS OF STANDARD CHARACTERS WITHOUT CLAIM TO ANY PARTICULAR FONT, STYLE, SIZE, OR COLOR.

OWNER OF U.S. REG. NO. 3,980,181.

NO CLAIM IS MADE TO THE EXCLUSIVE RIGHT TO USE "FOOD", APART FROM THE MARK AS SHOWN.

FOR CONTAINERS FOR HOUSEHOLD OR KITCHEN USE; HOUSEHOLD UTENSILS, NAMELY, KITCHEN TONGS, SPATULAS, SCRAPERS, CLEANING BRUSHES, SERVING PLATES AND DISHES, MIXING SPOONS, SLOTTED SPOONS, BOTTLE OPENERS, CROCKERY, NAMELY, POTS, DISHES, DRINKING CUPS AND SAUCERS, BOWLS, SERVING BOWLS AND TRAYS, BRUSHES FOR BASTING MEAT; CONTAINERS FOR BEVERAGES; CONTAINERS FOR FOOD; HEAT INSULATED CONTAINERS FOR BEVERAGES; HEAT RETAINING CONTAINERS FOR FOOD; INSULATED CONTAINERS FOR HOUSEHOLD OR KITCHEN USE; LUNCH BOXES; ISOTHERMIC BAGS FOR HOUSEHOLD OR KITCHEN USE; WATER BOTTLES; BEVERAGE COOLERS; DRINKING CONTAINERS; PORTABLE COOLERS; ICE CONTAINERS; PLASTIC CONTAINERS FOR HOUSEHOLD OR KITCHEN USE; LIDS FOR HOUSEHOLD OR KITCHEN CONTAINERS (U.S. CLS. 2, 13, 23, 29, 30, 33, 40 AND 50).

RAUL CORDOVA, EXAMINING ATTORNEY

CLASS 21—(Continued).

SN 85-570,185. WEISMAN, CARLA, VIRGINIA BEACH, VA. FILED 3-15-2012.



NO CLAIM IS MADE TO THE EXCLUSIVE RIGHT TO USE "S P A H2O", APART FROM THE MARK AS SHOWN.

THE COLOR(S) BLUE, LIGHT BLUE AND GRAY IS/ARE CLAIMED AS A FEATURE OF THE MARK.

THE MARK CONSISTS OF THE GRAY WORD "S P A" ABOVE THE LIGHT BLUE STYLIZED WORD "H2O", WITH THE APPEARANCE OF BLUE AND LIGHT BLUE WATER FILLING UP HALF OF THE LETTER "O".

FOR REUSABLE PLASTIC WATER BOTTLES SOLD EMPTY (U.S. CLS. 2, 13, 23, 29, 30, 33, 40 AND 50).

SANDRA BUJA, EXAMINING ATTORNEY

SN 85-581,760. DAN HAJDUK, MARIETTA, GA. FILED 3-28-2012.



THE MARK CONSISTS OF THE STYLIZED IMAGE OF A DOVE.

FOR GLOVE STRETCHERS (U.S. CLS. 2, 13, 23, 29, 30, 33, 40 AND 50).

CURTIS FRENCH, EXAMINING ATTORNEY

CLASS 21—(Continued).

SN 85-582,865. PATTEN, ROSS, PEREGIAN BEACH, AUSTRALIA, FILED 3-28-2012.



NO CLAIM IS MADE TO THE EXCLUSIVE RIGHT TO USE "RICE CUBE", APART FROM THE MARK AS SHOWN. THE MARK CONSISTS OF THE LITERAL ELEMENTS "RICE CUBE" WHEREIN THERE IS A GRAPHIC IMAGE DEPICTING A THREE SIDED CUBE PLACED JUST ABOVE LETTER "I" OF WORD "RICE" AS SHOWN IN THE MARK.

FOR FOOD MOLDS IN THE NATURE OF RICE MOLDS; FOOD PRESSES IN THE NATURE OF RICE PRESSES (U.S. CLS. 2, 13, 23, 29, 30, 33, 40 AND 50).

FIRST USE 3-8-2011; IN COMMERCE 3-8-2011.

CHARISMA HAMPTON, EXAMINING ATTORNEY

SN 85-593,914. ROBERTO RUIZ VELASCO GARCIA RULFO, GUADALAJARA, JALISCO, MEXICO, FILED 4-10-2012.



THE MARK CONSISTS OF THE STYLIZED LETTERS "BFW" INSIDE A SQUARE.

FOR STAINLESS STEEL BOWLS, STAINLESS STEEL SERVING TRAYS, ALUMINUM SERVING TRAYS, ALUMINUM TRAY FOR PIZZA, MIXING CUPS, PLASTIC AND STAINLESS STEEL STORAGE CONTAINERS WITH THEIR RESPECTIVE LIDS FOR HOUSEHOLD USE, ICE CUBE TRAYS, STAINLESS STEEL AND PLASTIC STRAINERS FOR HOUSEHOLD USE, POTATO FRYER BASKETS, BASKETS FOR DOMESTIC USE NOT OF METAL, FLATWARE ORGANIZER IN THE NATURE OF A FLATWARE CADDY, PLASTIC PITCHERS; HOUSEHOLD UTENSILS, NAMELY, PLASTIC AND METAL KITCHEN TONGS, SPATULAS, PLASTIC AND STAINLESS STEEL SERVING SPOONS, BASTING SPOONS, KITCHEN LADLES, SCOOPS, SKIMMERS, TURNERS, WHISKS, SIEVE, POURING AND STRAINING SPOUTS, FUNNELS, GRILLING UTENSILS NAMELY, SKEWERS, FORKS, TONGS, TURNERS; BAR SUPPLIES, NAMELY, CORKSCREWS, WINE BUCKETS, COCKTAIL SHAKERS, COCKTAIL MIXERS IN THE NATURE OF STIRRERS; DRESSING DISPENSERS, PLASTIC TUMBLERS, PLASTIC DISH COVER, SALT AND PEPPER SHAKERS, STAINLESS STEEL SAUCE DISPENSERS, TABLE ORGANIZER IN THE NATURE OF A LAZY SUSAN; TABLE ORGANIZER IN THE NATURE OF A DISH STAND (U.S. CLS. 2, 13, 23, 29, 30, 33, 40 AND 50).

ANDREA BUTLER, EXAMINING ATTORNEY

CLASS 21—(Continued).

SN 85-595,446. MUELLER TECHNOLOGIES, INC., WONDER LAKE, IL. FILED 4-11-2012.

CUP TREAT

THE MARK CONSISTS OF STANDARD CHARACTERS WITHOUT CLAIM TO ANY PARTICULAR FONT, STYLE, SIZE, OR COLOR.

NO CLAIM IS MADE TO THE EXCLUSIVE RIGHT TO USE "CUP", APART FROM THE MARK AS SHOWN.

FOR CUPS SOLD EMPTY MADE PRIMARILY OF PLASTIC BUT ALSO COMPOSED IN PART OF PAPER (U.S. CLS. 2, 13, 23, 29, 30, 33, 40 AND 50).

FIRST USE 3-29-2012; IN COMMERCE 3-29-2012.

ARETHA SOMERVILLE, EXAMINING ATTORNEY

SN 85-596,274. FREUDENBERG HOUSEHOLD PRODUCTS LP, AURORA, IL. FILED 4-12-2012.

POWERFIBERS

THE MARK CONSISTS OF STANDARD CHARACTERS WITHOUT CLAIM TO ANY PARTICULAR FONT, STYLE, SIZE, OR COLOR.

OWNER OF U.S. REG. NO. 2,974,558.

FOR MOPS; MOPHEAD REFILLS; YARNS SOLD AS AN INTEGRAL COMPONENT OF MOPS AND MOPHEAD REFILLS (U.S. CLS. 2, 13, 23, 29, 30, 33, 40 AND 50).

JAMES GRIFFIN, EXAMINING ATTORNEY

CLASS 21—(Continued).

SN 85-596,882. SYSCO CORPORATION, HOUSTON, TX. FILED 4-13-2012.



NO CLAIM IS MADE TO THE EXCLUSIVE RIGHT TO USE "QA", APART FROM THE MARK AS SHOWN.

THE MARK CONSISTS OF THESE STYLIZED LETTERS "Q" AND "A" WITH A LEAF DESIGN AS THE STEM ON THE "Q" AND THE BAR ACROSS THE LETTER "A".

FOR SHOE HORNS; SHOE SPONGES FOR CLEANING; SHOE POLISHING MITTS; METAL AND PLASTIC SERVING TRAYS; WASTE BASKETS; ICE BUCKETS; DRINKING GLASSES; CLEANING EQUIPMENT, NAMELY, SPONGES; CHINA DINNERWARE; HOUSEHOLD FOOD CONTAINERS; COOKING UTENSILS, NAMELY, SERVING SPOONS, BATTER DISPENSER AND SLOTTED SPOONS; BAR SUPPLIES, NAMELY, GLASSES, COCKTAIL SHAKERS, SWIZZLE STICKS; HAIR COMBS; TISSUE DISPENSERS; TOOTHPICKS; CLOTHS FOR WIPING OR DUSTING; ICE CREAM SCOOPS; DISHES; METAL COOKING PANS; MELAMINE DRINKING GLASSES AND MELAMINE DISHES; PASTRY BRUSHES; REUSABLE CLOTH WIPES; ARTICLES FOR CLEANING PURPOSES, NAMELY, GRIDDLE CLEANING STONES, SPONGES, SCOURING PADS; DISPENSERS FOR LIQUID OR GRANULATED SOAP FOR HOUSEHOLD AND COMMERCIAL USE; PAPER CUPS, PAPER PLATES AND FOAM CUPS; PLASTIC MUGS; SALT AND PEPPER SHAKERS; ALUMINUM SERVING TRAYS; CUTTING BOARDS; COFFEE STIRRERS; PAPER NAPKIN DISPENSERS; MOP HEADS AND BUCKETS; TRASH CAN COVERS; MELON SCOOPS; KITCHEN LADLES; NON-ELECTRIC CARPET SWEEPERS; SPATULAS; GRILL SCRAPERS; EMPTY PLASTIC BOTTLES; POTS; BROOMS; DISHWASHING AND POT CLEANING BRUSHES; NAIL BRUSHES; VEGETABLE BRUSHES; WIRE BRUSHES, NOT BEING MACHINE PARTS; SCRUBBING BRUSHES; GOBLETS; SPICE RACKS; DISPOSABLE LATEX OR PLASTIC GLOVES FOR GENERAL USE; RUBBER HOUSEHOLD GLOVES; BUTTER DISHES; KETCHUP DISPENSERS; DUST PANS, FRYING PANS AND GLASS PANS; BEVERAGE GLASSWARE; PLASTIC AND GLASS COFFEE DECANTERS; CHOPSTICKS; SERVING TONGS; PAPER TRAYS (U.S. CLS. 2, 13, 23, 29, 30, 33, 40 AND 50).

TINA MAI, EXAMINING ATTORNEY

SN 85-598,233. VALLEE ENTERPRISES LLC, DBA VALLEE ENTERPRISES LLC, WOODBURY, NJ. FILED 4-15-2012.

IDENTA STIR

THE MARK CONSISTS OF STANDARD CHARACTERS WITHOUT CLAIM TO ANY PARTICULAR FONT, STYLE, SIZE, OR COLOR.

NO CLAIM IS MADE TO THE EXCLUSIVE RIGHT TO USE "STIR", APART FROM THE MARK AS SHOWN.

FOR STIRRING RODS (U.S. CLS. 2, 13, 23, 29, 30, 33, 40 AND 50).

DOMINICK J. SALEMI, EXAMINING ATTORNEY

CLASS 21—(Continued).

SN 85-601,986. MAXEY, AMBER, CUMMING, GA. FILED 4-18-2012.

Trashy purse

THE MARK CONSISTS OF STANDARD CHARACTERS WITHOUT CLAIM TO ANY PARTICULAR FONT, STYLE, SIZE, OR COLOR.

FOR TRASH CANS (U.S. CLS. 2, 13, 23, 29, 30, 33, 40 AND 50).

ELIZABETH HUGHITT, EXAMINING ATTORNEY

SN 85-602,240. MICHAEL HOTTINGER, GREENDALE, WI. FILED 4-19-2012.

Flowerpots for Tots

THE MARK CONSISTS OF STANDARD CHARACTERS WITHOUT CLAIM TO ANY PARTICULAR FONT, STYLE, SIZE, OR COLOR.

FOR CERAMIC SCULPTURES, VASES, VESSELS, BOWLS, PLATES AND POTS; CLAY POTS; FLOWER AND PLANT CULTIVATION TRAYS; FLOWER BASKETS; FLOWER BOWLS; FLOWER POT HOLDERS; FLOWER POTS; FLOWER VASES; FLOWERPOTS; HOLDERS FOR FLOWERS AND PLANTS; SAUCERS FOR FLOWER POTS (U.S. CLS. 2, 13, 23, 29, 30, 33, 40 AND 50).

JOHN HWANG, EXAMINING ATTORNEY

SN 85-602,497. SQUOOSHI CORPORATION, SANTEE, CA. FILED 4-19-2012.

SQUOOSHI

THE MARK CONSISTS OF STANDARD CHARACTERS WITHOUT CLAIM TO ANY PARTICULAR FONT, STYLE, SIZE, OR COLOR.

FOR ALL PURPOSE PORTABLE HOUSEHOLD CONTAINERS; COLLAPSIBLE STORAGE CONTAINERS FOR DOMESTIC USE; CONTAINERS FOR HOUSEHOLD OR KITCHEN USE; CONTAINERS FOR HOUSEHOLD OR KITCHEN USE NOT OF PRECIOUS METAL; CONTAINERS FOR ICE; HOUSEHOLD CONTAINERS FOR FOODS; PLASTIC STORAGE CONTAINERS FOR HOUSEHOLD OR DOMESTIC USE; SOAP CONTAINERS (U.S. CLS. 2, 13, 23, 29, 30, 33, 40 AND 50).

KAREN SEVERSON, EXAMINING ATTORNEY

CLASS 21—(Continued).

SN 85-602,622. SILIPINT, INC., BEND, OR. FILED 4-19-2012.

Silishot

THE MARK CONSISTS OF STANDARD CHARACTERS WITHOUT CLAIM TO ANY PARTICULAR FONT, STYLE, SIZE, OR COLOR.

FOR CONTAINERS, NAMELY PINT GLASSES, SHOT GLASSES, BEVERAGE WARE AND DISHWARE (U.S. CLS. 2, 13, 23, 29, 30, 33, 40 AND 50).

FIRST USE 4-7-2012; IN COMMERCE 4-7-2012.
JOHN WILKE, EXAMINING ATTORNEY

SN 85-602,625. SILIPINT, INC., BEND, OR. FILED 4-19-2012.

silihuman

THE MARK CONSISTS OF STANDARD CHARACTERS WITHOUT CLAIM TO ANY PARTICULAR FONT, STYLE, SIZE, OR COLOR.

FOR CONTAINERS, NAMELY PINT GLASSES, SHOT GLASSES, BEVERAGE WARE AND DISHWARE (U.S. CLS. 2, 13, 23, 29, 30, 33, 40 AND 50).

JOHN WILKE, EXAMINING ATTORNEY

SN 85-602,895. GMZ ASSOCIATES LTD., BRENTWOOD, NY.
FILED 4-19-2012.

A BRUSH FOR ALL SEASONS

THE MARK CONSISTS OF STANDARD CHARACTERS WITHOUT CLAIM TO ANY PARTICULAR FONT, STYLE, SIZE, OR COLOR.

FOR TOOTHBRUSHES (U.S. CLS. 2, 13, 23, 29, 30, 33, 40 AND 50).

FONG HSU, EXAMINING ATTORNEY

CLASS 21—(Continued).

SN 85-602,896. JOOVY HOLDING CO., DALLAS, TX. FILED 4-19-2012.

DOOD

THE MARK CONSISTS OF STANDARD CHARACTERS WITHOUT CLAIM TO ANY PARTICULAR FONT, STYLE, SIZE, OR COLOR.

FOR DRINKING CUPS; DRINKING CUPS FOR BABIES AND CHILDREN AND PARTS AND FITTINGS THEREFOR, NAMELY, CUPS FOR BABIES AND CHILDREN SOLD AS A UNIT WITH VALVES AND LIDS; DRINKING CUPS FOR CHILDREN AND PARTS AND FITTINGS THEREFOR, NAMELY, DRINKING CUPS FOR CHILDREN SOLD AS A UNIT WITH NON-INSULATED LIDS; DRINKING CUPS FOR INFANTS AND PARTS AND FITTINGS THEREFOR, NAMELY, VALVES AND LIDS SOLD AS A UNIT; RE-USABLE OR DISPOSABLE PLASTIC OR SILICONE VALVES SOLD FOR USE WITH TRAINING CUPS FOR BABIES AND CHILDREN; TRAINING CUPS FOR BABIES AND CHILDREN (U.S. CLS. 2, 13, 23, 29, 30, 33, 40 AND 50).

ANGELA DUONG, EXAMINING ATTORNEY

SN 85-603,044. CUPSTIR, WEST PALM BEACH, FL. FILED 4-19-2012.

CUPSTIR

THE MARK CONSISTS OF STANDARD CHARACTERS WITHOUT CLAIM TO ANY PARTICULAR FONT, STYLE, SIZE, OR COLOR.

FOR CUPS AND MUGS WITH A SELF STIRRING MECHANISM (U.S. CLS. 2, 13, 23, 29, 30, 33, 40 AND 50).

CARYN GLASSER, EXAMINING ATTORNEY

SN 85-603,182. MONET BEAUTY PRODUCTS LTD., VANCOUVER, BC, CANADA, FILED 4-19-2012.

COMBPAL

THE MARK CONSISTS OF STANDARD CHARACTERS WITHOUT CLAIM TO ANY PARTICULAR FONT, STYLE, SIZE, OR COLOR.

FOR HAIR COMBS (U.S. CLS. 2, 13, 23, 29, 30, 33, 40 AND 50).

DAWN FELDMAN, EXAMINING ATTORNEY

CLASS 21—(Continued).

SN 85-603,318. OLIVIA GARDEN INTERNATIONAL, INC.,
WALNUT CREEK, CA. FILED 4-20-2012.

KERABRUSH

THE MARK CONSISTS OF STANDARD CHARACTERS
WITHOUT CLAIM TO ANY PARTICULAR FONT, STYLE,
SIZE, OR COLOR.

FOR HAIR BRUSHES (U.S. CLS. 2, 13, 23, 29, 30, 33, 40
AND 50).

FIRST USE 1-29-2012; IN COMMERCE 1-29-2012.
NAKIA HENRY, EXAMINING ATTORNEY

CLASS 21—(Continued).

SN 85-604,916. SUNSTAR AMERICAS, INC., CHICAGO, IL.
FILED 4-23-2012.

SOFT-PICKS

THE MARK CONSISTS OF STANDARD CHARACTERS
WITHOUT CLAIM TO ANY PARTICULAR FONT, STYLE,
SIZE, OR COLOR.

OWNER OF U.S. REG. NO. 3,074,874.

SEC. 2(F).

FOR DISPOSABLE PLASTIC TOOTHPICKS (U.S. CLS.
2, 13, 23, 29, 30, 33, 40 AND 50).

FIRST USE 1-0-2005; IN COMMERCE 1-0-2005.
JASON LOTT, EXAMINING ATTORNEY

SN 85-603,560. WKI HOLDING COMPANY, INC., ROSE-
MONT, IL. FILED 4-20-2012.

ENDURING ELEGANCE

THE MARK CONSISTS OF STANDARD CHARACTERS
WITHOUT CLAIM TO ANY PARTICULAR FONT, STYLE,
SIZE, OR COLOR.

FOR GLASS TABLEWARE, NAMELY, PLATES, CUPS,
MUGS, SAUCERS, SERVING DISHES AND BOWLS (U.S.
CLS. 2, 13, 23, 29, 30, 33, 40 AND 50).

FIRST USE 1-1-2011; IN COMMERCE 1-1-2011.
KRISTIN DAHLING, EXAMINING ATTORNEY

SN 85-607,089. WKI HOLDING COMPANY, INC., ROSE-
MONT, IL. FILED 4-24-2012.

VIVE

THE MARK CONSISTS OF STANDARD CHARACTERS
WITHOUT CLAIM TO ANY PARTICULAR FONT, STYLE,
SIZE, OR COLOR.

FOR GLASS TABLEWARE, NAMELY, PLATES, CUPS,
MUGS, SAUCERS, SERVING DISHES AND BOWLS (U.S.
CLS. 2, 13, 23, 29, 30, 33, 40 AND 50).

FIRST USE 8-1-2009; IN COMMERCE 8-1-2009.
KRISTIN DAHLING, EXAMINING ATTORNEY

SN 85-603,562. WKI HOLDING COMPANY, INC., ROSE-
MONT, IL. FILED 4-20-2012.

DURABLE BY DESIGN

THE MARK CONSISTS OF STANDARD CHARACTERS
WITHOUT CLAIM TO ANY PARTICULAR FONT, STYLE,
SIZE, OR COLOR.

FOR GLASS TABLEWARE, NAMELY, PLATES, CUPS,
MUGS, SAUCERS, SERVING DISHES AND BOWLS (U.S.
CLS. 2, 13, 23, 29, 30, 33, 40 AND 50).

FIRST USE 1-1-2011; IN COMMERCE 1-1-2011.
KRISTIN DAHLING, EXAMINING ATTORNEY

SN 85-612,323. TARGET BRANDS, INC., MINNEAPOLIS,
MN. FILED 4-30-2012.

UP & UP

THE MARK CONSISTS OF STANDARD CHARACTERS
WITHOUT CLAIM TO ANY PARTICULAR FONT, STYLE,
SIZE, OR COLOR.

OWNER OF U.S. REG. NOS. 4,013,299, 4,042,814 AND
OTHERS.

FOR BROOMS; MOPS; HOUSEHOLD CLEANING
BRUSHES AND SPONGES, NAMELY, FLOOR BRUSHES,
LINT BRUSHES, DUSTING BRUSHES, DISHWASHING
BRUSHES, POT CLEANING BRUSHES, SCRAPING
BRUSHES, TUB BRUSHES, BATH BRUSHES, WASHING
BRUSHES AND TOILET SPONGES; CLOTHES
BRUSHES; TOILET BRUSHES (U.S. CLS. 2, 13, 23, 29,
30, 33, 40 AND 50).

JEAN IM, EXAMINING ATTORNEY

CLASS 21—(Continued).

SN 85-612,327. TARGET BRANDS, INC., MINNEAPOLIS, MN. FILED 4-30-2012.



OWNER OF U.S. REG. NOS. 4,013,299, 4,042,814 AND OTHERS.

THE MARK CONSISTS OF AN ARROW DESIGN POINTING AT A 45 DEGREE DIAGONAL, UP AND TO THE RIGHT, WITH THE WORDS "UP & UP" INSIDE THE ARROW.

FOR BROOMS; MOPS; HOUSEHOLD CLEANING BRUSHES AND SPONGES, NAMELY, FLOOR BRUSHES, LINT BRUSHES, DUSTING BRUSHES, DISHWASHING BRUSHES, POT CLEANING BRUSHES, SCRAPING BRUSHES, TUB BRUSHES, BATH BRUSHES, WASHING BRUSHES AND TOILET SPONGES; CLOTHES BRUSHES; TOILET BRUSHES (U.S. CLS. 2, 13, 23, 29, 30, 33, 40 AND 50).

JEAN IM, EXAMINING ATTORNEY

SN 85-613,420. WKI HOLDING COMPANY, INC., ROSEMONT, IL. FILED 5-1-2012.

STYLE THAT PERFORMS

THE MARK CONSISTS OF STANDARD CHARACTERS WITHOUT CLAIM TO ANY PARTICULAR FONT, STYLE, SIZE, OR COLOR.

FOR CERAMIC BAKING DISHES, CASSEROLE DISHES AND SERVING DISHES, AND LIDS THEREFOR MADE OF GLASS AND/OR PLASTIC (U.S. CLS. 2, 13, 23, 29, 30, 33, 40 AND 50).

KRISTIN DAHLING, EXAMINING ATTORNEY

CLASS 21—(Continued).

SN 85-642,830. OLIVIA GARDEN INTERNATIONAL, INC., WALNUT CREEK, CA. FILED 6-4-2012.

DIVINE

THE MARK CONSISTS OF STANDARD CHARACTERS WITHOUT CLAIM TO ANY PARTICULAR FONT, STYLE, SIZE, OR COLOR.

FOR HAIR BRUSHES (U.S. CLS. 2, 13, 23, 29, 30, 33, 40 AND 50).

FIRST USE 1-29-2012; IN COMMERCE 1-29-2012.
NAKIA HENRY, EXAMINING ATTORNEY

CLASS 22—CORDAGE AND FIBERS

SN 85-435,981. LYNCH, STEPHANIE, BIRMINGHAM, AL. FILED 9-30-2011.

DROPARAZZI

THE MARK CONSISTS OF STANDARD CHARACTERS WITHOUT CLAIM TO ANY PARTICULAR FONT, STYLE, SIZE, OR COLOR.

FOR TETHERS IN THE NATURE OF STRAPS THAT ATTACH TO HIGH CHAIRS, STROLLERS, CAR SEATS, CHAIRS, TABLES, BAGS THAT CAN HOLD TOYS, BOTTLES, CUPS, WATER BOTTLES, KEYS AND OTHER ITEMS TO PREVENT THEM FROM FALLING TO THE GROUND (U.S. CLS. 1, 2, 7, 19, 22, 42 AND 50).

AISHA SALEM, EXAMINING ATTORNEY

SN 85-602,562. CHOI, HOSOO, RICHARDSON, TX. FILED 4-19-2012.

Fast Set

THE MARK CONSISTS OF STANDARD CHARACTERS WITHOUT CLAIM TO ANY PARTICULAR FONT, STYLE, SIZE, OR COLOR.

FOR BED TENTS; CANVAS CANOPIES; TARPULINS; TENTS; TENTS; TENTS FOR MOUNTAINEERING OR CAMPING (U.S. CLS. 1, 2, 7, 19, 22, 42 AND 50).

FIRST USE 4-1-2012; IN COMMERCE 4-1-2012.

TIMOTHY FINNEGAN, EXAMINING ATTORNEY

CLASS 23—YARNS AND THREADS

SN 85-604,481. CASCADE YARNS, INC., TUKWILA, WA.
FILED 4-20-2012.

PACIFIC

THE MARK CONSISTS OF STANDARD CHARACTERS WITHOUT CLAIM TO ANY PARTICULAR FONT, STYLE, SIZE, OR COLOR.

FOR YARN (U.S. CL. 43).
FIRST USE 9-0-2010; IN COMMERCE 11-0-2010.
DAVID MURRAY, EXAMINING ATTORNEY

CLASS 24—FABRICS

SN 79-106,753. SÖKTAS DOKUMA ISLETMELERI; SANAYI VE TICARET ANONIM SİRKETİ, İZMİR, TURKEY, FILED 9-28-2011.

MEANDER 71

THE MARK CONSISTS OF STANDARD CHARACTERS WITHOUT CLAIM TO ANY PARTICULAR FONT, STYLE, SIZE, OR COLOR.

PRIORITY DATE OF 3-29-2011 IS CLAIMED.
OWNER OF INTERNATIONAL REGISTRATION 1100646 DATED 9-28-2011, EXPIRES 9-28-2021.

FOR WOVEN AND NON-WOVEN FABRICS FOR THE MANUFACTURE OF CLOTHING, NAMELY, COTTON FABRICS, NYLON FABRICS, POLYESTER FABRICS, WOVEN LINEN FABRICS, HEMP-COTTON MIXED FABRICS, COTTON-NYLON MIXED FABRICS, COTTON-POLYESTER MIXED FABRICS, FIBERGLASS FABRICS FOR TEXTILE USE; FABRIC IMPERVIOUS TO GASES FOR AERONAUTICAL BALLOONS; WATER-PROOF FABRIC FOR MANUFACTURING CLOTHING, FURNITURE AND AUTOMOBILE UPHOLSTERY; FABRIC OF IMITATION ANIMAL SKINS; TEXTILE LININGS, NAMELY, LINEN LINING FABRIC FOR SHOES, TEXTILE USED AS LINING FOR CLOTHING; BUCKRAM; FILTERING MATERIALS OF TEXTILE, NAMELY, CHEMICAL FIBER FABRICS, SYNTHETIC FIBER FABRICS, INORGANIC FIBER MIXED FABRICS ALL FOR USE IN FILTERING LIQUIDS AND POWDERS; YARN DYED SHIRTING FABRICS IN THE NATURE OF KNITTED FABRICS OF DYED WOOL YARN FOR THE MANUFACTURE OF SHIRTS, PLAIN DYED SHIRTING FABRICS IN THE NATURE OF PLAIN DYED TEXTILE FABRICS FOR THE MANUFACTURE OF SHIRTS, UPHOLSTERY FABRICS (U.S. CLS. 42 AND 50).
ANDREA K. NADELMAN, EXAMINING ATTORNEY

CLASS 24—(Continued).

SN 79-109,443. TESSITURA TOSCANA TELERIE S.R.L., I-50019 SESTO FIORENTINO (FI), ITALY, FILED 12-12-2011.



OWNER OF INTERNATIONAL REGISTRATION 1107549 DATED 12-12-2011, EXPIRES 12-12-2021.

NO CLAIM IS MADE TO THE EXCLUSIVE RIGHT TO USE "TESSITURA" "TOSCANA" "TELERIE" AND "FIRENZE", APART FROM THE MARK AS SHOWN.

THE MARK CONSISTS OF THE DESIGN OF A CIRCLE ENCASING THREE PARTIALLY OVERLAPPED LETTERS "T" EACH HAVING IN ITS CENTRAL PART THE STYLED FIGURE OF A DIAMOND; THE WORDING "TESSITURA TOSCANA TELERIE" APPEARS IN FANCY BLOCK CAPITAL LETTERS AROUND THE CIRCUMFERENCE OF THE CIRCLE. THE DESIGN OF A HORIZONTAL LINE APPEARS BELOW THE CIRCLE DESIGN, WITH THE WORDING "FIRENZE" APPEARING BELOW THE LINE.

THE ENGLISH TRANSLATION OF "TESSITURA, TOSCANA, TELERIE AND FIRENZE", IN THE MARK IS RESPECTIVELY "WEAVING, TUSCANY, CANVAS AND FLORENCE".

FOR TEXTILES AND TEXTILE GOODS, NAMELY, TEXTILE FABRICS FOR THE MANUFACTURE OF BED LINEN AND TABLE LINEN; FINISHED ITEMS FOR BED AND TABLE LINEN, NAMELY, BED SHEETS, FLAT BED SHEETS, FITTED BED SHEETS, PILLOW CASES, DUVET COVERS, SHAMS, BED SKIRTS, COVERLETS, QUILTED COVERLETS, TABLECLOTHS OF TEXTILE, FABRIC TABLE RUNNERS, PLACEMATS OF TEXTILE, COASTERS OF TEXTILE, NAPKINS OF TEXTILE; BED BLANKETS; TEXTILE KITCHEN ACCESSORIES, NAMELY, KITCHEN TOWELS, POT HOLDERS, OVEN MITTS (U.S. CLS. 42 AND 50).
CHARISMA HAMPTON, EXAMINING ATTORNEY

SN 85-276,050. DIAS, MARIA D., LUDLOW, MA. AND DIAS, LISA M., LUDLOW, MA. FILED 3-24-2011.

DOGYSHEETS

THE MARK CONSISTS OF STANDARD CHARACTERS WITHOUT CLAIM TO ANY PARTICULAR FONT, STYLE, SIZE, OR COLOR.

SEC. 2(F).
FOR FITTED BED SHEETS FOR PETS (U.S. CLS. 42 AND 50).

FIRST USE 10-3-2007; IN COMMERCE 1-9-2008.
BARBARA BROWN, EXAMINING ATTORNEY

CLASS 24—(Continued).

SN 85-323,054. BUDS AND BUTTERFLIES, LLC, LAND O' LAKES, FL. FILED 5-17-2011.



THE COLOR(S) SILVER AND PURPLE IS/ARE CLAIMED AS A FEATURE OF THE MARK.

THE MARK CONSISTS OF A STYLIZED BUTTERFLY WITH A BODY CONSISTING OF AN INVERTED PURPLE RIBBON WHICH EXTENDS ABOVE AND BELOW THE WINGS AND IS FLANKED BY TWO SILVER WINGS, EACH FORMED IN THE SHAPE OF THE LETTER "B". THE COLOR WHITE IS BACKGROUND AND NOT PART OF THE MARK.

SEC. 2(F).

FOR GIFT PACKAGE WHICH CONSISTS PRIMARILY OF A UNIQUE, SYMBOLIC, DECORATIVE, NON-WEARABLE SINGLE BREASTED TEXTILE HALF-BRA USED AS A DECORATIVE WALL HANGING, AND ALSO INCLUDING BOOKS IN THE FIELD OF BREAST CANCER AWARENESS AND PREVENTION, COMPACT DISCS FEATURING INSPIRATIONAL MUSIC, PRINTED EDUCATIONAL MATERIALS BEING PAMPHLETS AND BROCHURES IN THE FIELD OF BREAST CANCER AWARENESS AND PREVENTION, AND AN INSPIRATIONAL CARD, ALL FOR THE PURPOSE OF PROMOTING CANCER AWARENESS AND TO SPECIFICALLY INSPIRE AND APPLAUD WOMEN, PATIENTS, SURVIVORS, AND FAMILY MEMBERS (U.S. CLS. 42 AND 50). FIRST USE 5-13-2011; IN COMMERCE 5-13-2011.

MARK RADEMACHER, EXAMINING ATTORNEY

SN 85-337,022. SUMMIT ENTERTAINMENT, LLC, SANTA MONICA, CA. FILED 6-3-2011.

TWILIGHT BRIDAL

THE MARK CONSISTS OF STANDARD CHARACTERS WITHOUT CLAIM TO ANY PARTICULAR FONT, STYLE, SIZE, OR COLOR.

OWNER OF U.S. REG. NOS. 3,867,985, 3,944,718 AND OTHERS.

NO CLAIM IS MADE TO THE EXCLUSIVE RIGHT TO USE "BRIDAL", APART FROM THE MARK AS SHOWN.

FOR BED LINENS; CLOTH NAPKINS; CHAIR WRAPS; CURTAINS OF TEXTILE OR PLASTIC; AND TABLE LINENS (U.S. CLS. 42 AND 50).

ASMAT KHAN, EXAMINING ATTORNEY

CLASS 24—(Continued).

SN 85-433,087. PETTENATI S/A INDUSTRIA TEXTIL, CAXIAS DO SUL, RS -, BRAZIL, FILED 9-27-2011.



THE MARK CONSISTS OF THE STYLIZED LETTER "X" IN THE WORD "XTREME".

FOR TEXTILE FABRICS FOR APPAREL; TEXTILE FABRICS FOR INDUSTRIAL USES; SOLID, JACQUARD AND PRINTED TEXTILE FABRICS HAVING VARIOUS TYPES OF CONSTRUCTION, YARN AND FINISHING COMBINATIONS FOR APPAREL AND INDUSTRIAL USES (U.S. CLS. 42 AND 50).

FIRST USE 8-0-2011; IN COMMERCE 8-0-2011.

NAKWAMA ANKRAH, EXAMINING ATTORNEY

SN 85-460,617. SOUTHERN FELT COMPANY, INC., NORTH AUGUSTA, SC. FILED 10-31-2011.

MICROCAP

THE MARK CONSISTS OF STANDARD CHARACTERS WITHOUT CLAIM TO ANY PARTICULAR FONT, STYLE, SIZE, OR COLOR.

FOR NON-WOVEN FELT FOR USE IN THE MANUFACTURER OF FILTER MEDIA (U.S. CLS. 42 AND 50).

ANTHONY RINKER, EXAMINING ATTORNEY

CLASS 24—(Continued).

SN 85-496,311. SHANGHAI SHUIXING HOMETEXTILE CO., LTD., SHANGHAI, CHINA, FILED 12-15-2011.



THE MARK CONSISTS OF WAVE DESIGN. FOR HOME TEXTILES, NAMELY, BED COVERS, QUILTS, QUILTS COVERS, SHEET SETS, BED SHEETS, PILLOWCASES, PILLOW COVERS, TOWELS, TOWELING COVERLETS, BATH TOWELS, CURTAINS, MOSQUITO NETS; HANDKERCHIEF OF TEXTILE; FABRIC FOR TEXTILE USE (U.S. CLS. 42 AND 50).
FIRST USE 11-28-2008; IN COMMERCE 11-28-2008.
SUSAN RICHARDS, EXAMINING ATTORNEY

SN 85-506,049. RENVOI BEBE LLC, PUTNAM VALLEY, NY. FILED 12-29-2011.

RENVOI BÉBÉ

THE MARK CONSISTS OF STANDARD CHARACTERS WITHOUT CLAIM TO ANY PARTICULAR FONT, STYLE, SIZE, OR COLOR.

NO CLAIM IS MADE TO THE EXCLUSIVE RIGHT TO USE "BÉBÉ", APART FROM THE MARK AS SHOWN. THE ENGLISH TRANSLATION OF "RENVOI BÉBÉ" IN THE MARK IS "BURP BABY".

FOR BABY BEDDING, NAMELY, BUNDLE BAGS, SWADDLING BLANKETS, CRIB BUMPER, FITTED CRIB SHEETS, CRIB SKIRTS, CRIB BLANKETS, AND DIAPER CHANGING PAD COVERS NOT OF PAPER; BABY BLANKETS; BATH LINEN; BATH SHEETS; BATH TOWELS; BLANKET THROWS; BURP CLOTHS; CHILDREN'S BLANKETS; CHILDREN'S TOWELS; CRIB BUMPER PADS; CRIB BUMPER; CRIB CANOPIES; CRIB SHEETS; DIAPER CHANGING PADS NOT OF PAPER; FABRIC DIAPER STACKERS; FABRIC DRAPES DESIGNED TO CONCEAL THE ACT OF BREASTFEEDING IN PUBLIC; RECEIVING BLANKETS (U.S. CLS. 42 AND 50).

FIRST USE 8-11-2011; IN COMMERCE 8-11-2011.
AHSEN KHAN, EXAMINING ATTORNEY

CLASS 24—(Continued).

SN 85-514,978. MMI-IPCO LLC, LAWRENCE, MA. FILED 1-12-2012.

POLARTEC BREATHING IS BELIEVING

THE MARK CONSISTS OF STANDARD CHARACTERS WITHOUT CLAIM TO ANY PARTICULAR FONT, STYLE, SIZE, OR COLOR.

OWNER OF U.S. REG. NOS. 1,869,644, 2,982,559 AND OTHERS.

FOR TEXTILE FABRICS FOR USE IN THE MANUFACTURE OF CLOTHING, HOME FURNISHINGS, UPHOLSTERY, FURNITURE, HOUSEWARES FURNISHINGS, CARPETS, FLOOR COVERINGS, WALL COVERINGS, CURTAINS, FURNITURE COVERS, BLANKETS, PILLOWS, BED LINENS, BATH LINENS, AND KITCHEN LINENS; TEXTILE FABRICS FOR USE IN THE MANUFACTURE OF HOUSEWARES, NAMELY, FURNITURE AND FURNISHINGS; TEXTILES FOR USE IN THE MANUFACTURE OF CARPETS AND FLOOR COVERINGS; TEXTILES, NAMELY, CURTAINS (U.S. CLS. 42 AND 50).

DAVID TAYLOR, EXAMINING ATTORNEY

SN 85-531,544. PAUL FRANK INDUSTRIES LLC, LOS ANGELES, CA. FILED 2-1-2012.

SMALL PAUL

THE MARK CONSISTS OF STANDARD CHARACTERS WITHOUT CLAIM TO ANY PARTICULAR FONT, STYLE, SIZE, OR COLOR.

OWNER OF U.S. REG. NO. 3,614,027.

FOR BED LINEN, BED SHEETS, FITTED BED SHEET COVERS, BED FLAT SHEETS AND PILLOW CASES (U.S. CLS. 42 AND 50).

MARTHA FROMM, EXAMINING ATTORNEY

SN 85-547,985. NEPTUNE RESEARCH, INC., LAKE PARK, FL. FILED 2-21-2012.

TITAN

THE MARK CONSISTS OF THE WORD "TITAN" WITH THE LETTER "A" STYLIZED IN THE FORM OF AN INCOMPLETE TRIANGLE.

FOR RESIN-SATURATED CARBON FIBER FABRIC FOR STRUCTURAL REPAIRS AND STRUCTURAL REINFORCEMENT (U.S. CLS. 42 AND 50).

FIRST USE 10-28-2011; IN COMMERCE 10-28-2011.
SKYE YOUNG, EXAMINING ATTORNEY

CLASS 24—(Continued).

SN 85-568,636. TIME'S UP, INC., LAS VEGAS, NV. FILED 3-13-2012.

PEEL & PLACE

THE MARK CONSISTS OF STANDARD CHARACTERS WITHOUT CLAIM TO ANY PARTICULAR FONT, STYLE, SIZE, OR COLOR.

FOR VINYL AND PLASTIC COUNTER MATS, NAMELY, PLACE MATS (U.S. CLS. 42 AND 50).
FIRST USE 1-27-1997; IN COMMERCE 1-27-1997.
ZACHARY BELLO, EXAMINING ATTORNEY

SN 85-573,308. WP, IP LLC, NEW YORK, NY. FILED 3-19-2012.

ONE FABULOUS TOWEL

THE MARK CONSISTS OF STANDARD CHARACTERS WITHOUT CLAIM TO ANY PARTICULAR FONT, STYLE, SIZE, OR COLOR.

NO CLAIM IS MADE TO THE EXCLUSIVE RIGHT TO USE "TOWEL", APART FROM THE MARK AS SHOWN.

FOR TOWELS, BATH SHEETS, FACE CLOTHS (U.S. CLS. 42 AND 50).

BARBARA BROWN, EXAMINING ATTORNEY

SN 85-595,453. COLLECTIVE LICENSING INTERNATIONAL, LLC, ENGLEWOOD, CO. FILED 4-11-2012.

PROLETE

THE MARK CONSISTS OF STANDARD CHARACTERS WITHOUT CLAIM TO ANY PARTICULAR FONT, STYLE, SIZE, OR COLOR.

OWNER OF U.S. REG. NO. 3,006,522.

FOR FABRIC FOR CLOTHING, NAMELY, TEXTILE FABRICS FOR THE MANUFACTURE OF CLOTHING, JERSEY FABRICS FOR CLOTHING, ELASTIC FABRICS FOR CLOTHING, POLYACTIC ACID FABRICS FOR MANUFACTURING CLOTHING, SPANDEX FABRIC FOR USE IN THE MANUFACTURE OF CLOTHING, WATERPROOF FABRIC FOR MANUFACTURING OF CLOTHING (U.S. CLS. 42 AND 50).

FIRST USE 3-1-2012; IN COMMERCE 3-1-2012.

JAY BESCH, EXAMINING ATTORNEY

CLASS 24—(Continued).

SN 85-596,138. THE SUN PRODUCTS CORPORATION, WILTON, CT. FILED 4-12-2012.



THE STIPPLING IS FOR SHADING PURPOSES ONLY. THE MARK CONSISTS OF A BEAR HOLDING UP TO ITS CHEEK, A TOWEL OR BLANKET THAT ACTS AS A BANNER IN FRONT OF THE BEAR.

FOR BABY BEDDING, NAMELY, CRIB SHEETS, CRIB LINENS, CRIB SKIRTS, CRIB BLANKETS, CHANGING TABLE PADS, CRIB PADS, CRIB BUMPERS; NAP MATS; BEDDING, NAMELY, MATTRESS COVERS, SHEETS, BLANKETS, PILLOWS, BED SKIRTS, BED LINENS, COMFORTERS, DUVET COVERS, BED SPREADS, BED CANOPIES, PILLOW CASES; FEATHER BEDS; THROWS; QUILTS (U.S. CLS. 42 AND 50).

PRISCILLA MILTON, EXAMINING ATTORNEY

SN 85-598,437. SPRINGS CREATIVE PRODUCTS GROUP, LLC, ROCK HILL, SC. FILED 4-16-2012.

MODERN STITCHES

THE MARK CONSISTS OF STANDARD CHARACTERS WITHOUT CLAIM TO ANY PARTICULAR FONT, STYLE, SIZE, OR COLOR.

NO CLAIM IS MADE TO THE EXCLUSIVE RIGHT TO USE "STITCHES", APART FROM THE MARK AS SHOWN.

FOR TEXTILE FABRIC SOLD BY THE YARD; PRE-CUT TEXTILE FABRIC; PACKAGED PRE-CUT TEXTILE FABRIC; ALL FOR USE IN HOME QUILTING, SEWING AND CRAFTS (U.S. CLS. 42 AND 50).

ALAIN LAPTER, EXAMINING ATTORNEY

CLASS 24—(Continued).

SN 85-600,174. ZENITH PRODUCTS CORPORATION, NEW CASTLE, DE. FILED 4-17-2012.

QuikHang

THE MARK CONSISTS OF STANDARD CHARACTERS WITHOUT CLAIM TO ANY PARTICULAR FONT, STYLE, SIZE, OR COLOR.

FOR SHOWER CURTAIN LINERS; SHOWER CURTAINS (U.S. CLS. 42 AND 50).

FIRST USE 7-16-2012; IN COMMERCE 7-16-2012.
VERNA BETH RIRIE, EXAMINING ATTORNEY

SN 85-604,981. SYSCO CORPORATION, HOUSTON, TX. FILED 4-23-2012.



NO CLAIM IS MADE TO THE EXCLUSIVE RIGHT TO USE "QA", APART FROM THE MARK AS SHOWN.

THE MARK CONSISTS OF THESE STYLIZED LETTERS "Q" AND "A" WITH A LEAF DESIGN AS THE STEM ON THE "Q" AND THE BAR ACROSS THE LETTER "A".

FOR POT HOLDERS; OVEN MITTS; LINEN AND LACE DOILIES; TOWELS; BEDSHEETS; BED BLANKETS; COMFORTERS; DUVETS; DUVET COVERS; MATTRESS PADS; TABLE LINEN; PILLOW CASES; PILLOW SHAMS; BED SKIRTS; PILLOW COVERS, NAMELY, PILLOW PROTECTORS; DECORATIVE FABRIC BED RUNNERS; FEATHERBED COVERS AND PROTECTORS (U.S. CLS. 42 AND 50).

TINA MAI, EXAMINING ATTORNEY

CLASS 24—(Continued).

SN 85-605,459. CASSANDRA ATHERTON, NEW YORK, NY. FILED 4-23-2012.

La Maison Sacre

THE MARK CONSISTS OF STANDARD CHARACTERS WITHOUT CLAIM TO ANY PARTICULAR FONT, STYLE, SIZE, OR COLOR.

THE ENGLISH TRANSLATION OF "LA MAISON SACRE" IN THE MARK IS "THE SACRED HOME".

FOR BABY BEDDING, NAMELY, BUNDLE BAGS, SWADDLING BLANKETS, CRIB BUMPERS, FITTED CRIB SHEETS, CRIB SKIRTS, CRIB BLANKETS, AND DIAPER CHANGING PAD COVERS NOT OF PAPER; BATH TOWELS; BED SHEETS; COMFORTERS; PILLOW CASES; PILLOW COVERS; PILLOW SHAMS; SHOWER CURTAINS; THROWS (U.S. CLS. 42 AND 50).

TRACY FLETCHER, EXAMINING ATTORNEY

SN 85-605,491. CASSANDRA ATHERTON, NEW YORK, NY. FILED 4-23-2012.

Sacre

THE MARK CONSISTS OF STANDARD CHARACTERS WITHOUT CLAIM TO ANY PARTICULAR FONT, STYLE, SIZE, OR COLOR.

THE ENGLISH TRANSLATION OF "SACRE" IN THE MARK IS "SACRED".

FOR BATH TOWELS; BED SHEETS; COMFORTERS; PILLOW CASES; PILLOW COVERS; PILLOW SHAMS; SHOWER CURTAINS; THROWS (U.S. CLS. 42 AND 50).

TRACY FLETCHER, EXAMINING ATTORNEY

SN 85-613,502. HEARST COMMUNICATIONS, INC., NEW YORK, NY. FILED 5-1-2012.

HOUSE BEAUTIFUL

THE MARK CONSISTS OF STANDARD CHARACTERS WITHOUT CLAIM TO ANY PARTICULAR FONT, STYLE, SIZE, OR COLOR.

OWNER OF U.S. REG. NOS. 273,427, 3,152,302 AND OTHERS.

FOR DRAPERIES, BED LINENS, BATH LINENS (U.S. CLS. 42 AND 50).

SETH A. RAPPAPORT, EXAMINING ATTORNEY

CLASS 24—(Continued).

SN 85-616,082. TIME'S UP, INC., LAS VEGAS, NV. FILED 5-3-2012.

DURATEC

THE MARK CONSISTS OF STANDARD CHARACTERS WITHOUT CLAIM TO ANY PARTICULAR FONT, STYLE, SIZE, OR COLOR.

FOR VINYL AND PLASTIC COUNTER MATS WITH RUBBER OR FOAM BACKING, NAMELY PLACE MATS (U.S. CLS. 42 AND 50).

ZACHARY BELLO, EXAMINING ATTORNEY

SN 85-657,296. DR. SEUSS ENTERPRISES, L.P., LA JOLLA, CA. FILED 6-20-2012.



OWNER OF U.S. REG. NOS. 2,250,620, 3,881,528 AND OTHERS.

THE NAME(S), PORTRAIT(S), AND/OR SIGNATURE(S) SHOWN IN THE MARK DOES NOT IDENTIFY A PARTICULAR LIVING INDIVIDUAL.

THE MARK CONSISTS OF THE WORDS "THE CAT IN THE HAT" IN A QUADRILATERAL SURROUNDED BY THE STYLIZED IMAGES OF A BOY, A GIRL WITH A BOW IN HER HAIR, A FISH IN A FISH BOWL WITH WATER SPILLING FROM IT, A CAT WEARING GLOVES AND A BOW TIE AND HOLDING A HAT, AND THE FANCIFUL IMAGE OF TWO CREATURES WITH FULL HAIR AND BIG EYES, ONE STANDING ON THE SHOULDERS OF THE OTHER WITH THE LITERAL ELEMENT "THING 2", ENCLOSED BY A CIRCLE, APPEARING ON THE CHEST OF THE BOTTOM CREATURE, AND THE WORDS "DR. SEUSS" IN THE LOWER RIGHT HAND CORNER OF THE QUADRILATERAL.

FOR FABRICS FOR TEXTILE USE (U.S. CLS. 42 AND 50).

FIRST USE 1-1-2011; IN COMMERCE 1-1-2011.

MATTHEW PAPPAS, EXAMINING ATTORNEY

CLASS 25—CLOTHING

SN 76-709,270. ELLMORE, MARK W., ALEXANDRIA, VA. FILED 10-3-2011.

KTTT

THE MARK CONSISTS OF THE STYLIZED LETTERS "KTTT". THE LAST LETTER "T" IS IN THE SHAPE OF A CROSS.

FOR CAMP SHIRTS, GOLF SHIRTS, KNIT SHIRTS, NIGHT SHIRTS, POLO SHIRTS, SHIRT FRONTS, SHIRTS, SLEEP SHIRTS, SWEAT SHIRTS, T-SHIRTS, WIND SHIRTS, AND WRISTBANDS (U.S. CLS. 22 AND 39).

FIRST USE 10-15-2001; IN COMMERCE 10-15-2001.

SANI KHOURI, EXAMINING ATTORNEY

SN 76-710,951. LANGFANG QUAN HONG DA TEXTILE INDUSTRY LTD., COMPANY, LANGFANG CITY, HEBEI, CHINA, FILED 3-19-2012.

Lang Yi Fang

THE MARK CONSISTS OF STYLIZED LITERAL ELEMENT "LANG YI FANG" WITH A SYMBOL THAT CAN BE SEEN AS A CAPITAL "L", "Y", OR "F" ON TOP OF THE LITERAL ELEMENT.

THE WORDING "LANG YI FANG" HAS NO MEANING IN A FOREIGN LANGUAGE.

FOR TEXTILE PRODUCTS, NAMELY, MEN'S, LADIES' AND CHILDREN'S LINEN UNIFORMS, SHIRTS, PANTS, T-SHIRTS, JACKETS, AND COATS; MEN'S, LADIES' AND CHILDREN'S LEATHER UNIFORMS, SHIRTS, PANTS, T-SHIRTS, JACKETS, AND COATS; KNITTED MEN'S, LADIES' AND CHILDREN'S UNIFORMS, SHIRTS, PANTS, T-SHIRTS, JACKETS, AND COATS; MEN'S, LADIES' AND CHILDREN'S DOWN UNIFORMS, SHIRTS, PANTS, T-SHIRTS, JACKETS, AND COATS; AND MEN'S, LADIES' AND CHILDREN'S LEATHERETTE UNIFORMS, SHIRTS, PANTS, T-SHIRTS, JACKETS, AND COATS (U.S. CLS. 22 AND 39).

THOMAS MANOR, EXAMINING ATTORNEY

CLASS 25—(Continued).

SN 76-711,119. GRECO, LUCRECIA, WINTER SPRINGS, FL. FILED 4-5-2012.



THE MARK CONSISTS OF AN AXE, WITH THE WORDS "COUNTRYCITYBOY" MAKING UP THE HANDLE OF THE AXE.

FOR SHIRTS, SWEATSHIRTS, HATS (U.S. CLS. 22 AND 39).

ANDREW LEASER, EXAMINING ATTORNEY

SN 76-711,318. GRECO, LUCRECIA, WINTER SPRINGS, FL. FILED 4-23-2012.



THE MARK CONSISTS OF A SNIPER RIFLE WITH A SCOPE, WITH THE WORDS "COUNTRYCITYBOY" MAKING UP THE BODY OF THE RIFLE.

FOR SHIRTS, SWEATSHIRTS, HATS (U.S. CLS. 22 AND 39).

ANDREW LEASER, EXAMINING ATTORNEY

SN 77-174,081. WRANGLER APPAREL CORP., WILMINGTON, DE. FILED 5-7-2007.

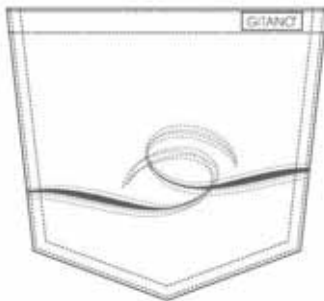

OWNER OF U.S. REG. NO. 1,119,681. THE MARK CONSISTS OF A STITCHING DESIGN APPLIED TO THE BACK POCKETS OF THE GOODS. THE WORDING "GITANO" APPEARS ON THE TOP RIGHT PORTION OF THE POCKET. THE REPRESENTATION OF THE POCKET ITSELF IS NOT PART OF THE MARK.

FOR BOTTOMS (U.S. CLS. 22 AND 39).

GINA HAYES, EXAMINING ATTORNEY

CLASS 25—(Continued).

SN 77-508,400. YAMUNA INTERNATIONAL, GAUTAM BUDH NAGAR, INDIA, FILED 6-25-2008.

GO GREEN

THE MARK CONSISTS OF STANDARD CHARACTERS WITHOUT CLAIM TO ANY PARTICULAR FONT, STYLE, SIZE, OR COLOR.

NO CLAIM IS MADE TO THE EXCLUSIVE RIGHT TO USE "GREEN", APART FROM THE MARK AS SHOWN.

FOR CLOTHING THAT IS GREEN FOR ECOLOGICAL PURPOSES, NAMELY, PANTS, SHIRTS, JACKETS, VESTS, SOCKS, CHAPS, CAPS, BREECHES, JODHPURS, POLO T-SHIRTS AND SIMILAR HORSE RIDING APPAREL AND ACCESSORIES, NAMELY, SWEATSHIRTS, RIDING TROUSERS, SHOWJUMPING JACKETS AND SHOW JACKETS (U.S. CLS. 22 AND 39).

FIRST USE 5-1-2008; IN COMMERCE 5-1-2008.

REGINA DRUMMOND, EXAMINING ATTORNEY

SN 77-592,739. HALL, CAMETRIA, ADELANTO, CA. FILED 10-14-2008.

Nerd*Herd

THE MARK CONSISTS OF STANDARD CHARACTERS WITHOUT CLAIM TO ANY PARTICULAR FONT, STYLE, SIZE, OR COLOR.

FOR T-SHIRTS (U.S. CLS. 22 AND 39).

CURTIS FRENCH, EXAMINING ATTORNEY

SN 77-705,007. LEONISA S.A., MEDELLIN, COLOMBIA, FILED 4-2-2009.



OWNER OF U.S. REG. NOS. 2,352,263, 3,981,800 AND OTHERS.

THE COLOR(S) BLACK, WHITE, BLUE AND PINK IS/ ARE CLAIMED AS A FEATURE OF THE MARK.

THE MARK CONSISTS OF , IN THE TOP RIGHT CORNER OF THE DESIGN, A STYLIZED LETTER "L" ENCLOSED IN A CIRCLE NEXT TO THE WORD "LEONISA" ALL IN THE COLOR BLUE ON A WHITE RECTANGULAR BACKGROUND, BELOW WHICH APPEARS THE

CLASS 25—(Continued).

WORDING "SI ES MUJER LATINA" IN WHITE ON A BLUE RECTANGULAR BACKGROUND. BELOW WHICH APPEARS THE WORDING "WWW.LEONISA.COM" IN WHITE; IN THE CENTER OF THE DESIGN IS THE WORDING "LA" IN WHITE AND "NUEVA GENERACION" IN PINK AND "DE REALCE" IN WHITE. BELOW WHICH IS THE WORDING "HI-MAX" IN PINK AND WHITE. BELOW WHICH IS THE WORDING "AUMENTA:CENTRA:LEVANTA" IN WHITE; ALL OF WHICH APPEAR ON A SQUARE BLACK BACKGROUND.

THE ENGLISH TRANSLATION OF "SI ES MUJER LATINA, LA NUEVA GENERACION DE REALCE, AUMENTA:CENTRA:LEVANTA" IN THE MARK IS "A TRULY LATIN WOMAN", "THE NEW GENERATION OF ENHANCEMENT, INCREASES:CENTERS:RAISES". THE TERM "LEONISA" HAS NO MEANING IN A FOREIGN LANGUAGE.

FOR FEMININE UNDERWEAR AND BATHROOM DRESSES IN THE NATURE OF BATH ROBES (U.S. CLS. 22 AND 39).

AMY ALFIERI, EXAMINING ATTORNEY

CLASS 25—(Continued).

SN 77-938,083. GREENFIELD, STEFANI, NEW YORK, NY. FILED 2-17-2010.



The logo for Yummy Sweater Co. features the word "Yummy" in a large, stylized, cursive font. Below it, the words "Sweater Co." are written in a smaller, simpler font.

OWNER OF U.S. REG. NOS. 3,516,796 AND 3,524,476.

NO CLAIM IS MADE TO THE EXCLUSIVE RIGHT TO USE "SWEATER CO.", APART FROM THE MARK AS SHOWN.

THE MARK CONSISTS OF THE WORDS "YUMMY SWEATER CO."

FOR CLOTHING, NAMELY, TEE SHIRTS, SHIRTS, TANK TOPS, SWEATERS, SWEAT SHIRTS, VESTS, DRESSES, SKIRTS, COATS, JACKETS, PANTS, JEANS, SHORTS, HATS, SCARVES AND FOOTWEAR (U.S. CLS. 22 AND 39).

FIRST USE 12-8-2009; IN COMMERCE 12-8-2009.

CHARLOTTE CORWIN, EXAMINING ATTORNEY

SN 77-822,258. HANCHETTE, STEVEN D, DBA HANCHETTE, STEVEN D, LAKE ELSINORE, CA. FILED 9-8-2009.

SN 78-965,610. HOVIS, IAN W, MILWAUKEE, WI. FILED 8-31-2006.

LE DIRTE



THE MARK CONSISTS OF STANDARD CHARACTERS WITHOUT CLAIM TO ANY PARTICULAR FONT, STYLE, SIZE, OR COLOR.

THE WORDING "LE DIRTE" HAS NO MEANING IN A FOREIGN LANGUAGE.

FOR T-SHIRTS, SWEAT SHIRTS (U.S. CLS. 22 AND 39).

BENJAMIN OKEKE, EXAMINING ATTORNEY

THE MARK CONSISTS OF THE WORDS "HANDLE IT", WHICH ARE LOCATED INSIDE OF THE MOTORCYCLE HANDLE BARS THAT HAVE HAND GRIPS WITH CONTROL LEVERS ABOVE THE HAND GRIPS.

FOR CLOTHING, NAMELY, APRONS, BANDANAS, BATHING SUITS, BEACH WEAR, BELTS, BERMUDA SHORTS, BLAZERS, BLOUSES, BODY SUITS, BOOTS, BOXER SHORTS, BRASSIERES, CAPS, COATS, DRESSES, GLOVES, GOLF SHIRTS, GYM SUITS, HATS, HEADBANDS, HEADWEAR, HOSIERY, JACKETS, JEANS, JERSEYS, JOGGING SUITS, JUMP SUITS, KNIT SHIRTS, KNITTED HATS, LEATHER HEADGEAR, NAMELY, HATS AND CAPS; LEATHER GLOVES, LEATHER JACKETS, LEATHER PANTS, MITTENS, NECKWEAR, OVERALLS, PAJAMAS, PANTS, PANTIES, PANTY HOSE, PARKAS, POLO SHIRTS, PONCHOS, PULLOVERS, RAINCOATS, RAINWEAR, ROBES, SCARVES, SHIRTS, SHOES, SHORTS, SKIRTS, SLEEPWEAR, SLIPPERS, SOCKS, SPORTCOATS, SUITS, SWEATPANTS, SWEATERS, SWEATSHIRTS, T-SHIRTS, TANKTOPS, TIES, TOPCOATS, UNDERWEAR, V-NECK SWEATERS, VESTS, VISORS, AND WRIST BANDS (U.S. CLS. 22 AND 39).

SOPHIA S. KIM, EXAMINING ATTORNEY

SN 78-967,259. WRANGLER APPAREL CORP., WILMINGTON, DE. FILED 9-5-2006.

P.S. GITANO

THE MARK CONSISTS OF STANDARD CHARACTERS WITHOUT CLAIM TO ANY PARTICULAR FONT, STYLE, SIZE, OR COLOR.

OWNER OF U.S. REG. NOS. 1,119,681 AND 3,706,916.

THE ENGLISH TRANSLATION OF "GITANO" IS "GYPSY".

FOR WOMEN'S JEANS, PANTS, TOPS AND SKIRTS (U.S. CLS. 22 AND 39).

KAPIL BHANOT, EXAMINING ATTORNEY

CLASS 25—(Continued).

SN 79-103,733. YOEK B.V., ZWANENBURG, NETHERLANDS, FILED 9-2-2011.



PRIORITY DATE OF 8-18-2011 IS CLAIMED.
OWNER OF INTERNATIONAL REGISTRATION 1093764 DATED 9-2-2011, EXPIRES 9-2-2021.
THE MARK CONSISTS OF THE STYLIZED WORDING "YOEK".

FOR CLOTHING, NAMELY, SHIRTS, SWEATERS, TUNICS, KAFTANS, BLOUSES, TOPS, KNIT BOTTOMS, KNIT DRESSES, KNIT JACKETS, KNIT SHIRTS, KNIT SKIRTS, KNIT TOPS, AND KNITTED UNDERWEAR, CARDIGANS, SHRUGS, GILETS, SKIRTS, SINGLET, DRESSES, COATS, JACKETS, PANTS, LEGGINGS, SWEATSHIRTS, UNDERWEAR AND SCARVES (U.S. CLS. 22 AND 39).

BRENDAN MCCAULEY, EXAMINING ATTORNEY

CLASS 25—(Continued).

SN 79-106,619. K8 S.R.L., ITALY, FILED 11-11-2011.

ERIKA CAVALLINI

THE MARK CONSISTS OF STANDARD CHARACTERS WITHOUT CLAIM TO ANY PARTICULAR FONT, STYLE, SIZE, OR COLOR.

PRIORITY DATE OF 10-28-2011 IS CLAIMED.
OWNER OF INTERNATIONAL REGISTRATION 1100327 DATED 11-11-2011, EXPIRES 11-11-2021.

THE NAME "ERIKA CAVALLINI" IDENTIFIES A LIVING INDIVIDUAL WHOSE CONSENT IS OF RECORD.

FOR BLAZERS; DRESSES; SWIMWEAR; HEADGEAR, NAMELY, HATS, CAPS AND KNIT CAPS; BLOUSES; FOOTWEAR; SHORTS; CHEMISETTES; SHIRTS AND SHORT-SLEEVES SHIRTS; CAMISOLES; COATS; BELTS; SOCKS; STOLEES; JACKETS; SKIRTS; GLOVES; RAIN-COATS; JERSEYS; UNDERSHIRTS; KNIT JACKETS; KNIT SHIRTS; KNIT DRESSES; KNIT SKIRTS; KNIT TOPS; KNIT GLOVES; KNITTED UNDERWEAR; SWEATERS; CLOAKS; CAPES; TROUSERS; PARKAS; CLOTHING MADE FROM IMITATION LEATHER, NAMELY, IMITATION LEATHER JACKETS, IMITATION LEATHER SKIRTS, IMITATION LEATHER PANTS, IMITATION LEATHER DRESSES, IMITATION LEATHER BELTS, IMITATION LEATHER GLOVES; CLOTHING MADE OF LEATHER, NAMELY, LEATHER JACKETS, LEATHER SKIRTS, LEATHER PANTS, LEATHER BELTS, LEATHER GLOVES, LEATHER DRESSES; SANDALS; SHOES; SHAWLS; SCARVES; OVERCOATS; PETTICOATS; BEACHWEAR; BOOTS; FUR STOLEES; T-SHIRTS; PANTSUITS; CARDIGANS (U.S. CLS. 22 AND 39).

SHANNON TWOHIG, EXAMINING ATTORNEY

SN 79-104,812. YOEK B.V., ZWANENBURG, NETHERLANDS, FILED 8-30-2011.



THE MARK CONSISTS OF STANDARD CHARACTERS WITHOUT CLAIM TO ANY PARTICULAR FONT, STYLE, SIZE, OR COLOR.

PRIORITY DATE OF 8-18-2011 IS CLAIMED.
OWNER OF INTERNATIONAL REGISTRATION 1096205 DATED 8-30-2011, EXPIRES 8-30-2021.

FOR CLOTHING, NAMELY, SHIRTS, SWEATERS, TUNICS, KAFTANS, BLOUSES, TOPS, KNIT BOTTOMS, KNIT DRESSES, KNIT JACKETS, KNIT SHIRTS, KNIT SKIRTS, KNIT TOPS, AND KNITTED UNDERWEAR, CARDIGANS, SHRUGS, GILETS, SKIRTS, SINGLET, DRESSES, COATS, JACKETS, PANTS, LEGGINGS, SWEATSHIRTS, UNDERWEAR AND SCARVES (U.S. CLS. 22 AND 39).

BRENDAN MCCAULEY, EXAMINING ATTORNEY

SN 79-107,058. LUCIANO LASTRUCCI S.R.L., ITALY, FILED 10-21-2011.



OWNER OF INTERNATIONAL REGISTRATION 1101362 DATED 10-21-2011, EXPIRES 10-21-2021.

NO CLAIM IS MADE TO THE EXCLUSIVE RIGHT TO USE "FIRENZE", APART FROM THE MARK AS SHOWN.

THE NAME(S), PORTRAIT(S), AND/OR SIGNATURE(S) SHOWN IN THE MARK IDENTIFIES "PAOLO LASTRUCCI", WHOSE CONSENT(S) TO REGISTER IS MADE OF RECORD.

THE ENGLISH TRANSLATION OF "FIRENZE" IN THE MARK IS "FLORENCE".

FOR SHIRTS; SUITS; BELTS FOR CLOTHING; CAMISOLES; COATS; FOOTWEAR; GLOVES; HATS; HOSIERY; JACKETS AND SOCKS; JEANS; PANTS; PULLOVERS; SCARVES; SHORTS; SWEATERS; T-SHIRTS; TIES (U.S. CLS. 22 AND 39).

CHRISTOPHER LAW, EXAMINING ATTORNEY

CLASS 25—(Continued).

SN 79-108,003. GRUPO MASCARÓ, S.L., FERRERIAS, ISLAS BALEARES, SPAIN, FILED 9-28-2011.



PRIORITY DATE OF 6-15-2011 IS CLAIMED.
OWNER OF INTERNATIONAL REGISTRATION 1103882 DATED 9-28-2011, EXPIRES 9-28-2021.

OWNER OF U.S. REG. NOS. 3,154,375, 3,838,111 AND 3,841,640.

THE COLOR(S) PINK AND GOLD IS/ARE CLAIMED AS A FEATURE OF THE MARK.

THE MARK CONSISTS OF THE GOLD WORDING "PRETTYBALLERINAS" IN STYLIZED FONT, TO THE RIGHT OF WHICH IS A GOLD OUTLINE OF A PAIR OF BALLET SHOES FROM AN OVERHEAD VIEW, AND THE BACKGROUND IS PINK.

FOR CLOTHING, NAMELY, SHIRTS, PANTS, JERSEYS, SHORTS AND TOPS; FOOTWEAR; HEADGEAR, NAMELY, CAPS, HATS AND SUNSHADES (U.S. CLS. 22 AND 39).

JASON BLAIR, EXAMINING ATTORNEY

SN 79-108,004. GRUPO MASCARÓ, S.L., FERRERIAS, ISLAS BALEARES, SPAIN, FILED 9-28-2011.



PRIORITY DATE OF 6-15-2011 IS CLAIMED.
OWNER OF INTERNATIONAL REGISTRATION 1103883 DATED 9-28-2011, EXPIRES 9-28-2021.

OWNER OF U.S. REG. NOS. 3,154,375, 3,838,111 AND 3,841,640.

THE COLOR(S) PINK AND GOLD IS/ARE CLAIMED AS A FEATURE OF THE MARK.

THE MARK CONSISTS OF THE GOLD WORDING "PRETTYBALLERINAS" IN STYLIZED FONT, ABOVE WHICH, CENTRALLY ALIGNED, IS A GOLD OUTLINE OF A PAIR OF BALLET SHOES FROM AN OVERHEAD VIEW, AND THE BACKGROUND IS PINK.

FOR CLOTHING, NAMELY, SHIRTS, PANTS, JERSEYS, SHORTS AND TOPS; FOOTWEAR; HEADGEAR, NAMELY, CAPS, HATS AND SUNSHADES (U.S. CLS. 22 AND 39).

JASON BLAIR, EXAMINING ATTORNEY

CLASS 25—(Continued).

SN 85-017,467. SOURCE INTERLINK MAGAZINES, LLC, EL SEGUNDO, CA. FILED 4-19-2010.

SLAM

THE MARK CONSISTS OF STANDARD CHARACTERS WITHOUT CLAIM TO ANY PARTICULAR FONT, STYLE, SIZE, OR COLOR.

OWNER OF U.S. REG. NOS. 2,288,824 AND 2,967,311.
FOR BASKETBALL PERFORMANCE APPAREL FOR CHILDREN, NAMELY, SOCKS, SHORTS, T-SHIRTS, AND SHOES (U.S. CLS. 22 AND 39).

CHRISTOPHER LAW, EXAMINING ATTORNEY

SN 85-021,901. JASON HEYWARD, ATLANTA, GA. FILED 4-23-2010.

HEY-MAKER

THE MARK CONSISTS OF STANDARD CHARACTERS WITHOUT CLAIM TO ANY PARTICULAR FONT, STYLE, SIZE, OR COLOR.

FOR ATHLETIC FOOTWEAR; ATHLETIC UNIFORMS; CAPS; FLEECE PULLOVERS; GLOVES; GOLF SHIRTS; GOLF TROUSERS; HATS; JACKETS; JEANS; JOGGING SUITS; LOUNGEWEAR; PANTS; POLO SHIRTS; RUGBY SHIRTS; SHIRTS; SHORTS; SLACKS; SLEEPWEAR; SOCKS; SPORTS JERSEYS; SWEAT SUITS; SWEATERS; T-SHIRTS; TANK TOPS; TIES; VISORS; WRIST BANDS (U.S. CLS. 22 AND 39).

KATHLEEN KOLACZ, EXAMINING ATTORNEY

SN 85-114,068. PURKETT, VARAN, CHICAGO, IL. FILED 8-23-2010.



THE MARK CONSISTS OF THE STYLIZED WORDING "G40c" WITH THE WORD "GIVE" ON THE SIDE AND "DO YOU G40?!" AT THE BOTTOM.

"G40" MEANS TO GIVE 40 CENTS.
FOR HATS; HOODED SWEAT SHIRTS; SHIRTS; T-SHIRTS (U.S. CLS. 22 AND 39).

FIRST USE 9-1-2006; IN COMMERCE 9-1-2006.

MICHELE SWAIN, EXAMINING ATTORNEY

CLASS 25—(Continued).

SN 85-230,403. TRIBAL SPORTSWEAR GENERAL PARTNERSHIP, MONTREAL, QUEBEC, CANADA, FILED 1-31-2011.

T TRAVEL BY TRIBAL

THE MARK CONSISTS OF STANDARD CHARACTERS WITHOUT CLAIM TO ANY PARTICULAR FONT, STYLE, SIZE, OR COLOR.

PRIORITY CLAIMED UNDER SEC. 44(D) ON CANADA APPLICATION NO. 1502898, FILED 11-5-2010, REG. NO. TMA819,491, DATED 3-8-2012, EXPIRES 3-8-2027.

OWNER OF U.S. REG. NOS. 1,843,013, 3,924,419 AND OTHERS.

NO CLAIM IS MADE TO THE EXCLUSIVE RIGHT TO USE "TRAVEL", APART FROM THE MARK AS SHOWN.

FOR CLOTHING, NAMELY, VESTS, JUMPSUITS, DRESSES; TOPS, NAMELY, SHIRTS, BLOUSES, SWEATERS; PANTS, CAPRIS AND SKIRTS (U.S. CLS. 22 AND 39).

KATHRYN COWARD, EXAMINING ATTORNEY

SN 85-232,216. TOUPS, NEAL, RACELAND, LA. FILED 2-2-2011.



THE MARK CONSISTS OF THE STYLIZED WORDING "PIERPUNKS" DISPLAYED IN THE SHAPE OF A FISH.

FOR HATS; JACKETS; SHORTS; T-SHIRTS, VISORS, CHILDREN'S HATS, JACKETS, SHORTS AND T-SHIRTS (U.S. CLS. 22 AND 39).

FIRST USE 5-1-2007; IN COMMERCE 5-1-2007.
NATALIE POLZER, EXAMINING ATTORNEY

SN 85-260,045. MILTON, FAYE, DBA MIL/WAT INTERNATIONAL, LLC, ARLINGTON, TX. FILED 3-7-2011.

TIE HARD TEN MY DESTINY! MY ABILITY! MY REALITY!

THE MARK CONSISTS OF STANDARD CHARACTERS WITHOUT CLAIM TO ANY PARTICULAR FONT, STYLE, SIZE, OR COLOR.

FOR ATHLETIC APPAREL, NAMELY, TEE SHIRTS, SWEATSHIRTS, PANTS, SHIRTS, PANTS, JACKETS, AND CAPS (U.S. CLS. 22 AND 39).

FIRST USE 1-3-2011; IN COMMERCE 1-3-2011.
LINDA LAVACHE, EXAMINING ATTORNEY

CLASS 25—(Continued).

SN 85-280,135. FAM, LLC, COMMERCE, CA. FILED 3-29-2011.



THE MARK CONSISTS OF THE WORDS "SLIM TECH" WITH A STYLIZED "S" DESIGN BETWEEN THE TWO WORDS.

FOR CLOTHING, NAMELY, BRA TOPS, PANTS, SHIRTS, SKIRTS, TIGHTS, TOPS, TEE-SHIRTS, SOCKS, UNDERWEAR, HATS AND HEADBANDS (U.S. CLS. 22 AND 39).

FIRST USE 3-23-2005; IN COMMERCE 3-23-2005.
DAVID TAYLOR, EXAMINING ATTORNEY

SN 85-311,606. GOTHE, AXEL, NEW YORK, NY. FILED 5-3-2011.



NO CLAIM IS MADE TO THE EXCLUSIVE RIGHT TO USE "COUTURE", APART FROM THE MARK AS SHOWN.

THE MARK CONSISTS OF THE STYLIZED WORD "LOVE", WITH THE IMAGE OF THE EARTH IN PLACE OF THE LETTER "O" AND THE WORD "COUTURE" BENEATH.

FOR CLOTHING, NAMELY, T-SHIRTS, DRESS SHIRTS, SWEATERS, COATS, HEAD WEAR, DRESSES, SKIRTS, JACKETS, SWEAT SUITS, SHORTS, PANTS, SHIRTS, BLOUSES, TANK TOPS, FOOTWEAR (U.S. CLS. 22 AND 39).

KRISTIN CARLSON, EXAMINING ATTORNEY

SN 85-377,194. CLIFFORD L. JEAN, DBA CLIFFORD JEAN, LAKE WORTH, FL. FILED 7-21-2011.



THE MARK CONSISTS OF THE WORDING "GOD GOT ME" IN STYLIZED SCRIPT WITH THE TAIL OF THE LOWERCASE LETTER "G" IN "GOD" SERVING TO UNDERLINE THE WORDING AND ENDING IN THE DESIGN OF A STAR UNDER THE "E" IN "ME." ABOVE THE WORDING IS THE DESIGN OF TWO EYES.

FOR T-SHIRTS (U.S. CLS. 22 AND 39).
EMILY CARLSEN, EXAMINING ATTORNEY

CLASS 25—(Continued).

SN 85-394,046. WEBB, GLORIA F., SHREVEPORT, LA.
FILED 8-10-2011.

CLASS 25—(Continued).

SN 85-399,558. HOPKINS, NATASCHA, BEVERLY HILLS,
CA. FILED 8-16-2011.

THE PLACE TO BE

THE MARK CONSISTS OF STANDARD CHARACTERS
WITHOUT CLAIM TO ANY PARTICULAR FONT, STYLE,
SIZE, OR COLOR.

FOR BASEBALL CAPS AND HATS; SHIRTS AND
SHORT-SLEEVED SHIRTS (U.S. CLS. 22 AND 39).

FIRST USE 7-1-2010; IN COMMERCE 3-15-2011.

SUSAN BILLHEIMER, EXAMINING ATTORNEY



SN 85-395,942. MISS DAISY FASHION LTD., GREAT NECK,
NY. FILED 8-11-2011.

MISS DAISY FASHION

THE MARK CONSISTS OF STANDARD CHARACTERS
WITHOUT CLAIM TO ANY PARTICULAR FONT, STYLE,
SIZE, OR COLOR.

NO CLAIM IS MADE TO THE EXCLUSIVE RIGHT TO
USE "FASHION", APART FROM THE MARK AS SHOWN.

FOR BELTS; BLOUSES; HATS; JACKETS; PONCHOS;
SCARVES; SHAWLS (U.S. CLS. 22 AND 39).

BRIDGETT SMITH, EXAMINING ATTORNEY

THE COLOR(S) GREEN, GREY AND WHITE IS/ARE
CLAIMED AS A FEATURE OF THE MARK.

THE MARK CONSISTS OF A GREY BOX WITH A WHITE
BACKGROUND WITH THE LETTERS "CN" IN GREEN
INSIDE OF THE BOX. SPELLED OUT UNDERNEATH THE
BOX ARE THE WORDS "CAPO-NATA", WITH "CAPO" IN
GREY STACKED OVER THE WORD "NATA" IN GREEN.

FOR ATHLETIC APPAREL, NAMELY, SHIRTS,
PANTS, JACKETS, FOOTWEAR, HATS AND CAPS;
ATHLETIC UNIFORMS; BODY SHAPERS; BODY
SHIRTS; BRAS; FOUNDATION GARMENTS; MOIST-
URE-WICKING SPORTS SHIRTS; SPORTS BRA; SPORTS
BRAS; SPORTS SHIRTS; STRAPLESS BRAS; SWEAT-
SHIRTS; SWEATSHIRTS FOR ATHLETIC WOMEN; UN-
DERGARMENTS; UNDERSHIRTS; WOMEN'S
ATHLETIC TOPS WITH BUILT-IN BRAS (U.S. CLS. 22
AND 39).

SUSAN LESLIE DUBOIS, EXAMINING ATTORNEY

CLASS 25—(Continued).

SN 85-402,740. SERVICIOS PROFESIONALES DE OPERACION, S.A. DE C.V., TIJUANA, BC, MEXICO, FILED 8-19-2011.



PRIORITY CLAIMED UNDER SEC. 44(D) ON MEXICO APPLICATION NO. 1204311, FILED 8-18-2011, REG. NO. 1265257, DATED 2-3-2012, EXPIRES 2-3-2022.

NO CLAIM IS MADE TO THE EXCLUSIVE RIGHT TO USE "CLUB TIJUANA", APART FROM THE MARK AS SHOWN.

THE COLOR(S) BLACK AND RED IS/ARE CLAIMED AS A FEATURE OF THE MARK.

THE MARK CONSISTS OF TWO BLACK CIRCLES FEATURING TWO RED DOTS BETWEEN THE CIRCLES AND THE WORDS "CLUB TIJUANA" AT THE TOP OF THE CIRCLE AND "XOLOITZCUINTLES DE CALIENTE" AT THE BOTTOM OF THE CIRCLE. THE WORDING IS ENTIRELY IN BLACK. INSIDE THE INNERMOST CIRCLE IS THE HEAD OF A XOLOITZCUINTLE DOG IN BLACK WITH A RED BACKGROUND.

THE ENGLISH TRANSLATION OF "DE CALIENTE" IN THE MARK IS "OF HOT".

FOR ATHLETIC SHOES; BOTTOMS; COMBATIVE SPORTS UNIFORMS; FOOTBALL SHOES; HATS; JERSEYS; SHOES; SPORTS CAPS AND HATS; TOPS (U.S. CLS. 22 AND 39).

HOWARD SMIGA, EXAMINING ATTORNEY

SN 85-408,819. PETER LIK IP COMPANY, LLC, LAS VEGAS, NV. FILED 8-26-2011.

LIK

THE MARK CONSISTS OF STANDARD CHARACTERS WITHOUT CLAIM TO ANY PARTICULAR FONT, STYLE, SIZE, OR COLOR.

OWNER OF U.S. REG. NO. 3,048,088.

FOR CLOTHING, NAMELY, T-SHIRTS, POLO-SHIRTS, TANK TOPS, JACKETS, JOGGING SUITS, SWEAT SHIRTS, SWEAT PANTS, JEANS, PANTS, SWIM WEAR, DRESS SHIRTS, BLOUSES, DRESS PANTS, ROBES, SLEEPWEAR, SCARVES, SOCKS, SLIPPERS, CAPS, HATS AND BANDANNAS; HEADWEAR; SHOES; LEATHER BELTS (U.S. CLS. 22 AND 39).

SOPHIA S. KIM, EXAMINING ATTORNEY

CLASS 25—(Continued).

SN 85-409,092. MILHOUSE, CLAUDE A, DBA I WINK NY, MT KISCO, NY. FILED 8-27-2011.



THE COLOR(S) BLACK AND RED IS/ARE CLAIMED AS A FEATURE OF THE MARK.

THE MARK CONSISTS OF THE COLORS BLACK FOR THE CHARACTERS "I" AND "NY" AND RED FOR THE ";)" CHARACTERS

FOR HATS; SHORT-SLEEVED OR LONG-SLEEVED T-SHIRTS; T-SHIRTS; T-SHIRTS FOR BABIES, ADULTS, CHILDREN, WOMEN, MEN (U.S. CLS. 22 AND 39).

MARK SPARACINO, EXAMINING ATTORNEY

SN 85-411,480. BYL LLC, LAS VEGAS, NV. FILED 8-31-2011.



THE MARK CONSISTS OF AN IMAGE OF A PHOENIX WITH ITS WINGS SPREAD OVERLAPPING AN IMAGE OF A MOTORCYCLE. ARCHING ABOVE THE IMAGES IS THE STYLIZED TEXT "WHAT'S BETWEEN" AND ARCHING BELOW IS THE STYLIZED TEXT "YOUR LEGS".

SEC. 2(F).

FOR CHAPS; HATS; JACKETS; PANTS; SHIRTS; SWEAT SHIRTS; VESTS (U.S. CLS. 22 AND 39).

FIRST USE 10-20-2005; IN COMMERCE 8-1-2010.

LINDA MICKLEBURGH, EXAMINING ATTORNEY

CLASS 25—(Continued).

SN 85-417,420. ALP, DUMAN, TA MORERA, LYNDHURST, NJ. FILED 9-8-2011.

MORERA

THE MARK CONSISTS OF STANDARD CHARACTERS WITHOUT CLAIM TO ANY PARTICULAR FONT, STYLE, SIZE, OR COLOR.

FOR APPAREL FOR DANCERS, NAMELY, TEE SHIRTS, SWEATSHIRTS, PANTS, LEGGINGS, SHORTS AND JACKETS; ATHLETIC APPAREL, NAMELY, SHIRTS, PANTS, JACKETS, FOOTWEAR, HATS AND CAPS, ATHLETIC UNIFORMS; BRAS; CLOTHING, NAMELY, BASE LAYERS; CLOTHING, NAMELY, MATERNITY BANDS; MOISTURE-WICKING SPORTS BRAS; SPORTS BRAS; UNDERWEAR; WOMEN'S ATHLETIC TOPS WITH BUILT-IN BRAS; WOMEN'S CLOTHING, NAMELY, SHIRTS, DRESSES, SKIRTS, BLOUSES (U.S. CLS. 22 AND 39).

FIRST USE 1-1-2008; IN COMMERCE 1-1-2008.
ARETHA SOMERVILLE, EXAMINING ATTORNEY

SN 85-419,358. STONE, BETTY, SOUTH EL MONTE, CA. FILED 9-9-2011.

KARYN'S COLLECTION

THE MARK CONSISTS OF STANDARD CHARACTERS WITHOUT CLAIM TO ANY PARTICULAR FONT, STYLE, SIZE, OR COLOR.

NO CLAIM IS MADE TO THE EXCLUSIVE RIGHT TO USE "COLLECTION", APART FROM THE MARK AS SHOWN.

FOR APPAREL AND CLOTHING, NAMELY, BOTTOMS, TOPS, SLACKS, JEANS, PANTS, TROUSERS, POLO SHIRTS, SWEATSHIRTS, T-SHIRTS, TANK TOPS, BLOUSES, SKIRTS, SHIRTS, SWEATERS, SCARVES, SWEAT PANTS, VESTS, UNDERWEAR, PANTIES, HOSIERY, SOCKS, BRAS, LINGERIES, ROBES, LOUNGEWEAR, JACKETS, COATS, BLAZERS, SLEEPWEAR, PAJAMAS, GLOVES, MITTENS, HEADWEAR, HATS, CAPS, VISORS, FOOTWEAR, SANDALS, SHOES, SLIPPERS, BOOTS, SNEAKERS, TENNIS SHOES; FASHION ACCESSORIES, NAMELY, BELTS (U.S. CLS. 22 AND 39).

DAWN HAN, EXAMINING ATTORNEY

CLASS 25—(Continued).

SN 85-422,812. SONOMACEUTICALS, SANTA ROSA, CA. FILED 9-14-2011.

SHEER SONOMA

THE MARK CONSISTS OF STANDARD CHARACTERS WITHOUT CLAIM TO ANY PARTICULAR FONT, STYLE, SIZE, OR COLOR.

NO CLAIM IS MADE TO THE EXCLUSIVE RIGHT TO USE "SONOMA", APART FROM THE MARK AS SHOWN.

FOR CLOTHING, NAMELY, APRONS, BELTS, BLOUSES, CAPS, DRESSES, GLOVES, HATS, JACKETS, PANTS, SHIRTS, SHORTS, SKIRTS, SOCKS, SWEATERS, SWEATSHIRTS, T-SHIRTS, VESTS (U.S. CLS. 22 AND 39).
MATTHEW MCDOWELL, EXAMINING ATTORNEY

SN 85-424,231. ZHANG ZHIHUI, GUANGDONG, CHINA. FILED 9-15-2011.



THE MARK CONSISTS OF CONCENTRIC OVALS WITH A STYLIZED LETTER "V" TO THE LEFT OF THE WORD "AIQINGNIAO" IN STYLIZED LOWER-CASE LETTERING.

THE WORDING "AIQINGNIAO" HAS NO MEANING IN A FOREIGN LANGUAGE.

FOR BOOT ACCESSORIES, NAMELY, FITTED DECORATIVE COVERS FOR BOOTS; BOOTS; BOOTS FOR SPORT; COATS; FOOTWEAR; HATS; HEELS; HOSIERY; NECKTIES; NON-SLIP SOLES FOR FOOTWEAR; SANDALS; SCARVES; SHIRTS; SLIPPERS; SPATS; TEE SHIRTS; TROUSERS; UNDERWEAR; UPPERS FOR JAPANESE STYLE SANDALS (U.S. CLS. 22 AND 39).

FIRST USE 9-10-2009; IN COMMERCE 9-10-2009.
MARY ROSSMAN, EXAMINING ATTORNEY

SN 85-425,675. SHOEBIZ, INC., SAN FRANCISCO, CA. FILED 9-19-2011.

SUTRO

THE MARK CONSISTS OF STANDARD CHARACTERS WITHOUT CLAIM TO ANY PARTICULAR FONT, STYLE, SIZE, OR COLOR.

FOR MEN'S, WOMEN'S AND CHILDREN'S FOOTWEAR, NAMELY, SHOES, BOOTS AND SANDALS AND BELTS, GLOVES AND HATS (U.S. CLS. 22 AND 39).

FIRST USE 3-14-2011; IN COMMERCE 3-14-2011.
WILLIAM JACKSON, EXAMINING ATTORNEY

CLASS 25—(Continued).

SN 85-434,267. ANY MERCY FOR ALL, LLC, BLOOMFIELD HILLS, MI. FILED 9-28-2011.

WHOM DO YOU TRUST?

THE MARK CONSISTS OF STANDARD CHARACTERS WITHOUT CLAIM TO ANY PARTICULAR FONT, STYLE, SIZE, OR COLOR.
FOR CLOTHING, NAMELY, T-SHIRTS, HATS, JERSEYS (U.S. CLS. 22 AND 39).
THOMAS MANOR, EXAMINING ATTORNEY

SN 85-437,184. LUKE GEORGE, DBA DANGL PRODUCTIONS, DETROIT, MI. FILED 10-1-2011.



NO CLAIM IS MADE TO THE EXCLUSIVE RIGHT TO USE "PRODUCTIONS", APART FROM THE MARK AS SHOWN.
THE MARK CONSISTS OF THE UN-SHADED WORDING, "DANGL" WITH THE LETTERS "D" AND "L" IN CAPS, WITH THE UN-SHADED WORDING, "PRODUCTIONS" IN LOWER CASE LETTERS, BELOW THE LETTERS, "DAN" ON A SHADED BACKGROUND WITH AN UN-SHADED BORDER.
FOR BOARD SHORTS; HOODED SWEAT SHIRTS; MOISTURE-WICKING SPORTS PANTS; MOISTURE-WICKING SPORTS SHIRTS; SHORT-SLEEVED OR LONG-SLEEVED T-SHIRTS; SHORTS; SPORTS PANTS; SPORTS SHIRTS; T-SHIRTS (U.S. CLS. 22 AND 39).
FIRST USE 6-1-2008; IN COMMERCE 1-1-2011.
ODESSA BIBBINS, EXAMINING ATTORNEY

SN 85-438,213. LONG AWAITED LLC, SANTA MONICA, CA. FILED 10-3-2011.

LONG AWAITED

THE MARK CONSISTS OF STANDARD CHARACTERS WITHOUT CLAIM TO ANY PARTICULAR FONT, STYLE, SIZE, OR COLOR.
FOR CLOTHING, NAMELY, SHIRTS, T-SHIRTS, JACKETS, COATS, SWEATSHIRTS, SWEATSHIRTS IN THE NATURE OF HOODED SWEATSHIRTS, SWEATPANTS, SHORTS, SOCKS; HEADWEAR AND FOOTWEAR (U.S. CLS. 22 AND 39).
MICHAEL WIENER, EXAMINING ATTORNEY

CLASS 25—(Continued).

SN 85-440,145. COY CLEVELAND, ROCKWALL, TX. FILED 10-5-2011.



THE MARK CONSISTS OF THE STYLIZED CONNECTED LETTERS "AA" WITH THE SECOND LETTER "A" BEING UPSIDE-DOWN.
FOR CLOTHING, NAMELY, SHIRTS, SHORTS, SOCKS, UNDERWEAR, LEGGINGS AND HATS (U.S. CLS. 22 AND 39).
MICHAEL LITZAU, EXAMINING ATTORNEY

SN 85-440,151. NOVASETA S.P.A., BIELLA, ITALY, FILED 10-5-2011.



OWNER OF ITALY REG. NO. 0001489226, DATED 4-27-2012, EXPIRES 4-27-2022.
THE MARK CONSISTS OF THE WORDS "CARNIVAL DE VENISE" WRITTEN ON TOP WITH A MASK WITH TWO THREADS ATTACHED ON THE BOTTOM.
THE ENGLISH TRANSLATION OF "CARNIVAL DE VENISE" IN THE MARK IS "CARNIVAL OF VENICE".
FOR NECKTIES, SCARVES, BOWTIES, CUMMERBUNDS, SHIRTS, SOCKS, SWEATERS, BELTS, SHOES, POCKET SQUARES, KERCHIEFS, GLOVES AND HEADGEAR, NAMELY, HATS AND CAPS (U.S. CLS. 22 AND 39).
FIRST USE 1-0-2011; IN COMMERCE 1-0-2011.
CHRIS WELLS, EXAMINING ATTORNEY

SN 85-440,514. SHERFY, JAMES, EUGENE, OR. FILED 10-6-2011.

Stay Handsome

THE MARK CONSISTS OF STANDARD CHARACTERS WITHOUT CLAIM TO ANY PARTICULAR FONT, STYLE, SIZE, OR COLOR.
FOR SHIRTS; SWEAT SHIRTS; SWEATERS; TANK TOPS (U.S. CLS. 22 AND 39).
BRENDAN MCCAULEY, EXAMINING ATTORNEY

CLASS 25—(Continued).

SN 85-441,201. L. MAYERS CLOTHING, HUNTINGTON, NY.
FILED 10-6-2011.

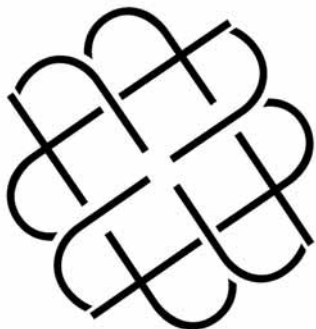

THE MARK CONSISTS OF A CIRCULAR DESIGN COMPOSED OF STRAIGHT AND CURVED LINES.

FOR CLOTHING AND APPAREL, NAMELY, SHIRTS, TOPS, TANK TOPS, T-SHIRTS, UNDERSHIRTS, SHORTS, PANTS, UNDERPANTS, SWIMWEAR AND WRIST BANDS; CASUAL CLOTHING, NAMELY, YOGA WEAR, NAMELY, YOGA PANTS, YOGA SHIRTS, YOGA TANK TOPS, YOGA T-SHIRTS AND YOGA SHORTS (U.S. CLS. 22 AND 39).

FIRST USE 5-19-2010; IN COMMERCE 10-1-2010.
ALEX KEAM, EXAMINING ATTORNEY

SN 85-441,287. LONESTAR SPEED SHOP, LLC, RICHMOND, TX. FILED 10-6-2011.



NO CLAIM IS MADE TO THE EXCLUSIVE RIGHT TO USE "LONESTAR SPEED SHOP", APART FROM THE MARK AS SHOWN.

THE MARK CONSISTS OF A STYLIZED DRAWING OF A CAR INCORPORATING THE STYLIZED LETTERS "LSS" ATOP A BANNER BEARING THE WORD "LONESTAR", ALL ABOVE THE WORDS "SPEED" AND "SHOP" SEPARATED BY A STAR FRAMED BY CURLICUES.

FOR BASEBALL CAPS AND HATS; SHIRTS AND SHORT-SLEEVED SHIRTS; SHORT-SLEEVED OR LONG-SLEEVED T-SHIRTS; SWEATSHIRTS (U.S. CLS. 22 AND 39).

KATHRYN COWARD, EXAMINING ATTORNEY

CLASS 25—(Continued).

SN 85-442,484. ELIZABETH BAE, LOS ANGELES, CA. FILED 10-7-2011.

DENIM OF VIRTUE

THE MARK CONSISTS OF STANDARD CHARACTERS WITHOUT CLAIM TO ANY PARTICULAR FONT, STYLE, SIZE, OR COLOR.

OWNER OF U.S. REG. NOS. 3,349,847 AND 3,458,151.
NO CLAIM IS MADE TO THE EXCLUSIVE RIGHT TO USE "DENIM", APART FROM THE MARK AS SHOWN.

FOR CLOTHING, NAMELY, PANTS, TROUSERS, SHORTS, SKIRTS, SHIRTS, TOPS, SWEATERS, JACKETS, DRESSES; BELTS, HEADWEAR, FOOTWEAR (U.S. CLS. 22 AND 39).

FIRST USE 4-28-2006; IN COMMERCE 4-28-2006.

DOMINIC J. FERRAIUOLO, EXAMINING ATTORNEY

SN 85-442,661. BARRETT BARKER, SEATTLE, WA. FILED 10-7-2011.

Heretic DFD1

THE MARK CONSISTS OF STANDARD CHARACTERS WITHOUT CLAIM TO ANY PARTICULAR FONT, STYLE, SIZE, OR COLOR.

FOR ATHLETIC APPAREL, NAMELY, SHIRTS, PANTS, JACKETS, FOOTWEAR, HATS AND CAPS, ATHLETIC UNIFORMS; CHILDREN'S AND INFANT'S APPAREL, NAMELY, JUMPERS, OVERALL SLEEPWEAR, PAJAMAS, ROMPERS AND ONE-PIECE GARMENTS; GLOVES FOR APPAREL; SCIENTIFIC AND TECHNOLOGICAL APPAREL, NAMELY, SHIRTS, PANTS, JACKETS, FOOTWEAR, HATS AND CAPS, UNIFORMS; VISCOUS GEL POLYMER SOLD AS A COMPONENT OF FINISHED CUSTOM CUSHIONED FOOTWEAR FOR NON-ORTHOPEDIC PURPOSES AND APPAREL (U.S. CLS. 22 AND 39).

FIRST USE 5-15-2011; IN COMMERCE 9-2-2011.

EDWARD FENNESSY, EXAMINING ATTORNEY

SN 85-442,824. BARATTA, OLIVIA MARIA, ATLANTA, GA. AND MYERS, JAIME, PEORIA, IL. FILED 10-8-2011.

NEW ORLEANS IS MY CHURCH

THE MARK CONSISTS OF STANDARD CHARACTERS WITHOUT CLAIM TO ANY PARTICULAR FONT, STYLE, SIZE, OR COLOR.

FOR CLOTHING, NAMELY, T-SHIRTS AND TANK TOPS; HEADGEAR, NAMELY CAPS AND VISORS (U.S. CLS. 22 AND 39).

JULIE WATSON, EXAMINING ATTORNEY

CLASS 25—(Continued).

SN 85-443,384. NEE, MARTIN S, HINGHAM, MA. FILED 10-10-2011.

THIS IS WHAT WE TRAIN FOR

THE MARK CONSISTS OF STANDARD CHARACTERS WITHOUT CLAIM TO ANY PARTICULAR FONT, STYLE, SIZE, OR COLOR.

FOR ATHLETIC APPAREL, NAMELY, SHIRTS, PANTS, JACKETS, FOOTWEAR, HATS AND CAPS, ATHLETIC UNIFORMS (U.S. CLS. 22 AND 39).

CHRISTOPHER SIDOTI, EXAMINING ATTORNEY

SN 85-445,296. MUNDER, ADAM, WEST PALM BEACH, FL. FILED 10-12-2011.

PLAYING HURT

THE MARK CONSISTS OF STANDARD CHARACTERS WITHOUT CLAIM TO ANY PARTICULAR FONT, STYLE, SIZE, OR COLOR.

FOR CLOTHING AND APPAREL, NAMELY, CAPS, SHIRTS, T-SHIRTS, UNDERWEAR, SOCKS, PANTS, SWEATERS, JACKETS, SHOES AND SANDALS, BATHING SUITS, BOARD SHORTS, WALKING SHORTS, WET SUITS, SWIM TRUNKS, CAPS WITH VISORS, VISORS, FLEECE PULLOVERS, SWEAT SHIRTS, SURF WEAR (U.S. CLS. 22 AND 39).

MIDGE BUTLER, EXAMINING ATTORNEY

SN 85-445,556. PLACID WAVE KOREA CO., LTD., SEOUL, REPUBLIC OF KOREA, FILED 10-12-2011.

PLAC
Jeans

NO CLAIM IS MADE TO THE EXCLUSIVE RIGHT TO USE "JEANS", APART FROM THE MARK AS SHOWN.

THE MARK CONSISTS OF THE TERM "PLAC" SPELLED USING ALL UPPER CASE LETTERS AND THE TERM "JEANS" SPATIALLY POSITIONED UNDER THE TERM "PLAC" AND SPELLED USING THE LETTER "J" IN UPPER CASE FORM AND THE REMAINING LETTERS "EANS" IN LOWER CASE FORM.

FOR BELTS FOR CLOTHING; COATS; FOOTWEAR; GLOVES AS CLOTHING; HEADWEAR; JACKETS; JEANS; SHIRTS; SOCKS; UNDERWEAR (U.S. CLS. 22 AND 39).

ALLISON HOLTZ, EXAMINING ATTORNEY

CLASS 25—(Continued).

SN 85-446,114. ALGEBROTHERS LLC, LOS ANGELES, CA. FILED 10-12-2011.

AlgeBrothers

THE MARK CONSISTS OF STANDARD CHARACTERS WITHOUT CLAIM TO ANY PARTICULAR FONT, STYLE, SIZE, OR COLOR.

FOR ATHLETIC APPAREL, NAMELY, SHIRTS, PANTS, JACKETS, FOOTWEAR, HATS AND CAPS, ATHLETIC UNIFORMS; SHIRTS; SHORT-SLEEVED OR LONG-SLEEVED T-SHIRTS; SHORT-SLEEVED SHIRTS; SLEEP SHIRTS; T-SHIRTS; WEARABLE GARMENTS AND CLOTHING, NAMELY, SHIRTS (U.S. CLS. 22 AND 39).

FIRST USE 1-1-2009; IN COMMERCE 1-1-2010.

HANNO RITTNER, EXAMINING ATTORNEY

SN 85-446,900. CORNISH, MICHAEL, DBA MY STICKY CLOTHING, JAMAICA, NY, AND HARTY, ANDRE, DBA MY STICKY CLOTHING, JAMAICA, NY. FILED 10-13-2011.



MYSTICKYCLOTHING.COM

THE MARK CONSISTS OF THE WORDING "MYSTICKYCLOTHING.COM" PRINTED UNDER THE CARICATURE OF A HUMAN FACE SHAPED IN THE FORM OF A MARIJUANA LEAF WITH A CIGARETTE HANGING FROM THE CARICATURE'S MOUTH.

FOR HOODED SWEATSHIRTS; SHORT-SLEEVED OR LONG-SLEEVED T-SHIRTS; SWEATSHIRTS; T-SHIRTS (U.S. CLS. 22 AND 39).

FIRST USE 8-20-2010; IN COMMERCE 8-20-2010.

LINDA E. BLOHM, EXAMINING ATTORNEY

CLASS 25—(Continued).

SN 85-448,378. FORGOTTEN SOULS PTY LTD, SYDNEY, AUSTRALIA, FILED 10-16-2011.



OWNER OF AUSTRALIA REG. NO. 1344491, DATED 12-17-2010, EXPIRES 2-16-2020.

THE COLOR(S) NAVY AND WHITE IS/ARE CLAIMED AS A FEATURE OF THE MARK.

THE MARK CONSISTS OF A GRAPHIC OF A CREST WITH SCROLLS ABOVE AND BELOW. THE SCROLL ABOVE THE CREST SAYS "FORGOTTEN SOULS" AND THE SCROLL BELOW THE CREST SAYS "IMPONITE FINEM PECORUM DOLORI". THE CREST, SCROLLS AND WORDING IS NAVY IN COLOUR, AND THE BACKGROUND AND INSIDE OF THE CREST AND SCROLLS ARE WHITE.

THE ENGLISH TRANSLATION OF "IMPONITE FINEM PECORUM DOLORI" IN THE MARK IS PUT AN END TO THE SUFFERING OF ANIMALS.

FOR ATHLETIC APPAREL, NAMELY, SHIRTS, PANTS, JACKETS, FOOTWEAR, HATS AND CAPS, ATHLETIC UNIFORMS; BABY BODYSUITS; BABY BOTTOMS; BABY BUNTING; BABY LAYETTES FOR CLOTHING; BABY TOPS; BELTS; BELTS FOR CLOTHING; BELTS MADE OUT OF CLOTH; BOTTOMS; BUTTON DOWN SHIRTS; CAMP SHIRTS; CHILDREN'S AND INFANT'S APPAREL, NAMELY, JUMPERS, OVERALL SLEEPWEAR, PAJAMAS, ROMPERS AND ONE-PIECE GARMENTS; CHILDREN'S AND INFANTS' APPAREL TREATED WITH FIRE AND HEAT RETARDANTS, NAMELY, JUMPERS, OVERALL SLEEPWEAR, PAJAMAS, ROMPERS AND ONE-PIECE GARMENTS; CLOTHING FOR BABIES, TODDLERS AND CHILDREN, TREATED WITH FIRE AND HEAT RETARDANTS, NAMELY, PAJAMAS, JACKETS, SHIRTS, PANTS, JUMPERS; COLLARED SHIRTS; DRESS SHIRTS; GLOVES AS CLOTHING; GOLF PANTS, SHIRTS AND SKIRTS; GOLF SHIRTS; HATS FOR INFANTS, BABIES, TODDLERS AND CHILDREN; HEADBANDS FOR CLOTHING; HOODED SWEAT SHIRTS; HOODED SWEATSHIRTS FOR MEN, WOMEN, CHILDREN AND BABIES; HOODS; INFANT AND TODDLER ONE PIECE CLOTHING; JACKETS; JERSEYS; KNIT SHIRTS; LONG-SLEEVED SHIRTS; MEN'S AND WOMEN'S JACKETS, COATS, TROUSERS, VESTS; MEN'S DRESS SOCKS; MEN'S SOCKS; NIGHT SHIRTS; OPEN-NECKED SHIRTS; OVER SHIRTS; PIQUE SHIRTS; POLO SHIRTS; RUGBY SHIRTS; SHIRTS; SHIRTS AND SHORT-SLEEVED SHIRTS; SHIRTS AND SLIPS; SHIRTS FOR INFANTS, BABIES, TODDLERS AND CHILDREN; SHIRTS FOR SUITS; SHORT SETS; SHORT-SLEEVED OR LONG-SLEEVED T-SHIRTS; SHORT-SLEEVED SHIRTS; SLEEP SHIRTS; SNAP CROTCH SHIRTS FOR INFANTS AND TODDLERS; SPORT SHIRTS; SPORTS SHIRTS; SPORTS SHIRTS WITH SHORT SLEEVES; SURF WEAR; SWEAT SHIRTS; SWEATSHIRTS FOR MEN, WOMEN, CHILDREN AND BABIES; SWIM SUITS; SWIM TRUNKS; SWIM WEAR; SWIM WEAR FOR GENTLEMEN AND LADIES; SWIMMING COSTUMES; SWIMMING TRUNKS; T-SHIRTS; T-SHIRTS FOR MEN, WOMEN, CHILDREN AND BABIES; TEE SHIRTS; TIES; TOPS; TURTLE NECK SHIRTS; WEARABLE GARMENTS AND CLOTHING, NAMELY, SHIRTS; WOMEN'S CLOTHING, NAMELY, SHIRTS, DRESSES, SKIRTS, BLOUSES (U.S. CLS. 22 AND 39).

ALYSSA STEEL, EXAMINING ATTORNEY

CLASS 25—(Continued).

SN 85-451,605. POSCELIN COMPANY LTD., KOWLOON, HONG KONG, FILED 10-19-2011.



THE MARK CONSISTS OF A CIRCLE ENCOMPASSING AN ABSTRACT DESIGN.

FOR CLOTHING, NAMELY, WOMEN'S CLOTHING IN THE NATURE OF BLOUSES, SKIRTS, SHIRTS, PANTS; MEN'S WEAR IN THE NATURE OF HATS, PANTS, JACKETS; ATHLETIC APPAREL IN THE NATURE OF SHIRTS, PANTS, JACKETS, FOOTWEAR, HATS AND CAPS, ATHLETIC UNIFORMS; BABY TOPS, BABY BOTTOMS; BEACHWEAR; BUSINESS ATTIRE IN THE NATURE OF SUITS; BRIDAL WEAR IN THE NATURE OF WEDDING GOWNS; CASUAL WEAR IN THE NATURE OF SWEATPANTS; CHILDREN'S CLOTHING IN THE NATURE OF PAJAMAS, JACKETS, SHIRTS, PANTS, JUMPERS; CLOTHING FOR FISHING IN THE NATURE OF FISHERMEN'S JACKETS, FISHING SHIRTS; EXERCISE CLOTHING IN THE NATURE OF HEADBANDS, SWEATPANTS; FORMAL WEAR IN THE NATURE OF SUITS; GOLF WEAR IN THE NATURE OF GOLF SHIRTS; GYM WEAR IN THE NATURE OF T-SHIRTS, SWEATPANTS; INFANT WEAR; LOUNGEWEAR; MATERNITY WEAR IN THE NATURE OF SHIRTS, PANTS, SHORTS; OUTDOOR WINTER RAINWEAR IN THE NATURE OF RAIN JACKETS; SKIWEAR, SLEEPWEAR, SPORTS WEAR IN THE NATURE OF SPORT SHIRTS, SPORTS BRAS; UNDERGARMENTS; JEANS; FOOTWEAR, NAMELY, SHOES; HATS; SOCKS; CLOTHING, NAMELY, GLOVES; SHAWLS; NECKTIES; SCARFS; STRAPS, NAMELY, SHOE STRAPS, STRAPS FOR BRAS; CLOTHING, NAMELY, BELTS (U.S. CLS. 22 AND 39).

BRIAN CALLAGHAN, EXAMINING ATTORNEY

SN 85-452,932. ANKLE & WRIST SWEATERS BY GRETA, INC., STANDISH, ME. FILED 10-21-2011.

Ankle & Wrist Sweaters by Greta, Inc.

THE MARK CONSISTS OF STANDARD CHARACTERS WITHOUT CLAIM TO ANY PARTICULAR FONT, STYLE, SIZE, OR COLOR.

NO CLAIM IS MADE TO THE EXCLUSIVE RIGHT TO USE "ANKLE AND WRIST SWEATERS" AND "INC.", APART FROM THE MARK AS SHOWN.

FOR ANKLE SOCKS; ANKLETS; SLIPPER SOCKS; SOCKS; SOCKS AND STOCKINGS; SWEATERS; WOOLEN SOCKS; WRISTBANDS (U.S. CLS. 22 AND 39).

FIRST USE 11-6-2008; IN COMMERCE 12-5-2010.
ANTHONY RINKER, EXAMINING ATTORNEY

CLASS 25—(Continued).

SN 85-456,830. CANADIAN FUR TRADE DEVELOPMENT INSTITUTE INC., AKA L'INSTITUT DEVELOPPEMENT DE L'INDUSTRIE DE LA FOURRURE CANADIENNE INC., MONTREAL, CANADA, FILED 10-26-2011.



NO CLAIM IS MADE TO THE EXCLUSIVE RIGHT TO USE "CANADIAN", APART FROM THE MARK AS SHOWN. THE MARK CONSISTS OF THE STYLIZED WORDS "BEAUTIFULLY CANADIAN" WITH A STYLIZED CANADIAN MAPLE LEAF AT THE BASE OF THE LETTER "F" IN "BEAUTIFULLY".

FOR CAPES; EAR BANDS; EAR MUFFS; FUR CLOAKS; FUR COATS; FUR COATS AND JACKETS; FUR HATS; FUR JACKETS; FUR MUFFS; FUR STOLEES; GLOVES INCLUDING THOSE MADE OF SKIN, HIDE OR FUR; LEGGINGS; MUFFLERS; SCARFS; SHAWLS; SHAWLS AND HEADSCARVES; SHAWLS AND STOLEES (U.S. CLS. 22 AND 39).

FIRST USE 9-1-2004; IN COMMERCE 9-1-2004.
ALYSSA STEEL, EXAMINING ATTORNEY

SN 85-459,765. SHELTON FINLEY, CHICAGO, IL. FILED 10-29-2011.

**THE (T.G.4.F.) MOVEMENT
THANK GOD 4 FAMILY!!!**

THE MARK CONSISTS OF STANDARD CHARACTERS WITHOUT CLAIM TO ANY PARTICULAR FONT, STYLE, SIZE, OR COLOR.

FOR A-SHIRTS; APPAREL FOR DANCERS, NAMELY, TEE SHIRTS, SWEATSHIRTS, PANTS, LEGGINGS, SHORTS AND JACKETS; ATHLETIC APPAREL, NAMELY, SHIRTS, PANTS, JACKETS, FOOTWEAR, HATS AND CAPS, ATHLETIC UNIFORMS; BODY SHIRTS; BUTTON DOWN SHIRTS; BUTTON-FRONT ALOHA SHIRTS; CAMOUFLAGE SHIRTS; CAMP SHIRTS; CLOTHING FOR ATHLETIC USE, NAMELY, PADDED SHIRTS; CLOTHING FOR BABIES, TODDLERS AND CHILDREN, TREATED WITH FIRE AND HEAT RETARDANTS, NAMELY, PAJAMAS, JACKETS, SHIRTS, PANTS, JUMPERS; CLOTHING SHIELDS, NAMELY, PADS APPLIED TO THE UNDERARMS OF SHIRTS, BLOUSES AND SWEATERS; COLLARED SHIRTS; DRESS SHIRTS; FISHING SHIRTS; GOLF PANTS, SHIRTS AND SKIRTS; GOLF SHIRTS; HOODED SWEAT SHIRTS; HUNTING SHIRTS; KNIT SHIRTS; LEATHER SHIRTS; LONG-SLEEVED SHIRTS; MATERNITY CLOTHING, NAMELY, SHIRTS; MOISTURE-WICKING SPORTS SHIRTS; NIGHT SHIRTS; OPEN-NECKED SHIRTS; OVER SHIRTS; PIQUE SHIRTS; POLO SHIRTS; RUGBY SHIRTS; SCIENTIFIC AND TECHNOLOGICAL APPAREL, NAMELY, SHIRTS, PANTS, JACKETS, FOOTWEAR, HATS AND CAPS, UNIFORMS;

CLASS 25—(Continued).

SHIRT FRONTS; SHIRT INSERTS, NAMELY, DICKIES; SHIRT YOKES; SHIRTS; SHIRTS AND SHORT-SLEEVED SHIRTS; SHIRTS AND SLIPS; SHIRTS FOR INFANTS, BABIES, TODDLERS AND CHILDREN; SHIRTS FOR SUITS; SHORT-SLEEVED OR LONG-SLEEVED T-SHIRTS; SHORT-SLEEVED SHIRTS; SLEEP SHIRTS; SLEEVES WORN SEPARATE AND APART FROM BLOUSES, SHIRTS AND OTHER TOPS; SNAP CROTCH SHIRTS FOR INFANTS AND TODDLERS; SPORT SHIRTS; SPORTS SHIRTS; SPORTS SHIRTS WITH SHORT SLEEVES; SUN PROTECTIVE CLOTHING, NAMELY, VISORS AND T-SHIRTS; SWEAT SHIRTS; T-SHIRTS; T-SHIRTS FOR GENERAL WEAR; TEE SHIRTS; TRIATHLON CLOTHING, NAMELY, TRIATHLON TIGHTS, TRIATHLON SHORTS, TRIATHLON SINGLETTS, TRIATHLON SHIRTS, TRIATHLON SUITS; TURTLE NECK SHIRTS; WEARABLE GARMENTS AND CLOTHING, NAMELY, SHIRTS; WIND SHIRTS; WOMEN'S CLOTHING, NAMELY, SHIRTS, DRESSES, SKIRTS, BLOUSES; YOGA SHIRTS (U.S. CLS. 22 AND 39).

TINA BROWN, EXAMINING ATTORNEY

SN 85-461,287. CANTY, DERRICK J., CENTRAL ISLIP, NY. FILED 11-1-2011.



THE MARK CONSISTS OF TWO TERMS, "STOP", AND "DROOLING"; WHEREIN BOTH TERMS ARE CAPITALIZED. THE TERM "STOP" IS ON TOP, WITH THE TERM "DROOLING" IS OVERLAYED OVER A DOG, WHEREIN THE EYES OF A DOG FUNCTION AS THE LETTERS "OO" IN THE TERM "DROOLING".

FOR HATS; JACKETS; PANTS; SHIRTS; SHOES; SHORTS (U.S. CLS. 22 AND 39).

ALEXANDER L. POWERS, EXAMINING ATTORNEY

SN 85-467,536. TEEN PERSPECTIVE, INC., UPPER SADDLE RIVER, NJ. FILED 11-8-2011.



THE COLOR(S) BLACK AND WHITE IS/ARE CLAIMED AS A FEATURE OF THE MARK.

THE MARK CONSISTS OF A WHITE LINE APPEARING

CLASS 25—(Continued).

ABOVE THE PHRASE "GRAB THE BULL BY THE HORNS" AND THE UNDERLINED WORDING "STOP BULLYING" APPEARING IN WHITE LETTERS WITH A BLACK BACKGROUND AND CONFIGURED OR ARRANGED IN THE SHAPE OF A BULL'S HEAD WITH WHITE HORNS PROTRUDING ON EACH SIDE OF THE DESIGN MARK. THE LETTERS "T" AND "P" APPEAR IN WHITE SURROUNDED BY A LINEAR DESIGN, WITH THE DESIGN OF A MAN APPEARING IN THE COLOR BLACK, SEPARATING BOTH LETTERS.

FOR ATHLETIC APPAREL, NAMELY, SHIRTS, PANTS, JACKETS, FOOTWEAR, HATS AND CAPS, ATHLETIC UNIFORMS; ATHLETIC UNIFORMS; BELTS; BELTS FOR CLOTHING; CLOTHING FOR ATHLETIC USE, NAMELY, PADDED ELBOW COMPRESSION SLEEVES BEING PART OF AN ATHLETIC GARMENT; CLOTHING FOR ATHLETIC USE, NAMELY, PADDED PANTS; CLOTHING FOR ATHLETIC USE, NAMELY, PADDED SHIRTS; CLOTHING FOR ATHLETIC USE, NAMELY, PADDED SHORTS; HATS; HATS FOR INFANTS, BABIES, TODDLERS AND CHILDREN; HEADGEAR, NAMELY, ATHLETIC HATS FOR CHILDREN, ADOLESCENTS AND YOUNG ADULTS; JACKETS; JERSEYS; PERSPIRATION ABSORBENT UNDERWEAR CLOTHING; RAIN JACKETS; SHORT-SLEEVED OR LONG-SLEEVED T-SHIRTS; SLEEVELESS JERSEYS; SPORTS JERSEYS; SPORTS JERSEYS AND BREECHES FOR SPORTS; SWEATSHIRTS; SWEATSHIRTS FOR CHILDREN, ADOLESCENTS AND YOUNG ADULTS; T-SHIRTS; T-SHIRTS FOR CHILDREN, ADOLESCENTS AND YOUNG ADULTS; WEARABLE GARMENTS AND CLOTHING, NAMELY, SHIRTS (U.S. CLS. 22 AND 39).

DAVID COLLIER, EXAMINING ATTORNEY

SN 85-467,540. COX, KEVIN, GLEN ALLEN, VA. AND RUBIS, SUSAN, GLEN ALLEN, VA. FILED 11-8-2011.



THE MARK CONSISTS OF THE WORDING "EIGHT UP WITH STUPID" AND A DESIGN ELEMENT COMPRISING TWO CIRCLES CONNECTING ONE ON TOP OF THE OTHER SURROUNDED BY IMAGES OF DRINKING CONTAINERS OR GLASSWARE. BEGINNING IN THE TOP CENTER AND MOVING CLOCKWISE, THE DESIGN ELEMENTS INCLUDE A WHISKY SHOT GLASS, TEST TUBE FOR SHOOTERS, KEG OF BEER, BEER PITCHER, BEER FUNNEL, PLASTIC CUP, BOTTLE OF WINE, AND A MARTINI GLASS WITH AN OLIVE GARNISH. ON THE TOP THERE IS THE STYLIZED TEXT "EIGHT". IN THE MIDDLE THERE IS THE STYLIZED TEXT "UP". AT THE BOTTOM THERE IS THE STYLIZED TEXT "WITH STUPID".

FOR T-SHIRTS (U.S. CLS. 22 AND 39).
LAURIE KAUFMAN, EXAMINING ATTORNEY

CLASS 25—(Continued).

SN 85-469,453. THE ORIGINAL FOOTWEAR COMPANY, AKA ORIGINAL SWAT, STOCKTON, CA. FILED 11-10-2011.

Tactical Performance Matters

THE MARK CONSISTS OF STANDARD CHARACTERS WITHOUT CLAIM TO ANY PARTICULAR FONT, STYLE, SIZE, OR COLOR.

FOR FOOTWEAR; FOOTWEAR FOR MEN; FOOTWEAR FOR MEN AND WOMEN; FOOTWEAR, NAMELY, WORK BOOTS; SOLES FOR FOOTWEAR; WATERPROOF FOOTWEAR (U.S. CLS. 22 AND 39).

FIRST USE 8-15-2011; IN COMMERCE 11-1-2011.
KATHRYN COWARD, EXAMINING ATTORNEY

SN 85-471,068. GRANADOS, ANABEL, OAKLAND, CA. FILED 11-12-2011.

SteelDoll

THE MARK CONSISTS OF STANDARD CHARACTERS WITHOUT CLAIM TO ANY PARTICULAR FONT, STYLE, SIZE, OR COLOR.

FOR CLOTHING, NAMELY, SHIRTS, SHORTS, PANTS, CAPS, HATS, JACKETS, SHOES, SWEAT BANDS, SOCKS, SPORTS BRAS, UNDERWEAR, UNDERGARMENTS, RASH GUARDS, GRAPPLING SHIRTS, COMPRESSION SHIRTS FOR ATHLETIC USE, COMPRESSION SHORTS FOR ATHLETIC USE, FIGHT SHORTS, MUAY THAI SHORTS, SHORTS, WARM-UP SUITS, BOARD SHORTS, SWIM SUITS, UNIFORMS (U.S. CLS. 22 AND 39).

FIRST USE 5-0-2010; IN COMMERCE 7-0-2010.
SETH A. RAPPAPORT, EXAMINING ATTORNEY

SN 85-473,665. BASSI, AVINASH, MR, NOTTINGHAM, UNITED KINGDOM, FILED 11-16-2011.

D555

THE MARK CONSISTS OF STANDARD CHARACTERS WITHOUT CLAIM TO ANY PARTICULAR FONT, STYLE, SIZE, OR COLOR.

OWNER OF ERPN CMNTY TM OFC REG. NO. 004307708, DATED 2-1-2006, EXPIRES 3-23-2015.

FOR BELTS; DENIM JACKETS; HATS; JACKETS; JEANS; MEN'S SUITS; SCARFS; SHIRTS; SHORTS; SOCKS; SWEATERS; SWEATSHIRTS; T-SHIRTS; TROUSERS; UNDERPANTS; WAIST BELTS (U.S. CLS. 22 AND 39).

CAROLINE WOOD, EXAMINING ATTORNEY

CLASS 25—(Continued).

SN 85-473,886. GRANADOS, ANABEL, OAKLAND, CA. FILED 11-16-2011.



THE MARK CONSISTS OF AN ANGRY GIRL. FOR CLOTHING, NAMELY, SHIRTS, SHORTS, PANTS, CAPS, HATS, JACKETS, SHOES, SWEAT BANDS, SOCKS, SPORTS BRAS, UNDERWEAR, UNDERGARMENTS, RASH GUARDS, GRAPPLING SHIRTS, COMPRESSION SHIRTS FOR ATHLETIC USE, COMPRESSION SHORTS FOR ATHLETIC USE, FIGHT SHORTS, MUAY THAI SHORTS, SHORTS, WARM-UP SUITS, BOARD SHORTS, SWIM SUITS, UNIFORMS (U.S. CLS. 22 AND 39).

FIRST USE 5-31-2010; IN COMMERCE 7-13-2010.
SETH A. RAPPAPORT, EXAMINING ATTORNEY

SN 85-475,085. TEAM SIZZLE FILMS, INC., BALTIMORE, MD. FILED 11-17-2011.

T-SIZZLE

THE MARK CONSISTS OF STANDARD CHARACTERS WITHOUT CLAIM TO ANY PARTICULAR FONT, STYLE, SIZE, OR COLOR.

THE NAME(S), PORTRAIT(S), AND/OR SIGNATURE(S) SHOWN IN THE MARK IDENTIFIES "TERRELL RAYMONN SUGGS", WHOSE CONSENT(S) TO REGISTER IS MADE OF RECORD.

FOR ADULT CLOTHING, NAMELY, SHIRTS, SWEATSHIRTS, HATS, CAPS, SHORTS, PANTS, UNDERWEAR, JACKETS (U.S. CLS. 22 AND 39).

JUDITH HELFMAN, EXAMINING ATTORNEY

SN 85-478,414. XCESSORY INTERNATIONAL LLC, NEW YORK, NY. FILED 11-21-2011.

SEASONAL CELEBRATIONS

THE MARK CONSISTS OF STANDARD CHARACTERS WITHOUT CLAIM TO ANY PARTICULAR FONT, STYLE, SIZE, OR COLOR.

NO CLAIM IS MADE TO THE EXCLUSIVE RIGHT TO USE "SEASONAL", APART FROM THE MARK AS SHOWN.

FOR SEASONAL APPAREL FOR ALL MAJOR HOLIDAYS, NAMELY, PANTS, SHIRTS, SHORTS, SWEATERS, HATS, COATS, SHOES AND SEASONAL COSTUMES FOR ALL MAJOR HOLIDAYS (U.S. CLS. 22 AND 39).

CHRISTINE MARTIN, EXAMINING ATTORNEY

CLASS 25—(Continued).

SN 85-482,757. EARTHAN ASSOCIATES, INC., MINNEAPOLIS, MN. FILED 11-29-2011.

EARTHININJA

THE MARK CONSISTS OF STANDARD CHARACTERS WITHOUT CLAIM TO ANY PARTICULAR FONT, STYLE, SIZE, OR COLOR.

OWNER OF U.S. REG. NO. 4,127,856.

FOR CLOTHING, NAMELY, SHIRTS (U.S. CLS. 22 AND 39).

FIRST USE 5-15-2012; IN COMMERCE 5-15-2012.

COLLEEN DOMBROW, EXAMINING ATTORNEY

SN 85-485,845. DWM DANCE STUDIOS, LLC, RIDGEFIELD, NJ. FILED 12-2-2011.



NO CLAIM IS MADE TO THE EXCLUSIVE RIGHT TO USE "DANCE STUDIOS" AND "EST. 2005", APART FROM THE MARK AS SHOWN.

THE MARK CONSISTS OF A CREST HAVING A CROWN AT THE TOP AND THE LETTERS "DWM" IN THE CENTER, THE WORDS "EST." AND "2005" NEAR THE BOTTOM, AND THE WORDS "DANCE STUDIOS" AT THE BOTTOM.

FOR APPAREL FOR DANCERS, NAMELY, TEE SHIRTS, SWEATSHIRTS, PANTS, LEGGINGS, SHORTS AND JACKETS; CARDIGANS; CROP TOPS; DANCE SHOES; DRESSES; EAR MUFFS; GLOVES; HEADGEAR, NAMELY, CAPS AND HATS; HOODED PULLOVERS; HOODED SWEATSHIRTS; JACKETS; LEGGINGS; LEOTARDS; LEOTARDS AND TIGHTS FOR WOMEN, MEN AND CHILDREN OF NYLON, COTTON OR OTHER TEXTILE FIBERS; PONCHOS; ROBES; SCARFS; SHAWLS; SHIRTS; SHOES; SHORTS; SKIRTS; SOCKS; SUITS; SWEAT PANTS; SWEAT SHIRTS; WARM UP SUITS; WOMEN'S CLOTHING, NAMELY, SHIRTS, DRESSES, SKIRTS, BLOUSES; WRAPS (U.S. CLS. 22 AND 39).

HEATHER BIDDULPH, EXAMINING ATTORNEY

CLASS 25—(Continued).

SN 85-491,121. COLE, JERMAINE, ROCKVILLE CENTRE, NY. FILED 12-8-2011.

DREAMVILLE

THE MARK CONSISTS OF STANDARD CHARACTERS WITHOUT CLAIM TO ANY PARTICULAR FONT, STYLE, SIZE, OR COLOR.

FOR BANDANAS; CAPS; CREW NECK SWEATERS; HOODED PULLOVERS; HOODED SWEATSHIRTS; SHORT-SLEEVED OR LONG-SLEEVED T-SHIRTS; SWEATERS; T-SHIRTS (U.S. CLS. 22 AND 39).

FIRST USE 6-0-2007; IN COMMERCE 6-0-2007.
ZACHARY BELLO, EXAMINING ATTORNEY

CLASS 25—(Continued).

SN 85-508,057. BAY GAME INC, DBA PURE EPIC, EMERYVILLE, CA. FILED 1-3-2012.



THE MARK CONSISTS OF THE WORDING "THE TRIPPY STIX" IN STYLIZED FORMAT WITH THE WORD "THE" APPEARING ABOVE THE WORD "TRIPPY" WHICH APPEARS ABOVE THE WORD "STIX".

FOR APPAREL, NAMELY, T-SHIRTS (U.S. CLS. 22 AND 39).

FIRST USE 3-5-2011; IN COMMERCE 3-25-2011.
ERIN FALK, EXAMINING ATTORNEY

SN 85-492,588. SENIOR MANAGEMENT GROUP, LLC, WAYNE, PA. FILED 12-12-2011.

RESTORE THE ROAR

THE MARK CONSISTS OF STANDARD CHARACTERS WITHOUT CLAIM TO ANY PARTICULAR FONT, STYLE, SIZE, OR COLOR.

FOR ATHLETIC APPAREL, NAMELY, SHIRTS, PANTS, JACKETS, FOOTWEAR, HATS AND CAPS, ATHLETIC UNIFORMS (U.S. CLS. 22 AND 39).

FIRST USE 12-1-2011; IN COMMERCE 12-1-2011.
BRENDAN MCCAULEY, EXAMINING ATTORNEY

SN 85-510,747. LI, LISA, FLUSHING, NY. FILED 1-6-2012.

SN 85-494,400. FOOTE ENTERPRISES, LLC, TEMECULA, CA. FILED 12-13-2011.

FOOTE PRINT WINERY

THE MARK CONSISTS OF STANDARD CHARACTERS WITHOUT CLAIM TO ANY PARTICULAR FONT, STYLE, SIZE, OR COLOR.

FOR CAPS; FOOTWEAR; GLOVES; HATS; JACKETS; PANTS; SCARVES; SHIRTS; SHORTS; SLEEPWEAR; SOCKS; SWEATERS; SWEATSHIRTS; SWIMWEAR; T-SHIRTS; TANK TOPS; UNDERWEAR (U.S. CLS. 22 AND 39).

BENJAMIN OKEKE, EXAMINING ATTORNEY



THE MARK CONSISTS OF THE STYLIZED WORDING "HOLI" WITH 5 HORIZONTAL LINES APPEARING ON THE RIGHT SIDE OF THE LETTER "O."

THE WORDING "HOLI" HAS NO MEANING IN A FOREIGN LANGUAGE.

FOR SCARFS AND TIES (U.S. CLS. 22 AND 39).
FIRST USE 12-1-2011; IN COMMERCE 12-1-2011.
DAVID I, EXAMINING ATTORNEY

CLASS 25—(Continued).

SN 85-515,007. MMI-IPCO LLC, LAWRENCE, MA. FILED 1-12-2012.

**POLARTEC BREATHING IS
BELIEVING**

THE MARK CONSISTS OF STANDARD CHARACTERS WITHOUT CLAIM TO ANY PARTICULAR FONT, STYLE, SIZE, OR COLOR.

OWNER OF U.S. REG. NOS. 1,869,644, 2,982,559 AND OTHERS.

FOR TEXTILE FABRIC PIECE GOODS SOLD AS A COMPONENT OF CLOTHING, NAMELY, COATS, JACKETS, PARKAS, RAINCOATS, PULLOVERS, SHIRTS, SPORTS JERSEYS, TROUSERS, PANTS, DRESSES, SKIRTS, PAJAMAS, UNDERCLOTHING, SCARVES, SHAWLS, GLOVES, MITTENS, HEADWEAR, NAMELY, HATS, CAPS, HEADBANDS, AND VISORS, FOOTWEAR, NAMELY, SPORT AND LEISURE SHOES, SLIPPERS, SOCKS, TIGHTS, STOCKINGS, AND HOSIERY (U.S. CLS. 22 AND 39).

DAVID TAYLOR, EXAMINING ATTORNEY

SN 85-517,198. SR HOLDINGS, LLC, LEXINGTON, MA. FILED 1-16-2012.

ASV TECHNOLOGY

THE MARK CONSISTS OF STANDARD CHARACTERS WITHOUT CLAIM TO ANY PARTICULAR FONT, STYLE, SIZE, OR COLOR.

OWNER OF U.S. REG. NOS. 4,018,958 AND 4,018,964.

NO CLAIM IS MADE TO THE EXCLUSIVE RIGHT TO USE "TECHNOLOGY", APART FROM THE MARK AS SHOWN.

FOR APPAREL, NAMELY, FOUL WEATHER GEAR; OUTER JACKETS; JACKETS; COATS; PULLOVERS; VESTS; TOPS; SHIRTS; T-SHIRTS; POLO SHIRTS; DRESS SHIRTS; SHORT-SLEEVED OR LONG-SLEEVED T-SHIRTS; SWEATERS; SWEATSHIRTS; THERMAL UNDERWEAR; SWIMWEAR; BEACH COVERUPS; COVERUPS; HOODED SWEATSHIRTS; HOODED PULLOVERS; SHORTS; PANTS; SWEATPANTS; JEANS; BOTTOMS; HEADWEAR; HATS; CAPS; BELTS; GLOVES; SUSPENDERS; SOCKS; HOSIERY; LEGGINGS; SCARVES (U.S. CLS. 22 AND 39).

ANGELA M. MICHELI, EXAMINING ATTORNEY

CLASS 25—(Continued).

SN 85-520,983. SWEIGERT, DAN K, DBA DAN K SWEIGERT, HURON, OH. FILED 1-20-2012.



THE COLOR(S) GREEN, BLUE, PURPLE, BLACK, AND WHITE IS/ARE CLAIMED AS A FEATURE OF THE MARK.

THE MARK CONSISTS OF A DESIGN OF A GLOBE CONTAINING CONTINENTS OVERWRITTEN WITH A YIN-YANG SYMBOL. HALF THE GLOBE APPEARS IN SHADES OF GREEN AND THE OTHER HALF APPEARS IN SHADES OF BLUE AND PURPLE. THERE IS A SPOT OF WHITE HIGHLIGHTING ON THE GLOBE. THE BLACK WORDING "EARTH AIR WATER ONE ANOTHER" APPEARS ABOVE THE GLOBE SEPARATED BY SMALL CIRCLES IN GREEN, LIGHT GREEN, AND BLUE. BELOW THE GLOBE IS THE WEB ADDRESS "WWW.NOTMUCHELSEMATTERS.COM". "WWW." AND ".COM" ARE BLACK. "NOT" IS GREEN. "MUCH" IS LIGHT GREEN. "ELSE" IS BLUE. "MATTERS" IS PURPLE. THE MARK APPEARS ON A WHITE BACKGROUND.

FOR APPAREL, NAMELY, SHIRTS, PANTS, COATS, DRESSES, SHORTS (U.S. CLS. 22 AND 39).

KIM MONINGHOFF, EXAMINING ATTORNEY

SN 85-522,044. LYNN PROMOTIONS, INC., UPLAND, CA. FILED 1-21-2012.



THE MARK CONSISTS OF A CIRCULAR BACKGROUND WITH A PERSON RIDING A SKATEBOARD DEPICTED IN THE MIDDLE OF THE CIRCLE. THE BACKGROUND CREATES THE IMAGE THAT THE PERSON IS SKATING INSIDE A PIPE.

FOR SHIRTS (U.S. CLS. 22 AND 39).

FIRST USE 6-1-2010; IN COMMERCE 6-1-2010.

ALICE BENMAMAN, EXAMINING ATTORNEY

CLASS 25—(Continued).

SN 85-526,302. FLATS BELLY WRAPS LLC, SAN JOSE, CA. FILED 1-26-2012.

Ultimate Postpartum Ultra

THE MARK CONSISTS OF STANDARD CHARACTERS WITHOUT CLAIM TO ANY PARTICULAR FONT, STYLE, SIZE, OR COLOR.

NO CLAIM IS MADE TO THE EXCLUSIVE RIGHT TO USE "ULTIMATE POSTPARTUM", APART FROM THE MARK AS SHOWN.

FOR CLOTHING, NAMELY, SHAPEWEAR, NAMELY, BODYSUITS, CAMISOLES, GIRDLES, BRAS, WAIST CINCHERS, THIGH SHAPERS, BOTTOM SHAPERS, STEP-INS, SLIPS, PANTIES, UNDERWEAR, LEGGINGS, CORSETS, HOSIERY, TIGHTS, SOCKS AND FOUNDATION GARMENTS WORN AROUND THE MIDSECTION OR THIGHS UP TO THE BREASTS TO CREATE A SLIMMING AND SMOOTH EFFECT (U.S. CLS. 22 AND 39).

RONALD MCMORROW, EXAMINING ATTORNEY

SN 85-527,266. ARREDONDO, BENITO, DBA COWBOY SWAGG, BEEVILLE, TX. FILED 1-27-2012.



THE MARK CONSISTS OF TWO WORDS, "COWBOY" AND "SWAGG" WITH ALL LETTERS IN STYLIZED FONT, AND THE "C" OF "COWBOY" AND "S" OF "SWAGG" BEING IN UPPER CASE RELATIVE TO THE OTHER LETTERS.

FOR ATHLETIC APPAREL, NAMELY, SHIRTS, PANTS, JACKETS, FOOTWEAR, HATS AND CAPS, ATHLETIC UNIFORMS (U.S. CLS. 22 AND 39).

FIRST USE 10-27-2011; IN COMMERCE 12-18-2011.

PAM WILLIS, EXAMINING ATTORNEY

CLASS 25—(Continued).

SN 85-527,718. GALLARDO FONSECA VIEIRA, ADRIANA, CAMPINAS, SAO PAULO, BRAZIL, AND PRADO NASCIMENTO, ANDREA, LOS ANGELES, CA. FILED 1-27-2012.



NO CLAIM IS MADE TO THE EXCLUSIVE RIGHT TO USE "FITNESS WEAR", APART FROM THE MARK AS SHOWN.

THE MARK CONSISTS OF A CIRCULAR DESIGN CONSISTING OF A STYLIZED "G" AND "A" TO THE LEFT OF THE WORDING "GLOSS ARMY" ABOVE THE WORDING "FITNESS WEAR" ALL SUPERIMPOSED ON A RECTANGULAR BACKGROUND.

FOR FOOTWEAR; ATHLETIC APPAREL, NAMELY, SHIRTS, PANTS, JACKETS, FOOTWEAR, HATS AND CAPS, ATHLETIC UNIFORMS; BIKINIS; BODY SHIRTS; CAPRI PANTS; GYM PANTS; GYM SHORTS; GYM SUITS; JOGGING PANTS; SWIMSUITS (U.S. CLS. 22 AND 39).

DORITT L. CARROLL, EXAMINING ATTORNEY

SN 85-528,082. ESTUPIGAN, JAIME M, ORLANDO, FL. FILED 1-29-2012.

AKO ITO

THE MARK CONSISTS OF STANDARD CHARACTERS WITHOUT CLAIM TO ANY PARTICULAR FONT, STYLE, SIZE, OR COLOR.

THE ENGLISH TRANSLATION OF "AKO ITO" IN THE MARK IS "THIS IS ME".

FOR APPAREL FOR DANCERS, NAMELY, TEE SHIRTS, SWEATSHIRTS, PANTS, LEGGINGS, SHORTS AND JACKETS; ATHLETIC APPAREL, NAMELY, SHIRTS, PANTS, JACKETS, FOOTWEAR, HATS AND CAPS, ATHLETIC UNIFORMS; BATHING COSTUMES FOR WOMEN; BATHING SUITS FOR MEN; CHILDREN'S AND INFANT'S APPAREL, NAMELY, JUMPERS, OVERALL SLEEPWEAR, PAJAMAS, ROMPERS AND ONE-PIECE GARMENTS; CHILDREN'S AND INFANTS' APPAREL TREATED WITH FIRE AND HEAT RETARDANTS, NAMELY, JUMPERS, OVERALL SLEEPWEAR, PAJAMAS, ROMPERS AND ONE-PIECE GARMENTS; COATS FOR MEN AND WOMEN; CUSTOM MADE TO MEASURE SUITS FOR MEN AND WOMEN; FOOTWEAR FOR MEN AND WOMEN; GLOVES FOR APPAREL; HOODED SWEATSHIRTS FOR BABIES, ADULTS, CHILDREN, WOMEN, MEN; LEOTARDS AND TIGHTS FOR WOMEN, MEN AND CHILDREN OF NYLON, COTTON OR OTHER TEXTILE FIBERS; MEN'S AND WOMEN'S JACKETS, COATS, TROUSERS, VESTS; MEN'S DRESS SOCKS; MEN'S SOCKS; MEN'S SUITS, WOMEN'S SUITS; MEN'S UNDERWEAR; SUSPENDER BELTS FOR MEN; SUSPENDER BELTS FOR WOMEN; SWEATSHIRTS FOR BABIES, ADULTS, CHILDREN, WOMEN, MEN; T-SHIRTS FOR BABIES, ADULTS, CHILDREN, WOMEN, MEN; WOMEN'S ATHLETIC TOPS WITH BUILT-IN BRAS; WOMEN'S CEREMONIAL DRESSES; WOMEN'S CLOTHING, NAMELY, SHIRTS, DRESSES, SKIRTS, BLOUSES; WOMEN'S FOLDABLE SLIPPERS; WOMEN'S HATS AND HOODS; WOMEN'S SHOES; WOMEN'S SHOES, NAMELY, FOLDABLE FLATS; WOMEN'S TOPS, NAMELY, CAMIS; WOMEN'S UNDERWEAR (U.S. CLS. 22 AND 39).

FIRST USE 1-3-1990; IN COMMERCE 1-3-1990.

JENNY PARK, EXAMINING ATTORNEY

CLASS 25—(Continued).

SN 85-532,006. BLACK MIKE, CHICAGO, IL. FILED 2-2-2012.



THE MARK CONSISTS OF AN IMAGE OF A DUCK TURNING TO LOOK BACKWARDS WITH ITS FLUFFY REAR FACING THE VIEWER. THE DUCK IS WEARING SUNGLASSES AND IS BLINKING ONE EYE. A PARTIAL RING OF LEAVES SURROUNDS THE DUCK. ABOVE THE DUCK IS THE STYLIZED TEXT "DUK" AND BELOW IT IS THE STYLIZED TEXT "BUDDA".

FOR HOODED SWEATSHIRTS; JEANS (U.S. CLS. 22 AND 39).

FIRST USE 12-19-2010; IN COMMERCE 12-19-2010.
BARBARA RUTLAND, EXAMINING ATTORNEY

SN 85-535,543. FRUITSHOP INTERNATIONAL CO., LTD., NEW TAIPEI CITY, TAIWAN, FILED 2-7-2012.



THE MARK CONSISTS OF TWO CHINESE CHARACTERS FORMED WITHIN A STYLIZED OVAL BACKGROUND.

THE ENGLISH TRANSLATION OF THE WORD "XIAO WAN" IN THE MARK IS "LITTLE, SMALL ROUNDED BALL LIKE OBJECT".

THE NON-LATIN CHARACTERS IN THE MARK TRANSLITERATE TO "XIAO WAN" AND THIS MEANS "LITTLE, SMALL ROUNDED BALL-LIKE OBJECT" IN ENGLISH.

FOR APRONS; BATH ROBES; BATHING CAPS; BATHING SUITS; BELTS; BOOTS; SHOWER CAPS; CLOTHING, NAMELY, PANTS, SHIRTS, TOPS; CLOTHING OF LEATHER, NAMELY, PANTS, SHIRTS, TOPS; COATS; FISHING VESTS; FOOTWEAR HEADGEAR, NAMELY, HATS AND CAPS; HOODS; HOSIERY; JUMPERS; LIVERIES; MONEY BELTS; NECKTIES PAJAMAS; CAP PEAKS; READY-MADE CLOTHING, NAMELY, PANTS, SHIRTS, TOPS; SANDALS; SCARVES; SHOES; SHOULDER WRAPS; SOCKS SWEATERS; SWIMSUITS; TEE-SHIRTS; TROUSER STRAPS; UNDERPANTS; UNDERWEAR; VESTS (U.S. CLS. 22 AND 39).

DANNEAN HETZEL, EXAMINING ATTORNEY

CLASS 25—(Continued).

SN 85-536,100. ROSA GEORGE W II, REVERE, MA. FILED 2-7-2012.



THE MARK CONSISTS OF THE WORDING "SCUMBAGS & SUPERSTARS" IN A CIRCLE FORM WITH A DESIGN OF TWO STARS SEPARATING THOSE WORDS WITH A DESIGN OF A SKULL WEARING AN INDIAN HEAD DRESS IN THE MIDDLE, WHICH IS SURROUNDED BY THE WORDING AND THE STARS.

FOR HOODED SWEAT SHIRTS; KNIT SHIRTS; LONG-SLEEVED SHIRTS; SWEAT SHIRTS; T-SHIRTS; TEE SHIRTS; WEARABLE GARMENTS AND CLOTHING, NAMELY, SHIRTS; WOMEN'S CLOTHING, NAMELY, SHIRTS, DRESSES, SKIRTS, BLOUSES (U.S. CLS. 22 AND 39).

FIRST USE 7-1-2010; IN COMMERCE 4-1-2011.
SAMUEL E. SHARPER JR., EXAMINING ATTORNEY

SN 85-542,928. STRANGE MUSIC, INC., BLUE SPRINGS, MO. FILED 2-15-2012.

CARIBOU LOU

THE MARK CONSISTS OF STANDARD CHARACTERS WITHOUT CLAIM TO ANY PARTICULAR FONT, STYLE, SIZE, OR COLOR.

FOR SHIRTS; T-SHIRTS; TOPS (U.S. CLS. 22 AND 39).
FIRST USE 12-7-2007; IN COMMERCE 12-7-2007.
SUNG IN, EXAMINING ATTORNEY

CLASS 25—(Continued).

SN 85-543,090. EULIE, LLC, PROVIDENCE, RI. FILED 2-15-2012.

UNDERBRELLA

THE MARK CONSISTS OF STANDARD CHARACTERS WITHOUT CLAIM TO ANY PARTICULAR FONT, STYLE, SIZE, OR COLOR.

FOR CLOTHING, NAMELY, APRONS, ATHLETIC PANTS, ATHLETIC SHORTS, ATHLETIC CAPRIS, ATHLETIC JACKETS, BUSTIERS, BEACH COVER-UPS, BELTS, BLAZERS, BLOUSES, BODY SUITS, BOXER SHORTS, BRAS, CAMISOLES, CHEMISES, COATS, DRESSES, FOUNDATION GARMENTS, GARTER BELTS, GIRDLES, GLOVES, GOWNS, HALTER TOPS, JACKETS, JEANS, JOGGING SUITS, KNIT SHIRTS, KNIT TOPS, LEOTARDS, LINGERIE, MATERNITY UNDERWEAR, MATERNITY TOPS, MATERNITY PANTS, MITTENS, NEGLIGEEES, NIGHT GOWNS, NIGHT SHIRTS, NURSING BRAS, PAJAMAS, PANTIES, PANTS, PANTYHOSE, ROBES, SANDALS, SARONGS, SCARVES, SHIRTS, SHORTS, SKIRTS, SLEEPWEAR, SLACKS, SLIPS, SPORTS BRAS, STOCKINGS, SUITS, SWEAT PANTS, SWEAT SHIRTS, SWEAT SHORTS, SWEAT SUITS, SWEATERS, SWIMSUITS, T-SHIRTS, TANK TOPS, TEDDIES, TIGHTS, TOPS, UNDERPANTS, UNDERSHIRTS, UNDERWEAR AND VESTS; STAIN-RESISTANT AND STAIN-REPELLANT CLOTHING, NAMELY, APRONS, ATHLETIC PANTS, ATHLETIC SHORTS, ATHLETIC CAPRIS, ATHLETIC JACKETS, BUSTIERS, BEACH COVER-UPS, BELTS, BLAZERS, BLOUSES, BODY SUITS, BOXER SHORTS, BRAS, CAMISOLES, CHEMISES, COATS, DRESSES, FOUNDATION GARMENTS, GARTER BELTS, GIRDLES, GLOVES, GOWNS, HALTER TOPS, JACKETS, JEANS, JOGGING SUITS, KNIT SHIRTS, KNIT TOPS, LEOTARDS, LINGERIE, MATERNITY UNDERWEAR, MATERNITY TOPS, MATERNITY PANTS, MITTENS, NEGLIGEEES, NIGHT GOWNS, NIGHT SHIRTS, NURSING BRAS, PAJAMAS, PANTIES, PANTS, PANTYHOSE, ROBES, SANDALS, SARONGS, SCARVES, SHIRTS, SHORTS, SKIRTS, SLEEPWEAR, SLACKS, SLIPS, SPORTS BRAS, STOCKINGS, SUITS, SWEAT PANTS, SWEAT SHIRTS, SWEAT SHORTS, SWEAT SUITS, SWEATERS, SWIMSUITS, T-SHIRTS, TANK TOPS, TEDDIES, TIGHTS, TOPS, UNDERPANTS, UNDERSHIRTS, UNDERWEAR AND VESTS; FOOTWEAR, NAMELY, BOOTS, SHOES, SLIPPERS, SNEAKERS AND SOCKS; STAIN-RESISTANT AND STAIN-REPELLANT FOOTWEAR, NAMELY, BOOTS, SHOES, SLIPPERS, SNEAKERS AND SOCKS; HEADWEAR, NAMELY, CAPS, HATS AND HEADBANDS; STAIN-RESISTANT AND STAIN-REPELLANT HEADWEAR, NAMELY, CAPS, HATS AND HEADBANDS (U.S. CLS. 22 AND 39).

STEVEN JACKSON, EXAMINING ATTORNEY

CLASS 25—(Continued).

SN 85-543,202. BRIGHT, GREGORY L., IRVINE, CA. FILED 2-15-2012.

MANUP

THE MARK CONSISTS OF STANDARD CHARACTERS WITHOUT CLAIM TO ANY PARTICULAR FONT, STYLE, SIZE, OR COLOR.

FOR BLOUSES; COATS; COATS FOR MEN AND WOMEN; FLEECE PULLOVERS; HATS; HOODED SWEATSHIRTS; JACKETS; POLO SHIRTS; SHIRTS; SWEAT PANTS; SWEAT SHIRTS; SWEATERS; T-SHIRTS; WIND-JACKETS; WRISTBANDS (U.S. CLS. 22 AND 39).

SAMUEL E. SHARPER JR., EXAMINING ATTORNEY

SN 85-546,025. JCD INC, DBA ADEA, SHREWSBURY, MA. FILED 2-17-2012.

adea
EVERYDAY LUXURY

OWNER OF U.S. REG. NO. 3,210,972.

NO CLAIM IS MADE TO THE EXCLUSIVE RIGHT TO USE "LUXURY", APART FROM THE MARK AS SHOWN.

THE COLOR(S) GRAY IS/ARE CLAIMED AS A FEATURE OF THE MARK.

THE MARK CONSISTS OF GRAY LETTERING, "ADEA" IN LARGER TYPE APPEARING ABOVE THE WORDS "EVERYDAY LUXURY" IN SMALLER GRAY LETTERING.

THE WORDING "ADEA" HAS NO MEANING IN A FOREIGN LANGUAGE.

SEC. 2(F).

FOR BRIEFS; LADIES' UNDERWEAR; MEN'S UNDERWEAR; TOPS; WOMEN'S CLOTHING, NAMELY, SHIRTS, DRESSES, SKIRTS, BLOUSES (U.S. CLS. 22 AND 39).

FIRST USE 10-1-2009; IN COMMERCE 10-1-2009.

JAMES A. RAUEN, EXAMINING ATTORNEY

CLASS 25—(Continued).

SN 85-549,917. ELEMENTS OF STYLE, LLC, CAMBRIDGE, MA. FILED 2-22-2012.



NO CLAIM IS MADE TO THE EXCLUSIVE RIGHT TO USE "NYC", APART FROM THE MARK AS SHOWN.

THE MARK CONSISTS OF THE WORDING "BONA FIDE NEW YORKER NYC" AND DESIGN. THE WORDING "BONA FIDE NEW YORKER" FORM A CIRCLE. THE TERM "BONA FIDE" FORMS THE TOP OF THE CIRCLE AND THE WORDING "NEW YORKER" FORMS THE BASE OF THE CIRCLE. THE STYLIZED ACRONYM "NYC" APPEARS IN THE CENTER OF THE WORDING.

FOR CLOTHING, NAMELY, T-SHIRTS, TANK TOPS, JERSEYS, SWEATSHIRTS, SHAWLS, PULLOVERS, SHIRTS, VESTS, BLOUSES, TUNICS, TROUSERS, LEGGINGS, PAJAMAS, NIGHTSHIRTS, UNDERGARMENTS, LINGERIE, ROBES, HEADWEAR, HATS, CAPS, JACKETS, SWEATERS, SCARVES, EXERCISE PANTS, YOGA PANTS, SWEAT PANTS, WARM-UP SUITS, SCRUBS NOT FOR MEDICAL PURPOSES, SHORTS, SOCKS, AND APRONS (U.S. CLS. 22 AND 39).

FIRST USE 12-18-2011; IN COMMERCE 12-18-2011.
MARY ROSSMAN, EXAMINING ATTORNEY

CLASS 25—(Continued).

SN 85-552,836. HOSOGAI, MEGUMI, DBA MEGUMI-O, LOS ANGELES, CA. FILED 2-25-2012.



THE NAME "MEGUMI O" IDENTIFIES THE PSEUDONYM OF MEGUMI HOSOGAI, A LIVING INDIVIDUAL WHOSE CONSENT IS OF RECORD

THE COLOR(S) RED, BLACK, YELLOW AND AUBURN IS/ARE CLAIMED AS A FEATURE OF THE MARK.

THE MARK CONSISTS OF AN ASIAN GIRL WITH ROUND HEAD AND YELLOW SKIN TONE, RED CIRCULAR LIPS, AUBURN HAIR AND WEARING BLACK JACKIE O STYLE SUNGLASSES. THE GIRL IS ALSO WEARING A RED AND BLACK KIMONO THAT HAS A BLACK FLORAL DESIGN AND WORDING AT THE BOTTOM OF THE KIMONO THAT SAYS "MEGUMI-O" IN RED LETTERING SET AGAINST A BLACK BACKGROUND.

FOR ADULT NOVELTY GAG CLOTHING ITEM, NAMELY, SOCKS; BABIES' PANTS; BABY LAYETTES FOR CLOTHING; BIBS NOT OF CLOTH OR PAPER; BOTTOMS; CHILDREN'S AND INFANTS' CLOTH BIBS; CHILDREN'S CLOTH EATING BIBS; CLOTH BIBS; CLOTH BIBS FOR ADULT DINERS; CLOTH BIBS FOR USE BY SENIOR CITIZENS OR PHYSICALLY- OR MENTALLY-CHALLENGED PERSONS; CLOTHING EXTENSION USED TO EXTEND THE NORMAL SIZE RANGE OF CLOTHING ITEMS TO ACCOMMODATE PREGNANCY SIZE CHANGES; CLOTHING FOR BABIES, TODDLERS AND CHILDREN, TREATED WITH FIRE AND HEAT RETARDANTS, NAMELY, PAJAMAS, JACKETS, SHIRTS, PANTS, JUMPERS; CLOTHING ITEMS, NAMELY, ADHESIVE POCKETS THAT MAY BE AFFIXED DIRECTLY TO THE BODY AS A DECORATIVE PIECE OF CLOTHING WITH UTILITY; CLOTHING ITEMS, NAMELY, ADHESIVE POCKETS THAT MAY BE AFFIXED DIRECTLY TO THE INSIDE OF CLOTHING FOR STORAGE AND SAFEKEEPING OF PERSONAL ITEMS; CLOTHING ITEMS, NAMELY, BLINDFOLDS WORN OVER THE EYES; CLOTHING ITEMS, NAMELY, GAGS WORN OVER THE MOUTH; CLOTHING SHIELDS, NAMELY, PADS APPLIED TO THE UNDERARMS OF SHIRTS, BLOUSES AND SWEATERS; CLOTHING, NAMELY, ARM WARMERS; CLOTHING, NAMELY, BASE LAYERS; CLOTHING, NAMELY, COWLS AND SMOKE RING SCARVES; CLOTHING, NAMELY, CROPS; CLOTHING, NAMELY, FOLK COSTUMES; CLOTHING, NAMELY, HAND-WAR-

SN 85-552,220. REACH CLOTHING LLC, OWASSO, OK. FILED 2-24-2012.



THE MARK CONSISTS OF THE STYLIZED WORDING "2RBR" WITH THE "2" LOCATED TO THE TOP LEFT SIDE OF THE "R" ABOVE THE STYLIZED WORDING "2REACH AND BE REACHED."

FOR CLOTHING, NAMELY, SHIRTS (U.S. CLS. 22 AND 39).

FIRST USE 3-1-2011; IN COMMERCE 3-1-2011.
CHRISTOPHER LAW, EXAMINING ATTORNEY

CLASS 25—(Continued).

MERS; CLOTHING, NAMELY, KHAKIS; CLOTHING, NAMELY, KNEE WARMERS; CLOTHING, NAMELY, MATERNITY BANDS; CLOTHING, NAMELY, NECK TUBES; CLOTHING, NAMELY, THOBES; CLOTHING, NAMELY, WRAP-AROUNDS; COMBINATIONS; CORSETS; DRAWERS; DUSTERS; EYESHADES; FOULARDS; GLOVES AS CLOTHING; HEADBANDS FOR CLOTHING; HOODS; INFANT AND TODDLER ONE PIECE CLOTHING; MANTLES; MUFFLERS; NON-DISPOSABLE CLOTH TRAINING PANTS; PAPER HATS FOR USE AS CLOTHING ITEMS; PARTY HATS; PERSPIRATION ABSORBENT UNDERWEAR CLOTHING; POCKET SQUARES; SHIFTS; SHORT SETS; SHOULDER WRAPS; SHOULDER WRAPS FOR CLOTHING; SWADDLING CLOTHES; TIES; TOPS; TRAVEL CLOTHING CONTAINED IN A PACKAGE COMPRISING REVERSIBLE JACKETS, PANTS, SKIRTS, TOPS AND A BELT OR SCARF; WEARABLE GARMENTS AND CLOTHING, NAMELY, NOVELTY T-SHIRTS; WOMEN'S CLOTHING, NAMELY, DRESSES, BLOUSES; WRAPS; WRIST BANDS; WRISTBANDS (U.S. CLS. 22 AND 39).

FIRST USE 2-14-2012; IN COMMERCE 2-24-2012.
JEFFREY LOOK, EXAMINING ATTORNEY

SN 85-553,074. BIG I SALES, LLC, HOLLY POND, AL. FILED 2-26-2012.

Whiskey Ltd

THE MARK CONSISTS OF STANDARD CHARACTERS WITHOUT CLAIM TO ANY PARTICULAR FONT, STYLE, SIZE, OR COLOR.

NO CLAIM IS MADE TO THE EXCLUSIVE RIGHT TO USE "LTD", APART FROM THE MARK AS SHOWN.

FOR APPAREL FOR DANCERS, NAMELY, TEE SHIRTS, SWEATSHIRTS, PANTS, LEGGINGS, SHORTS AND JACKETS; ATHLETIC APPAREL, NAMELY, SHIRTS, PANTS, JACKETS, FOOTWEAR, HATS AND CAPS, ATHLETIC UNIFORMS; BUTTON DOWN SHIRTS; DRESS SHIRTS; GOLF SHIRTS; HOODED SWEAT SHIRTS; LONG-SLEEVED SHIRTS; NIGHT SHIRTS; PIQUE SHIRTS; POLO SHIRTS; RUGBY SHIRTS; SHIRTS AND SHORT-SLEEVED SHIRTS; SHORT-SLEEVED OR LONG-SLEEVED T-SHIRTS; SHORT-SLEEVED SHIRTS; SLEEP SHIRTS; SWEAT SHIRTS; T-SHIRTS; TEE SHIRTS; WOMEN'S CLOTHING, NAMELY, SHIRTS, DRESSES, SKIRTS, BLOUSES (U.S. CLS. 22 AND 39).

FIRST USE 12-2-2011; IN COMMERCE 12-5-2011.
REBECCA SMITH, EXAMINING ATTORNEY

CLASS 25—(Continued).

SN 85-554,314. GONZALES, DAVID PEREZ, MILWAUKEE, WI. FILED 2-28-2012.



OWNER OF U.S. REG. NO. 4,017,424.
THE COLOR(S) WHITE, BLACK, GREEN, RED, WHITE AND BLUE IS/ARE CLAIMED AS A FEATURE OF THE MARK.

THE MARK CONSISTS OF THE FOLLOWING: THE WORDING LATIN BOSS IN A SPECIAL FONT IN THE COLOR BLACK ARCED OVER A GREEN FROG/COQUI CHARACTER WHO IS WRAPPED IN A RED, WHITE AND BLUE FLAG WITH A WHITE STAR WHILE STANDING ON GREEN LILY PAD ON A WHITE BACKGROUND.

FOR ADULT NOVELTY GAG CLOTHING ITEM, NAMELY, SOCKS; BABIES' PANTS; BABY LAYETTES FOR CLOTHING; BELTS; BELTS FOR CLOTHING; BELTS MADE OUT OF CLOTH; BIBS NOT OF CLOTH OR PAPER; BOTTOMS; CHILDREN'S AND INFANTS' CLOTH BIBS; CHILDREN'S CLOTH EATING BIBS; CLOTH BIBS; CLOTH BIBS FOR ADULT DINERS; CLOTH BIBS FOR USE BY SENIOR CITIZENS OR PHYSICALLY- OR MENTALLY-CHALLENGED PERSONS; CLOTHING EXTENSION USED TO EXTEND THE NORMAL SIZE RANGE OF CLOTHING ITEMS TO ACCOMMODATE PREGNANCY SIZE CHANGES; CLOTHING FOR ATHLETIC USE, NAMELY, PADDED ELBOW COMPRESSION SLEEVES BEING PART OF AN ATHLETIC GARMENT; CLOTHING FOR ATHLETIC USE, NAMELY, PADDED PANTS; CLOTHING FOR ATHLETIC USE, NAMELY, PADDED SHIRTS; CLOTHING FOR ATHLETIC USE, NAMELY, PADDED SHORTS; CLOTHING FOR BABIES, TODDLERS AND CHILDREN, TREATED WITH FIRE AND HEAT RETARDANTS, NAMELY, PAJAMAS, JACKETS, SHIRTS, PANTS, JUMPERS; CLOTHING FOR WEAR IN JUDO PRACTICES; CLOTHING FOR WEAR IN WRESTLING GAMES; CLOTHING ITEMS, NAMELY, ADHESIVE POCKETS THAT MAY BE AFFIXED DIRECTLY TO THE BODY AS A DECORATIVE PIECE OF CLOTHING WITH UTILITY; CLOTHING ITEMS, NAMELY, ADHESIVE POCKETS THAT MAY BE AFFIXED DIRECTLY TO THE INSIDE OF CLOTHING FOR STORAGE AND SAFEKEEPING OF PERSONAL ITEMS; CLOTHING ITEMS, NAMELY, BLINDFOLDS WORN OVER THE EYES; CLOTHING ITEMS, NAMELY, GAGS WORN OVER THE MOUTH; CLOTHING SHIELDS, NAMELY, PADS APPLIED TO THE UNDERARMS OF SHIRTS, BLOUSES AND SWEATERS; CLOTHING, NAMELY, ARM WARMERS; CLOTHING, NAMELY, ATHLETIC SLEEVES; CLOTHING, NAMELY, BASE LAYERS; CLOTHING, NAMELY, COWLS AND SMOKE RING SCARVES; CLOTHING, NAMELY, CROPS; CLOTHING, NAMELY, FOLK COSTUMES; CLOTHING, NAMELY, HAND-WARMERS; CLOTHING, NAMELY, KHAKIS; CLOTHING, NAMELY, KNEE WARMERS; CLOTHING, NAMELY, MATERNITY BANDS; CLOTHING, NAMELY, NECK TUBES; CLOTHING, NAMELY, THOBES; CLOTHING, NAMELY, WRAP-AROUNDS; COMBINATIONS; CORSETS; DRAWERS; DUSTERS; EYESHADES; FOULARDS; GLOVES AS CLOTHING; HEADBANDS FOR CLOTHING; HOODS; INFANT AND TODDLER ONE PIECE CLOTHING; JACKETS; JERSEYS; LEATHER BELTS; MANTLES; MUFFLERS; NON-DISPOSABLE CLOTH TRAINING PANTS; PAPER HATS FOR USE AS CLOTHING ITEMS; PARTS OF CLOTHING, NAMELY,

CLASS 25—(Continued).

GUSSETS FOR TIGHTS, GUSSETS FOR STOCKINGS, GUSSETS FOR BATHING SUITS, GUSSETS FOR UNDERWEAR, GUSSETS FOR LEOTARDS AND GUSSETS FOR FOOTLETS; PARTS OF CLOTHING, NAMELY, UNDERARM GUSSETS; PARTY HATS; PERSPIRATION ABSORBENT UNDERWEAR CLOTHING; POCKET SQUARES; SHIRTS; SHORT SETS; SHOULDER WRAPS; SHOULDER WRAPS FOR CLOTHING; SWADDLING CLOTHES; TIES; TOPS; TRAVEL CLOTHING CONTAINED IN A PACKAGE COMPRISING REVERSIBLE JACKETS, PANTS, SKIRTS, TOPS AND A BELT OR SCARF; TRIATHLON CLOTHING, NAMELY, TRIATHLON TIGHTS, TRIATHLON SHORTS, TRIATHLON SINGLET, TRIATHLON SHIRTS, TRIATHLON SUITS; UNDERARM CLOTHING SHIELDS; WEARABLE GARMENTS AND CLOTHING, NAMELY, SHIRTS; WOMEN'S CLOTHING, NAMELY, SHIRTS, DRESSES, SKIRTS, BLOUSES; WRAPS; WRIST BANDS; WRISTBANDS (U.S. CLS. 22 AND 39).

FIRST USE 1-1-2012; IN COMMERCE 1-1-2012.
JOHN DALIER, EXAMINING ATTORNEY

SN 85-562,044. 88 INTERNATIONAL, INC., NEW YORK, NY.
FILED 3-6-2012.

PROJECT INDIGO

THE MARK CONSISTS OF STANDARD CHARACTERS WITHOUT CLAIM TO ANY PARTICULAR FONT, STYLE, SIZE, OR COLOR.

FOR CLOTHING, NAMELY, JEANS, PANTS, T-SHIRTS, SWEATSHIRTS, WOVEN SHIRTS, SWEATERS, SHORTS, SKIRTS, CAPRIS AND JACKETS (U.S. CLS. 22 AND 39).

KIMBERLY PARKS, EXAMINING ATTORNEY

SN 85-562,953. AMERICAN BLUES COMPANY INC., NEW YORK, NY. FILED 3-7-2012.



OWNER OF U.S. REG. NO. 3,880,348.
THE MARK CONSISTS OF THE WORDING "RECOJEANS" IN STYLIZED FORM, TO THE RIGHT OF A SPIRAL ENDING WITH AN ARROW POINTING TO THE LEFT.
FOR COATS OF DENIM; DENIM JACKETS; DENIMS; JEANS; PANTS; SHORTS; TROUSERS; VESTS (U.S. CLS. 22 AND 39).

MATTHEW GALAN, EXAMINING ATTORNEY

CLASS 25—(Continued).

SN 85-563,956. RIVERSTONE VENTURES, LLC, OVERLAND PARK, KS. FILED 3-8-2012.

SO RELATIVE!

THE MARK CONSISTS OF STANDARD CHARACTERS WITHOUT CLAIM TO ANY PARTICULAR FONT, STYLE, SIZE, OR COLOR.

FOR CLOTHING, NAMELY, SHIRTS, SHORT SLEEVE T-SHIRTS, LONG SLEEVE T-SHIRTS, SWEATSHIRTS, HOODED SWEATSHIRTS, ZIPPED HOODED SWEATSHIRTS, SHORT SLEEVE BODYSUITS, LONG SLEEVE BODYSUITS, BLOOMERS, INFANT GOWNS, HATS, BEANIES, BABY CAPS, BASEBALL CAPS, CAPS, SOCKS, GLOVES, SCARVES, EAR MUFFS, ROMPERS, PANTS, SHORTS, SLIPPERS, DRESSES, CLOTH BIBS, APRONS, HALLOWEEN AND MASQUERADE COSTUMES, AND COSTUMES FOR USE IN CHILDREN'S DRESS UP PLAY (U.S. CLS. 22 AND 39).

FLORENTINA BLANDU, EXAMINING ATTORNEY

SN 85-564,351. CHIU SCIENCE INDUSTRY & TRADE GROUP LTD., HOHHOT, INNER MONGOLIA, CHINA, FILED 3-8-2012.

CHIYU FAMOUS SHOES

THE MARK CONSISTS OF STANDARD CHARACTERS WITHOUT CLAIM TO ANY PARTICULAR FONT, STYLE, SIZE, OR COLOR.

NO CLAIM IS MADE TO THE EXCLUSIVE RIGHT TO USE "FAMOUS SHOES", APART FROM THE MARK AS SHOWN.

THE ENGLISH TRANSLATION OF "CHIYU" IN THE MARK IS "CHI" IN CHINESE MEANS "GALLOP" IN ENGLISH. "YU" IN CHINESE MEANS "REPUTATION" IN ENGLISH.

FOR FOOTWEAR FOR MEN AND WOMEN (U.S. CLS. 22 AND 39).

NORA BUCHANAN WILL, EXAMINING ATTORNEY

SN 85-564,503. CORRIDAN, ANDREW, HONOLULU, HI. FILED 3-8-2012.



THE MARK CONSISTS OF STANDARD CHARACTERS WITHOUT CLAIM TO ANY PARTICULAR FONT, STYLE, SIZE, OR COLOR.

FOR BOARD SHORTS; COLLARED SHIRTS; HEADGEAR, NAMELY, HATS, VISORS, CAPS AND BEANIES; JACKETS; JOGGING SUITS; PANTS; SHORTS; SWEATSHIRTS; T-SHIRTS; TANK TOPS; VESTS; WALKING SHORTS (U.S. CLS. 22 AND 39).

WENDY GOODMAN, EXAMINING ATTORNEY

CLASS 25—(Continued).

SN 85-565,729. GUEST, ASHLEY, WILMINGTON, DE. FILED 3-9-2012.

Rink Rocket

THE MARK CONSISTS OF STANDARD CHARACTERS WITHOUT CLAIM TO ANY PARTICULAR FONT, STYLE, SIZE, OR COLOR.

NO CLAIM IS MADE TO THE EXCLUSIVE RIGHT TO USE "RINK", APART FROM THE MARK AS SHOWN.

FOR BOTTOMS; HATS; SWEAT SHIRTS; T-SHIRTS (U.S. CLS. 22 AND 39).

FIRST USE 1-8-2012; IN COMMERCE 1-8-2012.
MICHELE SWAIN, EXAMINING ATTORNEY

SN 85-566,095. HUSBAND, RONALD, SAN DIMAS, CA. FILED 3-10-2012.

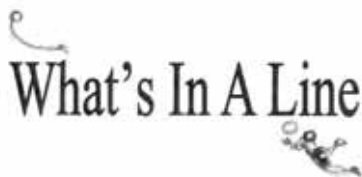

THE MARK CONSISTS OF A DESIGN FEATURING A BALL REPRESENTING A HEAD, ATTACHED TO A LINE REPRESENTING MOTION THAT LEADS TO A TRIANGLE WHICH REPRESENTS A FOOT. UNDERNEATH THE AFOREMENTIONED DESIGN, THE STYLIZED WORDING "WHAT'S IN A LINE" IS DEPICTED. UNDER THE WORDING AND TO THE RIGHT, THERE IS ANOTHER DESIGN OF A PERSON LUNGING TOWARD A BALL.

FOR CLOTHING FOR ATHLETIC USE, NAMELY, PADDED SHIRTS; SPORT COATS; SPORTS JACKETS; SPORTS JERSEYS; SPORTS PANTS; SPORTS SHIRTS; SPORTS SHIRTS WITH SHORT SLEEVES; SPORTS VESTS (U.S. CLS. 22 AND 39).

TRACY WHITTAKER-BROWN, EXAMINING ATTORNEY

SN 85-566,847. MICHELLE GLASS, HOLLYWOOD, FL. FILED 3-12-2012.

THE HYDRO-POCKET SPORTS BRA

THE MARK CONSISTS OF STANDARD CHARACTERS WITHOUT CLAIM TO ANY PARTICULAR FONT, STYLE, SIZE, OR COLOR.

NO CLAIM IS MADE TO THE EXCLUSIVE RIGHT TO USE "SPORTS BRA", APART FROM THE MARK AS SHOWN.

FOR SPORTS BRAS (U.S. CLS. 22 AND 39).
KAPIL BHANOT, EXAMINING ATTORNEY

CLASS 25—(Continued).

SN 85-570,775. COLORADO ROCKIES BASEBALL CLUB, LTD., DENVER, CO. FILED 3-15-2012.



THE MARK CONSISTS OF THE LETTERS "GJ" IN A STYLIZED TEXT FORM.

FOR CLOTHING, NAMELY, HEADWEAR, SHIRTS, SWEATERS, VESTS, BOTTOMS, DRESSES, SKIRTS, ATHLETIC UNIFORMS, JERSEYS, UNDERWEAR, SLEEPWEAR, ROBES, SWIMWEAR, JACKETS, PONCHOS, APRONS, WRAPS, INFANT WEAR, CLOTH BIBS, TIES, BELTS, FOOTWEAR, SOCKS, HOSIERY, SCARVES, GLOVES, MITTENS, HEADBANDS, AND WRISTBANDS (U.S. CLS. 22 AND 39).

JENNY PARK, EXAMINING ATTORNEY

SN 85-570,871. NED BOWEN'S "ALL OUT" LACROSSE CAMP, LLC, DENVER, CO. FILED 3-15-2012.

Be All Out

THE MARK CONSISTS OF STANDARD CHARACTERS WITHOUT CLAIM TO ANY PARTICULAR FONT, STYLE, SIZE, OR COLOR.

FOR SOCKS (U.S. CLS. 22 AND 39).

FIRST USE 1-31-2011; IN COMMERCE 1-31-2011.
EDWARD NELSON, EXAMINING ATTORNEY

CLASS 25—(Continued).

SN 85-572,225. RKO PICTURES, LOS ANGELES, CA. FILED 3-16-2012.



OWNER OF U.S. REG. NOS. 2,628,024, 3,318,872 AND OTHERS.

NO CLAIM IS MADE TO THE EXCLUSIVE RIGHT TO USE "STAGE", APART FROM THE MARK AS SHOWN.

THE MARK CONSISTS OF AN UPSIDE-DOWN STYLIZED TRIANGLE AND A LIGHTNING BOLT THAT RUNS DOWN THE MIDDLE OF THE TRIANGLE. THE WORD "STAGE" APPEARS INSIDE THE TRIANGLE AND IS INTERSECTED BY THE LIGHTNING BOLT WHILE "RKO", WITH SPACE IN BETWEEN EACH LETTER, RESTS ON THE BASE OF THE TRIANGLE.

FOR CLOTHING, FOOTWEAR AND HEADWEAR, NAMELY, T-SHIRTS, SWEAT SHIRTS, JERSEYS, SHORTS, SWEAT PANTS, JACKETS, HATS, CAPS, SCARVES, GLOVES, HOSIERY, NECKTIES, PAJAMAS, ROBES, NIGHT SHIRTS, NIGHT GOWNS, UNDERWEAR, HEAD BANDS, WRIST BANDS, SWIM SUITS, SKIRTS, SHIRTS, TANK TOPS, PANTS, COATS, SWEATERS, LEOTARDS, LEG WARMERS, STOCKINGS, SOCKS, PANTY HOSE, TIGHTS, BELTS, SHOES, ATHLETIC SHOES, SLIPPERS, BOOTS, SANDALS AND RAINWEAR (U.S. CLS. 22 AND 39).

LYNDSSEY KUYKENDALL, EXAMINING ATTORNEY

CLASS 25—(Continued).

SN 85-573,289. SIN TINI LLC, EL PASO, TX. FILED 3-19-2012.



THE COLOR(S) BLACK AND RED IS/ARE CLAIMED AS A FEATURE OF THE MARK.

THE MARK CONSISTS OF THE WORD "SIN" WITH A LINE APPEARING UNDER THE LETTERS "IN" AND "TINI" WITH A LINE APPEARING ABOVE THE LETTERS "TIN" ALL APPEARING IN THE COLOR BLACK, AND A MARTINI GLASS IN BLACK AND RED WITH A RED TAIL.

FOR CLOTHING, NAMELY, HATS, BELTS, T-SHIRTS, SWEATERS, SLEEVED AND UNSLEEVED SHIRTS AND PANTS (U.S. CLS. 22 AND 39).

JAY FLOWERS, EXAMINING ATTORNEY

SN 85-572,478. COASTAL SAILS, LLC, FRISCO, TX. FILED 3-17-2012.



THE COLOR(S) BLUE IS/ARE CLAIMED AS A FEATURE OF THE MARK.

THE MARK CONSISTS OF THE LETTER "C" REPRESENTING A FISHING HOOK WHICH IS ATTACHED TO THE LETTER "S" BELOW IT, ALL IN BLUE.

FOR HATS; SHIRTS; T-SHIRTS (U.S. CLS. 22 AND 39).
ROBIN CHOSID, EXAMINING ATTORNEY

emploi

THE MARK CONSISTS OF STANDARD CHARACTERS WITHOUT CLAIM TO ANY PARTICULAR FONT, STYLE, SIZE, OR COLOR.

THE ENGLISH TRANSLATION OF "EMPLOI" IS "EMPLOYMENT".

FOR (BASED ON USE IN COMMERCE) BELTS; COATS; DRESSES; KNIT DRESSES; SHIRTS; SKIRTS; WOVEN DRESSES (BASED ON INTENT TO USE) BLOUSES; JACKETS; LOUNGEWEAR; PANTS; SCARVES; SHAWLS; SHOES; SUITS; SWEATERS; T-SHIRTS; TROUSERS; UNDERWEAR (U.S. CLS. 22 AND 39).

FIRST USE 1-1-2012; IN COMMERCE 1-25-2012.
LINDA M. KING, EXAMINING ATTORNEY

CLASS 25—(Continued).

SN 85-579,225. FARSAI, RYAN A, LONG BEACH, CA. FILED 3-24-2012.



OWNER OF U.S. REG. NO. 3,617,894.
THE MARK CONSISTS OF A CIRCLE CONTAINING THE STYLIZED WORDING "MIDCALI" IN FRONT OF AN OUTLINE OF CALIFORNIA. AN INCOMPLETE CIRCLE ALSO APPEARS AROUND MOST OF THE CIRCLE DESIGN.

SEC. 2(F).

FOR ATHLETIC APPAREL, NAMELY, SHIRTS, PANTS, JACKETS, FOOTWEAR, HATS AND CAPS, ATHLETIC UNIFORMS; BABIES' PANTS; BASEBALL CAPS; BASEBALL CAPS AND HATS; BEANIES; BELTS; BELTS FOR CLOTHING; BELTS MADE OUT OF CLOTH; BERMUDA SHORTS; BOARD SHORTS; BODY SHIRTS; BOTTOMS; BOXER SHORTS; BUTTON DOWN SHIRTS; CAMOUFLAGE PANTS; CAMOUFLAGE SHIRTS; CAMP SHIRTS; CAP VISORS; CAPRI PANTS; CAPS; CAPS WITH VISORS; CARGO PANTS; CHILDREN'S AND INFANT'S APPAREL, NAMELY, JUMPERS, OVERALL SLEEPWEAR, PAJAMAS, ROMPERS AND ONE-PIECE GARMENTS; CLOTHING FOR BABIES, TODDLERS AND CHILDREN, TREATED WITH FIRE AND HEAT RETARDANTS, NAMELY, PAJAMAS, JACKETS, SHIRTS, PANTS, JUMPERS; CLOTHING, NAMELY, ARM WARMERS; CLOTHING, NAMELY, ATHLETIC SLEEVES; CLOTHING, NAMELY, KHAKIS; CROP PANTS; CYCLING SHORTS; DENIMS; DRAWERS; FABRIC BELTS; FISHING SHIRTS; FLEECE SHORTS; GLOVES AS CLOTHING; GOLF CAPS; GOLF PANTS, SHIRTS AND SKIRTS; GOLF SHIRTS; GOLF SHORTS; GYM PANTS; GYM SHORTS; HEAD SCARVES; HEAD SWEATBANDS; HEADBANDS AGAINST SWEATING; HOODED SWEAT SHIRTS; HOODS; HUNTING PANTS; HUNTING SHIRTS; INFANT AND TODDLER ONE PIECE CLOTHING; JACKETS; JEGGINGS, NAMELY, PANTS THAT ARE PARTIALLY JEANS AND PARTIALLY LEGGINGS; JOGGING PANTS; KNITTED CAPS; LONG-SLEEVED SHIRTS; LOUNGE PANTS; MOISTURE-WICKING SPORTS PANTS; MOISTURE-WICKING SPORTS SHIRTS; OPEN-NECKED SHIRTS; OVER SHIRTS; PAJAMA BOTTOMS; PAJAMAS; PANTIES, SHORTS AND BRIEFS; PANTS; PERSPIRATION ABSORBENT UNDERWEAR CLOTHING; PIQUE SHIRTS; POLO SHIRTS; SCARVES; SCIENTIFIC AND TECHNOLOGICAL APPAREL, NAMELY, SHIRTS, PANTS, JACKETS, FOOTWEAR, HATS AND CAPS, UNI-

CLASS 25—(Continued).

FORMS; SHIRTS; SHIRTS AND SHORT-SLEEVED SHIRTS; SHIRTS FOR INFANTS, BABIES, TODDLERS AND CHILDREN; SHORT TROUSERS; SHORT-SLEEVED OR LONG-SLEEVED T-SHIRTS; SHORT-SLEEVED SHIRTS; SHORTS; SKI PANTS; SKIRTS; SKIRTS AND DRESSES; SKULL CAPS; SNAP CROTCH SHIRTS FOR INFANTS AND TODDLERS; SNOW BOARDING SUITS; SNOW BOOTS; SNOW PANTS; SNOW SUITS; SNOWBOARD PANTS; SPORT SHIRTS; SPORTS CAPS AND HATS; SPORTS PANTS; SPORTS SHIRTS; SPORTS SHIRTS WITH SHORT SLEEVES; SUN VISORS; SWEAT BANDS; SWEAT JACKETS; SWEAT PANTS; SWEAT SHIRTS; SWEAT SHORTS; SWEAT SUITS; SWEATBANDS; T-SHIRTS; TEE SHIRTS; TOBOGGAN HATS, PANTS AND CAPS; TOPS; TURTLE NECK SHIRTS; VISORS; WATERPROOF JACKETS AND PANTS; WEARABLE GARMENTS AND CLOTHING, NAMELY, SHIRTS; WIND PANTS; WIND SHIRTS; WOMEN'S CLOTHING, NAMELY, SHIRTS, DRESSES, SKIRTS, BLOUSES; WRIST BANDS; WRISTBANDS; YOGA PANTS; YOGA SHIRTS (U.S. CLS. 22 AND 39).

FIRST USE 5-17-2005; IN COMMERCE 6-1-2006.
NELSON SNYDER, EXAMINING ATTORNEY

SN 85-579,358. GREENE, ERICA, A, TA A. S. A. P. INC., BRONX, NY. FILED 3-25-2012.



THE COLOR(S) TAN, BLACK, BEIGE, LIGHT BROWN AND BROWN IS/ARE CLAIMED AS A FEATURE OF THE MARK.

THE MARK CONSISTS OF A DESIGN OF A TAN HAND OUTLINED IN BLACK HOLDING A TAN, BEIGE AND BLACK CHURCH IN THE PALM OF THE HAND WITHIN A LIGHT BROWN SQUARE BACKGROUND OUTLINED IN BROWN. BENEATH THIS DESIGN IS THE LETTERING "A.S.A.P." IN BROWN

FOR T-SHIRTS FOR CHILDREN, MEN, WOMEN (U.S. CLS. 22 AND 39).

FIRST USE 3-8-2012; IN COMMERCE 3-8-2012.

KATHERINE STOIDES, EXAMINING ATTORNEY

CLASS 25—(Continued).

SN 85-583,586. YOON, CHANG KYUN, CERRITOS, CA. FILED 3-29-2012.

O-HA-YO

THE MARK CONSISTS OF STANDARD CHARACTERS WITHOUT CLAIM TO ANY PARTICULAR FONT, STYLE, SIZE, OR COLOR.

THE WORDING "O-HA-YO" HAS NO MEANING IN A FOREIGN LANGUAGE.

FOR LEGGINGS; LINGERIE; PAJAMAS; PANTS; SHIRTS; SOCKS; STOCKINGS; T-SHIRTS; UNDERWEAR (U.S. CLS. 22 AND 39).

FIRST USE 4-1-2002; IN COMMERCE 4-1-2002.
WON TEAK OH, EXAMINING ATTORNEY

SN 85-583,711. COOL CHICKS LLC, WEATOGUE, CT. FILED 3-29-2012.



THE MARK CONSISTS OF A BIRD CHICK, FOOTWEAR AND SUNGLASSES.

FOR BOTTOMS; CLOTHING FOR ATHLETIC USE, NAMELY, PADDED PANTS; CLOTHING FOR ATHLETIC USE, NAMELY, PADDED SHIRTS; CLOTHING FOR ATHLETIC USE, NAMELY, PADDED SHORTS; COMBINATIONS; JACKETS; JERSEYS; SHORT SETS; SUN PROTECTIVE CLOTHING, NAMELY, TOPS, BOTTOMS, SHIRTS PANTS BELTS, JACKETS, JERSEYS, DRESSES, BLOUSES, WRAPS, GLOVES, SUITS, SKIRTS, SOCKS, HEADBANDS, SHORTS, TIGHTS, HAT, AND ACCESSORIES, NAMELY, BELTS; TOPS; TRIATHLON CLOTHING, NAMELY, TRIATHLON TIGHTS, TRIATHLON SHORTS, TRIATHLON SINGLET, TRIATHLON SHIRTS, TRIATHLON SUITS; WOMEN'S CLOTHING, NAMELY, SHIRTS, DRESSES, SKIRTS, BLOUSES; WRAPS (U.S. CLS. 22 AND 39).

INGRID C. EULIN, EXAMINING ATTORNEY

CLASS 25—(Continued).

SN 85-583,958. DYO MANAGEMENT, INC., SMYRNA, GA. FILED 3-29-2012.



THE MARK CONSISTS OF THE LETTER "K" FORMED BY A VERTICAL LINE CURVING TO THE LEFT AND FADING AT THE TOP, CROSSING THROUGH BOTH LINES OF A LESS THAN SYMBOL TILTED SLIGHTLY DOWNWARD WITH AN ELONGATED BOTTOM LINE, WITH A SMALL "O" TO THE RIGHT OF THE "K", RESTING ON THE END OF THE BOTTOM LINE OF THE LESS THAN SYMBOL.

FOR APPAREL FOR DANCERS, NAMELY, TEE SHIRTS, SWEATSHIRTS, PANTS, LEGGINGS, SHORTS AND JACKETS; ATHLETIC APPAREL, NAMELY, SHIRTS, PANTS, JACKETS, FOOTWEAR, HATS AND CAPS, ATHLETIC UNIFORMS; FOOTWEAR; HEADBANDS; HEADGEAR, NAMELY, BASEBALL HATS, KNIT CAPS, BEANIES; LEOTARDS; SHIRTS; SWEAT PANTS; T-SHIRTS (U.S. CLS. 22 AND 39).

MATTHEW MCDOWELL, EXAMINING ATTORNEY

SN 85-584,005. DYO MANAGEMENT, INC., SMYRNA, GA. FILED 3-29-2012.



THE MARK CONSISTS OF A LARGE, BOLD OVAL WITH THE UPPER-CASE LETTERS "Y" AND "D" WITHIN IT, WITH A PERIOD BEFORE THE "Y", AFTER THE "Y", AND AFTER THE "D", WITH THE "Y" LARGER THAN THE "D", AND THE WORDS "OWN YOUR DESTINY" BELOW THE OVAL IN A SMALLER, CURSIVE FONT.

FOR BANDANAS; BASEBALL CAPS AND HATS; FOOTWEAR; HEADBANDS; HEADGEAR, NAMELY, BASEBALL HATS, KNIT CAPS, BEANIES; JACKETS; JEANS; SCARVES; SHIRTS; SHORTS; SWEATSHIRTS (U.S. CLS. 22 AND 39).

MATTHEW MCDOWELL, EXAMINING ATTORNEY

CLASS 25—(Continued).

SN 85-584,226. DIAZ, JOHN, WHITTIER, CA. FILED 3-29-2012.



THE MARK CONSISTS OF THE TEXT "JOHNNY'S" IN THE TOP PART OF DESIGN WITH A RACING FLAG ON EACH SIDE. MIDDLE PART OF DESIGN IS THE PROFILE OF A CAR. BOTTOM PART OF DESIGN IS "CHOP SHOP" AND BELOW THAT IS "VINTAGE . RODS & CUSTOMS". THE ENTIRE MARK IS ON A SHIELD-SHAPED SIGN.

FOR BASEBALL CAPS; HATS; T-SHIRTS (U.S. CLS. 22 AND 39).

LINDSEY RUBIN, EXAMINING ATTORNEY

SN 85-585,187. INDIGENOUS DESIGNS CORPORATION, SANTA ROSA, CA. FILED 3-30-2012.



NO CLAIM IS MADE TO THE EXCLUSIVE RIGHT TO USE "ARTISAN MADE", "FAIR TRADE" OR "ORGANIC", APART FROM THE MARK AS SHOWN.

THE MARK CONSISTS OF TWO CLOSELY SPACED APART CONCENTRIC CIRCLES FORMING A TWO-CIRCLE RING INCLUDING AN OUTER CIRCLE AND AN INNER CIRCLE; A SYMBOL REDOLENT OF NATIVE AMERICAN SYMBOLS COMPRISING A SMALL CONCENTRICALLY DISPOSED CENTRAL RING WITH ARROWS RADIATING OUTWARDLY FROM THE CENTRAL RING AT THE 12 O'CLOCK, 3 O'CLOCK, 6 O'CLOCK, AND 9 O'CLOCK POSITIONS AND FORMING RESPECTIVE QUADRANTS; SMOOTH ARCS DISPOSED BETWEEN THE 12-3, 3-6, AND 6-9 O'CLOCK POSITIONS, AND A ZIG-ZAG ARC DISPOSED BETWEEN THE 9-12 O'CLOCK POSITIONS, ALL ARCS POSITIONED AT THE LEVEL OF THE BARB ENDS OF HEADS ON EACH OF THE ARROWS; A W DISPOSED BETWEEN THE ARC AND CENTRAL RING IN THE 3-6 O'CLOCK QUADRANT, A PIE SLICE SHAPE DISPOSED BETWEEN THE ARC AND THE CENTRAL RING IN THE 3-6 O'CLOCK QUADRANT, A DOUBLE V (SMALL V WITHIN A LARGER V) DISPOSED BETWEEN THE ARC AND CENTRAL RING IN THE 6-9 O'CLOCK QUADRANT, AND A STRAIGHT STEM WITH TWO

CLASS 25—(Continued).

ANGLED SEGMENTS SEPARATED BY DOTS DISPOSED BETWEEN THE ZIG-ZAG ARC AND THE CENTRAL RING IN THE 9-10 O'CLOCK QUADRANT; A MEDIAL RING SPACED APART FROM THE OUTER PORTION OF THE SYMBOL; AND THE PHRASES "ARTISAN MADE" AND "FAIR TRADE + ORGANIC" CONCENTRICALLY DISPOSED BETWEEN THE INNER CIRCLE AND MEDIAL CIRCLE AND GENERALLY SURROUNDING THE MEDIAL CIRCLE, THE PHRASES SEPARATED FROM ONE ANOTHER ON EACH END BY DOTS.

FOR CLOTHING, NAMELY, SHIRTS, TEE SHIRTS, JACKETS AND COATS, PONCHOS, PULLOVER TOPS, SWEAT SHIRTS, SWEAT PANTS, SWEATERS, SCARVES, ROBES, SHORTS, VESTS, AND HATS ALL MADE FROM ORGANIC MATERIALS AND IN ACCORDANCE WITH FAIR TRADE GUIDELINES (U.S. CLS. 22 AND 39).

FIRST USE 1-0-2012; IN COMMERCE 1-0-2012.

JEFFREY LOOK, EXAMINING ATTORNEY

SN 85-586,369. KAHN LUCAS LANCASTER, INC., NEW YORK, NY. FILED 4-2-2012.

YOUNGLAND BABY

THE MARK CONSISTS OF STANDARD CHARACTERS WITHOUT CLAIM TO ANY PARTICULAR FONT, STYLE, SIZE, OR COLOR.

OWNER OF U.S. REG. NO. 760,775.

NO CLAIM IS MADE TO THE EXCLUSIVE RIGHT TO USE "BABY", APART FROM THE MARK AS SHOWN.

FOR INFANT AND TODDLER APPAREL, NAMELY, DRESSES, TOPS, PANTS, SHIRTS (U.S. CLS. 22 AND 39).

FIRST USE 10-1-2011; IN COMMERCE 10-1-2011.

JOSETTE BEVERLY, EXAMINING ATTORNEY

SN 85-588,396. YSASAGA, MICHAEL, CHICO, CA. FILED 4-4-2012.

48 FLIGHT STREET

THE MARK CONSISTS OF STANDARD CHARACTERS WITHOUT CLAIM TO ANY PARTICULAR FONT, STYLE, SIZE, OR COLOR.

FOR CLOTHING, NAMELY, T-SHIRTS, SHIRTS, SWEATSHIRTS AND HATS (U.S. CLS. 22 AND 39).

FIRST USE 4-3-2012; IN COMMERCE 4-3-2012.

DAVID YONTEF, EXAMINING ATTORNEY

CLASS 25—(Continued).

SN 85-589,063. BOYD, GLYNN T., GRETNA, LA. FILED 4-4-2012.

YES INDEED!

THE MARK CONSISTS OF STANDARD CHARACTERS WITHOUT CLAIM TO ANY PARTICULAR FONT, STYLE, SIZE, OR COLOR.

FOR CLOTHING, NAMELY, T-SHIRTS, SHIRTS, WARM-UP SUITS, SOCKS, HATS, SPORTS WEAR, NAMELY, SHIRTS, T-SHIRTS, PANTS, SHORTS, UNDERWEAR, SWEATSHIRTS, SWEATPANTS (U.S. CLS. 22 AND 39).

FRANK LATTUCA, EXAMINING ATTORNEY

SN 85-589,072. BOYD, GLYNN T., GRETNA, LA. FILED 4-4-2012.

JESUS! YES INDEED!

THE MARK CONSISTS OF STANDARD CHARACTERS WITHOUT CLAIM TO ANY PARTICULAR FONT, STYLE, SIZE, OR COLOR.

FOR CLOTHING, NAMELY, T-SHIRTS, SHIRTS, WARM-UP SUITS, SOCKS, HATS, SPORTS WEAR, NAMELY, SHIRTS, T-SHIRTS, PANTS, SHORTS, UNDERWEAR, SWEATSHIRTS, SWEATPANTS (U.S. CLS. 22 AND 39).

FRANK LATTUCA, EXAMINING ATTORNEY

SN 85-589,159. KRASNOW ENTERPRISES LTD./LES ENTREPRISES KRASNOW LTEE, WESTMOUNT, QUEBEC, CANADA, FILED 4-4-2012.

MARVIN K

THE MARK CONSISTS OF STANDARD CHARACTERS WITHOUT CLAIM TO ANY PARTICULAR FONT, STYLE, SIZE, OR COLOR.

OWNER OF CANADA REG. NO. TMA449354, DATED 10-27-1995, RENEWED AS REG. NO. TMA449354, DATED 8-31-2010, EXPIRES 10-27-2025.

OWNER OF U.S. REG. NO. 1,997,049.

THE NAME "MARVIN K" IN THE MARK IDENTIFIES A LIVING INDIVIDUAL WHOSE CONSENT IS OF RECORD.

FOR FOOTWEAR, NAMELY, SHOES, BOOTS, SANDALS, RUBBERS AND OVERSHOES (U.S. CLS. 22 AND 39).

JAMES LOVELACE, EXAMINING ATTORNEY

CLASS 25—(Continued).

SN 85-590,426. G-III LEATHER FASHIONS, INC., NEW YORK, NY. FILED 4-5-2012.

COLEBROOK & CO.

THE MARK CONSISTS OF STANDARD CHARACTERS WITHOUT CLAIM TO ANY PARTICULAR FONT, STYLE, SIZE, OR COLOR.

OWNER OF U.S. REG. NO. 2,560,696.

NO CLAIM IS MADE TO THE EXCLUSIVE RIGHT TO USE "& CO.", APART FROM THE MARK AS SHOWN. SEC. 2(F).

FOR JACKETS, COATS, VESTS, PANTS, SKIRTS, BLAZERS, SHORTS, DRESSES, SHIRTS, SUITS AND BLOUSES (U.S. CLS. 22 AND 39).

LUCY ARANT, EXAMINING ATTORNEY

SN 85-590,801. COEN, LISETTE, SAN FRANCISCO, CA. FILED 4-6-2012.

717

THE MARK CONSISTS OF STANDARD CHARACTERS WITHOUT CLAIM TO ANY PARTICULAR FONT, STYLE, SIZE, OR COLOR.

FOR CLOTHING, NAMELY, TOPS, BOTTOMS, BLAZERS, SHIRTS, PANTS, SLACKS, DRESSES, SWEATERS, DENIMS, JEANS, T-SHIRTS, SWEATSHIRTS, SWIM WEAR, SWIM COVER-UPS, SHORTS, UNDERWEAR, LOUNGEWEAR, LINGERIE, ROBES AND PAJAMAS, HEADWEAR, WORKOUT/EXERCISE PANTS, FLIP-FLOPS, SHOES, YOGA PANTS (U.S. CLS. 22 AND 39).

CATHERINE ROEHL, EXAMINING ATTORNEY

SN 85-590,808. RANA, KALPESH, PASSAIC, NJ. FILED 4-6-2012.



NO CLAIM IS MADE TO THE EXCLUSIVE RIGHT TO USE "STYLE", "DESIGN", "COMFORT", "ORIGINAL", AND "SINCE 1999", APART FROM THE MARK AS SHOWN.

THE MARK CONSISTS OF THE LITERAL ELEMENTS "STYLE DESIGN COMFORT ANTLERS ORIGINAL SINCE 1999" IN STYLIZED FORM. THERE IS AN IMAGE OF A DOTTED RECTANGLE SURROUNDING THE LITERAL

CLASS 25—(Continued).

TEXT, WHERE IN THE LITERAL ELEMENTS "STYLE DESIGN COMFORT" ARE WRITTEN UPWARD AND AT THE BOTTOM, THE WORD "ANTLERS" IS WRITTEN IN A STYLIZED FORM, THE "R" IN THIS WORD REPRESENTING A DEER FACE WITH LARGE ANTLERS EXTENDING UPWARD. THE DEER FACE LOOKS LIKE A SMALL "R". BELOW THE WORD "ANTLERS" IS THE LITERAL ELEMENT "ORIGINAL", WHICH IS CENTERED IN A SHADED BOX. THE WORDING "SINCE 1999" IS WRITTEN AT THE BOTTOM AS SHOWN IN THE FIGURE.

FOR CLOTHING, NAMELY, FOOTWEAR, HEADWEAR, TOPS, BOTTOMS, SHIRTS, T-SHIRTS, PANTS, JEANS, AND SHORTS (U.S. CLS. 22 AND 39).

CATHERINE ROEHL, EXAMINING ATTORNEY

CLASS 25—(Continued).

SN 85-590,899. STUDIO RAY LLC, NEW YORK, NY. FILED 4-6-2012.

ZX

THE MARK CONSISTS OF STANDARD CHARACTERS WITHOUT CLAIM TO ANY PARTICULAR FONT, STYLE, SIZE, OR COLOR.

OWNER OF U.S. REG. NOS. 2,049,955, 3,998,013 AND OTHERS.

FOR APPAREL, NAMELY, SWIM SHORTS, SWIM WEAR, LEGGINGS, SNOW WEAR, NAMELY, COATS, SCARVES, GLOVES; SNOW PANTS, SNOW JACKETS, ACTIVE WEAR, NAMELY, JOGGING SUITS, JOGGING PANTS, RUNNING SHORTS, SWEAT BANDS; SPORTS WEAR, NAMELY, TANK TOPS, T-SHIRTS, BIKINIS; JERSEYS, SHIRTS, SWEATERS, PANTS, SHORTS, HATS, CAPS, HEADBANDS, GLOVES, JACKETS, COATS, RAIN COATS, AND FOOTWEAR (U.S. CLS. 22 AND 39).

FIRST USE 7-1-1995; IN COMMERCE 7-1-1995.

LAURIE KAUFMAN, EXAMINING ATTORNEY

SN 85-590,888. CARLSON, GARY, NORTH BERGEN, NJ. FILED 4-6-2012.



SN 85-591,087. PEREZ, JONATHAN HUMBERTO, FALLBROOK, CA. FILED 4-6-2012.

BOXING FRATERNITY

NO CLAIM IS MADE TO THE EXCLUSIVE RIGHT TO USE "BRAND", APART FROM THE MARK AS SHOWN.

THE NAME(S), PORTRAIT(S), AND/OR SIGNATURE(S) SHOWN IN THE MARK DOES NOT IDENTIFY A PARTICULAR LIVING INDIVIDUAL.

THE MARK CONSISTS OF A RECTANGLE FEATURING A STYLIZED REPRESENTATION OF A MAN WITH A CIGARETTE IN HIS MOUTH. AT THE BOTTOM OF THE RECTANGLE IS THE STYLIZED TEXT: "ROBERT LOUGHLIN'S BRAND THE "BRUTE".

FOR JACKETS; SUITS; T-SHIRTS (U.S. CLS. 22 AND 39).

JAMES GRIFFIN, EXAMINING ATTORNEY

THE MARK CONSISTS OF STANDARD CHARACTERS WITHOUT CLAIM TO ANY PARTICULAR FONT, STYLE, SIZE, OR COLOR.

NO CLAIM IS MADE TO THE EXCLUSIVE RIGHT TO USE "BOXING", APART FROM THE MARK AS SHOWN.

FOR BOXING APPAREL, NAMELY, SHIRTS, SHORTS, SHOES, ROBES, SWEATERS, HOODED SWEATSHIRTS, BOXERS, UNDERWEAR, UNDERSHIRTS, BEANIES, AND HATS (U.S. CLS. 22 AND 39).

JENNIFER WILLISTON, EXAMINING ATTORNEY

CLASS 25—(Continued).

SN 85-591,219. STUDIO RAY LLC, NEW YORK, NY. FILED 4-6-2012.



OWNER OF U.S. REG. NOS. 3,771,390, 3,998,013 AND OTHERS.

THE MARK CONSISTS OF THE LETTERS "Z" AND "X" IN STYLIZED FONT. THE LETTER "Z" IS COMPRISED OF SEVERAL HORIZONTAL LINES IN THE SHAPE OF A Z.

FOR APPAREL, NAMELY, SWIM SHORTS, SWIM WEAR, LEGGINGS, SNOW WEAR, NAMELY, COATS, SCARVES, GLOVES; SNOW PANTS, SNOW JACKETS, ACTIVE WEAR, NAMELY, JOGGING SUITS, JOGGING PANTS, RUNNING SHORTS, SWEAT BANDS; SPORTS WEAR, NAMELY, TANK TOPS, T-SHIRTS, BIKINIS; JERSEYS, SHIRTS, SWEATERS, PANTS, SHORTS, HATS, CAPS, HEADBANDS, GLOVES, JACKETS, COATS, RAIN COATS, AND FOOTWEAR (U.S. CLS. 22 AND 39).

FIRST USE 7-1-1995; IN COMMERCE 7-1-1995.

Laurie Kaufman, Examining Attorney

SN 85-591,248. HASTIN, KORTNEY, HUNTINGTON BEACH, CA. FILED 4-6-2012.



NORMAN RUSSELL

THE NAME(S), PORTRAIT(S), AND/OR SIGNATURE(S) SHOWN IN THE MARK DOES NOT IDENTIFY A PARTICULAR LIVING INDIVIDUAL.

THE MARK CONSISTS OF A RAM'S HEAD INSIDE AN ENCLOSED CIRCLE, FOLLOWED BY THE WORDS "NORMAN RUSSELL".

FOR WOMEN'S AND MEN'S CLOTHING, NAMELY, T-SHIRTS, SHIRTS, TOPS, BABY TEES, TANK TOPS, LONG SLEEVE SHIRTS, SHORT SLEEVE SHIRTS, WOMEN SHIRTS, POLO SHIRTS, THERMAL SHIRTS, PANTS, DENIM PANTS, TROUSERS, CARGO PANTS, DENIM SHORTS, SHORTS, WALKING SHORTS; OUTERWEAR, NAMELY, JACKETS, LEATHER JACKETS, COATS, BLAZERS, SWEATSHIRTS, HOODED SWEATSHIRTS, SWEATERS, VESTS, PEA COATS, TOP COATS, OVERCOATS; BELTS, BEANIES, HATS, CAPS; AND FOOTWEAR, NAMELY, MEN'S BOOTS (U.S. CLS. 22 AND 39).

George Lorenzo, Examining Attorney

CLASS 25—(Continued).

SN 85-591,345. TROY HOCKEY ASSOCIATION, INC., DBA TROY ALBANY HOCKEY ASSOCIATION, WYNANTS-KILL, NY. FILED 4-6-2012.



NO CLAIM IS MADE TO THE EXCLUSIVE RIGHT TO USE "TROY-ALBANY", APART FROM THE MARK AS SHOWN.

THE MARK CONSISTS OF AN ARMORED PERSON HOLDING A HOCKEY STICK, THE ARMORED PERSON POSITIONED IN FRONT OF AN INVERTED TRIANGLE HAVING A BORDER. THE CHARACTERS "TROY-ALBANY" ARE CURVED WITHIN AN ARC, POSITIONED SUBSTANTIALLY ABOVE THE INVERTED TRIANGLE AND THE ARMORED PERSON'S HEAD, RESPECTIVELY. THE CHARACTERS "TITANS", HAVING A BORDER SURROUNDING ALL CHARACTERS, ARE POSITIONED IN FRONT OF THE ARMORED PERSON AND THE INVERTED TRIANGLE, RESPECTIVELY.

FOR HATS; JACKETS; PANTS; SWEATSHIRTS; T-SHIRTS (U.S. CLS. 22 AND 39).

FIRST USE 4-1-2012; IN COMMERCE 4-1-2012.

Matthew Galan, Examining Attorney

SN 85-591,347. THE EXECUTOR OF THE OTIS REDDING ESTATE, A GEORGIA ESTATE, COMPRISING ZELMA REDDING, A UNITED STATES CITIZEN., LOS ANGELES, CA. FILED 4-6-2012.

OTIS REDDING

THE MARK CONSISTS OF STANDARD CHARACTERS WITHOUT CLAIM TO ANY PARTICULAR FONT, STYLE, SIZE, OR COLOR.

THE NAME SHOWN IN THE MARK DOES NOT IDENTIFY A LIVING INDIVIDUAL.

FOR CLOTHING, NAMELY, FOOTWEAR AND HEADWEAR, T-SHIRTS, SWEAT SHIRTS, JERSEYS, SHORTS, SWEAT PANTS, JACKETS, HATS, CAPS, SCARVES, GLOVES, HOSIERY, NECKTIES, PAJAMAS, ROBES, NIGHT SHIRTS, NIGHT GOWNS, UNDERWEAR, HEAD BANDS, WRIST BANDS, INFANT ONE-PIECE GARMENTS, SWIM SUITS, SKIRTS, SHIRTS, TANK TOPS, PANTS, COATS, SWEATERS, LEOTARDS, LEG WARMERS, STOCKINGS, SOCKS, PANTY HOSE, TIGHTS, BELTS, SHOES, ATHLETIC SHOES, SLIPPERS, BOOTS, SANDALS AND RAINWEAR (U.S. CLS. 22 AND 39).

Catherine Roehl, Examining Attorney

CLASS 25—(Continued).

SN 85-591,415. THE EXECUTOR OF THE OTIS REDDING ESTATE, A GEORGIA ESTATE, COMPRISING ZELMA REDDING, A UNITED STATES CITIZEN, LOS ANGELES, CA. FILED 4-6-2012.

THE KING OF SOUL

THE MARK CONSISTS OF STANDARD CHARACTERS WITHOUT CLAIM TO ANY PARTICULAR FONT, STYLE, SIZE, OR COLOR.

THE NAME "THE KING OF SOUL" WAS THE NICKNAME OF OTIS REDDING WHO IS NOT A LIVING INDIVIDUAL.

FOR CLOTHING, NAMELY, FOOTWEAR AND HEADWEAR, T-SHIRTS, SWEAT SHIRTS, JERSEYS, SHORTS, SWEAT PANTS, JACKETS, HATS, CAPS, SCARVES, GLOVES, HOSIERY, NECKTIES, PAJAMAS, ROBES, NIGHT SHIRTS, NIGHT GOWNS, UNDERWEAR, HEAD BANDS, WRIST BANDS, INFANT ONE-PIECE GARMENTS, SWIM SUITS, SKIRTS, SHIRTS, TANK TOPS, PANTS, COATS, SWEATERS, LEOTARDS, LEG WARMERS, STOCKINGS, SOCKS, PANTY HOSE, TIGHTS, BELTS, SHOES, ATHLETIC SHOES, SLIPPERS, BOOTS, SANDALS AND RAINWEAR (U.S. CLS. 22 AND 39).

CATHERINE ROEHL, EXAMINING ATTORNEY

SN 85-591,616. WILLIAMS, BRAM, ROCKPORT, IN. FILED 4-6-2012.

LIFE GIG

THE MARK CONSISTS OF STANDARD CHARACTERS WITHOUT CLAIM TO ANY PARTICULAR FONT, STYLE, SIZE, OR COLOR.

FOR CLOTHING, NAMELY, TOPS, BOTTOMS, T-SHIRTS, GOLF SHIRTS, POLO SHIRTS, SWEATSHIRTS, TANK TOPS, PANTS, BLUE JEANS, SWEAT PANTS, HOODED SWEATSHIRTS, HATS (U.S. CLS. 22 AND 39).

ELLEN PERKINS, EXAMINING ATTORNEY

SN 85-591,759. SAMANIEGO, JOSE ALEXANDRO, LILBURN, GA. AND SAMANIEGO, DANIEL, LILBURN, GA. FILED 4-7-2012.

STGOB

THE MARK CONSISTS OF STANDARD CHARACTERS WITHOUT CLAIM TO ANY PARTICULAR FONT, STYLE, SIZE, OR COLOR.

THE WORDING "STGOB" HAS NO MEANING OTHER THAN TRADEMARK SIGNIFICANCE.

FOR CLOTHING, NAMELY, BEANIES, T-SHIRTS, SWEATERS, HOODED SWEATSHIRTS, SOCKS, HATS, PANTS (U.S. CLS. 22 AND 39).

FIRST USE 10-12-2011; IN COMMERCE 12-1-2011.

ANDREA HACK, EXAMINING ATTORNEY

CLASS 25—(Continued).

SN 85-591,927. CARTWRIGHT, HILLARY J., DBA PANDAPAREL, SEEKONK, MA. FILED 4-7-2012.

PandApparel

THE MARK CONSISTS OF STANDARD CHARACTERS WITHOUT CLAIM TO ANY PARTICULAR FONT, STYLE, SIZE, OR COLOR.

FOR BELTS FOR CLOTHING; CANVAS SHOES; DRESSES; EAR MUFFS; GLOVES FOR APPAREL; HATS; HOODED SWEATSHIRTS; JACKETS; JERSEYS; LEG WARMERS; LONG-SLEEVED SHIRTS; LOUNGE PANTS; NECKTIES; PAJAMAS; POLO SHIRTS; SCARVES; SHORT-SLEEVED OR LONG-SLEEVED T-SHIRTS; SHORTS; SLEEP MASKS; SWEATPANTS; SWEATSHIRTS; TANK TOPS; WOMEN'S SHOES; YOGA PANTS (U.S. CLS. 22 AND 39).

KELLEY WELLS, EXAMINING ATTORNEY

SN 85-592,018. A.G.E. XXI L.L.C., NARANJITO, PUERTO RICO, FILED 4-8-2012.



THE MARK CONSISTS OF IMAGE BASED ON THE TAINO COQUI TREE FROG. THERE IS A LEAF DRAWN UNDER THE RIGHT LEG OF THE COQUI. UNDER THE IMAGE IS THE STYLIZED WORD "A.G.E." NEXT TO THE ROMAN NUMERAL FOR "21".

FOR ATHLETIC APPAREL, NAMELY, SHIRTS, PANTS, JACKETS, FOOTWEAR, HATS AND CAPS, ATHLETIC UNIFORMS (U.S. CLS. 22 AND 39).

FIRST USE 11-16-2008; IN COMMERCE 11-16-2008.

LINDA E. BLOHM, EXAMINING ATTORNEY

CLASS 25—(Continued).

SN 85-592,255. DAVID GEDROCK, MEDINA, OH. AND TOM VIROSTECK, MEDINA, OH. FILED 4-9-2012.



THE MARK CONSISTS OF THE WORD "SHEARED" IN STYLIZED LETTERS TO THE LEFT OF AN ANTHROPO-MORPHIC TALKING SHEEP THAT HAS A SHEARED BODY WITH TWO BANDAGES IN THE FORM OF AN X NEAR ITS TAIL WITH THE WORD "SHEEP" IN STYLIZED LETTERS TO RIGHT OF THE SHEEP.

FOR HATS; SWEATSHIRTS; T-SHIRTS (U.S. CLS. 22 AND 39).

MAYUR VAGHANI, EXAMINING ATTORNEY

CLASS 25—(Continued).

SN 85-592,477. DEMARTINI, SAMANTHA, CLAYTON, CA. FILED 4-9-2012.

Fun. Fashion. Freedom.

THE MARK CONSISTS OF STANDARD CHARACTERS WITHOUT CLAIM TO ANY PARTICULAR FONT, STYLE, SIZE, OR COLOR.

NO CLAIM IS MADE TO THE EXCLUSIVE RIGHT TO USE "FASHION", APART FROM THE MARK AS SHOWN.

FOR LEOTARDS AND TIGHTS FOR WOMEN, MEN AND CHILDREN OF NYLON, COTTON OR OTHER TEXTILE FIBERS (U.S. CLS. 22 AND 39).

BARBARA A. GOLD, EXAMINING ATTORNEY

SN 85-592,596. LISA FINE/CAROLINA IRVING CORP., NEW YORK, NY. FILED 4-9-2012.



THE MARK CONSISTS OF AN OVAL OF SMALL DOTS SURROUNDING A SOLID OVAL SURROUNDING TWO HANDS, EACH WITH A CIRCLE OF DOTS ON THE PALM, AROUND THE WORDS "IRVING & FINE".

FOR BLOUSES; CAFTANS; COATS; DRESSES; JACKETS; SCARVES; TUNICS (U.S. CLS. 22 AND 39).

FIRST USE 12-0-2007; IN COMMERCE 12-0-2007.
DAVID COLLIER, EXAMINING ATTORNEY

SN 85-592,439. 305 FILMS, INC, MIAMI, FL. FILED 4-9-2012.



OWNER OF U.S. REG. NO. 4,153,771.
NO CLAIM IS MADE TO THE EXCLUSIVE RIGHT TO USE "FLORIDA", "MIAMI", AND THE GEOGRAPHICAL REPRESENTATION OF THE STATE OF FLORIDA, APART FROM THE MARK AS SHOWN.

THE MARK CONSISTS OF THE IMAGE OF A LICENSE PLATE, WITH THE WORD "FLORIDA" APPEARING AT THE TOP, THE WORDS "305 FILMS" APPEARING IN THE MIDDLE AND THE WORD "MIAMI" APPEARING AT THE BOTTOM, WITH THE OUTLINE OF THE STATE OF FLORIDA APPEARING IN THE BACKGROUND.

FOR CLOTHING, NAMELY TOPS, BOTTOMS, SHIRTS; HEADWEAR AND FOOTWEAR (U.S. CLS. 22 AND 39).

ZACHARY R. SPARER, EXAMINING ATTORNEY

SN 85-592,650. STEEL PIER OCEAN CAFÉ, LLC, OCEANVIEW, NJ. FILED 4-9-2012.

PIER BIER

THE MARK CONSISTS OF STANDARD CHARACTERS WITHOUT CLAIM TO ANY PARTICULAR FONT, STYLE, SIZE, OR COLOR.

THE ENGLISH TRANSLATION OF THE GERMAN WORD "BIER" IN THE MARK IS "BEER".

FOR HOODED SWEATSHIRTS; SWEATSHIRTS; T-SHIRTS (U.S. CLS. 22 AND 39).

MARK RADEMACHER, EXAMINING ATTORNEY

CLASS 25—(Continued).

SN 85-592,911. VIOLET LOVE BRANDS, INC., LOS ANGELES, CA. FILED 4-9-2012.



OWNER OF U.S. REG. NO. 3,236,982.

THE MARK CONSISTS OF THE LETTERS "RM" IN THE MIDDLE OF THE MARK. THE WORD "REBECCA" IS SUPERIMPOSED OVER THE LETTER "R," AND THE WORD "MICHAELS" IS SUPERIMPOSED OVER THE LETTER "M."

FOR BELTS; BERMUDA SHORTS; BOARD SHORTS; CAPRI PANTS; CAPS; DENIMS; GOLF SHIRTS; GYM SHORTS; HATS; HEAD SCARVES; HEADBANDS; HEADBANDS AGAINST SWEATING; INFANT AND TODDLER ONE-PIECE CLOTHING; JOGGING PANTS; KNIT SHIRTS; MUSCLE TOPS; PANTS; POLO SHIRTS; SCARVES; SHIRTS; SHORT SETS; SHORT-SLEEVED OR LONG-SLEEVED T-SHIRTS; SHORT-SLEEVED SHIRTS; SHORTS; SKI PANTS; SKIRTS; SKIRTS AND DRESSES; SNOW PANTS; SNOWBOARD PANTS; SWEAT PANTS; SWIMSUITS; T-SHIRTS; TANK TOPS; TOBOGGAN HATS, PANTS AND CAPS; TOPS; WATERPROOF JACKETS AND PANTS; WRAPS (U.S. CLS. 22 AND 39).

FIRST USE 4-1-2012; IN COMMERCE 4-1-2012.
DAVID HOFFMAN, EXAMINING ATTORNEY

SN 85-593,001. CHIKASAWA, JENNY, CAMARILLO, CA. FILED 4-9-2012.

Kalia SUP

THE MARK CONSISTS OF STANDARD CHARACTERS WITHOUT CLAIM TO ANY PARTICULAR FONT, STYLE, SIZE, OR COLOR.

NO CLAIM IS MADE TO THE EXCLUSIVE RIGHT TO USE "SUP", APART FROM THE MARK AS SHOWN.

FOR HATS; T-SHIRTS (U.S. CLS. 22 AND 39).
TINA L. SNAPP, EXAMINING ATTORNEY

CLASS 25—(Continued).

SN 85-593,152. HOT TODDY DESIGN LLC, WENHAM, MA. FILED 4-10-2012.



NO CLAIM IS MADE TO THE EXCLUSIVE RIGHT TO USE "DESIGN", APART FROM THE MARK AS SHOWN.

THE MARK CONSISTS OF A PORTRAIT OF A WOMAN WITH A RAISED LEFT HAND, ENCIRCLED IN AN OVAL, WITH THE WORDS "HOT TODDY" DESIGN UNDERNEATH.

FOR SCARVES (U.S. CLS. 22 AND 39).
FIRST USE 3-9-2012; IN COMMERCE 3-9-2012.
KELLEY WELLS, EXAMINING ATTORNEY

SN 85-593,834. RHEE, JOHN, LOS ANGELES, CA. FILED 4-10-2012.

the good & company

THE MARK CONSISTS OF STANDARD CHARACTERS WITHOUT CLAIM TO ANY PARTICULAR FONT, STYLE, SIZE, OR COLOR.

NO CLAIM IS MADE TO THE EXCLUSIVE RIGHT TO USE "COMPANY", APART FROM THE MARK AS SHOWN.
FOR BLOUSES; DENIMS; JACKETS; PANTS; SHIRTS; SHOES; SHORTS (U.S. CLS. 22 AND 39).

JEFFREY LOOK, EXAMINING ATTORNEY

SN 85-594,868. VS COLLECTIVE, LLC, BROOKLYN, NY. FILED 4-11-2012.

Venessa Arizaga

THE MARK CONSISTS OF STANDARD CHARACTERS WITHOUT CLAIM TO ANY PARTICULAR FONT, STYLE, SIZE, OR COLOR.

THE NAME(S), PORTRAIT(S), AND/OR SIGNATURE(S) SHOWN IN THE MARK IDENTIFIES "VENESSA ARIZAGA", WHOSE CONSENT(S) TO REGISTER IS MADE OF RECORD.

FOR BEACH COVER-UPS; BLOUSES; HATS; PANTS; SHIRTS; SHOES; T-SHIRTS (U.S. CLS. 22 AND 39).
JENNIFER WILLISTON, EXAMINING ATTORNEY

CLASS 25—(Continued).

SN 85-595,241. NELSON, NANCY, CARROLLTON, TX. FILED 4-11-2012.



NO CLAIM IS MADE TO THE EXCLUSIVE RIGHT TO USE "RAGS", APART FROM THE MARK AS SHOWN.

THE COLOR(S) LIGHT BLUE AND BLACK IS/ARE CLAIMED AS A FEATURE OF THE MARK.

THE MARK CONSISTS OF THE STYLIZED TERM "KOOL RAGZ" IN BLACK PLACED OVER A LIGHT BLUE BACKGROUND. EACH LETTER "O" IN "KOOL" IS UNDERLINED.

FOR HEADBANDS; HEADBANDS AGAINST SWEATING; HEADBANDS FOR CLOTHING (U.S. CLS. 22 AND 39).

AHSEN KHAN, EXAMINING ATTORNEY

SN 85-595,303. SKYE GROUP PTY LTD, SYDNEY, AUSTRALIA, FILED 4-11-2012.



NO CLAIM IS MADE TO THE EXCLUSIVE RIGHT TO USE "AUSTRALIA", APART FROM THE MARK AS SHOWN.

THE MARK CONSISTS OF THE STYLIZED WORDING "SKYE BLUE AZURA AUSTRALIA".

THE ENGLISH TRANSLATION OF "AZURA" IN THE MARK IS "BLUE".

FOR SWIM WEAR (U.S. CLS. 22 AND 39).
GINA HAYES, EXAMINING ATTORNEY

SN 85-595,318. ACHIME, EMEKA, COSTA MESA, CA. FILED 4-11-2012.



NO CLAIM IS MADE TO THE EXCLUSIVE RIGHT TO USE "INC", APART FROM THE MARK AS SHOWN.

THE MARK CONSISTS OF A STYLIZED CIRCLE (FACE) WITH A DRIPPING LIQUID EFFECT AND EYES OF A TRIANGULAR NATURE AT AN ANGLE. ABOVE THE FACE IS THE STYLIZED TEXT "ONE MOON INC" WITH A DRIPPING LIQUID EFFECT.

FOR CLOTHING, NAMELY, T-SHIRTS, SHORTS, SWEAT SHIRTS, PANTS, BIKINI-TOPS, AND HATS (U.S. CLS. 22 AND 39).

RENEE MCCRAY, EXAMINING ATTORNEY

CLASS 25—(Continued).

SN 85-595,354. LOS ANGELES POLO CLUB, INC., ENCINO, CA. FILED 4-11-2012.

LOS ANGELES POLO CLUB

THE MARK CONSISTS OF STANDARD CHARACTERS WITHOUT CLAIM TO ANY PARTICULAR FONT, STYLE, SIZE, OR COLOR.

NO CLAIM IS MADE TO THE EXCLUSIVE RIGHT TO USE "LOS ANGELES", APART FROM THE MARK AS SHOWN.

FOR CLOTHING, NAMELY, SHIRTS, POLO SHIRTS, POLO KNIT TOPS, T-SHIRTS, JACKETS, COATS, FABRIC BELTS, LEATHER BELTS, CAPS, HATS, VISORS, BEANIES, FLEECE PULLOVERS, SWEATERS, JEANS, PANTS, TROUSERS, OVERALLS, SWEAT PANTS, SWEATSHIRTS, TANK TOPS, SHORTS, SWIM SUITS, TRUNKS, BANDANNAS, SHOES, SANDALS, FOOTWEAR, THERMAL UNDERWEAR, UNDERWEAR, SOCKS, NIGHT GOWNS, PAJAMAS, WIND SHIRTS, PONCHOS, VESTS, PARKAS, YOGA PANTS, BATHROBES, JERSEYS, CAPRI PANTS, DRESSES, SKIRTS AND BLOUSES (U.S. CLS. 22 AND 39).

EDWARD NELSON, EXAMINING ATTORNEY

SN 85-595,687. STEVEN SWAN INTERNATIONAL, DBA STEVEN SWAN, SMYRNA, GA. FILED 4-12-2012.



THE NAME "STEVEN SWAN" IDENTIFIES A LIVING INDIVIDUAL WHOSE CONSENT IS OF RECORD.

THE MARK CONSISTS OF THE "S" THAT IS IN THE SHAPE OF A SWAN REPRESENTS THE "S" FOR "STEVEN" AND THE "S" FOR "SWAN".

FOR BALLROOM DANCING SHOES; BEACH SHOES; CANVAS SHOES; DANCE SHOES; FITTED SHOE OR BOOT COVERING TO PROTECT THE SHOES OR BOOT FROM WATER OR OTHER DAMAGE; HEEL PIECES FOR SHOES; INFANTS' SHOES AND BOOTS; INSOLES; LEATHER SHOES; LEISURE SHOES; RIDING SHOES; SANDALS AND BEACH SHOES; SHOE ACCESSORIES, NAMELY, FITTED DECORATIVE COVERS FOR SHOES; SHOE COVERS FOR USE WHEN WEARING SHOES; SHOE PEGS; SHOE SOLES; SHOES; WATERPROOF LEATHER SHOES; WATERPROOF LEATHER SHOES AND BOOTS; WELTS FOR BOOTS AND SHOES; WOMEN'S SHOES; WOMEN'S SHOES, NAMELY, FOLDABLE FLATS; WOODEN SHOES (U.S. CLS. 22 AND 39).

JACLYN KIDWELL WALKER, EXAMINING ATTORNEY

CLASS 25—(Continued).

SN 85-596,144. SUN PRODUCTS CORPORATION, THE, WILTON, CT. FILED 4-12-2012.



THE STIPPLING IS FOR SHADING PURPOSES ONLY. THE MARK CONSISTS OF A BEAR HOLDING UP TO ITS CHEEK, A TOWEL OR BLANKET THAT ACTS AS A BANNER IN FRONT OF THE BEAR. THE STYLIZED WORDING "SNUGGLE" APPEARS ON THE FRONT OF THE TOWEL OR BLANKET.

FOR INFANT, BABY, TODDLER AND CHILDREN'S CLOTHING, NAMELY, OVERALLS, JUMPSUITS, BODY SUITS, TOPS, T-SHIRTS, SHIRTS, COVERALLS, SWEATERS, CARDIGANS, SWIMWEAR, SWIMSUIT COVER-UPS, PAJAMAS, SLEEPWEAR, ROBES, ROMPERS, SKIRTS, COATS, JACKETS, SWEAT PANTS AND SWEATSHIRTS, PANTS, SHORTS, DRESSES, JUMPERS, UNDERWEAR, TIGHTS, LEGGINGS; INFANT, BABY, TODDLER AND CHILDREN'S FOOTWEAR, NAMELY, SOCKS, BOOTIES, BOOTS, SHOES, SNEAKERS, SLIPPERS, SANDALS; BABY, TODDLER AND CHILDREN'S HEADWEAR, NAMELY, BONNETS, CAPS, HATS, BEANIES; BABY BUNTINGS; CLOTH BIBS; BABY, TODDLER AND CHILDREN'S MITTENS, GLOVES AND SCARVES; MEN'S AND WOMEN'S APPAREL, NAMELY, TOPS, T-SHIRTS, SHIRTS, COVERALLS, SWEATERS, CARDIGANS, SWIMWEAR, SWIMSUIT COVER-UPS, PAJAMAS, SLEEPWEAR, ROBES, SKIRTS, COATS, JACKETS, SWEAT PANTS AND SWEATSHIRTS, PANTS, SHORTS, DRESSES, TIGHTS, LEGGINGS, UNDERWEAR AND INSULATED UNDERWEAR; MEN'S AND WOMEN'S FOOTWEAR, NAMELY, SOCKS, BOOTIES, BOOTS, SHOES, SNEAKERS, SLIPPERS, SANDALS; MEN'S AND WOMEN'S HEADWEAR, NAMELY, CAPS, HATS, BEANIES; DEODORIZING SHOE INSERTS FOR PRIMARILY NON-ORTHOPEDIC PURPOSES; MEN'S AND WOMEN'S MITTENS, GLOVES AND SCARVES (U.S. CLS. 22 AND 39).

PRISCILLA MILTON, EXAMINING ATTORNEY

SN 85-596,202. POOL, ERIC, GOOD HOPE, IL. FILED 4-12-2012.

BUSTN AT THE SEAMS APPAREL

THE MARK CONSISTS OF STANDARD CHARACTERS WITHOUT CLAIM TO ANY PARTICULAR FONT, STYLE, SIZE, OR COLOR.

NO CLAIM IS MADE TO THE EXCLUSIVE RIGHT TO USE "APPAREL", APART FROM THE MARK AS SHOWN.

FOR CLOTHING, NAMELY, TOPS, BOTTOMS, T SHIRTS, SWEAT SHIRTS, SWEAT PANTS, UNDERWEAR, SOCKS, HOODED SWEATSHIRTS, HATS, TANK TOPS (U.S. CLS. 22 AND 39).

MAUREEN DALL, EXAMINING ATTORNEY

CLASS 25—(Continued).

SN 85-596,217. HOT TOPIC MERCHANDISING, INC., CITY OF INDUSTRY, CA. FILED 4-12-2012.

OWNER OF U.S. REG. NO. 4,169,027.

THE MARK CONSISTS OF A HEART SHADED WITH A BORDER ON THE OUTSIDE NEXT TO THE STYLIZED WORD "LOVESICK" WHERE THE WORD "LOVE" IS UPPER CASE AND "SICK" IS IN LOWERCASE.

FOR BATHING SUITS; BEANIES; BOOTS; BRAS; DENIM JACKETS; DRESSES THAT MAY ALSO BE USED AS TOWELS; FLIP FLOPS; HEADGEAR, NAMELY, COWBOY HATS, FEDORA HATS, CAPS, AND TRUCKER HATS; LADIES' UNDERWEAR; LINGERIE; MONOKINIS; PANTIES, SHORTS AND BRIEFS; RAIN WEAR; SANDALS; SANDALS AND BEACH SHOES; SCARVES; SHOES; SOCKS AND STOCKINGS; SWIM TRUNKS; UNDERWEAR; WOMEN'S HATS AND HOODS (U.S. CLS. 22 AND 39).

MAYUR VAGHANI, EXAMINING ATTORNEY

SN 85-596,295. LARCIA SPORTS, LLC, SHAVERTOWN, PA. FILED 4-12-2012.

LARCIA

THE MARK CONSISTS OF STANDARD CHARACTERS WITHOUT CLAIM TO ANY PARTICULAR FONT, STYLE, SIZE, OR COLOR.

THE WORDING "LARCIA" HAS NO MEANING IN A FOREIGN LANGUAGE.

FOR FOOTWEAR; APPAREL, NAMELY, PANTS, SHORTS, SHIRTS, T-SHIRTS, PULLOVERS, SWEAT SHIRTS, SKIRTS, SWEATERS, JACKETS, SOCKS, HEADWEAR, GLOVES, BELTS, COATS, VESTS (U.S. CLS. 22 AND 39).

MEREDITH MARESCA, EXAMINING ATTORNEY

CLASS 25—(Continued).

SN 85-596,384. LARCIA SPORTS, LLC, SHAVERTOWN, PA. FILED 4-12-2012.

LARCIA SPORTS

THE MARK CONSISTS OF STANDARD CHARACTERS WITHOUT CLAIM TO ANY PARTICULAR FONT, STYLE, SIZE, OR COLOR.

NO CLAIM IS MADE TO THE EXCLUSIVE RIGHT TO USE "SPORTS", APART FROM THE MARK AS SHOWN.

THE WORDING "LARCIA" HAS NO MEANING IN A FOREIGN LANGUAGE.

FOR FOOTWEAR; APPAREL, NAMELY, PANTS, SHORTS, SHIRTS, T-SHIRTS, PULLOVERS, SWEAT SHIRTS, SKIRTS, SWEATERS, JACKETS, SOCKS, HEADWEAR, GLOVES, BELTS, COATS, VESTS (U.S. CLS. 22 AND 39).

MEREDITH MARESCA, EXAMINING ATTORNEY

CLASS 25—(Continued).

SN 85-596,514. COLOR STORY TEXTILE, INC., LOS ANGELES, CA. FILED 4-12-2012.



THE COLOR(S) BLACK, PINK AND WHITE IS/ARE CLAIMED AS A FEATURE OF THE MARK.

THE MARK CONSISTS OF THE WORDS "COLOR AND STORY" IN BLACK IN A VERTICAL FORMATION WHERE THE SECOND "O" IN COLOR AND THE "O" IN STORY OVERLAP. THESE WORDS ARE OVERLAID ON A WHITE BACKGROUND WITH SMALL PINK HEARTS.

FOR CAMISOLES; CARDIGANS; DRESSES; LONG-SLEEVED SHIRTS; SHIRTS; SKIRTS; T-SHIRTS (U.S. CLS. 22 AND 39).

FIRST USE 12-29-2011; IN COMMERCE 12-29-2011.

JOHN E. MICHOS, EXAMINING ATTORNEY

SN 85-596,504. NASH, LASHAWN, AUSTIN, TX. FILED 4-12-2012.

maidtron of honor



THE MARK CONSISTS OF STANDARD CHARACTERS WITHOUT CLAIM TO ANY PARTICULAR FONT, STYLE, SIZE, OR COLOR.

OWNER OF U.S. REG. NO. 4,126,047.

FOR APPAREL FOR DANCERS, NAMELY, TEE SHIRTS, SWEATSHIRTS, PANTS, LEGGINGS, SHORTS AND JACKETS; ATHLETIC APPAREL, NAMELY, SHIRTS, PANTS, JACKETS, FOOTWEAR, HATS AND CAPS, ATHLETIC UNIFORMS; CLOTHING FOR ATHLETIC USE, NAMELY, PADDED SHIRTS; HATS (U.S. CLS. 22 AND 39).

EMILY CARLSEN, EXAMINING ATTORNEY

THE COLOR(S) PINK IS/ARE CLAIMED AS A FEATURE OF THE MARK.

THE MARK CONSISTS OF THE PINK LETTERS "C" AND "S" STYLIZED AND FORMED INTO A HEART SHAPE.

FOR CAMISOLES; CARDIGANS; DRESSES; LONG-SLEEVED SHIRTS; SHIRTS; SKIRTS; T-SHIRTS (U.S. CLS. 22 AND 39).

FIRST USE 12-19-2011; IN COMMERCE 12-19-2011.

JOHN E. MICHOS, EXAMINING ATTORNEY

CLASS 25—(Continued).

SN 85-596,666. LOYALTY & HEAR LLC, CAMBRIA HEIGHTS, NY. FILED 4-12-2012.



NO CLAIM IS MADE TO THE EXCLUSIVE RIGHT TO USE "NEW YORK", APART FROM THE MARK AS SHOWN.

THE MARK CONSISTS OF THE LITERAL ELEMENTS "L&H NEW YORK" WRITTEN IN STYLIZED FORM WHEREIN SMALL IMAGES OF FOUR STARS TOGETHER ARE PLACED ABOVE THE LETTER "L" AS SHOWN IN THE MARK.

FOR CLOTHING, NAMELY, TOPS, BOTTOMS, SHIRTS, PANTS, HATS, JACKETS, COATS, SWEATERS, SWEATSHIRTS, HATS, GLOVES, SLEEPWEAR, SWIMWEAR (U.S. CLS. 22 AND 39).

EDWARD NELSON, EXAMINING ATTORNEY

SN 85-596,677. SIMONS, KELLEY, LONDON, ONTARIO, CANADA, FILED 4-12-2012.

LOOP, TWIST AND GO

THE MARK CONSISTS OF STANDARD CHARACTERS WITHOUT CLAIM TO ANY PARTICULAR FONT, STYLE, SIZE, OR COLOR.

FOR ACCESSORY FOR OPEN-BACKED SHOE, NAMELY, A SHOE STRAP THAT PREVENTS A PANT HEM FROM GOING BETWEEN THE HEEL OF THE FOOT AND THE INSOLE (U.S. CLS. 22 AND 39).

LEE-ANNE BERNIS, EXAMINING ATTORNEY

CLASS 25—(Continued).

SN 85-596,780. ALWAYS STRAPPED, WAIANAE, HI. FILED 4-12-2012.



THE MARK CONSISTS OF A STYLIZED LETTER "A" OVERLAPPED BY A STYLIZED LETTER "S" AND THE STYLIZED WORDS "ALWAYS STRAPPED" BELOW.

FOR MEN'S POLO SHIRTS, MEN'S BUTTONED DOWN COLLARED SHIRTS- SHORT/LONG SLEEVED, MEN'S T-SHIRTS SHORT/LONG SLEEVED, MEN'S TANK TOPS, MEN'S BOARD SURF SHORTS, MEN'S ATHLETIC SHORTS, MEN'S UNDERWEAR, MEN'S SWEATERS/HOODED SWEATSHIRTS, MEN'S SWEAT PANTS, MEN'S JEANS, MEN'S JACKETS, MEN'S SLIPPERS, WOMEN'S T-SHIRTS SHORT/LONG SLEEVED, WOMEN'S TANK TOPS, WOMEN'S BOARD SURF SHORTS, WOMEN'S ATHLETIC SHORTS, WOMEN'S UNDERWEAR, WOMEN'S SWEATERS/HOODED SWEATSHIRTS, WOMEN'S SWEAT PANTS, WOMEN'S JEANS, WOMEN'S JACKETS, WOMEN'S TUBE TOPS, WOMEN'S HALTER TOPS, WOMEN'S JUMP SUIT/ROMPERS, WOMEN'S DRESSES, BIKINIS- TWO PIECE AND FASHION ONE PIECE, WOMEN'S SLIPPERS, CHILDREN'S BOY/GIRL T-SHIRTS SHORT/LONG SLEEVED, CHILDREN'S BOY/GIRL TANK TOPS, CHILDREN'S BOY/GIRL ATHLETIC SHORTS, CHILDREN'S BOY/GIRL SWEATERS/HOODED SWEATSHIRTS, CHILDREN'S BOY/GIRL SWEAT PANTS, CHILDREN'S BOY/GIRL JACKETS, CHILDREN'S GIRL DRESSES, CHILDREN'S GIRL JUMP SUIT/ROMPERS, FITTED BASEBALL CAPS, SNAPBACK BASEBALL CAPS, FEDORA STYLED HATS, BEANIES, SCARVES AND BELTS (U.S. CLS. 22 AND 39).

JOHN WILKE, EXAMINING ATTORNEY

SN 85-597,304. BERNARD, TODD, DEER PARK, NY. FILED 4-13-2012.

MYBARBERIS

THE MARK CONSISTS OF STANDARD CHARACTERS WITHOUT CLAIM TO ANY PARTICULAR FONT, STYLE, SIZE, OR COLOR.

FOR CLOTHING, NAMELY, FOOTWEAR, HEADWEAR, TOPS, BOTTOMS, SHIRTS, T-SHIRTS, AND PANTS (U.S. CLS. 22 AND 39).

TIMOTHY O. SCHIMPF, EXAMINING ATTORNEY

CLASS 25—(Continued).

SN 85-597,773. WILD INTUITIONS, LLC, SUDBURY, MA. FILED 4-13-2012.

MARIWEAR

THE MARK CONSISTS OF STANDARD CHARACTERS WITHOUT CLAIM TO ANY PARTICULAR FONT, STYLE, SIZE, OR COLOR.

FOR LOUNGEWEAR; SLEEPWEAR (U.S. CLS. 22 AND 39).

ARETHA SOMERVILLE, EXAMINING ATTORNEY



SN 85-597,991. TEAM COUTURE LLC, ATLANTA, GA. FILED 4-13-2012.

TEAM COUTURE · TC TC YOUR TEAM · YOUR STYLE

THE MARK CONSISTS OF STANDARD CHARACTERS WITHOUT CLAIM TO ANY PARTICULAR FONT, STYLE, SIZE, OR COLOR.

NO CLAIM IS MADE TO THE EXCLUSIVE RIGHT TO USE "TEAM COUTURE", APART FROM THE MARK AS SHOWN.

FOR JACKETS; SHIRTS; SWEATERS (U.S. CLS. 22 AND 39).

ANDREW RHIM, EXAMINING ATTORNEY



SN 85-598,029. RASMUS, ANTONIO G., ELMONT, NY. FILED 4-13-2012.



THE COLORS BLACK AND WHITE REPRESENT BACKGROUND, OUTLINING, SHADING, AND/OR TRANSPARENT AREAS AND ARE NOT PART OF THE MARK.

THE MARK CONSISTS OF THE UPPER CASE LETTERS "RW", BELOW WHICH APPEARS THE WORD "RALLY" IN TITLE CASE FOLLOWED BY THE WORD "WIN" IN UPPER CASE LETTERS.

FOR ATHLETIC APPAREL, NAMELY, SHIRTS, PANTS, JACKETS, FOOTWEAR, HATS AND CAPS, ATHLETIC UNIFORMS (U.S. CLS. 22 AND 39).

FIRST USE 2-19-2011; IN COMMERCE 2-19-2011.
EDWARD FENNESSY, EXAMINING ATTORNEY

CLASS 25—(Continued).

SN 85-598,050. TAILOR KNIGHT, LITHIA SPRINGS, GA. FILED 4-14-2012.

Tailor Knight

THE MARK CONSISTS OF STANDARD CHARACTERS WITHOUT CLAIM TO ANY PARTICULAR FONT, STYLE, SIZE, OR COLOR.

THE NAME(S), PORTRAIT(S), AND/OR SIGNATURE(S) SHOWN IN THE MARK DOES NOT IDENTIFY A PARTICULAR LIVING INDIVIDUAL.

FOR BOW TIES; BUTTON DOWN SHIRTS; CAPS; COLLARED SHIRTS; DENIMS; DRESS PANTS; DRESS SHIRTS; FOOTWEAR; HATS; HEADWEAR; JEANS; LEATHER HEADWEAR; TIES; UNDERWEAR (U.S. CLS. 22 AND 39).

FIRST USE 1-6-2011; IN COMMERCE 2-20-2012.
ROSELLE HERRERA, EXAMINING ATTORNEY



SN 85-598,075. COOPERSTOWN MINOR LEAGUE BASEBALL VENTURES, LLC, FLY CREEK, NY. FILED 4-14-2012.



THE MARK CONSISTS OF THE LETTER "C" WITH TWO BIRD FEATHERS TRAILING FROM THE BACK OF THE LETTER. THE LETTER "C" IN A SERIF FONT AND CONTAINS A FIGURATIVE DESIGN OF A BASEBALL DIAMOND IN ITS CURVE.

FOR CLOTHING, NAMELY, ATHLETIC UNIFORMS; BANDANNAS; BELTS; BERMUDA SHORTS, BLOUSES, BOXER SHORTS, CAPS, CLOTH BIBS, COATS, GOLF SHIRTS, GYM SHORTS, GYM SUITS, HATS, INFANTWEAR, JACKETS, JERSEYS, PANTS, POLO SHIRTS, PONCHOS, RAIN COATS, SHIRTS, SHORTS, SWEAT BANDS, SWEAT PANTS, SWEAT SHIRTS, SWEAT SHORTS, SWEATERS, T-SHIRTS, TANK TOPS, TURTLENECK SWEATERS, V-NECK SWEATERS, WIND RESISTANT JACKETS AND WRIST BANDS (U.S. CLS. 22 AND 39).

FIRST USE 2-1-2010; IN COMMERCE 2-1-2010.
HENRY S. ZAK, EXAMINING ATTORNEY

CLASS 25—(Continued).

SN 85-598,124. ARMSTRONG, CECIL EARL, DALLAS, TX. FILED 4-14-2012.

**SHUCKEY DUCKEY QUACK!
QUACK!**

THE MARK CONSISTS OF STANDARD CHARACTERS WITHOUT CLAIM TO ANY PARTICULAR FONT, STYLE, SIZE, OR COLOR.

SEC. 2(F).
FOR CLOTHING, NAMELY, T-SHIRTS, SHORTS, SWEATSHIRTS, JACKETS, AND EMBROIDERED SHIRTS; HEADGEAR, NAMELY, HATS AND SWEATBANDS (U.S. CLS. 22 AND 39).
FIRST USE 1-15-1984; IN COMMERCE 1-15-1984.
TARAH HARDY, EXAMINING ATTORNEY

CLASS 25—(Continued).

SN 85-598,346. MOUNTAIN FORCE AG, ROTKREUZ, SWITZERLAND, FILED 4-16-2012.

MOUNTAIN FORCE

THE MARK CONSISTS OF STANDARD CHARACTERS WITHOUT CLAIM TO ANY PARTICULAR FONT, STYLE, SIZE, OR COLOR.

OWNER OF U.S. REG. NOS. 3,441,040 AND 4,065,707.
FOR CLOTHING, NAMELY, SNOW SUITS, SKI SWEATERS, SKI JACKETS, SKI PANTS, SKI UNDERWEAR, SWEAT SUITS, SWEATERS, PANTS, JACKETS; HEADWEAR, NAMELY, SKI HATS; FOOTWEAR, NAMELY, SKI BOOTS, TRAVEL BOOTS, CASUAL BOOTS, SOCKS, UNDERWEAR (U.S. CLS. 22 AND 39).
FIRST USE 1-2-2010; IN COMMERCE 1-2-2010.
DAVID MURRAY, EXAMINING ATTORNEY

SN 85-598,350. MICHAEL R.ESGRO, SAINT CLOUD, FL. FILED 4-16-2012.

SN 85-598,175. JONES, DARYL A., DBA JUDAH APPAREL, MIAMI GARDENS, FL. FILED 4-14-2012.



Come On 

THE MARK CONSISTS OF "COME ON" WEAR IT AND THE DESIGN OF A RECTANGLE FOR ATHLETIC APPAREL, NAMELY, SHIRTS, PANTS, JACKETS, FOOTWEAR, HATS AND CAPS, ATHLETIC UNIFORMS (U.S. CLS. 22 AND 39).
MIDGE BUTLER, EXAMINING ATTORNEY

SN 85-598,476. DURAN, LUIS, TAMPA, FL. FILED 4-16-2012.

NO CLAIM IS MADE TO THE EXCLUSIVE RIGHT TO USE "APPAREL" AND "EST. 2002", APART FROM THE MARK AS SHOWN.

THE MARK CONSISTS OF THE MAIN WORDS "JUDAH APPAREL" WITH "JUDAH" CAPITALIZED WITH A LION STANDING ON TWO LEGS IN THE LETTER "A". THE IMAGE HAS A LARGE RAM HORN WITH AN OPENING AT THE BOTTOM OF THE "J" AND OVER THE TOP OF THE "A". THE WORD "APPAREL" IS UNDERNEATH THE WORD "JUDAH". IN THE TOP LEFT HAND CORNER ARE THE WORDS AND NUMBERS "JUDGES 1.2" HOUSED IN A RECTANGULAR BOX, AND IN THE LOWER RIGHT CORNER ARE THE WORDS "EST. 2002" ALSO HOUSED IN A RECTANGULAR BOX.

FOR ATHLETIC APPAREL, NAMELY, SHIRTS, PANTS, JACKETS, FOOTWEAR, HATS AND CAPS, ATHLETIC UNIFORMS (U.S. CLS. 22 AND 39).
DAVID MURRAY, EXAMINING ATTORNEY



NO CLAIM IS MADE TO THE EXCLUSIVE RIGHT TO USE "STAY FLY", APART FROM THE MARK AS SHOWN. THE MARK CONSISTS OF A JET AIRPLANE WITH THE LETTERS "SFA" ON THE TAIL AND WORDS "STAY FLY ACADEMY" UNDER THE AIRPLANE.

FOR T-SHIRTS (U.S. CLS. 22 AND 39).
DAVID C. REIHNER, EXAMINING ATTORNEY

CLASS 25—(Continued).

SN 85-598,543. RAMIREZ, MICHAEL, LOMITA, CA. FILED 4-16-2012.



THE MARK CONSISTS OF THE STYLIZED TEXT "KRAZYNATIVE". BELOW THERE IS THE STYLIZED LETTERS "KN".

FOR BEANIES; BELTS; BLOUSES; DRESS PANTS; DRESS SHIRTS; HATS; JACKETS; PANTS; SHIRTS; SHOES; SWEATERS (U.S. CLS. 22 AND 39).
ELLEN PERKINS, EXAMINING ATTORNEY

SN 85-598,550. MONDINE, OSCAR, FORT WORTH, TX. FILED 4-16-2012.

prayin for my peep's peace
power love and unity

THE MARK CONSISTS OF STANDARD CHARACTERS WITHOUT CLAIM TO ANY PARTICULAR FONT, STYLE, SIZE, OR COLOR.

FOR CAPS; JACKETS; SHIRTS; SWEAT SHIRTS; T-SHIRTS; VISORS; WARM UP SUITS (U.S. CLS. 22 AND 39).
LESLIE RICHARDS, EXAMINING ATTORNEY

SN 85-598,612. LIPSON, ALICE, NORWALK, CT. FILED 4-16-2012.

It's about the music

THE MARK CONSISTS OF STANDARD CHARACTERS WITHOUT CLAIM TO ANY PARTICULAR FONT, STYLE, SIZE, OR COLOR.

FOR JACKETS; PANTS; SHIRTS (U.S. CLS. 22 AND 39).
CHARISMA HAMPTON, EXAMINING ATTORNEY

CLASS 25—(Continued).

SN 85-598,637. BUDDY BELK, COON RAPIDS, MN. FILED 4-16-2012.

Less Government. More Fun.

THE MARK CONSISTS OF STANDARD CHARACTERS WITHOUT CLAIM TO ANY PARTICULAR FONT, STYLE, SIZE, OR COLOR.

FOR HATS; HOODED SWEATSHIRTS; SHORT-SLEEVED OR LONG-SLEEVED T-SHIRTS; SWEATSHIRTS; T-SHIRTS (U.S. CLS. 22 AND 39).
BRENDAN MCCAULEY, EXAMINING ATTORNEY

SN 85-598,708. BERMAL, JAY, SAN DIEGO, CA. FILED 4-16-2012.

Reincarnate

THE MARK CONSISTS OF STANDARD CHARACTERS WITHOUT CLAIM TO ANY PARTICULAR FONT, STYLE, SIZE, OR COLOR.

FOR HATS; PANTS; SHIRTS; SWEAT SHIRTS; T-SHIRTS (U.S. CLS. 22 AND 39).
KATHERINE M. DUBRAY, EXAMINING ATTORNEY

SN 85-599,097. TAYLOR, STEPFAN, MANSFIELD, TX. FILED 4-16-2012.

KULABAFI

THE MARK CONSISTS OF STANDARD CHARACTERS WITHOUT CLAIM TO ANY PARTICULAR FONT, STYLE, SIZE, OR COLOR.

FOR HATS; JACKETS; SHIRTS; SWEATSHIRTS (U.S. CLS. 22 AND 39).
BRENDAN REGAN, EXAMINING ATTORNEY

CLASS 25—(Continued).

SN 85-599,337. BENNETT, FAYE, HAYWARD, CA. FILED 4-16-2012.

Lily Bot

THE MARK CONSISTS OF STANDARD CHARACTERS WITHOUT CLAIM TO ANY PARTICULAR FONT, STYLE, SIZE, OR COLOR.

FOR SHORT-SLEEVED OR LONG-SLEEVED T-SHIRTS; T-SHIRTS; T-SHIRTS FOR CHILDRENS, BABIES, ADULTS (U.S. CLS. 22 AND 39).

LEIGH LOWRY, EXAMINING ATTORNEY

CLASS 25—(Continued).

SN 85-599,437. PEKING WONI OVERSEAS INTERNATIONAL TRADING CO. LTD., BEIJING, CHINA, FILED 4-17-2012.

wan&lu

THE MARK CONSISTS OF STYLIZED WORDS WAN&LU. FOR BELTS; BOAS; HEADGEAR, NAMELY, HATS, CAPS; HOSIERY; KNIT DRESSES; LAYETTES; NECKTIES; OVERCOATS; SHIRTS; SHOES; SKIRTS; SUITS; SWEATERS; TROUSERS; UNDERWEAR (U.S. CLS. 22 AND 39).

FIRST USE 3-26-2010; IN COMMERCE 3-26-2010.
EMILY CARLSEN, EXAMINING ATTORNEY

SN 85-599,678. SUTHERLAND, ANDRAE, GREATER PORTMORE, JAMAICA, FILED 4-17-2012.

YAAOOWW

THE MARK CONSISTS OF STANDARD CHARACTERS WITHOUT CLAIM TO ANY PARTICULAR FONT, STYLE, SIZE, OR COLOR.

FOR BANDANAS; BASEBALL CAPS; FOOTWEAR; FOOTWEAR FOR MEN AND WOMEN; JEANS; LEATHER SHOES; LEISURE SHOES; POLO SHIRTS; SANDALS AND BEACH SHOES; SHIRTS AND SHORT-SLEEVED SHIRTS; SHIRTS FOR INFANTS, BABIES, TODDLERS AND CHILDREN; SHORT-SLEEVED OR LONG-SLEEVED T-SHIRTS; SNEAKERS; SWEATERS; SWEATSHIRTS; T-SHIRTS; TANK TOPS (U.S. CLS. 22 AND 39).

MICHAEL WEBSTER, EXAMINING ATTORNEY

SN 85-600,039. GATTI, LYN TALLARIDA, DBA SHINSHACKLE, SAN RAFAEL, CA. FILED 4-17-2012.

SHIN SHACKLE

THE MARK CONSISTS OF STANDARD CHARACTERS WITHOUT CLAIM TO ANY PARTICULAR FONT, STYLE, SIZE, OR COLOR.

NO CLAIM IS MADE TO THE EXCLUSIVE RIGHT TO USE "SHIN", APART FROM THE MARK AS SHOWN. FOR APPAREL, NAMELY, PANT LEG PROTECTIVE COVERS AND PANT LEG PROTECTIVE STRAPS FOR CYCLISTS (U.S. CLS. 22 AND 39).

FIRST USE 10-20-2011; IN COMMERCE 4-17-2012.

JANICE L. MCMORROW, EXAMINING ATTORNEY

SN 85-599,383. BURNS, BETH, CHICAGO, IL. FILED 4-16-2012.



THE MARK CONSISTS OF A FEMALE BIOLOGICAL SYMBOL WITH THE LETTERS "ER" IN PARENTHESIS INSIDE THE CIRCLE.

FOR CLOTHING, NAMELY, WOMEN'S T-SHIRTS AND HATS (U.S. CLS. 22 AND 39).

WILLIAM VERHOSEK, EXAMINING ATTORNEY

CLASS 25—(Continued).

SN 85-600,102. SATHER, ERIC, FALLBROOK, CA. FILED 4-17-2012.



THE MARK CONSISTS OF THE WORDING "WE NEED DUKE" WITH A DESIGN OF A FIVE-POINTED STAR AND BARBED WIRE BENEATH THE WORDING.

FOR HATS; HOODED SWEATSHIRTS; SHORT-SLEEVED OR LONG-SLEEVED T-SHIRTS; SWEATSHIRTS (U.S. CLS. 22 AND 39).

AISHA SALEM, EXAMINING ATTORNEY

CLASS 25—(Continued).

SN 85-600,242. 69MAX, INC., FAIRFIELD, CA. FILED 4-17-2012.



THE COLOR(S) BLUE, ORANGE, YELLOW, RED, BROWN AND BLACK IS/ARE CLAIMED AS A FEATURE OF THE MARK.

THE MARK CONSISTS OF THE TERM "5'9" WRITTEN IN YELLOW, WITH THE WORD "MAX" WRITTEN IN RED UNDERNEATH, DIRECTLY ADJACENT TO THAT IS AN ORANGE BASKETBALL WITH A BROWN GLOBE IMPRINTED ON IT. ALL THESE ITEMS ARE CONTAINED WITHIN A BLUE ROUND BACKGROUND WITH BLACK HORIZONTAL LINES, AND ALL ELEMENTS HAVE BLACK BORDERING.

FOR ATHLETIC APPAREL, NAMELY, SHIRTS, PANTS, JACKETS, FOOTWEAR, HATS AND CAPS, ATHLETIC UNIFORMS (U.S. CLS. 22 AND 39).

SUSAN LESLIE DUBOIS, EXAMINING ATTORNEY

SN 85-600,227. 69MAX, INC., FAIRFIELD, CA. FILED 4-17-2012.



THE COLOR(S) BLUE, ORANGE, YELLOW, BROWN, RED, AND BLACK IS/ARE CLAIMED AS A FEATURE OF THE MARK.

THE MARK CONSISTS OF THE NUMBER "6'9" WRITTEN IN YELLOW FOLLOWED BY THE INCHES SYMBOL, ALSO WRITTEN IN YELLOW AND THE WORD "MAX" WRITTEN IN RED UNDERNEATH, DIRECTLY ADJACENT TO THAT IS AN ORANGE BASKETBALL WITH A BROWN GLOBE IMPRINTED ON IT. ALL THESE ITEMS ARE CONTAINED WITHIN A BLUE ROUND BACKGROUND WITH BLACK HORIZONTAL LINES, AND ALL ELEMENTS HAVE BLACK BORDERING.

FOR ATHLETIC APPAREL, NAMELY, SHIRTS, PANTS, JACKETS, FOOTWEAR, HATS AND CAPS, ATHLETIC UNIFORMS (U.S. CLS. 22 AND 39).

SUSAN LESLIE DUBOIS, EXAMINING ATTORNEY

SN 85-600,296. K-2 CORPORATION, SEATTLE, WA. FILED 4-17-2012.

WETZOOT

THE MARK CONSISTS OF STANDARD CHARACTERS WITHOUT CLAIM TO ANY PARTICULAR FONT, STYLE, SIZE, OR COLOR.

FOR WETSUITS AND SWIMSUITS (U.S. CLS. 22 AND 39).

FIRST USE 12-10-2004; IN COMMERCE 3-15-2005.

KARANENDRA S. CHHINA, EXAMINING ATTORNEY

CLASS 25—(Continued).

SN 85-600,302. MILLER, CHRISTOPHER J., TAMPA, FL. FILED 4-17-2012.



THE MARK CONSISTS OF THE STYLIZED TEXT "LONGER JOHNS" WITH AN IMAGE OF AN ELEPHANT HEAD BETWEEN THE TWO WORDS.
FOR UNDERGARMENTS (U.S. CLS. 22 AND 39).
CHARISMA HAMPTON, EXAMINING ATTORNEY

SN 85-600,321. SLY, KELLY C., DBA DIGGIT, COLUMBIA, MO. FILED 4-17-2012.

DIGGIT

THE MARK CONSISTS OF STANDARD CHARACTERS WITHOUT CLAIM TO ANY PARTICULAR FONT, STYLE, SIZE, OR COLOR.
OWNER OF U.S. REG. NO. 3,122,803.
FOR CLOTHING, NAMELY, T-SHIRTS, SWEATSHIRTS AND PANTS, AND HEADWEAR (U.S. CLS. 22 AND 39).
FIRST USE 7-0-1998; IN COMMERCE 7-0-1998.
SUNG IN, EXAMINING ATTORNEY

SN 85-600,330. PARKER, ALISON, REDONDO BEACH, CA. AND HANNA, JONATHON, REDONDO BEACH, CA. AND CHRISTMAN, STEVE, REDONDO BEACH, CA. AND MASON, LINDSAY, REDONDO BEACH, CA. FILED 4-17-2012.



PEACE. LOVE. UNITY. RESPECT.

NO CLAIM IS MADE TO THE EXCLUSIVE RIGHT TO USE "APPAREL", APART FROM THE MARK AS SHOWN.
THE MARK CONSISTS OF THE STYLIZED TEXT "RAVE" ABOVE THE STYLIZED TEXT "DADDY". TO THE RIGHT IS A VERTICAL LINE. TO THE RIGHT OF THE LINE IS THE STYLIZED TEXT "APPAREL" WRITTEN VERTICALLY. BELOW THE ABOVE TEXT AND IMAGES IS THE STYLIZED TEXT "PEACE. LOVE. UNITY. RESPECT."
FOR SWEAT SHIRTS; T-SHIRTS; WRISTBANDS (U.S. CLS. 22 AND 39).
FIRST USE 1-19-2012; IN COMMERCE 1-19-2012.
LYNDSEY KUYKENDALL, EXAMINING ATTORNEY

CLASS 25—(Continued).

SN 85-600,483. ARIAS, MARIA GABRIELA, SANTA CLARA, CA. FILED 4-17-2012.



THE MARK CONSISTS OF AN ANGEL WITH ANGRY EYES, A DEVIL'S TAIL, AND A HALO.
FOR DRESSES; GLOVES; HATS; SCARVES; T-SHIRTS (U.S. CLS. 22 AND 39).
MICHELE SWAIN, EXAMINING ATTORNEY

SN 85-600,540. CROSS, JAMES, MICHIGAN CITY, IN. FILED 4-17-2012.



THE MARK CONSISTS OF THE WORDS "AUTHENTIC Z ZIP-A-TEE" SHOWING WITH A T-SHIRT WHEREIN "AUTHENTIC" IS WRITTEN ABOVE THE STYLIZED LETTER "Z" AND TO THE BELOW OF WHICH THE WORDS "ZIP-A-TEE" ARE WRITTEN AS SHOWN IN THE MARK.
FOR CLOTHING, NAMELY, FOOTWEAR, HEADWEAR, TOPS, BOTTOMS, SHIRTS, T-SHIRTS, JERSEYS, AND PANTS (U.S. CLS. 22 AND 39).
JENNY PARK, EXAMINING ATTORNEY

CLASS 25—(Continued).

SN 85-600,655. LEVY, JORDYN M., FLORHAM PARK, NJ. FILED 4-17-2012.

DENIM EXPERIMENT

THE MARK CONSISTS OF STANDARD CHARACTERS WITHOUT CLAIM TO ANY PARTICULAR FONT, STYLE, SIZE, OR COLOR.

NO CLAIM IS MADE TO THE EXCLUSIVE RIGHT TO USE "DENIM", APART FROM THE MARK AS SHOWN.

FOR SHORTS, JEANS, VESTS, T-SHIRTS AND JACKETS ALL MADE IN WHOLE OR SUBSTANTIALLY IN PART OF DENIM (U.S. CLS. 22 AND 39).

DAVID I, EXAMINING ATTORNEY

SN 85-600,767. LARSON, DONALD A., ST. CLAIR SHORES, MI. FILED 4-18-2012.

THOR'S COLISEUM

THE MARK CONSISTS OF STANDARD CHARACTERS WITHOUT CLAIM TO ANY PARTICULAR FONT, STYLE, SIZE, OR COLOR.

FOR GYM SHORTS; SHIRTS; SWEAT PANTS; SWEATSHIRTS; TANK TOPS; TEE SHIRTS; TOPS (U.S. CLS. 22 AND 39).

DAVID COLLIER, EXAMINING ATTORNEY

SN 85-600,876. MOSER, HILARY, URBANDALE, IA. AND MOSER, LARRY, URBANDALE, IA. FILED 4-18-2012.

FLIRTY
SKIRTY

THE COLOR(S) RED, GREEN, ORANGE, PURPLE, PINK, AND BLUE IS/ARE CLAIMED AS A FEATURE OF THE MARK.

THE MARK CONSISTS OF THE STYLIZED TEXT "FLIRTY". EACH LETTER IS A DIFFERENT COLOR, AND THE COLORS ARE AS FOLLOWS FROM LEFT TO RIGHT: RED, GREEN, ORANGE, PURPLE, PINK, AND BLUE. BELOW "FLIRTY" IS THE STYLIZED TEXT "SKIRTY". EACH LETTER IN "SKIRTY" IS A DIFFERENT COLOR, AND THE COLORS ARE AS FOLLOWS FROM LEFT TO RIGHT: BLUE, PINK, PURPLE, ORANGE, GREEN, AND RED.

FOR CLOTHING FOR TODDLERS, NAMELY, SHIRTS AND SKIRTS (U.S. CLS. 22 AND 39).

FIRST USE 2-15-2012; IN COMMERCE 2-15-2012.
MATTHEW PAPPAS, EXAMINING ATTORNEY

CLASS 25—(Continued).

SN 85-600,941. DOUBLE MEDIUM, MINOT, ND. FILED 4-18-2012.



THE COLOR(S) RED, BLACK, AND WHITE IS/ARE CLAIMED AS A FEATURE OF THE MARK.

THE MARK CONSISTS OF A SMALL CASE "D" IN BLACK, A CAPITOL "M" IN RED, THE TEXT "DOUBLE-MEDIUM" ALL CAPITOL LETTERS DIRECTLY BELOW THE "DM" AS DESCRIBED ABOVE. THE "DOUBLE" IS RED AND THE "MEDIUM" IS BLACK. BELOW THE WORD "MEDIUM" IS THE SLOGAN "PLAY BIG" IN BLACK.

FOR GOLF CAPS; GOLF SHIRTS; JACKETS; SWEAT SHIRTS; WIND SHIRTS (U.S. CLS. 22 AND 39).

JACLYN KIDWELL WALKER, EXAMINING ATTORNEY

SN 85-601,484. ACADEMY, LTD., KATY, TX. FILED 4-18-2012.

DURA-BLOCK

THE MARK CONSISTS OF STANDARD CHARACTERS WITHOUT CLAIM TO ANY PARTICULAR FONT, STYLE, SIZE, OR COLOR.

FOR CLOTHING, NAMELY, JACKETS, PANTS, BIB OVERALLS, GLOVES, BEANIES AND BALACLAVAS (U.S. CLS. 22 AND 39).

FIRST USE 8-13-2011; IN COMMERCE 8-13-2011.

CHARISMA HAMPTON, EXAMINING ATTORNEY

SN 85-601,639. LEYDE, BRIAN, LOPEZ ISLAND, WA. FILED 4-18-2012.

WARRIOR FREEDOM

THE MARK CONSISTS OF STANDARD CHARACTERS WITHOUT CLAIM TO ANY PARTICULAR FONT, STYLE, SIZE, OR COLOR.

FOR CLOTHING, NAMELY, TOPS, BOTTOMS, T-SHIRTS, YOGA PANTS, HATS, ONE PIECE GARMENTS FOR INFANTS AND TODDLERS, SWEATSHIRTS, SWEATPANTS, TANK TOPS, SOCKS, UNDERWEAR, JACKETS, COATS, GLOVES, SHOES (U.S. CLS. 22 AND 39).

FIRST USE 12-7-2005; IN COMMERCE 11-17-2011.
FRANK LATTUCA, EXAMINING ATTORNEY

CLASS 25—(Continued).

SN 85-601,688. SHAHAF GAL, NESS ZIONA, ISRAEL, FILED 4-18-2012.

BONES AND BALLOONS

THE MARK CONSISTS OF STANDARD CHARACTERS WITHOUT CLAIM TO ANY PARTICULAR FONT, STYLE, SIZE, OR COLOR.

FOR CLOTHING, NAMELY, PANTS, SHORTS, SHIRTS, SKIRTS, DRESSES, COATS; FOOTWEAR (U.S. CLS. 22 AND 39).

DEZMONA MIZELLE, EXAMINING ATTORNEY

CLASS 25—(Continued).

NAMELY, SHIRTS, PANTS, JACKETS, FOOTWEAR, HATS AND CAPS, UNIFORMS; SHIRT FRONTS; SHIRT INSERTS, NAMELY, DICKIES; SHIRT YOKES; SHIRTS; SHIRTS AND SHORT-SLEEVED SHIRTS; SHIRTS AND SLIPS; SHIRTS FOR INFANTS, BABIES, TODDLERS AND CHILDREN; SHIRTS FOR SUITS; SHORT-SLEEVED OR LONG-SLEEVED T-SHIRTS; SHORT-SLEEVED SHIRTS; SKI PANTS; SLEEP PANTS; SLEEP SHIRTS; SLEEVES WORN SEPARATE AND APART FROM BLOUSES, SHIRTS AND OTHER TOPS; SNAP CROTCH SHIRTS FOR INFANTS AND TODDLERS; SNOW PANTS; SNOWBOARD PANTS; SPORT SHIRTS; SPORTS PANTS; SPORTS SHIRTS; SPORTS SHIRTS WITH SHORT SLEEVES; SWEAT SHIRTS; T-SHIRTS; T-SHIRTS FOR WOMEN, MEN, CHILDREN; TEE SHIRTS; TRIATHLON CLOTHING, NAMELY, TRIATHLON TIGHTS, TRIATHLON SHORTS, TRIATHLON SINGLETTS, TRIATHLON SHIRTS, TRIATHLON SUITS; TURTLE NECK SHIRTS; WOMEN'S CLOTHING, NAMELY, SHIRTS, DRESSES, SKIRTS, BLOUSES (U.S. CLS. 22 AND 39).

KATHERINE STOIDES, EXAMINING ATTORNEY

SN 85-601,723. HARRIMAN, MARTHA D., DBA BEACH BUM COWGIRLS, CARLSBAD, CA. FILED 4-18-2012.

Beach Bum Cowgirls

THE MARK CONSISTS OF STANDARD CHARACTERS WITHOUT CLAIM TO ANY PARTICULAR FONT, STYLE, SIZE, OR COLOR.

FOR A-SHIRTS; APPAREL FOR DANCERS, NAMELY, TEE SHIRTS, SWEATSHIRTS, PANTS, LEGGINGS, SHORTS AND JACKETS; BABIES' PANTS; BALLOON PANTS; BLOUSES; BODY SHIRTS; BUTTON DOWN SHIRTS; BUTTON-FRONT ALOHA SHIRTS; CAMOUFLAGE PANTS; CAMP SHIRTS; CAPRI PANTS; CARGO PANTS; CLOTHING FOR ATHLETIC USE, NAMELY, PADDED PANTS; CLOTHING FOR ATHLETIC USE, NAMELY, PADDED SHIRTS; CLOTHING FOR BABIES, TODDLERS AND CHILDREN, TREATED WITH FIRE AND HEAT RETARDANTS, NAMELY, PAJAMAS, JACKETS, SHIRTS, PANTS, JUMPERS; COLLARED SHIRTS; CROP PANTS; DENIMS; DRESS PANTS; DRESS SHIRTS; FISHING SHIRTS; FLOOD PANTS; GOLF PANTS, SHIRTS AND SKIRTS; GOLF SHIRTS; GYM PANTS; HOODED SWEAT SHIRTS; HUNTING PANTS; HUNTING SHIRTS; JEGGINGS, NAMELY, PANTS THAT ARE PARTIALLY JEANS AND PARTIALLY LEGGINGS; JOGGING PANTS; KNIT SHIRTS; LEATHER SHIRTS; LONG-SLEEVED SHIRTS; MOISTURE-WICKING SPORTS SHIRTS; NIGHT SHIRTS; NON-DISPOSABLE CLOTH TRAINING PANTS; NURSE PANTS; OPEN-NECKED SHIRTS; OVER SHIRTS; PANTS; PETTI-PANTS; PIQUE SHIRTS; POLO SHIRTS; RUGBY SHIRTS; SCIENTIFIC AND TECHNOLOGICAL APPAREL,

SN 85-601,872. YELLOW BOX CORP., CHINO, CA. FILED 4-18-2012.



OWNER OF U.S. REG. NOS. 2,247,768 AND 3,792,972. THE MARK CONSISTS OF "YELLOW BOX" WITH FLOWER DESIGN.

FOR BEACH SHOES; FOOTWEAR; SANDALS; SHOES (U.S. CLS. 22 AND 39).

FIRST USE 1-1-2006; IN COMMERCE 1-1-2006.
B. PARADEWELAI, EXAMINING ATTORNEY

CLASS 25—(Continued).

SN 85-602,060. PERKINS GROUP PROPERTIES-CHINA, LLC, BELLEVUE, WA. FILED 4-19-2012.

ZBX

THE MARK CONSISTS OF STANDARD CHARACTERS WITHOUT CLAIM TO ANY PARTICULAR FONT, STYLE, SIZE, OR COLOR.

FOR MEN'S, WOMEN'S, CHILDREN'S, AND BABY CLOTHING, NAMELY, SHIRTS, T-SHIRTS, SWEATSHIRTS, SPORTS JERSEYS, SINGLETs, TANK TOPS, VESTS, SHIRT INSERTS, NAMELY, DICKIES, BLOUSES, COATS, OVERCOATS, PULLOVERS, JACKETS, SWEATERS, PULLOVERS, SKIRTS, DRESSES, SUNDRESSES, JUMPERS, SMOCKS, PANTS OF ALL LENGTHS, SWEATPANTS, SHORTS OF ALL LENGTHS, BEACHWEAR, SWIMWEAR, WETSUITS, BELTS, HATS, CAPS, VISORS, PONCHOS, SNOW SUITS, SCARVES, MUFFS, EARMUFFS, MITTENS, GLOVES, SLEEPWEAR, LEOTARDS, TIGHTS, ROMPERS, UNDERWEAR, HOSIERY, ONE-PIECE PULLOVERS, AND BABY BUNTINGS (U.S. CLS. 22 AND 39).

CHRISIE B. KING, EXAMINING ATTORNEY

SN 85-602,421. ANSON, BRANDAN, CHATSWORTH, CA. FILED 4-19-2012.



NO CLAIM IS MADE TO THE EXCLUSIVE RIGHT TO USE "BARBER", APART FROM THE MARK AS SHOWN.

THE MARK CONSISTS OF THE LITERAL ELEMENTS "ORGANIZED BARBER" WHEREIN WORDING "ORGANIZED" IS WRITTEN INSIDE A CIRCLE WITHIN WHICH THERE IS ANOTHER SOLID CIRCLE WHEREIN THERE IS AN IMAGE OF HUMAN FIGURE CONSISTING OF BARBER POLE DEPICTING THE HEAD, WEARING A TUXEDO AND HAIR CLIPPER AT THE BOTTOM DEPICTING THE ARM AND WORDING "BARBER" PLACED BELOW THIS IMAGE AS SHOWN IN THE MARK.

FOR CAPES FOR USE IN SALONS AND BARBER SHOPS; CLOTHING, NAMELY, TOPS, BOTTOMS, T-SHIRTS, SHIRTS, SWEATERS, JACKETS, COATS (U.S. CLS. 22 AND 39).

DORITT L. CARROLL, EXAMINING ATTORNEY

CLASS 25—(Continued).

SN 85-602,448. NAUTICA APPAREL, INC., NEW YORK, NY. FILED 4-19-2012.

NST

THE MARK CONSISTS OF STANDARD CHARACTERS WITHOUT CLAIM TO ANY PARTICULAR FONT, STYLE, SIZE, OR COLOR.

FOR MEN'S AND WOMEN'S JACKETS, COATS, TROUSERS, VESTS; PAJAMAS; PANTS; SHIRTS; SHORTS; SPORT SHIRTS; SWEATERS; T-SHIRTS; UNDERWEAR (U.S. CLS. 22 AND 39).

SUSAN LESLIE DUBOIS, EXAMINING ATTORNEY

SN 85-602,462. TRICIA I. HIGGINS, TOPEKA, KS. FILED 4-19-2012.

STAY IN YOUR HOOD

THE MARK CONSISTS OF STANDARD CHARACTERS WITHOUT CLAIM TO ANY PARTICULAR FONT, STYLE, SIZE, OR COLOR.

FOR HOODED APPAREL, NAMELY, TOPS (U.S. CLS. 22 AND 39).

LYNDSEY KUYKENDALL, EXAMINING ATTORNEY

SN 85-602,656. LOUIE, STEVE WAI, NEW YORK, NY. FILED 4-19-2012.

MISTE

THE MARK CONSISTS OF STANDARD CHARACTERS WITHOUT CLAIM TO ANY PARTICULAR FONT, STYLE, SIZE, OR COLOR.

FOR JEANS, JACKETS, SHORTS, SKIRTS, PANTS (U.S. CLS. 22 AND 39).

FIRST USE 1-1-2004; IN COMMERCE 1-1-2004.

JOHN GARTNER, EXAMINING ATTORNEY

CLASS 25—(Continued).

SN 85-602,786. SCHEMER, ROBERT, FORMERLY SAY-KHEL, JACKSONVILLE, FL. FILED 4-19-2012.

SAIKHEL

THE MARK CONSISTS OF STANDARD CHARACTERS WITHOUT CLAIM TO ANY PARTICULAR FONT, STYLE, SIZE, OR COLOR.

THE ENGLISH TRANSLATION OF THE WORD "SAIKHEL" IN THE MARK IS "COMMON SENSE".

FOR CLOTHING, NAMELY, TOPS, BOTTOMS, T-SHIRTS, SWEATSHIRTS, HATS, SHORTS, SKIRTS, DRESSES, PANTS, SWIMWEAR, BEACHWEAR, JACKETS, COATS, GLOVES, SOCKS, SHOES, UNDERWEAR (U.S. CLS. 22 AND 39).

AISHA SALEM, EXAMINING ATTORNEY

SN 85-602,997. MERRICKS, MARTIN, OXNARD, CA. FILED 4-19-2012.



NO CLAIM IS MADE TO THE EXCLUSIVE RIGHT TO USE THE PICTORIAL REPRESENTATION OF THE AFRICAN CONTINENT, APART FROM THE MARK AS SHOWN. THE MARK CONSISTS OF AN OUTLINE OF THE CONTINENT OF AFRICA WITH A RISING SUN AND SUN RAYS INSIDE THE OUTLINE.

FOR BLAZERS; DRESS SHIRTS; HATS; POLO SHIRTS; T-SHIRTS; VESTS (U.S. CLS. 22 AND 39).

TARAH HARDY, EXAMINING ATTORNEY

SN 85-603,087. VQ GROUP INTERNATIONAL INCORPORATED, PORTLAND, OR. FILED 4-19-2012.

ALL CAPS

THE MARK CONSISTS OF STANDARD CHARACTERS WITHOUT CLAIM TO ANY PARTICULAR FONT, STYLE, SIZE, OR COLOR.

FOR FOOTWEAR (U.S. CLS. 22 AND 39).

FIRST USE 5-1-2011; IN COMMERCE 5-1-2011.

KYLE PEETE, EXAMINING ATTORNEY

CLASS 25—(Continued).

SN 85-603,106. NYGARD INTERNATIONAL PARTNERSHIP, WINNIPEG, MANITOBA, CANADA, FILED 4-19-2012.

HUG

THE MARK CONSISTS OF STANDARD CHARACTERS WITHOUT CLAIM TO ANY PARTICULAR FONT, STYLE, SIZE, OR COLOR.

FOR WOMEN'S CLOTHING, NAMELY JEANS (U.S. CLS. 22 AND 39).

KYLE PEETE, EXAMINING ATTORNEY

SN 85-603,108. VQ GROUP INTERNATIONAL INCORPORATED, PORTLAND, OR. FILED 4-19-2012.

TO BE ANNOUNCED

THE MARK CONSISTS OF STANDARD CHARACTERS WITHOUT CLAIM TO ANY PARTICULAR FONT, STYLE, SIZE, OR COLOR.

FOR FOOTWEAR (U.S. CLS. 22 AND 39).

FIRST USE 10-1-2011; IN COMMERCE 10-1-2011.

KYLE PEETE, EXAMINING ATTORNEY

SN 85-603,112. HERNANDEZ, JOSE, HOUSTON, TX. FILED 4-19-2012.

No Bullyz

THE MARK CONSISTS OF STANDARD CHARACTERS WITHOUT CLAIM TO ANY PARTICULAR FONT, STYLE, SIZE, OR COLOR.

FOR BEANIES; CAPS; DRESS SHIRTS; HEADBANDS; HOODED SWEATSHIRTS; JACKETS; PANTS; POLO SHIRTS; SANDALS; SHIRTS; SHOES; SHORTS; SOCKS; SWEATERS; SWEATPANTS; SWEATSHIRTS; T-SHIRTS; UNDERWEAR; VISORS; WRISTBANDS (U.S. CLS. 22 AND 39).

FIRST USE 10-1-2011; IN COMMERCE 10-1-2011.

KYLE PEETE, EXAMINING ATTORNEY

CLASS 25—(Continued).

SN 85-603,273. PAREDES, EMILIO E, MARTINEZ, CA. FILED 4-19-2012.

PURE CLOTHING COMPANY

THE MARK CONSISTS OF STANDARD CHARACTERS WITHOUT CLAIM TO ANY PARTICULAR FONT, STYLE, SIZE, OR COLOR.

NO CLAIM IS MADE TO THE EXCLUSIVE RIGHT TO USE "CLOTHING COMPANY", APART FROM THE MARK AS SHOWN.

FOR BOTTOMS; CREW NECKS; EYESHADES; HATS; HOODS; JACKETS; PANTS; SHIRTS; SHOES; SOCKS; SWEATERS; SWEATSHIRTS; SWIMWEAR; T-SHIRTS; TANK TOPS; TOPS; UNDERWEAR (U.S. CLS. 22 AND 39).

JOHN WILKE, EXAMINING ATTORNEY

CLASS 25—(Continued).

SN 85-603,383. JUSTIN STURGIS, DBA DEVASCE, ANTI-OCH, TN. FILED 4-20-2012.



THE MARK CONSISTS OF AN UPPER CASE "D" AND "V" WITH THE "D" OVERLAPPING THE "V" WITH THE NAME "DEVASCE" UNDERNEATH.

FOR JEANS; POLO SHIRTS; SHIRTS; SHORT-SLEEVED OR LONG-SLEEVED T-SHIRTS; SHORT-SLEEVED SHIRTS; T-SHIRTS; TEE SHIRTS (U.S. CLS. 22 AND 39).

EDWARD FENNESSY, EXAMINING ATTORNEY

SN 85-603,564. S.A.S.C.O. TRADING, INC., NEW YORK, NY. FILED 4-20-2012.

PACIFIC FLYER

THE MARK CONSISTS OF STANDARD CHARACTERS WITHOUT CLAIM TO ANY PARTICULAR FONT, STYLE, SIZE, OR COLOR.

FOR CLOTHING, NAMELY, JACKETS, COATS, SHORTS, SHIRTS, PANTS, T-SHIRTS, SWIM WEAR, UNDERGARMENTS, SWEATSHIRTS, SWEAT PANTS, JOGGING SUITS, CAPS AND VESTS (U.S. CLS. 22 AND 39).

FIRST USE 8-27-1999; IN COMMERCE 8-27-1999.
NATALIE POLZER, EXAMINING ATTORNEY

SN 85-603,329. VILOOM, LLC, LAS VEGAS, NV. FILED 4-20-2012.

VILOOM

THE MARK CONSISTS OF STANDARD CHARACTERS WITHOUT CLAIM TO ANY PARTICULAR FONT, STYLE, SIZE, OR COLOR.

FOR BEANIES; HATS; HEADWEAR; HOODS; SCARVES; SHAWLS; SHRUGS; SWEATERS; T-SHIRTS; VESTS (U.S. CLS. 22 AND 39).

FIRST USE 4-1-2012; IN COMMERCE 4-1-2012.
EDWARD FENNESSY, EXAMINING ATTORNEY

SN 85-603,602. CHIKASAWA, JENNY, CAMARILLO, CA. FILED 4-20-2012.

SUP Paddle Strong

THE MARK CONSISTS OF STANDARD CHARACTERS WITHOUT CLAIM TO ANY PARTICULAR FONT, STYLE, SIZE, OR COLOR.

NO CLAIM IS MADE TO THE EXCLUSIVE RIGHT TO USE "SUP", APART FROM THE MARK AS SHOWN.
FOR HATS; T-SHIRTS (U.S. CLS. 22 AND 39).

TINA L. SNAPP, EXAMINING ATTORNEY

CLASS 25—(Continued).

SN 85-603,616. BRADFORD, JACOB, SAN DIEGO, CA. FILED 4-20-2012.

BRO AWAY

THE MARK CONSISTS OF STANDARD CHARACTERS WITHOUT CLAIM TO ANY PARTICULAR FONT, STYLE, SIZE, OR COLOR.

FOR HATS; SWEATSHIRTS; T-SHIRTS (U.S. CLS. 22 AND 39).

FIRST USE 7-0-2009; IN COMMERCE 7-0-2009.
MARTHA FROMM, EXAMINING ATTORNEY

CLASS 25—(Continued).

SN 85-603,775. MIA SHOES, INC., MIAMI, FL. FILED 4-20-2012.

LOOK BY MIA

THE MARK CONSISTS OF STANDARD CHARACTERS WITHOUT CLAIM TO ANY PARTICULAR FONT, STYLE, SIZE, OR COLOR.

OWNER OF U.S. REG. NOS. 2,259,181, 3,572,409 AND OTHERS.

FOR FOOTWEAR (U.S. CLS. 22 AND 39).
ELIZABETH KAJUBI, EXAMINING ATTORNEY

SN 85-603,665. JAMES SON, VERNON, CA. FILED 4-20-2012.

BELAH & CODEY

THE MARK CONSISTS OF STANDARD CHARACTERS WITHOUT CLAIM TO ANY PARTICULAR FONT, STYLE, SIZE, OR COLOR.

FOR WOMEN'S CLOTHING, NAMELY, SHIRTS, DRESSES, SKIRTS, BLOUSES (U.S. CLS. 22 AND 39).

FIRST USE 4-10-2012; IN COMMERCE 4-10-2012.
JOHN HWANG, EXAMINING ATTORNEY

SN 85-604,010. CASS, PAMELA, FREDERICK, MD. FILED 4-20-2012.

DREAM BEAUTIFUL

THE MARK CONSISTS OF STANDARD CHARACTERS WITHOUT CLAIM TO ANY PARTICULAR FONT, STYLE, SIZE, OR COLOR.

FOR CLOTHING, NAMELY, FOOTWEAR, HEADWEAR, TOPS, BOTTOMS, SHIRTS, T-SHIRTS, HOODED SWEATSHIRTS, AND PANTS; WOMEN'S AND GIRLS' CLOTHING, NAMELY, SHIRTS, DRESSES, SKIRTS, BLOUSES (U.S. CLS. 22 AND 39).

ALLISON SCHRODY, EXAMINING ATTORNEY

SN 85-603,677. PANZA, GINO, ORLANDO, FL. FILED 4-20-2012.

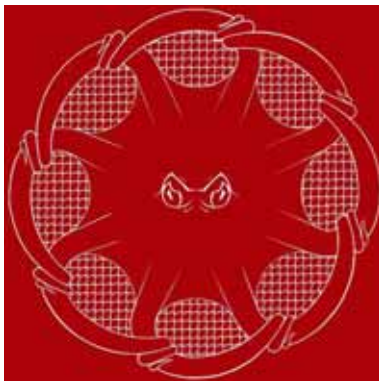

THE COLOR(S) RED AND WHITE IS/ARE CLAIMED AS A FEATURE OF THE MARK.

THE MARK CONSISTS OF AN OCTOPUS WITH EIGHT TENTACLES EXTENDING AND THAT ARE INTERCONNECTED THE CENTER OF THE OCTOPUS PRESENTS THE OCTOPUS' EYES AND BROW. THE OPEN SPACE BETWEEN THE MAIN BODY AND TENTACLES OF THE OCTOPUS PRESENTS A WHITE NET LIKE IMAGE. THE BODY AND TENTACLES OF THE OCTOPUS ARE RED.

FOR HATS; T-SHIRTS (U.S. CLS. 22 AND 39).
JOHN HWANG, EXAMINING ATTORNEY

SN 85-604,053. SRL, LLC, LEXINGTON, MA. FILED 4-20-2012.



OWNER OF U.S. REG. NOS. 1,236,944, 2,121,905 AND OTHERS.

THE MARK CONSISTS OF A SHADED HEART WITH "SR" IN THE MIDDLE OF THE HEART WITH THE WORDS "STRIDE RITE" ALONG THE BOTTOM RIGHT SIDE OF THE HEART.

FOR FOOTWEAR (U.S. CLS. 22 AND 39).
WILLIAM VERHOSEK, EXAMINING ATTORNEY

CLASS 25—(Continued).

SN 85-604,081. CURRINGTON, WILLIAM M., NASHVILLE, TN. FILED 4-20-2012.

BEER IS GOOD

THE MARK CONSISTS OF STANDARD CHARACTERS WITHOUT CLAIM TO ANY PARTICULAR FONT, STYLE, SIZE, OR COLOR.

FOR CLOTHING, NAMELY, SHIRTS, T-SHIRTS, TOPS, JERSEYS, SWEATSHIRTS, PANTS, SWEATPANTS, SHORTS; HEADWEAR; CAPS; HATS; VISORS; BANDANAS; GLOVES; SCARVES; FOOTWEAR; HOSIERY (U.S. CLS. 22 AND 39).

AHSEN KHAN, EXAMINING ATTORNEY

CLASS 25—(Continued).

SN 85-604,387. JERRY CROUCH, EL CAJON, CA. FILED 4-20-2012.

OVERLAND TRAILS

THE MARK CONSISTS OF STANDARD CHARACTERS WITHOUT CLAIM TO ANY PARTICULAR FONT, STYLE, SIZE, OR COLOR.

FOR BEANIES; GLOVES; HATS; PANTS; SHIRTS; SKI PANTS; SKI WEAR; SNOW PANTS; SNOWBOARD PANTS; THERMAL UNDERWEAR (U.S. CLS. 22 AND 39).

DAVID MURRAY, EXAMINING ATTORNEY

SN 85-604,141. NH3 SERVICE COMPANY, SALINAS, CA. FILED 4-20-2012.

ROOT ZONE

THE MARK CONSISTS OF STANDARD CHARACTERS WITHOUT CLAIM TO ANY PARTICULAR FONT, STYLE, SIZE, OR COLOR.

FOR ATHLETIC APPAREL, NAMELY, SHIRTS, PANTS, JACKETS, FOOTWEAR, HATS AND CAPS, ATHLETIC UNIFORMS (U.S. CLS. 22 AND 39).

KERI CANTONE, EXAMINING ATTORNEY

SN 85-604,388. PEACOCK EXPRESSIONS, LLC, TALLAHASSEE, FL. FILED 4-20-2012.



THE STIPPLING IS FOR SHADING PURPOSES ONLY. THE MARK CONSISTS OF AN ANIMATED PEACOCK, STANDING IN A CIRCLE WITH THE "LIVE LIFE CRAZY!" PHRASE UNDERNEATH THE CIRCLE.

FOR WEARABLE GARMENTS AND CLOTHING, NAMELY, SHIRTS (U.S. CLS. 22 AND 39).

NAKWAMA ANKRAH, EXAMINING ATTORNEY

SN 85-604,259. XTRACTION INC., SURFSIDE BEACH, SC. FILED 4-20-2012.



THE MARK CONSISTS OF A STYLIZED LETTER "X" WITH A FISH SKELETON MAKING UP THE CROSSMARK OF THE "X".

FOR HATS; SHORTS; T-SHIRTS (U.S. CLS. 22 AND 39). FIRST USE 2-1-2012; IN COMMERCE 2-1-2012.

ALEXANDER L. POWERS, EXAMINING ATTORNEY

SN 85-604,558. SUBLITEX, INC., VERNON, CA. FILED 4-21-2012.

FRENCH BAZAAR

THE MARK CONSISTS OF STANDARD CHARACTERS WITHOUT CLAIM TO ANY PARTICULAR FONT, STYLE, SIZE, OR COLOR.

FOR CLOTHING FOR MEN, WOMEN AND CHILDREN, NAMELY, SHIRTS, T-SHIRTS, DRESSES, KNIT BOTTOMS, SKIRTS, SWEATERS, JEANS, PANTS, HATS, SCARVES, SOCKS, TIGHTS AND JACKETS (U.S. CLS. 22 AND 39).

AMY HELLA, EXAMINING ATTORNEY

CLASS 25—(Continued).

SN 85-604,566. VIGIL, RUSSELL E., DENVER, CO. FILED 4-21-2012.



THE MARK CONSISTS OF "CHOLO POLO" ABOVE THE DESIGN OF A CAR SHOWING THE DRIVER LEANING OUT THE DRIVER SIDE WINDOW WITH AN UPRAISED MALLETT IN THE RIGHT HAND.

FOR T-SHIRTS (U.S. CLS. 22 AND 39).
SETH A. RAPPAPORT, EXAMINING ATTORNEY

CLASS 25—(Continued).

SN 85-604,651. GARIPPO, MARY C., BOSTON, MA. FILED 4-21-2012.

COME TOGETHER IN STYLE

THE MARK CONSISTS OF STANDARD CHARACTERS WITHOUT CLAIM TO ANY PARTICULAR FONT, STYLE, SIZE, OR COLOR.

FOR HATS; HATS FOR INFANTS, BABIES, TODDLERS AND CHILDREN; HEADGEAR, NAMELY, HATS, SCARVES, HEADBANDS; T-SHIRTS; T-SHIRTS FOR INFANTS, CHILDREN, ADULTS; TANK TOPS; YOGA SHIRTS (U.S. CLS. 22 AND 39).

CHERYL CLAYTON, EXAMINING ATTORNEY

SN 85-604,636. PARISI, JOSEPH A., MIDDLE GROVE, NY. FILED 4-21-2012.

Par 5

THE MARK CONSISTS OF STANDARD CHARACTERS WITHOUT CLAIM TO ANY PARTICULAR FONT, STYLE, SIZE, OR COLOR.

FOR ATHLETIC APPAREL, NAMELY, SHIRTS, PANTS, JACKETS, FOOTWEAR, HATS AND CAPS, ATHLETIC UNIFORMS; BOW TIES; GOLF CAPS; GOLF CLEATS; GOLF PANTS, SHIRTS AND SKIRTS; GOLF SHIRTS; GOLF SHOES; GOLF SHORTS; GOLF SPIKES; GOLF TROUSERS; KNICKERS; MEN'S DRESS SOCKS; MEN'S SOCKS; PLUS FOURS; SOCKS; TIES (U.S. CLS. 22 AND 39).

FIRST USE 6-1-2002; IN COMMERCE 6-1-2002.
GIANCARLO CASTRO, EXAMINING ATTORNEY

SN 85-604,690. REPENT CLOTHING LIMITED, VANCOUVER, BC, CANADA, FILED 4-22-2012.

REPENT

SN 85-604,643. COOL COUTURE LLC, ELIZABETHTOWN, KY. FILED 4-21-2012.



NO CLAIM IS MADE TO THE EXCLUSIVE RIGHT TO USE "COUTURE", APART FROM THE MARK AS SHOWN.

THE MARK CONSISTS OF THE WORD "COOL" WITH THE LETTER "C" LOOPED IN THE LETTER "O". THE LETTER "O" LOOPED IN THE LETTER "O". THE LETTER "O" LOOPED TO THE LETTER "L" WITH THE WORD "COUTURE" UNDER THE WORD "COOL", ALL IN UPPER-CASE.

FOR MEN'S AND WOMEN'S JACKETS, COATS, TROUSERS, VESTS; T-SHIRTS FOR MEN, WOMEN, YOUTH (U.S. CLS. 22 AND 39).

FIRST USE 2-14-2012; IN COMMERCE 2-14-2012.
GIANCARLO CASTRO, EXAMINING ATTORNEY

THE MARK CONSISTS OF STANDARD CHARACTERS WITHOUT CLAIM TO ANY PARTICULAR FONT, STYLE, SIZE, OR COLOR.

FOR SHIRTS, JACKETS, HOODED JACKETS, T-SHIRTS, CAPS, HATS, TOQUES, SWEATERS, SHIRTS, JERSEYS, SWEAT SHIRTS, PANTS, SWEAT PANTS, TANK TOPS, SHORTS (U.S. CLS. 22 AND 39).

BILL DAWE, EXAMINING ATTORNEY

CLASS 25—(Continued).

SN 85-604,695. MODICA, KEENAN E.J., PINOLE, CA. AND COLUNDA MODICA, PINOLE, CA. FILED 4-22-2012.

Walking Mannequin

THE MARK CONSISTS OF STANDARD CHARACTERS WITHOUT CLAIM TO ANY PARTICULAR FONT, STYLE, SIZE, OR COLOR.

FOR BUTTON DOWN SHIRTS; CLOTHING FOR BABIES, TODDLERS AND CHILDREN, TREATED WITH FIRE AND HEAT RETARDANTS, NAMELY, PAJAMAS, JACKETS, SHIRTS, PANTS, JUMPERS; CLOTHING SHIELDS, NAMELY, PADS APPLIED TO THE UNDER-ARMS OF SHIRTS, BLOUSES AND SWEATERS; COLLARED SHIRTS; DRESS PANTS; DRESS SHIRTS; DRESS SUITS; DRESSES; DRESSES MADE FROM SKINS; DRESSING GOWNS; DRESSING GOWNS AND BATH ROBES; EVENING DRESSES; GOLF PANTS, SHIRTS AND SKIRTS; HOODED SWEAT SHIRTS; JUMPER DRESSES; KNIT DRESSES; KNIT SHIRTS; LONG-SLEEVED SHIRTS; MEN'S DRESS SOCKS; NIGHT SHIRTS; OPEN-NECKED SHIRTS; OVER SHIRTS; PIQUE SHIRTS; POLO SHIRTS; RUGBY SHIRTS; SHIRTS AND SHORT-SLEEVED SHIRTS; SHIRTS FOR INFANTS, BABIES, TODDLERS AND CHILDREN; SHIRTS FOR SUITS; SHORT-SLEEVED OR LONG-SLEEVED T-SHIRTS; SHORT-SLEEVED SHIRTS; SKIRTS AND DRESSES; SLEEP SHIRTS; SWEAT SHIRTS; T-SHIRTS; WEARABLE GARMENTS AND CLOTHING, NAMELY, SHIRTS; WOMEN'S CEREMONIAL DRESSES; WOMEN'S CLOTHING, NAMELY, SHIRTS, DRESSES, SKIRTS, BLOUSES; WOVEN DRESSES (U.S. CLS. 22 AND 39).

LUCY ARANT, EXAMINING ATTORNEY

SN 85-604,702. MOORE, MAURICE, WICHITA, KS. FILED 4-22-2012.

Ten Tiny Toes

THE MARK CONSISTS OF STANDARD CHARACTERS WITHOUT CLAIM TO ANY PARTICULAR FONT, STYLE, SIZE, OR COLOR.

FOR FOOTWEAR (U.S. CLS. 22 AND 39).

BILL DAWE, EXAMINING ATTORNEY

CLASS 25—(Continued).

SN 85-604,729. FISHBIRD PRODUCTIONS, INC., ATLANTA, GA. FILED 4-22-2012.

Feeling Ishy?

THE MARK CONSISTS OF STANDARD CHARACTERS WITHOUT CLAIM TO ANY PARTICULAR FONT, STYLE, SIZE, OR COLOR.

FOR ATHLETIC APPAREL, NAMELY, SHIRTS, PANTS, JACKETS, FOOTWEAR, HATS AND CAPS, ATHLETIC UNIFORMS; BEACHWEAR; JACKETS; PAJAMAS; SWEATSHIRTS; SWIM WEAR; T-SHIRTS; UNDERWEAR (U.S. CLS. 22 AND 39).

CHRISTINE MARTIN, EXAMINING ATTORNEY

SN 85-604,767. KAYES, SHANNON, LIVERMORE, CA. FILED 4-22-2012.

HOT PACKAGE

THE MARK CONSISTS OF STANDARD CHARACTERS WITHOUT CLAIM TO ANY PARTICULAR FONT, STYLE, SIZE, OR COLOR.

FOR UNDERWEAR, FOOT SOCKS, T-SHIRTS, SLEEPWEAR, PANTS, JACKETS, HAND GLOVES, SHORTS, SWEATSHIRTS, ATHLETIC SHIRTS, HEADWEAR, FOOTWEAR (U.S. CLS. 22 AND 39).

KATHLEEN M. VANSTON, EXAMINING ATTORNEY

SN 85-604,779. LOST BOYS, MARTINEZ, CA. FILED 4-22-2012.

Hella Positive

THE MARK CONSISTS OF STANDARD CHARACTERS WITHOUT CLAIM TO ANY PARTICULAR FONT, STYLE, SIZE, OR COLOR.

FOR CREW NECKS; HATS; SHORTS; SOCKS; SWEAT SHIRTS; T-SHIRTS (U.S. CLS. 22 AND 39).

JORDAN BAKER, EXAMINING ATTORNEY

CLASS 25—(Continued).

SN 85-604,853. PAICH, JASON J., SAN FRANCISCO, CA. FILED 4-23-2012.



THE MARK CONSISTS OF A FACE WITH TWO POINTS THAT ARE EARS WITH TWO SLIGHTLY ANGLED EYES AND A SLIGHTLY OPENED MOUTH.

FOR ATHLETIC SHOES; BEANIES; BOXER SHORTS; HATS; JACKETS; KNITTED CAPS; PANTIES, SHORTS AND BRIEFS; PANTS; SHORTS; SOCKS; SWEATSHIRTS; SWEATSUITS; SWIMWEAR; T-SHIRTS; TENNIS SHOES; UNDERWEAR (U.S. CLS. 22 AND 39).

FIRST USE 1-1-2012; IN COMMERCE 1-21-2012.
JULIE WATSON, EXAMINING ATTORNEY

SN 85-604,855. HELEN TRAN, LOS ANGELES, CA. FILED 4-23-2012.



OWNER OF U.S. REG. NO. 3,244,456.
NO CLAIM IS MADE TO THE EXCLUSIVE RIGHT TO USE "JEANS", APART FROM THE MARK AS SHOWN.

THE COLOR(S) RED, SILVER, YELLOW, AND BLUE IS/ ARE CLAIMED AS A FEATURE OF THE MARK.

THE MARK CONSISTS OF THE WORDING "SD SILVER DIVA JEANS", IN WHICH THE LETTERS "S","D" APPEAR IN RED STYLIZED FONT ON A SILVER BACKGROUND, THE WORDS "SILVER DIVA" APPEAR IN RED STYLIZED FONT ON A SILVER RECTANGLE, AND THE WORD "JEANS" APPEARS IN RED STYLIZED FONT ON A YELLOW, BLUE, AND RED STRIPED RECTANGLE.

FOR BERMUDA SHORTS; BLOUSES; CAPRI PANTS; COATS; DENIM JACKETS; DENIMS; DRESSES; JACKETS; PANTS; SHIRTS; SHORTS; SWEATERS; T-SHIRTS; TANK TOPS (U.S. CLS. 22 AND 39).

JASON LOTT, EXAMINING ATTORNEY

CLASS 25—(Continued).

SN 85-604,867. MATTHEW R. BUXBAUM, RIVERDALE, NY. FILED 4-23-2012.

Calidelphia

THE MARK CONSISTS OF STANDARD CHARACTERS WITHOUT CLAIM TO ANY PARTICULAR FONT, STYLE, SIZE, OR COLOR.

FOR ATHLETIC APPAREL, NAMELY, SHIRTS, PANTS, JACKETS, FOOTWEAR, HATS AND CAPS, ATHLETIC UNIFORMS (U.S. CLS. 22 AND 39).

ALLISON SCHRODY, EXAMINING ATTORNEY

SN 85-604,891. LAWMAN HOLDINGS LIMITED, ROAD TOWN, TORTOLA, BR.VIRGIN ISLANDS, FILED 4-23-2012.

HEART OF STONE

THE MARK CONSISTS OF STANDARD CHARACTERS WITHOUT CLAIM TO ANY PARTICULAR FONT, STYLE, SIZE, OR COLOR.

FOR WEARING APPAREL, NAMELY, JEANS, PANTS, SHORTS, SKIRTS, JACKETS, OUTERWEAR IN THE NATURE OF VESTS, SWEATERS, SWEATSHIRTS, LONG SLEEVE SHIRTS, AND COATS, WOVEN SHIRTS, T-SHIRTS, BLOUSES, DRESSES, HATS, HEADWEAR, BELTS AND FOOTWEAR (U.S. CLS. 22 AND 39).

REBECCA SMITH, EXAMINING ATTORNEY

SN 85-604,999. RAMIREZ, MICHAEL, LOMITA, CA. FILED 4-23-2012.

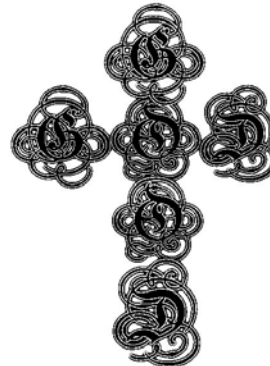

THE MARK CONSISTS OF A STYLIZED CROSS CONSISTING OF SIX DISTINCT DESIGNS. ON EACH DESIGN IS A LETTER. THE LETTERS READ "GOOD" VERTICALLY, AND "GOD" HORIZONTALLY, WITH A SINGLE LETTER "O" BEING SHARED BY BOTH WORDS.

FOR BEANIES; BELTS; BLOUSES; DRESS SHIRTS; HATS; JACKETS; PANTS; SHIRTS; SHOES; SWEATERS (U.S. CLS. 22 AND 39).

ELLEN PERKINS, EXAMINING ATTORNEY

CLASS 25—(Continued).

SN 85-605,007. FLETCHER, JERROD, ALACHUA, FL. FILED 4-23-2012.

Unapologetically Southern

THE MARK CONSISTS OF STANDARD CHARACTERS WITHOUT CLAIM TO ANY PARTICULAR FONT, STYLE, SIZE, OR COLOR.

FOR HATS; PANTS; SHIRTS; SWEAT SHIRTS (U.S. CLS. 22 AND 39).

FIRST USE 6-14-2011; IN COMMERCE 6-14-2011.

ERIN FALK, EXAMINING ATTORNEY

SN 85-605,022. SPANGENBERG, MICHAEL, CHANDLER, AZ. FILED 4-23-2012.



THE MARK CONSISTS OF AN OUTLINE OF THE STATE OF ARIZONA WITH THE STYLIZED TEXT "STATE FORTY EIGHT" INSIDE.

FOR T-SHIRTS (U.S. CLS. 22 AND 39).

LINDA MICKLEBURGH, EXAMINING ATTORNEY

SN 85-605,048. THANARITIROJ, MAESA, LONG BEACH, CA. FILED 4-23-2012.

**daddy fit - mommy fit -
fit mommy - fit daddy**

THE MARK CONSISTS OF STANDARD CHARACTERS WITHOUT CLAIM TO ANY PARTICULAR FONT, STYLE, SIZE, OR COLOR.

FOR HATS; HEADBANDS; JACKETS; LEGGINGS; SHORTS; SWEATPANTS; SWEATSHIRTS; T-SHIRTS; TANK TOPS; TIGHTS; VISORS (U.S. CLS. 22 AND 39).

LINDA MICKLEBURGH, EXAMINING ATTORNEY

CLASS 25—(Continued).

SN 85-605,146. RODRIGUEZ, CARLOS, IRVINE, CA. FILED 4-23-2012.

ORIGINAL SIN FREE

THE MARK CONSISTS OF STANDARD CHARACTERS WITHOUT CLAIM TO ANY PARTICULAR FONT, STYLE, SIZE, OR COLOR.

FOR ATHLETIC APPAREL, NAMELY, SHIRTS, PANTS, JACKETS, FOOTWEAR, HATS AND CAPS, ATHLETIC UNIFORMS (U.S. CLS. 22 AND 39).

BILL DAWE, EXAMINING ATTORNEY

SN 85-605,190. SOCK AND ACCESSORY BRANDS GLOBAL, INC., MOCKSVILLE, NC. FILED 4-23-2012.

SOCKAROOS

THE MARK CONSISTS OF STANDARD CHARACTERS WITHOUT CLAIM TO ANY PARTICULAR FONT, STYLE, SIZE, OR COLOR.

FOR HOSIERY; SOCKS (U.S. CLS. 22 AND 39).

KIM MONINGHOFF, EXAMINING ATTORNEY

SN 85-605,300. S2N, INC, JERICO, NY. FILED 4-23-2012.

Purple Stitch

THE MARK CONSISTS OF STANDARD CHARACTERS WITHOUT CLAIM TO ANY PARTICULAR FONT, STYLE, SIZE, OR COLOR.

FOR BODY SHIRTS; COLLARED SHIRTS; DRESS SHIRTS; KNIT SHIRTS; LONG-SLEEVED SHIRTS; NIGHT SHIRTS; OPEN-NECKED SHIRTS; POLO SHIRTS; SHIRTS; SHIRTS AND SHORT-SLEEVED SHIRTS; SHIRTS FOR SUITS; SPORT SHIRTS; SPORTS SHIRTS; SPORTS SHIRTS WITH SHORT SLEEVES (U.S. CLS. 22 AND 39).

CHERYL CLAYTON, EXAMINING ATTORNEY

CLASS 25—(Continued).

SN 85-605,377. HEALTH INTERNATIONAL CORPORATION,
ST. PETERSBURG, FL. FILED 4-23-2012.

HYPERACTIVE

THE MARK CONSISTS OF STANDARD CHARACTERS
WITHOUT CLAIM TO ANY PARTICULAR FONT, STYLE,
SIZE, OR COLOR.

OWNER OF U.S. REG. NOS. 2,610,418, 3,087,936 AND
3,236,133.

FOR ATHLETIC APPAREL, NAMELY, SHIRTS,
PANTS, JACKETS, FOOTWEAR, HATS AND CAPS,
ATHLETIC UNIFORMS; SHORTS; SOCKS; SWEAT-
SHIRTS; TOPS (U.S. CLS. 22 AND 39).

FIRST USE 1-2-2004; IN COMMERCE 1-2-2004.
LINDA ESTRADA, EXAMINING ATTORNEY

CLASS 25—(Continued).

SN 85-605,865. GARCIA, ABRAM, HEMET, CA. FILED 4-23-
2012.

SMOKAN REALM

THE MARK CONSISTS OF STANDARD CHARACTERS
WITHOUT CLAIM TO ANY PARTICULAR FONT, STYLE,
SIZE, OR COLOR.

FOR HATS; SHORTS; SWEATERS; T-SHIRTS (U.S.
CLS. 22 AND 39).

MICHAEL KEATING, EXAMINING ATTORNEY

SN 85-605,431. CASSANDRA ATHERTON, NEW YORK, NY.
FILED 4-23-2012.

La Maison Sacre

THE MARK CONSISTS OF STANDARD CHARACTERS
WITHOUT CLAIM TO ANY PARTICULAR FONT, STYLE,
SIZE, OR COLOR.

THE ENGLISH TRANSLATION OF "LA MAISON SACRE"
IN THE MARK IS "THE SACRED HOME".

FOR BABY BIBS NOT OF PAPER; BABY BODYSUITS;
BABY BOTTOMS; BABY BUNTING; BABY LAYETTES
FOR CLOTHING; BABY TOPS; HATS FOR INFANTS,
BABIES, TODDLERS AND CHILDREN; SCARVES;
SHIRTS FOR INFANTS, BABIES, TODDLERS AND
CHILDREN (U.S. CLS. 22 AND 39).

TRACY FLETCHER, EXAMINING ATTORNEY

SN 85-605,937. HAMPSHIRE GROUP, LIMITED, ANDER-
SON, SC. FILED 4-23-2012.

IQ INHERENT QUALITIES

THE MARK CONSISTS OF STANDARD CHARACTERS
WITHOUT CLAIM TO ANY PARTICULAR FONT, STYLE,
SIZE, OR COLOR.

FOR CLOTHING NAMELY, KNIT AND WOVEN TOPS,
LONG AND SHORT SLEEVE BUTTON DOWN SHIRTS,
POLOS, HENLEYS, T-SHIRTS AND FLEECE TOPS (U.S.
CLS. 22 AND 39).

RENEE MCCRAY, EXAMINING ATTORNEY

SN 85-605,745. JOHNSON, JEREMY, KEITHVILLE, LA.
FILED 4-23-2012.



THE MARK CONSISTS OF THE STYLIZED TEXT "T".
FOR T-SHIRTS (U.S. CLS. 22 AND 39).
FIRST USE 8-0-2007; IN COMMERCE 10-0-2010.
CHRISTINA SOBRAL, EXAMINING ATTORNEY

SN 85-605,940. ROTHCHILD, DEBORAH, MORGANVILLE,
NJ. FILED 4-23-2012.

**One Bib A Day Keeps The
Moisture Away**

THE MARK CONSISTS OF STANDARD CHARACTERS
WITHOUT CLAIM TO ANY PARTICULAR FONT, STYLE,
SIZE, OR COLOR.

FOR BIBS NOT OF PAPER (U.S. CLS. 22 AND 39).
B. PARADEWELAI, EXAMINING ATTORNEY

CLASS 25—(Continued).

SN 85-605,968. DEEP BLUE SEA HOLDINGS, LLC, IRVINE, CA. FILED 4-23-2012.

POONSHINE

THE MARK CONSISTS OF STANDARD CHARACTERS WITHOUT CLAIM TO ANY PARTICULAR FONT, STYLE, SIZE, OR COLOR.
FOR BELTS FOR CLOTHING; JACKETS; PANTS; SHORTS (U.S. CLS. 22 AND 39).
DORITT L. CARROLL, EXAMINING ATTORNEY

SN 85-607,023. DASE CLOTHING COMPANY, HIALEAH, FL. FILED 4-24-2012.



THE MARK CONSISTS OF THE STYLIZED TEXT "DASE". THE LETTER "D" HAS A FLAG TRAILING FROM THE STEM OF THE LETTER THAT EXTENDS ABOVE THE LETTERS "AS". THE FLAG SPLITS INTO THREE POINTS AT THE END. IN THE CENTER OF THE "D" IS A DOT. AT THE BOTTOM RIGHT OF THE DOT IS A SMALL CIRCLE CREATED BY NEGATIVE SPACE. THIS IMAGE AS A WHOLE REPRESENTS AN EYE. THE LETTERS "S" AND "E" ARE ROTATED AT DIFFERENT ANGLES.

THE WORDING DASE HAS NO MEANING IN A FOREIGN LANGUAGE.
FOR BOTTOMS; BUTTON DOWN SHIRTS; CAPRIS; CREW NECKS; DRESS SHIRTS; HATS; HOODED SWEAT SHIRTS; JEANS; LEGGINGS; POLO SHIRTS; SHIRTS; SHORTS; SKULLIES; SOCKS; T-SHIRTS; TANK TOPS; TOPS; TUBE TOPS; TUNICS; TURTLENECK SWEATERS; UNDERWEAR (U.S. CLS. 22 AND 39).
FIRST USE 7-31-2011; IN COMMERCE 8-31-2011.
ODESSA BIBBINS, EXAMINING ATTORNEY

CLASS 25—(Continued).

SN 85-607,259. WATSON, LEE YOUNG, NEWPORT BEACH, CA. FILED 4-24-2012.

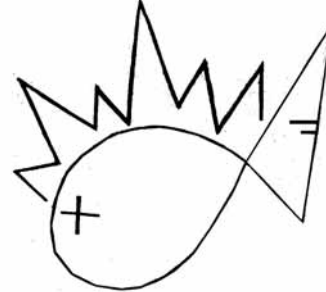

THE MARK CONSISTS OF AN OUTLINE OF A FISH AND WITH A LARGE FIN OUT LINE.THERE ARE 2 LINES GOING HORIZONTAL ON THE FIN AND A X FOR A EYE. AN OUTLINE OF A MOHAWK GOING FROM THE TOP ON THE FISH TOWARDS THE FIN.
FOR BATHING SUITS; BEANIES; DRESSES; HATS; JEANS; PANTS; SANDALS; SHIRTS; SHOES; SHORTS; SKIRTS; SOCKS; SWEATERS; T-SHIRTS; TANK TOPS (U.S. CLS. 22 AND 39).
FIRST USE 8-11-1991; IN COMMERCE 11-11-2009.
JENNY PARK, EXAMINING ATTORNEY

SN 85-607,265. BOSCO, NICOLE, MAHOPAC, NY. FILED 4-24-2012.

Without Leashes

THE MARK CONSISTS OF STANDARD CHARACTERS WITHOUT CLAIM TO ANY PARTICULAR FONT, STYLE, SIZE, OR COLOR.
FOR SWEATPANTS; SWEATSHIRTS; T-SHIRTS; TANK TOPS (U.S. CLS. 22 AND 39).
KATHERINE CHANG, EXAMINING ATTORNEY

SN 85-607,499. MIRTO CORPORACIÓN EMPRESARIAL, S.L., 28037 MADRID, SPAIN, FILED 4-25-2012.

LIZA

THE MARK CONSISTS OF STANDARD CHARACTERS WITHOUT CLAIM TO ANY PARTICULAR FONT, STYLE, SIZE, OR COLOR.
OWNER OF SPAIN REG. NO. 0382724, DATED 5-18-1961, EXPIRES 5-18-2021.
OWNER OF U.S. REG. NO. 3,111,713.
THE NAME(S), PORTRAIT(S), AND/OR SIGNATURE(S) SHOWN IN THE MARK DOES NOT IDENTIFY A PARTICULAR LIVING INDIVIDUAL.
FOR SHIRTS EXCLUDING KNIT SHIRTS (U.S. CLS. 22 AND 39).
JOHN WILKE, EXAMINING ATTORNEY

CLASS 25—(Continued).

SN 85-608,041. PROPPER INTERNATIONAL SALES, INC.,
WELDON SPRING, MO. FILED 4-25-2012.

PROPPER INDEPENDENT

THE MARK CONSISTS OF STANDARD CHARACTERS
WITHOUT CLAIM TO ANY PARTICULAR FONT, STYLE,
SIZE, OR COLOR.

OWNER OF U.S. REG. NOS. 2,134,684, 3,705,860 AND
OTHERS.

FOR CLOTHING, NAMELY, HATS, VISORS, GLOVES,
BELTS, PANTS, JEANS, SHIRTS, SHORTS, VESTS,
COATS, JACKETS, PONCHOS, COVERALLS, OVER-
ALLS, UNDERWEAR, SWEATERS, AND FOOTWEAR
(U.S. CLS. 22 AND 39).

FRANK LATTUCA, EXAMINING ATTORNEY

SN 85-608,084. PROPPER INTERNATIONAL SALES, INC.,
WELDON SPRING, MO. FILED 4-25-2012.

PROPPER CHAMBER

THE MARK CONSISTS OF STANDARD CHARACTERS
WITHOUT CLAIM TO ANY PARTICULAR FONT, STYLE,
SIZE, OR COLOR.

OWNER OF U.S. REG. NOS. 2,134,684, 3,705,860 AND
OTHERS.

FOR CLOTHING, NAMELY, HATS, VISORS, GLOVES,
BELTS, PANTS, JEANS, SHIRTS, SHORTS, VESTS,
COATS, JACKETS, PONCHOS, COVERALLS, OVER-
ALLS, UNDERWEAR, SWEATERS, AND FOOTWEAR
(U.S. CLS. 22 AND 39).

FRANK LATTUCA, EXAMINING ATTORNEY

SN 85-608,092. PROPPER INTERNATIONAL SALES, INC.,
WELDON SPRING, MO. FILED 4-25-2012.

PROPPER GAUGE

THE MARK CONSISTS OF STANDARD CHARACTERS
WITHOUT CLAIM TO ANY PARTICULAR FONT, STYLE,
SIZE, OR COLOR.

OWNER OF U.S. REG. NOS. 2,134,684, 3,705,860 AND
OTHERS.

FOR CLOTHING, NAMELY, HATS, VISORS, GLOVES,
BELTS, PANTS, JEANS, SHIRTS, SHORTS, VESTS,
COATS, JACKETS, PONCHOS, COVERALLS, OVER-
ALLS, UNDERWEAR, SWEATERS, AND FOOTWEAR
(U.S. CLS. 22 AND 39).

FRANK LATTUCA, EXAMINING ATTORNEY

CLASS 25—(Continued).

SN 85-608,195. PROPPER INTERNATIONAL SALES, INC.,
WELDON SPRING, MO. FILED 4-25-2012.

PROPPER GRIP

THE MARK CONSISTS OF STANDARD CHARACTERS
WITHOUT CLAIM TO ANY PARTICULAR FONT, STYLE,
SIZE, OR COLOR.

OWNER OF U.S. REG. NOS. 2,134,684, 2,435,882 AND
3,705,860.

FOR CLOTHING, NAMELY, HATS, VISORS, GLOVES,
BELTS, PANTS, JEANS, SHIRTS, SHORTS, VESTS,
COATS, JACKETS, PONCHOS, COVERALLS, OVER-
ALLS, UNDERWEAR, SWEATERS, AND FOOTWEAR
(U.S. CLS. 22 AND 39).

FRANK LATTUCA, EXAMINING ATTORNEY

SN 85-608,527. ZENIMAX MEDIA INC., ROCKVILLE, MD.
FILED 4-25-2012.

REVENGE SOLVES EVERYTHING

THE MARK CONSISTS OF STANDARD CHARACTERS
WITHOUT CLAIM TO ANY PARTICULAR FONT, STYLE,
SIZE, OR COLOR.

FOR CLOTHING, NAMELY, T-SHIRTS, SHIRTS,
SWEATSHIRTS, FLEECE PULLOVERS; HEADWEAR,
NAMELY, HATS (U.S. CLS. 22 AND 39).

ROBERT STRUCK, EXAMINING ATTORNEY

SN 85-608,778. GELMART INDUSTRIES INC., AKA GEL-
MART INTERNATIONAL, NEW YORK, NY. FILED 4-26-
2012.

TOO COOL FOR ATTITUDE

THE MARK CONSISTS OF STANDARD CHARACTERS
WITHOUT CLAIM TO ANY PARTICULAR FONT, STYLE,
SIZE, OR COLOR.

FOR CLOTHING, NAMELY, PANTS, SHORTS,
SWEATPANTS, SHIRTS, TEE-SHIRTS, SWEATSHIRTS,
BLOUSES, SKIRTS, LINGERIE, SLEEPWEAR, LOUNGE-
WEAR, SWIMWEAR, SOCKS, HOSIERY, BRAS, PAN-
TIES, SLIPS, MERRY WIDOWS, CAMISOLES, PAJAMAS,
NIGHTGOWNS, ROBES, TEDDIES, BODYSUITS, TAP
PANTS, PAREOS, SARONGS, GARTER BELTS, STOCK-
INGS, PANTYHOSE, UNDERWEAR, FOOTIES AND
TIGHTS (U.S. CLS. 22 AND 39).

MARK T. MULLEN, EXAMINING ATTORNEY

CLASS 25—(Continued).

SN 85-611,995. PERKINS GROUP PROPERTIES-CHINA, LLC, BELLEVUE, WA. FILED 4-30-2012.

ZBX

THE MARK CONSISTS OF STANDARD CHARACTERS WITHOUT CLAIM TO ANY PARTICULAR FONT, STYLE, SIZE, OR COLOR.

FOR FOOTWEAR, NAMELY BOOTS, SHOES, SNEAKERS, ATHLETIC SHOES, SLIPPERS, SOCKS AND SANDALS (U.S. CLS. 22 AND 39).

CHRISIE B. KING, EXAMINING ATTORNEY

SN 85-613,315. MCCC SPORTSWEAR, INC., LOVELAND, OH. FILED 5-1-2012.

MCCC SPORT

THE MARK CONSISTS OF STANDARD CHARACTERS WITHOUT CLAIM TO ANY PARTICULAR FONT, STYLE, SIZE, OR COLOR.

OWNER OF U.S. REG. NO. 2,300,621.

NO CLAIM IS MADE TO THE EXCLUSIVE RIGHT TO USE "SPORT". APART FROM THE MARK AS SHOWN.

FOR FLEECE TOPS; FLEECE PULLOVERS; FLEECE JACKETS; T-SHIRTS, SOCKS, SLIPPERS, SLEEPWEAR, BOXER SHORTS, HATS, BEANIES, GLOVES (U.S. CLS. 22 AND 39).

FIRST USE 9-30-2003; IN COMMERCE 9-30-2003. CHRISTINE MARTIN, EXAMINING ATTORNEY

SN 85-614,635. ZENIMAX MEDIA INC., ROCKVILLE, MD. FILED 5-2-2012.



THE MARK CONSISTS OF A THREE HEADED CREATURE SWALLOWING ITS OWN TAILS CREATING A CIRCLE.

FOR CLOTHING, NAMELY, T-SHIRTS, SHIRTS, SWEATSHIRTS, FLEECE PULLOVERS; HEADWEAR, NAMELY, HATS (U.S. CLS. 22 AND 39).

ROBERT STRUCK, EXAMINING ATTORNEY

CLASS 25—(Continued).

SN 85-615,002. VANITY SHOP OF GRAND FORKS, INC., FARGO, ND. FILED 5-2-2012.

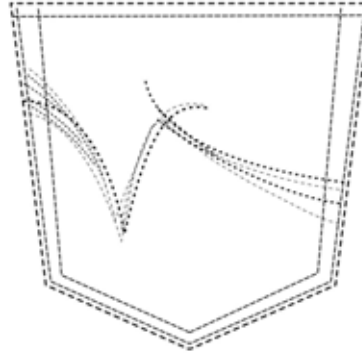

THE MARK CONSISTS OF A STYLIZED LETTER "V" DESIGN IN THE LEFT PORTION OF A JEAN POCKET AND DEPICTED BY SEVEN STITCHED LINES. TO THE RIGHT OF THE LETTER "V", FOUR STITCHED CURVED LINES ARE PRESENT, WITH THE TOP OF THE FOUR LINES INTERSECTING THE TOP OF THE RIGHT PORTION OF THE LETTER "V" AND SWOOPING DOWN, TO THE RIGHT. THE DOTTED LINES FORMING THE SHAPE OF THE POCKET ARE USED TO REPRESENT PLACEMENT OF THE MARK AND ARE NOT CLAIMED AS A FEATURE OF THE MARK.

FOR JEANS (U.S. CLS. 22 AND 39). MARILYN IZZI, EXAMINING ATTORNEY

SN 85-615,017. VANITY SHOP OF GRAND FORKS, INC., FARGO, ND. FILED 5-2-2012.

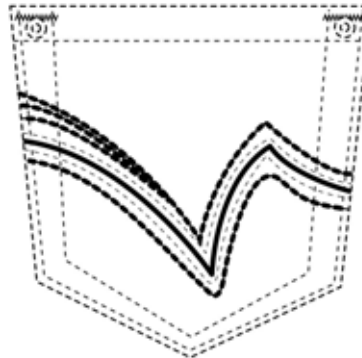

THE MARK CONSISTS OF A STYLIZED LETTER "V" DESIGN DEPICTED BY SIX STITCHED LINES AND ONE SOLID LINE WITH THE RIGHT PORTION OF THE LETTER "V" FORMING A CURVED LINE. THE DOTTED LINES FORMING THE SHAPE OF THE POCKET AND RIVETS ARE USED TO REPRESENT PLACEMENT OF THE MARK AND ARE NOT CLAIMED AS A FEATURE OF THE MARK.

FOR JEANS (U.S. CLS. 22 AND 39). MARILYN IZZI, EXAMINING ATTORNEY

CLASS 25—(Continued).

SN 85-615,024. VANITY SHOP OF GRAND FORKS, INC.,
FARGO, ND. FILED 5-2-2012.

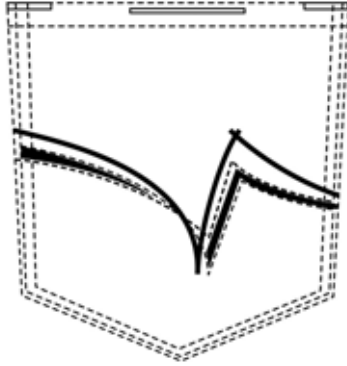

THE MARK CONSISTS OF A STYLIZED LETTER "V" DESIGN DEPICTED BY TWO STITCHED LINES AND TWO SOLID LINES WITH THE RIGHT PORTION OF THE LETTER "V" FORMING A CHEVRON. THE DOTTED LINES FORMING THE SHAPE OF THE POCKET ARE USED TO REPRESENT PLACEMENT OF THE MARK AND ARE NOT CLAIMED AS A FEATURE OF THE MARK.

FOR JEANS (U.S. CLS. 22 AND 39).
MARILYN IZZI, EXAMINING ATTORNEY

SN 85-615,549. NAUTICA APPAREL, INC., NEW YORK, NY.
FILED 5-3-2012.



THE MARK CONSISTS OF A STYLIZED LETTER "N".
FOR COATS; FOOTWEAR; HATS; JACKETS; PAJAMAS;
PANTS; SHIRTS; SHORTS; SOCKS; SWEATERS; T-SHIRTS;
UNDERWEAR (U.S. CLS. 22 AND 39).
SUSAN LESLIE DUBOIS, EXAMINING ATTORNEY

CLASS 25—(Continued).

SN 85-615,802. NAUTICA APPAREL, INC., NEW YORK, NY.
FILED 5-3-2012.

TAKES YOU TO THE WATER

THE MARK CONSISTS OF STANDARD CHARACTERS WITHOUT CLAIM TO ANY PARTICULAR FONT, STYLE, SIZE, OR COLOR.

FOR HATS; OUTER JACKETS; SHIRTS; T-SHIRTS (U.S. CLS. 22 AND 39).
SUSAN LESLIE DUBOIS, EXAMINING ATTORNEY

SN 85-615,829. RAYMOND KAHOU, ORMOND BEACH, FL. AND JOSEPH FISCELLA, WEST ISLIP, NY. FILED 5-3-2012.

Freedom Bowl

THE MARK CONSISTS OF STANDARD CHARACTERS WITHOUT CLAIM TO ANY PARTICULAR FONT, STYLE, SIZE, OR COLOR.

FOR ATHLETIC APPAREL, NAMELY, SHIRTS, PANTS, JACKETS, FOOTWEAR, HATS AND CAPS, ATHLETIC UNIFORMS; BASEBALL CAPS AND HATS; BUTTON DOWN SHIRTS; COLLARED SHIRTS; GOLF PANTS, SHIRTS AND SKIRTS; HATS; SHIRTS; SHORT-SLEEVED SHIRTS; SPORTS CAPS AND HATS; SPORTS SHIRTS; WEARABLE GARMENTS AND CLOTHING, NAMELY, SHIRTS (U.S. CLS. 22 AND 39).

FIRST USE 4-9-2012; IN COMMERCE 4-25-2012.
TRACY WHITTAKER-BROWN, EXAMINING ATTORNEY

SN 85-619,045. O'RITE INTERNATIONAL CORP., UNION CITY, CA. FILED 5-8-2012.

ULTRA DYNAMIC

THE MARK CONSISTS OF STANDARD CHARACTERS WITHOUT CLAIM TO ANY PARTICULAR FONT, STYLE, SIZE, OR COLOR.

FOR MEN'S CLOTHING NAMELY, SHIRTS, SWEATERS, PANTS, UNDERGARMENTS AND JACKETS (U.S. CLS. 22 AND 39).

FIRST USE 10-10-2000; IN COMMERCE 10-10-2000.
INGRID C. EULIN, EXAMINING ATTORNEY

CLASS 25—(Continued).

SN 85-624,199. RODRIGUEZ, CARLOS, IRVINE, CA. FILED 5-14-2012.

**Stained By One Cleansed By
Another**

THE MARK CONSISTS OF STANDARD CHARACTERS WITHOUT CLAIM TO ANY PARTICULAR FONT, STYLE, SIZE, OR COLOR.
FOR ATHLETIC APPAREL, NAMELY, SHIRTS, PANTS, JACKETS, FOOTWEAR, HATS AND CAPS, ATHLETIC UNIFORMS (U.S. CLS. 22 AND 39).
BILL DAWE, EXAMINING ATTORNEY

SN 85-624,216. RODRIGUEZ, CARLOS, IRVINE, CA. FILED 5-14-2012.

SBOCBA

THE MARK CONSISTS OF STANDARD CHARACTERS WITHOUT CLAIM TO ANY PARTICULAR FONT, STYLE, SIZE, OR COLOR.
FOR ATHLETIC APPAREL, NAMELY, SHIRTS, PANTS, JACKETS, FOOTWEAR, HATS AND CAPS, ATHLETIC UNIFORMS (U.S. CLS. 22 AND 39).
BILL DAWE, EXAMINING ATTORNEY

SN 85-625,779. JONATHAN PANNONE, PROVIDENCE, RI. FILED 5-15-2012.



THE MARK CONSISTS OF STYLIZED FISH SKELETON. FOR SPORTSWEAR, NAMELY, CAPS, GOLF CLEATS, SNEAKERS, PANTS, SHIRTS, SHORTS, TROUSERS, SKIRTS, SHOES, SWEATSHIRTS AND PULLOVERS (U.S. CLS. 22 AND 39).
STEVEN PEREZ, EXAMINING ATTORNEY

CLASS 25—(Continued).

SN 85-640,784. I AM OTHER ENTERTAINMENT, LLC, NEW YORK, NY. FILED 6-1-2012.

I AM OTHER

THE MARK CONSISTS OF STANDARD CHARACTERS WITHOUT CLAIM TO ANY PARTICULAR FONT, STYLE, SIZE, OR COLOR.

FOR CLOTHING, NAMELY, SHIRTS, LONG-SLEEVED SHIRTS, T-SHIRTS, UNDER SHIRTS, NIGHT SHIRTS, RUGBY SHIRTS, POLO SHIRTS, CARDIGANS, JERSEYS, SCRUBS NOT FOR MEDICAL PURPOSES, SMOCKS, PANTS, JEANS, CARGO PANTS, STRETCH PANTS, DENIM JEANS, SHORTS, BOXER SHORTS, TOPS, STRETCH TOPS, CROP TOPS, TANK TOPS, TANKINIS, SWEAT SHIRTS, HOODED SWEAT SHIRTS, SWEAT JACKETS, SWEAT SHORTS, SWEAT PANTS, WARM-UP SUITS, TRACK SUITS, SWEATERS, VESTS, FLEECE VESTS, PULLOVERS, JACKETS, REVERSIBLE JACKETS, WIND-RESISTANT JACKETS, SHELL JACKETS, SPORTS JACKETS, JEAN JACKETS, COATS, TURTLENECKS, SWIMWEAR, BEACHWEAR, TENNIS WEAR, LAYETTES, INFANTWEAR, INFANTS SLEEPERS, BOOTIES, CAPS, HATS, VISORS, HEADBANDS, WRIST BANDS, SWEAT BANDS, HEADWEAR, EAR MUFFS, APRONS, SCARVES, BANDANAS, BELTS, NECKWEAR, UNDERWEAR, SOCKS, LOUNGEWEAR, ROBES, UNDERCLOTHES, PAJAMAS, SLEEPWEAR, HOSIERY, GLOVES, MITTENS, RAIN SLICKERS, RAINWEAR, FOOTWEAR, SNEAKERS, SHOES, SANDALS, FLIP-FLOPS, AND SLIPPERS (U.S. CLS. 22 AND 39).
DAVID MURRAY, EXAMINING ATTORNEY

SN 85-649,305. NAUTICA APPAREL, INC., NEW YORK, NY. FILED 6-12-2012.

RAINBREAKER

THE MARK CONSISTS OF STANDARD CHARACTERS WITHOUT CLAIM TO ANY PARTICULAR FONT, STYLE, SIZE, OR COLOR.
FOR COATS; JACKETS; OUTER JACKETS (U.S. CLS. 22 AND 39).
SUSAN LESLIE DUBOIS, EXAMINING ATTORNEY

CLASS 25—(Continued).

SN 85-649,338. NAUTICA APPAREL, INC., NEW YORK, NY. FILED 6-12-2012.

NAUTICA RAINBREAKER

THE MARK CONSISTS OF STANDARD CHARACTERS WITHOUT CLAIM TO ANY PARTICULAR FONT, STYLE, SIZE, OR COLOR.

OWNER OF U.S. REG. NOS. 1,862,585, 3,837,562 AND OTHERS.

THE ENGLISH TRANSLATION OF "NAUTICA" IN THE MARK IS "NAUTICAL".

FOR COATS; JACKETS; OUTER JACKETS (U.S. CLS. 22 AND 39).

SUSAN LESLIE DUBOIS, EXAMINING ATTORNEY

SN 85-650,513. NAUTICA APPAREL, INC., NEW YORK, NY. FILED 6-13-2012.

SEA GYPSIES

THE MARK CONSISTS OF STANDARD CHARACTERS WITHOUT CLAIM TO ANY PARTICULAR FONT, STYLE, SIZE, OR COLOR.

FOR COATS; FOOTWEAR; HATS; JACKETS; JEANS; OUTER JACKETS; PANTS; SHIRTS; SHORTS; SWEATERS; SWIMWEAR; T-SHIRTS; WOMEN'S CLOTHING, NAMELY, SHIRTS, DRESSES, SKIRTS, BLOUSES (U.S. CLS. 22 AND 39).

SUSAN LESLIE DUBOIS, EXAMINING ATTORNEY

SN 85-650,544. ATHLETA, INC., PETALUMA, CA. FILED 6-13-2012.

POWER TO THE SHE

THE MARK CONSISTS OF STANDARD CHARACTERS WITHOUT CLAIM TO ANY PARTICULAR FONT, STYLE, SIZE, OR COLOR.

OWNER OF U.S. REG. NO. 4,169,343.

FOR CLOTHING, NAMELY, TOPS (U.S. CLS. 22 AND 39).

FIRST USE 3-22-2012; IN COMMERCE 3-22-2012.

AMY HELLA, EXAMINING ATTORNEY

CLASS 25—(Continued).

SN 85-663,750. NINE WEST DEVELOPMENT CORPORATION, WILMINGTON, DE. FILED 6-28-2012.

9W

THE MARK CONSISTS OF STANDARD CHARACTERS WITHOUT CLAIM TO ANY PARTICULAR FONT, STYLE, SIZE, OR COLOR.

OWNER OF U.S. REG. NOS. 1,170,312 AND 3,182,559.

FOR FOOTWEAR (U.S. CLS. 22 AND 39).

TINA MAI, EXAMINING ATTORNEY

SN 85-667,389. NUTRI-FUSION SYSTEMS, INC., SANDY, UT. FILED 7-2-2012.

NUTRI-FUSION SYSTEMS

THE MARK CONSISTS OF STANDARD CHARACTERS WITHOUT CLAIM TO ANY PARTICULAR FONT, STYLE, SIZE, OR COLOR.

FOR CLOTHING, NAMELY, T SHIRTS, BALL CAPS, SWEATSHIRTS, TANK TOPS (U.S. CLS. 22 AND 39).

CAITLIN WATTS-FITZGERALD, EXAMINING ATTORNEY

SN 85-674,130. MIA SHOES, INC., MIAMI, FL. FILED 7-11-2012.

MIA TOO

THE MARK CONSISTS OF STANDARD CHARACTERS WITHOUT CLAIM TO ANY PARTICULAR FONT, STYLE, SIZE, OR COLOR.

OWNER OF U.S. REG. NOS. 2,259,181, 3,471,359 AND 3,572,409.

FOR FOOTWEAR (U.S. CLS. 22 AND 39).

ELIZABETH KAJUBI, EXAMINING ATTORNEY

CLASS 25—(Continued).

SN 85-677,987. RETAIL ROYALTY COMPANY, LAS VEGAS, NV. FILED 7-16-2012.

PRETTY GOES WITH EVERYTHING

THE MARK CONSISTS OF STANDARD CHARACTERS WITHOUT CLAIM TO ANY PARTICULAR FONT, STYLE, SIZE, OR COLOR.
FOR UNDERWEAR (U.S. CLS. 22 AND 39).
ZHALEH DELANEY, EXAMINING ATTORNEY

SN 85-682,787. GELMART INDUSTRIES INC., NEW YORK, NY. FILED 7-20-2012.

CUPSY CURVY

THE MARK CONSISTS OF STANDARD CHARACTERS WITHOUT CLAIM TO ANY PARTICULAR FONT, STYLE, SIZE, OR COLOR.
FOR CLOTHING, NAMELY, PANTS, SHORTS, SWEATPANTS, OVERALLS, SHIRTS, TEE-SHIRTS, SWEATSHIRTS, BLOUSES, SKIRTS, DRESSES, LINGERIE, SLEEPWEAR, LOUNGEWEAR, SWIMWEAR, SOCKS, HOSIERY, BRAS, PANTIES, SLIPS, MERRY WIDOWS, CAMISOLES, PAJAMAS, NIGHTGOWNS, TEDDIES, BODYSUITS, TAP PANTS, PAREOS, AND TIGHTS (U.S. CLS. 22 AND 39).
MARK T. MULLEN, EXAMINING ATTORNEY

SN 85-682,815. GELMART INDUSTRIES INC., NEW YORK, NY. FILED 7-20-2012.

CUPSYTURVY

THE MARK CONSISTS OF STANDARD CHARACTERS WITHOUT CLAIM TO ANY PARTICULAR FONT, STYLE, SIZE, OR COLOR.
FOR CLOTHING, NAMELY, PANTS, SHORTS, SWEATPANTS, SHIRTS, TEE-SHIRTS, SWEATSHIRTS, BLOUSES, SKIRTS, DRESSES, LINGERIE, SLEEPWEAR, LOUNGEWEAR, SWIMWEAR, SOCKS, HOSIERY, BRAS, PANTIES, SLIPS, MERRY WIDOWS, CAMISOLES, PAJAMAS, NIGHTGOWNS, TEDDIES, BODYSUITS, TAP PANTS, PAREOS, AND TIGHTS (U.S. CLS. 22 AND 39).
MARK T. MULLEN, EXAMINING ATTORNEY

CLASS 26—FANCY GOODS

SN 85-267,911. CODD, STARR, DBA BABY DOLL INDIAN HAIR, HAWTHORNE, CA. FILED 3-15-2011.



THE COLOR(S) BROWN, PURPLE, PINK, BLACK AND WHITE IS/ARE CLAIMED AS A FEATURE OF THE MARK.
THE MARK CONSISTS OF THE BUST OF A WOMAN WITH BROWN SKIN AND BROWN IRIS, BLACK PUPILS, WHITE SCLERA, PINK LIPS, AND LONG BROWN HAIR INSIDE A PURPLE OVAL.
FOR HAIR EXTENSIONS; HAIR PIECES (U.S. CLS. 37, 39, 40, 42 AND 50).
FIRST USE 7-19-2010; IN COMMERCE 12-20-2010.
ALICE BENMAMAN, EXAMINING ATTORNEY

SN 85-337,024. SUMMIT ENTERTAINMENT, LLC, SANTA MONICA, CA. FILED 6-3-2011.

TWILIGHT BRIDAL

THE MARK CONSISTS OF STANDARD CHARACTERS WITHOUT CLAIM TO ANY PARTICULAR FONT, STYLE, SIZE, OR COLOR.
OWNER OF U.S. REG. NOS. 3,867,985, 3,944,718 AND OTHERS.
NO CLAIM IS MADE TO THE EXCLUSIVE RIGHT TO USE "BRIDAL", APART FROM THE MARK AS SHOWN.
FOR HAIR ACCESSORIES, NAMELY, BARRETTES, BOBBY PINS, AND CLIPS; HAIR ORNAMENTS; HAIR ORNAMENTS IN THE FORM OF COMBS; AND ARTIFICIAL FLOWERS INCLUDING FLOWER ARRANGEMENTS (U.S. CLS. 37, 39, 40, 42 AND 50).
ASMAT KHAN, EXAMINING ATTORNEY

CLASS 26—(Continued).

SN 85-435,052. NISSAN JIDOSHA KABUSHIKI KAISHA, TA NISSAN MOTOR CO., LTD., YOKOHAMA-SHI, KANAGAWA, JAPAN, FILED 9-29-2011.



PRIORITY CLAIMED UNDER SEC. 44(D) ON JAPAN APPLICATION NO. 2011-055230, FILED 8-3-2011, REG. NO. 5476603, DATED 3-9-2012, EXPIRES 3-9-2022.

OWNER OF U.S. REG. NOS. 1,546,304, 1,692,165 AND OTHERS.

THE MARK CONSISTS OF PARTIALLY SHADED SEMI-CIRCLE BROKEN BY AN INVERTED "V".

FOR CLOTHING BUCKLES; ORNAMENTAL NOVELTY PINS; SHOE BUCKLES (U.S. CLS. 37, 39, 40, 42 AND 50).

MICHELLE DUBOIS, EXAMINING ATTORNEY

SN 85-451,029. SHAKE-N-GO FASHION, INC., PORT WASHINGTON, NY, FILED 10-19-2011.

COS

THE MARK CONSISTS OF STANDARD CHARACTERS WITHOUT CLAIM TO ANY PARTICULAR FONT, STYLE, SIZE, OR COLOR.

FOR HAIR PRODUCTS, NAMELY, HAIR PIECES, HAIR EXTENSIONS, WIGS, PONYTAIL HAIR PIECES, AND WEAVING HAIR (U.S. CLS. 37, 39, 40, 42 AND 50). NELSON SNYDER, EXAMINING ATTORNEY

SN 85-461,442. MICHAELS STORES PROCUREMENT COMPANY, INC., IRVING, TX, FILED 11-1-2011.

IMAGIN8

THE MARK CONSISTS OF STANDARD CHARACTERS WITHOUT CLAIM TO ANY PARTICULAR FONT, STYLE, SIZE, OR COLOR.

OWNER OF U.S. REG. NO. 3,544,161.

FOR CLOTH PATCHES FOR CLOTHING; ORNAMENTAL CLOTH PATCHES; ORNAMENTAL DECORATIONS, NOT BEING JEWELRY FOR ATTACHMENT TO CLOTHING, NAMELY, RHINESTONES AND CRYSTALS; ARTIFICIAL FLOWER ACCESSORIES, NAMELY, FLOWERS FOR HEADBANDS; CLOTHING ACCESSORIES, NAMELY, PIN BACK BUTTONS; FALSE HAIR; SHOE LACES; FEATHER HAIR ACCESSORIES, NAMELY, CLIP-ON FEATHER HAIR EXTENSIONS (U.S. CLS. 37, 39, 40, 42 AND 50).

TRACY CROSS, EXAMINING ATTORNEY

CLASS 26—(Continued).

SN 85-481,764. HARRIS, JANE, NEW YORK, NY, FILED 11-28-2011.

The Virgin Hair Fantasy

THE MARK CONSISTS OF STANDARD CHARACTERS WITHOUT CLAIM TO ANY PARTICULAR FONT, STYLE, SIZE, OR COLOR.

NO CLAIM IS MADE TO THE EXCLUSIVE RIGHT TO USE "VIRGIN HAIR", APART FROM THE MARK AS SHOWN.

FOR HAIR CLIPS; HAIR EXTENSIONS; WIGS (U.S. CLS. 37, 39, 40, 42 AND 50).

FIRST USE 2-25-2011; IN COMMERCE 3-1-2011.

TRACY CROSS, EXAMINING ATTORNEY

SN 85-580,056. HALLOWELL, ROBERT LEROY II, LOS ANGELES, CA, FILED 3-26-2012.

HOT RAGS

THE MARK CONSISTS OF STANDARD CHARACTERS WITHOUT CLAIM TO ANY PARTICULAR FONT, STYLE, SIZE, OR COLOR.

FOR NON-ELECTRIC HAIR ROLLERS (U.S. CLS. 37, 39, 40, 42 AND 50).

DARRYL SPRUILL, EXAMINING ATTORNEY

SN 85-596,407. JANAJ INTERNATIONAL, LTD., DBA TRIMLAND, DEER PARK, NY, FILED 4-12-2012.

TRIMLAND USA

THE MARK CONSISTS OF STANDARD CHARACTERS WITHOUT CLAIM TO ANY PARTICULAR FONT, STYLE, SIZE, OR COLOR.

OWNER OF U.S. REG. NO. 4,066,824.

NO CLAIM IS MADE TO THE EXCLUSIVE RIGHT TO USE "USA", APART FROM THE MARK AS SHOWN.

FOR DECORATIVE CORDING; DECORATIVE CORDS; DECORATIVE NOVELTY TACKS FOR PINNING DRAPERY OR CLOTHING TO AID IN MAKING ALTERATIONS; DECORATIVE RIBBONS; FABRIC APPLIQUES; FRINGES; LACE TRIMMING; ORNAMENTAL BOWS OF TEXTILE FOR DECORATION; ORNAMENTAL RIBBONS MADE OF TEXTILES; RIBBONS OF TEXTILE MATERIALS; SEAM BINDING; TASSELS; WEBBING IN THE NATURE OF WOVEN FABRIC TAPE FOR SEWING PURPOSES (U.S. CLS. 37, 39, 40, 42 AND 50).

FIRST USE 4-9-2012; IN COMMERCE 4-9-2012.

JOSETTE BEVERLY, EXAMINING ATTORNEY

CLASS 26—(Continued).

SN 85-597,538. PONYTAIL PALS, MILWAUKEE, WI. FILED 4-13-2012.

PONYTAIL PALS

THE MARK CONSISTS OF STANDARD CHARACTERS WITHOUT CLAIM TO ANY PARTICULAR FONT, STYLE, SIZE, OR COLOR.

NO CLAIM IS MADE TO THE EXCLUSIVE RIGHT TO USE "PONYTAIL", APART FROM THE MARK AS SHOWN.

FOR HAIR GOODS, NAMELY, PONYTAIL HOLDERS, HAIR BOWS, HAIR ORNAMENTS, AND HAIR BANDS (U.S. CLS. 37, 39, 40, 42 AND 50).

NAAKWAMA ANKRAH, EXAMINING ATTORNEY

CLASS 26—(Continued).

SN 85-640,314. HOT TOPIC MERCHANDISING, INC., CITY OF INDUSTRY, CA. FILED 5-31-2012.

LOVESICK

THE MARK CONSISTS OF STANDARD CHARACTERS WITHOUT CLAIM TO ANY PARTICULAR FONT, STYLE, SIZE, OR COLOR.

OWNER OF U.S. REG. NO. 4,169,027.

FOR BARRETTES; CLAM CLIPS FOR HAIR; HAIR ACCESSORIES, NAMELY, JAW CLIPS; HAIR ACCESSORIES, NAMELY, SNAP CLIPS; HAIR ACCESSORIES, NAMELY, TWISTERS; HAIR BARRETTES; HAIR BOWS; HAIR BUCKLES; HAIR CLAMPS; HAIR CLIPS; HAIR EXTENSIONS; HAIR ORNAMENTS NOT OF PRECIOUS METAL; HAIR PIECES AND WIGS; HAIR PINS; HAIR RIBBONS; HAIR RIBBONS FOR JAPANESE HAIR STYLING (TEGARA); HAIR SCRUNCHIES; ORNAMENTS FOR THE HAIR; PONYTAIL HOLDERS AND HAIR RIBBONS; RUBBER BANDS FOR HAIR (U.S. CLS. 37, 39, 40, 42 AND 50).

MAYUR VAGHANI, EXAMINING ATTORNEY

CLASS 27—FLOOR COVERINGS

SN 85-410,456. FUTURE FOAM, INC., MIDDLETON, WI. FILED 8-30-2011.

OASIS

THE MARK CONSISTS OF STANDARD CHARACTERS WITHOUT CLAIM TO ANY PARTICULAR FONT, STYLE, SIZE, OR COLOR.

FOR CARPET UNDERLAYMENT (U.S. CLS. 19, 20, 37, 42 AND 50).

KYLE PEETE, EXAMINING ATTORNEY

SN 85-599,223. LONGE-OTTO, MISTURA, HOUSTON, TX. FILED 4-16-2012.



NO CLAIM IS MADE TO THE EXCLUSIVE RIGHT TO USE "HAIR", APART FROM THE MARK AS SHOWN.

THE MARK CONSISTS OF A WOMAN'S FACE WITH HAIR FLYING TO THE LEFT. TO THE LEFT OF THE WOMAN'S FACE IS THE STYLIZED TEXT "LOLA'S HAIR" ABOVE THE STYLIZED TEXT "SIMPLY LUXURY".

FOR HAIR EXTENSIONS (U.S. CLS. 37, 39, 40, 42 AND 50).

FIRST USE 5-1-2011; IN COMMERCE 5-1-2011. GEOFFREY FOSDICK, EXAMINING ATTORNEY

SN 85-596,995. BARE BONES, INC., BRADFORDWOODS, PA. FILED 4-13-2012.

UltraSkate

THE MARK CONSISTS OF STANDARD CHARACTERS WITHOUT CLAIM TO ANY PARTICULAR FONT, STYLE, SIZE, OR COLOR.

FOR SYNTHETIC ICE TILES EMPLOYED AS A SYNTHETIC SKATING SURFACE (U.S. CLS. 19, 20, 37, 42 AND 50).

GISELLE AGOSTO, EXAMINING ATTORNEY

CLASS 27—(Continued).

SN 85-602,470. HOUSE OF PERSIA, LLC, ATLANTA, GA. FILED 4-19-2012.

KNOT ENVY

THE MARK CONSISTS OF STANDARD CHARACTERS WITHOUT CLAIM TO ANY PARTICULAR FONT, STYLE, SIZE, OR COLOR.

FOR CARPETS; RUGS (U.S. CLS. 19, 20, 37, 42 AND 50).

JAY FLOWERS, EXAMINING ATTORNEY

SN 85-659,297. V.E.W., LTD., NEW YORK, NY. FILED 6-22-2012.

VERA WANG

THE MARK CONSISTS OF STANDARD CHARACTERS WITHOUT CLAIM TO ANY PARTICULAR FONT, STYLE, SIZE, OR COLOR.

OWNER OF U.S. REG. NOS. 1,797,058, 3,599,755 AND OTHERS.

THE NAME "VERA WANG" IDENTIFIES A LIVING INDIVIDUAL WHOSE CONSENT IS OF RECORD.

FOR AREA RUGS; ACCENT RUGS; BATH RUGS (U.S. CLS. 19, 20, 37, 42 AND 50).

SUNG IN, EXAMINING ATTORNEY

CLASS 28—TOYS AND SPORTING GOODS

SN 77-224,202. TAMIAN, RICHARD, SPARTA, NJ. FILED 7-8-2007.

DRAGON NAME-GAME

THE MARK CONSISTS OF STANDARD CHARACTERS WITHOUT CLAIM TO ANY PARTICULAR FONT, STYLE, SIZE, OR COLOR.

NO CLAIM IS MADE TO THE EXCLUSIVE RIGHT TO USE "NAME-GAME", APART FROM THE MARK AS SHOWN.

FOR DICE GAMES (U.S. CLS. 22, 23, 38 AND 50).

FIRST USE 6-28-2005; IN COMMERCE 6-28-2005.

DAWN HAN, EXAMINING ATTORNEY

CLASS 28—(Continued).

SN 79-106,723. FELISAZ S.A.S., FRANCE, FILED 10-26-2011.

PLUM

THE MARK CONSISTS OF STANDARD CHARACTERS WITHOUT CLAIM TO ANY PARTICULAR FONT, STYLE, SIZE, OR COLOR.

PRIORITY DATE OF 4-28-2011 IS CLAIMED.

OWNER OF INTERNATIONAL REGISTRATION 1100583 DATED 10-26-2011, EXPIRES 10-26-2021.

FOR SKI BINDINGS, BINDINGS FOR SURF BOARDS; ICE AND ROLLER SKATES; INLINE ROLLER SKATES; SNOWSHOES; CLIMBING HARNESSES; LEASHES FOR SURFBOARDS (U.S. CLS. 22, 23, 38 AND 50).

APRIL ROACH, EXAMINING ATTORNEY

SN 79-108,316. DONGGUAN CHI LOK BO; TOYS COMPANY LIMITED, GUANGDONG PROVINCE, CHINA, FILED 11-24-2011.



OWNER OF INTERNATIONAL REGISTRATION 1104653 DATED 11-24-2011, EXPIRES 11-24-2021.

THE MARK CONSISTS OF THE DESIGN OF CASTLE INSIDE A DOMED ARC WITH STARS ON BOTH SIDES OF THE ARC AND 9 STARS APPEAR INSIDE THE DOME ABOVE THE CASTLE. THE CASTLE HAS THREE TOWERS HAVE WINDOWS AND BRICK LIKE ACCENTS AND EACH TOWER IS TOPPED BY A FLAG POLE WITH A FLAG. THE BASE OF THE CASTLE IS DESIGNED LIKE A TOWER WITH BRICK LIKE ACCENTS. THE WORDING "CHI LOK BO" APPEARS BELOW THE CASTLE IN A BANNER. THREE CHINESE CHARACTERS APPEARS BELOW THE BANNER WITH THE WORDING "CHI LOK BO".

THE ENGLISH TRANSLATION OF THE FOREIGN WORD(S) IN THE MARK IS: "ZHI LE BAO", "ZHI" MEANS "INTELLIGENCE", "LE" MEANS "HAPPY", "BAO" MEANS "CASTLE".

THE TRANSLITERATION OF THE NON-LATIN CHARACTERS IN THE MARK IS: "ZHI LE BAO".

FOR CHILDREN'S RECREATIONAL EQUIPMENT, NAMELY, TOY VEHICLES, SKATEBOARD, TOY SCOOTERS; GAMES, NAMELY, HAND HELD UNITS FOR PLAYING VIDEO GAMES OTHER THAN THOSE ADAPTED FOR USE WITH AN EXTERNAL DISPLAY SCREEN OR MONITOR; PLAYGROUND EQUIPMENT, NAMELY, SLIDES; CHESS SETS; ICE SKATES; BALLS FOR GAMES; BATS FOR GAMES (U.S. CLS. 22, 23, 38 AND 50).

ROSELLE HERRERA, EXAMINING ATTORNEY

CLASS 28—(Continued).

SN 79-111,505. STOCS B.V., NETHERLANDS, FILED 3-21-2012.



OWNER OF INTERNATIONAL REGISTRATION 1112494 DATED 3-21-2012, EXPIRES 3-21-2022.

THE COLOR(S) RED, WHITE IS/ARE CLAIMED AS A FEATURE OF THE MARK.

THE MARK CONSISTS OF THE STYLIZED WORDING "STOCS" IN WHITE LETTERING APPEARING INSIDE A RED RECTANGLE DESIGN WITH CURVED CORNERS.

THE WORDING "STOCS" HAS NO MEANING IN A FOREIGN LANGUAGE.

FOR TOYS, NAMELY, CONSTRUCTION TOYS (U.S. CLS. 22, 23, 38 AND 50).

NATALIE POLZER, EXAMINING ATTORNEY

SN 85-112,381. PURE FISHING, INC., SPIRIT LAKE, IA. FILED 8-20-2010.

SILVER HAWK

THE MARK CONSISTS OF STANDARD CHARACTERS WITHOUT CLAIM TO ANY PARTICULAR FONT, STYLE, SIZE, OR COLOR.

FOR SPORTING GOODS, NAMELY, FISHING RODS; FISHING TACKLE (U.S. CLS. 22, 23, 38 AND 50).

MARK SHINER, EXAMINING ATTORNEY

SN 85-147,232. DISCOVERY COMMUNICATIONS, LLC, SILVER SPRING, MD. FILED 10-7-2010.

DC CUPCAKES

THE MARK CONSISTS OF STANDARD CHARACTERS WITHOUT CLAIM TO ANY PARTICULAR FONT, STYLE, SIZE, OR COLOR.

NO CLAIM IS MADE TO THE EXCLUSIVE RIGHT TO USE "CUPCAKES", APART FROM THE MARK AS SHOWN.

FOR TOY BAKEWARE AND COOKWARE (U.S. CLS. 22, 23, 38 AND 50).

TIMOTHY FINNEGAN, EXAMINING ATTORNEY

CLASS 28—(Continued).

SN 85-147,530. PLAY WITH ME INC., PEMBROKE PINES, FL. FILED 10-7-2010.



NO CLAIM IS MADE TO THE EXCLUSIVE RIGHT TO USE "BANDZ", APART FROM THE MARK AS SHOWN.

THE COLOR(S) GREEN, WHITE, GREY, YELLOW, ORANGE, FUCHSIA, RED, PURPLE, BLUE AND BLACK IS/ARE CLAIMED AS A FEATURE OF THE MARK.

THE MARK CONSISTS OF THE WORDING "FUNNY BANDZ" WITHIN COLORED, STYLIZED LETTERING SUPERIMPOSED AGAINST A COLORED GEOMETRIC BORDER ELEMENT DESIGN. THE LETTER "F" IS GREEN. THE LETTERS "U" IN "FUNNY" THE LETTER "D" IN "BANDZ" AND THE DOT WITHIN THE "D" ARE YELLOW. THE FIRST LETTER "N" IN "FUNNY" AND THE LETTER "Z" IN THE "BANDZ" ARE ORANGE. THE SECOND LETTER "N" IN "FUNNY" IS RED. THE LETTER "Y" IN "FUNNY", THE LETTER "B" IN "BANDZ" AND THE DOTS WITHIN THE "B" ARE PURPLE. THE LETTER "A" IN "BANDZ" AND THE DOT WITHIN THE "A" ARE FUCHSIA. THE LETTER "N" IN "BANDZ" AND THE BORDER ELEMENT DESIGN ARE BLUE. THE INTERIOR LINING OF THE BORDER DESIGN ELEMENT IS BLACK. THE BORDER ELEMENTS OF THE LETTERING WITHIN THE WORD "FUNNY" ARE WHITE AND GREY.

FOR TOYS, NAMELY, SILICONE BRACELETS (U.S. CLS. 22, 23, 38 AND 50).

FIRST USE 6-0-2010; IN COMMERCE 6-0-2010.

DANIEL CAPSHAW, EXAMINING ATTORNEY

SN 85-249,012. JAKKS PACIFIC, INC., MALIBU, CA. FILED 2-22-2011.

DOM PYRO

THE MARK CONSISTS OF STANDARD CHARACTERS WITHOUT CLAIM TO ANY PARTICULAR FONT, STYLE, SIZE, OR COLOR.

FOR TOYS, GAMES AND PLAYTHINGS, NAMELY, COLLECTABLE GAME PIECES, COLLECTABLE TOY FIGURES, PROMOTIONAL GAME CARDS; ACTION FIGURES, PLAYSETS AND ACCESSORIES THEREFOR; DOLLS, PLAYSETS, AND ACCESSORIES THEREFOR; PLAYING CARDS; TRADING CARD GAMES, HAND HELD UNIT FOR PLAYING ELECTRONIC GAMES; CHILDREN'S MULTIPLE ACTIVITY TOYS; ELECTRONIC LEARNING TOYS; BOARD GAMES, ACTION SKILL GAMES, AND PUZZLES (U.S. CLS. 22, 23, 38 AND 50).

HEATHER BIDDULPH, EXAMINING ATTORNEY

CLASS 28—(Continued).

SN 85-249,016. JAKKS PACIFIC, INC., MALIBU, CA. FILED 2-22-2011.

LOCK

THE MARK CONSISTS OF STANDARD CHARACTERS WITHOUT CLAIM TO ANY PARTICULAR FONT, STYLE, SIZE, OR COLOR.

FOR TOYS, GAMES AND PLAYTHINGS, NAMELY, COLLECTABLE GAME PIECES, COLLECTABLE TOY FIGURES, PROMOTIONAL GAME CARDS; ACTION FIGURES, PLAYSETS AND ACCESSORIES THEREFOR; DOLLS, PLAYSETS, AND ACCESSORIES THEREFOR; PLAYING CARDS; TRADING CARD GAMES, HAND HELD UNIT FOR PLAYING ELECTRONIC GAMES; CHILDREN'S MULTIPLE ACTIVITY TOYS; ELECTRONIC LEARNING TOYS; BOARD GAMES, ACTION SKILL GAMES, AND PUZZLES; ALL OF THE FOREGOING EXCLUDING TOYS, GAMES AND PLAYTHINGS WITH LOCKS (U.S. CLS. 22, 23, 38 AND 50).

HEATHER BIDDULPH, EXAMINING ATTORNEY

SN 85-263,193. BUZZ BEE TOYS, INC., MT. LAUREL, NJ. FILED 3-10-2011.



THE MARK CONSISTS OF THE WORDS "POWER-LOCK" INSIDE A HORIZONTAL RECTANGULAR BOX.

FOR TOY PROJECTILE SHOOTERS, NAMELY, TOY GUNS AND ACCESSORIES THEREFOR, NAMELY, FOAM DARTS (U.S. CLS. 22, 23, 38 AND 50).

NANCY CLARKE, EXAMINING ATTORNEY

SN 85-273,105. WORLD WRESTLING ENTERTAINMENT, INC., STAMFORD, CT. FILED 3-22-2011.

TEAM BRING IT

THE MARK CONSISTS OF STANDARD CHARACTERS WITHOUT CLAIM TO ANY PARTICULAR FONT, STYLE, SIZE, OR COLOR.

FOR TOYS, NAMELY, ACTION FIGURES AND ACCESSORIES THEREFOR; CASES FOR ACTION FIGURES; TOY WRESTLING RINGS; TOY VEHICLES; STUFFED TOYS; PLUSH TOYS; TOY BELTS; KNEE AND ELBOW PADS FOR ATHLETIC USE; TOY FOAM HANDS; COSTUME MASKS; DOLLS (U.S. CLS. 22, 23, 38 AND 50).

JOHN GARTNER, EXAMINING ATTORNEY

CLASS 28—(Continued).

SN 85-316,075. NOVATION DESIGN INC., BURLINGTON, ONTARIO, CANADA, FILED 5-9-2011.

POLYPUZZLE

THE MARK CONSISTS OF STANDARD CHARACTERS WITHOUT CLAIM TO ANY PARTICULAR FONT, STYLE, SIZE, OR COLOR.

PRIORITY CLAIMED UNDER SEC. 44(D) ON CANADA APPLICATION NO. 1523303, FILED 4-12-2011, REG. NO. TMA826,515, DATED 6-19-2012, EXPIRES 6-19-2027.

FOR CONSTRUCTION TOYS (U.S. CLS. 22, 23, 38 AND 50).

AMY C. KEAN, EXAMINING ATTORNEY

SN 85-336,062. ROBERT WAYNE GILBERT, DBA BETTER TOMORROWS, COLD SPRINGS, NV. FILED 6-2-2011.

BETTER TOMORROWS

THE MARK CONSISTS OF STANDARD CHARACTERS WITHOUT CLAIM TO ANY PARTICULAR FONT, STYLE, SIZE, OR COLOR.

FOR ACTION SKILL GAMES; ACTION TARGET GAMES; ACTION-TYPE TARGET GAMES; APPARATUS FOR ELECTRONIC GAMES OTHER THAN THOSE ADAPTED FOR USE WITH AN EXTERNAL DISPLAY SCREEN OR MONITOR; BACKGAMMON GAME SETS; BACKGAMMON GAMES; BINGO CARDS; BOARD GAMES; BUILDING GAMES; CARD GAME FOR BUSINESS TRAINING; CARD GAMES; DART GAMES; DICE GAMES; DISPOSABLE TICKET SETS FOR PLAYING GAMES OF CHANCE; EDUCATIONAL CARD GAMES; ELECTRONIC DART GAMES; ELECTRONIC EDUCATIONAL GAME MACHINES FOR CHILDREN; ELECTRONIC GAME EQUIPMENT WITH A WATCH FUNCTION; ELECTRONIC GAMES FOR THE TEACHING OF CHILDREN; ELECTRONIC GAMES OTHER THAN THOSE ADAPTED FOR USE WITH TELEVISION RECEIVERS ONLY; ELECTRONIC TARGETS FOR GAMES AND SPORTS; EQUIPMENT SOLD AS A UNIT FOR PLAYING A MEMORY GAME; EQUIPMENT SOLD AS A UNIT FOR PLAYING ACTION TYPE TARGET GAMES; EQUIPMENT SOLD AS A UNIT FOR PLAYING CARD GAMES; FLOOR-STANDING UNITS FOR PLAYING ELECTRONIC GAMES OTHER THAN IN CONJUNCTION WITH A TELEVISION OR COMPUTER; GAME CARDS; GAME EQUIPMENT SET SOLD AS A UNIT COMPRISED PRIMARILY OF A PLAYING BOARD AND PLAYING CARDS AND ALSO INCLUDING RULES OF PLAY, DRY ERASE BOARDS AND ERASERS, MARKERS, A TIMER AND T-SHIRTS; GAME EQUIPMENT SOLD AS A UNIT FOR PLAYING MIND-BODY EMOTIONAL AND PSYCHOLOGICAL GAMES FOR ADULT COUPLES AND INDIVIDUALS; GAME EQUIPMENT, NAMELY, CHIPS; GAME EQUIPMENT, NAMELY, THREE-DIMENSIONAL MODULAR PIECES FOR ASSEMBLY TO SIMULATE MINIATURE TERRAIN; GAME RANDOMIZER FOR RANDOMLY DETERMINING GAME PLAY IN A PARLOR GAME, SOLD AS A COMPONENT PART THEREOF; GAME TABLES; GAMING EQUIPMENT, NAMELY, GAME WHEELS; GAMING EQUIPMENT, NAMELY, PLAYING CARDS, CHIPS, GAMING TABLES AND GAMING CLOTHS; GAMING PAPER, NAMELY, PAPER PRINTED WITH REGULAR GRID AND HEXAGON PATTERNS FOR USE IN PLAYING WAR GAMES, ROLE PLAYING GAMES

CLASS 28—(Continued).

AND MINIATURE GAMES; HAND HELD UNITS FOR PLAYING ELECTRONIC GAMES OTHER THAN THOSE ADAPTED FOR USE WITH AN EXTERNAL DISPLAY SCREEN OR MONITOR; HAND-HELD GAMES WITH LIQUID CRYSTAL DISPLAYS; HORIZONTAL PINBALL MACHINE (KORINTO-GAME MACHINES); HORSE-SHOE GAMES; MEMORY GAMES; ORDINARY PLAYING CARDS; PARLOR GAMES; PARLOUR GAMES; PARTY GAMES; PLAYING CARD GAME ACCESSORIES, NAMELY, PLAYING CARD CASES, PLAYING CARD HOLDERS, MATS FOR USE IN CONNECTION WITH PLAYING CARD GAMES, PLAYING CARD SHUFFLING DEVICES AND DICE; PLAYING CARDS; PLAYING CARDS AND CARD GAMES; PLAYING PIECES IN THE NATURE OF MINIATURE ACTION FIGURES AND TOY MODEL VEHICLES FOR USE WITH TABLE TOP HOBBY BATTLE GAMES IN THE NATURE OF BATTLE, WAR AND SKIRMISH GAMES, AND FANTASY GAMES; POSITIONABLE PRINTED TOY FIGURES FOR USE IN GAMES; POSITIONABLE THREE DIMENSIONAL TOYS FOR USE IN GAMES; POSITIONABLE TWO DIMENSIONAL TOYS FOR USE IN GAMES; PRINTED POSITIONABLE TOYS FOR USE IN CHILDREN'S BOARD GAMES; PROMOTIONAL GAME CARDS; PROMOTIONAL GAME MATERIALS; PUZZLE GAMES; ROLE PLAYING GAMES; SCRATCH CARDS FOR PLAYING LOTTERY GAMES; STAND ALONE VIDEO GAME MACHINES; STAND ALONE VIDEO OUTPUT GAME MACHINES; STONE-PIECES POTS FOR GO GAME (GOKE POTS); TABLETOP GAMES; TABLETOP HOBBY BATTLE GAMES IN THE NATURE OF BATTLE, WAR AND SKIRMISH GAMES, AND FANTASY GAMES, AND PLAYING EQUIPMENT SOLD AS A UNIT THEREWITH; TABLETOP UNITS FOR PLAYING ELECTRONIC GAMES OTHER THAN IN CONJUNCTION WITH A TELEVISION OR COMPUTER; TARGET GAMES; TOY, NAMELY, BATTERY-POWERED COMPUTER GAME WITH LCD SCREEN WHICH FEATURES ANIMATION AND SOUND EFFECTS; TOYS, NAMELY, A DISK TO TOSS IN PLAYING A GAME WHEREIN OTHER DISKS ARE FLIPPED AND COLLECTED; TRADING CARD GAMES; TRIVIA GAME PLAYED WITH CARDS AND GAME COMPONENTS (U.S. CLS. 22, 23, 38 AND 50).

FIRST USE 1-1-1990; IN COMMERCE 1-1-1995.
ALICE BENMAMAN, EXAMINING ATTORNEY

SN 85-358,079. MADE IN MARS, INC., HACIENDA HEIGHTS, CA. FILED 6-28-2011.

BONEHEAD

THE MARK CONSISTS OF STANDARD CHARACTERS WITHOUT CLAIM TO ANY PARTICULAR FONT, STYLE, SIZE, OR COLOR.

NO CLAIM IS MADE TO THE EXCLUSIVE RIGHT TO USE "SKATEBOARDS", APART FROM THE MARK AS SHOWN.

FOR BALL BEARINGS FOR SKATEBOARDS; SKATEBOARD DECKS; SKATEBOARD GRIP TAPES; SKATEBOARD RAILS; SKATEBOARD RISER PADS; SKATEBOARD TRUCKS; SKATEBOARD WAX; SKATEBOARD WHEELS; SKATEBOARDS (U.S. CLS. 22, 23, 38 AND 50).

FIRST USE 5-1-2011; IN COMMERCE 5-1-2011.
HENRY S. ZAK, EXAMINING ATTORNEY

CLASS 28—(Continued).

SN 85-376,562. RAPID PLASTICS, INC., GILBERT, AZ. FILED 7-20-2011.

HUBSTACK

THE MARK CONSISTS OF STANDARD CHARACTERS WITHOUT CLAIM TO ANY PARTICULAR FONT, STYLE, SIZE, OR COLOR.

FOR YO-YOS (U.S. CLS. 22, 23, 38 AND 50).
FIRST USE 3-17-2007; IN COMMERCE 3-17-2007.
WILLIAM JACKSON, EXAMINING ATTORNEY

SN 85-384,820. SWING RIGHT, LLC, CEDAR FALLS, IA. FILED 7-29-2011.



NO CLAIM IS MADE TO THE EXCLUSIVE RIGHT TO USE "STICK", APART FROM THE MARK AS SHOWN.

THE MARK CONSISTS OF THE STYLIZED WORD "BENDER" IN UPPERCASE LETTERS, BELOW WHICH APPEARS THE WORD "STIK." ALSO IN UPPERCASE LETTERS, WITH A CURVING BAND FORMING AN ARC THAT JOINS THE LETTER "K" WITH THE DOT IN THE LETTER "I", ALL OF WHICH APPEARS INSIDE A CURVED BORDER.

FOR GOLF CLUB SWING AIDS, NAMELY, PORTABLE DEVICE IN THE NATURE OF A FOAM BALL ATTACHED TO AN ADJUSTABLE SUPPORT TO AID IN CONTROLLING HARD, ARM AND BODY MOVEMENT (U.S. CLS. 22, 23, 38 AND 50).

ALICE BENMAMAN, EXAMINING ATTORNEY

CLASS 28—(Continued).

SN 85-430,086. NYMBALL GAMES, INC., SUWANEE, GA.
FILED 9-23-2011.

NYMBALL GAMES

THE MARK CONSISTS OF STANDARD CHARACTERS WITHOUT CLAIM TO ANY PARTICULAR FONT, STYLE, SIZE, OR COLOR.

NO CLAIM IS MADE TO THE EXCLUSIVE RIGHT TO USE "GAMES", APART FROM THE MARK AS SHOWN.

FOR ACTION SKILL GAMES; BALLS FOR GAMES, BOARD GAMES, CARD GAMES, DICE GAMES, ELECTRONIC GAMES FOR THE TEACHING OF CHILDREN; MANIPULATIVE GAMES, PARTY GAMES, AND PUZZLE GAMES (U.S. CLS. 22, 23, 38 AND 50).

RAUL CORDOVA, EXAMINING ATTORNEY

SN 85-441,224. DISNEY ENTERPRISES, INC., BURBANK, CA. FILED 10-6-2011.

DUFFY THE DISNEY BEAR

THE MARK CONSISTS OF STANDARD CHARACTERS WITHOUT CLAIM TO ANY PARTICULAR FONT, STYLE, SIZE, OR COLOR.

OWNER OF U.S. REG. NOS. 3,235,413, 4,057,772 AND OTHERS.

NO CLAIM IS MADE TO THE EXCLUSIVE RIGHT TO USE "BEAR", APART FROM THE MARK AS SHOWN.

FOR ACTION SKILL GAMES; ACTION FIGURES AND ACCESSORIES THEREFOR; BOARD GAMES; CARD GAMES; CHILDREN'S MULTIPLE ACTIVITY TOYS; BADMINTON SETS; BALLOONS; BASKETBALLS; BATH TOYS; BASEBALL BATS; BASEBALLS; BEACH BALLS; BEAN BAGS; BEAN BAG DOLLS; TOY BUILDING BLOCKS; BOWLING BALLS; BUBBLE MAKING WANDS AND SOLUTION SETS; CHESS SETS; CHILDREN'S PLAY COSMETICS; CHRISTMAS STOCKINGS; CHRISTMAS TREE ORNAMENTS AND DECORATIONS; COLLECTABLE TOY FIGURES; CRIB MOBILES; CRIB TOYS; DISC TOSS TOYS; DOLLS; DOLL CLOTHING; DOLL ACCESSORIES; DOLL PLAYSETS; ELECTRIC ACTION TOYS; EQUIPMENT SOLD AS A UNIT FOR PLAYING CARD GAMES; FISHING TACKLE; FOOTBALLS; GOLF BALLS; GOLF GLOVES; GOLF BALL MARKERS; HAND-HELD UNITS FOR PLAYING ELECTRONIC GAMES OTHER THAN THOSE ADAPTED FOR USE WITH AN EXTERNAL DISPLAY SCREEN OR MONI-

CLASS 28—(Continued).

TOR; HOCKEY PUCKS; HOCKEY STICKS; INFANT TOYS; INFLATABLE TOYS; JIGSAW PUZZLES; JUMP ROPES; KITES; MAGIC TRICKS; MARBLES; MANIPULATIVE GAMES; MECHANICAL TOYS; MUSIC BOX TOYS; MUSICAL TOYS; PARLOR GAMES; PARTY FAVORS IN THE NATURE OF SMALL TOYS; PAPER PARTY HATS; PARTY GAMES; PLAYING CARDS; PLUSH TOYS; PUPPETS; ROLLER SKATES; RUBBER BALLS; SKATEBOARDS; SNOW BOARDS; SNOW GLOBES; SOCCER BALLS; SPINNING TOPS; SQUEEZE TOYS; STUFFED TOYS; TABLE TENNIS BALLS; TABLE TENNIS PADDLES AND RACKETS; TABLE TENNIS TABLES; TALKING TOYS; TARGET GAMES; TEDDY BEARS; TENNIS BALLS; TENNIS RACKETS; TOY ACTION FIGURES AND ACCESSORIES THEREFOR; TOY BUCKET AND SHOVEL SETS; TOY MOBILES; TOY VEHICLES; TOY SCOOTERS; TOY CARS; TOY MODEL HOBBYCRAFT KITS; TOY FIGURES; TOY BANKS; TOY TRUCKS; TOY WATCHES; TOY WEAPONS; VOLLEY BALLS; WIND-UP TOYS; YO-YOS (U.S. CLS. 22, 23, 38 AND 50).

KIMBERLY FRYE, EXAMINING ATTORNEY

SN 85-448,480. LMDM ENTERPRISES, LLC, BRIELLE, NJ.
FILED 10-16-2011.

FUZZBUCKETS

THE COLOR(S) PURPLE, GREEN, RED, PINK, ORANGE, BLUE AND YELLOW IS/ARE CLAIMED AS A FEATURE OF THE MARK.

THE MARK CONSISTS OF THE STYLIZED WORDING "FUZZBUCKETS". THE COLOR PURPLE APPEARS IN THE TEXT OF THE LETTERS "F" AND "T". THE COLOR GREEN APPEARS IN THE TEXT OF THE LETTER "U". THE COLOR RED APPEARS IN THE TEXT OF THE LETTERS "ZZ" AND "S". THE COLOR PINK APPEARS IN THE TEXT OF THE LETTER "B". THE COLOR ORANGE APPEARS IN THE TEXT OF THE LETTER "C". THE COLOR BLUE APPEARS IN THE TEXT OF THE LETTER "K". THE COLOR YELLOW APPEARS IN THE TEXT OF THE LETTER "E".

FOR PLUSH TOYS (U.S. CLS. 22, 23, 38 AND 50).
ELI HELLMAN, EXAMINING ATTORNEY

SN 85-451,654. SUZHOU EVERICH IMP.& EXP.CO.,LTD., SUZHOU,JIANGSU, CHINA, FILED 10-20-2011.

**Everich
Toys**

NO CLAIM IS MADE TO THE EXCLUSIVE RIGHT TO USE "TOY", APART FROM THE MARK AS SHOWN.

THE MARK CONSISTS OF "EVERICH TOY" AND A STYLIZED DESIGN OF A CAR OUTLINED BY A GEOMETRIC SHAPE.

FOR TOYS, NAMELY, BABY MULTIPLE ACTIVITY TOYS, BUILDING BLOCKS; DOMINOES; PARLOR GAMES; TOY SCOOTERS; TOY MOBILES; PLUSH TOYS; TOY VEHICLES; JIGSAW PUZZLES; RADIO-CONTROLLED TOY VEHICLES (U.S. CLS. 22, 23, 38 AND 50).
FIRST USE 9-1-2011; IN COMMERCE 9-1-2011.

KHANH LE, EXAMINING ATTORNEY

CLASS 28—(Continued).

SN 85-462,326. WHITE, MARY O., WAPPINGERS FALLS, NY. FILED 11-2-2011.

DREAM OWL

THE MARK CONSISTS OF STANDARD CHARACTERS WITHOUT CLAIM TO ANY PARTICULAR FONT, STYLE, SIZE, OR COLOR.

NO CLAIM IS MADE TO THE EXCLUSIVE RIGHT TO USE "OWL", APART FROM THE MARK AS SHOWN.

FOR PLUSH TOYS; STUFFED TOY ANIMALS; STUFFED TOYS; TOY ANIMALS; TOY FIGURES (U.S. CLS. 22, 23, 38 AND 50).

FIRST USE 5-7-2011; IN COMMERCE 5-7-2011.
MATTHEW KLINE, EXAMINING ATTORNEY

CLASS 28—(Continued).

SN 85-482,640. CALICO, LLC, URBANA, IL. FILED 11-29-2011.



NO CLAIM IS MADE TO THE EXCLUSIVE RIGHT TO USE "PLAY", APART FROM THE MARK AS SHOWN.

THE COLOR(S) RED AND WHITE IS/ARE CLAIMED AS A FEATURE OF THE MARK.

THE MARK CONSISTS OF THE STYLIZED WHITE WORD "PLAY" ABOVE THE STYLIZED WHITE WORD "PLAY", ALL ON A RED BACKGROUND.

FOR ROLE-PLAYING GAMES; STORY-TELLING GAMES, NAMELY, GAMES OF CONSTRUCTING SENTENCES FROM WORD TILES, AND PUZZLE GAMES, NAMELY, PUZZLE MAKING GAMES (U.S. CLS. 22, 23, 38 AND 50).

SUSAN STIGLITZ, EXAMINING ATTORNEY

SN 85-475,264. LEE, CALVIN, DBA FISH OF FURY, SAN MATEO, CA. FILED 11-17-2011.

FISH OF FURY

THE MARK CONSISTS OF STANDARD CHARACTERS WITHOUT CLAIM TO ANY PARTICULAR FONT, STYLE, SIZE, OR COLOR.

FOR GAMES AND TOYS, NAMELY, STUFFED TOYS, ACTION FIGURES, GAME PUZZLES (U.S. CLS. 22, 23, 38 AND 50).

JOHN HWANG, EXAMINING ATTORNEY

SN 85-509,354. ROTH, ETHAN M, CHATHAM, NJ. FILED 1-5-2012.

SPORT MELT

THE MARK CONSISTS OF STANDARD CHARACTERS WITHOUT CLAIM TO ANY PARTICULAR FONT, STYLE, SIZE, OR COLOR.

FOR NOVELTY ITEMS IN THE NATURE OF DISFIGURED HOCKEY PUCKS, LACROSSE BALLS, BASEBALLS, FOOTBALLS, TENNIS BALLS AND GOLF BALLS THAT APPEAR TO HAVE BEEN MELTED; NOVELTY ITEMS IN THE NATURE OF GAMING PIECES, NAMELY, CHESS FANTASY GAME AND CHECKER PIECES THAT APPEAR TO HAVE BEEN MELTED (U.S. CLS. 22, 23, 38 AND 50).

DAVID I, EXAMINING ATTORNEY

CLASS 28—(Continued).

SN 85-511,394. D-RED TECHNOLOGIES LIMITED, SHENZHEN, 518000, CHINA, FILED 1-9-2012.



NO CLAIM IS MADE TO THE EXCLUSIVE RIGHT TO USE "SMART", APART FROM THE MARK AS SHOWN.

THE MARK CONSISTS OF THE WORDS "SMART ICOP-TER" AND A BLACK SHADED ELLIPSE INSIDE AN INCOMPLETE ELLIPSE FORMED BY 2 CURVES.

THE WORDING "ICOPTER" HAS NO MEANING IN A FOREIGN LANGUAGE.

FOR RADIO CONTROLLED TOY VEHICLES (U.S. CLS. 22, 23, 38 AND 50).

GINA HAYES, EXAMINING ATTORNEY

SN 85-512,273. CLOUD B, INC., GARDENA, CA. FILED 1-9-2012.

TRANQUIL FRIENDS

THE MARK CONSISTS OF STANDARD CHARACTERS WITHOUT CLAIM TO ANY PARTICULAR FONT, STYLE, SIZE, OR COLOR.

OWNER OF U.S. REG. NO. 4,039,700.

FOR TOYS, NAMELY, PLUSH TOYS, SOFT SCULPTURED TOYS, HARD SCULPTURED TOYS (U.S. CLS. 22, 23, 38 AND 50).

ZACHARY BELLO, EXAMINING ATTORNEY

SN 85-526,947. BETTS TACKLE, LTD., FUQUAY VARINA, NC. FILED 1-27-2012.

FLO-GLO

THE MARK CONSISTS OF STANDARD CHARACTERS WITHOUT CLAIM TO ANY PARTICULAR FONT, STYLE, SIZE, OR COLOR.

FOR FISHING TACKLE (U.S. CLS. 22, 23, 38 AND 50).

FIRST USE 1-1-1991; IN COMMERCE 1-1-1991.

ANTHONY RINKER, EXAMINING ATTORNEY

CLASS 28—(Continued).

SN 85-540,396. TECHNOLINE LLC, CARLSTADT, NJ. FILED 2-11-2012.

LEG PRO

THE MARK CONSISTS OF STANDARD CHARACTERS WITHOUT CLAIM TO ANY PARTICULAR FONT, STYLE, SIZE, OR COLOR.

NO CLAIM IS MADE TO THE EXCLUSIVE RIGHT TO USE "LEG", APART FROM THE MARK AS SHOWN.

FOR EXERCISE MACHINES; EXERCISE PLATFORMS; EXERCISE TREADMILLS; EXERCISE WEIGHTS (U.S. CLS. 22, 23, 38 AND 50).

FIRST USE 2-10-2012; IN COMMERCE 2-10-2012.

WILLIAM VERHOSEK, EXAMINING ATTORNEY

SN 85-542,950. SCI BOX LLC, MOUNT VERNON, IL. FILED 2-15-2012.

THE HONEY HOLE

THE MARK CONSISTS OF STANDARD CHARACTERS WITHOUT CLAIM TO ANY PARTICULAR FONT, STYLE, SIZE, OR COLOR.

NO CLAIM IS MADE TO THE EXCLUSIVE RIGHT TO USE "HONEY", APART FROM THE MARK AS SHOWN.

FOR FISHING EQUIPMENT, NAMELY, SCENT DISPENSER FOR ATTRACTING FISH (U.S. CLS. 22, 23, 38 AND 50).

TEJBIR SINGH, EXAMINING ATTORNEY

CLASS 28—(Continued).

SN 85-555,362. MOOSE CREATIVE PTY LTD, EAST BENTLEIGH, AUSTRALIA, FILED 2-28-2012.

TOPPEE

THE MARK CONSISTS OF STANDARD CHARACTERS WITHOUT CLAIM TO ANY PARTICULAR FONT, STYLE, SIZE, OR COLOR.

PRIORITY CLAIMED UNDER SEC. 44(D) ON AUSTRALIA APPLICATION NO. 1466908, FILED 1-9-2012, REG. NO. 1448839, DATED 5-24-2012, EXPIRES 9-27-2021.

FOR TOYS, GAMES AND PLAYTHINGS, NAMELY, COLLECTIBLE FIGURINES, COLLECTIBLE ANIMAL FIGURINES, COLLECTIBLE TOYS, NAMELY, TOY FIGURES AND COLLECTIBLE TOY CHARACTERS AND COLLECTABLE BENDABLE TOY CHARACTERS, OUTFITS FOR TOYS, POUCHES FOR TOYS AND COLLECTOR CASES FOR TOYS; PUPPETS; PUZZLES; PACKAGED AMUSEMENT AND EDUCATIONAL GAMES, NAMELY, ELECTRONIC EDUCATIONAL GAME MACHINES FOR CHILDREN; TOY ENVIRONMENTS FOR USE WITH TOY CHARACTERS, NAMELY, PLAY PIECES IN THE NATURE OF TOY BUILDINGS, TOY VEHICLES, TOY BUILDING STRUCTURES, TOY CONSTRUCTION SETS; PLAY SETS FOR TOY CHARACTERS, PLAY TOY COSTUMES, FANTASY CHARACTER TOYS, TOY ACTION FIGURES AND ACCESSORIES THEREFOR (U.S. CLS. 22, 23, 38 AND 50).

RICHARD WHITE, EXAMINING ATTORNEY

CLASS 28—(Continued).

SN 85-556,037. MODIFY-TECH CO., LTD., TAOYUAN CITY 33049, TAIWAN, FILED 2-29-2012.



THE MARK CONSISTS OF A KNIGHTS MASK DESIGN RESEMBLING THE LETTER "M" WITH THE WORD "MODIFY" BENEATH.

FOR TOY GUNS AND THEIR ACCESSORIES, NAMELY, MAGAZINES, GUN SCOPES, BULLETS, BB BULLETS, AND ALL OTHER PARTS AND ACCESSORIES SOLD AS AN INTEGRAL COMPONENT OF THE GOODS; TOY CARS AND ALL OTHER PARTS AND ACCESSORIES SOLD AS AN INTEGRAL COMPONENT OF THE GOODS; TOY TRAINS AND ALL OTHER PARTS AND ACCESSORIES SOLD AS AN INTEGRAL COMPONENT OF THE GOODS; TOY AIRPLANES AND ALL OTHER PARTS AND ACCESSORIES SOLD AS AN INTEGRAL COMPONENT OF THE GOODS; TOY BOATS AND ALL OTHER PARTS AND ACCESSORIES SOLD AS AN INTEGRAL COMPONENT OF THE GOODS; RADIO CONTROLLED TOY CARS AND ALL OTHER PARTS AND ACCESSORIES SOLD AS AN INTEGRAL COMPONENT OF THE GOODS; RADIO CONTROLLED TOY TRAINS AND ALL OTHER PARTS AND ACCESSORIES SOLD AS AN INTEGRAL COMPONENT OF THE GOODS; RADIO CONTROLLED TOY AIRPLANES AND ALL OTHER PARTS AND ACCESSORIES SOLD AS AN INTEGRAL COMPONENT OF THE GOODS; RADIO CONTROLLED TOY BOATS AND ALL OTHER PARTS AND ACCESSORIES SOLD AS AN INTEGRAL COMPONENT OF THE GOODS; AND TOY TRAIN SETS AND THEIR ACCESSORIES, NAMELY, TOY TRAIN CONTROLLERS AND TRANSFORMERS, RAILS AND TRACKS, RAILROAD DIORAMAS, AND ALL OTHER PARTS AND ACCESSORIES SOLD AS AN INTEGRAL COMPONENT OF THE GOODS; BATTERY OPERATED ACTION TOYS (U.S. CLS. 22, 23, 38 AND 50).

FIRST USE 10-1-2011; IN COMMERCE 1-1-2012.
GISELLE AGOSTO, EXAMINING ATTORNEY

SN 85-558,782. ULTIMATE SHAD, LLC, ST. LOUIS, MO. FILED 3-2-2012.

ULTIMATE SHAD

THE MARK CONSISTS OF STANDARD CHARACTERS WITHOUT CLAIM TO ANY PARTICULAR FONT, STYLE, SIZE, OR COLOR.

NO CLAIM IS MADE TO THE EXCLUSIVE RIGHT TO USE "SHAD", APART FROM THE MARK AS SHOWN.

FOR ARTIFICIAL FISHING LURES (U.S. CLS. 22, 23, 38 AND 50).

FIRST USE 4-1-2007; IN COMMERCE 1-1-2009.
SUZANNE BLANE, EXAMINING ATTORNEY

CLASS 28—(Continued).

SN 85-564,383. PETERSEN, CHARLES, PAYSON, UT. FILED 3-8-2012.

CLASS 28—(Continued).

SN 85-570,770. COLORADO ROCKIES BASEBALL CLUB, LTD., DENVER, CO. FILED 3-15-2012.



SCOTT GOLF USA

OWNER OF U.S. REG. NOS. 1,842,521, 3,341,382 AND OTHERS.

NO CLAIM IS MADE TO THE EXCLUSIVE RIGHT TO USE "GRAND JUNCTION", APART FROM THE MARK AS SHOWN.

THE MARK CONSISTS OF THE WORD "ROCKIES" IN STYLIZED TEXT DISPLAYING DIRECTLY ABOVE IT A PARTIALLY SHADED SEMI-CIRCLE CONTAINING THE STYLIZED WORDS "GRAND JUNCTION", A MESA DESIGN AND A BASEBALL DESIGN.

FOR TOYS AND SPORTING GOODS, NAMELY, STUFFED TOYS, PLUSH TOYS, SOFT SCULPTURE FOAM TOYS, FOAM NOVELTY ITEMS, NAMELY, FOAM FINGERS, PUPPETS, BALLOONS, CHECKER SETS, CHESS SETS, DOMINOES, BOARD GAMES, CARD GAMES, DICE GAMES, TRIVIA GAME PLAYED WITH CARDS AND GAME COMPONENTS, PARLOR GAMES, PLAYING CARDS, DART BOARDS AND DART BOARD ACCESSORIES, NAMELY, DARTS, DART SHAFTS AND DART FLIGHTS, CORNHOLE SETS, NAMELY, BEAN BAG GAMES, TOY CARS AND TRUCKS, TOY TRAINS, TOY MOBILES, PUZZLES, YO-YO'S, TOY BANKS, TOY FIGURES, TOY VEHICLES, DOLLS AND DOLL ACCESSORIES, BOBBING HEAD DOLLS, DECORATIVE WIND SOCKS, MINIATURE BASEBALL BATS, MINI BATTING HELMET REPLICAS, TOY NECKLACES, MINIATURE TOY BASEBALLS, BASEBALLS, HOLDERS FOR BASEBALLS, AUTOGRAPHED BASEBALLS, PLAYGROUND BALLS, BEACH BALLS, GOLF BALLS, GOLF CLUB HEAD COVERS, GOLF CLUB BAGS, GOLF PUTTERS, BILLIARD ACCESSORIES, NAMELY, CUES, BILLIARD BALLS AND CUE CASES, BASEBALL BASES, BASEBALL BATS, BATTING GLOVES, PET TOYS, SNOW SLEDS FOR RECREATIONAL USE, SNOW GLOBES, COSTUME MASKS, CHRISTMAS TREE ORNAMENTS AND DECORATIONS, FLYING DISKS, ACTION FIGURES, BALLS FOR GAMES, GAMING EQUIPMENT, NAMELY, POKER CHIPS, GAME TABLES, INFLATABLE TOYS, BOWLING BALLS, BOWLING PINS, BOWLING BAGS, FISHING RODS AND REELS, AND LOTTERY TICKETS (U.S. CLS. 22, 23, 38 AND 50).

JENNY PARK, EXAMINING ATTORNEY

THE MARK CONSISTS OF STANDARD CHARACTERS WITHOUT CLAIM TO ANY PARTICULAR FONT, STYLE, SIZE, OR COLOR.

NO CLAIM IS MADE TO THE EXCLUSIVE RIGHT TO USE "GOLF USA", APART FROM THE MARK AS SHOWN.

FOR COVERS FOR GOLF CLUBS; DIVOT REPAIR TOOLS; GLOVES FOR GOLF; GOLF ACCESSORIES, NAMELY, CARRIERS AND DISPENSERS FOR GOLF BALLS; GOLF ACCESSORY POUCHES; GOLF BAGS; GOLF BALLS; GOLF CLUB GRIPS; GOLF CLUB HEADS; GOLF CLUB SHAFTS; GOLF CLUBS; GOLF FLAGS; GOLF IRONS; GOLF PUTTERS; GOLF TEES; HAND GRIPS FOR GOLF CLUBS (U.S. CLS. 22, 23, 38 AND 50).

SOPHIA S. KIM, EXAMINING ATTORNEY

CLASS 28—(Continued).

SN 85-572,122. CALLAWAY GOLF COMPANY, CARLSBAD, CA. FILED 3-16-2012.



NO CLAIM IS MADE TO THE EXCLUSIVE RIGHT TO USE "X OUTS", APART FROM THE MARK AS SHOWN. THE MARK CONSISTS OF THE LETTER "X" OVER THE WORD "OUTS" INSIDE A HEXAGONAL SHAPED BOX. FOR GOLF BALLS (U.S. CLS. 22, 23, 38 AND 50). INGA ERVIN, EXAMINING ATTORNEY

SN 85-573,038. OWEN, LARRY, EL SEGUNDO, CA. FILED 3-19-2012.



NO CLAIM IS MADE TO THE EXCLUSIVE RIGHT TO USE "8 BALL GOLF", APART FROM THE MARK AS SHOWN.

THE MARK CONSISTS OF THE STYLIZED PHRASE "8 BALL" ON A DIAGONAL ABOVE THE STYLIZED TERM "GOLF", ALSO ON A DIAGONAL, WHEREIN THE NUMBER "8" APPEARS INSIDE OF A STYLIZED DEPICTION OF A BILLIARDS BALL ALL OF WHICH APPEARS ABOVE THE STYLIZED PHRASE "THE SKILL OF BILLIARDS" ABOVE THE STYLIZED PHRASE "THE CHALLENGES OF GOLF".

FOR ACTION SKILL GAMES COMPRISED OF GOLF TEES, A RULE BOOK WITH DIAGRAMS, SCORE PADS, BALLOONS, STICKERS, WRITING PENS, AND 18 IDENTIFICATION CARDS (U.S. CLS. 22, 23, 38 AND 50).

MYRIAH HABEEB, EXAMINING ATTORNEY

CLASS 28—(Continued).

SN 85-582,682. PEEK-A-BOO TOYS, LTD., PENNSAUKEN, NJ. FILED 3-28-2012.



NO CLAIM IS MADE TO THE EXCLUSIVE RIGHT TO USE "FRUIT", APART FROM THE MARK AS SHOWN. THE MARK CONSISTS OF THE STYLIZED TEXT "HIPPIE" ABOVE THE STYLIZED TEXT "FRUIT". FOR PLUSH TOYS (U.S. CLS. 22, 23, 38 AND 50). FIRST USE 12-13-2011; IN COMMERCE 1-4-2012. JAMES STEIN, EXAMINING ATTORNEY

SN 85-586,540. GREENFIELDS OUTDOOR FITNESS, INC., SANTA ANA, CA. FILED 4-2-2012.

PROMOTING WELLNESS & FIGHTING OBESITY ONE COMMUNITY AT A TIME

THE MARK CONSISTS OF STANDARD CHARACTERS WITHOUT CLAIM TO ANY PARTICULAR FONT, STYLE, SIZE, OR COLOR.

OWNER OF U.S. REG. NO. 4,151,438.

FOR MANUALLY-OPERATED EXERCISE EQUIPMENT FOR PHYSICAL FITNESS PURPOSES: EXERCISE EQUIPMENT, NAMELY, USERS' OWN BODY-WEIGHT RESISTANCE EQUIPMENT NAMELY, SKI MACHINES, BUTTERFLY AND REVERSE BUTTERFLY PRESSES, LAT PULL, SHOULDER PRESS, CHEST PRESS AND VERTICAL PRESS STATIONS, ROWING MACHINES, STAIR CLIMBERS, LEG PRESSES, STATIONARY BICYCLES, AIR WALKERS, LEG CURL AND LEG EXTENSION STATIONS, STRETCHING STATIONS, ELLIPTICAL MACHINES; VARIOUS STATIC EXERCISE EQUIPMENT, NAMELY, DIP STATIONS, SIT-UP BENCHES, HORIZONTAL BARS, COMBINATION BARS, HORIZONTAL LADDERS, AND PARALLEL BARS; ALL OF THESE FOR USE OUTDOORS (U.S. CLS. 22, 23, 38 AND 50).

FIRST USE 11-1-2011; IN COMMERCE 11-1-2011.

KERI CANTONE, EXAMINING ATTORNEY

SN 85-588,774. LITTLE KIDS, INC., SEEKONK, MA. FILED 4-4-2012.

FUBBLES

THE MARK CONSISTS OF STANDARD CHARACTERS WITHOUT CLAIM TO ANY PARTICULAR FONT, STYLE, SIZE, OR COLOR.

FOR BUBBLE-MAKING WAND AND SOLUTION SETS; BUBBLE-MAKING BLOWERS; BUBBLE-MAKING TOYS; TOYS, NAMELY, BUBBLE-MAKING MACHINES (U.S. CLS. 22, 23, 38 AND 50).

SUZANNE BLANE, EXAMINING ATTORNEY

CLASS 28—(Continued).

SN 85-589,648. SHENZHEN JIAYU XINGLONG TECHNOLOGY DEVELOPMENT CO., LTD., SHENZHEN, CHINA, FILED 4-5-2012.



THE MARK CONSISTS OF STYLIZED LATIN WORDING "HOBYTE" AND A LEAF BENEATH WITH ITS LEFT END GOING ACROSS "H" AND "O".

FOR FISHING TACKLE; INFANT TOYS; MAGIC TRICKS; RADIO CONTROLLED TOY VEHICLES; SCALE MODEL AIRCRAFT; SCALE MODEL VEHICLES; STUFFED TOYS; TOY CARS; TOY MOBILES; TOY VEHICLES (U.S. CLS. 22, 23, 38 AND 50).

FIRST USE 9-0-2010; IN COMMERCE 6-0-2011.

DEBORAH MEINERS, EXAMINING ATTORNEY

SN 85-589,687. SLAYER INC., JACKSONVILLE BEACH, FL. FILED 4-5-2012.

Slayer Inc.

THE MARK CONSISTS OF STANDARD CHARACTERS WITHOUT CLAIM TO ANY PARTICULAR FONT, STYLE, SIZE, OR COLOR.

NO CLAIM IS MADE TO THE EXCLUSIVE RIGHT TO USE "INC.", APART FROM THE MARK AS SHOWN.

FOR ARTIFICIAL FISHING LURES (U.S. CLS. 22, 23, 38 AND 50).

FIRST USE 6-21-2001; IN COMMERCE 3-5-2007.

MARLENE BELL, EXAMINING ATTORNEY

CLASS 28—(Continued).

SN 85-591,420. THE EXECUTOR OF THE OTIS REDDING ESTATE, LOS ANGELES, CA. FILED 4-6-2012.

THE KING OF SOUL

THE MARK CONSISTS OF STANDARD CHARACTERS WITHOUT CLAIM TO ANY PARTICULAR FONT, STYLE, SIZE, OR COLOR.

THE NAME "THE KING OF SOUL" WAS THE NICK-NAME OF OTIS REDDING WHO IS NOT A LIVING INDIVIDUAL.

FOR TOYS, NAMELY, DOLLS, FIGURES; MODELED PLASTIC TOY FIGURINES, BENDABLE TOYS; DOLL PLAYSETS; DOLL CASES; CASES FOR TOY STRUCTURES; DOLL CLOTHING AND ACCESSORIES, NAMELY, CLOTHING FOR DOLLS, DOLL ROOMS, DOLL BEDS, DOLL HOUSES, TOY FABRICS AND LINENS FOR DOLLS AND STROLLERS FOR DOLLS; PLUSH TOYS; TOY CHARMS, NAMELY, FOR USE WITH DOLLS, FIGURES AND OTHER TOYS; TOY KEY CHAINS; TOY ROOM DECOR ACTIVITY SETS, NAMELY, TOY FURNITURE; TRADING CARD GAMES; BOBBLE HEAD DOLLS; PUPPETS; TOY CANDY DISPENSERS; TOY CANDY HOLDERS; CHRISTMAS TREE ORNAMENTS; DOLLS MADE OF RESIN, WOOD, CORK, REED, CANE, WICKER, HORN, BONE, IVORY, WHALEBONE, SHELL, AMBER, MOTHER-OF-PEARL, MEERSCHAUM AND PLASTIC; PLAYING CARDS; PAPER DOLLS; GAME CONTROLLERS FOR COMPUTER GAMES; COMPUTER GAME CONSOLES FOR USE WITH EXTERNAL DISPLAY SCREEN OR MONITOR; VIDEO GAME CONSOLES FOR USE WITH EXTERNAL DISPLAY SCREEN OR MONITOR (U.S. CLS. 22, 23, 38 AND 50).

CATHERINE ROEHL, EXAMINING ATTORNEY

SN 85-591,698. THE KYJEN COMPANY, INC., LITTLETON, CO. FILED 4-6-2012.

Moon Rover Rescue

THE MARK CONSISTS OF STANDARD CHARACTERS WITHOUT CLAIM TO ANY PARTICULAR FONT, STYLE, SIZE, OR COLOR.

FOR DOG TOYS (U.S. CLS. 22, 23, 38 AND 50).

FIRST USE 6-23-2011; IN COMMERCE 6-23-2011.

MARTHA FROMM, EXAMINING ATTORNEY

CLASS 28—(Continued).

SN 85-591,721. SPIDER SUE STUDIOS, LTD., LINDENHURST, NY. FILED 4-6-2012.

SPIDER SUE

THE MARK CONSISTS OF STANDARD CHARACTERS WITHOUT CLAIM TO ANY PARTICULAR FONT, STYLE, SIZE, OR COLOR.

THE NAME "SPIDER SUE" DOES NOT IDENTIFY A LIVING INDIVIDUAL.

FOR DOLLS, DOLL COSTUMES, DOLL CLOTHING, DOLL ACCESSORIES, PLAY SETS FOR DOLLS, ACTION FIGURES AND ACCESSORIES THEREFORE, PLAY SETS FOR ACTION FIGURES, TOY MODEL CRAFT KITS FOR CONSTRUCTING ACTION FIGURES (U.S. CLS. 22, 23, 38 AND 50).

FIRST USE 5-10-2011; IN COMMERCE 5-10-2011.

KEVEN MITTLER, EXAMINING ATTORNEY

SN 85-591,844. HARBO ENTERTAINMENT LLC, OMAHA, NE. FILED 4-7-2012.



NO CLAIM IS MADE TO THE EXCLUSIVE RIGHT TO USE "ARCADE GUNS", APART FROM THE MARK AS SHOWN.

THE MARK CONSISTS OF THE WORDING "A CADE GUNS" IN A STYLIZED MANNER. AN IMAGE OF A CROSSHAIR IS LOCATED TO THE LEFT OF THE WORDING. AN IMAGE OF AN ARCADE MACHINE CABINET IS LOCATED BETWEEN THE LETTERS "A" AND "C" AND IS MEANT TO SYMBOLIZE THE LETTER "R".

FOR GAME CONTROLLERS FOR COMPUTER GAMES; TOY HOLSTERS (U.S. CLS. 22, 23, 38 AND 50).

AMEEN IMAM, EXAMINING ATTORNEY

SN 85-593,024. KHALIL, ADEL A, LAKE PARK, FL. FILED 4-9-2012.

CORE 500

THE MARK CONSISTS OF STANDARD CHARACTERS WITHOUT CLAIM TO ANY PARTICULAR FONT, STYLE, SIZE, OR COLOR.

NO CLAIM IS MADE TO THE EXCLUSIVE RIGHT TO USE "CORE", APART FROM THE MARK AS SHOWN.

FOR MANUALLY-OPERATED EXERCISE EQUIPMENT FOR PHYSICAL FITNESS PURPOSES (U.S. CLS. 22, 23, 38 AND 50).

ZACHARY R. SPARER, EXAMINING ATTORNEY

CLASS 28—(Continued).

SN 85-593,365. CIRRUS FITNESS, LLC, NEW YORK, NY. FILED 4-10-2012.

CIRRUS FITNESS

THE MARK CONSISTS OF STANDARD CHARACTERS WITHOUT CLAIM TO ANY PARTICULAR FONT, STYLE, SIZE, OR COLOR.

NO CLAIM IS MADE TO THE EXCLUSIVE RIGHT TO USE "FITNESS", APART FROM THE MARK AS SHOWN.

FOR AEROBIC STEP MACHINES; BARBELLS; DUMBBELLS; ELLIPTICAL EXERCISE MACHINES; EXERCISE BALLS; EXERCISE BARS; EXERCISE BENCHES; EXERCISE EQUIPMENT, NAMELY, MANUALLY OPERATED JOGGING MACHINES; EXERCISE EQUIPMENT, NAMELY, STAIR-STEPPING MACHINES; EXERCISE EQUIPMENT, NAMELY, STATIONARY CYCLES; EXERCISE EQUIPMENT, NAMELY, ABDOMINAL BOARDS; EXERCISE EQUIPMENT, NAMELY, CHEST EXPANDERS; EXERCISE EQUIPMENT, NAMELY, CHEST PULLS; EXERCISE EQUIPMENT, NAMELY, SHOULDER STRETCHER USING A CABLE; EXERCISE EQUIPMENT, NAMELY, SHOULDER STRETCHER USING RESISTANCE CABLES; EXERCISE EQUIPMENT, NAMELY, VIRTUAL REALITY TRAINING CYCLES; EXERCISE EQUIPMENT, NAMELY, INFLATABLE BALLS; EXERCISE MACHINES; EXERCISE MACHINES INCORPORATING ELECTRONIC AND VIDEO GAME CONTROLLERS; EXERCISE PLATFORMS; EXERCISE TREADMILLS; EXERCISE WEIGHTS; EXERCISING EQUIPMENT, NAMELY, MANUALLY OPERATED JOGGING MACHINES; EXERCISING EQUIPMENT, NAMELY, POWERED TREADMILLS FOR RUNNING; EXERCISING EQUIPMENT, NAMELY, PULLEYS; EXERCISING EQUIPMENT, NAMELY, WEIGHT LIFTING MACHINES; EXERCISING PULLEYS; MANUAL LEG EXERCISERS; MANUALLY-OPERATED EXERCISE EQUIPMENT (U.S. CLS. 22, 23, 38 AND 50).

EVIN L. KOZAK, EXAMINING ATTORNEY

SN 85-595,042. IMMORTAL MARTIAL ARTS, INC., NEWARK, DE. FILED 4-11-2012.

SLAM 'N ROPES

THE MARK CONSISTS OF STANDARD CHARACTERS WITHOUT CLAIM TO ANY PARTICULAR FONT, STYLE, SIZE, OR COLOR.

NO CLAIM IS MADE TO THE EXCLUSIVE RIGHT TO USE "ROPES", APART FROM THE MARK AS SHOWN.

FOR EXERCISE EQUIPMENT, NAMELY, MANUALLY OPERATED HEAVY TRAINING ROPES WITH END CAPS FOR EXERCISE (U.S. CLS. 22, 23, 38 AND 50).

FIRST USE 3-15-2012; IN COMMERCE 3-15-2012.

LEE-ANNE BERNS, EXAMINING ATTORNEY

CLASS 28—(Continued).

SN 85-595,245. WHAT KIDS WANT! INC., NORTHRIDGE, CA. FILED 4-11-2012.

SURFIN' SOCK MONKEY

THE MARK CONSISTS OF STANDARD CHARACTERS WITHOUT CLAIM TO ANY PARTICULAR FONT, STYLE, SIZE, OR COLOR.

NO CLAIM IS MADE TO THE EXCLUSIVE RIGHT TO USE "SOCK MONKEY", APART FROM THE MARK AS SHOWN.

FOR AMUSEMENT PRODUCTS, NAMELY, BOUNCE BALLS FOR GAMES, KICKBOARDS IN THE NATURE OF SWIMMING KICK BOARDS, SAND TOYS IN THE NATURE OF SAND PAILS (U.S. CLS. 22, 23, 38 AND 50).
AHSEN KHAN, EXAMINING ATTORNEY

SN 85-595,455. JUNGO LLC, DBA JUNGO TOYS, LOS ANGELES, CA. FILED 4-11-2012.

Jungo Toys

THE MARK CONSISTS OF STANDARD CHARACTERS WITHOUT CLAIM TO ANY PARTICULAR FONT, STYLE, SIZE, OR COLOR.

NO CLAIM IS MADE TO THE EXCLUSIVE RIGHT TO USE "TOYS", APART FROM THE MARK AS SHOWN.

FOR HAND-POWERED NON-MECHANICAL FLYING TOY (U.S. CLS. 22, 23, 38 AND 50).

FIRST USE 11-3-2010; IN COMMERCE 3-1-2011.
JOHN DWYER, EXAMINING ATTORNEY

SN 85-597,379. EDWARD C. STEVENS, ALEXANDRIA, VA. FILED 4-13-2012.

MRS. ANNA CLAUS

THE MARK CONSISTS OF STANDARD CHARACTERS WITHOUT CLAIM TO ANY PARTICULAR FONT, STYLE, SIZE, OR COLOR.

THE NAME "MRS. ANNA CLAUS" DOES NOT IDENTIFY A LIVING INDIVIDUAL.

FOR DOLLS AND DOLL CLOTHING (U.S. CLS. 22, 23, 38 AND 50).

APRIL ROACH, EXAMINING ATTORNEY

CLASS 28—(Continued).

SN 85-597,411. JOHNSON, MARGARET I., HERMITAGE, PA. FILED 4-13-2012.

Let's Make Cents

THE MARK CONSISTS OF STANDARD CHARACTERS WITHOUT CLAIM TO ANY PARTICULAR FONT, STYLE, SIZE, OR COLOR.

FOR CHILDREN'S EDUCATIONAL TOYS FOR DEVELOPING FINE MOTOR SKILLS, COGNITIVE SKILLS, AND COUNTING SKILLS (U.S. CLS. 22, 23, 38 AND 50).

FIRST USE 3-25-2012; IN COMMERCE 3-30-2012.
SETH A. RAPPAPORT, EXAMINING ATTORNEY

SN 85-597,458. ZACHARY WEBER, LA GRANGE, IL. FILED 4-13-2012.



NO CLAIM IS MADE TO THE EXCLUSIVE RIGHT TO USE "VOODOO DOLLS" AND "TEAM PINS", APART FROM THE MARK AS SHOWN.

THE MARK CONSISTS OF A STYLIZED IMAGE OF A DOLL THAT LOOKS AS THOUGH IT IS MADE OF CLOTH AND BAMBOO/WICKER TYPE MATERIAL, AND THE STYLIZED TEXT "FANATICS VOODOO DOLLS AND FANATICS TEAM PINS".

FOR NOVELTY SPORTS ITEM, NAMELY, DOLLS BEARING RIVALS SPORTS TEAMS' COLORS, LOGOS AND / OR LIKENESSES, COMBINED WITH PUSH PINS BEARING OTHER SPORTS TEAMS' COLORS, LOGOS AND / OR LIKENESSES (U.S. CLS. 22, 23, 38 AND 50).

SAMUEL E. SHARPER JR., EXAMINING ATTORNEY

CLASS 28—(Continued).

SN 85-597,817. ELK RIVER CUSTOM RODS, LLC., PHILLIPS, WI. FILED 4-13-2012.

ELK RIVER CUSTOM RODS

THE MARK CONSISTS OF STANDARD CHARACTERS WITHOUT CLAIM TO ANY PARTICULAR FONT, STYLE, SIZE, OR COLOR.

NO CLAIM IS MADE TO THE EXCLUSIVE RIGHT TO USE "CUSTOM RODS", APART FROM THE MARK AS SHOWN.

FOR FISHING RODS (U.S. CLS. 22, 23, 38 AND 50).
FIRST USE 11-19-2007; IN COMMERCE 11-19-2007.
ZACHARY BELLO, EXAMINING ATTORNEY

CLASS 28—(Continued).

SN 85-598,541. MATTEL, INC., EL SEGUNDO, CA. FILED 4-16-2012.

BIG BOOTS ALWAYS LAND ON THEIR FEET

THE MARK CONSISTS OF STANDARD CHARACTERS WITHOUT CLAIM TO ANY PARTICULAR FONT, STYLE, SIZE, OR COLOR.

FOR TOY FIGURES AND ACCESSORIES THEREFOR; TOY FIGURE PLAYSETS AND ACCESSORIES THEREFOR; TOY VEHICLES AND ACCESSORIES THEREFOR; TOY VEHICLE PLAYSETS AND ACCESSORIES THEREFOR (U.S. CLS. 22, 23, 38 AND 50).
DOMINIC FATHY, EXAMINING ATTORNEY

SN 85-598,360. GATEWAY GAMING, LLC, PIEDMONT, SC. FILED 4-16-2012.

GO BANANAS

THE MARK CONSISTS OF STANDARD CHARACTERS WITHOUT CLAIM TO ANY PARTICULAR FONT, STYLE, SIZE, OR COLOR.

FOR GAMING EQUIPMENT, NAMELY, GAMING MACHINES BEING CONFIGURED TO OFFER ELECTRONIC SLOT GAMES, ELECTRONIC BINGO GAMES, ELECTRONIC CASINO GAMES, AND ELECTRONIC SWEEPSTAKES GAMES (U.S. CLS. 22, 23, 38 AND 50).
KATHERINE E. HALMEN, EXAMINING ATTORNEY

SN 85-598,544. MATTEL, INC., EL SEGUNDO, CA. FILED 4-16-2012.

DEVASTADIUM

THE MARK CONSISTS OF STANDARD CHARACTERS WITHOUT CLAIM TO ANY PARTICULAR FONT, STYLE, SIZE, OR COLOR.

FOR TOY FIGURES AND ACCESSORIES THEREFOR; TOY FIGURE PLAYSETS AND ACCESSORIES THEREFOR (U.S. CLS. 22, 23, 38 AND 50).
DOMINIC FATHY, EXAMINING ATTORNEY

SN 85-598,540. MATTEL, INC., EL SEGUNDO, CA. FILED 4-16-2012.

WE ALWAYS LAND ON OUR FEET

THE MARK CONSISTS OF STANDARD CHARACTERS WITHOUT CLAIM TO ANY PARTICULAR FONT, STYLE, SIZE, OR COLOR.

FOR TOY FIGURES AND ACCESSORIES THEREFOR; TOY FIGURE PLAYSETS AND ACCESSORIES THEREFOR; TOY VEHICLES AND ACCESSORIES THEREFOR; TOY VEHICLE PLAYSETS AND ACCESSORIES THEREFOR (U.S. CLS. 22, 23, 38 AND 50).
DOMINIC FATHY, EXAMINING ATTORNEY

SN 85-598,571. MATTEL, INC., EL SEGUNDO, CA. FILED 4-16-2012.

INVISI BILLY

THE MARK CONSISTS OF STANDARD CHARACTERS WITHOUT CLAIM TO ANY PARTICULAR FONT, STYLE, SIZE, OR COLOR.

FOR DOLLS, DOLL CLOTHING AND DOLL ACCESSORIES (U.S. CLS. 22, 23, 38 AND 50).
DOMINIC FATHY, EXAMINING ATTORNEY

CLASS 28—(Continued).

SN 85-598,574. MATTEL, INC., EL SEGUNDO, CA. FILED 4-16-2012.

ULTIMATE PLAY DAY

THE MARK CONSISTS OF STANDARD CHARACTERS WITHOUT CLAIM TO ANY PARTICULAR FONT, STYLE, SIZE, OR COLOR.

FOR DOLLS, DOLL CLOTHING AND DOLL ACCESSORIES (U.S. CLS. 22, 23, 38 AND 50).
DOMINIC FATHY, EXAMINING ATTORNEY

SN 85-598,580. MATTEL, INC., EL SEGUNDO, CA. FILED 4-16-2012.

SPLASH & NAP

THE MARK CONSISTS OF STANDARD CHARACTERS WITHOUT CLAIM TO ANY PARTICULAR FONT, STYLE, SIZE, OR COLOR.

FOR DOLLS, DOLL CLOTHING AND DOLL ACCESSORIES (U.S. CLS. 22, 23, 38 AND 50).
DOMINIC FATHY, EXAMINING ATTORNEY

SN 85-598,584. MATTEL, INC., EL SEGUNDO, CA. FILED 4-16-2012.

CATRINE DEMEW

THE MARK CONSISTS OF STANDARD CHARACTERS WITHOUT CLAIM TO ANY PARTICULAR FONT, STYLE, SIZE, OR COLOR.

THE NAME(S), PORTRAIT(S), AND/OR SIGNATURE(S) SHOWN IN THE MARK DOES NOT IDENTIFY A PARTICULAR LIVING INDIVIDUAL.

FOR DOLLS, DOLL CLOTHING AND DOLL ACCESSORIES (U.S. CLS. 22, 23, 38 AND 50).
DOMINIC FATHY, EXAMINING ATTORNEY

CLASS 28—(Continued).

SN 85-598,699. BERMAL, JAY, SAN DIEGO, CA. FILED 4-16-2012.

Reincarnate

THE MARK CONSISTS OF STANDARD CHARACTERS WITHOUT CLAIM TO ANY PARTICULAR FONT, STYLE, SIZE, OR COLOR.

FOR SKATEBOARD TRUCKS (U.S. CLS. 22, 23, 38 AND 50).
KATHERINE M. DUBRAY, EXAMINING ATTORNEY

SN 85-599,124. SWAGGER SPORTS, INC., OSSINING, NY. FILED 4-16-2012.

SWAGGER NETS

THE MARK CONSISTS OF STANDARD CHARACTERS WITHOUT CLAIM TO ANY PARTICULAR FONT, STYLE, SIZE, OR COLOR.

NO CLAIM IS MADE TO THE EXCLUSIVE RIGHT TO USE "NETS", APART FROM THE MARK AS SHOWN.
FOR NETS FOR SPORTS (U.S. CLS. 22, 23, 38 AND 50).
JORDAN BAKER, EXAMINING ATTORNEY

SN 85-599,261. FADESCAPE STUDIOS LLC, LYNWOOD, WA. FILED 4-16-2012.

STRATEGY OF WAR

NO CLAIM IS MADE TO THE EXCLUSIVE RIGHT TO USE "STRATEGY OF WAR", APART FROM THE MARK AS SHOWN.

THE MARK CONSISTS OF THE WORDS "STRATEGY OF WAR" ABOVE A STRAIGHT LINE DISSECTED IN THE MIDDLE BY A FIVE POINTED STAR.

FOR TRADING CARD GAMES (U.S. CLS. 22, 23, 38 AND 50).
CHARISMA HAMPTON, EXAMINING ATTORNEY

CLASS 28—(Continued).

SN 85-599,292. THE KYJEN COMPANY, INC., CENTEN-
NIAL, CO. FILED 4-16-2012.



NO CLAIM IS MADE TO THE EXCLUSIVE RIGHT TO
USE "DOG TOY PUZZLE", APART FROM THE MARK AS
SHOWN.

THE COLOR(S) RED, YELLOW, AND WHITE IS/ARE
CLAIMED AS A FEATURE OF THE MARK.

THE MARK CONSISTS OF THE TERM "STAR SPINNER"
IN WHITE WITH A RED OUTLINE AND THE TERM "DOG
TOY PUZZLE" IN YELLOW DIRECTLY BENEATH.

FOR DOG TOYS (U.S. CLS. 22, 23, 38 AND 50).
GIANCARLO CASTRO, EXAMINING ATTORNEY

CLASS 28—(Continued).

SN 85-599,579. PEARL PROSPORTS INC., SAVANNAH, NY.
FILED 4-17-2012.

PEARL PUTTER

THE MARK CONSISTS OF STANDARD CHARACTERS
WITHOUT CLAIM TO ANY PARTICULAR FONT, STYLE,
SIZE, OR COLOR.

NO CLAIM IS MADE TO THE EXCLUSIVE RIGHT TO
USE "PUTTER", APART FROM THE MARK AS SHOWN.
FOR GOLF PUTTERS (U.S. CLS. 22, 23, 38 AND 50).

FIRST USE 7-11-2011; IN COMMERCE 1-28-2012.
LOURDES AYALA, EXAMINING ATTORNEY

SN 85-599,603. LIMITLESS WELLNESS PROJECT LLC,
BEVERLY HILLS, CA. FILED 4-17-2012.



NO CLAIM IS MADE TO THE EXCLUSIVE RIGHT TO
USE "RESISTANCE", APART FROM THE MARK AS
SHOWN.

THE MARK CONSISTS OF BLOCK LETTERS "LR" WITH
A SIDWAYS FIGURE "8" DESIGN ENCOMPASSED WITH-
IN THE LETTER R AND WORDS "LIMITLESS RESIS-
TANCE" BELOW.

FOR EXERCISE MACHINES (U.S. CLS. 22, 23, 38 AND
50).
BRIDGETT SMITH, EXAMINING ATTORNEY

SN 85-599,309. THE KYJEN COMPANY, INC., CENTEN-
NIAL, CO. FILED 4-16-2012.



NO CLAIM IS MADE TO THE EXCLUSIVE RIGHT TO
USE "DOG TOY PUZZLE", APART FROM THE MARK AS
SHOWN.

THE MARK CONSISTS OF THE TERM "TREAT WHEEL"
IN WHITE WITH A RED OUTLINE AND THE TERM "DOG
TOY PUZZLE" IN YELLOW DIRECTLY BENEATH.

FOR DOG TOYS (U.S. CLS. 22, 23, 38 AND 50).
GIANCARLO CASTRO, EXAMINING ATTORNEY

CLASS 28—(Continued).

SN 85-599,634. BOSSA INTERNATIONAL, INC., MIAMI BEACH, FL. FILED 4-17-2012.



THE MARK CONSISTS OF THE DESIGN OF A BALL WITH WAVY PATTERNS IN CONTRASTING SHADING. FOR SOCCER BALLS; VOLLEYBALLS (U.S. CLS. 22, 23, 38 AND 50).
MICHAEL WIENER, EXAMINING ATTORNEY

SN 85-599,723. DIXIE MOO GAMES LLC, COUNCIL BLUFFS, IA. FILED 4-17-2012.

Dixie Moo Games LLC

THE MARK CONSISTS OF STANDARD CHARACTERS WITHOUT CLAIM TO ANY PARTICULAR FONT, STYLE, SIZE, OR COLOR.
NO CLAIM IS MADE TO THE EXCLUSIVE RIGHT TO USE "GAMES LLC", APART FROM THE MARK AS SHOWN.
FOR BOARD GAMES; PARLOR GAMES (U.S. CLS. 22, 23, 38 AND 50).
ZHALEH DELANEY, EXAMINING ATTORNEY

SN 85-600,214. BAHNE & COMPANY, INC., ENCINITAS, CA. FILED 4-17-2012.

BAHNE

THE MARK CONSISTS OF STANDARD CHARACTERS WITHOUT CLAIM TO ANY PARTICULAR FONT, STYLE, SIZE, OR COLOR.
FOR BAGS FOR SKATEBOARDS; BALL BEARINGS FOR SKATEBOARDS; NUTS AND BOLTS FOR SKATEBOARDS; PROTECTIVE PADDING FOR SKATEBOARDING; SKATEBOARD DECKS; SKATEBOARD GRIP TAPES; SKATEBOARD RISER PADS; SKATEBOARD TRUCKS; SKATEBOARD WHEELS; SKATEBOARDS (U.S. CLS. 22, 23, 38 AND 50).
FIRST USE 8-1-2002; IN COMMERCE 8-1-2002.
BRIAN PINO, EXAMINING ATTORNEY

CLASS 28—(Continued).

SN 85-600,731. GLOECKNER, JOHN, DUBUQUE, IA. FILED 4-18-2012.

DartMinder

THE MARK CONSISTS OF STANDARD CHARACTERS WITHOUT CLAIM TO ANY PARTICULAR FONT, STYLE, SIZE, OR COLOR.
FOR ACTION TARGET GAMES; ACTION-TYPE TARGET GAMES; DART BOARD OVERLAYS; DART BOARDS; DART GAMES; DARTS; ELECTRONIC DART GAMES; EQUIPMENT SOLD AS A UNIT FOR PLAYING ACTION TYPE TARGET GAMES; TARGET GAMES; TARGETS (U.S. CLS. 22, 23, 38 AND 50).
FIRST USE 1-21-2012; IN COMMERCE 1-21-2012.
MATTHEW PAPPAS, EXAMINING ATTORNEY

SN 85-600,993. AMERICAN SOCCER COMPANY, INC., WILMINGTON, CA. FILED 4-18-2012.

SCORE

THE MARK CONSISTS OF STANDARD CHARACTERS WITHOUT CLAIM TO ANY PARTICULAR FONT, STYLE, SIZE, OR COLOR.
OWNER OF U.S. REG. NOS. 1,422,027, 3,618,127 AND OTHERS.
FOR SPORTING EQUIPMENT, NAMELY, CORNER FLAGS AND CASES THEREFOR, PLAYING FIELD CONES FOR SOCCER AND SHIN GUARDS FOR ATHLETIC USE; BASKETBALLS; BASKETBALL TUBE BAGS; NETS FOR BALL GAMES; SOCCER BALLS; SOCCER BALL BAGS; SOCCER REFEREE EQUIPMENT, NAMELY, HOLDERS FOR CARRYING SIGNAL CARDS; SOCCER BALL GOAL NETS; NEEDLES FOR PUMPS FOR INFLATING SPORTS EQUIPMENT; AND PUMPS ESPECIALLY ADAPTED FOR USE WITH BALLS FOR GAMES (U.S. CLS. 22, 23, 38 AND 50).
FIRST USE 3-1-1986; IN COMMERCE 3-1-1986.
EDWARD NELSON, EXAMINING ATTORNEY

SN 85-601,046. MICHAEL J POFF LCSW PA, TAMPA, FL. FILED 4-18-2012.

WISE 'N UP

THE MARK CONSISTS OF STANDARD CHARACTERS WITHOUT CLAIM TO ANY PARTICULAR FONT, STYLE, SIZE, OR COLOR.
FOR BOARD GAMES (U.S. CLS. 22, 23, 38 AND 50).
LOURDES AYALA, EXAMINING ATTORNEY

CLASS 28—(Continued).

SN 85-601,346. HEARST COMMUNICATIONS, INC., NEW YORK, NY. FILED 4-18-2012.

POPULAR MECHANICS FOR KIDS

THE MARK CONSISTS OF STANDARD CHARACTERS WITHOUT CLAIM TO ANY PARTICULAR FONT, STYLE, SIZE, OR COLOR.
OWNER OF U.S. REG. NOS. 101,201, 3,169,152 AND OTHERS.
NO CLAIM IS MADE TO THE EXCLUSIVE RIGHT TO USE "FOR KIDS", APART FROM THE MARK AS SHOWN.
FOR TOY TOOLS (U.S. CLS. 22, 23, 38 AND 50).
SETH A. RAPPAPORT, EXAMINING ATTORNEY

SN 85-601,374. ICON HEALTH & FITNESS, INC., LOGAN, UT. FILED 4-18-2012.

BOOTY FIRM

THE MARK CONSISTS OF STANDARD CHARACTERS WITHOUT CLAIM TO ANY PARTICULAR FONT, STYLE, SIZE, OR COLOR.
FOR MANUALLY-OPERATED EXERCISE EQUIPMENT (U.S. CLS. 22, 23, 38 AND 50).
FIRST USE 4-17-2012; IN COMMERCE 4-17-2012.
TINA L. SNAPP, EXAMINING ATTORNEY

SN 85-601,939. ATHENA C. TSAKOPOULOS, DBA TREEHOUSE LANE, SACRAMENTO, CA. FILED 4-18-2012.

Treehouse Lane

THE MARK CONSISTS OF STANDARD CHARACTERS WITHOUT CLAIM TO ANY PARTICULAR FONT, STYLE, SIZE, OR COLOR.
NO CLAIM IS MADE TO THE EXCLUSIVE RIGHT TO USE "TREEHOUSE", APART FROM THE MARK AS SHOWN.
FOR TOY TREEHOUSE AND MANIPULATIVE GAMES FOR CHILDREN OF ALL AGES WHO LIVE WITH NEURODEVELOPMENTAL DISORDERS (U.S. CLS. 22, 23, 38 AND 50).
JOHN E. MICHOS, EXAMINING ATTORNEY

CLASS 28—(Continued).

SN 85-602,197. WINSLOW, DAVID, HIGHLAND VILLAGE, TX. FILED 4-19-2012.



THE MARK CONSISTS OF A STYLIZED TRIANGLE DESIGN WITH THE WORDS "POUR IT IN" WRITTEN BELOW THE TRIANGLE.
FOR GOLF TRAINING APPARATUS, NAMELY, A GOLF BALL ALIGNMENT AID (U.S. CLS. 22, 23, 38 AND 50).
JASON LOTT, EXAMINING ATTORNEY

SN 85-602,222. BATTAT INC., PLATTSBURGH, NY. FILED 4-19-2012.

SEA YA!

THE MARK CONSISTS OF STANDARD CHARACTERS WITHOUT CLAIM TO ANY PARTICULAR FONT, STYLE, SIZE, OR COLOR.
FOR INFANT DEVELOPMENT TOYS (U.S. CLS. 22, 23, 38 AND 50).
KELLEY WELLS, EXAMINING ATTORNEY

SN 85-602,413. PLAYCORE IP SUB, INC., CHATTANOOGA, TN. FILED 4-19-2012.

WRINKLE WALL CLIMBER

THE MARK CONSISTS OF STANDARD CHARACTERS WITHOUT CLAIM TO ANY PARTICULAR FONT, STYLE, SIZE, OR COLOR.
NO CLAIM IS MADE TO THE EXCLUSIVE RIGHT TO USE "WALL CLIMBER", APART FROM THE MARK AS SHOWN.
FOR PLAYGROUND EQUIPMENT, NAMELY, CLIMBING UNITS (U.S. CLS. 22, 23, 38 AND 50).
AHSEN KHAN, EXAMINING ATTORNEY

CLASS 28—(Continued).

SN 85-602,785. JOHNSTON & SELLERS, INC., STAFFORD, TX. FILED 4-19-2012.

CSPIN

THE MARK CONSISTS OF STANDARD CHARACTERS WITHOUT CLAIM TO ANY PARTICULAR FONT, STYLE, SIZE, OR COLOR.

FOR BASEBALL AND SOFTBALL TRAINING APPARATUS USED FOR PITCHING (U.S. CLS. 22, 23, 38 AND 50).

TRACY FLETCHER, EXAMINING ATTORNEY

SN 85-603,157. CALLAWAY GOLF COMPANY, CARLSBAD, CA. FILED 4-19-2012.

Designed To Benefit A Woman's Game

THE MARK CONSISTS OF STANDARD CHARACTERS WITHOUT CLAIM TO ANY PARTICULAR FONT, STYLE, SIZE, OR COLOR.

FOR GOLF BALLS (U.S. CLS. 22, 23, 38 AND 50).
CIMMERIAN COLEMAN, EXAMINING ATTORNEY

SN 85-603,162. CALLAWAY GOLF COMPANY, CARLSBAD, CA. FILED 4-19-2012.

For Distance, Play It Straight

THE MARK CONSISTS OF STANDARD CHARACTERS WITHOUT CLAIM TO ANY PARTICULAR FONT, STYLE, SIZE, OR COLOR.

FOR GOLF BALLS (U.S. CLS. 22, 23, 38 AND 50).
CIMMERIAN COLEMAN, EXAMINING ATTORNEY

SN 85-603,166. CALLAWAY GOLF COMPANY, CARLSBAD, CA. FILED 4-19-2012.

Bring The Heat On Every Swing

THE MARK CONSISTS OF STANDARD CHARACTERS WITHOUT CLAIM TO ANY PARTICULAR FONT, STYLE, SIZE, OR COLOR.

FOR GOLF BALLS (U.S. CLS. 22, 23, 38 AND 50).
CIMMERIAN COLEMAN, EXAMINING ATTORNEY

CLASS 28—(Continued).

SN 85-603,173. CALLAWAY GOLF COMPANY, CARLSBAD, CA. FILED 4-19-2012.

This Bird Will Fly

THE MARK CONSISTS OF STANDARD CHARACTERS WITHOUT CLAIM TO ANY PARTICULAR FONT, STYLE, SIZE, OR COLOR.

FOR GOLF BALLS (U.S. CLS. 22, 23, 38 AND 50).
CIMMERIAN COLEMAN, EXAMINING ATTORNEY

SN 85-603,313. ISLAMORADA SPORTSMAN INC., SUNRISE, FL. FILED 4-20-2012.

SKULLCANDY

THE MARK CONSISTS OF STANDARD CHARACTERS WITHOUT CLAIM TO ANY PARTICULAR FONT, STYLE, SIZE, OR COLOR.

FOR BODY BOARDS; SKATEBOARD DECKS; SKATEBOARDS; SKIM BOARDS; SNOW BOARDS; SURFBOARDS (U.S. CLS. 22, 23, 38 AND 50).

FIRST USE 11-28-2005; IN COMMERCE 1-2-2006.
NAKIA HENRY, EXAMINING ATTORNEY

SN 85-603,615. INNOVATIVE DESIGN & SOURCING, LLC, MILFORD, CT. FILED 4-20-2012.

GENERAL BARKER

THE MARK CONSISTS OF STANDARD CHARACTERS WITHOUT CLAIM TO ANY PARTICULAR FONT, STYLE, SIZE, OR COLOR.

FOR PET TOYS (U.S. CLS. 22, 23, 38 AND 50).
FIRST USE 6-30-2010; IN COMMERCE 11-24-2010.
MARTHA FROMM, EXAMINING ATTORNEY

CLASS 28—(Continued).

SN 85-603,793. GENESIS TENNIS LLC, DANIA, FL. FILED 4-20-2012.

Typhoon

THE MARK CONSISTS OF STANDARD CHARACTERS WITHOUT CLAIM TO ANY PARTICULAR FONT, STYLE, SIZE, OR COLOR.

FOR STRINGS FOR RACKETS; TENNIS RACKET STRINGS (U.S. CLS. 22, 23, 38 AND 50).

FIRST USE 6-0-2010; IN COMMERCE 6-0-2010.
DAVID MURRAY, EXAMINING ATTORNEY

SN 85-603,801. GENESIS TENNIS LLC, DANIA, FL. FILED 4-20-2012.

TWISTED RAZOR

THE MARK CONSISTS OF STANDARD CHARACTERS WITHOUT CLAIM TO ANY PARTICULAR FONT, STYLE, SIZE, OR COLOR.

FOR STRINGS FOR RACKETS; TENNIS RACKET STRINGS (U.S. CLS. 22, 23, 38 AND 50).

FIRST USE 3-0-2011; IN COMMERCE 3-0-2011.
DAVID MURRAY, EXAMINING ATTORNEY

SN 85-603,821. GENESIS TENNIS LLC, DANIA, FL. FILED 4-20-2012.

BLACK MAGIC

THE MARK CONSISTS OF STANDARD CHARACTERS WITHOUT CLAIM TO ANY PARTICULAR FONT, STYLE, SIZE, OR COLOR.

FOR STRINGS FOR RACKETS; TENNIS RACKET STRINGS (U.S. CLS. 22, 23, 38 AND 50).

FIRST USE 5-0-2009; IN COMMERCE 5-0-2009.
DAVID MURRAY, EXAMINING ATTORNEY

CLASS 28—(Continued).

SN 85-604,024. ZACHARY WEBER, LA GRANGE, IL. FILED 4-20-2012.



NO CLAIM IS MADE TO THE EXCLUSIVE RIGHT TO USE "VOODOO DOLLS" AND "TEAM PINS", APART FROM THE MARK AS SHOWN.

THE MARK CONSISTS OF A STYLIZED IMAGE OF A DOLL THAT LOOKS AS THOUGH IT IS MADE OF CLOTH AND BAMBOO/WICKER MATERIAL, AND THE STYLIZED TEXT "ON-CAMPUS VOODOO DOLLS AND ON-CAMPUS TEAM PINS".

FOR NOVELTY SPORTS ITEM, NAMELY, DOLLS BEARING RIVALS SPORTS TEAMS' COLORS, LOGOS AND / OR LIKENESSES, COMBINED WITH PUSH PINS BEARING OTHER SPORTS TEAMS' COLORS, LOGOS AND / OR LIKENESSES (U.S. CLS. 22, 23, 38 AND 50).

SAMUEL E. SHARPER JR., EXAMINING ATTORNEY

SN 85-604,103. ZACHARY WEBER, LA GRANGE, IL. FILED 4-20-2012.



NO CLAIM IS MADE TO THE EXCLUSIVE RIGHT TO USE "VOODOO DOLLS" AND "TEAM PINS", APART FROM THE MARK AS SHOWN.

THE MARK CONSISTS OF A STYLIZED IMAGE OF A DOLL THAT LOOKS AS THOUGH IT IS MADE OF CLOTH AND BAMBOO/WICKER TYPE MATERIAL, AND THE STYLIZED TEXT "FANSEDGE VOODOO DOLLS AND FANSEDGE TEAM PINS".

FOR NOVELTY SPORTS ITEM, NAMELY, DOLLS BEARING RIVAL SPORTS TEAMS' COLORS, LOGOS AND / OR LIKENESSES, COMBINED WITH PUSH PINS BEARING OTHER SPORTS TEAMS' COLORS, LOGOS AND / OR LIKENESSES (U.S. CLS. 22, 23, 38 AND 50).

SAMUEL E. SHARPER JR., EXAMINING ATTORNEY

CLASS 28—(Continued).

SN 85-604,138. 2 FUNGUYS, LLC, PHOENIX, AZ. FILED 4-20-2012.

MORAL DILEMMA

THE MARK CONSISTS OF STANDARD CHARACTERS WITHOUT CLAIM TO ANY PARTICULAR FONT, STYLE, SIZE, OR COLOR.

FOR BOARD GAMES; CARD GAMES (U.S. CLS. 22, 23, 38 AND 50).

VIVIAN MICZNIK FIRST, EXAMINING ATTORNEY

CLASS 28—(Continued).

SN 85-604,554. HARDIN, JEFF, CHASKA, MN. FILED 4-21-2012.

KAZKIN

THE MARK CONSISTS OF STANDARD CHARACTERS WITHOUT CLAIM TO ANY PARTICULAR FONT, STYLE, SIZE, OR COLOR.

FOR TOY GUNS (U.S. CLS. 22, 23, 38 AND 50).

AMY HELLA, EXAMINING ATTORNEY

SN 85-604,249. WALTERS, GEORGE, STATEN ISLAND, NY. FILED 4-20-2012.

SHISH - K - BALL

THE MARK CONSISTS OF STANDARD CHARACTERS WITHOUT CLAIM TO ANY PARTICULAR FONT, STYLE, SIZE, OR COLOR.

FOR CHILDREN'S EDUCATIONAL TOYS FOR DEVELOPING NUMERIC, ALPHABETIC, AND COGNITIVE SKILLS (U.S. CLS. 22, 23, 38 AND 50).

KIM SAITO, EXAMINING ATTORNEY

SN 85-604,556. HARDIN, JEFF, CHASKA, MN. FILED 4-21-2012.

FENRIR

THE MARK CONSISTS OF STANDARD CHARACTERS WITHOUT CLAIM TO ANY PARTICULAR FONT, STYLE, SIZE, OR COLOR.

FOR TOY GUNS (U.S. CLS. 22, 23, 38 AND 50).

AMY HELLA, EXAMINING ATTORNEY

SN 85-604,274. JETAVATION INC., REDDING, CA. FILED 4-20-2012.

Jetovator

THE MARK CONSISTS OF STANDARD CHARACTERS WITHOUT CLAIM TO ANY PARTICULAR FONT, STYLE, SIZE, OR COLOR.

FOR RIDEABLE TOYS AND ACCESSORIES THEREFOR (U.S. CLS. 22, 23, 38 AND 50).

WILLIAM BRECKENFELD, EXAMINING ATTORNEY

SN 85-604,772. ROOSTERFIN, INC., MORICHES, NY. FILED 4-22-2012.

PongCano

THE MARK CONSISTS OF STANDARD CHARACTERS WITHOUT CLAIM TO ANY PARTICULAR FONT, STYLE, SIZE, OR COLOR.

FOR ACTION SKILL GAMES (U.S. CLS. 22, 23, 38 AND 50).

FIRST USE 11-1-2010; IN COMMERCE 5-1-2011.

CHRISTINE MARTIN, EXAMINING ATTORNEY

CLASS 28—(Continued).

SN 85-605,105. PRESSLER, DAVID, BEVERLY HILLS, CA. FILED 4-23-2012.

DR. MAKER

THE MARK CONSISTS OF STANDARD CHARACTERS WITHOUT CLAIM TO ANY PARTICULAR FONT, STYLE, SIZE, OR COLOR.

FOR ACTION FIGURES AND ACCESSORIES THEREFOR; COLLECTABLE TOY FIGURES; POSITIONABLE TOY FIGURES (U.S. CLS. 22, 23, 38 AND 50). FIRST USE 9-20-2009; IN COMMERCE 9-20-2009. CHRIS DONINGER, EXAMINING ATTORNEY

CLASS 28—(Continued).

SN 85-605,704. SHARK BRANDING CORP., NEW YORK, NY. FILED 4-23-2012.

THE MOGULS GROUP

THE MARK CONSISTS OF STANDARD CHARACTERS WITHOUT CLAIM TO ANY PARTICULAR FONT, STYLE, SIZE, OR COLOR.

NO CLAIM IS MADE TO THE EXCLUSIVE RIGHT TO USE "GROUP", APART FROM THE MARK AS SHOWN.

FOR ATHLETIC EQUIPMENT, NAMELY, STRIKING BAGS; ATHLETIC EQUIPMENT, NAMELY, STRIKING SHIELDS; ATHLETIC SPORTING GOODS, NAMELY, ATHLETIC WRIST AND JOINT SUPPORTS; ATHLETIC TAPE; BADMINTON SETS; BASEBALL BATS; BASEBALL BATTING GLOVES; BASEBALL GLOVES; BASEBALLS; BASKETBALL GOALS; BASKETBALL TABLE TOP GAMES; BASKETBALLS; BATS FOR GAMES; BATTING GLOVES; BILLIARD EQUIPMENT; BOBBLEHEAD DOLLS; BODY-BUILDING APPARATUS; BOWLING BALLS; BOXING BAGS; BOXING GLOVES; DART GAMES; DARTS; EXERCISE BENCHES; EXERCISE EQUIPMENT, NAMELY, CHEST EXPANDERS; EXERCISE EQUIPMENT, NAMELY, CHEST PULLS; EXERCISE MACHINES; EXERCISING EQUIPMENT, NAMELY, WEIGHT LIFTING MACHINES; FOOTBALLS; PUNCHING BAGS; PUNCHING BALLS (U.S. CLS. 22, 23, 38 AND 50).

KERI CANTONE, EXAMINING ATTORNEY

SN 85-605,284. MY FURRY KIDS TOY BOX LLC, PARADISE VALLEY, AZ. FILED 4-23-2012.

My Furry Kids

THE MARK CONSISTS OF STANDARD CHARACTERS WITHOUT CLAIM TO ANY PARTICULAR FONT, STYLE, SIZE, OR COLOR.

FOR PET TOYS (U.S. CLS. 22, 23, 38 AND 50). KATINA MISTER, EXAMINING ATTORNEY

SN 85-605,714. AKERSTEIN, ARI, S, DBA AKROSOLUTIONS, LLC., SF, CA. FILED 4-23-2012.

COREwheels

FUNDAMENTALS

THE MARK CONSISTS OF STANDARD CHARACTERS WITHOUT CLAIM TO ANY PARTICULAR FONT, STYLE, SIZE, OR COLOR.

FOR PET TOYS (U.S. CLS. 22, 23, 38 AND 50). GIANCARLO CASTRO, EXAMINING ATTORNEY

THE MARK CONSISTS OF STANDARD CHARACTERS WITHOUT CLAIM TO ANY PARTICULAR FONT, STYLE, SIZE, OR COLOR.

FOR EXERCISE BARS; EXERCISE EQUIPMENT, NAMELY, ROLLING EXERCISE BARS (U.S. CLS. 22, 23, 38 AND 50).

RICHARD WHITE, EXAMINING ATTORNEY

CLASS 28—(Continued).

SN 85-605,934. HUANG, BRENDA, HOLLADAY, UT. FILED 4-23-2012.



THE MARK CONSISTS OF STYLIZED UPPER CASE M TYPEFACE CHARACTER WITH STYLIZED MAGIC BOX NAME POSITIONED DIRECTLY UNDERNEATH THE SYMBOL.

FOR AIRSOFT GUNS AND INTERNAL UPGRADE PARTS FOR AIRSOFT GUNS, NAMELY, AIR SEAL NOZZLE, CYLINDER HEAD, CYLINDER, PISTON HEAD, PISTON, SPRING, SPRING GUIDE, GEARS AND BEARING DESIGNED TO BE USED BY ADULTS FOR RECREATIONAL PURPOSES (U.S. CLS. 22, 23, 38 AND 50).

FIRST USE 5-1-2012; IN COMMERCE 5-1-2012.
B. PARADEWELAI, EXAMINING ATTORNEY

SN 85-605,935. MAXWELL, WARREN, PLANO, TX. FILED 4-23-2012.

Olympus

THE MARK CONSISTS OF STANDARD CHARACTERS WITHOUT CLAIM TO ANY PARTICULAR FONT, STYLE, SIZE, OR COLOR.

FOR ICE SKATE BLADES (U.S. CLS. 22, 23, 38 AND 50).

B. PARADEWELAI, EXAMINING ATTORNEY

SN 85-607,312. KURUL, FATMA D., BRISTOL, CT. FILED 4-25-2012.

Read the Pictures Draw the Words

THE MARK CONSISTS OF STANDARD CHARACTERS WITHOUT CLAIM TO ANY PARTICULAR FONT, STYLE, SIZE, OR COLOR.

FOR EDUCATIONAL CARD GAMES (U.S. CLS. 22, 23, 38 AND 50).

AMY HELLA, EXAMINING ATTORNEY

CLASS 28—(Continued).

SN 85-607,388. GATEWAY GAMING, LLC, PIEDMONT, SC. FILED 4-25-2012.

HOTWIRE

THE MARK CONSISTS OF STANDARD CHARACTERS WITHOUT CLAIM TO ANY PARTICULAR FONT, STYLE, SIZE, OR COLOR.

FOR GAMING EQUIPMENT, NAMELY, GAMING MACHINES (U.S. CLS. 22, 23, 38 AND 50).

KATHERINE E. HALMEN, EXAMINING ATTORNEY

SN 85-607,397. GATEWAY GAMING, LLC, PIEDMONT, SC. FILED 4-25-2012.

LIGHTNING HOT

THE MARK CONSISTS OF STANDARD CHARACTERS WITHOUT CLAIM TO ANY PARTICULAR FONT, STYLE, SIZE, OR COLOR.

FOR GAMING EQUIPMENT, NAMELY, GAMING MACHINES (U.S. CLS. 22, 23, 38 AND 50).

KATHERINE E. HALMEN, EXAMINING ATTORNEY

SN 85-608,449. CALLAWAY GOLF COMPANY, CARLSBAD, CA. FILED 4-25-2012.

V-Line

THE MARK CONSISTS OF STANDARD CHARACTERS WITHOUT CLAIM TO ANY PARTICULAR FONT, STYLE, SIZE, OR COLOR.

FOR GOLF BAGS; GOLF CLUBS; HEAD COVERS FOR GOLF CLUBS (U.S. CLS. 22, 23, 38 AND 50).

CIMMERIAN COLEMAN, EXAMINING ATTORNEY

CLASS 28—(Continued).

SN 85-610,454. GATEWAY GAMING, LLC, PIEDMONT, SC.
FILED 4-27-2012.

CASH BASH

THE MARK CONSISTS OF STANDARD CHARACTERS WITHOUT CLAIM TO ANY PARTICULAR FONT, STYLE, SIZE, OR COLOR.

FOR GAMING EQUIPMENT, NAMELY, GAMING MACHINES BEING CONFIGURED TO OFFER ELECTRONIC SLOT GAMES, ELECTRONIC BINGO GAMES, ELECTRONIC CASINO GAMES, AND ELECTRONIC SWEEPSTAKES GAMES (U.S. CLS. 22, 23, 38 AND 50).
KATHERINE E. HALMEN, EXAMINING ATTORNEY

CLASS 28—(Continued).

SN 85-627,098. ZOBMONDO!! ENTERTAINMENT LLC,
GREENBRAE, CA. FILED 5-16-2012.

Run Around Fractions

THE MARK CONSISTS OF STANDARD CHARACTERS WITHOUT CLAIM TO ANY PARTICULAR FONT, STYLE, SIZE, OR COLOR.

NO CLAIM IS MADE TO THE EXCLUSIVE RIGHT TO USE "FRACTIONS", APART FROM THE MARK AS SHOWN.

FOR CARD GAMES; EDUCATIONAL CARD GAMES; MEMORY GAMES (U.S. CLS. 22, 23, 38 AND 50).
CHRISTINE MARTIN, EXAMINING ATTORNEY

SN 85-612,315. MATTEL, INC., EL SEGUNDO, CA. FILED 4-30-2012.

SHIMMIES

THE MARK CONSISTS OF STANDARD CHARACTERS WITHOUT CLAIM TO ANY PARTICULAR FONT, STYLE, SIZE, OR COLOR.

FOR TOY ROBOTS; TALKING DOLLS; TOY FIGURES AND ACCESSORIES THEREFOR (U.S. CLS. 22, 23, 38 AND 50).

BRENDAN MCCAULEY, EXAMINING ATTORNEY

SN 85-630,572. K-2 CORPORATION, SEATTLE, WA. FILED 5-21-2012.

ELEKTRA

THE MARK CONSISTS OF STANDARD CHARACTERS WITHOUT CLAIM TO ANY PARTICULAR FONT, STYLE, SIZE, OR COLOR.

FOR SNOWSHOES AND POLES; BAGS SPECIALLY ADAPTED FOR SPORTS EQUIPMENT, NAMELY, SNOWSHOE AND POLE BAGS (U.S. CLS. 22, 23, 38 AND 50).

FIRST USE 8-15-2002; IN COMMERCE 8-15-2002.
KARANENDRA S. CHHINA, EXAMINING ATTORNEY

SN 85-612,318. MATTEL, INC., EL SEGUNDO, CA. FILED 4-30-2012.

FIJIT FAMILY

THE MARK CONSISTS OF STANDARD CHARACTERS WITHOUT CLAIM TO ANY PARTICULAR FONT, STYLE, SIZE, OR COLOR.

OWNER OF U.S. REG. NOS. 4,010,563 AND 4,126,648.
FOR TOY ROBOTS; TALKING DOLLS (U.S. CLS. 22, 23, 38 AND 50).

BRENDAN MCCAULEY, EXAMINING ATTORNEY

SN 85-631,948. THE KONG COMPANY, GOLDEN, CO.
FILED 5-22-2012.

Q TEASE

THE MARK CONSISTS OF STANDARD CHARACTERS WITHOUT CLAIM TO ANY PARTICULAR FONT, STYLE, SIZE, OR COLOR.

OWNER OF U.S. REG. NO. 3,126,864.
FOR PET TOYS (U.S. CLS. 22, 23, 38 AND 50).
CAITLIN WATTS-FITZGERALD, EXAMINING ATTORNEY

CLASS 28—(Continued).

SN 85-636,798. PLAYCORE IP SUB, INC., CHATTANOOGA, TN. FILED 5-29-2012.

CITADEL

THE MARK CONSISTS OF STANDARD CHARACTERS WITHOUT CLAIM TO ANY PARTICULAR FONT, STYLE, SIZE, OR COLOR.

FOR PLAYGROUND EQUIPMENT, NAMELY, TOWER CLIMBING UNITS (U.S. CLS. 22, 23, 38 AND 50).
AHSEN KHAN, EXAMINING ATTORNEY

SN 85-636,904. JETAVATION INC., REDDING, CA. FILED 5-29-2012.



THE MARK CONSISTS OF TRIDENT SHAPED BARS WITH TRIANGLE SEAT ON CENTER BAR WITH A DIAMOND SHAPE ABOVE TRIANGLE SEAT.

FOR RIDEABLE TOYS AND ACCESSORIES THEREFOR (U.S. CLS. 22, 23, 38 AND 50).

FIRST USE 5-21-2012; IN COMMERCE 5-21-2012.

WILLIAM BRECKENFELD, EXAMINING ATTORNEY

SN 85-645,808. HOBBICO, INC., CHAMPAIGN, IL. FILED 6-7-2012.

ARRMA

THE MARK CONSISTS OF STANDARD CHARACTERS WITHOUT CLAIM TO ANY PARTICULAR FONT, STYLE, SIZE, OR COLOR.

FOR RADIO-CONTROLLED MODEL VEHICLES (U.S. CLS. 22, 23, 38 AND 50).

FIRST USE 2-10-2011; IN COMMERCE 2-10-2011.

MATTHEW PAPPAS, EXAMINING ATTORNEY

CLASS 28—(Continued).

SN 85-645,815. HOBBICO, INC., CHAMPAIGN, IL. FILED 6-7-2012.

TEAM DURANGO

THE MARK CONSISTS OF STANDARD CHARACTERS WITHOUT CLAIM TO ANY PARTICULAR FONT, STYLE, SIZE, OR COLOR.

FOR RADIO-CONTROLLED MODEL VEHICLES (U.S. CLS. 22, 23, 38 AND 50).

FIRST USE 6-2-2009; IN COMMERCE 6-2-2009.

MATTHEW PAPPAS, EXAMINING ATTORNEY

SN 85-645,823. HOBBICO, INC., CHAMPAIGN, IL. FILED 6-7-2012.

DBOOTS

THE MARK CONSISTS OF STANDARD CHARACTERS WITHOUT CLAIM TO ANY PARTICULAR FONT, STYLE, SIZE, OR COLOR.

FOR RADIO-CONTROLLED MODEL VEHICLE COMPONENT PARTS, NAMELY, TIRES (U.S. CLS. 22, 23, 38 AND 50).

FIRST USE 2-3-2011; IN COMMERCE 2-3-2011.

MATTHEW PAPPAS, EXAMINING ATTORNEY

SN 85-655,925. EBSCO INDUSTRIES, INC., BIRMINGHAM, AL. FILED 6-19-2012.



OWNER OF U.S. REG. NO. 4,049,424.

THE MARK CONSISTS OF A PARTIAL STYLIZED OUTLINE OF A HARD BAIT FISHING LURE FROM SIDE PERSPECTIVE HAVING ONE CIRCULAR EYE PARTLY COVERED BY THE TOP PORTION OF THE OUTLINE AND HAVING A FISHING LURE LIP CONNECTED TO THE FACE PORTION OF THE PARTIAL BOTTOM OUTLINE WITH A CAPITAL LETTER "B" TO THE RIGHT OF THE LIP AND EYE.

FOR FISHING LURES; FISHING TACKLE (U.S. CLS. 22, 23, 38 AND 50).

FIRST USE 7-1-2004; IN COMMERCE 7-1-2004.

COLLEEN DOMBROW, EXAMINING ATTORNEY

CLASS 28—(Continued).

SN 85-659,447. LUCASFILM ENTERTAINMENT COMPANY LTD., SAN FRANCISCO, CA. FILED 6-22-2012.

501st

THE MARK CONSISTS OF STANDARD CHARACTERS WITHOUT CLAIM TO ANY PARTICULAR FONT, STYLE, SIZE, OR COLOR.

OWNER OF U.S. REG. NO. 3,710,063.
FOR TOY ACTION FIGURES; COLLECTIBLE TOY HELMETS (U.S. CLS. 22, 23, 38 AND 50).
JENNIFER RICHARDSON, EXAMINING ATTORNEY

SN 85-659,874. ZACHARY WEBER, LA GRANGE, IL. FILED 6-24-2012.

RIVALVS VODOO DOLLS

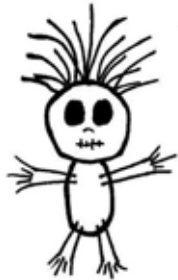

AND RIVALVS TEAM PINS

NO CLAIM IS MADE TO THE EXCLUSIVE RIGHT TO USE "VOODOO DOLLS" AND "TEAM PINS", APART FROM THE MARK AS SHOWN.

THE MARK CONSISTS OF A STYLIZED IMAGE OF A DOLL THAT LOOKS AS THOUGH IT IS MADE OF CLOTH AND BAMBOO WICKER TYPE MATERIAL, AND THE STYLIZED TEXT "RIVALVS VODOO DOLLS AND RIVALVS TEAM PINS".

FOR NOVELTY SPORTS ITEM, NAMELY, DOLLS AND PUSH PINS BEARING SPORTS TEAMS' COLORS, LOGOS AND OR LIKENESSES (U.S. CLS. 22, 23, 38 AND 50).

SAMUEL E. SHARPER JR., EXAMINING ATTORNEY

SN 85-671,608. TOY STATE INDUSTRIAL LTD., TSIMSHAT-SUI, KOWLOON, HONG KONG, FILED 7-9-2012.

MOTOR ISLAND

THE MARK CONSISTS OF STANDARD CHARACTERS WITHOUT CLAIM TO ANY PARTICULAR FONT, STYLE, SIZE, OR COLOR.

OWNER OF U.S. REG. NOS. 3,632,802 AND 3,659,079.
FOR TOY VEHICLES (U.S. CLS. 22, 23, 38 AND 50).
ODESSA BIBBINS, EXAMINING ATTORNEY

CLASS 28—(Continued).

SN 85-671,644. TOY STATE INDUSTRIAL LTD., TSIMSHAT-SUI, KOWLOON, HONG KONG, FILED 7-9-2012.

MONSTER POWER

THE MARK CONSISTS OF STANDARD CHARACTERS WITHOUT CLAIM TO ANY PARTICULAR FONT, STYLE, SIZE, OR COLOR.

FOR TOY VEHICLES (U.S. CLS. 22, 23, 38 AND 50).
ODESSA BIBBINS, EXAMINING ATTORNEY

SN 85-671,675. TOY STATE INDUSTRIAL LTD., TSIMSHAT-SUI, KOWLOON, HONG KONG, FILED 7-9-2012.

MONSTER FORCE

THE MARK CONSISTS OF STANDARD CHARACTERS WITHOUT CLAIM TO ANY PARTICULAR FONT, STYLE, SIZE, OR COLOR.

FOR TOY VEHICLES (U.S. CLS. 22, 23, 38 AND 50).
ODESSA BIBBINS, EXAMINING ATTORNEY

SN 85-686,871. MIAMI TRIBE OF OKLAHOMA BUSINESS DEVELOPMENT AUTHORITY, A TRIBAL ENTERPRISE OF THE MIAMI TRIBE OF OKLAHOMA, MIAMI, OK. FILED 7-25-2012.

GOLDEN PAGODAS

THE MARK CONSISTS OF STANDARD CHARACTERS WITHOUT CLAIM TO ANY PARTICULAR FONT, STYLE, SIZE, OR COLOR.

FOR GAMING MACHINES, NAMELY, BINGO-RELATED GAMES AND SLOT MACHINES (U.S. CLS. 22, 23, 38 AND 50).
KATHY DE JONGE, EXAMINING ATTORNEY

CLASS 28—(Continued).

SN 85-686,915. MIAMI TRIBE OF OKLAHOMA BUSINESS DEVELOPMENT AUTHORITY, A TRIBAL ENTERPRISE OF THE MIAMI TRIBE OF OKLAHOMA, MIAMI, OK. FILED 7-25-2012.

Treasures of the Amazon

THE MARK CONSISTS OF STANDARD CHARACTERS WITHOUT CLAIM TO ANY PARTICULAR FONT, STYLE, SIZE, OR COLOR.

FOR GAMING MACHINES, NAMELY, BINGO-RELATED GAMES AND SLOT MACHINES (U.S. CLS. 22, 23, 38 AND 50).

KATHY DE JONGE, EXAMINING ATTORNEY

SN 85-687,366. MIAMI TRIBE OF OKLAHOMA BUSINESS DEVELOPMENT AUTHORITY, A TRIBAL ENTERPRISE OF THE MIAMI TRIBE OF OKLAHOMA, MIAMI, OK. FILED 7-26-2012.

SECRET AGENT 7: LICENSE TO WIN

THE MARK CONSISTS OF STANDARD CHARACTERS WITHOUT CLAIM TO ANY PARTICULAR FONT, STYLE, SIZE, OR COLOR.

FOR GAMING MACHINES, NAMELY, BINGO-RELATED GAMES AND SLOT MACHINES (U.S. CLS. 22, 23, 38 AND 50).

KATHLEEN M. VANSTON, EXAMINING ATTORNEY

SN 85-688,627. MIAMI TRIBE OF OKLAHOMA BUSINESS DEVELOPMENT AUTHORITY, A TRIBAL ENTERPRISE OF THE MIAMI TRIBE OF OKLAHOMA, MIAMI, OK. FILED 7-27-2012.

GOLD DROP

THE MARK CONSISTS OF STANDARD CHARACTERS WITHOUT CLAIM TO ANY PARTICULAR FONT, STYLE, SIZE, OR COLOR.

FOR GAMING MACHINES, NAMELY, BINGO-RELATED GAMES AND SLOT MACHINES (U.S. CLS. 22, 23, 38 AND 50).

KATHY DE JONGE, EXAMINING ATTORNEY

CLASS 28—(Continued).

SN 85-689,207. MIAMI TRIBE OF OKLAHOMA BUSINESS DEVELOPMENT AUTHORITY, A TRIBAL ENTERPRISE OF THE MIAMI TRIBE OF OKLAHOMA, MIAMI, OK. FILED 7-27-2012.

FREE FOR ALL

THE MARK CONSISTS OF STANDARD CHARACTERS WITHOUT CLAIM TO ANY PARTICULAR FONT, STYLE, SIZE, OR COLOR.

FOR GAMING MACHINES, NAMELY, BINGO-RELATED GAMES AND SLOT MACHINES (U.S. CLS. 22, 23, 38 AND 50).

KATHY DE JONGE, EXAMINING ATTORNEY

CLASS 29—MEATS AND PROCESSED FOODS

SN 76-709,047. CEDAR BARISTA USA, LLC, CARLSTADT, NJ. FILED 9-13-2011.

MBM FOODS

THE MARK CONSISTS OF STANDARD CHARACTERS WITHOUT CLAIM TO ANY PARTICULAR FONT, STYLE, SIZE, OR COLOR.

NO CLAIM IS MADE TO THE EXCLUSIVE RIGHT TO USE "FOODS", APART FROM THE MARK AS SHOWN.

FOR FOOD PRODUCTS, NAMELY, PICKLED VEGETABLES IN THE NATURE OF CUCUMBERS, TURNIPS, WILD CUCUMBERS, AND EGGPLANT PICKLES; OLIVE OIL; PROCESSED BLACK AND GREEN OLIVES; APRICOT, STRAWBERRY AND FIG JAMS; PROCESSED HOT PEPPERS (U.S. CL. 46).

LINDA ESTRADA, EXAMINING ATTORNEY

CLASS 29—(Continued).

SN 76-709,048. CEDAR BARISTA USA, LLC, CARLSTADT, NJ. FILED 9-13-2011.



THE COLOR(S) BLUE, WHITE, YELLOW, AND GREEN IS/ARE CLAIMED AS A FEATURE OF THE MARK.

THE MARK CONSISTS OF THE FOLLOWING: A LANDSCAPE COMPOSED OF A FIELD COMPOSED OF BLUE AND WHITE HORIZONTAL LINES AND FEATURING THREE GREEN ROWS VERTICALLY CROSSING OVER AS WELL AS THE LETTERS "MBM" IN YELLOW ABOVE AGAINST A LIGHT BLUE SKY AND ALL OF THE ELEMENTS OF THE MARK SURROUNDED BY A CIRCLE BORDER.

FOR FOOD PRODUCTS, NAMELY, PICKLED VEGETABLES IN THE NATURE OF CUCUMBERS, TURNIPS, WILD CUCUMBERS, AND EGGPLANT PICKLES; OLIVE OIL; PROCESSED BLACK AND GREEN OLIVES; APRICOT, STRAWBERRY AND FIG JAMS; PROCESSED HOT PEPPERS (U.S. CL. 46).

LINDA ESTRADA, EXAMINING ATTORNEY

SN 78-936,569. FISCH, MICHAEL, NORDERSTEDT, FED REP GERMANY, FILED 7-25-2006.

SLAMMERS ENERGY MILK

THE MARK CONSISTS OF STANDARD CHARACTERS WITHOUT CLAIM TO ANY PARTICULAR FONT, STYLE, SIZE, OR COLOR.

NO CLAIM IS MADE TO THE EXCLUSIVE RIGHT TO USE "ENERGY MILK", APART FROM THE MARK AS SHOWN.

FOR MILK PRODUCTS EXCLUDING ICE CREAM, ICE MILK AND FROZEN YOGURT (U.S. CL. 46).

BENJAMIN OKEKE, EXAMINING ATTORNEY

CLASS 29—(Continued).

SN 79-106,831. LIDL STIFTUNG & CO. KG, 74167 NECK-ARSULM, FED REP GERMANY, FILED 10-7-2011.

FRUIT-KING

THE MARK CONSISTS OF STANDARD CHARACTERS WITHOUT CLAIM TO ANY PARTICULAR FONT, STYLE, SIZE, OR COLOR.

OWNER OF INTERNATIONAL REGISTRATION 0752909 DATED 1-30-2001, EXPIRES 1-30-2021.

FOR MILK, DAIRY PRODUCTS, NAMELY, BUTTER, CHEESE, FRESH MILK, CONDENSED MILK, POWDERED MILK, FRESH CREAM, SOUR CREAM, YOGHURT, BUTTER MILK, KEFIR, SOUR MILK, CURD, DAIRY DESSERTS, EXCLUDING ICE CREAM, ICE MILK AND FROZEN YOGHURT, MADE PRIMARILY FROM YOGHURT, CREAM AND/OR CURD, ALL AFOREMENTIONED GOODS ALSO WITH THE ADDITION OF FRUITS AND FRUIT SUPPLEMENTS (U.S. CL. 46).

AHSEN KHAN, EXAMINING ATTORNEY

SN 85-279,682. NATIONAL DELI, MIAMI, FL. FILED 3-29-2011.



NO CLAIM IS MADE TO THE EXCLUSIVE RIGHT TO USE "DELI", APART FROM THE MARK AS SHOWN.

THE MARK CONSISTS OF THE STYLIZED TEXT "DELI HOST" WITH A LINE AND TWO HALF SEMI CIRCLES.

FOR CORNED BEEF, BEEF PASTRAMI, AND ROAST BEEF ALL SEASONED WITH SOY (U.S. CL. 46).

FIRST USE 6-1-2001; IN COMMERCE 6-1-2001.

MARTHA SANTOMARTINO, EXAMINING ATTORNEY

SN 85-285,112. PRODUCTOS INDUSTRIALIZADOS DEL NOROESTE, S.A. DE C.V., CULIACAN, MEXICO, FILED 4-4-2011.

Ski-T

THE MARK CONSISTS OF STANDARD CHARACTERS WITHOUT CLAIM TO ANY PARTICULAR FONT, STYLE, SIZE, OR COLOR.

OWNER OF MEXICO REG. NO. 1206828, DATED 4-26-2010, EXPIRES 4-26-2020.

FOR MEAT, FISH, POULTRY, GAME; MEAT EXTRACTS; FROZEN, DRIED, CANNED AND COOKED FRUITS AND VEGETABLES; JELLIES, JAMS, COMPOTES, EGGS, MILK AND MILK PRODUCTS, EXCLUDING ICE CREAM, ICE MILK AND FROZEN YOGURT, EDIBLE OILS AND FATS (U.S. CL. 46).

SHAUNIA CARLYLE, EXAMINING ATTORNEY

CLASS 29—(Continued).

SN 85-408,475. WELLSHIRE FARMS WEST, INC., SWEDSBORO, NJ. FILED 8-26-2011.



NO CLAIM IS MADE TO THE EXCLUSIVE RIGHT TO USE "GOURMET", APART FROM THE MARK AS SHOWN.

THE MARK CONSISTS OF WORDS "GLOBAL GOURMET" CENTERED WITHIN AN OUTLINE RECTANGULAR BOX PLACED OVER THE LOWER PORTION OF AN OUTLINED OVAL SHAPE, WITH THE UPPER HALF OF THE OVAL CONTAINING IMAGES OF FAMOUS STRUCTURES FROM AROUND THE WORLD, AND WITH THE EXTREME LOWER PORTION OF THE OVAL CONTAINING FOUR SHAFTS OF WHEAT BEHIND AN OUTLINE CIRCLE WITH TWO "G'S".

FOR ALL NATURAL MEATS (U.S. CL. 46).
FIRST USE 11-17-2008; IN COMMERCE 11-17-2008.
ELIZABETH KAJUBI, EXAMINING ATTORNEY

SN 85-416,642. SQUIRREL BRAND, L.P., MCKINNEY, TX. FILED 9-7-2011.

**CAFE CARMELLATA AU SEL
PECANS**

THE MARK CONSISTS OF STANDARD CHARACTERS WITHOUT CLAIM TO ANY PARTICULAR FONT, STYLE, SIZE, OR COLOR.

OWNER OF U.S. REG. NOS. 3,629,071, 3,720,377 AND 3,942,385.

NO CLAIM IS MADE TO THE EXCLUSIVE RIGHT TO USE "AU SEL PECANS", APART FROM THE MARK AS SHOWN.

THE ENGLISH TRANSLATION OF THE WORDS "AU SEL" IN THE MARK IS IN SALT. THE WORDING "CARMELLATA" HAS NO MEANING IN A FOREIGN LANGUAGE.

FOR PREPARED PROCESSED NUT CANDIES, NAMELY, CANDIED PECANS (U.S. CL. 46).

FIRST USE 7-10-2011; IN COMMERCE 7-10-2011.
DOMINICK J. SALEMI, EXAMINING ATTORNEY

CLASS 29—(Continued).

SN 85-424,313. HOME MARKET FOODS INC., NORWOOD, MA. FILED 9-16-2011.



OWNER OF U.S. REG. NO. 2,400,643.

NO CLAIM IS MADE TO THE EXCLUSIVE RIGHT TO USE "BITES" OR "BITE SIZE", APART FROM THE MARK AS SHOWN.

THE MARK CONSISTS OF THE WORDS "SLAMMERZ BITE SIZE, BIG FLAVOR!" OUTLINED IN A SWIRL DESIGN LOGO. THE UPPER LEFT SIDE OF THE LOGO CONTAINS THE WORDS "ROLLER BITES" IN A SQUARE DESIGN.

FOR MEAT-BASED BREAKFAST AND SNACKING ITEMS, NAMELY, BITE-SIZE SNACKS MADE OF CHICKEN, BEEF, AND SAUSAGE (U.S. CL. 46).

TINA L. SNAPP, EXAMINING ATTORNEY

SN 85-428,496. ON-COR FROZEN FOODS, LLC, NORTHBROOK, IL. FILED 9-21-2011.



OWNER OF U.S. REG. NOS. 2,012,462 AND 3,138,649.

THE MARK CONSISTS OF THE WORDING "REDI-SERVE" AGAINST A BANNER SHAPED AS A QUADRILATERAL WITH THE LEFT SIDE CURVED TOWARDS THE BOTTOM AND THE RIGHT SIDE CURVED TOWARDS THE TOP. A SHADOW IS SHOWN BENEATH THE BANNER TO GIVE A THREE-DIMENSIONAL APPEARANCE.

FOR FROZEN ENTREES CONSISTING PRIMARILY OF MEAT, FISH, POULTRY, OR VEGETABLES (U.S. CL. 46).

EMILY CHUO, EXAMINING ATTORNEY

SN 85-429,843. LABEL WORKS, LLC, LOS ANGELES, CA. FILED 9-22-2011.

STELLA

THE MARK CONSISTS OF STANDARD CHARACTERS WITHOUT CLAIM TO ANY PARTICULAR FONT, STYLE, SIZE, OR COLOR.

OWNER OF U.S. REG. NOS. 3,130,722 AND 3,229,858.

FOR CANNED COOKED MEAT; SOUPS (U.S. CL. 46).
FIRST USE 8-31-2004; IN COMMERCE 8-31-2004.

STEVEN R. FINE, EXAMINING ATTORNEY

CLASS 29—(Continued).

SN 85-432,224. ANAGENIX, CHRISTCHURCH, 8041, NEW ZEALAND, FILED 9-26-2011.

APURA GREEN

THE MARK CONSISTS OF STANDARD CHARACTERS WITHOUT CLAIM TO ANY PARTICULAR FONT, STYLE, SIZE, OR COLOR.

NO CLAIM IS MADE TO THE EXCLUSIVE RIGHT TO USE "GREEN", APART FROM THE MARK AS SHOWN.

FOR NON-MEDICATED INGREDIENTS OR ADDITIVES FOR USE IN FOOD, NAMELY, EXTRACTS OF FRUIT OR VEGETABLES AND ESSENCES OF FRUIT OR VEGETABLES (U.S. CL. 46).

NAKIA HENRY, EXAMINING ATTORNEY

SN 85-440,032. LOEB'S FOODS, LLC, DEERFIELD BEACH, FL. FILED 10-5-2011.

PICKLE CRUNCH

THE MARK CONSISTS OF STANDARD CHARACTERS WITHOUT CLAIM TO ANY PARTICULAR FONT, STYLE, SIZE, OR COLOR.

OWNER OF U.S. REG. NOS. 3,933,065 AND 3,969,368.

NO CLAIM IS MADE TO THE EXCLUSIVE RIGHT TO USE "PICKLE", APART FROM THE MARK AS SHOWN.

FOR PROCESSED FRIED PICKLES (U.S. CL. 46).

NORA BUCHANAN WILL, EXAMINING ATTORNEY

SN 85-446,076. THE MEATLOAF BAKERY LLC, CHICAGO, IL. FILED 10-12-2011.

Chicken Shish Kaloaf

THE MARK CONSISTS OF STANDARD CHARACTERS WITHOUT CLAIM TO ANY PARTICULAR FONT, STYLE, SIZE, OR COLOR.

NO CLAIM IS MADE TO THE EXCLUSIVE RIGHT TO USE "CHICKEN SHISH", APART FROM THE MARK AS SHOWN.

THE ENGLISH TRANSLATION OF "SHISH" IN THE MARK IS "SKEWER".

FOR PREPARED READY-TO-EAT ENTREES CONSISTING PRIMARILY OF MEAT (U.S. CL. 46).

FIRST USE 12-10-2008; IN COMMERCE 12-10-2008.

CHARLES L. JENKINS, EXAMINING ATTORNEY

CLASS 29—(Continued).

SN 85-450,272. KHUU, YEN, BURLINGAME, CA. FILED 10-18-2011.



NO CLAIM IS MADE TO THE EXCLUSIVE RIGHT TO USE "BRAND" AND "BEAN CURD IN BRINE" AND THE NON-LATIN CHARACTERS THAT TRANSLITERATE TO "PAI" AND "LA FU RU", APART FROM THE MARK AS SHOWN.

THE MARK CONSISTS OF THE WORDING "BRIDGE BRAND SHUI KOU BRIDGE BEAN CURD IN BRINE" AND DESIGN. THE DESIGN CONSISTS OF A STYLIZED RECTANGLE. AN OVAL IS SUPERIMPOSED ON THE TOP CENTER OF THE RECTANGLE. WITHIN THE OVAL IS AN ARCHED BRIDGE. THE WORDING "BRIDGE BRAND" APPEARS ON THE TOP EDGE OF THE OVAL AND THE CHINESE CHARACTERS APPEAR ON THE BOTTOM EDGE OF THE OVAL. WITHIN THE RECTANGLE ARE CHINESE CHARACTERS AND BELOW THE CHINESE CHARACTERS IS THE WORDING "SHUI KOU BRIDGE BEAN CURD IN BRINE".

THE NON-LATIN CHARACTERS IN THE MARK TRANSLITERATE TO ON THE BOTTOM EDGE OF OVAL FROM LEFT TO RIGHT "QIAO PAI" AND BENEATH THE OVAL FROM LEFT TO RIGHT "SHUI KOU QIAO LA FU RU AND THIS MEANS "BRIDGE BRAND" AND "SHUI KOU BRIDGE BEAN CURD IN BRINE" IN ENGLISH.

FOR PROCESS FOOD, NAMELY, FERMENTED BEAN CURD IN BRINE, FERMENTED SOYBEAN PASTE, FERMENTS SOY BEAN (U.S. CL. 46).

FIRST USE 12-1-2006; IN COMMERCE 12-1-2006.

MARLENE BELL, EXAMINING ATTORNEY

SN 85-453,665. ALEA S.A., 221 00 TRIPOLIS, GREECE, FILED 10-21-2011.

MYKONOS MILLSTONE

THE MARK CONSISTS OF STANDARD CHARACTERS WITHOUT CLAIM TO ANY PARTICULAR FONT, STYLE, SIZE, OR COLOR.

NO CLAIM IS MADE TO THE EXCLUSIVE RIGHT TO USE "MYKONOS", APART FROM THE MARK AS SHOWN.

FOR OLIVE OIL; PROCESSED OLIVES (U.S. CL. 46).

FIRST USE 0-0-1978; IN COMMERCE 6-12-2009.

BARBARA RUTLAND, EXAMINING ATTORNEY

CLASS 29—(Continued).

SN 85-465,071. KRAFT FOODS GLOBAL BRANDS LLC, NORTHFIELD, IL. FILED 11-4-2011.

TROO

THE MARK CONSISTS OF STANDARD CHARACTERS WITHOUT CLAIM TO ANY PARTICULAR FONT, STYLE, SIZE, OR COLOR.

OWNER OF U.S. REG. NO. 3,561,585.
FOR REFRIGERATED FOODS PRODUCTS, NAMELY, DAIRY PRODUCTS, EXCLUDING ICE CREAM, ICE MILK AND FROZEN YOGURT (U.S. CL. 46).
JOSETTE BEVERLY, EXAMINING ATTORNEY

SN 85-465,825. CONOPCO, INC., ENGLEWOOD CLIFFS, NJ. FILED 11-7-2011.

THE MARK CONSISTS OF THE WORDING "SPREADING" INSIDE AN INCOMPLETE SHADED RECTANGULAR DESIGN ON TOP OF A STYLIZED VERSION OF THE WORD "GOODNESS" APPEARING AT THE BOTTOM OF THE INCOMPLETE SHADED RECTANGLE DESIGN.
FOR EDIBLE OILS AND FATS (U.S. CL. 46).
SAMUEL E. SHARPER JR., EXAMINING ATTORNEY

SN 85-467,336. ARTISANAL CHEESE LLC, NEW YORK, NY. FILED 11-8-2011.

NORTH COUNTRY BLUE

THE MARK CONSISTS OF STANDARD CHARACTERS WITHOUT CLAIM TO ANY PARTICULAR FONT, STYLE, SIZE, OR COLOR.

NO CLAIM IS MADE TO THE EXCLUSIVE RIGHT TO USE "BLUE", APART FROM THE MARK AS SHOWN.
FOR CHEESE (U.S. CL. 46).
FIRST USE 2-1-2011; IN COMMERCE 2-1-2011.
BRETT J. GOLDEN, EXAMINING ATTORNEY

CLASS 29—(Continued).

SN 85-500,304. GADRE MARINE EXPORT PRIVATE LIMITED, RATNAGIRI - 415 639, INDIA, FILED 12-20-2011.

THE MARK CONSISTS OF THE TERM "GADRÉ" AGAINST A LOOSELY RECTANGULAR SHAPE WITH ROUNDED CORNERS.

THE WORDING "GADRÉ" HAS NO MEANING IN A FOREIGN LANGUAGE.

FOR PROCESSED SEAFOOD; PROCESSED MEAT; MEAT AND MEAT EXTRACTS; PRESERVED MEATS AND SAUSAGES; PRESERVED, SALTED AND CANNED FISH; FISH PASTE; MEAT PASTE; FOOD PRODUCTS MADE FROM FISH AND FISH PASTE, NAMELY, FISH CROQUETTES; FOOD PRODUCTS MADE FROM MEAT AND MEAT PASTE, NAMELY, MEAT CROQUETTES; MEAT-BASED SNACK FOODS; STEAMED OR TOASTED CAKES OF FISH PASTE; FISH SAUSAGES; FISH FILLETS; FLAKES OF DRIED FISH MEAT; CRAB CLAW, CRABSTICK, CRAB FLAKES, CRAB CAKES; CRAB ROE PASTE; CRAB ROE PUREE; CRAB, SHELLFISH, SHRIMPS, AND LOBSTERS, NOT LIVE; FISH, POULTRY AND GAME, NOT LIVE; DRIED SEAFOOD IN POWDER FORM; FISHMEAL FOR HUMAN CONSUMPTION; SOUPS AND PREPARATIONS FOR MAKING SOUPS, SALMON, SALAD OIL; EDIBLE OIL AND FATS; FISH AND MEAT PRESERVES; PICKLES; MILK; EGGS; JELLIES; JAMS; PRESERVED, FROZEN, DRIED AND COOKED FRUITS AND VEGETABLES; FRUIT-BASED SNACK FOODS; VEGETABLE-BASED SNACK FOODS; FOOD ADDITIVES FOR CULINARY PURPOSES, NAMELY, NATURAL FOOD EXTRACTS DERIVED FROM FISH, FISH OIL, FISH PROTEIN, ALGAE, SEAWEED, FISH OR SHARK CARTILAGE, OR SEASHELLS NOT FOR MEDICINAL PURPOSES AND FOR HUMAN CONSUMPTION (U.S. CL. 46).

RUDY R. SINGLETON, EXAMINING ATTORNEY

SN 85-506,079. NELOWET, SCOTT H, JACKSONVILLE, FL. FILED 12-29-2011.

CUPID SIZE

THE MARK CONSISTS OF STANDARD CHARACTERS WITHOUT CLAIM TO ANY PARTICULAR FONT, STYLE, SIZE, OR COLOR.

FOR FRENCH FRY FOOD ITEM CONSISTING PRIMARILY OF FRENCH FRIES, BUT ALSO INCLUDING GRAVY AND TOPPINGS (U.S. CL. 46).
FIRST USE 11-1-2011; IN COMMERCE 11-1-2011.
TINA BROWN, EXAMINING ATTORNEY

CLASS 29—(Continued).

SN 85-506,083. NELOWET, SCOTT H, JACKSONVILLE, FL.
FILED 12-29-2011.

ETHEREAL SALTS

THE MARK CONSISTS OF STANDARD CHARACTERS WITHOUT CLAIM TO ANY PARTICULAR FONT, STYLE, SIZE, OR COLOR.

NO CLAIM IS MADE TO THE EXCLUSIVE RIGHT TO USE "SALTS", APART FROM THE MARK AS SHOWN.

FOR FRENCH FRY FOOD ITEM CONSISTING PRIMARILY OF FRENCH FRIES, BUT ALSO INCLUDING GRAVY AND TOPPINGS (U.S. CL. 46).

FIRST USE 11-1-2011; IN COMMERCE 11-1-2011.

TINA BROWN, EXAMINING ATTORNEY

CLASS 29—(Continued).

SN 85-539,568. TRI-UNION SEAFOODS LLC, SAN DIEGO,
CA. FILED 2-10-2012.



SN 85-510,072. LOEB'S FOODS, LLC, DEERFIELD BEACH,
FL. FILED 1-6-2012.

POTATO CRUNCH

THE MARK CONSISTS OF STANDARD CHARACTERS WITHOUT CLAIM TO ANY PARTICULAR FONT, STYLE, SIZE, OR COLOR.

OWNER OF U.S. REG. NOS. 3,933,065 AND 3,969,368.

NO CLAIM IS MADE TO THE EXCLUSIVE RIGHT TO USE "POTATO", APART FROM THE MARK AS SHOWN.

FOR PROCESSED POTATOES (U.S. CL. 46).

NORA BUCHANAN WILL, EXAMINING ATTORNEY

NO CLAIM IS MADE TO THE EXCLUSIVE RIGHT TO USE "NO DRAIN TUNA AND JUST A LITTLE WATER", APART FROM THE MARK AS SHOWN.

THE MARK CONSISTS OF A CIRCLE WITH "NO MESS!" ON THE TOP OF THE CIRCLE, A BANNER ACROSS THE MIDDLE OF THE CIRCLE WITH THE WORDS "NO DRAIN TUNA" ON IT WITH A RAIN DROP UNDERNEATH IT AND "JUST A LITTLE WATER" ON THE BOTTOM OF THE CIRCLE.

FOR SEAFOOD (U.S. CL. 46).

LESLEY LAMOTHE, EXAMINING ATTORNEY

SN 85-539,565. TRI-UNION SEAFOODS LLC, SAN DIEGO,
CA. FILED 2-10-2012.



SN 85-549,346. BUBBA FOODS, LLC, JACKSONVILLE, FL.
FILED 2-22-2012.

BUBBA GRILLERS

NO CLAIM IS MADE TO THE EXCLUSIVE RIGHT TO USE "NO DRAIN AND JUST A LITTLE WATER", APART FROM THE MARK AS SHOWN.

THE MARK CONSISTS OF A CIRCLE WITH "NO MESS!" ON THE TOP OF THE CIRCLE, A BANNER ACROSS THE MIDDLE OF THE CIRCLE WITH THE WORDS "NO DRAIN" ON IT WITH A RAIN DROP UNDERNEATH IT AND "JUST A LITTLE WATER" ON THE BOTTOM OF THE CIRCLE.

FOR SEAFOOD (U.S. CL. 46).

LESLEY LAMOTHE, EXAMINING ATTORNEY

THE MARK CONSISTS OF STANDARD CHARACTERS WITHOUT CLAIM TO ANY PARTICULAR FONT, STYLE, SIZE, OR COLOR.

NO CLAIM IS MADE TO THE EXCLUSIVE RIGHT TO USE "GRILLERS", APART FROM THE MARK AS SHOWN.

FOR PREPARED MEATS, SAUSAGE AND BRAT-WURST (U.S. CL. 46).

CHRIS WELLS, EXAMINING ATTORNEY

CLASS 29—(Continued).

SN 85-550,773. SUMIKIN BUSSAN INTERNATIONAL CORPORATION, SCHAUMBURG, IL. FILED 2-23-2012.



NO CLAIM IS MADE TO THE EXCLUSIVE RIGHT TO USE "SAVORY", APART FROM THE MARK AS SHOWN. THE COLOR(S) RED, BLACK AND WHITE IS/ARE CLAIMED AS A FEATURE OF THE MARK.

THE MARK CONSISTS OF A WHITE CURSIVE "S" THAT IS POSITIONED WITHIN A RED BOX WITH THE WORD "SAVORY" PRINTED BELOW THE BOX IN BLACK LETTERS.

FOR SEAFOOD, MEAT, PROCESSED SEAFOOD, PROCESSED MEAT PRODUCTS, NAMELY, PORK, BEEF AND CHICKEN (U.S. CL. 46).

FIRST USE 1-4-2011; IN COMMERCE 1-4-2011.

GIANCARLO CASTRO, EXAMINING ATTORNEY

SN 85-558,336. DELTA SEA PRODUCTS INCORPORATED, TARPON SPRINGS, FL. FILED 3-2-2012.



NO CLAIM IS MADE TO THE EXCLUSIVE RIGHT TO USE "SEA PRODUCTS INCORPORATED", APART FROM THE MARK AS SHOWN.

FOR SEAFOOD (U.S. CL. 46).

FIRST USE 12-20-1985; IN COMMERCE 12-20-1985.

KIMBERLY FRYE, EXAMINING ATTORNEY

CLASS 29—(Continued).

SN 85-566,726. TEDCAR PROPERTIES, LLC, WYOMISSING, PA. FILED 3-12-2012.



NO CLAIM IS MADE TO THE EXCLUSIVE RIGHT TO USE "PENNSYLVANIA PRIME", APART FROM THE MARK AS SHOWN.

THE MARK CONSISTS OF A STYLIZED STEER HEAD ON A KEYSTONE BACKGROUND, WITH THE WORDS "PENNSYLVANIA PRIME".

FOR BEEF (U.S. CL. 46).

FIRST USE 2-26-2012; IN COMMERCE 2-26-2012.

NAAKWAMA ANKRAH, EXAMINING ATTORNEY

SN 85-579,130. RITE STUFF FOODS, INC., JEROME, ID. FILED 3-24-2012.

Tater Rollers

THE MARK CONSISTS OF STANDARD CHARACTERS WITHOUT CLAIM TO ANY PARTICULAR FONT, STYLE, SIZE, OR COLOR.

NO CLAIM IS MADE TO THE EXCLUSIVE RIGHT TO USE "TATER", APART FROM THE MARK AS SHOWN.

FOR PROCESSED POTATOES (U.S. CL. 46).

FIRST USE 8-23-2011; IN COMMERCE 8-23-2011.

INGA ERVIN, EXAMINING ATTORNEY

SN 85-579,135. RITE STUFF FOODS, INC., JEROME, ID. FILED 3-24-2012.

Tater Mates

THE MARK CONSISTS OF STANDARD CHARACTERS WITHOUT CLAIM TO ANY PARTICULAR FONT, STYLE, SIZE, OR COLOR.

NO CLAIM IS MADE TO THE EXCLUSIVE RIGHT TO USE "TATER", APART FROM THE MARK AS SHOWN.

FOR PROCESSED POTATOES (U.S. CL. 46).

FIRST USE 8-23-2011; IN COMMERCE 8-23-2011.

INGA ERVIN, EXAMINING ATTORNEY

CLASS 29—(Continued).

SN 85-585,284. SENDIK'S MANAGEMENT, INC., WHITE-FISH BAY, WI. FILED 3-30-2012.

OUR NEVER. EVER. PROMISE

THE MARK CONSISTS OF STANDARD CHARACTERS WITHOUT CLAIM TO ANY PARTICULAR FONT, STYLE, SIZE, OR COLOR.

FOR MEAT (U.S. CL. 46).
FIRST USE 7-19-2012; IN COMMERCE 7-19-2012.
JUDITH HELFMAN, EXAMINING ATTORNEY

SN 85-587,892. AGROCOMERCIALIZADORA DE LA LAGUNA, S.P.R. DE R.L. DE C.V., GOMEZ PALACIO, DGO., MEXICO, FILED 4-3-2012.



THE MARK CONSISTS OF THE WORDING "LA MARLIERE" IN STYLIZED LETTERING.
THE WORDING "LA MARLIERE" HAS NO MEANING IN A FOREIGN LANGUAGE.
FOR PRESERVED, FROZEN, DRIED AND COOKED FRUITS AND VEGETABLES, COMPOTES (U.S. CL. 46).
FRED CARL, EXAMINING ATTORNEY

SN 85-588,107. MORGESE, NICOLE, NEW YORK, NY. FILED 4-3-2012.

PUT SOME THINK IN YOUR DRINK

THE MARK CONSISTS OF STANDARD CHARACTERS WITHOUT CLAIM TO ANY PARTICULAR FONT, STYLE, SIZE, OR COLOR.

FOR ALL NATURAL COFFEE CREAMERS BOOSTED WITH VITAMINS AND SUPPLEMENTS (U.S. CL. 46).
FIRST USE 9-1-2011; IN COMMERCE 9-1-2011.
JACQUELINE A. LAVINE, EXAMINING ATTORNEY

CLASS 29—(Continued).

SN 85-590,676. ODDYSSEY FOODS LLC, PHOENIX, AZ. FILED 4-5-2012.

THE BIG RIB

THE MARK CONSISTS OF STANDARD CHARACTERS WITHOUT CLAIM TO ANY PARTICULAR FONT, STYLE, SIZE, OR COLOR.

NO CLAIM IS MADE TO THE EXCLUSIVE RIGHT TO USE "RIB", APART FROM THE MARK AS SHOWN.
FOR PREPARED MEAT (U.S. CL. 46).
FIRST USE 2-23-2012; IN COMMERCE 2-23-2012.
TARAH HARDY, EXAMINING ATTORNEY

SN 85-592,021. ALASKAN LEADER FISHERIES LLC, SEATTLE, WA. FILED 4-8-2012.

Alaskan Leader

THE MARK CONSISTS OF STANDARD CHARACTERS WITHOUT CLAIM TO ANY PARTICULAR FONT, STYLE, SIZE, OR COLOR.

NO CLAIM IS MADE TO THE EXCLUSIVE RIGHT TO USE "ALASKAN", APART FROM THE MARK AS SHOWN.
FOR FISH; SEAFOOD (U.S. CL. 46).
FIRST USE 0-0-1991; IN COMMERCE 0-0-1991.
AMY KELLY, EXAMINING ATTORNEY

SN 85-592,469. KEYSTONE FOODS LLC, WEST CONSHOHOCKEN, PA. FILED 4-9-2012.



OWNER OF U.S. REG. NOS. 1,698,455 AND 2,788,438.
NO CLAIM IS MADE TO THE EXCLUSIVE RIGHT TO USE "FARMS", APART FROM THE MARK AS SHOWN.

THE MARK CONSISTS OF A STYLIZED REPRESENTATION OF A BARN WITH A SILO AND FARMLAND IN THE BACKGROUND. THIS PICTURE IS CONTAINED WITHIN AN OVAL FRAME. BELOW THE PICTURE THERE APPEARS THE WORDING "KEY FARMS" IN STYLIZED CAPITAL LETTERS WITH THE LETTERS "EY" AND "ARMS" UNDERLINED. THERE IS A BORDER AROUND THE WORDING WITH THE LEFT AND RIGHT SIDE OF THE BORDER SHAPED LIKE A CHEVRON.

FOR PREPARED POULTRY FOR RETAIL GROCERY STORES AND FARMERS MARKETS (U.S. CL. 46).
LYNDESEY KUYKENDALL, EXAMINING ATTORNEY

CLASS 29—(Continued).

SN 85-592,474. KEYSTONE FOODS LLC, WEST CONSHOHOCKEN, PA. FILED 4-9-2012.

KEY FARMS

THE MARK CONSISTS OF STANDARD CHARACTERS WITHOUT CLAIM TO ANY PARTICULAR FONT, STYLE, SIZE, OR COLOR.

OWNER OF U.S. REG. NOS. 1,698,455 AND 2,788,438.

NO CLAIM IS MADE TO THE EXCLUSIVE RIGHT TO USE "FARMS", APART FROM THE MARK AS SHOWN.

FOR PREPARED POULTRY FOR RETAIL GROCERY STORES AND FARMERS MARKETS (U.S. CL. 46).

LYNDSEY KUYKENDALL, EXAMINING ATTORNEY

SN 85-592,581. KUNZLER & COMPANY, INC., LANCASTER, PA. FILED 4-9-2012.

Kunzler

OWNER OF U.S. REG. NO. 1,459,396.
THE MARK CONSISTS OF THE WORD "KUNZLER" IN STYLIZED SCRIPT.

SEC. 2(F).

FOR PROCESSED MEAT (U.S. CL. 46).

FIRST USE 5-0-1991; IN COMMERCE 5-0-1991.

MICHAEL SOUDERS, EXAMINING ATTORNEY

CLASS 29—(Continued).

SN 85-592,856. MAINE NATURAL FRUIT LIMITED LIABILITY COMPANY, CLINTON, NJ. FILED 4-9-2012.



NO CLAIM IS MADE TO THE EXCLUSIVE RIGHT TO USE "NATURALLY HEALTHY MAINE WILD BLUEBERRIES" AND "THE PICTORIAL REPRESENTATION OF BLUEBERRIES", APART FROM THE MARK AS SHOWN.

THE COLOR(S) ORANGE, OLIVE GREEN, GREEN, BLUE, WHITE AND YELLOW IS/ARE CLAIMED AS A FEATURE OF THE MARK.

THE WORDING "NATURALLY HEALTHY" APPEARS IN THE COLOR YELLOW, THE WORDING "MAINE" APPEARS IN THE COLORS ORANGE, YELLOW AND WHITE, THE WORDING "WILD BLUEBERRIES" APPEAR IN THE COLOR WHITE, THE STYLIZED OVAL DESIGN APPEARS IN THE COLORS OLIVE GREEN AND GREEN WITH AN ORANGE AND YELLOW DESIGN WITH LIGHT RAYS, THE BLUEBERRIES APPEAR IN THE COLOR BLUE WITH GREEN LEAVES SURROUNDING THEM

FOR CANNED MAINE WILD BLUEBERRIES (U.S. CL. 46).

JAY FLOWERS, EXAMINING ATTORNEY

SN 85-593,272. PASTURE PRIDE CHEESE, LLC, CASHTON, WI. FILED 4-10-2012.

GUUSTO

THE MARK CONSISTS OF STANDARD CHARACTERS WITHOUT CLAIM TO ANY PARTICULAR FONT, STYLE, SIZE, OR COLOR.

THE WORDING "GUUSTO" HAS NO MEANING IN A FOREIGN LANGUAGE.

FOR CHEESE (U.S. CL. 46).

FIRST USE 3-15-2008; IN COMMERCE 4-2-2008.

EDWARD NELSON, EXAMINING ATTORNEY

CLASS 29—(Continued).

SN 85-594,297. GORTON'S INC., GLOUCESTER, MA. FILED 4-11-2012.

SMART & CRUNCHY

THE MARK CONSISTS OF STANDARD CHARACTERS WITHOUT CLAIM TO ANY PARTICULAR FONT, STYLE, SIZE, OR COLOR.

OWNER OF U.S. REG. NO. 4,016,447.

NO CLAIM IS MADE TO THE EXCLUSIVE RIGHT TO USE "CRUNCHY", APART FROM THE MARK AS SHOWN.

FOR FROZEN PRE-PACKAGED ENTREES CONSISTING PRIMARILY OF SEAFOOD; PREPARED ENTREES CONSISTING PRIMARILY OF SEAFOOD; SEAFOOD (U.S. CL. 46).

STEVEN R. FINE, EXAMINING ATTORNEY

CLASS 29—(Continued).

SN 85-595,190. FAT BEAGLE, LLC, MEMPHIS, TN. FILED 4-11-2012.



THE MARK CONSISTS OF A DOUBLE LINED UNBROKEN BLACK OVAL, WHEREIN THE WORDS "FAT" AND "BEAGLE" SITUATED INSIDE OF THE OVAL AND CONNECTED BY TWO ARCS TO FORM A SECOND OVAL, WITH THE WORD "FAT" ON THE TOP AND THE "BEAGLE" AT THE BOTTOM, A SMALLER SOLID BLACK OVAL CONTAINING A CARTOON IMAGE OF A DOG WEARING SUNGLASSES, WITH A RAISED LEFT EYEBROW LIES INSIDE OF THE OVAL FORMED BY THE WORDS "FAT" AND "BEAGLE" AND THE ARCS.

FOR PRESERVED FRUIT AND VEGETABLES (U.S. CL. 46).

CATHERINE ROEHL, EXAMINING ATTORNEY

SN 85-594,767. SF INVESTMENTS, INC., WILMINGTON, DE. FILED 4-11-2012.



OWNER OF U.S. REG. NO. 1,718,395. THE COLOR(S) RED, WHITE, GOLD AND YELLOW IS/ ARE CLAIMED AS A FEATURE OF THE MARK.

THE MARK CONSISTS OF A HALF CIRCLE WITH A YELLOW SUN WITH A GOLD BACKGROUND OUTLINED IN RED OVER THE WORD "SUNNYLAND" IN WHITE STYLIZED LETTERS WITHIN A RED RECTANGLE.

FOR MEAT (U.S. CL. 46).

FIRST USE 12-31-2000; IN COMMERCE 12-31-2000.

MICHAEL WIENER, EXAMINING ATTORNEY

SN 85-595,598. LOEB'S FOODS, LLC, DEERFIELD BEACH, FL. FILED 4-12-2012.



THE MARK CONSISTS OF A GREEN STYLIZED PICKLE CREATURE HAVING GREEN LEGS AND GREEN ARMS, WEARING RED AND WHITE SHOES AND WHITE GLOVES; THE PICKLE HAS TWO EYES IN THE COLORS WHITE, BROWN AND BLACK AND DARK GREEN EYEBROWS, A WHITE NOSE, AND AN OPEN SMILING MOUTH IN THE COLORS WHITE, BLACK AND RED.

FOR PROCESSED FRIED PICKLES (U.S. CL. 46).

SUZANNE BLANE, EXAMINING ATTORNEY

CLASS 29—(Continued).

SN 85-596,288. DEL TERRUNIO LLC, HOLLISTON, MA. FILED 4-12-2012.



NO CLAIM IS MADE TO THE EXCLUSIVE RIGHT TO USE "FREE RANGE BEEF", APART FROM THE MARK AS SHOWN.

THE COLOR(S) WHITE, ORANGE, AND BLACK IS/ARE CLAIMED AS A FEATURE OF THE MARK.

THE MARKS CONSISTS OF AN IMAGE OF A WHITE AND ORANGE COW STANDING ON ORANGE GROUND WITH A WHITE SUN HAVING WHITE AND ORANGE RAYS BEHIND THE COW, THE WORDING "DEL TERRUÑO" IN BLACK BELOW THE GROUND, THE WORDING "FREE RANGE BEEF" IN ORANGE UNDER "DEL TERRUÑO" AND "A TRADITION OF TASTE AND TENDERNESS" IN BLACK UNDER "FREE RANGE BEEF".

THE ENGLISH TRANSLATION OF "DEL TERRUÑO" IN THE MARK IS "FROM THE NATIVE REGION".

FOR FREE RANGE BEEF (U.S. CL. 46).
APRIL ROACH, EXAMINING ATTORNEY

SN 85-596,359. VIRGINIA DINER, INC., WAKEFIELD, VA. FILED 4-12-2012.



OWNER OF U.S. REG. NO. 1,560,301.

THE MARK CONSISTS OF A PERSONIFIED PEANUT IN THE SHELL WEARING OVERALLS WITH ITS FINGERS IN EITHER SIDE OF THE TOP OF THE OVERALLS. THERE IS A RIBBON BEARING THE NUMBER "1" ON ITS CHEST.

FOR CANDIED NUTS; CANNED PEANUTS; FLAVORED NUTS; NUT-BASED SNACK FOODS; PREPARED NUTS; PROCESSED ALMONDS; PROCESSED NUTS; PROCESSED PEANUTS; ROASTED NUTS; SEASONED NUTS; SHELLED NUTS; SNACK MIX CONSISTING OF PRIMARILY OF PROCESSED NUTS, SEEDS, DRIED FRUIT AND ALSO INCLUDING CHOCOLATE (U.S. CL. 46).

FIRST USE 1-30-1977; IN COMMERCE 1-30-1977.
EVIN L. KOZAK, EXAMINING ATTORNEY

CLASS 29—(Continued).

SN 85-600,429. GILANI, NIZAR, SNELLVILLE, GA. FILED 4-17-2012.

Iberian Gold

THE MARK CONSISTS OF STANDARD CHARACTERS WITHOUT CLAIM TO ANY PARTICULAR FONT, STYLE, SIZE, OR COLOR.

NO CLAIM IS MADE TO THE EXCLUSIVE RIGHT TO USE "IBERIAN", APART FROM THE MARK AS SHOWN.

FOR OLIVE OILS FROM THE IBERIAN PENINSULA (U.S. CL. 46).

REBECCA GILBERT, EXAMINING ATTORNEY

SN 85-600,440. BUTTER SHOPPE LLC, LAKEWOOD, CA. FILED 4-17-2012.

Butter Shoppe

THE MARK CONSISTS OF STANDARD CHARACTERS WITHOUT CLAIM TO ANY PARTICULAR FONT, STYLE, SIZE, OR COLOR.

NO CLAIM IS MADE TO THE EXCLUSIVE RIGHT TO USE "BUTTER", APART FROM THE MARK AS SHOWN.

FOR BUTTER (U.S. CL. 46).

APRIL ROACH, EXAMINING ATTORNEY

SN 85-600,504. WILD DUTCHMAN PRODUCTS INC., MOUND CITY, SD. FILED 4-17-2012.

Wild Dutchman



NO CLAIM IS MADE TO THE EXCLUSIVE RIGHT TO USE "SOUTH DAKOTA FRESH!!" AND THE GEOGRAPHICAL OUTLINE OF THE STATE OF SOUTH DAKOTA, APART FROM THE MARK AS SHOWN.

THE MARK CONSISTS OF THE LIKENESS OF THE GEOGRAPHICAL OUTLINE OF THE STATE OF SOUTH DAKOTA, WITH THE WORDS "SOUTH DAKOTA" ARCHED INSIDE AT THE TOP. THERE IS A DESIGN OF WINDMILL LOCATED TO THE LEFT, AND A DESIGN OF THREE SUNFLOWER PLANTS LOCATED TO THE RIGHT; THE WORDING "WILD DUTCHMAN" IS ABOVE THE STATE DESIGN, AND THE WORD "FRESH!!" IS WITHIN A STAR BURST DESIGN AND LOCATED AT THE BOTTOM OF THE STATE DESIGN.

FOR PROCESSED SUNFLOWER SEEDS FOR HUMAN CONSUMPTION (U.S. CL. 46).

FIRST USE 1-1-2000; IN COMMERCE 1-1-2000.
LINDA E. BLOHM, EXAMINING ATTORNEY

CLASS 29—(Continued).

SN 85-600,599. ALASKAN LEADER FISHERIES LLC, SEATTLE, WA. FILED 4-17-2012.



THE MARK CONSISTS OF TWO CONCENTRIC CIRCLES. INSIDE THE INNER CIRCLE IS THE LETTER CAPITAL "A". THE POINT OF THE "A" TOUCHES THE INNER CIRCLE. THE ARMS OF THE "A" ALSO TOUCH THE INNER CIRCLE.
 FOR FISH; SEAFOOD (U.S. CL. 46).
 FIRST USE 0-0-1991; IN COMMERCE 0-0-1991.
 AMY KELLY, EXAMINING ATTORNEY

SN 85-602,051. ELANA ISTRIN, BEVERLY HILLS, CA. FILED 4-19-2012.

BEACH BUM FOODS

THE MARK CONSISTS OF STANDARD CHARACTERS WITHOUT CLAIM TO ANY PARTICULAR FONT, STYLE, SIZE, OR COLOR.
 NO CLAIM IS MADE TO THE EXCLUSIVE RIGHT TO USE "FOODS", APART FROM THE MARK AS SHOWN.
 FOR FRUIT-BASED SNACK FOOD; SNACK FOOD DIPS; VEGETABLE-BASED SNACK FOODS (U.S. CL. 46).
 FIRST USE 3-15-2012; IN COMMERCE 3-15-2012.
 ANTHONY RINKER, EXAMINING ATTORNEY

CLASS 29—(Continued).

SN 85-602,236. A-WARE FOOD GROUP B.V., 3411 MD LOPIK, NETHERLANDS, FILED 4-19-2012.



OWNER OF U.S. REG. NO. 4,120,216.
 NO CLAIM IS MADE TO THE EXCLUSIVE RIGHT TO USE "CHEESE", APART FROM THE MARK AS SHOWN.
 THE MARK CONSISTS OF THE LETTER "A" INSIDE A SQUARE WITH HORIZONTAL LINES RUNNING THROUGH IT; BENEATH THE "A" IS THE TERM "CHEESE" INSIDE A RECTANGLE.
 FOR CHEESE; CHEESE FOOD; CHEESE SPREADS; CHEESE SUBSTITUTES (U.S. CL. 46).
 JUHI KAVEESHVAR, EXAMINING ATTORNEY

SN 85-602,643. POWERFUL MEN LLC, MIAMI BEACH, FL. FILED 4-19-2012.

Powerfuel Yogurt

THE MARK CONSISTS OF STANDARD CHARACTERS WITHOUT CLAIM TO ANY PARTICULAR FONT, STYLE, SIZE, OR COLOR.
 NO CLAIM IS MADE TO THE EXCLUSIVE RIGHT TO USE "YOGURT", APART FROM THE MARK AS SHOWN.
 FOR YOGURT-BASED BEVERAGES (U.S. CL. 46).
 DORITT L. CARROLL, EXAMINING ATTORNEY

SN 85-602,856. CHRISTINE CONRAD, PRIOR LAKE, MN. FILED 4-19-2012.

MEATEATER

THE MARK CONSISTS OF STANDARD CHARACTERS WITHOUT CLAIM TO ANY PARTICULAR FONT, STYLE, SIZE, OR COLOR.
 FOR FRIED MEAT; MEAT; SEASONED DEEP FRIED MEAT CONTAINING A BRAT, CHEESE, HAMBURGER, AND BACON (U.S. CL. 46).
 FIRST USE 7-1-2010; IN COMMERCE 7-1-2010.
 RONALD MCMORROW, EXAMINING ATTORNEY

CLASS 29—(Continued).

SN 85-603,309. ZHEJIANG MOGANSHAN FOODS CO., LTD., ZHEJIANG, CHINA, FILED 4-19-2012.



THE MARK CONSISTS OF MOUNTAIN DESIGN WHICH IS SURROUNDED BY CLOUDS AND THERE ARE THREE CHINESE CHARACTERS UNDER THE MOUNTAIN.

THE ENGLISH TRANSLATION OF "MO GAN SHAN" IN THE MARK IS "MO GAN MOUNTAIN".

THE NON-LATIN CHARACTERS IN THE MARK TRANSLITERATE TO MO GAN SHAN AND THIS MEANS MO GAN MOUNTAIN IN ENGLISH.

FOR CRYSTALLIZED FRUITS; FROSTED FRUITS; FRUITS IN PRESERVED FORM; PREPARED NUTS; PRESERVED VEGETABLES; PROCESSED SUNFLOWER SEEDS (U.S. CL. 46).

FIRST USE 7-12-2009; IN COMMERCE 7-12-2009.
FRANK LATTUCA, EXAMINING ATTORNEY

CLASS 29—(Continued).

SN 85-603,452. RESPECT FOODS, INC., NAPERVILLE, IL, FILED 4-20-2012.

RESPECT VALUE

THE MARK CONSISTS OF STANDARD CHARACTERS WITHOUT CLAIM TO ANY PARTICULAR FONT, STYLE, SIZE, OR COLOR.

FOR BOUILLON; CANNED FRUITS; CANNED VEGETABLES; COFFEE CREAMER; FROZEN CHICKEN PRODUCTS, NAMELY, FRIED CHICKEN; FROZEN CHICKEN; FROZEN PRE-PACKAGED ENTREES CONSISTING PRIMARILY OF SEAFOOD; INSTANT POTATOES; JELLIES; SEAFOOD; VEGETABLE-BASED COOKING SPRAY; FROZEN ENTREES CONSISTING PRIMARILY OF MEAT, FISH, POULTRY OR VEGETABLES; FROZEN MEALS CONSISTING PRIMARILY OF MEAT, FISH, POULTRY OR VEGETABLES (U.S. CL. 46).

TINA L. SNAPP, EXAMINING ATTORNEY

SN 85-604,749. ALASKAN LEADER FISHERIES LLC, SEATTLE, WA. FILED 4-22-2012.

SN 85-603,387. ALTICOR INC., ADA, MI. FILED 4-20-2012.

BODYKEY

THE MARK CONSISTS OF STANDARD CHARACTERS WITHOUT CLAIM TO ANY PARTICULAR FONT, STYLE, SIZE, OR COLOR.

PRIORITY CLAIMED UNDER SEC. 44(D) ON MEXICO APPLICATION NO. 1237913, FILED 12-16-2011.

FOR PREPARED PACKAGED MEALS CONSISTING PRIMARILY OF POULTRY, FISH, SEAFOOD, BEEF, PORK AND VEGETABLES; NUTRITIONALLY FORTIFIED PROCESSED FRUIT-BASED SNACK FOODS FORTIFIED WITH VITAMINS AND MINERALS; NUTRITIONALLY FORTIFIED PROCESSED NUT-BASED SNACK FOODS FORTIFIED WITH VITAMINS AND MINERALS; NUTRITIONALLY FORTIFIED PROCESSED FRUIT- AND NUT-BASED SNACK FOODS FORTIFIED WITH VITAMINS AND MINERALS; NUTRITIONALLY FORTIFIED PROCESSED FRUIT (U.S. CL. 46).

MAH ROSENBERG, EXAMINING ATTORNEY



NO CLAIM IS MADE TO THE EXCLUSIVE RIGHT TO USE "ECO FRIENDLY", APART FROM THE MARK AS SHOWN.

THE COLOR(S) GREEN, GREY, AND WHITE IS/ARE CLAIMED AS A FEATURE OF THE MARK.

THE MARK CONSISTS OF A GREEN LEAF LYING ON TOP OF THE SHANK OF A GREY FISH HOOK WITH WHITE HIGHLIGHTING, WITH THE WORDING "ECO FRIENDLY" IN GREEN UNDER THE FISH HOOK.

FOR FISH; SEAFOOD (U.S. CL. 46).
FIRST USE 3-1-2012; IN COMMERCE 3-1-2012.
AMY KELLY, EXAMINING ATTORNEY

CLASS 29—(Continued).

SN 85-605,286. REPUBLIC OF BEANS, INC., NEW YORK, NY. FILED 4-23-2012.

Republic of Beans

THE MARK CONSISTS OF STANDARD CHARACTERS WITHOUT CLAIM TO ANY PARTICULAR FONT, STYLE, SIZE, OR COLOR.

OWNER OF U.S. REG. NO. 2,923,117.
FOR DRIED BEANS (U.S. CL. 46).
FIRST USE 3-1-2001; IN COMMERCE 3-1-2001.
GIANCARLO CASTRO, EXAMINING ATTORNEY

SN 85-605,669. JULIO MUNIZ, MIAMI, FL. FILED 4-23-2012.

The Smart Snack At Your Fingertips

THE MARK CONSISTS OF STANDARD CHARACTERS WITHOUT CLAIM TO ANY PARTICULAR FONT, STYLE, SIZE, OR COLOR.

FOR CANDIED FRUIT SNACKS; DAIRY-BASED SNACK FOODS EXCLUDING ICE CREAM, ICE MILK AND FROZEN YOGURT; DEHYDRATED FRUIT SNACKS; DRIED FRUIT-BASED SNACKS; FRUIT AND SOY BASED SNACK FOOD; FRUIT-BASED SNACK FOOD; NUT AND SEED-BASED SNACK BARS; NUT-BASED SNACK FOODS; NUT-BASED SNACK FOODS, NAMELY, NUT CLUSTERS; NUT-BASED SNACK FOODS, NAMELY, NUT CRISPS; ORGANIC NUT AND SEED-BASED SNACK BARS; POTATO-BASED SNACK FOODS; SNACK DIPS; SNACK FOOD DIPS; SNACK MIX CONSISTING OF DEHYDRATED FRUIT AND PROCESSED NUTS; SNACK MIX CONSISTING OF PRIMARILY OF PROCESSED NUTS, SEEDS, DRIED FRUIT AND ALSO INCLUDING CHOCOLATE; SNACK MIX CONSISTING OF WASABI PEAS, PROCESSED NUTS, DEHYDRATED FRUIT AND/OR RAISINS; SNACK MIX CONSISTING PRIMARILY OF DEHYDRATED FRUITS, PROCESSED NUTS AND ALSO INCLUDING SESAME STICKS; SNACK MIX CONSISTING PRIMARILY OF PROCESSED FRUITS, PROCESSED NUTS AND/OR RAISINS; SNACK MIX CONSISTING PRIMARILY OF PROCESSED NUTS AND SALTED SQUASH SEEDS AND ALSO INCLUDING TOASTED CORN; SOY-BASED SNACK FOODS; VEGETABLE-BASED SNACK FOODS (U.S. CL. 46).

DOMINICK J. SALEMI, EXAMINING ATTORNEY

CLASS 29—(Continued).

SN 85-606,530. GORTON'S INC., GLOUCESTER, MA. FILED 4-24-2012.

5 STAR PANGASIUS

THE MARK CONSISTS OF STANDARD CHARACTERS WITHOUT CLAIM TO ANY PARTICULAR FONT, STYLE, SIZE, OR COLOR.

OWNER OF U.S. REG. NOS. 3,327,951 AND 3,327,953.
NO CLAIM IS MADE TO THE EXCLUSIVE RIGHT TO USE "PANGASIUS", APART FROM THE MARK AS SHOWN.

FOR FROZEN PRE-PACKAGED ENTREES CONSISTING PRIMARILY OF SEAFOOD; PREPARED ENTREES CONSISTING PRIMARILY OF SEAFOOD; SEAFOOD (U.S. CL. 46).

STEVEN R. FINE, EXAMINING ATTORNEY

SN 85-606,532. GORTON'S INC., GLOUCESTER, MA. FILED 4-24-2012.

5 STAR SWAI

THE MARK CONSISTS OF STANDARD CHARACTERS WITHOUT CLAIM TO ANY PARTICULAR FONT, STYLE, SIZE, OR COLOR.

OWNER OF U.S. REG. NOS. 3,327,951 AND 3,327,953.
NO CLAIM IS MADE TO THE EXCLUSIVE RIGHT TO USE "SWAI", APART FROM THE MARK AS SHOWN.

FOR FROZEN PRE-PACKAGED ENTREES CONSISTING PRIMARILY OF SEAFOOD; PREPARED ENTREES CONSISTING PRIMARILY OF SEAFOOD; SEAFOOD (U.S. CL. 46).

STEVEN R. FINE, EXAMINING ATTORNEY

CLASS 29—(Continued).

SN 85-609,260. SOUTHERN BELLE REFRIGERATED, LLC, TUPELO, MS. FILED 4-26-2012.



NO CLAIM IS MADE TO THE EXCLUSIVE RIGHT TO USE "FOODS", APART FROM THE MARK AS SHOWN.

THE MARK CONSISTS OF THE SILHOUETTE OF A WOMAN CONTAINED WITHIN AN OVAL, THE BACKGROUND OF WHICH IS SHADED, AND CENTERED ABOVE THE WORDS "SOUTHERN BELLE", WHICH ARE CENTERED ABOVE THE WORD "FOODS". ALL OF WHICH WORDING IS CONTAINED BY STYLIZED HORIZONTAL LINES LOCATED ABOVE AND BELOW THE ENTIRE WORDING.

FOR PROCESSED MEAT, NAMELY, FULLY COOKED HAM, FRANKFURTERS, BACON, DELI MEATS, BOLOGNA, SALAMI, WHOLE HOG SAUSAGES, BOILED HAMS, SMOKED HAMS, PACKAGED LUNCH MEATS, BULK AND PACKAGED SMOKED SAUSAGE, AND FRESH, FROZEN AND PROCESSED POULTRY PRODUCTS (U.S. CL. 46).

ELI HELLMAN, EXAMINING ATTORNEY

CLASS 29—(Continued).

SN 85-612,025. CSC BRANDS LP, CAMDEN, NJ. FILED 4-30-2012.



OWNER OF U.S. REG. NOS. 48,461, 698,271 AND 804,371. NO CLAIM IS MADE TO THE EXCLUSIVE RIGHT TO USE THE DEPICTION OF THE SOUP, APART FROM THE MARK AS SHOWN.

THE MARK CONSISTS OF A RECTANGLE WITH THE STYLIZED WORD "CAMPBELL'S" ON A SLANT APPEARING ON A SHADED RECTANGLE. AN IMAGE OF A BOWL CONTAINING SOUP WITH A SPRIG OF LEAVES APPEARS ON THE RIGHT SIDE INSIDE A PORTION OF A SQUARE.

FOR SOUPS (U.S. CL. 46).

FIRST USE 7-31-2011; IN COMMERCE 7-31-2011.

LEIGH CAROLINE CASE, EXAMINING ATTORNEY

SN 85-609,404. SAMMY WING WAH CHOW, BROOKLYN, NY. FILED 4-26-2012.



THE MARK CONSISTS OF THREE BIRDS FLYING WESTWARD, BUT FACING NORTHWEST, IN A V-SHAPE, WITH THE LEFTMOST BIRD BEING SLIGHTLY BIGGER THAN THE OTHER 2.

FOR EDIBLE BIRD'S NESTS (U.S. CL. 46).

FIRST USE 5-1-2011; IN COMMERCE 5-1-2011.

KATHLEEN M. VANSTON, EXAMINING ATTORNEY

SN 85-612,030. CSC BRANDS LP, CAMDEN, NJ. FILED 4-30-2012.



OWNER OF U.S. REG. NOS. 48,461, 698,271 AND 804,371. NO CLAIM IS MADE TO THE EXCLUSIVE RIGHT TO USE THE DEPICTION OF THE SOUP, APART FROM THE MARK AS SHOWN.

THE COLOR(S) RED, TAN, WHITE, BROWN, ORANGE-RED AND GREEN IS/ARE CLAIMED AS A FEATURE OF THE MARK.

THE MARK CONSISTS OF A TAN RECTANGLE WITH THE STYLIZED WORD "CAMPBELL'S" IN RED ON A SLANT APPEARING ON THE RECTANGLE. AN IMAGE OF A WHITE BOWL CONTAINING ORANGE-RED SOUP WITH A SPRIG OF GREEN LEAVES APPEARS ON THE RIGHT SIDE AGAINST A BROWN BACKGROUND INSIDE A PORTION OF A WHITE SQUARE.

FOR SOUPS (U.S. CL. 46).

FIRST USE 7-31-2011; IN COMMERCE 7-31-2011.

LEIGH CAROLINE CASE, EXAMINING ATTORNEY

CLASS 29—(Continued).

SN 85-619,857. A-WARE FOOD GROUP B.V., 3411 MD LOPIK, NETHERLANDS, FILED 5-8-2012.

WESTZANER

THE MARK CONSISTS OF STANDARD CHARACTERS WITHOUT CLAIM TO ANY PARTICULAR FONT, STYLE, SIZE, OR COLOR.

FOR CHEESE; CHEESE FOOD; CHEESE SPREADS; CHEESE SUBSTITUTES (U.S. CL. 46).
JUHI KAVEESHVAR, EXAMINING ATTORNEY

CLASS 29—(Continued).

SN 85-643,082. SUPERVALU INC., EDEN PRAIRIE, MN. FILED 6-5-2012.

IDEAL PORTIONS

THE MARK CONSISTS OF STANDARD CHARACTERS WITHOUT CLAIM TO ANY PARTICULAR FONT, STYLE, SIZE, OR COLOR.

NO CLAIM IS MADE TO THE EXCLUSIVE RIGHT TO USE "PORTIONS", APART FROM THE MARK AS SHOWN. FOR SEAFOOD AND CHICKEN (U.S. CL. 46).
WARREN L. OLANDRIA, EXAMINING ATTORNEY

SN 85-631,179. GORTON'S INC., GLOUCESTER, MA. FILED 5-21-2012.



OWNER OF U.S. REG. NOS. 716,235, 3,327,953 AND OTHERS.

NO CLAIM IS MADE TO THE EXCLUSIVE RIGHT TO USE "SINCE 1849" AND "BAKE", APART FROM THE MARK AS SHOWN.

THE COLOR(S) BLUE, WHITE, GOLD, GRAY, AND BROWN IS/ARE CLAIMED AS A FEATURE OF THE MARK.

THE MARK CONSISTS OF A FISHERMAN WITH A GRAY BEARD AND YELLOW RAINCOAT AND BLUE SWEATER HOLDING A BROWN AND GOLD SHIP'S WHEEL ABOVE THE WHITE WORDING "GORTON'S" ABOVE THE WHITE WORDING "TRUSTED SINCE 1849", ALL OF WHICH WITHIN A BLUE SIGN WITH A LIGHT BLUE BORDER, ALL ABOVE THE BROWN WORDING "SIMPLY BAKE" ABOVE A BROWN LINE.

FOR FROZEN PRE-PACKAGED ENTREES CONSISTING PRIMARILY OF SEAFOOD; PREPARED ENTREES CONSISTING PRIMARILY OF SEAFOOD; SEAFOOD (U.S. CL. 46).
STEVEN R. FINE, EXAMINING ATTORNEY

CLASS 30—STAPLE FOODS

SN 76-709,169. UNI-PRESIDENT ENTERPRISES CORP., TAINAN CITY, TAIWAN, FILED 9-21-2011.



OWNER OF U.S. REG. NOS. 3,090,612 AND 3,090,613.
NO CLAIM IS MADE TO THE EXCLUSIVE RIGHT TO USE THE NON-LATIN CHARACTERS THAT TRANSLITERATE TO "JINGGANG YULU LÜ CHA" AND "CHA", APART FROM THE MARK AS SHOWN.

THE MARK CONSISTS OF PRODUCT PACKAGING FOR APPLICANT'S GOODS, NAMELY, THE LITERAL AND DESIGN ELEMENTS OF LABELS ON BOTTLES FEATURING APPLICANT'S GOODS. IN THE CENTER OF THE BOTTLE ARE THE VERTICALLY POSITIONED NON-LATIN CHARACTERS THAT TRANSLITERATE TO "JINGGANG YULU LÜ CHA". ON THE RIGHT, ALSO PRESENTED VERTICALLY, ARE THE NON-LATIN CHARACTERS THAT TRANSLITERATE TO "CHA LI WANG". IMMEDIATELY BELOW THIS VERTICAL WORDING IS TALL, RECTANGULAR DESIGN OF CHINESE CHARACTERS. AT THE BOTTOM OF THE MARK APPEARS A WIDE CUP OR BOWL WITH A LEAF AND A DROPLET. THE BOTTLE SHAPE IS ONLY SHOWN FOR POSITIONING AND IS NOT CLAIMED AS A FEATURE OF THE MARK.

THE NON-LATIN CHARACTERS IN THE MARK TRANSLITERATE TO "JINGGANG YULU LÜ CHA" AND "CHA LI WANG" AND THIS MEANS "SHIZUOKA GOKURO GREEN TEA" AND "KING IN TEA" IN ENGLISH.

FOR TEA LEAVES, TEA, TEA-BASED BEVERAGES (U.S. CL. 46).
JORDAN BAKER, EXAMINING ATTORNEY

CLASS 30—(Continued).

SN 77-941,847. BOUDIN IP, INC., SAN FRANCISCO, CA.
FILED 2-22-2010.

THE ORIGINAL SAN FRANCISCO
SOURDOUGH

THE MARK CONSISTS OF STANDARD CHARACTERS WITHOUT CLAIM TO ANY PARTICULAR FONT, STYLE, SIZE, OR COLOR.

NO CLAIM IS MADE TO THE EXCLUSIVE RIGHT TO USE "SOURDOUGH", APART FROM THE MARK AS SHOWN.

SEC. 2(F).

FOR BAKERY PRODUCTS, NAMELY, SOURDOUGH FRENCH BREAD AND A VARIETY OF BREAD, COOKIES AND BAKERY GOODS (U.S. CL. 46).

FIRST USE 12-31-1973; IN COMMERCE 12-31-1973.

JACQUELINE A. LAVINE, EXAMINING ATTORNEY

CLASS 30—(Continued).

SN 79-095,245. AUGUST STORCK KG, FED REP GERMANY,
FILED 2-14-2011.



PRIORITY DATE OF 11-6-2010 IS CLAIMED.
OWNER OF INTERNATIONAL REGISTRATION 1071572
DATED 2-14-2011, EXPIRES 2-14-2021.

OWNER OF U.S. REG. NOS. 1,230,152, 3,708,969 AND OTHERS.

NO CLAIM IS MADE TO THE EXCLUSIVE RIGHT TO USE "ORIGINAL", APART FROM THE MARK AS SHOWN.

THE COLOR(S) GOLD AND BROWN IS/ARE CLAIMED AS A FEATURE OF THE MARK.

THE MARK CONSISTS OF THE TRADE DRESS APPLIED TO THE WRAPPER FOR INDIVIDUALLY WRAPPED PIECES OF CANDY, NAMELY, A GOLD BACKGROUND COLOR WITH AN OVAL APPEARANCE. THE GOLD BACKGROUND COLOR IS SOLID IN APPEARANCE AND THE CANDY IS NOT VISIBLE THROUGH THE GOLD BACKGROUND COLOR. IN THE CENTER OF THE OVAL ARE THE WORDS "WERTHER'S ORIGINAL" IN BROWN LETTERS. THE WORD "WERTHER'S" HAS AN UPPER CASE LETTER "W" AND THE REMAINING LETTERS ARE IN LOWERCASE. THE WORD "ORIGINAL" HAS AN UPPER CASE LETTER "O" AND THE REMAINING LETTERS ARE IN LOWERCASE. THE WORD "WERTHER'S" IS POSITIONED DIRECTLY ABOVE THE WORD "ORIGINAL". EXTENDING SYMMETRICALLY FROM THE RIGHT AND LEFT SIDES ARE TWISTED ENDS OF THE WRAPPER WHICH HAVE A CRINKLED APPEARANCE AND ARE GOLD TINTED IN COLOR. THE MATTER SHOWN IN DOTTED LINES IS NOT PART OF THE MARK AND SERVES ONLY TO SHOW THE POSITION OR PLACEMENT OF THE MARK.

FOR CONFECTIONERY, NAMELY, CANDY; CHOCOLATE AND CHOCOLATE PRODUCTS, NAMELY, CHOCOLATE TABLETS, CHOCOLATES, CHOCOLATE CANDY AND CHOCOLATE PRALINES (U.S. CL. 46).

RONALD MCMORROW, EXAMINING ATTORNEY

SN 78-741,964. THE KROGER CO. OF MICHIGAN, NOVI, MI.
FILED 10-27-2005.

CHOCOLATE MARSHMALLOW
COSMOS

THE MARK CONSISTS OF STANDARD CHARACTERS WITHOUT CLAIM TO ANY PARTICULAR FONT, STYLE, SIZE, OR COLOR.

NO CLAIM IS MADE TO THE EXCLUSIVE RIGHT TO USE "CHOCOLATE MARSHMALLOW", APART FROM THE MARK AS SHOWN.

FOR BREAKFAST CEREAL (U.S. CL. 46).

BENJAMIN OKEKE, EXAMINING ATTORNEY

CLASS 30—(Continued).

SN 79-104,000. GOSEI CORPORATION CO., LTD., JAPAN, FILED 9-14-2011.

송가네냉면

OWNER OF INTERNATIONAL REGISTRATION 1094435 DATED 9-14-2011, EXPIRES 9-14-2021.

NO CLAIM IS MADE TO THE EXCLUSIVE RIGHT TO USE NON-LATIN CHARACTER THAT TRANSLITERATE TO "NENMYON", APART FROM THE MARK AS SHOWN.

THE ENGLISH TRANSLATION OF THE FOREIGN WORD(S) IN THE MARK IS: "SONG FAMILY'S COLD NOODLES".

THE TRANSLITERATION OF THE NON-LATIN CHARACTERS IN THE MARK IS: "SONGANE NENMYON".

FOR KOREAN BUCKWHEAT NOODLES SERVED COLD (U.S. CL. 46).

PRISCILLA MILTON, EXAMINING ATTORNEY

CLASS 30—(Continued).

SN 79-108,265. TORAYA CONFECTIONERY CO., LTD., JAPAN, FILED 12-14-2011.

おもかげ

OWNER OF INTERNATIONAL REGISTRATION 1026763 DATED 11-5-2009, EXPIRES 11-5-2019.

OWNER OF U.S. REG. NOS. 1,906,719 AND 2,019,468.

THE MARK CONSISTS OF THE DESIGN OF FOUR JAPANESE CHARACTERS SHOWN VERTICALLY ONE ABOVE THE OTHER.

THE NON-LATIN CHARACTERS IN THE MARK TRANSLITERATE TO "OMOKAGE" AND THIS MEANS "LINGERING IMAGE" IN ENGLISH.

FOR BARS OF SWEET ADZUKI-BEAN JELLIED BEAN PASTE (YOHKAN); MIXES OF SWEET ADZUKI-BEAN JELLY; BEAN-JAM FILLED WAFERS (MONAKA); STEAMED BUNS STUFFED WITH SWEET BEAN-JAM FILLING (MANJU); DRIED SWEETS MADE FROM RICE FLOUR, SUGAR AND STARCH AND PRESSED INTO MOLDS (HIGASHI); FRUIT JELLY CANDY; DESSERT PUDDINGS; RICE CAKES; CAKES; PASTE MADE FROM RICE; CONFECTIONERY, NAMELY, PASTRIES, FROZEN CONFECTIONERY, FROZEN YOGHURT, CONFECTIONERY MADE OF SUGAR, PASTRY; BREAD; BUNS; SWEET RED DESSERT COULIS FLAVORED WITH ADZUKI-BEAN JELLIED BEAN PASTE AND CONTAINING ADZUKI-BEAN RICE CAKE (SHIRUKO) (U.S. CL. 46).

BARBARA A. GOLD, EXAMINING ATTORNEY

CLASS 30—(Continued).

SN 79-110,338. SHEMS GIDA; SANAYI VE TICARET LIMITED SIRKETI, TURKEY, FILED 12-20-2011.



OWNER OF INTERNATIONAL REGISTRATION 1068601 DATED 1-14-2011, EXPIRES 1-14-2021.

THE COLOR(S) BLACK, WHITE, GOLDEN YELLOW AND RED IS/ARE CLAIMED AS A FEATURE OF THE MARK.

THE MARK CONSISTS OF A BLACK RECTANGLE WITH A GOLDEN YELLOW CROWN ABOVE AN INNER RED RECTANGLE WITH A GOLDEN YELLOW OUTLINE. INSIDE THE INNER RECTANGLE IS THE WORDING "SHAZILI" IN WHITE. BELOW THE INNER RECTANGLE ARE TWO GOLDEN YELLOW LINES.

THE WORD(S) "SHAZILI" HAS NO MEANING IN A FOREIGN LANGUAGE.

FOR COFFEE, COCOA, ARTIFICIAL COFFEE, VEGETAL PREPARATIONS FOR USE AS COFFEE SUBSTITUTES, COCOA-BASED BEVERAGES, COFFEE-BASED BEVERAGES; TAPIOCA, SAGO; NOODLES, MACARONI, RAVIOLI; BAKERY PRODUCTS, NAMELY, SWEET BAKERY GOODS; PASTRIES, FLOUR-BASED PRODUCTS, NAMELY, CHIPS, PASTA; DOUGH PRODUCTS, NAMELY, PIZZA DOUGH, CAKE DOUGH, BREAD DOUGH; TARTS, CAKES, BREAD, PIZZAS, SANDWICHES, PUDDINGS, READY CAKE MIXES; HONEY, ROYAL JELLY FOR HUMAN CONSUMPTION FOR FOOD PURPOSES, PROPOLIS FOR HUMAN CONSUMPTION; KETCHUPS, MAYONNAISES, MUSTARDS, FLAVORINGS, SAUCES, SALAD DRESSINGS, SPICES, NAMELY, PEPPER, GINGER, CINNAMON POWDER, CURRY POWDER; YEAST, BAKING POWDER; FLOUR FOR FOOD, PROCESSED SEMOLINA, FOOD STARCH; GRANULATED SUGAR, CUBE SUGAR, POWDERED SUGAR; TEAS, ICED TEA; CHOCOLATE FOR CONFECTIONERY, CONFECTIONERY FOR DECORATING CHRISTMAS TREES BISCUITS, WAFFLES, CRACKERS, CHOCOLATES, CANDIES; CHEWING GUMS NOT FOR MEDICAL PURPOSES; ICE, ICE CREAMS, EDIBLE FRUIT ICES, SORBETS; SALT; READY TO EAT CEREALS; CEREAL PRODUCTS, NAMELY, CEREAL BASED SNACK FOODS AND BREAKFAST CEREALS; SNACKS MADE OF CEREALS, NAMELY, CORN FLAKES, OATMEAL; MOLASSES SYRUP FOR FOOD (U.S. CL. 46).

DANIEL CAPSHAW, EXAMINING ATTORNEY

CLASS 30—(Continued).

SN 79-112,507. OPEN-TYPE JOINT STOCK COMPANY; "ROT FRONT", RU-113184 MOSCOW, RUSSIAN FED., FILED 3-30-2012.



OWNER OF INTERNATIONAL REGISTRATION 1114920 DATED 3-30-2012, EXPIRES 3-30-2022.

NO CLAIM IS MADE TO THE EXCLUSIVE RIGHT TO USE THE NON-LATIN CHARACTERS THAT TRANSLITERATE TO "V SHOKOLADE", APART FROM THE MARK AS SHOWN.

THE COLOR(S) GREEN AND OCHRE IS/ARE CLAIMED AS A FEATURE OF THE MARK.

THE WORDS AND THE STYLIZED IMAGES OF THE SQUIRRELS AND THE NUTS APPEAR IN OCHRE COLOR, THE BACKGROUND APPEARS IN GREEN COLOR.

THE COLORS GREEN AND OCHRE ARE CLAIMED AS A FEATURE OF THE MARK; THE MARK CONSISTS OF THE STYLIZED IMAGES OF THE SQUIRRELS AND THE NUTS, THE WORDS IN THE CYRILLIC ALPHABET ARE TRANSLITERATED AS "GRILYAZH V SHOKOLADE"; THE WORDS AND THE STYLIZED IMAGES OF THE SQUIRRELS AND THE NUTS APPEAR IN OCHRE COLOR, THE BACKGROUND APPEARS IN GREEN COLOR.

THE ENGLISH TRANSLATION OF THE FOREIGN WORD(S) IN THE MARK IS: "GRILYAZH" - HAVE NO MEANING, "V SHOKOLADE" - IN CHOCOLATE.

THE TRANSLITERATION OF THE NON-LATIN CHARACTERS IN THE MARK IS: "GRILYAZH V SHOKOLADE".

FOR CHOCOLATE; SWEETMEATS CANDY; CARAMELS CANDY; WAFERS; HALVAH; COCOA (U.S. CL. 46).

RUDY R. SINGLETON, EXAMINING ATTORNEY

SN 79-113,192. CHOCOLADEFABRIKEN LINDT & SPRÜNGLI AG, CH-8802 KILCHBERG, SWITZERLAND, FILED 2-16-2012.



PRIORITY DATE OF 12-5-2011 IS CLAIMED.

OWNER OF INTERNATIONAL REGISTRATION 1116728 DATED 2-16-2012, EXPIRES 2-16-2022.

OWNER OF U.S. REG. NOS. 87,306, 3,499,381 AND OTHERS.

THE MARK CONSISTS OF THE WORDING "LINDT" WITH A CROWN ON TOP OF A DRAGON ABOVE A LINE ABOVE THE WORDING "CREATION".

FOR CHOCOLATES (U.S. CL. 46).

RAMONA ORTIGA, EXAMINING ATTORNEY

CLASS 30—(Continued).

SN 85-220,588. NEENAN, MAURICE TIMOTHY, SANTA YNEZ, CA. FILED 1-19-2011.

GRINGO STYLE SALSA

THE MARK CONSISTS OF STANDARD CHARACTERS WITHOUT CLAIM TO ANY PARTICULAR FONT, STYLE, SIZE, OR COLOR.

NO CLAIM IS MADE TO THE EXCLUSIVE RIGHT TO USE "SALSA", APART FROM THE MARK AS SHOWN.

THE ENGLISH TRANSLATION OF "GRINGO" IN THE MARK IS "FOREIGNER".

FOR SALSA (U.S. CL. 46).

FIRST USE 4-5-2004; IN COMMERCE 1-1-2005.

BRIAN CALLAGHAN, EXAMINING ATTORNEY

SN 85-245,513. S & B FOODS INC., TOKYO, JAPAN, FILED 2-17-2011.



NO CLAIM IS MADE TO THE EXCLUSIVE RIGHT TO USE "WASABI" AND THE NON-LATIN CHARACTERS WHICH TRANSLITERATE TO "WASABI", APART FROM THE MARK AS SHOWN.

THE MARK CONSISTS OF THE WORDING "S&B" WITH WORDING "WASABI" BELOW IT. UNDERNEATH AND TO THE LEFT OF THE WORDING "WASABI" IS A DESIGN. A LINE APPEARS ABOVE AND BELOW THE WORDING "WASABI". THERE ARE TWO VERTICAL LINES SURROUNDING THE WORDING AND A TRIANGULAR DESIGN CAUSED BY THE LOWER RIGHT CORNER OF THE MARK BEING FOLDED.

THE NON-LATIN CHARACTERS IN THE MARK TRANSLITERATE TO "WASABI" AND THIS MEANS "WASABI" IN ENGLISH.

FOR WASABI POWDER, NAMELY, HORSERADISH POWDER; WASABI PASTE, NAMELY, HORSERADISH PASTE; WASABI SAUCE, NAMELY, HORSERADISH SAUCE (U.S. CL. 46).

FIRST USE 1-30-2006; IN COMMERCE 1-30-2006.

JANICE KIM, EXAMINING ATTORNEY

CLASS 30—(Continued).

SN 85-361,040. CSM BAKERY PRODUCTS NA, INC., TUCKER, GA. FILED 6-30-2011.

SOURTOP

THE MARK CONSISTS OF STANDARD CHARACTERS WITHOUT CLAIM TO ANY PARTICULAR FONT, STYLE, SIZE, OR COLOR.

FOR CONCENTRATES, SYRUPS AND POWDERS USED IN THE PREPARATION OF ICINGS, GLAZES AND FROSTING; ICINGS; FROSTINGS; GLAZES FOR BAKERY GOODS (U.S. CL. 46).

SEAN CROWLEY, EXAMINING ATTORNEY

SN 85-380,095. RICHELIEU FOODS, INC., RANDOLPH, MA. FILED 7-25-2011.

SWEETACRE FARMS

THE MARK CONSISTS OF STANDARD CHARACTERS WITHOUT CLAIM TO ANY PARTICULAR FONT, STYLE, SIZE, OR COLOR.

NO CLAIM IS MADE TO THE EXCLUSIVE RIGHT TO USE "FARMS", APART FROM THE MARK AS SHOWN.

FOR SALSAS; MARINADES; SALAD DRESSINGS; BARBEQUE SAUCE; MAYONNAISE (U.S. CL. 46).

JAMES LOVELACE, EXAMINING ATTORNEY

CLASS 30—(Continued).

SN 85-383,890. AMOREPACIFIC CORPORATION, SEOUL, REPUBLIC OF KOREA, FILED 7-28-2011.



OWNER OF REPUBLIC OF KOREA REG. NO. 40-0901814, DATED 2-2-2012, EXPIRES 2-2-2022.

OWNER OF FRANCE REG. NO. 113852083, DATED 12-2-2011, EXPIRES 12-2-2021.

OWNER OF U.S. REG. NOS. 3,301,810, 3,449,442 AND 3,564,711.

NO CLAIM IS MADE TO THE EXCLUSIVE RIGHT TO USE "JEJU TEA" AND "SINCE 1979", APART FROM THE MARK AS SHOWN.

THE COLOR(S) GREEN IS/ARE CLAIMED AS A FEATURE OF THE MARK.

THE MARK CONSISTS OF THE WORDING "OSULLOC JEJU TEA GARDEN SINCE 1979" LOCATED BENEATH A DESIGN ELEMENT COMPRISING A CIRCULAR DESIGN FEATURING THE SKY, A MOUNTAIN AND A SEA. THE ENTIRE MARK APPEARS IN THE COLOR GREEN. THE COLOR WHITE REPRESENTS BACKGROUND, OUTLINING, SHADING, AND/OR TRANSPARENT AREAS AND IS NOT PART OF THE MARK.

FOR TEA; GREEN TEA; COFFEE; CEREAL-BASED PROCESSED PRODUCTS, NAMELY, BREAKFAST CEREALS AND CEREAL-BASED SNACK FOOD; LIME TEA; BARLEY LEAVES TEA; BARLEY TEA; PROCESSED TEA LEAVES; GINSENG TEA; TEA-BASED BEVERAGES (U.S. CL. 46).

LAURIE KAUFMAN, EXAMINING ATTORNEY

CLASS 30—(Continued).

SN 85-408,437. INDUSTRIAL MOLINERA DE CHILES EL BERCIANO, S.A., DISTRITO FEDERAL, MEXICO, FILED 8-26-2011.

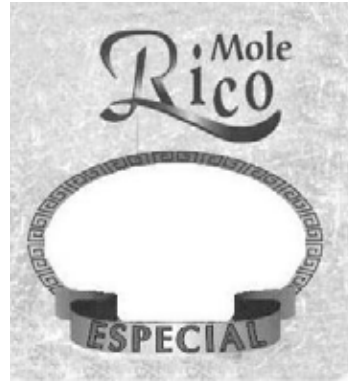

NO CLAIM IS MADE TO THE EXCLUSIVE RIGHT TO USE "MOLE RICO ESPECIAL", APART FROM THE MARK AS SHOWN.

THE MARK CONSISTS OF THE STYLIZED WORDS "MOLE RICO ESPECIAL" ON A MARBLED BACKGROUND WITH AN OVAL WITH A DECORATIVE BORDER ABOVE A BANNER WITH THE WORD "ESPECIAL".

THE ENGLISH TRANSLATION OF "RICO ESPECIAL" IN THE MARK IS "RICH SPECIAL".

FOR CHILI SAUCE; COOKING SAUCES; PASTA SAUCE; PICANTE SAUCE; SAUCES (U.S. CL. 46).

HOWARD B. LEVINE, EXAMINING ATTORNEY

SN 85-421,979. FIONA'S NATURAL FOODS, INC., DBA FIONA'S GRANOLA, THORNTON, CO. FILED 9-13-2011.



NO CLAIM IS MADE TO THE EXCLUSIVE RIGHT TO USE "ALL NATURAL GRANOLA", APART FROM THE MARK AS SHOWN.

THE NAME "FIONA" IDENTIFIES A LIVING INDIVIDUAL WHOSE CONSENT IS OF RECORD.

THE MARK CONSISTS OF AN OVAL DESIGN SUPERIMPOSED ON A DESIGN SIMILAR TO A HALF OVAL, ALL ABOVE A BANNER. A DESIGN OF FLOWERS AND LEAVES APPEARS IN THE CENTER OF THE DESIGN. THE WORDING "FIONA'S ALL NATURAL" APPEARS IN THE BORDER OF THE OVAL. THE WORD "GRANOLA" APPEARS IN THE BANNER DESIGN.

FOR GRANOLA; GRANOLA SNACKS; GRANOLA-BASED SNACK BARS; MUESLI (U.S. CL. 46).

FIRST USE 1-1-2002; IN COMMERCE 1-1-2002.

MAUREEN DALL, EXAMINING ATTORNEY

CLASS 30—(Continued).

SN 85-428,511. ON-COR FROZEN FOODS, LLC, NORTH-BROOK, IL. FILED 9-21-2011.



OWNER OF U.S. REG. NOS. 2,012,462 AND 3,138,649.
THE MARK CONSISTS OF THE WORDING "REDI-SERVE" AGAINST A BANNER SHAPED AS A QUADRILATERAL WITH THE LEFT SIDE CURVED TOWARDS THE BOTTOM AND THE RIGHT SIDE CURVED TOWARDS THE TOP. A SHADOW IS SHOWN BENEATH THE BANNER TO GIVE A THREE-DIMENSIONAL APPEARANCE.
FOR FROZEN ENTREES CONSISTING PRIMARILY OF PASTA OR RICE (U.S. CL. 46).
EMILY CHUO, EXAMINING ATTORNEY

SN 85-431,668. MI-SUN, OUM, GYEONGGI-DO, REPUBLIC OF KOREA, FILED 9-26-2011.



THE COLOR(S) GREEN AND WHITE IS/ARE CLAIMED AS A FEATURE OF THE MARK.

THE MARK CONSISTS OF A STYLIZED GREEN LEAF DESIGN OUTLINING A STYLIZED LETTER "B" IN WHITE OVER THE WORDING "BAMBUSLAND" IN GREEN.

FOR BAMBOO TEA; FRUIT TEA; GREEN TEA; TEA SUBSTITUTES; BARLEY TEA; ICED TEA; STAMINA ENHANCING TEA; GINSENG TEA; TEA; TEA LEAVES, NAMELY, LOOSE LEAF TEAS AND TEA SOLD IN LOOSE TEA FORM, IN CADDIES, BAGS OR CAPSULES; BLACK TEA; LEMON TEA; VANILLA TEA; BLUEBERRY TEA; POMEGRANATE TEA; TEA-BASED BEVERAGES; BAMBOO SALT; SOY SAUCE AND SOY BEAN PASTE; SOYA SAUCE; SOYA BEAN PASTE; GOCHU-JANG BEING FERMENTED HOT PEPPER PASTE; JA-JANG BEING BLACK PASTE FOR NOODLE SAUCE; CHONGGUG-JANG BEING FERMENTED SOY-BEAN PASTE; CHUN-JANG BEING CHINESE SOYBEAN PASTE (U.S. CL. 46).
ALICIA COLLINS, EXAMINING ATTORNEY

CLASS 30—(Continued).

SN 85-432,204. MCCORMICK & COMPANY, INCORPORATED, SPARKS, MD. FILED 9-26-2011.

EASY ROASTS

THE MARK CONSISTS OF STANDARD CHARACTERS WITHOUT CLAIM TO ANY PARTICULAR FONT, STYLE, SIZE, OR COLOR.

NO CLAIM IS MADE TO THE EXCLUSIVE RIGHT TO USE "ROASTS", APART FROM THE MARK AS SHOWN.
FOR SEASONING MIXES AND ROASTING BAGS COMBINED IN UNITARY PACKAGES (U.S. CL. 46).
MARK RADEMACHER, EXAMINING ATTORNEY

SN 85-434,461. ARMANDO'S PASTA FACTORY, INC., WILMINGTON, DE. FILED 9-28-2011.

ARMANDO'S PASTA FACTORY

THE MARK CONSISTS OF STANDARD CHARACTERS WITHOUT CLAIM TO ANY PARTICULAR FONT, STYLE, SIZE, OR COLOR.

NO CLAIM IS MADE TO THE EXCLUSIVE RIGHT TO USE "PASTA FACTORY", APART FROM THE MARK AS SHOWN.

FOR FRESH AND FROZEN PASTAS, STUFFED AND UNSTUFFED PASTAS, PASTA SAUCES, AND PRE-COOKED AND READY-TO-SERVE PASTA (U.S. CL. 46).
KATHLEEN KOLACZ, EXAMINING ATTORNEY

SN 85-436,648. HODGSON MILL, INC., EFFINGHAM, IL. FILED 9-30-2011.

HAVE A GRAIN DAY!

THE MARK CONSISTS OF STANDARD CHARACTERS WITHOUT CLAIM TO ANY PARTICULAR FONT, STYLE, SIZE, OR COLOR.

FOR MIXES, NAMELY, COOKIE, MUFFIN, BREAD, PANCAKE, WAFFLE, BATTER FOR FRIED FOODS, PIZZA CRUST, CAKE AND BROWNIES; FLOUR; PASTA; BREAKFAST CEREAL; COUSCOUS; YEAST; DRIED WHEAT GLUTEN POWDER; WHEAT BRAN FOR HUMAN CONSUMPTION; WHEAT GERM FOR HUMAN CONSUMPTION; SEASONINGS; BAKING ADDITIVES, NAMELY, XANTHAN GUM; BULGUR WHEAT FOR HUMAN CONSUMPTION; CORN MEAL; CORN STARCH (U.S. CL. 46).
KATHRYN COWARD, EXAMINING ATTORNEY

CLASS 30—(Continued).

SN 85-442,110. CLABBER GIRL CORPORATION, TERRE HAUTE, IN. FILED 10-7-2011.

DAVIS

THE MARK CONSISTS OF STANDARD CHARACTERS WITHOUT CLAIM TO ANY PARTICULAR FONT, STYLE, SIZE, OR COLOR.

OWNER OF U.S. REG. NOS. 297,821 AND 304,098.
SEC. 2(F).
FOR CORN STARCH; CORN STARCH FLOUR (U.S. CL. 46).
MICHAEL WEBSTER, EXAMINING ATTORNEY

SN 85-445,477. WHEELER, JAMES R., ROCKLIN, CA. FILED 10-12-2011.

SLURP-UP

THE MARK CONSISTS OF STANDARD CHARACTERS WITHOUT CLAIM TO ANY PARTICULAR FONT, STYLE, SIZE, OR COLOR.

FOR FROZEN CONFECTIONS, BAKERY DESSERTS, ICE CREAM DESSERTS, FROZEN YOGURT, ICE CREAM (U.S. CL. 46).
REBECCA SMITH, EXAMINING ATTORNEY

SN 85-445,710. PET INCORPORATED, MINNEAPOLIS, MN. FILED 10-12-2011.

RECIPE STARTERS

THE MARK CONSISTS OF STANDARD CHARACTERS WITHOUT CLAIM TO ANY PARTICULAR FONT, STYLE, SIZE, OR COLOR.

FOR FOOD PRODUCTS, NAMELY, SAUCES (U.S. CL. 46).
FIRST USE 7-16-2012; IN COMMERCE 7-16-2012.
JEFFREY LOOK, EXAMINING ATTORNEY

CLASS 30—(Continued).

SN 85-447,088. BEDESSEE IMPORTS LTD., TORONTO, ONTARIO, CANADA, FILED 10-13-2011.



THE MARK CONSISTS OF THE WORDS "DASH OF FLAVA" IN FANCIFUL SCRIPT ENCLOSED WITHIN A ROUNDED RECTANGLE.

SEC. 2(F).
FOR CHILI POWDERS; CHILI SAUCE; CHILI SEASONING; CINNAMON; CINNAMON POWDER; CLOVE POWDER; CLOVES; CURRY POWDER; DRIED CHILI PEPPERS; EDIBLE SPICES; GARLIC POWDER; GINGER; MUSTARD; MUSTARD POWDER; PEPPER; PEPPER POWDER; PEPPER SPICE; PROCESSED GARLIC FOR USE AS SEASONING; SEASONING MIXES; SEASONING PASTES; SEASONINGS; SPICE BLENDS; SPICE RUBS; SPICES (U.S. CL. 46).

FIRST USE 6-30-2000; IN COMMERCE 6-30-2000.
AHSEN KHAN, EXAMINING ATTORNEY

SN 85-447,200. BEDESSEE IMPORTS LTD., TORONTO, ONTARIO, CANADA, FILED 10-13-2011.

THE MARK CONSISTS OF THE WORD "FLAVA" IN STYLIZED LETTERING.

SEC. 2(F).
FOR CHILI POWDERS; CHILI SAUCE; CHILI SEASONING; CINNAMON; CINNAMON POWDER; CLOVE POWDER; CLOVES; CURRY POWDER; DRIED CHILI PEPPERS; EDIBLE SPICES; GARLIC POWDER; GINGER; MUSTARD; MUSTARD POWDER; PEPPER; PEPPER POWDER; PEPPER SPICE; PROCESSED GARLIC FOR USE AS SEASONING; SEASONING MIXES; SEASONING PASTES; SEASONINGS; SPICE BLENDS; SPICE RUBS; SPICES (U.S. CL. 46).

FIRST USE 6-30-2000; IN COMMERCE 6-30-2000.
AHSEN KHAN, EXAMINING ATTORNEY

CLASS 30—(Continued).

SN 85-447,221. REHM, MICHAEL, GRIFFIN, GA. FILED 10-13-2011.

GEORGIA'S OWN BARBECUE
SAUCE

THE MARK CONSISTS OF STANDARD CHARACTERS WITHOUT CLAIM TO ANY PARTICULAR FONT, STYLE, SIZE, OR COLOR.

NO CLAIM IS MADE TO THE EXCLUSIVE RIGHT TO USE "GEORGIA'S" AND "BARBECUE SAUCE", APART FROM THE MARK AS SHOWN.

FOR BARBECUE SAUCE (U.S. CL. 46).
TEJBIR SINGH, EXAMINING ATTORNEY

SN 85-450,948. TOPCO HOLDINGS, INC., SKOKIE, IL. FILED 10-19-2011.

THE TEA SOCIETY

THE MARK CONSISTS OF STANDARD CHARACTERS WITHOUT CLAIM TO ANY PARTICULAR FONT, STYLE, SIZE, OR COLOR.

NO CLAIM IS MADE TO THE EXCLUSIVE RIGHT TO USE "TEA", APART FROM THE MARK AS SHOWN.

FOR TEA, ICED TEA, TEA-BASED BEVERAGES, AND LOOSE TEA IN UNIQUE CARTONS, CANISTERS, SINGLE SERVE CUPS, SINGLE SERVE STICKS, AND TEA BAGS (U.S. CL. 46).

KAREN BRACEY, EXAMINING ATTORNEY

CLASS 30—(Continued).

SN 85-453,341. SUNSAUCE FOODS INDUSTRIAL CORP., LTD, CHANGWAD PETCHABURI, THAILAND, FILED 10-21-2011.



PRIORITY CLAIMED UNDER SEC. 44(D) ON THAILAND APPLICATION NO. 813062, FILED 7-14-2011.

OWNER OF U.S. REG. NO. 3,009,927.

NO CLAIM IS MADE TO THE EXCLUSIVE RIGHT TO USE "SAUCE", APART FROM THE MARK AS SHOWN.

THE MARK CONSISTS OF AN ENLARGED LETTER "S" WHICH HAS A BORDER THEREAROUND; STYLIZED SUN RAYS ARE LOCATED ABOVE AND SPACED FROM AN UPPER PORTION OF THE ENLARGED LETTER "S"; THE STYLIZED SUN RAYS HAVE A BORDER THEREAROUND AND EXTEND GENERALLY OUTWARDLY; POSITIONED TO THE LEFT OF THE ENLARGED LETTER "S" IS THE WORD "SUN"; POSITIONED TO THE RIGHT OF THE ENLARGED LETTER "S" ARE THE LETTERS "AUCE".

FOR SAUCES, EXCEPT SALAD DRESSINGS; FLAVORINGS OTHER THAN ESSENTIAL OIL; CONDIMENTS NAMELY SUKI-SAUCE, CHICKEN SAUCE, CHILI SAUCE, BARBEQUE SAUCE, TOMATO SAUCE, SEAFOOD SAUCE, FISH SAUCE, SOY SAUCE, CLEAR SOY SAUCE, BLACK SOY SAUCE AND OYSTER SAUCE (U.S. CL. 46).

HENRY S. ZAK, EXAMINING ATTORNEY

SN 85-462,125. KAMEDA SEIKA CO., LTD., NIIGATA, JAPAN, FILED 11-2-2011.

Soft Salad

THE MARK CONSISTS OF STANDARD CHARACTERS WITHOUT CLAIM TO ANY PARTICULAR FONT, STYLE, SIZE, OR COLOR.

FOR CONFECTIONERY, NAMELY, RICE CRACKERS, PELLET-SHAPED RICE CRACKERS, RICE CAKES, RICE-BASED SNACK FOODS, CEREAL-BASED SNACK FOODS (U.S. CL. 46).

ALICE BENMAMAN, EXAMINING ATTORNEY

CLASS 30—(Continued).

SN 85-467,806. GUIZHOU EXPENSIVE TEA CO.,LTD, GUIZHOU PROVINCE., CHINA, FILED 11-9-2011.

绿宝石
EMERAIL

THE MARK CONSISTS OF "EMERAIL" AND THREE CHINESE CHARACTERS.

THE WORDING "EMERAIL" HAS NO MEANING IN A FOREIGN LANGUAGE.

THE NON-LATIN CHARACTERS IN THE MARK TRANSLITERATE TO THREE CHINESE CHARACTERS WITH PING YING (STANDARD CHINESE PRONUNCIATION SYSTEM)-LV BAO SHI AND THIS MEANS EMERALD IN ENGLISH.

FOR ARTIFICIAL COFFEE AND TEA; BEVERAGES MADE OF TEA; BEVERAGES WITH A TEA BASE; BLACK TEA; CHAI TEA; COFFEE AND TEA; DISPOSABLE CUPS WITH A TEA-FILLED POUCH ULTRASONICALLY WELDED TO ONE SIDE OF THE BOTTOM OF THE CUP, WHICH ALLOWS THE NATURAL FIBER POUCH TO FLOAT NEAR THE BOTTOM; FLAVOURINGS OF TEA; FRUIT TEAS; GINSENG TEA; GREEN TEA; HERB TEA; HERBAL TEA; ICED TEA; INSTANT TEA; JAPANESE GREEN TEA; LIME TEA; MIXES IN THE NATURE OF CONCENTRATES, SYRUPS OR POWDERS USED IN THE PREPARATION OF TEA BASED BEVERAGES; OOLONG TEA; SAGE TEA; SYRUPS FOR MAKING TEA; TEA; TEA BAGS; TEA EXTRACTS; TEA FOR INFUSIONS; TEA OF PARCHED POWDER OF BARLEY WITH HUSK (MUGI-CHA); TEA OF SALTY KELP POWDER (KOMBU-CHA); TEA PODS; TEA SUBSTITUTES; TEA-BASED BEVERAGES; TEA-BASED BEVERAGES WITH FRUIT FLAVORING; THEINE-FREE TEA SWEETENED WITH SWEETENERS (U.S. CL. 46).

FIRST USE 12-12-2009; IN COMMERCE 6-5-2011.

BILL DAWE, EXAMINING ATTORNEY

CLASS 30—(Continued).

SN 85-492,401. TORAYA CONFECTIONERY CO., LTD., TOKYO, JAPAN, FILED 12-11-2011.

と
ら
や

OWNER OF U.S. REG. NOS. 1,933,489, 1,943,331 AND 2,022,315.

THE MARK CONSISTS OF THE DESIGN OF THREE JAPANESE CHARACTERS SHOWN VERTICALLY ONE ABOVE THE OTHER.

THE ENGLISH TRANSLATION OF THE VERTICAL CHARACTERS IN THE MARK IS "TORAYA".

THE NON-LATIN CHARACTERS IN THE MARK TRANSLITERATE TO "TORAYA" AND THIS MEANS "STORE OF THE TIGER" IN ENGLISH.

FOR BARS OF SWEET ADZUKI-BEAN JELLIED BEAN PASTE (YOHKAN); MIXES OF SWEET ADZUKI-BEAN JELLY; BEAN-JAM FILLED WAFERS (MONAKA); STEAMED BUNS STUFFED WITH SWEET BEAN-JAM FILLING (MANJU); DRIED SWEETS MADE FROM RICE FLOUR, SUGAR AND STARCH AND PRESSED INTO MOLDS (HIGASHI); FRUIT JELLY CANDY; DESSERT PUDDINGS; RICE CAKES; CAKES; PASTE MADE FROM RICE; CONFECTIONERY, NAMELY, PASTRIES, FROZEN CONFECTIONERY, FROZEN YOGHURT, CONFECTIONERY MADE OF SUGAR, PASTRY; BREAD; BUNS; SWEET RED DESSERT COULIS FLAVORED WITH ADZUKI-BEAN JELLIED BEAN PASTE AND CONTAINING ADZUKI-BEAN RICE CAKE (SHIRUKO) (U.S. CL. 46).

BARBARA A. GOLD, EXAMINING ATTORNEY

SN 85-497,586. CANADA BREAD FROZEN BAKERY LTD., LAVAL, CANADA, FILED 12-16-2011.

CARDIO SMART

THE MARK CONSISTS OF STANDARD CHARACTERS WITHOUT CLAIM TO ANY PARTICULAR FONT, STYLE, SIZE, OR COLOR.

NO CLAIM IS MADE TO THE EXCLUSIVE RIGHT TO USE "CARDIO", APART FROM THE MARK AS SHOWN.

FOR BAKERY PRODUCTS, NAMELY, ALL TYPES OF BREADS, ROLLS, BUNS, CAKES, COOKIES, MUFFINS, MORNING BUNS, CROISSANTS, BAGELS, FLAT-BREADS, TURNOVERS, CINNAMON ROLLS, DOUGHNUTS, BISCUITS, SCONES, FRUIT BITES, NAMELY, FRUIT FILLED FLAKY PASTRY, BUTTER TARTS, STRUDEL (U.S. CL. 46).

JOHN KELLY, EXAMINING ATTORNEY

CLASS 30—(Continued).

SN 85-497,673. CANADA BREAD FROZEN BAKERY LTD., LAVAL, CANADA, FILED 12-16-2011.

IMMUNO SMART

THE MARK CONSISTS OF STANDARD CHARACTERS WITHOUT CLAIM TO ANY PARTICULAR FONT, STYLE, SIZE, OR COLOR.

NO CLAIM IS MADE TO THE EXCLUSIVE RIGHT TO USE "IMMUNO", APART FROM THE MARK AS SHOWN.

FOR BAKERY PRODUCTS, NAMELY, ALL TYPES OF BREADS, ROLLS, BUNS, CAKES, COOKIES, MUFFINS, MORNING BUNS, CROISSANTS, BAGELS, FLAT-BREADS, TURNOVERS, CINNAMON ROLLS, DOUGH-NUTS, BISCUITS, SCONES, FRUIT BITES, NAMELY, FRUIT FILLED FLAKY PASTRY, BUTTER TARTS, STRUDEL (U.S. CL. 46).

JOHN KELLY, EXAMINING ATTORNEY

SN 85-497,718. CANADA BREAD FROZEN BAKERY LTD., LAVAL, CANADA, FILED 12-16-2011.

CHOLESTEROL SMART

THE MARK CONSISTS OF STANDARD CHARACTERS WITHOUT CLAIM TO ANY PARTICULAR FONT, STYLE, SIZE, OR COLOR.

NO CLAIM IS MADE TO THE EXCLUSIVE RIGHT TO USE "CHOLESTEROL", APART FROM THE MARK AS SHOWN.

FOR BAKERY PRODUCTS, NAMELY, ALL TYPES OF BREADS, ROLLS, BUNS, CAKES, COOKIES, MUFFINS, MORNING BUNS, CROISSANTS, BAGELS, FLAT-BREADS, TURNOVERS, CINNAMON ROLLS, DOUGH-NUTS, BISCUITS, SCONES, FRUIT BITES, NAMELY, FRUIT FILLED FLAKY PASTRY, BUTTER TARTS, STRUDEL (U.S. CL. 46).

JOHN KELLY, EXAMINING ATTORNEY

CLASS 30—(Continued).

SN 85-502,212. A SPRINKLE AND A DASH LLC, PORT WASHINGTON, NY. FILED 12-22-2011.

my cup of cake

WARM BELGIAN CHOCOLATE SOUFFLE CAKE THAT YOU MAKE IN JUST UNDER 3 MINUTES!



NO CLAIM IS MADE TO THE EXCLUSIVE RIGHT TO USE "CUP OF CAKE" AND "WARM BELGIAN CHOCOLATE SOUFFLE CAKE THAT YOU MAKE IN JUST UNDER 3 MINUTES", APART FROM THE MARK AS SHOWN.

THE MARK CONSISTS OF THE UPPER PORTION OF THE MARK CONSISTS OF THE WORDS "MY CUP OF CAKE" IN STYLIZED FONT, THE WORDS "WARM BELGIAN SOUFFLE CAKE" IN A SMALLER FONT BELOW THE WORDS "MY CUP OF CAKE", THE WORDS "THAT YOU MAKE IN JUST UNDER 3 MINUTES!" BELOW THE WORDS "WARM BELGIAN SOUFFLE CAKE" AND THE WORDS "3 MINUTES!" UNDERLINED, WHILE THE BOTTOM PORTION OF THE MARK CONSISTS OF A CENTERED IMAGE OF A COFFEE MUG TOPPED WITH A POLKA DOTTED PLUME AND A STEMMED CHERRY TOPPING THE PLUME WITH A THREE FINGERED HAND HOLDING THE HANDLE OF THE MUG ON ITS RIGHT SIDE AND AN ARM CLOTHED IN A STRIPPED SLEEVE EXTENDING FROM THAT TO THE RIGHT BORDER OF THE PAGE, AND A SET OF SOLID HORIZONTAL BARS FORMING THE TOP AND BOTTOM BORDERS.

FOR OVEN READY DESSERTS, NAMELY SOUFFLE CAKES (U.S. CL. 46).

FIRST USE 2-4-2011; IN COMMERCE 2-4-2011.
CHRISTOPHER LAW, EXAMINING ATTORNEY

SN 85-505,616. DAILHE, ANAAN, SAN PEDRO, CA. FILED 12-29-2011.

NUTRIMORSELS

THE MARK CONSISTS OF STANDARD CHARACTERS WITHOUT CLAIM TO ANY PARTICULAR FONT, STYLE, SIZE, OR COLOR.

FOR CANDY BARS; CEREAL BASED ENERGY BARS; CHOCOLATES CONTAINING NUTRIENTS; GRAIN-BASED FOOD BARS ALSO CONTAINING NUTS; GRANOLA-BASED SNACK BARS; HIGH-PROTEIN CEREAL BARS; READY TO EAT, CEREAL DERIVED FOOD BARS (U.S. CL. 46).

MATTHEW MCDOWELL, EXAMINING ATTORNEY

CLASS 30—(Continued).

SN 85-525,036. DIBOWSKI, KATRIN, 08017 BARCELONA, SPAIN, AND DIBOWSKI, CHRISTIAN, 08017 BARCELONA, SPAIN, FILED 1-25-2012.



THE COLOR(S) PINK AND WHITE IS/ARE CLAIMED AS A FEATURE OF THE MARK.

THE MARK CONSISTS OF THE STYLIZED WORD "PUNTOSMILE" IN WHITE AND A STYLIZED CIRCLE IN THE COLOR WHITE WITH A CURVED LINE REPRESENTING A SMILE IN THE COLOR WHITE IN THE INSIDE WITH A DOT ON THE OUTSIDE OF THE CIRCLE IN THE COLOR WHITE, INSIDE OF A SOLID PINK SQUARE DESIGN WITH ROUNDED CORNERS.

THE ENGLISH TRANSLATION OF "PUNTO" IS "POINT", FOR BREAD, SWEET AND SAVORY BAKERY GOODS, AND PIZZA (U.S. CL. 46).

MICHAEL WEBSTER, EXAMINING ATTORNEY

CLASS 30—(Continued).

SN 85-544,829. CHARLESTON COFFEE ROASTERS, INC., CHARLESTON, SC. FILED 2-16-2012.

CHARLESTON COFFEE ROASTERS

THE MARK CONSISTS OF STANDARD CHARACTERS WITHOUT CLAIM TO ANY PARTICULAR FONT, STYLE, SIZE, OR COLOR.

NO CLAIM IS MADE TO THE EXCLUSIVE RIGHT TO USE "COFFEE ROASTERS", APART FROM THE MARK AS SHOWN.

SEC. 2(F).

FOR COFFEE, CAFFEINE-FREE COFFEE AND COFFEE BEANS (U.S. CL. 46).

FIRST USE 6-15-2007; IN COMMERCE 6-15-2007.

ELISSA GARBER KON, EXAMINING ATTORNEY

SN 85-551,084. STRINGBEANS, LLC, FENTON, MO. FILED 2-23-2012.

SN 85-534,397. RECKITT BENCKISER LLC, PARSIPPANY, NJ. FILED 2-6-2012.



NO CLAIM IS MADE TO THE EXCLUSIVE RIGHT TO USE "50 YEARS OF GREAT BBQ", APART FROM THE MARK AS SHOWN.

THE COLOR(S) BLACK AND BEIGE IS/ARE CLAIMED AS A FEATURE OF THE MARK.

THE MARK CONSISTS OF THE STYLIZED WORDS "50 YEARS OF GREAT BBQ" WITH THE "50" APPEARING ABOVE "YEARS OF GREAT BBQ", ALL IN BEIGE AND OUTLINED AND SHADOWED IN BLACK, SURROUNDED BY A BEIGE TEXTURED CIRCLE.

FOR BARBEQUE SAUCE; MARINADES; SAUCES AND GLAZES FOR FOOD (U.S. CL. 46).

SHAILA SETTLES, EXAMINING ATTORNEY



NO CLAIM IS MADE TO THE EXCLUSIVE RIGHT TO USE "COFFEE CO.", "FRESHLY", OR "ROASTED", APART FROM THE MARK AS SHOWN.

THE MARK CONSISTS OF AN UPRIGHT GUITAR HEADSTOCK WITH SIX STRINGS CONNECTING TO SIX SCREWS EACH NEAR A COFFEE BEAN OUTSIDE THE HEADSTOCK, THE HEADSTOCK CENTERED UPON A CIRCLE, THE HEADSTOCK CENTERED UPON WIDENING RAYS EXTENDING OUTWARDLY FROM THE CENTER OF THE CIRCLE, THE WORDS "STRINGBEAN COFFEE CO." NEAR THE TOP OF THE HEADSTOCK, THE WORD "FRESHLY" TO THE LEFT OF THE HEADSTOCK, AND THE WORD "ROASTED" TO THE RIGHT OF THE HEADSTOCK.

FOR COFFEE (U.S. CL. 46).

FIRST USE 1-31-2012; IN COMMERCE 1-31-2012.

JUHI KAVEESHVAR, EXAMINING ATTORNEY

CLASS 30—(Continued).

SN 85-552,386. MOM BRANDS COMPANY, MINNEAPOLIS, MN. FILED 2-24-2012.



OWNER OF U.S. REG. NOS. 3,971,870 AND 4,132,284.
THE COLOR(S) DARK BLUE, BLUE, GREEN AND WHITE IS/ARE CLAIMED AS A FEATURE OF THE MARK.
THE MARK CONSISTS OF A WHITE SQUARE WITH THE WORDS "BAG THE BOX" IN DARK BLUE WITH A DOTTED LINE IN BLUE BELOW THE WORDS "BAG THE"; THE LETTER "O" HAS A SMILEY EARTH FACE WITH EYELASHES THAT IS GREEN AND BLUE; THE WHITE SQUARE IS ENCASED IN A BLUE SQUARE WITH "BAGTHEBOX.COM" IN THE COLOR WHITE AND LOCATED VERTICALLY NEXT TO THE WHITE SQUARE.
FOR BREAKFAST CEREAL (U.S. CL. 46).
BARBARA RUTLAND, EXAMINING ATTORNEY

SN 85-554,963. HOLY SPIRITS, LLC, MILWAUKEE, WI. FILED 2-28-2012.

FATHER DOM'S

THE MARK CONSISTS OF STANDARD CHARACTERS WITHOUT CLAIM TO ANY PARTICULAR FONT, STYLE, SIZE, OR COLOR.
THE NAME(S), PORTRAIT(S), AND/OR SIGNATURE(S) SHOWN IN THE MARK IDENTIFIES FATHER DOMENIC ROSCIOLI, WHOSE CONSENT(S) TO REGISTER IS MADE OF RECORD.
FOR CAKES, PANCAKE MIXES, BREAD MIXES, BISCUIT MIXES, OATMEAL, COCOA MIXES, COFFEE (U.S. CL. 46).
FIRST USE 2-28-2012; IN COMMERCE 2-28-2012.
SOPHIA S. KIM, EXAMINING ATTORNEY

CLASS 30—(Continued).

SN 85-558,997. ROAST HAUS COFFEE, HIGHLAND PARK, IL. FILED 3-2-2012.



NO CLAIM IS MADE TO THE EXCLUSIVE RIGHT TO USE "COFFEE", APART FROM THE MARK AS SHOWN.
THE MARK CONSISTS OF THE WORDS "ROAST HAUS COFFEE" ACCENTED BY TRIBAL-ART STYLE DESIGN ELEMENTS AND A FLAMING COFFEE BEAN AS THE FOCAL-POINT OF THE DESIGN.
THE ENGLISH TRANSLATION OF "HAUS" IN THE MARK IS "HOUSE".
FOR ROASTED COFFEE BEANS (U.S. CL. 46).
FIRST USE 2-26-2012; IN COMMERCE 2-26-2012.
KATHLEEN LORENZO, EXAMINING ATTORNEY

SN 85-566,939. PERFETTI VAN MELLE S.P.A., LAINATE, ITALY, FILED 3-12-2012.

HAPPYDENT

THE MARK CONSISTS OF STANDARD CHARACTERS WITHOUT CLAIM TO ANY PARTICULAR FONT, STYLE, SIZE, OR COLOR.
OWNER OF ITALY REG. NO. 305849, DATED 9-2-1977, EXPIRES 5-23-2017.
OWNER OF U.S. REG. NO. 3,081,450.
FOR CONFECTIONARY, NAMELY, CANDIES, CHEW CANDIES, CHEWING GUM, BUBBLE GUM (U.S. CL. 46).
JOHN WILKE, EXAMINING ATTORNEY

SN 85-566,973. PERFETTI VAN MELLE S.P.A., LAINATE, ITALY, FILED 3-12-2012.

BIG BABOL

THE MARK CONSISTS OF STANDARD CHARACTERS WITHOUT CLAIM TO ANY PARTICULAR FONT, STYLE, SIZE, OR COLOR.
OWNER OF ITALY REG. NO. 318104, DATED 10-2-1979, EXPIRES 2-23-2019.
OWNER OF U.S. REG. NO. 3,081,450.
FOR CONFECTIONERY, NAMELY, CANDIES, CHEW CANDIES, CHEWING GUM, BUBBLE GUM (U.S. CL. 46).
JOHN WILKE, EXAMINING ATTORNEY

CLASS 30—(Continued).

SN 85-572,170. KHONG GUAN CORPORATION, UNION CITY, CA. FILED 3-16-2012.

Uncle Charles

THE MARK CONSISTS OF STANDARD CHARACTERS WITHOUT CLAIM TO ANY PARTICULAR FONT, STYLE, SIZE, OR COLOR.

THE NAME "UNCLE CHARLES" DOES NOT IDENTIFY A LIVING INDIVIDUAL.

FOR BAKERY GOODS; BAKERY PRODUCTS; COOKIES (U.S. CL. 46).

MARLENE BELL, EXAMINING ATTORNEY

SN 85-573,944. SLAUSON GREGORY ROBERT, DBA DONUT O RAMA, GLADSTONE, OR. FILED 3-19-2012.

DONUTORAMA

THE MARK CONSISTS OF STANDARD CHARACTERS WITHOUT CLAIM TO ANY PARTICULAR FONT, STYLE, SIZE, OR COLOR.

FOR DONUTS (U.S. CL. 46).

FIRST USE 11-11-2011; IN COMMERCE 11-11-2011.

BARBARA A. GOLD, EXAMINING ATTORNEY

SN 85-576,717. MAATOUK FACTORIES SAL, BCHAMOUN, LEBANON, FILED 3-22-2012.



NO CLAIM IS MADE TO THE EXCLUSIVE RIGHT TO USE "1960", APART FROM THE MARK AS SHOWN.

THE MARK CONSISTS OF A DESIGN OF A COFFEE BEAN, WITH ARABIC WORD MAATOUK WRITTEN IN ARABIC AND ENGLISH CENTERED, WITH 1960 UNDERNEATH.

THE WORDING "MAATOUK" HAS NO MEANING IN A FOREIGN LANGUAGE.

THE NON-LATIN CHARACTERS IN THE MARK TRANSLITERATE TO "MAATOUK" AND THIS HAS NO MEANING IN A FOREIGN LANGUAGE.

FOR COFFEE (U.S. CL. 46).

FIRST USE 2-25-2011; IN COMMERCE 2-25-2011.

RAMONA ORTIGA, EXAMINING ATTORNEY

CLASS 30—(Continued).

SN 85-577,982. PALO PRODUCTS LLC, NEW YORK, NY. FILED 3-23-2012.

PALO ROOT TEA

THE MARK CONSISTS OF STANDARD CHARACTERS WITHOUT CLAIM TO ANY PARTICULAR FONT, STYLE, SIZE, OR COLOR.

OWNER OF U.S. REG. NO. 3,565,443.

NO CLAIM IS MADE TO THE EXCLUSIVE RIGHT TO USE "ROOT TEA", APART FROM THE MARK AS SHOWN.

THE ENGLISH TRANSLATION OF "PALO" IN THE MARK IS "WOOD, TREE, STICK OR BAT".

FOR BEVERAGES MADE OF TEA; BEVERAGES WITH A TEA BASE; COFFEE AND TEA; FLAVOURINGS OF TEA; FRUIT TEAS; HERB TEA; HERBAL TEA; ICED TEA; INSTANT TEA; TEA BAGS; TEA EXTRACTS; TEA FOR INFUSIONS; TEA-BASED BEVERAGES (U.S. CL. 46).

DEZMONA MIZELLE, EXAMINING ATTORNEY

SN 85-578,210. MAUI KOMBUCHA, INC., HAIKU, HI. FILED 3-23-2012.



NO CLAIM IS MADE TO THE EXCLUSIVE RIGHT TO USE "KOMBUCHA", APART FROM THE MARK AS SHOWN.

THE COLOR(S) BLUE, YELLOW AND GRAY IS/ARE CLAIMED AS A FEATURE OF THE MARK.

THE MARK CONSISTS OF A CIRCLE IN YELLOW ON TOP AND BLUE OUTLINED IN GRAY ON THE BOTTOM HALF CONTAINING THREE JAPANESE CHARACTERS IN GRAY. THE STYLIZED WORDS "MAUI KOMBUCHA" APPEAR SUPERIMPOSED ACROSS THE TOP HALF OF THE CIRCLE IN BLUE OUTLINED IN GRAY WITH A BLUE UNDERLINE OUTLINED IN GRAY.

THE WORDING "MAUI KOMBUCHA" HAS NO MEANING IN A FOREIGN LANGUAGE.

THE NON-LATIN CHARACTERS IN THE MARK TRANSLITERATE TO "AI KANSHA" AND THIS MEANS "LOVE & GRATITUDE" IN ENGLISH.

SEC. 2(F) AS TO "MAUI".

FOR TEA; TEA-BASED BEVERAGES (U.S. CL. 46).

FIRST USE 0-0-2005; IN COMMERCE 0-0-2005.

GINA FINK, EXAMINING ATTORNEY

CLASS 30—(Continued).

SN 85-582,077. HAN LION GROUP LIMITED, ROAD TOWN, TORTOLA, BR.VIRGIN ISLANDS, FILED 3-28-2012.

EAT DRINK TEA

THE MARK CONSISTS OF STANDARD CHARACTERS WITHOUT CLAIM TO ANY PARTICULAR FONT, STYLE, SIZE, OR COLOR.

NO CLAIM IS MADE TO THE EXCLUSIVE RIGHT TO USE "TEA", APART FROM THE MARK AS SHOWN.

FOR TEA; NON-MEDICATED TEA PRODUCTS; NON-MEDICATED TEA BEVERAGES AND EXTRACTS; AROMATIC TEAS OTHER THAN FOR MEDICINAL USE; BEVERAGES MADE OF TEA; HERBAL BEVERAGES, EXTRACTS, INFUSIONS AND TEA OTHER THAN FOR MEDICINAL USE; ARTIFICIAL TEA OTHER THAN FOR MEDICINAL USE; AROMATIC BEVERAGES MADE OF TEA; FRUIT FLAVORED TEA OTHER THAN FOR MEDICINAL USE; FRUIT TEA OTHER THAN FOR MEDICINAL USE; HERBAL TEA OTHER THAN FOR MEDICINAL USE (U.S. CL. 46).

FIRST USE 7-22-2010; IN COMMERCE 9-3-2010.
ELLEN PERKINS, EXAMINING ATTORNEY

CLASS 30—(Continued).

SN 85-586,441. FAT SMACK'S, BELLEVILLE, IL. FILED 4-2-2012.



NO CLAIM IS MADE TO THE EXCLUSIVE RIGHT TO USE "BBQ SAUCE", APART FROM THE MARK AS SHOWN.

THE MARK CONSISTS OF A STYLIZED IMAGE OF A YOUNG BOY WITH A BBQ HAND PRINT ON HIS FACE. THE STYLIZED TEXT "FAT SMACK'S" IS LOCATED ABOVE THE IMAGE OF THE BOY AND THE TEXT "BBQ SAUCE" IS LOCATED BELOW THE IMAGE OF THE BOY.

FOR BARBECUE SAUCE (U.S. CL. 46).
CURTIS FRENCH, EXAMINING ATTORNEY

SN 85-586,152. ADDICTION SAUCES LLC, WILMINGTON, NC. FILED 4-2-2012.



THE MARK CONSISTS OF THE SILHOUETTE OF A MAN HOLDING A PEPPER, SURROUNDED BY A PARTIALLY FILLED VERTICAL RECTANGLE WITH FRAYED EDGES AND ROUNDED CORNERS.

FOR HOT SAUCES, KETCHUPS, SPICE BLENDS, SALAD DRESSINGS, VINAIGRETTES (U.S. CL. 46).
KEVEN MITTLER, EXAMINING ATTORNEY

SN 85-587,791. FLEET WHOLESALE SUPPLY CO., INC., APPLETON, WI. FILED 4-3-2012.

MAE'S CORNER MARKET

THE MARK CONSISTS OF STANDARD CHARACTERS WITHOUT CLAIM TO ANY PARTICULAR FONT, STYLE, SIZE, OR COLOR.

OWNER OF U.S. REG. NOS. 4,157,319 AND 4,157,320.
NO CLAIM IS MADE TO THE EXCLUSIVE RIGHT TO USE "MARKET", APART FROM THE MARK AS SHOWN.

FOR PIZZA; SANDWICHES, NAMELY, BREAKFAST AND SUB SANDWICHES (U.S. CL. 46).
JAMES STEIN, EXAMINING ATTORNEY

CLASS 30—(Continued).

SN 85-587,798. FLEET WHOLESALE SUPPLY CO., INC., APPLETON, WI. FILED 4-3-2012.



OWNER OF U.S. REG. NOS. 4,157,319 AND 4,157,320.
NO CLAIM IS MADE TO THE EXCLUSIVE RIGHT TO USE "MARKET", APART FROM THE MARK AS SHOWN.

THE MARK CONSISTS OF THE WORDS "MAE'S CORNER MARKET" WITH THE IMAGES OF A BARN AND SILO ABOVE AND SQUARES IN A CHECKERBOARD PATTERN THAT RESEMBLE A TABLECLOTH BELOW.

FOR PIZZA; SANDWICHES, NAMELY, BREAKFAST AND SUB SANDWICHES (U.S. CL. 46).
JAMES STEIN, EXAMINING ATTORNEY

SN 85-588,025. BONA DEA BAKING COMPANY, LLC, AUSTIN, TX. FILED 4-3-2012.

Bona Dea

THE MARK CONSISTS OF STANDARD CHARACTERS WITHOUT CLAIM TO ANY PARTICULAR FONT, STYLE, SIZE, OR COLOR.

FOR GLUTEN FREE FLOUR AND MIXES, NAMELY, MIXES FOR BAKERY GOODS AND MIXES FOR MAKING BAKING BATTERS (U.S. CL. 46).

FIRST USE 5-4-2010; IN COMMERCE 5-4-2010.

KATHERINE M. DUBRAY, EXAMINING ATTORNEY

CLASS 30—(Continued).

SN 85-589,621. CRYSTAL RIVER ORGANICS LLC., CARBONDALE, CO. FILED 4-5-2012.

HEALTHY MINDS

THE MARK CONSISTS OF STANDARD CHARACTERS WITHOUT CLAIM TO ANY PARTICULAR FONT, STYLE, SIZE, OR COLOR.

NO CLAIM IS MADE TO THE EXCLUSIVE RIGHT TO USE "HEALTHY", APART FROM THE MARK AS SHOWN.

FOR CEREAL BASED SNACK BARS; CEREAL BASED HIGH PROTEIN SNACK BARS AND POWDERS; CEREAL BASED HIGH ENERGY BARS NOT FOR USE AS A MEAL REPLACEMENT; CEREALS AND PREPARATIONS MADE FROM CEREALS, NAMELY, BREAKFAST CEREALS, PROCESSED CEREALS AND CEREAL BASED SNACK FOODS; SALAD DRESSINGS, CONDIMENTS, NAMELY, SALSAS, MARINADES; PREPARED AND PACKAGED READY TO EAT MEALS CONSISTING PRIMARILY OF PASTA OR RICE (U.S. CL. 46).

JACLYN KIDWELL WALKER, EXAMINING ATTORNEY

SN 85-589,917. C. L. SWANSON CORPORATION, MADISON, WI. FILED 4-5-2012.

Billy Brew

THE MARK CONSISTS OF STANDARD CHARACTERS WITHOUT CLAIM TO ANY PARTICULAR FONT, STYLE, SIZE, OR COLOR.

NO CLAIM IS MADE TO THE EXCLUSIVE RIGHT TO USE "BREW", APART FROM THE MARK AS SHOWN.

FOR INSTANT COFFEE (U.S. CL. 46).

AMY KERTGATE, EXAMINING ATTORNEY

SN 85-590,814. MOKA FLY LLC, BLOOMFIELD HILLS, MI. FILED 4-6-2012.

MOKAFLY

THE MARK CONSISTS OF STANDARD CHARACTERS WITHOUT CLAIM TO ANY PARTICULAR FONT, STYLE, SIZE, OR COLOR.

FOR ICED COFFEE; COFFEE; COCOA-BASED BEVERAGES AND PREPARED COCOA-BASED BEVERAGES (U.S. CL. 46).

NAKWAMA ANKRAH, EXAMINING ATTORNEY

CLASS 30—(Continued).

SN 85-590,878. PURE & SIMPLE FARM, LLC, NEW MARKET, VA. FILED 4-6-2012.



NO CLAIM IS MADE TO THE EXCLUSIVE RIGHT TO USE 'PURE' AND 'FARM', APART FROM THE MARK AS SHOWN.

THE MARK CONSISTS OF THE STYLIZED TEXT "PURE AND SIMPLE FARM" WHERE THE WORD "AND" IS SMALLER AND SITS BELOW AN IMAGE OF A BEE.

FOR HONEY; PROPOLIS FOR FOOD PURPOSES (U.S. CL. 46).

FIRST USE 12-29-2008; IN COMMERCE 1-3-2009.
WON TEAK OH, EXAMINING ATTORNEY

SN 85-592,028. WIEMEYER LAPORTE GENERAL PARTNERSHIP, DBA NO NO BURGER, OAKLAND, CA. FILED 4-8-2012.

No No Burger

THE MARK CONSISTS OF STANDARD CHARACTERS WITHOUT CLAIM TO ANY PARTICULAR FONT, STYLE, SIZE, OR COLOR.

NO CLAIM IS MADE TO THE EXCLUSIVE RIGHT TO USE "BURGER", APART FROM THE MARK AS SHOWN.

FOR SOY BURGER SANDWICHES (U.S. CL. 46).

FIRST USE 8-15-2011; IN COMMERCE 11-12-2011.
NICHOLAS COLEMAN, EXAMINING ATTORNEY

SN 85-592,046. MIXTE INC., REDWOOD CITY, CA. FILED 4-8-2012.

Mixte Coffee

THE MARK CONSISTS OF STANDARD CHARACTERS WITHOUT CLAIM TO ANY PARTICULAR FONT, STYLE, SIZE, OR COLOR.

NO CLAIM IS MADE TO THE EXCLUSIVE RIGHT TO USE "COFFEE", APART FROM THE MARK AS SHOWN.

FOR BEVERAGES MADE OF COFFEE; BEVERAGES WITH A COFFEE BASE; COFFEE; COFFEE; COFFEE BASED BEVERAGES; COFFEE BEVERAGES WITH MILK; COFFEE-BASED BEVERAGE CONTAINING MILK; COFFEE-BASED BEVERAGES; ICED COFFEE; PREPARED COFFEE AND COFFEE-BASED BEVERAGES (U.S. CL. 46).

ELIZABETH KAJUBI, EXAMINING ATTORNEY

CLASS 30—(Continued).

SN 85-593,912. SCHNEIDER, MICHAEL D, SALT LAKE CITY, UT. FILED 4-10-2012.



NO CLAIM IS MADE TO THE EXCLUSIVE RIGHT TO USE "SPECIAL SAUCE", APART FROM THE MARK AS SHOWN.

THE MARK CONSISTS OF THE WORDING "SOME GUYS" AT THE TOP WITHIN A RECTANGULAR BORDER DESIGN OVERLAPPING A DIAMOND DESIGN, WITH THE LONG TAIL OF THE LETTER "Y" IN THE WORD "GUYS" CREATING AN OVAL SHAPE UNDERNEATH THE WORDING. THERE IS A DESIGN OF SQUIRTING LIQUID EMANATING FROM THE TOP OF THE LETTER "E" IN THE WORD "SOME." AT THE BOTTOM OF THE EXTERIOR RECTANGULAR DESIGN APPEAR THE WORDS "SPECIAL SAUCE" APPEARING WITHIN A RECTANGLE BORDER. THE EXTERIOR RECTANGLE DESIGN INCLUDES HALF CIRCLES PROTRUDING AT THE TOP AND BOTTOM.

FOR BARBEQUE SAUCE; DIPPING SAUCES; READY-MADE SAUCES; SALAD SAUCES; SAUCES (U.S. CL. 46).
CHRISTOPHER SIDOTI, EXAMINING ATTORNEY

SN 85-593,982. AMAZONAS IMPORTS, INC., SUN VALLEY, CA. FILED 4-10-2012.

PERUANITA

THE MARK CONSISTS OF STANDARD CHARACTERS WITHOUT CLAIM TO ANY PARTICULAR FONT, STYLE, SIZE, OR COLOR.

OWNER OF U.S. REG. NO. 3,220,048.

THE ENGLISH TRANSLATION OF "PERUANITA" IN THE MARK IS "LITTLE PERUVIAN GIRL".

FOR SEASONINGS; SAUCES; FLOUR FOR FOOD; FOOD STARCH; COCOA; HUSKED BARLEY; SUGAR; PROCESSED HERBS; SPICES; CAKES; CRACKERS; COOKIES; WAFERS; INSTANT PUDDING MIXES; CORN CURLS; CONDIMENTS, NAMELY, KETCHUP; HONEY; BREAD MIXES; DONUT MIXES; PROCESSED WHEAT; VANILLA; TAMALES; TORTILLAS; HERB TEAS; FRUIT TEAS; SALSA; MIXES IN THE NATURE OF FLOUR POWDERS USED IN THE PREPARATION OF FLOUR-BASED FOOD BEVERAGES (U.S. CL. 46).

DAVID YONTEF, EXAMINING ATTORNEY

CLASS 30—(Continued).

SN 85-594,265. GRANNY CAROL'S INC, LAGUNA WOODS, CA. FILED 4-11-2012.

GRANNY CAROL'S

THE MARK CONSISTS OF STANDARD CHARACTERS WITHOUT CLAIM TO ANY PARTICULAR FONT, STYLE, SIZE, OR COLOR.

THE NAME "GRANNY CAROL" IDENTIFIES "CAROL DOLAN", A LIVING INDIVIDUAL WHOSE CONSENT IS OF RECORD.

FOR YOGURT COATED SNACKS CONSISTING PRIMARILY OF CEREAL GRAINS, DRIED FRUITS AND NUTS (U.S. CL. 46).

FIRST USE 1-1-2009; IN COMMERCE 1-9-2009.
JOHN WILKE, EXAMINING ATTORNEY

SN 85-596,379. VASQUEZ BULNES, BERNARDO, SAN ANTONIO, TX. FILED 4-12-2012.

LaMejico Panadería
A bit of México in USA.

NO CLAIM IS MADE TO THE EXCLUSIVE RIGHT TO USE "PANADERIA LA MEJICO", APART FROM THE MARK AS SHOWN.

THE MARK CONSISTS OF THE STYLIZED TEXT "LA-MEJICO". ABOVE THE LETTERS "CO" IS THE STYLIZED TEXT "PANADERIA". BELOW THE LETTERS "LAME" IS THE STYLIZED TEXT "A BIT OF MEXICO IN USA."

THE ENGLISH TRANSLATION OF "PANADERIA LAMEJICO" IN THE MARK IS "BAKERY OF MEXICO".

FOR BAKERY GOODS (U.S. CL. 46).
FIRST USE 1-6-2011; IN COMMERCE 1-6-2011.
LINDSEY RUBIN, EXAMINING ATTORNEY

CLASS 30—(Continued).

SN 85-596,390. RAVOTTI, ERIC, GIBSONIA, PA. FILED 4-12-2012.



NO CLAIM IS MADE TO THE EXCLUSIVE RIGHT TO USE "COFFEE", APART FROM THE MARK AS SHOWN.

THE COLOR WHITE REPRESENTS BACKGROUND, OUTLINING, SHADING, AND/OR TRANSPARENT AREAS AND IS NOT PART OF THE MARK.

THE COLOR(S) GREEN AND BROWN IS/ARE CLAIMED AS A FEATURE OF THE MARK.

THE MARK CONSISTS OF THE ARTISTIC RENDERING OF A COFFEE CUP IN BROWN AND GREEN WITH THE BOTTOM OF THE CUP DRAWN TO RESEMBLE A LEAF. THE STEAM COMING OUT OF THE CUP IS DRAWN IN BROWN AND IN THE SHAPE OF A HEART. BELOW THE AFOREMENTIONED IS THE STYLIZED WORDS "GENER-OASTA" IN GREEN AND "COFFEE" IN BROWN.

FOR COFFEE; COFFEE BEANS (U.S. CL. 46).
PRISCILLA MILTON, EXAMINING ATTORNEY

SN 85-596,558. PALERMO, ALEXANDER, LOS ANGELES, CA. FILED 4-12-2012.

JOE'S MAC & CHEESE

THE MARK CONSISTS OF STANDARD CHARACTERS WITHOUT CLAIM TO ANY PARTICULAR FONT, STYLE, SIZE, OR COLOR.

NO CLAIM IS MADE TO THE EXCLUSIVE RIGHT TO USE "MAC & CHEESE", APART FROM THE MARK AS SHOWN.

FOR MACARONI AND CHEESE (U.S. CL. 46).
JAMES LOVELACE, EXAMINING ATTORNEY

CLASS 30—(Continued).

SN 85-596,676. DANA FRANCES CONRAD AND DANIEL BRYCE CONRAD PARTNERSHIP, LAKEWOOD, WA. FILED 4-12-2012.



NO CLAIM IS MADE TO THE EXCLUSIVE RIGHT TO USE "CRÊPE", APART FROM THE MARK AS SHOWN.

THE MARK CONSISTS OF TWO HANDS HOLDING A PAPER-WRAPPED CREPE, SURROUNDED ON THE LEFT SIDE BY LAVENDER, A HONEY STICK WITH HONEY DRIPPING FROM IT, TWO STRAWBERRIES AND THEIR LEAVES. UNDERNEATH THE HANDS ARE A BUNCH OF RASPBERRIES AND THEIR LEAVES. THE HANDS ARE SURROUNDED ON THE RIGHT SIDE BY ARUGULA, CHANTERELLE MUSHROOMS, AN OPEN WEDGE OF BRIE CHEESE, BASIL AND ANOTHER HERB. THE WORD "SAINT" IS ON THE LEFT SIDE, THE WORD "CRÊPE" IS ON THE RIGHT SIDE. PICTURE AND WORDS ARE ALL BORDERED WITH A STAINED GLASS-STYLE FRAME.

FOR CREPES (U.S. CL. 46).

FIRST USE 5-12-2012; IN COMMERCE 5-12-2012.

JENNIFER RICHARDSON, EXAMINING ATTORNEY

CLASS 30—(Continued).

SN 85-598,827. AUNT AGGIE DE'S PRALINES, INC., SINTON, TX. FILED 4-16-2012.

Aunt Aggie De's Pralines

THE MARK CONSISTS OF STANDARD CHARACTERS WITHOUT CLAIM TO ANY PARTICULAR FONT, STYLE, SIZE, OR COLOR.

NO CLAIM IS MADE TO THE EXCLUSIVE RIGHT TO USE "PRALINES", APART FROM THE MARK AS SHOWN. THE NAME(S), PORTRAIT(S), AND/OR SIGNATURE(S) SHOWN IN THE MARK DOES NOT IDENTIFY A PARTICULAR LIVING INDIVIDUAL.

FOR CANDY; PRALINES; TOPPING SYRUP (U.S. CL. 46).

FIRST USE 11-30-1988, THE MARK WAS FIRST USED ANYWHERE IN A DIFFERENT FORM OTHER THAN THAT SOUGHT TO BE REGISTERED AT LEAST AS EARLY AS 11/30/1988; IN COMMERCE 12-31-1988, THE MARK WAS FIRST USED IN COMMERCE IN A DIFFERENT FORM OTHER THAN THAT SOUGHT TO BE REGISTERED AT LEAST AS EARLY AS 12/31/1988.

GEOFFREY FOSDICK, EXAMINING ATTORNEY

SN 85-598,917. AUNT AGGIE DE'S PRALINES, INC., SINTON, TX. FILED 4-16-2012.

SN 85-598,670. EMPIRE CREATIVE, LLC, NEW YORK, NY. FILED 4-16-2012.

Pelican Punch



THE COLOR(S) BROWN IS/ARE CLAIMED AS A FEATURE OF THE MARK.

THE MARK CONSISTS OF A BROWN SQUIRREL WEARING A HAT AND EATING A PRALINE.

FOR CANDY; PRALINES; TOPPING SYRUP (U.S. CL. 46).

FIRST USE 11-30-1988, THE MARK WAS FIRST USED ANYWHERE IN A DIFFERENT FORM OTHER THAN THAT SOUGHT TO BE REGISTERED AT LEAST AS EARLY AS 11/30/1988; IN COMMERCE 12-31-1988, THE MARK WAS FIRST USED IN COMMERCE IN A DIFFERENT FORM OTHER THAN THAT SOUGHT TO BE REGISTERED AT LEAST AS EARLY AS 12/31/1988.

GEOFFREY FOSDICK, EXAMINING ATTORNEY

THE MARK CONSISTS OF STANDARD CHARACTERS WITHOUT CLAIM TO ANY PARTICULAR FONT, STYLE, SIZE, OR COLOR.

NO CLAIM IS MADE TO THE EXCLUSIVE RIGHT TO USE "PUNCH", APART FROM THE MARK AS SHOWN.

FOR TEA; TEA BAGS; HERBAL TEA FOR FOOD PURPOSES (U.S. CL. 46).

AMY ALFIERI, EXAMINING ATTORNEY

CLASS 30—(Continued).

SN 85-599,299. STRACI, SHARON L., NEW YORK, NY. FILED 4-16-2012.

The Woman Behind the Sauce

THE MARK CONSISTS OF STANDARD CHARACTERS WITHOUT CLAIM TO ANY PARTICULAR FONT, STYLE, SIZE, OR COLOR.

NO CLAIM IS MADE TO THE EXCLUSIVE RIGHT TO USE "WOMAN" OR "SAUCE", APART FROM THE MARK AS SHOWN.

FOR ALIMENTARY PASTA; PASTA; PIZZA SAUCE; READY-MADE SAUCES; SPAGHETTI SAUCE; TOMATO SAUCE (U.S. CL. 46).

GIANCARLO CASTRO, EXAMINING ATTORNEY

SN 85-600,652. SAUCE OF AGES, LLC, CARLSBAD, CA. FILED 4-17-2012.

Sauce of Ages

THE MARK CONSISTS OF STANDARD CHARACTERS WITHOUT CLAIM TO ANY PARTICULAR FONT, STYLE, SIZE, OR COLOR.

FOR ARTICHOKE SAUCE; BAKING SPICES; BARBECUE DRY RUB; BARBECUE SAUCE; CHEESE SAUCE; CHICKEN WING SAUCE; CHILI OIL FOR USE AS A SEASONING OR CONDIMENT; CHILI SAUCE; CHIMICHURRI SAUCE; CHOCOLATE SAUCE; CHUTNEYS; COCKTAIL SAUCES; COLE SLAW DRESSING; COLESLAW DRESSING; CONDIMENT, NAMELY, PEPPER SAUCE; COOKING SAUCES; CURRY SAUCE; DIPPING SAUCES; DRY SPICE RUB FOR MEATS AND FISH; EDIBLE SPICES; FLAVOURED VINEGAR; GRILLING SAUCES; HOT CHILI PEPPER SAUCE; HOT PEPPER POWDER; HOT SAUCE; PASTA SAUCE; PESTO SAUCE; PICANTE SAUCE; PICO DE GALLO SAUCE; PIZZA SAUCE; READY-MADE SAUCES; SALAD DRESSING; SALAD SAUCES; SAUCE MIXES; SAUCES; SAUCES FOR BARBECUED MEAT; SOY SAUCE; SPAGHETTI SAUCE; SPICE BLENDS; SPICE RUBS; STEAK SAUCE; TARTAR SAUCE; TERIYAKI SAUCE; TOMATO SAUCE; VINEGAR (U.S. CL. 46).

ZACHARY CROMER, EXAMINING ATTORNEY

CLASS 30—(Continued).

SN 85-600,893. RIGHT TASTY, BROOKLYN, NY. FILED 4-18-2012.

Right Tasty

THE MARK CONSISTS OF STANDARD CHARACTERS WITHOUT CLAIM TO ANY PARTICULAR FONT, STYLE, SIZE, OR COLOR.

NO CLAIM IS MADE TO THE EXCLUSIVE RIGHT TO USE "TASTY", APART FROM THE MARK AS SHOWN.

FOR SALAD DRESSINGS; SAUCES; VINAIGRETTES (U.S. CL. 46).

NICHOLAS COLEMAN, EXAMINING ATTORNEY

SN 85-601,158. RENAISSANCE KITCHEN, INC., CRYSTAL LAKE, IL. FILED 4-18-2012.

Renaissance Grains

THE MARK CONSISTS OF STANDARD CHARACTERS WITHOUT CLAIM TO ANY PARTICULAR FONT, STYLE, SIZE, OR COLOR.

NO CLAIM IS MADE TO THE EXCLUSIVE RIGHT TO USE "GRAINS", APART FROM THE MARK AS SHOWN.

FOR PROCESSED CEREALS; PROCESSED GRAINS; PILAF; PROCESSED CEREAL-BASED FOOD TO BE USED AS A BREAKFAST FOOD, SNACK FOOD OR INGREDIENT FOR MAKING OTHER FOODS; WHOLE GRAIN BASED SALAD (U.S. CL. 46).

ELISSA GARBER KON, EXAMINING ATTORNEY

SN 85-601,383. RENAISSANCE KITCHEN, INC., CRYSTAL LAKE, IL. FILED 4-18-2012.

Renaissance Kitchen

THE MARK CONSISTS OF STANDARD CHARACTERS WITHOUT CLAIM TO ANY PARTICULAR FONT, STYLE, SIZE, OR COLOR.

NO CLAIM IS MADE TO THE EXCLUSIVE RIGHT TO USE "KITCHEN", APART FROM THE MARK AS SHOWN.

FOR PROCESSED CEREALS; PROCESSED GRAINS; PILAF; PROCESSED CEREAL-BASED FOOD TO BE USED AS A BREAKFAST FOOD, SNACK FOOD OR INGREDIENT FOR MAKING OTHER FOODS; WHOLE GRAIN BASED SALAD (U.S. CL. 46).

ELISSA GARBER KON, EXAMINING ATTORNEY

CLASS 30—(Continued).

SN 85-601,738. HERITAGE COFFEE CO. L.L.C., ST. LOUIS, MO. FILED 4-18-2012.

CHRONICLE

THE MARK CONSISTS OF STANDARD CHARACTERS WITHOUT CLAIM TO ANY PARTICULAR FONT, STYLE, SIZE, OR COLOR.

FOR COFFEE; BEVERAGES MADE OF COFFEE; WHOLE AND GROUND COFFEE BEANS; NON-ALCOHOLIC BEVERAGES MADE WITH A BASE OF COFFEE; BEVERAGES MADE WITH A BASE OF COFFEE; READY-TO-DRINK COFFEE (U.S. CL. 46).

DANIEL S. STRINGER, EXAMINING ATTORNEY

SN 85-601,748. HERITAGE COFFEE CO. L.L.C., ST. LOUIS, MO. FILED 4-18-2012.

CONTROL THE NARRATIVE

THE MARK CONSISTS OF STANDARD CHARACTERS WITHOUT CLAIM TO ANY PARTICULAR FONT, STYLE, SIZE, OR COLOR.

FOR COFFEE; BEVERAGES MADE OF COFFEE; WHOLE AND GROUND COFFEE BEANS; NON-ALCOHOLIC BEVERAGES MADE WITH A BASE OF COFFEE; BEVERAGES MADE WITH A BASE OF COFFEE; READY-TO-DRINK COFFEE (U.S. CL. 46).

DANIEL S. STRINGER, EXAMINING ATTORNEY

SN 85-601,769. HEAVENLY SCENT POPCORN, LLC, GODFREY, IL. FILED 4-18-2012.

HEAVENLY SCENT POPCORN

THE MARK CONSISTS OF STANDARD CHARACTERS WITHOUT CLAIM TO ANY PARTICULAR FONT, STYLE, SIZE, OR COLOR.

NO CLAIM IS MADE TO THE EXCLUSIVE RIGHT TO USE "POPCORN", APART FROM THE MARK AS SHOWN. FOR POPCORN; CARAMEL COATED APPLES (U.S. CL. 46).

FIRST USE 1-0-2012; IN COMMERCE 1-0-2012.

MATTHEW GALAN, EXAMINING ATTORNEY

CLASS 30—(Continued).

SN 85-601,852. ANDREW BAYSINGER, DBA DROSKI, LLC, BELLEFONTE, PA. FILED 4-18-2012.



NO CLAIM IS MADE TO THE EXCLUSIVE RIGHT TO USE "HOMEMADE CHOCOLATE SAUCE", APART FROM THE MARK AS SHOWN.

THE NAME "AUNT SAL" AND THE PORTRAIT IN THE MARK DO NOT IDENTIFY A LIVING INDIVIDUAL.

THE COLOR(S) RED, GRAY, BLACK, CREAM, AND WHITE IS/ARE CLAIMED AS A FEATURE OF THE MARK.

THE MARK CONSISTS OF THE WORDS "AUNT SAL'S HOMEMADE CHOCOLATE SAUCE" IN WHITE LETTERS WITH BLACK OUTLINES ON A RED BANNER WITH A GRAY BACKING BELOW A BLACK AND WHITE PORTRAIT OF A WOMAN WITHIN A RED, BLACK AND WHITE DECORATIVE PICTURE FRAME, ALL ON A CREAM COLORED RECTANGULAR BACKGROUND.

FOR CHOCOLATE SAUCE (U.S. CL. 46).

FIRST USE 7-3-2010; IN COMMERCE 7-7-2010.

JOHN WILKE, EXAMINING ATTORNEY

SN 85-602,252. RUE SERVICES CORPORATION, WARRENDALE, PA. FILED 4-19-2012.

RUESWEETS

THE MARK CONSISTS OF STANDARD CHARACTERS WITHOUT CLAIM TO ANY PARTICULAR FONT, STYLE, SIZE, OR COLOR.

OWNER OF U.S. REG. NOS. 2,123,489, 4,093,339 AND OTHERS.

THE ENGLISH TRANSLATION OF THE WORD "RUE" IN THE MARK IS "STREET".

FOR CANDY (U.S. CL. 46).

FIRST USE 12-31-2004; IN COMMERCE 12-31-2004.

REBECCA SMITH, EXAMINING ATTORNEY

CLASS 30—(Continued).

SN 85-602,729. ABRACO GROUP, LLC, CORAL GABLES, FL.
FILED 4-19-2012.

WAFFLELOOS

THE MARK CONSISTS OF STANDARD CHARACTERS WITHOUT CLAIM TO ANY PARTICULAR FONT, STYLE, SIZE, OR COLOR.

FOR SNACK CAKES (U.S. CL. 46).
FIRST USE 12-21-2011; IN COMMERCE 12-21-2011.
BRENDAN REGAN, EXAMINING ATTORNEY

SN 85-602,745. GOOD CHOICE TRADING INC., HAYWARD, CA. FILED 4-19-2012.

**YUME BRAND**

NO CLAIM IS MADE TO THE EXCLUSIVE RIGHT TO USE "BRAND", APART FROM THE MARK AS SHOWN.

THE MARK CONSISTS OF THE WORD "YUME" IN CALLIGRAPHY STYLE INSIDE A CIRCULAR RING. WITH "YUME BRAND" BELOW.

THE ENGLISH TRANSLATION OF THE WORD "YUME" IN THE MARK IS "DREAM".

FOR CHILI PODS FOR USE AS A SEASONING; SPICES (U.S. CL. 46).

FIRST USE 1-1-2012; IN COMMERCE 1-1-2012.
SAMUEL E. SHARPER JR., EXAMINING ATTORNEY

SN 85-603,120. NANCY ALISA GIBBONS ADDISON, DALLAS, TX. FILED 4-19-2012.

Sexy Sea Salt

THE MARK CONSISTS OF STANDARD CHARACTERS WITHOUT CLAIM TO ANY PARTICULAR FONT, STYLE, SIZE, OR COLOR.

NO CLAIM IS MADE TO THE EXCLUSIVE RIGHT TO USE "SEA SALT", APART FROM THE MARK AS SHOWN.

FOR COOKING SALT; EDIBLE SALT; MINERAL SALT FOR HUMAN CONSUMPTION; SALT; SEA SALT FOR COOKING (U.S. CL. 46).

FIRST USE 9-10-2011; IN COMMERCE 9-10-2011.
ANTHONY RINKER, EXAMINING ATTORNEY

CLASS 30—(Continued).

SN 85-603,388. ALTICOR INC., ADA, MI. FILED 4-20-2012.

BODYKEY

THE MARK CONSISTS OF STANDARD CHARACTERS WITHOUT CLAIM TO ANY PARTICULAR FONT, STYLE, SIZE, OR COLOR.

PRIORITY CLAIMED UNDER SEC. 44(D) ON MEXICO APPLICATION NO. 1237915, FILED 12-16-2011.

FOR PREPARED PACKED MEALS CONSISTING PRIMARILY OF PASTA, RICE OR OTHER GRAINS; CORN SYRUP; FLOUR; GRAIN-BASED SNACK FOODS FORTIFIED WITH VITAMINS AND MINERALS; NUTRITIONALLY FORTIFIED COOKIES; CORN SYRUP-, FLOUR-, AND GRAIN-BASED SNACK FOODS FORTIFIED WITH VITAMINS AND MINERALS (U.S. CL. 46).

MIAH ROSENBERG, EXAMINING ATTORNEY

SN 85-603,449. RESPECT FOODS, INC., NAPERVILLE, IL. FILED 4-20-2012.

RESPECT VALUE

THE MARK CONSISTS OF STANDARD CHARACTERS WITHOUT CLAIM TO ANY PARTICULAR FONT, STYLE, SIZE, OR COLOR.

FOR BREAD MIXES; BROWNIE MIXES; CAKE MIXES; CHEESEBURGER SANDWICHES; COFFEE; COOKIE MIXES; COOKIES; CRACKERS; GRAVY MIXES; HAMBURGER SANDWICHES; HONEY; INSTANT CHINESE NOODLES; INSTANT NOODLES; MACARONI AND CHEESE; MUFFIN MIXES; NOODLES AND SAUCE MIXES COMBINED IN UNITARY PACKAGES; NOODLES AND SEASONING MIXES COMBINED IN UNITARY PACKAGES; NOODLES, SAUCE, AND SEASONING TOPPINGS COMBINED IN UNITARY PACKAGES; PACKAGED MEAL KITS CONSISTING PRIMARILY OF PASTA OR RICE; PACKAGED MEAL MIXES CONSISTING PRIMARILY OF PASTA OR RICE; PASTA SAUCE; POT PIES; RICE AND SEASONING MIX COMBINED IN UNITARY PACKAGES; SALSA; SANDWICHES; SAUCE MIXES; SEASONING MIXES; SEASONING MIXES FOR SOUPS; TEA; FROZEN ENTREES CONSISTING PRIMARILY OF PASTA OR RICE; FROZEN MEALS CONSISTING PRIMARILY OF PASTA OR RICE; FROZEN RICE; SIDE DISHES CONSISTING PRIMARILY OF PASTA OR RICE (U.S. CL. 46).

TINA L. SNAPP, EXAMINING ATTORNEY

CLASS 30—(Continued).

SN 85-603,800. SILVER, BARNARD S, SALT LAKE CITY, UT. FILED 4-20-2012.

Frē

THE MARK CONSISTS OF STANDARD CHARACTERS WITHOUT CLAIM TO ANY PARTICULAR FONT, STYLE, SIZE, OR COLOR.
FOR SUGAR SUBSTITUTES (U.S. CL. 46).
FIRST USE 12-14-2010; IN COMMERCE 12-14-2010.
GISELLE AGOSTO, EXAMINING ATTORNEY

SN 85-604,189. IL ET ELLE FLOTTANTES, LLC, DBA CAT & MOUSSE, LLC, NEW YORK, NY. FILED 4-20-2012.

JUST ENOUGH OF A (VERY)
GOOD THING

THE MARK CONSISTS OF STANDARD CHARACTERS WITHOUT CLAIM TO ANY PARTICULAR FONT, STYLE, SIZE, OR COLOR.
FOR BAKERY DESSERTS; CUSTARDS; CUSTARD-BASED FILLINGS FOR CAKES AND PIES; PUDDINGS; INSTANT DESSERT PUDDINGS; INSTANT PUDDING MIXES; CHOCOLATE TRUFFLES; CHOCOLATE CONFECTIONS; FUDGE; BROWNIES; DESSERT MOUSSE; CHEESECAKE-BASED DESSERTS; CHOCOLATE-BASED SNACK FOODS; CHOCOLATE COVERED CONFECTIONS COMPRISED OF FRUIT AND NUTS (U.S. CL. 46).
INGRID C. EULIN, EXAMINING ATTORNEY

SN 85-604,207. REESE, LESTIA, S, DBA ESEER FOODS, PLANO, TX. FILED 4-20-2012.



THE COLOR(S) PURPLE, YELLOW AND YELLOWISH-GOLD IS/ARE CLAIMED AS A FEATURE OF THE MARK.
THE MARK CONSISTS OF THE WORD "NIYAH'S SIGNATURE" IN DARK PURPLE WITH A YELLOW HAND

CLASS 30—(Continued).

PRINT ABOVE THE WORD "NIYAH'S". FROM THE RIGHT TO THE LEFT OF MARK IT START YELLOW THEN GRADUALLY TURNS BURNT YELLOWISH-GOLD. THROUGHOUT THE BACKGROUND THERE IS VARIOUS DOT STARTING OFF FROM THE RIGHT SIDE SPACED APART THEN THE DOTS ARE MUCH CLOSER AS THEY SPREAD TO THE LEFT OF THE MARK. THE BACKGROUND IS SHAPED LIKE AN OVAL THAT GETS BIGGER TOWARD THE BOTTOM. BUT IT'S CUT OFF NEAR THE TOP AND THE BOTTOM.
FOR DIPPING SAUCES (U.S. CL. 46).
WILLIAM ROSSMAN, EXAMINING ATTORNEY

SN 85-604,382. MORAN, JEFF, CORONA DEL MAR, CA. AND HILLYARD, BRETT, CORONA DEL MAR, CA. FILED 4-20-2012.

ello

THE MARK CONSISTS OF STANDARD CHARACTERS WITHOUT CLAIM TO ANY PARTICULAR FONT, STYLE, SIZE, OR COLOR.
FOR CANDY; CHEWING GUM (U.S. CL. 46).
FIRST USE 1-1-2011; IN COMMERCE 6-1-2011.
ROBIN MITTLER, EXAMINING ATTORNEY

SN 85-604,840. THE BIG COMPANY, LLC, IRVINE, CA. FILED 4-23-2012.

CedarHouse

THE MARK CONSISTS OF STANDARD CHARACTERS WITHOUT CLAIM TO ANY PARTICULAR FONT, STYLE, SIZE, OR COLOR.
FOR FLAVOURINGS AND SEASONINGS; FOOD SEASONINGS; SEASONED COATING FOR MEAT, FISH, POULTRY; SEASONINGS (U.S. CL. 46).
FIRST USE 11-17-2011; IN COMMERCE 1-29-2012.
DAVID MURRAY, EXAMINING ATTORNEY

SN 85-604,956. EARTHGRAINS BAKERY GROUP, INC., DOWNERS GROVE, IL. FILED 4-23-2012.

THERE'S A TREASURE OF
GOODNESS IN EVERY RAINBO

THE MARK CONSISTS OF STANDARD CHARACTERS WITHOUT CLAIM TO ANY PARTICULAR FONT, STYLE, SIZE, OR COLOR.
FOR BAKERY GOODS (U.S. CL. 46).
BILL DAWE, EXAMINING ATTORNEY

CLASS 30—(Continued).

SN 85-605,833. SEITENBACHER GMBH & CO., NATURKOST, BUCHEN, FED REP GERMANY, FILED 4-23-2012.

iCereal

THE MARK CONSISTS OF STANDARD CHARACTERS WITHOUT CLAIM TO ANY PARTICULAR FONT, STYLE, SIZE, OR COLOR.

FOR BREAKFAST CEREALS; CEREAL-BASED SNACK FOODS; PROCESSED CEREALS; CEREAL-BASED ENERGY BARS (NOT FOR USE AS A MEAL REPLACEMENT); MUESLI; MUESLI BARS (U.S. CL. 46).

JEFF DEFORD, EXAMINING ATTORNEY

SN 85-605,839. SEITENBACHER GMBH & CO., NATURKOST, BUCHEN, FED REP GERMANY, FILED 4-23-2012.

iMusli

THE MARK CONSISTS OF STANDARD CHARACTERS WITHOUT CLAIM TO ANY PARTICULAR FONT, STYLE, SIZE, OR COLOR.

FOR BREAKFAST CEREALS; CEREAL-BASED SNACK FOODS; PROCESSED CEREALS; CEREAL-BASED ENERGY BARS (NOT FOR USE AS A MEAL REPLACEMENT); MUESLI; MUESLI BARS (U.S. CL. 46).

JEFF DEFORD, EXAMINING ATTORNEY

SN 85-607,000. ENRIQUEZ GUTIERREZ, MARTHA ELVIRA, SAN YSIDRO, CA. FILED 4-24-2012.

SAN JUAN DE LOS LAGOS

THE MARK CONSISTS OF STANDARD CHARACTERS WITHOUT CLAIM TO ANY PARTICULAR FONT, STYLE, SIZE, OR COLOR.

THE ENGLISH TRANSLATION OF "SAN JUAN DE LOS LAGOS" IN THE MARK IS "SAINT JOHN OF THE LAKES".

FOR CANDIES (U.S. CL. 46).

FIRST USE 2-28-2011; IN COMMERCE 2-28-2011.

ANTHONY RINKER, EXAMINING ATTORNEY

CLASS 30—(Continued).

SN 85-611,532. HERSHEY CHOCOLATE & CONFECTIONERY CORPORATION, WHEAT RIDGE, CO. FILED 4-30-2012.

HERSHEY'S CHOCOLATE MILK DOTS

THE MARK CONSISTS OF STANDARD CHARACTERS WITHOUT CLAIM TO ANY PARTICULAR FONT, STYLE, SIZE, OR COLOR.

OWNER OF U.S. REG. NOS. 54,041, 863,592 AND 1,291,374. NO CLAIM IS MADE TO THE EXCLUSIVE RIGHT TO USE "CHOCOLATE MILK", APART FROM THE MARK AS SHOWN.

SEC. 2(F) AS TO "HERSHEY'S".
FOR INSTANT FLAVORING POWDERS FOR ADDITION TO MILK (U.S. CL. 46).

MARGERY A. TIERNEY, EXAMINING ATTORNEY

SN 85-614,392. NSN WORLDWIDE LLC, KELSEYVILLE, CA. FILED 5-2-2012.

ENGAGE ORGANICS

THE MARK CONSISTS OF STANDARD CHARACTERS WITHOUT CLAIM TO ANY PARTICULAR FONT, STYLE, SIZE, OR COLOR.

NO CLAIM IS MADE TO THE EXCLUSIVE RIGHT TO USE "ORGANICS", APART FROM THE MARK AS SHOWN.

FOR EDIBLE SPICES; FLAVOURINGS AND SEASONINGS; FOOD SEASONINGS; PROCESSED GARLIC FOR USE AS SEASONING; SEASONING MIXES; SPICE BLENDS; SPICES; ALL OF THE FOREGOING BEING ORGANIC (U.S. CL. 46).

ALICIA COLLINS, EXAMINING ATTORNEY

CLASS 30—(Continued).

SN 85-620,796. KRAFT FOODS GLOBAL BRANDS LLC, NORTHFIELD, IL. FILED 5-9-2012.



OWNER OF U.S. REG. NO. 4,092,919.
THE MARK CONSISTS OF A SMILING NOODLE.
SEC. 2(F).
FOR MACARONI AND CHEESE (U.S. CL. 46).
FIRST USE 12-30-2010; IN COMMERCE 12-30-2010.
MARY CRAWFORD, EXAMINING ATTORNEY

SN 85-621,941. BEST MAID PRODUCTS, INC., FORT WORTH, TX. FILED 5-10-2012.

I'M KIND OF A BIG DILL

THE MARK CONSISTS OF STANDARD CHARACTERS WITHOUT CLAIM TO ANY PARTICULAR FONT, STYLE, SIZE, OR COLOR.
FOR PICKLES (U.S. CL. 46).
TARAH HARDY, EXAMINING ATTORNEY

SN 85-628,127. GLUTENFREEDA FOODS, INC., BURLINGTON, WA. FILED 5-17-2012.

WE MAKE GLUTEN-FREE DELICIOUS...IT'S WHAT WE DO

THE MARK CONSISTS OF STANDARD CHARACTERS WITHOUT CLAIM TO ANY PARTICULAR FONT, STYLE, SIZE, OR COLOR.
FOR GLUTEN FREE PRODUCTS, NOT FOR MEDICAL PURPOSES, NAMELY, GRANOLA AND OATMEAL (U.S. CL. 46).
FIRST USE 12-0-2008; IN COMMERCE 12-0-2008.
ASMAT KHAN, EXAMINING ATTORNEY

CLASS 30—(Continued).

SN 85-629,790. WM. BOLTHOUSE FARMS, INC., BAKERSFIELD, CA. FILED 5-18-2012.

BOLTHOUSE FARMS

THE MARK CONSISTS OF STANDARD CHARACTERS WITHOUT CLAIM TO ANY PARTICULAR FONT, STYLE, SIZE, OR COLOR.
OWNER OF U.S. REG. NOS. 2,871,484, 3,439,232 AND OTHERS.
NO CLAIM IS MADE TO THE EXCLUSIVE RIGHT TO USE "FARMS", APART FROM THE MARK AS SHOWN.
FOR SALAD DRESSINGS (U.S. CL. 46).
FIRST USE 12-0-2007; IN COMMERCE 12-0-2007.
ANGELA DUONG, EXAMINING ATTORNEY

SN 85-634,431. AMERICA'S DRIVE-IN BRAND PROPERTIES LLC, OKLAHOMA CITY, OK. FILED 5-24-2012.

MASTER BLASTS

THE MARK CONSISTS OF STANDARD CHARACTERS WITHOUT CLAIM TO ANY PARTICULAR FONT, STYLE, SIZE, OR COLOR.
OWNER OF U.S. REG. NOS. 1,453,414, 3,276,505 AND 3,778,763.
FOR ICE CREAM (U.S. CL. 46).
JOHN E. MICHOS, EXAMINING ATTORNEY

CLASS 30—(Continued).

SN 85-641,588. MOKA FLY LLC, BLOOMFIELD HILLS, MI. FILED 6-2-2012.



NO CLAIM IS MADE TO THE EXCLUSIVE RIGHT TO USE "MOCHA", APART FROM THE MARK AS SHOWN.

THE MARK CONSISTS OF THE LITERAL ELEMENTS "MOKAFLY" WHEREIN A STYLIZED LETTER "M" IS ENCRYPTED OVER A SOLID SQUARE BELOW WHICH THE WORDING "MOKAFLY" IS WRITTEN AS SHOWN IN THE MARK.

FOR ICED COFFEE; COFFEE; COCOA-BASED BEVERAGES AND PREPARED COCOA-BASED BEVERAGES (U.S. CL. 46).

NAAKWAMA ANKRAH, EXAMINING ATTORNEY

SN 85-645,906. DAVID MICHAEL & CO., INC., PHILADELPHIA, PA. FILED 6-7-2012.

BUTTER PLUS

THE MARK CONSISTS OF STANDARD CHARACTERS WITHOUT CLAIM TO ANY PARTICULAR FONT, STYLE, SIZE, OR COLOR.

NO CLAIM IS MADE TO THE EXCLUSIVE RIGHT TO USE "BUTTER", APART FROM THE MARK AS SHOWN.

FOR BUTTER FLAVOR USED IN FOOD PRODUCTS (U.S. CL. 46).

FIRST USE 10-4-1971; IN COMMERCE 10-4-1971.

DOMINICK J. SALEMI, EXAMINING ATTORNEY

CLASS 30—(Continued).

SN 85-667,200. TROPICAL SMOOTHIE FRANCHISE DEVELOPMENT CORPORATION, AKA TROPICAL SMOOTHIE CAFE, DESTIN, FL. FILED 7-2-2012.

TROPICAL TACOS

THE MARK CONSISTS OF STANDARD CHARACTERS WITHOUT CLAIM TO ANY PARTICULAR FONT, STYLE, SIZE, OR COLOR.

OWNER OF U.S. REG. NOS. 2,103,370, 2,892,598 AND OTHERS.

NO CLAIM IS MADE TO THE EXCLUSIVE RIGHT TO USE "TACOS", APART FROM THE MARK AS SHOWN.

FOR TACOS (U.S. CL. 46).

LOURDES AYALA, EXAMINING ATTORNEY

CLASS 31—NATURAL AGRICULTURAL PRODUCTS

SN 76-711,235. SUPERNATURALS GRAFTED VEGETABLES LLC, VISTA, CA. FILED 4-17-2012.

MIGHTY VEGGIES

THE MARK CONSISTS OF STANDARD CHARACTERS WITHOUT CLAIM TO ANY PARTICULAR FONT, STYLE, SIZE, OR COLOR.

OWNER OF U.S. REG. NO. 4,172,521.

NO CLAIM IS MADE TO THE EXCLUSIVE RIGHT TO USE "VEGGIES", APART FROM THE MARK AS SHOWN.

FOR LIVE PLANTS, NAMELY, GRAFTED VEGETABLE PLANTS (U.S. CLS. 1 AND 46).

FIRST USE 7-0-2011; IN COMMERCE 7-0-2011.

SEAN CROWLEY, EXAMINING ATTORNEY

SN 79-105,207. SANYPET S.P.A., ITALY, FILED 10-4-2011.



PRIORITY DATE OF 4-20-2011 IS CLAIMED. OWNER OF INTERNATIONAL REGISTRATION 1097176 DATED 10-4-2011, EXPIRES 10-4-2021.

NO CLAIM IS MADE TO THE EXCLUSIVE RIGHT TO USE "FRUIT", APART FROM THE MARK AS SHOWN.

THE MARK CONSISTS OF THE WORDING "MR FRUIT" IN A STYLIZED FONT, WITH THE WORD "FRUIT" APPEARING INSIDE OF A CIRCLE.

FOR FOODSTUFFS FOR ANIMALS, LITTER FOR ANIMALS (U.S. CLS. 1 AND 46).

JAMES MACFARLANE, EXAMINING ATTORNEY

CLASS 31—(Continued).

SN 85-291,759. FORMAN, DAVID, NATICK, MA. AND FORMAN, STACIE, NATICK, MA. FILED 4-11-2011.

b.f.f. Best Feline Friend

THE MARK CONSISTS OF STANDARD CHARACTERS WITHOUT CLAIM TO ANY PARTICULAR FONT, STYLE, SIZE, OR COLOR.

FOR CAT FOOD (U.S. CLS. 1 AND 46).
FIRST USE 4-1-2009; IN COMMERCE 4-1-2009.
TIMOTHY FINNEGAN, EXAMINING ATTORNEY

SN 85-291,894. EXPORTALIZAS MEXICANAS S.A DE C.V., CULIACAN SINALOA, MEXICO, FILED 4-11-2011.



PRIORITY CLAIMED UNDER SEC. 44(D) ON MEXICO APPLICATION NO. 1163564, FILED 3-6-2011.

OWNER OF U.S. REG. NO. 2,163,280.
NO CLAIM IS MADE TO THE EXCLUSIVE RIGHT TO USE "RESERVE", APART FROM THE MARK AS SHOWN.
THE MARK CONSISTS OF "RENE RESERVE" STYLIZED INSIDE A RECTANGLE. THE WORD "RENE" APPEARS OVER THE WORD "RESERVE", WHICH APPEARS IN A SMALLER SIZE.

THE WORDING "RENE" HAS NO MEANING IN A FOREIGN LANGUAGE.

FOR FRESH FRUITS AND VEGETABLES EXCLUDING APPLES (U.S. CLS. 1 AND 46).
ELIZABETH HUGHITT, EXAMINING ATTORNEY

SN 85-424,426. BOOMAN FLORAL INC., VISTA, CA. FILED 9-16-2011.



NO CLAIM IS MADE TO THE EXCLUSIVE RIGHT TO USE "PLANTS", APART FROM THE MARK AS SHOWN.

THE MARK CONSISTS OF THE WORD "XTREEM" WITH A BIG "X" AND A FLOWER AND LEAVES ON TOP OF "TREEM". THEN UNDER "TREEM" IS THE WORD "PLANTS" IN A SMALLER FONT.

FOR LIVE PLANTS (U.S. CLS. 1 AND 46).
FIRST USE 7-31-2009; IN COMMERCE 7-31-2009.
HENRY S. ZAK, EXAMINING ATTORNEY

CLASS 31—(Continued).

SN 85-457,924. WRIGHT, BRUCE DAVID, SARASOTA, FL. FILED 10-27-2011.

BIO dog

THE MARK CONSISTS OF STANDARD CHARACTERS WITHOUT CLAIM TO ANY PARTICULAR FONT, STYLE, SIZE, OR COLOR.

NO CLAIM IS MADE TO THE EXCLUSIVE RIGHT TO USE "DOG", APART FROM THE MARK AS SHOWN.
FOR DOG FOOD; DOG TREATS (U.S. CLS. 1 AND 46).
JENNY PARK, EXAMINING ATTORNEY

SN 85-457,927. WRIGHT, BRUCE DAVID, SARASOTA, FL. FILED 10-27-2011.

BIO cat

THE MARK CONSISTS OF STANDARD CHARACTERS WITHOUT CLAIM TO ANY PARTICULAR FONT, STYLE, SIZE, OR COLOR.

NO CLAIM IS MADE TO THE EXCLUSIVE RIGHT TO USE "CAT", APART FROM THE MARK AS SHOWN.
FOR CAT FOOD (U.S. CLS. 1 AND 46).
JENNY PARK, EXAMINING ATTORNEY

SN 85-499,132. NZG SPECIALTIES, INC., LOS ANGELES, CA. FILED 12-19-2011.

Gourmet 

OWNER OF U.S. REG. NO. 2,966,870.

NO CLAIM IS MADE TO THE EXCLUSIVE RIGHT TO USE "GOURMET", APART FROM THE MARK AS SHOWN.

THE MARK CONSISTS OF THE WORD "GOURMET" AND A LEAF OFF OF THE "T" IN "GOURMET".

FOR FRESH ASPARAGUS; FRESH BLUEBERRIES; FRESH FRUIT AND VEGETABLES; FRESH STRAWBERRIES (U.S. CLS. 1 AND 46).

FIRST USE 1-1-1999; IN COMMERCE 1-1-1999.
KATHRYN COWARD, EXAMINING ATTORNEY

CLASS 31—(Continued).

SN 85-586,052. ICC INDUSTRIAL COMERCIO EXPORTACAO E IMPORTACAO LTDA, SAO PAULO, BRAZIL, FILED 4-2-2012.

LYSCCELL

THE MARK CONSISTS OF STANDARD CHARACTERS WITHOUT CLAIM TO ANY PARTICULAR FONT, STYLE, SIZE, OR COLOR.

FOR AUTOLYZED YEAST OBTAINED FROM MOLASSES FERMENTATION FOR USE AS ANIMAL FEED; AUTOLYZED YEAST OBTAINED FROM MOLASSES FERMENTATION FOR ANIMAL CONSUMPTION (U.S. CLS. 1 AND 46).

FIRST USE 2-2-2009; IN COMMERCE 6-1-2010.
LINDA POWELL, EXAMINING ATTORNEY

CLASS 31—(Continued).

SN 85-586,533. SUNRISE SUN-RIPENED TOMATOES, INC., BROOKLYN, NY. FILED 4-2-2012.



OWNER OF U.S. REG. NO. 3,417,347.

NO CLAIM IS MADE TO THE EXCLUSIVE RIGHT TO USE "REAL TOMATOES", APART FROM THE MARK AS SHOWN.

THE MARK CONSISTS OF THE FOLLOWING: THE WORD "LUCKY'S" DEPICTED IN A STYLIZED SCRIPTED FONT NEXT TO DEPICTIONS OF TOMATOES, ROWS OF CROPS, AND LINES FOR THE CLOUDS IN THE SKY AND THE WORDS "REAL TOMATOES" DEPICTED BENEATH THE WORD "LUCKY'S", ALL OF THE ABOVE DEPICTED WITHIN A RECTANGULAR DESIGN.

FOR FRESH TOMATOES (U.S. CLS. 1 AND 46).
FIRST USE 2-14-2008; IN COMMERCE 2-14-2008.
ANNE E. GUSTASON, EXAMINING ATTORNEY

SN 85-586,553. SUNRISE SUN-RIPENED TOMATOES, INC., BROOKLYN, NY. FILED 4-2-2012.



OWNER OF U.S. REG. NO. 3,417,347.

NO CLAIM IS MADE TO THE EXCLUSIVE RIGHT TO USE "REAL TOMATOES", APART FROM THE MARK AS SHOWN.

THE COLOR(S) WHITE, YELLOW, RED, LIGHT GREEN, DARK GREEN, LIGHT BLUE, MEDIUM BLUE AND DARK BLUE IS/ARE CLAIMED AS A FEATURE OF THE MARK.

THE MARK CONSISTS OF THE FOLLOWING: THE WORD "LUCKY'S" IN THE COLORS YELLOW AND WHITE WITH A RED AND DARK GREEN BORDER, DEPICTED IN A STYLIZED SCRIPTED FONT NEXT TO DEPICTIONS OF TOMATOES IN THE COLORS RED AND DARK GREEN AND THE WORDS "REAL TOMATOES" IN THE COLOR WHITE ON A DARK GREEN BACKGROUND DEPICTED BENEATH THE WORD "LUCKY'S", WITH THE CROPS IN LIGHT GREEN AND DARK GREEN AND THE IMAGE OF THE SKY IN LIGHT BLUE, MEDIUM BLUE, AND DARK BLUE ALL OF THE ABOVE DEPICTED WITHIN A RECTANGULAR DESIGN IN THE COLOR YELLOW.

FOR FRESH TOMATOES (U.S. CLS. 1 AND 46).
FIRST USE 2-14-2008; IN COMMERCE 2-14-2008.
ANNE E. GUSTASON, EXAMINING ATTORNEY

SN 85-586,509. SUNRISE SUN-RIPENED TOMATOES, INC., BROOKLYN, NY. FILED 4-2-2012.



OWNER OF U.S. REG. NO. 3,417,347.

THE COLOR(S) WHITE, GREEN, YELLOW, AND RED IS/ARE CLAIMED AS A FEATURE OF THE MARK.

THE MARK CONSISTS OF THE FOLLOWING: THE WORD "LUCKY'S" IN THE COLORS WHITE AND YELLOW WITH A RED AND GREEN BORDER DEPICTED IN A STYLIZED SCRIPTED FONT.

FOR FRESH TOMATOES (U.S. CLS. 1 AND 46).
FIRST USE 2-14-2008; IN COMMERCE 2-14-2008.
ANNE E. GUSTASON, EXAMINING ATTORNEY

CLASS 31—(Continued).

SN 85-591,814. REDBARN PET PRODUCTS, LLC, LONG BEACH, CA. FILED 4-7-2012.

DENTA DOGGIE

THE MARK CONSISTS OF STANDARD CHARACTERS WITHOUT CLAIM TO ANY PARTICULAR FONT, STYLE, SIZE, OR COLOR.

NO CLAIM IS MADE TO THE EXCLUSIVE RIGHT TO USE "DOGGIE", APART FROM THE MARK AS SHOWN.

FOR DOG AND PET FOOD TREATS (U.S. CLS. 1 AND 46).

WILLIAM JACKSON, EXAMINING ATTORNEY

SN 85-596,426. ICC INDUSTRIAL COMERCIO EXPORTACAO E IMPORTACAO LTDA, SAO PAULO, BRAZIL, FILED 4-12-2012.

RUMEN YEAST

THE MARK CONSISTS OF STANDARD CHARACTERS WITHOUT CLAIM TO ANY PARTICULAR FONT, STYLE, SIZE, OR COLOR.

NO CLAIM IS MADE TO THE EXCLUSIVE RIGHT TO USE "YEAST", APART FROM THE MARK AS SHOWN.

FOR MOLASSES YEAST WITH ENHANCED LEVELS OF INTRACELLULAR CONTENT FOR ANIMAL FEED (U.S. CLS. 1 AND 46).

FIRST USE 2-4-2008; IN COMMERCE 5-7-2009.
LINDA POWELL, EXAMINING ATTORNEY

SN 85-599,508. SUNSHINE MILLS, INC, RED BAY, AL. FILED 4-17-2012.

HAPPY GO LUCKY

THE MARK CONSISTS OF STANDARD CHARACTERS WITHOUT CLAIM TO ANY PARTICULAR FONT, STYLE, SIZE, OR COLOR.

FOR DOG AND CAT FOOD (U.S. CLS. 1 AND 46).
PAUL E. FAHRENKOPF, EXAMINING ATTORNEY

CLASS 31—(Continued).

SN 85-601,818. THE BURCHELL NURSERY, INC., OAKDALE, CA. FILED 4-18-2012.

**GOODNESS YOU CAN GROW
TOMORROW'S HARVEST BY
BURCHELL NURSERY, INC.**

THE MARK CONSISTS OF STANDARD CHARACTERS WITHOUT CLAIM TO ANY PARTICULAR FONT, STYLE, SIZE, OR COLOR.

OWNER OF U.S. REG. NOS. 1,621,524 AND 2,693,903.
NO CLAIM IS MADE TO THE EXCLUSIVE RIGHT TO USE "NURSERY, INC.", APART FROM THE MARK AS SHOWN.

FOR LIVE FRUIT TREES (U.S. CLS. 1 AND 46).

FIRST USE 5-1-2011; IN COMMERCE 5-1-2011.
CHRISTOPHER LAW, EXAMINING ATTORNEY

SN 85-602,515. HYDRO-STACKER, LLC, MYAKKA CITY, FL. FILED 4-19-2012.

Hydro~Taste

THE MARK CONSISTS OF WORDS "HYDRO-TASTE" HAVING A STRAWBERRY IN PLACE OF THE LETTER "O" IN THE WORD "HYDRO".

FOR HYDROPONICALLY GROWN FRUITS AND VEGETABLES (U.S. CLS. 1 AND 46).

FIRST USE 10-11-2003; IN COMMERCE 10-11-2003.
DOMINIC J. FERRAIUOLO, EXAMINING ATTORNEY

SN 85-602,977. MASTERSTOUCH BRAND L.L.C., NOGALES, AZ. FILED 4-19-2012.

AZTEC SWEET

THE MARK CONSISTS OF STANDARD CHARACTERS WITHOUT CLAIM TO ANY PARTICULAR FONT, STYLE, SIZE, OR COLOR.

NO CLAIM IS MADE TO THE EXCLUSIVE RIGHT TO USE "SWEET", APART FROM THE MARK AS SHOWN.

FOR FRESH PEPPERS (U.S. CLS. 1 AND 46).

FIRST USE 12-0-2009; IN COMMERCE 12-0-2009.
RONALD AIKENS, EXAMINING ATTORNEY

CLASS 31—(Continued).

SN 85-605,010. BASF PLANT SCIENCE COMPANY GMBH, LUDWIGSHAFEN, FED REP GERMANY, FILED 4-23-2012.

NUTRIDENSE

THE MARK CONSISTS OF STANDARD CHARACTERS WITHOUT CLAIM TO ANY PARTICULAR FONT, STYLE, SIZE, OR COLOR.

FOR SEED CORN AND AGRICULTURAL GRAIN FOR PLANTING (U.S. CLS. 1 AND 46).

FIRST USE 1-31-1998; IN COMMERCE 1-31-1998.
BRIAN CALLAGHAN, EXAMINING ATTORNEY

SN 85-605,071. BASF PLANT SCIENCE COMPANY GMBH, LUDWIGSHAFEN, FED REP GERMANY, FILED 4-23-2012.



NutriDense

THE MARK CONSISTS OF "NUTRIDENSE" AND AN ARCED LINE TERMINATING WITH AN ARROW.

FOR SEED CORN AND AGRICULTURAL GRAIN FOR PLANTING (U.S. CLS. 1 AND 46).

FIRST USE 12-23-2000; IN COMMERCE 12-23-2000.
BRIAN CALLAGHAN, EXAMINING ATTORNEY

SN 85-606,477. AGROCOMERCIALIZADORA DE LA LAGUNA, S.P.R. DE R.L. DE C.V., GOMEZ PALACIO, DGO., MEXICO, FILED 4-24-2012.

La Marliere

THE MARK CONSISTS OF THE WORDING "LA MARLIERE" IN STYLIZED LETTERING.

THE WORDING "LA MARLIERE" HAS NO MEANING IN A FOREIGN LANGUAGE.

FOR HORTICULTURAL AND FORESTRY PRODUCTS NOT INCLUDED IN OTHER CLASSES, NAMELY, SEEDS AND BULBS; FRESH FRUITS AND VEGETABLES (U.S. CLS. 1 AND 46).

FRED CARL, EXAMINING ATTORNEY

CLASS 31—(Continued).

SN 85-645,938. WM. BOLTHOUSE FARMS, INC., BAKERSFIELD, CA. FILED 6-7-2012.

SHAKEDOWNS

THE MARK CONSISTS OF STANDARD CHARACTERS WITHOUT CLAIM TO ANY PARTICULAR FONT, STYLE, SIZE, OR COLOR.

FOR FRESH VEGETABLES, NAMELY, CARROTS, SEASONED CARROTS (U.S. CLS. 1 AND 46).

ANGELA DUONG, EXAMINING ATTORNEY

SN 85-653,685. KVP INTERNATIONAL, INC., IRWINDALE, CA. FILED 6-15-2012.

HENNEFORD FARMS

THE MARK CONSISTS OF STANDARD CHARACTERS WITHOUT CLAIM TO ANY PARTICULAR FONT, STYLE, SIZE, OR COLOR.

FOR PET TREATS (U.S. CLS. 1 AND 46).
ANDREW RHIM, EXAMINING ATTORNEY

CLASS 32—LIGHT BEVERAGES

SN 78-923,419. XL ENERGY DRINK CORP., NEW YORK, NY. FILED 7-6-2006.



OWNER OF U.S. REG. NO. 2,516,239.
NO CLAIM IS MADE TO THE EXCLUSIVE RIGHT TO USE "ENERGY", APART FROM THE MARK AS SHOWN.
THE COLOR(S) RED, WHITE, BLUE, GRAY IS/ARE CLAIMED AS A FEATURE OF THE MARK.
THE MARK CONSISTS OF BLUE BACKGROUND, THE WORDS "XL" OUTLINED IN GRAY, LETTERED IN RED, AND SHADOWED IN BLUE. THE WORDS "ENERGY BLAST" IN RED UNDER THE WORDS "XL" WITH A WHITE BOTTOM BORDER/BACKGROUND.
FOR NON-ALCOHOLIC BEVERAGES, NAMELY, ENERGY DRINKS (U.S. CLS. 45, 46 AND 48).
SAMUEL E. SHARPER JR., EXAMINING ATTORNEY

SN 79-103,940. BOTTLE GREEN DRINKS COMPANY, GLOUCESTERSHIRE GL5 5ET, UNITED KINGDOM, FILED 4-14-2011.

BOTTLEPINK

THE MARK CONSISTS OF STANDARD CHARACTERS WITHOUT CLAIM TO ANY PARTICULAR FONT, STYLE, SIZE, OR COLOR.
OWNER OF INTERNATIONAL REGISTRATION 1094279 DATED 4-14-2011, EXPIRES 4-14-2021.
FOR NON-ALCOHOLIC BEVERAGES, NAMELY, CARBONATED BEVERAGES; FRUIT DRINKS AND FRUIT JUICES; SYRUPS FOR BEVERAGES; PREPARATIONS FOR MAKING BEVERAGES, NAMELY, FRUIT DRINKS; NON-ALCOHOLIC CORDIALS; NON-ALCOHOLIC BEVERAGES, NAMELY, SQUASH BASED BEVERAGES; NON-ALCOHOLIC CORDIALS, NAMELY, ELDERFLOWER CORDIAL (U.S. CLS. 45, 46 AND 48).
PAUL MORENO, EXAMINING ATTORNEY

CLASS 32—(Continued).

SN 79-107,186. DUVEL MOORTGAT, NAAMLOZE VEN-NOOTSCHAP, B-2870 PUURS, BELGIUM, FILED 11-3-2011.

DUVEL SINGLE

THE MARK CONSISTS OF STANDARD CHARACTERS WITHOUT CLAIM TO ANY PARTICULAR FONT, STYLE, SIZE, OR COLOR.
PRIORITY DATE OF 8-29-2011 IS CLAIMED.
OWNER OF INTERNATIONAL REGISTRATION 1101773 DATED 11-3-2011, EXPIRES 11-3-2021.
OWNER OF U.S. REG. NOS. 1,305,213, 1,934,804 AND 3,449,696.
NO CLAIM IS MADE TO THE EXCLUSIVE RIGHT TO USE "SINGLE", APART FROM THE MARK AS SHOWN.
THE ENGLISH TRANSLATION OF "DUVEL" IN THE MARK IS "DEVIL".
FOR BEERS, NAMELY, ALE, LAGER, PORTER AND STOUT (U.S. CLS. 45, 46 AND 48).
JORDAN BAKER, EXAMINING ATTORNEY

SN 79-107,609. GUILIN LAYN NATURAL INGREDIENTS CORP., GUANGXI, CHINA, FILED 12-9-2011.

莱茵生物

OWNER OF INTERNATIONAL REGISTRATION 1102757 DATED 12-9-2011, EXPIRES 12-9-2021.
OWNER OF U.S. REG. NO. 3,712,293.
NO CLAIM IS MADE TO THE EXCLUSIVE RIGHT TO USE THE NON-LATIN CHARACTERS THAT TRANSLITERATE TO "SHENG WU", APART FROM THE MARK AS SHOWN.
THE MARK CONSISTS OF FOUR STYLIZED CHINESE CHARACTERS.
THE ENGLISH TRANSLATION OF THE FOREIGN WORD(S) IN THE MARK IS: "LAI YIN" DOES NOT HAVE ANY MEANING; "SHENG WU" MEANS "BIOLOGY" IN ENGLISH.
THE TRANSLITERATION OF THE NON-LATIN CHARACTERS IN THE MARK IS: "LAI YIN SHENG WU".
FOR BEER; NON-ALCOHOLIC FRUIT EXTRACTS FOR USE IN THE PREPARATION OF BEVERAGES; NON-ALCOHOLIC BEVERAGES, NAMELY, CARBONATED BEVERAGES; SOFT DRINKS, NAMELY, SODAS; PREPARATIONS FOR MAKING FRUIT DRINKS; ESSENCES FOR MAKING NON-ALCOHOLIC BEVERAGES (U.S. CLS. 45, 46 AND 48).
BARBARA GAYNOR, EXAMINING ATTORNEY

CLASS 32—(Continued).

SN 85-152,972. FULL STEAM, LLC, CARLSBAD, CA. FILED 10-14-2010.



NO CLAIM IS MADE TO THE EXCLUSIVE RIGHT TO USE "ENERGY TEA", APART FROM THE MARK AS SHOWN.

THE MARK CONSISTS OF A STYLIZED ROBOT DRAGON WITH STEAM COMING OUT OF HIS MOUTH WITH THE STYLIZED LETTERING, "STEAM ENERGY TEA" BELOW, THERE ARE DROP SHADOWS ON THE LETTERS.

FOR TEA-BASED ENERGY DRINK (U.S. CLS. 45, 46 AND 48).

CHERYL CLAYTON, EXAMINING ATTORNEY

SN 85-273,262. THE NORSEMEN BREWING COMPANY, LLC, DBA NORSEMEN BREWING COMPANY, ELK HORN, IA. FILED 3-22-2011.

Norsemen Brewing Company

THE MARK CONSISTS OF STANDARD CHARACTERS WITHOUT CLAIM TO ANY PARTICULAR FONT, STYLE, SIZE, OR COLOR.

NO CLAIM IS MADE TO THE EXCLUSIVE RIGHT TO USE "BREWING COMPANY", APART FROM THE MARK AS SHOWN.

FOR BEER, ALE, LAGER, STOUT AND PORTER; SOFT DRINKS, NAMELY, ROOT BEER SODA (U.S. CLS. 45, 46 AND 48).

ALLISON HOLTZ, EXAMINING ATTORNEY

CLASS 32—(Continued).

SN 85-273,289. THE NORSEMEN BREWING COMPANY, LLC, DBA NORSEMEN BREWING COMPANY, ELK HORN, IA. FILED 3-22-2011.



NO CLAIM IS MADE TO THE EXCLUSIVE RIGHT TO USE "BREWING COMPANY", APART FROM THE MARK AS SHOWN.

THE MARK CONSISTS OF THE WORD "NORSEMEN" IN STYLIZED FORM POSITIONED OVER "BREWING COMPANY"; ALL WORDS IN CAPITALIZED FORM, WITH A VIKING SHIP'S MAST, SAIL, STERN AND BOW FORMING THE "N" OF "NORSEMEN" AND A FLAG WAVING RIGHT TO LEFT ATOP THE MAST. "NORSEMEN" APPEARS WITH IRON RIVETS PLACED TOP-CENTER AND BOTTOM-CENTER OF EACH LETTER.

FOR BEER, ALE, LAGER, STOUT AND PORTER; SOFT DRINKS, NAMELY, ROOT BEER SODA (U.S. CLS. 45, 46 AND 48).

ALLISON HOLTZ, EXAMINING ATTORNEY

SN 85-398,118. FLORA MANUFACTURING AND DISTRIBUTING, LTD., BURNABY, BRITISH COLUM, CANADA, FILED 8-15-2011.

MOSSBRAE SPRINGS

THE MARK CONSISTS OF STANDARD CHARACTERS WITHOUT CLAIM TO ANY PARTICULAR FONT, STYLE, SIZE, OR COLOR.

NO CLAIM IS MADE TO THE EXCLUSIVE RIGHT TO USE "SPRINGS", APART FROM THE MARK AS SHOWN.

FOR SPRING WATER (U.S. CLS. 45, 46 AND 48).

DAVID I, EXAMINING ATTORNEY

SN 85-398,123. FLORA MANUFACTURING AND DISTRIBUTING, LTD., BURNABY, BRITISH COLUM, CANADA, FILED 8-15-2011.

MOSSBRAE FALLS

THE MARK CONSISTS OF STANDARD CHARACTERS WITHOUT CLAIM TO ANY PARTICULAR FONT, STYLE, SIZE, OR COLOR.

FOR SPRING WATER (U.S. CLS. 45, 46 AND 48).

DAVID I, EXAMINING ATTORNEY

CLASS 32—(Continued).

SN 85-407,567. Y WATER INC., SANTA MONICA, CA. FILED 8-25-2011.

Y JUICY WATER

THE MARK CONSISTS OF STANDARD CHARACTERS WITHOUT CLAIM TO ANY PARTICULAR FONT, STYLE, SIZE, OR COLOR.

OWNER OF U.S. REG. NOS. 3,406,344, 3,793,511 AND OTHERS.

NO CLAIM IS MADE TO THE EXCLUSIVE RIGHT TO USE "JUICY WATER", APART FROM THE MARK AS SHOWN.

FOR FRUIT BEVERAGES, NAMELY, FRUIT JUICE DRINKS, FRUIT JUICE DRINKS CONTAINING WATER AND FRUIT FLAVORED WATER (U.S. CLS. 45, 46 AND 48).

ZACHARY CROMER, EXAMINING ATTORNEY

CLASS 32—(Continued).

SN 85-419,031. GRENADE BEVERAGE LLC, ORANGE, CA. FILED 9-9-2011.

El Gallito

THE MARK CONSISTS OF STANDARD CHARACTERS WITHOUT CLAIM TO ANY PARTICULAR FONT, STYLE, SIZE, OR COLOR.

THE ENGLISH TRANSLATION OF "EL GALLITO" IN THE MARK IS "THE LITTLE ROOSTER".

FOR BEVERAGES, NAMELY, CARBONATED AND NON-CARBONATED ENERGY OR SPORTS DRINKS (U.S. CLS. 45, 46 AND 48).

JESSICA FATHY, EXAMINING ATTORNEY

SN 85-419,753. SOROKWASZ SPRINGS, LLC, FORMERLY OREGON TRAIL MOUNTAIN SPRING WATER, LLC, COPPELL, TX. FILED 9-11-2011.

Oregon Trail Mountain Spring Water

THE MARK CONSISTS OF STANDARD CHARACTERS WITHOUT CLAIM TO ANY PARTICULAR FONT, STYLE, SIZE, OR COLOR.

NO CLAIM IS MADE TO THE EXCLUSIVE RIGHT TO USE "MOUNTAIN SPRING WATER", APART FROM THE MARK AS SHOWN.

SEC. 2(F).
FOR SPRING WATER (U.S. CLS. 45, 46 AND 48).
FIRST USE 10-1-1997; IN COMMERCE 10-1-1997.
LINDA ORNDORFF, EXAMINING ATTORNEY

SN 85-415,512. GAL PALS, FALL CITY, WA. FILED 9-6-2011.

C.A.R.E. COURAGEOUS · AMAZING · RESILIENT · EXCEPTIONAL

THE MARK CONSISTS OF STANDARD CHARACTERS WITHOUT CLAIM TO ANY PARTICULAR FONT, STYLE, SIZE, OR COLOR.

FOR BOTTLED WATER (U.S. CLS. 45, 46 AND 48).
FIRST USE 6-1-2011; IN COMMERCE 8-15-2011.
KATHLEEN M. VANSTON, EXAMINING ATTORNEY

SN 85-415,524. GAL PALS, FALL CITY, WA. FILED 9-6-2011.

H.E.A.T. HOT · EXHASUTED · AGITATED · TEMPERAMENTAL

THE MARK CONSISTS OF STANDARD CHARACTERS WITHOUT CLAIM TO ANY PARTICULAR FONT, STYLE, SIZE, OR COLOR.

FOR BOTTLED WATER (U.S. CLS. 45, 46 AND 48).
FIRST USE 6-1-2011; IN COMMERCE 8-15-2011.
KATHLEEN M. VANSTON, EXAMINING ATTORNEY

SN 85-424,005. GRUPO ROJAS & CO., MOCA, DOMINICAN REP, FILED 9-15-2011.



NO CLAIM IS MADE TO THE EXCLUSIVE RIGHT TO USE "FAST FLUID REPLACEMENT", APART FROM THE MARK AS SHOWN.

THE MARK CONSISTS OF AN OVAL SHAPED CAPSULE ARRANGED HORIZONTALLY. INSIDE THE CAPSULE IS THE WORD "REPLAY" IN ALL CAPS AND STYLIZED

CLASS 32—(Continued).

LETTERS WHERE THE SYLLABLE "RE" IS LIGHTER THAN THE SYLLABLE "PLAY". THE WORD "RED" APPEARS UNDER THE WORD "REPLAY" IN A SMALLER SIZE AND IN ALL CAPS. TO THE CAPSULE'S RIGHT THERE IS A PICTURE SIMULATING A PERSON WITH ARMS RAISED AND LEGS APART FORMING AN X, WITH TWO LINES SURROUNDING ITS WAIST AND INTERSECTING EACH OTHER SIMILAR TO AN ORBIT. UNDERNEATH THE CAPSULE IS THE PHRASE "FAST FLUID REPLACEMENT" IN ALL CAPS.

FOR SPORTS DRINKS CONTAINING ELECTROLYTES (U.S. CLS. 45, 46 AND 48).

ARETHA SOMERVILLE, EXAMINING ATTORNEY

SN 85-443,781. JACKSON, III, CURTIS J., NEW YORK, NY. FILED 10-10-2011.



OWNER OF U.S. REG. NOS. 2,807,302, 3,102,330 AND OTHERS.

THE NAME AND/OR SIGNATURE "50 CENT" SHOWN IN THE MARK IDENTIFIES THE PROFESSIONAL NAME OF CURTIS J. JACKSON III, WHOSE CONSENT TO REGISTER IS MADE OF RECORD.

THE MARK CONSISTS OF THE STYLIZED NUMBER "50", FOLLOWED BY THE STYLIZED WORD "CENT".

FOR NON-ALCOHOLIC ENERGY DRINKS (U.S. CLS. 45, 46 AND 48).

FIRST USE 9-13-2011; IN COMMERCE 9-13-2011.

BRENDAN REGAN, EXAMINING ATTORNEY

SN 85-450,353. GREAT AMERICAN PRODUCTS, INC., DESTIN, FL. FILED 10-18-2011.

CRUCIAL ENERGY

THE MARK CONSISTS OF STANDARD CHARACTERS WITHOUT CLAIM TO ANY PARTICULAR FONT, STYLE, SIZE, OR COLOR.

NO CLAIM IS MADE TO THE EXCLUSIVE RIGHT TO USE "ENERGY", APART FROM THE MARK AS SHOWN.

FOR ENERGY DRINKS; NON-ALCOHOLIC DRINKS, NAMELY, ENERGY SHOTS (U.S. CLS. 45, 46 AND 48).

RICHARD WHITE, EXAMINING ATTORNEY

CLASS 32—(Continued).

SN 85-451,749. CROWELL, JANA, VALDEZ, AK. FILED 10-20-2011.



THE MARK CONSISTS OF AN IMAGE OF A BEAR'S HEAD WITH ITS MOUTH OPEN AND PAWS ON EACH SIDE. THE BEAR APPEARS TO BE RIPPING THROUGH SOMETHING. THE STYLIZED TEXT "GRIZZWIZZ" IS ABOVE THE BEAR AND THE STYLIZED TEXT "GRIZZINATOR" IS BELOW THE BEAR.

FOR ENERGY DRINKS (U.S. CLS. 45, 46 AND 48).

FIRST USE 2-4-2011; IN COMMERCE 2-4-2011.

TRACY FLETCHER, EXAMINING ATTORNEY

SN 85-475,487. JACKALOPE BREWING COMPANY, LLC, NASHVILLE, TN. FILED 11-17-2011.

Bearwalker

THE MARK CONSISTS OF STANDARD CHARACTERS WITHOUT CLAIM TO ANY PARTICULAR FONT, STYLE, SIZE, OR COLOR.

FOR ALE; ALES; BEER; BEER, ALE, LAGER, STOUT AND PORTER; BEERS (U.S. CLS. 45, 46 AND 48).

FIRST USE 5-21-2011; IN COMMERCE 5-21-2011.

DARRYL SPRUILL, EXAMINING ATTORNEY

SN 85-484,952. VIKING RIVER CRUISES (BERMUDA) LTD., HAMILTON, BERMUDA, FILED 12-1-2011.

AQUAVIT TERRACE

THE MARK CONSISTS OF STANDARD CHARACTERS WITHOUT CLAIM TO ANY PARTICULAR FONT, STYLE, SIZE, OR COLOR.

NO CLAIM IS MADE TO THE EXCLUSIVE RIGHT TO USE "AQUAVIT", APART FROM THE MARK AS SHOWN.

FOR BEER (U.S. CLS. 45, 46 AND 48).

AMY KELLY, EXAMINING ATTORNEY

CLASS 32—(Continued).

SN 85-485,111. VIKING RIVER CRUISES (BERMUDA) LTD., HAMILTON, BERMUDA, FILED 12-1-2011.

AQUAVIT LOUNGE

THE MARK CONSISTS OF STANDARD CHARACTERS WITHOUT CLAIM TO ANY PARTICULAR FONT, STYLE, SIZE, OR COLOR.

NO CLAIM IS MADE TO THE EXCLUSIVE RIGHT TO USE "AQUAVIT", APART FROM THE MARK AS SHOWN. FOR BEER (U.S. CLS. 45, 46 AND 48).
AMY KELLY, EXAMINING ATTORNEY

SN 85-493,934. KABBALAH CENTRE INTERNATIONAL, INC., LOS ANGELES, CA. FILED 12-13-2011.

**kabbalah
water**

OWNER OF U.S. REG. NOS. 2,523,263, 3,070,708 AND OTHERS.

NO CLAIM IS MADE TO THE EXCLUSIVE RIGHT TO USE "WATER", APART FROM THE MARK AS SHOWN.

THE MARK CONSISTS OF THE WORDING "KABBALAH WATER" IN STYLIZED LETTERS.

FOR BOTTLED DRINKING WATER (U.S. CLS. 45, 46 AND 48).

FIRST USE 5-0-2004; IN COMMERCE 5-0-2004.

ELISSA GARBER KON, EXAMINING ATTORNEY

SN 85-514,070. COMERCIALIZADORA ELORO, S.A., XA-LOSTOC, MEXICO, FILED 1-11-2012.

JUMEX FRUIT

THE MARK CONSISTS OF STANDARD CHARACTERS WITHOUT CLAIM TO ANY PARTICULAR FONT, STYLE, SIZE, OR COLOR.

OWNER OF U.S. REG. NOS. 973,533, 2,718,757 AND 2,746,272.

NO CLAIM IS MADE TO THE EXCLUSIVE RIGHT TO USE "FRUIT", APART FROM THE MARK AS SHOWN.

FOR FRUIT DRINKS; FRUIT DRINKS MADE WITH FRUIT MIXED WITH TEA, JUICES, NECTARS, WATER, PURE WATER, MINERAL WATER, FLAVORED WATER; FLAVORED WATER WITH FRUIT; AERATED DRINKS; NON-ALCOHOLIC BEVERAGES, NAMELY, ENERGY DRINKS; POWDERS USED IN THE PREPARATION OF FRUIT-BASED BEVERAGES AND DRINKS (U.S. CLS. 45, 46 AND 48).

NAAKWAMA ANKRAH, EXAMINING ATTORNEY

CLASS 32—(Continued).

SN 85-562,579. EVERFRESH BEVERAGES, INC., DBA SUNDANCE BEVERAGE COMPANY, FORT LAUDERDALE, FL. FILED 3-7-2012.



NO CLAIM IS MADE TO THE EXCLUSIVE RIGHT TO USE "CALORIE SWEETENER SODIUM FREE" AND "NOTHING ARTIFICIAL", APART FROM THE MARK AS SHOWN.

THE COLOR(S) LIGHT BLUE AND DARK BLUE IS/ARE CLAIMED AS A FEATURE OF THE MARK.

THE MARK CONSISTS OF A SMALLER LIGHT BLUE CIRCLE WITHIN A LARGER LIGHT BLUE CIRCLE. THE WORDS "CALORIE SWEETENER SODIUM" APPEAR AT THE TOP INSIDE OF THE TWO CIRCLE WITH DOTS APPEARING BETWEEN THE WORDS "CALORIE" AND "SWEETENER" AND "SWEETENER" AND "SODIUM". THE WORD "FREE" APPEARS INSIDE THE SMALLER CIRCLE IN DARK BLUE AND IS SUPERIMPOSED ON THE WORD "FREE" IN LIGHT BLUE.

FOR SPARKLING WATER (U.S. CLS. 45, 46 AND 48).
MARILYN IZZI, EXAMINING ATTORNEY

SN 85-564,857. KOMPANIA PIWOWARSKA, S.A. SPOLKA KOMANDYTOWA, 61-285 POZNAN, POLAND, FILED 3-9-2012.



OWNER OF U.S. REG. NOS. 2,765,079 AND 3,159,279.

NO CLAIM IS MADE TO THE EXCLUSIVE RIGHT TO USE "THE ORIGINAL RECIPE", "BROWARY", "A.D. 1629", "1629", "MADE IN POLAND", "GRONIE", "LONDON 2002", "GRAN PRIX", "2005 MUNCHEN", "THE BREWING INDUSTRY INTERNATIONAL AWARDS", "PREMIUM LAGER BEER", AND "EXCELLENT QUALITY OF BEER", APART FROM THE MARK AS SHOWN.

THE COLOR(S) RED, GOLD, BLACK, WHITE, AND GREY IS/ARE CLAIMED AS A FEATURE OF THE MARK.

THE MARK CONSISTS OF A STYLIZED CROWN-SHAPED WHITE BEER LABEL WITH BROKEN GOLD LINES AND GREY HIGHLIGHTING FORMING THE OUTLINE OF THE LABEL; THE GOLD LABEL BORDER CONTAINS THE TERMS "THE ORIGINAL RECIPE" AT

CLASS 32—(Continued).

THE TOP, "PREMIUM LAGER BEER" IN WHITE IN THE LOWER LEFT CORNER, AND "EXCELLENT QUALITY OF BEER" IN WHITE IN THE LOWER RIGHT CORNER; AT THE TOP OF THE LABEL THE TERMS "TYSKIE BROWARY" AND "KSIAZECE A.D. 1629" APPEAR IN BLACK AND ARE BISECTED BY THE TIP OF A RED CROWN WITH GOLD AND WHITE LINING AT THE TOP CENTER OF THE LABEL THAT CONTAINS THE WHITE TERMS "TYSKIE 1629" AROUND THE BOTTOM RIM OF THE CROWN; GOLD STYLIZED LEAFING AND GREY HORIZONTAL LINING ARE SET AROUND THE RED CROWN WITH THE TERMS "MADE IN" AND "POLAND" APPEARING IN RED AND SET IN THE GREY LINE FIELDS THAT ARE BISECTED BY THE CROWN; A LARGE RED QUADRILATERAL WITH CURVED SIDES RUNS ACROSS THE CENTER OF THE LABEL FROM LEFT TO RIGHT THAT CARRIES THE LARGE TERM "TYSKIE" IN WHITE AND RED THREE-DIMENSIONAL LETTERING; A RED BAND PARALLELS THE TOP AND BOTTOM SIDES OF THE QUADRILATERAL; THE BOTTOM PARALLEL LINE IS BISECTED BY THE SMALL TERM "GRONIE" IN RED; BELOW THIS THE TERMS "GRAND PRIX" APPEAR IN GOLD LETTERING OUTLINED IN BLACK; BELOW THIS THERE ARE TWO GOLD AND WHITE COINS; "GRAND PRIX" AND THE COINS ARE SUPERIMPOSED ON A GREY BANNER CONTAINING THE GREY TERMS "TYSKI BROWARY KSIAZECE" ABOVE A GREY LANDSCAPE OF A BREWERY; "LONDON 2002" APPEARS IN BLACK IN THE SPACE TO THE LEFT OF "GRAND PRIX"; "2005 MUNCHEN" APPEARS IN BLACK TO THE RIGHT OF "GRAND PRIX"; THE TERMS "THE BREWING INDUSTRY" APPEAR IN SMALL BLACK FONT TO THE LEFT OF THE COINS AND THE TERMS "INTERNATIONAL AWARDS" APPEAR IN SMALL BLACK FONT TO THE RIGHT OF THE COINS.

THE ENGLISH TRANSLATION OF "TYSKIE" AND "TYSKIE BROWARY KSIAZECE"; "GRONIE"; AND "MUNCHEN" IN THE MARK IS "THING OR PERSON ORIGINATING FROM THE CITY OF TYCHY, POLAND" AND "THING OR PERSON ORIGINATING FROM THE CITY OF TYCHY, POLAND PRINCE'S BREWERY"; "GROUP"; AND "MUNICH".

FOR BEER (U.S. CLS. 45, 46 AND 48).
FIRST USE 7-10-2009; IN COMMERCE 7-10-2009.
ANTHONY RINKER, EXAMINING ATTORNEY

SN 85-570,461. ALLTECH, INC., NICHOLASVILLE, KY.
FILED 3-15-2012.

KENTUCKY ALE

THE MARK CONSISTS OF STANDARD CHARACTERS WITHOUT CLAIM TO ANY PARTICULAR FONT, STYLE, SIZE, OR COLOR.

OWNER OF U.S. REG. NOS. 3,203,795, 3,203,796 AND 3,830,032.

NO CLAIM IS MADE TO THE EXCLUSIVE RIGHT TO USE "ALE", APART FROM THE MARK AS SHOWN.

SEC. 2(F).
FOR ALE; BEER (U.S. CLS. 45, 46 AND 48).
FIRST USE 4-10-2000; IN COMMERCE 6-27-2001.
KELLEY WELLS, EXAMINING ATTORNEY

CLASS 32—(Continued).

SN 85-570,471. ALLTECH, INC., NICHOLASVILLE, KY.
FILED 3-15-2012.

KENTUCKY LIGHT

THE MARK CONSISTS OF STANDARD CHARACTERS WITHOUT CLAIM TO ANY PARTICULAR FONT, STYLE, SIZE, OR COLOR.

OWNER OF U.S. REG. NOS. 3,203,795, 3,203,796 AND 3,830,032.

NO CLAIM IS MADE TO THE EXCLUSIVE RIGHT TO USE "LIGHT", APART FROM THE MARK AS SHOWN.

SEC. 2(F).
FOR ALE; BEER (U.S. CLS. 45, 46 AND 48).
FIRST USE 2-28-2003; IN COMMERCE 8-29-2003.
KELLEY WELLS, EXAMINING ATTORNEY

SN 85-578,262. ARS NOVA PGM, LLC, NEW YORK, NY.
FILED 3-23-2012.

BLACK DYNAMITE

THE MARK CONSISTS OF STANDARD CHARACTERS WITHOUT CLAIM TO ANY PARTICULAR FONT, STYLE, SIZE, OR COLOR.

FOR SPORTS DRINKS, DRINKING WATER; ENERGY DRINKS; FRUIT DRINKS; FRUIT JUICES; NON-ALCOHOLIC BEVERAGES CONTAINING FRUIT JUICES; SOFT DRINKS; ISOTONIC DRINKS; NON-CARBONATED FRUIT FLAVORED BEVERAGES; FLAVORED AND UNFLAVORED CARBONATED DRINKING WATER; NON-CARBONATED FLAVORED WATER; VEGETABLE DRINKS, NAMELY, VEGETABLE JUICES; SMOOTHIES; SOY BASED BEVERAGES NOT BEING MILK SUBSTITUTES; MINERAL WATER AND DRINKING WATER WITH VITAMINS (U.S. CLS. 45, 46 AND 48).

DOMINIC FATHY, EXAMINING ATTORNEY

CLASS 32—(Continued).

SN 85-584,050. COLD SPRING BREWING COMPANY, COLD SPRINGS, MN. FILED 3-29-2012.



OWNER OF U.S. REG. NO. 4,154,819.
NO CLAIM IS MADE TO THE EXCLUSIVE RIGHT TO USE "BREWHOUSE", APART FROM THE MARK AS SHOWN.

THE MARK CONSISTS OF A STYLIZED VERSION OF THE WORDING "THIRD STREET BREWHOUSE" SURROUNDED BY A BARREL-SHAPED HEXAGON.

FOR BEER, ALE, LAGER, STOUT AND PORTER (U.S. CLS. 45, 46 AND 48).

FIRST USE 3-1-2012; IN COMMERCE 3-1-2012.
CIMMERIAN COLEMAN, EXAMINING ATTORNEY

CLASS 32—(Continued).

SN 85-590,381. THE NORSEMEN BREWING COMPANY, LLC, DBA NORSEMEN BREWING COMPANY, ELK HORN, IA. FILED 4-5-2012.



THE MARK CONSISTS OF THE LETTER "N" IN STYLIZED FORM, WITH A VIKING SHIP'S MAST, SAIL, STERN AND BOW FORMING THE "N", A FLAG WAVING RIGHT TO LEFT ATOP THE MAST AND AN IRON RIVET BOTTOM-CENTER.

FOR BEER, ALE, LAGER, STOUT AND PORTER; SOFT DRINKS, NAMELY, ROOT BEER (U.S. CLS. 45, 46 AND 48).

INGRID C. EULIN, EXAMINING ATTORNEY

SN 85-590,904. UTAH BREWERS COOPERATIVE, L.C., SALT LAKE CITY, UT. FILED 4-6-2012.

POLYGAMY PORTER

SN 85-585,712. LEONARD, CHRISTOPHER W., SCHWENKSVILLE, PA. FILED 3-31-2012.



NO CLAIM IS MADE TO THE EXCLUSIVE RIGHT TO USE "BEER", APART FROM THE MARK AS SHOWN.

THE COLOR(S) YELLOW AND BLACK IS/ARE CLAIMED AS A FEATURE OF THE MARK.

THE MARK CONSISTS OF HORIZONTAL BLACK WORDS "COPPER CROW" FOLLOWED BY A BLACK LINE AND THE VERTICAL WORD "BEER" ON A YELLOW BACKGROUND. THE WORDING IS IN A RECTANGULAR DESIGN WITH A BLACK BORDER.

FOR BEER; BEER, ALE AND LAGER; BEER, ALE AND PORTER; BEER, ALE, LAGER, STOUT AND PORTER; BEER, ALE, LAGER, STOUT, PORTER, SHANDY; BEERS; BLACK BEER; BREWED MALT-BASED ALCOHOLIC BEVERAGE IN THE NATURE OF A BEER; FLAVORED BEERS; MALT BEER; MALT LIQUOR; NON-ALCOHOLIC BEER; PALE BEER; PORTER (U.S. CLS. 45, 46 AND 48).

INGA ERVIN, EXAMINING ATTORNEY

THE MARK CONSISTS OF STANDARD CHARACTERS WITHOUT CLAIM TO ANY PARTICULAR FONT, STYLE, SIZE, OR COLOR.

NO CLAIM IS MADE TO THE EXCLUSIVE RIGHT TO USE "PORTER", APART FROM THE MARK AS SHOWN.

FOR BEER, ALE, LAGER, STOUT AND PORTER; BEERS (U.S. CLS. 45, 46 AND 48).

FIRST USE 4-15-2001; IN COMMERCE 4-15-2001.
ELISSA GARBER KON, EXAMINING ATTORNEY

SN 85-591,095. EL-KHECHEN, BASSAM, ESSEN, FED REP GERMANY, FILED 4-6-2012.



THE MARK CONSISTS OF THE WORD "EIGHTYSEVEN" SPELLED OUT IN LOWER CASE LETTERS ALL WITHIN A RECTANGLE. THE COLORS BLACK AND WHITE REPRESENT THE BACKGROUND AND OUTLINING AREAS ONLY AND ARE NOT PART OF THE MARK.

FOR NON-ALCOHOLIC BEVERAGES, NAMELY, ENERGY DRINKS (U.S. CLS. 45, 46 AND 48).

LEE-ANNE BERNS, EXAMINING ATTORNEY

CLASS 32—(Continued).

SN 85-591,929. HOLMES, MICHAEL J., BROCKTON, MA.
FILED 4-7-2012.



NO CLAIM IS MADE TO THE EXCLUSIVE RIGHT TO USE "BREW", APART FROM THE MARK AS SHOWN.

THE MARK CONSISTS OF THE WORD "HOCKOMOCK" AT THE TOP CENTER OF THE LOGO WITH THE SECOND "O" BEING AN ILLUSTRATION OF A UFO. UNDERNEATH HOCKOMOCK CENTERED IS THE WORD "BREW". IN THE CENTER OF THE LOGO IS A TRIANGLE THAT ENCOMPASSES A SASQUATCH FACE. THE TOP POINT OF THE TRIANGLE COMES DOWN FROM THE SECOND O/UFO IN "HOCKOMOCK". A TAIL END OF A SNAKE WRAPS AROUND THE BOTTOM LEFT OF THE LOGO. A SNAKE HEAD WRAPS AROUND THE BOTTOM RIGHT CORNER. UNDERNEATH THE TRIANGLE CENTERED BETWEEN THE SNAKE HEAD AND TAIL, ARE THE WORDS "EVIL SPIRITS".

FOR BEER (U.S. CLS. 45, 46 AND 48).
KELLEY WELLS, EXAMINING ATTORNEY

SN 85-592,886. DESCHUTES BREWERY, INC., BEND, OR.
FILED 4-9-2012.

FLAGLINE GOLDEN ALE

THE MARK CONSISTS OF STANDARD CHARACTERS WITHOUT CLAIM TO ANY PARTICULAR FONT, STYLE, SIZE, OR COLOR.

NO CLAIM IS MADE TO THE EXCLUSIVE RIGHT TO USE "GOLDEN ALE", APART FROM THE MARK AS SHOWN.

FOR ALE (U.S. CLS. 45, 46 AND 48).
WON TEAK OH, EXAMINING ATTORNEY

CLASS 32—(Continued).

SN 85-593,224. A&S BREWING COLLABORATIVE LLC,
BURLINGTON, VT. FILED 4-10-2012.



OWNER OF U.S. REG. NO. 3,727,843.
NO CLAIM IS MADE TO THE EXCLUSIVE RIGHT TO USE "BREWERY", APART FROM THE MARK AS SHOWN. THE MARK CONSISTS OF THE TOP OF A BUILDING, SITTING ON CLOUDS, WITH AN ANGEL HALO AND RAYS OF SUNLIGHT SURROUNDING THE BUILDING APPEARING ABOVE THE STYLIZED WORDS "ANGEL CITY BREWERY".

FOR ALE; BEER (U.S. CLS. 45, 46 AND 48).
RICHARD WHITE, EXAMINING ATTORNEY

SN 85-594,325. KRISTIAN REGALE, INC., PARAMUS, NJ.
FILED 4-11-2012.

FRISA

THE MARK CONSISTS OF STANDARD CHARACTERS WITHOUT CLAIM TO ANY PARTICULAR FONT, STYLE, SIZE, OR COLOR.

THE ENGLISH TRANSLATION OF "FRISA" IS "FRIEZE". FOR SPARKLING JUICE BEVERAGE; NON-ALCOHOLIC BEVERAGES, NAMELY, CARBONATED BEVERAGES (U.S. CLS. 45, 46 AND 48).

JANICE L. MCMORROW, EXAMINING ATTORNEY

SN 85-595,380. WASHINGTON, JR., WILSON, GLEN ALLEN,
VA. FILED 4-11-2012.

BLUE EAGLE

THE MARK CONSISTS OF STANDARD CHARACTERS WITHOUT CLAIM TO ANY PARTICULAR FONT, STYLE, SIZE, OR COLOR.

FOR DRINKING WATER; DRINKING WATER WITH VITAMINS; MINERAL WATER; BOTTLED WATER; ENERGY DRINK, NAMELY, ENERGY WATER (U.S. CLS. 45, 46 AND 48).

FIRST USE 3-1-2012; IN COMMERCE 3-18-2012.
ZHALEH DELANEY, EXAMINING ATTORNEY

CLASS 32—(Continued).

SN 85-596,273. PEPSICO, INC., PURCHASE, NY. FILED 4-12-2012.

HOW DEW DOES THE OUTDOORS

THE MARK CONSISTS OF STANDARD CHARACTERS WITHOUT CLAIM TO ANY PARTICULAR FONT, STYLE, SIZE, OR COLOR.

OWNER OF U.S. REG. NOS. 820,362, 3,674,349 AND OTHERS.

FOR SOFT DRINKS (U.S. CLS. 45, 46 AND 48).

JUDITH HELFMAN, EXAMINING ATTORNEY

CLASS 32—(Continued).

SN 85-598,667. ZIPLINE BREWING COMPANY, LLC, LINCOLN, NE. FILED 4-16-2012.

Brave New Brew

THE MARK CONSISTS OF STANDARD CHARACTERS WITHOUT CLAIM TO ANY PARTICULAR FONT, STYLE, SIZE, OR COLOR.

FOR BEERS (U.S. CLS. 45, 46 AND 48).

KERI CANTONE, EXAMINING ATTORNEY

SN 85-596,349. LPB, HUNT VALLEY, MD. FILED 4-12-2012.

PUBLIC WORKS ALE

THE MARK CONSISTS OF STANDARD CHARACTERS WITHOUT CLAIM TO ANY PARTICULAR FONT, STYLE, SIZE, OR COLOR.

NO CLAIM IS MADE TO THE EXCLUSIVE RIGHT TO USE "ALE", APART FROM THE MARK AS SHOWN.

FOR BEER, ALE, LAGER, STOUT AND PORTER; BEERS (U.S. CLS. 45, 46 AND 48).

DEBORAH LOBO, EXAMINING ATTORNEY



SN 85-598,758. CEG BRANDS, LLC, LINDENHURST, NY. FILED 4-16-2012.

SN 85-598,379. RETSEL CORPORATION, RAPID CITY, SD. FILED 4-16-2012.



THE MARK CONSISTS OF THE MARK IS SYMBOLIC OF THREE OVERLAPPING JUICE SEEDS WITH THE BRAND NAME "FRAVA" IN THE CENTER OF THE IMAGE.

FOR FRUIT JUICES AND FRUIT DRINKS (U.S. CLS. 45, 46 AND 48).

ANGELA M. MICHELI, EXAMINING ATTORNEY

SN 85-599,852. SAMCHAQUI, SAMIR, GOUSSAINVILLE, FRANCE, FILED 4-17-2012.

NO CLAIM IS MADE TO THE EXCLUSIVE RIGHT TO USE "BLACK HILLS BREWING CO." AND "EST. 1878", APART FROM THE MARK AS SHOWN.

THE COLOR(S) WHITE, RED, ORANGE, BLACK AND GREEN IS/ARE CLAIMED AS A FEATURE OF THE MARK.

THE MARK CONSISTS OF THE WORDING "BLACK HILLS BREWING CO." IN WHITE LETTERING PRESENTED AGAINST A RED CIRCULAR BACKGROUND OUTLINED IN ORANGE. SUPERIMPOSED OVER THE CIRCLE IS A DIAMOND SHAPE OUTLINED IN ORANGE CONTAINING A SILHOUETTE OF A BLACK MOUNTAIN RANGE WITH A GREEN FOREGROUND AND WHITE SKY. SUPERIMPOSED OVER THE MOUNTAIN RANGE IS THE WORDING "EST. 1878" IN WHITE.

FOR BEERS (U.S. CLS. 45, 46 AND 48).

WILLIAM VERHOSEK, EXAMINING ATTORNEY

JAWS ENERGY DRINK

THE MARK CONSISTS OF STANDARD CHARACTERS WITHOUT CLAIM TO ANY PARTICULAR FONT, STYLE, SIZE, OR COLOR.

NO CLAIM IS MADE TO THE EXCLUSIVE RIGHT TO USE "ENERGY DRINK", APART FROM THE MARK AS SHOWN.

FOR ENERGY DRINKS (U.S. CLS. 45, 46 AND 48).

FIRST USE 10-1-2011; IN COMMERCE 10-1-2011.

JESSICA A. POWERS, EXAMINING ATTORNEY

CLASS 32—(Continued).

SN 85-599,896. SAMCHAOU, SAMIR, GOUSSAINVILLE, FRANCE, FILED 4-17-2012.



NO CLAIM IS MADE TO THE EXCLUSIVE RIGHT TO USE "ENERGY DRINK", APART FROM THE MARK AS SHOWN.

THE COLOR(S) BLUE, LIGHT BLUE, RED, AND BLACK IS/ARE CLAIMED AS A FEATURE OF THE MARK.

THE MARK CONSISTS OF TWO BLACK RECTANGLES, ONE ON TOP OF THE OTHER, SEPARATED BY THE WORDING "JAWS ENERGY DRINK" IN RED STYLIZED LETTERING. ON EACH RECTANGLE IS A WAVE-LIKE PATTERN IN BLUE AND LIGHT BLUE. THE COLOR WHITE IS MERELY FOR BACKGROUND AND IS NOT CLAIMED AS A FEATURE OF THE MARK.

FOR ENERGY DRINKS (U.S. CLS. 45, 46 AND 48).

FIRST USE 10-1-2011; IN COMMERCE 10-1-2011.

JESSICA A. POWERS, EXAMINING ATTORNEY

SN 85-600,749. GSV EMPIRE, GLENDALE, CA. FILED 4-18-2012.

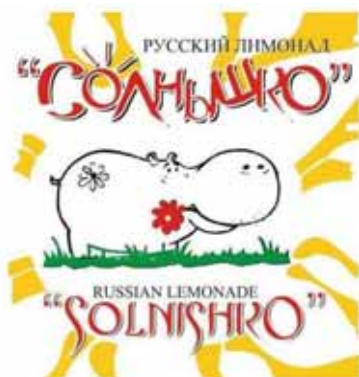

NO CLAIM IS MADE TO THE EXCLUSIVE RIGHT TO USE THE NON-LATIN CHARACTERS THAT TRANSLITERATE TO RUSSKYI LIMONAD OR "RUSSIAN LEMONADE, APART FROM THE MARK AS SHOWN.

THE COLOR(S) YELLOW, RED, GREEN, BLACK & WHITE IS/ARE CLAIMED AS A FEATURE OF THE MARK.

THE MARK CONSISTS OF A WHITE HIPPOPOTAMUS, OUTLINED IN BLACK, WITH A WHITE FLOWER, OUTLINED IN BLACK, ON ITS HIND QUARTER AND HOLDING A RED, WHITE AND BLACK FLOWER IN ITS MOUTH. THE HIPPOPOTAMUS IS STANDING ON GREEN GRASS. ABOVE THE HIPPOPOTAMUS APPEARS THE CYRILLIC

CLASS 32—(Continued).

WORDING THAT TRANSLITERATES TO RUSSKYI LIMONAD IN BLACK. BETWEEN THAT WORDING AND THE HIPPOPOTAMUS IS THE CYRILLIC WORDING THAT TRANSLITERATES TO "SOLNISHKO" IN RED AND OUTLINED IN BLACK AND WHITE. BELOW THE HIPPOPOTAMUS IS THE WORDING "RUSSIAN LEMONADE" IN BLACK, AND BELOW THAT IS THE WORD "SOLNISHKO" IN RED AND OUTLINED IN BLACK AND WHITE. SURROUNDING ALL OF THE ELEMENTS ARE RANDOMLY SHAPED YELLOW FIGURES.

THE ENGLISH TRANSLATION OF "SOLNISHKO" IN THE MARK IS SUN AND IS USED COLLOQUIALLY TO MEAN SWEETHEART.

THE NON-LATIN CHARACTERS IN THE MARK TRANSLITERATE TO RUSSKYI LIMONAD AND "SOLNISHKO" AND THIS MEANS "RUSSIAN LEMONADE" AND SUN WHICH IS USED COLLOQUIALLY TO MEAN SWEETHEART IN ENGLISH.

FOR LEMONADE; LEMONADES (U.S. CLS. 45, 46 AND 48).

FIRST USE 1-10-2010; IN COMMERCE 1-10-2010.

MARGERY A. TIERNEY, EXAMINING ATTORNEY

SN 85-601,087. IR HOLDINGS INTERNATIONAL, LLC, WESTON, CT. FILED 4-18-2012.

THE MOST DELICIOUS FRUIT KNOWN TO MAN

THE MARK CONSISTS OF STANDARD CHARACTERS WITHOUT CLAIM TO ANY PARTICULAR FONT, STYLE, SIZE, OR COLOR.

FOR FRUIT DRINKS; FRUIT JUICES (U.S. CLS. 45, 46 AND 48).

ASMAT KHAN, EXAMINING ATTORNEY

SN 85-601,652. MAGNUS, LLC, FRESNO, CA. FILED 4-18-2012.

GROWLING BEAR

THE MARK CONSISTS OF STANDARD CHARACTERS WITHOUT CLAIM TO ANY PARTICULAR FONT, STYLE, SIZE, OR COLOR.

FOR BEERS (U.S. CLS. 45, 46 AND 48).

KIMBERLY PARKS, EXAMINING ATTORNEY

CLASS 32—(Continued).

SN 85-602,265. IR HOLDINGS INTERNATIONAL, LLC, WESTON, CT. FILED 4-19-2012.

THE MOST DELICIOUS FRUIT
ON EARTH

THE MARK CONSISTS OF STANDARD CHARACTERS WITHOUT CLAIM TO ANY PARTICULAR FONT, STYLE, SIZE, OR COLOR.
FOR FRUIT DRINKS; FRUIT JUICES (U.S. CLS. 45, 46 AND 48).
ASMAT KHAN, EXAMINING ATTORNEY

SN 85-602,317. DISRUPTIVE, LLC, NASHVILLE, TN. FILED 4-19-2012.

Everly

THE MARK CONSISTS OF STANDARD CHARACTERS WITHOUT CLAIM TO ANY PARTICULAR FONT, STYLE, SIZE, OR COLOR.
FOR FRUIT DRINKS ENHANCED WITH VITAMINS; CONCENTRATES, SYRUPS OR POWDERS USED IN THE PREPARATION OF FRUIT-FLAVORED BEVERAGES (U.S. CLS. 45, 46 AND 48).
DAVID TOOLEY, EXAMINING ATTORNEY

SN 85-602,414. PALMA LIGHT, LLC, SAN FRANCISCO, CA. FILED 4-19-2012.

When life gives you
lemons...

THE MARK CONSISTS OF STANDARD CHARACTERS WITHOUT CLAIM TO ANY PARTICULAR FONT, STYLE, SIZE, OR COLOR.
FOR BEER (U.S. CLS. 45, 46 AND 48).
AHSEN KHAN, EXAMINING ATTORNEY

CLASS 32—(Continued).

SN 85-602,884. EMERLING INTERNATIONAL FOODS INC., BUFFALO, NY. FILED 4-19-2012.

HillTween

THE MARK CONSISTS OF STANDARD CHARACTERS WITHOUT CLAIM TO ANY PARTICULAR FONT, STYLE, SIZE, OR COLOR.
FOR FRUIT JUICES (U.S. CLS. 45, 46 AND 48).
FONG HSU, EXAMINING ATTORNEY

SN 85-603,391. ALTICOR INC., ADA, MI. FILED 4-20-2012.

BODYKEY

THE MARK CONSISTS OF STANDARD CHARACTERS WITHOUT CLAIM TO ANY PARTICULAR FONT, STYLE, SIZE, OR COLOR.
PRIORITY CLAIMED UNDER SEC. 44(D) ON MEXICO APPLICATION NO. 1237917, FILED 12-16-2011.
FOR SPORTS DRINKS; ISOTONIC DRINKS AND DRINK MIXES; FRUIT DRINKS AND FRUIT JUICES; PREPARATIONS FOR MAKING FLAVORED WATERS OR NON-ALCOHOLIC BEVERAGES, NAMELY, NON-ALCOHOLIC FRUIT JUICE BEVERAGES, NON-ALCOHOLIC PUNCH, NON-ALCOHOLIC NON-CARBONATED FRUIT BEVERAGES AND NON-ALCOHOLIC NON-CARBONATED SOFT DRINKS; AROMATIZED BEVERAGES BASED ON FRUIT, PROTEIN, CORDIAL, SUGAR AND OTHER FLUID NUTRIENTS, NAMELY, PROTEIN DRINKS FOR USE AS FOOD FILLERS AND NOT FOR USE AS A MEAL REPLACEMENT (U.S. CLS. 45, 46 AND 48).
MIAH ROSENBERG, EXAMINING ATTORNEY

SN 85-603,445. RESPECT FOODS, INC., NAPERVILLE, IL. FILED 4-20-2012.

RESPECT VALUE

THE MARK CONSISTS OF STANDARD CHARACTERS WITHOUT CLAIM TO ANY PARTICULAR FONT, STYLE, SIZE, OR COLOR.
FOR CONCENTRATES AND POWDERS USED IN THE PREPARATION OF ENERGY DRINKS AND FRUIT-FLAVORED BEVERAGES; CONCENTRATES, SYRUPS OR POWDERS FOR MAKING SOFT DRINKS OR TEA-FLAVORED BEVERAGES (U.S. CLS. 45, 46 AND 48).
TINA L. SNAPP, EXAMINING ATTORNEY

CLASS 32—(Continued).

SN 85-605,159. AQUA TECHNOLOGY SYSTEMS, LLC, MOSINEE, WI. FILED 4-23-2012.

THE BEST THING FOR YOUR
BODY JUST GOT BETTER

THE MARK CONSISTS OF STANDARD CHARACTERS WITHOUT CLAIM TO ANY PARTICULAR FONT, STYLE, SIZE, OR COLOR.

FOR HIGH PH DRINKING WATER (U.S. CLS. 45, 46 AND 48).

LOURDES AYALA, EXAMINING ATTORNEY

CLASS 32—(Continued).

SN 85-618,717. CUMBERLAND FARMS, INC., FRAMINGHAM, MA. FILED 5-7-2012.

CHILLZICLE

THE MARK CONSISTS OF STANDARD CHARACTERS WITHOUT CLAIM TO ANY PARTICULAR FONT, STYLE, SIZE, OR COLOR.

FOR FRUIT ICE BARS, FROZEN CONFECTIONS, NAMELY, ICES, FROZEN FRUIT FLAVORED FREEZER POPS (U.S. CLS. 45, 46 AND 48).

CARYN GLASSER, EXAMINING ATTORNEY

SN 85-606,278. BEST MAID PRODUCTS, INC., FORT WORTH, TX. FILED 4-24-2012.

POWER THROUGH MUSCLE CRAMPS

THE MARK CONSISTS OF STANDARD CHARACTERS WITHOUT CLAIM TO ANY PARTICULAR FONT, STYLE, SIZE, OR COLOR.

FOR PICKLED FLAVORED SOFT DRINKS (U.S. CLS. 45, 46 AND 48).

TARAH HARDY, EXAMINING ATTORNEY

SN 85-622,641. CAPITAL BREWERY COMPANY, INC., MIDDLETON, WI. FILED 5-11-2012.

EXPERIENCE LEISURE WITH
DIGNITY

THE MARK CONSISTS OF STANDARD CHARACTERS WITHOUT CLAIM TO ANY PARTICULAR FONT, STYLE, SIZE, OR COLOR.

FOR BEER (U.S. CLS. 45, 46 AND 48).
FIRST USE 5-7-2012; IN COMMERCE 5-7-2012.

TASHIA BUNCH, EXAMINING ATTORNEY

SN 85-606,470. BEST MAID PRODUCTS, INC., FORT WORTH, TX. FILED 4-24-2012.

POWER THROUGH PAIN

THE MARK CONSISTS OF STANDARD CHARACTERS WITHOUT CLAIM TO ANY PARTICULAR FONT, STYLE, SIZE, OR COLOR.

FOR PICKLED FLAVORED SOFT DRINK (U.S. CLS. 45, 46 AND 48).

TARAH HARDY, EXAMINING ATTORNEY

SN 85-626,697. MILLERCOORS LLC, CHICAGO, IL. FILED 5-16-2012.

VINTAGE COLLECTION

THE MARK CONSISTS OF STANDARD CHARACTERS WITHOUT CLAIM TO ANY PARTICULAR FONT, STYLE, SIZE, OR COLOR.

OWNER OF U.S. REG. NO. 4,160,323.

NO CLAIM IS MADE TO THE EXCLUSIVE RIGHT TO USE "COLLECTION", APART FROM THE MARK AS SHOWN.

FOR BEER (U.S. CLS. 45, 46 AND 48).

EVERLYN BRADLEY, EXAMINING ATTORNEY

CLASS 32—(Continued).

SN 85-627,491. UTAH BREWERS COOPERATIVE, L.C., SALT LAKE CITY, UT. FILED 5-16-2012.

Ghostrider White IPA

THE MARK CONSISTS OF STANDARD CHARACTERS WITHOUT CLAIM TO ANY PARTICULAR FONT, STYLE, SIZE, OR COLOR.

NO CLAIM IS MADE TO THE EXCLUSIVE RIGHT TO USE "WHITE IPA", APART FROM THE MARK AS SHOWN. FOR BEER, ALE, LAGER, STOUT AND PORTER; BEERS (U.S. CLS. 45, 46 AND 48).

ELISSA GARBER KON, EXAMINING ATTORNEY

CLASS 32—(Continued).

SN 85-641,454. DESCHUTES BREWERY, INC., BEND, OR. FILED 6-1-2012.

FRESH SQUEEZED IPA

THE MARK CONSISTS OF STANDARD CHARACTERS WITHOUT CLAIM TO ANY PARTICULAR FONT, STYLE, SIZE, OR COLOR.

NO CLAIM IS MADE TO THE EXCLUSIVE RIGHT TO USE "FRESH" AND "IPA", APART FROM THE MARK AS SHOWN.

FOR ALE (U.S. CLS. 45, 46 AND 48).
FIRST USE 9-4-2010; IN COMMERCE 9-4-2010.
WON TEAK OH, EXAMINING ATTORNEY

SN 85-656,739. DIAGEO NORTH AMERICA, INC., NORWALK, CT. FILED 6-20-2012.

SN 85-640,936. A&S BREWING COLLABORATIVE LLC, BURLINGTON, VT. FILED 6-1-2012.



OWNER OF U.S. REG. NO. 3,727,843.
NO CLAIM IS MADE TO THE EXCLUSIVE RIGHT TO USE "BREWERY", APART FROM THE MARK AS SHOWN.

THE MARK CONSISTS OF THE STYLIZED DESIGN OF A TAP HANDLE THAT FEATURES A WOMAN IN FULL LENGTH FROM HEAD TO TOE, WITH FABRIC COVERING THE TORSO AND HIPS, BARE ARMS DOWN AND TO THE SIDE, SET AGAINST A FULL ARRAY OF WINGS WITH THE TOP OF THE HANDLE FEATURING AN IMAGE OF THE TOP OF A BUILDING, SITTING ON CLOUDS, WITH AN ANGEL HALO AND RAYS OF SUNLIGHT SURROUNDING THE BUILDING APPEARING ABOVE THE STYLIZED WORDS "ANGEL CITY BREWERY".

FOR ALE; BEER (U.S. CLS. 45, 46 AND 48).
RICHARD WHITE, EXAMINING ATTORNEY

SMIRNOFF ICE BLACK

THE MARK CONSISTS OF STANDARD CHARACTERS WITHOUT CLAIM TO ANY PARTICULAR FONT, STYLE, SIZE, OR COLOR.

OWNER OF U.S. REG. NOS. 513,428, 3,102,068 AND OTHERS.

FOR BREWED MALT-BASED ALCOHOLIC BEVERAGE IN THE NATURE OF A BEER (U.S. CLS. 45, 46 AND 48).

FIRST USE 4-10-2012; IN COMMERCE 4-10-2012.
CHRISTINA SOBRAL, EXAMINING ATTORNEY

SN 85-673,155. ANARCHY BEVERAGE COMPANY, LAFLIN, PA. FILED 7-10-2012.

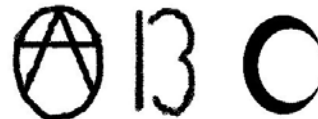

THE MARK CONSISTS OF AN ANARCHY "A", THE NUMBER "1"3 MEANT TO LOOK LIKE A B, AND A CRESCENT MOON FOR THE LETTER "C".

FOR ENERGY DRINKS (U.S. CLS. 45, 46 AND 48).
REBECCA SMITH, EXAMINING ATTORNEY

CLASS 32—(Continued).

SN 85-682,409. ANARCHY BEVERAGE COMPANY, WILKES BARRE, PA. FILED 7-20-2012.



THE MARK CONSISTS OF THE STYLIZED LETTERS "EE" IN WHICH THE LETTERS ARE FACING ONE ANOTHER, THE SECOND LETTER E BEING BACKWARDS. THE LETTERS TOGETHER FORM A DIAMOND SHAPE.

FOR ENERGY DRINKS (U.S. CLS. 45, 46 AND 48).
REBECCA SMITH, EXAMINING ATTORNEY

CLASS 33—WINES AND SPIRITS

SN 76-711,285. SILENUS INTERNATIONAL GROUP, INC., NAPA, CA. FILED 4-19-2012.

SILENUS EAGLE

THE MARK CONSISTS OF STANDARD CHARACTERS WITHOUT CLAIM TO ANY PARTICULAR FONT, STYLE, SIZE, OR COLOR.

FOR WINES (U.S. CLS. 47 AND 49).
ZACHARY CROMER, EXAMINING ATTORNEY

SN 76-711,286. SILENUS INTERNATIONAL GROUP, INC., NAPA, CA. FILED 4-19-2012.

DANAIS

THE MARK CONSISTS OF STANDARD CHARACTERS WITHOUT CLAIM TO ANY PARTICULAR FONT, STYLE, SIZE, OR COLOR.

FOR WINE (U.S. CLS. 47 AND 49).
ZACHARY CROMER, EXAMINING ATTORNEY

CLASS 33—(Continued).

SN 76-711,311. SILENUS INTERNATIONAL GROUP, INC., NAPA, CA. FILED 4-23-2012.

SILENUS

THE MARK CONSISTS OF STANDARD CHARACTERS WITHOUT CLAIM TO ANY PARTICULAR FONT, STYLE, SIZE, OR COLOR.

FOR WINE (U.S. CLS. 47 AND 49).
FIRST USE 9-1-2011; IN COMMERCE 9-1-2011.
EDWARD FENNESSY, EXAMINING ATTORNEY

SN 77-921,902. DAVID BOWLER, LLC, DBA DAVID BOWLER WINE, NEW YORK, NY. FILED 1-27-2010.

THE PEOPLE'S ZIN

THE MARK CONSISTS OF STANDARD CHARACTERS WITHOUT CLAIM TO ANY PARTICULAR FONT, STYLE, SIZE, OR COLOR.

NO CLAIM IS MADE TO THE EXCLUSIVE RIGHT TO USE "ZIN", APART FROM THE MARK AS SHOWN.
FOR WINE (U.S. CLS. 47 AND 49).
NICHOLAS ALTREE, EXAMINING ATTORNEY

SN 78-178,175. LUNNY, CHRISTOPHER, D, SAN FRANCISCO, CA. FILED 10-24-2002.

TWISTED VINEYARDS

NO CLAIM IS MADE TO THE EXCLUSIVE RIGHT TO USE "VINEYARDS", APART FROM THE MARK AS SHOWN.

FOR WINE (U.S. CLS. 47 AND 49).
LINDA LAVACHE, EXAMINING ATTORNEY

CLASS 33—(Continued).

SN 79-103,408. CHAMPAGNE PERRIER-JOUËT, FRANCE, FILED 9-6-2011.



PRIORITY DATE OF 3-28-2011 IS CLAIMED.
OWNER OF INTERNATIONAL REGISTRATION 1092992 DATED 9-6-2011, EXPIRES 9-6-2021.

OWNER OF U.S. REG. NOS. 888,376, 3,388,599 AND OTHERS.

THE MARK CONSISTS OF THE WORDS "BELLE EPOQUE" AND "PERRIER-JOUËT" APPEARING TO THE RIGHT OF A DESIGN COMPRISED OF FLOWERS, FLOWERS STEMS AND LEAVES IN A SEMI-CIRCLE SHAPE.

THE ENGLISH TRANSLATION OF "BELLE EPOQUE" IN THE MARK IS "BEAUTIFUL AGE". THE WORDING "PERRIER-JOUËT" HAS NO MEANING IN A FOREIGN LANGUAGE.

FOR ALCOHOLIC BEVERAGES EXCEPT BEER (U.S. CLS. 47 AND 49).

KATHERINE E. HALMEN, EXAMINING ATTORNEY

CLASS 33—(Continued).

SN 79-106,325. LIDL STIFTUNG & CO. KG, FED REP GERMANY, FILED 10-18-2011.

MASSARI

OWNER OF INTERNATIONAL REGISTRATION 0885343 DATED 4-26-2006, EXPIRES 4-26-2016.

THE ENGLISH TRANSLATION OF "MASSARI" IN THE MARK IS "AGRICULTURAL ESTATE BAILIFFS".

FOR ALCOHOLIC BEVERAGES EXCEPT BEERS, NAMELY, PORT WINE, DISTILLED SPIRITS, LIQUORS, SAMBUCA, COCKTAILS ON BASIS OF DISTILLED SPIRITS, LIQUORS AND/OR SAMBUCA, VERMOUTH, ALCOPOPS, ALCOHOLIC BEVERAGE PRODUCTS PREPARED WITH INTERMEDIATE ALCOHOL CONTENT, NAMELY, FORTIFIED WINES AND LIQUEURS (U.S. CLS. 47 AND 49).

WARREN L. OLANDRIA, EXAMINING ATTORNEY

SN 79-106,289. DOMAINE D'EUGENIE, FRANCE, FILED 11-22-2011.

Domaine d'Eugénie

THE MARK CONSISTS OF STANDARD CHARACTERS WITHOUT CLAIM TO ANY PARTICULAR FONT, STYLE, SIZE, OR COLOR.

PRIORITY DATE OF 7-6-2011 IS CLAIMED.

OWNER OF INTERNATIONAL REGISTRATION 1099657 DATED 11-22-2011, EXPIRES 11-22-2021.

NO CLAIM IS MADE TO THE EXCLUSIVE RIGHT TO USE "DOMAINE", APART FROM THE MARK AS SHOWN.

THE ENGLISH TRANSLATION OF THE FOREIGN WORD(S) IN THE MARK IS: DOMAIN (ESTATE) OF "EUGÉNIE".

FOR AOC WINES, NAMELY, WINES WITH PROTECTED APPELLATION OF ORIGIN (U.S. CLS. 47 AND 49).

TASHIA BUNCH, EXAMINING ATTORNEY

SN 79-106,329. LIDL STIFTUNG & CO. KG, FED REP GERMANY, FILED 10-12-2011.

CEPA LEBREL

THE MARK CONSISTS OF STANDARD CHARACTERS WITHOUT CLAIM TO ANY PARTICULAR FONT, STYLE, SIZE, OR COLOR.

OWNER OF INTERNATIONAL REGISTRATION 0914672 DATED 2-14-2007, EXPIRES 2-14-2017.

THE ENGLISH TRANSLATION OF "CEPA LEBREL" IN THE MARK IS "STOCK SIGHTHOUND".

FOR ALCOHOLIC BEVERAGES EXCEPT BEERS, NAMELY, WINES, SPARKLING WINES, WINE CONTAINING COCKTAILS, DISTILLED SPIRITS, LIQUEURS, BRANDY, BITTERS, ALCOPOPS (U.S. CLS. 47 AND 49).

WARREN L. OLANDRIA, EXAMINING ATTORNEY

CLASS 33—(Continued).

SN 79-107,155. MONTENEGRO S.R.L., I-40069 ZOLA PREDOSA (BO), ITALY, FILED 12-1-2011.



OWNER OF INTERNATIONAL REGISTRATION 1101639 DATED 12-1-2011, EXPIRES 12-1-2021.

OWNER OF U.S. REG. NO. 1,234,790.

NO CLAIM IS MADE TO THE EXCLUSIVE RIGHT TO USE "COCA" AND "LIME", APART FROM THE MARK AS SHOWN.

THE COLOR(S) SILVER, BLACK, YELLOW, ORANGE, RED, BLUE, WHITE, GREEN AND LIGHT GREEN IS/ARE CLAIMED AS A FEATURE OF THE MARK.

THE MARK CONSISTS OF THE FOLLOWING: A BLACK HORIZONTAL BAR ABOVE THE WORDING "CO" IN THE COLOR BLACK WITH THE LETTER "O" ENCIRCLING A GLASS OUTLINED IN BLACK AND CONTAINING A LIGHT GREEN LIQUID WITH GREEN AND YELLOW FRUIT SEGMENTS FALLING INTO IT; BELOW THE "CO" IS THE WORDING "CA" IN THE COLOR BLACK; BELOW THAT IS THE WORDING "LI" IN THE COLOR BLACK. TO THE LEFT OF THE PROFILE OF A WOMAN OUTLINED IN BLACK WITH ORANGE HAIR, EYE OUTLINED IN BLACK AND RED LIPS; THE WOMAN FACES THE PROFILE OF A MAN, ALSO OUTLINED IN BLACK WITH RED HAIR, A YELLOW BOWTIE AND A BLUE EYE, ALL OF WHICH IS ABOVE THE WORDING "ME" IN THE COLOR BLACK; A GREEN HORIZONTAL BAR IS BELOW THE WORDING "ME" AND A BLACK HORIZONTAL BAR CONTAINING THE WORDING "COCABUTON" IN THE COLOR WHITE IS AT THE BOTTOM OF THE DESIGN ELEMENT; THE ENTIRE DESIGN ELEMENT HAS A SILVER BACKGROUND.

THE WORD(S) "COCABUTON" AND "BUTON" HAS NO MEANING IN A FOREIGN LANGUAGE.

FOR ALCOHOLIC LIQUORS, APERITIFS, DIGESTIVES AND ALCOHOLIC BITTERS, MADE OF COCA LEAVES AND LIME (U.S. CLS. 47 AND 49).

SUZANNE BLANE, EXAMINING ATTORNEY

CLASS 33—(Continued).

SN 79-107,199. ANHUI GUJING DISTILLERY COMPANY LIMITED, CHINA, FILED 12-6-2011.

GUJING

OWNER OF INTERNATIONAL REGISTRATION 1101635 DATED 12-6-2011, EXPIRES 12-6-2021.

OWNER OF U.S. REG. NO. 3,436,338.

THE ENGLISH TRANSLATION OF "GUJING" IN THE MARK IS "ANCIENT WELL".

FOR ALCOHOLIC FRUITS EXTRACTS; WINE; LIQUEURS; SPIRITS; BRANDY; WHISKY; ALCOHOLIC BEVERAGES, EXCEPT BEER; ALCOHOLIC BEVERAGES CONTAINING FRUIT; RICE ALCOHOL; YELLOW WINE (U.S. CLS. 47 AND 49).

MARILYN IZZI, EXAMINING ATTORNEY

SN 79-107,532. THE BENRIACH DISTILLERY COMPANY LIMITED, UNITED KINGDOM, FILED 11-11-2011.

CLAN MURRAY

THE MARK CONSISTS OF STANDARD CHARACTERS WITHOUT CLAIM TO ANY PARTICULAR FONT, STYLE, SIZE, OR COLOR.

OWNER OF INTERNATIONAL REGISTRATION 1102526 DATED 11-11-2011, EXPIRES 11-11-2021.

FOR ALCOHOLIC BEVERAGES EXCEPT BEER, BUT IN SO FAR AS WHISKY AND WHISKY-BASED LIQUEURS ARE CONCERNED, ONLY SCOTCH WHISKY AND SCOTCH WHISKY-BASED LIQUEURS PRODUCED IN SCOTLAND (U.S. CLS. 47 AND 49).

TASNEEM HUSSAIN, EXAMINING ATTORNEY

SN 79-107,917. THE BENRIACH DISTILLERY COMPANY LIMITED, EDINBURG EH28 8PL, UNITED KINGDOM, FILED 11-11-2011.

BENRIACH

THE MARK CONSISTS OF STANDARD CHARACTERS WITHOUT CLAIM TO ANY PARTICULAR FONT, STYLE, SIZE, OR COLOR.

OWNER OF INTERNATIONAL REGISTRATION 1103646 DATED 11-11-2011, EXPIRES 11-11-2021.

THE ENGLISH TRANSLATION OF "BENRIACH" IN THE MARK IS "HILL OF THE RED DEER".

FOR MALT WHISKY THE PRODUCE OF SCOTLAND (U.S. CLS. 47 AND 49).

TASNEEM HUSSAIN, EXAMINING ATTORNEY

CLASS 33—(Continued).

SN 79-108,194. GFA DU DOMAINE MOULINET, POMEROL, FRANCE, FILED 11-21-2011.



PRIORITY DATE OF 10-20-2011 IS CLAIMED.
OWNER OF INTERNATIONAL REGISTRATION 1104368 DATED 11-21-2011, EXPIRES 11-21-2021.

NO CLAIM IS MADE TO THE EXCLUSIVE RIGHT TO USE "CHATEAU" AND "POMEROL", APART FROM THE MARK AS SHOWN.

THE COLOR(S) BLACK AND RED IS/ARE CLAIMED AS A FEATURE OF THE MARK.

THE MARK CONSISTS OF TWO BLACK LIONS ON EACH SIDE AND IN THE MIDDLE A RED AND BLACK COAT OF ARMS WITH A BLACK LILY FLOWER ON THE TOP OF IT. UNDERNEATH THE DESIGN ELEMENT ARE THE WORDS "CHATEAU MOULINET POMEROL" IN BLACK.

FOR AOC WINES WITH THE PROTECTED APPELLATION OF ORIGIN POMEROL FROM THE WINE-MAKING ESTATE CALLED CHATEAU MOULINET (U.S. CLS. 47 AND 49).

SHAUNIA CARLYLE, EXAMINING ATTORNEY

SN 79-113,696. FEDERAL STATE UNITARY ENTERPRISE; "TRADING HOUSE "KREMLEVSKIY": ADMINISTRATION OF THE PRESIDENT; OF THE RUSSIAN FEDERATION, RUSSIAN FED., FILED 3-30-2012.

КРЕМЛЕВСКОЕ ИГРИСТОЕ

OWNER OF INTERNATIONAL REGISTRATION 1118281 DATED 3-30-2012, EXPIRES 3-30-2022.

NO CLAIM IS MADE TO THE EXCLUSIVE RIGHT TO USE "IGRISTOYE.", APART FROM THE MARK AS SHOWN.

THE ENGLISH TRANSLATION OF THE FOREIGN WORD(S) IN THE MARK IS: KREMLIN SPARKLING.

THE TRANSLITERATION OF THE NON-LATIN CHARACTERS IN THE MARK IS: KREMLEVSKOYE IGRISTOYE.

FOR WINE, NAMELY SPARKLING WINE (U.S. CLS. 47 AND 49).

NAPOLEON SHARMA, EXAMINING ATTORNEY

SN 79-113,779. INVER HOUSE DISTILLERS LIMITED, UNITED KINGDOM, FILED 4-18-2012.

HANKEY BANNISTER

THE MARK CONSISTS OF STANDARD CHARACTERS WITHOUT CLAIM TO ANY PARTICULAR FONT, STYLE, SIZE, OR COLOR.

OWNER OF INTERNATIONAL REGISTRATION 1118521 DATED 4-18-2012, EXPIRES 4-18-2022.

FOR WINES, SPIRITS AND LIQUEURS (U.S. CLS. 47 AND 49).

GENE MACIOL, EXAMINING ATTORNEY

CLASS 33—(Continued).

SN 85-155,497. SPEAKEASY MARKETING LLC, NASHVILLE, TN. FILED 10-18-2010.

WHISPER CREEK TENNESSEE SIPPING CREAM

THE MARK CONSISTS OF STANDARD CHARACTERS WITHOUT CLAIM TO ANY PARTICULAR FONT, STYLE, SIZE, OR COLOR.

NO CLAIM IS MADE TO THE EXCLUSIVE RIGHT TO USE "TENNESSEE SIPPING CREAM", APART FROM THE MARK AS SHOWN.

FOR ALCOHOLIC BEVERAGES, NAMELY, WHISKEY-BASED CREAM LIQUEURS AND CORDIALS (U.S. CLS. 47 AND 49).

FIRST USE 12-6-2011; IN COMMERCE 12-15-2011.

KRISTIN DAHLING, EXAMINING ATTORNEY

SN 85-209,091. COOPER'S CHASE DISTILLERY, L.L.C., WEST POINT, NE. FILED 1-3-2011.

Cooper's Chase

THE MARK CONSISTS OF STANDARD CHARACTERS WITHOUT CLAIM TO ANY PARTICULAR FONT, STYLE, SIZE, OR COLOR.

FOR DISTILLED SPIRITS (U.S. CLS. 47 AND 49).

FIRST USE 10-15-2009; IN COMMERCE 10-15-2009.

AISHA SALEM, EXAMINING ATTORNEY

SN 85-286,812. GHOST HORSE VINEYARDS, LLC, NAPA, CA. FILED 4-5-2011.

THE OCCULT WINE EXPERIENCE

THE MARK CONSISTS OF STANDARD CHARACTERS WITHOUT CLAIM TO ANY PARTICULAR FONT, STYLE, SIZE, OR COLOR.

NO CLAIM IS MADE TO THE EXCLUSIVE RIGHT TO USE "WINE", APART FROM THE MARK AS SHOWN.

FOR ALCOHOLIC BEVERAGES EXCEPT BEERS (U.S. CLS. 47 AND 49).

FIRST USE 3-17-2009; IN COMMERCE 3-17-2009.

MAYUR VAGHANI, EXAMINING ATTORNEY

CLASS 33—(Continued).

SN 85-354,699. AGAVERA CAMICHINES, S.A. DE C.V., JALISCO, MEXICO, FILED 6-23-2011.



THE MARK CONSISTS OF A THREE-DIMENSIONAL CONFIGURATION OF THE CONTAINER FOR THE GOODS COMPRISED OF A ROUND BOTTLE FEATURING A ROUND OPENING ON THREE SIDES LEADING TO AN OPEN CENTER CONTAINING A FIGURE OF AN ANGEL. THE MARK CONSISTS OF THE ENTIRE BOTTLE EXCLUDING THE BOTTLE CAP SHOWN IN DOTTED LINES.

FOR TEQUILA (U.S. CLS. 47 AND 49).
REBECCA SMITH, EXAMINING ATTORNEY

SN 85-380,716. CLUB CARIBE DISTILLERS LLC, TOA BAJA, PUERTO RICO, FILED 7-26-2011.



NO CLAIM IS MADE TO THE EXCLUSIVE RIGHT TO USE "SPICED RUM", APART FROM THE MARK AS SHOWN.

THE COLOR(S) BEIGE, GOLD AND BROWN IS/ARE CLAIMED AS A FEATURE OF THE MARK.

THE MARK CONSISTS OF A GOLD OVAL WITH TWO THIN CONCENTRIC OVALS INSIDE. ON THE TOP PART, THERE IS A GOLD BANNER WITH THE WORDS "SPICED RUM" IN BEIGE. THE BACKGROUND INSIDE THE OVAL IS BEIGE, WITH A SKULL AND BONES DESIGN IN BROWN ON TOP OF THE BEIGE BACKGROUND. BELOW SAID DESIGN, ARE THE WORDS "BLACK ROBERTS" IN BROWN. BELOW IS AN INTRICATE DESIGN IN BROWN COLOR.

FOR RUM (U.S. CLS. 47 AND 49).
TASHIA BUNCH, EXAMINING ATTORNEY

CLASS 33—(Continued).

SN 85-395,903. A&SS, PALOS VERDES ESTATES, CA. FILED 8-11-2011.

Menu Cellars

THE MARK CONSISTS OF STANDARD CHARACTERS WITHOUT CLAIM TO ANY PARTICULAR FONT, STYLE, SIZE, OR COLOR.

NO CLAIM IS MADE TO THE EXCLUSIVE RIGHT TO USE "CELLARS", APART FROM THE MARK AS SHOWN.
FOR WINE (U.S. CLS. 47 AND 49).
SUNG IN, EXAMINING ATTORNEY

SN 85-396,537. VINIFERA WINE CO., LLC, AUBURN HILLS, MI. FILED 8-12-2011.

THE BRIDGE

THE MARK CONSISTS OF STANDARD CHARACTERS WITHOUT CLAIM TO ANY PARTICULAR FONT, STYLE, SIZE, OR COLOR.

FOR WINE (U.S. CLS. 47 AND 49).
FIRST USE 3-0-2011; IN COMMERCE 3-0-2011.
ERIN FALK, EXAMINING ATTORNEY

SN 85-410,604. LLOYD CARUSO, LLC, MT. PLEASANT, SC. FILED 8-30-2011.

CHILLED DILLS

THE MARK CONSISTS OF STANDARD CHARACTERS WITHOUT CLAIM TO ANY PARTICULAR FONT, STYLE, SIZE, OR COLOR.

NO CLAIM IS MADE TO THE EXCLUSIVE RIGHT TO USE "CHILLED", APART FROM THE MARK AS SHOWN.
FOR ALCOHOLIC BEVERAGES, NAMELY, FLAVOR INFUSED VODKA (U.S. CLS. 47 AND 49).
NANCY CLARKE, EXAMINING ATTORNEY

CLASS 33—(Continued).

SN 85-426,813. DANIEL A. DANIEL, TBILISI, REP OF GEORGIA, FILED 9-20-2011.

FLAMINGO

THE MARK CONSISTS OF STANDARD CHARACTERS WITHOUT CLAIM TO ANY PARTICULAR FONT, STYLE, SIZE, OR COLOR.

FOR VODKA (U.S. CLS. 47 AND 49).
FIRST USE 1-1-2005; IN COMMERCE 1-1-2005.
STEVEN JACKSON, EXAMINING ATTORNEY

SN 85-439,189. J. ARMANDO BERMUDEZ & CO., C. POR A., SANTIAGO, DOMINICAN REP, FILED 10-4-2011.

BERMUDEZ

THE MARK CONSISTS OF STANDARD CHARACTERS WITHOUT CLAIM TO ANY PARTICULAR FONT, STYLE, SIZE, OR COLOR.

SEC. 2(F).
FOR RUM (U.S. CLS. 47 AND 49).
FIRST USE 0-0-1852; IN COMMERCE 9-15-1970.
LINDA E. BLOHM, EXAMINING ATTORNEY

SN 85-443,266. ALEJANDRO BARAJAS ARECHIGA, MINNEAPOLIS, MN. FILED 10-10-2011.

EL NIVEL

THE MARK CONSISTS OF STANDARD CHARACTERS WITHOUT CLAIM TO ANY PARTICULAR FONT, STYLE, SIZE, OR COLOR.

THE ENGLISH TRANSLATION OF "EL NIVEL" IN THE MARK IS "THE LEVEL".
FOR TEQUILA (U.S. CLS. 47 AND 49).
TIMOTHY FINNEGAN, EXAMINING ATTORNEY

CLASS 33—(Continued).

SN 85-443,398. HARD LUCK DISTRIBUTERS, LLC, ST. CLAIR SHORES, MI. FILED 10-10-2011.

RED FISH

THE MARK CONSISTS OF STANDARD CHARACTERS WITHOUT CLAIM TO ANY PARTICULAR FONT, STYLE, SIZE, OR COLOR.

FOR SPIRITS (U.S. CLS. 47 AND 49).
FIRST USE 2-0-2010; IN COMMERCE 2-0-2010.
SEAN CROWLEY, EXAMINING ATTORNEY

SN 85-444,845. STONE EDGE WINERY, LLC, SONOMA, CA. FILED 10-11-2011.



OWNER OF U.S. REG. NO. 3,990,331.
NO CLAIM IS MADE TO THE EXCLUSIVE RIGHT TO USE "2007", APART FROM THE MARK AS SHOWN.

THE MARK CONSISTS OF A CIRCULAR DESIGN WITH A THICK IRREGULAR CIRCUMFERENCE. INSIDE IS A ROOT-LIKE DESIGN SURROUNDED BY A CIRCULAR DESIGN CONSISTING OF SHORT, CURVED BROKEN LINES. CIRCLING THIS DESIGN ALONG THE INSIDE EDGE OF THE CIRCLE IS THE WORDING "SURROUND SURROUND SURROUND 2007", EACH WORDING SEPARATED BY A SMALL SOLID CIRCLE.

FOR WINE (U.S. CLS. 47 AND 49).
FIRST USE 12-14-2009; IN COMMERCE 12-14-2009.
WENDY JUN, EXAMINING ATTORNEY

SN 85-445,442. 750 ML, LLC, MILFORD, DE. FILED 10-12-2011.

HARD NUTTS

THE MARK CONSISTS OF STANDARD CHARACTERS WITHOUT CLAIM TO ANY PARTICULAR FONT, STYLE, SIZE, OR COLOR.

FOR ALCOHOLIC BEVERAGES EXCEPT BEERS (U.S. CLS. 47 AND 49).
DAVID C. REIHNER, EXAMINING ATTORNEY

CLASS 33—(Continued).

SN 85-445,502. EMBOTELLADORA JARAL DE BERRIO, S.A. DE C.V., SAN FELIPE, GUANAJUATO, MEXICO, FILED 10-12-2011.

JARAL

THE MARK CONSISTS OF STANDARD CHARACTERS WITHOUT CLAIM TO ANY PARTICULAR FONT, STYLE, SIZE, OR COLOR.

THE NAME(S), PORTRAIT(S), AND/OR SIGNATURE(S) SHOWN IN THE MARK DOES NOT IDENTIFY A PARTICULAR LIVING INDIVIDUAL.

THE WORDING "JARAL" HAS NO MEANING IN A FOREIGN LANGUAGE.

FOR ALCOHOLIC BEVERAGES, NAMELY, MEZCAL (U.S. CLS. 47 AND 49).

LINDA M. KING, EXAMINING ATTORNEY

SN 85-445,539. EMBOTELLADORA JARAL DE BERRIO, S.A. DE C.V., SAN FELIPE, GUANAJUATO, MEXICO, FILED 10-12-2011.

JARAL DE BERRIO

THE MARK CONSISTS OF STANDARD CHARACTERS WITHOUT CLAIM TO ANY PARTICULAR FONT, STYLE, SIZE, OR COLOR.

THE NAME(S), PORTRAIT(S), AND/OR SIGNATURE(S) SHOWN IN THE MARK DOES NOT IDENTIFY A PARTICULAR LIVING INDIVIDUAL.

THE WORDING "JARAL DE BERRIO" HAS NO MEANING IN A FOREIGN LANGUAGE.

FOR ALCOHOLIC BEVERAGES, NAMELY, MEZCAL (U.S. CLS. 47 AND 49).

LINDA M. KING, EXAMINING ATTORNEY

SN 85-450,812. VINA VENTISQUERO LIMITADA, RANCA-GUA, CHILE, FILED 10-19-2011.

QUEULAT

THE MARK CONSISTS OF STANDARD CHARACTERS WITHOUT CLAIM TO ANY PARTICULAR FONT, STYLE, SIZE, OR COLOR.

OWNER OF CHILE REG. NO. 657041, DATED 2-4-2003, EXPIRES 2-3-2013.

FOR ALCOHOLIC BEVERAGES, NAMELY, GIN, VODKA, AND BRANDY SPIRITS; WINE (U.S. CLS. 47 AND 49).

SIMON TENG, EXAMINING ATTORNEY

CLASS 33—(Continued).

SN 85-452,346. ITZLER, JESSE, NEW YORK, NY, AND BLAKELY, SARA, NEW YORK, NY. FILED 10-20-2011.

SOAKED

THE MARK CONSISTS OF STANDARD CHARACTERS WITHOUT CLAIM TO ANY PARTICULAR FONT, STYLE, SIZE, OR COLOR.

FOR ALCOHOLIC BEVERAGES EXCEPT BEERS (U.S. CLS. 47 AND 49).

THOMAS MANOR, EXAMINING ATTORNEY

SN 85-453,131. MANGRIA LLC, LOS ANGELES, CA. FILED 10-21-2011.

MANGRIA

THE MARK CONSISTS OF STANDARD CHARACTERS WITHOUT CLAIM TO ANY PARTICULAR FONT, STYLE, SIZE, OR COLOR.

FOR WINES; PREPARED WINE COCKTAILS; WINE COOLERS, AND WINE PUNCH (U.S. CLS. 47 AND 49).

BERNICE MIDDLETON, EXAMINING ATTORNEY

SN 85-456,975. DRAGON SPIRITS LIMITED, TSIM SHA TSUI, KOWLOON, HONG KONG, FILED 10-26-2011.

Royal Dragon Vodka

THE MARK CONSISTS OF STANDARD CHARACTERS WITHOUT CLAIM TO ANY PARTICULAR FONT, STYLE, SIZE, OR COLOR.

NO CLAIM IS MADE TO THE EXCLUSIVE RIGHT TO USE "VODKA", APART FROM THE MARK AS SHOWN.

FOR VODKA; VODKA BASED PRODUCTS (U.S. CLS. 47 AND 49).

JAMES STEIN, EXAMINING ATTORNEY

CLASS 33—(Continued).

SN 85-479,301. BROOKS, NAKEISHA, CHICAGO, IL. AND GRANT, MARK, CHICAGO, IL. FILED 11-22-2011.

Rasta Love Punch

THE MARK CONSISTS OF STANDARD CHARACTERS WITHOUT CLAIM TO ANY PARTICULAR FONT, STYLE, SIZE, OR COLOR.

NO CLAIM IS MADE TO THE EXCLUSIVE RIGHT TO USE "PUNCH", APART FROM THE MARK AS SHOWN.

FOR ALCOHOLIC BEVERAGES CONTAINING FRUIT; ALCOHOLIC BEVERAGES EXCEPT BEERS; ALCOHOLIC BEVERAGES OF FRUIT; ALCOHOLIC BEVERAGES, NAMELY, NATURAL BLENDED FRUIT JUICES COMBINED WITH RUM; ALCOHOLIC FRUIT COCKTAIL DRINKS; ALCOHOLIC MIXED BEVERAGES EXCEPT BEERS; ALCOHOLIC PUNCH; ALCOHOLIC PUNCHES; PREPARED ALCOHOLIC COCKTAIL; SPIRITS (U.S. CLS. 47 AND 49).

FIRST USE 7-1-2007; IN COMMERCE 7-1-2007.

WENDY JUN, EXAMINING ATTORNEY

CLASS 33—(Continued).

SN 85-490,576. LEWIS, JEAN-CLAUDE, DETROIT, MI. FILED 12-8-2011.

Real Redneck

THE MARK CONSISTS OF STANDARD CHARACTERS WITHOUT CLAIM TO ANY PARTICULAR FONT, STYLE, SIZE, OR COLOR.

NO CLAIM IS MADE TO THE EXCLUSIVE RIGHT TO USE "REAL", APART FROM THE MARK AS SHOWN.

FOR ALCOHOLIC COCKTAIL MIXES (U.S. CLS. 47 AND 49).

RONALD MCMORROW, EXAMINING ATTORNEY

SN 85-484,975. VIKING RIVER CRUISES (BERMUDA) LTD., HAMILTON, BERMUDA, FILED 12-1-2011.

AQUAVIT TERRACE

THE MARK CONSISTS OF STANDARD CHARACTERS WITHOUT CLAIM TO ANY PARTICULAR FONT, STYLE, SIZE, OR COLOR.

NO CLAIM IS MADE TO THE EXCLUSIVE RIGHT TO USE "AQUAVIT", APART FROM THE MARK AS SHOWN.

FOR VODKA, LIQUEURS AND DISTILLED SPIRITS (U.S. CLS. 47 AND 49).

AMY KELLY, EXAMINING ATTORNEY

SN 85-494,777. BULMERS LIMITED, CO. DUBLIN, IRELAND, FILED 12-14-2011.



SN 85-486,313. VIKING RIVER CRUISES (BERMUDA) LTD., HAMILTON, BERMUDA, FILED 12-2-2011.

AQUAVIT LOUNGE

THE MARK CONSISTS OF STANDARD CHARACTERS WITHOUT CLAIM TO ANY PARTICULAR FONT, STYLE, SIZE, OR COLOR.

NO CLAIM IS MADE TO THE EXCLUSIVE RIGHT TO USE "AQUAVIT", APART FROM THE MARK AS SHOWN.

FOR VODKA, LIQUEURS AND DISTILLED SPIRITS (U.S. CLS. 47 AND 49).

AMY KELLY, EXAMINING ATTORNEY

OWNER OF U.S. REG. NOS. 2,737,211, 3,844,166 AND OTHERS.

NO CLAIM IS MADE TO THE EXCLUSIVE RIGHT TO USE "CLONMEL IRELAND" AND "PREMIUM IRISH APPLE CIDER" AND "IMPORTED" AND "SELECTIONS" AND "BERRY BLEND" AND "PEACH" AND "GENUINE IRISH CIDER SINCE 1935", APART FROM THE MARK AS SHOWN.

THE MARK CONSISTS OF A REPRESENTATION OF THREE STYLIZED CIDER VATS WITH THE FIGURE OF AN APPLE AND LEAVES ON TOP OF THE VATS AND THE FIGURE OF BERRIES BEHIND THE VATS, WITH A RIBBON WITH THE WORDS "IMPORTED MAGNERS SELECTIONS" AN ARCH WITH THE WORDS "PREMIUM IRISH APPLE CIDER" AND THE WORDS "WITH BERRY BLEND & A TASTE OF PEACH" ALL SURROUNDED BY THE WORDS "WM. MAGNER OF CLONMEL, IRELAND" AND "GENUINE IRISH CIDER SINCE 1935".

FOR HARD CIDER (U.S. CLS. 47 AND 49).

CAROLINE WOOD, EXAMINING ATTORNEY

CLASS 33—(Continued).

SN 85-502,849. SOUTH RIVER VINEYARD INC., DBA SOUTH RIVER WINERY, GENEVA, OH. FILED 12-23-2011.

Red Eagle Distillery

THE MARK CONSISTS OF STANDARD CHARACTERS WITHOUT CLAIM TO ANY PARTICULAR FONT, STYLE, SIZE, OR COLOR.

NO CLAIM IS MADE TO THE EXCLUSIVE RIGHT TO USE "DISTILLERY", APART FROM THE MARK AS SHOWN.

FOR DISTILLED SPIRITS (U.S. CLS. 47 AND 49).
CORY BOONE, EXAMINING ATTORNEY

SN 85-502,893. SOUTH RIVER VINEYARD INC., DBA SOUTH RIVER WINERY, GENEVA, OH. FILED 12-23-2011.

Red Eagle Spirits

THE MARK CONSISTS OF STANDARD CHARACTERS WITHOUT CLAIM TO ANY PARTICULAR FONT, STYLE, SIZE, OR COLOR.

NO CLAIM IS MADE TO THE EXCLUSIVE RIGHT TO USE "SPIRITS", APART FROM THE MARK AS SHOWN.

FOR DISTILLED SPIRITS (U.S. CLS. 47 AND 49).
CORY BOONE, EXAMINING ATTORNEY

SN 85-513,472. CL NR. 1 APS, KØBENHAVN K DK 1251, DENMARK. FILED 1-10-2012.

CLOC

THE MARK CONSISTS OF STANDARD CHARACTERS WITHOUT CLAIM TO ANY PARTICULAR FONT, STYLE, SIZE, OR COLOR.

FOR WINES; SPIRITS; LIQUEURS; ALCOHOLIC BEVERAGES EXCEPT BEERS (U.S. CLS. 47 AND 49).
KAREN BRACEY, EXAMINING ATTORNEY

CLASS 33—(Continued).

SN 85-535,774. STEVENS-KANG, JULIE, SANTA MONICA, CA. AND JOHNSTON, PAMELA, FULLERTON, CA. AND BAKER, JOAN, VILLA PARK, CA. FILED 2-7-2012.

Be Tini Spirits

THE MARK CONSISTS OF STANDARD CHARACTERS WITHOUT CLAIM TO ANY PARTICULAR FONT, STYLE, SIZE, OR COLOR.

NO CLAIM IS MADE TO THE EXCLUSIVE RIGHT TO USE "TINI SPIRITS", APART FROM THE MARK AS SHOWN.

FOR ALCOHOLIC MIXED BEVERAGES EXCEPT BEERS; APERITIFS WITH A WINE BASE; DISTILLED SPIRITS; PREPARED ALCOHOLIC COCKTAIL; PREPARED WINE COCKTAILS; WINE (U.S. CLS. 47 AND 49).

ZACHARY BELLO, EXAMINING ATTORNEY

SN 85-541,875. MICHAEL GLICKMAN, NEW YORK, NY. FILED 2-14-2012.

Pop Shots

THE MARK CONSISTS OF STANDARD CHARACTERS WITHOUT CLAIM TO ANY PARTICULAR FONT, STYLE, SIZE, OR COLOR.

NO CLAIM IS MADE TO THE EXCLUSIVE RIGHT TO USE "SHOTS", APART FROM THE MARK AS SHOWN.

FOR BLENDED SPIRITS; BRANDY SPIRITS; CHINESE SPIRIT OF SORGHUM (GAOLIAN-JIOU); DISTILLED SPIRITS; DISTILLED SPIRITS OF RICE (AWAMORI); DISTILLED SPIRITS OF RICE, CORN, BARLEY, POTATO, SUGERCANE, MOLASSES; POTABLE SPIRITS; SHOCHU (SPIRITS); SPIRITS; SPIRITS AND LIQUEURS (U.S. CLS. 47 AND 49).

SUE LAWRENCE, EXAMINING ATTORNEY

CLASS 33—(Continued).

SN 85-544,962. CYRIL LOVES VODKA, LLC, FRANKLIN SQUARE, NY. FILED 2-16-2012.



NO CLAIM IS MADE TO THE EXCLUSIVE RIGHT TO USE "CHARGE MODIFIED ORGANIC ARTISANAL VODKA 80 PROOF", APART FROM THE MARK AS SHOWN.

THE COLOR(S) GOLD AND BLACK IS/ARE CLAIMED AS A FEATURE OF THE MARK.

THE MARK CONSISTS OF THE NAME "CYRIL'S" IN STYLIZED FONT IN GOLD COLOR ON A BLACK RECTANGULAR BACKGROUND WITH A GOLD BORDER, ABOVE; A BLACK LION OF MEDIEVAL DESIGN, TRIMMED IN GOLD, HOLDING A SHIELD THAT IS TILTED AND WITH THE SHIELD CONTAINING THE LETTERS "CM" IN STYLIZED GOLD FONT AND A GOLD LIGHTNING BOLT ON A BLACK BACKGROUND, WITH THE SHIELD TRIMMED IN GOLD; AND WITH THE LION STANDING ON A 3-TIERED BLACK PLATFORM WITH GOLD BORDER AND THE PLATFORM CONTAINING THE WORDS "ORGANIC ARTISANAL VODKA", ON THE 1ST TIER, "CHARGE MODIFIED", IN GOLD STYLIZED FONT, ON THE 2ND TIER; AND THE WORDS "80 PROOF" IN GOLD STYLIZED FONT IN THE BASE OF THE PLATFORM, THE 3RD TIER.

FOR VODKA (U.S. CLS. 47 AND 49).
RICHARD WHITE, EXAMINING ATTORNEY

SN 85-548,790. VINTAGE ROCKEFELLER WINE & SPIRITS GROUP CORP, OAKDALE, NY. FILED 2-21-2012.

Vintage Rockefeller

THE MARK CONSISTS OF STANDARD CHARACTERS WITHOUT CLAIM TO ANY PARTICULAR FONT, STYLE, SIZE, OR COLOR.

FOR SPARKLING WINES (U.S. CLS. 47 AND 49).
ALLISON SCHRODY, EXAMINING ATTORNEY

CLASS 33—(Continued).

SN 85-552,063. NAKEISHA BROOKS, CHICAGO, IL. AND MARK GRENT, CHICAGO, IL. FILED 2-24-2012.



NO CLAIM IS MADE TO THE EXCLUSIVE RIGHT TO USE "PUNCH", APART FROM THE MARK AS SHOWN.

THE COLOR(S) GREEN, BLACK, WHITE, GRAY, RED, AND YELLOW IS/ARE CLAIMED AS A FEATURE OF THE MARK.

THE MARK CONSISTS OF A RECTANGLE WITH A GREEN BACKGROUND CONTAINING A LARGE CIRCLE IN THE CENTER OF THE RECTANGLE WHOSE VERTICAL DIAMETER EXTENDS FROM THE TOP EDGE TO THE BOTTOM EDGE OF THE RECTANGLE AND WHOSE HORIZONTAL DIAMETER LEAVES A SMALL SPACE BETWEEN THE RESPECTIVE LEFT AND RIGHT EDGES OF THE RECTANGLE AND CIRCLE; THE LARGE CIRCLE CONTAINS A SMALL CIRCLE WITHIN IT; THE SPACE BETWEEN THE LARGE AND SMALL CIRCLES IS FILLED WITH A REPEATING PATTERN OF THIN WHITE AND THICK BLACK STRAIGHT LINES CONNECTING THE EDGES OF THE CIRCLES; THE SMALLER CIRCLE IS FILLED WITH COLORED LAYERS IN THE ORDER OF BLACK, RED, YELLOW, GREEN AND BLACK; THE TOP BLACK LAYER OF COLOR CONTAINS TWO RED CIRCLES, ONE RED HEART, ONE RED HALF CIRCLE, AND ONE SMALL YELLOW CIRCLE; THE RED LAYER CONTAINS FOUR SMALL, YELLOW CIRCLES OF VARIOUS SIZES; THE GREEN LAYER CONTAINS ONE SMALL YELLOW CIRCLE; THE BOTTOM BLACK LAYER CONTAINS TWO SMALL GREEN CIRCLES; 4 BLACK AND WHITE PALM TREES (IN THE ORDER OF BLACK, WHITE, WHITE, BLACK) OVERLAY ON TOP OF THE LOWER YELLOW, GREEN, AND BLACK COLORED LAYERS; A WHITE PATTERNED BANNER WITH "RASTA LOVE PUNCH" IN BLACK CAPITAL LETTERS OVERLAYS THE BOTTOM OF THE CIRCLES; AND THE OUTER EDGE OF THE LARGE CIRCLE CONTAINS GRAY ORNAMENTAL LINES.

FOR ALCOHOLIC BEVERAGES CONTAINING FRUIT; ALCOHOLIC BEVERAGES EXCEPT BEERS; ALCOHOLIC BEVERAGES OF FRUIT; ALCOHOLIC BEVERAGES, NAMELY, NATURAL BLENDED FRUIT JUICES COMBINED WITH RUM; ALCOHOLIC FRUIT COCKTAIL DRINKS; ALCOHOLIC MIXED BEVERAGES EXCEPT BEERS; ALCOHOLIC PUNCH; ALCOHOLIC PUNCHES; PREPARED ALCOHOLIC COCKTAIL; SPIRITS (U.S. CLS. 47 AND 49).

FIRST USE 7-1-2007; IN COMMERCE 7-1-2007.
WENDY JUN, EXAMINING ATTORNEY

CLASS 33—(Continued).

SN 85-555,816. PARAMOUNT DISTILLERS, INC., CLEVELAND, OH. FILED 2-29-2012.

STRAIGHT WESTERN

THE MARK CONSISTS OF STANDARD CHARACTERS WITHOUT CLAIM TO ANY PARTICULAR FONT, STYLE, SIZE, OR COLOR.

NO CLAIM IS MADE TO THE EXCLUSIVE RIGHT TO USE "STRAIGHT", APART FROM THE MARK AS SHOWN. FOR ALCOHOLIC BEVERAGES EXCEPT BEER (U.S. CLS. 47 AND 49).

FIRST USE 10-12-1967; IN COMMERCE 10-12-1967.
ELLEN PERKINS, EXAMINING ATTORNEY

SN 85-558,127. LION'S CATHEDRAL PRODUCTIONS, LLC, DBA ART OF THE DRINK, NEW YORK, NY. FILED 3-1-2012.

NUPTINI

THE MARK CONSISTS OF STANDARD CHARACTERS WITHOUT CLAIM TO ANY PARTICULAR FONT, STYLE, SIZE, OR COLOR.

FOR PREPARED ALCOHOLIC COCKTAIL (U.S. CLS. 47 AND 49).

FIRST USE 6-1-2011; IN COMMERCE 6-1-2011.
APRIL HESIK, EXAMINING ATTORNEY

CLASS 33—(Continued).

SN 85-572,780. HOKKAIDO MUMINMURA CO., LTD., DBA HOKKAIDO MUMINMURA CO., LTD., ASAHIKAWA HOKKAIDO, JAPAN, FILED 3-19-2012.



THE COLOR(S) WHITE AND BLUE IS/ARE CLAIMED AS A FEATURE OF THE MARK.

THE MARK CONSISTS OF THE WHITE WORD "IKI", ABOVE WHITE NON-LATIN CHARACTERS, ABOVE "[COOL]" IN WHITE ABOVE A WHITE MOUNTAIN ALL ON A BLUE BACKGROUND.

THE ENGLISH TRANSLATION OF "IKI" IN THE MARK IS "COOL".

THE NON-LATIN CHARACTERS IN THE MARK TRANSLITERATE TO "IKI" AND THIS MEANS "COOL" IN ENGLISH.

FOR SAKE (U.S. CLS. 47 AND 49).

FIRST USE 1-6-2012; IN COMMERCE 2-15-2012.

BRENDAN MCCAULEY, EXAMINING ATTORNEY

SN 85-572,823. LEDAIN, ULISES, AVENTURA, FL. FILED 3-19-2012.

DOMA VALLEY

THE MARK CONSISTS OF STANDARD CHARACTERS WITHOUT CLAIM TO ANY PARTICULAR FONT, STYLE, SIZE, OR COLOR.

THE ENGLISH TRANSLATION OF "DOMA" IN THE MARK IS DRESSAGE.

FOR WINES (U.S. CLS. 47 AND 49).

TIMOTHY FINNEGAN, EXAMINING ATTORNEY

CLASS 33—(Continued).

SN 85-575,171. BEVERAGE VENTURES, INC., ORANGE, CA.
FILED 3-20-2012.



NO CLAIM IS MADE TO THE EXCLUSIVE RIGHT TO USE "IRISH" OR "FLAVOUR INFUSED WHISKEY", APART FROM THE MARK AS SHOWN.

THE COLOR(S) BLACK, KELLY GREEN AND GOLD IS/ARE CLAIMED AS A FEATURE OF THE MARK.

THE MARK CONSISTS OF A KELLY GREEN THREE LEAF CLOVER BELOW THE WORD "HOOLIGAN'S", IN GOLD, AND ABOVE THE WORD "IRISH", ALSO IN GOLD. UNDERNEATH "IRISH" ARE THE WORDS "FLAVOUR INFUSED WHISKEY", IN GOLD SCRIPT, ALL ON A BLACK BACKGROUND.

FOR ALCOHOLIC BEVERAGES EXCEPT BEERS (U.S. CLS. 47 AND 49).

JULIE VEPPUMTHARA, EXAMINING ATTORNEY

SN 85-575,389. DIFFUSION GEORGES VESSELLE, BOUZY, FRANCE, FILED 3-21-2012.

A.J. de MARGERIE

THE MARK CONSISTS OF STANDARD CHARACTERS WITHOUT CLAIM TO ANY PARTICULAR FONT, STYLE, SIZE, OR COLOR.

OWNER OF FRANCE REG. NO. 1311770, DATED 6-6-1985, EXPIRES 6-6-2015.

THE NAME(S), PORTRAIT(S), AND/OR SIGNATURE(S) SHOWN IN THE MARK DOES NOT IDENTIFY A PARTICULAR LIVING INDIVIDUAL.

FOR ALCOHOLIC BEVERAGES EXCEPT BEER (U.S. CLS. 47 AND 49).

ROBERT STRUCK, EXAMINING ATTORNEY

CLASS 33—(Continued).

SN 85-576,775. HITE USA, INC., DBA HITE USA, LOS ANGELES, CA. FILED 3-22-2012.

CHAM COOL

THE MARK CONSISTS OF STANDARD CHARACTERS WITHOUT CLAIM TO ANY PARTICULAR FONT, STYLE, SIZE, OR COLOR.

FOR SOJU, NAMELY, AN IMPORTED KOREAN ALCOHOLIC BEVERAGE THAT CONTAINS NOT MORE THAN 24 PERCENT OF ALCOHOL BY VOLUME AND IS DERIVED FROM AGRICULTURAL PRODUCTS; DISTILLED SPIRITS (U.S. CLS. 47 AND 49).

RAMONA ORTIGA, EXAMINING ATTORNEY

SN 85-586,205. CORPORACION SANCHEZ CARRASCAL, S.L., VALENCIA, SPAIN, FILED 4-2-2012.



THE COLOR(S) WHITE, PURPLE AND GOLD IS/ARE CLAIMED AS A FEATURE OF THE MARK.

THE MARK CONSISTS OF A RECTANGLE WITH THE WHITE BACKGROUND THAT CONTAINS ON THE LEFT A SOIL DIVIDED IN THE COLORS PURPLE AND GOLD SEPARATED BY A CURVED WHITE LINE WITH ROOTS EXTENDING FROM THE TOP LEFT AND ON THE RIGHT SIDE THE LETTERS "SANCHEZ CARRASCAL" IN PURPLE AND GOLD.

FOR WINE (U.S. CLS. 47 AND 49).

SHANNON TWOHIG, EXAMINING ATTORNEY

SN 85-587,227. NTH DEGREE DISTILLING, LLC, PROSPECT, KY. FILED 4-3-2012.

HONEY I DO

THE MARK CONSISTS OF STANDARD CHARACTERS WITHOUT CLAIM TO ANY PARTICULAR FONT, STYLE, SIZE, OR COLOR.

NO CLAIM IS MADE TO THE EXCLUSIVE RIGHT TO USE "HONEY", APART FROM THE MARK AS SHOWN.

FOR ALCOHOLIC BEVERAGES, NAMELY, DISTILLED SPIRITS (U.S. CLS. 47 AND 49).

ROBERT STRUCK, EXAMINING ATTORNEY

CLASS 33—(Continued).

SN 85-590,015. FROST, CHARLES L., CLAREMONT, CA. FILED 4-5-2012.



NO CLAIM IS MADE TO THE EXCLUSIVE RIGHT TO USE "TROPICAL RUM PUNCH", APART FROM THE MARK AS SHOWN.

THE STIPPLING IS FOR SHADING PURPOSES ONLY.

THE NAME(S), PORTRAIT(S), AND/OR SIGNATURE(S) SHOWN IN THE MARK DOES NOT IDENTIFY A PARTICULAR LIVING INDIVIDUAL.

THE MARK CONSISTS OF THE WORD "CHARLEY" AT THE TOP IN A CURVED ARCH. THE CENTER CONTAINS A LADY SITTING ON A SURFBOARD WEARING A POLKA-DOT BIKINI WITH A TROPICAL FLOWER IN HER HAIR. SURROUNDING HER ARE VARIOUS TROPICAL FLOWERS AND TWELVE SMALL PALM TREES; OF WHICH SIX ARE ON EITHER SIDE OF HER. AT THE BOTTOM IS THE WORD "MARLEY" WHICH IS DEPICTED IN AN INVERSE ARCH. AT THE VERY BOTTOM, IN SMALLER BOLD PRINT, ARE THE WORDS "A FINE TROPICAL RUM PUNCH".

FOR ALCOHOLIC PUNCH (U.S. CLS. 47 AND 49).

FIRST USE 1-1-2011; IN COMMERCE 1-1-2011.

WANDA KAY PRICE, EXAMINING ATTORNEY

SN 85-592,202. THE 86 COMPANY, NEW YORK, NY. FILED 4-9-2012.

HABLAMOS

THE MARK CONSISTS OF STANDARD CHARACTERS WITHOUT CLAIM TO ANY PARTICULAR FONT, STYLE, SIZE, OR COLOR.

THE ENGLISH TRANSLATION OF "HABLAMOS" IS "WE TALK".

FOR TEQUILA (U.S. CLS. 47 AND 49).

BRIAN PINO, EXAMINING ATTORNEY

CLASS 33—(Continued).

SN 85-592,626. THE 86 COMPANY, NEW YORK, NY. FILED 4-9-2012.

CABEZA

THE MARK CONSISTS OF STANDARD CHARACTERS WITHOUT CLAIM TO ANY PARTICULAR FONT, STYLE, SIZE, OR COLOR.

THE ENGLISH TRANSLATION OF "CABEZA" IS "HEAD".

FOR TEQUILA (U.S. CLS. 47 AND 49).

BRIAN PINO, EXAMINING ATTORNEY

SN 85-593,228. A&S BREWING COLLABORATIVE LLC, BURLINGTON, VT. FILED 4-10-2012.



OWNER OF U.S. REG. NO. 3,727,843.

NO CLAIM IS MADE TO THE EXCLUSIVE RIGHT TO USE "BREWERY", APART FROM THE MARK AS SHOWN.

THE MARK CONSISTS OF THE TOP OF A BUILDING, SITTING ON CLOUDS, WITH AN ANGEL HALO AND RAYS OF SUNLIGHT SURROUNDING THE BUILDING APPEARING ABOVE THE STYLIZED WORDS "ANGEL CITY BREWERY".

FOR HARD CIDER (U.S. CLS. 47 AND 49).

RICHARD WHITE, EXAMINING ATTORNEY

SN 85-594,270. HANZELL VINEYARDS, LTD., SONOMA, CA. FILED 4-11-2012.

SESSIONS VINEYARD

THE MARK CONSISTS OF STANDARD CHARACTERS WITHOUT CLAIM TO ANY PARTICULAR FONT, STYLE, SIZE, OR COLOR.

NO CLAIM IS MADE TO THE EXCLUSIVE RIGHT TO USE "VINEYARD", APART FROM THE MARK AS SHOWN.

FOR WINE (U.S. CLS. 47 AND 49).

BRENDAN REGAN, EXAMINING ATTORNEY

CLASS 33—(Continued).

SN 85-594,275. HANZELL VINEYARDS, LTD., SONOMA, CA.
FILED 4-11-2012.

DAY VINEYARD

THE MARK CONSISTS OF STANDARD CHARACTERS WITHOUT CLAIM TO ANY PARTICULAR FONT, STYLE, SIZE, OR COLOR.

NO CLAIM IS MADE TO THE EXCLUSIVE RIGHT TO USE "VINEYARD", APART FROM THE MARK AS SHOWN. FOR WINE (U.S. CLS. 47 AND 49).
BRENDAN REGAN, EXAMINING ATTORNEY

SN 85-594,276. HANZELL VINEYARDS, LTD., SONOMA, CA.
FILED 4-11-2012.

DE BRYE VINEYARD

THE MARK CONSISTS OF STANDARD CHARACTERS WITHOUT CLAIM TO ANY PARTICULAR FONT, STYLE, SIZE, OR COLOR.

NO CLAIM IS MADE TO THE EXCLUSIVE RIGHT TO USE "VINEYARD", APART FROM THE MARK AS SHOWN. FOR WINE (U.S. CLS. 47 AND 49).
BRENDAN REGAN, EXAMINING ATTORNEY

SN 85-595,540. CHINA MART USA, LLC, LOS ANGELES, CA.
FILED 4-12-2012.



NO CLAIM IS MADE TO THE EXCLUSIVE RIGHT TO USE "GOLDEN STATE GROCERS", APART FROM THE MARK AS SHOWN.

THE COLOR(S) BLUE, RED, AND BLACK IS/ARE CLAIMED AS A FEATURE OF THE MARK.

THE MARK CONSISTS OF SIX BLUE STARS ABOVE TWO RED SWIRLS WITH THE WORDING "GOLDEN STATE GROCERS" IN BLACK IN A SEMICIRCULAR MANNER OVER THE GENERALLY CIRCULAR PRESENTATION OF THE DESIGN ELEMENTS.

FOR WINES AND FORTIFIED WINES (U.S. CLS. 47 AND 49).

FIRST USE 4-11-2012; IN COMMERCE 4-11-2012.
LINDA POWELL, EXAMINING ATTORNEY

CLASS 33—(Continued).

SN 85-596,527. VIENNA DISTRIBUTION, SALEM, OR.
FILED 4-12-2012.



NO CLAIM IS MADE TO THE EXCLUSIVE RIGHT TO USE "OREGON TERRITORY CELLARS", APART FROM THE MARK AS SHOWN.

THE MARK CONSISTS OF THE WORD "OREGON" UNDERSCORED BY THE WORDS "TERRITORY CELLARS" AND OVERSCORED BY A WINE GLASS FILLED WITH A CIRCLE.

FOR WINE (U.S. CLS. 47 AND 49).
FIRST USE 2-1-2012; IN COMMERCE 2-1-2012.
INGRID C. EULIN, EXAMINING ATTORNEY

SN 85-597,095. CHATAM INTERNATIONAL INCORPORATED, WILMINGTON, DE. FILED 4-13-2012.

**FLYING OUT IN SPACE
IMPORTED FROM SWEDEN A
CLOUDBERRY LIQUEUR**

THE MARK CONSISTS OF STANDARD CHARACTERS WITHOUT CLAIM TO ANY PARTICULAR FONT, STYLE, SIZE, OR COLOR.

NO CLAIM IS MADE TO THE EXCLUSIVE RIGHT TO USE "IMPORTED FROM SWEDEN" AND "A CLOUDBERRY LIQUEUR", APART FROM THE MARK AS SHOWN.

FOR LIQUEURS (U.S. CLS. 47 AND 49).
JEAN IM, EXAMINING ATTORNEY

SN 85-597,373. VIÑA DEL NUEVO MUNDO S.A., SANTA CRUZ, CHILE, FILED 4-13-2012.

LAS NIÑAS DE APALTA

THE MARK CONSISTS OF STANDARD CHARACTERS WITHOUT CLAIM TO ANY PARTICULAR FONT, STYLE, SIZE, OR COLOR.

NO CLAIM IS MADE TO THE EXCLUSIVE RIGHT TO USE "APALTA", APART FROM THE MARK AS SHOWN.

THE ENGLISH TRANSLATION OF "LAS NIÑAS DE" IN THE MARK IS "THE GIRLS FROM".

FOR WINES (U.S. CLS. 47 AND 49).
KAREN SEVERSON, EXAMINING ATTORNEY

CLASS 33—(Continued).

SN 85-598,210. HORST, BARBARA A, DENVER, CO. FILED 4-15-2012.

Roxborough Red

THE MARK CONSISTS OF STANDARD CHARACTERS WITHOUT CLAIM TO ANY PARTICULAR FONT, STYLE, SIZE, OR COLOR.

NO CLAIM IS MADE TO THE EXCLUSIVE RIGHT TO USE "RED", APART FROM THE MARK AS SHOWN.

FOR WINES (U.S. CLS. 47 AND 49).

ELISSA GARBER KON, EXAMINING ATTORNEY

SN 85-598,211. HORST, BARBARA A, DENVER, CO. FILED 4-15-2012.

Waterton White

THE MARK CONSISTS OF STANDARD CHARACTERS WITHOUT CLAIM TO ANY PARTICULAR FONT, STYLE, SIZE, OR COLOR.

NO CLAIM IS MADE TO THE EXCLUSIVE RIGHT TO USE "WHITE", APART FROM THE MARK AS SHOWN.

FOR WINES (U.S. CLS. 47 AND 49).

ELISSA GARBER KON, EXAMINING ATTORNEY

SN 85-598,870. PREMIUM BLEND, INC., HIALEAH, FL. FILED 4-16-2012.

VETERANS SALUTE

THE MARK CONSISTS OF STANDARD CHARACTERS WITHOUT CLAIM TO ANY PARTICULAR FONT, STYLE, SIZE, OR COLOR.

FOR WINE (U.S. CLS. 47 AND 49).

EVIN L. KOZAK, EXAMINING ATTORNEY

CLASS 33—(Continued).

SN 85-599,420. PEÑA GOMEZ, CARLOS GUILLERMO, GUADALAJARA, MEXICO, FILED 4-17-2012.

Alarde'

THE MARK CONSISTS OF THE WORD "ALARDE" IN STYLIZED FORM AND DROPLETS NEXT TO THE LETTERS "A" AND "E".

THE ENGLISH TRANSLATION OF "ALARDE" IN THE MARK IS "BOAST".

FOR TEQUILA (U.S. CLS. 47 AND 49).

FIRST USE 3-1-2012; IN COMMERCE 3-1-2012.

AMY KERTGATE, EXAMINING ATTORNEY

SN 85-600,166. REN ACQUISITION, INC., PLYMOUTH, CA. FILED 4-17-2012.



THE MARK CONSISTS OF AN EAGLE AND A WREN WITH A CROWN ON ITS HEAD PERCHED WITHIN THE BRANCHES OF A GRAPEVINE.

FOR WINE (U.S. CLS. 47 AND 49).

VERNA BETH RIRIE, EXAMINING ATTORNEY

SN 85-600,259. THIN AIR DISTILLATION LLC, LAFAYETTE, CO. FILED 4-17-2012.

THIN AIR DISTILLATION

THE MARK CONSISTS OF STANDARD CHARACTERS WITHOUT CLAIM TO ANY PARTICULAR FONT, STYLE, SIZE, OR COLOR.

NO CLAIM IS MADE TO THE EXCLUSIVE RIGHT TO USE "DISTILLATION", APART FROM THE MARK AS SHOWN.

FOR RUM, WHISKEY, BRANDY, FRUIT BRANDY, GIN, VODKA, LIQUEURS, DISTILLED SPIRITS (U.S. CLS. 47 AND 49).

JORDAN BAKER, EXAMINING ATTORNEY

CLASS 33—(Continued).

SN 85-600,324. LAUGHLIN, DUSTIN, NORTH RICHLAND HILLS, TX. FILED 4-17-2012.

Finest Shot In The Game

THE MARK CONSISTS OF STANDARD CHARACTERS WITHOUT CLAIM TO ANY PARTICULAR FONT, STYLE, SIZE, OR COLOR.

FOR SPIRITS; TEQUILA (U.S. CLS. 47 AND 49).
LYNDSEY KUYKENDALL, EXAMINING ATTORNEY

SN 85-600,431. CHECKERBOARD VINEYARDS, LLC, CALISTOGA, CA. FILED 4-17-2012.

NASH CREEK

THE MARK CONSISTS OF STANDARD CHARACTERS WITHOUT CLAIM TO ANY PARTICULAR FONT, STYLE, SIZE, OR COLOR.

OWNER OF U.S. REG. NO. 3,046,553.
FOR WINE (U.S. CLS. 47 AND 49).
MATTHEW KLINE, EXAMINING ATTORNEY

SN 85-600,434. CHECKERBOARD VINEYARDS, LLC, CALISTOGA, CA. FILED 4-17-2012.

CHECKERBOARD

THE MARK CONSISTS OF STANDARD CHARACTERS WITHOUT CLAIM TO ANY PARTICULAR FONT, STYLE, SIZE, OR COLOR.

OWNER OF U.S. REG. NO. 3,077,018.
FOR WINE (U.S. CLS. 47 AND 49).
FIRST USE 11-3-2005; IN COMMERCE 11-3-2005.
MATTHEW KLINE, EXAMINING ATTORNEY

CLASS 33—(Continued).

SN 85-600,560. ROBERT MONTGOMERY, SANTA MONICA, CA. FILED 4-17-2012.

MONTGOMERY VINEYARD

THE MARK CONSISTS OF STANDARD CHARACTERS WITHOUT CLAIM TO ANY PARTICULAR FONT, STYLE, SIZE, OR COLOR.

OWNER OF U.S. REG. NO. 3,682,773.
NO CLAIM IS MADE TO THE EXCLUSIVE RIGHT TO USE "VINEYARD", APART FROM THE MARK AS SHOWN. SEC. 2(F).

FOR WINE (U.S. CLS. 47 AND 49).
FIRST USE 5-0-2010; IN COMMERCE 5-0-2010.
MICHAEL TANNER, EXAMINING ATTORNEY

SN 85-600,986. DANCING PINES DISTILLERY LLC, LOVELAND, CO. FILED 4-18-2012.

Dancing Pines

THE MARK CONSISTS OF STANDARD CHARACTERS WITHOUT CLAIM TO ANY PARTICULAR FONT, STYLE, SIZE, OR COLOR.

FOR DISTILLED SPIRITS (U.S. CLS. 47 AND 49).
FIRST USE 9-3-2010; IN COMMERCE 9-3-2010.
GENE MACIOL, EXAMINING ATTORNEY

SN 85-601,066. RIONDO USA LLC, ALLENDALE, NJ. FILED 4-18-2012.



THE MARK CONSISTS OF THE TEXT "FRIZECCO" IN A STYLIZED FORMATION.

FOR DISTILLED SPIRITS; WINE (U.S. CLS. 47 AND 49).
BRENDAN REGAN, EXAMINING ATTORNEY

CLASS 33—(Continued).

SN 85-601,632. MAGNUS, LLC, FRESNO, CA. FILED 4-18-2012.

GROWLING BEAR

THE MARK CONSISTS OF STANDARD CHARACTERS WITHOUT CLAIM TO ANY PARTICULAR FONT, STYLE, SIZE, OR COLOR.

FOR WINES (U.S. CLS. 47 AND 49).
KIMBERLY PARKS, EXAMINING ATTORNEY

SN 85-602,680. RAVEN'S GLENN LTD., FRESNO, OH. FILED 4-19-2012.



THE MARK CONSISTS OF AN INVERTED T WITH A LONG HORIZONTAL BAR AND A SHORT VERTICAL BAR. THE INVERTED T IS SURROUNDED BY THREE THIN BORDERS. THE WORDS "RIVER GLENN" APPEAR IN DOLPHIN FONT WITHIN THE HORIZONTAL BAR. THE VERTICAL BAR CONTAINS A BOX. THE LETTERS RG APPEAR WITHIN THE BOX.

FOR WINE (U.S. CLS. 47 AND 49).
JOHN GARTNER, EXAMINING ATTORNEY

SN 85-602,757. SOUTHERN LIQUEUR COMPANY LIMITED, STELLENBOSCH, SOUTH AFRICA. FILED 4-19-2012.

THE SPIRIT OF AFRICA

THE MARK CONSISTS OF STANDARD CHARACTERS WITHOUT CLAIM TO ANY PARTICULAR FONT, STYLE, SIZE, OR COLOR.

NO CLAIM IS MADE TO THE EXCLUSIVE RIGHT TO USE "AFRICA", APART FROM THE MARK AS SHOWN.
FOR LIQUEUR (U.S. CLS. 47 AND 49).
FIRST USE 6-0-2010; IN COMMERCE 6-0-2010.
TASHIA BUNCH, EXAMINING ATTORNEY

CLASS 33—(Continued).

SN 85-603,153. HASKELL'S, INC., MINNEAPOLIS, MN. FILED 4-19-2012.

KOALA RANCH

THE MARK CONSISTS OF STANDARD CHARACTERS WITHOUT CLAIM TO ANY PARTICULAR FONT, STYLE, SIZE, OR COLOR.

NO CLAIM IS MADE TO THE EXCLUSIVE RIGHT TO USE "RANCH", APART FROM THE MARK AS SHOWN.
FOR WINES (U.S. CLS. 47 AND 49).
FIRST USE 4-0-2004; IN COMMERCE 4-0-2004.
DORITT L. CARROLL, EXAMINING ATTORNEY

SN 85-603,174. HIGH WEST DISTILLERY, SALT LAKE CITY, UT. FILED 4-19-2012.

Son Of Bourye

THE MARK CONSISTS OF STANDARD CHARACTERS WITHOUT CLAIM TO ANY PARTICULAR FONT, STYLE, SIZE, OR COLOR.

FOR WHISKEY (U.S. CLS. 47 AND 49).
FIRST USE 10-17-2011; IN COMMERCE 10-17-2011.
DAWN FELDMAN, EXAMINING ATTORNEY

SN 85-603,724. ROWDY RED WINE COMPANY LLC, BURBANK, CA. FILED 4-20-2012.

VANISHING POINT

THE MARK CONSISTS OF STANDARD CHARACTERS WITHOUT CLAIM TO ANY PARTICULAR FONT, STYLE, SIZE, OR COLOR.

FOR WINE (U.S. CLS. 47 AND 49).
MARC LEIPZIG, EXAMINING ATTORNEY

CLASS 33—(Continued).

SN 85-603,879. BOO YA L.L.C., DEERFIELD BEACH, FL. FILED 4-20-2012.

BOOYA

THE MARK CONSISTS OF STANDARD CHARACTERS WITHOUT CLAIM TO ANY PARTICULAR FONT, STYLE, SIZE, OR COLOR.

OWNER OF U.S. REG. NO. 3,599,105. FOR WINE AND CIDER (U.S. CLS. 47 AND 49). HEATHER SAPP, EXAMINING ATTORNEY

SN 85-604,830. FLC HOLDINGS, LLC, DOVER, DE. FILED 4-22-2012.

Clarion

THE MARK CONSISTS OF STANDARD CHARACTERS WITHOUT CLAIM TO ANY PARTICULAR FONT, STYLE, SIZE, OR COLOR.

FOR SPIRITS, NAMELY WHISKY AND BOURBON WHISKY (U.S. CLS. 47 AND 49). JACLYN KIDWELL WALKER, EXAMINING ATTORNEY

SN 85-605,070. ROTELLA HOLDINGS LLC, NAPLES, FL. FILED 4-23-2012.

VITAMIN V VODKA

THE MARK CONSISTS OF STANDARD CHARACTERS WITHOUT CLAIM TO ANY PARTICULAR FONT, STYLE, SIZE, OR COLOR.

NO CLAIM IS MADE TO THE EXCLUSIVE RIGHT TO USE "VODKA", APART FROM THE MARK AS SHOWN. FOR VODKA (U.S. CLS. 47 AND 49). KELLEY WELLS, EXAMINING ATTORNEY

CLASS 33—(Continued).

SN 85-607,740. GREENBRIER IA, INC., WHITE SULPHUR SPRING, WV. FILED 4-25-2012.

Springs Est. 1778

THE MARK CONSISTS OF STANDARD CHARACTERS WITHOUT CLAIM TO ANY PARTICULAR FONT, STYLE, SIZE, OR COLOR.

NO CLAIM IS MADE TO THE EXCLUSIVE RIGHT TO USE "EST. 1778", APART FROM THE MARK AS SHOWN. FOR VODKA, GIN, RUM, BOURBON, TEQUILA (U.S. CLS. 47 AND 49).

CHRISTINA SOBRAL, EXAMINING ATTORNEY

SN 85-608,073. GREENBRIER IA, INC., WHITE SULPHUR SPRING, WV. FILED 4-25-2012.

Springs
Est.
1778

NO CLAIM IS MADE TO THE EXCLUSIVE RIGHT TO USE "EST. 1778", APART FROM THE MARK AS SHOWN.

THE MARK CONSISTS OF THE WORD "SPRINGS" OVER THE ABBREVIATION "EST." OVER THE NUMBER "1778". FOR VODKA; RUM; GIN; BOURBON (U.S. CLS. 47 AND 49).

CHRISTINA SOBRAL, EXAMINING ATTORNEY

SN 85-609,514. LICORES BAINES SA, 31013PAMPLONA, NAVARRA, SPAIN, FILED 4-26-2012.

WILD DREAM

THE MARK CONSISTS OF STANDARD CHARACTERS WITHOUT CLAIM TO ANY PARTICULAR FONT, STYLE, SIZE, OR COLOR.

FOR ALCOHOLIC BEVERAGES EXCEPT BEERS (U.S. CLS. 47 AND 49). FIRST USE 3-26-2012; IN COMMERCE 4-10-2012. ALEX KEAM, EXAMINING ATTORNEY

CLASS 33—(Continued).

SN 85-610,106. ABC LIQUORS, INC., ORLANDO, FL. FILED 4-27-2012.

MEXICAN SUNRISE

THE MARK CONSISTS OF STANDARD CHARACTERS WITHOUT CLAIM TO ANY PARTICULAR FONT, STYLE, SIZE, OR COLOR.

SEC. 2(F).
FOR LIQUOR, NAMELY, TEQUILA (U.S. CLS. 47 AND 49).

FIRST USE 6-18-1980; IN COMMERCE 6-18-1980.
MARK RADEMACHER, EXAMINING ATTORNEY

CLASS 33—(Continued).

SN 85-627,429. LEDAIN, ULISES, AVENTURA, FL. FILED 5-16-2012.

DOMA

THE MARK CONSISTS OF STANDARD CHARACTERS WITHOUT CLAIM TO ANY PARTICULAR FONT, STYLE, SIZE, OR COLOR.

THE ENGLISH TRANSLATION OF "DOMA" IN THE MARK IS "DRESSAGE".

FOR WINE (U.S. CLS. 47 AND 49).
TIMOTHY FINNEGAN, EXAMINING ATTORNEY

SN 85-612,706. GLICKMAN, MICHAEL, NEW YORK, NY. FILED 4-30-2012.

PopShots

THE MARK CONSISTS OF STANDARD CHARACTERS WITHOUT CLAIM TO ANY PARTICULAR FONT, STYLE, SIZE, OR COLOR.

FOR BLENDED SPIRITS; BLENDED WHISKY; BRANDY SPIRITS; CHINESE MIXED LIQUOR (WUJIAPIE-JIU); CHINESE SPIRIT OF SORGHUM (GAOLIAN-JIU); CHINESE WHITE LIQUOR (BAIGANR); DISTILLED SPIRITS; DISTILLED SPIRITS OF RICE (AWAMORI); DISTILLED SPIRITS OF RICE, CORN, BARLEY, POTATO, SUGARCANE, MOLASSES; POTABLE SPIRITS; SHOCHU (SPIRITS); SPIRITS; SPIRITS AND LIQUEURS (U.S. CLS. 47 AND 49).

SUE LAWRENCE, EXAMINING ATTORNEY

SN 85-633,107. CHATAM INTERNATIONAL INCORPORATED, WILMINGTON, DE. FILED 5-23-2012.

DREAM CATCHER THE IRISH DREAM

THE MARK CONSISTS OF STANDARD CHARACTERS WITHOUT CLAIM TO ANY PARTICULAR FONT, STYLE, SIZE, OR COLOR.

OWNER OF U.S. REG. NOS. 2,926,515 AND 4,031,937.
FOR DISTILLED SPIRITS; LIQUEURS (U.S. CLS. 47 AND 49).

JEAN IM, EXAMINING ATTORNEY

SN 85-616,553. COASTAL WINE MERCHANT, DBA COASTAL INDUSTRIAL PARTNERS, SAN FRANCISCO, CA. FILED 5-4-2012.

Soaring High

THE MARK CONSISTS OF STANDARD CHARACTERS WITHOUT CLAIM TO ANY PARTICULAR FONT, STYLE, SIZE, OR COLOR.

FOR WINES (U.S. CLS. 47 AND 49).

GRETCHEN ULRICH, EXAMINING ATTORNEY

SN 85-635,151. DIAGEO NORTH AMERICA, INC., NORWALK, CT. FILED 5-25-2012.

SMIRNOFF SORBET

THE MARK CONSISTS OF STANDARD CHARACTERS WITHOUT CLAIM TO ANY PARTICULAR FONT, STYLE, SIZE, OR COLOR.

OWNER OF U.S. REG. NOS. 513,428, 2,686,697 AND 3,589,789.

FOR VODKA-BASED ALCOHOLIC BEVERAGES (U.S. CLS. 47 AND 49).

CHRISTINA SOBRAL, EXAMINING ATTORNEY

CLASS 33—(Continued).

SN 85-655,080. DIAGEO NORTH AMERICA, INC., NORWALK, CT. FILED 6-19-2012.



THE MARK CONSISTS OF A SEAHORSE IN A MOSAIC DESIGN.
FOR ALCOHOLIC BEVERAGES EXCEPT BEERS (U.S. CLS. 47 AND 49).
CHRISTINA SOBRAL, EXAMINING ATTORNEY

SN 85-655,081. DIAGEO NORTH AMERICA, INC., NORWALK, CT. FILED 6-19-2012.

BLUECREST

THE MARK CONSISTS OF THE TERM "BLUECREST" IN A STYLIZED FONT.
FOR ALCOHOLIC BEVERAGES EXCEPT BEERS (U.S. CLS. 47 AND 49).
CHRISTINA SOBRAL, EXAMINING ATTORNEY

SN 85-656,163. DIAGEO NORTH AMERICA, INC., NORWALK, CT. FILED 6-19-2012.

BLUECREST

THE MARK CONSISTS OF STANDARD CHARACTERS WITHOUT CLAIM TO ANY PARTICULAR FONT, STYLE, SIZE, OR COLOR.
FOR ALCOHOLIC BEVERAGES EXCEPT BEERS (U.S. CLS. 47 AND 49).
CHRISTINA SOBRAL, EXAMINING ATTORNEY

CLASS 33—(Continued).

SN 85-656,568. DIAGEO NORTH AMERICA, INC., NORWALK, CT. FILED 6-20-2012.

STE PIERRE SMIRNOFF FLS

THE MARK CONSISTS OF STANDARD CHARACTERS WITHOUT CLAIM TO ANY PARTICULAR FONT, STYLE, SIZE, OR COLOR.

OWNER OF U.S. REG. NOS. 513,428, 1,253,139 AND OTHERS.

THE NAME(S), PORTRAIT(S), AND/OR SIGNATURE(S) SHOWN IN THE MARK DOES NOT IDENTIFY A PARTICULAR LIVING INDIVIDUAL.

FOR ALCOHOLIC BEVERAGES EXCEPT BEERS (U.S. CLS. 47 AND 49).

FIRST USE 3-17-1934; IN COMMERCE 3-17-1934.
CHRISTINA SOBRAL, EXAMINING ATTORNEY

SN 85-665,907. ORTIZ, SAL, CHINO, CA. FILED 6-29-2012.

Rex Vodka

THE MARK CONSISTS OF STANDARD CHARACTERS WITHOUT CLAIM TO ANY PARTICULAR FONT, STYLE, SIZE, OR COLOR.

NO CLAIM IS MADE TO THE EXCLUSIVE RIGHT TO USE "VODKA", APART FROM THE MARK AS SHOWN.

FOR DISTILLED SPIRITS; LIQUOR; LIQUOR AND LIQUEUR BEVERAGES, NAMELY, VODKA; SPIRITS; VODKA (U.S. CLS. 47 AND 49).

RONALD MCMORROW, EXAMINING ATTORNEY

SN 85-665,970. ORTIZ, SAL, CHINO, CA. FILED 6-29-2012.

King Rex Vodka

THE MARK CONSISTS OF STANDARD CHARACTERS WITHOUT CLAIM TO ANY PARTICULAR FONT, STYLE, SIZE, OR COLOR.

NO CLAIM IS MADE TO THE EXCLUSIVE RIGHT TO USE "VODKA", APART FROM THE MARK AS SHOWN.

FOR DISTILLED SPIRITS; LIQUOR; LIQUOR AND LIQUEUR BEVERAGES, NAMELY, VODKA; VODKA (U.S. CLS. 47 AND 49).

RONALD MCMORROW, EXAMINING ATTORNEY

CLASS 33—(Continued).

SN 85-666,010. ORTIZ, SAL, CHINO, CA. FILED 6-29-2012.

King Rex Bourbon

THE MARK CONSISTS OF STANDARD CHARACTERS WITHOUT CLAIM TO ANY PARTICULAR FONT, STYLE, SIZE, OR COLOR.

NO CLAIM IS MADE TO THE EXCLUSIVE RIGHT TO USE "BOURBON", APART FROM THE MARK AS SHOWN. FOR BOURBON; DISTILLED SPIRITS; LIQUOR; LIQUOR AND LIQUEUR BEVERAGES, NAMELY, BOURBON (U.S. CLS. 47 AND 49).

RONALD MCMORROW, EXAMINING ATTORNEY

SN 85-667,062. DIAGEO NORTH AMERICA, INC., NORWALK, CT. FILED 7-2-2012.



OWNER OF U.S. REG. NOS. 513,428, 4,151,609 AND OTHERS.

THE MARK CONSISTS OF A STYLIZED ARCHED BANNER DISPLAYING THE WORD "SMIRNOFF". FOR ALCOHOLIC BEVERAGES EXCEPT BEERS (U.S. CLS. 47 AND 49).

FIRST USE 12-31-1958; IN COMMERCE 12-31-1958. CHRISTINA SOBRAL, EXAMINING ATTORNEY

SN 85-667,887. BRONCO WINE COMPANY, CERES, CA. FILED 7-3-2012.

THREE ROCKS

THE MARK CONSISTS OF STANDARD CHARACTERS WITHOUT CLAIM TO ANY PARTICULAR FONT, STYLE, SIZE, OR COLOR.

FOR WINE (U.S. CLS. 47 AND 49). GRETCHEN ULRICH, EXAMINING ATTORNEY

CLASS 33—(Continued).

SN 85-682,604. COURVOISIER S.A.S., JARNAC, FRANCE, FILED 7-20-2012.

COURVOISIOLOGY

THE MARK CONSISTS OF STANDARD CHARACTERS WITHOUT CLAIM TO ANY PARTICULAR FONT, STYLE, SIZE, OR COLOR.

OWNER OF U.S. REG. NOS. 311,352, 4,084,283 AND OTHERS.

FOR ALCOHOLIC BEVERAGES EXCEPT BEERS (U.S. CLS. 47 AND 49).

DAVID YONTEF, EXAMINING ATTORNEY

CLASS 34—SMOKERS' ARTICLES

SN 79-106,981. RICHMOND TOBACCO TRADING LIMITED, UNITED KINGDOM, FILED 8-31-2011.



OWNER OF INTERNATIONAL REGISTRATION 1101121 DATED 8-31-2011, EXPIRES 8-31-2021.

THE COLOR(S) MAROON, BLACK, BURGUNDY, BRIGHT RED, YELLOW AND BEIGE IS/ARE CLAIMED AS A FEATURE OF THE MARK.

THE MARK CONSISTS OF A YELLOW RECTANGLE WITH AN OVERALL RECTANGULAR SHAPE IN MAROON, BURGUNDY, AND BLACK WITH A BLACK AND BEIGE BORDER FEATURING A BRIGHT RED SHIELD

CLASS 34—(Continued).

WITH BEIGE VINE AND UNICORN DESIGNS SURROUNDING IT AND A BLACK BORDER ABOVE A BRIGHT RED SHIELD CONTAINING A STYLIZED BEIGE "R" WITH A BEIGE CROWN ON TOP BORDERED IN BLACK WITH THREE OVERLAPPING BEIGE CIRCLES ON EACH SIDE BORDERED IN BLACK. BELOW THE SHIELD AND CIRCLES IS A BEIGE, YELLOW AND BLACK BANNER CONTAINING THE STYLIZED BEIGE WORDING "AROMA RICH" WITH A BLACK BORDER. AT THE BOTTOM IS ANOTHER BEIGE BANNER WITH A BLACK BORDER.

FOR ABSORBENT PAPER FOR TOBACCO PIPES; CIGARETTE PAPER; LIGHTERS FOR SMOKERS; TOBACCO POUCHES; BOOKS OF CIGARETTE PAPERS; HUMIDORS; MATCH BOXES; CIGAR HOLDERS; CIGARETTE HOLDERS; MOUTHPIECES FOR CIGARETTE HOLDERS; MOUTHPIECES OF YELLOW AMBER FOR CIGAR AND CIGARETTE HOLDERS; CIGARETTES; CIGARETTES CONTAINING TOBACCO SUBSTITUTES, NOT FOR MEDICAL PURPOSES; CIGARILLOS; CIGARS; TOBACCO; CHEWING TOBACCO; SNUFF; SNUFF BOXES; HERBS FOR SMOKING; TOBACCO PIPES; POCKET MACHINES FOR ROLLING CIGARETTES; CIGARETTE FILTERS; CIGARETTE TIPS; CIGAR CASES; CIGARETTE CASES (U.S. CLS. 2, 8, 9 AND 17).

KRISTINA MORRIS, EXAMINING ATTORNEY

SN 85-336,322. RODRIGO CIGARS, INC., BETHEL PARK, PA. AND RODRIGUEZ, GEORGE L., PITTSBURGH, PA. FILED 6-2-2011.



NO CLAIM IS MADE TO THE EXCLUSIVE RIGHT TO USE "HANDMADE ULTRA PREMIUM", APART FROM THE MARK AS SHOWN.

THE MARK CONSISTS OF THREE TOBACCO LEAVES GATHERED OVER A FIVE POINT STAR GUARDED BY TWO LIONS ON EITHER SIDE WITH LARGE TOBACCO LEAF TAILS. THE WORDMARK "RODRIGO" APPEARS BELOW THE GRAPHIC LOGO IMAGE AND "HANDMADE ULTRA PREMIUM" APPEARS AT THE BOTTOM OF THE MARK BELOW "RODRIGO".

FOR CIGARS (U.S. CLS. 2, 8, 9 AND 17).

FIRST USE 9-8-2010; IN COMMERCE 10-8-2010.

DEBORAH MEINERS, EXAMINING ATTORNEY

SN 85-441,695. LEVYTSKYI, OLEG, BROOKLYN, NY. AND MORDARSKAIA, NATALIA, BROOKLYN, NY. AND LEVYTSKYI, STANISLAV, ODESSA, UKRAINE, FILED 10-7-2011.

BLANKS

THE MARK CONSISTS OF STANDARD CHARACTERS WITHOUT CLAIM TO ANY PARTICULAR FONT, STYLE, SIZE, OR COLOR.

FOR ROLLING TOBACCO, NAMELY, PRE-ROLLED SMOKING TUBES (U.S. CLS. 2, 8, 9 AND 17).

LOURDES AYALA, EXAMINING ATTORNEY

CLASS 34—(Continued).

SN 85-443,026. K. HANSOTIA & CO., INC., MIAMI, FL. FILED 10-10-2011.

HELL

THE MARK CONSISTS OF STANDARD CHARACTERS WITHOUT CLAIM TO ANY PARTICULAR FONT, STYLE, SIZE, OR COLOR.

FOR CIGARS (U.S. CLS. 2, 8, 9 AND 17).

NAKIA HENRY, EXAMINING ATTORNEY

SN 85-443,031. K. HANSOTIA & CO., INC., MIAMI, FL. FILED 10-10-2011.

MARQUIS DE SADE

THE MARK CONSISTS OF STANDARD CHARACTERS WITHOUT CLAIM TO ANY PARTICULAR FONT, STYLE, SIZE, OR COLOR.

THE NAME(S), PORTRAIT(S), AND/OR SIGNATURE(S) SHOWN IN THE MARK DOES NOT IDENTIFY A PARTICULAR LIVING INDIVIDUAL.

THE WORDING "MARQUIS DE SADE" HAS NO MEANING IN A FOREIGN LANGUAGE.

FOR CIGARS (U.S. CLS. 2, 8, 9 AND 17).

NAKIA HENRY, EXAMINING ATTORNEY

SN 85-447,191. HUMICON LLC, HAUPPAUGE, NY. FILED 10-13-2011.

FOYLE

THE MARK CONSISTS OF STANDARD CHARACTERS WITHOUT CLAIM TO ANY PARTICULAR FONT, STYLE, SIZE, OR COLOR.

FOR CIGAR BOXES; CIGARS (U.S. CLS. 2, 8, 9 AND 17).

FIRST USE 2-6-2012; IN COMMERCE 2-6-2012.

ARETHA SOMERVILLE, EXAMINING ATTORNEY

CLASS 34—(Continued).

SN 85-468,914. THE 101 CORPORATION, LOS ANGELES, CA. FILED 11-9-2011.

DARUMA

THE MARK CONSISTS OF STANDARD CHARACTERS WITHOUT CLAIM TO ANY PARTICULAR FONT, STYLE, SIZE, OR COLOR.

FOR CIGARS, CIGARETTES, HUMIDORS, CIGAR AND CIGARETTE LIGHTERS NOT OF PRECIOUS METAL AND NOT FOR AUTOMOBILES, ASHTRAYS NOT OF PRECIOUS METAL; CIGAR AND CIGARETTE LIGHTERS OF PRECIOUS METAL, NOT FOR AUTOMOBILES, AND ASHTRAYS OF PRECIOUS METAL (U.S. CLS. 2, 8, 9 AND 17).

KATHLEEN KOLACZ, EXAMINING ATTORNEY

SN 85-484,550. PREMIER HOLDINGS DISTRIBUTOR LLC, DORAL, FL. FILED 12-1-2011.



THE COLOR(S) BLUE, WHITE AND GRAY IS/ARE CLAIMED AS A FEATURE OF THE MARK.

THE MARK CONSISTS OF THE LETTER "B" IN GRAY INSIDE A WHITE SHIELD BETWEEN TWO WHITE TIGERS WITH CROWNS WITH A BLUE BACKGROUND AND THE WORD "BELLMON" UNDERNEATH IN GRAY WITH SEVEN GRAY STARS IN AN ARCH ABOVE IT.

FOR CIGARETTES (U.S. CLS. 2, 8, 9 AND 17).
FIRST USE 4-0-2011; IN COMMERCE 4-0-2011.
GILBERT SWIFT, EXAMINING ATTORNEY

SN 85-551,999. MANUFACTURA DE TABACOS (MATASA) S.A., MIAMI, FL. FILED 2-24-2012.

VEGA MAGNA

THE MARK CONSISTS OF STANDARD CHARACTERS WITHOUT CLAIM TO ANY PARTICULAR FONT, STYLE, SIZE, OR COLOR.

OWNER OF U.S. REG. NO. 3,573,846.
THE ENGLISH TRANSLATION OF "VEGA MAGNA" IN THE MARK IS "BIG FERTILE MEADOW".
FOR CIGARS (U.S. CLS. 2, 8, 9 AND 17).
ANGELA DUONG, EXAMINING ATTORNEY

CLASS 34—(Continued).

SN 85-572,576. TOKHA DOKHA LLC, NASHVILLE, TN. FILED 3-18-2012.

Tokha Dokha

THE MARK CONSISTS OF STANDARD CHARACTERS WITHOUT CLAIM TO ANY PARTICULAR FONT, STYLE, SIZE, OR COLOR.

NO CLAIM IS MADE TO THE EXCLUSIVE RIGHT TO USE "DOKHA", APART FROM THE MARK AS SHOWN.

FOR ASIAN LONG TOBACCO PIPE SHEATHS; ASIAN LONG TOBACCO PIPES (KISERU); LEAF TOBACCO; PIPE POUCHES; PIPE TOBACCO; ROLL YOUR OWN TOBACCO; ROLLING TOBACCO; SMOKING PIPE CLEANERS; SMOKING PIPES; SMOKING TOBACCO; TOBACCO; TOBACCO FILTERS; TOBACCO PIPE CLEANERS; TOBACCO PIPES; TOBACCO WATER PIPES; TOBACCO, CIGARS AND CIGARETTES (U.S. CLS. 2, 8, 9 AND 17).

MICHELE SWAIN, EXAMINING ATTORNEY

SN 85-598,848. ZAN ENTERPRISES, BIG SANDY, TX. FILED 4-16-2012.

ZANS

THE MARK CONSISTS OF STANDARD CHARACTERS WITHOUT CLAIM TO ANY PARTICULAR FONT, STYLE, SIZE, OR COLOR.

FOR ELECTRONIC CIGARETTES; ELECTRONIC CIGARETTES FOR USE AS AN ALTERNATIVE TO TRADITIONAL CIGARETTES (U.S. CLS. 2, 8, 9 AND 17).

LUCY ARANT, EXAMINING ATTORNEY

CLASS 34—(Continued).

SN 85-604,156. COMPAÑIA INDUSTRIAL DE TABACOS MONTE-PAZ S.A., MONTEVIDEO, URUGUAY, FILED 4-20-2012.



NO CLAIM IS MADE TO THE EXCLUSIVE RIGHT TO USE "XXX AND FILTRO", APART FROM THE MARK AS SHOWN.

THE MARK CONSISTS OF A RECTANGLE, WITH THE WORDS REPUBLICANA IN A STYLIZED FONT ALONG THE LOWER PORTION OF THE LEFT BORDER OF THE RECTANGLE, AND THE WORDS XXX FILTRO IN A STYLIZED FONT LOCATED AT THE BOTTOM RIGHT CORNER OF THE RECTANGLE. SEVERAL VERTICAL LINES ARE LOCATED AT THE CENTER OF THE RECTANGLE, WITH AN IMAGE OF A HAT INSIDE A CLEAR CIRCLE LOCATED AT THE CENTER OF THE VERTICAL LINES.

THE ENGLISH TRANSLATION OF "REPUBLICANA" AND "FILTRO" IN THE MARK IS "REPUBLIC" AND "FILTER".

FOR CIGARETTES (U.S. CLS. 2, 8, 9 AND 17).
JOHN E. MICHOS, EXAMINING ATTORNEY

CLASS 34—(Continued).

SN 85-679,602. ONEIDA INDIAN NATION OF NEW YORK, AKA ONEIDA NATION OF NEW YORK, THE ONEIDA INDIAN NATION OF NEW YORK, THE ONEIDA INDIAN NATION, ONEIDA INDIAN NATION, THE ONEIDA NATION, OR ONEIDA NATION, ONEIDA, NY. FILED 7-17-2012.



THE MARK CONSISTS OF TWO INTERLOCKING STYLIZED LETTERS "S".

FOR TOBACCO PRODUCTS, NAMELY, CIGARETTES (U.S. CLS. 2, 8, 9 AND 17).

KATHLEEN M. VANSTON, EXAMINING ATTORNEY

SN 85-679,669. DREW ESTATE HOLDING COMPANY LLC, MIAMI, FL. FILED 7-17-2012.

SN 85-605,727. EPC IP CO. LLC, MIAMI, FL. FILED 4-23-2012.

Perez-Carrillo

THE MARK CONSISTS OF STANDARD CHARACTERS WITHOUT CLAIM TO ANY PARTICULAR FONT, STYLE, SIZE, OR COLOR.

THE NAME PEREZ-CARRILLO IDENTIFIES A LIVING INDIVIDUAL WHOSE CONSENT IS OF RECORD.

FOR CIGARS (U.S. CLS. 2, 8, 9 AND 17).
ANTHONY RINKER, EXAMINING ATTORNEY

G FRESH

THE MARK CONSISTS OF STANDARD CHARACTERS WITHOUT CLAIM TO ANY PARTICULAR FONT, STYLE, SIZE, OR COLOR.

NO CLAIM IS MADE TO THE EXCLUSIVE RIGHT TO USE "FRESH", APART FROM THE MARK AS SHOWN.

FOR TOBACCO, CIGARS, MASS MARKET CIGARS, CIGARILLOS AND RELATED PRODUCTS, NAMELY, CIGAR BOXES, LIGHTERS AND HOLDERS NOT OF PRECIOUS METAL, ASHTRAYS, CIGAR CUTTERS, HUMIDORS AND CIGAR TUBES (U.S. CLS. 2, 8, 9 AND 17).

FIRST USE 5-11-2012; IN COMMERCE 5-11-2012.
DOMINICK J. SALEMI, EXAMINING ATTORNEY

CLASS 34—(Continued).

SN 85-679,677. DREW ESTATE HOLDING COMPANY LLC, MIAMI, FL. FILED 7-17-2012.

G-FRESH

THE MARK CONSISTS OF STANDARD CHARACTERS WITHOUT CLAIM TO ANY PARTICULAR FONT, STYLE, SIZE, OR COLOR.

FOR TOBACCO, CIGARS, MASS MARKET CIGARS, CIGARILLOS AND RELATED PRODUCTS, NAMELY, CIGAR BOXES, LIGHTERS AND HOLDERS NOT OF PRECIOUS METAL, ASHTRAYS, CIGAR CUTTERS, HUMIDORS AND CIGAR TUBES (U.S. CLS. 2, 8, 9 AND 17).

DOMINICK J. SALEMI, EXAMINING ATTORNEY

SERVICE MARKS

CLASS 35—ADVERTISING AND BUSINESS

SN 76-708,018. SABMD, LLC, MANASSAS, VA. FILED 6-16-2011.



NO CLAIM IS MADE TO THE EXCLUSIVE RIGHT TO USE "DIRECT CAR BUYING.COM", APART FROM THE MARK AS SHOWN.

THE COLOR(S) BLACK AND ORANGE IS/ARE CLAIMED AS A FEATURE OF THE MARK.

THE MARK CONSISTS OF THE OUTLINE OF A CAR IN THE COLOR BLACK. UNDERNEATH THE OUTLINE OF THE CAR IS THE STYLIZED WORDING "DIRECTCARBUYING.COM". THE WORDING "DIRECT" AND ".COM" APPEARS IN THE COLOR BLACK, AND THE WORDING "CARBUYING" APPEARS IN THE COLOR ORANGE. UNDERNEATH THE WORDING IS THE MIRRORED REFLECTION OF THE WORDING.

FOR AUTOMOBILE DEALERSHIP SERVICES; AUTOMOBILE DEALERSHIPS FEATURING PRE-OWNED AUTOMOBILES; ONLINE RETAIL AUTOMOBILE DEALERSHIPS, NAMELY, OPERATING A WEBSITE THAT ALLOWS CUSTOMERS TO CHOOSE A CAR, PAY FOR THE CAR AND FILL OUT ALL THE PAPERWORK FOR THE CAR ONLINE; ONLINE RETAIL STORE SERVICES FEATURING AUTOMOBILES; ONLINE ORDERING SERVICES IN THE FIELD OF MOTOR VEHICLES (U.S. CLS. 100, 101 AND 102).

MARCIE MILONE, EXAMINING ATTORNEY

CLASS 35—(Continued).

SN 76-708,019. SABMD, LLC, MANASSAS, VA. FILED 6-16-2011.



NO CLAIM IS MADE TO THE EXCLUSIVE RIGHT TO USE "DIRECT CAR SELLING.COM", APART FROM THE MARK AS SHOWN.

THE COLOR(S) BLACK AND ORANGE IS/ARE CLAIMED AS A FEATURE OF THE MARK.

THE MARK CONSISTS OF THE OUTLINE OF A CAR IN THE COLOR BLACK. UNDERNEATH THE OUTLINE OF THE CAR IS THE STYLIZED WORDING "DIRECTCARSELLING.COM". THE WORDING "DIRECT" AND ".COM" APPEARS IN THE COLOR BLACK, AND THE WORDING "CARSELLING" APPEARS IN THE COLOR ORANGE. UNDERNEATH THE WORDING IS THE MIRRORED REFLECTION OF THE WORDING.

FOR AUTOMOBILE DEALERSHIP SERVICES; AUTOMOBILE DEALERSHIPS FEATURING PRE-OWNED AUTOMOBILES; ONLINE RETAIL AUTOMOBILE DEALERSHIPS, NAMELY, OPERATING A WEBSITE THAT ALLOWS CUSTOMERS TO CHOOSE A CAR, PAY FOR THE CAR AND FILL OUT ALL THE PAPERWORK FOR THE CAR ONLINE RETAIL STORE SERVICES FEATURING AUTOMOBILES; ONLINE ORDERING SERVICES IN THE FIELD OF MOTOR VEHICLES (U.S. CLS. 100, 101 AND 102).

MARCIE MILONE, EXAMINING ATTORNEY

SN 76-708,208. SABMD, LLC, MANASSAS, VA. FILED 7-1-2011.



NO CLAIM IS MADE TO THE EXCLUSIVE RIGHT TO USE "DIRECT CAR BUYING", APART FROM THE MARK AS SHOWN.

THE COLOR(S) BLACK AND ORANGE IS/ARE CLAIMED AS A FEATURE OF THE MARK.

THE MARK CONSISTS OF THE OUTLINE OF A CAR IN THE COLOR BLACK. UNDERNEATH THE OUTLINE OF THE CAR IS THE STYLIZED WORDING "DIRECTCARBUYING". THE WORD "DIRECT" APPEARS IN THE COLOR BLACK, AND THE WORDING "CARBUYING" APPEARS IN THE COLOR ORANGE. UNDERNEATH THE WORDING IS THE MIRRORED REFLECTION OF THE WORDING.

FOR AUTOMOBILE DEALERSHIP SERVICES; AUTOMOBILE DEALERSHIPS FEATURING PRE-OWNED AUTOMOBILES; ONLINE RETAIL AUTOMOBILE DEALERSHIPS, NAMELY, OPERATING A WEBSITE THAT ALLOWS CUSTOMERS TO CHOOSE A CAR, PAY FOR THE CAR AND FILL OUT ALL THE PAPERWORK FOR THE CAR ONLINE; ONLINE RETAIL STORE SERVICES FEATURING AUTOMOBILES; ONLINE ORDERING SERVICES IN THE FIELD OF MOTOR VEHICLES (U.S. CLS. 100, 101 AND 102).

MARCIE MILONE, EXAMINING ATTORNEY

CLASS 35—(Continued).

SN 76-708,209. SABMD, LLC, MANASSAS, VA. FILED 7-1-2011.



NO CLAIM IS MADE TO THE EXCLUSIVE RIGHT TO USE "DIRECT CAR SELLING", APART FROM THE MARK AS SHOWN.

THE COLOR(S) BLACK AND ORANGE IS/ARE CLAIMED AS A FEATURE OF THE MARK.

THE MARK CONSISTS OF THE OUTLINE OF A CAR IN THE COLOR BLACK. UNDERNEATH THE OUTLINE OF THE CAR IS THE STYLIZED WORDING "DIRECTCARSELLING". THE WORD "DIRECT" APPEARS IN THE COLOR BLACK, AND THE WORDING "CARSELLING" APPEARS IN THE COLOR ORANGE. UNDERNEATH THE WORDING IS THE MIRRORRED REFLECTION OF THE WORDING.

FOR AUTOMOBILE DEALERSHIP SERVICES; AUTOMOBILE DEALERSHIPS FEATURING PRE-OWNED AUTOMOBILES; ONLINE RETAIL AUTOMOBILE DEALERSHIPS, NAMELY, OPERATING A WEBSITE THAT ALLOWS CUSTOMERS TO CHOOSE A CAR, PAY FOR THE CAR AND FILL OUT ALL THE PAPERWORK FOR THE CAR ONLINE; ONLINE RETAIL STORE SERVICES FEATURING AUTOMOBILES; ONLINE ORDERING SERVICES IN THE FIELD OF MOTOR VEHICLES (U.S. CLS. 100, 101 AND 102).

MARCIE MILONE, EXAMINING ATTORNEY

CLASS 35—(Continued).

SN 76-711,190. THOMPSON, VERNON, SAN ANTONIO, TX. FILED 4-11-2012.

PREMIER

THE MARK CONSISTS OF STANDARD CHARACTERS WITHOUT CLAIM TO ANY PARTICULAR FONT, STYLE, SIZE, OR COLOR.

FOR RETAIL STORE SERVICES, MAIL ORDER SERVICES, AND ON-LINE RETAIL STORE SERVICES IN THE FIELD OF LAW ENFORCEMENT, FIRE AND RESCUE, PUBLIC SAFETY, SECURITY, AND POSTAL UNIFORM ACCESSORIES, GEAR, AND EQUIPMENT (U.S. CLS. 100, 101 AND 102).

FIRST USE 4-0-1994; IN COMMERCE 4-0-1994.
AHSEN KHAN, EXAMINING ATTORNEY

SN 76-711,103. SABMD, LLC, MANASSAS, VA. FILED 4-2-2012.

EASTERNS AUTOMOTIVE GROUP

THE MARK CONSISTS OF STANDARD CHARACTERS WITHOUT CLAIM TO ANY PARTICULAR FONT, STYLE, SIZE, OR COLOR.

OWNER OF U.S. REG. NOS. 2,909,589 AND 3,529,588.

NO CLAIM IS MADE TO THE EXCLUSIVE RIGHT TO USE "AUTOMOTIVE GROUP", APART FROM THE MARK AS SHOWN.

FOR AUTOMOBILE DEALERSHIPS (U.S. CLS. 100, 101 AND 102).

FIRST USE 2-0-2001; IN COMMERCE 2-0-2001.

SAMUEL E. SHARPER JR., EXAMINING ATTORNEY

SN 77-938,113. GREENFIELD, STEFANI, NEW YORK, NY. FILED 2-17-2010.

SN 76-711,185. INSURANCE OFFICE OF AMERICA, INC., LONGWOOD, FL. FILED 4-10-2012.

RISKSCORE

THE MARK CONSISTS OF STANDARD CHARACTERS WITHOUT CLAIM TO ANY PARTICULAR FONT, STYLE, SIZE, OR COLOR.

FOR ONLINE COMPILING AND ANALYZING OF BUSINESS DATA RELATED TO A BUSINESS' SAFETY CULTURE, CLAIMS MANAGEMENT, TRAINING AND COMPLIANCE PROGRAMS FOR BUSINESS PURPOSES (U.S. CLS. 100, 101 AND 102).

CARYN GLASSER, EXAMINING ATTORNEY

OWNER OF U.S. REG. NOS. 3,516,796 AND 3,524,476.
NO CLAIM IS MADE TO THE EXCLUSIVE RIGHT TO USE "SWEATER CO.", APART FROM THE MARK AS SHOWN.

THE MARK CONSISTS OF THE WORDS "YUMMY SWEATER CO.".

FOR ON LINE RETAIL STORE SERVICES FEATURING CLOTHING AND ACCESSORIES, NAMELY, BAGS, EYEWEAR AND JEWELRY AND RETAIL STORE SERVICES FEATURING CLOTHING AND ACCESSORIES, NAMELY, BAGS, EYEWEAR AND JEWELRY (U.S. CLS. 100, 101 AND 102).

CHARLOTTE CORWIN, EXAMINING ATTORNEY

CLASS 35—(Continued).

SN 79-104,800. OUTLET ANDALUCIA, S.L., E-41927 MAIR-ENA DEL ALJARAFE (SEVILLA), SPAIN, FILED 8-26-2011.



OWNER OF INTERNATIONAL REGISTRATION 1096181 DATED 8-26-2011, EXPIRES 8-26-2021.

NO CLAIM IS MADE TO THE EXCLUSIVE RIGHT TO USE "OUTLET", APART FROM THE MARK AS SHOWN.

THE COLOR(S) GARNET RED, BLUE, AND WHITE IS/ARE CLAIMED AS A FEATURE OF THE MARK.

THE MARK CONSISTS OF A SQUARE WHOSE TOP 3/5 IS A RED RECTANGLE CONTAINING THE STYLIZED WHITE LETTERS, NUMBERS AND WORDING "THE" AND "FIRST", AND WHOSE 2/5 BOTTOM PORTION IS A BLUE RECTANGLE CONTAINING THE STYLIZED WHITE WORD "OUTLET".

FOR RETAIL STORE SERVICES AND ON-LINE RETAIL STORE SERVICES VIA GLOBAL COMPUTER NETWORKS FEATURING ARTICLES OF CLOTHING, FABRICS AND TEXTILE GOODS; ADVERTISING; IMPORT-EXPORT SERVICES (U.S. CLS. 100, 101 AND 102).
MARCIE MILONE, EXAMINING ATTORNEY

SN 79-105,306. BLACK SWAN MANAGEMENT LIMITED, NEWCASTLE UPON TYNE, UNITED KINGDOM, FILED 6-22-2011.

TransformationDNA

THE MARK CONSISTS OF STANDARD CHARACTERS WITHOUT CLAIM TO ANY PARTICULAR FONT, STYLE, SIZE, OR COLOR.

PRIORITY DATE OF 12-22-2010 IS CLAIMED.

OWNER OF INTERNATIONAL REGISTRATION 1097430 DATED 6-22-2011, EXPIRES 6-22-2021.

FOR BUSINESS CONSULTANCY SERVICES, BUSINESS MANAGEMENT AND ORGANIZATION CONSULTANCY SERVICES; BUSINESS EFFECTIVENESS CONSULTANCY SERVICES; BUSINESS APPRAISALS; BUSINESS RESEARCH; COMPILATION AND SYSTEMIZATION OF INFORMATION INTO COMPUTER DATABASES; BUSINESS INFORMATION; BUSINESS ADVICE RELATING TO STRATEGIC MARKETING; BUSINESS STRATEGY SERVICES; BUSINESS DEVELOPMENT SERVICES; PREPARATION OF BUSINESS, COMMERCIAL OR ECONOMIC REPORTS; BUSINESS FEASIBILITY STUDIES; BUSINESS STATISTICAL INFORMATION SERVICES; CONSULTANCY RELATING TO BUSINESS EFFICIENCY; BUSINESS RISK ANALYSIS AND BUSINESS RISK MANAGEMENT (U.S. CLS. 100, 101 AND 102).

REBECCA POVARCHUK, EXAMINING ATTORNEY

CLASS 35—(Continued).

SN 79-106,416. CLACKTION SEARCH S.L., E-08039 BARCELONA, SPAIN, FILED 9-28-2011.

CLACKTION

THE MARK CONSISTS OF STANDARD CHARACTERS WITHOUT CLAIM TO ANY PARTICULAR FONT, STYLE, SIZE, OR COLOR.

OWNER OF INTERNATIONAL REGISTRATION 1099732 DATED 9-28-2011, EXPIRES 9-28-2021.

FOR ADVERTISING; BUSINESS MANAGEMENT; BUSINESS ADMINISTRATION AND MANAGEMENT; OFFICE FUNCTIONS, NAMELY, MARKETING SERVICES; ADVERTISING AND BUSINESS CONSULTANCY; ADVERTISING AND BUSINESS ADVISE SERVICES, BUSINESS INVESTIGATIONS, AND BUSINESS AND ADVERTISING INFORMATION ALL FOR BUSINESS CONSULTANCY ON THE USE OF DIGITAL MEDIA, TELECOMMUNICATIONS SERVICES, THE INTERNET, INTRANETS AND EXTRANETS, INTERACTIVE TELEVISION, CD-ROMS, DVDS AND ELECTRONIC MEDIA PRODUCTS, AND MOBILE TELEPHONY BOTH FOR COMPANIES AND FOR THEIR CUSTOMERS; CONSULTANCY ON THE SUBJECT OF BUSINESS RELATING TO DESIGN, DEVELOPMENT, PROJECT MANAGEMENT, RESEARCH AND MAINTENANCE OF ELECTRONIC GOODS; ADVERTISING, MARKETING AND PROMOTION SERVICES; SERVICES INVOLVING PURCHASING OF MEANS OF COMMUNICATION, NAMELY, PROVIDING CONSULTING SERVICES IN THE FIELD OF FACILITATING THE PLANNING, BUYING, AND SELLING OF MEDIA; MEDIA BUYING SERVICES, NAMELY, SECURING AIR-TIME ON ALL FORMS OF COMMUNICATION STATIONS, SYSTEMS, NETWORKS, ONLINE MEDIA AND SERVICES FOR THE PURPOSE OF THE PROMOTION OF THE SERVICES FOR OTHERS; MARKET ANALYSIS AND RESEARCH SERVICES; MARKET RESEARCH CONSULTATION SERVICES; MEDIA MONITORING SERVICES, NAMELY, MONITORING PRINT MEDIA, TELEVISION, RADIO, AND OTHER MEDIA FOR CUSTOMER-SPECIFIC TOPICS, GATHERING RELEVANT CONTENT ON THOSE TOPICS, AND PROVIDING DOCUMENTATION AND ANALYSIS OF THAT MEDIA CONTENT TO OTHERS FOR BUSINESS PURPOSES; ADVERTISING CONSULTATION, NAMELY, PURCHASE, NEGOTIATION, PLANNING AND FACILITATING ADVERTISING SPACE AND TIME AND PLACEMENT OF ADVERTISEMENTS ON COMMUNICATIONS MEDIA; PRODUCING ADVERTISING AND ANNOUNCEMENTS OF ALL VARIETIES, NAMELY, DESIGN OF ADVERTISING MATERIALS FOR OTHERS; SERVICES INVOLVING SUPPORT THE MARKET, NAMELY, PROVIDING BUSINESS CONSULTATION TO FREELANCERS, START-UPS, EXISTING BUSINESS AND NONPROFIT ORGANIZATIONS; ANALYSIS AND COMPILATION OF STATISTICS; DATA ENTRY SERVICES IN THE NATURE OF CLERICAL SERVICES; ASSISTANCE AND ADVICE REGARDING BUSINESS ADMINISTRATION OF MANAGEMENT (U.S. CLS. 100, 101 AND 102).

JENNIFER WILLISTON, EXAMINING ATTORNEY

CLASS 35—(Continued).

SN 79-110,137. DKSH INTERNATIONAL LTD., SWITZERLAND, FILED 11-29-2011.



THE MARK CONSISTS OF STANDARD CHARACTERS WITHOUT CLAIM TO ANY PARTICULAR FONT, STYLE, SIZE, OR COLOR.

PRIORITY DATE OF 8-17-2011 IS CLAIMED.

OWNER OF INTERNATIONAL REGISTRATION 1110127 DATED 11-29-2011, EXPIRES 11-29-2021.

THE ENGLISH TRANSLATION OF "LUNA" IN THE MARK IS "MOON".

FOR ADVERTISING AND MARKETING SERVICES, NAMELY, PROMOTING THE GOODS AND SERVICES OF OTHERS; BUSINESS MANAGEMENT SERVICES; BUSINESS ADMINISTRATION; PROVIDING OFFICE FUNCTIONS; RETAIL STORE SERVICES AND WHOLESALE STORE SERVICES FEATURING CHEMICALS USED IN INDUSTRY, SCIENCE, PHOTOGRAPHY, AGRICULTURE, HORTICULTURE AND FORESTRY, UNPROCESSED ARTIFICIAL RESINS, UNPROCESSED PLASTICS, MANURES, FIRE EXTINGUISHING COMPOSITIONS, TEMPERING AND SOLDERING PREPARATIONS, CHEMICAL SUBSTANCES FOR PRESERVING FOODSTUFF, TANNING SUBSTANCES, ADHESIVES USED IN INDUSTRY, PAINTS, VARNISHES, LACQUERS, PRESERVATIVES AGAINST RUST AND AGAINST DETERIORATION OF WOOD, COLORANTS, MORDANTS, RAW NATURAL RESINS, METALS IN FOIL AND POWDER FORM FOR PAINTERS, DECORATORS, PRINTERS AND ARTISTS, BLEACHING PREPARATIONS AND OTHER SUBSTANCES FOR LAUNDRY USE, CLEANING, POLISHING, SCOURING AND ABRASIVE PREPARATIONS, SOAPS, PERFUMERY, ESSENTIAL OILS, ARTICLES FOR BODY AND BEAUTY-CARE, HAIR LOTIONS, DENTIFRICES (U.S. CLS. 100, 101 AND 102).

LOURDES AYALA, EXAMINING ATTORNEY

SN 79-113,769. GRUMPLES GROUP PTY LTD, SYDNEY, AUSTRALIA, FILED 2-22-2012.



THE MARK CONSISTS OF STANDARD CHARACTERS WITHOUT CLAIM TO ANY PARTICULAR FONT, STYLE, SIZE, OR COLOR.

PRIORITY DATE OF 2-17-2012 IS CLAIMED.

OWNER OF INTERNATIONAL REGISTRATION 1118493 DATED 2-22-2012, EXPIRES 2-22-2022.

FOR ADVERTISING SERVICES PROVIDED OVER THE INTERNET, NAMELY, ONLINE CLASSIFIED ADVERTISEMENTS, BANNER ADVERTISEMENTS, MULTIVARIATE AND MULTIVARIABLE TEST MARKETING AND SPONSORED LINKS ADVERTISEMENTS IN THE NATURE OF PAY-PER-CLICK ADVERTISEMENTS; SOCIAL MEDIA MARKETING AND DIGITAL MARKETING SERVICES; BUSINESS DATA ANALYSIS, NAMELY, COMPILATION, MANAGEMENT AND ANALYSIS, AND RETRIEVAL OF DATA AND STATISTICS RELATING TO SEARCH ENGINE OPTIMIZATION, WEB ADVERTISING AND WEB TRAFFIC ANALYSIS; MARKETING ADVISORY SERVICES, NAMELY, INTERNET MARKETING, ELECTRONIC MARKETING AND EMAIL MARKETING ADVISORY SERVICES; MARKETING DATA COMPILATION AND ANALYSIS; MARKETING MANAGEMENT SERVICES,

CLASS 35—(Continued).

NAMELY, ONLINE MARKETING MANAGEMENT AND ONLINE BRAND MANAGEMENT; MARKETING SERVICES RELATING TO SEARCH ENGINE OPTIMISATION, NAMELY, SERVICES FOR IMPROVEMENT OF VISIBILITY OF WEBSITES OR WEBPAGES IN ORGANIC AND ALGORITHMIC SEARCH RESULTS OF SEARCH ENGINES; MARKETING SERVICES RELATING TO MEASURES FOR IMPROVING PERFORMANCE OF WEBSITES AND WEBPAGES, NAMELY, ANALYSING AND EDITING OF CONTENT AND HTML AND ASSOCIATED CODING OF WEBSITES AND WEBPAGES; MARKETING SERVICES RELATING TO DEVELOPING, CREATING, MANAGING AND OPTIMISING WEB PRESENCE FOR WEBSITES AND WEBPAGES; MARKETING SERVICES RELATING TO SEARCH ENGINE MARKETING, NAMELY, PROMOTION OF WEBSITES AND WEBPAGES THROUGH USE OF ONLINE CLASSIFIED ADVERTISEMENTS, BANNER ADVERTISEMENTS, MULTIVARIATE AND MULTIVARIABLE TEST MARKETING AND SPONSORED LINK ADVERTISEMENTS IN THE NATURE OF PAY-PER-CLICK ADVERTISEMENTS; ONLINE MARKETING SERVICES; PLANNING OF MARKETING STRATEGIES, NAMELY, ONLINE MARKETING STRATEGIES; PROMOTION AND ADVERTISING SERVICES FOR BUSINESS (U.S. CLS. 100, 101 AND 102).

KRISTIN CARLSON, EXAMINING ATTORNEY

SN 79-114,065. THE SKULLHEAD LUXEMBOURG, LUXEMBOURG, FILED 3-8-2012.



OWNER OF INTERNATIONAL REGISTRATION 1119253 DATED 3-8-2012, EXPIRES 3-8-2022.

OWNER OF U.S. REG. NOS. 3,696,095 AND 3,763,359.

FOR ADVERTISING; COMMERCIAL ADMINISTRATION OF THE LICENSING OF THE GOODS AND SERVICES OF OTHERS; ON-LINE RETAIL STORE SERVICES FEATURING COSMETICS, OPTICAL GOODS, CLOTHING, FOOTWEAR, JEWELRY, BAGS, LUGGAGE AND LEATHER GOODS, FASHION ACCESSORIES; DEMONSTRATION OF GOODS; DISTRIBUTION OF SAMPLES; ORGANIZATION OF EXHIBITIONS FOR COMMERCIAL OR ADVERTISING PURPOSES; RETAIL STORE SERVICES OF COSMETICS, OPTICAL GOODS, CLOTHING, FOOTWEAR, JEWELRY, BAGS, LUGGAGE AND LEATHER GOODS, FASHION ACCESSORIES; AND WHOLESALE DISTRIBUTORSHIP OF COSMETICS, OPTICAL GOODS, CLOTHING AND FOOTWEAR, JEWELRY, BAGS, LUGGAGE AND LEATHER GOODS, FASHION ACCESSORIES (U.S. CLS. 100, 101 AND 102).

INGRID C. EULIN, EXAMINING ATTORNEY

SN 79-114,891. B.C. STRATEGY LTD., 64361 TEL AVIV, ISRAEL, FILED 3-25-2012.



OWNER OF INTERNATIONAL REGISTRATION 1121414 DATED 3-25-2012, EXPIRES 3-25-2022.

FOR BUSINESS MANAGEMENT, BUSINESS ADMINISTRATION; BUSINESS DEVELOPMENT; BUSINESS AND PERSONAL CONSULTING SERVICES, DEVELOPMENT, MARKETING AND SALES PROMOTION CONSULTING; ALL INCLUDED IN THIS CLASS (U.S. CLS. 100, 101 AND 102).

JACLYN KIDWELL WALKER, EXAMINING ATTORNEY

CLASS 35—(Continued).

SN 85-176,274. AMERICAN MUNICIPAL POWER, INC., COLUMBUS, OH. FILED 11-14-2010.



NO CLAIM IS MADE TO THE EXCLUSIVE RIGHT TO USE "EFFICIENCY", APART FROM THE MARK AS SHOWN.

THE COLOR(S) GREEN AND GOLD IS/ARE CLAIMED AS A FEATURE OF THE MARK.

THE MARK CONSISTS OF A GREEN SWIRL DESIGN TO THE LEFT OF THE WORDING "EFFICIENCYSMART" WITH THE WORDING "EFFICIENCY" COLORED GOLD AND A STYLIZED LETTER "S" IN THE FORM OF A DOLLAR SIGN IN PLACE OF THE LETTER "S" IN THE WORD "SMART" AS IN "SMART", ALL COLORED GREEN. THE COLOR WHITE REPRESENTS A TRANSPARENT AREA AND IS NOT A PART OF THE MARK.

FOR BUSINESS VENTURE DEVELOPMENT AND FORMATION CONSULTING SERVICES FOR THE RENEWABLE ENERGY INDUSTRY; CONDUCTING ENERGY AUDITS OF COMMERCIAL AND INSTITUTIONAL FACILITIES FOR THE PURPOSE OF IMPROVING ENERGY EFFICIENCY; CONSULTATION IN THE FIELD OF ENERGY EFFICIENCY; CONSULTING SERVICES IN THE FIELD OF ENERGY EFFICIENCY FOR COMMERCIAL AND INSTITUTIONAL FACILITIES; CONSULTING SERVICES IN THE FIELD OF ENERGY USAGE MANAGEMENT AND ENERGY EFFICIENCY; CONSULTING SERVICES IN THE FIELDS OF ENERGY CONSUMPTION AND USAGE CONSERVATION TO IMPROVE ENERGY EFFICIENCY; ENERGY AUDITING; ENERGY USAGE MANAGEMENT; HOME ENERGY ASSESSMENT SERVICES FOR THE PURPOSE OF DETERMINING ENERGY EFFICIENCY OR USAGE MANAGEMENT; INFORMATION IN THE FIELD OF ENERGY EFFICIENCY; PROMOTING THE BENEFITS OF ENERGY EFFICIENT LIGHTING TECHNOLOGIES TO PROFESSIONALS IN THE LIGHTING FIELD; PROVISION OF INFORMATION, ADVICE AND CONSULTANCY IN RELATION TO ENERGY EFFICIENCY (U.S. CLS. 100, 101 AND 102).

FIRST USE 3-31-2009; IN COMMERCE 3-31-2009.

RUDY R. SINGLETON, EXAMINING ATTORNEY

CLASS 35—(Continued).

SN 85-176,285. AMERICAN MUNICIPAL POWER, INC., COLUMBUS, OH. FILED 11-14-2010.

Efficiency Smart

THE MARK CONSISTS OF STANDARD CHARACTERS WITHOUT CLAIM TO ANY PARTICULAR FONT, STYLE, SIZE, OR COLOR.

NO CLAIM IS MADE TO THE EXCLUSIVE RIGHT TO USE "EFFICIENCY", APART FROM THE MARK AS SHOWN.

FOR BUSINESS VENTURE DEVELOPMENT AND FORMATION CONSULTING SERVICES FOR THE RENEWABLE ENERGY INDUSTRY; CONDUCTING ENERGY AUDITS OF COMMERCIAL AND INSTITUTIONAL FACILITIES FOR THE PURPOSE OF IMPROVING ENERGY EFFICIENCY; CONSULTATION IN THE FIELD OF ENERGY EFFICIENCY; CONSULTING SERVICES IN THE FIELD OF ENERGY EFFICIENCY FOR COMMERCIAL AND INSTITUTIONAL FACILITIES; CONSULTING SERVICES IN THE FIELD OF ENERGY USAGE MANAGEMENT AND ENERGY EFFICIENCY; CONSULTING SERVICES IN THE FIELDS OF ENERGY CONSUMPTION AND USAGE CONSERVATION TO IMPROVE ENERGY EFFICIENCY; ENERGY AUDITING; ENERGY USAGE MANAGEMENT; HOME ENERGY ASSESSMENT SERVICES FOR THE PURPOSE OF DETERMINING ENERGY EFFICIENCY OR USAGE MANAGEMENT; INFORMATION IN THE FIELD OF ENERGY EFFICIENCY; PROMOTING THE BENEFITS OF ENERGY EFFICIENT LIGHTING TECHNOLOGIES TO PROFESSIONALS IN THE LIGHTING FIELD; PROVISION OF INFORMATION, ADVICE AND CONSULTANCY IN RELATION TO ENERGY EFFICIENCY (U.S. CLS. 100, 101 AND 102).

FIRST USE 3-31-2009; IN COMMERCE 3-31-2009.

RUDY R. SINGLETON, EXAMINING ATTORNEY

SN 85-226,892. LRP PUBLICATIONS, INC., PALM BEACH GARDENS, FL. FILED 1-26-2011.

HR TECHNOLOGY CONFERENCE & EXPOSITION

THE MARK CONSISTS OF STANDARD CHARACTERS WITHOUT CLAIM TO ANY PARTICULAR FONT, STYLE, SIZE, OR COLOR.

OWNER OF U.S. REG. NO. 2,411,509.

NO CLAIM IS MADE TO THE EXCLUSIVE RIGHT TO USE "CONFERENCE & EXPOSITION", APART FROM THE MARK AS SHOWN.

SEC. 2(F).

FOR ARRANGING AND CONDUCTING BUSINESS CONFERENCES IN THE FIELD OF HUMAN RESOURCE TECHNOLOGY (U.S. CLS. 100, 101 AND 102).

FIRST USE 10-6-1997; IN COMMERCE 10-6-1997.

ROBIN MITTLER, EXAMINING ATTORNEY

CLASS 35—(Continued).

SN 85-230,994. BAKER & TAYLOR, INC., CHARLOTTE, NC. FILED 2-1-2011.

CUSTOMIZED LIBRARY SERVICES

THE MARK CONSISTS OF STANDARD CHARACTERS WITHOUT CLAIM TO ANY PARTICULAR FONT, STYLE, SIZE, OR COLOR.

NO CLAIM IS MADE TO THE EXCLUSIVE RIGHT TO USE "LIBRARY SERVICES", APART FROM THE MARK AS SHOWN.

SEC. 2(F).

FOR PROVIDING TECHNICAL INVENTORY MANAGEMENT SOLUTIONS TO LIBRARIES IN THE NATURE OF CUSTOMIZED ELECTRONIC CATALOG SYSTEM AND SHELF READY MATERIALS, NAMELY, TECHNICAL INVENTORY PROCESSING OF BOOKS, REFERENCE MATERIALS AND SOFTWARE FOR LIBRARY CIRCULATION (U.S. CLS. 100, 101 AND 102).

FIRST USE 10-0-1998; IN COMMERCE 0-0-1999.

ALYSSA STEEL, EXAMINING ATTORNEY

CLASS 35—(Continued).

SN 85-279,571. AMERICAN CONSERVATIVE UNION, ALEXANDRIA, VA. FILED 3-29-2011.

conservative.org

NO CLAIM IS MADE TO THE EXCLUSIVE RIGHT TO USE "CONSERVATIVE.ORG", APART FROM THE MARK AS SHOWN.

THE COLOR(S) BLUE AND RED IS/ARE CLAIMED AS A FEATURE OF THE MARK.

THE MARK CONSISTS OF "CONSERVATIVE.ORG" IN BLUE WITH A RED STAR DESIGN IN THE SECOND "O".

FOR ASSOCIATION SERVICES, NAMELY, PROMOTING POLITICAL INTERESTS OF INDIVIDUALS AND GROUPS (U.S. CLS. 100, 101 AND 102).

FIRST USE 2-0-2011; IN COMMERCE 2-0-2011.

TRACY CROSS, EXAMINING ATTORNEY

SN 85-267,129. FRONTLINE SELLING, LLC, RIDGEFIELD PARK, NJ. FILED 3-15-2011.

Vision-Lock

THE MARK CONSISTS OF STANDARD CHARACTERS WITHOUT CLAIM TO ANY PARTICULAR FONT, STYLE, SIZE, OR COLOR.

FOR BUSINESS SALES PLANNING, CONSULTING, AND DEVELOPMENT (U.S. CLS. 100, 101 AND 102).

FIRST USE 6-18-2002; IN COMMERCE 6-18-2002.

SEAN CROWLEY, EXAMINING ATTORNEY

SN 85-283,693. MYCYBERTWIN NORTH AMERICA, INC., NEW YORK, NY. FILED 4-1-2011.

MYCYBERTWIN

THE MARK CONSISTS OF STANDARD CHARACTERS WITHOUT CLAIM TO ANY PARTICULAR FONT, STYLE, SIZE, OR COLOR.

FOR ADVERTISING AND ADVERTISEMENT SERVICES (U.S. CLS. 100, 101 AND 102).

SUE LAWRENCE, EXAMINING ATTORNEY

SN 85-275,161. ZS ASSOCIATES, INC., EVANSTON, IL. FILED 3-23-2011.

APO

THE MARK CONSISTS OF STANDARD CHARACTERS WITHOUT CLAIM TO ANY PARTICULAR FONT, STYLE, SIZE, OR COLOR.

FOR PROFESSIONAL BUSINESS, SALES AND MARKETING ADVISORY AND CONSULTANCY SERVICES, EXCLUDING BUSINESS ACQUISITION AND MERGER CONSULTATION SERVICES, WITH A FOCUS ON ANALYTICS, FOR ENABLING COMPANIES TO OUTSOURCE AND IMPROVE THEIR SALES AND MARKETING OPERATIONS IN THE AREAS OF SALES, COMPENSATION, INFORMATION MANAGEMENT AND REPORTING, TERRITORY AND ACCOUNT PLANNING, MARKETING CAMPAIGN DESIGN AND MANAGEMENT, AND OTHER OPERATIONS (U.S. CLS. 100, 101 AND 102).

LESLIE RICHARDS, EXAMINING ATTORNEY

SN 85-288,713. MAXPOINT INTERACTIVE, INC., MORRISVILLE, NC. FILED 4-7-2011.

MAXPOINT

THE MARK CONSISTS OF THE WORD "MAXPOINT" WITH A DESIGN OF A PUSH PIN IN THE CENTER OF THE LETTER "O" AND A SHADOW OF THE PIN IN THE LOWER-RIGHT HAND CORNER BENEATH THE LETTER "O".

FOR ONLINE ADVERTISING SERVICES PROVIDED TO MEDIA BUYERS, NAMELY, DIGITAL MEDIA BUYING SERVICES IN THE NATURE OF IDENTIFYING IDEAL TARGET AUDIENCE FOR ONLINE ADVERTISING CAMPAIGNS (U.S. CLS. 100, 101 AND 102).

WENDY JUN, EXAMINING ATTORNEY

CLASS 35—(Continued).

SN 85-309,131. LECOMTE, BENOIT M, GRAND PRAIRIE, TX. FILED 4-30-2011.

the longest swim

THE MARK CONSISTS OF STANDARD CHARACTERS WITHOUT CLAIM TO ANY PARTICULAR FONT, STYLE, SIZE, OR COLOR.

FOR EVENT PLANNING AND MANAGEMENT FOR MARKETING, BRANDING, PROMOTING OR ADVERTISING THE GOODS AND SERVICES OF OTHERS (U.S. CLS. 100, 101 AND 102).

FIRST USE 4-21-2011; IN COMMERCE 4-21-2011.
GINA HAYES, EXAMINING ATTORNEY

SN 85-311,300. WANDERTEC INC., FLAGSTAFF, AZ. FILED S.R. 5-3-2011; AM. P.R. 7-22-2012.

J.O.Y.B.A.G.

THE MARK CONSISTS OF STANDARD CHARACTERS WITHOUT CLAIM TO ANY PARTICULAR FONT, STYLE, SIZE, OR COLOR.

FOR ADVERTISING, MARKETING AND PROMOTIONAL SERVICES PROVIDED BY MEANS OF INDIRECT METHODS OF MARKETING COMMUNICATIONS, NAMELY, SOCIAL MEDIA, SEARCH ENGINE MARKETING, INTERNET MARKETING, BLOGGING, AND OTHER FORMS OF PASSIVE, SHARABLE OR VIRAL COMMUNICATIONS CHANNELS FOR PARTICULAR STYLES OF BICYCLES THAT OFFER AS MANY CONVENIENCES OF AN AUTOMOBILE AS POSSIBLE (U.S. CLS. 100, 101 AND 102).

FIRST USE 4-25-2011; IN COMMERCE 4-25-2011.
JULIE GUTTADAURO, EXAMINING ATTORNEY

SN 85-312,049. JIM PATTISON ENTERPRISES LTD., VANCOUVER, BC, V6E 2H2, CANADA, FILED 5-4-2011.

RS2

THE MARK CONSISTS OF STANDARD CHARACTERS WITHOUT CLAIM TO ANY PARTICULAR FONT, STYLE, SIZE, OR COLOR.

PRIORITY CLAIMED UNDER SEC. 44(D) ON CANADA APPLICATION NO. 1525468, FILED 4-28-2011, REG. NO. TMA822,285, DATED 4-17-2012, EXPIRES 4-17-2027.

FOR ADMINISTERING AND MANAGING DISPLAY ARRANGEMENTS AND INCENTIVE REBATE PROGRAMS TO PROMOTE THE SALE OF PUBLICATIONS, PERIODICALS AND MAGAZINES (U.S. CLS. 100, 101 AND 102).

INGRID C. EULIN, EXAMINING ATTORNEY

CLASS 35—(Continued).

SN 85-314,914. ESOBI INC., GEORGE TOWN, CAYMAN ISLANDS, FILED 5-6-2011.



PRIORITY CLAIMED UNDER SEC. 44(D) ON TAIWAN APPLICATION NO. 099066073, FILED 12-31-2010.

NO CLAIM IS MADE TO THE EXCLUSIVE RIGHT TO USE "NEWS", APART FROM THE MARK AS SHOWN.

THE MARK CONSISTS OF THE WORDS "NEWS XPRESSO" IN A STYLIZED FONT. THE "O" IN "XPRESSO" IS IN THE SHAPE OF A COFFEE BEAN.

FOR PLANNING, DESIGN, PRODUCTION, AGENCY AND PUBLICITY OF ADVERTISEMENT AND PROPAGANDA MATERIAL DELIVERY, NAMELY, ADVERTISING AGENCY SERVICES, ADVERTISING AND PUBLICITY SERVICES; PLANNING AND DESIGN FOR ADVERTISEMENT, NAMELY, DESIGN OF ADVERTISING MATERIALS FOR OTHERS; PRODUCTION OF ADVERTISEMENT MATERIALS; ADVERTISING AGENCIES; ADVERTISING PUBLICITY AND PROPAGANDA MATERIAL DELIVERY, NAMELY, ADVERTISING AND PUBLICITY SERVICES; AUCTIONEERING; ON-LINE AUCTION SERVICES; BUSINESS INVESTIGATIONS; MARKETING RESEARCH SERVICES; PUBLIC RELATIONS; ELECTRONIC BILLBOARD ADVERTISING; INTERNET BILLBOARD ADVERTISING; MAIL ORDER SERVICE FEATURING MAGAZINES AND SOFTWARE OF APPLICATION PROGRAM FOR THE PURPOSE OF COLLECTING MATERIAL; OPERATING AN ON-LINE SHOPPING SITE IN THE FIELD OF SOFTWARE OF APPLICATION PROGRAM FOR THE PURPOSE OF COLLECTING MATERIAL; COMPUTERIZED DATABASE MANAGEMENT (U.S. CLS. 100, 101 AND 102).

SANI KHOURI, EXAMINING ATTORNEY

SN 85-317,594. CANNER, JASON A, DBA CURE IT, FOREST PARK, IL. AND FOWLER, MARY V., FRANKFORT, IL. FILED 5-10-2011.



NO CLAIM IS MADE TO THE EXCLUSIVE RIGHT TO USE "CHILDHOOD CANCER", APART FROM THE MARK AS SHOWN.

THE COLOR(S) YELLOW, GOLD, AND GRAY IS/ARE CLAIMED AS A FEATURE OF THE MARK.

THE MARK CONSISTS OF A GRAY BACKGROUND WITH A RIBBON ON THE LEFT SIDE WHICH IS GOLD IN COLOR AND THE BOTTOM RIGHT PORTION OF THE RIBBON IS YELLOW IN COLOR, AND IN THE CENTER AND RIGHT SIDE IS THE WORDING "FACE IT. FIGHT IT." WHICH IS CAPITALIZED AND YELLOW IN COLOR, THE WORDING "CURE IT" WHICH IS CAPITALIZED AND GOLD IN COLOR, AND THE WORDING "CONQUERING CHILDHOOD CANCER" WHICH IS CAPITALIZED AND GOLD COLOR.

FOR ASSOCIATION SERVICES, NAMELY, PROMOTING THE PUBLIC INTEREST AND AWARENESS IN CANCER RESEARCH AND EDUCATION (U.S. CLS. 100, 101 AND 102).

FIRST USE 3-15-2011; IN COMMERCE 4-1-2011.
CURTIS FRENCH, EXAMINING ATTORNEY

CLASS 35—(Continued).

SN 85-320,332. SMALLBIZPROS, INC., WESTWOOD, MA. FILED 5-13-2011.

WHERE YOUR SUCCESS TAKES
ROOT

THE MARK CONSISTS OF STANDARD CHARACTERS WITHOUT CLAIM TO ANY PARTICULAR FONT, STYLE, SIZE, OR COLOR.

FOR BOOKKEEPING AND ACCOUNTING SERVICES AND OFFERING BUSINESS MANAGEMENT ASSISTANCE IN THE ESTABLISHMENT AND/OR OPERATION OF BOOKKEEPING AND ACCOUNTING ESTABLISHMENTS (U.S. CLS. 100, 101 AND 102).

FIRST USE 6-30-2005; IN COMMERCE 6-30-2005.
MARY CRAWFORD, EXAMINING ATTORNEY

SN 85-347,869. 1APPLY LLC, BAINBRIDGE ISLAND, WA. FILED 6-16-2011.

1apply

THE MARK CONSISTS OF STANDARD CHARACTERS WITHOUT CLAIM TO ANY PARTICULAR FONT, STYLE, SIZE, OR COLOR.

FOR JOB AND PERSONNEL PLACEMENT (U.S. CLS. 100, 101 AND 102).

FIRST USE 11-7-2004; IN COMMERCE 11-7-2004.
APRIL HESIK, EXAMINING ATTORNEY

SN 85-363,894. CAPELL, PHILIP J., WOODBURY, NY. FILED 7-6-2011.

GOSCHMOOZE

THE MARK CONSISTS OF STANDARD CHARACTERS WITHOUT CLAIM TO ANY PARTICULAR FONT, STYLE, SIZE, OR COLOR.

FOR ON-LINE BUSINESS NETWORKING SERVICES; PROVIDING A WEBSITE FEATURING INFORMATION IN THE FIELD OF BUSINESS NETWORKING; ARRANGING AND CONDUCTING SPECIAL EVENTS FOR BUSINESS PURPOSES; PROVIDING BUSINESS NETWORKING OPPORTUNITIES AND ORGANIZING EVENTS FOR BUSINESS PURPOSES FOR MEMBERS TO PROFILE THEIR BUSINESSES AND EXCHANGE BUSINESS IDEAS, REFERRALS, CONTACTS, SERVICES, AND GENERAL BUSINESS INTERESTS; CONSULTATION IN THE FIELD OF BUSINESS NETWORKING, NAMELY, PROVIDING ASSISTANCE IN ESTABLISHING A NETWORK OF BUSINESS CONTACTS; BUSINESS NETWORKING CONSULTATION (U.S. CLS. 100, 101 AND 102).

ROBERT C. CLARK JR., EXAMINING ATTORNEY

CLASS 35—(Continued).

SN 85-383,836. SEQUIM LAVENDER GROWERS ASSOCIATION, SEQUIM, WA. FILED 7-28-2011.

Sequim Lavender Festival
Weekend

THE MARK CONSISTS OF STANDARD CHARACTERS WITHOUT CLAIM TO ANY PARTICULAR FONT, STYLE, SIZE, OR COLOR.

OWNER OF U.S. REG. NOS. 3,312,072, 3,312,073 AND 3,476,655.

NO CLAIM IS MADE TO THE EXCLUSIVE RIGHT TO USE "LAVENDER FESTIVAL WEEKEND", APART FROM THE MARK AS SHOWN.

SEC. 2(F) AS TO "SEQUIM LAVENDER FESTIVAL".

FOR ADVERTISING AND MARKETING FOR CIVIC AND COMMUNITY FESTIVALS CENTERED AROUND LAVENDER, AND ENTERTAINMENT AND EDUCATIONAL EVENTS RELATED THERETO, ART, CRAFTS, FOOD, MUSIC AND FARM EXHIBITIONS, PROMOTING THE GOODS AND SERVICES OF OTHERS BY ARRANGING FOR SPONSORS TO AFFILIATE THEIR GOODS AND SERVICES WITH CIVIC AND COMMUNITY FESTIVALS CENTERED AROUND LAVENDER, AND ENTERTAINMENT AND EDUCATIONAL EVENTS RELATED THERETO, ART, CRAFTS, FOOD, MUSIC AND FARM EXHIBITIONS, ARRANGING AND CONDUCTING OF STREET, CRAFT AND ART FAIRS AND EXHIBITIONS FOR BUSINESS AND ADVERTISING PURPOSES IN THE FIELD OF AGRICULTURAL FARMING, NAMELY, CULTIVATING, HARVESTING, PROCESSING, MANUFACTURING AND MARKETING OF FARM-GROWN MATERIALS, INCLUDING LAVENDER, HERBS, VEGETABLES AND FLOWERS INTO VALUE-ADDED PRODUCTS IN THE CULINARY, HEALING, CRAFT, COSMETIC AND DECORATIVE ARTS FIELDS (U.S. CLS. 100, 101 AND 102).

FIRST USE 7-28-2011; IN COMMERCE 7-28-2011.
MAUREEN DALL, EXAMINING ATTORNEY

SN 85-387,159. UNIVERSITY OF NEW HAMPSHIRE, DURHAM, NH. FILED 8-2-2011.

KNOW YOUR POWER

THE MARK CONSISTS OF STANDARD CHARACTERS WITHOUT CLAIM TO ANY PARTICULAR FONT, STYLE, SIZE, OR COLOR.

FOR PROMOTIONAL SERVICES, NAMELY, PROVIDING SOCIAL MARKETING CAMPAIGNS TO TEACH THAT EVERYONE IN THE COMMUNITY HAS A ROLE TO PLAY IN ENDING SEXUAL ASSAULT, RELATIONSHIP VIOLENCE AND STALKING (U.S. CLS. 100, 101 AND 102).

FIRST USE 1-31-2005; IN COMMERCE 12-31-2006.
PATRICIA EVANKO, EXAMINING ATTORNEY

CLASS 35—(Continued).

SN 85-391,671. CACIOPPO MARCELLO, DBA HOTSPITALITY.COM, L.A., CA. FILED 8-7-2011.

HOTSPITALITY.COM
The Job you want. The
Staff you need.

THE MARK CONSISTS OF STANDARD CHARACTERS WITHOUT CLAIM TO ANY PARTICULAR FONT, STYLE, SIZE, OR COLOR.

FOR ON-LINE BUSINESS NETWORKING SERVICES IN THE NATURE OF PROVIDING LEADS TO INDIVIDUALS SEEKING WORK IN THE HOSPITALITY INDUSTRY INCLUDING RESTAURANTS, BARS, NIGHTCLUBS AND SPECIAL EVENTS (U.S. CLS. 100, 101 AND 102).

FIRST USE 4-15-2008; IN COMMERCE 4-15-2008.
WENDY GOODMAN, EXAMINING ATTORNEY

SN 85-402,789. SERVICIOS PROFESIONALES DE OPERACIÓN, S.A. DE C.V., TIJUANA, BC, MEXICO, FILED 8-19-2011.



OWNER OF MEXICO REG. NO. 992787, DATED 7-16-2007, EXPIRES 4-3-2017.

NO CLAIM IS MADE TO THE EXCLUSIVE RIGHT TO USE "CLUB TIJUANA", APART FROM THE MARK AS SHOWN.

THE COLOR(S) BLACK AND RED IS/ARE CLAIMED AS A FEATURE OF THE MARK.

THE MARK CONSISTS OF TWO BLACK CIRCLES FEATURING TWO RED DOTS BETWEEN THE CIRCLES AND THE WORDS "CLUB TIJUANA" AT THE TOP OF THE CIRCLE AND "XOLOITZCUINTLES DE CALIENTE" AT THE BOTTOM OF THE CIRCLE. THE WORDING IS ENTIRELY IN BLACK. INSIDE THE INNERMOST CIRCLE IS THE HEAD OF A XOLOITZCUINTLE DOG IN BLACK WITH A RED BACKGROUND.

THE ENGLISH TRANSLATION OF "DE CALIENTE" IN THE MARK IS OF HOT.

FOR ADVERTISING AND MARKETING; BUSINESS ADMINISTRATION AND OFFICE WORK; BUSINESS MANAGEMENT; COMMERCIAL BUSINESS MANAGEMENT (U.S. CLS. 100, 101 AND 102).

HOWARD SMIGA, EXAMINING ATTORNEY

CLASS 35—(Continued).

SN 85-405,157. HANDLED.COM LLC, WACO, TX. FILED 8-23-2011.

HANDLED.COM

THE MARK CONSISTS OF STANDARD CHARACTERS WITHOUT CLAIM TO ANY PARTICULAR FONT, STYLE, SIZE, OR COLOR.

FOR PROVIDING CLIENT REFERRAL PROGRAMS FOR COMMERCIAL AND RESIDENTIAL PLUMBING SERVICE, ELECTRICAL SERVICE, APPLIANCE SERVICE, GLASS REPAIR AND INSTALLATION SERVICE, HEATING AND AIR CONDITIONING SERVICE; PROVIDING CLIENT REFERRAL PROGRAMS FOR DISASTER RESTORATION SERVICE, NAMELY, RESTORING BUILDING INTERIORS, CARPET AND FURNISHINGS DAMAGED BY FIRE, WATER, SMOKE AND OTHER DISASTERS AND COMMERCIAL AND RESIDENTIAL BUILDING CLEANING AND MOLD PREVENTION SERVICE AND CARPET, UPHOLSTERY AND DRAPERY CLEANING, SPOT, STAIN REMOVAL SERVICE; PROVIDING CLIENT REFERRAL PROGRAMS FOR CARPET, DRAPERY AND UPHOLSTERY DEODORIZING SERVICE; PROVIDING CLIENT REFERRAL PROGRAMS FOR PROFESSIONAL LAWN AND GROUNDS CARE SERVICE (U.S. CLS. 100, 101 AND 102).

JEFF DEFORD, EXAMINING ATTORNEY

SN 85-408,812. PETER LIK IP COMPANY, LLC, LAS VEGAS, NV. FILED 8-26-2011.



OWNER OF U.S. REG. NO. 3,048,088.

THE MARK CONSISTS OF THE WORD "LIK" VERTICALLY CONTAINED INSIDE A SQUARE.

FOR RETAIL AND ON-LINE RETAIL STORE SERVICES FEATURING PHOTOGRAPHIC PRINTS, POSTERS, POSTCARDS, NON-FICTION BOOKS CONTAINING PHOTOGRAPHS, AND CLOTHING; ART GALLERIES (U.S. CLS. 100, 101 AND 102).

FIRST USE 3-31-2010; IN COMMERCE 3-31-2010.

SOPHIA S. KIM, EXAMINING ATTORNEY

CLASS 35—(Continued).

SN 85-408,821. PETER LIK IP COMPANY, LLC, LAS VEGAS, NV. FILED 8-26-2011.

LIK

THE MARK CONSISTS OF STANDARD CHARACTERS WITHOUT CLAIM TO ANY PARTICULAR FONT, STYLE, SIZE, OR COLOR.

OWNER OF U.S. REG. NO. 3,048,088.

FOR RETAIL AND ON-LINE RETAIL STORE SERVICES FEATURING PHOTOGRAPHIC PRINTS, POSTERS, POSTCARDS, NON-FICTION BOOKS CONTAINING PHOTOGRAPHS, AND CLOTHING; ART GALLERIES (U.S. CLS. 100, 101 AND 102).

FIRST USE 5-31-2003; IN COMMERCE 5-31-2003.
SOPHIA S. KIM, EXAMINING ATTORNEY

SN 85-413,473. VOGELSANG AEROSCALE, CHAPEL HILL, NC. FILED 9-1-2011.

Aeroscale

THE MARK CONSISTS OF STANDARD CHARACTERS WITHOUT CLAIM TO ANY PARTICULAR FONT, STYLE, SIZE, OR COLOR.

FOR ON-LINE RETAIL STORE SERVICES FEATURING MODEL AIRPLANES AND PARTS THEREOF (U.S. CLS. 100, 101 AND 102).

FIRST USE 1-1-2009; IN COMMERCE 1-1-2009.
ANDREW LEASER, EXAMINING ATTORNEY

SN 85-415,496. GAL PALS, FALL CITY, WA. FILED 9-6-2011.

GAL PALS

THE MARK CONSISTS OF STANDARD CHARACTERS WITHOUT CLAIM TO ANY PARTICULAR FONT, STYLE, SIZE, OR COLOR.

FOR THE BRINGING TOGETHER, FOR THE BENEFIT OF OTHERS, OF A VARIETY OF GOODS, ENABLING CUSTOMERS TO CONVENIENTLY VIEW AND PURCHASE THOSE GOODS IN THE FIELD OF ALCOHOLIC AND NON-ALCOHOLIC BEVERAGES (U.S. CLS. 100, 101 AND 102).

KATHLEEN M. VANSTON, EXAMINING ATTORNEY

CLASS 35—(Continued).

SN 85-420,963. GREEN, PATRICK, DACULA, GA. FILED 9-13-2011.

MPACT CONSULTING: MEDICAL
PROFESSIONALS ACHIEVING
AND CREATING TOGETHER

THE MARK CONSISTS OF STANDARD CHARACTERS WITHOUT CLAIM TO ANY PARTICULAR FONT, STYLE, SIZE, OR COLOR.

NO CLAIM IS MADE TO THE EXCLUSIVE RIGHT TO USE "CONSULTING", APART FROM THE MARK AS SHOWN.

FOR BUSINESS MANAGEMENT AND CONSULTING SERVICES FOR THE HEALTH CARE INDUSTRY, NAMELY, CUSTOMER SERVICE, PATIENT SATISFACTION, ACCOUNTING SERVICES, MARKETING SERVICES, PROVIDING INDUSTRY EXPERTISE AND ASSISTANCE IN DEVELOPING NETWORKING PARTNERSHIPS (U.S. CLS. 100, 101 AND 102).

DANNEAN HETZEL, EXAMINING ATTORNEY

SN 85-421,224. THE PRETESTING COMPANY, INC., TENN., NJ. FILED 9-13-2011.



PRETESTING
GROUP

OWNER OF U.S. REG. NOS. 3,161,159 AND 3,189,128.

NO CLAIM IS MADE TO THE EXCLUSIVE RIGHT TO USE "GROUP", APART FROM THE MARK AS SHOWN.

THE MARK CONSISTS OF THE WORDING "PRETESTING GROUP" BENEATH A DESIGN CONSISTING OF SIX INTERLOCKING SQUARE-LIKE SHAPES FORMING A CIRCULAR DESIGN WITH A PLUS SIGN APPEARING IN THE CENTER OF THE DESIGN. ABOVE THE DESIGN ARE FIVE STRAIGHT LINES EXTENDING OUTWARD IN AN ARCH-LIKE PATTERN.

SEC. 2(F) AS TO "PRETESTING".

FOR ADVERTISING RESEARCH SERVICES (U.S. CLS. 100, 101 AND 102).

FIRST USE 7-25-2011; IN COMMERCE 7-25-2011.

EUGENIA MARTIN, EXAMINING ATTORNEY

CLASS 35—(Continued).

SN 85-424,911. KAHALA FRANCHISING, L.L.C., SCOTTSDALE, AZ. FILED 9-16-2011.



OWNER OF U.S. REG. NO. 4,080,868.
NO CLAIM IS MADE TO THE EXCLUSIVE RIGHT TO USE "PIZZA" AND "TAKE AND BAKE", APART FROM THE MARK AS SHOWN.

THE MARK CONSISTS OF THE WORDS "PIZZA FRESH" IN A STYLIZED FONT IN A SHADED BOX ABOVE THE WORDS "TAKE N BAKE". A CIRCLE APPEARS BEFORE AND AFTER THE LETTER "N" IN THE WORDS "TAKE N BAKE".

FOR RETAIL STORE SERVICES FEATURING PIZZA (U.S. CLS. 100, 101 AND 102).

KRISTIN DAHLING, EXAMINING ATTORNEY

SN 85-427,567. TOMASSETTI, ROBERT A. DBA FRESH AIR ADVERTISING, WOOSTER, OH. FILED 9-20-2011.

Fresh Air Advertising

THE MARK CONSISTS OF STANDARD CHARACTERS WITHOUT CLAIM TO ANY PARTICULAR FONT, STYLE, SIZE, OR COLOR.

NO CLAIM IS MADE TO THE EXCLUSIVE RIGHT TO USE "ADVERTISING", APART FROM THE MARK AS SHOWN.

FOR AUDIO AND VIDEO PRODUCTION OF ADVERTISING AND MARKETING PROGRAMS (U.S. CLS. 100, 101 AND 102).

FIRST USE 3-1-1985; IN COMMERCE 3-1-1985.

JOHN HWANG, EXAMINING ATTORNEY

CLASS 35—(Continued).

SN 85-427,991. M3 LTD, LLC, EDMOND, OK. FILED 9-21-2011.



NO CLAIM IS MADE TO THE EXCLUSIVE RIGHT TO USE "M3" AND "MUNITIONS", APART FROM THE MARK AS SHOWN.

THE STIPPLING IS FOR SHADING PURPOSES ONLY.
THE MARK CONSISTS OF A CIRCULAR LOGO WITH CROSSED RIFLES AT THE BOTTOM. THE TEXT "MAJOR MALFUNCTION'S MUNITIONS" WRAPS AROUND THE OUTSIDE TOP OF THE CIRCLE. THE TEXT "M3" IS IN THE TOP CENTER PORTION OF THE CIRCLE. RIFLE AMMUNITIONS WRAP AROUND THE OUTSIDE BOTTOM OF THE CIRCLE, AND THE TEXT "MAJOR-MALFUNCTION.COM" BELOW THE IMAGE.

FOR DISTRIBUTORSHIP SERVICES IN THE FIELD OF SILENCERS FOR FIREARMS (U.S. CLS. 100, 101 AND 102).

FIRST USE 9-1-2007; IN COMMERCE 9-1-2007.

LINDA ESTRADA, EXAMINING ATTORNEY

SN 85-428,150. THE AUTHORS GUILD, INC., NEW YORK, NY. FILED 9-21-2011.



THE MARK CONSISTS OF THE WORD "BOOKTALK" IN STYLIZED LETTERING, TO THE RIGHT OF WHICH IS A SPEAKING BUBBLE IN THE FORM OF AN OPEN BOOK, AND BELOW WHICH IS THE WORD "NATION" IN STYLIZED LETTERING.

FOR ON-LINE RETAIL STORE SERVICES FEATURING BOOKS (U.S. CLS. 100, 101 AND 102).

AMY C. KEAN, EXAMINING ATTORNEY

CLASS 35—(Continued).

SN 85-428,164. THE AUTHORS GUILD, INC., NEW YORK, NY. FILED 9-21-2011.



THE MARK CONSISTS OF A SPEAKING BUBBLE IN THE FORM OF AN OPEN BOOK.
FOR ON-LINE RETAIL STORE SERVICES FEATURING BOOKS (U.S. CLS. 100, 101 AND 102).
AMY C. KEAN, EXAMINING ATTORNEY

SN 85-428,355. THE POSITIVE PROS LLC, SARASOTA, FL. FILED 9-21-2011.

THE POSITIVE PRO'S

THE MARK CONSISTS OF STANDARD CHARACTERS WITHOUT CLAIM TO ANY PARTICULAR FONT, STYLE, SIZE, OR COLOR.
NO CLAIM IS MADE TO THE EXCLUSIVE RIGHT TO USE "POSITIVE", APART FROM THE MARK AS SHOWN.
FOR PROVIDING A WEBSITE FEATURING INFORMATION AND RELATED NEWS THAT RECOGNIZES AND PROMOTES THE POSITIVE ACCOMPLISHMENTS OF HUMANITY (U.S. CLS. 100, 101 AND 102).
DAWN FELDMAN, EXAMINING ATTORNEY

SN 85-428,816. SPROKET MARKETS LIMITED, WELLINGTON, NEW ZEALAND, FILED 9-21-2011.

PARTSTRADER

THE MARK CONSISTS OF STANDARD CHARACTERS WITHOUT CLAIM TO ANY PARTICULAR FONT, STYLE, SIZE, OR COLOR.
FOR OPERATING AN ON-LINE MARKETPLACE FEATURING AUTOMOTIVE VEHICLE PARTS (U.S. CLS. 100, 101 AND 102).
FIRST USE 6-17-2009; IN COMMERCE 6-17-2009.
GEOFFREY FOSDICK, EXAMINING ATTORNEY

CLASS 35—(Continued).

SN 85-428,837. SPROKET MARKETS LIMITED, WELLINGTON, NEW ZEALAND, FILED 9-22-2011.



THE MARK CONSISTS OF THE WORDS "PARTSTRADER" ABOVE THE WORDS "RIGHT PARTS - RIGHT TIME - RIGHT PRICE" WITH FOUR GEAR WHEELS TO THE RIGHT.
FOR OPERATING AN ON-LINE MARKETPLACE FEATURING AUTOMOTIVE VEHICLE PARTS (U.S. CLS. 100, 101 AND 102).
FIRST USE 6-17-2009; IN COMMERCE 6-17-2009.
GEOFFREY FOSDICK, EXAMINING ATTORNEY

SN 85-428,939. COLLINSON AND COMPANY, INC., NORCROSS, GA. FILED 9-22-2011.

CONNECT MARKETPLACE

THE MARK CONSISTS OF STANDARD CHARACTERS WITHOUT CLAIM TO ANY PARTICULAR FONT, STYLE, SIZE, OR COLOR.
NO CLAIM IS MADE TO THE EXCLUSIVE RIGHT TO USE "MARKETPLACE", APART FROM THE MARK AS SHOWN.
FOR ORGANIZING, PROMOTING AND CONDUCTING EXHIBITIONS, TRADESHOWS AND EVENTS FOR BUSINESS PURPOSES (U.S. CLS. 100, 101 AND 102).
FIRST USE 3-1-2009; IN COMMERCE 3-1-2009.
VIVIAN MICZNIK FIRST, EXAMINING ATTORNEY

SN 85-429,804. MARA SOFFERIN AND JORDANA BEALE, WILLIAMSVILLE, NY. FILED 9-22-2011.

ROCK YOUR CAUSE

THE MARK CONSISTS OF STANDARD CHARACTERS WITHOUT CLAIM TO ANY PARTICULAR FONT, STYLE, SIZE, OR COLOR.
FOR CHARITABLE SERVICES, NAMELY, PROMOTING AND ORGANIZING CHARITABLE GIVING CAMPAIGNS OF OTHERS (U.S. CLS. 100, 101 AND 102).
FIRST USE 5-1-2008; IN COMMERCE 5-1-2008.
FRANK LATTUCA, EXAMINING ATTORNEY

CLASS 35—(Continued).

SN 85-430,738. ECO 360, LLC, SUFFOLK, VA. FILED 9-23-2011.

SUNDRESS SATURDAYS

THE MARK CONSISTS OF STANDARD CHARACTERS WITHOUT CLAIM TO ANY PARTICULAR FONT, STYLE, SIZE, OR COLOR.

NO CLAIM IS MADE TO THE EXCLUSIVE RIGHT TO USE "SATURDAYS", APART FROM THE MARK AS SHOWN.

FOR ADVERTISING SERVICES RENDERED TO DRAW PEOPLE TO RESTAURANTS, SPORTS EVENTS, CONCERTS, PARTIES, AND OTHER EVENTS BY USING FLIERS, APPAREL, WEBSITE/FACEBOOK AND OTHER SOCIAL MEDIA FOR PROMOTING THE EVENTS (U.S. CLS. 100, 101 AND 102).

MARK RADEMACHER, EXAMINING ATTORNEY

SN 85-430,758. ECO 360, LLC, SUFFOLK, VA. FILED 9-23-2011.

SUNDRESS SUNDAYS

THE MARK CONSISTS OF STANDARD CHARACTERS WITHOUT CLAIM TO ANY PARTICULAR FONT, STYLE, SIZE, OR COLOR.

NO CLAIM IS MADE TO THE EXCLUSIVE RIGHT TO USE "SUNDAYS", APART FROM THE MARK AS SHOWN.

FOR ADVERTISING SERVICES RENDERED TO DRAW PEOPLE TO RESTAURANTS, SPORTS EVENTS, CONCERTS, PARTIES, AND OTHER EVENTS BY USING FLIERS, APPAREL, WEBSITE/FACEBOOK AND OTHER SOCIAL MEDIA FOR PROMOTING THE EVENTS (U.S. CLS. 100, 101 AND 102).

MARK RADEMACHER, EXAMINING ATTORNEY

SN 85-431,710. AMERICAN ASSOCIATION OF PROFESSIONAL LANDMEN, FORT WORTH, TX. FILED 9-26-2011.



OWNER OF U.S. REG. NOS. 1,850,968, 4,146,343 AND 4,153,555.

THE MARK CONSISTS OF THE LETTERS "AAPL" ABOVE THE WORDS "AMERICA'S LANDMEN" WITH A CURVED LINE BETWEEN THEM.

FOR TRADE ASSOCIATION SERVICES, NAMELY, PROMOTING THE INTERESTS OF OIL AND GAS RESOURCE EXPLORERS AND DEVELOPERS (U.S. CLS. 100, 101 AND 102).

FIRST USE 7-0-2009; IN COMMERCE 7-0-2009.

TINA MAI, EXAMINING ATTORNEY

CLASS 35—(Continued).

SN 85-431,905. PRESCIANT LTD, LONDON, UNITED KINGDOM, FILED 9-26-2011.

PRESCIANT

THE MARK CONSISTS OF STANDARD CHARACTERS WITHOUT CLAIM TO ANY PARTICULAR FONT, STYLE, SIZE, OR COLOR.

FOR BUSINESS AND BUSINESS MANAGEMENT CONSULTING IN THE FIELDS OF BRAND DEVELOPMENT, MARKETING, BUSINESS INNOVATION, BUSINESS MERGER AND ACQUISITIONS, BUSINESS ORGANIZATION AND BUSINESS GROWTH STRATEGY (U.S. CLS. 100, 101 AND 102).

ZHALEH DELANEY, EXAMINING ATTORNEY

SN 85-433,802. IMMERGE, LLC, CORAL GABLES, FL. FILED 9-28-2011.



THE COLOR(S) LIGHT RED, RED, DARK RED, ORANGE RED, RED ORANGE, LIGHT ORANGE, ORANGE, DARK ORANGE, ORANGE YELLOW, YELLOW ORANGE, LIGHT YELLOW, YELLOW, DARK YELLOW, YELLOW GREEN, GREEN YELLOW, LIGHT GREEN, GREEN, DARK GREEN, GREEN BLUE, BLUE GREEN, LIGHT BLUE, BLUE, DARK BLUE, WHITE AND GRAY IS/ARE CLAIMED AS A FEATURE OF THE MARK.

THE MARK CONSISTS OF CIRCLES IN DIFFERENT SIZES IN LIGHT RED, RED, DARK RED, ORANGE RED, RED ORANGE, LIGHT ORANGE, ORANGE, DARK ORANGE, ORANGE YELLOW, YELLOW ORANGE, LIGHT YELLOW, YELLOW, DARK YELLOW, YELLOW GREEN, GREEN YELLOW, LIGHT GREEN, GREEN, DARK GREEN, GREEN BLUE, BLUE GREEN, LIGHT BLUE, BLUE, DARK BLUE WITH WHITE ON TOP AND GRAY ON THE BOTTOM OF EACH CIRCLE FORMING THREE OVALS INTERSECTING ONE ANOTHER FORMING AN OVERALL TRIANGULAR SHAPE.

FOR MARKETING AND ADVERTISING SERVICES IN THE NATURE OF DESIGNING AND IMPLEMENTING DIRECT MARKETING, WORD OF MOUTH, VIRAL, BUZZ, EXPERIENTIAL MARKETING, AND ADVERTISING SOLUTIONS (U.S. CLS. 100, 101 AND 102).

SALLY SHIH, EXAMINING ATTORNEY

CLASS 35—(Continued).

SN 85-433,806. IMMERGE, LLC, CORAL GABLES, FL. FILED 9-28-2011.

CLASS 35—(Continued).

SN 85-435,862. CARECLARITY, INC., SAN FRANCISCO, CA. FILED 9-29-2011.

You have the brands, we
have the people

THE MARK CONSISTS OF STANDARD CHARACTERS WITHOUT CLAIM TO ANY PARTICULAR FONT, STYLE, SIZE, OR COLOR.

FOR MARKETING AND ADVERTISING SERVICES IN THE NATURE OF DESIGNING AND IMPLEMENTING DIRECT MARKETING, WORD OF MOUTH, VIRAL, BUZZ, EXPERIENTIAL MARKETING, AND ADVERTISING SOLUTIONS (U.S. CLS. 100, 101 AND 102).
SALLY SHIH, EXAMINING ATTORNEY

CARECLARITY

THE MARK CONSISTS OF STANDARD CHARACTERS WITHOUT CLAIM TO ANY PARTICULAR FONT, STYLE, SIZE, OR COLOR.

FOR BUSINESS DATA ANALYSIS; BUSINESS INFORMATION MANAGEMENT, NAMELY, ELECTRONIC REPORTING OF BUSINESS INFORMATION, BUSINESS ANALYTICS, NAMELY, BUSINESS INVESTIGATIONS, EVALUATIONS, EXPERT APPRAISALS, INFORMATION AND RESEARCH, TRADE SPEND BUSINESS MANAGEMENT; BUSINESS INFORMATION REPORTING SERVICES FOR HOSPITALS, NAMELY, PROVIDING HOSPITAL SPECIFIC REPORTS FOR THE PURPOSE OF ANALYZING GOVERNMENT REIMBURSEMENT DATA AND DRIVE BUSINESS DECISION MAKING; BUSINESS MANAGEMENT CONSULTANCY AND ADVISORY SERVICES; COLLECTING AND ANALYZING CLAIMS DATA FROM HEALTHCARE ORGANIZATIONS FOR BUSINESS PURPOSES; CONSULTING IN THE FIELDS OF HEALTHCARE OPERATIONS MANAGEMENT AND HOSPITAL OPERATIONS MANAGEMENT; PROMOTING THE EXCHANGE OF INFORMATION AND RESOURCES WITHIN THE SCIENTIFIC RESEARCH AND MEDICAL COMMUNITIES TO ACHIEVE ADVANCES IN THE FIELD OF HEALTHCARE; PROVIDING REIMBURSEMENT BENCHMARKING INFORMATION AND OTHER MARKET INTELLIGENCE TO HEALTHCARE ORGANIZATIONS (U.S. CLS. 100, 101 AND 102).

FIRST USE 2-1-2010; IN COMMERCE 5-1-2010.
JEFF DEFORD, EXAMINING ATTORNEY

SN 85-433,810. IMMERGE, LLC, CORAL GABLES, FL. FILED 9-28-2011.

Where people and brands
connect

THE MARK CONSISTS OF STANDARD CHARACTERS WITHOUT CLAIM TO ANY PARTICULAR FONT, STYLE, SIZE, OR COLOR.

FOR MARKETING AND ADVERTISING SERVICES IN THE NATURE OF DESIGNING AND IMPLEMENTING DIRECT MARKETING, WORD OF MOUTH, VIRAL, BUZZ, EXPERIENTIAL MARKETING, AND ADVERTISING SOLUTIONS (U.S. CLS. 100, 101 AND 102).
SALLY SHIH, EXAMINING ATTORNEY

SN 85-435,886. SABLITSKY, CHELSEA, NEW YORK, NY. FILED 9-29-2011.

STREET LOCKERS

THE MARK CONSISTS OF STANDARD CHARACTERS WITHOUT CLAIM TO ANY PARTICULAR FONT, STYLE, SIZE, OR COLOR.

NO CLAIM IS MADE TO THE EXCLUSIVE RIGHT TO USE "LOCKERS", APART FROM THE MARK AS SHOWN.

FOR RETAIL STORE SERVICES FEATURING LOCKERS AND CHANGING ROOMS IN THE NATURE OF PORTABLE NON-METAL STRUCTURES FOR RESIDENTS AND TOURISTS IN DIFFERENT CITIES (U.S. CLS. 100, 101 AND 102).

ALICIA COLLINS, EXAMINING ATTORNEY

CLASS 35—(Continued).

SN 85-437,733. FAMILY DOLLAR STORES OF MICHIGAN INC., MATTHEWS, NC. FILED 10-3-2011.

 The logo for Family Dollar features the words "FAMILY" and "DOLLAR" in a bold, sans-serif font. The word "FAMILY" is in red and "DOLLAR" is in orange. A circular graphic element is positioned between the two words, containing a stylized white figure.

OWNER OF U.S. REG. NOS. 950,085, 3,458,787 AND 3,608,799.

THE COLOR(S) RED, ORANGE AND WHITE IS/ARE CLAIMED AS A FEATURE OF THE MARK.

THE MARK CONSISTS OF THE WORD "FAMILY" IN RED AND THE WORD "DOLLAR" IN ORANGE, WITH A CIRCULAR GRAPHIC DESIGN BETWEEN THE WORDS "FAMILY" AND "DOLLAR". IN THE CIRCULAR GRAPHIC DESIGN, THE BACKGROUND IS RED AND THERE ARE TWO SILHOUETTES OF INDIVIDUALS IN WHITE AND TWO SILHOUETTES OF INDIVIDUALS IN ORANGE INSIDE THE CIRCULAR DESIGN.

FOR RETAIL VARIETY STORE SERVICES (U.S. CLS. 100, 101 AND 102).

FIRST USE 6-15-2007; IN COMMERCE 6-15-2007.
MARLENE BELL, EXAMINING ATTORNEY

CLASS 35—(Continued).

SN 85-438,280. AGUIBAL INCORPORATED, TA SEASONS OLIVE OIL & VINEGAR TAPROOM, BETHLEHEM, PA. FILED 10-3-2011.

 The logo for Seasons Olive Oil & Vinegar Taproom consists of the words "SEASONS OLIVE OIL & VINEGAR TAPROOM" in a serif font, arranged in two lines.

THE MARK CONSISTS OF STANDARD CHARACTERS WITHOUT CLAIM TO ANY PARTICULAR FONT, STYLE, SIZE, OR COLOR.

NO CLAIM IS MADE TO THE EXCLUSIVE RIGHT TO USE "OLIVE OIL & VINEGAR TAPROOM", APART FROM THE MARK AS SHOWN.

FOR RETAIL AND ON-LINE GROCERY STORE SERVICES FEATURING HOME DELIVERY SERVICE; RETAIL GROCERY STORES (U.S. CLS. 100, 101 AND 102).

FIRST USE 4-4-2009; IN COMMERCE 4-20-2009.
KATINA MISTER, EXAMINING ATTORNEY

SN 85-437,946. JAMES P. LAROSE, WEST COLUMBIA, SC. FILED 10-3-2011.

 The logo for DonorScope features the word "DonorScope" in a sans-serif font. "Donor" is in orange and "Scope" is in blue. Below it is the tagline "...transforming prospect research" in a smaller font. To the right is a circular icon with "dot com" inside.

NO CLAIM IS MADE TO THE EXCLUSIVE RIGHT TO USE "DOT COM", APART FROM THE MARK AS SHOWN.

THE COLOR(S) ORANGE, BLUE, LIGHT BLUE, YELLOW AND WHITE IS/ARE CLAIMED AS A FEATURE OF THE MARK.

THE MARK CONSISTS OF THE WORDING "DONORSCOPE" IN ORANGE WITH THE LETTERS "D" AND "S" IN CAPS "D" AND THE INNER CIRCLE OF THE LETTER "O" IN THE TERM "SCOPE" IN BLUE WITH A LIGHT BULB IN THE CENTER OF SAID LETTER IN THE COLOR YELLOW; AT THE END OF THE WORD "DONORSOPE" IS A BLUE CIRCLE OUTLINED WITH A LIGHTER BLUE CIRCLE WITH THE WORDS "DOT" IN LIGHT BLUE AND "COM" IN WHITE; UNDERNEATH THE WORD "DONORSOPE" IS "...TRANSFORMING PROSPECT RESEARCH" IN BLUE.

FOR DATABASE MANAGEMENT FOR DONOR IDENTIFICATION AND CULTIVATION (U.S. CLS. 100, 101 AND 102).

FIRST USE 7-1-2011; IN COMMERCE 7-1-2011.
BILL DAWE, EXAMINING ATTORNEY

SN 85-438,331. PATE, WAYNE, BROOKLYN, NY. FILED 10-4-2011.

 The logo for Print Maison consists of the words "Print Maison" in a serif font.

NO CLAIM IS MADE TO THE EXCLUSIVE RIGHT TO USE "PRINT", APART FROM THE MARK AS SHOWN.

THE MARK CONSISTS OF THE WORDING "PRINT MAISON" IN STYLIZED FONT.

THE ENGLISH TRANSLATION OF "MAISON" IN THE MARK IS "HOUSE".

FOR ON-LINE RETAIL STORE SERVICES FEATURING PAPER GOODS, PRINTED PAPER GOODS, PRINTED TEXTILES, PRINTED MATERIALS, ARTWORK, SILKSCREEN PRINTS, ART PRINTS, PRINTS, BOOKS, TEXTILES, GREETING CARDS, POST CARDS, PRINTED TOTE BAGS, PRINTED HOME WARES, TRAYS, PLATES, AND CUPS (U.S. CLS. 100, 101 AND 102).

JULIE VEPPUMTHARA, EXAMINING ATTORNEY

CLASS 35—(Continued).

SN 85-438,341. PATE, WAYNE, BROOKLYN, NY. FILED 10-4-2011.

PRINT MAISON

THE MARK CONSISTS OF STANDARD CHARACTERS WITHOUT CLAIM TO ANY PARTICULAR FONT, STYLE, SIZE, OR COLOR.

NO CLAIM IS MADE TO THE EXCLUSIVE RIGHT TO USE "PRINT", APART FROM THE MARK AS SHOWN.

THE ENGLISH TRANSLATION OF "MAISON" IN THE MARK IS "HOUSE".

FOR ON-LINE RETAIL STORE SERVICES FEATURING PAPER GOODS, PRINTED PAPER GOODS, PRINTED TEXTILES, PRINTED MATERIALS, ARTWORK, SILKSCREEN PRINTS, ART PRINTS, PRINTS, BOOKS, TEXTILES, GREETING CARDS, POST CARDS, PRINTED TOTE BAGS, PRINTED HOME WARES, TRAYS, PLATES, AND CUPS (U.S. CLS. 100, 101 AND 102).

JULIE VEPPUMTHARA, EXAMINING ATTORNEY

CLASS 35—(Continued).

SN 85-438,675. JEFFERSON, PHUNG H., LAS VEGAS, NV. FILED 10-4-2011.

Moose Network

THE MARK CONSISTS OF STANDARD CHARACTERS WITHOUT CLAIM TO ANY PARTICULAR FONT, STYLE, SIZE, OR COLOR.

NO CLAIM IS MADE TO THE EXCLUSIVE RIGHT TO USE "NETWORK", APART FROM THE MARK AS SHOWN.

FOR PROMOTING THE GOODS AND SERVICES OF OTHERS BY PROVIDING AN INTERACTIVE WEBSITE WHERE USERS CAN INCREASE THE CURRENT VALUE OF AN ONLINE DISCOUNT BEING OFFERED BY PURCHASING THE GOODS AND SERVICES ASSOCIATED WITH THAT DISCOUNT IN THE FORM OF AN ONLINE COUPON, VOUCHER OR GIFT CARD (U.S. CLS. 100, 101 AND 102).

LAURIE MAYES, EXAMINING ATTORNEY

SN 85-438,441. HAMPTON, DWAYNE, LAWRENCEVILLE, GA. FILED 10-4-2011.



NO CLAIM IS MADE TO THE EXCLUSIVE RIGHT TO USE "FINANCIAL MEDIA", APART FROM THE MARK AS SHOWN.

THE MARK CONSISTS OF THE STYLIZED TEXT "2ENGAGE". TO THE RIGHT IS THE STYLIZED TEXT "FINANCIAL" ABOVE THE STYLIZED TEXT "MEDIA". UNDERNEATH "2ENGAGE FINANCIAL MEDIA" IS THE STYLIZED TEXT "EMPOWERING STAKEHOLDER ENGAGEMENT".

FOR HELPING PUBLICALLY TRADED COMPANIES BUILD THEIR RELATIONS IN A POSITIVE MANNER WITH THEIR STAKEHOLDERS BY PROMOTING AND MARKETING THEMSELVES IN AN IMPROVED MANNER BY DESIGNING AND PUBLISHING THEIR SHAREHOLDER DOCUMENTS, SUCH AS ANNUAL REPORTS AND PROXY STATEMENTS, AS WELL AS SUBMITTING THEIR FINANCIAL RESULTS TO THE SECURITY EXCHANGE COMMISSION (U.S. CLS. 100, 101 AND 102).

FIRST USE 12-1-2011; IN COMMERCE 12-1-2011.
PAUL E. FAHRENKOPF, EXAMINING ATTORNEY

SN 85-438,690. JEFFERSON, PHUNG H., LAS VEGAS, NV. FILED 10-4-2011.



NO CLAIM IS MADE TO THE EXCLUSIVE RIGHT TO USE "NETWORK", APART FROM THE MARK AS SHOWN. THE COLOR(S) TEAL, BURNT ORANGE, BLACK, WHITE IS/ARE CLAIMED AS A FEATURE OF THE MARK.

THE MARK CONSISTS OF THE LANGUAGE "MOOSE NETWORK" WHERE THE LETTERS "M"-SE "NETWORK" ARE TEAL WITH THE TWO LETTER "O"'S IN "MOOSE" ARE OUTLINED IN BURNT ORANGE WITH BLACK AND WHITE EYES AND WITH BURNT ORANGE ANTLERS PROTRUDING FROM THE BLACK AND WHITE EYES.

FOR PROMOTING THE GOODS AND SERVICES OF OTHERS BY PROVIDING AN INTERACTIVE WEBSITE WHERE USERS CAN INCREASE THE CURRENT VALUE OF AN ONLINE DISCOUNT BEING OFFERED BY PURCHASING THE GOODS AND SERVICES ASSOCIATED WITH THAT DISCOUNT IN THE FORM OF AN ONLINE COUPON, VOUCHER OR GIFT CARD (U.S. CLS. 100, 101 AND 102).

LAURIE MAYES, EXAMINING ATTORNEY

CLASS 35—(Continued).

SN 85-438,752. CC 1 BEER DISTRIBUTORS CORP., TOA BAJA, PUERTO RICO, FILED 10-4-2011.



THE MARK CONSISTS OF THE WORD "BODEGAR", WITH GRAPES BENEATH THE "E" AND THE "G". A SILHOUETTE OF A WINE BOTTLE IS WITHIN THE "A".
FOR DISTRIBUTORSHIPS IN THE FIELD OF WINE AND LIQUORS; RETAIL STORE SERVICES IN THE FIELD OF WINE AND LIQUORS (U.S. CLS. 100, 101 AND 102).

FIRST USE 7-15-2002; IN COMMERCE 7-15-2002.
MARK SPARACINO, EXAMINING ATTORNEY

SN 85-439,474. CITY LIGHT CAPITAL, LLC, NEW YORK, NY. FILED 10-5-2011.

IMPACT PACT

THE MARK CONSISTS OF STANDARD CHARACTERS WITHOUT CLAIM TO ANY PARTICULAR FONT, STYLE, SIZE, OR COLOR.

NO CLAIM IS MADE TO THE EXCLUSIVE RIGHT TO USE "IMPACT", APART FROM THE MARK AS SHOWN.

FOR PROMOTING PUBLIC AWARENESS OF IMPACT INVESTING (U.S. CLS. 100, 101 AND 102).

KELLY TRUSILO, EXAMINING ATTORNEY

SN 85-441,356. MISHKHAH, LLC, DENVER, CO. FILED 10-6-2011.

MISHKHAH

THE MARK CONSISTS OF STANDARD CHARACTERS WITHOUT CLAIM TO ANY PARTICULAR FONT, STYLE, SIZE, OR COLOR.

THE WORDING "MISHKHAH" HAS NO MEANING IN A FOREIGN LANGUAGE.

FOR ON-LINE RETAIL STORE SERVICES FEATURING RELIGIOUS THEMED PRODUCTS, NAMELY, PRE-RECORDED DIGITAL AND ELECTRONIC MEDIA FEATURING MUSIC, SOUND RECORDINGS, HYMNS, PRAYER ARRANGEMENTS, MEDITATIONS AND PHOTOGRAPHS; DIGITAL MEDIA FEATURING RELIGIOUS CONTENT; SHEET MUSIC; E-BOOKS; MYRRH; INCENSE; PERFUME; OIL AND MYRRH RESIN; FABRICS; TAPESTRIES; WORSHIP FABRICS; ARCHITECTURAL REMNANTS; RELIGIOUS STATUES AND RELIGIOUS FIGURINES; INDIVIDUAL PRAYER STATIONS (U.S. CLS. 100, 101 AND 102).

DAVID C. REIHNER, EXAMINING ATTORNEY

CLASS 35—(Continued).

SN 85-441,548. UTOPIA, INC., MUNDELEIN, IL. FILED 10-7-2011.

EDLM

THE MARK CONSISTS OF STANDARD CHARACTERS WITHOUT CLAIM TO ANY PARTICULAR FONT, STYLE, SIZE, OR COLOR.

FOR BUSINESS CONSULTING SERVICES IN THE FIELD OF DATA MANAGEMENT (U.S. CLS. 100, 101 AND 102).

FIRST USE 7-1-2008; IN COMMERCE 10-1-2008.
JUDITH HELFMAN, EXAMINING ATTORNEY

SN 85-441,791. CONVERSOCIAL (UK) LIMITED, LONDON, UNITED KINGDOM, FILED 10-7-2011.

CONVERSOCIAL

THE MARK CONSISTS OF STANDARD CHARACTERS WITHOUT CLAIM TO ANY PARTICULAR FONT, STYLE, SIZE, OR COLOR.

OWNER OF ERPN CMNTY TM OFC REG. NO. 010256691, DATED 2-23-2012, EXPIRES 2-23-2022.

FOR MARKETING; ADVERTISING; BUSINESS MANAGEMENT; BUSINESS ADMINISTRATION; OPERATION OF ONLINE AND TELEPHONE CUSTOMER SUPPORT CENTERS FOR OTHERS; OPERATION OF CALL CENTERS; DATA PROCESSING AND ANALYTICS; CUSTOMER RELATIONSHIP MANAGEMENT; PROVIDING AN ONLINE PORTAL FOR CUSTOMER RELATIONSHIP MANAGEMENT AND ENGAGEMENT; OPERATION OF CALL CENTERS; PROVISION OF DIRECTORY INFORMATION, NAMELY, PROVISION OF TELEPHONE DIRECTORY INFORMATION (U.S. CLS. 100, 101 AND 102).

DAVID TOOLEY, EXAMINING ATTORNEY

CLASS 35—(Continued).

SN 85-441,846. MPH INDUSTRIES, INC., OWENSBORO, KY.
FILED 10-7-2011.

ON-DUTY DEPOT

THE MARK CONSISTS OF STANDARD CHARACTERS WITHOUT CLAIM TO ANY PARTICULAR FONT, STYLE, SIZE, OR COLOR.

NO CLAIM IS MADE TO THE EXCLUSIVE RIGHT TO USE "DEPOT", APART FROM THE MARK AS SHOWN.

FOR ON-LINE RETAIL STORE SERVICES FEATURING A WIDE VARIETY OF CONSUMER GOODS, NAMELY, LAW ENFORCEMENT, SECURITY AND SAFETY RELATED PRODUCTS; WHOLESALE AND RETAIL STORE SERVICES FEATURING A WIDE VARIETY OF CONSUMER GOODS, NAMELY, LAW ENFORCEMENT, SECURITY AND SAFETY RELATED PRODUCTS (U.S. CLS. 100, 101 AND 102).

ANNE MADDEN, EXAMINING ATTORNEY

CLASS 35—(Continued).

SN 85-443,394. DENTAL HUNTERS, INC., BOSTON, MA.
FILED 10-10-2011.

Dental Hunters

THE MARK CONSISTS OF STANDARD CHARACTERS WITHOUT CLAIM TO ANY PARTICULAR FONT, STYLE, SIZE, OR COLOR.

NO CLAIM IS MADE TO THE EXCLUSIVE RIGHT TO USE "DENTAL", APART FROM THE MARK AS SHOWN.

FOR EMPLOYMENT AGENCY SERVICES, NAMELY, TEMPORARY AND PERMANENT PLACEMENT OF HEALTH CARE PROFESSIONALS; EMPLOYMENT HIRING, RECRUITING, PLACEMENT, STAFFING AND CAREER NETWORKING SERVICES; EMPLOYMENT SERVICES, NAMELY, PROVIDING A WEB SITE WITH ONLINE VIDEO, AUDIO AND TEXTUAL INTERVIEWING APPLICATIONS TO SUPPORT RECRUITING, ADMISSIONS, AND GENERAL CANDIDATE SCREENING PROCESSES; PROVIDING AN EMPLOYER WITH CANDIDATES OR POTENTIAL EMPLOYEES TO FILL TEMPORARY, CONTRACT AND PERMANENT POSITIONS; PROVIDING AN ON-LINE SEARCHABLE DATABASE FEATURING EMPLOYMENT OPPORTUNITIES AND CONTENT ABOUT EMPLOYMENT RELEVANT TO DENTISTRY; PROVIDING ON-LINE EMPLOYMENT INFORMATION IN THE FIELD OF DENTISTRY (U.S. CLS. 100, 101 AND 102).

FIRST USE 5-12-2011; IN COMMERCE 5-12-2011.

AHSEN KHAN, EXAMINING ATTORNEY

SN 85-444,033. FIVE OAKS MARKETING, INC., ANKENY, IA. FILED 10-11-2011.

HOME WISHES

THE MARK CONSISTS OF STANDARD CHARACTERS WITHOUT CLAIM TO ANY PARTICULAR FONT, STYLE, SIZE, OR COLOR.

FOR ONLINE RETAIL STORE SERVICES FEATURING A WIDE VARIETY OF CONSUMER GOODS OF OTHERS; ONLINE RETAIL STORE SERVICES FEATURING HOME AND OUTDOOR PRODUCTS IN THE NATURE OF HOME DÉCOR, FURNITURE, LAMPS AND LIGHTING, CLEANING AND HOUSEHOLD PRODUCTS, STORAGE AND ORGANIZATIONAL PRODUCTS, TOYS AND KIDS FURNITURE, JEWELRY BOXES, HOLIDAY DÉCOR, OUTDOOR LIVING PRODUCTS, NAMELY, ARBORS, PERGOLAS, TRELLISES, BARBEQUE GRILLS AND SMOKERS, BIRDHOUSES AND FEEDERS, DOORMATS AND RUGS, PORTABLE FIREPLACES, FOUNTAINS AND BIRD BATHS, GREENHOUSES AND STORAGE SHEDS, LANDSCAPE LIGHTING, LAWN AND GARDEN SUPPLIES, PATIO FURNITURE, PET PRODUCTS, SECURITY LIGHTING, SPORTS AND RECREATION PRODUCTS, UMBRELLAS AND SHADES (U.S. CLS. 100, 101 AND 102).

FIRST USE 10-5-2005; IN COMMERCE 10-5-2005.

MARY CRAWFORD, EXAMINING ATTORNEY

SN 85-442,053. STORYMANAGER, INC., HONOLULU, HI.
FILED 10-7-2011.

BIZGYM

THE MARK CONSISTS OF STANDARD CHARACTERS WITHOUT CLAIM TO ANY PARTICULAR FONT, STYLE, SIZE, OR COLOR.

FOR BUSINESS PLANNING (U.S. CLS. 100, 101 AND 102).

FIRST USE 1-11-2011; IN COMMERCE 1-11-2011.

EMILY CARLSEN, EXAMINING ATTORNEY

CLASS 35—(Continued).

SN 85-444,522. AMERICA,S GOT PRODUCT, LLC, EVER-GREEN, CO. FILED 10-11-2011.

AMERICA'S GOT PRODUCT

THE MARK CONSISTS OF STANDARD CHARACTERS WITHOUT CLAIM TO ANY PARTICULAR FONT, STYLE, SIZE, OR COLOR.

FOR PROVIDING A WEB SITE FEATURING PRODUCT RATINGS OF THE CONSUMER GOODS OF OTHERS IN THE FIELD OF AUTOMOBILES AND APPLIANCES (U.S. CLS. 100, 101 AND 102).

FIRST USE 8-1-2008; IN COMMERCE 8-1-2008.

RONALD MCMORROW, EXAMINING ATTORNEY

SN 85-444,644. MY JOB CHART, INC., QUEEN CREEK, AZ. FILED 10-11-2011.

WHERE KIDS, WORK AND REWARD CLICK

THE MARK CONSISTS OF STANDARD CHARACTERS WITHOUT CLAIM TO ANY PARTICULAR FONT, STYLE, SIZE, OR COLOR.

FOR INTERACTIVE ONLINE EDUCATIONAL WEBSITE FOR CHILDREN AND FAMILIES FEATURING A CUSTOMIZED, USER-GENERATED REWARDS SYSTEM ENABLING USERS TO INPUT INFORMATION ABOUT TASKS TO BE ACCOMPLISHED AND TO MONITOR AND RECORD ACCOMPLISHMENT OF TASKS AS WELL AS REWARD POINTS EARNED, SAVED, DONATED OR USED TO PURCHASE GOODS AND SERVICES OF OTHERS (U.S. CLS. 100, 101 AND 102).

FIRST USE 3-0-2011; IN COMMERCE 3-0-2011.

SUSAN STIGLITZ, EXAMINING ATTORNEY

SN 85-444,888. WORLD VISION, INC., FEDERAL WAY, WA. FILED 10-11-2011.

GIVEN

THE MARK CONSISTS OF STANDARD CHARACTERS WITHOUT CLAIM TO ANY PARTICULAR FONT, STYLE, SIZE, OR COLOR.

FOR CHARITABLE SERVICES, NAMELY, PUBLIC ADVOCACY IN SUPPORT OF VOLUNTEER PROGRAMS AND PROJECTS TO ADDRESS THE CAUSES OF INJUSTICE AND POVERTY WORLDWIDE (U.S. CLS. 100, 101 AND 102).

PRISCILLA MILTON, EXAMINING ATTORNEY

CLASS 35—(Continued).

SN 85-444,950. HOLLY B. HOLDINGS LLC, COLUMBUS, OH. FILED 10-11-2011.

GETTING PERSONAL

THE MARK CONSISTS OF STANDARD CHARACTERS WITHOUT CLAIM TO ANY PARTICULAR FONT, STYLE, SIZE, OR COLOR.

FOR ADDRESSING OF ENVELOPES; ONLINE RETAIL STORE SERVICES FEATURING STANDARD, CUSTOMIZABLE AND PERSONALIZED GREETING CARDS (U.S. CLS. 100, 101 AND 102).

TRACY FLETCHER, EXAMINING ATTORNEY

SN 85-445,493. COUNTDOWN TO SAVE, INC., INDIANAPOLIS, IN. FILED 10-12-2011.

CONVENIENT MOBILE SAVINGS

THE MARK CONSISTS OF STANDARD CHARACTERS WITHOUT CLAIM TO ANY PARTICULAR FONT, STYLE, SIZE, OR COLOR.

NO CLAIM IS MADE TO THE EXCLUSIVE RIGHT TO USE "MOBILE SAVINGS", APART FROM THE MARK AS SHOWN.

FOR THE BRINGING TOGETHER, FOR THE BENEFIT OF OTHERS, OF A VARIETY OF OFFERS, NAMELY, COUPONS AND DISCOUNTS FOR GOODS OR SERVICES OF OTHERS, ENABLING CUSTOMERS TO CONVENIENTLY ACCESS AND PURCHASE THOSE OFFERS VIA ELECTRONIC ON-DEMAND TRANSMISSION, PROMOTIONAL SERVICES, NAMELY, PROMOTING THE GOODS OF OTHERS BY PROVIDING DIGITAL ON-DEMAND DELIVERY TO CONSUMERS VIA INSTANT MESSAGING OF INFORMATION REGARDING COUPONS, DISCOUNTS OR SPECIAL OFFERS RELATING TO GOODS OR SERVICES OF OTHERS (U.S. CLS. 100, 101 AND 102).

FIRST USE 7-1-2010; IN COMMERCE 7-1-2010.

TEJBIR SINGH, EXAMINING ATTORNEY

CLASS 35—(Continued).

SN 85-445,727. PRODUCTS DIRECT, INC., HAROLD, KY. FILED 10-12-2011.



NO CLAIM IS MADE TO THE EXCLUSIVE RIGHT TO USE "PRODUCTS" AND "DIRECT", APART FROM THE MARK AS SHOWN.

THE MARK CONSISTS OF THE WORD "PORTION" OF THE MARK ENCLOSED WITHIN A RECTANGULAR SPACE CONTAINING CURVED EDGES WITH THE WORD "DIRECT" PRECEDED BY THE IMAGE OF A HOUSE.

FOR ON-LINE RETAIL STORE SERVICES FEATURING HOME IMPROVEMENT PRODUCTS, NAMELY, HARDWOOD FLOORING, LAMINATE FLOORING, MARBLE, BATHROOM VANITIES, BATHROOM CABINET HARDWARE, KITCHEN ISLANDS, KITCHEN CABINET HARDWARE, CABINETS, FAUCETS, AND MIRRORS (U.S. CLS. 100, 101 AND 102).

FIRST USE 7-1-2011; IN COMMERCE 7-1-2011. THOMAS MANOR, EXAMINING ATTORNEY

CLASS 35—(Continued).

SN 85-448,928. DALLAS MAVERICKS LIMITED, DALLAS, TX. FILED 10-17-2011.

MAVGEAR

THE MARK CONSISTS OF STANDARD CHARACTERS WITHOUT CLAIM TO ANY PARTICULAR FONT, STYLE, SIZE, OR COLOR.

FOR RETAIL STORE SERVICES, COMPUTERIZED ON-LINE RETAIL STORE SERVICES, ONLINE ORDERING SERVICES, ELECTRONIC RETAIL STORE SERVICES VIA COMPUTER, AND ELECTRONIC MAIL ORDER CATALOG SERVICES, ALL FEATURING AN ARRAY OF BASKETBALL-THEMED MERCHANDISE; PROMOTING THE GOODS AND SERVICES OF OTHERS BY ARRANGING FOR SPONSORS TO AFFILIATE THESE GOODS AND SERVICES WITH A BASKETBALL PROGRAM; PROMOTING THE SALE OF GOODS AND SERVICES OF OTHERS THROUGH THE DISTRIBUTION OF PROMOTIONAL CONTESTS PROVIDED OVER THE INTERNET; CONDUCTING PUBLIC OPINION POLL SURVEYS AND PUBLIC OPINION POLL SURVEYS IN THE FIELD OF BASKETBALL FOR NON-BUSINESS, NON-MARKETING PURPOSES OVER THE INTERNET (U.S. CLS. 100, 101 AND 102).

FIRST USE 3-1-2001; IN COMMERCE 3-1-2001. LESLEY LAMOTHE, EXAMINING ATTORNEY

SN 85-449,712. ITAL-WEST, INC., DBA LA FURNITURE STORE, VERNON, CA. FILED 10-18-2011.

SN 85-447,636. CITY OF CLIFTON, CLIFTON, TX. FILED 10-14-2011.



DEEP IN THE ART OF TEXAS

THE MARK CONSISTS OF STANDARD CHARACTERS WITHOUT CLAIM TO ANY PARTICULAR FONT, STYLE, SIZE, OR COLOR.

FOR ADVERTISING AND MARKETING (U.S. CLS. 100, 101 AND 102).

FIRST USE 1-0-2007; IN COMMERCE 1-0-2007. KATHRYN COWARD, EXAMINING ATTORNEY

NO CLAIM IS MADE TO THE EXCLUSIVE RIGHT TO USE "LA FURNITURE STORE", APART FROM THE MARK AS SHOWN.

THE COLOR(S) ORANGE, WHITE AND GRAY IS/ARE CLAIMED AS A FEATURE OF THE MARK.

THE MARK CONSISTS OF THE LETTERS "LA" WITH THE WORDS "FURNITURE STORE" UNDERNEATH IT, BOTH IN WHITE FONT. SPECIFICALLY, THERE IS A SQUARE WHEREIN THE TOP PORTION IS GRAY AND THE GRAY PORTION EXTENDS TO THE OUTERMOST

CLASS 35—(Continued).

RIGHT SIDE OF THE SQUARE. THERE IS A WHITE WAVE LIKE LINE WHICH EXTENDS FROM THE UPPER LEFT SIDE OF THE SQUARE AND EXTENDS TO THE BOTTOM RIGHT SIDE OF THE SQUARE. WITHIN THE GRAY SQUARE IS AN ORANGE PORTION WHICH EXTENDS FROM THE BOTTOM OF THE SQUARE AND MEETS THE WAVE LIKE WHITE LINE IN THE MIDDLE OF THE SQUARE. WITHIN THE ORANGE PORTION ARE THE LETTERS "LA" WITH THE WORDS "FURNITURE STORE" UNDERNEATH THE LETTERS.

FOR RETAIL FURNITURE STORES (U.S. CLS. 100, 101 AND 102).

FIRST USE 6-0-2009; IN COMMERCE 6-0-2009.
LIEF MARTIN, EXAMINING ATTORNEY

SN 85-451,273. NETRACORP, LLC, OLATHE, KS. FILED 10-19-2011.

GUILT

THE MARK CONSISTS OF STANDARD CHARACTERS WITHOUT CLAIM TO ANY PARTICULAR FONT, STYLE, SIZE, OR COLOR.

FOR ON-LINE ADVERTISING AND MARKETING SERVICES (U.S. CLS. 100, 101 AND 102).
BRENDAN REGAN, EXAMINING ATTORNEY

SN 85-452,703. SOMRAJ SINGH, FREMONT, CA. FILED 10-20-2011.

SaveMax

THE MARK CONSISTS OF STANDARD CHARACTERS WITHOUT CLAIM TO ANY PARTICULAR FONT, STYLE, SIZE, OR COLOR.

FOR ADMINISTRATION OF A DISCOUNT PROGRAM FOR ENABLING PARTICIPANTS TO OBTAIN DISCOUNTS ON GOODS AND SERVICES THROUGH USE OF A DISCOUNT MEMBERSHIP CARD; ADMINISTRATION OF A PROGRAM FOR ENABLING PARTICIPANTS TO OBTAIN DISCOUNTS ON GOODS AND RECEIVE IMPROVED SERVICES; ADVERTISING AND MARKETING; ADVERTISING AND PROMOTIONAL SERVICES; ADVERTISING AND PUBLICITY SERVICES, NAMELY, PROMOTING THE GOODS, SERVICES, BRAND IDENTITY AND COMMERCIAL INFORMATION AND NEWS OF THIRD PARTIES THROUGH PRINT, AUDIO, VIDEO, DIGITAL AND ON-LINE MEDIUM; ADVERTISING, MARKETING AND PROMOTION SERVICES; AN INTERACTIVE WEB SITE FOR USERS TO REVIEW AND RATE INTERNET CONTENT, PEOPLE, COMPANIES, PRODUCTS AND/OR SERVICES UTILIZING A SOFTWARE APPLICATION TO AWARD POINTS WHEREBY WEB SITE USERS ARE ELIGIBLE TO EXCHANGE POINTS EARNED FOR PROMOTIONAL ITEMS CONSISTING OF COUPONS, REBATES, DISCOUNTS OR SPECIAL OFFERINGS ON GOODS AND/OR SERVICE PROVIDED BY WEB SITE SPONSORS; ARRANGING AND CONDUCTING BUSINESS CONFERENCES; ARRANGING AND CONDUCTING OF FAIRS AND EXHIBITIONS FOR BUSINESS AND ADVERTISING PURPOSES; BANNER ADVERTISING; BUSINESS ADVISORY AND CONSULTANCY SERVICES RELATING TO EXPORT, EXPORT SERVICES, EXPORT PRO-

CLASS 35—(Continued).

MOTION INFORMATION AND SERVICES; BUSINESS ASSISTANCE, ADVISORY SERVICES AND CONSULTANCY IN THE FIELDS OF BUDGETING, BOOKKEEPING, PREPARATION AND FILING OF CLAIMS, PREPARATION AND FILING OF FORMS, BILL PAYING, ORGANIZING AND PROCESSING PAPERWORK, DEVELOPMENT OF PLAN TO ACHIEVE GOALS AND REFERRAL SERVICES TO BEREAVEMENT COUNSELORS; BUSINESS CONSULTATION SERVICES TO ASSIST NON-PROFIT ORGANIZATIONS IN PLANNING, MANAGING, AND CONDUCTING FUNDRAISING ACTIVITIES VIA A GLOBAL COMPUTER NETWORK; BUSINESS INFORMATION MANAGEMENT, NAMELY, ELECTRONIC REPORTING OF BUSINESS INFORMATION, BUSINESS ANALYTICS, NAMELY, BUSINESS INVESTIGATIONS, EVALUATIONS, EXPERT APPRAISALS, INFORMATION AND RESEARCH, TRADE SPEND BUSINESS MANAGEMENT; BUSINESS MONITORING AND CONSULTING SERVICES, NAMELY, TRACKING WEB SITES AND APPLICATIONS OF OTHERS TO PROVIDE STRATEGY, INSIGHT, MARKETING, SALES, OPERATION, PRODUCT DESIGN, PARTICULARLY SPECIALIZING IN THE USE OF ANALYTIC AND STATISTIC MODELS FOR THE UNDERSTANDING AND PREDICTING OF CONSUMERS, BUSINESSES, AND MARKET TRENDS AND ACTIONS; COMPILATION OF ADVERTISEMENTS FOR USE AS WEB PAGES ON THE INTERNET; COOPERATIVE ADVERTISING AND MARKETING; DESIGN OF ADVERTISING MATERIALS FOR OTHERS; DESIGN OF INTERNET ADVERTISING; DIRECT MAIL ADVERTISING SERVICES; DIRECT MARKETING ADVERTISING FOR OTHERS; GENERAL BUSINESS NETWORKING REFERRAL SERVICES, NAMELY, PROMOTING THE GOODS AND SERVICES OF OTHERS BY PASSING BUSINESS LEADS AND REFERRALS AMONG GROUP MEMBERS; INTERNET ADVERTISING SERVICES; LAYOUT SERVICES FOR ADVERTISING PURPOSES; MARKETING SERVICES, NAMELY, PROMOTING OR ADVERTISING THE GOODS AND SERVICES OF OTHERS; MARKETING, ADVERTISING, AND PROMOTING THE RETAIL GOODS AND SERVICES OF OTHERS THROUGH WIRELESS ELECTRONIC DEVICES; MARKETING, PROMOTIONAL AND ADVERTISING SERVICES PROVIDED BY MOBILE TELEPHONE CONNECTIONS; MEMBERSHIP CLUB SERVICES PROVIDING DISCOUNTS AND PROCESSING REBATES FOR THE SERVICES OF OTHERS; MEMBERSHIP CLUB SERVICES PROVIDING DISCOUNTS TO MEMBERS ON REAL ESTATE COMMISSIONS AND MORTGAGE FEES; ORGANIZATION OF EVENTS, EXHIBITIONS, FAIRS AND SHOWS FOR COMMERCIAL, PROMOTIONAL AND ADVERTISING PURPOSES; ORGANIZING, PROMOTING AND CONDUCTING EXHIBITIONS, TRADESHOWS AND EVENTS FOR BUSINESS PURPOSES; PROMOTING THE GOODS AND SERVICES OF OTHERS BY PROVIDING A WEBSITE FEATURING COUPONS, REBATES, PRICE-COMPARISON INFORMATION, PRODUCT REVIEWS, LINKS TO THE RETAIL WEBSITES OF OTHERS, AND DISCOUNT INFORMATION; PROMOTING THE GOODS AND SERVICES OF OTHERS BY PROVIDING AN INTERACTIVE WEBSITE WHERE USERS CAN INCREASE THE CURRENT VALUE OF AN ONLINE DISCOUNT BEING OFFERED BY PURCHASING THE GOODS AND SERVICES ASSOCIATED WITH THAT DISCOUNT IN THE FORM OF AN ONLINE COUPON, VOUCHER OR GIFT CARD; PROVIDING A SEARCHABLE ONLINE ADVERTISING GUIDE FEATURING THE GOODS AND SERVICES OF ONLINE VENDORS; PROVIDING A WEB SITE WHERE USERS CAN POST ITEMS FOR SALE THROUGH ONLINE CLASSIFIED ADVERTISEMENTS; PROVIDING A WEB SITE WHERE USERS CAN POST RATINGS, REVIEWS AND RECOMMENDATIONS ON EMPLOYERS AND EMPLOYEES AND PLACES OF EMPLOYMENT FOR USE BY EMPLOYEES, EMPLOYERS, BUSINESS OWNERS, AND CONSUMERS; PROVIDING A WEB SITE WHICH FEATURES ADVERTISEMENTS FOR THE GOODS AND SERVICES OF OTHERS ON A GLOBAL COMPUTER NETWORK; PROVIDING A WEB-BASED ON-LINE PORTAL THAT PROVIDES CUSTOMER ACCESS TO THEIR ELECTRIC BILL ACCOUNT INFORMATION, ENERGY USAGE PATTERN INFORMATION,

CLASS 35—(Continued).

AND ENERGY CONSUMPTION AND USAGE DATA, FOR PURPOSES OF UTILITY ACCOUNT BUSINESS MANAGEMENT AND ENERGY USAGE MANAGEMENT; PROVIDING ADVERTISING, MARKETING AND PROMOTIONAL SERVICES, NAMELY, DEVELOPMENT OF ADVERTISING CAMPAIGNS PROVIDED THROUGH CABLE TELEVISION BROADCAST, WEB CASTS, RADIO BROADCASTS, NEWSPAPERS, MAGAZINES, ONLINE BANNERS, OUTDOOR BILLBOARDS, WILD POSTINGS, BUS AND SUBWAY ADS; REAL ESTATE ADVERTISING SERVICES (U.S. CLS. 100, 101 AND 102).

DAVID MURRAY, EXAMINING ATTORNEY

CLASS 35—(Continued).

SN 85-455,654. PERMISSION INTERACTIVE, INC., SANTEE, CA. FILED 10-25-2011.

ETHOS EDITABLE

SN 85-455,123. LISTEN UP ESPANOL, LLC, PORTLAND, ME. FILED 10-25-2011.



THE MARK CONSISTS OF A STYLIZED TREATMENT OF SOUND WAVES EMANATING FROM THE LETTERS "L","I" IN "LISTENUPESPANOL", WHICH IS IN A STYLIZED FONT.

THE ENGLISH TRANSLATION OF "ESPANOL" IN THE MARK IS "SPANISH".

FOR MANAGEMENT OF TELEPHONE CALL CENTERS FOR OTHERS, NAMELY, CALL CENTER OUTSOURCING SERVICES, SALES AND BUSINESS PROCESS OUTSOURCING SERVICES IN THE FIELD OF CALL MANAGEMENT, TELEMARKETING AND CUSTOMER MANAGEMENT, CALL MANAGEMENT SERVICES FOR INBOUND AND OUTBOUND CALL SERVICES, TELEMARKETING, CUSTOMER SERVICE MANAGEMENT (U.S. CLS. 100, 101 AND 102).

FIRST USE 9-30-2006; IN COMMERCE 9-30-2006.

FRANK LATTUCA, EXAMINING ATTORNEY

THE MARK CONSISTS OF STANDARD CHARACTERS WITHOUT CLAIM TO ANY PARTICULAR FONT, STYLE, SIZE, OR COLOR.

NO CLAIM IS MADE TO THE EXCLUSIVE RIGHT TO USE "EDITABLE", APART FROM THE MARK AS SHOWN.

FOR ADVERTISING SERVICES, NAMELY, PROMOTING AND MARKETING THE GOODS AND SERVICES OF OTHERS THROUGH DEDICATED E-COMMERCE SHOPPING WEBSITES (U.S. CLS. 100, 101 AND 102).

STEVEN PEREZ, EXAMINING ATTORNEY

SN 85-455,124. LISTEN UP ESPANOL, LLC, PORTLAND, ME. FILED 10-25-2011.

DELIVERING AWESOMENESS

THE MARK CONSISTS OF STANDARD CHARACTERS WITHOUT CLAIM TO ANY PARTICULAR FONT, STYLE, SIZE, OR COLOR.

FOR MANAGEMENT OF TELEPHONE CALL CENTERS FOR OTHERS, NAMELY, CALL CENTER OUTSOURCING SERVICES, SALES AND BUSINESS PROCESS OUTSOURCING SERVICES IN THE FIELD OF CALL MANAGEMENT, TELEMARKETING AND CUSTOMER MANAGEMENT, CALL MANAGEMENT SERVICES FOR INBOUND AND OUTBOUND CALL SERVICES, TELEMARKETING, CUSTOMER SERVICE MANAGEMENT (U.S. CLS. 100, 101 AND 102).

FIRST USE 1-31-2009; IN COMMERCE 1-31-2009.

FRANK LATTUCA, EXAMINING ATTORNEY

SN 85-455,894. GEORGE LITTLE MANAGEMENT, LLC, WHITE PLAINS, NY. FILED 10-25-2011.

GLM

THE MARK CONSISTS OF STANDARD CHARACTERS WITHOUT CLAIM TO ANY PARTICULAR FONT, STYLE, SIZE, OR COLOR.

OWNER OF U.S. REG. NOS. 2,456,730 AND 2,544,531.

FOR ORGANIZING AND CONDUCTING TRADE SHOWS IN THE FIELDS OF SURF, SKATE AND ACTION SPORTS EQUIPMENT AND APPAREL (U.S. CLS. 100, 101 AND 102).

JERI J. FICKES, EXAMINING ATTORNEY

CLASS 35—(Continued).

SN 85-456,284. FAMILY TREE RV BRAND MANAGEMENT, INC., ATKINSON, IL. FILED 10-26-2011.



NO CLAIM IS MADE TO THE EXCLUSIVE RIGHT TO USE "RV", APART FROM THE MARK AS SHOWN.

THE MARK CONSISTS OF AN IMAGE OF A TREE WITH THE WORDS "FAMILY TREE RV" IN BLOCKED CAPITAL LETTERS DIRECTLY BELOW AND CENTERED UNDER THE TREE TRUNK, BROKEN INTO TWO LINES OF TEXT WITH "FAMILY" IN THE FIRST LINE AND "TREE RV" IN THE SECOND.

FOR FACILITATING GROUP PURCHASES OF RECREATIONAL VEHICLES AND RECREATIONAL VEHICLE PARTS AND ACCESSORIES (U.S. CLS. 100, 101 AND 102).

ESTHER A. BORSUK, EXAMINING ATTORNEY

SN 85-461,653. NOVEQ, DBA NOVEQ MEDICAL, PALO ALTO, CA. FILED 11-1-2011.



NO CLAIM IS MADE TO THE EXCLUSIVE RIGHT TO USE "MEDICAL", APART FROM THE MARK AS SHOWN.

THE COLOR(S) GREY, PURPLE IS/ARE CLAIMED AS A FEATURE OF THE MARK.

THE MARK CONSISTS OF "NOVEQ" WRITTEN IN GREY EXCEPT FOR THE LETTER O IN PURPLE. THE LETTER "O" IS DESIGNED WITH HORIZONTAL LINE AND TWO CIRCULAR ARROWS CLOCKWISE. UNDERNEATH THE WORD "NOVEQ" IS THE WORD MEDICAL WRITTEN IN PURPLE.

FOR INTERNATIONAL BUSINESS CONSULTING SERVICES RELATING TO THE RESEARCH, DEVELOPMENT, AND MARKETING OF MEDICAL SUPPLIES, DEVICES, AND EQUIPMENT (U.S. CLS. 100, 101 AND 102).

AMY C. KEAN, EXAMINING ATTORNEY

CLASS 35—(Continued).

SN 85-462,299. DAN, ZHAOHONG, WALNUT, CA. FILED 11-2-2011.



NO CLAIM IS MADE TO THE EXCLUSIVE RIGHT TO USE "FROZEN YOGURT COFFEE & BREAD", APART FROM THE MARK AS SHOWN.

THE MARK CONSISTS OF THE WORD "HALSINGLAND" ON THE LEFT WITH THE DOT ABOVE THE LETTER "I" REPLACED WITH A STAR. ON THE RIGHT IS A CIRCLE WITH THE WORDS "HALSINGLAND FROZEN YOGURT COFFEE & BREAD" CIRCLING AROUND AND SEPARATED BY STARS, WITH A CENTER IMAGE OF A GOAT STANDING ON A ROCK WITH A BACKGROUND OF CLOUD AND SHADE.

FOR RETAIL BAKERY SHOPS; SELF-SERVE FROZEN YOGURT SHOP SERVICES (U.S. CLS. 100, 101 AND 102).
SOPHIA S. KIM, EXAMINING ATTORNEY

SN 85-464,409. GENCORP INSURANCE GROUP, EAST GREENWICH, RI. FILED 11-4-2011.



NO CLAIM IS MADE TO THE EXCLUSIVE RIGHT TO USE "SURETY ALLIANCE", APART FROM THE MARK AS SHOWN.

THE MARK CONSISTS OF A STYLIZED LETTER "A" WITH AN OVERLAYED, OVAL RUNNING THROUGH THE STYLIZED LETTER "A". THE WORDS "SURETYALLIANCE" WITH NO SPACE BETWEEN "SURETY" AND "ALLIANCE" ARE ALIGNED DIRECTLY BELOW THE STYLIZED LETTER "A".

FOR TRADE ASSOCIATION SERVICES, NAMELY, PROMOTING THE INTERESTS OF A PEER GROUP OF PROFESSIONAL CONSTRUCTION AND COMMERCIAL SURETY BROKERAGES (U.S. CLS. 100, 101 AND 102).

TINA BROWN, EXAMINING ATTORNEY

SN 85-464,680. ELECTRONIC TELE-COMMUNICATIONS, INC., WAUKESHA, WI. FILED 11-4-2011.



THE MARK CONSISTS OF STANDARD CHARACTERS WITHOUT CLAIM TO ANY PARTICULAR FONT, STYLE, SIZE, OR COLOR.

FOR DISTRIBUTION OF TELEPHONE-DELIVERED COMMERCIAL ANNOUNCEMENT MESSAGES OF OTHERS (U.S. CLS. 100, 101 AND 102).

FIRST USE 1-14-1998; IN COMMERCE 1-14-1998.

JULIE WATSON, EXAMINING ATTORNEY

CLASS 35—(Continued).

SN 85-469,287. RIEGELS, DOUGLAS G., DBA DRIFTWOOD RESORTS, VALLEY, VIRGIN GORDA, BR.VIRGIN ISLANDS, FILED 11-10-2011.

Driftwood Resorts BVI Branded Genuine

THE MARK CONSISTS OF STANDARD CHARACTERS WITHOUT CLAIM TO ANY PARTICULAR FONT, STYLE, SIZE, OR COLOR.

NO CLAIM IS MADE TO THE EXCLUSIVE RIGHT TO USE "RESORTS BVI" AND "BRANDED", APART FROM THE MARK AS SHOWN.

FOR ADMINISTRATIVE HOTEL MANAGEMENT; BUSINESS MANAGEMENT OF HOTELS FOR OTHERS; HOTEL MANAGEMENT FOR OTHERS; MANAGING AND OPERATING RESORT HOTELS AND BUSINESS CONFERENCE CENTERS OF OTHERS (U.S. CLS. 100, 101 AND 102).

FIRST USE 7-1-2011; IN COMMERCE 7-1-2011.
MICHELE SWAIN, EXAMINING ATTORNEY

SN 85-475,114. TEAM SIZZLE FILMS, INC., BALTIMORE, MD. FILED 11-17-2011.

T-SIZZLE

THE MARK CONSISTS OF STANDARD CHARACTERS WITHOUT CLAIM TO ANY PARTICULAR FONT, STYLE, SIZE, OR COLOR.

THE NAME(S), PORTRAIT(S), AND/OR SIGNATURE(S) SHOWN IN THE MARK IDENTIFIES "TERRELL RAYMONN SUGGS", WHOSE CONSENT(S) TO REGISTER IS MADE OF RECORD.

FOR ENDORSEMENT SERVICES, NAMELY, PROMOTING THE GOODS AND SERVICES OF OTHERS (U.S. CLS. 100, 101 AND 102).

JUDITH HELFMAN, EXAMINING ATTORNEY

SN 85-482,041. PERMISSION INTERACTIVE, INC., SANTEE, CA. FILED 11-28-2011.



NO CLAIM IS MADE TO THE EXCLUSIVE RIGHT TO USE "CART", APART FROM THE MARK AS SHOWN.

THE MARK CONSISTS OF A LARGE "V" WITH "ORTEX" ALSO IN CAPITAL LETTERS BUT IN A SMALLER FONT IMMEDIATELY TO THE RIGHT SIDE OF IT; AND THE WORD "CART" ALSO IN CAPITAL LETTERS WITH THE SMALLER FONT CENTERED UNDERNEATH "ORTEX"; A SWIRL APPEARS INSIDE THE "V".

FOR ADVERTISING SERVICES, NAMELY, PROMOTING AND MARKETING THE GOODS AND SERVICES OF OTHERS THROUGH DEDICATED E-COMMERCE SHOPPING WEBSITES (U.S. CLS. 100, 101 AND 102).

STEVEN PEREZ, EXAMINING ATTORNEY

CLASS 35—(Continued).

SN 85-482,815. COWBOY CAMPSITE MEMBERS ASSOCIATION, STANWOOD, WA. FILED 11-29-2011.

Cowboy Campsite

THE MARK CONSISTS OF STANDARD CHARACTERS WITHOUT CLAIM TO ANY PARTICULAR FONT, STYLE, SIZE, OR COLOR.

NO CLAIM IS MADE TO THE EXCLUSIVE RIGHT TO USE "CAMPSITE", APART FROM THE MARK AS SHOWN.

FOR HOMEOWNER ASSOCIATION SERVICES, NAMELY, PROMOTING THE INTERESTS OF HOMEOWNERS IN A SPECIFIC COMMUNITY AND MARKETING THE COMMUNITY NATIONWIDE TO PROSPECTIVE NEW RESIDENTS AND PROPERTY OWNERS (U.S. CLS. 100, 101 AND 102).

FIRST USE 9-22-2011; IN COMMERCE 9-22-2011.
CHARLES L. JENKINS, EXAMINING ATTORNEY

SN 85-483,068. OUR TOWN ZIP, LLC, SAN JOSE, CA. FILED 11-29-2011.

ZipdealZ

THE MARK CONSISTS OF STANDARD CHARACTERS WITHOUT CLAIM TO ANY PARTICULAR FONT, STYLE, SIZE, OR COLOR.

FOR ADVERTISEMENT FOR OTHERS ON THE INTERNET; ADVERTISING AND COMMERCIAL INFORMATION SERVICES, VIA THE INTERNET; ADVERTISING AND MARKETING SERVICES, NAMELY, PROMOTING THE GOODS AND SERVICES OF OTHERS; ADVERTISING ON THE INTERNET FOR OTHERS; ADVERTISING SERVICES, NAMELY, PROMOTING AND MARKETING THE GOODS AND SERVICES OF OTHERS THROUGH ALL PUBLIC COMMUNICATION MEANS; DEVELOPING PROMOTIONAL CAMPAIGNS FOR BUSINESS; PROMOTING THE GOODS AND SERVICES OF OTHERS BY MEANS OF DISTRIBUTING ADVERTISING ON THE INTERNET; PROMOTING THE GOODS OF OTHERS, NAMELY, PROVIDING COUPONS, REBATES AND VOUCHERS FOR THE GOODS OF OTHERS; PROMOTING THE GOODS OF OTHERS, NAMELY, PROVIDING INFORMATION REGARDING DISCOUNTS, COUPONS, REBATES, VOUCHERS AND SPECIAL OFFERS FOR THE GOODS OF OTHERS; PROMOTIONAL SERVICES, NAMELY, PROMOTING THE GOODS OF OTHERS BY MEANS OF PROVIDING ONLINE COUPONS (U.S. CLS. 100, 101 AND 102).

ELIZABETH HUGHITT, EXAMINING ATTORNEY

CLASS 35—(Continued).

SN 85-484,946. FARGHALY, MOHAMED, HIGHLAND, IN. AND MAHAREM, MAHAMED, FISHERS, IN. AND EL-RAGHY, MAHAMED, HIGHLAND, IN. AND ELSAYED, HOSSAM, EAST CHICAGO, IN. FILED 12-1-2011.

Glitter

THE MARK CONSISTS OF STANDARD CHARACTERS WITHOUT CLAIM TO ANY PARTICULAR FONT, STYLE, SIZE, OR COLOR.

FOR COMPUTERIZED ON-LINE RETAIL STORE SERVICES IN THE FIELD OF JEWELRY, CLOTHING, AND ACCESSORIES; DEALERSHIPS IN THE FIELD OF JEWELRY, CLOTHING, AND ACCESSORIES; DISCOUNT STORES IN THE FIELD OF JEWELRY, CLOTHING, AND ACCESSORIES; MARKETING SERVICES, NAMELY, RETAIL STORE SERVICES IN THE FIELD OF JEWELRY, CLOTHING, AND ACCESSORIES; ON-LINE RETAIL STORE SERVICES FEATURING A WIDE VARIETY OF CONSUMER GOODS OF OTHERS; ON-LINE RETAIL STORE SERVICES FEATURING JEWELRY, CLOTHING, AND ACCESSORIES; ON-LINE WHOLESALE STORE SERVICES FEATURING JEWELRY, CLOTHING, AND ACCESSORIES; RETAIL APPAREL STORES; RETAIL CLOTHING BOUTIQUES; RETAIL CONVENIENCE STORES; RETAIL DISCOUNT STORE SERVICES IN THE FIELD OF JEWELRY, CLOTHING, AND ACCESSORIES; RETAIL GIFT SHOPS; RETAIL JEWELRY STORES; RETAIL SHOPS FEATURING JEWELRY, CLOTHING, AND ACCESSORIES; RETAIL STORE SERVICES FEATURING A WIDE VARIETY OF CONSUMER GOODS OF OTHERS; RETAIL STORE SERVICES FEATURING JEWELRY, CLOTHING, AND ACCESSORIES; RETAIL JEWELRY, CLOTHING, AND ACCESSORIES STORES; WHOLESALE STORE SERVICES FEATURING JEWELRY, CLOTHING, AND ACCESSORIES (U.S. CLS. 100, 101 AND 102).

FIRST USE 7-31-2008; IN COMMERCE 7-31-2008.
AMY ALFIERI, EXAMINING ATTORNEY

CLASS 35—(Continued).

SN 85-490,864. FRED'S CAPITAL MANAGEMENT COMPANY, WILMINGTON, DE. FILED 12-8-2011.



OWNER OF U.S. REG. NOS. 2,273,124 AND 3,605,714.
NO CLAIM IS MADE TO THE EXCLUSIVE RIGHT TO USE "DOLLAR", APART FROM THE MARK AS SHOWN.
THE COLOR(S) BLUE, GREEN, YELLOW, AND WHITE IS/ARE CLAIMED AS A FEATURE OF THE MARK.

THE MARK CONSISTS OF THE WORDS "FRED'S SUPER DOLLAR" WITHIN A RECTANGLE WHICH IS BISECTED HORIZONTALLY BY A WHITE CURVED LINE WITH THE WORD "FRED'S" IN WHITE LETTERING AND A YELLOW APOSTROPHE AGAINST A BLUE BACKGROUND IN THE UPPER SECTION OF THE RECTANGLE, AND THE WORDS "SUPER DOLLAR" IN WHITE LETTERING ON A GREEN BACKGROUND IN THE LOWER PORTION OF THE RECTANGLE.

FOR RETAIL GENERAL MERCHANDISE STORE SERVICES; RETAIL PHARMACY SERVICES (U.S. CLS. 100, 101 AND 102).

FIRST USE 7-0-2010; IN COMMERCE 7-0-2010.
SANI KHOURI, EXAMINING ATTORNEY

SN 85-490,885. FRED'S CAPITAL MANAGEMENT COMPANY, WILMINGTON, DE. FILED 12-8-2011.



OWNER OF U.S. REG. NOS. 2,273,124 AND 3,605,714.
THE COLOR(S) BLUE AND YELLOW IS/ARE CLAIMED AS A FEATURE OF THE MARK.

THE MARK CONSISTS OF THE WORD "FRED'S" IN BLUE LETTERING AND A YELLOW APOSTROPHE ABOVE A CURVED BLUE LINE.

FOR RETAIL GENERAL MERCHANDISE STORE SERVICES; RETAIL PHARMACY SERVICES (U.S. CLS. 100, 101 AND 102).

FIRST USE 7-0-2010; IN COMMERCE 7-0-2010.
SANI KHOURI, EXAMINING ATTORNEY

CLASS 35—(Continued).

SN 85-496,594. NORANDEX BUILDING MATERIALS DISTRIBUTION, INC., HUDSON, OH. FILED 12-15-2011.

PROMISES KEPT. GUARANTEED!

THE MARK CONSISTS OF STANDARD CHARACTERS WITHOUT CLAIM TO ANY PARTICULAR FONT, STYLE, SIZE, OR COLOR.

FOR CLIENT SERVICE COMMITMENT PROGRAM, NAMELY, ADMINISTRATION OF A DISCOUNT PROGRAM ENABLING PARTICIPANTS TO OBTAIN DISCOUNTS ON THE COST OF GOODS (U.S. CLS. 100, 101 AND 102).

SCOTT BIBB, EXAMINING ATTORNEY

SN 85-497,005. PROFESSIONAL STAFFING SERVICES, INC., DBA RJ-STAFFING, NANUET, NY. FILED 12-16-2011.

RJ-STAFFING

THE MARK CONSISTS OF STANDARD CHARACTERS WITHOUT CLAIM TO ANY PARTICULAR FONT, STYLE, SIZE, OR COLOR.

FOR EMPLOYMENT AGENCY SERVICES, NAMELY, FILLING THE TEMPORARY AND PERMANENT STAFFING NEEDS OF BUSINESSES (U.S. CLS. 100, 101 AND 102).

FIRST USE 4-1-1999; IN COMMERCE 4-1-1999.
DAVID TAYLOR, EXAMINING ATTORNEY

SN 85-497,069. PROJECT PR, LLC, MINNEAPOLIS, MN. FILED 12-16-2011.



NO CLAIM IS MADE TO THE EXCLUSIVE RIGHT TO USE "PROJECT PR", APART FROM THE MARK AS SHOWN.

THE MARK CONSISTS OF A RECTANGLE THAT HAS ROUNDED CORNERS ON THE UPPER RIGHT AND LOWER LEFT SIDES. UNDER THE LEFT AND BOTTOM OF THE RECTANGLE IS AN EXTENDED OUTLINE OF THE RECTANGLE'S SHAPE. INSIDE THE RECTANGLE IS THE STYLIZED TEXT "PROJECT" THAT IS UNDERLINED BY THREE HORIZONTAL LINES. TO THE RIGHT OF THE RECTANGLE IS A STICK PERSON HOLDING A RECTANGULAR FOLDER THAT FEATURES THE STYLIZED TEXT "PR." THE STICK PERSON HAS HIS OTHER HAND ON HIS HIP.

FOR BUSINESS MANAGEMENT CONSULTANCY AS WELL AS DEVELOPMENT OF PROCESSES FOR THE ANALYSIS AND THE IMPLEMENTATION OF STRATEGY PLANS AND MANAGEMENT PROJECTS; PUBLIC RELATIONS (U.S. CLS. 100, 101 AND 102).

MAUREEN DALL, EXAMINING ATTORNEY

CLASS 35—(Continued).

SN 85-498,607. ICAP SERVICES NORTH AMERICA, LLC, JERSEY CITY, NJ. FILED 12-19-2011.

i-Repo

THE MARK CONSISTS OF STANDARD CHARACTERS WITHOUT CLAIM TO ANY PARTICULAR FONT, STYLE, SIZE, OR COLOR.

OWNER OF U.S. REG. NO. 3,128,215.
SEC. 2(F).

FOR PROVIDING FINANCIAL INDICES IN THE NATURE OF A COLLECTION OF REPURCHASE AGREEMENT INDICES FOR VARIOUS REGIONS CALCULATED BY ICAP, AN INTERDEALER BROKER, BASED UPON ICAP'S REPURCHASE AGREEMENT BROKERAGE ACTIVITY; THESE INDICES ARE VOLUME WEIGHTED ADJUSTED AND INCORPORATE DAILY ACTIVITY OF THE OVERNIGHT GENERAL COLLATERAL LEVELS THAT ARE TRANSACTED THROUGH ICAP'S BROKERING OPERATIONS (U.S. CLS. 100, 101 AND 102).

FIRST USE 4-11-2006; IN COMMERCE 4-11-2006.
JANET LEE, EXAMINING ATTORNEY

SN 85-500,034. LA MER TECHNOLOGY, INC., NEW YORK, NY. FILED 12-20-2011.



OWNER OF U.S. REG. NOS. 1,245,722, 2,751,557 AND OTHERS.

NO CLAIM IS MADE TO THE EXCLUSIVE RIGHT TO USE "SELECT AUTHORIZED RETAILER", APART FROM THE MARK AS SHOWN.

THE MARK CONSISTS OF A RECTANGLE WITH THE STYLIZED WORDS "LA MER" ON ONE LINE AND THE STYLIZED WORDS "SELECT AUTHORIZED RETAILER" DIRECTLY BELOW.

THE ENGLISH TRANSLATION OF "LA MER" IN THE MARK IS "THE SEA".

FOR RETAIL STORE SERVICES FEATURING PERSONAL CARE PRODUCTS, COSMETICS, TOILETRIES, BODY PRODUCTS, SKIN CARE PRODUCTS, FRAGRANCES FOR PERSONAL USE AND BEAUTY TREATMENT PRODUCTS; ONLINE RETAIL STORE SERVICES FEATURING PERSONAL CARE PRODUCTS, COSMETICS, TOILETRIES, BODY PRODUCTS, SKIN CARE PRODUCTS, FRAGRANCES FOR PERSONAL USE AND BEAUTY TREATMENT PRODUCTS (U.S. CLS. 100, 101 AND 102).

JAMES STEIN, EXAMINING ATTORNEY

CLASS 35—(Continued).

SN 85-503,330. RESOURCE COMMERCIAL FLOORING NETWORK, LLC, AURORA, CO. FILED 12-23-2011.

EXPERIUS DISTRIBUTION

THE MARK CONSISTS OF STANDARD CHARACTERS WITHOUT CLAIM TO ANY PARTICULAR FONT, STYLE, SIZE, OR COLOR.

NO CLAIM IS MADE TO THE EXCLUSIVE RIGHT TO USE "DISTRIBUTION", APART FROM THE MARK AS SHOWN.

THE WORDING "EXPERIUS" HAS NO MEANING IN A FOREIGN LANGUAGE.

FOR ONLINE RETAIL AND WHOLESALE STORE SERVICES FEATURING FLOORING (U.S. CLS. 100, 101 AND 102).

BRIAN PINO, EXAMINING ATTORNEY

CLASS 35—(Continued).

SN 85-507,586. KEVIN BEARE, NEW CANAAN, CT. FILED 1-3-2012.

KINDLY

THE MARK CONSISTS OF STANDARD CHARACTERS WITHOUT CLAIM TO ANY PARTICULAR FONT, STYLE, SIZE, OR COLOR.

FOR DONATION MATCHING SERVICES PROVIDED ON THE WORLD WIDE WEB FOR MATCHING INDIVIDUALS AND ENTITIES WHO HAVE TIME AND/OR MONEY TO DONATE TO ORGANIZATIONS THAT CAN ACCEPT SUCH DONATIONS; DONATION TRACKING SERVICES PROVIDED ON THE WORLD WIDE WEB FOR TRACKING THE TIME AND/OR MONEY THAT INDIVIDUALS AND ENTITIES DONATE TO ORGANIZATIONS THAT CAN ACCEPT SUCH DONATIONS, AND FOR PUBLICIZING AND PROMOTING CHARITABLE DONATIONS; GOOD DEED TRACKING SERVICES FOR INDIVIDUALS AND ENTITIES, NAMELY, MANAGEMENT AND COMPILATION OF COMPUTERIZED DATABASES IN THE FIELD OF VOLUNTEER ACTIVITIES AND CHARITABLE ACTIVITIES (U.S. CLS. 100, 101 AND 102).

MARK SHINER, EXAMINING ATTORNEY

SN 85-510,009. JOJO'S CUPCAKES & CREAM, LLC, AKA JOJO'S CUPCAKES & CREAM, EASTON, MD. FILED 1-5-2012.



NO CLAIM IS MADE TO THE EXCLUSIVE RIGHT TO USE "CUPCAKES & CREAM" AND "DELICIOUS", APART FROM THE MARK AS SHOWN.

THE MARK CONSISTS OF A CUPCAKE WITH 40 FLOWER SPRINKLES DEPICTING THE CUPCAKE FROSTING AND TOPPED WITH A BOW; THE BASE OF THE CUPCAKE CONTAINS THE WORDING "JOJO'S CUPCAKES & CREAM" WHICH APPEARS ON THE LINER OF THE CUPCAKE; THE WORDS "IRRESISTIBLY DELICIOUS!" APPEAR UNDERNEATH THE CUPCAKE.

FOR RETAIL STORE AND ONLINE RETAIL STORE SERVICES FEATURING GOURMET CUPCAKES, BAKED GOODS, ICE CREAM AND BEVERAGES (U.S. CLS. 100, 101 AND 102).

FIRST USE 6-1-2011; IN COMMERCE 6-29-2011.

MARC LEIPZIG, EXAMINING ATTORNEY

SN 85-504,695. BENBILT BUILDING SYSTEMS LP, GREENSBURG, PA. FILED 12-28-2011.



NO CLAIM IS MADE TO THE EXCLUSIVE RIGHT TO USE "ENTRY", APART FROM THE MARK AS SHOWN.

THE MARK CONSISTS OF THE WORDS "ENTRY LOGIX" WITH THE WORD "LOGIX" ENCASED IN BLOCKS AND THE WORD "ENTRY" IMMEDIATELY ABOVE THE BLOCKS. THE LOGO ALSO FEATURES A SOLID LINE BENEATH THE BLOCKS AND PARALLEL TO THE WRITTEN TEXT.

FOR ON-LINE ORDERING SERVICES FEATURING RESIDENTIAL DOORS (U.S. CLS. 100, 101 AND 102).

FIRST USE 6-1-2011; IN COMMERCE 6-1-2011.

CHARLES L. JENKINS, EXAMINING ATTORNEY

CLASS 35—(Continued).

SN 85-516,066. GOTTLINGER, CHARLES, FORT COLLINS, CO. FILED 1-13-2012.

HANDS ON TOOLS

THE MARK CONSISTS OF STANDARD CHARACTERS WITHOUT CLAIM TO ANY PARTICULAR FONT, STYLE, SIZE, OR COLOR.

NO CLAIM IS MADE TO THE EXCLUSIVE RIGHT TO USE "TOOLS", APART FROM THE MARK AS SHOWN.

FOR ONLINE RETAIL STORES SERVICES FEATURING TOOLS, MECHANIC TOOLS, INDUSTRIAL TOOLS, BODY SHOP TOOLS, PAINT, CLEANING SUPPLIES AND PARTS; ONLINE RETAIL HARDWARE DEPARTMENT STORE SERVICES (U.S. CLS. 100, 101 AND 102).

FIRST USE 1-1-2000; IN COMMERCE 1-1-2000.

COLLEEN KEARNEY, EXAMINING ATTORNEY

CLASS 35—(Continued).

SN 85-517,489. BUDGET BLINDS COMMERCIAL SOLUTIONS, LLC, ORANGE, CA. FILED 1-16-2012.

BB COMMERCIAL SOLUTIONS

THE MARK CONSISTS OF STANDARD CHARACTERS WITHOUT CLAIM TO ANY PARTICULAR FONT, STYLE, SIZE, OR COLOR.

NO CLAIM IS MADE TO THE EXCLUSIVE RIGHT TO USE "COMMERCIAL SOLUTIONS", APART FROM THE MARK AS SHOWN.

FOR COMMERCIAL ACCOUNT SOLICITATION SERVICES, NAMELY, GENERATION OF ACCOUNTS WITH COMMERCIAL CUSTOMERS FOR THE BENEFIT OF DISTRIBUTORS OF WINDOW COVERINGS (U.S. CLS. 100, 101 AND 102).

KAPIL BHANOT, EXAMINING ATTORNEY

SN 85-516,800. ROBERTSON, AMEER, MONTCLAIR, NJ. FILED 1-14-2012.



THE COLOR(S) SILVER, TURQUOISE, LIME GREEN, WHITE, GRAY, AND BLACK IS/ARE CLAIMED AS A FEATURE OF THE MARK.

THE MARK CONSISTS OF THE WORDING "4 X FLEX" WITH THE "4" IN SILVER WITH WHITE OUTLINING, THE "X" IN LIME GREEN WITH GRAY SHADING, AND THE TERM "FLEX" IN TURQUOISE WITH GRAY AND BLACK SHADING, ALL ON A WHITE BACKGROUND.

FOR ADVICE RELATING TO THE ORGANISATION AND MANAGEMENT OF BUSINESS; ADVISORY SERVICE FOR ORGANIZATIONAL ISSUES AND BUSINESS ADMINISTRATION, WITH AND WITHOUT THE HELP OF ELECTRONIC DATA BASES; ADVISORY SERVICES RELATING TO BUSINESS MANAGEMENT AND BUSINESS OPERATIONS; ASSISTANCE AND ADVICE REGARDING BUSINESS ORGANIZATION AND MANAGEMENT; ASSISTANCE WITH BUSINESS MANAGEMENT AND PLANNING; ASSISTANCE, ADVICE AND CONSULTANCY WITH REGARD TO BUSINESS PLANNING, BUSINESS ANALYSIS, BUSINESS MANAGEMENT AND BUSINESS ORGANIZATION RELATING TO PURCHASING FUNCTIONS (U.S. CLS. 100, 101 AND 102).

KIM MONINGHOFF, EXAMINING ATTORNEY

SN 85-517,651. GOTTLINGER, CHARLES, FORT COLLINS, CO. FILED 1-17-2012.



NO CLAIM IS MADE TO THE EXCLUSIVE RIGHT TO USE "TOOLS" AND "MECHANIC & BODY SHOP TOOLS & SUPPLIES", APART FROM THE MARK AS SHOWN.

THE MARK CONSISTS OF THE LITERAL ELEMENTS "HANDS ON TOOLS, MECHANIC & BODY SHOP TOOLS & SUPPLIES" ARE WRITTEN IN A STYLIZED FORM. THERE IS AN IMAGE OF A HAND HOLDING A TOOL IN BETWEEN THE WORDS "HANDS" AND "TOOLS", WHERE IN THE WORD "ON" IS WRITTEN, BELOW IT THE WORDS "MECHANIC & BODY SHOP TOOLS & SUPPLIES" ARE WRITTEN IN, AS SHOWN IN THE FIGURE.

FOR ONLINE RETAIL STORES SERVICES FEATURING TOOLS, MECHANIC TOOLS, INDUSTRIAL TOOLS, BODY SHOP TOOLS, PAINT, CLEANING SUPPLIES AND PARTS; ONLINE RETAIL HARDWARE DEPARTMENT STORE SERVICES (U.S. CLS. 100, 101 AND 102).

FIRST USE 1-1-2000; IN COMMERCE 1-1-2000.

COLLEEN KEARNEY, EXAMINING ATTORNEY

CLASS 35—(Continued).

SN 85-518,861. PEOPLE FRIENDLY PRODUCTS, INC., OMAHA, NE. FILED 1-18-2012.

Making Your World A Clean Healthy Place

THE MARK CONSISTS OF STANDARD CHARACTERS WITHOUT CLAIM TO ANY PARTICULAR FONT, STYLE, SIZE, OR COLOR.

FOR WHOLESALE AND RETAIL STORE SERVICES AND ONLINE WHOLESALE AND RETAIL STORE SERVICES FEATURING JANITORIAL SUPPLIES AND EQUIPMENT, CLEANING PRODUCTS, AIR PURIFIERS, HERBS AND FOOD PRODUCTS (U.S. CLS. 100, 101 AND 102).

FIRST USE 11-11-2011; IN COMMERCE 11-11-2011.
DOMINIC FATHY, EXAMINING ATTORNEY

SN 85-518,923. GRONK NATION, L.L.C., MIROMAR LAKES, FL. FILED 1-18-2012.

Gronk Nation

THE MARK CONSISTS OF STANDARD CHARACTERS WITHOUT CLAIM TO ANY PARTICULAR FONT, STYLE, SIZE, OR COLOR.

THE NAME(S), PORTRAIT(S), AND/OR SIGNATURE(S) SHOWN IN THE MARK IDENTIFIES ROBERT GRONKOWSKI, CHRISTOPHER GRONKOWSKI, DANIEL GRONKOWSKI, WHOSE CONSENT(S) TO REGISTER IS MADE OF RECORD.

FOR ENDORSEMENT SERVICES, NAMELY, PROMOTING THE GOODS AND SERVICES OF OTHERS (U.S. CLS. 100, 101 AND 102).

FIRST USE 2-18-2011; IN COMMERCE 2-18-2011.
GEOFFREY FOSDICK, EXAMINING ATTORNEY

SN 85-521,084. NORTHSTAR HOSPITALITY, LLC, LEXINGTON, KY. FILED 1-20-2012.



MINT JULEP hospitality

NO CLAIM IS MADE TO THE EXCLUSIVE RIGHT TO USE "HOSPITALITY", APART FROM THE MARK AS SHOWN.

THE MARK CONSISTS OF A PILLOW EMBOSSED WITH A MINT LEAF AND THE WORDS "MINT JULEP HOSPITALITY".

FOR HOTEL OPERATIONS AND MANAGEMENT SERVICES FOR OTHERS (U.S. CLS. 100, 101 AND 102).
AMY HELLA, EXAMINING ATTORNEY

CLASS 35—(Continued).

SN 85-524,294. BUDGET BLINDS COMMERCIAL SOLUTIONS, LLC, ORANGE, CA. FILED 1-24-2012.



NO CLAIM IS MADE TO THE EXCLUSIVE RIGHT TO USE "COMMERCIAL SOLUTIONS", APART FROM THE MARK AS SHOWN.

THE COLOR(S) RED, WHITE AND GRAY IS/ARE CLAIMED AS A FEATURE OF THE MARK.

THE MARK CONSISTS OF A VERTICAL RED RECTANGLE WITH THE WORD "COMMERCIAL" IN RED TYPE TO THE RIGHT, THE ITALICIZED INITIALS "BB" IN WHITE IN THE BOTTOM RIGHT HAND CORNER OF THE RED RECTANGLE AND THE WORD "SOLUTIONS" IN GRAY UNDER THE WORD "COMMERCIAL".

FOR COMMERCIAL ACCOUNT SOLICITATION SERVICES, NAMELY, GENERATION OF ACCOUNTS WITH COMMERCIAL CUSTOMERS FOR THE BENEFIT OF DISTRIBUTORS OF WINDOW COVERINGS (U.S. CLS. 100, 101 AND 102).

KAPIL BHANOT, EXAMINING ATTORNEY

SN 85-525,338. LASER STREAM MEDIA, INC., DBA LASER STREAM VIDEO, MARIETTA, GA. FILED 1-25-2012.

Laser Stream Video

THE MARK CONSISTS OF STANDARD CHARACTERS WITHOUT CLAIM TO ANY PARTICULAR FONT, STYLE, SIZE, OR COLOR.

NO CLAIM IS MADE TO THE EXCLUSIVE RIGHT TO USE "STREAM VIDEO", APART FROM THE MARK AS SHOWN.

FOR ASSISTING OTHERS IN ONLINE MARKETING OF THEIR BUSINESSES (U.S. CLS. 100, 101 AND 102).

FIRST USE 8-31-2006; IN COMMERCE 8-31-2006.
FRANK LATTUCA, EXAMINING ATTORNEY

SN 85-526,497. SCANABILITIES, LLC, HOLLYWOOD, FL. FILED 1-26-2012.

SCANABILITIES

THE MARK CONSISTS OF STANDARD CHARACTERS WITHOUT CLAIM TO ANY PARTICULAR FONT, STYLE, SIZE, OR COLOR.

FOR PROVIDING ONLINE BUSINESS MARKETING, ADVERTISING, AND PROMOTIONAL SERVICES, NAMELY, ONLINE MARKETING SERVICES FEATURING QUICK RESPONSE CODES (U.S. CLS. 100, 101 AND 102).

FIRST USE 12-1-2011; IN COMMERCE 12-1-2011.
JOSETTE BEVERLY, EXAMINING ATTORNEY

CLASS 35—(Continued).

SN 85-529,566. TBC TRADEMARKS, LLC, LAS VEGAS, NV.
FILED 1-31-2012.



OWNER OF U.S. REG. NOS. 3,158,155, 3,196,225 AND 3,201,020.

NO CLAIM IS MADE TO THE EXCLUSIVE RIGHT TO USE "TIRE" AND "ONLINE.COM", APART FROM THE MARK AS SHOWN.

THE MARK CONSISTS OF THE WORDS "CARROLL TIRE ONLINE.COM", WITH "CARROLL TIRE" ABOVE "ONLINE.COM" WITH A DEPICTION OF TIRE BEHIND THE WORDS WITH A LINE ABOVE AND BELOW THE WORDS.

FOR COMPUTERIZED ON-LINE ORDERING SERVICES IN THE FIELD OF TIRES; WHOLESALE STORES, ORDERING SERVICES, AND DISTRIBUTORSHIPS FEATURING TIRES (U.S. CLS. 100, 101 AND 102).

FIRST USE 6-0-2008; IN COMMERCE 6-0-2008.
ELLEN BURNS, EXAMINING ATTORNEY

SN 85-533,407. CITY OF NEW BRAUNFELS, NEW BRAUNFELS, TX. FILED 2-3-2012.



OWNER OF U.S. REG. NOS. 2,215,092 AND 4,025,553.
NO CLAIM IS MADE TO THE EXCLUSIVE RIGHT TO USE "DOWNTOWN NEW BRAUNFELS", APART FROM THE MARK AS SHOWN.

THE COLOR(S) GREEN, RED, AND BROWN IS/ARE CLAIMED AS A FEATURE OF THE MARK.

THE MARK CONSISTS OF A RED OVAL SURROUNDED BY A GREEN DIAMOND-SHAPED DESIGN WITH CURVED EDGES. THE DIAMOND SHAPE IS SPLIT INTO FOUR EQUAL PARTS WHICH ARE DESIGNATED BY OPENINGS BETWEEN THE PARTS AND THE OUTER EDGE OF THE OVAL HAS A BORDER, OF THE SAME WIDTH AS THE SPLITS IN THE DIAMOND, AROUND IT, SLIGHTLY DOWN AND TO THE RIGHT OF THE DESIGN IS THE LITERAL ELEMENT "DOWNTOWN" IN STYLIZED BROWN LETTERING AND UNDERNEATH THAT IS THE LITERAL ELEMENT "NEW BRAUNFELS" IN ALL CAPITAL BROWN LETTERS. THE COLOR WHITE IN THE DRAWING IS FOR BACKGROUND PURPOSES ONLY AND IS NOT A PART OF THE MARK.

FOR PROMOTING ECONOMIC DEVELOPMENT IN THE DOWNTOWN AREA OF THE CITY OF NEW BRAUNFELS, TEXAS (U.S. CLS. 100, 101 AND 102).

FIRST USE 2-2-2012; IN COMMERCE 2-2-2012.
KATHLEEN KOLACZ, EXAMINING ATTORNEY

CLASS 35—(Continued).

SN 85-535,224. RETRO BAKERY, LLC, LAS VEGAS, NV.
FILED 2-6-2012.

RETRO BAKERY

THE MARK CONSISTS OF STANDARD CHARACTERS WITHOUT CLAIM TO ANY PARTICULAR FONT, STYLE, SIZE, OR COLOR.

NO CLAIM IS MADE TO THE EXCLUSIVE RIGHT TO USE "BAKERY", APART FROM THE MARK AS SHOWN.

FOR RETAIL BAKERY SHOPS (U.S. CLS. 100, 101 AND 102).

FIRST USE 2-10-2008; IN COMMERCE 2-10-2008.
BRENDAN MCCAULEY, EXAMINING ATTORNEY

SN 85-535,766. ACCESS TO PATIENTS, LLC, KING OF PRUSSIA, PA. FILED 2-7-2012.

A2P

THE MARK CONSISTS OF STANDARD CHARACTERS WITHOUT CLAIM TO ANY PARTICULAR FONT, STYLE, SIZE, OR COLOR.

THE WORDING "A2P" HAS NO MEANING IN A FOREIGN LANGUAGE.

FOR ADVERTISING, MARKETING, PUBLICITY AND PROMOTION SERVICES FOR OTHERS IN THE FIELD OF CLINICAL TRIAL PATIENT RECRUITMENT (U.S. CLS. 100, 101 AND 102).

FIRST USE 10-31-2011; IN COMMERCE 10-31-2011.
MYRIAH HABEEB, EXAMINING ATTORNEY

SN 85-537,226. LOVE'S TRAVEL STOPS & COUNTRY STORES, INC., OKLAHOMA CITY, OK. FILED 2-8-2012.



OWNER OF U.S. REG. NOS. 2,660,340 AND 2,684,326.
NO CLAIM IS MADE TO THE EXCLUSIVE RIGHT TO USE "REWARDS", APART FROM THE MARK AS SHOWN.

FOR PROMOTING THE SALE OF MOTOR FUEL THROUGH THE ADMINISTRATION OF INCENTIVE AWARD PROGRAMS, NAMELY, AWARDING POINTS FOR MOTOR FUEL, FOOD, BEVERAGE AND MERCHANDISE PURCHASES TO BE REDEEMED FOR FOOD, BEVERAGES, MERCHANDISE, PERSONAL HYGIENE SERVICES, TRUCK WEIGHING SERVICES, CHECK CASHING FEES AND/OR DOCUMENT HANDLING SERVICES AT PROPRIETOR'S ASSOCIATED RETAIL STORES (U.S. CLS. 100, 101 AND 102).

KATHLEEN KOLACZ, EXAMINING ATTORNEY

CLASS 35—(Continued).

SN 85-537,243. LOVE'S TRAVEL STOPS & COUNTRY STORES, INC., OKLAHOMA CITY, OK. FILED 2-8-2012.

MY LOVE REWARDS

THE MARK CONSISTS OF STANDARD CHARACTERS WITHOUT CLAIM TO ANY PARTICULAR FONT, STYLE, SIZE, OR COLOR.

OWNER OF U.S. REG. NOS. 2,660,340 AND 2,684,326.

NO CLAIM IS MADE TO THE EXCLUSIVE RIGHT TO USE "REWARDS", APART FROM THE MARK AS SHOWN.

FOR PROMOTING THE SALE OF MOTOR FUEL THROUGH THE ADMINISTRATION OF INCENTIVE AWARD PROGRAMS, NAMELY, AWARDED POINTS FOR MOTOR FUEL, FOOD, BEVERAGE AND MERCHANDISE PURCHASES TO BE REDEEMED FOR FOOD, BEVERAGES, MERCHANDISE, PERSONAL HYGIENE SERVICES, TRUCK WEIGHING SERVICES, CHECK CASHING FEES AND/OR DOCUMENT HANDLING SERVICES AT PROPRIETOR'S ASSOCIATED RETAIL STORES (U.S. CLS. 100, 101 AND 102).

KATHLEEN KOLACZ, EXAMINING ATTORNEY

CLASS 35—(Continued).

SN 85-539,305. FRIENDS MORE, INC., DBA ATELIER JEWELERS, FLORAL PARK, NY. FILED 2-10-2012.

Atelier Jewelers

THE MARK CONSISTS OF STANDARD CHARACTERS WITHOUT CLAIM TO ANY PARTICULAR FONT, STYLE, SIZE, OR COLOR.

NO CLAIM IS MADE TO THE EXCLUSIVE RIGHT TO USE "JEWELERS", APART FROM THE MARK AS SHOWN. SEC. 2(F).

FOR MAIL ORDER SERVICES FEATURING JEWELRY; MOBILE VENDING IN THE FIELD OF JEWELRY; ON-LINE WHOLESALE STORE SERVICES FEATURING JEWELRY; RETAIL JEWELRY STORES; STREET VENDOR SERVICES FEATURING JEWELRY; VENDING IN THE FIELD OF JEWELRY; WHOLESALE STORE SERVICES FEATURING JEWELRY (U.S. CLS. 100, 101 AND 102).

FIRST USE 3-1-2000; IN COMMERCE 3-1-2000.
ANDREW LEASER, EXAMINING ATTORNEY

SN 85-541,002. PURPOSE PLACEMENT SERVICES, LLC, VIRGINIA BEACH, VA. FILED 2-13-2012.



SN 85-537,721. GRONK NATION, L.L.C., MIROMAR LAKES, FL. FILED 2-8-2012.

Get Gronk'd

THE MARK CONSISTS OF STANDARD CHARACTERS WITHOUT CLAIM TO ANY PARTICULAR FONT, STYLE, SIZE, OR COLOR.

THE NAME(S), PORTRAIT(S), AND/OR SIGNATURE(S) SHOWN IN THE MARK IDENTIFIES ROBERT GRONKOWSKI, CHRISTOPHER GRONKOWSKI, DANIEL GRONKOWSKI, WHOSE CONSENT(S) TO REGISTER IS MADE OF RECORD.

FOR ENDORSEMENT SERVICES, NAMELY, PROMOTING THE GOODS AND SERVICES OF OTHERS (U.S. CLS. 100, 101 AND 102).

FIRST USE 2-18-2011; IN COMMERCE 2-18-2011.
GEOFFREY FOSDICK, EXAMINING ATTORNEY

NO CLAIM IS MADE TO THE EXCLUSIVE RIGHT TO USE "PURPOSE PLACEMENT SERVICES LLC", APART FROM THE MARK AS SHOWN.

THE COLOR(S) LIGHT BLUE, BLUE, DARK BLUE, BLACK, AND WHITE IS/ARE CLAIMED AS A FEATURE OF THE MARK.

THE MARK CONSISTS OF STYLIZED WHITE STACKED LETTERS IN WHITE: TWO LIGHT BLUE SQUARES WITH 1/4 BOTTOM RIGHT CORNER OF TOP SQUARE OF DARK BLUE FRAMED IN BLACK WITH WHITE LETTER "P"; 1/4 LEFT TOP OF BOTTOM SQUARE OF DARK BLUE FRAMED IN BLACK WITH WHITE LETTER "S"; ONE DARK BLUE SQUARE WITH WHITE LETTER "P" FRAMED IN BLACK; THE WORDING "PURPOSE PLACEMENT SERVICES LLC" IN WHITE IS ABOVE THE WORDING "HELPING PEOPLE CONNECT" IN WHITE ALL TO THE RIGHT OF THE DESIGN. THE TERM "LLC" IN SMALL FONT IS BELOW THE LETTERS "ES" OF THE TERM "SERVICES". THE BACKGROUND APPEARS IN BLUE.

FOR EMPLOYMENT HIRING, RECRUITING, PLACEMENT, STAFFING AND CAREER NETWORKING SERVICES (U.S. CLS. 100, 101 AND 102).

FIRST USE 1-1-2011; IN COMMERCE 3-1-2011.
SALLY SHIH, EXAMINING ATTORNEY

CLASS 35—(Continued).

SN 85-542,078. FISCHER DIESEL PERFORMANCE LLC, TRUXTON, MO. FILED 2-14-2012.



NO CLAIM IS MADE TO THE EXCLUSIVE RIGHT TO USE "DIESEL", APART FROM THE MARK AS SHOWN.

THE COLOR(S) BLACK AND ORANGE IS/ARE CLAIMED AS A FEATURE OF THE MARK.

THE MARK CONSISTS OF A BLACK RECTANGLE SLOPING SLIGHT DOWN AND TO THE LEFT CONTAINING AN ORANGE DIAMOND PLATE PATTERN WITH ORANGE LETTERS COMPRISING THE WORD "DIESEL" WITH A STYLIZED DIRTY APPEARANCE TO THE LETTERS ON THE FRONT AND ALSO A BLACK RECTANGLE SLOPING DOWN AND TO THE RIGHT CONTAINING AN ORANGE DIAMOND PLATE PATTERN CONTAINING ORANGE LETTERS COMPRISING THE WORD "DUDES" WITH A STYLIZED DIRTY APPEARANCE TO THE LETTERS.

FOR ON-LINE RETAIL STORE SERVICES FEATURING AFTERMARKET DIESEL PERFORMANCE PARTS (U.S. CLS. 100, 101 AND 102).

FIRST USE 1-20-2012; IN COMMERCE 1-20-2012.
TINA MAI, EXAMINING ATTORNEY

SN 85-542,571. ACCESS TO PATIENTS, LLC, KING OF PRUSSIA, PA. FILED 2-14-2012.



THE MARK CONSISTS OF LOWER CASE LETTERS "A" AND "P" WITH A CIRCLE UNDER THE "A" AND A CIRCLE OVER THE "P".

THE WORDING "AP" HAS NO MEANING IN A FOREIGN LANGUAGE.

FOR ADVERTISING, MARKETING, PUBLICITY AND PROMOTION SERVICES FOR OTHERS IN THE FIELD OF CLINICAL TRIAL PATIENT RECRUITMENT (U.S. CLS. 100, 101 AND 102).

FIRST USE 10-31-2011; IN COMMERCE 10-31-2011.
MYRIAH HABEEB, EXAMINING ATTORNEY

CLASS 35—(Continued).

SN 85-544,227. GONZALO ESTELA PASTOR, DENIA, SPAIN, FILED 2-16-2012.

SingularWINE

THE MARK CONSISTS OF STANDARD CHARACTERS WITHOUT CLAIM TO ANY PARTICULAR FONT, STYLE, SIZE, OR COLOR.

PRIORITY CLAIMED UNDER SEC. 44(D) ON ERPNTY TM OFC APPLICATION NO. 010650729, FILED 2-16-2012, REG. NO. 010650729, DATED 6-14-2012, EXPIRES 6-2-2022.

FOR PROVIDING SPACE AT A WEB SITE FOR THE ADVERTISEMENT OF THE GOODS AND SERVICES OF OTHERS (U.S. CLS. 100, 101 AND 102).

DANIEL CAPSHAW, EXAMINING ATTORNEY

SN 85-546,079. HARDY, RENEE L., DBA COMMON THREAD, TAOS, NM. AND HARDY, DAVID E., DBA COMMON THREAD, TAOS, NM. FILED 2-17-2012.

LLOOM

THE MARK CONSISTS OF STANDARD CHARACTERS WITHOUT CLAIM TO ANY PARTICULAR FONT, STYLE, SIZE, OR COLOR.

FOR ON-LINE RETAIL STORE SERVICES FEATURING TEXTILES, FURNITURE, AND ACCESSORIES; RETAIL STORE SERVICES FEATURING TEXTILES, FURNITURE, AND ACCESSORIES (U.S. CLS. 100, 101 AND 102).

FIRST USE 1-23-2005; IN COMMERCE 0-0-2006.
SUE LAWRENCE, EXAMINING ATTORNEY

SN 85-547,122. ULTRASHARP, SAINT CHARLES, MO. FILED 2-20-2012.

Scissor King

THE MARK CONSISTS OF STANDARD CHARACTERS WITHOUT CLAIM TO ANY PARTICULAR FONT, STYLE, SIZE, OR COLOR.

NO CLAIM IS MADE TO THE EXCLUSIVE RIGHT TO USE "SCISSOR", APART FROM THE MARK AS SHOWN.

FOR RETAIL STORE SERVICES FEATURING BEAUTY SUPPLIES; WHOLESALE STORE SERVICES FEATURING BEAUTY SUPPLIES (U.S. CLS. 100, 101 AND 102).

JANICE KIM, EXAMINING ATTORNEY

CLASS 35—(Continued).

SN 85-547,666. GREEN SOLE CORPORATION, ROWLAND HEIGHTS, CA. FILED 2-20-2012.

Shoes 4ever

THE MARK CONSISTS OF STANDARD CHARACTERS WITHOUT CLAIM TO ANY PARTICULAR FONT, STYLE, SIZE, OR COLOR.

NO CLAIM IS MADE TO THE EXCLUSIVE RIGHT TO USE "SHOES", APART FROM THE MARK AS SHOWN.

FOR RETAIL STORE SERVICES FEATURING WOMEN'S SHOES (U.S. CLS. 100, 101 AND 102).

FIRST USE 1-1-2011; IN COMMERCE 1-1-2011.

CHARISMA HAMPTON, EXAMINING ATTORNEY

SN 85-548,229. NATIONAL BILLING ASSOCIATES, INC., BIRMINGHAM, AL. FILED 2-21-2012.



NO CLAIM IS MADE TO THE EXCLUSIVE RIGHT TO USE "RENAL BILLING", APART FROM THE MARK AS SHOWN.

THE MARK CONSISTS OF THE WORDS "RENAL BILLING" SIDE-BY-SIDE IN LOWER-CASE LETTERS, WITH DESIGNS GENERALLY IN THE SHAPE OF SHEETS OF PAPER ABOVE THE WORDS AND DOLLAR BILLS BELOW THE WORDS.

FOR MEDICAL BILLING OUTSOURCING SERVICES (U.S. CLS. 100, 101 AND 102).

FIRST USE 2-0-2012; IN COMMERCE 2-0-2012.

ALYSSA STEEL, EXAMINING ATTORNEY

SN 85-548,609. BELLA COSA INC., DBA BELLA COSA JEWELERS, WILLOWBROOK, IL. FILED 2-21-2012.

BELLA COSA

THE MARK CONSISTS OF STANDARD CHARACTERS WITHOUT CLAIM TO ANY PARTICULAR FONT, STYLE, SIZE, OR COLOR.

THE ENGLISH TRANSLATION OF "BELLA COSA" IN THE MARK IS "BEAUTIFUL THING".

FOR RETAIL JEWELRY STORE AND ONLINE RETAIL JEWELRY STORE SERVICES (U.S. CLS. 100, 101 AND 102).

FIRST USE 12-31-1999; IN COMMERCE 10-17-2000.

LEIGH CAROLINE CASE, EXAMINING ATTORNEY

CLASS 35—(Continued).

SN 85-551,038. LEO BURNETT COMPANY, INC., CHICAGO, IL. FILED 2-23-2012.

THE LEO SHOP

THE MARK CONSISTS OF STANDARD CHARACTERS WITHOUT CLAIM TO ANY PARTICULAR FONT, STYLE, SIZE, OR COLOR.

NO CLAIM IS MADE TO THE EXCLUSIVE RIGHT TO USE "SHOP", APART FROM THE MARK AS SHOWN.

FOR ONLINE RETAIL GIFT SHOP (U.S. CLS. 100, 101 AND 102).

FIRST USE 2-14-2012; IN COMMERCE 2-14-2012.

ELLEN PERKINS, EXAMINING ATTORNEY

SN 85-551,649. SINA DRUG CORP., DBA ONCOMED, THE ONCOLOGY PHARMACY, GREAT NECK, NY. FILED 2-24-2012.

Onco360

THE MARK CONSISTS OF STANDARD CHARACTERS WITHOUT CLAIM TO ANY PARTICULAR FONT, STYLE, SIZE, OR COLOR.

OWNER OF U.S. REG. NOS. 4,093,849, 4,093,937 AND OTHERS.

FOR RETAIL PHARMACY SERVICES (U.S. CLS. 100, 101 AND 102).

JOHN KELLY, EXAMINING ATTORNEY

SN 85-551,655. SINA DRUG CORP., DBA ONCOMED, THE ONCOLOGY PHARMACY, GREAT NECK, NY. FILED 2-24-2012.

Onco360.com

THE MARK CONSISTS OF STANDARD CHARACTERS WITHOUT CLAIM TO ANY PARTICULAR FONT, STYLE, SIZE, OR COLOR.

OWNER OF U.S. REG. NOS. 4,093,849, 4,093,937 AND OTHERS.

FOR RETAIL PHARMACY SERVICES (U.S. CLS. 100, 101 AND 102).

JOHN KELLY, EXAMINING ATTORNEY

CLASS 35—(Continued).

SN 85-551,766. AD-GEN, LLC, CANONSBURG, PA. FILED 2-24-2012.

For Sale by Inventor

THE MARK CONSISTS OF STANDARD CHARACTERS WITHOUT CLAIM TO ANY PARTICULAR FONT, STYLE, SIZE, OR COLOR.

FOR ADVERTISING AND MARKETING SERVICES, NAMELY, PROMOTING THE GOODS AND SERVICES OF OTHERS; ADVERTISING, MARKETING AND PROMOTIONAL SERVICES RELATED TO ALL INDUSTRIES FOR THE PURPOSE OF FACILITATING NETWORKING AND SOCIALIZING OPPORTUNITIES FOR BUSINESS PURPOSES; ADVERTISING, PROMOTION, AND MARKETING SERVICES IN THE NATURE OF MARKETING PROGRAMS OF NEW PRODUCTS AND PRODUCT LICENSES FOR MANUFACTURERS, RETAILERS, AND NEW PRODUCT LICENSEES; BUSINESS CONSULTATION AND MANAGEMENT REGARDING MARKETING ACTIVITIES AND LAUNCHING OF NEW PRODUCTS; PROMOTING, ADVERTISING AND MARKETING OF THE BRANDS, PRODUCTS, SERVICES AND ONLINE WEBSITES OF INDIVIDUALS, BUSINESSES AND NON-PROFIT ORGANIZATIONS (U.S. CLS. 100, 101 AND 102).

FIRST USE 1-0-2012; IN COMMERCE 1-0-2012.
JACLYN KIDWELL WALKER, EXAMINING ATTORNEY

SN 85-551,784. SINA DRUG CORP., DBA ONCOMED, THE ONCOLOGY PHARMACY, GREAT NECK, NY. FILED 2-24-2012.

OncoSOURCE.com

THE MARK CONSISTS OF STANDARD CHARACTERS WITHOUT CLAIM TO ANY PARTICULAR FONT, STYLE, SIZE, OR COLOR.

OWNER OF U.S. REG. NOS. 4,093,849, 4,093,937 AND OTHERS.

FOR RETAIL PHARMACY SERVICES (U.S. CLS. 100, 101 AND 102).

JOHN KELLY, EXAMINING ATTORNEY

SN 85-553,551. FOGARTY, JEREMY, MARSHALLTOWN, IA. FILED 2-27-2012.



THE COLOR(S) RED, YELLOW, ORANGE, BLUE, GREEN, PURPLE AND GREY IS/ARE CLAIMED AS A FEATURE OF THE MARK.

THE MARK CONSISTS OF THE WORDING "THE ORANGIESTORE" WITH A LETTER "R" APPEARING WITHIN THE FIRST LETTER "O" AND WITH ALL THE COLORS OF

CLASS 35—(Continued).

THE RAINBOW FLOWING FROM LEFT TO RIGHT WITHIN THE WORD. THE LETTER "T" IS RED, "H" IS YELLOW AND GREEN, "E" IS BLUE AND PURPLE. THE CIRCLE APPEARS AS RED, ORANGE, YELLOW, GREEN, BLUE AND PURPLE. THE "R" WITHIN THE CIRCLE APPEARS AS RED, ORANGE, YELLOW AND GREEN. THE LETTER "R" APPEARS IN PURPLE, "A" APPEARS IN RED, "N" APPEARS IN ORANGE, "G" APPEARS IN ORANGE AND YELLOW, "I" APPEARS IN YELLOW, "E" APPEARS IN YELLOW AND GREEN, "S" APPEARS IN GREEN, "T" APPEARS IN GREEN AND BLUE, "O" AND "R" APPEAR IN BLUE, AND "E" APPEARS IN BLUE AND PURPLE. AN ORANGE COLORED IMAGE OF A SLICE OF AN ORANGE APPEARS BEHIND THE LETTERS "I" AND "E". A GREY SHADOW OF THE WORDING IS CAST BEHIND.

FOR ON-LINE RETAIL STORE SERVICES FEATURING A WIDE VARIETY OF CONSUMER GOODS OF OTHERS; RETAIL STORE SERVICES FEATURING A WIDE VARIETY OF CONSUMER GOODS OF OTHERS (U.S. CLS. 100, 101 AND 102).

KELLY TRUSILO, EXAMINING ATTORNEY

SN 85-553,853. COALITION TO PROTECT AMERICA'S HEALTH CARE, WASHINGTON D.C., DC. FILED 2-27-2012.

Coalition to Protect America's Health Care

THE MARK CONSISTS OF STANDARD CHARACTERS WITHOUT CLAIM TO ANY PARTICULAR FONT, STYLE, SIZE, OR COLOR.

SEC. 2(F).

FOR ADVERTISING AND PROMOTIONAL SERVICES FOR HOSPITALS AND THE HEALTH CARE INDUSTRY; AND PROMOTING PUBLIC AWARENESS OF HEALTH CARE ISSUES AND HEALTH CARE SERVICES (U.S. CLS. 100, 101 AND 102).

FIRST USE 7-24-2000; IN COMMERCE 7-24-2000.
GIANCARLO CASTRO, EXAMINING ATTORNEY

CLASS 35—(Continued).

SN 85-554,724. SHOPZOOEY, INC., LAKE MARY, FL. FILED 2-28-2012.



THE MARK CONSISTS OF A DESIGN OF A SMILEY FACE ON A SHOPPING BAG.

FOR MARKETING SERVICES, NAMELY, ONLINE RETAIL STORE SERVICES IN THE FIELD OF A WIDE VARIETY OF CONSUMER GOODS OF OTHERS; ONLINE MARKETING SERVICES; PROMOTING THE GOODS AND SERVICES OF OTHERS BY PROVIDING A WEBSITE FEATURING DISCOUNT VOUCHERS, AND SPECIALIZED COUPONS; PROMOTING THE GOODS AND SERVICES OF OTHERS, NAMELY, PROVIDING PRICE-COMPARISON INFORMATION REGARDING DISCOUNTS, COUPONS, REBATES, VOUCHERS AND SPECIAL OFFERS FOR THE GOODS AND SERVICES OF OTHERS (U.S. CLS. 100, 101 AND 102).

FIRST USE 4-1-2012; IN COMMERCE 4-1-2012.
KIM MONINGHOFF, EXAMINING ATTORNEY

SN 85-554,731. SHOPZOOEY, INC., LAKE MARY, FL. FILED 2-28-2012.



THE MARK CONSISTS OF A DESIGN OF A SMILEY FACE ON A SHOPPING BAG.

FOR MARKETING SERVICES, NAMELY, ONLINE RETAIL STORE SERVICES IN THE FIELD OF A WIDE VARIETY OF CONSUMER GOODS OF OTHERS; ONLINE MARKETING SERVICES; PROMOTING THE GOODS AND SERVICES OF OTHERS BY PROVIDING A WEBSITE FEATURING DISCOUNT VOUCHERS, AND SPECIALIZED COUPONS; PROMOTING THE GOODS AND SERVICES OF OTHERS, NAMELY, PROVIDING PRICE-COMPARISON INFORMATION REGARDING DISCOUNTS, COUPONS, REBATES, VOUCHERS AND SPECIAL OFFERS FOR THE GOODS AND SERVICES OF OTHERS (U.S. CLS. 100, 101 AND 102).

KIM MONINGHOFF, EXAMINING ATTORNEY

CLASS 35—(Continued).

SN 85-555,083. AUTOMOTIVE EQUIPMENT SERVICE, INC., OLATHE, KS. FILED 2-28-2012.

LAWNPARTS

THE MARK CONSISTS OF STANDARD CHARACTERS WITHOUT CLAIM TO ANY PARTICULAR FONT, STYLE, SIZE, OR COLOR.

OWNER OF U.S. REG. NO. 2,570,748.
SEC. 2(F).

FOR DISTRIBUTORSHIP SERVICES IN THE FIELD OF LAWN MOWERS, SNOWBLOWERS, POWER TRIMMERS, CHAIN SAWS AND PARTS AND ACCESSORIES THEREFOR; RETAIL STORE SERVICES FEATURING LAWN MOWERS, SNOWBLOWERS, POWER TRIMMERS, CHAIN SAWS AND GENERATORS, AND PARTS AND ACCESSORIES THEREFOR (U.S. CLS. 100, 101 AND 102).
FIRST USE 1-1-2003; IN COMMERCE 1-1-2003.

ARETHA SOMERVILLE, EXAMINING ATTORNEY

SN 85-555,438. SEAY, CHRISTOPHER, ATLANTA, GA. FILED 2-28-2012.

B+UR-

THE MARK CONSISTS OF STANDARD CHARACTERS WITHOUT CLAIM TO ANY PARTICULAR FONT, STYLE, SIZE, OR COLOR.

FOR CHARITABLE SERVICES, NAMELY, PROMOTING PUBLIC AWARENESS OF THE IMPORTANCE OF TESTING FOR STDS, HIV, AND OTHER DISEASES SO ONE MAY KNOW THEIR STATUS (U.S. CLS. 100, 101 AND 102).

FIRST USE 3-5-2012; IN COMMERCE 3-5-2012.
AISHA SALEM, EXAMINING ATTORNEY

SN 85-555,508. PRESENTFULL LTD, WINDSOR, UNITED KINGDOM, FILED 2-28-2012.

PRESENTFULL

THE MARK CONSISTS OF STANDARD CHARACTERS WITHOUT CLAIM TO ANY PARTICULAR FONT, STYLE, SIZE, OR COLOR.

FOR ON-LINE PROFESSIONAL NETWORKING SERVICES; PROVIDING NETWORKING OPPORTUNITIES FOR INDIVIDUALS SEEKING EMPLOYMENT; EMPLOYMENT HIRING, RECRUITING, PLACEMENT, STAFFING AND CAREER NETWORKING SERVICES; ONLINE PLATFORM FEATURING EMPLOYMENT INFORMATION TO HELP GRADUATES, STUDENTS AND APPRENTICES GET JOBS (U.S. CLS. 100, 101 AND 102).

WILLIAM BRECKENFELD, EXAMINING ATTORNEY

CLASS 35—(Continued).

SN 85-555,528. NORDSTROM, INC., SEATTLE, WA. FILED 2-28-2012.

SHOPPING GENIUS

THE MARK CONSISTS OF STANDARD CHARACTERS WITHOUT CLAIM TO ANY PARTICULAR FONT, STYLE, SIZE, OR COLOR.

NO CLAIM IS MADE TO THE EXCLUSIVE RIGHT TO USE "SHOPPING", APART FROM THE MARK AS SHOWN.

FOR RETAIL STORE SERVICES, ONLINE RETAIL STORE SERVICES, CATALOG, MOBILE AND TELEPHONE ORDERING SERVICES ALL FEATURING APPAREL, APPAREL ACCESSORIES, FOOTWEAR, HATS, OUTERWEAR, SMALL LEATHER GOODS, HANDBAG, LUGGAGE, LAPTOP AND MOBILE PHONE CASES AND COVERS, JEWELRY, COSMETICS, FRAGRANCES, SKIN AND BEAUTY SUPPLIES, HAIR ACCESSORIES, BEDDING SUPPLIES, STATIONARY, GIFTS, PICTURE FRAMES, STATIONARY, CANDLES, DECORATIVE PILLOWS AND THROWS, AND BAR SUPPLIES (U.S. CLS. 100, 101 AND 102).

SUZANNE BLANE, EXAMINING ATTORNEY

CLASS 35—(Continued).

SN 85-558,000. NATIONAL CORPORATE RESEARCH, LTD., NEW YORK, NY. FILED 3-1-2012.

NCR NATIONAL CORPORATE RESEARCH, LTD.

THE MARK CONSISTS OF STANDARD CHARACTERS WITHOUT CLAIM TO ANY PARTICULAR FONT, STYLE, SIZE, OR COLOR.

NO CLAIM IS MADE TO THE EXCLUSIVE RIGHT TO USE "NATIONAL CORPORATE RESEARCH, LTD.", APART FROM THE MARK AS SHOWN.

FOR COMMERCIAL REGISTERED AGENT SERVICES (U.S. CLS. 100, 101 AND 102).

FIRST USE 9-26-1996; IN COMMERCE 9-26-1996.

COLLEEN MULCRONE, EXAMINING ATTORNEY

SN 85-559,396. MANAGEMENT AND STRATEGY INSTITUTE, LLC, DOWNINGTOWN, PA. FILED 3-3-2012.

Six Sigma Black Belt Professional (SSBBP)

THE MARK CONSISTS OF STANDARD CHARACTERS WITHOUT CLAIM TO ANY PARTICULAR FONT, STYLE, SIZE, OR COLOR.

NO CLAIM IS MADE TO THE EXCLUSIVE RIGHT TO USE "SIX SIGMA BLACK BELT PROFESSIONAL", APART FROM THE MARK AS SHOWN.

FOR TESTING TO DETERMINE PROFESSIONAL COMPETENCY, NAMELY, TESTING AND EVALUATING PROFESSIONALS INVOLVED IN SIX SIGMA TO DETERMINE THEIR LEVEL OF RELATED EXPERIENCE, EDUCATION AND COMPETENCY; BUSINESS SERVICES FOR OTHERS, NAMELY, CREDENTIALING INDIVIDUALS INVOLVED IN SIX SIGMA; AND BUSINESS SERVICES FOR OTHERS, NAMELY, VERIFYING AND MONITORING THE CREDENTIALS OF PROFESSIONALS IN THE FIELD OF SIX SIGMA (U.S. CLS. 100, 101 AND 102).

FIRST USE 1-14-2012; IN COMMERCE 1-14-2012.

GINA HAYES, EXAMINING ATTORNEY

SN 85-556,726. LEO BURNETT COMPANY, INC., CHICAGO, IL. FILED 2-29-2012.

SHOPPERSCOPE

THE MARK CONSISTS OF STANDARD CHARACTERS WITHOUT CLAIM TO ANY PARTICULAR FONT, STYLE, SIZE, OR COLOR.

FOR ADVERTISING AGENCY SERVICES IN ALL MEDIA; ADVERTISING SERVICES, NAMELY, PROVIDING MARKET RESEARCH AND MARKET ANALYSIS SERVICES OF CUSTOMERS AND POTENTIAL CUSTOMERS FOR THE BRANDS OR PRODUCT CATEGORIES OF CLIENTS AND THEIR COMPETITORS (U.S. CLS. 100, 101 AND 102).

FIRST USE 10-10-2011; IN COMMERCE 10-10-2011.

ELLEN PERKINS, EXAMINING ATTORNEY

CLASS 35—(Continued).

SN 85-559,427. CEPPOS, ALAN, WATER MILL, NY. AND RAMBAUD, FREDERIC, WATER MILL, NY. FILED 3-3-2012.

PYQ

THE MARK CONSISTS OF STANDARD CHARACTERS WITHOUT CLAIM TO ANY PARTICULAR FONT, STYLE, SIZE, OR COLOR.

FOR ADVERTISING SERVICES, NAMELY, PROMOTING THE GIFT CARDS OF OTHERS; COMPUTERIZED ON-LINE GIFT ORDERING SERVICE WHICH MATCHES THE GIFT GIVER'S REQUIREMENTS WITH THE GIFT RECIPIENT'S WANTS AND NEEDS; COMPUTERIZED ON-LINE RETAIL STORE SERVICES IN THE FIELD OF GIFTS; FRANCHISING, NAMELY, OFFERING BUSINESS MANAGEMENT ASSISTANCE IN THE ESTABLISHMENT AND/OR OPERATION OF RETAIL GIFT SHOPS; GIFT REGISTRY SERVICES; ISSUING GIFT CERTIFICATES WHICH MAY THEN BE REDEEMED FOR GOODS OR SERVICES; MERCHANDISING SERVICES FOR INDUCING THE PURCHASING PUBLIC TO BUY THE GOODS OF OTHERS THROUGH A PROMOTIONAL GIFT REDEMPTION PROGRAM; MOBILE RETAIL STORE SERVICES FEATURING GIFTS; ON-LINE RETAIL CONSIGNMENT STORES FEATURING GIFTS; ON-LINE RETAIL GIFT SHOPS; ON-LINE RETAIL STORE SERVICES FEATURING A WIDE VARIETY OF CONSUMER GOODS OF OTHERS; ON-LINE RETAIL STORE SERVICES FEATURING DOWNLOADABLE PRE-RECORDED MUSIC AND VIDEO; ON-LINE RETAIL STORE SERVICES FEATURING PHYSICAL AND VIRTUAL MERCHANDISE FOR USE BY MEMBERS OF AN ONLINE COMMUNITY IN CONNECTION WITH A DESIGNATED WEBSITE FEATURING FICTIONAL CHARACTERS; ON-LINE WHOLESALE STORE SERVICES FEATURING GIFTS; PROMOTING THE GOODS AND SERVICES OF OTHERS BY PROVIDING AN INTERACTIVE WEBSITE WHERE USERS CAN INCREASE THE CURRENT VALUE OF AN ONLINE DISCOUNT BEING OFFERED BY PURCHASING THE GOODS AND SERVICES ASSOCIATED WITH THAT DISCOUNT IN THE FORM OF AN ONLINE COUPON, VOUCHER OR GIFT CARD; PROMOTING THE GOODS AND SERVICES OF OTHERS THROUGH INFOMERCIALS PLAYED ON CUSTOMER POINT OF PURCHASE TELEVISION MONITORS IN RETAIL STORES; PROMOTIONAL SERVICES, NAMELY, PROMOTING THE GOODS OF OTHERS BY MEANS OF PROVIDING ONLINE GIFT CARDS; PROMOTIONAL SERVICES, NAMELY, PROMOTING THE GOODS OF OTHERS BY MEANS OF PROVIDING ONLINE GIFT CERTIFICATES; PROMOTIONAL SERVICES, NAMELY, PROMOTING THE GOODS OF OTHERS BY PROVIDING PROMOTIONAL GIFTS, COUPONS, AND PROMOTIONAL MERCHANDISE; PROVIDING INCENTIVE AWARD PROGRAMS FOR CUSTOMERS AND EMPLOYEES THROUGH THE DISTRIBUTION OF PREPAID STORED VALUE CARDS FOR THE PURPOSE OF PROMOTING AND REWARDING LOYALTY; PROVIDING SOUND AND MUSIC LISTENING EQUIPMENT IN RETAIL STORES FOR CUSTOMERS TO PREVIEW COMPACT DISCS, TAPES, DVD'S, DVR'S, AND OTHER MEDIA PRIOR TO PURCHASE; RETAIL AND ON-LINE GROCERY STORE SERVICES FEATURING HOME DELIVERY SERVICE; RETAIL APPAREL STORES; RETAIL BUILDING SUPPLY STORE SERVICES FEATURING GIFTS IN THE NATURE OF BUILDING SUPPLIES SOLD AS GIFTS; RETAIL CONSIGNMENT STORES FEATURING GIFTS RETAIL CONVENIENCE STORES; RETAIL DEPARTMENT STORE SERVICES; RETAIL DISCOUNT STORE SERVICES IN THE FIELD OF GIFTS; RETAIL DRUG STORE SERVICES; RETAIL GIFT SHOPS; RETAIL LAWN, GARDEN AND NURSERY STORES; RETAIL PET STORES; RETAIL SPORTING GOODS STORES; RETAIL STORE SERVICES FEATURING A WIDE VARIETY OF CONSUMER GOODS OF OTHERS; RETAIL STORE SERVICES FEATURING CONVENIENCE STORE ITEMS AND GASOLINE; RETAIL

CLASS 35—(Continued).

STORE SERVICES FEATURING GREEN AND ECO-FRIENDLY PRODUCTS IN THE NATURE OF GIFTS IN THE NATURE OF GREEN AND ECO-FRIENDLY PRODUCTS SOLD AS GIFTS; RETAIL STORE SERVICES FEATURING ICE CREAM FOR CONSUMPTION OFF THE PREMISES; RETAIL STORE SERVICES FEATURING TELECOMMUNICATIONS SERVICE PLANS AND TELECOMMUNICATIONS SERVICE ACTIVATION; RETAIL STORE SERVICES FEATURING VIRTUAL GOODS, NAMELY, GIFTS FOR USE IN ONLINE VIRTUAL WORLDS; RETAIL STORE SERVICES FEATURING GIFTS PROVIDED VIA WIRELESS COMMUNICATIONS; RETAIL STORE SERVICES FEATURING GIFTS ACCESSIBLE ON-LINE AND BY TELEPHONE, FACSIMILE AND MAIL ORDER; RETAIL STORE SERVICES IN THE FIELD OF GIFTS FEATURING A BONUS INCENTIVE PROGRAM FOR CUSTOMERS; RETAIL STORE SERVICES IN THE FIELD OF GIFTS THAT CAN BE PURCHASED UNDER A RENT-TO-OWN CONTRACT; RETAIL STORE SERVICES, AVAILABLE THROUGH COMPUTER COMMUNICATIONS AND INTERACTIVE TELEVISION, FEATURING GIFTS; RETAIL VARIETY STORES; TEMPORARY RETAIL STORES SET UP ON-SITE AT SCHOOLS TO PROVIDE SHOPPING FACILITIES FOR STUDENTS; TURNKEY RETAIL START-UP SERVICES, NAMELY, COORDINATION AND ASSUMPTION OF RESPONSIBILITY FOR ALL ASPECTS OF THE STORE-OPENING PROCESS OF OTHERS; WHOLESALE STORE SERVICES FEATURING GIFTS (U.S. CLS. 100, 101 AND 102).

FIRST USE 2-15-2012; IN COMMERCE 2-15-2012.

JENNIFER WILLISTON, EXAMINING ATTORNEY

SN 85-559,936. CHIEF FINANCIAL OFFICER RESOURCE LLC, CHAPPAQUA, NY. FILED 3-5-2012.

CFO Resource

THE MARK CONSISTS OF STANDARD CHARACTERS WITHOUT CLAIM TO ANY PARTICULAR FONT, STYLE, SIZE, OR COLOR.

NO CLAIM IS MADE TO THE EXCLUSIVE RIGHT TO USE "CFO", APART FROM THE MARK AS SHOWN.

FOR ACCOUNTANCY SERVICES; ACCOUNTING CONSULTATION (U.S. CLS. 100, 101 AND 102).

JENNIFER WILLISTON, EXAMINING ATTORNEY

CLASS 35—(Continued).

SN 85-560,292. TEXAS-ISRAEL CHAMBER OF COMMERCE, INC., RICHARDSON, TX. FILED 3-5-2012.



NO CLAIM IS MADE TO THE EXCLUSIVE RIGHT TO USE "TEXAS ISRAEL CHAMBER OF COMMERCE", APART FROM THE MARK AS SHOWN.

THE COLOR(S) BLUE, RED AND WHITE IS/ARE CLAIMED AS A FEATURE OF THE MARK.

THE MARK CONSISTS OF A SIX-POINTED STAR OUTLINED IN BLUE AND WHITE WHERE THE LEFT HALF IS BLUE WITH A WHITE FIVE-POINTED STAR LOCATED IN THE BLUE SECTION, THE UPPER RIGHT PORTION OF THE LARGE STAR IS WHITE AND THE LOWER RIGHT PORTION IS RED; TO THE RIGHT OF THE DESIGN APPEAR THE WORDS "TEXAS-ISRAEL" IN BLUE LETTERS UNDERLINED WITH A BLUE LINE THAT IS LOCATED ABOVE THE RED WORDS "CHAMBER OF COMMERCE".

FOR CHAMBER OF COMMERCE SERVICES, NAMELY, PROMOTING BUSINESS IN THE STATE OF TEXAS AND THE COUNTRY OF ISRAEL (U.S. CLS. 100, 101 AND 102).

FIRST USE 2-7-2012, THE MARK WAS FIRST USED ANYWHERE IN A DIFFERENT FORM OTHER THAN THAT SOUGHT TO BE REGISTERED AT LEAST AS EARLY AS 09/25/2007 ; IN COMMERCE 2-7-2012, THE MARK WAS FIRST USED IN COMMERCE IN A DIFFERENT FORM OTHER THAN THAT SOUGHT TO BE REGISTERED AT LEAST AS EARLY AS 09/25/2007.

CHRISTOPHER BUONGIORNO, EXAMINING ATTORNEY

CLASS 35—(Continued).

SN 85-562,706. SOW SEEDS, LLC, DBA SOW SEEDS, WAUWATOSA, WI. FILED 3-7-2012.



THE COLOR(S) BROWN, TAN, GREEN IS/ARE CLAIMED AS A FEATURE OF THE MARK.

THE MARK CONSISTS OF THE BROWN STYLIZED WORDING "SOW SEEDS". BETWEEN THE WORDS "SOW" AND "SEEDS" ARE THREE TAN SEEDS AND, SPROUTING FROM THE SEEDS, TWO GREEN LEAVES. A DARK GREEN CROSS FORMS THE VEINS OF THE LARGER LEAF.

FOR ADVERTISING AND DIRECTORY SERVICES, NAMELY, PROMOTING THE SERVICES OF OTHERS BY PROVIDING A WEB PAGE FEATURING LINKS TO THE WEBSITES OF OTHERS; ADVERTISING AND MARKETING SERVICES PROVIDED BY MEANS OF INDIRECT METHODS OF MARKETING COMMUNICATIONS, NAMELY, SOCIAL MEDIA, SEARCH ENGINE MARKETING, INQUIRY MARKETING, INTERNET MARKETING, MOBILE MARKETING, BLOGGING AND OTHER FORMS OF PASSIVE, SHARABLE OR VIRAL COMMUNICATIONS CHANNELS; CHARITABLE SERVICES, NAMELY, PROVIDING A FREE ONLINE RESOURCE IN THE NATURE OF A WEBSITE FOR CONNECTING PEOPLE WHO HAVE SERVICE NEEDS WITH PEOPLE WHO ARE WILLING TO PROVIDE VOLUNTEER SERVICES; COMPUTERIZED ON-LINE ORDERING FEATURING GENERAL MERCHANDISE AND GENERAL CONSUMER GOODS; ON-LINE RETAIL STORE SERVICES FEATURING PHYSICAL AND VIRTUAL MERCHANDISE FOR USE BY MEMBERS OF AN ONLINE COMMUNITY IN CONNECTION WITH A DESIGNATED WEBSITE FEATURING FICTIONAL CHARACTERS; PROVIDING A WEBSITE FEATURING AN ONLINE MARKETPLACE FOR EXCHANGING GOODS AND SERVICES WITH OTHER USERS; PROVISION OF SPACE ON WEBSITES FOR ADVERTISING GOODS AND SERVICES; THE BRINGING TOGETHER, FOR THE BENEFIT OF OTHERS, OF A VARIETY OF GOODS AND SERVICES, ENABLING CUSTOMERS TO CONVENIENTLY VIEW AND PURCHASE THOSE GOODS AND SERVICES FROM AN INTERNET WEBSITE PARTICULARLY SPECIALIZING IN THE MARKETING OF THE SALE OF GOODS AND SERVICES OF OTHERS (U.S. CLS. 100, 101 AND 102).

BARBARA GAYNOR, EXAMINING ATTORNEY

SN 85-562,912. SOW SEEDS, LLC, DBA SOW SEEDS, WAUWATOSA, WI. FILED 3-7-2012.



THE COLOR(S) SIENNA AND YELLOW IS/ARE CLAIMED AS A FEATURE OF THE MARK.

THE MARK CONSISTS OF A RECTANGLE. THE BOR-

CLASS 35—(Continued).

DER OF THE RECTANGLE IS DARK YELLOW; THE INTERIOR OF THE RECTANGLE IS SIENNA. IN THE INTERIOR OF THE RECTANGLE IS THE STYLIZED WORDING "SOW SEEDS" IN DARK YELLOW. TO THE RIGHT OF THE WORDING IS THE DARK YELLOW SILHOUETTE OF A MAN WITH A SACHEL SCATTERING DARK YELLOW SEEDS ON THE GROUND. AT THE MAN'S FEET ARE ALTERNATING BANDS OF SIENNA AND DARK YELLOW THAT REPRESENT A CULTIVATED FIELD.

FOR CHARITABLE SERVICES, NAMELY, ORGANIZING AND CONDUCTING VOLUNTEER PROGRAMS AND COMMUNITY SERVICE PROJECTS; CHARITABLE SERVICES, NAMELY, PROVIDING A FREE ONLINE RESOURCE IN THE NATURE OF A WEBSITE FOR CONNECTING PEOPLE WHO HAVE SERVICE NEEDS WITH PEOPLE WHO ARE WILLING TO PROVIDE VOLUNTEER SERVICES; COMPUTERIZED ON-LINE ORDERING FEATURING GENERAL MERCHANDISE AND GENERAL CONSUMER GOODS; DEVELOPING AND COORDINATING VOLUNTEER PROJECTS FOR CHARITABLE ORGANIZATIONS; ON-LINE RETAIL STORE SERVICES FEATURING PHYSICAL AND VIRTUAL MERCHANDISE FOR USE BY MEMBERS OF AN ONLINE COMMUNITY IN CONNECTION WITH A DESIGNATED WEBSITE FEATURING FICTIONAL CHARACTERS; PRODUCT MERCHANDISING; THE BRINGING TOGETHER, FOR THE BENEFIT OF OTHERS, OF A VARIETY OF GOODS AND SERVICES, ENABLING CUSTOMERS TO CONVENIENTLY VIEW AND PURCHASE THOSE GOODS AND SERVICES FROM AN INTERNET WEB SITE PARTICULARLY SPECIALIZING IN THE MARKETING OF THE SALE OF GOODS AND SERVICES OF OTHERS (U.S. CLS. 100, 101 AND 102).

BARBARA GAYNOR, EXAMINING ATTORNEY

CLASS 35—(Continued).

SN 85-564,395. BENJAMIN JOHN COLEMAN, DBA THE ORIGAMI BONSAI COMPANY, PAWTUCKET, RI. FILED 3-8-2012.

The Origami Bonsai Company

THE MARK CONSISTS OF STANDARD CHARACTERS WITHOUT CLAIM TO ANY PARTICULAR FONT, STYLE, SIZE, OR COLOR.

NO CLAIM IS MADE TO THE EXCLUSIVE RIGHT TO USE "COMPANY", APART FROM THE MARK AS SHOWN. FOR PUBLIC RELATIONS (U.S. CLS. 100, 101 AND 102).

FIRST USE 10-1-2011; IN COMMERCE 10-25-2011.
SOPHIA S. KIM, EXAMINING ATTORNEY

SN 85-563,263. LEO BURNETT COMPANY, INC., CHICAGO, IL. FILED 3-7-2012.

SN 85-566,837. MARRIOTT VACATIONS WORLDWIDE CORPORATION, ORLANDO, FL. FILED 3-12-2012.

THE MARK CONSISTS OF THE STYLIZED WORD "SHOPPER" ABOVE THE STYLIZED WORD "SCOPE" WITH A PAIR OF EYEGLASSES MAKING UP THE "O" AND "P" IN BOTH "SHOPPER" AND "SCOPE".

FOR ADVERTISING AGENCY SERVICES IN ALL MEDIA; ADVERTISING SERVICES, NAMELY, PROVIDING MARKET RESEARCH AND MARKET ANALYSIS SERVICES OF CUSTOMERS AND POTENTIAL CUSTOMERS FOR THE BRANDS OR PRODUCT CATEGORIES OF CLIENTS AND THEIR COMPETITORS (U.S. CLS. 100, 101 AND 102).

FIRST USE 10-10-2011; IN COMMERCE 10-10-2011.
ELLEN PERKINS, EXAMINING ATTORNEY

HORIZONS BY MVW

THE MARK CONSISTS OF STANDARD CHARACTERS WITHOUT CLAIM TO ANY PARTICULAR FONT, STYLE, SIZE, OR COLOR.

OWNER OF U.S. REG. NO. 2,550,971.
FOR PROVIDING HOTEL AND RESORT MANAGEMENT SERVICES FOR OTHERS; BUSINESS MANAGEMENT SERVICES FOR TIMESHARE, HOTEL AND RESORT PROPERTIES; ADVERTISING AND PROMOTION SERVICES IN THE FIELD OF HOTELS, RESORTS AND VACATION TIME SHARES; PROMOTING HOTEL, RESORT AND TIME SHARE SERVICES BY MEANS OF AN INCENTIVE AWARD PROGRAM (U.S. CLS. 100, 101 AND 102).

NAKIA HENRY, EXAMINING ATTORNEY

CLASS 35—(Continued).

SN 85-568,538. FRONTIER VENTURES MANAGEMENT LIMITED, TORTOLA, BR.VIRGIN ISLANDS, FILED 3-13-2012.

FRONTIER VENTURES

THE MARK CONSISTS OF STANDARD CHARACTERS WITHOUT CLAIM TO ANY PARTICULAR FONT, STYLE, SIZE, OR COLOR.

NO CLAIM IS MADE TO THE EXCLUSIVE RIGHT TO USE "VENTURES", APART FROM THE MARK AS SHOWN.

FOR ADVERTISING; MARKETING; BUSINESS MANAGEMENT SERVICES; BUSINESS MANAGEMENT AND ADMINISTRATION; BUSINESS CONSULTANCY SERVICES; PROVISION OF OFFICE SERVICES, NAMELY, THE PROVISION OF OFFICE FUNCTIONS; PROVISION OF BUSINESS CONSULTANCY SERVICES RELATING TO THE ACQUIRING AND DISPOSAL OF INTERESTS IN CORPORATE ENTITIES; ALL OF THE AFORESAID SERVICES RELATING TO STARTUP, GROWTH AND EMERGING COMPANIES; ADVISORY SERVICES RELATING TO ALL OF THE AFORESAID SERVICES (U.S. CLS. 100, 101 AND 102).

JULIE VEPPUMTHARA, EXAMINING ATTORNEY

SN 85-569,106. HONEY-BRIDGE INC, VIRGINIA BEACH, VA. FILED 3-14-2012.



NO CLAIM IS MADE TO THE EXCLUSIVE RIGHT TO USE "IT'S A BUYER'S MARKET", APART FROM THE MARK AS SHOWN.

THE MARK CONSISTS OF A SHOPPING CART BEHIND THE STYLIZED TEXT "MUNOH" IN "MUNOHMART", AND THE SLOGAN "IT'S A BUYER'S MARKET" UNDERNEATH.

THE WORD(S) "MUNOH" HAS NO MEANING IN A FOREIGN LANGUAGE.

FOR ON-LINE BIDDING AND TRADING WEBSITE IN WHICH BUYERS AND SELLERS POST PRODUCTS AND SERVICES TO BE AUCTIONED VIA THE INTERNET (U.S. CLS. 100, 101 AND 102).

DANIEL CAPSHAW, EXAMINING ATTORNEY

CLASS 35—(Continued).

SN 85-570,893. GUARDIAN PROSTAR, INC., GRAND JUNCTION, CO. FILED 3-15-2012.

EARTHWORM

THE MARK CONSISTS OF STANDARD CHARACTERS WITHOUT CLAIM TO ANY PARTICULAR FONT, STYLE, SIZE, OR COLOR.

FOR BUSINESS MANAGEMENT CONSULTATION FOR UTILITY AND PIPELINE COMPANIES IN THE FIELD OF UTILITY ASSET MANAGEMENT AND UTILITY LOCATION DATA MANAGEMENT (U.S. CLS. 100, 101 AND 102).

CIMMERIAN COLEMAN, EXAMINING ATTORNEY

SN 85-570,961. NORDSTROM, INC., SEATTLE, WA. FILED 3-15-2012.

HAPPY STYLE HUNTING

THE MARK CONSISTS OF STANDARD CHARACTERS WITHOUT CLAIM TO ANY PARTICULAR FONT, STYLE, SIZE, OR COLOR.

NO CLAIM IS MADE TO THE EXCLUSIVE RIGHT TO USE "STYLE", APART FROM THE MARK AS SHOWN.

FOR RETAIL STORE SERVICES, ONLINE RETAIL STORE SERVICES, CATALOG, MOBILE AND TELEPHONE ORDERING SERVICES ALL FEATURING APPAREL, APPAREL ACCESSORIES, FOOTWEAR, HATS, OUTERWEAR, SMALL LEATHER GOODS, HANDBAG, LUGGAGE, LAPTOP AND MOBILE PHONE CASES AND COVERS, JEWELRY, COSMETICS, FRAGRANCES, SKIN AND BEAUTY SUPPLIES, HAIR ACCESSORIES, BEDDING SUPPLIES, STATIONARY, GIFTS, PICTURE FRAMES, STATIONARY, CANDLES, DECORATIVE PILLOWS AND THROWS, AND BAR SUPPLIES (U.S. CLS. 100, 101 AND 102).

FIRST USE 9-12-2011; IN COMMERCE 9-12-2011.

SUZANNE BLANE, EXAMINING ATTORNEY

SN 85-572,165. ACTIVE MINDS, INC., WASHINGTON, DC. FILED 3-16-2012.

SEND SILENCE PACKING

THE MARK CONSISTS OF STANDARD CHARACTERS WITHOUT CLAIM TO ANY PARTICULAR FONT, STYLE, SIZE, OR COLOR.

FOR PROMOTING PUBLIC AWARENESS IN THE FIELD OF COMMUNITY MENTAL HEALTH (U.S. CLS. 100, 101 AND 102).

FIRST USE 4-0-2008; IN COMMERCE 4-0-2008.

MARLENE BELL, EXAMINING ATTORNEY

CLASS 35—(Continued).

SN 85-572,183. IBARRA, PEDRO, PASADENA, CA. FILED 3-16-2012.

Hightimes Pasadena Car Club

THE MARK CONSISTS OF STANDARD CHARACTERS WITHOUT CLAIM TO ANY PARTICULAR FONT, STYLE, SIZE, OR COLOR.

NO CLAIM IS MADE TO THE EXCLUSIVE RIGHT TO USE "PASADENA CAR CLUB", APART FROM THE MARK AS SHOWN.

FOR CLUB SERVICES, NAMELY, PROMOTING THE INTERESTS OF CAR ENTHUSIASTS (U.S. CLS. 100, 101 AND 102).

FIRST USE 8-2-1999; IN COMMERCE 9-1-1999.
MARLENE BELL, EXAMINING ATTORNEY

SN 85-572,464. AVAPAY PTY. LTD., DARLINGTON 2008, AUSTRALIA, FILED 3-17-2012.

Avapay

THE MARK CONSISTS OF STANDARD CHARACTERS WITHOUT CLAIM TO ANY PARTICULAR FONT, STYLE, SIZE, OR COLOR.

FOR ON-LINE TRADING SERVICES, NAMELY, OPERATING ON-LINE MARKETPLACES FOR SELLERS AND BUYERS OF GOODS AND/OR SERVICES; PROVIDING ON-LINE FACILITIES FEATURING TRANSACTION ORDER ENTRY, ORDER DIRECTING AND ORDER CONFIRMATION SERVICES TO CUSTOMERS IN THE FIELD OF ON-LINE MARKETPLACES FOR A VARIETY OF GOODS AND SERVICES (U.S. CLS. 100, 101 AND 102).

MATTHEW MCDOWELL, EXAMINING ATTORNEY

SN 85-572,714. THE CARBON BASIS COMPANY LTD., DBA THE CARBON BASIS COMPANY LTD., EDMONTON, CANADA, FILED 3-18-2012.

ClimateStar

THE MARK CONSISTS OF STANDARD CHARACTERS WITHOUT CLAIM TO ANY PARTICULAR FONT, STYLE, SIZE, OR COLOR.

FOR PROVIDING A DATABASE FOR TRACKING, MONITORING, MAPPING AND GENERATING REPORTS ABOUT PRODUCT LIFE-CYCLE GREENHOUSE GAS EMISSIONS (U.S. CLS. 100, 101 AND 102).

NORA BUCHANAN WILL, EXAMINING ATTORNEY

CLASS 35—(Continued).

SN 85-573,667. PARTSIMPLE TECHNOLOGIES, LLC, AKA PART SIMPLE, GLENDALE HEIGHTS, IL. FILED 3-19-2012.

Part Simple

THE MARK CONSISTS OF STANDARD CHARACTERS WITHOUT CLAIM TO ANY PARTICULAR FONT, STYLE, SIZE, OR COLOR.

NO CLAIM IS MADE TO THE EXCLUSIVE RIGHT TO USE "PART", APART FROM THE MARK AS SHOWN.

FOR ON-LINE RETAIL STORE SERVICES FEATURING HOUSEHOLD AND ELECTRONIC APPLIANCES AND HOUSEHOLD AND ELECTRONIC APPLIANCE COMPONENTS, SUPPLIES AND ACCESSORIES, NAMELY, REFURBISHED AND NEW REPLACEMENT PARTS FOR USE IN HOUSEHOLD AND ELECTRONIC APPLIANCES AND ACCESSORIES THEREFOR; OPERATING ON-LINE MARKETPLACES FOR SELLERS OF GOODS AND/OR SERVICES DIRECTED TO REFURBISHED AND NEW REPLACEMENT PARTS FOR HOUSEHOLD AND ELECTRONIC APPLIANCES (U.S. CLS. 100, 101 AND 102).

FIRST USE 7-22-2011; IN COMMERCE 7-22-2011.
ASMAT KHAN, EXAMINING ATTORNEY

SN 85-574,084. VANDER STOEP, CAROL, AUSTIN, TX. FILED 3-20-2012.



NO CLAIM IS MADE TO THE EXCLUSIVE RIGHT TO USE "MOUTH", "HEALTHY MOUTH", OR "RHD", APART FROM THE MARK AS SHOWN.

THE NAME(S), PORTRAIT(S), AND/OR SIGNATURE(S) SHOWN IN THE MARK IDENTIFIES "CAROL VANDER STOEP", WHOSE CONSENT(S) TO REGISTER IS MADE OF RECORD.

THE MARK CONSISTS OF THE STYLIZED WORDS "MOUTH MATTERS". BELOW THE WORDS IS A LINE THAT SPIKES AND APPEARS TO BE A HEART MONITORING LINE. THE LETTER "T" IN "MOUTH" AND THE LETTER "M" AND "T" IN "MATTERS" ARE MADE UP BY THE SPIKES IN THE LINES BELOW THE WORDS. BELOW THE LINE ARE THE STYLIZED WORDS "CAROL VANDER STOEP, RDH". TO THE LEFT OF THE WORDS IS A CIRCLE WITHIN ANOTHER CIRCLE. THE INNER CIRCLE HAS A TREE AND A REFLECTION OF A TREE IN IT, ALONG WITH ANOTHER HEART MONITOR LINE. AT THE TOP OF THE OUTER CIRCLE ARE THE WORDS "HEALTHY MOUTH" AND AT THE BOTTOM OF THE OUTER CIRCLE ARE THE WORDS "HEALTHY BODY".

FOR BUSINESS CONSULTATION IN THE FIELD OF ORAL HYGIENE.; ORGANISATION AND CONDUCTING OF PRODUCT PRESENTATIONS (U.S. CLS. 100, 101 AND 102).

FIRST USE 1-0-2012; IN COMMERCE 1-0-2012.
JEFFREY LOOK, EXAMINING ATTORNEY

CLASS 35—(Continued).

SN 85-574,270. PROFESSIONAL LIABILITY UNDERWRITING SOCIETY, MINNEAPOLIS, MN. FILED 3-20-2012.



OWNER OF U.S. REG. NO. 2,533,352.

THE MARK CONSISTS OF TWO CONCENTRIC RECTANGLES, THE INNER RECTANGLE SEPARATED BY A HORIZONTAL LINE. THE TOP PORTION OF THE INNER RECTANGLE HAS THE TERM "RPLU". THE BOTTOM PORTION OF THE INNER RECTANGLE HAS FIVE STARS.

FOR BUSINESS SERVICES, NAMELY, CREDENTIALING OF PROFESSIONAL LIABILITY PROFESSIONALS (U.S. CLS. 100, 101 AND 102).

FIRST USE 9-7-1999; IN COMMERCE 9-7-1999.
MICHAEL WIENER, EXAMINING ATTORNEY

SN 85-574,495. MLE MERCHANDISING & SIGN SOLUTIONS, INC., DBA MLE, INC., BENSENVILLE, IL. FILED 3-20-2012.



NO CLAIM IS MADE TO THE EXCLUSIVE RIGHT TO USE "LIVE INTERFACE FIELD TECHNOLOGY", APART FROM THE MARK AS SHOWN.

THE MARK CONSISTS OF A THREE-DIMENSIONAL CIRCLE THAT CONTAINS A SIDEWAYS BOX WITH AN ARROW POINTING RIGHT AND AN ARROW POINTING LEFT. ALONG THE RIGHT SIDE OF THE CIRCLE, STARTING AT THE TOP, ARE THE WORDS "LIVE", "INTERFACE", "FIELD" AND "TECHNOLOGY" STACKED ON TOP OF EACH OTHER. THE FIRST LETTER OF EACH WORD IS BOLDED AND THE WORDS ARE STACKED SUCH THAT THESE BOLDED FIRST LETTERS SPELL THE WORD "LIFT" VERTICALLY.

FOR SPECIALTY MERCHANDISING SERVICES, NAMELY, PROMOTING THE GOODS AND SERVICES OF OTHERS BY PROVIDING CUSTOMIZED ADVERTISING MATERIALS IN THE NATURE OF INTERIOR AND EXTERIOR SIGNAGE AND MARKETING DISPLAYS FOR BRANDED PRODUCTS IN A WIDE RANGE OF INDUSTRIES INCLUDING BANKING, RETAIL, PROPERTY MANAGEMENT, GROCERY, RESTAURANT AND OTHERS (U.S. CLS. 100, 101 AND 102).

LINDA LAVACHE, EXAMINING ATTORNEY

CLASS 35—(Continued).

SN 85-576,816. FENTON COMMUNICATIONS, INC., NEW YORK, NY. FILED 3-22-2012.

PROGRESS ACCELERATED

THE MARK CONSISTS OF STANDARD CHARACTERS WITHOUT CLAIM TO ANY PARTICULAR FONT, STYLE, SIZE, OR COLOR.

FOR PUBLIC RELATIONS SERVICES; MARKETING CONSULTING SERVICES, NAMELY, CREATING PUBLIC INTEREST MARKETING COMMUNICATIONS CAMPAIGNS FOR OTHERS; BUSINESS MARKETING CONSULTING SERVICES IN THE FIELD OF PUBLIC INTEREST ISSUE CAMPAIGNS; MARKET RESEARCH AND ANALYSIS; MARKETING SERVICES, NAMELY, PROMOTING THE CAUSES OF OTHERS; MARKETING SERVICES, NAMELY, CONSUMER MARKETING RESEARCH IN THE NATURE OF MONITORING MEDIA COVERAGE; MARKETING SERVICES, NAMELY, CONSUMER MARKETING RESEARCH IN THE NATURE OF MONITORING SOCIAL MEDIA (U.S. CLS. 100, 101 AND 102).

FIRST USE 12-0-2008; IN COMMERCE 12-0-2008.
JOHN KELLY, EXAMINING ATTORNEY

SN 85-577,316. FILENE'S BASEMENT, LLC, SEACAUCUS, NJ. FILED 3-22-2012.

**STANLEY B. BY STANLEY
BLACKER**

THE MARK CONSISTS OF STANDARD CHARACTERS WITHOUT CLAIM TO ANY PARTICULAR FONT, STYLE, SIZE, OR COLOR.

OWNER OF U.S. REG. NOS. 1,379,293, 2,862,769 AND 3,557,293.

THE NAME(S), PORTRAIT(S), AND/OR SIGNATURE(S) SHOWN IN THE MARK DOES NOT IDENTIFY A PARTICULAR LIVING INDIVIDUAL.

FOR RETAIL STORE SERVICES AND ONLINE RETAIL STORE SERVICES FEATURING CLOTHING, WATCHES, JEWELRY, EYEWEAR, TOTE BAGS, UMBRELLAS AND LEATHER ACCESSORIES, NAMELY, WALLETS, HANDBAGS, KEY CHAINS (U.S. CLS. 100, 101 AND 102).

KAREN BRACEY, EXAMINING ATTORNEY

CLASS 35—(Continued).

SN 85-577,788. SCOTT, CHARLES, ALEXANDRIA, VA. FILED 3-23-2012.

CLASS 35—(Continued).

SN 85-579,543. KANGOL LIMITED, SHIREBROOK, UNITED KINGDOM, FILED 3-26-2012.

PAY YOURSELF FIRST

THE MARK CONSISTS OF STANDARD CHARACTERS WITHOUT CLAIM TO ANY PARTICULAR FONT, STYLE, SIZE, OR COLOR.

FOR MEMBERSHIP CLUB SERVICES PROVIDING DISCOUNTS AND PROCESSING REBATES FOR THE SERVICES OF OTHERS; ADMINISTRATION OF A PROGRAM FOR ENABLING PARTICIPANTS TO OBTAIN DISCOUNTS ON PRODUCTS AND SERVICES; PROMOTING THE GOODS OF OTHERS, NAMELY, PROVIDING INFORMATION REGARDING DISCOUNTS, COUPONS, REBATES, VOUCHERS AND SPECIAL OFFERS FOR THE GOODS OF OTHERS (U.S. CLS. 100, 101 AND 102).

FIRST USE 0-0-2011; IN COMMERCE 0-0-2011.
STEVEN JACKSON, EXAMINING ATTORNEY



OWNER OF U.S. REG. NOS. 3,988,639, 4,153,667 AND OTHERS.

THE MARK CONSISTS OF A KANGAROO DESIGN OVER THE WORD "KANGOL".

FOR RETAIL STORE SERVICES IN THE FIELDS OF CLOTHING, FOOTWEAR, HEADGEAR, BAGS, AND RELATED FASHION ACCESSORIES; ON-LINE RETAIL STORE SERVICES IN THE FIELD OF CLOTHING, FOOTWEAR, HEADGEAR, BAGS AND RELATED FASHION ACCESSORIES; RETAIL STORE SERVICES IN THE FIELDS OF CLOTHING, FOOTWEAR, HEADGEAR, BAGS AND RELATED FASHION ACCESSORIES ACCESSIBLE ON-LINE AND BY TELEPHONE AND MAIL ORDER; BUSINESS AND MANAGEMENT ADVICE; BUSINESS CONSULTANCY AND BUSINESS INFORMATION SERVICES; COMPILATION AND PROVISION OF TRADE, BUSINESS, PRICE AND STATISTICAL INFORMATION AND DATABASES; PREPARATION OF BUSINESS REPORTS; ADVERTISING SERVICES, BUSINESS ADMINISTRATION, MARKETING AND MARKETING PLANNING; ADVISORY AND CONSULTANCY SERVICES RELATING TO MARKETING, MARKETING ASSESSMENT SERVICES; BUSINESS PLANNING AND DEVELOPMENT, SERVICES RELATING TO STOCK CONTROL, SCANNING, TAGGING AND SECURITY; SETTING UP, ORGANIZATION, ADMINISTRATION, OPERATION AND SUPERVISION OF CUSTOMER LOYALTY, SALES, INCENTIVES AND PROMOTIONAL ACTIVITY SCHEMES AND ADVICE, CONSULTANCY AND INFORMATION SERVICES RELATING TO SUCH SERVICES, NAMELY, PROVIDING INCENTIVE AWARD PROGRAMS FOR CUSTOMERS THROUGH ISSUANCE AND PROCESSING OF LOYALTY POINTS FOR ON-LINE PURCHASE OF COMPANY'S GOODS AND SERVICES; BUSINESS MANAGEMENT FOCUSED ON ADVISING CLIENTS FOR THE ESTABLISHMENT AND MANAGEMENT OF RETAIL STORES; PROVIDING OFFICE FUNCTIONS; PROVISION OF SPACE ON WEBSITES FOR ADVERTISING GOODS AND SERVICES; DIRECT MAIL ADVERTISING SERVICES; DISTRIBUTION OF SAMPLES AND DISTRIBUTING THE PROMOTIONAL ITEMS OF OTHERS FOR PUBLICITY AND ADVERTISING PURPOSES; MARKETING SERVICES (U.S. CLS. 100, 101 AND 102).

INGRID C. EULIN, EXAMINING ATTORNEY

SN 85-579,088. MANAGEMENT AND STRATEGY INSTITUTE, LLC, DOWNINGTON, PA. FILED 3-24-2012.

Sarbanes-Oxley Trained Professional (SOTP)

THE MARK CONSISTS OF STANDARD CHARACTERS WITHOUT CLAIM TO ANY PARTICULAR FONT, STYLE, SIZE, OR COLOR.

NO CLAIM IS MADE TO THE EXCLUSIVE RIGHT TO USE "SARBANES-OXLEY TRAINED PROFESSIONAL", APART FROM THE MARK AS SHOWN.

FOR TESTING TO DETERMINE PROFESSIONAL COMPETENCY, NAMELY, TESTING AND EVALUATING PROFESSIONALS IN THEIR UNDERSTANDING OF THE SARBANES-OXLEY ACT; TO DETERMINE THEIR LEVEL OF RELATED EXPERIENCE, EDUCATION AND COMPETENCY; BUSINESS SERVICES FOR OTHERS, NAMELY, CREDENTIALING INDIVIDUALS INVOLVED IN SARBANES-OXLEY; AND BUSINESS SERVICES FOR OTHERS, NAMELY, VERIFYING AND MONITORING THE CREDENTIALS OF PROFESSIONALS IN THEIR UNDERSTANDING OF THE SARBANES-OXLEY ACT (U.S. CLS. 100, 101 AND 102).

FIRST USE 1-14-2012; IN COMMERCE 1-14-2012.
GINA HAYES, EXAMINING ATTORNEY

CLASS 35—(Continued).

SN 85-579,548. KANGOL LIMITED, SHIREBROOK, UNITED KINGDOM, FILED 3-26-2012.

KANGOL

THE MARK CONSISTS OF STANDARD CHARACTERS WITHOUT CLAIM TO ANY PARTICULAR FONT, STYLE, SIZE, OR COLOR.

OWNER OF U.S. REG. NOS. 3,988,639, 4,153,667 AND OTHERS.

FOR RETAIL STORE SERVICES IN THE FIELDS OF CLOTHING, FOOTWEAR, HEADGEAR, BAGS, AND RELATED FASHION ACCESSORIES; ON-LINE RETAIL STORE SERVICES IN THE FIELD OF CLOTHING, FOOTWEAR, HEADGEAR, BAGS AND RELATED FASHION ACCESSORIES; RETAIL STORE SERVICES IN THE FIELDS OF CLOTHING, FOOTWEAR, HEADGEAR, BAGS AND RELATED FASHION ACCESSORIES ACCESSIBLE ON-LINE AND BY TELEPHONE AND MAIL ORDER; BUSINESS AND MANAGEMENT ADVICE; BUSINESS CONSULTANCY AND BUSINESS INFORMATION SERVICES; COMPILATION AND PROVISION OF TRADE, BUSINESS, PRICE AND STATISTICAL INFORMATION AND DATABASES; PREPARATION OF BUSINESS REPORTS; ADVERTISING SERVICES, BUSINESS ADMINISTRATION, MARKETING AND MARKETING PLANNING; ADVISORY AND CONSULTANCY SERVICES RELATING TO MARKETING, MARKETING ASSESSMENT SERVICES; BUSINESS PLANNING AND DEVELOPMENT, SERVICES RELATING TO STOCK CONTROL, SCANNING, TAGGING AND SECURITY; SETTING UP, ORGANIZATION, ADMINISTRATION, OPERATION AND SUPERVISION OF CUSTOMER LOYALTY, SALES, INCENTIVES AND PROMOTIONAL ACTIVITY SCHEMES AND ADVICE, CONSULTANCY AND INFORMATION SERVICES RELATING TO SUCH SERVICES, NAMELY, PROVIDING INCENTIVE AWARD PROGRAMS FOR CUSTOMERS THROUGH ISSUANCE AND PROCESSING OF LOYALTY POINTS FOR ON-LINE PURCHASE OF COMPANY'S GOODS AND SERVICES; BUSINESS MANAGEMENT FOCUSED ON ADVISING CLIENTS FOR THE ESTABLISHMENT AND MANAGEMENT OF RETAIL STORES; PROVIDING OFFICE FUNCTIONS; PROVISION OF SPACE ON WEBSITES FOR ADVERTISING GOODS AND SERVICES; DIRECT MAIL ADVERTISING SERVICES; DISTRIBUTION OF SAMPLES AND DISTRIBUTING THE PROMOTIONAL ITEMS OF OTHERS FOR PUBLICITY AND ADVERTISING PURPOSES; MARKETING SERVICES (U.S. CLS. 100, 101 AND 102).

INGRID C. EULIN, EXAMINING ATTORNEY

CLASS 35—(Continued).

SN 85-579,760. THE ROOT LIST INC, DBA CRAVELOCAL, ORLANDO, FL. FILED 3-26-2012.

Crave Local

THE MARK CONSISTS OF STANDARD CHARACTERS WITHOUT CLAIM TO ANY PARTICULAR FONT, STYLE, SIZE, OR COLOR.

FOR ADMINISTRATION OF A CONSUMER LOYALTY PROGRAM TO PROMOTE RESTAURANT SERVICES AND RETAIL SERVICES OF OTHERS; ADMINISTRATION OF A PROGRAM FOR ENABLING PARTICIPANTS TO OBTAIN DISCOUNTS ON PRODUCTS AND SERVICES; AN INTERACTIVE WEB SITE FOR USERS TO REVIEW AND RATE INTERNET CONTENT, PEOPLE, COMPANIES, PRODUCTS AND/OR SERVICES UTILIZING A SOFTWARE APPLICATION TO AWARD POINTS WHEREBY WEB SITE USERS ARE ELIGIBLE TO EXCHANGE POINTS EARNED FOR PROMOTIONAL ITEMS CONSISTING OF COUPONS, REBATES, DISCOUNTS OR SPECIAL OFFERINGS ON GOODS AND/OR SERVICE PROVIDED BY WEB SITE SPONSORS (U.S. CLS. 100, 101 AND 102).

FIRST USE 6-9-2009; IN COMMERCE 6-9-2009.

BARBARA BROWN, EXAMINING ATTORNEY

SN 85-579,897. CHRISTMAS & ASSOCIATES, INC., CAMDEN, NY. FILED 3-26-2012.



THE MARK CONSISTS OF A LOGO IMAGE OF A FULL MOON WITH PINE TREES POSITIONED WITHIN THE MOON'S SILHOUETTE AND THE WORDS "CAMPFITTERS LIFE'S ALWAYS BETTER AT CAMP" TO THE SIDE OF THE LOGO.

FOR ON-LINE RETAIL STORE SERVICES FEATURING MERCHANDISE FOR OUTFITTING A CAMP, NAMELY, APPAREL, OUTDOOR GEAR, CAMP ACTIVITIES, NAMELY, GAMES, MUSIC AND BOOKS, CABIN DÉCOR, NAMELY, LIGHTING, RUGS, PRINTS, SIGNS, AND POSTERS, DINNERWARE AND COOKWARE, CANDLES, SOAPS, AND PANCAKE MIXES (U.S. CLS. 100, 101 AND 102).

FIRST USE 1-1-2012; IN COMMERCE 1-1-2012.

TRACY CROSS, EXAMINING ATTORNEY

CLASS 35—(Continued).

SN 85-580,122. FURLINED, LLC, SANTA MONICA, CA. FILED 3-26-2012.



THE MARK CONSISTS OF THE LITERAL ELEMENT "FURLINED" FOLLOWED BY A COMMA, ALL OF WHICH IS EVENLY DIVIDED ACROSS FIVE RECTANGULAR BOXES IN HORIZONTAL ALIGNMENT. IN THE FIRST BOX, BEGINNING ON THE LEFT, IS THE LETTER "F" AND THE LEFT HALF OF THE LETTER "U", IN THE SECOND BOX IS THE RIGHT HALF OF THE LETTER "U" AND THE LETTER "R", IN THE THIRD BOX ARE THE LETTERS "L" AND "I", IN THE FOURTH BOX ARE THE LETTERS "N" AND "E", AND IN THE FIFTH BOX ARE THE EDGES OF THE PRONGS OF THE LETTER "E", THE LETTER "D" AND THE COMMA.

FOR PRODUCTION OF ADVERTISING MATTER AND COMMERCIALS; PRODUCTION OF TELEVISION COMMERCIALS (U.S. CLS. 100, 101 AND 102).
KATHLEEN KOLACZ, EXAMINING ATTORNEY

CLASS 35—(Continued).

SN 85-580,992. PHILLIPS, STEVEN, MINNEAPOLIS, MN. FILED 3-27-2012.



THE MARK CONSISTS OF "PAC+" WITH A STYLIZED SLASH DESIGN THROUGH THE "A" AND THE "C", ABOVE A SOLID LINE, AND WITH "PACPLUS.ORG" BENEATH THE LINE.

FOR POLITICAL ACTION COMMITTEE SERVICES, NAMELY, PROMOTING THE INTERESTS OF PEOPLE OF COLOR AND PROGRESSIVES IN THE FIELD OF POLITICS (U.S. CLS. 100, 101 AND 102).
JIM RINGLE, EXAMINING ATTORNEY

SN 85-580,131. FURLINED, LLC, SANTA MONICA, CA. FILED 3-26-2012.



THE MARK CONSISTS OF STANDARD CHARACTERS WITHOUT CLAIM TO ANY PARTICULAR FONT, STYLE, SIZE, OR COLOR.

FOR PRODUCTION OF ADVERTISING MATTER AND COMMERCIALS; PRODUCTION OF TELEVISION COMMERCIALS (U.S. CLS. 100, 101 AND 102).
KATHLEEN KOLACZ, EXAMINING ATTORNEY

SN 85-581,293. IK RETAIL GROUP, INC., WASHINGTON, DC. FILED 3-27-2012.



OWNER OF U.S. REG. NO. 4,174,833.
NO CLAIM IS MADE TO THE EXCLUSIVE RIGHT TO USE "EMPORIUM", APART FROM THE MARK AS SHOWN.

THE MARK CONSISTS OF THE WORD "EMPORIUM" IN STYLIZED FONT, IN WHICH THE LETTER "O" IS SHADED AND CONTAINS THE WORDING "DNA 2050", WHICH IS ALSO SHOWN IN STYLIZED FONT

FOR RETAIL STORE SERVICES FEATURING MEN'S AND WOMEN'S CLOTHING AND ACCESSORIES (U.S. CLS. 100, 101 AND 102).
ESTHER BELENKER, EXAMINING ATTORNEY

CLASS 35—(Continued).

SN 85-581,810. WILD MARKETING & MEDIA, LLC, BALLWIN, MO. FILED 3-28-2012.



NO CLAIM IS MADE TO THE EXCLUSIVE RIGHT TO USE "KID" AND "SAINT LOUIS", APART FROM THE MARK AS SHOWN.

THE COLOR(S) GRAY, TAN, RED, ORANGE, GREEN, LIGHT BLUE, BLUE, BROWN, BLACK, YELLOW, AND PINK IS/ARE CLAIMED AS A FEATURE OF THE MARK.

THE MARK CONSISTS OF THE FACES OF TWO CARTOON CHILDREN IN ORANGE, BLACK, TAN, LIGHT TAN, YELLOW, GRAY, BROWN AND LIGHT BROWN, BOTH SMILING WITH A LIGHT YELLOW CIRCLE OVAL BEHIND THEM. BELOW THE FACES IS THE WORD "KID" WITH THE LETTER "K" IN RED, THE LETTER "I" IN ORANGE, AND THE LETTER "D" IN GREEN. BELOW THE WORD "KID" IS THE WORD "CITY" IN LIGHT BLUE. BELOW THAT, IN SMALLER TEXT, ARE THE WORDS "SAINT LOUIS" IN DARKER BLUE.

FOR ORGANIZING BUSINESS EXPOSITIONS FOR PARENTS SEEKING PRODUCTS AND SERVICES FOR THEIR FAMILIES (U.S. CLS. 100, 101 AND 102).

FIRST USE 9-1-2010; IN COMMERCE 9-1-2010.
TINA MAI, EXAMINING ATTORNEY

SN 85-583,140. EXACTCARE PHARMACY, VALLEY VIEW, OH. FILED 3-29-2012.

ExactCare Pharmacy

THE MARK CONSISTS OF STANDARD CHARACTERS WITHOUT CLAIM TO ANY PARTICULAR FONT, STYLE, SIZE, OR COLOR.

NO CLAIM IS MADE TO THE EXCLUSIVE RIGHT TO USE "PHARMACY", APART FROM THE MARK AS SHOWN.

FOR PHARMACEUTICAL SERVICES, NAMELY, PROCESSING PRESCRIPTION ORDERS FOR PATIENTS (U.S. CLS. 100, 101 AND 102).

FIRST USE 1-31-2010; IN COMMERCE 1-31-2010.
KRISTIN DAHLING, EXAMINING ATTORNEY

CLASS 35—(Continued).

SN 85-583,251. SKI'S OPEN HEART FOUNDATION, DBA SKI'S OPEN HEART FOUNDATION, EAST PATCHOGUE, NY. FILED 3-29-2012.



NO CLAIM IS MADE TO THE EXCLUSIVE RIGHT TO USE "FOUNDATION", APART FROM THE MARK AS SHOWN.

THE COLOR(S) ORANGE AND BLACK IS/ARE CLAIMED AS A FEATURE OF THE MARK.

THE MARK CONSISTS OF THE WORDING "SKI'S" IN ORANGE, WHERE THE "S" AFTER THE APOSTROPHE SERVES AS THE LEFT SIDE OF A HEART AND WHERE THE RIGHT SIDE OF THE HEART IS IN BLACK. THE WORDING "OPEN HEART" APPEARS IN BLACK UNDERNEATH THE WORDING "SKI'S " AND THE WORDING "FOUNDATION" APPEARS IN BLACK UNDERNEATH "OPEN HEART".

FOR CHARITABLE SERVICES, NAMELY, COORDINATION OF NON-MONETARY CONTRIBUTIONS TO CHARITIES AND NON-PROFITS; PROMOTING THE CHARITABLE SERVICES OF OTHERS, NAMELY, PROVIDING INDIVIDUALS WITH INFORMATION ABOUT VARIOUS CHARITIES FOR THE PURPOSE OF MAKING DONATIONS TO CHARITIES (U.S. CLS. 100, 101 AND 102).

FIRST USE 3-26-2012; IN COMMERCE 3-26-2012.
JANICE KIM, EXAMINING ATTORNEY

SN 85-583,959. WATERSAVERS IRRIGATION, INC., DBA IRRIGATION SUPPLY OUTLET, SAN RAFAEL, CA. FILED 3-29-2012.



NO CLAIM IS MADE TO THE EXCLUSIVE RIGHT TO USE "IRRIGATION SUPPLY OUTLET", APART FROM THE MARK AS SHOWN.

THE COLOR(S) DARK BLUE, LIGHT BLUE, GREEN AND WHITE IS/ARE CLAIMED AS A FEATURE OF THE MARK.

THE MARK CONSISTS OF A TEARDROP SHAPED WATER DROP ABOVE TWO SEMI-CIRCLES TO THE LEFT OF THE WORDING "IRRIGATION SUPPLY OUTLET". THE COLOR DARK BLUE APPEARS IN THE TEXT OF THE WORDING "IRRIGATION", AND IN THE EXTERIOR OUTLINE OF THE WATER DROP. THE COLOR LIGHT BLUE APPEARS IN THE TEXT OF THE WORDING "SUPPLY OUTLET", AND AS THE INTERIOR SHADING FOR THE WATER DROP. THE COLOR GREEN APPEARS AS THE SHADING IN THE TWO SEMI-CIRCLES. THE COLOR WHITE APPEARS AS THE SHADING FOR THE INTERIOR OUTLINE OF THE WATER DROP, AND AS THE SHADING AT THE CENTER OF THE WATER DROP.

FOR WHOLESALE STORE SERVICES FEATURING IRRIGATION SUPPLIES (U.S. CLS. 100, 101 AND 102).

FIRST USE 2-1-2011; IN COMMERCE 4-1-2011.
ELI HELLMAN, EXAMINING ATTORNEY

CLASS 35—(Continued).

SN 85-583,966. INNOVATIVE PACK DESIGNS, LLC, CASTLE ROCK, CO. FILED 3-29-2012.

INNOVATIVE PACK DESIGNS

THE MARK CONSISTS OF STANDARD CHARACTERS WITHOUT CLAIM TO ANY PARTICULAR FONT, STYLE, SIZE, OR COLOR.

NO CLAIM IS MADE TO THE EXCLUSIVE RIGHT TO USE "PACK DESIGNS", APART FROM THE MARK AS SHOWN.

FOR ON-LINE ORDERING SERVICES FEATURING TEXTILE-BASED PORTABLE EQUIPMENT-STORAGE PRODUCTS THAT FEATURE A POUCH ATTACHMENT LADDER SYSTEM (PALS), WHICH USES A LATTICE OF STRAPPING FOR SUPPORTING AND HOLDING EQUIPMENT (U.S. CLS. 100, 101 AND 102).
KIMBERLY PARKS, EXAMINING ATTORNEY

SN 85-584,023. DYO MANAGEMENT, INC., SMYRNA, GA. FILED 3-29-2012.



NO CLAIM IS MADE TO THE EXCLUSIVE RIGHT TO USE "INC.", APART FROM THE MARK AS SHOWN.

THE MARK CONSISTS OF A LARGE, THICK, DARK CIRCLE SURROUNDED BY A THIN LIGHT BORDER WITH A DARK OUTLINE, WITH THE DARK, LOWER-CASE LETTERS "D" AND "Y" INSIDE THE CIRCLE AND THE LOWER-CASE WORD "INC." BELOW THE "Y", WITH THE STEM OF THE "D" EXTENDING AROUND TO THE RIGHT TO FORM THE RIGHT SIDE OF THE CIRCLE AND THE TAIL OF THE "Y" EXTENDING UP AND TO THE LEFT TO FORM THE LEFT SIDE OF THE CIRCLE.

FOR BUSINESS CONSULTATION; BUSINESS MANAGEMENT AND CONSULTATION IN THE FIELD OF MEDIA, ENTERTAINMENT, AND TECHNOLOGY (U.S. CLS. 100, 101 AND 102).

MATTHEW MCDOWELL, EXAMINING ATTORNEY

CLASS 35—(Continued).

SN 85-584,513. KEYS CARIBBEAN RESORTS LLC, KEY WEST, FL. FILED 3-30-2012.

KEYS CARIBBEAN

THE MARK CONSISTS OF STANDARD CHARACTERS WITHOUT CLAIM TO ANY PARTICULAR FONT, STYLE, SIZE, OR COLOR.

OWNER OF U.S. REG. NO. 3,295,862.
SEC. 2(F).

FOR BUSINESS MANAGEMENT OF HOTELS FOR OTHERS; HOTEL MANAGEMENT FOR OTHERS; MANAGING AND OPERATING RESORT HOTELS AND BUSINESS CONFERENCE CENTERS OF OTHERS; PROVIDING HOTEL RATE COMPARISON INFORMATION (U.S. CLS. 100, 101 AND 102).

FIRST USE 1-10-2007; IN COMMERCE 1-10-2007.
DANIEL CAPSHAW, EXAMINING ATTORNEY

SN 85-585,016. TIRE'S WAREHOUSE, INC., CORONA, CA. FILED 3-30-2012.

PARTNERS PROGRAM

THE MARK CONSISTS OF STANDARD CHARACTERS WITHOUT CLAIM TO ANY PARTICULAR FONT, STYLE, SIZE, OR COLOR.

NO CLAIM IS MADE TO THE EXCLUSIVE RIGHT TO USE "PROGRAM", APART FROM THE MARK AS SHOWN.

FOR ADMINISTRATION OF A CUSTOMER LOYALTY PROGRAM WHICH PROVIDES REBATES BASED ON THE NUMBER OF TIRES PURCHASED IN A BUYING PERIOD; ARRANGING AND CONDUCTING INCENTIVE REWARD PROGRAMS TO PROMOTE THE SALE OF TIRES (U.S. CLS. 100, 101 AND 102).

FIRST USE 9-0-2008; IN COMMERCE 9-0-2008.

LEIGH CAROLINE CASE, EXAMINING ATTORNEY

SN 85-586,344. CANDY ON A MISSION, PHILADELPHIA, PA. FILED 4-2-2012.

Candy On A Mission

THE MARK CONSISTS OF STANDARD CHARACTERS WITHOUT CLAIM TO ANY PARTICULAR FONT, STYLE, SIZE, OR COLOR.

NO CLAIM IS MADE TO THE EXCLUSIVE RIGHT TO USE "CANDY", APART FROM THE MARK AS SHOWN.

FOR ON-LINE RETAIL STORE SERVICES FEATURING CONFECTIONS, NAMELY, CHOCOLATES, CANDY, JELLY BEANS, SNACKS, IN GIFT BASKETS OR GIFT BOXES (U.S. CLS. 100, 101 AND 102).

NELSON SNYDER, EXAMINING ATTORNEY

CLASS 35—(Continued).

SN 85-586,825. MINUTEMAN PRESS INTERNATIONAL, INC., FARMINGDALE, NY. FILED 4-2-2012.

CLASS 35—(Continued).

SN 85-587,959. PALM SPRINGS DESERT RESORT COMMUNITIES CONVENTION AND VISITORS AUTHORITY, RANCHO MIRAGE, CA. FILED 4-3-2012.

MINUTEMAN XPRESS ADS

THE MARK CONSISTS OF STANDARD CHARACTERS WITHOUT CLAIM TO ANY PARTICULAR FONT, STYLE, SIZE, OR COLOR.

OWNER OF U.S. REG. NOS. 2,314,083, 4,035,077 AND OTHERS.

NO CLAIM IS MADE TO THE EXCLUSIVE RIGHT TO USE "ADS", APART FROM THE MARK AS SHOWN.

FOR ADVERTISING SERVICES, NAMELY, DESIGNING AND DISTRIBUTING PRINT ADVERTISING FOR OTHERS (U.S. CLS. 100, 101 AND 102).

FIRST USE 4-18-2011; IN COMMERCE 4-18-2011.
JAMES GRIFFIN, EXAMINING ATTORNEY

NO CLAIM IS MADE TO THE EXCLUSIVE RIGHT TO USE "GREATER PALM SPRINGS CONVENTION & VISITORS BUREAU", APART FROM THE MARK AS SHOWN.

THE MARK CONSISTS OF STYLISTIC DESCRIPTION OF AN AERIAL VIEW OF A PALM TREE ABOVE THE WORDS "GREATER PALM SPRINGS CONVENTION AND VISITORS BUREAU."

FOR CONVENTION AND VISITORS BUREAU SERVICES, NAMELY, PROMOTING CONVENTIONS AND TOURISM IN THE GREATER PALM SPRINGS AREA (U.S. CLS. 100, 101 AND 102).

FIRST USE 2-29-2012; IN COMMERCE 2-29-2012.
MARIA-VICTORIA SUAREZ, EXAMINING ATTORNEY

SN 85-587,111. SUGARBUSH ORIGINALS, INC., SHELBYVILLE, MI. FILED 4-2-2012.

SN 85-588,023. TILEMAX, SUNLAND, CA. FILED 4-3-2012.

Streak Free Michigan**TILEMAX**

THE MARK CONSISTS OF STANDARD CHARACTERS WITHOUT CLAIM TO ANY PARTICULAR FONT, STYLE, SIZE, OR COLOR.

SEC. 2(F).
FOR ON-LINE RETAIL STORE SERVICES FEATURING MICROFIBER CLEANING CLOTHS (U.S. CLS. 100, 101 AND 102).

FIRST USE 4-0-2006; IN COMMERCE 4-0-2006.
VIVIAN MICZNIK FIRST, EXAMINING ATTORNEY

THE MARK CONSISTS OF STANDARD CHARACTERS WITHOUT CLAIM TO ANY PARTICULAR FONT, STYLE, SIZE, OR COLOR.

FOR RETAIL STORE SERVICES FEATURING TILE, NATURAL STONE AND STONE TILE, AND BAMBOO, HARDWOOD AND LAMINATE FLOORING; WHOLESALE STORE SERVICES FEATURING TILE, NATURAL STONE AND STONE TILE, AND BAMBOO, HARDWOOD AND LAMINATE FLOORING (U.S. CLS. 100, 101 AND 102).

KATHERINE M. DUBRAY, EXAMINING ATTORNEY

CLASS 35—(Continued).

SN 85-588,120. RUSSELL, SHAROLYN A., TAMPA, FL. FILED 4-3-2012.

Paris Flea

THE MARK CONSISTS OF STANDARD CHARACTERS WITHOUT CLAIM TO ANY PARTICULAR FONT, STYLE, SIZE, OR COLOR.

NO CLAIM IS MADE TO THE EXCLUSIVE RIGHT TO USE "FLEA", APART FROM THE MARK AS SHOWN. SEC. 2(F).

FOR RETAIL STORE AND WHOLESALE STORE SERVICES FEATURING HOME FURNISHINGS, LIGHTING, FLOOR COVERINGS, LINENS, BEDDING, UPHOLSTERY GOODS, WALL ART, MIRRORS, FURNITURE, CUSTOM FURNITURE, CASE GOODS IN THE NATURE OF CHANDELIERS, CABINETRY, WALL PAPER, SILK FLORAL AND OTHER SIMILAR HOME FURNISHINGS, ACCESSIBLE ON-LINE AND BY TELEPHONE, FACSIMILE AND MAIL ORDER (U.S. CLS. 100, 101 AND 102).

FIRST USE 4-1-1994; IN COMMERCE 4-1-1994.
KHANH LE, EXAMINING ATTORNEY

SN 85-588,154. BAR KEEPER LLC., LOS ANGELES, CA. FILED 4-3-2012.

BAR KEEPER-A HEAD SHOP FOR ALCOHOL LOVERS

THE MARK CONSISTS OF STANDARD CHARACTERS WITHOUT CLAIM TO ANY PARTICULAR FONT, STYLE, SIZE, OR COLOR.

NO CLAIM IS MADE TO THE EXCLUSIVE RIGHT TO USE "BAR KEEPER", APART FROM THE MARK AS SHOWN.

FOR RETAIL STORE SERVICES FEATURING BEER, WINE, SPIRITS, BAR TOOLS, BAR GLASSWARE, WINE GLASSES, CORKSCREWS, WINE RACKS, COCKTAIL GIFT BOXES, ALCOHOL MIXERS, BOOKS, BEAKERS, NEW AND VINTAGE BARWARE. ON-LINE RETAIL STORE SERVICES FEATURING BEER, WINE, SPIRITS, BAR TOOLS, BAR GLASSWARE, WINE GLASSES, CORKSCREWS, WINE RACKS, COCKTAIL GIFT BOXES, ALCOHOL MIXERS, BOOKS, BEAKERS, NEW AND VINTAGE BARWARE (U.S. CLS. 100, 101 AND 102).

FIRST USE 1-7-2006; IN COMMERCE 1-7-2006.
GINA HAYES, EXAMINING ATTORNEY

CLASS 35—(Continued).

SN 85-588,176. BAR KEEPER LLC., LOS ANGELES, CA. FILED 4-3-2012.

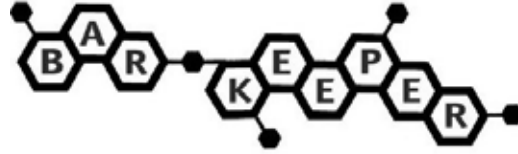

NO CLAIM IS MADE TO THE EXCLUSIVE RIGHT TO USE "BAR KEEPER", APART FROM THE MARK AS SHOWN.

THE MARK CONSISTS OF NINE ATTACHED HEXAGON BOXES EACH CONTAINING A SINGLE LETTER.

FOR RETAIL STORE SERVICES FEATURING BEER, WINE, SPIRITS, BAR TOOLS, BAR GLASSWARE, WINE GLASSES, CORKSCREWS, WINE RACKS, COCKTAIL GIFT BOXES, ALCOHOL MIXERS, BOOKS, BEAKERS, NEW AND VINTAGE BARWARE. ON-LINE RETAIL STORE SERVICES FEATURING BEER, WINE, SPIRITS, BAR TOOLS, BAR GLASSWARE, WINE GLASSES, CORKSCREWS, WINE RACKS, COCKTAIL GIFT BOXES, ALCOHOL MIXERS, BOOKS, BEAKERS, NEW AND VINTAGE BARWARE (U.S. CLS. 100, 101 AND 102).

FIRST USE 1-7-2006; IN COMMERCE 1-7-2006.
GINA HAYES, EXAMINING ATTORNEY

SN 85-588,261. PALM SPRINGS DESERT RESORT COMMUNITIES CONVENTION AND VISITORS AUTHORITY, RANCHO MIRAGE, CA. FILED 4-3-2012.



NO CLAIM IS MADE TO THE EXCLUSIVE RIGHT TO USE "GREATER PALM SPRINGS", APART FROM THE MARK AS SHOWN.

THE MARK CONSISTS OF STYLISTIC DEPICTION OF AERIAL VIEW OF A PALM TREE ABOVE THE WORDS "GREATER PALM SPRINGS OASIS A BRAND NEW DAY."

FOR CONVENTION AND VISITORS BUREAU SERVICES, NAMELY, PROMOTING CONVENTIONS AND TOURISM IN THE GREATER PALM SPRINGS AREA (U.S. CLS. 100, 101 AND 102).

FIRST USE 2-29-2012; IN COMMERCE 2-29-2012.
MARIA-VICTORIA SUAREZ, EXAMINING ATTORNEY

CLASS 35—(Continued).

SN 85-588,466. AZERA MEDICAL STAFFING, INC., WIL-
LIAMSVILLE, NY. FILED 4-4-2012.

AZERA MEDICAL STAFFING

THE MARK CONSISTS OF STANDARD CHARACTERS WITHOUT CLAIM TO ANY PARTICULAR FONT, STYLE, SIZE, OR COLOR.

NO CLAIM IS MADE TO THE EXCLUSIVE RIGHT TO USE "MEDICAL STAFFING", APART FROM THE MARK AS SHOWN.

THE WORDING "AZERA" HAS NO MEANING IN A FOREIGN LANGUAGE.

FOR EMPLOYMENT AGENCY SERVICES, NAMELY, TEMPORARY AND PERMANENT PLACEMENT OF HEALTH CARE PROFESSIONALS (U.S. CLS. 100, 101 AND 102).

GIANCARLO CASTRO, EXAMINING ATTORNEY

SN 85-588,753. LEW, ELIZABETH, NORWALK, CT. FILED 4-4-2012.

"Turn Up Your Style"

THE MARK CONSISTS OF STANDARD CHARACTERS WITHOUT CLAIM TO ANY PARTICULAR FONT, STYLE, SIZE, OR COLOR.

FOR RESELLER SERVICES AND DISTRIBUTORSHIP SERVICES IN THE NATURE OF A PERSONAL STYLE PROGRAM ACCESSED BY BUYERS OVER THE INTERNET WHICH FEATURES THE PURCHASE A LICENSE AND INPUT OF PERSONAL PHYSICAL CHARACTERISTICS OF THE CONSUMER RESULTING IN THE PROGRAM PRODUCING A STYLE GUIDE FOR THE CONSUMER TO FOLLOW WHEN THEY SHOP FOR CLOTHING AND ACCESSORIES (U.S. CLS. 100, 101 AND 102).

FIRST USE 10-5-2011; IN COMMERCE 10-5-2011.

THOMAS MANOR, EXAMINING ATTORNEY

SN 85-588,934. ELITE STRENGTH & FITNESS SYSTEMS, LLC, DBA SYNERGY HEALTH PRODUCTS, BEL AIR, MD. FILED 4-4-2012.



NO CLAIM IS MADE TO THE EXCLUSIVE RIGHT TO USE "HEALTH PRODUCTS", APART FROM THE MARK AS SHOWN.

THE COLOR(S) BLUE, GREEN, ORANGE, AND TEAL IS/ARE CLAIMED AS A FEATURE OF THE MARK.

THE MARK IS BORDERED / CONTAINED BY A BLUE LINE IN THE SHAPE OF AN ELLIPSE. CENTERED INSIDE AND ORIENTED TOWARDS THE TOP OF THE ELLIPSE IS

CLASS 35—(Continued).

A SPHERICAL OBJECT BORDERED WITH GREEN EDGES THAT FADE TO A TEAL COLOR WITHIN THE BODY OF THE SPHERE. TWO ORANGE SWOOSH OBJECTS ARE CENTERED ABOVE THE SPHERE. CENTERED AND SLIGHTLY ORIENTED TOWARDS THE INSIDE TOP OF THE ELLIPSE ARE THE WORDS SYNERGY HEALTH PRODUCTS IN BLUE. ALONG THE INSIDE BOTTOM BORDER OF THE ELLIPSE ARE THE WORDS "QUALITY PRODUCTS FOR A HEALTHY LIFESTYLE". THE COLOR WHITE IS EMPLOYED MERELY AS BACKGROUND.

FOR RETAIL STORE, ONLINE RETAIL, AND MAIL ORDER CATALOG SERVICES FEATURING HEALTH FOODS, DIETARY SUPPLEMENTS, NUTRITIONAL SUPPLEMENTS, HERBS, VITAMINS, SPORTS NUTRITION PRODUCTS, FITNESS PRODUCTS AND APPAREL, BODY CARE, DIAGNOSTIC EXERCISE AND HEALTH ASSESSMENT PRODUCTS (U.S. CLS. 100, 101 AND 102).

FIRST USE 7-30-2007; IN COMMERCE 7-30-2007.

DOMINICK J. SALEMI, EXAMINING ATTORNEY

SN 85-589,027. SEKULES, KATE, DBA REFASHIONER, BROOKLYN, NY. FILED 4-4-2012.

Refashioner

THE MARK CONSISTS OF STANDARD CHARACTERS WITHOUT CLAIM TO ANY PARTICULAR FONT, STYLE, SIZE, OR COLOR.

OWNER OF U.S. REG. NO. 4,008,827.

FOR ON-LINE RETAIL CONSIGNMENT STORES FEATURING CLOTHING AND ACCESSORIES (U.S. CLS. 100, 101 AND 102).

FIRST USE 7-14-2010; IN COMMERCE 7-14-2010.

ALYSSA STEEL, EXAMINING ATTORNEY

SN 85-589,087. ALLIANCE POWERSPORTS INC., MIRA LOMA, CA. FILED 4-4-2012.

alliance powersports

NO CLAIM IS MADE TO THE EXCLUSIVE RIGHT TO USE "POWERSPORTS", APART FROM THE MARK AS SHOWN.

THE COLOR(S) RED IS/ARE CLAIMED AS A FEATURE OF THE MARK.

THE MARK CONSISTS OF THE WORD "ALLIANCE" IN RED FONT, AND THE COMBINED WORDS "POWERSPORTS" IN RED FONT.

FOR RESELLER SERVICES, NAMELY, DISTRIBUTORSHIP SERVICES IN THE FIELD OF SCOOTERS AND MOTORCYCLES (U.S. CLS. 100, 101 AND 102).

FIRST USE 4-1-2011; IN COMMERCE 4-1-2011.

KELLY TRUSILO, EXAMINING ATTORNEY

CLASS 35—(Continued).

SN 85-589,473. RISESMART, INC., SAN JOSE, CA. FILED 4-4-2012.

REDEPLOYMENT CONCIERGE

THE MARK CONSISTS OF STANDARD CHARACTERS WITHOUT CLAIM TO ANY PARTICULAR FONT, STYLE, SIZE, OR COLOR.

OWNER OF U.S. REG. NO. 3,840,280.
NO CLAIM IS MADE TO THE EXCLUSIVE RIGHT TO USE "REDEPLOYMENT", APART FROM THE MARK AS SHOWN.

FOR EMPLOYMENT OUTPLACEMENT SERVICES AND EMPLOYMENT COUNSELING (U.S. CLS. 100, 101 AND 102).
JEANIE LEE, EXAMINING ATTORNEY

CLASS 35—(Continued).

SN 85-589,854. GADSON, DENISE, DORCHESTER, SC. FILED 4-5-2012.



NO CLAIM IS MADE TO THE EXCLUSIVE RIGHT TO USE "K12 CAREER HUB CAREER SERVICES FOR K12 PROFESSIONALS", APART FROM THE MARK AS SHOWN. THE COLOR(S) RED, GOLD, AND BLACK IS/ARE CLAIMED AS A FEATURE OF THE MARK.

THE MARK CONSISTS OF THE TEXT "K12 CAREER-HUB" WRITTEN IN RED LETTERS, THERE ARE TWO GOLD ARROWS CIRCLING THE "K12". UNDER "CAREER HUB" IS A SOLID, BLACK HORIZONTAL LINE. "CAREER SERVICES FOR K12 PROFESSIONALS" IS WRITTEN IN BLACK UNDER THE SOLID BLACK LINE.

FOR EMPLOYMENT AGENCY SERVICES FOR KINDERGARTEN THROUGH TWELFTH GRADE EDUCATION PROFESSIONALS (U.S. CLS. 100, 101 AND 102).
KATHRYN COWARD, EXAMINING ATTORNEY

SN 85-589,866. BRIGHAM, CARLTON S., RIVERDALE, MD. FILED 4-5-2012.

**Supreme Council Of North
America Ancient and
Accepted Rite**

THE MARK CONSISTS OF STANDARD CHARACTERS WITHOUT CLAIM TO ANY PARTICULAR FONT, STYLE, SIZE, OR COLOR.

NO CLAIM IS MADE TO THE EXCLUSIVE RIGHT TO USE "COUNCIL OF NORTH AMERICA", APART FROM THE MARK AS SHOWN.

FOR ASSOCIATION SERVICES, NAMELY, ORGANIZING CHAPTERS OF A FRATERNITY AND PROMOTING THE INTERESTS OF THE MEMBERS THEREOF (U.S. CLS. 100, 101 AND 102).

FIRST USE 5-1-2006; IN COMMERCE 5-1-2006.
BARBARA BROWN, EXAMINING ATTORNEY

SN 85-589,625. FOGERTY, BRUCE, DBA WORTHWHILE PRODUCTIONS, DALLAS, TX. FILED 4-5-2012.

EASTER CROSS WITNESS

THE MARK CONSISTS OF STANDARD CHARACTERS WITHOUT CLAIM TO ANY PARTICULAR FONT, STYLE, SIZE, OR COLOR.

NO CLAIM IS MADE TO THE EXCLUSIVE RIGHT TO USE "EASTER CROSS", APART FROM THE MARK AS SHOWN.

FOR PROMOTIONAL CAMPAIGNS IN THE FIELD OF EVANGELISM AND RELIGION, NAMELY, PROMOTING INTERDENOMINATIONAL EASTER SERVICES; PROMOTIONAL CAMPAIGNS IN THE FIELD OF EVANGELISM AND RELIGION, NAMELY, PROMOTING UNITY AMONG DIFFERENT RELIGIOUS BRANCHES UNDER AN EASTER THEME; PROMOTIONAL CAMPAIGNS IN THE FIELD OF EVANGELISM AND RELIGION, NAMELY, PROVIDING CUSTOM CROSSES FOR PLACES OF INTERDENOMINATIONAL WORSHIP; PUBLIC ADVOCACY OF UNITY AMONG DIFFERENT RELIGIOUS BRANCHES; PROMOTING PUBLIC AWARENESS OF INTERDENOMINATIONAL WORSHIP BY PROVIDING CUSTOM CROSSES (U.S. CLS. 100, 101 AND 102).

FIRST USE 0-0-2005; IN COMMERCE 0-0-2005.
JACLYN KIDWELL WALKER, EXAMINING ATTORNEY

SN 85-590,190. WORLD CHOICE INVESTMENTS, LLC, PIGEON FORGE, TN. FILED 4-5-2012.

PIRATES VOYAGE KID'S CLUB

THE MARK CONSISTS OF STANDARD CHARACTERS WITHOUT CLAIM TO ANY PARTICULAR FONT, STYLE, SIZE, OR COLOR.

OWNER OF U.S. REG. NOS. 4,046,677, 4,046,678 AND 4,046,679.

NO CLAIM IS MADE TO THE EXCLUSIVE RIGHT TO USE "KID'S CLUB", APART FROM THE MARK AS SHOWN.

FOR MEMBERSHIP CLUB SERVICES, NAMELY, PROVIDING DISCOUNTS TO AND PROMOTING DINING AND ENTERTAINMENT SERVICES, AND DISSEMINATING RELATED MATERIALS AND MERCHANDISE IN CONNECTION THEREWITH TO CHILDREN (U.S. CLS. 100, 101 AND 102).

REBECCA EISINGER, EXAMINING ATTORNEY

CLASS 35—(Continued).

SN 85-590,229. WORLD CHOICE INVESTMENTS, LLC, PIGEON FORGE, TN. FILED 4-5-2012.



OWNER OF U.S. REG. NOS. 4,046,677, 4,046,679 AND OTHERS.

NO CLAIM IS MADE TO THE EXCLUSIVE RIGHT TO USE "KID'S CLUB", APART FROM THE MARK AS SHOWN.

THE MARK CONSISTS OF A SEA LION IN A PIRATE COSTUME LYING IN A PUDDLE OF WATER WITH DROPS OF WATER AROUND HIS TAIL INCLUDING THE WORDS "PIRATES VOYAGE KID'S CLUB" ABOVE AND AROUND THE SEA LION.

FOR MEMBERSHIP CLUB SERVICES, NAMELY, PROVIDING DISCOUNTS TO AND PROMOTING DINING AND ENTERTAINMENT SERVICES, AND DISSEMINATING RELATED MATERIALS AND MERCHANDISE IN CONNECTION THEREWITH TO CHILDREN (U.S. CLS. 100, 101 AND 102).

REBECCA EISINGER, EXAMINING ATTORNEY

SN 85-590,306. MARSHALL REDDICK REALTY, AKA MARSHALL REDDICK REAL ESTATE NETWORK, SANTA ANA, CA. FILED 4-5-2012.

ReddickWatch

THE MARK CONSISTS OF STANDARD CHARACTERS WITHOUT CLAIM TO ANY PARTICULAR FONT, STYLE, SIZE, OR COLOR.

OWNER OF U.S. REG. NO. 3,421,227.

FOR ADVERTISING AND MARKETING SERVICES, NAMELY, PROMOTING THE GOODS AND SERVICES OF OTHERS; ADVERTISING SERVICES, NAMELY, PROMOTING AND MARKETING THE GOODS AND SERVICES OF OTHERS IN THE FIELD OF REAL ESTATE VIA PRINT AND ELECTRONIC MEDIA (U.S. CLS. 100, 101 AND 102).

FIRST USE 11-27-2006; IN COMMERCE 11-27-2006.

DAVID COLLIER, EXAMINING ATTORNEY

CLASS 35—(Continued).

SN 85-590,729. KOOKIEDOODLE CRAFTS, OVERLAND PARK, KS. FILED 4-5-2012.



NO CLAIM IS MADE TO THE EXCLUSIVE RIGHT TO USE "CRAFTS", APART FROM THE MARK AS SHOWN.

THE MARK CONSISTS OF THE WORDS "KOOKIEDOODLE" AND "CRAFT" (IN A SMALLER FONT TO THE BOTTOM RIGHT OF THE WORD "KOOKIEDOODLE") IN AN OVAL SHAPE; "KOOKIEDOODLE" IS TYPED IN A STYLIZED FONT AND THE LETTERS APPEAR LIKE HANDWRITING/OR A PENCIL SKETCH. THE FIRST LETTER IS CAPITALIZED AND THERE IS A GLUE BOTTLE ABOVE THE FIRST "O", THE SECOND "O" AND THE NEXT LETTER "K" ARE ENCASED IN A RECTANGULAR PIECE OF PAPER AND HAS A PAIR OF SCISSORS CUTTING INTO THE PAPER LOCATED AT THE BOTTOM RIGHT OF THE DESIGN. THE NEXT LETTER "E" HAS A PAINTBRUSH DIRECTLY ABOVE IT. THE LETTER "D" DOESN'T HAVE ANYTHING ABOVE IT AND THE DOUBLE "OO'S" THAT FOLLOW NEXT HAVE LITTLE EYES WITHIN THEM AND EYEGGLASS FRAMES AROUND THEM. (AGAIN, THE WORD "CRAFT" IS LOCATED DIRECTLY BELOW THEM. THE NEXT LETTER "D" HAS A MARKER DIRECTLY ABOVE IT. THE LAST TWO LETTERS "L" AND "E" DON'T HAVE ANY ARTWORK ATTACHED TO THEM.

FOR RETAIL STORE SERVICES FEATURING HOBBY AND CRAFT PRODUCTS (U.S. CLS. 100, 101 AND 102).

INGRID C. EULIN, EXAMINING ATTORNEY

SN 85-590,734. PLUSDEV LLC, PASADENA, CA. FILED 4-5-2012.

AppSafari

THE MARK CONSISTS OF STANDARD CHARACTERS WITHOUT CLAIM TO ANY PARTICULAR FONT, STYLE, SIZE, OR COLOR.

FOR PROVIDING A WEB SITE FEATURING THE RATINGS, REVIEWS AND RECOMMENDATIONS OF MOBILE APPLICATIONS FOR OTHERS (U.S. CLS. 100, 101 AND 102).

FIRST USE 7-3-2007; IN COMMERCE 7-3-2007.

LESLIE RICHARDS, EXAMINING ATTORNEY

CLASS 35—(Continued).

SN 85-590,958. MOMSWHOTHINK.COM, LLC, SAN FRANCISCO, CA. FILED 4-6-2012.

MOMS WHO THINK

THE MARK CONSISTS OF STANDARD CHARACTERS WITHOUT CLAIM TO ANY PARTICULAR FONT, STYLE, SIZE, OR COLOR.

NO CLAIM IS MADE TO THE EXCLUSIVE RIGHT TO USE "MOMS", APART FROM THE MARK AS SHOWN.

FOR ON-LINE BUYERS GUIDE SERVICE PROVIDING INFORMATION IN THE FIELD OF MOTHERS, MOTHERHOOD, PARENTING AND HOMEMAKING, TOGETHER WITH RELATED PRODUCTS AND SERVICES; PROMOTIONAL SERVICES, NAMELY, PROMOTING THE GOODS OF OTHERS BY MEANS OF AN ONLINE WEBSITE; PROVIDING A SEARCHABLE ON-LINE ADVERTISING WEBSITE AND INFORMATIONAL GUIDE FEATURING THE GOODS AND SERVICES OF OTHER VENDORS VIA THE INTERNET IN THE FIELD OF MOTHERS, MOTHERHOOD, PARENTING AND HOMEMAKING; PROVIDING AN ON-LINE COMMERCIAL INFORMATION DIRECTORY ON THE INTERNET; PROVIDING AN ON-LINE COMPUTER DATABASE IN THE FIELD OF LOCATING PRODUCTS, DESCRIBING PRODUCTS, RATING PRODUCTS, PRICING PRODUCTS AND COMPARING PRICES OF PRODUCTS; PROVIDING AN ONLINE VIDEO BUSINESS DIRECTORY; PROVIDING ON-LINE BUSINESS INFORMATION OF OTHERS, NAMELY, ADVERTISEMENTS OR SOLICITATIONS; PROVIDING ON-LINE REFERRALS IN THE FIELD OF MOTHERS, MOTHERHOOD, PARENTING AND HOMEMAKING, AND RELATED PRODUCTS AND SERVICES (U.S. CLS. 100, 101 AND 102).

FIRST USE 12-31-2002; IN COMMERCE 12-31-2002.
SANI KHOURI, EXAMINING ATTORNEY

SN 85-591,051. PEOPLES FLOWER SHOPS, INC., ALBUQUERQUE, NM. FILED 4-6-2012.

SAVON CASH & CARRY

THE MARK CONSISTS OF STANDARD CHARACTERS WITHOUT CLAIM TO ANY PARTICULAR FONT, STYLE, SIZE, OR COLOR.

NO CLAIM IS MADE TO THE EXCLUSIVE RIGHT TO USE "CASH & CARRY", APART FROM THE MARK AS SHOWN.

FOR RETAIL FLORIST SHOP SERVICES FEATURING FLOWERS, PLANTS, AND FLOWER ACCESSORIES (U.S. CLS. 100, 101 AND 102).

FIRST USE 12-31-1966; IN COMMERCE 12-31-1987.
EVELYN BRADLEY, EXAMINING ATTORNEY

CLASS 35—(Continued).

SN 85-591,375. SMITH, LUNDY, PLAYA DEL REY, CA. FILED 4-6-2012.

Zapple

THE MARK CONSISTS OF STANDARD CHARACTERS WITHOUT CLAIM TO ANY PARTICULAR FONT, STYLE, SIZE, OR COLOR.

FOR ONLINE RETAIL STORE SERVICES FEATURING CUSTOMIZED AND PERSONALIZED PLAYING CARDS, FLASHCARDS, STATIONERY AND GAMES (U.S. CLS. 100, 101 AND 102).

DAVID MURRAY, EXAMINING ATTORNEY

SN 85-591,425. TABSLICER INC., LOMBARD, IL. FILED 4-6-2012.



THE COLOR(S) BLACK, GRAY, GREEN, LIGHT GREEN, YELLOW, AND WHITE IS/ARE CLAIMED AS A FEATURE OF THE MARK.

THE MARK CONSISTS OF THE WORDING "TABSLICER" WHEREIN THE LETTERS "T","A","B" ARE IN BLACK AND OUTLINED IN GRAY, AND WHERE THE "S" IS DEPICTED AS A LIME, AND WHERE THE LETTERS "L","I","C","E","R" APPEAR IN GREEN OUTLINED IN LIGHT GREEN. THE LIME SLICE THAT MAKES UP THE LETTER "S" IS GREEN, YELLOW, AND WHITE AND HAS A BLACK SWORD THROUGH THE LIME. THE BACKGROUND OF THE MARK IS TRANSPARENT.

FOR ADVERTISING, MARKETING, AND PROMOTING THE GOODS AND SERVICES OF OTHERS VIA ONLINE WEBSITE BY OFFERING COUPONS, PROMOTIONS IN THE NATURE OF ONLINE DISCOUNTS, DEALS, DISCOUNTS, PACKAGES IN THE NATURE OF ONLINE DISCOUNTS WHEN SEPARATE GOODS ARE BOUGHT TOGETHER, CUSTOMER LOYALTY REWARDS PROGRAMS, DISCOUNT INFORMATION, REBATES, AND PRODUCT REVIEWS; ISSUING AND PROCESSING OF CUSTOMER LOYALTY PROGRAMS FOR FREQUENT USE OF PARTICIPATING BUSINESSES, INCLUDING PROVIDING CUSTOMER LOYALTY REWARDS OF PREPAID CASH CARDS (U.S. CLS. 100, 101 AND 102).

FIRST USE 3-1-2012; IN COMMERCE 3-20-2012.
ANDREA HACK, EXAMINING ATTORNEY

CLASS 35—(Continued).

SN 85-591,602. MU SIGMA, INC., NORTHBROOK, IL. FILED 4-6-2012.

DIPP

THE MARK CONSISTS OF STANDARD CHARACTERS WITHOUT CLAIM TO ANY PARTICULAR FONT, STYLE, SIZE, OR COLOR.

FOR ASSISTANCE, ADVISORY SERVICES AND CONSULTANCY WITH REGARD TO BUSINESS PLANNING, BUSINESS ANALYSIS, BUSINESS MANAGEMENT, AND BUSINESS ORGANIZATION (U.S. CLS. 100, 101 AND 102).

FIRST USE 4-2-2010; IN COMMERCE 4-2-2010.
LEE-ANNE BERNS, EXAMINING ATTORNEY

CLASS 35—(Continued).

EYELASHES, BLACK EYEBROWS, BLACK HAIR, GREEN NOSE AND GRAY MOUTH; A DRESS ON THE FIGURE IN GREEN, WITH A LACE DESIGN ON THE DRESS IN BLACK AND WITH YELLOW HIGHLIGHTS ON THE DRESS; AT THE LOWER RIGHT CORNER OF THE MARK, A SPIDER FIGURE IN GREEN WITH BLACK LEGS AND BLACK EYES AND MOUTH; A BLACK CROOKED LINE SUSPENDED BELOW THE LETTER "O" IN THE WORD "STUDIOS"; FOUR SHORT BLACK LINES PLACED ON EITHER SIDE OF THE SPIDER FIGURE.

FOR WHOLESALE AND RETAIL STORE SERVICES AND CATALOG AND ON- LINE RETAIL STORE SERVICES ALL IN THE FIELD OF TOYS, GIFT AND HOME FURNISHING PRODUCTS (U.S. CLS. 100, 101 AND 102).

FIRST USE 12-3-2001; IN COMMERCE 4-1-2002.
ANDREW LEASER, EXAMINING ATTORNEY

SN 85-591,756. CEO OF ME, LLC, LEXINGTON, NC. FILED 4-7-2012.

CEO OF ME

SN 85-591,748. SPIDER SUE STUDIOS, LTD, LINDENHURST, NY. FILED 4-6-2012.



NO CLAIM IS MADE TO THE EXCLUSIVE RIGHT TO USE "STUDIOS", APART FROM THE MARK AS SHOWN.

THE COLOR(S) WHITE, BLACK, GREEN, YELLOW, GRAY AND FLESH COLOR IS/ARE CLAIMED AS A FEATURE OF THE MARK.

THE MARK CONSISTS OF THE WORDS SPIDER SUE STUDIOS IN GREEN AND OUTLINED IN BLACK, WITH THE WORDS "SPIDER" AND "SUE" APPEARING AT THE TOP OF THE MARK, AND THE WORD "STUDIOS" APPEARING AT THE BOTTOM OF THE MARK; A SPIDER WEB OUTLINED IN BLACK WITH A WHITE CENTER WITH GREEN AND YELLOW HIGHLIGHTS AND CURVED LINES IN BLACK AND WITH SEGMENTED LINES IN BLACK AND YELLOW PROTRUDING FROM EACH OF THE EIGHT POINTS OF THE SPIDER WEB; A FANCIFUL CHARACTER AT THE CENTER OF THE MARK WITH FACE, NECK AND ARMS IN FLESH COLOR, AND WITH THE WHITE OF THE FIGURE'S EYES IN WHITE WITH A GREEN IRIS AND WITH BLACK PUPIL IN EACH EYE WITH A WHITE DOT IN THE PUPIL OF EACH EYE, BLACK

THE MARK CONSISTS OF STANDARD CHARACTERS WITHOUT CLAIM TO ANY PARTICULAR FONT, STYLE, SIZE, OR COLOR.

FOR ADVERTISING AND MARKETING SERVICES PROVIDED BY MEANS OF INDIRECT METHODS OF MARKETING COMMUNICATIONS, NAMELY, SOCIAL MEDIA, SEARCH ENGINE MARKETING, INQUIRY, MARKETING, INTERNET MARKETING, MOBILE MARKETING, BLOGGING AND OTHER FORMS OF PASSIVE, SHARABLE OR VIRAL COMMUNICATIONS CHANNELS; ADVERTISING, MARKETING AND PROMOTIONAL SERVICES RELATED TO ALL INDUSTRIES FOR THE PURPOSE OF FACILITATING NETWORKING AND SOCIALIZING OPPORTUNITIES FOR BUSINESS PURPOSES; ASSISTANCE, ADVISORY SERVICES AND CONSULTANCY WITH REGARD TO BUSINESS PLANNING, BUSINESS ANALYSIS, BUSINESS MANAGEMENT, BUSINESS ORGANIZATION, MARKETING AND CUSTOMER ANALYSIS; BRANDING SERVICES, NAMELY, CONSULTING, DEVELOPMENT, MANAGEMENT AND MARKETING OF BRANDS FOR BUSINESSES; CREATIVE MARKETING DESIGN SERVICES; PROMOTING, ADVERTISING AND MARKETING ON-LINE WEB SITES OF OTHERS; THE BRINGING TOGETHER, FOR THE BENEFIT OF OTHERS, OF A VARIETY OF GOODS AND SERVICES, ENABLING CUSTOMERS TO CONVENIENTLY VIEW AND PURCHASE THOSE GOODS AND SERVICES FROM AN INTERNET WEB SITE PARTICULARLY SPECIALIZING IN THE MARKETING OF THE SALE OF GOODS AND SERVICES OF OTHERS; SOCIAL MEDIA STRATEGY AND MARKETING CONSULTANCY FOCUSING ON HELPING CLIENTS CREATE AND EXTEND THEIR PRODUCT AND BRAND STRATEGIES BY BUILDING VIRALLY ENGAGING MARKETING SOLUTIONS; PROMOTING, ADVERTISING AND MARKETING OF THE BRANDS, PRODUCTS, SERVICES AND ONLINE WEBSITES OF INDIVIDUALS, BUSINESSES AND NON-PROFIT ORGANIZATIONS; ON-LINE ADVERTISING AND MARKETING SERVICES; BUSINESS MANAGEMENT CONSULTING WITH RELATION TO STRATEGY, MARKETING, PRODUCTION, PERSONNEL AND RETAIL SALE MATTERS; ADVICE IN THE FIELD OF BUSINESS MANAGEMENT AND MARKETING; ADVERTISING, MARKETING AND PROMOTION SERVICES THROUGH DIRECT SALES, AND MULTI LEVEL MARKETING FOR SMALL BUSINESSES AND SELF EMPLOYED ENTREPRENEURS (U.S. CLS. 100, 101 AND 102).

FIRST USE 7-0-2011; IN COMMERCE 7-0-2011.
EMILY CARLSEN, EXAMINING ATTORNEY

CLASS 35—(Continued).

SN 85-591,765. PRONET SOLUTIONS CORPORATION, HOUSTON, TX. FILED 4-7-2012.

CHAMBERPLANET

THE MARK CONSISTS OF STANDARD CHARACTERS WITHOUT CLAIM TO ANY PARTICULAR FONT, STYLE, SIZE, OR COLOR.

FOR PROVIDING AN ON-LINE COMMERCIAL INFORMATION DIRECTORY ON THE INTERNET (U.S. CLS. 100, 101 AND 102).

FIRST USE 4-17-2008; IN COMMERCE 4-17-2008.
KATHY DE JONGE, EXAMINING ATTORNEY

SN 85-591,779. COKKINIAS, STEPHEN ANDREW, ORLANDO, FL. FILED 4-7-2012.



NO CLAIM IS MADE TO THE EXCLUSIVE RIGHT TO USE "CONSULTING", APART FROM THE MARK AS SHOWN.

THE MARK CONSISTS OF A CIRCULAR CHINESE CHARACTER DEPICTING THE WORD "INCENSE" IN THE FORM OF A CIRCULAR STAMP, CENTERED BELOW WHICH IS FOUND THE WORD "INNSENSE". THE WORD "INNSENSE" HAS A SLIGHTLY LARGER LETTER "I" AND ALSO THE FIRST LETTER "S" IS SLIGHTLY LARGER. AND CENTERED BELOW THE WORD "INNSENSE" IS THE WORD "CONSULTING" IN A SLIGHTLY SMALLER FONT.

THE NON-LATIN CHARACTERS IN THE MARK TRANSLITERATE TO "XIANG" AND THIS MEANS "INCENSE" IN ENGLISH.

FOR MANAGEMENT AND BUSINESS CONSULTING SERVICES IN THE FIELD OF TRAINING AND RECRUITMENT (U.S. CLS. 100, 101 AND 102).

FIRST USE 9-13-2011; IN COMMERCE 9-13-2011.
ZACHARY R. SPARER, EXAMINING ATTORNEY

CLASS 35—(Continued).

SN 85-592,102. MAG MUTUAL INSURANCE COMPANY, ATLANTA, GA. FILED 4-9-2012.

MagMutual Owners Circle

THE MARK CONSISTS OF STANDARD CHARACTERS WITHOUT CLAIM TO ANY PARTICULAR FONT, STYLE, SIZE, OR COLOR.

FOR PROVIDING A LOYALTY REWARDS PROGRAM FOR MEDICAL PROFESSIONAL LIABILITY POLICY-HOLDERS WHICH PROVIDES DIVIDENDS BASED ON YEARS OF AFFILIATION (U.S. CLS. 100, 101 AND 102).
FIRST USE 1-3-2012; IN COMMERCE 3-30-2012.

KARANENDRA S. CHHINA, EXAMINING ATTORNEY

SN 85-592,109. MAG MUTUAL INSURANCE COMPANY, ATLANTA, GA. FILED 4-9-2012.

Owners Circle

THE MARK CONSISTS OF STANDARD CHARACTERS WITHOUT CLAIM TO ANY PARTICULAR FONT, STYLE, SIZE, OR COLOR.

FOR PROVIDING A LOYALTY REWARDS PROGRAM FOR MEDICAL PROFESSIONAL LIABILITY POLICY-HOLDERS WHICH PROVIDES DIVIDENDS BASED ON YEARS OF AFFILIATION (U.S. CLS. 100, 101 AND 102).
FIRST USE 1-3-2012; IN COMMERCE 4-2-2012.

KARANENDRA S. CHHINA, EXAMINING ATTORNEY

SN 85-592,139. OILMATIC SYSTEMS, L.L.C., KEASBEY, NJ. FILED 4-9-2012.

OILMATIC

THE MARK CONSISTS OF STANDARD CHARACTERS WITHOUT CLAIM TO ANY PARTICULAR FONT, STYLE, SIZE, OR COLOR.

OWNER OF U.S. REG. NO. 3,017,369.
FOR DISTRIBUTORSHIP SERVICES IN THE FIELD OF COOKING OIL (U.S. CLS. 100, 101 AND 102).

FIRST USE 11-11-2001; IN COMMERCE 11-11-2001.
ELIZABETH HUGHITT, EXAMINING ATTORNEY

CLASS 35—(Continued).

SN 85-592,163. TOMETICH, CHRISTIAN, CELEBRATION, FL. FILED 4-9-2012.

CANDY MONSTER

THE MARK CONSISTS OF STANDARD CHARACTERS WITHOUT CLAIM TO ANY PARTICULAR FONT, STYLE, SIZE, OR COLOR.

NO CLAIM IS MADE TO THE EXCLUSIVE RIGHT TO USE "CANDY", APART FROM THE MARK AS SHOWN.

FOR RETAIL STORE SERVICES FEATURING CANDY, CHOCOLATES, GUM, BAKERY ITEMS, GIFT CONTAINERS AND BASKETS, SMALL TOYS AND STUFFED ANIMALS (U.S. CLS. 100, 101 AND 102).

TRICIA SONNEBORN, EXAMINING ATTORNEY

SN 85-592,173. PREMIER, INC., CHARLOTTE, NC. FILED 4-9-2012.

PREMIER EXCHANGE

THE MARK CONSISTS OF STANDARD CHARACTERS WITHOUT CLAIM TO ANY PARTICULAR FONT, STYLE, SIZE, OR COLOR.

NO CLAIM IS MADE TO THE EXCLUSIVE RIGHT TO USE "EXCHANGE", APART FROM THE MARK AS SHOWN.

FOR PROVIDING A WEBSITE FEATURING AN ONLINE MARKETPLACE FOR THE PURCHASE AND SALE OF HEALTH CARE SERVICE ASSETS (U.S. CLS. 100, 101 AND 102).

JOHN HWANG, EXAMINING ATTORNEY

SN 85-592,175. OILMATIC SYSTEMS, L.L.C., KEASBEY, NJ. FILED 4-9-2012.



OWNER OF U.S. REG. NO. 3,017,369.

THE MARK CONSISTS OF THE WORD "OILMATIC" WITH THE DOT OF THE INITIAL "I" REPRESENTED BY AN OIL DROPLET AND WITH A PARTIALLY CIRCULAR DESIGN ELEMENT SURROUNDING PORTIONS OF THE WORD.

FOR DISTRIBUTORSHIP SERVICES FEATURING COOKING SUPPLIES FOR THE FOOD SERVICE INDUSTRY (U.S. CLS. 100, 101 AND 102).

FIRST USE 11-11-2001; IN COMMERCE 11-11-2001.

ELIZABETH HUGHITT, EXAMINING ATTORNEY

CLASS 35—(Continued).

SN 85-592,176. ALLIANCE FOR GRAY MARKET AND COUNTERFEIT ABATEMENT, LOS GATOS, CA. FILED 4-9-2012.



OWNER OF U.S. REG. NOS. 2,680,325 AND 2,942,765. NO CLAIM IS MADE TO THE EXCLUSIVE RIGHT TO USE "GLOBAL", APART FROM THE MARK AS SHOWN.

THE COLOR(S) BLUE AND GRAY IS/ARE CLAIMED AS A FEATURE OF THE MARK.

THE MARK CONSISTS OF THE LETTERS "AGMA" IN CAPITAL LETTERS BESIDE A PARTIAL GLOBE WITH THE WORD "GLOBAL" IN SMALL CAPS UNDERNEATH THE GLOBE; A THIN LINE IS UNDERNEATH THE WORDS "AGMA GLOBAL"; "AGMA" AND THE PARTIAL GLOBE ARE IN THE COLOR BLUE WITH "GLOBAL" AND THE UNDERLINE IN THE COLOR GRAY.

FOR TRADE ASSOCIATION SERVICES, NAMELY, PROMOTING THE INTERESTS OF TECHNOLOGY COMPANIES IN COMBATING DECEPTIVE DISTRIBUTION ACTIVITIES AND COUNTERFEIT ACTIVITY (U.S. CLS. 100, 101 AND 102).

FIRST USE 3-28-2012; IN COMMERCE 3-28-2012.

LINDA POWELL, EXAMINING ATTORNEY

SN 85-592,177. THE VANGUARDIAN GROUP INC., ASHLAND CITY, TN. FILED 4-9-2012.



NO CLAIM IS MADE TO THE EXCLUSIVE RIGHT TO USE "GROUP, INC.", APART FROM THE MARK AS SHOWN.

THE MARK CONSISTS OF A CIRCLE ENCLOSED WITHIN THE BOUNDARY OF A SQUARE. THE CIRCLE TOUCHES THE EDGE OF THE SQUARE. A STYLIZED LETTER "V" IS INSIDE THE CIRCLE AND SQUARE. THE TOP LEFT OF THE "V" COINCIDES WITH THE TOP LEFT CORNER OF THE SQUARE AND THE TOP RIGHT OF THE "V" COINCIDES WITH THE TOP RIGHT OF THE SQUARE. THE BOTTOM OF THE "V" TOUCHES THE MIDPOINT OF THE EDGE OF THE BOTTOM OF THE SQUARE. TO THE RIGHT OF THE SQUARE IS THE STYLIZED TEXT "THE VANGUARDIAN GROUP, INC" ABOVE THE STYLIZED TEXT "BUSINESS PERFORMANCE. EVOLVED."

FOR BUSINESS DATA ANALYSIS (U.S. CLS. 100, 101 AND 102).

LINDA POWELL, EXAMINING ATTORNEY

CLASS 35—(Continued).

SN 85-592,343. SMITH, LUNDY, PLAYA DEL REY, CA. FILED 4-9-2012.

Personalized Play

THE MARK CONSISTS OF STANDARD CHARACTERS WITHOUT CLAIM TO ANY PARTICULAR FONT, STYLE, SIZE, OR COLOR.

NO CLAIM IS MADE TO THE EXCLUSIVE RIGHT TO USE "PERSONALIZED", APART FROM THE MARK AS SHOWN.

FOR ONLINE RETAIL STORE SERVICES FEATURING CUSTOMIZED AND PERSONALIZED PLAYING CARDS, FLASHCARDS, STATIONERY AND GAMES (U.S. CLS. 100, 101 AND 102).

DAVID MURRAY, EXAMINING ATTORNEY

SN 85-592,504. TUERFF-DAVIS ENVIROMEDIA INC., AUSTIN, TX. FILED 4-9-2012.

HELP KEEP ADVERTISING HONEST

THE MARK CONSISTS OF STANDARD CHARACTERS WITHOUT CLAIM TO ANY PARTICULAR FONT, STYLE, SIZE, OR COLOR.

FOR ADVERTISING, CONSULTING IN THE FIELD OF ADVERTISING AND PUBLIC RELATIONS, AND PUBLIC RELATIONS SERVICES (U.S. CLS. 100, 101 AND 102).

FIRST USE 3-8-2012; IN COMMERCE 3-8-2012.
MICHAEL ENGEL, EXAMINING ATTORNEY

SN 85-592,527. INSPHERE INSURANCE SOLUTIONS, INC., NORTH RICHLAND HILLS, TX. FILED 4-9-2012.

INSPHERE INFRONT

THE MARK CONSISTS OF STANDARD CHARACTERS WITHOUT CLAIM TO ANY PARTICULAR FONT, STYLE, SIZE, OR COLOR.

OWNER OF U.S. REG. NOS. 3,826,236, 4,053,227 AND OTHERS.

FOR BUSINESS SERVICES IN THE NATURE OF INDEPENDENT CONTRACTOR AGENT RECRUITING FOR A NETWORK OF INSURANCE AGENTS; OFFERING BUSINESS ADVICE, INFORMATION AND CONSULTATION, FOR INDEPENDENT CONTRACTOR AGENTS' INSURANCE BUSINESS ACTIVITIES (U.S. CLS. 100, 101 AND 102).

ANDREW RHIM, EXAMINING ATTORNEY

CLASS 35—(Continued).

SN 85-592,531. INSPHERE INSURANCE SOLUTIONS, INC., NORTH RICHLAND HILLS, TX. FILED 4-9-2012.



OWNER OF U.S. REG. NOS. 3,826,236, 4,053,227 AND OTHERS.

THE MARK CONSISTS OF THE WORD "INSPHERE" APPEARING OVER THE WORD "INFRONT" WITH FIVE SQUARES APPEARING BELOW THE WORD "INFRONT".

FOR BUSINESS SERVICES IN THE NATURE OF INDEPENDENT CONTRACTOR AGENT RECRUITING FOR A NETWORK OF INSURANCE AGENTS; OFFERING BUSINESS ADVICE, INFORMATION AND CONSULTATION, FOR INDEPENDENT CONTRACTOR AGENTS' INSURANCE BUSINESS ACTIVITIES (U.S. CLS. 100, 101 AND 102).

ANDREW RHIM, EXAMINING ATTORNEY

SN 85-592,537. INSPHERE INSURANCE SOLUTIONS, INC., NORTH RICHLAND HILLS, TX. FILED 4-9-2012.

THE INSPHERE WAY

THE MARK CONSISTS OF STANDARD CHARACTERS WITHOUT CLAIM TO ANY PARTICULAR FONT, STYLE, SIZE, OR COLOR.

OWNER OF U.S. REG. NOS. 3,826,236, 4,053,227 AND OTHERS.

FOR BUSINESS SERVICES IN THE NATURE OF INDEPENDENT CONTRACTOR AGENT RECRUITING FOR A NETWORK OF INSURANCE AGENTS; OFFERING BUSINESS ADVICE, INFORMATION AND CONSULTATION, FOR INDEPENDENT CONTRACTOR AGENTS' INSURANCE BUSINESS ACTIVITIES (U.S. CLS. 100, 101 AND 102).

ANDREW RHIM, EXAMINING ATTORNEY

CLASS 35—(Continued).

SN 85-592,539. INSPHERE INSURANCE SOLUTIONS, INC., NORTH RICHLAND HILLS, TX. FILED 4-9-2012.



OWNER OF U.S. REG. NOS. 3,826,236, 4,053,227 AND OTHERS.

THE MARK CONSISTS OF THE WORDING "THE INSPHERE WAY" AND OF A DESIGN OF A SQUARE CONTAINING A PLANET ECLIPSING THE SUN, WITH THE LETTERS "I","N" OF THE WORD "INSPHERE" OVERLAPPING THE PLANET.

FOR BUSINESS SERVICES IN THE NATURE OF INDEPENDENT CONTRACTOR AGENT RECRUITING FOR A NETWORK OF INSURANCE AGENTS; OFFERING BUSINESS ADVICE, INFORMATION AND CONSULTATION, FOR INDEPENDENT CONTRACTOR AGENTS' INSURANCE BUSINESS ACTIVITIES (U.S. CLS. 100, 101 AND 102).

ANDREW RHIM, EXAMINING ATTORNEY

CLASS 35—(Continued).

SN 85-592,549. INSPHERE INSURANCE SOLUTIONS, INC., NORTH RICHLAND HILLS, TX. FILED 4-9-2012.



OWNER OF U.S. REG. NOS. 3,826,236, 4,053,227 AND OTHERS.

THE MARK CONSISTS OF THE WORD "INSPHERE" APPEARING OVER THE WORD "INROUTE" WITH EIGHT SQUARES APPEARING BELOW THE WORD "INROUTE".

FOR BUSINESS SERVICES IN THE NATURE OF INDEPENDENT CONTRACTOR AGENT RECRUITING FOR A NETWORK OF INSURANCE AGENTS; OFFERING BUSINESS ADVICE, INFORMATION AND CONSULTATION, FOR INDEPENDENT CONTRACTOR AGENTS' INSURANCE BUSINESS ACTIVITIES (U.S. CLS. 100, 101 AND 102).

ANDREW RHIM, EXAMINING ATTORNEY

SN 85-592,543. INSPHERE INSURANCE SOLUTIONS, INC., NORTH RICHLAND HILLS, TX. FILED 4-9-2012.

INSPHERE INROUTE

THE MARK CONSISTS OF STANDARD CHARACTERS WITHOUT CLAIM TO ANY PARTICULAR FONT, STYLE, SIZE, OR COLOR.

OWNER OF U.S. REG. NOS. 3,826,236, 4,053,227 AND OTHERS.

FOR BUSINESS SERVICES IN THE NATURE OF INDEPENDENT CONTRACTOR AGENT RECRUITING FOR A NETWORK OF INSURANCE AGENTS; OFFERING BUSINESS ADVICE, INFORMATION AND CONSULTATION, FOR INDEPENDENT CONTRACTOR AGENTS' INSURANCE BUSINESS ACTIVITIES (U.S. CLS. 100, 101 AND 102).

ANDREW RHIM, EXAMINING ATTORNEY

SN 85-592,671. HACKMAN, ALFRED N., STUDIO CITY, CA. FILED 4-9-2012.

Seamless Short Sale

THE MARK CONSISTS OF STANDARD CHARACTERS WITHOUT CLAIM TO ANY PARTICULAR FONT, STYLE, SIZE, OR COLOR.

NO CLAIM IS MADE TO THE EXCLUSIVE RIGHT TO USE "SHORT SALE", APART FROM THE MARK AS SHOWN.

FOR PROMOTIONAL MARKETING AND REPRESENTATION SERVICES FOR SALES TO THE PUBLIC SECTOR; PROVIDING AN INTERACTIVE REAL ESTATE WEBSITE WHICH PROMOTES HOUSING AND APARTMENT PROPERTIES THROUGH OFFERING PROSPECTIVE TENANTS VIDEO WALK THROUGHS, PROPERTY DESCRIPTIONS, TEXT, PRICE, LOCATION, MAPS AND OTHER INFORMATION THAT WOULD BE INFLUENTIAL TO A PROSPECTIVE TENANT IN MAKING A RENTAL DECISION; PROVIDING REAL ESTATE LEADS FOR PROSPECTIVE PURCHASERS; REAL ESTATE ADVERTISING SERVICES; REAL ESTATE AUCTIONS; REAL ESTATE MARKETING ANALYSIS; REAL ESTATE MARKETING SERVICES IN THE FIELD OF HOMES AND CONDOMINIUMS; REAL ESTATE MARKETING SERVICES, NAMELY, ON-LINE SERVICES FEATURING THE PROMOTION OF RESIDENTIAL NEW CONSTRUCTION, WHICH ALSO CONTAINS BACK OFFICE SOLUTIONS FOR BUILDERS; REAL ESTATE MARKETING SERVICES, NAMELY, ON-LINE SERVICES FEATURING TOURS OF RESIDENTIAL AND COMMERCIAL REAL ESTATE; SALES PROMOTION SERVICES (U.S. CLS. 100, 101 AND 102).

FIRST USE 6-1-2009; IN COMMERCE 6-1-2009.

NANCY CLARKE, EXAMINING ATTORNEY

CLASS 35—(Continued).

SN 85-592,826. MY LOVE GROUP CORPORATION, NEW YORK, NY. FILED 4-9-2012.

MY LOVE WEDDING RING

THE MARK CONSISTS OF STANDARD CHARACTERS WITHOUT CLAIM TO ANY PARTICULAR FONT, STYLE, SIZE, OR COLOR.

OWNER OF U.S. REG. NO. 4,007,417.

NO CLAIM IS MADE TO THE EXCLUSIVE RIGHT TO USE "WEDDING RING", APART FROM THE MARK AS SHOWN.

FOR ONLINE RETAIL STORE SERVICES FEATURING JEWELRY AND ACCESSORIES (U.S. CLS. 100, 101 AND 102).

FIRST USE 6-0-2010; IN COMMERCE 6-0-2010.

AHSEN KHAN, EXAMINING ATTORNEY

CLASS 35—(Continued).

SN 85-593,118. SUNBURST, SOUTH BEND, IN. FILED 4-10-2012.

SUNBURST

THE MARK CONSISTS OF STANDARD CHARACTERS WITHOUT CLAIM TO ANY PARTICULAR FONT, STYLE, SIZE, OR COLOR.

FOR PROMOTIONAL SPONSORSHIP OF ATHLETIC COMPETITION EVENTS (U.S. CLS. 100, 101 AND 102).

FIRST USE 6-9-1984; IN COMMERCE 6-9-1984.

CHRISTINE MARTIN, EXAMINING ATTORNEY

SN 85-593,026. KUZAVA, TIMOTHY, LITTLETON, CO. FILED 4-9-2012.

KELLEY'S HEROES

THE MARK CONSISTS OF STANDARD CHARACTERS WITHOUT CLAIM TO ANY PARTICULAR FONT, STYLE, SIZE, OR COLOR.

FOR BUSINESS EVALUATION AND VERIFICATION OF BUSINESSES' INTEGRITY, HONESTY, AND CHARITABLE CONTRIBUTIONS, FOR THE PURPOSE OF PROVIDING INFORMATION ABOUT BUSINESSES TO PROSPECTIVE CUSTOMERS AND EMPLOYEES TO ASSIST THEM IN MAKING EMPLOYMENT AND PURCHASING DECISIONS; COMPILATION OF BUSINESS DIRECTORIES; PROVIDING A WEB SITE FEATURING BUSINESS INFORMATION IN THE FORM OF AUDIO AND VIDEO INTERVIEWS, TRANSCRIPTS AND OTHER EDUCATIONAL MATERIALS; PROVIDING A WEB SITE FEATURING THE RATINGS, REVIEWS AND RECOMMENDATIONS ON EMPLOYERS AND EMPLOYEES AND PLACES OF EMPLOYMENT FOR USE BY EMPLOYEES, EMPLOYERS, BUSINESS OWNERS, AND CONSUMERS; PROVIDING AN ON-LINE SEARCHABLE DATABASE FEATURING BUSINESS INFORMATION AND BUSINESS CONTACTS; PROVIDING INDEPENDENT RATINGS AND REVIEWS OF OTHER BUSINESSES FOR COMMERCIAL PURPOSES (U.S. CLS. 100, 101 AND 102).

KIMBERLY FRYE, EXAMINING ATTORNEY

SN 85-593,244. SAFE-SAFETY AGAINST FORCED EXPLOITATION, INC., CAPE CORAL, FL. FILED S.R. 4-10-2012; AM. P.R. 7-26-2012.



NO CLAIM IS MADE TO THE EXCLUSIVE RIGHT TO USE "SAFETY AGAINST FORCED EXPLOITATION", APART FROM THE MARK AS SHOWN.

THE COLOR(S) BLACK, RED AND WHITE IS/ARE CLAIMED AS A FEATURE OF THE MARK.

THE MARK CONSISTS OF THE WORDING "SAFETY AGAINST FORCED EXPLOITATION" IN WHITE, WITH THE STYLIZED "X" IN RED, THE FACE OF THE GIRL IS IN BLACK WITH A WHITE OUTLINE AND RED MOUTH FORMED BY A "X" AND ALL OF WHICH APPEARS UPON A BLACK RECTANGLE AND A SMALLER RECTANGLE OUTLINED IN WHITE APPEARS WITHIN THE LARGER RECTANGLE.

FOR CHARITABLE SERVICES, NAMELY, ORGANIZING AND DEVELOPING PROJECTS THAT AIM TO PROMOTE GLOBAL AWARENESS ABOUT HUMAN TRAFFICKING AND COMMERCIAL SEX INDUSTRY (U.S. CLS. 100, 101 AND 102).

FIRST USE 6-1-2010; IN COMMERCE 11-1-2010.

EDWARD NELSON, EXAMINING ATTORNEY

CLASS 35—(Continued).

SN 85-593,373. CIRRUS FITNESS, LLC, NEW YORK, NY.
FILED 4-10-2012.

CIRRUS FITNESS

THE MARK CONSISTS OF STANDARD CHARACTERS WITHOUT CLAIM TO ANY PARTICULAR FONT, STYLE, SIZE, OR COLOR.

NO CLAIM IS MADE TO THE EXCLUSIVE RIGHT TO USE "FITNESS", APART FROM THE MARK AS SHOWN.

FOR ONLINE RETAIL STORE SERVICES FEATURING FITNESS EQUIPMENT, NAMELY, AEROBIC STEP MACHINES, BARBELLS, DUMBBELLS, ELLIPTICAL EXERCISE MACHINES, EXERCISE BALLS, EXERCISE BARS, EXERCISE BENCHES, MANUALLY OPERATED JOGGING MACHINES, STAIR-STEPPING MACHINES, STATIONARY CYCLES, ABDOMINAL BOARDS, CHEST EXPANDERS, CHEST PULLS, SHOULDER STRETCHER USING A CABLE, SHOULDER STRETCHER USING RESISTANCE CABLES, VIRTUAL REALITY TRAINING CYCLES, INFLATABLE BALLS, EXERCISE MACHINES, EXERCISE MACHINES INCORPORATING ELECTRONIC AND VIDEO GAME CONTROLLERS, EXERCISE PLATFORMS, EXERCISE TREADMILLS, EXERCISE WEIGHTS, POWERED TREADMILLS FOR RUNNING, WEIGHT LIFTING MACHINES, EXERCISING PULL-EYS, MANUAL LEG EXERCISERS, AND MANUALLY-OPERATED EXERCISE EQUIPMENT (U.S. CLS. 100, 101 AND 102).

EVIN L. KOZAK, EXAMINING ATTORNEY

SN 85-593,418. COAST DENTAL SERVICES, INC., TAMPA, FL. FILED 4-10-2012.

YOUR PRACTICE. ONLY BETTER.

THE MARK CONSISTS OF STANDARD CHARACTERS WITHOUT CLAIM TO ANY PARTICULAR FONT, STYLE, SIZE, OR COLOR.

FOR DENTAL PRACTICE MANAGEMENT SERVICES FOR OTHERS AND DENTAL PRACTICE PERSONNEL RECRUITING SERVICES (U.S. CLS. 100, 101 AND 102).

FIRST USE 3-16-2012; IN COMMERCE 3-16-2012.
MARGARET POWER, EXAMINING ATTORNEY

CLASS 35—(Continued).

SN 85-593,672. GOLD COUNTRY, INC., MINNETONKA, MN.
FILED 4-10-2012.

NAME OF THE GAME

THE MARK CONSISTS OF STANDARD CHARACTERS WITHOUT CLAIM TO ANY PARTICULAR FONT, STYLE, SIZE, OR COLOR.

FOR RETAIL SHOPS FEATURING CLOTHING, SPORTS APPAREL AND GIFT ITEMS (U.S. CLS. 100, 101 AND 102).

FIRST USE 4-10-1992; IN COMMERCE 4-10-1992.
SUSAN STIGLITZ, EXAMINING ATTORNEY

SN 85-593,686. WEBB SOCIAL MEDIA & MARKETING GROUP, LLC, SAN ANTONIO, TX. FILED 4-10-2012.

Perpetual Marketing

THE MARK CONSISTS OF STANDARD CHARACTERS WITHOUT CLAIM TO ANY PARTICULAR FONT, STYLE, SIZE, OR COLOR.

NO CLAIM IS MADE TO THE EXCLUSIVE RIGHT TO USE "MARKETING", APART FROM THE MARK AS SHOWN.

FOR MARKETING CONSULTING, NAMELY, DESIGN AND DEVELOPMENT OF MARKETING CAMPAIGNS FOR OTHERS (U.S. CLS. 100, 101 AND 102).

FIRST USE 1-1-2012; IN COMMERCE 1-15-2012.
KAREN K. BUSH, EXAMINING ATTORNEY

SN 85-594,003. SOCIAL REALITY, INC., BEVERLY HILLS, CA. FILED 4-10-2012.



NO CLAIM IS MADE TO THE EXCLUSIVE RIGHT TO USE "GROUP AD", APART FROM THE MARK AS SHOWN. THE COLOR(S) GRAY, WHITE, RED, BLUE, DARK BLUE, ORANGE, YELLOW, GREEN AND TEAL IS/ARE CLAIMED AS A FEATURE OF THE MARK.

THE MARK CONSISTS OF THE WORDS "GROUP AD" WITH "GROUP" IN GRAY LETTERS AND "AD" IN WHITE LETTERS ON A BACKGROUND OF THREE ROUNDED TRIANGLES IN THE COLORS RED, YELLOW AND BLUE WITH THE OVERLAPPING PORTIONS OF THE TRIANGLES BEING ORANGE, GREEN, TEAL AND DARK BLUE.

FOR INTERNET ADVERTISING SERVICES; SOCIAL MEDIA STRATEGY AND MARKETING CONSULTANCY FOCUSING ON HELPING CLIENTS CREATE AND EXTEND THEIR PRODUCT AND BRAND STRATEGIES BY BUILDING VIRALLY ENGAGING MARKETING SOLUTIONS (U.S. CLS. 100, 101 AND 102).

FIRST USE 1-1-2012; IN COMMERCE 1-1-2012.
JOHN WILKE, EXAMINING ATTORNEY

CLASS 35—(Continued).

SN 85-594,128. KUZAVA, TIMOTHY, LITTLETON, CO.
FILED 4-10-2012.

TEN COMMANDMENTS COMPANY

THE MARK CONSISTS OF STANDARD CHARACTERS WITHOUT CLAIM TO ANY PARTICULAR FONT, STYLE, SIZE, OR COLOR.

NO CLAIM IS MADE TO THE EXCLUSIVE RIGHT TO USE "COMPANY", APART FROM THE MARK AS SHOWN.

FOR BUSINESS EVALUATION AND VERIFICATION OF BUSINESSES' INTEGRITY, HONESTY, AND CHARITABLE CONTRIBUTIONS, FOR THE PURPOSE OF PROVIDING INFORMATION ABOUT BUSINESSES TO PROSPECTIVE CUSTOMERS AND EMPLOYEES TO ASSIST THEM IN MAKING EMPLOYMENT AND PURCHASING DECISIONS; COMPILATION OF BUSINESS DIRECTORIES; PROVIDING A WEB SITE FEATURING BUSINESS INFORMATION IN THE FORM OF AUDIO AND VIDEO INTERVIEWS, TRANSCRIPTS AND OTHER EDUCATIONAL MATERIALS; PROVIDING A WEB SITE FEATURING THE RATINGS, REVIEWS AND RECOMMENDATIONS ON EMPLOYERS AND EMPLOYEES AND PLACES OF EMPLOYMENT FOR USE BY EMPLOYEES, EMPLOYERS, BUSINESS OWNERS, AND CONSUMERS; PROVIDING AN ON-LINE SEARCHABLE DATABASE FEATURING BUSINESS INFORMATION AND BUSINESS CONTACTS; PROVIDING INDEPENDENT RATINGS AND REVIEWS OF OTHER BUSINESSES FOR COMMERCIAL PURPOSES (U.S. CLS. 100, 101 AND 102).

KIMBERLY FRYE, EXAMINING ATTORNEY

CLASS 35—(Continued).

SN 85-594,471. BARTERBENDER, LLC, CORONA, CA.
FILED 4-11-2012.

BARTERBENDER

THE MARK CONSISTS OF STANDARD CHARACTERS WITHOUT CLAIM TO ANY PARTICULAR FONT, STYLE, SIZE, OR COLOR.

FOR ELECTRONIC TRADING PLATFORM FOR GOODS, NAMELY, ONLINE TRADING SERVICES IN WHICH PRODUCTS ARE POSTED TO BE SOLD OR BARTERED ON THE INTERNET (U.S. CLS. 100, 101 AND 102).

TINA MAI, EXAMINING ATTORNEY

SN 85-594,311. PORUCHNY, TOM, WHITE HOUSE, TN.
FILED 4-11-2012.



NO CLAIM IS MADE TO THE EXCLUSIVE RIGHT TO USE "MAILER", APART FROM THE MARK AS SHOWN.

THE COLOR(S) BLACK, BLUE, PINK AND YELLOW IS/ARE CLAIMED AS A FEATURE OF THE MARK.

THE MARK CONSISTS OF BLACK, YELLOW, PINK AND BLUE WAVING POSTAGE LINES WITH A BLACK ZEBRA STRIPPED STAMP. WITHIN THE STAMP IS A BLUE, PINK AND YELLOW ZEBRA. BELOW THIS IS "STANDOUT" IN BLACK STYLIZED FONT WITH "MAILER" BELOW IN SMALLER BLUE STYLIZED FONT. BELOW THIS IS "THE SIMPLEST WAY TO STANDOUT IN EVERY MAILBOX!" IN BLACK STYLIZED FONT EXCEPT FOR "STANDOUT", WHICH IS IN LARGE BLUE STYLIZED FONT.

FOR DIRECT MAIL ADVERTISING SERVICES (U.S. CLS. 100, 101 AND 102).

FIRST USE 1-15-2012; IN COMMERCE 1-15-2012.

KELLEY WELLS, EXAMINING ATTORNEY

SN 85-594,620. PRUCOR, DEL MAR, CA. FILED 4-11-2012.

Prucor Disruptive Solutions

THE MARK CONSISTS OF STANDARD CHARACTERS WITHOUT CLAIM TO ANY PARTICULAR FONT, STYLE, SIZE, OR COLOR.

NO CLAIM IS MADE TO THE EXCLUSIVE RIGHT TO USE "DISRUPTIVE SOLUTIONS", APART FROM THE MARK AS SHOWN.

FOR BUSINESS MANAGEMENT CONSULTANCY SERVICES; MARKET RESEARCH (U.S. CLS. 100, 101 AND 102).

CHRISIE B. KING, EXAMINING ATTORNEY

CLASS 35—(Continued).

SN 85-594,624. MOBILE SKILLET, LLC, CHESTNUT HILL, MA. FILED 4-11-2012.



THE MARK CONSISTS OF THE WORDING "MOBILESKILLET" UNDER THE DESIGN OF A FRYING PAN WITH A STYLIZED TWO-POINT FLAME RESEMBLING THE LETTER "M".

FOR DESIGN AND DEVELOPMENT OF MOBILE SOFTWARE APPLICATIONS IN THE FIELD OF COOKING AND RECIPES; PROVIDING A WEB-BASED SYSTEM THAT ALLOWS THIRD PARTIES TO CREATE MOBILE SOFTWARE APPLICATIONS AND MOBILE WEBSITES IN THE FIELD OF COOKING AND RECIPES, NAMELY, WEBSITES OPTIMIZED FOR VIEWING ON MOBILE DEVICES, TO ADVERTISE THEIR PRODUCTS AND SERVICES VIA MOBILE AND HANDHELD DEVICES (U.S. CLS. 100, 101 AND 102).

FIRST USE 3-29-2012; IN COMMERCE 3-29-2012.
HANNO RITTNER, EXAMINING ATTORNEY

SN 85-594,977. MEDALLIA, INC., PALO ALTO, CA. FILED 4-11-2012.

MEDALLIA PROMOTE

THE MARK CONSISTS OF STANDARD CHARACTERS WITHOUT CLAIM TO ANY PARTICULAR FONT, STYLE, SIZE, OR COLOR.

OWNER OF U.S. REG. NO. 3,795,880.

NO CLAIM IS MADE TO THE EXCLUSIVE RIGHT TO USE "PROMOTE", APART FROM THE MARK AS SHOWN.

FOR CONSUMER SURVEY SERVICES; CONSUMER MARKETING RESEARCH AND CONSULTING RELATED THERETO; SOCIAL MEDIA STRATEGY AND MARKETING CONSULTANCY (U.S. CLS. 100, 101 AND 102).

MARK SHINER, EXAMINING ATTORNEY

CLASS 35—(Continued).

SN 85-595,268. VECTOUR GROUP, LLC, BIRMINGHAM, AL. FILED 4-11-2012.

VECTOUR GROUP

THE MARK CONSISTS OF STANDARD CHARACTERS WITHOUT CLAIM TO ANY PARTICULAR FONT, STYLE, SIZE, OR COLOR.

NO CLAIM IS MADE TO THE EXCLUSIVE RIGHT TO USE "GROUP", APART FROM THE MARK AS SHOWN.

FOR TRANSPORTATION MANAGEMENT SERVICES, NAMELY, PLANNING AND COORDINATING TRANSPORTATION OF PEOPLE FOR OTHERS (U.S. CLS. 100, 101 AND 102).

FIRST USE 2-1-2012; IN COMMERCE 2-1-2012.

ALYSSA STEEL, EXAMINING ATTORNEY

SN 85-595,392. SUMMER ENERGY, LLC, HOUSTON, TX. FILED 4-11-2012.

SUMMER ENERGY

THE MARK CONSISTS OF STANDARD CHARACTERS WITHOUT CLAIM TO ANY PARTICULAR FONT, STYLE, SIZE, OR COLOR.

NO CLAIM IS MADE TO THE EXCLUSIVE RIGHT TO USE "ENERGY", APART FROM THE MARK AS SHOWN.

FOR RETAIL ELECTRICITY PROVIDER SERVICES THAT ALLOW CUSTOMERS TO PURCHASE ELECTRICITY (U.S. CLS. 100, 101 AND 102).

FIRST USE 4-0-2011; IN COMMERCE 2-0-2012.

KEVON CHISOLM, EXAMINING ATTORNEY

CLASS 35—(Continued).

SN 85-595,475. CALIFORNIA DISTRIBUTION CENTER, INC., SIGNAL HILL, CA. FILED 4-11-2012.



NO CLAIM IS MADE TO THE EXCLUSIVE RIGHT TO USE "WINDOWS", APART FROM THE MARK AS SHOWN.

THE MARK CONSISTS OF EIGHT BOXES, 4 ACROSS, 2 HIGH, THE LINING SHOWN IN THE DRAWING IS A FEATURE OF THE MARK AND IS NOT MEANT TO INDICATE COLOR, AND THE TEXT "1 ST WINDOWS" BELOW.

FOR RESELLER SERVICES, NAMELY, DISTRIBUTORSHIP SERVICES IN THE FIELD OF WINDOWS AND DOORS (U.S. CLS. 100, 101 AND 102).

FIRST USE 8-1-2001; IN COMMERCE 8-1-2001.

DOMINICK J. SALEMI, EXAMINING ATTORNEY

SN 85-595,931. ROSS, VERONICA, FORT VALLEY, GA. AND MOORE, RUSSELL, TUCKER, GA. FILED 4-12-2012.

BLASIAN BEAUTIES

THE MARK CONSISTS OF STANDARD CHARACTERS WITHOUT CLAIM TO ANY PARTICULAR FONT, STYLE, SIZE, OR COLOR.

NO CLAIM IS MADE TO THE EXCLUSIVE RIGHT TO USE "BLASIAN", APART FROM THE MARK AS SHOWN.

FOR MODELING AGENCY SERVICES; MODELING FOR ADVERTISING OR SALES PROMOTION (U.S. CLS. 100, 101 AND 102).

ANNE E. GUSTASON, EXAMINING ATTORNEY

CLASS 35—(Continued).

SN 85-596,140. UDRESSIT COMPANY, MAQUOKETA, IA. FILED 4-12-2012.

ONE LAST GOODBYE

THE MARK CONSISTS OF STANDARD CHARACTERS WITHOUT CLAIM TO ANY PARTICULAR FONT, STYLE, SIZE, OR COLOR.

OWNER OF U.S. REG. NOS. 4,014,011, 4,162,477 AND OTHERS.

FOR ADVERTISING AND MARKETING; ADVERTISING AND MARKETING SERVICES, NAMELY, PROMOTING THE GOODS AND SERVICES OF OTHERS (U.S. CLS. 100, 101 AND 102).

SANI KHOURI, EXAMINING ATTORNEY

SN 85-596,153. UDRESSIT COMPANY, MAQUOKETA, IA. FILED 4-12-2012.

ONE LAST TAILGATE

THE MARK CONSISTS OF STANDARD CHARACTERS WITHOUT CLAIM TO ANY PARTICULAR FONT, STYLE, SIZE, OR COLOR.

OWNER OF U.S. REG. NOS. 4,014,011, 4,162,477 AND OTHERS.

FOR ADVERTISING AND MARKETING; ADVERTISING AND MARKETING SERVICES, NAMELY, PROMOTING THE GOODS AND SERVICES OF OTHERS (U.S. CLS. 100, 101 AND 102).

SANI KHOURI, EXAMINING ATTORNEY

SN 85-596,200. DIGIOVANNI, ANTHONY, APOLLO BEACH, FL. FILED 4-12-2012.

THE BUSINESS SHARKS

THE MARK CONSISTS OF STANDARD CHARACTERS WITHOUT CLAIM TO ANY PARTICULAR FONT, STYLE, SIZE, OR COLOR.

NO CLAIM IS MADE TO THE EXCLUSIVE RIGHT TO USE "BUSINESS", APART FROM THE MARK AS SHOWN.

FOR PROFESSIONAL BUSINESS CONSULTING; ACCOUNTING SERVICES (U.S. CLS. 100, 101 AND 102).

TASHIA BUNCH, EXAMINING ATTORNEY

CLASS 35—(Continued).

SN 85-596,399. STALLEX SKIN CARE, INC., BURLINGTON FLATS, NY. FILED 4-12-2012.

BEAUTYRX

THE MARK CONSISTS OF STANDARD CHARACTERS WITHOUT CLAIM TO ANY PARTICULAR FONT, STYLE, SIZE, OR COLOR.

OWNER OF U.S. REG. NO. 4,086,285.
FOR ONLINE RETAIL STORE SERVICES FEATURING SKIN CARE PRODUCTS (U.S. CLS. 100, 101 AND 102).

FIRST USE 4-17-2011; IN COMMERCE 4-17-2011.
JOSETTE BEVERLY, EXAMINING ATTORNEY

CLASS 35—(Continued).

SN 85-596,768. IDOLIAN MOBILE, INC., NEWPORT BEACH, CA. FILED 4-12-2012.



NO CLAIM IS MADE TO THE EXCLUSIVE RIGHT TO USE "TABLETS FOR EVERYONE", APART FROM THE MARK AS SHOWN.

THE COLOR(S) ORANGE AND BLACK IS/ARE CLAIMED AS A FEATURE OF THE MARK.

THE MARK CONSISTS OF "IDOLIAN" WHERE "IDOL" IS IN ORANGE WITH A BLACK DOT ABOVE THE LETTER "I" AND "IAN" IS IN BLACK WITH AN ORANGE DOT ABOVE THE LETTER "I". TO THE RIGHT OF THAT IN SCRIPT ARE THE WORDS "TABLETS FOR EVERYONE" IN BLACK.

FOR ON-LINE RETAIL STORE SERVICES FEATURING TABLET COMPUTERS AND TABLET COMPUTER ACCESSORIES; RETAIL STORE SERVICES FEATURING TABLET COMPUTERS AND TABLET COMPUTER ACCESSORIES; WHOLESALE STORE SERVICES FEATURING TABLET COMPUTERS AND TABLET COMPUTER ACCESSORIES (U.S. CLS. 100, 101 AND 102).

FIRST USE 11-18-2010; IN COMMERCE 11-18-2010.
JOHN E. MICHOS, EXAMINING ATTORNEY

SN 85-596,906. STALLEX SKIN CARE, INC., BURLINGTON FLATS, NY. FILED 4-13-2012.

BEAUTYRX SKINCARE BY DR. SCHULTZ

THE MARK CONSISTS OF STANDARD CHARACTERS WITHOUT CLAIM TO ANY PARTICULAR FONT, STYLE, SIZE, OR COLOR.

OWNER OF U.S. REG. NOS. 3,932,629 AND 3,945,559.
THE NAME DR. SCHULTZ IDENTIFIES A LIVING INDIVIDUAL WHOSE CONSENT IS OF RECORD.
FOR ONLINE RETAIL STORE SERVICES FEATURING SKIN CARE PRODUCTS (U.S. CLS. 100, 101 AND 102).

FIRST USE 4-17-2011; IN COMMERCE 4-17-2011.
JOSETTE BEVERLY, EXAMINING ATTORNEY

SN 85-596,709. NUVO MEDIA, LLC, ATLANTA, GA. FILED 4-12-2012.

Deal Ninja

THE MARK CONSISTS OF STANDARD CHARACTERS WITHOUT CLAIM TO ANY PARTICULAR FONT, STYLE, SIZE, OR COLOR.

NO CLAIM IS MADE TO THE EXCLUSIVE RIGHT TO USE "DEAL", APART FROM THE MARK AS SHOWN.

FOR PROMOTING THE GOODS AND SERVICES OF OTHERS THROUGH THE DISTRIBUTION OF DISCOUNT OFFERS AND COUPONS; ADVERTISING AND COMMERCIAL INFORMATION SERVICES, VIA THE INTERNET; ADVERTISING VIA ELECTRONIC MEDIA AND SPECIFICALLY THE INTERNET; ADVICE AND INFORMATION ABOUT CUSTOMER SERVICES AND PRODUCT MANAGEMENT AND PRICES ON INTERNET SITES IN CONNECTION WITH PURCHASES MADE OVER THE INTERNET; PROVIDING A SEARCHABLE ONLINE ADVERTISING GUIDE FEATURING THE GOODS AND SERVICES OF OTHER ON-LINE VENDORS ON THE INTERNET; PROVIDING ADVERTISING SPACE ON THE INTERNET; PROVIDING CONSUMER PRODUCT INFORMATION VIA THE INTERNET (U.S. CLS. 100, 101 AND 102).

FIRST USE 1-5-2012; IN COMMERCE 1-5-2012.
ANDREW RHIM, EXAMINING ATTORNEY

SN 85-597,026. DENLORS TOOLS PLUS LLC, RIVERVIEW, FL. FILED 4-13-2012.

denlors tools

THE MARK CONSISTS OF STANDARD CHARACTERS WITHOUT CLAIM TO ANY PARTICULAR FONT, STYLE, SIZE, OR COLOR.

NO CLAIM IS MADE TO THE EXCLUSIVE RIGHT TO USE "TOOLS", APART FROM THE MARK AS SHOWN.

FOR RETAIL STORE SERVICES FEATURING AUTOMOTIVE TOOLS SHOP SUPPLIES AND EQUIPMENT (U.S. CLS. 100, 101 AND 102).

FIRST USE 6-1-2005; IN COMMERCE 6-1-2005.
JOHN E. MICHOS, EXAMINING ATTORNEY

CLASS 35—(Continued).

SN 85-597,086. WHITE SHARK MEDIA INC., ATLANTA, GA. FILED 4-13-2012.

White Shark Media

THE MARK CONSISTS OF STANDARD CHARACTERS WITHOUT CLAIM TO ANY PARTICULAR FONT, STYLE, SIZE, OR COLOR.

NO CLAIM IS MADE TO THE EXCLUSIVE RIGHT TO USE "MEDIA", APART FROM THE MARK AS SHOWN.

FOR ADVERTISING AND MARKETING SERVICES PROVIDED BY MEANS OF INDIRECT METHODS OF MARKETING COMMUNICATIONS, NAMELY, SOCIAL MEDIA, SEARCH ENGINE MARKETING, INQUIRY MARKETING, INTERNET MARKETING, MOBILE MARKETING, BLOGGING AND OTHER FORMS OF PASSIVE, SHARABLE OR VIRAL COMMUNICATIONS CHANNELS (U.S. CLS. 100, 101 AND 102).

FIRST USE 12-15-2010; IN COMMERCE 12-15-2010.
JASON LOTT, EXAMINING ATTORNEY

SN 85-597,308. ASIAN OASIS, DBA FLOATING LOTUS, ROCKPORT, MA. FILED 4-13-2012.

Floating Lotus

THE MARK CONSISTS OF STANDARD CHARACTERS WITHOUT CLAIM TO ANY PARTICULAR FONT, STYLE, SIZE, OR COLOR.

FOR RETAIL STORE SERVICES FEATURING WOMEN'S AND MEN'S CLOTHING; ON-LINE RETAIL STORE SERVICES FEATURING WOMEN'S AND MEN'S CLOTHING; WHOLESALE STORE SERVICES FEATURING WOMEN'S AND MEN'S CLOTHING (U.S. CLS. 100, 101 AND 102).

FIRST USE 9-5-2003; IN COMMERCE 9-5-2003.
DAVID YONTEF, EXAMINING ATTORNEY

SN 85-597,456. INFORMATION PLANNING AND MANAGEMENT, INC., DBA IPMS, INC., STERLING, VA. FILED 4-13-2012.

IT'S ABOUT THE STORE

THE MARK CONSISTS OF STANDARD CHARACTERS WITHOUT CLAIM TO ANY PARTICULAR FONT, STYLE, SIZE, OR COLOR.

FOR RETAIL CONSULTING SERVICES IN THE FIELDS OF BUSINESS ADMINISTRATION, BUSINESS OPERATION AND BUSINESS MERCHANDISING DISPLAY SERVICES (U.S. CLS. 100, 101 AND 102).

SAMUEL E. SHARPER JR., EXAMINING ATTORNEY

CLASS 35—(Continued).

SN 85-597,461. INFORMATION PLANNING AND MANAGEMENT, INC., DBA IPMS, INC., STERLING, VA. FILED 4-13-2012.

RETAIL FITNESS

THE MARK CONSISTS OF STANDARD CHARACTERS WITHOUT CLAIM TO ANY PARTICULAR FONT, STYLE, SIZE, OR COLOR.

NO CLAIM IS MADE TO THE EXCLUSIVE RIGHT TO USE "RETAIL", APART FROM THE MARK AS SHOWN.

FOR RETAIL CONSULTING SERVICES IN THE FIELDS OF BUSINESS ADMINISTRATION, BUSINESS OPERATION AND BUSINESS MERCHANDISING DISPLAY SERVICES (U.S. CLS. 100, 101 AND 102).

SAMUEL E. SHARPER JR., EXAMINING ATTORNEY

SN 85-597,705. EDIE HOWARD, AUGUSTA, KS. FILED 4-13-2012.



THE MARK CONSISTS OF THE STYLIZED TEXT "MY SPECIAL CHILD" WITH A SLIGHTLY LEFT SLANTED HEART DESIGN LOCATED ON THE RIGHT SIDE OF THE TEXT "MY" AND CENTERED ABOVE THE TEXT "SPECIAL CHILD".

FOR PRODUCTION AND DISTRIBUTION OF AUDIO AND VISUAL CONTENT DEALING WITH SUBJECTS OF HUMAN INTEREST, DEVELOPMENT, HEALTH, EDUCATION, AND LEARNING FOR BROADCAST AND DISTRIBUTION OVER TELEVISION AND RADIO, THROUGH FILM, ON CABLE, THROUGH PRINT AND DIGITAL MEDIA, AT PUBLIC EVENTS, AND OVER THE INTERNET (U.S. CLS. 100, 101 AND 102).

FIRST USE 9-30-2010; IN COMMERCE 2-1-2011.
KATHERINE M. DUBRAY, EXAMINING ATTORNEY

CLASS 35—(Continued).

SN 85-597,770. LAKES OF PARKWAY HOMEOWNERS ASSOCIATION, INC., DBA LAKES OF PARKWAY, HOUSTON, TX. FILED 4-13-2012.

LAKES OF PARKWAY

THE MARK CONSISTS OF STANDARD CHARACTERS WITHOUT CLAIM TO ANY PARTICULAR FONT, STYLE, SIZE, OR COLOR.

NO CLAIM IS MADE TO THE EXCLUSIVE RIGHT TO USE "LAKES", APART FROM THE MARK AS SHOWN.

FOR HOMEOWNER ASSOCIATION SERVICES, NAMELY, PROMOTING THE INTERESTS OF HOMEOWNERS IN A SPECIFIC COMMUNITY AND MARKETING THE COMMUNITY NATIONWIDE TO PROSPECTIVE NEW RESIDENTS AND PROPERTY OWNERS (U.S. CLS. 100, 101 AND 102).

FIRST USE 10-20-1995; IN COMMERCE 10-20-1995.
ARETHA SOMERVILLE, EXAMINING ATTORNEY

SN 85-598,044. MOUGEOTTE, STEVE, GREENFIELD, IN. FILED 4-14-2012.

SAVER GATOR

THE MARK CONSISTS OF STANDARD CHARACTERS WITHOUT CLAIM TO ANY PARTICULAR FONT, STYLE, SIZE, OR COLOR.

NO CLAIM IS MADE TO THE EXCLUSIVE RIGHT TO USE "SAVER", APART FROM THE MARK AS SHOWN.

FOR ADVERTISING SERVICES; DIRECT MAIL ADVERTISING SERVICES; DISSEMINATION OF ADVERTISING MATTER; ON-LINE ADVERTISING ON A COMPUTER NETWORK; ADVERTISING ON INDOOR BILLBOARDS; PROMOTING AND MARKETING THE GOODS AND SERVICES OF OTHERS BY DISTRIBUTING ADVERTISING MATERIAL, COUPONS AND DISCOUNT OFFERS VIA TEXT MESSAGES; PROMOTING THE GOODS OF OTHERS, NAMELY, PROVIDING INFORMATION REGARDING DISCOUNTS, COUPONS, REBATES, VOUCHERS AND SPECIAL OFFERS FOR THE GOODS OF OTHERS; PROMOTING THE GOODS AND SERVICES OF OTHERS BY PROVIDING A WEBSITE FEATURING COUPONS, REBATES, PRICE-COMPARISON INFORMATION, PRODUCT REVIEWS, LINKS TO THE RETAIL WEBSITES OF OTHERS, AND DISCOUNT INFORMATION (U.S. CLS. 100, 101 AND 102).

ANDREA HACK, EXAMINING ATTORNEY

CLASS 35—(Continued).

SN 85-598,129. WOJECK, JAMES F., MONROE, CT. FILED 4-14-2012.

Urban Staples

THE MARK CONSISTS OF STANDARD CHARACTERS WITHOUT CLAIM TO ANY PARTICULAR FONT, STYLE, SIZE, OR COLOR.

NO CLAIM IS MADE TO THE EXCLUSIVE RIGHT TO USE "STAPLES", APART FROM THE MARK AS SHOWN.

FOR ON-LINE RETAIL STORE SERVICES FEATURING A WIDE VARIETY OF CONSUMER GOODS OF OTHERS; PROMOTING AND SHOWCASING THE GOODS OF OTHERS IN THE FIELD OF HOME SUNDRIES BY MEANS OF AN ON-LINE SHOPPING SITE WITH LINKS TO THE RETAIL ADVERTISEMENTS OF OTHERS; PROMOTING THE GOODS AND SERVICES OF OTHERS BY PROVIDING HYPERTEXT LINKS TO THE WEB SITES OF OTHERS; PROVIDING A SEARCHABLE WEBSITE FEATURING THE GOODS AND SERVICES OF OTHER VENDORS; RETAIL CONVENIENCE STORES; RETAIL STORE SERVICES FEATURING A WIDE VARIETY OF CONSUMER GOODS OF OTHERS; RETAIL STORE SERVICES FEATURING CONVENIENCE STORE ITEMS AND GASOLINE; RETAIL STORE SERVICES FEATURING TELECOMMUNICATIONS SERVICE PLANS AND TELECOMMUNICATIONS SERVICE ACTIVATION; RETAIL VARIETY STORES (U.S. CLS. 100, 101 AND 102).

FIRST USE 4-1-2012; IN COMMERCE 4-1-2012.
DAVID MURRAY, EXAMINING ATTORNEY

SN 85-598,412. GLOBAL CHILD NUTRITION FOUNDATION, OXON HILL, MD. FILED 4-16-2012.

GCNF GLOBAL CHILD
NUTRITION FOUNDATION

THE MARK CONSISTS OF STANDARD CHARACTERS WITHOUT CLAIM TO ANY PARTICULAR FONT, STYLE, SIZE, OR COLOR.

NO CLAIM IS MADE TO THE EXCLUSIVE RIGHT TO USE "FOUNDATION", APART FROM THE MARK AS SHOWN.

SEC. 2(F) AS TO GLOBAL CHILD NUTRITION.

FOR PROMOTING PUBLIC AWARENESS OF THE NEED FOR CHILDREN TO RECEIVE ADEQUATE NUTRITION FOR LEARNING AND ACHIEVING THEIR POTENTIAL AND TO DEVELOP AND OPERATE SUCCESSFUL, SUSTAINABLE, SCHOOL FEEDING PROGRAMS; ARRANGING AND CONDUCTING BUSINESS CONFERENCES IN THE FIELDS OF CHILDREN'S NUTRITION; BUSINESS CONSULTING SERVICES IN THE FIELDS OF ADMINISTRATION, MANAGEMENT AND OPERATION OF CHILDREN'S NUTRITION PROGRAMS; AND BUSINESS NETWORKING (U.S. CLS. 100, 101 AND 102).

FIRST USE 12-13-2006; IN COMMERCE 12-13-2006.
RAUL CORDOVA, EXAMINING ATTORNEY

CLASS 35—(Continued).

SN 85-598,429. NUVO MEDIA, LLC, ATLANTA, GA. FILED 4-16-2012.



NO CLAIM IS MADE TO THE EXCLUSIVE RIGHT TO USE "DEAL", APART FROM THE MARK AS SHOWN.

THE MARK CONSISTS OF A NINJA PUNCHING THE AIR WITH ITS RIGHT HAND, AND HOLDING A SMALL SALES TAG IN EACH HAND. THE NINJA APPEARS TO THE LEFT OF THE STYLIZED WORDING "DEAL NINJA", AND THE WORD "DEAL" APPEARS INSIDE A LARGER STYLIZED SALES TAG.

FOR PROMOTING THE GOODS AND SERVICES OF OTHERS THROUGH THE DISTRIBUTION OF DISCOUNT OFFERS AND COUPONS; ADVERTISING AND COMMERCIAL INFORMATION SERVICES, VIA THE INTERNET; ADVERTISING VIA ELECTRONIC MEDIA AND SPECIFICALLY THE INTERNET; ADVICE AND INFORMATION ABOUT CUSTOMER SERVICES AND PRODUCT MANAGEMENT AND PRICES ON INTERNET SITES IN CONNECTION WITH PURCHASES MADE OVER THE INTERNET; PROVIDING A SEARCHABLE ONLINE ADVERTISING GUIDE FEATURING THE GOODS AND SERVICES OF OTHER ON-LINE VENDORS ON THE INTERNET; PROVIDING ADVERTISING SPACE ON THE INTERNET; PROVIDING CONSUMER PRODUCT INFORMATION VIA THE INTERNET (U.S. CLS. 100, 101 AND 102).

FIRST USE 1-27-2012; IN COMMERCE 1-27-2012.
ANDREW RHIM, EXAMINING ATTORNEY

SN 85-598,484. CASHA, SHANNON A., BRENTWOOD, CA. FILED 4-16-2012.



NO CLAIM IS MADE TO THE EXCLUSIVE RIGHT TO USE "BRENTWOOD" AND "ARMORY", APART FROM THE MARK AS SHOWN.

THE MARK CONSISTS OF THE STYLIZED IMAGE OF A

CLASS 35—(Continued).

SHIELD. THE TOP OF THE SHIELD HAS THE STYLIZED IMAGE OF A CROWN WITH A HORIZONTAL LINE TO THE RIGHT AND LEFT OF THE CROWN. BELOW THE CROWN ARE THE STYLIZED LETTER "BA". BELOW THOSE LETTERS IS THE STYLIZED IMAGE OF A VINE WITH LEAVES. ON EITHER SIDE OF THE SHIELD IS THE STYLIZED IMAGE OF A GUN. ABOVE THE SHIELD IS THE STYLIZED IMAGE OF A WINGED ANIMAL. ABOVE THE ANIMAL IS THE STYLIZED WORD "BRENTWOOD". BELOW THE SHIELD IS THE STYLIZED WORD "ARMORY". FOR ON-LINE RETAIL STORE SERVICES FEATURING FIREARMS, AMMUNITION, AND KNIVES; RETAIL STORE SERVICES FEATURING FIREARMS, AMMUNITION, AND KNIVES (U.S. CLS. 100, 101 AND 102).

FIRST USE 2-1-2012; IN COMMERCE 2-1-2012.
TINA BROWN, EXAMINING ATTORNEY

SN 85-598,531. TAIWAN MISSION FOUNDATION, INC., BAYSIDE, NY. FILED 4-16-2012.



NO CLAIM IS MADE TO THE EXCLUSIVE RIGHT TO USE THE DESIGN OF THE ISLAND OF TAIWAN, APART FROM THE MARK AS SHOWN.

THE COLOR(S) DARK GREEN, MEDIUM GREEN, LIGHT GREEN, AND WHITE IS/ARE CLAIMED AS A FEATURE OF THE MARK.

THE MARK CONSISTS OF A GLOBE OUTLINED IN DARK GREEN SHOWING DARK GREEN LONGITUDINAL AND LATITUDINAL LINES WITH WHITE SPACE BETWEEN THE LINES, AND THE SHAPE OF TAIWAN IN DARK GREEN ON THE BOTTOM RIGHT OF THE GLOBE, AND TWO LIGHT AND MEDIUM GREEN LEAVES PARTLY OVERLAPPING WITH AND ABOVE THE SHAPE OF TAIWAN, AND THE INITIALS "TMF" IN LIGHT GREEN TO THE LEFT OF THE SHAPE OF TAIWAN.

FOR CHARITABLE SERVICES, NAMELY, PROVIDING CHARITABLE OUTREACH PROGRAMS IN THE NATURE OF ORGANIZING AND CONDUCTING VOLUNTEER PROGRAMS AND COMMUNITY SERVICE PROJECTS FOR TAIWANESE COMMUNITIES IN TAIWAN, THE UNITED STATES, AND AROUND THE WORLD (U.S. CLS. 100, 101 AND 102).

FIRST USE 1-31-2012; IN COMMERCE 1-31-2012.
NICHOLAS COLEMAN, EXAMINING ATTORNEY

CLASS 35—(Continued).

SN 85-598,575. LUDWIG, GINA, LAKE FOREST, CA. FILED 4-16-2012.

last minute wedding deals

THE MARK CONSISTS OF STANDARD CHARACTERS WITHOUT CLAIM TO ANY PARTICULAR FONT, STYLE, SIZE, OR COLOR.

NO CLAIM IS MADE TO THE EXCLUSIVE RIGHT TO USE "WEDDING DEALS", APART FROM THE MARK AS SHOWN.

FOR CLASSIFIED ADVERTISING SERVICES IN THE FIELDS OF WEDDING PLANNING AND COORDINATION SERVICES (U.S. CLS. 100, 101 AND 102).

FIRST USE 1-1-2011; IN COMMERCE 1-1-2011.
SIMON TENG, EXAMINING ATTORNEY

SN 85-598,577. LEAD HORSE MARKETING LLC, ATLANTA, GA. FILED 4-16-2012.

Lead Horse Marketing

THE MARK CONSISTS OF STANDARD CHARACTERS WITHOUT CLAIM TO ANY PARTICULAR FONT, STYLE, SIZE, OR COLOR.

NO CLAIM IS MADE TO THE EXCLUSIVE RIGHT TO USE "MARKETING", APART FROM THE MARK AS SHOWN.

FOR ONLINE BUSINESS MARKETING SERVICES; ADVERTISING AND MARKETING SERVICES PROVIDED BY MEANS OF SEARCH ENGINE MARKETING (U.S. CLS. 100, 101 AND 102).

FIRST USE 3-1-2012; IN COMMERCE 3-1-2012.
SIMON TENG, EXAMINING ATTORNEY

SN 85-598,851. PAPPADEMAS, JAMES , R., MILL VALLEY, CA. FILED 4-16-2012.

Seniors Prefer

THE MARK CONSISTS OF STANDARD CHARACTERS WITHOUT CLAIM TO ANY PARTICULAR FONT, STYLE, SIZE, OR COLOR.

NO CLAIM IS MADE TO THE EXCLUSIVE RIGHT TO USE "SENIORS", APART FROM THE MARK AS SHOWN.

FOR ADVERTISING AND MARKETING SERVICES PROVIDED BY MEANS OF INDIRECT METHODS OF MARKETING COMMUNICATIONS, NAMELY, SOCIAL MEDIA, SEARCH ENGINE MARKETING, INQUIRY MARKETING, INTERNET MARKETING, MOBILE MARKETING, BLOGGING AND OTHER FORMS OF PASSIVE, SHARABLE OR VIRAL COMMUNICATIONS CHANNELS; PROVIDING CONSUMER PRODUCT INFORMATION VIA THE INTERNET (U.S. CLS. 100, 101 AND 102).

MICHAEL SOUDERS, EXAMINING ATTORNEY

CLASS 35—(Continued).

SN 85-598,965. CATALINA MARKETING CORPORATION, ST. PETERSBURG, FL. FILED 4-16-2012.

CATALINA BUYERVISION

THE MARK CONSISTS OF STANDARD CHARACTERS WITHOUT CLAIM TO ANY PARTICULAR FONT, STYLE, SIZE, OR COLOR.

OWNER OF U.S. REG. NOS. 2,461,395 AND 2,606,388.
FOR ADVERTISING AND MARKETING SERVICES, NAMELY, PROMOTING THE GOODS AND SERVICES OF OTHERS (U.S. CLS. 100, 101 AND 102).

FIRST USE 3-9-2012; IN COMMERCE 3-9-2012.
REBECCA GILBERT, EXAMINING ATTORNEY

SN 85-599,176. WOUND SUMMIT OUTREACH INC., DBA SAVE A LEG, SAVE A LIFE FOUNDATION, JACKSONVILLE, FL. FILED 4-16-2012.



NO CLAIM IS MADE TO THE EXCLUSIVE RIGHT TO USE "FOUNDATION", APART FROM THE MARK AS SHOWN.

THE COLOR(S) TURQUOISE, DARK BLUE AND WHITE IS/ARE CLAIMED AS A FEATURE OF THE MARK.

THE MARK CONSISTS OF A CIRCLE, THE RIGHT HALF OF WHICH IS TURQUOISE, AND THE LEFT HALF OF WHICH IS DARK BLUE. IN THE CENTER OF THE CIRCLE IS A STYLIZED STAR WITH EIGHT POINTS. THE RIGHT HALF OF THE STAR IS DARK BLUE WITH WHITE ACCENTS ON THE LOWER HALF OF TWO OF THE POINTS (THE SECOND AND THIRD FROM THE TOP). THERE IS A WHITE TRIANGLE IN THE CENTER OF THE FOURTH POINT FROM THE TOP. THE LEFT HALF OF THE STAR IS TURQUOISE WITH WHITE ACCENTS ON THE UPPER HALF OF TWO OF THE POINTS (THE THIRD AND FOURTH FROM THE TOP). THERE IS A DARK BLUE TRIANGLE IN THE CENTER OF THE SECOND POINT FROM THE TOP. IN THE CENTER OF THE STAR IS A CIRCLE. THE LEFT HALF OF THE CIRCLE IS DARK BLUE AND THE RIGHT HALF OF THE CIRCLE IS TURQUOISE. TO THE RIGHT OF ALL THESE IMAGES IS THE TURQUOISE STYLIZED TEXT "SAVE A LEG" ABOVE THE TURQUOISE STYLIZED TEXT "SAVE A LIFE". BELOW "SAVE A LIFE" IS THE DARK BLUE STYLIZED TEXT "FOUNDATION".

FOR PROMOTING PUBLIC AWARENESS OF PERIPHERAL ARTERIAL DISEASE, DIABETES, AND THE PREVENTION OF LOWER EXTREMITY AMPUTATION (U.S. CLS. 100, 101 AND 102).

FIRST USE 7-10-2008; IN COMMERCE 7-10-2008.
GIANCARLO CASTRO, EXAMINING ATTORNEY

CLASS 35—(Continued).

SN 85-599,221. KHALSA, GURUMANTRA S., SAN DIEGO, CA. FILED 4-16-2012.



NO CLAIM IS MADE TO THE EXCLUSIVE RIGHT TO USE "OF AMERICA", APART FROM THE MARK AS SHOWN.

THE MARK CONSISTS OF A MAGNIFYING GLASS CONTAINING THREE STYLIZED HUMAN SILHOUETTES, TO THE RIGHT OF THE MAGNIFYING GLASS IS THE STYLIZED TEXT "FUNDS FINDERS OF AMERICA".

FOR PREPARATION OF REPORTS RELATING TO FINANCE AND INVESTMENTS; MARKET RESEARCH BY MEANS OF A COMPUTER DATABASE; PREPARATION OF FINANCIAL STATEMENTS; REAL ESTATE TRANSACTION AUDITING SERVICES (U.S. CLS. 100, 101 AND 102).

FIRST USE 8-21-2011; IN COMMERCE 8-21-2011.
GEOFFREY FOSDICK, EXAMINING ATTORNEY

SN 85-599,323. CVPARTNERS, INC., SAN FRANCISCO, CA. FILED 4-16-2012.

CVPARTNERS

THE MARK CONSISTS OF STANDARD CHARACTERS WITHOUT CLAIM TO ANY PARTICULAR FONT, STYLE, SIZE, OR COLOR.

FOR EMPLOYMENT AGENCY SERVICES; EMPLOYMENT STAFFING SERVICES; EMPLOYMENT RELATED SERVICES, NAMELY, PROVIDING JOB PLACEMENT, CONTRACT PLACEMENT, AND PERMANENT PLACEMENT SERVICES, CAREER DEVELOPMENT CONSULTING, EMPLOYMENT RECRUITMENT, EMPLOYMENT HIRING, EMPLOYMENT COUNSELING, TIME SHEET PREPARATION, AND GENERAL EMPLOYMENT INFORMATION TO OTHERS; CAREER NETWORKING SERVICES; CONTRACT AND PERMANENT STAFFING AGENCY SERVICES FEATURING PROFESSIONALS IN BOOKKEEPING, ACCOUNTING AND FINANCE; PROVIDING CAREER INFORMATION VIA A WEBSITE ON A NETWORK; PROVIDING INFORMATION ON JOBS VIA A WEBSITE ON A NETWORK; PROVIDING AN ONLINE COMPUTER DATABASE IN THE FIELDS OF CONTRACT AND PERMANENT STAFFING (U.S. CLS. 100, 101 AND 102).

FIRST USE 2-28-2001; IN COMMERCE 2-28-2001.
JAMES GRIFFIN, EXAMINING ATTORNEY

CLASS 35—(Continued).

SN 85-599,338. CVPARTNERS, INC., SAN FRANCISCO, CA. FILED 4-16-2012.

CVPARTNERS IN TECHNOLOGY

THE MARK CONSISTS OF STANDARD CHARACTERS WITHOUT CLAIM TO ANY PARTICULAR FONT, STYLE, SIZE, OR COLOR.

NO CLAIM IS MADE TO THE EXCLUSIVE RIGHT TO USE "TECHNOLOGY", APART FROM THE MARK AS SHOWN.

FOR EMPLOYMENT AGENCY SERVICES; EMPLOYMENT STAFFING SERVICES; EMPLOYMENT RELATED SERVICES, NAMELY, PROVIDING JOB PLACEMENT, CONTRACT PLACEMENT, AND PERMANENT PLACEMENT SERVICES, CAREER DEVELOPMENT CONSULTING, EMPLOYMENT RECRUITMENT, EMPLOYMENT HIRING, EMPLOYMENT COUNSELING, TIME SHEET PREPARATION, AND GENERAL EMPLOYMENT INFORMATION TO OTHERS; CAREER NETWORKING SERVICES; CONTRACT AND PERMANENT STAFFING AGENCY SERVICES FEATURING PROFESSIONALS IN INFORMATION TECHNOLOGY AND PROJECT MANAGEMENT AS WELL AS BUSINESS ANALYST CONSULTANTS AND INFRASTRUCTURE OPERATIONS CONSULTANTS; PROVIDING CAREER INFORMATION VIA A WEBSITE ON A NETWORK; PROVIDING INFORMATION ON JOBS VIA A WEBSITE ON A NETWORK; PROVIDING AN ONLINE COMPUTER DATABASE IN THE FIELDS OF CONTRACT AND PERMANENT STAFFING (U.S. CLS. 100, 101 AND 102).

FIRST USE 1-31-2004; IN COMMERCE 1-31-2004.
JAMES GRIFFIN, EXAMINING ATTORNEY

SN 85-599,344. CVPARTNERS, INC., SAN FRANCISCO, CA. FILED 4-16-2012.

CVPARTNERS EXECUTIVE SEARCH

THE MARK CONSISTS OF STANDARD CHARACTERS WITHOUT CLAIM TO ANY PARTICULAR FONT, STYLE, SIZE, OR COLOR.

NO CLAIM IS MADE TO THE EXCLUSIVE RIGHT TO USE "EXECUTIVE SEARCH", APART FROM THE MARK AS SHOWN.

FOR EMPLOYMENT AGENCY SERVICES; EMPLOYMENT STAFFING SERVICES; EMPLOYMENT RELATED SERVICES, NAMELY, PROVIDING JOB PLACEMENT, CONTRACT PLACEMENT, AND PERMANENT PLACEMENT SERVICES, CAREER DEVELOPMENT CONSULTING, EMPLOYMENT RECRUITMENT, EMPLOYMENT HIRING, EMPLOYMENT COUNSELING, TIME SHEET PREPARATION, AND GENERAL EMPLOYMENT INFORMATION TO OTHERS; CAREER NETWORKING SERVICES; CONTRACT AND PERMANENT STAFFING AGENCY SERVICES FEATURING PROFESSIONALS IN FINANCE, ACCOUNTING, INFORMATION TECHNOLOGY AND HUMAN RESOURCES; PROVIDING CAREER INFORMATION VIA A WEBSITE ON A NETWORK; PROVIDING INFORMATION ON JOBS VIA A WEBSITE ON A NETWORK; PROVIDING AN ONLINE COMPUTER DATABASE IN THE FIELDS OF CONTRACT AND PERMANENT STAFFING (U.S. CLS. 100, 101 AND 102).

FIRST USE 11-30-2005; IN COMMERCE 11-30-2005.
JAMES GRIFFIN, EXAMINING ATTORNEY

CLASS 35—(Continued).

SN 85-599,398. WERBAK, INC., POMPTON PLAINS, NJ.
FILED 4-16-2012.

POMPTON PHARMACY

THE MARK CONSISTS OF STANDARD CHARACTERS WITHOUT CLAIM TO ANY PARTICULAR FONT, STYLE, SIZE, OR COLOR.

NO CLAIM IS MADE TO THE EXCLUSIVE RIGHT TO USE "PHARMACY", APART FROM THE MARK AS SHOWN.

SEC. 2(F).

FOR RETAIL PHARMACY SERVICES (U.S. CLS. 100, 101 AND 102).

FIRST USE 1-1-2003; IN COMMERCE 1-1-2003.

AMY HELLA, EXAMINING ATTORNEY

SN 85-599,463. STEVEN CONCEICAO, ROSELLE PARK, NJ.
FILED 4-17-2012.

BIDTHEFIX

THE MARK CONSISTS OF STANDARD CHARACTERS WITHOUT CLAIM TO ANY PARTICULAR FONT, STYLE, SIZE, OR COLOR.

FOR BUSINESS SERVICES, NAMELY, PROVIDING AN ONLINE NETWORK FOR CONTRACTORS TO RECEIVE LEADS AND BIDDING OPPORTUNITIES BY MEANS OF AN ONLINE MARKETPLACE FOR THE PURPOSE OF DEVELOPING BUSINESS IN THE REPAIR, REHABILITATION, RECONSTRUCTION INDUSTRY (U.S. CLS. 100, 101 AND 102).

FIRST USE 9-22-2011; IN COMMERCE 9-22-2011.

EDWARD NELSON, EXAMINING ATTORNEY

SN 85-599,493. SIMPLY CHIC LLC, WESTERVILLE, OH.
FILED 4-17-2012.

FOREVER CHIC

THE MARK CONSISTS OF STANDARD CHARACTERS WITHOUT CLAIM TO ANY PARTICULAR FONT, STYLE, SIZE, OR COLOR.

FOR ON-LINE RETAIL STORE SERVICES FEATURING APPAREL, JEWELRY, SHOES, PURSES, FASHION ACCESSORIES AND GENERAL MERCHANDISE; RETAIL STORE SERVICES FEATURING APPAREL, JEWELRY, SHOES, PURSES, FASHION ACCESSORIES AND GENERAL MERCHANDISE (U.S. CLS. 100, 101 AND 102).

WANDA KAY PRICE, EXAMINING ATTORNEY

CLASS 35—(Continued).

SN 85-600,167. ANALYTICSIQ, INC., ATLANTA, GA. FILED
4-17-2012.

EMAILIQ

THE MARK CONSISTS OF STANDARD CHARACTERS WITHOUT CLAIM TO ANY PARTICULAR FONT, STYLE, SIZE, OR COLOR.

FOR BUSINESS MONITORING AND CONSULTING SERVICES, NAMELY, TRACKING WEB SITES AND APPLICATIONS OF OTHERS TO PROVIDE STRATEGY, INSIGHT, MARKETING, SALES, OPERATION, PRODUCT DESIGN, PARTICULARLY SPECIALIZING IN THE USE OF ANALYTIC AND STATISTIC MODELS FOR THE UNDERSTANDING AND PREDICTING OF CONSUMERS, BUSINESSES, AND MARKET TRENDS AND ACTIONS (U.S. CLS. 100, 101 AND 102).

FIRST USE 11-1-2011; IN COMMERCE 2-1-2012.

BRIAN PINO, EXAMINING ATTORNEY

SN 85-600,285. LAKES OF PARKWAY HOMEOWNERS ASSOCIATION, INC., DBA LAKES OF PARKWAY, HOUSTON, TX. FILED 4-17-2012.



Lakes of Parkway

THE MARK CONSISTS OF AN OAK TREE WITH THE LOWER HALF OF THE TRUNK NOT SHOWING, UNDER WHICH THE WORDS "LAKES OF PARKWAY" APPEAR IN ITALIC SCRIPT.

FOR HOMEOWNER ASSOCIATION SERVICES, NAMELY, PROMOTING THE INTERESTS OF HOMEOWNERS IN A SPECIFIC COMMUNITY AND MARKETING THE COMMUNITY NATIONWIDE TO PROSPECTIVE NEW RESIDENTS AND PROPERTY OWNERS (U.S. CLS. 100, 101 AND 102).

FIRST USE 5-1-2008; IN COMMERCE 5-1-2008.

ARETHA SOMERVILLE, EXAMINING ATTORNEY

CLASS 35—(Continued).

SN 85-600,286. CAPALYST, INC., CHEYENNE, WY. FILED 4-17-2012.

DOMIKNOW

THE MARK CONSISTS OF STANDARD CHARACTERS WITHOUT CLAIM TO ANY PARTICULAR FONT, STYLE, SIZE, OR COLOR.

FOR ADVERTISING AND MARKETING (U.S. CLS. 100, 101 AND 102).

FIRST USE 1-13-2007; IN COMMERCE 1-13-2007.
SUNG IN, EXAMINING ATTORNEY

SN 85-600,327. NEXTADVISOR, INC., SAN FRANCISCO, CA. FILED 4-17-2012.

NextAdvisor

THE MARK CONSISTS OF STANDARD CHARACTERS WITHOUT CLAIM TO ANY PARTICULAR FONT, STYLE, SIZE, OR COLOR.

FOR PROMOTING THE GOODS AND SERVICES OF OTHERS BY PROVIDING A WEBSITE FEATURING PRODUCT AND SERVICE REVIEWS FOR CONSUMERS (U.S. CLS. 100, 101 AND 102).

FIRST USE 1-1-2006; IN COMMERCE 1-1-2006.
LYNDSEY KUYKENDALL, EXAMINING ATTORNEY

SN 85-600,371. 900 PHARMACY, LLC, CHICAGO, IL. FILED 4-17-2012.



NO CLAIM IS MADE TO THE EXCLUSIVE RIGHT TO USE "PHARMACY", APART FROM THE MARK AS SHOWN.

THE COLOR(S) BLUE AND WHITE IS/ARE CLAIMED AS A FEATURE OF THE MARK.

THE MARK CONSISTS OF THE NUMBER "900" IN BLUE POSITIONED IMMEDIATELY ABOVE THE WORD "PHARMACY" IN BLUE. THE IMAGES REPRESENTING THE ZEROS IN THE NUMBER "900" CONSIST OF BLUE OVALS EACH WITH AN IMAGE OF AN OPEN HUMAN HAND IN WHITE REACHING FOR THE OTHER.

FOR MAIL ORDER PHARMACY SERVICES; PHARMACEUTICAL SERVICES, NAMELY, PROCESSING ONLINE AND TELEPHONE PRESCRIPTION ORDERS IN RETAIL AND CENTRAL FILL PHARMACIES; RETAIL PHARMACY SERVICES (U.S. CLS. 100, 101 AND 102).

FIRST USE 8-11-2011; IN COMMERCE 8-11-2011.
KATHERINE E. HALMEN, EXAMINING ATTORNEY

CLASS 35—(Continued).

SN 85-600,435. ENCUITY RESEARCH, LLC, RALEIGH, NC. FILED 4-17-2012.



NO CLAIM IS MADE TO THE EXCLUSIVE RIGHT TO USE "RESEARCH", APART FROM THE MARK AS SHOWN. THE MARK CONSISTS OF THE STYLIZED LITERAL ELEMENTS "ENCUITY RESEARCH" ALONG WITH A STYLIZED DESIGN CONSISTING OF SHADED CIRCLES FORMING A TRIANGLE OVER THE LETTER "I".

THE WORDING "ENCUITY" HAS NO MEANING IN A FOREIGN LANGUAGE.

FOR MARKET RESEARCH SERVICES, HEALTHCARE BUSINESS DATA ANALYSIS, AND MARKET RESEARCH CONSULTATION SERVICES IN THE PHARMACEUTICAL AND MEDICAL SERVICES INDUSTRIES (U.S. CLS. 100, 101 AND 102).

EVIN L. KOZAK, EXAMINING ATTORNEY

SN 85-600,508. GIFT EFFECT LLC, VENICE, CA. FILED 4-17-2012.

THE GIFT EFFECT

THE MARK CONSISTS OF STANDARD CHARACTERS WITHOUT CLAIM TO ANY PARTICULAR FONT, STYLE, SIZE, OR COLOR.

FOR ADVERTISING, MARKETING AND PROMOTION SERVICES; ADVERTISING, MARKETING AND PROMOTION SERVICES IN THE FIELD OF THE AIRLINE INDUSTRY, HOSPITALITY, SCHOOLS, STADIUMS, ENTERTAINMENT VENUES, AND RETAIL ENVIRONMENTS (U.S. CLS. 100, 101 AND 102).

BRENDAN REGAN, EXAMINING ATTORNEY

SN 85-600,784. KINDRED, TERESA BELL, SUMMER SHADE, KY. FILED 4-18-2012.

BELLVIEW BLUEBERRY FARMS

THE MARK CONSISTS OF STANDARD CHARACTERS WITHOUT CLAIM TO ANY PARTICULAR FONT, STYLE, SIZE, OR COLOR.

NO CLAIM IS MADE TO THE EXCLUSIVE RIGHT TO USE "BLUEBERRY FARMS", APART FROM THE MARK AS SHOWN.

FOR RETAIL SHOPS FEATURING FOODS CONTAINING BLUEBERRIES AND CLOTHING AND HOUSEWARES RELATED TO BLUEBERRIES (U.S. CLS. 100, 101 AND 102).

LINDA LAVACHE, EXAMINING ATTORNEY

CLASS 35—(Continued).

SN 85-601,065. FSQA CONSULTING LTD., OAKVILLE, ONTARIO, CANADA, FILED 4-18-2012.



THE MARK CONSISTS OF THE STYLIZED IMAGE OF THE LETTER "C" WITH THE STYLIZED IMAGE OF A WOLF HEAD TO THE RIGHT OF IT.

FOR CATALOG ORDERING SERVICE FEATURING NAUTICAL-RELATED CLOTHING AND GIFT ITEMS; COMPUTERIZED ON-LINE ORDERING FEATURING GENERAL MERCHANDISE AND GENERAL CONSUMER GOODS; ON-LINE RETAIL GIFT SHOPS; ON-LINE RETAIL STORE SERVICES FEATURING A WIDE VARIETY OF CONSUMER GOODS OF OTHERS; ON-LINE RETAIL STORE SERVICES FEATURING NAUTICAL-RELATED CLOTHING AND GIFT ITEMS; OPERATING AN ON-LINE SHOPPING SITE IN THE FIELD OF NAUTICAL-RELATED CLOTHING AND GIFT ITEMS; RETAIL SHOPS FEATURING NAUTICAL-RELATED CLOTHING AND GIFT ITEMS; RETAIL NAUTICAL-RELATED CLOTHING AND GIFT ITEMS STORES (U.S. CLS. 100, 101 AND 102).

FIRST USE 4-0-2009; IN COMMERCE 4-0-2009.
BRENDAN REGAN, EXAMINING ATTORNEY

SN 85-601,153. AMAZING TECHNOLOGIES LLC, DALLAS, TX, FILED 4-18-2012.

AMAZING

THE MARK CONSISTS OF STANDARD CHARACTERS WITHOUT CLAIM TO ANY PARTICULAR FONT, STYLE, SIZE, OR COLOR.

FOR VALUE-ADDED RESELLER SERVICES, NAMELY, DISTRIBUTORSHIP SERVICES FEATURING COMPUTER SOFTWARE (U.S. CLS. 100, 101 AND 102).

FIRST USE 4-0-2012; IN COMMERCE 4-0-2012.
DOUGLAS LEE, EXAMINING ATTORNEY

CLASS 35—(Continued).

SN 85-601,169. FLORIDA HIGH SCHOOL ATHLETIC ASSOCIATION, INC., GAINESVILLE, FL, FILED 4-18-2012.



NO CLAIM IS MADE TO THE EXCLUSIVE RIGHT TO USE "FLORIDA HIGH SCHOOL ATHLETIC ASSOCIATION" AND THE REPRESENTATION OF THE MAP OF FLORIDA, APART FROM THE MARK AS SHOWN.

THE COLOR(S) BLUE, GREEN, AND ORANGE IS/ARE CLAIMED AS A FEATURE OF THE MARK.

THE MARK CONSISTS OF THE SHAPE OF THE STATE OF "FLORIDA" IN ORANGE SUPERIMPOSED ON STYLIZED SHIELD CONSISTING OF AN OUTER EDGE IN BLUE AND AN INNER DESIGN OUTLINING THE OUTER EDGE IN GREEN; ABOVE THE SHIELD IS AN ORANGE RISING SUN; TO THE RIGHT OF THE DESIGN ELEMENT IS THE WORDING "FLORIDA" IN BLUE LETTING, UNDERSCORED BY AN ORANGE LINE AND BELOW THE LINE APPEARS THE WORDING "HIGH SCHOOL ATHLETIC ASSOCIATION" IN GREEN.

FOR ASSOCIATION SERVICES, NAMELY, PROMOTING THE INTERESTS OF HIGH SCHOOL ATHLETICS IN THE STATE OF FLORIDA (U.S. CLS. 100, 101 AND 102).

FIRST USE 10-1-2011; IN COMMERCE 1-1-2012.
BILL DAWE, EXAMINING ATTORNEY

SN 85-601,282. SARNIKOWSKI, SCOTT, SAN JOSE, CA, FILED 4-18-2012.

Stealth Advantage

THE MARK CONSISTS OF STANDARD CHARACTERS WITHOUT CLAIM TO ANY PARTICULAR FONT, STYLE, SIZE, OR COLOR.

FOR BUSINESS MANAGEMENT CONSULTATION IN THE FIELD OF EXECUTIVE AND LEADERSHIP DEVELOPMENT (U.S. CLS. 100, 101 AND 102).

FIRST USE 4-18-2012; IN COMMERCE 4-18-2012.
ANNE FARRELL, EXAMINING ATTORNEY

CLASS 35—(Continued).

SN 85-601,319. MOON SR., ANTHONY, BALTIMORE, MD. FILED 4-18-2012.

ATPAC SERVICES

THE MARK CONSISTS OF STANDARD CHARACTERS WITHOUT CLAIM TO ANY PARTICULAR FONT, STYLE, SIZE, OR COLOR.

NO CLAIM IS MADE TO THE EXCLUSIVE RIGHT TO USE "SERVICES", APART FROM THE MARK AS SHOWN.

FOR ACCOUNTING SERVICES; TAX PREPARATION; TAX ADVISORY SERVICES; TAX CONSULTATION; PAYROLL PREPARATION; PAYROLL PROCESSING SERVICES; ACCOUNT AUDITING; BUSINESS AUDITING; BUSINESS CONSULTING AND INFORMATION SERVICES (U.S. CLS. 100, 101 AND 102).

FIRST USE 1-2-2004; IN COMMERCE 1-2-2004.
APRIL HESIK, EXAMINING ATTORNEY



SN 85-601,410. NO. 14 LLC, NEW YORK, NY. FILED 4-18-2012.

NO. 14

THE MARK CONSISTS OF STANDARD CHARACTERS WITHOUT CLAIM TO ANY PARTICULAR FONT, STYLE, SIZE, OR COLOR.

FOR MARKETING AND PROMOTIONAL CONSULTING SERVICES RELATED TO THE ENDORSEMENT OF THIRD PARTY CONSUMER PRODUCTS (U.S. CLS. 100, 101 AND 102).

ERIN FALK, EXAMINING ATTORNEY

CLASS 35—(Continued).

SN 85-601,450. ALL-ADS-UP, LLC, STATEN ISLAND, NY. FILED 4-18-2012.

ALL-ADS-UP

THE MARK CONSISTS OF STANDARD CHARACTERS WITHOUT CLAIM TO ANY PARTICULAR FONT, STYLE, SIZE, OR COLOR.

FOR AD SERVING, NAMELY, PLACING ADVERTISEMENTS ON WEBSITES FOR OTHERS USING SPECIALIZED COMPUTER SOFTWARE; ADVERTISEMENT AND PUBLICITY SERVICES BY TELEVISION, RADIO, MAIL; ADVERTISEMENT FOR OTHERS ON THE INTERNET; ADVERTISING AND COMMERCIAL INFORMATION SERVICES, VIA THE INTERNET; ADVERTISING AND DIRECTORY SERVICES, NAMELY, PROMOTING THE SERVICES OF OTHERS BY PROVIDING A WEB PAGE FEATURING LINKS TO THE WEBSITES OF OTHERS; ADVERTISING AND MARKETING; ADVERTISING AND MARKETING SERVICES, NAMELY, PROMOTING THE GOODS AND SERVICES OF OTHERS; ADVERTISING AND PROMOTION SERVICES AND RELATED CONSULTING; ADVERTISING AND PROMOTIONAL SERVICES; ADVERTISING AND PUBLICITY SERVICES; ADVERTISING ON THE INTERNET FOR OTHERS; ADVERTISING SERVICES; ADVERTISING SERVICES, NAMELY, CREATING CORPORATE AND BRAND IDENTITY FOR OTHERS; ADVERTISING SERVICES, NAMELY, PROMOTING AND MARKETING THE GOODS AND SERVICES OF OTHERS THROUGH ALL PUBLIC COMMUNICATION MEANS; ADVERTISING THROUGH ALL PUBLIC COMMUNICATION MEANS; ADVERTISING, MARKETING AND PROMOTION SERVICES (U.S. CLS. 100, 101 AND 102).

INGRID C. EULIN, EXAMINING ATTORNEY



SN 85-601,480. DEWORM THE WORLD, CAMBRIDGE, MA. FILED 4-18-2012.

Deworm the World

THE MARK CONSISTS OF STANDARD CHARACTERS WITHOUT CLAIM TO ANY PARTICULAR FONT, STYLE, SIZE, OR COLOR.

NO CLAIM IS MADE TO THE EXCLUSIVE RIGHT TO USE "DEWORM", APART FROM THE MARK AS SHOWN.

FOR CHARITABLE SERVICES, NAMELY, ORGANIZING AND DEVELOPING PROJECTS THAT AIM TO IMPROVE THE LIVES OF UNDERPRIVILEGED AND IMPOVERISHED PEOPLE (U.S. CLS. 100, 101 AND 102).

FIRST USE 8-2-2007; IN COMMERCE 8-2-2007.

ELISSA GARBER KON, EXAMINING ATTORNEY

CLASS 35—(Continued).

SN 85-601,606. STARTUP TANK, LLC, NEW YORK, NY. FILED 4-18-2012.

Startup Tank

THE MARK CONSISTS OF STANDARD CHARACTERS WITHOUT CLAIM TO ANY PARTICULAR FONT, STYLE, SIZE, OR COLOR.

NO CLAIM IS MADE TO THE EXCLUSIVE RIGHT TO USE "STARTUP", APART FROM THE MARK AS SHOWN.

FOR PROVIDING A WEBSITE FEATURING AN ON-LINE MARKETPLACE FOR EXCHANGING GOODS AND SERVICES WITH OTHER USERS; PROVIDING A WEBSITE FEATURING COMPANY PROFILES ENTREPRENEURS CAN USE TO ATTRACT VENTURE CAPITAL; PROVIDING A WEBSITE FOR USERS WITH SPECIFIC INFORMED RECOMMENDATIONS OF SPECIFIC CONSUMER PRODUCTS AND SERVICES VALIDATED BY THE USERS' INPUTTED PREFERENCES AND SOCIAL NETWORK (U.S. CLS. 100, 101 AND 102).

JIM RINGLE, EXAMINING ATTORNEY

SN 85-601,679. SWIFT TECHNICAL GROUP HOLDINGS LTD., HOUSTON, TX. FILED 4-18-2012.

Whatever it takes, wherever it takes us

THE MARK CONSISTS OF STANDARD CHARACTERS WITHOUT CLAIM TO ANY PARTICULAR FONT, STYLE, SIZE, OR COLOR.

FOR EMPLOYMENT HIRING, RECRUITING, PLACEMENT, STAFFING AND CAREER NETWORKING SERVICES; EXECUTIVE RECRUITING SERVICES; PERSONNEL PLACEMENT AND RECRUITMENT; PROFESSIONAL STAFFING AND RECRUITING SERVICES; RECRUITMENT AND PLACEMENT OF PERSONNEL IN THE FIELD OF OIL AND GAS (U.S. CLS. 100, 101 AND 102).

CAROLINE WOOD, EXAMINING ATTORNEY

SN 85-601,715. BAT SHIRT CRAZY, LLC, AUSTIN, TX. FILED 4-18-2012.

BAT SHIRT CRAZY

THE MARK CONSISTS OF STANDARD CHARACTERS WITHOUT CLAIM TO ANY PARTICULAR FONT, STYLE, SIZE, OR COLOR.

FOR RETAIL STORE SERVICES FEATURING MUGS, KEY CHAINS, T-SHIRTS, AND BABY OUTFITS (U.S. CLS. 100, 101 AND 102).

KATHERINE STOIDES, EXAMINING ATTORNEY

CLASS 35—(Continued).

SN 85-601,806. AGILE MARKETING GROUP, CARRBORO, NC. FILED 4-18-2012.

Freebooksy

THE MARK CONSISTS OF STANDARD CHARACTERS WITHOUT CLAIM TO ANY PARTICULAR FONT, STYLE, SIZE, OR COLOR.

FOR ADVERTISING AND MARKETING SERVICES, NAMELY, PROMOTING THE GOODS AND SERVICES OF OTHERS; ON-LINE ADVERTISING AND MARKETING SERVICES (U.S. CLS. 100, 101 AND 102).

FIRST USE 1-1-2012; IN COMMERCE 1-1-2012.

COLLEEN MULCRONE, EXAMINING ATTORNEY

SN 85-601,906. SZYMON MASIAK, DBA MASIAK SZYMON MASIAKVFX, KOZY, POLAND, FILED 4-18-2012.



motionvfx

PRIORITY CLAIMED UNDER SEC. 44(D) ON ERPNCMNTY TM OFC APPLICATION NO. 010605608, FILED 1-31-2012, REG. NO. 010605608, DATED 6-29-2012, EXPIRES 1-31-2022.

THE MARK CONSISTS OF A BLACK CIRCLE WITH A LETTER "M" IN THE MIDDLE OF THE CIRCLE AND THE WORD "MOTIONVFX" WRITTEN BELOW THE CIRCLE.

FOR ADVERTISING AND PROMOTIONAL SERVICES (U.S. CLS. 100, 101 AND 102).

TASNEEM HUSSAIN, EXAMINING ATTORNEY

CLASS 35—(Continued).

SN 85-602,025. PAUL FARKAS, NEW YORK, NY. FILED 4-18-2012.

**ULN THE ULTRA LIFESTYLE
NETWORK**

THE MARK CONSISTS OF STANDARD CHARACTERS WITHOUT CLAIM TO ANY PARTICULAR FONT, STYLE, SIZE, OR COLOR.

NO CLAIM IS MADE TO THE EXCLUSIVE RIGHT TO USE "ULTRA LIFESTYLE NETWORK", APART FROM THE MARK AS SHOWN.

FOR ADVERTISING AND MARKETING; BRAND POSITIONING SERVICES; BRANDING SERVICES, NAMELY, CONSULTING, DEVELOPMENT, MANAGEMENT AND MARKETING OF BRANDS FOR BUSINESSES; BUSINESS MERCHANDISING DISPLAY SERVICES; FASHION SHOW EXHIBITIONS FOR COMMERCIAL PURPOSES; MOBILE RETAIL STORE SERVICES FEATURING HIGH-END FASHION ACCESSORIES, LUXURY GOODS, HOME DECOR, AND VEHICLES; PREPARING AUDIOVISUAL PRESENTATIONS FOR USE IN ADVERTISING; PRODUCT MERCHANDISING; PROVIDING A SEARCHABLE WEB SITE FEATURING THE GOODS AND SERVICES OF OTHER VENDORS; RETAIL STORE SERVICES IN THE FIELD OF HIGH-END FASHION ACCESSORIES, LUXURY CONSUMER PRODUCTS AND GOODS, HOME DECOR, AND VEHICLES FEATURING A BONUS INCENTIVE PROGRAM FOR CUSTOMERS; SOCIAL MEDIA STRATEGY AND MARKETING CONSULTANT FOCUSING ON HELPING CLIENTS CREATE AND EXTEND THEIR PRODUCT AND BRAND STRATEGIES BY BUILDING VIRALLY ENGAGING MARKETING SOLUTIONS; WINDOW DRESSING AND DISPLAY ARRANGEMENT SERVICES (U.S. CLS. 100, 101 AND 102).
MICHAEL WIENER, EXAMINING ATTORNEY

SN 85-602,116. YOU'VE BEEN ANGELED, LLC, FALMOUTH, ME. FILED 4-19-2012.

YOU'VE BEEN ANGELED

THE MARK CONSISTS OF STANDARD CHARACTERS WITHOUT CLAIM TO ANY PARTICULAR FONT, STYLE, SIZE, OR COLOR.

FOR ON-LINE RETAIL GIFT SHOPS; ON-LINE RETAIL STORE SERVICES FEATURING FINE ART AND GIFT ITEMS (U.S. CLS. 100, 101 AND 102).

ANTHONY RINKER, EXAMINING ATTORNEY

CLASS 35—(Continued).

SN 85-602,161. BEADAHOLIQUE INC., GLENDALE, CA. FILED 4-19-2012.

Beadaholique

THE MARK CONSISTS OF STANDARD CHARACTERS WITHOUT CLAIM TO ANY PARTICULAR FONT, STYLE, SIZE, OR COLOR.

FOR ON-LINE RETAIL STORE SERVICES FEATURING BEADS AND JEWELRY MAKING SUPPLIES (U.S. CLS. 100, 101 AND 102).

FIRST USE 1-20-2000; IN COMMERCE 9-20-2000.

LEIGH CAROLINE CASE, EXAMINING ATTORNEY

SN 85-602,183. TROPHY TAGGERS OUTDOOR NETWORK, LLC, TRAVERSE CITY, MI. FILED 4-19-2012.

TROPHY TAGGERS

THE MARK CONSISTS OF STANDARD CHARACTERS WITHOUT CLAIM TO ANY PARTICULAR FONT, STYLE, SIZE, OR COLOR.

FOR ON-LINE RETAIL STORE SERVICES FEATURING HUNTING GOODS, FISHING GOODS, OUTDOOR EQUIPMENT AND APPAREL (U.S. CLS. 100, 101 AND 102).

FIRST USE 3-1-2010; IN COMMERCE 3-1-2010.

SETH A. RAPPAPORT, EXAMINING ATTORNEY

SN 85-602,205. BAXTER, DOUGLAS A., CALABASAS, CA. FILED 4-19-2012.

ROBOT&CHILD

THE MARK CONSISTS OF THE TEXT "ROBOT & CHILD" ON A STYLIZED RECTANGULAR BACKGROUND.

FOR COMPILATION, PRODUCTION AND DISSEMINATION OF ADVERTISING MATTER; MARKETING CONSULTING; ON-LINE ADVERTISING AND MARKETING SERVICES (U.S. CLS. 100, 101 AND 102).

FIRST USE 1-1-2011; IN COMMERCE 1-1-2011.

KELLEY WELLS, EXAMINING ATTORNEY

CLASS 35—(Continued).

SN 85-602,396. NINE WEST DEVELOPMENT CORPORATION, WILMINGTON, DE. FILED 4-19-2012.

STEPS FOR A CAUSE

THE MARK CONSISTS OF STANDARD CHARACTERS WITHOUT CLAIM TO ANY PARTICULAR FONT, STYLE, SIZE, OR COLOR.

FOR ON-LINE RETAIL STORE SERVICES FEATURING FOOTWEAR, BELTS, HANDBAGS, JEWELRY, SUNGLASSES AND LEGWEAR (U.S. CLS. 100, 101 AND 102).
FIRST USE 8-31-2010; IN COMMERCE 8-31-2010.
TINA MAI, EXAMINING ATTORNEY

SN 85-602,444. HIGH PLAINS WINEGROWERS, LEVELAND, TX. FILED 4-19-2012.

Where Great Wine Is Born

THE MARK CONSISTS OF STANDARD CHARACTERS WITHOUT CLAIM TO ANY PARTICULAR FONT, STYLE, SIZE, OR COLOR.

FOR ADVERTISING, MARKETING AND PROMOTION SERVICES IN THE FIELD OF VINTNERS AND WINE GROWING; ASSOCIATION SERVICES, NAMELY, PROMOTING THE INTERESTS OF VINTNERS AND WINE GROWERS; ASSOCIATION SERVICES, NAMELY, PROMOTING PUBLIC AWARENESS OF WINE GROWERS AND GRAPE QUALITY IN THE HIGH PLAINS OF TEXAS (U.S. CLS. 100, 101 AND 102).

FIRST USE 3-6-2012; IN COMMERCE 3-6-2012.
JAY FLOWERS, EXAMINING ATTORNEY

SN 85-602,521. GREENSTACK, INC., SEBASTOPOL, CA. FILED 4-19-2012.

GREENSTACK

THE MARK CONSISTS OF STANDARD CHARACTERS WITHOUT CLAIM TO ANY PARTICULAR FONT, STYLE, SIZE, OR COLOR.

FOR ADMINISTRATION OF DISCOUNT, MEMBERSHIP, LOYALTY, AND AFFINITY SERVICES AND PROGRAMS; MEMBERSHIP CLUB SERVICES PROVIDING DISCOUNTS AND PROCESSING REBATES FOR THE GOODS AND SERVICES OF OTHERS; ADVERTISING THE GOODS AND SERVICES OF OTHERS THROUGH WEB SITES, MOBILE APPLICATIONS, AND SOCIAL NETWORKS; PROVIDING A WEB SITE FEATURING ON-LINE REGISTRATION SERVICES FOR THIRD-PARTY MEMBERSHIPS (U.S. CLS. 100, 101 AND 102).

DOMINIC J. FERRAIUOLO, EXAMINING ATTORNEY

CLASS 35—(Continued).

SN 85-602,607. INTERNATIONAL SLURRY SURFACING ASSOCIATION, ANNAPOLIS, MD. FILED 4-19-2012.



THE MARK CONSISTS OF A STYLIZED GLOBE REPRESENTED BY CURVED GRADUATED LINES WITH THE WORD ISSA IMPOSED OVER THE MIDDLE AND THE WORDS PRESERVING PAVEMENT BENEATH ISSA IN A SLIGHTLY SMALLER FONT.

FOR TRADE ASSOCIATION SERVICES, NAMELY, PROMOTING THE INTERESTS OF THE SLURRY SEAL, MICRO SURFACING, ASPHALT BASED CHIPSEAL AND ASPHALT BASED CRACK TREATMENT INDUSTRY (U.S. CLS. 100, 101 AND 102).

FIRST USE 9-30-2011; IN COMMERCE 9-30-2011.
TEJBIR SINGH, EXAMINING ATTORNEY

SN 85-602,623. CAPITOL SOLUTIONS GOVERNMENT RELATIONS CONSULTANTS, LLC, WASHINGTON, DC. FILED 4-19-2012.

DC4 COALITION

THE MARK CONSISTS OF STANDARD CHARACTERS WITHOUT CLAIM TO ANY PARTICULAR FONT, STYLE, SIZE, OR COLOR.

NO CLAIM IS MADE TO THE EXCLUSIVE RIGHT TO USE "COALITION", APART FROM THE MARK AS SHOWN.

FOR LOBBYING SERVICES, NAMELY, PROMOTING THE INTERESTS OF PEOPLE, BUSINESSES, AND AGENCIES WHO PROVIDE AND/OR USE INFORMATION TECHNOLOGY OR CLOUD-BASED SERVICES, IN THE FIELDS OF FEDERAL POLITICS, LEGISLATION AND REGULATION (U.S. CLS. 100, 101 AND 102).

DAVID TOOLEY, EXAMINING ATTORNEY

CLASS 35—(Continued).

SN 85-602,646. DAVIES CONSULTING, LLC, CHEVY CHASE, MD. FILED 4-19-2012.



THE COLOR(S) LIGHT GREEN, DARK GREEN, AND GRAY IS/ARE CLAIMED AS A FEATURE OF THE MARK.

THE MARK CONSISTS OF TWO CHEVRONS AND A COMBINATION OF THE LITERAL ELEMENTS "DAVIES CONSULTING". THE COLORS INCLUDED ARE LIGHT GREEN, ON THE LEFT AND UPPER FACING CHEVRON, DARK GREEN, ON THE RIGHT AND LOWER FACING CHEVRON AND THE LITERAL ELEMENT "CONSULTING," AND GRAY IN THE LITERAL ELEMENT "DAVIES".

FOR BUSINESS CONSULTING AND INFORMATION SERVICES (U.S. CLS. 100, 101 AND 102).

FIRST USE 10-1-2011; IN COMMERCE 12-23-2011.
ZACHARY BELLO, EXAMINING ATTORNEY

SN 85-602,651. SHAPE TOMORROW, HOUSTON, TX. FILED 4-19-2012.



THE MARK CONSISTS OF A STICK FIGURE IMAGE OF A HUMAN WITH A TAPE-MEASURE CINCHING IN THE WAIST.

FOR PROMOTING PUBLIC AWARENESS OF OBESITY AND RELATED DISEASES AND PROMOTING ACTIVITIES AND PROJECTS FOR ADDRESSING OBESITY AND RELATED DISEASES (U.S. CLS. 100, 101 AND 102).

ZACHARY BELLO, EXAMINING ATTORNEY

CLASS 35—(Continued).

SN 85-602,707. MDPONS, INC., CUMMING, GA. FILED 4-19-2012.



THE COLOR(S) LIGHT GREEN, DARK GREEN, AND WHITE IS/ARE CLAIMED AS A FEATURE OF THE MARK.

THE MARK CONSISTS OF LIGHT GREEN TUBULAR CIRCLE WITH A DARK GREEN CENTER AND A WHITE PLUS SIGN IN THE CENTER, WITH A LIGHT GREEN DOWNWARD-POINTING ARROW ATTACHED TO THE OUTSIDE BOTTOM CENTER OF THE CIRCLE, WITH A HORIZONTAL SHADOW BELOW THE ARROW, WITH THE WORD HEALTHPONS TO THE RIGHT, WITH HEALTH IN WHITE LETTERS AND PONS IN LIGHT GREEN LETTERS.

FOR PROMOTING MEDICAL SERVICES AND HEALTH CARE PRODUCTS OF OTHERS THROUGH THE DISTRIBUTION OF DISCOUNT COUPONS AND REBATES (U.S. CLS. 100, 101 AND 102).

TASNEEM HUSSAIN, EXAMINING ATTORNEY

SN 85-602,747. DON STEVENS, INC, EAGAN, MN. FILED 4-19-2012.

DON STEVENS

THE MARK CONSISTS OF STANDARD CHARACTERS WITHOUT CLAIM TO ANY PARTICULAR FONT, STYLE, SIZE, OR COLOR.

THE NAME "DON STEVENS" DOES NOT IDENTIFY A LIVING INDIVIDUAL.

FOR WHOLESALE DISTRIBUTORSHIPS FEATURING HVAC, FOOD SERVICE AND LODGING EQUIPMENT (U.S. CLS. 100, 101 AND 102).

FIRST USE 12-31-1960; IN COMMERCE 12-31-1960.
SAMUEL E. SHARPER JR., EXAMINING ATTORNEY

SN 85-602,816. YOUR HOMETOWNE MARKETING LLC, BURNT HILLS, NY. FILED 4-19-2012.



THE MARK CONSISTS OF THE STYLIZED TEXT "YOUR HOMETOWNE IT'S ALRIGHT HERE!". THERE IS A STAR AND STRIPES IN THE O TO RESEMBLE THE AMERICAN FLAG.

FOR DIRECT MAIL ADVERTISING SERVICES (U.S. CLS. 100, 101 AND 102).

FIRST USE 4-1-2010; IN COMMERCE 4-1-2010.
KRISTIN DAHLING, EXAMINING ATTORNEY

CLASS 35—(Continued).

SN 85-602,828. HOT STONE COMMUNICATIONS, SAN RAFAEL, CA. FILED 4-19-2012.

Hot Stone Communications

THE MARK CONSISTS OF STANDARD CHARACTERS WITHOUT CLAIM TO ANY PARTICULAR FONT, STYLE, SIZE, OR COLOR.

NO CLAIM IS MADE TO THE EXCLUSIVE RIGHT TO USE "COMMUNICATIONS", APART FROM THE MARK AS SHOWN.

FOR PUBLIC RELATIONS AND ADVERTISING CONSULTANCY (U.S. CLS. 100, 101 AND 102).

FIRST USE 1-1-2009; IN COMMERCE 1-1-2009.

NICHOLAS COLEMAN, EXAMINING ATTORNEY

SN 85-602,857. ADAMS, CHANTEL, CANTON, GA. FILED 4-19-2012.

Princess Generation

THE MARK CONSISTS OF STANDARD CHARACTERS WITHOUT CLAIM TO ANY PARTICULAR FONT, STYLE, SIZE, OR COLOR.

FOR CHARITABLE SERVICES, NAMELY, ORGANIZING AND CONDUCTING VOLUNTEER PROGRAMS AND COMMUNITY SERVICE PROJECTS (U.S. CLS. 100, 101 AND 102).

RONALD MCMORROW, EXAMINING ATTORNEY

SN 85-602,926. LEGACY FRONTIERS INC., HUGO, MN. FILED 4-19-2012.

LIVING YOUR SNOW DAY

THE MARK CONSISTS OF STANDARD CHARACTERS WITHOUT CLAIM TO ANY PARTICULAR FONT, STYLE, SIZE, OR COLOR.

FOR BUSINESS MANAGEMENT CONSULTATION SERVICES FOR OTHERS IN THE FIELDS OF LEADERSHIP TALENT DEVELOPMENT SERVICES, JOB SUITABILITY ASSESSMENT SERVICES, JOB COACHING SERVICES, EMPLOYEE PRODUCTIVITY AND MOTIVATION CONSULTING SERVICES, AND CUSTOMER RELATIONSHIP MANAGEMENT ENHANCEMENT SERVICES (U.S. CLS. 100, 101 AND 102).

ELISSA GARBER KON, EXAMINING ATTORNEY

CLASS 35—(Continued).

SN 85-602,941. 360I LLC, NEW YORK, NY. FILED 4-19-2012.

PINFLUENCER

THE MARK CONSISTS OF STANDARD CHARACTERS WITHOUT CLAIM TO ANY PARTICULAR FONT, STYLE, SIZE, OR COLOR.

FOR SOCIAL MEDIA STRATEGY AND MARKETING CONSULTANCY FOCUSING ON HELPING MARKETING PROFESSIONAL CLIENTS CREATE AND EXTEND THEIR PRODUCT AND BRAND STRATEGIES BY CONNECTING THESE MARKETERS TO PERSONS WHO CURATE HYPERLINKS AND MULTIMEDIA CONTENT (U.S. CLS. 100, 101 AND 102).

ZACHARY CROMER, EXAMINING ATTORNEY

SN 85-602,967. HANDLER EXECUTIVE SEARCH, ATLANTA, GA. FILED 4-19-2012.

Career Handler The Job Search System

THE MARK CONSISTS OF STANDARD CHARACTERS WITHOUT CLAIM TO ANY PARTICULAR FONT, STYLE, SIZE, OR COLOR.

NO CLAIM IS MADE TO THE EXCLUSIVE RIGHT TO USE "CAREER" AND "JOB SEARCH SYSTEM", APART FROM THE MARK AS SHOWN.

FOR PROVIDING CAREER INFORMATION; PROVIDING EMPLOYMENT COUNSELING INFORMATION ON HOW TO SUCCESSFULLY TRANSITION JOBS (U.S. CLS. 100, 101 AND 102).

FIRST USE 1-15-2011; IN COMMERCE 9-1-2011.

CHRISIE B. KING, EXAMINING ATTORNEY

SN 85-602,976. IPAYMENT, INC., WESTLAKE VILLAGE, CA. FILED 4-19-2012.

WHERE SMALL BUSINESS & TECHNOLOGY UNITE.

THE MARK CONSISTS OF STANDARD CHARACTERS WITHOUT CLAIM TO ANY PARTICULAR FONT, STYLE, SIZE, OR COLOR.

FOR ADMINISTRATION OF A PROGRAM FOR ENABLING PARTICIPANTS TO OBTAIN DISCOUNTS ON PRODUCTS AND SERVICES; PROMOTING THE GOODS AND SERVICES OF OTHERS BY PROVIDING A WEBSITE FEATURING DISCOUNT INFORMATION ON THE GOODS AND SERVICES OF OTHERS (U.S. CLS. 100, 101 AND 102).

PAM WILLIS, EXAMINING ATTORNEY

CLASS 35—(Continued).

SN 85-603,149. THE IVY FARM INC., LOCUSTVILLE, VA. FILED 4-19-2012.

Hedges and Edges

THE MARK CONSISTS OF STANDARD CHARACTERS WITHOUT CLAIM TO ANY PARTICULAR FONT, STYLE, SIZE, OR COLOR.

FOR WHOLESALE STORE SERVICES FEATURING LIVE PLANTS (U.S. CLS. 100, 101 AND 102).
MICHAEL WIENER, EXAMINING ATTORNEY

SN 85-603,348. SOCIAL PEPPER, LLC, BEND, OR. FILED 4-20-2012.

Social Pepper

THE MARK CONSISTS OF STANDARD CHARACTERS WITHOUT CLAIM TO ANY PARTICULAR FONT, STYLE, SIZE, OR COLOR.

NO CLAIM IS MADE TO THE EXCLUSIVE RIGHT TO USE "SOCIAL", APART FROM THE MARK AS SHOWN.

FOR BUSINESS CONSULTING SERVICES IN THE FIELD OF SOCIAL MEDIA; SOCIAL MEDIA STRATEGY AND MARKETING CONSULTANCY FOCUSING ON HELPING CLIENTS CREATE AND EXTEND THEIR PRODUCT AND BRAND STRATEGIES BY BUILDING VIRALLY ENGAGING MARKETING SOLUTIONS (U.S. CLS. 100, 101 AND 102).

FIRST USE 4-13-2012; IN COMMERCE 4-13-2012.
TRACY FLETCHER, EXAMINING ATTORNEY

SN 85-603,349. SOCIAL PEPPER, LLC, BEND, OR. FILED 4-20-2012.



THE MARK CONSISTS OF A DESIGN THAT DEPICTS A SPEECH BUBBLE. WITHIN RIGHT PORTION OF THE SPEECH BUBBLE ARE FOUR SQUARES, TWO ON TOP AND TWO BELOW.

FOR BUSINESS CONSULTING SERVICES IN THE FIELD OF SOCIAL MEDIA; SOCIAL MEDIA STRATEGY AND MARKETING CONSULTANCY FOCUSING ON HELPING CLIENTS CREATE AND EXTEND THEIR PRODUCT AND BRAND STRATEGIES BY BUILDING VIRALLY ENGAGING MARKETING SOLUTIONS (U.S. CLS. 100, 101 AND 102).

FIRST USE 4-13-2012; IN COMMERCE 4-13-2012.
TRACY FLETCHER, EXAMINING ATTORNEY

CLASS 35—(Continued).

SN 85-603,394. DOMUS, INC., PHILADELPHIA, PA. FILED 4-20-2012.

NEXT

THE MARK CONSISTS OF STANDARD CHARACTERS WITHOUT CLAIM TO ANY PARTICULAR FONT, STYLE, SIZE, OR COLOR.

FOR ADVERTISING AND MARKETING CONSULTANCY (U.S. CLS. 100, 101 AND 102).
CURTIS FRENCH, EXAMINING ATTORNEY

SN 85-603,511. HIGH PLAINS WINEGROWERS, LEVELAND, TX. FILED 4-20-2012.



NO CLAIM IS MADE TO THE EXCLUSIVE RIGHT TO USE "WINEGROWERS" AND THE GEOGRAPHIC OUTLINE OF THE STATE OF TEXAS, APART FROM THE MARK AS SHOWN.

THE MARK CONSISTS OF AN OUTLINE OF THE SHAPE OF THE STATE OF TEXAS, THE RIGHT SIDE BEING FADED OUT AND THE RIGHT SIDE FURTHER BEING OVERLAID BY THE WORDS HIGH PLAINS WINEGROWERS. THE STATE OUTLINE IS OVERLAID IN ITS UPPER LEFT CORNER BY A CLUSTER OF GRAPES.

FOR ADVERTISING, MARKETING AND PROMOTION SERVICES IN THE FIELD OF VINTNERS AND WINE GROWING; ASSOCIATION SERVICES, NAMELY, PROMOTING THE INTERESTS OF VINTNERS AND WINE GROWERS; ASSOCIATION SERVICES, NAMELY, PROMOTING PUBLIC AWARENESS OF WINE GROWERS AND GRAPE QUALITY IN THE HIGH PLAINS OF TEXAS (U.S. CLS. 100, 101 AND 102).

FIRST USE 3-6-2012; IN COMMERCE 3-6-2012.
JAY FLOWERS, EXAMINING ATTORNEY

CLASS 35—(Continued).

SN 85-603,531. GOVPARTNERS, LLC, ASHBURN, VA. FILED 4-20-2012.

Prepare to win. Perform to
expand.

THE MARK CONSISTS OF STANDARD CHARACTERS WITHOUT CLAIM TO ANY PARTICULAR FONT, STYLE, SIZE, OR COLOR.

FOR CONSULTING IN THE FIELD OF PROCURING GOVERNMENT CONTRACTS FOR THE PURCHASE OF GOODS AND LABOR CONTRACTING SERVICES; PROVIDING ADVICE AND ASSISTANCE TO COMMERCIAL ENTITIES RELATING TO THE ESTABLISHMENT AND MAINTENANCE OF BUSINESS AND CONTRACTUAL RELATIONSHIPS WITH FEDERAL, STATE AND LOCAL GOVERNMENTS (U.S. CLS. 100, 101 AND 102).

FIRST USE 3-28-2012; IN COMMERCE 3-28-2012.
JOHN HWANG, EXAMINING ATTORNEY

SN 85-603,547. ELAINE T. QUINN, CHICAGO, IL. FILED 4-20-2012.

Where Smart Solos Find
Solutions

THE MARK CONSISTS OF STANDARD CHARACTERS WITHOUT CLAIM TO ANY PARTICULAR FONT, STYLE, SIZE, OR COLOR.

FOR BUSINESS ASSISTANCE, ADVISORY AND CONSULTING SERVICES IN THE FIELD OF SELF-MANAGEMENT, MOTIVATION, RESOURCE MANAGEMENT, TIME MANAGEMENT FOR SELF-EMPLOYED SOLO PROFESSIONALS; BUSINESS CONSULTING AND INFORMATION SERVICES; BUSINESS CONSULTING SERVICES, NAMELY, PROVIDING ASSISTANCE IN DEVELOPMENT OF BUSINESS STRATEGIES AND CREATIVE IDEATION; BUSINESS CONSULTING, MANAGEMENT, PLANNING AND SUPERVISION; BUSINESS DEVELOPMENT CONSULTING SERVICES; BUSINESS MANAGEMENT CONSULTING AND ADVISORY SERVICES; BUSINESS MANAGEMENT CONSULTING, STRATEGIC PLANNING AND BUSINESS ADVISORY SERVICES PROVIDED TO SELF-EMPLOYED SOLO PROFESSIONALS; BUSINESS SUPPORT SERVICES, NAMELY, BUSINESS CONSULTING TO FREELANCERS, START-UPS, EXISTING BUSINESSES AND NON-PROFIT ORGANIZATIONS; CONSULTING SERVICES IN BUSINESS LEADERSHIP DEVELOPMENT AND BUSINESS MANAGEMENT; CONSULTING SERVICES IN THE FIELD OF INTERNET MARKETING; NEW BUSINESS VENTURE DEVELOPMENT AND FORMATION CONSULTING SERVICES; PROFESSIONAL BUSINESS CONSULTING (U.S. CLS. 100, 101 AND 102).

FIRST USE 12-28-2011; IN COMMERCE 2-6-2012.
MIDGE BUTLER, EXAMINING ATTORNEY

CLASS 35—(Continued).

SN 85-603,673. POSTIFY, LLC, DAYTON, OH. FILED 4-20-2012.

POSTIFY

THE MARK CONSISTS OF STANDARD CHARACTERS WITHOUT CLAIM TO ANY PARTICULAR FONT, STYLE, SIZE, OR COLOR.

FOR ADVERTISING AND INFORMATION DISTRIBUTION SERVICES, NAMELY, PROVIDING CLASSIFIED ADVERTISING SPACE VIA THE GLOBAL COMPUTER NETWORK (U.S. CLS. 100, 101 AND 102).

MARK RADEMACHER, EXAMINING ATTORNEY

SN 85-603,754. BUOYANT CONCEPTS, INC., BOCA RATON, FL. FILED 4-20-2012.

triple dibs

THE MARK CONSISTS OF STANDARD CHARACTERS WITHOUT CLAIM TO ANY PARTICULAR FONT, STYLE, SIZE, OR COLOR.

FOR ADVERTISING AND PUBLICITY SERVICES; ADVERTISING AND PUBLICITY SERVICES, NAMELY, PROMOTING THE GOODS, SERVICES, BRAND IDENTITY AND COMMERCIAL INFORMATION AND NEWS OF THIRD PARTIES THROUGH PRINT, AUDIO, VIDEO, DIGITAL AND ON-LINE MEDIUM; ADVERTISING BY TRANSMISSION OF ON-LINE PUBLICITY FOR THIRD PARTIES THROUGH ELECTRONIC COMMUNICATIONS NETWORKS; ADVERTISING SERVICES; ON-LINE ADVERTISING AND MARKETING SERVICES; ON-LINE ADVERTISING ON COMPUTER COMMUNICATION NETWORKS; ON-LINE ADVERTISING ON COMPUTER NETWORKS; ON-LINE ADVERTISING SERVICES FOR OTHERS; ONLINE ADVERTISEMENTS; ONLINE ADVERTISING AND PROMOTIONAL SERVICES; ONLINE ADVERTISING VIA A COMPUTER COMMUNICATIONS NETWORK; PROMOTING THE SALE OF GOODS AND SERVICES OF OTHERS BY CONDUCTING ONLINE PROMOTIONAL CONTESTS; PROMOTING THE SALE OF GOODS AND SERVICES OF OTHERS THROUGH THE DISTRIBUTION OF PRINTED MATERIAL AND PROMOTIONAL CONTESTS; PROMOTING, ADVERTISING AND MARKETING OF THE BRANDS, PRODUCTS, SERVICES AND ONLINE WEBSITES OF INDIVIDUALS, BUSINESSES AND NONPROFIT ORGANIZATIONS; PROMOTING, ADVERTISING AND MARKETING ON-LINE WEBSITES OF OTHERS; PROMOTING, ADVERTISING AND MARKETING THE ON-LINE DATABASES AND ELECTRONIC PUBLICATIONS OF OTHERS; PROVIDING A SEARCHABLE ON-LINE ADVERTISING WEBSITE AND GUIDE FEATURING THE GOODS AND SERVICES OF OTHER VENDORS VIA THE INTERNET; PROVIDING A SEARCHABLE ONLINE ADVERTISING GUIDE FEATURING THE GOODS AND SERVICES OF ONLINE VENDORS; PROVIDING CONSUMER INFORMATION SERVICES AND MAKING REFERRALS IN THE FIELD OF ENTERTAINMENT SERVICES FOR PRODUCTS, SERVICES, EVENTS, ACTIVITIES, FACILITIES AND LOCATIONS (U.S. CLS. 100, 101 AND 102).

SUE LAWRENCE, EXAMINING ATTORNEY

CLASS 35—(Continued).

SN 85-603,756. AGENDA WISE, AUSTIN, TX. FILED 4-20-2012.

AgendaWise

THE MARK CONSISTS OF STANDARD CHARACTERS WITHOUT CLAIM TO ANY PARTICULAR FONT, STYLE, SIZE, OR COLOR.

FOR WEBSITE PROVIDING INFORMATION IN THE FIELD OF POLITICS, PUBLIC POLICY AND PUBLIC DISCOURSE (U.S. CLS. 100, 101 AND 102).

FIRST USE 2-2-2011; IN COMMERCE 2-2-2011.
INGA ERVIN, EXAMINING ATTORNEY

SN 85-603,795. NUBONAU, INC., ENCINITAS, CA. FILED 4-20-2012.

NUBONAU

THE MARK CONSISTS OF STANDARD CHARACTERS WITHOUT CLAIM TO ANY PARTICULAR FONT, STYLE, SIZE, OR COLOR.

OWNER OF U.S. REG. NOS. 3,839,337, 3,839,343 AND 4,080,670.

FOR ONLINE RETAIL STORE SERVICES FEATURING BATH AND BODY PRODUCTS, COSMETIC PRODUCTS, BEAUTY ACCESSORIES, CANDLES AND FRAGRANCES (U.S. CLS. 100, 101 AND 102).

FIRST USE 1-29-2010; IN COMMERCE 1-29-2010.
SANJEEV VOHRA, EXAMINING ATTORNEY

SN 85-603,798. PERUZZI PONTIAC/GMC TRUCK, INC., FAIRLESS HILLS, PA. FILED 4-20-2012.

OUR BUSINESS IS YOU!

THE MARK CONSISTS OF STANDARD CHARACTERS WITHOUT CLAIM TO ANY PARTICULAR FONT, STYLE, SIZE, OR COLOR.

FOR AUTOMOBILE DEALERSHIP SERVICES (U.S. CLS. 100, 101 AND 102).

FIRST USE 4-30-2007; IN COMMERCE 4-30-2007.
SETH A. RAPPAPORT, EXAMINING ATTORNEY

CLASS 35—(Continued).

SN 85-603,889. MOONLIGHT DIGITAL COMMUNICATIONS LLC, DBA 24G LLC, CLAWSON, MI. FILED 4-20-2012.

INTheGame

THE MARK CONSISTS OF STANDARD CHARACTERS WITHOUT CLAIM TO ANY PARTICULAR FONT, STYLE, SIZE, OR COLOR.

FOR ADVERTISING, MARKETING, AND PROMOTING THE GOODS AND SERVICES OF OTHERS VIA INTERACTIVE PHOTOGRAPHY (U.S. CLS. 100, 101 AND 102).

FIRST USE 1-11-2012; IN COMMERCE 1-11-2012.
IRA J. GOODSaid, EXAMINING ATTORNEY

SN 85-604,028. MEREDITH, RICHARD J., LAKE FOREST, CA. FILED 4-20-2012.

Der Kleiner Kampfwagens

THE MARK CONSISTS OF STANDARD CHARACTERS WITHOUT CLAIM TO ANY PARTICULAR FONT, STYLE, SIZE, OR COLOR.

THE ENGLISH TRANSLATION OF "DER KLEINER KAMPFWAGENS" IN THE MARK IS "THE LITTLE FIGHTING VEHICLES".

SEC. 2(F).

FOR ARRANGING AND CONDUCTING TRADE SHOW EXHIBITIONS IN THE FIELD OF AUTOMOBILE RACES, SHOWS AND EVENTS; ARRANGING AND CONDUCTING TRADE SHOWS IN THE FIELD OF AUTOMOBILE RACES, SHOWS AND EVENTS; CONDUCTING TRADE SHOWS IN THE FIELD OF AUTOMOBILE RACES, SHOWS AND EVENTS (U.S. CLS. 100, 101 AND 102).

FIRST USE 4-30-1977; IN COMMERCE 4-30-1977.
CHRISTINA SOBRAL, EXAMINING ATTORNEY

SN 85-604,055. CRAFT & GROWLER LLC, DALLAS, TX. FILED 4-20-2012.

CRAFT AND GROWLER

THE MARK CONSISTS OF STANDARD CHARACTERS WITHOUT CLAIM TO ANY PARTICULAR FONT, STYLE, SIZE, OR COLOR.

NO CLAIM IS MADE TO THE EXCLUSIVE RIGHT TO USE "GROWLER", APART FROM THE MARK AS SHOWN.

FOR RETAIL STORE SERVICES FEATURING GROWLERS AND GROWLER ACCESSORIES, BOTTLED BEER, BEER FOR CONSUMPTION OFF-PREMISES CONTAINED IN GROWLERS, AND BEER FOR CONSUMPTION ON-PREMISES (U.S. CLS. 100, 101 AND 102).

KATHERINE STOIDES, EXAMINING ATTORNEY

CLASS 35—(Continued).

SN 85-604,131. SARASOTA CONVENTION AND VISITORS BUREAU, INC., SARASOTA, FL. FILED 4-20-2012.

VISIT SARASOTA COUNTY

THE MARK CONSISTS OF STANDARD CHARACTERS WITHOUT CLAIM TO ANY PARTICULAR FONT, STYLE, SIZE, OR COLOR.

NO CLAIM IS MADE TO THE EXCLUSIVE RIGHT TO USE "SARASOTA COUNTY", APART FROM THE MARK AS SHOWN.

FOR CONVENTION AND VISITORS BUREAU SERVICES, NAMELY, PROMOTING TOURISM, BUSINESS AND CONVENTIONS IN AND AROUND THE SARASOTA COUNTY, FLORIDA AREA (U.S. CLS. 100, 101 AND 102).

INGA ERVIN, EXAMINING ATTORNEY

SN 85-604,168. UNITED STATES PLASTIC CORPORATION, LIMA, OH. FILED 4-20-2012.

NEATLYSMART

THE MARK CONSISTS OF STANDARD CHARACTERS WITHOUT CLAIM TO ANY PARTICULAR FONT, STYLE, SIZE, OR COLOR.

FOR RETAIL AND ONLINE RETAIL STORE SERVICES IN THE FIELD OF ORGANIZATIONAL PRODUCTS AND HOME FURNISHINGS; RETAIL AND ONLINE RETAIL STORE SERVICES FEATURING A WIDE VARIETY OF CONSUMER GOODS OF OTHERS (U.S. CLS. 100, 101 AND 102).

KAPIL BHANOT, EXAMINING ATTORNEY

SN 85-604,183. MARK SIMPSON, SCOTTSDALE, AZ. FILED 4-20-2012.

Dentist Hunters

THE MARK CONSISTS OF STANDARD CHARACTERS WITHOUT CLAIM TO ANY PARTICULAR FONT, STYLE, SIZE, OR COLOR.

NO CLAIM IS MADE TO THE EXCLUSIVE RIGHT TO USE "DENTIST", APART FROM THE MARK AS SHOWN, FOR DENTIST REFERRALS (U.S. CLS. 100, 101 AND 102).

FIRST USE 1-12-2012; IN COMMERCE 1-12-2012.
DAVID C. REIHNER, EXAMINING ATTORNEY

CLASS 35—(Continued).

SN 85-604,240. UNITED STATES PLASTIC CORPORATION, LIMA, OH. FILED 4-20-2012.



THE MARK CONSISTS OF THE WORDS NEATLY AND SMART EACH INSIDE A HORIZONTAL OBLONG SHAPE WITH ROUNDED CORNERS THAT OVERLAP, HAVING TWO VERTICAL CIRCLES IN THE CENTER.

FOR RETAIL AND ONLINE RETAIL STORE SERVICES IN THE FIELD OF ORGANIZATIONAL PRODUCTS AND HOME FURNISHINGS; RETAIL AND ONLINE RETAIL STORE SERVICES FEATURING A WIDE VARIETY OF CONSUMER GOODS OF OTHERS (U.S. CLS. 100, 101 AND 102).

KAPIL BHANOT, EXAMINING ATTORNEY

SN 85-604,306. DATAQUICK INFORMATION SYSTEMS, INC., SAN DIEGO, CA. FILED 4-20-2012.

APPRAISALQ

THE MARK CONSISTS OF STANDARD CHARACTERS WITHOUT CLAIM TO ANY PARTICULAR FONT, STYLE, SIZE, OR COLOR.

FOR COLLECTION AND COMPILATION OF INFORMATION INTO COMPUTER DATABASES IN THE FIELD OF REAL ESTATE AND REAL PROPERTY INFORMATION; PROVIDING A DATABASE FEATURING REAL PROPERTY TAX INFORMATION; PROVIDING AN ON-LINE COMPUTER DATABASE FEATURING TRADE INFORMATION IN THE FIELD OF REAL ESTATE AND REAL PROPERTY INFORMATION (U.S. CLS. 100, 101 AND 102).

FIRST USE 11-11-2011; IN COMMERCE 1-15-2012.
BRENDAN MCCAULEY, EXAMINING ATTORNEY

SN 85-604,407. TSA STORES, INC. ENGLEWOOD, CO. FILED 4-20-2012.

EVERY 4 YEARS THE WORLD COMES TOGETHER

THE MARK CONSISTS OF STANDARD CHARACTERS WITHOUT CLAIM TO ANY PARTICULAR FONT, STYLE, SIZE, OR COLOR.

FOR RETAIL SPORTING GOODS STORE SERVICES; PROMOTING THE SALE OF THE GOODS AND SERVICES OF OTHERS THROUGH THE DISTRIBUTION OF PRINTED MATERIAL (U.S. CLS. 100, 101 AND 102).

ANTHONY RINKER, EXAMINING ATTORNEY

CLASS 35—(Continued).

SN 85-604,501. MANAGEMENT AND STRATEGY INSTITUTE, LLC, DOWNTOWN, PA. FILED 4-20-2012.

Lean Black Belt Professional (LBBP)

THE MARK CONSISTS OF STANDARD CHARACTERS WITHOUT CLAIM TO ANY PARTICULAR FONT, STYLE, SIZE, OR COLOR.

NO CLAIM IS MADE TO THE EXCLUSIVE RIGHT TO USE "LEAN BLACK BELT PROFESSIONAL", APART FROM THE MARK AS SHOWN.

FOR TESTING TO DETERMINE PROFESSIONAL COMPETENCY, NAMELY, TESTING AND EVALUATING PROFESSIONALS INVOLVED IN SIX SIGMA TO DETERMINE THEIR LEVEL OF RELATED EXPERIENCE, EDUCATION AND COMPETENCY; BUSINESS SERVICES FOR OTHERS, NAMELY, CREDENTIALING INDIVIDUALS INVOLVED IN SIX SIGMA; AND BUSINESS SERVICES FOR OTHERS, NAMELY, VERIFYING AND MONITORING THE CREDENTIALS OF PROFESSIONALS IN THE FIELD OF SIX SIGMA (U.S. CLS. 100, 101 AND 102).

FIRST USE 1-14-2012; IN COMMERCE 1-14-2012.
GINA HAYES, EXAMINING ATTORNEY

SN 85-604,519. BENEPERKS, LLC, KERNERSVILLE, NC. FILED 4-20-2012.

benePerks

THE MARK CONSISTS OF STANDARD CHARACTERS WITHOUT CLAIM TO ANY PARTICULAR FONT, STYLE, SIZE, OR COLOR.

FOR ADMINISTRATION OF A PROGRAM FOR ENABLING PARTICIPANTS TO OBTAIN DISCOUNTS ON PRODUCTS AND SERVICES (U.S. CLS. 100, 101 AND 102).

FIRST USE 4-5-2012; IN COMMERCE 4-5-2012.
SANJEEV VOHRA, EXAMINING ATTORNEY

SN 85-604,546. DPITMEDIA, LLC, ANNAPOLIS, MD. FILED 4-21-2012.

CARBON FIBER IS THE NEW BLACK

THE MARK CONSISTS OF STANDARD CHARACTERS WITHOUT CLAIM TO ANY PARTICULAR FONT, STYLE, SIZE, OR COLOR.

FOR ONLINE RETAIL STORE SERVICES FEATURING CLOTHING, APPAREL AND ACCESSORIES, GENERAL CONSUMER GOODS, AND ITEMS MADE OF CARBON FIBER MATERIAL (U.S. CLS. 100, 101 AND 102).

FIRST USE 3-27-2011; IN COMMERCE 3-27-2011.
JACLYN KIDWELL WALKER, EXAMINING ATTORNEY

CLASS 35—(Continued).

SN 85-604,547. ELAINE T. QUINN, CHICAGO, IL. FILED 4-21-2012.

SMART

THE MARK CONSISTS OF STANDARD CHARACTERS WITHOUT CLAIM TO ANY PARTICULAR FONT, STYLE, SIZE, OR COLOR.

FOR PROVIDING ASSISTANCE IN THE DEVELOPMENT OF SKILLS AND TRAITS TO IMPROVE BUSINESS PRODUCTIVITY, INCLUDING SELF-MANAGEMENT, MOTIVATION, ACTION HABITS, RESOURCE MANAGEMENT AND TIME MANAGEMENT, FOR SELF-EMPLOYED SOLO PROFESSIONALS; BUSINESS ASSISTANCE, ADVISORY AND CONSULTING SERVICES IN THE FIELD OF SELF-MANAGEMENT, MOTIVATION, RESOURCE MANAGEMENT, TIME MANAGEMENT FOR SELF-EMPLOYED SOLO PROFESSIONALS; BUSINESS MANAGEMENT CONSULTING, STRATEGIC PLANNING AND BUSINESS ADVISORY SERVICES PROVIDED TO SELF-EMPLOYED SOLO PROFESSIONALS; BUSINESS CONSULTING AND INFORMATION SERVICES; BUSINESS CONSULTING SERVICES, NAMELY, PROVIDING ASSISTANCE IN DEVELOPMENT OF BUSINESS STRATEGIES AND CREATIVE IDEATION; BUSINESS CONSULTING, MANAGEMENT, PLANNING AND SUPERVISION; BUSINESS DEVELOPMENT CONSULTING SERVICES; BUSINESS MANAGEMENT CONSULTING AND ADVISORY SERVICES; BUSINESS SUPPORT SERVICES, NAMELY, BUSINESS CONSULTING TO FREELANCERS, START-UPS, EXISTING BUSINESSES AND NON-PROFIT ORGANIZATIONS; CONSULTING SERVICES IN BUSINESS LEADERSHIP DEVELOPMENT AND BUSINESS MANAGEMENT; CONSULTING SERVICES IN THE FIELD OF INTERNET MARKETING; NEW BUSINESS VENTURE DEVELOPMENT AND FORMATION CONSULTING SERVICES; PROFESSIONAL BUSINESS CONSULTING (U.S. CLS. 100, 101 AND 102).

FIRST USE 2-5-2012; IN COMMERCE 2-6-2012.
MIDGE BUTLER, EXAMINING ATTORNEY

SN 85-604,580. RANDOLPH LABIDOU, DBA POLLSTING, ORLANDO, FL. FILED 4-21-2012.

Pollsting Every question does not end with a yes or no answer

THE MARK CONSISTS OF STANDARD CHARACTERS WITHOUT CLAIM TO ANY PARTICULAR FONT, STYLE, SIZE, OR COLOR.

FOR CONDUCTING PUBLIC OPINION POLLS (U.S. CLS. 100, 101 AND 102).

ALEXANDER L. POWERS, EXAMINING ATTORNEY

CLASS 35—(Continued).

SN 85-604,641. PAUL FARKAS, NEW YORK, NY. FILED 4-21-2012.

**SOCIAL B2B THE LUXURY
COLLAB AND B2BRM**

THE MARK CONSISTS OF STANDARD CHARACTERS WITHOUT CLAIM TO ANY PARTICULAR FONT, STYLE, SIZE, OR COLOR.

NO CLAIM IS MADE TO THE EXCLUSIVE RIGHT TO USE "B2B" AND "COLLAB", APART FROM THE MARK AS SHOWN.

FOR ADVERTISING AND PROMOTION SERVICES AND RELATED CONSULTING; BUSINESS MERCHANDISING DISPLAY SERVICES; BUSINESS SERVICES, NAMELY, PROVIDING AN ONLINE NETWORK FOR CONTRACTORS TO RECEIVE LEADS AND BIDDING OPPORTUNITIES BY MEANS OF AN ONLINE MARKETPLACE FOR THE PURPOSE OF DEVELOPING BUSINESS; INTEGRATED TRACKING AND MANAGEMENT OF COMMERCIAL TRANSACTIONS ON A GLOBAL COMPUTER NETWORK; MEDIA PLANNING, NAMELY, ADVISING THE CLIENT ON THE CORRECT TIMES AND STATIONS TO ADVERTISE BASED ON MEDIA ANALYSIS OF THE MARKET FOR THAT MEDIA; ON-LINE TRADING SERVICES IN WHICH SELLER POSTS PRODUCTS TO BE AUCTIONED AND BIDDING IS DONE VIA THE INTERNET (U.S. CLS. 100, 101 AND 102).

MICHAEL WIENER, EXAMINING ATTORNEY

SN 85-604,687. JAY, JAMES RANDOLPH, BOSTON, MA. FILED 4-22-2012.

Pious Poultry

THE MARK CONSISTS OF STANDARD CHARACTERS WITHOUT CLAIM TO ANY PARTICULAR FONT, STYLE, SIZE, OR COLOR.

FOR ON-LINE RETAIL STORE SERVICES FEATURING CLOTHING, ACCESSORIES, AND PRINTED MATTER; RETAIL STORE SERVICES FEATURING CLOTHING, ACCESSORIES, AND PRINTED MATTER (U.S. CLS. 100, 101 AND 102).

FIRST USE 6-29-2011; IN COMMERCE 4-11-2012.
REBECCA SMITH, EXAMINING ATTORNEY

CLASS 35—(Continued).

SN 85-604,717. WALLACE, BILL, AUSTIN, TX. FILED 4-22-2012.

ConnectedThoughts

THE MARK CONSISTS OF STANDARD CHARACTERS WITHOUT CLAIM TO ANY PARTICULAR FONT, STYLE, SIZE, OR COLOR.

FOR BUSINESS MANAGEMENT CONSULTATION (U.S. CLS. 100, 101 AND 102).

INGRID C. EULIN, EXAMINING ATTORNEY

SN 85-604,838. GREENWALD, RYAN P, CARLSBAD, CA. FILED 4-23-2012.

FITFO

THE MARK CONSISTS OF STANDARD CHARACTERS WITHOUT CLAIM TO ANY PARTICULAR FONT, STYLE, SIZE, OR COLOR.

FOR PROVIDING A SEARCHABLE ON-LINE ADVERTISING WEBSITE AND GUIDE FEATURING THE GOODS AND SERVICES OF OTHER VENDORS VIA THE INTERNET; PROVIDING A SEARCHABLE ONLINE ADVERTISING WEBSITE AND INFORMATIONAL GUIDE FEATURING THE GOODS AND SERVICES OF OTHER VENDORS VIA THE INTERNET IN THE FIELD OF SPORTS AND EVENT TRAVEL; PROVIDING A SEARCHABLE WEBSITE FEATURING THE GOODS AND SERVICES OF OTHER VENDORS (U.S. CLS. 100, 101 AND 102).

INGRID C. EULIN, EXAMINING ATTORNEY

SN 85-604,965. DAVIS, KEVIN, NEW ORLEANS, LA. FILED 4-23-2012.

Sigma Eta Xi Inc.

THE MARK CONSISTS OF STANDARD CHARACTERS WITHOUT CLAIM TO ANY PARTICULAR FONT, STYLE, SIZE, OR COLOR.

NO CLAIM IS MADE TO THE EXCLUSIVE RIGHT TO USE "INC.", APART FROM THE MARK AS SHOWN.

FOR CHARITABLE SERVICES, NAMELY, ORGANIZING AND CONDUCTING VOLUNTEER PROGRAMS AND COMMUNITY SERVICE PROJECTS (U.S. CLS. 100, 101 AND 102).

LAURIE MAYES, EXAMINING ATTORNEY

CLASS 35—(Continued).

SN 85-605,024. GUILT FREE LIFE, LLC, GILBERT, AZ.
FILED 4-23-2012.

Build Your Stash

THE MARK CONSISTS OF STANDARD CHARACTERS WITHOUT CLAIM TO ANY PARTICULAR FONT, STYLE, SIZE, OR COLOR.

FOR ON-LINE RETAIL STORE SERVICES FEATURING LOOSE BEADS IN BULK (U.S. CLS. 100, 101 AND 102).

FIRST USE 4-2-2012; IN COMMERCE 4-2-2012.
BILL DAWE, EXAMINING ATTORNEY

SN 85-605,052. MASSACHUSETTS DENTAL SOCIETY,
SOUTHBOROUGH, MA. FILED 4-23-2012.

Your Mouth Can Say a Lot About You

THE MARK CONSISTS OF STANDARD CHARACTERS WITHOUT CLAIM TO ANY PARTICULAR FONT, STYLE, SIZE, OR COLOR.

FOR PROMOTING PUBLIC AWARENESS OF THE RELATIONSHIP BETWEEN ORAL HEALTH AND OVERALL HEALTH (U.S. CLS. 100, 101 AND 102).

FIRST USE 8-17-2009; IN COMMERCE 8-17-2009.
NATALIE POLZER, EXAMINING ATTORNEY

SN 85-605,206. HOME TEAM MARKETING, CLEVELAND,
OH. FILED 4-23-2012.

Home Team Marketing University

THE MARK CONSISTS OF STANDARD CHARACTERS WITHOUT CLAIM TO ANY PARTICULAR FONT, STYLE, SIZE, OR COLOR.

OWNER OF U.S. REG. NOS. 4,082,460, 4,092,615 AND 4,124,977.

NO CLAIM IS MADE TO THE EXCLUSIVE RIGHT TO USE "MARKETING UNIVERSITY", APART FROM THE MARK AS SHOWN.

FOR PROVIDING MARKETING SERVICES TO COLLEGES AND UNIVERSITIES BY MEANS OF SIGNAGE, PA ANNOUNCEMENTS, PROGRAM ADS AND THE LIKE PROVIDED AT HIGH SCHOOL EVENTS (U.S. CLS. 100, 101 AND 102).

FIRST USE 6-23-2011; IN COMMERCE 6-23-2011.
ANDREA K. NADELMAN, EXAMINING ATTORNEY

CLASS 35—(Continued).

SN 85-605,274. CHERE VOUGHT, COTO DE CAZA, CA.
FILED 4-23-2012.

A PLAN FOR SENIOR CARE

THE MARK CONSISTS OF STANDARD CHARACTERS WITHOUT CLAIM TO ANY PARTICULAR FONT, STYLE, SIZE, OR COLOR.

FOR REFERRAL SERVICES IN THE FIELD OF ASSISTING SENIOR CITIZENS IN THE LOCATION OF SENIOR HOUSING, ASSISTED LIVING FACILITIES, SKILLED NURSING FACILITIES, RETIREMENT LIVING, RESIDENTIAL BOARD AND CARE HOMES, SECURED MEMORY CARE FACILITIES, AND HOME CARE (U.S. CLS. 100, 101 AND 102).

GIANCARLO CASTRO, EXAMINING ATTORNEY

SN 85-605,283. CHERE VOUGHT, COTO DE CAZA, CA.
FILED 4-23-2012.

GUIDING YOU THROUGH YOUR SEARCH

THE MARK CONSISTS OF STANDARD CHARACTERS WITHOUT CLAIM TO ANY PARTICULAR FONT, STYLE, SIZE, OR COLOR.

FOR REFERRAL SERVICES IN THE FIELD OF ASSISTING SENIOR CITIZENS IN THE LOCATION OF SENIOR HOUSING, ASSISTED LIVING FACILITIES, SKILLED NURSING FACILITIES, RETIREMENT LIVING, RESIDENTIAL BOARD AND CARE HOMES, SECURED MEMORY CARE FACILITIES, AND HOME CARE (U.S. CLS. 100, 101 AND 102).

GIANCARLO CASTRO, EXAMINING ATTORNEY

SN 85-605,447. MUNCHAMERICA INC., EAST ISLIP, NY.
FILED 4-23-2012.

MUNCHAMERICA

THE MARK CONSISTS OF STANDARD CHARACTERS WITHOUT CLAIM TO ANY PARTICULAR FONT, STYLE, SIZE, OR COLOR.

FOR PROVIDING MARKETING AND PROMOTION OF SPECIAL EVENTS; ADVERTISING AND PROMOTIONAL SERVICES; PROMOTING THE GOODS AND SERVICES OF OTHERS VIA ELECTRONIC COMMUNICATIONS THAT FEATURE COUPONS, VOUCHERS, REBATES, PRICE-COMPARISON INFORMATION, PRODUCT REVIEWS, LINKS TO THE RETAIL WEBSITES OF OTHERS, AND DISCOUNT INFORMATION; ADMINISTRATION OF A CUSTOMER LOYALTY PROGRAM FOR ENABLING PARTICIPANTS TO OBTAIN UNIQUE BENEFITS AND PERKS THROUGH USE OF A MEMBERSHIP PROGRAM (U.S. CLS. 100, 101 AND 102).

MIDGE BUTLER, EXAMINING ATTORNEY

CLASS 35—(Continued).

SN 85-605,472. CASSANDRA ATHERTON, NEW YORK, NY.
FILED 4-23-2012.

La Maison Sacre

THE MARK CONSISTS OF STANDARD CHARACTERS WITHOUT CLAIM TO ANY PARTICULAR FONT, STYLE, SIZE, OR COLOR.

THE ENGLISH TRANSLATION OF "LA MAISON SACRE" IN THE MARK IS "THE SACRED HOME".

FOR RETAIL SHOPS FEATURING GIFTS AND ACCESSORIES, CRAFTS, DECORATIVE PILLOWS AND TOWELS, SHEETS, COMFORTERS, HOME FURNISHINGS, TOWELS, SHOWER CURTAINS, SCARVES, JEWELRY, BOOKS, CANDLES, BABY CLOTHING; RETAIL STORE SERVICES FEATURING GIFTS AND ACCESSORIES, CRAFTS, DECORATIVE PILLOWS AND TOWELS, SHEETS, COMFORTERS, HOME FURNISHINGS, TOWELS, SHOWER CURTAINS, SCARVES, JEWELRY, BOOKS, CANDLES, BABY CLOTHING ACCESSIBLE ON-LINE AND BY TELEPHONE, FACSIMILE AND MAIL ORDER (U.S. CLS. 100, 101 AND 102).
TRACY FLETCHER, EXAMINING ATTORNEY

SN 85-605,564. MARKETING TOOLS, LLC, OSHKOSH, WI.
FILED 4-23-2012.

PLAN AHEAD & SAVE

THE MARK CONSISTS OF STANDARD CHARACTERS WITHOUT CLAIM TO ANY PARTICULAR FONT, STYLE, SIZE, OR COLOR.

FOR CATALOG ORDERING SERVICE FEATURING GENERAL MERCHANDISE AND GENERAL CONSUMER GOODS; MAIL ORDER CATALOG SERVICES FEATURING GENERAL MERCHANDISE AND GENERAL CONSUMER GOODS; ON-LINE RETAIL STORE SERVICES FEATURING GENERAL MERCHANDISE AND GENERAL CONSUMER GOODS; PREPARATION OF CUSTOMIZED PROMOTIONAL AND MERCHANDISING MATERIALS FOR OTHERS (U.S. CLS. 100, 101 AND 102).

FIRST USE 9-1-2011; IN COMMERCE 9-1-2011.
SUE LAWRENCE, EXAMINING ATTORNEY

CLASS 35—(Continued).

SN 85-605,578. MUNCHAMERICA INC., EAST ISLIP, NY.
FILED 4-23-2012.

MUNCHMODE

THE MARK CONSISTS OF STANDARD CHARACTERS WITHOUT CLAIM TO ANY PARTICULAR FONT, STYLE, SIZE, OR COLOR.

FOR PROVIDING MARKETING AND PROMOTION OF SPECIAL EVENTS; ADVERTISING AND PROMOTIONAL SERVICES; PROMOTING THE GOODS AND SERVICES OF OTHERS VIA ELECTRONIC COMMUNICATIONS THAT FEATURE COUPONS, VOUCHERS, REBATES, PRICE-COMPARISON INFORMATION, PRODUCT REVIEWS, LINKS TO THE RETAIL WEBSITES OF OTHERS, AND DISCOUNT INFORMATION; ADMINISTRATION OF A CUSTOMER LOYALTY PROGRAM FOR ENABLING PARTICIPANTS TO OBTAIN UNIQUE BENEFITS AND PERKS THROUGH USE OF A MEMBERSHIP PROGRAM (U.S. CLS. 100, 101 AND 102).

MIDGE BUTLER, EXAMINING ATTORNEY

SN 85-605,674. SOLOHEALTH, INC., DULUTH, GA. FILED 4-23-2012.

THE FRONT PORCH OF HEALTHCARE

THE MARK CONSISTS OF STANDARD CHARACTERS WITHOUT CLAIM TO ANY PARTICULAR FONT, STYLE, SIZE, OR COLOR.

FOR ADVERTISING, MARKETING AND PROMOTING THE GOODS AND SERVICES OF HEALTH RELATED COMPANIES AND HEALTH RELATED PROFESSIONALS USING SELF-SERVICE KIOSKS (U.S. CLS. 100, 101 AND 102).

KAREN BRACEY, EXAMINING ATTORNEY

SN 85-605,685. HOWARD, DANINA, RENO, NV. FILED 4-23-2012.

HEDGEROW

THE MARK CONSISTS OF STANDARD CHARACTERS WITHOUT CLAIM TO ANY PARTICULAR FONT, STYLE, SIZE, OR COLOR.

FOR ON-LINE RETAIL STORE SERVICES FEATURING HOME GOODS AND HOME ACCESSORIES (U.S. CLS. 100, 101 AND 102).

IRA J. GOODSID, EXAMINING ATTORNEY

CLASS 35—(Continued).

SN 85-605,712. MT. WASHINGTON WOLFPACK LACROSSE CLUB FOUNDATION, INC., TOWSON, MD. FILED 4-23-2012.

Keepers of the Tradition

THE MARK CONSISTS OF STANDARD CHARACTERS WITHOUT CLAIM TO ANY PARTICULAR FONT, STYLE, SIZE, OR COLOR.

FOR ASSOCIATION SERVICES, NAMELY, PROMOTING THE INTERESTS OF THE MT. WASHINGTON WOLFPACK LACROSSE CLUB AND ITS MEMBERS (U.S. CLS. 100, 101 AND 102).

ALEXANDER L. POWERS, EXAMINING ATTORNEY

CLASS 35—(Continued).

SN 85-605,749. MEDIA SPACE, INC., HOPKINS, MN. FILED 4-23-2012.



SN 85-605,721. BAVARIAN SOUNDWERKS, LLC, ATLANTA, GA. FILED 4-23-2012.

BAVSOUND

THE MARK CONSISTS OF STANDARD CHARACTERS WITHOUT CLAIM TO ANY PARTICULAR FONT, STYLE, SIZE, OR COLOR.

FOR RETAIL STORE AND ON-LINE RETAIL STORE SERVICES FEATURING VEHICLE ELECTRONICS AND VEHICLE AUDIO EQUIPMENT (U.S. CLS. 100, 101 AND 102).

DAVID MURRAY, EXAMINING ATTORNEY

THE MARK CONSISTS OF A STYLIZED "M". FOR ADVERTISING AND MARKETING; ADVERTISING AND MARKETING CONSULTANCY (U.S. CLS. 100, 101 AND 102).

FIRST USE 2-8-2011; IN COMMERCE 2-8-2011.

KAREN BRACEY, EXAMINING ATTORNEY

SN 85-605,796. GLOBALTEL MEDIA, INC., AKA THINKCHE, INC., SAN DIEGO, CA. FILED 4-23-2012.

ThinkCHE

SN 85-605,747. BODI & ASSOCIATES, VENICE, FL. FILED 4-23-2012.

Business Beware

THE MARK CONSISTS OF STANDARD CHARACTERS WITHOUT CLAIM TO ANY PARTICULAR FONT, STYLE, SIZE, OR COLOR.

NO CLAIM IS MADE TO THE EXCLUSIVE RIGHT TO USE "BUSINESS", APART FROM THE MARK AS SHOWN.

FOR COLLECTION AND COMPILATION OF INFORMATION INTO COMPUTER DATABASES IN THE FIELD OF REVIEWS AND RECOMMENDATIONS ON CUSTOMERS FOR USE BY BUSINESSES AND BUSINESS OWNERS; PROVIDING A WEB SITE WHERE USERS CAN POST RATINGS, REVIEWS AND RECOMMENDATIONS ON EMPLOYERS AND EMPLOYEES AND PLACES OF EMPLOYMENT FOR USE BY EMPLOYEES, EMPLOYERS, BUSINESS OWNERS, AND CONSUMERS (U.S. CLS. 100, 101 AND 102).

FIRST USE 5-17-2008; IN COMMERCE 6-6-2010.

APRIL HESIK, EXAMINING ATTORNEY

THE MARK CONSISTS OF STANDARD CHARACTERS WITHOUT CLAIM TO ANY PARTICULAR FONT, STYLE, SIZE, OR COLOR.

FOR ADVERTISING AND MARKETING CONSULTANCY; ADVERTISING AND MARKETING SERVICES PROVIDED BY MEANS OF INDIRECT METHODS OF MARKETING COMMUNICATIONS, NAMELY, SOCIAL MEDIA, SEARCH ENGINE MARKETING, INQUIRY MARKETING, INTERNET MARKETING, MOBILE MARKETING, BLOGGING AND OTHER FORMS OF PASSIVE, SHARABLE OR VIRAL COMMUNICATIONS CHANNELS; BRANDING SERVICES, NAMELY, CONSULTING, DEVELOPMENT, MANAGEMENT AND MARKETING OF BRANDS FOR BUSINESSES; PUBLIC RELATIONS (U.S. CLS. 100, 101 AND 102).

SUNG IN, EXAMINING ATTORNEY

CLASS 35—(Continued).

SN 85-605,805. CANNON, JR., JOHN, MOUNT LAUREL, NJ. FILED 4-23-2012.



THE MARK CONSISTS OF A HOUSE SHAPED AS STRAIGHT-EDGED RAZOR WITH AN "A-FRAMED" ROOF. BELOW THERE IS THE STYLIZED TEXT "HOME". FOR RETAIL STORE SERVICES FEATURING T-SHIRTS, SWEAT-SHIRTS, JEANS AND OTHER APPAREL ACCESSORIES (U.S. CLS. 100, 101 AND 102).
ROBERT STRUCK, EXAMINING ATTORNEY

SN 85-605,809. BOOKS-A-MILLION, INC., BIRMINGHAM, AL. FILED 4-23-2012.

MILLIONAIRE'S CLUB

THE MARK CONSISTS OF STANDARD CHARACTERS WITHOUT CLAIM TO ANY PARTICULAR FONT, STYLE, SIZE, OR COLOR.
OWNER OF U.S. REG. NO. 2,051,736.
FOR CUSTOMER LOYALTY SERVICES AND CUSTOMER CLUB SERVICES, FOR COMMERCIAL, PROMOTIONAL AND/OR ADVERTISING PURPOSES (U.S. CLS. 100, 101 AND 102).
FIRST USE 3-31-1988; IN COMMERCE 5-31-1988.
AMEEN IMAM, EXAMINING ATTORNEY

CLASS 35—(Continued).

SN 85-605,811. JTM INDUSTRIES, COEUR D ALENE, ID. FILED 4-23-2012.

JTM Industries

THE MARK CONSISTS OF STANDARD CHARACTERS WITHOUT CLAIM TO ANY PARTICULAR FONT, STYLE, SIZE, OR COLOR.
NO CLAIM IS MADE TO THE EXCLUSIVE RIGHT TO USE "INDUSTRIES", APART FROM THE MARK AS SHOWN.
THE NAME(S), PORTRAIT(S), AND/OR SIGNATURE(S) SHOWN IN THE MARK DOES NOT IDENTIFY A PARTICULAR LIVING INDIVIDUAL.
FOR RETAIL STORE SERVICES FEATURING SIGNS, BANNERS, AUTO PARTS AND ACCESSORIES THEREOF; MOTORCYCLE PARTS AND ACCESSORIES THEREOF; WHOLESALE STORE SERVICES FEATURING SIGNS, BANNERS, AUTO PARTS AND ACCESSORIES THEREOF, MOTORCYCLE PARTS AND ACCESSORIES THEREOF (U.S. CLS. 100, 101 AND 102).
DAVID HOFFMAN, EXAMINING ATTORNEY

SN 85-605,818. JTM INDUSTRIES, COEUR D ALENE, ID. FILED 4-23-2012.



NO CLAIM IS MADE TO THE EXCLUSIVE RIGHT TO USE "INDUSTRIES", APART FROM THE MARK AS SHOWN.
THE NAME(S), PORTRAIT(S), AND/OR SIGNATURE(S) SHOWN IN THE MARK DOES NOT IDENTIFY A PARTICULAR LIVING INDIVIDUAL.
THE COLOR(S) BLACK, RED, GRAY AND WHITE IS/ARE CLAIMED AS A FEATURE OF THE MARK.
THE MARK CONSISTS OF THE WORDING "JTM" IN STYLIZED FONT AND IN THE COLOR OF RED WITH SHADING IN THE COLOR OF GRAY. DIRECTLY BELOW THE CHARACTERS "TM" WITHIN THE WORDING "JTM" IS THE WORDING "INDUSTRIES" IN STYLIZED FONT AND IN THE COLOR OF WHITE WITH AN OUTLINE IN THE COLOR OF BLACK. THE BACKGROUND COLOR BLACK IS NOT CLAIMED AS A FEATURE OF THE MARK.
FOR RETAIL STORE SERVICES FEATURING SIGNS, BANNERS, AUTO PARTS AND ACCESSORIES THEREOF; MOTORCYCLE PARTS AND ACCESSORIES THEREOF; WHOLESALE STORE SERVICES FEATURING SIGNS, BANNERS, AUTO PARTS AND ACCESSORIES THEREOF, MOTORCYCLE PARTS AND ACCESSORIES THEREOF (U.S. CLS. 100, 101 AND 102).
DAVID HOFFMAN, EXAMINING ATTORNEY

CLASS 35—(Continued).

SN 85-605,828. THINKEDU, CARROLLTON, TX. FILED 4-23-2012.

Thinkedu

THE MARK CONSISTS OF STANDARD CHARACTERS WITHOUT CLAIM TO ANY PARTICULAR FONT, STYLE, SIZE, OR COLOR.

FOR ON-LINE RETAIL STORE SERVICES FEATURING ACADEMIC COMPUTER SOFTWARE, COMPUTER ACCESSORIES, AND BOOKS (U.S. CLS. 100, 101 AND 102).

MARK RADEMACHER, EXAMINING ATTORNEY

CLASS 35—(Continued).

SN 85-607,243. HELD, JACOB, WOODMERE, NY. FILED 4-24-2012.

izak

THE MARK CONSISTS OF THE STYLIZED TEXT "IZAK". FOR MARKETING CONSULTING (U.S. CLS. 100, 101 AND 102).

JANET LEE, EXAMINING ATTORNEY

SN 85-605,905. SORAGENT, SCOTT ANTHONY, DBA VALUEPON, GLENDALE, CA. FILED 4-23-2012.

VALUEPON

THE MARK CONSISTS OF STANDARD CHARACTERS WITHOUT CLAIM TO ANY PARTICULAR FONT, STYLE, SIZE, OR COLOR.

FOR PROMOTING THE GOODS AND SERVICES OF OTHERS BY PROVIDING A WEBSITE FEATURING COUPONS, REBATES, PRICE-COMPARISON INFORMATION, PRODUCT REVIEWS, LINKS TO THE RETAIL WEBSITES OF OTHERS, AND DISCOUNT INFORMATION (U.S. CLS. 100, 101 AND 102).

KATHERINE M. DUBRAY, EXAMINING ATTORNEY

SN 85-607,267. LOIS DITOMMASO, NORTHRIDGE, CA. FILED 4-24-2012.

Manic Monday

THE MARK CONSISTS OF STANDARD CHARACTERS WITHOUT CLAIM TO ANY PARTICULAR FONT, STYLE, SIZE, OR COLOR.

FOR ON-LINE RETAIL STORE IN THE FIELD OF CLOTHING AND FASHION WEAR ACCESSORIES (U.S. CLS. 100, 101 AND 102).

CARYN GLASSER, EXAMINING ATTORNEY

SN 85-607,001. LIGHTDALE LLC, SANTA MONICA, CA. FILED 4-24-2012.

LIGHTDALE

THE MARK CONSISTS OF STANDARD CHARACTERS WITHOUT CLAIM TO ANY PARTICULAR FONT, STYLE, SIZE, OR COLOR.

FOR STRATEGIC MARKETING SERVICES (U.S. CLS. 100, 101 AND 102).

ANTHONY RINKER, EXAMINING ATTORNEY

SN 85-608,369. WEINSTEIN, JOSHUA, LOS ANGELES, CA. FILED 4-25-2012.

Respect  Renters
www.respectrenters.com

THE MARK CONSISTS OF THE STYLIZED TEXT "RESPECT RENTERS" WITH AN IMAGE OF A HOUSE BETWEEN THE WORDS. A HORIZONTAL LINE EXTENDS FROM THE BASE OF THE HOUSE TO THE RIGHT AND LEFT, UNDER BOTH WORDS. BELOW THE LINE IS THE STYLIZED TEXT "WWW.RESPECTRENTERS.COM".

FOR PROMOTING PUBLIC AWARENESS OF THE RIGHTS OF RENTERS; PUBLIC ADVOCACY TO PROMOTE AWARENESS OF THE RIGHTS OF RENTERS (U.S. CLS. 100, 101 AND 102).

THOMAS MANOR, EXAMINING ATTORNEY

CLASS 35—(Continued).

SN 85-610,382. NATIONAL FEDERATION OF STATE HIGH SCHOOL ASSOCIATIONS, INDIANAPOLIS, IN. FILED 4-27-2012.

NATIONAL FEDERATION OF
HIGH SCHOOLS

THE MARK CONSISTS OF STANDARD CHARACTERS WITHOUT CLAIM TO ANY PARTICULAR FONT, STYLE, SIZE, OR COLOR.

OWNER OF U.S. REG. NOS. 3,119,209 AND 3,119,275. SEC. 2(F).
FOR PROMOTING AND ENCOURAGING PHYSICAL FITNESS PROGRAMS, AMATEUR SPORTS PARTICIPATION AND ATHLETIC PROGRAMS AT THE HIGH SCHOOL LEVEL (U.S. CLS. 100, 101 AND 102).
JANET LEE, EXAMINING ATTORNEY

CLASS 35—(Continued).

SN 85-613,740. DATAQUICK INFORMATION SYSTEMS, INC., SAN DIEGO, CA. FILED 5-1-2012.

PORTFOLIOQ

THE MARK CONSISTS OF STANDARD CHARACTERS WITHOUT CLAIM TO ANY PARTICULAR FONT, STYLE, SIZE, OR COLOR.

FOR BUSINESS RISK ASSESSMENT SERVICES; BUSINESS RISK MANAGEMENT; BUSINESS RISK MANAGEMENT CONSULTATION; COLLECTION AND COMPILATION OF INFORMATION INTO COMPUTER DATABASES IN THE FIELD OF REAL ESTATE AND REAL PROPERTY LIEN RISK INFORMATION AND ANALYSIS; FINANCIAL RECORD-KEEPING FOR REAL ESTATE AND REAL PROPERTY LIEN RISK INFORMATION AND ANALYSIS; PROVIDING A DATABASE FEATURING REAL PROPERTY TAX INFORMATION; PROVIDING AN ON-LINE COMPUTER DATABASE FEATURING TRADE INFORMATION IN THE FIELD OF REAL ESTATE AND REAL PROPERTY LIEN RISK INFORMATION AND ANALYSIS; TAX LIEN MANAGEMENT SERVICES (U.S. CLS. 100, 101 AND 102).

FIRST USE 3-12-2012; IN COMMERCE 3-19-2012.
BRENDAN MCCAULEY, EXAMINING ATTORNEY

SN 85-610,677. NEW LIFE INDUSTRIES, INC., SOMERSET, KY. FILED 4-27-2012.

NEWLIFE

THE MARK CONSISTS OF STANDARD CHARACTERS WITHOUT CLAIM TO ANY PARTICULAR FONT, STYLE, SIZE, OR COLOR.

OWNER OF U.S. REG. NO. 3,343,088.
FOR ONLINE RETAIL STORE SERVICES FEATURING IMPRINTED T-SHIRTS (U.S. CLS. 100, 101 AND 102).
FIRST USE 9-16-1983; IN COMMERCE 9-16-1983.
RONALD DELGIZZI, EXAMINING ATTORNEY

SN 85-615,188. DICKENS BOOKS, LTD., MILWAUKEE, WI. FILED 5-2-2012.

KNOWLEDGEBLOCKS

THE MARK CONSISTS OF STANDARD CHARACTERS WITHOUT CLAIM TO ANY PARTICULAR FONT, STYLE, SIZE, OR COLOR.

FOR PROVIDING AN INTERACTIVE WEBSITE FEATURING EDUCATIONAL INFORMATION IN THE FIELD OF BUSINESS (U.S. CLS. 100, 101 AND 102).
FIRST USE 5-21-2012; IN COMMERCE 5-21-2012.
EMILY CHUO, EXAMINING ATTORNEY

CLASS 35—(Continued).

SN 85-618,517. ARTHUR WILLIAMS INDUSTRIES LLC, CINCINNATI, OH. FILED 5-7-2012.

ArthurWilliams Industries

THE MARK CONSISTS OF STANDARD CHARACTERS WITHOUT CLAIM TO ANY PARTICULAR FONT, STYLE, SIZE, OR COLOR.

OWNER OF U.S. REG. NO. 3,368,073.

NO CLAIM IS MADE TO THE EXCLUSIVE RIGHT TO USE "INDUSTRIES", APART FROM THE MARK AS SHOWN.

THE NAME(S), PORTRAIT(S), AND/OR SIGNATURE(S) SHOWN IN THE MARK DOES NOT IDENTIFY A PARTICULAR LIVING INDIVIDUAL.

FOR DISTRIBUTORSHIP SERVICES AND MANUFACTURER'S REPRESENTATIVE SERVICES IN THE FIELDS OF PLASTIC BAGS, JANITORIAL SUPPLIES, SHELVING, MERCHANDISE RACKS, STORE FIXTURES AND COOLING FANS (U.S. CLS. 100, 101 AND 102).

FIRST USE 6-30-2011; IN COMMERCE 6-30-2011.

ANNE FARRELL, EXAMINING ATTORNEY

SN 85-619,828. T-MOBILE USA, INC., BELLEVUE, WA. FILED 5-8-2012.



THE MARK CONSISTS OF THE LETTER "M" FASHIONED TO RESEMBLE TWO MUSICAL NOTES SUPERIMPOSED OVER A ROUGHLY OVAL OBJECT WITH A LIGHTLY SHADED BORDER AROUND THE CIRCUMFERENCE OF THE OVAL AND A DARKER SHADED INTERIOR.

FOR ONLINE RETAIL STORE SERVICES FEATURING DOWNLOADABLE MOBILE TELECOMMUNICATIONS DEVICE SOFTWARE FOR RECEIVING AND PLAYING STREAMED AUDIO CONTENT, NAMELY, STREAMED MUSIC AND SPOKEN WORD CONTENT; ONLINE RETAIL STORE SERVICES FEATURING DOWNLOADABLE MOBILE TELECOMMUNICATIONS DEVICE SOFTWARE FOR SAMPLING AND IDENTIFYING AMBIENT AUDIO CONTENT; ONLINE RETAIL STORE SERVICES FEATURING RINGBACK TONE SERVICES (U.S. CLS. 100, 101 AND 102).

FIRST USE 4-4-2012; IN COMMERCE 4-4-2012.

CATHERINE ROEHL, EXAMINING ATTORNEY

CLASS 35—(Continued).

SN 85-620,755. BED BATH & BEYOND PROCUREMENT CO. INC., FARMINGDALE, NY. FILED 5-9-2012.

BUCKS BOOKS & BEYOND

THE MARK CONSISTS OF STANDARD CHARACTERS WITHOUT CLAIM TO ANY PARTICULAR FONT, STYLE, SIZE, OR COLOR.

FOR PROMOTING THE SALE OF GOODS AND SERVICES OF OTHERS THROUGH THE DISTRIBUTION OF PRINTED MATERIAL AND PROMOTIONAL CONTESTS (U.S. CLS. 100, 101 AND 102).

FIRST USE 7-3-2012; IN COMMERCE 7-3-2012.

DOUGLAS LEE, EXAMINING ATTORNEY

SN 85-622,037. PAUL FARKAS, NEW YORK, NY. FILED 5-10-2012.

**SOCIAL LUXURY UNLOCK
EXPERIENCE AND EXCLUSIVES**

THE MARK CONSISTS OF STANDARD CHARACTERS WITHOUT CLAIM TO ANY PARTICULAR FONT, STYLE, SIZE, OR COLOR.

NO CLAIM IS MADE TO THE EXCLUSIVE RIGHT TO USE "LUXURY", APART FROM THE MARK AS SHOWN.

FOR BUSINESS MERCHANDISING DISPLAY SERVICES; BUSINESS NETWORKING OF PEER TO PEER LEARNING GROUPS OF HIGH NET WORTH INDIVIDUALS; COMPUTERIZED ON-LINE GIFT ORDERING SERVICE WHICH MATCHES THE GIFT GIVER'S REQUIREMENTS WITH THE GIFT RECIPIENT'S WANTS AND NEEDS; MOBILE VENDING IN THE FIELD OF HIGH END FASHION ACCESSORIES AND LUXURY CONSUMER PRODUCTS AND GOODS; ON-LINE AUCTION SERVICES IN WHICH BUYERS WHO DONATE TO CHARITY RECEIVE ADDITIONAL BIDDING RIGHTS; PROMOTING THE SALE OF CREDIT CARD ACCOUNTS THROUGH THE ADMINISTRATION OF INCENTIVE AWARD PROGRAMS; PROMOTION OF BUSINESS OPPORTUNITIES; PROVIDING A WEB SITE THAT FEATURES AN ON-LINE MARKET FOR USERS TO LIST OFFERED OR WANTED PERSONAL AND BUSINESS ASSETS AND SKILLS FOR HIRE, RENT, SALE OR AUCTION TRANSACTED ON THE BASIS OF PREDEFINED PERFORMANCE AND CLOSING TERMS AND CONDITIONS; PROVIDING A WEB-BASED SYSTEM AND ONLINE PORTALS IN THE FIELD OF CONSUMER-TO-BUSINESS COMMERCE FOR CONSUMERS TO ENTER, MANAGE AND MODIFY THEIR CONSUMER PREFERENCE INFORMATION FOR USE BY MERCHANTS TO CREATE AND MANAGE OFFERS FOR DELIVERY TO CONSUMERS; PROVIDING INDEPENDENT RATINGS AND REVIEWS OF OTHER BUSINESSES FOR COMMERCIAL PURPOSES; PROVISION OF ADVERTISING SPACE BY ELECTRONIC MEANS AND GLOBAL INFORMATION NETWORKS; SALES PROMOTION FOR OTHERS PROVIDED THROUGH THE DISTRIBUTION AND THE ADMINISTRATION OF PRIVILEGED USER CARDS; SPECIAL EVENT PLANNING FOR BUSINESS PURPOSES (U.S. CLS. 100, 101 AND 102).

MICHAEL WIENER, EXAMINING ATTORNEY

CLASS 35—(Continued).

SN 85-622,260. BETTERPOWER INC., OKLAHOMA CITY, OK. FILED 5-10-2012.

powerdoctor

THE MARK CONSISTS OF STANDARD CHARACTERS WITHOUT CLAIM TO ANY PARTICULAR FONT, STYLE, SIZE, OR COLOR.

FOR RETAIL STORE SERVICES FEATURING BATTERIES, POWER SUPPLIES, CABLING, AND POWER DISTRIBUTION ITEMS; WHOLESALE STORE SERVICES FEATURING BATTERIES, POWER SUPPLIES, CABLING, AND POWER DISTRIBUTION ITEMS (U.S. CLS. 100, 101 AND 102).

DAVID COLLIER, EXAMINING ATTORNEY



SN 85-622,972. SMARTY HAD A PARTY, LLC, ST. LOUIS, MO. FILED 5-11-2012.

SMARTY

THE MARK CONSISTS OF STANDARD CHARACTERS WITHOUT CLAIM TO ANY PARTICULAR FONT, STYLE, SIZE, OR COLOR.

OWNER OF U.S. REG. NO. 3,777,476.
FOR ON-LINE RETAIL STORE SERVICES FEATURING CATERING AND ENTERTAINMENT SUPPLIES (U.S. CLS. 100, 101 AND 102).

MARGERY A. TIERNEY, EXAMINING ATTORNEY

CLASS 35—(Continued).

SN 85-623,018. SMARTY HAD A PARTY, LLC, ST. LOUIS, MO. FILED 5-11-2012.

SMARTYWARE

THE MARK CONSISTS OF STANDARD CHARACTERS WITHOUT CLAIM TO ANY PARTICULAR FONT, STYLE, SIZE, OR COLOR.

OWNER OF U.S. REG. NO. 3,777,476.
FOR ON-LINE RETAIL STORE SERVICES FEATURING CATERING AND ENTERTAINMENT SUPPLIES, PARTY SUPPLIES, DISPOSABLE DINNERWARE, CATERING SUPPLIES, DISPOSABLE CATERING SUPPLIES, CHAIR COVERS, DISPOSABLE CHAIR COVERS, CLOTH CHAIR COVERS, CHAIR SASHES, CHAIR BOWS, COCKTAIL GLASSES, WINE GLASSES, CHAMPAGNE GLASSES, GLASS TOASTING FLUTES, MARTINI GLASSES, PUNCH ACCESSORIES, DISPOSABLE GLASSES, DISPOSAL CHAMPAGNE FLUTES, COFFEE MUGS, DISPOSABLE COFFEE MUGS, CUPS AND TUMBLERS, DISPOSABLE CUPS AND TUMBLERS, FLATWARE, FORKS, SPOONS, KNIVES, DISPOSABLE FLATWARE, DINNERWARE, DISHES, PLATES, BOWLS, DISPOSABLE DISHWARE, NAPKINS, CLOTH NAPKINS, DISPOSABLE NAPKINS, NAPKIN RINGS, CHAIFAIT DISHES, DESERT DISHES, DISPOSABLE SOUP DISHES, DISPOSABLE SALAD BOWLS, SOUP BOWLS, SALAD BOWLS, TABLE LINENS, TABLECLOTHS, TABLECLOTH OVERLAYS, TABLE RUNNERS, TABLE SKIRTS, PLASTIC TABLECLOTHS, RESTAURANT WARE, DISPOSABLE TABLECLOTHS, CAKE STANDS, CAKE TOPPERS, CANDLES, CANDLE HOLDERS, FLOWERS, FAUX FLOWERS, FAUX FLOWER PETALS, SALT SHAKERS, PEPPER SHAKERS, TIARAS, HAIR JEWELRY, PUNCH FOUNTAINS, ALUMINUM PANS, GUEST BOOKS, PICTURE FRAMES, GLASS VASES, SHOT GLASSES, PEN SETS, FLOWER BASKETS, WEDDING GIFTS, HOSTESS GIFTS, BRIDESMAIDS GIFTS, WEDDING ACCESSORIES, RING PILLOWS, GIFT CARD HOLDERS, TABLE FOUNTAINS, CENTERPIECES, DESERT DECORATING PRODUCTS, DESSERT DECORATING ACCESSORIES (U.S. CLS. 100, 101 AND 102).

MARGERY A. TIERNEY, EXAMINING ATTORNEY



SN 85-623,071. SMARTY HAD A PARTY, LLC, ST. LOUIS, MO. FILED 5-11-2012.

SMARTIER

THE MARK CONSISTS OF STANDARD CHARACTERS WITHOUT CLAIM TO ANY PARTICULAR FONT, STYLE, SIZE, OR COLOR.

OWNER OF U.S. REG. NO. 3,777,476.
FOR ON-LINE RETAIL STORE SERVICES FEATURING CATERING AND ENTERTAINMENT SUPPLIES (U.S. CLS. 100, 101 AND 102).

MARGERY A. TIERNEY, EXAMINING ATTORNEY

CLASS 35—(Continued).

SN 85-623,115. SMARTY HAD A PARTY, LLC, ST. LOUIS, MO. FILED 5-11-2012.

SMARTIEST

THE MARK CONSISTS OF STANDARD CHARACTERS WITHOUT CLAIM TO ANY PARTICULAR FONT, STYLE, SIZE, OR COLOR.

OWNER OF U.S. REG. NO. 3,777,476.
FOR ON-LINE RETAIL STORE SERVICES FEATURING CATERING AND ENTERTAINMENT SUPPLIES (U.S. CLS. 100, 101 AND 102).

MARGERY A. TIERNEY, EXAMINING ATTORNEY

SN 85-623,196. SCION TECHNOLOGIES, LLC, MASON, OH. FILED 5-11-2012.

CELEBRITYMOBILE

THE MARK CONSISTS OF STANDARD CHARACTERS WITHOUT CLAIM TO ANY PARTICULAR FONT, STYLE, SIZE, OR COLOR.

FOR ADVERTISING, MARKETING, AND PROMOTING THE GOODS AND SERVICES OF OTHERS BY DISTRIBUTING ADVERTISING MATERIAL, COUPONS AND DISCOUNT OFFERS VIA TEXT MESSAGING, SMS MESSAGING, MULTIMEDIA MESSAGING, INTERACTIVE VOICE RESPONSE TECHNOLOGY AND MOBILE INTERACTIVE MEDIA (U.S. CLS. 100, 101 AND 102).

KATHERINE E. HALMEN, EXAMINING ATTORNEY

SN 85-623,969. PAUL FARKAS, NEW YORK, NY. FILED 5-14-2012.

ULN SHOE WEEK

THE MARK CONSISTS OF STANDARD CHARACTERS WITHOUT CLAIM TO ANY PARTICULAR FONT, STYLE, SIZE, OR COLOR.

NO CLAIM IS MADE TO THE EXCLUSIVE RIGHT TO USE "SHOE WEEK", APART FROM THE MARK AS SHOWN.

FOR CUSTOMER LOYALTY SERVICES AND CUSTOMER CLUB SERVICES, FOR COMMERCIAL, PROMOTIONAL AND/OR ADVERTISING PURPOSES; FASHION SHOW EXHIBITIONS FOR COMMERCIAL PURPOSES; ONLINE SERVICE FOR CONNECTING SOCIAL NETWORK USERS WITH RETAILERS FOR THE PURPOSE OF FACILITATING DISCOUNTED PURCHASES; ORGANIZATION OF FASHION SHOWS FOR COMMERCIAL PURPOSES (U.S. CLS. 100, 101 AND 102).

MICHAEL WIENER, EXAMINING ATTORNEY

CLASS 35—(Continued).

SN 85-624,470. CLIMATE MASTER, INC., OKLAHOMA CITY, OK. FILED 5-14-2012.

GEOELITE

THE MARK CONSISTS OF STANDARD CHARACTERS WITHOUT CLAIM TO ANY PARTICULAR FONT, STYLE, SIZE, OR COLOR.

FOR INDEPENDENT SALES REPRESENTATIVES IN THE FIELD OF HEATING AND COOLING SYSTEMS (U.S. CLS. 100, 101 AND 102).

LESLIE RICHARDS, EXAMINING ATTORNEY

SN 85-628,012. AOL INC., DULLES, VA. FILED 5-17-2012.

FISHBOWL LABS

THE MARK CONSISTS OF STANDARD CHARACTERS WITHOUT CLAIM TO ANY PARTICULAR FONT, STYLE, SIZE, OR COLOR.

FOR BUSINESS DEVELOPMENT SERVICES, NAMELY, PROVIDING START-UP SUPPORT FOR BUSINESSES OF OTHERS; INCUBATION SERVICES, NAMELY, PROVIDING WORK SPACE CONTAINING BUSINESS EQUIPMENT TO ENTREPRENEURS, FREELANCERS, START-UPS, AND EXISTING BUSINESSES (U.S. CLS. 100, 101 AND 102).

ALLISON HOLTZ, EXAMINING ATTORNEY

SN 85-630,049. PAUL FARKAS, NEW YORK, NY. FILED 5-19-2012.

ULN HANDBAG AND SHOE LOUNGE

THE MARK CONSISTS OF STANDARD CHARACTERS WITHOUT CLAIM TO ANY PARTICULAR FONT, STYLE, SIZE, OR COLOR.

NO CLAIM IS MADE TO THE EXCLUSIVE RIGHT TO USE "HANDBAG AND SHOE", APART FROM THE MARK AS SHOWN.

FOR ADVERTISING, MARKETING AND PROMOTING THE GOODS AND SERVICES OF OTHERS USING KIOSKS; CONTESTS AND INCENTIVE AWARD PROGRAMS TO PROMOTE THE SALE OF PRODUCTS AND SERVICES OF OTHERS; FASHION SHOW EXHIBITIONS FOR COMMERCIAL PURPOSES; ORGANIZING, PROMOTING AND CONDUCTING EXHIBITIONS, TRADESHOWS AND EVENTS FOR BUSINESS PURPOSES; PREPARING AUDIOVISUAL DISPLAYS IN THE FIELD OF FASHION ADVERTISING; RETAIL SHOP-IN-SHOP STORE SERVICES FEATURING HIGH-END FASHION ACCESSORIES AND LUXURY CONSUMER PRODUCTS AND GOODS (U.S. CLS. 100, 101 AND 102).

MICHAEL WIENER, EXAMINING ATTORNEY

CLASS 35—(Continued).

SN 85-630,074. PAUL FARKAS, NEW YORK, NY. FILED 5-20-2012.

**DAILY HEELS AND COLORED
SOLES**

THE MARK CONSISTS OF STANDARD CHARACTERS WITHOUT CLAIM TO ANY PARTICULAR FONT, STYLE, SIZE, OR COLOR.

NO CLAIM IS MADE TO THE EXCLUSIVE RIGHT TO USE "HEELS AND COLORED SOLES", APART FROM THE MARK AS SHOWN.

FOR ADVERTISING AND MARKETING; CUSTOMER LOYALTY SERVICES AND CUSTOMER CLUB SERVICES, FOR COMMERCIAL, PROMOTIONAL AND/OR ADVERTISING PURPOSES; FASHION SHOW EXHIBITIONS FOR COMMERCIAL PURPOSES; ONLINE SERVICE FOR CONNECTING SOCIAL NETWORK USERS WITH RETAILERS FOR THE PURPOSE OF FACILITATING DISCOUNTED PURCHASES; OPERATING AN ON-LINE SHOPPING SITE IN THE FIELD OF HIGH END FASHION ACCESSORIES AND LUXURY CONSUMER PRODUCTS AND GOODS; PROMOTING THE GOODS AND SERVICES OF OTHERS BY PROVIDING A WEBSITE FEATURING FLASH LUXURY LIFESTYLE OFFERS; RETAIL DISCOUNT STORE SERVICES IN THE FIELD OF HIGH-END FASHION ACCESSORIES AND LUXURY CONSUMER PRODUCTS AND GOODS (U.S. CLS. 100, 101 AND 102).

MICHAEL WIENER, EXAMINING ATTORNEY

SN 85-632,428. PAUL FARKAS, NEW YORK, NY. FILED 5-22-2012.

**DAILY HEELS SQUEALS AND
BRANDTEXTUAL GEOGIVEAWAYS**

THE MARK CONSISTS OF STANDARD CHARACTERS WITHOUT CLAIM TO ANY PARTICULAR FONT, STYLE, SIZE, OR COLOR.

NO CLAIM IS MADE TO THE EXCLUSIVE RIGHT TO USE "HEELS", APART FROM THE MARK AS SHOWN.

FOR MOBILE RETAIL STORE SERVICES FEATURING HIGH-END FASHION ACCESSORIES AND LUXURY CONSUMER PRODUCTS AND GOODS; ONLINE SERVICE FOR CONNECTING SOCIAL NETWORK USERS WITH RETAILERS FOR THE PURPOSE OF FACILITATING DISCOUNTED PURCHASES; OPERATING AN ON-LINE SHOPPING SITE IN THE FIELD OF HIGH-END FASHION ACCESSORIES AND LUXURY CONSUMER PRODUCTS AND GOODS; PROMOTING THE GOODS AND SERVICES OF OTHERS BY PROVIDING A WEBSITE FEATURING FLASH LUXURY LIFESTYLE OFFERS; PROVIDING INCENTIVE AWARD PROGRAMS FOR CUSTOMERS THROUGH ISSUANCE AND PROCESSING OF LOYALTY POINTS FOR ON-LINE PURCHASE OF COMPANY'S GOODS AND SERVICES (U.S. CLS. 100, 101 AND 102).

MICHAEL WIENER, EXAMINING ATTORNEY

CLASS 35—(Continued).

SN 85-640,795. I AM OTHER ENTERTAINMENT, LLC, NEW YORK, NY. FILED 6-1-2012.

I AM OTHER

THE MARK CONSISTS OF STANDARD CHARACTERS WITHOUT CLAIM TO ANY PARTICULAR FONT, STYLE, SIZE, OR COLOR.

FOR ON-LINE ORDERING SERVICES AND ON-LINE RETAIL STORE SERVICES, ELECTRONIC RETAILING SERVICES VIA COMPUTERS, AND RETAIL STORE SERVICES AVAILABLE THROUGH COMPUTER COMMUNICATIONS, ALL OF THE AFORESAID FEATURING RECORDED PRODUCT, MUSIC RELATED ITEMS, CLOTHING AND ACCESSORIES THEREFOR, PRINTED PROMOTIONAL MATTER SUCH AS POSTERS, BOOKS, AUDIO BOOKS, AND PUBLICATIONS, AND NOVELTY ITEMS; MANAGEMENT OF MUSICAL ARTISTS; PROMOTING THE CONCERTS OF OTHERS; PROMOTION OF LIVE AND RECORDED MUSICAL PERFORMANCES VIA ELECTRONIC, PRINT, AUDIO OR VISUAL MEDIA (U.S. CLS. 100, 101 AND 102).

DAVID MURRAY, EXAMINING ATTORNEY

SN 85-648,901. TERILLION, INC., ALPINE, UT. FILED 6-11-2012.



THE COLOR(S) BLUE IS/ARE CLAIMED AS A FEATURE OF THE MARK.

THE MARK CONSISTS OF FIVE BLUE CHECK MARKS ARRANGED TO CREATE A STAR WITH FIVE POINTS, REPRESENTING THE TERILLION STAR.

FOR CONSUMER SURVEY SERVICES; PROVIDING INDEPENDENT RATINGS AND REVIEWS OF OTHER BUSINESSES FOR COMMERCIAL PURPOSES (U.S. CLS. 100, 101 AND 102).

FIRST USE 4-11-2012; IN COMMERCE 4-11-2012.
BARBARA GAYNOR, EXAMINING ATTORNEY

CLASS 35—(Continued).

SN 85-649,711. MT. WASHINGTON WOLFPACK LACROSSE CLUB FOUNDATION, INC., TOWSON, MD. FILED 6-12-2012.

For the Glory of the Game

THE MARK CONSISTS OF STANDARD CHARACTERS WITHOUT CLAIM TO ANY PARTICULAR FONT, STYLE, SIZE, OR COLOR.

FOR ASSOCIATION SERVICES, NAMELY, PROMOTING THE INTERESTS OF THE MT. WASHINGTON WOLFPACK LACROSSE CLUB AND ITS MEMBERS (U.S. CLS. 100, 101 AND 102).

ALEXANDER L. POWERS, EXAMINING ATTORNEY



SN 85-654,272. NINE WEST DEVELOPMENT CORPORATION, WILMINGTON, DE. FILED 6-18-2012.

EASY INSIDERS

THE MARK CONSISTS OF STANDARD CHARACTERS WITHOUT CLAIM TO ANY PARTICULAR FONT, STYLE, SIZE, OR COLOR.

OWNER OF U.S. REG. NOS. 2,061,593 AND 2,927,864. FOR ON-LINE BUYERS GUIDE SERVICE PROVIDING INFORMATION IN THE FIELD OF FOOTWEAR; ON-LINE RETAIL STORE SERVICES FEATURING FOOTWEAR (U.S. CLS. 100, 101 AND 102).

TINA MAI, EXAMINING ATTORNEY



SN 85-656,683. RAIRICK, DAVID M., MARS HILL, NC. FILED 6-20-2012.

DEALBURGLAR

THE MARK CONSISTS OF STANDARD CHARACTERS WITHOUT CLAIM TO ANY PARTICULAR FONT, STYLE, SIZE, OR COLOR.

FOR PROVIDING ON-LINE AUCTION SERVICES (U.S. CLS. 100, 101 AND 102).

CARYN GLASSER, EXAMINING ATTORNEY

CLASS 35—(Continued).

SN 85-656,708. RAIRICK, DAVID M., MARS HILL, NC. FILED 6-20-2012.

DEALBURGLAR.COM

THE MARK CONSISTS OF STANDARD CHARACTERS WITHOUT CLAIM TO ANY PARTICULAR FONT, STYLE, SIZE, OR COLOR.

FOR PROVIDING ON-LINE AUCTION SERVICES (U.S. CLS. 100, 101 AND 102).

CARYN GLASSER, EXAMINING ATTORNEY



SN 85-656,741. RAIRICK, DAVID M., MARS HILL, NC. FILED 6-20-2012.



THE MARK CONSISTS OF "DEAL" APPEARS STACKED ON TOP OF "BURGLAR" IN A STYLIZED FORM.

FOR PROVIDING ON-LINE AUCTION SERVICES (U.S. CLS. 100, 101 AND 102).

CARYN GLASSER, EXAMINING ATTORNEY



SN 85-656,758. RAIRICK, DAVID M., MARS HILL, NC. FILED 6-20-2012.



THE MARK CONSISTS OF "DEAL" STACKED ON TOP OF "BURGLAR.COM" IN A STYLIZED FORM.

FOR PROVIDING ON-LINE AUCTION SERVICES (U.S. CLS. 100, 101 AND 102).

CARYN GLASSER, EXAMINING ATTORNEY

CLASS 35—(Continued).

SN 85-656,789. RAIRICK, DAVID M., MARS HILL, NC. FILED 6-20-2012.

DEALBURGLAR

THE MARK CONSISTS OF "DEALBURGLAR" IN A STYLIZED FORMAT.
FOR PROVIDING ON-LINE AUCTION SERVICES (U.S. CLS. 100, 101 AND 102).
CARYN GLASSER, EXAMINING ATTORNEY

CLASS 35—(Continued).

SN 85-665,330. ORDER BAND SAW BLADES LLC, HOUSTON, TX. FILED 6-29-2012.

We've Got Flex Appeal

THE MARK CONSISTS OF STANDARD CHARACTERS WITHOUT CLAIM TO ANY PARTICULAR FONT, STYLE, SIZE, OR COLOR.
FOR DISTRIBUTORSHIP SERVICES IN THE FIELD OF BAND SAW BLADES (U.S. CLS. 100, 101 AND 102).
FIRST USE 6-1-2011; IN COMMERCE 6-1-2011.
PATRICIA EVANKO, EXAMINING ATTORNEY

SN 85-656,828. RAIRICK, DAVID M., MARS HILL, NC. FILED 6-20-2012.

DEALBURGLAR.COM

THE MARK CONSISTS OF "DEALBURGLAR.COM" IN A STYLIZED FORMAT.
FOR PROVIDING ON-LINE AUCTION SERVICES (U.S. CLS. 100, 101 AND 102).
CARYN GLASSER, EXAMINING ATTORNEY

SN 85-675,260. WKI HOLDING COMPANY, INC., ROSEMONT, IL. FILED 7-12-2012.

COOKING MADE EASY

THE MARK CONSISTS OF STANDARD CHARACTERS WITHOUT CLAIM TO ANY PARTICULAR FONT, STYLE, SIZE, OR COLOR.
FOR RETAIL STORE SERVICES FEATURING HOUSEWARES, KITCHENWARE, BAKEWARE, COOKWARE, DINNERWARE, TABLEWARE, SERVING WARE AND FOOD AND HOUSEHOLD STORAGE PRODUCTS (U.S. CLS. 100, 101 AND 102).
KRISTIN DAHLING, EXAMINING ATTORNEY

SN 85-658,354. HOT TOPIC MERCHANDISING, INC., CITY OF INDUSTRY, CA. FILED 6-21-2012.

TORRID

OWNER OF U.S. REG. NOS. 2,589,762, 3,425,796 AND OTHERS.
THE MARK CONSISTS OF THE WORD "TORRID" IN STYLIZED FORMAT.
FOR RETAIL STORE SERVICES FEATURING CLOTHING, DENIM, BAGS, SHOES, FASHION ACCESSORIES, JEWELRY, COSMETICS, PERFUME, LINGERIE, SWIMWEAR, SCARVES, HATS, HAIR GOODS, NOVELTY GOODS, AND GIFTS (U.S. CLS. 100, 101 AND 102).
FIRST USE 6-1-2011; IN COMMERCE 8-1-2011.
MAYUR VAGHANI, EXAMINING ATTORNEY

SN 85-684,537. AMERICA'S DRIVE-IN BRAND PROPERTIES LLC, OKLAHOMA CITY, OK. FILED 7-23-2012.

MY SONIC

THE MARK CONSISTS OF STANDARD CHARACTERS WITHOUT CLAIM TO ANY PARTICULAR FONT, STYLE, SIZE, OR COLOR.
OWNER OF U.S. REG. NOS. 776,766, 3,007,979 AND 3,088,615.
FOR CUSTOMER LOYALTY SERVICES AND CUSTOMER CLUB SERVICES, FOR COMMERCIAL, PROMOTIONAL AND/OR ADVERTISING PURPOSES (U.S. CLS. 100, 101 AND 102).
JOHN E. MICHOS, EXAMINING ATTORNEY

CLASS 36—INSURANCE AND FINANCIAL

SN 76-627,103. ING BANK, FSB, WILMINGTON, DE. FILED 1-7-2005.

ORANGE CHECKING ACCOUNT

THE MARK CONSISTS OF STANDARD CHARACTERS WITHOUT CLAIM TO ANY PARTICULAR FONT, STYLE, SIZE, OR COLOR.

NO CLAIM IS MADE TO THE EXCLUSIVE RIGHT TO USE "CHECKING ACCOUNT", APART FROM THE MARK AS SHOWN.

FOR BANKING SERVICES; ON-LINE BANKING SERVICES; CHECKING ACCOUNT SERVICES (U.S. CLS. 100, 101 AND 102).

CHARLES L. JENKINS, EXAMINING ATTORNEY

SN 76-708,210. SABMD, LLC, MANASSAS, VA. FILED 7-1-2011.



NO CLAIM IS MADE TO THE EXCLUSIVE RIGHT TO USE "DIRECT CAR FINANCING", APART FROM THE MARK AS SHOWN.

THE COLOR(S) BLACK AND ORANGE IS/ARE CLAIMED AS A FEATURE OF THE MARK.

THE MARK CONSISTS OF THE OUTLINE OF A CAR IN THE COLOR BLACK. UNDERNEATH THE OUTLINE OF THE CAR IS THE STYLIZED WORDING "DIRECTCARFINANCING". THE WORD "DIRECT" APPEARS IN THE COLOR BLACK, AND THE WORDING "CARFINANCING" APPEARS IN THE COLOR ORANGE. UNDERNEATH THE WORDING IS THE MIRRORED REFLECTION OF THE WORDING.

FOR AUTOMOBILE LEASE FINANCING; FINANCING RELATED TO AUTOMOBILES (U.S. CLS. 100, 101 AND 102).

MARCIE MILONE, EXAMINING ATTORNEY

SN 77-629,551. PEOPLE'S UNITED BANK, BRIDGEPORT, CT. FILED 12-9-2008.

Commercial Finance

NO CLAIM IS MADE TO THE EXCLUSIVE RIGHT TO USE "COMMERCIAL FINANCE" AND "BANK", APART FROM THE MARK AS SHOWN.

THE MARK CONSISTS OF THE WORDS "COMMERCIAL FINANCE" ABOVE THE WORDS "PEOPLE'S UNITED BANK", WITH AN OVAL SHAPE BEHIND THE WORDS "PEOPLE'S UNITED".

FOR FINANCING SERVICES (U.S. CLS. 100, 101 AND 102).

APRIL HESIK, EXAMINING ATTORNEY

CLASS 36—(Continued).

SN 77-629,575. PEOPLE'S UNITED BANK, BRIDGEPORT, CT. FILED 12-9-2008.

Institutional Trust

NO CLAIM IS MADE TO THE EXCLUSIVE RIGHT TO USE "INSTITUTIONAL TRUST" AND "BANK", APART FROM THE MARK AS SHOWN.

THE MARK CONSISTS OF THE WORDS "INSTITUTIONAL TRUST" ABOVE THE WORDS "PEOPLE'S UNITED BANK", WITH AN OVAL SHAPE BEHIND THE WORDS "PEOPLE'S UNITED".

FOR FINANCIAL SERVICES, NAMELY, TRUST AND ASSET MANAGEMENT SERVICES PROVIDED TO CORPORATIONS, NON-PROFIT ORGANIZATIONS AND MUNICIPALITIES (U.S. CLS. 100, 101 AND 102).

APRIL HESIK, EXAMINING ATTORNEY

SN 77-629,594. PEOPLE'S UNITED BANK, BRIDGEPORT, CT. FILED 12-9-2008.

International Trade

NO CLAIM IS MADE TO THE EXCLUSIVE RIGHT TO USE "INTERNATIONAL TRADE" AND "BANK", APART FROM THE MARK AS SHOWN.

THE MARK CONSISTS OF THE WORDS "INTERNATIONAL TRADE" ABOVE THE WORDS "PEOPLE'S UNITED BANK", WITH AN OVAL SHAPE BEHIND THE WORDS "PEOPLE'S UNITED".

FOR FINANCIAL SERVICES, NAMELY, ISSUANCE OF LETTERS OF CREDIT; INTERNATIONAL COLLECTIONS FINANCE, NAMELY, THE SETTLING OF INTERNATIONAL AND COMMERCIAL TRANSACTIONS THROUGH OBTAINING THE PROCEEDS OF A SALE IN CASH OR IN EXCHANGE FOR FORMAL DEBT INSTRUCTIONS (U.S. CLS. 100, 101 AND 102).

APRIL HESIK, EXAMINING ATTORNEY

CLASS 36—(Continued).

SN 77-922,523. ZETA TAU ALPHA FOUNDATION, INC., INDIANAPOLIS, IN. FILED 1-28-2010.

THINK PINK

THE MARK CONSISTS OF STANDARD CHARACTERS WITHOUT CLAIM TO ANY PARTICULAR FONT, STYLE, SIZE, OR COLOR.

OWNER OF U.S. REG. NO. 2,809,724.

FOR CHARITABLE FUNDRAISING; CHARITABLE FUNDRAISING SERVICES BY MEANS OF ORGANIZING AND CONDUCTING SPECIAL EVENTS; CHARITABLE SERVICES, NAMELY, ORGANIZING FUNDRAISING SERVICES AND EVENTS TO RAISE FUNDS IN THE FIELD OF BREAST CANCER AWARENESS, EDUCATION AND RESEARCH (U.S. CLS. 100, 101 AND 102).

FIRST USE 0-0-1997; IN COMMERCE 0-0-1997.
SUSAN STIGLITZ, EXAMINING ATTORNEY

SN 79-092,075. KABUSHIKI KAISHA CHIBA GINKO (THE CHIBA BANK, LTD.), JAPAN, FILED 12-2-2010.

千葉銀行

OWNER OF INTERNATIONAL REGISTRATION 1063762 DATED 12-2-2010, EXPIRES 12-2-2020.

THE MARK CONSISTS OF JAPANESE KANJI CHARACTERS THAT MEAN "CHIBA BANK".

THE NON-LATIN CHARACTERS IN THE MARK TRANSLITERATE TO "CHIBA GINKO" AND THIS MEANS "CHIBA BANK" IN ENGLISH.

SEC. 2(F).

FOR BANKING SERVICES, NAMELY, ACCEPTANCE OF DEPOSITS AND ACCEPTANCE OF FIXED INTERVAL INSTALLMENT DEPOSITS; LOAN FINANCING AND DISCOUNT OF BILLS; DOMESTIC EXCHANGE SETTLEMENT, NAMELY, MONETARY EXCHANGE, MONETARY EXCHANGE OPERATIONS; SECURITY SERVICES, NAMELY, GUARANTEEING LOANS IN THE NATURE OF LIABILITY GUARANTEE AND ACCEPTANCE OF BILLS; SECURITIES LENDING; ACQUISITION AND TRANSFER OF MONETARY CLAIMS; SAFE DEPOSIT SERVICES, NAMELY, SAFEKEEPING OF VALUABLES INCLUDING SECURITIES AND PRECIOUS METALS; MONEY EXCHANGE; TRUSTEE SERVICES IN THE NATURE OF TRUSTEESHIP OF FINANCIAL FUTURES CONTRACTS; AGENCIES FOR BOND SUBSCRIPTIONS; FOREIGN EXCHANGE

CLASS 36—(Continued).

TRANSACTIONS; LETTER-OF-CREDIT RELATED SERVICES, NAMELY, ISSUING LETTERS OF CREDIT; TRADING IN SECURITIES, NAMELY, BUYING AND SELLING OF SECURITIES; TRADING OF SECURITIES INDEX FUTURES; TRADING OF SECURITIES OPTIONS; TRADING OF OVERSEAS MARKET SECURITIES FUTURES; AGENCIES OR BROKERAGE FOR TRADING OF SECURITIES, SECURITIES INDEX FUTURES, SECURITIES OPTIONS, AND OVERSEAS MARKET SECURITIES FUTURE; AGENCIES OR BROKERAGE FOR ENTRUSTING AGENTS WITH ON-COMMISSION TRADING IN DOMESTIC MARKETS OF SECURITIES, SECURITIES INDEX FUTURES AND SECURITIES OPTIONS; AGENCIES OR BROKERAGE FOR ENTRUSTING AGENTS WITH ON-COMMISSION TRADING IN OVERSEAS MARKETS OF SECURITIES, AND SECURITIES INDEX FUTURES; SECURITIES UNDERWRITING; ISSUANCE OF SECURITIES BEING FINANCIAL INVESTMENT SERVICES, NAMELY, TRANSACTION OF SECURITIES SUBSCRIPTION AND OFFERING (U.S. CLS. 100, 101 AND 102).

LEIGH LOWRY, EXAMINING ATTORNEY

SN 79-093,168. KABUSHIKI KAISHA CHIBA GINKO (THE CHIBA BANK, LTD.), JAPAN, FILED 12-14-2010.

OWNER OF INTERNATIONAL REGISTRATION 1066731 DATED 12-14-2010, EXPIRES 12-14-2020.

THE COLOR(S) RED IS/ARE CLAIMED AS A FEATURE OF THE MARK.

THE MARK CONSISTS OF RED JAPANESE HIRAGANA CHARACTERS THAT MEAN "CHIBA BANK".

THE NON-LATIN CHARACTERS IN THE MARK TRANSLITERATE TO "CHIBAGIN" AND THIS MEANS "CHIBA BANK" IN ENGLISH.

SEC. 2(F).

FOR BANKING SERVICES, NAMELY, ACCEPTANCE OF DEPOSITS AND ACCEPTANCE OF FIXED INTERVAL INSTALLMENT DEPOSITS; LOAN FINANCING AND DISCOUNT OF BILLS; DOMESTIC EXCHANGE SETTLEMENT, NAMELY, MONETARY EXCHANGE, MONETARY EXCHANGE OPERATIONS; SECURITY SERVICES, NAMELY, GUARANTEEING LOANS IN THE NATURE OF LIABILITY GUARANTEE AND ACCEPTANCE OF BILLS; SECURITIES LENDING; ACQUISITION AND TRANSFER OF MONETARY CLAIMS; SAFE DEPOSIT SERVICES, NAMELY, SAFEKEEPING OF VALUABLES INCLUDING SECURITIES AND PRECIOUS METALS; MONEY EXCHANGE; TRUSTEE SERVICES IN THE NATURE OF TRUSTEESHIP OF FINANCIAL FUTURES CONTRACTS; AGENCIES FOR BOND SUBSCRIPTIONS; FOREIGN EXCHANGE TRANSACTIONS; LETTER-OF-CREDIT RELATED SERVICES, NAMELY, ISSUING LETTERS OF CREDIT; TRADING IN SECURITIES, NAMELY, BUYING AND SELLING OF SECURITIES; TRADING OF SECURITIES INDEX FUTURES; TRADING OF SECURITIES OPTIONS; TRADING OF OVERSEAS MARKET SECURITIES FUTURES; AGENCIES OR BROKERAGE FOR TRADING OF SECURITIES, SECURITIES INDEX FUTURES, SECURITIES OPTIONS, AND OVERSEAS MARKET SECURITIES FUTURE; AGENCIES OR BROKERAGE FOR ENTRUSTING AGENTS WITH ON-COMMISSION TRADING IN DOMESTIC MARKETS OF SECURITIES, SECURITIES INDEX FUTURES AND SECURITIES OPTIONS; AGENCIES OR BROKERAGE FOR ENTRUSTING AGENTS WITH ON-COMMISSION TRADING IN OVERSEAS MARKETS OF SECURITIES, AND SECURITIES INDEX FUTURES; SECURITIES UNDERWRITING; ISSUANCE OF SECURITIES BEING FINANCIAL INVESTMENT SERVICES, NAMELY, TRANSACTION OF SECURITIES SUBSCRIPTION AND OFFERING (U.S. CLS. 100, 101 AND 102).

LEIGH LOWRY, EXAMINING ATTORNEY

CLASS 36—(Continued).

SN 79-105,499. BARCLAYS BANK PLC, LONDON E14 5HP, UNITED KINGDOM, FILED 10-12-2011.

BARCLAYS PING IT

THE MARK CONSISTS OF STANDARD CHARACTERS WITHOUT CLAIM TO ANY PARTICULAR FONT, STYLE, SIZE, OR COLOR.

PRIORITY DATE OF 10-5-2011 IS CLAIMED.

OWNER OF INTERNATIONAL REGISTRATION 1097585 DATED 10-12-2011, EXPIRES 10-12-2021.

OWNER OF U.S. REG. NOS. 3,049,848, 3,724,221 AND OTHERS.

FOR FINANCIAL SERVICES, NAMELY, PROVIDING ELECTRONIC PROCESSING OF ELECTRONIC FUNDS TRANSFER, ELECTRONIC CHECK AND ELECTRONIC PAYMENTS; PEER TO PEER PAYMENT SERVICES, NAMELY, PROVIDING SECURE MONETARY TRANSACTIONS AND PAYMENT OPTIONS; FUNDS TRANSFER SERVICES, NAMELY, ELECTRONIC TRANSFER OF MONEY; CREDIT CARD, CHARGE CARD, CASH CARD, CHEQUE GUARANTEE CARD, PURCHASE, PAYMENT AND DEBIT CARD SERVICES; PROVISION OF FINANCE, MONEY EXCHANGE AND MONEY TRANSMISSION SERVICES, NAMELY, MONEY TRANSFER; CREDIT, DISCOUNT AND LOYALTY CARD SERVICES; PROVIDING SECURE MONETARY TRANSACTIONS AND PAYMENT OPTIONS, NAMELY, CONSUMER TO BUSINESS PAYMENT SERVICES (U.S. CLS. 100, 101 AND 102).

BENJAMIN OKEKE, EXAMINING ATTORNEY

CLASS 36—(Continued).

SN 79-110,264. MAN GROUP PLC, UNITED KINGDOM, FILED 12-19-2011.

WATERSIGHT

THE MARK CONSISTS OF STANDARD CHARACTERS WITHOUT CLAIM TO ANY PARTICULAR FONT, STYLE, SIZE, OR COLOR.

PRIORITY DATE OF 11-22-2011 IS CLAIMED.

OWNER OF INTERNATIONAL REGISTRATION 1109582 DATED 12-19-2011, EXPIRES 12-19-2021.

FOR FINANCIAL SERVICES, NAMELY, FINANCIAL EVALUATION, PROVIDING FINANCIAL INFORMATION, FINANCIAL MANAGEMENT CONSULTANCY AND BANKING MANAGEMENT; INVESTMENT SERVICES, NAMELY, COMMODITY INVESTMENT ADVICE; INVESTMENT FUND MANAGEMENT, NAMELY, MANAGEMENT OF MUTUAL FUNDS AND CAPITAL INVESTMENT FUNDS; MANAGEMENT AND CREATION OF INVESTMENT PRODUCTS IN THE NATURE OF FINANCIAL SERVICES, NAMELY, ESTABLISHING AND MANAGING MUTUAL AND CAPITAL INVESTMENT FUNDS FOR OTHERS; CONDUCTING DERIVATIVES TRANSACTIONS IN THE FIELDS OF BANKING, FINANCE AND INVESTMENTS, NAMELY, THE TRADING OF FINANCIAL INSTRUMENTS, SECURITIES, SHARES, OPTIONS AND OTHER DERIVATIVE PRODUCTS; QUOTATION OF STOCK EXCHANGE PRICES; PROVIDING INFORMATION, ADVISORY AND CONSULTANCY SERVICES RELATING TO THE AFORESAID SERVICES, NAMELY, FINANCIAL ADVISORY AND CONSULTANCY SERVICES IN THE FIELDS OF BANKING, FINANCE AND INVESTMENTS, ALL PROVIDED ON-LINE FROM A COMPUTER DATABASE AND FROM THE INTERNET (U.S. CLS. 100, 101 AND 102).

LINDA LAVACHE, EXAMINING ATTORNEY

SN 79-109,107. GARD AS, N-4836 ARENDAL, NORWAY, FILED 11-24-2011.



PRIORITY DATE OF 11-14-2011 IS CLAIMED.
OWNER OF INTERNATIONAL REGISTRATION 1106714 DATED 11-24-2011, EXPIRES 11-24-2021.

THE COLOR(S) BLUE, WHITE AND BLACK IS/ARE CLAIMED AS A FEATURE OF THE MARK.

THE MARK CONSISTS OF A WHITE LINK INSIDE OF A BLUE OVAL AND THE WORDING "GARD" IN BLACK.

FOR INSURANCE OPERATIONS FOR MARINE INSURANCE, NAMELY, INSURANCE CLAIMS PROCESSING, INSURANCE AGENCIES, AND INSURANCE UNDERWRITING (U.S. CLS. 100, 101 AND 102).

APRIL ROACH, EXAMINING ATTORNEY

SN 85-101,692. GALLERY OF HOMES INTERNATIONAL, LLC, LAKE MARY, FL. FILED 8-6-2010.

Gallery of Homes Premier Properties

THE MARK CONSISTS OF STANDARD CHARACTERS WITHOUT CLAIM TO ANY PARTICULAR FONT, STYLE, SIZE, OR COLOR.

OWNER OF U.S. REG. NOS. 948,080, 1,206,486 AND 1,206,487.

NO CLAIM IS MADE TO THE EXCLUSIVE RIGHT TO USE "HOMES" AND "PREMIER PROPERTIES", APART FROM THE MARK AS SHOWN.

FOR REAL ESTATE BROKERAGE (U.S. CLS. 100, 101 AND 102).

FIRST USE 8-1-2010; IN COMMERCE 8-1-2010.

MICHELLE DUBOIS, EXAMINING ATTORNEY

CLASS 36—(Continued).

SN 85-101,713. GALLERY OF HOMES INTERNATIONAL, LLC, LAKE MARY, FL. FILED 8-6-2010.

Gallery of Homes

THE MARK CONSISTS OF STANDARD CHARACTERS WITHOUT CLAIM TO ANY PARTICULAR FONT, STYLE, SIZE, OR COLOR.

OWNER OF U.S. REG. NOS. 948,080, 1,206,486 AND 1,206,487.

NO CLAIM IS MADE TO THE EXCLUSIVE RIGHT TO USE "HOMES", APART FROM THE MARK AS SHOWN.

FOR REAL ESTATE BROKERAGE (U.S. CLS. 100, 101 AND 102).

FIRST USE 8-6-2010; IN COMMERCE 8-6-2010.
MICHELLE DUBOIS, EXAMINING ATTORNEY

SN 85-108,267. GALLERY OF HOMES INTERNATIONAL, LLC, LAKE MARY, FL. FILED 8-16-2010.



OWNER OF U.S. REG. NOS. 948,080, 1,206,486 AND 1,206,487.

NO CLAIM IS MADE TO THE EXCLUSIVE RIGHT TO USE "HOMES", APART FROM THE MARK AS SHOWN.

THE COLOR(S) GRAY, BLUE, BLACK AND WHITE IS/ARE CLAIMED AS A FEATURE OF THE MARK.

THE MARK CONSISTS OF THE LANGUAGE "GALLERY OF HOMES" IN BLUE WITH GRAY SHADING, AND AN OUTLINE OF A HOUSE IN BLUE WITH GRAY SHADING WITH A BLACK AND GRAY ROOF, ALL CONTAINING WHITE HIGHLIGHTS. THE INTERIOR OF THE HOUSE IS TRANSPARENT.

FOR REAL ESTATE BROKERAGE (U.S. CLS. 100, 101 AND 102).

FIRST USE 8-6-2010; IN COMMERCE 8-6-2010.
MICHELLE DUBOIS, EXAMINING ATTORNEY

SN 85-108,329. GALLERY OF HOMES INTERNATIONAL, LLC, LAKE MARY, FL. FILED 8-16-2010.



OWNER OF U.S. REG. NOS. 948,080, 1,206,486 AND 1,206,487.

NO CLAIM IS MADE TO THE EXCLUSIVE RIGHT TO USE "HOMES" AND "PREMIER PROPERTIES", APART FROM THE MARK AS SHOWN.

THE COLOR(S) GREEN, GREENISH-BLUE, BEIGE, BURGUNDY, GRAY, AND WHITE IS/ARE CLAIMED AS A FEATURE OF THE MARK.

THE MARK CONSISTS OF WHEEL CONTAINING

CLASS 36—(Continued).

BLOCKS OF COLORS WITH A SMALLER WHEEL INSIDE THE BIGGER ONE. THE BLOCKS OF COLOR ARE VARIOUS SHADES OF GREEN, GREENISH-BLUE, BEIGE, BURGUNDY, GRAY AND WHITE, WITH WHITE OUTLINING. INSIDE BOTH WHEELS IS A BEIGE HOUSE WITH GREEN ROOF AND GRAY DOOR, ALL APPEARING ON A GRAY CIRCULAR BACKGROUND. TO THE RIGHT OF THE WHEEL IS THE LANGUAGE "GALLERY OF HOMES PREMIER PROPERTIES". "GALLERY OF HOMES" IS IN A GREENISH-BLUE COLOR WHILE "PREMIER PROPERTIES" IS IN A BURGUNDY COLOR.

FOR REAL ESTATE BROKERAGE (U.S. CLS. 100, 101 AND 102).

FIRST USE 8-6-2010; IN COMMERCE 8-6-2010.
MICHELLE DUBOIS, EXAMINING ATTORNEY

SN 85-228,557. SET FOR LIFE FINANCIAL, LLC, CHANDLER, AZ. FILED 1-28-2011.

SET FOR LIFE

THE MARK CONSISTS OF STANDARD CHARACTERS WITHOUT CLAIM TO ANY PARTICULAR FONT, STYLE, SIZE, OR COLOR.

FOR BANKING SERVICES, NAMELY, PROVIDING ELECTRONIC PROCESSING OF PREPAID DEBIT, ACH, CREDIT CARD, CHECK, MERCHANT TRANSACTIONS VIA A GLOBAL COMPUTER NETWORK; ON-LINE BANKING SERVICES, NAMELY, PROVIDING MOBILE AND WEB-BASED ACCESS TO AND MANAGEMENT OF USER ACCOUNTS, MONEY TRANSFER SERVICES, AND BILL PAY SERVICES VIA A GLOBAL COMPUTER NETWORK (U.S. CLS. 100, 101 AND 102).

FIRST USE 9-0-2008; IN COMMERCE 9-0-2008.
SCOTT BIBB, EXAMINING ATTORNEY

SN 85-252,205. HOVG, LLC, DBA BAY AREA CREDIT SERVICE, LLC, ANTIOCH, CA. FILED 2-25-2011.

Bay Area Credit Service

THE MARK CONSISTS OF STANDARD CHARACTERS WITHOUT CLAIM TO ANY PARTICULAR FONT, STYLE, SIZE, OR COLOR.

NO CLAIM IS MADE TO THE EXCLUSIVE RIGHT TO USE "CREDIT SERVICE", APART FROM THE MARK AS SHOWN.

SEC. 2(F).

FOR FINANCIAL SERVICES, NAMELY ASSET RECEIVABLE MANAGEMENT, INCLUDING FIRST AND THIRD-PARTY DEBT COLLECTIONS (U.S. CLS. 100, 101 AND 102).

FIRST USE 10-29-2003; IN COMMERCE 10-29-2003.
CHARISMA HAMPTON, EXAMINING ATTORNEY

CLASS 36—(Continued).

SN 85-262,654. DEVYNE INTERVENTION, INC., ATLANTA, GA. FILED 3-9-2011.

POWER OF MUSIC CHANGES LIVES

THE MARK CONSISTS OF STANDARD CHARACTERS WITHOUT CLAIM TO ANY PARTICULAR FONT, STYLE, SIZE, OR COLOR.

FOR CHARITABLE SERVICES PERTAINING TO THE INTERESTS AND WELL-BEING OF CHILDREN, NAMELY THE PRODUCTION OF FUNDRAISING ACTIVITIES, SPECIAL EVENTS, MUSICAL CONCERTS FOR THE PURPOSE OF RAISING FUNDS WHICH ENABLE FINANCIALLY, PHYSICALLY, EMOTIONALLY AND EDUCATIONALLY DISADVANTAGED CHILDREN TO ATTEND SUMMER CAMPS AND SPECIAL ACTIVITIES DESIGNED SPECIFICALLY FOR THE NEEDS OF THE CHILDREN CONCERNED (U.S. CLS. 100, 101 AND 102).

DEZMONA MIZELLE, EXAMINING ATTORNEY

SN 85-288,545. ZAARLY, INC., SAN FRANCISCO, CA. FILED 4-7-2011.

Z A A R L Y

THE MARK CONSISTS OF STANDARD CHARACTERS WITHOUT CLAIM TO ANY PARTICULAR FONT, STYLE, SIZE, OR COLOR.

FOR PROVIDING ON-LINE COMPUTER DATABASES AND ON-LINE SEARCHABLE DATABASES FEATURING INFORMATION, CLASSIFIED LISTINGS AND ANNOUNCEMENTS ABOUT HOUSING, APARTMENTS, CONDOMINIUMS, TOWN HOMES, REAL ESTATE, COMMERCIAL REAL ESTATE, ROOMMATE-WANTED, AND RENTAL AND LEASING AND CLASSIFIED LISTINGS FOR THE FORGOING; ELECTRONIC COMMERCE PAYMENT SERVICES, NAMELY, PROCESSING PAYMENTS FOR THE PURCHASE OF GOODS AND SERVICES VIA AN ELECTRONIC COMMUNICATIONS NETWORK; FINANCIAL SERVICES, NAMELY, ELECTRONIC FUNDS TRANSFER VIA ELECTRONIC COMMUNICATIONS NETWORKS; CLEARING AND RECONCILING FINANCIAL TRANSACTIONS VIA ELECTRONIC COMMUNICATIONS NETWORKS; PROVIDING A WIDE VARIETY OF PAYMENT AND FINANCIAL SERVICES, NAMELY, CREDIT CARD SERVICES, ISSUING CREDIT CARDS AND LINES OF CREDIT, PROCESSING AND TRANSMISSION OF BILLS AND PAYMENTS THEREOF, BILL PAYMENT SERVICES WITH GUARANTEED PAYMENT DELIVERY, AND BROKERAGE OF MONEY MARKET FUNDS, ALL CONDUCTED VIA A GLOBAL COMMUNICATIONS NETWORK; PROVIDING ELECTRONIC PROCESSING OF ACH AND CREDIT CARD TRANSACTIONS AND ELECTRONIC PAYMENTS VIA A GLOBAL COMPUTER NETWORK; ARRANGING OF LOANS; CREDIT AND LOAN SERVICES; ELECTRONIC LOAN ORIGINATION SERVICES; PROVIDING TEMPORARY LOANS; REVOLVING LOANS; CREDIT CARD PAYMENT PROCESSING SERVICES; CREDIT CARD SERVICES; LEASING OF REAL ESTATE; PROVIDING REAL ESTATE LISTINGS VIA THE INTERNET; REAL ESTATE BROKERAGE; REAL ESTATE CONSULTATION; REAL ESTATE CONSULTANCY; REAL ESTATE PROCUREMENT FOR OTHERS; REAL ESTATE VALUATION SERVICES; PROVIDING REAL ESTATE LISTINGS AND REAL ESTATE

CLASS 36—(Continued).

INFORMATION VIA THE INTERNET; CHARGE CARD AND CREDIT CARD SERVICES; CREDIT CARD AND DEBIT CARD SERVICES; CREDIT CARD AND PAYMENT CARD SERVICES; CREDIT CARD AUTHORIZATION SERVICES; CREDIT CARD SERVICES; CREDIT CARD VERIFICATION; ELECTRONIC TRANSFER OF MONEY; ELECTRONIC TRANSFER OF FUNDS; ELECTRONIC TRANSFERS OF MONEY; FINANCIAL TRANSACTION SERVICES, NAMELY, PROVIDING SECURE COMMERCIAL TRANSACTIONS AND PAYMENT OPTIONS USING A MOBILE DEVICE AT A POINT OF SALE; ISSUING CREDIT CARDS; ISSUING PREPAID CREDIT CARDS; ISSUING STORED VALUE CARDS; PAYMENT PROCESSING SERVICES, NAMELY, CREDIT CARD AND DEBIT CARD TRANSACTION PROCESSING SERVICES; PROVIDING A DATABASE OF INFORMATION ABOUT RESIDENTIAL REAL ESTATE LISTINGS IN DIFFERENT NEIGHBORHOODS AND COMMUNITIES; PROVIDING A DATABASE OF RESIDENTIAL REAL ESTATE LISTINGS WITHIN NEIGHBORHOODS AND COMMUNITIES SPECIFICALLY IDENTIFIED BY USERS; PROVIDING AN INTERNET WEBSITE PORTAL OFFERING INFORMATION IN THE FIELDS OF REAL ESTATE CONCERNING THE PURCHASE AND SALE OF NEW AND RESALE HOMES AND CONDOS; PROVIDING INFORMATION IN THE FIELD OF REAL ESTATE BY MEANS OF LINKING THE WEBSITE TO OTHER WEB SITES FEATURING REAL ESTATE INFORMATION; REAL ESTATE TIME-SHARING (U.S. CLS. 100, 101 AND 102).

GISELLE AGOSTO, EXAMINING ATTORNEY

SN 85-296,235. ZAARLY, INC., SAN FRANCISCO, CA. FILED 4-15-2011.



THE MARK CONSISTS OF A STYLIZED LETTER 'Z' WITH LINES PORTRUDING FROM THE TOP AND BOTTOM OF THE 'Z'.

FOR PROVIDING ON-LINE COMPUTER DATABASES AND ON-LINE SEARCHABLE DATABASES FEATURING INFORMATION, CLASSIFIED LISTINGS AND ANNOUNCEMENTS ABOUT HOUSING, APARTMENTS, CONDOMINIUMS, TOWN HOMES, REAL ESTATE, COMMERCIAL REAL ESTATE, ROOMMATE-WANTED, AND RENTAL AND LEASING AND CLASSIFIED LISTINGS FOR THE FORGOING; ELECTRONIC COMMERCE PAYMENT SERVICES, NAMELY, PROCESSING PAYMENTS FOR THE PURCHASE OF GOODS AND SERVICES VIA AN ELECTRONIC COMMUNICATIONS NETWORK; FINANCIAL SERVICES, NAMELY, ELECTRONIC FUNDS TRANSFER VIA ELECTRONIC COMMUNICATIONS NETWORKS; CLEARING AND RECONCILING FINANCIAL TRANSACTIONS VIA ELECTRONIC COMMUNICATIONS NETWORKS; PROVIDING A WIDE VARIETY OF PAYMENT AND FINANCIAL SERVICES, NAMELY, CREDIT CARD SERVICES, ISSUING CREDIT CARDS AND LINES OF CREDIT, PROCESSING AND TRANSMISSION OF BILLS AND PAYMENTS THEREOF, BILL PAYMENT SERVICES WITH GUARANTEED PAYMENT DELIVERY, AND BROKERAGE OF MONEY MARKET FUNDS,

CLASS 36—(Continued).

ALL CONDUCTED VIA A GLOBAL COMMUNICATIONS NETWORK; PROVIDING ELECTRONIC PROCESSING OF ACH AND CREDIT CARD TRANSACTIONS AND ELECTRONIC PAYMENTS VIA A GLOBAL COMPUTER NETWORK; ARRANGING OF LOANS; CREDIT AND LOAN SERVICES; ELECTRONIC LOAN ORIGINATION SERVICES; PROVIDING TEMPORARY LOANS; REVOLVING LOANS; CREDIT CARD PAYMENT PROCESSING SERVICES; CREDIT CARD SERVICES; LEASING OF REAL ESTATE; PROVIDING REAL ESTATE LISTINGS VIA THE INTERNET; REAL ESTATE BROKERAGE; REAL ESTATE CONSULTATION; REAL ESTATE CONSULTANCY; REAL ESTATE PROCUREMENT FOR OTHERS; REAL ESTATE VALUATION SERVICES; PROVIDING REAL ESTATE LISTINGS AND REAL ESTATE INFORMATION VIA THE INTERNET; CHARGE CARD AND CREDIT CARD SERVICES; CREDIT CARD AND DEBIT CARD SERVICES; CREDIT CARD AND PAYMENT CARD SERVICES; CREDIT CARD AUTHORIZATION SERVICES; CREDIT CARD SERVICES; CREDIT CARD VERIFICATION; ELECTRONIC TRANSFER OF MONEY; ELECTRONIC TRANSFER OF FUNDS; ELECTRONIC TRANSFERS OF MONEY; FINANCIAL TRANSACTION SERVICES, NAMELY, PROVIDING SECURE COMMERCIAL TRANSACTIONS AND PAYMENT OPTIONS USING A MOBILE DEVICE AT A POINT OF SALE; ISSUING CREDIT CARDS; ISSUING PREPAID CREDIT CARDS; ISSUING STORED VALUE CARDS; PAYMENT PROCESSING SERVICES, NAMELY, CREDIT CARD AND DEBIT CARD TRANSACTION PROCESSING SERVICES; PROVIDING A DATABASE OF INFORMATION ABOUT RESIDENTIAL REAL ESTATE LISTINGS IN DIFFERENT NEIGHBORHOODS AND COMMUNITIES; PROVIDING A DATABASE OF RESIDENTIAL REAL ESTATE LISTINGS WITHIN NEIGHBORHOODS AND COMMUNITIES SPECIFICALLY IDENTIFIED BY USERS; PROVIDING AN INTERNET WEBSITE PORTAL OFFERING INFORMATION IN THE FIELDS OF REAL ESTATE CONCERNING THE PURCHASE AND SALE OF NEW AND RESALE HOMES AND CONDOS; PROVIDING INFORMATION IN THE FIELD OF REAL ESTATE BY MEANS OF LINKING THE WEB SITE TO OTHER WEB SITES FEATURING REAL ESTATE INFORMATION; REAL ESTATE TIME-SHARING (U.S. CLS. 100, 101 AND 102).

GISELLE AGOSTO, EXAMINING ATTORNEY

SN 85-315,630. PENNSYLVANIA STATE EMPLOYEES CREDIT UNION, HARRISBURG, PA. FILED 5-9-2011.

INVEST IN YOUR DREAMS

THE MARK CONSISTS OF STANDARD CHARACTERS WITHOUT CLAIM TO ANY PARTICULAR FONT, STYLE, SIZE, OR COLOR.

FOR ESTATE PLANNING; FINANCIAL CONSULTANCY IN THE FIELD OF RETIREMENT PLANNING, COLLEGE EDUCATION PLANNING AND BUSINESS PLANNING; INSURANCE CONSULTANCY; FINANCIAL PLANNING AND INVESTMENT ADVISORY SERVICES IN THE FIELD OF RETIREMENT PLANNING, COLLEGE EDUCATION PLANNING AND BUSINESS PLANNING; FINANCIAL PLANNING FOR RETIREMENT (U.S. CLS. 100, 101 AND 102).

FIRST USE 10-22-2009; IN COMMERCE 10-22-2009.

RENEE MCCRAY, EXAMINING ATTORNEY

CLASS 36—(Continued).

SN 85-364,504. CITIGROUP INC., NEW YORK, NY. FILED 7-6-2011.

CITI INGENUITY

THE MARK CONSISTS OF STANDARD CHARACTERS WITHOUT CLAIM TO ANY PARTICULAR FONT, STYLE, SIZE, OR COLOR.

OWNER OF U.S. REG. NOS. 2,424,088, 3,007,963 AND OTHERS.

FOR FINANCIAL SERVICES, NAMELY, COMMERCIAL AND CONSUMER LENDING AND FINANCING; BANKING SERVICES; CREDIT CARD SERVICES; SECURITIES TRADING, FINANCIAL CONSULTING AND SECURITIES UNDERWRITING SERVICES FOR OTHERS; INVESTMENT MANAGEMENT, FINANCIAL PLANNING AND CONSULTING; INVESTMENT BANKING SERVICES; MORTGAGE LENDING SERVICES; CASH MANAGEMENT SERVICES; FINANCIAL SERVICES, NAMELY, SECURITIES BROKERAGE, CLEARING AND CUSTODY SERVICES, FINANCIAL TRUST PLANNING, SECURITIES DEPOSIT SERVICES (U.S. CLS. 100, 101 AND 102).

ANNE E. GUSTASON, EXAMINING ATTORNEY

SN 85-389,689. LINCOLN NATIONAL CORPORATION, RADNOR, PA. FILED 8-4-2011.

YOU'RE IN CHARGE

THE MARK CONSISTS OF STANDARD CHARACTERS WITHOUT CLAIM TO ANY PARTICULAR FONT, STYLE, SIZE, OR COLOR.

FOR INSURANCE UNDERWRITING AND ADMINISTRATION SERVICES, NAMELY, LIFE INSURANCE, DISABILITY INSURANCE, DENTAL INSURANCE, ACCIDENT INSURANCE, HEALTH INSURANCE AND CRITICAL ILLNESS INSURANCE; FINANCIAL SERVICES, NAMELY, INVESTMENT MANAGEMENT OF AND DISTRIBUTION OF ANNUITIES; FINANCIAL AND INSURANCE SERVICES, NAMELY, ADMINISTRATION AND MANAGEMENT OF ANNUITY CONTRACTS AND CONSULTATION IN THE FIELD OF DEVELOPING ANNUITY PRODUCTS FOR OTHERS; INSURANCE SERVICES, NAMELY, ADMINISTRATION OF VISION INSURANCE, FINANCIAL CONSULTATION, NAMELY, MUTUAL FUND ADVISORY SERVICES; MUTUAL FUND INVESTMENT; ESTABLISHING MUTUAL FUNDS FOR OTHERS; FINANCIAL PLANNING AND INVESTMENT ADVISORY SERVICES; INSTITUTIONAL INVESTMENT MANAGEMENT SERVICES, INVESTMENT PLANNING SERVICES, NAMELY, INVESTMENT CONSULTATION AND ADVICE; FINANCIAL AND ANNUITY UNDERWRITING SERVICES, NAMELY, UNDERWRITING AND ADMINISTERING RETIREMENT PLANS, ANNUITIES, MUTUAL FUNDS AND DEFINED CONTRIBUTION PLANS; AND OFFERING INDIVIDUAL RETIREMENT ACCOUNTS FOR INDIVIDUAL RETIREMENT (U.S. CLS. 100, 101 AND 102).

FIRST USE 11-15-2011; IN COMMERCE 11-15-2011.

EMILY CARLSEN, EXAMINING ATTORNEY

CLASS 36—(Continued).

SN 85-391,793. REDSTONE FEDERAL CREDIT UNION, HUNTSVILLE, AL. FILED 8-8-2011.

REDSTONE DISCOUNTS!

THE MARK CONSISTS OF STANDARD CHARACTERS WITHOUT CLAIM TO ANY PARTICULAR FONT, STYLE, SIZE, OR COLOR.

NO CLAIM IS MADE TO THE EXCLUSIVE RIGHT TO USE "DISCOUNTS", APART FROM THE MARK AS SHOWN.

FOR BANKING SERVICES, NAMELY, CREDIT CARD AND DEBIT CARD SERVICES; PROVIDING CREDIT CARD AND DEBIT CARD SERVICES WITH LOYALTY AND CONSUMER INCENTIVE PROGRAMS; EXCLUDING REAL ESTATE FINANCING SERVICES (U.S. CLS. 100, 101 AND 102).

FIRST USE 11-30-2010; IN COMMERCE 11-30-2010.

DOMINIC J. FERRAIUOLO, EXAMINING ATTORNEY

SN 85-391,796. REDSTONE FEDERAL CREDIT UNION, HUNTSVILLE, AL. FILED 8-8-2011.

REDSTONE FEDERAL CREDIT UNION

THE MARK CONSISTS OF STANDARD CHARACTERS WITHOUT CLAIM TO ANY PARTICULAR FONT, STYLE, SIZE, OR COLOR.

NO CLAIM IS MADE TO THE EXCLUSIVE RIGHT TO USE "FEDERAL CREDIT UNION", APART FROM THE MARK AS SHOWN.

FOR CREDIT UNION AND BANKING SERVICES; CHECKING ACCOUNT SERVICES; SAVINGS ACCOUNT SERVICES; CREDIT CARD, CHARGE CARD AND DEBIT CARD SERVICES; CREDIT AND LOAN SERVICES; ONLINE BANKING SERVICES; ELECTRONIC BANKING VIA A GLOBAL COMPUTER NETWORK; MORTGAGE LENDING; ATM SERVICES; ATM BANKING SERVICES; CONSUMER LENDING SERVICES; COMMERCIAL LENDING SERVICES; INSURANCE AND FINANCIAL INFORMATION AND CONSULTANCY SERVICES; INVESTMENT ADVICE; BILL PAYMENT SERVICES OFFERED THROUGH A WEBSITE; FINANCIAL PLANNING AND INVESTMENT ADVISORY SERVICES; SAFETY DEPOSIT BOX SERVICES; TELEPHONE BANKING SERVICES; EXCLUDING REAL ESTATE FINANCING SERVICES (U.S. CLS. 100, 101 AND 102).

FIRST USE 11-28-1951; IN COMMERCE 11-28-1951.

DOMINIC J. FERRAIUOLO, EXAMINING ATTORNEY

CLASS 36—(Continued).

SN 85-394,626. REDSTONE FEDERAL CREDIT UNION, HUNTSVILLE, AL. FILED 8-10-2011.



NO CLAIM IS MADE TO THE EXCLUSIVE RIGHT TO USE "DISCOUNTS", APART FROM THE MARK AS SHOWN.

THE MARK CONSISTS OF THE WORD "REDSTONE" IN ALL CAPS, WITH THE STYLIZED WORD "DISCOUNTS!" BELOW, WITH A LEFT-POINTING CURVED ARROW ABOVE THE WORD, "REDSTONE", AND A RIGHT-POINTING, CURVED ARROW BELOW BOTH WORDS.

FOR BANKING SERVICES, NAMELY, CREDIT CARD AND DEBIT CARD SERVICES; PROVIDING CREDIT CARD AND DEBIT CARD SERVICES WITH LOYALTY AND CONSUMER INCENTIVE PROGRAMS; EXCLUDING REAL ESTATE FINANCING SERVICES (U.S. CLS. 100, 101 AND 102).

FIRST USE 11-30-2010; IN COMMERCE 11-30-2010.

DOMINIC J. FERRAIUOLO, EXAMINING ATTORNEY

SN 85-397,013. CALIFORNIA CAPITAL INSURANCE COMPANY, DBA CAPITAL INSURANCE GROUP, MONTEREY, CA. FILED 8-12-2011.

CIGLive

THE MARK CONSISTS OF STANDARD CHARACTERS WITHOUT CLAIM TO ANY PARTICULAR FONT, STYLE, SIZE, OR COLOR.

OWNER OF U.S. REG. NO. 2,827,056.

FOR INSURANCE SERVICES, NAMELY, UNDERWRITING AUTOMOBILE, PROPERTY AND LIABILITY, FARM, AND BUSINESS INSURANCE (U.S. CLS. 100, 101 AND 102).

FIRST USE 9-10-2010; IN COMMERCE 9-10-2010.

ALLISON SCHRODY, EXAMINING ATTORNEY

CLASS 36—(Continued).

SN 85-410,963. RICHARD B. STEWARD, MESA, AZ. FILED 8-30-2011.

YESS

THE MARK CONSISTS OF STANDARD CHARACTERS WITHOUT CLAIM TO ANY PARTICULAR FONT, STYLE, SIZE, OR COLOR.

FOR BANKING SERVICES, NAMELY, CHECKING ACCOUNT SERVICES, SAVINGS ACCOUNT SERVICES, ACH ACCOUNT SERVICES, BILL PAYMENT SERVICES, DEBIT CARD SERVICES, CREDIT CARD SERVICES, AND LOAN SERVICES (U.S. CLS. 100, 101 AND 102).
SHAUNIA CARLYLE, EXAMINING ATTORNEY

SN 85-413,836. INSURORS OF TEXAS GENERAL AGENCY, LTD., WACO, TX. FILED 9-2-2011.



NO CLAIM IS MADE TO THE EXCLUSIVE RIGHT TO USE "INSURORS", APART FROM THE MARK AS SHOWN. THE MARK CONSISTS OF FOUR OVERLAPPING FIVE-POINT STARS TO THE RIGHT OF WHICH ARE THE WORDS "INSURORS OF TEXAS".

SEC. 2(F) AS TO "INSURORS OF TEXAS".
FOR ADMINISTRATION OF EMPLOYEE BENEFIT PLANS CONCERNING INSURANCE AND FINANCE; ADMINISTRATION OF PRE-PAID HEALTH CARE PLANS; ADVICE RELATING TO INVESTMENTS; CONSULTING AND INFORMATION CONCERNING INSURANCE; FINANCIAL ADVICE AND CONSULTANCY SERVICES; FINANCIAL INVESTMENT BROKERAGE SERVICES; FINANCIAL PLANNING; INSURANCE AGENCY AND BROKERAGE; INSURANCE AND FINANCIAL INFORMATION AND CONSULTANCY SERVICES; INSURANCE BROKERAGE IN THE FIELD OF PROPERTY, CASUALTY, WORKER'S COMPENSATION, PROFESSIONAL LIABILITY, GENERAL LIABILITY, HOME, LIFE, AUTOMOBILE; INSURANCE BROKERAGE SERVICES; INSURANCE CONSULTING IN THE FIELD OF PROPERTY, CASUALTY, WORKER'S COMPENSATION, PROFESSIONAL LIABILITY, GENERAL LIABILITY, HOME, LIFE, AUTOMOBILE INSURANCE; INSURANCE INFORMATION AND CONSULTANCY; INVESTMENT ADVISORY SERVICES; INVESTMENT BROKERAGE; INVESTMENT CONSULTATION (U.S. CLS. 100, 101 AND 102).

FIRST USE 1-1-1980; IN COMMERCE 1-1-1980.
ANGELA DUONG, EXAMINING ATTORNEY

CLASS 36—(Continued).

SN 85-415,205. AMERICAN REALTY CAPITAL DAILY NET ASSET VALUE TRUST, JENKINTOWN, PA. FILED 9-6-2011.

THE NON-TRADED, LIQUID REIT

THE MARK CONSISTS OF STANDARD CHARACTERS WITHOUT CLAIM TO ANY PARTICULAR FONT, STYLE, SIZE, OR COLOR.

FOR REAL ESTATE INVESTMENT SERVICES (U.S. CLS. 100, 101 AND 102).
SUSAN STIGLITZ, EXAMINING ATTORNEY

SN 85-415,300. AMERICAN REALTY CAPITAL DAILY NET ASSET VALUE TRUST, JENKINTOWN, PA. FILED 9-6-2011.

THE NON-TRADED, TRADED REIT

THE MARK CONSISTS OF STANDARD CHARACTERS WITHOUT CLAIM TO ANY PARTICULAR FONT, STYLE, SIZE, OR COLOR.

FOR REAL ESTATE INVESTMENT SERVICES (U.S. CLS. 100, 101 AND 102).
SUSAN STIGLITZ, EXAMINING ATTORNEY

SN 85-420,531. REDSTONE FEDERAL CREDIT UNION, HUNTSVILLE, AL. FILED 9-12-2011.

REDSTONE BUSINESS PLUS!

THE MARK CONSISTS OF STANDARD CHARACTERS WITHOUT CLAIM TO ANY PARTICULAR FONT, STYLE, SIZE, OR COLOR.

NO CLAIM IS MADE TO THE EXCLUSIVE RIGHT TO USE "BUSINESS", APART FROM THE MARK AS SHOWN.

FOR CREDIT UNION AND BANKING SERVICES; CHECKING ACCOUNT SERVICES; DEBIT CARD SERVICES; CREDIT AND LOAN SERVICES; ONLINE BANKING SERVICES; ELECTRONIC BANKING VIA A GLOBAL COMPUTER NETWORK; ATM SERVICES; ATM BANKING SERVICES; BILL PAYMENT SERVICES OFFERED THROUGH A WEBSITE; SAFE DEPOSIT BOX SERVICES; TELEPHONE BANKING SERVICES; EXCLUDING REAL ESTATE FINANCING SERVICES (U.S. CLS. 100, 101 AND 102).

FIRST USE 5-31-2011; IN COMMERCE 5-31-2011.
DOMINIC J. FERRAIUOLO, EXAMINING ATTORNEY

CLASS 36—(Continued).

SN 85-420,535. REDSTONE FEDERAL CREDIT UNION, HUNTSVILLE, AL. FILED 9-12-2011.



NO CLAIM IS MADE TO THE EXCLUSIVE RIGHT TO USE "BUSINESS", APART FROM THE MARK AS SHOWN. THE MARK CONSISTS OF THE WORD "REDSTONE" IN ALL CAPS, WITH THE STYLIZED WORDS "BUSINESS PLUS!" BELOW, WITH A LEFT-POINTING CURVED ARROW ABOVE THE WORD, "REDSTONE", AND A RIGHT-POINTING, CURVED ARROW BELOW THE WORDS, "BUSINESS PLUS!"

FOR CREDIT UNION AND BANKING SERVICES; CHECKING ACCOUNT SERVICES; DEBIT CARD SERVICES; CREDIT AND LOAN SERVICES; ONLINE BANKING SERVICES; ELECTRONIC BANKING VIA A GLOBAL COMPUTER NETWORK; ATM SERVICES; ATM BANKING SERVICES; BILL PAYMENT SERVICES OFFERED THROUGH A WEBSITE; SAFE DEPOSIT BOX SERVICES; TELEPHONE BANKING SERVICES; EXCLUDING REAL ESTATE FINANCING SERVICES (U.S. CLS. 100, 101 AND 102).

FIRST USE 5-31-2011; IN COMMERCE 5-31-2011.
DOMINIC J. FERRAIUOLO, EXAMINING ATTORNEY

SN 85-421,794. PPS ADVISORS, INC., HOLBROOK, NY. FILED 9-13-2011.

PPS ADVISORS

THE MARK CONSISTS OF STANDARD CHARACTERS WITHOUT CLAIM TO ANY PARTICULAR FONT, STYLE, SIZE, OR COLOR.

NO CLAIM IS MADE TO THE EXCLUSIVE RIGHT TO USE "ADVISORS", APART FROM THE MARK AS SHOWN. FOR INVESTMENT ADVISORY SERVICES (U.S. CLS. 100, 101 AND 102).

FIRST USE 2-0-2010; IN COMMERCE 2-0-2010.
CHRISTINA SOBRAL, EXAMINING ATTORNEY

CLASS 36—(Continued).

SN 85-429,088. HOMER TLC, INC., WILMINGTON, DE. FILED 9-22-2011.

THE HOME DEPOT

THE MARK CONSISTS OF STANDARD CHARACTERS WITHOUT CLAIM TO ANY PARTICULAR FONT, STYLE, SIZE, OR COLOR.

OWNER OF U.S. REG. NOS. 1,188,191, 3,885,173 AND OTHERS.

NO CLAIM IS MADE TO THE EXCLUSIVE RIGHT TO USE "HOME", APART FROM THE MARK AS SHOWN.

FOR CREDIT CARD SERVICES (U.S. CLS. 100, 101 AND 102).

FIRST USE 6-1-1979; IN COMMERCE 6-1-1979.
MARIA-VICTORIA SUAREZ, EXAMINING ATTORNEY

SN 85-429,560. GRAYHAWK CAPITAL, LLC, PHOENIX, AZ. FILED 9-22-2011.

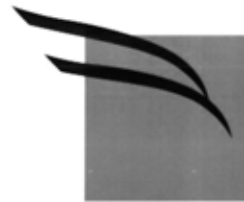

THE MARK CONSISTS OF A BOX WITH TWO LINES BEGINNING PARALLEL OUTSIDE THE UPPER LEFT CORNER OF THE BOX AND SWOOSHING DOWN ENDING TOWARDS THE RIGHT SIDE OF THE BOX, MEETING TO FORM A STYLIZATION OF AN EAGLE'S HEAD.

FOR PROVIDING VENTURE CAPITAL FINANCING, NAMELY, UNDERWRITING, ACQUIRING, MANAGING AND DISPOSING OF DEBT AND EQUITY SECURITIES, GENERALLY IN PRIVATELY HELD OPERATING COMPANIES; PROVIDING VENTURE CAPITAL FUND MANAGEMENT, NAMELY, FORMATION AND OPERATION OF VENTURE CAPITAL FUNDS ENGAGED IN THE BUSINESS OF UNDERWRITING, ACQUIRING, MANAGING AND DISPOSING OF DEBT AND EQUITY SECURITIES GENERALLY IN PRIVATELY HELD OPERATING COMPANIES; PROVIDING PRIVATE EQUITY FUND INVESTMENTS, NAMELY, UNDERWRITING, ACQUIRING, MANAGING AND DISPOSING OF DEBT AND EQUITY SECURITIES, GENERALLY IN PRIVATELY HELD OPERATING COMPANIES; PROVIDING PRIVATE EQUITY FUND MANAGEMENT, NAMELY, FORMATION AND OPERATION OF PRIVATE EQUITY FUNDS ENGAGED IN THE BUSINESS OF UNDERWRITING, ACQUIRING, MANAGING AND DISPOSING OF DEBT AND EQUITY SECURITIES GENERALLY IN PRIVATELY HELD OPERATING COMPANIES (U.S. CLS. 100, 101 AND 102).

FIRST USE 5-0-2003; IN COMMERCE 5-0-2003.
B. PARADEWELAI, EXAMINING ATTORNEY

CLASS 36—(Continued).

SN 85-430,743. EVE PARTNERS, LLC, ATLANTA, GA. FILED 9-23-2011.

EVE PARTNERS

THE MARK CONSISTS OF STANDARD CHARACTERS WITHOUT CLAIM TO ANY PARTICULAR FONT, STYLE, SIZE, OR COLOR.

NO CLAIM IS MADE TO THE EXCLUSIVE RIGHT TO USE "PARTNERS", APART FROM THE MARK AS SHOWN.

FOR FINANCIAL RESTRUCTURING SERVICES; INFORMATION, ADVISORY, CONSULTANCY AND RESEARCH SERVICES RELATING TO FINANCE AND INVESTMENTS; BUSINESS VALUATION SERVICES (U.S. CLS. 100, 101 AND 102).

FIRST USE 12-3-2001; IN COMMERCE 12-3-2001.
EMILY CARLSEN, EXAMINING ATTORNEY

SN 85-431,487. CROSSWATER CAPITAL MANAGEMENT LTD., PEMBROKE, BERMUDA, FILED 9-26-2011.

CROSSWATER

THE MARK CONSISTS OF STANDARD CHARACTERS WITHOUT CLAIM TO ANY PARTICULAR FONT, STYLE, SIZE, OR COLOR.

FOR HEDGE FUND MANAGEMENT SERVICES; INVESTMENT MANAGEMENT SERVICES (U.S. CLS. 100, 101 AND 102).

SUSAN STIGLITZ, EXAMINING ATTORNEY

SN 85-435,074. REV WORLDWIDE, INC., AUSTIN, TX. FILED 9-29-2011.

RENTSAFE

THE MARK CONSISTS OF STANDARD CHARACTERS WITHOUT CLAIM TO ANY PARTICULAR FONT, STYLE, SIZE, OR COLOR.

FOR INSURANCE BROKERAGE, NAMELY, PROVIDING INSURANCE UNDERWRITTEN BY OTHERS FOR PERSONAL PROPERTY AND LIABILITY OF RESIDENTIAL TENANTS; INSURANCE ADMINISTRATION SERVICES, NAMELY, ASSISTING OTHERS WITH COLLECTING INSURANCE PREMIUMS; FINANCIAL SERVICES, NAMELY, ELECTRONIC DEBIT AND CREDIT CARD SERVICES, PREPAID CARD SERVICES, NAMELY, PROCESSING ELECTRONIC INSURANCE PREMIUM PAYMENTS THROUGH PREPAID CARDS, AND ELECTRONIC REMOTE CHECK DEPOSIT SERVICES AND BILL PAYMENT SERVICES (U.S. CLS. 100, 101 AND 102).

JERI J. FICKES, EXAMINING ATTORNEY

CLASS 36—(Continued).

SN 85-437,448. SHARE OUR STRENGTH, WASHINGTON, DC. FILED 10-3-2011.

COOKING MATTERS

THE MARK CONSISTS OF STANDARD CHARACTERS WITHOUT CLAIM TO ANY PARTICULAR FONT, STYLE, SIZE, OR COLOR.

NO CLAIM IS MADE TO THE EXCLUSIVE RIGHT TO USE "COOKING", APART FROM THE MARK AS SHOWN.

FOR CHARITABLE FUNDRAISING (U.S. CLS. 100, 101 AND 102).

FIRST USE 10-16-2010; IN COMMERCE 10-16-2010.
CIMMERIAN COLEMAN, EXAMINING ATTORNEY

SN 85-441,341. LACONIA SAVINGS BANK, LACONIA, NH. FILED 10-6-2011.



**Bank of
New Hampshire**

NO CLAIM IS MADE TO THE EXCLUSIVE RIGHT TO USE "BANK OF NEW HAMPSHIRE", APART FROM THE MARK AS SHOWN.

THE MARK CONSISTS OF A SQUARE CONTAINING A DESIGN OF A LAKE IN FRONT OF TWO MOUNTAINS WITH THE SUN PARTIALLY COMING UP BETWEEN THE TWO MOUNTAINS. TO THE RIGHT OF THE SQUARE ARE THE WORDS "BANK OF" WITH THE WORDS "NEW HAMPSHIRE" DIRECTLY BELOW. THE WHITE PORTIONS OF THE MARK ARE TRANSPARENT BACKGROUND AND WHITE IS NOT A CLAIMED AS A FEATURE OF THE MARK.

FOR BANKING; FINANCIAL SERVICES, NAMELY, FINANCIAL ADVISORY SERVICES, FINANCIAL PLANNING SERVICES; ONLINE BANKING; FINANCIAL PLANNING; RETIREMENT FINANCIAL PLANNING; INVESTMENT AND TRUST SERVICES, NAMELY, INVESTMENT MANAGEMENT, TRUSTEE SERVICES, FINANCIAL PLANNING; INSURANCE BROKERAGE (U.S. CLS. 100, 101 AND 102).

ALLISON SCHRODY, EXAMINING ATTORNEY

CLASS 36—(Continued).

SN 85-447,116. BANCO DE SABADELL, S.A., BARCELONA, SPAIN, FILED 10-13-2011.

SABADELL BANK & TRUST

THE MARK CONSISTS OF STANDARD CHARACTERS WITHOUT CLAIM TO ANY PARTICULAR FONT, STYLE, SIZE, OR COLOR.

OWNER OF U.S. REG. NOS. 3,395,810, 3,935,172 AND 4,009,678.

NO CLAIM IS MADE TO THE EXCLUSIVE RIGHT TO USE "BANK & TRUST", APART FROM THE MARK AS SHOWN.

SEC. 2(F).

FOR FINANCIAL SERVICES, NAMELY, BANKING AND INVESTMENT MANAGEMENT SERVICES; FIDUCIARY SERVICES, NAMELY, FIDUCIARY REPRESENTATIVE SERVICES; TRUSTEE SERVICES (U.S. CLS. 100, 101 AND 102).

ALICIA COLLINS, EXAMINING ATTORNEY

SN 85-447,130. BANCO DE SABADELL, S.A., BARCELONA, SPAIN, FILED 10-13-2011.

Sabadell Bank & Trust

Wealth Management Division of Sabadell United Bank, N.A.



OWNER OF U.S. REG. NOS. 3,395,810, 4,009,678 AND OTHERS.

NO CLAIM IS MADE TO THE EXCLUSIVE RIGHT TO USE "BANK & TRUST", "WEALTH MANAGEMENT DIVISION", AND "BANK, N.A.", APART FROM THE MARK AS SHOWN.

THE MARK CONSISTS OF THE WORDS "SABADELL BANK & TRUST" WITH "WEALTH MANAGEMENT DIVISION OF SABADELL UNITED BANK, N.A.", BENEATH, AND TO THE RIGHT OF BOTH A LARGE CAPITAL "S" AND A SMALL CAPITAL "B" TO THE RIGHT OF THE CAPITAL "S", WITHIN A FILLED IN CIRCLE.

SEC. 2(F) AS TO "SABADELL".

FOR FINANCIAL SERVICES, NAMELY, BANKING AND INVESTMENT MANAGEMENT SERVICES; FIDUCIARY SERVICES, NAMELY, FIDUCIARY REPRESENTATIVE SERVICES; TRUSTEE SERVICES (U.S. CLS. 100, 101 AND 102).

ALICIA COLLINS, EXAMINING ATTORNEY

CLASS 36—(Continued).

SN 85-447,141. BANCO DE SABADELL, S.A., BARCELONA, SPAIN, FILED 10-13-2011.

Sabadell
Bank & Trust

Wealth Management Division of Sabadell United Bank, N.A.



OWNER OF U.S. REG. NOS. 3,395,810, 4,009,678 AND OTHERS.

NO CLAIM IS MADE TO THE EXCLUSIVE RIGHT TO USE "BANK & TRUST", "WEALTH MANAGEMENT DIVISION", AND "BANK, N.A.", APART FROM THE MARK AS SHOWN.

THE MARK CONSISTS OF THE WORD "SABADELL", WITH "BANK & TRUST" BENEATH, AND WITH "WEALTH MANAGEMENT DIVISION OF SABADELL UNITED BANK, N.A.", BENEATH "BANK & TRUST", AND TO THE RIGHT OF THE LINES OF TEXT A LARGE CAPITAL "S" AND A SMALL CAPITAL "B" TO THE RIGHT OF THE CAPITAL "S", WITHIN A FILLED IN CIRCLE.

SEC. 2(F) AS TO "SABADELL".

FOR FINANCIAL SERVICES, NAMELY, BANKING AND INVESTMENT MANAGEMENT SERVICES; FIDUCIARY SERVICES, NAMELY, FIDUCIARY REPRESENTATIVE SERVICES; TRUSTEE SERVICES (U.S. CLS. 100, 101 AND 102).

ALICIA COLLINS, EXAMINING ATTORNEY

SN 85-449,650. USADVISORS NETWORK, LLC, EDEN PRAIRIE, MN. FILED 10-18-2011.

USAdvisors Network

THE MARK CONSISTS OF STANDARD CHARACTERS WITHOUT CLAIM TO ANY PARTICULAR FONT, STYLE, SIZE, OR COLOR.

NO CLAIM IS MADE TO THE EXCLUSIVE RIGHT TO USE "NETWORK", APART FROM THE MARK AS SHOWN.

SEC. 2(F).

FOR FINANCIAL CONSULTANCY AND INSURANCE CONSULTANCY (U.S. CLS. 100, 101 AND 102).

FIRST USE 3-16-2007; IN COMMERCE 3-16-2007.

JOHN HWANG, EXAMINING ATTORNEY

CLASS 36—(Continued).

SN 85-453,115. WINKLER CONSULTING GROUP, INC., MT. PLEASANT, SC. FILED 10-21-2011.

REDEFINING FUNDRAISING
EXCELLENCE

THE MARK CONSISTS OF STANDARD CHARACTERS WITHOUT CLAIM TO ANY PARTICULAR FONT, STYLE, SIZE, OR COLOR.

FOR CONSULTING SERVICES IN THE FIELD OF CHARITABLE FUNDRAISING (U.S. CLS. 100, 101 AND 102).

FIRST USE 10-0-2009; IN COMMERCE 10-0-2009.
WILLIAM BRECKENFELD, EXAMINING ATTORNEY

SN 85-457,493. TARGET BRANDS, INC., MINNEAPOLIS, MN. FILED 10-27-2011.



PRESS

Path to Reading Excellence
in School Sites

NO CLAIM IS MADE TO THE EXCLUSIVE RIGHT TO USE "SCHOOL", APART FROM THE MARK AS SHOWN.

THE MARK CONSISTS OF A SILHOUETTE OF A STYLIZED OPEN BOOK ABOVE THE ACRONYM, "PRESS", FOLLOWED BY THE PHRASE "PATH TO READING EXCELLENCE IN SCHOOL SITES".

FOR CHARITABLE FUNDRAISING SERVICES FOR SCHOOLS (U.S. CLS. 100, 101 AND 102).
ROBERT C. CLARK JR., EXAMINING ATTORNEY

SN 85-459,918. FUNDERTAINMENT, INC., GLENDALE, CA. FILED 10-31-2011.

Fundertainment

THE MARK CONSISTS OF STANDARD CHARACTERS WITHOUT CLAIM TO ANY PARTICULAR FONT, STYLE, SIZE, OR COLOR.

FOR CHARITABLE FUNDRAISING SERVICES, NAMELY, BY PROVIDING INDIVIDUALS WITH THE INFORMATION AND OPPORTUNITY TO MAKE MONETARY DONATIONS TO THEIR FAVORITE CHARITY (U.S. CLS. 100, 101 AND 102).

FIRST USE 3-4-2011; IN COMMERCE 3-15-2011.
DAWN FELDMAN, EXAMINING ATTORNEY

CLASS 36—(Continued).

SN 85-470,419. EBX HOLDING LTDA, RIO DE JANEIRO, BRAZIL, FILED 11-11-2011.

EBX

THE MARK CONSISTS OF STANDARD CHARACTERS WITHOUT CLAIM TO ANY PARTICULAR FONT, STYLE, SIZE, OR COLOR.

FOR FUNDRAISING, NAMELY, BUSINESS FUNDRAISING FOR OTHERS, FINANCIAL INFORMATION, FINANCIAL SPONSORSHIP OF ENTERTAINMENT, SPORTING AND CULTURAL ACTIVITIES; FINANCIAL SPONSORSHIP OF INFRASTRUCTURE IMPROVEMENT PROJECTS; CAPITAL INVESTMENT; INVESTMENT OF FUNDS FOR OTHERS; FINANCIAL MANAGEMENT; PROVIDING VENTURE CAPITAL AND DEVELOPMENT CAPITAL TO OTHER HOME AND FOREIGN COMPANIES INCORPORATED UNDER ANY CORPORATE FORM AND FOR ANY CORPORATE PURPOSE (U.S. CLS. 100, 101 AND 102).

WILLIAM JACKSON, EXAMINING ATTORNEY

SN 85-475,252. ZIONS BANCORPORATION, SALT LAKE CITY, UT. FILED 11-17-2011.

Amazing

OWNER OF U.S. REG. NOS. 3,764,987 AND 3,764,988.
THE MARK CONSISTS OF THE WORD "AMAZING" WITH THE LETTERS "A","M","A" AND "ING" UNDERLINED. BELOW THE LETTER "Z" IS A CIRCLE THAT IS DIVIDED IN THE MIDDLE.

FOR BANKING SERVICES, NAMELY, CREDIT CARD SERVICES AND LENDING SERVICES (U.S. CLS. 100, 101 AND 102).

JOHN DWYER, EXAMINING ATTORNEY

CLASS 36—(Continued).

SN 85-476,122. UNITED SERVICE ORGANIZATIONS, INC., ARLINGTON, VA. FILED 11-18-2011.

USO wishBOOK

OWNER OF U.S. REG. NOS. 1,731,529, 3,311,868 AND OTHERS.

THE MARK CONSISTS OF THE WORDS "USO WISH-BOOK" AND A STAR ON THE TOP OF LETTER "I".

FOR CHARITABLE FUND RAISING SERVICES (U.S. CLS. 100, 101 AND 102).

FIRST USE 11-1-2011; IN COMMERCE 11-1-2011.

EDWARD NELSON, EXAMINING ATTORNEY

CLASS 36—(Continued).

SN 85-485,026. ROCKLAND TRUST COMPANY, ROCK- LAND, MA. FILED 12-1-2011.

ROCKLAND DIRECT

THE MARK CONSISTS OF STANDARD CHARACTERS WITHOUT CLAIM TO ANY PARTICULAR FONT, STYLE, SIZE, OR COLOR.

OWNER OF U.S. REG. NOS. 3,633,895, 3,641,954 AND 3,910,066.

NO CLAIM IS MADE TO THE EXCLUSIVE RIGHT TO USE "DIRECT", APART FROM THE MARK AS SHOWN.

SEC. 2(F) AS TO "ROCKLAND".

FOR ON-LINE BANKING SERVICES (U.S. CLS. 100, 101 AND 102).

CORY BOONE, EXAMINING ATTORNEY

SN 85-477,509. RBS CITIZENS FINANCIAL GROUP, INC., PROVIDENCE, RI. FILED 11-21-2011.

THE ART OF SAVESMANSHIP

THE MARK CONSISTS OF STANDARD CHARACTERS WITHOUT CLAIM TO ANY PARTICULAR FONT, STYLE, SIZE, OR COLOR.

FOR BANKING SERVICES; ONLINE SAVING INCEN- TIVE PROGRAM IN THE FIELD OF BANKING, NAMELY, PROVIDING A WEBSITE FEATURING IN- TERACTION PRESENTATIONS WHERE USERS CAN ACQUIRE INFORMATION ABOUT GOOD MONEY- MANAGEMENT HABITS AND THE BENEFITS OF SAV- ING MONEY FOR FINANCIAL PLANNING PURPOSES (U.S. CLS. 100, 101 AND 102).

AMY ALFIERI, EXAMINING ATTORNEY

SN 85-486,957. CROSSWATER CAPITAL MANAGEMENT LTD., HAMILTON HM 12, BERMUDA, FILED 12-5-2011.



THE COLOR(S) BLUE AND GREY IS/ARE CLAIMED AS A FEATURE OF THE MARK.

THE MARK CONSISTS OF THE TERM "CROSSWATER" IN ALL UPPERCASE BLUE LETTERS BELOW FOUR STYLIZED LINES REPRESENTING WATER, THE FIRST TWO LINES BEING IN BLUE AND THE THIRD AND FOURTH LINES BEING IN GRAY.

FOR HEDGE FUND MANAGEMENT SERVICES; IN- VESTMENT MANAGEMENT SERVICES (U.S. CLS. 100, 101 AND 102).

SUSAN STIGLITZ, EXAMINING ATTORNEY

SN 85-477,516. RBS CITIZENS FINANCIAL GROUP, INC., PROVIDENCE, RI. FILED 11-21-2011.

THE VIRTUES OF SAVING

THE MARK CONSISTS OF STANDARD CHARACTERS WITHOUT CLAIM TO ANY PARTICULAR FONT, STYLE, SIZE, OR COLOR.

FOR BANKING SERVICES; ONLINE SAVING INCEN- TIVE PROGRAM IN THE FIELD OF BANKING, NAMELY, PROVIDING A WEBSITE FEATURING IN- TERACTION PRESENTATIONS WHERE USERS CAN ACQUIRE INFORMATION ABOUT GOOD MONEY- MANAGEMENT HABITS AND THE BENEFITS OF SAV- ING MONEY FOR FINANCIAL PLANNING PURPOSES (U.S. CLS. 100, 101 AND 102).

AMY ALFIERI, EXAMINING ATTORNEY

SN 85-489,225. NEA FEDERAL CREDIT UNION, BARDO- NIA, NY. FILED 12-7-2011.



NO CLAIM IS MADE TO THE EXCLUSIVE RIGHT TO USE "FEDERAL CREDIT UNION", APART FROM THE MARK AS SHOWN.

THE MARK CONSISTS OF A THREE-DIMENSIONAL PERSPECTIVE OF A PYRAMID, WITH TWELVE POINTED

CLASS 36—(Continued).

EXTENSIONS DEPICTING LIGHT APPEARING BEHIND THE TOP QUARTER OF THE PYRAMID, A HORIZONTAL LINE EXTENDING ACROSS THE FRONT FACE OF THE TOP QUARTER OF THE PYRAMID, WITH THE LITERAL ELEMENT "NEA" READING FROM LEFT TO RIGHT ACROSS THE FRONT FACE OF THE LOWER HALF OF THE PYRAMID, THE "A" IN "NEA" APPEARING SLIGHTLY BELOW THE "E", AND THE LITERAL ELEMENT "FEDERAL CREDIT UNION" READING LEFT TO RIGHT, BELOW THE PYRAMID.

FOR CREDIT UNION SERVICES (U.S. CLS. 100, 101 AND 102).

FIRST USE 11-3-2011; IN COMMERCE 11-3-2011.
JOHN KELLY, EXAMINING ATTORNEY

CLASS 36—(Continued).

SN 85-513,114. LIBERTY MUTUAL INSURANCE COMPANY, BOSTON, MA. FILED 1-10-2012.

SN 85-511,876. THINK FINANCE, INC., FT. WORTH, TX. FILED 1-9-2012.

FINANCIAL FLEXIBILITY

THE MARK CONSISTS OF STANDARD CHARACTERS WITHOUT CLAIM TO ANY PARTICULAR FONT, STYLE, SIZE, OR COLOR.

NO CLAIM IS MADE TO THE EXCLUSIVE RIGHT TO USE "FINANCIAL", APART FROM THE MARK AS SHOWN.

FOR FINANCIAL SERVICES, NAMELY, PROVIDING SHORT TERM LOANS VIA THE INTERNET, PHONE, AND RETAIL LOCATIONS; CONSULTING SERVICES CONCERNING THE PROVISION OF SHORT TERM LENDING PROGRAMS; STORED-VALUE AND CREDIT CARD SERVICES (U.S. CLS. 100, 101 AND 102).

LIEF MARTIN, EXAMINING ATTORNEY



SN 85-513,087. LIBERTY MUTUAL INSURANCE COMPANY, BOSTON, MA. FILED 1-10-2012.

A LIBERTY MUTUAL COMPANY

THE MARK CONSISTS OF STANDARD CHARACTERS WITHOUT CLAIM TO ANY PARTICULAR FONT, STYLE, SIZE, OR COLOR.

OWNER OF U.S. REG. NOS. 1,405,249, 3,994,941 AND OTHERS.

NO CLAIM IS MADE TO THE EXCLUSIVE RIGHT TO USE "MUTUAL COMPANY", APART FROM THE MARK AS SHOWN.

FOR INSURANCE UNDERWRITING SERVICES FOR ALL TYPES OF INSURANCE; INSURANCE CONSULTANCY; INSURANCE INFORMATION SERVICES; INSURANCE ADMINISTRATION (U.S. CLS. 100, 101 AND 102).

FIRST USE 1-10-2012; IN COMMERCE 1-10-2012.
JORDAN BAKER, EXAMINING ATTORNEY

OWNER OF U.S. REG. NOS. 1,405,249, 3,994,941 AND OTHERS.

NO CLAIM IS MADE TO THE EXCLUSIVE RIGHT TO USE "MUTUAL" AND "AGENCY CORPORATION", APART FROM THE MARK AS SHOWN.

THE MARK CONSISTS OF A STYLIZED DRAWING INSPIRED BY THE UPPER PORTION OF THE STATUE OF LIBERTY, A HORIZONTAL LINE AND THE WORDS "LIBERTY MUTUAL" ABOVE THE LINE AND "AGENCY CORPORATION" BELOW THE LINE.

FOR INSURANCE UNDERWRITING SERVICES FOR ALL TYPES OF INSURANCE; INSURANCE CONSULTANCY; INSURANCE INFORMATION SERVICES; INSURANCE ADMINISTRATION (U.S. CLS. 100, 101 AND 102).

FIRST USE 1-10-2012, THE MARK WAS FIRST USED ANYWHERE IN A DIFFERENT FORM OTHER THAN THAT SOUGHT TO BE REGISTERED AT LEAST AS EARLY AS 08/26/1985.; IN COMMERCE 1-10-2012, THE MARK WAS FIRST USED IN COMMERCE IN A DIFFERENT FORM OTHER THAN THAT SOUGHT TO BE REGISTERED AT LEAST AS EARLY AS 08/26/1985..

JORDAN BAKER, EXAMINING ATTORNEY

CLASS 36—(Continued).

SN 85-520,604. THE BANK OF NOVA SCOTIA, TORONTO, ONTARIO, CANADA, FILED 1-19-2012.

CLASS 36—(Continued).

SN 85-520,610. THE BANK OF NOVA SCOTIA, TORONTO, ONTARIO, CANADA, FILED 1-19-2012.

SCOTIABANK



THE MARK CONSISTS OF STANDARD CHARACTERS WITHOUT CLAIM TO ANY PARTICULAR FONT, STYLE, SIZE, OR COLOR.

OWNER OF U.S. REG. NOS. 3,369,781, 3,449,906 AND OTHERS.

FOR INSURANCE BROKERAGE IN THE FIELDS OF PROPERTY, CASUALTY AND LIFE INSURANCE; FINANCIAL AFFAIRS AND MONETARY AFFAIRS, NAMELY, FINANCIAL INFORMATION, MANAGEMENT AND ANALYSIS SERVICES, MONETARY EXCHANGE, TRUST COMPANY SERVICES, NAMELY, ESTATE TRUST MANAGEMENT SERVICES; REAL ESTATE AFFAIRS, NAMELY, REST ESTATE FINANCING SERVICES AND CORPORATE AND INVESTMENT BANKING SERVICES; FINANCIAL ADVISORY SERVICES RELATING TO MERGERS AND ACQUISITIONS; CAPITAL MARKETS SERVICES, NAMELY, CAPITAL INVESTMENT SERVICES IN THE FIELDS OF EQUITIES, FIXED INCOME, SALES AND TRADING OF COMMODITIES FUTURES, FOREIGN CURRENCY, CAPITAL INVESTMENT RESEARCH, FOREIGN EXCHANGE TRANSACTIONS, FOREIGN EXCHANGE PAYMENT PROCESSING, FOREIGN EXCHANGE BUREAUX, FINANCIAL RISK MANAGEMENT AND COMMODITIES BROKERAGE AND EXCHANGE; FINANCIAL DEALER SERVICES, NAMELY, DEALING IN SECURITIES AS A MARKET MAKER AND IN TRADING COMMODITIES, SECURITIES, OPTIONS, FUTURES, EQUITIES AND FIXED INCOME PRODUCTS IN THE CANADIAN AND OVERSEAS SECURITIES MARKETS, CLEARING TRADES FOR COMMODITIES, FUTURES AND FOREIGN EXCHANGE AND BROKERAGE SERVICES IN THE PRECIOUS AND BASE METAL MARKETS (U.S. CLS. 100, 101 AND 102).

KATHY DE JONGE, EXAMINING ATTORNEY

OWNER OF U.S. REG. NOS. 1,062,927, 3,411,886 AND OTHERS.

THE MARK CONSISTS OF THE WORD "SCOTIABANK" WITH THE LETTER "S" BEFORE THE WORD AND A GLOBE IN THE CENTER OF THE "S".

FOR INSURANCE BROKERAGE IN THE FIELDS OF PROPERTY, CASUALTY AND LIFE INSURANCE; FINANCIAL AFFAIRS AND MONETARY AFFAIRS, NAMELY, FINANCIAL INFORMATION, MANAGEMENT AND ANALYSIS SERVICES, MONETARY EXCHANGE, TRUST COMPANY SERVICES, NAMELY, ESTATE TRUST MANAGEMENT SERVICES; REAL ESTATE AFFAIRS, NAMELY, REST ESTATE FINANCING SERVICES AND CORPORATE AND INVESTMENT BANKING SERVICES; FINANCIAL ADVISORY SERVICES RELATING TO MERGERS AND ACQUISITIONS; CAPITAL MARKETS SERVICES, NAMELY, CAPITAL INVESTMENT SERVICES IN THE FIELDS OF EQUITIES, FIXED INCOME, SALES AND TRADING OF COMMODITIES FUTURES, FOREIGN CURRENCY, CAPITAL INVESTMENT RESEARCH, FOREIGN EXCHANGE TRANSACTIONS, FOREIGN EXCHANGE PAYMENT PROCESSING, FOREIGN EXCHANGE BUREAUX, FINANCIAL RISK MANAGEMENT AND COMMODITIES BROKERAGE AND EXCHANGE; FINANCIAL DEALER SERVICES, NAMELY, DEALING IN SECURITIES AS A MARKET MAKER AND IN TRADING COMMODITIES, SECURITIES, OPTIONS, FUTURES, EQUITIES AND FIXED INCOME PRODUCTS IN THE CANADIAN AND OVERSEAS SECURITIES MARKETS, CLEARING TRADES FOR COMMODITIES, FUTURES AND FOREIGN EXCHANGE AND BROKERAGE SERVICES IN THE PRECIOUS AND BASE METAL MARKETS (U.S. CLS. 100, 101 AND 102).

KATHY DE JONGE, EXAMINING ATTORNEY

CLASS 36—(Continued).

SN 85-523,857. INTERCONTINENTALEXCHANGE, INC.,
ATLANTA, GA. FILED 1-24-2012.

CLASS 36—(Continued).

SN 85-523,908. INTERCONTINENTALEXCHANGE, INC.,
ATLANTA, GA. FILED 1-24-2012.

GWAVE

BWAVE

THE MARK CONSISTS OF STANDARD CHARACTERS WITHOUT CLAIM TO ANY PARTICULAR FONT, STYLE, SIZE, OR COLOR.

FOR FINANCIAL AFFAIRS AND MONETARY AFFAIRS, NAMELY, FINANCIAL INFORMATION, MANAGEMENT AND ANALYSIS SERVICES; FINANCIAL EXCHANGE SERVICES; QUOTATION OF STOCK EXCHANGE PRICES; CALCULATING, COMPILING, AND ANALYZING PRICE INDICES FOR OTHERS; PROVIDING INFORMATION IN THE FIELD OF PRICE INDICES FOR COMMODITIES, OPTIONS, FUTURES, STOCKS AND BONDS; FINANCIAL CLEARING AND CLEARING HOUSE SERVICES, NAMELY, CLEARING TRADES FOR COMMODITIES, OPTIONS, FUTURES, STOCKS AND BONDS; MARKET-MAKING ALSO KNOWN AS THE QUOTING OF BOTH A BUY PRICE AND A SELL PRICE IN A FINANCIAL INSTRUMENT OR COMMODITY; THE TRADING AND ONLINE TRADING OF COMMODITIES, OPTIONS, FUTURES, STOCKS AND BONDS; BROKERAGE IN THE FIELDS OF COMMODITIES, OPTIONS, FUTURES, STOCKS AND BONDS; FINANCIAL APPRAISAL AND VALUATION SERVICES; PREPARATION AND COMPILATION OF FINANCIAL REPORTS FOR OTHERS; MONITORING OF GLOBAL FINANCIAL MARKETS FOR OTHERS, ALSO KNOWN AS, GLOBAL INVESTMENT RESEARCH SERVICES; FINANCIAL RESEARCH AND ANALYSIS SERVICES; FINANCIAL ADMINISTRATION OF STOCK EXCHANGE TRADING OF SHARES AND OTHER FINANCIAL INSTRUMENTS; FINANCIAL INFORMATION SERVICES AND ADVISORY SERVICES RELATING TO ALL THE AFORESAID, NAMELY, THE TRADING, EXCHANGE, VALUATION, QUOTATION, APPRAISAL, AND BROKERAGE OF COMMODITIES, OPTIONS, FUTURES, STOCKS AND BONDS; INVESTMENT ADVISORY SERVICES; AND PROVIDING ALL OF THE FOREGOING SERVICES ON-LINE FROM A GLOBAL COMPUTER NETWORK OR THE INTERNET (U.S. CLS. 100, 101 AND 102).

FIRST USE 1-11-2002; IN COMMERCE 1-11-2002.
RONALD AIKENS, EXAMINING ATTORNEY

THE MARK CONSISTS OF STANDARD CHARACTERS WITHOUT CLAIM TO ANY PARTICULAR FONT, STYLE, SIZE, OR COLOR.

FOR FINANCIAL SERVICES, NAMELY, OPERATING A FINANCIAL EXCHANGE FOR TRADING COMMODITIES, OPTIONS, FUTURES, STOCKS AND BONDS; FINANCIAL AFFAIRS AND MONETARY AFFAIRS, NAMELY, FINANCIAL INFORMATION, MANAGEMENT AND ANALYSIS SERVICES; FINANCIAL EXCHANGE SERVICES; QUOTATION OF STOCK EXCHANGE PRICES; CALCULATING, COMPILING, AND ANALYZING PRICE INDICES FOR OTHERS; PROVIDING INFORMATION IN THE FIELD OF PRICE INDICES FOR COMMODITIES, OPTIONS, FUTURES, STOCKS AND BONDS; CLEARING AND CLEARING HOUSE SERVICES, NAMELY, CLEARING TRADES FOR COMMODITIES, OPTIONS, FUTURES, STOCKS AND BONDS; MARKET-MAKING, ALSO KNOWN AS QUOTING BOTH A BUY PRICE AND A SELL PRICE IN A FINANCIAL INSTRUMENT OR COMMODITY; THE TRADING AND ONLINE TRADING OF COMMODITIES, OPTIONS, FUTURES, STOCKS AND BONDS; BROKERAGE IN THE FIELDS OF COMMODITIES, OPTIONS, FUTURES, STOCKS AND BONDS; FINANCIAL APPRAISAL AND VALUATION SERVICES; PREPARATION AND COMPILATION OF FINANCIAL REPORTS FOR OTHERS; MONITORING OF GLOBAL FINANCIAL MARKETS FOR OTHERS, ALSO KNOWN AS, GLOBAL INVESTMENT RESEARCH SERVICES; FINANCIAL RESEARCH AND ANALYSIS SERVICES; FINANCIAL ADMINISTRATION OF STOCK EXCHANGE TRADING OF SHARES AND OTHER FINANCIAL INSTRUMENTS; ORGANIZING, ADMINISTERING AND SUPERVISING OF FINANCIAL TRANSACTIONS OF OTHERS INVOLVING THE EXCHANGE OF COMMODITIES, OPTIONS, FUTURES, STOCKS AND BONDS; INFORMATION AND ADVISORY SERVICES RELATING TO ALL THE AFORESAID, NAMELY, THE TRADING, EXCHANGE, VALUATION, QUOTATION, APPRAISAL, AND BROKERAGE OF COMMODITIES, OPTIONS, FUTURES, STOCKS AND BONDS; INVESTMENT AND TRADING ADVISORY SERVICES; AND PROVIDING ALL OF THE FOREGOING SERVICES ON-LINE FROM A GLOBAL COMPUTER NETWORK OR THE INTERNET (U.S. CLS. 100, 101 AND 102).

FIRST USE 1-11-2002; IN COMMERCE 1-11-2002.
RONALD AIKENS, EXAMINING ATTORNEY

CLASS 36—(Continued).

SN 85-526,489. KAARYA, LLC, TORRANCE, CA. FILED 1-26-2012.

eBridge

THE MARK CONSISTS OF STANDARD CHARACTERS WITHOUT CLAIM TO ANY PARTICULAR FONT, STYLE, SIZE, OR COLOR.

FOR FINANCIAL SERVICES RELATED TO AUTOMOBILE SERVICES, NAMELY, ELECTRONIC PROCESSING OF ACH PAYMENTS, CREDIT CARD TRANSACTIONS, DEBIT CARD TRANSACTIONS, ELECTRONIC CHECK TRANSACTIONS, PURCHASE DISCOUNTS, AND PURCHASE REFUNDS BETWEEN DEALERSHIPS OR OTHER REPAIR FACILITIES AND CUSTOMERS USING MOBILE PAYMENT SYSTEMS AND INTERNET PAYMENT SYSTEMS; FINANCIAL SERVICES RELATED TO AUTOMOBILE SERVICES, NAMELY, ELECTRONIC PROCESSING OF TRANSACTIONS BETWEEN DEALERSHIPS OR OTHER REPAIR FACILITIES AND CUSTOMERS BY WIRELESS AND WIRED ON-SITE CARD SWIPE SERVICES, NAMELY, CREDIT CARD AND DEBIT CARD TRANSACTION PROCESSING SERVICES (U.S. CLS. 100, 101 AND 102).

FIRST USE 1-14-2012; IN COMMERCE 1-14-2012.
LINDA LAVACHE, EXAMINING ATTORNEY

CLASS 36—(Continued).

SN 85-530,186. HEALTHCARE REAL ESTATE CAPITAL, PALM BEACH, FL. FILED 1-31-2012.

+IRE

THE MARK CONSISTS OF A STYLIZED LETTER "H" FOLLOWED BY THE LETTERS "RE".

FOR REAL ESTATE CONSULTING SERVICES, NAMELY, THE EVALUATION OF REAL ESTATE; FINANCIAL DUE DILIGENCE SERVICES AND INVESTMENT CONSULTING IN THE FIELD OF REAL ESTATE; REAL ESTATE FINANCIAL PROCUREMENT IN CONNECTION WITH HOSPITALS, MEDICAL OFFICE BUILDINGS, AND AMBULATORY SURGICAL CENTERS (U.S. CLS. 100, 101 AND 102).

FIRST USE 1-2-2009; IN COMMERCE 1-2-2009.
GINA HAYES, EXAMINING ATTORNEY

SN 85-530,753. ALLSTATE INSURANCE COMPANY, NORTHBROOK, IL. FILED 2-1-2012.

ENCOMPASS ONE

THE MARK CONSISTS OF STANDARD CHARACTERS WITHOUT CLAIM TO ANY PARTICULAR FONT, STYLE, SIZE, OR COLOR.

OWNER OF U.S. REG. NOS. 2,837,616, 3,402,552 AND OTHERS.

FOR INSURANCE SERVICES, NAMELY, INSURANCE UNDERWRITING IN THE FIELDS OF PROPERTY AND CASUALTY INSURANCE; INSURANCE CLAIMS ADMINISTRATION (U.S. CLS. 100, 101 AND 102).

TINA L. SNAPP, EXAMINING ATTORNEY

SN 85-528,523. HEALTHCARE REAL ESTATE CAPITAL, PALM BEACH, FL. FILED 1-30-2012.

HEALTHCARE REAL ESTATE
CAPITAL

THE MARK CONSISTS OF STANDARD CHARACTERS WITHOUT CLAIM TO ANY PARTICULAR FONT, STYLE, SIZE, OR COLOR.

NO CLAIM IS MADE TO THE EXCLUSIVE RIGHT TO USE "REAL ESTATE CAPITAL", APART FROM THE MARK AS SHOWN.

FOR REAL ESTATE CONSULTING SERVICES, NAMELY, THE EVALUATION OF REAL ESTATE; FINANCIAL DUE DILIGENCE SERVICES AND INVESTMENT CONSULTING IN THE FIELD OF REAL ESTATE; REAL ESTATE FINANCIAL PROCUREMENT IN CONNECTION WITH HOSPITALS, MEDICAL OFFICE BUILDINGS, AND AMBULATORY SURGICAL CENTERS (U.S. CLS. 100, 101 AND 102).

FIRST USE 6-8-2007; IN COMMERCE 6-8-2007.
GINA HAYES, EXAMINING ATTORNEY

SN 85-530,873. ALLSTATE INSURANCE COMPANY, NORTHBROOK, IL. FILED 2-1-2012.



THE MARK CONSISTS OF OVERLAPPING CIRCULAR LINES.

FOR INSURANCE SERVICES, NAMELY, INSURANCE UNDERWRITING IN THE FIELDS OF PROPERTY AND CASUALTY INSURANCE; INSURANCE CLAIMS ADMINISTRATION (U.S. CLS. 100, 101 AND 102).

ZACHARY BELLO, EXAMINING ATTORNEY

CLASS 36—(Continued).

SN 85-533,348. BLUE CHAIR, LLC, KANSAS CITY, MO. FILED 2-3-2012.

Blue Chair, LLC

THE MARK CONSISTS OF STANDARD CHARACTERS WITHOUT CLAIM TO ANY PARTICULAR FONT, STYLE, SIZE, OR COLOR.

NO CLAIM IS MADE TO THE EXCLUSIVE RIGHT TO USE "LLC", APART FROM THE MARK AS SHOWN.

FOR EQUITY CAPITAL INVESTMENT; MANAGEMENT OF BUILDINGS; PROVIDING VENTURE CAPITAL, DEVELOPMENT CAPITAL, PRIVATE EQUITY AND INVESTMENT FUNDING (U.S. CLS. 100, 101 AND 102).

FIRST USE 12-21-2009; IN COMMERCE 12-21-2009.
RONALD MCMORROW, EXAMINING ATTORNEY

CLASS 36—(Continued).

SN 85-540,975. GIVING OF LIFE, A TENNESSEE NONPROFIT CORPORATION, CHATTANOOGA, TN. FILED 2-13-2012.

GIVING OF LIFE

THE MARK CONSISTS OF STANDARD CHARACTERS WITHOUT CLAIM TO ANY PARTICULAR FONT, STYLE, SIZE, OR COLOR.

FOR CHARITABLE FUNDRAISING SERVICES, NAMELY, PROVIDING AN INTERNET BASED PLATFORM FOR AWARDING GRANTS TO RELIGIOUS ORGANIZATIONS (U.S. CLS. 100, 101 AND 102).

FIRST USE 6-20-2011; IN COMMERCE 6-20-2011.
DORITT L. CARROLL, EXAMINING ATTORNEY

SN 85-538,411. NEW WORLD MALL, LLC, FLUSHING, NY. FILED 2-9-2012.

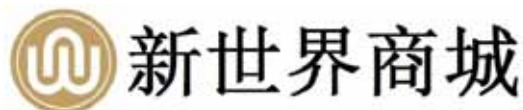

NO CLAIM IS MADE TO THE EXCLUSIVE RIGHT TO USE THE NON-LATIN CHARACTERS THAT TRANSLITERATE TO SHANG CHENG, APART FROM THE MARK AS SHOWN.

THE COLOR(S) GOLD, BLACK AND WHITE IS/ARE CLAIMED AS A FEATURE OF THE MARK.

THE MARK CONSISTS OF A LOGO COMPRISING THE LETTERING "NW" IN STYLIZED FONT IN WHITE WITHIN A SMALL GOLD CIRCLE, SUCH CIRCLE BORDERED BY A SMALL WHITE CIRCLE AND WITH A LARGER GOLD CIRCLE AS AN OUTER BORDER, TO THE LEFT OF THIS ELEMENT ARE FIVE CHINESE CHARACTERS IN BLACK THAT TRANSLATE INTO NEW WORLD MALL.

THE NON-LATIN CHARACTERS IN THE MARK TRANSLITERATE TO XIN SHI JIE SHANG CHENG AND THIS MEANS NEW WORLD MALL OR NEW UNIVERSE OR GLOBE MALL OR SHOPPING CENTER IN ENGLISH.

FOR SHOPPING MALL SERVICES, NAMELY, BROKERAGE, RENTAL, LEASING AND MANAGEMENT OF COMMERCIAL PROPERTY, OFFICES, OFFICE AND SHOPPING CENTER SPACE (U.S. CLS. 100, 101 AND 102).

FIRST USE 7-31-2010; IN COMMERCE 7-31-2010.
ALAIN LAPTEY, EXAMINING ATTORNEY

SN 85-541,018. GIVING OF LIFE, A TENNESSEE NONPROFIT CORPORATION, CHATTANOOGA, TN. FILED 2-13-2012.



THE MARK CONSISTS OF THE WORDS "GIVING OF LIFE" WITH TWO OVERLAPPING LEAVES BETWEEN THE WORDS "GIVING" AND "OF".

FOR CHARITABLE FUNDRAISING SERVICES, NAMELY, PROVIDING AN INTERNET BASED PLATFORM FOR AWARDING GRANTS TO RELIGIOUS ORGANIZATIONS (U.S. CLS. 100, 101 AND 102).

FIRST USE 2-7-2012, THE MARK WAS FIRST USED ANYWHERE IN A DIFFERENT FORM OTHER THAN THAT SOUGHT TO BE REGISTERED AT LEAST AS EARLY AS 06/20/2011.; IN COMMERCE 2-7-2012, THE MARK WAS FIRST USED IN COMMERCE IN A DIFFERENT FORM OTHER THAN THAT SOUGHT TO BE REGISTERED AT LEAST AS EARLY AS 06/20/2011..

DORITT L. CARROLL, EXAMINING ATTORNEY

CLASS 36—(Continued).

SN 85-542,530. MENDOZA, LEONOR, MIAMI, FL. FILED 2-14-2012.



NO CLAIM IS MADE TO THE EXCLUSIVE RIGHT TO USE "REALTY GROUP", APART FROM THE MARK AS SHOWN.

THE COLOR(S) YELLOW AND GREY IS/ARE CLAIMED AS A FEATURE OF THE MARK.

THE MARK CONSISTS OF THE WORDING "BRILLIANCE REALTY GROUP" IN GREY AND LIGHT GREY, WITH A YELLOW AND LIGHT YELLOW DESIGN RESEMBLING A PARTIAL SUN.

FOR REAL ESTATE BROKERAGE (U.S. CLS. 100, 101 AND 102).

FIRST USE 2-1-2012; IN COMMERCE 2-1-2012.
TINA MAI, EXAMINING ATTORNEY

SN 85-544,471. SUMMIT CITY HOLDINGS, LLC, FORT WAYNE, IN. FILED S.R. 2-16-2012; AM. P.R. 2-16-2012.



THE COLOR(S) BLACK, GRAY, AND BLUE IS/ARE CLAIMED AS A FEATURE OF THE MARK.

THE MARK CONSISTS OF AN INVERTED "V" DOUBLE-LINED IN GRAY; BELOW THIS SYMBOL IS "DUPONT" IN BLACK LETTERING FOLLOWED BY "TRIANGLE" IN LIGHT BLUE.

FOR RENTAL OF MOBILE HOMES (U.S. CLS. 100, 101 AND 102).

FIRST USE 1-20-2012; IN COMMERCE 1-20-2012.
JOHN GARTNER, EXAMINING ATTORNEY

CLASS 36—(Continued).

SN 85-554,993. HOLY SPIRITS, LLC, MILWAUKEE, WI. FILED 2-28-2012.



NO CLAIM IS MADE TO THE EXCLUSIVE RIGHT TO USE "PREMIUM PRODUCTS", APART FROM THE MARK AS SHOWN.

THE NAME(S), PORTRAIT(S), AND/OR SIGNATURE(S) SHOWN IN THE MARK IDENTIFIES FATHER DOMENIC ROSCIOLI, WHOSE CONSENT(S) TO REGISTER IS MADE OF RECORD.

THE MARK CONSISTS OF A CIRCLE WITH THE PORTRAIT OF A PRIEST AT ITS CENTER AND THE WORDS "FATHER DOM'S" ABOUT THE PORTRAIT, AND A RIBBON BELOW BEARING THE WORDS "PREMIUM PRODUCTS".

FOR CHARITABLE FUNDRAISING PROGRAMS FOR CHARITIES AND NONPROFIT ORGANIZATIONS, NAMELY, ASSISTING OTHERS IN RAISING MONEY THROUGH THE SALE OF CAKES, BAKING MIXES, PANCAKE MIXES, OATMEAL, SOUP MIXES, COCOA, AND COFFEE; ASSISTING CHARITIES AND NONPROFIT ORGANIZATIONS IN THE PLANNING, MANAGEMENT AND CONDUCTING OF CHARITABLE FUNDRAISING ACTIVITIES VIA THE SALE OF CAKES, BAKING MIXES, PANCAKE MIXES, OATMEAL, SOUP MIXES, COCOA, AND COFFEE (U.S. CLS. 100, 101 AND 102).

FIRST USE 2-28-2012; IN COMMERCE 2-28-2012.
SOPHIA S. KIM, EXAMINING ATTORNEY

SN 85-555,488. WORLDWIDE FOOD SALES, INC., SAN PEDRO, CA. FILED 2-28-2012.



THE COLOR(S) GREEN AND WHITE IS/ARE CLAIMED AS A FEATURE OF THE MARK.

THE MARK CONSISTS OF A FORK, A PLATE, AND A KNIFE, WITH THE PLATE CONTAINING A STYLIZED GLOBE FORMED BY PARALLEL AND MERIDIAN LINES. ALL THE FOREGOING APPEAR IN WHITE AND ARE SUPERIMPOSED ON A GREEN RECTANGULAR BACKGROUND.

FOR COMMODITY TRADING OF FROZEN AND CANNED FRUIT AND VEGETABLES FOR OTHERS (U.S. CLS. 100, 101 AND 102).

FIRST USE 4-19-2005; IN COMMERCE 4-19-2005.
LIEF MARTIN, EXAMINING ATTORNEY

CLASS 36—(Continued).

SN 85-556,728. LOCKTON, INC., KANSAS CITY, MO. FILED 2-29-2012.

LOCKTON WORKFORCE RISK MANAGEMENT

THE MARK CONSISTS OF STANDARD CHARACTERS WITHOUT CLAIM TO ANY PARTICULAR FONT, STYLE, SIZE, OR COLOR.

OWNER OF U.S. REG. NOS. 2,624,149, 3,753,000 AND OTHERS.

NO CLAIM IS MADE TO THE EXCLUSIVE RIGHT TO USE "WORKFORCE RISK MANAGEMENT", APART FROM THE MARK AS SHOWN.

FOR FINANCIAL RISK MANAGEMENT CONSULTING SERVICES REGARDING EMPLOYEE BENEFITS AND WORKERS COMPENSATION PLANS (U.S. CLS. 100, 101 AND 102).

JESSICA FATHY, EXAMINING ATTORNEY

SN 85-558,859. SALESIAN MISSIONS, NEW ROCHELLE, NY. FILED 3-2-2012.

Misiones Salesianas

THE MARK CONSISTS OF STANDARD CHARACTERS WITHOUT CLAIM TO ANY PARTICULAR FONT, STYLE, SIZE, OR COLOR.

OWNER OF U.S. REG. NOS. 2,616,864, 3,947,191 AND OTHERS.

NO CLAIM IS MADE TO THE EXCLUSIVE RIGHT TO USE "MISIONES", APART FROM THE MARK AS SHOWN.

THE ENGLISH TRANSLATION OF "MISIONES SALESIANAS" IN THE MARK IS "SALESIAN MISSIONS". SEC. 2(F).

FOR CHARITABLE FUNDRAISING SERVICES; CHARITABLE FUNDRAISING SERVICES, NAMELY, RAISING FUNDS TO CARE FOR POOR YOUTH AROUND THE GLOBE (U.S. CLS. 100, 101 AND 102).

FIRST USE 1-0-2011; IN COMMERCE 1-0-2011.

MARK SHINER, EXAMINING ATTORNEY

CLASS 36—(Continued).

SN 85-560,260. NVOICEPAY, INC., PORTLAND, OR. FILED 3-5-2012.

NVP CARD

THE MARK CONSISTS OF STANDARD CHARACTERS WITHOUT CLAIM TO ANY PARTICULAR FONT, STYLE, SIZE, OR COLOR.

NO CLAIM IS MADE TO THE EXCLUSIVE RIGHT TO USE "CARD", APART FROM THE MARK AS SHOWN.

FOR PROVIDING A VIRTUAL PAYMENT CARD THAT ALLOWS ELECTRONIC PAYMENT OF ACCOUNTS PAYABLE INVOICES TO VENDORS ENROLLED IN A PRIVATE PAYMENT CARD NETWORK (U.S. CLS. 100, 101 AND 102).

FIRST USE 12-28-2011; IN COMMERCE 1-4-2012.

CIMMERIAN COLEMAN, EXAMINING ATTORNEY

SN 85-564,200. COMBINED PROPERTIES, INC., MALDEN, MA. FILED 3-8-2012.

Combined Properties

THE MARK CONSISTS OF STANDARD CHARACTERS WITHOUT CLAIM TO ANY PARTICULAR FONT, STYLE, SIZE, OR COLOR.

NO CLAIM IS MADE TO THE EXCLUSIVE RIGHT TO USE "PROPERTIES", APART FROM THE MARK AS SHOWN.

FOR REAL ESTATE MANAGEMENT SERVICES (U.S. CLS. 100, 101 AND 102).

FIRST USE 5-24-1977; IN COMMERCE 5-24-1977.

SOPHIA S. KIM, EXAMINING ATTORNEY

SN 85-569,562. OAK STREET FUNDING LLC, CARMEL, IN. FILED 3-14-2012.

OAK STREET LENDING

THE MARK CONSISTS OF STANDARD CHARACTERS WITHOUT CLAIM TO ANY PARTICULAR FONT, STYLE, SIZE, OR COLOR.

OWNER OF U.S. REG. NOS. 2,929,595, 3,041,510 AND 4,123,944.

NO CLAIM IS MADE TO THE EXCLUSIVE RIGHT TO USE "LENDING", APART FROM THE MARK AS SHOWN.

FOR FINANCIAL SERVICES, NAMELY, MONEY LENDING (U.S. CLS. 100, 101 AND 102).

FIRST USE 3-9-2012; IN COMMERCE 3-9-2012.

STEVEN JACKSON, EXAMINING ATTORNEY

CLASS 36—(Continued).

SN 85-569,573. OAK STREET FUNDING LLC, CARMEL, IN.
FILED 3-14-2012.



OWNER OF U.S. REG. NOS. 2,929,595, 3,041,510 AND 4,123,944.

NO CLAIM IS MADE TO THE EXCLUSIVE RIGHT TO USE "LENDING", APART FROM THE MARK AS SHOWN.

THE MARK CONSISTS OF A THREE DIMENSIONAL DEPICTION OF THE EXTERIOR OF A BUILDING STRUCTURE COMPOSED OF HORIZONTAL AND DIAGONAL BARS WITH THE WORDS "OAK STREET LENDING" POSITIONED TO ITS LEFT.

FOR FINANCIAL SERVICES, NAMELY, MONEY LENDING (U.S. CLS. 100, 101 AND 102).

FIRST USE 3-9-2012; IN COMMERCE 3-9-2012.
STEVEN JACKSON, EXAMINING ATTORNEY

SN 85-574,161. WHEATON BANK & TRUST COMPANY,
WHEATON, IL. FILED 3-20-2012.

GLEN ELLYN BANK & TRUST

THE MARK CONSISTS OF STANDARD CHARACTERS WITHOUT CLAIM TO ANY PARTICULAR FONT, STYLE, SIZE, OR COLOR.

OWNER OF U.S. REG. NO. 3,074,955.

NO CLAIM IS MADE TO THE EXCLUSIVE RIGHT TO USE "BANK & TRUST", APART FROM THE MARK AS SHOWN.

SEC. 2(F).

FOR BANKING SERVICES (U.S. CLS. 100, 101 AND 102).

FIRST USE 11-23-2005; IN COMMERCE 11-23-2005.
THOMAS MANOR, EXAMINING ATTORNEY

CLASS 36—(Continued).

SN 85-575,545. SELECTHEALTH, INC., MURRAY, UT.
FILED 3-21-2012.

GENERIC SAMPLE

THE MARK CONSISTS OF STANDARD CHARACTERS WITHOUT CLAIM TO ANY PARTICULAR FONT, STYLE, SIZE, OR COLOR.

SEC. 2(F).

FOR UNDERWRITING, ADMINISTRATION AND MANAGEMENT OF PRESCRIPTION DRUG BENEFITS, PRESCRIPTION DRUG PLANS AND SPECIALTY PHARMACY BENEFITS (U.S. CLS. 100, 101 AND 102).

FIRST USE 9-30-2003; IN COMMERCE 9-30-2003.
DEBORAH LOBO, EXAMINING ATTORNEY

SN 85-575,687. SELECTHEALTH, INC., MURRAY, UT.
FILED 3-21-2012.

SELECT CARE

THE MARK CONSISTS OF STANDARD CHARACTERS WITHOUT CLAIM TO ANY PARTICULAR FONT, STYLE, SIZE, OR COLOR.

OWNER OF U.S. REG. NOS. 3,808,620, 3,823,259 AND OTHERS.

NO CLAIM IS MADE TO THE EXCLUSIVE RIGHT TO USE "CARE", APART FROM THE MARK AS SHOWN.

FOR UNDERWRITING AND ADMINISTRATION OF MEDICAL, HEALTH AND PRESCRIPTION DRUG INSURANCE PLANS (U.S. CLS. 100, 101 AND 102).

FIRST USE 4-3-2006; IN COMMERCE 4-3-2006.
DEBORAH LOBO, EXAMINING ATTORNEY

SN 85-577,929. CADIAN CAPITAL MANAGEMENT, LLC,
NEW YORK, NY. FILED 3-23-2012.

CADIAN CAPITAL

THE MARK CONSISTS OF STANDARD CHARACTERS WITHOUT CLAIM TO ANY PARTICULAR FONT, STYLE, SIZE, OR COLOR.

NO CLAIM IS MADE TO THE EXCLUSIVE RIGHT TO USE "CAPITAL", APART FROM THE MARK AS SHOWN.

FOR FINANCIAL SERVICES, NAMELY, INVESTMENT MANAGEMENT AND ADVISORY SERVICES (U.S. CLS. 100, 101 AND 102).

FIRST USE 10-1-2007; IN COMMERCE 10-1-2007.
SUZANNE BLANE, EXAMINING ATTORNEY

CLASS 36—(Continued).

SN 85-581,048. HORIZON TRUST COMPANY, ALBUQUERQUE, NM. FILED 3-27-2012.

Horizon Trust Company

THE MARK CONSISTS OF STANDARD CHARACTERS WITHOUT CLAIM TO ANY PARTICULAR FONT, STYLE, SIZE, OR COLOR.

NO CLAIM IS MADE TO THE EXCLUSIVE RIGHT TO USE "TRUST COMPANY", APART FROM THE MARK AS SHOWN.

FOR INDIVIDUAL RETIREMENT ACCOUNT SERVICES; TRUST SERVICES, NAMELY, INVESTMENT AND TRUST COMPANY SERVICES (U.S. CLS. 100, 101 AND 102).

FIRST USE 7-18-2011; IN COMMERCE 7-18-2011. CATHERINE ROEHL, EXAMINING ATTORNEY

CLASS 36—(Continued).

SN 85-581,101. LIBERTY MUTUAL INSURANCE COMPANY, BOSTON, MA. FILED 3-27-2012.

LIBERTY INSURANCE UNDERWRITERS INC.

THE MARK CONSISTS OF STANDARD CHARACTERS WITHOUT CLAIM TO ANY PARTICULAR FONT, STYLE, SIZE, OR COLOR.

OWNER OF U.S. REG. NOS. 1,405,249, 3,653,280 AND OTHERS.

NO CLAIM IS MADE TO THE EXCLUSIVE RIGHT TO USE "INSURANCE UNDERWRITERS INC.", APART FROM THE MARK AS SHOWN.

FOR INSURANCE SERVICES, NAMELY, INSURANCE UNDERWRITING AND ADMINISTRATION OF INSURANCE IN THE FIELDS OF GENERAL LIABILITY, DIRECTORS' AND OFFICERS' LIABILITY, PROFESSIONAL INDEMNITY, NAMELY, ERRORS AND OMISSIONS COVERAGE FOR ARCHITECTS, ENGINEERS, ACCOUNTANTS, LAWYERS, INSURANCE CARRIERS, REAL ESTATE APPRAISERS, HOME INSPECTORS, AND TEMPORARY STAFFING FIRMS, KIDNAP AND RANSOM, EMPLOYMENT PRACTICES, ENVIRONMENTAL LOSS, EXCESS AND UMBRELLA CASUALTY IN THE FIELDS OF GENERAL LIABILITY, DIRECTORS' AND OFFICERS' LIABILITY, PROFESSIONAL INDEMNITY, NAMELY, ERRORS AND OMISSIONS COVERAGE FOR ARCHITECTS, ENGINEERS, ACCOUNTANTS, LAWYERS, INSURANCE CARRIERS, REAL ESTATE APPRAISERS, HOME INSPECTORS, AND TEMPORARY STAFFING FIRMS, EMPLOYMENT PRACTICES, ENVIRONMENTAL LOSS, PRODUCT LIABILITY, MARINE AND OCEAN MARINE, NAMELY, CARGO AND COMMERCIAL HULL PROTECTION AND INDEMNITY, FIDELITY, OFFSHORE ENERGY, EXCESS MARINE LIABILITY, OIL, GAS AND PETROCHEMICALS, POWER GENERATION, CONSTRUCTION AND ERECTION, ENGINEERING, AND DELAYED BUSINESS INTERRUPTION; REINSURANCE UNDERWRITING; INSURANCE BROKERAGE SERVICES; INSURANCE CLAIMS ADMINISTRATION AND ADJUSTMENT SERVICES PROVIDED AS PART OF INSURED PROGRAMS; INSURANCE CONSULTING SERVICES IN THE ABOVE-LISTED INSURANCE FIELDS; PROVIDING INSURANCE INFORMATION; AND PROVISION OF THE ABOVE-LISTED INSURANCE SERVICES ONLINE FROM A COMPUTER DATABASE OR VIA THE INTERNET (U.S. CLS. 100, 101 AND 102).

FIRST USE 11-30-1999; IN COMMERCE 11-30-1999. ALEXANDER L. POWERS, EXAMINING ATTORNEY

SN 85-583,834. NORTH AMERICAN TRADING & LOGISTICS, LLC, GRAND RAPIDS, MI. FILED 3-29-2012.

NORTH AMERICAN TRADING & LOGISTICS

THE MARK CONSISTS OF STANDARD CHARACTERS WITHOUT CLAIM TO ANY PARTICULAR FONT, STYLE, SIZE, OR COLOR.

NO CLAIM IS MADE TO THE EXCLUSIVE RIGHT TO USE "TRADING", APART FROM THE MARK AS SHOWN. SEC. 2(F).

FOR COMMODITY INVESTMENT ADVICE; COMMODITY TRADING FOR OTHERS (U.S. CLS. 100, 101 AND 102).

FIRST USE 1-31-2001; IN COMMERCE 1-31-2001. JEAN IM, EXAMINING ATTORNEY

CLASS 36—(Continued).

SN 85-583,870. WELLS FARGO & COMPANY, MINNEAPOLIS, MN. FILED 3-29-2012.

MY RETIREMENT PLAN

THE MARK CONSISTS OF STANDARD CHARACTERS WITHOUT CLAIM TO ANY PARTICULAR FONT, STYLE, SIZE, OR COLOR.

NO CLAIM IS MADE TO THE EXCLUSIVE RIGHT TO USE "RETIREMENT PLAN", APART FROM THE MARK AS SHOWN.

FOR FINANCIAL RETIREMENT PLANNING SERVICES; PROVIDING INFORMATION ON THE FINANCIAL ASPECTS OF RETIREMENT; PROVIDING ONLINE FINANCIAL CALCULATORS (U.S. CLS. 100, 101 AND 102).

MAYUR VAGHANI, EXAMINING ATTORNEY

CLASS 36—(Continued).

SN 85-584,674. SELECTHEALTH, INC., MURRAY, UT. FILED 3-30-2012.

SELECT CARE PLUS

THE MARK CONSISTS OF STANDARD CHARACTERS WITHOUT CLAIM TO ANY PARTICULAR FONT, STYLE, SIZE, OR COLOR.

OWNER OF U.S. REG. NOS. 3,823,259, 3,895,561 AND OTHERS.

NO CLAIM IS MADE TO THE EXCLUSIVE RIGHT TO USE "CARE", APART FROM THE MARK AS SHOWN.

FOR UNDERWRITING AND ADMINISTRATION OF MEDICAL, HEALTH AND PRESCRIPTION DRUG INSURANCE PLANS (U.S. CLS. 100, 101 AND 102).

FIRST USE 4-3-2006; IN COMMERCE 4-3-2006.

DEBORAH LOBO, EXAMINING ATTORNEY

SN 85-584,346. LINDSEY AND LINDSEY WEALTH MANAGEMENT, INC., WESTLAKE VILLAGE, CA. FILED 3-30-2012.



NO CLAIM IS MADE TO THE EXCLUSIVE RIGHT TO USE "WEALTH MANAGEMENT", APART FROM THE MARK AS SHOWN.

THE MARK CONSISTS OF THE LITERAL ELEMENTS "LINDSEY & LINDSEY WEALTH MANAGEMENT" WRITTEN IN STYLIZED FORM WHEREIN THE WORDS "& LINDSEY" ARE WRITTEN BENEATH THE WORD "LINDSEY" AND BENEATH "& LINDSEY" THE WORDS "WEALTH MANAGEMENT" ARE WRITTEN AND AN IMAGE OF THREE MOUNTAINS IN A RANGE IS PLACED ABOVE THE WORD "LINDSEY" AS SHOWN IN THE MARK.

FOR INSURANCE AND FINANCIAL SERVICES, NAMELY, PROVIDING ADVICE IN THE FIELD OF, AND BROKERING, ANNUITIES, EQUITIES, STOCKS, MUTUAL FUNDS, LIFE INSURANCE, LONG TERM CARE INSURANCE, MUNICIPAL BONDS, CORPORATE BONDS, UNIT INVESTMENT TRUSTS; FINANCIAL PLANNING SERVICES (U.S. CLS. 100, 101 AND 102).

JEFFREY LOOK, EXAMINING ATTORNEY

SN 85-585,372. THE GOLDEN STAR USA FOUNDATION INC., FISHERS, IN. FILED 3-30-2012.



THE GOLDEN STAR USA
FOUNDATION

NO CLAIM IS MADE TO THE EXCLUSIVE RIGHT TO USE "USA" AND "FOUNDATION", APART FROM THE MARK AS SHOWN.

THE COLOR(S) BLACK, PURPLE, GOLD, GRAY AND WHITE IS/ARE CLAIMED AS A FEATURE OF THE MARK.

THE MARK CONSISTS OF A STAR OUTLINED IN PURPLE WITH GOLD INSIDE AND A WHITE DIAMOND CENTER WITH FIVE GRAY SPOKES EMANATING FROM THE INDENTIONS, WITH THE WORDS "THE GOLDEN STAR USA" IN BLACK AND "FOUNDATION" IN PURPLE, STACKED UNDERNEATH THE STAR.

FOR CHARITABLE FOUNDATION SERVICES, NAMELY, PROVIDING FINANCIAL SUPPORT AND FUNDRAISING ACTIVITIES FOR MILITARY FAMILIES (U.S. CLS. 100, 101 AND 102).

FIRST USE 11-30-2010; IN COMMERCE 11-30-2010.

JOHN WILKE, EXAMINING ATTORNEY

CLASS 36—(Continued).

SN 85-585,444. THE GOLDEN STAR USA FOUNDATION INC., FISHERS, IN. FILED 3-30-2012.



THE COLOR(S) YELLOW, GOLD AND TAN IS/ARE CLAIMED AS A FEATURE OF THE MARK.

THE MARK CONSISTS OF A RIBBON WITH A YELLOW, GOLD AND TAN CAMOUFLAGE PATTERN FORMING A HEART SHAPE.

FOR CHARITABLE FOUNDATION SERVICES, NAMELY, PROVIDING FINANCIAL SUPPORT AND FUNDRAISING ACTIVITIES FOR MILITARY FAMILIES (U.S. CLS. 100, 101 AND 102).

FIRST USE 11-30-2010; IN COMMERCE 11-30-2010.
JOHN WILKE, EXAMINING ATTORNEY

SN 85-585,674. HOPE LOANPORT, INC., WASHINGTON, DC. FILED 3-31-2012.

HOPE LOANPORT HOMEOWNER
CONNECT

THE MARK CONSISTS OF STANDARD CHARACTERS WITHOUT CLAIM TO ANY PARTICULAR FONT, STYLE, SIZE, OR COLOR.

OWNER OF U.S. REG. NO. 3,917,935.

NO CLAIM IS MADE TO THE EXCLUSIVE RIGHT TO USE "HOMEOWNER CONNECT", APART FROM THE MARK AS SHOWN.

FOR FINANCIAL SERVICES, NAMELY, PROVIDING A WEB-BASED PORTAL THAT FACILITATES LOAN MODIFICATIONS AND OTHER OPTIONS FOR HOMEOWNERS TO PREVENT FORECLOSURE (U.S. CLS. 100, 101 AND 102).

EMILY CHUO, EXAMINING ATTORNEY

CLASS 36—(Continued).

SN 85-586,547. JETEX FZCO, DUBAI, UNITED ARAB EMIR., FILED 4-2-2012.

JETEX

THE MARK CONSISTS OF STANDARD CHARACTERS WITHOUT CLAIM TO ANY PARTICULAR FONT, STYLE, SIZE, OR COLOR.

FOR AIRCRAFT BROKERAGE (U.S. CLS. 100, 101 AND 102).

JACQUELINE A. LAVINE, EXAMINING ATTORNEY

SN 85-587,013. LANDMAX, INC., VICTORIA, CANADA, FILED 4-2-2012.

LANDMAX

THE MARK CONSISTS OF STANDARD CHARACTERS WITHOUT CLAIM TO ANY PARTICULAR FONT, STYLE, SIZE, OR COLOR.

FOR REAL ESTATE BROKERAGE SERVICES; REAL ESTATE CONSULTING AND ADVISORY SERVICES; REAL ESTATE VALUATION SERVICES; REAL ESTATE MULTIPLE LISTING SERVICES; MORTGAGE BROKERAGE SERVICES; REAL ESTATE FINANCING SERVICES; INSURANCE BROKERAGE SERVICES (U.S. CLS. 100, 101 AND 102).

BRIDGETT SMITH, EXAMINING ATTORNEY

SN 85-588,625. ZENPAYMENTS, LLC, DBA ZENPAY, GREAT NECK, NY. FILED 4-4-2012.

ZenPay

THE MARK CONSISTS OF STANDARD CHARACTERS WITHOUT CLAIM TO ANY PARTICULAR FONT, STYLE, SIZE, OR COLOR.

FOR CREDIT CARD PAYMENT PROCESSING SERVICES; MERCHANT SERVICES, NAMELY, PAYMENT TRANSACTION PROCESSING SERVICES; PAYMENT PROCESSING SERVICES, NAMELY, CREDIT CARD AND DEBIT CARD TRANSACTION PROCESSING SERVICES; PROVIDING ELECTRONIC PROCESSING OF ELECTRONIC FUNDS TRANSFER, ACH, CREDIT CARD, DEBIT CARD, ELECTRONIC CHECK AND ELECTRONIC PAYMENTS (U.S. CLS. 100, 101 AND 102).

GIANCARLO CASTRO, EXAMINING ATTORNEY

CLASS 36—(Continued).

SN 85-589,095. OPENING VILLAGE DOORS FOUNDATION, GRAND RAPIDS, MI. FILED 4-4-2012.



OWNER OF U.S. REG. NO. 3,831,562.
NO CLAIM IS MADE TO THE EXCLUSIVE RIGHT TO USE "FOUNDATION", APART FROM THE MARK AS SHOWN.

THE MARK CONSISTS OF THREE HOUSES ON A SEMI-CIRCLE BACKGROUND, WITH THE WORDS "OPENING VILLAGE DOORS FOUNDATION" UNDERNEATH.

FOR CHARITABLE FUNDRAISING, NAMELY, BY PROVIDING INDIVIDUALS WITH THE INFORMATION AND OPPORTUNITY TO MAKE MONETARY DONATIONS (U.S. CLS. 100, 101 AND 102).

FIRST USE 6-5-2009; IN COMMERCE 6-5-2009.
MARGERY A. TIERNEY, EXAMINING ATTORNEY

SN 85-589,378. BRAND ADVENTURES, LLC, DALLAS, TX. FILED 4-4-2012.

COWBOY BAIL BONDS

THE MARK CONSISTS OF STANDARD CHARACTERS WITHOUT CLAIM TO ANY PARTICULAR FONT, STYLE, SIZE, OR COLOR.

NO CLAIM IS MADE TO THE EXCLUSIVE RIGHT TO USE "BAIL BONDS", APART FROM THE MARK AS SHOWN.

FOR BAIL BONDING (U.S. CLS. 100, 101 AND 102).
FIRST USE 7-31-1997; IN COMMERCE 7-31-1997.
KIMBERLY PARKS, EXAMINING ATTORNEY

SN 85-589,666. HENRY PROPERTY MANAGEMENT, LLC, CARY, NC. FILED 4-5-2012.



THE MARK CONSISTS OF A STYLIZED LETTER "H" THAT FORMS A HOUSE.

FOR REAL ESTATE MANAGEMENT; LEASING OF REAL ESTATE (U.S. CLS. 100, 101 AND 102).
FIRST USE 3-1-2010; IN COMMERCE 4-2-2010.
MARLENE BELL, EXAMINING ATTORNEY

CLASS 36—(Continued).

SN 85-590,686. TAQTIQA, AKA TAQTIQA.COM, WILMINGTON, DE. FILED 4-5-2012.



THE MARK CONSISTS OF THE CAPITALIZED LETTER "T", PLACED WITHIN AN ENCOMPASSING CIRCLE. THE ENCOMPASSING CIRCLE IS BROKEN INTO FOUR SEGMENTS.

FOR FINANCIAL ANALYSIS AND RESEARCH SERVICES; FINANCIAL INFORMATION; FINANCIAL INFORMATION PROCESSING; FINANCIAL INFORMATION SERVICES PROVIDED ON-LINE FROM A COMPUTER DATABASE OR A GLOBAL COMPUTER NETWORK, NAMELY, PROVIDING INFORMATION IN THE FIELD OF FINANCIAL CLASSIFICATION OF COMPANIES AND SECURITIES; PROVIDING ON-LINE FINANCIAL CALCULATORS; PROVISION OF FINANCIAL INFORMATION (U.S. CLS. 100, 101 AND 102).
BRIAN PINO, EXAMINING ATTORNEY

SN 85-591,063. THE MUSTACHE OPEN ENTERPRISES LLC, SCOTTSDALE, AZ. FILED 4-6-2012.

THE MUSTACHE OPEN

THE MARK CONSISTS OF STANDARD CHARACTERS WITHOUT CLAIM TO ANY PARTICULAR FONT, STYLE, SIZE, OR COLOR.

NO CLAIM IS MADE TO THE EXCLUSIVE RIGHT TO USE "OPEN", APART FROM THE MARK AS SHOWN.

FOR CHARITABLE FUNDRAISING SERVICES BY MEANS OF AN ENTERTAINMENT EVENT (U.S. CLS. 100, 101 AND 102).

DAVID COLLIER, EXAMINING ATTORNEY

CLASS 36—(Continued).

SN 85-592,189. INVOLVEDFAN.COM, LLC., MIAMI, FL. FILED 4-9-2012.



NO CLAIM IS MADE TO THE EXCLUSIVE RIGHT TO USE ".COM", APART FROM THE MARK AS SHOWN.

THE MARK CONSISTS OF THE STYLIZED WORDS "INVOLVED FAN .COM" WITH "INVOLVED" APPEARING TO THE LEFT OF "FAN .COM", WHICH IS CONTAINED IN A STYLIZED PENNANT/FLAG.

FOR ON-LINE BUSINESS FUNDRAISING SERVICES FOR ATHLETES (U.S. CLS. 100, 101 AND 102).

FIRST USE 12-1-2011; IN COMMERCE 12-1-2011.

TRICIA SONNEBORN, EXAMINING ATTORNEY

SN 85-592,379. FARMSTART, LLP, ENFIELD, CT. FILED 4-9-2012.



NO CLAIM IS MADE TO THE EXCLUSIVE RIGHT TO USE "FARM" AND "LLP" AND "SEED CAPITAL", APART FROM THE MARK AS SHOWN.

THE MARK CONSISTS OF THE WORDING "FARM-START, LLP SEED CAPITAL" WITH A DRAWING OF A SEEDLING BETWEEN THE WORDS "FARM" AND "START".

FOR FINANCIAL CONSULTATION AND MONEY LENDING TO BEGINNING FARMERS AND NEW FARMER COOPERATIVES (U.S. CLS. 100, 101 AND 102).

FIRST USE 7-21-2006; IN COMMERCE 7-21-2006.

MARK T. MULLEN, EXAMINING ATTORNEY

SN 85-593,695. JOHN HANCOCK LIFE INSURANCE COMPANY (U.S.A.), BOSTON, MA. FILED 4-10-2012.

VUL TARGETTRACK

THE MARK CONSISTS OF STANDARD CHARACTERS WITHOUT CLAIM TO ANY PARTICULAR FONT, STYLE, SIZE, OR COLOR.

NO CLAIM IS MADE TO THE EXCLUSIVE RIGHT TO USE "VUL", APART FROM THE MARK AS SHOWN.

FOR INSURANCE ADMINISTRATION (U.S. CLS. 100, 101 AND 102).

NANCY CLARKE, EXAMINING ATTORNEY

CLASS 36—(Continued).

SN 85-594,171. GHX VENTURES LLC, AUSTIN, TX. FILED 4-11-2012.

GHX Ventures

THE MARK CONSISTS OF STANDARD CHARACTERS WITHOUT CLAIM TO ANY PARTICULAR FONT, STYLE, SIZE, OR COLOR.

NO CLAIM IS MADE TO THE EXCLUSIVE RIGHT TO USE "VENTURES", APART FROM THE MARK AS SHOWN.

FOR ADVICE RELATING TO INVESTMENTS; ADVISING OTHERS CONCERNING INVESTMENTS IN INTELLECTUAL PROPERTY ASSETS AND INTANGIBLE BUSINESS ASSETS, BOTH DIRECTLY AND INDIRECTLY THROUGH OTHER ENTITIES; CAPITAL INVESTMENT CONSULTING; CAPITAL INVESTMENT SERVICES; CONSULTANCY OF CAPITAL INVESTMENT; REAL ESTATE INVESTMENT SERVICES (U.S. CLS. 100, 101 AND 102).

TINA L. SNAPP, EXAMINING ATTORNEY

SN 85-594,260. ONE DOOR RESIDENTIAL MANAGEMENT, LLC, TELLURIDE, CO. FILED 4-11-2012.

ONE DOOR

THE MARK CONSISTS OF STANDARD CHARACTERS WITHOUT CLAIM TO ANY PARTICULAR FONT, STYLE, SIZE, OR COLOR.

FOR REAL ESTATE MANAGEMENT SERVICES (U.S. CLS. 100, 101 AND 102).

MICHAEL ENGEL, EXAMINING ATTORNEY

SN 85-594,690. BEAUTIFUL SAVIOR LUTHERAN CHURCH AND ACADEMY CHARITIES, TUCSON, AZ. FILED 4-11-2012.

"LUNCH-BREAK"

THE MARK CONSISTS OF STANDARD CHARACTERS WITHOUT CLAIM TO ANY PARTICULAR FONT, STYLE, SIZE, OR COLOR.

FOR CHARITABLE SERVICES, NAMELY, PROVIDING FINANCIAL ASSISTANCE TO MEET THE PHYSICAL, PSYCHOLOGICAL, SOCIAL AND OTHER SPECIAL NEEDS OF CHILDREN (U.S. CLS. 100, 101 AND 102).

FIRST USE 2-21-2011; IN COMMERCE 2-21-2011.

JIM RINGLE, EXAMINING ATTORNEY

CLASS 36—(Continued).

SN 85-595,041. TIMESHARE KING, INC., THE, ORLANDO, FL. FILED 4-11-2012.

THE HARBORSIDE KING

THE MARK CONSISTS OF STANDARD CHARACTERS WITHOUT CLAIM TO ANY PARTICULAR FONT, STYLE, SIZE, OR COLOR.

FOR REAL ESTATE TIMESHARE SERVICES (U.S. CLS. 100, 101 AND 102).

FIRST USE 4-2-2008; IN COMMERCE 6-1-2008.
HOWARD SMIGA, EXAMINING ATTORNEY

SN 85-595,157. HANNAH'S HOPE FOR GIANT AXONAL NEUROPATHY, INC., DBA HANNAH'S HOPE FUND, REXFORD, NY. FILED 4-11-2012.

HANNAH'S HOPE FUND

THE MARK CONSISTS OF STANDARD CHARACTERS WITHOUT CLAIM TO ANY PARTICULAR FONT, STYLE, SIZE, OR COLOR.

NO CLAIM IS MADE TO THE EXCLUSIVE RIGHT TO USE "FUND", APART FROM THE MARK AS SHOWN.

FOR ACCEPTING AND ADMINISTERING MONETARY CHARITABLE CONTRIBUTIONS; ACCEPTING AND ADMINISTERING MONETARY CHARITABLE CONTRIBUTIONS TO FUND MEDICAL RESEARCH; CHARITABLE FOUNDATION SERVICES, NAMELY, PROVIDING FUNDRAISING ACTIVITIES TO SUPPORT MEDICAL RESEARCH AND PROCEDURES FOR THOSE IN NEED; CHARITABLE FUNDRAISING; CHARITABLE FUNDRAISING TO SUPPORT MEDICAL RESEARCH AND TREATMENT OF GIANT AXONAL NEUROPATHY (GAN); CHARITABLE SERVICES, NAMELY, ORGANIZING FUNDRAISING SERVICES AND EVENTS TO RAISE FUNDS IN THE FIELD OF MEDICAL RESEARCH AND TREATMENT OF GIANT AXONAL NEUROPATHY (GAN) (U.S. CLS. 100, 101 AND 102).

FIRST USE 7-31-2008; IN COMMERCE 7-31-2008.
LEE-ANNE BERNIS, EXAMINING ATTORNEY

CLASS 36—(Continued).

SN 85-595,335. EMPIRE WEST TITLE AGENCY, LLC, PHOENIX, AZ. FILED 4-11-2012.

EMPIRE WEST TITLE AGENCY

THE MARK CONSISTS OF STANDARD CHARACTERS WITHOUT CLAIM TO ANY PARTICULAR FONT, STYLE, SIZE, OR COLOR.

NO CLAIM IS MADE TO THE EXCLUSIVE RIGHT TO USE "TITLE AGENCY", APART FROM THE MARK AS SHOWN.

FOR PROVIDING HOME WARRANTY ADMINISTRATION; REAL ESTATE ESCROW SERVICES; REAL ESTATE TITLE INSURANCE UNDERWRITING SERVICES (U.S. CLS. 100, 101 AND 102).

FIRST USE 6-2-2008; IN COMMERCE 6-2-2008.
CHRISTINE MARTIN, EXAMINING ATTORNEY

SN 85-595,603. CELL PHONE REPAIR LLC, ORLANDO, FL. FILED 4-12-2012.



OWNER OF U.S. REG. NOS. 3,014,015 AND 3,444,694.
THE MARK CONSISTS OF A SHIELD INSIDE OF WHICH IS A PLUS SIGN INSIDE OF WHICH IS THE TERM "CPR" AND ALL TO THE LEFT OF THE WORD "SHIELD".

FOR PROVIDING WARRANTIES ON GOODS MANUFACTURED BY OTHERS, NAMELY, PDAS, CELLULAR PHONES, MOBILE PHONES, SMARTPHONES, TELEPHONES, AND MOBILE ELECTRONIC DEVICES (U.S. CLS. 100, 101 AND 102).

RENEE MCCRAY, EXAMINING ATTORNEY

SN 85-595,979. MAKI FOUNDATION, ASPEN, CO. FILED 4-12-2012.

Maki Foundation

THE MARK CONSISTS OF STANDARD CHARACTERS WITHOUT CLAIM TO ANY PARTICULAR FONT, STYLE, SIZE, OR COLOR.

NO CLAIM IS MADE TO THE EXCLUSIVE RIGHT TO USE "FOUNDATION", APART FROM THE MARK AS SHOWN.

FOR PROVIDING GRANTS FOR ENVIRONMENTAL PROTECTION (U.S. CLS. 100, 101 AND 102).

FIRST USE 12-5-1980; IN COMMERCE 7-30-1981.
NAAKWAMA ANKRAH, EXAMINING ATTORNEY

CLASS 36—(Continued).

SN 85-595,996. CAROLINA JEWELRY & PAWN, INC., DURHAM, NC. FILED 4-12-2012.

PICASSO PAWN LIKE NO PAWN
SHOP YOU HAVE EVER SEEN!

THE MARK CONSISTS OF STANDARD CHARACTERS WITHOUT CLAIM TO ANY PARTICULAR FONT, STYLE, SIZE, OR COLOR.

OWNER OF U.S. REG. NO. 3,912,030.
NO CLAIM IS MADE TO THE EXCLUSIVE RIGHT TO USE "PAWN", APART FROM THE MARK AS SHOWN. FOR PAWN SHOPS (U.S. CLS. 100, 101 AND 102).
FIRST USE 9-0-2011; IN COMMERCE 9-0-2011.
TOBY BULLOFF, EXAMINING ATTORNEY

SN 85-596,109. MAZDA MOTOR OF AMERICA, INC., IRVINE, CA. FILED 4-12-2012.

MEC

THE MARK CONSISTS OF STANDARD CHARACTERS WITHOUT CLAIM TO ANY PARTICULAR FONT, STYLE, SIZE, OR COLOR.

FOR EXTENDED WARRANTY SERVICES, NAMELY, SERVICE CONTRACTS; PROVIDING EXTENDED WARRANTIES ON AUTOMOBILES (U.S. CLS. 100, 101 AND 102).
KELLY TRUSILO, EXAMINING ATTORNEY

SN 85-596,257. BERKADIA COMMERCIAL MORTGAGE LLC, HORSHAM, PA. FILED 4-12-2012.

THE SERVICER'S SERVICER

THE MARK CONSISTS OF STANDARD CHARACTERS WITHOUT CLAIM TO ANY PARTICULAR FONT, STYLE, SIZE, OR COLOR.

NO CLAIM IS MADE TO THE EXCLUSIVE RIGHT TO USE "SERVICER", APART FROM THE MARK AS SHOWN. FOR FINANCIAL SERVICES, NAMELY, THIRD PARTY SERVICING OF COMMERCIAL LOANS, INCLUDING FINANCIAL ASSET MANAGEMENT, LOAN ADMINISTRATION, AND DEFAULT MITIGATION SERVICES (U.S. CLS. 100, 101 AND 102).
MAYUR VAGHANI, EXAMINING ATTORNEY

CLASS 36—(Continued).

SN 85-596,286. AVEX FUNDING CORPORATION, MILPITAS, CA. FILED 4-12-2012.

AVEX FUNDING A MORTGAGE BANK
YOU CAN TRUST

THE MARK CONSISTS OF STANDARD CHARACTERS WITHOUT CLAIM TO ANY PARTICULAR FONT, STYLE, SIZE, OR COLOR.

NO CLAIM IS MADE TO THE EXCLUSIVE RIGHT TO USE "FUNDING", APART FROM THE MARK AS SHOWN. FOR MORTGAGE BANKING SERVICES, NAMELY, ORIGINATION, ACQUISITION, SERVICING, SECURITIZATION AND BROKERAGE OF MORTGAGE LOANS (U.S. CLS. 100, 101 AND 102).
FIRST USE 10-1-2009; IN COMMERCE 10-1-2009.
JAMES GRIFFIN, EXAMINING ATTORNEY

SN 85-596,325. FIREKEEPER INVESTMENTS LLC, GREENWICH, CT. FILED 4-12-2012.

Firekeeper Investments

THE MARK CONSISTS OF STANDARD CHARACTERS WITHOUT CLAIM TO ANY PARTICULAR FONT, STYLE, SIZE, OR COLOR.

NO CLAIM IS MADE TO THE EXCLUSIVE RIGHT TO USE "INVESTMENTS", APART FROM THE MARK AS SHOWN.
FOR INVESTMENT CONSULTATION; INVESTMENT MANAGEMENT (U.S. CLS. 100, 101 AND 102).
GILBERT SWIFT, EXAMINING ATTORNEY

SN 85-596,410. MASSACHUSETTS EDUCATIONAL FINANCING AUTHORITY, BOSTON, MA. FILED 4-12-2012.

U.PLAN

THE MARK CONSISTS OF STANDARD CHARACTERS WITHOUT CLAIM TO ANY PARTICULAR FONT, STYLE, SIZE, OR COLOR.

FOR FINANCIAL SERVICES, NAMELY, PROVIDING EDUCATIONAL SAVINGS AND PRE-PAID TUITION PROGRAMS FOR COLLEGES AND UNIVERSITIES; INVESTMENT OF FUNDS FOR OTHERS FOR THE PURPOSE OF FINANCING HIGHER EDUCATION (U.S. CLS. 100, 101 AND 102).
FIRST USE 0-0-1995; IN COMMERCE 0-0-1995.
SANDRA BUJA, EXAMINING ATTORNEY

CLASS 36—(Continued).

SN 85-596,427. ABOWD & ROSE FINANCIAL GROUP, LLC,
CARSON CITY, NV. FILED 4-12-2012.



NO CLAIM IS MADE TO THE EXCLUSIVE RIGHT TO USE "FINANCIAL GROUP", APART FROM THE MARK AS SHOWN.

THE MARK CONSISTS OF A STYLIZED DRAWING OF A CHECKERBOARD OF SQUARES WITH THE STYLIZED WORDING "ABOWD & ROSE FINANCIAL GROUP".

FOR FINANCIAL CONSULTING (U.S. CLS. 100, 101 AND 102).

AMEEN IMAM, EXAMINING ATTORNEY

SN 85-596,447. THE WITTE MUSEUM, SAN ANTONIO, TX.
FILED 4-12-2012.



THE MARK CONSISTS OF A STYLIZED "W".
FOR CHARITABLE SERVICES, NAMELY, ORGANIZING FUNDRAISING SERVICES AND EVENTS TO RAISE FUNDS IN THE FIELD OF MUSEUMS (U.S. CLS. 100, 101 AND 102).

HEATHER SAPP, EXAMINING ATTORNEY

SN 85-596,464. ABOWD & ROSE FINANCIAL GROUP, LLC,
CARSON CITY, NV. FILED 4-12-2012.

Abowd & Rose Financial
Group

THE MARK CONSISTS OF STANDARD CHARACTERS WITHOUT CLAIM TO ANY PARTICULAR FONT, STYLE, SIZE, OR COLOR.

NO CLAIM IS MADE TO THE EXCLUSIVE RIGHT TO USE "FINANCIAL GROUP", APART FROM THE MARK AS SHOWN.

FOR FINANCIAL CONSULTING (U.S. CLS. 100, 101 AND 102).

AMEEN IMAM, EXAMINING ATTORNEY

CLASS 36—(Continued).

SN 85-596,492. NORTH ISLAND FINANCIAL CREDIT UNION, DBA NORTH ISLAND CREDIT UNION, SAN DIEGO, CA. FILED 4-12-2012.

NiftiCard

THE MARK CONSISTS OF STANDARD CHARACTERS WITHOUT CLAIM TO ANY PARTICULAR FONT, STYLE, SIZE, OR COLOR.

OWNER OF U.S. REG. NO. 3,041,759.

FOR ATM BANKING SERVICES; BANKING AND FINANCING SERVICES (U.S. CLS. 100, 101 AND 102).

FIRST USE 12-15-1998; IN COMMERCE 12-15-1998.

KARANENDRA S. CHHINA, EXAMINING ATTORNEY

SN 85-596,983. DRAKE DAVIS FOUNDATION, INC.,
ATLANTA, GA. FILED 4-13-2012.

SPEAK UP REACH OUT

THE MARK CONSISTS OF STANDARD CHARACTERS WITHOUT CLAIM TO ANY PARTICULAR FONT, STYLE, SIZE, OR COLOR.

FOR CHARITABLE FOUNDATION SERVICES, NAMELY, PROVIDING FUNDRAISING ACTIVITIES BY MEANS OF HOSTING AN ANNUAL GOLF TOURNAMENT AND OTHER FUNDRAISING ACTIVITIES; CHARITABLE FOUNDATION SERVICES, NAMELY, PROVIDING FUNDING, SCHOLARSHIPS AND/OR FINANCIAL ASSISTANCE TO RAISE AWARENESS FOR SUICIDE PREVENTION AND ASSIST PEOPLE WHOSE LIVES HAVE BEEN AFFECTED BY SUICIDE (U.S. CLS. 100, 101 AND 102).

FIRST USE 1-31-2007; IN COMMERCE 1-31-2007.

LINDA M. KING, EXAMINING ATTORNEY

SN 85-597,020. HARGRODER COMPANIES, INC., LAFAYETTE, LA. FILED 4-13-2012.

CompScore

THE MARK CONSISTS OF STANDARD CHARACTERS WITHOUT CLAIM TO ANY PARTICULAR FONT, STYLE, SIZE, OR COLOR.

FOR PROVIDING INFORMATION IN THE FIELD OF THE WORKERS' COMPENSATION INDUSTRY (U.S. CLS. 100, 101 AND 102).

HANNO RITTNER, EXAMINING ATTORNEY

CLASS 36—(Continued).

SN 85-597,170. PLAZA BANK, IRVINE, CA. FILED 4-13-2012.



OWNER OF U.S. REG. NO. 3,300,001.
NO CLAIM IS MADE TO THE EXCLUSIVE RIGHT TO USE "BANK", APART FROM THE MARK AS SHOWN.

THE MARK CONSISTS OF A STYLIZED FANCIFUL LETTER "P" CENTERED ABOVE THE WORDING "PLAZA BANK" AND THE WORDING "ADVANCING SMALL BUSINESS" CENTERED BELOW THE WORDING "PLAZA BANK".

FOR BANKING SERVICES (U.S. CLS. 100, 101 AND 102).

EMILY CHUO, EXAMINING ATTORNEY

SN 85-597,479. BEXIL AMERICAN MORTGAGE INC., SAN DIEGO, CA. FILED 4-13-2012.

AMERICAN MORTGAGE NETWORK

THE MARK CONSISTS OF STANDARD CHARACTERS WITHOUT CLAIM TO ANY PARTICULAR FONT, STYLE, SIZE, OR COLOR.

OWNER OF U.S. REG. NO. 3,245,979.

NO CLAIM IS MADE TO THE EXCLUSIVE RIGHT TO USE "MORTGAGE NETWORK", APART FROM THE MARK AS SHOWN.

SEC. 2(F).
FOR MORTGAGE BANKING SERVICES, NAMELY, ORIGINATION, ACQUISITION, SERVICING, AND BROKERAGE OF MORTGAGE LOANS (U.S. CLS. 100, 101 AND 102).

FIRST USE 11-0-2001; IN COMMERCE 11-0-2001.
APRIL HESIK, EXAMINING ATTORNEY

CLASS 36—(Continued).

SN 85-597,542. NICHOLAS SERVICES, COLUMBUS, MS. FILED 4-13-2012.

Innovative Private Air
Travel

THE MARK CONSISTS OF STANDARD CHARACTERS WITHOUT CLAIM TO ANY PARTICULAR FONT, STYLE, SIZE, OR COLOR.

NO CLAIM IS MADE TO THE EXCLUSIVE RIGHT TO USE "PRIVATE AIR TRAVEL", APART FROM THE MARK AS SHOWN.

FOR OFFERING AIRCRAFT FRACTIONAL OWNERSHIP PROGRAMS TO OTHERS (U.S. CLS. 100, 101 AND 102).

FIRST USE 5-5-2005; IN COMMERCE 5-5-2005.

NAKWAMA ANKRAH, EXAMINING ATTORNEY

SN 85-597,584. CRAIG REALTY GROUP CITADEL, LLC, IRVINE, CA. FILED 4-13-2012.



NO CLAIM IS MADE TO THE EXCLUSIVE RIGHT TO USE "OUTLETS", APART FROM THE MARK AS SHOWN.

THE MARK CONSISTS OF A HORSE WITH WINGS TO THE LEFT OF THE WORDING CITADEL OUTLETS

FOR LEASING OF RETAIL SHOPPING MALL SPACE AND TENANT SERVICES, NAMELY, BUILDING MANAGEMENT OF RETAIL SHOPPING MALL SPACE (U.S. CLS. 100, 101 AND 102).

FIRST USE 1-1-2002; IN COMMERCE 1-1-2002.

SCOTT OSLICK, EXAMINING ATTORNEY

SN 85-597,611. INVESTORSHUB.COM, INC., TALLAHASSEE, FL. FILED 4-13-2012.

IHUB

THE MARK CONSISTS OF STANDARD CHARACTERS WITHOUT CLAIM TO ANY PARTICULAR FONT, STYLE, SIZE, OR COLOR.

FOR PROVIDING PRICE QUOTATIONS FOR STOCKS; PROVIDING AN INTERACTIVE WEB SITE IN THE FIELD OF FINANCIAL NEWS (U.S. CLS. 100, 101 AND 102).

FIRST USE 2-3-2004; IN COMMERCE 2-3-2004.
MARTHA FROMM, EXAMINING ATTORNEY

CLASS 36—(Continued).

SN 85-599,020. EVOLUTION CAPITAL MANAGEMENT PARTNERS LLC, PEPPER PIKE, OH. FILED 4-16-2012.

LEADERS IN GROWING SMALL
BUSINESSES

THE MARK CONSISTS OF STANDARD CHARACTERS WITHOUT CLAIM TO ANY PARTICULAR FONT, STYLE, SIZE, OR COLOR.

FOR FINANCING SERVICES, NAMELY PRIVATE EQUITY FINANCING AND MEZZANINE FINANCING; INVESTMENT SERVICES, NAMELY PRIVATE EQUITY INVESTMENT SERVICES AND MEZZANINE INVESTMENT SERVICES; AND MANAGEMENT OF PRIVATE EQUITY FUNDS (U.S. CLS. 100, 101 AND 102).

ALICE BENMAMAN, EXAMINING ATTORNEY

SN 85-599,029. EVOLUTION CAPITAL MANAGEMENT PARTNERS LLC, PEPPER PIKE, OH. FILED 4-16-2012.

THE LEADER IN GROWING
SECOND STAGE COMPANIES

THE MARK CONSISTS OF STANDARD CHARACTERS WITHOUT CLAIM TO ANY PARTICULAR FONT, STYLE, SIZE, OR COLOR.

FOR FINANCING SERVICES, NAMELY PRIVATE EQUITY FINANCING AND MEZZANINE FINANCING; INVESTMENT SERVICES, NAMELY PRIVATE EQUITY INVESTMENT SERVICES AND MEZZANINE INVESTMENT SERVICES; AND MANAGEMENT OF PRIVATE EQUITY FUNDS (U.S. CLS. 100, 101 AND 102).

ALICE BENMAMAN, EXAMINING ATTORNEY

SN 85-599,037. EVOLUTION CAPITAL MANAGEMENT PARTNERS LLC, PEPPER PIKE, OH. FILED 4-16-2012.

THE LEADERS IN NAVIGATING
NO MAN'S LAND

THE MARK CONSISTS OF STANDARD CHARACTERS WITHOUT CLAIM TO ANY PARTICULAR FONT, STYLE, SIZE, OR COLOR.

FOR FINANCING SERVICES, NAMELY PRIVATE EQUITY FINANCING AND MEZZANINE FINANCING; INVESTMENT SERVICES, NAMELY PRIVATE EQUITY INVESTMENT SERVICES AND MEZZANINE INVESTMENT SERVICES; AND MANAGEMENT OF PRIVATE EQUITY FUNDS (U.S. CLS. 100, 101 AND 102).

ALICE BENMAMAN, EXAMINING ATTORNEY

CLASS 36—(Continued).

SN 85-599,455. WILLIS NORTH AMERICA INC., NASHVILLE, TN. FILED 4-17-2012.

SocialRehabGuard

THE MARK CONSISTS OF STANDARD CHARACTERS WITHOUT CLAIM TO ANY PARTICULAR FONT, STYLE, SIZE, OR COLOR.

FOR INSURANCE SERVICES, NAMELY, INSURANCE AGENCY AND BROKERAGE SERVICES FOR SOCIAL REHABILITATION SERVICES (U.S. CLS. 100, 101 AND 102).

STEVEN JACKSON, EXAMINING ATTORNEY

SN 85-599,459. WILLIS NORTH AMERICA INC., NASHVILLE, TN. FILED 4-17-2012.

AdultDayCareGuard

THE MARK CONSISTS OF STANDARD CHARACTERS WITHOUT CLAIM TO ANY PARTICULAR FONT, STYLE, SIZE, OR COLOR.

FOR INSURANCE SERVICES, NAMELY, INSURANCE AGENCY AND BROKERAGE SERVICES FOR ADULT DAY CARE FACILITIES (U.S. CLS. 100, 101 AND 102).

STEVEN JACKSON, EXAMINING ATTORNEY

SN 85-600,338. SEAWALL FINANCIAL LLC, MIDLOTHIAN, VA. FILED 4-17-2012.

Seawall Financial LLC

THE MARK CONSISTS OF STANDARD CHARACTERS WITHOUT CLAIM TO ANY PARTICULAR FONT, STYLE, SIZE, OR COLOR.

NO CLAIM IS MADE TO THE EXCLUSIVE RIGHT TO USE "FINANCIAL LLC", APART FROM THE MARK AS SHOWN.

FOR INSURANCE AGENCY AND BROKERAGE; INSURANCE CONSULTATION (U.S. CLS. 100, 101 AND 102).

FIRST USE 8-30-2007; IN COMMERCE 8-30-2007.

LYNDSY KUYKENDALL, EXAMINING ATTORNEY

CLASS 36—(Continued).

SN 85-600,770. OHIO VALLEY COMMUNITY CREDIT UNION, CLARINGTON, OH. FILED 4-18-2012.



ONLINE ACCESS | BILL PAY | MOBILE

NO CLAIM IS MADE TO THE EXCLUSIVE RIGHT TO USE "ONLINE ACCESS", "BILL PAY", AND "MOBILE", APART FROM THE MARK AS SHOWN.

THE MARK CONSISTS OF THE WORD "CURCU" WITH TWO SWOOSHES ATTACHED TO THE LEFT SIDE OF THE FIRST "C" AND TWO SWOOSHES ATTACHED TO THE RIGHT SIDE OF THE CAPITAL "U", WITH THE LOWER-CASE "R" OVERLAPPING THE SECOND CAPITAL "C", AND THE WORDS "ONLINE ACCESS", "BILL PAY", AND "MOBILE" SEPARATED BY VERTICAL SLASH MARKS BELOW THE WORD "CURCU".

FOR BANKING SERVICES, NAMELY, PROVIDING ONLINE BANKING SERVICES (U.S. CLS. 100, 101 AND 102).

MICHAEL SOUDERS, EXAMINING ATTORNEY

CLASS 36—(Continued).

SN 85-601,463. FIRST BUSINESS FINANCIAL SERVICES, INC., MADISON, WI. FILED 4-18-2012.

FBIZ

THE MARK CONSISTS OF STANDARD CHARACTERS WITHOUT CLAIM TO ANY PARTICULAR FONT, STYLE, SIZE, OR COLOR.

FOR BANKING SERVICES; FINANCIAL ADMINISTRATION OF QUALIFIED RETIREMENT PLANS; INVESTMENT MANAGEMENT SERVICES; INVESTMENT ADVISORY SERVICES; FINANCIAL RISK MANAGEMENT CONSULTATION SERVICES; FINANCING SERVICES; FINANCIAL ANALYSIS AND CONSULTATION SERVICES; ESTATE TRUST MANAGEMENT SERVICES (U.S. CLS. 100, 101 AND 102).

FIRST USE 10-17-2005; IN COMMERCE 10-17-2005.

JAY BESCH, EXAMINING ATTORNEY

SN 85-601,878. WEISS, BOB, NEW YORK, NY. FILED 4-18-2012.

SN 85-601,341. PROGRESSIVE MEDICAL, INC., WESTERVILLE, OH. FILED 4-18-2012.

Hate Button

AUTOMED SOLUTIONS

THE MARK CONSISTS OF STANDARD CHARACTERS WITHOUT CLAIM TO ANY PARTICULAR FONT, STYLE, SIZE, OR COLOR.

NO CLAIM IS MADE TO THE EXCLUSIVE RIGHT TO USE "SOLUTIONS", APART FROM THE MARK AS SHOWN.

FOR PHARMACY BENEFIT MANAGEMENT SERVICES (U.S. CLS. 100, 101 AND 102).

FIRST USE 7-11-2011; IN COMMERCE 7-11-2011.

TARAH HARDY, EXAMINING ATTORNEY

THE MARK CONSISTS OF STANDARD CHARACTERS WITHOUT CLAIM TO ANY PARTICULAR FONT, STYLE, SIZE, OR COLOR.

NO CLAIM IS MADE TO THE EXCLUSIVE RIGHT TO USE "BUTTON", APART FROM THE MARK AS SHOWN.

FOR FINANCIAL TRANSACTION PROCESSING SERVICES, NAMELY, CLEARING AND RECONCILING FINANCIAL TRANSACTIONS VIA COMPUTER AND COMMUNICATION NETWORKS; ELECTRONIC PROCESSING AND TRANSMISSION OF BILL PAYMENT DATA FOR USERS OF COMPUTER AND COMMUNICATION NETWORKS; ELECTRONIC FUNDS TRANSFER SERVICES; BILL PAYMENT SERVICES; FINANCIAL EXCHANGE SERVICES, NAMELY, PROVIDING A VIRTUAL CURRENCY FOR USE BY MEMBERS OF AN ONLINE COMMUNITY VIA COMPUTER AND COMMUNICATION NETWORKS (U.S. CLS. 100, 101 AND 102).

TARAH HARDY, EXAMINING ATTORNEY

CLASS 36—(Continued).

SN 85-601,893. WEISS, BOB, NEW YORK, NY. FILED 4-18-2012.

Great Button

THE MARK CONSISTS OF STANDARD CHARACTERS WITHOUT CLAIM TO ANY PARTICULAR FONT, STYLE, SIZE, OR COLOR.

NO CLAIM IS MADE TO THE EXCLUSIVE RIGHT TO USE "BUTTON", APART FROM THE MARK AS SHOWN.

FOR FINANCIAL TRANSACTION PROCESSING SERVICES, NAMELY, CLEARING AND RECONCILING FINANCIAL TRANSACTIONS VIA COMPUTER AND COMMUNICATION NETWORKS; ELECTRONIC PROCESSING AND TRANSMISSION OF BILL PAYMENT DATA FOR USERS OF COMPUTER AND COMMUNICATION NETWORKS; ELECTRONIC FUNDS TRANSFER SERVICES; BILL PAYMENT SERVICES; FINANCIAL EXCHANGE SERVICES, NAMELY, PROVIDING A VIRTUAL CURRENCY FOR USE BY MEMBERS OF AN ONLINE COMMUNITY VIA COMPUTER AND COMMUNICATION NETWORKS (U.S. CLS. 100, 101 AND 102).

TARAH HARDY, EXAMINING ATTORNEY

CLASS 36—(Continued).

SN 85-601,901. WEISS, BOB, NEW YORK, NY. FILED 4-18-2012.

Love Button

THE MARK CONSISTS OF STANDARD CHARACTERS WITHOUT CLAIM TO ANY PARTICULAR FONT, STYLE, SIZE, OR COLOR.

NO CLAIM IS MADE TO THE EXCLUSIVE RIGHT TO USE "BUTTON", APART FROM THE MARK AS SHOWN.

FOR FINANCIAL TRANSACTION PROCESSING SERVICES, NAMELY, CLEARING AND RECONCILING FINANCIAL TRANSACTIONS VIA COMPUTER AND COMMUNICATION NETWORKS; ELECTRONIC PROCESSING AND TRANSMISSION OF BILL PAYMENT DATA FOR USERS OF COMPUTER AND COMMUNICATION NETWORKS; ELECTRONIC FUNDS TRANSFER SERVICES; BILL PAYMENT SERVICES; FINANCIAL EXCHANGE SERVICES, NAMELY, PROVIDING A VIRTUAL CURRENCY FOR USE BY MEMBERS OF AN ONLINE COMMUNITY VIA COMPUTER AND COMMUNICATION NETWORKS (U.S. CLS. 100, 101 AND 102).

TARAH HARDY, EXAMINING ATTORNEY

SN 85-601,899. WEISS, BOB, NEW YORK, NY. FILED 4-18-2012.

Cringe Button

THE MARK CONSISTS OF STANDARD CHARACTERS WITHOUT CLAIM TO ANY PARTICULAR FONT, STYLE, SIZE, OR COLOR.

NO CLAIM IS MADE TO THE EXCLUSIVE RIGHT TO USE "BUTTON", APART FROM THE MARK AS SHOWN.

FOR FINANCIAL TRANSACTION PROCESSING SERVICES, NAMELY, CLEARING AND RECONCILING FINANCIAL TRANSACTIONS VIA COMPUTER AND COMMUNICATION NETWORKS; ELECTRONIC PROCESSING AND TRANSMISSION OF BILL PAYMENT DATA FOR USERS OF COMPUTER AND COMMUNICATION NETWORKS; ELECTRONIC FUNDS TRANSFER SERVICES; BILL PAYMENT SERVICES; FINANCIAL EXCHANGE SERVICES, NAMELY, PROVIDING A VIRTUAL CURRENCY FOR USE BY MEMBERS OF AN ONLINE COMMUNITY VIA COMPUTER AND COMMUNICATION NETWORKS (U.S. CLS. 100, 101 AND 102).

TARAH HARDY, EXAMINING ATTORNEY

SN 85-602,100. HERITAGE FEDERAL CREDIT UNION, NEWBURGH, IN. FILED 4-19-2012.

HERITAGE FEDERAL CREDIT UNION

THE MARK CONSISTS OF STANDARD CHARACTERS WITHOUT CLAIM TO ANY PARTICULAR FONT, STYLE, SIZE, OR COLOR.

OWNER OF U.S. REG. NO. 2,933,620.

NO CLAIM IS MADE TO THE EXCLUSIVE RIGHT TO USE "FEDERAL CREDIT UNION", APART FROM THE MARK AS SHOWN.

FOR BANKING AND CREDIT UNION SERVICES (U.S. CLS. 100, 101 AND 102).

FIRST USE 1-8-2003; IN COMMERCE 1-8-2003.

KERI CANTONE, EXAMINING ATTORNEY

CLASS 36—(Continued).

SN 85-602,269. TOWN AND COUNTRY FINANCIAL CORPORATION, DBA TOWN & COUNTRY BANCORP, INC., SPRINGFIELD, IL. FILED 4-19-2012.

CLASS 36—(Continued).

SN 85-602,293. CHILDREN'S HEART PROGRAM VOLUNTEER COUNCIL, INC., AUGUSTA, GA. FILED 4-19-2012.



Town and Country Bank

THE MARK CONSISTS OF GIRL AND BOY HOLDING HANDS TO FORM THE SHAPE OF A HEART.

FOR CHARITABLE FOUNDATION SERVICES, NAMELY, PROVIDING FUNDRAISING ACTIVITIES TO SUPPORT MEDICAL RESEARCH AND PROCEDURES FOR THOSE IN NEED; CHARITABLE FOUNDATION SERVICES, NAMELY, PROVIDING FUNDRAISING ACTIVITIES, FUNDING, SCHOLARSHIPS AND/OR FINANCIAL ASSISTANCE FOR PATIENTS WITH CONGENITAL AND ACQUIRED HEART DISEASE, THEIR FAMILIES AND THOSE WHO CARE FOR THEM; CHARITABLE FOUNDATION SERVICES, NAMELY, PROVIDING FUNDRAISING ACTIVITIES, SUPPLEMENTAL FUNDING, CAPITAL IMPROVEMENT FUNDING, SCHOLARSHIPS AND FINANCIAL ASSISTANCE FOR PROGRAMS AND SERVICES OF OTHERS (U.S. CLS. 100, 101 AND 102).

FIRST USE 7-0-1995; IN COMMERCE 7-0-1995.
LIEF MARTIN, EXAMINING ATTORNEY

THE MARK CONSISTS OF STANDARD CHARACTERS WITHOUT CLAIM TO ANY PARTICULAR FONT, STYLE, SIZE, OR COLOR.

NO CLAIM IS MADE TO THE EXCLUSIVE RIGHT TO USE "BANK", APART FROM THE MARK AS SHOWN.

FOR ATM BANKING SERVICES; BANKING; BANKING AND FINANCING SERVICES; BANKING CONSULTATION; BANKING SERVICES; BANKING SERVICES FEATURING THE PROVISION OF CERTIFICATES OF DEPOSIT; BANKING SERVICES PROVIDED BY MOBILE TELEPHONE CONNECTIONS; ELECTRONIC BANKING VIA A GLOBAL COMPUTER NETWORK; FINANCIAL SERVICES, NAMELY, FUNDING ONLINE CASH ACCOUNTS FROM PREPAID CASH CARDS, BANK ACCOUNTS AND CREDIT CARD ACCOUNTS; HOME BANKING; INVESTMENT BANKING SERVICES; ISSUANCE OF BANK CHECKS; MERCHANT BANKING AND INVESTMENT BANKING SERVICES; MERCHANT BANKING SERVICES; MORTGAGE BANKING; MORTGAGE BANKING SERVICES, NAMELY, ORIGATION, ACQUISITION, SERVICING, SECURITIZATION AND BROKERAGE OF MORTGAGE LOANS; ON-LINE BANKING SERVICES; PROVIDING BANK ACCOUNT INFORMATION BY TELEPHONE; SAVINGS BANK SERVICES; TELEPHONE BANKING SERVICES (U.S. CLS. 100, 101 AND 102).

FIRST USE 5-18-2011; IN COMMERCE 5-18-2011.
ROBIN CHOSID, EXAMINING ATTORNEY

SN 85-602,391. KEEP PADDLIN, HIALEAH, FL. FILED 4-19-2012.

Keep Paddlin

THE MARK CONSISTS OF STANDARD CHARACTERS WITHOUT CLAIM TO ANY PARTICULAR FONT, STYLE, SIZE, OR COLOR.

FOR CHARITABLE FUNDRAISING SERVICES BY MEANS OF ARRANGING AND CONDUCTING RACING EVENTS (U.S. CLS. 100, 101 AND 102).

FIRST USE 6-1-2010; IN COMMERCE 6-1-2010.
LINDA E. BLOHM, EXAMINING ATTORNEY

CLASS 36—(Continued).

SN 85-602,743. POOCHIE-PETS, LLC, SIMSBURY, CT. FILED 4-19-2012.

SAVING SPOT

THE MARK CONSISTS OF STANDARD CHARACTERS WITHOUT CLAIM TO ANY PARTICULAR FONT, STYLE, SIZE, OR COLOR.
FOR CHARITABLE FUNDRAISING SERVICES (U.S. CLS. 100, 101 AND 102).
SAMUEL E. SHARPER JR., EXAMINING ATTORNEY

SN 85-602,877. SUSSEX BANK, FRANKLIN, NJ. FILED 4-19-2012.

CLOSER TO OUR CUSTOMERS

THE MARK CONSISTS OF STANDARD CHARACTERS WITHOUT CLAIM TO ANY PARTICULAR FONT, STYLE, SIZE, OR COLOR.
FOR BANKING SERVICES (U.S. CLS. 100, 101 AND 102).
FIRST USE 2-15-2012; IN COMMERCE 2-15-2012.
AMY KELLY, EXAMINING ATTORNEY

SN 85-602,952. METROPOLITAN LIFE INSURANCE COMPANY, NEW YORK, NY. FILED 4-19-2012.

METLIFE, YOU CARE, WE CARE

THE MARK CONSISTS OF STANDARD CHARACTERS WITHOUT CLAIM TO ANY PARTICULAR FONT, STYLE, SIZE, OR COLOR.
OWNER OF U.S. REG. NOS. 1,541,862, 2,814,241 AND OTHERS.
FOR INSURANCE SERVICES, NAMELY, UNDERWRITING, ISSUANCE AND ADMINISTRATION OF SHORT AND LONG TERM DISABILITY PLANS (U.S. CLS. 100, 101 AND 102).
ANGELA DUONG, EXAMINING ATTORNEY

CLASS 36—(Continued).

SN 85-602,982. IPAYMENT, INC., WESTLAKE VILLAGE, CA. FILED 4-19-2012.

WHERE SMALL BUSINESS & TECHNOLOGY UNITE.

THE MARK CONSISTS OF STANDARD CHARACTERS WITHOUT CLAIM TO ANY PARTICULAR FONT, STYLE, SIZE, OR COLOR.
FOR CREDIT CARD PAYMENT PROCESSING SERVICES; MERCHANT SERVICES, NAMELY, PAYMENT TRANSACTION PROCESSING SERVICES (U.S. CLS. 100, 101 AND 102).
PAM WILLIS, EXAMINING ATTORNEY

SN 85-603,100. FITEQ, INC., TIBURON, CA. FILED 4-19-2012.

MULTITEQ

THE MARK CONSISTS OF STANDARD CHARACTERS WITHOUT CLAIM TO ANY PARTICULAR FONT, STYLE, SIZE, OR COLOR.
FOR CASH REPLACEMENT RENDERED BY CREDIT CARD; CHARGE CARD AND CREDIT CARD SERVICES; CREDIT AND CASH CARD SERVICES; CREDIT AND DEBIT CARD SERVICES; CREDIT CARD AND DEBIT CARD SERVICES; CREDIT CARD AND PAYMENT CARD SERVICES; CREDIT CARD AUTHORIZATION SERVICES; CREDIT CARD PAYMENT PROCESSING SERVICES; CREDIT CARD SERVICES; CREDIT CARD TRANSACTION PROCESSING SERVICES; CREDIT CARD VERIFICATION; DEBIT CARD SERVICES; ELECTRONIC CREDIT CARD TRANSACTIONS; FINANCIAL ADMINISTRATION OF ELECTRONIC PAYMENT TRANSACTIONS AND CUSTOMER LOYALTY REWARDS PROGRAMS; FINANCIAL SERVICES, NAMELY, ADMINISTRATION OF TRANSACTIONS INVOLVING FUNDS DRAWN FROM SECURITIES, STOCKS, FUNDS, EQUITIES, BONDS, CASH, OR OTHER TYPES OF FINANCIAL INVESTMENTS IN RETIREMENT PLANS USING A CREDIT OR DEBIT CARD OVER A GLOBAL DATA NETWORK; FINANCIAL SERVICES, NAMELY, FUNDING ONLINE CASH ACCOUNTS FROM PREPAID CASH CARDS, BANK ACCOUNTS AND CREDIT CARD ACCOUNTS; FRAUD REIMBURSEMENT SERVICES IN THE FIELD OF CREDIT CARD PURCHASES; ISSUANCE OF CREDIT CARDS; ISSUING CREDIT CARDS; ISSUING OF CREDIT CARDS; ISSUING STORED VALUE CARDS; ON-LINE BANKING SERVICES FEATURING ELECTRONIC ALERTS THAT ALERT CREDIT AND DEBIT CARD USERS WHEN A SINGLE TRANSACTION EXCEEDS A CERTAIN AMOUNT; PAYMENT PROCESSING SERVICES, NAMELY, CREDIT CARD AND DEBIT CARD TRANSACTION PROCESSING SERVICES; PRE-PAID PURCHASE CARD SERVICES, NAMELY, PROCESSING

CLASS 36—(Continued).

ELECTRONIC PAYMENTS MADE THROUGH PREPAID CARDS; PRE-PAID PURCHASE CARD SERVICES, NAMELY, PROCESSING ELECTRONIC PAYMENTS THROUGH PRE-PAID CARDS; PROCESSING ELECTRONIC PAYMENTS MADE THROUGH PREPAID CARDS; PROVIDING CASH AND OTHER REBATES FOR CREDIT CARD USE AS PART OF A CUSTOMER LOYALTY PROGRAM; PROVIDING ELECTRONIC PROCESSING OF ACH AND CREDIT CARD TRANSACTIONS AND ELECTRONIC PAYMENTS VIA A GLOBAL COMPUTER NETWORK; PROVIDING ELECTRONIC PROCESSING OF CREDIT CARD TRANSACTIONS AND ELECTRONIC PAYMENTS VIA A GLOBAL COMPUTER NETWORK; PROVIDING ELECTRONIC PROCESSING OF ELECTRONIC FUNDS TRANSFER, ACH, CREDIT CARD, DEBIT CARD, ELECTRONIC CHECK AND ELECTRONIC PAYMENTS; PROVIDING REBATES AT PARTICIPATING ESTABLISHMENTS OF OTHERS THROUGH USE OF A MEMBERSHIP CARD; PROVISION AND FINANCIAL ADMINISTRATION OF A DEBIT CARD SAVINGS PROGRAM (U.S. CLS. 100, 101 AND 102).

MARGARET POWER, EXAMINING ATTORNEY

SN 85-603,155. CREATIVE SPACES COMMERCIAL REAL ESTATE, SAN FRANCISCO, CA. FILED 4-19-2012.

CUSTOM SPACES

THE MARK CONSISTS OF STANDARD CHARACTERS WITHOUT CLAIM TO ANY PARTICULAR FONT, STYLE, SIZE, OR COLOR.

FOR REAL ESTATE BROKERAGE; REAL ESTATE CONSULTATION (U.S. CLS. 100, 101 AND 102).

FIRST USE 4-5-2012; IN COMMERCE 4-5-2012.

LINDA POWELL, EXAMINING ATTORNEY

SN 85-603,191. TICKETSHIELD, LLC, N. BAY VILLAGE, FL. FILED 4-19-2012.

Ticketshield

THE MARK CONSISTS OF STANDARD CHARACTERS WITHOUT CLAIM TO ANY PARTICULAR FONT, STYLE, SIZE, OR COLOR.

FOR ADMINISTRATION OF PRE-PAID LEGAL PLANS CONCERNING INSURANCE AND FINANCE; CLAIMS ADJUSTMENT IN THE FIELD OF INSURANCE; INSURANCE AGENCY AND BROKERAGE (U.S. CLS. 100, 101 AND 102).

FIRST USE 4-19-2012; IN COMMERCE 4-19-2012.

TRACY FLETCHER, EXAMINING ATTORNEY

CLASS 36—(Continued).

SN 85-603,542. TAYLOR MORRISON, INC., SCOTTSDALE, AZ. FILED 4-20-2012.



ARO
ABLE. READY. OWN.

THE MARK CONSISTS OF THE BLOCK LETTERS ARO WITH AN UPWARD POINTING RIGHT ARROW DEFINING THE CENTER OF THE LETTER O WHEREIN THE BLOCK LETTERS ARO APPEAR ABOVE THE TAGLINE ABLE. READY. OWN., WHICH IS WRITTEN IN A SMALLER FONT THAN ARO.

FOR CONSULTING SERVICES, NAMELY, ASSISTING AND COUNSELING POTENTIAL HOME BUYERS TO HELP THEM IMPROVE THEIR ABILITY TO QUALIFY FOR AFFORDABLE HOME LOANS (U.S. CLS. 100, 101 AND 102).

FIRST USE 10-1-2011; IN COMMERCE 10-1-2011.

KAREN K. BUSH, EXAMINING ATTORNEY

SN 85-603,919. ORCHARD GLOBAL CAPITAL GROUP (S) PTE LTD., SINGAPORE, SINGAPORE, FILED 4-20-2012.

OGAM

THE MARK CONSISTS OF STANDARD CHARACTERS WITHOUT CLAIM TO ANY PARTICULAR FONT, STYLE, SIZE, OR COLOR.

FOR FINANCIAL ANALYSIS AND INFORMATION; CAPITAL INVESTMENTS CONSULTANCY; INFORMATION, ADVISORY, CONSULTANCY AND RESEARCH SERVICES RELATING TO FINANCE AND INVESTMENTS; FINANCIAL ADVICE AND CONSULTANCY SERVICES; INVESTMENT CONSULTANCY; FINANCIAL MANAGEMENT; FISCAL VALUATIONS; FUND INVESTMENTS; OPERATE AND MANAGE MUTUAL FUNDS (U.S. CLS. 100, 101 AND 102).

SETH A. RAPPAPORT, EXAMINING ATTORNEY

CLASS 36—(Continued).

SN 85-604,164. BEACON FINANCIAL GROUP INC., WARREN, NJ. FILED 4-20-2012.

CLASS 36—(Continued).

SN 85-604,317. DATAQUICK INFORMATION SYSTEMS, INC., SAN DIEGO, CA. FILED 4-20-2012.

APPRAISALQ

BEACON FINANCIAL GROUP

THE MARK CONSISTS OF STANDARD CHARACTERS WITHOUT CLAIM TO ANY PARTICULAR FONT, STYLE, SIZE, OR COLOR.

FOR FINANCIAL VALUATION OF PERSONAL PROPERTY AND REAL ESTATE; LAND VALUATION; REAL ESTATE APPRAISAL AND VALUATION; REAL ESTATE VALUATION SERVICES; REAL ESTATE VALUATIONS; VALUATIONS IN REAL ESTATE MATTERS (U.S. CLS. 100, 101 AND 102).

FIRST USE 11-11-2011; IN COMMERCE 1-15-2012.
BRENDAN MCCAULEY, EXAMINING ATTORNEY

THE MARK CONSISTS OF STANDARD CHARACTERS WITHOUT CLAIM TO ANY PARTICULAR FONT, STYLE, SIZE, OR COLOR.

NO CLAIM IS MADE TO THE EXCLUSIVE RIGHT TO USE "FINANCIAL GROUP", APART FROM THE MARK AS SHOWN.

FOR REGISTERED INVESTMENT ADVISORY SERVICES; FINANCIAL CONSULTANCY, NAMELY, FINANCIAL PLANNING AND INVESTMENT ADVISORY SERVICES AND INSURANCE CONSULTANCY; FINANCIAL ADVISORY SERVICES; FINANCIAL SERVICES, NAMELY, A TOTAL PORTFOLIO OFFERING FOR CLIENTS CONSISTING OF BOTH SEPARATE ACCOUNTS THAT HOLD STOCKS, BONDS, ELECTRONICALLY TRADED FUNDS, UNIT INVESTMENT TRUSTS, DIRECT PARTICIPATION PROGRAMS SUCH AS REAL ESTATE INVESTMENT TRUST AND MUTUAL FUNDS FOR EQUITY AND FIXED INCOME INVESTMENTS; FINANCIAL PLANNING; ADVISORY SERVICES IN THE FIELD OF EMPLOYEE BENEFITS FOR GROUP HEALTHCARE AND BUSINESS INSURANCE OFFERED TO EMPLOYEES IN ADDITION TO STANDARD BENEFITS SUCH AS MEDICAL, DENTAL, LIFE INSURANCE INCLUDING SHORT TERM DISABILITY, LONG TERM DISABILITY, CANCER INSURANCE, ACCIDENTAL DEATH, LONG TERM CARE AND DISMEMBERMENT; FINANCIAL PLANNING AND INVESTMENT ADVISORY SERVICES; FINANCIAL PLANNING FOR RETIREMENT; FINANCIAL SERVICES, NAMELY, PROVIDING AN INVESTMENT OPTION AVAILABLE FOR VARIABLE ANNUITY AND VARIABLE LIFE INSURANCE PRODUCTS; FINANCIAL SERVICES, NAMELY, WEALTH MANAGEMENT SERVICES RELATING TO FINANCIAL PLANNING AND INVESTMENT ADVISORY SERVICES; FINANCIAL TRUST PLANNING; INVESTMENT ADVISORY SERVICES; INVESTMENT MANAGEMENT; INVESTMENT MANAGEMENT OF AND DISTRIBUTION OF ANNUITIES; INVESTMENT MANAGEMENT OF AND DISTRIBUTION OF VARIABLE ANNUITIES; PROVIDING ADVICE IN THE FIELD OF FINANCE, FINANCIAL INVESTMENTS, FINANCIAL VALUATIONS, AND THE FINANCIAL ASPECTS OF RETIREMENT; STRATEGIC FINANCIAL ADVISORY SERVICES (U.S. CLS. 100, 101 AND 102).

FIRST USE 8-23-1996; IN COMMERCE 8-23-1996.
LINDA E. BLOHM, EXAMINING ATTORNEY

SN 85-604,392. WEISS, BOB, NEW YORK, NY. FILED 4-20-2012.

Hate

THE MARK CONSISTS OF STANDARD CHARACTERS WITHOUT CLAIM TO ANY PARTICULAR FONT, STYLE, SIZE, OR COLOR.

FOR FINANCIAL TRANSACTION PROCESSING SERVICES, NAMELY, CLEARING AND RECONCILING FINANCIAL TRANSACTIONS VIA COMPUTER AND COMMUNICATION NETWORKS; ELECTRONIC PROCESSING AND TRANSMISSION OF BILL PAYMENT DATA FOR USERS OF COMPUTER AND COMMUNICATION NETWORKS; ELECTRONIC FUNDS TRANSFER SERVICES; BILL PAYMENT SERVICES; FINANCIAL EXCHANGE SERVICES, NAMELY, PROVIDING A VIRTUAL CURRENCY FOR USE BY MEMBERS OF AN ONLINE COMMUNITY VIA COMPUTER AND COMMUNICATION NETWORKS (U.S. CLS. 100, 101 AND 102).

ALYSSA STEEL, EXAMINING ATTORNEY

CLASS 36—(Continued).

SN 85-604,451. WEISS, BOB, NEW YORK, NY. FILED 4-20-2012.

Cringe

THE MARK CONSISTS OF STANDARD CHARACTERS WITHOUT CLAIM TO ANY PARTICULAR FONT, STYLE, SIZE, OR COLOR.

FOR FINANCIAL TRANSACTION PROCESSING SERVICES, NAMELY, CLEARING AND RECONCILING FINANCIAL TRANSACTIONS VIA COMPUTER AND COMMUNICATION NETWORKS; ELECTRONIC PROCESSING AND TRANSMISSION OF BILL PAYMENT DATA FOR USERS OF COMPUTER AND COMMUNICATION NETWORKS; ELECTRONIC FUNDS TRANSFER SERVICES; BILL PAYMENT SERVICES; FINANCIAL EXCHANGE SERVICES, NAMELY, PROVIDING A VIRTUAL CURRENCY FOR USE BY MEMBERS OF AN ONLINE COMMUNITY VIA COMPUTER AND COMMUNICATION NETWORKS (U.S. CLS. 100, 101 AND 102).
ALYSSA STEEL, EXAMINING ATTORNEY

SN 85-604,985. AZIZ NAHAS, NEW YORK, NY. FILED 4-23-2012.

INARA

THE MARK CONSISTS OF STANDARD CHARACTERS WITHOUT CLAIM TO ANY PARTICULAR FONT, STYLE, SIZE, OR COLOR.

FOR FINANCIAL SERVICES, NAMELY, INVESTMENT MANAGEMENT SERVICES, INVESTMENT ADVISORY SERVICES AND ASSET MANAGEMENT SERVICES (U.S. CLS. 100, 101 AND 102).
ANNE E. GUSTASON, EXAMINING ATTORNEY

SN 85-605,227. PRESCIENT HOLDINGS (PTY) LTD, WES-TLAKE, SOUTH AFRICA, FILED 4-23-2012.

Prescient Investment Management

THE MARK CONSISTS OF STANDARD CHARACTERS WITHOUT CLAIM TO ANY PARTICULAR FONT, STYLE, SIZE, OR COLOR.

NO CLAIM IS MADE TO THE EXCLUSIVE RIGHT TO USE "INVESTMENT MANAGEMENT", APART FROM THE MARK AS SHOWN.

FOR INVESTMENT MANAGEMENT (U.S. CLS. 100, 101 AND 102).
KIM MONINGHOFF, EXAMINING ATTORNEY

CLASS 36—(Continued).

SN 85-605,238. CITYSPIRE, INC., NEW YORK, NY. FILED 4-23-2012.

CitySpire

THE MARK CONSISTS OF STANDARD CHARACTERS WITHOUT CLAIM TO ANY PARTICULAR FONT, STYLE, SIZE, OR COLOR.

FOR REAL ESTATE SERVICES, NAMELY, LEASING, BROKERAGE, MANAGEMENT, CONSULTATION, AND FINANCING RELATED TO REAL ESTATE; LEASING OF RETAIL SPACE, FULLY EQUIPPED EXECUTIVE OFFICE SPACE (U.S. CLS. 100, 101 AND 102).

FIRST USE 12-31-1988; IN COMMERCE 12-31-1989.
KIM MONINGHOFF, EXAMINING ATTORNEY

SN 85-605,423. HEARTLAND BANK, FORMERLY HEARTLAND COMMUNITY BANK, LITTLE ROCK, AR. FILED 4-23-2012.

The Independent Bank for Independent People

THE MARK CONSISTS OF STANDARD CHARACTERS WITHOUT CLAIM TO ANY PARTICULAR FONT, STYLE, SIZE, OR COLOR.

FOR BANKING; BANKING AND FINANCING SERVICES; BANKING SERVICES; BANKING SERVICES FEATURING THE PROVISION OF CERTIFICATES OF DEPOSIT; BANKING SERVICES PROVIDED BY MOBILE TELEPHONE CONNECTIONS; ELECTRONIC BANKING VIA A GLOBAL COMPUTER NETWORK; MORTGAGE BANKING; MORTGAGE BANKING SERVICES, NAMELY, ORIGATION, ACQUISITION, SERVICING, SECURITIZATION AND BROKERAGE OF MORTGAGE LOANS; ON-LINE BANKING SERVICES (U.S. CLS. 100, 101 AND 102).

VIVIAN MICZNIK FIRST, EXAMINING ATTORNEY

SN 85-605,468. MCCARTHY, BURGESS & WOLFF, INC., CLEVELAND, OH. FILED 4-23-2012.

McCarthy, Burgess & Wolff

THE MARK CONSISTS OF STANDARD CHARACTERS WITHOUT CLAIM TO ANY PARTICULAR FONT, STYLE, SIZE, OR COLOR.

FOR COLLECTION OF DEBTS; DEBT COLLECTION; DEBT COLLECTION AGENCIES (U.S. CLS. 100, 101 AND 102).

FIRST USE 8-31-2000; IN COMMERCE 8-31-2000.
GEORGE LORENZO, EXAMINING ATTORNEY

CLASS 36—(Continued).

SN 85-605,513. ALZHEIMER'S ASSOCIATION DESERT SOUTHWEST CHAPTER, PHOENIX, AZ. FILED 4-23-2012.

WINE TO REMEMBER

THE MARK CONSISTS OF STANDARD CHARACTERS WITHOUT CLAIM TO ANY PARTICULAR FONT, STYLE, SIZE, OR COLOR.

FOR CHARITABLE FUNDRAISING SERVICES, BY MEANS OF ORGANIZING AND CONDUCTING SPECIAL EVENTS AND CHARITY AUCTIONS TO RAISE FUNDS FOR ALZHEIMER'S RESEARCH, ADVOCACY AND SERVICES TO THOSE AFFECTED (U.S. CLS. 100, 101 AND 102).

FIRST USE 5-22-2011; IN COMMERCE 5-22-2011.
EDWARD FENNESSY, EXAMINING ATTORNEY

SN 85-605,527. MCCARTHY, BURGESS & WOLFF, INC., CLEVELAND, OH. FILED 4-23-2012.

MB&W

THE MARK CONSISTS OF STANDARD CHARACTERS WITHOUT CLAIM TO ANY PARTICULAR FONT, STYLE, SIZE, OR COLOR.

FOR COLLECTION OF DEBTS; DEBT COLLECTION; DEBT COLLECTION AGENCIES (U.S. CLS. 100, 101 AND 102).

FIRST USE 8-31-2000; IN COMMERCE 8-31-2000.
GEORGE LORENZO, EXAMINING ATTORNEY

SN 85-605,532. ALZHEIMER'S ASSOCIATION DESERT SOUTHWEST CHAPTER, PHOENIX, AZ. FILED 4-23-2012.

A LOVE NOT FORGOTTEN

THE MARK CONSISTS OF STANDARD CHARACTERS WITHOUT CLAIM TO ANY PARTICULAR FONT, STYLE, SIZE, OR COLOR.

FOR CHARITABLE FUNDRAISING SERVICES, BY MEANS OF ORGANIZING AND CONDUCTING ENTERTAINMENT, SPECIAL EVENTS, AND CHARITY AUCTIONS TO RAISE FUNDS FOR ALZHEIMER'S RESEARCH, ADVOCACY AND SERVICES TO THOSE AFFECTED (U.S. CLS. 100, 101 AND 102).

FIRST USE 1-0-2009; IN COMMERCE 1-0-2009.
EDWARD FENNESSY, EXAMINING ATTORNEY

CLASS 36—(Continued).

SN 85-605,582. STREETLINKS LLC, KANSAS CITY, MO. FILED 4-23-2012.

VERICOMP

THE MARK CONSISTS OF STANDARD CHARACTERS WITHOUT CLAIM TO ANY PARTICULAR FONT, STYLE, SIZE, OR COLOR.

FOR APPRAISAL SERVICES, NAMELY, PROVIDING A SECOND OPINION FOR REAL ESTATE APPRAISALS AND VERIFICATION OF REAL ESTATE APPRAISALS; REAL ESTATE VALUATION SERVICES (U.S. CLS. 100, 101 AND 102).

MICHAEL KEATING, EXAMINING ATTORNEY

SN 85-605,610. STREETLINKS LLC, KANSAS CITY, MO. FILED 4-23-2012.

VALUECOMP

THE MARK CONSISTS OF STANDARD CHARACTERS WITHOUT CLAIM TO ANY PARTICULAR FONT, STYLE, SIZE, OR COLOR.

FOR APPRAISAL SERVICES, NAMELY, PROVIDING A SECOND OPINION FOR REAL ESTATE APPRAISALS AND VERIFICATION OF REAL ESTATE APPRAISALS; REAL ESTATE VALUATION SERVICES (U.S. CLS. 100, 101 AND 102).

MICHAEL KEATING, EXAMINING ATTORNEY

SN 85-605,731. CRESTONE CAPITAL ADVISORS LLC, BOULDER, CO. FILED 4-23-2012.

CRESTONE

THE MARK CONSISTS OF STANDARD CHARACTERS WITHOUT CLAIM TO ANY PARTICULAR FONT, STYLE, SIZE, OR COLOR.

OWNER OF U.S. REG. NO. 2,722,642.
FOR INVESTMENT ADVISORY AND WEALTH MANAGEMENT SERVICES; FINANCIAL SERVICES, NAMELY, ADVISORY SERVICES REGARDING ESTATE PLANNING, TAX PLANNING, CHARITABLE GIVING, WEALTH PRESERVATION AND ASSET PROTECTION, RETIREMENT PLANNING AND MODELING, AND FINANCIAL RISK AND DEBT MANAGEMENT (U.S. CLS. 100, 101 AND 102).

FIRST USE 10-3-2001; IN COMMERCE 10-3-2001.
DOMINIC FATHY, EXAMINING ATTORNEY

CLASS 36—(Continued).

SN 85-605,777. CORTLAND BANCORP, CORTLAND, OH. FILED 4-23-2012.

STRONGSAVER

THE MARK CONSISTS OF STANDARD CHARACTERS WITHOUT CLAIM TO ANY PARTICULAR FONT, STYLE, SIZE, OR COLOR.

FOR BANKING SERVICES; PROVIDING INFORMATION IN THE FIELD OF PERSONAL FINANCE (U.S. CLS. 100, 101 AND 102).

THEODORE MCBRIDE, EXAMINING ATTORNEY



SN 85-605,784. ALABAMA CREDIT UNION, TUSCALOOSA, AL. FILED 4-23-2012.

ACUZiposit

THE MARK CONSISTS OF STANDARD CHARACTERS WITHOUT CLAIM TO ANY PARTICULAR FONT, STYLE, SIZE, OR COLOR.

FOR FINANCIAL SERVICES, NAMELY, ELECTRONIC REMOTE CHECK DEPOSIT SERVICES (U.S. CLS. 100, 101 AND 102).

FIRST USE 5-10-2011; IN COMMERCE 5-10-2011. REBECCA GILBERT, EXAMINING ATTORNEY



SN 85-607,104. BAKER, JOHN, CHICAGO, IL. FILED 4-24-2012.

Charidia

THE MARK CONSISTS OF STANDARD CHARACTERS WITHOUT CLAIM TO ANY PARTICULAR FONT, STYLE, SIZE, OR COLOR.

FOR CHARITABLE FUNDRAISING; CHARITABLE FUNDRAISING SERVICES (U.S. CLS. 100, 101 AND 102).

NICHOLAS COLEMAN, EXAMINING ATTORNEY

CLASS 36—(Continued).

SN 85-607,252. RON LEE, EVANS, GA. FILED 4-24-2012.

Discover the Pathway

THE MARK CONSISTS OF STANDARD CHARACTERS WITHOUT CLAIM TO ANY PARTICULAR FONT, STYLE, SIZE, OR COLOR.

FOR CHARITABLE FOUNDATION SERVICES, NAMELY, PROVIDING FUNDRAISING ACTIVITIES, FUNDING, SCHOLARSHIPS AND/OR FINANCIAL ASSISTANCE FOR WOUNDED VETERANS; CHARITABLE FOUNDATION SERVICES, NAMELY, PROVIDING FUNDRAISING ACTIVITIES, SUPPLEMENTAL FUNDING, CAPITAL IMPROVEMENT FUNDING, SCHOLARSHIPS AND FINANCIAL ASSISTANCE FOR PROGRAMS AND SERVICES OF OTHERS; CHARITABLE FUNDRAISING SERVICES BY MEANS OF SELLING FINE ART PHOTOGRAPHY TO RAISE FUNDS FOR PROMOTION OF HEALING THROUGH THE VISUAL ARTS; CHARITABLE FUNDRAISING SERVICES FOR PROMOTING RESEARCH, EDUCATION AND OTHER ACTIVITIES RELATING TO ART THERAPY; CHARITABLE FUNDRAISING TO SUPPORT WOUNDED VETERANS AND HEALING (U.S. CLS. 100, 101 AND 102).

FIRST USE 11-6-2011; IN COMMERCE 1-31-2012. JOHN WILKE, EXAMINING ATTORNEY



SN 85-608,408. WEINSTEIN, JOSHUA, LOS ANGELES, CA. FILED 4-25-2012.

Your Home. Our Investment.

THE MARK CONSISTS OF STANDARD CHARACTERS WITHOUT CLAIM TO ANY PARTICULAR FONT, STYLE, SIZE, OR COLOR.

FOR REAL ESTATE RENTAL SERVICES, NAMELY, RENTAL OF RESIDENTIAL HOUSING (U.S. CLS. 100, 101 AND 102).

THOMAS MANOR, EXAMINING ATTORNEY

CLASS 36—(Continued).

SN 85-610,979. SKILLING, JOSETTE, BETHESDA, MD. FILED 4-27-2012.

BethesdaBuzz

THE MARK CONSISTS OF STANDARD CHARACTERS WITHOUT CLAIM TO ANY PARTICULAR FONT, STYLE, SIZE, OR COLOR.

FOR ARRANGING OF LEASES AND RENTAL AGREEMENTS FOR REAL ESTATE ; ASSESSMENT AND MANAGEMENT OF REAL ESTATE ; CLASSIFIED REAL ESTATE LISTINGS OF APARTMENT RENTALS AND HOUSING RENTALS ; COMMERCIAL AND RESIDENTIAL REAL ESTATE AGENCY SERVICES ; FINANCIAL DUE DILIGENCE SERVICES IN THE FIELD OF REAL ESTATE ; FINANCIAL INVESTMENT IN THE FIELD OF REAL ESTATE ; FINANCIAL SERVICES, NAMELY, REAL ESTATE NOTE BROKERAGE ; FINANCIAL VALUATION OF PERSONAL PROPERTY AND REAL ESTATE ; LAND ACQUISITION, NAMELY, REAL ESTATE BROKERAGE ; LEASE OF REAL ESTATE ; LEASING OF REAL ESTATE ; PROVIDING A DATABASE OF INFORMATION ABOUT RESIDENTIAL REAL ESTATE LISTINGS IN DIFFERENT NEIGHBORHOODS AND COMMUNITIES ; PROVIDING A DATABASE OF RESIDENTIAL REAL ESTATE LISTINGS WITHIN NEIGHBORHOODS AND COMMUNITIES SPECIFICALLY IDENTIFIED BY USERS ; PROVIDING AN INTERNET WEBSITE PORTAL OFFERING INFORMATION IN THE FIELDS OF REAL ESTATE CONCERNING THE PURCHASE AND SALE OF NEW AND RESALE HOMES AND CONDOS ; PROVIDING INFORMATION IN THE FIELD OF REAL ESTATE BY MEANS OF LINKING THE WEB SITE TO OTHER WEB SITES FEATURING REAL ESTATE INFORMATION ; PROVIDING INFORMATION IN THE FIELD OF REAL ESTATE VIA THE INTERNET ; PROVIDING REAL ESTATE LISTINGS AND REAL ESTATE INFORMATION VIA THE INTERNET ; PROVIDING REAL ESTATE LISTINGS VIA THE INTERNET ; REAL ESTATE ACQUISITION SERVICES ; REAL ESTATE AGENCIES ; REAL ESTATE BROKERAGE ; REAL ESTATE CONSULTATION ; REAL ESTATE CONSULTANCY ; REAL ESTATE EQUITY SHARING, NAMELY, MANAGING AND ARRANGING FOR CO-OWNERSHIP OF REAL ESTATE ; REAL ESTATE LISTING ; REAL ESTATE LISTING SERVICES FOR HOUSING RENTALS AND APARTMENT RENTALS ; REAL ESTATE MANAGEMENT SERVICES ; REAL ESTATE MANAGEMENT OF RESIDENTIAL REAL ESTATE ; REAL ESTATE MULTIPLE LISTING SERVICES ; REAL ESTATE PROCUREMENT FOR OTHERS ; REAL ESTATE RENTAL SERVICES, NAMELY, RENTAL OF RESIDENTIAL HOUSING ; REAL ESTATE SERVICE, NAMELY, RENTAL PROPERTY MANAGEMENT ; REAL ESTATE SERVICES, NAMELY, PROVIDING ONLINE QUESTIONS TO HELP USERS DETERMINE THE BEST NEIGHBORHOODS AND COMMUNITIES SUITED TO THEIR INDIVIDUAL NEEDS AND PREFERENCES ; REAL ESTATE SYNDICATION ; REAL ESTATE VALUATIONS ; RESIDENTIAL REAL ESTATE AGENCY SERVICES ; VALUATIONS IN REAL ESTATE MATTERS (U.S. CLS. 100, 101 AND 102). FIRST USE 10-17-2007; IN COMMERCE 10-17-2007. KAREN K. BUSH, EXAMINING ATTORNEY

CLASS 36—(Continued).

SN 85-613,754. DATAQUICK INFORMATION SYSTEMS, INC., SAN DIEGO, CA. FILED 5-1-2012.

PORTFOLIOQ

THE MARK CONSISTS OF STANDARD CHARACTERS WITHOUT CLAIM TO ANY PARTICULAR FONT, STYLE, SIZE, OR COLOR.

FOR FINANCIAL RISK MANAGEMENT; FINANCIAL RISK MANAGEMENT CONSULTATION; FINANCIAL VALUATION OF PERSONAL PROPERTY AND REAL ESTATE; FINANCIAL VALUATIONS; FISCAL VALUATIONS; FISCAL VALUATIONS AND ASSESSMENTS; LAND VALUATION; REAL ESTATE APPRAISAL AND VALUATION; REAL ESTATE VALUATION SERVICES; REAL ESTATE VALUATIONS; VALUATIONS IN REAL ESTATE MATTERS (U.S. CLS. 100, 101 AND 102). FIRST USE 3-12-2012; IN COMMERCE 3-19-2012.

BRENDAN MCCAULEY, EXAMINING ATTORNEY

SN 85-621,499. DRAKE DAVIS FOUNDATION, INC., ATLANTA, GA. FILED 5-10-2012.



THE MARK CONSISTS OF THE WORDS "SPEAK UP" AND "REACH OUT" IN A CIRCLE WITH ARROWS BETWEEN THE WORDS AND THE LETTERS "DD" IN THE CENTER OF THE CIRCLE.

FOR CHARITABLE FOUNDATION SERVICES, NAMELY, PROVIDING FUNDRAISING ACTIVITIES BY MEANS OF HOSTING AN ANNUAL GOLF TOURNAMENT AND OTHER FUNDRAISING ACTIVITIES; CHARITABLE FOUNDATION SERVICES, NAMELY, PROVIDING FUNDING, SCHOLARSHIPS AND/OR FINANCIAL ASSISTANCE TO RAISE AWARENESS FOR SUICIDE PREVENTION AND ASSIST PEOPLE WHOSE LIVES HAVE BEEN AFFECTED BY SUICIDE (U.S. CLS. 100, 101 AND 102).

FIRST USE 1-31-2007; IN COMMERCE 1-31-2007. LINDA M. KING, EXAMINING ATTORNEY

CLASS 36—(Continued).

SN 85-627,990. AOL INC., DULLES, VA. FILED 5-17-2012.

FISHBOWL LABS

THE MARK CONSISTS OF STANDARD CHARACTERS WITHOUT CLAIM TO ANY PARTICULAR FONT, STYLE, SIZE, OR COLOR.

FOR INCUBATION SERVICES, NAMELY, RENTAL OF OFFICE SPACE TO ENTREPRENEURS, FREELANCERS, START-UPS, AND EXISTING BUSINESSES (U.S. CLS. 100, 101 AND 102).

ALLISON HOLTZ, EXAMINING ATTORNEY

CLASS 36—(Continued).

SN 85-638,133. INSURANCE LOUNGE, INC., GRANTS PASS, OR. FILED 5-30-2012.



FOR INSURANCE SERVICES, NAMELY, BROKERAGE, ADMINISTRATION, AND UNDERWRITING OF PROPERTY, CASUALTY, AUTO, HOME, LIFE, INDIVIDUAL HEALTH, DISABILITY, LONG TERM CARE, MEDICARE, INVESTMENT, AND RETIREMENT INSURANCE PRODUCTS (U.S. CLS. 100, 101 AND 102).

RAUL CORDOVA, EXAMINING ATTORNEY

SN 85-642,387. GOVERNMENT EMPLOYEES HEALTH ASSOCIATION, INC., INDEPENDENCE, MO. FILED 6-4-2012.

**BETTER HEALTH STARTS WITH
BETTER CHOICES**

THE MARK CONSISTS OF STANDARD CHARACTERS WITHOUT CLAIM TO ANY PARTICULAR FONT, STYLE, SIZE, OR COLOR.

FOR INSURANCE SERVICES, NAMELY, UNDERWRITING, ISSUANCE AND ADMINISTRATION OF HEALTH INSURANCE AND DENTAL INSURANCE (U.S. CLS. 100, 101 AND 102).

SIMON TENG, EXAMINING ATTORNEY

SN 85-645,630. TEACHERS INSURANCE AND ANNUITY ASSOCIATION OF AMERICA, NEW YORK, NY. FILED 6-7-2012.

TIAA-CREF

THE MARK CONSISTS OF STANDARD CHARACTERS WITHOUT CLAIM TO ANY PARTICULAR FONT, STYLE, SIZE, OR COLOR.

OWNER OF U.S. REG. NOS. 1,605,921, 2,731,742 AND OTHERS.

FOR BANKING SERVICES AND TRUST SERVICES, NAMELY, FIDUCIARY REPRESENTATIVE AND INVESTMENT MANAGEMENT SERVICES (U.S. CLS. 100, 101 AND 102).

DEBORAH LOBO, EXAMINING ATTORNEY

SN 85-637,425. MAZDA MOTOR OF AMERICA, INC., IRVINE, CA. FILED 5-29-2012.



OWNER OF U.S. REG. NOS. 2,697,170, 3,981,297 AND OTHERS.

NO CLAIM IS MADE TO THE EXCLUSIVE RIGHT TO USE "EXTENDED", APART FROM THE MARK AS SHOWN.

THE MARK CONSISTS OF THE WORD "MAZDA" BENEATH A FLATTENED OVAL SHAPE CONTAINING A DESIGN SUGGESTING A PAIR OF WINGS, ALL TO THE LEFT OF THE WORDS "MAZDA EXTENDED CONFIDENCE", WITH A HORIZONTAL LINE BETWEEN "MAZDA EXTENDED" AND "CONFIDENCE", AND A SERIES OF SIX SLANTED LINES SHOWN AFTER "CONFIDENCE".

FOR EXTENDED WARRANTY SERVICES, NAMELY, SERVICE CONTRACTS; PROVIDING EXTENDED WARRANTIES ON AUTOMOBILES (U.S. CLS. 100, 101 AND 102).

KELLY TRUSILO, EXAMINING ATTORNEY

CLASS 36—(Continued).

SN 85-645,639. TEACHERS INSURANCE AND ANNUITY ASSOCIATION OF AMERICA, NEW YORK, NY. FILED 6-7-2012.



OWNER OF U.S. REG. NOS. 1,605,921, 2,731,742 AND OTHERS.

THE MARK CONSISTS OF THE WORDS TIAA CREF INSIDE A MITERED BOX DESIGN.

FOR BANKING SERVICES AND TRUST SERVICES, NAMELY, FIDUCIARY REPRESENTATIVE AND INVESTMENT MANAGEMENT SERVICES (U.S. CLS. 100, 101 AND 102).

DEBORAH LOBO, EXAMINING ATTORNEY

SN 85-658,596. CNA FINANCIAL CORPORATION, CHICAGO, IL. FILED 6-21-2012.

CNA PARAMOUNT

THE MARK CONSISTS OF STANDARD CHARACTERS WITHOUT CLAIM TO ANY PARTICULAR FONT, STYLE, SIZE, OR COLOR.

OWNER OF U.S. REG. NOS. 802,010, 3,742,499 AND OTHERS.

FOR INSURANCE UNDERWRITING IN THE FIELD OF PROPERTY AND GENERAL LIABILITY (U.S. CLS. 100, 101 AND 102).

JENNIFER RICHARDSON, EXAMINING ATTORNEY

CLASS 36—(Continued).

SN 85-661,038. MOROZOWSKI, DEAN, SANTA CRUZ, CA. FILED 6-25-2012.

FUEL FOR YOUR WALLET

THE MARK CONSISTS OF STANDARD CHARACTERS WITHOUT CLAIM TO ANY PARTICULAR FONT, STYLE, SIZE, OR COLOR.

FOR INSURANCE AND FINANCIAL SERVICES, NAMELY, PROVIDING TEMPORARY LOANS; CREDIT AND LOAN SERVICES; CHECK CASHING; CASH ADVANCE SERVICES, NAMELY, PAYDAY LOAN SERVICES; CASH ADVANCE SERVICES FOR BUSINESSES AND MERCHANTS; BILL PAYMENT SERVICES; PROVIDING MONETARY EXCHANGE SERVICES, NAMELY, EXCHANGING GOLD OF OTHERS FOR CASH; FINANCIAL SERVICES, NAMELY, CHECK CASHING AND CASH ADVANCE SERVICES NAMELY PAYDAY LOAN SERVICES (U.S. CLS. 100, 101 AND 102).

JAMES LOVELACE, EXAMINING ATTORNEY

SN 85-664,263. METROPOLITAN LIFE INSURANCE COMPANY, NEW YORK, NY. FILED 6-28-2012.

A NEW LOOK ON LIFE

THE MARK CONSISTS OF STANDARD CHARACTERS WITHOUT CLAIM TO ANY PARTICULAR FONT, STYLE, SIZE, OR COLOR.

FOR INSURANCE SERVICES, NAMELY, UNDERWRITING, ISSUANCE AND ADMINISTRATION OF LIFE INSURANCE AND BENEFICIARY BENEFITS (U.S. CLS. 100, 101 AND 102).

FIRST USE 2-28-2010; IN COMMERCE 2-28-2010.

ANGELA DUONG, EXAMINING ATTORNEY

SN 85-668,032. MARCO POLO XTF INC., NEW YORK, NY. FILED 7-3-2012.

XTF

THE MARK CONSISTS OF STANDARD CHARACTERS WITHOUT CLAIM TO ANY PARTICULAR FONT, STYLE, SIZE, OR COLOR.

FOR FINANCIAL SERVICES, NAMELY, MARKET MAKING, EXECUTION AND FINANCIAL ADVICE FOR EXCHANGE TRADED FUNDS (U.S. CLS. 100, 101 AND 102).

FIRST USE 6-29-2005; IN COMMERCE 6-29-2005.

ZACHARY CROMER, EXAMINING ATTORNEY

CLASS 37—CONSTRUCTION AND REPAIR

SN 77-382,895. CENTURION PARTNERS, LLC, NEWPORT BEACH, CA. FILED 1-29-2008.



NO CLAIM IS MADE TO THE EXCLUSIVE RIGHT TO USE "PARTNERS", APART FROM THE MARK AS SHOWN. THE STIPPLING IS A FEATURE OF THE MARK. THE MARK CONSISTS OF WORDS "CENTURION PARTNERS" AND CIRCLE DESIGN.
FOR REAL ESTATE DEVELOPMENT (U.S. CLS. 100, 103 AND 106).
ANDREA HACK, EXAMINING ATTORNEY

SN 77-867,292. NETWORK CRITICAL SOLUTIONS LIMITED, CAVERSHAM, BERKSHIRE, UNITED KINGDOM, FILED 11-6-2009.



PRIORITY CLAIMED UNDER SEC. 44(D) ON ERPN CMNTY TM OFC APPLICATION NO. 008650525, FILED 10-29-2009, REG. NO. 008650525, DATED 5-3-2010, EXPIRES 10-29-2019.
NO CLAIM IS MADE TO THE EXCLUSIVE RIGHT TO USE "NETWORK", APART FROM THE MARK AS SHOWN. THE COLOR(S) LIGHT BLUE AND DARK BLUE IS/ARE CLAIMED AS A FEATURE OF THE MARK.
THE MARK CONSISTS OF THE WORDING "NETWORK CRITICAL" IN DARK BLUE TO THE RIGHT OF A DESIGN. THE DESIGN CONSISTS OF A CIRCLE SEPARATED IN THE MIDDLE BY A ZIG-ZAG BREAK REPRESENTING A PULSE WAVE LINE. THE PORTION OF THE CIRCLE ABOVE THE LINE IS LIGHT BLUE, WHILE THE LOWER PORTION IS DARK BLUE.
FOR INSTALLATION, SERVICING, MAINTENANCE AND REPAIR OF COMPUTER HARDWARE AND PERIPHERALS (U.S. CLS. 100, 103 AND 106).
CORY BOONE, EXAMINING ATTORNEY

CLASS 37—(Continued).

SN 85-168,912. PROPARK, INC., HARTFORD, CT. FILED 11-4-2010.

rEvolution

THE MARK CONSISTS OF STANDARD CHARACTERS WITHOUT CLAIM TO ANY PARTICULAR FONT, STYLE, SIZE, OR COLOR.
FOR PROVIDING ELECTRIC VEHICLE CHARGING STATIONS IN PARKING GARAGES (U.S. CLS. 100, 103 AND 106).
GISELLE AGOSTO, EXAMINING ATTORNEY

SN 85-284,486. GSSD INVESTMENTS, LLC, MAGNOLIA, TX. FILED 4-2-2011.

DRIVER'S AUTO REPAIR

THE MARK CONSISTS OF STANDARD CHARACTERS WITHOUT CLAIM TO ANY PARTICULAR FONT, STYLE, SIZE, OR COLOR.
NO CLAIM IS MADE TO THE EXCLUSIVE RIGHT TO USE "AUTO REPAIR", APART FROM THE MARK AS SHOWN.
SEC. 2(F).
FOR VEHICLE REPAIR AND MAINTENANCE (U.S. CLS. 100, 103 AND 106).
FIRST USE 1-1-2005; IN COMMERCE 1-1-2005.
TRACY FLETCHER, EXAMINING ATTORNEY

SN 85-314,977. WEEKLY BROS. INC., IDLEYLD PARK, OR. FILED 5-6-2011.

Weekly Bros.

THE MARK CONSISTS OF STANDARD CHARACTERS WITHOUT CLAIM TO ANY PARTICULAR FONT, STYLE, SIZE, OR COLOR.
NO CLAIM IS MADE TO THE EXCLUSIVE RIGHT TO USE "BROS.", APART FROM THE MARK AS SHOWN.
FOR BUILDING CONSTRUCTION; BUILDING CONSTRUCTION AND REPAIR; BUILDING CONSTRUCTION SERVICES; BUILDING CONSTRUCTION SUPERVISION; CONSTRUCTION DEWATERING, NAMELY, THE REMOVAL OF SURFACE WATERS AND GROUNDWATER TO FACILITATE THE CONSTRUCTION OF STRUCTURES AND PIPELINES; CONSTRUCTION OF BUILDINGS; CONSTRUCTION PLANNING; CONSTRUCTION PROJECT MANAGEMENT SERVICES; CIVIL, INDUSTRIAL, AND MECHANICAL CONSTRUCTION SERVICES, NAMELY, CONSTRUCTION OF ROADS, UNDERGROUND UTILITIES, WASTEWATER TREATMENT PLANTS, POWER PLANTS, PIPELINES, BRIDGES, BUILDINGS, AND OTHER RELATED STRUCTURES; EXCAVATION SERVICES; DAM CONSTRUCTION AND MODIFICATION;

CLASS 37—(Continued).

CONSTRUCTION OF COFFERDAMS; CONCRETE STRUCTURE CONSTRUCTION; ENVIRONMENTAL CONSTRUCTION, NAMELY, CONSTRUCTION OF ENVIRONMENTAL CONTAINMENT SYSTEMS, CONSTRUCTION OF ENVIRONMENTALLY-CONSCIOUS BUILDINGS, WETLANDS, WILDLIFE HABITAT AREAS AND STRUCTURES, FISH LADDERS, AND WATERWAY ENHANCEMENTS; REPAIRS, NAMELY, BUILDING REPAIRS, STORM WATER DAMAGE RESTORATION REPAIRS, EMERGENCY UTILITY REPAIRS, NAMELY, ELECTRICAL REPAIRS AND GAS PIPELINE REPAIRS, EMERGENCY POWER PLANT REPAIRS OF PIPELINES AND BUILDINGS, AND DISASTER REPAIRS, NAMELY, ELECTRICAL, PIPELINE, AND WATER DAMAGE RESTORATION IN THE FIELD OF WATER, SMOKE, AND FIRE DAMAGE DUE TO NATURAL DISASTERS; DEMOLITION OF BUILDING STRUCTURES; CONSTRUCTION AND REPAIR OF WATER DIVERSION STRUCTURES, INSTALLATION OF WORK AREA ISOLATION STRUCTURES, NAMELY, BARRICADES, GATES, AND FENCES, AND CONSTRUCTION DEWATERING, NAMELY, THE REMOVAL OF SURFACE WATERS AND GROUNDWATER TO FACILITATE THE CONSTRUCTION OF STRUCTURES AND PIPELINES (U.S. CLS. 100, 103 AND 106).

FIRST USE 3-16-1994; IN COMMERCE 3-16-1994.
CARYN GLASSER, EXAMINING ATTORNEY

CLASS 37—(Continued).

SN 85-418,340. RUNCORE INNOVATION TECHNOLOGY CO., LTD., HUNAN, CHINA, FILED 9-9-2011.

源科

THE MARK CONSISTS OF TWO CHINESE CHARACTERS.

THE NON-LATIN CHARACTERS IN THE MARK TRANSLITERATE TO "YUAN KE" AND THIS MEANS "ORIGINATE FROM TECHNOLOGY" IN ENGLISH.

FOR INSTALLATION, MAINTENANCE AND REPAIR OF COMPUTER HARDWARE (U.S. CLS. 100, 103 AND 106).

WARREN L. OLANDRIA, EXAMINING ATTORNEY

SN 85-400,499. LANDCAR AGENCY, INC., SANDY, UT. FILED 8-17-2011.



OWNER OF U.S. REG. NO. 3,568,209.
NO CLAIM IS MADE TO THE EXCLUSIVE RIGHT TO USE "CARE" AND "AUTO", APART FROM THE MARK AS SHOWN.

THE MARK CONSISTS OF THE WORDING "TOTAL CARE AUTO" WITH THE WORDING "POWERED BY LANDCAR" UNDERNEATH WITH THE LETTER "T" IN THE MIDDLE OF THE THIRD CIRCLE TO THE LEFT.

FOR VEHICLE REPAIR AND MAINTENANCE SERVICES; VEHICLE MAINTENANCE PROGRAM (U.S. CLS. 100, 103 AND 106).

JOSETTE BEVERLY, EXAMINING ATTORNEY

SN 85-437,646. HASAPOPOULOS, JOHN, WHITE BEAR LAKE, MN. FILED 10-3-2011.

Timbershield

THE MARK CONSISTS OF STANDARD CHARACTERS WITHOUT CLAIM TO ANY PARTICULAR FONT, STYLE, SIZE, OR COLOR.

FOR CONSTRUCTING DECKS; RENOVATION IN THE FIELD OF DECKS (U.S. CLS. 100, 103 AND 106).

FIRST USE 4-30-2011; IN COMMERCE 4-30-2011.

NAKWAMA ANKRAH, EXAMINING ATTORNEY

SN 85-437,668. HASAPOPOULOS, JOHN, WHITE BEAR LAKE, MN. FILED 10-3-2011.

Never Seal Your Deck Again

THE MARK CONSISTS OF STANDARD CHARACTERS WITHOUT CLAIM TO ANY PARTICULAR FONT, STYLE, SIZE, OR COLOR.

OWNER OF U.S. REG. NO. 3,602,278.

FOR CONSTRUCTING DECKS; RENOVATION IN THE FIELD OF DECKS (U.S. CLS. 100, 103 AND 106).

FIRST USE 4-30-2011; IN COMMERCE 4-30-2011.

NAKWAMA ANKRAH, EXAMINING ATTORNEY

CLASS 37—(Continued).

SN 85-443,533. AIRGAS, INC., RADNOR, PA. FILED 10-10-2011.

 The logo for "easyLease" features the word "easy" in a blue, lowercase, sans-serif font, followed by "Lease" in a red, lowercase, sans-serif font. The "L" in "Lease" is significantly larger and more prominent than the other letters.

THE COLOR(S) BLUE AND RED IS/ARE CLAIMED AS A FEATURE OF THE MARK.

THE MARK CONSISTS OF THE WORD "EASY" IN BLUE IN A LOWER CASE, STYLIZED FONT FOLLOWED, IN SUBSCRIPT, BY THE WORD "LEASE" IN RED IN A STYLIZED, RIGHT-LEANING FONT WITH THE FIRST LETTER OF THE WORD BEING CAPITALIZED.

FOR LEASING OF WELDING EQUIPMENT, WELDING-RELATED EQUIPMENT, AND CUTTING EQUIPMENT, ALL FOR METAL FABRICATION (U.S. CLS. 100, 103 AND 106).

ANTHONY RINKER, EXAMINING ATTORNEY

CLASS 37—(Continued).

SN 85-444,433. FITNESS EMS, LLC, CHAMBLEE, GA. FILED 10-11-2011.

 The logo for "FITNESS EMS" features the word "FITNESS" in a bold, black, sans-serif font, followed by a circular emblem containing a stylized "E" and "M" with a bolt through them, and the word "EMS" in a bold, black, sans-serif font.

NO CLAIM IS MADE TO THE EXCLUSIVE RIGHT TO USE "FITNESS", APART FROM THE MARK AS SHOWN.

THE MARK CONSISTS OF THE WORDS "FITNESS" AND "EMS" WHERE THE WORDS ARE SEPARATED BY THREE OVALS THAT ARE JOINED AT THE CENTER WITH A BOLT; THE LETTERS "E", "M" AND "S" ARE EACH IN ONE OF THE OVALS.

FOR PROVIDING A WEBSITE FEATURING INFORMATION ON THE MAINTENANCE OF EXERCISE AND FITNESS EQUIPMENT AND THE MAINTENANCE OF EXERCISE AND FITNESS EQUIPMENT, NAMELY, MAINTENANCE SCHEDULES FOR EXERCISE AND FITNESS EQUIPMENT (U.S. CLS. 100, 103 AND 106).

FIRST USE 12-0-2009; IN COMMERCE 12-0-2009.

SETH A. RAPPAPORT, EXAMINING ATTORNEY

SN 85-444,428. CARPET SPECIALISTS, LTD., MARYLAND HEIGHTS, MO. FILED 10-11-2011.

 The logo for "CS FLOORING" features the letters "CS" in a bold, black, sans-serif font, enclosed within a square grid pattern. To the right of the grid is the word "FLOORING" in a bold, black, sans-serif font, with a swirl design underneath it. Below "FLOORING" are the words "carpet • vinyl • ceramic • hardwood" in a smaller, lowercase, sans-serif font.

NO CLAIM IS MADE TO THE EXCLUSIVE RIGHT TO USE "FLOORING" "CARPET" "VINYL" "CERAMIC" AND "HARDWOOD", APART FROM THE MARK AS SHOWN.

THE MARK CONSISTS OF THE WORDING "CS" EN-CIRCLED BY THREE ARROWS. BEHIND THE DESIGN IS A SQUARE WITH A GRID PATTERN. TO THE RIGHT IS THE WORD "FLOORING" WITH AN UNDERLINE TURNING TO A SWIRL DESIGN TO THE RIGHT. UNDERNEATH THE WORD "FLOORING" ARE THE WORDS "CARPET" "VINYL" "CERAMIC" AND "HARDWOOD" SEPARATED EACH BY A CIRCLE.

FOR INSTALLATION OF FLOOR COVERINGS (U.S. CLS. 100, 103 AND 106).

FIRST USE 4-11-2008; IN COMMERCE 4-16-2008.

TARAH HARDY, EXAMINING ATTORNEY

SN 85-509,616. RESICOM CUSTOM PAINTING & MAINTENANCE, INC., LEMONT, IL. FILED 1-5-2012.

BRAND PROTECTION THROUGH
MAINTENANCE, REPAIR, AND
RENOVATION

THE MARK CONSISTS OF STANDARD CHARACTERS WITHOUT CLAIM TO ANY PARTICULAR FONT, STYLE, SIZE, OR COLOR.

OWNER OF U.S. REG. NO. 3,711,557.

FOR BUILDING CONSTRUCTION, PAINTING, BUILDING RENOVATION, BUILDING MAINTENANCE AND REPAIR, AND CONSULTING SERVICES RELATED THERETO; CONSULTING SERVICES RELATING TO THE DEVELOPMENT AND IMPLEMENTATION OF MAINTENANCE PROCEDURES FOR RETAIL AND COMMERCIAL REAL ESTATE PROPERTIES (U.S. CLS. 100, 103 AND 106).

FIRST USE 9-0-2009; IN COMMERCE 9-0-2009.

HENRY S. ZAK, EXAMINING ATTORNEY

CLASS 37—(Continued).

SN 85-546,056. BARBERA HOME IMPROVEMENTS, AKA BARBERA HOME IMPROVEMENT, PARMA, OH. FILED 2-17-2012.

BHI

THE MARK CONSISTS OF STANDARD CHARACTERS WITHOUT CLAIM TO ANY PARTICULAR FONT, STYLE, SIZE, OR COLOR.

FOR HOMEBUILDING AND REMODELING SERVICES (U.S. CLS. 100, 103 AND 106).
FIRST USE 1-2-2004; IN COMMERCE 4-20-2004.
MATTHEW KLINE, EXAMINING ATTORNEY

SN 85-546,270. BARBERA HOME IMPROVEMENTS, AKA BARBERA HOME IMPROVEMENT, PARMA, OH. FILED 2-17-2012.



THE MARK CONSISTS OF AN OUTLINE OF A HOUSE WITH THE CAPITAL LETTERS "BHI" ENCASED WITHIN THE HOUSE AND SUBSTANTIALLY FILLING AN INSIDE AREA OF THE HOUSE. THE LETTERS ASCEND TOWARD THE APEX OF THE HOUSE SUCH THAT THE SLOPE OF AN UPPER PORTION OF RESPECTIVE LETTERS IS PARALLEL TO A ROOFING STRUCTURE OF THE HOUSE. THE LETTER "H" IS DIVIDED AT THE APEX, WITH A FIRST UPPER PORTION OF THE "H" SLOPING IN A FIRST DIRECTION AND A SECOND UPPER PORTION OF THE "H" SLOPING IN A SECOND DIRECTION.

FOR HOMEBUILDING AND REMODELING SERVICES (U.S. CLS. 100, 103 AND 106).
FIRST USE 1-2-2004; IN COMMERCE 4-20-2004.
MATTHEW KLINE, EXAMINING ATTORNEY

CLASS 37—(Continued).

SN 85-561,152. PEST MANAGEMENT SYSTEMS, INC., GREENSBORO, NC. FILED 3-6-2012.



NO CLAIM IS MADE TO THE EXCLUSIVE RIGHT TO USE "PEST MANAGEMENT SYSTEMS, INC.", APART FROM THE MARK AS SHOWN.

THE MARK CONSISTS OF A BALL WITH A SERIES OF LINES WHICH GO FROM THIN TO THICK FROM LEFT TO RIGHT, WITH THE LETTERS "PMI" ADJACENT TO THE BALL, THE LETTERS "PM" ARE IN CAPS AND THE LETTER "I" IS IN LOWER CASE, WITH THE NAME "PEST MANAGEMENT SYSTEMS INC." IN ALL CAPS BELOW THE LETTERS "PMI".

FOR PEST CONTROL SERVICES (U.S. CLS. 100, 103 AND 106).
FIRST USE 6-1-1999; IN COMMERCE 6-1-1999.
ARETHA SOMERVILLE, EXAMINING ATTORNEY

SN 85-569,302. ORANGE COUNTY COMPUTER, INC., LAKE FOREST, CA. FILED 3-14-2012.

ORANGE COUNTY COMPUTER

THE MARK CONSISTS OF STANDARD CHARACTERS WITHOUT CLAIM TO ANY PARTICULAR FONT, STYLE, SIZE, OR COLOR.

NO CLAIM IS MADE TO THE EXCLUSIVE RIGHT TO USE "COMPUTER", APART FROM THE MARK AS SHOWN.

SEC. 2(F).
FOR INSTALLATION, MAINTENANCE AND REPAIR OF COMPUTER HARDWARE; INSTALLATION, MAINTENANCE AND REPAIR OF ETHERNET AND WIRELESS NETWORKING HARDWARE (U.S. CLS. 100, 103 AND 106).

FIRST USE 11-30-1998; IN COMMERCE 11-30-1998.
ZACHARY BELLO, EXAMINING ATTORNEY

CLASS 37—(Continued).

SN 85-570,962. DATA DUDES, LLC, MANSFIELD, TX. FILED 3-15-2012.

Data Dudes

THE MARK CONSISTS OF STANDARD CHARACTERS WITHOUT CLAIM TO ANY PARTICULAR FONT, STYLE, SIZE, OR COLOR.

FOR COMPUTER HARDWARE INSTALLATION AND REPAIR, INCLUDING MOBILE PERFORMANCE OF SUCH SERVICES ON CUSTOMER PREMISES; COMPUTER INSTALLATION AND REPAIR; CUSTOMIZING COMPUTER HARDWARE; INSTALLATION AND REPAIR OF COMPUTER HARDWARE; INSTALLATION OF COMPUTER NETWORKING HARDWARE; INSTALLATION OF COMPUTER SYSTEMS; INSTALLATION, MAINTENANCE AND REPAIR OF COMPUTER HARDWARE; INSTALLATION, MAINTENANCE AND REPAIR OF ETHERNET AND WIRELESS NETWORKING HARDWARE; INSTALLATION, REPAIR AND MAINTENANCE OF COMPUTERS AND COMPUTER PERIPHERALS; MAINTENANCE AND REPAIR OF COMPUTER HARDWARE; MAINTENANCE AND REPAIR OF COMPUTER NETWORKING HARDWARE; MAINTENANCE AND REPAIR OF TELECOMMUNICATIONS NETWORKING HARDWARE, APPARATUS, AND INSTRUMENTS; MAINTENANCE OF COMPUTER HARDWARE; MAINTENANCE OF COMPUTER HARDWARE SYSTEMS; REPAIR OF COMPUTER HARDWARE; REPAIR OF DAMAGED COMPUTERS; REPAIR OR MAINTENANCE OF COMPUTERS; TECHNICAL SUPPORT SERVICES, NAMELY, TROUBLESHOOTING IN THE NATURE OF THE REPAIR OF COMPUTER HARDWARE; UPDATING OF COMPUTER HARDWARE; UPGRADING OF COMPUTER HARDWARE (U.S. CLS. 100, 103 AND 106).

FIRST USE 3-1-2012; IN COMMERCE 3-15-2012.
PAUL MORENO, EXAMINING ATTORNEY

SN 85-575,599. THE KLEANE KARE TEAM, INC., RICHMOND, VA. FILED 3-21-2012.

KLEANE KARE

THE MARK CONSISTS OF STANDARD CHARACTERS WITHOUT CLAIM TO ANY PARTICULAR FONT, STYLE, SIZE, OR COLOR.

NO CLAIM IS MADE TO THE EXCLUSIVE RIGHT TO USE "CLEAN", APART FROM THE MARK AS SHOWN.

FOR BUILDING CLEANING SERVICES, NAMELY, JANITORIAL AND CUSTODIAL SERVICES, GREEN CLEANING OF BUILDINGS, FLOOR CLEANING, AND HIGH RISE WINDOW CLEANING; PARKING LOT CLEANING; NATURAL STONE RESTORATION; WINDOW SEALING AND CAULKING; POWER WASHING, ALL OF THE FOREGOING EXCLUDING CONSTRUCTION AND REPAIR SERVICES, FIRE AND WATER DAMAGE RESTORATION AND DISASTER RECOVERY SERVICES, AND DISASTER RESTORATION SERVICES (U.S. CLS. 100, 103 AND 106).

FIRST USE 12-31-1998; IN COMMERCE 3-31-2001.
ELISSA GARBER KON, EXAMINING ATTORNEY

CLASS 37—(Continued).

SN 85-579,288. AWESOME AUTOMATIONS, INC., SAN DIEGO, CA. FILED 3-25-2012.



Awesome Automations

NO CLAIM IS MADE TO THE EXCLUSIVE RIGHT TO USE "AUTOMATIONS", APART FROM THE MARK AS SHOWN.

THE COLOR(S) BRIGHT GREEN AND BRIGHT BLUE IS/ARE CLAIMED AS A FEATURE OF THE MARK.

THE MARK CONSISTS OF THE WORDING "AWESOME AUTOMATIONS" IN BRIGHT GREEN WITH A BRIGHT BLUE WIRELESS ICON ABOVE THE "I" IN "AUTOMATIONS".

FOR INSTALLATION OF AUTOMATION SYSTEMS FOR HOME, BUSINESS, AND MOTOR VEHICLES THAT ARE COMPRISED OF WIRED AND WIRELESS CONTROLLERS, CONTROLLED DEVICES, AND SOFTWARE FOR MONITORING AND CONTROLLING LIGHTING, CLIMATE CONTROL, SURVEILLANCE CAMERAS, ALARM SYSTEMS, AUDIO AND VIDEO EQUIPMENT, HOME THEATER, SPRINKLER SYSTEMS, WINDOW COVERINGS, SAID SYSTEMS ALSO CAPABLE OF MONITORING AND REDUCING ENERGY CONSUMPTION THROUGH CUSTOMIZABLE USER INTERFACE OPTIONS ON SMART PHONES, TABLETS, AND COMPUTERS (U.S. CLS. 100, 103 AND 106).

SEAN CROWLEY, EXAMINING ATTORNEY

SN 85-579,756. MICHAEL L. HOLCOMB, WICHITA, KS. FILED 3-26-2012.



NO CLAIM IS MADE TO THE EXCLUSIVE RIGHT TO USE "AUTO REPAIR", APART FROM THE MARK AS SHOWN.

THE COLOR(S) PINK, BLACK AND WHITE IS/ARE CLAIMED AS A FEATURE OF THE MARK.

THE MARK CONSISTS OF PINK DOG WITH WHITE ON HIS FACE, WEARING A WHITE HAT WITH A BLACK WRENCH IN HIS MOUTH STANDING IN FRONT OF A BLACK AUTOMOBILE WHEEL WITH WHITE SPOKES OVER THE WORDING "MICHELLE'S" IN WHITE LETTERING WITH BLACK OUTLINE ABOVE "AUTO REPAIR" IN BLACK LETTERING.

FOR AUTOMOBILE REPAIR AND MAINTENANCE; AUTOMOTIVE MAINTENANCE AND REPAIR; CAR REPAIR AND MAINTENANCE (U.S. CLS. 100, 103 AND 106).

BARBARA BROWN, EXAMINING ATTORNEY

CLASS 37—(Continued).

SN 85-589,158. POOL SERVICES NETWORK, INC., LINDEN, VA. FILED 4-4-2012.



NO CLAIM IS MADE TO THE EXCLUSIVE RIGHT TO USE "POOL SERVICES NETWORK", APART FROM THE MARK AS SHOWN.

THE COLOR(S) BLUE, LIGHT BLUE AND SILVER IS/ARE CLAIMED AS A FEATURE OF THE MARK.

THE MARK CONSISTS OF "POOL" IN BLUE STYLIZED FONT WITH LIGHT BLUE WAVES WITHIN THE TWO "OO"'S. BELOW "POOL" IS "SERVICES" IN BLUE STYLIZED FONT. BELOW "SERVICES" IS "NETWORK" IN SILVER STYLIZED FONT. "YOUR POOL IS WAITING" IN SMALLER BLUE STYLIZED FONT AND UNDERLINED.

FOR SWIMMING POOL CLEANING SERVICES; SWIMMING POOL MAINTENANCE (U.S. CLS. 100, 103 AND 106).

FIRST USE 3-0-2012; IN COMMERCE 3-0-2012.
JAMES LOVELACE, EXAMINING ATTORNEY

CLASS 37—(Continued).

SN 85-590,886. G&D ELECTRIC, INC., GREENVILLE, MI. FILED 4-6-2012.



OWNER OF U.S. REG. NO. 3,384,982.

NO CLAIM IS MADE TO THE EXCLUSIVE RIGHT TO USE "SERVICE", "ELECTRIC", "PLUMBING" AND "SEWER SERVICE", APART FROM THE MARK AS SHOWN.

THE STIPPLING IS A FEATURE OF THE MARK AND DOES NOT INDICATE COLOR.

THE MARK CONSISTS OF A SMILING, MALE PROFESSOR CHARACTER WITH PATTERN BALDNESS AND A MOUSTACHE, WEARING GLASSES, AN UNDERSHIRT, LAB COAT AND BOW TIE. THE CHARACTER IS HOLDING A LIGHT BULB IN HIS LEFT AND A BAG WITH PLUNGER PROTRUDING FROM THE UPPER RIGHT SIDE IN HIS RIGHT HAND. THE WORDS "THE SERVICE PROFESSOR" APPEAR IN A SHADED OVAL ON THE CHARACTER'S LEFT SIDE. THE LIGHT BULB CONTAINS STIPPLING REPRESENTING ILLUMINATION AND THE CHARACTER'S GLASSES CONTAIN STIPPLING REPRESENTING REFLECTED LIGHT. THE WORDS "ELECTRIC", "PLUMBING" AND "SEWER SERVICE" APPEAR BELOW THE PROFESSOR AND SHADED OVAL.

FOR ELECTRICAL AND PLUMBING CONTRACTOR SERVICES; DRAIN AND SEWER CLEANING AND ROOTER SERVICES (U.S. CLS. 100, 103 AND 106).

JAMES GRIFFIN, EXAMINING ATTORNEY

SN 85-590,012. COLE, JEFF, MCDONOUGH, GA. FILED 4-5-2012.

TIRED OF MOPPING? CALL US!

THE MARK CONSISTS OF STANDARD CHARACTERS WITHOUT CLAIM TO ANY PARTICULAR FONT, STYLE, SIZE, OR COLOR.

FOR MAINTENANCE AND REPAIR OF CLEANING EQUIPMENT (U.S. CLS. 100, 103 AND 106).

FIRST USE 6-1-2010; IN COMMERCE 6-1-2010.
WANDA KAY PRICE, EXAMINING ATTORNEY

SN 85-592,183. AGING IN THE COMFORT OF HOME, OZARK, MO. FILED 4-9-2012.



Aging In The Comfort Of Home

THE MARK CONSISTS OF A ROUNDED SQUARE CONTAINING A STYLIZED OUTLINE OF A HOUSE. A BORDER SURROUNDS THE SQUARE. BELOW THE SQUARE IS THE STYLIZED TEXT "AGING IN THE COMFORT OF HOME".

FOR HOME REMODELING SERVICES, FOR THE AGING AND THE INFIRM TO PROLONG THE STAY WITHIN THEIR HOMES (U.S. CLS. 100, 103 AND 106).

FIRST USE 7-0-2009; IN COMMERCE 7-0-2009.
LINDA POWELL, EXAMINING ATTORNEY

CLASS 37—(Continued).

SN 85-592,658. JEREMY MACLIVER, PHOENIX, AZ. FILED 4-9-2012.

REPAIR FORCE ONE

THE MARK CONSISTS OF STANDARD CHARACTERS WITHOUT CLAIM TO ANY PARTICULAR FONT, STYLE, SIZE, OR COLOR.
 NO CLAIM IS MADE TO THE EXCLUSIVE RIGHT TO USE "REPAIR", APART FROM THE MARK AS SHOWN.
 FOR AUTOMOTIVE COLLISION REPAIR (U.S. CLS. 100, 103 AND 106).
 JIM RINGLE, EXAMINING ATTORNEY

SN 85-594,910. SIRIUS TECHNOLOGIES, INC., DBA FLIGHT DISPLAY SYSTEMS, ALPHARETTA, GA. FILED 4-11-2012.

FORM FIT FUNCTION PLUS

THE MARK CONSISTS OF STANDARD CHARACTERS WITHOUT CLAIM TO ANY PARTICULAR FONT, STYLE, SIZE, OR COLOR.
 NO CLAIM IS MADE TO THE EXCLUSIVE RIGHT TO USE "FORM FIT FUNCTION", APART FROM THE MARK AS SHOWN.
 FOR AVIONICS RETROFIT AND CONVERSION SERVICES (U.S. CLS. 100, 103 AND 106).
 FIRST USE 2-0-2012; IN COMMERCE 2-0-2012.
 REBECCA SMITH, EXAMINING ATTORNEY

SN 85-596,181. KANGAROO CAR CARE, SPRINGFIELD, VA. FILED 4-12-2012.



THE COLOR(S) MAROON IS/ARE CLAIMED AS A FEATURE OF THE MARK.
 THE MARK CONSISTS OF MAROON OUTLINE OF KANGAROO IN FORWARD MOVING MOTION.
 FOR AUTOMOBILE WASHING AND CLEANING SERVICES (U.S. CLS. 100, 103 AND 106).
 FIRST USE 2-15-2010; IN COMMERCE 2-15-2010.
 CHRISTOPHER BUONGIORNO, EXAMINING ATTORNEY

CLASS 37—(Continued).

SN 85-596,808. GREEN LUBE, LLC, DBA OIL N GO, SOUTH BURLINGTON, VT. FILED 4-13-2012.



NO CLAIM IS MADE TO THE EXCLUSIVE RIGHT TO USE "OIL", APART FROM THE MARK AS SHOWN.
 THE COLOR(S) GREEN, BLACK AND WHITE IS/ARE CLAIMED AS A FEATURE OF THE MARK.
 THE MARK CONSISTS OF AN UPRIGHT RECTANGLE WITH SLIGHTLY ROUNDED CORNERS THAT IS DIVIDED INTO TWO SAME-SIZED SQUARES. THE TOP SQUARE IS GREEN, AND THE LOWER SQUARE IS BLACK. CENTERED WITHIN EACH SQUARE IS A CIRCLE. THE CIRCLE IN THE TOP SQUARE IS BLACK, AND CIRCLE IN THE LOWER SQUARE IS GREEN. THE WORD "OIL" IS IN UPPERCASE, WHITE LETTERS IN THE TOP, BLACK CIRCLE, AND THE WORD "GO" IS IN UPPERCASE, WHITE LETTERS IN THE LOWER GREEN CIRCLE. A WHITE, LOWERCASE LETTER "N" IS IN THE LOWER RIGHT CORNER OF THE TOP, GREEN SQUARE.
 FOR VEHICLE REPAIR AND MAINTENANCE SERVICES; VEHICLE OIL CHANGE AND LUBRICATION SERVICES (U.S. CLS. 100, 103 AND 106).
 FIRST USE 12-31-1996; IN COMMERCE 12-31-1996.
 MARK SPARACINO, EXAMINING ATTORNEY

SN 85-596,811. GREEN LUBE, LLC, DBA OIL N GO, SOUTH BURLINGTON, VT. FILED 4-13-2012.

OIL N GO

THE MARK CONSISTS OF STANDARD CHARACTERS WITHOUT CLAIM TO ANY PARTICULAR FONT, STYLE, SIZE, OR COLOR.
 NO CLAIM IS MADE TO THE EXCLUSIVE RIGHT TO USE "OIL", APART FROM THE MARK AS SHOWN.
 FOR VEHICLE REPAIR AND MAINTENANCE SERVICES; VEHICLE OIL CHANGE AND LUBRICATION SERVICES (U.S. CLS. 100, 103 AND 106).
 FIRST USE 12-13-1996; IN COMMERCE 12-13-1996.
 MARK SPARACINO, EXAMINING ATTORNEY

CLASS 37—(Continued).

SN 85-598,971. 4 SERVICE GROUP, L.L.C., ELKRIDGE, MD.
FILED 4-16-2012.

4 Service Group

THE MARK CONSISTS OF STANDARD CHARACTERS WITHOUT CLAIM TO ANY PARTICULAR FONT, STYLE, SIZE, OR COLOR.

NO CLAIM IS MADE TO THE EXCLUSIVE RIGHT TO USE "SERVICE GROUP", APART FROM THE MARK AS SHOWN.

FOR INSTALLATION, MAINTENANCE AND REPAIR OF PROTECTIVE COATINGS FOR FLOORS (U.S. CLS. 100, 103 AND 106).

FIRST USE 3-1-2011; IN COMMERCE 3-1-2011.
JIM RINGLE, EXAMINING ATTORNEY

SN 85-600,677. PINNACLE CONSTRUCTION SUPPORT GROUP INC, TALLAHASSEE, FL. FILED 4-17-2012.

Not Just A Project..... A Relationship

THE MARK CONSISTS OF STANDARD CHARACTERS WITHOUT CLAIM TO ANY PARTICULAR FONT, STYLE, SIZE, OR COLOR.

FOR BUILDING CONSTRUCTION; BUILDING CONSTRUCTION AND REPAIR; BUILDING CONSTRUCTION INFORMATION; BUILDING CONSTRUCTION OBSERVATION, NAMELY, STATIC INSPECTION, FUNCTIONAL VERIFICATION INSPECTION, PERFORMANCE VERIFICATION INSPECTION; BUILDING CONSTRUCTION SERVICES; BUILDING CONSTRUCTION SUPERVISION; BUILDING CONSTRUCTION, REMODELING AND REPAIR; CONSTRUCTION AND CONSTRUCTION MANAGEMENT OF TUNNELS AND UNDERGROUND STRUCTURES; CONSTRUCTION AND INSTALLATION OF MASONRY WALLS AND STRUCTURES; CONSTRUCTION AND RENOVATION OF BUILDINGS; CONSTRUCTION AND REPAIR OF BUILDINGS; CONSTRUCTION AND REPAIR OF MOVIE AND THEATRICAL SETS AND SCENERY; CONSTRUCTION CONSULTANCY; CONSTRUCTION CONSULTATION; CONSTRUCTION OF AIRPORTS; CONSTRUCTION OF BUILDINGS; CONSTRUCTION OF MEDICAL ESTABLISHMENTS; CONSTRUCTION PLANNING; CONSTRUCTION PROJECT MANAGEMENT SERVICES; CONSTRUCTION SERVICES, NAMELY, PLANNING, LAYING OUT AND CUSTOM CONSTRUCTION OF COMMERCIAL BUILDINGS; CONSTRUCTION SERVICES, NAMELY, PLANNING, LAYING OUT AND CUSTOM CONSTRUCTION OF RESIDENTIAL AND COMMERCIAL COMMUNITIES; CONSTRUCTION SUPERVISION; CONSULTATION IN BUILDING CONSTRUCTION SUPERVISION; CONSULTATION SERVICES IN THE FIELD OF CONSTRUCTION OF ENVIRONMENTALLY-CONSCIOUS BUILDINGS; CONSULTING IN THE FIELD OF BUILDING CONSTRUCTION; CONSULTING IN THE FIELD OF HOSPITAL CONSTRUCTION; FACTORY CONSTRUCTION; GENERAL CONSTRUCTION CONTRACTING; REAL ESTATE DEVELOPMENT AND CONSTRUCTION OF COMMERCIAL, RESIDENTIAL AND HOTEL PROPERTY; RESIDENTIAL AND COMMERCIAL BUILDING CONSTRUCTION; TECHNICAL CONSULTATION IN THE FIELD OF BUILDING CONSTRUCTION (U.S. CLS. 100, 103 AND 106).

LINDA POWELL, EXAMINING ATTORNEY

CLASS 37—(Continued).

SN 85-601,868. SUPERIOR STEAM, INC., SPRINGFIELD, GA.
FILED 4-18-2012.

Go Green With Superior Steam

THE MARK CONSISTS OF STANDARD CHARACTERS WITHOUT CLAIM TO ANY PARTICULAR FONT, STYLE, SIZE, OR COLOR.

FOR RESTAURANT HOOD CLEANING; RESTAURANT HOOD FILTER CLEANING AND MAINTENANCE; COMMERCIAL CONCRETE CLEANING (U.S. CLS. 100, 103 AND 106).

FIRST USE 1-1-2010; IN COMMERCE 1-1-2010.
PAM WILLIS, EXAMINING ATTORNEY

SN 85-602,173. RHINO DESIGN BUILD, LLC, SAN ANTONIO, TX. FILED 4-19-2012.



THE MARK CONSISTS OF AN OUTLINE OF A RHINO, FOR GENERAL BUILDING CONTRACTOR SERVICES (U.S. CLS. 100, 103 AND 106).
GEORGE LORENZO, EXAMINING ATTORNEY

SN 85-602,701. ROOCK AUTOSPORT INC., ATLANTA, GA.
FILED 4-19-2012.

ROOCK

THE MARK CONSISTS OF STANDARD CHARACTERS WITHOUT CLAIM TO ANY PARTICULAR FONT, STYLE, SIZE, OR COLOR.

SEC. 2(F).

FOR AUTOMOBILE CUSTOMIZATION SERVICES; AUTOMOBILE RECONDITIONING SERVICES; AUTOMOBILE REPAIR AND MAINTENANCE; AUTOMOBILE SERVICE STATION SERVICES; AUTOMOTIVE UPGRADE SERVICES, NAMELY, SUPERCHARGING, TURBOCHARGING AND PERFORMANCE UPGRADES OF AUTOMOBILES (U.S. CLS. 100, 103 AND 106).

FIRST USE 2-0-1990; IN COMMERCE 9-0-1999.
SETH A. RAPPAPORT, EXAMINING ATTORNEY

CLASS 37—(Continued).

SN 85-603,035. ROBINSON HEATING & AIR, INC., KENNESAW, GA. FILED 4-19-2012.

BABY IT'S COLD OUTSIDE! CALL
ROBINSON HEATING & AIR

THE MARK CONSISTS OF STANDARD CHARACTERS WITHOUT CLAIM TO ANY PARTICULAR FONT, STYLE, SIZE, OR COLOR.

OWNER OF U.S. REG. NO. 4,111,506.

NO CLAIM IS MADE TO THE EXCLUSIVE RIGHT TO USE "HEATING & AIR", APART FROM THE MARK AS SHOWN.

FOR INSTALLATION, MAINTENANCE AND REPAIR OF HEATING, VENTILATING AND AIR CONDITIONING EQUIPMENT (U.S. CLS. 100, 103 AND 106).

FIRST USE 7-0-2009; IN COMMERCE 7-0-2009.

GIANCARLO CASTRO, EXAMINING ATTORNEY

CLASS 37—(Continued).

SN 85-672,281. RAINFOREST WORKS, INC., CHANDLER, AZ. FILED 7-9-2012.



NO CLAIM IS MADE TO THE EXCLUSIVE RIGHT TO USE "PLUMBING & AIR", APART FROM THE MARK AS SHOWN.

THE MARK CONSISTS OF THE SHAPE OF A LEAF WITH THE TEXT "RAINFOREST PLUMBING & AIR". IT INCLUDES VEINS AND LEAF-SHAPED ACCENTS.

FOR AIR CONDITIONING CONTRACTOR SERVICES; PLUMBING SERVICES (U.S. CLS. 100, 103 AND 106).

FIRST USE 12-27-1999; IN COMMERCE 12-27-1999.

ANDREW LEASER, EXAMINING ATTORNEY

SN 85-604,699. CHERRYCOM, INC., SAN FRANCISCO, CA. FILED 4-22-2012.

CHERRY

THE MARK CONSISTS OF STANDARD CHARACTERS WITHOUT CLAIM TO ANY PARTICULAR FONT, STYLE, SIZE, OR COLOR.

FOR AUTOMOBILE CLEANING AND CAR WASHING (U.S. CLS. 100, 103 AND 106).

FIRST USE 11-8-2011; IN COMMERCE 11-8-2011.

MIDGE BUTLER, EXAMINING ATTORNEY

CLASS 38—COMMUNICATION

SN 77-895,324. EGGESTAD, KARL H. STABEKK, NORWAY, FILED 12-17-2009.



PRIORITY CLAIMED UNDER SEC. 44(D) ON NORWAY APPLICATION NO. 200913459, FILED 12-17-2009, REG. NO. 255128, DATED 4-15-2010, EXPIRES 4-15-2020.

NO CLAIM IS MADE TO THE EXCLUSIVE RIGHT TO USE "NORDIC WEATHER TELEVISION", APART FROM THE MARK AS SHOWN.

THE COLOR(S) GRAY, BLUE, LIGHT BLUE, RED, LIGHT RED, YELLOW, GREEN AND WHITE IS/ARE CLAIMED AS A FEATURE OF THE MARK.

THE MARK CONSISTS OF THE GRAY WORDING "NORDIC WEATHER TELEVISION" ON A WHITE CLOUD OUTLINED IN GRAY. BEHIND THE CLOUD IS A GLOBE WITH GRAY MERIDIAN LINES ON A WHITE BACKGROUND. FROM THE LEFT CORNER OF THE CLOUD IS A RAINBOW WITH THE COLORS BLUE, LIGHT BLUE, DARK BLUE, YELLOW, RED, LIGHT RED AND GREEN.

FOR AUDIO AND VIDEO BROADCASTING SERVICES OVER THE INTERNET; AUDIO BROADCASTING; BROADCAST OF CABLE TELEVISION PROGRAMMES; BROADCASTING OF RADIO AND TELEVISION PROGRAMMES; BROADCASTING OF RADIO PROGRAMMES; BROADCASTING OF TELEVISION PROGRAMMES; BROADCASTING OF VIDEO AND AUDIO PROGRAMMING OVER THE INTERNET; BROADCASTING PROGRAMS VIA A GLOBAL COMPUTER NETWORK; BROADCASTING SERVICES AND PROVISION OF TELECOMMUNICATION ACCESS TO FILMS AND TELEVISION PROGRAMMES PROVIDED VIA A VIDEO-ON-DEMAND SERVICE; BROADCASTING SERVICES AND PROVISION OF TELECOMMUNICATION ACCESS TO VIDEO AND AUDIO CONTENT PROVIDED VIA A VIDEO-ON-DEMAND SERVICE VIA THE INTERNET; BROADCASTING SERVICES,

SN 85-606,884. TAYLOR MORRISON, INC., SCOTTSDALE, AZ. FILED 4-24-2012.

ELEM3NTS

THE MARK CONSISTS OF STANDARD CHARACTERS WITHOUT CLAIM TO ANY PARTICULAR FONT, STYLE, SIZE, OR COLOR.

FOR REAL ESTATE DEVELOPMENT, CONSTRUCTION, LAND PLANNING, AND LAND DEVELOPMENT SERVICES, NAMELY, CUSTOM CONSTRUCTION OF HOMES, BUILDINGS, AND RESIDENTIAL AND COMMERCIAL COMMUNITIES ALL IN A MANNER TO PROMOTE GREEN, ENVIRONMENTALLY-FRIENDLY, EFFICIENT, AND SUSTAINABLE HOMES, BUILDINGS, AND COMMUNITIES (U.S. CLS. 100, 103 AND 106).

FIRST USE 4-21-2012; IN COMMERCE 4-21-2012.

KAREN K. BUSH, EXAMINING ATTORNEY

CLASS 38—(Continued).

NAMELY, TRANSMISSION OF ADVERTISING PROGRAMS AND MEDIA ADVERTISING COMMUNICATIONS VIA DIGITAL COMMUNICATIONS NETWORKS; CABLE TELEVISION BROADCASTING; CABLE TELEVISION BROADCASTING SERVICES; CABLE TELEVISION TRANSMISSION; CELLULAR TELEPHONE COMMUNICATION; COMMUNICATION BY ELECTRONIC COMPUTER TERMINALS; COMMUNICATION BY MOBILE TELEPHONE; COMMUNICATION SERVICES, NAMELY, ELECTRONIC TRANSMISSION OF DATA AND DOCUMENTS AMONG USERS OF COMPUTERS; COMMUNICATION SERVICES, NAMELY, TRANSMISSION OF VOICE, AUDIO, VISUAL IMAGES AND DATA BY TELECOMMUNICATIONS NETWORKS, WIRELESS COMMUNICATION NETWORKS, THE INTERNET, INFORMATION SERVICES NETWORKS AND DATA NETWORKS; COMMUNICATION VIA ANALOGUE AND DIGITAL COMPUTER TERMINALS; COMMUNICATION VIA COMPUTER TERMINALS, BY DIGITAL TRANSMISSION OR BY SATELLITE; COMMUNICATION VIA FIBRE OPTICAL NETWORKS; COMMUNICATION VIA FIBRE-OPTIC NETWORKS; COMMUNICATION VIA OPTICAL FIBRE NETWORKS; COMMUNICATION VIA RADIO, TELEGRAPH, TELEPHONE AND TELEVISION TRANSMISSIONS; COMMUNICATIONS BY MEANS OF MOBILE PHONES; COMMUNICATIONS BY MOBILE PHONES; COMMUNICATIONS BY TELEPHONE; COMMUNICATIONS BY TELEVISION FOR MEETING; COMMUNICATIONS SERVICES, NAMELY, TRANSMITTING STREAMED SOUND AND AUDIOVISUAL RECORDINGS VIA THE INTERNET; COMMUNICATIONS VIA FIBER-OPTIC NETWORKS; COMMUNICATIONS VIA FIBRE-OPTIC NETWORKS; COMMUNICATIONS VIA MULTINATIONAL TELECOMMUNICATION NETWORKS; COMPUTER AIDED TRANSMISSION OF INFORMATION AND IMAGES; COMPUTER SERVICES, NAMELY, PROVIDING ON-LINE FACILITIES FOR REAL-TIME INTERACTION WITH OTHER COMPUTER USERS CONCERNING TOPICS OF EDUCATION; COMPUTER SERVICES, NAMELY, PROVIDING ON-LINE FACILITIES FOR REAL-TIME INTERACTION WITH OTHER COMPUTER USERS CONCERNING TOPICS OF GENERAL INTEREST; COMPUTER TRANSMISSION OF ONLINE BASED SERVICES ACCESSED VIA A NETWORK REFERENCE, NAMELY, A URI, VISUAL CODE, NAMELY, BARCODES, TAG, NAMELY, RFID, TERMINAL, NAMELY, PC OR MOBILE DEVICE, OR ANY COMBINATION THEREOF; COMPUTER-AIDED TRANSMISSION OF MESSAGES; COMPUTERIZED TELEPHONY SERVICES; DATA CASTING; DATA COMMUNICATION BY ELECTRONIC MAIL; DATA TRANSMISSION AND RECEPTION SERVICES VIA TELECOMMUNICATION MEANS; DELIVERY OF MESSAGES BY ELECTRONIC TRANSMISSION; DIGITAL NETWORK TELECOMMUNICATIONS SERVICES; E-MAIL DATA SERVICES; E-MAIL FORWARDING SERVICES; ELECTRONIC BULLETIN BOARD SERVICES; ELECTRONIC DATA INTERCHANGE; ELECTRONIC DATA TRANSMISSION; ELECTRONIC DELIVERY OF IMAGES AND PHOTOGRAPHS VIA A GLOBAL COMPUTER NETWORK; ELECTRONIC EXCHANGE OF DATA STORED IN DATABASES ACCESSIBLE VIA TELECOMMUNICATION NETWORKS; ELECTRONIC MAIL; ELECTRONIC MAIL AND MESSAGING SERVICES; ELECTRONIC MAIL SERVICES; ELECTRONIC MAIL SERVICES FOR DATA AND VOICE; ELECTRONIC MESSAGE SENDING; ELECTRONIC MESSAGE TRANSMISSION; ELECTRONIC STORE-AND-FORWARD MESSAGING; ELECTRONIC TRANSMISSION AND STREAMING OF DIGITAL MEDIA CONTENT FOR OTHERS VIA GLOBAL AND LOCAL COMPUTER NETWORKS; ELECTRONIC TRANSMISSION OF DATA AND DOCUMENTS VIA COMPUTER TERMINALS; ELECTRONIC TRANSMISSION OF DATA AND DOCUMENTS VIA COMPUTER TERMINALS AND ELECTRONIC DEVICES; ELECTRONIC TRANSMISSION OF MAIL AND MESSAGES; ELECTRONIC TRANSMISSION OF MESSAGES; ELECTRONIC TRANSMISSION OF MESSAGES AND DATA; ELECTRONIC TRANSMISSION OF VOICE, DATA AND IMAGES BY TELEVISION AND VIDEO BROADCASTING; ELECTRONIC, ELECTRIC, AND DIGITAL TRANSMISSION OF VOICE, DATA, IMAGES, SIGNALS, AND MESSAGES; HIGH BIT-RATE DATA TRANSMISSION SERVICES FOR TELECOMMUNICATION NETWORK OPERATORS; INFORMATION TRANSMISSION SERVICES VIA DIGITAL NETWORKS;

CLASS 38—(Continued).

INFORMATION TRANSMISSION VIA ELECTRONIC COMMUNICATIONS NETWORKS; INSTANT MESSAGING SERVICES; INTERACTIVE DELIVERY OF VIDEO OVER DIGITAL NETWORKS; INTERNET BASED PAGING AND ALERTING SERVICES, NAMELY, PROVIDING A WEB SITE AT WHICH USERS CAN SEND MESSAGES TO ELECTRONIC PAGING DEVICES; INTERNET BROADCASTING SERVICES; INTERNET PROTOCOL TELEVISION (IPTV) TRANSMISSION SERVICES; INTERNET RADIO BROADCASTING SERVICES; MESSAGE COLLECTION AND TRANSMISSION; MESSAGE SENDING AND RECEIVING SERVICES; MESSAGE SENDING, RECEIVING AND FORWARDING; MOBILE MEDIA SERVICES IN THE NATURE OF ELECTRONIC TRANSMISSION OF ENTERTAINMENT MEDIA CONTENT; MOBILE RADIO COMMUNICATION; MOBILE RADIO TELEPHONE SERVICES; MOBILE TELEPHONE COMMUNICATION; NETWORK CONFERRING SERVICES; NEWS AGENCIES, NAMELY, THE TRANSMISSION OF NEWS ITEMS TO NEWS REPORTING ORGANIZATIONS; NEWS AGENCY SERVICES FOR ELECTRONIC TRANSMISSION; ON-LINE DOCUMENT DELIVERY VIA A GLOBAL COMPUTER NETWORK; ON-LINE SERVICES, NAMELY, MESSAGE SENDING; PAY-PER-VIEW TELEVISION TRANSMISSION SERVICES; PEER-TO-PEER NETWORK COMPUTER SERVICES, NAMELY, ELECTRONIC TRANSMISSION OF AUDIO, VIDEO AND OTHER DATA AND DOCUMENTS AMONG COMPUTERS; PODCASTING SERVICES; PROVIDING ACCESS TO DATABASES; PROVIDING AN ON-LINE FORUM FOR COMPANIES TO SHOWCASE, DISPLAY, DEMONSTRATE AND PROMOTE NEW AND INNOVATIVE IDEAS, PRODUCTS AND SERVICES IN THE CONVENTION/MEETING MANAGEMENT ARENA; PROVIDING CHAT LINES UTILIZING THE INTERNET; PROVIDING CO-LOCATION SERVICES FOR VOICE, VIDEO AND DATA COMMUNICATIONS APPLICATIONS; PROVIDING E-MAIL AND INSTANT MESSAGING SERVICES; PROVIDING ELECTRONIC TRANSMISSION OF CREDIT CARD TRANSACTION DATA AND ELECTRONIC PAYMENT DATA VIA A GLOBAL COMPUTER NETWORK; PROVIDING ELECTRONIC TRANSMISSION OF INFORMATION TO PERSONS WHO ARE DEAF OR HEARING IMPAIRED VIA THE INTERNET, TELEPHONES AND WIRELESS DEVICES; PROVIDING FACILITIES AND EQUIPMENT FOR TELEPRESENCE CONFERRING; PROVIDING FACILITIES AND EQUIPMENT FOR VIDEO CONFERRING; PROVIDING INTERNET CHATROOMS; PROVIDING MULTIPLE USE ACCESS TO GLOBAL COMPUTER INFORMATION NETWORKS FOR THE TRANSFER AND DISSEMINATION OF A WIDE RANGE OF INFORMATION; PROVIDING MULTIPLE USER ACCESS TO PROPRIETARY COLLECTIONS OF INFORMATION BY MEANS OF GLOBAL COMPUTER INFORMATION NETWORKS; PROVIDING MULTIPLE-USER ACCESS TO A GLOBAL COMPUTER INFORMATION NETWORK; PROVIDING ON-LINE CHAT ROOMS AND ELECTRONIC BULLETIN BOARDS FOR TRANSMISSION OF MESSAGES AMONG USERS IN THE FIELD OF GENERAL INTEREST; PROVIDING ON-LINE CHAT ROOMS FOR TRANSMISSION OF MESSAGES AMONG COMPUTER USERS CONCERNING WEATHER, ENVIRONMENT AND CLIMATE; PROVIDING ON-LINE COMMUNICATIONS LINKS WHICH TRANSFER THE WEB SITE USER TO OTHER LOCAL AND GLOBAL WEB PAGES; PROVIDING ON-LINE ELECTRONIC BULLETIN BOARDS FOR TRANSMISSION OF MESSAGES AMONG COMPUTER USERS CONCERNING WEATHER, ENVIRONMENT AND CLIMATE; PROVIDING ON-LINE FORUMS FOR TRANSMISSION OF MESSAGES AMONG COMPUTER USERS; PROVIDING ON-LINE FORUMS FOR TRANSMISSION OF MESSAGES AMONG COMPUTER USERS CONCERNING WEATHER, ENVIRONMENT AND CLIMATE; PROVIDING ON-LINE LIST-SERVERS FOR TRANSMISSION OF MESSAGES AMONG COMPUTER USERS CONCERNING WEATHER, ENVIRONMENT AND CLIMATE; PROVIDING TELECOMMUNICATION CONNECTIONS TO THE INTERNET OR DATABASES; PROVIDING TELECOMMUNICATION CONNECTIVITY SERVICES FOR TRANSFER OF IMAGES, MESSAGES, AUDIO, VISUAL, AUDIOVISUAL AND MULTIMEDIA WORKS; PROVIDING TELECOMMUNICATIONS CONNECTIONS TO A GLOBAL COMPUTER NETWORK; PROVIDING TELECOMMUNICATIONS CONNECTIONS TO THE INTERNET OR DATABASES; PROVIDING VOICE COM-

CLASS 38—(Continued).

MUNICATION SERVICES VIA THE INTERNET; PROVISION OF ACCESS TO ELECTRONIC SITES; PROVISION OF ACCESS TO THE INTERNET; PROVISION OF VIDEO CONFERENCING SERVICES; PROVISION OF VOICE SHORT MESSAGE SERVICES (VSMS); RADIO AND TELEVISION BROADCASTING SERVICES; RADIO AND TELEVISION PROGRAMME BROADCASTING; SATELLITE COMMUNICATION SERVICES; SATELLITE TELEVISION BROADCASTING; SATELLITE TRANSMISSION SERVICES, TELEVISION AND RADIO BROADCASTING SERVICES; SATELLITE, CABLE, NETWORK TRANSMISSION OF SOUNDS, IMAGES, SIGNALS AND DATA; SIGNAL TRANSMISSION FOR ELECTRONIC COMMERCE VIA TELECOMMUNICATION SYSTEMS AND DATA COMMUNICATION SYSTEMS; SOUND AND PICTURE TRANSMISSION VIA SATELLITE; STREAMING OF AUDIO MATERIAL ON THE INTERNET; STREAMING OF AUDIO, VISUAL AND AUDIOVISUAL MATERIAL VIA A GLOBAL COMPUTER NETWORK; STREAMING OF VIDEO MATERIAL ON THE INTERNET; SUBSCRIPTION TELEVISION BROADCASTING; TELECOMMUNICATION SERVICES, NAMELY, TRANSMISSION OF PODCASTS; TELECOMMUNICATION SERVICES, NAMELY, TRANSMISSION OF VOICE, DATA AND DOCUMENTS, IN THE FIELD OF ENVIRONMENTAL PROTECTION; TELECOMMUNICATION SERVICES, NAMELY, TRANSMISSION OF VOICE, DATA, GRAPHICS, IMAGES, AUDIO AND VIDEO BY MEANS OF TELECOMMUNICATIONS NETWORKS, WIRELESS COMMUNICATION NETWORKS, AND THE INTERNET; TELECOMMUNICATION SERVICES, NAMELY, TRANSMISSION OF VOICE, DATA, GRAPHICS, SOUND AND VIDEO BY MEANS OF BROADBAND POWER LINE OR WIRELESS NETWORKS; TELECOMMUNICATIONS BY E-MAIL; TELECONFERENCING AND VIDEO CONFERENCING SERVICES; TELEVISION AND RADIO BROADCASTING SERVICES; TELEVISION BROADCASTING; TELEVISION BROADCASTING INFORMATION; TELEVISION PROGRAMME BROADCASTING; TELEVISION PROGRAMME BROADCASTING VIA CABLE; TEXT AND NUMERIC WIRELESS DIGITAL MESSAGING SERVICES; TRANSFER OF DATA BY TELECOMMUNICATION; TRANSFER OF DATA BY TELECOMMUNICATIONS; TRANSMISSION AND DISTRIBUTION OF DATA OR AUDIO VISUAL IMAGES VIA A GLOBAL COMPUTER NETWORK OR THE INTERNET; TRANSMISSION AND RECEIVING BY RADIO; TRANSMISSION AND RECEPTION OF DATABASE INFORMATION VIA THE TELECOMMUNICATION NETWORK; TRANSMISSION OF DATA, SOUND AND IMAGES BY SATELLITE; TRANSMISSION OF INFORMATION IN THE AUDIOVISUAL FIELD; TRANSMISSION OF INFORMATION THROUGH VIDEO COMMUNICATION SYSTEMS; TRANSMISSION OF INFORMATION VIA NATIONAL AND INTERNATIONAL NETWORKS; TRANSMISSION OF MESSAGES; TRANSMISSION OF MESSAGES OVER ELECTRONIC MEDIA; TRANSMISSION OF NEWS; TRANSMISSION OF RADIO AND TELEVISION PROGRAMMES BY SATELLITE; TRANSMISSION OF SDI-FORMATTED TELEVISION AND AUDIO SIGNALS OVER FIBER OPTIC CABLES; TRANSMISSION OF SHORT MESSAGES; TRANSMISSION OF SOUND AND VISION VIA SATELLITE OR INTERACTIVE MULTIMEDIA NETWORKS; TRANSMISSION OF SOUND, PICTURE AND DATA SIGNALS; TRANSMISSION OF SOUND, VIDEO AND INFORMATION; TRANSMISSION OF SOUND, VIDEO AND INFORMATION FROM WEB CAMS, VIDEO CAMERAS OR MOBILE PHONES, ALL FEATURING LIVE OR RECORDED MATERIALS; TRANSMISSION OF STOCK MARKET INFORMATION WITH THE HELP OF TELECOMMUNICATION MEDIA; VIDEO BROADCASTING; VIDEO BROADCASTING SERVICES OVER THE INTERNET OR OTHER COMMUNICATIONS NETWORK FEATURING THE UPLOADED, POSTED AND TAGGED VIDEOS OF OTHERS; VIDEO BROADCASTING SERVICES OVER THE INTERNET OR OTHER COMMUNICATIONS NETWORK, NAMELY, SHOWING, DISPLAYING, AND ELECTRONICALLY TRANSMITTING VIDEO CLIPS; VIDEO BROADCASTING SERVICES VIA THE INTERNET; VIDEO CONFERENCING SERVICES; VIDEO NARROWCASTING SERVICES; VIDEO ON DEMAND TRANSMISSIONS; VIDEO STREAMING SERVICES VIA THE INTERNET, FEATURING INDEPENDENT FILMS AND MOVIES; VIDEO TELECONFERENCING; VIDEO TRANSMISSION OVER DIGI-

CLASS 38—(Continued).

TAL NETWORKS; VIDEO-ON-DEMAND TRANSMISSION SERVICES; VIDEO-ON-DEMAND TRANSMISSION SERVICES VIA THE INTERNET; VIRTUAL CHATROOMS ESTABLISHED VIA TEXT MESSAGING; WEBCASTING SERVICES; WEB CONFERENCING SERVICES; WEB MESSAGING; WEB SITE FORWARDING SERVICES; WEBCASTING SERVICES; WIRELESS BROADBAND COMMUNICATION SERVICES; WIRELESS COMMUNICATIONS SERVICES, NAMELY, TRANSMISSION OF GRAPHICS TO MOBILE TELEPHONES; WIRELESS DIGITAL MESSAGING SERVICES; WIRELESS ELECTRONIC TRANSMISSION OF VOICE SIGNALS, DATA, FACSIMILES, IMAGES AND INFORMATIONS; WIRELESS VOICE MAIL SERVICES (U.S. CLS. 100, 101 AND 104).

BERYL GARDNER, EXAMINING ATTORNEY

SN 79-113,572. INOPSY EUROPE BV, NL-2132 JD HOOFDORP, NETHERLANDS, FILED 3-6-2012.



PRIORITY DATE OF 9-6-2011 IS CLAIMED.
OWNER OF INTERNATIONAL REGISTRATION 1117922 DATED 3-6-2012, EXPIRES 3-6-2022.

THE COLOR(S) PINK AND WHITE IS/ARE CLAIMED AS A FEATURE OF THE MARK.

THE MARK CONSISTS OF THE WORDING "INOPSY" IN WHITE ON A PINK RECTANGULAR BACKGROUND.

FOR TELECOMMUNICATION SERVICES, NAMELY, TRANSMITTING MESSAGES, IMAGES, LIVE AND PRE-RECORDED SOUND AND AUDIO-VISUAL CONTENT VIA THE INTERNET; INTERNET TELEPHONY AND VIDEO-CONFERENCE SERVICES; TELEPHONE CONFERENCE SERVICES AND TELEPHONE CONFERENCES SERVICES VIA A COMPUTER NETWORK; INSTANT MESSAGING SERVICES; STREAMING OF AUDIO-VISUAL MATERIAL ON THE INTERNET; VOICE OVER INTERNET PROTOCOL (VOIP) SERVICES (U.S. CLS. 100, 101 AND 104).

DAVID HOFFMAN, EXAMINING ATTORNEY

CLASS 38—(Continued).

SN 85-030,896. EMBARQ HOLDINGS COMPANY LLC,
OVERLAND PARK, KS. FILED 5-5-2010.



broadband from CenturyLink

NO CLAIM IS MADE TO THE EXCLUSIVE RIGHT TO USE "PURE BROADBAND", APART FROM THE MARK AS SHOWN.

THE MARK CONSISTS OF THE STYLIZED WORDING "PURE BROADBAND FROM CENTURYLINK" WITH THE WORD "PURE" FEATURED ON A HORIZONTALLY-ORIENTED RECTANGLE AND THE WORDING "BROADBAND FROM CENTURYLINK" FEATURED BENEATH THE RECTANGLE. WITH THE WORD "BROADBAND" APPEARING UNDER THE RIGHT HALF OF THE RECTANGLE AND THE WORDING "FROM CENTURYLINK" EXTENDING TO THE RIGHT BEYOND THE RECTANGLE.

FOR BROADBAND INTERNET ACCESS SERVICES, NAMELY, PROVIDING HIGH-SPEED INTERNET ACCESS FOR THE TRANSFER AND DISSEMINATION OF A WIDE RANGE OF INFORMATION; PROVIDING TRANSMISSION SERVICES VIA THE FOREGOING BROADBAND HIGH-SPEED INTERNET ACCESS, NAMELY, PROVIDING E-MAIL SERVICES, TELEVISION BROADCASTING SERVICES, DIGITAL MUSIC DELIVERY SERVICES, AND VIDEO-ON-DEMAND TRANSMISSION SERVICES (U.S. CLS. 100, 101 AND 104).
CYNTHIA TRIPI, EXAMINING ATTORNEY

SN 85-233,209. GOLDBERG, STUART W., PENTICTON, BC,
CANADA, FILED 2-3-2011.

loveyougram

THE MARK CONSISTS OF STANDARD CHARACTERS WITHOUT CLAIM TO ANY PARTICULAR FONT, STYLE, SIZE, OR COLOR.

FOR DELIVERY OF PERSONALIZED GREETING CARDS TO OTHERS VIA ELECTRONIC MAIL (U.S. CLS. 100, 101 AND 104).

DEIRDRE ROBERTSON, EXAMINING ATTORNEY

CLASS 38—(Continued).

SN 85-233,224. STUART W. GOLDBERG, PENTICTON, BC,
CANADA, FILED 2-3-2011.

sorrygram

THE MARK CONSISTS OF STANDARD CHARACTERS WITHOUT CLAIM TO ANY PARTICULAR FONT, STYLE, SIZE, OR COLOR.

FOR DELIVERY OF PERSONALIZED GREETING CARDS TO OTHERS VIA ELECTRONIC MAIL (U.S. CLS. 100, 101 AND 104).

ROSELLE HERRERA, EXAMINING ATTORNEY

SN 85-276,246. BOBBY MOSCOW, LLC, CLARKSTON, MI,
FILED 3-24-2011.

MADE IN DETROIT MUSIC
FESTIVAL

THE MARK CONSISTS OF STANDARD CHARACTERS WITHOUT CLAIM TO ANY PARTICULAR FONT, STYLE, SIZE, OR COLOR.

OWNER OF U.S. REG. NOS. 2,912,784, 3,306,606 AND 3,486,593.

NO CLAIM IS MADE TO THE EXCLUSIVE RIGHT TO USE "MUSIC FESTIVAL", APART FROM THE MARK AS SHOWN.

FOR TELECOMMUNICATIONS SERVICES, NAMELY, TRANSMISSION OF WEBCASTS; WEBCASTING; RADIO AND INTERNET BROADCASTING; WEBCASTING MUSIC AND MUSIC FESTIVAL PERFORMANCES OVER THE INTERNET; STREAMING OF AUDIO AND VISUAL RECORDINGS FEATURING MUSIC AND A MUSIC FESTIVAL OVER THE INTERNET; PROVIDING ON-LINE CHAT ROOMS FOR TRANSMISSION OF MESSAGES AMONG COMPUTER USERS CONCERNING MUSIC, MUSICAL PERFORMANCES, MUSICAL PERFORMERS AND ENTERTAINMENT (U.S. CLS. 100, 101 AND 104).

HELENE LIWINSKI, EXAMINING ATTORNEY

SN 85-283,683. MYCYBERTWIN NORTH AMERICA, INC.,
NEW YORK, NY. FILED 4-1-2011.

MYCYBERTWIN

THE MARK CONSISTS OF STANDARD CHARACTERS WITHOUT CLAIM TO ANY PARTICULAR FONT, STYLE, SIZE, OR COLOR.

FOR PROVIDING INTERNET CHATROOMS (U.S. CLS. 100, 101 AND 104).

SUE LAWRENCE, EXAMINING ATTORNEY

CLASS 38—(Continued).

SN 85-350,963. SAUNDERS, TYE WILLIAM, GOBLES, MI. FILED 6-20-2011.

YOSHREDDING
YOUTHBRASHING
 GlobalCastYourSelf

THE MARK CONSISTS OF THE WORDING "YOSHREDDING" ON TOP OF THE MIRRORED WORDING "YOUTHBRASHING" IN A SOLID RECTANGLE, ALL ABOVE THE WORDING "GLOBALCASTYOURSELF".

FOR AERONAUTICAL TELECOMMUNICATION SERVICES; BROADCASTING SERVICES AND PROVISION OF TELECOMMUNICATION ACCESS TO FILMS AND TELEVISION PROGRAMMES PROVIDED VIA A VIDEO-ON-DEMAND SERVICE; BROADCASTING SERVICES AND PROVISION OF TELECOMMUNICATION ACCESS TO VIDEO AND AUDIO CONTENT PROVIDED VIA A VIDEO-ON-DEMAND SERVICE VIA THE INTERNET; COMMUNICATION SERVICES, NAMELY, TRANSMISSION OF VOICE, AUDIO, VISUAL IMAGES AND DATA BY TELECOMMUNICATIONS NETWORKS, WIRELESS COMMUNICATION NETWORKS, THE INTERNET, INFORMATION SERVICES NETWORKS AND DATA NETWORKS; DATA TRANSMISSION AND RECEPTION SERVICES VIA TELECOMMUNICATION MEANS; DIGITAL NETWORK TELECOMMUNICATIONS SERVICES; ELECTRONIC EXCHANGE OF DATA STORED IN DATABASES ACCESSIBLE VIA TELECOMMUNICATION NETWORKS; INTERNET CAFE SERVICES, NAMELY, PROVIDING TELECOMMUNICATIONS CONNECTIONS TO THE INTERNET IN A CAFE ENVIRONMENT; PROVIDING TELECOMMUNICATION ACCESS TO LIBRARIES RELATED TO THE MANAGEMENT OF ELECTRONIC JOURNALS AND SIMILAR MATERIALS IN A MANNER APPROPRIATE FOR LOADING AND AUTOMATICALLY UPDATING THEIR LOCAL COMPUTER SYSTEMS USED FOR MANAGING ELECTRONIC RESOURCES; PROVIDING TELECOMMUNICATION CONNECTIONS TO THE INTERNET OR DATABASES; PROVIDING TELECOMMUNICATION CONNECTIVITY SERVICES FOR TRANSFER OF IMAGES, MESSAGES, AUDIO, VISUAL, AUDIOVISUAL AND MULTIMEDIA WORKS; PROVIDING TELECOMMUNICATIONS CONNECTIONS TO A GLOBAL COMPUTER NETWORK; PROVIDING TELECOMMUNICATIONS CONNECTIONS TO THE INTERNET OR DATABASES; PROVIDING THIRD PARTY USERS WITH ACCESS TO TELECOMMUNICATION INFRASTRUCTURE; SIGNAL TRANSMISSION FOR ELECTRONIC COMMERCE VIA TELECOMMUNICATION SYSTEMS AND DATA COMMUNICATION SYSTEMS; TELECOMMUNICATION ACCESS SERVICES; TELECOMMUNICATION CONSULTATION IN THE NATURE OF TECHNICAL CONSULTING IN THE FIELD OF AUDIO, TEXT AND VISUAL DATA TRANSMISSION AND COMMUNICATION; TELECOMMUNICATION SERVICES, NAMELY, PROVIDING ACCESS TO PICTURES, VIDEO, ALARM STATUS, BUILDING PLANS AND OTHER BUILDING AND SECURITY INFORMATION AT A REMOTE STATION; TELECOMMUNICATION SERVICES, NAMELY, PROVIDING E-MAIL NOTIFICATION ALERTS VIA THE INTERNET; TELECOMMUNICATION SERVICES, NAMELY, PROVIDING E-MAIL NOTIFICATION ALERTS VIA THE INTERNET NOTIFYING INDIVIDUALS OF EVENTS; TELECOMMUNICATION SERVICES, NAMELY, PROVIDING E-MAIL NOTIFICATION ALERTS VIA THE INTERNET NOTIFYING VEHICLE OWNERS OF TIMING OF VEHICLE MAINTENANCE; TELECOMMUNICATION SERVICES, NAMELY, PROVIDING ELECTRONIC MESSAGE ALERTS VIA THE INTERNET; TELECOMMUNICATION SERVICES, NAMELY, TRANSMISSION OF PODCASTS; TELECOMMUNICATION SERVICES, NAMELY, TRANSMISSION OF VOICE, DATA, GRAPHICS, IMAGES, AUDIO AND VIDEO BY MEANS OF TELECOMMUNICATIONS NETWORKS, WIRELESS COMMUNICATION NETWORKS, AND THE INTERNET; TELECOMMUNICATION SERVICES, NAMELY, TRANSMISSION OF VOICE, DATA, GRAPHICS, SOUND AND VIDEO BY MEANS OF BROADBAND POWER LINE OR WIRELESS

CLASS 38—(Continued).

NETWORKS; TELECOMMUNICATION SERVICES, NAMELY, TRANSMISSION OF WEBCASTS; TELECOMMUNICATIONS BY E-MAIL; TELECOMMUNICATIONS SERVICES FOR PROVIDING MULTIPLE-USER ACCESS TO A GLOBAL COMPUTER NETWORK; TRANSFER OF DATA BY TELECOMMUNICATION; TRANSFER OF DATA BY TELECOMMUNICATIONS; TRANSMISSION AND RECEPTION OF DATABASE INFORMATION VIA THE TELECOMMUNICATION NETWORK; TRANSMISSION OF DATABASE INFORMATION VIA TELECOMMUNICATIONS NETWORKS (U.S. CLS. 100, 101 AND 104).

FIRST USE 3-16-1985; IN COMMERCE 3-16-1985.
 LEIGH LOWRY, EXAMINING ATTORNEY

SN 85-355,327. SAUNDERS, TYE WILLIAM, GOBLES, MI. FILED 6-24-2011.

YOUSURF
YOUBOARD
 BoardCastYourSelf

THE MARK CONSISTS OF THE WORDING "YOUSURF" ON TOP OF THE MIRRORED WORDING "YOUBOARD" IN A SOLID RECTANGLE, ALL ABOVE THE WORDING "BOARDCASTYOURSELF".

FOR BROADCASTING SERVICES AND PROVISION OF TELECOMMUNICATION ACCESS TO FILMS AND TELEVISION PROGRAMMES PROVIDED VIA A VIDEO-ON-DEMAND SERVICE; BROADCASTING SERVICES AND PROVISION OF TELECOMMUNICATION ACCESS TO VIDEO AND AUDIO CONTENT PROVIDED VIA A VIDEO-ON-DEMAND SERVICE VIA THE INTERNET; COMMUNICATION SERVICES, NAMELY, TRANSMISSION OF VOICE, AUDIO, VISUAL IMAGES AND DATA BY TELECOMMUNICATIONS NETWORKS, WIRELESS COMMUNICATION NETWORKS, THE INTERNET, INFORMATION SERVICES NETWORKS AND DATA NETWORKS; COMMUNICATIONS VIA MULTINATIONAL TELECOMMUNICATION NETWORKS; DATA TRANSMISSION AND RECEPTION SERVICES VIA TELECOMMUNICATION MEANS; ELECTRONIC EXCHANGE OF DATA STORED IN DATABASES ACCESSIBLE VIA TELECOMMUNICATION NETWORKS; INTERNET CAFE SERVICES, NAMELY, PROVIDING TELECOMMUNICATIONS CONNECTIONS TO THE INTERNET IN A CAFE ENVIRONMENT; PROVIDING TELECOMMUNICATION ACCESS TO LIBRARIES RELATED TO THE MANAGEMENT OF ELECTRONIC JOURNALS AND SIMILAR MATERIALS IN A MANNER APPROPRIATE FOR LOADING AND AUTOMATICALLY UPDATING THEIR LOCAL COMPUTER SYSTEMS USED FOR MANAGING ELECTRONIC RESOURCES; PROVIDING TELECOMMUNICATION CHANNELS FOR TELESHOPPING SERVICES; PROVIDING TELECOMMUNICATION CONNECTIONS TO THE INTERNET OR DATABASES; PROVIDING TELECOMMUNICATION CONNECTIVITY SERVICES FOR TRANSFER OF IMAGES, MESSAGES, AUDIO, VISUAL, AUDIOVISUAL AND MULTIMEDIA WORKS; PROVIDING TELECOMMUNICATIONS CONNECTIONS TO A GLOBAL COMPUTER NETWORK; PROVIDING TELECOMMUNICATIONS CONNECTIONS TO THE INTERNET OR DATABASES; TELECOMMUNICATION ACCESS SERVICES; TELECOMMUNICATION SERVICES, NAMELY, PROVIDING ACCESS TO PICTURES, VIDEO, ALARM STATUS, BUILDING PLANS AND OTHER BUILDING AND SECURITY INFORMATION AT A REMOTE STATION; TELECOMMUNICATION SERVICES, NAMELY, PROVIDING E-MAIL NOTIFICATION ALERTS VIA THE INTERNET; TELECOMMUNICATION SERVICES, NAMELY, PROVIDING E-MAIL NOTIFICATION ALERTS VIA THE INTERNET NOTIFYING

CLASS 38—(Continued).

ING INDIVIDUALS OF EVENTS; TELECOMMUNICATION SERVICES, NAMELY, PROVIDING ELECTRONIC MESSAGE ALERTS VIA THE INTERNET; TELECOMMUNICATION SERVICES, NAMELY, TRANSMISSION OF PODCASTS; TELECOMMUNICATION SERVICES, NAMELY, TRANSMISSION OF VOICE, DATA, GRAPHICS, IMAGES, AUDIO AND VIDEO BY MEANS OF TELECOMMUNICATIONS NETWORKS, WIRELESS COMMUNICATION NETWORKS, AND THE INTERNET; TELECOMMUNICATION SERVICES, NAMELY, TRANSMISSION OF VOICE, DATA, GRAPHICS, SOUND AND VIDEO BY MEANS OF BROADBAND POWER LINE OR WIRELESS NETWORKS; TELECOMMUNICATION SERVICES, NAMELY, TRANSMISSION OF WEBCASTS; TELECOMMUNICATIONS BY E-MAIL; TELECOMMUNICATIONS SERVICES FOR PROVIDING MULTIPLE-USER ACCESS TO A GLOBAL COMPUTER NETWORK; TRANSFER OF DATA BY TELECOMMUNICATIONS; TRANSMISSION OF DATABASE INFORMATION VIA TELECOMMUNICATIONS NETWORKS (U.S. CLS. 100, 101 AND 104).

FIRST USE 3-16-1985; IN COMMERCE 3-16-1985.
LEIGH LOWRY, EXAMINING ATTORNEY

SN 85-355,442. SAUNDERS, TYE WILLIAM, GOBLES, MI. FILED 6-24-2011.



THE MARK CONSISTS OF THE WORDING "YOUSHRED" ON TOP OF THE MIRRORED WORDING "YOUTHBRASH" IN A SOLID RECTANGLE, ALL ABOVE THE WORDING "THRASHCASTYOURSELF".

FOR BROADCASTING SERVICES AND PROVISION OF TELECOMMUNICATION ACCESS TO FILMS AND TELEVISION PROGRAMMES PROVIDED VIA A VIDEO-ON-DEMAND SERVICE; BROADCASTING SERVICES AND PROVISION OF TELECOMMUNICATION ACCESS TO VIDEO AND AUDIO CONTENT PROVIDED VIA A VIDEO-ON-DEMAND SERVICE VIA THE INTERNET; COMMUNICATION SERVICES, NAMELY, TRANSMISSION OF VOICE, AUDIO, VISUAL IMAGES AND DATA BY TELECOMMUNICATIONS NETWORKS, WIRELESS COMMUNICATION NETWORKS, THE INTERNET, INFORMATION SERVICES NETWORKS AND DATA NETWORKS; COMMUNICATIONS VIA MULTINATIONAL TELECOMMUNICATION NETWORKS; ELECTRONIC EXCHANGE OF DATA STORED IN DATABASES ACCESSIBLE VIA TELECOMMUNICATION NETWORKS; INTERNET CAFE SERVICES, NAMELY, PROVIDING TELECOMMUNICATIONS CONNECTIONS TO THE INTERNET IN A CAFE ENVIRONMENT; PROVIDING ACCESS TO TELECOMMUNICATION NETWORKS; PROVIDING TELECOMMUNICATION ACCESS TO LIBRARIES RELATED TO THE MANAGEMENT OF ELECTRONIC JOURNALS AND SIMILAR MATERIALS IN A MANNER APPROPRIATE FOR LOADING AND AUTOMATICALLY UPDATING THEIR LOCAL COMPUTER SYSTEMS USED FOR MANAGING ELECTRONIC RESOURCES; PROVIDING TELECOMMUNICATION CHANNELS FOR TELESOPPING SERVICES; PROVIDING TELECOMMUNICATION CONNECTIONS TO THE INTERNET OR DATABASES; PROVIDING TELECOMMUNICATION CONNECTIVITY SERVICES FOR TRANSFER OF IMAGES, MESSAGES, AUDIO, VISUAL, AUDIOVISUAL AND MULTIMEDIA WORKS; PROVIDING TELECOMMUNICATIONS CONNECTIONS TO A GLOBAL COMPUTER NETWORK; PROVIDING TELECOMMUNICATIONS CONNECTIONS TO THE INTERNET OR DATABASES; TELECOMMUNICATION ACCESS SERVICES; TELECOMMUNICATION SERVICES, NAMELY, PROVIDING E-MAIL NOTIFICATION ALERTS VIA THE INTERNET; TELECOMMUNICATION SERVICES, NAMELY, PROVIDING E-MAIL NOTIFICATION ALERTS VIA THE INTERNET NOTIFYING IN-

CLASS 38—(Continued).

INDIVIDUALS OF EVENTS; TELECOMMUNICATION SERVICES, NAMELY, PROVIDING ELECTRONIC MESSAGE ALERTS VIA THE INTERNET; TELECOMMUNICATION SERVICES, NAMELY, PROVIDING INTERNET ACCESS VIA BROADBAND OPTICAL OR WIRELESS NETWORKS; TELECOMMUNICATION SERVICES, NAMELY, TRANSMISSION OF PODCASTS; TELECOMMUNICATION SERVICES, NAMELY, TRANSMISSION OF VOICE, DATA, GRAPHICS, IMAGES, AUDIO AND VIDEO BY MEANS OF TELECOMMUNICATIONS NETWORKS, WIRELESS COMMUNICATION NETWORKS, AND THE INTERNET; TELECOMMUNICATION SERVICES, NAMELY, TRANSMISSION OF VOICE, DATA, GRAPHICS, SOUND AND VIDEO BY MEANS OF BROADBAND POWER LINE OR WIRELESS NETWORKS; TELECOMMUNICATION SERVICES, NAMELY, TRANSMISSION OF WEBCASTS; TELECOMMUNICATIONS BY E-MAIL; TELECOMMUNICATIONS SERVICES FOR PROVIDING MULTIPLE-USER ACCESS TO A GLOBAL COMPUTER NETWORK; TRANSFER OF DATA BY TELECOMMUNICATIONS; TRANSMISSION OF DATABASE INFORMATION VIA TELECOMMUNICATIONS NETWORKS (U.S. CLS. 100, 101 AND 104).

FIRST USE 3-16-1985; IN COMMERCE 3-16-1985.
LEIGH LOWRY, EXAMINING ATTORNEY

SN 85-414,004. MBLOX INCORPORATED, SUNNYVALE, CA. FILED 9-2-2011.



THE MARK CONSISTS OF THE LETTER "M" HAVING A DOT WITH CURVED BANDS ENCLOSED IN A SQUARE.

FOR TELECOMMUNICATION SERVICES, NAMELY, PROVIDING WIRELESS ELECTRONIC TRANSMISSION OF VOICE SIGNALS, DATA, FACSIMILES, IMAGES AND INFORMATION TO THIRD PARTIES; PROVIDING INSTANT MESSAGING SERVICES; TEXT AND NUMERIC WIRELESS DIGITAL MESSAGING SERVICES VIA MOBILE PHONES OR OTHER DEVICES; ELECTRONIC TRANSMISSION OF COMMUNICATIONS, DATA, IMAGES TEXT AND AUDIO CONTENT (U.S. CLS. 100, 101 AND 104).

KATHRYN COWARD, EXAMINING ATTORNEY

CLASS 38—(Continued).

SN 85-420,834. MILLER, J. MICHAEL, LIVERMORE, CA.
FILED 9-12-2011.

MUZOOK

THE MARK CONSISTS OF STANDARD CHARACTERS WITHOUT CLAIM TO ANY PARTICULAR FONT, STYLE, SIZE, OR COLOR.

FOR COLLABORATION TOOLS AND SERVICES, NAMELY, TELECOMMUNICATION ACCESS SERVICES ALLOWING PARTIES TO VIEW, LISTEN TO, ADAPT, AND SHARE MATERIALS; COLLABORATION TOOLS AND SERVICES, NAMELY, TELECOMMUNICATION ACCESS SERVICES WHICH ALLOW PARTIES TO VIEW, LISTEN TO, ADAPT, AND SHARE MATERIALS DELIVERED OVER THE INTERNET AND OVER ANOTHER PUBLICLY ACCESSIBLE NETWORK; COLLABORATION TOOLS AND SERVICES, NAMELY, TELECOMMUNICATION ACCESS SERVICES ALLOWING PARTIES TO VIEW, LISTEN TO, ADAPT, AND SHARE MATERIALS, FOR ENABLING PERSONS SUCH AS WRITERS, MUSICAL ARTISTS AND ILLUSTRATORS TO COLLABORATE WITH EACH OTHER OVER A PUBLICLY ACCESSIBLE NETWORK; COLLABORATION TOOLS AND SERVICES, NAMELY, TELECOMMUNICATION ACCESS SERVICES ALLOWING PARTIES TO VIEW, LISTEN TO, ADAPT, AND SHARE MATERIALS FOR ENABLING PERSONS SUCH AS WRITERS, MUSICAL ARTISTS AND ILLUSTRATORS TO COLLABORATE WITH EACH OTHER TO CREATE WORKS INCORPORATING MULTIPLE MEDIA ELEMENTS SUCH AS NARRATIVE TEXTUAL CONTENT, MUSIC AND ILLUSTRATIONS IN WORKS OF FICTION AND NON-FICTION; COLLABORATION SERVICES, NAMELY, PROVIDING EMAIL SERVICES AND INFORMATION SERVICES, NAMELY, INFORMATION TRANSMISSION SERVICES VIA DIGITAL NETWORKS TO ALLOW SHARED COLLABORATION FOR ENABLING PERSONS SUCH AS WRITERS, MUSICAL ARTISTS AND ILLUSTRATORS TO COLLABORATE WITH EACH OTHER TO CREATE WORKS INCORPORATING MULTIPLE MEDIA ELEMENTS SUCH AS NARRATIVE TEXTUAL CONTENT, MUSIC AND ILLUSTRATIONS IN WORKS OF FICTION AND NON-FICTION; PROVIDING SERVICES IN THE NATURE OF TELECOMMUNICATION SERVICES, NAMELY, ELECTRONIC TRANSMISSION OF VOICE, AUDIO, VISUAL IMAGES, AND DATA BY TELECOMMUNICATION NETWORKS; TELECOMMUNICATION ACCESS SERVICES, ALLOWING FOR THE CREATION OF WORKS AND INCORPORATING MULTIPLE MEDIA ELEMENTS SUCH AS NARRATIVE TEXTUAL CONTENT, MUSIC AND ILLUSTRATIONS IN WORKS OF FICTION AND NON-FICTION FOR ELECTRONIC DEVICES SUCH AS SMARTPHONES, COMPUTERS, E-READERS, TOUCHSCREEN COMPUTERS, AND TABLETS; COLLABORATION SERVICES, NAMELY, TELECOMMUNICATION ACCESS SERVICES WHICH ALLOW PARTIES TO VIEW, ADAPT, AND SHARE MATERIALS SUCH AS SUCH AS NARRATIVE TEXTUAL CONTENT, MUSIC AND ILLUSTRATIONS IN WORKS OF FICTION AND NON-FICTION TO ENABLE PERSONS SUCH AS WRITERS, MUSICAL ARTISTS AND ILLUSTRATORS TO COLLABORATE WITH EACH OTHER WITHIN OR ACROSS DISCIPLINES TO COMPARE WORK OVER A PUBLICLY ACCESSIBLE NETWORK TO COMPOSE E-BOOKS; AND WORKS INCORPORATING MULTIPLE MEDIA ELEMENTS SUCH AS NARRATIVE TEXTUAL CONTENT, MUSIC AND ILLUSTRATIONS IN WORKS OF FICTION AND NON-FICTION FOR ELECTRONIC DEVICES SUCH AS SMARTPHONES, COMPUTERS, E-READERS, TOUCHSCREEN COMPUTERS, AND TABLETS (U.S. CLS. 100, 101 AND 104).

WILLIAM ROSSMAN, EXAMINING ATTORNEY

CLASS 38—(Continued).

SN 85-440,375. FOLGER MEDIA, INC., GRAPEVINE, TX.
FILED 10-5-2011.

BLAKE FM

THE MARK CONSISTS OF STANDARD CHARACTERS WITHOUT CLAIM TO ANY PARTICULAR FONT, STYLE, SIZE, OR COLOR.

NO CLAIM IS MADE TO THE EXCLUSIVE RIGHT TO USE "FM", APART FROM THE MARK AS SHOWN.

FOR RADIO BROADCASTING; RADIO BROADCASTING CONSULTATION; RADIO BROADCASTING VIA TERRESTRIAL RADIO, SATELLITE RADIO AND THE INTERNET; AUDIO AND VIDEO BROADCASTING SERVICES OVER THE INTERNET; INTERNET RADIO BROADCASTING SERVICES; INTERNET RADIO SERVICES, NAMELY, TRANSMISSION OF AUDIO MATERIAL VIA THE INTERNET (U.S. CLS. 100, 101 AND 104).

DOMINICK J. SALEMI, EXAMINING ATTORNEY

SN 85-441,798. CONVERSOCIAL (UK) LIMITED, LONDON,
UNITED KINGDOM, FILED 10-7-2011.

CONVERSOCIAL

THE MARK CONSISTS OF STANDARD CHARACTERS WITHOUT CLAIM TO ANY PARTICULAR FONT, STYLE, SIZE, OR COLOR.

OWNER OF ERPN CMNTY TM OFC REG. NO. 010256691,
DATED 2-23-2012, EXPIRES 2-23-2022.

FOR PROVIDING ON-LINE CHAT ROOMS FOR SOCIAL NETWORKING PLATFORMS; PROVIDING ACCESS TO TELECOMMUNICATION NETWORKS; ONLINE COMMUNICATION SERVICES, NAMELY, EMAIL, INSTANT MESSAGING, TELEPHONE, AND FAX TRANSMISSION SERVICES (U.S. CLS. 100, 101 AND 104).

DAVID TOOLEY, EXAMINING ATTORNEY

SN 85-444,604. JUDI'S HOUSE, DENVER, CO. FILED 10-11-
2011.



Comprehensive
Grief Care

NO CLAIM IS MADE TO THE EXCLUSIVE RIGHT TO USE "COMPREHENSIVE GRIEF CARE", APART FROM THE MARK AS SHOWN.

THE COLOR(S) RED, YELLOW, BLUE, ORANGE, GREEN, MAGENTA, BLACK AND WHITE IS/ARE CLAIMED AS A FEATURE OF THE MARK.

THE MARK CONSISTS OF THE INTERLINKING CAPITAL LETTERS "CGC" AND THE WORDS "COMPREHENSIVE GRIEF CARE". THE LETTERS AND WORDS ARE IN BLACK. THE LETTERS "CGC" ARE TO THE LEFT OF THE WORDS "COMPREHENSIVE GRIEF CARE" AND ARE INTERLINKED TO FORM A CURVACEOUS INVERTED TRIANGLE, WITH THE LETTERS "CG" FORMING THE INVERTED BASE OF THE TRIANGLE ABOVE THE SEC-

CLASS 38—(Continued).

OND LETTER "C". EACH OF THE LETTERS OVERLAY THREE OVERLAPPING CIRCLES OF PRIMARY COLORS COMPRISED OF RED (THE UPPER LETTER "C"), YELLOW ("G") AND BLUE (THE LOWER LETTER "C"), WHERE THE COLORS OVERLAP THEY FORM A COLOR WHEEL, SUCH THAT THE AREA WHERE RED AND YELLOW OVERLAP IS ORANGE, THE AREA WHERE RED AND BLUE OVERLAP IS MAGENTA, THE AREA WHERE YELLOW AND BLUE OVERLAP IS GREEN, AND THE AREA WHERE ALL PRIMARY COLORS OVERLAP IS WHITE. THE WORDS "COMPREHENSIVE GRIEF CARE" APPEAR TO THE RIGHT OF THE LETTERS "CGC", THE FIRST LETTER OF EACH WORD CAPITALIZED AND BOLD, WITH "COMPREHENSIVE" APPEARING ABOVE "GRIEF CARE" AND THE TWO WORD GROUPINGS LEFT-JUSTIFIED.

FOR PROVIDING AN ONLINE FORUM FOR GRIEF CARE PROVIDERS, COMMUNITY PARTNERS, RESEARCHERS, CONSUMERS AND OTHERS FOR THE SHARING AND TRANSMISSION OF INFORMATION, RESOURCES, DATA, AND ELECTRONIC MEDIA CONCERNING INSIGHTS INTO BEREAVEMENT, GRIEF CARE AND SUPPORT, AND GRIEF RESEARCH, AND ASSISTING BEREAVED PERSONS IN ACCESSING GRIEF-RELATED SERVICES (U.S. CLS. 100, 101 AND 104).

ESTHER A. BORSUK, EXAMINING ATTORNEY

SN 85-449,108. TELEINET, LLC, DORAL, FL. FILED 10-17-2011.



NO CLAIM IS MADE TO THE EXCLUSIVE RIGHT TO USE "CELU" AND "MOVIL", APART FROM THE MARK AS SHOWN.

THE COLOR(S) BLUE AND ORANGE IS/ARE CLAIMED AS A FEATURE OF THE MARK.

THE MARK CONSISTS OF THE LETTER "CELU" IN BLUE AND THE LETTERS "MOVIL" IN ORANGE; THE LETTER "I" IN "MOVIL" HAS A BLUE DOT WITH AN ORANGE AND BLUE SPHERE TO THE LEFT OF THE MARK.

THE ENGLISH TRANSLATION OF "CELUMOVIL" IN THE MARK IS A COMBINATION OF TWO SPANISH WORDS, TRANSLATING INTO CELLULAR FOR "CELU" AND MOBILE FOR "MOVIL".

FOR CELLULAR PHONE SERVICES (U.S. CLS. 100, 101 AND 104).

FIRST USE 9-0-2011; IN COMMERCE 9-0-2011.
LAKEISHA LEWIS, EXAMINING ATTORNEY

CLASS 38—(Continued).

SN 85-455,928. AMERICAN BROADCASTING COMPANIES, INC., NEW YORK, NY. FILED 10-25-2011.

ABC SPARK

THE MARK CONSISTS OF STANDARD CHARACTERS WITHOUT CLAIM TO ANY PARTICULAR FONT, STYLE, SIZE, OR COLOR.

FOR BROADCASTING SERVICES, NAMELY, TELEVISION BROADCASTING, CABLE TELEVISION BROADCASTING, SATELLITE TELEVISION BROADCASTING, CLOSED CIRCUIT TELEVISION BROADCASTING, RADIO BROADCASTING, CABLE RADIO BROADCASTING, INTERNET RADIO BROADCASTING, BROADCASTING VIA THE INTERNET, BROADCASTING OF AUDIO AND VIDEO PROGRAMMING VIA COMPUTER COMMUNICATIONS NETWORKS, WIRELESS BROADCASTING (U.S. CLS. 100, 101 AND 104).

NICHOLAS ALTREE, EXAMINING ATTORNEY

SN 85-488,847. UNIVERSE MIAMI, LLC, DBA UNIVERSE MIAMI, MIAMI LAKES, FL. FILED 12-6-2011.

Universe Miami

THE MARK CONSISTS OF STANDARD CHARACTERS WITHOUT CLAIM TO ANY PARTICULAR FONT, STYLE, SIZE, OR COLOR.

NO CLAIM IS MADE TO THE EXCLUSIVE RIGHT TO USE "MIAMI", APART FROM THE MARK AS SHOWN.

FOR BROADCASTING OF VIDEO AND AUDIO PROGRAMMING OVER THE INTERNET (U.S. CLS. 100, 101 AND 104).

FIRST USE 6-17-2011; IN COMMERCE 6-17-2011.
RAUL CORDOVA, EXAMINING ATTORNEY

SN 85-509,705. NEWPORT TELEVISION LLC, KANSAS CITY, MO. FILED 1-5-2012.

10 AT 10

THE MARK CONSISTS OF STANDARD CHARACTERS WITHOUT CLAIM TO ANY PARTICULAR FONT, STYLE, SIZE, OR COLOR.

NO CLAIM IS MADE TO THE EXCLUSIVE RIGHT TO USE "AT 10", APART FROM THE MARK AS SHOWN.

FOR RADIO BROADCASTING, TELEVISION BROADCASTING, AND INTERNET BROADCASTING (U.S. CLS. 100, 101 AND 104).

FIRST USE 10-24-2011; IN COMMERCE 10-24-2011.
MATTHEW MCDOWELL, EXAMINING ATTORNEY

CLASS 38—(Continued).

SN 85-554,308. WOOTEN, GARY W, AUSTIN, TX. FILED 2-28-2012.

Cards From Cats

THE MARK CONSISTS OF STANDARD CHARACTERS WITHOUT CLAIM TO ANY PARTICULAR FONT, STYLE, SIZE, OR COLOR.

NO CLAIM IS MADE TO THE EXCLUSIVE RIGHT TO USE "CARDS", APART FROM THE MARK AS SHOWN.

FOR TRANSMISSION OF PET GREETING CARDS ONLINE (U.S. CLS. 100, 101 AND 104).

CHRISTINE MARTIN, EXAMINING ATTORNEY

SN 85-564,671. UXNOVO, INC., AKA WATCHUP, PALO ALTO, CA. FILED 3-8-2012.

Watchup

THE MARK CONSISTS OF STANDARD CHARACTERS WITHOUT CLAIM TO ANY PARTICULAR FONT, STYLE, SIZE, OR COLOR.

FOR AUDIO AND VIDEO BROADCASTING SERVICES OVER THE INTERNET IN THE FIELD OF NEWS, SPORTS AND ENTERTAINMENT; BROADCASTING PROGRAMS VIA A GLOBAL COMPUTER NETWORK; ELECTRONIC TRANSMISSION OF DATA AND DOCUMENTS VIA COMPUTER TERMINALS AND ELECTRONIC DEVICES; MOBILE MEDIA SERVICES IN THE NATURE OF ELECTRONIC TRANSMISSION OF ENTERTAINMENT MEDIA CONTENT; PROVIDING ONLINE CHAT ROOMS AND ELECTRONIC BULLETIN BOARDS FOR TRANSMISSION OF MESSAGES AMONG USERS IN THE FIELD OF GENERAL INTEREST; TRANSMISSION OF INFORMATION IN THE AUDIO-VISUAL FIELD; TRANSMISSION OF SOUND, VIDEO AND INFORMATION FROM WEB CAMS, VIDEO CAMERAS OR MOBILE PHONES, ALL FEATURING LIVE OR RECORDED MATERIALS (U.S. CLS. 100, 101 AND 104).

FIRST USE 2-20-2012; IN COMMERCE 2-20-2012.

ALICIA COLLINS, EXAMINING ATTORNEY

SN 85-598,453. @RADICAL.MEDIA LLC, NEW YORK, NY. FILED 4-16-2012.

THNKR

THE MARK CONSISTS OF STANDARD CHARACTERS WITHOUT CLAIM TO ANY PARTICULAR FONT, STYLE, SIZE, OR COLOR.

FOR BROADCASTING OF TELEVISION PROGRAMS VIA TELEVISION, SATELLITE, WIRELESS, FIBER OPTICS, CABLE, AND A GLOBAL COMPUTER NETWORK (U.S. CLS. 100, 101 AND 104).

KATHERINE E. HALMEN, EXAMINING ATTORNEY

CLASS 38—(Continued).

SN 85-598,626. AVAST SOFTWARE A.S., 140 00 PRAGUE 4, CZECH REPUBLIC, FILED 4-16-2012.

AVAST! SECURELINE

THE MARK CONSISTS OF STANDARD CHARACTERS WITHOUT CLAIM TO ANY PARTICULAR FONT, STYLE, SIZE, OR COLOR.

OWNER OF U.S. REG. NOS. 3,082,991 AND 4,174,242.

NO CLAIM IS MADE TO THE EXCLUSIVE RIGHT TO USE "SECURE LINE", APART FROM THE MARK AS SHOWN.

FOR PROVIDING VIRTUAL PRIVATE NETWORK (VPN) SERVICES, NAMELY, PRIVATE AND SECURE ELECTRONIC COMMUNICATIONS OVER A PRIVATE OR PUBLIC COMPUTER NETWORK (U.S. CLS. 100, 101 AND 104).

DOMINIC FATHY, EXAMINING ATTORNEY

SN 85-600,875. CONSOLIDATED ELECTRIC COOPERATIVE, INC., MOUNT GILEAD, OH. FILED 4-18-2012.



Good People. Strong Connections.

NO CLAIM IS MADE TO THE EXCLUSIVE RIGHT TO USE "FIBER OPTIC NETWORK", APART FROM THE MARK AS SHOWN.

THE MARK CONSISTS OF THREE ARCS ABOVE THE WORDING "ENLITE". BENEATH THE WORD "ENLITE" APPEARS THE WORDING "FIBER OPTIC NETWORK", BENEATH WHICH APPEARS THE WORDING "GOOD PEOPLE. STRONG CONNECTIONS."

FOR COMMUNICATIONS VIA FIBER-OPTIC NETWORKS; TELECOMMUNICATIONS SERVICES, NAMELY, PROVIDING FIBER OPTIC NETWORK SERVICES (U.S. CLS. 100, 101 AND 104).

FIRST USE 2-22-2012; IN COMMERCE 2-22-2012.

ANDREW RHIM, EXAMINING ATTORNEY

CLASS 38—(Continued).

SN 85-601,834. WEISS, BOB, NEW YORK, NY. FILED 4-18-2012.

Hate Button

THE MARK CONSISTS OF STANDARD CHARACTERS WITHOUT CLAIM TO ANY PARTICULAR FONT, STYLE, SIZE, OR COLOR.

NO CLAIM IS MADE TO THE EXCLUSIVE RIGHT TO USE "BUTTON", APART FROM THE MARK AS SHOWN.

FOR PROVIDING ACCESS TO COMPUTER DATABASES IN THE FIELDS OF SOCIAL NETWORKING, SOCIAL INTRODUCTION AND DATING; PEER-TO-PEER PHOTO SHARING SERVICES, NAMELY, ELECTRONIC TRANSMISSION OF DIGITAL PHOTO FILES AMONG INTERNET USERS; PROVIDING ACCESS TO COMPUTER, ELECTRONIC AND ONLINE DATABASES; TELECOMMUNICATIONS SERVICES, NAMELY, ELECTRONIC TRANSMISSION OF DATA, MESSAGES AND INFORMATION; PROVIDING ONLINE FORUMS FOR COMMUNICATION ON TOPICS OF GENERAL INTEREST; PROVIDING ONLINE COMMUNICATIONS LINKS WHICH TRANSFER WEB SITE USERS TO OTHER LOCAL AND GLOBAL WEB PAGES; PROVIDING ACCESS TO WEB SITES FOR OTHERS HOSTED ON COMPUTER SERVERS ACCESSIBLE VIA A GLOBAL COMPUTER NETWORK; PROVIDING ACCESS TO THIRD PARTY WEB SITES BY ENABLING USERS TO LOG IN THROUGH A UNIVERSAL USERNAME AND PASSWORD VIA A GLOBAL COMPUTER NETWORK AND OTHER COMMUNICATION NETWORKS; PROVIDING ONLINE CHAT ROOMS AND ELECTRONIC BULLETIN BOARDS FOR TRANSMISSION OF MESSAGES AMONG USERS IN THE FIELD OF GENERAL INTEREST; AUDIO, TEXT AND VIDEO BROADCASTING SERVICES OVER COMPUTER OR OTHER COMMUNICATION NETWORKS, NAMELY, UPLOADING, POSTING, DISPLAYING, TAGGING, AND ELECTRONICALLY TRANSMITTING DATA, INFORMATION, AUDIO AND VIDEO IMAGES; DELIVERY OF DIGITAL MUSIC BY ELECTRONIC TRANSMISSION; TELECOMMUNICATIONS SERVICES, NAMELY, PROVIDING ONLINE AND TELECOMMUNICATION FACILITIES FOR REAL-TIME INTERACTION BETWEEN AND AMONG USERS OF COMPUTERS, MOBILE AND HANDHELD COMPUTERS, AND WIRED AND WIRELESS COMMUNICATION DEVICES CONCERNING TOPICS OF GENERAL INTEREST; ELECTRONIC TRANSMISSION OF MESSAGES, NAMELY, ENABLING INDIVIDUALS TO SEND AND RECEIVE MESSAGES VIA EMAIL, INSTANT MESSAGING OR A WEBSITE ON THE INTERNET IN THE FIELD OF GENERAL INTEREST; PROVIDING ONLINE CHAT ROOMS AND ELECTRONIC BULLETIN BOARDS FOR TRANSMISSION OF MESSAGES AMONG USERS IN THE FIELD OF GENERAL INTEREST; COMPUTER SERVICES, NAMELY, CREATING AN ONLINE COMMUNITY FORUM FOR USERS TO SHARE INFORMATION, PHOTOS, AUDIO AND VIDEO CONTENT ABOUT THEMSELVES, THEIR EMOTIONS, OPINIONS, INTERESTS AND DAILY ACTIVITIES, TO GET FEEDBACK FROM THEIR PEERS, TO FORM VIRTUAL COMMUNITIES, AND TO ENGAGE IN SOCIAL NETWORKING (U.S. CLS. 100, 101 AND 104).

TARAH HARDY, EXAMINING ATTORNEY

CLASS 38—(Continued).

SN 85-601,856. WEISS, BOB, NEW YORK, NY. FILED 4-18-2012.

Cringe Button

THE MARK CONSISTS OF STANDARD CHARACTERS WITHOUT CLAIM TO ANY PARTICULAR FONT, STYLE, SIZE, OR COLOR.

NO CLAIM IS MADE TO THE EXCLUSIVE RIGHT TO USE "BUTTON", APART FROM THE MARK AS SHOWN.

FOR PROVIDING ACCESS TO COMPUTER DATABASES IN THE FIELDS OF SOCIAL NETWORKING, SOCIAL INTRODUCTION AND DATING; PEER-TO-PEER PHOTO SHARING SERVICES, NAMELY, ELECTRONIC TRANSMISSION OF DIGITAL PHOTO FILES AMONG INTERNET USERS; PROVIDING ACCESS TO COMPUTER, ELECTRONIC AND ONLINE DATABASES; TELECOMMUNICATIONS SERVICES, NAMELY, ELECTRONIC TRANSMISSION OF DATA, MESSAGES AND INFORMATION; PROVIDING ONLINE FORUMS FOR COMMUNICATION ON TOPICS OF GENERAL INTEREST; PROVIDING ONLINE COMMUNICATIONS LINKS WHICH TRANSFER WEB SITE USERS TO OTHER LOCAL AND GLOBAL WEB PAGES; PROVIDING ACCESS TO WEB SITES FOR OTHERS HOSTED ON COMPUTER SERVERS ACCESSIBLE VIA A GLOBAL COMPUTER NETWORK; PROVIDING ACCESS TO THIRD PARTY WEB SITES BY ENABLING USERS TO LOG IN THROUGH A UNIVERSAL USERNAME AND PASSWORD VIA A GLOBAL COMPUTER NETWORK AND OTHER COMMUNICATION NETWORKS; PROVIDING ONLINE CHAT ROOMS AND ELECTRONIC BULLETIN BOARDS FOR TRANSMISSION OF MESSAGES AMONG USERS IN THE FIELD OF GENERAL INTEREST; AUDIO, TEXT AND VIDEO BROADCASTING SERVICES OVER COMPUTER OR OTHER COMMUNICATION NETWORKS, NAMELY, UPLOADING, POSTING, DISPLAYING, TAGGING, AND ELECTRONICALLY TRANSMITTING DATA, INFORMATION, AUDIO AND VIDEO IMAGES; DELIVERY OF DIGITAL MUSIC BY ELECTRONIC TRANSMISSION; TELECOMMUNICATIONS SERVICES, NAMELY, PROVIDING ONLINE AND TELECOMMUNICATION FACILITIES FOR REAL-TIME INTERACTION BETWEEN AND AMONG USERS OF COMPUTERS, MOBILE AND HANDHELD COMPUTERS, AND WIRED AND WIRELESS COMMUNICATION DEVICES CONCERNING TOPICS OF GENERAL INTEREST; ELECTRONIC TRANSMISSION OF MESSAGES, NAMELY, ENABLING INDIVIDUALS TO SEND AND RECEIVE MESSAGES VIA EMAIL, INSTANT MESSAGING OR A WEBSITE ON THE INTERNET IN THE FIELD OF GENERAL INTEREST; PROVIDING ONLINE CHAT ROOMS AND ELECTRONIC BULLETIN BOARDS FOR TRANSMISSION OF MESSAGES AMONG USERS IN THE FIELD OF GENERAL INTEREST; COMPUTER SERVICES, NAMELY, CREATING AN ONLINE COMMUNITY FORUM FOR USERS TO SHARE INFORMATION, PHOTOS, AUDIO AND VIDEO CONTENT ABOUT THEMSELVES, THEIR EMOTIONS, OPINIONS, INTERESTS AND DAILY ACTIVITIES, TO GET FEEDBACK FROM THEIR PEERS, TO FORM VIRTUAL COMMUNITIES, AND TO ENGAGE IN SOCIAL NETWORKING (U.S. CLS. 100, 101 AND 104).

TARAH HARDY, EXAMINING ATTORNEY

CLASS 38—(Continued).

SN 85-601,863. WEISS, BOB, NEW YORK, NY. FILED 4-18-2012.

Love Button

THE MARK CONSISTS OF STANDARD CHARACTERS WITHOUT CLAIM TO ANY PARTICULAR FONT, STYLE, SIZE, OR COLOR.

NO CLAIM IS MADE TO THE EXCLUSIVE RIGHT TO USE "BUTTON", APART FROM THE MARK AS SHOWN.

FOR PROVIDING ACCESS TO COMPUTER DATABASES IN THE FIELDS OF SOCIAL NETWORKING, SOCIAL INTRODUCTION AND DATING; PEER-TO-PEER PHOTO SHARING SERVICES, NAMELY, ELECTRONIC TRANSMISSION OF DIGITAL PHOTO FILES AMONG INTERNET USERS; PROVIDING ACCESS TO COMPUTER, ELECTRONIC AND ONLINE DATABASES; TELECOMMUNICATIONS SERVICES, NAMELY, ELECTRONIC TRANSMISSION OF DATA, MESSAGES AND INFORMATION; PROVIDING ONLINE FORUMS FOR COMMUNICATION ON TOPICS OF GENERAL INTEREST; PROVIDING ONLINE COMMUNICATIONS LINKS WHICH TRANSFER WEB SITE USERS TO OTHER LOCAL AND GLOBAL WEB PAGES; PROVIDING ACCESS TO WEB SITES FOR OTHERS HOSTED ON COMPUTER SERVERS ACCESSIBLE VIA A GLOBAL COMPUTER NETWORK; PROVIDING ACCESS TO THIRD PARTY WEB SITES BY ENABLING USERS TO LOG IN THROUGH A UNIVERSAL USERNAME AND PASSWORD VIA A GLOBAL COMPUTER NETWORK AND OTHER COMMUNICATION NETWORKS; PROVIDING ONLINE CHAT ROOMS AND ELECTRONIC BULLETIN BOARDS FOR TRANSMISSION OF MESSAGES AMONG USERS IN THE FIELD OF GENERAL INTEREST; AUDIO, TEXT AND VIDEO BROADCASTING SERVICES OVER COMPUTER OR OTHER COMMUNICATION NETWORKS, NAMELY, UPLOADING, POSTING, DISPLAYING, TAGGING, AND ELECTRONICALLY TRANSMITTING DATA, INFORMATION, AUDIO AND VIDEO IMAGES; DELIVERY OF DIGITAL MUSIC BY ELECTRONIC TRANSMISSION; TELECOMMUNICATIONS SERVICES, NAMELY, PROVIDING ONLINE AND TELECOMMUNICATION FACILITIES FOR REAL-TIME INTERACTION BETWEEN AND AMONG USERS OF COMPUTERS, MOBILE AND HANDHELD COMPUTERS, AND WIRED AND WIRELESS COMMUNICATION DEVICES CONCERNING TOPICS OF GENERAL INTEREST; ELECTRONIC TRANSMISSION OF MESSAGES, NAMELY, ENABLING INDIVIDUALS TO SEND AND RECEIVE MESSAGES VIA EMAIL, INSTANT MESSAGING OR A WEBSITE ON THE INTERNET IN THE FIELD OF GENERAL INTEREST; PROVIDING ONLINE CHAT ROOMS AND ELECTRONIC BULLETIN BOARDS FOR TRANSMISSION OF MESSAGES AMONG USERS IN THE FIELD OF GENERAL INTEREST; COMPUTER SERVICES, NAMELY, CREATING AN ONLINE COMMUNITY FORUM FOR USERS TO SHARE INFORMATION, PHOTOS, AUDIO AND VIDEO CONTENT ABOUT THEMSELVES, THEIR EMOTIONS, OPINIONS, INTERESTS AND DAILY ACTIVITIES, TO GET FEEDBACK FROM THEIR PEERS, TO FORM VIRTUAL COMMUNITIES, AND TO ENGAGE IN SOCIAL NETWORKING (U.S. CLS. 100, 101 AND 104).

TARAH HARDY, EXAMINING ATTORNEY

CLASS 38—(Continued).

SN 85-602,015. VIVOX, INC., NATICK, MA. FILED 4-18-2012.

SOCIAL DIALTONE

THE MARK CONSISTS OF STANDARD CHARACTERS WITHOUT CLAIM TO ANY PARTICULAR FONT, STYLE, SIZE, OR COLOR.

FOR COMMUNICATIONS VIA MULTINATIONAL TELECOMMUNICATION NETWORKS AND COMPUTER NETWORKS; TRANSMISSION OF INFORMATION VIA NATIONAL AND INTERNATIONAL NETWORKS; VOICE OVER INTERNET PROTOCOL (VOIP) COMMUNICATIONS; DELIVERY OF DATA, GRAPHICS, IMAGES, AUDIO, TEXT, VIDEO, AND MULTIMEDIA CONTENT BY MEANS OF CELLULAR AND WIRELESS COMMUNICATION, ELECTRONIC COMMUNICATIONS NETWORKS, AND COMPUTER NETWORKS; ELECTRONIC TRANSMISSION OF DATA AND DOCUMENTS OVER COMPUTER TERMINALS AND NETWORKS; PROVIDING ONLINE FACILITIES FOR REAL-TIME INTERACTION WITH OTHER COMPUTER USERS CONCERNING TOPICS OF GENERAL INTEREST; INSTANT MESSAGING SERVICES; VOICE MAIL SERVICES AND ELECTRONIC MAIL SERVICES; PROVIDING ACCESS TO COMPUTER DATABASES; PROVIDING ACCESS TO ONLINE COMPUTER DATABASES (U.S. CLS. 100, 101 AND 104).

SANI KHOURI, EXAMINING ATTORNEY

SN 85-605,432. LEBOUTHILLIER III, THEODORE J., FAIRFIELD, CT. FILED 4-23-2012.

Karmail

THE MARK CONSISTS OF STANDARD CHARACTERS WITHOUT CLAIM TO ANY PARTICULAR FONT, STYLE, SIZE, OR COLOR.

FOR ELECTRONIC TRANSMISSION OF MAIL AND MESSAGES (U.S. CLS. 100, 101 AND 104).

JOHN WILKE, EXAMINING ATTORNEY

CLASS 38—(Continued).

SN 85-631,321. @RADICAL.MEDIA LLC, NEW YORK, NY. FILED 5-22-2012.



THE MARK CONSISTS OF THE LETTERS "THNKR" IN STYLIZED LETTERING, TO THE RIGHT OF WHICH IS THE DESIGN OF A TELEVISION WITH A DOT ON THE OUTSIDE OF THE LOWER LEFT HAND CORNER.

FOR BROADCASTING OF TELEVISION PROGRAMS VIA TELEVISION, SATELLITE, WIRELESS, FIBER OPTICS, CABLE, AND A GLOBAL COMPUTER NETWORK (U.S. CLS. 100, 101 AND 104).

KATHERINE E. HALMEN, EXAMINING ATTORNEY

SN 85-634,015. @RADICAL.MEDIA LLC, NEW YORK, NY. FILED 5-24-2012.



THE MARK CONSISTS OF THE DESIGN OF A TELEVISION WITHIN WHICH IS THE LETTER "T", WITH A DOT ON THE OUTSIDE OF THE LOWER LEFT HAND CORNER.

FOR BROADCASTING OF TELEVISION PROGRAMS VIA TELEVISION, SATELLITE, WIRELESS, FIBER OPTICS, CABLE, AND A GLOBAL COMPUTER NETWORK (U.S. CLS. 100, 101 AND 104).

KATHERINE E. HALMEN, EXAMINING ATTORNEY

SN 85-676,221. METROPCS WIRELESS, INC., RICHARDSON, TX. FILED 7-13-2012.

4G FOR ME

THE MARK CONSISTS OF STANDARD CHARACTERS WITHOUT CLAIM TO ANY PARTICULAR FONT, STYLE, SIZE, OR COLOR.

NO CLAIM IS MADE TO THE EXCLUSIVE RIGHT TO USE "4G", APART FROM THE MARK AS SHOWN.

FOR TELECOMMUNICATIONS SERVICES, NAMELY, WIRELESS TELEPHONY AND WIRELESS BROADBAND COMMUNICATIONS SERVICES FOR THE TRANSMISSION OF VOICE, VIDEO, IMAGES, DATA AND INFORMATION; STREAMING OF DIGITAL MEDIA CONTENT FOR OTHERS VIA COMPUTER NETWORKS; PROVIDING E-MAIL SERVICES (U.S. CLS. 100, 101 AND 104).

KIMBERLY FRYE, EXAMINING ATTORNEY

CLASS 39—TRANSPORTATION AND STORAGE

SN 76-709,314. COACH AMERICA HOLDINGS, INC., DALLAS, TX. FILED 10-5-2011.

COACH AMERICA

THE MARK CONSISTS OF STANDARD CHARACTERS WITHOUT CLAIM TO ANY PARTICULAR FONT, STYLE, SIZE, OR COLOR.

OWNER OF U.S. REG. NOS. 3,438,628, 3,720,266 AND 3,936,103.

NO CLAIM IS MADE TO THE EXCLUSIVE RIGHT TO USE "COACH", APART FROM THE MARK AS SHOWN. SEC. 2(F).

FOR TRANSPORTATION SERVICES, NAMELY, TRANSPORTATION OF PASSENGERS BY BUS, MOTOR COACH CHARTER SERVICES, TOUR GUIDE SERVICES, CONDUCTING SIGHTSEEING TOURS FOR OTHERS, AND AIRPORT PASSENGER SHUTTLE SERVICES (U.S. CLS. 100 AND 105).

FIRST USE 4-0-2006; IN COMMERCE 4-0-2006.

BILL DAWE, EXAMINING ATTORNEY

SN 77-827,919. BLUE SPRUCE LLC, GUILFORD, CT. FILED 9-16-2009.

American West Steamboat Company

THE MARK CONSISTS OF STANDARD CHARACTERS WITHOUT CLAIM TO ANY PARTICULAR FONT, STYLE, SIZE, OR COLOR.

NO CLAIM IS MADE TO THE EXCLUSIVE RIGHT TO USE "AMERICAN" AND "STEAMBOAT COMPANY", APART FROM THE MARK AS SHOWN.

FOR CRUISE SHIP SERVICES; TRANSPORTATION OF PASSENGERS BY SHIP; ARRANGING AND CONDUCTING CRUISES FOR OTHERS (U.S. CLS. 100 AND 105).

KEVON CHISOLM, EXAMINING ATTORNEY

SN 77-827,963. BLUE SPRUCE LLC, GUILFORD, CT. FILED 9-16-2009.

American West Cruises

THE MARK CONSISTS OF STANDARD CHARACTERS WITHOUT CLAIM TO ANY PARTICULAR FONT, STYLE, SIZE, OR COLOR.

NO CLAIM IS MADE TO THE EXCLUSIVE RIGHT TO USE "AMERICAN" AND "CRUISES", APART FROM THE MARK AS SHOWN.

FOR CRUISE SHIP SERVICES; TRANSPORTATION OF PASSENGERS BY SHIP; ARRANGING AND CONDUCTING CRUISES FOR OTHERS (U.S. CLS. 100 AND 105).

KEVON CHISOLM, EXAMINING ATTORNEY

CLASS 39—(Continued).

SN 85-399,502. RODRIGUEZ VILLA, MAURO, CANCUN, MEXICO, AND CHAVEZ GARCIA, JOSE IGNACIO, CANCUN, MEXICO, FILED 8-16-2011.



OWNER OF MEXICO REG. NO. 1179063, DATED 9-17-2009, EXPIRES 9-17-2019.

NO CLAIM IS MADE TO THE EXCLUSIVE RIGHT TO USE "REWARDS", APART FROM THE MARK AS SHOWN.

THE MARK CONSISTS OF AN ICON OF A PERSON WITH ARMS UPS, AND THE WORDS "VACANCY REWARDS" STACKED ON THE RIGHT OF THE IMAGE.

FOR ORGANIZATION OF TRAVEL SERVICES (U.S. CLS. 100 AND 105).

FIRST USE 4-1-2005; IN COMMERCE 4-1-2005.
LESLIE RICHARDS, EXAMINING ATTORNEY

SN 85-418,820. DATA IMAGE, INC., NEWARK, OH. FILED 9-9-2011.

DataStore

THE MARK CONSISTS OF STANDARD CHARACTERS WITHOUT CLAIM TO ANY PARTICULAR FONT, STYLE, SIZE, OR COLOR.

FOR ONLINE ARCHIVAL SERVICES, NAMELY, ELECTRONIC DOCUMENT AND E-MAIL ARCHIVING SERVICES (U.S. CLS. 100 AND 105).

REGINA DRUMMOND, EXAMINING ATTORNEY

SN 85-442,203. CONWAY'S BUS SERVICE, INC., CUMBERLAND, RI. FILED 10-7-2011.

CONWAY TOURS

THE MARK CONSISTS OF STANDARD CHARACTERS WITHOUT CLAIM TO ANY PARTICULAR FONT, STYLE, SIZE, OR COLOR.

NO CLAIM IS MADE TO THE EXCLUSIVE RIGHT TO USE "TOURS", APART FROM THE MARK AS SHOWN.

SEC. 2(F).

FOR TOUR SERVICES FOR INDIVIDUALS AND GROUPS, NAMELY, VACATION DESTINATION TOURS, TOUR ARRANGEMENTS, MOTORBUS TOURS, GUIDED TOURS, SIGHTSEEING AND EXCURSION TOURS (U.S. CLS. 100 AND 105).

FIRST USE 0-0-1926; IN COMMERCE 0-0-1926.

TRACY WHITTAKER-BROWN, EXAMINING ATTORNEY

CLASS 39—(Continued).

SN 85-470,000. GOLDEN GATE BRIDGE, HIGHWAY AND TRANSPORTATION DISTRICT, SAN FRANCISCO, CA. FILED 11-10-2011.



OWNER OF U.S. REG. NOS. 2,662,471, 2,668,642 AND OTHERS.

NO CLAIM IS MADE TO THE EXCLUSIVE RIGHT TO USE "TRANSIT", APART FROM THE MARK AS SHOWN.

THE MARK CONSISTS OF A CIRCLE DESIGN WITH THE IMAGE OF A BRIDGE AGAINST A BACKGROUND OF SKY AT THE CENTER, THE WORDS "GOLDEN GATE" ARCH OVER THE BRIDGE, THE WORD "TRANSIT" FORMS AN INVERTED ARCH BENEATH THE BRIDGE, THE WORDING CREATES A BANNER ENCIRCLING THE BRIDGE DESIGN.

FOR BRIDGE OPERATION SERVICES; PROVIDING INFORMATION ABOUT BRIDGE OPERATION AND TRANSPORTATION SERVICES (U.S. CLS. 100 AND 105).

FIRST USE 7-26-2010; IN COMMERCE 7-26-2010.

JASON TURNER, EXAMINING ATTORNEY

SN 85-488,057. VIRTUOSO, LTD., FORT WORTH, TX. FILED 12-6-2011.

TRAVEL PERSONA

THE MARK CONSISTS OF STANDARD CHARACTERS WITHOUT CLAIM TO ANY PARTICULAR FONT, STYLE, SIZE, OR COLOR.

NO CLAIM IS MADE TO THE EXCLUSIVE RIGHT TO USE "TRAVEL", APART FROM THE MARK AS SHOWN.

FOR PROVIDING AN INTERACTIVE WEBSITE THAT PROVIDES INFORMATION ABOUT TRAVEL PRODUCTS AND SERVICES THAT IS TAILORED TO THE SPECIFIC USER BASED ON PERSONAL ASSESSMENT QUESTIONS ASKED OF THE USER (U.S. CLS. 100 AND 105).

JULIE WATSON, EXAMINING ATTORNEY

CLASS 39—(Continued).

SN 85-488,215. VIRTUOSO, LTD., FORT WORTH, TX. FILED 12-6-2011.

VIRTUOSO TRAVELER

THE MARK CONSISTS OF STANDARD CHARACTERS WITHOUT CLAIM TO ANY PARTICULAR FONT, STYLE, SIZE, OR COLOR.

OWNER OF U.S. REG. NOS. 3,095,926, 3,884,601 AND OTHERS.

NO CLAIM IS MADE TO THE EXCLUSIVE RIGHT TO USE "TRAVELER", APART FROM THE MARK AS SHOWN.

FOR PROVIDING TRAVEL INFORMATION OVER THE INTERNET WITH THE INFORMATION TAILORED TO THE SPECIFIC USER BASED ON PERSONAL TRAVEL ASSESSMENT QUESTIONS ASKED OF THE USER (U.S. CLS. 100 AND 105).

JULIE WATSON, EXAMINING ATTORNEY

SN 85-498,371. GRAPHIC COW GRAPHIC DESIGN AND SCREENPRINTING CO., THE, GREENVILLE, SC. FILED 12-19-2011.

COWTAGGING

THE MARK CONSISTS OF STANDARD CHARACTERS WITHOUT CLAIM TO ANY PARTICULAR FONT, STYLE, SIZE, OR COLOR.

FOR PROVIDING INDIVIDUAL LABELING AND PACKAGING OF BULK ORDERED CUSTOM MERCHANDISE FOR OTHERS (U.S. CLS. 100 AND 105).

FIRST USE 9-14-2004; IN COMMERCE 9-14-2004.

MYRIAH HABEBE, EXAMINING ATTORNEY

CLASS 39—(Continued).

SN 85-512,110. AEROVIAS DE MEXICO, S.A. DE C.V., COL. CUAUHTEMOC, D.F., MEXICO, FILED 1-9-2012.



PRIORITY CLAIMED UNDER SEC. 44(D) ON MEXICO APPLICATION NO. 1236407, FILED 12-15-2011, REG. NO. 1288593, DATED 12-15-2011, EXPIRES 12-15-2021.

OWNER OF U.S. REG. NO. 1,857,939.

THE MARK CONSISTS OF A STYLIZED CAPITAL LETTER "T" AND A LOWER CASE "i" ABOVE THE WORD "CLUB" IN ALL CAPITAL LETTERS; THE WORD "PREMIER" IS IN CURSIVE LETTERS AND THE WORD "TITANIO" IS ALSO IN CAPITAL LETTERS UNDERNEATH "PREMIER".

THE ENGLISH TRANSLATION OF "TITANIO" IN THE MARK IS "TITANIUM".

FOR TRANSPORTATION SERVICES, NAMELY, AIRLINE PASSENGER SERVICES FEATURING A FREQUENT FLYER BONUS PROGRAM, TRANSPORTATION OF PASSENGERS, AIRPORT SERVICES, FREIGHT, GOODS AND MAIL BY AIR AND LAND; STORAGE OF GOODS OF ALL KINDS IN WAREHOUSES AND SHIPPING CONTAINERS; CRATING OF GOODS, NAMELY, PACKING OF GOODS FOR TRANSPORTATION BY AIR AND TRUCK, PARCEL DELIVERY BY AIR AND TRUCK (U.S. CLS. 100 AND 105).

KATHLEEN LORENZO, EXAMINING ATTORNEY

SN 85-543,572. ALASKA AIRLINES, INC., SEATTLE, WA. FILED 2-15-2012.



THE MARK CONSISTS OF A PAWPRINT IN A HEXAGON ABOVE THE WORD "PETSTREAK".

FOR TRANSPORTATION OF ANIMALS, PACKAGES, FREIGHT AND CARGO BY AIR (U.S. CLS. 100 AND 105).

FIRST USE 10-0-2011; IN COMMERCE 10-0-2011.

BRIAN NEVILLE, EXAMINING ATTORNEY

CLASS 39—(Continued).

SN 85-558,375. GRUPO AEROMEXICO, S.A. DE C.V., DISTRICTO FEDERAL, MEXICO, FILED 3-2-2012.



OWNER OF U.S. REG. NOS. 1,938,267, 2,276,355 AND 2,293,104.

NO CLAIM IS MADE TO THE EXCLUSIVE RIGHT TO USE "MEXICO'S GLOBAL AIRLINE", APART FROM THE MARK AS SHOWN.

THE COLOR(S) RED AND BLUE IS/ARE CLAIMED AS A FEATURE OF THE MARK.

THE MARK CONSISTS OF AN EAGLE HEAD IN THE COLOR BLUE TO THE LEFT OF THE WORD "AEROMEXICO" IN BLUE CAPITAL LETTERS; A RED CURVED WAVY LINE UNDER THE WORD "MEXICO"; WITH "MEXICO'S GLOBAL AIRLINE" IN BLUE LETTERS.

THE WORDING "AEROMEXICO" HAS NO MEANING IN A FOREIGN LANGUAGE.

FOR TRANSPORTATION SERVICES, NAMELY, TRANSPORTATION OF PASSENGERS AND GOODS BY AIR; TRANSPORTATION OF CARGO AND FREIGHT BY AIR; AIR CARGO STORAGE AND HANDLING SERVICES; PACKING OF GOODS FOR TRANSPORTATION BY AIR, TRUCK, TRAIN, AND SHIP; PARCEL DELIVERY BY AIR, TRUCK, CAR, TRAIN, AND SHIP; AIRCRAFT CHARTERING SERVICES; TRAVEL SERVICES, NAMELY, ARRANGING TOURS, CRUISES, AND OTHER TRAVEL PACKAGES; TRAVEL AGENCY AND BOOKING SERVICES, NAMELY, MAKING RESERVATIONS AND BOOKINGS FOR TRANSPORTATION; ONLINE TRAVEL AGENCY AND BOOKING SERVICES, NAMELY, MAKING RESERVATIONS AND BOOKINGS FOR TRANSPORTATION VIA THE INTERNET; TRAVEL INFORMATION SERVICES; CONSULTING SERVICES RELATED TO AIR TRANSPORTATION AND TRAVEL; PROVIDING A PROGRAM OF BONUS AWARDS FOR FREQUENT TRAVELERS (U.S. CLS. 100 AND 105).

KARANENDRA S. CHHINA, EXAMINING ATTORNEY

SN 85-584,275. PIGGYBACK EXPRESS, LLC, HOWELL, MI. FILED 3-29-2012.

PIGGYBACK EXPRESS

THE MARK CONSISTS OF STANDARD CHARACTERS WITHOUT CLAIM TO ANY PARTICULAR FONT, STYLE, SIZE, OR COLOR.

NO CLAIM IS MADE TO THE EXCLUSIVE RIGHT TO USE "EXPRESS", APART FROM THE MARK AS SHOWN.

FOR TRUCKING SERVICES, NAMELY, HAULING OF AUTOMOBILES (U.S. CLS. 100 AND 105).

KELLY TRUSILO, EXAMINING ATTORNEY

CLASS 39—(Continued).

SN 85-584,414. J DOG FRANCHISES, INC., WAYNE, PA. FILED 3-30-2012.

J Dog Junk Removal

THE MARK CONSISTS OF STANDARD CHARACTERS WITHOUT CLAIM TO ANY PARTICULAR FONT, STYLE, SIZE, OR COLOR.

NO CLAIM IS MADE TO THE EXCLUSIVE RIGHT TO USE "JUNK REMOVAL", APART FROM THE MARK AS SHOWN.

FOR JUNK REMOVAL; JUNK, TRASH AND DEBRIS REMOVAL (U.S. CLS. 100 AND 105).

FIRST USE 7-1-2010; IN COMMERCE 7-1-2010.

THEODORE MCBRIDE, EXAMINING ATTORNEY

SN 85-591,144. SPRAGUE OPERATING RESOURCES LLC, PORTSMOUTH, NH. FILED 4-6-2012.

FUELCONTROL

THE MARK CONSISTS OF STANDARD CHARACTERS WITHOUT CLAIM TO ANY PARTICULAR FONT, STYLE, SIZE, OR COLOR.

FOR TRANSPORTATION AND STORAGE OF FUELS (U.S. CLS. 100 AND 105).

KERI CANTONE, EXAMINING ATTORNEY

SN 85-591,178. SPRAGUE OPERATING RESOURCES LLC, PORTSMOUTH, NH. FILED 4-6-2012.

FLEETCONTROL

THE MARK CONSISTS OF STANDARD CHARACTERS WITHOUT CLAIM TO ANY PARTICULAR FONT, STYLE, SIZE, OR COLOR.

FOR TRANSPORTATION AND STORAGE OF FUELS (U.S. CLS. 100 AND 105).

KERI CANTONE, EXAMINING ATTORNEY

CLASS 39—(Continued).

SN 85-591,366. BEIJING JINGDONG 360 DU E-COMMERCE LTD., BEIJING, CHINA, FILED 4-6-2012.



NO CLAIM IS MADE TO THE EXCLUSIVE RIGHT TO USE "EXPRESS", APART FROM THE MARK AS SHOWN.

THE MARK CONSISTS OF THE TERM "360BUY EXPRESS" ON TWO LINES WITH A PORTION OF "360BUY" ABOVE THE FRONT PORTION OF THE WORD "EXPRESS"; A PORTION OF THE TERM IS IN A DARK CIRCLE; FOUR ARROWS COME OUT OF THE LEFT SIDE OF THE "E" IN "EXPRESS".

FOR TRANSPORT OF PERSONS AND GOODS; FREIGHTING SERVICES; GUARDED TRANSPORT OF VALUABLES; MARITIME TOWAGE SERVICES; VEHICLE TOWING; PACKAGING OF GOODS FOR TRANSPORTATION; PILOTING; DELIVERY OF GOODS; COURIER SERVICES; PARCEL DELIVERY; DELIVERY OF GOODS BY MAIL ORDER; FLOWER DELIVERY; STORAGE OF GOODS; RENTAL OF WAREHOUSES; PHYSICAL STORAGE OF ELECTRONICALLY-STORED DATA OR DOCUMENTS; ARRANGING OF TOURS; TRAVEL RESERVATION; VEHICLE RENTAL; CHAUFFEUR SERVICES (U.S. CLS. 100 AND 105).

GEOFFREY FOSDICK, EXAMINING ATTORNEY

SN 85-593,993. HOPKINS, THOMAS, DAYTON, NV. AND HOPKINS, VERA, DAYTON, NV. FILED 4-10-2012.



NO CLAIM IS MADE TO THE EXCLUSIVE RIGHT TO USE "TRUCKING", APART FROM THE MARK AS SHOWN.

THE MARK CONSISTS OF THE LETTERING "H&S" IN STYLIZED FONT IN-BETWEEN DESIGNS COMPRISED OF ELEVEN LINES OF DIFFERENT LENGTHS DISPLAYED HORIZONTALLY ALL ABOVE THE WORD "TRUCKING".

FOR TRUCKING SERVICES, NAMELY, HAULING OF OIL FIELD AND GEOTHERMAL DRILLING SUPPLIES AND EQUIPMENT (U.S. CLS. 100 AND 105).

FIRST USE 6-1-2006; IN COMMERCE 6-6-2006.

DAVID YONTEF, EXAMINING ATTORNEY

CLASS 39—(Continued).

SN 85-595,309. BOSTON CHAUFFEUR INC., BEVERLY, MA. FILED 4-11-2012.

Boston Chauffeur

THE MARK CONSISTS OF STANDARD CHARACTERS WITHOUT CLAIM TO ANY PARTICULAR FONT, STYLE, SIZE, OR COLOR.

NO CLAIM IS MADE TO THE EXCLUSIVE RIGHT TO USE "CHAUFFEUR", APART FROM THE MARK AS SHOWN.

SEC. 2(F).

FOR CHAUFFEUR SERVICES; LIMOUSINE SERVICES (U.S. CLS. 100 AND 105).

FIRST USE 2-2-2001; IN COMMERCE 2-2-2001.

SARA BENJAMIN, EXAMINING ATTORNEY

SN 85-596,547. WOLFE, KATHLEEN, WAKE FOREST, NC. FILED 4-12-2012.

Get Down to Disness

THE MARK CONSISTS OF STANDARD CHARACTERS WITHOUT CLAIM TO ANY PARTICULAR FONT, STYLE, SIZE, OR COLOR.

FOR TRAVEL INFORMATION SERVICES; TRAVEL ROUTE PLANNING; TRAVEL PLANNING FOR INDIVIDUALS, FAMILIES, AND GROUPS FOR SPECIAL OCCASIONS (U.S. CLS. 100 AND 105).

JAMES LOVELACE, EXAMINING ATTORNEY

SN 85-598,069. ANDREW SHIPUK, TROUTDALE, OR. FILED 4-14-2012.



NO CLAIM IS MADE TO THE EXCLUSIVE RIGHT TO USE "TRANSPORT", APART FROM THE MARK AS SHOWN.

FOR FREIGHT TRANSPORTATION BY TRUCK; FREIGHTING SERVICES (U.S. CLS. 100 AND 105).

APRIL ROACH, EXAMINING ATTORNEY

CLASS 39—(Continued).

SN 85-598,980. CONTOS, JON G., SAN MATEO, CA. FILED 4-16-2012.



NO CLAIM IS MADE TO THE EXCLUSIVE RIGHT TO USE "PROPANE DELIVERY SERVICE" AND "1-877-427-2968", APART FROM THE MARK AS SHOWN.

THE COLOR(S) GRAY, RED, YELLOW, AND BLACK IS/ARE CLAIMED AS A FEATURE OF THE MARK.

THE MARK CONSISTS OF A STYLIZED DEPICTION OF A GRAY PROPANE TANK TO THE LEFT AND BEHIND A BLACK RECTANGULAR BACKGROUND CARRIER WITH A YELLOW RECTANGULAR BACKGROUND CARRIER SUPERIMPOSED OVER A PORTION OF THE BLACK RECTANGULAR BACKGROUND CARRIER. INSIDE THE YELLOW BACKGROUND CARRIER IS THE WORDING "1-877-GAS2" IN YELLOW SET AGAINST A RED ARROW AND TO THE RIGHT APPEARS THE WORD "YOU" IN RED AND OUTLINED IN BLACK. BENEATH AND SET AGAINST THE BLACK RECTANGULAR BACKGROUND CARRIER APPEARS THE WORDING "PROPANE DELIVERY SERVICE" IN YELLOW TO THE LEFT OF THE NUMBERING "1-877-427-2968" IN YELLOW. BENEATH APPEARS THE WORDING "DON'T RUN OUT-WE DELIVER" IN RED. THE BACKGROUND OF THE ENTIRE MARK IS TRANSLUCENT.

FOR DISTRIBUTION SERVICES, NAMELY, DELIVERY OF PROPANE CYLINDERS (U.S. CLS. 100 AND 105).

FIRST USE 4-1-2000; IN COMMERCE 4-1-2000.
JIM RINGLE, EXAMINING ATTORNEY

SN 85-603,714. LEADER LLC, KANSAS CITY, MO. FILED 4-20-2012.

LEADER

THE MARK CONSISTS OF STANDARD CHARACTERS WITHOUT CLAIM TO ANY PARTICULAR FONT, STYLE, SIZE, OR COLOR.

FOR TRANSPORTATION OF PASSENGERS AND/OR GOODS BY AIR, WATER, AND LAND (U.S. CLS. 100 AND 105).

DAWN FELDMAN, EXAMINING ATTORNEY

CLASS 39—(Continued).

SN 85-644,594. CITY TOURS USA, INC., AKA CITY TOURS DIRECT, EAST RUTHERFORD, NJ. FILED 6-6-2012.



NO CLAIM IS MADE TO THE EXCLUSIVE RIGHT TO USE TOURS, APART FROM THE MARK AS SHOWN.

THE COLOR(S) MIDNIGHT BLACK, FIRE ENGINE RED AND PEARL WHITE IS/ARE CLAIMED AS A FEATURE OF THE MARK.

THE MARK CONSISTS OF TWO LINES OF WORDING. THE TOP LINE WORDING "CITY TOURS" IS IN THE COLOR MIDNIGHT BLACK AND THE BOTTOM LINE WORDING "DIRECT" IN THE COLOR FIRE ENGINE RED. THE LETTER "D" IN THE WORDING "DIRECT" IS STYLIZED WITH AN ARROW IN THE COLOR PEARL WHITE THAT DISSECTS THE VERTICAL UPRIGHT STROKE OF THE STYLIZED LETTER "D" WITH THE STEM OF THE ARROW AND FORMS THE VERTICAL ARC OF THE STYLIZED LETTER "D" WITH THE POINT OF THE ARROW.

SEC. 2(F) AS TO "CITY".

FOR CONDUCTING SIGHTSEEING TOURS BY GROUND USING COACH BUSES AND USING AN ONLINE PORTAL AND WEBSITE WHERE THE CUSTOMER CAN PURCHASE THE TOURS DIRECTLY; CONDUCTING SIGHTSEEING TOURS FOR OTHERS; ORGANISATION OF SIGHTSEEING TOURS; ORGANIZATION OF EXCURSIONS, SIGHTSEEING TOURS, HOLIDAYS, TOURS AND TRAVEL; ORGANIZATION, BOOKING AND ARRANGEMENT OF EXCURSIONS, DAY TRIPS AND SIGHTSEEING TOURS; PERSONAL TOUR GUIDE SERVICES; TOUR CONDUCTING; TOUR CONDUCTING OR ESCORTING; TOUR GUIDE SERVICES; TOUR OPERATING; TOUR OPERATING AND ORGANISING; TOUR ORGANISING; TRAVEL AND TOUR INFORMATION SERVICE; TRAVEL AND TOUR TICKET RESERVATION SERVICE (U.S. CLS. 100 AND 105).

FIRST USE 6-1-2011; IN COMMERCE 6-1-2011.
ALAIN LAPTER, EXAMINING ATTORNEY

CLASS 40—MATERIAL TREATMENT

SN 85-064,107. STATE ATOMIC ENERGY CORPORATION "ROSATOM", 119017 MOSCOW, RUSSIAN FED., FILED 6-16-2010.



PRIORITY CLAIMED UNDER SEC. 44(D) ON RUSSIAN FED. APPLICATION NO. 2010712051, FILED 4-14-2010, REG. NO. 427878, DATED 1-18-2011, EXPIRES 4-14-2020.

THE COLOR(S) WHITE, BLACK, DARK BLUE, BLUE, LIGHT BLUE, DARK GREY, GREY IS/ARE CLAIMED AS A FEATURE OF THE MARK.

THE MARK CONSISTS OF A BULLSEYE DESIGN WITH A SOLID TWISTING RIBBON DESIGN IN THE COLORS BLACK, DARK BLUE, BLUE AND LIGHT BLUE FORMING THE BORDER OF A CIRCLE, BROKEN INTO THREE SECTIONS BY THREE WHITE CURVED LINES, WITH AN INTERIOR IRREGULAR TRIANGLE IN WHITE AROUND AN INNER SOLID BLACK, DARK BLUE, BLUE CIRCLE, ALL APPEARING ABOVE THE WORD "ROSATOM" IN WHICH THE LETTERS "ROS" ARE DARK GREY AND THE LETTERS "ATOM" ARE GREY.

FOR WASTE TREATMENT IN THE NATURE OF VITRIFICATION OF HAZARDOUS MATERIALS, NAMELY, ENCASING CHEMICALS, NUCLEAR MATERIALS, NUCLEAR WASTE, FISSION PRODUCTS, RADIOACTIVE MATERIALS IN VITREOUS MATERIAL OR GLASS; MATERIAL TREATMENT IN THE NATURE OF VULCANIZATION; ELECTROPLATING; DECONTAMINATION OF HAZARDOUS MATERIALS IN THE NATURE OF CHEMICALS, NUCLEAR MATERIALS, NUCLEAR WASTE, FISSION PRODUCTS AND RADIOACTIVE MATERIALS FROM BUILDINGS, PLANTS AND LAND; METAL TEMPERING; GILDING; PROVIDING INFORMATION IN THE FIELD OF MATERIAL TREATMENT; CADMIUM PLATING; METAL CASTING; BOILER-MAKING; MATERIAL TREATMENT IN THE NATURE OF MAGNETIZATION OF METALS; METAL TREATING IN THE NATURE OF ELECTROPLATING AND METAL COATING; METAL TREATING AND CASTING; METAL TREATING IN THE NATURE OF HARDENING OF METAL AND METAL PRODUCTS; NICKEL PLATING; WATER TREATING; WOODWORKING; METAL TREATING; WASTE TREATMENT, NAMELY, TREATMENT OF SPENT NUCLEAR FUEL, FISSION PRODUCTS, NEUTRON POISONS, NEUTRON MODERATING MATERIALS AND WASTE; WASTE TREATMENT, NAMELY, REPROCESSING OF NUCLEAR FUELS; WASTE TREATMENT, NAMELY, TRANSFORMATION OF WASTE; PROVIDING SERVICES IN THE FIELD OF MECHANICAL AND THERMAL TREATMENT OF METALS; PURIFICATION OF AIR; SOLDERING; METAL PLATING; GOLD PLATING; RENTAL OF ELECTRIC POWER GENERATORS; CUSTOM ASSEMBLING OF PRODUCTS FOR OTHERS IN AREAS RELATED TO NUCLEAR INDUSTRY AND ENERGY; GRINDING; SAWING IN THE NATURE OF SAWMILL SERVICES; SOLDERING IN THE NATURE OF WELDING; SILVER-PLATING; INCINERATION OF WASTE AND TRASH; CUSTOM ASSEMBLY FOR OTHERS IN THE FIELD OF INSPECTION AND SAFETY EQUIPMENT FOR RESEARCH AND ENGINEERING IN

CLASS 40—(Continued).

AREAS RELATED TO NUCLEAR INDUSTRY AND ENERGY; PROCESSING OF OIL; METAL TREATING IN THE NATURE OF URANIUM AND PLUTONIUM ENRICHMENT, CONVERSION, RE-CONVERSION AND LASER ISOTOPE SEPARATION; METAL TREATING IN THE NATURE OF PROCESSING TO OBTAIN METALS FROM NATIVE EARTH ORES; RECYCLING FOR FUELS, ORES, NUCLEAR MATERIALS, URANIUM, PLUTONIUM AND NUCLEAR WASTE; DECONTAMINATION OF HAZARDOUS MATERIALS; NUCLEAR WASTE TREATMENT; WASTE TREATMENT IN THE NATURE OF PROCESSING OF NUCLEAR MATERIALS; ENERGY PRODUCTION SERVICES, NUCLEAR ENERGY PRODUCTION SERVICES; DESTRUCTION AND INCINERATION SERVICES FOR WASTE, NUCLEAR WASTE AND NUCLEAR WASTE IN THE NATURE OF SPENT FUEL; RECYCLING SERVICES FOR NUCLEAR WASTE; MILL WORKING; CHROMIUM PLATING; GALVANIZING; OPTICAL GLASS GRINDING; RADIOACTIVE WASTE TREATMENT (U.S. CLS. 100, 103 AND 106).

NELSON SNYDER, EXAMINING ATTORNEY

SN 85-262,230. TOLEDO REFINING COMPANY LLC, OREGON, OH. FILED 3-9-2011.



NO CLAIM IS MADE TO THE EXCLUSIVE RIGHT TO USE "TOLEDO REFINING COMPANY", APART FROM THE MARK AS SHOWN.

THE COLOR(S) RED, NAVY BLUE, TURQUOISE BLUE IS/ARE CLAIMED AS A FEATURE OF THE MARK.

THE MARK CONSISTS OF THE TERMINOLOGY "TOLEDO REFINING COMPANY" WITH A HALF CIRCLE DESIGN. THE TERMINOLOGY "TOLEDO" APPEARS IN THE COLOR NAVY BLUE. THE TERMINOLOGY "REFINING COMPANY" APPEARS IN THE COLOR TURQUOISE BLUE. THE HALF CIRCLE DESIGN APPEARS IN THE COLOR RED.

FOR CHEMICAL PROCESSING SERVICES, NAMELY, PROCESSING OF PETROLEUM FEEDSTOCKS AND CHEMICALS, NAMELY, MIXED PROPYLENE; PETROLEUM REFINING; PRODUCTION OF LUBRICANT BASESTOCKS FOR OTHERS; OIL REFINERY SERVICES; PROCESSING AND REFINING OF CRUDE OIL AND PETROCHEMICAL PRODUCTS; PROCESSING AND TREATMENT OF PETROCHEMICAL PRODUCTS; REFINERIES FOR PRODUCING PETROCHEMICALS; PROCESSING AND TREATING PETROCHEMICALS; PRODUCTION, TREATMENT AND REFINEMENT OF FUEL, DIESEL FUEL, BIOFUEL AND BIODIESEL FUEL FOR OTHERS; PRODUCTION OF ASPHALT FOR OTHERS (U.S. CLS. 100, 103 AND 106).

FIRST USE 3-1-2011; IN COMMERCE 3-1-2011.

APRIL ROACH, EXAMINING ATTORNEY

CLASS 40—(Continued).

SN 85-371,114. WYOMING ARMORY LLC, CODY, WY.
FILED 7-14-2011.



NO CLAIM IS MADE TO THE EXCLUSIVE RIGHT TO USE "WYOMING ARMORY", APART FROM THE MARK AS SHOWN.

THE MARK CONSISTS OF THE STYLIZED TEXT "WYOMING ARMORY". THE CAPITAL "W" SITS ABOVE AND TO THE LEFT OF THE CAPITAL "A" WHICH OVERLAPS THE BOTTOM OF THE "W". AN ARROW SERVES AS THE CROSSBAR FOR THE CAPITAL "A". THE LETTERS "YOMING" ARE UNDERLINED AND APPEAR TO THE RIGHT OF THE CAPITAL "W". BELOW THIS LINE ARE THE LETTERS "RMORY".

FOR MANUFACTURING SERVICES FOR OTHERS IN THE FIELD OF FIREARMS (U.S. CLS. 100, 103 AND 106).
FIRST USE 9-15-2008; IN COMMERCE 12-1-2008.
SUNG IN, EXAMINING ATTORNEY

SN 85-434,479. CREDO PETROLEUM CORPORATION, DENVER, CO. FILED 9-28-2011.

CALLIOPE

THE MARK CONSISTS OF STANDARD CHARACTERS WITHOUT CLAIM TO ANY PARTICULAR FONT, STYLE, SIZE, OR COLOR.

OWNER OF U.S. REG. NO. 2,494,681.
FOR GAS PRODUCTION SERVICES FROM GAS WELLS (U.S. CLS. 100, 103 AND 106).
FIRST USE 4-0-2000; IN COMMERCE 4-0-2000.
DAWN HAN, EXAMINING ATTORNEY

SN 85-437,650. NORTH COUNTRY WOODSHOP LLC, BURNSVILLE, MN. FILED 10-3-2011.

NORTH COUNTRY WOODSHOP

THE MARK CONSISTS OF STANDARD CHARACTERS WITHOUT CLAIM TO ANY PARTICULAR FONT, STYLE, SIZE, OR COLOR.

NO CLAIM IS MADE TO THE EXCLUSIVE RIGHT TO USE "WOODSHOP", APART FROM THE MARK AS SHOWN.

FOR PROVIDING WORKSHOP FACILITIES FOR WOODWORKING (U.S. CLS. 100, 103 AND 106).
FIRST USE 1-5-2011; IN COMMERCE 2-1-2011.
ZACHARY BELLO, EXAMINING ATTORNEY

CLASS 40—(Continued).

SN 85-441,870. RETRO BAKERY, LLC, LAS VEGAS, NV.
FILED 10-7-2011.

RETRO BAKERY

THE MARK CONSISTS OF STANDARD CHARACTERS WITHOUT CLAIM TO ANY PARTICULAR FONT, STYLE, SIZE, OR COLOR.

NO CLAIM IS MADE TO THE EXCLUSIVE RIGHT TO USE "BAKERY", APART FROM THE MARK AS SHOWN.

FOR BAKERY SERVICES, NAMELY, THE MANUFACTURE OF BAKERY PRODUCTS TO ORDER AND/OR SPECIFICATION OF OTHERS (U.S. CLS. 100, 103 AND 106).

FIRST USE 2-10-2008; IN COMMERCE 2-10-2008.
BRENDAN MCCAULEY, EXAMINING ATTORNEY

SN 85-496,648. DEE GEE HOLDINGS, LLC, MELBOURNE, FL. FILED 12-15-2011.



OWNER OF U.S. REG. NO. 3,809,347.

NO CLAIM IS MADE TO THE EXCLUSIVE RIGHT TO USE "TECHNOLOGIES" AND "MACHINE & TOOL DIVISION", APART FROM THE MARK AS SHOWN.

THE MARK CONSISTS OF A STYLIZED LETTER "C" WHICH INCLUDES A GEAR DESIGN ON AN INSIDE PORTION THEREOF, FOLLOWED BY THE WORDS "CRAIG TECHNOLOGIES" OVER "MACHINE & TOOL DIVISION".

FOR MACHINE SHOP SERVICES, NAMELY, MACHINING PARTS FOR OTHERS; METAL FABRICATION AND FINISHING SERVICES (U.S. CLS. 100, 103 AND 106).

FIRST USE 2-1-2011; IN COMMERCE 2-1-2011.
JESSICA FATHY, EXAMINING ATTORNEY

CLASS 40—(Continued).

SN 85-502,870. DEE GEE HOLDINGS, LLC, MELBOURNE, FL. FILED 12-23-2011.



OWNER OF U.S. REG. NO. 3,809,347.
NO CLAIM IS MADE TO THE EXCLUSIVE RIGHT TO USE "TECHNOLOGIES" AND "MACHINE & TOOL DIVISION", APART FROM THE MARK AS SHOWN.

THE MARK CONSISTS OF A STYLIZED LETTER "C" WHICH INCLUDES A GEAR DESIGN ON AN INSIDE PORTION THEREOF, FOLLOWED BY THE WORDS "CRAIG" ABOVE "TECHNOLOGIES" OVER "MACHINE & TOOL DIVISION". A LINE APPEARS ABOVE THE WORDING "MACHINE & TOOL DIVISION".

FOR MACHINE SHOP SERVICES, NAMELY, MACHINING PARTS FOR OTHERS; METAL FABRICATION AND FINISHING SERVICES (U.S. CLS. 100, 103 AND 106).

FIRST USE 2-1-2011; IN COMMERCE 2-1-2011.
JESSICA FATHY, EXAMINING ATTORNEY

SN 85-504,443. KLEIN, BONNIE, LOS ANGELES, CA. FILED 12-27-2011.

Bonnie Bell Bakes

THE MARK CONSISTS OF STANDARD CHARACTERS WITHOUT CLAIM TO ANY PARTICULAR FONT, STYLE, SIZE, OR COLOR.

NO CLAIM IS MADE TO THE EXCLUSIVE RIGHT TO USE "BAKES", APART FROM THE MARK AS SHOWN.

THE NAME(S), PORTRAIT(S), AND/OR SIGNATURE(S) SHOWN IN THE MARK IDENTIFIES BONNIE KLEIN, WHOSE CONSENT(S) TO REGISTER IS MADE OF RECORD.

FOR BAKERY SERVICES, NAMELY, THE MANUFACTURE OF BAKERY PRODUCTS TO ORDER AND/OR SPECIFICATION OF OTHERS (U.S. CLS. 100, 103 AND 106).

FIRST USE 6-1-2011; IN COMMERCE 6-1-2011.
MICHELE SWAIN, EXAMINING ATTORNEY

CLASS 40—(Continued).

SN 85-506,967. C.O.R.E.X. S.P.A. S.S., SALERNO, ITALY, FILED 12-31-2011.



THE COLOR(S) BLACK, WHITE, RED AND YELLOW IS/ARE CLAIMED AS A FEATURE OF THE MARK.

THE MARK CONSISTS OF THE WORD "COREX" IN WHITE LETTERS ON A SQUARE BLACK BACKGROUND WITH THE "O" IN "COREX" FILLED IN WITH RED AND A YELLOW HALF CIRCLE ABOVE THE LETTER "O".

FOR FOOD CANNING SERVICES, FOOD PROCESSING SERVICES (U.S. CLS. 100, 103 AND 106).

FIRST USE 1-1-1979; IN COMMERCE 1-1-1979.
CHRISTOPHER SIDOTI, EXAMINING ATTORNEY

SN 85-553,136. NTH DEGREE DISTILLING, LLC, PROSPECT, KY. FILED 2-27-2012.

NTH DEGREE DISTILLING

THE MARK CONSISTS OF STANDARD CHARACTERS WITHOUT CLAIM TO ANY PARTICULAR FONT, STYLE, SIZE, OR COLOR.

NO CLAIM IS MADE TO THE EXCLUSIVE RIGHT TO USE "DISTILLING", APART FROM THE MARK AS SHOWN.

FOR SPIRITS AND WHISKEY DISTILLERY SERVICES (U.S. CLS. 100, 103 AND 106).

ROBERT STRUCK, EXAMINING ATTORNEY

SN 85-563,590. TSRC CORPORATION, TAIPEI CITY, TAIWAN, FILED 3-8-2012.

TAIPOL

OWNER OF TAIWAN REG. NO. 74743, DATED 3-1-1995, EXPIRES 2-28-2015.

THE MARK CONSISTS OF STYLIZED ENGLISH LETTERS "TAIPOL".

THE WORDING "TAIPOL" HAS NO MEANING IN A FOREIGN LANGUAGE.

FOR PROCESSING OPERATION FOR RUBBER PRODUCTS IN THE NATURE OF RAW AND SEMI-FINISHED RUBBER FEATURING COMPOUNDING AND HEATING (U.S. CLS. 100, 103 AND 106).

AHSEN KHAN, EXAMINING ATTORNEY

CLASS 40—(Continued).

SN 85-577,809. CEF INDUSTRIES, LLC, ADDISON, IL. FILED 3-23-2012.



NO CLAIM IS MADE TO THE EXCLUSIVE RIGHT TO USE "AEROSPACE SOLUTIONS", APART FROM THE MARK AS SHOWN.

THE MARK CONSISTS OF THE LARGE LETTERS "CEF" IN UPPERCASE TYPE, UNDERNEATH THE LETTERS, ARE THE WORDS, "AEROSPACE SOLUTIONS"; A SILHOUETTE OF AN AIRPLANE APPEARS ABOVE THE "E" IN "CEF" AND LEAVES A JET TRAIL THROUGH THE CENTER OF THE "C" IN "CEF", TRAILING BELOW THE WORDS "AEROSPACE SOLUTIONS".

FOR MANUFACTURE OF ENGINEERED AEROSPACE PRODUCTS, NAMELY, ELECTROMECHANICAL PRODUCTS AND MECHANICAL PRODUCTS, NAMELY, LINEAR ACTUATORS, ROTARY ACTUATORS, BALL SCREWS, COMPRESSORS, PUMPS, GEAR BOXES, CONTROL ELECTRONICS, FLEXIBLE SHAFTS AND SYSTEMS, NAMELY, CARGO HANDLING SYSTEMS FOR CIVIL AND MILITARY APPLICATIONS TO ORDER AND/OR SPECIFICATION OF OTHERS (U.S. CLS. 100, 103 AND 106).

JOHN KELLY, EXAMINING ATTORNEY

SN 85-585,661. BARE ASS-SET CYCLES, UNION, MO. FILED 3-31-2012.

Bare Ass-Set Cycles

THE MARK CONSISTS OF STANDARD CHARACTERS WITHOUT CLAIM TO ANY PARTICULAR FONT, STYLE, SIZE, OR COLOR.

NO CLAIM IS MADE TO THE EXCLUSIVE RIGHT TO USE "CYCLES", APART FROM THE MARK AS SHOWN.

FOR CUSTOM BUILDING OF MOTORCYCLES (U.S. CLS. 100, 103 AND 106).

SCOTT OSCLICK, EXAMINING ATTORNEY

CLASS 40—(Continued).

SN 85-591,903. TERRY, HEATHER, FORTSON, GA. FILED 4-7-2012.



NO CLAIM IS MADE TO THE EXCLUSIVE RIGHT TO USE "TOPICALS", APART FROM THE MARK AS SHOWN. THE COLOR(S) GREEN IS/ARE CLAIMED AS A FEATURE OF THE MARK.

THE MARK CONSISTS OF THE LETTERS "HMD" IN GREEN ABOVE THE TERM "TOPICALS" IN GREEN. AT THE TOP OF THE LETTER "H" IS A CLUSTER OF LEAVES, ALSO IN GREEN. THE COLOR WHITE REPRESENTS BACKGROUND AND IS NOT CLAIMED AS PART OF THE MARK.

FOR MANUFACTURING SERVICES FOR OTHERS IN THE FIELD OF ALL NATURAL OINTMENTS MADE WITH CERTIFIED ORGANIC INGREDIENTS FOR CUTS, BURNS, WOUNDS, DIAPER RASH, ECZEMA, AND MANY OTHER SKIN CARE APPLICATIONS FOR BOTH HUMAN AND PET USE (U.S. CLS. 100, 103 AND 106).

JESSICA A. POWERS, EXAMINING ATTORNEY

SN 85-597,554. SAKER AIRCRAFT, INC., LOS ANGELES, CA. FILED 4-13-2012.

Saker Aircraft

THE MARK CONSISTS OF STANDARD CHARACTERS WITHOUT CLAIM TO ANY PARTICULAR FONT, STYLE, SIZE, OR COLOR.

NO CLAIM IS MADE TO THE EXCLUSIVE RIGHT TO USE "AIRCRAFT", APART FROM THE MARK AS SHOWN.

FOR MANUFACTURING SERVICES FOR OTHERS IN THE FIELD OF AIRCRAFTS (U.S. CLS. 100, 103 AND 106).

JOHN DWYER, EXAMINING ATTORNEY

CLASS 40—(Continued).

SN 85-599,599. STITCHES & SCREENS, INC., ATLANTIC BEACH, FL. FILED 4-17-2012.



NO CLAIM IS MADE TO THE EXCLUSIVE RIGHT TO USE "STITCHES & SCREENS", APART FROM THE MARK AS SHOWN.

THE MARK CONSISTS OF A CIRCLE CONTAINING THE STYLIZED WORDS STITCHES & SCREENS. THE "&" APPEARS IN A SMALL CIRCLE. INSIDE THE MAIN CIRCLE IS A SECOND CIRCLED CONTAINING A STYLIZED LETTER "S".

FOR SCREEN PRINTING SERVICES; EMBROIDERY SERVICES (U.S. CLS. 100, 103 AND 106).

FIRST USE 0-0-1996; IN COMMERCE 0-0-1996.
BRIDGETT SMITH, EXAMINING ATTORNEY

CLASS 40—(Continued).

SN 85-600,676. SUNSHINE GLOBE CORPORATION, BRANDYWINE, MD. FILED 4-17-2012.

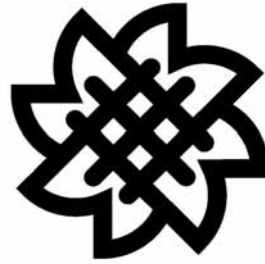

THE MARK CONSISTS OF A FABRIC WEAVING INSIDE A SUNSHINE.

FOR MANUFACTURING SERVICES FOR OTHERS IN THE FIELD OF TEXTILES (U.S. CLS. 100, 103 AND 106).

FIRST USE 1-3-2012; IN COMMERCE 1-3-2012.
LINDA POWELL, EXAMINING ATTORNEY

SN 85-601,134. SAKER AIRCRAFT, INC., LOS ANGELES, CA. FILED 4-18-2012.

SN 85-600,464. VAN LANKVELT, ERIK, WESTMINSTER, CO. FILED 4-17-2012.

Guerrilla Brewing Company



THE MARK CONSISTS OF STANDARD CHARACTERS WITHOUT CLAIM TO ANY PARTICULAR FONT, STYLE, SIZE, OR COLOR.

NO CLAIM IS MADE TO THE EXCLUSIVE RIGHT TO USE "BREWING COMPANY", APART FROM THE MARK AS SHOWN.

FOR BREWERY SERVICES (U.S. CLS. 100, 103 AND 106).

REBECCA GILBERT, EXAMINING ATTORNEY

NO CLAIM IS MADE TO THE EXCLUSIVE RIGHT TO USE "AIRCRAFT", APART FROM THE MARK AS SHOWN.

THE MARK CONSISTS OF A FALCON'S HEAD OUTLINE IN THE BACKGROUND, ALL WITHIN A CIRCLE. ON THE FRONT THERE IS THE STYLIZED TEXT "SAKER AIRCRAFT".

FOR MANUFACTURING SERVICES FOR OTHERS IN THE FIELD OF AIRCRAFTS (U.S. CLS. 100, 103 AND 106).

JOHN DWYER, EXAMINING ATTORNEY

CLASS 40—(Continued).

SN 85-601,729. HERITAGE COFFEE CO. L.L.C., ST. LOUIS, MO. FILED 4-18-2012.

CHRONICLE

THE MARK CONSISTS OF STANDARD CHARACTERS WITHOUT CLAIM TO ANY PARTICULAR FONT, STYLE, SIZE, OR COLOR.

FOR COFFEE ROASTING AND PROCESSING (U.S. CLS. 100, 103 AND 106).
DANIEL S. STRINGER, EXAMINING ATTORNEY

SN 85-601,733. HERITAGE COFFEE CO. L.L.C., ST. LOUIS, MO. FILED 4-18-2012.

CONTROL THE NARRATIVE

THE MARK CONSISTS OF STANDARD CHARACTERS WITHOUT CLAIM TO ANY PARTICULAR FONT, STYLE, SIZE, OR COLOR.

FOR COFFEE ROASTING AND PROCESSING (U.S. CLS. 100, 103 AND 106).
DANIEL S. STRINGER, EXAMINING ATTORNEY

SN 85-601,941. PACIFIC COMMERCIAL SERVICES, LLC, DBA PACIFIC COMMERCIAL SERVICES, LLC, HONOLULU, HI. FILED 4-18-2012.



NO CLAIM IS MADE TO THE EXCLUSIVE RIGHT TO USE "PACIFIC COMMERCIAL SERVICES, LLC", APART FROM THE MARK AS SHOWN.

THE COLOR(S) BLUE, WHITE, AND BLACK IS/ARE CLAIMED AS A FEATURE OF THE MARK.

THE MARK CONSISTS OF A BLUE RECTANGULAR BOX WITH BOLD WHITE COLORED CAPITAL LETTERS "P", "C", AND "S" CENTERED IN THE BLUE RECTANGULAR BOX. BELOW THE BLUE RECTANGULAR BOX ARE THE WORDS "PACIFIC", "COMMERCIAL", AND "SERVICES" IN BOLD BLACK CAPITALS FOLLOWED BY A COMMA AND CAPITAL LETTERS "L", "L", AND "C" ALSO IN BLACK COLOR.

FOR ENVIRONMENTAL REMEDIATION SERVICES, NAMELY, TREATMENT OF SOIL, HAZARDOUS WASTE, NONHAZARDOUS WASTE, AND WATER (U.S. CLS. 100, 103 AND 106).

FIRST USE 2-1-2001; IN COMMERCE 2-1-2001.
JOHN E. MICHOS, EXAMINING ATTORNEY

CLASS 40—(Continued).

SN 85-602,825. BELTWAY BREWING COMPANY, LLC, STERLING, VA. FILED 4-19-2012.

BREWING UP POSSIBILITIES

THE MARK CONSISTS OF STANDARD CHARACTERS WITHOUT CLAIM TO ANY PARTICULAR FONT, STYLE, SIZE, OR COLOR.

NO CLAIM IS MADE TO THE EXCLUSIVE RIGHT TO USE "BREWING", APART FROM THE MARK AS SHOWN. FOR BREWERY SERVICES (U.S. CLS. 100, 103 AND 106).

NICHOLAS COLEMAN, EXAMINING ATTORNEY

SN 85-603,694. SLY, KELLY C., DBA DIGGIT, COLUMBIA, MO. FILED 4-20-2012.

DIGGIT

THE MARK CONSISTS OF STANDARD CHARACTERS WITHOUT CLAIM TO ANY PARTICULAR FONT, STYLE, SIZE, OR COLOR.

OWNER OF U.S. REG. NO. 3,122,803.
FOR DESIGN PRINTING FOR OTHERS; EMBROIDERY; EMBROIDERY SERVICES; SCREEN PRINTING (U.S. CLS. 100, 103 AND 106).

FIRST USE 7-0-1998; IN COMMERCE 7-0-1998.
SUNG IN, EXAMINING ATTORNEY

SN 85-604,368. SANDBAGS LLC, LAS VEGAS, NV. FILED 4-20-2012.



THE COLOR(S) ORANGE, GRAY AND BLACK IS/ARE CLAIMED AS A FEATURE OF THE MARK.

THE MARK CONSISTS OF THE STYLIZED LETTER "S" IN GRAY AND OUTLINED IN BLACK AND ORANGE, WITH A BLACK SQUARE BACKGROUND.

FOR CUSTOM FABRICATION AND PRODUCTION OF SANDBAGS; CUSTOM MANUFACTURE OF SANDBAGS; MANUFACTURE OF SANDBAGS TO ORDER AND/OR SPECIFICATION FOR OTHERS; MANUFACTURING SERVICES FOR OTHERS IN THE FIELD OF SANDBAGS (U.S. CLS. 100, 103 AND 106).

FIRST USE 4-18-2012; IN COMMERCE 4-18-2012.
FONG HSU, EXAMINING ATTORNEY

CLASS 40—(Continued).

SN 85-606,887. CUSTOM LASER ENGRAVERS, LLC, DALLAS, TX. FILED 4-24-2012.

FROM ELEGANT TO EXTREME
AND EVERYTHING IN-BETWEEN!

THE MARK CONSISTS OF STANDARD CHARACTERS WITHOUT CLAIM TO ANY PARTICULAR FONT, STYLE, SIZE, OR COLOR.

FOR ENGRAVING (U.S. CLS. 100, 103 AND 106).
FIRST USE 5-31-2011; IN COMMERCE 5-31-2011.
ARETHA SOMERVILLE, EXAMINING ATTORNEY

SN 85-629,128. WRIGHT, BRUCE DAVID, SARASOTA, FL.
FILED 5-18-2012.

BIO home

THE MARK CONSISTS OF STANDARD CHARACTERS WITHOUT CLAIM TO ANY PARTICULAR FONT, STYLE, SIZE, OR COLOR.

NO CLAIM IS MADE TO THE EXCLUSIVE RIGHT TO USE "HOME", APART FROM THE MARK AS SHOWN.

FOR ENVIRONMENTAL REMEDIATION SERVICES, NAMELY, TREATMENT OF ELECTROMAGNETIC FIELDS AND MOLD (U.S. CLS. 100, 103 AND 106).

DEZMONA MIZELLE, EXAMINING ATTORNEY

CLASS 41—EDUCATION AND ENTERTAINMENT

SN 76-564,762. LIBERMAN TELEVISION OF HOUSTON LLC, BURBANK, CA. FILED 12-11-2003.

LA RAZA TV

SUBJECT TO CONCURRENT USE PROCEEDING WITH THE SPANISH BROADCASTING SYSTEM, INC., (OWNER OF APPLICATION NOS. 76214043 AND 76213224), AND LA RAZA CHICAGO, INC., (OWNER OF APPLICATIONS NOS. 76372222, 76385716, 76396687, 76344398, 76344399 AND 78370758.) APPLICANT CLAIMS THE EXCLUSIVE RIGHT TO USE THE MARK IN THE AREA COMPRISING TEXAS, NEW MEXICO, ARKANSAS, AND OKLAHOMA.

NO CLAIM IS MADE TO THE EXCLUSIVE RIGHT TO USE "TV", APART FROM THE MARK AS SHOWN.

THE ENGLISH TRANSLATION OF THE WORD "LA RAZA TV" IN THE MARK IS "THE PEOPLE'S TV".

FOR ENTERTAINMENT, NAMELY, A CONTINUING SPANISH LANGUAGE TELEVISION SHOW FEATURING MUSIC VIDEOS, MUSICAL PERFORMANCES AND VARIETY ACTS (U.S. CLS. 100, 101 AND 107).

FIRST USE 8-6-2001; IN COMMERCE 8-6-2001.

CAITLIN WATTS-FITZGERALD, EXAMINING ATTORNEY

SN 76-711,164. ROB THE CARTEL, VALLEY VILLAGE, CA.
FILED 4-10-2012.

ROB THE CARTEL

THE MARK CONSISTS OF STANDARD CHARACTERS WITHOUT CLAIM TO ANY PARTICULAR FONT, STYLE, SIZE, OR COLOR.

FOR ENTERTAINMENT, NAMELY, LIVE PERFORMANCES BY A MUSICAL BAND, AND VISUAL AND AUDIO PERFORMANCES BY A MUSICAL BAND (U.S. CLS. 100, 101 AND 107).

VERNA BETH RIRIE, EXAMINING ATTORNEY

SN 76-711,173. PROGRESSIVE DEFENSE SYSTEMS, LLC, SHARON, MA. FILED 4-10-2012.

SURVIVING THE CALL

THE MARK CONSISTS OF STANDARD CHARACTERS WITHOUT CLAIM TO ANY PARTICULAR FONT, STYLE, SIZE, OR COLOR.

FOR PROVIDING A SERIES OF CLASSES FOR FIRST RESPONDERS IN THE FIELD OF NON-VIOLENT SELF-DEFENSE DESIGNED SPECIFICALLY TO AVOID CLAIMS OF POLICE BRUTALITY AND EXCESSIVE FORCE (U.S. CLS. 100, 101 AND 107).

FIRST USE 3-10-2012; IN COMMERCE 3-10-2012.

LINDA POWELL, EXAMINING ATTORNEY

CLASS 41—(Continued).

SN 77-947,575. NOBEL LEARNING COMMUNITIES, INC., WEST CHESTER, PA. FILED 3-1-2010.

THE RHOADES SCHOOL

THE MARK CONSISTS OF STANDARD CHARACTERS WITHOUT CLAIM TO ANY PARTICULAR FONT, STYLE, SIZE, OR COLOR.

NO CLAIM IS MADE TO THE EXCLUSIVE RIGHT TO USE "SCHOOL", APART FROM THE MARK AS SHOWN. SEC. 2(F).

FOR EDUCATIONAL SERVICES, NAMELY, PROVIDING COURSES OF INSTRUCTION AT THE KINDERGARTEN THROUGH EIGHTH GRADE LEVEL (U.S. CLS. 100, 101 AND 107).

FIRST USE 4-30-1980; IN COMMERCE 4-30-1980.
AMY ALFIERI, EXAMINING ATTORNEY

SN 77-961,527. CHRISTINE HILDEBRAND, MILL VALLEY, CA. FILED 3-17-2010.

Life Foundations

THE MARK CONSISTS OF STANDARD CHARACTERS WITHOUT CLAIM TO ANY PARTICULAR FONT, STYLE, SIZE, OR COLOR.

NO CLAIM IS MADE TO THE EXCLUSIVE RIGHT TO USE "LIFE", APART FROM THE MARK AS SHOWN.

FOR PROVIDING GROUP COACHING AND LEARNING FORUMS IN THE FIELD OF LEADERSHIP DEVELOPMENT; EDUCATIONAL SERVICES, NAMELY, CONDUCTING EDUCATIONAL PROGRAMS, WORKSHOPS AND WEB-BASED SEMINARS AND MULTIMEDIA DEMONSTRATIONS FOCUSED ON HELPING PEOPLE AND BUSINESSES LIVE THEIR FULL POTENTIAL IN THE FIELD OF BUSINESS DEVELOPMENT; LIFE COACHING SERVICES IN THE FIELD OF BUSINESS DEVELOPMENT AND PERSONAL DEVELOPMENT; BUSINESS TRAINING IN THE FIELD OF BUSINESS DEVELOPMENT; EDUCATIONAL AND ENTERTAINMENT SERVICES, NAMELY, PROVIDING MOTIVATIONAL SPEAKING SERVICES IN THE FIELD OF BUSINESS DEVELOPMENT AND PERSONAL DEVELOPMENT; PROVIDING EDUCATIONAL MENTORING SERVICES AND PROGRAMS IN THE FIELD OF BUSINESS DEVELOPMENT AND PERSONAL DEVELOPMENT (U.S. CLS. 100, 101 AND 107).

FIRST USE 1-1-2008; IN COMMERCE 1-1-2008.
INGA ERVIN, EXAMINING ATTORNEY

CLASS 41—(Continued).

SN 79-108,263. SCUBASTAR SDN BHD, 88100 KOTA KINABALU, SABAH, MALAYSIA, FILED 4-18-2010.

MISS SCUBA

THE MARK CONSISTS OF STANDARD CHARACTERS WITHOUT CLAIM TO ANY PARTICULAR FONT, STYLE, SIZE, OR COLOR.

OWNER OF INTERNATIONAL REGISTRATION 0962549 DATED 4-1-2008, EXPIRES 4-1-2018.

NO CLAIM IS MADE TO THE EXCLUSIVE RIGHT TO USE "SCUBA", APART FROM THE MARK AS SHOWN.

FOR PRESENTATION AND ORGANIZATION OF BEAUTY PAGEANTS, BEAUTY CONTESTS AND BEAUTY COMPETITIONS; PRESENTATION AND ORGANIZATION OF LIVE AWARDS SHOWS, LIVE MUSICAL PERFORMANCES AND LIVE VARIETY PROGRAMS; EDUCATION SERVICES, NAMELY, PROVIDING SEMINARS AND WORKSHOPS RELATING TO CONSERVATION OF THE ENVIRONMENT (U.S. CLS. 100, 101 AND 107).

CURTIS FRENCH, EXAMINING ATTORNEY

SN 85-118,048. COOLSCI PRODUCTIONS, RALEIGH, NC. FILED 8-28-2010.

**Special Giftings: Personal &
Professional Development
from the Inside Out**

THE MARK CONSISTS OF STANDARD CHARACTERS WITHOUT CLAIM TO ANY PARTICULAR FONT, STYLE, SIZE, OR COLOR.

FOR BUSINESS EDUCATION AND TRAINING SERVICES, NAMELY, DEVELOPING, AND FACILITATING CUSTOMIZED IN-COMPANY LEADERSHIP AND EXECUTIVE DEVELOPMENT PROGRAMS, PROVIDING EXECUTIVE COACHING SERVICES, AND PROVIDING PUBLIC AND IN-COMPANY KEYNOTE PRESENTATIONS TO BUSINESS LEADERS; LIFE COACHING SERVICES IN THE FIELD OF PROFESSIONAL, PERSONAL AND SPIRITUAL DEVELOPMENT (U.S. CLS. 100, 101 AND 107).

TRACY FLETCHER, EXAMINING ATTORNEY

CLASS 41—(Continued).

SN 85-130,028. HARDEVELD, TEHUTA A, MIRAMAR, FL. FILED 9-15-2010.



THE MARK CONSISTS OF "TEHUTA".
 FOR CONSULTATION AND ADVICE REGARDING MUSICAL SELECTIONS AND ARRANGEMENTS FOR SOUND RECORDINGS AND LIVE PERFORMANCES; ENTERTAINMENT AND EDUCATION SERVICES IN THE NATURE OF LIVE DANCE AND MUSICAL PERFORMANCES; ENTERTAINMENT IN THE NATURE OF DANCE PERFORMANCES; ENTERTAINMENT IN THE NATURE OF LIVE PERFORMANCES BY TEHUTA; ENTERTAINMENT IN THE NATURE OF LIVE RADIO PERSONALITY PERFORMANCES; ENTERTAINMENT IN THE NATURE OF ORCHESTRA PERFORMANCES; ENTERTAINMENT IN THE NATURE OF SYMPHONY ORCHESTRA PERFORMANCES; ENTERTAINMENT IN THE NATURE OF VISUAL AND AUDIO PERFORMANCES BY TEHUTA; ENTERTAINMENT IN THE NATURE OF VISUAL AND AUDIO PERFORMANCES, AND MUSICAL, VARIETY, NEWS AND COMEDY SHOWS; ENTERTAINMENT IN THE NATURE OF VISUAL AND AUDIO PERFORMANCES, NAMELY, MUSICAL BAND, ROCK GROUP, GYMNASTIC, DANCE, AND BALLET PERFORMANCES; ENTERTAINMENT IN THE NATURE OF VISUAL AND AUDIO PERFORMANCES BY AN ACTOR; ENTERTAINMENT IN THE NATURE OF LIVE COMEDY SHOWS BY TEHUTA; ENTERTAINMENT SERVICES IN THE NATURE OF LIVE MUSICAL PERFORMANCES; ENTERTAINMENT SERVICES IN THE NATURE OF PRESENTING LIVE MUSICAL PERFORMANCES; ENTERTAINMENT SERVICES, NAMELY, PERFORMING AND COMPETING IN MOTOR SPORTS EVENTS; ENTERTAINMENT SERVICES, NAMELY, PROVIDING A WEB SITE FEATURING NON-DOWNLOADABLE MUSICAL PERFORMANCES, MUSICAL VIDEOS, RELATED FILM CLIPS, PHOTOGRAPHS, AND OTHER MULTIMEDIA MATERIALS FEATURING PERFORMANCES BY TEHUTA; ENTERTAINMENT SERVICES, NAMELY, WRESTLING EXHIBITS AND PERFORMANCES BY A PROFESSIONAL WRESTLER AND ENTERTAINER; ENTERTAINMENT, NAMELY, LIVE PERFORMANCES BY A MUSICAL BAND; ENTERTAINMENT, NAMELY, LIVE PERFORMANCES BY MUSICAL BANDS; LIVE PERFORMANCES FEATURING PRERECORDED VOCAL AND INSTRUMENTAL PERFORMANCES VIEWED ON A BIG SCREEN; PERFORMANCE HALL RENTAL SERVICES; PLANNING ARRANGEMENT OF SHOWING MOVIES, SHOWS, PLAYS OR MUSICAL PERFORMANCES; PRESENTATION OF LIVE SHOW PERFORMANCES; PRESENTATION OF MUSICAL PERFORMANCE; PROVIDING AN INTERNET WEBSITE PORTAL FEATURING LINKS TO MUSICAL ARTIST WEBSITES AND MUSIC PERFORMANCE TICKET INFORMATION; PROVISION OF INFORMATION RELATING TO LIVE PERFORMANCES, ROAD SHOWS, LIVE STAGE EVENTS, THEATRICAL PERFORMANCES, LIVE MUSIC CONCERTS AND AUDIENCE PARTICIPATION IN SUCH EVENTS; RADIO ENTERTAINMENT SERVICES, NAMELY, RADIO PROGRAMS FEATURING PERFORMANCES BY A TEHUTA; RENTAL OF TEXTILE TAPESTRIES AND ORNAMENTAL WALL HANGINGS FOR USE AS STAGE AND SCREEN CURTAINS IN THEATERS AND PERFORMANCE HALLS; THEATRICAL AND MUSICAL FLOOR SHOWS PROVIDED AT PERFORMANCE VENUES (U.S. CLS. 100, 101 AND 107).
 FIRST USE 8-27-1983; IN COMMERCE 8-27-1983.
 ARETHA SOMERVILLE, EXAMINING ATTORNEY

CLASS 41—(Continued).

SN 85-152,641. PERCY 3D MEDIA INC., TORONTO, ON, CANADA, FILED 10-14-2010.



PRIORITY CLAIMED UNDER SEC. 44(D) ON CANADA APPLICATION NO. 1497974, FILED 9-30-2010, REG. NO. TMA812040, DATED 11-18-2011, EXPIRES 11-18-2026.
 NO CLAIM IS MADE TO THE EXCLUSIVE RIGHT TO USE "3D", APART FROM THE MARK AS SHOWN.
 THE MARK CONSISTS OF "PERCY 3D" IN STYLIZED LETTERS.
 FOR CREATIVE WEB SERVICES, NAMELY, PRODUCING PERSONALIZED VIDEOS FOR ENTERTAINMENT INITIATIVES (U.S. CLS. 100, 101 AND 107).
 KIM SAITO, EXAMINING ATTORNEY

SN 85-165,844. PERCY 3D MEDIA INC., TORONTO, ON, CANADA, FILED 11-1-2010.



PRIORITY CLAIMED UNDER SEC. 44(D) ON CANADA APPLICATION NO. 1499700, FILED 10-14-2010, REG. NO. TMA812043, DATED 11-18-2011, EXPIRES 11-18-2026.
 NO CLAIM IS MADE TO THE EXCLUSIVE RIGHT TO USE "3D", APART FROM THE MARK AS SHOWN.
 THE MARK CONSISTS OF THE STYLIZED WORDING "PERCY 3D PUT YOURSELF IN THE PICTURE".
 FOR CREATIVE WEB SERVICES, NAMELY, PRODUCING PERSONALIZED VIDEOS FOR ENTERTAINMENT INITIATIVES (U.S. CLS. 100, 101 AND 107).
 KIM SAITO, EXAMINING ATTORNEY

SN 85-258,089. STEVE LEONI, BURLINGTON, ONTARIO, CANADA, FILED 3-4-2011.

FAT ATHLETE

THE MARK CONSISTS OF STANDARD CHARACTERS WITHOUT CLAIM TO ANY PARTICULAR FONT, STYLE, SIZE, OR COLOR.
 PRIORITY CLAIMED UNDER SEC. 44(D) ON CANADA APPLICATION NO. 1494900, FILED 9-7-2010, REG. NO. 828696, DATED 7-27-2012, EXPIRES 7-27-2027.
 FOR PROVIDING NEWS AND INFORMATION IN THE FIELD OF SPORTS, NAMELY, SPORTS SCORES, SPORTS TEAMS, AND SPORTS CELEBRITIES, VIA AN INTERNET WEBSITE (U.S. CLS. 100, 101 AND 107).
 REBECCA EISINGER, EXAMINING ATTORNEY

CLASS 41—(Continued).

SN 85-275,383. ADVENT IP, P.C., L.L.O., OMAHA, NE. FILED 3-24-2011.

ADVENTION

THE MARK CONSISTS OF STANDARD CHARACTERS WITHOUT CLAIM TO ANY PARTICULAR FONT, STYLE, SIZE, OR COLOR.

FOR ENTERTAINMENT AND EDUCATIONAL SERVICES, NAMELY, PROVIDING RECOGNITION AND INCENTIVES BY THE WAY OF AWARDS TO DEMONSTRATE EXCELLENCE IN THE FIELD OF TECHNOLOGY INNOVATION; ENTERTAINMENT AND EDUCATIONAL SERVICES, NAMELY, PROVIDING RECOGNITION AND INCENTIVES BY THE WAY OF AWARDS TO PROMOTE SCIENTIFIC INNOVATION; ENTERTAINMENT AND EDUCATIONAL SERVICES, NAMELY, PROVIDING EDUCATIONAL CONFERENCES IN THE FIELD OF SCIENTIFIC INNOVATION (U.S. CLS. 100, 101 AND 107).

GRETCHEN ULRICH, EXAMINING ATTORNEY

CLASS 41—(Continued).

SN 85-279,521. AMERICAN CONSERVATIVE UNION, ALEXANDRIA, VA. FILED 3-29-2011.

ACUF

THE MARK CONSISTS OF STANDARD CHARACTERS WITHOUT CLAIM TO ANY PARTICULAR FONT, STYLE, SIZE, OR COLOR.

FOR EDUCATIONAL SERVICES, NAMELY, PROVIDING ON-LINE INSTRUCTION IN THE FIELDS OF POLITICS, POLITICAL THOUGHT, PHILOSOPHY, POLITICAL AND SOCIAL THEORY AND POLICY, WESTERN CIVILIZATIONS AND AMERICAN VALUES; ON-LINE LIBRARY SERVICES, NAMELY, PROVIDING ELECTRONIC LIBRARY SERVICES FEATURING BOOKS, ARTICLES, ESSAYS AND COMMENTARIES IN THE FIELDS OF POLITICS, POLITICAL THOUGHT, PHILOSOPHY, POLITICAL AND SOCIAL THEORY AND POLICY, WESTERN CIVILIZATIONS AND AMERICAN VALUES VIA AN ON-LINE COMPUTER NETWORK (U.S. CLS. 100, 101 AND 107).

FIRST USE 6-1-1983; IN COMMERCE 6-1-1983.
TRACY CROSS, EXAMINING ATTORNEY

SN 85-278,041. FIGHT LIKE A GIRL, INC., EAGLE, CO. FILED 3-27-2011.



OWNER OF U.S. REG. NO. 3,023,953.
THE NAME(S), PORTRAIT(S), AND/OR SIGNATURE(S) SHOWN IN THE MARK IDENTIFIES KIMBERLY ROCK, WHOSE CONSENT(S) TO REGISTER IS MADE OF RECORD.

THE MARK CONSISTS OF A LADIES SPIKED HIGH HEEL SHOE HITTING THE GROUND WITH HARD IMPACT CAUSING AN EXPLOSION, TO THE LEFT OF WHICH ARE THE WORDS "KYM ROCK'S FIGHT LIKE A GIRL".

FOR CONDUCTING WORKSHOPS AND SEMINARS IN THE FIELD OF MARITAL ARTS, SELF DEFENSE AND SELF DEFENSE TRAINING; INSTRUCTION IN THE FIELD OF MARTIAL ARTS AND SELF DEFENSE; MARTIAL ARTS INSTRUCTION; ON-LINE JOURNALS, NAMELY, BLOGS FEATURING DISCUSSION AND INFORMATION IN THE FIELD OF MARTIAL ARTS AND SELF DEFENSE; PROVIDING ON-LINE NEWSLETTERS IN THE FIELD OF MARTIAL ARTS AND SELF DEFENSE; WORKSHOPS AND SEMINARS IN THE FIELD OF MARTIAL ARTS AND SELF DEFENSE (U.S. CLS. 100, 101 AND 107).

FIRST USE 4-1-2004; IN COMMERCE 4-1-2004.
NICHOLAS COLEMAN, EXAMINING ATTORNEY

SN 85-280,935. AMERICAN ASSOCIATION FOR THE ADVANCEMENT OF SCIENCE, WASHINGTON, DC, DC. FILED 3-30-2011.

**AAAS SCIENCE & TECHNOLOGY
POLICY FELLOWSHIPS**

THE MARK CONSISTS OF STANDARD CHARACTERS WITHOUT CLAIM TO ANY PARTICULAR FONT, STYLE, SIZE, OR COLOR.

OWNER OF U.S. REG. NOS. 2,337,007 AND 2,426,988.
NO CLAIM IS MADE TO THE EXCLUSIVE RIGHT TO USE "SCIENCE & TECHNOLOGY POLICY FELLOWSHIPS", APART FROM THE MARK AS SHOWN.

FOR ARRANGING, ORGANIZING AND CONDUCTING FELLOWSHIP PROGRAMS FOR THE PLACEMENT OF FELLOWS IN POSITIONS WITH MEMBERS OF CONGRESS OR IN CONGRESSIONAL COMMITTEES IN THE AREAS OF SCIENCE, TECHNOLOGY AND PUBLIC POLICY; CONDUCTING SEMINARS, CONFERENCES AND TRAINING PROGRAMS IN THE FIELDS OF SCIENCE, TECHNOLOGY, AND PUBLIC POLICY (U.S. CLS. 100, 101 AND 107).

FIRST USE 1-1-1974; IN COMMERCE 1-1-1974.
JENNIFER MARTIN, EXAMINING ATTORNEY

CLASS 41—(Continued).

SN 85-281,153. CYNTHIA SUTTER, MINNEAPOLIS, MN. FILED 3-30-2011.

THE SPIRITED TABLE

THE MARK CONSISTS OF STANDARD CHARACTERS WITHOUT CLAIM TO ANY PARTICULAR FONT, STYLE, SIZE, OR COLOR.

FOR ENTERTAINMENT IN THE NATURE OF ONGOING TELEVISION AND INTERNET PROGRAMS IN THE FIELDS OF SPIRITUALITY, FOOD, NEWS, AND VARIETY (U.S. CLS. 100, 101 AND 107).

SHAUNIA CARLYLE, EXAMINING ATTORNEY

SN 85-292,748. AUDIO X-PRESS LLC, LOUISVILLE, KY. FILED 4-12-2011.



THE MARK CONSISTS OF CAPITALIZED LETTER "M" OVER CAPITALIZED LETTER "W".

FOR WEDDING PLANNING AND COORDINATION SERVICES (U.S. CLS. 100, 101 AND 107).

FIRST USE 1-6-2011; IN COMMERCE 1-6-2011.

MARGARET POWER, EXAMINING ATTORNEY

SN 85-306,489. CINEMAS DE LA REPÚBLICA. S.A. DE C.V., MORELIA, MICHOACÁN, MEXICO, FILED 4-27-2011.



PRIORITY CLAIMED UNDER SEC. 44(D) ON MEXICO APPLICATION NO. 1174003, FILED 4-20-2011, REG. NO. 1238350, DATED 9-19-2011, EXPIRES 4-20-2021.

THE MARK CONSISTS OF PIECES OF FILM THAT FORM BOTH A STAR IN THE MIDDLE AND ALSO A LARGER STAR SHAPE AS THE PERIMETER TO THE LEFT OF THE WORD "CINÉPOLIS".

FOR MOVIE THEATERS (U.S. CLS. 100, 101 AND 107).

SHAUNIA CARLYLE, EXAMINING ATTORNEY

CLASS 41—(Continued).

SN 85-308,944. TWENTIETH CENTURY FOX FILM CORPORATION, LOS ANGELES, CA. FILED 4-29-2011.

AMERICAN HORROR STORY

THE MARK CONSISTS OF STANDARD CHARACTERS WITHOUT CLAIM TO ANY PARTICULAR FONT, STYLE, SIZE, OR COLOR.

SEC. 2(F).

FOR ENTERTAINMENT SERVICES IN THE NATURE OF A TELEVISION SERIES FEATURING DRAMA; PROVIDING ON-LINE INFORMATION IN THE FIELD OF TELEVISION AND VIDEO ENTERTAINMENT FEATURING DRAMA VIA THE INTERNET; ENTERTAINMENT SERVICES IN THE NATURE OF NON-DOWNLOADABLE VIDEOS AND IMAGES FEATURING TELEVISION SHOWS AND ENTERTAINMENT TRANSMITTED VIA THE INTERNET AND WIRELESS COMMUNICATION NETWORKS; ON-LINE JOURNALS, NAMELY, BLOGS FEATURING PERSONAL OPINIONS IN THE FIELD OF GENERAL INTEREST AND DRAMA (U.S. CLS. 100, 101 AND 107).

FIRST USE 10-5-2011; IN COMMERCE 10-5-2011.

JULIE WATSON, EXAMINING ATTORNEY

SN 85-310,693. MADIGAN, WILLIAM V., ATLANTA, GA. FILED 5-3-2011.

EDUGAMESTAR

THE MARK CONSISTS OF STANDARD CHARACTERS WITHOUT CLAIM TO ANY PARTICULAR FONT, STYLE, SIZE, OR COLOR.

FOR EDUCATION SERVICES, NAMELY, PROVIDING ONLINE COGNITIVE ASSESSMENTS AND TRAINING PROGRAMS THAT HELP IDENTIFY COGNITIVE STRENGTHS AND WEAKNESSES OF AN INDIVIDUAL (U.S. CLS. 100, 101 AND 107).

FIRST USE 4-1-2011; IN COMMERCE 4-1-2011.

DARRYL SPRULL, EXAMINING ATTORNEY

CLASS 41—(Continued).

SN 85-313,597. THE JOURNAL OF BONE AND JOINT SURGERY, INC., NEEDHAM, MA. FILED 5-5-2011.

**J B & J S ESSENTIAL
SURGICAL TECHNIQUES**

THE MARK CONSISTS OF STANDARD CHARACTERS WITHOUT CLAIM TO ANY PARTICULAR FONT, STYLE, SIZE, OR COLOR.

OWNER OF U.S. REG. NOS. 2,619,833 AND 2,725,441.

NO CLAIM IS MADE TO THE EXCLUSIVE RIGHT TO USE "ESSENTIAL SURGICAL TECHNIQUES", APART FROM THE MARK AS SHOWN.

FOR PROVIDING ON-LINE REPORTS, ARTICLES, AND PUBLICATIONS, NAMELY, JOURNALS, BOOKLETS, MANUALS AND GUIDES, IN THE FIELD OF MEDICAL AND SURGICAL TECHNIQUES (U.S. CLS. 100, 101 AND 107).

MARK RADEMACHER, EXAMINING ATTORNEY

CLASS 41—(Continued).

SN 85-326,823. MELETIO, DONNA M, DBA WRITING REMARKS, THE GRADING ASSISTANT LLC, DALLAS, TX. FILED 5-21-2011.

**WRITING |
REMARKS**

THE COLOR(S) BLUE AND WHITE IS/ARE CLAIMED AS A FEATURE OF THE MARK.

THE MARK CONSISTS OF THE WORDING "WRITING REMARKS" IN THE COLOR BLUE AGAINST A WHITE BACKGROUND. THE WORDS ARE SEPARATED BY A VERTICAL BLUE SLASH AND THE WORDS ARE NOT ON THE SAME LINE.

SEC. 2(F).

FOR EDUCATIONAL SERVICES, NAMELY, PROVIDING ONLINE INSTRUCTION IN THE FIELD OF ENGLISH COMPOSITION VIA AN ONLINE WEBSITE (U.S. CLS. 100, 101 AND 107).

FIRST USE 2-6-2006; IN COMMERCE 3-1-2008.

LINDA ESTRADA, EXAMINING ATTORNEY

SN 85-353,422. DAVID MCLANE ENTERPRISES, INC., INDIANAPOLIS, IN. FILED 6-22-2011.

SN 85-322,175. FALGAS, SHANE, COCOA, FL. FILED 5-16-2011.

SUGA SHANE

THE MARK CONSISTS OF STANDARD CHARACTERS WITHOUT CLAIM TO ANY PARTICULAR FONT, STYLE, SIZE, OR COLOR.

THE NAME "SUGA SHANE" IDENTIFIES THE STAGE NAME OF "SHANE FALGAS", A LIVING INDIVIDUAL WHOSE CONSENT IS OF RECORD.

FOR ENTERTAINMENT, NAMELY, LIVE MUSIC CONCERTS; MULTIMEDIA ENTERTAINMENT SERVICES IN THE NATURE OF RECORDING, PRODUCTION AND POST-PRODUCTION SERVICES IN THE FIELDS OF MUSIC, VIDEO, AND FILMS (U.S. CLS. 100, 101 AND 107).

FIRST USE 1-1-2005; IN COMMERCE 1-1-2010.

DOMINIC J. FERRAIUOLO, EXAMINING ATTORNEY

WOW!

THE MARK CONSISTS OF STANDARD CHARACTERS WITHOUT CLAIM TO ANY PARTICULAR FONT, STYLE, SIZE, OR COLOR.

OWNER OF U.S. REG. NO. 2,327,174.

FOR ENTERTAINMENT IN THE NATURE OF LIVE PROFESSIONAL WRESTLING MATCHES AND EXHIBITIONS, SPORTS AND ATHLETIC COMPETITIONS, AND AWARDS PROGRAMS ALL IN THE FIELD OF WRESTLING; ONGOING TELEVISION PROGRAMS IN THE FIELD OF SPORTS AND ATHLETIC TRAINING AND COMPETITIONS, AWARDS PROGRAMS, PROFESSIONAL WRESTLING ALL IN THE FIELD OF WRESTLING; ORGANIZING AND CONDUCTING PROFESSIONAL WRESTLING MATCHES AND EXHIBITIONS; PRODUCTION AND SYNDICATION OF TELEVISION PROGRAMS FEATURING SPORTS AND ATHLETIC COMPETITIONS, AWARDS PROGRAMS, PROFESSIONAL WRESTLING MATCHES, EXHIBITIONS AND PERFORMANCES, ALL IN THE FIELD OF WRESTLING (U.S. CLS. 100, 101 AND 107).

KATHRYN COWARD, EXAMINING ATTORNEY

CLASS 41—(Continued).

SN 85-358,141. UNIVERSITY OF CONNECTICUT, STORRS, CT. FILED 6-28-2011.

UCTV

THE MARK CONSISTS OF STANDARD CHARACTERS WITHOUT CLAIM TO ANY PARTICULAR FONT, STYLE, SIZE, OR COLOR.

FOR ENTERTAINMENT SERVICES, NAMELY, THE PROVISION OF CONTINUING PROGRAMS AND SEGMENTS FEATURING NEWS, COMEDY, COMMENTARY, TALENT SEARCH, AND VARIETY SHOWS, AND REALITY BASED SHOWS DELIVERED BY TELEVISION AND THE INTERNET; PRODUCTION OF TELEVISION PROGRAMS (U.S. CLS. 100, 101 AND 107).

FIRST USE 9-1-1991; IN COMMERCE 9-1-1991.
SHANNON TWOHIG, EXAMINING ATTORNEY

SN 85-377,710. ENCORPS, INC., DBA ENCORPS TEACHERS PROGRAM, SAN FRANCISCO, CA. FILED 7-21-2011.



STEMposium

THE COLOR(S) GRAY, LIGHT BLUE, LIGHT GREEN, YELLOW AND ORANGE IS/ARE CLAIMED AS A FEATURE OF THE MARK.

THE MARK CONSISTS OF "STEMPOSIUM" DISPLAYED IN GRAY, WITH 4 SQUARES ABOVE THE TYPE. THE FIRST SQUARE IS LIGHT BLUE BOX WITH AN IMAGE OF A BEAKER; THE SECOND SQUARE IS LIGHT GREEN WITH AN IMAGE OF PIXELS; THE THIRD SQUARE IS YELLOW WITH AN IMAGE OF A COMPASS; AND THE FOURTH SQUARE IS ORANGE WITH AN IMAGE OF AN X. THE COLOR WHITE REPRESENTS BACKGROUND COLOR AND IS NOT PART OF THE MARK.

FOR EDUCATION IN THE FIELD OF SCIENCE, TECHNOLOGY, ENGINEERING AND MATH EDUCATION RENDERED THROUGH VIDEO CONFERENCE; EDUCATIONAL SERVICES, NAMELY, CONDUCTING SYMPOSIA IN THE FIELD OF SCIENCE, TECHNOLOGY, ENGINEERING AND MATH EDUCATION AND DISTRIBUTION OF PRINTED MATERIALS IN CONNECTION THEREWITH IN HARD COPY OR ELECTRONIC FORMAT ON THE SAME TOPICS; EDUCATIONAL SERVICES, NAMELY, CONDUCTING SYMPOSIA IN THE FIELD OF SCIENCE, TECHNOLOGY, ENGINEERING AND MATH EDUCATION; EDUCATIONAL SERVICES, NAMELY, DEVELOPING, ARRANGING, AND CONDUCTING EDUCATIONAL CONFERENCES AND PROGRAMS AND PROVIDING COURSES OF INSTRUCTION IN THE FIELD OF SCIENCE, TECHNOLOGY, ENGINEERING AND MATH EDUCATION; ORGANIZING LIVE EXHIBITIONS AND CONFERENCES IN THE FIELDS OF EDUCATION, CULTURE, SPORTS AND ENTERTAINMENT FOR NON-BUSINESS AND NON-COMMERCIAL PURPOSES; ORGANIZING ON-LINE EXHIBITIONS AND CONFERENCES IN THE FIELDS OF EDUCATION, CULTURE, SPORTS AND ENTERTAINMENT FOR NON-BUSINESS AND NON-COMMERCIAL PURPOSES (U.S. CLS. 100, 101 AND 107).

FIRST USE 10-15-2010; IN COMMERCE 10-15-2010.
MICHELE SWAIN, EXAMINING ATTORNEY

CLASS 41—(Continued).

SN 85-379,357. KINDER FIT, L.L.C., DALLAS, TX. FILED 7-24-2011.



NO CLAIM IS MADE TO THE EXCLUSIVE RIGHT TO USE "FIT", APART FROM THE MARK AS SHOWN.

THE COLOR(S) RED, YELLOW, BLUE, GREEN, WHITE, TAN AND BLACK IS/ARE CLAIMED AS A FEATURE OF THE MARK.

THE MARK CONSISTS OF THE WORD "KINDER" IN RED OUTLINED IN BLACK IN FRONT OF A YELLOW SHADING ALL ABOVE A FANCIFUL CARTOON BOY STANDING AND FLEXING HIS MUSCLES. THE BOY IS IN TAN COLOR WITH YELLOW HAIR WEARING A GREEN AND YELLOW HORIZONTALLY STRIPED SHIRT WITH A RED LETTER "F" ON HIS CHEST, THE BOY IS WEARING BLUE SHORTS, WHITE SOCKS AND RED AND WHITE TENNIS SHOES AND THE WORD "FIT" IN RED IN FRONT OF YELLOW SHADING IS BELOW THE BOY, WITH BLACK OUTLINES AND BLACK SHADING OF THESE DESIGN FEATURES AND LITERAL ELEMENTS.

THE ENGLISH TRANSLATION OF THE WORD "KINDER" IN THE MARK IS "CHILDREN".

FOR PROVIDING A DEVELOPMENTAL CLASS TO HELP CHILDREN WITH THEIR MOTOR SKILLS, COGNITIVE SKILLS, SOCIAL SKILLS AND WITH PHYSICAL BODY DEVELOPMENT (U.S. CLS. 100, 101 AND 107).

FIRST USE 0-0-1992; IN COMMERCE 0-0-1994.
DOMINIC J. FERRAIUOLO, EXAMINING ATTORNEY

SN 85-381,346. HURLEY, SAMARA B., HOUSTON, TX. FILED 7-26-2011.

Kidiquette

THE MARK CONSISTS OF STANDARD CHARACTERS WITHOUT CLAIM TO ANY PARTICULAR FONT, STYLE, SIZE, OR COLOR.

FOR EDUCATIONAL SERVICES, NAMELY, CONDUCTING CLASSES, SEMINARS, CONFERENCES, WORKSHOPS, RETREATS, CAMPS AND FIELD TRIPS IN THE FIELD OF CHARACTER EDUCATION AND SOCIAL SKILLS AND DISTRIBUTION OF TRAINING MATERIAL IN CONNECTION THEREWITH (U.S. CLS. 100, 101 AND 107).

FIRST USE 11-1-2009; IN COMMERCE 11-1-2009.
WON TEAK OH, EXAMINING ATTORNEY

CLASS 41—(Continued).

SN 85-386,365. AMERICAN PUBLIC UNIVERSITY SYSTEM, INC., CHARLES TOWN, WV. FILED 8-1-2011.



THE MARK CONSISTS OF A STYLIZED DESIGN OF AN EAGLE HEAD BETWEEN THE WORDS "GOLDEN EAGLES". THE INITIALS "AMU" APPEAR ABOVE THE WORD "EAGLES".

FOR ORGANIZING AND HOSTING OF EVENTS FOR CULTURAL PURPOSES; ORGANIZING AND OFFERING CULTURAL EVENTS, SHOWS AND EXHIBITIONS (U.S. CLS. 100, 101 AND 107).

ALLISON SCHRODY, EXAMINING ATTORNEY

CLASS 41—(Continued).

SN 85-390,383. HASBRO, INC., PAWTUCKET, RI. FILED 8-5-2011.

UNIT:E

THE MARK CONSISTS OF STANDARD CHARACTERS WITHOUT CLAIM TO ANY PARTICULAR FONT, STYLE, SIZE, OR COLOR.

FOR ENTERTAINMENT SERVICES, NAMELY, THE PRODUCTION AND DISTRIBUTION OF MOTION PICTURES, ONGOING TELEVISION PROGRAMS, TELEVISION GAME SHOWS AND ANIMATED TELEVISION SERIES ALL IN THE FIELD OF CHILDREN'S ENTERTAINMENT; ENTERTAINMENT SERVICES, NAMELY, PRODUCTION AND DISTRIBUTION OF ONGOING PROGRAMS IN THE FIELD OF CHILDREN'S ENTERTAINMENT ACCESSIBLE BY TELEVISION, SATELLITES, RADIO, AUDIO, VIDEO, ELECTRONIC MEDIA AND COMPUTER NETWORKS; PROVIDING NEWS AND INFORMATION IN THE FIELD OF ENTERTAINMENT; ENTERTAINMENT SERVICES, NAMELY, PROVIDING ONLINE COMPUTER GAMES AND INTERACTIVE MULTIPLAYER ONLINE COMPUTER GAMES VIA GLOBAL NETWORKS; FAN CLUB SERVICES; ORGANIZING AND CONDUCTING ONLINE COMPUTER GAME TOURNAMENTS AND EXHIBITIONS IN THE FIELD OF GAMES FOR ENTERTAINMENT PURPOSES; PROVIDING INDUSTRY INFORMATION ONLINE VIA A GLOBAL NETWORK, NAMELY, ONLINE PUBLICATIONS IN THE NATURE OF ARTICLES AND MAGAZINES ON TOYS AND GAMES (U.S. CLS. 100, 101 AND 107).

JEFF DEFORD, EXAMINING ATTORNEY

SN 85-386,755. UNIVERSITY OF NEW HAMPSHIRE, DURHAM, NH. FILED 8-2-2011.

BRINGING IN THE BYSTANDER

THE MARK CONSISTS OF STANDARD CHARACTERS WITHOUT CLAIM TO ANY PARTICULAR FONT, STYLE, SIZE, OR COLOR.

FOR EDUCATIONAL SERVICES, NAMELY, CONDUCTING WORKSHOPS, SEMINARS, CLASSES AND CONFERENCES TO TEACH THAT EVERYONE IN THE COMMUNITY HAS A ROLE TO PLAY IN ENDING SEXUAL ASSAULT, RELATIONSHIP VIOLENCE AND STALKING (U.S. CLS. 100, 101 AND 107).

FIRST USE 2-1-2009; IN COMMERCE 2-1-2009. PATRICIA EVANKO, EXAMINING ATTORNEY

SN 85-392,623. LAS VEGAS VALLEY WATER DISTRICT, LAS VEGAS, NV. FILED 8-8-2011.



NO CLAIM IS MADE TO THE EXCLUSIVE RIGHT TO USE "FESTIVAL", APART FROM THE MARK AS SHOWN.

THE MARK CONSISTS OF A TREE AND STREAM DESIGN WITHIN A SQUARE TO THE LEFT OF THE WORDING.

FOR CONDUCTING ENTERTAINMENT EXHIBITIONS IN THE NATURE OF WINE AND BEER FESTIVALS; ENTERTAINMENT, NAMELY, LIVE PERFORMANCES BY MUSICAL BANDS (U.S. CLS. 100, 101 AND 107).

FIRST USE 2-3-2010; IN COMMERCE 6-29-2010. JASON TURNER, EXAMINING ATTORNEY

CLASS 41—(Continued).

SN 85-395,787. UNCOMMON CARIBBEAN MEDIA, FORT LAUDERDALE, FL. FILED 8-11-2011.



NO CLAIM IS MADE TO THE EXCLUSIVE RIGHT TO USE "CARIBBEAN", APART FROM THE MARK AS SHOWN.

THE MARK CONSISTS OF THE WORDS "UNCOMMON CARIBBEAN" IN ALL-CAPS USING THE CAPTAIN'S TABLE FONT WITH A COMPASS-LIKE ROUND IMAGE USED FOR THE FIRST LETTER "O" IN THE WORD "UNCOMMON". A SAILBOAT IMAGE IS ALSO EMBEDDED IN THE LETTER "U" IN "UNCOMMON" WITH ADDITIONAL GRAPHICAL FLOURISHES WITHIN THE LETTERS "C" AND "O" IN "UNCOMMON", AS WELL AS THE "C" IN "CARIBBEAN".

FOR ON-LINE JOURNALS, NAMELY, BLOGS FEATURING TRAVEL AND CULTURE (U.S. CLS. 100, 101 AND 107).

FIRST USE 2-5-2010; IN COMMERCE 3-1-2010.
JULIE GUTTADAURO, EXAMINING ATTORNEY

SN 85-396,327. KERCHNER, JANICE R., IRVINE, CA. FILED 8-12-2011.



NO CLAIM IS MADE TO THE EXCLUSIVE RIGHT TO USE "COLLEGE", APART FROM THE MARK AS SHOWN.

THE MARK CONSISTS OF THE TEXT "COLLEGE ADVANTAGE" WITH THE "ADD" PORTION HIGHLIGHTED TO BE A PLAY ON WORDS, "ADD" (ATTENTION DEFICIT DISORDER) AND BEGINNING OF ADVANTAGE, AND A GRADUATION CAP OVER THE "ADD" PORTION.

FOR COLLEGE COUNSELING SERVICES, NAMELY, ASSISTING STUDENTS WHO STRUGGLE ACADEMICALLY DUE TO LEARNING DISABILITIES IN FINDING COLLEGES AND UNIVERSITIES AND COMPLETING THE APPLICATION PROCESS (U.S. CLS. 100, 101 AND 107).

FIRST USE 6-1-2005; IN COMMERCE 6-1-2005.
KEVIN CORWIN, EXAMINING ATTORNEY

CLASS 41—(Continued).

SN 85-402,814. SERVICIOS PROFESIONALES DE OPERACION, S.A. DE C.V., TIJUANA, BC, MEXICO, FILED 8-19-2011.



OWNER OF MEXICO REG. NO. 993940, DATED 7-23-2011, EXPIRES 4-3-2017.

NO CLAIM IS MADE TO THE EXCLUSIVE RIGHT TO USE "CLUB TIJUANA", APART FROM THE MARK AS SHOWN.

THE COLOR(S) BLACK AND RED IS/ARE CLAIMED AS A FEATURE OF THE MARK.

THE MARK CONSISTS OF TWO BLACK CIRCLES FEATURING TWO RED DOTS BETWEEN THE CIRCLES AND THE WORDS "CLUB TIJUANA" AT THE TOP OF THE CIRCLE AND "XOLOITZCUINTLES DE CALIENTE" AT THE BOTTOM OF THE CIRCLE. THE WORDING IS ENTIRELY IN BLACK. INSIDE THE INNERMOST CIRCLE IS THE HEAD OF A XOLOITZCUINTLE DOG IN BLACK WITH A RED BACKGROUND.

THE ENGLISH TRANSLATION OF "DE CALIENTE" IN THE MARK IS "OF HOT".

FOR ARRANGING, ORGANIZING, CONDUCTING, AND HOSTING SOCIAL ENTERTAINMENT EVENTS; ATHLETIC TRAINING SERVICES; EDUCATIONAL SERVICES IN THE NATURE OF SPORT SCHOOLS; ORGANIZING EXHIBITIONS FOR SPORT AND CULTURAL ACTIVITIES (U.S. CLS. 100, 101 AND 107).

HOWARD SMIGA, EXAMINING ATTORNEY

SN 85-405,014. FITNESS ONBOARD, LLC, PENSACOLA, FL. FILED 8-23-2011.

FITNESS ONBOARD

THE MARK CONSISTS OF STANDARD CHARACTERS WITHOUT CLAIM TO ANY PARTICULAR FONT, STYLE, SIZE, OR COLOR.

NO CLAIM IS MADE TO THE EXCLUSIVE RIGHT TO USE "FITNESS", APART FROM THE MARK AS SHOWN.

FOR PHYSICAL FITNESS TRAINING SERVICES; PROVIDING ASSISTANCE, PERSONAL TRAINING AND PHYSICAL FITNESS CONSULTATION TO INDIVIDUALS TO HELP THEM MAKE PHYSICAL FITNESS, STRENGTH, CONDITIONING, AND EXERCISE IMPROVEMENT IN THEIR DAILY LIVING (U.S. CLS. 100, 101 AND 107).

FIRST USE 9-1-2010; IN COMMERCE 9-1-2010.
DOMINIC J. FERRAIUOLO, EXAMINING ATTORNEY

CLASS 41—(Continued).

SN 85-409,697. FIRE ATHLETE FITNESS, CEDAR PARK, TX. FILED 8-29-2011.



NO CLAIM IS MADE TO THE EXCLUSIVE RIGHT TO USE "ATHLETE", APART FROM THE MARK AS SHOWN. THE MARK CONSISTS OF A CIRCLE WITH THE STYLIZED TEXT "FIRE" ALONG THE LEFT SIDE OF THE CIRCLE AND THE STYLIZED TEXT "ATHLETE" ALONG THE RIGHT SIDE. IN THE MIDDLE OF THE CIRCLE IS A STYLIZED CAPITAL BLOCK "A", OVERLAPPING THE CIRCLE AND "A" IS A STYLIZED LETTER "F" IN THE SHAPE OF A PICK HEAD AXE. FOR PHYSICAL FITNESS STUDIO SERVICES, NAMELY, PROVIDING GROUP EXERCISE INSTRUCTION, EQUIPMENT, AND FACILITIES (U.S. CLS. 100, 101 AND 107). FIRST USE 6-1-2008; IN COMMERCE 5-1-2011. JEAN IM, EXAMINING ATTORNEY

SN 85-410,112. VINTAGE WINGS OF CANADA, OTTAWA, ONTARIO, CANADA, FILED 8-29-2011.

WARBIRD U

THE MARK CONSISTS OF STANDARD CHARACTERS WITHOUT CLAIM TO ANY PARTICULAR FONT, STYLE, SIZE, OR COLOR. PRIORITY CLAIMED UNDER SEC. 44(D) ON CANADA APPLICATION NO. 1516983, FILED 2-28-2011, REG. NO. TMA824,824, DATED 5-25-2012, EXPIRES 5-25-2027. NO CLAIM IS MADE TO THE EXCLUSIVE RIGHT TO USE "WARBIRD", APART FROM THE MARK AS SHOWN. FOR CONDUCTING AIR SHOW EXHIBITIONS; EDUCATION, NAMELY, CONDUCTING CLASSES FOR THE PUBLIC ABOUT AIRCRAFT, MILITARY AIRCRAFT AND AVIATION HISTORY; ENTERTAINMENT, NAMELY, PROVIDING A WEBSITE FEATURING INFORMATION ON AIRCRAFT AND AVIATION HISTORY FOR ENTERTAINMENT PURPOSES (U.S. CLS. 100, 101 AND 107). JASON TURNER, EXAMINING ATTORNEY

CLASS 41—(Continued).

SN 85-414,063. FÉDÉRATION INTERNATIONALE DE SKI, OBERHOFEN AM THUNERSEE, SWITZERLAND, FILED 9-2-2011.



PRIORITY CLAIMED UNDER SEC. 44(D) ON SWITZERLAND APPLICATION NO. 53218/2011, FILED 3-17-2011, REG. NO. 618094, DATED 8-15-2011, EXPIRES 3-17-2021. NO CLAIM IS MADE TO THE EXCLUSIVE RIGHT TO USE "WORLD SNOW DAY", APART FROM THE MARK AS SHOWN. THE COLOR(S) BLACK, YELLOW, RED, LIGHT BLUE, DARK BLUE IS/ARE CLAIMED AS A FEATURE OF THE MARK. THE MARK CONSISTS OF A RECTANGULAR-SHAPED BORDER IN RED WITH THE LETTERS "FIS" IN BLACK INTERSECTING THE TOP OF THE BORDER AND WITH STYLIZED YELLOW AND DARK BLUE SKIS SEPARATING THE "F" AND THE "I" AND THE "I" AND "S", RESPECTIVELY; AND THE STYLIZED WORDS "WORLD SNOW DAY" WITHIN THE BORDER, WITH "WORLD" AND "DAY" IN RED AND WITH "SNOW" IN LIGHT BLUE; AND WITH A STYLIZED EARTH IN BLUE SURROUNDED AND BORDERED IN STYLIZED BLUE SNOWFLAKES INTERSECTING THE LOWER RIGHT HAND CORNER OF THE BORDER.

FOR PROVIDING OF TRAINING SERVICES IN THE FIELDS OF SNOW SPORTS; ENTERTAINMENT IN THE NATURE OF INTERNATIONAL SPORTING EVENTS, NAMELY, SNOW SPORTS PERFORMANCES FEATURING SKIING AND SNOW BOARDING; ORGANIZING INTERNATIONAL COMMUNITY SPORTING AND CULTURAL EVENTS, TELEVISION SHOW PRODUCTION IN THE FIELD OF SPORTING AND CULTURAL ENTERTAINMENT; ORGANIZATION OF CULTURAL AND EDUCATIONAL EXHIBITIONS IN THE FIELD OF SPORTS; ENTERTAINMENT SERVICES PROVIDED AT OR RELATING TO SPORTS EVENTS, NAMELY, PRESENTATION OF LIVE SHOW PERFORMANCES IN THE NATURE OF OPENING AND CLOSING CEREMONIES OF INTERNATIONAL SPORTS EVENTS; ORGANIZATION OF SPORTING COMPETITIONS, NAMELY, SNOW SPORTS COMPETITIONS; MANAGEMENT OF SPORTING FACILITIES, NAMELY, PROVIDING SPORTS FACILITIES; PROVIDING ON-LINE INFORMATION IN THE FIELD OF SPORTS ENTERTAINMENT AND SPORTS EDUCATION VIA A COMPUTER DATABASE OR THE INTERNET; PROVIDING ON-LINE ELECTRONIC PUBLICATIONS, NAMELY, PUBLICATION OF ELECTRONIC MAGAZINES AND NEWSPAPERS; PUBLICATION OF BOOKS, REVIEWS, JOURNALS, MAGAZINES, TEXTS OTHER THAN PUBLICITY TEXTS; ON-LINE PUBLICATION OF ELECTRONIC BOOKS, REVIEWS, JOURNALS, MAGAZINES, TEXTS OTHER THAN PUBLICITY TEXTS; PROVIDING SPORT RECORDS IN CONNECTION WITH SPORTS AND SPORTING EVENTS; PROVIDING INFORMATION IN THE FIELD OF SPORTS, NAMELY, PROVIDING SPORTING RESULTS; PROVIDING ON-LINE INFORMATION IN THE FIELD OF SPORTING EVENTS VIA A COMPUTER DATABASE OR FROM THE INTERNET; SPORT CAMP SERVICES (U.S. CLS. 100, 101 AND 107). NATALIE POLZER, EXAMINING ATTORNEY

CLASS 41—(Continued).

SN 85-415,227. COLUMBUS CURLING CLUB, COLUMBUS, OH. FILED 9-6-2011.



NO CLAIM IS MADE TO THE EXCLUSIVE RIGHT TO USE "CURLING CLUB", APART FROM THE MARK AS SHOWN.

THE MARK CONSISTS OF THE LITERAL ELEMENT "COLUMBUS" ABOVE A DIVIDING LINE THAT IS POSITIONED ABOVE THE LITERAL ELEMENTS "CURLING CLUB". TWO SPACED APART SEMI-CIRCULAR DESIGNS THAT PARTIALLY ENCIRCLE THE LITERAL ELEMENTS, AND A CURLING STONE POSITIONED ON A PORTION OF THE OUTERMOST SEMI-CIRCULAR DESIGN.

SEC. 2(F) AS TO "COLUMBUS CURLING CLUB".
FOR ORGANIZING, ARRANGING, AND CONDUCTING CURLING EVENTS (U.S. CLS. 100, 101 AND 107).
FIRST USE 8-25-2011; IN COMMERCE 8-25-2011.
AMY ALFIERI, EXAMINING ATTORNEY

CLASS 41—(Continued).

SN 85-418,005. ASSESSMENT TECHNOLOGIES INSTITUTE, L.L.C., STILWELL, KS. FILED 9-8-2011.

ACHIEVE

THE MARK CONSISTS OF STANDARD CHARACTERS WITHOUT CLAIM TO ANY PARTICULAR FONT, STYLE, SIZE, OR COLOR.

FOR PROVIDING ONLINE EDUCATIONAL SERVICES, NAMELY, NON-DOWNLOADABLE TUTORIALS IN THE FIELD OF NURSING AND ALLIED HEALTH EDUCATION (U.S. CLS. 100, 101 AND 107).

ELLEN BURNS, EXAMINING ATTORNEY

SN 85-420,362. SIERCHIO THOMAS R., TOMS RIVER, NJ. AND CAVALLARO GIULIO G. JR., BLOOMFIELD, NJ. FILED 9-12-2011.

Men Of Good Will

THE MARK CONSISTS OF STANDARD CHARACTERS WITHOUT CLAIM TO ANY PARTICULAR FONT, STYLE, SIZE, OR COLOR.

FOR ENTERTAINMENT IN THE NATURE OF ON-GOING TELEVISION PROGRAMS IN THE FIELD OF DRAMEDY (U.S. CLS. 100, 101 AND 107).

GISELLE AGOSTO, EXAMINING ATTORNEY

SN 85-417,051. GLOBO COMUNICACAO E PARTICIPACOES S.A., RIO DE JANEIRO, BRAZIL, FILED 9-7-2011.



OWNER OF U.S. REG. NO. 4,058,443.
NO CLAIM IS MADE TO THE EXCLUSIVE RIGHT TO USE "BRAZILIAN DAY USA", APART FROM THE MARK AS SHOWN.

THE MARK CONSISTS OF THE WORDING "BRAZILIAN DAY" IN ALL CAPITAL LETTERS ABOVE THE LETTERING "USA" WHEREIN THE "U" HAS STARS IMPRINTED THEREON AND THE "S" AND "A" HAVE PARALLEL HORIZONTAL LINES RUNNING THROUGH THEM.

FOR PRODUCTION OF TELEVISION PROGRAMS; ENTERTAINMENT IN THE NATURE OF ON-GOING TELEVISION PROGRAMS IN THE FIELD OF NEWS, SPORTS, VARIETY AND EDUCATION; AND ORGANIZING COMMUNITY CULTURAL EVENTS (U.S. CLS. 100, 101 AND 107).

JEFFERY COWARD, EXAMINING ATTORNEY

SN 85-420,722. JABBAWOCKEEZ, LLC, LOS ANGELES, CA. FILED 9-12-2011.

MUS.I.C.

THE MARK CONSISTS OF STANDARD CHARACTERS WITHOUT CLAIM TO ANY PARTICULAR FONT, STYLE, SIZE, OR COLOR.

NO CLAIM IS MADE TO THE EXCLUSIVE RIGHT TO USE "MUSIC", APART FROM THE MARK AS SHOWN.

FOR ENTERTAINMENT IN THE NATURE OF DANCE PERFORMANCES; ENTERTAINMENT IN THE NATURE OF LIVE PERFORMANCES BY A DANCE GROUP; ENTERTAINMENT IN THE NATURE OF THEATER PRODUCTIONS (U.S. CLS. 100, 101 AND 107).

FIRST USE 0-0-2010; IN COMMERCE 0-0-2010.

KATHERINE STOIDES, EXAMINING ATTORNEY

CLASS 41—(Continued).

SN 85-422,186. KAMPUS SMAKK, THIBODAUX, LA. FILED 9-14-2011.

Kampus Smakk We at ya nekk

THE MARK CONSISTS OF STANDARD CHARACTERS WITHOUT CLAIM TO ANY PARTICULAR FONT, STYLE, SIZE, OR COLOR.

FOR ARRANGING AND CONDUCTING SPECIAL EVENTS FOR SOCIAL ENTERTAINMENT PURPOSES; CONSULTATION IN THE FIELD OF SPECIAL EVENT PLANNING FOR SOCIAL ENTERTAINMENT PURPOSES; SPECIAL EVENT PLANNING FOR SOCIAL ENTERTAINMENT PURPOSES (U.S. CLS. 100, 101 AND 107).

FIRST USE 1-1-2009; IN COMMERCE 1-1-2010.
DARRYL SPRUILL, EXAMINING ATTORNEY

CLASS 41—(Continued).

SN 85-429,540. KOCH TAVARES PROMOCOES E EVENTOS LTDA., COTIA, SÃO PAULO, BRAZIL, FILED 9-22-2011.



SN 85-425,551. ANACLERIO, CHERI A., SAN DIEGO, CA. FILED 9-18-2011.

Carnivore Rex

THE MARK CONSISTS OF STANDARD CHARACTERS WITHOUT CLAIM TO ANY PARTICULAR FONT, STYLE, SIZE, OR COLOR.

FOR ENTERTAINMENT IN THE NATURE OF VISUAL AND AUDIO PERFORMANCES, NAMELY, MUSICAL BAND, ROCK GROUP, GYMNASTIC, DANCE, AND BALLET PERFORMANCES; ENTERTAINMENT SERVICES BY A MUSICAL ARTIST AND PRODUCER, NAMELY, MUSICAL COMPOSITION FOR OTHERS AND PRODUCTION OF MUSICAL SOUND RECORDINGS; ENTERTAINMENT, NAMELY, LIVE PERFORMANCES BY A MUSICAL BAND; PRODUCTION OF SOUND AND MUSIC VIDEO RECORDINGS (U.S. CLS. 100, 101 AND 107).

AMY KELLY, EXAMINING ATTORNEY

OWNER OF U.S. REG. NO. 2,716,868.

NO CLAIM IS MADE TO THE EXCLUSIVE RIGHT TO USE "WORLD BEACH GAMES", APART FROM THE MARK AS SHOWN.

THE MARK CONSISTS OF THE STYLIZED WORDING "WORLD" WITH THE LETTERS "W", "R", "L" AND "D" CAPITAL LETTERS AND THE LETTER "O" IS DEPICTED AS A DESIGN AND DRAWING OF THE SUN WITH RAYS EMANATING OUTWARD FROM THE DESIGN. BELOW THE STYLIZED WORDING "WORLD" ARE TWO WAVY LINES. THE STYLIZED WORDING "BEACH GAMES" APPEARS TO THE LOWER LEFT OF AND SUPERIMPOSED UPON THE WAVY LINES. THE DESIGN ELEMENTS OF A VOLLEYBALL, SOCCER BALL AND FOOTBALL, RESPECTIVELY APPEARING IN THE ORDER OF LEFT TO RIGHT, APPEAR TO THE LOWER RIGHT OF AND SUPERIMPOSED UPON THE WAVY LINES.

FOR ENTERTAINMENT SERVICES IN THE NATURE OF ORGANIZING AND CONDUCTING SPORTING EVENTS, NAMELY, SWIMMING COMPETITIONS, SOCCER COMPETITIONS, VOLLEYBALL COMPETITIONS AND TENNIS COMPETITIONS; ENTERTAINMENT SERVICES IN THE NATURE OF ORGANIZING AND CONDUCTING EXHIBITIONS FOR ENTERTAINMENT PURPOSES; ENTERTAINMENT SERVICES IN THE NATURE OF ORGANIZING AND CONDUCTING TOURNAMENTS IN THE NATURE OF TENNIS, GOLF, VOLLEYBALL AND SOCCER; PRODUCTION AND DISTRIBUTION OF RADIO, MOTION PICTURE FILMS AND PRODUCTION AND DISTRIBUTION OF TELEVISION PROGRAMS IN THE FIELD OF SPORTS; EDUCATIONAL SERVICES, NAMELY, ORGANIZING AND CONDUCTING SEMINARS, CONFERENCES, WORKSHOPS, AND SYMPOSIA IN THE FIELD OF SPORTS (U.S. CLS. 100, 101 AND 107).

NAPOLEON SHARMA, EXAMINING ATTORNEY

CLASS 41—(Continued).

SN 85-431,950. CURTIS STARKS, BIRMINGHAM, AL. FILED 9-26-2011.



THE COLOR(S) RED, BLACK AND WHITE IS/ARE CLAIMED AS A FEATURE OF THE MARK.

THE MARK CONSISTS OF A RED DOT WITH THE WORD "EVO" INSIDE THE DOT IN WHITE, THE WORDS "BEFIT" IN BLACK UNDERNEATH THE WORD "EVO" AND THE WORDS "WE CHANGE LIVES" UNDERNEATH "BEFIT" WITH THE WORDS "WE CHANGE" IN BLACK AND THE WORD "LIVES" IN RED.

FOR PERSONAL TRAINING PROVIDED IN CONNECTION WITH WEIGHT LOSS AND EXERCISE PROGRAMS; PERSONAL TRAINING SERVICES, NAMELY, STRENGTH AND CONDITIONING TRAINING; PROVIDING ASSISTANCE, PERSONAL TRAINING AND PHYSICAL FITNESS CONSULTATION TO INDIVIDUALS TO HELP THEM MAKE PHYSICAL FITNESS, STRENGTH, CONDITIONING, AND EXERCISE IMPROVEMENT IN THEIR DAILY LIVING (U.S. CLS. 100, 101 AND 107).

FIRST USE 11-1-2010; IN COMMERCE 11-1-2010.
GIANCARLO CASTRO, EXAMINING ATTORNEY

SN 85-436,869. VINTAGE WINGS OF CANADA, OTTAWA, ONTARIO, CANADA, FILED 9-30-2011.

WARBIRD UNIVERSITY

THE MARK CONSISTS OF STANDARD CHARACTERS WITHOUT CLAIM TO ANY PARTICULAR FONT, STYLE, SIZE, OR COLOR.

PRIORITY CLAIMED UNDER SEC. 44(D) ON CANADA APPLICATION NO. 1523704, FILED 4-14-2011, REG. NO. TMA824825, DATED 5-25-2012, EXPIRES 5-25-2027.

NO CLAIM IS MADE TO THE EXCLUSIVE RIGHT TO USE "WARBIRD", APART FROM THE MARK AS SHOWN.

FOR MUSEUMS, NAMELY, DISPLAY OF AIRCRAFT AND AVIATION HISTORICAL ITEMS; CONDUCTING AIR SHOW EXHIBITS; EDUCATIONAL SERVICES, NAMELY, PROVIDING SEMINARS, LECTURES, CLASSES, AND WORKSHOPS IN THE FIELD OF AIRCRAFT, MILITARY AIRCRAFT AND AVIATION; ENTERTAINMENT SERVICES, NAMELY, PROVIDING A WEB SITE FEATURING INFORMATION ABOUT HISTORICAL AIRCRAFT AND AVIATION HISTORY FOR ENTERTAINMENT PURPOSES (U.S. CLS. 100, 101 AND 107).

JASON TURNER, EXAMINING ATTORNEY

CLASS 41—(Continued).

SN 85-437,258. DWM DANCE STUDIOS, LLC, RIDGEFIELD, NJ. FILED 10-2-2011.

DWM DANCE STUDIOS

THE MARK CONSISTS OF STANDARD CHARACTERS WITHOUT CLAIM TO ANY PARTICULAR FONT, STYLE, SIZE, OR COLOR.

NO CLAIM IS MADE TO THE EXCLUSIVE RIGHT TO USE "DANCE STUDIOS", APART FROM THE MARK AS SHOWN.

FOR DANCE EVENTS; DANCE INSTRUCTION; DANCE INSTRUCTION FOR CHILDREN; DANCE SCHOOLS; DANCE STUDIOS; ORGANIZATION OF DANCING EVENTS; PERFORMANCE HALL RENTAL SERVICES; PHYSICAL FITNESS STUDIO SERVICES, NAMELY, PROVIDING EXERCISE CLASSES, BODY SCULPTING CLASSES, AND GROUP FITNESS CLASSES; PROVIDING DANCE HALLS (U.S. CLS. 100, 101 AND 107).

FIRST USE 9-1-2011; IN COMMERCE 9-1-2011.
HEATHER BIDDULPH, EXAMINING ATTORNEY

SN 85-437,261. DWM DANCE STUDIOS, LLC, RIDGEFIELD, NJ. FILED 10-2-2011.



NO CLAIM IS MADE TO THE EXCLUSIVE RIGHT TO USE "DANCE STUDIOS", APART FROM THE MARK AS SHOWN.

FOR DANCE EVENTS; DANCE INSTRUCTION; DANCE INSTRUCTION FOR CHILDREN; DANCE SCHOOLS; DANCE STUDIOS; ORGANIZATION OF DANCING EVENTS; PERFORMANCE HALL RENTAL SERVICES; PHYSICAL FITNESS STUDIO SERVICES, NAMELY, PROVIDING EXERCISE CLASSES, BODY SCULPTING CLASSES, AND GROUP FITNESS CLASSES; PROVIDING DANCE HALLS (U.S. CLS. 100, 101 AND 107).

FIRST USE 9-1-2011; IN COMMERCE 9-1-2011.
HEATHER BIDDULPH, EXAMINING ATTORNEY

CLASS 41—(Continued).

SN 85-438,094. PRANA LIVING, LLC, CARLSBAD, CA. FILED 10-3-2011.

PRANA LIVING

THE MARK CONSISTS OF STANDARD CHARACTERS WITHOUT CLAIM TO ANY PARTICULAR FONT, STYLE, SIZE, OR COLOR.

OWNER OF U.S. REG. NOS. 1,803,298, 2,677,150 AND OTHERS.

THE ENGLISH TRANSLATION OF "PRANA" IN THE MARK IS "BREATH OF LIFE".

FOR EDUCATIONAL SERVICES, NAMELY, PROVIDING ONLINE INSTRUCTION IN THE FIELD OF YOGA, MEDITATION, DANCE, ROCK CLIMBING AND EXERCISE AND FITNESS; PROVIDING CLASSES, WORKSHOPS, SEMINARS AND CAMPS IN THE FIELDS OF FITNESS, EXERCISE, ROCK CLIMBING AND YOGA (U.S. CLS. 100, 101 AND 107).

DAVID H. STINE, EXAMINING ATTORNEY

SN 85-438,898. ROCKITTECH LLC, NEW YORK, NY. FILED 10-4-2011.

ExRATED

THE MARK CONSISTS OF STANDARD CHARACTERS WITHOUT CLAIM TO ANY PARTICULAR FONT, STYLE, SIZE, OR COLOR.

FOR PROVIDING A WEBSITE FOR SUBMITTING AND DISPLAYING REVIEWS OF PAST RELATIONSHIP PARTNERS FOR ENTERTAINMENT PURPOSES (U.S. CLS. 100, 101 AND 107).

FIRST USE 7-4-2011; IN COMMERCE 7-4-2011.

KATHERINE CHANG, EXAMINING ATTORNEY

SN 85-439,050. SARRIA, ROLANDO, SCOTTSDALE, AZ. FILED 10-4-2011.

RAGE IN THE CAGE

THE MARK CONSISTS OF STANDARD CHARACTERS WITHOUT CLAIM TO ANY PARTICULAR FONT, STYLE, SIZE, OR COLOR.

FOR ENTERTAINMENT IN THE NATURE OF CAGE FIGHTING GAMES AND MIXED MARTIAL ARTS (U.S. CLS. 100, 101 AND 107).

FIRST USE 1-1-1998; IN COMMERCE 11-4-1998.

ANNE E. GUSTASON, EXAMINING ATTORNEY

CLASS 41—(Continued).

SN 85-441,683. DAVIS, ERIC GENE, DBA DJ ONE TYME, TOLEDO, OH. FILED 10-7-2011.

DJONETyme.COM

THE MARK CONSISTS OF STANDARD CHARACTERS WITHOUT CLAIM TO ANY PARTICULAR FONT, STYLE, SIZE, OR COLOR.

THE NAME(S), PORTRAIT(S), AND/OR SIGNATURE(S) SHOWN IN THE MARK IDENTIFIES "ERIC GENE DAVIS", WHOSE CONSENT(S) TO REGISTER IS MADE OF RECORD.

FOR DISC JOCKEY SERVICES; DISC JOCKEYS FOR PARTIES AND SPECIAL EVENTS (U.S. CLS. 100, 101 AND 107).

FIRST USE 1-12-1994; IN COMMERCE 1-12-1994.

SETH A. RAPPAPORT, EXAMINING ATTORNEY

SN 85-442,368. MUZE CORPORATION, SAN FRANCISCO, CA. FILED 10-7-2011.

MYOO

THE MARK CONSISTS OF STANDARD CHARACTERS WITHOUT CLAIM TO ANY PARTICULAR FONT, STYLE, SIZE, OR COLOR.

FOR EDUCATION SERVICES, TELEVISED EDUCATIONAL SERVICES AND ONLINE EDUCATIONAL SERVICES, NAMELY, CONDUCTING COURSES AND SEMINARS IN THE FIELD OF BUSINESS, FINANCE AND THE ENVIRONMENT; PRODUCTION OF BUSINESS, FINANCIAL AND ENVIRONMENTAL TELEVISION PROGRAMS; FILM PRODUCTION; PHOTOGRAPHIC REPORTING; EDUCATIONAL SERVICES, NAMELY, CONDUCTING COURSES AND SEMINARS IN THE FIELD OF ENVIRONMENTAL AND ECOLOGICAL ISSUES; PROVISION OF NEWS ON-LINE IN THE FIELD OF ECOLOGY AND THE ENVIRONMENT; PUBLICATION OF EDUCATIONAL PRINTED MATTER RELATING TO BUSINESS, FINANCE AND THE ENVIRONMENT; ORGANIZATION OF COMPETITIONS RELATING TO ENVIRONMENTAL AND ECOLOGICAL ISSUES (U.S. CLS. 100, 101 AND 107).

RAUL CORDOVA, EXAMINING ATTORNEY

CLASS 41—(Continued).

SN 85-442,433. DE ROTHSCHILD, DAVID MAYER, BUCKINGHAMSHIRE, UNITED KINGDOM, FILED 10-7-2011.

PLASTIKI

THE MARK CONSISTS OF STANDARD CHARACTERS WITHOUT CLAIM TO ANY PARTICULAR FONT, STYLE, SIZE, OR COLOR.

FOR EDUCATION SERVICES, TELEVISED EDUCATIONAL SERVICES AND ONLINE EDUCATIONAL SERVICES, NAMELY, CONDUCTING COURSES AND SEMINARS IN THE FIELD OF BUSINESS, FINANCE AND THE ENVIRONMENT; PRODUCTION OF BUSINESS, FINANCIAL AND ENVIRONMENTAL TELEVISION PROGRAMS; FILM PRODUCTION; PHOTOGRAPHIC REPORTING; EDUCATIONAL SERVICES, NAMELY, CONDUCTING COURSES AND SEMINARS IN THE FIELD OF ENVIRONMENTAL AND ECOLOGICAL ISSUES; PROVISION OF NEWS ON-LINE IN THE FIELD OF ECOLOGY AND THE ENVIRONMENT; PUBLICATION OF EDUCATIONAL PRINTED MATTER RELATING TO BUSINESS, FINANCE AND THE ENVIRONMENT; CONDUCTING EDUCATIONAL EXHIBITIONS AND CONFERENCES IN RELATION TO BUSINESS, FINANCIAL AND ENVIRONMENTAL ISSUES (U.S. CLS. 100, 101 AND 107).

RAUL CORDOVA, EXAMINING ATTORNEY

CLASS 41—(Continued).

SN 85-442,733. NAMCO BANDAI GAMES INC., SHINAGAWA-KU TOKYO, JAPAN, FILED 10-7-2011.

TANK BATTALION BLITZ

THE MARK CONSISTS OF STANDARD CHARACTERS WITHOUT CLAIM TO ANY PARTICULAR FONT, STYLE, SIZE, OR COLOR.

OWNER OF U.S. REG. NO. 3,583,710.

NO CLAIM IS MADE TO THE EXCLUSIVE RIGHT TO USE "TANK", APART FROM THE MARK AS SHOWN.

FOR ENTERTAINMENT SERVICES, NAMELY, PROVIDING A COMPUTER GAME THAT MAY BE ACCESSED NETWORK-WIDE BY NETWORK USERS VIA MOBILE PHONES AND COMPUTERS; PROVIDING COMPUTER GAMES VIA NETWORK BETWEEN COMMUNICATIONS NETWORKS AND COMPUTERS (U.S. CLS. 100, 101 AND 107).

CAROLINE WOOD, EXAMINING ATTORNEY

SN 85-442,660. DWM DANCE STUDIOS, LLC, RIDGEFIELD, NJ. FILED 10-7-2011.



NO CLAIM IS MADE TO THE EXCLUSIVE RIGHT TO USE "DANCE STUDIOS", APART FROM THE MARK AS SHOWN.

THE MARK CONSISTS OF A CREST HAVING A CROWN AT THE TOP AND THE LETTERS "DWM" IN THE CENTER AND THE WORDS "DANCE STUDIOS" AT THE BOTTOM.

FOR DANCE EVENTS; DANCE INSTRUCTION; DANCE INSTRUCTION FOR CHILDREN; DANCE SCHOOLS; DANCE STUDIOS; ORGANIZATION OF DANCING EVENTS; PERFORMANCE HALL RENTAL SERVICES; PHYSICAL FITNESS STUDIO SERVICES, NAMELY, PROVIDING EXERCISE CLASSES, BODY SCULPTING CLASSES, AND GROUP FITNESS CLASSES; PROVIDING DANCE HALLS (U.S. CLS. 100, 101 AND 107).

FIRST USE 9-1-2011; IN COMMERCE 9-1-2011.

HEATHER BIDDULPH, EXAMINING ATTORNEY

SN 85-443,596. FORD MOTOR COMPANY, DEARBORN, MI. FILED 10-10-2011.

TRADECYCLE360

THE MARK CONSISTS OF STANDARD CHARACTERS WITHOUT CLAIM TO ANY PARTICULAR FONT, STYLE, SIZE, OR COLOR.

FOR EDUCATIONAL SERVICES, NAMELY, TRAINING SERVICES FOR AUTOMOTIVE DEALERS RELATING TO THE SELLING AND LEASING OF AUTOMOBILES (U.S. CLS. 100, 101 AND 107).

DEZMONA MIZELLE, EXAMINING ATTORNEY

CLASS 41—(Continued).

SN 85-444,602. MEDNAX SERVICES, INC., SUNRISE, FL. FILED 10-11-2011.



NO CLAIM IS MADE TO THE EXCLUSIVE RIGHT TO USE "NEONATOLOGY AND HALL OF FAME", APART FROM THE MARK AS SHOWN.

THE COLOR(S) BLUE, DARK BLUE, LIGHT YELLOW, YELLOW, CREAM, AND BLACK IS/ARE CLAIMED AS A FEATURE OF THE MARK.

THE MARK CONSISTS OF THE WORDING "LEGENDS OF NEONATOLOGY" IN BLUE SCRIPT DISPLAYED WITHIN DARK BLUE AND BLACK DIAMOND-SHAPED CARRIERS AND AGAINST A STRIPED YELLOW DIAMOND BACKGROUND DESIGN. A STYLIZED DEPICTION OF AN UNFURLING YELLOW, LIGHT YELLOW, CREAM, AND BLACK SCROLL ON WHICH THE WORDING "HALL OF FAME" APPEARS IN BLACK LOWERCASE LETTERING IS OVER THE BOTTOM CORNER OF THE DIAMOND.

FOR PROVIDING CONFERENCES AND SEMINARS IN THE FIELDS OF NEONATOLOGY AND PERINATOLOGY; PROVIDING RECOGNITION BY THE WAY OF AWARDS AND AWARDS CEREMONIES RECOGNIZING OUTSTANDING CONTRIBUTIONS EXCELLENCE IN THE FIELDS OF NEONATOLOGY AND PERINATOLOGY (U.S. CLS. 100, 101 AND 107).

FIRST USE 2-0-2007; IN COMMERCE 2-0-2007.
SALLY SHIH, EXAMINING ATTORNEY

SN 85-444,952. HOLLY B. HOLDINGS LLC, COLUMBUS, OH. FILED 10-11-2011.

GETTING PERSONAL

THE MARK CONSISTS OF STANDARD CHARACTERS WITHOUT CLAIM TO ANY PARTICULAR FONT, STYLE, SIZE, OR COLOR.

FOR PROVIDING ON-LINE ELECTRONIC PUBLICATIONS, NAMELY, NON-DOWNLOADABLE NEWSLETTERS IN THE FIELD OF GREETING CARDS (U.S. CLS. 100, 101 AND 107).

TRACY FLETCHER, EXAMINING ATTORNEY

CLASS 41—(Continued).

SN 85-445,238. BELVEDERE STORIES, INC., CORAL GABLES, FL. FILED 10-12-2011.



NO CLAIM IS MADE TO THE EXCLUSIVE RIGHT TO USE "STORIES", APART FROM THE MARK AS SHOWN.

THE COLOR(S) PINK, RED, BROWN, AND WHITE IS/ARE CLAIMED AS A FEATURE OF THE MARK.

THE MARK CONSISTS OF A PINK AND LIGHT BROWN CIRCLE WITH WHITE LINES, CONTAINING THE LETTER "B" IN LIGHT BROWN, RED, AND WHITE IN THE MIDDLE, AND THE WORDS "BELVEDERE STORIES" IN RED DIRECTLY BELOW THE CIRCLE.

FOR FILM AND VIDEO FILM PRODUCTION; PRODUCTION AND DISTRIBUTION OF VIDEOS IN THE FIELD OF WEDDINGS (U.S. CLS. 100, 101 AND 107).

JAMES A. RAUEN, EXAMINING ATTORNEY

SN 85-446,070. FLASH FROZEN PHOTOGRAPHY, INC., WOODLAND HILLS, CA. FILED 10-12-2011.

Flash Frozen Photography

THE MARK CONSISTS OF STANDARD CHARACTERS WITHOUT CLAIM TO ANY PARTICULAR FONT, STYLE, SIZE, OR COLOR.

NO CLAIM IS MADE TO THE EXCLUSIVE RIGHT TO USE "PHOTOGRAPHY", APART FROM THE MARK AS SHOWN.

FOR DIGITAL IMAGING SERVICES; PHOTOGRAPHY; PHOTOGRAPHY SERVICES; PORTRAIT PHOTOGRAPHY (U.S. CLS. 100, 101 AND 107).

FIRST USE 10-1-2005; IN COMMERCE 10-11-2006.
LINDA E. BLOHM, EXAMINING ATTORNEY

CLASS 41—(Continued).

SN 85-448,065. XAVIER UNIVERSITY, CINCINNATI, OH. FILED 10-14-2011.

American Dream Economic Index

THE MARK CONSISTS OF STANDARD CHARACTERS WITHOUT CLAIM TO ANY PARTICULAR FONT, STYLE, SIZE, OR COLOR.

OWNER OF U.S. REG. NOS. 3,866,997, 3,869,901 AND 3,969,676.

NO CLAIM IS MADE TO THE EXCLUSIVE RIGHT TO USE "ECONOMIC INDEX", APART FROM THE MARK AS SHOWN.

FOR ONLINE PUBLICATIONS IN THE NATURE OF RESEARCH REPORTS FEATURING INFORMATION AND TRENDS PERTAINING TO AMERICANS' SATISFACTION, FREEDOM, AND PROGRESS WITH RESPECT TO THEIR FINANCES, JOB, HOME OWNERSHIP, AND HEALTH CARE (U.S. CLS. 100, 101 AND 107).

FIRST USE 10-1-2011; IN COMMERCE 10-1-2011.

NICHOLAS COLEMAN, EXAMINING ATTORNEY

SN 85-449,167. XAVIER UNIVERSITY, CINCINNATI, OH. FILED 10-17-2011.

American Dream Composite Index

THE MARK CONSISTS OF STANDARD CHARACTERS WITHOUT CLAIM TO ANY PARTICULAR FONT, STYLE, SIZE, OR COLOR.

OWNER OF U.S. REG. NOS. 3,866,997, 3,869,901 AND 3,969,676.

NO CLAIM IS MADE TO THE EXCLUSIVE RIGHT TO USE "COMPOSITE INDEX", APART FROM THE MARK AS SHOWN.

FOR ONLINE PUBLICATIONS IN THE NATURE OF RESEARCH REPORTS FEATURING INFORMATION, STATISTICS, AND TRENDS MEASURING THE EXTENT TO WHICH PEOPLE LIVING IN THE UNITED STATES ARE ACHIEVING SUCCESS, HEALTH, AND HAPPINESS (U.S. CLS. 100, 101 AND 107).

FIRST USE 10-1-2011; IN COMMERCE 10-1-2011.

NICHOLAS COLEMAN, EXAMINING ATTORNEY

CLASS 41—(Continued).

SN 85-449,969. SKITS OUTREACH SERVICES, INC., HUDSON, WI. FILED 10-18-2011.



NO CLAIM IS MADE TO THE EXCLUSIVE RIGHT TO USE "YOUTH", APART FROM THE MARK AS SHOWN.

THE COLOR(S) RED, BLACK AND GRAY IS/ARE CLAIMED AS A FEATURE OF THE MARK.

THE MARK CONSISTS OF THREE PEOPLE SHADED IN BLACK IN DANCE POSITIONS REACHING UPWARD TOWARD FOUR STARS IN BLACK, CONSISTING OF THREE SMALL STARS AND ONE LARGER STAR. A CRESCENT SHAPED DESIGN IN GRAY IS BEHIND THE THREE PEOPLE. UNDERNEATH THE PEOPLE ARE THE STYLIZED UPPER CASE RED LETTERS "S.O.S." UNDERNEATH "S.O.S." IS THE STYLIZED RED WORD "FOR" IN LOWER CASE LETTERS WITH A SPACE AND THE STYLIZED RED WORD "YOUTH" IN LOWER CASE LETTERS.

FOR EDUCATIONAL SERVICES, NAMELY, CONDUCTING YOUTH PROGRAMS IN THE FIELD OF THEATER; ENTERTAINMENT SERVICES NAMELY, PROVIDING MOTIVATIONAL THEATRICAL PERFORMANCES FOR YOUTH (U.S. CLS. 100, 101 AND 107).

FIRST USE 9-0-2010; IN COMMERCE 9-0-2010.

DEBORAH LOBO, EXAMINING ATTORNEY

SN 85-451,505. SCOTT CREATIVE FOODS, INC., INDIANLANTIC, FL. FILED 10-19-2011.

COOKIN IS GOOD

THE MARK CONSISTS OF STANDARD CHARACTERS WITHOUT CLAIM TO ANY PARTICULAR FONT, STYLE, SIZE, OR COLOR.

FOR ENTERTAINMENT AND EDUCATIONAL SERVICES IN THE NATURE OF AN ONGOING SERIES OF COOKING SHOWS BROADCAST OVER BROADCAST MEDIA AND INTERNET MEDIA; ENTERTAINMENT SERVICES, NAMELY, PROVIDING ONLINE INFORMATION OVER A GLOBAL COMMUNICATION NETWORK BY MEANS OF NON-DOWNLOADABLE ARTICLES, BLOGS, PHOTOS, IMAGES, AUDIO, MULTIMEDIA, AND VIDEO FEATURING COOKING INSTRUCTION AND COOKING SHOWS (U.S. CLS. 100, 101 AND 107).

JULIE WATSON, EXAMINING ATTORNEY

CLASS 41—(Continued).

SN 85-451,692. TRIVARELLI, ANTHONY, PHILADELPHIA, PA. FILED 10-20-2011.

THE PHILADELPHIA SCOURGE

THE MARK CONSISTS OF STANDARD CHARACTERS WITHOUT CLAIM TO ANY PARTICULAR FONT, STYLE, SIZE, OR COLOR.

NO CLAIM IS MADE TO THE EXCLUSIVE RIGHT TO USE "PHILADELPHIA", APART FROM THE MARK AS SHOWN.

FOR PROVIDING A WEBSITE FEATURING BLOGS AND NON-DOWNLOADABLE PUBLICATIONS IN THE NATURE OF ARTICLES IN THE FIELDS OF NEWS, OPINION, COMMENTARY, FICTIONAL SHORT STORIES AND HUMAN INTEREST STORIES; PROVIDING A WEBSITE FEATURING NON-DOWNLOADABLE PICTURES, GRAPHICS, AND VIDEOS FEATURING NEWS, OPINION AND COMMENTARY IN THE FIELD OF CURRENT EVENTS, FICTIONAL SHORT STORIES AND HUMAN INTEREST STORIES IN CLASS 41 (U.S. CLS. 100, 101 AND 107).

AHSEN KHAN, EXAMINING ATTORNEY

SN 85-451,955. DEJOUR, PATRICK, PLANTATION, FL. FILED 10-20-2011.

PATRICK CARL JOSEPH DEJOUR

THE MARK CONSISTS OF STANDARD CHARACTERS WITHOUT CLAIM TO ANY PARTICULAR FONT, STYLE, SIZE, OR COLOR.

THE NAME(S), PORTRAIT(S), AND/OR SIGNATURE(S) SHOWN IN THE MARK IDENTIFIES PATRICK DEJOUR, WHOSE CONSENT(S) TO REGISTER IS MADE OF RECORD.

FOR EDUCATIONAL AND ENTERTAINMENT SERVICES, NAMELY, PROVIDING MOTIVATIONAL AND EDUCATIONAL SPEAKERS IN THE FIELD OF SELF-AND PERSONAL IMPROVEMENT; EDUCATIONAL SERVICES, NAMELY, CONDUCTING CLASSES, SEMINARS, CONFERENCES, AND WORKSHOPS IN THE FIELD OF MOTIVATIONAL SPEAKING AND COUNSELING AND DISTRIBUTION OF COURSE AND EDUCATIONAL MATERIALS IN CONNECTION THEREWITH; TRAINING SERVICES, IN THE FIELD OF PERSONAL IMPROVEMENT AND MOTIVATIONAL SERVICES, NAMELY PROVIDING MOTIVATIONAL SPEAKERS AND TRAINING EXERCISES IN THE FIELD OF SELF AND PERSONAL IMPROVEMENT (U.S. CLS. 100, 101 AND 107).

DEZMONA MIZELLE, EXAMINING ATTORNEY

CLASS 41—(Continued).

SN 85-452,116. MILLER, CYNTHIA L., DBA CYNTHIA LEE MILLER, LEAWOOD, KS. FILED 10-20-2011.

Live Life Exceptionally
Well

THE MARK CONSISTS OF STANDARD CHARACTERS WITHOUT CLAIM TO ANY PARTICULAR FONT, STYLE, SIZE, OR COLOR.

FOR EDUCATIONAL SERVICES, NAMELY, PROVIDING MOTIVATIONAL SPEAKING, SEMINARS AND EDUCATIONAL EXHIBITIONS REGARDING CIVILITY, BRAND IMAGING AND PERSONAL IMAGE, AND DISTRIBUTION OF TEACHING MATERIALS IN CONNECTION THEREWITH (U.S. CLS. 100, 101 AND 107).

KELLY TRUSILO, EXAMINING ATTORNEY

SN 85-452,757. ENGLERT, TIMOTHY J., VALLEY COTTAGE, NY. FILED 10-21-2011.

KNICKERBOCKER

THE MARK CONSISTS OF STANDARD CHARACTERS WITHOUT CLAIM TO ANY PARTICULAR FONT, STYLE, SIZE, OR COLOR.

FOR ORGANIZING AND CONDUCTING A COMMUNITY ICE FESTIVAL FEATURING A VARIETY OF WINTER-THEMED ACTIVITIES, NAMELY, ICE SCULPTURE EXHIBITS, CHILDREN'S ACTIVITIES, WINTER SPORTING EVENTS AND ACTIVITIES, ART EXHIBITIONS, LIVE PERFORMANCES BY MUSICIANS AND MUSICAL GROUPS, FACE PAINTING, GAMES, AND THE LIKE (U.S. CLS. 100, 101 AND 107).

STEVEN PEREZ, EXAMINING ATTORNEY

SN 85-453,669. INSIDE EDGE CONSULTING GROUP, CORP., PRINCETON, NJ. FILED 10-21-2011.



NO CLAIM IS MADE TO THE EXCLUSIVE RIGHT TO USE "A SERVICE PROVIDED BY", APART FROM THE MARK AS SHOWN.

THE COLOR(S) BLUE, FUSCHIA, WHITE, BLACK IS/ARE CLAIMED AS A FEATURE OF THE MARK.

THE MARK CONSISTS OF IN THE UPPER-LEFT CORNER IS A STYLIZED VERSION OF "RXAPID" WHERE THE LETTER "X" IS ATTACHED TO THE BOTTOM-RIGHT OF THE LETTER "R" AND THE BOTTOM-LEFT OF THE LETTER "A." THE LETTERS "R" AND "X" ARE IN BLUE, THE LETTER "A" IS BLUE ON THE LEFT-SIDE AND FUSCHIA ON THE MIDDLE BAR AND RIGHT SIDE, THE LETTERS "P", "I", AND "D" ARE IN FUSCHIA. IMMEDIATELY BELOW AND SLIGHTLY TO THE RIGHT OF

CLASS 41—(Continued).

"RXAPID" ARE THE WORDS "RX ADHERENCE THROUGH PROVIDER INSIGHTS AND DATA" IN BLACK LETTERING, ON THE RIGHT SIDE OF THE MARK, INSIDE A BLUE RECTANGLE, ON THE TOP ARE THE WORDS "A SERVICE PROVIDED BY" IN LOWER CASE WHITE LETTERING, FOLLOWED BY THE WORD "INSIDE" IN BLACK, AND WHICH HAS BEEN ROTATED CLOCKWISE NINETY DEGREES, IMMEDIATELY ADJACENT ON THE RIGHT SIDE OF THE WORD "INSIDE" IS A STYLIZED VERSION OF THE WORD "EDGE" IN WHITE.

FOR EDUCATION SERVICES, NAMELY, PROVIDING CAREER RE-TRAINING FOR INDIVIDUALS IN THE PHARMACEUTICAL INDUSTRY IN THE FIELDS OF PATIENT COMPLIANCE AND ADHERENCE, PHARMACEUTICALS, BIOTECHNOLOGY AND CLINICAL TRIALS IN THE HEALTHCARE INDUSTRY; EDUCATION SERVICES, NAMELY, PROVIDING ON-LINE INSTRUCTION IN THE FIELD OF PATIENT COMPLIANCE AND ADHERENCE IN THE PHARMACEUTICAL, BIOTECHNOLOGY AND THE HEALTHCARE INDUSTRIES; EDUCATION SERVICES, NAMELY, PROVIDING INSTRUCTION IN THE FIELD OF PATIENT COMPLIANCE AND ADHERENCE IN THE PHARMACEUTICAL, BIOTECHNOLOGY AND THE HEALTHCARE INDUSTRIES; EDUCATIONAL SERVICES, NAMELY, CONDUCTING INFORMAL ON-LINE PROGRAMS IN THE FIELDS OF PATIENT COMPLIANCE AND ADHERENCE IN THE PHARMACEUTICAL, BIOTECHNOLOGY AND HEALTHCARE INDUSTRIES, AND PRINTABLE MATERIALS DISTRIBUTED THEREWITH; EDUCATIONAL SERVICES, NAMELY, CONDUCTING PROGRAMS IN THE FIELD OF PATIENT COMPLIANCE AND ADHERENCE IN THE PHARMACEUTICAL, BIOTECHNOLOGY AND THE HEALTHCARE INDUSTRIES; EDUCATIONAL SERVICES, NAMELY, CONDUCTING SEMINARS, WORKSHOPS AND CLASSES IN THE FIELD OF PATIENT COMPLIANCE AND ADHERENCE IN THE PHARMACEUTICAL, BIOTECHNOLOGY AND THE HEALTHCARE INDUSTRIES; EDUCATIONAL SERVICES, NAMELY, CONDUCTING SEMINARS, WORKSHOPS AND CLASSES IN THE FIELD OF PATIENT COMPLIANCE AND ADHERENCE IN THE PHARMACEUTICAL, BIOTECHNOLOGY AND THE HEALTHCARE INDUSTRIES AND DISTRIBUTION OF COURSE MATERIAL IN CONNECTION THEREWITH; EDUCATIONAL SERVICES, NAMELY, DEVELOPING, ARRANGING, AND CONDUCTING EDUCATIONAL CONFERENCES AND PROGRAMS AND PROVIDING COURSES OF INSTRUCTION IN THE FIELD OF PATIENT COMPLIANCE AND ADHERENCE IN THE PHARMACEUTICAL, BIOTECHNOLOGY AND THE HEALTHCARE INDUSTRIES; EDUCATIONAL SERVICES, NAMELY, PROVIDING CONTINUING PROFESSIONAL EDUCATION COURSES IN THE FIELD OF PATIENT COMPLIANCE AND ADHERENCE IN THE PHARMACEUTICAL, BIOTECHNOLOGY AND THE HEALTHCARE INDUSTRIES; EDUCATIONAL SERVICES, NAMELY, PROVIDING COURSES OF INSTRUCTION AT THE POST-DOCTORATE LEVEL AND DISTRIBUTION OF COURSE MATERIAL IN CONNECTION THEREWITH; EDUCATIONAL SERVICES, NAMELY, PROVIDING ONLINE INSTRUCTION IN THE FIELD OF PATIENT COMPLIANCE AND ADHERENCE IN THE PHARMACEUTICAL, BIOTECHNOLOGY AND THE HEALTHCARE INDUSTRIES; PROVIDING INFORMATION ABOUT EDUCATION (U.S. CLS. 100, 101 AND 107).

FIRST USE 3-1-2011; IN COMMERCE 3-1-2011.

COURTNEY ALVAREZ, EXAMINING ATTORNEY

CLASS 41—(Continued).

SN 85-454,513. FREMANTLEMEDIA NORTH AMERICA, INC., BURBANK, CA. FILED 10-24-2011.

THE BIG BLUFF

THE MARK CONSISTS OF STANDARD CHARACTERS WITHOUT CLAIM TO ANY PARTICULAR FONT, STYLE, SIZE, OR COLOR.

FOR ENTERTAINMENT SERVICES IN THE NATURE OF A REALITY-BASED GAME SHOW SERIES DELIVERED BY TELEVISION, RADIO, SATELLITE, THE INTERNET, STREAMING OR MOBILE COMMUNICATIONS IN THE FIELD OF A REALITY-BASED GAME SHOW SERIES; ENTERTAINMENT SERVICES, NAMELY, PROVIDING AN INTERACTIVE NON-DOWNLOADABLE COMPUTER GAME, AVAILABLE ON-LINE AND THROUGH MOBILE TELEPHONE OR COMMUNICATIONS NETWORKS; ENTERTAINMENT SERVICES, NAMELY, PROVIDING INTERACTIVE WEB JOURNALS AND BLOGS FEATURING INFORMATION AND STORIES IN THE FIELD OF REALITY-BASED GAME SHOWS, AVAILABLE ON-LINE AND THROUGH MOBILE TELEPHONE OR COMMUNICATIONS NETWORKS; PROVIDING ENTERTAINMENT INFORMATION ABOUT A REALITY-BASED GAME SHOW TELEVISION SERIES, THROUGH ON-LINE AND THROUGH MOBILE TELEPHONE OR COMMUNICATIONS NETWORKS; ENTERTAINMENT SERVICES IN THE NATURE OF SWEEPSTAKES SERVICES; ENTERTAINMENT SERVICES IN THE NATURE OF AN AMUSEMENT PARK ATTRACTION, NAMELY, A THEMED AREA (U.S. CLS. 100, 101 AND 107).

TINA MAI, EXAMINING ATTORNEY

SN 85-455,466. JOHNSON, DORI A., DBA PADDLESCULPT, MINNEAPOLIS, MN. FILED 10-25-2011.

Paddlesculpt

THE MARK CONSISTS OF STANDARD CHARACTERS WITHOUT CLAIM TO ANY PARTICULAR FONT, STYLE, SIZE, OR COLOR.

FOR PERSONAL FITNESS TRAINING SERVICES AND CONSULTANCY; RENTAL OF SPORTS EQUIPMENT (U.S. CLS. 100, 101 AND 107).

ANDREA HACK, EXAMINING ATTORNEY

CLASS 41—(Continued).

SN 85-455,936. AMERICAN BROADCASTING COMPANIES, INC., NEW YORK, NY. FILED 10-25-2011.

ABC SPARK

THE MARK CONSISTS OF STANDARD CHARACTERS WITHOUT CLAIM TO ANY PARTICULAR FONT, STYLE, SIZE, OR COLOR.

FOR PRODUCTION, PRESENTATION, DISTRIBUTION, AND RENTAL OF MOTION PICTURE FILMS; PRODUCTION, PRESENTATION, DISTRIBUTION, AND RENTAL OF TELEVISION AND RADIO PROGRAMS; PRODUCTION, PRESENTATION, AND RENTAL OF SOUND AND VISUAL RECORDINGS; PRODUCTION OF LIVE-ACTION AND ANIMATED ENTERTAINMENT SHOWS AND INTERACTIVE PROGRAMS FOR DISTRIBUTION VIA AUDIO AND VISUAL MEDIA, AND ELECTRONIC MEANS; PRODUCTION AND PROVISION OF ENTERTAINMENT NEWS AND ENTERTAINMENT INFORMATION VIA COMMUNICATION AND COMPUTER NETWORKS; PROVIDING ENTERTAINMENT SERVICES VIA A GLOBAL COMMUNICATION NETWORK IN THE NATURE OF ONLINE GAMES AND WEBSITES FEATURING A WIDE VARIETY OF GENERAL INTEREST ENTERTAINMENT INFORMATION RELATING TO MOTION PICTURE FILMS, TELEVISION SHOW PROGRAMS, MUSICAL VIDEOS, RELATED FILM CLIPS, PHOTOGRAPHS, AND OTHER MULTIMEDIA MATERIALS; AMUSEMENT PARK AND THEME PARK SERVICES; EDUCATIONAL AND ENTERTAINMENT SERVICES RENDERED IN OR RELATING TO THEME PARKS, NAMELY LIVE STAGE SHOWS, LIVE AMUSEMENT PARK SHOWS, LIVE PERFORMANCES BY COSTUMED CHARACTERS, AND PRESENTATION OF LIVE THEATRICAL PERFORMANCES; PRESENTATION OF LIVE STAGE SHOWS; PRESENTATION OF LIVE SHOW PERFORMANCES; THEATER PRODUCTIONS; ENTERTAINER SERVICES, NAMELY, LIVE APPEARANCES BY A PROFESSIONAL ENTERTAINER (U.S. CLS. 100, 101 AND 107).

NICHOLAS ALTREE, EXAMINING ATTORNEY

SN 85-457,496. TARGET BRANDS, INC., MINNEAPOLIS, MN. FILED 10-27-2011.



Path to Reading Excellence
in School Sites

NO CLAIM IS MADE TO THE EXCLUSIVE RIGHT TO USE "READING EXCELLENCE IN SCHOOL", APART FROM THE MARK AS SHOWN.

THE MARK CONSISTS OF A SILHOUETTE OF A STYLIZED OPEN BOOK ABOVE THE ACRONYM, "PRESS", FOLLOWED BY THE PHRASE "PATH TO READING EXCELLENCE IN SCHOOL SITES".

FOR EDUCATIONAL SERVICES, NAMELY, PROVIDING A READING PROGRAM COMPRISED OF TUTORING IN THE FIELD OF LITERACY AND READING DEVELOPMENT (U.S. CLS. 100, 101 AND 107).

ROBERT C. CLARK JR., EXAMINING ATTORNEY

CLASS 41—(Continued).

SN 85-459,225. DIRECTORS LIVE, LLC, MONTGOMERY, IL. FILED 10-28-2011.



NO CLAIM IS MADE TO THE EXCLUSIVE RIGHT TO USE "DIRECTORS LIVE" AND "INDIE ENTERTAINMENT NETWORK", APART FROM THE MARK AS SHOWN.

THE COLOR(S) GREY, RED, BLACK, AND WHITE IS/ ARE CLAIMED AS A FEATURE OF THE MARK.

THE MARK CONSISTS OF THE STYLIZED WORDS "DIRECTORS" IN GREY AND "LIVE" IN RED, WHICH COLORS ARE SHADED DARK TO LIGHT FROM BOTTOM TO TOP. THE STYLIZED WORDS "INDIE ENTERTAINMENT NETWORK" APPEAR BELOW IN WHITE. A GREY STAR IS USED IN PLACE OF THE PERIOD IN THE LETTER "I" IN "DIRECTORS" AND A RED STAR IS USED OVER IN PLACE OF THE PERIOD IN THE LETTER "I" IN "LIVE". A GREY STAR IS ENCLOSED IN THE LETTER "O" IN THE WORD "DIRECTORS". THE ENTIRE MARK IS ON A BLACK BACKGROUND.

FOR ENTERTAINMENT SERVICES, NAMELY, PROVIDING A WEB SITE FEATURING FILM, VIDEO, PHOTOGRAPHIC, AND AUDIO PRESENTATIONS FEATURING MOVIES, MOTION PICTURES, AND POPULAR CULTURE; PROVISION OF NON-DOWNLOADABLE MOTION PICTURES VIA A VIDEO-ON-DEMAND SERVICE (U.S. CLS. 100, 101 AND 107).

FIRST USE 1-31-2010; IN COMMERCE 1-31-2010.

BRENDAN MCCAULEY, EXAMINING ATTORNEY

SN 85-468,724. NASHVILLE CONVENTION & VISITORS BUREAU, NASHVILLE, TN. FILED 11-9-2011.



THE MARK CONSISTS OF A MUSIC NOTE. FOR HOSTING SOCIAL ENTERTAINMENT EVENTS, NAMELY, LIVE OUTDOOR NEW YEAR'S EVE PARTIES FOR OTHERS (U.S. CLS. 100, 101 AND 107).

FIRST USE 9-0-2009; IN COMMERCE 9-0-2009.

HENRY S. ZAK, EXAMINING ATTORNEY

CLASS 41—(Continued).

SN 85-474,002. EMUZE, LLC, BOSTON, MA. FILED 11-16-2011.



THE MARK CONSISTS OF A STYLIZED STAR DESIGN, FOR ENTERTAINMENT SERVICES, NAMELY, PROVIDING A WEBSITE FEATURING ENTERTAINMENT INFORMATION AND AN ONLINE PORTAL FOR ARTISTS, ACTORS, MUSICIANS, COMEDIANS, ENTERTAINERS, WRITERS, DESIGNERS, AND STYLISTS TO SHOWCASE THEIR TALENT (U.S. CLS. 100, 101 AND 107).

FIRST USE 8-1-2011; IN COMMERCE 8-1-2011.
SKYE YOUNG, EXAMINING ATTORNEY

SN 85-474,551. LEAGUE OF CALIFORNIA CITIES, SACRAMENTO, CA. FILED 11-16-2011.

**CALIFORNIA CIVIC
LEADERSHIP INSTITUTE**

THE MARK CONSISTS OF STANDARD CHARACTERS WITHOUT CLAIM TO ANY PARTICULAR FONT, STYLE, SIZE, OR COLOR.

NO CLAIM IS MADE TO THE EXCLUSIVE RIGHT TO USE "INSTITUTE", APART FROM THE MARK AS SHOWN, SEC. 2(F).

FOR EDUCATION SERVICES, NAMELY, MENTORING IN THE FIELD OF RECRUITMENT AND PROFESSIONAL TRAINING OF LOCAL OFFICIALS RELATED TO CAMPAIGNS, GRASSROOTS OUTREACH, POLICY, ADVOCACY, LEGISLATIVE PROCESS AND POLITICS; EDUCATIONAL SERVICES, NAMELY, CONDUCTING NON-DOWNLOADABLE SEMINARS, NON-DOWNLOADABLE WEBINARS, CONFERENCES AND WORKSHOPS IN THE FIELD OF RECRUITMENT AND PROFESSIONAL TRAINING OF LOCAL OFFICIALS RELATED TO CAMPAIGNS, GRASSROOTS OUTREACH, POLICY, ADVOCACY, LEGISLATIVE PROCESS AND POLITICS AND DISTRIBUTION OF EDUCATIONAL MATERIALS IN CONNECTION THEREWITH; EDUCATIONAL SERVICES, NAMELY, PROVIDING A LEARNING AND INNOVATION CENTER FEATURING

CLASS 41—(Continued).

FULLY CUSTOMIZED LEADERSHIP, MOTIVATIONAL, EDUCATIONAL, AND BRAINSTORMING TRAINING; EDUCATIONAL SERVICES, NAMELY, PROVIDING EDUCATIONAL SPEAKERS IN THE FIELD OF RECRUITMENT AND PROFESSIONAL TRAINING OF LOCAL OFFICIALS RELATED TO CAMPAIGNS, GRASSROOTS OUTREACH, POLICY, ADVOCACY, LEGISLATIVE PROCESS AND POLITICS; EDUCATIONAL SERVICES, NAMELY, PROVIDING INCENTIVES TO CANDIDATES FOR THE STATE LEGISLATURE TO DEMONSTRATE EXCELLENCE IN THE FIELD OF POLICY, CAMPAIGNS, GRASSROOTS OUTREACH, POLICY, ADVOCACY, AND STATE LEGISLATIVE PROCESS AND POLITICS THROUGH THE ISSUANCE OF AWARDS; PROVIDING ONLINE INTERVIEWS FEATURING LAWMAKERS IN THE FIELD OF PENDING LEGISLATION FOR EDUCATIONAL PURPOSES; PUBLIC SECTOR BUSINESS TRAINING; PUBLICATION OF DOCUMENTS IN THE FIELD OF TRAINING, SCIENCE, PUBLIC LAW AND SOCIAL AFFAIRS (U.S. CLS. 100, 101 AND 107).

FIRST USE 2-25-2005; IN COMMERCE 9-1-2005.
JAMES STEIN, EXAMINING ATTORNEY

SN 85-475,106. TEAM SIZZLE FILMS, INC., BALTIMORE, MD. FILED 11-17-2011.

T-SIZZLE

THE MARK CONSISTS OF STANDARD CHARACTERS WITHOUT CLAIM TO ANY PARTICULAR FONT, STYLE, SIZE, OR COLOR.

THE NAME(S), PORTRAIT(S), AND/OR SIGNATURE(S) SHOWN IN THE MARK IDENTIFIES TERRELL RAYMONN SUGGS, WHOSE CONSENT(S) TO REGISTER IS MADE OF RECORD.

FOR ENTERTAINMENT SERVICES, NAMELY, PERSONAL APPEARANCES BY A SPORTS CELEBRITY (U.S. CLS. 100, 101 AND 107).

JUDITH HELFMAN, EXAMINING ATTORNEY

SN 85-481,136. JOHNSON, DAVID J., NEW YORK, NY. FILED 11-27-2011.

**"And down the stretch they
come"**

THE MARK CONSISTS OF STANDARD CHARACTERS WITHOUT CLAIM TO ANY PARTICULAR FONT, STYLE, SIZE, OR COLOR.

FOR ENTERTAINMENT SERVICES, NAMELY, PARTICIPATION IN ANNOUNCING AND CALLING HORSE RACES FOR OTHERS (U.S. CLS. 100, 101 AND 107).

FIRST USE 4-28-1968; IN COMMERCE 4-28-1968.
PRISCILLA MILTON, EXAMINING ATTORNEY

CLASS 41—(Continued).

SN 85-485,798. PFIIP, LLC, NEWINGTON, NH. FILED 12-2-2011.

NEW LOCATION! SAME PLANET!

THE MARK CONSISTS OF STANDARD CHARACTERS WITHOUT CLAIM TO ANY PARTICULAR FONT, STYLE, SIZE, OR COLOR.

FOR PHYSICAL FITNESS INSTRUCTION AND TRAINING; HEALTH CLUB SERVICES, NAMELY, PROVIDING INSTRUCTION AND EQUIPMENT IN THE FIELD OF PHYSICAL EXERCISE (U.S. CLS. 100, 101 AND 107).

TEJBIR SINGH, EXAMINING ATTORNEY

SN 85-488,158. VIRTUOSO, LTD., FORT WORTH, TX. FILED 12-6-2011.

VIRTUOSO TRAVELER

THE MARK CONSISTS OF STANDARD CHARACTERS WITHOUT CLAIM TO ANY PARTICULAR FONT, STYLE, SIZE, OR COLOR.

OWNER OF U.S. REG. NOS. 3,095,926, 3,884,601 AND OTHERS.

NO CLAIM IS MADE TO THE EXCLUSIVE RIGHT TO USE "TRAVELER", APART FROM THE MARK AS SHOWN.

FOR PROVIDING ONLINE NON-DOWNLOADABLE PUBLICATIONS IN THE NATURE OF MAGAZINES IN THE FIELD OF TRAVEL (U.S. CLS. 100, 101 AND 107).

JULIE WATSON, EXAMINING ATTORNEY

SN 85-488,913. LIFESTYLE HEALTH NETWORKS, LLC, ATHENS, GA. FILED 12-6-2011.

OPTIME

THE MARK CONSISTS OF STANDARD CHARACTERS WITHOUT CLAIM TO ANY PARTICULAR FONT, STYLE, SIZE, OR COLOR.

FOR EDUCATIONAL SERVICES, NAMELY, CONDUCTING ONLINE PROGRAMS IN THE FIELD OF HEALTHCARE, HEALTH AND WELLNESS, EXERCISE, DIET AND PERSONAL ACCOUNTABILITY; PERSONAL TRAINER SERVICES, NAMELY, PROVIDING PERSONAL TRAINING IN CONNECTION WITH WEIGHT LOSS AND EXERCISE PROGRAMS; PERSONAL COACHING SERVICES IN THE FIELD HEALTH; PHYSICAL FITNESS INSTRUCTION (U.S. CLS. 100, 101 AND 107).

FIRST USE 11-22-2011; IN COMMERCE 11-22-2011.

LUCY ARANT, EXAMINING ATTORNEY

CLASS 41—(Continued).

SN 85-490,034. LUGO, NICOLAS ZENEN, MIAMI BEACH, FL. FILED 12-7-2011.

The Grid

THE MARK CONSISTS OF STANDARD CHARACTERS WITHOUT CLAIM TO ANY PARTICULAR FONT, STYLE, SIZE, OR COLOR.

FOR PROVIDING AMUSEMENT ARCADE SERVICES (U.S. CLS. 100, 101 AND 107).

BERYL GARDNER, EXAMINING ATTORNEY

SN 85-491,641. INDIANA INSTITUTE OF TECHNOLOGY, INC., FORT WAYNE, IN. FILED 12-9-2011.



THE MARK CONSISTS OF A STYLIZED DESIGN OF THE HEAD OF A WARRIOR FACING THE LEFT. THE WARRIOR IS WEARING A HELMET AND HOLDING A SHIELD. THE WORDING "I TECH" IN STYLIZED FORM APPEARS ON THE SHIELD. THE "TECH" APPEARS BETWEEN TWO HORIZONTAL LINES.

FOR ENTERTAINMENT IN THE NATURE OF COMPETITIONS IN THE FIELD OF BASEBALL, BASKETBALL, BOWLING, CROSS COUNTRY, GOLF, LACROSSE, SOCCER, SOFTBALL, TENNIS, TRACK AND FIELD, VOLLEYBALL AND WRESTLING (U.S. CLS. 100, 101 AND 107).

FIRST USE 1-1-2011; IN COMMERCE 1-1-2011.

NANCY CLARKE, EXAMINING ATTORNEY

CLASS 41—(Continued).

SN 85-492,544. LEVS, JOSHUA, ATLANTA, GA. FILED 12-12-2011.

BE THE CUPS AND ICE

THE MARK CONSISTS OF STANDARD CHARACTERS WITHOUT CLAIM TO ANY PARTICULAR FONT, STYLE, SIZE, OR COLOR.

FOR EDUCATIONAL AND ENTERTAINMENT SERVICES, NAMELY, PROVIDING MOTIVATIONAL SPEAKING SERVICES IN THE FIELD OF PERSONAL DEVELOPMENT (U.S. CLS. 100, 101 AND 107).

JAMES LOVELACE, EXAMINING ATTORNEY

SN 85-492,748. SOUNDBRUSH RECORDS LLC, BROOKLYN, NY. FILED 12-12-2011.

SOUNDBRUSH RECORDS

THE MARK CONSISTS OF STANDARD CHARACTERS WITHOUT CLAIM TO ANY PARTICULAR FONT, STYLE, SIZE, OR COLOR.

NO CLAIM IS MADE TO THE EXCLUSIVE RIGHT TO USE "RECORDS", APART FROM THE MARK AS SHOWN.

FOR RECORD PRODUCTION, AUDIO RECORDING AND PRODUCTION, AND VIDEOTAPE PRODUCTION, ALL FEATURING MUSIC; RECORD PRODUCTION, AUDIO RECORDING AND PRODUCTION, AND VIDEOTAPE PRODUCTION, ALL FEATURING MUSIC RESULTING FROM A COLLABORATION BETWEEN MUSICIANS AND VISUAL ARTISTS AND/OR THE INSPIRATIONS OF MUSICIANS BY VISUAL ARTISTS (U.S. CLS. 100, 101 AND 107).

FIRST USE 8-17-2003; IN COMMERCE 8-17-2003.
COURTNEY ALVAREZ, EXAMINING ATTORNEY

SN 85-494,719. POINTS OF LIFE, LLC, WALMUT CREEK, CA. FILED 12-14-2011.

POINTS OF LIFE

THE MARK CONSISTS OF STANDARD CHARACTERS WITHOUT CLAIM TO ANY PARTICULAR FONT, STYLE, SIZE, OR COLOR.

FOR EDUCATION SERVICES, NAMELY, PROVIDING LIVE AND ON-LINE CLASSES, SEMINARS, WORKSHOPS AND COURSES IN THE FIELD OF TEACHING FAMILIES TO PLAN FOR LIFE'S STAGES IN RELATION TO ELDER CARE; LIFE COACHING SERVICES IN THE FIELD OF TEACHING FAMILIES TO PLAN FOR LIFE'S STAGES IN RELATION TO ELDER CARE (U.S. CLS. 100, 101 AND 107).

FIRST USE 1-0-2011; IN COMMERCE 1-0-2011.
SOPHIA S. KIM, EXAMINING ATTORNEY

CLASS 41—(Continued).

SN 85-498,506. ALISSA IIDA, LAS VEGAS, NV. FILED 12-19-2011.

**D.A.N.C.E.
Discover A New Creative
Energy**

THE MARK CONSISTS OF STANDARD CHARACTERS WITHOUT CLAIM TO ANY PARTICULAR FONT, STYLE, SIZE, OR COLOR.

NO CLAIM IS MADE TO THE EXCLUSIVE RIGHT TO USE "DANCE", APART FROM THE MARK AS SHOWN.

FOR EDUCATIONAL SERVICES, NAMELY, CONDUCTING LIVE CLASSES, SEMINARS, WORKSHOPS, AND LECTURES IN THE FIELDS OF MENTAL, PHYSICAL AND SPIRITUAL WELLNESS AND PERSONAL MOTIVATION AND INSPIRATION (U.S. CLS. 100, 101 AND 107).

FIRST USE 9-1-2011; IN COMMERCE 9-1-2011.
HEATHER BIDDULPH, EXAMINING ATTORNEY

SN 85-499,560. BRETT SEGALL, WESTON, MA. FILED 12-20-2011.

CMDY

THE MARK CONSISTS OF STANDARD CHARACTERS WITHOUT CLAIM TO ANY PARTICULAR FONT, STYLE, SIZE, OR COLOR.

FOR ENTERTAINMENT SERVICES, NAMELY, PROVIDING A WEB SITE FEATURING NEWS AND HUMOR; PROVIDING ON-LINE JOURNALS, NAMELY BLOGS IN THE FIELD OF HUMOR; ENTERTAINMENT SERVICES, NAMELY, PROVIDING A WEBSITE FEATURING AUDIO CLIPS, VIDEO CLIPS, PERFORMANCES, VIDEOS, FILM CLIPS, PHOTOGRAPHS FEATURING HUMOR (U.S. CLS. 100, 101 AND 107).

JEFF DEFORD, EXAMINING ATTORNEY

CLASS 41—(Continued).

SN 85-503,632. SMITH, CRAIG, OLD BROOKVILLE, NY.
FILED 12-25-2011.

Scholar Zen

THE MARK CONSISTS OF STANDARD CHARACTERS WITHOUT CLAIM TO ANY PARTICULAR FONT, STYLE, SIZE, OR COLOR.

NO CLAIM IS MADE TO THE EXCLUSIVE RIGHT TO USE "SCHOLAR", APART FROM THE MARK AS SHOWN.

FOR CONSULTATION IN THE FIELD OF K-12 EDUCATIONAL SYSTEMS; EDUCATING AT SENIOR HIGH SCHOOLS; EDUCATING AT UNIVERSITY OR COLLEGES; EDUCATION SERVICES IN THE NATURE OF EARLY CHILDHOOD INSTRUCTION; EDUCATION SERVICES, NAMELY, PROVIDING KINDERGARTEN THROUGH 12TH GRADE (K-12) CLASSROOM INSTRUCTION; EDUCATIONAL AND ENTERTAINMENT SERVICES, NAMELY, PROVIDING MOTIVATIONAL AND EDUCATIONAL SPEAKERS; EDUCATIONAL COUNSELING SERVICES TO ASSIST STUDENTS IN PLANNING AND PREPARING FOR FURTHER EDUCATION; EDUCATIONAL EXAMINATION SERVICES; EDUCATIONAL SERVICES, NAMELY, DEVELOPING CURRICULUM FOR EDUCATORS; EDUCATIONAL SERVICES, NAMELY, PROVIDING A LEARNING AND INNOVATION CENTER FEATURING FULLY CUSTOMIZED LEADERSHIP, MOTIVATIONAL, EDUCATIONAL, AND BRAINSTORMING TRAINING; ENTERTAINMENT SERVICES, NAMELY, PROVIDING A WEBSITE AT WHICH THE GENERAL PUBLIC CAN RECEIVE ADVICE FROM AN INDIVIDUAL OR ENTITY CONCERNING HAPPINESS, SUCH ADVICE BEING FOR ENTERTAINMENT PURPOSES ONLY; INFORMATION IN THE FIELD OF PARENTING CONCERNING EDUCATION OF CHILDREN; ON-LINE EDUCATIONAL PARENTAL TRAINING CLASSES; PHYSICAL EDUCATION SERVICES; PROVIDING A WEB SITE FEATURING ON-LINE PUBLICATIONS IN THE FIELD OF NEWS ARTICLES FOR CHILDREN; PROVIDING A WEB SITE THAT FEATURES INFORMATION ABOUT ONLINE HIGHER EDUCATION RESOURCES; PROVIDING A WEBSITE FEATURING INFORMATION IN THE FIELDS OF EDUCATION AND ENTERTAINMENT FOR CHILDREN; PROVIDING A WEBSITE FEATURING INFORMATION ON EXERCISE AND FITNESS; PROVIDING ADVICE AND INFORMATION TO ADULT FAMILY MEMBERS ON APPROPRIATE ENTERTAINMENT AND LEISURE ACTIVITIES FOR YOUNGER FAMILY MEMBERS; PROVIDING AN ACADEMIC HONOR SOCIETY IN WHICH STUDENTS ARE ADMITTED IN RECOGNITION OF ACADEMIC ACHIEVEMENT; PROVIDING ASSISTANCE, PERSONAL TRAINING AND PHYSICAL FITNESS CONSULTATION TO INDIVIDUALS TO HELP THEM MAKE PHYSICAL FITNESS, STRENGTH, CONDITIONING, AND EXERCISE IMPROVEMENT IN THEIR DAILY LIVING; PROVIDING INFORMATION ON PHYSICAL EXERCISE; PROVIDING INFORMATION RELATING TO EDUCATION SERVICES FOR CHILDREN; PROVIDING INFORMATION RELATING TO EDUCATIONAL AND ENTERTAINMENT ACTIVITIES AND EVENTS FOR CHILDREN; PROVIDING INFORMATION RELATING TO EDUCATIONAL SERVICES (U.S. CLS. 100, 101 AND 107).

SOPHIA S. KIM, EXAMINING ATTORNEY

CLASS 41—(Continued).

SN 85-514,315. MUSICALLY YOURS, INC., MILLBURN, NJ.
FILED 1-11-2012.

MUSIC PRELUDES

THE MARK CONSISTS OF STANDARD CHARACTERS WITHOUT CLAIM TO ANY PARTICULAR FONT, STYLE, SIZE, OR COLOR.

OWNER OF U.S. REG. NO. 3,054,080.

NO CLAIM IS MADE TO THE EXCLUSIVE RIGHT TO USE "MUSIC", APART FROM THE MARK AS SHOWN.

FOR MUSIC EDUCATION AND DISTRIBUTING COURSE MATERIAL IN CONNECTION THEREWITH; CONSULTANCY SERVICES IN THE AREA OF OFFERING MUSIC EDUCATION; ENTERTAINMENT SERVICES, NAMELY, PROVIDING PRERECORDED MUSIC, INFORMATION IN THE FIELD OF MUSIC INSTRUCTION, AND COMMENTARY AND ARTICLES ABOUT MUSIC INSTRUCTION; EDUCATION SERVICES IN THE NATURE OF EARLY CHILDHOOD INSTRUCTION (U.S. CLS. 100, 101 AND 107).

FIRST USE 5-6-1987; IN COMMERCE 5-6-1987.

TEJBIR SINGH, EXAMINING ATTORNEY

SN 85-516,211. PLANET HOLLYWOOD (REGION IV), INC.,
ORLANDO, FL. FILED 1-13-2012.

PLANET24SEVEN

THE MARK CONSISTS OF STANDARD CHARACTERS WITHOUT CLAIM TO ANY PARTICULAR FONT, STYLE, SIZE, OR COLOR.

OWNER OF U.S. REG. NO. 3,305,833.

FOR ENTERTAINMENT SERVICES, NAMELY, PROVIDING A WEBSITE FOR VIEWING NON-DOWNLOADABLE VIDEO, AUDIO AND MULTIMEDIA MATERIALS IN THE NATURE OF MOVIE TRAILERS, FILMS, RED CARPET EVENTS, REALITY INTERVIEWS, AND OTHER ENTERTAINMENT INFORMATION VIA A GLOBAL COMMUNICATIONS NETWORKS; PRODUCING AUDIO RECORDINGS, VIDEOS, AND MULTIMEDIA MATERIALS FEATURING MOVIE TRAILERS, FILMS, RED CARPET EVENTS, REALITY INTERVIEW, AND OTHER ENTERTAINMENT, FASHION AND LIFESTYLE INFORMATION FOR THE WEBSITES OF OTHERS; ENTERTAINMENT SERVICES, NAMELY, PROVIDING AN ON-GOING SERIES FEATURING MOVIE TRAILERS, FILMS, REALITY INTERVIEWS, ENTERTAINMENT, FASHION AND LIFESTYLE INFORMATION, AND OTHER TOPICS OF GENERAL INTEREST VIA A GLOBAL COMPUTER NETWORK (U.S. CLS. 100, 101 AND 107).

ANDREW LEASER, EXAMINING ATTORNEY

CLASS 41—(Continued).

SN 85-519,165. INTELLECTUAL PROPERTY ASSETS MANAGEMENT, INC., MIAMI, FL. FILED 1-18-2012.

WANNADO

THE MARK CONSISTS OF STANDARD CHARACTERS WITHOUT CLAIM TO ANY PARTICULAR FONT, STYLE, SIZE, OR COLOR.

OWNER OF U.S. REG. NOS. 3,174,726, 3,680,319 AND OTHERS.

FOR PROVIDING FACILITIES FOR RECREATIONAL ACTIVITIES; AMUSEMENT PARKS; CHILDREN'S ENTERTAINMENT AND AMUSEMENT CENTERS, NAMELY, INTERACTIVE PLAY AREAS; PROVIDING SPORTS FACILITIES; PROVIDING THEME PARK SERVICES; GYMNASIUMS; EDUCATIONAL THEME PARK SERVICES (U.S. CLS. 100, 101 AND 107).

JAY FLOWERS, EXAMINING ATTORNEY

SN 85-519,173. INTELLECTUAL PROPERTY ASSETS MANAGEMENT, INC., MIAMI, FL. FILED 1-18-2012.

WANNADO CITY

THE MARK CONSISTS OF STANDARD CHARACTERS WITHOUT CLAIM TO ANY PARTICULAR FONT, STYLE, SIZE, OR COLOR.

OWNER OF U.S. REG. NOS. 3,174,726, 3,680,319 AND OTHERS.

FOR PROVIDING FACILITIES FOR RECREATIONAL ACTIVITIES; AMUSEMENT PARKS; CHILDREN'S ENTERTAINMENT AND AMUSEMENT CENTERS, NAMELY, INTERACTIVE PLAY AREAS; PROVIDING SPORTS FACILITIES; PROVIDING THEME PARK SERVICES; GYMNASIUMS; EDUCATIONAL THEME PARK SERVICES (U.S. CLS. 100, 101 AND 107).

JAY FLOWERS, EXAMINING ATTORNEY

CLASS 41—(Continued).

SN 85-519,512. PLANET HOLLYWOOD (REGION IV), INC., ORLANDO, FL. FILED 1-18-2012.

PLANET247

THE MARK CONSISTS OF STANDARD CHARACTERS WITHOUT CLAIM TO ANY PARTICULAR FONT, STYLE, SIZE, OR COLOR.

OWNER OF U.S. REG. NO. 3,305,833.

FOR ENTERTAINMENT SERVICES, NAMELY, PROVIDING A WEBSITE FOR VIEWING NON-DOWNLOADABLE VIDEO, AUDIO AND MULTIMEDIA MATERIALS IN THE NATURE OF MOVIE TRAILERS, FILMS, RED CARPET EVENTS, REALITY INTERVIEWS, AND OTHER ENTERTAINMENT INFORMATION VIA A GLOBAL COMMUNICATIONS NETWORKS; PRODUCING AUDIO RECORDINGS, VIDEOS, AND MULTIMEDIA MATERIALS FEATURING MOVIE TRAILERS, FILMS, RED CARPET EVENTS, REALITY INTERVIEW, AND OTHER ENTERTAINMENT, FASHION AND LIFESTYLE INFORMATION FOR THE WEBSITES OF OTHERS; ENTERTAINMENT SERVICES, NAMELY, PROVIDING AN ON-GOING SERIES FEATURING MOVIE TRAILERS, FILMS, REALITY INTERVIEWS, ENTERTAINMENT, FASHION AND LIFESTYLE INFORMATION, AND OTHER TOPICS OF GENERAL INTEREST VIA A GLOBAL COMPUTER NETWORK (U.S. CLS. 100, 101 AND 107).

ANDREW LEASER, EXAMINING ATTORNEY

SN 85-522,163. MICHAEL KEANE, SANTA MONICA, CA. FILED 1-22-2012.

THE KILL MACHINE

THE MARK CONSISTS OF STANDARD CHARACTERS WITHOUT CLAIM TO ANY PARTICULAR FONT, STYLE, SIZE, OR COLOR.

FOR ENTERTAINMENT SERVICES, NAMELY, PRODUCTION AND DISTRIBUTION OF MOTION PICTURES, TELEVISION PROGRAMS, DOCUMENTARY PROGRAMS AND MOTION PICTURES, ANIMATED PROGRAMS AND MOTION PICTURES, COMPUTER, VIDEO AND ELECTRONIC GAMES (U.S. CLS. 100, 101 AND 107).

JACQUELINE A. LAVINE, EXAMINING ATTORNEY

CLASS 41—(Continued).

SN 85-524,999. CENTRAL RECOVERY HOLDINGS, LLC, LAS VEGAS, NV. FILED 1-25-2012.

CLASS 41—(Continued).

SN 85-529,571. ANGRY, TRAVIS, PEORIA, AZ. FILED 1-31-2012.



CHANGE IF I CAN, YOU CAN

NO CLAIM IS MADE TO THE EXCLUSIVE RIGHT TO USE "RECOVERY PRESS", APART FROM THE MARK AS SHOWN.

THE MARK CONSISTS OF THE TEXT "CRP" CENTERED ABOVE THE TEXT "CENTRAL RECOVERY PRESS" WITH AN EIGHT POINT STAR CENTERED INSIDE THE "C" OF THE TEXT "CRP".

FOR PUBLISHING OF TEXTS, BOOKS, JOURNALS AND OTHER PRINTED MATTER; PROVIDING A WEBSITE FEATURING INFORMATION ABOUT PUBLICATIONS IN THE NATURE OF TEXTS, BOOKS AND JOURNALS IN THE FIELDS OF CHEMICAL DEPENDENCY, ADDICTION TREATMENT, PAIN MANAGEMENT, COUNSELING AND OTHER MEDICAL REHABILITATION SERVICES; ON-LINE ELECTRONIC NEWSLETTERS DELIVERED BY E-MAIL IN THE FIELDS OF CHEMICAL DEPENDENCY, ADDICTION TREATMENT, PAIN MANAGEMENT, COUNSELING AND OTHER MEDICAL REHABILITATION SERVICES (U.S. CLS. 100, 101 AND 107).

FIRST USE 6-27-2011; IN COMMERCE 6-27-2011.
ROBERT C. CLARK JR., EXAMINING ATTORNEY

THE MARK CONSISTS OF STANDARD CHARACTERS WITHOUT CLAIM TO ANY PARTICULAR FONT, STYLE, SIZE, OR COLOR.

FOR ENTERTAINMENT SERVICES IN THE NATURE OF PERSONAL APPEARANCES BY AN AUTHOR AND SELF IMPROVEMENT MOTIVATIONAL SPECIALIST (U.S. CLS. 100, 101 AND 107).

FIRST USE 9-6-2009; IN COMMERCE 11-3-2011.
ELLEN PERKINS, EXAMINING ATTORNEY

SN 85-525,231. SCRIPPS MEDIA, INC., CINCINNATI, OH. FILED 1-25-2012.

MARCONEWS.COM



THE MARK CONSISTS OF STANDARD CHARACTERS WITHOUT CLAIM TO ANY PARTICULAR FONT, STYLE, SIZE, OR COLOR.

SEC. 2(F).
FOR PROVIDING AN INTERACTIVE COMPUTER DATABASE CONTAINING INFORMATION IN THE FIELD OF SPORTS, ENTERTAINMENT, FINE ARTS AND LOCAL AND NATIONAL NEWS (U.S. CLS. 100, 101 AND 107).

FIRST USE 8-21-2000; IN COMMERCE 8-21-2000.
WILLIAM VERHOSEK, EXAMINING ATTORNEY

THE MARK CONSISTS OF THE WORD "GRISWOLDS" OVER A STYLIZED DESIGN OF A PENTAGRAM.

FOR ENTERTAINMENT IN THE NATURE OF A LIVE MUSICAL GROUP (U.S. CLS. 100, 101 AND 107).

FIRST USE 12-2-2011; IN COMMERCE 12-9-2011.
KHANH LE, EXAMINING ATTORNEY

CLASS 41—(Continued).

SN 85-533,180. ROCK CLUB PARTNERS LLC, CHICAGO, IL.
FILED 2-3-2012.

Altered Stage

THE MARK CONSISTS OF STANDARD CHARACTERS WITHOUT CLAIM TO ANY PARTICULAR FONT, STYLE, SIZE, OR COLOR.

NO CLAIM IS MADE TO THE EXCLUSIVE RIGHT TO USE "STAGE", APART FROM THE MARK AS SHOWN.

FOR EDUCATIONAL SERVICES, NAMELY, CONDUCTING CLASSES, SEMINARS, CONFERENCES AND WORKSHOPS IN THE FIELDS OF MUSIC PERFORMANCE, SONG WRITING AND LIVE MUSICAL PERFORMANCE AND DISTRIBUTION OF TRAINING MATERIALS IN CONNECTION THEREWITH; MEMBERSHIP CLUB SERVICES, NAMELY, PROVIDING TRAINING TO MEMBERS IN THE FIELD OF MUSIC PERFORMANCE, SONG WRITING, LIVE MUSICAL PERFORMANCE, CONCERTS AND ENTERTAINMENT IN THE NATURE OF PERFORMING LIVE MUSICAL SHOWS, EVENTS AND CONCERTS (U.S. CLS. 100, 101 AND 107).

MARC LEIPZIG, EXAMINING ATTORNEY

SN 85-534,448. GMS SWEDEN AB, STOCKHOLM, SWEDEN,
FILED 2-6-2012.

GMS E-Learning

THE MARK CONSISTS OF STANDARD CHARACTERS WITHOUT CLAIM TO ANY PARTICULAR FONT, STYLE, SIZE, OR COLOR.

OWNER OF SWEDEN REG. NO. CTMNO0100972, DATED 11-28-2011, EXPIRES 11-28-2021.

NO CLAIM IS MADE TO THE EXCLUSIVE RIGHT TO USE "E-LEARNING", APART FROM THE MARK AS SHOWN.

FOR CONSULTATION IN THE FIELD OF K-12 EDUCATIONAL SYSTEMS; CONTINUING EDUCATION SERVICES, NAMELY, PROVIDING LIVE AND ON-LINE CONTINUING PROFESSIONAL EDUCATION SEMINARS IN THE FIELD OF LANGUAGE TRAINING (U.S. CLS. 100, 101 AND 107).

MATTHEW KLINE, EXAMINING ATTORNEY

CLASS 41—(Continued).

SN 85-536,689. ARNOLD, RAYMOND, EASTERN, MA.
FILED 2-8-2012.



THE COLOR(S) BLACK AND ORANGE IS/ARE CLAIMED AS A FEATURE OF THE MARK.

THE MARK CONSISTS OF THE TERM "CURV" IN LARGE STYLIZED BLACK FONT WITH THE TERM "METRIX" NEXT TO IT IN SMALLER BLACK STYLIZED FONT, EXTENDING FROM THE LETTER "R" OF THE WORD "CURV" IS AN ORANGE FEATHER THAT EXTENDS TO FORM THE LOWER LEFT LEG OF THE "X" IN THE WORD "METRIX".

FOR BEAUTY ARTS INSTRUCTION; EDUCATION SERVICES, NAMELY, PROVIDING LIVE AND ON-LINE CLASSES, SEMINARS, AND WORKSHOPS IN THE FIELD OF HAIR; TEACHING OF BEAUTY SKILLS (U.S. CLS. 100, 101 AND 107).

ASMAT KHAN, EXAMINING ATTORNEY

SN 85-546,291. AMERICAN JEWISH COMMITTEE, THE,
NEW YORK, NY. FILED 2-17-2012.



THE MARK CONSISTS OF A FRONT-FACING DIRECTOR'S CHAIR WITH A JEWISH STAR DISPLAYED ON THE CHAIR BACK, ENCLOSED WITHIN A CIRCLE THAT CONSISTS OF AN INNER SHADED PORTION CIRCUMSCRIBED BY AN OUTER SHADED BAND CONTAINING SHADED SQUARES.

FOR ENTERTAINMENT SERVICES, NAMELY, PLANNING AND CONDUCTING A SERIES OF FILM FESTIVALS (U.S. CLS. 100, 101 AND 107).

FIRST USE 2-8-2011; IN COMMERCE 2-8-2011.

ODESSA BIBBINS, EXAMINING ATTORNEY

CLASS 41—(Continued).

SN 85-547,566. CAMP KESEM NATIONAL, LAFAYETTE, CA. FILED 2-20-2012.



OWNER OF U.S. REG. NOS. 2,992,058 AND 3,044,668.
NO CLAIM IS MADE TO THE EXCLUSIVE RIGHT TO USE "CAMP", APART FROM THE MARK AS SHOWN.

THE MARK CONSISTS OF THE WORDS "CAMP KESEM" RENDERED IN A FANCIFUL TYPEFACE, BENEATH A PICTURE OF A STYLIZED CATERPILLAR FACING TO THE RIGHT, FORMED BY A SERIES OF CONNECTED AND OVERLAPPING CIRCLES, AND FEATURING AN ARCHED BACK, TWO SETS OF STYLIZED FEET, AND THE SIDE VIEW OF A FACE FEATURING ONE EYE AND AN OPEN MOUTH.

FOR PROVIDING TRAINING SERVICES IN THE AREAS OF ADMINISTRATION, PLANNING AND OPERATIONS FOR CAMPS FOR CHILDREN WHO HAVE OR HAVE HAD A PARENT WITH CANCER (U.S. CLS. 100, 101 AND 107).

FIRST USE 2-14-2007; IN COMMERCE 2-14-2007.
DOMINICK J. SALEMI, EXAMINING ATTORNEY

SN 85-550,821. CONDREN, JOHN F., MORGAN HILL, CA. FILED 2-23-2012.

championship

THE MARK CONSISTS OF STANDARD CHARACTERS WITHOUT CLAIM TO ANY PARTICULAR FONT, STYLE, SIZE, OR COLOR.

OWNER OF U.S. REG. NOS. 4,001,805 AND 4,018,554.
FOR ENTERTAINMENT IN THE NATURE OF AUTOMOBILE RACES (U.S. CLS. 100, 101 AND 107).

FIRST USE 5-1-2011; IN COMMERCE 5-1-2011.
TRICIA SONNEBORN, EXAMINING ATTORNEY

SN 85-551,029. PALADINO, DAVE, ELMWOOD PARK, NJ. FILED 2-23-2012.

STRIKE-ZONE

THE MARK CONSISTS OF STANDARD CHARACTERS WITHOUT CLAIM TO ANY PARTICULAR FONT, STYLE, SIZE, OR COLOR.

FOR PHYSICAL FITNESS TRAINING AND INSTRUCTION SERVICES, NAMELY, MARTIAL ARTS TRAINING AND INSTRUCTION; CONDUCTING FITNESS CLASSES IN THE FIELD OF MARTIAL ARTS (U.S. CLS. 100, 101 AND 107).

FIRST USE 7-8-2010; IN COMMERCE 7-8-2010.
TIMOTHY FINNEGAN, EXAMINING ATTORNEY

CLASS 41—(Continued).

SN 85-552,658. VILLAGE VOICE MEDIA HOLDINGS, LLC, PHOENIX, AZ. FILED 2-24-2012.

LA Weekly Gold Standard

THE MARK CONSISTS OF STANDARD CHARACTERS WITHOUT CLAIM TO ANY PARTICULAR FONT, STYLE, SIZE, OR COLOR.

OWNER OF U.S. REG. NOS. 1,650,744, 2,142,064 AND 3,379,111.

SEC. 2(F) AS TO "LA WEEKLY".

FOR ARRANGING AND CONDUCTING SPECIAL EVENTS FOR SOCIAL AND ENTERTAINMENT PURPOSES, NAMELY, EVENTS FEATURING RESTAURANTS AND WINE PURVEYORS THAT ALLOW FOR EATING AND DRINKING IN A SINGLE LOCATION (U.S. CLS. 100, 101 AND 107).

FIRST USE 3-8-2009; IN COMMERCE 3-8-2009.
INGA ERVIN, EXAMINING ATTORNEY

SN 85-554,791. PIVARAL, ALEJANDRO, GUATEMALA, GUATEMALA, FILED 2-28-2012.

THE MARK CONSISTS OF A MAP MARKER WITH THE STYLIZED TEXT "BUNKER GLAM".

FOR ENTERTAINMENT SERVICES, NAMELY, PROVIDING A WEB SITE FEATURING PHOTOGRAPHS OF PEOPLE ATTENDING SOCIAL, CULTURAL, AND SPORTS EVENTS, REVIEWS OF MUSIC AND OTHER INFORMATION RELATED TO ORGANIZING CULTURAL, SPORTS, AND SOCIAL EVENTS (U.S. CLS. 100, 101 AND 107).

KELLY BOULTON, EXAMINING ATTORNEY

SN 85-556,143. TRIGIRL SPORTS, DBA TRIGIRL SPORTS, FRIENDSWOOD, TX. FILED 2-29-2012.

MuddyGirl

THE MARK CONSISTS OF STANDARD CHARACTERS WITHOUT CLAIM TO ANY PARTICULAR FONT, STYLE, SIZE, OR COLOR.

FOR ARRANGING AND CONDUCTING ATHLETIC COMPETITIONS; ORGANIZING, ARRANGING, AND CONDUCTING MUD RUN EVENTS (U.S. CLS. 100, 101 AND 107).

FIRST USE 2-1-2012; IN COMMERCE 2-1-2012.
TARAH HARDY, EXAMINING ATTORNEY

CLASS 41—(Continued).

SN 85-556,747. IROK EVENTS, LLC, HENDERSON, NV. FILED 2-29-2012.

iROK

THE MARK CONSISTS OF STANDARD CHARACTERS WITHOUT CLAIM TO ANY PARTICULAR FONT, STYLE, SIZE, OR COLOR.

FOR ENTERTAINMENT IN THE NATURE OF LIVE MUSICAL PERFORMERS, DJ'S, AND PERFORMANCE ARTISTS; CONDUCTING ENTERTAINMENT EXHIBITIONS IN THE NATURE OF MUSIC FESTIVALS, ART EXHIBITIONS, AND DANCES (U.S. CLS. 100, 101 AND 107).

FIRST USE 6-1-2005; IN COMMERCE 6-1-2005.
ALEXANDER L. POWERS, EXAMINING ATTORNEY

SN 85-562,989. PLAYTIKA LTD., TEL AVIV, ISRAEL, FILED 3-7-2012.



THE COLOR(S) BEIGE, BLACK, RED, GRAY AND PINK IS/ARE CLAIMED AS A FEATURE OF THE MARK.

THE MARK CONSISTS OF THE STYLIZED IMAGE OF A MEDITATING ASIAN MAN WITH BEIGE FACE, EARS AND HANDS, BLACK EYEBROWS WITH A RED DOT BETWEEN THEM, BLACK EYES, NOSE AND MOUTH, PINK CHEEKS, RED TONGUE AND RED CLOTHING, WITH A GRAY OVAL DESIGN APPEARING BELOW THE DESIGN OF A MAN.

FOR ENTERTAINMENT SERVICES, NAMELY, PROVIDING ON-LINE COMPUTER GAMES AND GAME APPLICATIONS, ENHANCEMENTS WITHIN ONLINE COMPUTER GAMES, AND GAME APPLICATIONS WITHIN ONLINE COMPUTER GAMES; PROVIDING ONLINE REVIEWS OF COMPUTER GAMES, AND PROVIDING OF INFORMATION RELATING TO COMPUTER GAMES; PROVIDING AN INTERNET WEBSITE PORTAL IN THE FIELD OF COMPUTER GAMES AND GAMING; ENTERTAINMENT SERVICES, NAMELY, PROVIDING VIRTUAL ENVIRONMENTS IN WHICH USERS CAN INTERACT THROUGH SOCIAL GAMES FOR RECREATIONAL, LEISURE OR ENTERTAINMENT PURPOSES (U.S. CLS. 100, 101 AND 107).

FIRST USE 12-16-2010; IN COMMERCE 12-16-2010.
RICHARD WHITE, EXAMINING ATTORNEY

CLASS 41—(Continued).

SN 85-563,979. LIFE BY DESIGN COACHING SERVICES LLC, LAFAYETTE, CO. FILED 3-8-2012.

Beyond Divorce

THE MARK CONSISTS OF STANDARD CHARACTERS WITHOUT CLAIM TO ANY PARTICULAR FONT, STYLE, SIZE, OR COLOR.

NO CLAIM IS MADE TO THE EXCLUSIVE RIGHT TO USE "DIVORCE", APART FROM THE MARK AS SHOWN.

FOR PROVIDING PERSONAL COACHING SERVICES, TRAINING, WORKSHOPS, SEMINARS, AND ON-LINE NON-DOWNLOADABLE PUBLICATIONS IN THE NATURE OF BLOGS AND E-ZINES, ALL IN THE FIELD OF PERSONAL RELATIONSHIPS (U.S. CLS. 100, 101 AND 107).

FIRST USE 1-12-2012; IN COMMERCE 1-12-2012.
CYNTHIA TRIPI, EXAMINING ATTORNEY

SN 85-565,227. PRISON FELLOWSHIP INTERNATIONAL, WASHINGTON, DC. FILED 3-9-2012.

ART FROM INSIDE

THE MARK CONSISTS OF STANDARD CHARACTERS WITHOUT CLAIM TO ANY PARTICULAR FONT, STYLE, SIZE, OR COLOR.

NO CLAIM IS MADE TO THE EXCLUSIVE RIGHT TO USE "ART", APART FROM THE MARK AS SHOWN.

FOR ARRANGING AND CONDUCTING ART SHOWS, ART EXHIBITIONS, AND COMPETITIONS FEATURING WORKS OF ART PRODUCED BY INMATES (U.S. CLS. 100, 101 AND 107).

JACQUELINE A. LAVINE, EXAMINING ATTORNEY

SN 85-567,053. HARRIS, REVEREND PRENTISS W., EAST MOLINE, IL. FILED 3-12-2012.



THE MARK CONSISTS OF BLOCK CAPITAL LETTERS "ZYX" WITH THE BLOCK CAPITAL LETTERS "ABC" ALTERNATING BETWEEN THE "ZYX" LETTERS; UNDERNEATH THE CAPITAL LETTERS ARE TWO LINES WITH ARROWS, ONE POINTING RIGHT AND ONE POINTING LEFT WITH THE WORDS "MASTERY STANDARD FOR EXCELLENCE" IN BETWEEN THE ARROWED LINES.

FOR EDUCATIONAL SERVICES, NAMELY, CONDUCTING INSPIRATIONAL WORKSHOPS IN THE FIELD OF RELIGION AND SPIRITUALITY (U.S. CLS. 100, 101 AND 107).

FIRST USE 12-4-2011; IN COMMERCE 12-4-2011.
KATHLEEN LORENZO, EXAMINING ATTORNEY

CLASS 41—(Continued).

SN 85-568,630. NOBLE PIG, LLC, MCMINNVILLE, OR.
FILED 3-13-2012.

NOBLE PIG

THE MARK CONSISTS OF STANDARD CHARACTERS WITHOUT CLAIM TO ANY PARTICULAR FONT, STYLE, SIZE, OR COLOR.

OWNER OF U.S. REG. NO. 3,854,981.

FOR ENTERTAINMENT SERVICES, NAMELY, WINE TASTINGS; ENTERTAINMENT SERVICES, NAMELY, DRINK AND FOOD TASTINGS; ON-LINE JOURNALS, NAMELY, BLOGS FEATURING ARTICLES IN THE FIELDS OF FOOD, WINE, AND DINING; PROVIDING A WEBSITE FEATURING BLOGS AND NON-DOWNLOADABLE PUBLICATIONS IN THE NATURE OF ARTICLES, REVIEWS, AND INFORMATIONAL BROCHURES IN THE FIELDS OF FOOD, WINE, AND DINING; PROVIDING ENTERTAINMENT INFORMATION IN THE FIELD OF WINE AND FOOD TASTINGS; PROVIDING ONLINE ENTERTAINMENT INFORMATION IN THE NATURE OF EVENT LISTINGS RELATED TO FOOD, RECIPES, RESTAURANTS AND WINE (U.S. CLS. 100, 101 AND 107).

FIRST USE 2-10-2008; IN COMMERCE 2-10-2008.

GRETCHEN ULRICH, EXAMINING ATTORNEY

CLASS 41—(Continued).

SN 85-572,935. FURMAN UNIVERSITY, GREENVILLE, SC.
FILED 3-19-2012.



NO CLAIM IS MADE TO THE EXCLUSIVE RIGHT TO USE "SOUTH CAROLINA", APART FROM THE MARK AS SHOWN.

THE MARK CONSISTS OF "ONE SOUTH CAROLINA" WITH A DESIGN DEPICTING THE STATE OF SOUTH CAROLINA.

FOR CONDUCTING WORKSHOPS AND SEMINARS IN DIVERSITY LEADERSHIP INITIATIVES (U.S. CLS. 100, 101 AND 107).

FIRST USE 7-21-2011; IN COMMERCE 7-21-2011.

LINDSEY RUBIN, EXAMINING ATTORNEY

SN 85-573,212. MARGARITAVILLE ENTERPRISES, LLC,
PALM BEACH, FL. FILED 3-19-2012.

JIMMY BUFFETT'S POOL PARTY

SN 85-569,412. RICHARDSON, RUSS, MORENO VALLEY,
CA. FILED 3-14-2012.

WALTZING WARRIORS

THE MARK CONSISTS OF STANDARD CHARACTERS WITHOUT CLAIM TO ANY PARTICULAR FONT, STYLE, SIZE, OR COLOR.

NO CLAIM IS MADE TO THE EXCLUSIVE RIGHT TO USE "WALTZING", APART FROM THE MARK AS SHOWN. FOR PROVIDING DANCE INSTRUCTION (U.S. CLS. 100, 101 AND 107).

FIRST USE 2-8-2012; IN COMMERCE 2-8-2012.

LINDA ORNDORFF, EXAMINING ATTORNEY

THE MARK CONSISTS OF STANDARD CHARACTERS WITHOUT CLAIM TO ANY PARTICULAR FONT, STYLE, SIZE, OR COLOR.

OWNER OF U.S. REG. NOS. 2,201,538, 2,275,049 AND OTHERS.

NO CLAIM IS MADE TO THE EXCLUSIVE RIGHT TO USE "POOL PARTY", APART FROM THE MARK AS SHOWN.

THE NAME(S), PORTRAIT(S), AND/OR SIGNATURE(S) SHOWN IN THE MARK IDENTIFIES JIMMY BUFFETT, WHOSE CONSENT(S) TO REGISTER IS MADE OF RECORD.

FOR ENTERTAINMENT SERVICES IN THE NATURE OF LIVE MUSICAL PERFORMANCES; ENTERTAINMENT SERVICES IN THE NATURE OF SWIMMING POOL PARTIES (U.S. CLS. 100, 101 AND 107).

KIMBERLY PARKS, EXAMINING ATTORNEY

CLASS 41—(Continued).

SN 85-576,456. MACROOS INC., GRAND CAYMAN KY1-1107, CAYMAN ISLANDS, FILED 3-22-2012.

FLYTING POKER

THE MARK CONSISTS OF STANDARD CHARACTERS WITHOUT CLAIM TO ANY PARTICULAR FONT, STYLE, SIZE, OR COLOR.

NO CLAIM IS MADE TO THE EXCLUSIVE RIGHT TO USE "POKER", APART FROM THE MARK AS SHOWN.

THE WORDING "FLYTING" HAS NO MEANING IN A FOREIGN LANGUAGE.

FOR EDUCATIONAL SERVICES, NAMELY, PROVIDING A LEARNING AND INNOVATION CENTER FEATURING FULLY CUSTOMIZED LEADERSHIP, MOTIVATIONAL, EDUCATIONAL, AND BRAINSTORMING TRAINING; ENTERTAINMENT INFORMATION; ENTERTAINMENT SERVICES, NAMELY, PROVIDING ON-LINE COMPUTER GAMES; GAME EQUIPMENT RENTAL; MUSIC PRODUCTION SERVICES; ONLINE ELECTRONIC PUBLISHING OF BOOKS AND PERIODICALS; ORGANIZATION OF SHOWS FOR CULTURAL PURPOSES; ORGANIZATION OF SPORTS COMPETITIONS; PARTY PLANNING; TELEVISION SHOW PRODUCTION (U.S. CLS. 100, 101 AND 107).

EMILY CARLSEN, EXAMINING ATTORNEY

SN 85-576,591. PHANTOM INCORPORATED, DBA ART ATTACK, EDMONTON, CANADA, FILED 3-22-2012.

SHANKZ

THE MARK CONSISTS OF THE WORD "SHANKZ" IN ALL CAPS.

FOR ENTERTAINMENT SERVICES, NAMELY, PROVIDING GLOW IN THE DARK MINIATURE GOLF COURSES (U.S. CLS. 100, 101 AND 107).

FIRST USE 2-2-2004; IN COMMERCE 2-2-2004.

NORA BUCHANAN WILL, EXAMINING ATTORNEY

SN 85-576,803. THE RICHARDSON COMPANY, PHILADELPHIA, PA. FILED 3-22-2012.

SKILLGAUGE

THE MARK CONSISTS OF STANDARD CHARACTERS WITHOUT CLAIM TO ANY PARTICULAR FONT, STYLE, SIZE, OR COLOR.

SEC. 2(F).

FOR EDUCATIONAL SERVICES, NAMELY, ADMINISTERING AND EVALUATING EDUCATIONAL ONLINE TESTS AND PROVIDING TEST RESULTS IN THE AREA OF SALES, SERVICE, AND SALES COACHING (U.S. CLS. 100, 101 AND 107).

FIRST USE 5-1-2006; IN COMMERCE 5-1-2006.

ARETHA SOMERVILLE, EXAMINING ATTORNEY

CLASS 41—(Continued).

SN 85-577,003. RUG BURN, LLC, HOLLYWOOD, CA. FILED 3-22-2012.

Rug Burn

THE MARK CONSISTS OF STANDARD CHARACTERS WITHOUT CLAIM TO ANY PARTICULAR FONT, STYLE, SIZE, OR COLOR.

FOR ENTERTAINMENT SERVICES, NAMELY, CREATION, DEVELOPMENT AND PRODUCTION OF MULTIMEDIA ENTERTAINMENT CONTENT AVAILABLE VIA INTERNET, BROADBAND, VOD, TELEVISION, WIRELESS DEVICES AND HOME VIDEO DEVICES; CREATION AND DEVELOPMENT OF CONCEPTS FOR TELEVISION SHOWS AND MOVIES; PRODUCTION AND DISTRIBUTION OF TELEVISION SHOWS AND MOVIES; PROVIDING A WEBSITE FEATURING MULTIMEDIA ENTERTAINMENT CONTENT FEATURING ANIMATED ENTERTAINMENT (U.S. CLS. 100, 101 AND 107).

TINA BROWN, EXAMINING ATTORNEY

SN 85-577,084. O'NEILL PROPERTIES GROUP, L.P., KING OF PRUSSIA, PA. FILED 3-22-2012.

THE MOUNT

THE MARK CONSISTS OF STANDARD CHARACTERS WITHOUT CLAIM TO ANY PARTICULAR FONT, STYLE, SIZE, OR COLOR.

FOR PROVIDING FACILITIES FOR PERFORMING ARTS IN THE NATURE OF SHOWS AND MUSIC (U.S. CLS. 100, 101 AND 107).

MICHAEL WEBSTER, EXAMINING ATTORNEY

CLASS 41—(Continued).

SN 85-578,233. REAVES, WILLIAM THOMAS, HERMOSA BEACH, CA. FILED 3-23-2012.

THA ALUMNI MUSIC GROUP

THE MARK CONSISTS OF STANDARD CHARACTERS WITHOUT CLAIM TO ANY PARTICULAR FONT, STYLE, SIZE, OR COLOR.

NO CLAIM IS MADE TO THE EXCLUSIVE RIGHT TO USE "MUSIC GROUP", APART FROM THE MARK AS SHOWN.

FOR CONSULTATION AND ADVICE REGARDING MUSICAL SELECTIONS AND ARRANGEMENTS FOR SOUND RECORDINGS AND LIVE PERFORMANCES; DISC JOCKEY SERVICES; DISC JOCKEYS FOR PARTIES AND SPECIAL EVENTS; MUSIC PRODUCTION SERVICES; PROVISION OF INFORMATION RELATING TO LIVE PERFORMANCES, ROAD SHOWS, LIVE STAGE EVENTS, THEATRICAL PERFORMANCES, LIVE MUSIC CONCERTS AND AUDIENCE PARTICIPATION IN SUCH EVENTS; VIDEO PRODUCTION SERVICES; RECORD LABEL SERVICES, NAMELY, MUSIC PRODUCTION SERVICES, AND ORGANIZING SOCIAL ENTERTAINMENT EVENTS FEATURING LIVE MUSICAL PERFORMANCES; ENTERTAINMENT IN THE NATURE OF VISUAL AND AUDIO PERFORMANCES BY MUSICAL ACTS (U.S. CLS. 100, 101 AND 107).

FIRST USE 1-11-2010; IN COMMERCE 1-11-2010.
KEVEN MITTLER, EXAMINING ATTORNEY

SN 85-578,335. AM RACING LLC, AUSTIN, TX. FILED 3-23-2012.



THE COLOR(S) GREY AND RED IS/ARE CLAIMED AS A FEATURE OF THE MARK.

THE MARK CONSISTS OF AN UNSYMMETRICAL STAR DIVIDED IN HALF WITH ANOTHER STAR SUPERIMPOSED ON TOP. THE TOP PORTION OF THE LARGER STAR IS GREY. THE LOWER PORTION OF THE LARGER STAR IS RED. THE SUPERIMPOSED STAR IS TRANSPARENT TO THE BACKGROUND.

FOR ENTERTAINMENT SERVICES, NAMELY, PARTICIPATION IN MOTORSPORT RACING (U.S. CLS. 100, 101 AND 107).

FIRST USE 3-5-2011; IN COMMERCE 3-5-2011.
NAKIA HENRY, EXAMINING ATTORNEY

CLASS 41—(Continued).

SN 85-578,976. THE WESTERN STOCK SHOW ASSOCIATION, DENVER, CO. FILED 3-23-2012.

COLORADO VS THE WORLD

THE MARK CONSISTS OF STANDARD CHARACTERS WITHOUT CLAIM TO ANY PARTICULAR FONT, STYLE, SIZE, OR COLOR.

NO CLAIM IS MADE TO THE EXCLUSIVE RIGHT TO USE "COLORADO", APART FROM THE MARK AS SHOWN.

FOR EDUCATIONAL, ENTERTAINMENT AND RECREATIONAL SERVICES, NAMELY, ORGANIZING AND CONDUCTING RODEO, LIVESTOCK AND HORSE SHOWS AND EVENTS (U.S. CLS. 100, 101 AND 107).

FIRST USE 1-7-2012; IN COMMERCE 1-7-2012.
INGA ERVIN, EXAMINING ATTORNEY

SN 85-579,552. NEGRI, LUIGI, MIAMI, FL. FILED 3-26-2012.

Executive Oxygen

THE MARK CONSISTS OF STANDARD CHARACTERS WITHOUT CLAIM TO ANY PARTICULAR FONT, STYLE, SIZE, OR COLOR.

FOR EDUCATION SERVICES, NAMELY, PROVIDING ONLINE CLASSES IN THE FIELD OF BUSINESS NOT ASSOCIATED WITH LEGAL TOPICS (U.S. CLS. 100, 101 AND 107).

B. PARADEWELAI, EXAMINING ATTORNEY

SN 85-581,288. THE TRACOM CORPORATION, CENTENNIAL, CO. FILED 3-27-2012.

NO CLAIM IS MADE TO THE EXCLUSIVE RIGHT TO USE "BEHAVIORAL EQ", APART FROM THE MARK AS SHOWN.

THE MARK CONSISTS OF THE WORDING "BEHAVIORALEQ" PRESENTED IN STYLIZED FONT. THE "Q" CONTAINS A SPHERE IN ITS CENTER AND HAS RADIATING LINES OF VARYING LENGTHS EMANATING FROM THE LETTER.

FOR EDUCATIONAL SERVICES, NAMELY, CONDUCTING CLASSES, SEMINARS AND WORKSHOPS IN THE FIELDS OF LEADERSHIP, MANAGEMENT, PERSONAL DEVELOPMENT AND EDUCATION, TEAM BUILDING, SALES TRAINING, AND EXECUTIVE COACHING, AND THE DISTRIBUTION OF TRAINING MATERIAL IN CONNECTION THEREWITH (U.S. CLS. 100, 101 AND 107).

GRETCHEN ULRICH, EXAMINING ATTORNEY

CLASS 41—(Continued).

SN 85-581,652. A SAFE HAVEN FOUNDATION, CHICAGO, IL. FILED 3-27-2012.



OWNER OF U.S. REG. NO. 2,740,608.
THE COLOR(S) GREEN AND GRAY IS/ARE CLAIMED AS A FEATURE OF THE MARK.

THE MARK CONSISTS OF THE WORDS "A SAFE HAVEN" WITH THE TERM "SAFE" IN GREEN AND "A HAVEN" IN GREY. A FANCIFUL IMAGE OF A HOUSE DESIGN WITH ARROWS IS TO THE LEFT OF THE WORDING AND IN GREEN.

FOR CHARITABLE SERVICES, NAMELY, PROVIDING TRAINING IN THE FIELD OF TRANSFORMING PEOPLE FROM HOMELESSNESS TO SELF-SUFFICIENCY, PROVIDING HOLISTIC COACHING TO THE HOMELESS THROUGH A SCALABLE MODEL, PROVIDING ABUSE TREATMENT AND RECOVERY INFORMATION TO THE HOMELESS, PROVIDING LIFE SKILLS COACHING TO THE HOMELESS, PROVIDING LIFE COACHING FOR JOB TRAINING AND PLACEMENT, PROVIDING LIFE COACHING TO THE HOMELESS TO SECURE PERMANENT HOUSING; LIFE COACHING SERVICES IN THE FIELD OF TRANSFORMING PEOPLE FROM HOMELESSNESS TO SELF-SUFFICIENCY, PROVIDING HOLISTIC COACHING TO THE HOMELESS THROUGH A SCALABLE MODEL, PROVIDING ABUSE TREATMENT AND RECOVERY INFORMATION TO THE HOMELESS, PROVIDING LIFE SKILLS COACHING TO THE HOMELESS, PROVIDING LIFE COACHING FOR JOB TRAINING AND PLACEMENT, PROVIDING LIFE COACHING TO THE HOMELESS TO SECURE PERMANENT HOUSING; PERSONAL COACHING SERVICES IN THE FIELD OF TRANSFORMING PEOPLE FROM HOMELESSNESS TO SELF-SUFFICIENCY, PROVIDING HOLISTIC COACHING TO THE HOMELESS THROUGH A SCALABLE MODEL, PROVIDING ABUSE TREATMENT AND RECOVERY INFORMATION TO THE HOMELESS, PROVIDING LIFE SKILLS COACHING TO THE HOMELESS, PROVIDING LIFE COACHING FOR JOB TRAINING AND PLACEMENT, PROVIDING LIFE COACHING TO THE HOMELESS TO SECURE PERMANENT HOUSING; PROVIDING GROUP COACHING IN THE FIELD OF TRANSFORMING PEOPLE FROM HOMELESSNESS TO SELF-SUFFICIENCY, PROVIDING HOLISTIC COACHING TO THE HOMELESS THROUGH A SCALABLE MODEL, PROVIDING ABUSE TREATMENT AND RECOVERY INFORMATION TO THE HOMELESS, PROVIDING LIFE SKILLS COACHING TO THE HOMELESS, PROVIDING LIFE COACHING FOR JOB TRAINING AND PLACEMENT, PROVIDING LIFE COACHING TO THE HOMELESS TO SECURE PERMANENT HOUSING (U.S. CLS. 100, 101 AND 107).

FIRST USE 3-20-2012; IN COMMERCE 3-20-2012.
CURTIS FRENCH, EXAMINING ATTORNEY

CLASS 41—(Continued).

SN 85-582,338. NATIONAL ASSOCIATION OF CERTIFIED VALUATORS AND ANALYSTS, SALT LAKE CITY, UT. FILED 3-28-2012.

AROUND THE VALUATION WORLD
IN SIXTY MINUTES

THE MARK CONSISTS OF STANDARD CHARACTERS WITHOUT CLAIM TO ANY PARTICULAR FONT, STYLE, SIZE, OR COLOR.

NO CLAIM IS MADE TO THE EXCLUSIVE RIGHT TO USE "VALUATION" AND "SIXTY MINUTES", APART FROM THE MARK AS SHOWN.

FOR EDUCATIONAL SERVICES, NAMELY A NON-DOWNLOADABLE WEBINAR IN THE FIELD OF BUSINESS VALUATION (U.S. CLS. 100, 101 AND 107).

RONALD MCMORROW, EXAMINING ATTORNEY

SN 85-582,362. WORKERS' COMPENSATION INSTITUTE, INC., TALLAHASSEE, FL. FILED 3-28-2012.



NO CLAIM IS MADE TO THE EXCLUSIVE RIGHT TO USE "WORKERS' COMPENSATION EDUCATIONAL CONFERENCE", APART FROM THE MARK AS SHOWN.

THE MARK CONSISTS OF THE LETTERS "WC" INSIDE A BOX TO THE LEFT OF THE LETTERS "EC" OVER THE WORDS "WORKERS' COMPENSATION EDUCATIONAL CONFERENCE" WITH 5 CURVED LINES TO THE UPPER LEFT OF "WC".

FOR EDUCATIONAL SERVICES, NAMELY, CONDUCTING CLASSES, WORKSHOPS, SEMINARS, AND CONFERENCES IN THE FIELD OF WORKERS' COMPENSATION AND DISTRIBUTION OF TRAINING MATERIAL IN CONNECTION THEREWITH (U.S. CLS. 100, 101 AND 107).

KRISTINA MORRIS, EXAMINING ATTORNEY

CLASS 41—(Continued).

SN 85-582,438. WERANONT, ARISARA, LOS ANGELES, CA. FILED 3-28-2012.

PIIQ

THE MARK CONSISTS OF STANDARD CHARACTERS WITHOUT CLAIM TO ANY PARTICULAR FONT, STYLE, SIZE, OR COLOR.

THE WORD(S) "PIIQ" HAS NO MEANING IN A FOREIGN LANGUAGE.

FOR PROVIDING A WEBSITE FEATURING INFORMATION ON THE TIMES, DATES AND LOCATIONS OF LOCAL SOCIAL ENTERTAINMENT EVENTS, SPORTING EVENTS AND ENTERTAINMENT ACTIVITIES AND EVENTS FOR CHILDREN; PROVIDING A WEBSITE FEATURING AN ONLINE DATABASE FEATURING TIMES, DATES AND LOCATIONS OF LOCAL SOCIAL ENTERTAINMENT EVENTS, SPORTING EVENTS AND ENTERTAINMENT ACTIVITIES AND EVENTS FOR CHILDREN (U.S. CLS. 100, 101 AND 107).

JAY BESCH, EXAMINING ATTORNEY

SN 85-582,484. LEHIGH VALLEY PHYSICIAN HOSPITAL ORGANIZATION, INC., DBA VALLEY PREFERRED, ALLENTOWN, PA. FILED 3-28-2012.

**ACHIEVING CLINICAL
EXCELLENCE**

THE MARK CONSISTS OF STANDARD CHARACTERS WITHOUT CLAIM TO ANY PARTICULAR FONT, STYLE, SIZE, OR COLOR.

NO CLAIM IS MADE TO THE EXCLUSIVE RIGHT TO USE "CLINICAL EXCELLENCE", APART FROM THE MARK AS SHOWN.

FOR CONDUCTING INCENTIVE AWARD PROGRAMS FOR MEMBER PHYSICIANS TO MEET FINANCIAL, EFFICIENCY, QUALITY AND PATIENT SATISFACTION GOALS (U.S. CLS. 100, 101 AND 107).

CAROLINE WOOD, EXAMINING ATTORNEY

CLASS 41—(Continued).

SN 85-582,496. MEURER, IRENE, RIVERSIDE, CA. FILED 3-28-2012.



NO CLAIM IS MADE TO THE EXCLUSIVE RIGHT TO USE "DANCE COMPANY", APART FROM THE MARK AS SHOWN.

THE MARK CONSISTS OF THE LITERAL ELEMENTS "JUST 4 ME DANCE COMPANY" WHEREIN THREE SILHOUETTE IMAGES OF A DANCING ADULT GIRL IN THE CENTER, A LITTLE GIRL AND A LITTLE BOY ON THE LEFT SIDE ARE PLACED IN A WAY TO SEPARATE THE WORDINGS "JUST 4 ME AND DANCE COMPANY" PLACED ABOVE AND BELOW THE IMAGES RESPECTIVELY AND ALL THESE ARE PLACED IN A PARTLY SHADED RECTANGLE WITH CUT EDGES AS SHOWN IN THE MARK.

FOR EDUCATION AND ENTERTAINMENT SERVICES, NAMELY, A MOBILE DANCE EDUCATION PROGRAM FOR PRESCHOOL AND SCHOOL AGE CHILDREN; DANCE INSTRUCTION FOR CHILDREN (U.S. CLS. 100, 101 AND 107).

FIRST USE 12-1-2010; IN COMMERCE 1-1-2011.

RONALD MCMORROW, EXAMINING ATTORNEY

SN 85-582,520. ACTIVISION PUBLISHING, INC., SANTA MONICA, CA. FILED 3-28-2012.

SKYLANDERS UNIVERSE

THE MARK CONSISTS OF STANDARD CHARACTERS WITHOUT CLAIM TO ANY PARTICULAR FONT, STYLE, SIZE, OR COLOR.

OWNER OF U.S. REG. NOS. 4,159,230, 4,159,234 AND OTHERS.

FOR ENTERTAINMENT SERVICES, NAMELY, PROVIDING A WEBSITE FEATURING GAMES AND PUZZLES AND DOWNLOADABLE PRINTABLE MATERIALS IN CONNECTION THEREWITH, NAMELY, PRINTABLE COLORING PAGES, BOARD GAMES, AND DIORAMAS; ENTERTAINMENT SERVICES, NAMELY, CONDUCTING CONTESTS ONLINE; ENTERTAINMENT SERVICES, NAMELY, PROVIDING A WEBSITE FOR ORGANIZING, PLANNING AND EXECUTING EVENTS BETWEEN COMPUTER GAME PLAYERS AND INTEREST GROUPS (U.S. CLS. 100, 101 AND 107).

KIM SAITO, EXAMINING ATTORNEY

CLASS 41—(Continued).

SN 85-582,661. PUNCH DRUNK INC., SEATTLE, WA. FILED 3-28-2012.



NO CLAIM IS MADE TO THE EXCLUSIVE RIGHT TO USE "COMBAT GAMES", APART FROM THE MARK AS SHOWN.

THE MARK CONSISTS OF THE WORD "COGA" ABOVE THE WORDING "COMBAT GAMES". A STYLIZED DEPICTION OF A LIGHTNING BOLT WITH A CLENCHED FIST AT THE TOP BURSTS THROUGH THE WORDS AND DIVIDES THE LETTERS "CO" FROM "GA" IN THE TERM "COGA" AND THE WORD "COMBAT" FROM THE WORD "GAMES" IN THE TERM "COMBAT GAMES". THE ENTIRE MARK IS SURROUNDED BY SHADING.

FOR ENTERTAINMENT SERVICES IN THE NATURE OF LIVE MIXED MARTIAL ARTS (MMA) EVENTS (U.S. CLS. 100, 101 AND 107).

FIRST USE 10-15-2011; IN COMMERCE 10-15-2011.
JIM RINGLE, EXAMINING ATTORNEY

SN 85-583,490. HAWGFY PRODUCTIONS, INCORPORATED, AUSTIN, TX. FILED 3-29-2012.

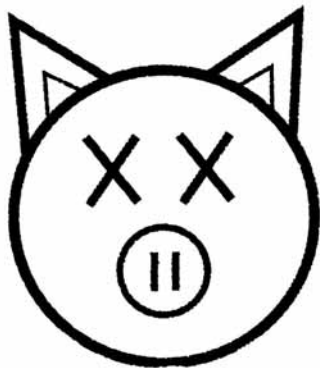

THE MARK CONSISTS OF STYLIZED REPRESENTATION OF THE FACE OF A PIG, WITH AN "X" FOR EACH EYE.

FOR ENTERTAINMENT SERVICES, NAMELY, PRODUCTION OF SPECIAL EFFECTS INCLUDING MODEL-MAKING SERVICES AND RELATED PHYSICAL PRODUCTION ELEMENTS FOR USE IN MOTION PICTURES (U.S. CLS. 100, 101 AND 107).

FIRST USE 3-3-2008; IN COMMERCE 3-3-2008.
JENNIFER WILLISTON, EXAMINING ATTORNEY

CLASS 41—(Continued).

SN 85-584,471. PIZZA HUT, INC., PLANO, TX. FILED 3-30-2012.

READ YOUR HEART OUT

THE MARK CONSISTS OF STANDARD CHARACTERS WITHOUT CLAIM TO ANY PARTICULAR FONT, STYLE, SIZE, OR COLOR.

FOR CHILDREN'S EDUCATIONAL SERVICES, NAMELY, CONDUCTING PROGRAMS OF READING INSTRUCTION AND DISTRIBUTION OF EDUCATIONAL MATERIALS IN CONNECTION THEREWITH; CHILDREN'S EDUCATIONAL SERVICES, NAMELY, CONDUCTING INCENTIVE AWARD PROGRAMS TO ENCOURAGE READING (U.S. CLS. 100, 101 AND 107).

LINDA M. KING, EXAMINING ATTORNEY

SN 85-584,672. STEPFILM LLC, SAN FRANCISCO, CA. FILED 3-30-2012.

dirtybird

THE MARK CONSISTS OF STANDARD CHARACTERS WITHOUT CLAIM TO ANY PARTICULAR FONT, STYLE, SIZE, OR COLOR.

FOR ENTERTAINMENT SERVICES, NAMELY, LIVE MUSIC CONCERTS; ENTERTAINMENT SERVICES IN THE NATURE OF LIVE PERFORMANCES BY MUSICAL ARTISTS OR MUSICAL GROUPS; ENTERTAINMENT SERVICES IN THE NATURE OF DANCE CLUB SERVICES FEATURING LIVE AND PRE-RECORDED MUSIC, VIDEOS AND DANCING (U.S. CLS. 100, 101 AND 107).

FIRST USE 6-8-2003; IN COMMERCE 1-9-2005.
NATALIE POLZER, EXAMINING ATTORNEY

SN 85-584,857. KROWN LIFE, LLC, DBA RSE MUSIC GROUP, MIAMI, FL. FILED 3-30-2012.

**KL
KROWN LIFE**

THE MARK CONSISTS OF STANDARD CHARACTERS WITHOUT CLAIM TO ANY PARTICULAR FONT, STYLE, SIZE, OR COLOR.

FOR COMPOSITION OF MUSIC FOR OTHERS; CONSULTATION AND ADVICE REGARDING MUSICAL SELECTIONS AND ARRANGEMENTS FOR SOUND RECORDINGS AND LIVE PERFORMANCES; ENTERTAINMENT IN THE NATURE OF LIVE PERFORMANCES BY MUSICAL ARTISTS; ENTERTAINMENT IN THE NATURE OF VISUAL AND AUDIO PERFORMANCES BY MUSICAL ARTISTS.; ENTERTAINMENT INFORMATION SERVICES, NAMELY, PROVIDING INFORMATION AND NEWS RELEASES ABOUT A MUSICAL ARTIST; ENTERTAINMENT SERVICES BY A MUSICAL ARTIST AND PRODUCER, NAMELY, MUSI-

CLASS 41—(Continued).

CAL COMPOSITION FOR OTHERS AND PRODUCTION OF MUSICAL SOUND RECORDINGS; ENTERTAINMENT SERVICES IN THE NATURE OF LIVE MUSICAL PERFORMANCES; ENTERTAINMENT SERVICES IN THE NATURE OF PRESENTING LIVE MUSICAL PERFORMANCES; ENTERTAINMENT SERVICES IN THE NATURE OF RECORDING, PRODUCTION AND POST-PRODUCTION SERVICES IN THE FIELD OF MUSIC; ENTERTAINMENT SERVICES IN THE NATURE OF LIP SYNCING PERFORMANCES; ENTERTAINMENT SERVICES, NAMELY, AN ON-LINE ACTIVITY WHERE YOU CREATE YOUR OWN MUSIC VIDEOS; ENTERTAINMENT SERVICES, NAMELY, DANCE EVENTS BY A RECORDING ARTIST; ENTERTAINMENT SERVICES, NAMELY, PROVIDING A WEB SITE FEATURING NON-DOWNLOADABLE MUSICAL PERFORMANCES, MUSICAL VIDEOS, RELATED FILM CLIPS, PHOTOGRAPHS, AND OTHER MULTIMEDIA MATERIALS FEATURING MUSICAL ARTISTS; ENTERTAINMENT SERVICES, NAMELY, PROVIDING INFORMATION ABOUT A RECORDING ARTIST VIA AN ONLINE NETWORK; ENTERTAINMENT SERVICES, NAMELY, PROVIDING NON-DOWNLOADABLE PRERECORDED MUSIC, INFORMATION IN THE FIELD OF MUSIC, AND COMMENTARY AND ARTICLES ABOUT MUSIC, ALL ON-LINE VIA A GLOBAL COMPUTER NETWORK; ENTERTAINMENT, NAMELY, LIVE MUSIC CONCERTS; ENTERTAINMENT, NAMELY, LIVE PERFORMANCES BY A MUSICAL BAND; ENTERTAINMENT, NAMELY, LIVE PERFORMANCES BY MUSICAL BANDS; LIVE PERFORMANCES BY A MUSICAL GROUP; MULTIMEDIA ENTERTAINMENT SERVICES IN THE NATURE OF RECORDING, PRODUCTION AND POST-PRODUCTION SERVICES IN THE FIELDS OF MUSIC, VIDEO, AND FILMS; MUSIC COMPOSITION FOR OTHERS; MUSIC COMPOSITION SERVICES; MUSIC PRODUCTION SERVICES; MUSIC VIDEO PRODUCTION; PLANNING ARRANGEMENT OF SHOWING MOVIES, SHOWS, PLAYS OR MUSICAL PERFORMANCES; PRESENTATION OF LIVE SHOW PERFORMANCES; PRESENTATION OF MUSICAL PERFORMANCE; PRODUCTION OF MUSICAL SOUND RECORDING; PRODUCTION OF MUSICAL VIDEOS; PRODUCTION OF SOUND AND MUSIC VIDEO RECORDINGS; PROVIDING A WEBSITE FEATURING INFORMATION IN THE FIELD OF MUSIC AND ENTERTAINMENT; PROVIDING A WEBSITE FOR ENTERTAINMENT PURPOSES FEATURING MUSICAL ARTIST ABOUT TOUR DATES, INTERVIEWS, AND AUTOGRAPHY SIGNINGS; PROVIDING AN INTERNET WEBSITE PORTAL FEATURING LINKS TO MUSICAL ARTIST WEBSITES AND MUSIC PERFORMANCE TICKET INFORMATION; PROVISION OF INFORMATION RELATING TO LIVE PERFORMANCES, ROAD SHOWS, LIVE STAGE EVENTS, THEATRICAL PERFORMANCES, LIVE MUSIC CONCERTS AND AUDIENCE PARTICIPATION IN SUCH EVENTS (U.S. CLS. 100, 101 AND 107).

FIRST USE 1-1-2010; IN COMMERCE 1-1-2010.

JACLYN KIDWELL WALKER, EXAMINING ATTORNEY

CLASS 41—(Continued).

SN 85-585,511. COLLINS, BRIAN TODD, #49-08, CA. FILED 3-30-2012.

KID INK

THE MARK CONSISTS OF STANDARD CHARACTERS WITHOUT CLAIM TO ANY PARTICULAR FONT, STYLE, SIZE, OR COLOR.

THE NAME(S), PORTRAIT(S), AND/OR SIGNATURE(S) SHOWN IN THE MARK IDENTIFIES "KID INK" THE STAGE NAME OF "BRIAN TODD COLLINS", WHOSE CONSENT(S) TO REGISTER IS MADE OF RECORD.

FOR ENTERTAINMENT, NAMELY, LIVE MUSIC CONCERTS; PROVISION OF INFORMATION RELATING TO LIVE PERFORMANCES, ROAD SHOWS, LIVE STAGE EVENTS, THEATRICAL PERFORMANCES, LIVE MUSIC CONCERTS AND AUDIENCE PARTICIPATION IN SUCH EVENTS (U.S. CLS. 100, 101 AND 107).

FIRST USE 7-8-2010; IN COMMERCE 7-8-2010.

KATHERINE M. DUBRAY, EXAMINING ATTORNEY

SN 85-585,756. HILIA, LLC, NEWARK, DE. FILED 3-31-2012.

Hilia Fights

THE MARK CONSISTS OF STANDARD CHARACTERS WITHOUT CLAIM TO ANY PARTICULAR FONT, STYLE, SIZE, OR COLOR.

NO CLAIM IS MADE TO THE EXCLUSIVE RIGHT TO USE "FIGHTS", APART FROM THE MARK AS SHOWN.

THE ENGLISH TRANSLATION OF "HILIA" IN THE MARK IS "1000" OR "ONE THOUSAND".

FOR ENTERTAINMENT SERVICES, NAMELY, CONDUCTING MARTIAL ARTS COMPETITIONS, EVENTS AND PERSONAL APPEARANCES FOR LIVE AND PRE-RECORDED TRANSMISSION BY MEANS OF CABLE, BROADCAST, SATELLITE AND OTHER MEDIA (U.S. CLS. 100, 101 AND 107).

RONALD AIKENS, EXAMINING ATTORNEY

CLASS 41—(Continued).

SN 85-585,844. ZEONIX, SEOUL, REPUBLIC OF KOREA, FILED 3-31-2012.

SWORD GIRLS

THE MARK CONSISTS OF STANDARD CHARACTERS WITHOUT CLAIM TO ANY PARTICULAR FONT, STYLE, SIZE, OR COLOR.

FOR ELECTRONIC GAMES SERVICES PROVIDED BY MEANS OF THE INTERNET; ENTERTAINMENT IN THE NATURE OF AN ON-GOING SPECIAL VARIETY, NEWS, MUSIC OR COMEDY SHOW FEATURING VIDEO GAMES, ONLINE GAMES, CARD GAMES, ANIMATION AND COMICS BROADCAST OVER TELEVISION, SATELLITE, AUDIO, AND VIDEO MEDIA; ENTERTAINMENT IN THE NATURE OF VIDEO GAMES, ONLINE GAMES, CARD GAMES; ENTERTAINMENT SERVICES, NAMELY, PROVIDING A WEB SITE FEATURING PHOTOGRAPHIC, AUDIO, VIDEO AND PROSE PRESENTATIONS FEATURING VIDEO GAMES, ONLINE GAMES, CARD GAMES, ANIMATION AND COMICS; ENTERTAINMENT SERVICES, NAMELY, PROVIDING A WEBSITE FEATURING GAMES AND PUZZLES; ENTERTAINMENT SERVICES, NAMELY, PROVIDING AN ON-LINE BOARD GAME; ENTERTAINMENT SERVICES, NAMELY, PROVIDING AN ON-LINE COMPUTER GAME; ENTERTAINMENT SERVICES, NAMELY, PROVIDING BRAIN TRAINING GAMES ON-LINE AND IN MOBILE WIRELESS FORM; ENTERTAINMENT SERVICES, NAMELY, PROVIDING ON-LINE COMPUTER GAMES; ENTERTAINMENT SERVICES, NAMELY, PROVIDING ON-LINE REVIEWS OF SUBJECT MATTER PERTAINING TO THE INDUSTRIES OF ANIMATION, VIDEO GAMES, COMICS AND ON-LINE CARD GAMES; ENTERTAINMENT SERVICES, NAMELY, PROVIDING ONLINE VIDEO GAMES; INTERACTIVE ONLINE WEB JOURNALS FEATURING SUBJECT MATTER PERTAINING TO THE INDUSTRIES OF ANIMATION, VIDEO GAMES, COMICS AND ON-LINE CARD GAMES; ONLINE ELECTRONIC PUBLISHING OF BOOKS AND PERIODICALS; PRODUCTION OF VIDEO AND COMPUTER GAME SOFTWARE; PROVIDING A COMPUTER GAME FOR USE NETWORK-WIDE BY NETWORK USERS; PROVIDING A WEBSITE FOR ENTERTAINMENT PURPOSES FEATURING FAN ART, NEWS, UPDATES, STORIES, HINTS AND TIPS ABOUT THE APPRECIATION OF THE INDUSTRIES OF ANIMATION, VIDEO GAMES, COMICS AND ONLINE CARD GAMES; PROVIDING RATINGS FOR TELEVISION, MOVIE, MUSIC, VIDEO AND VIDEO GAME CONTENT (U.S. CLS. 100, 101 AND 107).

FIRST USE 1-1-2012; IN COMMERCE 3-28-2012.
MICHAEL LITZAU, EXAMINING ATTORNEY

CLASS 41—(Continued).

SN 85-585,942. JERRY STEPHAN, LUTZ, FL. FILED 4-1-2012.

COMMUNAL TABLE

THE MARK CONSISTS OF STANDARD CHARACTERS WITHOUT CLAIM TO ANY PARTICULAR FONT, STYLE, SIZE, OR COLOR.

FOR ENTERTAINMENT SERVICES IN THE NATURE OF A SERIES OF ON-GOING REALITY BASED TELEVISION PROGRAMS ABOUT CELEBRITIES AND OTHER PATRONS DINING AND DRINKING TOGETHER AT DIFFERENT DINING ESTABLISHMENTS WORLDWIDE (U.S. CLS. 100, 101 AND 107).

JOHN WILKE, EXAMINING ATTORNEY

SN 85-586,802. MCCREARY, ROBERT, LARKSPUR, CA. FILED 4-2-2012.



NO CLAIM IS MADE TO THE EXCLUSIVE RIGHT TO USE "ADVANCED MARITIME EDUCATION", APART FROM THE MARK AS SHOWN.

THE COLOR(S) WHITE, RED AND BLUE IS/ARE CLAIMED AS A FEATURE OF THE MARK.

THE MARK CONSISTS OF THE WHITE WORDS "ADVANCED MARITIME EDUCATION", WITH THE "E" FORMED OF A STYLIZED RED AND WHITE STRIPED FLAG WITH A BLUE RECTANGLE IN THE UPPER LEFT HAND CORNER, CONTAINING A WHITE IMAGE OF AN ANCHOR SURROUNDED BY STARS. BLACK IS A BACKGROUND COLOR, NOT TO BE INCLUDED AS A COLOR CLAIM.

FOR EDUCATION SERVICES, NAMELY, PROVIDING CLASSES IN THE FIELD OF MARITIME AND BOATING; EDUCATIONAL TESTING SERVICES (U.S. CLS. 100, 101 AND 107).

TOBY BULLOFF, EXAMINING ATTORNEY

SN 85-587,451. NETILEUMS INC, SANTA MONICA, CA. FILED 4-3-2012.

Netileum

THE MARK CONSISTS OF STANDARD CHARACTERS WITHOUT CLAIM TO ANY PARTICULAR FONT, STYLE, SIZE, OR COLOR.

FOR INFORMATION SERVICES, NAMELY, PROVIDING A WEB SITE FEATURING AUDIO, VIDEO, PHOTOGRAPHIC AND PROSE PRESENTATIONS FEATURING BIOGRAPHICAL INFORMATION OF DECEASED INDIVIDUALS (U.S. CLS. 100, 101 AND 107).

SALLY SHIH, EXAMINING ATTORNEY

CLASS 41—(Continued).

SN 85-587,538. BORDERSTAN MEDIA, LLC, WASHINGTON, DC. FILED 4-3-2012.



NO CLAIM IS MADE TO THE EXCLUSIVE RIGHT TO USE "DUPONT . LOGAN . U STREET", APART FROM THE MARK AS SHOWN.

THE COLOR(S) GREEN, BLACK, AND WHITE IS/ARE CLAIMED AS A FEATURE OF THE MARK.

THE MARK CONSISTS OF A WHITE BACKGROUND AND THE LOWERCASE GREEN TYPE OF THE WORD "BORDERSTAN", UNDER WHICH ARE THE LOWER-CASE WORDS "DUPONT . LOGAN . U . STREET" IN BLACK. TO THE RIGHT OF THE TEXT "BORDERSTAN" IS A GREEN OUTLINE ROUGHLY IN THE SHAPE OF THE CITY OF WASHINGTON, DC. TO THE RIGHT OF THE TEXT, AND WITHIN THE CITY OUTLINE, IS A GREEN STAR.

FOR NEWS AGENCIES, NAMELY, GATHERING AND DISSEMINATION OF NEWS (U.S. CLS. 100, 101 AND 107).

FIRST USE 7-29-2008; IN COMMERCE 7-29-2008.
JASON BLAIR, EXAMINING ATTORNEY

SN 85-587,905. NATIONAL STUDENT ATHLETE CHAMPIONSHIP, INC., HOUSTON, TX. FILED 4-3-2012.

NSAC NATIONAL STUDENT ATHLETE CHAMPIONSHIP

THE MARK CONSISTS OF STANDARD CHARACTERS WITHOUT CLAIM TO ANY PARTICULAR FONT, STYLE, SIZE, OR COLOR.

NO CLAIM IS MADE TO THE EXCLUSIVE RIGHT TO USE "NATIONAL STUDENT ATHLETE CHAMPIONSHIP", APART FROM THE MARK AS SHOWN.

FOR AMATEUR YOUTH SPORTS SERVICES, NAMELY, ORGANIZING AND PROVIDING YOUTH SPORTS ACTIVITIES; ARRANGING AND CONDUCTING ATHLETIC COMPETITIONS; ARRANGING AND CONDUCTING INCENTIVE AWARD PROGRAMS TO ENCOURAGE THE FREQUENT, CONTINUED AND EFFECTIVE PRACTICE OF PHYSICAL EXERCISE; CONTESTS AND INCENTIVE AWARD PROGRAMS TO ENCOURAGE STUDENTS AND ORGANIZATION MEMBERS TO SET UP AND ACHIEVE GOALS IN ATTENDANCE, CITIZENSHIP AND CONDUCT; EDUCATION SERVICES, NAMELY, PROVIDING COMPETITIONS IN THE FIELD OF ATHLETICS; EDUCATIONAL AND ENTERTAINMENT SERVICES FOR CHILDREN, NAMELY, PROVIDING INTERACTIVE PLAY AREAS, INSTRUCTIONAL CLASSES IN THE FIELD OF ATHLETICS AND SOCIAL GATHERINGS FOR CHILDREN; EDUCATIONAL SERVICES, NAMELY, PROVIDING INCENTIVES TO STUDENTS TO DEMONSTRATE EXCELLENCE IN THE FIELD OF ATHLETICS; EDUCATIONAL SERVICES, NAMELY, PROVIDING INCENTIVES TO STUDENTS TO DEMONSTRATE EXCELLENCE IN THE FIELD OF ATHLETICS THROUGH THE ISSUANCE OF AWARDS; ENCOURAGING AMATEUR SPORTS AND PHYSICAL EDUCATION BY ORGANIZING, SANCTIONING, CONDUCTING, REGULATING AND GOVERNING

CLASS 41—(Continued).

AMATEUR ATHLETIC PROGRAMS AND ACTIVITIES; ENTERTAINMENT IN THE NATURE OF COMPETITIONS IN THE FIELD OF ATHLETICS; ENTERTAINMENT IN THE NATURE OF TRACK AND FIELD COMPETITIONS; ENTERTAINMENT IN THE NATURE OF ATHLETIC TOURNAMENTS; ENTERTAINMENT SERVICES, NAMELY, CONTEST AND INCENTIVE AWARD PROGRAMS DESIGNED TO REWARD PROGRAM PARTICIPANTS WHO EXCEL IN ATHLETICS; INSTITUTING, REGULATING AND AWARDED AMATEUR ATHLETIC CHAMPIONSHIPS; ORGANISATION OF GAMES; ORGANISATION OF SPORTS COMPETITIONS; ORGANIZATION OF SPORTS COMPETITIONS; ORGANIZING COMMUNITY SPORTING AND CULTURAL EVENTS. ORGANIZING SPORTING EVENTS, NAMELY, OLYMPIC-STYLE, ATHLETIC COMPETITIONS AMONG STUDENTS; ORGANIZING, ARRANGING, AND CONDUCTING OLYMPIC-STYLE, ATHLETIC COMPETITION EVENTS; PROVIDING AN IN-PERSON STUDENT FORUM IN THE FIELD OF ATHLETICS (U.S. CLS. 100, 101 AND 107).

TARAH HARDY, EXAMINING ATTORNEY

SN 85-587,995. NATIONAL STUDENT ATHLETE CHAMPIONSHIP, INC., HOUSTON, TX. FILED 4-3-2012.



NO CLAIM IS MADE TO THE EXCLUSIVE RIGHT TO USE "NATIONAL STUDENT ATHLETE CHAMPIONSHIP", APART FROM THE MARK AS SHOWN.

THE MARK CONSISTS OF TWELVE CURVED EDGE SQUARES STACKED IN THREE ROWS WITH FOUR ACROSS. THE TOP ROW CONSISTS OF FOUR OUTLINED SQUARES CONTAINING FROM LEFT TO RIGHT A FOOTBALL, A VOLLEYBALL, A GOLF BALL, AND A MORTARBOARD WITH A SCROLL. THE MIDDLE ROW OF FOUR SQUARES CONTAINS THE LETTERS "N S A C". BELOW THE MIDDLE ROW IS THE WORDING "NATIONAL STUDENT ATHLETE CHAMPIONSHIP". THE LAST ROW OF FOUR OUTLINE SQUARES CONTAINS FROM LEFT TO RIGHT A CLOSED AND OPEN BOOK, A BASKETBALL, A BASEBALL, AND A SOCCER BALL.

FOR AMATEUR YOUTH SPORTS SERVICES, NAMELY, ORGANIZING AND PROVIDING YOUTH SPORTS ACTIVITIES; ARRANGING AND CONDUCTING ATHLETIC COMPETITIONS; ARRANGING AND CONDUCTING INCENTIVE AWARD PROGRAMS TO ENCOURAGE THE FREQUENT, CONTINUED AND EFFECTIVE PRACTICE OF PHYSICAL EXERCISE; CONTESTS AND INCENTIVE AWARD PROGRAMS TO ENCOURAGE STUDENTS AND ORGANIZATION MEMBERS TO SET UP AND ACHIEVE GOALS IN ATTENDANCE, CITIZENSHIP AND CONDUCT; EDUCATION SERVICES, NAMELY, PROVIDING COMPETITIONS IN THE FIELD OF ATHLETICS; EDUCATIONAL AND ENTERTAINMENT SERVICES FOR CHILDREN, NAMELY, PROVIDING INTERACTIVE PLAY AREAS, INSTRUCTIONAL CLASSES IN THE FIELD OF ATHLETICS AND SOCIAL GATHERINGS FOR CHILDREN; EDUCATIONAL SERVICES, NAMELY, PROVIDING INCENTIVES TO STUDENTS TO DEMONSTRATE EXCELLENCE IN THE FIELD OF ATHLETICS; EDUCATIONAL SERVICES, NAMELY, PROVIDING INCENTIVES TO STUDENTS TO DEMONSTRATE EXCELLENCE IN THE FIELD OF ATHLETICS THROUGH THE ISSUANCE OF AWARDS; ENCOURAGING AMATEUR SPORTS AND PHYSICAL EDUCATION BY ORGANIZING, SANCTIONING, CONDUCTING, REGULATING AND GOVERNING

CLASS 41—(Continued).

ING, CONDUCTING, REGULATING AND GOVERNING AMATEUR ATHLETIC PROGRAMS AND ACTIVITIES; ENTERTAINMENT IN THE NATURE OF COMPETITIONS IN THE FIELD OF ATHLETICS; ENTERTAINMENT IN THE NATURE OF TRACK AND FIELD COMPETITIONS; ENTERTAINMENT IN THE NATURE OF ATHLETIC TOURNAMENTS; ENTERTAINMENT SERVICES, NAMELY, CONTEST AND INCENTIVE AWARD PROGRAMS DESIGNED TO REWARD PROGRAM PARTICIPANTS WHO EXCEL IN ATHLETICS; INSTITUTING, REGULATING AND AWARDED AMATEUR ATHLETIC CHAMPIONSHIPS; ORGANISATION OF GAMES; ORGANISATION OF SPORTS COMPETITIONS; ORGANIZATION OF SPORTS COMPETITIONS; ORGANIZING COMMUNITY SPORTING AND CULTURAL EVENTS; ORGANIZING SPORTING EVENTS, NAMELY, OLYMPIC-STYLE, ATHLETIC COMPETITIONS AMONG STUDENTS; ORGANIZING, ARRANGING, AND CONDUCTING OLYMPIC-STYLE, ATHLETIC COMPETITION EVENTS; PROVIDING AN IN-PERSON STUDENT FORUM IN THE FIELD OF ATHLETICS (U.S. CLS. 100, 101 AND 107).

TARAH HARDY, EXAMINING ATTORNEY

SN 85-588,809. JAYDEN JAYMES, INC., CANOGA PARK, CA. FILED 4-4-2012.

SEXSQUAD

THE MARK CONSISTS OF STANDARD CHARACTERS WITHOUT CLAIM TO ANY PARTICULAR FONT, STYLE, SIZE, OR COLOR.

FOR ENTERTAINMENT, NAMELY, A CONTINUING ADULT ENTERTAINMENT SHOW BROADCAST OVER RADIO; ENTERTAINMENT, NAMELY, PROVIDING AN ON-GOING RADIO PROGRAM IN THE FIELD OF ADULT ENTERTAINMENT HOSTED BY ADULT ENTERTAINERS AND BROADCAST OVER RADIO AND INTERNET; ENTERTAINMENT SERVICES, NAMELY, PROVIDING PODCASTS IN THE FIELD OF ADULT ENTERTAINMENT (U.S. CLS. 100, 101 AND 107).

DAWN HAN, EXAMINING ATTORNEY

SN 85-589,638. HAWKINS, SHANEE VASHON, ANTIOCH, CA. FILED 4-5-2012.

Back 2 Hip Hop

THE MARK CONSISTS OF STANDARD CHARACTERS WITHOUT CLAIM TO ANY PARTICULAR FONT, STYLE, SIZE, OR COLOR.

NO CLAIM IS MADE TO THE EXCLUSIVE RIGHT TO USE "HIP HOP", APART FROM THE MARK AS SHOWN.

FOR ENTERTAINMENT SERVICES IN THE NATURE OF AN ON-GOING REALITY BASED TELEVISION PROGRAM (U.S. CLS. 100, 101 AND 107).

KIMBERLY PERRY, EXAMINING ATTORNEY

CLASS 41—(Continued).

SN 85-589,810. JOHN FITZGERALD KENNEDY LIBRARY FOUNDATION INCORPORATED, BOSTON, MA. FILED 4-5-2012.

JOHN F. KENNEDY MAKE A DIFFERENCE AWARD

THE MARK CONSISTS OF STANDARD CHARACTERS WITHOUT CLAIM TO ANY PARTICULAR FONT, STYLE, SIZE, OR COLOR.

NO CLAIM IS MADE TO THE EXCLUSIVE RIGHT TO USE "AWARD", APART FROM THE MARK AS SHOWN.

THE NAME "JOHN F. KENNEDY" IN THE MARK DOES NOT IDENTIFY A LIVING INDIVIDUAL.

FOR PROVIDING RECOGNITION BY MEANS OF AWARDS TO HONOR OUTSTANDING ACHIEVEMENTS IN THE FIELD OF COMMUNITY SERVICE (U.S. CLS. 100, 101 AND 107).

STEVEN R. FINE, EXAMINING ATTORNEY

SN 85-589,898. ZULU RACING, LLC, ROSWELL, GA. FILED 4-5-2012.

AREA 13.1

THE MARK CONSISTS OF STANDARD CHARACTERS WITHOUT CLAIM TO ANY PARTICULAR FONT, STYLE, SIZE, OR COLOR.

NO CLAIM IS MADE TO THE EXCLUSIVE RIGHT TO USE "13.1", APART FROM THE MARK AS SHOWN.

FOR ATHLETIC AND SPORTS EVENT SERVICES, NAMELY, ARRANGING, ORGANIZING, OPERATING AND CONDUCTING MARATHON RACES (U.S. CLS. 100, 101 AND 107).

FIRST USE 1-1-2012; IN COMMERCE 1-1-2012.

ESTHER A. BORSUK, EXAMINING ATTORNEY

CLASS 41—(Continued).

SN 85-590,106. LYNN HAYES, CARRBORO, NC. FILED 4-5-2012.

ASTROLOGICAL MUSINGS

THE MARK CONSISTS OF STANDARD CHARACTERS WITHOUT CLAIM TO ANY PARTICULAR FONT, STYLE, SIZE, OR COLOR.

NO CLAIM IS MADE TO THE EXCLUSIVE RIGHT TO USE "ASTROLOGICAL", APART FROM THE MARK AS SHOWN.

FOR EDUCATION SERVICES, NAMELY, PROVIDING LIVE AND ON-LINE SEMINARS AND WEB-LOG POSTINGS IN THE FIELD OF FORECASTING AND CHARTING THE MOVEMENT OF STAR SYSTEMS THROUGH THE SOLAR CALENDAR AND THE AFFECT SAID MOVEMENTS OF THE STAR SYSTEMS HAVE ON THE EMOTIONAL, SPIRITUAL AND PHYSICAL MANIFESTATIONS OF INDIVIDUAL PERSONS (U.S. CLS. 100, 101 AND 107).

FIRST USE 11-30-2005; IN COMMERCE 11-30-2005.
WILLIAM VERHOSEK, EXAMINING ATTORNEY

SN 85-590,239. INTERNET SOCIETY, RESTON, VA. FILED 4-5-2012.



**INTERNET
HALL of FAME**

OWNER OF U.S. REG. NOS. 2,580,507, 2,717,698 AND 2,732,469.

NO CLAIM IS MADE TO THE EXCLUSIVE RIGHT TO USE "INTERNET HALL OF FAME", APART FROM THE MARK AS SHOWN.

THE MARK CONSISTS OF THE WORDING "INTERNET HALL OF FAME" BELOW A DESIGN. THE DESIGN FEATURES A DARK CIRCLE WITH LIGHT LINES INSIDE OF IT THAT RESEMBLE RAYS OF LIGHT FORMED BY SHOOTING STARS.

FOR PROVIDING RECOGNITION AND INCENTIVES BY THE WAY OF AWARDS TO CONTRIBUTORS TO THE DEVELOPMENT OF THE INTERNET (U.S. CLS. 100, 101 AND 107).

CORY BOONE, EXAMINING ATTORNEY

CLASS 41—(Continued).

SN 85-590,711. ANGELA VALENTE ROMEO, PALM SPRINGS, CA. FILED 4-5-2012.

COLLIDING WORLDS

THE MARK CONSISTS OF STANDARD CHARACTERS WITHOUT CLAIM TO ANY PARTICULAR FONT, STYLE, SIZE, OR COLOR.

FOR ENTERTAINMENT SERVICES, NAMELY, THE PROVISION OF CONTINUING PROGRAMS FEATURING ART IN ALL ITS FORMS DELIVERED BY BROADCAST TELEVISION, RADIO, SATELLITE, AND THE INTERNET (U.S. CLS. 100, 101 AND 107).

FIRST USE 6-1-2011; IN COMMERCE 6-1-2011.
JASON BLAIR, EXAMINING ATTORNEY

SN 85-590,890. MICHAEL PORTMAN PHOTOGRAPHY, INC., ATLANTA, GA. FILED 4-6-2012.



THE MARK CONSISTS OF THE STYLIZED TEXT "MWP". FOR PHOTOGRAPHY (U.S. CLS. 100, 101 AND 107). FIRST USE 11-15-2011; IN COMMERCE 11-15-2011.
JAMES GRIFFIN, EXAMINING ATTORNEY

SN 85-591,331. LABORGAMING, LLC, GOODYEAR, AZ. FILED 4-6-2012.

Fantasy-Pro

THE MARK CONSISTS OF STANDARD CHARACTERS WITHOUT CLAIM TO ANY PARTICULAR FONT, STYLE, SIZE, OR COLOR.

FOR ENTERTAINMENT SERVICES, NAMELY, PROVIDING ONLINE GAMES THAT HELP INCREASE WORKPLACE PRODUCTIVITY (U.S. CLS. 100, 101 AND 107).

FIRST USE 3-5-2012; IN COMMERCE 3-5-2012.
ELLEN BURNS, EXAMINING ATTORNEY

CLASS 41—(Continued).

SN 85-591,351. THE EXECUTOR OF THE OTIS REDDING ESTATE, A GEORGIA ESTATE, COMPRISING ZELMA REDDING, A UNITED STATES CITIZEN," TMEP §803.03(E), LOS ANGELES, CA. FILED 4-6-2012.

OTIS REDDING

THE MARK CONSISTS OF STANDARD CHARACTERS WITHOUT CLAIM TO ANY PARTICULAR FONT, STYLE, SIZE, OR COLOR.

THE NAME SHOWN IN THE MARK DOES NOT IDENTIFY A LIVING INDIVIDUAL.

FOR PROVIDING A WEBSITE FEATURING INFORMATION REGARDING THE FIELD OF ENTERTAINMENT (U.S. CLS. 100, 101 AND 107).

CATHERINE ROEHL, EXAMINING ATTORNEY

SN 85-591,422. THE EXECUTOR OF THE OTIS REDDING ESTATE, A GEORGIA ESTATE, COMPRISING ZELMA REDDING, A UNITED STATES CITIZEN., LOS ANGELES, CA. FILED 4-6-2012.

THE KING OF SOUL

THE MARK CONSISTS OF STANDARD CHARACTERS WITHOUT CLAIM TO ANY PARTICULAR FONT, STYLE, SIZE, OR COLOR.

THE NAME "THE KING OF SOUL" WAS THE NICKNAME OF OTIS REDDING WHO IS NOT A LIVING INDIVIDUAL.

FOR PROVIDING A WEBSITE FEATURING INFORMATION REGARDING THE FIELD OF ENTERTAINMENT (U.S. CLS. 100, 101 AND 107).

CATHERINE ROEHL, EXAMINING ATTORNEY

SN 85-591,449. CARLSBAD CHAMBER OF COMMERCE, CARLSBAD, CA. FILED 4-6-2012.

**Boots in Business A
Military Mentoring Program**

THE MARK CONSISTS OF STANDARD CHARACTERS WITHOUT CLAIM TO ANY PARTICULAR FONT, STYLE, SIZE, OR COLOR.

NO CLAIM IS MADE TO THE EXCLUSIVE RIGHT TO USE "A MILITARY MENTORING PROGRAM", APART FROM THE MARK AS SHOWN.

FOR EDUCATION SERVICES, NAMELY, MENTORING IN THE FIELD OF SUPPORTING THE TRANSITIONS OF VETERANS FROM THE MILITARY TO CIVILIAN EMPLOYMENT; PROVIDING EDUCATIONAL MENTORING SERVICES AND PROGRAMS IN THE FIELD OF SUPPORTING THE TRANSITIONS OF VETERANS FROM THE MILITARY TO CIVILIAN EMPLOYMENT (U.S. CLS. 100, 101 AND 107).

FIRST USE 5-19-2010; IN COMMERCE 9-7-2011.

CATHERINE ROEHL, EXAMINING ATTORNEY

CLASS 41—(Continued).

SN 85-591,817. NEW YORK OUTRIGGER, INC., NEW YORK, NY. FILED 4-7-2012.

NEW YORK OUTRIGGER

THE MARK CONSISTS OF STANDARD CHARACTERS WITHOUT CLAIM TO ANY PARTICULAR FONT, STYLE, SIZE, OR COLOR.

NO CLAIM IS MADE TO THE EXCLUSIVE RIGHT TO USE "OUTRIGGER", APART FROM THE MARK AS SHOWN.

SEC. 2(F).

FOR PROVIDING EDUCATION AND TRAINING ABOUT OUTRIGGER CANOE PADDLING AND ITS ROOTS IN POLYNESIAN CULTURE THROUGH VARIOUS OUTREACH AND COMPETITIVE PADDLING PROGRAMS (U.S. CLS. 100, 101 AND 107).

FIRST USE 11-0-1996; IN COMMERCE 8-14-2000.

JOHN DWYER, EXAMINING ATTORNEY

SN 85-591,924. VINCENT M WEST, ENGLEWOOD, NJ. FILED 4-7-2012.

**ABOUT THAT LIFE TV-RADIO
A.T.L TV-RADIO**

THE MARK CONSISTS OF STANDARD CHARACTERS WITHOUT CLAIM TO ANY PARTICULAR FONT, STYLE, SIZE, OR COLOR.

NO CLAIM IS MADE TO THE EXCLUSIVE RIGHT TO USE "TV-RADIO", APART FROM THE MARK AS SHOWN.

FOR FILM AND VIDEO FILM PRODUCTION; FILM AND VIDEO PRODUCTION; FILM AND VIDEO PRODUCTION CONSULTING SERVICES; FILM AND VIDEO TAPE FILM PRODUCTION; MOTION PICTURE FILM PRODUCTION; MOTION PICTURE SONG PRODUCTION; MULTIMEDIA ENTERTAINMENT SERVICES IN THE NATURE OF DEVELOPMENT, PRODUCTION AND POST-PRODUCTION SERVICES IN THE FIELDS OF VIDEO AND FILMS; MULTIMEDIA ENTERTAINMENT SERVICES IN THE NATURE OF RECORDING, PRODUCTION AND POST-PRODUCTION SERVICES IN THE FIELDS OF MUSIC, VIDEO, AND FILMS; MULTIMEDIA ENTERTAINMENT SOFTWARE PRODUCTION SERVICES; MUSIC PRODUCTION SERVICES; MUSIC SELECTION SERVICES FOR USE IN TELEVISION, FILM, RADIO AND VIDEO GAMES; MUSIC VIDEO PRODUCTION; OPERATION OF ROBOTIC CAMERAS, VIDEO EQUIPMENT AND/OR AUDIO EQUIPMENT FOR PRODUCTION OF INTERNET TELECONFERENCING, TELECONFERENCING OR TELEVISION PROGRAMS; OPERATION OF VIDEO EQUIPMENT OR AUDIO EQUIPMENT ETC. FOR PRODUCTION OF RADIO OR TELEVISION PROGRAMS; PHOTOGRAPHIC AND VIDEO SERVICES, NAMELY, PHOTOGRAPHIC AND VIDEO CAPTURE; POST-PRODUCTION EDITING SERVICES IN THE FIELD OF MUSIC, VIDEOS AND FILM; PRODUCTION OF AUDIO RECORDING; PRODUCTION OF CABLE TELEVISION PROGRAMS; PRODUCTION OF CLOSED CAPTION TELEVISION PROGRAMS; PRODUCTION OF DVDS FEATURING HIP-HOP ARTISTS, FASHION, STREET LIFE; PRODUCTION OF DVDS, VIDEOTAPES AND TELEVISION PROGRAMS FEATURING HIP-HOP ARTISTS, FASHION, STREET LIFE; PRODUCTION OF FILM STUDIES; PRODUCTION OF FILMS; PRODUCTION OF HUMOROUS VIDEOS FOR THE INTERNET; PRODUCTION OF MONOSCOPIC AND/OR STEREO-

CLASS 41—(Continued).

SCOPIC, ELECTRONIC, DIGITAL VIDEO AND/OR FILM; PRODUCTION OF MUSICAL VIDEOS; PRODUCTION OF RADIO AND TELEVISION PROGRAMMES; PRODUCTION OF RADIO AND TELEVISION PROGRAMS; PRODUCTION OF RADIO OR TELEVISION PROGRAMS; PRODUCTION OF RADIO PROGRAMMES; PRODUCTION OF RADIO PROGRAMS; PRODUCTION OF SOUND AND IMAGE RECORDINGS ON SOUND AND IMAGE CARRIERS; PRODUCTION OF SOUND AND MUSIC VIDEO RECORDINGS; PRODUCTION OF SOUND RECORDINGS; PRODUCTION OF SOUND RECORDINGS, NAMELY, HIP-HOP MUSIC; PRODUCTION OF TELEVISION AND RADIO PROGRAMMES; PRODUCTION OF TELEVISION PROGRAMS; PRODUCTION OF VIDEO AND COMPUTER GAME SOFTWARE; PROVIDING AUDIO OR VIDEO STUDIOS; PROVIDING FACILITIES FOR PRODUCING VIDEO, CINEMA AND PHOTOGRAPHY PRODUCTIONS; PROVIDING INFORMATION RELATING TO SPORTING, CULTURAL AND LIVE THEATRICAL PRODUCTIONS; PROVIDING RATINGS FOR TELEVISION, MOVIE, MUSIC, VIDEO AND VIDEO GAME CONTENT; PROVISION OF INFORMATION RELATING TO MULTIMEDIA ENTERTAINMENT SOFTWARE PRODUCTION SERVICES; PROVISION OF INFORMATION RELATING TO TELEVISION, MOTION PICTURE FILM, AUDIO AND RADIO PRODUCTION; PROVISION OF INFORMATION RELATING TO THEATRE PRODUCTIONS; PROVISION OF NON-DOWNLOADABLE FILMS AND MOVIES VIA A VIDEO-ON-DEMAND SERVICE; PROVISION OF NON-DOWNLOADABLE FILMS AND TELEVISION PROGRAMMES VIA A VIDEO-ON-DEMAND SERVICE; RADIO ENTERTAINMENT PRODUCTION; VIDEO RECORDING OF PERSONAL GENEALOGICAL DOCUMENTARIES; VIDEO RECORDING SERVICES; VIDEO TAPE EDITING; VIDEO TAPE FILM PRODUCTION; VIDEOTAPE PRODUCTION (U.S. CLS. 100, 101 AND 107).

WILLIAM JACKSON, EXAMINING ATTORNEY

CLASS 41—(Continued).

SN 85-591,976. COLORADO SPRINGS FINE ARTS CENTER, COLORADO SPRINGS, CO. FILED 4-8-2012.

BROADMOOR ART ACADEMY

THE MARK CONSISTS OF STANDARD CHARACTERS WITHOUT CLAIM TO ANY PARTICULAR FONT, STYLE, SIZE, OR COLOR.

NO CLAIM IS MADE TO THE EXCLUSIVE RIGHT TO USE "ART ACADEMY", APART FROM THE MARK AS SHOWN.

FOR ART EXHIBITION SERVICES; CONDUCTING WORKSHOPS AND SEMINARS IN FINE ARTS; EDUCATIONAL SERVICES IN THE NATURE OF FINE ARTS SCHOOLS; ENTERTAINMENT IN THE NATURE OF DANCE PERFORMANCES, THEATRICAL PRODUCTIONS, FILMS, FILM FESTIVALS, LIVE VOCAL AND INSTRUMENTAL MUSICAL PERFORMANCES AND FINE ARTS EXHIBITIONS; MUSEUMS (U.S. CLS. 100, 101 AND 107).

RENEE MCCRAY, EXAMINING ATTORNEY

SN 85-592,011. TERRACENTRIC PRESS LLC, SAN FRANCISCO, CA. FILED 4-8-2012.

SN 85-591,938. NEW YORK OUTRIGGER, INC., NEW YORK, NY. FILED 4-7-2012.

LIBERTY CHALLENGE

THE MARK CONSISTS OF STANDARD CHARACTERS WITHOUT CLAIM TO ANY PARTICULAR FONT, STYLE, SIZE, OR COLOR.

NO CLAIM IS MADE TO THE EXCLUSIVE RIGHT TO USE "CHALLENGE", APART FROM THE MARK AS SHOWN.

FOR ORGANIZING, ARRANGING, AND CONDUCTING OUTRIGGER CANOE EVENTS (U.S. CLS. 100, 101 AND 107).

FIRST USE 7-0-1998; IN COMMERCE 7-0-1998.
JOHN DWYER, EXAMINING ATTORNEY



NO CLAIM IS MADE TO THE EXCLUSIVE RIGHT TO USE "PRESS LLC", APART FROM THE MARK AS SHOWN.

THE MARK CONSISTS OF AN ILLUSTRATED FLOWER WITH FOUR ASYMMETRIC PETALS AND FIVE LEAVES. THE PETALS AND THREE OF THE LEAVES ARE ENCAPSULATED BY A CIRCLE, AND TWO LEAVES ARE ON THE OUTSIDE OF THE CIRCLE. THE IMAGE IS ON TOP AND TO THE RIGHT OF THE WORDS "TERRA CENTRIC PRESS LLC".

FOR PUBLISHING OF BOOKS, E-BOOKS, AUDIO BOOKS, MUSIC AND ILLUSTRATIONS (U.S. CLS. 100, 101 AND 107).

FIRST USE 5-15-2011; IN COMMERCE 5-15-2011.
KIMBERLY FRYE, EXAMINING ATTORNEY

CLASS 41—(Continued).

SN 85-592,372. ISH-PRODUCTIONS INC., CHICAGO, IL. FILED 4-9-2012.

ISH

THE MARK CONSISTS OF STANDARD CHARACTERS WITHOUT CLAIM TO ANY PARTICULAR FONT, STYLE, SIZE, OR COLOR.

FOR EDUCATIONAL SERVICES, NAMELY, CONDUCTING LIVE AND ON-LINE CLASSES, SEMINARS, CONFERENCES, AND WORKSHOPS IN THE FIELD OF LEADERSHIP DEVELOPMENT AND DISTRIBUTION OF COURSE MATERIAL IN CONNECTION THEREWITH; AND MOTIVATIONAL COACHING AND EXECUTIVE COACHING IN THE FIELD OF LEADERSHIP DEVELOPMENT (U.S. CLS. 100, 101 AND 107).

FIRST USE 1-31-2012; IN COMMERCE 1-31-2012.
BILL DAWE, EXAMINING ATTORNEY

CLASS 41—(Continued).

SN 85-592,675. OREGON SOCIAL LEARNING CENTER, EUGENE, OR. FILED 4-9-2012.

KEEP

THE MARK CONSISTS OF STANDARD CHARACTERS WITHOUT CLAIM TO ANY PARTICULAR FONT, STYLE, SIZE, OR COLOR.

FOR PSYCHOSOCIAL EDUCATIONAL SERVICES, NAMELY, CONDUCTING GROUP CLASSES AND WORKSHOPS IN THE FIELD OF FOSTER PARENT SKILLS, FOR FOSTER AND KINSHIP PARENTS AND CASEWORKERS AND OTHER PROFESSIONALS (U.S. CLS. 100, 101 AND 107).

FIRST USE 9-30-2007; IN COMMERCE 9-30-2007.
MATTHEW KLINE, EXAMINING ATTORNEY

SN 85-592,901. MARK & MARLO PRODUCTIONS, LLC, HUDSON, OH. FILED 4-9-2012.

COMEDY IN HIGH DEFINITION

THE MARK CONSISTS OF STANDARD CHARACTERS WITHOUT CLAIM TO ANY PARTICULAR FONT, STYLE, SIZE, OR COLOR.

NO CLAIM IS MADE TO THE EXCLUSIVE RIGHT TO USE "COMEDY", APART FROM THE MARK AS SHOWN.

FOR ENTERTAINMENT IN THE NATURE OF COMEDY SHOWS (U.S. CLS. 100, 101 AND 107).

RENEE MCCRAY, EXAMINING ATTORNEY

SN 85-592,663. NEW RELEASE, LLC, BROOKLYN, NY. FILED 4-9-2012.

MISTER SATURDAY NIGHT

THE MARK CONSISTS OF STANDARD CHARACTERS WITHOUT CLAIM TO ANY PARTICULAR FONT, STYLE, SIZE, OR COLOR.

THE NAME(S), PORTRAIT(S), AND/OR SIGNATURE(S) SHOWN IN THE MARK DOES NOT IDENTIFY A PARTICULAR LIVING INDIVIDUAL.

FOR ENTERTAINMENT SERVICES, NAMELY, DISC JOCKEY SERVICES, DISC JOCKEYS FOR PARTIES AND SPECIAL EVENTS; LIVE SPECIAL EVENT PLANNING FOR SOCIAL ENTERTAINMENT PURPOSES; ARRANGING AND CONDUCTING SPECIAL EVENTS FOR SOCIAL ENTERTAINMENT PURPOSES; RECORD PRODUCTION SERVICES; PRODUCTION OF SOUND RECORDINGS FEATURING MUSIC (U.S. CLS. 100, 101 AND 107).

FIRST USE 1-1-2009; IN COMMERCE 1-17-2009.
GEOFFREY FOSDICK, EXAMINING ATTORNEY

SN 85-593,052. WITT, MORGAN, SAN DIEGO, CA. FILED 4-9-2012.

strictlysocial

THE MARK CONSISTS OF STANDARD CHARACTERS WITHOUT CLAIM TO ANY PARTICULAR FONT, STYLE, SIZE, OR COLOR.

FOR PROVIDING INFORMATION, NEWS AND COMMENTARY IN THE FIELDS OF ART, FASHION, MUSIC AND POP CULTURE (U.S. CLS. 100, 101 AND 107).

SETH A. RAPPAPORT, EXAMINING ATTORNEY

CLASS 41—(Continued).

SN 85-593,279. COLLINS, KRISTEN, TOLEDO, OH. FILED 4-10-2012.

CLASS 41—(Continued).

SN 85-593,560. NEW RELEASE, LLC, BROOKLYN, NY. FILED 4-10-2012.



Raq the Casbah

THE NAME(S), PORTRAIT(S), AND/OR SIGNATURE(S) SHOWN IN THE MARK DOES NOT IDENTIFY A PARTICULAR LIVING INDIVIDUAL.

THE COLOR(S) YELLOW IS/ARE CLAIMED AS A FEATURE OF THE MARK.

THE MARK CONSISTS OF A YELLOW WOOD CUT DESIGN FEATURING A FACE ON A MOON.

FOR ENTERTAINMENT SERVICES, NAMELY, DISC JOCKEY SERVICES, DISC JOCKEYS FOR PARTIES AND SPECIAL EVENTS; LIVE SPECIAL EVENT PLANNING FOR SOCIAL ENTERTAINMENT PURPOSES; ARRANGING AND CONDUCTING SPECIAL EVENTS FOR SOCIAL ENTERTAINMENT PURPOSES; RECORD PRODUCTION SERVICES; PRODUCTION OF SOUND RECORDINGS FEATURING MUSIC (U.S. CLS. 100, 101 AND 107).

FIRST USE 9-1-2009; IN COMMERCE 10-3-2009.
GEOFFREY FOSDICK, EXAMINING ATTORNEY

THE MARK CONSISTS OF STANDARD CHARACTERS WITHOUT CLAIM TO ANY PARTICULAR FONT, STYLE, SIZE, OR COLOR.

FOR ENTERTAINMENT IN THE NATURE OF AN ONGOING SPECIAL VARIETY, NEWS, MUSIC OR COMEDY SHOW FEATURING MUSICAL AND DANCE PERFORMANCES BROADCAST OVER TELEVISION, SATELLITE, AUDIO, AND VIDEO MEDIA; ENTERTAINMENT IN THE NATURE OF LIVE PERFORMANCES BY A DANCE AND MUSIC GROUP; ENTERTAINMENT IN THE NATURE OF VISUAL AND AUDIO PERFORMANCES BY A DANCE AND MUSIC GROUP; ENTERTAINMENT IN THE NATURE OF VISUAL AND AUDIO PERFORMANCES, AND MUSICAL, VARIETY, NEWS AND COMEDY SHOWS; ENTERTAINMENT IN THE NATURE OF VISUAL AND AUDIO PERFORMANCES, NAMELY, MUSICAL BAND, ROCK GROUP, GYMNASTIC, DANCE, AND BALLET PERFORMANCES; ENTERTAINMENT IN THE NATURE OF LIVE MUSICAL PERFORMANCES; ENTERTAINMENT SERVICES IN THE NATURE OF LIVE MUSICAL PERFORMANCES; ENTERTAINMENT, NAMELY, LIVE MUSIC CONCERTS; ENTERTAINMENT, NAMELY, LIVE PERFORMANCES BY A MUSICAL BAND; ENTERTAINMENT, NAMELY, LIVE PERFORMANCES BY MUSICAL BANDS; LIVE PERFORMANCES BY A MUSICAL GROUP (U.S. CLS. 100, 101 AND 107).

FIRST USE 1-1-2010; IN COMMERCE 1-1-2010.
MARK RADEMACHER, EXAMINING ATTORNEY

SN 85-593,640. THE CFO GROUP, INC, RENO, NV. FILED 4-10-2012.

FIVE STAR EFFECT

THE MARK CONSISTS OF STANDARD CHARACTERS WITHOUT CLAIM TO ANY PARTICULAR FONT, STYLE, SIZE, OR COLOR.

FOR ARRANGING AND CONDUCTING EDUCATIONAL CONFERENCES (U.S. CLS. 100, 101 AND 107).
BRIAN NEVILLE, EXAMINING ATTORNEY

CLASS 41—(Continued).

SN 85-593,919. COLOMER, JUAN, LOS ANGELES, CA. FILED 4-10-2012.

LA Grand Ensemble

THE MARK CONSISTS OF STANDARD CHARACTERS WITHOUT CLAIM TO ANY PARTICULAR FONT, STYLE, SIZE, OR COLOR.

NO CLAIM IS MADE TO THE EXCLUSIVE RIGHT TO USE "LA" AND "ENSEMBLE", APART FROM THE MARK AS SHOWN.

FOR ENTERTAINMENT SERVICES IN THE NATURE OF LIVE MUSICAL PERFORMANCES (U.S. CLS. 100, 101 AND 107).

FIRST USE 3-21-2012; IN COMMERCE 3-21-2012.
TARAH HARDY, EXAMINING ATTORNEY

CLASS 41—(Continued).

SN 85-594,299. OWENS STATE COMMUNITY COLLEGE, TOLEDO, OH. FILED 4-11-2012.



THE MARK CONSISTS OF A FANCIFUL "E". FOR EDUCATIONAL SERVICES AND EDUCATION-RELATED ENTERTAINMENT SERVICES, SPECIFICALLY, CONDUCTING SPORTING EVENTS AND RECREATION PROGRAMS, NAMELY, FITNESS CLASSES, GOLF, SOCCER, BASEBALL, BASKETBALL, VOLLEYBALL AND SOFTBALL (U.S. CLS. 100, 101 AND 107).

FIRST USE 8-1-2008; IN COMMERCE 8-1-2008.
KATHLEEN LORENZO, EXAMINING ATTORNEY

SN 85-594,308. WORKERS UNITE FILM FESTIVAL, INC., NEW YORK, NY. FILED 4-11-2012.



NO CLAIM IS MADE TO THE EXCLUSIVE RIGHT TO USE "FILM FESTIVAL", APART FROM THE MARK AS SHOWN.

THE COLOR(S) BLACK, DARK GRAY AND RED IS/ARE CLAIMED AS A FEATURE OF THE MARK.

THE MARK CONSISTS OF AN ABSTRACTED IMAGE OF A FILM REEL IN DARK GRAY, WHICH CONSISTS OF A CIRCLE WITHIN ANOTHER CIRCLE, WITH A LINE INTERSECTING THE CIRCLES GOING TOP TO BOTTOM, AND ANOTHER LINE INTERSECTING THE CIRCLES GOING LEFT TO RIGHT, AND TWO ADDITIONAL LINES FORMING THE IMAGE OF A BEAM OF LIGHT IN THE TOP RIGHT QUADRANT, FOLLOWED BY THE WORDS "WORKERS UNITE" IN BLACK ON TOP OF THE RIGHT HALF OF THE ABSTRACTED FILM REEL USING STYLIZED CAPITALIZED LETTERS, FOLLOWED BY AN EXCLAMATION POINT "!" IN RED, FOLLOWED BY THE WORDS "FILM FESTIVAL" IN BLACK USING STYLIZED CAPITALIZED LETTERS.

FOR ENTERTAINMENT SERVICES, NAMELY, MOTION PICTURE AND FILM PRODUCTION SERVICES; ORGANIZING AND CONDUCTING FILM FESTIVAL ENTERTAINMENT EXHIBITIONS; PROVIDING ONLINE INFORMATION REGARDING MOTION PICTURE FILMS, AND MOTION PICTURE FILM INDUSTRY EVENTS OFFERED VIA A GLOBAL COMPUTER NETWORK; CONDUCTING AWARD SHOWS RELATED TO THE MOTION PICTURE FILM INDUSTRY; PLANNING AND CONDUCTING MOTION PICTURE FILM SCREENING EVENTS IN THE NATURE OF CLASSIC AND CONTEMPORARY MOVIES, DOCUMENTARIES AND SHORT FILMS; PLANNING AND CONDUCTING CULTURAL EVENTS, ENTERTAINMENT EXHIBITIONS, CONFERENCES AND PANEL DISCUSSIONS IN THE FIELDS OF ART, LITERATURE, MUSIC, AND CINEMA (U.S. CLS. 100, 101 AND 107).

FIRST USE 11-28-2011; IN COMMERCE 11-28-2011.
SAMUEL E. SHARPER JR., EXAMINING ATTORNEY

SN 85-593,988. AKKA SOCCER, MEDFORD, NJ. FILED 4-10-2012.



NO CLAIM IS MADE TO THE EXCLUSIVE RIGHT TO USE "AKKA SOCCER", APART FROM THE MARK AS SHOWN.

THE MARK CONSISTS OF THE WORDS "AKKA SOCCER" IN STYLIZED FONT ALONGSIDE AN ARROW DESIGN POINTING DOWNWARD.

FOR SOCCER INSTRUCTION; ENTERTAINMENT IN THE NATURE OF SOCCER GAMES AND SOCCER TOURNAMENTS; ORGANIZATION OF SOCCER GAMES; SOCCER CAMPS (U.S. CLS. 100, 101 AND 107).

FIRST USE 1-2-2008; IN COMMERCE 2-3-2009.
DAVID YONTEF, EXAMINING ATTORNEY

CLASS 41—(Continued).

SN 85-594,359. WORKERS UNITE FILM FESTIVAL, INC.,
NEW YORK, NY. FILED 4-11-2012.

WORKERS UNITE FILM FESTIVAL

THE MARK CONSISTS OF STANDARD CHARACTERS WITHOUT CLAIM TO ANY PARTICULAR FONT, STYLE, SIZE, OR COLOR.

NO CLAIM IS MADE TO THE EXCLUSIVE RIGHT TO USE "FILM FESTIVAL", APART FROM THE MARK AS SHOWN.

FOR ENTERTAINMENT SERVICES, NAMELY, MOTION PICTURE AND FILM PRODUCTION SERVICES; ORGANIZING AND CONDUCTING FILM FESTIVAL ENTERTAINMENT EXHIBITIONS; PROVIDING ONLINE INFORMATION REGARDING MOTION PICTURE FILMS, AND MOTION PICTURE FILM INDUSTRY EVENTS OFFERED VIA A GLOBAL COMPUTER NETWORK; CONDUCTING AWARD SHOWS RELATED TO THE MOTION PICTURE FILM INDUSTRY; PLANNING AND CONDUCTING MOTION PICTURE FILM SCREENING EVENTS IN THE NATURE OF CLASSIC AND CONTEMPORARY MOVIES, DOCUMENTARIES AND SHORT FILMS; PLANNING AND CONDUCTING CULTURAL EVENTS, ENTERTAINMENT EXHIBITIONS, CONFERENCES AND PANEL DISCUSSIONS IN THE FIELDS OF ART, LITERATURE, MUSIC, AND CINEMA (U.S. CLS. 100, 101 AND 107).

FIRST USE 11-28-2011; IN COMMERCE 11-28-2011.

SAMUEL E. SHARPER JR., EXAMINING ATTORNEY

SN 85-594,553. CULTIVATED WIT LLC, NEW YORK, NY.
FILED 4-11-2012.

Cultivated Wit

THE MARK CONSISTS OF STANDARD CHARACTERS WITHOUT CLAIM TO ANY PARTICULAR FONT, STYLE, SIZE, OR COLOR.

FOR ENTERTAINMENT IN THE NATURE OF AN ONGOING SPECIAL VARIETY, NEWS, MUSIC OR COMEDY SHOW FEATURING POLITICS, COMEDY, ENTERTAINMENT, COMMENTARY, AND CONTEMPORARY CULTURE BROADCAST OVER TELEVISION, SATELLITE, AUDIO, AND VIDEO MEDIA; ENTERTAINMENT IN THE NATURE OF VISUAL AND AUDIO PERFORMANCES, AND MUSICAL, VARIETY, NEWS AND COMEDY SHOWS; ENTERTAINMENT SERVICES IN THE NATURE OF COMEDY SHOWS; ENTERTAINMENT SERVICES, NAMELY, A MULTIMEDIA PROGRAM SERIES FEATURING COMEDY, ACTION AND ADVENTURE DISTRIBUTED VIA VARIOUS PLATFORMS ACROSS MULTIPLE FORMS OF TRANSMISSION MEDIA; ENTERTAINMENT SERVICES, NAMELY, AN ONGOING SERIES FEATURING POLITICS, COMEDY, ENTERTAINMENT, COMMENTARY, AND CONTEMPORARY CULTURE PROVIDED THROUGH TELEVISION, RADIO, MOBILE DEVICES, AND INTERNET; ENTERTAINMENT SERVICES, NAMELY, PROVIDING INFORMATION BY MEANS OF A GLOBAL COMPUTER NETWORK IN THE FIELDS OF CELEBRITIES, ENTERTAINMENT, AND POPULAR CULTURE; ENTERTAINMENT SERVICES, NAMELY, PROVIDING ONGOING WEBISODES FEATURING POLITICS, COMEDY, ENTERTAINMENT, COMMENTARY, AND CONTEMPORARY CULTURE VIA A GLOBAL COMPUTER NETWORK; ENTERTAINMENT SERVICES,

CLASS 41—(Continued).

NAMELY, THE PROVISION OF CONTINUING VARIETY SHOWS FEATURING POLITICS, COMEDY, ENTERTAINMENT, COMMENTARY, AND CONTEMPORARY CULTURE DELIVERED BY TELEVISION, RADIO, MOBILE DEVICES, AND INTERNET; ENTERTAINMENT, NAMELY, A CONTINUING POLITICS, COMEDY, ENTERTAINMENT, COMMENTARY, AND CONTEMPORARY CULTURE SHOW BROADCAST OVER TELEVISION, SATELLITE, AUDIO, AND VIDEO MEDIA; ENTERTAINMENT, NAMELY, A CONTINUING VARIETY AND NEWS SHOW BROADCAST OVER TELEVISION, RADIO, MOBILE DEVICES, AND INTERNET; ORGANIZATION OF EVENTS FOR CULTURAL PURPOSES; ORGANIZATION OF SHOWS FOR CULTURAL PURPOSES; ORGANIZING CULTURAL AND ARTS EVENTS; ORGANIZING EXHIBITIONS FOR POLITICS, COMEDY, ENTERTAINMENT, COMMENTARY, AND CONTEMPORARY CULTURE; PRESENTATION OF LIVE COMEDY SHOWS; PROVIDING A WEBSITE FEATURING BLOGS AND NON-DOWNLOADABLE PUBLICATIONS IN THE NATURE OF ARTICLES IN THE FIELD(S) OF POLITICS, COMEDY, ENTERTAINMENT, COMMENTARY, AND CONTEMPORARY CULTURE; PROVIDING AN IN-PERSON CULTURAL, EDUCATIONAL, AND ENTERTAINMENT FORUM IN THE FIELD OF POLITICS, COMEDY, ENTERTAINMENT, COMMENTARY, AND CONTEMPORARY CULTURE; PROVIDING AN INTERNET NEWS PORTAL FEATURING LINKS TO NEWS STORIES AND ARTICLES IN THE FIELD OF CURRENT EVENTS; PROVIDING AN INTERNET WEBSITE PORTAL IN THE FIELD OF ENTERTAINMENT, CULTURAL AND SPORTING EVENTS; PROVIDING AN ONLINE MONTHLY COLUMN IN THE FIELD OF POLITICS, COMEDY, ENTERTAINMENT, COMMENTARY, AND CONTEMPORARY CULTURE; WRITING OF ARTICLES FOR JOURNALS OTHER THAN FOR ADVERTISING OR PUBLICITY; WRITING OF ARTICLES FOR PERIODICALS OTHER THAN FOR ADVERTISING OR PUBLICITY; WRITING OF TEXTS OTHER THAN PUBLICITY TEXTS (U.S. CLS. 100, 101 AND 107).

SHAVELL MCPHERSON, EXAMINING ATTORNEY

SN 85-594,593. SUSAN BARRETT KELLY AND ASSOCIATES, EVANSTON, IL. FILED 4-11-2012.

Development Sherpa

THE MARK CONSISTS OF STANDARD CHARACTERS WITHOUT CLAIM TO ANY PARTICULAR FONT, STYLE, SIZE, OR COLOR.

NO CLAIM IS MADE TO THE EXCLUSIVE RIGHT TO USE "DEVELOPMENT", APART FROM THE MARK AS SHOWN.

FOR ON-LINE JOURNALS, NAMELY, BLOGS FEATURING INFORMATION ON DEVELOPMENT AND DEVELOPMENT TOOLS FOR PEOPLE AND TEAMS IN ORGANIZATIONS (U.S. CLS. 100, 101 AND 107).

JUHI KAVEESHVAR, EXAMINING ATTORNEY

CLASS 41—(Continued).

SN 85-594,610. NSHAPE, LLC, CHATTANOOGA, TN. FILED 4-11-2012.

nShape365

THE MARK CONSISTS OF STANDARD CHARACTERS WITHOUT CLAIM TO ANY PARTICULAR FONT, STYLE, SIZE, OR COLOR.

FOR PROVIDING INFORMATION IN THE FIELD OF EXERCISE TRAINING (U.S. CLS. 100, 101 AND 107).
ROBIN MITTLER, EXAMINING ATTORNEY

SN 85-594,636. ALL SPORTS MARKETING, INC., TORONTO, CANADA, FILED 4-11-2012.

Your Online Starting Line

THE MARK CONSISTS OF STANDARD CHARACTERS WITHOUT CLAIM TO ANY PARTICULAR FONT, STYLE, SIZE, OR COLOR.

FOR PROVIDING A WEBSITE FEATURING SPORTS INFORMATION RELATING TO ENDURANCE TRAINING AND FEATURING ONLINE SPORTS TRAINING AND SPORTS TRAINING ADVICE AND INFORMATION RELATING TO SPORTING EVENTS IN THE FIELD OF RUNNING, CYCLING, TRIATHLONS, AND ADVENTURE RACES (U.S. CLS. 100, 101 AND 107).

FIRST USE 4-30-2007; IN COMMERCE 4-30-2007.
ZACHARY CROMER, EXAMINING ATTORNEY

SN 85-595,065. FAITHFUL FOUR, LLC, LAWNSIDE, NJ. FILED 4-11-2012.

BURNZ CIGAR VAULT & LOUNGE

THE MARK CONSISTS OF STANDARD CHARACTERS WITHOUT CLAIM TO ANY PARTICULAR FONT, STYLE, SIZE, OR COLOR.

NO CLAIM IS MADE TO THE EXCLUSIVE RIGHT TO USE "CIGAR VAULT & LOUNGE", APART FROM THE MARK AS SHOWN.

FOR CIGAR LOUNGE SERVICES (U.S. CLS. 100, 101 AND 107).

FIRST USE 11-12-2011; IN COMMERCE 11-12-2011.
KATHERINE CHANG, EXAMINING ATTORNEY

CLASS 41—(Continued).

SN 85-595,289. PEARL MUSIC, LLC, AUSTIN, TX. FILED 4-11-2012.



NO CLAIM IS MADE TO THE EXCLUSIVE RIGHT TO USE "GUITAR", APART FROM THE MARK AS SHOWN.

THE COLOR(S) TAN, BLACK, BLUE AND WHITE IS/ARE CLAIMED AS A FEATURE OF THE MARK.

THE MARK CONSISTS OF THE STYLIZED IMAGE OF A MAN OUTLINED IN BLACK WITH WHITE SKIN, BLACK HAIR AND FEATURES, WEARING A TAN OUTFIT WITH BLACK BELT AND TRIM, AND WEARING A GUITAR BEHIND HIS BACK WITH A BLACK HANDLE AND A BLUE STRAP IN FRONT, NEXT TO THE STYLIZED BLACK WORDS "GUITAR DOJO". THE REMAINDER OF THE WHITE IN THE MARK IS BACKGROUND AREA WHICH IS NOT A PART OF THE MARK.

FOR EDUCATIONAL SERVICES, NAMELY, CONDUCTING CLASSES IN THE FIELD OF GUITAR (U.S. CLS. 100, 101 AND 107).

FIRST USE 6-0-2011; IN COMMERCE 6-0-2011.
REBECCA GILBERT, EXAMINING ATTORNEY

SN 85-595,466. RODGERS & ASSOCIATES, INC., MILWAUKEE, WI. FILED 4-11-2012.

PERSUASION MATTERS

THE MARK CONSISTS OF STANDARD CHARACTERS WITHOUT CLAIM TO ANY PARTICULAR FONT, STYLE, SIZE, OR COLOR.

FOR MOTIVATIONAL SPEAKING AND COMPETENCY BASED TRAINING IN THE FIELD OF SALES, LEADERSHIP, MANAGEMENT, PERSONAL DEVELOPMENT AND COMMUNICATION INCLUDING THE DISTRIBUTION OF PRINTED MATERIALS IN CONNECTION THEREWITH (U.S. CLS. 100, 101 AND 107).

TASHIA BUNCH, EXAMINING ATTORNEY

CLASS 41—(Continued).

SN 85-595,509. PERONDI, CHRIS, DBA STUNT DOG EXPERIENCE, FRENCH CAMP, CA. FILED 4-11-2012.



NO CLAIM IS MADE TO THE EXCLUSIVE RIGHT TO USE "STUNT DOG", APART FROM THE MARK AS SHOWN.

THE COLOR(S) YELLOW, RED, BLUE, BLACK, WHITE, AND GREY IS/ARE CLAIMED AS A FEATURE OF THE MARK.

THE MARK CONSISTS OF THE WORDING "STUNT DOG EXPERIENCE" IS IN YELLOW WITH A RED, WHITE, AND BLUE OUTLINE. THE STARS APPEAR AROUND THE WORDING ALTERNATING BLUE, RED AND YELLOW. THE CUSTOM DOG IS PICTURED IN THE UPPER RIGHT HAND CORNER AND IS JUMPING THROUGH A HOOP OF FIRE. THE DOG IS PRIMARILY BLACK WITH WHITE AND GREY MARKINGS. THE DOG IS WEARING A RED VEST WITH A YELLOW STAR IN THE MIDDLE OF IT. THE VEST HAS A BLUE CAPE. THE HOOP OF FIRE IS RED WITH A BLUE OUTLINE. YELLOW FLAMES APPEAR ABOVE AND BELOW THE HOOP OF FIRE.

FOR CONDUCTING ENTERTAINMENT EXHIBITIONS IN THE NATURE OF THEME PARKS, STATE FAIRS, COUNTY FAIRS, FESTIVALS, EXPOS, PERFORMING ARTS THEATRES; ENTERTAINMENT IN THE NATURE OF LIVE PERFORMANCES BY STUNT DOGS; ENTERTAINMENT IN THE NATURE OF TRICK DOG SHOWS, STUNT DOG SHOWS, DOG BEHAVIOR SHOWS, AND FLYING DISCS DOG SHOWS FOR THEME PARKS, PERFORMING ARTS THEATRES, FAIRS, FESTIVALS, EXPOS, AND SPORTING EVENTS; ENTERTAINMENT, NAMELY, PRODUCTION OF STAGE SHOW ACTS, THEATRE SHOWS, AND PLAYS (U.S. CLS. 100, 101 AND 107).

FIRST USE 6-25-2009; IN COMMERCE 6-8-2010.
SUSAN BILLHEIMER, EXAMINING ATTORNEY

SN 85-595,665. CINCINNATI PUBLIC RADIO, INC., CINCINNATI, OH. FILED 4-12-2012.

LOCAL EXPOSURE

THE MARK CONSISTS OF STANDARD CHARACTERS WITHOUT CLAIM TO ANY PARTICULAR FONT, STYLE, SIZE, OR COLOR.

NO CLAIM IS MADE TO THE EXCLUSIVE RIGHT TO USE "LOCAL", APART FROM THE MARK AS SHOWN.

FOR ENTERTAINMENT SERVICES, NAMELY, PROVIDING PODCASTS IN THE FIELD OF ARTS, EVENTS AND LOCAL NEIGHBORHOOD CULTURAL ACTIVITIES (U.S. CLS. 100, 101 AND 107).

FIRST USE 11-1-2011; IN COMMERCE 11-1-2011.
JACLYN KIDWELL WALKER, EXAMINING ATTORNEY

CLASS 41—(Continued).

SN 85-595,680. ELI BAINBRIDGE AND COMPANY, INC., WEST NEWTON, MA. FILED 4-12-2012.

Bainbridge Editions

THE MARK CONSISTS OF STANDARD CHARACTERS WITHOUT CLAIM TO ANY PARTICULAR FONT, STYLE, SIZE, OR COLOR.

NO CLAIM IS MADE TO THE EXCLUSIVE RIGHT TO USE "EDITIONS", APART FROM THE MARK AS SHOWN. FOR BOOK PUBLISHING; PUBLISHING OF BOOKS, E-BOOKS, AUDIO BOOKS, MUSIC AND ILLUSTRATIONS (U.S. CLS. 100, 101 AND 107).

JACLYN KIDWELL WALKER, EXAMINING ATTORNEY

SN 85-596,038. BOARD OF COOPERATIVE EDUCATIONAL SERVICES RENSSELAER-COLUMBIA-GREENE COUNTIES, DBA QUESTAR III, CASTLETON, NY. AND BOARD OF COOPERATIVE EDUCATIONAL SERVICES ALBANY-SCHOHARIE-SCHENECTADY-SARATOGA COUNTIES, AKA CAPITAL REGION BOCES, ALBANY, NY. FILED 4-12-2012.

TECH VALLEY HIGH SCHOOL

THE MARK CONSISTS OF STANDARD CHARACTERS WITHOUT CLAIM TO ANY PARTICULAR FONT, STYLE, SIZE, OR COLOR.

OWNER OF U.S. REG. NO. 3,819,926.

NO CLAIM IS MADE TO THE EXCLUSIVE RIGHT TO USE "HIGH SCHOOL", APART FROM THE MARK AS SHOWN.

SEC. 2(F).

FOR EDUCATIONAL SERVICES, NAMELY, STUDENT EDUCATIONAL SERVICES IN THE NATURE OF PROVIDING COURSES OF INSTRUCTION AT THE SECONDARY SCHOOL LEVEL, DISTRIBUTING COURSE MATERIALS IN CONNECTION WITH A SECONDARY SCHOOL, DEVELOPING A CURRICULUM FOR USE IN SECONDARY SCHOOLS FOR EDUCATORS, AND PROFESSIONAL DEVELOPMENT TRAINING AND CURRICULUM AND LESSON PLANNING FOR K-12 SCHOOL LEVEL EDUCATORS; EDUCATION CONSULTING SERVICES FOR OTHERS IN THE FIELDS OF PROFESSIONAL DEVELOPMENT TRAINING AND CURRICULUM AND LESSON PLANNING FOR K-12 SCHOOL LEVEL EDUCATORS (U.S. CLS. 100, 101 AND 107).

FIRST USE 2-28-2007; IN COMMERCE 2-28-2007.
MORGAN WYNNE, EXAMINING ATTORNEY

CLASS 41—(Continued).

SN 85-596,072. I3-JAX, INC., JACKSONVILLE, FL. FILED 4-12-2012.



THE COLOR(S) BLACK, WHITE, YELLOW/GREEN IDENTIFIED AS PANTONE 394 C AND CYAN/BLUE IDENTIFIED AS PANTONE 5493 C IS/ARE CLAIMED AS A FEATURE OF THE MARK.

THE MARK CONSISTS OF THE WORDS "EPOCH" IN WHITE AND "PROJECT" IN BLACK WITH THE WORD "EPOCH" POSITIONED WITHIN A SHADED BLOCK COLORED IN A YELLOW/GREEN COLOR IDENTIFIED AS PANTONE 394 C, AND THE LETTER "O" IN "EPOCH" SHADED IN THE CENTER A CYAN/BLUE COLOR IDENTIFIED AS PANTONE 5493.

FOR CONDUCTING EDUCATIONAL EXHIBITIONS IN THE NATURE OF COMPETITIONS AND EXHIBITIONS OF ART, SCIENCE, INVENTIONS, INNOVATION AND OTHER CREATIONS AND CREATIVE ACTIVITIES; CONDUCTING ENTERTAINMENT EXHIBITIONS IN THE NATURE OF COMPETITIONS AND EXHIBITIONS OF ART, SCIENCE, INVENTIONS, INNOVATION AND OTHER CREATIONS AND CREATIVE ACTIVITIES (U.S. CLS. 100, 101 AND 107).

DOMINIC J. FERRAUOLO, EXAMINING ATTORNEY

CLASS 41—(Continued).

SN 85-596,132. SK MOVEMENT, INC., LOS ANGELES, CA. FILED 4-12-2012.

Fluid Feminine Movement

THE MARK CONSISTS OF STANDARD CHARACTERS WITHOUT CLAIM TO ANY PARTICULAR FONT, STYLE, SIZE, OR COLOR.

NO CLAIM IS MADE TO THE EXCLUSIVE RIGHT TO USE "FEMININE", APART FROM THE MARK AS SHOWN. FOR PHYSICAL FITNESS TRAINING OF INDIVIDUALS AND GROUPS (U.S. CLS. 100, 101 AND 107).

FIRST USE 1-1-2008; IN COMMERCE 3-1-2012.
KEVON CHISOLM, EXAMINING ATTORNEY

SN 85-596,128. STATE FAIR OF TEXAS, DALLAS, TX. FILED 4-12-2012.



NO CLAIM IS MADE TO THE EXCLUSIVE RIGHT TO USE "FAIR PARK", APART FROM THE MARK AS SHOWN. THE COLOR(S) RED, BLUE, PINK, WHITE, BROWN, ORANGE, GREEN, YELLOW, PURPLE, AND BLACK IS/ARE CLAIMED AS A FEATURE OF THE MARK.

THE MARK CONSISTS OF THE WORDING "SUMMER" IS WRITTEN IN AN ARC PATTERN; BELOW THE WORD "SUMMER" IS THE TERM "ADVENTURES"; THE LETTERS COMPRISING "SUMMER" ARE ALL WHITE AND EACH LETTER IS SURROUNDED BY A BLUE SOLID BOX BACKGROUND; THE LETTERS COMPRISING "ADVENTURES" ARE WRITTEN IN A VARIETY OF COLORS, NAMELY, RED, ORANGE, BLUE, PURPLE, GREEN, PINK AND YELLOW; AN IMAGE OF SAND IS PLACED BELOW THE WORD "ADVENTURES"; THE WORDS "IN FAIR PARK" ARE WRITTEN IN BLACK FONT ON TOP OF THE BROWN SAND; A BROWN AND GREEN PALM TREE IS PLACED ON THE LEFT SIDE OF THE MARK.

FOR ARRANGING AND CONDUCTING ENTERTAINMENT AND AMUSEMENT SERVICES, NAMELY, SHOWS, RIDES AND GAMES; ARRANGING AND CONDUCTING EDUCATIONAL SERVICES IN THE NATURE OF PUBLIC EXHIBITS AND PRESENTATIONS FEATURING ACHIEVEMENTS IN THE ARTS AND SCIENCES (U.S. CLS. 100, 101 AND 107).

KEVON CHISOLM, EXAMINING ATTORNEY

SN 85-596,289. SARAH J. FITNESS, FREDERICKSBURG, VA. FILED 4-12-2012.



NO CLAIM IS MADE TO THE EXCLUSIVE RIGHT TO USE "FITNESS", APART FROM THE MARK AS SHOWN.

THE NAME "SARAH J." IDENTIFIES THE NICKNAME OF SARAH JENNINGS, A LIVING INDIVIDUAL WHOSE CONSENT IS OF RECORD.

THE MARK CONSISTS OF A SQUARE WITH THE STYLIZED TEXT "SJ" ACROSS IT. THE LETTER "J" IS DOTTED WITH A SMALL YIN YANG SYMBOL. UNDER THE "SJ" IS THE STYLIZED TEXT "RE-CREATE YOURSELF" WRITTEN AT AN ANGLE. WRITTEN VERTICALLY ALONG THE RIGHT SIDE OF THE SQUARE IS THE STYLIZED TEXT "SARAH J. FITNESS".

FOR PERSONAL FITNESS TRAINING SERVICES AND CONSULTANCY; PHYSICAL FITNESS TRAINING SERVICES (U.S. CLS. 100, 101 AND 107).

CHRISIE B. KING, EXAMINING ATTORNEY

CLASS 41—(Continued).

SN 85-596,300. THE NATURE CONSERVANCY, ARLINGTON, VA. FILED 4-12-2012.



THE MARK CONSISTS OF A GLOBE WITH OUTLINES OF THE CONTINENTS AND WITH A GINGHAM PATTERN THROUGHOUT THE GLOBE.

FOR ORGANIZING AND HOSTING OF COMMUNITY EVENTS, NAMELY, LIVE MUSIC, CONCERTS, EDUCATIONAL SPEAKERS, SPORTING EVENTS, CULTURAL EVENTS AND CHILDREN'S ACTIVITIES IN THE FIELD OF CONSERVATION OF NATURAL RESOURCES AND PRESERVATION OF ENDANGERED SPECIES (U.S. CLS. 100, 101 AND 107).

ANNE FARRELL, EXAMINING ATTORNEY

CLASS 41—(Continued).

SN 85-596,582. MOON SHADOW MEDIA, LLC, ST PAUL, MN. FILED 4-12-2012.

THE ENTERTAINMENT EXPERIENCE

THE MARK CONSISTS OF STANDARD CHARACTERS WITHOUT CLAIM TO ANY PARTICULAR FONT, STYLE, SIZE, OR COLOR.

NO CLAIM IS MADE TO THE EXCLUSIVE RIGHT TO USE "ENTERTAINMENT", APART FROM THE MARK AS SHOWN.

FOR BUSINESS TRAINING IN THE FIELD OF BUSINESS DEVELOPMENT, AND PROVIDING DISC JOCKEY AND HOSTING SERVICES FOR PARTIES AND SPECIAL EVENTS; EDUCATIONAL SERVICES, NAMELY, CONDUCTING SEMINARS AND WORKSHOPS IN THE FIELDS OF BUSINESS DEVELOPMENT, AND PROVIDING DISC JOCKEY AND HOSTING SERVICES FOR PARTIES AND SPECIAL EVENTS AND DISTRIBUTION OF TRAINING MATERIALS IN CONNECTION THEREWITH; PROFESSIONAL COACHING SERVICES IN THE FIELD OF BUSINESS DEVELOPMENT, AND PROVIDING DISC JOCKEY AND HOSTING SERVICES FOR PARTIES AND SPECIAL EVENTS (U.S. CLS. 100, 101 AND 107).

FIRST USE 1-0-2011; IN COMMERCE 1-0-2011.

LINDA MICKLEBURGH, EXAMINING ATTORNEY

SN 85-596,523. THE WITTE MUSEUM, SAN ANTONIO, TX. FILED 4-12-2012.



THE MARK CONSISTS OF A STYLIZED "W".
FOR EDUCATION SERVICES, NAMELY, PROVIDING EXHIBITS, LECTURES, SEMINARS AND WORKSHOPS IN THE FIELD OF TEXAS HISTORY; MUSEUM SERVICES (U.S. CLS. 100, 101 AND 107).

HEATHER SAPP, EXAMINING ATTORNEY

SN 85-596,598. KATIE A PALOMAR, DBA YELLOW BIRD EVENTS AND DESIGNS, RIVERSIDE, CA. FILED 4-12-2012.

Yellow Bird Events And Designs

THE MARK CONSISTS OF STANDARD CHARACTERS WITHOUT CLAIM TO ANY PARTICULAR FONT, STYLE, SIZE, OR COLOR.

NO CLAIM IS MADE TO THE EXCLUSIVE RIGHT TO USE "EVENTS AND DESIGNS", APART FROM THE MARK AS SHOWN.

FOR PARTY AND WEDDING PLANNING, COORDINATION AND CONSULTATION SERVICES (U.S. CLS. 100, 101 AND 107).

AMY HELLA, EXAMINING ATTORNEY

CLASS 41—(Continued).

SN 85-596,613. NAMAST INTEGRATIVE CONSULTING, INC., DALLAS, TX. FILED 4-12-2012.



THE COLOR(S) BLUE, GREEN AND GRAY IS/ARE CLAIMED AS A FEATURE OF THE MARK.

THE MARK CONSISTS OF A SPHERICAL, GLOBE-LIKE SHAPE OF GREEN AND BLUE TO THE LEFT OF THE WORDING. THE MARK ALSO CONSISTS OF THE WORD "NAMAST", WITH THE "N" CAPITALIZED, THE LETTERS "N", "A", "M", "A", AND "T" IN BLUE AND THE LETTER "S" IN GREEN. FINALLY, THE MARK CONSISTS OF THE STATEMENT "TRANSFORMING POTENTIAL INTO OUTCOMES", PRINTED ALL IN CAPITAL LETTERS AND ALL IN GRAY, ORIENTED BELOW THE WORD "NAMAST". THE WHITE SHOWN IN THE MARK IS FOR BACKGROUND PURPOSES ONLY AND IS NOT INTENDED AS A FEATURE OF THE MARK.

FOR PROFESSIONAL COACHING SERVICES IN THE FIELD OF LEADERSHIP DEVELOPMENT, ORGANIZATIONAL EFFECTIVENESS, AND NATURE BASED COACHING (U.S. CLS. 100, 101 AND 107).

FIRST USE 5-1-2011; IN COMMERCE 5-1-2011.

AMY ALFIERI, EXAMINING ATTORNEY

CLASS 41—(Continued).

SN 85-596,689. NATZEL, ROBERT JOSEPH, LONG BEACH, CA. FILED 4-12-2012.



NO CLAIM IS MADE TO THE EXCLUSIVE RIGHT TO USE "WORKOUTS.COM", APART FROM THE MARK AS SHOWN.

THE MARK CONSISTS OF A GEOMETRIC FIGURE REPRESENTING A HUMAN CROSSING A FINISH LINE RIBBON, ACCOMPANIED BY THE WORDS "1ST PLACE WORKOUTS.COM".

FOR PERSONAL FITNESS TRAINING SERVICES AND CONSULTANCY; PERSONAL FITNESS TRAINING SERVICES FEATURING AEROBIC AND ANAEROBIC ACTIVITIES COMBINED WITH RESISTANCE AND FLEXIBILITY TRAINING; PHYSICAL EDUCATION SERVICES; PHYSICAL FITNESS CONSULTATION; PHYSICAL FITNESS INSTRUCTION; PHYSICAL FITNESS TRAINING OF INDIVIDUALS AND GROUPS; PHYSICAL FITNESS TRAINING SERVICES; PROVIDING A WEB SITE FEATURING INFORMATION ON EXERCISE AND FITNESS; PROVIDING A WEBSITE FEATURING INFORMATION ON EXERCISE AND FITNESS; PROVIDING AN INTERACTIVE WEBSITE FEATURING INFORMATION AND LINKS RELATING TO FITNESS; PROVIDING ASSISTANCE, PERSONAL TRAINING AND PHYSICAL FITNESS CONSULTATION TO CORPORATE CLIENTS TO HELP THEIR EMPLOYEES MAKE PHYSICAL FITNESS, STRENGTH, CONDITIONING, AND EXERCISE ALTERATIONS IN THEIR DAILY LIVING; PROVIDING ASSISTANCE, PERSONAL TRAINING AND PHYSICAL FITNESS CONSULTATION TO INDIVIDUALS TO HELP THEM MAKE PHYSICAL FITNESS, STRENGTH, CONDITIONING, AND EXERCISE IMPROVEMENT IN THEIR DAILY LIVING; PROVIDING CLASSES, WORKSHOPS, SEMINARS AND CAMPS IN THE FIELDS OF FITNESS, EXERCISE, BOXING, KICK BOXING AND MIXED MARTIAL ARTS; PROVIDING INFORMATION ON PHYSICAL EXERCISE (U.S. CLS. 100, 101 AND 107).

FIRST USE 1-1-2011; IN COMMERCE 1-1-2011.

SUSAN STIGLITZ, EXAMINING ATTORNEY

CLASS 41—(Continued).

SN 85-596,866. LAIOSA, DENISE VALENTINE, DBA NORWELL KARATE, MARSHFIELD, MA. FILED 4-13-2012.



THE MARK CONSISTS OF A DRAGON IN THE FORM OF AN OPEN CIRCLE. THE DRAGON ENCIRCLES THREE GRAPHICALLY ENHANCED UECHI-RYU AND SHOHEI-RYU SYMBOLS REPRESENTING MIND, BODY, AND SPIRIT. THE DRAGON AND UECHI/SHOHEI-RYU SYMBOLS ARE ENCIRCLED BY AN OPEN CIRCLE BRUSH STROKE.

FOR MARTIAL ARTS INSTRUCTION (U.S. CLS. 100, 101 AND 107).

FIRST USE 7-21-2011; IN COMMERCE 10-1-2011.

STEVEN PEREZ, EXAMINING ATTORNEY

CLASS 41—(Continued).

SN 85-596,993. OSDE ORGANIZACIÓN DE SERVICIOS DIRECTOS EMPRESARIOS, BUENOS AIRES, ARGENTINA, AND FUNDACION OSDE, BUENOS AIRES, ARGENTINA, FILED 4-13-2012.

FUNDACION OSDE

SN 85-596,908. CHARLES BENNETT, DECATUR, GA. AND AMEET DOSHI, MARIETTA, GA. FILED 4-13-2012.

whichever you're here for,
we hope you dig it

THE MARK CONSISTS OF STANDARD CHARACTERS WITHOUT CLAIM TO ANY PARTICULAR FONT, STYLE, SIZE, OR COLOR.

FOR ENTERTAINMENT SERVICES, NAMELY, PROVIDING AN ON-GOING RADIO PROGRAM IN THE FIELD OF LIBRARIES AND ROCK AND ROLL (U.S. CLS. 100, 101 AND 107).

FIRST USE 1-24-2010; IN COMMERCE 1-24-2010.

CAROLINE WOOD, EXAMINING ATTORNEY

THE MARK CONSISTS OF STANDARD CHARACTERS WITHOUT CLAIM TO ANY PARTICULAR FONT, STYLE, SIZE, OR COLOR.

OWNER OF U.S. REG. NOS. 2,280,218 AND 3,026,367.

NO CLAIM IS MADE TO THE EXCLUSIVE RIGHT TO USE "FUNDACION", APART FROM THE MARK AS SHOWN.

THE ENGLISH TRANSLATION OF "FUNDACION" IN THE MARK IS "FOUNDATION".

FOR EDUCATIONAL SERVICES, NAMELY, SPONSORING, ORGANIZING AND CONDUCTING FORUMS, CONGRESSES, SEMINARS, CONFERENCES AND SYMPOSIA IN THE FIELD OF MEDICINE AND MEDICAL SERVICES (U.S. CLS. 100, 101 AND 107).

LINDA M. KING, EXAMINING ATTORNEY

CLASS 41—(Continued).

SN 85-597,205. LOUDCLOUD SYSTEMS, INC, DALLAS, TX.
FILED 4-13-2012.



OWNER OF U.S. REG. NO. 4,095,476.

THE MARK CONSISTS OF THE WORDS "LOUDCLOUD" WITH A BOLT OF LIGHTNING BETWEEN THE RIGHT SIDE OF THE "D" AND THE LEFT SIDE OF THE "C" IN "LOUDCLOUD".

FOR ANALYZING EDUCATIONAL TESTS SCORES AND DATA FOR OTHERS; BUSINESS TRAINING IN THE FIELD OF DEVELOPING AND FACILITATING CUSTOMIZED IN-COMPANY LEADERSHIP AND EXECUTIVE DEVELOPMENT PROGRAMS, PROVIDING EXECUTIVE COACHING SERVICES, AND PROVIDING PUBLIC AND IN-COMPANY KEYNOTE PRESENTATIONS TO BUSINESS LEADERS; COMPUTER EDUCATION TRAINING SERVICES; EDUCATING AT UNIVERSITY OR COLLEGES; EDUCATION SERVICES IN THE NATURE OF COURSES AT THE UNIVERSITY LEVEL; EDUCATION SERVICES, NAMELY, PROVIDING ON-LINE CLASSROOM TRAINING IN THE FIELD OF TEACHER CERTIFICATION AND CONTINUING EDUCATION FOR TEACHERS AND PRINCIPALS; EDUCATIONAL COURSE MONITORING, NAMELY, TRACKING STUDENT PERFORMANCE; EDUCATIONAL EXAMINATION SERVICES; EDUCATIONAL SERVICES, NAMELY, CONDUCTING DISTANCE LEARNING INSTRUCTION AT THE SECONDARY, COLLEGE, UNIVERSITY, AND GRADUATE LEVEL; EDUCATIONAL SERVICES, NAMELY, DEVELOPING CURRICULUM FOR EDUCATORS; EDUCATIONAL SERVICES, NAMELY, PROVIDING COURSES OF INSTRUCTION AT THE SECONDARY, COLLEGE, UNIVERSITY, AND GRADUATE LEVEL AND DISTRIBUTION OF COURSE MATERIAL IN CONNECTION THEREWITH; PROVIDING COURSES OF INSTRUCTION AT THE UNDERGRADUATE AND GRADUATE LEVEL; PROVIDING INFORMATION ABOUT EDUCATION; PROVIDING INFORMATION RELATING TO EDUCATION SERVICES FOR CHILDREN; PROVIDING INFORMATION RELATING TO EDUCATIONAL SERVICES (U.S. CLS. 100, 101 AND 107).

DAVID MURRAY, EXAMINING ATTORNEY

CLASS 41—(Continued).

SN 85-597,297. PRO FASTPITCH, LTD., DBA NATIONAL PRO FASTPITCH, HERMITAGE, TN. FILED 4-13-2012.

Carolina Diamonds

THE MARK CONSISTS OF STANDARD CHARACTERS WITHOUT CLAIM TO ANY PARTICULAR FONT, STYLE, SIZE, OR COLOR.

NO CLAIM IS MADE TO THE EXCLUSIVE RIGHT TO USE "CAROLINA", APART FROM THE MARK AS SHOWN.

FOR ENTERTAINMENT SERVICES, NAMELY, PARTICIPATION IN WOMAN'S PROFESSIONAL FASTPITCH SOFTBALL GAMES; ORGANIZATION OF SPORTS COMPETITIONS; ORGANIZING SPORTING EVENTS, NAMELY, WOMAN'S PROFESSIONAL FASTPITCH SOFTBALL GAMES (U.S. CLS. 100, 101 AND 107).

FIRST USE 3-1-2012; IN COMMERCE 3-1-2012.

ZHALEH DELANEY, EXAMINING ATTORNEY

SN 85-597,348. PHILIP MADISON JONES, LOS ANGELES, CA. FILED 4-13-2012.

REVENGER PUBLISHING

THE MARK CONSISTS OF STANDARD CHARACTERS WITHOUT CLAIM TO ANY PARTICULAR FONT, STYLE, SIZE, OR COLOR.

NO CLAIM IS MADE TO THE EXCLUSIVE RIGHT TO USE "PUBLISHING", APART FROM THE MARK AS SHOWN.

FOR BOOK AND REVIEW PUBLISHING; BOOK PUBLISHING; ENTERTAINMENT SERVICES, NAMELY, MULTIMEDIA PRODUCTION SERVICES; MAGAZINE PUBLISHING; ON-LINE PUBLICATION OF COMICS AND SCIENCE FICTION; ONLINE ELECTRONIC PUBLISHING OF BOOKS AND PERIODICALS; PUBLICATION AND EDITING OF PRINTED MATTER; PUBLICATION OF AN E-ZINE; PUBLICATION OF BOOKS; PUBLICATION OF BOOKS, OF MAGAZINES, OF JOURNALS, OF NEWSPAPERS, OF PERIODICALS, OF CATALOGS, OF BROCHURES; PUBLICATION OF ELECTRONIC MAGAZINES; PUBLICATION OF MAGAZINES; PUBLICATION OF COMIC BOOKS (U.S. CLS. 100, 101 AND 107).

KELLY BOULTON, EXAMINING ATTORNEY

CLASS 41—(Continued).

SN 85-597,581. DESTINY CONNECTION, SANTA MARIA, CA. FILED 4-13-2012.

CLASS 41—(Continued).

SN 85-597,708. PRO FASTPITCH, LTD., DBA NATIONAL PRO FASTPITCH, HERMITAGE, TN. FILED 4-13-2012.

Tattoo Prophet

THE MARK CONSISTS OF STANDARD CHARACTERS WITHOUT CLAIM TO ANY PARTICULAR FONT, STYLE, SIZE, OR COLOR.

NO CLAIM IS MADE TO THE EXCLUSIVE RIGHT TO USE "TATTOO", APART FROM THE MARK AS SHOWN.

FOR ENTERTAINMENT SERVICES IN THE NATURE OF AN ON-GOING REALITY BASED TELEVISION PROGRAM (U.S. CLS. 100, 101 AND 107).

DAVID ELTON, EXAMINING ATTORNEY

SN 85-597,621. GHME PRODUCTIONS, INC., FORMERLY GREATER HEIGHTS MUSIC ENTERTAINMENT, INC., CHESAPEAKE, VA. FILED 4-13-2012.



NO CLAIM IS MADE TO THE EXCLUSIVE RIGHT TO USE "PRODUCTIONS", APART FROM THE MARK AS SHOWN.

THE COLOR(S) BLACK, PINK, WHITE, AND PURPLE IS/ ARE CLAIMED AS A FEATURE OF THE MARK.

THE MARK CONSISTS OF A SILHOUETTE DESIGN OF THE SIDE VIEW OF A WOMAN'S FACE AND HAND IN BLACK WITH A WHITE BUTTERFLY JUST ABOVE HER HAND INSIDE OF A PINK AND FADING TO PURPLE SQUARE DESIGN. THE TERM "GHME" APPEARS IN STYLIZED BLACK LETTERING TO THE RIGHT OF THE SQUARE DESIGN AND THE TERM "PRODUCTIONS" APPEARS IN STYLIZED BLACK LETTERING BELOW THE SQUARE DESIGN. A PURPLE FADING TO PINK UNDERLINE APPEARS BELOW THE TERM "PRODUCTIONS" AND A BLACK VINE DESIGN WITH LEAVES APPEARS BELOW THIS UNDERLINE AND TO THE RIGHT OF THE TERM "GHME".

FOR AUDIO AND VIDEO RECORDING SERVICES; DAY CAMP SERVICES; PHOTOGRAPHY SERVICES; PROVIDING CHILDREN'S PARTY CENTERS FOR THE PURPOSE OF ENTERTAINING CHILDREN AND CELEBRATING BIRTHDAYS (U.S. CLS. 100, 101 AND 107).

FIRST USE 6-1-2011; IN COMMERCE 6-1-2011.
NATALIE POLZER, EXAMINING ATTORNEY



NO CLAIM IS MADE TO THE EXCLUSIVE RIGHT TO USE "CAROLINA", APART FROM THE MARK AS SHOWN.

THE MARK CONSISTS OF THE WORDS "CAROLINA DIAMONDS" WITH A STYLIZED PIE SHAPE AND A SECOND STYLIZED SHADED PIE SHAPE THAT CONTAINS SEVERAL FOUR-POINTED STARS INSET WITHIN THE LARGER PIE SHAPE ALL REPRESENTING A STYLIZED BASEBALL DIAMOND. A THIRD SMALLER STYLIZED DIAMOND SHAPE, WITH BASEBALL-STYLE STITCHING, IS SET INSIDE THE SMALLER SHADED PIE SHAPE REPRESENTING A BASEBALL FEATURING SEVERAL FOUR-POINTED STARS. A STYLIZED LETTER "C" WITH A STAR AT THE END SURROUNDS THE SMALLER STYLIZED DIAMOND SHAPE. THE WORD "CAROLINA" APPEARS INSIDE THE LARGER PIE SHAPE AT THE TOP, AND THE STYLIZED AND UNDERLINED WORD "DIAMONDS" APPEARS AT THE BOTTOM OF THE PIE SHAPE SUPERIMPOSED THEREON, WITH THE LETTER "O" IN "DIAMONDS" FORMING A FOUR-POINTED STAR.

FOR ENTERTAINMENT SERVICES, NAMELY, PARTICIPATION IN WOMAN'S PROFESSIONAL FASTPITCH SOFTBALL GAMES; ORGANIZATION OF SPORTS COMPETITIONS; ORGANIZING SPORTING EVENTS, NAMELY, WOMAN'S PROFESSIONAL FASTPITCH SOFTBALL GAMES (U.S. CLS. 100, 101 AND 107).

FIRST USE 3-1-2012; IN COMMERCE 3-1-2012.
ZHALEH DELANEY, EXAMINING ATTORNEY

CLASS 41—(Continued).

SN 85-597,720. HOSPICE SUPPORT SERVICES OF THE NORTHERN NECK, INC., WARSAW, VA. FILED 4-13-2012.



NO CLAIM IS MADE TO THE EXCLUSIVE RIGHT TO USE "HOSPICE REGATTA", APART FROM THE MARK AS SHOWN.

THE MARK CONSISTS OF A SILHOUETTE OF A PILGRIMS' SAILING VESSEL WITH A WAVY LINE BELOW IT. ARCHING ABOVE THE IMAGE IS THE STYLIZED TEXT "TURKEY SHOOT" ABOVE THE STYLIZED TEXT "A HOSPICE REGATTA".

FOR ORGANIZING AND CONDUCTING A REGATTA EVENT THE PROCEEDS OF WHICH ARE DONATED TO CHARITY (U.S. CLS. 100, 101 AND 107).

FIRST USE 11-0-1991; IN COMMERCE 10-0-2002.
ANDREA HACK, EXAMINING ATTORNEY

CLASS 41—(Continued).

SN 85-597,848. PRO FASTPITCH, LTD., DBA NATIONAL PRO FASTPITCH, HERMITAGE, TN. FILED 4-13-2012.



THE MARK CONSISTS OF A STYLIZED DIAMOND SHAPE, WITH BASEBALL-STYLE STITCHING AND REPRESENTING A BASEBALL, ALONG WITH A STYLIZED LETTER "C" WITH A STAR AT THE END SURROUNDING THE STYLIZED DIAMOND SHAPE.

FOR ENTERTAINMENT SERVICES, NAMELY, PARTICIPATION IN WOMAN'S PROFESSIONAL FASTPITCH SOFTBALL GAMES; ORGANIZATION OF SPORTS COMPETITIONS; ORGANIZING SPORTING EVENTS, NAMELY, WOMAN'S PROFESSIONAL FASTPITCH SOFTBALL GAMES (U.S. CLS. 100, 101 AND 107).

FIRST USE 4-4-2012; IN COMMERCE 4-4-2012.
ZHALEH DELANEY, EXAMINING ATTORNEY

SN 85-597,839. PRO FASTPITCH, LTD., DBA NATIONAL PRO FASTPITCH, HERMITAGE, TN. FILED 4-13-2012.



THE MARK CONSISTS OF A REPRESENTATION OF A HUMAN FACE INSIDE A STYLIZED DIAMOND SHAPE WITH ARMS EXTENDING FROM THE STYLIZED DIAMOND SHAPE HOLDING A STYLIZED SWINGING BAT. SEVERAL FOUR-POINTED STARS APPEAR THROUGHOUT THE DESIGN.

FOR ENTERTAINMENT SERVICES, NAMELY, PARTICIPATION IN WOMAN'S PROFESSIONAL FASTPITCH SOFTBALL GAMES; ORGANIZATION OF SPORTS COMPETITIONS; ORGANIZING SPORTING EVENTS, NAMELY, WOMAN'S PROFESSIONAL FASTPITCH SOFTBALL GAMES (U.S. CLS. 100, 101 AND 107).

FIRST USE 4-4-2012; IN COMMERCE 4-4-2012.
ZHALEH DELANEY, EXAMINING ATTORNEY

SN 85-598,031. HARLEM GLOBETROTTERS INTERNATIONAL, INC., PHOENIX, AZ. FILED 4-13-2012.

THE ORIGINAL HARLEM
GLOBETROTTERS SUMMER
SKILLS CLINICS

THE MARK CONSISTS OF STANDARD CHARACTERS WITHOUT CLAIM TO ANY PARTICULAR FONT, STYLE, SIZE, OR COLOR.

OWNER OF U.S. REG. NOS. 542,474, 4,112,767 AND OTHERS.

NO CLAIM IS MADE TO THE EXCLUSIVE RIGHT TO USE "SUMMER SKILLS CLINICS", APART FROM THE MARK AS SHOWN.

FOR SPORTS TRAINING SERVICES; SPORT CAMPS; SPORTS CLINICS; PERSONAL TRAINING SERVICES, NAMELY, STRENGTH AND CONDITIONING TRAINING; EDUCATIONAL SERVICES, NAMELY, PROVIDING CLASSES, SEMINARS, WORKSHOPS IN THE FIELDS OF EXERCISE AND FITNESS; BASKETBALL CLINICS; BASKETBALL TRAINING SERVICES; BASKETBALL WORKSHOPS (U.S. CLS. 100, 101 AND 107).

JEAN IM, EXAMINING ATTORNEY

CLASS 41—(Continued).

SN 85-598,049. MILLION DOLLAR ROUND TABLE.TV LLC, YERRINGTON, NV. FILED 4-14-2012.

MILLION DOLLAR MASTERMIND

THE MARK CONSISTS OF STANDARD CHARACTERS WITHOUT CLAIM TO ANY PARTICULAR FONT, STYLE, SIZE, OR COLOR.

FOR VOCATIONAL GUIDANCE; PROVIDING ONLINE TRAINING IN THE FORM OF COURSES, SEMINARS, AND WORKSHOPS IN THE FIELD OF HELPING PEOPLE BEGIN AND ESTABLISH BUSINESSES, SALES AND MARKETING STRATEGIES, AND PRODUCT DEVELOPMENT; EDUCATIONAL SERVICES, NAMELY, CONDUCTING CLASSES, SEMINARS, CONFERENCES, AND WORKSHOPS IN THE FIELD OF HELPING PEOPLE BEGIN AND ESTABLISH BUSINESSES, SALES AND MARKETING STRATEGIES, AND PRODUCT DEVELOPMENT AND DISTRIBUTION OF TRAINING MATERIALS IN CONNECTION THEREWITH (U.S. CLS. 100, 101 AND 107).

FIRST USE 1-12-2012; IN COMMERCE 1-12-2012.
ROSELLE HERRERA, EXAMINING ATTORNEY

SN 85-598,089. BELL, CHRISTOPHER, DBA IMPROV UNLIMITED, ELMHURST, IL. FILED 4-14-2012.

Improv Unlimited

THE MARK CONSISTS OF STANDARD CHARACTERS WITHOUT CLAIM TO ANY PARTICULAR FONT, STYLE, SIZE, OR COLOR.

NO CLAIM IS MADE TO THE EXCLUSIVE RIGHT TO USE "IMPROV", APART FROM THE MARK AS SHOWN.

FOR ENTERTAINMENT IN THE NATURE OF LIVE PERFORMANCES BY ACTORS PERFORMING IMPROVISED SCENES; ENTERTAINMENT IN THE NATURE OF MAGIC SHOWS; ENTERTAINMENT IN THE NATURE OF THEATER PRODUCTIONS (U.S. CLS. 100, 101 AND 107).

FIRST USE 3-31-2004; IN COMMERCE 3-31-2004.
ANDREA HACK, EXAMINING ATTORNEY

CLASS 41—(Continued).

SN 85-598,107. TRUENYC, NEW YORK, NY. FILED 4-14-2012.

TrueStartups

THE MARK CONSISTS OF STANDARD CHARACTERS WITHOUT CLAIM TO ANY PARTICULAR FONT, STYLE, SIZE, OR COLOR.

FOR EDUCATIONAL SERVICES, NAMELY, PROVIDING ONLINE AND IN PERSON CLASSES, SEMINARS, AND WORKSHOPS IN THE FIELD OF BUSINESS, ENTREPRENEURSHIP, MENTAL HEALTH, FITNESS, POSITIVE ATTITUDE, AND LIFE CHANGES (U.S. CLS. 100, 101 AND 107).

FIRST USE 4-13-2012; IN COMMERCE 4-13-2012.
AMY ALFIERI, EXAMINING ATTORNEY

SN 85-598,112. TRUENYC, NEW YORK, NY. FILED 4-14-2012.

**Learning is Easy. Change
is Hard!**

THE MARK CONSISTS OF STANDARD CHARACTERS WITHOUT CLAIM TO ANY PARTICULAR FONT, STYLE, SIZE, OR COLOR.

FOR EDUCATIONAL SERVICES, NAMELY, PROVIDING ONLINE AND IN PERSON CLASSES, SEMINARS, AND WORKSHOPS IN THE FIELD OF BUSINESS, ENTREPRENEURSHIP, MENTAL HEALTH, FITNESS, POSITIVE ATTITUDE, AND LIFE CHANGES (U.S. CLS. 100, 101 AND 107).

FIRST USE 4-13-2012; IN COMMERCE 4-13-2012.
AMY ALFIERI, EXAMINING ATTORNEY

SN 85-598,267. MICHELE KAYAL, ARLINGTON, VA. FILED 4-15-2012.

AMERICAN FOOD ROOTS

THE MARK CONSISTS OF STANDARD CHARACTERS WITHOUT CLAIM TO ANY PARTICULAR FONT, STYLE, SIZE, OR COLOR.

NO CLAIM IS MADE TO THE EXCLUSIVE RIGHT TO USE "AMERICAN FOOD", APART FROM THE MARK AS SHOWN.

FOR ONLINE PUBLICATION IN THE NATURE OF A MULTIMEDIA MAGAZINE FEATURING ARTICLES, INTERVIEWS, RECIPES, AUDIO, VIDEO, PHOTOGRAPHS, AND REVIEWS REGARDING AMERICAN FOOD AND CULTURE (U.S. CLS. 100, 101 AND 107).

NICHOLAS COLEMAN, EXAMINING ATTORNEY

CLASS 41—(Continued).

SN 85-598,269. MICHELE KAYAL, ARLINGTON, VA. FILED 4-15-2012.



NO CLAIM IS MADE TO THE EXCLUSIVE RIGHT TO USE "AMERICAN FOOD", APART FROM THE MARK AS SHOWN.

THE MARK CONSISTS OF THE WORDS "AMERICAN FOOD ROOTS" WHERE THE WORD "AMERICAN" IS STYLIZED AND BETWEEN STARS AND OVER "FOOD ROOTS" WITH THE MARK SITTING OVER AN IMAGE OF A FORK.

FOR ONLINE PUBLICATION IN THE NATURE OF A MULTIMEDIA MAGAZINE FEATURING ARTICLES, INTERVIEWS, RECIPES, AUDIO, VIDEO, PHOTOGRAPHS, AND REVIEWS REGARDING AMERICAN FOOD AND CULTURE (U.S. CLS. 100, 101 AND 107).

NICHOLAS COLEMAN, EXAMINING ATTORNEY

SN 85-598,549. WINN, TIFFANY, PUUNENE, HI. FILED 4-16-2012.

The Imperfect Chef

THE MARK CONSISTS OF STANDARD CHARACTERS WITHOUT CLAIM TO ANY PARTICULAR FONT, STYLE, SIZE, OR COLOR.

NO CLAIM IS MADE TO THE EXCLUSIVE RIGHT TO USE "CHEF", APART FROM THE MARK AS SHOWN.

FOR EDUCATIONAL SERVICES, NAMELY, PROVIDING COOKING CLASSES (U.S. CLS. 100, 101 AND 107).

LESLIE RICHARDS, EXAMINING ATTORNEY

SN 85-598,551. HOWE, DAVID, LEMONT, IL. FILED 4-16-2012.

T-Rexplorers

THE MARK CONSISTS OF STANDARD CHARACTERS WITHOUT CLAIM TO ANY PARTICULAR FONT, STYLE, SIZE, OR COLOR.

FOR EDUCATIONAL SERVICES, NAMELY, CONDUCTING PROGRAMS IN THE FIELD OF DINOSAURS (U.S. CLS. 100, 101 AND 107).

LESLIE RICHARDS, EXAMINING ATTORNEY

CLASS 41—(Continued).

SN 85-598,743. MATCHFIGHTS, LLC, CORONA DEL MAR, CA. FILED 4-16-2012.

WCFC World Championship Full Contact

THE MARK CONSISTS OF STANDARD CHARACTERS WITHOUT CLAIM TO ANY PARTICULAR FONT, STYLE, SIZE, OR COLOR.

NO CLAIM IS MADE TO THE EXCLUSIVE RIGHT TO USE "WORLD CHAMPIONSHIP FULL CONTACT", APART FROM THE MARK AS SHOWN.

FOR ENTERTAINMENT SERVICES IN THE NATURE OF LIVE MIXED MARTIAL ARTS (MMA) EVENTS; ORGANIZING LIVE MIXED MARTIAL ARTS EVENTS AND COMPETITIONS; PRESENTATION OF MIXED MARTIAL ARTS (MMA) EVENTS; PROVIDING CLASSES, WORKSHOPS, SEMINARS AND CAMPS IN THE FIELDS OF FITNESS, EXERCISE, BOXING, KICK BOXING AND MIXED MARTIAL ARTS (U.S. CLS. 100, 101 AND 107).

FIRST USE 12-25-2009; IN COMMERCE 4-3-2010.

SUSAN STIGLITZ, EXAMINING ATTORNEY

SN 85-598,881. TALENTHOUSE, INC., PALO ALTO, CA. FILED 4-16-2012.



THE MARK CONSISTS OF THE LETTERS "TLNT" IN STYLIZED BLOCK FORM.

FOR ENTERTAINMENT SERVICES, NAMELY, PROVIDING A WEBSITE FEATURING NON-DOWNLOADABLE AUDIO AND VIDEO OF MUSICAL PERFORMANCES, MUSIC VIDEOS, CURRENT EVENT NEWS, AND PHOTOGRAPHS, FILM CLIPS, AND DOCUMENTARIES FEATURING OR ABOUT DRAMA, COMEDY, FASHION, ART, AND MUSICAL SUBJECTS (U.S. CLS. 100, 101 AND 107).

CORY BOONE, EXAMINING ATTORNEY

CLASS 41—(Continued).

SN 85-599,163. SAIL REVOLUTION, APTOS, CA. FILED 4-16-2012.



NO CLAIM IS MADE TO THE EXCLUSIVE RIGHT TO USE "SAIL", APART FROM THE MARK AS SHOWN.

THE COLOR(S) WHITE, RED AND BLACK IS/ARE CLAIMED AS A FEATURE OF THE MARK.

THE MARK CONSISTS OF A RED STAR WITH THE STYLIZED TEXT "SAIL REVOLUTION" OVERLAID IN WHITE LETTERING AND OUTLINED IN BLACK. THE SLOGAN, "THE REVOLUTION STARTS NOW!" IS SITUATED TO THE LOWER RIGHT IN WHITE AND BLACK OUTLINE.

FOR PROVIDING A WEBSITE FEATURING INFORMATION RELATING TO THE SPORT OF SAILING (U.S. CLS. 100, 101 AND 107).

FIRST USE 1-1-2011; IN COMMERCE 1-1-2011.

RONALD MCMORROW, EXAMINING ATTORNEY

CLASS 41—(Continued).

SN 85-599,375. FULL ARMOR MEDIA AND ENTERTAINMENT LLC, LOS ANGELES, CA. FILED 4-16-2012.

MIND, BODY AND SOUL MUSIC FESTIVAL

THE MARK CONSISTS OF STANDARD CHARACTERS WITHOUT CLAIM TO ANY PARTICULAR FONT, STYLE, SIZE, OR COLOR.

NO CLAIM IS MADE TO THE EXCLUSIVE RIGHT TO USE "MUSIC FESTIVAL", APART FROM THE MARK AS SHOWN.

FOR ARRANGING AND CONDUCTING OF CONCERTS; CONCERT BOOKING; ENTERTAINMENT SERVICES IN THE NATURE OF LIVE MUSICAL PERFORMANCES; ENTERTAINMENT SERVICES IN THE NATURE OF PRESENTING LIVE MUSICAL PERFORMANCES; ENTERTAINMENT, NAMELY, LIVE MUSIC CONCERTS; ENTERTAINMENT, NAMELY, LIVE PERFORMANCES BY A MUSICAL BAND; ENTERTAINMENT, NAMELY, LIVE PERFORMANCES BY MUSICAL BANDS; MUSIC PRODUCTION SERVICES; PROVISION OF INFORMATION RELATING TO LIVE PERFORMANCES, ROAD SHOWS, LIVE STAGE EVENTS, THEATRICAL PERFORMANCES, LIVE MUSIC CONCERTS AND AUDIENCE PARTICIPATION IN SUCH EVENTS (U.S. CLS. 100, 101 AND 107).

FIRST USE 1-19-1999; IN COMMERCE 1-19-1999.

WILLIAM VERHOSEK, EXAMINING ATTORNEY

SN 85-599,583. 4 EYES CREATIVE SERVICES, NEW YORK, NY. FILED 4-17-2012.

4 EyesPhotography

THE MARK CONSISTS OF STANDARD CHARACTERS WITHOUT CLAIM TO ANY PARTICULAR FONT, STYLE, SIZE, OR COLOR.

FOR PHOTOGRAPHY SERVICES (U.S. CLS. 100, 101 AND 107).

FIRST USE 8-1-2001; IN COMMERCE 9-1-2001.

BRIDGETT SMITH, EXAMINING ATTORNEY

SN 85-599,359. BENEVENTANO, KELLY, DBA WHAT A DOG WANTS PET PHOTOGRAPHY & DESIGNS, CENTEREACH, NY. FILED 4-16-2012.



THE MARK CONSISTS OF THE WORDS "WHAT A DOG WANTS" AND A STYLIZED DESIGN OF A CROWN, HEART, BONE AND SILHOUETTE OF A DOG INSIDE THE HEART.

FOR PHOTOGRAPHY (U.S. CLS. 100, 101 AND 107).

KHANH LE, EXAMINING ATTORNEY

SN 85-599,602. WELLESLEY INFORMATION SERVICES, LLC, DEDHAM, MA. FILED 4-17-2012.

DATA INFORMED

THE MARK CONSISTS OF STANDARD CHARACTERS WITHOUT CLAIM TO ANY PARTICULAR FONT, STYLE, SIZE, OR COLOR.

NO CLAIM IS MADE TO THE EXCLUSIVE RIGHT TO USE "DATA", APART FROM THE MARK AS SHOWN.

FOR ONLINE MAGAZINE IN THE FIELD OF DATA MANAGEMENT AND ANALYTICS (U.S. CLS. 100, 101 AND 107).

EDWARD FENNESSY, EXAMINING ATTORNEY

CLASS 41—(Continued).

SN 85-599,867. THOMAS, RAYMOND, VINELAND, NJ.
FILED 4-17-2012.

REELZ on WHEELZ

THE MARK CONSISTS OF STANDARD CHARACTERS WITHOUT CLAIM TO ANY PARTICULAR FONT, STYLE, SIZE, OR COLOR.

FOR MOTION PICTURE AND VIDEO RENTAL SERVICES; MOVIE THEATERS (U.S. CLS. 100, 101 AND 107).
FIRST USE 6-0-2000; IN COMMERCE 6-0-2000.
RICHARD WHITE, EXAMINING ATTORNEY

SN 85-599,884. DICKENS BOOKS, LTD., MILWAUKEE, WI.
FILED 4-17-2012.

CHANGETHIS

THE MARK CONSISTS OF STANDARD CHARACTERS WITHOUT CLAIM TO ANY PARTICULAR FONT, STYLE, SIZE, OR COLOR.

FOR ON-LINE PUBLICATION OF ESSAYS AND ARTICLES IN THE FIELDS OF ART, BUSINESS, ECONOMICS, POLITICS, SELF-IMPROVEMENT, HEALTHCARE, SCIENCE, TECHNOLOGY, AND PUBLIC POLICY; PROVIDING ONLINE NEWSLETTERS IN THE FIELDS OF ART, BUSINESS, ECONOMICS, POLITICS, SELF-IMPROVEMENT, HEALTHCARE, SCIENCE, TECHNOLOGY, AND PUBLIC POLICY VIA E-MAIL; PROVIDING A WEBSITE FEATURING NON-DOWNLOADABLE PUBLICATIONS IN THE NATURE OF ESSAYS AND ARTICLES IN THE FIELDS OF ART, BUSINESS, ECONOMICS, POLITICS, SELF-IMPROVEMENT, HEALTHCARE, SCIENCE, TECHNOLOGY, AND PUBLIC POLICY (U.S. CLS. 100, 101 AND 107).

FIRST USE 8-0-2004; IN COMMERCE 8-0-2004.
EMILY CHUO, EXAMINING ATTORNEY

CLASS 41—(Continued).

SN 85-599,911. BILLION SOULS INC., ORLANDO, FL. FILED
4-17-2012.

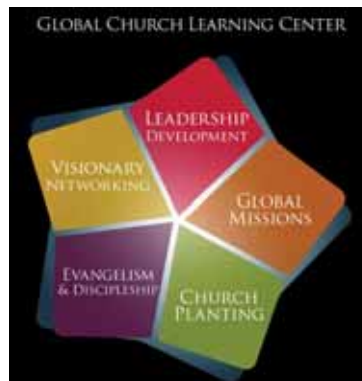

NO CLAIM IS MADE TO THE EXCLUSIVE RIGHT TO USE "GLOBAL CHURCH LEARNING CENTER", "NETWORKING", "LEADERSHIP DEVELOPMENT", "GLOBAL MISSIONS", "CHURCH PLANTING" AND "EVANGELISM AND DISCIPLESHIP", APART FROM THE MARK AS SHOWN.

THE COLOR(S) YELLOW, RED, ORANGE, PURPLE, GREEN, BLACK, BLUE AND WHITE IS/ARE CLAIMED AS A FEATURE OF THE MARK.

THE MARK CONSISTS OF A FIVE-POINT STAR IN FIVE DIFFERENT SECTIONS DIVIDED BY BLUE LINES FEATURING THE PHRASES "VISIONARY NETWORKING" IN WHITE LETTERING ON A YELLOW BACKGROUND, "LEADERSHIP DEVELOPMENT" IN WHITE LETTERING ON A RED BACKGROUND, "GLOBAL MISSIONS" IN WHITE LETTERING ON AN ORANGE BACKGROUND, "CHURCH PLANTING" IN WHITE LETTERING ON A GREEN BACKGROUND, AND "EVANGELISM & DISCIPLESHIP" IN WHITE LETTERING ON A PURPLE BACKGROUND. AT THE TOP OF THE STAR, THE PHRASE "GLOBAL CHURCH LEARNING CENTER" IS FEATURED IN WHITE. THE ENTIRE MARK IS ON A BLACK BACKGROUND.

FOR EDUCATIONAL SERVICES, NAMELY, CONDUCTING SEMINARS AND CONFERENCES IN THE FIELD OF RELIGION AND LEADERSHIP TRAINING (U.S. CLS. 100, 101 AND 107).

FIRST USE 1-1-2011; IN COMMERCE 1-1-2011.
DAVID MURRAY, EXAMINING ATTORNEY

SN 85-600,117. R.C. THOMAS COMPANY LLC, OLIVIA, MN.
FILED 4-17-2012.

PLANTING CUSTOMERS

THE MARK CONSISTS OF STANDARD CHARACTERS WITHOUT CLAIM TO ANY PARTICULAR FONT, STYLE, SIZE, OR COLOR.

FOR EDUCATIONAL SERVICES, NAMELY, CONDUCTING TRAINING IN THE FIELD OF AGRICULTURAL SALES THROUGH LIVE SEMINARS AND PRERECORDED AUDIO INSTRUCTION, AND DISTRIBUTING COURSE MATERIAL IN CONNECTION THEREWITH (U.S. CLS. 100, 101 AND 107).

FIRST USE 12-31-1998; IN COMMERCE 12-31-1998.
BARBARA BROWN, EXAMINING ATTORNEY

CLASS 41—(Continued).

SN 85-600,418. BAVARIA INN RESTAURANT, INC., DBA SHOTGUN WILLIE'S, GLENDALE, CO. FILED 4-17-2012.

SHOTGUN WILLIE'S

THE MARK CONSISTS OF STANDARD CHARACTERS WITHOUT CLAIM TO ANY PARTICULAR FONT, STYLE, SIZE, OR COLOR.

FOR NIGHTCLUBS FEATURING ADULT ENTERTAINMENT (U.S. CLS. 100, 101 AND 107).
FIRST USE 4-30-1982; IN COMMERCE 4-30-1982.
PAUL E. FAHRENKOPF, EXAMINING ATTORNEY

SN 85-600,536. MOSCA, JOHANNA, AKA MAHESHVARI, SEDONA, AZ. FILED 4-17-2012.

2/3 Club

THE MARK CONSISTS OF STANDARD CHARACTERS WITHOUT CLAIM TO ANY PARTICULAR FONT, STYLE, SIZE, OR COLOR.

NO CLAIM IS MADE TO THE EXCLUSIVE RIGHT TO USE "CLUB", APART FROM THE MARK AS SHOWN.

FOR EDUCATIONAL SERVICES, NAMELY, CONDUCTING SEMINARS, WEBINARS, RETREATS, WORKSHOPS IN THE FIELD OF SENIOR EMPOWERMENT AND DISTRIBUTION OF EDUCATIONAL MATERIALS IN CONNECTION THEREWITH (U.S. CLS. 100, 101 AND 107).

KIMBERLY FRYE, EXAMINING ATTORNEY

SN 85-600,654. TUTORMARK, LLC, HENDERSON, NV. FILED 4-17-2012.

TOMMY TUTOR

THE MARK CONSISTS OF STANDARD CHARACTERS WITHOUT CLAIM TO ANY PARTICULAR FONT, STYLE, SIZE, OR COLOR.

NO CLAIM IS MADE TO THE EXCLUSIVE RIGHT TO USE "TUTOR", APART FROM THE MARK AS SHOWN.

THE NAME "TOMMY TUTOR" DOES NOT IDENTIFY A LIVING INDIVIDUAL.

FOR EDUCATION SERVICES, NAMELY, PROVIDING TUTORING IN THE FIELD OF READING, WRITING AND MATH SKILLS, AND DISTRIBUTING EDUCATIONAL WORKSHEETS IN CONNECTION WITH TUTORING SERVICES (U.S. CLS. 100, 101 AND 107).

MICHAEL WIENER, EXAMINING ATTORNEY

CLASS 41—(Continued).

SN 85-600,672. PURE ADVISORY GROUP, INC, SAN DIEGO, CA. FILED 4-17-2012.

YOUR MONEY, YOUR WEALTH

THE MARK CONSISTS OF STANDARD CHARACTERS WITHOUT CLAIM TO ANY PARTICULAR FONT, STYLE, SIZE, OR COLOR.

FOR ENTERTAINMENT SERVICES, NAMELY, PROVIDING AN ON-GOING RADIO PROGRAM IN THE FIELD OF FINANCIAL AND INVESTMENT ADVICE; ENTERTAINMENT SERVICES, NAMELY, PROVIDING PODCASTS IN THE FIELD OF INVESTMENT AND FINANCIAL ADVICE (U.S. CLS. 100, 101 AND 107).

FIRST USE 9-24-2011; IN COMMERCE 9-24-2011.
LINDA POWELL, EXAMINING ATTORNEY

SN 85-600,678. SCHIEMER, MICHAEL, BRIGHTON, MA. FILED 4-17-2012.

Frugal Fitness

THE MARK CONSISTS OF STANDARD CHARACTERS WITHOUT CLAIM TO ANY PARTICULAR FONT, STYLE, SIZE, OR COLOR.

NO CLAIM IS MADE TO THE EXCLUSIVE RIGHT TO USE "FITNESS", APART FROM THE MARK AS SHOWN.

FOR PROVIDING A WEBSITE FEATURING INFORMATION ON EXERCISE AND FITNESS (U.S. CLS. 100, 101 AND 107).

FIRST USE 4-1-2010; IN COMMERCE 4-1-2011.
MICHAEL WIENER, EXAMINING ATTORNEY

SN 85-600,739. CLEAR BLUE KNOWLEDGE, INC., LAKE ALFRED, FL. FILED 4-18-2012.

CBK

THE MARK CONSISTS OF STANDARD CHARACTERS WITHOUT CLAIM TO ANY PARTICULAR FONT, STYLE, SIZE, OR COLOR.

FOR OPEN-ACCESS PUBLISHING SERVICES, NAMELY, PUBLICATION OF ELECTRONIC PEER REVIEWED SCIENTIFIC AND SCHOLARLY JOURNALS (U.S. CLS. 100, 101 AND 107).

DAVID COLLIER, EXAMINING ATTORNEY

CLASS 41—(Continued).

SN 85-601,305. RADIO CITY TRADEMARKS, LLC, NEW YORK, NY. FILED 4-18-2012.



OWNER OF U.S. REG. NOS. 1,209,117, 2,283,460 AND OTHERS.

THE MARK CONSISTS OF THE WORD "ROCKETTES" WITH THREE STYLIZED REPRESENTATIONS OF DANCERS IN THE CENTER OF THE WORD.

FOR ENTERTAINMENT SERVICES IN THE NATURE OF LIVE AND TELEVISED STAGE PERFORMANCES, AND LIVE AND TELEVISED APPEARANCES BY PROFESSIONAL DANCERS AND ENTERTAINERS (U.S. CLS. 100, 101 AND 107).

FIRST USE 3-10-2012; IN COMMERCE 3-10-2012.
CATHERINE ROEHL, EXAMINING ATTORNEY

SN 85-601,379. COMMITTEE ENTERTAINMENT, LLC, MIAMI, FL. FILED 4-18-2012.

STATE OF EMERGENCY

THE MARK CONSISTS OF STANDARD CHARACTERS WITHOUT CLAIM TO ANY PARTICULAR FONT, STYLE, SIZE, OR COLOR.

FOR PROVIDING ENTERTAINMENT, NAMELY, LIVE MUSICAL PERFORMANCES AND DANCE EVENTS (U.S. CLS. 100, 101 AND 107).

FIRST USE 1-30-2012; IN COMMERCE 2-23-2012.
JAMES LOVELACE, EXAMINING ATTORNEY

SN 85-601,397. COMMITTEE ENTERTAINMENT, LLC, MIAMI, FL. FILED 4-18-2012.

CAN'T STOP THE STATE

THE MARK CONSISTS OF STANDARD CHARACTERS WITHOUT CLAIM TO ANY PARTICULAR FONT, STYLE, SIZE, OR COLOR.

FOR PROVIDING ENTERTAINMENT, NAMELY, LIVE MUSICAL PERFORMANCES AND DANCE EVENTS (U.S. CLS. 100, 101 AND 107).

FIRST USE 1-30-2012; IN COMMERCE 2-23-2012.
JAMES LOVELACE, EXAMINING ATTORNEY

CLASS 41—(Continued).

SN 85-601,414. GUIDEME INC., EUGENE, OR. FILED 4-18-2012.

FANTUITION

THE MARK CONSISTS OF STANDARD CHARACTERS WITHOUT CLAIM TO ANY PARTICULAR FONT, STYLE, SIZE, OR COLOR.

FOR ENTERTAINMENT SERVICES, NAMELY, PROVIDING ON-LINE COMPUTER GAMES (U.S. CLS. 100, 101 AND 107).

FIRST USE 10-12-2011; IN COMMERCE 10-12-2011.
ERIN FALK, EXAMINING ATTORNEY

SN 85-601,420. COMMITTEE ENTERTAINMENT, LLC, MIAMI, FL. FILED 4-18-2012.

RMF

THE MARK CONSISTS OF STANDARD CHARACTERS WITHOUT CLAIM TO ANY PARTICULAR FONT, STYLE, SIZE, OR COLOR.

FOR PROVIDING ENTERTAINMENT, NAMELY, LIVE MUSICAL PERFORMANCES AND DANCE EVENTS (U.S. CLS. 100, 101 AND 107).

FIRST USE 8-0-2009; IN COMMERCE 9-6-2009.
JAMES LOVELACE, EXAMINING ATTORNEY

SN 85-601,516. SMITH, JASON, HURRICANE, UT. FILED 4-18-2012.



NO CLAIM IS MADE TO THE EXCLUSIVE RIGHT TO USE "MARATHON", APART FROM THE MARK AS SHOWN.

THE MARK CONSISTS OF THE WORDS "SAND HOLLOW" WITH A KOKOPELLI FIGURE RUNNING IN BETWEEN THE WORDS "SAND" AND "HOLLOW" FACING TO THE LEFT, AND THE WORD "MARATHON" UNDER THE WORD "HOLLOW".

FOR ATHLETIC AND SPORTS EVENT SERVICES, NAMELY, ARRANGING, ORGANIZING, OPERATING AND CONDUCTING MARATHON RACES; ORGANIZING, ARRANGING, AND CONDUCTING RUNNING EVENTS (U.S. CLS. 100, 101 AND 107).

FIRST USE 1-11-2011; IN COMMERCE 1-11-2011.
JESSICA A. POWERS, EXAMINING ATTORNEY

CLASS 41—(Continued).

SN 85-601,536. LEDELL, MONAICA, WICHITA, KS. FILED 4-18-2012.

MOMMY BREADWINNER

THE MARK CONSISTS OF STANDARD CHARACTERS WITHOUT CLAIM TO ANY PARTICULAR FONT, STYLE, SIZE, OR COLOR.

FOR EDUCATION AND ENTERTAINMENT SERVICES; NAMELY PROVIDING A WEBSITE TO PROVIDE ON-LINE CLASSES, SEMINARS, AND LECTURES IN THE FIELD OF PROFESSIONAL COACHING; EDUCATIONAL SERVICES, NAMELY, PROVIDING EDUCATIONAL INFORMATION IN THE FORMAT OF CLASSES, LECTURES, AND SEMINARS, IN THE FIELD OF BUSINESS, AND DISTRIBUTING COURSE MATERIAL IN THE NATURE OF TEXTBOOKS AND MANUALS THEREWITH; PROVIDING CONTINUING BUSINESS EDUCATION COURSES AND DISTRIBUTING COURSE MATERIAL IN THE NATURE OF TEXTBOOKS, PRE-RECORDED CDS AND DVDS, MANUALS, BLOGS, VIDEOS, EMAIL NEWSLETTER, THEREWITH; PROVIDING CONTINUING BUSINESS EDUCATION COURSES AND DISTRIBUTING COURSE MATERIAL BUSINESS NEWSLETTERS AND MAGAZINES, IN CONNECTION THEREWITH; AND PROFESSIONAL COACHING SERVICES IN THE FIELD OF BUSINESS; EDUCATIONAL SERVICES, NAMELY, CONDUCTING CLASSES, WORKSHOPS AND SEMINARS IN THE FIELD OF SMALL BUSINESS MARKETING AND INTERNET MARKETING AND DISTRIBUTION OF COURSE MATERIAL (U.S. CLS. 100, 101 AND 107).

TIMOTHY FINNEGAN, EXAMINING ATTORNEY

SN 85-601,619. NUERNBERGER, EDWIN P., HONESDALE, PA. FILED 4-18-2012.

**Strategic Intelligence
Skills**

THE MARK CONSISTS OF STANDARD CHARACTERS WITHOUT CLAIM TO ANY PARTICULAR FONT, STYLE, SIZE, OR COLOR.

OWNER OF U.S. REG. NO. 3,083,927.
SEC. 2(F).

FOR EDUCATIONAL SERVICES, NAMELY, PERSONAL TRAINING IN EFFECTIVE LISTENING, CALMLY MEETING ADVERSITY, MAINTAINING FOCUSED ATTENTION, EFFECTIVE ENVISIONING AND MEETING CHANGE WITH ENTHUSIASM (U.S. CLS. 100, 101 AND 107).

FIRST USE 10-30-2003; IN COMMERCE 10-30-2003.
FRANK LATTUCA, EXAMINING ATTORNEY

CLASS 41—(Continued).

SN 85-601,708. FERRELL, STEVEN, SAN CLEMENTE, CA. FILED 4-18-2012.

YOUR HEALING MACHINE

THE MARK CONSISTS OF STANDARD CHARACTERS WITHOUT CLAIM TO ANY PARTICULAR FONT, STYLE, SIZE, OR COLOR.

NO CLAIM IS MADE TO THE EXCLUSIVE RIGHT TO USE "HEALING", APART FROM THE MARK AS SHOWN.

FOR ON-LINE JOURNALS, NAMELY, BLOGS FEATURING INFORMATION ABOUT HEALING THE BODY AND MIND THROUGH DIET, LIFESTYLE, SUPPLEMENTS, AND PHYSICAL EXERCISE (U.S. CLS. 100, 101 AND 107).

KATHERINE STOIDES, EXAMINING ATTORNEY

SN 85-601,725. BLAST BOY LLC, DBA WAN.NYBLAST, RICHMOND, VA. FILED 4-18-2012.

BLAST BOY

THE MARK CONSISTS OF STANDARD CHARACTERS WITHOUT CLAIM TO ANY PARTICULAR FONT, STYLE, SIZE, OR COLOR.

FOR ENTERTAINMENT SERVICES, NAMELY, THE PRODUCTION OF ORIGINAL SOUND RECORDINGS, FILM AND VIDEO; MEDIA PRODUCTION LOCATION SCOUTING SERVICES FOR ENTERTAINMENT PURPOSES; AND ENTERTAINMENT SERVICES IN THE NATURE OF LIVE MUSICAL PERFORMANCES (U.S. CLS. 100, 101 AND 107).

FIRST USE 2-2-2011; IN COMMERCE 2-2-2011.

KATHERINE STOIDES, EXAMINING ATTORNEY

SN 85-601,734. HORNE, DANIELLE, CASTRO VALLEY, CA. FILED 4-18-2012.

PURITY IN PROGRESS

THE MARK CONSISTS OF STANDARD CHARACTERS WITHOUT CLAIM TO ANY PARTICULAR FONT, STYLE, SIZE, OR COLOR.

FOR EDUCATIONAL SERVICES, NAMELY, CONDUCTING WORKSHOPS AND SEMINARS THAT ARE BASED ON THE TEACHINGS OF THE BIBLE IN THE AREAS OF SELF-AWARENESS, RAISING WOMEN'S SELF-ESTEEM, AND DATING BOUNDARIES; PRODUCTION OF DVDS FEATURING WORKSHOPS AND SEMINARS THAT ARE BASED ON THE TEACHINGS OF THE BIBLE IN THE AREAS OF SELF-AWARENESS, RAISING WOMEN'S SELF-ESTEEM, AND DATING BOUNDARIES (U.S. CLS. 100, 101 AND 107).

ZACHARY BELLO, EXAMINING ATTORNEY

CLASS 41—(Continued).

SN 85-601,938. DEVAKI ANANDA MURCH, OGDEN, UT. FILED 4-18-2012.

owlbytes

THE MARK CONSISTS OF STANDARD CHARACTERS WITHOUT CLAIM TO ANY PARTICULAR FONT, STYLE, SIZE, OR COLOR.

FOR PROVIDING AN EDUCATIONAL WEBSITE FEATURING INSTRUCTION FOR EDUCATORS IN THE FIELD OF MEDIA TECHNOLOGY (U.S. CLS. 100, 101 AND 107).

JOHN E. MICHOS, EXAMINING ATTORNEY

SN 85-602,041. DR ENTERPRISES, LLC, WARWICK, RI. FILED 4-19-2012.

AS3

THE MARK CONSISTS OF STANDARD CHARACTERS WITHOUT CLAIM TO ANY PARTICULAR FONT, STYLE, SIZE, OR COLOR.

FOR TRAINING SERVICES IN THE FIELD OF SALES TECHNIQUES AND METHODS (U.S. CLS. 100, 101 AND 107).

FIRST USE 10-22-2009; IN COMMERCE 10-22-2009.
ANTHONY RINKER, EXAMINING ATTORNEY

SN 85-602,074. DE SAN JUAN GUERRERO, BASILIO, FLORENCE, ITALY, FILED 4-19-2012.

DIGIQUALIA

THE MARK CONSISTS OF STANDARD CHARACTERS WITHOUT CLAIM TO ANY PARTICULAR FONT, STYLE, SIZE, OR COLOR.

FOR FILM PRODUCTION; VIDEO RECORDING OF DOCUMENTARIES; MULTIMEDIA ENTERTAINMENT SERVICES IN THE NATURE OF DEVELOPMENT, PRODUCTION AND POST-PRODUCTION SERVICES IN THE FIELDS OF VIDEO AND FILMS; EDUCATION SERVICES, NAMELY, PROVIDING TUTORIAL SESSIONS IN THE FIELD OF PAINTING, DRAWING, SCULPTURE, PHOTOGRAPHY, MUSIC AND ILLUSTRATION AND USE OF COMPUTER PROGRAMS FOR CREATING AND MANIPULATING GRAPHIC IMAGES AND DIGITAL CONTENT (U.S. CLS. 100, 101 AND 107).

AMY ALFIERI, EXAMINING ATTORNEY

CLASS 41—(Continued).

SN 85-602,333. BRAUN, MEGHAN, ARDMORE, PA. FILED 4-19-2012.

URBAN BARRE

THE MARK CONSISTS OF STANDARD CHARACTERS WITHOUT CLAIM TO ANY PARTICULAR FONT, STYLE, SIZE, OR COLOR.

NO CLAIM IS MADE TO THE EXCLUSIVE RIGHT TO USE "BARRE". APART FROM THE MARK AS SHOWN.

FOR PHYSICAL FITNESS CONDITIONING CLASSES; PHYSICAL FITNESS INSTRUCTION (U.S. CLS. 100, 101 AND 107).

CHRISTINA SOBRAL, EXAMINING ATTORNEY

SN 85-602,360. BORN TO DANCE BALLROOM INC., REDMOND, WA. FILED 4-19-2012.

BRIORA

THE MARK CONSISTS OF STANDARD CHARACTERS WITHOUT CLAIM TO ANY PARTICULAR FONT, STYLE, SIZE, OR COLOR.

FOR DANCE CLUB SERVICES; DANCE EVENTS; DANCE INSTRUCTION; DANCE INSTRUCTION FOR CHILDREN; DANCE RESERVATION SERVICES, NAMELY, ARRANGING FOR ADMISSION TO DANCE EVENTS; DANCE SCHOOLS; DANCE STUDIOS; EDUCATION SERVICES, NAMELY, PROVIDING CLASSES AND INSTRUCTION IN THE FIELD OF DANCE; ENTERTAINMENT IN THE NATURE OF DANCE PERFORMANCES; ENTERTAINMENT IN THE NATURE OF VISUAL AND AUDIO PERFORMANCES, NAMELY, MUSICAL BAND, ROCK GROUP, GYMNASTIC, DANCE, AND BALLET PERFORMANCES; ENTERTAINMENT SERVICES IN THE NATURE OF LIVE DANCE PERFORMANCES; PHYSICAL FITNESS STUDIO SERVICES, NAMELY, PROVIDING EXERCISE CLASSES, BODY SCULPTING CLASSES, AND GROUP FITNESS CLASSES; PROVIDING DANCE HALLS; PROVIDING FITNESS AND EXERCISE STUDIO SERVICES, NAMELY, PILATES INSTRUCTION AND TRAINING; RENTAL OF DANCE FLOORS; TRAINING OF DANCE INSTRUCTORS (U.S. CLS. 100, 101 AND 107).

JEFFREY LOOK, EXAMINING ATTORNEY

CLASS 41—(Continued).

SN 85-602,365. JOSE LUIS TERRAZAS, OSWEGO, IL. FILED 4-19-2012.

GRUPO MONTEZ DE DURANGO

THE MARK CONSISTS OF STANDARD CHARACTERS WITHOUT CLAIM TO ANY PARTICULAR FONT, STYLE, SIZE, OR COLOR.

OWNER OF U.S. REG. NO. 3,012,699.
NO CLAIM IS MADE TO THE EXCLUSIVE RIGHT TO USE "GRUPO", APART FROM THE MARK AS SHOWN.

THE ENGLISH TRANSLATION OF "GRUPO MONTEZ DE DURANGO" IN THE MARK IS "BOBCATS OF DURANGO GROUP".

FOR LIVE PERFORMANCES BY A MUSICAL GROUP (U.S. CLS. 100, 101 AND 107).

FIRST USE 1-5-1997; IN COMMERCE 1-5-1997.
JEFFREY LOOK, EXAMINING ATTORNEY

CLASS 41—(Continued).

SN 85-602,520. VETMEDTEAM, LLC, SEMINOLE, FL. FILED 4-19-2012.



OWNER OF U.S. REG. NO. 2,935,734.
THE COLOR(S) DARK BLUE, LIGHT BLUE, BLUE GREEN, GREEN, YELLOW GREEN IS/ARE CLAIMED AS A FEATURE OF THE MARK.

THE MARK CONSISTS OF THE WORDS "VETMEDTEAM" WITH "VET" AND "TEAM" IN DARK BLUE AND "MED" IN LIGHT BLUE, OVER THE SMALLER PHRASE "PROVIDING EDUCATIONAL PATHWAYS TO GREAT CAREERS" IN DARK BLUE, ALL TO THE RIGHT OF A STYLIZED TREE WITH NINE BRANCHES WITH ARROWS AT THEIR END POINTS, THE COLORS MORPHING FROM BLUE GREEN AT THE BOTTOM THROUGH GREEN AND YELLOW GREEN AT THE TOP LEFT WHILE THE TOP RIGHT REMAINS BLUE GREEN.

FOR EDUCATIONAL SERVICES, NAMELY, CONDUCTING ON-LINE COURSES IN THE FIELD OF VETERINARY CARE FOR PEOPLE WHO WORK IN VETERINARY HOSPITALS (U.S. CLS. 100, 101 AND 107).

FIRST USE 1-2-2012; IN COMMERCE 1-2-2012.
DOMINIC J. FERRAIUOLO, EXAMINING ATTORNEY

SN 85-602,668. SEAWORLD PARKS & ENTERTAINMENT LLC, ORLANDO, FL. FILED 4-19-2012.

SN 85-602,451. LIVE IN FITNESS ENTERPRISE, INC., LOS ANGELEA, CA. FILED 4-19-2012.

LIVE IN FITNESS



THE MARK CONSISTS OF STANDARD CHARACTERS WITHOUT CLAIM TO ANY PARTICULAR FONT, STYLE, SIZE, OR COLOR.

NO CLAIM IS MADE TO THE EXCLUSIVE RIGHT TO USE "FITNESS", APART FROM THE MARK AS SHOWN.

FOR PHYSICAL FITNESS INSTRUCTION; PERSONAL TRAINING PROVIDED IN CONNECTION WITH WEIGHT LOSS AND EXERCISE PROGRAMS (U.S. CLS. 100, 101 AND 107).

JAY FLOWERS, EXAMINING ATTORNEY

OWNER OF U.S. REG. NOS. 1,195,498, 4,138,306 AND OTHERS.

NO CLAIM IS MADE TO THE EXCLUSIVE RIGHT TO USE "PICTURES", APART FROM THE MARK AS SHOWN.

THE MARK CONSISTS OF A FIN DESIGN WITHIN A PARTIAL CIRCLE ABOVE THE STYLIZED WORDING "SEAWORLD PICTURES".

FOR PRODUCTION AND DISTRIBUTION OF MOVIES (U.S. CLS. 100, 101 AND 107).

FIRST USE 4-0-2011; IN COMMERCE 6-24-2011.
NELSON SNYDER, EXAMINING ATTORNEY

CLASS 41—(Continued).

SN 85-602,670. MINNESOTA STATE AGRICULTURAL SOCIETY (MINNESOTA STATE FAIR), A STATE AGENCY ORGANIZED UNDER THE LAWS OF MINNESOTA, ST. PAUL, MN. FILED 4-19-2012.

MIGHTY MIDWAY

THE MARK CONSISTS OF STANDARD CHARACTERS WITHOUT CLAIM TO ANY PARTICULAR FONT, STYLE, SIZE, OR COLOR.

NO CLAIM IS MADE TO THE EXCLUSIVE RIGHT TO USE "MIDWAY", APART FROM THE MARK AS SHOWN.

FOR ENTERTAINMENT SERVICES IN THE NATURE OF A CARNIVAL ATTRACTION, NAMELY, A THEMED AREA (U.S. CLS. 100, 101 AND 107).

FIRST USE 4-4-1995; IN COMMERCE 4-4-1995.
LINDA E. BLOHM, EXAMINING ATTORNEY

SN 85-602,719. MINNESOTA STATE AGRICULTURAL SOCIETY (MINNESOTA STATE FAIR), A STATE AGENCY ORGANIZED UNDER THE LAWS OF MINNESOTA, ST. PAUL, MN. FILED 4-19-2012.

KIDWAY

THE MARK CONSISTS OF STANDARD CHARACTERS WITHOUT CLAIM TO ANY PARTICULAR FONT, STYLE, SIZE, OR COLOR.

FOR ENTERTAINMENT SERVICES IN THE NATURE OF A CARNIVAL ATTRACTION, NAMELY, A THEMED AREA (U.S. CLS. 100, 101 AND 107).

FIRST USE 4-4-1995; IN COMMERCE 4-4-1995.
LINDA E. BLOHM, EXAMINING ATTORNEY

SN 85-602,775. VIRGINIA LOTTERY, RICHMOND, VA. FILED 4-19-2012.

WE'RE GAME

THE MARK CONSISTS OF STANDARD CHARACTERS WITHOUT CLAIM TO ANY PARTICULAR FONT, STYLE, SIZE, OR COLOR.

FOR ENTERTAINMENT, NAMELY, CONDUCTING PERIODICAL GAME OF CHANCE WHEREIN THE PARTICIPANTS WHO CORRECTLY SELECT THE WINNING NUMBERS ARE PROVIDED WITH A MONETARY AWARD (U.S. CLS. 100, 101 AND 107).

STEVEN R. FINE, EXAMINING ATTORNEY

CLASS 41—(Continued).

SN 85-602,805. WAGNER, HEIDI, BOULDER, CO. FILED 4-19-2012.

THE PASSIONS PROJECT

THE MARK CONSISTS OF STANDARD CHARACTERS WITHOUT CLAIM TO ANY PARTICULAR FONT, STYLE, SIZE, OR COLOR.

FOR PHOTOGRAPHY; PHOTOGRAPHY SERVICES; PORTRAIT PHOTOGRAPHY (U.S. CLS. 100, 101 AND 107).

ZACHARY CROMER, EXAMINING ATTORNEY

SN 85-602,812. SUGAR LOCO, LLC, DBA SUGAR LOCO, CENTENNIAL, CO. FILED 4-19-2012.

Sugar Loco

THE MARK CONSISTS OF STANDARD CHARACTERS WITHOUT CLAIM TO ANY PARTICULAR FONT, STYLE, SIZE, OR COLOR.

FOR ON-LINE JOURNALS, NAMELY, BLOGS FEATURING DESSERT REVIEWS, RECIPES, RESTAURANT DESSERT REVIEWS AND DESSERT RELATED PRODUCT REVIEWS (U.S. CLS. 100, 101 AND 107).

FIRST USE 1-15-2010; IN COMMERCE 1-15-2010.
TRACY FLETCHER, EXAMINING ATTORNEY

SN 85-602,848. HARLAND, JENNIFER, SAN FRANCISCO, CA. AND HARLAND, ELIZABETH, SAN FRANCISCO, CA. FILED 4-19-2012.

Who's The Catch

THE MARK CONSISTS OF STANDARD CHARACTERS WITHOUT CLAIM TO ANY PARTICULAR FONT, STYLE, SIZE, OR COLOR.

FOR ENTERTAINMENT SERVICES, NAMELY, PROVIDING ONLINE ELECTRONIC GAMES (U.S. CLS. 100, 101 AND 107).

JESSICA A. POWERS, EXAMINING ATTORNEY

CLASS 41—(Continued).

SN 85-602,988. ACHIEVE, INC., WASHINGTON, DC. FILED 4-19-2012.

AMERICAN DIPLOMA PROJECT
NETWORK

THE MARK CONSISTS OF STANDARD CHARACTERS WITHOUT CLAIM TO ANY PARTICULAR FONT, STYLE, SIZE, OR COLOR.

OWNER OF U.S. REG. NOS. 2,933,149 AND 2,943,264.

NO CLAIM IS MADE TO THE EXCLUSIVE RIGHT TO USE "NETWORK", APART FROM THE MARK AS SHOWN. SEC. 2(F).

FOR EDUCATIONAL SERVICES, NAMELY, ASSESSMENT OF EDUCATIONAL PROFICIENCIES NECESSARY FOR HIGH SCHOOL GRADUATES TO COMPETE SUCCESSFULLY IN COLLEGE OR IN THE WORKPLACE; CONSULTING WITH SECONDARY EDUCATIONAL INSTITUTIONS TO ASSURE THAT, UPON GRADUATION, STUDENTS HAVE THE NECESSARY SKILLS TO COMPETE SUCCESSFULLY IN COLLEGE OR IN THE WORKPLACE (U.S. CLS. 100, 101 AND 107).

FIRST USE 2-27-2005; IN COMMERCE 2-27-2005.
AMY HELLA, EXAMINING ATTORNEY

CLASS 41—(Continued).

SN 85-603,143. MARIETTA MUSEUM OF ART & WHIMSY, INC., SARASOTA, FL. FILED 4-19-2012.

MARIETTA MUSEUM OF ART &
WHIMSY

THE MARK CONSISTS OF STANDARD CHARACTERS WITHOUT CLAIM TO ANY PARTICULAR FONT, STYLE, SIZE, OR COLOR.

NO CLAIM IS MADE TO THE EXCLUSIVE RIGHT TO USE "MUSEUM OF ART", APART FROM THE MARK AS SHOWN.

FOR MUSEUMS (U.S. CLS. 100, 101 AND 107).

FIRST USE 10-9-2010; IN COMMERCE 10-9-2010.

DORITT L. CARROLL, EXAMINING ATTORNEY

SN 85-603,086. RICHARD M. SANTOS, DBA SILVA SANTOS, VISTA, CA. FILED 4-19-2012.

SILVA SANTOS

THE MARK CONSISTS OF STANDARD CHARACTERS WITHOUT CLAIM TO ANY PARTICULAR FONT, STYLE, SIZE, OR COLOR.

THE NAME(S), PORTRAIT(S), AND/OR SIGNATURE(S) SHOWN IN THE MARK IDENTIFIES RICHARD M. SANTOS, WHOSE CONSENT(S) TO REGISTER IS MADE OF RECORD.

FOR ENTERTAINMENT SERVICES BY A MUSICAL ARTIST AND PRODUCER, NAMELY, MUSICAL COMPOSITION FOR OTHERS AND PRODUCTION OF MUSICAL SOUND RECORDINGS; ENTERTAINMENT SERVICES IN THE NATURE OF LIVE MUSICAL PERFORMANCES; ENTERTAINMENT SERVICES IN THE NATURE OF PRESENTING LIVE MUSICAL PERFORMANCES (U.S. CLS. 100, 101 AND 107).

FIRST USE 4-1-2012; IN COMMERCE 4-1-2012.
KRISTINA MORRIS, EXAMINING ATTORNEY

SN 85-603,163. REALFIT GYM, HIGHLAND PARK, IL. FILED 4-19-2012.



THE MARK CONSISTS OF WINGS WITH A SEMI CIRCLE TYPE HALO ABOVE THE LETTERS "RF". BELOW THERE IS THE STYLIZED TEXT "REALFIT GYM TRANSFORM BODY+ MIND" WITH A LINE IN THE MIDDLE.

FOR PHYSICAL FITNESS INSTRUCTION (U.S. CLS. 100, 101 AND 107).

FIRST USE 6-15-2011; IN COMMERCE 6-15-2011.
LINDA POWELL, EXAMINING ATTORNEY

CLASS 41—(Continued).

SN 85-603,281. ALDIKO LIMITED, 100 CYBERPORT ROAD, HONG KONG, FILED 4-19-2012.

ALDIKO

THE MARK CONSISTS OF STANDARD CHARACTERS WITHOUT CLAIM TO ANY PARTICULAR FONT, STYLE, SIZE, OR COLOR.

THE WORDING ALDIKO HAS NO MEANING IN A FOREIGN LANGUAGE.

FOR EDUCATION SERVICES, NAMELY, PROVIDING LIVE AND ON-LINE CLASSES IN THE FIELD OF GENERAL INTEREST; ENTERTAINMENT INFORMATION; ENTERTAINMENT SERVICES, NAMELY, MULTIMEDIA PRODUCTION SERVICES; BOOK PUBLISHING; ELECTRONIC DESKTOP PUBLISHING; PROVISION OF INFORMATION RELATING TO PUBLISHING OF ELECTRONIC PUBLICATIONS; PUBLISHING SERVICES, IN PARTICULAR PUBLISHING OF BOOKS, MAGAZINES, PERIODICALS AND MEDIA CONTENT IN DIGITAL FORMAT (U.S. CLS. 100, 101 AND 107).

FIRST USE 6-2-2009; IN COMMERCE 6-2-2009.
RONALD DELGIZZI, EXAMINING ATTORNEY

SN 85-603,386. MOHR RETAIL, LLC, RIDGEWOOD, NJ, FILED 4-20-2012.

EVERY DAY IS A CHANCE TO LEARN MOHR

THE MARK CONSISTS OF STANDARD CHARACTERS WITHOUT CLAIM TO ANY PARTICULAR FONT, STYLE, SIZE, OR COLOR.

OWNER OF U.S. REG. NOS. 3,176,758 AND 3,886,676.

FOR EDUCATIONAL SERVICES, NAMELY CONDUCTING SEMINARS IN THE FIELD OF RETAIL SALES, SERVICE, NEGOTIATION, AND MANAGEMENT (U.S. CLS. 100, 101 AND 107).

FIRST USE 2-0-2004; IN COMMERCE 2-0-2004.
BILL DAWE, EXAMINING ATTORNEY

SN 85-603,411. SPANISH BROADCASTING SYSTEM, INC, COCONUT GROVE, FL. FILED 4-20-2012.

RODAJE

THE MARK CONSISTS OF STANDARD CHARACTERS WITHOUT CLAIM TO ANY PARTICULAR FONT, STYLE, SIZE, OR COLOR.

THE ENGLISH TRANSLATION OF "RODAJE" IN THE MARK IS "CAMERAS ROLLING".

FOR ENTERTAINMENT SERVICES IN THE NATURE OF ONGOING TELEVISION PROGRAMS IN THE FIELDS OF MUSIC AND VARIETY (U.S. CLS. 100, 101 AND 107).

ANTHONY RINKER, EXAMINING ATTORNEY

CLASS 41—(Continued).

SN 85-603,489. THE FABULOUS BROTHERS LTD., LONDON, UNITED KINGDOM, FILED 4-20-2012.

JOYWRIDE

THE MARK CONSISTS OF STANDARD CHARACTERS WITHOUT CLAIM TO ANY PARTICULAR FONT, STYLE, SIZE, OR COLOR.

FOR ENTERTAINMENT SERVICES, NAMELY, LIVE MUSIC PERFORMANCES AND PROVIDING PUBLIC APPEARANCES BY A PERFORMING ARTIST, NAMELY, MUSICIANS AND MUSICAL RECORDING ARTISTS; ENTERTAINMENT, NAMELY LIVE PERFORMANCES BY A MUSICAL BAND; PROVIDING A WEBSITE FEATURING AUDIO-VISUAL CONTENT, NAMELY, MUSIC PERFORMANCES AND MUSIC VIDEOS; PROVIDING A WEBSITE FEATURING INFORMATION ON A PERFORMING ARTIST, INCLUDING TOURING, APPEARANCES, NEWS, BIOGRAPHY, PHOTOGRAPHS, AND OTHER ENTERTAINMENT INFORMATION (U.S. CLS. 100, 101 AND 107).

APRIL HESIK, EXAMINING ATTORNEY

SN 85-603,528. PROMETHEUS GLOBAL MEDIA, LLC, NEW YORK, NY. FILED 4-20-2012.

NEXTECH

THE MARK CONSISTS OF STANDARD CHARACTERS WITHOUT CLAIM TO ANY PARTICULAR FONT, STYLE, SIZE, OR COLOR.

FOR EDUCATIONAL SERVICES, NAMELY, CONDUCTING LIVE AND ONLINE CONFERENCES IN THE FIELD OF ADVERTISING AND MARKETING AND DISTRIBUTION OF TRAINING MATERIAL IN CONNECTION THEREWITH (U.S. CLS. 100, 101 AND 107).

FIRST USE 5-1-2012; IN COMMERCE 5-1-2012.
IRA J. GOODSaid, EXAMINING ATTORNEY

CLASS 41—(Continued).

SN 85-603,554. SYDFIT, LLC, ROCHESTER, MI. FILED 4-20-2012.

SYDFIT

THE MARK CONSISTS OF STANDARD CHARACTERS WITHOUT CLAIM TO ANY PARTICULAR FONT, STYLE, SIZE, OR COLOR.

FOR PERSONAL FITNESS TRAINING SERVICES, NAMELY STRENGTH CONDITIONING AND EXERCISE TRAINING FOR INDIVIDUALS AND GROUPS; PERSONAL FITNESS CONSULTANCY SERVICES; PHYSICAL FITNESS CONSULTATION, INSTRUCTION AND TRAINING FOR INDIVIDUALS AND GROUPS INCLUDING STRENGTH TRAINING, CONDITIONING AND EXERCISE; EDUCATIONAL SERVICES, NAMELY CONDUCTING CLASSES, WORKSHOPS, SEMINARS AND PRESENTING TALKS ON THE BENEFITS OF EXERCISE AND FITNESS FOR ALL AGES; DEVELOPING AND CONDUCTING PHYSICAL TRAINING SERVICES AND PHYSICAL FITNESS INSTRUCTION FOR SPECIAL POPULATIONS (U.S. CLS. 100, 101 AND 107).
LINDA ESTRADA, EXAMINING ATTORNEY

SN 85-603,676. JOZUA BENJAMIN HECKROOT, BLOEMFONTEIN, SOUTH AFRICA, FILED 4-20-2012.

FREE ETERNITY

THE MARK CONSISTS OF STANDARD CHARACTERS WITHOUT CLAIM TO ANY PARTICULAR FONT, STYLE, SIZE, OR COLOR.

FOR PROVIDING A WEB SITE THAT FEATURES INFORMATION ABOUT ONLINE HIGHER EDUCATION RESOURCES (U.S. CLS. 100, 101 AND 107).
JOHN HWANG, EXAMINING ATTORNEY

SN 85-603,719. FARCEPEDIA, LLC, ROCKVILLE, MD. FILED 4-20-2012.

FARCEPEDIA

THE MARK CONSISTS OF STANDARD CHARACTERS WITHOUT CLAIM TO ANY PARTICULAR FONT, STYLE, SIZE, OR COLOR.

FOR ENTERTAINMENT SERVICES, NAMELY, PROVIDING A WEBSITE FEATURING HUMOR, VIDEOS AND JOKES; PROVIDING LINKS TO THE WEBSITES OF OTHERS FEATURING HUMOR, VIDEOS AND JOKES (U.S. CLS. 100, 101 AND 107).

FIRST USE 4-1-2012; IN COMMERCE 4-1-2012.
JOHN HWANG, EXAMINING ATTORNEY

CLASS 41—(Continued).

SN 85-603,760. THE CHEMICAL HERITAGE FOUNDATION, PHILADELPHIA, PA. FILED 4-20-2012.

WE TELL the STORY of CHEMISTRY.

THE MARK CONSISTS OF STANDARD CHARACTERS WITHOUT CLAIM TO ANY PARTICULAR FONT, STYLE, SIZE, OR COLOR.

FOR EDUCATION SERVICES, NAMELY, PROVIDING SEMINARS, CLASSES, WORKSHOPS, CONFERENCES, PRESENTATIONS, EVENTS, EXHIBITS, LIBRARY RESOURCES AND PROGRAMS IN FIELDS OF CHEMICAL AND MOLECULAR SCIENCE (U.S. CLS. 100, 101 AND 107).

FIRST USE 7-0-2009; IN COMMERCE 7-0-2009.
MIDGE BUTLER, EXAMINING ATTORNEY

SN 85-603,776. RUIZ PRODUCTIONS, LLC, LAS VEGAS, NV. FILED 4-20-2012.



THE COLOR(S) BROWN, GREEN, LIGHT YELLOW, DARK YELLOW AND WHITE IS/ARE CLAIMED AS A FEATURE OF THE MARK.

THE MARK CONSISTS OF A STYLIZED FIGURE OF A BROWN MAN WITH ARMS RAISED, STANDING ON A GREEN TEARDROP SHAPE, A SECOND LIGHT YELLOW AND DARK YELLOW TEARDROP SHAPE OVER THE HEAD OF THE MAN CONTAINING A WHITE SUN DESIGN ON THE RIGHT SIDE OF THE TEARDROP.

FOR EDUCATION SERVICES, NAMELY, PROVIDING CLASSES, SEMINARS, LECTURES AND WORKSHOPS IN THE FIELD OF PERSONAL AWARENESS (U.S. CLS. 100, 101 AND 107).

FIRST USE 5-0-2010; IN COMMERCE 5-0-2010.
KHANH LE, EXAMINING ATTORNEY

CLASS 41—(Continued).

SN 85-603,912. APOLLO GROUP, INC., PHOENIX, AZ. FILED 4-20-2012.

MPAS

THE MARK CONSISTS OF STANDARD CHARACTERS WITHOUT CLAIM TO ANY PARTICULAR FONT, STYLE, SIZE, OR COLOR.

FOR EDUCATIONAL SERVICES, NAMELY, POST-SECONDARY COURSES IN THE FIELDS OF FINANCE AND FINANCIAL PLANNING, RISK MANAGEMENT, INVESTMENTS, FINANCIAL PORTFOLIO MANAGEMENT, TAXATION, RETIREMENT PLANNING AND ESTATE PLANNING (U.S. CLS. 100, 101 AND 107).

ELI HELLMAN, EXAMINING ATTORNEY

SN 85-604,047. UNTHINKABLE ADVENTURES, TORRANCE, CA. FILED 4-20-2012.

Unthinkable Adventures

THE MARK CONSISTS OF STANDARD CHARACTERS WITHOUT CLAIM TO ANY PARTICULAR FONT, STYLE, SIZE, OR COLOR.

FOR CONDUCTING WORKSHOPS AND SEMINARS IN AWARENESS SKILLS, COMMUNICATION SKILLS, CREATIVITY AND TEAMWORK (U.S. CLS. 100, 101 AND 107).

ROBERT STRUCK, EXAMINING ATTORNEY

SN 85-604,106. MIFFLIN, JENNIFER A., MOKENA, IL. AND WITT, SUZANNE C., EVERGREEN PARK, IL. FILED 4-20-2012.

CHIRPYGIRLS

THE MARK CONSISTS OF STANDARD CHARACTERS WITHOUT CLAIM TO ANY PARTICULAR FONT, STYLE, SIZE, OR COLOR.

FOR ON-LINE JOURNALS, NAMELY, BLOGS FEATURING LIFESTYLE TOPICS, SUBJECTS AND FEATURES, PUBLIC RELATIONS TOPICS AND NICHE CONTENT TOPICS (U.S. CLS. 100, 101 AND 107).

FIRST USE 11-12-2011; IN COMMERCE 11-12-2011.

TOBY BULLOFF, EXAMINING ATTORNEY

CLASS 41—(Continued).

SN 85-604,139. "D" & BIG "E", LLC, BEAR, DE. FILED 4-20-2012.

The Silver Bull

THE MARK CONSISTS OF STANDARD CHARACTERS WITHOUT CLAIM TO ANY PARTICULAR FONT, STYLE, SIZE, OR COLOR.

FOR PRODUCTION AND DISTRIBUTION OF TELEVISION SHOWS AND MOVIES (U.S. CLS. 100, 101 AND 107).

KELLY BOULTON, EXAMINING ATTORNEY

SN 85-604,289. JAMES DURBIN, WEST HOLLYWOOD, CA. FILED 4-20-2012.

OUTCAST ARMY

THE MARK CONSISTS OF STANDARD CHARACTERS WITHOUT CLAIM TO ANY PARTICULAR FONT, STYLE, SIZE, OR COLOR.

FOR FAN CLUBS (U.S. CLS. 100, 101 AND 107).

ESTHER A. BORSUK, EXAMINING ATTORNEY

SN 85-604,465. GOT GAME SPORTS LLC, LOS ANGELES, CA. FILED 4-20-2012.

GOT GAME SPORTS

THE MARK CONSISTS OF STANDARD CHARACTERS WITHOUT CLAIM TO ANY PARTICULAR FONT, STYLE, SIZE, OR COLOR.

NO CLAIM IS MADE TO THE EXCLUSIVE RIGHT TO USE "SPORTS", APART FROM THE MARK AS SHOWN.

FOR COACHING IN THE FIELD OF SPORTS EXCLUDING BASKETBALL; OPERATION OF SPORTS CAMPS EXCLUDING BASKETBALL ACTIVITIES; PROVIDING AFTER SCHOOL EDUCATIONAL PROGRAMS FOR CHILDREN IN GRADES KINDERGARTEN THROUGH THE 8TH GRADE; SPORT CAMPS EXCLUDING BASKETBALL ACTIVITIES; SPORTS CAMP SERVICES EXCLUDING BASKETBALL ACTIVITIES; SUMMER CAMPS EXCLUDING BASKETBALL ACTIVITIES (U.S. CLS. 100, 101 AND 107).

FIRST USE 7-15-2004; IN COMMERCE 7-15-2004.

DAVID MURRAY, EXAMINING ATTORNEY

CLASS 41—(Continued).

SN 85-604,557. AUBURN UNIVERSITY, AUBURN, AL.
FILED 4-21-2012.

REAL CENTS REAL CHANGE

THE MARK CONSISTS OF STANDARD CHARACTERS WITHOUT CLAIM TO ANY PARTICULAR FONT, STYLE, SIZE, OR COLOR.

FOR EDUCATIONAL SERVICES, NAMELY, A LEARNING SERIES IN THE NATURE OF CLASSES, SEMINARS, AND CAMPS TO EDUCATE CHILDREN AND TEENAGERS REGARDING BASIC FINANCIAL AND PHILANTHROPIC CONCEPTS AND PRINCIPLES; EDUCATIONAL SERVICES, NAMELY, PROVIDING A CAMP TO EDUCATE CHILDREN AND TEENAGERS REGARDING BASIC FINANCIAL AND PHILANTHROPIC CONCEPTS AND PRINCIPLES (U.S. CLS. 100, 101 AND 107).

DAVID COLLIER, EXAMINING ATTORNEY

SN 85-604,639. PUGH, JERIS, RICHMOND HILL, NY. FILED
4-21-2012.

Martial Arfs

THE MARK CONSISTS OF STANDARD CHARACTERS WITHOUT CLAIM TO ANY PARTICULAR FONT, STYLE, SIZE, OR COLOR.

FOR DOG TRAINING THAT BLENDS THE CONCEPTS OF VARIOUS TRADITIONAL MARTIAL ARTS PRINCIPLES AND PHILOSOPHIES WITH PROGRESSIVE CANINE EXERCISES AND ACTIVITIES IN ORDER TO IMPROVE PHYSICAL FITNESS AND BODY AWARENESS, AS WELL AS TO TEACH BEHAVIOR MODIFICATION AND OBEDIENCE (U.S. CLS. 100, 101 AND 107).

GIANCARLO CASTRO, EXAMINING ATTORNEY

SN 85-604,791. MONCEL, BETHANY, NEW ORLEANS, LA.
FILED 4-22-2012.

Budget Bytes

THE MARK CONSISTS OF STANDARD CHARACTERS WITHOUT CLAIM TO ANY PARTICULAR FONT, STYLE, SIZE, OR COLOR.

FOR ON-LINE JOURNALS, NAMELY, BLOGS FEATURING BUDGET CONSCIOUS RECIPES AND MEAL PLANNING (U.S. CLS. 100, 101 AND 107).

FIRST USE 5-20-2009; IN COMMERCE 5-20-2009.
MARY CRAWFORD, EXAMINING ATTORNEY

CLASS 41—(Continued).

SN 85-604,813. TALENTHOUSE, INC., PALO ALTO, CA.
FILED 4-22-2012.

sponsored engagement engine

THE MARK CONSISTS OF STANDARD CHARACTERS WITHOUT CLAIM TO ANY PARTICULAR FONT, STYLE, SIZE, OR COLOR.

FOR ENTERTAINMENT SERVICES, NAMELY, PROVIDING A WEBSITE FEATURING NON-DOWNLOADABLE AUDIO AND VIDEO OF MUSICAL PERFORMANCES, MUSIC VIDEOS, CURRENT EVENT NEWS, AND PHOTOGRAPHS, FILM CLIPS, AND DOCUMENTARIES FEATURING OR ABOUT DRAMA, COMEDY, FASHION, ART, AND MUSICAL SUBJECTS (U.S. CLS. 100, 101 AND 107).

CORY BOONE, EXAMINING ATTORNEY

SN 85-604,909. COMCAST CORPORATION, PHILADELPHIA, PA. FILED 4-23-2012.

**EVERY MINUTE. EVERY
MEDAL. EVERY SCREEN.**

THE MARK CONSISTS OF STANDARD CHARACTERS WITHOUT CLAIM TO ANY PARTICULAR FONT, STYLE, SIZE, OR COLOR.

FOR ENTERTAINMENT SERVICES, NAMELY, THE PROVISION OF CONTINUING LIVE AND PRE-RECORDED PROGRAMS IN THE FIELD OF SPORTS AND SPORTING EVENTS AND RELATED PERSONS AND ACTIVITIES, DISTRIBUTED VIA TELEVISION, CABLE TELEVISION, SATELLITE, THE INTERNET, WIRELESS NETWORKS, MOBILE NETWORKS AND OTHER ELECTRONIC COMMUNICATIONS NETWORKS; PROVISION OF NON-DOWNLOADABLE TELEVISION PROGRAMS IN THE FIELD OF SPORTS AND SPORTING EVENTS AND RELATED PERSONS AND ACTIVITIES VIA A VIDEO-ON-DEMAND SERVICE (U.S. CLS. 100, 101 AND 107).

VERNA BETH RIRIE, EXAMINING ATTORNEY

SN 85-604,925. REVOLUTION X LLC, SKILLMAN, NJ.
FILED 4-23-2012.

RE VX

THE MARK CONSISTS OF STANDARD CHARACTERS WITHOUT CLAIM TO ANY PARTICULAR FONT, STYLE, SIZE, OR COLOR.

FOR SPINNING AND SUSPENSION EXERCISE CLASSES AND INSTRUCTION (U.S. CLS. 100, 101 AND 107).

ALLISON SCHRODY, EXAMINING ATTORNEY

CLASS 41—(Continued).

SN 85-604,992. SCOTT, KARLA D., FAIRVIEW HEIGHTS, IL.
FILED 4-23-2012.

**SOJOURN Sisters on a
journey of unity
restoration and nurturing**

THE MARK CONSISTS OF STANDARD CHARACTERS WITHOUT CLAIM TO ANY PARTICULAR FONT, STYLE, SIZE, OR COLOR.

FOR EDUCATION SERVICES, NAMELY, PROVIDING WORKSHOPS IN THE FIELD OF HOLISTIC HEALTH AND WELLNESS (U.S. CLS. 100, 101 AND 107).

JAMES STEIN, EXAMINING ATTORNEY

SN 85-605,002. "D" & BIG "E", LLC, BEAR, HI. FILED 4-23-2012.



THE MARK CONSISTS OF A PICTURE OF A BULL IN A CIRCLE WITH THE NUMBER "79" IN A STAR ON THE REAR OF THE BULL AND THE WORDS "THE SILVER BULL" ABOVE THE BULL.

FOR PRODUCTION AND DISTRIBUTION OF TELEVISION SHOWS AND MOVIES (U.S. CLS. 100, 101 AND 107).

KELLY BOULTON, EXAMINING ATTORNEY

SN 85-605,033. KEELEY, SUSANNE PHILLIPS, EVANSTON, IL. FILED 4-23-2012.

GoStrong

THE MARK CONSISTS OF STANDARD CHARACTERS WITHOUT CLAIM TO ANY PARTICULAR FONT, STYLE, SIZE, OR COLOR.

FOR EDUCATION SERVICES, NAMELY, PROVIDING MENTORING, TUTORING, CLASSES, SEMINARS AND WORKSHOPS IN THE FIELD OF STUDY SKILLS (U.S. CLS. 100, 101 AND 107).

FIRST USE 5-10-2009; IN COMMERCE 5-30-2009.

JOHN WILKE, EXAMINING ATTORNEY

CLASS 41—(Continued).

SN 85-605,125. TRES AGUILAS, LTD., SPRING BRANCH, TX. FILED 4-23-2012.

HACIENDA TRES AGUILAS

THE MARK CONSISTS OF STANDARD CHARACTERS WITHOUT CLAIM TO ANY PARTICULAR FONT, STYLE, SIZE, OR COLOR.

THE ENGLISH TRANSLATION OF "HACIENDA TRES AGUILAS" IN THE MARK IS "THREE EAGLES RANCH".

FOR EDUCATION SERVICES, NAMELY, PROVIDING CLASSES, SEMINARS, CONFERENCES, WORKSHOPS AND ONE-ON-ONE TRAINING IN THE FIELD OF EQUINE THERAPY; EDUCATION SERVICES, NAMELY, PROVIDING CLASSES, SEMINARS, CONFERENCES, WORKSHOPS AND ONE-ON-ONE TRAINING IN THE FIELD OF HUMAN DEVELOPMENT, ADVANCEMENT AND LEADERSHIP; INSTRUCTIONAL SERVICES, NAMELY, TEACHING OTHERS ABOUT EQUINE THERAPY AND THE USE OF HORSES TO FACILITATE LEARNING ABOUT HUMAN DEVELOPMENT, ADVANCEMENT AND LEADERSHIP (U.S. CLS. 100, 101 AND 107).

FIRST USE 12-31-1975; IN COMMERCE 12-31-1975.

LUCY ARANT, EXAMINING ATTORNEY

SN 85-605,137. HOMEPORTFOLIO, INC., NEWTON, MA. FILED 4-23-2012.

HOMEPORTFOLIO

THE MARK CONSISTS OF STANDARD CHARACTERS WITHOUT CLAIM TO ANY PARTICULAR FONT, STYLE, SIZE, OR COLOR.

FOR ON-LINE JOURNALS, NAMELY, BLOGS FEATURING HOME DECORATING, HOME IMPROVEMENT, HOME PURCHASE, OR HOME CONSTRUCTION; PROVIDING ON-LINE MAGAZINES IN THE FIELD OF HOME DECORATING, HOME IMPROVEMENT, HOME PURCHASE, OR HOME CONSTRUCTION (U.S. CLS. 100, 101 AND 107).

FIRST USE 9-1-2006; IN COMMERCE 9-1-2006.

LUCY ARANT, EXAMINING ATTORNEY

CLASS 41—(Continued).

SN 85-605,156. CHEREACE RICHARDS, BOWIE, MD. FILED 4-23-2012.

FAITH FOCUS ACTION

THE MARK CONSISTS OF STANDARD CHARACTERS WITHOUT CLAIM TO ANY PARTICULAR FONT, STYLE, SIZE, OR COLOR.

FOR BUSINESS TRAINING IN THE FIELD OF PERSONAL AND LEADERSHIP DEVELOPMENT AND EXECUTIVE COACHING (U.S. CLS. 100, 101 AND 107).

FIRST USE 3-26-2010; IN COMMERCE 3-26-2010.
PAM WILLIS, EXAMINING ATTORNEY

CLASS 41—(Continued).

SN 85-605,242. THE INSTITUTE OF ELECTRICAL AND ELECTRONICS ENGINEERS, INC., PISCATAWAY, NJ. FILED 4-23-2012.

IEEEXTREME

THE MARK CONSISTS OF STANDARD CHARACTERS WITHOUT CLAIM TO ANY PARTICULAR FONT, STYLE, SIZE, OR COLOR.

OWNER OF U.S. REG. NOS. 1,770,511, 3,666,752 AND OTHERS.

FOR ARRANGING AND CONDUCTING COMPUTER PROGRAMMING COMPETITIONS FOR STUDENTS; PROVIDING A WEBSITE THROUGH WHICH PEOPLE LOCATE INFORMATION ABOUT COMPUTER PROGRAMMING COMPETITIONS FOR STUDENTS (U.S. CLS. 100, 101 AND 107).

FIRST USE 3-31-2007; IN COMMERCE 3-31-2007.
C. DIONNE CLYBURN, EXAMINING ATTORNEY

SN 85-605,178. IDANCECITY, SAN ANTONIO, TX. FILED 4-23-2012.

udancecity

THE MARK CONSISTS OF STANDARD CHARACTERS WITHOUT CLAIM TO ANY PARTICULAR FONT, STYLE, SIZE, OR COLOR.

FOR DANCE INSTRUCTION; DANCE STUDIOS (U.S. CLS. 100, 101 AND 107).

DOMINIC FATHY, EXAMINING ATTORNEY

SN 85-605,551. RUN FOR THE PARKS LLC, PORTLAND, OR. FILED 4-23-2012.

RUN FOR THE PARKS

SN 85-605,221. VIACOM INTERNATIONAL INC., NEW YORK, NY. FILED 4-23-2012.

WENDELL & VINNIE

THE MARK CONSISTS OF STANDARD CHARACTERS WITHOUT CLAIM TO ANY PARTICULAR FONT, STYLE, SIZE, OR COLOR.

FOR ENTERTAINMENT SERVICES IN THE NATURE OF CONTINUING PROGRAM SERIES, FEATURING LIVE ACTION, COMEDY AND DRAMA PROVIDED THROUGH CABLE TELEVISION, BROADCAST TELEVISION, INTERNET, VIDEO-ON-DEMAND, AND THROUGH OTHER FORMS OF TRANSMISSION MEDIA; PROVIDING ONLINE INFORMATION IN THE FIELD OF ENTERTAINMENT CONCERNING TELEVISION PROGRAMS (U.S. CLS. 100, 101 AND 107).

KATHLEEN M. VANSTON, EXAMINING ATTORNEY

THE MARK CONSISTS OF STANDARD CHARACTERS WITHOUT CLAIM TO ANY PARTICULAR FONT, STYLE, SIZE, OR COLOR.

FOR ORGANIZING, ARRANGING, AND CONDUCTING RUNNING EVENTS (U.S. CLS. 100, 101 AND 107).

MIDGE BUTLER, EXAMINING ATTORNEY

CLASS 41—(Continued).

SN 85-605,635. THE INSTITUTE OF ELECTRICAL AND ELECTRONICS ENGINEERS, INC., PISCATAWAY, NJ. FILED 4-23-2012.

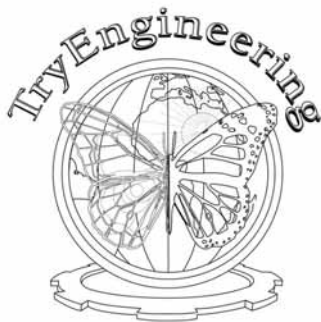

THE MARK CONSISTS OF THE STYLIZED WORD "TRYENGINEERING," IN AN ARC ABOVE A GLOBE ON WHICH PARTS OF EUROPE, AFRICA, AND SOUTH AMERICA ARE VISIBLE IN THE BACKGROUND OF VERTICAL LONGITUDINAL LINES. THE GLOBE IS OVERLAID WITH A BUTTERFLY AND IT SITS INSIDE THE CENTER OF A GEAR.

FOR PROVIDING INFORMATION AND NEWS IN THE FIELDS OF TEACHING METHODOLOGY AND EDUCATION AND EDUCATIONAL COUNSELING SERVICES TO ASSIST STUDENTS IN PLANNING AND PREPARING FOR FURTHER EDUCATION; CAREER COUNSELING, NAMELY, PROVIDING ADVICE CONCERNING EDUCATION OPTIONS TO PURSUE CAREER OPPORTUNITIES; PROVIDING A WEBSITE THAT FEATURES INFORMATION ON ATTENDING COLLEGE AND UNIVERSITY WITH AN EMPHASIS ON STUDENTS INTERESTED IN STUDYING ENGINEERING; PROVIDING LINKS TO WEBSITES OF OTHERS FEATURING ENTERTAINMENT SERVICES, NAMELY, ON-LINE COMPUTER GAMES (U.S. CLS. 100, 101 AND 107).

FIRST USE 6-5-2006; IN COMMERCE 6-5-2006.

C. DIONNE CLYBURN, EXAMINING ATTORNEY

SN 85-605,646. CHALK HOLDINGS, INC., CHICAGO, IL. FILED 4-23-2012.



THE MARK CONSISTS OF THE WORD "CHALK" STYLIZED, WITH A SMILEY FACE DESIGN ENCLOSED IN THE LETTER "C", AND SUNRAYS EXTENDING FROM THE LETTER "C".

FOR EDUCATIONAL SERVICES, NAMELY PRE-SCHOOLS (U.S. CLS. 100, 101 AND 107).

FIRST USE 9-30-2004; IN COMMERCE 9-30-2004.

DOMINICK J. SALEMI, EXAMINING ATTORNEY

CLASS 41—(Continued).

SN 85-605,677. THE INSTITUTE OF ELECTRICAL AND ELECTRONICS ENGINEERS, INC., PISCATAWAY, NJ. FILED 4-23-2012.



THE MARK CONSISTS OF THE STYLIZED WORD "TRYNANO.ORG," IN AN ARC ABOVE A GLOBE ON WHICH PARTS OF EUROPE, AFRICA, AND SOUTH AMERICA ARE VISIBLE IN THE BACKGROUND OF VERTICAL LONGITUDINAL LINES. THE GLOBE IS OVERLAID WITH TWO ROWS OF HEXAGONS IN A HONEYCOMB PATTERN, WITH A CIRCLE OVER EACH VERTEX OF EACH HEXAGON. LINES EMANATE OUTWARD FROM ONE OF THESE CIRCLES IN A SUNBURST PATTERN AND THE GLOBE SITS INSIDE THE CENTER OF A GEAR.

FOR PROVIDING INFORMATION AND NEWS IN THE FIELDS OF TEACHING METHODOLOGY AND EDUCATION AND EDUCATIONAL COUNSELING SERVICES TO ASSIST STUDENTS IN PLANNING AND PREPARING FOR FURTHER EDUCATION; CAREER COUNSELING, NAMELY, PROVIDING ADVICE CONCERNING EDUCATION OPTIONS TO PURSUE CAREER OPPORTUNITIES; PROVIDING A WEBSITE THAT FEATURES INFORMATION ON ATTENDING COLLEGE AND UNIVERSITY WITH AN EMPHASIS ON STUDENTS INTERESTED IN STUDYING NANOTECHNOLOGY AND NANOSCIENCE; PROVIDING LINKS TO WEBSITES OF OTHERS FEATURING ENTERTAINMENT SERVICES, NAMELY, ON LINE COMPUTER GAMES (U.S. CLS. 100, 101 AND 107).

FIRST USE 5-26-2009; IN COMMERCE 5-26-2009.

C. DIONNE CLYBURN, EXAMINING ATTORNEY

SN 85-605,713. THE CONRAD FOUNDATION, IRVINE, CA. FILED 4-23-2012.

GET YOUR GENIUS ON

THE MARK CONSISTS OF STANDARD CHARACTERS WITHOUT CLAIM TO ANY PARTICULAR FONT, STYLE, SIZE, OR COLOR.

FOR EDUCATIONAL SERVICES, NAMELY, DEVELOPING CURRICULUM IN THE FIELD OF SCIENCE; EDUCATIONAL SERVICES, NAMELY, CONDUCTING CLASSES, MEETINGS, CONFERENCES, COMPETITIONS AND WORKSHOPS IN THE FIELD OF SCIENCE (U.S. CLS. 100, 101 AND 107).

FIRST USE 1-0-2010; IN COMMERCE 1-0-2010.

KAREN K. BUSH, EXAMINING ATTORNEY

CLASS 41—(Continued).

SN 85-605,722. THE INSTITUTE OF ELECTRICAL AND ELECTRONICS ENGINEERS, INC., PISCATAWAY, NJ. FILED 4-23-2012.



THE MARK CONSISTS OF THE WORDS "IEEE TRYCOMPUTING.ORG" WITH THE UPPER-CASE LETTERS "IEEE" DIRECTLY ABOVE THE WORD "TRY" AND THE LETTER "O" IN "COMPUTING" INTERSECTED AT THE TOP BY A SHORT VERTICAL LINE, SO THAT IT RESEMBLES A COMPUTER POWER SYMBOL, AND THE LETTERS "ORG" IN SMALLER LOWER-CASE LETTERS.

FOR PROVIDING INFORMATION AND NEWS IN THE FIELDS OF TEACHING METHODOLOGY AND EDUCATION AND EDUCATIONAL COUNSELING SERVICES TO ASSIST STUDENTS IN PLANNING AND PREPARING FOR FURTHER EDUCATION; CAREER COUNSELING, NAMELY, PROVIDING ADVICE CONCERNING EDUCATION OPTIONS TO PURSUE CAREER OPPORTUNITIES; PROVIDING A WEBSITE THAT FEATURES INFORMATION ON ATTENDING COLLEGE AND UNIVERSITY WITH AN EMPHASIS ON STUDENTS INTERESTED IN STUDYING COMPUTING; PROVIDING LINKS TO WEBSITES OF OTHERS FEATURING ENTERTAINMENT SERVICES, NAMELY, ONLINE COMPUTER GAMES (U.S. CLS. 100, 101 AND 107).
C. DIONNE CLYBURN, EXAMINING ATTORNEY

SN 85-605,762. BODI & ASSOCIATES, VENICE, FL. FILED 4-23-2012.



THE MARK CONSISTS OF STANDARD CHARACTERS WITHOUT CLAIM TO ANY PARTICULAR FONT, STYLE, SIZE, OR COLOR.

FOR ON-LINE JOURNALS, NAMELY, BLOGS FEATURING ARTICLES IN THE FIELD OF UNSCRUPULOUS CUSTOMERS; PROVIDING A WEBSITE FEATURING BLOGS AND NON-DOWNLOADABLE PUBLICATIONS IN THE NATURE OF ARTICLES IN THE FIELD(S) OF UNSCRUPULOUS CUSTOMERS (U.S. CLS. 100, 101 AND 107).

FIRST USE 5-24-2010; IN COMMERCE 5-24-2010.
APRIL HESIK, EXAMINING ATTORNEY

CLASS 41—(Continued).

SN 85-605,789. CRESTONE CAPITAL ADVISORS LLC, BOULDER, CO. FILED 4-23-2012.

FINDING MEANING IN MONEY

THE MARK CONSISTS OF STANDARD CHARACTERS WITHOUT CLAIM TO ANY PARTICULAR FONT, STYLE, SIZE, OR COLOR.

FOR EDUCATIONAL SERVICES, NAMELY, CONDUCTING CONFERENCES IN THE FIELD OF INVESTMENTS, WEALTH MANAGEMENT, TAX PLANNING, CHARITABLE GIVING, WEALTH PRESERVATION, ASSET PROTECTION, AND RETIREMENT PLANNING (U.S. CLS. 100, 101 AND 107).

FIRST USE 6-11-2008; IN COMMERCE 6-11-2008.
DOMINIC FATHY, EXAMINING ATTORNEY

SN 85-605,840. PEDDLER RECORDS INC., MIAMI, FL. FILED 4-23-2012.



THE MARK CONSISTS OF STANDARD CHARACTERS WITHOUT CLAIM TO ANY PARTICULAR FONT, STYLE, SIZE, OR COLOR.

FOR AUDIO AND VIDEO RECORDING SERVICES; ENTERTAINMENT IN THE NATURE OF LIVE PERFORMANCES BY A MUSICAL ARTIST; ENTERTAINMENT SERVICES IN THE NATURE OF RECORDING, PRODUCTION AND POST-PRODUCTION SERVICES IN THE FIELD OF MUSIC; ENTERTAINMENT SERVICES, NAMELY, PROVIDING A WEB SITE FEATURING NON-DOWNLOADABLE MUSICAL PERFORMANCES, MUSICAL VIDEOS, RELATED FILM CLIPS, PHOTOGRAPHS, AND OTHER MULTIMEDIA MATERIALS FEATURING MUSIC AND ENTERTAINMENT; ENTERTAINMENT SERVICES, NAMELY, PROVIDING NON-DOWNLOADABLE PRERECORDED MUSIC, INFORMATION IN THE FIELD OF MUSIC, AND COMMENTARY AND ARTICLES ABOUT MUSIC, ALL ON-LINE VIA A GLOBAL COMPUTER NETWORK; ENTERTAINMENT, NAMELY, LIVE MUSIC CONCERTS; LIVE PERFORMANCES BY A MUSICAL GROUP; MULTIMEDIA ENTERTAINMENT SERVICES IN THE NATURE OF RECORDING, PRODUCTION AND POST-PRODUCTION SERVICES IN THE FIELDS OF MUSIC, VIDEO, AND FILMS; MUSIC PRODUCTION SERVICES; RECORD PRODUCTION; SOUND RECORDING STUDIOS; VIDEOTAPE PRODUCTION (U.S. CLS. 100, 101 AND 107).

JEFF DEFORD, EXAMINING ATTORNEY

CLASS 41—(Continued).

SN 85-605,900. WORLD SERIES OF FOOD TRUCKS, LLC, HENDERSON, NV. FILED 4-23-2012.

World Series of Food Trucks

THE MARK CONSISTS OF STANDARD CHARACTERS WITHOUT CLAIM TO ANY PARTICULAR FONT, STYLE, SIZE, OR COLOR.

NO CLAIM IS MADE TO THE EXCLUSIVE RIGHT TO USE "FOOD TRUCKS", APART FROM THE MARK AS SHOWN.

FOR ENTERTAINMENT SERVICES, NAMELY, CONDUCTING EVENTS AND CONTESTS IN THE FIELD OF FOOD TRUCKS (U.S. CLS. 100, 101 AND 107).

Laurie Mayes, Examining Attorney

SN 85-605,929. CES PERFORMANCE, LLC, LUBBOCK, TX. FILED 4-23-2012.



THE MARK CONSISTS OF AN ILLUSTRATION OF A FOOTBALL PLAYER LOCATED OVER THE PHRASE "BIG MAN'S" WHICH IS FLANKED ON EITHER SIDE WITH A STAR. BENEATH "BIG MAN'S" IS THE TERM "BRAWL".

FOR SPORTS CAMPS; FOOTBALL CAMPS; ARRANGING AND CONDUCTING ATHLETIC COMPETITIONS (U.S. CLS. 100, 101 AND 107).

FIRST USE 4-18-2012; IN COMMERCE 4-18-2012.
Christina Sobral, Examining Attorney

SN 85-605,930. CES PERFORMANCE, LLC, LUBBOCK, TX. FILED 4-23-2012.

BIG MAN'S BRAWL

THE MARK CONSISTS OF STANDARD CHARACTERS WITHOUT CLAIM TO ANY PARTICULAR FONT, STYLE, SIZE, OR COLOR.

FOR SPORTS CAMPS; FOOTBALL CAMPS; ARRANGING AND CONDUCTING ATHLETIC COMPETITIONS (U.S. CLS. 100, 101 AND 107).

FIRST USE 4-18-2012; IN COMMERCE 4-18-2012.
Christina Sobral, Examining Attorney

CLASS 41—(Continued).

SN 85-606,784. FIXED POINT FOUNDATION, BIRMINGHAM, AL. FILED 4-24-2012.

HE THINKS HARD, SO YOU DON'T HAVE TO

THE MARK CONSISTS OF STANDARD CHARACTERS WITHOUT CLAIM TO ANY PARTICULAR FONT, STYLE, SIZE, OR COLOR.

FOR ENTERTAINMENT SERVICES, NAMELY AN ONGOING SERIES IN THE FIELD OF MINISTRY AND BIBLE STUDIES PROVIDED VIA RADIO BROADCASTS (U.S. CLS. 100, 101 AND 107).

Esther A. Borsuk, Examining Attorney

SN 85-607,092. HYNES, BEAU RYAN, STUDIO CITY, CA. FILED 4-24-2012.

RadNerd

THE MARK CONSISTS OF STANDARD CHARACTERS WITHOUT CLAIM TO ANY PARTICULAR FONT, STYLE, SIZE, OR COLOR.

FOR ENTERTAINMENT SERVICES, NAMELY, MULTIMEDIA PRODUCTION SERVICES (U.S. CLS. 100, 101 AND 107).

Nicholas Coleman, Examining Attorney

SN 85-607,261. CHAMBERS, CASE, ABILENE, TX. FILED 4-24-2012.

Eagle Ford Bash

THE MARK CONSISTS OF STANDARD CHARACTERS WITHOUT CLAIM TO ANY PARTICULAR FONT, STYLE, SIZE, OR COLOR.

FOR ENTERTAINMENT IN THE NATURE OF A MUSIC FESTIVAL (U.S. CLS. 100, 101 AND 107).

Jenny Park, Examining Attorney

CLASS 41—(Continued).

SN 85-607,263. DANI ALPERT, BELMAR, NJ. FILED 4-24-2012.

THE GIRLFRIEND MOM

THE MARK CONSISTS OF STANDARD CHARACTERS WITHOUT CLAIM TO ANY PARTICULAR FONT, STYLE, SIZE, OR COLOR.

FOR ON-LINE JOURNALS, NAMELY, BLOGS FEATURING THE HUMORISTIC VIEWS AND PERSPECTIVE OF A WOMAN LIVING WITH A MAN, WHO HAS CHILDREN, UNMARRIED, AND HAS NEVER WANTED CHILDREN OF HER OWN (U.S. CLS. 100, 101 AND 107).
FIRST USE 2-3-2011; IN COMMERCE 2-3-2011.

ROBERT STRUCK, EXAMINING ATTORNEY

SN 85-607,271. DANI ALPERT, BELMAR, NJ. FILED 4-24-2012.

THE GIRLFRIEND MOM

THE MARK CONSISTS OF STANDARD CHARACTERS WITHOUT CLAIM TO ANY PARTICULAR FONT, STYLE, SIZE, OR COLOR.

FOR ENTERTAINMENT SERVICES, NAMELY, A MULTIMEDIA PROGRAM SERIES FEATURING COMEDY, ACTION AND ADVENTURE DISTRIBUTED VIA VARIOUS PLATFORMS ACROSS MULTIPLE FORMS OF TRANSMISSION MEDIA (U.S. CLS. 100, 101 AND 107).

ROBERT STRUCK, EXAMINING ATTORNEY

SN 85-608,006. DES MOINES AREA COMMUNITY COLLEGE, ANKENY, IA. FILED 4-25-2012.

INNOMAKE

THE MARK CONSISTS OF STANDARD CHARACTERS WITHOUT CLAIM TO ANY PARTICULAR FONT, STYLE, SIZE, OR COLOR.

FOR EDUCATIONAL SERVICES, NAMELY, CONDUCTING CLASSES AND SEMINARS IN THE FIELD OF ENTREPRENEURSHIP AND BUSINESS DEVELOPMENT AND DISTRIBUTION OF EDUCATIONAL MATERIALS IN CONNECTION THEREWITH (U.S. CLS. 100, 101 AND 107).

THOMAS MANOR, EXAMINING ATTORNEY

CLASS 41—(Continued).

SN 85-608,531. ZENIMAX MEDIA INC., ROCKVILLE, MD. FILED 4-25-2012.

REVENGE SOLVES EVERYTHING

THE MARK CONSISTS OF STANDARD CHARACTERS WITHOUT CLAIM TO ANY PARTICULAR FONT, STYLE, SIZE, OR COLOR.

FOR ENTERTAINMENT SERVICES, NAMELY, PROVIDING ON-LINE INTERACTIVE COMPUTER GAMES AND PROVIDING INFORMATION RELATING TO ELECTRONIC COMPUTER GAMES VIA THE INTERNET (U.S. CLS. 100, 101 AND 107).

ROBERT STRUCK, EXAMINING ATTORNEY

SN 85-609,181. CLIMATE MASTER, INC., OKLAHOMA CITY, OK. FILED 4-26-2012.

GEODAY

THE MARK CONSISTS OF STANDARD CHARACTERS WITHOUT CLAIM TO ANY PARTICULAR FONT, STYLE, SIZE, OR COLOR.

FOR PROVIDING EDUCATIONAL TRAINING AND WORKSHOPS FOR PROFESSIONALS AND INDUSTRIAL PERSONNEL IN THE FIELDS OF GEOTHERMAL EXCHANGE RESEARCH, APPLICATION, SYSTEM EQUIPMENT, INSTALLATIONS AND RELATED DESIGNS AND COSTS (U.S. CLS. 100, 101 AND 107).

FIRST USE 9-21-2011; IN COMMERCE 9-21-2011.

LESLIE RICHARDS, EXAMINING ATTORNEY

SN 85-609,238. AOL INC., DULLES, VA. FILED 4-26-2012.

UR + 1

THE MARK CONSISTS OF STANDARD CHARACTERS WITHOUT CLAIM TO ANY PARTICULAR FONT, STYLE, SIZE, OR COLOR.

FOR ENTERTAINMENT SERVICES, NAMELY, PROVIDING INFORMATION IN THE FIELDS OF CELEBRITIES, ENTERTAINMENT, AND POPULAR CULTURE; ENTERTAINMENT IN THE NATURE OF COMPETITIONS IN THE FIELD OF CELEBRITIES AND CELEBRITY BUZZ; ENTERTAINMENT SERVICES, NAMELY, CONDUCTING CONTESTS (U.S. CLS. 100, 101 AND 107).

ALLISON HOLTZ, EXAMINING ATTORNEY

CLASS 41—(Continued).

SN 85-612,708. AOL INC., DULLES, VA. FILED 4-30-2012.

DREAM CATCHERS

THE MARK CONSISTS OF STANDARD CHARACTERS WITHOUT CLAIM TO ANY PARTICULAR FONT, STYLE, SIZE, OR COLOR.

FOR ENTERTAINMENT SERVICES IN THE NATURE OF ONGOING VIDEO PROGRAMS PROVIDED VIA COMPUTER NETWORKS FEATURING REALITY PROGRAMMING AND DOCUMENTARY CONTENT IN THE NATURE OF INDIVIDUALS ACHIEVING THEIR GOALS (U.S. CLS. 100, 101 AND 107).

ALLISON HOLTZ, EXAMINING ATTORNEY

SN 85-614,637. ZENIMAX MEDIA INC., ROCKVILLE, MD. FILED 5-2-2012.



THE MARK CONSISTS OF A THREE HEADED CREATURE SWALLOWING ITS OWN TAILS CREATING A CIRCLE.

FOR ENTERTAINMENT SERVICES, NAMELY, PROVIDING ON-LINE INTERACTIVE COMPUTER GAMES; ENTERTAINMENT SERVICES, NAMELY, PROVIDING INFORMATION RELATING TO ELECTRONIC COMPUTER GAMES VIA THE INTERNET; MULTIMEDIA ENTERTAINMENT SOFTWARE PUBLISHING SERVICES; PUBLISHING INTERACTIVE COMPUTER AND VIDEO GAME SOFTWARE (U.S. CLS. 100, 101 AND 107).

ROBERT STRUCK, EXAMINING ATTORNEY

CLASS 41—(Continued).

SN 85-616,686. VIACOM INTERNATIONAL INC., NEW YORK, NY. FILED 5-4-2012.

VHI PRESENTS ROCK THE ROLE

THE MARK CONSISTS OF STANDARD CHARACTERS WITHOUT CLAIM TO ANY PARTICULAR FONT, STYLE, SIZE, OR COLOR.

OWNER OF U.S. REG. NOS. 2,995,834, 3,818,997 AND OTHERS.

FOR ENTERTAINMENT SERVICES IN THE NATURE OF CONTINUING PROGRAM SERIES, FEATURING LIVE ACTION, COMEDY AND DRAMA PROVIDED THROUGH CABLE TELEVISION, BROADCAST TELEVISION, INTERNET, VIDEO-ON-DEMAND, AND THROUGH OTHER FORMS OF TRANSMISSION MEDIA; PROVIDING ONLINE INFORMATION IN THE FIELD OF ENTERTAINMENT CONCERNING TELEVISION PROGRAMS (U.S. CLS. 100, 101 AND 107).

KATHLEEN M. VANSTON, EXAMINING ATTORNEY

SN 85-618,053. FIFTH THIRD BANCORP, CINCINNATI, OH. FILED 5-7-2012.

EMPOWER U

THE MARK CONSISTS OF STANDARD CHARACTERS WITHOUT CLAIM TO ANY PARTICULAR FONT, STYLE, SIZE, OR COLOR.

FOR EDUCATIONAL SERVICES, NAMELY, CONDUCTING PROGRAMS IN THE FIELD OF FINANCIAL LITERACY AND TOPICS (U.S. CLS. 100, 101 AND 107).

FIRST USE 3-10-2012; IN COMMERCE 3-10-2012. JEFFERY COWARD, EXAMINING ATTORNEY

SN 85-618,221. STARVALUE PRODUCTIONS, INC, WEST CHESTER, PA. FILED 5-7-2012.

StarValue Productions, Inc.

THE MARK CONSISTS OF STANDARD CHARACTERS WITHOUT CLAIM TO ANY PARTICULAR FONT, STYLE, SIZE, OR COLOR.

NO CLAIM IS MADE TO THE EXCLUSIVE RIGHT TO USE "PRODUCTIONS, INC.", APART FROM THE MARK AS SHOWN.

FOR ENTERTAINMENT MEDIA PRODUCTION SERVICES FOR MOTION PICTURES, TELEVISION AND INTERNET (U.S. CLS. 100, 101 AND 107).

JOHN DWYER, EXAMINING ATTORNEY

CLASS 41—(Continued).

SN 85-618,483. VIACOM INTERNATIONAL INC., NEW YORK, NY. FILED 5-7-2012.

RIDICULOUSNESS

THE MARK CONSISTS OF STANDARD CHARACTERS WITHOUT CLAIM TO ANY PARTICULAR FONT, STYLE, SIZE, OR COLOR.

FOR ENTERTAINMENT SERVICES IN THE NATURE OF CONTINUING PROGRAM SERIES, FEATURING LIVE ACTION, COMEDY AND DRAMA PROVIDED THROUGH CABLE TELEVISION, BROADCAST TELEVISION, INTERNET, VIDEO-ON-DEMAND, AND THROUGH OTHER FORMS OF TRANSMISSION MEDIA; PROVIDING ONLINE INFORMATION IN THE FIELD OF ENTERTAINMENT CONCERNING TELEVISION PROGRAMS (U.S. CLS. 100, 101 AND 107).

FIRST USE 8-29-2011; IN COMMERCE 8-29-2011.
KATHLEEN M. VANSTON, EXAMINING ATTORNEY

SN 85-618,552. CLIMATE MASTER, INC., OKLAHOMA CITY, OK. FILED 5-7-2012.

GEORANCH

THE MARK CONSISTS OF STANDARD CHARACTERS WITHOUT CLAIM TO ANY PARTICULAR FONT, STYLE, SIZE, OR COLOR.

FOR PROVIDING EDUCATIONAL TRAINING AND WORKSHOPS FOR PROFESSIONALS AND INDUSTRIAL PERSONNEL IN THE FIELDS OF GEOTHERMAL EXCHANGE RESEARCH, APPLICATION, SYSTEM EQUIPMENT, INSTALLATIONS AND RELATED DESIGNS AND COSTS (U.S. CLS. 100, 101 AND 107).

LESLIE RICHARDS, EXAMINING ATTORNEY

SN 85-618,567. CLIMATE MASTER, INC., OKLAHOMA CITY, OK. FILED 5-7-2012.

GEOPOND

THE MARK CONSISTS OF STANDARD CHARACTERS WITHOUT CLAIM TO ANY PARTICULAR FONT, STYLE, SIZE, OR COLOR.

FOR PROVIDING EDUCATIONAL TRAINING AND WORKSHOPS FOR PROFESSIONALS AND INDUSTRIAL PERSONNEL IN THE FIELDS OF GEOTHERMAL EXCHANGE RESEARCH, APPLICATION, SYSTEM EQUIPMENT, INSTALLATIONS AND RELATED DESIGNS AND COSTS (U.S. CLS. 100, 101 AND 107).

LESLIE RICHARDS, EXAMINING ATTORNEY

CLASS 41—(Continued).

SN 85-619,403. BOARD OF GOVERNORS OF THE COLORADO STATE UNIVERSITY SYSTEM, ACTING BY AND THROUGH COLORADO STATE UNIVERSITY, DENVER, CO. FILED 5-8-2012.

Colorado State University

OWNER OF U.S. REG. NOS. 1,492,718, 2,039,973 AND OTHERS.

NO CLAIM IS MADE TO THE EXCLUSIVE RIGHT TO USE "STATE UNIVERSITY", APART FROM THE MARK AS SHOWN.

THE MARK CONSISTS OF THE WORDS "COLORADO STATE UNIVERSITY" IN STYLIZED FONT.

SEC. 2(F).

FOR EDUCATIONAL SERVICES, NAMELY PROVIDING COURSES OF INSTRUCTION AT THE UNIVERSITY LEVEL AND EDUCATIONAL RESEARCH; ENTERTAINMENT IN THE NATURE OF ARRANGING AND CONDUCTING COLLEGIATE ATHLETIC EVENTS, AND MUSIC CONCERTS, PLAYS AND CULTURAL EVENTS (U.S. CLS. 100, 101 AND 107).

FIRST USE 12-31-1987; IN COMMERCE 12-31-1987.

SHAILA SETTLES, EXAMINING ATTORNEY

SN 85-621,978. VIACOM INTERNATIONAL INC., NEW YORK, NY. FILED 5-10-2012.

MODEL EMPLOYEE

THE MARK CONSISTS OF STANDARD CHARACTERS WITHOUT CLAIM TO ANY PARTICULAR FONT, STYLE, SIZE, OR COLOR.

FOR ENTERTAINMENT SERVICES IN THE NATURE OF CONTINUING PROGRAM SERIES, FEATURING LIVE ACTION, COMEDY AND DRAMA PROVIDED THROUGH CABLE TELEVISION, BROADCAST TELEVISION, INTERNET, VIDEO-ON-DEMAND, AND THROUGH OTHER FORMS OF TRANSMISSION MEDIA; PROVIDING ONLINE INFORMATION IN THE FIELD OF ENTERTAINMENT CONCERNING TELEVISION PROGRAMS (U.S. CLS. 100, 101 AND 107).

KATHLEEN M. VANSTON, EXAMINING ATTORNEY

CLASS 41—(Continued).

SN 85-622,890. VIACOM INTERNATIONAL INC., NEW YORK, NY. FILED 5-11-2012.

VH1 CO-STAR

THE MARK CONSISTS OF STANDARD CHARACTERS WITHOUT CLAIM TO ANY PARTICULAR FONT, STYLE, SIZE, OR COLOR.

OWNER OF U.S. REG. NOS. 2,995,834, 3,818,997 AND OTHERS.

FOR ENTERTAINMENT SERVICES, NAMELY, PROVIDING ENTERTAINMENT INFORMATION RELATED TO TELEVISION PROGRAMMING; PROVIDING ON-LINE JOURNALS, NAMELY, BLOGS FEATURING USER-DEFINED CONTENT IN THE FIELD OF TELEVISION AND SOCIAL NETWORKING (U.S. CLS. 100, 101 AND 107).

FIRST USE 1-1-2011; IN COMMERCE 1-1-2011.
KATHLEEN M. VANSTON, EXAMINING ATTORNEY

SN 85-622,891. VIACOM INTERNATIONAL INC., NEW YORK, NY. FILED 5-11-2012.

MTV CO-STAR

THE MARK CONSISTS OF STANDARD CHARACTERS WITHOUT CLAIM TO ANY PARTICULAR FONT, STYLE, SIZE, OR COLOR.

OWNER OF U.S. REG. NOS. 1,955,606, 1,985,017 AND OTHERS.

FOR ENTERTAINMENT SERVICES, NAMELY, PROVIDING ENTERTAINMENT INFORMATION RELATED TO TELEVISION PROGRAMMING; PROVIDING ON-LINE JOURNALS, NAMELY, BLOGS FEATURING USER-DEFINED CONTENT IN THE FIELD OF TELEVISION AND SOCIAL NETWORKING (U.S. CLS. 100, 101 AND 107).

KATHLEEN M. VANSTON, EXAMINING ATTORNEY

SN 85-627,688. PAWPRINTS PHOTOGRAPHY, LLC, ANANDALE, VA. FILED 5-16-2012.

PAWPRINTS PHOTOGRAPHY

THE MARK CONSISTS OF STANDARD CHARACTERS WITHOUT CLAIM TO ANY PARTICULAR FONT, STYLE, SIZE, OR COLOR.

NO CLAIM IS MADE TO THE EXCLUSIVE RIGHT TO USE "PHOTOGRAPHY", APART FROM THE MARK AS SHOWN.

FOR PHOTOGRAPHY SERVICES FOR PETS (U.S. CLS. 100, 101 AND 107).

FIRST USE 7-1-2001; IN COMMERCE 7-1-2001.
COLLEEN KEARNEY, EXAMINING ATTORNEY

CLASS 41—(Continued).

SN 85-629,500. SPANISH BROADCASTING SYSTEM, INC. COCONUT GROVE, FL. FILED 5-18-2012.

LO MEJOR DE... EL VACILON

THE MARK CONSISTS OF STANDARD CHARACTERS WITHOUT CLAIM TO ANY PARTICULAR FONT, STYLE, SIZE, OR COLOR.

THE ENGLISH TRANSLATION OF "LO MEJOR DE EL VACILON" IN THE MARK IS "THE BEST OF THE PARTY".

FOR ENTERTAINMENT SERVICES IN THE NATURE OF ONGOING TELEVISION PROGRAMS IN THE FIELDS OF MUSIC, COMEDY AND VARIETY (U.S. CLS. 100, 101 AND 107).

ANTHONY RINKER, EXAMINING ATTORNEY

SN 85-636,929. LITTLE TRUCKER TRADING CO., LLC, LOS ANGELES, CA. FILED 5-29-2012.

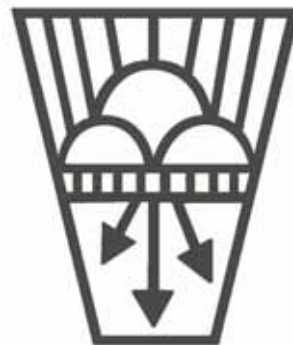

THE MARK CONSISTS OF THREE SEMI-CIRCLES WITH SEVEN LINES RADIATING UP PLACED ABOVE A SERIES OF SQUARES OVER THREE ARROWS POINTING DOWN ALL ENCLOSED IN A QUADRILATERAL.

FOR ENTERTAINMENT SERVICES IN THE NATURE OF LIVE MUSICAL PERFORMANCES (U.S. CLS. 100, 101 AND 107).

LYNDSEY KUYKENDALL, EXAMINING ATTORNEY

CLASS 41—(Continued).

SN 85-636,997. GLOBAL CHILD NUTRITION FOUNDATION, OXON HILL, MD. FILED 5-29-2012.

GLOBAL CHILD NUTRITION
FORUM

THE MARK CONSISTS OF STANDARD CHARACTERS WITHOUT CLAIM TO ANY PARTICULAR FONT, STYLE, SIZE, OR COLOR.

NO CLAIM IS MADE TO THE EXCLUSIVE RIGHT TO USE "FORUM", APART FROM THE MARK AS SHOWN.

SEC. 2(F).

FOR PROVIDING AN IN-PERSON EDUCATION FORUM IN THE FIELDS OF CHILDREN'S NUTRITION, SCHOOL FEEDING PROGRAMS AND THE ADMINISTRATION, MANAGEMENT AND OPERATION OF CHILDREN'S NUTRITION PROGRAMS AND SCHOOL FEEDING PROGRAMS; ARRANGING AND CONDUCTING CLASSES, SEMINARS AND WORKSHOPS IN THE FIELDS OF CHILDREN'S NUTRITION, SCHOOL FEEDING PROGRAMS AND THE ADMINISTRATION, MANAGEMENT AND OPERATION OF CHILDREN'S NUTRITION PROGRAMS AND SCHOOL FEEDING PROGRAMS, AND DISTRIBUTION OF COURSE MATERIALS IN CONNECTION THEREWITH (U.S. CLS. 100, 101 AND 107).

FIRST USE 0-0-1997; IN COMMERCE 0-0-1997.
RAUL CORDOVA, EXAMINING ATTORNEY

SN 85-637,270. DREAMWORKS ANIMATION L.L.C., GLENDALE, CA. FILED 5-29-2012.

DINOTRUX

THE MARK CONSISTS OF STANDARD CHARACTERS WITHOUT CLAIM TO ANY PARTICULAR FONT, STYLE, SIZE, OR COLOR.

FOR ENTERTAINMENT SERVICES IN THE NATURE OF AN ANIMATED TELEVISION SERIES (U.S. CLS. 100, 101 AND 107).

SHAVELL MCPHERSON, EXAMINING ATTORNEY

CLASS 41—(Continued).

SN 85-637,917. MODUS COOPERANDI, INC., SEATTLE, WA. FILED 5-30-2012.

LEAN COFFEE

THE MARK CONSISTS OF STANDARD CHARACTERS WITHOUT CLAIM TO ANY PARTICULAR FONT, STYLE, SIZE, OR COLOR.

FOR EDUCATIONAL SERVICES, NAMELY, SEMINARS IN THE FIELD OF PROJECT MANAGEMENT, PERSONAL, GROUP AND ENTERPRISE-LEVEL PRODUCTIVITY, ORGANIZATIONAL AND OPERATIONAL EFFICIENCY AND DISTRIBUTION OF EDUCATIONAL MATERIALS IN CONNECTION THEREWITH; BUSINESS TRAINING IN THE FIELD OF PROJECT MANAGEMENT, PERSONAL, GROUP AND ENTERPRISE-LEVEL PRODUCTIVITY, ORGANIZATIONAL AND OPERATIONAL EFFICIENCY, AND DISTRIBUTION OF TRAINING MATERIALS IN CONNECTION THEREWITH (U.S. CLS. 100, 101 AND 107).

FIRST USE 1-1-2010; IN COMMERCE 1-1-2010.

MICHAEL SOUDERS, EXAMINING ATTORNEY

SN 85-661,008. AOL INC., DULLES, VA. FILED 6-25-2012.

GET OUT THERE

THE MARK CONSISTS OF STANDARD CHARACTERS WITHOUT CLAIM TO ANY PARTICULAR FONT, STYLE, SIZE, OR COLOR.

FOR ENTERTAINMENT SERVICES, NAMELY, AN ONGOING ONLINE VIDEO SERIES IN THE FIELD OF ETHNIC CULTURES (U.S. CLS. 100, 101 AND 107).

ALLISON HOLTZ, EXAMINING ATTORNEY

SN 85-662,198. BLACK ENTERTAINMENT TELEVISION LLC, DBA BET, WASHINGTON, DC. FILED 6-26-2012.

LOOPED IN LIVE

THE MARK CONSISTS OF STANDARD CHARACTERS WITHOUT CLAIM TO ANY PARTICULAR FONT, STYLE, SIZE, OR COLOR.

NO CLAIM IS MADE TO THE EXCLUSIVE RIGHT TO USE "LIVE", APART FROM THE MARK AS SHOWN.

FOR ENTERTAINMENT IN THE NATURE OF ONGOING TELEVISION PROGRAMS IN THE FIELDS OF CURRENT NEWS, ENTERTAINMENT EVENTS, TECHNOLOGICAL ADVANCEMENTS, MUSIC AND TOPICS OF INTERESTS IN POP CULTURE (U.S. CLS. 100, 101 AND 107).

PAULA MAHONEY, EXAMINING ATTORNEY

CLASS 41—(Continued).

SN 85-676,405. STEPHENSON, MICHAEL O, TRINIDAD, CA. FILED 7-13-2012.

THE KARMANAUTS

THE MARK CONSISTS OF STANDARD CHARACTERS WITHOUT CLAIM TO ANY PARTICULAR FONT, STYLE, SIZE, OR COLOR.

FOR ENTERTAINMENT SERVICES IN THE NATURE OF LIVE MUSICAL PERFORMANCES; ENTERTAINMENT SERVICES, NAMELY, PROVIDING A WEB SITE FEATURING NON-DOWNLOADABLE MUSICAL PERFORMANCES, MUSICAL VIDEOS, RELATED FILM CLIPS, PHOTOGRAPHS, AND OTHER MULTIMEDIA MATERIALS FEATURING MUSIC BY A MUSICAL BAND (U.S. CLS. 100, 101 AND 107).

FIRST USE 1-0-2010; IN COMMERCE 1-0-2010.
AHSEN KHAN, EXAMINING ATTORNEY

CLASS 42—(Continued).

SN 77-299,454. SMITH, SUSAN J., DBA ROOMS THAT WORK, FARMINGTON, CT. FILED 10-9-2007.

Rooms That Work

THE MARK CONSISTS OF STANDARD CHARACTERS WITHOUT CLAIM TO ANY PARTICULAR FONT, STYLE, SIZE, OR COLOR.

FOR HOME STAGING CONSULTATION, NAMELY, TEMPORARY INTERIOR AND EXTERIOR HOME DECORATION CONSULTATION FOR THE PURPOSE OF MAKING HOMES MORE APPEALING TO PROSPECTIVE BUYERS; INTERIOR DECORATING; INTERIOR DECORATION CONSULTATION; TEMPORARY INTERIOR AND EXTERIOR HOME DECORATION CONSULTATION, NAMELY, HOME STAGING CONSULTATION FOR THE PURPOSE OF MAKING HOMES MORE APPEALING TO PROSPECTIVE BUYERS (U.S. CLS. 100 AND 101).

FIRST USE 4-11-2007; IN COMMERCE 4-11-2007.
ALEX KEAM, EXAMINING ATTORNEY

CLASS 42—SCIENTIFIC AND COMPUTER SERVICES

SN 76-711,172. GAME PREP LLC, VENETIA, PA. FILED 4-10-2012.



THE MARK CONSISTS OF THE WORDS "GAME PREP" SEPARATED BY THE HEAD OF A DOG WEARING A CAP BEARING THE LETTERS "GPU". BELOW THE WORD "GAME" IS THE WORDING "WHERE SPORTS" AND BELOW THE WORD "PREP" IS THE WORDING "AND TECHNOLOGY MEET."

FOR PROVIDING A WEBSITE THAT ENABLES USERS TO SUBSCRIBE TO COACHING, MENTORING, AND/OR EDUCATIONAL SERVICES AND TO ENABLE USERS TO AUTHOR AND PUBLISH INSTRUCTIONAL CONTENT FOR OTHERS (U.S. CLS. 100 AND 101).

LINDA POWELL, EXAMINING ATTORNEY

SN 77-736,761. BAYSWATER URANIUM CORPORATION, VANCOUVER, BC, CANADA, FILED 5-14-2009.

FUELING THE NUCLEAR RENAISSANCE

THE MARK CONSISTS OF STANDARD CHARACTERS WITHOUT CLAIM TO ANY PARTICULAR FONT, STYLE, SIZE, OR COLOR.

PRIORITY CLAIMED UNDER SEC. 44(D) ON CANADA APPLICATION NO. 1435193, FILED 4-20-2009.

FOR EXPLORATION SERVICES IN THE FIELD OF NATURAL RESOURCES INCLUDING URANIUM (U.S. CLS. 100 AND 101).

FIRST USE 8-0-2008; IN COMMERCE 8-0-2008.
DAYNA BROWNE, EXAMINING ATTORNEY

CLASS 42—(Continued).

SN 77-867,297. NETWORK CRITICAL SOLUTIONS LIMITED, CAVERSHAM, BERKSHIRE, UNITED KINGDOM, FILED 11-6-2009.



PRIORITY CLAIMED UNDER SEC. 44(D) ON ERPN CMNTY TM OFC APPLICATION NO. 008650525, FILED 10-29-2009, REG. NO. 008650525, DATED 5-3-2010, EXPIRES 10-29-2019.

NO CLAIM IS MADE TO THE EXCLUSIVE RIGHT TO USE "NETWORK", APART FROM THE MARK AS SHOWN. THE COLOR(S) LIGHT BLUE AND DARK BLUE IS/ARE CLAIMED AS A FEATURE OF THE MARK.

THE MARK CONSISTS OF THE WORDING "NETWORK CRITICAL" IN DARK BLUE TO THE RIGHT OF A DESIGN. THE DESIGN CONSISTS OF A CIRCLE SEPARATED IN THE MIDDLE BY A ZIG-ZAG BREAK REPRESENTING A PULSE WAVE LINE. THE PORTION OF THE CIRCLE ABOVE THE LINE IS LIGHT BLUE, WHILE THE LOWER PORTION IS DARK BLUE.

FOR COMPUTER PROGRAMMING SERVICES; COMPUTER SYSTEM DESIGN; CONSULTANCY IN THE FIELDS OF COMPUTER HARDWARE, COMPUTER SOFTWARE, COMPUTER NETWORK MONITORING, DATA MONITORING, DATA SECURITY AND DATA TRACKING (U.S. CLS. 100 AND 101).

CORY BOONE, EXAMINING ATTORNEY

CLASS 42—(Continued).

SN 85-042,073. KRYPTOS LOGIC, HERMOSA BEACH, CA, FILED 5-18-2010.

Kryptos Logic

THE MARK CONSISTS OF STANDARD CHARACTERS WITHOUT CLAIM TO ANY PARTICULAR FONT, STYLE, SIZE, OR COLOR.

FOR SOFTWARE COPY PROTECTION, NAMELY, INSERTING SOFTWARE PROTECTION PROGRAMS AND SECURITY PROGRAMS ON MAGNETIC MEDIA; COMPUTER SECURITY CONSULTANCY; SOFTWARE SECURITY, NAMELY, MAINTENANCE OF COMPUTER SOFTWARE RELATING TO COMPUTER SECURITY AND PREVENTION OF COMPUTER RISKS (U.S. CLS. 100 AND 101).

FIRST USE 3-20-2008; IN COMMERCE 4-14-2009.
ROBERT STRUCK, EXAMINING ATTORNEY

SN 79-097,843. PROVASI S.R.L., ITALY, FILED 4-19-2011.

**HOSPITALITY
PROJECT
by PROVASI**

PRIORITY DATE OF 4-12-2011 IS CLAIMED. OWNER OF INTERNATIONAL REGISTRATION 1078553 DATED 4-19-2011, EXPIRES 4-19-2021.

NO CLAIM IS MADE TO THE EXCLUSIVE RIGHT TO USE "HOSPITALITY PROJECT", APART FROM THE MARK AS SHOWN.

THE MARK CONSISTS OF THE WORDING "PP HOSPITALITY PROJECT BY PROVASI", WITH THE SECOND LETTER "P" IN "PP" PRINTED BACKWARDS, AND ARRANGED SO THAT THE CURVED PORTIONS OF THE TWO LETTERS INTERSECT.

FOR SCIENTIFIC AND TECHNOLOGICAL SERVICES AND RESEARCH AND DESIGN RELATING THERETO, NAMELY, DESIGN OF NEW PRODUCTS FOR OTHER, ENGINEERING SERVICES; INDUSTRIAL ANALYSIS AND RESEARCH SERVICES, NAMELY, INDUSTRIAL DESIGN, SCIENTIFIC RESEARCH; DESIGN AND DEVELOPMENT OF COMPUTER HARDWARE AND SOFTWARE (U.S. CLS. 100 AND 101).

LIEF MARTIN, EXAMINING ATTORNEY

SN 85-252,517. FERRIER, ERIC, DBA IDIGITALTEK, FORT LAUDERDALE, CA. FILED 2-26-2011.

IDIGITALTEK

THE MARK CONSISTS OF STANDARD CHARACTERS WITHOUT CLAIM TO ANY PARTICULAR FONT, STYLE, SIZE, OR COLOR.

FOR COMPUTER MODELING SERVICES, NAMELY, COMPUTER SIMULATION FROM COMPUTER PROGRAMS FOR OTHERS; COMPUTER PROGRAMMING; COMPUTER PROGRAMMING AND COMPUTER SYSTEM ANALYSIS; COMPUTER PROGRAMMING AND SOFTWARE DESIGN; COMPUTER PROGRAMMING CONSULTANCY; COMPUTER PROGRAMMING FOR OTHERS; COMPUTER PROGRAMMING SERVICES; COMPUTER SOFTWARE DESIGN, COMPUTER PROGRAMMING, OR MAINTENANCE OF COMPUTER SOFTWARE; COMPUTER SOFTWARE DEVELOPMENT AND COMPUTER PROGRAMMING DEVELOPMENT FOR OTHERS; CREATING OF COMPUTER PROGRAMS; DATA CONVERSION OF COMPUTER PROGRAMS AND DATA, NOT PHYSICAL CONVERSION; DESIGN AND DEVELOPMENT OF COMPUTERS AND PROGRAMS FOR COMPUTERS; PROGRAMMING OF COMPUTER SOFTWARE FOR OTHERS (U.S. CLS. 100 AND 101).

FIRST USE 5-1-2005; IN COMMERCE 5-1-2005.
MAYUR VAGHANI, EXAMINING ATTORNEY

CLASS 42—(Continued).

SN 85-283,672. MYCYBERTWIN NORTH AMERICA, INC., NEW YORK, NY. FILED 4-1-2011.

MYCYBERTWIN

THE MARK CONSISTS OF STANDARD CHARACTERS WITHOUT CLAIM TO ANY PARTICULAR FONT, STYLE, SIZE, OR COLOR.

FOR DESIGN AND DEVELOPMENT OF COMPUTER HARDWARE; SOFTWARE AS A SERVICE (SAAS) SERVICES, NAMELY, HOSTING SOFTWARE FOR USE BY OTHERS FOR USE DESIGNING, DEVELOPING AND IMPLEMENTING ARTIFICIALLY INTELLIGENT VIRTUAL AGENTS TO ASSIST USERS IN ENGAGING WITH AN ORGANIZATION OR OBTAINING INFORMATION ABOUT AN ORGANIZATION'S PRODUCTS AND SERVICES (U.S. CLS. 100 AND 101).

SUE LAWRENCE, EXAMINING ATTORNEY

CLASS 42—(Continued).

SN 85-295,116. ZHONE TECHNOLOGIES, INC., OAKLAND, CA. FILED 4-14-2011.

IP ZHONE

THE MARK CONSISTS OF STANDARD CHARACTERS WITHOUT CLAIM TO ANY PARTICULAR FONT, STYLE, SIZE, OR COLOR.

OWNER OF U.S. REG. NO. 2,725,113.

FOR COMPUTER SERVICES, NAMELY, DESIGNING AND IMPLEMENTING A NEXT-GENERATION MULTI-SERVICE TELECOMMUNICATIONS ACCESS NETWORK UTILIZING CIRCUIT, PACKET AND FIBER NETWORKS FOR SERVICE PROVIDERS, BUSINESSES, GOVERNMENT AGENCIES, MEDICAL FACILITIES, AND THE HOSPITALITY INDUSTRY (U.S. CLS. 100 AND 101).

FIRST USE 7-23-2010; IN COMMERCE 7-23-2010.

MICHAEL KEATING, EXAMINING ATTORNEY

SN 85-284,572. APLIFI, INC., POMPANO BEACH, FL. FILED 4-2-2011.

APLIFI

THE MARK CONSISTS OF STANDARD CHARACTERS WITHOUT CLAIM TO ANY PARTICULAR FONT, STYLE, SIZE, OR COLOR.

FOR APPLICATION SERVICE PROVIDER AND SOFTWARE AS A SERVICE (SAAS) SERVICES, NAMELY, HOSTING, MANAGING, DEVELOPING, MAINTAINING AND PROVIDING WEB-BASED, ONLINE NON-DOWNLOADABLE APPLICATIONS, SOFTWARE AND WEBSITES FOR USE BY OTHERS FOR MARKETING AND MANAGING CLIENT, AGENCIES, CARRIERS AND OTHER FINANCIAL, ANNUITIES OR INSURANCE INDUSTRY RELATIONSHIPS, FOR CLIENT RELATIONSHIP MANAGEMENT AND MARKETING FOR THE INSURANCE, ANNUITIES AND FINANCIAL INDUSTRIES, FOR ELECTRONIC POLICY AND POST ISSUE DOCUMENT DELIVERY FOR THE INSURANCE, ANNUITIES AND FINANCIAL INDUSTRIES, ANNUITY AND FINANCIAL QUOTING, CUSTOMER RELATIONSHIP MANAGEMENT, MANAGING PROSPECTS FOR THE INSURANCE, ANNUITY AND FINANCIAL INDUSTRIES, PROCESSING ELECTRONIC APPLICATIONS FOR THE INSURANCE, ANNUITY AND FINANCIAL INDUSTRIES, CASE AND POLICY MANAGEMENT, UNDERWRITING AUTOMATION, E-POLICY DELIVERY AND IN-FORCE CASE MANAGEMENT, PROCESSING OF INSURANCE AND FINANCIAL APPLICATIONS, COMPLIANCE OF INSURANCE, MANAGEMENT OF ORDERS FOR THE FINANCIAL, ANNUITIES AND INSURANCE INDUSTRIES, MANAGEMENT OF DISTRIBUTOR BUSINESS AND CARRIER PRODUCT PROFILE ORDERING RULES AND FORMS FOR THE FINANCIAL, ANNUITIES AND INSURANCE INDUSTRIES (U.S. CLS. 100 AND 101).

FIRST USE 3-7-2011; IN COMMERCE 3-7-2011.

DORITT L. CARROLL, EXAMINING ATTORNEY

SN 85-297,049. APLIFI, INC., POMPANO BEACH, FL. FILED 4-16-2011.

**WE SIMPLIFY SELLING
INSURANCE**

THE MARK CONSISTS OF STANDARD CHARACTERS WITHOUT CLAIM TO ANY PARTICULAR FONT, STYLE, SIZE, OR COLOR.

FOR APPLICATION SERVICE PROVIDER AND SOFTWARE AS A SERVICE (SAAS) SERVICES, NAMELY, HOSTING, MANAGING, DEVELOPING, MAINTAINING AND PROVIDING WEB-BASED, ONLINE NON-DOWNLOADABLE APPLICATIONS, SOFTWARE AND WEBSITES FOR USE BY OTHERS FOR MARKETING AND MANAGING CLIENT, AGENCIES, CARRIERS AND OTHER FINANCIAL, ANNUITIES OR INSURANCE INDUSTRY RELATIONSHIPS, FOR CLIENT RELATIONSHIP MANAGEMENT AND MARKETING FOR THE INSURANCE, ANNUITIES AND FINANCIAL INDUSTRIES, FOR ELECTRONIC POLICY AND POST ISSUE DOCUMENT DELIVERY FOR THE INSURANCE, ANNUITIES AND FINANCIAL INDUSTRIES, ANNUITY AND FINANCIAL QUOTING, CUSTOMER RELATIONSHIP MANAGEMENT, MANAGING PROSPECTS FOR THE INSURANCE, ANNUITY AND FINANCIAL INDUSTRIES, PROCESSING ELECTRONIC APPLICATIONS FOR THE INSURANCE, ANNUITY AND FINANCIAL INDUSTRIES, CASE AND POLICY MANAGEMENT, UNDERWRITING AUTOMATION, E-POLICY DELIVERY AND IN-FORCE CASE MANAGEMENT, PROCESSING OF INSURANCE AND FINANCIAL APPLICATIONS, COMPLIANCE OF INSURANCE, MANAGEMENT OF ORDERS FOR THE FINANCIAL, ANNUITIES AND INSURANCE INDUSTRIES, MANAGEMENT OF DISTRIBUTOR BUSINESS AND CARRIER PRODUCT PROFILE ORDERING RULES AND FORMS FOR THE FINANCIAL, ANNUITIES AND INSURANCE INDUSTRIES (U.S. CLS. 100 AND 101).

FIRST USE 11-30-2009; IN COMMERCE 11-30-2009.

DORITT L. CARROLL, EXAMINING ATTORNEY

CLASS 42—(Continued).

SN 85-297,349. APLIFI, INC., POMPANO BEACH, FL. FILED 4-18-2011.



THE COLOR(S) RED, ORANGE, WHITE AND BLACK IS/ARE CLAIMED AS A FEATURE OF THE MARK.

THE MARK CONSISTS OF TWO SLIGHTLY CURVED PAPER SHAPED OBJECTS, ONE RED AND ONE ORANGE, FORMING A FANCIFUL CAPITAL LETTER "A" WITH A PORTION OF THE ORANGE PAPER SHAPED OBJECT REMOVED AND SHOWN AS WHITE HOLES WITH THE REMOVED PORTION IN ORANGE AND LOCATED TO THE RIGHT AND WITH THE TERM "APLIFI" IN LOWER CASE LETTERS TO THE RIGHT OF THE PAPER SHAPED OBJECTS AND SHOWN IN BLACK EXCEPT FOR THE DOTS IN THE TWO LOWER CASE LETTER "I" WHICH ARE ORANGE IN COLOR.

FOR APPLICATION SERVICE PROVIDER AND SOFTWARE AS A SERVICE (SAAS) SERVICES, NAMELY, HOSTING, MANAGING, DEVELOPING, MAINTAINING AND PROVIDING WEB-BASED, ONLINE NON-DOWNLOADABLE APPLICATIONS, SOFTWARE AND WEBSITES FOR USE BY OTHERS FOR MARKETING AND MANAGING CLIENT, AGENCIES, CARRIERS AND OTHER FINANCIAL, ANNUITIES OR INSURANCE INDUSTRY RELATIONSHIPS, FOR CLIENT RELATIONSHIP MANAGEMENT AND MARKETING FOR THE INSURANCE, ANNUITIES AND FINANCIAL INDUSTRIES, FOR ELECTRONIC POLICY AND POST ISSUE DOCUMENT DELIVERY FOR THE INSURANCE, ANNUITIES AND FINANCIAL INDUSTRIES, ANNUITY AND FINANCIAL QUOTING, CUSTOMER RELATIONSHIP MANAGEMENT, MANAGING PROSPECTS FOR THE INSURANCE, ANNUITY AND FINANCIAL INDUSTRIES, PROCESSING ELECTRONIC APPLICATIONS FOR THE INSURANCE, ANNUITY AND FINANCIAL INDUSTRIES, CASE AND POLICY MANAGEMENT, UNDERWRITING AUTOMATION, E-POLICY DELIVERY AND IN-FORCE CASE MANAGEMENT, PROCESSING OF INSURANCE AND FINANCIAL APPLICATIONS, COMPLIANCE OF INSURANCE, MANAGEMENT OF ORDERS FOR THE FINANCIAL, ANNUITIES AND INSURANCE INDUSTRIES, MANAGEMENT OF DISTRIBUTOR BUSINESS AND CARRIER PRODUCT PROFILE ORDERING RULES AND FORMS FOR THE FINANCIAL, ANNUITIES AND INSURANCE INDUSTRIES (U.S. CLS. 100 AND 101).

FIRST USE 3-7-2011; IN COMMERCE 3-7-2011.

DORITT L. CARROLL, EXAMINING ATTORNEY

CLASS 42—(Continued).

SN 85-314,928. ESOBI INC., GEORGE TOWN, CAYMAN ISLANDS, FILED 5-6-2011.



PRIORITY CLAIMED UNDER SEC. 44(D) ON TAIWAN APPLICATION NO. 099066074, FILED 12-31-2010.

NO CLAIM IS MADE TO THE EXCLUSIVE RIGHT TO USE "NEWS", APART FROM THE MARK AS SHOWN.

THE MARK CONSISTS OF THE WORDS "NEWS XPRESSO" IN A STYLIZED FONT. THE "O" IN "XPRESSO" IS IN THE SHAPE OF A COFFEE BEAN.

FOR COMPUTER GRAPHICS DESIGN SERVICES; COMPUTER GRAPHICS SERVICES; COMPUTER PROGRAMMING; RENTAL OF COMPUTER HARDWARE; DEVELOPMENT AND CREATION OF COMPUTER PROGRAMMES FOR DATA PROCESSING; RENTAL OF WEB SERVERS; COMPUTER SERVICES, NAMELY, PROVIDING TEMPORARY USE OF ONLINE AND NON-DOWNLOADABLE SOFTWARE FEATURING A MEDIA AGGREGATOR AND SEARCH ENGINE FOR INTERNET CONTENT; PLANNING AND DEVELOPING WEB SITES FOR OTHERS; DESIGNING WEBSITES FOR OTHERS; FASHION DESIGN CONSULTING SERVICES; CONSULTING SERVICES IN THE FIELD OF ENVIRONMENTAL ASSESSMENT AND PLANNING; DESIGN OF PRODUCT STYLE AND CONFIGURATION, NAMELY, NEW PRODUCT DESIGN SERVICE; DESIGN OF INDUSTRIAL PRODUCTS; DESIGN OF COMPUTER HARDWARE; PACKAGING DESIGN; WEATHER FORECASTING; PROVIDING METEOROLOGICAL INFORMATION; PLANNING AND DEVELOPMENT OF ELECTRONIC COMMUNICATIONS NETWORKS; RENTAL OF LABORATORY APPARATUS AND INSTRUMENTS (U.S. CLS. 100 AND 101).

SANI KHOURI, EXAMINING ATTORNEY

SN 85-355,521. OCLC ONLINE COMPUTER LIBRARY CENTER, INC., DUBLIN, OH. FILED 6-24-2011.

OCLC WEB-SCALE MANAGEMENT
SERVICES

THE MARK CONSISTS OF STANDARD CHARACTERS WITHOUT CLAIM TO ANY PARTICULAR FONT, STYLE, SIZE, OR COLOR.

OWNER OF U.S. REG. NOS. 3,002,772, 3,613,046 AND OTHERS.

NO CLAIM IS MADE TO THE EXCLUSIVE RIGHT TO USE "WEB-SCALE MANAGEMENT SERVICES", APART FROM THE MARK AS SHOWN.

FOR DESIGNING, DEVELOPING, AND HOSTING CLOUD-BASED DATABASES, SEARCH ENGINES, AND SYSTEM SOFTWARE THAT ADMINISTER LIBRARY WORKFLOWS, RESOURCES AND OPERATIONS AND PROVIDING TEMPORARY USE OF ON-LINE NON-DOWNLOADABLE OPERATING SOFTWARE FOR ACCESSING AND USING A CLOUD COMPUTING NETWORK (U.S. CLS. 100 AND 101).

DAVID I, EXAMINING ATTORNEY

CLASS 42—(Continued).

SN 85-368,662. NERIUM BIOTECHNOLOGY, INC., SAN ANTONIO, TX. FILED 7-12-2011.

NBIO-PL2

THE MARK CONSISTS OF STANDARD CHARACTERS WITHOUT CLAIM TO ANY PARTICULAR FONT, STYLE, SIZE, OR COLOR.

FOR RESEARCH AND DEVELOPMENT IN THE BIOTECHNOLOGY FIELDS, NAMELY, CONDUCTING EXTRACTION SERVICES IN FIELD OF PLANTS (U.S. CLS. 100 AND 101).

RAUL CORDOVA, EXAMINING ATTORNEY

SN 85-403,863. EMDEON BUSINESS SERVICES LLC, NASHVILLE, TN. FILED 8-22-2011.

DENTAL CONNECT

THE MARK CONSISTS OF STANDARD CHARACTERS WITHOUT CLAIM TO ANY PARTICULAR FONT, STYLE, SIZE, OR COLOR.

NO CLAIM IS MADE TO THE EXCLUSIVE RIGHT TO USE "DENTAL", APART FROM THE MARK AS SHOWN.

FOR APPLICATION SERVICE PROVIDER (ASP) SERVICES FEATURING SOFTWARE IN THE FIELD OF HEALTHCARE FOR USE BY AND BETWEEN INSURANCE COMPANIES AND HEALTHCARE PROVIDERS FOR PAYER QUERY AND ACCESS OF CLAIM, REAL-TIME ELIGIBILITY/STATUS, AND BILLING TRANSACTIONS; PROVIDING A WEB PORTAL FEATURING AN APPLICATION FOR USE BY AND BETWEEN INSURANCE COMPANIES AND HEALTHCARE PROVIDERS TO ALLOW A PAYER TO QUERY AND ACCESS CLAIM, REAL-TIME ELIGIBILITY/CLAIM STATUS, AND BILLING TRANSACTIONS (U.S. CLS. 100 AND 101).

ELLEN BURNS, EXAMINING ATTORNEY

CLASS 42—(Continued).

SN 85-412,615. PRESIDENT AND FELLOWS OF HARVARD COLLEGE, CAMBRIDGE, MA. FILED 9-1-2011.

HARVARD UNIVERSITY

THE MARK CONSISTS OF STANDARD CHARACTERS WITHOUT CLAIM TO ANY PARTICULAR FONT, STYLE, SIZE, OR COLOR.

OWNER OF U.S. REG. NOS. 1,578,190, 2,600,446 AND 2,699,321.

FOR CONSULTING IN THE FIELD OF INFORMATION TECHNOLOGY; PLANNING, DESIGN AND MANAGEMENT OF INFORMATION TECHNOLOGY SYSTEMS; PROVIDING INFORMATION TECHNOLOGY CONSULTING AND TECHNOLOGY SUPPORT SERVICES, NAMELY, DIAGNOSING COMPUTER HARDWARE AND SOFTWARE PROBLEMS AND WORD PROCESSING AND COMMUNICATIONS APPLICATIONS, SETUP OF ELECTRONIC EQUIPMENT, AND ASSISTANCE WITH COMPUTER-BASED INFORMATION SYSTEMS AND COMPONENTS; PROVIDING A WEB SITE FEATURING INFORMATION AND LINKS REGARDING COLLEGE INFORMATION TECHNOLOGY SERVICES; WEB SITE MANAGEMENT, DEVELOPMENT, AND HOSTING SERVICES (U.S. CLS. 100 AND 101).

FIRST USE 7-0-1996; IN COMMERCE 7-0-1996.

ARETHA SOMERVILLE, EXAMINING ATTORNEY

SN 85-415,708. GEEMMODITY LTD, JERUSALEM, ISRAEL, FILED 9-6-2011.

Geemmo

THE MARK CONSISTS OF STANDARD CHARACTERS WITHOUT CLAIM TO ANY PARTICULAR FONT, STYLE, SIZE, OR COLOR.

THE WORDING "GEEMMO" OR "GEEM MO" HAS NO MEANING IN A FOREIGN LANGUAGE.

FOR PLATFORM AS A SERVICE (PAAS) FEATURING AN ENTERTAINMENT AND COMMERCE COMPUTER SOFTWARE PLATFORM THAT MAY BE ACCESSED BY MOBILE, TABLET, SMARTPHONE, PC AND LAPTOP DEVICES FOR SOCIAL NETWORKING AND FOR VIEWING IMAGES OF REAL ITEMS AND CONVERTING THOSE IMAGES TO VIRTUAL ITEMS IN A COLLECTION, FOR EXHIBITING COLLECTIONS, AND FOR TRADING VIRTUAL ITEMS (U.S. CLS. 100 AND 101).

FIRST USE 8-11-2010; IN COMMERCE 8-11-2010.

MARY ROSSMAN, EXAMINING ATTORNEY

CLASS 42—(Continued).

SN 85-418,120. MMI INNOVATIONS, INC., WEST HOLLYWOOD, CA. FILED 9-8-2011.

Text To Video Everywhere

THE MARK CONSISTS OF STANDARD CHARACTERS WITHOUT CLAIM TO ANY PARTICULAR FONT, STYLE, SIZE, OR COLOR.

FOR SOFTWARE AS A SERVICE (SAAS) SERVICES FEATURING SOFTWARE FOR CREATING VIDEOS (U.S. CLS. 100 AND 101).

FIRST USE 9-1-2010; IN COMMERCE 12-29-2010.

JOHN KELLY, EXAMINING ATTORNEY

SN 85-418,174. SILICON GRAPHICS INTERNATIONAL CORP., FREMONT, CA. FILED 9-8-2011.

SHMEM

THE MARK CONSISTS OF STANDARD CHARACTERS WITHOUT CLAIM TO ANY PARTICULAR FONT, STYLE, SIZE, OR COLOR.

SEC. 2(F).

FOR PROVIDING TEMPORARY USE OF ON-LINE NON-DOWNLOADABLE COMPUTER SOFTWARE IN THE NATURE OF AN APPLICATION PROGRAMMING INTERFACE (API) TO EXCHANGE DATA BETWEEN COOPERATING PARALLEL PROCESSES (U.S. CLS. 100 AND 101).

FIRST USE 12-31-1995; IN COMMERCE 12-31-1995.

SUSAN STIGLITZ, EXAMINING ATTORNEY

SN 85-423,616. TWILIGHTLIVING.COM, INC., SEATTLE, WA. FILED 9-15-2011.

CARE FINDER-PRO

THE MARK CONSISTS OF STANDARD CHARACTERS WITHOUT CLAIM TO ANY PARTICULAR FONT, STYLE, SIZE, OR COLOR.

NO CLAIM IS MADE TO THE EXCLUSIVE RIGHT TO USE "CARE", APART FROM THE MARK AS SHOWN.

FOR PROVIDING TEMPORARY USE OF WEB-BASED NON-DOWNLOADABLE COMPUTER APPLICATION SOFTWARE FOR HOSPITALS AND OTHER ACUTE AND POST-ACUTE CARE ORGANIZATIONS TO MANAGE THE DISCHARGE AND AFTERCARE INSTRUCTIONS OF PATIENTS (U.S. CLS. 100 AND 101).

FIRST USE 11-16-2003; IN COMMERCE 1-31-2004.

TASHIA BUNCH, EXAMINING ATTORNEY

CLASS 42—(Continued).

SN 85-425,306. BEACH.COM, INC, NEW YORK, NY. FILED 9-17-2011.



NO CLAIM IS MADE TO THE EXCLUSIVE RIGHT TO USE "BEACH.COM", APART FROM THE MARK AS SHOWN.

THE COLOR(S) BLUE, YELLOW AND TAN IS/ARE CLAIMED AS A FEATURE OF THE MARK.

THE MARK CONSISTS OF LITERAL ELEMENTS "BEACH.COM" WHEREIN AN IMAGE CONSISTS OF SHINING SUN IN YELLOW COLOR HAS TWO WAVES IN TAN AND BLUE COLOR ADJACENT TO THE SUN AND TO RIGHT SIDE OF SUN AND WAVES THE LITERAL ELEMENTS "BEACH.COM" IN BLUE AND YELLOW COLOR RESPECTIVELY AS SHOWN IN THE MARK.

SEC. 2(F).

FOR PROVIDING A WEBSITE FEATURING A SEARCH ENGINE FOR BEACH INFORMATION, VACATION PLANNING AND BOOKING, BEACH REAL ESTATE, RENTAL PROPERTIES, ACTIVITIES AND ENTERTAINMENT (U.S. CLS. 100 AND 101).

FIRST USE 3-1-1995; IN COMMERCE 12-27-1996.

DAVID HOFFMAN, EXAMINING ATTORNEY

SN 85-427,921. SCENIOS LLC, NEW YORK, NY. FILED 9-21-2011.

SCENIOS

THE MARK CONSISTS OF STANDARD CHARACTERS WITHOUT CLAIM TO ANY PARTICULAR FONT, STYLE, SIZE, OR COLOR.

THE WORDING "SCENIOS" HAS NO MEANING IN A FOREIGN LANGUAGE.

FOR PLATFORM AS A SERVICE (PAAS) FEATURING COMPUTER SOFTWARE PLATFORMS FOR ONLINE PRODUCTION MANAGEMENT AND COLLABORATION FOR THE FILM AND TELEVISION INDUSTRY (U.S. CLS. 100 AND 101).

FONG HSU, EXAMINING ATTORNEY

CLASS 42—(Continued).

SN 85-429,243. AIRTIME MEDIA, INC., SAN FRANCISCO, CA. FILED 9-22-2011.

AIRTIME

THE MARK CONSISTS OF STANDARD CHARACTERS WITHOUT CLAIM TO ANY PARTICULAR FONT, STYLE, SIZE, OR COLOR.

FOR APPLICATION SERVICE PROVIDER (ASP) SERVICES FEATURING COMPUTER SOFTWARE FOR PROVIDING ACCESS TO AND ALLOWING COMMUNICATION WITHIN INTERNET CHATROOMS; APPLICATION SERVICE PROVIDER (ASP) SERVICES FEATURING COMPUTER SOFTWARE FOR VIDEO CONFERENCING; APPLICATION SERVICE PROVIDER (ASP) SERVICES FEATURING COMPUTER SOFTWARE FOR WEB CONFERENCING; APPLICATION SERVICE PROVIDER (ASP) SERVICES FEATURING COMPUTER SOFTWARE FOR PROVIDING INTEGRATED COMMUNICATION WITH COMPUTERIZED GLOBAL NETWORKS; APPLICATION SERVICE PROVIDER (ASP) SERVICES FEATURING COMPUTER SOFTWARE FOR VIDEO TELEPHONY; APPLICATION SERVICE PROVIDER (ASP) SERVICES FEATURING COMPUTER SOFTWARE FOR TRANSMISSION OF VOICE, DATA, GRAPHICS, IMAGES, AUDIO AND VIDEO BY MEANS OF TELECOMMUNICATIONS NETWORKS, WIRELESS COMMUNICATION NETWORKS, AND THE INTERNET (U.S. CLS. 100 AND 101).

JEFF DEFORD, EXAMINING ATTORNEY

CLASS 42—(Continued).

SN 85-435,522. LEARNING THROUGH SPORTS, LLC, BIRMINGHAM, AL. FILED 9-29-2011.



NO CLAIM IS MADE TO THE EXCLUSIVE RIGHT TO USE "KID'S COLLEGE", APART FROM THE MARK AS SHOWN.

THE COLOR(S) YELLOWISH GREEN, YELLOWISH ORANGE, REDDISH ORANGE, GREEN, LIGHT BLUE, BLUE, WHITE AND GRAY IS/ARE CLAIMED AS A FEATURE OF THE MARK.

THE MARK CONSISTS OF THE WORDS "KID'S COLLEGE" WITHIN A BLUE OVAL DISPLAYING LIGHT BLUE REFLECTIONS, SAID OVAL HAVING A PERIMETER THAT TRANSITIONS FROM GREEN TO LIGHT BLUE, SAID WORDS HAVING WHITE INTERIORS AND REDDISH ORANGE AND GRAY DROP SHADOWS AND GRAY INTERIOR HIGHLIGHTS, SAID OVAL HAVING A STYLIZED YELLOWISH GREEN ARC ABOVE IT AND A STYLIZED YELLOWISH ORANGE ARC BELOW IT, SAID OVAL AND ARCS HAVING GRAY DROP SHADOWS.

FOR PROVIDING A WEB SITE FEATURING TEMPORARY USE OF NON-DOWNLOADABLE SOFTWARE FOR TEACHING EDUCATIONAL SUBJECTS (U.S. CLS. 100 AND 101).

FIRST USE 6-1-2002; IN COMMERCE 6-1-2002.

LIEF MARTIN, EXAMINING ATTORNEY

SN 85-434,527. LOGIC NATION, INC., SHREVEPORT, LA. FILED 9-28-2011.

Logic Nation

THE MARK CONSISTS OF STANDARD CHARACTERS WITHOUT CLAIM TO ANY PARTICULAR FONT, STYLE, SIZE, OR COLOR.

FOR COMPUTER SERVICES, NAMELY, CREATING AN ON-LINE COMMUNITY FOR REGISTERED USERS TO PARTICIPATE IN DISCUSSIONS, GET FEEDBACK FROM THEIR PEERS, FORM VIRTUAL COMMUNITIES, AND ENGAGE IN SOCIAL NETWORKING SERVICES IN THE FIELD OF GENERAL INTEREST; COMPUTER SERVICES, NAMELY, CREATING AN ON-LINE COMMUNITY FOR REGISTERED USERS TO CONDUCT OPEN DISCUSSIONS; PROVIDING CUSTOMIZED ON-LINE WEB PAGES AND DATA FEEDS FEATURING USER-DEFINED INFORMATION, WHICH INCLUDES BLOG POSTS, NEW MEDIA CONTENT, OTHER ON-LINE CONTENT, AND ON-LINE WEB LINKS TO OTHER WEBSITES (U.S. CLS. 100 AND 101).

ALAIN LAPTER, EXAMINING ATTORNEY

SN 85-435,545. LEARNING THROUGH SPORTS, LLC, BIRMINGHAM, AL. FILED 9-29-2011.



NO CLAIM IS MADE TO THE EXCLUSIVE RIGHT TO USE "EDUCATION SYSTEMS", APART FROM THE MARK AS SHOWN.

THE COLOR(S) REDDISH ORANGE, GRAY, AND WHITE IS/ARE CLAIMED AS A FEATURE OF THE MARK.

THE MARK CONSISTS OF THE LETTERS "LTS", IN WHITE, IN THREE REDDISH ORANGE BOXES, ABOVE THE WORDS "EDUCATION SYSTEMS", IN WHITE, IN A GRAY BOX.

FOR PROVIDING A WEB SITE FEATURING TEMPORARY USE OF NON-DOWNLOADABLE SOFTWARE FOR TEACHING EDUCATIONAL SUBJECTS (U.S. CLS. 100 AND 101).

FIRST USE 3-1-2011; IN COMMERCE 3-1-2011.

LIEF MARTIN, EXAMINING ATTORNEY

CLASS 42—(Continued).

SN 85-435,671. ADVANTONE, INC., PLANTATION, FL. FILED 9-29-2011.

Advantone

THE MARK CONSISTS OF STANDARD CHARACTERS WITHOUT CLAIM TO ANY PARTICULAR FONT, STYLE, SIZE, OR COLOR.

FOR APPLICATION SERVICE PROVIDER (ASP) FEATURING SOFTWARE FOR USE IN DATABASE MANAGEMENT FOR INTERACTIVE VOICE RESPONSE PROCESSING, VIRTUAL PREDICTIVE DIALING, VIRTUAL AUTOMATED CALL DISTRIBUTION, OUT-BOUND NOTIFICATION CALL ROUTING AND RELATED WEB SERVICES AND REPORTING (U.S. CLS. 100 AND 101).

FIRST USE 9-1-2011; IN COMMERCE 9-1-2011.
LOURDES AYALA, EXAMINING ATTORNEY

SN 85-436,986. LEARNING THROUGH SPORTS, LLC, BIRMINGHAM, AL. FILED 9-30-2011.



NO CLAIM IS MADE TO THE EXCLUSIVE RIGHT TO USE "SPORTSMANSHIP", APART FROM THE MARK AS SHOWN.

THE COLOR(S) DARK BLUE AND LIGHT BLUE IS/ARE CLAIMED AS A FEATURE OF THE MARK.

THE MARK CONSISTS OF THE WORDS "STAR SPORTSMANSHIP" IN DARK BLUE LETTERS WITH LIGHT BLUE BORDERS, WHEREIN THE LETTER "A" IN "STAR" CONTAINS A FIVE-POINTED STAR DESIGN WITH A LIGHT BLUE BORDER. THE COLOR WHITE REPRESENTS BACKGROUND AREAS AND IS NOT PART OF THE MARK.

FOR PROVIDING A WEB SITE FEATURING TEMPORARY USE OF NON-DOWNLOADABLE SOFTWARE FOR TEACHING EDUCATIONAL SUBJECTS (U.S. CLS. 100 AND 101).

FIRST USE 6-1-2004; IN COMMERCE 6-1-2004.
LIEF MARTIN, EXAMINING ATTORNEY

CLASS 42—(Continued).

SN 85-440,491. ASTIR IT SOLUTIONS INC., SOUTH PLAINFIELD, NJ. FILED 10-6-2011.

Information. Insight. Results.

THE MARK CONSISTS OF STANDARD CHARACTERS WITHOUT CLAIM TO ANY PARTICULAR FONT, STYLE, SIZE, OR COLOR.

FOR BUSINESS TECHNOLOGY SOFTWARE CONSULTATION SERVICES; COMPUTER SERVICES, NAMELY, REMOTE MANAGEMENT OF THE INFORMATION TECHNOLOGY (IT) SYSTEMS OF OTHERS; CONSULTING IN THE FIELD OF INFORMATION TECHNOLOGY; CONSULTING IN THE FIELD OF VIRTUALIZATION TECHNOLOGIES FOR ENTERPRISES AND BUSINESSES; INFORMATION TECHNOLOGY CONSULTATION; PLANNING, DESIGN AND IMPLEMENTATION OF COMPUTER TECHNOLOGIES FOR OTHERS; PLANNING, DESIGN AND MANAGEMENT OF INFORMATION TECHNOLOGY SYSTEMS; PROVIDING INFORMATION IN THE FIELDS OF TECHNOLOGY AND SOFTWARE DEVELOPMENT VIA AN ON-LINE WEBSITE; TECHNICAL CONSULTING SERVICES IN THE FIELDS OF DATACENTER ARCHITECTURE, PUBLIC AND PRIVATE CLOUD COMPUTING SOLUTIONS, AND EVALUATION AND IMPLEMENTATION OF INTERNET TECHNOLOGY AND SERVICES; TECHNOLOGICAL CONSULTATION IN THE TECHNOLOGY FIELD OF INFORMATION TECHNOLOGY; TECHNOLOGY SPECIFICATION, NAMELY, ANALYZING TECHNOLOGY REQUIREMENTS AND DEVELOPING RECOMMENDATIONS FOR THE COMPUTER SOFTWARE AND SYSTEMS AND OTHER TECHNOLOGY NEEDED TO MEET THOSE REQUIREMENTS, IN THE FIELD OF INFORMATION TECHNOLOGY (U.S. CLS. 100 AND 101).

FIRST USE 6-1-2006; IN COMMERCE 6-1-2006.
RONALD DELGIZZI, EXAMINING ATTORNEY

SN 85-441,626. CONTENTRAVEN, LLC, MARLBOROUGH, MA. FILED 10-7-2011.



NO CLAIM IS MADE TO THE EXCLUSIVE RIGHT TO USE "CONTENT", APART FROM THE MARK AS SHOWN. THE MARK CONSISTS OF THE IMAGE OF A RAVEN MADE UP OF RECTANGLES OF VARYING SIZES. TO THE LEFT OF THE BOTTOM PORTION OF THE RAVEN IS THE WORD "CONTENT" AND BELOW THE FOREGOING IS THE WORD "RAVEN".

FOR APPLICATION SERVICE PROVIDER (ASP) FEATURING SOFTWARE FOR SECURE CONTENT DELIVERY; SOFTWARE AS A SERVICE (SAAS) SERVICES FEATURING SOFTWARE FOR SECURE CONTENT DELIVERY ONLINE, OFFLINE AND MOBILE (U.S. CLS. 100 AND 101).

FIRST USE 7-15-2011; IN COMMERCE 7-15-2011.
KATHERINE CHANG, EXAMINING ATTORNEY

CLASS 42—(Continued).

SN 85-441,709. INTWINE INNOVATIONS, LLC, DBA INTWINE CONNECT, LLC, CHAGRIN FALLS, OH. FILED 10-7-2011.

CloudBUS

THE MARK CONSISTS OF STANDARD CHARACTERS WITHOUT CLAIM TO ANY PARTICULAR FONT, STYLE, SIZE, OR COLOR.

FOR COMPUTER SOFTWARE AND FIRMWARE DESIGN AND DEVELOPMENT; SOFTWARE AS A SERVICE (SAAS) SERVICES FEATURING SOFTWARE FOR NETWORKING, WEB APPLICATION HOSTING, AND WEB SERVICES IN THE NATURE OF SOFTWARE TO SUPPORT MACHINE-TO-MACHINE INTERACTION OVER A NETWORK; PROVIDING ON-LINE, NON-DOWNLOADABLE, INTERNET-BASED SOFTWARE APPLICATIONS FOR DATA COLLECTION, DATA MANAGEMENT AND OPERATIONAL CONTROL OF ELECTRONIC SYSTEMS AND DEVICES (U.S. CLS. 100 AND 101).

LINDA LAVACHE, EXAMINING ATTORNEY

SN 85-441,804. CONVERSOCIAL (UK) LIMITED, LONDON, UNITED KINGDOM, FILED 10-7-2011.

CONVERSOCIAL

THE MARK CONSISTS OF STANDARD CHARACTERS WITHOUT CLAIM TO ANY PARTICULAR FONT, STYLE, SIZE, OR COLOR.

OWNER OF ERPN CMNTY TM OFC REG. NO. 010256691, DATED 2-23-2012, EXPIRES 2-23-2022.

FOR PROVISION, DESIGN AND DEVELOPMENT OF NON-DOWNLOADABLE AND WEB-BASED COMPUTER SOFTWARE AND SOFTWARE APPLICATIONS INCLUDING SOFTWARE APPLICATIONS FOR MOBILE DEVICES, SUCH AS SMART PHONES AND TABLETS, INCLUDING DOWNLOADABLE AND WEB-BASED SOFTWARE AND SOFTWARE APPLICATIONS, NAMELY, FOR USE IN DATABASE MANAGEMENT AND CUSTOMER RELATIONSHIP MANAGEMENT; TECHNOLOGICAL SERVICES AND RESEARCH AND DESIGN RELATING THERETO IN THE FIELD OF SOFTWARE DESIGN AND DEVELOPMENT; COMPUTER PROGRAMMING, INSTALLATION, MAINTENANCE AND REPAIR OF COMPUTER SOFTWARE AND SOFTWARE APPLICATIONS; COMPUTER CONSULTANCY SERVICES; SOFTWARE AS A SERVICE INCLUDING CLOUD COMPUTING FEATURING SOFTWARE FOR DATABASE MANAGEMENT AND CUSTOMER RELATIONSHIP MANAGEMENT; WEBSITE HOSTING SERVICES; PROVIDING AN INTERNET WEBSITE PORTAL IN THE FIELDS OF TECHNOLOGY AND SOFTWARE DEVELOPMENT (U.S. CLS. 100 AND 101).

DAVID TOOLEY, EXAMINING ATTORNEY

CLASS 42—(Continued).

SN 85-443,241. HOOPZ PLANET INFO PRIVATE LIMITED, WAKAD 411 057, INDIA, FILED 10-10-2011.

HOOPZ PLANET INFO

THE MARK CONSISTS OF STANDARD CHARACTERS WITHOUT CLAIM TO ANY PARTICULAR FONT, STYLE, SIZE, OR COLOR.

NO CLAIM IS MADE TO THE EXCLUSIVE RIGHT TO USE "INFO", APART FROM THE MARK AS SHOWN.

FOR DESIGN AND DEVELOPMENT OF SOFTWARE SOLUTIONS FOR CONTEXTUAL DIGITAL MARKETING, INFORMATION AND CONTENT DISCOVERY AND SEARCH SOLUTIONS ON COMPUTER SYSTEMS (U.S. CLS. 100 AND 101).

MAYUR VAGHANI, EXAMINING ATTORNEY

SN 85-444,341. ICON ARCHITECTURAL GROUP, PLLC, GRAND FORKS, ND. FILED 10-11-2011.

ICON ARCHITECTURAL GROUP

THE MARK CONSISTS OF STANDARD CHARACTERS WITHOUT CLAIM TO ANY PARTICULAR FONT, STYLE, SIZE, OR COLOR.

NO CLAIM IS MADE TO THE EXCLUSIVE RIGHT TO USE "ARCHITECTURAL GROUP", APART FROM THE MARK AS SHOWN.

FOR ARCHITECTURAL DESIGN, ENGINEERING DESIGN FOR RESIDENTIAL BUILDINGS, COMMERCIAL BUILDINGS AND OTHER STRUCTURES (U.S. CLS. 100 AND 101).

FIRST USE 4-23-2002; IN COMMERCE 4-23-2002.

TEJBIR SINGH, EXAMINING ATTORNEY

SN 85-446,622. THE TRIZETTO GROUP, INC., GREENWOOD VILLAGE, CO. FILED 10-13-2011.

MDE

THE MARK CONSISTS OF STANDARD CHARACTERS WITHOUT CLAIM TO ANY PARTICULAR FONT, STYLE, SIZE, OR COLOR.

FOR DESIGN AND DEVELOPMENT OF SOFTWARE; TECHNICAL CONSULTING IN THE AREA OF COMPUTER SOFTWARE; SOFTWARE MAINTENANCE; PROFESSIONAL AND TECHNICAL SUPPORT, NAMELY, SUPPORT IN THE FIELD OF DETECTING COMPUTER SOFTWARE MALFUNCTIONS AND CORRECTING THESE MALFUNCTIONS VIA TELEPHONE AND INTERNET (U.S. CLS. 100 AND 101).

FIRST USE 10-31-2006; IN COMMERCE 10-31-2006.

INGA ERVIN, EXAMINING ATTORNEY

CLASS 42—(Continued).

SN 85-450,315. LEVEL 3 COMMUNICATIONS, LLC, BROOMFIELD, CO. FILED 10-18-2011.

CDDN

THE MARK CONSISTS OF THE LETTER "CDDN" WHERE THE FIRST LETTER "D" IS A MIRROR IMAGE OF THE SECOND LETTER "D".

FOR PROVIDING VIRTUAL COMPUTER SYSTEMS AND VIRTUAL COMPUTER ENVIRONMENTS THROUGH CLOUD COMPUTING (U.S. CLS. 100 AND 101).

MATTHEW MCDOWELL, EXAMINING ATTORNEY

CLASS 42—(Continued).

SN 85-454,614. MASCO CABINETRY LLC, ANN ARBOR, MI. FILED 10-24-2011.

TRUVUE

THE MARK CONSISTS OF STANDARD CHARACTERS WITHOUT CLAIM TO ANY PARTICULAR FONT, STYLE, SIZE, OR COLOR.

FOR COMPUTER SERVICES, NAMELY, PROVIDING AN ONLINE WEB HOSTING PLATFORM FOR OTHERS TO ALLOW USERS TO PREVIEW AND SELECT COUNTERTOP PATTERNS (U.S. CLS. 100 AND 101).

AMY C. KEAN, EXAMINING ATTORNEY

SN 85-450,418. TECHCOM INTERNATIONAL CORPORATION, LAGUNA NIGUEL, CA. FILED 10-18-2011.

TECHCOM

THE MARK CONSISTS OF STANDARD CHARACTERS WITHOUT CLAIM TO ANY PARTICULAR FONT, STYLE, SIZE, OR COLOR.

FOR ENGINEERING SERVICES, NAMELY, NUCLEAR POWER DISTRIBUTED CONTROL SYSTEM DESIGN, NUCLEAR POWER ADVANCED CONTROL SYSTEMS DESIGN, NUCLEAR POWER INSTRUMENT AND CONTROL SYSTEM DESIGN, NUCLEAR POWER MECHANICAL SYSTEM DESIGN, AND, NUCLEAR POWER ELECTRICAL SYSTEM DESIGN (U.S. CLS. 100 AND 101).

FIRST USE 1-31-1999; IN COMMERCE 1-31-1999.
ZACHARY BELLO, EXAMINING ATTORNEY

SN 85-455,301. CORN PRODUCTS DEVELOPMENT INC., WESTCHESTER, IL. FILED 10-25-2011.

TEXICON

SN 85-450,430. TECHCOM INTERNATIONAL CORPORATION, LAGUNA NIGUEL, CA. FILED 10-18-2011.

TCI

THE MARK CONSISTS OF STANDARD CHARACTERS WITHOUT CLAIM TO ANY PARTICULAR FONT, STYLE, SIZE, OR COLOR.

FOR ENGINEERING SERVICES, NAMELY, NUCLEAR POWER DISTRIBUTED CONTROL SYSTEM DESIGN, NUCLEAR POWER ADVANCED CONTROL SYSTEMS DESIGN, NUCLEAR POWER INSTRUMENT AND CONTROL SYSTEM DESIGN, NUCLEAR POWER MECHANICAL SYSTEM DESIGN, AND, NUCLEAR POWER ELECTRICAL SYSTEM DESIGN (U.S. CLS. 100 AND 101).

FIRST USE 1-31-1999; IN COMMERCE 1-31-1999.
ZACHARY BELLO, EXAMINING ATTORNEY

THE MARK CONSISTS OF STANDARD CHARACTERS WITHOUT CLAIM TO ANY PARTICULAR FONT, STYLE, SIZE, OR COLOR.

FOR SCIENTIFIC AND TECHNOLOGICAL SERVICES, NAMELY, RESEARCH AND DESIGN IN THE FIELD OF FOOD AND BEVERAGE INGREDIENT ATTRIBUTES; RESEARCH ON FOOD AND BEVERAGE INGREDIENT ATTRIBUTES; DESIGN AND INDUSTRIAL TESTING OF NEW PRODUCTS, NAMELY, NEW FOOD AND BEVERAGE INGREDIENT ATTRIBUTES. CONSULTANCY AND ADVISORY SERVICES IN THE FIELD OF ANALYSIS, SELECTION AND DEVELOPMENT OF FOOD AND BEVERAGE INGREDIENT ATTRIBUTES (U.S. CLS. 100 AND 101).

SHARON MEIER, EXAMINING ATTORNEY

CLASS 42—(Continued).

SN 85-462,204. KONTORSPLATSEN BUSINESS GROUP AB, GOTEBOURG, SWEDEN, FILED 11-2-2011.



THE MARK CONSISTS OF A REPRESENTATION OF A CLOUD HAVING TWO EYES AND SMILING MOUTH AND SURROUNDED BY A BACKGROUND WITH THREE DIFFERENT SHADINGS ALL WITHIN A RECTANGLE WITH ROUNDED CORNERS THAT IS SUPERIMPOSED OVER ANOTHER RECTANGLE TO PROVIDE AN OUTLINE WITH SQUARE EDGES.

FOR RENTAL OF WEB SERVERS; CONSULTING SERVICES IN THE FIELD OF DESIGN, SELECTION, IMPLEMENTATION AND USE OF COMPUTER SOFTWARE SYSTEMS FOR OTHERS; DESIGNING AND DEVELOPING COMPUTER HARDWARE AND SOFTWARE; CONSULTANCY IN THE FIELD OF COMPUTER SOFTWARE; COMPUTER PROGRAMMING; DESIGNING COMPUTER SOFTWARE AND APPLICATIONS; UPDATING OF COMPUTER SOFTWARE AND APPLICATIONS; CONSULTING SERVICES IN THE FIELD OF DESIGN, SELECTION, IMPLEMENTATION AND USE OF COMPUTER HARDWARE SYSTEMS FOR OTHERS; GRAPHIC DESIGNING; RENTAL OF COMPUTER SOFTWARE AND APPLICATIONS; RECOVERY OF COMPUTER DATA; MAINTENANCE OF COMPUTER SOFTWARE; COMPUTER SYSTEMS ANALYSIS; COMPUTER SYSTEMS DESIGN; WEB HOSTING SERVICES; INSTALLATION OF COMPUTER SOFTWARE; DATA CONVERSIONS OF COMPUTER PROGRAMS AND DATA; COMPUTER HARDWARE CONSULTING SERVICES IN THE FIELD OF ANALYSIS OF COMPUTER HARDWARE; COMPUTER SOFTWARE CONSULTING SERVICE IN THE FIELD OF ANALYSIS OF COMPUTER SOFTWARE; CONSULTANCY AND SUPPORT SERVICES IN THE FIELD OF THE INSTALLATION AND ADAPTATION OF COMPUTER SOFTWARE; ANALYSIS AND DESIGN OF COMPUTER SYSTEMS, SOFTWARE AND INFORMATION SYSTEMS FOR OTHERS; COMPUTER ENGINEERING; COMPUTER TIME SHARING; DESIGN OF WEB SITES; DESIGN OF COMPUTER SOFTWARE, WEB SITES AND WEB PAGES; PROVIDING INFORMATION REGARDING THE USE OF COMPUTER PROGRAMS; COMPUTER SOFTWARE ENGINEERING; SERVICES FOR CALIBRATION AND ADJUSTMENT OF COMPUTER PROGRAMS; CONSULTANCY SERVICES RELATED TO COMPUTER SECURITY; QUALITY CHECK OF COMPUTER SOFTWARE; MAINTENANCE OF COMPUTER SOFTWARE; CREATING COMPUTER PROGRAMS FOR COMPUTER PROCESSES; TECHNICAL SUPPORT, NAMELY, TROUBLESHOOTING OF COMPUTER SOFTWARE PROBLEMS; TIME SHARING SERVICES OF COMPUTERS; DESIGNING OF HOME PAGES AND WEB SITES; DEVELOPING OF APPLICATIONS FOR COMPUTER PROGRAMS; DEVELOPING OF COMPUTER BASED NETWORKS; DEVELOPING OF COMPUTER SYSTEMS (U.S. CLS. 100 AND 101).

MATTHEW KLINE, EXAMINING ATTORNEY

CLASS 42—(Continued).

SN 85-471,694. THINKAGE, LLC, KINGSTON, NH. FILED 11-14-2011.

CLASH. JUSTICE. HONOR.

THE MARK CONSISTS OF STANDARD CHARACTERS WITHOUT CLAIM TO ANY PARTICULAR FONT, STYLE, SIZE, OR COLOR.

FOR PROVIDING AN INTERACTIVE WEBSITE FEATURING ONLINE NON-DOWNLOADABLE SOFTWARE THAT ENABLES REGISTERED USERS TO CREATE AND MANAGE PROFILES, UPLOAD, DOWNLOAD, POST, DISPLAY, TAG, SHARE, DISTRIBUTE AND OTHERWISE PROVIDE AUDIO, VIDEO AND MULTIMEDIA CONTENT AND INFORMATION AND TO REVIEW, RATE, RANK AND COMMENT ON THE POSTINGS OF OTHER REGISTERED USERS FOR PURPOSES OF ENTERTAINMENT AND DISCUSSION (U.S. CLS. 100 AND 101).

LEIGH CAROLINE CASE, EXAMINING ATTORNEY

SN 85-471,954. THINKAGE, LLC, KINGSTON, NH. FILED 11-14-2011.

Rangl

THE COLOR(S) BLACK, TURQUOISE AND WHITE IS/ ARE CLAIMED AS A FEATURE OF THE MARK.

THE MARK CONSISTS OF THE WORD "RANGLE" IN TURQUOISE LETTERS OUTLINED IN WHITE AND BLACK. THE LETTER "R" IS IN UPPERCASE LETTERING AND THE LETTERS "A", "N", "G", AND "L" ARE IN LOWERCASE LETTERING.

FOR PROVIDING AN INTERACTIVE WEBSITE FEATURING ONLINE NON-DOWNLOADABLE SOFTWARE THAT ENABLES REGISTERED USERS TO CREATE AND MANAGE PROFILES, UPLOAD, DOWNLOAD, POST, DISPLAY, TAG, SHARE, DISTRIBUTE AND OTHERWISE PROVIDE AUDIO, VIDEO AND MULTIMEDIA CONTENT AND INFORMATION AND TO REVIEW, RATE, RANK AND COMMENT ON THE POSTINGS OF OTHER REGISTERED USERS FOR PURPOSES OF ENTERTAINMENT AND DISCUSSION (U.S. CLS. 100 AND 101).

LEIGH CAROLINE CASE, EXAMINING ATTORNEY

CLASS 42—(Continued).

SN 85-475,190. SYNTA PHARMACEUTICALS CORP., LEXINGTON, MA. FILED 11-17-2011.



THE COLOR(S) GREEN AND BLACK IS/ARE CLAIMED AS A FEATURE OF THE MARK.

THE MARK CONSISTS OF A STYLIZED PAIR OF LUNGS AND TRACHEA CUT OUT FROM A GREEN CIRCLE, ALL ON A BLACK SQUARE CARRIER.

FOR MEDICAL AND SCIENTIFIC RESEARCH, NAMELY, CONDUCTING CLINICAL TRIALS FOR OTHERS (U.S. CLS. 100 AND 101).

LINDA POWELL, EXAMINING ATTORNEY

SN 85-475,711. DICOM SYSTEMS, INC, SAN FRANCISCO, CA. FILED 11-17-2011.

dcmsys

THE MARK CONSISTS OF STANDARD CHARACTERS WITHOUT CLAIM TO ANY PARTICULAR FONT, STYLE, SIZE, OR COLOR.

FOR DIGITAL ENHANCEMENT AND MANIPULATION OF RADIOLOGICAL DATA BY MEANS OF COMPUTERIZED SOFTWARE FOR USE IN THE FIELD OF TELERADIOLOGY (U.S. CLS. 100 AND 101).

FIRST USE 2-13-2008; IN COMMERCE 2-13-2008.
RONALD DELGIZZI, EXAMINING ATTORNEY

CLASS 42—(Continued).

SN 85-476,990. MEGA CLOUD PTE LTD, SINGAPORE, SINGAPORE, FILED 11-18-2011.



THE COLOR(S) DARK BLUE AND LIGHT BLUE IS/ARE CLAIMED AS A FEATURE OF THE MARK.

THE MARK CONSISTS OF WORD "MEGA" IN DARK BLUE AND WORD "CLOUD" IN LIGHT BLUE WITH CLOUD DESIGN AROUND THE WORD "CLOUD".

FOR SOFTWARE AS SERVICE (SAAS) SERVICES, NAMELY, HOSTING OF SOFTWARE FOR USE BY OTHERS FOR USE IN DATABASE MANAGEMENT, FOR USE AS A SPREADSHEET, FOR WORD PROCESSING, FOR UPLOADING AND DOWNLOADING MUSIC AND VIDEO FOR SHARING WITH OTHERS FOR ENTERTAINMENT PURPOSES; COMPUTER SERVICES, NAMELY, PROVIDING A WEB-BASED SYSTEM AND ONLINE PORTAL FEATURING ON-LINE NON-DOWNLOADABLE SOFTWARE THAT ENABLES USERS TO ACCESS TRAINING AND EDUCATION MATERIALS IN THE FIELD OF INFORMATION TECHNOLOGY, ACCOUNTING AND FINANCE; COMPUTER SERVICE, NAMELY, ACTING AS AN APPLICATION SERVICE PROVIDER IN THE FIELD OF KNOWLEDGE MANAGEMENT TO HOST COMPUTER APPLICATION SOFTWARE FOR THE STORAGE AND SHARING OF DATA AND INFORMATION; DESIGN AND DEVELOPMENT OF COMPUTER HARDWARE AND SOFTWARE; APPLICATION SERVICE PROVIDER, NAMELY, HOSTING COMPUTER SOFTWARE APPLICATIONS OF OTHERS (U.S. CLS. 100 AND 101).

LEIGH LOWRY, EXAMINING ATTORNEY

SN 85-499,598. ENTRATA SOFTWARE LLC, DOVER, DE. FILED 12-20-2011.

Entrata

THE MARK CONSISTS OF STANDARD CHARACTERS WITHOUT CLAIM TO ANY PARTICULAR FONT, STYLE, SIZE, OR COLOR.

THE ENGLISH TRANSLATION OF "ENTRATA" IN THE MARK IS "ENTRANCE, ENTRY, WAY IN, GATEWAY".

FOR SOFTWARE AS A SERVICE (SAAS) SERVICES FEATURING SOFTWARE FOR AUTOMATING THE MANAGEMENT, ACCOUNTING, RENTING, AND LEASING FOR OWNERS OR MANAGERS OF MULTI-FAMILY HOUSING RENTAL PROPERTIES (U.S. CLS. 100 AND 101).

ROBERT STRUCK, EXAMINING ATTORNEY

CLASS 42—(Continued).

SN 85-508,644. MAROHN, CHARLES, EAST GULL LAKE, MN. FILED 1-4-2012.

Strong Towns

THE MARK CONSISTS OF STANDARD CHARACTERS WITHOUT CLAIM TO ANY PARTICULAR FONT, STYLE, SIZE, OR COLOR.

NO CLAIM IS MADE TO THE EXCLUSIVE RIGHT TO USE "TOWNS", APART FROM THE MARK AS SHOWN.

FOR CONSULTING SERVICES IN THE FIELD OF COMMUNITY PLANNING AND INFRASTRUCTURE DEVELOPMENT (U.S. CLS. 100 AND 101).

FIRST USE 7-1-2009; IN COMMERCE 12-1-2010.
TEJBIR SINGH, EXAMINING ATTORNEY

SN 85-514,389. REDDY, PRAVEEN, EDMONTON, CANADA, FILED 1-11-2012.

Paperhater

THE MARK CONSISTS OF STANDARD CHARACTERS WITHOUT CLAIM TO ANY PARTICULAR FONT, STYLE, SIZE, OR COLOR.

FOR PROVIDING A WEBSITE FEATURING NON-DOWNLOADABLE SOFTWARE FOR PROCESSING DIGITAL IMAGES (U.S. CLS. 100 AND 101).

FIRST USE 4-1-2011; IN COMMERCE 4-1-2011.
DOUGLAS LEE, EXAMINING ATTORNEY

SN 85-517,278. COGNOSANTE HOLDINGS, LLC, MCLEAN, VA. FILED 1-16-2012.

ESANTE

THE MARK CONSISTS OF STANDARD CHARACTERS WITHOUT CLAIM TO ANY PARTICULAR FONT, STYLE, SIZE, OR COLOR.

FOR SOFTWARE AS A SERVICE FEATURING SOFTWARE FOR PROVIDING ROUTING OF HEALTHCARE INFORMATION, HEALTHCARE BENEFITS INFORMATION, TRANSACTION INFORMATION, COST AND PAYMENT INFORMATION, AND FORMS RELATED TO THE FOREGOING; CONSULTING IN THE FIELD OF INFORMATION TECHNOLOGY; INTEGRATION OF COMPUTER SYSTEMS AND NETWORKS; AND SAAS FEATURING SOFTWARE THAT SUPPORTS THE IDENTIFICATION, TRACKING AND DISPOSITION INCLUDING RECOVERY EFFORTS OF OVERPAYMENT, UNDERPAYMENT AND FRAUD MATTERS IN THE GOVERNMENT HEALTHCARE SPACE, INCLUDING WITH RESPECT TO MEDICAID AND MEDICARE CLAIMS AND TO SUPPORT AUDITS OF MEDICARE/ MEDICAID CLAIMS (U.S. CLS. 100 AND 101).

BRIDGETT SMITH, EXAMINING ATTORNEY

CLASS 42—(Continued).

SN 85-517,821. AUGMENTED DYNAMICS, INC., HUNTINGTON BEACH, CA. FILED 1-17-2012.

A NEW REALITY FOR EVERYONE

THE MARK CONSISTS OF STANDARD CHARACTERS WITHOUT CLAIM TO ANY PARTICULAR FONT, STYLE, SIZE, OR COLOR.

FOR PROVIDING ON-LINE, NON-DOWNLOADABLE SOFTWARE FOR USE IN MIXING PHYSICAL OBJECTS WITH PERSPECTIVE BASED DIGITAL CONTENT TO CREATE AUGMENTED REALITY APPLICATIONS AND TECHNOLOGY, FOR CREATING MOBILE WEB APPLICATIONS, FOR GENERATING CUSTOM QUICK RESPONSE CODES, FOR CREATING COUPONS, CONTESTS, AND GAMES, FOR PUBLISHING 3D AUGMENTED REALITY GRAPHICS AND ANIMATION AND MOBILE WEB CONTENT, FOR USE IN CREATING CUSTOMIZED MARKETING CAMPAIGNS USING SUCH DISCOVERY METHODS AS QUICK RESPONSE CODES, NEAR FIELD COMMUNICATION, AND OBJECT RECOGNITION TECHNOLOGIES; APPLICATION SERVICE PROVIDER FEATURING SOFTWARE FOR USE IN MIXING PHYSICAL OBJECTS WITH PERSPECTIVE BASED DIGITAL CONTENT TO CREATE AUGMENTED REALITY APPLICATIONS AND TECHNOLOGY, FOR CREATING MOBILE WEB APPLICATIONS, FOR GENERATING CUSTOM QUICK RESPONSE CODES, FOR CREATING COUPONS, CONTESTS, AND GAMES, FOR PUBLISHING 3D AUGMENTED REALITY GRAPHICS AND ANIMATION AND MOBILE WEB CONTENT, FOR USE IN CREATING CUSTOMIZED MARKETING CAMPAIGNS USING SUCH DISCOVERY METHODS AS QUICK RESPONSE CODES, NEAR FIELD COMMUNICATION, AND OBJECT RECOGNITION TECHNOLOGIES; PROVIDING A WEB HOSTING PLATFORM FOR INTERACTIVE PRINTED MATERIALS FOR PUBLISHERS AND COMMERCIAL PRINTERS; DESIGN AND DEVELOPMENT OF COMPUTER SOFTWARE (U.S. CLS. 100 AND 101).

EDWARD NELSON, EXAMINING ATTORNEY

SN 85-519,260. CROTIN, RYAN, WHITBY, CANADA, FILED 1-18-2012.

ATHLETIC BARCODES

THE MARK CONSISTS OF STANDARD CHARACTERS WITHOUT CLAIM TO ANY PARTICULAR FONT, STYLE, SIZE, OR COLOR.

NO CLAIM IS MADE TO THE EXCLUSIVE RIGHT TO USE "BARCODES", APART FROM THE MARK AS SHOWN.

FOR PROVIDING ELECTRONIC VERIFICATION OF DIGITAL BARCODES THAT THEN ALLOWS ACCESS TO CONTENT, NAMELY, ATHLETIC TRAINING AND PERFORMANCE PARAMETERS OF INDIVIDUALS (U.S. CLS. 100 AND 101).

TEJBIR SINGH, EXAMINING ATTORNEY

CLASS 42—(Continued).

SN 85-520,869. LUMAPIX, INC., BROSSARD, QUEBEC, CANADA, FILED 1-19-2012.

FULLSCALE

THE MARK CONSISTS OF STANDARD CHARACTERS WITHOUT CLAIM TO ANY PARTICULAR FONT, STYLE, SIZE, OR COLOR.

FOR PROVIDING TEMPORARY USE OF ON-LINE, NON-DOWNLOADABLE, REBRANDABLE SOFTWARE TOOLS FOR THE CREATION, PUBLISHING, END-USER CUSTOMIZATION AND SALE OF A WIDE VARIETY OF GRAPHICAL AND/OR DIGITAL CONTENT AND PRODUCTS (U.S. CLS. 100 AND 101).

FIRST USE 11-11-2011; IN COMMERCE 11-11-2011.
MIDGE BUTLER, EXAMINING ATTORNEY

CLASS 42—(Continued).

SN 85-531,392. GRAYHAIR SOFTWARE, INC., MOUNT LAUREL, NJ. FILED 2-1-2012.

ENROUTE

THE MARK CONSISTS OF STANDARD CHARACTERS WITHOUT CLAIM TO ANY PARTICULAR FONT, STYLE, SIZE, OR COLOR.

FOR PLATFORM AS A SERVICE (PAAS) FEATURING COMPUTER SOFTWARE PLATFORMS FOR PROVIDING TO OTHERS THE RECEIPT AND OPTIMIZATION OF POSTAL DATA DURING THE LIFE CYCLE OF A MAIL CAMPAIGN IN THE POSTAL STREAM FROM ENTRY INTO THE SUPPLY CHAIN THROUGH THE UNITED STATES POSTAL SYSTEM TO THE FINAL DELIVERY DESTINATION (U.S. CLS. 100 AND 101).

JACQUELINE A. LAVINE, EXAMINING ATTORNEY

SN 85-527,305. WRIGHT INTERNET STRATEGIES, LLC, DBA SAFFIRE EVENTS, AUSTIN, TX. FILED 1-27-2012.



NO CLAIM IS MADE TO THE EXCLUSIVE RIGHT TO USE "EVENTS", APART FROM THE MARK AS SHOWN.

THE COLOR(S) BLACK, AQUA, BLUE, TEAL, LIGHT BLUE AND WHITE IS/ARE CLAIMED AS A FEATURE OF THE MARK.

THE MARK CONSISTS OF FLAME LOGO COMPRISED OF A BLACK FLAME WITH A TIP CURLING TO THE RIGHT ENCOMPASSING A SMALLER GRADIENT-FILLED AQUA BLUE FLAME WITH A TIP CURLING LEFT THAT IS LIGHT BLUE AT THE BOTTOM AND TEAL AT THE TOP. THE "SAF" IS BLACK, "FIRE" IS TEAL AT THE TOP AND AQUA BLUE AT THE BOTTOM. THE WORD "EVENTS" IS LIGHT BLUE AT THE TOP AND AQUA BLUE AT THE BOTTOM.

FOR PROVIDING A WEBSITE FEATURING NON-DOWNLOADABLE SOFTWARE FOR ONLINE MARKETING, EVENT MANAGEMENT, CONTENT MANAGEMENT, CONTACT MANAGEMENT, SOCIAL MEDIA MARKETING, ECOMMERCE AND VOLUNTEER AND SPONSOR MANAGEMENT (U.S. CLS. 100 AND 101).

FIRST USE 9-1-2010; IN COMMERCE 9-1-2010.
MICHELE SWAIN, EXAMINING ATTORNEY

SN 85-531,902. BRAVO, IRMA, NEW YORK, NY. FILED 2-2-2012.

Irma Bravo

THE MARK CONSISTS OF STANDARD CHARACTERS WITHOUT CLAIM TO ANY PARTICULAR FONT, STYLE, SIZE, OR COLOR.

THE NAME "IRMA BRAVO" IDENTIFIES A LIVING INDIVIDUAL WHOSE CONSENT IS OF RECORD.

FOR ARCHITECTURAL DESIGN; COLOR ANALYSIS FOR PURPOSES OF INTERIOR DESIGN; COMMERCIAL ART DESIGN; CONSULTING SERVICES IN THE FIELD OF ARCHITECTURAL DESIGN; DESIGN OF INTERIOR DECOR; DESIGN OF TEXTILES; DESIGNING OF PACKAGING AND WRAPPING MATERIALS; FASHION DESIGN CONSULTING SERVICES; FURNITURE DESIGN SERVICES; GRAPHIC DESIGN; INDUSTRIAL DESIGN; INTERIOR DESIGN SERVICES; PACKAGING DESIGN (U.S. CLS. 100 AND 101).

FIRST USE 12-12-2008; IN COMMERCE 12-12-2008.
ALEX KEAM, EXAMINING ATTORNEY

CLASS 42—(Continued).

SN 85-537,120. INFUZ, INC., ST. LOUIS, MO. FILED 2-8-2012.

INFUZ

THE MARK CONSISTS OF STANDARD CHARACTERS WITHOUT CLAIM TO ANY PARTICULAR FONT, STYLE, SIZE, OR COLOR.

OWNER OF U.S. REG. NOS. 2,516,825 AND 2,516,828.

FOR DESIGN OF SOFTWARE, WEB SITES AND VISUALIZATION TECHNOLOGIES FOR ADVERTISEMENT OF COMMERCIAL PRODUCT AND BUSINESS OF OTHERS AND RELATED SOFTWARE AND WEB SITE DESIGN CONSULTING SERVICES IN THE FIELD OF INTERACTIVE ADVERTISING, MARKETING, MEDIA, ELECTRONIC COMMERCE AND ELECTRONIC BUSINESS (U.S. CLS. 100 AND 101).

FIRST USE 10-30-2010; IN COMMERCE 10-30-2010.

WILLIAM ROSSMAN, EXAMINING ATTORNEY

SN 85-540,773. JANET RICE INTERIORS, LLC, DBA JANET RICE INTERIORS, DALLAS, TX. FILED 2-13-2012.

101 By Janet Rice

THE MARK CONSISTS OF STANDARD CHARACTERS WITHOUT CLAIM TO ANY PARTICULAR FONT, STYLE, SIZE, OR COLOR.

THE NAME(S), PORTRAIT(S), AND/OR SIGNATURE(S) SHOWN IN THE MARK IDENTIFIES "JANET RICE", WHOSE CONSENT(S) TO REGISTER IS MADE OF RECORD.

FOR DESIGN FOR OTHERS IN THE FIELD OF INTERIOR DESIGN; DESIGN OF CUSTOMIZED BOOKS; DESIGN OF INTERIOR DECOR; INTERIOR DECORATING; INTERIOR DECORATION CONSULTATION; INTERIOR DESIGN SERVICES; INTERIOR DESIGN SERVICES INCLUDING SPACE PLANNING, FURNITURE SELECTION, MATERIAL AND SURFACE SELECTION; INTERIOR DESIGN SERVICES, NAMELY, CREATING A CUSTOM DESIGN SOLUTION FOR ONE OR MORE ROOMS, FEATURING AS PART OF THE INTERIOR DESIGN SERVICES, PRODUCTION OF A CUSTOMIZED BOOK CONTAINING A SCALE RENDERING, DETAILED INSTRUCTIONS, PRODUCT SPECIFICATIONS, AND SOURCES (U.S. CLS. 100 AND 101).

FIRST USE 7-1-2011; IN COMMERCE 7-1-2011.

CURTIS FRENCH, EXAMINING ATTORNEY

CLASS 42—(Continued).

SN 85-545,425. ERRUND, INC., AMHERST, MA. FILED 2-17-2012.

ERRUND

THE MARK CONSISTS OF STANDARD CHARACTERS WITHOUT CLAIM TO ANY PARTICULAR FONT, STYLE, SIZE, OR COLOR.

FOR COMPUTER SERVICES, NAMELY, CREATING AN ON-LINE COMMUNITY FOR REGISTERED USERS TO ENGAGE IN SERVICE, SOCIAL, BUSINESS AND COMMUNITY NETWORKING; PROVIDING WEB-BASED ONLINE NON-DOWNLOADABLE SOFTWARE FOR CREATING AN ONLINE MARKETPLACE FOR SERVICES FEATURING POSTING, SPECIFYING AND IDENTIFYING THE SCOPE AND COMPONENTS OF SERVICE REQUESTS; PROVIDING A WEBSITE THAT GIVES USERS THE ABILITY TO CREATE CUSTOMIZED WEB PAGES FEATURING USER-DEFINED INFORMATION FEATURING PERSONAL PROFILES, AUDIO, VIDEO, PHOTOGRAPHIC IMAGES, TEXT, GRAPHICS AND DATA; PROVIDING WEB-BASED ONLINE NON-DOWNLOADABLE SOFTWARE THAT ENABLES USERS TO SEARCH AND LOCATE SERVICE REQUESTS AND OTHER USERS; COMPUTER SERVICES, NAMELY, CREATING AN ON-LINE COMMUNITY FOR REGISTERED USERS TO PARTICIPATE IN DISCUSSIONS AND GET FEEDBACK FROM THEIR PEERS (U.S. CLS. 100 AND 101).

FIRST USE 11-10-2010; IN COMMERCE 2-9-2012.

KATHERINE E. HALMEN, EXAMINING ATTORNEY

SN 85-550,165. PAGEMARK TECHNOLOGY, INC., REDMOND, WA. FILED 2-22-2012.

Pelta

THE MARK CONSISTS OF STANDARD CHARACTERS WITHOUT CLAIM TO ANY PARTICULAR FONT, STYLE, SIZE, OR COLOR.

THE ENGLISH TRANSLATION OF "Pelta" IN THE MARK IS "SMALL SHIELD".

FOR DESIGN AND IMPLEMENTATION OF SOFTWARE AND TECHNOLOGY SOLUTIONS FOR THE PURPOSE OF PRODUCT AND DOCUMENT AUTHENTICATION AND TRACKING, AND BRAND MONITORING AND PROTECTION, TO PROTECT AGAINST COUNTERFEITING, TAMPERING, AND DIVERSION, AND TO ENSURE THE INTEGRITY OF GENUINE PRODUCTS AND DOCUMENTS (U.S. CLS. 100 AND 101).

FIRST USE 11-15-2010; IN COMMERCE 5-23-2011.

NICHOLAS ALTREE, EXAMINING ATTORNEY

CLASS 42—(Continued).

SN 85-551,117. SHIN, MIJEONG, CHICAGO, IL. FILED 2-23-2012.



THE COLOR(S) PURPLE AND GOLD IS/ARE CLAIMED AS A FEATURE OF THE MARK.

THE MARK CONSISTS OF THE WORDING "CUBEHILLS" IN PURPLE AND A STAR DESIGN COMPRISING 16 TRIANGLES IN ALTERNATING PURPLE AND GOLD COLORS WITH THE TRIANGLES MEETING AT A POINT IN THE CENTER OF THE STAR. THE WORDING "CUBEHILLS" APPEARS BELOW THE DESIGN ELEMENT IN AN INVERTED CURVE.

FOR CONSULTING SERVICES IN THE FIELD OF FENG SHUI DESIGN (U.S. CLS. 100 AND 101).

FIRST USE 2-1-2011; IN COMMERCE 3-1-2011.

LAURIE KAUFMAN, EXAMINING ATTORNEY

SN 85-561,907. YIELDEX, INC., NEW YORK, NY. FILED 3-6-2012.

YIELDEX

THE MARK CONSISTS OF STANDARD CHARACTERS WITHOUT CLAIM TO ANY PARTICULAR FONT, STYLE, SIZE, OR COLOR.

FOR SOFTWARE AS A SERVICE (SAAS) SERVICES FEATURING SOFTWARE FOR USE IN THE ANALYSIS, DELIVERY, DISTRIBUTION, MANAGEMENT, FORECASTING AND OPTIMIZATION OF ADVERTISING INVENTORY AND ADVERTISING REVENUE (U.S. CLS. 100 AND 101).

FIRST USE 1-8-2007; IN COMMERCE 8-4-2008.

JOSETTE BEVERLY, EXAMINING ATTORNEY

CLASS 42—(Continued).

SN 85-564,667. RAINWAVE, LLC, AUBURN, AL. FILED 3-8-2012.

RAINGRAPH "YOUR RAIN BY THE MINUTE"

THE MARK CONSISTS OF STANDARD CHARACTERS WITHOUT CLAIM TO ANY PARTICULAR FONT, STYLE, SIZE, OR COLOR.

NO CLAIM IS MADE TO THE EXCLUSIVE RIGHT TO USE "RAIN GRAPH", APART FROM THE MARK AS SHOWN.

FOR RAINFALL INFORMATION SERVICES, NAMELY, MEASURING, RECORDING, AND REPORTING RAINFALL INFORMATION (U.S. CLS. 100 AND 101).

EMILY CARLSEN, EXAMINING ATTORNEY

SN 85-564,808. UBM IP LUXEMBOURG S.À.R.L., PRINCE HENRI, LUXEMBOURG, FILED 3-9-2012.

MiGo

THE MARK CONSISTS OF STANDARD CHARACTERS WITHOUT CLAIM TO ANY PARTICULAR FONT, STYLE, SIZE, OR COLOR.

FOR PROVIDING ON-LINE NON-DOWNLOADABLE SOFTWARE FOR PROVIDING REAL-TIME TRAVEL-RELATED INFORMATION FEATURING FORECASTING, REPORTING AND MANAGING TRAVEL DISRUPTIONS AND RESPONDING TO TRAVEL DISRUPTIONS WITH ALTERNATE TRAVEL ROUTES, TRANSPORTATION AND OTHER TRAVEL OPTIONS (U.S. CLS. 100 AND 101).

REGINA DRUMMOND, EXAMINING ATTORNEY

SN 85-567,164. GROUPTHIGH LLC, BOULDER, CO. FILED 3-12-2012.

GroupHigh

THE MARK CONSISTS OF STANDARD CHARACTERS WITHOUT CLAIM TO ANY PARTICULAR FONT, STYLE, SIZE, OR COLOR.

FOR COMPUTER SERVICES, NAMELY, PROVIDING SEARCH PLATFORMS TO ALLOW USERS TO IDENTIFY BLOGGERS AND BLOGS ON THE INTERNET (U.S. CLS. 100 AND 101).

FIRST USE 12-1-2010; IN COMMERCE 5-1-2011.

KYLE PEETE, EXAMINING ATTORNEY

CLASS 42—(Continued).

SN 85-569,758. AXELERATE LLC, FORMERLY MP TECH LLC, BELLEVUE, WA. FILED 3-14-2012.

Axelerate

THE MARK CONSISTS OF STANDARD CHARACTERS WITHOUT CLAIM TO ANY PARTICULAR FONT, STYLE, SIZE, OR COLOR.

FOR COMPUTER AND INFORMATION TECHNOLOGY CONSULTING; COMPUTER PROJECT MANAGEMENT SERVICES; PRODUCT DEVELOPMENT CONSULTATION (U.S. CLS. 100 AND 101).

FIRST USE 1-0-2007; IN COMMERCE 1-0-2007.
APRIL HESIK, EXAMINING ATTORNEY

SN 85-569,899. AXELERATE LLC, FORMERLY MP TECH LLC, BELLEVUE, WA. FILED 3-14-2012.

The speed of business. Multiplied.

THE MARK CONSISTS OF STANDARD CHARACTERS WITHOUT CLAIM TO ANY PARTICULAR FONT, STYLE, SIZE, OR COLOR.

FOR COMPUTER AND INFORMATION TECHNOLOGY CONSULTING; COMPUTER PROJECT MANAGEMENT SERVICES; PRODUCT DEVELOPMENT CONSULTATION (U.S. CLS. 100 AND 101).

FIRST USE 1-1-2012; IN COMMERCE 1-1-2012.
APRIL HESIK, EXAMINING ATTORNEY

SN 85-570,460. PREVALENT NETWORKS, LLC, WARREN, NJ. FILED 3-15-2012.



NO CLAIM IS MADE TO THE EXCLUSIVE RIGHT TO USE "COMPLIANCE AS A SERVICE", APART FROM THE MARK AS SHOWN.

THE COLOR(S) BLUE, WHITE, BLACK AND TEAL IS/ ARE CLAIMED AS A FEATURE OF THE MARK.

THE MARK CONSISTS OF A STYLIZED BLUE CIRCLE CONTAINING A STYLIZED WHITE LETTER "P", ABOVE A WHITE STYLIZED CLOUD OUTLINED IN BLACK. NEXT TO THE CIRCLE IS THE BLACK WORD "PREVALENT" ABOVE THE TEAL WORD "COMPLIANCE" ABOVE THE TEAL WORDS "AS A SERVICE".

FOR CLOUD COMPUTING FEATURING SOFTWARE FOR USE IN MANAGING A COMPLIANCE REGULATION DATABASE (U.S. CLS. 100 AND 101).

FIRST USE 9-0-2011; IN COMMERCE 9-0-2011.
SHAILA SETTLES, EXAMINING ATTORNEY

CLASS 42—(Continued).

SN 85-575,174. PROJECT B DESIGN GROUP, DALLAS, TX. FILED 3-20-2012.

Project B Design Group

THE MARK CONSISTS OF STANDARD CHARACTERS WITHOUT CLAIM TO ANY PARTICULAR FONT, STYLE, SIZE, OR COLOR.

NO CLAIM IS MADE TO THE EXCLUSIVE RIGHT TO USE "DESIGN GROUP", APART FROM THE MARK AS SHOWN.

FOR INTERIOR DESIGN SERVICES INCLUDING SPACE PLANNING, FURNITURE SELECTION, MATERIAL AND SURFACE SELECTION (U.S. CLS. 100 AND 101).

ALAIN LAPTER, EXAMINING ATTORNEY

SN 85-575,818. GROWBUDDY, LONE TREE, CO. FILED 3-21-2012.

GrowBuddy

THE MARK CONSISTS OF STANDARD CHARACTERS WITHOUT CLAIM TO ANY PARTICULAR FONT, STYLE, SIZE, OR COLOR.

FOR PROVIDING A MEMBERS-ONLY WEBSITE FEATURING TECHNOLOGY WHICH PROVIDES MEMBERS WITH A SECURE ENVIRONMENT TO EXCHANGE IDEAS BETWEEN MEMBERS AND MAINTAIN, TRACK AND MANAGE NUTRIENT SCHEDULES, GROWTH SYSTEMS, AND OTHER PROCESSES AND PROCEDURES IN CONNECTION WITH HORTICULTURAL OPERATIONS; PROVIDING A SECURED-ACCESS, MEMBERS ONLY WEBSITE FEATURING TECHNOLOGY THAT GIVES MEMBERS THE ABILITY TO EXCHANGE IDEAS BETWEEN MEMBERS AND MAINTAIN, TRACK AND MANAGE NUTRIENT SCHEDULES, GROWTH SYSTEMS, AND OTHER PROCESSES AND PROCEDURES IN CONNECTION WITH HORTICULTURAL OPERATIONS; PROVIDING A WEB SITE FEATURING TECHNOLOGY THAT ENABLES USERS TO EXCHANGE IDEAS BETWEEN USERS AND MAINTAIN, TRACK AND MANAGE NUTRIENT SCHEDULES, GROWTH SYSTEMS, AND OTHER PROCESSES AND PROCEDURES IN CONNECTION WITH HORTICULTURAL OPERATIONS; PROVIDING A WEBSITE FEATURING ON-LINE NON-DOWNLOADABLE SOFTWARE THAT ENABLES USERS TO EXCHANGE IDEAS BETWEEN USERS AND MAINTAIN, TRACK AND MANAGE NUTRIENT SCHEDULES, GROWTH SYSTEMS, AND OTHER PROCESSES AND PROCEDURES IN CONNECTION WITH HORTICULTURAL OPERATIONS; PROVIDING A WEBSITE THAT FEATURES TECHNOLOGY THAT ENABLES THE SECURE EXCHANGE OF INFORMATION BY USERS (U.S. CLS. 100 AND 101).

FIRST USE 1-0-2011; IN COMMERCE 1-0-2011.
BERYL GARDNER, EXAMINING ATTORNEY

CLASS 42—(Continued).

SN 85-576,971. INVENTSAI, LLC, CANONSBURG, PA. FILED 3-22-2012.

InventSAI

THE MARK CONSISTS OF STANDARD CHARACTERS WITHOUT CLAIM TO ANY PARTICULAR FONT, STYLE, SIZE, OR COLOR.

FOR RESEARCH AND DEVELOPMENT OF NEW PRODUCTS; RESEARCH AND DEVELOPMENT OF NEW PRODUCTS FOR OTHERS (U.S. CLS. 100 AND 101). FIRST USE 1-0-2001; IN COMMERCE 1-0-2001.
LEIGH LOWRY, EXAMINING ATTORNEY

SN 85-582,767. VYCLONE, INC., NEWBURY PARK, CA. FILED 3-28-2012.

REALLY SOCIAL MEDIA

THE MARK CONSISTS OF STANDARD CHARACTERS WITHOUT CLAIM TO ANY PARTICULAR FONT, STYLE, SIZE, OR COLOR.

NO CLAIM IS MADE TO THE EXCLUSIVE RIGHT TO USE "SOCIAL MEDIA", APART FROM THE MARK AS SHOWN.

FOR PROVIDING AN INTERACTIVE WEBSITE FEATURING TECHNOLOGY THAT ALLOWS USERS TO VIEW, SYNCHRONIZE, EDIT AND SHARE VIDEOS RECORDED FROM MULTIPLE SOURCES (U.S. CLS. 100 AND 101).

KAREN BRACEY, EXAMINING ATTORNEY

SN 85-582,871. GLOBAL PRACTICE NETWORK, SAN DIEGO, CA. FILED 3-28-2012.



THE MARK CONSISTS OF THE STYLIZED WORD "ELEVATE" WITH THE LAST "E" RAISED HIGHER AND A SHADOW BELOW THAT "E". THE TEXT "CDS" HOVERS ABOVE IN A CLOUD TO THE RIGHT OF "ELEVATE".

FOR SOFTWARE AS A SERVICE (SAAS) SERVICES FEATURING SOFTWARE FOR ENABLING SECURE DELIVERY AND SHARING OF DOCUMENTS AND DATA BETWEEN CLIENTS AND OTHER PROFESSIONALS (U.S. CLS. 100 AND 101).

NAKWAMA ANKRAH, EXAMINING ATTORNEY

CLASS 42—(Continued).

SN 85-583,642. BEG, WAHEED, DBA GHZ NETWORKS, ANNANDALE, VA. FILED 3-29-2012.



NO CLAIM IS MADE TO THE EXCLUSIVE RIGHT TO USE "NETWORKS" AND "FAST.RELIABLE.SECURE.", APART FROM THE MARK AS SHOWN.

THE COLOR(S) OLIVE GREEN, GREEN AND BLACK IS/ARE CLAIMED AS A FEATURE OF THE MARK.

THE MARK CONSISTS OF THE LETTERS "GHZ" IN GREEN AND OLIVE GREEN NEXT TO THE WORD "NETWORKS". THE LETTER "O" IN "NETWORKS" CONSISTS OF THE DESIGN OF A CUBE IN GREEN WITH THE LETTERS "GHZ" IN OLIVE GREEN INSIDE OF IT. THE REMAINING LETTERS IN THE WORD "NETWORKS" ARE BLACK. THE PHRASE "FAST.RELIABLE.SECURE." APPEARS BELOW THE WORD "NETWORKS" IN GREEN.

FOR COMPUTER SERVICES, NAMELY, ON-SITE MANAGEMENT OF INFORMATION TECHNOLOGY (IT) SYSTEMS; COMPUTER SERVICES, NAMELY, REMOTE AND ON-SITE MANAGEMENT OF COMPUTERS, SERVERS AND NETWORK OF OTHERS (U.S. CLS. 100 AND 101).

FIRST USE 2-1-2009; IN COMMERCE 2-1-2009.

AHSEN KHAN, EXAMINING ATTORNEY

SN 85-585,440. WEBSTER FINANCIAL CORPORATION, WATERBURY, CT. FILED 3-30-2012.

HEALTH E-VANTAGE

THE MARK CONSISTS OF STANDARD CHARACTERS WITHOUT CLAIM TO ANY PARTICULAR FONT, STYLE, SIZE, OR COLOR.

NO CLAIM IS MADE TO THE EXCLUSIVE RIGHT TO USE "HEALTH", APART FROM THE MARK AS SHOWN.

FOR PROVIDING AN INTERACTIVE WEB SITE FEATURING TECHNOLOGY THAT ENABLES USERS TO ORGANIZE, MANAGE AND PAY THEIR HEALTHCARE EXPENSES; PROVIDING USE OF ONLINE NON-DOWNLOADABLE SOFTWARE THAT ENABLES USERS TO ORGANIZE, MANAGE AND PAY THEIR HEALTHCARE EXPENSES (U.S. CLS. 100 AND 101).

DANIEL CAPSHAW, EXAMINING ATTORNEY

CLASS 42—(Continued).

SN 85-588,052. SOCIAL IQ NETWORKS INC., BURLINGAME, CA. FILED 4-3-2012.



NO CLAIM IS MADE TO THE EXCLUSIVE RIGHT TO USE "SOCIAL NETWORKS", APART FROM THE MARK AS SHOWN.

THE COLOR(S) BLACK, BLUE AND WHITE IS/ARE CLAIMED AS A FEATURE OF THE MARK.

THE MARK CONSISTS OF THE TERMS "SOCIAL NETWORKS" IN BLACK, FOLLOWED BY A CONVERSATION BALLOON IN BLUE HAVING THE LETTERS "IQ" INSIDE IN WHITE.

FOR SOFTWARE AS A SERVICE (SAAS) SERVICES, NAMELY, HOSTING SOFTWARE FOR USE BY OTHERS FOR USE IN DISCOVERING, MANAGING AND SECURING SOCIAL NETWORKING ACCOUNTS ASSOCIATED WITH A BRAND OR ENTERPRISE (U.S. CLS. 100 AND 101).

FIRST USE 3-31-2011; IN COMMERCE 6-21-2011.

RAUL CORDOVA, EXAMINING ATTORNEY

SN 85-589,781. TRACERISK, LLC, SAN JUAN CAPISTRANO, CA. FILED 4-5-2012.



THE COLOR(S) BLUE AND GRAY IS/ARE CLAIMED AS A FEATURE OF THE MARK.

THE MARK CONSISTS OF THE STYLIZED WORDING TRACERISK TRACE YOUR RISK TO ITS SOURCE AND RECTANGLE DESIGNS. THE LARGEST RECTANGLE IS IN SHADES OF GRAY WITH A DARK GRAY MIDDLE. THE NEXT LARGEST RECTANGLE IS IN SHADES OF GRAY WITH A BLUE MIDDLE. THE SMALLEST RECTANGLE IS COMPLETELY BLUE. IN THE WORDING TRACERISK, THE WORD TRACE IS GRAY, WHILE THE WORD RISK IS BLUE. THE WORDING TRACERISK HAS A GRAY SHADOW. THE WORDING TRACE YOUR RISK TO ITS SOURCE IS BLUE.

FOR PROVIDING A WEB SITE FEATURING TEMPORARY USE OF NON-DOWNLOADABLE SOFTWARE FOR BUSINESSES TO ACCESS AND ASSESS INTERNAL BUSINESS PRACTICES, MAINTAIN DOCUMENTS AND SCHEDULE ALERTS AND NOTIFICATIONS AS IT RELATES TO IMPORTANT BUSINESS ISSUES (U.S. CLS. 100 AND 101).

FIRST USE 1-1-2012; IN COMMERCE 3-15-2012.

BRIAN PINO, EXAMINING ATTORNEY

CLASS 42—(Continued).

SN 85-589,906. AXOGEN, INC., ALACHUA, FL. FILED 4-5-2012.

RANGER

THE MARK CONSISTS OF STANDARD CHARACTERS WITHOUT CLAIM TO ANY PARTICULAR FONT, STYLE, SIZE, OR COLOR.

FOR SCIENTIFIC RESEARCH FOR MEDICAL PURPOSES IN THE AREA OF NERVE REPAIR AND RECONSTRUCTION; SCIENTIFIC RESEARCH FOR MEDICAL PURPOSES IN THE FIELD OF PLASTIC, ORTHOPEDIC, NEUROLOGY, UROLOGY, AND/OR ENT SURGERY FOR TREATMENT OF NERVE INJURIES IN HUMANS; PROVIDING MEDICAL AND SCIENTIFIC RESEARCH INFORMATION RELATING TO MEDICAL TREATMENT IN THE NATURE OF RESULTS OF SCIENTIFIC RESEARCH AND CLINICAL DATA IN THE AREA OF NERVE REPAIR AND RECONSTRUCTION PROVIDED THROUGH A DATABASE THAT ALLOWS INPUT AND COLLECTION OF DATA AND INFORMATION; CLINICAL RESEARCH IN THE AREA OF NERVE REPAIR AND RECONSTRUCTION TO PROVIDE INFORMATION ON FUNCTIONAL RECOVERY AND TREATMENT OUTCOMES (U.S. CLS. 100 AND 101).

JESSICA A. POWERS, EXAMINING ATTORNEY

SN 85-590,019. DECIPHER, INC., FRESNO, CA. FILED 4-5-2012.

Beacon Survey Solutions

THE MARK CONSISTS OF STANDARD CHARACTERS WITHOUT CLAIM TO ANY PARTICULAR FONT, STYLE, SIZE, OR COLOR.

NO CLAIM IS MADE TO THE EXCLUSIVE RIGHT TO USE "SURVEY SOLUTIONS", APART FROM THE MARK AS SHOWN.

FOR PROVIDING ONLINE NON-DOWNLOADABLE SOFTWARE FOR USE IN DATA COLLECTION AND DATA MANAGEMENT IN THE FIELD OF MARKET RESEARCH (U.S. CLS. 100 AND 101).

WANDA KAY PRICE, EXAMINING ATTORNEY

CLASS 42—(Continued).

SN 85-590,533. PROSITES, INC., TEMECULA, CA. FILED 4-5-2012.

TAP FOR APP

THE MARK CONSISTS OF STANDARD CHARACTERS WITHOUT CLAIM TO ANY PARTICULAR FONT, STYLE, SIZE, OR COLOR.

FOR CREATING AND HOSTING ICON IMAGES FOR OTHERS FOR THE PURPOSES OF BOOKMARKING AND LINKING TO WEBSITES ON A TOUCH-ENABLED DEVICE (U.S. CLS. 100 AND 101).

LINDA M. KING, EXAMINING ATTORNEY

SN 85-590,597. KIPNIS INSPECTIONS, INC., MANALAPAN, NJ. FILED 4-5-2012.

INSPECT IT NEIL

THE MARK CONSISTS OF STANDARD CHARACTERS WITHOUT CLAIM TO ANY PARTICULAR FONT, STYLE, SIZE, OR COLOR.

NO CLAIM IS MADE TO THE EXCLUSIVE RIGHT TO USE "INSPECT", APART FROM THE MARK AS SHOWN.

FOR INSPECTIONS OF HOMES AND COMMERCIAL PROPERTIES (U.S. CLS. 100 AND 101).

FIRST USE 1-31-2008; IN COMMERCE 1-31-2008.

FRANK LATTUCA, EXAMINING ATTORNEY

SN 85-590,747. TAQTIQA, DBA TAQOVERFLOW.COM, WILMINGTON, DE. FILED 4-5-2012.

TAQ OVERFLOW

THE MARK CONSISTS OF STANDARD CHARACTERS WITHOUT CLAIM TO ANY PARTICULAR FONT, STYLE, SIZE, OR COLOR.

NO CLAIM IS MADE TO THE EXCLUSIVE RIGHT TO USE "TAQ", APART FROM THE MARK AS SHOWN.

THE WORDING TAQ HAS NO MEANING IN A FOREIGN LANGUAGE.

FOR APPLICATION SERVICE PROVIDER FEATURING APPLICATION PROGRAMMING INTERFACE (API) SOFTWARE FOR RETRIEVING AND DISPLAYING USER SPECIFIC REPUTATION METRICS; COMPUTER SERVICES, NAMELY, CREATING AN ON-LINE COMMUNITY FOR REGISTERED USERS TO PARTICIPATE IN DISCUSSIONS, GET FEEDBACK FROM THEIR PEERS, FORM VIRTUAL COMMUNITIES, AND ENGAGE IN SOCIAL NETWORKING SERVICES IN THE FIELD OF FINANCE/FINANCIAL ECONOMICS AND FINANCIAL MARKETS; COMPUTER SERVICES, NAMELY, CREATING AN ON-LINE COMMUNITY FOR REGISTERED USERS TO ASK AND ANSWER QUESTIONS ON A VARIETY OF TOPICS OF INTEREST IN FINANCE/FINANCIAL ECONOMICS AND FINAN-

CLASS 42—(Continued).

cial markets; COMPUTER SERVICES, NAMELY, HOSTING AN INTERACTIVE WEB SITE THAT ALLOWS REGISTERED USERS INTERESTED IN FINANCE/FINANCIAL ECONOMICS AND FINANCIAL MARKETS TO PARTICIPATE IN DISCUSSIONS, GET FEEDBACK FROM THEIR PEERS, FORM VIRTUAL COMMUNITIES, AND ENGAGE IN SOCIAL NETWORKING; COMPUTER SERVICES, NAMELY, INTERACTIVE HOSTING SERVICES WHICH ALLOW THE USER TO PUBLISH AND SHARE THEIR OWN CONTENT AND IMAGES ONLINE; COMPUTER SERVICES, NAMELY, PROVIDING AN INTERACTIVE WEB SITE FEATURING TECHNOLOGY THAT ALLOWS USERS TO COLLECT, STORE, MANAGE, DELIVER AND SHOWCASE ELECTRONIC AND PAPER-BASED CONTENT; COMPUTER SERVICES, NAMELY, PROVIDING AN INTERACTIVE WEB SITE FEATURING TECHNOLOGY THAT ALLOWS USERS TO CONSOLIDATE AND MANAGE SOCIAL NETWORKS, ACCOUNTS, AND CONNECTIONS TO EXISTING AND EMERGING APPLICATION PROGRAMMING INTERFACES (APIS); COMPUTER SERVICES, NAMELY, PROVIDING CUSTOMIZED WEB PAGES FEATURING USER-DEFINED INFORMATION; COMPUTER SERVICES, NAMELY, PROVIDING SEARCH ENGINES FOR OBTAINING DATA ON A GLOBAL COMPUTER NETWORK; COMPUTER SERVICES, NAMELY, PROVIDING SEARCH ENGINES FOR OBTAINING INFORMATION RELATED TO FINANCE/FINANCIAL ECONOMICS AND FINANCIAL MARKETS ON A GLOBAL COMPUTER NETWORK; COMPUTER SERVICES, NAMELY, PROVIDING SEARCH PLATFORMS TO ALLOW USERS TO RANK RESULTS ACCORDING TO THE REPUTATION OF THE INFORMATION PROVIDER; CREATING AN ON-LINE COMMUNITY FOR PEOPLE INTERESTED IN FINANCE/FINANCIAL ECONOMICS AND FINANCIAL MARKET FOR THE PURPOSE OF ASKING QUESTIONS, COMMENTING ON AND ANSWERING QUESTIONS AND RATING THE QUESTIONS, ANSWERS AND COMMENTS; DATA CONVERSION OF ELECTRONIC INFORMATION; PROVIDING A SECURED-ACCESS, MEMBERS ONLY WEBSITE FEATURING TECHNOLOGY THAT GIVES MEMBERS THE ABILITY TO ASK QUESTIONS, COMMENT ON AND ANSWER QUESTIONS, AS WELL AS RATE THE QUESTIONS, ANSWERS AND COMMENTS; PROVIDING A WEBSITE THAT FEATURES TECHNOLOGY THAT ENABLES THE SECURE EXCHANGE OF INFORMATION BY USERS; PROVIDING A WEBSITE THAT GIVES COMPUTER USERS THE ABILITY TO SHARE, EXCHANGE AND COMMENT ON COMPUTER CODE AS TEXT; PROVIDING AN ON-LINE NETWORK ENVIRONMENT THAT FEATURES TECHNOLOGY THAT ENABLES USERS TO SHARE DATA; PROVIDING AN ONLINE NETWORK SERVICE THAT ENABLES USERS TO SHARE DATA IN THE FIELD OF FINANCE/FINANCIAL ECONOMICS AND FINANCIAL MARKETS; PROVIDING CUSTOMIZED COMPUTER SEARCHING SERVICES, NAMELY, SEARCHING AND RETRIEVING INFORMATION AT THE CUSTOMER'S SPECIFIC REQUEST VIA THE INTERNET; PROVIDING INFORMATION IN THE FIELDS OF TECHNOLOGY AND SOFTWARE DEVELOPMENT VIA AN ON-LINE WEBSITE; PROVIDING SCIENTIFIC INFORMATION IN THE FIELD OF FINANCE/FINANCIAL ECONOMICS AND FINANCIAL MARKETS (U.S. CLS. 100 AND 101).

BRIAN PINO, EXAMINING ATTORNEY

CLASS 42—(Continued).

SN 85-591,069. CONSONA CORPORATION, INDIANAPOLIS, IN. FILED 4-6-2012.

YOU SAY YOU WANT A RESOLUTION?

THE MARK CONSISTS OF STANDARD CHARACTERS WITHOUT CLAIM TO ANY PARTICULAR FONT, STYLE, SIZE, OR COLOR.

FOR PROVIDING ON-LINE NON-DOWNLOADABLE SOFTWARE FOR USE IN CREATING, SEARCHING AND RETRIEVING INFORMATION FROM DATABASES, COMPUTER AND PUBLIC NETWORKS, FOR USE IN ANALYZING AND INDEXING INFORMATION FOR THE PURPOSE OF RESOLVING CUSTOMER ISSUES ACROSS MULTIPLE CHANNELS, AND FOR USE IN MANAGING BUSINESS PROCESSES, ALL IN THE FIELDS OF CUSTOMER RELATIONSHIP MANAGEMENT AND KNOWLEDGE MANAGEMENT (U.S. CLS. 100 AND 101).

KATHERINE M. DUBRAY, EXAMINING ATTORNEY

SN 85-591,073. CONSONA CORPORATION, INDIANAPOLIS, IN. FILED 4-6-2012.

RESOLUTIONIZING

THE MARK CONSISTS OF STANDARD CHARACTERS WITHOUT CLAIM TO ANY PARTICULAR FONT, STYLE, SIZE, OR COLOR.

FOR PROVIDING ON-LINE NON-DOWNLOADABLE SOFTWARE FOR USE IN CREATING, SEARCHING AND RETRIEVING INFORMATION FROM DATABASES, COMPUTER AND PUBLIC NETWORKS, FOR USE IN ANALYZING AND INDEXING INFORMATION FOR THE PURPOSE OF RESOLVING CUSTOMER ISSUES ACROSS MULTIPLE CHANNELS, AND FOR USE IN MANAGING BUSINESS PROCESSES, ALL IN THE FIELDS OF CUSTOMER RELATIONSHIP MANAGEMENT AND KNOWLEDGE MANAGEMENT (U.S. CLS. 100 AND 101).

KATHERINE M. DUBRAY, EXAMINING ATTORNEY

CLASS 42—(Continued).

SN 85-591,078. CONSONA CORPORATION, INDIANAPOLIS, IN. FILED 4-6-2012.

RESOLUTIONARY

THE MARK CONSISTS OF STANDARD CHARACTERS WITHOUT CLAIM TO ANY PARTICULAR FONT, STYLE, SIZE, OR COLOR.

FOR PROVIDING ON-LINE NON-DOWNLOADABLE SOFTWARE FOR USE IN CREATING, SEARCHING AND RETRIEVING INFORMATION FROM DATABASES, COMPUTER AND PUBLIC NETWORKS, FOR USE IN ANALYZING AND INDEXING INFORMATION FOR THE PURPOSE OF RESOLVING CUSTOMER ISSUES ACROSS MULTIPLE CHANNELS, AND FOR USE IN MANAGING BUSINESS PROCESSES, ALL IN THE FIELDS OF CUSTOMER RELATIONSHIP MANAGEMENT AND KNOWLEDGE MANAGEMENT (U.S. CLS. 100 AND 101).

KATHERINE M. DUBRAY, EXAMINING ATTORNEY

SN 85-591,805. ZEEHI LLC, BOULDER, CO. FILED 4-7-2012.

CueCast

THE MARK CONSISTS OF STANDARD CHARACTERS WITHOUT CLAIM TO ANY PARTICULAR FONT, STYLE, SIZE, OR COLOR.

FOR APPLICATION SERVICE PROVIDER, NAMELY, HOSTING, MANAGING, DEVELOPING, AND MAINTAINING SOFTWARE APPLICATIONS AND WEB SITES USED IN THE PRODUCTION OF LIVE PERFORMANCES, SPORTING EVENTS, TELEVISION, FILM AND OTHER LIVE OR RECORDED ENTERTAINMENT, AND FOR USE IN STAGE AND VENUE LIGHTING, SOUND SYSTEMS, SOUND AND AUDIO DATA STORAGE AND DATA SHARING, SOUND RECORDING, PYROTECHNICS, SCRIPT AND SCORE MANAGEMENT, AND SET AND PRODUCTION OPERATIONS AND MANAGEMENT; APPLICATION SERVICE PROVIDER, NAMELY, HOSTING, MANAGING, DEVELOPING, AND MAINTAINING SOFTWARE INTERFACE APPLICATIONS FOR USE IN DIGITAL AUDIO MIXING CONSOLES, STAGE AND HOUSE LIGHTING BOARDS, AND IN OTHER ASPECTS OF THE PRODUCTION OF TELEVISION, FILM, LIVE ENTERTAINMENT AND SPORTING EVENTS; CROSS-PLATFORM CONVERSION OF DIGITAL CONTENT INTO OTHER FORMS OF DIGITAL CONTENT (U.S. CLS. 100 AND 101).

KIMBERLY FRYE, EXAMINING ATTORNEY

CLASS 42—(Continued).

SN 85-591,964. MARCO, MIKE Z., DBA IDEAS FOR A BETTER WORLD, CHICAGO, IL. FILED 4-8-2012.

Ideas For A Better World

THE MARK CONSISTS OF STANDARD CHARACTERS WITHOUT CLAIM TO ANY PARTICULAR FONT, STYLE, SIZE, OR COLOR.

FOR PROVIDING A SOCIAL NETWORKING WEBSITE WHICH FEATURES TECHNOLOGY THAT ENABLES USERS TO GIVE CHARITABLE FINANCIAL GIFTS TO OTHERS; PROVIDING A WEBSITE THAT GIVES USERS THE ABILITY TO REVIEW VARIOUS PRINT, PHOTOGRAPHIC, GRAPHIC IMAGE, AND AUDIO AND VIDEO CONTENT AND UTILIZE A CUSTOM TEMPLATE TO PROVIDE INPUT, LIKES, DISLIKES, EDITS, CHANGES, MODIFICATIONS, OPINIONS, SUGGESTIONS, AND COMMENTS AND ENGAGE IN SOCIAL, BUSINESS AND COMMUNITY NETWORKING (U.S. CLS. 100 AND 101).

FIRST USE 12-10-2009; IN COMMERCE 12-10-2009.
SETH A. RAPPAPORT, EXAMINING ATTORNEY

SN 85-592,243. NANOCOPOEIA, INC., ST. PAUL, MN. FILED 4-9-2012.

ELECTRONANOSPRAY

THE MARK CONSISTS OF STANDARD CHARACTERS WITHOUT CLAIM TO ANY PARTICULAR FONT, STYLE, SIZE, OR COLOR.

FOR RESEARCH AND DEVELOPMENT OF PHARMACEUTICAL PRODUCTS FOR OTHERS; DEVELOPMENT OF PHARMACEUTICAL DRUG FORMULAS FOR OTHERS (U.S. CLS. 100 AND 101).

JENNIFER WILLISTON, EXAMINING ATTORNEY

SN 85-592,265. NANOCOPOEIA, INC., ST. PAUL, MN. FILED 4-9-2012.

NANOCOPOEIA

THE MARK CONSISTS OF STANDARD CHARACTERS WITHOUT CLAIM TO ANY PARTICULAR FONT, STYLE, SIZE, OR COLOR.

FOR RESEARCH AND DEVELOPMENT OF PHARMACEUTICAL PRODUCTS FOR OTHERS; DEVELOPMENT OF PHARMACEUTICAL DRUG FORMULAS FOR OTHERS (U.S. CLS. 100 AND 101).

JENNIFER WILLISTON, EXAMINING ATTORNEY

CLASS 42—(Continued).

SN 85-592,344. M.R. WILLIAMS, INC, HENDERSON, NC. FILED 4-9-2012.

Verge Connect

THE MARK CONSISTS OF STANDARD CHARACTERS WITHOUT CLAIM TO ANY PARTICULAR FONT, STYLE, SIZE, OR COLOR.

NO CLAIM IS MADE TO THE EXCLUSIVE RIGHT TO USE "CONNECT", APART FROM THE MARK AS SHOWN.

FOR COMPUTER SOFTWARE DEVELOPMENT IN THE FIELD OF MOBILE APPLICATIONS (U.S. CLS. 100 AND 101).

FIRST USE 3-1-2012; IN COMMERCE 3-1-2012.
CHRISIE B. KING, EXAMINING ATTORNEY

SN 85-593,168. JUAREZ, LISA, PARRISH, FL. FILED 4-10-2012.

MEDIAVIRTUE

THE MARK CONSISTS OF STANDARD CHARACTERS WITHOUT CLAIM TO ANY PARTICULAR FONT, STYLE, SIZE, OR COLOR.

FOR COMPUTER GRAPHICS DESIGN SERVICES; DESIGN AND CREATING WEB SITES FOR OTHERS; DESIGN AND DEVELOPMENT OF COMPUTER HARDWARE; DESIGN AND DEVELOPMENT OF COMPUTER SOFTWARE; DESIGN AND DEVELOPMENT OF PHONE SOFTWARE AND SOFTWARE APPLICATIONS FOR USE IN DIGITAL MARKETING AND PRINT MARKETING; DESIGN OF MOBILE TELEPHONES; DEVELOPMENT OF NEW TECHNOLOGY FOR OTHERS IN THE FIELD OF COMPUTERS (U.S. CLS. 100 AND 101).

JEFF DEFORD, EXAMINING ATTORNEY

SN 85-593,295. CONSONA CORPORATION, INDIANAPOLIS, IN. FILED 4-10-2012.

JOIN THE RESOLUTION

THE MARK CONSISTS OF STANDARD CHARACTERS WITHOUT CLAIM TO ANY PARTICULAR FONT, STYLE, SIZE, OR COLOR.

FOR PROVIDING ON-LINE NON-DOWNLOADABLE SOFTWARE FOR USE IN CREATING, SEARCHING AND RETRIEVING INFORMATION FROM DATABASES, COMPUTER AND PUBLIC NETWORKS, FOR USE IN ANALYZING AND INDEXING INFORMATION FOR THE PURPOSE OF RESOLVING CUSTOMER ISSUES ACROSS MULTIPLE CHANNELS, AND FOR USE IN MANAGING BUSINESS PROCESSES, ALL IN THE FIELDS OF CUSTOMER RELATIONSHIP MANAGEMENT AND KNOWLEDGE MANAGEMENT (U.S. CLS. 100 AND 101).

KATHERINE M. DUBRAY, EXAMINING ATTORNEY

CLASS 42—(Continued).

SN 85-593,301. CONSONA CORPORATION, INDIANAPOLIS, IN. FILED 4-10-2012.

RESOLUTIONIZE

THE MARK CONSISTS OF STANDARD CHARACTERS WITHOUT CLAIM TO ANY PARTICULAR FONT, STYLE, SIZE, OR COLOR.

FOR PROVIDING ON-LINE NON-DOWNLOADABLE SOFTWARE FOR USE IN CREATING, SEARCHING AND RETRIEVING INFORMATION FROM DATABASES, COMPUTER AND PUBLIC NETWORKS, FOR USE IN ANALYZING AND INDEXING INFORMATION FOR THE PURPOSE OF RESOLVING CUSTOMER ISSUES ACROSS MULTIPLE CHANNELS, AND FOR USE IN MANAGING BUSINESS PROCESSES, ALL IN THE FIELDS OF CUSTOMER RELATIONSHIP MANAGEMENT AND KNOWLEDGE MANAGEMENT (U.S. CLS. 100 AND 101).

KATHERINE M. DUBRAY, EXAMINING ATTORNEY

CLASS 42—(Continued).

SN 85-593,508. LACONIC SECURITY, LLC, BROOMFIELD, CO. FILED 4-10-2012.

LACONIC SECURITY

THE MARK CONSISTS OF STANDARD CHARACTERS WITHOUT CLAIM TO ANY PARTICULAR FONT, STYLE, SIZE, OR COLOR.

NO CLAIM IS MADE TO THE EXCLUSIVE RIGHT TO USE "SECURITY", APART FROM THE MARK AS SHOWN. FOR COMPUTER SECURITY CONSULTANCY; COMPUTER SERVICES FOR SECURITY OPERATIONS AND APPLICATION, NAMELY, RESTRICTING ACCESS TO AND BY COMPUTER NETWORKS TO AND OF UN-DESIRED WEB SITES, MEDIA AND INDIVIDUALS AND FACILITIES; AND NETWORK SECURITY TESTING SERVICES, NAMELY, SCANNING AND PENETRATION TESTING OF COMPUTERS AND NETWORKS TO ASSESS INFORMATION SECURITY VULNERABILITY (U.S. CLS. 100 AND 101).

FIRST USE 9-15-2008; IN COMMERCE 10-15-2008.
VIVIAN MICZNIK FIRST, EXAMINING ATTORNEY

SN 85-593,446. TIMELESS TECHNOLOGIES (2007) INC., CHARLOTTETOWN, CANADA, FILED 4-10-2012.

DOMAINHOLE

THE MARK CONSISTS OF STANDARD CHARACTERS WITHOUT CLAIM TO ANY PARTICULAR FONT, STYLE, SIZE, OR COLOR.

PRIORITY CLAIMED UNDER SEC. 44(D) ON CANADA APPLICATION NO. 1547958, FILED 10-11-2011.

FOR DOMAIN NAME SEARCH SERVICES, NAMELY, CONDUCTING ONLINE COMPUTERIZED SEARCHES FOR THE AVAILABILITY OF DOMAIN NAMES (U.S. CLS. 100 AND 101).

FIRST USE 4-0-2011; IN COMMERCE 4-0-2011.
LAURIE KAUFMAN, EXAMINING ATTORNEY

SN 85-593,722. JOHN HANCOCK LIFE INSURANCE COMPANY (U.S.A.), BOSTON, MA. FILED 4-10-2012.

VUL TARGETTRACK

THE MARK CONSISTS OF STANDARD CHARACTERS WITHOUT CLAIM TO ANY PARTICULAR FONT, STYLE, SIZE, OR COLOR.

NO CLAIM IS MADE TO THE EXCLUSIVE RIGHT TO USE "VUL", APART FROM THE MARK AS SHOWN.

FOR SOFTWARE AS A SERVICE (SAAS) SERVICES FEATURING SOFTWARE FOR USE BY FINANCIAL PROFESSIONALS IN MANAGING INSURANCE PORTFOLIOS (U.S. CLS. 100 AND 101).

NANCY CLARKE, EXAMINING ATTORNEY

CLASS 42—(Continued).

SN 85-593,856. ZEN PLANNER, LLC, LITTLETON, CO. FILED 4-10-2012.

ZEN PLANNER

THE MARK CONSISTS OF STANDARD CHARACTERS WITHOUT CLAIM TO ANY PARTICULAR FONT, STYLE, SIZE, OR COLOR.

NO CLAIM IS MADE TO THE EXCLUSIVE RIGHT TO USE "PLANNER", APART FROM THE MARK AS SHOWN.

FOR SOFTWARE AS A SERVICE (SAAS) SERVICES FEATURING SOFTWARE FOR APPOINTMENT AND RESERVATION SCHEDULING, CALENDARING, MEMBERSHIP SERVICE MANAGEMENT, CUSTOMER RELATIONSHIP MANAGEMENT, BILLING AND PAYMENT MANAGEMENT, AND BUSINESS MANAGEMENT, ALL FOR MEMBERSHIP-BASED BUSINESSES IN THE FIELDS OF PHYSICAL FITNESS, WELLNESS, BEAUTY, HEALTH, AND SPORTS CLUBS (U.S. CLS. 100 AND 101).

FIRST USE 10-2-2007; IN COMMERCE 10-2-2007.
KATHERINE CHANG, EXAMINING ATTORNEY

CLASS 42—(Continued).

SN 85-594,425. INSPECT-RITE QUALITY HOME INSPECTIONS, LLC, BRILLION, WI. FILED 4-11-2012.



NO CLAIM IS MADE TO THE EXCLUSIVE RIGHT TO USE "INSPECT" AND "QUALITY HOME INSPECTIONS", APART FROM THE MARK AS SHOWN.

THE MARK CONSISTS OF A HOUSE WITH A CHECK MARK AND THE TEXT "INSPECT RITE" FLOWING OUT OF THE HOUSE, THE CHECK MARK BEING BEHIND CENTER OF "INSPECT" AND "RITE", AND THE TEXT "QUALITY HOME INSPECTIONS" BELOW ON A RECTANGULAR BACKGROUND WHICH CONNECTS TO THE HOUSE ON THE LEFT.

FOR INSPECTIONS OF HOUSES NOT DURING CONSTRUCTION (U.S. CLS. 100 AND 101).

FIRST USE 3-24-2012; IN COMMERCE 3-24-2012.
VIVIAN MICZNIK FIRST, EXAMINING ATTORNEY

SN 85-594,710. TASH & CO LLC, NATICK, MA. FILED 4-11-2012.

SN 85-594,356. EPIPHANY IT, UPPER MARLBORO, MD. FILED 4-11-2012.

Epiphany IT, LLC

THE MARK CONSISTS OF STANDARD CHARACTERS WITHOUT CLAIM TO ANY PARTICULAR FONT, STYLE, SIZE, OR COLOR.

NO CLAIM IS MADE TO THE EXCLUSIVE RIGHT TO USE "IT, LLC", APART FROM THE MARK AS SHOWN.

FOR COMPUTER SERVICES, NAMELY, REMOTE AND ON-SITE MANAGEMENT OF ELECTRONIC MESSAGING SYSTEMS AND THE INFORMATION TECHNOLOGY (IT) SYSTEMS (U.S. CLS. 100 AND 101).

FIRST USE 2-23-2012; IN COMMERCE 2-23-2012.
SAMUEL E. SHARPER JR., EXAMINING ATTORNEY



NO CLAIM IS MADE TO THE EXCLUSIVE RIGHT TO USE TILE, APART FROM THE MARK AS SHOWN.

THE MARK CONSISTS OF A PIECE OF DECORATIVE TILE WITH WAVY EDGES AND LINES BEARING THE WORDS TANGO TILE.

FOR WEB SITE FEATURING TEMPORARY USE OF NON-DOWNLOADABLE SOFTWARE THAT ENABLES USERS TO BROWSE AND PURCHASE DIRECTLY FLOORING TILES, CEILING TILES AND WALL TILES OF ALL TYPES AND COMPOSITIONS FOR RESIDENTIAL AND COMMERCIAL USE (U.S. CLS. 100 AND 101).

KIMBERLY PERRY, EXAMINING ATTORNEY

CLASS 42—(Continued).

SN 85-594,743. MICHAEL COHEN, PLAINVIEW, NY. FILED 4-11-2012.

mandatemanager

THE MARK CONSISTS OF STANDARD CHARACTERS WITHOUT CLAIM TO ANY PARTICULAR FONT, STYLE, SIZE, OR COLOR.

FOR PROVIDING A WEBSITE FEATURING TECHNOLOGY THAT ENABLES USERS TO TRACK AND MANAGE REGULATORY COMPLIANCE MATERIAL, PROFESSIONAL CERTIFICATION MATERIAL AND RESOURCES USED FOR OBTAINING CERTIFICATION AND MAINTAINING COMPLIANCE (U.S. CLS. 100 AND 101).

FIRST USE 1-15-2005; IN COMMERCE 4-1-2005.
DANIEL S. STRINGER, EXAMINING ATTORNEY

CLASS 42—(Continued).

SN 85-595,531. VENTURE PILOT LLC, DBA VENTUREPILOT, AUSTIN, TX. FILED 4-12-2012.

VENTUREPILOT

THE MARK CONSISTS OF STANDARD CHARACTERS WITHOUT CLAIM TO ANY PARTICULAR FONT, STYLE, SIZE, OR COLOR.

FOR APPLICATION SERVICE PROVIDER, NAMELY, HOSTING, MANAGING, DEVELOPING, ANALYZING, AND MAINTAINING APPLICATIONS, SOFTWARE AND WEB SITES OF OTHERS IN THE FIELDS OF BUSINESS MANAGEMENT AND MARKETING. DOMAIN NAME SEARCH SERVICES, NAMELY, CONDUCTING ONLINE COMPUTERIZED SEARCHES FOR THE AVAILABILITY OF DOMAIN NAMES (U.S. CLS. 100 AND 101).

FIRST USE 8-10-2007; IN COMMERCE 5-1-2008.
KATINA MISTER, EXAMINING ATTORNEY

SN 85-594,877. PATTERSON, AARON, REDDING, CA. FILED 4-11-2012.

LOVETANKS

THE MARK CONSISTS OF STANDARD CHARACTERS WITHOUT CLAIM TO ANY PARTICULAR FONT, STYLE, SIZE, OR COLOR.

FOR PROVIDING A WEBSITE FEATURING NON-DOWNLOADABLE SOFTWARE THAT PROVIDES USERS WITH TOOLS FOR IMPROVING COMMUNICATION IN PERSONAL RELATIONSHIPS (U.S. CLS. 100 AND 101).

FIRST USE 2-1-2012; IN COMMERCE 2-8-2012.
ALYSSA STEEL, EXAMINING ATTORNEY

SN 85-595,945. ALTAVITAS INC., SUNNYVALE, CA. FILED 4-12-2012.

BABY ZOE

THE MARK CONSISTS OF STANDARD CHARACTERS WITHOUT CLAIM TO ANY PARTICULAR FONT, STYLE, SIZE, OR COLOR.

THE NAME IN THE MARK DOES NOT IDENTIFY A LIVING INDIVIDUAL.

FOR PROVIDING AN INTERACTIVE WEBSITE FEATURING TECHNOLOGY THAT ALLOWS USERS TO TRACK, MANAGE, SHARE AND STORE DATA RELATED TO HEALTH, DAILY ACTIVITIES AND CHILD CARE (U.S. CLS. 100 AND 101).

REBECCA SMITH, EXAMINING ATTORNEY

SN 85-594,975. MEDALLIA, INC., PALO ALTO, CA. FILED 4-11-2012.

MEDALLIA PROMOTE

THE MARK CONSISTS OF STANDARD CHARACTERS WITHOUT CLAIM TO ANY PARTICULAR FONT, STYLE, SIZE, OR COLOR.

OWNER OF U.S. REG. NO. 3,795,880.
NO CLAIM IS MADE TO THE EXCLUSIVE RIGHT TO USE "PROMOTE", APART FROM THE MARK AS SHOWN.

FOR SOFTWARE AS A SERVICE (SAAS) THAT ALLOWS CONSUMERS TO LINK TO THIRD PARTY WEBSITES AND SOCIAL MEDIA BEFORE EXITING CONSUMER SURVEYS (U.S. CLS. 100 AND 101).

MARK SHINER, EXAMINING ATTORNEY

SN 85-596,223. FORT HILL COMPANY, WILMINGTON, DE. FILED 4-12-2012.

WE ACHIEVE

THE MARK CONSISTS OF STANDARD CHARACTERS WITHOUT CLAIM TO ANY PARTICULAR FONT, STYLE, SIZE, OR COLOR.

FOR PROVIDING TEMPORARY USE OF ON-LINE, NON-DOWNLOADABLE SOFTWARE TO COLLECT AND IDENTIFY ACTIONS, IDEAS, INSIGHTS, OR ACHIEVEMENTS RESULTING FROM PROGRAMS, COURSES, MEETINGS, SESSIONS, CONFERENCES, AND OTHER EVENTS, AND TO ENABLE USERS TO SEE THE SUBMISSIONS OF OTHER USERS AND TO CREATE A RANKED LIST OF THE MOST COMPELLING ITEMS SUBMITTED (U.S. CLS. 100 AND 101).

ZACHARY CROMER, EXAMINING ATTORNEY

CLASS 42—(Continued).

SN 85-596,233. VACCINE AND GENE THERAPY INSTITUTE OF FLORIDA CORP., PORT ST. LUCIE, FL. FILED 4-12-2012.

FLORIDA INNOVATION PARTNERS

THE MARK CONSISTS OF STANDARD CHARACTERS WITHOUT CLAIM TO ANY PARTICULAR FONT, STYLE, SIZE, OR COLOR.

NO CLAIM IS MADE TO THE EXCLUSIVE RIGHT TO USE "FLORIDA" AND "PARTNERS", APART FROM THE MARK AS SHOWN.

FOR SCIENTIFIC STUDY AND RESEARCH FOR MEDICAL PURPOSES IN THE FIELD OF PREVENTION, TREATMENT AND MANAGEMENT OF ILLNESS AND INFECTIOUS DISEASES; RESEARCH AND DEVELOPMENT OF VACCINES AND MEDICINES (U.S. CLS. 100 AND 101).

MIAH ROSENBERG, EXAMINING ATTORNEY

SN 85-597,036. EDGEMED HEALTHCARE SOLUTIONS, INC., DEERFIELD BEACH, FL. FILED 4-13-2012.

HEALTHCARE ABOVE ALL

THE MARK CONSISTS OF STANDARD CHARACTERS WITHOUT CLAIM TO ANY PARTICULAR FONT, STYLE, SIZE, OR COLOR.

NO CLAIM IS MADE TO THE EXCLUSIVE RIGHT TO USE "HEALTHCARE", APART FROM THE MARK AS SHOWN.

FOR APPLICATION SERVICE PROVIDER, NAMELY, HOSTING, MANAGING, DEVELOPING, ANALYZING, AND MAINTAINING APPLICATIONS, SOFTWARE, AND WEB SITES, OF OTHERS IN THE FIELDS OF HEALTHCARE, BENEFITS PROGRAMS, EMPLOYEE PRODUCTIVITY, RISK MANAGEMENT; PROVIDING ON-LINE, NON-DOWNLOADABLE, INTERNET-BASED SOFTWARE APPLICATION FOR MEDICAL BILLING FOR PHYSICIANS AND HEALTH CARE INSTITUTIONS (U.S. CLS. 100 AND 101).

MICHAEL WIENER, EXAMINING ATTORNEY

CLASS 42—(Continued).

SN 85-597,195. SUCCESS IS THE BEST REVENGE, INC., MANCHESTER, NH. FILED 4-13-2012.

Vent. Move On. Move Up.

THE MARK CONSISTS OF STANDARD CHARACTERS WITHOUT CLAIM TO ANY PARTICULAR FONT, STYLE, SIZE, OR COLOR.

FOR COMPUTER SERVICES, NAMELY, CREATING AN ON-LINE COMMUNITY FOR REGISTERED USERS TO PARTICIPATE IN DISCUSSIONS, GET FEEDBACK FROM THEIR PEERS, FORM VIRTUAL COMMUNITIES, AND ENGAGE IN SOCIAL NETWORKING SERVICES IN THE FIELD OF CAREER ADVANCEMENT; COMPUTER SERVICES, NAMELY, PROVIDING AN INTERACTIVE WEB SITE FEATURING TECHNOLOGY THAT ALLOWS USERS TO COLLECT, STORE, MANAGE, DELIVER AND SHOWCASE ELECTRONIC AND PAPER-BASED CONTENT; COMPUTER SERVICES, NAMELY, PROVIDING CUSTOMIZED WEB PAGES FEATURING USER-DEFINED INFORMATION; CREATING AN ON-LINE COMMUNITY FOR EMPLOYEES AND JOB SEEKERS; HOSTING ON-LINE WEB FACILITIES FOR OTHERS FOR EMPLOYEES AND JOB SEEKERS; PROVIDING A MEMBERS-ONLY WEBSITE FEATURING TECHNOLOGY WHICH PROVIDES MEMBERS WITH THE ABILITY TO ANIMATE USER-GENERATED PLOTLINES; PROVIDING A WEB SITE ALLOWING USERS TO UPLOAD ON-LINE VIDEOS FOR SHARING WITH OTHERS FOR MOTIVATIONAL AND INSPIRATIONAL PURPOSES; PROVIDING A WEB SITE FEATURING TEMPORARY USE OF NON-DOWNLOADABLE SOFTWARE ALLOWING WEB SITE USERS TO UPLOAD, POST AND DISPLAY ON-LINE VIDEOS FOR SHARING WITH OTHERS FOR ENTERTAINMENT PURPOSES; PROVIDING A WEB SITE FEATURING TEMPORARY USE OF NON-DOWNLOADABLE SOFTWARE ALLOWING WEB SITE USERS TO UPLOAD, POST AND DISPLAY ON-LINE VIDEOS FOR SHARING WITH OTHERS FOR ENTERTAINMENT PURPOSES; PROVIDING A WEB SITE FEATURING TEMPORARY USE OF NON-DOWNLOADABLE SOFTWARE FOR ANIMATION AND TEXT-GENERATION; PROVIDING A WEB SITE THAT GIVES COMPUTER USERS THE ABILITY TO UPLOAD AND SHARE USER-GENERATED VIDEOS, ESSAYS AND ARTICLES ON A WIDE VARIETY OF TOPICS AND SUBJECTS; PROVIDING A WEBSITE FEATURING NON-DOWNLOADABLE SOFTWARE FOR ANIMATION AND TEXT-GENERATION; PROVIDING A WEBSITE FEATURING ON-LINE NON-DOWNLOADABLE SOFTWARE THAT ENABLES USERS TO ANIMATE, COMPOSE, AND SEND CONTENT; PROVIDING A WEBSITE FEATURING RESOURCES, NAMELY, A WEBSITE FEATURING PRIMARILY NON-DOWNLOADABLE SOFTWARE FOR ANIMATION AND ALSO FEATURING NON-DOWNLOADABLE PUBLICATIONS IN THE NATURE OF USER-GENERATED CONTENT IN THE FIELD OF CAREER ADVANCEMENT; PROVIDING A WEBSITE FEATURING TECHNOLOGY THAT ENABLES USERS TO UPLOAD AND SHARE USER-GENERATED VIDEOS ON A WIDE VARIETY OF TOPICS AND SUBJECTS; PROVIDING A WEBSITE FEATURING TECHNOLOGY THAT ENABLES USERS TO ANIMATE USER-GENERATED PLOTLINES; PROVIDING A WEBSITE THAT GIVES COMPUTER USERS THE ABILITY TO ELECTRONICALLY SEND CONTENT GENERATED ON SAID WEBSITE TO ANONYMOUS THIRD-PARTIES; PROVIDING AN ONLINE NON-DOWNLOADABLE INTERNET-BASED SYSTEM APPLICATION FEATURING TECHNOLOGY ENABLING USERS TO ANIMATE AND COMPILE CONTENT; PROVIDING TEMPORARY USE OF ON-LINE NON-DOWNLOADABLE SOFTWARE AND APPLICATIONS FOR ANIMATION AND TEXT GENERATION; PROVIDING TEMPORARY USE OF ON-LINE NON-DOWNLOADABLE SOFTWARE FOR ANIMATION AND COMPILATION OF USER CONTENT (U.S. CLS. 100 AND 101).

TIMOTHY O. SCHIMPF, EXAMINING ATTORNEY

CLASS 42—(Continued).

SN 85-597,202. SUCCESS IS THE BEST REVENGE, INC., MANCHESTER, NH. FILED 4-13-2012.

Bad Boss Pageant

THE MARK CONSISTS OF STANDARD CHARACTERS WITHOUT CLAIM TO ANY PARTICULAR FONT, STYLE, SIZE, OR COLOR.

FOR COMPUTER SERVICES, NAMELY, CREATING AN ON-LINE COMMUNITY FOR REGISTERED USERS TO PARTICIPATE IN DISCUSSIONS, GET FEEDBACK FROM THEIR PEERS, FORM VIRTUAL COMMUNITIES, AND ENGAGE IN SOCIAL NETWORKING SERVICES IN THE FIELD OF CAREER ADVANCEMENT; COMPUTER SERVICES, NAMELY, CREATING AN ON-LINE COMMUNITY FOR REGISTERED USERS TO GENERATE AND SEND USER-GENERATED CONTENT; COMPUTER SERVICES, NAMELY, HOSTING AN INTERACTIVE WEB SITE THAT ALLOWS ANIMATION OF USER-GENERATED PLOT LINES; COMPUTER SERVICES, NAMELY, HOSTING AND MAINTAINING AN ON-LINE WEB SITE FOR OTHERS FOR SHARING USER-GENERATED CONTENT; COMPUTER SERVICES, NAMELY, INTERACTIVE HOSTING SERVICES WHICH ALLOW THE USER TO PUBLISH AND SHARE THEIR OWN CONTENT AND IMAGES ON-LINE; COMPUTER SERVICES, NAMELY, PROVIDING AN INTERACTIVE WEB SITE FEATURING TECHNOLOGY THAT ALLOWS USERS TO COLLECT, STORE, MANAGE, DELIVER AND SHOWCASE ELECTRONIC AND PAPER-BASED CONTENT; COMPUTER SERVICES, NAMELY, PROVIDING CUSTOMIZED WEB PAGES FEATURING USER-DEFINED INFORMATION; CREATING AN ON-LINE COMMUNITY FOR EMPLOYEES AND JOB-SEEKERS; CREATING AN ON-LINE COMMUNITY FOR EMPLOYEES AND JOB-SEEKERS FOR THE PURPOSE OF CAREER ADVANCEMENT; PROVIDING A MEMBERS-ONLY WEBSITE FEATURING TECHNOLOGY WHICH PROVIDES MEMBERS WITH THE ABILITY TO ANIMATE USER-GENERATED PLOT LINES AND SHARE VIDEOS AND TEXT; PROVIDING A SECURED-ACCESS, MEMBERS ONLY WEBSITE FEATURING TECHNOLOGY THAT GIVES MEMBERS THE ABILITY TO ANIMATE USER-GENERATED PLOT LINES AND SHARE VIDEOS AND TEXT; PROVIDING A WEB SITE ALLOWING USERS TO UPLOAD ON-LINE VIDEOS FOR SHARING WITH OTHERS FOR MOTIVATIONAL AND INSPIRATIONAL PURPOSES; PROVIDING A WEB SITE FEATURING TECHNOLOGY THAT ENABLES USERS TO VOTE ON USER-GENERATED CONTENT; PROVIDING A WEB SITE FEATURING TEMPORARY USE OF NON-DOWNLOADABLE SOFTWARE ALLOWING WEB SITE USERS TO UPLOAD ON-LINE VIDEOS FOR SHARING WITH OTHERS FOR ENTERTAINMENT PURPOSES; PROVIDING A WEB SITE FEATURING TEMPORARY USE OF NON-DOWNLOADABLE SOFTWARE ALLOWING WEB SITE USERS TO UPLOAD, POST AND DISPLAY ONLINE VIDEOS FOR SHARING WITH OTHERS FOR ENTERTAINMENT PURPOSES; PROVIDING A WEB SITE THAT GIVES COMPUTER USERS THE ABILITY TO UPLOAD AND SHARE USER-GENERATED VIDEOS, ESSAYS AND ARTICLES ON A WIDE VARIETY OF TOPICS AND SUBJECTS; PROVIDING A WEB SITE THAT GIVES COMPUTER USERS THE ABILITY TO UPLOAD AND SHARE VIDEOS PROVIDING INSPIRATION AND MOTIVATION FOR WOMEN; PROVIDING A WEBSITE FEATURING NON-DOWNLOADABLE SOFTWARE FOR ANIMATION AND TEXT-GENERATION; PROVIDING A WEBSITE FEATURING ON-LINE NON-DOWNLOADABLE SOFTWARE THAT ENABLES USERS TO ANIMATE AND COMPILE CONTENT; PROVIDING A WEBSITE FEATURING RESOURCES, NAMELY, NON-DOWNLOADABLE SOFTWARE FOR ANIMATION AND TEXT COMPILATION; PROVIDING A WEBSITE FEATURING TECHNOLOGY THAT ENABLES USERS TO UPLOAD AND SHARE USER-GENERATED VIDEOS ON A WIDE VARIETY OF TOPICS AND SUBJECTS; PROVIDING A WEBSITE FEATURING TECHNOLOGY THAT ENABLES USERS

CLASS 42—(Continued).

TO VOTE ON USER-GENERATED CONTENT; PROVIDING A WEBSITE THAT GIVES COMPUTER USERS THE ABILITY TO ELECTRONICALLY SEND CONTENT GENERATED ON SAID WEBSITE TO ANONYMOUS THIRD-PARTIES; PROVIDING A WEBSITE THAT GIVES USERS THE ABILITY TO CREATE CUSTOMIZED WEB PAGES FEATURING USER-DEFINED INFORMATION; PROVIDING A WEBSITE THAT GIVES USERS THE ABILITY TO REVIEW VARIOUS PRINT, PHOTOGRAPHIC, GRAPHIC IMAGE, AND AUDIO AND VIDEO CONTENT AND UTILIZE A CUSTOM TEMPLATE TO PROVIDE INPUT, LIKES, DISLIKES, EDITS, CHANGES, MODIFICATIONS, OPINIONS, SUGGESTIONS, AND COMMENTS AND ENGAGE IN SOCIAL, BUSINESS AND COMMUNITY NETWORKING; PROVIDING AN INTERACTIVE WEBSITE FEATURING TECHNOLOGY THAT ALLOWS USERS TO VOTE AND COMMENT ON USER-GENERATED CONTENT; PROVIDING AN ON-LINE NON-DOWNLOADABLE INTERNET-BASED SYSTEM APPLICATION FEATURING TECHNOLOGY ENABLING USERS TO ANIMATE USER-GENERATED PLOT LINES (U.S. CLS. 100 AND 101).

TIMOTHY O. SCHIMPF, EXAMINING ATTORNEY

SN 85-597,215. BRIAN KLINKA, WESTFORD, MA. FILED 4-13-2012.

Next Wave Energy and Power Systems

THE MARK CONSISTS OF STANDARD CHARACTERS WITHOUT CLAIM TO ANY PARTICULAR FONT, STYLE, SIZE, OR COLOR.

NO CLAIM IS MADE TO THE EXCLUSIVE RIGHT TO USE "ENERGY AND POWER SYSTEMS", APART FROM THE MARK AS SHOWN.

FOR ENGINEERING SERVICES IN THE FIELD OF RENEWABLE ENERGY (U.S. CLS. 100 AND 101).

SUSAN STIGLITZ, EXAMINING ATTORNEY

SN 85-597,320. WORKBUZZ, LLC, SANTA MONICA, CA. FILED 4-13-2012.

WorkBuzz

THE MARK CONSISTS OF STANDARD CHARACTERS WITHOUT CLAIM TO ANY PARTICULAR FONT, STYLE, SIZE, OR COLOR.

FOR COMPUTER SERVICES, NAMELY, CREATING AN ON-LINE COMMUNITY ON AN INTERACTIVE WEBSITE FOR REGISTERED USERS TO REVIEW AND RATE THEIR WORK PEERS (U.S. CLS. 100 AND 101).

DAVID YONTEF, EXAMINING ATTORNEY

CLASS 42—(Continued).

SN 85-597,344. CRITICAL SYSTEMS, LLC, MARIETTA, GA. FILED 4-13-2012.

TOTALREPORT

THE MARK CONSISTS OF STANDARD CHARACTERS WITHOUT CLAIM TO ANY PARTICULAR FONT, STYLE, SIZE, OR COLOR.

FOR DESIGN AND INSPECTION OF FIRE ALARM, DETECTION AND SUPPRESSION SYSTEMS; INSPECTIONS OF FIRE ALARMS, FIRE SUPPRESSION SYSTEMS, FIRE EXTINGUISHERS, SPRINKLER SYSTEMS, SPECIAL HAZARDS, EMERGENCY LIGHTING.; TESTING, MONITORING AND INSPECTION OF STATIONARY BATTERIES (U.S. CLS. 100 AND 101).

FIRST USE 10-15-2002; IN COMMERCE 10-15-2002.
APRIL ROACH, EXAMINING ATTORNEY

CLASS 42—(Continued).

SN 85-597,945. BEAR RIVER ASSOCIATES, INCORPORATED, OAKLAND, CA. FILED 4-13-2012.

MAILCENTER21

THE MARK CONSISTS OF STANDARD CHARACTERS WITHOUT CLAIM TO ANY PARTICULAR FONT, STYLE, SIZE, OR COLOR.

FOR ENGINEERING, DESIGN, PROGRAMMING AND INTEGRATION SERVICES FOR COMPUTER HARDWARE AND SOFTWARE SYSTEMS THAT MANAGE, TRACK, INSPECT, SORT, DIGITIZE, STORE, SAFEGUARD, AUTOMATE AND ROUTE, AND ESTABLISH CHAIN OF CUSTODY FOR, MAIL AND PACKAGES THAT ARE RECEIVED BY AN ORGANIZATION, TRANSPORTED WITHIN THE ORGANIZATION FROM ONE LOCATION TO ANOTHER, AND ORIGINATED BY THE ORGANIZATION FOR DELIVERY TO A DIFFERENT LOCATION OR TO A COMMON CARRIER (U.S. CLS. 100 AND 101).

FIRST USE 4-30-2010; IN COMMERCE 4-30-2010.
KATHERINE E. HALMEN, EXAMINING ATTORNEY

SN 85-597,398. LICENSELOGIX, LLC, NEW YORK, NY. FILED 4-13-2012.

Client License Information Center (CLiC)

THE MARK CONSISTS OF STANDARD CHARACTERS WITHOUT CLAIM TO ANY PARTICULAR FONT, STYLE, SIZE, OR COLOR.

NO CLAIM IS MADE TO THE EXCLUSIVE RIGHT TO USE "CLIENT LICENSE INFORMATION CENTER", APART FROM THE MARK AS SHOWN.

FOR SOFTWARE AS A SERVICE (SAAS) SERVICES FEATURING SOFTWARE FOR THE ONGOING MANAGEMENT AND COMPLIANCE OF BUSINESS LICENSES AND BUSINESS PERMITS (U.S. CLS. 100 AND 101).

FIRST USE 2-1-2012; IN COMMERCE 2-1-2012.
CHRISTINE MARTIN, EXAMINING ATTORNEY

SN 85-598,195. FUTURECRYPT LLC, KIHEI, HI. FILED 4-15-2012.

FUTURECRYPT

THE MARK CONSISTS OF STANDARD CHARACTERS WITHOUT CLAIM TO ANY PARTICULAR FONT, STYLE, SIZE, OR COLOR.

FOR DATA ENCRYPTION AND DECODING SERVICES (U.S. CLS. 100 AND 101).

FIRST USE 4-1-2012; IN COMMERCE 4-1-2012.
KEVEN MITTLER, EXAMINING ATTORNEY

CLASS 42—(Continued).

SN 85-598,373. AXOGEN, INC., ALACHUA, FL. FILED 4-16-2012.



THE MARK CONSISTS OF THE WORD "RANGER" IN STYLIZED TEXT IN FRONT OF AN OVAL ENCIRCLING A HONEYCOMB DESIGN.

FOR SCIENTIFIC RESEARCH FOR MEDICAL PURPOSES IN THE AREA OF NERVE REPAIR AND RECONSTRUCTION; SCIENTIFIC RESEARCH FOR MEDICAL PURPOSES IN THE FIELD OF PLASTIC, ORTHOPEDIC, NEUROLOGY, UROLOGY, AND/OR ENT SURGERY FOR TREATMENT OF NERVE INJURIES IN HUMANS; PROVIDING MEDICAL AND SCIENTIFIC RESEARCH INFORMATION RELATING TO MEDICAL TREATMENT IN THE NATURE OF RESULTS OF SCIENTIFIC RESEARCH AND CLINICAL DATA IN THE AREA OF NERVE REPAIR AND RECONSTRUCTION PROVIDED THROUGH A DATABASE THAT ALLOWS INPUT AND COLLECTION OF DATA AND INFORMATION; CLINICAL RESEARCH IN THE AREA OF NERVE REPAIR AND RECONSTRUCTION TO PROVIDE INFORMATION ON FUNCTIONAL RECOVERY AND TREATMENT OUTCOMES (U.S. CLS. 100 AND 101).

JESSICA A. POWERS, EXAMINING ATTORNEY

SN 85-598,862. SCHOTT, JEFF, FAIRFAX, VA. FILED 4-16-2012.

war bird technologies

THE MARK CONSISTS OF STANDARD CHARACTERS WITHOUT CLAIM TO ANY PARTICULAR FONT, STYLE, SIZE, OR COLOR.

NO CLAIM IS MADE TO THE EXCLUSIVE RIGHT TO USE "TECHNOLOGIES", APART FROM THE MARK AS SHOWN.

FOR COMPUTER SOFTWARE DEVELOPMENT (U.S. CLS. 100 AND 101).

MARK T. MULLEN, EXAMINING ATTORNEY

CLASS 42—(Continued).

SN 85-598,975. BOXADOR INC., LOS ANGELES, CA. FILED 4-16-2012.

Wazala

THE MARK CONSISTS OF STANDARD CHARACTERS WITHOUT CLAIM TO ANY PARTICULAR FONT, STYLE, SIZE, OR COLOR.

FOR SOFTWARE AS A SERVICE (SAAS) SERVICES, NAMELY, HOSTING E-COMMERCE SOFTWARE FOR USE BY OTHERS TO ALLOW USERS TO PERFORM ELECTRONIC BUSINESS TRANSACTIONS AT THEIR OWN WEBSITES (U.S. CLS. 100 AND 101).

FIRST USE 5-10-2010; IN COMMERCE 5-10-2010.

JIM RINGLE, EXAMINING ATTORNEY

SN 85-599,066. GOOD START GENETICS, INC., CAMBRIDGE, MA. FILED 4-16-2012.

GSG LABSOLUTIONS

THE MARK CONSISTS OF STANDARD CHARACTERS WITHOUT CLAIM TO ANY PARTICULAR FONT, STYLE, SIZE, OR COLOR.

FOR PROVIDING A WEBSITE FEATURING TECHNOLOGY THAT ENABLES A USER TO ORDER PRE-NATAL TESTS AND RETRIEVE PATIENT LAB RESULTS (U.S. CLS. 100 AND 101).

JENNIFER RICHARDSON, EXAMINING ATTORNEY

SN 85-599,382. RENT JUNGLE, LLC, PITTSBURGH, PA. FILED 4-16-2012.

Mine Labs

THE MARK CONSISTS OF STANDARD CHARACTERS WITHOUT CLAIM TO ANY PARTICULAR FONT, STYLE, SIZE, OR COLOR.

NO CLAIM IS MADE TO THE EXCLUSIVE RIGHT TO USE "MINE", APART FROM THE MARK AS SHOWN.

FOR TECHNOLOGY CONSULTATION SERVICES IN THE FIELDS OF, INFORMATION MANAGEMENT AND BUSINESS INTELLIGENCE; DATA MINING; COMPUTER SERVICES, NAMELY, PROVIDING ON-LINE NON-DOWNLOADABLE SOFTWARE FOR DATA MINING, DATA QUERY, AND DATA ANALYSIS; COMPUTER SERVICES IN THE NATURE OF PROVIDING SEARCH ENGINES FOR OBTAINING DATA OVER COMPUTER NETWORKS, THE INTERNET AND WIRELESS NETWORKS (U.S. CLS. 100 AND 101).

FIRST USE 11-4-2011; IN COMMERCE 11-4-2011.

WILLIAM VERHOSEK, EXAMINING ATTORNEY

CLASS 42—(Continued).

SN 85-599,961. CAKEBLEND LLC, CHERRY HILL, NJ. FILED 4-17-2012.

CAKEBLEND

THE MARK CONSISTS OF STANDARD CHARACTERS WITHOUT CLAIM TO ANY PARTICULAR FONT, STYLE, SIZE, OR COLOR.

FOR COMPUTER SERVICES, NAMELY, CREATING AN ON-LINE COMMUNITY FOR REGISTERED USERS TO COLLABORATE ON MUSIC COMPOSITION, PERFORMANCE, RECORDING, AND FILMING; COMPUTER SERVICES, NAMELY, HOSTING ON-LINE WEB FACILITIES FOR OTHERS FOR ORGANIZING AND CONDUCTING ONLINE MEETINGS, GATHERINGS, AND INTERACTIVE DISCUSSIONS; HOSTING AN ONLINE WEBSITE FEATURING MUSICAL COLLABORATION; PROVIDING AN ONLINE NON-DOWNLOADABLE INTERNET-BASED SYSTEM APPLICATION FEATURING TECHNOLOGY ENABLING USERS TO COLLABORATE IN THE COMPOSITION, RECORDING, PERFORMANCE, AND FILMING OF MUSICAL WORKS (U.S. CLS. 100 AND 101).

LESLEY LAMOTHE, EXAMINING ATTORNEY

SN 85-600,129. THE GREEN SQUAD, INC., TARPON SPRINGS, FL. FILED 4-17-2012.

GREEN SQUAD

THE MARK CONSISTS OF STANDARD CHARACTERS WITHOUT CLAIM TO ANY PARTICULAR FONT, STYLE, SIZE, OR COLOR.

OWNER OF U.S. REG. NO. 4,154,275.
NO CLAIM IS MADE TO THE EXCLUSIVE RIGHT TO USE "GREEN", APART FROM THE MARK AS SHOWN.

FOR ENVIRONMENTAL SERVICES, NAMELY, TECHNICAL CONSULTATION RELATED TO THE DEVELOPMENT OF ENVIRONMENTALLY FRIENDLY PRODUCTS IN THE NATURE OF TANKLESS HOT WATER HEATERS, ENERGY RECOVERY UNITS, HIGH EFFICIENCY AIR CONDITIONING UNITS, AIR AND WATER FILTERS, SOLAR HEATING UNITS, INSULATED WINDOWS, TINTED WINDOWS, WINDOW FILM, FOAM INSULATION, RECYCLED CLOTHING AND PAPER PRODUCTS, INSULATED ROOFING, ATTIC FANS AND VENTS, SOLAR ROOF FANS, WIND ENERGY GENERATORS, LOW FLOW TOILETS AND SINK FAUCETS, INSULATED DOORS, WEATHER STRIPPING, ENERGY EFFICIENT LIGHTING, COMPACT FLUORESCENT LIGHT BULBS, LOW WATER LANDSCAPING SYSTEMS, ZEROSCAPE LANDSCAPING SYSTEMS, LOW WATER IRRIGATION SYSTEMS, DRIP AND MAT IRRIGATIONS SYSTEMS, NON TOXIC CLEANING PRODUCTS FOR CLOTHES, BATHROOMS, KITCHENS AND FLOORS, FERTILIZERS AND PEST CONTROL CHEMICALS AND BUILDING PRODUCTS, NAMELY, PAINT, FLOORING, CARPET, TILES (U.S. CLS. 100 AND 101).

JESSICA A. POWERS, EXAMINING ATTORNEY

CLASS 42—(Continued).

SN 85-600,555. SMRTV, INC., EMERYVILLE, CA. FILED 4-17-2012.



OWNER OF U.S. REG. NO. 4,077,986.
THE COLOR(S) RED AND WHITE IS/ARE CLAIMED AS A FEATURE OF THE MARK.

THE MARK CONSISTS OF A RED BUBBLE, WITH THE OUTLINE OF A STYLIZED TELEVISION WITH AN ANTENNA AND KNOB CONTROLS IN WHITE INSIDE THE BUBBLE.

FOR COMPUTER SERVICES, NAMELY, CREATING AN ON-LINE COMMUNITY FOR REGISTERED USERS TO PARTICIPATE IN DISCUSSIONS, GET FEEDBACK FROM THEIR PEERS, FORM VIRTUAL COMMUNITIES, AND ENGAGE IN SOCIAL NETWORKING SERVICES IN THE FIELD OF INTERACTIVE TELEVISION (U.S. CLS. 100 AND 101).

FIRST USE 4-3-2012; IN COMMERCE 4-3-2012.
EDWARD NELSON, EXAMINING ATTORNEY

SN 85-600,853. ASSETPOINT, LLC, GREENVILLE, SC. FILED 4-18-2012.

TABSOURCE

THE MARK CONSISTS OF STANDARD CHARACTERS WITHOUT CLAIM TO ANY PARTICULAR FONT, STYLE, SIZE, OR COLOR.

FOR PROVIDING A WEBSITE FEATURING NON-DOWNLOADABLE SOFTWARE FOR MANAGEMENT, ADMINISTRATION, AND ANALYSIS OF BIDS, BIDDERS AND SUPPLIERS (U.S. CLS. 100 AND 101).

FIRST USE 5-1-2011; IN COMMERCE 5-1-2011.
TINA L. SNAPP, EXAMINING ATTORNEY

CLASS 42—(Continued).

SN 85-600,988. NEO GROUP INC, DBA SERVING SCIENCE SHARING SCIENCE, CAMBRIDGE, MA. FILED 4-18-2012.

SERVING SCIENCE, SHARING SCIENCE

THE MARK CONSISTS OF STANDARD CHARACTERS WITHOUT CLAIM TO ANY PARTICULAR FONT, STYLE, SIZE, OR COLOR.

NO CLAIM IS MADE TO THE EXCLUSIVE RIGHT TO USE "SCIENCE", APART FROM THE MARK AS SHOWN.

FOR BIOLOGICAL RESEARCH (U.S. CLS. 100 AND 101).

FIRST USE 6-15-2009; IN COMMERCE 6-15-2009.
AISHA SALEM, EXAMINING ATTORNEY

CLASS 42—(Continued).

SN 85-601,553. DOTCOMGUY, LLC, CALABASAS, CA. FILED 4-18-2012.

TECHNOLOGY MADE SIMPLE...SUPPORTING THE WORLD OF COMPUTERS

THE MARK CONSISTS OF STANDARD CHARACTERS WITHOUT CLAIM TO ANY PARTICULAR FONT, STYLE, SIZE, OR COLOR.

FOR CONSULTING SERVICES IN THE FIELD OF DESIGN, SELECTION, IMPLEMENTATION AND USE OF COMPUTER HARDWARE AND SOFTWARE SYSTEMS FOR OTHERS; CONSULTING SERVICES IN THE FIELD OF DESIGN, SELECTION, IMPLEMENTATION AND USE OF CONSUMER ELECTRONICS FOR OTHERS; CONSULTING SERVICES IN THE FIELD OF OFFICE AND HOME AUTOMATION; INSTALLATION OF COMPUTER SOFTWARE; COMPUTER SOFTWARE DESIGN, COMPUTER PROGRAMMING AND MAINTENANCE OF COMPUTER SOFTWARE; DESIGN OF COMPUTER HARDWARE, COMMUNICATIONS HARDWARE AND SOFTWARE AND COMPUTER NETWORKS FOR OTHERS (U.S. CLS. 100 AND 101).

SANI KHOURI, EXAMINING ATTORNEY

SN 85-601,359. ASSETPOINT, LLC, GREENVILLE, SC. FILED 4-18-2012.



THE MARK CONSISTS OF OVAL INSIDE A CURVED ARROW OVER THE TEXT "TABSOURCE".

FOR PROVIDING A WEBSITE FEATURING NON-DOWNLOADABLE SOFTWARE FOR MANAGEMENT, ADMINISTRATION, AND ANALYSIS OF BIDS, BIDDERS AND SUPPLIERS (U.S. CLS. 100 AND 101).

FIRST USE 5-1-2011; IN COMMERCE 5-1-2011.
TINA L. SNAPP, EXAMINING ATTORNEY

SN 85-601,475. ECENTIV INC., PORTLAND, OR. FILED 4-18-2012.



THE COLOR(S) RED, BLUE, GREEN, YELLOW AND WHITE IS/ARE CLAIMED AS A FEATURE OF THE MARK. THE MARK CONSISTS OF A DESIGN OF OVERLAPPING YELLOW, BLUE, RED, AND GREEN CONVERSATION BALLOONS ON A WHITE BACKGROUND.

FOR PROVIDING ON-LINE NON-DOWNLOADABLE SOFTWARE FOR DATABASE MANAGEMENT AND MULTIMEDIA COMMUNICATIONS (U.S. CLS. 100 AND 101).

FIRST USE 4-17-2012; IN COMMERCE 4-17-2012.
STEVEN R. FINE, EXAMINING ATTORNEY

SN 85-601,936. UNIVERSITY OF FASHION, INC., PORTOLA VALLEY, CA. FILED 4-18-2012.

MASTER DESIGN ONE STEP AT A TIME

THE MARK CONSISTS OF STANDARD CHARACTERS WITHOUT CLAIM TO ANY PARTICULAR FONT, STYLE, SIZE, OR COLOR.

NO CLAIM IS MADE TO THE EXCLUSIVE RIGHT TO USE "DESIGN", APART FROM THE MARK AS SHOWN.

FOR PROVIDING A WEBSITE FEATURING NON-DOWNLOADABLE INSTRUCTIONAL VIDEOS IN THE FIELD OF FASHION DESIGN (U.S. CLS. 100 AND 101).

FIRST USE 5-28-2008; IN COMMERCE 5-28-2008.
JOHN E. MICHOS, EXAMINING ATTORNEY

CLASS 42—(Continued).

SN 85-602,077. NEWSTUBE.TV LLC, BROOKLYN, NY. FILED 4-19-2012.

NEWSTUBE

THE MARK CONSISTS OF STANDARD CHARACTERS WITHOUT CLAIM TO ANY PARTICULAR FONT, STYLE, SIZE, OR COLOR.

FOR PROVIDING A WEBSITE FEATURING TECHNOLOGY THAT ENABLES USERS TO UPLOAD, SHARE, SELL AND RETAIN OWNERSHIP OF USER-GENERATED VIDEOS ON A WIDE VARIETY OF TOPICS AND SUBJECTS RELATING TO CURRENT EVENTS; COMPUTER SERVICES, NAMELY, CREATING AN ON-LINE COMMUNITY FOR REGISTERED USERS TO ENGAGE IN SOCIAL NETWORKING, TO SUBSCRIBE TO OTHER USERS AND TO RATE AND COMMENT ON CONTENT (U.S. CLS. 100 AND 101).

FIRST USE 1-31-2010; IN COMMERCE 1-1-2011.
BRENDAN MCCAULEY, EXAMINING ATTORNEY

SN 85-602,091. RIGHT NETWORKS, LLC, HUDSON, NH. FILED 4-19-2012.

The Right Way to The Cloud

THE MARK CONSISTS OF STANDARD CHARACTERS WITHOUT CLAIM TO ANY PARTICULAR FONT, STYLE, SIZE, OR COLOR.

FOR COMPUTER SERVICES, NAMELY, CLOUD HOSTING PROVIDER SERVICES; COMPUTER SERVICES, NAMELY, INTEGRATION OF PRIVATE AND PUBLIC CLOUD COMPUTING ENVIRONMENTS; CONSULTING SERVICES IN THE FIELD OF CLOUD COMPUTING; PROVIDING VIRTUAL COMPUTER SYSTEMS AND VIRTUAL COMPUTER ENVIRONMENTS THROUGH CLOUD COMPUTING; TECHNICAL CONSULTING SERVICES IN THE FIELDS OF DATACENTER ARCHITECTURE, PUBLIC AND PRIVATE CLOUD COMPUTING SOLUTIONS, AND EVALUATION AND IMPLEMENTATION OF INTERNET TECHNOLOGY AND SERVICES; TECHNICAL SUPPORT SERVICES, NAMELY, REMOTE AND ON-SITE INFRASTRUCTURE MANAGEMENT SERVICES FOR MONITORING, ADMINISTRATION AND MANAGEMENT OF PUBLIC AND PRIVATE CLOUD COMPUTING IT AND APPLICATION SYSTEMS (U.S. CLS. 100 AND 101).

FIRST USE 9-18-2011; IN COMMERCE 9-18-2011.
SCOTT OSCLICK, EXAMINING ATTORNEY

CLASS 42—(Continued).

SN 85-602,181. VIRDOCS, TROY, MI. FILED 4-19-2012.

Virdocs

THE MARK CONSISTS OF STANDARD CHARACTERS WITHOUT CLAIM TO ANY PARTICULAR FONT, STYLE, SIZE, OR COLOR.

FOR CLOUD COMPUTING FEATURING SOFTWARE FOR USE IN VIEWING DIGITAL DOCUMENTS (U.S. CLS. 100 AND 101).

FIRST USE 5-4-2011; IN COMMERCE 5-4-2011.
SETH A. RAPPAPORT, EXAMINING ATTORNEY

SN 85-602,323. ROUNDSCAPES, LLC, LINCOLN, NE. FILED 4-19-2012.

42

THE MARK CONSISTS OF STANDARD CHARACTERS WITHOUT CLAIM TO ANY PARTICULAR FONT, STYLE, SIZE, OR COLOR.

FOR COMPUTER SERVICES, NAMELY, DESIGNING AND IMPLEMENTING WEB PAGES FOR OTHERS (U.S. CLS. 100 AND 101).

FIRST USE 3-27-2012; IN COMMERCE 3-27-2012.
DAVID HOFFMAN, EXAMINING ATTORNEY

SN 85-602,338. LIFEBEYONDBARRIERS, LLC, DETROIT, MI. FILED 4-19-2012.

LIFE BEYOND BARRIERS

THE MARK CONSISTS OF STANDARD CHARACTERS WITHOUT CLAIM TO ANY PARTICULAR FONT, STYLE, SIZE, OR COLOR.

FOR PRODUCT DEVELOPMENT, RESEARCH, AND CONSULTING SERVICES IN THE FIELD OF ENGINEERING, NAMELY DEVELOPING REHABILITATION, HEALTH CARE, AND DAILY LIVING PRODUCTS FOR THOSE WITH PHYSICAL DISABILITIES (U.S. CLS. 100 AND 101).

CHRISIE B. KING, EXAMINING ATTORNEY

CLASS 42—(Continued).

SN 85-602,400. ROUNDSCAPES, LLC, LINCOLN, NE. FILED 4-19-2012.



THE MARK CONSISTS OF THE NUMBER "4", THE NUMBER "2", A TRIANGULAR DESIGN CONSISTING OF OVERLAPPING ACUTE ANGLES, AND A DEER SKULL WITH ANTLERS. THE FOUR SEPARATE ELEMENTS ARE SEPARATED BY AN "X".

FOR COMPUTER SERVICES, NAMELY, DESIGNING AND IMPLEMENTING WEB PAGES FOR OTHERS (U.S. CLS. 100 AND 101).

FIRST USE 3-27-2012; IN COMMERCE 3-27-2012.
DAVID HOFFMAN, EXAMINING ATTORNEY

CLASS 42—(Continued).

SN 85-602,749. MAXIMUM IMPRESSION, LLC, ST. PAUL, MN. FILED 4-19-2012.



THE MARK CONSISTS OF A STYLIZED PERSON INSIDE A TRIANGLE. THERE ARE FOUR EXCLAMATION MARKS AT THE TOP OF THE TRIANGLE.

FOR DESIGN AND DEVELOPMENT OF COMPUTER SOFTWARE; DESIGN, CREATION, HOSTING, MAINTENANCE OF WEBSITES FOR OTHERS; GRAPHIC DESIGN SERVICES (U.S. CLS. 100 AND 101).

FIRST USE 12-16-2002; IN COMMERCE 12-16-2002.
SAMUEL E. SHARPER JR., EXAMINING ATTORNEY

SN 85-602,548. TERRACON CONSULTANTS, INC., LENEXA, KS. FILED 4-19-2012.

Drash

THE MARK CONSISTS OF STANDARD CHARACTERS WITHOUT CLAIM TO ANY PARTICULAR FONT, STYLE, SIZE, OR COLOR.

FOR ENGINEERING CONSULTING SERVICES (U.S. CLS. 100 AND 101).

FIRST USE 7-8-1993; IN COMMERCE 7-8-1993.
DOMINIC J. FERRAIUOLO, EXAMINING ATTORNEY

SN 85-603,178. MEDICALISTICS L.L.C., GARLAND, TX. FILED 4-19-2012.

MEDICALISTICS

THE MARK CONSISTS OF STANDARD CHARACTERS WITHOUT CLAIM TO ANY PARTICULAR FONT, STYLE, SIZE, OR COLOR.

FOR SOFTWARE DEVELOPMENT AND CONSULTANCY SERVICES IN THE FIELD OF PROVIDING ELECTRONIC HEALTH RECORD SOLUTIONS FOR THE PRIVATE AND PUBLIC HEALTHCARE INDUSTRIES (U.S. CLS. 100 AND 101).

FIRST USE 6-0-2010; IN COMMERCE 6-0-2010.
TRACY FLETCHER, EXAMINING ATTORNEY

CLASS 42—(Continued).

SN 85-603,192. MEDICALISTICS L.L.C., GARLAND, TX.
FILED 4-19-2012.



THE MARK CONSISTS OF THE TERM "MEDICALISTICS" IN STYLIZED FONT UNDER TWO CURVED LINES.
FOR SOFTWARE DEVELOPMENT AND CONSULTANCY SERVICES IN THE FIELD OF PROVIDING ELECTRONIC HEALTH RECORD SOLUTIONS FOR THE PRIVATE AND PUBLIC HEALTHCARE INDUSTRIES (U.S. CLS. 100 AND 101).

FIRST USE 6-0-2010; IN COMMERCE 6-0-2010.
TRACY FLETCHER, EXAMINING ATTORNEY

CLASS 42—(Continued).

SN 85-603,916. BLOOM INSURANCE AGENCY, LLC, BLOOMINGTON, IN. FILED 4-20-2012.



THE MARK CONSISTS OF THE FIGURE OF A MAN WEARING A SUIT STANDING IN FRONT OF THE WORD "ASCEND" WHICH APPEARS WITH A STYLIZED "A".

FOR SOFTWARE AS A SERVICE (SAAS) SERVICES FEATURING SOFTWARE FOR FACILITATING, TRACKING AND MONITORING INSURANCE SALES BY AGENTS FOR REGULATORY COMPLIANCE AND QUALITY PURPOSES (U.S. CLS. 100 AND 101).

CHRISTINA SOBRAL, EXAMINING ATTORNEY

SN 85-603,749. CHERRYCOM, INC., SAN FRANCISCO, CA.
FILED 4-20-2012.

CHERRY

THE MARK CONSISTS OF STANDARD CHARACTERS WITHOUT CLAIM TO ANY PARTICULAR FONT, STYLE, SIZE, OR COLOR.

FOR PROVIDING A WEBSITE THAT ENABLES THE LOCATION OF A MOTOR VEHICLE TO BE SENT TO AN ONLINE SERVICE THAT DISPATCHES PERSONNEL TO WASH AND DETAIL THE MOTOR VEHICLE AT THAT LOCATION (U.S. CLS. 100 AND 101).

FIRST USE 11-8-2011; IN COMMERCE 11-8-2011.
MIDGE BUTLER, EXAMINING ATTORNEY

SN 85-604,510. BROWN, ROBERT R, GALLOWAY, NJ.
FILED 4-20-2012.

Fanecdote

THE MARK CONSISTS OF STANDARD CHARACTERS WITHOUT CLAIM TO ANY PARTICULAR FONT, STYLE, SIZE, OR COLOR.

FOR COMPUTER SERVICES, NAMELY, CREATING AN ON-LINE COMMUNITY FOR REGISTERED USERS TO ENGAGE IN SOCIAL NETWORKING, IN ORDER TO SHARE ANECDOTAL ACCOUNTS OF ENCOUNTERS WITH SPORTS AND ENTERTAINMENT CELEBRITIES (U.S. CLS. 100 AND 101).

CORY BOONE, EXAMINING ATTORNEY

SN 85-603,789. JASTREMSKI, MICHAEL, PHILADELPHIA, PA. FILED 4-20-2012.

OPENPHOTO

THE MARK CONSISTS OF STANDARD CHARACTERS WITHOUT CLAIM TO ANY PARTICULAR FONT, STYLE, SIZE, OR COLOR.

FOR PEER-TO-BROWSER PHOTO SHARING SERVICES, NAMELY, PROVIDING A WEBSITE FEATURING TECHNOLOGY ENABLING USERS TO UPLOAD, VIEW, AND DOWNLOAD DIGITAL PHOTOS (U.S. CLS. 100 AND 101).

FIRST USE 1-1-2002; IN COMMERCE 1-1-2002.
DAVID H. STINE, EXAMINING ATTORNEY

SN 85-604,664. L2F INC, AKA L2F AUTOMATION, WALNUT CREEK, CA. FILED 4-22-2012.

L2F

THE MARK CONSISTS OF STANDARD CHARACTERS WITHOUT CLAIM TO ANY PARTICULAR FONT, STYLE, SIZE, OR COLOR.

FOR DESIGN OF PRODUCTION FACILITIES; DESIGNING OF MACHINES, APPARATUS, INSTRUMENTS OR SYSTEMS COMPOSED OF SUCH MACHINES, APPARATUS AND INSTRUMENTS (U.S. CLS. 100 AND 101).

FIRST USE 6-18-2010; IN COMMERCE 6-18-2010.
JAY FLOWERS, EXAMINING ATTORNEY

CLASS 42—(Continued).

SN 85-605,087. VIEAU ASSOCIATES. INC., EDINA, MN.
FILED 4-23-2012.

The Original Pollution Sleuths

THE MARK CONSISTS OF STANDARD CHARACTERS WITHOUT CLAIM TO ANY PARTICULAR FONT, STYLE, SIZE, OR COLOR.

FOR CONSULTING SERVICES IN THE FIELD OF ENVIRONMENTAL EVALUATION, ASSESSMENT AND PLANNING FOR COMMERCIAL AND RESIDENTIAL PROPERTIES AND BUILDINGS; ENVIRONMENTAL TESTING AND INSPECTION SERVICES FOR COMMERCIAL AND RESIDENTIAL PROPERTIES AND BUILDINGS (U.S. CLS. 100 AND 101).

AHSEN KHAN, EXAMINING ATTORNEY

SN 85-605,144. HOMEPORTFOLIO, INC., NEWTON, MA.
FILED 4-23-2012.

HOMEPORTFOLIO

THE MARK CONSISTS OF STANDARD CHARACTERS WITHOUT CLAIM TO ANY PARTICULAR FONT, STYLE, SIZE, OR COLOR.

FOR COMPUTER SERVICES, NAMELY, IMPLEMENTING DATABASES OF COMPUTER USERS INTERESTED IN SIMILAR PRODUCTS AND SERVICES; COMPUTER SERVICES, NAMELY, IMPLEMENTING DATABASES OF CONSUMERS AND PROFESSIONALS IN THE HOME DESIGN INDUSTRY, INCLUDING PROVIDING DIRECTORY LISTINGS, SHARING OF PREFERENCES, AND PRODUCT SELECTION SERVICES; AND COMPUTER SERVICES, NAMELY, PROVIDING ON-LINE BROCHURES AND OTHER ELECTRONIC PUBLICATIONS IN THE FIELDS OF DECORATING, HOME IMPROVEMENT, HOME PURCHASE, OR HOME CONSTRUCTION (U.S. CLS. 100 AND 101).

FIRST USE 9-1-2006; IN COMMERCE 9-1-2006.
LUCY ARANT, EXAMINING ATTORNEY

CLASS 42—(Continued).

SN 85-605,251. RIDDAR, CODY W, DBA BINARY DIGITS,
SAN DIEGO, CA. FILED 4-23-2012.

Binary Digits

THE MARK CONSISTS OF STANDARD CHARACTERS WITHOUT CLAIM TO ANY PARTICULAR FONT, STYLE, SIZE, OR COLOR.

FOR COMPUTER PROGRAMMING AND SOFTWARE DESIGN; COMPUTER SOFTWARE CONSULTING; COMPUTER SOFTWARE DEVELOPMENT; COMPUTER SOFTWARE DEVELOPMENT AND COMPUTER PROGRAMMING DEVELOPMENT FOR OTHERS; CONSULTANCY IN THE FIELD OF SOFTWARE DESIGN; CONSULTING SERVICES IN THE FIELD OF PROVIDING ONLINE, NON-DOWNLOADABLE SOFTWARE AND APPLICATIONS; CREATING, MAINTAINING, AND MODERNIZING COMPUTER SOFTWARE; CREATION, DESIGN, DEVELOPMENT AND MAINTENANCE OF WEB SITES FOR THIRD PARTIES (U.S. CLS. 100 AND 101).

FIRST USE 4-19-2011; IN COMMERCE 4-19-2011.
LINDA ORNDORFF, EXAMINING ATTORNEY

SN 85-605,618. STREETLINKS LLC, KANSAS CITY, MO.
FILED 4-23-2012.

LENDERX

THE MARK CONSISTS OF STANDARD CHARACTERS WITHOUT CLAIM TO ANY PARTICULAR FONT, STYLE, SIZE, OR COLOR.

FOR SOFTWARE AS A SERVICE (SAAS) SERVICES FEATURING SOFTWARE FOR MORTGAGE LENDERS, BANKS AND APPRAISERS TO MANAGE THE REAL ESTATE APPRAISAL PROCESS; SOFTWARE AS A SERVICE (SAAS) SERVICES FEATURING SOFTWARE FOR USE IN REAL ESTATE APPRAISAL MANAGEMENT; SOFTWARE AS A SERVICE (SAAS) SERVICES FEATURING SOFTWARE FOR USE IN VALUATION OF REAL ESTATE (U.S. CLS. 100 AND 101).

FIRST USE 3-0-2011; IN COMMERCE 3-0-2011.
MICHAEL KEATING, EXAMINING ATTORNEY

CLASS 42—(Continued).

SN 85-612,083. DONLEN CORPORATION, NORTHBROOK, IL. FILED 4-30-2012.

DONLEN ASSET MANAGER

THE MARK CONSISTS OF STANDARD CHARACTERS WITHOUT CLAIM TO ANY PARTICULAR FONT, STYLE, SIZE, OR COLOR.

OWNER OF U.S. REG. NOS. 3,033,780, 7,789,810 AND OTHERS.

NO CLAIM IS MADE TO THE EXCLUSIVE RIGHT TO USE "ASSET MANAGER", APART FROM THE MARK AS SHOWN.

FOR SOFTWARE AS A SERVICE (SAAS) FEATURING SOFTWARE THAT PROVIDES A USER WITH THE ABILITY TO UPLOAD AND ORGANIZE DATA AND THEN CREATE CUSTOMIZED REPORTS BASED UPON SAID DATA (U.S. CLS. 100 AND 101).

GISSELLE AGOSTO, EXAMINING ATTORNEY

CLASS 42—(Continued).

SN 85-638,789. THE TRACOM CORPORATION, CENTENNIAL, CO. FILED 5-30-2012.

SOCIAL STYLE NAVIGATOR

THE MARK CONSISTS OF STANDARD CHARACTERS WITHOUT CLAIM TO ANY PARTICULAR FONT, STYLE, SIZE, OR COLOR.

OWNER OF U.S. REG. NOS. 3,006,775, 3,889,013 AND 4,130,147.

NO CLAIM IS MADE TO THE EXCLUSIVE RIGHT TO USE "NAVIGATOR", APART FROM THE MARK AS SHOWN.

FOR APPLICATION SERVICE PROVIDER, NAMELY, HOSTING, MANAGING, DEVELOPING, AND MAINTAINING EDUCATIONAL AND TRAINING APPLICATIONS, SOFTWARE, AND WEB SITES, IN THE FIELDS OF LEADERSHIP, MANAGEMENT, TEAM BUILDING, PERSONAL DEVELOPMENT AND SALES (U.S. CLS. 100 AND 101).

FIRST USE 9-14-2011; IN COMMERCE 9-14-2011.
GRETCHEN ULRICH, EXAMINING ATTORNEY

SN 85-612,748. DATAMOTIVE, INC., COCOA BEACH, FL. FILED 4-30-2012.

BRAND FOUNDRY

THE MARK CONSISTS OF STANDARD CHARACTERS WITHOUT CLAIM TO ANY PARTICULAR FONT, STYLE, SIZE, OR COLOR.

NO CLAIM IS MADE TO THE EXCLUSIVE RIGHT TO USE "BRAND", APART FROM THE MARK AS SHOWN.

FOR COMPUTER SOFTWARE DESIGN; COMPUTER SOFTWARE DEVELOPMENT; CONSULTANCY IN THE FIELD OF SOFTWARE DESIGN (U.S. CLS. 100 AND 101).

DAVID YONTEF, EXAMINING ATTORNEY

SN 85-648,600. HERSHEY CHOCOLATE & CONFECTIONERY CORPORATION, HERSHEY, PA. FILED 6-11-2012.

JUST CUZ

THE MARK CONSISTS OF STANDARD CHARACTERS WITHOUT CLAIM TO ANY PARTICULAR FONT, STYLE, SIZE, OR COLOR.

FOR COMPUTERIZED ONLINE GIFT ORDERING SERVICES WHICH SENDS THE GIFT RECIPIENT A COUPON WHICH MAY BE REDEEMED FOR THE GOODS PURCHASED BY THE GIFT GIVER (U.S. CLS. 100 AND 101).

MARGERIE A. TIERNEY, EXAMINING ATTORNEY

SN 85-636,427. NEO GROUP INC, DBA MASSPEP, QUINCY, MA. FILED 5-27-2012.

MassPep

THE MARK CONSISTS OF STANDARD CHARACTERS WITHOUT CLAIM TO ANY PARTICULAR FONT, STYLE, SIZE, OR COLOR.

FOR BIOLOGICAL RESEARCH (U.S. CLS. 100 AND 101).

AISHA SALEM, EXAMINING ATTORNEY

SN 85-649,741. AOL INC., DULLES, VA. FILED 6-12-2012.

SKYE

THE MARK CONSISTS OF STANDARD CHARACTERS WITHOUT CLAIM TO ANY PARTICULAR FONT, STYLE, SIZE, OR COLOR.

FOR PROVIDING WEATHER AND METEOROLOGICAL INFORMATION AND NEWS RELATED THERETO; WEATHER FORECASTING; WEATHER REPORTING (U.S. CLS. 100 AND 101).

FIRST USE 6-14-2012; IN COMMERCE 6-14-2012.
ALLISON HOLTZ, EXAMINING ATTORNEY

CLASS 42—(Continued).

SN 85-654,789. MITEK SYSTEMS, INC., SAN DIEGO, CA. FILED 6-18-2012.

POINT. SHOOT. ENROLL.

THE MARK CONSISTS OF STANDARD CHARACTERS WITHOUT CLAIM TO ANY PARTICULAR FONT, STYLE, SIZE, OR COLOR.

OWNER OF U.S. REG. NOS. 3,992,519 AND 4,096,880. FOR PROVIDING TEMPORARY USE OF ON-LINE NON-DOWNLOADABLE COMPUTER SOFTWARE FOR DOCUMENT IMAGING, INTELLIGENT CHARACTER AND IMAGE RECOGNITION, AND DOCUMENT ANALYSIS (U.S. CLS. 100 AND 101).

ANDREA HACK, EXAMINING ATTORNEY

SN 85-654,807. MITEK SYSTEMS, INC., SAN DIEGO, CA. FILED 6-18-2012.

POINT. SHOOT. FUND.

THE MARK CONSISTS OF STANDARD CHARACTERS WITHOUT CLAIM TO ANY PARTICULAR FONT, STYLE, SIZE, OR COLOR.

OWNER OF U.S. REG. NOS. 3,992,519 AND 4,096,880. FOR PROVIDING TEMPORARY USE OF ON-LINE NON-DOWNLOADABLE COMPUTER SOFTWARE FOR DOCUMENT IMAGING, INTELLIGENT CHARACTER AND IMAGE RECOGNITION, AND DOCUMENT ANALYSIS (U.S. CLS. 100 AND 101).

ANDREA HACK, EXAMINING ATTORNEY

SN 85-654,815. MITEK SYSTEMS, INC., SAN DIEGO, CA. FILED 6-18-2012.

POINT. SHOOT. SHOP.

THE MARK CONSISTS OF STANDARD CHARACTERS WITHOUT CLAIM TO ANY PARTICULAR FONT, STYLE, SIZE, OR COLOR.

OWNER OF U.S. REG. NOS. 3,992,519 AND 4,096,880. FOR PROVIDING TEMPORARY USE OF ON-LINE NON-DOWNLOADABLE COMPUTER SOFTWARE FOR DOCUMENT IMAGING, INTELLIGENT CHARACTER AND IMAGE RECOGNITION, AND DOCUMENT ANALYSIS (U.S. CLS. 100 AND 101).

ANDREA HACK, EXAMINING ATTORNEY

CLASS 42—(Continued).

SN 85-659,021. NEXGEN EXPERIENCE, LLC, DBA NEXGEN, NEW YORK, NY. FILED 6-22-2012.

BOEVO

THE MARK CONSISTS OF STANDARD CHARACTERS WITHOUT CLAIM TO ANY PARTICULAR FONT, STYLE, SIZE, OR COLOR.

FOR COMPUTER SERVICES, NAMELY, PROVIDING ON-LINE VIRTUAL COMMUNITIES FOR REGISTERED USERS TO ORGANIZE GROUPS AND EVENTS, PARTICIPATE IN DISCUSSIONS, AND ENGAGE IN SOCIAL, BUSINESS AND COMMUNITY NETWORKING (U.S. CLS. 100 AND 101).

ANNE FARRELL, EXAMINING ATTORNEY

SN 85-666,080. MITEK SYSTEMS, INC., SAN DIEGO, CA. FILED 6-29-2012.

MITEK MOBILE

THE MARK CONSISTS OF STANDARD CHARACTERS WITHOUT CLAIM TO ANY PARTICULAR FONT, STYLE, SIZE, OR COLOR.

OWNER OF U.S. REG. NOS. 2,379,045 AND 2,379,046. NO CLAIM IS MADE TO THE EXCLUSIVE RIGHT TO USE "MOBILE", APART FROM THE MARK AS SHOWN.

FOR PROVIDING TEMPORARY USE OF ON-LINE NON-DOWNLOADABLE COMPUTER SOFTWARE FOR DOCUMENT IMAGING, INTELLIGENT CHARACTER AND IMAGE RECOGNITION, AND DOCUMENT ANALYSIS; DESIGN AND ENGINEERING SERVICES (U.S. CLS. 100 AND 101).

ANDREA HACK, EXAMINING ATTORNEY

SN 85-683,029. GOOD START GENETICS, INC., CAMBRIDGE, MA. FILED 7-20-2012.

GoodStart TestSelect

THE MARK CONSISTS OF STANDARD CHARACTERS WITHOUT CLAIM TO ANY PARTICULAR FONT, STYLE, SIZE, OR COLOR.

OWNER OF U.S. REG. NO. 4,096,815. FOR PROVIDING A WEBSITE FEATURING NON-DOWNLOADABLE SOFTWARE IN THE NATURE OF A QUESTIONNAIRE FOR USE IN ASSESSING THE NEED FOR SPECIFIC GENETIC TESTS IN THE FIELD OF REPRODUCTIVE HEALTH AND PROVIDING RECOMMENDATIONS FOR USER SPECIFIC GENETIC TESTS BASED UPON USER ENTERED HEALTH INFORMATION (U.S. CLS. 100 AND 101).

JENNIFER RICHARDSON, EXAMINING ATTORNEY

CLASS 42—(Continued).

SN 85-977,129. SWITCH COMMUNICATIONS GROUP LLC, AKA SWITCH, LAS VEGAS, NV. FILED 8-25-2011.

SWITCH

THE MARK CONSISTS OF STANDARD CHARACTERS WITHOUT CLAIM TO ANY PARTICULAR FONT, STYLE, SIZE, OR COLOR.

OWNER OF U.S. REG. NOS. 3,217,279, 3,984,966 AND OTHERS.

SEC. 2(F) AS TO "SWITCH".

FOR COLOCATION FACILITY DEVELOPMENT SERVICES, NAMELY, DESIGNING SECURE, ENVIRONMENTALLY CONTROLLED FACILITIES AND TECHNICAL MONITORING OF COMPUTERS AND TELECOMMUNICATION EQUIPMENT OF OTHERS; PROVIDING SECURE ENVIRONMENTALLY CONTROLLED FACILITIES AND TECHNICAL MONITORING OF COMPUTER AND TELECOMMUNICATIONS EQUIPMENT FOR OTHERS FOR BUSINESS CONTINUITY, DISASTER AVOIDANCE AND COMPUTER RECOVERY SERVICES (U.S. CLS. 100 AND 101).

FIRST USE 11-30-2003; IN COMMERCE 11-30-2003.

SUE LAWRENCE, EXAMINING ATTORNEY

CLASS 43—(Continued).

SN 77-595,806. MY/ZP IP GROUP LTD., AUSTIN, TX. FILED 10-20-2008.

THE GROVE

THE MARK CONSISTS OF STANDARD CHARACTERS WITHOUT CLAIM TO ANY PARTICULAR FONT, STYLE, SIZE, OR COLOR.

OWNER OF U.S. REG. NO. 2,806,693.

FOR RESTAURANT AND BAR SERVICES (U.S. CLS. 100 AND 101).

TRACY FLETCHER, EXAMINING ATTORNEY

SN 79-106,084. INTERCITYHOTEL GMBH, FED REP GERMANY, FILED 10-13-2011.

InterCityHotel

THE MARK CONSISTS OF STANDARD CHARACTERS WITHOUT CLAIM TO ANY PARTICULAR FONT, STYLE, SIZE, OR COLOR.

PRIORITY DATE OF 4-29-2011 IS CLAIMED.

OWNER OF INTERNATIONAL REGISTRATION 1099036 DATED 10-13-2011, EXPIRES 10-13-2021.

OWNER OF U.S. REG. NO. 1,792,029.

FOR PROVIDING TEMPORARY HOUSING ACCOMMODATIONS AND HOTEL ACCOMMODATION SERVICES; PROVIDING FOOD AND DRINK (U.S. CLS. 100 AND 101).

ESTHER BELENKER, EXAMINING ATTORNEY

CLASS 43—HOTEL AND RESTAURANT SERVICES

SN 76-709,085. JKLM VENTURES, LLC, WASHINGTON, DC. FILED 9-15-2011.

TRIPPLE

THE MARK CONSISTS OF STANDARD CHARACTERS WITHOUT CLAIM TO ANY PARTICULAR FONT, STYLE, SIZE, OR COLOR.

FOR PROVIDING DESCRIPTIONS, RENTAL PRICING, LOCATION, MAPS, INDICATIONS OF RENTAL INQUIRIES, INDICATIONS OF RENTAL BOOKINGS, HISTORY OF RENTAL OCCUPANCY, TRAVEL DIRECTIONS AND RESERVATIONS FOR TEMPORARY ACCOMMODATIONS FOR RENT VIA THE INTERNET; AGENCY SERVICES FOR THE RESERVATION OF TEMPORARY ACCOMMODATIONS; PROVIDING A WEBSITE FOR MAKING RESERVATIONS AND BOOKINGS OF TEMPORARY LODGING (U.S. CLS. 100 AND 101).

SHANNON TWOHIG, EXAMINING ATTORNEY

SN 85-063,111. BUFFALO WILD WINGS, INC., MINNEAPOLIS, MN. FILED 6-15-2010.

TABLEGATING

THE MARK CONSISTS OF STANDARD CHARACTERS WITHOUT CLAIM TO ANY PARTICULAR FONT, STYLE, SIZE, OR COLOR.

FOR RESTAURANT SERVICES (U.S. CLS. 100 AND 101).

FIRST USE 7-6-2010; IN COMMERCE 7-6-2010.

MICHAEL SOUDERS, EXAMINING ATTORNEY

CLASS 43—(Continued).

SN 85-247,305. CY, LLC, ST. LOUIS, MO. FILED 2-21-2011.

CHAVA'S

THE MARK CONSISTS OF STANDARD CHARACTERS WITHOUT CLAIM TO ANY PARTICULAR FONT, STYLE, SIZE, OR COLOR.

FOR MEXICAN RESTAURANT SERVICES (U.S. CLS. 100 AND 101).

FIRST USE 3-0-2006; IN COMMERCE 3-0-2006.

BARBARA RUTLAND, EXAMINING ATTORNEY

SN 85-264,691. VICTORY BREWING COMPANY, DOWNTOWN, PA. FILED 3-11-2011.

VICTORY

THE MARK CONSISTS OF STANDARD CHARACTERS WITHOUT CLAIM TO ANY PARTICULAR FONT, STYLE, SIZE, OR COLOR.

OWNER OF U.S. REG. NOS. 2,751,912 AND 2,829,014. FOR RESTAURANT, BAR AND CATERING SERVICES (U.S. CLS. 100 AND 101).

FIRST USE 6-27-1994; IN COMMERCE 6-27-1994.

SANJEEV VOHRA, EXAMINING ATTORNEY

SN 85-383,729. COQUILLE ECONOMIC DEVELOPMENT CORPORATION, DBA THE MILL CASINO HOTEL AND RV PARK, NORTH BEND, OR. FILED 7-28-2011.



NO CLAIM IS MADE TO THE EXCLUSIVE RIGHT TO USE "WAREHOUSE," "EST 2007," AND "ENTERTAINMENT & SPIRITS", APART FROM THE MARK AS SHOWN.

THE COLOR(S) BLUE, GOLD, BLACK AND WHITE IS/ARE CLAIMED AS A FEATURE OF THE MARK.

THE MARK CONSISTS OF THE WORD "WAREHOUSE" IN GOLD WITH BLACK OUTLINE ABOVE A GOLD OVAL WITH BLACK VERTICAL LINES ACROSS THE ENTIRE BACKGROUND OF THE OVAL AND THE NUMBER "101"

CLASS 43—(Continued).

IN THE CENTER APPEARING IN BLUE WITH WHITE AND BLACK OUTLINE; EXTENDING FROM THE LEFT AND RIGHT SIDES OF THE OVAL IS A GOLD HORIZONTAL BAR WITH BLACK OUTLINE, AND AT THE END OF EACH SIDE ARE GOLD CIRCLES OUTLINED IN BLACK; UNDERNEATH THE LEFT GOLD CIRCLE IS "EST" IN BLACK AND UNDERNEATH THE RIGHT GOLD CIRCLE IS "2007" IN BLACK; UNDERNEATH THE ENTIRE OVAL/CIRCLE DESIGN IS THE WORDING "ENTERTAINMENT & SPIRITS" IN BLUE CURVED LETTERS.

FOR BAR AND COCKTAIL LOUNGE SERVICES; BAR AND RESTAURANT SERVICES (U.S. CLS. 100 AND 101).

FIRST USE 4-10-2007; IN COMMERCE 4-10-2007.

SHAILA SETTLES, EXAMINING ATTORNEY

SN 85-394,063. MITSUKOSHI (U.S.A.), INC., ORLANDO, FL. FILED 8-10-2011.

KABUKI CAFE

THE MARK CONSISTS OF STANDARD CHARACTERS WITHOUT CLAIM TO ANY PARTICULAR FONT, STYLE, SIZE, OR COLOR.

NO CLAIM IS MADE TO THE EXCLUSIVE RIGHT TO USE "CAFE", APART FROM THE MARK AS SHOWN.

THE ENGLISH TRANSLATION OF "KABUKI" IN THE MARK IS "CLASSICAL JAPANESE DANCE DRAMA".

FOR RESTAURANT AND BAR SERVICES (U.S. CLS. 100 AND 101).

FIRST USE 7-25-2011; IN COMMERCE 7-25-2011.

TRACY CROSS, EXAMINING ATTORNEY

SN 85-412,665. TINY TAVERNS, LLC, DENVER, CO. FILED 9-1-2011.



NO CLAIM IS MADE TO THE EXCLUSIVE RIGHT TO USE "INN", APART FROM THE MARK AS SHOWN.

THE MARK CONSISTS OF THE STYLIZED TEXT "DIVE INN" AND A GRAPHIC OF A GIRL SITTING ON THE EDGE OF A DIVING BOARD WHICH UNDERLINES THE WORD "DIVE".

FOR RESTAURANT AND BAR SERVICES (U.S. CLS. 100 AND 101).

FIRST USE 5-1-2011; IN COMMERCE 6-1-2011.

MEGHAN REINHART, EXAMINING ATTORNEY

CLASS 43—(Continued).

SN 85-421,766. FREDDY'S, L.L.C., WICHITA, KS. FILED 9-13-2011.



OWNER OF U.S. REG. NOS. 2,918,942, 3,968,515 AND OTHERS.

NO CLAIM IS MADE TO THE EXCLUSIVE RIGHT TO USE "FROZEN CUSTARD & STEAKBURGERS", APART FROM THE MARK AS SHOWN.

THE MARK CONSISTS OF THE WORDS "FREDDY'S FROZEN CUSTARD & STEAKBURGERS" WITH "FREDDY'S" IN CURSIVE AND "FROZEN CUSTARD &" IN THE TAIL OF THE "Y" AND "STEAKBURGERS" BELOW, ALL IN A RECTANGULAR SHAPE THAT INCLUDES AN ICE CREAM CONE AT THE TOP CENTER WITH TWO HORIZONTAL LINES ON EITHER SIDE OF THE CONE.

FOR RESTAURANT SERVICES (U.S. CLS. 100 AND 101).

FIRST USE 8-10-2009; IN COMMERCE 8-10-2009.
ANNE FARRELL, EXAMINING ATTORNEY

SN 85-427,778. PATE, RICHARD, BIRMINGHAM, AL. FILED 9-21-2011.

PATE'S COSTAS FAMOUS BAR-B-Q & STEAK PIT

THE MARK CONSISTS OF STANDARD CHARACTERS WITHOUT CLAIM TO ANY PARTICULAR FONT, STYLE, SIZE, OR COLOR.

NO CLAIM IS MADE TO THE EXCLUSIVE RIGHT TO USE "FAMOUS BAR-B-Q" AND "STEAK PIT", APART FROM THE MARK AS SHOWN.

THE NAME(S), PORTRAIT(S), AND/OR SIGNATURE(S) SHOWN IN THE MARK IDENTIFIES RICHARD "PATE", WHOSE CONSENT(S) TO REGISTER IS MADE OF RECORD.

FOR RESTAURANT SERVICES, INCLUDING DINE-IN, CATERING, DELIVERY AND TAKE OUT SERVICES (U.S. CLS. 100 AND 101).

KATHLEEN KOLACZ, EXAMINING ATTORNEY

CLASS 43—(Continued).

SN 85-436,864. LYFE KITCHEN IP HOLDINGS, LLC, CHICAGO, IL. FILED 9-30-2011.

LYFE KITCHEN LOVE YOUR FOOD EVERYDAY

THE MARK CONSISTS OF STANDARD CHARACTERS WITHOUT CLAIM TO ANY PARTICULAR FONT, STYLE, SIZE, OR COLOR.

NO CLAIM IS MADE TO THE EXCLUSIVE RIGHT TO USE "KITCHEN", APART FROM THE MARK AS SHOWN. THE WORDING "LYFE" HAS NO MEANING IN A FOREIGN LANGUAGE.

FOR RESTAURANT SERVICES, NAMELY, PROVIDING OF FOOD AND BEVERAGES FOR CONSUMPTION ON AND OFF THE PREMISES (U.S. CLS. 100 AND 101).
WENDY JUN, EXAMINING ATTORNEY

SN 85-440,173. CHOU, J., DBA J. CHOW'S CHICKEN RIBS SALADS, KENSINGTON, MD. FILED 10-5-2011.

The California Chicken Salad Place

THE MARK CONSISTS OF STANDARD CHARACTERS WITHOUT CLAIM TO ANY PARTICULAR FONT, STYLE, SIZE, OR COLOR.

SEC. 2(F).

FOR EAT-IN AND CARRY-OUT RESTAURANT AND CATERING SERVICES, FEATURING CHICKEN, RIBS, CHICKEN SALAD, WRAP SANDWICHES, AND DRINKS (U.S. CLS. 100 AND 101).

FIRST USE 9-9-1989; IN COMMERCE 9-9-1989.

KATHERINE CHANG, EXAMINING ATTORNEY

SN 85-440,504. BEANIE BROWN COFFEE & CREAMERY, INC., ARCHDALE, NC. FILED 10-6-2011.

BEANIE BROWN

THE MARK CONSISTS OF STANDARD CHARACTERS WITHOUT CLAIM TO ANY PARTICULAR FONT, STYLE, SIZE, OR COLOR.

THE NAME SHOWN IN THE MARK DOES NOT IDENTIFY A PARTICULAR LIVING INDIVIDUAL.

FOR RESTAURANT SERVICES (U.S. CLS. 100 AND 101).

BRENDAN MCCAULEY, EXAMINING ATTORNEY

CLASS 43—(Continued).

SN 85-441,103. THE UNGAR GROUP, LLC, DBA U/S SPORTS ADVISORS, INDIANAPOLIS, IN. FILED 10-6-2011.

I EIGHT ONE

THE MARK CONSISTS OF STANDARD CHARACTERS WITHOUT CLAIM TO ANY PARTICULAR FONT, STYLE, SIZE, OR COLOR.
FOR PROVIDING RESTAURANT REVIEWS (U.S. CLS. 100 AND 101).
FIRST USE 2-10-2010; IN COMMERCE 2-10-2010.
FRANK LATTUCA, EXAMINING ATTORNEY

CLASS 43—(Continued).

SN 85-446,288. PAMPLONA TAPAS BAR AND RESTAURANT, LLC, LAFAYETTE, LA. FILED 10-13-2011.



SN 85-445,759. THE CREME BRULEE CART USA LLC, SAN FRANCISCO, CA. FILED 10-12-2011.



THE COLOR(S) ARE BLACK, WHITE AND RED IS/ARE CLAIMED AS A FEATURE OF THE MARK.

THE MARK CONSISTS OF THE FOLLOWING: A BLACK BULL DESIGN WITH WHITE HORNS ON A RED RECTANGULAR BACKGROUND.

FOR RESTAURANT SERVICES (U.S. CLS. 100 AND 101).

FIRST USE 10-1-2007; IN COMMERCE 10-1-2007.
WILLIAM ROSSMAN, EXAMINING ATTORNEY

NO CLAIM IS MADE TO THE EXCLUSIVE RIGHT TO USE "THE CREME BRULEE CART", APART FROM THE MARK AS SHOWN.

THE MARK CONSISTS OF THE DESIGN OF A CHEF'S HAT ON WHEELS TO THE LEFT OF THE WORDING "THE CREME BRULEE CART".

FOR PROVIDING OF FOOD FEATURING CREME BRULEE VIA A MOBILE TRUCK (U.S. CLS. 100 AND 101).

FIRST USE 3-0-2009; IN COMMERCE 3-0-2009.
BILL DAWE, EXAMINING ATTORNEY

SN 85-452,375. SINISTER CULINARY GROUP, LLC, SEATTLE, WA. FILED 10-20-2011.

SINISTER BURGER

SN 85-446,262. GANSEVOORT HOTEL GROUP LLC, GARDEN CITY, NY. FILED 10-13-2011.

GOODNIGHT GANSEVOORT

THE MARK CONSISTS OF STANDARD CHARACTERS WITHOUT CLAIM TO ANY PARTICULAR FONT, STYLE, SIZE, OR COLOR.

OWNER OF U.S. REG. NO. 2,919,312.
FOR BAR AND COCKTAIL LOUNGE SERVICES (U.S. CLS. 100 AND 101).

WILLIAM VERHOSEK, EXAMINING ATTORNEY

THE MARK CONSISTS OF STANDARD CHARACTERS WITHOUT CLAIM TO ANY PARTICULAR FONT, STYLE, SIZE, OR COLOR.

NO CLAIM IS MADE TO THE EXCLUSIVE RIGHT TO USE "BURGER", APART FROM THE MARK AS SHOWN.

FOR RESTAURANT, BAR AND CATERING SERVICES (U.S. CLS. 100 AND 101).

STEVEN PEREZ, EXAMINING ATTORNEY

CLASS 43—(Continued).

SN 85-459,954. PRIME GROWTH ASSETS LIMITED, ROAD TOWN, TORTOLA, BR. VIRGIN ISLANDS, FILED 10-31-2011.



OWNER OF U.S. REG. NOS. 3,726,282 AND 3,729,320. NO CLAIM IS MADE TO THE EXCLUSIVE RIGHT TO USE "CAFE", APART FROM THE MARK AS SHOWN. THE MARK CONSISTS OF THE DESIGN OF A CUP VIEWED FROM ABOVE WITH TWO CURVED BANDS IN FRONT OF IT, ALL AT THE FRONT OF A DIAMOND BACKGROUND, AND THE WORDS "ENZO" CAFE BELOW THE DIAMOND BACKGROUND WHERE THE WORD "CAFE" IS IN SMALLER SIZE. THE WORDING "ENZO" HAS NO MEANING IN A FOREIGN LANGUAGE. FOR BOARDING FOR ANIMALS; BOARDING HOUSES; CAFE SERVICES; CAFETERIA SERVICES; CANTEEN SERVICES; CRÈCHE SERVICES; HOTEL ACCOMMODATION SERVICES; PROVIDING OF FOOD AND DRINK; PROVIDING TEMPORARY HOUSING ACCOMMODATIONS; RENTAL OF CHAIRS, TABLES, TABLE LINEN, GLASSWARE; RETIREMENT HOMES; SNACK BAR SERVICES; TOURIST HOMES (U.S. CLS. 100 AND 101). LINDA MICKLEBURGH, EXAMINING ATTORNEY

SN 85-463,298. SUSHI-TERIA LLC, DBA SUSHI-TERIA, BROOKLYN, NY. FILED 11-3-2011.

Sushi-teria

THE MARK CONSISTS OF STANDARD CHARACTERS WITHOUT CLAIM TO ANY PARTICULAR FONT, STYLE, SIZE, OR COLOR. FOR FAST FOOD JAPANESE RESTAURANT SERVICES (U.S. CLS. 100 AND 101). FIRST USE 5-1-2011; IN COMMERCE 10-19-2011. AMY KELLY, EXAMINING ATTORNEY

CLASS 43—(Continued).

SN 85-465,050. JMC KOA, INC., HONOLULU, HI. FILED 11-4-2011.

KOA PANCAKE HOUSE

THE MARK CONSISTS OF STANDARD CHARACTERS WITHOUT CLAIM TO ANY PARTICULAR FONT, STYLE, SIZE, OR COLOR. NO CLAIM IS MADE TO THE EXCLUSIVE RIGHT TO USE "PANCAKE HOUSE", APART FROM THE MARK AS SHOWN. FOR RESTAURANT SERVICES (U.S. CLS. 100 AND 101). FIRST USE 12-31-2000; IN COMMERCE 12-31-2000. MARILYN IZZI, EXAMINING ATTORNEY

SN 85-467,443. SOUTHWEST AIRLINES CO., DALLAS, TX. FILED 11-8-2011.



OWNER OF U.S. REG. NOS. 3,297,309, 3,751,595 AND 4,027,740. THE COLOR(S) BLUE, RED, YELLOW AND GRAY IS/ ARE CLAIMED AS A FEATURE OF THE MARK. THE MARK CONSISTS OF A DESIGN OF AN AIRPLANE WHERE THE TOP PORTION OF THE AIRPLANE APPEARS IN BLUE, THE BOTTOM PORTION APPEARS IN RED, WITH THE TWO PORTIONS BEING DIVIDED BY A CURVING YELLOW LINE, AND THE WINGS AND ENGINE FRONT IN GRAY. FOR PROVIDING INFORMATION ABOUT HOTELS AND TEMPORARY ACCOMMODATIONS; TRAVEL AGENCY SERVICES, NAMELY, MAKING RESERVATIONS AND BOOKINGS FOR HOTELS AND TEMPORARY ACCOMMODATIONS (U.S. CLS. 100 AND 101). FIRST USE 3-30-2004; IN COMMERCE 3-30-2004. WILLIAM VERHOSEK, EXAMINING ATTORNEY

CLASS 43—(Continued).

SN 85-496,037. DLC2, LLC, DBA JERSEY GRILLE, RED BANK, NJ. FILED 12-15-2011.



NO CLAIM IS MADE TO THE EXCLUSIVE RIGHT TO USE "JERSEY GRILLE", APART FROM THE MARK AS SHOWN.

THE COLOR(S) BLACK, GREEN, BROWN, RED AND WHITE IS/ARE CLAIMED AS A FEATURE OF THE MARK.

THE MARK CONSISTS OF A BLACK OVAL WITH THE WORDS "JERSEY GRILLE" IN CENTER, "JERSEY" IS APPLE GREEN IN SCRIPT FORMAT OVER THE WORD "GRILLE" IN WHITE, WITH A SECTION OF A BURGER ON RIGHT SIDE OF OVAL, WITH LIGHT BROWN ROLL WITH BLACK SEEDS, RED TOMATO, DARK BROWN BURGER, GREEN EDGE OF LETTUCE WITH BLACK BACKGROUND, AND THE WORDS "FABULOUS.", "FRESH.", "EVERYDAY." IN GREEN ALONG BOTTOM OF BLACK OVAL.

FOR RESTAURANT SERVICES, INCLUDING SIT-DOWN SERVICE OF FOOD AND TAKE-OUT RESTAURANT SERVICES (U.S. CLS. 100 AND 101).

DOMINIC J. FERRAIUOLO, EXAMINING ATTORNEY

SN 85-500,690. PIZZA INN, INC., THE COLONY, TX. FILED 12-21-2011.

Pie-partisan

THE MARK CONSISTS OF STANDARD CHARACTERS WITHOUT CLAIM TO ANY PARTICULAR FONT, STYLE, SIZE, OR COLOR.

FOR RESTAURANT SERVICES; CARRY-OUT RESTAURANT SERVICES; PROVIDING INFORMATION VIA THE INTERNET IN THE FIELD OF DINING, NAMELY, PROVIDING INFORMATION ON RESTAURANTS AND RESTAURANT LOCATIONS (U.S. CLS. 100 AND 101).

FIRST USE 11-7-2011; IN COMMERCE 11-7-2011.

MARK T. MULLEN, EXAMINING ATTORNEY

CLASS 43—(Continued).

SN 85-500,702. PIZZA INN, INC., THE COLONY, TX. FILED 12-21-2011.

Pie-Sect

THE MARK CONSISTS OF STANDARD CHARACTERS WITHOUT CLAIM TO ANY PARTICULAR FONT, STYLE, SIZE, OR COLOR.

FOR RESTAURANT SERVICES; CARRY-OUT RESTAURANT SERVICES; PROVIDING INFORMATION VIA THE INTERNET IN THE FIELD OF DINING, NAMELY, PROVIDING INFORMATION ON RESTAURANTS AND RESTAURANT LOCATIONS (U.S. CLS. 100 AND 101).

MARK T. MULLEN, EXAMINING ATTORNEY

SN 85-500,706. PIZZA INN, INC., THE COLONY, TX. FILED 12-21-2011.

Pie-odegradable

THE MARK CONSISTS OF STANDARD CHARACTERS WITHOUT CLAIM TO ANY PARTICULAR FONT, STYLE, SIZE, OR COLOR.

FOR RESTAURANT SERVICES; CARRY-OUT RESTAURANT SERVICES; PROVIDING INFORMATION VIA THE INTERNET IN THE FIELD OF DINING, NAMELY, PROVIDING INFORMATION ON RESTAURANTS AND RESTAURANT LOCATIONS (U.S. CLS. 100 AND 101).

MARK T. MULLEN, EXAMINING ATTORNEY

SN 85-500,717. PIZZA INN, INC., THE COLONY, TX. FILED 12-21-2011.

Pie-athlon

THE MARK CONSISTS OF STANDARD CHARACTERS WITHOUT CLAIM TO ANY PARTICULAR FONT, STYLE, SIZE, OR COLOR.

FOR RESTAURANT SERVICES; CARRY-OUT RESTAURANT SERVICES; PROVIDING INFORMATION VIA THE INTERNET IN THE FIELD OF DINING, NAMELY, PROVIDING INFORMATION ON RESTAURANTS AND RESTAURANT LOCATIONS (U.S. CLS. 100 AND 101).

MARK T. MULLEN, EXAMINING ATTORNEY

CLASS 43—(Continued).

SN 85-500,723. PIZZA INN, INC., THE COLONY, TX. FILED 12-21-2011.

CLASS 43—(Continued).

SN 85-503,068. WILLIAMS, JENNIFER M, SICKLERVILLE, NJ. FILED 12-23-2011.

Pie-focal



THE MARK CONSISTS OF STANDARD CHARACTERS WITHOUT CLAIM TO ANY PARTICULAR FONT, STYLE, SIZE, OR COLOR.

FOR RESTAURANT SERVICES; CARRY-OUT RESTAURANT SERVICES; PROVIDING INFORMATION VIA THE INTERNET IN THE FIELD OF DINING, NAMELY, PROVIDING INFORMATION ON RESTAURANTS AND RESTAURANT LOCATIONS (U.S. CLS. 100 AND 101).

MARK T. MULLEN, EXAMINING ATTORNEY

NO CLAIM IS MADE TO THE EXCLUSIVE RIGHT TO USE "GRILLED-CHEESE", APART FROM THE MARK AS SHOWN.

THE COLOR(S) RED, WHITE, BLACK, YELLOW, BLUE, AND ORANGE IS/ARE CLAIMED AS A FEATURE OF THE MARK.

THE MARK CONSISTS OF AN INDUSTRIAL STYLE FACTORY COLORED IN RED, WHITE AND BLACK, WITH A CONVEYER BELT, THE CONVEYOR BELT CARRYING YELLOW SANDWICHES; ALONG WITH A CARTOON CHARACTER, HOLDING A YELLOW SANDWICH, THE CARTOON CHARACTER HAVING A YELLOW HELMET, RED FACE, BLACK AND WHITE EYES, BLUE BODY, ORANGE NOSE AND TONGUE, WHITE HANDS, AND BLACK RED AND WHITE SNEAKERS.

FOR BOOKING OF CATERING SERVICES FOR OTHERS; CATERING SERVICES (U.S. CLS. 100 AND 101).

FIRST USE 1-5-2006; IN COMMERCE 1-5-2006.

WARREN L. OLANDRIA, EXAMINING ATTORNEY

SN 85-500,967. HAMANASI LTD, VIENNA, VA. FILED 12-21-2011.

HAMANASI

SN 85-506,396. BECERRA III, ERNEST, DBA SAN DIEGO TACO COMPANY, CHULA VISTA, CA. FILED 12-30-2011.

San Diego Taco Company

The King of all TACOS

THE MARK CONSISTS OF STANDARD CHARACTERS WITHOUT CLAIM TO ANY PARTICULAR FONT, STYLE, SIZE, OR COLOR.

THE WORDING "HAMANASI" HAS NO MEANING IN A FOREIGN LANGUAGE.

FOR HOTEL SERVICES (U.S. CLS. 100 AND 101).

FIRST USE 3-1-1999; IN COMMERCE 3-1-1999.

ELLEN PERKINS, EXAMINING ATTORNEY

THE MARK CONSISTS OF STANDARD CHARACTERS WITHOUT CLAIM TO ANY PARTICULAR FONT, STYLE, SIZE, OR COLOR.

NO CLAIM IS MADE TO THE EXCLUSIVE RIGHT TO USE "SAN DIEGO TACO COMPANY", APART FROM THE MARK AS SHOWN.

FOR CATERING SERVICES (U.S. CLS. 100 AND 101).

FIRST USE 6-12-2011; IN COMMERCE 12-30-2011.

KATHERINE CHANG, EXAMINING ATTORNEY

CLASS 43—(Continued).

SN 85-517,809. QUEEN CITY Q LLC, WAXHAW, NC. FILED 1-17-2012.



THE COLOR(S) RED, BROWN, AND ORANGE IS/ARE CLAIMED AS A FEATURE OF THE MARK.

THE MARK CONSISTS OF A BROWN CAPITAL LETTER "Q", WITH A RED OUTLINE ALONG BOTH THE OUTER AND INNER EDGE OF THE LETTER; WITH AN ORANGE FLAME WITH RED SHADING IN THE CURVED SECTIONS OF THE FLAME FORMING THE CURVED TAIL OF THE "Q", LOCATED ON THE LOWER RIGHT SIDE OF THE LETTER AND EXTENDING DOWN ACROSS THE OUTER PORTION OF THE LETTER AND UP THROUGH THE INNER OVAL.

FOR RESTAURANT SERVICES FEATURING BARBECUE (U.S. CLS. 100 AND 101).

FIRST USE 1-16-2012; IN COMMERCE 1-16-2012.

EDWARD NELSON, EXAMINING ATTORNEY

SN 85-518,337. MYRON GREEN CORPORATION, MERRIAM, KS. FILED 1-17-2012.

BISTRO FRESH

THE MARK CONSISTS OF STANDARD CHARACTERS WITHOUT CLAIM TO ANY PARTICULAR FONT, STYLE, SIZE, OR COLOR.

OWNER OF U.S. REG. NO. 3,169,999.

NO CLAIM IS MADE TO THE EXCLUSIVE RIGHT TO USE "FRESH", APART FROM THE MARK AS SHOWN.

FOR FOOD SERVICES, NAMELY, CAFETERIA AND CATERING SERVICES (U.S. CLS. 100 AND 101).

HENRY S. ZAK, EXAMINING ATTORNEY

CLASS 43—(Continued).

SN 85-537,238. LARKSPUR HOTELS AND RESTAURANTS, LARKSPUR, CA. FILED 2-8-2012.



OWNER OF U.S. REG. NOS. 3,054,357, 3,100,004 AND 3,401,713.

NO CLAIM IS MADE TO THE EXCLUSIVE RIGHT TO USE "COLLECTION", APART FROM THE MARK AS SHOWN.

THE MARK CONSISTS OF THE WORD "LARKSPUR" ABOVE THE WORD "COLLECTION" IN STYLIZED FONT. TO THE RIGHT SIDE OF THE WORDING IS A FANCIFUL BRANCH AND LEAF DESIGN.

FOR HOTELS; PROVIDING TEMPORARY HOUSING ACCOMMODATIONS (U.S. CLS. 100 AND 101).

FIRST USE 9-1-2008; IN COMMERCE 9-1-2008.

MIAH ROSENBERG, EXAMINING ATTORNEY

SN 85-541,485. THE PHOENIX RESTAURANT GROUP, LLC, SANDY, UT. FILED 2-13-2012.

America's First Brazilian Steakhouse

NO CLAIM IS MADE TO THE EXCLUSIVE RIGHT TO USE "BRAZILIAN STEAKHOUSE", APART FROM THE MARK AS SHOWN.

THE MARK CONSISTS OF STYLIZED WORDING INSIDE A RECTANGULAR BOX WITH THE WORDS "AMERICA'S FIRST BRAZILIAN STEAKHOUSE" WITH THE WORD "FIRST" ITALICIZED.

SEC. 2(F).

FOR RESTAURANT SERVICES, INCLUDING SIT-DOWN SERVICE OF FOOD AND TAKE-OUT RESTAURANT SERVICES (U.S. CLS. 100 AND 101).

FIRST USE 6-1-2002; IN COMMERCE 6-1-2002.

BILL DAWE, EXAMINING ATTORNEY

SN 85-546,495. RG GLOBAL LLC, ROUND LAKE, IL. FILED 2-17-2012.

Rick Gresh

THE MARK CONSISTS OF STANDARD CHARACTERS WITHOUT CLAIM TO ANY PARTICULAR FONT, STYLE, SIZE, OR COLOR.

THE NAME "RICK GRESH" IDENTIFIES A LIVING INDIVIDUAL WHOSE CONSENT IS OF RECORD.

FOR FOOD PREPARATION SERVICES; RESTAURANT SERVICES (U.S. CLS. 100 AND 101).

FIRST USE 1-1-1998; IN COMMERCE 1-1-2011.

KIMBERLY PARKS, EXAMINING ATTORNEY

CLASS 43—(Continued).

SN 85-563,369. MARKHAM, JAMES, DEL MAR, CA. FILED 3-7-2012.

PROJECT PIE

THE MARK CONSISTS OF STANDARD CHARACTERS WITHOUT CLAIM TO ANY PARTICULAR FONT, STYLE, SIZE, OR COLOR.

NO CLAIM IS MADE TO THE EXCLUSIVE RIGHT TO USE "PIE", APART FROM THE MARK AS SHOWN. FOR RESTAURANT AND CATERING SERVICES (U.S. CLS. 100 AND 101).

ELIZABETH KAJUBI, EXAMINING ATTORNEY

SN 85-565,184. NOBLE PIG, LLC, MCMINNVILLE, OR. FILED 3-9-2012.

NOBLE PIG

THE MARK CONSISTS OF STANDARD CHARACTERS WITHOUT CLAIM TO ANY PARTICULAR FONT, STYLE, SIZE, OR COLOR.

OWNER OF U.S. REG. NO. 3,854,981. FOR PROVIDING OF FOOD AND DRINK; RESTAURANT AND BAR SERVICES IN THE NATURE OF A TASTING ROOM; PROVIDING INFORMATION IN THE FIELDS OF FOOD PREPARATION AND DRINKS; PROVIDING REVIEWS OF RESTAURANTS; PROVIDING ONLINE INFORMATION IN THE FIELDS OF FOOD PREPARATIONS, RECIPES, RESTAURANTS AND WINE CHARACTERISTICS (U.S. CLS. 100 AND 101).

FIRST USE 2-10-2008; IN COMMERCE 2-10-2008. GRETCHEN ULRICH, EXAMINING ATTORNEY

SN 85-566,712. CARUSO PROPERTY MANAGEMENT, INC., LOS ANGELES, CA. FILED 3-12-2012.

Gentle Den

THE MARK CONSISTS OF STANDARD CHARACTERS WITHOUT CLAIM TO ANY PARTICULAR FONT, STYLE, SIZE, OR COLOR.

FOR BAR SERVICES; RESTAURANT SERVICES (U.S. CLS. 100 AND 101).

SKYE YOUNG, EXAMINING ATTORNEY

CLASS 43—(Continued).

SN 85-570,167. ANGELA R. SHYLLON AND SALAAM A. SHYLLON, HYATTSVILLE, MD. FILED 3-15-2012.



THE MARK CONSISTS OF THE WORDING "TRADISHTIONS" WITH A BOWL WITH STEAM OVER THE LETTERS "DISH" IN "TRADISHTIONS".

FOR RESTAURANT SERVICES (U.S. CLS. 100 AND 101).

STEVEN R. FINE, EXAMINING ATTORNEY

SN 85-571,461. P & O RESTAURANTS, LLC, RANCHO SANTA FE, CA. FILED 3-16-2012.

O's American Kitchen

THE MARK CONSISTS OF STANDARD CHARACTERS WITHOUT CLAIM TO ANY PARTICULAR FONT, STYLE, SIZE, OR COLOR.

NO CLAIM IS MADE TO THE EXCLUSIVE RIGHT TO USE "AMERICAN KITCHEN", APART FROM THE MARK AS SHOWN.

FOR RESTAURANT SERVICES (U.S. CLS. 100 AND 101).

SOPHIA S. KIM, EXAMINING ATTORNEY

SN 85-573,493. JAMES TUNG CHING PI, WOODSIDE, NY. FILED 3-19-2012.



Tung Shing House

Since 1971

NO CLAIM IS MADE TO THE EXCLUSIVE RIGHT TO USE THE NON-LATIN CHARACTER THAT TRANSLITERATES TO "LOU" AND "HOUSE" AND "SINCE 1971", APART FROM THE MARK AS SHOWN.

THE COLOR(S) RED, WHITE AND BLACK IS/ARE CLAIMED AS A FEATURE OF THE MARK.

THE MARK CONSISTS OF A VERTICAL RECTANGLE IN RED WITH THREE WHITE CHINESE CHARACTERS READ

CLASS 43—(Continued).

FROM TOP TO BOTTOM INSIDE OF THE RECTANGLE; INSIDE OF THE RED RECTANGLE ARE TWO CONJOINED WHITE SQUARE BOXES WITH RED INTERIORS THAT DIVIDE THE RECTANGLE INTO TWO SECTIONS; THE CENTER HORIZONTAL WHITE LINE WITHIN THE RECTANGULAR DESIGN THAT IS SHARED BY THE CONJOINING SQUARES RUNS THROUGH THE MIDDLE CHINESE CHARACTER; UNDERNEATH THE RECTANGULAR DESIGN ARE THE WORDS "TUNG SHING HOUSE" AND "SINCE 1971" ALL APPEARING IN BLACK. THE ENGLISH TRANSLATION OF "TUNG SHING" IN THE MARK IS "EAST STAR".

THE NON-LATIN CHARACTERS IN THE MARK TRANSLITERATE TO DONG SHING LOU AND THIS MEANS "EAST STAR HOUSE" IN ENGLISH.

FOR BAR SERVICES; CATERING SERVICES; RESTAURANT AND CATERING SERVICES; RESTAURANT SERVICES; RESTAURANT SERVICES FEATURING CHINESE CUISINE; RESTAURANT SERVICES, INCLUDING SIT-DOWN SERVICE OF FOOD AND TAKE-OUT RESTAURANT SERVICES; RESTAURANT SERVICES, NAMELY, PROVIDING OF FOOD AND BEVERAGES FOR CONSUMPTION ON AND OFF THE PREMISES (U.S. CLS. 100 AND 101).

FIRST USE 12-10-2005; IN COMMERCE 12-10-2005.
MARY CRAWFORD, EXAMINING ATTORNEY

SN 85-578,209. STEAK N SHAKE LLC, INDIANAPOLIS, IN. FILED 3-23-2012.

THE ORIGINAL STEAKBURGER

THE MARK CONSISTS OF STANDARD CHARACTERS WITHOUT CLAIM TO ANY PARTICULAR FONT, STYLE, SIZE, OR COLOR.

OWNER OF U.S. REG. NOS. 2,435,279, 3,589,597 AND OTHERS.

NO CLAIM IS MADE TO THE EXCLUSIVE RIGHT TO USE "STEAKBURGER", APART FROM THE MARK AS SHOWN.

SEC. 2(F).
FOR RESTAURANT SERVICES (U.S. CLS. 100 AND 101).

FIRST USE 5-1-2000; IN COMMERCE 5-1-2000.
SCOTT BIBB, EXAMINING ATTORNEY

SN 85-579,787. 3143 WEST LOGAN BLVD MANAGER, LLC, CHICAGO, IL. FILED 3-26-2012.

Billy Sunday

THE MARK CONSISTS OF STANDARD CHARACTERS WITHOUT CLAIM TO ANY PARTICULAR FONT, STYLE, SIZE, OR COLOR.

THE NAME(S), PORTRAIT(S), AND/OR SIGNATURE(S) SHOWN IN THE MARK DOES NOT IDENTIFY A PARTICULAR LIVING INDIVIDUAL.

FOR COCKTAIL LOUNGE SERVICES; COCKTAIL PARLOR SERVICES; SELF-SERVICE RESTAURANTS (U.S. CLS. 100 AND 101).

FIRST USE 5-1-2012; IN COMMERCE 5-1-2012.
EUGENIA MARTIN, EXAMINING ATTORNEY

CLASS 43—(Continued).

SN 85-583,535. SAN FRANCISCO SOURDOUGH EATERY, INC., COEUR D'ALENE, ID. FILED 3-29-2012.



NO CLAIM IS MADE TO THE EXCLUSIVE RIGHT TO USE "THE PREMIUM DELI CAFE", APART FROM THE MARK AS SHOWN.

THE MARK CONSISTS OF A STAR WITHIN ANOTHER STAR NEXT TO THE LETTERS "SFSE" NEXT TO ANOTHER STAR WITHIN ANOTHER STAR ABOVE THE WORDS "THE PREMIUM DELI CAFE".

FOR RESTAURANT SERVICES (U.S. CLS. 100 AND 101).

FIRST USE 10-31-2011; IN COMMERCE 10-31-2011.
JOHN E. MICHOS, EXAMINING ATTORNEY

SN 85-583,545. SAN FRANCISCO SOURDOUGH EATERY, INC., COEUR D'ALENE, ID. FILED 3-29-2012.



OWNER OF U.S. REG. NOS. 3,786,767 AND 3,918,490.

NO CLAIM IS MADE TO THE EXCLUSIVE RIGHT TO USE "SAN FRANCISCO STYLE SOURDOUGH EATERY" AND "ESTABLISHED IN 1999", APART FROM THE MARK AS SHOWN.

THE MARK CONSISTS OF THE WORDING "SAN FRANCISCO STYLE SOURDOUGH EATERY ESTABLISHED IN 1999" AND A DESIGN ELEMENT COMPRISING A STREETCAR. THE WORDING "ESTABLISHED IN 1999" APPEARS ON THE FRONT OF THE STREETCAR. THE WORDING "SAN FRANCISCO STYLE SOURDOUGH EATERY" APPEARS BELOW THE DESIGN ELEMENT. A CIRCLE SURROUNDS THE STREETCAR ELEMENT OF THE MARK AND WITHIN THE UPPER PART OF THE CIRCLE IS A STAR FOLLOWED BY THE WORDING "SAN FRANCISCO" AND ANOTHER STAR. WITHIN THE LOWER PART OF THE CIRCLE IS THE WORDING "STYLE SOURDOUGH EATERY".

FOR RESTAURANT SERVICES (U.S. CLS. 100 AND 101).

FIRST USE 10-31-2011; IN COMMERCE 10-31-2011.
JOHN E. MICHOS, EXAMINING ATTORNEY

CLASS 43—(Continued).

SN 85-586,844. LEE JR., LOUIS, GAINESVILLE, FL. FILED 4-2-2012.



NO CLAIM IS MADE TO THE EXCLUSIVE RIGHT TO USE "BAR-B-QUE" AND "FRIED CHICKEN", APART FROM THE MARK AS SHOWN.

THE STIPPLING IS FOR SHADING PURPOSES ONLY.

THE MARK CONSISTS OF THE TEXT "LL'S BAR-B-QUE" ON A ROCKER AT THE TOP, BELOW ARE 3 CIRCLES, FROM LEFT TO RIGHT IS THE HEAD OF A BULL, THE HEAD OF A WILD BOAR, AND THE HEAD OF A ROOSTER. BELOW THE IMAGES ARE THE WORDS "FRIED CHICKEN" ON A ROCKER.

FOR RESTAURANT SERVICES (U.S. CLS. 100 AND 101).

ANNE E. GUSTASON, EXAMINING ATTORNEY

SN 85-587,611. SEIB, EVE A, DUNWOODY, GA. FILED 4-3-2012.

Sweet Tweets Ice Cream Truck

THE MARK CONSISTS OF STANDARD CHARACTERS WITHOUT CLAIM TO ANY PARTICULAR FONT, STYLE, SIZE, OR COLOR.

NO CLAIM IS MADE TO THE EXCLUSIVE RIGHT TO USE "ICE CREAM TRUCK", APART FROM THE MARK AS SHOWN.

FOR PROVIDING OF FOOD AND DRINK VIA A MOBILE TRUCK (U.S. CLS. 100 AND 101).

KEVIN CORWIN, EXAMINING ATTORNEY

SN 85-588,022. ANHEUSER-BUSCH, LLC, ST. LOUIS, MO. FILED 4-3-2012.

BUD LIGHT

THE MARK CONSISTS OF STANDARD CHARACTERS WITHOUT CLAIM TO ANY PARTICULAR FONT, STYLE, SIZE, OR COLOR.

OWNER OF U.S. REG. NOS. 1,261,873, 2,802,093 AND OTHERS.

FOR ENTERTAINMENT SERVICES, NAMELY, PROVIDING NEWS AND INFORMATION IN THE FIELD OF BEER (U.S. CLS. 100 AND 101).

FIRST USE 10-15-2001; IN COMMERCE 10-15-2001.

KATHERINE M. DUBRAY, EXAMINING ATTORNEY

CLASS 43—(Continued).

SN 85-588,521. BRC HOSPITALITY LLC, MIAMI, FL. FILED 4-4-2012.

CAFE CON LECHE A LA FLACA

THE MARK CONSISTS OF STANDARD CHARACTERS WITHOUT CLAIM TO ANY PARTICULAR FONT, STYLE, SIZE, OR COLOR.

NO CLAIM IS MADE TO THE EXCLUSIVE RIGHT TO USE "CAFE CON LECHE", APART FROM THE MARK AS SHOWN.

THE ENGLISH TRANSLATION OF "CAFE CON LECHE A LA FLACA" IN THE MARK IS "COFFEE WITH MILK THE SKINNY GIRL".

FOR RESTAURANT SERVICES (U.S. CLS. 100 AND 101).

SUZANNE BLANE, EXAMINING ATTORNEY

SN 85-588,536. BRC HOSPITALITY LLC, MIAMI, FL. FILED 4-4-2012.

CORTADITO A LA FLACA

THE MARK CONSISTS OF STANDARD CHARACTERS WITHOUT CLAIM TO ANY PARTICULAR FONT, STYLE, SIZE, OR COLOR.

NO CLAIM IS MADE TO THE EXCLUSIVE RIGHT TO USE "CORTADITO", APART FROM THE MARK AS SHOWN.

THE ENGLISH TRANSLATION OF "LA FLACA" IN THE MARK IS THE SKINNY GIRL.

FOR RESTAURANT SERVICES (U.S. CLS. 100 AND 101).

SUZANNE BLANE, EXAMINING ATTORNEY

SN 85-588,591. BRC HOSPITALITY LLC, MIAMI, FL. FILED 4-4-2012.

CAFE CUBANO A LA FLACA

THE MARK CONSISTS OF STANDARD CHARACTERS WITHOUT CLAIM TO ANY PARTICULAR FONT, STYLE, SIZE, OR COLOR.

NO CLAIM IS MADE TO THE EXCLUSIVE RIGHT TO USE "CAFE CUBANO", APART FROM THE MARK AS SHOWN.

THE ENGLISH TRANSLATION OF "LA FLACA" IN THE MARK IS THE SKINNY GIRL.

FOR RESTAURANT SERVICES (U.S. CLS. 100 AND 101).

SUZANNE BLANE, EXAMINING ATTORNEY

CLASS 43—(Continued).

SN 85-589,548. LIEBERMAN, ARNOLD P., AGOURA HILLS, CA. FILED 4-4-2012.

COFFEE DAN'S

THE MARK CONSISTS OF STANDARD CHARACTERS WITHOUT CLAIM TO ANY PARTICULAR FONT, STYLE, SIZE, OR COLOR.

NO CLAIM IS MADE TO THE EXCLUSIVE RIGHT TO USE "COFFEE", APART FROM THE MARK AS SHOWN.

FOR RESTAURANT AND CAFE SERVICES, BAR AND COFFEE SHOP SERVICES, CAFE SERVING BAKERY PRODUCTS, PREPARATION OF FOOD AND BEVERAGES, AND SERVING OF FOOD AND DRINK/ BEVERAGES (U.S. CLS. 100 AND 101).

BILL DAWE, EXAMINING ATTORNEY

SN 85-590,481. FORMA HOLDING, LLC, EL PASO, TX. FILED 4-5-2012.



NO CLAIM IS MADE TO THE EXCLUSIVE RIGHT TO USE "PIZZERIA", APART FROM THE MARK AS SHOWN.

THE MARK CONSISTS OF THE WORDS "FORMA" ON TOP OF THE WORD "PIZZERIA". THE "O" IN WORD "FORMA" IS IN THE SHAPE OF A PIZZA CUTTER. A LINE SEPARATES THE TWO WORDS.

THE ENGLISH TRANSLATION OF "FORMA" IN THE MARK IS "FORM".

FOR CATERING SERVICES (U.S. CLS. 100 AND 101).
FIRST USE 1-26-2012; IN COMMERCE 1-26-2012.
MARK SHINER, EXAMINING ATTORNEY

CLASS 43—(Continued).

SN 85-590,704. RSR RESTAURANT GROUP, INC., CALABASAS, CA. FILED 4-5-2012.



NO CLAIM IS MADE TO THE EXCLUSIVE RIGHT TO USE "COFFEE", APART FROM THE MARK AS SHOWN.

THE MARK CONSISTS OF AN IMAGE OF A BICYCLE AND THE WORDS "10 SPEED COFFEE".

FOR RESTAURANT AND CAFE SERVICES (U.S. CLS. 100 AND 101).

JEFFREY LOOK, EXAMINING ATTORNEY

SN 85-590,797. PULEO, CHRISTINA, DALLAS, TX. FILED 4-6-2012.

RUSTY ROOF ROADHOUSE

THE MARK CONSISTS OF STANDARD CHARACTERS WITHOUT CLAIM TO ANY PARTICULAR FONT, STYLE, SIZE, OR COLOR.

NO CLAIM IS MADE TO THE EXCLUSIVE RIGHT TO USE "ROADHOUSE", APART FROM THE MARK AS SHOWN.

FOR RESTAURANT SERVICES; BAR SERVICES; CATERING SERVICES (U.S. CLS. 100 AND 101).

KIMBERLY PARKS, EXAMINING ATTORNEY

SN 85-592,405. TOMMY SCOTT, INC, BETHESDA, MD. FILED 4-9-2012.

BCS Barbecue

THE MARK CONSISTS OF STANDARD CHARACTERS WITHOUT CLAIM TO ANY PARTICULAR FONT, STYLE, SIZE, OR COLOR.

NO CLAIM IS MADE TO THE EXCLUSIVE RIGHT TO USE "BARBECUE", APART FROM THE MARK AS SHOWN.

FOR DELICATESSEN SERVICES; RESTAURANT AND CAFE SERVICES; RESTAURANT SERVICES; RESTAURANT SERVICES; INCLUDING SIT-DOWN SERVICE OF FOOD AND TAKE-OUT RESTAURANT SERVICES; RESTAURANT SERVICES, NAMELY, PROVIDING OF FOOD AND BEVERAGES FOR CONSUMPTION ON AND OFF THE PREMISES; SELF-SERVICE RESTAURANTS; TAKE-OUT RESTAURANT SERVICES (U.S. CLS. 100 AND 101).

FIRST USE 2-1-2011; IN COMMERCE 2-1-2011.

BARBARA GAYNOR, EXAMINING ATTORNEY

CLASS 43—(Continued).

SN 85-592,681. ELGIN, EVELYN, FALLS CHURCH, VA.
FILED 4-9-2012.

ALLMOODS COOKBOOK

THE MARK CONSISTS OF STANDARD CHARACTERS WITHOUT CLAIM TO ANY PARTICULAR FONT, STYLE, SIZE, OR COLOR.

NO CLAIM IS MADE TO THE EXCLUSIVE RIGHT TO USE "COOKBOOK", APART FROM THE MARK AS SHOWN.

FOR PROVIDING A WEBSITE FEATURING INFORMATION IN THE FIELD OF THE CULINARY ARTS (U.S. CLS. 100 AND 101).

ALEX KEAM, EXAMINING ATTORNEY

CLASS 43—(Continued).

SN 85-593,828. TJF USA, LLC, ALTAMONTE SPRINGS, FL.
FILED 4-10-2012.

BURRITO THURSDITO

THE MARK CONSISTS OF STANDARD CHARACTERS WITHOUT CLAIM TO ANY PARTICULAR FONT, STYLE, SIZE, OR COLOR.

NO CLAIM IS MADE TO THE EXCLUSIVE RIGHT TO USE "BURRITO", APART FROM THE MARK AS SHOWN.

FOR RESTAURANT SERVICES, INCLUDING SIT-DOWN SERVICE OF FOOD AND TAKE-OUT RESTAURANT SERVICES (U.S. CLS. 100 AND 101).

FIRST USE 3-23-2012; IN COMMERCE 3-23-2012.

JEFFREY LOOK, EXAMINING ATTORNEY

SN 85-592,690. FRONT BURNER PRODUCTIONS, LLC, DBA
FOODNIKS, TIBURON, CA. FILED 4-9-2012.



SN 85-595,121. PROMEDICA HEALTH SYSTEM, INC., TOLEDO, OH. FILED 4-11-2012.

KAITLYN'S COTTAGE

THE COLOR(S) BLACK, WHITE, AND SILVER IS/ARE CLAIMED AS A FEATURE OF THE MARK.

THE MARK CONSISTS OF THE LITERAL ELEMENT "FOODNIKS TO EAT, TO ENJOY, TO GO" AND A FOUR SIDED EMBLEM WITH ROUNDED EDGES WITH A BLACK BACKGROUND AND A WHITE BORDER. IN THE MIDDLE OF THE EMBLEM ARE THE LETTERS "FOODN" IN WHITE IN A STYLIZED FONT IN LOWER CASE, THEN A PICTURE OF A SILVER FORK, REPRESENTING A STYLIZED LETTER "I", FOLLOWED BY THE LETTERS "KS", IN WHITE IN A LOWER CASE STYLIZED FONT. BELOW THAT DESIGN ARE THE WORDS, "TO EAT, TO ENJOY, TO GO" IN A STRAIGHT LINE IN WHITE IN A LOWER CASE STYLIZED FONT.

FOR RESTAURANT SERVICES, INCLUDING SIT-DOWN SERVICE OF FOOD AND TAKE-OUT RESTAURANT SERVICES AND CATERING SERVICES (U.S. CLS. 100 AND 101).

FIRST USE 9-26-2007; IN COMMERCE 9-26-2007.

ALEX KEAM, EXAMINING ATTORNEY

THE MARK CONSISTS OF STANDARD CHARACTERS WITHOUT CLAIM TO ANY PARTICULAR FONT, STYLE, SIZE, OR COLOR.

FOR RESPITE CARE SERVICES, NAMELY, PROVIDING TEMPORARY HOUSING ACCOMMODATIONS TO TEENS AND ADULTS WITH SPECIAL NEEDS (U.S. CLS. 100 AND 101).

EMILY CHUO, EXAMINING ATTORNEY

CLASS 43—(Continued).

SN 85-595,788. PARIS CROISSANT CO., LTD., KYOUNGKI-DO, REPUBLIC OF KOREA, FILED 4-12-2012.



OWNER OF REPUBLIC OF KOREA REG. NO. 41-0212267, DATED 6-22-2011, EXPIRES 6-22-2021.

OWNER OF U.S. REG. NOS. 3,308,466, 3,582,119 AND OTHERS.

NO CLAIM IS MADE TO THE EXCLUSIVE RIGHT TO USE "BAGUETTE", APART FROM THE MARK AS SHOWN.

THE COLOR(S) BLUE AND WHITE IS/ARE CLAIMED AS A FEATURE OF THE MARK.

THE MARK CONSISTS OF THE WORDS "PARIS BAGUETTE" IN WHITE WITH A STYLIZED DESIGN OF THE EIFFEL TOWER IN WHITE BETWEEN THE WORDS, ON A BLUE RECTANGULAR BACKGROUND.

FOR COFFEE SHOP SERVICES; RESTAURANTS; SNACK-BARS; CAFE; CAFETERIAS; CANTEENS SERVICES; SELF-SERVICE RESTAURANTS; FOOD AND DRINK CATERING; NON-STOP RESTAURANT SERVICES PROVIDED AT HIGHWAY REST AREAS (U.S. CLS. 100 AND 101).

THOMAS MANOR, EXAMINING ATTORNEY

CLASS 43—(Continued).

SN 85-596,370. LEGACY TM, L.P., HOUSTON, TX. FILED 4-12-2012.



OWNER OF U.S. REG. NOS. 1,163,145, 2,285,458 AND OTHERS.

THE MARK CONSISTS OF THE WORD "NINFA'S" WITH A WIDE LINE UNDERNEATH CONTAINING THE WORDS "ON NAVIGATION" AND THE DRAWING OF A PARROT PERCHED ON TOP OF THE LETTER "N".

FOR RESTAURANT SERVICES; BAR SERVICES; CATERING SERVICES; TAKE OUT RESTAURANT SERVICES (U.S. CLS. 100 AND 101).

FIRST USE 12-31-2007; IN COMMERCE 12-31-2007.
WILLIAM P. SHANAHAN, EXAMINING ATTORNEY

SN 85-596,929. RRI FINANCIAL, INC., COLUMBUS, OH. FILED 4-13-2012.

SN 85-596,120. FAMILY VALUE INVESTMENT CORPORATION, COCOA, FL. FILED 4-12-2012.



NO CLAIM IS MADE TO THE EXCLUSIVE RIGHT TO USE "CATERING", APART FROM THE MARK AS SHOWN.

THE MARK CONSISTS OF THE DESIGN OF A CHEF WEARING AN APRON AND A CHEF HAT AND CARRYING A TRAY WITH A DOME COVER, ALL IN THE MIDDLE OF THE WORDS "BOB'S CATERING" AND THE WORD "OPTIONS" AND ABOVE A HORIZONTAL LINE.

FOR FOOD AND DRINK PREPARATION FOR OTHERS (U.S. CLS. 100 AND 101).

TINA MAI, EXAMINING ATTORNEY

RED ROOF INN PLUS +

THE MARK CONSISTS OF STANDARD CHARACTERS WITHOUT CLAIM TO ANY PARTICULAR FONT, STYLE, SIZE, OR COLOR.

OWNER OF U.S. REG. NOS. 984,159, 2,224,076 AND OTHERS.

NO CLAIM IS MADE TO THE EXCLUSIVE RIGHT TO USE "INN", APART FROM THE MARK AS SHOWN.

FOR HOTEL SERVICES; MOTEL SERVICES (U.S. CLS. 100 AND 101).

FIRST USE 9-10-2011; IN COMMERCE 9-10-2011.
ALICE BENMAMAN, EXAMINING ATTORNEY

CLASS 43—(Continued).

SN 85-597,152. PIT FIRE MANAGEMENT CO., LLC, LOS ANGELES, CA. FILED 4-13-2012.



OWNER OF U.S. REG. NO. 3,802,924.
NO CLAIM IS MADE TO THE EXCLUSIVE RIGHT TO USE "PITFIRE ARTISAN PIZZA", APART FROM THE MARK AS SHOWN.

THE MARK CONSISTS OF THE WORDING "PITFIRE ARTISAN PIZZA", ALONG WITH THE LETTER "P" INSIDE A FLAME, ALL CONTAINED WITHIN IN A DIAMOND SHAPED BOX WHICH HAS A DOUBLE BORDER.

FOR RESTAURANT SERVICES FEATURING GOURMET PIZZA, PASTA AND SALADS (U.S. CLS. 100 AND 101).

FIRST USE 10-31-2008; IN COMMERCE 10-31-2008.
KATHERINE STOIDES, EXAMINING ATTORNEY

SN 85-597,187. PIT FIRE MANAGEMENT CO., LLC, LOS ANGELES, CA. FILED 4-13-2012.



THE MARK CONSISTS OF A STYLIZED LETTER "P" WITHIN A FLAME.

FOR RESTAURANT SERVICES FEATURING GOURMET PIZZA, PASTA AND SALADS (U.S. CLS. 100 AND 101).

FIRST USE 10-31-2008; IN COMMERCE 10-31-2008.
KATHERINE STOIDES, EXAMINING ATTORNEY

CLASS 43—(Continued).

SN 85-597,599. HALL, LAURA S., DURHAM, NC. FILED 4-13-2012.

Bon Vivant Catering

THE MARK CONSISTS OF STANDARD CHARACTERS WITHOUT CLAIM TO ANY PARTICULAR FONT, STYLE, SIZE, OR COLOR.

NO CLAIM IS MADE TO THE EXCLUSIVE RIGHT TO USE "CATERING", APART FROM THE MARK AS SHOWN. FOR CATERING SERVICES (U.S. CLS. 100 AND 101). FIRST USE 6-1-2003; IN COMMERCE 6-1-2003.
KELLEY WELLS, EXAMINING ATTORNEY

SN 85-598,607. APRILIA RISCA, ABILENE, TX. FILED 4-16-2012.



THE COLOR(S) LIGHT YELLOW, DARK YELLOW, RED, BROWN, WHITE, DARK GRAY, AND LIGHT GRAY IS/ ARE CLAIMED AS A FEATURE OF THE MARK.

THE MARK CONSISTS OF A RED DRAGON'S HEAD WITH LIGHT YELLOW HORNS, NOSTRILS AND MOUTH WEARING A WHITE CHEF'S HAT. THE DRAGON'S EYES ARE LIGHT YELLOW ON THE OUTSIDE AND BROWN WITH A WHITE DOT IN THE MIDDLE. UNDERNEATH THE DRAGON HEAD APPEARS THE WORDING "DRAGON LICIOUS" SPELLED OUT ON TWO LINES. THE TOP OF ALL THE LETTERS ARE LIGHT YELLOW AND THE BOTTOM ARE DARK YELLOW. UNDERNEATH THE LETTER "D" APPEARS THE DRAGON'S TAIL IN DARK YELLOW AND RED. THE ENTIRE WORDING AND DESIGN ARE ENCOMPASSED IN A RECTANGLE THAT FADES FROM DARK GRAY AT TOP, LIGHT GRAY IN THE MIDDLE AND WHITE AT THE BOTTOM.

FOR RESTAURANT SERVICES, INCLUDING SIT-DOWN SERVICE OF FOOD AND TAKE-OUT RESTAURANT SERVICES (U.S. CLS. 100 AND 101).

COURTNEY ALVAREZ, EXAMINING ATTORNEY

CLASS 43—(Continued).

SN 85-598,681. CC INVESTMENTS, LLC, GRAND JUNCTION, CO. FILED 4-16-2012.



THE COLOR(S) GREEN, GREY, WHITE, BLACK, RED AND PINK IS/ARE CLAIMED AS A FEATURE OF THE MARK.

THE MARK CONSISTS OF A STYLIZED ALLIGATOR FACE DESIGN HOLDING A SKELETON HUMAN ARM IN ITS MOUTH IN A GREY OVAL WITH BLACK AND WHITE BORDER. THE SKIN OF THE ALLIGATOR IS GREEN AND OUTLINED IN BLACK, THE INSIDE OF ITS MOUTH IS RED WITH PINK GUMS AND ITS TEETH AND EYES ARE WHITE WITH SHADES OF GREY AND OUTLINED IN BLACK. THE SKELETON HUMAN ARM DESIGN IS WHITE, WITH SHADES OF LIGHT GREY AND OUTLINED IN BLACK.

FOR RESTAURANT SERVICES, INCLUDING SIT-DOWN SERVICE OF FOOD AND TAKE-OUT RESTAURANT SERVICES (U.S. CLS. 100 AND 101).

NATALIE POLZER, EXAMINING ATTORNEY

CLASS 43—(Continued).

SN 85-599,252. SULPHUR CREEK ASSOCIATES II, L.P., ST. HELENA, CA. FILED 4-16-2012.



OWNER OF U.S. REG. NOS. 2,002,708 AND 2,121,473. NO CLAIM IS MADE TO THE EXCLUSIVE RIGHT TO USE "NAPA VALLEY", APART FROM THE MARK AS SHOWN.

THE MARK CONSISTS OF THE IMAGE OF A STREET LAMP CENTERED ABOVE THE WORDS "SOUTHBRIDGE NAPA VALLEY".

FOR HOTEL SERVICES, PROVIDING CONVENTION FACILITIES AND CATERING SERVICES (U.S. CLS. 100 AND 101).

FIRST USE 2-20-2012; IN COMMERCE 2-20-2012. SANDRA BUJA, EXAMINING ATTORNEY

SN 85-598,943. ERNEST GENE STREET, DALLAS, TX. FILED 4-16-2012.

Liberty Chicken

THE MARK CONSISTS OF STANDARD CHARACTERS WITHOUT CLAIM TO ANY PARTICULAR FONT, STYLE, SIZE, OR COLOR.

NO CLAIM IS MADE TO THE EXCLUSIVE RIGHT TO USE "CHICKEN", APART FROM THE MARK AS SHOWN.

FOR RESTAURANT AND CAFE SERVICES (U.S. CLS. 100 AND 101).

EVIN L. KOZAK, EXAMINING ATTORNEY

SN 85-599,667. HERNANDO RUIZ-JIMENEZ, OLD GREENWICH, CT. FILED 4-17-2012.

Etapas

THE MARK CONSISTS OF STANDARD CHARACTERS WITHOUT CLAIM TO ANY PARTICULAR FONT, STYLE, SIZE, OR COLOR.

THE ENGLISH TRANSLATION OF "ETAPAS" IN THE MARK IS "STAGES".

FOR BAR SERVICES; RESTAURANT SERVICES (U.S. CLS. 100 AND 101).

RAUL CORDOVA, EXAMINING ATTORNEY

CLASS 43—(Continued).

SN 85-600,288. NIHI FRANCHISING INC., CANTON, MI.
FILED 4-17-2012.

Neehee's

THE MARK CONSISTS OF STANDARD CHARACTERS WITHOUT CLAIM TO ANY PARTICULAR FONT, STYLE, SIZE, OR COLOR.

THE WORDING NEEHEE'S HAS NO MEANING IN A FOREIGN LANGUAGE.

FOR RESTAURANT SERVICES (U.S. CLS. 100 AND 101).

FIRST USE 1-15-2008; IN COMMERCE 1-15-2008.
KERI CANTONE, EXAMINING ATTORNEY

SN 85-600,913. ROUX BROTHERS, LLC, WOODVILLE, MS.
FILED 4-18-2012.

ROUX 61

THE MARK CONSISTS OF STANDARD CHARACTERS WITHOUT CLAIM TO ANY PARTICULAR FONT, STYLE, SIZE, OR COLOR.

FOR BAR SERVICES; RESTAURANT SERVICES (U.S. CLS. 100 AND 101).

FIRST USE 11-20-2011; IN COMMERCE 11-20-2011.
MATTHEW PAPPAS, EXAMINING ATTORNEY

SN 85-601,368. LFP RESTAURANT HOLDINGS, LLC, CHICAGO, IL. FILED 4-18-2012.

BODIE'S ALL-AMERICAN

THE MARK CONSISTS OF STANDARD CHARACTERS WITHOUT CLAIM TO ANY PARTICULAR FONT, STYLE, SIZE, OR COLOR.

FOR RESTAURANT AND BAR SERVICES; CATERING SERVICES (U.S. CLS. 100 AND 101).

TINA L. SNAPP, EXAMINING ATTORNEY

CLASS 43—(Continued).

SN 85-601,574. THE ALPEN HOUSE LIMITED, AURORA, ONTARIO, CANADA, FILED 4-18-2012.

ADENA GOURMET GRILL

THE MARK CONSISTS OF STANDARD CHARACTERS WITHOUT CLAIM TO ANY PARTICULAR FONT, STYLE, SIZE, OR COLOR.

NO CLAIM IS MADE TO THE EXCLUSIVE RIGHT TO USE "GOURMET GRILL", APART FROM THE MARK AS SHOWN.

FOR RESTAURANT SERVICES (U.S. CLS. 100 AND 101).

JIM RINGLE, EXAMINING ATTORNEY

SN 85-601,680. HERITAGE COFFEE CO. L.L.C., ST. LOUIS, MO. FILED 4-18-2012.

CONTROL THE NARRATIVE

THE MARK CONSISTS OF STANDARD CHARACTERS WITHOUT CLAIM TO ANY PARTICULAR FONT, STYLE, SIZE, OR COLOR.

FOR RESTAURANT; CAFÉ; SNACK BAR; COFFEE BAR AND COFFEE HOUSE; CARRY OUT RESTAURANT, AND TAKE OUT RESTAURANT SERVICES; CATERING SERVICES; COFFEE SUPPLY SERVICES FOR OFFICES; CONTRACT FOOD SERVICES; FOOD PREPARATION; PREPARATION OF CARRY OUT FOODS AND BEVERAGES (U.S. CLS. 100 AND 101).

DANIEL S. STRINGER, EXAMINING ATTORNEY

SN 85-602,185. THE HALAL GUYS, INC., ASTORIA, NY. FILED 4-19-2012.

THE HALAL GUYS

THE MARK CONSISTS OF STANDARD CHARACTERS WITHOUT CLAIM TO ANY PARTICULAR FONT, STYLE, SIZE, OR COLOR.

NO CLAIM IS MADE TO THE EXCLUSIVE RIGHT TO USE "HALAL", APART FROM THE MARK AS SHOWN.

FOR RESTAURANT SERVICES PROVIDED VIA MOBILE FOOD CARTS (U.S. CLS. 100 AND 101).

FIRST USE 11-0-2000; IN COMMERCE 11-0-2000.
HOWARD B. LEVINE, EXAMINING ATTORNEY

CLASS 43—(Continued).

SN 85-602,193. THE HALAL GUYS, INC., ASTORIA, NY.
FILED 4-19-2012.



NO CLAIM IS MADE TO THE EXCLUSIVE RIGHT TO USE "HALAL" AND "GYRO AND CHICKEN", APART FROM THE MARK AS SHOWN.

THE MARK CONSISTS OF THE STYLIZED WORDING "THE HALAL GUYS GYRO AND CHICKEN" IN A CIRCLE WITH A ROTISSERIE AND GYRO MEAT AND A HORIZONTAL LINE BACKGROUND WITHIN A SECOND CONCENTRIC CIRCLE

FOR RESTAURANT SERVICES PROVIDED VIA MOBILE FOOD CARTS (U.S. CLS. 100 AND 101).

FIRST USE 1-0-2001; IN COMMERCE 1-0-2001.
HOWARD B. LEVINE, EXAMINING ATTORNEY

SN 85-602,305. BUFFALO WINGS & RINGS, LLC, CINCINNATI, OH. FILED 4-19-2012.

BUFFALOVE

THE MARK CONSISTS OF STANDARD CHARACTERS WITHOUT CLAIM TO ANY PARTICULAR FONT, STYLE, SIZE, OR COLOR.

FOR RESTAURANT SERVICES, NAMELY, PROVIDING OF FOOD AND BEVERAGES FOR CONSUMPTION ON AND OFF THE PREMISES (U.S. CLS. 100 AND 101).

FIRST USE 4-18-2012; IN COMMERCE 4-18-2012.
LIEF MARTIN, EXAMINING ATTORNEY

CLASS 43—(Continued).

SN 85-602,435. LIVE IN FITNESS ENTERPRISE, INC., LOS ANGELES, CA. FILED 4-19-2012.

EAT FRESH BY LIVE IN FITNESS ENTERPRISE

THE MARK CONSISTS OF STANDARD CHARACTERS WITHOUT CLAIM TO ANY PARTICULAR FONT, STYLE, SIZE, OR COLOR.

FOR FOOD PREPARATION SERVICES FEATURING HEALTHY MEAL CATERING AND DELIVERY AS WELL AS THE PREPARATION OF FOOD KITS COMPOSED OF MEAT, POULTRY, FISH, SEAFOOD, GRAINS, LEGUMES, FRUITS, DAIRY, AND/OR VEGETABLES AND SAUCES OR SEASONINGS, READY FOR COOKING AND ASSEMBLY AS A MEAL (U.S. CLS. 100 AND 101).

JAY FLOWERS, EXAMINING ATTORNEY

SN 85-602,544. RICHARDS, CLIFFORD, SAN LUIS OBISPO, CA. FILED 4-19-2012.

HAPPYTOWN

THE MARK CONSISTS OF STANDARD CHARACTERS WITHOUT CLAIM TO ANY PARTICULAR FONT, STYLE, SIZE, OR COLOR.

FOR RESTAURANT SERVICES; CAFE SERVICES (U.S. CLS. 100 AND 101).

DOMINIC J. FERRAIUOLO, EXAMINING ATTORNEY

SN 85-602,788. MILL CREEK RESTAURANT, INC., NEW YORK, NY. FILED 4-19-2012.

THE BELL & ANCHOR

THE MARK CONSISTS OF STANDARD CHARACTERS WITHOUT CLAIM TO ANY PARTICULAR FONT, STYLE, SIZE, OR COLOR.

FOR RESTAURANT SERVICES; BAR SERVICES (U.S. CLS. 100 AND 101).

TRACY FLETCHER, EXAMINING ATTORNEY

CLASS 43—(Continued).

SN 85-602,797. CROWDER ENTERPRISES, LLC, SOUTH HILL, VA. FILED 4-19-2012.



NO CLAIM IS MADE TO THE EXCLUSIVE RIGHT TO USE "RIBS & BBQ", APART FROM THE MARK AS SHOWN. THE COLOR(S) RED, BLACK, WHITE, AND PINK IS/ARE CLAIMED AS A FEATURE OF THE MARK.

THE COLOR RED APPEARS IN THE WORDING "BONE-SUCKERZ" AND IN THE DESIGN OF A PIG'S HAT, A PIG'S OVERALLS AND RIBS; THE COLOR BLACK APPEARS IN THE WORDING "RIBS & BBQ", AS OUTLINE FOR THE WORDING "BONESUCKERZ", AND AS VARIOUS LINES AND SHADING THROUGHOUT THE DESIGN; THE COLOR WHITE APPEARS THROUGHOUT THE DESIGN OF A PIG AND RIBS; THE COLOR PINK APPEARS IN THE DESIGN OF A PIG AND A TRAY.

FOR RESTAURANT SERVICES (U.S. CLS. 100 AND 101).

FIRST USE 2-24-2012; IN COMMERCE 2-24-2012.
AISHA SALEM, EXAMINING ATTORNEY

CLASS 43—(Continued).

SN 85-603,244. GORDON RAMSAY HOLDINGS LIMITED, LONDON, UNITED KINGDOM, FILED 4-19-2012.

MOO BAR

THE MARK CONSISTS OF STANDARD CHARACTERS WITHOUT CLAIM TO ANY PARTICULAR FONT, STYLE, SIZE, OR COLOR.

NO CLAIM IS MADE TO THE EXCLUSIVE RIGHT TO USE "BAR", APART FROM THE MARK AS SHOWN.

FOR RESTAURANT AND BAR SERVICES (U.S. CLS. 100 AND 101).

JOHN WILKE, EXAMINING ATTORNEY

SN 85-602,807. MILL CREEK RESTAURANT, INC., NEW YORK, NY. FILED 4-19-2012.

ANCHOR'S AWAY

THE MARK CONSISTS OF STANDARD CHARACTERS WITHOUT CLAIM TO ANY PARTICULAR FONT, STYLE, SIZE, OR COLOR.

FOR RESTAURANT AND CATERING SERVICES; TAKE-OUT RESTAURANT SERVICES; RESTAURANT SERVICES, INCLUDING SIT-DOWN SERVICE OF FOOD AND TAKE-OUT RESTAURANT SERVICES; RESTAURANT SERVICES, NAMELY, PROVIDING OF FOOD AND BEVERAGES FOR CONSUMPTION ON AND OFF THE PREMISES (U.S. CLS. 100 AND 101).

TRACY FLETCHER, EXAMINING ATTORNEY

SN 85-603,508. MUMFORD, RAYMOND, BUFFALO, NY. FILED 4-20-2012.



SN 85-603,223. CANNON, SHARRON L., NEW YORK CITY, NY. FILED 4-19-2012.

Jock's

THE MARK CONSISTS OF STANDARD CHARACTERS WITHOUT CLAIM TO ANY PARTICULAR FONT, STYLE, SIZE, OR COLOR.

FOR BAR SERVICES (U.S. CLS. 100 AND 101).

FIRST USE 2-1-2010; IN COMMERCE 2-1-2010.

MARLENE BELL, EXAMINING ATTORNEY

THE MARK CONSISTS OF A STYLIZED HEAD OF A LION WEARING A CROWN. ALONG THE BASE OF THE CROWN ARE THE STYLIZED NUMBERS "4642" WITH A DOT IN BETWEEN EACH NUMBER. THE LION'S MOUTH IS OPEN AND INSIDE ITS MOUTH IS THE STYLIZED TEXT "ME". BELOW THE LION IS THE STYLIZED TEXT "AMAT VICTORIA CURAM".

THE ENGLISH TRANSLATION OF "AMAT VICTORIA CURAM" IN THE MARK IS "VICTORY LOVES PREPARATION".

FOR RESTAURANT SERVICES (U.S. CLS. 100 AND 101).

JOHN WILKE, EXAMINING ATTORNEY

CLASS 43—(Continued).

SN 85-604,117. MARK DIMARTINO, LAS VEGAS, NV. FILED 4-20-2012.

PIZZA BUDDHA

THE MARK CONSISTS OF STANDARD CHARACTERS WITHOUT CLAIM TO ANY PARTICULAR FONT, STYLE, SIZE, OR COLOR.

NO CLAIM IS MADE TO THE EXCLUSIVE RIGHT TO USE "PIZZA", APART FROM THE MARK AS SHOWN.

FOR BAR SERVICES; RESTAURANT SERVICES (U.S. CLS. 100 AND 101).

TIMOTHY FINNEGAN, EXAMINING ATTORNEY

SN 85-604,123. MARK DIMARTINO, LAS VEGAS, NV. FILED 4-20-2012.

GOOD KARMA, GREAT PIZZA

THE MARK CONSISTS OF STANDARD CHARACTERS WITHOUT CLAIM TO ANY PARTICULAR FONT, STYLE, SIZE, OR COLOR.

FOR BAR SERVICES; RESTAURANT SERVICES (U.S. CLS. 100 AND 101).

TIMOTHY FINNEGAN, EXAMINING ATTORNEY

SN 85-604,152. AMERICA'S DRIVE-IN BRAND PROPERTIES LLC, OKLAHOMA CITY, OK. FILED 4-20-2012.

THE GREAT SKEEDADDLE

THE MARK CONSISTS OF STANDARD CHARACTERS WITHOUT CLAIM TO ANY PARTICULAR FONT, STYLE, SIZE, OR COLOR.

FOR RESTAURANT SERVICES (U.S. CLS. 100 AND 101).

JOHN E. MICHOS, EXAMINING ATTORNEY

CLASS 43—(Continued).

SN 85-604,205. ARCIERI, DAWN, HOUSTON, TX. FILED 4-20-2012.

one bite kitchen

THE MARK CONSISTS OF STANDARD CHARACTERS WITHOUT CLAIM TO ANY PARTICULAR FONT, STYLE, SIZE, OR COLOR.

FOR RESTAURANT AND CATERING SERVICES (U.S. CLS. 100 AND 101).

CHRISTOPHER BUONGIORNO, EXAMINING ATTORNEY

SN 85-604,770. TROPICAL SMOOTHIE FRANCHISE DEVELOPMENT CORPORATION, AKA TROPICAL SMOOTHIE CAFE, DESTIN, FL. FILED 4-22-2012.

The logo for TROPICAL SMOOTHIE CAFÉ features the words "TROPICAL SMOOTHIE" in a bold, yellow, sans-serif font with a purple outline, stacked above the word "CAFÉ" in a similar font. The "É" has a small accent mark.

OWNER OF U.S. REG. NOS. 2,763,722, 2,918,995 AND OTHERS.

NO CLAIM IS MADE TO THE EXCLUSIVE RIGHT TO USE "SMOOTHIE CAFÉ", APART FROM THE MARK AS SHOWN.

THE COLOR(S) YELLOW AND PURPLE IS/ARE CLAIMED AS A FEATURE OF THE MARK.

THE MARK CONSISTS OF A STYLIZED PRESENTATION OF THE WORDS "TROPICAL SMOOTHIE" APPEARING OVER THE WORD "CAFÉ"; THE WORDS "TROPICAL SMOOTHIE CAFÉ" APPEAR IN YELLOW WITH A BORDER OF PURPLE.

FOR JUICE BAR SERVICES; RESTAURANT SERVICES (U.S. CLS. 100 AND 101).

LOURDES AYALA, EXAMINING ATTORNEY

CLASS 43—(Continued).

SN 85-604,771. TROPICAL SMOOTHIE FRANCHISE DEVELOPMENT CORPORATION, AKA TROPICAL SMOOTHIE CAFÉ, DESTIN, FL. FILED 4-22-2012.



OWNER OF U.S. REG. NOS. 2,763,722, 2,918,995 AND OTHERS.

NO CLAIM IS MADE TO THE EXCLUSIVE RIGHT TO USE "SMOOTHIE CAFÉ", APART FROM THE MARK AS SHOWN.

THE COLOR(S) YELLOW AND PURPLE IS/ARE CLAIMED AS A FEATURE OF THE MARK.

THE MARK CONSISTS OF A STYLIZED PRESENTATION OF THE WORDS "TROPICAL SMOOTHIE" APPEARING OVER THE WORD "CAFÉ"; THE WORDS "TROPICAL" AND "SMOOTHIE" ARE CURVED; THE WORDS "TROPICAL SMOOTHIE CAFÉ" APPEAR IN YELLOW WITH A BORDER OF PURPLE.

FOR JUICE BAR SERVICES; RESTAURANT SERVICES (U.S. CLS. 100 AND 101).

FIRST USE 7-11-2005; IN COMMERCE 7-11-2005.

LOURDES AYALA, EXAMINING ATTORNEY

SN 85-605,241. THE THIRD CORNER, INC., SAN DIEGO, CA. FILED 4-23-2012.

3RD CORNER

THE MARK CONSISTS OF STANDARD CHARACTERS WITHOUT CLAIM TO ANY PARTICULAR FONT, STYLE, SIZE, OR COLOR.

FOR BAR SERVICES; BISTRO SERVICES; RESTAURANT SERVICES; WINE BARS (U.S. CLS. 100 AND 101).

FIRST USE 4-20-2001; IN COMMERCE 11-14-2006.

BRENDAN REGAN, EXAMINING ATTORNEY

SN 85-605,252. THE THIRD CORNER, INC., SAN DIEGO, CA. FILED 4-23-2012.



THE MARK CONSISTS OF THE CHARACTERS "3RD" SUPERIMPOSED OVER AN ARTISTIC RENDERING OF A BUNCH OF GRAPES, WITH THE WORD "CORNER" EXTENDING TO THE SIDE.

FOR BAR SERVICES; BISTRO SERVICES; RESTAURANT SERVICES; WINE BARS (U.S. CLS. 100 AND 101).

FIRST USE 1-1-2011; IN COMMERCE 1-1-2011.

BRENDAN REGAN, EXAMINING ATTORNEY

CLASS 43—(Continued).

SN 85-605,742. CHEFFIELD RESTAURANTS INC., BAITING HOLLOW, NY. FILED 4-23-2012.

Buoy One

THE MARK CONSISTS OF STANDARD CHARACTERS WITHOUT CLAIM TO ANY PARTICULAR FONT, STYLE, SIZE, OR COLOR.

FOR RESTAURANT SERVICES (U.S. CLS. 100 AND 101).

FIRST USE 4-1-2004; IN COMMERCE 4-1-2004.

C. DIONNE CLYBURN, EXAMINING ATTORNEY

SN 85-605,813. ASPEN SKIING COMPANY, ASPEN, CO. FILED 4-23-2012.

LIGHTEN UP

THE MARK CONSISTS OF STANDARD CHARACTERS WITHOUT CLAIM TO ANY PARTICULAR FONT, STYLE, SIZE, OR COLOR.

FOR HOTEL SERVICES (U.S. CLS. 100 AND 101).

FIRST USE 4-15-2012; IN COMMERCE 4-15-2012.

JEFF DEFORD, EXAMINING ATTORNEY

SN 85-605,827. ASPEN SKIING COMPANY, ASPEN, CO. FILED 4-23-2012.

LIMELIGHT

THE MARK CONSISTS OF STANDARD CHARACTERS WITHOUT CLAIM TO ANY PARTICULAR FONT, STYLE, SIZE, OR COLOR.

OWNER OF U.S. REG. NO. 3,542,840.

FOR HOTEL SERVICES (U.S. CLS. 100 AND 101).

FIRST USE 0-0-1953; IN COMMERCE 0-0-1970.

JEFF DEFORD, EXAMINING ATTORNEY

CLASS 43—(Continued).

SN 85-605,842. ASPEN SKIING COMPANY, ASPEN, CO.
FILED 4-23-2012.

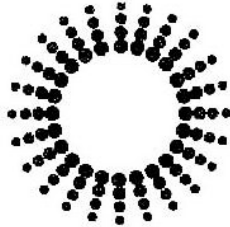

THE MARK CONSISTS OF A FANCIFUL LIGHT DESIGN.
FOR HOTEL SERVICES (U.S. CLS. 100 AND 101).
FIRST USE 4-15-2012; IN COMMERCE 4-15-2012.
JEFF DEFORD, EXAMINING ATTORNEY

SN 85-605,919. THE ALLISON INN & SPA LLC, NEWBERG,
OR. FILED 4-23-2012.

JORY

THE MARK CONSISTS OF STANDARD CHARACTERS
WITHOUT CLAIM TO ANY PARTICULAR FONT, STYLE,
SIZE, OR COLOR.
FOR RESTAURANT SERVICES OFFERED IN ASSO-
CIATION WITH HOTEL OR RESORT ACCOMMODA-
TIONS (U.S. CLS. 100 AND 101).
FIRST USE 8-0-2009; IN COMMERCE 8-0-2009.
CHRISTINA SOBRAL, EXAMINING ATTORNEY

SN 85-606,879. GO!99 PARTNERS, LLC, NEW YORK, NY.
FILED 4-24-2012.

GO!99

THE MARK CONSISTS OF STANDARD CHARACTERS
WITHOUT CLAIM TO ANY PARTICULAR FONT, STYLE,
SIZE, OR COLOR.
FOR RESTAURANT SERVICES (U.S. CLS. 100 AND
101).
FIRST USE 1-1-2011; IN COMMERCE 5-17-2011.
GIANCARLO CASTRO, EXAMINING ATTORNEY

CLASS 43—(Continued).

SN 85-607,545. THE HALAL GUYS, INC., ASTORIA, NY.
FILED 4-25-2012.



THE MARK CONSISTS OF A FOOD CART AND CUSTOMER LINE.
FOR RESTAURANT SERVICES PROVIDED VIA MOBILE FOOD CARTS (U.S. CLS. 100 AND 101).
FIRST USE 1-0-2001; IN COMMERCE 1-0-2001.
HOWARD B. LEVINE, EXAMINING ATTORNEY

SN 85-607,871. THACH, LINDA, BROOKLYN, NY. FILED 4-25-2012.

LITTLE SKIPS

THE MARK CONSISTS OF STANDARD CHARACTERS
WITHOUT CLAIM TO ANY PARTICULAR FONT, STYLE,
SIZE, OR COLOR.
FOR CAFE SERVICES, TEA HOUSE, COFFEE SHOPS,
AND RESTAURANT SERVICES (U.S. CLS. 100 AND 101).
FIRST USE 2-17-2009; IN COMMERCE 2-17-2009.
SUSAN LESLIE DUBOIS, EXAMINING ATTORNEY

SN 85-614,273. BRENWOOD HOSPITALITY LLC, GREENWICH, CT. FILED 5-2-2012.

J House

THE MARK CONSISTS OF STANDARD CHARACTERS
WITHOUT CLAIM TO ANY PARTICULAR FONT, STYLE,
SIZE, OR COLOR.
FOR HOTEL SERVICES, MOTEL SERVICES, MOTOR
INN LODGING SERVICES, RESORT LODGING SERVICES;
RESTAURANT, BAR, CAFE AND COCKTAIL LOUNGE SERVICES;
PROVISION OF FACILITIES FOR MEETINGS, CONFERENCES,
BANQUETS, EXHIBITIONS AND SOCIAL FUNCTIONS
FACILITIES FOR SPECIAL OCCASIONS (U.S. CLS. 100 AND 101).
FIRST USE 5-17-2012; IN COMMERCE 5-17-2012.
GINA HAYES, EXAMINING ATTORNEY

CLASS 43—(Continued).

SN 85-616,761. DELTA AIR LINES, INC., ATLANTA, GA.
FILED 5-4-2012.

BUBBLE BAR

THE MARK CONSISTS OF STANDARD CHARACTERS WITHOUT CLAIM TO ANY PARTICULAR FONT, STYLE, SIZE, OR COLOR.

NO CLAIM IS MADE TO THE EXCLUSIVE RIGHT TO USE "BAR", APART FROM THE MARK AS SHOWN.

FOR PROVIDING FOOD AND DRINK EXCLUSIVELY IN AIR TRANSIENT PRIVATE CLUB LOUNGES (U.S. CLS. 100 AND 101).

DANNEAN HETZEL, EXAMINING ATTORNEY

SN 85-628,228. CRIDLIN, CHILES, HENRICO, VA. FILED 5-17-2012.

HOWLING GOOD BBQ

THE MARK CONSISTS OF STANDARD CHARACTERS WITHOUT CLAIM TO ANY PARTICULAR FONT, STYLE, SIZE, OR COLOR.

NO CLAIM IS MADE TO THE EXCLUSIVE RIGHT TO USE "BBQ", APART FROM THE MARK AS SHOWN.

FOR RESTAURANT AND CATERING SERVICES (U.S. CLS. 100 AND 101).

FIRST USE 9-25-2011; IN COMMERCE 4-4-2012.

JENNY PARK, EXAMINING ATTORNEY

SN 85-628,731. STEVEN SIDLE, HOLLYWOOD, FL. FILED 5-17-2012.

Le Tub Saloon

THE MARK CONSISTS OF STANDARD CHARACTERS WITHOUT CLAIM TO ANY PARTICULAR FONT, STYLE, SIZE, OR COLOR.

NO CLAIM IS MADE TO THE EXCLUSIVE RIGHT TO USE "SALOON", APART FROM THE MARK AS SHOWN.

FOR COCKTAIL LOUNGE SERVICES; PREPARATION OF FOOD AND BEVERAGES; PROVIDING OF FOOD AND DRINK; RESTAURANT AND CAFE SERVICES; RESTAURANT SERVICES, INCLUDING SIT-DOWN SERVICE OF FOOD AND TAKE-OUT RESTAURANT SERVICES (U.S. CLS. 100 AND 101).

FIRST USE 0-0-1974; IN COMMERCE 0-0-1974.

MARK SHINER, EXAMINING ATTORNEY

CLASS 43—(Continued).

SN 85-670,489. DAVID CHANG, LLC, NEW YORK, NY.
FILED 7-6-2012.

LUCKY ピーチ

OWNER OF U.S. REG. NOS. 3,241,296, 3,768,197 AND 4,098,985.

THE MARK CONSISTS OF THE WORD "LUCKY" IN BLOCK LETTERS AND THE KATAKANA CHARACTER FOR THE WORD "PEACH".

THE NON-LATIN CHARACTERS IN THE MARK TRANSLITERATE TO "P'CH" AND THIS MEANS "PEACH" IN ENGLISH.

FOR RESTAURANT SERVICES, INCLUDING SIT-DOWN SERVICE OF FOOD AND TAKE-OUT RESTAURANT SERVICES; RESTAURANT SERVICES, NAMELY, PROVIDING OF FOOD AND BEVERAGES FOR CONSUMPTION ON AND OFF THE PREMISES (U.S. CLS. 100 AND 101).

ANGELA M. MICHELI, EXAMINING ATTORNEY

SN 85-674,263. SEMINOLE TRIBE OF FLORIDA, HOLLYWOOD, FL. FILED 7-11-2012.



NO CLAIM IS MADE TO THE EXCLUSIVE RIGHT TO USE "BEACH CLUB", APART FROM THE MARK AS SHOWN.

THE COLOR(S) TAN, LIGHT BROWN, MEDIUM BROWN, AND BLUE IS/ARE CLAIMED AS A FEATURE OF THE MARK.

THE MARK CONSISTS OF THE STYLIZED WORDS "BEACH CLUB" IN BLUE, ON A TAN SURFBOARD WITH STYLIZED FLOWERS AND LEAVES IN LIGHT BROWN AND MEDIUM BROWN ACROSS THE TOP OF THE BOARD. THE COLOR WHITE IN THE BACKGROUND IS NOT CLAIMED AS A FEATURE OF THE MARK.

FOR RESTAURANT SERVICES (U.S. CLS. 100 AND 101).

FIRST USE 5-11-2004; IN COMMERCE 5-11-2004.

KATHY DE JONGE, EXAMINING ATTORNEY

CLASS 44—MEDICAL, BEAUTY AND AGRICULTURAL SERVICES

SN 76-707,375. ANDRIEN D. GAINES, DBA RAS A.D., IRVING, TX. FILED 4-25-2011.



NO CLAIM IS MADE TO THE EXCLUSIVE RIGHT TO USE "INDEPENDENT BARBER", APART FROM THE MARK AS SHOWN.

THE COLOR(S) GREEN, RED, BLACK, BLUE, TEAL, BROWN, ORANGE, WHITE AND YELLOW IS/ARE CLAIMED AS A FEATURE OF THE MARK.

THE MARK CONSISTS OF THE WORDING "COOLVIBES" IN BLUE AND THE WORDING "INDEPENDENT BARBER ETC." IN BLACK, A DESIGN TWO PALM TREES IN BROWN, GREEN AND TEAL, A DESIGN OF THE SUN IN ORANGE AND WHITE, A BARBER POLE SHOWN IN BLACK, WHITE, RED AND BLUE, A COLORED SQUARE AREA ABOVE THE WORD "INDEPENDENT", COMPRISED OF THREE SMALL BANDS IN GREEN, YELLOW AND ORANGE FROM TOP TO BOTTOM, AND BLUE SHADING IN THE UPPER CORNERS.

FOR BARBER SERVICES (U.S. CLS. 100 AND 101).
FIRST USE 6-16-2009; IN COMMERCE 2-27-2012.
FRED CARL, EXAMINING ATTORNEY

SN 76-707,937. EYE PLASTIC SURGERY, P.C., BRYN MAWR, PA. FILED 6-10-2011.

YOU. NATURALLY.

THE MARK CONSISTS OF STANDARD CHARACTERS WITHOUT CLAIM TO ANY PARTICULAR FONT, STYLE, SIZE, OR COLOR.

FOR COSMETIC SURGERY SERVICES (U.S. CLS. 100 AND 101).

FIRST USE 7-0-2010; IN COMMERCE 7-0-2010.
ESTHER BELENKER, EXAMINING ATTORNEY

CLASS 44—(Continued).

SN 76-710,724. GREEN EARTH LAWN & SHRUB CARE, LLC, SHELTON, CT. FILED 2-27-2012.



NO CLAIM IS MADE TO THE EXCLUSIVE RIGHT TO USE "LAWN & SHRUB CARE", APART FROM THE MARK AS SHOWN.

THE MARK CONSISTS OF CAPITAL LETTERS "G" AND "E" INTERTWINED IN A CIRCLE WITH THE WORDS "GREEN EARTH" IN A LARGE FONT NEXT TO THE CIRCLE WITH THE WORDS "LAWN & SHRUB CARE" BENEATH THE WORDS "GREEN EARTH" IN A SMALLER FONT.

FOR LAWN AND SHRUB CARE; LAWN CARE, NAMELY, LAWN FERTILIZATION (U.S. CLS. 100 AND 101).

BRIAN PINO, EXAMINING ATTORNEY

SN 76-711,029. JOHN MOHNICKEY, MCKINNEY, TX. FILED 3-27-2012.



NO CLAIM IS MADE TO THE EXCLUSIVE RIGHT TO USE "PROMPT ORTHOPEDIC CLINIC", APART FROM THE MARK AS SHOWN.

THE COLOR(S) YELLOW AND GREEN IS/ARE CLAIMED AS A FEATURE OF THE MARK.

THE LITERAL ELEMENT OF THE MARK CONSISTS OF "PROMPT ORTHOPEDIC CLINIC". THE MARK CONSISTS OF THE WORDING "PROMPT ORTHOPEDIC CLINIC" IN STYLIZED UPPERCASE LETTERING. THE WORDING "ORTHOPEDIC CLINIC" APPEARS IN DARK GREEN WRITTEN UNDERNEATH THE WORD "PROMPT". A GRADIENT APPEARS IN THE WORD "PROMPT" STARTING DARK YELLOW AT THE TOP AND FADING YELLOW TOWARDS THE BOTTOM. NINE VARIOUS SIZE CIRCLES IN SHADES OF LIGHT GREEN, GREEN, DARK GREEN AND YELLOW APPEARS FORMING A CURVE TO THE UPPER LEFT CORNER OF THE WORD "PROMPT".

FOR ORTHOPEDIC CARE (U.S. CLS. 100 AND 101).
KIMBERLY PERRY, EXAMINING ATTORNEY

CLASS 44—(Continued).

SN 77-161,090. SENSATIONAL SKIN CENTERS, PLLC, SCOTTSDALE, AZ. FILED 4-19-2007.

SENSATIONAL SKIN

THE MARK CONSISTS OF STANDARD CHARACTERS WITHOUT CLAIM TO ANY PARTICULAR FONT, STYLE, SIZE, OR COLOR.

NO CLAIM IS MADE TO THE EXCLUSIVE RIGHT TO USE "SKIN", APART FROM THE MARK AS SHOWN.

FOR COSMETIC SKIN AND LASER MEDICAL SERVICES FEATURING TREATMENTS FOR ACNE, ACNE SCARS, PIGMENTATION, ROSACEA, WRINKLES, AGE SPOTS, SKIN DISCOLORATION, SUN DAMAGE, SPIDER VEINS, FACIAL VEINS, FACIAL AND BODY HAIR, SAGGING SKIN, LASER TREATMENTS FOR SKIN RESURFACING, SKIN TIGHTENING AND SKIN LEVELING; SKIN CARE SALON SERVICES FEATURING MICRODERMABRASION, GLYCOLIC PEELS, DEEP PORE CLEANSING AND EXTRACTIONS, FACIALS AND PARAFFIN DIPS (U.S. CLS. 100 AND 101).

FIRST USE 10-1-1998; IN COMMERCE 10-1-1999.
JAY BESCH, EXAMINING ATTORNEY

SN 78-434,129. CHRIS SPENCER, LAGUNA BEACH, CA. FILED 6-11-2004.

SCRIPTS

NO CLAIM IS MADE TO THE EXCLUSIVE RIGHT TO USE "THE RX PRESCRIPTION SYMBOL", APART FROM THE MARK AS SHOWN.

THE MARK CONSISTS OF THE STYLIZED WORDING "SCRIPTS" WHEREIN THE LETTER "R" APPEARS AS THE "RX" PRESCRIPTION SYMBOL.

FOR PRESCRIPTION DRUG DEPENDENCY TREATMENT CENTERS (U.S. CLS. 100 AND 101).

FIRST USE 11-1-2003; IN COMMERCE 11-1-2003.
MICHAEL TANNER, EXAMINING ATTORNEY

SN 79-106,070. SPA ESPRIT GROUP FRANCHISE PTE. LTD., SINGAPORE, FILED 10-4-2011.

XXXSTRIP

THE MARK CONSISTS OF STANDARD CHARACTERS WITHOUT CLAIM TO ANY PARTICULAR FONT, STYLE, SIZE, OR COLOR.

OWNER OF INTERNATIONAL REGISTRATION 1098991 DATED 10-4-2011, EXPIRES 10-4-2021.

OWNER OF U.S. REG. NO. 3,854,078.

FOR HYGIENIC AND BEAUTY CARE FOR HUMAN BEINGS; PERSONAL HAIR REMOVAL SERVICES (U.S. CLS. 100 AND 101).

JAMES MACFARLANE, EXAMINING ATTORNEY

CLASS 44—(Continued).

SN 79-106,495. SPA ESPRIT GROUP FRANCHISE PTE. LTD., SINGAPORE, FILED 10-4-2011.

XXSTRIP

THE MARK CONSISTS OF STANDARD CHARACTERS WITHOUT CLAIM TO ANY PARTICULAR FONT, STYLE, SIZE, OR COLOR.

OWNER OF INTERNATIONAL REGISTRATION 1099996 DATED 10-4-2011, EXPIRES 10-4-2021.

OWNER OF U.S. REG. NO. 3,854,078.
FOR HYGIENE AND BEAUTY CARE FOR HUMAN BEINGS, HAIR REMOVAL BY WAXING; MANICURING (U.S. CLS. 100 AND 101).

JAMES MACFARLANE, EXAMINING ATTORNEY

SN 85-397,565. BROWN, KELVIN, LITHIA SPRINGS, GA. FILED 8-14-2011.

With Precision

THE MARK CONSISTS OF STANDARD CHARACTERS WITHOUT CLAIM TO ANY PARTICULAR FONT, STYLE, SIZE, OR COLOR.

NO CLAIM IS MADE TO THE EXCLUSIVE RIGHT TO USE "WITH PRECISION", APART FROM THE MARK AS SHOWN.

FOR PROVIDING A WEB SITE FEATURING INFORMATION IN THE FIELD OF MENTAL HEALTH AND PHYSICAL HEALTH, INCLUDING LIVING A HEALTHY AND DISEASE FREE LIFE; PROVIDING A WEBSITE FEATURING CONTENT REGARDING HEALTHY LIVING AND LIFESTYLE WELLNESS; PROVIDING AN INTERACTIVE WEBSITE FEATURING INFORMATION AND LINKS RELATING TO HEALTHY LIVING AND WEIGHT LOSS; PROVIDING HEALTHY LIFESTYLE AND NUTRITION SERVICES, NAMELY, PERSONAL ASSESSMENTS, PERSONALIZED ROUTINES, MAINTENANCE SCHEDULES, AND COUNSELING; PROVIDING INFORMATION ON MAINTAINING A HEALTHY LIFESTYLE AND LOSING WEIGHT (U.S. CLS. 100 AND 101).

FIRST USE 8-26-2008; IN COMMERCE 8-26-2008.
KIMBERLY PERRY, EXAMINING ATTORNEY

SN 85-421,416. GENESIS IP, LLC, KENNETT SQUARE, PA. FILED 9-13-2011.

BRAIN MATTERS

THE MARK CONSISTS OF STANDARD CHARACTERS WITHOUT CLAIM TO ANY PARTICULAR FONT, STYLE, SIZE, OR COLOR.

FOR HEALTH CARE SERVICES, NAMELY, REHABILITATION PATIENT CARE SERVICES AND EDUCATION AND WELLNESS PROGRAMS AIMED AT SUPPORTING AND PROMOTING COGNITIVE WELLNESS FOR OLDER ADULTS WITH OR WITHOUT COGNITIVE IMPAIRMENT (U.S. CLS. 100 AND 101).

NORA BUCHANAN WILL, EXAMINING ATTORNEY

CLASS 44—(Continued).

SN 85-424,093. MYHEALTHTEAMS, INC., SAN FRANCISCO, CA. FILED 9-15-2011.

MYAUTISMTEAM

THE MARK CONSISTS OF STANDARD CHARACTERS WITHOUT CLAIM TO ANY PARTICULAR FONT, STYLE, SIZE, OR COLOR.

FOR PROVIDING A WEBSITE FEATURING INFORMATION ON AUTISM; PROVIDING AN INTERNET-BASED DATABASE OF PATIENT MEDICAL INFORMATION WHERE PATIENTS CAN INQUIRE ABOUT AUTISM-RELATED MEDICAL ISSUES AND PROCEDURES FROM OTHER PATIENTS AND AN RELAY INFORMATION ABOUT THEIR MEDICAL EXPERIENCES FOR SUPPORT AND COMMUNITY (U.S. CLS. 100 AND 101).

FIRST USE 4-15-2011; IN COMMERCE 4-15-2011.
DAVID TAYLOR, EXAMINING ATTORNEY

SN 85-424,100. MYHEALTHTEAMS, INC., SAN FRANCISCO, CA. FILED 9-15-2011.

MYBREASTCANCERTEAM

THE MARK CONSISTS OF STANDARD CHARACTERS WITHOUT CLAIM TO ANY PARTICULAR FONT, STYLE, SIZE, OR COLOR.

FOR PROVIDING A WEBSITE FEATURING INFORMATION ON BREAST CANCER; PROVIDING AN INTERNET-BASED DATABASE OF PATIENT MEDICAL INFORMATION WHERE PATIENTS CAN INQUIRE ABOUT BREAST CANCER-RELATED MEDICAL ISSUES AND PROCEDURES FROM OTHER PATIENTS AND CAN RELAY INFORMATION ABOUT THEIR MEDICAL EXPERIENCES FOR SUPPORT AND COMMUNITY (U.S. CLS. 100 AND 101).

DAVID TAYLOR, EXAMINING ATTORNEY

SN 85-431,584. THE SEROTA GROUP, LLC, WOODBURY, CT. FILED 9-26-2011.

ORTHO*SWIFT*
Care on Arrival

NO CLAIM IS MADE TO THE EXCLUSIVE RIGHT TO USE "CARE ON ARRIVAL", APART FROM THE MARK AS SHOWN.

THE COLOR(S) BLUE, RED AND BLACK IS/ARE CLAIMED AS A FEATURE OF THE MARK.

THE MARK CONSISTS OF THE STYLIZED BLUE LETTERS "ORTHO" NEXT TO THE STYLIZED RED LETTERS "SWIFT" ABOVE THE SMALLER STYLIZED BLACK WORDS "CARE ON ARRIVAL".

FOR HEALTH CARE (U.S. CLS. 100 AND 101).
CURTIS FRENCH, EXAMINING ATTORNEY

CLASS 44—(Continued).

SN 85-436,984. THE CENTER FOR ORTHOPEDIC AND RESEARCH EXCELLENCE, INC., PHOENIX, AZ. FILED 9-30-2011.



THE MARK CONSISTS OF THE IMAGE OF A QUADRANGLE WITHIN AN ELONGATED RECTANGULAR SHAPE WITH A CIRCULAR DOT ON EACH CORNER.

FOR PROVIDING MEDICAL INFORMATION FOR USE BY MEDICAL PRACTITIONERS USED TO FURTHER RELATIONSHIPS WITH HOSPITALS, PAYORS AND INDUSTRY PARTNERS (U.S. CLS. 100 AND 101).

FIRST USE 2-14-2011; IN COMMERCE 2-14-2011.
ELLEN PERKINS, EXAMINING ATTORNEY

SN 85-436,999. THE CENTER FOR ORTHOPEDIC AND RESEARCH EXCELLENCE, INC., PHOENIX, AZ. FILED 9-30-2011.



THE COLOR(S) BLACK, BLUE AND WHITE IS/ARE CLAIMED AS A FEATURE OF THE MARK.

THE MARK CONSISTS OF THE IMAGE OF A WHITE TRIAD WITHIN A BLUE ELONGATED TRIANGULAR SHAPE WITH A BLACK CIRCULAR DOT ON EACH CORNER.

FOR PROVIDING MEDICAL INFORMATION FOR USE BY MEDICAL PRACTITIONERS USED TO FURTHER RELATIONSHIPS WITH HOSPITALS, PAYORS AND INDUSTRY PARTNERS (U.S. CLS. 100 AND 101).

FIRST USE 2-14-2011; IN COMMERCE 2-14-2011.
ELLEN PERKINS, EXAMINING ATTORNEY

CLASS 44—(Continued).

SN 85-437,001. THE CENTER FOR ORTHOPEDIC AND RESEARCH EXCELLENCE, INC., PHOENIX, AZ. FILED 9-30-2011.



THE MARK CONSISTS OF THE IMAGE OF A RECTANGLE WITHIN AN ELONGATED RECTANGULAR SHAPE WITH A CIRCULAR DOT ON EACH CORNER.

FOR PROVIDING MEDICAL INFORMATION FOR USE BY MEDICAL PRACTITIONERS USED TO FURTHER RELATIONSHIPS WITH HOSPITALS, PAYORS AND INDUSTRY PARTNERS (U.S. CLS. 100 AND 101).

ELLEN PERKINS, EXAMINING ATTORNEY

SN 85-438,688. WERK THOROUGHbred CONSULTANTS, INC., FREEMONT, CA. FILED 10-4-2011.



THE MARK CONSISTS OF THE WORDING "GEONICKS" WITH THE PORTION "GEO" INTERTWINED WITH THE LETTER "N" OF "NICKS" AND A SUNBURST DESIGN CONTAINING VERTICAL AND HORIZONTAL LINES INSIDE THE CIRCLE APPEARING BEHIND AND ABOVE THE WORDING "NICKS".

FOR CONSULTING AND INFORMATION SERVICES FOR THE HORSE BREEDING INDUSTRIES, NAMELY, PROVIDING INFORMATION REGARDING MATING PATTERNS VIA THE INTERNET (U.S. CLS. 100 AND 101).

FIRST USE 9-9-2011; IN COMMERCE 9-9-2011.
JENNY PARK, EXAMINING ATTORNEY

CLASS 44—(Continued).

SN 85-443,182. ADVENTIST HEALTH SYSTEM/SUNBELT, INC., WINTER PARK, FL. FILED 10-10-2011.

LIVE TO A HEALTHY 100

THE MARK CONSISTS OF STANDARD CHARACTERS WITHOUT CLAIM TO ANY PARTICULAR FONT, STYLE, SIZE, OR COLOR.

FOR MEDICAL SERVICES; PROVIDING ASSISTANCE, HEALTH, WELLNESS AND FITNESS EVALUATION AND CONSULTATION TO INDIVIDUALS TO HELP THEM MAKE GENERAL HEALTH, WELLNESS AND NUTRITION CHANGES TO INCREASE HEALTHY LIFE SPANS; PROVIDING INFORMATION ABOUT DIETARY SUPPLEMENTS AND NUTRITION; PROVIDING IN-PERSON HOLISTIC HEALTH CARE SERVICES; CONSULTING SERVICES TO EMPLOYERS, EMPLOYEES, COMMUNITY ORGANIZATIONS, AND INDIVIDUALS TO ASSIST THEM IN MAKING GENERAL HEALTH, WELLNESS AND NUTRITIONAL CHANGES IN DAILY LIVING TO INCREASE HEALTHY LIFE SPANS; PROVIDING A WEBSITE FEATURING INFORMATION ON GENERAL HEALTH, WELLNESS AND NUTRITION TO ASSIST IN DAILY LIVING TO INCREASE HEALTHY LIFE SPANS; PROVIDING HEALTH INFORMATION REGARDING AGING TO ASSIST IN DAILY LIVING TO INCREASE HEALTHY LIFE SPANS; COUNSELING AND ADVICE IN THE FIELD OF DIET; COUNSELING IN THE FIELD OF FIELD OF HEALTH, NAMELY, COUNSELING REGARDING THE EFFECTS OF THE ENVIRONMENT ON ONE'S HEALTH (U.S. CLS. 100 AND 101).

FIRST USE 3-0-2010; IN COMMERCE 3-0-2010.
EVELYN BRADLEY, EXAMINING ATTORNEY

SN 85-447,151. PROFESSIONAL RESEARCH CONSULTANTS, INC., OMAHA, NE. FILED 10-13-2011.



NO CLAIM IS MADE TO THE EXCLUSIVE RIGHT TO USE "HEALTHFORECAST.NET", APART FROM THE MARK AS SHOWN.

THE MARK CONSISTS OF THE WORD "HEALTHFORECAST.NET" WITH THE STYLIZED IMAGE OF A SUN TO THE LEFT THEREOF.

FOR PROVIDING INTERNET WEBSITES FEATURING COMMUNITY HEALTH ASSESSMENT AND RELATED HEALTH CARE INFORMATION (U.S. CLS. 100 AND 101).

FIRST USE 10-11-2011; IN COMMERCE 10-11-2011.
LUCY ARANT, EXAMINING ATTORNEY

CLASS 44—(Continued).

SN 85-450,396. LTAYH, LLC, DAYTONA BEACH, FL. FILED 10-18-2011.

Let's Talk About Your Hair

THE MARK CONSISTS OF STANDARD CHARACTERS WITHOUT CLAIM TO ANY PARTICULAR FONT, STYLE, SIZE, OR COLOR.

FOR PROVIDING AN ONLINE COMPUTER DATABASE FOR COSMETOLOGISTS AND CUSTOMERS OF COSMETOLOGISTS IN THE FIELD OF HAIR CUTTING, STYLING AND COLORING; PROVIDING A WEB SITE FEATURING INFORMATION FOR COSMETOLOGISTS AND CUSTOMERS OF COSMETOLOGISTS IN THE FIELD OF HAIR CUTTING, STYLING AND COLORING, AND FEATURING DISCUSSIONS IN THE FIELD OF BEAUTY AND STYLE AS IT RELATES TO HAIR STYLES, HAIR PRODUCTS, AND COSMETIC MAKE-UP (U.S. CLS. 100 AND 101).

FIRST USE 9-1-2009; IN COMMERCE 9-1-2009.
ELI HELLMAN, EXAMINING ATTORNEY

SN 85-472,523. CENTENE CORPORATION, ST. LOUIS, MO. FILED 11-15-2011.



SUNFLOWER STATE
HEALTH PLAN

NO CLAIM IS MADE TO THE EXCLUSIVE RIGHT TO USE "SUNFLOWER STATE HEALTH PLAN", APART FROM THE MARK AS SHOWN.

THE MARK CONSISTS OF PEOPLE HOLDING HANDS FORMING A STYLIZED FLOWER DESIGN TO THE LEFT OF THE TERMS "SUNFLOWER STATE HEALTH PLAN".

FOR MANAGED HEALTH CARE SERVICES (U.S. CLS. 100 AND 101).

RAUL CORDOVA, EXAMINING ATTORNEY

SN 85-477,050. CENTRAL RECOVERY HOLDINGS, LLC, LAS VEGAS, NV. FILED 11-18-2011.

CENTRAL RECOVERY

THE MARK CONSISTS OF STANDARD CHARACTERS WITHOUT CLAIM TO ANY PARTICULAR FONT, STYLE, SIZE, OR COLOR.

NO CLAIM IS MADE TO THE EXCLUSIVE RIGHT TO USE "RECOVERY", APART FROM THE MARK AS SHOWN.

FOR ADDICTION TREATMENT SERVICES, NAMELY, MEDICALLY-MANAGED WITHDRAWAL AND CHEMICAL DEPENDENCY SERVICES; MEDICAL EVALUATION SERVICES, NAMELY, FUNCTIONAL ASSESSMENT PROGRAM FOR CLIENTS RECEIVING MEDICAL REHABILITATION SERVICES FOR PURPOSES OF GUIDING TREATMENT AND ASSESSING PROGRAM EFFECTIVENESS (U.S. CLS. 100 AND 101).

FIRST USE 11-12-2010; IN COMMERCE 11-12-2010.
ROBERT C. CLARK JR., EXAMINING ATTORNEY

CLASS 44—(Continued).

SN 85-486,226. LEVILLE, KEVIN, NEW CANAAN, CT. FILED 12-2-2011.

AMERICA EATS RIGHT

THE MARK CONSISTS OF STANDARD CHARACTERS WITHOUT CLAIM TO ANY PARTICULAR FONT, STYLE, SIZE, OR COLOR.

OWNER OF U.S. REG. NOS. 3,662,109 AND 3,898,699.
FOR PROVIDING NUTRITIONAL HEALTH COUNSELING; PROVIDING PERSONAL HEALTH AND EATING ASSESSMENTS; PROVIDING A WEBSITE FEATURING INFORMATION ABOUT HEALTH, WELLNESS AND NUTRITION; PROVIDING INFORMATION IN THE FIELDS OF HEALTH, NUTRITION AND LIFESTYLE WELLNESS (U.S. CLS. 100 AND 101).

JEFFREY LOOK, EXAMINING ATTORNEY

SN 85-518,617. GARCIA, ALBERTO RUBEN CARRILLO, SAN PEDRO GARZA GARCIA, MEXICO, FILED 1-17-2012.

¡NO DUELE BE HAPPY!

THE MARK CONSISTS OF STANDARD CHARACTERS WITHOUT CLAIM TO ANY PARTICULAR FONT, STYLE, SIZE, OR COLOR.

THE ENGLISH TRANSLATION OF "NO DUELE" IN THE MARK IS "DOES NOT HURT".

FOR DENTAL SERVICES (U.S. CLS. 100 AND 101).

FIRST USE 4-13-2007; IN COMMERCE 4-13-2007.
LESLEY LAMOTHE, EXAMINING ATTORNEY

SN 85-520,643. CENTRAL RECOVERY HOLDINGS, LLC, LAS VEGAS, NV. FILED 1-19-2012.

CENTRAL RECOVERY TREATMENT

THE MARK CONSISTS OF STANDARD CHARACTERS WITHOUT CLAIM TO ANY PARTICULAR FONT, STYLE, SIZE, OR COLOR.

NO CLAIM IS MADE TO THE EXCLUSIVE RIGHT TO USE "RECOVERY TREATMENT", APART FROM THE MARK AS SHOWN.

FOR ADDICTION TREATMENT SERVICES, NAMELY, MEDICALLY-MANAGED WITHDRAWAL AND CHEMICAL DEPENDENCY SERVICES; MEDICAL EVALUATION SERVICES, NAMELY, FUNCTIONAL ASSESSMENT PROGRAM FOR CLIENTS RECEIVING MEDICAL REHABILITATION SERVICES FOR PURPOSES OF GUIDING TREATMENT AND ASSESSING PROGRAM EFFECTIVENESS (U.S. CLS. 100 AND 101).

FIRST USE 2-23-2006; IN COMMERCE 2-23-2006.
ROBERT C. CLARK JR., EXAMINING ATTORNEY

CLASS 44—(Continued).

SN 85-525,323. ADOPT A VINE PTY LTD, DBA ADOPTAVINE.COM, GISBORNE, AUSTRALIA, FILED 1-25-2012.

adopt-a-vine

THE MARK CONSISTS OF STANDARD CHARACTERS WITHOUT CLAIM TO ANY PARTICULAR FONT, STYLE, SIZE, OR COLOR.

SEC. 2(F).

FOR MEMBERSHIP CLUB SERVICES IN THE NATURE OF PROVIDING A PROGRAM FOR ADOPTING A VINE FOR THE CULTIVATION OF GRAPES; VINEYARD AND WINERY SERVICES, NAMELY, THE CULTIVATION OF GRAPES FOR OTHERS THROUGH A VINE ADOPTION PROGRAM (U.S. CLS. 100 AND 101).

FIRST USE 8-1-2004; IN COMMERCE 8-1-2004.

MIDGE BUTLER, EXAMINING ATTORNEY

CLASS 44—(Continued).

SN 85-543,664. NICKLAUS COMPANIES, LLC, NORTH PALM BEACH, FL. FILED 2-15-2012.



THE MARK CONSISTS OF A SIDEWAYS FACING GOLDEN BEAR OUTLINED IN BLACK AND FEATURING ONE EYE SHADED IN BLACK. THE BEAR IS STANDING INSIDE OF A PINK HEART.

FOR HEALTHCARE (U.S. CLS. 100 AND 101).
BRIAN CALLAGHAN, EXAMINING ATTORNEY

SN 85-529,673. ISENHATH, JOHN O., STAUNTON, VA. FILED S.R. 1-31-2012; AM. P.R. 7-24-2012.

Clarify Before You Amplify

THE MARK CONSISTS OF STANDARD CHARACTERS WITHOUT CLAIM TO ANY PARTICULAR FONT, STYLE, SIZE, OR COLOR.

FOR SPEECH AND HEARING THERAPY (U.S. CLS. 100 AND 101).

FIRST USE 1-23-2012; IN COMMERCE 1-23-2012.

LINDSEY RUBIN, EXAMINING ATTORNEY

SN 85-548,258. CHILDREN'S HEALTHCARE OF ATLANTA, INC., ATLANTA, GA. FILED 2-21-2012.

CHILDREN'S HEALTHCARE OF
ATLANTA

SN 85-532,944. 22 BOOM, WEST PALM BEACH, FL. FILED 2-3-2012.

22Boom.com | Where the
beauty industry & clients
connect

THE MARK CONSISTS OF STANDARD CHARACTERS WITHOUT CLAIM TO ANY PARTICULAR FONT, STYLE, SIZE, OR COLOR.

FOR PROVIDING AN ONLINE DETAILED SEARCHABLE INTERNET DATABASE FEATURING INFORMATION REGARDING OF THE BEAUTY INDUSTRY USING CRITERIA BASED ON SPECIFIC HAIR TYPE AND LOCATION (U.S. CLS. 100 AND 101).

FIRST USE 1-22-2010; IN COMMERCE 1-22-2010.

SUE LAWRENCE, EXAMINING ATTORNEY

THE MARK CONSISTS OF STANDARD CHARACTERS WITHOUT CLAIM TO ANY PARTICULAR FONT, STYLE, SIZE, OR COLOR.

OWNER OF U.S. REG. NOS. 2,518,187, 2,967,161 AND OTHERS.

SEC. 2(F).

FOR PEDIATRIC HEALTHCARE SERVICES (U.S. CLS. 100 AND 101).

FIRST USE 9-1-1999; IN COMMERCE 9-1-1999.

AISHA SALEM, EXAMINING ATTORNEY

CLASS 44—(Continued).

SN 85-553,108. LI YANPING, DUNHUA JILIN, CHINA, CHINA, FILED 2-27-2012.

审 美

THE MARK CONSISTS OF TWO CHINESE CHARACTERS.

THE NON-LATIN CHARACTERS IN THE MARK TRANSLITERATE TO SHEN MEI AND THIS HAS NO MEANING IN A FOREIGN LANGUAGE.

FOR BEAUTY SALONS; COSMETIC FACE CARE SERVICES; HAIRDRESSING SALONS; HAIRDRESSING SERVICES; MANAGED HEALTH CARE SERVICES; MANICURING; MASSAGES; OPERATION OF PUBLIC BATHS FOR SANITARY PURPOSES; PROVIDING BATH HOUSES; PROVIDING TURKISH BATH FACILITIES (U.S. CLS. 100 AND 101).

FIRST USE 2-22-2012; IN COMMERCE 2-22-2012.
SANJEEV VOHRA, EXAMINING ATTORNEY

SN 85-555,395. THE LITTLE CLINIC, LLC, BRENTWOOD, TN. FILED 2-28-2012.

THE LITTLE CLINIC

THE MARK CONSISTS OF STANDARD CHARACTERS WITHOUT CLAIM TO ANY PARTICULAR FONT, STYLE, SIZE, OR COLOR.

OWNER OF U.S. REG. NOS. 3,172,681, 3,196,023 AND OTHERS.

NO CLAIM IS MADE TO THE EXCLUSIVE RIGHT TO USE "CLINIC", APART FROM THE MARK AS SHOWN. SEC. 2(F).

FOR HEALTHCARE SERVICES, NAMELY, WALK-IN MEDICAL CLINIC SERVICES, NON-EMERGENCY MEDICAL DIAGNOSTICS IN THE NATURE OF MEDICAL DIAGNOSTIC TESTING, MONITORING AND REPORTING SERVICES, MEDICAL TREATMENT, HEALTH MAINTENANCE SERVICES IN THE NATURE OF PROVIDING WELLNESS AND HEALTH-RELATED CONSULTING SERVICES, HEALTHCARE INFORMATION SERVICES, MEDICAL CONSULTATION, MEDICAL TESTING, WELLNESS SERVICES IN THE NATURE OF HEALTH CARE WELLNESS PROGRAMS, AND WELLNESS CONSULTING, PREVENTIVE HEALTH CARE AND FOLLOW UP SERVICES IN THE NATURE OF MEDICAL SCREENING AND MEDICAL TESTING FOR DIAGNOSTIC OR TREATMENT PURPOSES, AND ADMINISTRATION OF VACCINATIONS AND INJECTIONS (U.S. CLS. 100 AND 101).

FIRST USE 8-2-2005; IN COMMERCE 8-2-2005.
TINA BROWN, EXAMINING ATTORNEY

CLASS 44—(Continued).

SN 85-558,588. PASTORE, ROBERT, NEW YORK, NY. FILED 3-2-2012.

ROBERT PASTORE, PHD

THE MARK CONSISTS OF STANDARD CHARACTERS WITHOUT CLAIM TO ANY PARTICULAR FONT, STYLE, SIZE, OR COLOR.

NO CLAIM IS MADE TO THE EXCLUSIVE RIGHT TO USE "PHD", APART FROM THE MARK AS SHOWN.

THE NAME(S), PORTRAIT(S), AND/OR SIGNATURE(S) SHOWN IN THE MARK IDENTIFIES "ROBERT PASTORE", WHOSE CONSENT(S) TO REGISTER IS MADE OF RECORD.

FOR NUTRITIONAL THERAPY SERVICES, NUTRITIONAL COUNSELING, AND DIETARY AND NUTRITIONAL GUIDANCE (U.S. CLS. 100 AND 101).

FIRST USE 1-1-1996; IN COMMERCE 1-1-1996.
KEVEN MITTLER, EXAMINING ATTORNEY

SN 85-561,353. ST. RITA'S MEDICAL CENTER, LIMA, OH. FILED 3-6-2012.

D5 4U

THE MARK CONSISTS OF STANDARD CHARACTERS WITHOUT CLAIM TO ANY PARTICULAR FONT, STYLE, SIZE, OR COLOR.

FOR A HEALTHCARE BENEFIT PLAN FOR EMPLOYEES, NAMELY, HEALTH CARE SERVICES IN THE NATURE OF A DISEASE MANAGEMENT PROGRAM FOR TRACKING AND MANAGING DIABETES (U.S. CLS. 100 AND 101).

FIRST USE 9-1-2011; IN COMMERCE 9-1-2011.
MICHELLE DUBOIS, EXAMINING ATTORNEY

SN 85-563,014. ROYAL FRIESIANS LLC, NEWPORT, RI. FILED 3-7-2012.

Royal Friesian

THE MARK CONSISTS OF STANDARD CHARACTERS WITHOUT CLAIM TO ANY PARTICULAR FONT, STYLE, SIZE, OR COLOR.

NO CLAIM IS MADE TO THE EXCLUSIVE RIGHT TO USE "FRIESIAN", APART FROM THE MARK AS SHOWN.

FOR HORSE BREEDING AND STUD SERVICES (U.S. CLS. 100 AND 101).

MARGERIE A. TIERNEY, EXAMINING ATTORNEY

CLASS 44—(Continued).

SN 85-564,290. ROGERS, BRUCE A., HAVERTOWN, PA. FILED 3-8-2012.

The Medical Standard

THE MARK CONSISTS OF STANDARD CHARACTERS WITHOUT CLAIM TO ANY PARTICULAR FONT, STYLE, SIZE, OR COLOR.

NO CLAIM IS MADE TO THE EXCLUSIVE RIGHT TO USE "MEDICAL", APART FROM THE MARK AS SHOWN.

FOR DIETARY AND NUTRITIONAL GUIDANCE; MEDICAL SERVICES; PROVIDING HEALTHY LIFESTYLE AND NUTRITION SERVICES, NAMELY, PERSONAL ASSESSMENTS, PERSONALIZED ROUTINES, MAINTENANCE SCHEDULES, AND COUNSELING; WEIGHT MANAGEMENT SERVICES, NAMELY, PROVIDING WEIGHT LOSS AND/OR WEIGHT MAINTENANCE PROGRAMS; WELLNESS AND HEALTH-RELATED CONSULTING SERVICES (U.S. CLS. 100 AND 101).

FIRST USE 2-29-2012; IN COMMERCE 2-29-2012.
NORA BUCHANAN WILL, EXAMINING ATTORNEY

SN 85-567,041. EBERLY, GREGORY L., PALM DESERT, CA. FILED 3-12-2012.

Pot-A-Plant

THE MARK CONSISTS OF STANDARD CHARACTERS WITHOUT CLAIM TO ANY PARTICULAR FONT, STYLE, SIZE, OR COLOR.

FOR HORTICULTURAL SERVICES; STRESS REDUCTION THERAPY (U.S. CLS. 100 AND 101).

DEZMONA MIZELLE, EXAMINING ATTORNEY

SN 85-568,570. CHRISTIDIS, MELINA, DBA MELINA FITNESS, LONG BEACH, CA. FILED 3-13-2012.

FitTox

THE MARK CONSISTS OF STANDARD CHARACTERS WITHOUT CLAIM TO ANY PARTICULAR FONT, STYLE, SIZE, OR COLOR.

FOR PROVIDING ASSISTANCE, FITNESS EVALUATION AND CONSULTATION TO INDIVIDUALS TO HELP THEM MAKE HEALTH, WELLNESS AND NUTRITIONAL CHANGES IN THEIR DAILY LIVING TO IMPROVE HEALTH (U.S. CLS. 100 AND 101).

FIRST USE 2-1-2012; IN COMMERCE 2-1-2012.
JENNIFER WILLISTON, EXAMINING ATTORNEY

CLASS 44—(Continued).

SN 85-570,946. AIRROSTI REHAB CENTERS, LLC, SAN ANTONIO, TX. FILED 3-15-2012.

AIRROSTI REHAB CENTERS

THE MARK CONSISTS OF STANDARD CHARACTERS WITHOUT CLAIM TO ANY PARTICULAR FONT, STYLE, SIZE, OR COLOR.

OWNER OF U.S. REG. NOS. 4,121,862 AND 4,121,863.

NO CLAIM IS MADE TO THE EXCLUSIVE RIGHT TO USE "REHAB CENTERS", APART FROM THE MARK AS SHOWN.

FOR PHYSICAL REHABILITATION; HEALTH CARE SERVICES, NAMELY, MANUAL THERAPY, MYOFASCIAL RELEASE, AND THERAPEUTIC EXERCISES (U.S. CLS. 100 AND 101).

FIRST USE 2-1-2004; IN COMMERCE 2-1-2004.
BRENDAN MCCAULEY, EXAMINING ATTORNEY

SN 85-573,504. LANGHAM HOTELS INTERNATIONAL LIMITED, WANCHAI, HONG KONG, FILED 3-19-2012.



OWNER OF HONG KONG REG. NO. 300257779, DATED 7-28-2004, EXPIRES 7-28-2014.

OWNER OF U.S. REG. NOS. 3,116,106 AND 3,595,895.

NO CLAIM IS MADE TO THE EXCLUSIVE RIGHT TO USE "SPA", APART FROM THE MARK AS SHOWN.

THE MARK CONSISTS OF THREE VERTICAL PAINT BRUSH STROKES, ONE MEDIUM BRUSH STROKE ON THE LEFT, ONE SMALL BRUSH STROKE IN THE MIDDLE AND ONE LARGE BRUSH STROKE ON THE RIGHT WITH THE WORDS "CHUAN SPA" BELOW THE MEDIUM AND SMALL BRUSH STROKE AND TO THE LEFT OF THE LARGE BRUSH STROKE.

THE ENGLISH TRANSLATION OF "CHUAN" IN THE MARK IS "RIVER".

THE NON-LATIN CHARACTERS IN THE MARK TRANSLITERATE TO "CHUAN" AND THIS MEANS RIVER IN ENGLISH.

FOR HEALTH SPA SERVICES, NAMELY, COSMETIC BODY CARE SERVICES; HYGIENE AND BEAUTY CARE SERVICES, NAMELY, MANICURE, PEDICURE AND HAIRDRESSING SERVICES; OPERATION OF SAUNA FACILITIES; MASSAGE SERVICES; AROMATHERAPY SERVICES; SUN TANNING SALON SERVICES; COSMETIC AND MAKE-UP ANALYSIS; BEAUTY SALONS; BEAUTY CARE CONSULTATION IN THE FIELD OF CONDITIONING, CARE AND APPEARANCE OF THE SKIN, BODY, FACE, EYES, HAIR, TEETH AND NAILS; FOOD AND NUTRITION CONSULTATION; HEALTHCARE CONSULTATION (U.S. CLS. 100 AND 101).

DOUGLAS LEE, EXAMINING ATTORNEY

CLASS 44—(Continued).

SN 85-575,770. IRINA GANELIS, M.D., P.C., DBA LOS ANGELES EYE INSTITUTE, BEVERLY HILLS, CA. FILED 3-21-2012.



THE COLOR(S) BLUE, WHITE, AND BLACK IS/ARE CLAIMED AS A FEATURE OF THE MARK.

THE MARK CONSISTS OF A DESIGN OF AN EYE FORMED BY TWO BLUE, STYLIZED HANDS POSITIONED SO THAT THE INDEX FINGERS AND THUMBS CREATE THE OVAL SHAPE OF THE EYE AND EYELASHES, AND IN BETWEEN THEM THE CIRCULAR IRIS IS BLUE AND THE PUPIL IS BLACK. WHITE AND LIGHT BLUE ARE USED TO CREATE THE EFFECT OF POINTS OF LIGHT REFLECTING ON THE IRIS.

FOR OPHTHALMOLOGY SERVICES (U.S. CLS. 100 AND 101).

FIRST USE 8-1-2011; IN COMMERCE 8-1-2011.
CORY BOONE, EXAMINING ATTORNEY

SN 85-582,323. SKYN LOUNGE, LLC, LOUISVILLE, KY. FILED 3-28-2012.

SKYN LOUNGE

THE MARK CONSISTS OF STANDARD CHARACTERS WITHOUT CLAIM TO ANY PARTICULAR FONT, STYLE, SIZE, OR COLOR.

NO CLAIM IS MADE TO THE EXCLUSIVE RIGHT TO USE "SKIN", APART FROM THE MARK AS SHOWN.

FOR HEALTH SPA SERVICES FOR HEALTH AND WELLNESS OF THE BODY AND SPIRIT, NAMELY, PROVIDING MASSAGE, FACIAL AND BODY TREATMENT SERVICES, COSMETIC BODY CARE SERVICES (U.S. CLS. 100 AND 101).

FIRST USE 1-24-2011; IN COMMERCE 1-24-2011.
MORGAN WYNNE, EXAMINING ATTORNEY

CLASS 44—(Continued).

SN 85-582,966. HAVENWOOD GROUP, PURCELLVILLE, VA. FILED 3-28-2012.

Havenwood

THE MARK CONSISTS OF STANDARD CHARACTERS WITHOUT CLAIM TO ANY PARTICULAR FONT, STYLE, SIZE, OR COLOR.

FOR AQUACULTURE SERVICES, NAMELY, THE CULTIVATION AND BREEDING OF PLANTS OR ANIMALS IN A WATER ENVIRONMENT (U.S. CLS. 100 AND 101).

LOURDES AYALA, EXAMINING ATTORNEY

SN 85-586,138. NO MAS VELLO, S.L., MADRID, SPAIN, FILED 4-2-2012.



OWNER OF U.S. REG. NO. 4,058,296.
NO CLAIM IS MADE TO THE EXCLUSIVE RIGHT TO USE "VELLO" OR "MEDICAL", APART FROM THE MARK AS SHOWN.

THE COLOR(S) GREEN AND BLACK IS/ARE CLAIMED AS A FEATURE OF THE MARK.

THE MARK CONSISTS OF THE STYLIZED WORDS "NO + VELLO" IN GREEN ABOVE THE WORD "MEDICAL" IN BLACK.

THE ENGLISH TRANSLATION OF "NO VELLO" IN THE MARK IS "NO HAIR".

FOR INTENSE PULSE LIGHT SKIN ENHANCEMENT PROCEDURES; NON-SURGICAL PROCEDURE USING INFRARED AND RADIO FREQUENCY TO NON-INVASIVELY FIRM, LIFT, TIGHTEN, REJUVENATE AND ENHANCE THE SOFT TISSUE OF THE BREASTS; MEDICAL SKIN CARE SERVICES, NAMELY, SKIN DEPIGMENTATION, ANTI-ACNE TREATMENTS, PORE MINIMIZING AND WRINKLE REDUCTION; MEDICAL SERVICES, NAMELY, VASCULAR THERAPY; SKIN CARE SALONS; TEETH WHITENING SERVICES; INTENSE PULSE LIGHT TREATMENTS FOR ACNE, REJUVENATION, SCARS, TATTOO REMOVAL AND FOR FACIALS AND MASSAGE (U.S. CLS. 100 AND 101).

KRISTINA MORRIS, EXAMINING ATTORNEY

CLASS 44—(Continued).

SN 85-589,121. ASTELLAS US LLC, DEERFIELD, IL. FILED 4-4-2012.

QUICK START

THE MARK CONSISTS OF STANDARD CHARACTERS WITHOUT CLAIM TO ANY PARTICULAR FONT, STYLE, SIZE, OR COLOR.

FOR HEALTH CARE SERVICES, NAMELY, PROVIDING PATIENT ACCESS PROGRAMS TO PROVIDE DRUGS FREE OF CHARGE ON AN EXPEDITED BASIS TO ELIGIBLE PATIENTS (U.S. CLS. 100 AND 101).

FIRST USE 12-1-2007; IN COMMERCE 12-1-2007.
EDWARD NELSON, EXAMINING ATTORNEY

SN 85-592,245. ELEMENTS BEHAVIORAL HEALTH, INC., LONG BEACH, CA. FILED 4-9-2012.



NO CLAIM IS MADE TO THE EXCLUSIVE RIGHT TO USE "MALIBU", APART FROM THE MARK AS SHOWN.

THE COLOR(S) GOLD AND TEAL IS/ARE CLAIMED AS A FEATURE OF THE MARK.

THE MARK CONSISTS OF THE WORDS "MALIBU VISTA" IN STYLIZED FORM IN GOLD HAVING A CURVED TEAL LINE FROM LEFT TO RIGHT UNDER THE WORDS LOOPING UP AND ENCIRCLING THE "A" IN "VISTA".

FOR MENTAL HEALTH SERVICES; COUNSELING SERVICES IN THE FIELDS OF MENTAL HEALTH, ADDICTION AND SOBRIETY; CONSULTING SERVICES IN THE FIELD OF MENTAL HEALTH TREATMENT; CONSULTING SERVICES REGARDING MENTAL HEALTH AND ADDICTION TREATMENT FOR PATIENTS; CONSULTING SERVICES IN THE FIELD OF PATIENT SERVICES, NAMELY CONSULTING SERVICES IN THE FIELD OF MENTAL HEALTH AND ADDICTION TREATMENT; DRUG AND ALCOHOL ADDICTION TREATMENT AND REHABILITATION SERVICES; INDIVIDUAL PSYCHOTHERAPY AND GROUP PSYCHOTHERAPY SERVICES FOR FOSTERING GOOD MENTAL HEALTH, INDEPENDENCE, PERSONAL AND FAMILY RELATIONSHIPS, AND SOBRIETY; REHABILITATION OF SEXUALLY ADDICTED PATIENTS; DRUG AND ALCOHOL REHABILITATION SERVICES; ADDICTION TREATMENT SERVICES; GAMBLING ADDICTION TREATMENT SERVICES; REHABILITATION OF PATIENTS EXPERIENCING POST-TRAUMATIC STRESS DISORDER (PTSD), SEX ADDICTION, MOOD DISORDERS, DEPRESSION, ANXIETY, PERSONALITY DISORDERS, AND EATING DISORDERS, NAMELY BULIMIA AND ANOREXIA; PROVIDING A WEB SITE FEATURING INFORMATION IN THE FIELD OF MENTAL HEALTH AND WELLNESS (U.S. CLS. 100 AND 101).

MIDGE BUTLER, EXAMINING ATTORNEY

CLASS 44—(Continued).

SN 85-592,619. PURE BRANDS CO INC., COLD SPRING HARBOR, NY. FILED 4-9-2012.

Carb Connect

THE MARK CONSISTS OF STANDARD CHARACTERS WITHOUT CLAIM TO ANY PARTICULAR FONT, STYLE, SIZE, OR COLOR.

NO CLAIM IS MADE TO THE EXCLUSIVE RIGHT TO USE "CARB", APART FROM THE MARK AS SHOWN.

FOR PROVIDING A WEBSITE FEATURING INFORMATION AND ADVICE IN THE FIELDS OF DIET, WEIGHT LOSS, DIET PLANNING AND LIFESTYLE WELLNESS (U.S. CLS. 100 AND 101).

PATRICIA EVANKO, EXAMINING ATTORNEY

SN 85-592,634. MARCIA BERLIN PRODUCTIONS, INC., MARIETTA, GA. FILED 4-9-2012.

life preserver diet

THE MARK CONSISTS OF STANDARD CHARACTERS WITHOUT CLAIM TO ANY PARTICULAR FONT, STYLE, SIZE, OR COLOR.

NO CLAIM IS MADE TO THE EXCLUSIVE RIGHT TO USE "DIET", APART FROM THE MARK AS SHOWN.

FOR PROVIDING A WEBSITE FEATURING INFORMATION AND ADVICE IN THE FIELDS OF DIET, WEIGHT LOSS, DIET PLANNING AND LIFESTYLE WELLNESS (U.S. CLS. 100 AND 101).

FIRST USE 5-24-2011; IN COMMERCE 9-1-2011.

IRA J. GOODSaid, EXAMINING ATTORNEY

CLASS 44—(Continued).

SN 85-593,036. OPERADORA DE FRANQUICIAS BELLALÁSER, S. DE R. L. DE C.V., METEPEC, MEXICO, FILED 4-9-2012.



THE MARK CONSISTS OF THE WORD "BELLALÁSER" WITHIN AN OUTLINED LEAF SITTING ABOVE A SMALLER OUTLINED LEAF. TO THE LEFT OF THE LEAVES AND WORDING IS AN OUTLINE OF A FEMALE FIGURE.

FOR HYGIENIC AND BEAUTY CARE; MEDICAL CLINIC PROVIDING WEIGHT LOSS SOLUTIONS, SERVICES AND PROGRAMS, NUTRITION COUNSELING, HORMONE THERAPY, INCLUDING, BIOIDENTICAL HORMONE REPLACEMENT, ANTI AGING THERAPY, AND NATURAL HORMONE THERAPY, MEDICAL AESTHETIC PROCEDURES, INCLUDING, LASER HAIR REMOVAL, LASER PEELS, BOTULINUM TOXIN TREATMENTS, MICRODERMABRASION, LIPOSUCTION, VEIN TREATMENTS, VEIN THERAPY, CELLULITE TREATMENTS, BODY CONTOURING TREATMENTS, INJECTABLE FILLER TREATMENTS, FACIALS, AND SKIN CARE; MEDICAL SKIN CARE SERVICES (U.S. CLS. 100 AND 101).

TARAH HARDY, EXAMINING ATTORNEY

SN 85-593,054. K9S 4 MOBILITY, CHEYENNE, WY. FILED 4-10-2012.



NO CLAIM IS MADE TO THE EXCLUSIVE RIGHT TO USE THE UNIVERSAL HANDICAP SYMBOL, APART FROM THE MARK AS SHOWN.

THE MARK CONSISTS OF "K9S 4 MOBILITY" WRITTEN ABOVE A DOG THAT IS FACING A PERSON IN A WHEELCHAIR.

FOR CHARITABLE SERVICES, NAMELY, PROVIDING TRAINED SERVICE DOGS FOR PEOPLE WITH PHYSICAL DISABILITIES (U.S. CLS. 100 AND 101).

FIRST USE 3-25-2012; IN COMMERCE 4-1-2012.
KRISTIN DAHLING, EXAMINING ATTORNEY

CLASS 44—(Continued).

SN 85-595,740. BELL, EVA, OMAHA, NE. FILED 4-12-2012.

Fresh Before Five

THE MARK CONSISTS OF STANDARD CHARACTERS WITHOUT CLAIM TO ANY PARTICULAR FONT, STYLE, SIZE, OR COLOR.

FOR PROVIDING A WEBSITE FEATURING INFORMATION AND ADVICE IN THE FIELDS OF DIET, WEIGHT LOSS, DIET PLANNING AND LIFESTYLE WELLNESS (U.S. CLS. 100 AND 101).

KIMBERLY PARKS, EXAMINING ATTORNEY

SN 85-597,060. BIO-REFERENCE LABORATORIES, INC., ELMWOOD PARK, NJ. FILED 4-13-2012.

DNA DIAGNOSTIC EXPERTS

THE MARK CONSISTS OF STANDARD CHARACTERS WITHOUT CLAIM TO ANY PARTICULAR FONT, STYLE, SIZE, OR COLOR.

OWNER OF U.S. REG. NOS. 2,975,735 AND 4,007,835.
NO CLAIM IS MADE TO THE EXCLUSIVE RIGHT TO USE "DNA DIAGNOSTIC", APART FROM THE MARK AS SHOWN.

SEC. 2(F).

FOR MEDICAL TESTING FOR DIAGNOSTIC OR TREATMENT PURPOSES (U.S. CLS. 100 AND 101).

FIRST USE 3-31-2007; IN COMMERCE 3-31-2007.

KELLY TRUSILO, EXAMINING ATTORNEY

SN 85-597,125. POSH SPA FUR DOGS LLC, STAMFORD, CT. FILED 4-13-2012.

POSH SPA FUR DOGS

THE MARK CONSISTS OF STANDARD CHARACTERS WITHOUT CLAIM TO ANY PARTICULAR FONT, STYLE, SIZE, OR COLOR.

NO CLAIM IS MADE TO THE EXCLUSIVE RIGHT TO USE "SPA FOR DOGS", APART FROM THE MARK AS SHOWN.

FOR DOG GROOMING SERVICES (U.S. CLS. 100 AND 101).

FIRST USE 5-4-2011; IN COMMERCE 2-1-2012.

EMILY CHUO, EXAMINING ATTORNEY

CLASS 44—(Continued).

SN 85-597,161. VISITING NURSE HOME CARE, LINCOLN, RI. FILED 4-13-2012.



THE MARK CONSISTS OF STYLIZED EXTERIOR FRONT OF HOME.

FOR HOME HEALTH CARE SERVICES; HOME HEALTH CARE SERVICES, NAMELY, NURSING CARE, MEDICATION ADMINISTRATION, POST-SURGICAL CARE AND WOUND CARE; REHABILITATION SERVICES, NAMELY, PHYSICAL THERAPY, OCCUPATIONAL THERAPY, AND SPEECH THERAPY; PALLIATIVE CARE SERVICES; COLOSTOMY HEALTH CARE SERVICES; HOME HEALTH CARE SERVICES, NAMELY, HEALTH CARE RELATING TO CATHETER USE; MEDICAL SERVICES, NAMELY, ADMINISTERING ANTIBIOTICS, NUTRITIONAL SUPPLEMENTS, AND BLOOD INTRAVENOUSLY; PRIVATE DUTY NURSING CARE SERVICES; SPECIALTY NURSING SERVICES; MEDICAL SOCIAL WORK, NAMELY, PSYCHOLOGICAL CONSULTATION AND PSYCHOLOGICAL TESTING IN THE NATURE OF SOCIAL/EMOTIONAL ASSESSMENT (U.S. CLS. 100 AND 101).
FIRST USE 1-9-2012; IN COMMERCE 1-9-2012.

KATHERINE STOIDES, EXAMINING ATTORNEY

CLASS 44—(Continued).

SN 85-598,565. ERROL MD, LLC, VERONA, NJ. FILED 4-16-2012.

Errol MD

THE MARK CONSISTS OF STANDARD CHARACTERS WITHOUT CLAIM TO ANY PARTICULAR FONT, STYLE, SIZE, OR COLOR.

NO CLAIM IS MADE TO THE EXCLUSIVE RIGHT TO USE "MD", APART FROM THE MARK AS SHOWN.

FOR PROVIDING MEDICAL INFORMATION, CONSULTANCY AND ADVISORY SERVICES (U.S. CLS. 100 AND 101).

MIDGE BUTLER, EXAMINING ATTORNEY

SN 85-597,733. ENCORE WELLNESS & WEIGHT LOSS MANAGEMENT, INC., INGLEWOOD, CA. FILED 4-13-2012.



NO CLAIM IS MADE TO THE EXCLUSIVE RIGHT TO USE "WELLNESS & WEIGHT LOSS", APART FROM THE MARK AS SHOWN.

THE MARK CONSISTS OF THE IMAGE OF A STICK FIGURE IN THE TOP LEFT WITH THE WORD "ENCORE" IN THE TOP RIGHT AND THE WORDS "WELLNESS & WEIGHT LOSS" ACROSS THE BOTTOM.

FOR PROVIDING WELLNESS SERVICES, NAMELY, WEIGHT LOSS PROGRAMS (U.S. CLS. 100 AND 101).

FIRST USE 9-6-2011; IN COMMERCE 9-30-2011.
TRACY FLETCHER, EXAMINING ATTORNEY

SN 85-598,573. STARTING OVER SOBER, BRADFORD, MA. FILED 4-16-2012.



NO CLAIM IS MADE TO THE EXCLUSIVE RIGHT TO USE "LLC", APART FROM THE MARK AS SHOWN.

THE COLOR(S) GREEN, YELLOW, AND BLACK IS/ARE CLAIMED AS A FEATURE OF THE MARK.

THE MARK CONSISTS OF A BLACK SILHOUETTE OF A HOUSE WITH A YELLOW RISING SUN AND WITH GREEN STYLIZED TEXT THAT READS "SOS STARTING OVER SOBER LLC".

FOR ADDICTION TREATMENT SERVICES; REHABILITATION OF ALCOHOL ADDICTED PATIENTS; REHABILITATION OF DRUG ADDICTED PATIENTS (U.S. CLS. 100 AND 101).

FIRST USE 1-1-2012; IN COMMERCE 2-1-2012.
NICHOLAS COLEMAN, EXAMINING ATTORNEY

CLASS 44—(Continued).

SN 85-598,609. LOGISTICAL ENIGMA, NASHVILLE, TN. FILED 4-16-2012.



NO CLAIM IS MADE TO THE EXCLUSIVE RIGHT TO USE "L.L.C.", APART FROM THE MARK AS SHOWN.

THE MARK CONSISTS OF A HORSE JUMPING OVER A FENCE COMPRISED OF THE STYLIZED LETTERS "LE". BELOW IS THE STYLIZED TEXT "LOGISTICAL ENIGMA L.L.C." WITH A CURVED LINE BELOW.

FOR HORSE BREEDING AND STUD SERVICES (U.S. CLS. 100 AND 101).

FIRST USE 8-29-2011; IN COMMERCE 8-29-2011.
BRENDAN MCCAULEY, EXAMINING ATTORNEY

CLASS 44—(Continued).

SN 85-599,051. GOOD START GENETICS, INC., CAMBRIDGE, MA. FILED 4-16-2012.

GIVING THE NEXT GENERATION
A GOOD START

THE MARK CONSISTS OF STANDARD CHARACTERS WITHOUT CLAIM TO ANY PARTICULAR FONT, STYLE, SIZE, OR COLOR.

FOR GENETIC TESTING FOR MEDICAL PURPOSES; PRENATAL MEDICAL TESTING FOR GENETIC DISORDERS FOR DIAGNOSTIC PURPOSES (U.S. CLS. 100 AND 101).

JENNIFER RICHARDSON, EXAMINING ATTORNEY

SN 85-598,819. LEGACY SENIOR SERVICES, LLC, CLEVELAND, TN. FILED 4-16-2012.

PURPOSEFUL DAY

THE MARK CONSISTS OF STANDARD CHARACTERS WITHOUT CLAIM TO ANY PARTICULAR FONT, STYLE, SIZE, OR COLOR.

FOR THERAPY SERVICES FOR THE PREVENTION AND TREATMENT OF ALZHEIMER'S DISEASE AND MEMORY DISORDERS (U.S. CLS. 100 AND 101).
DEZMONA MIZELLE, EXAMINING ATTORNEY

SN 85-599,063. GOOD START GENETICS, INC., CAMBRIDGE, MA. FILED 4-16-2012.

GSG SOLUTIONS

THE MARK CONSISTS OF STANDARD CHARACTERS WITHOUT CLAIM TO ANY PARTICULAR FONT, STYLE, SIZE, OR COLOR.

NO CLAIM IS MADE TO THE EXCLUSIVE RIGHT TO USE "SOLUTIONS", APART FROM THE MARK AS SHOWN.

FOR CUSTOMER CARE SERVICES, NAMELY, PROVIDING MEDICAL INFORMATION IN THE FIELD OF GENETIC TESTING; GENETIC COUNSELING SERVICES RELATING TO PATIENT PRE- AND POST PATIENT TESTING; PREPARATION OF PATIENT AND CLINIC REPORTS BASED UPON PATIENT PROVIDED HEALTH INFORMATION IN THE NATURE OF PROVIDING RECOMMENDATIONS AS TO GENETIC TESTING; PROVIDING A WEBSITE FEATURING MEDICAL INFORMATION REGARDING GENETICS (U.S. CLS. 100 AND 101).

JENNIFER RICHARDSON, EXAMINING ATTORNEY

SN 85-598,949. CHINA DOLL NAILS, DBA CHINA DOLL NAILS, BRONX, NY. FILED 4-16-2012.

China Doll Nails

THE MARK CONSISTS OF STANDARD CHARACTERS WITHOUT CLAIM TO ANY PARTICULAR FONT, STYLE, SIZE, OR COLOR.

NO CLAIM IS MADE TO THE EXCLUSIVE RIGHT TO USE "NAILS", APART FROM THE MARK AS SHOWN.

FOR NAIL CARE SERVICES (U.S. CLS. 100 AND 101).
FIRST USE 6-13-2010; IN COMMERCE 6-13-2010.
ROBERT STRUCK, EXAMINING ATTORNEY

CLASS 44—(Continued).

SN 85-599,068. GOOD START GENETICS, INC., CAMBRIDGE, MA. FILED 4-16-2012.

GOODSTART SELECT

THE MARK CONSISTS OF STANDARD CHARACTERS WITHOUT CLAIM TO ANY PARTICULAR FONT, STYLE, SIZE, OR COLOR.

OWNER OF U.S. REG. NO. 4,096,815.

NO CLAIM IS MADE TO THE EXCLUSIVE RIGHT TO USE "SELECT", APART FROM THE MARK AS SHOWN.

FOR GENETIC TESTING FOR MEDICAL PURPOSES; PRENATAL AND PRECONCEPTION GENETIC CARRIER MEDICAL TESTING FOR GENETIC AND AUTOSOMAL RECESSIVE DISORDERS FOR DIAGNOSTIC PURPOSES; ISOLATING, TESTING, ANALYZING, AND EVALUATING NUCLEIC ACIDS FOR MEDICAL DIAGNOSTIC PURPOSES (U.S. CLS. 100 AND 101).

JENNIFER RICHARDSON, EXAMINING ATTORNEY

SN 85-599,166. ENCORE WELLNESS & WEIGHT LOSS MANAGEMENT, INC., INGLEWOOD, CA. FILED 4-16-2012.

ENCORE WELLNESS & WEIGHT LOSS

THE MARK CONSISTS OF STANDARD CHARACTERS WITHOUT CLAIM TO ANY PARTICULAR FONT, STYLE, SIZE, OR COLOR.

NO CLAIM IS MADE TO THE EXCLUSIVE RIGHT TO USE "WELLNESS & WEIGHT LOSS", APART FROM THE MARK AS SHOWN.

FOR PROVIDING WELLNESS SERVICES, NAMELY, WEIGHT LOSS PROGRAMS (U.S. CLS. 100 AND 101).

FIRST USE 9-6-2011; IN COMMERCE 9-30-2011.

TRACY FLETCHER, EXAMINING ATTORNEY

SN 85-599,762. GENERATIONS R.C., INC., HURRICANE, WV. FILED 4-17-2012.

Generations Physical Therapy

THE MARK CONSISTS OF STANDARD CHARACTERS WITHOUT CLAIM TO ANY PARTICULAR FONT, STYLE, SIZE, OR COLOR.

OWNER OF U.S. REG. NO. 4,144,951.

NO CLAIM IS MADE TO THE EXCLUSIVE RIGHT TO USE "PHYSICAL THERAPY", APART FROM THE MARK AS SHOWN.

FOR MEDICAL, PHYSICAL REHABILITATION AND PHYSICAL THERAPY SERVICES; PHYSICAL REHABILITATION (U.S. CLS. 100 AND 101).

FIRST USE 5-1-1997; IN COMMERCE 5-1-1997.

DAVID MURRAY, EXAMINING ATTORNEY

CLASS 44—(Continued).

SN 85-600,801. GOOD START GENETICS, INC., CAMBRIDGE, MA. FILED 4-18-2012.

HELPING TO GIVE THE NEXT GENERATION A GOOD START

THE MARK CONSISTS OF STANDARD CHARACTERS WITHOUT CLAIM TO ANY PARTICULAR FONT, STYLE, SIZE, OR COLOR.

FOR GENETIC TESTING FOR MEDICAL PURPOSES; PRENATAL MEDICAL TESTING FOR GENETIC DISORDERS FOR DIAGNOSTIC PURPOSES (U.S. CLS. 100 AND 101).

JENNIFER RICHARDSON, EXAMINING ATTORNEY

SN 85-601,993. MICHAEL J LOVETT, DBA PUREAIR LAWN CARE, SPARKS, NV. FILED 4-18-2012.



NO CLAIM IS MADE TO THE EXCLUSIVE RIGHT TO USE "LAWN CARE", APART FROM THE MARK AS SHOWN.

THE COLOR(S) LIGHT BLUE, DARK BLUE, WHITE, LIGHT GRAY, GREEN IS/ARE CLAIMED AS A FEATURE OF THE MARK.

THE MARK CONSISTS OF THE WORD "PURE" IN THE COLOR LIGHT BLUE, AND THE WORD "AIR" IN THE COLOR DARK BLUE; THE WORDING "LAWN CARE" IN THE COLOR LIGHT GRAY, WITH TWO GRASS BLADES IN THE COLOR GREEN IN FRONT OF THE LETTER "U" IN THE WORD "PURE", PROTRUDING TO THE LEFT; THERE ARE TWO WATER DROPLETS IN THE COLORS DARK BLUE, LIGHT BLUE AND WHITE IN EACH WATER DROPLET, BOTH WATER DROPLETS ARE ABOVE THE LETTER "I" IN THE WORD "AIR", THE WORD "LAWN CARE" IS IN ALL CAPITAL LETTERS AND IS LOCATED BELOW THE LETTERS "EAIR" IN THE WORD "PUREAIR" FOR LANDSCAPE GARDENING; LAWN CARE; LAWN MOWING SERVICES (U.S. CLS. 100 AND 101).

FIRST USE 9-1-2011; IN COMMERCE 9-1-2011.

LINDA E. BLOHM, EXAMINING ATTORNEY

CLASS 44—(Continued).

SN 85-602,233. CLEARNAILZ, LLC, FORT WORTH, TX. FILED 4-19-2012.



THE MARK CONSISTS OF THE WORD "CLEARNAILZ" WITH FIVE OVALS OF VARYING SIZE OUTLINING THE TOP HALF OF THE LETTER "C". THE OVALS BEGIN WITH THE LARGEST OVAL AT THE TOP OF THE LETTER "C" AND MOVE COUNTER-CLOCKWISE ENDING WITH THE SMALLEST AT THE MIDDLE OF THE "C". BLACK, WHITE AND GRAY REPRESENT BACKGROUND, SHADING AND ARE NOT PART OF THE MARK.

FOR NAIL CARE SERVICES; NON-INVASIVE COSMETIC MEDICAL PROCEDURES; PROVIDING LASER THERAPY FOR TREATING MEDICAL CONDITIONS (U.S. CLS. 100 AND 101).

FIRST USE 10-26-2010; IN COMMERCE 3-4-2011.
LESLEY LAMOTHE, EXAMINING ATTORNEY

CLASS 44—(Continued).

SN 85-604,397. BUER, DAVID, ATLANTA, GA. FILED 4-20-2012.

F.A.T.

THE MARK CONSISTS OF STANDARD CHARACTERS WITHOUT CLAIM TO ANY PARTICULAR FONT, STYLE, SIZE, OR COLOR.

FOR PROVIDING A WEBSITE FEATURING INFORMATION ABOUT HEALTH, WELLNESS AND NUTRITION; HEALTH CARE SERVICES, NAMELY, WELLNESS PROGRAMS; COUNSELING SERVICES IN THE FIELDS OF HEALTH, NUTRITION AND LIFESTYLE WELLNESS; PROVIDING WELLNESS SERVICES, NAMELY, PERSONAL ASSESSMENTS, PERSONALIZED ROUTINES, MAINTENANCE SCHEDULES, AND COUNSELING; WEIGHT REDUCTION DIET PLANNING AND SUPERVISION (U.S. CLS. 100 AND 101).

NAKWAMA ANKRAH, EXAMINING ATTORNEY

SN 85-603,476. MARYLAND MASSAGE THERAPY CENTER LLC, DBA NINOTCH, AN URBAN RETREAT LLC, BETHESDA, MD. FILED 4-20-2012.

Ninotch

THE MARK CONSISTS OF STANDARD CHARACTERS WITHOUT CLAIM TO ANY PARTICULAR FONT, STYLE, SIZE, OR COLOR.

FOR AIRBRUSH SKIN TANNING SERVICES FOR HUMANS FOR COSMETIC PURPOSES; MASSAGE THERAPY SERVICES (U.S. CLS. 100 AND 101).

FIRST USE 3-1-2008; IN COMMERCE 3-1-2008.
ESTHER BELENKER, EXAMINING ATTORNEY

SN 85-604,596. LAWRENCE SCARIANO M.D., LLC, DBA GOMD, CASTLE ROCK, CO. FILED 4-21-2012.



THE MARK CONSISTS OF THE LITERAL WORD "GOMD" WHERE THE "G" "M" AND "D" ARE CAPITALIZED AND THE SMALL "O" IS REPRESENTED BY THE COILED TUBE OF A STETHOSCOPE.

FOR CONSULTING IN THE FIELD OF HEALTH AND WELLNESS TO BRING ABOUT PERSONAL HAPPINESS; CONSULTING SERVICES IN THE FIELD OF HEALTH; CONSULTING SERVICES IN THE FIELD OF MEDICAL CARE; HEALTH CARE; HEALTH SPA SERVICES FOR HEALTH AND WELLNESS OF THE MIND, BODY AND SPIRIT OFFERED IN OR FROM A REMOTE, MOBILE OR TEMPORARY ON-SITE LOCATION; HEALTHCARE; HOME HEALTH CARE SERVICES; PHYSICIAN SERVICES; PROVIDING HEALTH INFORMATION; PROVIDING HEALTHCARE INFORMATION; URGENT MEDICAL CARE CENTERS (U.S. CLS. 100 AND 101).

FIRST USE 4-5-2012; IN COMMERCE 4-5-2012.
STEVEN JACKSON, EXAMINING ATTORNEY

SN 85-604,004. AMY BRENNER MD & ASSOCIATES, LLC, WEST CHESTER, OH. FILED 4-20-2012.

MYFLOW

THE MARK CONSISTS OF STANDARD CHARACTERS WITHOUT CLAIM TO ANY PARTICULAR FONT, STYLE, SIZE, OR COLOR.

FOR PHYSICIAN SERVICES (U.S. CLS. 100 AND 101).
KATHERINE CHANG, EXAMINING ATTORNEY

CLASS 44—(Continued).

SN 85-605,077. SHEAR EXPRESS, INC., THE VILLAGES, FL. FILED 4-23-2012.

ROOT466

THE MARK CONSISTS OF STANDARD CHARACTERS WITHOUT CLAIM TO ANY PARTICULAR FONT, STYLE, SIZE, OR COLOR.

FOR HAIR SALON SERVICES; NAIL CARE SERVICES; SKIN CARE SALONS; TANNING SALONS (U.S. CLS. 100 AND 101).

FIRST USE 6-21-2004; IN COMMERCE 6-21-2004.
DOMINIC FATHY, EXAMINING ATTORNEY

CLASS 44—(Continued).

SN 85-605,101. WASHINGTON, TENISHA, MIRAMAR, FL. FILED 4-23-2012.

Tl'Zani

THE MARK CONSISTS OF STANDARD CHARACTERS WITHOUT CLAIM TO ANY PARTICULAR FONT, STYLE, SIZE, OR COLOR.

FOR BEAUTY SALON SERVICES; BEAUTY SALONS; CHARITABLE SERVICES, NAMELY, PROVIDING BEAUTY AND HAIR CARE SERVICES TO PERSONS SEEKING EMPLOYMENT; COSMETIC SERVICES, NAMELY, NON-PERMANENT HAIR REMOVAL; HAIR COLOR SALON SERVICES; HAIR COLOURING SERVICES; HAIR CUTTING; HAIR CUTTING SERVICES; HAIR REPLACEMENT; HAIR REPLACEMENT, HAIR ADDITION, AND HAIR EXTENSION SERVICES; HAIR SALON SERVICES; HAIR SALON SERVICES, NAMELY, HAIR CUTTING, STYLING, COLORING, AND HAIR EXTENSION SERVICES; HAIR SALON SERVICES, NAMELY, TREATMENTS TO PROTECT HAIR FROM EFFECTS OF EXPOSURE TO SUNLIGHT, HEAT, HUMIDITY AND CHLORINATED WATER; HAIR STYLING; HAIRDRESSING SALONS; MAKING RESERVATIONS AND BOOKINGS FOR OTHERS AT BEAUTY SALONS; PROVIDING INFORMATION IN THE FIELD OF HAIR STYLING; PROVIDING ON-SITE BEAUTY SERVICES, NAMELY, HAIR STYLING AND MAKE-UP APPLICATION SERVICES (U.S. CLS. 100 AND 101).

FIRST USE 10-15-2007; IN COMMERCE 12-15-2008.
KAREN BRACEY, EXAMINING ATTORNEY

SN 85-605,100. SHEAR EXPRESS, INC., THE VILLAGES, FL. FILED 4-23-2012.

DIMENSIONSHAIR

THE MARK CONSISTS OF STANDARD CHARACTERS WITHOUT CLAIM TO ANY PARTICULAR FONT, STYLE, SIZE, OR COLOR.

FOR HAIR SALON SERVICES; NAIL CARE SERVICES; SKIN CARE SALONS; TANNING SALONS (U.S. CLS. 100 AND 101).

FIRST USE 1-29-2007; IN COMMERCE 1-29-2007.
DOMINIC FATHY, EXAMINING ATTORNEY

SN 85-605,334. JOHN WARE RESEARCH GROUP, INC., DBA JOHN WARE RESEARCH GROUP, INC, WORCESTER, MA. FILED 4-23-2012.

QOLIX

THE MARK CONSISTS OF STANDARD CHARACTERS WITHOUT CLAIM TO ANY PARTICULAR FONT, STYLE, SIZE, OR COLOR.

FOR MEDICAL EVALUATION SERVICES, NAMELY, FUNCTIONAL ASSESSMENT PROGRAM FOR PATIENTS RECEIVING MEDICAL REHABILITATION SERVICES FOR PURPOSES OF GUIDING TREATMENT AND ASSESSING PROGRAM EFFECTIVENESS; PROVIDING AN INTERNET WEBSITE FOR MEDICAL PROFESSIONALS AND MEDICAL PATIENTS FEATURING MEDICAL INFORMATION FROM REMOTE LOCATIONS VIA ELECTRONIC PATIENT MONITORING DEVICES THAT FEED IN FORMATION TO THE WEB SITE THAT CAN BE ACCESSED IN REAL-TIME BY MEDICAL PROFESSIONALS FOR PURPOSES OF MONITORING AND DIAGNOSING MEDICAL CONDITIONS (U.S. CLS. 100 AND 101).

IRA J. GOODSaid, EXAMINING ATTORNEY

CLASS 44—(Continued).

SN 85-605,452. JOHN WARE RESEARCH GROUP, INC., DBA JOHN WARE RESEARCH GROUP, INC, WORCESTER, MA. FILED 4-23-2012.

QDIS

THE MARK CONSISTS OF STANDARD CHARACTERS WITHOUT CLAIM TO ANY PARTICULAR FONT, STYLE, SIZE, OR COLOR.

FOR PROVIDING A WEBSITE FEATURING INFORMATION IN THE FIELD OF THE DIAGNOSIS AND TREATMENT OF DISEASE (U.S. CLS. 100 AND 101).

IRA J. GOODSaid, EXAMINING ATTORNEY

SN 85-605,497. BOSTWICK LABORATORIES, INC., GLEN ALLEN, VA. FILED 4-23-2012.

BLADDERVYSION

THE MARK CONSISTS OF STANDARD CHARACTERS WITHOUT CLAIM TO ANY PARTICULAR FONT, STYLE, SIZE, OR COLOR.

FOR HEALTHCARE AND MEDICAL SERVICES, NAMELY, PATHOLOGY AND MOLECULAR TESTING FOR IDENTIFYING THE PROGNOSIS AND GUIDING THE TREATMENT OF DISEASE (U.S. CLS. 100 AND 101).

FIRST USE 7-31-2011; IN COMMERCE 7-31-2011.
THEODORE MCBRIDE, EXAMINING ATTORNEY

SN 85-605,505. BOSTWICK LABORATORIES, INC., GLEN ALLEN, VA. FILED 4-23-2012.

PROSTACLEAR

THE MARK CONSISTS OF STANDARD CHARACTERS WITHOUT CLAIM TO ANY PARTICULAR FONT, STYLE, SIZE, OR COLOR.

FOR HEALTHCARE AND MEDICAL SERVICES, NAMELY, PATHOLOGY AND MOLECULAR TESTING FOR IDENTIFYING THE PROGNOSIS AND GUIDING THE TREATMENT OF DISEASE (U.S. CLS. 100 AND 101).

FIRST USE 10-31-2011; IN COMMERCE 10-31-2011.
THEODORE MCBRIDE, EXAMINING ATTORNEY

CLASS 44—(Continued).

SN 85-605,512. BOSTWICK LABORATORIES, INC., GLEN ALLEN, VA. FILED 4-23-2012.



THE MARK CONSISTS OF THE WORD "PROSTAVYSION" WHICH APPEARS TO THE RIGHT OF A DESIGN ELEMENT CONSISTING OF AN UN-SHADED CHECK MARK APPEARING ON THREE SHADED HORIZONTAL RECTANGULAR BARS.

FOR HEALTHCARE AND MEDICAL SERVICES, NAMELY, PATHOLOGY AND MOLECULAR TESTING FOR IDENTIFYING THE PROGNOSIS AND GUIDING THE TREATMENT OF DISEASE (U.S. CLS. 100 AND 101).

FIRST USE 3-31-2011; IN COMMERCE 3-31-2011.
THEODORE MCBRIDE, EXAMINING ATTORNEY

SN 85-605,633. SAFESTITCH MEDICAL, INC., MIAMI, FL. FILED 4-23-2012.

**WHERE SAFETY MEETS
INNOVATION**

THE MARK CONSISTS OF STANDARD CHARACTERS WITHOUT CLAIM TO ANY PARTICULAR FONT, STYLE, SIZE, OR COLOR.

FOR PROVIDING A WEBSITE FEATURING INFORMATION ABOUT MEDICAL PROCEDURES AND MEDICAL PRODUCTS; PROVIDING MEDICAL INFORMATION, CONSULTANCY AND ADVISORY SERVICES (U.S. CLS. 100 AND 101).

FIRST USE 2-28-2008; IN COMMERCE 2-28-2008.
SUNG IN, EXAMINING ATTORNEY

SN 85-605,636. SLEEP APNEA TREATMENT CENTERS OF AMERICA FRANCHISING, LLC, TAMPA, FL. FILED 4-23-2012.

**SLEEP BETTER. LIVE
HEALTHIER.**

THE MARK CONSISTS OF STANDARD CHARACTERS WITHOUT CLAIM TO ANY PARTICULAR FONT, STYLE, SIZE, OR COLOR.

FOR HEALTHCARE SERVICES, NAMELY, TREATMENT OF PATIENTS WITH SNORING AND SLEEP APNEA DISORDERS (U.S. CLS. 100 AND 101).

ROBERT STRUCK, EXAMINING ATTORNEY

CLASS 44—(Continued).

SN 85-605,680. THE CHANDRASI EYE GROUP, LLC, GILBERT, AZ. FILED 4-23-2012.

EYESTOP

THE MARK CONSISTS OF STANDARD CHARACTERS WITHOUT CLAIM TO ANY PARTICULAR FONT, STYLE, SIZE, OR COLOR.

FOR OPTICIAN AND OPTOMETRIC SERVICES (U.S. CLS. 100 AND 101).

FIRST USE 11-1-2010; IN COMMERCE 11-1-2010.
MAYUR VAGHANI, EXAMINING ATTORNEY

SN 85-606,049. KELLY S LAST DDS PC, EVERGREEN, CO. FILED 4-24-2012.

ELEVATION DENTAL

THE MARK CONSISTS OF STANDARD CHARACTERS WITHOUT CLAIM TO ANY PARTICULAR FONT, STYLE, SIZE, OR COLOR.

NO CLAIM IS MADE TO THE EXCLUSIVE RIGHT TO USE "DENTAL", APART FROM THE MARK AS SHOWN.

FOR DENTIST SERVICES; DENTAL SERVICES, NAMELY, PROVIDING GENERAL, COSMETIC AND IMPLANT DENTISTRY SERVICES; DENTAL SERVICES, NAMELY, PERFORMING RESTORATIVE AND COSMETIC PROCEDURES (U.S. CLS. 100 AND 101).

LINDA MICKLEBURGH, EXAMINING ATTORNEY

SN 85-606,760. GLCE GROUP, LLC, CHANTILLY, VA. FILED 4-24-2012.

SenCura

THE MARK CONSISTS OF STANDARD CHARACTERS WITHOUT CLAIM TO ANY PARTICULAR FONT, STYLE, SIZE, OR COLOR.

FOR HOME HEALTH CARE SERVICES (U.S. CLS. 100 AND 101).

KAREN SEVERSON, EXAMINING ATTORNEY

CLASS 44—(Continued).

SN 85-629,463. G HEALTH CONCEPTS, INC., WHITEHALL, PA. FILED 5-18-2012.



THE COLOR(S) WHITE, BLUE, AND BLACK IS/ARE CLAIMED AS A FEATURE OF THE MARK.

THE MARK CONSISTS OF A TRIANGLE COMPRISED OF FOUR HORIZONTAL BARS IN WHITE WITH A BLACK OUTLINE, AND FOUR INCLINED BARS IN BLUE WITH A BLACK OUTLINE, THE WHOLE BEING ARRANGED IN THE STYLIZED FORM OF A HELIX, ALL ON A TRANSPARENT BACKGROUND.

FOR HOLISTIC HEALTH SERVICES TO FACILITATE HEALTH AND HAPPINESS FOR THE WHOLE INDIVIDUAL AND THE ENVIRONMENT (U.S. CLS. 100 AND 101).

TRACY FLETCHER, EXAMINING ATTORNEY

SN 85-637,396. BIO-REFERENCE LABORATORIES, INC., ELMWOOD PARK, NJ. FILED 5-29-2012.

InheriGen

THE MARK CONSISTS OF STANDARD CHARACTERS WITHOUT CLAIM TO ANY PARTICULAR FONT, STYLE, SIZE, OR COLOR.

FOR MEDICAL TESTING FOR GENETIC ABNORMALITIES (U.S. CLS. 100 AND 101).

FIRST USE 12-8-2011; IN COMMERCE 12-8-2011.
KELLY TRUSILO, EXAMINING ATTORNEY

SN 85-637,934. BIO-REFERENCE LABORATORIES, INC., ELMWOOD PARK, NJ. FILED 5-30-2012.

GenCerv

THE MARK CONSISTS OF STANDARD CHARACTERS WITHOUT CLAIM TO ANY PARTICULAR FONT, STYLE, SIZE, OR COLOR.

FOR MEDICAL TESTING FOR RISK OF DEVELOPING CERVICAL CANCER (U.S. CLS. 100 AND 101).

FIRST USE 4-7-2012; IN COMMERCE 4-7-2012.
KELLY TRUSILO, EXAMINING ATTORNEY

CLASS 44—(Continued).

SN 85-648,386. AMY BRENNER MD & ASSOCIATES, LLC,
WEST CHESTER, OH. FILED 6-11-2012.

CLASS 44—(Continued).

SN 85-668,314. BERNARD BUBMAN, LOS ANGELES, CA.
AND DAVID HAKIMIAN, LOS ANGELES, CA. AND
NOAH BUBMAN, LOS ANGELES, CA. FILED 7-3-2012.

LAUGH, COUGH, SNEEZE, LEAK

THE MARK CONSISTS OF STANDARD CHARACTERS
WITHOUT CLAIM TO ANY PARTICULAR FONT, STYLE,
SIZE, OR COLOR.

FOR PHYSICIAN SERVICES (U.S. CLS. 100 AND 101).
KATHERINE CHANG, EXAMINING ATTORNEY

EARTHBAR VIBRANCE CENTER

SN 85-649,520. PARTNERS HEALTHCARE SYSTEM, INC.,
BOSTON, MA. FILED 6-12-2012.



OWNER OF U.S. REG. NOS. 2,375,555, 3,445,770 AND
OTHERS.

NO CLAIM IS MADE TO THE EXCLUSIVE RIGHT TO
USE "HEALTHCARE" AND "INTERNATIONAL", APART
FROM THE MARK AS SHOWN.

THE MARK CONSISTS OF THE WORDS PARTNERS
HEALTHCARE INTERNATIONAL, WITH THREE CURVED
LINES ABOVE THE WORD PARTNERS, AND A SINGLE
VERTICAL LINE SEPARATING PARTNERS HEALTHCARE
FROM INTERNATIONAL.

FOR CONSULTING SERVICES IN THE FIELD OF
HEALTH; HEALTH CARE; HOSPITALS; MEDICAL AS-
SISTANCE SERVICES; MEDICAL INFORMATION;
MEDICAL SERVICES; PROVIDING HEALTH INFOR-
MATION; PROVISION OF HEALTH CARE AND MEDI-
CAL SERVICES BY HEALTH CARE PROFESSIONALS
VIA THE INTERNET OR TELECOMMUNICATION NET-
WORKS (U.S. CLS. 100 AND 101).

FIRST USE 2-0-2011; IN COMMERCE 2-0-2011.
SANJEEV VOHRA, EXAMINING ATTORNEY

THE MARK CONSISTS OF STANDARD CHARACTERS
WITHOUT CLAIM TO ANY PARTICULAR FONT, STYLE,
SIZE, OR COLOR.

OWNER OF U.S. REG. NOS. 3,725,420 AND 4,041,728.

NO CLAIM IS MADE TO THE EXCLUSIVE RIGHT TO
USE "CENTER", APART FROM THE MARK AS SHOWN.

FOR CONSULTING SERVICES IN THE FIELD OF
HEALTH; CONSULTING SERVICES IN THE FIELD OF
HORMONE REPLACEMENT THERAPY; CONSULTING
SERVICES IN THE FIELD OF WOMEN'S HEALTH;
CONSULTING SERVICES IN THE FIELDS OF DIAG-
NOSTIC MEDICAL TESTING AND NUTRITION; CON-
SULTING SERVICES IN THE FIELDS OF HEALTH AND
NUTRITION; COUNSELING SERVICES IN THE FIELDS
OF HEALTH, HERBALISM, AND LIFESTYLE WELL-
NESS; COUNSELING SERVICES IN THE FIELDS OF
HEALTH, NUTRITION AND LIFESTYLE WELLNESS;
MEDICAL AND PHARMACEUTICAL CONSULTATION;
MEDICAL CONSULTATIONS; MEDICAL COUNSELING;
MEDICAL DIAGNOSTIC TESTING, MONITORING AND
REPORTING SERVICES; MEDICAL INFORMATION;
MEDICAL SCREENING; MEDICAL SERVICES; PROVID-
ING ASSISTANCE, FITNESS EVALUATION AND CON-
SULTATION TO INDIVIDUALS TO HELP THEM MAKE
HEALTH, WELLNESS AND NUTRITIONAL CHANGES
IN THEIR DAILY LIVING TO IMPROVE HEALTH;
PROVIDING MEDICAL INFORMATION; PROVIDING
MEDICAL INFORMATION, CONSULTANCY AND AD-
VISORY SERVICES; PROVIDING WELLNESS SERVICES,
NAMELY, PERSONAL ASSESSMENTS, PERSONALIZED
ROUTINES, MAINTENANCE SCHEDULES, AND COUN-
SELING; VITAMIN THERAPY; WELLNESS AND
HEALTH-RELATED CONSULTING SERVICES (U.S.
CLS. 100 AND 101).

KATHLEEN M. VANSTON, EXAMINING ATTORNEY

CLASS 45—PERSONAL AND LEGAL SERVICES

SN 85-288,551. ZAARLY, INC., SAN FRANCISCO, CA. FILED 4-7-2011.

ZAARLY

THE MARK CONSISTS OF STANDARD CHARACTERS WITHOUT CLAIM TO ANY PARTICULAR FONT, STYLE, SIZE, OR COLOR.

FOR CONCIERGE SERVICES FOR OTHERS COMPRISING MAKING REQUESTED PERSONAL ARRANGEMENTS AND RESERVATIONS AND PROVIDING CUSTOMER-SPECIFIC INFORMATION TO MEET INDIVIDUAL NEEDS RENDERED TOGETHER IN RETAIL STORES, OFFICE BUILDINGS, HOTELS, RESIDENTIAL COMPLEXES, AND HOMES; ORGANIZATIONAL SERVICES FOR HOME OR PERSONAL PURPOSES, NAMELY, ORGANIZING OFFICES, ORGANIZING CLOSET SPACE, PREPARING PERSONAL SCHEDULES, AND RUNNING PERSONAL ERRANDS; PERSONAL CONCIERGE SERVICES FOR OTHERS COMPRISING MAKING REQUESTED PERSONAL ARRANGEMENTS AND RESERVATIONS, RUNNING ERRANDS AND PROVIDING CUSTOMER SPECIFIC INFORMATION TO MEET INDIVIDUAL NEEDS, ALL RENDERED IN RETAIL STORES, OFFICE BUILDINGS, HOTELS, RESIDENTIAL COMPLEXES, AND HOMES; PERSONAL REMINDER SERVICES IN THE AREA OF UPCOMING IMPORTANT DATES AND EVENTS; PROVIDING INFORMATION IN THE FIELD OF TIME MANAGEMENT TO INDIVIDUALS FOR PERSONAL PURPOSES; PROVIDING NON-MEDICAL PERSONAL ASSISTANT SERVICES FOR OTHERS IN THE NATURE OF PLANNING, ORGANIZING, COORDINATING, ARRANGING, AND ASSISTING INDIVIDUALS TO PERFORM DAILY TASKS; RUNNING ERRANDS FOR OTHERS; CONCIERGE SERVICES FOR OTHERS COMPRISING MAKING REQUESTED PERSONAL ARRANGEMENTS AND RESERVATIONS AND PROVIDING CUSTOMER-SPECIFIC INFORMATION TO MEET INDIVIDUAL NEEDS RENDERED TOGETHER IN A VIRTUAL CAPACITY, PERFORMED REMOTELY; CONCIERGE SERVICES FOR OTHERS COMPRISING MAKING REQUESTED PERSONAL ARRANGEMENTS AND RESERVATIONS AND PROVIDING CUSTOMER-SPECIFIC INFORMATION TO MEET INDIVIDUAL NEEDS RENDERED TOGETHER IN AN APARTMENT COMPLEX, BUSINESS CONFERENCE, SHOPPING CENTER, HOME, OFFICE, OR RETAIL ESTABLISHMENT; INTERNET BASED SOCIAL NETWORKING, INTRODUCTION, AND DATING SERVICES; INTERNET-BASED SOCIAL NETWORKING SERVICES; ONLINE SOCIAL NETWORKING SERVICES PROVIDED THROUGH A COMMUNITY WEBSITE; PROVIDING A SOCIAL NETWORKING WEBSITE AT WHICH A USER CAN GIVE CHARITABLE GIFTS TO OTHERS (U.S. CLS. 100 AND 101).

GISELLE AGOSTO, EXAMINING ATTORNEY

CLASS 45—(Continued).

SN 85-296,240. ZAARLY, INC., SAN FRANCISCO, CA. FILED 4-15-2011.



THE MARK CONSISTS OF A STYLIZED LETTER 'Z' WITH LINES PROTRUDING FROM THE TOP AND BOTTOM OF THE 'Z'.

FOR CONCIERGE SERVICES FOR OTHERS COMPRISING MAKING REQUESTED PERSONAL ARRANGEMENTS AND RESERVATIONS AND PROVIDING CUSTOMER-SPECIFIC INFORMATION TO MEET INDIVIDUAL NEEDS RENDERED TOGETHER IN RETAIL STORES, OFFICE BUILDINGS, HOTELS, RESIDENTIAL COMPLEXES, AND HOMES; ORGANIZATIONAL SERVICES FOR HOME OR PERSONAL PURPOSES, NAMELY, ORGANIZING OFFICES, ORGANIZING CLOSET SPACE, PREPARING PERSONAL SCHEDULES, AND RUNNING PERSONAL ERRANDS; PERSONAL CONCIERGE SERVICES FOR OTHERS COMPRISING MAKING REQUESTED PERSONAL ARRANGEMENTS AND RESERVATIONS, RUNNING ERRANDS AND PROVIDING CUSTOMER SPECIFIC INFORMATION TO MEET INDIVIDUAL NEEDS, ALL RENDERED IN RETAIL STORES, OFFICE BUILDINGS, HOTELS, RESIDENTIAL COMPLEXES, AND HOMES; PERSONAL REMINDER SERVICES IN THE AREA OF UPCOMING IMPORTANT DATES AND EVENTS; PROVIDING INFORMATION IN THE FIELD OF TIME MANAGEMENT TO INDIVIDUALS FOR PERSONAL PURPOSES; PROVIDING NON-MEDICAL PERSONAL ASSISTANT SERVICES FOR OTHERS IN THE NATURE OF PLANNING, ORGANIZING, COORDINATING, ARRANGING, AND ASSISTING INDIVIDUALS TO PERFORM DAILY TASKS; RUNNING ERRANDS FOR OTHERS. CONCIERGE SERVICES FOR OTHERS COMPRISING MAKING REQUESTED PERSONAL ARRANGEMENTS AND RESERVATIONS AND PROVIDING CUSTOMER-SPECIFIC INFORMATION TO MEET INDIVIDUAL NEEDS RENDERED TOGETHER IN A VIRTUAL CAPACITY, PERFORMED REMOTELY; INTERNET BASED SOCIAL NETWORKING, INTRODUCTION, AND DATING SERVICES; INTERNET-BASED SOCIAL NETWORKING SERVICES; ONLINE SOCIAL NETWORKING SERVICES PROVIDED THROUGH A COMMUNITY WEBSITE; PROVIDING A SOCIAL NETWORKING WEBSITE AT WHICH A USER CAN GIVE CHARITABLE GIFTS TO OTHERS (U.S. CLS. 100 AND 101).

GISELLE AGOSTO, EXAMINING ATTORNEY

CLASS 45—(Continued).

SN 85-299,928. SECURITY SALES AND SOLUTIONS INC., DELTONA, FL. FILED 4-20-2011.



THE MARK CONSISTS OF AN ARCH THAT COMES TO A SHARP POINT IN THE CENTER, OVER THE TOP OF THE WORDING "SURELINK", AND AN ARCH THAT COMES TO A SHARP POINT IN THE CENTER UNDERNEATH THE WORDING "SURELINK". SO IN EFFECT, THE WORDING "SURELINK" IS IN THE MIDDLE, WITH THE TWO POINTED ARCHES ABOVE AND BELOW THE TEXT.

FOR MONITORING OF ALARMS (U.S. CLS. 100 AND 101).

FIRST USE 3-1-2011; IN COMMERCE 3-1-2011.

NICHOLAS COLEMAN, EXAMINING ATTORNEY

SN 85-312,213. NEWBORNS IN NEED, INC., PFAFFTOWN, NC. FILED 5-4-2011.



NO CLAIM IS MADE TO THE EXCLUSIVE RIGHT TO USE "NEWBORNS IN NEED", APART FROM THE MARK AS SHOWN.

THE NAME(S), PORTRAIT(S), AND/OR SIGNATURE(S) SHOWN IN THE MARK DOES NOT IDENTIFY A PARTICULAR LIVING INDIVIDUAL.

THE MARK CONSISTS OF AN IMAGE OF A BABY WITHIN A CIRCLE WITH THE WORDS "NEWBORNS IN NEED" AROUND THE TOP OF THE CIRCLE AND THE WORDS "ONE HEART ONE MISSION" AROUND THE BOTTOM OF THE CIRCLE.

FOR CHARITABLE SERVICES, NAMELY, PROVIDING CLOTHING TO NEEDY PERSONS (U.S. CLS. 100 AND 101).

FIRST USE 12-31-1992; IN COMMERCE 12-31-1992.

LOURDES AYALA, EXAMINING ATTORNEY

CLASS 45—(Continued).

SN 85-407,116. CLARION COUNCIL FOR EDUCATIONAL GREATNESS, INC., FORT LAUDERDALE, FL. FILED 8-25-2011.



THE COLOR(S) GREEN, BROWN, AND BEIGE IS/ARE CLAIMED AS A FEATURE OF THE MARK.

THE MARK CONSISTS OF FIVE ADULT MALE STICK FIGURES IN A ROW, ALTERNATING COLORS BROWN AND GREEN WITH A ROW OF SMALLER STICK FIGURES DEPICTING ALTERNATING GIRL AND BOY APPEARING IN BEIGE SUPERIMPOSED OVER THE ADULT STICK FIGURES. A SOLID BROWN LINE APPEARS UNDERNEATH THE FIGURES AND THE WORDS "THE LINE" APPEAR BENEATH IN GREEN.

FOR ORGANIZING AND CONDUCTING SUPPORT GROUPS FOR TEACHERS IN THE FIELD OF EDUCATION FOR THE PURPOSE OF ENHANCING STUDENT ACHIEVEMENT (U.S. CLS. 100 AND 101).

ELLEN PERKINS, EXAMINING ATTORNEY

SN 85-408,040. NANNIES AS NEEDED LLC, MILFORD, CT. FILED 8-26-2011.

Nannies As Needed

THE MARK CONSISTS OF STANDARD CHARACTERS WITHOUT CLAIM TO ANY PARTICULAR FONT, STYLE, SIZE, OR COLOR.

NO CLAIM IS MADE TO THE EXCLUSIVE RIGHT TO USE "NANNIES", APART FROM THE MARK AS SHOWN.

FOR BABY SITTING (U.S. CLS. 100 AND 101).

FIRST USE 12-1-2003; IN COMMERCE 1-5-2004.

CHARLOTTE CORWIN, EXAMINING ATTORNEY

CLASS 45—(Continued).

SN 85-418,275. CONDRA, MERINDA K., LUBBOCK, TX. FILED 9-8-2011.

ADOPTION COVENANT

THE MARK CONSISTS OF STANDARD CHARACTERS WITHOUT CLAIM TO ANY PARTICULAR FONT, STYLE, SIZE, OR COLOR.

NO CLAIM IS MADE TO THE EXCLUSIVE RIGHT TO USE "ADOPTION", APART FROM THE MARK AS SHOWN. SEC. 2(F).

FOR ADOPTION AGENCIES; ADOPTION COUNSELING; ADOPTION PLACEMENT; PROVIDING INFORMATION CONCERNING CHARITABLE CAUSES AND HUMANITARIAN EFFORTS IN THE FIELD OF SOCIAL JUSTICE (U.S. CLS. 100 AND 101).

FIRST USE 10-15-2003; IN COMMERCE 10-15-2003.
ROBIN MITTLER, EXAMINING ATTORNEY

SN 85-432,355. HOGLUND, CHWIALKOWSKI & MROZIK, PLLC, ROSEVILLE, MN. FILED 9-26-2011.

Hoglund Law Offices

THE MARK CONSISTS OF STANDARD CHARACTERS WITHOUT CLAIM TO ANY PARTICULAR FONT, STYLE, SIZE, OR COLOR.

NO CLAIM IS MADE TO THE EXCLUSIVE RIGHT TO USE "LAW OFFICES", APART FROM THE MARK AS SHOWN.

THE NAME(S), PORTRAIT(S), AND/OR SIGNATURE(S) SHOWN IN THE MARK IDENTIFIES ROBERT HOGLUND, WHOSE CONSENT(S) TO REGISTER IS MADE OF RECORD.

SEC. 2(F).
FOR LEGAL SERVICES (U.S. CLS. 100 AND 101).
FIRST USE 10-31-1990; IN COMMERCE 10-31-1990.
EMILY CARLSEN, EXAMINING ATTORNEY

CLASS 45—(Continued).

SN 85-433,917. ADVENTIST HEALTH SYSTEM/SUNBELT, INC., WINTER PARK, FL. FILED 9-28-2011.



OWNER OF U.S. REG. NOS. 3,440,069, 3,931,737 AND OTHERS.

THE MARK CONSISTS OF AN OVERALL HEXAGONAL SHAPE FORMED BY THREE INTERLOCKED LETTER "F'S".

FOR PROVIDING PERSONAL SUPPORT SERVICES FOR FAMILIES OF HOSPITAL PATIENTS, NAMELY, EMOTIONAL, LIFESTYLE, AND SPIRITUAL COUNSELING AND EMOTIONAL SUPPORT; AND PROVIDING PERSONAL SUPPORT IN THE NATURE OF EMOTIONAL, LIFESTYLE, AND SPIRITUAL COUNSELING AVAILABLE TO THE GENERAL PUBLIC; PROVIDING A WEBSITE FEATURING INFORMATION ON SPIRITUAL HEALTH TO ASSIST IN DAILY LIVING.; MINISTERIAL SERVICES (U.S. CLS. 100 AND 101).

FIRST USE 12-15-1985; IN COMMERCE 12-15-1985.
MICHAEL WEBSTER, EXAMINING ATTORNEY

SN 85-434,932. KABBALAH CENTRE INTERNATIONAL, INC., LOS ANGELES, CA. FILED 9-29-2011.

UKABBALAH

THE MARK CONSISTS OF STANDARD CHARACTERS WITHOUT CLAIM TO ANY PARTICULAR FONT, STYLE, SIZE, OR COLOR.

OWNER OF U.S. REG. NOS. 2,709,764, 4,086,044 AND OTHERS.

FOR PROVIDING A WEB SITE FEATURING INFORMATION REGARDING RELIGION AND SPIRITUALITY (U.S. CLS. 100 AND 101).

FIRST USE 10-5-2008; IN COMMERCE 10-5-2008.
ELISSA GARBER KON, EXAMINING ATTORNEY

CLASS 45—(Continued).

SN 85-439,246. LAW OFFICES OF JASON A. DIAMOND, P.A., HOLLYWOOD, FL. FILED 10-4-2011.

TRAFFIC TICKET TEAM

THE MARK CONSISTS OF STANDARD CHARACTERS WITHOUT CLAIM TO ANY PARTICULAR FONT, STYLE, SIZE, OR COLOR.

NO CLAIM IS MADE TO THE EXCLUSIVE RIGHT TO USE "TRAFFIC TICKET", APART FROM THE MARK AS SHOWN.

SEC. 2(F).

FOR LEGAL SERVICES (U.S. CLS. 100 AND 101).

FIRST USE 1-1-2000; IN COMMERCE 1-1-2000.

BRENDAN MCCAULEY, EXAMINING ATTORNEY

CLASS 45—(Continued).

SN 85-444,953. HOLLY B. HOLDINGS LLC, COLUMBUS, OH. FILED 10-11-2011.

GETTING PERSONAL

THE MARK CONSISTS OF STANDARD CHARACTERS WITHOUT CLAIM TO ANY PARTICULAR FONT, STYLE, SIZE, OR COLOR.

FOR PROVIDING SOCIAL EXPRESSION PRODUCTS, NAMELY, PROVIDING A SELECTION OF ON-LINE ELECTRONIC GREETING CARDS (U.S. CLS. 100 AND 101).

TRACY FLETCHER, EXAMINING ATTORNEY

SN 85-450,452. CREDIBILITY CORP., MALIBU, CA. FILED 10-18-2011.

CREDIBILITY CORP.

THE MARK CONSISTS OF STANDARD CHARACTERS WITHOUT CLAIM TO ANY PARTICULAR FONT, STYLE, SIZE, OR COLOR.

NO CLAIM IS MADE TO THE EXCLUSIVE RIGHT TO USE "CORP.", APART FROM THE MARK AS SHOWN.

FOR FRAUD AND IDENTITY THEFT PROTECTION SERVICES (U.S. CLS. 100 AND 101).

ANTHONY RINKER, EXAMINING ATTORNEY

SN 85-450,881. REEVES, KARI, WATKINSVILLE, GA. FILED 10-19-2011.

SPIRITUAL DESIGN

THE MARK CONSISTS OF STANDARD CHARACTERS WITHOUT CLAIM TO ANY PARTICULAR FONT, STYLE, SIZE, OR COLOR.

NO CLAIM IS MADE TO THE EXCLUSIVE RIGHT TO USE "SPIRITUAL", APART FROM THE MARK AS SHOWN.

FOR RELIGIOUS SERVICES, NAMELY, PROVIDING SPIRITUAL GUIDANCE THROUGH THE INTEGRATION OF ART AND SPIRITUAL FORMATION (U.S. CLS. 100 AND 101).

MICHAEL WEBSTER, EXAMINING ATTORNEY

SN 85-441,246. KABBALAH CENTRE INTERNATIONAL, INC., LOS ANGELES, CA. FILED 10-6-2011.



OWNER OF U.S. REG. NOS. 2,216,217, 2,500,610 AND OTHERS.

THE MARK CONSISTS OF A SHIELD DESIGN WITH THE BOTTOM HALF SHADED FEATURING A STYLIZED LION DESIGN AND THE TOP HALF UNSHADED FORMING A RECTANGLE WITH THE HEBREW LETTERS SAMECH VAV DALET.

THE ENGLISH TRANSLATION OF "SAMECH VAV DALET" IN THE MARK IS "SECRET".

THE NON-LATIN CHARACTERS IN THE MARK TRANSLITERATE TO SAMECH VAV DALET AND THIS MEANS SECRET IN ENGLISH.

FOR PROVIDING A WEB SITE FEATURING INFORMATION REGARDING RELIGION AND SPIRITUALITY (U.S. CLS. 100 AND 101).

FIRST USE 10-5-2008; IN COMMERCE 10-5-2008.

ELISSA GARBER KON, EXAMINING ATTORNEY

CLASS 45—(Continued).

SN 85-455,202. CAROME, ASLI, WASHINGTON, DC. FILED 10-25-2011.

CAROME LAW, P.C.

THE MARK CONSISTS OF STANDARD CHARACTERS WITHOUT CLAIM TO ANY PARTICULAR FONT, STYLE, SIZE, OR COLOR.

NO CLAIM IS MADE TO THE EXCLUSIVE RIGHT TO USE "LAW, P.C.", APART FROM THE MARK AS SHOWN. FOR LEGAL SERVICES; MEDIATION (U.S. CLS. 100 AND 101).

FIRST USE 10-24-2011; IN COMMERCE 10-24-2011.
DOUGLAS LEE, EXAMINING ATTORNEY

SN 85-486,204. LEVILLE, KEVIN, NEW CANAAN, CT. FILED 12-2-2011.

EAT RIGHT CAFÉ

THE MARK CONSISTS OF STANDARD CHARACTERS WITHOUT CLAIM TO ANY PARTICULAR FONT, STYLE, SIZE, OR COLOR.

FOR PROVIDING INTERNET-BASED SOCIAL NETWORK SERVICES (U.S. CLS. 100 AND 101).

JEFFREY LOOK, EXAMINING ATTORNEY

SN 85-487,925. HIRERIGHT, INC., IRVINE, CA. FILED 12-6-2011.

WIDESCREEN PLUS

THE MARK CONSISTS OF STANDARD CHARACTERS WITHOUT CLAIM TO ANY PARTICULAR FONT, STYLE, SIZE, OR COLOR.

FOR PRE-EMPLOYMENT BACKGROUND SCREENING SERVICES; INVESTIGATIVE SERVICES, NAMELY, CONDUCTING CRIMINAL BACKGROUND CHECKS OF PUBLIC RECORDS (U.S. CLS. 100 AND 101).

FIRST USE 1-17-2011; IN COMMERCE 1-17-2011.
RONALD AIKENS, EXAMINING ATTORNEY

CLASS 45—(Continued).

SN 85-524,846. ASSOCIATION OF STATE AND PROVINCIAL PSYCHOLOGY BOARDS, PEACHTREE CITY, GA. FILED 1-25-2012.

**ASPPB PSYCHOLOGY LICENSURE
UNIVERSAL SYSTEM (PLUS)**

THE MARK CONSISTS OF STANDARD CHARACTERS WITHOUT CLAIM TO ANY PARTICULAR FONT, STYLE, SIZE, OR COLOR.

OWNER OF U.S. REG. NOS. 2,482,393 AND 2,544,423.
NO CLAIM IS MADE TO THE EXCLUSIVE RIGHT TO USE "PSYCHOLOGY LICENSURE" AND "UNIVERSAL SYSTEM", APART FROM THE MARK AS SHOWN.

FOR AN ONLINE COMPILATION AND VERIFICATION SERVICE THAT ENABLES PSYCHOLOGY PROFESSIONALS TO APPLY FOR LICENSURE IN AN INITIAL, SECOND OR SUBSEQUENT U.S. STATE OR CANADIAN PROVINCE WHEREBY A PSYCHOLOGY PROFESSIONAL ENTERS LICENSURE APPLICATION DATA WHICH IS COMPILED, VERIFIED AND FORWARDED TO THE DESIGNATED PSYCHOLOGY LICENSING BOARD OR BOARDS (U.S. CLS. 100 AND 101).

FIRST USE 8-0-2011; IN COMMERCE 8-0-2011.
KATHLEEN M. VANSTON, EXAMINING ATTORNEY

SN 85-524,862. ASSOCIATION OF STATE AND PROVINCIAL PSYCHOLOGY BOARDS, PEACHTREE CITY, GA. FILED 1-25-2012.

**ASPPB INTERJURISDICTIONAL
PRACTICE CERTIFICATE (IPC)**

THE MARK CONSISTS OF STANDARD CHARACTERS WITHOUT CLAIM TO ANY PARTICULAR FONT, STYLE, SIZE, OR COLOR.

OWNER OF U.S. REG. NOS. 2,482,393 AND 2,544,423.
NO CLAIM IS MADE TO THE EXCLUSIVE RIGHT TO USE "INTERJURISDICTIONAL PRACTICE CERTIFICATE", APART FROM THE MARK AS SHOWN.

FOR VERIFYING THE CREDENTIALS OF PSYCHOLOGY PROFESSIONALS TO FACILITATE THE GRANTING OF TEMPORARY PERMISSION TO PRACTICE IN A SECOND OR SUBSEQUENT JURISDICTION (U.S. CLS. 100 AND 101).

FIRST USE 6-0-2010; IN COMMERCE 6-0-2010.
KATHLEEN M. VANSTON, EXAMINING ATTORNEY

CLASS 45—(Continued).

SN 85-535,853. WILD KARMA, INC., DBA DIVINE HOME CARE, SAN LEANDRO, CA. FILED 2-7-2012.



OWNER OF U.S. REG. NO. 4,111,857.
NO CLAIM IS MADE TO THE EXCLUSIVE RIGHT TO USE "HOME CARE", APART FROM THE MARK AS SHOWN.

THE COLOR(S) BLACK AND GREEN IS/ARE CLAIMED AS A FEATURE OF THE MARK.

THE MARK CONSISTS OF A LARGE BLACK CURSIVE "D" WITH THE WORD "DIVINE" SPELLED OUT IN BLACK, WITH THE "N" IN A GREEN HOUSE SHAPE. THE WORDS "HOME CARE" IN CAPITALIZED FORMAT IN GREEN APPEAR UNDER THE WORD "DIVINE".

FOR IN-HOME SUPPORT SERVICES TO SENIOR PERSONS, NAMELY, GERIATRIC CARE MANAGEMENT SERVICES IN THE NATURE OF THE COORDINATION OF NECESSARY SERVICES AND PERSONAL CARE FOR OLDER INDIVIDUALS; PROVIDING NON-MEDICAL IN-HOME PERSONAL SERVICES FOR INDIVIDUALS INCLUDING CHECKING HOME CONDITION, SUPPLIES AND INDIVIDUAL WELL-BEING, SCHEDULING APPOINTMENTS, RUNNING ERRANDS, MAKING SAFETY CHECKS, AND PROVIDING ONLINE INFORMATION RELATED TO THESE PERSONAL SERVICES (U.S. CLS. 100 AND 101).

FIRST USE 7-1-2007; IN COMMERCE 7-1-2007.

KATHERINE M. DUBRAY, EXAMINING ATTORNEY

SN 85-538,630. LICENSELOGIX, LLC, NEW YORK, NY. FILED 2-9-2012.

LicenseLogix

THE MARK CONSISTS OF STANDARD CHARACTERS WITHOUT CLAIM TO ANY PARTICULAR FONT, STYLE, SIZE, OR COLOR.

FOR REGULATORY COMPLIANCE CONSULTING FOR COMPANIES AND ORGANIZATIONS IN THE FIELD OF OBTAINING AND MAINTAINING ALL REQUIRED BUSINESS LICENSES AND PERMITS; MONITORING REGULATORY REQUIREMENTS FOR COMPANIES AND ORGANIZATIONS IN THE FIELD OF ALL REQUIRED BUSINESS LICENSES AND PERMITS FOR REGULATORY COMPLIANCE PURPOSES; OBTAINING ALL REQUIRED GOVERNMENT AND REGULATORY LICENSES AND PERMITS FOR BUSINESSES (U.S. CLS. 100 AND 101).

FIRST USE 5-12-2011; IN COMMERCE 5-12-2011.

CHRISTINE MARTIN, EXAMINING ATTORNEY

CLASS 45—(Continued).

SN 85-555,570. MARLA BECHTEL, PASADENA, CA. FILED 2-28-2012.



THE MARK CONSISTS OF THE STYLIZED WORDING "GO!" APPEARING OVER THE DESIGN OF AN INCOMPLETE SQUARE ALL OVER THE STYLIZED WORDING "WEGOTTAGO!.COM" WITH THE WORDING ".COM" APPEARING OVER THE EXCLAMATION POINT.

FOR INTERNET-BASED SOCIAL NETWORKING SERVICES (U.S. CLS. 100 AND 101).

AMY C. KEAN, EXAMINING ATTORNEY

SN 85-563,635. GUARDAIR CORPORATION, CHICOPEE, MA. FILED 3-8-2012.

WE TAKE WORKER SAFETY SERIOUSLY

THE MARK CONSISTS OF STANDARD CHARACTERS WITHOUT CLAIM TO ANY PARTICULAR FONT, STYLE, SIZE, OR COLOR.

FOR PROVIDING INFORMATION IN THE FIELD OF WORKPLACE SAFETY, NAMELY, INFORMATION ABOUT WORKER SAFETY WITH RESPECT TO USING PNEUMATIC AIR GUNS AND VACUUMS (U.S. CLS. 100 AND 101).

KIMBERLY PARKS, EXAMINING ATTORNEY

SN 85-571,757. YAKIFY, INC., MANHATTAN BEACH, CA. FILED 3-16-2012.

YAKIFY

THE MARK CONSISTS OF STANDARD CHARACTERS WITHOUT CLAIM TO ANY PARTICULAR FONT, STYLE, SIZE, OR COLOR.

FOR ON-LINE SOCIAL NETWORKING SERVICES (U.S. CLS. 100 AND 101).

FIRST USE 1-2-2012; IN COMMERCE 2-6-2012.

WARREN L. OLANDRIA, EXAMINING ATTORNEY

CLASS 45—(Continued).

SN 85-586,316. HARTMANN DOHERTY ROSA BERMAN & BULBULIA, LLC, RIVER EDGE, NJ. FILED 4-2-2012.

Counsel for Business.
Counsel for Life.

THE MARK CONSISTS OF STANDARD CHARACTERS WITHOUT CLAIM TO ANY PARTICULAR FONT, STYLE, SIZE, OR COLOR.

FOR LEGAL CONSULTATION SERVICES; LEGAL CONSULTING SERVICES IN THE FIELD OF CRIMINAL LAW, CORPORATE LAW, REAL ESTATE, TRUSTS AND ESTATES, TAX PLANNING, BUSINESS PLANNING, TRADEMARK AND PATENT LAW, ELDER LAW AND MATRIMONIAL LAW; LEGAL DOCUMENT PREPARATION AND RESEARCH SERVICES FOR ATTORNEYS; LEGAL RESEARCH; LEGAL SERVICES; PROVIDING CUSTOMIZED LEGAL INFORMATION, COUNSELING, AND ADVICE, AND LITIGATION SERVICES IN THE FIELD OF CRIMINAL LAW, CORPORATE LAW, REAL ESTATE, TRUSTS AND ESTATES, TAX PLANNING, BUSINESS PLANNING, TRADEMARK AND PATENT LAW, ELDER LAW AND MATRIMONIAL LAW (U.S. CLS. 100 AND 101).

FIRST USE 2-15-2012; IN COMMERCE 2-15-2012.
JOSETTE BEVERLY, EXAMINING ATTORNEY

CLASS 45—(Continued).

SN 85-590,882. 24 HR LOCKOUTS, SAN ANTONIO, TX. FILED 4-6-2012.



NO CLAIM IS MADE TO THE EXCLUSIVE RIGHT TO USE "24 HR LOCKOUTS", APART FROM THE MARK AS SHOWN.

THE MARK CONSISTS OF THE STYLIZED TEXT "24HR" RESTING ON TOP OF THE STYLIZED TEXT "LOCKOUTS" WITH A QUARTER CLOCK SYMBOL AROUND THE UPPER LEFT SIDE OF THE TEXT.

FOR LOCKSMITHING, NAMELY, OPENING OF LOCKS (U.S. CLS. 100 AND 101).

FIRST USE 1-1-2009; IN COMMERCE 1-1-2009.
WON TEAK OH, EXAMINING ATTORNEY

SN 85-587,508. LATONYA T. WILLIAMS, JACKSONVILLE, AR. FILED 4-3-2012.



THE COLOR(S) WHITE, LIGHT BLUE AND BLUE IS/ARE CLAIMED AS A FEATURE OF THE MARK.

THE MARK CONSISTS OF THE STYLIZED WORDING "WHO-IS-THEY" IN WHITE COLOR, SUPERIMPOSED OVER A LIGHT-BLUE QUESTION MARK DESIGN. THESE ARE SET AGAINST A CIRCLE BACKGROUND FILLED IN BLUE COLOR.

FOR PROVIDING A SOCIAL NETWORKING WEBSITE FOR ENTERTAINMENT PURPOSES (U.S. CLS. 100 AND 101).

DAWN HAN, EXAMINING ATTORNEY

SN 85-591,758. KELLY / WARNER, PLLC, TEMPE, AZ. FILED 4-7-2012.



THE COLOR(S) GREEN, BLACK AND WHITE IS/ARE CLAIMED AS A FEATURE OF THE MARK.

THE MARK CONSISTS OF THE PHRASE "KELLY / WARNER" IN BLACK TEXT, ALONG WITH A GREEN CIRCLE CONTAINING TWO WHITE CHECK MARK-LIKE GRAPHICS WHICH, TOGETHER, RESEMBLE THE LETTER "W", ALL OF THE AFOREMENTIONED ELEMENTS BEING ON A WHITE BACKGROUND.

FOR LEGAL CONSULTATION SERVICES; LEGAL CONSULTING SERVICES IN THE FIELD OF INTERNET LAW, BUSINESS LAW, AND MARKETING LAW; LEGAL DOCUMENT PREPARATION AND RESEARCH SERVICES FOR ATTORNEYS; LEGAL RESEARCH; LEGAL SERVICES; LEGAL SERVICES, NAMELY, INTELLECTUAL PROPERTY CONSULTING SERVICES IN THE FIELD OF IDENTIFICATION, STRATEGY, ANALYTICS, AND INVENTION; LEGAL SERVICES, NAMELY, PREPARATION OF APPLICATIONS FOR TRADEMARK REGISTRATION; LEGAL SERVICES, NAMELY, PROCESS SERVING; LEGAL SERVICES, NAMELY, PROVIDING CUSTOMIZED DOCUMENTATION, INFORMATION, COUNSELING, ADVICE AND CONSULTATION SERVICES IN ALL AREAS OF INTERNET LAW, BUSINESS LAW, AND MARKETING LAW; LEGAL SERVICES, NAMELY, SERVICE OF ACTUAL LEGAL NOTICE; LEGAL SERVICES, NAMELY, TRADEMARK MAINTENANCE SERVICES; LEGAL SERVICES, NAMELY, TRADEMARK SEARCHING AND CLEARANCE SERVICES; LITIGATION SUPPORT SERVICES,

CLASS 45—(Continued).

NAMELY, CONDUCTING ELECTRONIC LEGAL DISCOVERY IN THE NATURE OF REVIEWING E-MAILS AND OTHER ELECTRONICALLY STORED INFORMATION THAT COULD BE RELEVANT EVIDENCE IN A LAWSUIT; ONLINE NEWS REPORTING AND EXPERT LEGAL COMMENTARY SERVICES IN THE FIELD OF LEGAL NEWS; PROFESSIONAL LEGAL CONSULTATIONS RELATING TO FRANCHISING; PROVIDING A WEB SITE FEATURING INFORMATION ON THE DEVELOPMENT OF PRIVACY, SECURITY AND DATA GOVERNANCE LAW; PROVIDING CUSTOMIZED LEGAL INFORMATION, COUNSELING, AND ADVICE, AND LITIGATION SERVICES IN THE FIELD OF INTERNET LAW, BUSINESS LAW, AND MARKETING LAW; PROVIDING INFORMATION IN THE FIELD OF INTELLECTUAL PROPERTY LEGAL SERVICES ; PROVIDING INFORMATION RELATING TO LEGAL AFFAIRS; PROVIDING ON-LINE INFORMATION AND NEWS IN THE FIELD OF LAW; PROVIDING ON-LINE INFORMATION IN THE FIELD OF INTELLECTUAL PROPERTY LEGAL SERVICES (U.S. CLS. 100 AND 101).

FIRST USE 3-21-2012; IN COMMERCE 3-21-2012.
LEE-ANNE BERNIS, EXAMINING ATTORNEY

SN 85-592,753. UHURU NETWORK LLC, CLOVIS, CA.
FILED 4-9-2012.

Stylishlyme

THE MARK CONSISTS OF THE STYLIZED TEXT "STYLISHLIME".

FOR PROVIDING A WEB SITE FEATURING INFORMATION AND CONTENT IN FASHION (U.S. CLS. 100 AND 101).

MICHELLE DUBOIS, EXAMINING ATTORNEY

SN 85-594,645. ROBERTS, JOHN, DBA ROBERTS IP LAW,
COLUMBUS, IN. FILED 4-11-2012.

Got IP?

THE MARK CONSISTS OF STANDARD CHARACTERS WITHOUT CLAIM TO ANY PARTICULAR FONT, STYLE, SIZE, OR COLOR.

NO CLAIM IS MADE TO THE EXCLUSIVE RIGHT TO USE "IP", APART FROM THE MARK AS SHOWN.

FOR INTELLECTUAL PROPERTY CONSULTATION (U.S. CLS. 100 AND 101).

FIRST USE 3-10-2012; IN COMMERCE 3-10-2012.
INGRID C. EULIN, EXAMINING ATTORNEY

CLASS 45—(Continued).

SN 85-595,205. AFFINITY LAW GROUP, LLC, ST. LOUIS,
MO. FILED 4-11-2012.



NO CLAIM IS MADE TO THE EXCLUSIVE RIGHT TO USE "LAW GROUP, LLC", APART FROM THE MARK AS SHOWN.

THE COLOR(S) GREEN, BLACK, GRAY AND GOLD IS/ARE CLAIMED AS A FEATURE OF THE MARK.

THE MARK CONSISTS OF A RECTANGLE SHAPE WITH A CLEAR TRIANGLE LOCATED IN THE MIDDLE OF THE RECTANGLE SHAPE CREATING TWO TRAPEZOIDS, A GREEN TRAPEZOID ON THE LEFT AND A GOLD TRAPEZOID ON THE RIGHT, ON EACH SIDE OF THE TRIANGLE, FOLLOWED BY THE STYLIZED WORD "AFFINITY" IN BLACK LOCATED TO THE RIGHT OF THE SHAPES WITH THE WORDS, "LAW GROUP, LLC" IN GRAY LOCATED DIRECTLY BELOW "AFFINITY".

FOR LEGAL SERVICES (U.S. CLS. 100 AND 101).

FIRST USE 10-27-2007; IN COMMERCE 11-1-2007.

REBECCA SMITH, EXAMINING ATTORNEY

SN 85-595,750. SMITH, WELCH, WEBB & WHITE, LLC,
MCDONOUGH, GA. FILED 4-12-2012.



THE COLOR(S) BLUE AND WHITE IS/ARE CLAIMED AS A FEATURE OF THE MARK.

THE MARK CONSISTS OF A WHITE "S" SET INSIDE OF A DARK BLUE SHIELD SHAPED BACKGROUND WITH A LIGHTER BLUE BANNER BISECTING THE DARK BLUE SHIELD AND INSIDE THE BANNER ARE THE WHITE LETTERS "W W W" WITH A WHITE DOT CENTERED ON EACH SIDE OF THE MIDDLE "W".

FOR ATTORNEY SERVICES (U.S. CLS. 100 AND 101).

FIRST USE 5-16-2011; IN COMMERCE 5-16-2011.

CHRISIE B. KING, EXAMINING ATTORNEY

CLASS 45—(Continued).

SN 85-595,816. AUTHOR SOLUTIONS, INC., BLOOMINGTON, IN. FILED 4-12-2012.

LEGACY KEEPERS

THE MARK CONSISTS OF STANDARD CHARACTERS WITHOUT CLAIM TO ANY PARTICULAR FONT, STYLE, SIZE, OR COLOR.

NO CLAIM IS MADE TO THE EXCLUSIVE RIGHT TO USE "LEGACY", APART FROM THE MARK AS SHOWN.

FOR INTERVIEWING INDIVIDUALS FOR THE PURPOSE OF PRESERVING THEIR PERSONAL HISTORIES; PREPARATION OF CUSTOM BOOKS, E-BOOKS, VIDEO FILES AND AUDIO FILES FEATURING PERSONAL HISTORIES (U.S. CLS. 100 AND 101).

FIRST USE 9-0-2011; IN COMMERCE 9-0-2011.
TINA MAI, EXAMINING ATTORNEY

SN 85-595,927. CHNL, INC., SANTA MONICA, CA. FILED 4-12-2012.

CHNL

THE MARK CONSISTS OF STANDARD CHARACTERS WITHOUT CLAIM TO ANY PARTICULAR FONT, STYLE, SIZE, OR COLOR.

FOR ON-LINE SOCIAL NETWORKING SERVICES; ONLINE SOCIAL NETWORKING SERVICES PROVIDED THROUGH A COMMUNITY WEBSITE (U.S. CLS. 100 AND 101).

FIRST USE 6-0-2011; IN COMMERCE 6-0-2011.
BRIAN CALLAGHAN, EXAMINING ATTORNEY

SN 85-596,562. EZRA BRUTZKUS GUBNER, LLP, WOODLAND HILLS, CA. FILED 4-12-2012.

YOUR COUNSEL MATTERS.

THE MARK CONSISTS OF STANDARD CHARACTERS WITHOUT CLAIM TO ANY PARTICULAR FONT, STYLE, SIZE, OR COLOR.

FOR LEGAL SERVICES; LEGAL ADVISORY AND MEDIATION SERVICES (U.S. CLS. 100 AND 101).

FIRST USE 4-4-2012; IN COMMERCE 4-4-2012.
JAMES LOVELACE, EXAMINING ATTORNEY

CLASS 45—(Continued).

SN 85-598,764. DAN BAUM, BOULDER, CO. FILED 4-16-2012.

FRENZUP

THE MARK CONSISTS OF STANDARD CHARACTERS WITHOUT CLAIM TO ANY PARTICULAR FONT, STYLE, SIZE, OR COLOR.

FOR ONLINE SOCIAL NETWORKING SERVICES (U.S. CLS. 100 AND 101).

ANGELA M. MICHELI, EXAMINING ATTORNEY

SN 85-601,677. HIGGS FLETCHER & MACK LLP, SAN DIEGO, CA. FILED 4-18-2012.

HFM

THE MARK CONSISTS OF STANDARD CHARACTERS WITHOUT CLAIM TO ANY PARTICULAR FONT, STYLE, SIZE, OR COLOR.

FOR LEGAL SERVICES (U.S. CLS. 100 AND 101).
CAROLINE WOOD, EXAMINING ATTORNEY

SN 85-601,814. WEISS, BOB, NEW YORK, NY. FILED 4-18-2012.

Great Button

THE MARK CONSISTS OF STANDARD CHARACTERS WITHOUT CLAIM TO ANY PARTICULAR FONT, STYLE, SIZE, OR COLOR.

NO CLAIM IS MADE TO THE EXCLUSIVE RIGHT TO USE "BUTTON", APART FROM THE MARK AS SHOWN.

FOR SOCIAL INTRODUCTION, NETWORKING AND DATING SERVICES; ONLINE SOCIAL NETWORKING SERVICES; PROVIDING A WEBSITE ON THE INTERNET FOR THE PURPOSE OF SOCIAL NETWORKING; PROVIDING ON-LINE COMPUTER DATABASES AND ON-LINE SEARCHABLE DATABASES IN THE FIELD OF SOCIAL NETWORKING; PROVIDING SOCIAL SERVICES AND INFORMATION IN THE FIELD OF PERSONAL DEVELOPMENT, NAMELY, SELF-IMPROVEMENT, SELF-FULFILLMENT, CHARITABLE, PHILANTHROPIC, VOLUNTEER, PUBLIC AND COMMUNITY SERVICES, AND HUMANITARIAN ACTIVITIES; IDENTIFICATION VERIFICATION SERVICES, NAMELY, PROVIDING AUTHENTICATION OF PERSONAL IDENTIFICATION INFORMATION (U.S. CLS. 100 AND 101).

TARAH HARDY, EXAMINING ATTORNEY

CLASS 45—(Continued).

SN 85-601,821. WEISS, BOB, NEW YORK, NY. FILED 4-18-2012.

Cringe Button

THE MARK CONSISTS OF STANDARD CHARACTERS WITHOUT CLAIM TO ANY PARTICULAR FONT, STYLE, SIZE, OR COLOR.

NO CLAIM IS MADE TO THE EXCLUSIVE RIGHT TO USE "BUTTON", APART FROM THE MARK AS SHOWN.

FOR SOCIAL INTRODUCTION, NETWORKING AND DATING SERVICES; ONLINE SOCIAL NETWORKING SERVICES; PROVIDING A WEBSITE ON THE INTERNET FOR THE PURPOSE OF SOCIAL NETWORKING; PROVIDING ON-LINE COMPUTER DATABASES AND ON-LINE SEARCHABLE DATABASES IN THE FIELD OF SOCIAL NETWORKING; PROVIDING SOCIAL SERVICES AND INFORMATION IN THE FIELD OF PERSONAL DEVELOPMENT, NAMELY, SELF-IMPROVEMENT, SELF-FULFILLMENT, CHARITABLE, PHILANTHROPIC, VOLUNTEER, PUBLIC AND COMMUNITY SERVICES, AND HUMANITARIAN ACTIVITIES; IDENTIFICATION VERIFICATION SERVICES, NAMELY, PROVIDING AUTHENTICATION OF PERSONAL IDENTIFICATION INFORMATION (U.S. CLS. 100 AND 101).

TARAH HARDY, EXAMINING ATTORNEY

SN 85-602,529. MERRITT REA, CHARLOTTE, NC. FILED 4-19-2012.

FashionFrontRunner

THE MARK CONSISTS OF STANDARD CHARACTERS WITHOUT CLAIM TO ANY PARTICULAR FONT, STYLE, SIZE, OR COLOR.

FOR FASHION CONSULTING SERVICES; FASHION INFORMATION; FASHION TREND CONSULTING FOR THE FASHION INDUSTRY; FASHION TREND CONSULTING SERVICES; PERSONAL FASHION CONSULTING SERVICES; PERSONAL STYLIST SERVICES, NAMELY, EVALUATING THE PHYSICAL ATTRIBUTES, LIFESTYLE, AND FASHION STYLES OF OTHERS AND RECOMMENDING CLOTHING AND ACCESSORIES TO ACHIEVE THE PERSONAL IMAGE DESIRED BY THE CLIENT (U.S. CLS. 100 AND 101).

DOMINIC J. FERRAIUOLO, EXAMINING ATTORNEY

CLASS 45—(Continued).

SN 85-602,750. LIEUNGH, JOSEPH, FOX POINT, WI. FILED 4-19-2012.

STEPPING INTO THE CANVAS

THE MARK CONSISTS OF STANDARD CHARACTERS WITHOUT CLAIM TO ANY PARTICULAR FONT, STYLE, SIZE, OR COLOR.

FOR PROVIDING ON-LINE INFORMATION IN THE FIELD OF SPIRITUALITY, SELF-HELP, AND PERSONAL EMPOWERMENT SUBJECT MATTERS; PROVIDING INFORMATION IN THE FIELD OF PERSONAL DEVELOPMENT, NAMELY, SELF-IMPROVEMENT, SELF-FULFILLMENT, SELF-MASTERY, AND INTERPERSONAL COMMUNICATION; COUNSELING IN THE FIELD OF PERSONAL DEVELOPMENT, NAMELY, SELF-IMPROVEMENT, SELF-FULFILLMENT, SELF-MASTERY AND INTERPERSONAL COMMUNICATION (U.S. CLS. 100 AND 101).

SAMUEL E. SHARPER JR., EXAMINING ATTORNEY

SN 85-602,993. CREDENTIAL PROTECTION, LLC, TEMECULA, CA. FILED 4-19-2012.



OWNER OF U.S. REG. NOS. 4,130,073, 4,130,074 AND 4,130,075.

NO CLAIM IS MADE TO THE EXCLUSIVE RIGHT TO USE "VERIFIED REVIEWS", APART FROM THE MARK AS SHOWN.

THE MARK CONSISTS OF A BOX CONTAINING A SERRATED EDGE CIRCLE. INSIDE THE CIRCLE IS A STYLIZED SHIELD WITH THE LETTERS "CP". CURVING AROUND THE UPPER SHIELD IS THE WORDING "VERIFIED REVIEWS".

FOR VERIFICATION SERVICES, NAMELY, PROVIDING AUTHENTICATION OF CONSUMER REVIEWS OF BUSINESS AND PROFESSIONAL SERVICES (U.S. CLS. 100 AND 101).

FIRST USE 1-16-2012; IN COMMERCE 1-16-2012.

TARAH HARDY, EXAMINING ATTORNEY

CLASS 45—(Continued).

SN 85-603,189. MARCELLA C. ROMAYA, SOLANA BEACH, CA. FILED 4-19-2012.

HEALTHDATE.COM

THE MARK CONSISTS OF STANDARD CHARACTERS WITHOUT CLAIM TO ANY PARTICULAR FONT, STYLE, SIZE, OR COLOR.

FOR COMPUTER DATING SERVICES; DATING SERVICES; DATING SERVICES, NAMELY, PROVIDING AN ON-LINE COMPUTER DATABASE FEATURING SINGLE PEOPLE INTERESTED IN MEETING OTHER SINGLE PEOPLE (U.S. CLS. 100 AND 101).

RAUL CORDOVA, EXAMINING ATTORNEY

CLASS 45—(Continued).

SN 85-604,352. WEISS, BOB, NEW YORK, NY. FILED 4-20-2012.

Hate

THE MARK CONSISTS OF STANDARD CHARACTERS WITHOUT CLAIM TO ANY PARTICULAR FONT, STYLE, SIZE, OR COLOR.

FOR SOCIAL INTRODUCTION, NETWORKING AND DATING SERVICES; ONLINE SOCIAL NETWORKING SERVICES; PROVIDING A WEBSITE ON THE INTERNET FOR THE PURPOSE OF SOCIAL NETWORKING; PROVIDING ON-LINE COMPUTER DATABASES AND ON-LINE SEARCHABLE DATABASES IN THE FIELD OF SOCIAL NETWORKING; PROVIDING SOCIAL SERVICES AND INFORMATION IN THE FIELD OF PERSONAL DEVELOPMENT, NAMELY, SELF-IMPROVEMENT, SELF-FULFILLMENT, CHARITABLE, PHILANTHROPIC, VOLUNTEER, PUBLIC AND COMMUNITY SERVICES, AND HUMANITARIAN ACTIVITIES; IDENTIFICATION VERIFICATION SERVICES, NAMELY, PROVIDING AUTHENTICATION OF PERSONAL IDENTIFICATION INFORMATION (U.S. CLS. 100 AND 101).

ALYSSA STEEL, EXAMINING ATTORNEY

SN 85-603,667. NEW ENGLAND LINEN SUPPLY, PAWTUCKET, RI. FILED 4-20-2012.

JUST WHAT THE DOCTOR ORDERED

THE MARK CONSISTS OF STANDARD CHARACTERS WITHOUT CLAIM TO ANY PARTICULAR FONT, STYLE, SIZE, OR COLOR.

FOR RENTAL OF CLOTHING; RENTAL OF UNIFORMS (U.S. CLS. 100 AND 101).

FIRST USE 5-23-2002; IN COMMERCE 5-23-2002.

SETH A. RAPPAPORT, EXAMINING ATTORNEY

SN 85-604,371. GODS HELPING HAND OUTREACH MINISTRIES, INC., BEVERLY HILLS, CA. FILED 4-20-2012.

LET'S GO, GOD'S PEOPLE!!!

SN 85-604,329. SECUREAUTH CORPORATION, IRVINE, CA. FILED 4-20-2012.

ASSERT YOUR IDENTITY

THE MARK CONSISTS OF STANDARD CHARACTERS WITHOUT CLAIM TO ANY PARTICULAR FONT, STYLE, SIZE, OR COLOR.

FOR PROVIDING USER AUTHENTICATION SERVICES IN E-COMMERCE TRANSACTIONS (U.S. CLS. 100 AND 101).

SANI KHOURI, EXAMINING ATTORNEY

THE MARK CONSISTS OF STANDARD CHARACTERS WITHOUT CLAIM TO ANY PARTICULAR FONT, STYLE, SIZE, OR COLOR.

FOR RELIGIOUS SERVICES, NAMELY, MINISTERIAL SERVICES (U.S. CLS. 100 AND 101).

FIRST USE 11-30-2011; IN COMMERCE 11-30-2011.

MAYUR VAGHANI, EXAMINING ATTORNEY

CLASS 45—(Continued).

SN 85-604,464. WEISS, BOB, NEW YORK, NY. FILED 4-20-2012.

Cringe

THE MARK CONSISTS OF STANDARD CHARACTERS WITHOUT CLAIM TO ANY PARTICULAR FONT, STYLE, SIZE, OR COLOR.

FOR SOCIAL INTRODUCTION, NETWORKING AND DATING SERVICES; ONLINE SOCIAL NETWORKING SERVICES; PROVIDING A WEBSITE ON THE INTERNET FOR THE PURPOSE OF SOCIAL NETWORKING; PROVIDING ON-LINE COMPUTER DATABASES AND ON-LINE SEARCHABLE DATABASES IN THE FIELD OF SOCIAL NETWORKING; PROVIDING SOCIAL SERVICES AND INFORMATION IN THE FIELD OF PERSONAL DEVELOPMENT, NAMELY, SELF-IMPROVEMENT, SELF-FULFILLMENT, CHARITABLE, PHILANTHROPIC, VOLUNTEER, PUBLIC AND COMMUNITY SERVICES, AND HUMANITARIAN ACTIVITIES; IDENTIFICATION VERIFICATION SERVICES, NAMELY, PROVIDING AUTHENTICATION OF PERSONAL IDENTIFICATION INFORMATION (U.S. CLS. 100 AND 101).

ALYSSA STEEL, EXAMINING ATTORNEY

SN 85-604,970. GATES, GEOFFREY, W. LOS ANGELES, CA. AND GATES, SHARON, W. LOS ANGELES, CA. FILED 4-23-2012.

One Night Affair

THE MARK CONSISTS OF STANDARD CHARACTERS WITHOUT CLAIM TO ANY PARTICULAR FONT, STYLE, SIZE, OR COLOR.

FOR RENTAL OF CLOTHING (U.S. CLS. 100 AND 101).

FIRST USE 10-1-1986; IN COMMERCE 10-1-1986.

VIVIAN MICZNIK FIRST, EXAMINING ATTORNEY

CLASS 45—(Continued).

SN 85-605,136. FISHYPIC, LLC, DBA FISHYPIC, DELRAY BEACH, FL. FILED 4-23-2012.

FishyPic

THE MARK CONSISTS OF STANDARD CHARACTERS WITHOUT CLAIM TO ANY PARTICULAR FONT, STYLE, SIZE, OR COLOR.

FOR ONLINE SOCIAL NETWORKING SERVICES IN THE FIELD OF FISHING (U.S. CLS. 100 AND 101).

FIRST USE 4-12-2012; IN COMMERCE 4-20-2012.

LOURDES AYALA, EXAMINING ATTORNEY

SN 85-605,944. BARKS AND WIGGLES BOXER RESCUE, CONOVER, NC. FILED 4-23-2012.

"Rescuing one dog may not
change the world , but for
that one dog the world will
be changed forever"

THE MARK CONSISTS OF STANDARD CHARACTERS WITHOUT CLAIM TO ANY PARTICULAR FONT, STYLE, SIZE, OR COLOR.

FOR ANIMAL RESCUE SERVICES, NAMELY, ARRANGING FOR THE ADOPTION OF RESCUED ANIMALS (U.S. CLS. 100 AND 101).

FIRST USE 9-17-2010; IN COMMERCE 9-17-2010.

B. PARADEWELAI, EXAMINING ATTORNEY

SECTION 4.—PRIOR UNITED STATES CLASSIFICATION

APPLICATION IN ONE CLASS

COLLECTIVE MEMBERSHIP MARKS

CLASS 200—COLLECTIVE MEMBERSHIP
SN 85-445,927. UNITED TRANSPORTATION SECURITY
PROFESSIONALS OF AMERICA, LONG BEACH, CA.
FILED 10-12-2011.

UNITED TRANSPORTATION
SECURITY PROFESSIONALS OF
AMERICA

THE MARK CONSISTS OF STANDARD CHARACTERS
WITHOUT CLAIM TO ANY PARTICULAR FONT, STYLE,
SIZE, OR COLOR.

NO CLAIM IS MADE TO THE EXCLUSIVE RIGHT TO
USE "TRANSPORTATION SECURITY PROFESSIONALS OF
AMERICA", APART FROM THE MARK AS SHOWN.

FOR INDICATING MEMBERSHIP IN A FRATERNAL
ORGANIZATION OF TRANSPORTATION SECURITY
WORKERS.

FIRST USE 7-30-2006; IN COMMERCE 7-30-2006.
SEAN CROWLEY, EXAMINING ATTORNEY

SN 85-452,802. MILITARY ORDER OF THE LOYAL LEGION
OF THE UNITED STATES, PHILADELPHIA, PA. FILED
10-21-2011.



THE COLOR(S) GOLD, AZURE, WHITE, AND RED IS/
ARE CLAIMED AS A FEATURE OF THE MARK.
THE MARK CONSISTS OF THE COLOR RED APPEARS

IN THE CENTER CIRCLE. THE COLOR AZURE APPEARS
IN THE SECOND OUTER LINE OF THE FOUR POINTS OF
THE STAR. THE COLOR GOLD APPEARS AS THE OUT-
LINE OF ALL THE POINTS OF THE STAR, IN THE OUTER
AND INNER CIRCLE BORDERS OF THE INNER CIRCLE.
THE STYLIZED DESIGN OF THE EAGLE, AND THE
WORDING "LEX REGIT ARMA TUENTUR" AND THE
DOT AND CROSS BETWEEN THIS WORDING. THE
COLOR WHITE APPEARS IN THE BACKGROUND IN
THE FOUR POINTS OF THE STAR.

THE ENGLISH TRANSLATION OF "LEX REGIT ARMA
TUENTUR" IN THE MARK IS LAWS RULE ARMS PRO-
TECT.

FOR INDICATING MEMBERSHIP IN A(N) ORGANI-
ZATION IS A PATRIOTIC, HISTORICAL AND EDUCA-
TIONAL SOCIETY DEDICATED TO PRESERVING AND
PROMOTING THE MEMORY OF ABRAHAM LINCOLN
AND THE CIVIL WAR THROUGH PROGRAMS, SPE-
CIAL EVENTS, SCHOLARSHIP, AND OTHER ACTIV-
ITIES.

FIRST USE 1-1-1900; IN COMMERCE 1-1-1900.
DANNEAN HETZEL, EXAMINING ATTORNEY

SN 85-454,684. TENNESSEE PEACEMAKERS MOTOR-
CYCLE CLUB, INC., BLOUNTVILLE, TN. FILED 10-24-
2011.



NO CLAIM IS MADE TO THE EXCLUSIVE RIGHT TO
USE "M.C." OR "KENTUCKY", APART FROM THE MARK
AS SHOWN.

THE COLOR(S) RED, WHITE AND BLACK IS/ARE
CLAIMED AS A FEATURE OF THE MARK.

THE MARK CONSISTS OF A BLACK AND WHITE
SKULL AND CROSSBONES WEARING A BLACK MOTOR-
CYCLE HELMET. TO THE RIGHT OF THE SKULL IS A
WHITE RECTANGLE WITH A BLACK OUTLINE DISPLA-
YING THE LETTERS "M.C." IN RED. ABOVE THE SKULL IS
THE WORD "PEACEMAKERS" IN RED ON A WHITE
ARCH WITH A BLACK OUTLINE, AND BELOW THE
SKULL IS THE WORD "KENTUCKY" IN RED ON A WHITE
ARCH WITH A BLACK OUTLINE.

FOR INDICATING MEMBERSHIP IN A SOCIAL CLUB
FOR MOTORCYCLE ENTHUSIASTS.

FIRST USE 12-31-2000; IN COMMERCE 12-31-2000.
KATHERINE CHANG, EXAMINING ATTORNEY

SN 85-487,995. MILITARY ORDER OF THE LOYAL LEGION OF THE UNITED STATES, PHILADELPHIA, PA. FILED 12-6-2011.



NO CLAIM IS MADE TO THE EXCLUSIVE RIGHT TO USE "US", APART FROM THE MARK AS SHOWN.

THE COLOR(S) GOLD, AZURE, WHITE, AND RED IS/ARE CLAIMED AS A FEATURE OF THE MARK.

THE MARK CONSISTS OF THE COLOR RED APPEARS IN THE CENTER CIRCLE. THE COLOR AZURE APPEARS IN THE SECOND OUTER LINE OF THE FOUR POINTS OF THE STAR. THE COLOR GOLD APPEARS AS THE OUTLINE OF ALL THE POINTS OF THE CROSS, INNER BORDER OF THE STAR, OUTER CIRCLE IN THE CENTER, STYLIZED DESIGN OF THE SWORDS AND CREST, AND THE STARS IN THE CIRCLE. THE COLOR WHITE APPEARS IN THE INNER BACKGROUND OF THE STAR. THE COLOR BLACK IS NOT CLAIMED AS A FEATURE OF THE MARK, AND IS ONLY USED TO REPRESENT THE WORDING "M O LOYAL LEGION U S M D C C C L X V" AND THE DOTS AND CROSS BETWEEN THE WORDING, WHICH APPEAR IN GOLD.

FOR INDICATING MEMBERSHIP IN AN ORGANIZATION THAT IS A PATRIOTIC, HISTORICAL AND EDUCATIONAL SOCIETY DEDICATED TO PRESERVING AND PROMOTING THE MEMORY OF ABRAHAM LINCOLN AND THE CIVIL WAR THROUGH PROGRAMS, SPECIAL EVENTS, SCHOLARSHIP, AND OTHER ACTIVITIES.

FIRST USE 1-1-1900; IN COMMERCE 1-1-1900.
DANNEAN HETZEL, EXAMINING ATTORNEY

THE COLOR(S) WHITE, BLACK, BLUE, YELLOW, GOLD, AND ORANGE IS/ARE CLAIMED AS A FEATURE OF THE MARK.

THE MARK CONSISTS OF AN ARCH IN THE SHAPE OF A VERTICAL HORSESHOE WITH A BLUE BACKGROUND, LINED IN YELLOW AND CONTAINING THE YELLOW WORDING, "AMERICAN VETERANS", WITH THE WHITE LETTERS, "MC" BETWEEN TWO WING IN THE COLORS, YELLOW GOLD AND ORANGE EMANATING FROM A WHITE AND BLACK SKULL WITH A BLUE BAND ON THE HEAD WITH THE WHITE STYLIZED WORDING, "MOTOR" ABOVE IT, WITH TWO WHITE AND BLACK CROSS BONES AT THE NECK OF THE SKULL, WITH THE WHITE WORDING "CYCLES" PRINTED ON A BLUE BACKGROUND SURROUNDED BY YELLOW FEATHERS, WITH A RECTANGLE BELOW, WITH A BLUE BACKGROUND LINED IN YELLOW, CONTAINING THE YELLOW ABBREVIATION "KANS."

FOR INDICATING MEMBERSHIP IN A MOTOR-CYCLE CLUB.

FIRST USE 12-10-2005; IN COMMERCE 12-10-2005.
ODESSA BIBBINS, EXAMINING ATTORNEY

SN 85-571,493. COLORADO EMERALD SOCIETY, DENVER, CO. FILED 3-16-2012.



NO CLAIM IS MADE TO THE EXCLUSIVE RIGHT TO USE "COLORADO" OR "SOCIETY", APART FROM THE MARK AS SHOWN.

THE COLOR(S) GREEN, RED, BLUE, GOLD, SILVER, AND BLACK IS/ARE CLAIMED AS A FEATURE OF THE MARK.

THE MARK CONSISTS OF THE WORDS "COLORADO EMERALD SOCIETY" IN GREEN LETTERING, LOCATED IN A CIRCLE AROUND A CELTIC HIGH CROSS AND SWORD. THE SWORD IS ARRANGED VERTICALLY AND BISECTS THE VERTICAL LENGTH OF THE CROSS. THE SWORD CONSISTS OF A GOLD-COLORED HILT, WITH A GREEN SHAMROCK LOCATED WITHIN A SILVER POMMEL. THE GUARD OF THE SWORD IS RED WITH SILVER OUTLINE. IDENTICAL DOG HEADS WITH MOUTHS AGAPE ARE LOCATED AT THE EACH EDGE OF THE GUARD. THE DOGS ARE GREEN, WITH GOLD SNOUT AND MOUTH. THE RED WITH SILVER OUTLINE PORTION OF THE GUARD ALSO COMPRISES A PORTION OF A LARGER, RED WITH SILVER OUTLINE CIRCLE THAT SURROUNDS THE INTERSECTING PARTS OF THE LARGER CROSS. THE CROSS IS OUTLINED IN SILVER. THE UPPER SECTION OF THE VERTICAL PORTION OF THE CROSS ABOVE THE INTERSECTION POINT RED WITH A SILVER OUTLINE. THE BLADE OF THE SWORD, WHICH IS COLORED SILVER, SITS ATOP THE LONGER, LOWER

SN 85-536,136. AMERICAN VETERANS MC, KANS. CHAPTER, BENTON, KS. FILED 2-7-2012.



NO CLAIM IS MADE TO THE EXCLUSIVE RIGHT TO USE "AMERICAN VETERANS", "MC", "MOTOR CYCLES", AND "KANS.", APART FROM THE MARK AS SHOWN.

SECTION OF THE VERTICAL PORTION OF THE CROSS, AND IS BISECTED BY A BLACK LINE THAT TERMINATES JUST BEFORE THE TIP OF THE BLADE. THIS LOWER SECTION OF THE CROSS AND THE HORIZONTAL ELEMENT OF THE CROSS ARE GREEN, WITHIN A SILVER OUTLINE, AND CONTAIN A GREEN-COLORED CELTIC KNOT PATTERN. THE INTERSECTION OF THE CROSS CONTAINS A BLUE CIRCLE WITH A GOLD-COLORED HARP. THE STRINGS OF THE HARP ARE COLORED BLACK.

FOR INDICATING MEMBERSHIP IN A FRATERNAL ORGANIZATION DEDICATED TO PROMOTING IRISH HERITAGE AND TRADITIONS AMONGST PUBLIC SAFETY AGENCIES.

FIRST USE 0-0-1999; IN COMMERCE 1-1-2000.
 APRIL HESIK, EXAMINING ATTORNEY

SN 85-592,876. MCGOLEY, KUNTA, DOTHAN, AL. FILED 4-9-2012.



THE MARK CONSISTS OF AN IMAGE OF THE GRIM REAPER HOLDING A SCYTHE WITH HIS LEFT HAND AS SHOWN IN THE MARK.

FOR INDICATING MEMBERSHIP IN A MOTOR-CYCLE CLUB.

AMY ALFIERI, EXAMINING ATTORNEY

CERTIFICATION MARKS

CLASS A—GOODS

SN 85-433,102. R.N.G. CORPORATION, ST. MARKS, FL. FILED 9-27-2011.



NO CLAIM IS MADE TO THE EXCLUSIVE RIGHT TO USE "FOOD SAFETY", APART FROM THE MARK AS SHOWN.

THE COLOR(S) GOLD, BLUE, RED, YELLOW AND WHITE IS/ARE CLAIMED AS A FEATURE OF THE MARK.

THE MARK CONSISTS OF THE WORDS "WHERE FOOD SAFETY STARTS" IN RED STACKED ATOP EACH OTHER IN A WHITE CIRCLE CONTAINING A YELLOW EDGE. BENEATH THE WORD "STARTS", A RED CHECKMARK IS DEPICTED. BEYOND THE YELLOW-EDGED WHITE CIRCLE, A YELLOW-EDGED BLUE RING IS DEPICTED. WITHIN THIS BLUE RING IS DEPICTED A YELLOW LAUREL WREATH. ABOVE THIS WREATH, THREE YELLOW STARS ARE DEPICTED. BENEATH THE WREATH, THE BOTTOM OF THE RED CHECKMARK IS DEPICTED. A GOLD SCALLOPED CIRCULAR SHAPE IS DEPICTED BEYOND THE OUTER YELLOW EDGE OF THE BLUE CIRCLE.

THE CERTIFICATION MARK, AS INTENDED TO BE USED BY AUTHORIZED PERSONS, IS INTENDED TO CERTIFY THAT THE APPLICABLE GOODS MEET WITH THE REQUIREMENTS AND STANDARDS OF QUALITY AND PRACTICES ADOPTED BY THE CERTIFIER RELATING TO CATTLE, BEEF, AND BEEF FOOD PRODUCT FEEDING, REARING, TREATING, HANDLING, PROCESSING, PREPARING, PRODUCTION, PACKAGING, TRACKING, TRANSPORTATION, DISTRIBUTION, STORING, INSPECTING, AND TESTING TO REDUCE THE RISKS OF FOOD-BORNE ILLNESS, TRACKING AND TRACEABILITY, AND COMPLIANCE WITH ANIMAL WELFARE STANDARDS.

FOR BEEF.
 JANICE KIM, EXAMINING ATTORNEY

CLASS B—SERVICES

SN 85-472,263. GOOGLE INC., MOUNTAIN VIEW, CA. FILED 11-14-2011.



THE COLOR(S) BLUE, RED, YELLOW, GREEN, AND WHITE IS/ARE CLAIMED AS A FEATURE OF THE MARK.

THE MARK CONSISTS OF A CIRCLE DIVIDED INTO FOUR EQUAL SECTIONS, EACH A DIFFERENT COLOR, IN THE SEQUENCE BLUE-RED-YELLOW-GREEN, SURROUNDING A GREEN CHECKMARK ON A WHITE CIRCLE.

THE CERTIFICATION MARK, AS USED BY PARTIES AUTHORIZED BY THE CERTIFIER, CERTIFIES THAT MERCHANTS OFFERING ONLINE RETAIL STORE SERVICES COMPLY WITH CERTAIN GUIDELINES AND STANDARDS DESIGNATED BY THE CERTIFIER REGARDING THE ACCURACY, CONDITION, AND SHIPPING TIME FOR ITEMS ORDERED BY CONSUMERS; THE AMOUNTS BILLED FOR ORDERED ITEMS; AND THE IMPLEMENTATION OF RETURN POLICIES FOR ITEMS ORDERED.

FOR RETAIL STORE SERVICES, SHIPPING SERVICES, DELIVERY SERVICES, BILLING SERVICES, AND MANAGEMENT OF RETURNED MERCHANDISE SERVICES.

FIRST USE 10-3-2011; IN COMMERCE 10-3-2011.
 LEIGH CAROLINE CASE, EXAMINING ATTORNEY

SN 85-513,092. GEA, INC., DBA GRAND ESTATES AUCTION COMPANY, CHARLOTTE, NC. FILED 1-10-2012.

SN 85-541,739. VENTAJAS LLC, CULPEPER, VA. FILED 2-14-2012.

D.L.A.S.



THE MARK CONSISTS OF STANDARD CHARACTERS WITHOUT CLAIM TO ANY PARTICULAR FONT, STYLE, SIZE, OR COLOR.

THE CERTIFICATION MARK, AS INTENDED TO BE USED BY AUTHORIZED PERSONS, IS INTENDED TO CERTIFY THAT THE SERVICES ARE PERFORMED BY PERSONS WHO HAVE MET THE REQUIREMENTS FOR CERTIFICATION ESTABLISHED BY THE CERTIFIER WITH RESPECT TO EXPERIENCE AND PROFESSIONALISM.

FOR REAL ESTATE AUCTIONS AND REAL ESTATE MARKETING SERVICES.
CHRISTOPHER SIDOTI, EXAMINING ATTORNEY

OWNER OF U.S. REG. NO. 4,044,959.
NO CLAIM IS MADE TO THE EXCLUSIVE RIGHT TO USE "CERTIFIED INSTRUCTOR", APART FROM THE MARK AS SHOWN.

THE MARK CONSISTS OF THE WORDS "VENTAJAS" AND "MAKING THE ADVANTAGE YOURS" INSIDE A CIRCLE WITH A STYLIZED SHELL AND A RIBBON AND THE WORDS "CERTIFIED INSTRUCTOR" BENEATH THE CIRCLE.

THE ENGLISH TRANSLATION OF "VENTAJAS" IN THE MARK IS "ADVANTAGES".

THE CERTIFICATION MARK, AS INTENDED TO BE USED BY AUTHORIZED PERSONS, IS INTENDED TO CERTIFY THAT THE INDIVIDUAL DISPLAYING THE MARK HAS SUCCESSFULLY COMPLETED A PRESCRIBED COURSE OF EDUCATION AND TRAINING, AND HAS DEMONSTRATED ACHIEVEMENT OF SPECIFIC SKILLS IN THE PROVIDING OF INSTRUCTION TO INDIVIDUALS PREPARING FOR EXAMINATIONS IN THE FIELD OF SOCIAL WORK.

FOR EDUCATIONAL SERVICES, NAMELY, PROVIDING LIVE AND ONLINE CLASSES, SEMINARS, WORKSHOPS, DEMONSTRATIONS, TUTORIAL SESSIONS, AND MENTORING IN THE FIELD OF EXAM PREPARATION FOR SOCIAL WORKERS.

BRIAN NEVILLE, EXAMINING ATTORNEY

* * * * *

TRADEMARK REGISTRATIONS ISSUED

PRINCIPAL REGISTER

SECTION 1.— INTERNATIONAL CLASSIFICATION

The short titles associated below with the international class numbers are terms designed merely for quick identification and are not an official part of the international classification. The full names of international classes are given in section 6.1 of the trademark rules of practice.

The designation "U.S. Cl." appearing in this section refers to the U.S. class in effect prior to Sep. 1, 1973 rather than the international class which applies to applications filed on or after that date. For adoption of international classification see notice in the OFFICIAL GAZETTE of Jun. 26, 1973 (911 O.G. TM 210).

CLASS 1—CHEMICALS

- 4,208,168. **BIO-ONE (STANDARD CHARACTER)**. BIO-ONE, INC., (U.S. CLS. 1, 5, 6, 10, 26 AND 46). SN 77-320,110. PUB. 7-3-2012. FILED 11-2-2007.
- 4,208,251. **WEVO (STANDARD CHARACTER)**. WEVO-CHEMIE GMBH, MULTIPLE CLASS, (INT. CLS. 1, 2, 17 AND 42), (U.S. CLS. 1, 5, 6, 10, 11, 12, 13, 16, 26, 35, 46, 50, 100 AND 101). SN 79-092,532. PUB. 7-3-2012. FILED 11-22-2010.
- 4,208,253. **VIVACOAT (STANDARD CHARACTER)**. J. RETTENMAIER & SÖHNE GMBH + CO. KG, MULTIPLE CLASS, (INT. CLS. 1 AND 5), (U.S. CLS. 1, 5, 6, 10, 18, 26, 44, 46, 51 AND 52). SN 79-093,793. PUB. 7-3-2012. FILED 11-8-2010.
- 4,208,271. **AIMTEC (STANDARD CHARACTER)**. LIPOTEC, S.A., MULTIPLE CLASS, (INT. CLS. 1, 3 AND 5), (U.S. CLS. 1, 4, 5, 6, 10, 18, 26, 44, 46, 50, 51 AND 52). SN 79-098,405. PUB. 3-20-2012. FILED 3-24-2011.
- 4,208,318. **LXPLOSION (STANDARD CHARACTER)**. GEA FARM TECHNOLOGIES GMBH, MULTIPLE CLASS, (INT. CLS. 1, 3, 5 AND 7), (U.S. CLS. 1, 4, 5, 6, 10, 13, 18, 19, 21, 23, 26, 31, 34, 35, 44, 46, 50, 51 AND 52). SN 79-102,060. PUB. 7-3-2012. FILED 5-11-2011.
- 4,208,326. **AMIZATE (STANDARD CHARACTER)**. ZYMTECH HOLDING AG C/O BUCHHALTUNGS- UND REVISION AG, MULTIPLE CLASS, (INT. CLS. 1, 5, 29, 30, 31 AND 32), (U.S. CLS. 1, 5, 6, 10, 18, 26, 44, 45, 46, 48, 51 AND 52). SN 79-102,344. PUB. 7-3-2012. FILED 5-3-2011.
- 4,208,343. **MISCELLANEOUS DESIGN**. FAIST CHEMTEC GMBH, MULTIPLE CLASS, (INT. CLS. 1, 7, 11, 12, 17 AND 19), (U.S. CLS. 1, 5, 6, 10, 12, 13, 19, 21, 23, 26, 31, 33, 34, 35, 44, 46 AND 50). SN 79-102,759. PUB. 7-3-2012. FILED 2-24-2011.
- 4,208,372. **GRIPX (STANDARD CHARACTER)**. SWETREE TECHNOLOGIES AB, (U.S. CLS. 1, 5, 6, 10, 26 AND 46). SN 79-104,005. PUB. 7-3-2012. FILED 9-9-2011.
- 4,208,397. **SHENQIANG AND DESIGN**. YIWU SHENQIANG ADHESIVE CO., LTD., (U.S. CLS. 1, 5, 6, 10, 26 AND 46). SN 79-106,812. PUB. 7-3-2012. FILED 11-24-2011.
- 4,208,398. **EPICUTIN (STYLIZED)**. CHEMISCHES LABORATORIUM; DR. KURT RICHTER GMBH, (U.S. CLS. 1, 5, 6, 10, 26 AND 46). SN 79-106,828. PUB. 7-3-2012. FILED 11-9-2011.
- 4,208,401. **UNI PEX AND DESIGN**. GROUPE UNIPEX, MULTIPLE CLASS, (INT. CLS. 1, 35, 39 AND 42), (U.S. CLS. 1, 5, 6, 10, 26, 46, 100, 101, 102 AND 105). SN 79-107,234. PUB. 7-3-2012. FILED 8-29-2011.
- 4,208,412. **ELANCURE (STANDARD CHARACTER)**. ELANTAS GMBH, MULTIPLE CLASS, (INT. CLS. 1, 2 AND 17), (U.S. CLS. 1, 5, 6, 10, 11, 12, 13, 16, 26, 35, 46 AND 50). SN 79-108,225. PUB. 7-3-2012. FILED 9-5-2011.
- 4,208,420. **SERM (STANDARD CHARACTER)**. ADVANCED SOFTMATERIALS INC., (U.S. CLS. 1, 5, 6, 10, 26 AND 46). SN 79-108,850. PUB. 7-3-2012. FILED 12-6-2011.
- 4,208,437. **SUGAPOLISH (STANDARD CHARACTER)**. BIOGRUND GMBH, (U.S. CLS. 1, 5, 6, 10, 26 AND 46). SN 79-111,232. PUB. 7-3-2012. FILED 12-28-2011.
- 4,208,439. **XELOREX (STANDARD CHARACTER)**. BASF SE, (U.S. CLS. 1, 5, 6, 10, 26 AND 46). SN 79-111,694. PUB. 7-3-2012. FILED 2-17-2012.
- 4,208,445. **ELICLEAR (STANDARD CHARACTER)**. COATEX S.A.S., (U.S. CLS. 1, 5, 6, 10, 26 AND 46). SN 79-112,552. PUB. 7-3-2012. FILED 2-2-2012.
- 4,208,481. **BLUE GOOSE BIOREFINERIES INC. (STANDARD CHARACTER)**. BLUE GOOSE BIOREFINERIES INC., MULTIPLE CLASS, (INT. CLS. 1, 4 AND 40), (U.S. CLS. 1, 5, 6, 10, 15, 26, 46, 100, 103 AND 106). SN 85-123,993. PUB. 7-3-2012. FILED 9-7-2010.
- 4,208,490. **VESSGARD (STANDARD CHARACTER)**. CAPPS UK LIMITED, MULTIPLE CLASS, (INT. CLS. 1 AND 2), (U.S. CLS. 1, 5, 6, 10, 11, 16, 26 AND 46). SN 85-148,268. PUB. 7-3-2012. FILED 10-8-2010.
- 4,208,502. **ENVIROBOND (STANDARD CHARACTER)**. CANADIAN ENERGY SERVICES L.P., MULTIPLE CLASS, (INT. CLS. 1 AND 37), (U.S. CLS. 1, 5, 6, 10, 26, 46, 100, 103 AND 106). SN 85-171,773. PUB. 5-8-2012. FILED 11-8-2010.
- 4,208,503. **POLARBOND (STANDARD CHARACTER)**. CANADIAN ENERGY SERVICES L.P., MULTIPLE CLASS, (INT. CLS. 1 AND 4), (U.S. CLS. 1, 5, 6, 10, 15, 26 AND 46). SN 85-171,791. PUB. 5-8-2012. FILED 11-8-2010.
- 4,208,504. **POLYCORE (STANDARD CHARACTER)**. CANADIAN ENERGY SERVICES L.P., MULTIPLE CLASS, (INT. CLS. 1 AND 37), (U.S. CLS. 1, 5, 6, 10, 26, 46, 100, 103 AND 106). SN 85-171,802. PUB. 5-8-2012. FILED 11-8-2010.
- 4,208,505. **COTTONSEAL (STANDARD CHARACTER)**. CANADIAN ENERGY SERVICES L.P., (U.S. CLS. 1, 5, 6, 10, 26 AND 46). SN 85-171,812. PUB. 5-8-2012. FILED 11-8-2010.
- 4,208,506. **WHITEFURY (STANDARD CHARACTER)**. CANADIAN ENERGY SERVICES L.P., MULTIPLE CLASS, (INT. CLS. 1 AND 37), (U.S. CLS. 1, 5, 6, 10, 26, 46, 100, 103 AND 106). SN 85-171,827. PUB. 5-8-2012. FILED 11-8-2010.
- 4,208,507. **POLARWHITE (STANDARD CHARACTER)**. CANADIAN ENERGY SERVICES L.P., MULTIPLE CLASS, (INT. CLS. 1 AND 37), (U.S. CLS. 1, 5, 6, 10, 26, 46, 100, 103 AND 106). SN 85-171,843. PUB. 5-8-2012. FILED 11-8-2010.
- 4,208,538. **SUPERSOLID PLUS (STANDARD CHARACTER)**. DISORB SYSTEMS, INC., (U.S. CLS. 1, 5, 6, 10, 26 AND 46). SN 85-212,892. PUB. 7-3-2012. FILED 1-7-2011.
- 4,208,542. **SUPER SOLIDIFIER PLUS (STANDARD CHARACTER)**. DISORB SYSTEMS, INC., (U.S. CLS. 1, 5, 6, 10, 26 AND 46). SN 85-223,025. PUB. 7-3-2012. FILED 1-21-2011.
- 4,208,548. **MONODOSE AND DESIGN**. MONOSOL LLC, (U.S. CLS. 1, 5, 6, 10, 26 AND 46). SN 85-229,922. PUB. 7-3-2012. FILED 1-31-2011.
- 4,208,619. **NUCLEOSOMICS (STANDARD CHARACTER)**. SINGAPORE VOLITION PTE. LIMITED, MULTIPLE CLASS, (INT. CLS. 1, 5, 10 AND 42), (U.S. CLS. 1, 5, 6, 10, 18, 26, 39, 44, 46, 51, 52, 100 AND 101). SN 85-326,500. PUB. 7-3-2012. FILED 5-20-2011.
- 4,208,621. **RAPIDFLUX (STANDARD CHARACTER)**. WEATHERFORD/LAMB, INC., (U.S. CLS. 1, 5, 6, 10, 26 AND 46). SN 85-328,282. PUB. 7-3-2012. FILED 5-24-2011.
- 4,208,648. **REHUMALB (STANDARD CHARACTER)**. MITSUBISHI TANABE PHARMA CORPORATION, (U.S. CLS. 1, 5, 6, 10, 26 AND 46). SN 85-345,307. PUB. 7-3-2012. FILED 6-14-2011.
- 4,208,775. **AQUAVUE (STANDARD CHARACTER)**. INDUSTRIAL CONTROL DEVELOPMENT, INC. DBA ICD HIGH PERFORMANCE COATING, MULTIPLE CLASS, (INT.

- CLS. 1 AND 2), (U.S. CLS. 1, 5, 6, 10, 11, 16, 26 AND 46). SN 85-376,872. PUB. 7-3-2012. FILED 7-21-2011.
- 4,208,858. **SANIFIL (STANDARD CHARACTER)**. BORTEK INDUSTRIES, INC., MULTIPLE CLASS, (INT. CLS. 1, 2, 3, 5, 16, 20 AND 21), (U.S. CLS. 1, 2, 4, 5, 6, 10, 11, 13, 16, 18, 22, 23, 25, 26, 29, 30, 32, 33, 37, 38, 40, 44, 46, 50, 51 AND 52). SN 85-398,890. PUB. 7-3-2012. FILED 8-16-2011.
- 4,208,862. **S SANIFIL AND DESIGN**. BORTEK INDUSTRIES, INC., MULTIPLE CLASS, (INT. CLS. 1, 2, 3, 5, 16, 20 AND 21), (U.S. CLS. 1, 2, 4, 5, 6, 10, 11, 13, 16, 18, 22, 23, 25, 26, 29, 30, 32, 33, 37, 38, 40, 44, 46, 50, 51 AND 52). SN 85-400,218. PUB. 7-3-2012. FILED 8-17-2011.
- 4,209,046. **ANTHONY & SYLVAN (STANDARD CHARACTER)**. ANTHONY & SYLVAN POOLS CORPORATION, DBA ANTHONY & SYLVAN POOLS, MULTIPLE CLASS, (INT. CLS. 1, 5, 19, 35 AND 37), (U.S. CLS. 1, 5, 6, 10, 12, 18, 26, 33, 44, 46, 50, 51, 52, 100, 101, 102, 103 AND 106). SN 85-470,516. PUB. 7-3-2012. FILED 11-11-2011.
- 4,209,630. **NEOSSANCE (STANDARD CHARACTER)**. AMYRIS, INC., MULTIPLE CLASS, (INT. CLS. 1 AND 3), (U.S. CLS. 1, 4, 5, 6, 10, 26, 46, 50, 51 AND 52). SN 85-541,582. PUB. 7-3-2012. FILED 2-13-2012.
- 4,209,634. **ANAQUA (STYLIZED)**. SOLVE-PRO SCIENTIFIC RESEARCH LIMITED, (U.S. CLS. 1, 5, 6, 10, 26 AND 46). SN 85-541,693. PUB. 7-3-2012. FILED 2-14-2012.
- 4,209,664. **XH-6 (STANDARD CHARACTER)**. UOP LLC, (U.S. CLS. 1, 5, 6, 10, 26 AND 46). SN 85-542,156. PUB. 7-3-2012. FILED 2-14-2012.
- 4,209,665. **XH-5 (STANDARD CHARACTER)**. UOP LLC, (U.S. CLS. 1, 5, 6, 10, 26 AND 46). SN 85-542,160. PUB. 7-3-2012. FILED 2-14-2012.
- 4,209,666. **XH-11 (STANDARD CHARACTER)**. UOP LLC, (U.S. CLS. 1, 5, 6, 10, 26 AND 46). SN 85-542,163. PUB. 7-3-2012. FILED 2-14-2012.
- 4,209,785. **INCREDISORB (STANDARD CHARACTER)**. ROSI, THOMAS R., (U.S. CLS. 1, 5, 6, 10, 26 AND 46). SN 85-544,000. PUB. 7-3-2012. FILED 2-15-2012.
- 4,209,789. **GEMCAL (STANDARD CHARACTER)**. GOOD EARTH MINERALS, LLC, MULTIPLE CLASS, (INT. CLS. 1 AND 5), (U.S. CLS. 1, 5, 6, 10, 18, 26, 44, 46, 51 AND 52). SN 85-544,095. PUB. 7-3-2012. FILED 2-16-2012.
- 4,209,847. **INNOTHANE (STANDARD CHARACTER)**. INNOVATIVE POLYMERS, INC., (U.S. CLS. 1, 5, 6, 10, 26 AND 46). SN 85-545,104. PUB. 7-3-2012. FILED 2-16-2012.
- 4,209,949. **PURI-CAL (STANDARD CHARACTER)**. COLUMBIA RIVER CARBONATES, (U.S. CLS. 1, 5, 6, 10, 26 AND 46). SN 85-547,657. PUB. 7-3-2012. FILED 2-20-2012.
- 4,210,026. **INNOTUF (STANDARD CHARACTER)**. INNOVATIVE POLYMERS, INC., (U.S. CLS. 1, 5, 6, 10, 26 AND 46). SN 85-556,793. PUB. 7-3-2012. FILED 2-29-2012.
- 4,210,200. **INNOGREEN (STANDARD CHARACTER)**. INNOVATIVE POLYMERS, INC., (U.S. CLS. 1, 5, 6, 10, 26 AND 46). SN 85-612,485. PUB. 7-3-2012. FILED 4-30-2012.

CLASS 2—PAINTS

- 4,208,251 (*See Class 1 for this trademark*).
- 4,208,269. **SUPER-LUMINOVA (STANDARD CHARACTER)**. LUMINOVA AG, SCHWEIZ, (U.S. CLS. 6, 11 AND 16). SN 79-098,114. PUB. 7-3-2012. FILED 4-15-2011.
- 4,208,367. **RICOH PRODUCTION PRINT SOLUTIONS (STANDARD CHARACTER)**. RICOH COMPANY, LTD., MULTIPLE CLASS, (INT. CLS. 2, 9, 16, 20, 35, 37, 40 AND 42), (U.S. CLS. 2, 5, 6, 11, 13, 16, 21, 22, 23, 25, 26, 29, 32, 36, 37, 38, 50, 100, 101, 102, 103 AND 106). SN 79-103,701. PUB. 7-3-2012. FILED 5-16-2011.
- 4,208,406. **X (STYLIZED)**. CANON KABUSHIKI KAISHA, (U.S. CLS. 6, 11 AND 16). SN 79-107,775. PUB. 7-3-2012. FILED 12-1-2011.
- 4,208,412 (*See Class 1 for this trademark*).
- 4,208,490 (*See Class 1 for this trademark*).
- 4,208,775 (*See Class 1 for this trademark*).
- 4,208,793. **PREVENTEX (STANDARD CHARACTER)**. HART SOLUTIONS GROUP, INC., (U.S. CLS. 6, 11 AND 16). SN 85-380,804. PUB. 7-3-2012. FILED 7-26-2011.
- 4,208,858 (*See Class 1 for this trademark*).

- 4,208,862 (*See Class 1 for this trademark*).
- 4,209,395. **CABIN COLORS (STANDARD CHARACTER)**. WILDWOODS MANUFACTURING COMPANY LLC, MULTIPLE CLASS, (INT. CLS. 2 AND 20), (U.S. CLS. 2, 6, 11, 13, 16, 22, 25, 32 AND 50). SN 85-525,969. PUB. 7-3-2012. FILED 1-26-2012.
- 4,209,427. **C CERAMIFIX TOUCH UP SOLUTIONS AND DESIGN**. CERAMIFIX LLC, DBA CERAMIFIX, (U.S. CLS. 6, 11 AND 16). SN 85-527,576. PUB. 7-3-2012. FILED 1-27-2012.
- 4,209,646. **NOVOGRATZ AND DESIGN**. NOVOGRATZ, ROBERT, AND NOVOGRATZ, CORTNEY, MULTIPLE CLASS, (INT. CLS. 2 AND 42), (U.S. CLS. 6, 11, 16, 100 AND 101). SN 85-541,871. PUB. 7-3-2012. FILED 2-14-2012.
- 4,209,802. **TRU-FLEX (STANDARD CHARACTER)**. COMPLEMENTARY COATINGS CORP., (U.S. CLS. 6, 11 AND 16). SN 85-544,369. PUB. 7-3-2012. FILED 2-16-2012.
- 4,210,137. **STORMPLATE (STANDARD CHARACTER)**. COMPLEMENTARY COATINGS CORP., (U.S. CLS. 6, 11 AND 16). SN 85-586,144. PUB. 7-3-2012. FILED 4-2-2012.

CLASS 3—COSMETICS AND CLEANING PREPARATIONS

- 4,208,126. **BLING (STYLIZED)**. HIP HOP STOCK EXCHANGE & INVESTMENT INC., (U.S. CLS. 1, 4, 6, 50, 51 AND 52). SN 76-624,072. PUB. 7-3-2012. FILED 12-13-2004.
- 4,208,137. **METALWAX AND DESIGN**. MACPRO DISTRIBUTORS, (U.S. CLS. 1, 4, 6, 50, 51 AND 52). SN 76-708,370. PUB. 7-3-2012. FILED 7-15-2011.
- 4,208,166. **SUISSE PROGRAMME (STANDARD CHARACTER)**. SUISSE PROGRAMME LIMITED, (U.S. CLS. 1, 4, 6, 50, 51 AND 52). SN 77-202,572. PUB. 7-3-2012. FILED 6-11-2007.
- 4,208,187. **WOMEN'S WELLNESS (STANDARD CHARACTER)**. RWACHSBERG HOLDINGS INC., MULTIPLE CLASS, (INT. CLS. 3, 5, 29, 30, 32 AND 33), (U.S. CLS. 1, 4, 6, 18, 44, 45, 46, 47, 48, 49, 50, 51 AND 52). SN 77-769,041. PUB. 7-3-2012. FILED 6-26-2009.
- 4,208,200. **RESTORING NECK CREAM AND DESIGN**. AMOR-EPACIFIC CORPORATION, (U.S. CLS. 1, 4, 6, 50, 51 AND 52). SN 77-899,133. PUB. 7-3-2012. FILED 12-22-2009.
- 4,208,236. **BLUMARINE BELLISSIMA (STYLIZED)**. BLUFIN S.P.A., (U.S. CLS. 1, 4, 6, 50, 51 AND 52). SN 79-071,598. PUB. 7-3-2012. FILED 3-18-2009.
- 4,208,243. **GERONIMO STILTON AND DESIGN**. ATLANTY-CA SPA, MULTIPLE CLASS, (INT. CLS. 3, 9, 16, 20, 24, 25, 28, 29, 30, 32, 41 AND 43), (U.S. CLS. 1, 2, 4, 5, 6, 13, 21, 22, 25, 26, 29, 32, 36, 37, 38, 39, 42, 45, 46, 48, 50, 51, 52, 100, 101 AND 107). SN 79-089,599. PUB. 7-3-2012. FILED 7-26-2010.
- 4,208,263. **MISCELLANEOUS DESIGN**. NIKOLAJ POSCH, MULTIPLE CLASS, (INT. CLS. 3, 5, 30, 32 AND 33), (U.S. CLS. 1, 4, 6, 18, 44, 45, 46, 47, 48, 49, 50, 51 AND 52). SN 79-095,897. PUB. 7-3-2012. FILED 9-24-2010.
- 4,208,271 (*See Class 1 for this trademark*).
- 4,208,277. **JUSTCAVALLI (STYLIZED)**. ROBERTO CAVALLI S.P.A., MULTIPLE CLASS, (INT. CLS. 3, 9, 14, 18 AND 25), (U.S. CLS. 1, 2, 3, 4, 6, 21, 22, 23, 26, 27, 28, 36, 38, 39, 41, 50, 51 AND 52). SN 79-099,730. PUB. 7-3-2012. FILED 6-1-2011.
- 4,208,283. **C AND DESIGN**. ROBERTO CAVALLI S.P.A., MULTIPLE CLASS, (INT. CLS. 3, 9, 14, 18 AND 25), (U.S. CLS. 1, 2, 3, 4, 6, 21, 22, 23, 26, 27, 28, 36, 38, 39, 41, 50, 51 AND 52). SN 79-100,479. PUB. 7-3-2012. FILED 6-1-2011.
- 4,208,289. **BVB (STYLIZED)**. SISYPHUS TRADING LLP, MULTIPLE CLASS, (INT. CLS. 3, 4, 8, 9, 14, 18, 20, 21, 24, 28, 34 AND 43), (U.S. CLS. 1, 2, 3, 4, 6, 8, 9, 13, 15, 17, 21, 22, 23, 25, 26, 27, 28, 29, 30, 32, 33, 36, 38, 40, 41, 42, 44, 50, 51, 52, 100 AND 101). SN 79-100,919. PUB. 7-3-2012. FILED 5-23-2011.
- 4,208,300. **ALGOBOTO (STYLIZED)**. EXAMONE ENTERPRISES LTD, (U.S. CLS. 1, 4, 6, 50, 51 AND 52). SN 79-101,632. PUB. 7-3-2012. FILED 7-6-2011.
- 4,208,308. **STAG (STYLIZED)**. AVRUPA ILAÇ VE KOZMETİK SANAYİ TICARET ANONİM ŞİRKETİ, MULTIPLE CLASS, (INT. CLS. 3, 5 AND 10), (U.S. CLS. 1, 4, 6, 18, 26, 39, 44, 46, 50, 51 AND 52). SN 79-101,849. PUB. 7-3-2012. FILED

- 3-10-2011.
4,208,318 (*See Class 1 for this trademark*).
- 4,208,320. **GHD GOLD (STANDARD CHARACTER)**. JEMELLA GROUP LIMITED C/O EVERSHEDS LLP, MULTIPLE CLASS, (INT. CLS. 3, 9 AND 11), (U.S. CLS. 1, 4, 6, 13, 21, 23, 26, 31, 34, 36, 38, 50, 51 AND 52). SN 79-102,096. PUB. 7-3-2012. FILED 10-21-2010.
- 4,208,334. **CROSSHATCH MCR AND DESIGN**. BOI TRADING COMPANY LTD., MULTIPLE CLASS, (INT. CLS. 3, 18 AND 25), (U.S. CLS. 1, 2, 3, 4, 6, 22, 39, 41, 50, 51 AND 52). SN 79-102,659. PUB. 7-3-2012. FILED 8-2-2011.
- 4,208,363. **BLANC CAR (STANDARD CHARACTER)**. DR. ZIMMERMANN GES.M.B.H. & CO., (U.S. CLS. 1, 4, 6, 50, 51 AND 52). SN 79-103,472. PUB. 7-3-2012. FILED 6-30-2011.
- 4,208,378. **GOOD GIRL (STANDARD CHARACTER)**. CAROLINA HERRERA LTD, (U.S. CLS. 1, 4, 6, 50, 51 AND 52). SN 79-104,822. PUB. 7-3-2012. FILED 9-26-2011.
- 4,208,381. **FARFOR PRINCESS (STANDARD CHARACTER)**. V.A.G. CHEMIE HANDELSGESELLSCHAFT MBH, MULTIPLE CLASS, (INT. CLS. 3, 5, 14, 41 AND 44), (U.S. CLS. 1, 2, 4, 6, 18, 27, 28, 44, 46, 50, 51, 52, 100, 101 AND 107). SN 79-105,297. PUB. 5-22-2012. FILED 7-7-2011.
- 4,208,390. **VARISAN (STANDARD CHARACTER)**. CIZETA MEDICALI S.P.A., MULTIPLE CLASS, (INT. CLS. 3 AND 5), (U.S. CLS. 1, 4, 6, 18, 44, 46, 50, 51 AND 52). SN 79-106,249. PUB. 7-3-2012. FILED 9-21-2011.
- 4,208,409. **TPM (STANDARD CHARACTER)**. PHOSPHAGENICS LIMITED, (U.S. CLS. 1, 4, 6, 50, 51 AND 52). SN 79-108,036. PUB. 7-3-2012. FILED 3-17-2011.
- 4,208,411. **APISENSITIVE (STYLIZED)**. MELVITA, (U.S. CLS. 1, 4, 6, 50, 51 AND 52). SN 79-108,125. PUB. 7-3-2012. FILED 11-7-2011.
- 4,208,417. **ATODERM (STYLIZED)**. LABORATOIRE BIODERMA, (U.S. CLS. 1, 4, 6, 50, 51 AND 52). SN 79-108,521. PUB. 7-3-2012. FILED 12-13-2011.
- 4,208,422. **GRAND BAL (STANDARD CHARACTER)**. PARFUMS CHRISTIAN DIOR, MULTIPLE CLASS, (INT. CLS. 3 AND 4), (U.S. CLS. 1, 4, 6, 15, 50, 51 AND 52). SN 79-109,254. PUB. 7-3-2012. FILED 1-9-2012.
- 4,208,430. **ODU ISPAHAN (STANDARD CHARACTER)**. PARFUMS CHRISTIAN DIOR, MULTIPLE CLASS, (INT. CLS. 3 AND 4), (U.S. CLS. 1, 4, 6, 15, 50, 51 AND 52). SN 79-109,980. PUB. 7-3-2012. FILED 1-9-2012.
- 4,208,444. **MISCELLANEOUS DESIGN**. LUMENE OY, MULTIPLE CLASS, (INT. CLS. 3 AND 44), (U.S. CLS. 1, 4, 6, 50, 51, 52, 100 AND 101). SN 79-112,551. PUB. 7-3-2012. FILED 1-18-2012.
- 4,208,454. **BECKHAM (STANDARD CHARACTER)**. BECKHAM, DAVID, (U.S. CLS. 1, 4, 6, 50, 51 AND 52). SN 85-039,117. PUB. 7-3-2012. FILED 5-14-2010.
- 4,208,467. **EAU DE L'AME (STYLIZED)**. THEFACESHOP CO., LTD., (U.S. CLS. 1, 4, 6, 50, 51 AND 52). SN 85-083,113. PUB. 7-3-2012. FILED 7-13-2010.
- 4,208,478. **CANTERBURY (STANDARD CHARACTER)**. CANTERBURY LIMITED, MULTIPLE CLASS, (INT. CLS. 3, 9 AND 28), (U.S. CLS. 1, 4, 6, 21, 22, 23, 26, 36, 38, 50, 51 AND 52). SN 85-110,929. PUB. 5-29-2012. FILED 8-19-2010.
- 4,208,541. **SCHWARZKOPF PROFESSIONAL AND DESIGN**. HENKEL AG & CO. KGAA, (U.S. CLS. 1, 4, 6, 50, 51 AND 52). SN 85-222,943. PUB. 4-26-2011. FILED 1-21-2011.
- 4,208,598. **PACIFIC DIRECT (STANDARD CHARACTER)**. PACIFIC DIRECT LIMITED, MULTIPLE CLASS, (INT. CLS. 3, 21, 25 AND 35), (U.S. CLS. 1, 2, 4, 6, 13, 22, 23, 29, 30, 33, 39, 40, 50, 51, 52, 100, 101 AND 102). SN 85-304,805. PUB. 7-3-2012. FILED 4-26-2011.
- 4,208,627. **BUCKETS OF BLOOD AND DESIGN**. EX MORTIS, INC., (U.S. CLS. 1, 4, 6, 50, 51 AND 52). SN 85-333,889. PUB. 7-3-2012. FILED 5-31-2011.
- 4,208,721. **LIQUID CCT (STANDARD CHARACTER)**. SASI HOLDINGS PTY LTD, (U.S. CLS. 1, 4, 6, 50, 51 AND 52). SN 85-368,892. PUB. 7-3-2012. FILED 7-12-2011.
- 4,208,722. **MINERAL CCT (STANDARD CHARACTER)**. SASI HOLDINGS PTY LTD, (U.S. CLS. 1, 4, 6, 50, 51 AND 52). SN 85-368,898. PUB. 7-3-2012. FILED 7-12-2011.
- 4,208,723. **K-GRAVEL (STANDARD CHARACTER)**. SASI HOLDINGS PTY LTD, (U.S. CLS. 1, 4, 6, 50, 51 AND 52). SN 85-368,904. PUB. 7-3-2012. FILED 7-12-2011.
- 4,208,724. **FRIZZY LOGIC (STANDARD CHARACTER)**. SASI HOLDINGS PTY LTD, (U.S. CLS. 1, 4, 6, 50, 51 AND 52). SN 85-368,909. PUB. 7-3-2012. FILED 7-12-2011.
- 4,208,725. **SURF BOMB (STANDARD CHARACTER)**. SASI HOLDINGS PTY LTD, (U.S. CLS. 1, 4, 6, 50, 51 AND 52). SN 85-368,914. PUB. 7-3-2012. FILED 7-12-2011.
- 4,208,774. **SAC (STANDARD CHARACTER)**. TROVOGUE INC, (U.S. CLS. 1, 4, 6, 50, 51 AND 52). SN 85-376,871. PUB. 7-3-2012. FILED 7-21-2011.
- 4,208,789. **TREAT YOURSELF TO BEAUTY (STANDARD CHARACTER)**. BEAUTY TREATS INTERNATIONAL CO., INC., (U.S. CLS. 1, 4, 6, 50, 51 AND 52). SN 85-379,422. PUB. 7-3-2012. FILED 7-24-2011.
- 4,208,796. **A AND DESIGN**. ANASTASIA BEVERLY HILLS, INC., MULTIPLE CLASS, (INT. CLS. 3, 8 AND 21), (U.S. CLS. 1, 2, 4, 6, 13, 23, 28, 29, 30, 33, 40, 44, 50, 51 AND 52). SN 85-381,511. PUB. 7-3-2012. FILED 7-26-2011.
- 4,208,858 (*See Class 1 for this trademark*).
- 4,208,862 (*See Class 1 for this trademark*).
- 4,208,898. **DR.MORITA AND DESIGN**. MORITA BIOTECH CORP., (U.S. CLS. 1, 4, 6, 50, 51 AND 52). SN 85-411,589. PUB. 7-3-2012. FILED 8-31-2011.
- 4,208,906. **WOODFIRE (STANDARD CHARACTER)**. STARLUME, INC., MULTIPLE CLASS, (INT. CLS. 3 AND 4), (U.S. CLS. 1, 4, 6, 15, 50, 51 AND 52). SN 85-412,945. PUB. 7-3-2012. FILED 9-1-2011.
- 4,208,977. **RAINSOFT AND DESIGN**. AQUION, INC., MULTIPLE CLASS, (INT. CLS. 3, 6, 7 AND 11), (U.S. CLS. 1, 2, 4, 6, 12, 13, 14, 19, 21, 23, 25, 31, 34, 35, 50, 51 AND 52). SN 85-444,210. PUB. 3-27-2012. FILED 10-11-2011.
- 4,209,035. **LINDA ROSS (STANDARD CHARACTER)**. EPICORE BY LINDA ROSS, MULTIPLE CLASS, (INT. CLS. 3 AND 44), (U.S. CLS. 1, 4, 6, 50, 51, 52, 100 AND 101). SN 85-465,572. PUB. 7-3-2012. FILED 11-6-2011.
- 4,209,036. **DEODORIZES CLEANS PERFUMES TEN FLORAL AND DESIGN**. MISTOLIN CARIBE, INC., (U.S. CLS. 1, 4, 6, 50, 51 AND 52). SN 85-466,538. PUB. 7-3-2012. FILED 11-7-2011.
- 4,209,097. **ROSEMARY AND DESIGN**. SHENZHEN HUA-SHEN IMPORT & EXPORT CO.,LTD, MULTIPLE CLASS, (INT. CLS. 3, 18, 25 AND 33), (U.S. CLS. 1, 2, 3, 4, 6, 22, 39, 41, 47, 49, 50, 51 AND 52). SN 85-490,133. PUB. 7-3-2012. FILED 12-8-2011.
- 4,209,127. **C CLINIQUE AND DESIGN**. CLINIQUE LABORATORIES, LLC, (U.S. CLS. 1, 4, 6, 50, 51 AND 52). SN 85-497,461. PUB. 7-3-2012. FILED 12-16-2011.
- 4,209,136. **W HOMEMADE ESPECIALLY FOR YOU IN MICHIGAN SOAPS AND SUCH AND DESIGN**. BRUNING, KELLY L., DBA SOAPS AND SUCH, L.L.C, (U.S. CLS. 1, 4, 6, 50, 51 AND 52). SN 85-499,305. PUB. 7-3-2012. FILED 12-19-2011.
- 4,209,193. **RX GOOD NEIGHBOR PHARMACY AND DESIGN**. AMERISOURCEBERGEN DRUG CORPORATION, MULTIPLE CLASS, (INT. CLS. 3, 5 AND 10), (U.S. CLS. 1, 4, 6, 18, 26, 39, 44, 46, 50, 51 AND 52). SN 85-510,230. PUB. 7-3-2012. FILED 1-6-2012.
- 4,209,298. **ÅKVA (STANDARD CHARACTER)**. RAGSDALE, CHRISTINA M., (U.S. CLS. 1, 4, 6, 50, 51 AND 52). SN 85-521,927. PUB. 7-3-2012. FILED 1-20-2012.
- 4,209,320. **SERVICEMASTER CLEAN (STANDARD CHARACTER)**. SERVICEMASTER BRANDS, L.L.C., (U.S. CLS. 1, 4, 6, 50, 51 AND 52). SN 85-522,878. PUB. 7-3-2012. FILED 1-23-2012.
- 4,209,348. **SIMPLY B, MD (STANDARD CHARACTER)**. KDT ENTERPRISES, LLC, (U.S. CLS. 1, 4, 6, 50, 51 AND 52). SN 85-523,994. PUB. 7-3-2012. FILED 1-24-2012.
- 4,209,358. **EM ELAINE'S MANE NATURAL HAIR AND SKIN OILS AND DESIGN**. MITCHELL, ELAINE, (U.S. CLS. 1, 4, 6, 50, 51 AND 52). SN 85-524,612. PUB. 7-3-2012. FILED 1-25-2012.
- 4,209,376. **ISLAND VANILLA (STANDARD CHARACTER)**. PACIFICA, INC., (U.S. CLS. 1, 4, 6, 50, 51 AND 52). SN 85-525,289. PUB. 7-3-2012. FILED 1-25-2012.
- 4,209,377. **COLOR QUENCH (STANDARD CHARACTER)**. PACIFICA, INC., (U.S. CLS. 1, 4, 6, 50, 51 AND 52). SN 85-525,310. PUB. 7-3-2012. FILED 1-25-2012.
- 4,209,388. **TRANSITION NATURAL (STANDARD CHARACTER)**. PROFESSIONAL PRODUCTS UNLIMITED, INC., (U.S. CLS. 1, 4, 6, 50, 51 AND 52). SN 85-525,876. PUB. 7-3-

2012. FILED 1-26-2012.
- 4,209,454. **PEDI-SORB (STANDARD CHARACTER)**. PEDINOL PHARMACAL, INC., (U.S. CLS. 1, 4, 6, 50, 51 AND 52). SN 85-530,211. PUB. 7-3-2012. FILED 1-31-2012.
- 4,209,534. **ULTRA FLUFFY (STANDARD CHARACTER)**. BLUE CROSS LABORATORIES, (U.S. CLS. 1, 4, 6, 50, 51 AND 52). SN 85-539,258. PUB. 7-3-2012. FILED 2-10-2012.
- 4,209,598. **CAMILLE&MAE FINE TOILETRIES AND DESIGN**. VANILLA SUGAR PTY LTD., (U.S. CLS. 1, 4, 6, 50, 51 AND 52). SN 85-541,134. PUB. 7-3-2012. FILED 2-13-2012.
- 4,209,600. **G'S PIMP JUICE AND DESIGN**. LAZZARO CAR CARE PRODUCTS, (U.S. CLS. 1, 4, 6, 50, 51 AND 52). SN 85-541,159. PUB. 7-3-2012. FILED 2-13-2012.
- 4,209,601. **SOFT & MOIST (STYLIZED)**. MIDLAND PRODUCTS LLC, (U.S. CLS. 1, 4, 6, 50, 51 AND 52). SN 85-541,171. PUB. 7-3-2012. FILED 2-13-2012.
- 4,209,620. **SPREAD THE LOVE (STANDARD CHARACTER)**. BOODA ORGANICS, INC., (U.S. CLS. 1, 4, 6, 50, 51 AND 52). SN 85-541,399. PUB. 7-3-2012. FILED 2-13-2012.
- 4,209,628. **FOR ALL YOUR DIRTY TOYS (STANDARD CHARACTER)**. JW SALES, INC., (U.S. CLS. 1, 4, 6, 50, 51 AND 52). SN 85-541,525. PUB. 7-3-2012. FILED 2-13-2012.
- 4,209,630 (*See Class 1 for this trademark*).
- 4,209,663. **LOCOCLEAN (STANDARD CHARACTER)**. ADDITIVE TECHNOLOGIES, LLC, (U.S. CLS. 1, 4, 6, 50, 51 AND 52). SN 85-542,153. PUB. 7-3-2012. FILED 2-14-2012.
- 4,209,694. **FLY WITH ME (STANDARD CHARACTER)**. NYX, LOS ANGELES INC., (U.S. CLS. 1, 4, 6, 50, 51 AND 52). SN 85-542,655. PUB. 7-3-2012. FILED 2-14-2012.
- 4,209,696. **"STAY MATTE BUT NOT FLAT" (STANDARD CHARACTER)**. NYX, LOS ANGELES INC., (U.S. CLS. 1, 4, 6, 50, 51 AND 52). SN 85-542,685. PUB. 7-3-2012. FILED 2-14-2012.
- 4,209,735. **EVO8 PS AND DESIGN**. EVOLUTION TECHNOLOGIES INTERNATIONAL, (U.S. CLS. 1, 4, 6, 50, 51 AND 52). SN 85-543,310. PUB. 7-3-2012. FILED 2-15-2012.
- 4,209,793. **I MIST YOU (...HAVE YOU MIST ME?) (STANDARD CHARACTER)**. AUSTRALIAN GOLD, LLC, (U.S. CLS. 1, 4, 6, 50, 51 AND 52). SN 85-544,180. PUB. 7-3-2012. FILED 2-16-2012.
- 4,209,805. **SLOPPY JOE (STANDARD CHARACTER)**. G2 REVOLUTION, LLC, (U.S. CLS. 1, 4, 6, 50, 51 AND 52). SN 85-544,434. PUB. 7-3-2012. FILED 2-16-2012.
- 4,209,813. **PROFESSOR GOODHABITS (STANDARD CHARACTER)**. SOAP TIME, LLC, (U.S. CLS. 1, 4, 6, 50, 51 AND 52). SN 85-544,534. PUB. 7-3-2012. FILED 2-16-2012.
- 4,209,859. **MOSHEKO AND DESIGN**. OPERATION SPECIALITY RETAIL LLC, (U.S. CLS. 1, 4, 6, 50, 51 AND 52). SN 85-545,397. PUB. 7-3-2012. FILED 2-16-2012.
- 4,209,874. **H-E-B AND DESIGN**. HEB GROCERY COMPANY, LP, (U.S. CLS. 1, 4, 6, 50, 51 AND 52). SN 85-545,729. PUB. 7-3-2012. FILED 2-17-2012.
- 4,209,885. **NOBOMIST (STANDARD CHARACTER)**. BIOFORTE USA LLC, (U.S. CLS. 1, 4, 6, 50, 51 AND 52). SN 85-546,055. PUB. 7-3-2012. FILED 2-17-2012.
- 4,209,886. **POTION PANTRY (STANDARD CHARACTER)**. TAMMY M BATLEY, DBA POTION PANTRY, (U.S. CLS. 1, 4, 6, 50, 51 AND 52). SN 85-546,061. PUB. 7-3-2012. FILED 2-17-2012.
- 4,209,917. **FINULITE (STANDARD CHARACTER)**. FINULITE LLC, (U.S. CLS. 1, 4, 6, 50, 51 AND 52). SN 85-546,595. PUB. 7-3-2012. FILED 2-17-2012.
- 4,209,967. **KLEANLOGIK (STANDARD CHARACTER)**. CONCEPT LABORATORIES, INC., (U.S. CLS. 1, 4, 6, 50, 51 AND 52). SN 85-548,784. PUB. 7-3-2012. FILED 2-21-2012.
- 4,210,000. **MIRACLE PLUS (STANDARD CHARACTER)**. CONCEPT LABORATORIES, INC., MULTIPLE CLASS, (INT. CLS. 3 AND 5), (U.S. CLS. 1, 4, 6, 18, 44, 46, 50, 51 AND 52). SN 85-553,651. PUB. 7-3-2012. FILED 2-27-2012.
- 4,210,001. **PASSIONISTA FRUIT (STANDARD CHARACTER)**. THE PROCTER & GAMBLE COMPANY, (U.S. CLS. 1, 4, 6, 50, 51 AND 52). SN 85-553,702. PUB. 7-3-2012. FILED 2-27-2012.
- 4,210,012. **LIGHTS, CAMERA, LASHES! (STANDARD CHARACTER)**. TARTE, INC., (U.S. CLS. 1, 4, 6, 50, 51 AND 52). SN 85-555,203. PUB. 7-3-2012. FILED 2-28-2012.
- 4,210,013. **LIGHTS, CAMERA, SPLASHES! (STANDARD CHARACTER)**. TARTE, INC., (U.S. CLS. 1, 4, 6, 50, 51 AND 52). SN 85-555,249. PUB. 7-3-2012. FILED 2-28-2012.
- 4,210,015. **GIFTED (STANDARD CHARACTER)**. TARTE, INC., (U.S. CLS. 1, 4, 6, 50, 51 AND 52). SN 85-555,366. PUB. 7-3-2012. FILED 2-28-2012.
- 4,210,046. **P R E M I U M SPA AND DESIGN**. VANILLA SUGAR PTY LTD., (U.S. CLS. 1, 4, 6, 50, 51 AND 52). SN 85-563,449. PUB. 7-3-2012. FILED 3-7-2012.
- 4,210,094. **ARBONNE THE DAZZLER (STANDARD CHARACTER)**. ARBONNE INTERNATIONAL, LLC, (U.S. CLS. 1, 4, 6, 50, 51 AND 52). SN 85-576,541. PUB. 7-3-2012. FILED 3-22-2012.
- 4,210,095. **ARBONNE THE DYNAMO (STANDARD CHARACTER)**. ARBONNE INTERNATIONAL, LLC, (U.S. CLS. 1, 4, 6, 50, 51 AND 52). SN 85-576,549. PUB. 7-3-2012. FILED 3-22-2012.
- 4,210,138. **GIT-R-DONE (STANDARD CHARACTER)**. GIT-R-DONE PRODUCTIONS, INC., (U.S. CLS. 1, 4, 6, 50, 51 AND 52). SN 85-586,487. PUB. 7-3-2012. FILED 4-2-2012.
- 4,210,149. **SPARK (STANDARD CHARACTER)**. DE ROBLIN, INC., (U.S. CLS. 1, 4, 6, 50, 51 AND 52). SN 85-591,486. PUB. 7-3-2012. FILED 4-6-2012.
- 4,210,152. **XBI XTREME BEAUTY INTERNATIONAL AND DESIGN**. XTREME TOOLS INTERNATIONAL, INC., (U.S. CLS. 1, 4, 6, 50, 51 AND 52). SN 85-593,300. PUB. 7-3-2012. FILED 4-10-2012.
- 4,210,189. **ASHIEDA (STANDARD CHARACTER)**. EHRlich, SARAH, MULTIPLE CLASS, (INT. CLS. 3 AND 5), (U.S. CLS. 1, 4, 6, 18, 44, 46, 50, 51 AND 52). SN 85-607,543. PUB. 7-3-2012. FILED 4-25-2012.
- 4,210,203. **SKINTENSIFY (STYLIZED)**. LCL ENTERPRISES, INC., (U.S. CLS. 1, 4, 6, 50, 51 AND 52). SN 85-614,928. PUB. 7-3-2012. FILED 5-2-2012.
- 4,210,224. **PHYTO UV SHIELD (STANDARD CHARACTER)**. COSWAY COMPANY, INC., (U.S. CLS. 1, 4, 6, 50, 51 AND 52). SN 85-977,223. PUB. 1-24-2012. FILED 11-18-2010.

CLASS 4—LUBRICANTS AND FUELS

- 4,208,222. **MAGIC LIGHT QUALITY CANDLES AND DESIGN**. VELAS HISPANIOLA, S.A., DBA VELAS HISPANIOLA, S.A., (U.S. CLS. 1, 6 AND 15). SN 77-967,285. PUB. 9-13-2011. FILED 3-24-2010.
- 4,208,289 (*See Class 3 for this trademark*).
- 4,208,393. **THE WILD GEESSE SOLDIERS AND HEROES (STANDARD CHARACTER)**. LODESTAR ANSTALT; (A LIECHTENSTEIN COMPANY), MULTIPLE CLASS, (INT. CLS. 4, 9, 14, 25 AND 34), (U.S. CLS. 1, 2, 6, 8, 9, 15, 17, 21, 22, 23, 26, 27, 28, 36, 38, 39 AND 50). SN 79-106,485. PUB. 7-3-2012. FILED 7-14-2011.
- 4,208,422 (*See Class 3 for this trademark*).
- 4,208,430 (*See Class 3 for this trademark*).
- 4,208,481 (*See Class 1 for this trademark*).
- 4,208,503 (*See Class 1 for this trademark*).
- 4,208,644. **RWE (STANDARD CHARACTER)**. RWE AKTIENGESELLSCHAFT, MULTIPLE CLASS, (INT. CLS. 4, 7, 9, 35, 36, 37, 39 AND 40), (U.S. CLS. 1, 6, 13, 15, 19, 21, 23, 26, 31, 34, 35, 36, 38, 100, 101, 102, 103, 105 AND 106). SN 85-343,815. PUB. 7-3-2012. FILED 6-10-2011.
- 4,208,673. **CLEAN AIR (STANDARD CHARACTER)**. WAY OUT WAX INC., (U.S. CLS. 1, 6 AND 15). SN 85-354,990. PUB. 7-3-2012. FILED 6-24-2011.
- 4,208,676. **CLEAN AIR ALL-NATURAL SMOKE & ODOR REMOVER AND DESIGN**. WAY OUT WAX INC., (U.S. CLS. 1, 6 AND 15). SN 85-356,534. PUB. 7-3-2012. FILED 6-27-2011.
- 4,208,906 (*See Class 3 for this trademark*).
- 4,208,931. **PEABODY (STANDARD CHARACTER)**. PEABODY ENERGY CORPORATION, MULTIPLE CLASS, (INT. CLS. 4 AND 35), (U.S. CLS. 1, 6, 15, 100, 101 AND 102). SN 85-421,085. PUB. 7-3-2012. FILED 9-13-2011.
- 4,208,944. **SPERIAN ENERGY (STANDARD CHARACTER)**. SPERIAN ENERGY CORP., (U.S. CLS. 1, 6 AND 15). SN 85-429,910. PUB. 7-3-2012. FILED 9-22-2011.
- 4,209,154. **LA COSTA AND DESIGN**. LA COSTA CANDLE, (U.S. CLS. 1, 6 AND 15). SN 85-503,650. PUB. 7-3-2012.

- FILED 12-25-2011.
 4,209,568. **AQUAMATTE (STANDARD CHARACTER)**. MICRO POWDERS, INC., (U.S. CLS. 1, 6 AND 15). SN 85-540,685. PUB. 7-3-2012. FILED 2-13-2012.
 4,209,748. **P AND DESIGN. PATRIOT BIODIESEL, LLC**, (U.S. CLS. 1, 6 AND 15). SN 85-543,459. PUB. 7-3-2012. FILED 2-15-2012.
 4,210,181. **AMFLO (STANDARD CHARACTER)**. PLEWS, INC., (U.S. CLS. 1, 6 AND 15). SN 85-604,068. PUB. 7-3-2012. FILED 4-20-2012.

CLASS 5—PHARMACEUTICALS

- 4,208,125. **MOLEMAX (STANDARD CHARACTER)**. BONIDE PRODUCTS, INC., (U.S. CLS. 6, 18, 44, 46, 51 AND 52). SN 76-570,251. PUB. 7-3-2012. FILED 1-15-2004.
 4,208,130. **NUTRI-FEM (STANDARD CHARACTER)**. THORNE RESEARCH, INC., (U.S. CLS. 6, 18, 44, 46, 51 AND 52). SN 76-694,833. PUB. 7-3-2012. FILED 12-15-2008.
 4,208,132. **VERNALIS (STANDARD CHARACTER)**. VERNALIS DEVELOPMENT LIMITED, MULTIPLE CLASS, (INT. CLS. 5 AND 42), (U.S. CLS. 6, 18, 44, 46, 51, 52, 100 AND 101). SN 76-699,990. PUB. 12-13-2011. FILED 10-22-2009.
 4,208,165. **BRAVADO MOISTURE-WICK WASHABLE BREAST PADS (STANDARD CHARACTER)**. MEDELA HOLDING AG, MULTIPLE CLASS, (INT. CLS. 5 AND 35), (U.S. CLS. 6, 18, 44, 46, 51, 52, 100, 101 AND 102). SN 77-182,238. PUB. 8-16-2011. FILED 5-16-2007.
 4,208,187 (*See Class 3 for this trademark*).
 4,208,226. **MASTER FORMULA**. MARK SISSON, (U.S. CLS. 6, 18, 44, 46, 51 AND 52). SN 78-079,899. PUB. 7-3-2012. FILED 8-17-2001.
 4,208,231. **PROSTAVAC (STYLIZED)**. AMVAC AG, (U.S. CLS. 6, 18, 44, 46, 51 AND 52). SN 79-048,489. PUB. 11-3-2009. FILED 11-26-2007.
 4,208,241. **ARGETELE (STANDARD CHARACTER)**. SANOFI, (U.S. CLS. 6, 18, 44, 46, 51 AND 52). SN 79-087,746. PUB. 7-3-2012. FILED 9-20-2010.
 4,208,253 (*See Class 1 for this trademark*).
 4,208,263 (*See Class 3 for this trademark*).
 4,208,268. **GELO (STANDARD CHARACTER)**. G. POHL-BOSKAMP GMBH & CO. KG, (U.S. CLS. 6, 18, 44, 46, 51 AND 52). SN 79-097,740. PUB. 2-7-2012. FILED 3-31-2011.
 4,208,271 (*See Class 1 for this trademark*).
 4,208,284. **WHITE BEE (STANDARD CHARACTER)**. MONTENEGRO S.R.L., MULTIPLE CLASS, (INT. CLS. 5 AND 32), (U.S. CLS. 6, 18, 44, 45, 46, 48, 51 AND 52). SN 79-100,497. PUB. 7-3-2012. FILED 6-13-2011.
 4,208,294. **COLDNER (STANDARD CHARACTER)**. PRONOVA LABORATORIES B.V., MULTIPLE CLASS, (INT. CLS. 5 AND 10), (U.S. CLS. 6, 18, 26, 39, 44, 46, 51 AND 52). SN 79-101,323. PUB. 7-3-2012. FILED 7-7-2011.
 4,208,308 (*See Class 3 for this trademark*).
 4,208,318 (*See Class 1 for this trademark*).
 4,208,326 (*See Class 1 for this trademark*).
 4,208,333. **HPCM HEALTH PROFESSIONALS FOR CELLULAR MEDICINE (STANDARD CHARACTER)**. MATTHIAS RATH, MULTIPLE CLASS, (INT. CLS. 5, 16, 38, 41, 42 AND 44), (U.S. CLS. 2, 5, 6, 18, 22, 23, 29, 37, 38, 44, 46, 50, 51, 52, 100, 101, 104 AND 107). SN 79-102,638. PUB. 7-3-2012. FILED 7-22-2011.
 4,208,347. **EFLA (STANDARD CHARACTER)**. FRUTAROM SWITZERLAND LTD., MULTIPLE CLASS, (INT. CLS. 5 AND 30), (U.S. CLS. 6, 18, 44, 46, 51 AND 52). SN 79-102,844. PUB. 7-3-2012. FILED 4-8-2011.
 4,208,349. **HPCM (STANDARD CHARACTER)**. MATTHIAS RATH, MULTIPLE CLASS, (INT. CLS. 5, 16, 38, 41, 42 AND 44), (U.S. CLS. 2, 5, 6, 18, 22, 23, 29, 37, 38, 44, 46, 50, 51, 52, 100, 101, 104 AND 107). SN 79-102,876. PUB. 7-3-2012. FILED 7-22-2011.
 4,208,359. **EMMI (STANDARD CHARACTER)**. EMMI AG, MULTIPLE CLASS, (INT. CLS. 5, 29, 30 AND 32), (U.S. CLS. 6, 18, 44, 45, 46, 48, 51 AND 52). SN 79-103,230. PUB. 7-3-2012. FILED 8-12-2011.
 4,208,371. **DRY LIKE ME AND DESIGN. DRY LIKE ME LIMITED**, (U.S. CLS. 6, 18, 44, 46, 51 AND 52). SN 79-103,968. PUB. 7-3-2012. FILED 12-21-2010.
 4,208,381 (*See Class 3 for this trademark*).
 4,208,384. **APPLETREE (STANDARD CHARACTER)**. APPLE-TREE AG, MULTIPLE CLASS, (INT. CLS. 5, 42 AND 44), (U.S. CLS. 6, 18, 44, 46, 51, 52, 100 AND 101). SN 79-105,416. PUB. 7-3-2012. FILED 10-12-2011.
 4,208,390 (*See Class 3 for this trademark*).
 4,208,391. **HEBERPROT-P (STANDARD CHARACTER)**. HEBER BIOTEC, S.A.; (CONSEJO DE STADO), (U.S. CLS. 6, 18, 44, 46, 51 AND 52). SN 79-106,460. PUB. 7-3-2012. FILED 5-11-2011.
 4,208,403. **LOZANOC (STANDARD CHARACTER)**. MAYNE PHARMA INTERNATIONAL PTY LTD, (U.S. CLS. 6, 18, 44, 46, 51 AND 52). SN 79-107,377. PUB. 7-3-2012. FILED 11-22-2011.
 4,208,415. **COLPERMIN AND DESIGN. TILLOTTS PHARMA AG**, (U.S. CLS. 6, 18, 44, 46, 51 AND 52). SN 79-108,395. PUB. 7-3-2012. FILED 11-25-2011.
 4,208,449. **AI24 (STANDARD CHARACTER)**. THE SEMEX ALLIANCE, MULTIPLE CLASS, (INT. CLS. 5, 9, 10, 31, 35, 42 AND 44), (U.S. CLS. 1, 6, 18, 21, 23, 26, 36, 38, 39, 44, 46, 51, 52, 100, 101 AND 102). SN 85-006,464. PUB. 7-3-2012. FILED 4-5-2010.
 4,208,493. **ECO AND DESIGN. ECO ANIMAL HEALTH LIMITED**, (U.S. CLS. 6, 18, 44, 46, 51 AND 52). SN 85-151,476. PUB. 7-3-2012. FILED 10-13-2010.
 4,208,500. **DOSTAR (STANDARD CHARACTER)**. SANOFI, MULTIPLE CLASS, (INT. CLS. 5, 9 AND 10), (U.S. CLS. 6, 18, 21, 23, 26, 36, 38, 39, 44, 46, 51 AND 52). SN 85-168,388. PUB. 7-3-2012. FILED 11-3-2010.
 4,208,531. **ROSAVIT C AND DESIGN. COMERCIALIZADORA MD, S.A. DE C.V.**, (U.S. CLS. 6, 18, 44, 46, 51 AND 52). SN 85-202,772. PUB. 8-23-2011. FILED 12-21-2010.
 4,208,533. **OSTEO CALCIO 600-EX AND DESIGN. COMERCIALIZADORA MD, S.A. DE C.V.**, (U.S. CLS. 6, 18, 44, 46, 51 AND 52). SN 85-205,165. PUB. 4-24-2012. FILED 12-23-2010.
 4,208,619 (*See Class 1 for this trademark*).
 4,208,642. **GROGREEN AND DESIGN. GROGREEN, INC.**, MULTIPLE CLASS, (INT. CLS. 5 AND 44), (U.S. CLS. 6, 18, 44, 46, 51, 52, 100 AND 101). SN 85-341,515. PUB. 7-3-2012. FILED 6-8-2011.
 4,208,670. **GIA AND DESIGN. GIALIVE, INC.** (U.S. CLS. 6, 18, 44, 46, 51 AND 52). SN 85-353,655. PUB. 7-3-2012. FILED 6-23-2011.
 4,208,684. **PRESCRIPTION DIET (STANDARD CHARACTER)**. HILL'S PET NUTRITION, INC., (U.S. CLS. 6, 18, 44, 46, 51 AND 52). SN 85-359,224. PUB. 7-3-2012. FILED 6-29-2011.
 4,208,695. **ALOE PLUM S (STANDARD CHARACTER)**. YS HEALTH, (U.S. CLS. 6, 18, 44, 46, 51 AND 52). SN 85-361,264. PUB. 7-3-2012. FILED 6-30-2011.
 4,208,713. **LIVER NO. 1 (STANDARD CHARACTER)**. LIU, LILI, (U.S. CLS. 6, 18, 44, 46, 51 AND 52). SN 85-366,688. PUB. 7-3-2012. FILED 7-8-2011.
 4,208,716. **AFA+ (STANDARD CHARACTER)**. SHANNON HAMILTON, (U.S. CLS. 6, 18, 44, 46, 51 AND 52). SN 85-367,622. PUB. 7-3-2012. FILED 7-11-2011.
 4,208,727. **TISSUESEAL AND DESIGN. TISSUESEAL, LLC**, (U.S. CLS. 6, 18, 44, 46, 51 AND 52). SN 85-369,344. PUB. 7-3-2012. FILED 7-12-2011.
 4,208,731. **PULMO GRIP (STANDARD CHARACTER)**. SACA TUEME, VICTOR JORGE, (U.S. CLS. 6, 18, 44, 46, 51 AND 52). SN 85-371,128. PUB. 7-3-2012. FILED 7-14-2011.
 4,208,785. **ERECT 3X (STANDARD CHARACTER)**. LO VI POR TV, LLC, (U.S. CLS. 6, 18, 44, 46, 51 AND 52). SN 85-378,901. PUB. 7-3-2012. FILED 7-22-2011.
 4,208,803. **MISCELLANEOUS DESIGN. DONG WHA PHARM. CO., LTD.**, MULTIPLE CLASS, (INT. CLS. 5 AND 32), (U.S. CLS. 6, 18, 44, 45, 46, 48, 51 AND 52). SN 85-383,925. PUB. 7-3-2012. FILED 7-28-2011.
 4,208,806. **AVILOMICS (STANDARD CHARACTER)**. AVILA THERAPEUTICS, INC., (U.S. CLS. 6, 18, 44, 46, 51 AND 52). SN 85-384,807. PUB. 7-3-2012. FILED 7-29-2011.
 4,208,838. **IMMUNOLOGIX (STANDARD CHARACTER)**. JOSE OLALDE, (U.S. CLS. 6, 18, 44, 46, 51 AND 52). SN 85-393,434. PUB. 7-3-2012. FILED 8-9-2011.
 4,208,858 (*See Class 1 for this trademark*).
 4,208,862 (*See Class 1 for this trademark*).

- 4,208,916. **GROOVYCHEEKS AND DESIGN**. MRLC TRADING LLC, DBA GROOVYCHEEKS, (U.S. CLS. 6, 18, 44, 46, 51 AND 52). SN 85-415,009. PUB. 7-3-2012. FILED 9-5-2011.
- 4,208,945. **GOLDLUCK (STYLIZED)**. ARIVITA PRODUCTS USA LLC, (U.S. CLS. 6, 18, 44, 46, 51 AND 52). SN 85-430,003. PUB. 7-3-2012. FILED 9-22-2011.
- 4,209,007. **GC-MSM 3550 (STANDARD CHARACTER)**. PROGRESSIVE LABORATORIES, INC., (U.S. CLS. 6, 18, 44, 46, 51 AND 52). SN 85-450,581. PUB. 7-3-2012. FILED 10-19-2011.
- 4,209,046 (*See Class 1 for this trademark*).
- 4,209,075. **NOMOSQUITOZ (STANDARD CHARACTER)**. NONATZ INC, (U.S. CLS. 6, 18, 44, 46, 51 AND 52). SN 85-481,061. PUB. 7-3-2012. FILED 11-27-2011.
- 4,209,135. **NATURAL CELLULAR DEFENSE (STANDARD CHARACTER)**. WAIORA INTERNATIONAL LTD., (U.S. CLS. 6, 18, 44, 46, 51 AND 52). SN 85-498,991. PUB. 7-3-2012. FILED 12-19-2011.
- 4,209,153. **SUPER BETA PROSTATE (STANDARD CHARACTER)**. NEW VITALITY SBP HOLDINGS, INC., (U.S. CLS. 6, 18, 44, 46, 51 AND 52). SN 85-503,374. PUB. 7-3-2012. FILED 12-23-2011.
- 4,209,172. **INSTANT FLUSH (STANDARD CHARACTER)**. PIV ENTERPRISES, INC., (U.S. CLS. 6, 18, 44, 46, 51 AND 52). SN 85-505,888. PUB. 5-29-2012. FILED 12-29-2011.
- 4,209,193 (*See Class 3 for this trademark*).
- 4,209,199. **NEWTRITIOUS IS DELICIOUS! (STANDARD CHARACTER)**. ARLEN, MICHAEL W, (U.S. CLS. 6, 18, 44, 46, 51 AND 52). SN 85-511,162. PUB. 3-27-2012. FILED 1-7-2012.
- 4,209,209. **SLIM ELIXIR PLUS (STANDARD CHARACTER)**. JOSE DE JESUS GARCIA, (U.S. CLS. 6, 18, 44, 46, 51 AND 52). SN 85-513,966. PUB. 7-3-2012. FILED 1-11-2012.
- 4,209,250. **RUBBER ARM MUSCLE RUB RA AND DESIGN**. RUBBER ARM, INC., (U.S. CLS. 6, 18, 44, 46, 51 AND 52). SN 85-519,179. PUB. 7-3-2012. FILED 1-18-2012.
- 4,209,258. **IMMPOWER D3 (STANDARD CHARACTER)**. AMERICAN BIOSCIENCES, INC., (U.S. CLS. 6, 18, 44, 46, 51 AND 52). SN 85-519,956. PUB. 7-3-2012. FILED 1-19-2012.
- 4,209,272. **BIOSANES (STANDARD CHARACTER)**. NANJI MASSO, (U.S. CLS. 6, 18, 44, 46, 51 AND 52). SN 85-520,547. PUB. 7-3-2012. FILED 1-19-2012.
- 4,209,292. **ESSENTIAL NUTRACEUTICALS (STANDARD CHARACTER)**. ESSENTIAL NUTRACEUTICALS, LLC, (U.S. CLS. 6, 18, 44, 46, 51 AND 52). SN 85-521,429. PUB. 7-3-2012. FILED 1-20-2012.
- 4,209,440. **ISOBAND (STANDARD CHARACTER)**. BSN MEDICAL, INC), MULTIPLE CLASS, (INT. CLS. 5 AND 10), (U.S. CLS. 6, 18, 26, 39, 44, 46, 51 AND 52). SN 85-528,848. PUB. 7-3-2012. FILED 1-30-2012.
- 4,209,475. **NCB NCB TECHNOLOGY (STYLIZED)**. ASN GROUP CORPORATION, (U.S. CLS. 6, 18, 44, 46, 51 AND 52). SN 85-532,623. PUB. 7-3-2012. FILED 2-2-2012.
- 4,209,481. **TNT TOTAL NAIL TREATMENT (STANDARD CHARACTER)**. JSBD, LLC, (U.S. CLS. 6, 18, 44, 46, 51 AND 52). SN 85-533,767. PUB. 7-3-2012. FILED 2-3-2012.
- 4,209,549. **OCUCEL (STANDARD CHARACTER)**. HI-HEALTH SUPERMART CORPORATION, (U.S. CLS. 6, 18, 44, 46, 51 AND 52). SN 85-539,873. PUB. 7-3-2012. FILED 2-10-2012.
- 4,209,552. **LIL' WIZARDS (STANDARD CHARACTER)**. HI-HEALTH SUPERMART CORPORATION, (U.S. CLS. 6, 18, 44, 46, 51 AND 52). SN 85-539,904. PUB. 7-3-2012. FILED 2-10-2012.
- 4,209,641. **BUDDYSLIM (STANDARD CHARACTER)**. WHOLE HEALTH LIFESTYLE, LLC, (U.S. CLS. 6, 18, 44, 46, 51 AND 52). SN 85-541,787. PUB. 7-3-2012. FILED 2-14-2012.
- 4,209,673. **PROSTALAR (STANDARD CHARACTER)**. MEDVEAL, LLC, (U.S. CLS. 6, 18, 44, 46, 51 AND 52). SN 85-542,323. PUB. 7-3-2012. FILED 2-14-2012.
- 4,209,716. **SUNRISE (STANDARD CHARACTER)**. LFW DAIRY CORP, DBA J&J DAIRY, (U.S. CLS. 6, 18, 44, 46, 51 AND 52). SN 85-543,086. PUB. 7-3-2012. FILED 2-15-2012.
- 4,209,771. **OLFINE (STANDARD CHARACTER)**. OLNATURA, INC., (U.S. CLS. 6, 18, 44, 46, 51 AND 52). SN 85-543,789. PUB. 7-3-2012. FILED 2-15-2012.
- 4,209,776. **OLMODIN (STANDARD CHARACTER)**. OLNATURA, INC., (U.S. CLS. 6, 18, 44, 46, 51 AND 52). SN 85-543,839. PUB. 7-3-2012. FILED 2-15-2012.
- 4,209,789 (*See Class 1 for this trademark*).
- 4,209,798. **EPIZYME (STANDARD CHARACTER)**. VET BRANDS INTERNATIONAL, INC., (U.S. CLS. 6, 18, 44, 46, 51 AND 52). SN 85-544,274. PUB. 7-3-2012. FILED 2-16-2012.
- 4,209,808. **VIAVIA1 (STANDARD CHARACTER)**. GRAHAM & BUFFETT, LTD., MULTIPLE CLASS, (INT. CLS. 5 AND 32), (U.S. CLS. 6, 18, 44, 45, 46, 48, 51 AND 52). SN 85-544,472. PUB. 7-3-2012. FILED 2-16-2012.
- 4,209,839. **BOTTLE BRIGHT (STANDARD CHARACTER)**. CLEAN ETHICS LLC, (U.S. CLS. 6, 18, 44, 46, 51 AND 52). SN 85-544,920. PUB. 7-3-2012. FILED 2-16-2012.
- 4,209,840. **CITRUPRESS IV (STANDARD CHARACTER)**. ASKLEPION PHARMACEUTICALS, LLC, (U.S. CLS. 6, 18, 44, 46, 51 AND 52). SN 85-544,923. PUB. 7-3-2012. FILED 2-16-2012.
- 4,209,876. **CALM/RECHARGE (STANDARD CHARACTER)**. ALLERGY RESEARCH GROUP LLC, DBA ALLERGY RESEARCH GROUP, (U.S. CLS. 6, 18, 44, 46, 51 AND 52). SN 85-545,794. PUB. 7-3-2012. FILED 2-17-2012.
- 4,209,929. **TRAVEL-LYTE (STANDARD CHARACTER)**. NOURICHE NUTRITION LTD, (U.S. CLS. 6, 18, 44, 46, 51 AND 52). SN 85-546,781. PUB. 7-3-2012. FILED 2-18-2012.
- 4,210,000 (*See Class 3 for this trademark*).
- 4,210,059. **YOR (STANDARD CHARACTER)**. PERFICIO NETWORKS, INC., DBA YOR HEALTH, (U.S. CLS. 6, 18, 44, 46, 51 AND 52). SN 85-567,471. PUB. 7-3-2012. FILED 3-12-2012.
- 4,210,079. **SAV-A-HOOF (STANDARD CHARACTER)**. SHOE BOND SYSTEMS, INC., DBA SBS EQUINE PRODUCTS, (U.S. CLS. 6, 18, 44, 46, 51 AND 52). SN 85-573,049. PUB. 7-3-2012. FILED 3-19-2012.
- 4,210,085. **FIELD N° FOREST (STANDARD CHARACTER)**. FLEET WHOLESALE SUPPLY CO., INC., (U.S. CLS. 6, 18, 44, 46, 51 AND 52). SN 85-575,246. PUB. 7-3-2012. FILED 3-21-2012.
- 4,210,096. **UTIFEM (STANDARD CHARACTER)**. GLOBAL QUALITY HEALTH, INC., (U.S. CLS. 6, 18, 44, 46, 51 AND 52). SN 85-576,763. PUB. 7-3-2012. FILED 3-22-2012.
- 4,210,119. **ADATO (STANDARD CHARACTER)**. BAUSCH & LOMB INCORPORATED, (U.S. CLS. 6, 18, 44, 46, 51 AND 52). SN 85-581,457. PUB. 7-3-2012. FILED 3-27-2012.
- 4,210,173. **BODY FUSE (STANDARD CHARACTER)**. EXCLUSIVE NUTRITION PRODUCTS, INC., (U.S. CLS. 6, 18, 44, 46, 51 AND 52). SN 85-599,408. PUB. 7-3-2012. FILED 4-17-2012.
- 4,210,189 (*See Class 3 for this trademark*).
- 4,210,208. **GENEE (STANDARD CHARACTER)**. HUHEM, MITCH, (U.S. CLS. 6, 18, 44, 46, 51 AND 52). SN 85-617,926. PUB. 7-3-2012. FILED 5-6-2012.
- 4,210,209. **MUCUSOL (STANDARD CHARACTER)**. ANIMAL SCIENCE PRODUCTS, INC., (U.S. CLS. 6, 18, 44, 46, 51 AND 52). SN 85-618,597. PUB. 7-3-2012. FILED 5-7-2012.
- 4,210,210. **BEAUTY FROM THE SEA (STANDARD CHARACTER)**. SARKLI-REPECHAGE, LTD., (U.S. CLS. 6, 18, 44, 46, 51 AND 52). SN 85-618,883. PUB. 7-3-2012. FILED 5-7-2012.
- 4,210,214. **QNASL (STYLIZED)**. TEVA RESPIRATORY, LLC, (U.S. CLS. 6, 18, 44, 46, 51 AND 52). SN 85-621,557. PUB. 7-3-2012. FILED 5-10-2012.
- 4,210,215. **QNASL (STYLIZED)**. TEVA RESPIRATORY, LLC, (U.S. CLS. 6, 18, 44, 46, 51 AND 52). SN 85-621,560. PUB. 7-3-2012. FILED 5-10-2012.
- 4,210,228. **MISCELLANEOUS DESIGN**. HELSINN HEALTHCARE SA, MULTIPLE CLASS, (INT. CLS. 5, 9 AND 16), (U.S. CLS. 2, 5, 6, 18, 21, 22, 23, 26, 29, 36, 37, 38, 44, 46, 50, 51 AND 52). SN 85-977,268. PUB. 11-29-2011. FILED 3-31-2010.

CLASS 6—METAL GOODS

- 4,208,198. **PRO-LITE (STANDARD CHARACTER)**. PROGRESSIVE FASTENING, INC., (U.S. CLS. 2, 12, 13, 14, 23, 25 AND 50). SN 77-898,378. PUB. 7-3-2012. FILED 12-21-2009.
- 4,208,266. **NORMA AND DESIGN**. NORMA GERMANY GMBH, MULTIPLE CLASS, (INT. CLS. 6 AND 17), (U.S. CLS. 1, 2, 5, 12, 13, 14, 23, 25, 35 AND 50). SN 79-097,359. PUB. 7-3-2012. FILED 2-8-2011.
- 4,208,279. **KEYANG (STANDARD CHARACTER)**. KEYANG ELECTRIC MACHINERY CO., LTD, MULTIPLE CLASS,

- (INT. CLS. 6, 7, 8, 9, 17 AND 20), (U.S. CLS. 1, 2, 5, 12, 13, 14, 19, 21, 22, 23, 25, 26, 28, 31, 32, 34, 35, 36, 38, 44 AND 50). SN 79-099,922. PUB. 7-3-2012. FILED 1-29-2011.
- 4,208,361. **BUILDALINE (STYLIZED)**, GOODRIDGE UK LIMITED, MULTIPLE CLASS, (INT. CLS. 6 AND 12), (U.S. CLS. 2, 12, 13, 14, 19, 21, 23, 25, 31, 35, 44 AND 50). SN 79-103,308. PUB. 7-3-2012. FILED 3-31-2011.
- 4,208,366. **GREENONETEC (STANDARD CHARACTER)**, GREENONETEC SOLARINDUSTRIE GMBH, MULTIPLE CLASS, (INT. CLS. 6, 11 AND 42), (U.S. CLS. 2, 12, 13, 14, 21, 23, 25, 31, 34, 50, 100 AND 101). SN 79-103,666. PUB. 7-3-2012. FILED 8-10-2011.
- 4,208,414. **RHEINZINK (STANDARD CHARACTER)**, RHEINZINK GMBH & CO. KG, MULTIPLE CLASS, (INT. CLS. 6, 37 AND 40), (U.S. CLS. 2, 12, 13, 14, 23, 25, 50, 100, 103 AND 106). SN 79-108,377. PUB. 7-3-2012. FILED 11-21-2011.
- 4,208,431. **MEGABAND (STANDARD CHARACTER)**, TITAN UMREIFUNGSTECHNIK; GMBH & CO. KG, MULTIPLE CLASS, (INT. CLS. 6 AND 17), (U.S. CLS. 1, 2, 5, 12, 13, 14, 23, 25, 35 AND 50). SN 79-110,190. PUB. 7-3-2012. FILED 2-10-2012.
- 4,208,472. **ROMAN STONE (STANDARD CHARACTER)**, ROMAN STONE CONSTRUCTION CO., MULTIPLE CLASS, (INT. CLS. 6, 9 AND 19), (U.S. CLS. 1, 2, 12, 13, 14, 21, 23, 25, 26, 33, 36, 38 AND 50). SN 85-094,674. PUB. 7-3-2012. FILED 7-28-2010.
- 4,208,475. **CROSINOX (STANDARD CHARACTER)**, JULIUS CRONENBERG OH, (U.S. CLS. 2, 12, 13, 14, 23, 25 AND 50). SN 85-102,800. PUB. 12-6-2011. FILED 8-9-2010.
- 4,208,520. **CLEANRIVER (STANDARD CHARACTER)**, MIDPOINT INTERNATIONAL INC., MULTIPLE CLASS, (INT. CLS. 6 AND 20), (U.S. CLS. 2, 12, 13, 14, 22, 23, 25, 32 AND 50). SN 85-192,456. PUB. 7-3-2012. FILED 12-7-2010.
- 4,208,618. **OBRAZE (STANDARD CHARACTER)**, ECI, LLC, (U.S. CLS. 2, 12, 13, 14, 23, 25 AND 50). SN 85-325,721. PUB. 7-3-2012. FILED 5-20-2011.
- 4,208,628. **W AND DESIGN**, WINPAK LTD., MULTIPLE CLASS, (INT. CLS. 6, 7, 17, 40 AND 42), (U.S. CLS. 1, 2, 5, 12, 13, 14, 19, 21, 23, 25, 31, 34, 35, 50, 100, 101, 103 AND 106). SN 85-334,109. PUB. 7-3-2012. FILED 5-31-2011.
- 4,208,631. **SAS GLOBAL POWER (STANDARD CHARACTER)**, SAS GLOBAL CORPORATION, MULTIPLE CLASS, (INT. CLS. 6, 7 AND 11), (U.S. CLS. 2, 12, 13, 14, 19, 21, 23, 25, 31, 34, 35 AND 50). SN 85-336,272. PUB. 7-3-2012. FILED 6-2-2011.
- 4,208,632. **SAS SAS GLOBAL POWER ADVANCEMENTS IN COAL PROCESSING & COMBUSTION AND DESIGN**, SAS GLOBAL CORPORATION, MULTIPLE CLASS, (INT. CLS. 6, 7 AND 11), (U.S. CLS. 2, 12, 13, 14, 19, 21, 23, 25, 31, 34, 35 AND 50). SN 85-336,288. PUB. 7-3-2012. FILED 6-2-2011.
- 4,208,649. **ECORE CABLES (STANDARD CHARACTER)**, INTEGRATED NETWORK CABLE, (U.S. CLS. 2, 12, 13, 14, 23, 25 AND 50). SN 85-345,340. PUB. 7-3-2012. FILED 6-14-2011.
- 4,208,652. **FIBERON (STANDARD CHARACTER)**, FIBER COMPOSITES, LLC, MULTIPLE CLASS, (INT. CLS. 6 AND 19), (U.S. CLS. 1, 2, 12, 13, 14, 23, 25, 33 AND 50). SN 85-346,912. PUB. 7-3-2012. FILED 6-15-2011.
- 4,208,977 (*See Class 3 for this trademark*).
- 4,209,095. **PIDSO PROPAGATION IDEAS & SOLUTIONS (STANDARD CHARACTER)**, KIENMAYER, CHRISTOPH, MULTIPLE CLASS, (INT. CLS. 6, 9 AND 42), (U.S. CLS. 2, 12, 13, 14, 21, 23, 25, 26, 36, 38, 50, 100 AND 101). SN 85-489,781. PUB. 7-3-2012. FILED 12-7-2011.
- 4,209,166. **ORION (STANDARD CHARACTER)**, PRICE, KEVIN, (U.S. CLS. 2, 12, 13, 14, 23, 25 AND 50). SN 85-505,319. PUB. 7-3-2012. FILED 12-29-2011.
- 4,209,482. **L3 (STANDARD CHARACTER)**, D-GENERATION, INC., (U.S. CLS. 2, 12, 13, 14, 23, 25 AND 50). SN 85-534,208. PUB. 7-3-2012. FILED 2-5-2012.
- 4,209,678. **EVAVLT (STANDARD CHARACTER)**, GRANITE SECURITY PRODUCTS, INC., (U.S. CLS. 2, 12, 13, 14, 23, 25 AND 50). SN 85-542,418. PUB. 7-3-2012. FILED 2-14-2012.
- 4,209,704. **CPW AMERICA (STANDARD CHARACTER)**, CORINTH PIPEWORKS S.A., (U.S. CLS. 2, 12, 13, 14, 23, 25 AND 50). SN 85-542,817. PUB. 7-3-2012. FILED 2-14-2012.
- 4,209,706. **CORINTH PIPEWORKS (STANDARD CHARACTER)**, CORINTH PIPEWORKS S.A., (U.S. CLS. 2, 12, 13, 14, 23, 25 AND 50). SN 85-542,852. PUB. 7-3-2012. FILED 2-14-

2012.

- 4,209,933. **AMERICA THE BEAUTIFUL (STANDARD CHARACTER)**, D-GENERATION, INC., MULTIPLE CLASS, (INT. CLS. 6 AND 20), (U.S. CLS. 2, 12, 13, 14, 22, 23, 25, 32 AND 50). SN 85-546,842. PUB. 7-3-2012. FILED 2-19-2012.

CLASS 7—MACHINERY

- 4,208,167. **MISCELLANEOUS DESIGN**, ARCTIC CAT INC., MULTIPLE CLASS, (INT. CLS. 7, 12 AND 25), (U.S. CLS. 13, 19, 21, 22, 23, 31, 34, 35, 39 AND 44). SN 77-295,648. PUB. 9-7-2010. FILED 10-3-2007.
- 4,208,225. **DUNLOP (STANDARD CHARACTER)**, DNA (HOUSEMARKS) LIMITED, MULTIPLE CLASS, (INT. CLS. 7, 12, 14, 18, 25 AND 28), (U.S. CLS. 1, 2, 3, 13, 19, 21, 22, 23, 27, 28, 31, 34, 35, 38, 39, 41, 44 AND 50). SN 77-983,079. PUB. 7-3-2012. FILED 9-20-2006.
- 4,208,237. **DELTA (STANDARD CHARACTER)**, STAM BOUW-MACHINES B.V., (U.S. CLS. 13, 19, 21, 23, 31, 34 AND 35). SN 79-081,690. PUB. 7-3-2012. FILED 2-15-2010.
- 4,208,255. **CIOS (STANDARD CHARACTER)**, BUCYRUS EUROPE GMBH, MULTIPLE CLASS, (INT. CLS. 7, 9 AND 12), (U.S. CLS. 13, 19, 21, 23, 26, 31, 34, 35, 36, 38 AND 44). SN 79-094,662. PUB. 1-17-2012. FILED 6-29-2010.
- 4,208,257. **COOL BUBBLE AND DESIGN**, KUHNE ANLAGENBAU GMBH, MULTIPLE CLASS, (INT. CLS. 7, 9, 16 AND 42), (U.S. CLS. 2, 5, 13, 19, 21, 22, 23, 26, 29, 31, 34, 35, 36, 37, 38, 50, 100 AND 101). SN 79-094,804. PUB. 7-3-2012. FILED 10-19-2010.
- 4,208,265. **COOL BUBBLE (STANDARD CHARACTER)**, KUHNE ANLAGENBAU GMBH, MULTIPLE CLASS, (INT. CLS. 7, 9, 16 AND 42), (U.S. CLS. 2, 5, 13, 19, 21, 22, 23, 26, 29, 31, 34, 35, 36, 37, 38, 50, 100 AND 101). SN 79-097,276. PUB. 7-3-2012. FILED 10-19-2010.
- 4,208,270. **IB AND DESIGN**, MURATA KIKAI KABUSHIKI KAISHA, TA MURATA MACHINERY, LTD., MULTIPLE CLASS, (INT. CLS. 7 AND 9), (U.S. CLS. 13, 19, 21, 23, 26, 31, 34, 35, 36 AND 38). SN 79-098,189. PUB. 7-3-2012. FILED 12-17-2010.
- 4,208,272. **TOOLTRONIC (STANDARD CHARACTER)**, MAPAL FABRIK FÜR PRÄZISIONSWERKZEUGE DR. KRESS KG, MULTIPLE CLASS, (INT. CLS. 7, 9 AND 37), (U.S. CLS. 13, 19, 21, 23, 26, 31, 34, 35, 36, 38, 100, 103 AND 106). SN 79-098,481. PUB. 7-3-2012. FILED 12-23-2010.
- 4,208,279 (*See Class 6 for this trademark*).
- 4,208,286. **MISCELLANEOUS DESIGN**, MAINSTREAM RENEWABLE POWER LIMITED, MULTIPLE CLASS, (INT. CLS. 7, 9, 37, 39, 40 AND 42), (U.S. CLS. 13, 19, 21, 23, 26, 31, 34, 35, 36, 38, 100, 101, 103, 105 AND 106). SN 79-100,756. PUB. 7-3-2012. FILED 7-5-2011.
- 4,208,313. **ETERNIUM (STANDARD CHARACTER)**, TECHNOLOGIES AVANCEES ET MEMBRANES INDUSTRIELLES, MULTIPLE CLASS, (INT. CLS. 7 AND 11), (U.S. CLS. 13, 19, 21, 23, 31, 34 AND 35). SN 79-101,947. PUB. 7-3-2012. FILED 7-19-2011.
- 4,208,318 (*See Class 1 for this trademark*).
- 4,208,319. **ALBATROS ENERGY AND DESIGN**, ALBATROS ENERGY SA, MULTIPLE CLASS, (INT. CLS. 7, 35, 36, 37 AND 40), (U.S. CLS. 13, 19, 21, 23, 31, 34, 35, 100, 101, 102, 103 AND 106). SN 79-102,088. PUB. 7-3-2012. FILED 6-20-2011.
- 4,208,343 (*See Class 1 for this trademark*).
- 4,208,360. **MULTIFLEX-QUENCH (STANDARD CHARACTER)**, SMS SIEMAG AG, MULTIPLE CLASS, (INT. CLS. 7, 9, 11 AND 42), (U.S. CLS. 13, 19, 21, 23, 26, 31, 34, 35, 36, 38, 100 AND 101). SN 79-103,289. PUB. 7-3-2012. FILED 8-17-2011.
- 4,208,365. **MISCELLANEOUS DESIGN**, BALLANTINES INTERVEST LTD, MULTIPLE CLASS, (INT. CLS. 7, 8, 9 AND 35), (U.S. CLS. 13, 19, 21, 23, 26, 28, 31, 34, 35, 36, 38, 44, 100, 101 AND 102). SN 79-103,641. PUB. 7-3-2012. FILED 3-31-2011.
- 4,208,389. **SOLEMA AND DESIGN**, SOLEMA S.R.L., MULTIPLE CLASS, (INT. CLS. 7, 35 AND 42), (U.S. CLS. 13, 19, 21, 23, 31, 34, 35, 100, 101 AND 102). SN 79-106,101. PUB. 7-3-2012. FILED 5-20-2011.
- 4,208,419. **TRUEANGLE (STANDARD CHARACTER)**, ATLAS

- COPCO TOOLS AB, MULTIPLE CLASS, (INT. CLS. 7 AND 9), (U.S. CLS. 13, 19, 21, 23, 26, 31, 34, 35, 36 AND 38). SN 79-108,615. PUB. 7-3-2012. FILED 12-8-2011.
- 4,208,424. **ROTOCAP (STANDARD CHARACTER)**. GAT; GESELLSCHAFT FÜR ANTRIEBSTECHNIK MBH, MULTIPLE CLASS, (INT. CLS. 7, 9 AND 10), (U.S. CLS. 13, 19, 21, 23, 26, 31, 34, 35, 36, 38, 39 AND 44). SN 79-109,471. PUB. 7-3-2012. FILED 10-18-2011.
- 4,208,447. **VÖGELE V AND DESIGN**. JOSEPH VÖGELE AG, MULTIPLE CLASS, (INT. CLS. 7, 9, 35 AND 37), (U.S. CLS. 13, 19, 21, 23, 26, 31, 34, 35, 36, 38, 100, 101, 102, 103 AND 106). SN 85-000,958. PUB. 7-3-2012. FILED 3-29-2010.
- 4,208,448. **VÖGELE (STANDARD CHARACTER)**. JOSEPH VÖGELE AG, MULTIPLE CLASS, (INT. CLS. 7, 9, 35 AND 37), (U.S. CLS. 13, 19, 21, 23, 26, 31, 34, 35, 36, 38, 100, 101, 102, 103 AND 106). SN 85-001,019. PUB. 7-3-2012. FILED 3-29-2010.
- 4,208,460. **DYNOMAX (STANDARD CHARACTER)**. DYNOMAX DRILLING TOOLS INC., (U.S. CLS. 13, 19, 21, 23, 31, 34 AND 35). SN 85-054,486. PUB. 6-7-2011. FILED 6-3-2010.
- 4,208,557. **VERNATHERM (STANDARD CHARACTER)**. ROS-TRA VERNATHERM LLC, MULTIPLE CLASS, (INT. CLS. 7, 9 AND 11), (U.S. CLS. 13, 19, 21, 23, 26, 31, 34, 35, 36 AND 38). SN 85-246,458. PUB. 7-3-2012. FILED 2-18-2011.
- 4,208,590. **CHEMITHON AND DESIGN**. THE CHEMITHON CORPORATION, MULTIPLE CLASS, (INT. CLS. 7, 9, 11, 40, 41 AND 42), (U.S. CLS. 13, 19, 21, 23, 26, 31, 34, 35, 36, 38, 100, 101, 103, 106 AND 107). SN 85-296,280. PUB. 7-3-2012. FILED 4-15-2011.
- 4,208,591. **CHEMITHON (STANDARD CHARACTER)**. THE CHEMITHON CORPORATION, MULTIPLE CLASS, (INT. CLS. 7, 9, 11, 40, 41 AND 42), (U.S. CLS. 13, 19, 21, 23, 26, 31, 34, 35, 36, 38, 100, 101, 103, 106 AND 107). SN 85-296,289. PUB. 7-3-2012. FILED 4-15-2011.
- 4,208,628 (*See Class 6 for this trademark*).
- 4,208,631 (*See Class 6 for this trademark*).
- 4,208,632 (*See Class 6 for this trademark*).
- 4,208,644 (*See Class 4 for this trademark*).
- 4,208,735. **CAPT (STANDARD CHARACTER)**. CELINA ALUMINUM PRECISION TECHNOLOGY, INC., MULTIPLE CLASS, (INT. CLS. 7 AND 12), (U.S. CLS. 13, 19, 21, 23, 31, 34, 35 AND 44). SN 85-372,230. PUB. 7-3-2012. FILED 7-15-2011.
- 4,208,751. **WHITE RACING ENGINES AND DESIGN**. WHITE, FRED, DBA WHITE PERFORMANCE AND MACHINE, (U.S. CLS. 13, 19, 21, 23, 31, 34 AND 35). SN 85-374,081. PUB. 7-3-2012. FILED 7-18-2011.
- 4,208,782. **HOLZKRAFT AND DESIGN**. STURMER MASCHINEN GMBH, MULTIPLE CLASS, (INT. CLS. 7 AND 8), (U.S. CLS. 13, 19, 21, 23, 28, 31, 34, 35 AND 44). SN 85-378,353. PUB. 7-3-2012. FILED 7-22-2011.
- 4,208,836. **SYI (STYLIZED)**. SAN YUN INDUSTRIAL CO., LTD., MULTIPLE CLASS, (INT. CLS. 7 AND 12), (U.S. CLS. 13, 19, 21, 23, 31, 34, 35 AND 44). SN 85-392,368. PUB. 7-3-2012. FILED 8-8-2011.
- 4,208,924. **PHD (STANDARD CHARACTER)**. AMERICAN TORCH TIP COMPANY, (U.S. CLS. 13, 19, 21, 23, 31, 34 AND 35). SN 85-418,071. PUB. 7-3-2012. FILED 9-8-2011.
- 4,208,942. **TRIPAC INTERNATIONAL INC. AND DESIGN**. TRIPAC INTERNATIONAL, MULTIPLE CLASS, (INT. CLS. 7 AND 25), (U.S. CLS. 13, 19, 21, 22, 23, 31, 34, 35 AND 39). SN 85-429,244. PUB. 7-3-2012. FILED 9-22-2011.
- 4,208,977 (*See Class 3 for this trademark*).
- 4,209,019. **GELLI ARTS (STANDARD CHARACTER)**. GELLI ARTS LLC, (U.S. CLS. 13, 19, 21, 23, 31, 34 AND 35). SN 85-458,919. PUB. 7-3-2012. FILED 10-28-2011.
- 4,209,098. **PURGE PRO (STANDARD CHARACTER)**. GEOTHERMAL SUPPLY CO., INC., (U.S. CLS. 13, 19, 21, 23, 31, 34 AND 35). SN 85-490,149. PUB. 7-3-2012. FILED 12-8-2011.
- 4,209,129. **LIGHTNING SAW AND DESIGN**. COOPER, MICHAEL K, DBA LIGHTNING-SAW, (U.S. CLS. 13, 19, 21, 23, 31, 34 AND 35). SN 85-497,592. PUB. 7-3-2012. FILED 12-16-2011.
- 4,209,266. **DENPI (STANDARD CHARACTER)**. DENSO CORPORATION, MULTIPLE CLASS, (INT. CLS. 7 AND 9), (U.S. CLS. 13, 19, 21, 23, 26, 31, 34, 35, 36 AND 38). SN 85-520,179. PUB. 7-3-2012. FILED 1-19-2012.
- 4,209,492. **FLEX-LIP (STANDARD CHARACTER)**. NOR-DOCK, INC., (U.S. CLS. 13, 19, 21, 23, 31, 34 AND 35). SN 85-536,218. PUB. 7-3-2012. FILED 2-7-2012.
- 4,209,550. **VOYAGER (STANDARD CHARACTER)**. INTEGRATED POOL PRODUCTS (PTY) LTD, (U.S. CLS. 13, 19, 21, 23, 31, 34 AND 35). SN 85-539,881. PUB. 7-3-2012. FILED 2-10-2012.
- 4,209,638. **AUTOWED (STANDARD CHARACTER)**. LANYON, SAM G, TA CONCEPT SHED, (U.S. CLS. 13, 19, 21, 23, 31, 34 AND 35). SN 85-541,730. PUB. 7-3-2012. FILED 2-14-2012.
- 4,209,723. **RJS AND DESIGN**. RJS CORPORATION, (U.S. CLS. 13, 19, 21, 23, 31, 34 AND 35). SN 85-543,216. PUB. 7-3-2012. FILED 2-15-2012.
- 4,210,164. **PFP (STANDARD CHARACTER)**. FTS INTERNATIONAL SERVICES, LLC, (U.S. CLS. 13, 19, 21, 23, 31, 34 AND 35). SN 85-596,361. PUB. 7-3-2012. FILED 4-12-2012.

CLASS 8—HAND TOOLS

- 4,208,279 (*See Class 6 for this trademark*).
- 4,208,289 (*See Class 3 for this trademark*).
- 4,208,328. **TSU (STANDARD CHARACTER)**. ALLFLEX EUROPE, MULTIPLE CLASS, (INT. CLS. 8 AND 10), (U.S. CLS. 23, 26, 28, 39 AND 44). SN 79-102,381. PUB. 7-3-2012. FILED 7-29-2011.
- 4,208,365 (*See Class 7 for this trademark*).
- 4,208,463. **ROSATOM AND DESIGN**. STATE ATOMIC ENERGY CORPORATION "ROSATOM", (U.S. CLS. 23, 28 AND 44). SN 85-063,438. PUB. 6-12-2012. FILED 6-15-2010.
- 4,208,617. **MEMORX (STANDARD CHARACTER)**. MEDISANA AG, MULTIPLE CLASS, (INT. CLS. 8, 10, 11, 12 AND 44), (U.S. CLS. 13, 19, 21, 23, 26, 28, 31, 34, 35, 39, 44, 100 AND 101). SN 85-325,000. PUB. 2-28-2012. FILED 5-19-2011.
- 4,208,782 (*See Class 7 for this trademark*).
- 4,208,796 (*See Class 3 for this trademark*).
- 4,209,515. **SPIROOLI (STANDARD CHARACTER)**. NATIONAL EXPRESS, INC., (U.S. CLS. 23, 28 AND 44). SN 85-538,019. PUB. 7-3-2012. FILED 2-9-2012.
- 4,209,925. **TALONZ (STYLIZED)**. UNIVERSAL RELATIONS INCORPORATED, (U.S. CLS. 23, 28 AND 44). SN 85-546,709. PUB. 7-3-2012. FILED 2-18-2012.
- 4,209,962. **HEB AND DESIGN**. HEB GROCERY COMPANY, LP, (U.S. CLS. 23, 28 AND 44). SN 85-548,334. PUB. 7-3-2012. FILED 2-21-2012.
- 4,210,225. **A-TACS (STANDARD CHARACTER)**. DIGITAL CONCEALMENT SYSTEMS, LLC, MULTIPLE CLASS, (INT. CLS. 8, 9, 13, 18, 25 AND 45), (U.S. CLS. 1, 2, 3, 9, 21, 22, 23, 26, 28, 36, 38, 39, 41, 44, 100 AND 101). SN 85-977,239. PUB. 5-29-2012. FILED 7-22-2011.

CLASS 9—ELECTRICAL AND SCIENTIFIC APPARATUS

- 4,208,123. **ORANGE**. ORANGE BRAND SERVICES, LTD, MULTIPLE CLASS, (INT. CLS. 9, 16 AND 41), (U.S. CLS. 2, 5, 21, 22, 23, 26, 29, 36, 37, 38, 50, 100, 101 AND 107). SN 76-215,122. PUB. 10-27-2009. FILED 2-23-2001.
- 4,208,124. **ORANGE PAGES**. ORANGE BRAND SERVICES, LTD., MULTIPLE CLASS, (INT. CLS. 9, 16, 18, 25, 28, 35, 36, 37, 38, 39, 41 AND 42), (U.S. CLS. 1, 2, 3, 5, 21, 22, 23, 26, 29, 36, 37, 38, 39, 41, 50, 100, 101, 102, 103, 104, 105, 106 AND 107). SN 76-309,149. PUB. 12-30-2003. FILED 9-4-2001.
- 4,208,181. **BRAVE (STANDARD CHARACTER)**. SHIRE PHARMACEUTICALS LIMITED, MULTIPLE CLASS, (INT. CLS. 9, 16, 41 AND 42), (U.S. CLS. 2, 5, 21, 22, 23, 26, 29, 36, 37, 38, 50, 100, 101 AND 107). SN 77-556,253. PUB. 3-27-2012. FILED 8-26-2008.
- 4,208,193. **DUAL WEB (STANDARD CHARACTER)**. LG ELECTRONICS INC., (U.S. CLS. 21, 23, 26, 36 AND 38). SN 77-839,110. PUB. 7-3-2012. FILED 10-1-2009.
- 4,208,199. **TURNING ENERGY INTO INCOME (STANDARD CHARACTER)**. SGE IP HOLDCO, LLC, MULTIPLE CLASS, (INT. CLS. 9, 16, 35 AND 41), (U.S. CLS. 2, 5, 21, 22, 23, 26, 29,

- 36, 37, 38, 50, 100, 101, 102 AND 107). SN 77-898,789. PUB. 7-3-2012. FILED 12-22-2009.
- 4,208,223. **AIRSCOUTER (STANDARD CHARACTER)**. BROTHER INDUSTRIES, LTD., (U.S. CLS. 21, 23, 26, 36 AND 38). SN 77-968,938. PUB. 2-14-2012. FILED 3-25-2010.
- 4,208,233. **NETOP SOLUTIONS (STANDARD CHARACTER)**. NETOP BUSINESS SOLUTIONS A/S, MULTIPLE CLASS, (INT. CLS. 9, 16, 38 AND 42), (U.S. CLS. 2, 5, 21, 22, 23, 26, 29, 36, 37, 38, 50, 100, 101 AND 104). SN 79-066,888. PUB. 7-3-2012. FILED 12-22-2008.
- 4,208,234. **NETOP AND DESIGN**. NETOP BUSINESS SOLUTIONS A/S, MULTIPLE CLASS, (INT. CLS. 9, 16, 38 AND 42), (U.S. CLS. 2, 5, 21, 22, 23, 26, 29, 36, 37, 38, 50, 100, 101 AND 104). SN 79-066,889. PUB. 7-3-2012. FILED 12-22-2008.
- 4,208,243 (*See Class 3 for this trademark*).
- 4,208,245. **TOPWINGS AND DESIGN**. THALES AVIONICS S.A., MULTIPLE CLASS, (INT. CLS. 9, 37 AND 38), (U.S. CLS. 21, 23, 26, 36, 38, 100, 101, 103, 104 AND 106). SN 79-091,252. PUB. 7-3-2012. FILED 11-4-2010.
- 4,208,246. **FOLLIES (STANDARD CHARACTER)**. MUGLER MANFRED THIERRY C/O AKLEA SOCIÉTÉ D'AVOCATS, MULTIPLE CLASS, (INT. CLS. 9 AND 41), (U.S. CLS. 21, 23, 26, 36, 38, 100, 101 AND 107). SN 79-091,430. PUB. 7-3-2012. FILED 11-30-2010.
- 4,208,247. **NAGASHIMA OHNO & TSUNEMATSU (STANDARD CHARACTER)**. INOUE HIROKI, AND ISHIZUKA HIROYUKI, MULTIPLE CLASS, (INT. CLS. 9, 16, 35, 36, 41 AND 45), (U.S. CLS. 2, 5, 21, 22, 23, 26, 29, 36, 37, 38, 50, 100, 101, 102 AND 107). SN 79-091,656. PUB. 7-3-2012. FILED 7-30-2010.
- 4,208,248. **IMI (STANDARD CHARACTER)**. KRAUSS-MAFFEI WEGMANN GMBH & CO. KG, (U.S. CLS. 21, 23, 26, 36 AND 38). SN 79-092,194. PUB. 7-3-2012. FILED 11-19-2010.
- 4,208,250. **MITA-TEKNIK AND DESIGN**. MITA-TEKNIK A/S, MULTIPLE CLASS, (INT. CLS. 9, 11 AND 37), (U.S. CLS. 13, 21, 23, 26, 31, 34, 36, 38, 100, 103 AND 106). SN 79-092,516. PUB. 7-3-2012. FILED 1-19-2011.
- 4,208,252. **MITA-TEKNIK (STANDARD CHARACTER)**. MITA-TEKNIK A/S, MULTIPLE CLASS, (INT. CLS. 9, 11 AND 37), (U.S. CLS. 13, 21, 23, 26, 31, 34, 36, 38, 100, 103 AND 106). SN 79-092,758. PUB. 7-3-2012. FILED 1-27-2011.
- 4,208,255 (*See Class 7 for this trademark*).
- 4,208,257 (*See Class 7 for this trademark*).
- 4,208,258. **OME AND DESIGN**. GLENCOE SOFTWARE INC., MULTIPLE CLASS, (INT. CLS. 9, 35 AND 42), (U.S. CLS. 21, 23, 26, 36, 38, 100, 101 AND 102). SN 79-094,939. PUB. 7-3-2012. FILED 1-20-2011.
- 4,208,260. **SMIDGIT (STANDARD CHARACTER)**. HUSH ENTERPRISES PTY LTD, AND STANDBY STAFF SERVICES AUSTRALIA PTY LTD, MULTIPLE CLASS, (INT. CLS. 9, 41 AND 44), (U.S. CLS. 21, 23, 26, 36, 38, 100, 101 AND 107). SN 79-095,521. PUB. 7-3-2012. FILED 11-29-2010.
- 4,208,261. **NANOCASTER (STYLIZED)**. TV1 GMBH, MULTIPLE CLASS, (INT. CLS. 9, 38, 41 AND 42), (U.S. CLS. 21, 23, 26, 36, 38, 100, 101, 104 AND 107). SN 79-095,528. PUB. 7-3-2012. FILED 11-2-2010.
- 4,208,262. **IISU (STANDARD CHARACTER)**. SOFTKINETIC, SOCIÉTÉ ANONYME, MULTIPLE CLASS, (INT. CLS. 9, 28, 38, 41 AND 42), (U.S. CLS. 21, 22, 23, 26, 36, 38, 50, 100, 101, 104 AND 107). SN 79-095,827. PUB. 7-3-2012. FILED 12-29-2010.
- 4,208,264. **AIR TIES WIRELESS NETWORKS AND DESIGN**. AIRTIES KABLOSUZ ILETISIM SANAYI VE DIS TICARET A.S., MULTIPLE CLASS, (INT. CLS. 9, 38 AND 42), (U.S. CLS. 21, 23, 26, 36, 38, 100, 101 AND 104). SN 79-095,938. PUB. 7-3-2012. FILED 2-22-2011.
- 4,208,265 (*See Class 7 for this trademark*).
- 4,208,270 (*See Class 7 for this trademark*).
- 4,208,272 (*See Class 7 for this trademark*).
- 4,208,274. **EEGEO (STANDARD CHARACTER)**. EEGEO LIMITED, MULTIPLE CLASS, (INT. CLS. 9, 38, 41 AND 42), (U.S. CLS. 21, 23, 26, 36, 38, 100, 101, 104 AND 107). SN 79-099,250. PUB. 7-3-2012. FILED 3-17-2011.
- 4,208,275. **KITEO (STANDARD CHARACTER)**. KITEO GMBH & CO. KG, MULTIPLE CLASS, (INT. CLS. 9, 11, 35 AND 42), (U.S. CLS. 13, 21, 23, 26, 31, 34, 36, 38, 100, 101 AND 102). SN 79-099,583. PUB. 7-3-2012. FILED 4-13-2011.
- 4,208,277 (*See Class 3 for this trademark*).
- 4,208,278. **BRIAN COX (STANDARD CHARACTER)**. BRIAN COX, MULTIPLE CLASS, (INT. CLS. 9, 16, 28 AND 41), (U.S. CLS. 2, 5, 21, 22, 23, 26, 29, 36, 37, 38, 50, 100, 101 AND 107). SN 79-099,893. PUB. 7-3-2012. FILED 5-4-2011.
- 4,208,279 (*See Class 6 for this trademark*).
- 4,208,283 (*See Class 3 for this trademark*).
- 4,208,285. **BIMAL AND DESIGN**. BIMAL S.R.L., MULTIPLE CLASS, (INT. CLS. 9, 37 AND 42), (U.S. CLS. 21, 23, 26, 36, 38, 100, 101, 103 AND 106). SN 79-100,672. PUB. 7-3-2012. FILED 6-28-2011.
- 4,208,286 (*See Class 7 for this trademark*).
- 4,208,289 (*See Class 3 for this trademark*).
- 4,208,291. **MISCELLANEOUS DESIGN**. ZINKIA ENTERTAINMENT, S.A., MULTIPLE CLASS, (INT. CLS. 9, 16, 28, 35 AND 41), (U.S. CLS. 2, 5, 21, 22, 23, 26, 29, 36, 37, 38, 50, 100, 101, 102 AND 107). SN 79-101,137. PUB. 7-3-2012. FILED 5-16-2011.
- 4,208,303. **ELEPHANT TALK (STANDARD CHARACTER)**. ELEPHANT TALK EUROPE HOLDING BV, MULTIPLE CLASS, (INT. CLS. 9, 35, 37, 38 AND 42), (U.S. CLS. 21, 23, 26, 36, 38, 100, 101, 102, 103, 104 AND 106). SN 79-101,714. PUB. 7-3-2012. FILED 5-9-2011.
- 4,208,307. **ASSISTANCE PSA AND DESIGN**. ASSISTANCE SOFTWARE GROUP B.V., (U.S. CLS. 21, 23, 26, 36 AND 38). SN 79-101,845. PUB. 7-3-2012. FILED 7-1-2011.
- 4,208,312. **ON OFF TEK AND DESIGN**. PABLO JAVIER HERMOSILLA RIOS, (U.S. CLS. 21, 23, 26, 36 AND 38). SN 79-101,938. PUB. 7-3-2012. FILED 6-30-2011.
- 4,208,314. **SLEEP INFUSER (STANDARD CHARACTER)**. GINGO BILOBA S.A., MULTIPLE CLASS, (INT. CLS. 9, 10 AND 11), (U.S. CLS. 13, 21, 23, 26, 31, 34, 36, 38, 39 AND 44). SN 79-101,956. PUB. 7-3-2012. FILED 6-29-2011.
- 4,208,320 (*See Class 3 for this trademark*).
- 4,208,322. **INTACT AN EXCELLENT SOLUTION. AND DESIGN**. INTACT CONSULT GMBH, MULTIPLE CLASS, (INT. CLS. 9, 42 AND 44), (U.S. CLS. 21, 23, 26, 36, 38, 100 AND 101). SN 79-102,207. PUB. 7-3-2012. FILED 6-16-2011.
- 4,208,327. **ITRNOMAD (STANDARD CHARACTER)**. DC RMS LIMITED, (U.S. CLS. 21, 23, 26, 36 AND 38). SN 79-102,348. PUB. 7-3-2012. FILED 7-8-2011.
- 4,208,337. **IDAIR (STANDARD CHARACTER)**. LUFTHANSA TECHNIK AG, MULTIPLE CLASS, (INT. CLS. 9, 11, 12, 35, 37, 38, 39 AND 42), (U.S. CLS. 13, 19, 21, 23, 26, 31, 34, 35, 36, 38, 44, 100, 101, 102, 103, 104, 105 AND 106). SN 79-102,692. PUB. 7-3-2012. FILED 2-18-2011.
- 4,208,342. **CAMP BESTIVAL (STANDARD CHARACTER)**. GORHAM,ROBERT, AND HUGHES,JOHN, MULTIPLE CLASS, (INT. CLS. 9, 16, 25, 41, 43 AND 44), (U.S. CLS. 2, 5, 21, 22, 23, 26, 29, 36, 37, 38, 39, 50, 100, 101 AND 107). SN 79-102,758. PUB. 7-3-2012. FILED 6-14-2011.
- 4,208,348. **GIMOTA (STANDARD CHARACTER)**. GIMOTA AG, MULTIPLE CLASS, (INT. CLS. 9 AND 12), (U.S. CLS. 19, 21, 23, 26, 31, 35, 36, 38 AND 44). SN 79-102,851. PUB. 7-3-2012. FILED 3-1-2011.
- 4,208,350. **THE CIRCLE OF FRIENDS CO AND DESIGN**. MODERN BASIC 08 AB, MULTIPLE CLASS, (INT. CLS. 9, 18 AND 25), (U.S. CLS. 1, 2, 3, 21, 22, 23, 26, 36, 38, 39 AND 41). SN 79-102,910. PUB. 7-3-2012. FILED 6-7-2011.
- 4,208,355. **FORTRUS (STANDARD CHARACTER)**. FORTRUS LIMITED, MULTIPLE CLASS, (INT. CLS. 9, 39 AND 42), (U.S. CLS. 21, 23, 26, 36, 38, 100, 101 AND 105). SN 79-103,149. PUB. 7-3-2012. FILED 5-10-2011.
- 4,208,356. **DEADLIGHT (STYLIZED)**. TEQUILA WORKS, S.L., MULTIPLE CLASS, (INT. CLS. 9, 16, 25 AND 28), (U.S. CLS. 2, 5, 21, 22, 23, 26, 29, 36, 37, 38, 39 AND 50). SN 79-103,162. PUB. 7-3-2012. FILED 7-12-2011.
- 4,208,360 (*See Class 7 for this trademark*).
- 4,208,364. **MISCELLANEOUS DESIGN**. BACH TECHNOLOGY GMBH, MULTIPLE CLASS, (INT. CLS. 9, 15, 28, 35, 36, 38, 39, 41 AND 42), (U.S. CLS. 2, 21, 22, 23, 26, 36, 38, 50, 100, 101, 102, 104, 105 AND 107). SN 79-103,516. PUB. 7-3-2012. FILED 4-5-2011.
- 4,208,365 (*See Class 7 for this trademark*).
- 4,208,367 (*See Class 2 for this trademark*).
- 4,208,373. **HOEV AND DESIGN**. HOYA CORPORATION, (U.S. CLS. 21, 23, 26, 36 AND 38). SN 79-104,288. PUB. 7-3-2012. FILED 7-20-2011.
- 4,208,377. **SIMULVIEW (STANDARD CHARACTER)**. KA-

- BUSHIKI KAISHA SONY COMPUTER ENTERTAINMENT; (ALSO TRADING AS; SONY COMPUTER ENTERTAINMENT INC.), (U.S. CLS. 21, 23, 26, 36 AND 38). SN 79-104,643. PUB. 7-3-2012. FILED 6-28-2011.
- 4,208,382. **KINOLAMPA AND DESIGN**. OBSCHESTVO S OGRANICHENNOY OTVETSTVENNOSTYU "VORONEZHSKAYA TORGOVAYA KOMPANIA", MULTIPLE CLASS, (INT. CLS. 9, 35, 38 AND 42), (U.S. CLS. 21, 23, 26, 36, 38, 100, 101, 102 AND 104). SN 79-105,314. PUB. 7-3-2012. FILED 9-14-2011.
- 4,208,388. **DRAGONTRAIL (STANDARD CHARACTER)**. ASAHI GLASS COMPANY, LIMITED, MULTIPLE CLASS, (INT. CLS. 9, 12, 19, 20 AND 21), (U.S. CLS. 1, 2, 12, 13, 19, 21, 22, 23, 25, 26, 29, 30, 31, 32, 33, 35, 36, 38, 40, 44 AND 50). SN 79-106,049. PUB. 7-3-2012. FILED 7-12-2011.
- 4,208,393 (*See Class 4 for this trademark*).
- 4,208,396. **ORICO AND DESIGN**. ORICO TECHNOLOGIES CO., LTD., (U.S. CLS. 21, 23, 26, 36 AND 38). SN 79-106,808. PUB. 7-3-2012. FILED 11-16-2011.
- 4,208,404. **PURSOS (STANDARD CHARACTER)**. OSRAM AG, AKA OSRAM AKTIENGESELLSCHAFT, MULTIPLE CLASS, (INT. CLS. 9 AND 11), (U.S. CLS. 13, 21, 23, 26, 31, 34, 36 AND 38). SN 79-107,542. PUB. 7-3-2012. FILED 11-7-2011.
- 4,208,407. **PRO-NATURE TECHNOLOGY AND DESIGN**. DTL CORPORACIÓN, S.L., MULTIPLE CLASS, (INT. CLS. 9, 11, 35, 37, 40, 41 AND 42), (U.S. CLS. 13, 21, 23, 26, 31, 34, 36, 38, 100, 101, 102, 103, 106 AND 107). SN 79-107,850. PUB. 7-3-2012. FILED 8-30-2011.
- 4,208,408. **COLOSSEO ENTERPRISE ARENA SYSTEM AND DESIGN**. MONOGRAM TECHNOLOGIES, SPOL. S R.O., MULTIPLE CLASS, (INT. CLS. 9, 11, 37, 41 AND 42), (U.S. CLS. 13, 21, 23, 26, 31, 34, 36, 38, 100, 101, 103, 106 AND 107). SN 79-107,953. PUB. 7-3-2012. FILED 8-29-2011.
- 4,208,413. **DEXTR (STANDARD CHARACTER)**. IDEATRON PTY LTD, (U.S. CLS. 21, 23, 26, 36 AND 38). SN 79-108,308. PUB. 7-3-2012. FILED 12-15-2011.
- 4,208,419 (*See Class 7 for this trademark*).
- 4,208,424 (*See Class 7 for this trademark*).
- 4,208,425. **VALID-SW (STANDARD CHARACTER)**. VALID-SOFT UK LIMITED, MULTIPLE CLASS, (INT. CLS. 9, 42 AND 45), (U.S. CLS. 21, 23, 26, 36, 38, 100 AND 101). SN 79-109,473. PUB. 7-3-2012. FILED 10-31-2011.
- 4,208,428. **MAMBINO (STANDARD CHARACTER)**. MAMBO GRAPHICS PTY LIMITED, MULTIPLE CLASS, (INT. CLS. 9, 14, 16, 18 AND 25), (U.S. CLS. 1, 2, 3, 5, 21, 22, 23, 26, 27, 28, 29, 36, 37, 38, 39, 41 AND 50). SN 79-109,893. PUB. 7-3-2012. FILED 5-9-2011.
- 4,208,429. **COVER POWERED BY BUNTE AND DESIGN**. HUBERT BURDA; MEDIA HOLDING KOMMANDITGESELLSCHAFT, MULTIPLE CLASS, (INT. CLS. 9, 16 AND 41), (U.S. CLS. 2, 5, 21, 22, 23, 26, 29, 36, 37, 38, 50, 100, 101 AND 107). SN 79-109,954. PUB. 7-3-2012. FILED 6-18-2011.
- 4,208,433. **MEKK (STANDARD CHARACTER)**. KENNETH KNIGHT, MULTIPLE CLASS, (INT. CLS. 9, 12 AND 25), (U.S. CLS. 19, 21, 22, 23, 26, 31, 35, 36, 38, 39 AND 44). SN 79-110,593. PUB. 7-3-2012. FILED 11-24-2011.
- 4,208,441. **ICHOR (STANDARD CHARACTER)**. TOKYO ELECTRON KOREA LTD., (U.S. CLS. 21, 23, 26, 36 AND 38). SN 79-111,867. PUB. 7-3-2012. FILED 2-9-2012.
- 4,208,447 (*See Class 7 for this trademark*).
- 4,208,448 (*See Class 7 for this trademark*).
- 4,208,449 (*See Class 5 for this trademark*).
- 4,208,455. **SPACE UPDATE AND DESIGN**. SPACE UPDATE, INC., (U.S. CLS. 21, 23, 26, 36 AND 38). SN 85-042,889. PUB. 7-3-2012. FILED 5-19-2010.
- 4,208,458. **BALLROOM BABIES (STANDARD CHARACTER)**. RIVAL RABBIT MANAGEMENT, MULTIPLE CLASS, (INT. CLS. 9, 25 AND 41), (U.S. CLS. 21, 22, 23, 26, 36, 38, 39, 100, 101 AND 107). SN 85-052,406. PUB. 4-24-2012. FILED 6-2-2010.
- 4,208,469. **PERCEPTA (STANDARD CHARACTER)**. ADVANCED CHEMISTRY DEVELOPMENT INC., (U.S. CLS. 21, 23, 26, 36 AND 38). SN 85-087,670. PUB. 7-3-2012. FILED 7-19-2010.
- 4,208,472 (*See Class 6 for this trademark*).
- 4,208,473. **STYLOS TECH (STYLIZED)**. MERCADO CALOCA DIEGO GEOVANNI, (U.S. CLS. 21, 23, 26, 36 AND 38). SN 85-094,856. PUB. 7-3-2012. FILED 7-28-2010.
- 4,208,478 (*See Class 3 for this trademark*).
- 4,208,482. **THE SHUTTLE (STANDARD CHARACTER)**. SPIREON, INC., (U.S. CLS. 21, 23, 26, 36 AND 38). SN 85-127,922. PUB. 7-3-2012. FILED 9-13-2010.
- 4,208,483. **TMA (STANDARD CHARACTER)**. GEN-PROBE INCORPORATED, (U.S. CLS. 21, 23, 26, 36 AND 38). SN 85-129,336. PUB. 7-3-2012. FILED 9-14-2010.
- 4,208,484. **SIDE WING (STANDARD CHARACTER)**. LG ELECTRONICS INC., (U.S. CLS. 21, 23, 26, 36 AND 38). SN 85-137,631. PUB. 7-3-2012. FILED 9-24-2010.
- 4,208,488. **IEC LOCK (STANDARD CHARACTER)**. SCOLMORE INTERNATIONAL LIMITED, (U.S. CLS. 21, 23, 26, 36 AND 38). SN 85-145,358. PUB. 11-22-2011. FILED 10-5-2010.
- 4,208,494. **TFW TRAINING FOR WARRIORS AND DESIGN**. TRAINING FOR WARRIORS LLC, MULTIPLE CLASS, (INT. CLS. 9, 16 AND 41), (U.S. CLS. 2, 5, 21, 22, 23, 26, 29, 36, 37, 38, 50, 100, 101 AND 107). SN 85-159,392. PUB. 3-27-2012. FILED 10-22-2010.
- 4,208,495. **INTERNATIONAL INSTITUTE OF IRIDOLOGY AND DESIGN**. PESEK, DAVID JAMES, MULTIPLE CLASS, (INT. CLS. 9, 16, 41 AND 44), (U.S. CLS. 2, 5, 21, 22, 23, 26, 29, 36, 37, 38, 50, 100, 101 AND 107). SN 85-162,555. PUB. 7-3-2012. FILED 10-27-2010.
- 4,208,499. **PRIVATE SPACE (STANDARD CHARACTER)**. PRIVATE SPACE, (U.S. CLS. 21, 23, 26, 36 AND 38). SN 85-166,506. PUB. 7-3-2012. FILED 11-1-2010.
- 4,208,500 (*See Class 5 for this trademark*).
- 4,208,510. **4R ENERGY AND DESIGN**. 4R ENERGY CORPORATION, MULTIPLE CLASS, (INT. CLS. 9, 37 AND 40), (U.S. CLS. 21, 23, 26, 36, 38, 100, 103 AND 106). SN 85-179,272. PUB. 4-17-2012. FILED 11-17-2010.
- 4,208,511. **ALTBASE HDB (STANDARD CHARACTER)**. ALTBASE CO., LTD., (U.S. CLS. 21, 23, 26, 36 AND 38). SN 85-183,283. PUB. 7-3-2012. FILED 11-23-2010.
- 4,208,518. **ECOMETER (STANDARD CHARACTER)**. GILBARCO INC., (U.S. CLS. 21, 23, 26, 36 AND 38). SN 85-190,983. PUB. 7-3-2012. FILED 12-6-2010.
- 4,208,529. **DOLI (STANDARD CHARACTER)**. DOLI ELEKTRONIK GMBH, (U.S. CLS. 21, 23, 26, 36 AND 38). SN 85-200,554. PUB. 6-5-2012. FILED 12-17-2010.
- 4,208,534. **GSI MEDIA (STYLIZED)**. GSIMEDIA CORP., (U.S. CLS. 21, 23, 26, 36 AND 38). SN 85-205,241. PUB. 7-3-2012. FILED 12-23-2010.
- 4,208,545. **SLIM NARROW SLIM DEPTH & NARROW BEZEL AND DESIGN**. LG ELECTRONICS INC., (U.S. CLS. 21, 23, 26, 36 AND 38). SN 85-228,103. PUB. 7-3-2012. FILED 1-27-2011.
- 4,208,546. **PHOTO MODE AND DESIGN**. LG ELECTRONICS INC., (U.S. CLS. 21, 23, 26, 36 AND 38). SN 85-228,108. PUB. 7-3-2012. FILED 1-27-2011.
- 4,208,547. **3D AND DESIGN**. LG ELECTRONICS INC., (U.S. CLS. 21, 23, 26, 36 AND 38). SN 85-228,182. PUB. 7-3-2012. FILED 1-27-2011.
- 4,208,555. **NVIVO (STANDARD CHARACTER)**. QSR INTERNATIONAL PTY LTD, DBA QSR INTERNATIONAL PTY LTD, MULTIPLE CLASS, (INT. CLS. 9 AND 41), (U.S. CLS. 21, 23, 26, 36, 38, 100, 101 AND 107). SN 85-242,060. PUB. 7-3-2012. FILED 2-14-2011.
- 4,208,557 (*See Class 7 for this trademark*).
- 4,208,563. **TEMPTRACK (STANDARD CHARACTER)**. DVM SYSTEMS, LLC, MULTIPLE CLASS, (INT. CLS. 9 AND 42), (U.S. CLS. 21, 23, 26, 36, 38, 100 AND 101). SN 85-253,224. PUB. 7-3-2012. FILED 2-28-2011.
- 4,208,572. **RACHAEL RAY (STANDARD CHARACTER)**. RAY MARKS CO. LLC, (U.S. CLS. 21, 23, 26, 36 AND 38). SN 85-271,508. PUB. 7-3-2012. FILED 3-19-2011.
- 4,208,577. **LOCAID AND DESIGN**. LOC-AID TECHNOLOGIES, INC., MULTIPLE CLASS, (INT. CLS. 9, 16 AND 42), (U.S. CLS. 2, 5, 21, 22, 23, 26, 29, 36, 37, 38, 50, 100 AND 101). SN 85-278,861. PUB. 7-3-2012. FILED 3-28-2011.
- 4,208,578. **PISA (STANDARD CHARACTER)**. PULS GMBH, (U.S. CLS. 21, 23, 26, 36 AND 38). SN 85-279,979. PUB. 7-3-2012. FILED 3-29-2011.
- 4,208,579. **Y M AND DESIGN**. YOUNG MONEY ENTERTAINMENT, LLC, AKA YOUNG MONEY ENTERTAINMENT, MULTIPLE CLASS, (INT. CLS. 9 AND 41), (U.S.

- CLS. 21, 23, 26, 36, 38, 100, 101 AND 107). SN 85-280,163. PUB. 12-27-2011. FILED 3-29-2011.
- 4,208,585. **6 DEGREES (STANDARD CHARACTER)**. ICONNECT DEVELOPMENT, LLC, (U.S. CLS. 21, 23, 26, 36 AND 38). SN 85-286,794. PUB. 7-3-2012. FILED 4-5-2011.
- 4,208,590 (*See Class 7 for this trademark*).
- 4,208,591 (*See Class 7 for this trademark*).
- 4,208,601. **STUDENT LOCKER AND DESIGN. INNOVATIVE KNOWLEDGE, INC.**, (U.S. CLS. 21, 23, 26, 36 AND 38). SN 85-307,883. PUB. 7-3-2012. FILED 4-28-2011.
- 4,208,605. **ACCENSUM AND DESIGN. ACCENSUM IBERICA, S.L.**, (U.S. CLS. 21, 23, 26, 36 AND 38). SN 85-314,160. PUB. 7-3-2012. FILED 5-6-2011.
- 4,208,622. **BEACON AND DESIGN. BEACON PICTURES, LLC**, (U.S. CLS. 21, 23, 26, 36 AND 38). SN 85-329,846. PUB. 7-3-2012. FILED 5-25-2011.
- 4,208,624. **SCRIBBLY (STANDARD CHARACTER)**. HOOGLIET, MARC J.H., DBA SCRIBBLY, MULTIPLE CLASS, (INT. CLS. 9 AND 45), (U.S. CLS. 21, 23, 26, 36, 38, 100 AND 101). SN 85-330,607. PUB. 7-3-2012. FILED 5-26-2011.
- 4,208,637. **KEYS OF FORTUNE (STANDARD CHARACTER)**. ARISTOCRAT TECHNOLOGIES AUSTRALIA PTY LTD., (U.S. CLS. 21, 23, 26, 36 AND 38). SN 85-338,509. PUB. 7-3-2012. FILED 6-6-2011.
- 4,208,644 (*See Class 4 for this trademark*).
- 4,208,658. **SUPER 4 AND DESIGN. GIGA-BYTE TECHNOLOGY CO., LTD.**, (U.S. CLS. 21, 23, 26, 36 AND 38). SN 85-350,196. PUB. 7-3-2012. FILED 6-20-2011.
- 4,208,659. **SUPER 4 (STANDARD CHARACTER)**. GIGA-BYTE TECHNOLOGY CO., LTD., (U.S. CLS. 21, 23, 26, 36 AND 38). SN 85-350,236. PUB. 7-3-2012. FILED 6-20-2011.
- 4,208,667. **BLOGGIE DUO (STANDARD CHARACTER)**. SONY CORPORATION, (U.S. CLS. 21, 23, 26, 36 AND 38). SN 85-352,639. PUB. 7-3-2012. FILED 6-22-2011.
- 4,208,678. **STREETWISE CADLINK AND DESIGN. HANGAR 14 SOLUTIONS, LLC**, (U.S. CLS. 21, 23, 26, 36 AND 38). SN 85-357,448. PUB. 7-3-2012. FILED 6-27-2011.
- 4,208,682. **BUDWRAP (STANDARD CHARACTER)**. WILLIAMS, MARK R., (U.S. CLS. 21, 23, 26, 36 AND 38). SN 85-358,476. PUB. 7-3-2012. FILED 6-28-2011.
- 4,208,692. **WHODOO (STANDARD CHARACTER)**. PIONEER KABUSHIKI KAISHA D/B/A PIONEER CORPORATION, MULTIPLE CLASS, (INT. CLS. 9 AND 42), (U.S. CLS. 21, 23, 26, 36, 38, 100 AND 101). SN 85-360,932. PUB. 7-3-2012. FILED 6-30-2011.
- 4,208,702. **EM'S 4 KIDS AND DESIGN. EM'S 4 KIDS LLC**, (U.S. CLS. 21, 23, 26, 36 AND 38). SN 85-363,722. PUB. 7-3-2012. FILED 7-6-2011.
- 4,208,707. **ALEXIS JORDAN (STANDARD CHARACTER)**. ALEXIS JORDAN, (U.S. CLS. 21, 23, 26, 36 AND 38). SN 85-365,804. PUB. 7-3-2012. FILED 7-7-2011.
- 4,208,709. **CRUZER EDGE (STANDARD CHARACTER)**. SANDISK CORPORATION, (U.S. CLS. 21, 23, 26, 36 AND 38). SN 85-365,905. PUB. 7-3-2012. FILED 7-7-2011.
- 4,208,728. **STAR ROC (STANDARD CHARACTER)**. STAR ROC, LLC, (U.S. CLS. 21, 23, 26, 36 AND 38). SN 85-370,300. PUB. 7-3-2012. FILED 7-13-2011.
- 4,208,729. **ZOMBIE SMASH! AND DESIGN. ZYNGA INC.**, MULTIPLE CLASS, (INT. CLS. 9 AND 41), (U.S. CLS. 21, 23, 26, 36, 38, 100, 101 AND 107). SN 85-370,813. PUB. 7-3-2012. FILED 7-13-2011.
- 4,208,740. **SHARKPRO SOFTWARE AND DESIGN. SHARKPRO SOFTWARE CORPORATION**, (U.S. CLS. 21, 23, 26, 36 AND 38). SN 85-373,098. PUB. 7-3-2012. FILED 7-16-2011.
- 4,208,742. **VIBEDECK (STYLIZED)**. VIBEDECK LLP, (U.S. CLS. 21, 23, 26, 36 AND 38). SN 85-373,281. PUB. 7-3-2012. FILED 7-17-2011.
- 4,208,778. **ISABELLA & FERDINAND SPANISH LANGUAGE ADVENTURES (STANDARD CHARACTER)**. ISABELLA & FERDINAND LLC, MULTIPLE CLASS, (INT. CLS. 9, 16 AND 41), (U.S. CLS. 2, 5, 21, 22, 23, 26, 29, 36, 37, 38, 50, 100, 101 AND 107). SN 85-376,939. PUB. 7-3-2012. FILED 7-21-2011.
- 4,208,784. **ECB (STANDARD CHARACTER)**. NATIONAL APPLIED CONSTRUCTION PRODUCTS INC., MULTIPLE CLASS, (INT. CLS. 9 AND 19), (U.S. CLS. 1, 12, 21, 23, 26, 33, 36, 38 AND 50). SN 85-378,672. PUB. 7-3-2012. FILED 7-22-2011.
- 4,208,800. **D-IMAGER (STANDARD CHARACTER)**. PANASONIC CORPORATION, (U.S. CLS. 21, 23, 26, 36 AND 38). SN 85-383,843. PUB. 7-3-2012. FILED 7-28-2011.
- 4,208,810. **ETAS DRIVING EMBEDDED EXCELLENCE AND DESIGN**. ETAS ENTWICKLUNGS-UND APPLIKATIONSWERKZEUGE FUER ELEKTRONISCHE SYSTEME GMBH, MULTIPLE CLASS, (INT. CLS. 9 AND 42), (U.S. CLS. 21, 23, 26, 36, 38, 100 AND 101). SN 85-386,172. PUB. 7-3-2012. FILED 8-1-2011.
- 4,208,811. **CHROMA SHUFFLE (STANDARD CHARACTER)**. SIFTEO, INC., MULTIPLE CLASS, (INT. CLS. 9 AND 28), (U.S. CLS. 21, 22, 23, 26, 36, 38 AND 50). SN 85-386,334. PUB. 7-3-2012. FILED 8-1-2011.
- 4,208,812. **TRACK-AND-SHARE (STANDARD CHARACTER)**. VERIDIAN HEALTHCARE, LLC, (U.S. CLS. 21, 23, 26, 36 AND 38). SN 85-386,383. PUB. 1-17-2012. FILED 8-1-2011.
- 4,208,817. **ELECTRONIC ORIGINAL (STANDARD CHARACTER)**. EORIGINAL, INC., MULTIPLE CLASS, (INT. CLS. 9, 38 AND 39), (U.S. CLS. 21, 23, 26, 36, 38, 100, 101, 104 AND 105). SN 85-388,172. PUB. 7-3-2012. FILED 8-3-2011.
- 4,208,818. **M MARS HILL CHURCH AND DESIGN**. MARS HILL CHURCH, MULTIPLE CLASS, (INT. CLS. 9, 41 AND 45), (U.S. CLS. 21, 23, 26, 36, 38, 100, 101 AND 107). SN 85-388,182. PUB. 7-3-2012. FILED 8-3-2011.
- 4,208,824. **CREDIT UNION NATIONAL ASSOCIATION (STANDARD CHARACTER)**. CREDIT UNION NATIONAL ASSOCIATION, INC., (U.S. CLS. 21, 23, 26, 36 AND 38). SN 85-388,709. PUB. 3-27-2012. FILED 8-3-2011.
- 4,208,828. **DAVID SHADE (STANDARD CHARACTER)**. DAVID SHADE CORPORATION, MULTIPLE CLASS, (INT. CLS. 9, 16 AND 41), (U.S. CLS. 2, 5, 21, 22, 23, 26, 29, 36, 37, 38, 50, 100, 101 AND 107). SN 85-390,064. PUB. 7-3-2012. FILED 8-4-2011.
- 4,208,829. **HOLOGRAM AND DESIGN. BOPRO ENTERPRISE CO., LTD.**, (U.S. CLS. 21, 23, 26, 36 AND 38). SN 85-390,290. PUB. 7-3-2012. FILED 8-5-2011.
- 4,208,832. **BACKSIDE (STANDARD CHARACTER)**. G PRIME MEDIA, LLC, (U.S. CLS. 21, 23, 26, 36 AND 38). SN 85-391,401. PUB. 7-3-2012. FILED 8-6-2011.
- 4,208,841. **REFLECTION POS (STANDARD CHARACTER)**. NATIONAL COMPUTER CORPORATION, INC., (U.S. CLS. 21, 23, 26, 36 AND 38). SN 85-393,775. PUB. 1-31-2012. FILED 8-9-2011.
- 4,208,852. **INSIGHT AUDIT (STANDARD CHARACTER)**. CRANWARE, INC., (U.S. CLS. 21, 23, 26, 36 AND 38). SN 85-396,485. PUB. 7-3-2012. FILED 8-12-2011.
- 4,208,853. **INSIGHT PAYMENT VARIANCE ANALYZER (STANDARD CHARACTER)**. CRANWARE, INC., (U.S. CLS. 21, 23, 26, 36 AND 38). SN 85-396,526. PUB. 7-3-2012. FILED 8-12-2011.
- 4,208,861. **HOYALUX ID (STANDARD CHARACTER)**. HOYA CORPORATION, (U.S. CLS. 21, 23, 26, 36 AND 38). SN 85-399,967. PUB. 7-3-2012. FILED 8-17-2011.
- 4,208,865. **ONTIME (STANDARD CHARACTER)**. VESIGO STUDIOS, LLC, (U.S. CLS. 21, 23, 26, 36 AND 38). SN 85-400,739. PUB. 1-17-2012. FILED 8-17-2011.
- 4,208,880. **IHT (STANDARD CHARACTER)**. PETROLEUM ANALYZER COMPANY, L.P., (U.S. CLS. 21, 23, 26, 36 AND 38). SN 85-404,369. PUB. 7-3-2012. FILED 8-23-2011.
- 4,208,882. **LEDGEX (STANDARD CHARACTER)**. LEDGEX SYSTEMS LLC, (U.S. CLS. 21, 23, 26, 36 AND 38). SN 85-404,606. PUB. 7-3-2012. FILED 8-23-2011.
- 4,208,883. **LEDGEX SYSTEMS (STANDARD CHARACTER)**. LEDGEX SYSTEMS LLC, (U.S. CLS. 21, 23, 26, 36 AND 38). SN 85-404,632. PUB. 7-3-2012. FILED 8-23-2011.
- 4,208,884. **EP AND DESIGN. EPTRONICS, INC.**, (U.S. CLS. 21, 23, 26, 36 AND 38). SN 85-404,850. PUB. 7-3-2012. FILED 8-23-2011.
- 4,208,894. **IGET (STANDARD CHARACTER)**. IGET IT FAST LLC, DBA IGET IT FAST, (U.S. CLS. 21, 23, 26, 36 AND 38). SN 85-409,362. PUB. 7-3-2012. FILED 8-29-2011.
- 4,208,903. **BUSINESS RADIOX (STANDARD CHARACTER)**. BUSINESS RADIOX, LLC, MULTIPLE CLASS, (INT. CLS. 9, 35, 38, 41 AND 42), (U.S. CLS. 21, 23, 26, 36, 38, 100, 101, 102, 104 AND 107). SN 85-412,506. PUB. 7-3-2012. FILED 8-31-2011.
- 4,208,914. **LENTEVISION (STANDARD CHARACTER)**. LO VI POR TV, LLC, (U.S. CLS. 21, 23, 26, 36 AND 38). SN 85-

- 414,875. PUB. 7-3-2012. FILED 9-4-2011.
- 4,208,917. **LIGHTPAD (STANDARD CHARACTER)**. ARTOGRAPH, INC., (U.S. CLS. 21, 23, 26, 36 AND 38). SN 85-415,183. PUB. 7-3-2012. FILED 9-6-2011.
- 4,208,922. **SQWAWK.COM (STYLIZED)**. TARGETED CIRCUITRY, LLC, DBA SQWAWK.COM, (U.S. CLS. 21, 23, 26, 36 AND 38). SN 85-417,334. PUB. 7-3-2012. FILED 9-8-2011.
- 4,208,929. **REFRAZE (STANDARD CHARACTER)**. SOUTHERN FOX LLC, (U.S. CLS. 21, 23, 26, 36 AND 38). SN 85-420,495. PUB. 7-3-2012. FILED 9-12-2011.
- 4,208,937. **SNAP-N-STAC (STANDARD CHARACTER)**. THOMAS & BETTS INTERNATIONAL, INC., (U.S. CLS. 21, 23, 26, 36 AND 38). SN 85-423,211. PUB. 7-3-2012. FILED 9-15-2011.
- 4,208,941. **VALENTINO THE MUSICAL AND DESIGN**. DEJOSIA, FRANCESCA, AND MANDRACCHIA, CHARLES, MULTIPLE CLASS, (INT. CLS. 9 AND 41), (U.S. CLS. 21, 23, 26, 36, 38, 100, 101 AND 107). SN 85-428,785. PUB. 7-3-2012. FILED 9-21-2011.
- 4,208,948. **THE TIMELINE OF YOUR LIFE (STANDARD CHARACTER)**. ORPHIONICS, LLC, MULTIPLE CLASS, (INT. CLS. 9, 35, 38, 41, 42 AND 45), (U.S. CLS. 21, 23, 26, 36, 38, 100, 101, 102, 104 AND 107). SN 85-431,097. PUB. 7-3-2012. FILED 9-23-2011.
- 4,208,953. **SENSIBOT (STANDARD CHARACTER)**. INOS AUTOMATIONSSOFTWARE GMBH, MULTIPLE CLASS, (INT. CLS. 9 AND 10), (U.S. CLS. 21, 23, 26, 36, 38, 39 AND 44). SN 85-435,174. PUB. 7-3-2012. FILED 9-29-2011.
- 4,208,959. **APPS4U2BU (STANDARD CHARACTER)**. APPS4U2BU, INC., AKA ANDREW CHEN, (U.S. CLS. 21, 23, 26, 36 AND 38). SN 85-436,192. PUB. 7-3-2012. FILED 9-30-2011.
- 4,208,980. **PAUL WALL (STANDARD CHARACTER)**. PAUL MICHAEL SLAYTON, MULTIPLE CLASS, (INT. CLS. 9 AND 41), (U.S. CLS. 21, 23, 26, 36, 38, 100, 101 AND 107). SN 85-444,828. PUB. 7-3-2012. FILED 10-11-2011.
- 4,208,987. **BIOMETRICOM INCORPORATED AND DESIGN**. BIOMETRICOM, INC., (U.S. CLS. 21, 23, 26, 36 AND 38). SN 85-447,303. PUB. 7-3-2012. FILED 10-14-2011.
- 4,208,992. **MS SHIFT (STYLIZED)**. MS SHIFT, INC., (U.S. CLS. 21, 23, 26, 36 AND 38). SN 85-447,776. PUB. 7-3-2012. FILED 10-14-2011.
- 4,208,999. **ECHOXS (STANDARD CHARACTER)**. ECHOXS ENTERTAINMENT, LLC, MULTIPLE CLASS, (INT. CLS. 9 AND 41), (U.S. CLS. 21, 23, 26, 36, 38, 100, 101 AND 107). SN 85-448,940. PUB. 7-3-2012. FILED 10-17-2011.
- 4,209,018. **LABLION AND DESIGN**. INTEGRATED BUSINESS SOLUTIONS GROUP, AKA IBSG, (U.S. CLS. 21, 23, 26, 36 AND 38). SN 85-458,895. PUB. 7-3-2012. FILED 10-28-2011.
- 4,209,023. **I-FLEX (STANDARD CHARACTER)**. FIKE EUROPE BVBA, (U.S. CLS. 21, 23, 26, 36 AND 38). SN 85-460,754. PUB. 7-3-2012. FILED 10-31-2011.
- 4,209,037. **INTERACTIVE BUDDY (STANDARD CHARACTER)**. ROTAR, DANIEL M., AKA SHOCK VALUE; SHOCK VALUE GAMES, (U.S. CLS. 21, 23, 26, 36 AND 38). SN 85-466,621. PUB. 7-3-2012. FILED 11-7-2011.
- 4,209,053. **ASSOCIATED RESEARCH, INC. AND DESIGN**. ASSOCIATED RESEARCH, INC., (U.S. CLS. 21, 23, 26, 36 AND 38). SN 85-472,650. PUB. 7-3-2012. FILED 11-15-2011.
- 4,209,056. **RIGHT ROAD FOR KIDS! (STANDARD CHARACTER)**. PHILLIPS, PAULA, DBA RIGHT ROAD PRODUCTIONS, (U.S. CLS. 21, 23, 26, 36 AND 38). SN 85-472,912. PUB. 7-3-2012. FILED 11-15-2011.
- 4,209,059. **MISCELLANEOUS DESIGN**. KIDZOUT, INC., (U.S. CLS. 21, 23, 26, 36 AND 38). SN 85-473,349. PUB. 3-27-2012. FILED 11-15-2011.
- 4,209,067. **FORESITE (STANDARD CHARACTER)**. ENOW, INC., (U.S. CLS. 21, 23, 26, 36 AND 38). SN 85-477,128. PUB. 7-3-2012. FILED 11-19-2011.
- 4,209,070. **STRANGE HILL HIGH (STANDARD CHARACTER)**. FREMANTLEMEDIA LIMITED, MULTIPLE CLASS, (INT. CLS. 9, 16, 25, 28 AND 41), (U.S. CLS. 2, 5, 21, 22, 23, 26, 29, 36, 37, 38, 39, 50, 100, 101 AND 107). SN 85-478,520. PUB. 7-3-2012. FILED 11-22-2011.
- 4,209,079. **STRIKE X AND DESIGN**. AEROCOOL ADVANCED TECHNOLOGIES CORPORATION, (U.S. CLS. 21, 23, 26, 36 AND 38). SN 85-483,667. PUB. 7-3-2012. FILED 11-30-2011.
- 4,209,095 (*See Class 6 for this trademark*).
- 4,209,102. **TERABRITE (STANDARD CHARACTER)**. DONALD S. MONOPOLI JR., DBA TERABRITE, (U.S. CLS. 21, 23, 26, 36 AND 38). SN 85-491,141. PUB. 7-3-2012. FILED 12-8-2011.
- 4,209,104. **CARA QUICI AND DESIGN**. CARA QUICI, MULTIPLE CLASS, (INT. CLS. 9 AND 41), (U.S. CLS. 21, 23, 26, 36, 38, 100, 101 AND 107). SN 85-491,691. PUB. 7-3-2012. FILED 12-9-2011.
- 4,209,142. **VISIBLECHEK (STANDARD CHARACTER)**. ABL SA, (U.S. CLS. 21, 23, 26, 36 AND 38). SN 85-500,870. PUB. 7-3-2012. FILED 12-21-2011.
- 4,209,152. **MISCELLANEOUS DESIGN**. MARTINGALE & COMPANY, MULTIPLE CLASS, (INT. CLS. 9, 16 AND 35), (U.S. CLS. 2, 5, 21, 22, 23, 26, 29, 36, 37, 38, 50, 100, 101 AND 102). SN 85-503,017. PUB. 7-3-2012. FILED 12-23-2011.
- 4,209,168. **C AND DESIGN**. GLORY LTD., (U.S. CLS. 21, 23, 26, 36 AND 38). SN 85-505,540. PUB. 7-3-2012. FILED 12-29-2011.
- 4,209,192. **LINDA AND DESIGN**. HEGWOOD, LINDA I., (U.S. CLS. 21, 23, 26, 36 AND 38). SN 85-510,124. PUB. 7-3-2012. FILED 1-6-2012.
- 4,209,194. **BACKATCHA BOOKS (STANDARD CHARACTER)**. MERX GLOBAL LLC, (U.S. CLS. 21, 23, 26, 36 AND 38). SN 85-510,326. PUB. 7-3-2012. FILED 1-6-2012.
- 4,209,195. **BACKATCHA (STANDARD CHARACTER)**. MERX GLOBAL LLC, (U.S. CLS. 21, 23, 26, 36 AND 38). SN 85-510,337. PUB. 7-3-2012. FILED 1-6-2012.
- 4,209,196. **LOG OUT AND LIVE (STANDARD CHARACTER)**. LOG OUT AND LIVE, LLC., MULTIPLE CLASS, (INT. CLS. 9, 16 AND 25), (U.S. CLS. 2, 5, 21, 22, 23, 26, 29, 36, 37, 38, 39 AND 50). SN 85-510,972. PUB. 7-3-2012. FILED 1-6-2012.
- 4,209,234. **E3 MINI (STANDARD CHARACTER)**. DESIGNETICS, INC., (U.S. CLS. 21, 23, 26, 36 AND 38). SN 85-517,900. PUB. 7-3-2012. FILED 1-17-2012.
- 4,209,236. **DIMPLE PLUGS (STANDARD CHARACTER)**. MARTIN, JOHN A., (U.S. CLS. 21, 23, 26, 36 AND 38). SN 85-518,077. PUB. 7-3-2012. FILED 1-17-2012.
- 4,209,261. **RAMPCAST (STANDARD CHARACTER)**. VAISALA OYJ, MULTIPLE CLASS, (INT. CLS. 9, 37, 38, 40 AND 42), (U.S. CLS. 21, 23, 26, 36, 38, 100, 101, 103, 104 AND 106). SN 85-519,992. PUB. 7-3-2012. FILED 1-19-2012.
- 4,209,263. **ANTHILLPRO (STANDARD CHARACTER)**. URBAN CODE, INCORPORATED, FORMERLY STARBELLY PRODUCTIONS, INCORPORATED, (U.S. CLS. 21, 23, 26, 36 AND 38). SN 85-520,036. PUB. 7-3-2012. FILED 1-19-2012.
- 4,209,266 (*See Class 7 for this trademark*).
- 4,209,276. **GLOMPER (STANDARD CHARACTER)**. ALEXANDER BORODICH, DBA WOWNRG LTD, (U.S. CLS. 21, 23, 26, 36 AND 38). SN 85-520,924. PUB. 7-3-2012. FILED 1-20-2012.
- 4,209,277. **KING PRECISION AND DESIGN**. KING PRODUCTS AND EQUIPMENT LLC., (U.S. CLS. 21, 23, 26, 36 AND 38). SN 85-520,939. PUB. 7-3-2012. FILED 1-20-2012.
- 4,209,278. **SURETUNE (STANDARD CHARACTER)**. SAPIENS STEERING BRAIN STIMULATION B.V., MULTIPLE CLASS, (INT. CLS. 9, 10 AND 44), (U.S. CLS. 21, 23, 26, 36, 38, 39, 44, 100 AND 101). SN 85-521,008. PUB. 7-3-2012. FILED 1-20-2012.
- 4,209,284. **SKYVILLE RECORDS (STANDARD CHARACTER)**. SKYLINE MUSIC PUBLISHING, LLC, (U.S. CLS. 21, 23, 26, 36 AND 38). SN 85-521,214. PUB. 7-3-2012. FILED 1-20-2012.
- 4,209,296. **INFLITE COMPOSITE EMI BACKSHELL SYSTEM RUSSTECH AND DESIGN**. RUSSTECH ENGINEERING CO., INC., (U.S. CLS. 21, 23, 26, 36 AND 38). SN 85-521,765. PUB. 7-3-2012. FILED 1-20-2012.
- 4,209,317. **EXADEL (STANDARD CHARACTER)**. EXADEL, INC., (U.S. CLS. 21, 23, 26, 36 AND 38). SN 85-522,703. PUB. 7-3-2012. FILED 1-23-2012.
- 4,209,323. **WATER WATCHER AND DESIGN**. CASPERDAISY LTD CO., (U.S. CLS. 21, 23, 26, 36 AND 38). SN 85-523,003. PUB. 7-3-2012. FILED 1-23-2012.
- 4,209,367. **AT THE DOOR (STANDARD CHARACTER)**. EVENTBRITE, INC., (U.S. CLS. 21, 23, 26, 36 AND 38). SN 85-524,942. PUB. 7-3-2012. FILED 1-25-2012.
- 4,209,368. **CADWORX DRAFTPRO (STANDARD CHARACTER)**. INTERGRAPH CORPORATION, (U.S. CLS. 21, 23, 26, 36 AND 38). SN 85-525,007. PUB. 7-3-2012. FILED 1-25-

- 2012.
- 4,209,371. **FRIENDLY POINTS (STANDARD CHARACTER)**. FRIENDLY POINTS, LLC, (U.S. CLS. 21, 23, 26, 36 AND 38). SN 85-525,078. PUB. 7-3-2012. FILED 1-25-2012.
- 4,209,375. **P PLATT AND DESIGN. HARMONY INVESTMENTS LIMITED PARTNERSHIP**, (U.S. CLS. 21, 23, 26, 36 AND 38). SN 85-525,285. PUB. 7-3-2012. FILED 1-25-2012.
- 4,209,402. **RUGGED MARINE (STANDARD CHARACTER)**. SPEARS, JENNIFER, (U.S. CLS. 21, 23, 26, 36 AND 38). SN 85-526,158. PUB. 7-3-2012. FILED 1-26-2012.
- 4,209,435. **SLIPFIT (STANDARD CHARACTER)**. PERFORMANCE FABRICS, INC., (U.S. CLS. 21, 23, 26, 36 AND 38). SN 85-528,484. PUB. 7-3-2012. FILED 1-30-2012.
- 4,209,493. **78% SEVENTY EIGHT PERCENT AND DESIGN. LEVY SHAY ELIEZER, MULTIPLE CLASS, (INT. CLS. 9 AND 18)**, (U.S. CLS. 1, 2, 3, 21, 22, 23, 26, 36, 38 AND 41). SN 85-536,593. PUB. 7-3-2012. FILED 2-8-2012.
- 4,209,512. **CHOICE (STANDARD CHARACTER)**. 509, INC., DBA 3PMOBILE, (U.S. CLS. 21, 23, 26, 36 AND 38). SN 85-537,873. PUB. 7-3-2012. FILED 2-9-2012.
- 4,209,528. **SHIFT TO THE HEART (STANDARD CHARACTER)**. HEARTMATH, LLC, MULTIPLE CLASS, (INT. CLS. 9, 16 AND 41), (U.S. CLS. 2, 5, 21, 22, 23, 26, 29, 36, 37, 38, 50, 100, 101 AND 107). SN 85-538,886. PUB. 7-3-2012. FILED 2-9-2012.
- 4,209,530. **MOBILEPRO3 (STANDARD CHARACTER)**. IN-FIELD SALES/PRO LLC, (U.S. CLS. 21, 23, 26, 36 AND 38). SN 85-539,087. PUB. 7-3-2012. FILED 2-10-2012.
- 4,209,551. **MATTERDADDY (STANDARD CHARACTER)**. MATTERDADDY LLC, (U.S. CLS. 21, 23, 26, 36 AND 38). SN 85-539,887. PUB. 7-3-2012. FILED 2-10-2012.
- 4,209,560. **V-SMART (STANDARD CHARACTER)**. SUNITA TELECOM. CO., LTD., (U.S. CLS. 21, 23, 26, 36 AND 38). SN 85-540,268. PUB. 7-3-2012. FILED 2-11-2012.
- 4,209,572. **BIOVIGIL AND DESIGN. BIOVIGIL HYGIENE TECHNOLOGIES, LLC**, (U.S. CLS. 21, 23, 26, 36 AND 38). SN 85-540,854. PUB. 7-3-2012. FILED 2-13-2012.
- 4,209,574. **DESIGNERS (STANDARD CHARACTER)**. FORTY FOUR GROUP LLC, DBA ORIGAUDIO, (U.S. CLS. 21, 23, 26, 36 AND 38). SN 85-540,894. PUB. 7-3-2012. FILED 2-13-2012.
- 4,209,575. **MISCELLANEOUS DESIGN. BIOVIGIL HYGIENE TECHNOLOGIES, LLC**, (U.S. CLS. 21, 23, 26, 36 AND 38). SN 85-540,899. PUB. 7-3-2012. FILED 2-13-2012.
- 4,209,599. **ACCU-CT (STANDARD CHARACTER)**. CONTINENTAL CONTROL SYSTEMS, LLC, (U.S. CLS. 21, 23, 26, 36 AND 38). SN 85-541,146. PUB. 7-3-2012. FILED 2-13-2012.
- 4,209,608. **RELIABIT (STANDARD CHARACTER)**. RELIABIT, LLC, (U.S. CLS. 21, 23, 26, 36 AND 38). SN 85-541,242. PUB. 7-3-2012. FILED 2-13-2012.
- 4,209,610. **CHAMILLION (STANDARD CHARACTER)**. MULTIMEDIA GAMES, INC., (U.S. CLS. 21, 23, 26, 36 AND 38). SN 85-541,279. PUB. 7-3-2012. FILED 2-13-2012.
- 4,209,614. **ICHAT (STANDARD CHARACTER)**. APPLE INC., MULTIPLE CLASS, (INT. CLS. 9 AND 38), (U.S. CLS. 21, 23, 26, 36, 38, 100, 101 AND 104). SN 85-541,331. PUB. 7-3-2012. FILED 2-13-2012.
- 4,209,617. **COVIDEO (STANDARD CHARACTER)**. AUTOMOBILE PROTECTION CORPORATION-APCO, (U.S. CLS. 21, 23, 26, 36 AND 38). SN 85-541,372. PUB. 7-3-2012. FILED 2-13-2012.
- 4,209,636. **MARVO (STYLIZED)**. SHENZHEN MARK TECHNOLOGIES CO., LTD., (U.S. CLS. 21, 23, 26, 36 AND 38). SN 85-541,699. PUB. 7-3-2012. FILED 2-14-2012.
- 4,209,637. **SB4001 (STANDARD CHARACTER)**. SERPENT AUDIO LLC, (U.S. CLS. 21, 23, 26, 36 AND 38). SN 85-541,712. PUB. 7-3-2012. FILED 2-14-2012.
- 4,209,639. **DI (STYLIZED)**. LOGI D INC., (U.S. CLS. 21, 23, 26, 36 AND 38). SN 85-541,754. PUB. 7-3-2012. FILED 2-14-2012.
- 4,209,661. **MISCELLANEOUS DESIGN. NATIONAL QUALITY FORUM, MULTIPLE CLASS, (INT. CLS. 9, 16, 41 AND 42)**, (U.S. CLS. 2, 5, 21, 22, 23, 26, 29, 36, 37, 38, 50, 100, 101 AND 107). SN 85-542,124. PUB. 7-3-2012. FILED 2-14-2012.
- 4,209,667. **WEBHOTEL (STANDARD CHARACTER)**. DATA-VANTAGE CORPORATION, (U.S. CLS. 21, 23, 26, 36 AND 38). SN 85-542,190. PUB. 7-3-2012. FILED 2-14-2012.
- 4,209,669. **3DSO (STANDARD CHARACTER)**. PRODUCTION CONTROL SERVICES, INC., (U.S. CLS. 21, 23, 26, 36 AND 38). SN 85-542,216. PUB. 7-3-2012. FILED 2-14-2012.
- 4,209,671. **ANSWER FACTORY (STANDARD CHARACTER)**. CYFEON SOLUTIONS, INC., (U.S. CLS. 21, 23, 26, 36 AND 38). SN 85-542,274. PUB. 7-3-2012. FILED 2-14-2012.
- 4,209,683. **VITREAVIEW (STANDARD CHARACTER)**. VITAL IMAGES, INC., (U.S. CLS. 21, 23, 26, 36 AND 38). SN 85-542,448. PUB. 7-3-2012. FILED 2-14-2012.
- 4,209,698. **MAKING GOOD SOUND GREAT (STANDARD CHARACTER)**. AUDIOCONTROL INC., (U.S. CLS. 21, 23, 26, 36 AND 38). SN 85-542,744. PUB. 7-3-2012. FILED 2-14-2012.
- 4,209,699. **TURBONOTE (STANDARD CHARACTER)**. THE TRUSTEES OF THE BASKIN-KERR TRUST, A NEW ZEALAND TRUST COMPRISING VICKI CATHRYN HYDE AND TERENCE JAMES LEO FOOTE, CITIZENS OF NEW ZEALAND, (U.S. CLS. 21, 23, 26, 36 AND 38). SN 85-542,745. PUB. 7-3-2012. FILED 2-14-2012.
- 4,209,701. **WHITE COLLAR (STANDARD CHARACTER)**. TWENTIETH CENTURY FOX FILM CORPORATION, (U.S. CLS. 21, 23, 26, 36 AND 38). SN 85-542,794. PUB. 7-3-2012. FILED 2-14-2012.
- 4,209,729. **CHANGE THE FIRST FIVE YEARS AND YOU CHANGE EVERYTHING (STANDARD CHARACTER)**. OUNCE OF PREVENTION FUND, MULTIPLE CLASS, (INT. CLS. 9, 35 AND 41), (U.S. CLS. 21, 23, 26, 36, 38, 100, 101, 102 AND 107). SN 85-543,250. PUB. 7-3-2012. FILED 2-15-2012.
- 4,209,745. **GRATIFON (STANDARD CHARACTER)**. YOSEF, OZ, MULTIPLE CLASS, (INT. CLS. 9 AND 35), (U.S. CLS. 21, 23, 26, 36, 38, 100, 101 AND 102). SN 85-543,433. PUB. 7-3-2012. FILED 2-15-2012.
- 4,209,755. **CIRCO (STYLIZED)**. TARGET BRANDS, INC., (U.S. CLS. 21, 23, 26, 36 AND 38). SN 85-543,574. PUB. 7-3-2012. FILED 2-15-2012.
- 4,209,757. **CIRCO (STANDARD CHARACTER)**. TARGET BRANDS, INC., (U.S. CLS. 21, 23, 26, 36 AND 38). SN 85-543,580. PUB. 7-3-2012. FILED 2-15-2012.
- 4,209,760. **COILDESIGNER (STANDARD CHARACTER)**. OPTIMIZED THERMAL SYSTEMS, (U.S. CLS. 21, 23, 26, 36 AND 38). SN 85-543,624. PUB. 7-3-2012. FILED 2-15-2012.
- 4,209,794. **SHINE (STANDARD CHARACTER)**. KAPLAN EARLY LEARNING COMPANY, (U.S. CLS. 21, 23, 26, 36 AND 38). SN 85-544,194. PUB. 7-3-2012. FILED 2-16-2012.
- 4,209,801. **X2N (STANDARD CHARACTER)**. DIMARZIO, INC., (U.S. CLS. 21, 23, 26, 36 AND 38). SN 85-544,353. PUB. 7-3-2012. FILED 2-16-2012.
- 4,209,831. **CODERED AND DESIGN. FLI MARKETING INC.**, (U.S. CLS. 21, 23, 26, 36 AND 38). SN 85-544,726. PUB. 7-3-2012. FILED 2-16-2012.
- 4,209,836. **HIP MERMAID PRODUCTIONS (STANDARD CHARACTER)**. MARCUS, BRIAN, DBA HIP MERMAID PRODUCTIONS, (U.S. CLS. 21, 23, 26, 36 AND 38). SN 85-544,893. PUB. 7-3-2012. FILED 2-16-2012.
- 4,209,846. **TACTICAL TRAILER (STANDARD CHARACTER)**. MADDEN, PAUL DANIEL, (U.S. CLS. 21, 23, 26, 36 AND 38). SN 85-545,064. PUB. 7-3-2012. FILED 2-16-2012.
- 4,209,851. **GOPOLE (STANDARD CHARACTER)**. AR2 PRODUCTS, (U.S. CLS. 21, 23, 26, 36 AND 38). SN 85-545,210. PUB. 7-3-2012. FILED 2-16-2012.
- 4,209,853. **GET HOOKED UP (STANDARD CHARACTER)**. HUMBLE FISH, INC., DBA SKUNK JUICE EARBUDS, (U.S. CLS. 21, 23, 26, 36 AND 38). SN 85-545,258. PUB. 7-3-2012. FILED 2-16-2012.
- 4,209,862. **ATRIO (STANDARD CHARACTER)**. PAR TECHNOLOGY CORPORATION, MULTIPLE CLASS, (INT. CLS. 9 AND 42), (U.S. CLS. 21, 23, 26, 36, 38, 100 AND 101). SN 85-545,508. PUB. 7-3-2012. FILED 2-17-2012.
- 4,209,863. **A T R I O AND DESIGN. PAR TECHNOLOGY CORPORATION, MULTIPLE CLASS, (INT. CLS. 9 AND 42)**, (U.S. CLS. 21, 23, 26, 36, 38, 100 AND 101). SN 85-545,517. PUB. 7-3-2012. FILED 2-17-2012.
- 4,209,901. **PANTOVISION (STANDARD CHARACTER)**. ABM INTERNATIONAL, INC., (U.S. CLS. 21, 23, 26, 36 AND 38). SN 85-546,308. PUB. 7-3-2012. FILED 2-17-2012.
- 4,209,915. **ZIPOPTICAL (STANDARD CHARACTER)**. ZIPOPTICAL LLC, (U.S. CLS. 21, 23, 26, 36 AND 38). SN 85-546,577. PUB. 7-3-2012. FILED 2-17-2012.

- 4,209,920. **MISCELLANEOUS DESIGN. BRAIN PARADE, LLC**, (U.S. CLS. 21, 23, 26, 36 AND 38). SN 85-546,619. PUB. 7-3-2012. FILED 2-17-2012.
- 4,209,928. **ADAPTIVEWORX (STANDARD CHARACTER). MANGNALL, LLOYD W.**, (U.S. CLS. 21, 23, 26, 36 AND 38). SN 85-546,778. PUB. 7-3-2012. FILED 2-18-2012.
- 4,209,954. **INNOVATIVE LEISURE RECORDS (STANDARD CHARACTER). INNOVATIVE LEISURE, INC., AKA INNOVATIVE LEISURE RECORDS**, (U.S. CLS. 21, 23, 26, 36 AND 38). SN 85-547,746. PUB. 7-3-2012. FILED 2-20-2012.
- 4,209,968. **DOCMAGICXL (STANDARD CHARACTER). DOCMAGIC, INC.**, (U.S. CLS. 21, 23, 26, 36 AND 38). SN 85-548,840. PUB. 7-3-2012. FILED 2-21-2012.
- 4,209,972. **HOLD YOUR HORSES (STANDARD CHARACTER). DESIGN WORKS STUDIOS, DBA DESIGN WORKS GAMING**, (U.S. CLS. 21, 23, 26, 36 AND 38). SN 85-549,909. PUB. 7-3-2012. FILED 2-22-2012.
- 4,209,981. **POWERVIEW (STANDARD CHARACTER). PELLA CORPORATION, MULTIPLE CLASS, (INT. CLS. 9 AND 35)**, (U.S. CLS. 21, 23, 26, 36, 38, 100, 101 AND 102). SN 85-551,108. PUB. 7-3-2012. FILED 2-23-2012.
- 4,209,982. **HAWK (STANDARD CHARACTER). CLEAVERBROOKS, INC.**, (U.S. CLS. 21, 23, 26, 36 AND 38). SN 85-551,156. PUB. 7-3-2012. FILED 2-23-2012.
- 4,209,984. **U AND DESIGN. UBER TECHNOLOGIES INC., MULTIPLE CLASS, (INT. CLS. 9 AND 39)**, (U.S. CLS. 21, 23, 26, 36, 38, 100 AND 105). SN 85-551,540. PUB. 7-3-2012. FILED 2-23-2012.
- 4,209,987. **CASH CAKES (STANDARD CHARACTER). DESIGN WORKS STUDIOS, DBA DESIGN WORKS GAMING**, (U.S. CLS. 21, 23, 26, 36 AND 38). SN 85-552,047. PUB. 7-3-2012. FILED 2-24-2012.
- 4,209,989. **RSKILLS (STANDARD CHARACTER). SCHOLASTIC INC.**, (U.S. CLS. 21, 23, 26, 36 AND 38). SN 85-552,206. PUB. 7-3-2012. FILED 2-24-2012.
- 4,210,031. **GIT-R-DONE (STANDARD CHARACTER). GIT-R-DONE PRODUCTIONS, INC.**, (U.S. CLS. 21, 23, 26, 36 AND 38). SN 85-558,812. PUB. 7-3-2012. FILED 3-2-2012.
- 4,210,039. **AUTOPILOT (STANDARD CHARACTER). ARROW INTERNATIONAL INVESTMENT CORP.**, (U.S. CLS. 21, 23, 26, 36 AND 38). SN 85-561,308. PUB. 7-3-2012. FILED 3-6-2012.
- 4,210,058. **BEAR TRACKS (STANDARD CHARACTER). DESIGN WORKS STUDIOS, DBA DESIGN WORKS GAMING**, (U.S. CLS. 21, 23, 26, 36 AND 38). SN 85-566,763. PUB. 7-3-2012. FILED 3-12-2012.
- 4,210,060. **JPQUALITY (STANDARD CHARACTER). JACOBSPARTS INCORPORATED**, (U.S. CLS. 21, 23, 26, 36 AND 38). SN 85-567,855. PUB. 7-3-2012. FILED 3-13-2012.
- 4,210,067. **COMFORTMOIST (STANDARD CHARACTER). BAUSCH & LOMB INCORPORATED**, (U.S. CLS. 21, 23, 26, 36 AND 38). SN 85-568,999. PUB. 7-3-2012. FILED 3-14-2012.
- 4,210,089. **EXECUTIVEFREEDOM (STANDARD CHARACTER). SEAL INNOTECH, LLC, DBA APPSFREEDOM**, (U.S. CLS. 21, 23, 26, 36 AND 38). SN 85-576,069. PUB. 7-3-2012. FILED 3-21-2012.
- 4,210,090. **PROCUREMENTFREEDOM (STANDARD CHARACTER). SEAL INNOTECH, LLC, DBA APPSFREEDOM**, (U.S. CLS. 21, 23, 26, 36 AND 38). SN 85-576,077. PUB. 7-3-2012. FILED 3-21-2012.
- 4,210,091. **HRFREEDOM (STANDARD CHARACTER). SEAL INNOTECH, LLC, DBA APPSFREEDOM**, (U.S. CLS. 21, 23, 26, 36 AND 38). SN 85-576,078. PUB. 7-3-2012. FILED 3-21-2012.
- 4,210,092. **SALESFREEDOM (STANDARD CHARACTER). SEAL INNOTECH, LLC, DBA APPSFREEDOM**, (U.S. CLS. 21, 23, 26, 36 AND 38). SN 85-576,081. PUB. 7-3-2012. FILED 3-21-2012.
- 4,210,093. **FIELDSERVICEFREEDOM (STANDARD CHARACTER). SEAL INNOTECH, LLC, DBA APPSFREEDOM**, (U.S. CLS. 21, 23, 26, 36 AND 38). SN 85-576,084. PUB. 7-3-2012. FILED 3-21-2012.
- 4,210,104. **NIS-ELEMENTS (STANDARD CHARACTER). NIKON CORPORATION**, (U.S. CLS. 21, 23, 26, 36 AND 38). SN 85-578,453. PUB. 7-3-2012. FILED 3-23-2012.
- 4,210,115. **LALALOOPSY SEW MAGICAL! SEW CUTE! AND DESIGN. MGA ENTERTAINMENT, INC.**, (U.S. CLS. 21, 23, 26, 36 AND 38). SN 85-580,300. PUB. 7-3-2012. FILED 3-26-2012.
- 4,210,116. **LALALOOPSY (STANDARD CHARACTER). MGA ENTERTAINMENT, INC.**, (U.S. CLS. 21, 23, 26, 36 AND 38). SN 85-580,351. PUB. 7-3-2012. FILED 3-26-2012.
- 4,210,120. **SUBWAY LIVE IQ AND DESIGN. DOCTOR'S ASSOCIATES INC., MULTIPLE CLASS, (INT. CLS. 9 AND 35)**, (U.S. CLS. 21, 23, 26, 36, 38, 100, 101 AND 102). SN 85-581,786. PUB. 7-3-2012. FILED 3-28-2012.
- 4,210,121. **SUBWAY IQ AND DESIGN. DOCTOR'S ASSOCIATES INC., MULTIPLE CLASS, (INT. CLS. 9 AND 35)**, (U.S. CLS. 21, 23, 26, 36, 38, 100, 101 AND 102). SN 85-581,798. PUB. 7-3-2012. FILED 3-28-2012.
- 4,210,127. **IR*EDI (STANDARD CHARACTER). RADLEY CORPORATION**, (U.S. CLS. 21, 23, 26, 36 AND 38). SN 85-583,250. PUB. 7-3-2012. FILED 3-29-2012.
- 4,210,159. **SCHOLASTIC (STANDARD CHARACTER). SCHOLASTIC INC.**, (U.S. CLS. 21, 23, 26, 36 AND 38). SN 85-596,258. PUB. 7-3-2012. FILED 4-12-2012.
- 4,210,160. **SCHOLASTIC AND DESIGN. SCHOLASTIC INC.**, (U.S. CLS. 21, 23, 26, 36 AND 38). SN 85-596,265. PUB. 7-3-2012. FILED 4-12-2012.
- 4,210,161. **THE MAGIC SCHOOL BUS (STANDARD CHARACTER). SCHOLASTIC INC.**, (U.S. CLS. 21, 23, 26, 36 AND 38). SN 85-596,299. PUB. 7-3-2012. FILED 4-12-2012.
- 4,210,162. **THE 39 CLUES (STANDARD CHARACTER). SCHOLASTIC INC.**, (U.S. CLS. 21, 23, 26, 36 AND 38). SN 85-596,311. PUB. 7-3-2012. FILED 4-12-2012.
- 4,210,163. **GOOSEBUMPS (STANDARD CHARACTER). SCHOLASTIC INC.**, (U.S. CLS. 21, 23, 26, 36 AND 38). SN 85-596,323. PUB. 7-3-2012. FILED 4-12-2012.
- 4,210,174. **CLAMPLOCK (STANDARD CHARACTER). SPX CORPORATION**, (U.S. CLS. 21, 23, 26, 36 AND 38). SN 85-600,747. PUB. 7-3-2012. FILED 4-18-2012.
- 4,210,176. **FLAMINGO (STANDARD CHARACTER). FLAMINGO LAS VEGAS PROPCO, LLC**, (U.S. CLS. 21, 23, 26, 36 AND 38). SN 85-601,471. PUB. 7-3-2012. FILED 4-18-2012.
- 4,210,198. **MISCELLANEOUS DESIGN. POUND PAYMENTS, INC., DBA BALANCED, POUNDPAY, MULTIPLE CLASS, (INT. CLS. 9 AND 36)**, (U.S. CLS. 21, 23, 26, 36, 38, 100, 101 AND 102). SN 85-611,445. PUB. 7-3-2012. FILED 4-29-2012.
- 4,210,216. **INTOCIRCUIT AND DESIGN. HISGADGET INC.**, (U.S. CLS. 21, 23, 26, 36 AND 38). SN 85-622,350. PUB. 7-3-2012. FILED 5-10-2012.
- 4,210,225 (*See Class 8 for this trademark.*)
- 4,210,228 (*See Class 5 for this trademark.*)

CLASS 10—MEDICAL APPARATUS

- 4,208,183. **ACUSTA AND DESIGN. AMENITY SERVICE CO., LTD.**, MULTIPLE CLASS, (INT. CLS. 10 AND 44), (U.S. CLS. 26, 39, 44, 100 AND 101). SN 77-623,138. PUB. 7-14-2009. FILED 11-28-2008.
- 4,208,273. **XPULSE (STANDARD CHARACTER). FOTONA D.D.**, MULTIPLE CLASS, (INT. CLS. 10 AND 44), (U.S. CLS. 26, 39, 44, 100 AND 101). SN 79-099,034. PUB. 7-3-2012. FILED 5-30-2011.
- 4,208,282. **NOX-T3 (STANDARD CHARACTER). NOX MEDICAL EHF**, (U.S. CLS. 26, 39 AND 44). SN 79-100,445. PUB. 7-3-2012. FILED 6-16-2011.
- 4,208,294 (*See Class 5 for this trademark.*)
- 4,208,301. **ARCTICA (STANDARD CHARACTER). KALTENBACH & VOIGT GMBH**, (U.S. CLS. 26, 39 AND 44). SN 79-101,660. PUB. 7-3-2012. FILED 6-22-2011.
- 4,208,308 (*See Class 3 for this trademark.*)
- 4,208,314 (*See Class 9 for this trademark.*)
- 4,208,324. **OWMO (STYLIZED). SHANGHAI OWMO INDUSTRIAL CO.,LTD.**, (U.S. CLS. 26, 39 AND 44). SN 79-102,289. PUB. 7-3-2012. FILED 8-16-2011.
- 4,208,328 (*See Class 8 for this trademark.*)
- 4,208,353. **ADVANT MEDICAL AND DESIGN. ADVANT MEDICAL LIMITED, MULTIPLE CLASS, (INT. CLS. 10, 39 AND 42)**, (U.S. CLS. 26, 39, 44, 100, 101 AND 105). SN 79-103,009. PUB. 7-3-2012. FILED 8-17-2011.
- 4,208,385. **HUMIPAK AND DESIGN. WESTFIELD MEDICAL LIMITED**, (U.S. CLS. 26, 39 AND 44). SN 79-105,561. PUB. 7-

- 3-2012. FILED 9-22-2011.
- 4,208,395. **TELEZON (STANDARD CHARACTER)**. SSB TECHNOLOGY PTY LTD, (U.S. CLS. 26, 39 AND 44). SN 79-106,502. PUB. 4-3-2012. FILED 11-4-2011.
- 4,208,405. **MEDENTIKA (STANDARD CHARACTER)**. MEDENTIKA GMBH, MULTIPLE CLASS, (INT. CLS. 10, 40 AND 41), (U.S. CLS. 26, 39, 44, 100, 101, 103, 106 AND 107). SN 79-107,750. PUB. 7-3-2012. FILED 12-8-2011.
- 4,208,424 (*See Class 7 for this trademark*).
- 4,208,440. **LOTUS (STANDARD CHARACTER)**. SIEMENS MEDICAL INSTRUMENTS PTE LTD, (U.S. CLS. 26, 39 AND 44). SN 79-111,752. PUB. 7-3-2012. FILED 2-7-2012.
- 4,208,449 (*See Class 5 for this trademark*).
- 4,208,500 (*See Class 5 for this trademark*).
- 4,208,554. **VESOFLOW AND DESIGN**. CAREMED SUPPLY INC., (U.S. CLS. 26, 39 AND 44). SN 85-238,925. PUB. 7-3-2012. FILED 2-10-2011.
- 4,208,565. **GAMMACLIP (STANDARD CHARACTER)**. SPECMED, LLC, (U.S. CLS. 26, 39 AND 44). SN 85-258,730. PUB. 3-27-2012. FILED 3-4-2011.
- 4,208,588. **SENOVO (STANDARD CHARACTER)**. BIOTRONIK SE & CO. KG, (U.S. CLS. 26, 39 AND 44). SN 85-294,812. PUB. 2-14-2012. FILED 4-14-2011.
- 4,208,600. **FAST SHOOT (STANDARD CHARACTER)**. FUJIFILM CORPORATION, (U.S. CLS. 26, 39 AND 44). SN 85-307,395. PUB. 1-31-2012. FILED 4-28-2011.
- 4,208,608. **OOGAA AND DESIGN**. SKOLNIK, SAMANTHA J, TA OOGAA HOME LLC, (U.S. CLS. 26, 39 AND 44). SN 85-318,792. PUB. 7-3-2012. FILED 5-12-2011.
- 4,208,617 (*See Class 8 for this trademark*).
- 4,208,619 (*See Class 1 for this trademark*).
- 4,208,681. **NEW LUBRICATED INSTANT-ON FOR UNINTERRUPTED PLEASURE ULTIMATE PREMIUM BRAND LATEX CONDOMS SCIENTIFICALLY PROVED APPLICATOR* FOR ULTIMATE PLEASURE EXPERIENCE AND DESIGN**. CONDAX LLC., (U.S. CLS. 26, 39 AND 44). SN 85-358,436. PUB. 7-3-2012. FILED 6-28-2011.
- 4,208,769. **TRUEDRAW AND DESIGN**. NIPRO DIAGNOSTICS, INC., (U.S. CLS. 26, 39 AND 44). SN 85-376,398. PUB. 7-3-2012. FILED 7-20-2011.
- 4,208,953 (*See Class 9 for this trademark*).
- 4,209,032. **THERMIPAQ AND DESIGN**. THERMIONICS, INC., (U.S. CLS. 26, 39 AND 44). SN 85-464,003. PUB. 7-3-2012. FILED 11-3-2011.
- 4,209,050. **KAI SPOT RESPIRATION RATE CHECK AND DESIGN**. KAI MEDICAL, INC., (U.S. CLS. 26, 39 AND 44). SN 85-472,279. PUB. 7-3-2012. FILED 11-14-2011.
- 4,209,100. **MISCELLANEOUS DESIGN**. DB ORTHODONTICS LTD, (U.S. CLS. 26, 39 AND 44). SN 85-490,495. PUB. 7-3-2012. FILED 12-8-2011.
- 4,209,108. **ULTRA SOFT FINGER TIP (STANDARD CHARACTER)**. ADVANCED RESPONSE CORP., (U.S. CLS. 26, 39 AND 44). SN 85-491,939. PUB. 7-3-2012. FILED 12-9-2011.
- 4,209,193 (*See Class 3 for this trademark*).
- 4,209,240. **BIO AND DESIGN**. BLUE SKY BIO LLC, (U.S. CLS. 26, 39 AND 44). SN 85-518,292. PUB. 7-3-2012. FILED 1-17-2012.
- 4,209,251. **SNUGLY BABY (STANDARD CHARACTER)**. IDM GROUP LLC, MULTIPLE CLASS, (INT. CLS. 10, 24 AND 25), (U.S. CLS. 22, 26, 39, 42, 44 AND 50). SN 85-519,374. PUB. 7-3-2012. FILED 1-18-2012.
- 4,209,278 (*See Class 9 for this trademark*).
- 4,209,423. **SOCLEAN (STANDARD CHARACTER)**. INCEPTUS, INC., DBA BETTER REST SOLUTIONS, (U.S. CLS. 26, 39 AND 44). SN 85-527,341. PUB. 7-3-2012. FILED 1-27-2012.
- 4,209,440 (*See Class 5 for this trademark*).
- 4,209,498. **LEBALLON C (STYLIZED)**. CONTRALCO, (U.S. CLS. 26, 39 AND 44). SN 85-537,092. PUB. 7-3-2012. FILED 2-8-2012.
- 4,209,595. **MEDEBRA (STANDARD CHARACTER)**. BRAS TO HELP SAVE THE TA TAS, LLC, (U.S. CLS. 26, 39 AND 44). SN 85-541,102. PUB. 7-3-2012. FILED 2-13-2012.
- 4,209,649. **ESCHMANN (STANDARD CHARACTER)**. ESCHMANN HOLDINGS LIMITED, (U.S. CLS. 26, 39 AND 44). SN 85-541,921. PUB. 7-3-2012. FILED 2-14-2012.
- 4,209,781. **MISCELLANEOUS DESIGN**. AVANTIS MEDICAL SYSTEMS, INC., (U.S. CLS. 26, 39 AND 44). SN 85-543,958. PUB. 7-3-2012. FILED 2-15-2012.
- 4,209,782. **MISCELLANEOUS DESIGN**. AVANTIS MEDICAL SYSTEMS, INC., (U.S. CLS. 26, 39 AND 44). SN 85-543,964. PUB. 7-3-2012. FILED 2-15-2012.
- 4,209,892. **VERSO (STANDARD CHARACTER)**. CAREFUSION 2200, INC., (U.S. CLS. 26, 39 AND 44). SN 85-546,163. PUB. 7-3-2012. FILED 2-17-2012.
- 4,209,961. **H-E-B AND DESIGN**. HEB GROCERY COMPANY, LP, (U.S. CLS. 26, 39 AND 44). SN 85-548,284. PUB. 7-3-2012. FILED 2-21-2012.
- 4,209,995. **EQUISCOPE (STANDARD CHARACTER)**. BIOMEDICAL DEVELOPMENT CORPORATION, (U.S. CLS. 26, 39 AND 44). SN 85-552,912. PUB. 7-3-2012. FILED 2-25-2012.
- 4,209,996. **ELECTRO-EQUISCOPE (STANDARD CHARACTER)**. BIOMEDICAL DEVELOPMENT CORPORATION, (U.S. CLS. 26, 39 AND 44). SN 85-552,917. PUB. 7-3-2012. FILED 2-25-2012.
- 4,210,034. **CLIKFIT (STANDARD CHARACTER)**. EAR TECHNOLOGY CORPORATION, (U.S. CLS. 26, 39 AND 44). SN 85-559,769. PUB. 7-3-2012. FILED 3-5-2012.
- 4,210,141. **SPROUT (STANDARD CHARACTER)**. FLEET WHOLESALE SUPPLY CO., INC., (U.S. CLS. 26, 39 AND 44). SN 85-587,549. PUB. 7-3-2012. FILED 4-3-2012.
- 4,210,142. **FF FLEET FARM AND DESIGN**. FLEET WHOLESALE SUPPLY CO., INC., MULTIPLE CLASS, (INT. CLS. 10 AND 16), (U.S. CLS. 2, 5, 22, 23, 26, 29, 37, 38, 39, 44 AND 50). SN 85-587,556. PUB. 7-3-2012. FILED 4-3-2012.
- 4,210,143. **MILLS FLEET FARM (STANDARD CHARACTER)**. FLEET WHOLESALE SUPPLY CO., INC., MULTIPLE CLASS, (INT. CLS. 10 AND 16), (U.S. CLS. 2, 5, 22, 23, 26, 29, 37, 38, 39, 44 AND 50). SN 85-587,563. PUB. 7-3-2012. FILED 4-3-2012.
- 4,210,175. **TRINIA (STANDARD CHARACTER)**. BICON, LLC, (U.S. CLS. 26, 39 AND 44). SN 85-601,193. PUB. 7-3-2012. FILED 4-18-2012.
- 4,210,185. **ALLEGRETTO WAVE (STANDARD CHARACTER)**. ALCON LABORATORIES, INC., MULTIPLE CLASS, (INT. CLS. 10 AND 37), (U.S. CLS. 26, 39, 44, 100, 103 AND 106). SN 85-605,057. PUB. 7-3-2012. FILED 4-23-2012.

CLASS 11—ENVIRONMENTAL CONTROL APPARATUS

- 4,208,249. **DRYGAIR (STANDARD CHARACTER)**. MISHA REFRIGERATION 2010 LTD., (U.S. CLS. 13, 21, 23, 31 AND 34). SN 79-092,240. PUB. 7-3-2012. FILED 12-22-2010.
- 4,208,250 (*See Class 9 for this trademark*).
- 4,208,252 (*See Class 9 for this trademark*).
- 4,208,275 (*See Class 9 for this trademark*).
- 4,208,304. **1 PRIMOGIORNO AND DESIGN**. FOSHAN AMSTRONG IMPORT & EXPORT CO., LTD., (U.S. CLS. 13, 21, 23, 31 AND 34). SN 79-101,764. PUB. 7-3-2012. FILED 5-30-2011.
- 4,208,313 (*See Class 7 for this trademark*).
- 4,208,314 (*See Class 9 for this trademark*).
- 4,208,320 (*See Class 3 for this trademark*).
- 4,208,337 (*See Class 9 for this trademark*).
- 4,208,343 (*See Class 1 for this trademark*).
- 4,208,358. **QOSY (STANDARD CHARACTER)**. NOVADelta - COMÉRCIO E INDÚSTRIA DE CAFÉS, S.A., MULTIPLE CLASS, (INT. CLS. 11 AND 30), (U.S. CLS. 13, 21, 23, 31, 34 AND 46). SN 79-103,214. PUB. 7-3-2012. FILED 7-8-2011.
- 4,208,360 (*See Class 7 for this trademark*).
- 4,208,366 (*See Class 6 for this trademark*).
- 4,208,380. **ZAMID (STANDARD CHARACTER)**. ZIEHL-ABEGG AG, (U.S. CLS. 13, 21, 23, 31 AND 34). SN 79-105,218. PUB. 7-3-2012. FILED 6-30-2011.
- 4,208,392. **MISCELLANEOUS DESIGN**. KOWA COMPANY, LTD., (U.S. CLS. 13, 21, 23, 31 AND 34). SN 79-106,475. PUB. 7-3-2012. FILED 10-28-2011.
- 4,208,404 (*See Class 9 for this trademark*).
- 4,208,407 (*See Class 9 for this trademark*).
- 4,208,408 (*See Class 9 for this trademark*).
- 4,208,436. **TISTOLINE (STANDARD CHARACTER)**. DALLMER GMBH & CO. KG, (U.S. CLS. 13, 21, 23, 31 AND 34). SN 79-110,804. PUB. 7-3-2012. FILED 2-3-2012.

- 4,208,557 (*See Class 7 for this trademark*).
- 4,208,567. **CTP AIR POLLUTION CONTROL AND DESIGN**. CHEMISCH THERMISCHE PROZESSTECHNIK GMBH, (U.S. CLS. 13, 21, 23, 31 AND 34). SN 85-260,530. PUB. 7-3-2012. FILED 3-8-2011.
- 4,208,590 (*See Class 7 for this trademark*).
- 4,208,591 (*See Class 7 for this trademark*).
- 4,208,595. **LAUNCH BOX (STANDARD CHARACTER)**. MAGIC-FLIGHT GENERAL MANUFACTURING, INC., MULTIPLE CLASS, (INT. CLS. 11 AND 34), (U.S. CLS. 2, 8, 9, 13, 17, 21, 23, 31 AND 34). SN 85-300,509. PUB. 7-3-2012. FILED 4-20-2011.
- 4,208,617 (*See Class 8 for this trademark*).
- 4,208,631 (*See Class 6 for this trademark*).
- 4,208,632 (*See Class 6 for this trademark*).
- 4,208,672. **MAXON TECHNOLOGIES (STANDARD CHARACTER)**. THE TRUSTEES OF THE "ISSAC ZAHARONI AND SUZANNE ZAHARONI INTER VIVOS TRUST", (U.S. CLS. 13, 21, 23, 31 AND 34). SN 85-354,360. PUB. 7-3-2012. FILED 6-23-2011.
- 4,208,688. **AQUACULTURE SYSTEMS TECHNOLOGIES AND DESIGN**. AQUACULTURE SYSTEMS TECHNOLOGIES, LLC, (U.S. CLS. 13, 21, 23, 31 AND 34). SN 85-360,125. PUB. 7-3-2012. FILED 6-30-2011.
- 4,208,689. **PROPELLER BEAD (STANDARD CHARACTER)**. AQUACULTURE SYSTEMS TECHNOLOGIES, LLC, (U.S. CLS. 13, 21, 23, 31 AND 34). SN 85-360,130. PUB. 7-3-2012. FILED 6-30-2011.
- 4,208,807. **PANFAN (STANDARD CHARACTER)**. PANFAN MARKETING LTD, (U.S. CLS. 13, 21, 23, 31 AND 34). SN 85-384,959. PUB. 7-3-2012. FILED 7-29-2011.
- 4,208,840. **IRON ZAPPER AND DESIGN**. SAFEWAY WATER, LLC, (U.S. CLS. 13, 21, 23, 31 AND 34). SN 85-393,721. PUB. 7-3-2012. FILED 8-9-2011.
- 4,208,921. **RAPID-FIT (STANDARD CHARACTER)**. LSP PRODUCTS GROUP, INC., (U.S. CLS. 13, 21, 23, 31 AND 34). SN 85-416,793. PUB. 7-3-2012. FILED 9-7-2011.
- 4,208,977 (*See Class 3 for this trademark*).
- 4,208,981. **PRO ELECTRIC FIREPLACES AND DESIGN**. PROELECTRICFIREPLACE.COM, DIVISION OF TWIN STAR INTL., (U.S. CLS. 13, 21, 23, 31 AND 34). SN 85-446,132. PUB. 7-3-2012. FILED 10-12-2011.
- 4,209,218. **SUMMERS PLUMBING HEATING & COOLING AND DESIGN**. SUMMERS PLUMBING HEATING AND COOLING, INC., MULTIPLE CLASS, (INT. CLS. 11 AND 37), (U.S. CLS. 13, 21, 23, 31, 34, 100, 103 AND 106). SN 85-515,709. PUB. 7-3-2012. FILED 1-13-2012.
- 4,209,267. **EJECTOR CYCLE (STANDARD CHARACTER)**. DENSO CORPORATION, (U.S. CLS. 13, 21, 23, 31 AND 34). SN 85-520,261. PUB. 7-3-2012. FILED 1-19-2012.
- 4,209,271. **WARM HEART HUGS (STANDARD CHARACTER)**. STANSFIELD, DOUG, (U.S. CLS. 13, 21, 23, 31 AND 34). SN 85-520,500. PUB. 7-3-2012. FILED 1-19-2012.
- 4,209,311. **AMERICAN PRO (STANDARD CHARACTER)**. AFKA GROUP INTERNATIONAL, INC., (U.S. CLS. 13, 21, 23, 31 AND 34). SN 85-522,587. PUB. 7-3-2012. FILED 1-23-2012.
- 4,209,618. **RA-KEY (STANDARD CHARACTER)**. FARAGO, MARGARET E., AND FARAGO, STEPHEN A., (U.S. CLS. 13, 21, 23, 31 AND 34). SN 85-541,385. PUB. 7-3-2012. FILED 2-13-2012.
- 4,209,685. **SOLO-CONTROL (STANDARD CHARACTER)**. METROPOLITAN AIR TECHNOLOGY LLC, (U.S. CLS. 13, 21, 23, 31 AND 34). SN 85-542,490. PUB. 7-3-2012. FILED 2-14-2012.
- 4,209,732. **SOLO-CONTROL AND DESIGN**. METROPOLITAN AIR TECHNOLOGY LLC, (U.S. CLS. 13, 21, 23, 31 AND 34). SN 85-543,281. PUB. 7-3-2012. FILED 2-15-2012.
- 4,209,803. **XS (STANDARD CHARACTER)**. NITE IZE, INC., (U.S. CLS. 13, 21, 23, 31 AND 34). SN 85-544,390. PUB. 7-3-2012. FILED 2-16-2012.
- 4,209,911. **NANOSOX (STANDARD CHARACTER)**. DURKEE AMERICA INC., MULTIPLE CLASS, (INT. CLS. 11 AND 19), (U.S. CLS. 1, 12, 13, 21, 23, 31, 33, 34 AND 50). SN 85-546,503. PUB. 7-3-2012. FILED 2-17-2012.
- 4,210,047. **CRISPERKEEPER (STANDARD CHARACTER)**. SEARS BRANDS, LLC, (U.S. CLS. 13, 21, 23, 31 AND 34). SN 85-564,238. PUB. 7-3-2012. FILED 3-8-2012.
- 4,210,148. **ARTIST EDITIONS (STANDARD CHARACTER)**. KOHLER CO., (U.S. CLS. 13, 21, 23, 31 AND 34). SN 85-590,280. PUB. 7-3-2012. FILED 4-5-2012.
- 4,210,169. **ARTIST EDITIONS (STYLIZED)**. KOHLER CO., (U.S. CLS. 13, 21, 23, 31 AND 34). SN 85-597,694. PUB. 7-3-2012. FILED 4-13-2012.
- 4,210,182. **XCAD (STYLIZED)**. XCAD VALVE & IRRIGATION, (U.S. CLS. 13, 21, 23, 31 AND 34). SN 85-604,342. PUB. 7-3-2012. FILED 4-20-2012.

CLASS 12—VEHICLES

- 4,208,122. **ORANGE AND DESIGN**. ORANGE BRAND SERVICES, LTD., MULTIPLE CLASS, (INT. CLS. 12, 35 AND 36), (U.S. CLS. 19, 21, 23, 31, 35, 44, 100, 101 AND 102). SN 76-142,527. PUB. 10-5-2004. FILED 10-6-2000.
- 4,208,167 (*See Class 7 for this trademark*).
- 4,208,224. **DURATRAY (STANDARD CHARACTER)**. CONYMET DURATRAY PTY LIMITED, (U.S. CLS. 19, 21, 23, 31, 35 AND 44). SN 77-982,881. PUB. 10-4-2011. FILED 5-29-2009.
- 4,208,225 (*See Class 7 for this trademark*).
- 4,208,254. **SKYPORT (STANDARD CHARACTER)**. SKYPORT A.S., MULTIPLE CLASS, (INT. CLS. 12 AND 39), (U.S. CLS. 19, 21, 23, 31, 35, 44, 100 AND 105). SN 79-094,017. PUB. 7-3-2012. FILED 6-16-2010.
- 4,208,255 (*See Class 7 for this trademark*).
- 4,208,267. **CONTINUOUS COMPOUND AND DESIGN**. CONTINENTAL REIFEN DEUTSCHLAND GMBH, (U.S. CLS. 19, 21, 23, 31, 35 AND 44). SN 79-097,662. PUB. 7-3-2012. FILED 4-28-2011.
- 4,208,290. **STILL CUBE XX (STANDARD CHARACTER)**. STILL GMBH, MULTIPLE CLASS, (INT. CLS. 12, 36 AND 39), (U.S. CLS. 19, 21, 23, 31, 35, 44, 100, 101, 102 AND 105). SN 79-100,949. PUB. 7-3-2012. FILED 4-28-2011.
- 4,208,323. **METRIX (STANDARD CHARACTER)**. SCOTT USA LIMITED, (U.S. CLS. 19, 21, 23, 31, 35 AND 44). SN 79-102,279. PUB. 1-17-2012. FILED 8-3-2011.
- 4,208,337 (*See Class 9 for this trademark*).
- 4,208,340. **BICISUPPORT AND DESIGN**. BICISUPPORT S.R.L., (U.S. CLS. 19, 21, 23, 31, 35 AND 44). SN 79-102,721. PUB. 7-3-2012. FILED 4-4-2011.
- 4,208,343 (*See Class 1 for this trademark*).
- 4,208,344. **ERIDE (STANDARD CHARACTER)**. SCOTT USA LIMITED, MULTIPLE CLASS, (INT. CLS. 12 AND 25), (U.S. CLS. 19, 21, 22, 23, 31, 35, 39 AND 44). SN 79-102,811. PUB. 7-3-2012. FILED 9-2-2011.
- 4,208,348 (*See Class 9 for this trademark*).
- 4,208,351. **AXIS (STANDARD CHARACTER)**. SCOTT USA LIMITED, MULTIPLE CLASS, (INT. CLS. 12 AND 28), (U.S. CLS. 19, 21, 22, 23, 31, 35, 38, 44 AND 50). SN 79-102,927. PUB. 7-3-2012. FILED 8-19-2011.
- 4,208,361 (*See Class 6 for this trademark*).
- 4,208,370. **ZEN (STANDARD CHARACTER)**. CHAUDEURGE, JEAN-MICHEL, FRANÇOIS, (U.S. CLS. 19, 21, 23, 31, 35 AND 44). SN 79-103,869. PUB. 7-3-2012. FILED 9-30-2011.
- 4,208,388 (*See Class 9 for this trademark*).
- 4,208,402. **AST SUSPENSION AND DESIGN**. AST ADVANCED SUSPENSION TECHNOLOGY B.V., (U.S. CLS. 19, 21, 23, 31, 35 AND 44). SN 79-107,269. PUB. 7-3-2012. FILED 10-5-2011.
- 4,208,433 (*See Class 9 for this trademark*).
- 4,208,523. **SPACE (STANDARD CHARACTER)**. TAMARACK INDUSTRIES, LLC, (U.S. CLS. 19, 21, 23, 31, 35 AND 44). SN 85-196,663. PUB. 7-3-2012. FILED 12-13-2010.
- 4,208,528. **CONCOURS (STANDARD CHARACTER)**. KAWASAKI JUKOGYO KABUSHIKI KAISHA, DBA KAWASAKI HEAVY INDUSTRIES, LTD., (U.S. CLS. 19, 21, 23, 31, 35 AND 44). SN 85-197,736. PUB. 7-3-2012. FILED 12-14-2010.
- 4,208,532. **M MAMBA (STYLIZED)**. CUSTOM MOTORCYCLES MAMBA INC., (U.S. CLS. 19, 21, 23, 31, 35 AND 44). SN 85-202,922. PUB. 7-3-2012. FILED 12-21-2010.
- 4,208,611. **@LUTCHES AND DESIGN**. WEI, HOU, (U.S. CLS. 19, 21, 23, 31, 35 AND 44). SN 85-322,221. PUB. 7-3-2012. FILED 5-16-2011.
- 4,208,617 (*See Class 8 for this trademark*).
- 4,208,735 (*See Class 7 for this trademark*).

4,208,836 (*See Class 7 for this trademark*).
 4,208,893. **EV ZERO EMISSION AND DESIGN**. BYD COMPANY LIMITED, (U.S. CLS. 19, 21, 23, 31, 35 AND 44). SN 85-407,959. PUB. 7-3-2012. FILED 8-26-2011.
 4,208,979. **SKOOTCASE (STANDARD CHARACTER)**. WORLDS APART LIMITED, MULTIPLE CLASS, (INT. CLS. 12, 18 AND 28), (U.S. CLS. 1, 2, 3, 19, 21, 22, 23, 31, 35, 38, 41, 44 AND 50). SN 85-444,658. PUB. 6-12-2012. FILED 10-11-2011.
 4,208,993. **MISCELLANEOUS DESIGN**. WESTWINN GROUP ENTERPRISES INC., (U.S. CLS. 19, 21, 23, 31, 35 AND 44). SN 85-448,187. PUB. 7-3-2012. FILED 10-14-2011.
 4,209,160. **CRUZ (STANDARD CHARACTER)**. MONAHAN PRODUCTS LLC, (U.S. CLS. 19, 21, 23, 31, 35 AND 44). SN 85-504,419. PUB. 7-3-2012. FILED 12-27-2011.
 4,209,366. **USHIGHLAND (STANDARD CHARACTER)**. US HIGHLAND, INC., (U.S. CLS. 19, 21, 23, 31, 35 AND 44). SN 85-524,933. PUB. 7-3-2012. FILED 1-25-2012.
 4,209,396. **FOX EVOLUTION SERIES (STANDARD CHARACTER)**. FOX FACTORY, INC., (U.S. CLS. 19, 21, 23, 31, 35 AND 44). SN 85-525,995. PUB. 7-3-2012. FILED 1-26-2012.
 4,209,504. **P8 (STANDARD CHARACTER)**. PIRELLI TYRE S.P.A., (U.S. CLS. 19, 21, 23, 31, 35 AND 44). SN 85-537,417. PUB. 7-3-2012. FILED 2-8-2012.
 4,209,516. **XL SPECIALIZED TRAILERS (STYLIZED)**. XL SPECIALIZED TRAILERS, INC., (U.S. CLS. 19, 21, 23, 31, 35 AND 44). SN 85-538,106. PUB. 7-3-2012. FILED 2-9-2012.
 4,209,687. **PERFECT (STANDARD CHARACTER)**. ROCA AUTO PARTS, CORP., (U.S. CLS. 19, 21, 23, 31, 35 AND 44). SN 85-542,527. PUB. 7-3-2012. FILED 2-14-2012.
 4,209,730. **MOBILE TRAC (STANDARD CHARACTER)**. ALLIED WHEEL COMPONENTS, INC., (U.S. CLS. 19, 21, 23, 31, 35 AND 44). SN 85-543,258. PUB. 7-3-2012. FILED 2-15-2012.
 4,209,758. **ALLASO (STANDARD CHARACTER)**. KK-YAS, CORPORATION, (U.S. CLS. 19, 21, 23, 31, 35 AND 44). SN 85-543,591. PUB. 7-3-2012. FILED 2-15-2012.
 4,209,823. **GEODRONE (STANDARD CHARACTER)**. TREXA LLC, (U.S. CLS. 19, 21, 23, 31, 35 AND 44). SN 85-544,616. PUB. 7-3-2012. FILED 2-16-2012.
 4,209,914. **SPIRIT (STANDARD CHARACTER)**. AUTONOMOUS TRACTOR CORPORATION, (U.S. CLS. 19, 21, 23, 31, 35 AND 44). SN 85-546,571. PUB. 7-3-2012. FILED 2-17-2012.
 4,209,941. **PINNACLE (STANDARD CHARACTER)**. PINNACLE COMPANIES, INC., (U.S. CLS. 19, 21, 23, 31, 35 AND 44). SN 85-547,169. PUB. 7-3-2012. FILED 2-20-2012.
 4,210,051. **DABRYAN (STANDARD CHARACTER)**. ACCUBUILT, INC., MULTIPLE CLASS, (INT. CLS. 12, 35, 40 AND 42), (U.S. CLS. 19, 21, 23, 31, 35, 44, 100, 101, 102, 103 AND 106). SN 85-565,410. PUB. 7-3-2012. FILED 3-9-2012.
 4,210,171. **HPXX (STANDARD CHARACTER)**. DAYCO PRODUCTS, LLC, (U.S. CLS. 19, 21, 23, 31, 35 AND 44). SN 85-598,461. PUB. 7-3-2012. FILED 4-16-2012.
 4,210,201. **CAPTIVA (STANDARD CHARACTER)**. NAUTIC GLOBAL GROUP, INC., (U.S. CLS. 19, 21, 23, 31, 35 AND 44). SN 85-613,139. PUB. 7-3-2012. FILED 5-1-2012.

CLASS 13—FIREARMS

4,209,539. **NOVESKE AND DESIGN**. NOVESKE RIFLEWORKS LLC, (U.S. CLS. 2 AND 9). SN 85-539,361. PUB. 7-3-2012. FILED 2-10-2012.
 4,209,605. **ERGO (STANDARD CHARACTER)**. FALCON INDUSTRIES, INC., (U.S. CLS. 2 AND 9). SN 85-541,192. PUB. 7-3-2012. FILED 2-13-2012.
 4,209,763. **10/22 TAKEDOWN (STANDARD CHARACTER)**. STURM, RUGER & COMPANY, INC., (U.S. CLS. 2 AND 9). SN 85-543,693. PUB. 7-3-2012. FILED 2-15-2012.
 4,209,786. **TUFFORCE (STANDARD CHARACTER)**. TUFFORCE LLC, (U.S. CLS. 2 AND 9). SN 85-544,010. PUB. 7-3-2012. FILED 2-15-2012.
 4,209,791. **ATLAS (STANDARD CHARACTER)**. B-5, INC., (U.S. CLS. 2 AND 9). SN 85-544,129. PUB. 7-3-2012. FILED 2-16-2012.
 4,209,955. **SUREGRIP (STANDARD CHARACTER)**. FALCON

INDUSTRIES, INC., (U.S. CLS. 2 AND 9). SN 85-547,787. PUB. 7-3-2012. FILED 2-21-2012.
 4,209,956. **RHINO HIDE (STANDARD CHARACTER)**. FALCON INDUSTRIES, INC., (U.S. CLS. 2 AND 9). SN 85-547,789. PUB. 7-3-2012. FILED 2-21-2012.
 4,210,028. **IF YOU HAVE ONE SHOT, MAKE IT AN ACCU-SHOT (STANDARD CHARACTER)**. B-5, INC., (U.S. CLS. 2 AND 9). SN 85-557,823. PUB. 7-3-2012. FILED 3-1-2012.
 4,210,183. **ERGO SURE GRIP (STANDARD CHARACTER)**. FALCON INDUSTRIES, INC., (U.S. CLS. 2 AND 9). SN 85-604,565. PUB. 7-3-2012. FILED 4-21-2012.
 4,210,225 (*See Class 8 for this trademark*).

CLASS 14—JEWELRY

4,208,186. **EARTH RING (STANDARD CHARACTER)**. TAMMY KOHL, (U.S. CLS. 2, 27, 28 AND 50). SN 77-723,875. PUB. 7-3-2012. FILED 4-28-2009.
 4,208,225 (*See Class 7 for this trademark*).
 4,208,277 (*See Class 3 for this trademark*).
 4,208,283 (*See Class 3 for this trademark*).
 4,208,289 (*See Class 3 for this trademark*).
 4,208,293. **A AVIATOR AND DESIGN**. BURAN SA, (U.S. CLS. 2, 27, 28 AND 50). SN 79-101,317. PUB. 7-3-2012. FILED 7-5-2011.
 4,208,325. **ANTOINE MARTIN (STANDARD CHARACTER)**. MHO AG, (U.S. CLS. 2, 27, 28 AND 50). SN 79-102,326. PUB. 7-3-2012. FILED 7-17-2011.
 4,208,338. **MYFC (STANDARD CHARACTER)**. FOREVER18 RETAIL GMBH, MULTIPLE CLASS, (INT. CLS. 14, 18 AND 25), (U.S. CLS. 1, 2, 3, 22, 27, 28, 39, 41 AND 50). SN 79-102,696. PUB. 7-3-2012. FILED 5-10-2011.
 4,208,379. **NOMOS GLASHÜTTE (STYLIZED)**. NOMOS GLASHÜTTE/SA; ROLAND SCHWERTNER KG, (U.S. CLS. 2, 27, 28 AND 50). SN 79-105,037. PUB. 7-3-2012. FILED 10-6-2011.
 4,208,381 (*See Class 3 for this trademark*).
 4,208,383. **AMADEUS (STANDARD CHARACTER)**. RAYMOND WEIL S.A., (U.S. CLS. 2, 27, 28 AND 50). SN 79-105,355. PUB. 7-3-2012. FILED 6-12-2011.
 4,208,393 (*See Class 4 for this trademark*).
 4,208,394. **TUDORWATCH (STANDARD CHARACTER)**. MONTRES TUDOR SA, (U.S. CLS. 2, 27, 28 AND 50). SN 79-106,487. PUB. 7-3-2012. FILED 11-11-2011.
 4,208,410. **SWITCH & FUN THE ORIGINAL AND DESIGN**. JOCHEN BENZEL, (U.S. CLS. 2, 27, 28 AND 50). SN 79-108,098. PUB. 7-3-2012. FILED 8-26-2011.
 4,208,428 (*See Class 9 for this trademark*).
 4,208,461. **MEANINGFUL REMINDER (STANDARD CHARACTER)**. ION-RAY COMPANY LTD., (U.S. CLS. 2, 27, 28 AND 50). SN 85-055,189. PUB. 12-13-2011. FILED 6-4-2010.
 4,208,470. **AG (STYLIZED)**. AMERICAS GOLD, INC., (U.S. CLS. 2, 27, 28 AND 50). SN 85-089,926. PUB. 7-3-2012. FILED 7-21-2010.
 4,208,514. **GOLDEN SHADOW (STANDARD CHARACTER)**. UNIVERSAL GENEVE S.A., (U.S. CLS. 2, 27, 28 AND 50). SN 85-186,909. PUB. 7-3-2012. FILED 11-30-2010.
 4,208,571. **MISCELLANEOUS DESIGN**. MARTIN FLYER JEWELRY, LLC., (U.S. CLS. 2, 27, 28 AND 50). SN 85-268,424. PUB. 7-3-2012. FILED 3-16-2011.
 4,208,786. **MISCELLANEOUS DESIGN**. BLAZING WAHINE LLC, MULTIPLE CLASS, (INT. CLS. 14 AND 18), (U.S. CLS. 1, 2, 3, 22, 27, 28, 41 AND 50). SN 85-379,133. PUB. 7-3-2012. FILED 7-22-2011.
 4,208,888. **LEVER-SET AND DESIGN**. LEVERSET, INC., DBA LEVERSET, INC., (U.S. CLS. 2, 27, 28 AND 50). SN 85-405,395. PUB. 7-3-2012. FILED 8-23-2011.
 4,208,895. **FEARLESS WOMEN JEWELRY (STANDARD CHARACTER)**. HALPIN, MARY ANN, DBA MARY ANN HALPIN PHOTOGRAPHY, (U.S. CLS. 2, 27, 28 AND 50). SN 85-410,216. PUB. 7-3-2012. FILED 8-30-2011.
 4,208,939. **INFINITAS (STANDARD CHARACTER)**. MICHAEL HILL FRANCHISE PTY LIMITED, MULTIPLE CLASS, (INT. CLS. 14 AND 35), (U.S. CLS. 2, 27, 28, 50, 100, 101 AND 102). SN 85-428,077. PUB. 7-3-2012. FILED 9-21-2011.
 4,208,997. **SEMPER FI DIAMONDS (STANDARD CHARAC-**

- TER). MITCHELL, VANESSA, (U.S. CLS. 2, 27, 28 AND 50). SN 85-448,657. PUB. 7-3-2012. FILED 10-17-2011.
- 4,209,125. **MOTHER'S PEAPOD (STANDARD CHARACTER)**. LUGOSCH DESIGNS, INC., (U.S. CLS. 2, 27, 28 AND 50). SN 85-497,083. PUB. 7-3-2012. FILED 12-16-2011.
- 4,209,190. **925 W (STANDARD CHARACTER)**. JEWELPOP INC., DBA KAMELEON JEWELRY, (U.S. CLS. 2, 27, 28 AND 50). SN 85-510,100. PUB. 7-3-2012. FILED 1-6-2012.
- 4,209,191. **925 I (STANDARD CHARACTER)**. JEWELPOP INC., DBA KAMELEON JEWELRY, (U.S. CLS. 2, 27, 28 AND 50). SN 85-510,105. PUB. 7-3-2012. FILED 1-6-2012.
- 4,209,350. **CLEAVAGE CANDY (STANDARD CHARACTER)**. FRAYER, KIMBERLY D. (U.S. CLS. 2, 27, 28 AND 50). SN 85-524,146. PUB. 7-3-2012. FILED 1-24-2012.
- 4,209,363. **LIMI (STANDARD CHARACTER)**. HOLLY M. RIDDEL, (U.S. CLS. 2, 27, 28 AND 50). SN 85-524,879. PUB. 7-3-2012. FILED 1-25-2012.
- 4,209,468. **JEAN DESSES (STANDARD CHARACTER)**. STAR-DUST CAPITAL SARL, MULTIPLE CLASS, (INT. CLS. 14, 18 AND 25), (U.S. CLS. 1, 2, 3, 22, 27, 28, 39, 41 AND 50). SN 85-531,774. PUB. 7-3-2012. FILED 2-2-2012.
- 4,209,585. **TRIP.I.T.S. (STANDARD CHARACTER)**. CHLOE & CO., LLC., (U.S. CLS. 2, 27, 28 AND 50). SN 85-541,013. PUB. 7-3-2012. FILED 2-13-2012.
- 4,209,616. **COLLECTIVEHABIT (STANDARD CHARACTER)**. COLLECTIVE HABIT, INC., MULTIPLE CLASS, (INT. CLS. 14, 25 AND 35), (U.S. CLS. 2, 22, 27, 28, 39, 50, 100, 101 AND 102). SN 85-541,357. PUB. 7-3-2012. FILED 2-13-2012.
- 4,209,753. **BRINGO (STANDARD CHARACTER)**. RADVANSKY, ANNETTE AMANDA, (U.S. CLS. 2, 27, 28 AND 50). SN 85-543,557. PUB. 7-3-2012. FILED 2-15-2012.
- 4,209,796. **JEWELS 4 HAIR (STYLIZED)**. HARRIS, JOANNE, MULTIPLE CLASS, (INT. CLS. 14 AND 26), (U.S. CLS. 2, 27, 28, 37, 39, 40, 42 AND 50). SN 85-544,239. PUB. 7-3-2012. FILED 2-16-2012.
- 4,209,815. **FIRSTIME MANUFACTORY (STANDARD CHARACTER)**. LICENSE PRODUCTS INC, DBA FIRSTIME MANUFACTORY, (U.S. CLS. 2, 27, 28 AND 50). SN 85-544,554. PUB. 7-3-2012. FILED 2-16-2012.
- 4,209,904. **KE (STYLIZED)**. KAREN EGREN, LLC, (U.S. CLS. 2, 27, 28 AND 50). SN 85-546,376. PUB. 7-3-2012. FILED 2-17-2012.
- 4,209,986. **BRASH (STANDARD CHARACTER)**. PAYLESS SHOESOURCE WORLDWIDE, INC., (U.S. CLS. 2, 27, 28 AND 50). SN 85-551,736. PUB. 7-3-2012. FILED 2-24-2012.
- 4,210,006. **SOMETHING HEALTHY (STANDARD CHARACTER)**. WELLNESS INTERACTIVE, INC., (U.S. CLS. 2, 27, 28 AND 50). SN 85-554,204. PUB. 7-3-2012. FILED 2-27-2012.
- 4,210,043. **YPM (STANDARD CHARACTER)**. ALL IN RETREATS LLC, (U.S. CLS. 2, 27, 28 AND 50). SN 85-562,883. PUB. 7-3-2012. FILED 3-7-2012.
- 4,210,098. **WHEN IT IS TIME FOR SOMETHING SPECIAL (STANDARD CHARACTER)**. DE BOULLE DIAMOND & JEWELRY, INC., MULTIPLE CLASS, (INT. CLS. 14 AND 35), (U.S. CLS. 2, 27, 28, 50, 100, 101 AND 102). SN 85-577,053. PUB. 7-3-2012. FILED 3-22-2012.

CLASS 15—MUSICAL INSTRUMENTS

- 4,208,364 (*See Class 9 for this trademark*).
- 4,208,421. **A R E AND DESIGN**. YAMAHA CORPORATION, (U.S. CLS. 2, 21 AND 36). SN 79-108,865. PUB. 7-3-2012. FILED 9-22-2011.
- 4,208,530. **MISCELLANEOUS DESIGN**. SORENSON SEWING, INC., DBA MOORADIAN COVER COMPANY, (U.S. CLS. 2, 21 AND 36). SN 85-201,520. PUB. 7-3-2012. FILED 12-20-2010.
- 4,209,124. **CAPITAL EDITION (STANDARD CHARACTER)**. KHS AMERICA, INC., (U.S. CLS. 2, 21 AND 36). SN 85-496,921. PUB. 7-3-2012. FILED 12-15-2011.
- 4,209,217. **JUPITER (STANDARD CHARACTER)**. KHS MUSICAL INSTRUMENTS LTD, (U.S. CLS. 2, 21 AND 36). SN 85-515,464. PUB. 7-3-2012. FILED 1-12-2012.

CLASS 16—PAPER GOODS AND PRINTED MATTER

- 4,208,123 (*See Class 9 for this trademark*).
- 4,208,124 (*See Class 9 for this trademark*).
- 4,208,151. **LADDAWN AND DESIGN**. LADDAWN, INC., (U.S. CLS. 2, 5, 22, 23, 29, 37, 38 AND 50). SN 76-709,928. PUB. 7-3-2012. FILED 12-7-2011.
- 4,208,154. **LADDAWN AND DESIGN**. LADDAWN, INC., (U.S. CLS. 2, 5, 22, 23, 29, 37, 38 AND 50). SN 76-710,182. PUB. 7-3-2012. FILED 1-5-2012.
- 4,208,162. **THE SOURCE FOR INTELLIGENT LUXURY LIVING (STANDARD CHARACTER)**. DISCOVER MAGAZINE, INC., (U.S. CLS. 2, 5, 22, 23, 29, 37, 38 AND 50). SN 77-084,701. PUB. 7-3-2012. FILED 1-17-2007.
- 4,208,164. **MISCELLANEOUS DESIGN**. HUNAN GREAT-DREAMS CARTOON MEDIA LIMITED COMPANY, MULTIPLE CLASS, (INT. CLS. 16, 20, 24, 25 AND 28), (U.S. CLS. 2, 5, 13, 22, 23, 25, 29, 32, 37, 38, 39, 42 AND 50). SN 77-135,646. PUB. 7-3-2012. FILED 3-20-2007.
- 4,208,175. **DEWEY FROM DETROIT (STANDARD CHARACTER)**. BRAUN, MARY J, MULTIPLE CLASS, (INT. CLS. 16, 21 AND 25), (U.S. CLS. 2, 5, 13, 22, 23, 29, 30, 33, 37, 38, 39, 40 AND 50). SN 77-441,118. PUB. 7-3-2012. FILED 4-6-2008.
- 4,208,180. **INVISIBLE HAND STUDIOS (STANDARD CHARACTER)**. FREEDOM DEVELOPMENT, LLC, DBA INVISIBLE HAND STUDIOS, (U.S. CLS. 2, 5, 22, 23, 29, 37, 38 AND 50). SN 77-555,057. PUB. 10-27-2009. FILED 8-25-2008.
- 4,208,181 (*See Class 9 for this trademark*).
- 4,208,188. **KITCHENS OF THE WORLD (STANDARD CHARACTER)**. THE CANADIAN COUNCIL OF THE BLIND, (U.S. CLS. 2, 5, 22, 23, 29, 37, 38 AND 50). SN 77-788,545. PUB. 5-31-2011. FILED 7-23-2009.
- 4,208,191. **SHAGGY DOG PRESS (STANDARD CHARACTER)**. QUACKENBUSH, MICHAEL, (U.S. CLS. 2, 5, 22, 23, 29, 37, 38 AND 50). SN 77-816,361. PUB. 12-21-2010. FILED 8-31-2009.
- 4,208,199 (*See Class 9 for this trademark*).
- 4,208,233 (*See Class 9 for this trademark*).
- 4,208,234 (*See Class 9 for this trademark*).
- 4,208,242. **UMAN (STYLIZED)**. NL&F S.A., MULTIPLE CLASS, (INT. CLS. 16 AND 35), (U.S. CLS. 2, 5, 22, 23, 29, 37, 38, 50, 100, 101 AND 102). SN 79-088,767. PUB. 7-3-2012. FILED 5-27-2010.
- 4,208,243 (*See Class 3 for this trademark*).
- 4,208,247 (*See Class 9 for this trademark*).
- 4,208,257 (*See Class 7 for this trademark*).
- 4,208,265 (*See Class 7 for this trademark*).
- 4,208,278 (*See Class 9 for this trademark*).
- 4,208,291 (*See Class 9 for this trademark*).
- 4,208,298. **LEARNING IN A BOX AND DESIGN**. EDISON LEARNING INTERNATIONAL LTD, MULTIPLE CLASS, (INT. CLS. 16 AND 41), (U.S. CLS. 2, 5, 22, 23, 29, 37, 38, 50, 100, 101 AND 107). SN 79-101,505. PUB. 7-3-2012. FILED 6-27-2011.
- 4,208,321. **MISCELLANEOUS DESIGN**. MZ HOLDING AG, MULTIPLE CLASS, (INT. CLS. 16, 35 AND 41), (U.S. CLS. 2, 5, 22, 23, 29, 37, 38, 50, 100, 101, 102 AND 107). SN 79-102,179. PUB. 7-3-2012. FILED 7-14-2011.
- 4,208,333 (*See Class 5 for this trademark*).
- 4,208,342 (*See Class 9 for this trademark*).
- 4,208,346. **FRANKS & CO (STANDARD CHARACTER)**. FRANKS & CO LIMITED, MULTIPLE CLASS, (INT. CLS. 16, 35, 41, 42 AND 45), (U.S. CLS. 2, 5, 22, 23, 29, 37, 38, 50, 100, 101, 102 AND 107). SN 79-102,827. PUB. 7-3-2012. FILED 6-21-2011.
- 4,208,349 (*See Class 5 for this trademark*).
- 4,208,356 (*See Class 9 for this trademark*).
- 4,208,367 (*See Class 2 for this trademark*).
- 4,208,426. **VAN GOGH MUSEUM AMSTERDAM (STYLIZED)**. STICHTING VAN GOGH MUSEUM, MULTIPLE CLASS, (INT. CLS. 16 AND 21), (U.S. CLS. 2, 5, 13, 22, 23, 29, 30, 33, 37, 38, 40 AND 50). SN 79-109,635. PUB. 7-3-2012. FILED 10-13-2011.
- 4,208,428 (*See Class 9 for this trademark*).
- 4,208,429 (*See Class 9 for this trademark*).
- 4,208,446. **TABLE FOR TWO AND DESIGN**. TABLE FOR TWO INTERNATIONAL, MULTIPLE CLASS, (INT. CLS. 16, 21, 24, 32, 33, 35, 36, 41 AND 43), (U.S. CLS. 2, 5, 13, 22, 23,

- 29, 30, 33, 37, 38, 40, 42, 45, 46, 47, 48, 49, 50, 100, 101, 102 AND 107). SN 79-975,227. PUB. 7-3-2012. FILED 1-18-2011.
- 4,208,486. **DURACARD (STANDARD CHARACTER)**. DURACARD, LLC. (U.S. CLS. 2, 5, 22, 23, 29, 37, 38 AND 50). SN 85-141,321. PUB. 1-24-2012. FILED 9-29-2010.
- 4,208,494 (*See Class 9 for this trademark*).
- 4,208,495 (*See Class 9 for this trademark*).
- 4,208,517. **CP&G LINE WWW.CPGLINE.COM AND DESIGN**. PROGRESS COMMERCIAL PRINTING & GRAPHICS, INC., AKA PROGRESS PRINTING COMPANY, (U.S. CLS. 2, 5, 22, 23, 29, 37, 38 AND 50). SN 85-190,383. PUB. 7-3-2012. FILED 12-3-2010.
- 4,208,566. **SEED AND DESIGN**. CROW, SHARLA MARIE, MULTIPLE CLASS, (INT. CLS. 16 AND 41), (U.S. CLS. 2, 5, 22, 23, 29, 37, 38, 50, 100, 101 AND 107). SN 85-259,707. PUB. 7-3-2012. FILED 3-7-2011.
- 4,208,577 (*See Class 9 for this trademark*).
- 4,208,581. **POLAR BEAR POST (STANDARD CHARACTER)**. SANTA CLAUSET TOYS LC, MULTIPLE CLASS, (INT. CLS. 16 AND 28), (U.S. CLS. 2, 5, 22, 23, 29, 37, 38 AND 50). SN 85-281,641. PUB. 7-3-2012. FILED 3-30-2011.
- 4,208,582. **PRESTIGE (STANDARD CHARACTER)**. ECOLOGICAL FIBERS, INC., (U.S. CLS. 2, 5, 22, 23, 29, 37, 38 AND 50). SN 85-281,991. PUB. 8-30-2011. FILED 3-31-2011.
- 4,208,587. **THERMATAC (STANDARD CHARACTER)**. NEKOOSA COATED PRODUCTS, LLC, (U.S. CLS. 2, 5, 22, 23, 29, 37, 38 AND 50). SN 85-290,569. PUB. 7-3-2012. FILED 4-8-2011.
- 4,208,596. **CONCEALED CARRY MAGAZINE (STANDARD CHARACTER)**. DELTA MEDIA, LLC, (U.S. CLS. 2, 5, 22, 23, 29, 37, 38 AND 50). SN 85-303,716. PUB. 7-3-2012. FILED 4-25-2011.
- 4,208,599. **LOVE IS BIGGER (STANDARD CHARACTER)**. SOUL SOUP, INC., MULTIPLE CLASS, (INT. CLS. 16 AND 20), (U.S. CLS. 2, 5, 13, 22, 23, 25, 29, 32, 37, 38 AND 50). SN 85-306,857. PUB. 9-13-2011. FILED 4-28-2011.
- 4,208,620. **WARGAMES ILLUSTRATED (STANDARD CHARACTER)**. BATTLEFRONT MINIATURES LIMITED, (U.S. CLS. 2, 5, 22, 23, 29, 37, 38 AND 50). SN 85-328,261. PUB. 7-3-2012. FILED 5-24-2011.
- 4,208,655. **BASEBALL LIFE AND DESIGN**. PICANO, MICHAEL J., DBA VARSITY SPORT SHOP, (U.S. CLS. 2, 5, 22, 23, 29, 37, 38 AND 50). SN 85-348,130. PUB. 7-3-2012. FILED 6-16-2011.
- 4,208,668. **WHERE IS REASON? (STANDARD CHARACTER)**. REELING SPIRIT PRODUCTIONS, MULTIPLE CLASS, (INT. CLS. 16 AND 41), (U.S. CLS. 2, 5, 22, 23, 29, 37, 38, 50, 100, 101 AND 107). SN 85-352,858. PUB. 7-3-2012. FILED 6-22-2011.
- 4,208,677. **THE POET IN ME (STANDARD CHARACTER)**. JORDAN, VENSON D., AND JORDAN, LAURA E., (U.S. CLS. 2, 5, 22, 23, 29, 37, 38 AND 50). SN 85-357,355. PUB. 7-3-2012. FILED 6-27-2011.
- 4,208,710. **DC ROLLERGIRLS (STANDARD CHARACTER)**. DC ROLLERGIRLS, MULTIPLE CLASS, (INT. CLS. 16, 25, 35 AND 41), (U.S. CLS. 2, 5, 22, 23, 29, 37, 38, 39, 50, 100, 101, 102 AND 107). SN 85-366,351. PUB. 7-3-2012. FILED 7-8-2011.
- 4,208,715. **REMEMBER 2 PRAY (STANDARD CHARACTER)**. DONNELLI, BEN O, (U.S. CLS. 2, 5, 22, 23, 29, 37, 38 AND 50). SN 85-367,444. PUB. 7-3-2012. FILED 7-10-2011.
- 4,208,744. **THE HEALTHY WORKPLACE PROJECT (STYLIZED)**. KIMBERLY-CLARK WORLDWIDE, INC., MULTIPLE CLASS, (INT. CLS. 16 AND 44), (U.S. CLS. 2, 5, 22, 23, 29, 37, 38, 50, 100 AND 101). SN 85-373,406. PUB. 7-3-2012. FILED 7-18-2011.
- 4,208,778 (*See Class 9 for this trademark*).
- 4,208,802. **PEEL-N-STICK PROMISES (STANDARD CHARACTER)**. CAUGHRAN, MARSHA, (U.S. CLS. 2, 5, 22, 23, 29, 37, 38 AND 50). SN 85-383,887. PUB. 7-3-2012. FILED 7-28-2011.
- 4,208,820. **CUNA (STANDARD CHARACTER)**. CREDIT UNION NATIONAL ASSOCIATION, INC., (U.S. CLS. 2, 5, 22, 23, 29, 37, 38 AND 50). SN 85-388,442. PUB. 3-27-2012. FILED 8-3-2011.
- 4,208,823. **CREDIT UNION NATIONAL ASSOCIATION (STANDARD CHARACTER)**. CREDIT UNION NATIONAL ASSOCIATION, INC., (U.S. CLS. 2, 5, 22, 23, 29, 37, 38 AND 50). SN 85-388,707. PUB. 3-27-2012. FILED 8-3-2011.
- 4,208,827. **LEPAGE'S (STANDARD CHARACTER)**. KITARU INNOVATIONS INC., (U.S. CLS. 2, 5, 22, 23, 29, 37, 38 AND 50). SN 85-389,731. PUB. 7-3-2012. FILED 8-4-2011.
- 4,208,828 (*See Class 9 for this trademark*).
- 4,208,850. **SAGE (STANDARD CHARACTER)**. CATALYST PAPER CORPORATION, (U.S. CLS. 2, 5, 22, 23, 29, 37, 38 AND 50). SN 85-396,266. PUB. 1-17-2012. FILED 8-12-2011.
- 4,208,851. **SAGE AND DESIGN**. CATALYST PAPER CORPORATION, (U.S. CLS. 2, 5, 22, 23, 29, 37, 38 AND 50). SN 85-396,272. PUB. 1-17-2012. FILED 8-12-2011.
- 4,208,858 (*See Class 1 for this trademark*).
- 4,208,862 (*See Class 1 for this trademark*).
- 4,208,873. **WHAT WOULD MADAME DEFARGE KNIT? (STANDARD CHARACTER)**. CRAFTING-A-LIFE, INC., (U.S. CLS. 2, 5, 22, 23, 29, 37, 38 AND 50). SN 85-402,453. PUB. 7-3-2012. FILED 8-19-2011.
- 4,208,878. **FUEL YOUR FORCE (STANDARD CHARACTER)**. PROFICIENT LEARNING, LLC, MULTIPLE CLASS, (INT. CLS. 16 AND 41), (U.S. CLS. 2, 5, 22, 23, 29, 37, 38, 50, 100, 101 AND 107). SN 85-403,390. PUB. 7-3-2012. FILED 8-22-2011.
- 4,208,905. **PHILLIPS NIZER (STANDARD CHARACTER)**. PHILLIPS NIZER LLP, (U.S. CLS. 2, 5, 22, 23, 29, 37, 38 AND 50). SN 85-412,813. PUB. 7-3-2012. FILED 9-1-2011.
- 4,208,927. **SCIENCE OF LIGHT (STANDARD CHARACTER)**. COLE, FREEDOM TOBIAS, MULTIPLE CLASS, (INT. CLS. 16 AND 41), (U.S. CLS. 2, 5, 22, 23, 29, 37, 38, 50, 100, 101 AND 107). SN 85-419,496. PUB. 7-3-2012. FILED 9-9-2011.
- 4,208,938. **THE SOCIETY DIARIES (STANDARD CHARACTER)**. M.M.G. COMMUNICATIONS, INC., (U.S. CLS. 2, 5, 22, 23, 29, 37, 38 AND 50). SN 85-423,446. PUB. 7-3-2012. FILED 9-15-2011.
- 4,208,946. **HASH MAGAZINE (STANDARD CHARACTER)**. SO, MONICA, AND RYAN, SEAN, (U.S. CLS. 2, 5, 22, 23, 29, 37, 38 AND 50). SN 85-430,573. PUB. 7-3-2012. FILED 9-23-2011.
- 4,209,000. **HUNTER CHICK (STANDARD CHARACTER)**. COUNTRY LIFE OUTFITTERS INC, MULTIPLE CLASS, (INT. CLS. 16 AND 25), (U.S. CLS. 2, 5, 22, 23, 29, 37, 38, 39 AND 50). SN 85-448,998. PUB. 3-27-2012. FILED 10-17-2011.
- 4,209,065. **RED CURBS (STANDARD CHARACTER)**. RED CURBS, LLC, MULTIPLE CLASS, (INT. CLS. 16, 25 AND 28), (U.S. CLS. 2, 5, 22, 23, 29, 37, 38, 39 AND 50). SN 85-474,909. PUB. 7-3-2012. FILED 11-17-2011.
- 4,209,070 (*See Class 9 for this trademark*).
- 4,209,099. **FAMILY NORTH CAROLINA (STANDARD CHARACTER)**. NORTH CAROLINA FAMILY POLICY COUNCIL, (U.S. CLS. 2, 5, 22, 23, 29, 37, 38 AND 50). SN 85-490,169. PUB. 7-3-2012. FILED 12-8-2011.
- 4,209,105. **S.A.T (STUDENT AWARENESS TOOLS) (STANDARD CHARACTER)**. "MASK" MOTHERS AWARENESS ON SCHOOL AGE KIDS, MULTIPLE CLASS, (INT. CLS. 16 AND 41), (U.S. CLS. 2, 5, 22, 23, 29, 37, 38, 50, 100, 101 AND 107). SN 85-491,811. PUB. 7-3-2012. FILED 12-9-2011.
- 4,209,117. **SUPER ABSORBENT BAMBOO CORE AND DESIGN**. PETKIN, INC., (U.S. CLS. 2, 5, 22, 23, 29, 37, 38 AND 50). SN 85-494,354. PUB. 7-3-2012. FILED 12-13-2011.
- 4,209,122. **DISEASE TECHNIQUE TECHNOLOGY DTT (STANDARD CHARACTER)**. RAMSAY, CHRISTOPHER, (U.S. CLS. 2, 5, 22, 23, 29, 37, 38 AND 50). SN 85-495,839. PUB. 7-3-2012. FILED 12-15-2011.
- 4,209,141. **OUTDOORS, OUTSCORES (STANDARD CHARACTER)**. GNT LLC, (U.S. CLS. 2, 5, 22, 23, 29, 37, 38 AND 50). SN 85-500,211. PUB. 7-3-2012. FILED 12-20-2011.
- 4,209,152 (*See Class 9 for this trademark*).
- 4,209,171. **SCRIPTURE FOR LITTLE SAINTS (STANDARD CHARACTER)**. SANDERS, HENRY, (U.S. CLS. 2, 5, 22, 23, 29, 37, 38 AND 50). SN 85-505,817. PUB. 7-3-2012. FILED 12-29-2011.
- 4,209,196 (*See Class 9 for this trademark*).
- 4,209,198. **DIVIDERLOCKS (STANDARD CHARACTER)**. SUPPLYONE, (U.S. CLS. 2, 5, 22, 23, 29, 37, 38 AND 50). SN 85-511,046. PUB. 7-3-2012. FILED 1-6-2012.
- 4,209,208. **GMSP (STANDARD CHARACTER)**. GRAPHIC MANAGEMENT SPECIALTY PRODUCTS, INC., MULTIPLE CLASS, (INT. CLS. 16, 21 AND 40), (U.S. CLS. 2, 5, 13, 22, 23, 29, 30, 33, 37, 38, 40, 50, 100, 103 AND 106). SN 85-513,795. PUB. 7-3-2012. FILED 1-11-2012.
- 4,209,211. **FF FARM FOUNDATION AND DESIGN**. FARM

- FOUNDATION, NFP, MULTIPLE CLASS, (INT. CLS. 16, 36, 41 AND 42), (U.S. CLS. 2, 5, 22, 23, 29, 37, 38, 50, 100, 101, 102 AND 107). SN 85-514,330. PUB. 7-3-2012. FILED 1-11-2012.
- 4,209,214. **PLAN FOR WHAT IF AND DESIGN. PLAN FOR WHAT IF, LLC**, (U.S. CLS. 2, 5, 22, 23, 29, 37, 38 AND 50). SN 85-514,643. PUB. 7-3-2012. FILED 1-12-2012.
- 4,209,219. **E AND DESIGN. AZOCAR, PATRICIA**, (U.S. CLS. 2, 5, 22, 23, 29, 37, 38 AND 50). SN 85-515,773. PUB. 7-3-2012. FILED 1-13-2012.
- 4,209,370. **HIGHPOINT PRESS (STANDARD CHARACTER). JDBASSOCIATES, LLC**, (U.S. CLS. 2, 5, 22, 23, 29, 37, 38 AND 50). SN 85-525,076. PUB. 7-3-2012. FILED 1-25-2012.
- 4,209,383. **ETHICAL WARRIOR (STANDARD CHARACTER). RESOLUTION GROUP INTERNATIONAL LLC, MULTIPLE CLASS**, (INT. CLS. 16 AND 41), (U.S. CLS. 2, 5, 22, 23, 29, 37, 38, 50, 100, 101 AND 107). SN 85-525,758. PUB. 7-3-2012. FILED 1-26-2012.
- 4,209,431. **KILLER ACID (STANDARD CHARACTER). CORRADETTI, ROBERT CULLEN, MULTIPLE CLASS**, (INT. CLS. 16 AND 25), (U.S. CLS. 2, 5, 22, 23, 29, 37, 38, 39 AND 50). SN 85-527,995. PUB. 7-3-2012. FILED 1-29-2012.
- 4,209,456. **SOCIAL PRINT (STANDARD CHARACTER). INTERNATIONAL SOCIAL PRINT PAPER LTD., MULTIPLE CLASS**, (INT. CLS. 16 AND 35), (U.S. CLS. 2, 5, 22, 23, 29, 37, 38, 50, 100, 101 AND 102). SN 85-530,414. PUB. 7-3-2012. FILED 1-31-2012.
- 4,209,510. **L3 (STANDARD CHARACTER). D-GENERATION, INC.**, (U.S. CLS. 2, 5, 22, 23, 29, 37, 38 AND 50). SN 85-537,818. PUB. 7-3-2012. FILED 2-9-2012.
- 4,209,528 (*See Class 9 for this trademark*).
- 4,209,586. **INDEPENDENT THINKING (STANDARD CHARACTER). EVERCORE PARTNERS SERVICES EAST LLC, MULTIPLE CLASS**, (INT. CLS. 16, 36 AND 41), (U.S. CLS. 2, 5, 22, 23, 29, 37, 38, 50, 100, 101, 102 AND 107). SN 85-541,026. PUB. 7-3-2012. FILED 2-13-2012.
- 4,209,645. **ASTROMYTHOS (STANDARD CHARACTER). SIDERIADIS, JON**, (U.S. CLS. 2, 5, 22, 23, 29, 37, 38 AND 50). SN 85-541,870. PUB. 7-3-2012. FILED 2-14-2012.
- 4,209,655. **FASHIONERY (STANDARD CHARACTER). THE MACBETH GROUP, INC.**, (U.S. CLS. 2, 5, 22, 23, 29, 37, 38 AND 50). SN 85-541,981. PUB. 7-3-2012. FILED 2-14-2012.
- 4,209,661 (*See Class 9 for this trademark*).
- 4,209,662. **FOR SERIOUS GOLFERS ONLY (STANDARD CHARACTER). TURNSTILE PUBLISHING COMPANY, MULTIPLE CLASS**, (INT. CLS. 16 AND 41), (U.S. CLS. 2, 5, 22, 23, 29, 37, 38, 50, 100, 101 AND 107). SN 85-542,145. PUB. 7-3-2012. FILED 2-14-2012.
- 4,209,686. **MISCELLANEOUS DESIGN. COSGROVE, MICHAEL T.**, MULTIPLE CLASS, (INT. CLS. 16 AND 41), (U.S. CLS. 2, 5, 22, 23, 29, 37, 38, 50, 100, 101 AND 107). SN 85-542,503. PUB. 7-3-2012. FILED 2-14-2012.
- 4,209,708. **ENJOY WEED (STANDARD CHARACTER). SANCHEZ, ROBERT, AND SANCHEZ, CHARLENE, MULTIPLE CLASS**, (INT. CLS. 16, 21, 25 AND 34), (U.S. CLS. 2, 5, 8, 9, 13, 17, 22, 23, 29, 30, 33, 37, 38, 39, 40 AND 50). SN 85-542,894. PUB. 7-3-2012. FILED 2-14-2012.
- 4,209,719. **JOURNAL BANDOLIER (STANDARD CHARACTER). OINEN, EMILY**, (U.S. CLS. 2, 5, 22, 23, 29, 37, 38 AND 50). SN 85-543,165. PUB. 7-3-2012. FILED 2-15-2012.
- 4,209,747. **MODKID (STANDARD CHARACTER). MODKID LLC, MULTIPLE CLASS**, (INT. CLS. 16 AND 25), (U.S. CLS. 2, 5, 22, 23, 29, 37, 38, 39 AND 50). SN 85-543,442. PUB. 7-3-2012. FILED 2-15-2012.
- 4,209,783. **THE LOCAL'S HOTTEST (STANDARD CHARACTER). DASTERISK DEVELOPMENT GROUP LLC**, (U.S. CLS. 2, 5, 22, 23, 29, 37, 38 AND 50). SN 85-543,980. PUB. 7-3-2012. FILED 2-15-2012.
- 4,209,880. **B-POP (STANDARD CHARACTER). KULP, CHRISTOPHER G.**, MULTIPLE CLASS, (INT. CLS. 16, 18, 25 AND 28), (U.S. CLS. 1, 2, 3, 5, 22, 23, 29, 37, 38, 39, 41 AND 50). SN 85-545,995. PUB. 7-3-2012. FILED 2-17-2012.
- 4,209,910. **ECORRCRATE (STANDARD CHARACTER). DANIEL BONEBRAKE**, (U.S. CLS. 2, 5, 22, 23, 29, 37, 38 AND 50). SN 85-546,493. PUB. 7-3-2012. FILED 2-17-2012.
- 4,209,944. **SWEET 61 (STANDARD CHARACTER). CANNON, DEBORAH A.**, (U.S. CLS. 2, 5, 22, 23, 29, 37, 38 AND 50). SN 85-547,545. PUB. 7-3-2012. FILED 2-20-2012.
- 4,209,976. **I'M GREEN (STANDARD CHARACTER). BIOPLANET CORP.**, MULTIPLE CLASS, (INT. CLS. 16 AND 21), (U.S. CLS. 2, 5, 13, 22, 23, 29, 30, 33, 37, 38, 40 AND 50). SN 85-550,182. PUB. 7-3-2012. FILED 2-22-2012.
- 4,209,978. **THE NEW PIONEER (STANDARD CHARACTER). HARRIS PUBLICATIONS, INC.**, (U.S. CLS. 2, 5, 22, 23, 29, 37, 38 AND 50). SN 85-550,750. PUB. 7-3-2012. FILED 2-23-2012.
- 4,209,980. **REAL GARDENS (STANDARD CHARACTER). HARRIS PUBLICATIONS, INC.**, (U.S. CLS. 2, 5, 22, 23, 29, 37, 38 AND 50). SN 85-551,101. PUB. 7-3-2012. FILED 2-23-2012.
- 4,209,983. **REAL KITCHENS (STANDARD CHARACTER). HARRIS PUBLICATIONS, INC.**, (U.S. CLS. 2, 5, 22, 23, 29, 37, 38 AND 50). SN 85-551,289. PUB. 7-3-2012. FILED 2-23-2012.
- 4,210,023. **MOTORMAID (STANDARD CHARACTER). SINCLAIR WORLDWIDE, INC.**, MULTIPLE CLASS, (INT. CLS. 16 AND 21), (U.S. CLS. 2, 5, 13, 22, 23, 29, 30, 33, 37, 38, 40 AND 50). SN 85-556,593. PUB. 7-3-2012. FILED 2-29-2012.
- 4,210,087. **JWM (STANDARD CHARACTER). MARRIOTT INTERNATIONAL, INC.**, (U.S. CLS. 2, 5, 22, 23, 29, 37, 38 AND 50). SN 85-575,642. PUB. 7-3-2012. FILED 3-21-2012.
- 4,210,109. **MULTICHANNEL MERCHANT (STANDARD CHARACTER). PENTON BUSINESS MEDIA, INC.**, MULTIPLE CLASS, (INT. CLS. 16 AND 41), (U.S. CLS. 2, 5, 22, 23, 29, 37, 38, 50, 100, 101 AND 107). SN 85-579,623. PUB. 7-3-2012. FILED 3-26-2012.
- 4,210,139. **FROM GRATITUDE TO BLISS (STANDARD CHARACTER). NOURISH BY NATURE, INC.**, (U.S. CLS. 2, 5, 22, 23, 29, 37, 38 AND 50). SN 85-586,525. PUB. 7-3-2012. FILED 4-2-2012.
- 4,210,142 (*See Class 10 for this trademark*).
- 4,210,143 (*See Class 10 for this trademark*).
- 4,210,218. **LIPRAGEOUS (STANDARD CHARACTER). CHEM-CORP PTY LTD**, (U.S. CLS. 2, 5, 22, 23, 29, 37, 38 AND 50). SN 85-624,152. PUB. 7-3-2012. FILED 5-14-2012.
- 4,210,226. **PALOMA'S NEST (STANDARD CHARACTER). PALOMA'S NEST, LLC, MULTIPLE CLASS**, (INT. CLS. 16, 20, 26 AND 28), (U.S. CLS. 2, 5, 13, 22, 23, 25, 29, 32, 37, 38, 39, 40, 42 AND 50). SN 85-977,246. PUB. 8-23-2011. FILED 3-24-2011.
- 4,210,228 (*See Class 5 for this trademark*).

CLASS 17—RUBBER GOODS

- 4,208,169. **DURA-BAR (STANDARD CHARACTER). GARCIA, RAYMUNDO MALDONADO**, (U.S. CLS. 1, 5, 12, 13, 35 AND 50). SN 77-336,682. PUB. 7-3-2012. FILED 11-26-2007.
- 4,208,235. **RESYSTA (STANDARD CHARACTER). PATENTA ASIA LTD.**, MULTIPLE CLASS, (INT. CLS. 17, 20 AND 35), (U.S. CLS. 1, 2, 5, 12, 13, 22, 25, 32, 35, 50, 100, 101 AND 102). SN 79-067,104. PUB. 7-13-2010. FILED 12-3-2008.
- 4,208,251 (*See Class 1 for this trademark*).
- 4,208,266 (*See Class 6 for this trademark*).
- 4,208,279 (*See Class 6 for this trademark*).
- 4,208,343 (*See Class 1 for this trademark*).
- 4,208,412 (*See Class 1 for this trademark*).
- 4,208,431 (*See Class 6 for this trademark*).
- 4,208,628 (*See Class 6 for this trademark*).
- 4,208,736. **LINCOLN PRODUCTS (STANDARD CHARACTER). FERGUSON ENTERPRISES, INC.**, (U.S. CLS. 1, 5, 12, 13, 35 AND 50). SN 85-372,472. PUB. 7-3-2012. FILED 7-15-2011.
- 4,208,960. **Z-LOCK (STANDARD CHARACTER). TAMA PLASTIC INDUSTRY**, (U.S. CLS. 1, 5, 12, 13, 35 AND 50). SN 85-436,385. PUB. 3-27-2012. FILED 9-30-2011.
- 4,209,085. **MICROFOIL (STANDARD CHARACTER). NORTH-WESTERN OHIO FOAM PACKAGING, INC.**, (U.S. CLS. 1, 5, 12, 13, 35 AND 50). SN 85-486,115. PUB. 7-3-2012. FILED 12-2-2011.
- 4,209,333. **FUTURAGEL (STANDARD CHARACTER). FUTURE FOAM, INC.**, (U.S. CLS. 1, 5, 12, 13, 35 AND 50). SN 85-523,635. PUB. 7-3-2012. FILED 1-24-2012.
- 4,209,691. **CRETE-HEAT (STANDARD CHARACTER). CRETE-HEAT, LLC**, (U.S. CLS. 1, 5, 12, 13, 35 AND 50).

- SN 85-542,586. PUB. 7-3-2012. FILED 2-14-2012.
 4,209,985. **SURE-FLOW (STANDARD CHARACTER)**. TEKNOR APEX COMPANY, (U.S. CLS. 1, 5, 12, 13, 35 AND 50). SN 85-551,667. PUB. 7-3-2012. FILED 2-24-2012.
 4,210,020. **GOLD LABEL (STANDARD CHARACTER)**. DAYCO PRODUCTS, LLC, (U.S. CLS. 1, 5, 12, 13, 35 AND 50). SN 85-556,163. PUB. 7-3-2012. FILED 2-29-2012.
 4,210,074. **ALLFLEX (STANDARD CHARACTER)**. NITRON INTERNATIONAL LLC, (U.S. CLS. 1, 5, 12, 13, 35 AND 50). SN 85-570,522. PUB. 7-3-2012. FILED 3-15-2012.

CLASS 18—LEATHER GOODS

- 4,208,124 (*See Class 9 for this trademark*).
 4,208,196. **REITWORLD; NAREIT'S ANNUAL CONVENTION FOR ALL THINGS REIT (STANDARD CHARACTER)**. NATIONAL ASSOCIATION OF REAL ESTATE INVESTMENT TRUSTS, INC., MULTIPLE CLASS, (INT. CLS. 18, 21 AND 41), (U.S. CLS. 1, 2, 3, 13, 22, 23, 29, 30, 33, 40, 41, 50, 100, 101 AND 107). SN 77-870,444. PUB. 7-3-2012. FILED 11-11-2009.
 4,208,225 (*See Class 7 for this trademark*).
 4,208,259. **BAXTER AND DESIGN. BAXTER S.R.L.**, MULTIPLE CLASS, (INT. CLS. 18 AND 20), (U.S. CLS. 1, 2, 3, 13, 22, 25, 32, 41 AND 50). SN 79-095,042. PUB. 7-3-2012. FILED 1-25-2011.
 4,208,276. **BENT CRISS (STANDARD CHARACTER)**. GREEN BROTHERS, MULTIPLE CLASS, (INT. CLS. 18, 25 AND 28), (U.S. CLS. 1, 2, 3, 22, 23, 38, 39, 41 AND 50). SN 79-099,599. PUB. 7-3-2012. FILED 6-3-2011.
 4,208,277 (*See Class 3 for this trademark*).
 4,208,283 (*See Class 3 for this trademark*).
 4,208,289 (*See Class 3 for this trademark*).
 4,208,310. **GIORGIO & MARIO (STANDARD CHARACTER)**. MONSIEUR MARIO ROSA, MULTIPLE CLASS, (INT. CLS. 18 AND 25), (U.S. CLS. 1, 2, 3, 22, 39 AND 41). SN 79-101,907. PUB. 7-3-2012. FILED 7-20-2011.
 4,208,334 (*See Class 3 for this trademark*).
 4,208,338 (*See Class 14 for this trademark*).
 4,208,350 (*See Class 9 for this trademark*).
 4,208,368. **MISCELLANEOUS DESIGN. CARIMAX CORPORATION**, (U.S. CLS. 1, 2, 3, 22 AND 41). SN 79-103,713. PUB. 7-3-2012. FILED 9-8-2011.
 4,208,374. **M MIRA LA MARELA AND DESIGN. MARÍA LUISA ADÁNEZ BARBA**, (U.S. CLS. 1, 2, 3, 22 AND 41). SN 79-104,364. PUB. 7-3-2012. FILED 7-21-2011.
 4,208,386. **SPHEREWIND (STANDARD CHARACTER)**. X-TECHNOLOGY SWISS GMBH, MULTIPLE CLASS, (INT. CLS. 18, 25 AND 28), (U.S. CLS. 1, 2, 3, 22, 23, 38, 39, 41 AND 50). SN 79-105,578. PUB. 7-3-2012. FILED 9-14-2011.
 4,208,428 (*See Class 9 for this trademark*).
 4,208,477. **WET CEMENT (STANDARD CHARACTER)**. 1502 VENTURE CAPITAL, DBA WET CEMENT, MULTIPLE CLASS, (INT. CLS. 18 AND 25), (U.S. CLS. 1, 2, 3, 22, 39 AND 41). SN 85-109,407. PUB. 6-14-2011. FILED 8-17-2010.
 4,208,501. **GARMENTOTE (STANDARD CHARACTER)**. CLEMCO PRODUCTS, INC., (U.S. CLS. 1, 2, 3, 22 AND 41). SN 85-170,196. PUB. 7-3-2012. FILED 11-5-2010.
 4,208,569. **L L U H T A AND DESIGN. L-FASHION GROUP OY**, MULTIPLE CLASS, (INT. CLS. 18 AND 25), (U.S. CLS. 1, 2, 3, 22, 39 AND 41). SN 85-264,448. PUB. 2-7-2012. FILED 3-11-2011.
 4,208,639. **MIRACLE CANE (STANDARD CHARACTER)**. HAWKESWORTH ENTERPRISES, INC., (U.S. CLS. 1, 2, 3, 22 AND 41). SN 85-340,127. PUB. 7-3-2012. FILED 6-7-2011.
 4,208,694. **ANGEL BY L'MARTINO (STANDARD CHARACTER)**. L & LEUNG HANDBAGS MFY. LTD., MULTIPLE CLASS, (INT. CLS. 18 AND 25), (U.S. CLS. 1, 2, 3, 22, 39 AND 41). SN 85-361,149. PUB. 7-3-2012. FILED 6-30-2011.
 4,208,700. **XOWAJU (STANDARD CHARACTER)**. WIETHE, MARKUS, MULTIPLE CLASS, (INT. CLS. 18, 25, 28, 35, 39 AND 45), (U.S. CLS. 1, 2, 3, 22, 23, 38, 39, 41, 50, 100, 101, 102 AND 105). SN 85-363,452. PUB. 7-3-2012. FILED 7-5-2011.
 4,208,786 (*See Class 14 for this trademark*).
 4,208,979 (*See Class 12 for this trademark*).
 4,209,097 (*See Class 3 for this trademark*).

- 4,209,116. **GRABBY-TABBY (STANDARD CHARACTER)**. STILL, PAYETTE S., (U.S. CLS. 1, 2, 3, 22 AND 41). SN 85-493,988. PUB. 7-3-2012. FILED 12-13-2011.
 4,209,178. **LOVE RADIUS (STANDARD CHARACTER)**. JE PORTE MON BEBE, MULTIPLE CLASS, (INT. CLS. 18 AND 25), (U.S. CLS. 1, 2, 3, 22, 39 AND 41). SN 85-507,358. PUB. 7-3-2012. FILED 1-3-2012.
 4,209,308. **MAITRES DU TEMPS (STANDARD CHARACTER)**. 88 RODEO HOLDINGS INC., (U.S. CLS. 1, 2, 3, 22 AND 41). SN 85-522,521. PUB. 7-3-2012. FILED 1-23-2012.
 4,209,404. **LEXIWYNN (STANDARD CHARACTER)**. LEXIWYNN DESIGNS LLC, MULTIPLE CLASS, (INT. CLS. 18 AND 35), (U.S. CLS. 1, 2, 3, 22, 41, 100, 101 AND 102). SN 85-526,238. PUB. 7-3-2012. FILED 1-26-2012.
 4,209,442. **BORLINO (STYLIZED)**. RATLIFF, DARRELL S., DBA BORLINO LLC., (U.S. CLS. 1, 2, 3, 22 AND 41). SN 85-528,976. PUB. 7-3-2012. FILED 1-30-2012.
 4,209,468 (*See Class 14 for this trademark*).
 4,209,493 (*See Class 9 for this trademark*).
 4,209,571. **TRINITY RANCH AND DESIGN. LIU, JIAN**, (U.S. CLS. 1, 2, 3, 22 AND 41). SN 85-540,737. PUB. 7-3-2012. FILED 2-13-2012.
 4,209,578. **L AND DESIGN. SHOE, S.L.**, MULTIPLE CLASS, (INT. CLS. 18, 25 AND 35), (U.S. CLS. 1, 2, 3, 22, 39, 41, 100, 101 AND 102). SN 85-540,910. PUB. 7-3-2012. FILED 2-13-2012.
 4,209,623. **BE YOUR BEST YOU! AND DESIGN. WHARTON-FIELDS, DONNA**, (U.S. CLS. 1, 2, 3, 22 AND 41). SN 85-541,463. PUB. 7-3-2012. FILED 2-13-2012.
 4,209,877. **MISCELLANEOUS DESIGN. FOUND MY ANIMAL, LLC**, (U.S. CLS. 1, 2, 3, 22 AND 41). SN 85-545,939. PUB. 7-3-2012. FILED 2-17-2012.
 4,209,880 (*See Class 16 for this trademark*).
 4,209,918. **CANDICE (STANDARD CHARACTER)**. CHENSON INDUSTRIAL CO. LTD., INC., (U.S. CLS. 1, 2, 3, 22 AND 41). SN 85-546,600. PUB. 7-3-2012. FILED 2-17-2012.
 4,210,225 (*See Class 8 for this trademark*).

CLASS 19—NON-METALLIC BUILDING MATERIALS

- 4,208,287. **DINESEN (STANDARD CHARACTER)**. JELS SAVVÆRK A/S, MULTIPLE CLASS, (INT. CLS. 19, 20 AND 37), (U.S. CLS. 1, 2, 12, 13, 22, 25, 32, 33, 50, 100, 103 AND 106). SN 79-100,765. PUB. 7-3-2012. FILED 7-4-2011.
 4,208,343 (*See Class 1 for this trademark*).
 4,208,388 (*See Class 9 for this trademark*).
 4,208,472 (*See Class 6 for this trademark*).
 4,208,652 (*See Class 6 for this trademark*).
 4,208,671. **ELEVATION (STANDARD CHARACTER)**. MGC CONSULTING LLC, (U.S. CLS. 1, 12, 33 AND 50). SN 85-354,089. PUB. 7-3-2012. FILED 6-23-2011.
 4,208,784 (*See Class 9 for this trademark*).
 4,209,046 (*See Class 1 for this trademark*).
 4,209,118. **MAGICMEND (STANDARD CHARACTER)**. MAGIC PLASTICS, INC., (U.S. CLS. 1, 12, 33 AND 50). SN 85-494,467. PUB. 7-3-2012. FILED 12-13-2011.
 4,209,587. **MUD STOPPER (STANDARD CHARACTER)**. MUD STOPPER, (U.S. CLS. 1, 12, 33 AND 50). SN 85-541,035. PUB. 7-3-2012. FILED 2-13-2012.
 4,209,631. **BIG MINI (STANDARD CHARACTER)**. SPELLBOUND DEVELOPMENT GROUP, INC., (U.S. CLS. 1, 12, 33 AND 50). SN 85-541,583. PUB. 7-3-2012. FILED 2-13-2012.
 4,209,769. **HARTSTONE (STANDARD CHARACTER)**. HARTSTONE, INC., (U.S. CLS. 1, 12, 33 AND 50). SN 85-543,781. PUB. 7-3-2012. FILED 2-15-2012.
 4,209,911 (*See Class 11 for this trademark*).

CLASS 20—FURNITURE AND ARTICLES NOT OTHERWISE CLASSIFIED

- 4,208,161. **ACRALYTE (STANDARD CHARACTER)**. HARBOR FURNITURE MANUFACTURING, INC., (U.S. CLS. 2, 13,

- 22, 25, 32 AND 50). SN 76-710,628. PUB. 7-3-2012. FILED 2-14-2012.
- 4,208,164 (*See Class 16 for this trademark*).
- 4,208,219. **SIMPLE GREEN AND DESIGN**. CHING FENG HOME FASHIONS CO., LTD., (U.S. CLS. 2, 13, 22, 25, 32 AND 50). SN 77-957,146. PUB. 4-17-2012. FILED 3-11-2010.
- 4,208,235 (*See Class 17 for this trademark*).
- 4,208,243 (*See Class 3 for this trademark*).
- 4,208,259 (*See Class 18 for this trademark*).
- 4,208,279 (*See Class 6 for this trademark*).
- 4,208,287 (*See Class 19 for this trademark*).
- 4,208,289 (*See Class 3 for this trademark*).
- 4,208,367 (*See Class 2 for this trademark*).
- 4,208,388 (*See Class 9 for this trademark*).
- 4,208,435. **FINESSE (STYLIZED)**. TONNELLERIE SAINT MARTIN, (U.S. CLS. 2, 13, 22, 25, 32 AND 50). SN 79-110,705. PUB. 7-3-2012. FILED 2-16-2012.
- 4,208,453. **IML AND DESIGN**. LES CONTENANTS I.M.L. D'AMÉRIQUE DU NORD INC., MULTIPLE CLASS, (INT. CLS. 20, 21, 40 AND 42), (U.S. CLS. 2, 13, 22, 23, 25, 29, 30, 32, 33, 40, 50, 100, 101, 103 AND 106). SN 85-035,772. PUB. 7-3-2012. FILED 5-11-2010.
- 4,208,520 (*See Class 6 for this trademark*).
- 4,208,599 (*See Class 16 for this trademark*).
- 4,208,664. **AUSTROFLEX (STANDARD CHARACTER)**. AXEL BLOOM, (U.S. CLS. 2, 13, 22, 25, 32 AND 50). SN 85-352,108. PUB. 7-3-2012. FILED 6-21-2011.
- 4,208,717. **DANIELSON DESIGNS THE COMPANY WITH A STORY AND DESIGN**. GANZ, (U.S. CLS. 2, 13, 22, 25, 32 AND 50). SN 85-367,830. PUB. 7-3-2012. FILED 7-11-2011.
- 4,208,733. **BIG BOX BUSTER AND DESIGN**. A&I MANUFACTURING, INC., (U.S. CLS. 2, 13, 22, 25, 32 AND 50). SN 85-371,822. PUB. 7-3-2012. FILED 7-14-2011.
- 4,208,858 (*See Class 1 for this trademark*).
- 4,208,862 (*See Class 1 for this trademark*).
- 4,208,943. **MICHAEL AMINI (STANDARD CHARACTER)**. AMINI INNOVATION CORP., MULTIPLE CLASS, (INT. CLS. 20 AND 24), (U.S. CLS. 2, 13, 22, 25, 32, 42 AND 50). SN 85-429,751. PUB. 7-3-2012. FILED 9-22-2011.
- 4,209,020. **OIL BUDDY (STYLIZED)**. MASTERLINK MARKETING INC., (U.S. CLS. 2, 13, 22, 25, 32 AND 50). SN 85-459,327. PUB. 7-3-2012. FILED 10-28-2011.
- 4,209,029. **PERSONAL TOUCH ADJUST YOUR SLEEP EXPERIENCE AND DESIGN**. PERSONAL TOUCH BED, (U.S. CLS. 2, 13, 22, 25, 32 AND 50). SN 85-462,260. PUB. 7-3-2012. FILED 11-2-2011.
- 4,209,112. **SWAP-A-TOP (STANDARD CHARACTER)**. FELDNER, SARAH, DBA SIMPLY SARAH DESIGNS, (U.S. CLS. 2, 13, 22, 25, 32 AND 50). SN 85-492,301. PUB. 7-3-2012. FILED 12-10-2011.
- 4,209,139. **SHOWER CAP (STANDARD CHARACTER)**. LACEBARK, INC., (U.S. CLS. 2, 13, 22, 25, 32 AND 50). SN 85-499,610. PUB. 7-3-2012. FILED 12-20-2011.
- 4,209,290. **BIOFRESH (STANDARD CHARACTER)**. MICHAEL ROTHBARD, (U.S. CLS. 2, 13, 22, 25, 32 AND 50). SN 85-521,268. PUB. 7-3-2012. FILED 1-20-2012.
- 4,209,395 (*See Class 2 for this trademark*).
- 4,209,450. **COLORDOME (STANDARD CHARACTER)**. SCOTT MACHINE DEVELOPMENT CORPORATION, (U.S. CLS. 2, 13, 22, 25, 32 AND 50). SN 85-529,855. PUB. 7-3-2012. FILED 1-31-2012.
- 4,209,476. **PICTURE GARDEN (STANDARD CHARACTER)**. TAGAWA GREENHOUSE ENTERPRISES, LLC, MULTIPLE CLASS, (INT. CLS. 20 AND 21), (U.S. CLS. 2, 13, 22, 23, 25, 29, 30, 32, 33, 40 AND 50). SN 85-532,957. PUB. 7-3-2012. FILED 2-3-2012.
- 4,209,681. **MIX AND DESIGN**. MATRIX IMPORTS, INC., (U.S. CLS. 2, 13, 22, 25, 32 AND 50). SN 85-542,446. PUB. 7-3-2012. FILED 2-14-2012.
- 4,209,774. **COFFIQUE (STANDARD CHARACTER)**. SEAN RONES, (U.S. CLS. 2, 13, 22, 25, 32 AND 50). SN 85-543,837. PUB. 7-3-2012. FILED 2-15-2012.
- 4,209,817. **MATRESS ENHANCER (STANDARD CHARACTER)**. MICHAEL ROTHBARD, (U.S. CLS. 2, 13, 22, 25, 32 AND 50). SN 85-544,566. PUB. 7-3-2012. FILED 2-16-2012.
- 4,209,825. **PRIMAGUARD THERA-MATT DUAL AND DESIGN**. FIRST CHOICE MEDICAL SUPPLY LLC, (U.S. CLS. 2, 13, 22, 25, 32 AND 50). SN 85-544,670. PUB. 7-3-2012. FILED 2-16-2012.
- 4,209,826. **PRIMAGUARD BARI-MATT MAX AND DESIGN**. FIRST CHOICE MEDICAL SUPPLY LLC, (U.S. CLS. 2, 13, 22, 25, 32 AND 50). SN 85-544,690. PUB. 7-3-2012. FILED 2-16-2012.
- 4,209,827. **PRIMAGUARD THERA-MATT XTRA AND DESIGN**. FIRST CHOICE MEDICAL SUPPLY LLC, (U.S. CLS. 2, 13, 22, 25, 32 AND 50). SN 85-544,697. PUB. 7-3-2012. FILED 2-16-2012.
- 4,209,828. **PRIMAGUARD THERA-MATT AND DESIGN**. FIRST CHOICE MEDICAL SUPPLY LLC, (U.S. CLS. 2, 13, 22, 25, 32 AND 50). SN 85-544,704. PUB. 7-3-2012. FILED 2-16-2012.
- 4,209,933 (*See Class 6 for this trademark*).
- 4,209,945. **NAV (STANDARD CHARACTER)**. CONKLIN OFFICE SERVICES, INC., (U.S. CLS. 2, 13, 22, 25, 32 AND 50). SN 85-547,585. PUB. 7-3-2012. FILED 2-20-2012.
- 4,209,946. **LIFTY (STANDARD CHARACTER)**. CONKLIN OFFICE SERVICES, INC., (U.S. CLS. 2, 13, 22, 25, 32 AND 50). SN 85-547,591. PUB. 7-3-2012. FILED 2-20-2012.
- 4,209,960. **LIFE BALANCE (STANDARD CHARACTER)**. E. S. KLUFT & COMPANY, LLC, (U.S. CLS. 2, 13, 22, 25, 32 AND 50). SN 85-548,256. PUB. 7-3-2012. FILED 2-21-2012.
- 4,210,123. **LIFE BALANCE AND DESIGN**. E. S. KLUFT & COMPANY, LLC, (U.S. CLS. 2, 13, 22, 25, 32 AND 50). SN 85-582,611. PUB. 7-3-2012. FILED 3-28-2012.
- 4,210,156. **STATUS (STANDARD CHARACTER)**. CONKLIN OFFICE SERVICES, INC., (U.S. CLS. 2, 13, 22, 25, 32 AND 50). SN 85-595,496. PUB. 7-3-2012. FILED 4-11-2012.
- 4,210,226 (*See Class 16 for this trademark*).

CLASS 21—HOUSEWARES AND GLASS

- 4,208,145. **HEALTH E-Z HAY FEEDER (STANDARD CHARACTER)**. HEALTH EZ, LLC, (U.S. CLS. 2, 13, 23, 29, 30, 33, 40 AND 50). SN 76-708,653. PUB. 7-3-2012. FILED 8-8-2011.
- 4,208,175 (*See Class 16 for this trademark*).
- 4,208,177. **J SCRUB (STANDARD CHARACTER)**. ASSOCIATED BRANDS LIMITED PARTNERSHIP, (U.S. CLS. 2, 13, 23, 29, 30, 33, 40 AND 50). SN 77-475,154. PUB. 7-3-2012. FILED 5-15-2008.
- 4,208,196 (*See Class 18 for this trademark*).
- 4,208,244. **MISCELLANEOUS DESIGN**. DA LIAN YA TU TOU ZI ZI XUN YOU XIAN GONG SI, (U.S. CLS. 2, 13, 23, 29, 30, 33, 40 AND 50). SN 79-090,350. PUB. 7-3-2012. FILED 11-25-2010.
- 4,208,289 (*See Class 3 for this trademark*).
- 4,208,296. **TEA MILL AND DESIGN**. GUANGZHOU HENG-FU TEA INDUSTRY CO., LTD., MULTIPLE CLASS, (INT. CLS. 21 AND 30), (U.S. CLS. 2, 13, 23, 29, 30, 33, 40, 46 AND 50). SN 79-101,351. PUB. 7-3-2012. FILED 5-9-2011.
- 4,208,369. **BEYOND (STANDARD CHARACTER)**. WARIMEX WAREN-IMPORT-EXPORT-HANDELS GMBH, (U.S. CLS. 2, 13, 23, 29, 30, 33, 40 AND 50). SN 79-103,856. PUB. 7-3-2012. FILED 9-2-2011.
- 4,208,387. **MICHEL MERCIER (STANDARD CHARACTER)**. MICHEL MERCIER LIMITED, (U.S. CLS. 2, 13, 23, 29, 30, 33, 40 AND 50). SN 79-105,732. PUB. 7-3-2012. FILED 10-6-2011.
- 4,208,388 (*See Class 9 for this trademark*).
- 4,208,418. **BOHEMIA CZECH REPUBLIC B LEAD CRYSTAL OVER 24% PBO AND DESIGN**. CRYSTAL BOHEMIA, A.S., (U.S. CLS. 2, 13, 23, 29, 30, 33, 40 AND 50). SN 79-108,524. PUB. 7-3-2012. FILED 10-20-2011.
- 4,208,426 (*See Class 16 for this trademark*).
- 4,208,446 (*See Class 16 for this trademark*).
- 4,208,453 (*See Class 20 for this trademark*).
- 4,208,466. **BARBETZ ORIENTAL GRILL PUB AND DESIGN**. NOLBOO CO., LTD., (U.S. CLS. 2, 13, 23, 29, 30, 33, 40 AND 50). SN 85-080,528. PUB. 7-3-2012. FILED 7-8-2010.
- 4,208,553. **VARGA (STYLIZED)**. VARGA, ILDIKO, (U.S. CLS. 2, 13, 23, 29, 30, 33, 40 AND 50). SN 85-238,802. PUB. 7-3-2012. FILED 2-10-2011.
- 4,208,556. **CORE ACACIA AND DESIGN**. BRUMIS IMPORTS INC., DBA CORE BAMBOO, (U.S. CLS. 2, 13, 23, 29, 30, 33, 40 AND 50). SN 85-246,311. PUB. 7-3-2012. FILED 2-18-2011.

4,208,580. **ROBIE (STANDARD CHARACTER)**. THE FRANK LLOYD WRIGHT FOUNDATION, (U.S. CLS. 2, 13, 23, 29, 30, 33, 40 AND 50). SN 85-281,419. PUB. 7-3-2012. FILED 3-30-2011.

4,208,598 (*See Class 3 for this trademark*).

4,208,640. **BEERS NOT BOMBS (STANDARD CHARACTER)**. FROM WAR TO PEACE, (U.S. CLS. 2, 13, 23, 29, 30, 33, 40 AND 50). SN 85-341,024. PUB. 7-3-2012. FILED 6-8-2011.

4,208,665. **LOOFAHWORLD (STANDARD CHARACTER)**. LOOFAH ART, LLC, (U.S. CLS. 2, 13, 23, 29, 30, 33, 40 AND 50). SN 85-352,110. PUB. 7-3-2012. FILED 6-21-2011.

4,208,796 (*See Class 3 for this trademark*).

4,208,858 (*See Class 1 for this trademark*).

4,208,862 (*See Class 1 for this trademark*).

4,208,900. **WINETANIUM (STANDARD CHARACTER)**. OUR-AY LLC, (U.S. CLS. 2, 13, 23, 29, 30, 33, 40 AND 50). SN 85-412,286. PUB. 7-3-2012. FILED 8-31-2011.

4,209,092. **STARDUST ARTWORKS (STANDARD CHARACTER)**. WILSON, KAREN LEROHL, (U.S. CLS. 2, 13, 23, 29, 30, 33, 40 AND 50). SN 85-489,130. PUB. 7-3-2012. FILED 12-7-2011.

4,209,170. **MICROCLEAN (STANDARD CHARACTER)**. LEE, EUNCHANG, (U.S. CLS. 2, 13, 23, 29, 30, 33, 40 AND 50). SN 85-505,742. PUB. 7-3-2012. FILED 12-29-2011.

4,209,208 (*See Class 16 for this trademark*).

4,209,385. **GO JUMP IN THE LAKE (STANDARD CHARACTER)**. GO JUMP IN THE LAKE, LLC, (U.S. CLS. 2, 13, 23, 29, 30, 33, 40 AND 50). SN 85-525,838. PUB. 7-3-2012. FILED 1-26-2012.

4,209,471. **UNIQUE AND DESIGN**. VITRO VIDRIO Y CRISTAL, S.A. DE C.V., (U.S. CLS. 2, 13, 23, 29, 30, 33, 40 AND 50). SN 85-532,233. PUB. 7-3-2012. FILED 2-2-2012.

4,209,476 (*See Class 20 for this trademark*).

4,209,497. **DISHFUL THINKING! (STANDARD CHARACTER)**. HINKLE, ELIZABETH, (U.S. CLS. 2, 13, 23, 29, 30, 33, 40 AND 50). SN 85-536,932. PUB. 7-3-2012. FILED 2-8-2012.

4,209,531. **SCUBA (STYLIZED)**. RADIUS CORPORATION, (U.S. CLS. 2, 13, 23, 29, 30, 33, 40 AND 50). SN 85-539,097. PUB. 7-3-2012. FILED 2-10-2012.

4,209,532. **PURE BABY (STYLIZED)**. RADIUS CORPORATION, (U.S. CLS. 2, 13, 23, 29, 30, 33, 40 AND 50). SN 85-539,103. PUB. 7-3-2012. FILED 2-10-2012.

4,209,556. **P PARTY PEACOCK AND DESIGN**. BERRY PLASTICS CORPORATION, (U.S. CLS. 2, 13, 23, 29, 30, 33, 40 AND 50). SN 85-539,957. PUB. 7-3-2012. FILED 2-10-2012.

4,209,651. **FROSTICK (STANDARD CHARACTER)**. THORNTONS INC., (U.S. CLS. 2, 13, 23, 29, 30, 33, 40 AND 50). SN 85-541,950. PUB. 7-3-2012. FILED 2-14-2012.

4,209,708 (*See Class 16 for this trademark*).

4,209,838. **ROADSTER (STANDARD CHARACTER)**. WILLIAMS INDUSTRIES, INC., (U.S. CLS. 2, 13, 23, 29, 30, 33, 40 AND 50). SN 85-544,912. PUB. 7-3-2012. FILED 2-16-2012.

4,209,857. **ALL IS WELL INSPIRE FUELED BY OPTIMISM. POWERED BY HOPE! AND DESIGN**. RICHARD AKWO, MULTIPLE CLASS, (INT. CLS. 21 AND 25), (U.S. CLS. 2, 13, 22, 23, 29, 30, 33, 39, 40 AND 50). SN 85-545,361. PUB. 7-3-2012. FILED 2-16-2012.

4,209,958. **GRIP-EASY (STANDARD CHARACTER)**. FALCON INDUSTRIES, INC., (U.S. CLS. 2, 13, 23, 29, 30, 33, 40 AND 50). SN 85-548,042. PUB. 7-3-2012. FILED 2-21-2012.

4,209,976 (*See Class 16 for this trademark*).

4,210,023 (*See Class 16 for this trademark*).

4,210,084. **PAIN IN DE ASS (STANDARD CHARACTER)**. O.C. SEACRETS, INC., MULTIPLE CLASS, (INT. CLS. 21 AND 33), (U.S. CLS. 2, 13, 23, 29, 30, 33, 40, 47, 49 AND 50). SN 85-574,051. PUB. 7-3-2012. FILED 3-20-2012.

4,210,158. **SOFTSPOUT (STANDARD CHARACTER)**. GABI CONCEPTS LTD., (U.S. CLS. 2, 13, 23, 29, 30, 33, 40 AND 50). SN 85-596,232. PUB. 7-3-2012. FILED 4-12-2012.

4,210,172. **JUMBOS (STANDARD CHARACTER)**. STAINO, LLC, (U.S. CLS. 2, 13, 23, 29, 30, 33, 40 AND 50). SN 85-598,711. PUB. 7-3-2012. FILED 4-16-2012.

CLASS 22—CORDAGE AND FIBERS

4,208,690. **SPRINGTIDE (STANDARD CHARACTER)**. PIEH,

WENDY LEE, MULTIPLE CLASS, (INT. CLS. 22, 35 AND 44), (U.S. CLS. 1, 2, 7, 19, 22, 42, 50, 100, 101 AND 102). SN 85-360,778. PUB. 7-3-2012. FILED 6-30-2011.

4,210,221. **GENERAL AGRICULTURE (STANDARD CHARACTER)**. GENERAL AGRICULTURE, MULTIPLE CLASS, (INT. CLS. 22, 31 AND 44), (U.S. CLS. 1, 2, 7, 19, 22, 42, 46, 50, 100 AND 101). SN 85-976,743. PUB. 7-3-2012. FILED 8-22-2011.

CLASS 23—YARNS AND THREADS

4,208,336. **COATS COATS COLOUR EXPRESS AND DESIGN**. J. & P. COATS, LIMITED, MULTIPLE CLASS, (INT. CLS. 23, 26 AND 40), (U.S. CLS. 37, 39, 40, 42, 43, 50, 100, 103 AND 106). SN 79-102,683. PUB. 7-3-2012. FILED 8-20-2011.

4,210,029. **TCOOL (STYLIZED)**. TEX-RAY INDUSTRIAL CO., LTD., (U.S. CL. 43). SN 85-558,185. PUB. 7-3-2012. FILED 3-2-2012.

CLASS 24—FABRICS

4,208,164 (*See Class 16 for this trademark*).

4,208,243 (*See Class 3 for this trademark*).

4,208,289 (*See Class 3 for this trademark*).

4,208,446 (*See Class 16 for this trademark*).

4,208,705. **SOCIETY X (STANDARD CHARACTER)**. SOCIETY X LLC, (U.S. CLS. 42 AND 50). SN 85-364,870. PUB. 7-3-2012. FILED 7-7-2011.

4,208,855. **FRET (STANDARD CHARACTER)**. FRET FABRICS, (U.S. CLS. 42 AND 50). SN 85-398,326. PUB. 1-31-2012. FILED 8-15-2011.

4,208,871. **SNUGGLETIME (STANDARD CHARACTER)**. PET-JAMAS LLC, DBA SNUGGLETIME, (U.S. CLS. 42 AND 50). SN 85-402,177. PUB. 1-17-2012. FILED 8-19-2011.

4,208,943 (*See Class 20 for this trademark*).

4,209,251 (*See Class 10 for this trademark*).

4,209,684. **TEXTYLES (STANDARD CHARACTER)**. BEAVER PAPER & GRAPHIC MEDIA, INC., (U.S. CLS. 42 AND 50). SN 85-542,467. PUB. 7-3-2012. FILED 2-14-2012.

4,209,926. **EVERYDAY NAY (STANDARD CHARACTER)**. NAY ET AL, INC., MULTIPLE CLASS, (INT. CLS. 24 AND 25), (U.S. CLS. 22, 39, 42 AND 50). SN 85-546,725. PUB. 7-3-2012. FILED 2-18-2012.

4,210,010. **INSPIRED.KRAVET (STANDARD CHARACTER)**. KRAVET INC., MULTIPLE CLASS, (INT. CLS. 24, 26 AND 27), (U.S. CLS. 19, 20, 37, 39, 40, 42 AND 50). SN 85-554,638. PUB. 7-3-2012. FILED 2-28-2012.

CLASS 25—CLOTHING

4,208,124 (*See Class 9 for this trademark*).

4,208,144. **NC (STYLIZED)**. MICHAEL A. CERNIGLIA, (U.S. CLS. 22 AND 39). SN 76-708,616. PUB. 7-3-2012. FILED 8-5-2011.

4,208,147. **BREKENS B AND DESIGN**. BROWN, JAMES E., (U.S. CLS. 22 AND 39). SN 76-708,940. PUB. 7-3-2012. FILED 8-31-2011.

4,208,160. **DIAMOND NATION AND DESIGN**. DIAMOND NATION, (U.S. CLS. 22 AND 39). SN 76-710,617. PUB. 7-3-2012. FILED 2-14-2012.

4,208,164 (*See Class 16 for this trademark*).

4,208,167 (*See Class 7 for this trademark*).

4,208,175 (*See Class 16 for this trademark*).

4,208,220. **PLAYBACK (STYLIZED)**. REGENERATION PARTNERS, LLC, (U.S. CLS. 22 AND 39). SN 77-962,126. PUB. 7-13-2010. FILED 3-18-2010.

4,208,225 (*See Class 7 for this trademark*).

4,208,232. **BIOGYM (STANDARD CHARACTER)**. HERBERT GSCHWENDER, MULTIPLE CLASS, (INT. CLS. 25 AND 28), (U.S. CLS. 22, 23, 38, 39 AND 50). SN 79-058,183. PUB. 7-3-2012. FILED 7-28-2008.

- 4,208,239. **MOWA SECE AND DESIGN**. ZHU CHANGCHUN, (U.S. CLS. 22 AND 39). SN 79-084,858. PUB. 7-3-2012. FILED 4-5-2010.
- 4,208,243 (*See Class 3 for this trademark*).
- 4,208,256. **SHOES OF PREY (STANDARD CHARACTER)**. SHOES OF PREY PTY LTD, MULTIPLE CLASS, (INT. CLS. 25 AND 35), (U.S. CLS. 22, 39, 100, 101 AND 102). SN 79-094,746. PUB. 7-3-2012. FILED 2-10-2011.
- 4,208,276 (*See Class 18 for this trademark*).
- 4,208,277 (*See Class 3 for this trademark*).
- 4,208,283 (*See Class 3 for this trademark*).
- 4,208,288. **NORTHPROOF (STANDARD CHARACTER)**. NOKIAN TYRES PLC, MULTIPLE CLASS, (INT. CLS. 25 AND 35), (U.S. CLS. 22, 39, 100, 101 AND 102). SN 79-100,887. PUB. 7-3-2012. FILED 5-26-2011.
- 4,208,292. **EDUARD DRESSLER (STYLIZED)**. BUGATTI HOLDING BRINKMANN GMBH & CO. KG, (U.S. CLS. 22 AND 39). SN 79-101,162. PUB. 7-3-2012. FILED 7-20-2011.
- 4,208,305. **COCOLOPEZ (STANDARD CHARACTER)**. MR DEREK MCMINN, MULTIPLE CLASS, (INT. CLS. 25, 41, 43 AND 44), (U.S. CLS. 22, 39, 100, 101 AND 107). SN 79-101,783. PUB. 7-3-2012. FILED 7-3-2007.
- 4,208,310 (*See Class 18 for this trademark*).
- 4,208,334 (*See Class 3 for this trademark*).
- 4,208,338 (*See Class 14 for this trademark*).
- 4,208,342 (*See Class 9 for this trademark*).
- 4,208,344 (*See Class 12 for this trademark*).
- 4,208,350 (*See Class 9 for this trademark*).
- 4,208,354. **MILO & LILIROSE AND DESIGN**. BG DESIGN SÄRL, (U.S. CLS. 22 AND 39). SN 79-103,118. PUB. 7-3-2012. FILED 8-25-2011.
- 4,208,356 (*See Class 9 for this trademark*).
- 4,208,357. **LA DECOLLETTE AND DESIGN**. RACHEL YVONNE DE BOER-VAN ECK, (U.S. CLS. 22 AND 39). SN 79-103,186. PUB. 7-3-2012. FILED 4-18-2011.
- 4,208,386 (*See Class 18 for this trademark*).
- 4,208,393 (*See Class 4 for this trademark*).
- 4,208,423. **LES PLUMESŪ DE LIU.JO AND DESIGN**. LIU.JO S.P.A., (U.S. CLS. 22 AND 39). SN 79-109,340. PUB. 7-3-2012. FILED 12-20-2011.
- 4,208,428 (*See Class 9 for this trademark*).
- 4,208,433 (*See Class 9 for this trademark*).
- 4,208,452. **BECKER SURFBOARDS (STANDARD CHARACTER)**. SEAL TRADEMARKS PTY LTD, MULTIPLE CLASS, (INT. CLS. 25, 28 AND 35), (U.S. CLS. 22, 23, 38, 39, 50, 100, 101 AND 102). SN 85-012,059. PUB. 7-3-2012. FILED 4-12-2010.
- 4,208,458 (*See Class 9 for this trademark*).
- 4,208,468. **DALLY GEAR AND DESIGN**. NEVILLE, FRANK W, (U.S. CLS. 22 AND 39). SN 85-084,081. PUB. 3-27-2012. FILED 7-14-2010.
- 4,208,477 (*See Class 18 for this trademark*).
- 4,208,485. **DAPPER DUDE (STANDARD CHARACTER)**. CHRIS PEGULA, (U.S. CLS. 22 AND 39). SN 85-138,547. PUB. 7-3-2012. FILED 9-27-2010.
- 4,208,491. **BFM BASSFUELEDMISCHIEF AND DESIGN**. CODE OF ARMS LLC, (U.S. CLS. 22 AND 39). SN 85-149,208. PUB. 9-13-2011. FILED 10-10-2010.
- 4,208,550. **WHEEL, SNIPE, PARTY! (STANDARD CHARACTER)**. GONGSHOW GEAR INC., MULTIPLE CLASS, (INT. CLS. 25 AND 35), (U.S. CLS. 22, 39, 100, 101 AND 102). SN 85-234,092. PUB. 7-3-2012. FILED 2-4-2011.
- 4,208,569 (*See Class 18 for this trademark*).
- 4,208,598 (*See Class 3 for this trademark*).
- 4,208,610. **RIPS (STANDARD CHARACTER)**. ASIA APPAREL COMPANY, LLC, (U.S. CLS. 22 AND 39). SN 85-320,087. PUB. 7-3-2012. FILED 5-13-2011.
- 4,208,612. **WITH TOMMY JOHN TAILORED STRETCH TECHNOLOGY AND DESIGN**. TOMMY JOHN, INC., (U.S. CLS. 22 AND 39). SN 85-322,778. PUB. 1-10-2012. FILED 5-17-2011.
- 4,208,635. **1949 ESCOBAR HENAO IN PEACE WE TRUST AND DESIGN**. SANTOS CABALLERO, MARIA ISABEL, AND MARROQUIN SANTOS, JUAN SEBASTIAN, (U.S. CLS. 22 AND 39). SN 85-338,344. PUB. 7-3-2012. FILED 6-5-2011.
- 4,208,647. **HOOKED CARPE DIEM (STYLIZED)**. HOOKED NATION, INC., (U.S. CLS. 22 AND 39). SN 85-344,792. PUB. 12-6-2011. FILED 6-13-2011.
- 4,208,666. **FASHION FRIENDS & FUN (STANDARD CHARACTER)**. CABI, LLC, (U.S. CLS. 22 AND 39). SN 85-352,589. PUB. 7-3-2012. FILED 6-22-2011.
- 4,208,675. **LIVE LIFE HOOKED, CARPE DIEM! (STANDARD CHARACTER)**. HOOKED NATION, INC., (U.S. CLS. 22 AND 39). SN 85-355,276. PUB. 12-13-2011. FILED 6-24-2011.
- 4,208,683. **HR HAWAIIAN ROYALTY AND DESIGN**. CASTRO, CHERYL E, (U.S. CLS. 22 AND 39). SN 85-358,914. PUB. 7-3-2012. FILED 6-28-2011.
- 4,208,694 (*See Class 18 for this trademark*).
- 4,208,700 (*See Class 18 for this trademark*).
- 4,208,710 (*See Class 16 for this trademark*).
- 4,208,743. **GOLD STATURE (STYLIZED)**. SHANTOU CITY SHUIA INDUSTRY CO., LTD., (U.S. CLS. 22 AND 39). SN 85-373,363. PUB. 7-3-2012. FILED 7-17-2011.
- 4,208,753. **BIA BRAZIL B (STYLIZED)**. TROPIC WEAR CONFECÇÕES LTDA. - ME, (U.S. CLS. 22 AND 39). SN 85-374,211. PUB. 7-3-2012. FILED 7-18-2011.
- 4,208,757. **APPLAUZI AND DESIGN**. VILLALOBOS AGUAYO, LILIANA, (U.S. CLS. 22 AND 39). SN 85-374,667. PUB. 7-3-2012. FILED 7-19-2011.
- 4,208,771. **SOULJA STRONG STRIVEN SURVIVING ISLAMIC SOULJA AND DESIGN**. MUHAMMAD, FAREED, (U.S. CLS. 22 AND 39). SN 85-376,597. PUB. 7-3-2012. FILED 7-20-2011.
- 4,208,772. **F.A.Y.S.O.B. (STANDARD CHARACTER)**. FAYSOB, LLC, (U.S. CLS. 22 AND 39). SN 85-376,608. PUB. 7-3-2012. FILED 7-20-2011.
- 4,208,791. **YOKO CHAN (STYLIZED)**. YOKO CHAN CO., LTD., MULTIPLE CLASS, (INT. CLS. 25 AND 35), (U.S. CLS. 22, 39, 100, 101 AND 102). SN 85-380,107. PUB. 7-3-2012. FILED 7-25-2011.
- 4,208,794. **NYC AND DESIGN**. BRANDON STACHEL, (U.S. CLS. 22 AND 39). SN 85-380,898. PUB. 7-3-2012. FILED 7-26-2011.
- 4,208,830. **CREATE SEPARATION (STANDARD CHARACTER)**. POE, MATT, (U.S. CLS. 22 AND 39). SN 85-390,897. PUB. 7-3-2012. FILED 8-5-2011.
- 4,208,839. **ANTRAX (STANDARD CHARACTER)**. SEROM FASHION COMPANY, (U.S. CLS. 22 AND 39). SN 85-393,685. PUB. 7-3-2012. FILED 8-9-2011.
- 4,208,846. **412 AND DESIGN**. SHOP412, (U.S. CLS. 22 AND 39). SN 85-395,714. PUB. 7-3-2012. FILED 8-11-2011.
- 4,208,892. **RICK JAMES (STANDARD CHARACTER)**. THE JAMES AMBROSE JOHNSON, JR. 1999 TRUST, (U.S. CLS. 22 AND 39). SN 85-407,099. PUB. 7-3-2012. FILED 8-25-2011.
- 4,208,915. **M N AND DESIGN**. MU SIGMA NU, INC., (U.S. CLS. 22 AND 39). SN 85-414,906. PUB. 7-3-2012. FILED 9-4-2011.
- 4,208,918. **IT'S SMOKIN' HOT! (STANDARD CHARACTER)**. FRIEDRICHS, VICKI M., DBA IT'S SMOKIN' HOT!, (U.S. CLS. 22 AND 39). SN 85-415,716. PUB. 7-3-2012. FILED 9-6-2011.
- 4,208,920. **A AND DESIGN**. DEWINE SEEDS-SILVER DOLLAR BASEBALL, LLC, (U.S. CLS. 22 AND 39). SN 85-416,359. PUB. 7-3-2012. FILED 9-7-2011.
- 4,208,942 (*See Class 7 for this trademark*).
- 4,208,950. **MACKINAC NECKERS AND DESIGN**. BLEVINS, BILL JOSEPH, DBA CAMERA SIGNATURE, AND CARR, KAREN LENA, DBA CAMERA SIGNATURE, AND CARR, ROBERT, DBA CAMERA SIGNATURE, (U.S. CLS. 22 AND 39). SN 85-434,714. PUB. 7-3-2012. FILED 9-28-2011.
- 4,208,964. **JUST DANCE APPAREL (STANDARD CHARACTER)**. THE JOSEPH ROMANO, JOHN RUSSO-ZIRKEL AND CRUISE RUSSO JOINT VENTURE, (U.S. CLS. 22 AND 39). SN 85-439,809. PUB. 7-3-2012. FILED 10-5-2011.
- 4,208,971. **J. DEMPSEY (STANDARD CHARACTER)**. FITUMI, LLC, (U.S. CLS. 22 AND 39). SN 85-442,167. PUB. 7-3-2012. FILED 10-7-2011.
- 4,209,000 (*See Class 16 for this trademark*).
- 4,209,048. **CUTE COTTON (STANDARD CHARACTER)**. SMITH, JESSICA MARIE, DBA GEORGIA BOY CLOTHING COMPANY, (U.S. CLS. 22 AND 39). SN 85-471,364. PUB. 7-3-2012. FILED 11-14-2011.
- 4,209,052. **BE YOURSELF AND YOU WILL ALWAYS BE IN FASHION (STANDARD CHARACTER)**. JED TRADERS, INC., (U.S. CLS. 22 AND 39). SN 85-472,337. PUB. 7-3-2012.

- FILED 11-14-2011.
 4,209,065 (*See Class 16 for this trademark*).
 4,209,070 (*See Class 9 for this trademark*).
 4,209,082. **SLIP...AAHHS (STANDARD CHARACTER)**. HAWAIIAN JELLYS, LLC, (U.S. CLS. 22 AND 39). SN 85-485,117. PUB. 7-3-2012. FILED 12-1-2011.
 4,209,086. **I JEANS (STANDARD CHARACTER)**. 3681441 CANADA INC., (U.S. CLS. 22 AND 39). SN 85-487,149. PUB. 4-24-2012. FILED 12-5-2011.
 4,209,097 (*See Class 3 for this trademark*).
 4,209,145. **NEVER TOO PRETTY TO HIT LIKE A BOY (STANDARD CHARACTER)**. PRIME TIME BOXING, INC., (U.S. CLS. 22 AND 39). SN 85-501,542. PUB. 7-3-2012. FILED 12-21-2011.
 4,209,146. **NÍSOLO AND DESIGN**. CLEARY, ZOE, AND WOODYARD, PATRICK, (U.S. CLS. 22 AND 39). SN 85-501,901. PUB. 7-3-2012. FILED 12-22-2011.
 4,209,178 (*See Class 18 for this trademark*).
 4,209,189. **TRI LUNATICS (STANDARD CHARACTER)**. GALINDO, GUADALUPE J, AKA TRI LUNATICS, (U.S. CLS. 22 AND 39). SN 85-509,519. PUB. 7-3-2012. FILED 1-5-2012.
 4,209,196 (*See Class 9 for this trademark*).
 4,209,213. **UNDERWEAR THAT'S FUN TO WEAR (STANDARD CHARACTER)**. FRUIT OF THE LOOM, INC., (U.S. CLS. 22 AND 39). SN 85-514,386. PUB. 7-3-2012. FILED 1-11-2012.
 4,209,235. **DYNA (STYLIZED)**. CABA, STEVE, (U.S. CLS. 22 AND 39). SN 85-518,075. PUB. 7-3-2012. FILED 1-17-2012.
 4,209,246. **MR. BEE GOOD MR. BEE GOOD AND DESIGN**. COX, DEBI, (U.S. CLS. 22 AND 39). SN 85-518,938. PUB. 7-3-2012. FILED 1-18-2012.
 4,209,251 (*See Class 10 for this trademark*).
 4,209,273. **ROCKIN BOHEMIAN AND DESIGN**. ROCKIN BOHEMIAN, MULTIPLE CLASS, (INT. CLS. 25 AND 35), (U.S. CLS. 22, 39, 100, 101 AND 102). SN 85-520,679. PUB. 7-3-2012. FILED 1-19-2012.
 4,209,286. **COMMUNITY UNIT SCHOOL DISTRICT 300 AND DESIGN**. COMMUNITY UNIT SCHOOL DISTRICT 300, MULTIPLE CLASS, (INT. CLS. 25 AND 41), (U.S. CLS. 22, 39, 100, 101 AND 107). SN 85-521,230. PUB. 7-3-2012. FILED 1-20-2012.
 4,209,328. **INDIANA'S GAME INDIANA'S TEAM (STANDARD CHARACTER)**. PACERS BASKETBALL, LLC, (U.S. CLS. 22 AND 39). SN 85-523,144. PUB. 7-3-2012. FILED 1-23-2012.
 4,209,355. **DO U SPEAK GREEN? (STANDARD CHARACTER)**. FUSION CLOTHING COMPANY, (U.S. CLS. 22 AND 39). SN 85-524,578. PUB. 7-3-2012. FILED 1-25-2012.
 4,209,364. **F FYASKO AND DESIGN**. KAMIL, ADIL, (U.S. CLS. 22 AND 39). SN 85-524,899. PUB. 7-3-2012. FILED 1-25-2012.
 4,209,378. **COAST TEE'S (STANDARD CHARACTER)**. MEYER, ANGELA L., DBA COAST TEE'S, (U.S. CLS. 22 AND 39). SN 85-525,415. PUB. 7-3-2012. FILED 1-25-2012.
 4,209,431 (*See Class 16 for this trademark*).
 4,209,468 (*See Class 14 for this trademark*).
 4,209,508. **BUCKET AND DESIGN**. BUCKET CLOTHING LLC, (U.S. CLS. 22 AND 39). SN 85-537,676. PUB. 7-3-2012. FILED 2-8-2012.
 4,209,509. **BEER BELONGS (STANDARD CHARACTER)**. CUNNINGHAM, CLARK W., (U.S. CLS. 22 AND 39). SN 85-537,771. PUB. 7-3-2012. FILED 2-9-2012.
 4,209,513. **ECO EXTREME CULINARY OUTFITTERS AND DESIGN**. EXTREME CULINARY OUTFITTERS, (U.S. CLS. 22 AND 39). SN 85-537,952. PUB. 7-3-2012. FILED 2-9-2012.
 4,209,553. **MERONA (STANDARD CHARACTER)**. TARGET BRANDS, INC., (U.S. CLS. 22 AND 39). SN 85-539,910. PUB. 7-3-2012. FILED 2-10-2012.
 4,209,564. **BELIEVE THE HYPE (STANDARD CHARACTER)**. BELIEVE THE HYPE, LLC, (U.S. CLS. 22 AND 39). SN 85-540,563. PUB. 7-3-2012. FILED 2-12-2012.
 4,209,578 (*See Class 18 for this trademark*).
 4,209,606. **BRUISED, NEVER BROKEN (STANDARD CHARACTER)**. KEMISTRE 8, LLC, (U.S. CLS. 22 AND 39). SN 85-541,220. PUB. 7-3-2012. FILED 2-13-2012.
 4,209,616 (*See Class 14 for this trademark*).
 4,209,621. **EDOGGS BE EXCEPTIONAL AND DESIGN**. TYLER OCZKOWSKI, AND TAMMY OCZKOWSKI, AND CHRIS OCZKOWSKI, (U.S. CLS. 22 AND 39). SN 85-541,409. PUB. 7-3-2012. FILED 2-13-2012.
 4,209,625. **OWN WHO YOU ARE (STANDARD CHARACTER)**. DEAF EYES BLIND EARS, (U.S. CLS. 22 AND 39). SN 85-541,483. PUB. 7-3-2012. FILED 2-13-2012.
 4,209,626. **BILLY BIG RIGGER (STANDARD CHARACTER)**. DODGE, TIMOTHY, (U.S. CLS. 22 AND 39). SN 85-541,491. PUB. 7-3-2012. FILED 2-13-2012.
 4,209,635. **HOODYWRAP (STANDARD CHARACTER)**. PHILLIPS, AARON, (U.S. CLS. 22 AND 39). SN 85-541,698. PUB. 7-3-2012. FILED 2-14-2012.
 4,209,643. **MISCELLANEOUS DESIGN**. WALDREP, ASHLEY R, DBA SEREIA, (U.S. CLS. 22 AND 39). SN 85-541,857. PUB. 7-3-2012. FILED 2-14-2012.
 4,209,682. **MISCELLANEOUS DESIGN**. ESHELMAN, CHARLES, MULTIPLE CLASS, (INT. CLS. 25 AND 41), (U.S. CLS. 22, 39, 100, 101 AND 107). SN 85-542,447. PUB. 7-3-2012. FILED 2-14-2012.
 4,209,700. **THE FREE AND THE BRAVE (STANDARD CHARACTER)**. MAHARRY, AYANNA, (U.S. CLS. 22 AND 39). SN 85-542,765. PUB. 7-3-2012. FILED 2-14-2012.
 4,209,702. **LOVESQUE (STANDARD CHARACTER)**. LOVESQUE, (U.S. CLS. 22 AND 39). SN 85-542,811. PUB. 7-3-2012. FILED 2-14-2012.
 4,209,708 (*See Class 16 for this trademark*).
 4,209,718. **OWNER OPERATOR (STANDARD CHARACTER)**. CHILLER USA OUTFITTERS LLC, (U.S. CLS. 22 AND 39). SN 85-543,138. PUB. 7-3-2012. FILED 2-15-2012.
 4,209,744. **TATY (STANDARD CHARACTER)**. TATYANA, LLC, (U.S. CLS. 22 AND 39). SN 85-543,431. PUB. 7-3-2012. FILED 2-15-2012.
 4,209,747 (*See Class 16 for this trademark*).
 4,209,790. **G & ACOSTA (STANDARD CHARACTER)**. G & ACOSTA, (U.S. CLS. 22 AND 39). SN 85-544,098. PUB. 7-3-2012. FILED 2-16-2012.
 4,209,797. **JESSICA ANN (STANDARD CHARACTER)**. GERSON & GERSON, INC., (U.S. CLS. 22 AND 39). SN 85-544,265. PUB. 7-3-2012. FILED 2-16-2012.
 4,209,824. **ASHLEY ANN (STANDARD CHARACTER)**. GERSON & GERSON, INC., (U.S. CLS. 22 AND 39). SN 85-544,624. PUB. 7-3-2012. FILED 2-16-2012.
 4,209,833. **UNITED BY THE BALL (STANDARD CHARACTER)**. TONA COLEY, MULTIPLE CLASS, (INT. CLS. 25 AND 35), (U.S. CLS. 22, 39, 100, 101 AND 102). SN 85-544,835. PUB. 7-3-2012. FILED 2-16-2012.
 4,209,857 (*See Class 21 for this trademark*).
 4,209,858. **SWAMP ROYALTY (STANDARD CHARACTER)**. GUIST BROTHERS ENTERTAINMENT GROUP, LLC, (U.S. CLS. 22 AND 39). SN 85-545,362. PUB. 7-3-2012. FILED 2-16-2012.
 4,209,873. **KRSP (STANDARD CHARACTER)**. KRSP LIFE LLC, (U.S. CLS. 22 AND 39). SN 85-545,718. PUB. 7-3-2012. FILED 2-17-2012.
 4,209,880 (*See Class 16 for this trademark*).
 4,209,887. **DEEGAN (STYLIZED)**. BRIAN DEEGAN, (U.S. CLS. 22 AND 39). SN 85-546,091. PUB. 7-3-2012. FILED 2-17-2012.
 4,209,888. **H-E-B AND DESIGN**. HEB GROCERY COMPANY, LP, (U.S. CLS. 22 AND 39). SN 85-546,095. PUB. 7-3-2012. FILED 2-17-2012.
 4,209,894. **BADGLEY MISCHKA (STANDARD CHARACTER)**. BADGLEY MISCHKA LICENSING LLC, (U.S. CLS. 22 AND 39). SN 85-546,194. PUB. 7-3-2012. FILED 2-17-2012.
 4,209,913. **COLOR THREAD (STANDARD CHARACTER)**. DAMORE UNIVERSAL INC, DBA COLOR THREAD, (U.S. CLS. 22 AND 39). SN 85-546,542. PUB. 7-3-2012. FILED 2-17-2012.
 4,209,926 (*See Class 24 for this trademark*).
 4,209,948. **IF YOU CAN'T OUT ROPE 'EM, OUT DRESS 'EM (STANDARD CHARACTER)**. ROD PATRICK INC., (U.S. CLS. 22 AND 39). SN 85-547,649. PUB. 7-3-2012. FILED 2-20-2012.
 4,209,998. **BOOMTHO! (STANDARD CHARACTER)**. BENSON, RODRIQUE, (U.S. CLS. 22 AND 39). SN 85-553,431. PUB. 7-3-2012. FILED 2-27-2012.
 4,210,005. **TENDY (STANDARD CHARACTER)**. GUANGJING CO., LTD., (U.S. CLS. 22 AND 39). SN 85-554,188. PUB. 7-3-2012. FILED 2-27-2012.

- 4,210,007. **SOMETHING HEALTHY (STANDARD CHARACTER)**. WELLNESS INTERACTIVE, INC., (U.S. CLS. 22 AND 39). SN 85-554,206. PUB. 7-3-2012. FILED 2-27-2012.
- 4,210,053. **ALEX AND AVA (STANDARD CHARACTER)**. D2S PROPERTIES, LLC, (U.S. CLS. 22 AND 39). SN 85-566,014. PUB. 7-3-2012. FILED 3-9-2012.
- 4,210,061. **MISCELLANEOUS DESIGN**. MILLER INTERNATIONAL, INC., (U.S. CLS. 22 AND 39). SN 85-568,087. PUB. 7-3-2012. FILED 3-13-2012.
- 4,210,070. **M AND DESIGN**. THE NATIONAL ASSOCIATION OF PROFESSIONAL BASEBALL LEAGUES, INC., (U.S. CLS. 22 AND 39). SN 85-569,440. PUB. 7-3-2012. FILED 3-14-2012.
- 4,210,077. **FW AND DESIGN**. THE NATIONAL ASSOCIATION OF PROFESSIONAL BASEBALL LEAGUES, INC., (U.S. CLS. 22 AND 39). SN 85-571,782. PUB. 7-3-2012. FILED 3-16-2012.
- 4,210,080. **JOYPEACE (STANDARD CHARACTER)**. KIM, JOORI, (U.S. CLS. 22 AND 39). SN 85-573,112. PUB. 7-3-2012. FILED 3-19-2012.
- 4,210,082. **YOUR NEIGHBORS (STANDARD CHARACTER)**. U.O. MERCHANDISE, INC., (U.S. CLS. 22 AND 39). SN 85-573,375. PUB. 7-3-2012. FILED 3-19-2012.
- 4,210,105. **KARMAZEN (STANDARD CHARACTER)**. MADRUGA, MARSHALL, (U.S. CLS. 22 AND 39). SN 85-578,463. PUB. 7-3-2012. FILED 3-23-2012.
- 4,210,107. **IRISH I WERE HIGH (STANDARD CHARACTER)**. DETROIT HYDROPONICS, INC., DBA THE CULTIVATION STATION, (U.S. CLS. 22 AND 39). SN 85-579,098. PUB. 7-3-2012. FILED 3-24-2012.
- 4,210,117. **ROLAND KLEIN (STYLIZED)**. ROLAND KLEIN, LTD., (U.S. CLS. 22 AND 39). SN 85-580,545. PUB. 7-3-2012. FILED 3-27-2012.
- 4,210,122. **PRETTY BROWN GIRL (STANDARD CHARACTER)**. PRETTY BROWN GIRL L.L.C., (U.S. CLS. 22 AND 39). SN 85-582,356. PUB. 7-3-2012. FILED 3-28-2012.
- 4,210,188. **HAWKINGS MCGILL (STANDARD CHARACTER)**. U.O. MERCHANDISE, INC., (U.S. CLS. 22 AND 39). SN 85-607,532. PUB. 7-3-2012. FILED 4-25-2012.
- 4,210,225 (*See Class 8 for this trademark*).

CLASS 26—FANCY GOODS

- 4,208,336 (*See Class 23 for this trademark*).
- 4,208,634. **DISNEY (STANDARD CHARACTER)**. DISNEY ENTERPRISES, INC., (U.S. CLS. 37, 39, 40, 42 AND 50). SN 85-338,047. PUB. 7-3-2012. FILED 6-3-2011.
- 4,209,772. **JUNK (STYLIZED)**. JUNK BRANDS LLC, (U.S. CLS. 37, 39, 40, 42 AND 50). SN 85-543,792. PUB. 7-3-2012. FILED 2-15-2012.
- 4,209,796 (*See Class 14 for this trademark*).
- 4,210,010 (*See Class 24 for this trademark*).
- 4,210,226 (*See Class 16 for this trademark*).

CLASS 27—FLOOR COVERINGS

- 4,208,399. **UNICLIC (STANDARD CHARACTER)**. UNILIN BEHEER B.V., (U.S. CLS. 19, 20, 37, 42 AND 50). SN 79-107,004. PUB. 7-3-2012. FILED 9-20-2011.
- 4,208,720. **SWG 1 SOUTHWEST GREENS GOLF & GRASS AND DESIGN**. SOUTHWEST GREENS INTERNATIONAL, LLC, MULTIPLE CLASS, (INT. CLS. 27, 37, 42 AND 44), (U.S. CLS. 19, 20, 37, 42, 50, 100, 101, 103 AND 106). SN 85-368,702. PUB. 7-3-2012. FILED 7-12-2011.
- 4,209,111. **FOVAMA (STANDARD CHARACTER)**. AHMADI & SONS, INC., DBA FOVAMA, (U.S. CLS. 19, 20, 37, 42 AND 50). SN 85-492,293. PUB. 7-3-2012. FILED 12-10-2011.
- 4,210,010 (*See Class 24 for this trademark*).
- 4,210,154. **MEMORYSTEP (STANDARD CHARACTER)**. L&P PROPERTY MANAGEMENT COMPANY, (U.S. CLS. 19, 20, 37, 42 AND 50). SN 85-594,421. PUB. 7-3-2012. FILED 4-11-2012.
- 4,210,157. **MICROBLEND (STANDARD CHARACTER)**. L&P

- PROPERTY MANAGEMENT COMPANY, (U.S. CLS. 19, 20, 37, 42 AND 50). SN 85-596,077. PUB. 7-3-2012. FILED 4-12-2012.

CLASS 28—TOYS AND SPORTING GOODS

- 4,208,124 (*See Class 9 for this trademark*).
- 4,208,164 (*See Class 16 for this trademark*).
- 4,208,170. **ONLY HEARTS L'IL KIDS (STANDARD CHARACTER)**. ONLY HEARTS L'IL KIDS, (U.S. CLS. 22, 23, 38 AND 50). SN 77-361,114. PUB. 7-3-2012. FILED 12-28-2007.
- 4,208,225 (*See Class 7 for this trademark*).
- 4,208,232 (*See Class 25 for this trademark*).
- 4,208,243 (*See Class 3 for this trademark*).
- 4,208,262 (*See Class 9 for this trademark*).
- 4,208,276 (*See Class 18 for this trademark*).
- 4,208,278 (*See Class 9 for this trademark*).
- 4,208,289 (*See Class 3 for this trademark*).
- 4,208,291 (*See Class 9 for this trademark*).
- 4,208,309. **LO SCARABEO AND DESIGN**. LO SCARABEO S.R.L., (U.S. CLS. 22, 23, 38 AND 50). SN 79-101,905. PUB. 7-3-2012. FILED 7-25-2011.
- 4,208,351 (*See Class 12 for this trademark*).
- 4,208,356 (*See Class 9 for this trademark*).
- 4,208,364 (*See Class 9 for this trademark*).
- 4,208,386 (*See Class 18 for this trademark*).
- 4,208,452 (*See Class 25 for this trademark*).
- 4,208,457. **WATERMAT (STANDARD CHARACTER)**. H2O POD, INC., (U.S. CLS. 22, 23, 38 AND 50). SN 85-048,294. PUB. 7-3-2012. FILED 5-26-2010.
- 4,208,478 (*See Class 3 for this trademark*).
- 4,208,575. **SPEECH TREATS (STANDARD CHARACTER)**. NJERI DUBLIN, DBA CLINIQUE D'ORTHOPHONIE MONTERÉGIE, (U.S. CLS. 22, 23, 38 AND 50). SN 85-277,931. PUB. 7-3-2012. FILED 3-26-2011.
- 4,208,581 (*See Class 16 for this trademark*).
- 4,208,593. **SOCCER TOWER (STANDARD CHARACTER)**. GRIT INC., (U.S. CLS. 22, 23, 38 AND 50). SN 85-297,111. PUB. 7-3-2012. FILED 4-16-2011.
- 4,208,700 (*See Class 18 for this trademark*).
- 4,208,704. **SPEED BAG (STANDARD CHARACTER)**. BURN MACHINE, LLC, (U.S. CLS. 22, 23, 38 AND 50). SN 85-364,211. PUB. 7-3-2012. FILED 7-6-2011.
- 4,208,738. **ARACHNOID (STANDARD CHARACTER)**. JW PET COMPANY, INC., (U.S. CLS. 22, 23, 38 AND 50). SN 85-372,811. PUB. 7-3-2012. FILED 7-15-2011.
- 4,208,811 (*See Class 9 for this trademark*).
- 4,208,819. **DRAEGO-MAN (STANDARD CHARACTER)**. MATTEL, INC., (U.S. CLS. 22, 23, 38 AND 50). SN 85-388,343. PUB. 7-3-2012. FILED 8-3-2011.
- 4,208,834. **STOP CRY BABY (STYLIZED)**. APPLIYA INC., (U.S. CLS. 22, 23, 38 AND 50). SN 85-392,238. PUB. 7-3-2012. FILED 8-8-2011.
- 4,208,868. **ARCHERY TAG (STANDARD CHARACTER)**. DEERSPACE LLC, DBA ARCHERY TAG, (U.S. CLS. 22, 23, 38 AND 50). SN 85-401,270. PUB. 7-3-2012. FILED 8-18-2011.
- 4,208,872. **SNUGGLEBAGS (STANDARD CHARACTER)**. PETJAMAS LLC, DBA SNUGGLETIME, (U.S. CLS. 22, 23, 38 AND 50). SN 85-402,187. PUB. 1-17-2012. FILED 8-19-2011.
- 4,208,947. **MISCELLANEOUS DESIGN**. INNOVATION FIRST, INC., (U.S. CLS. 22, 23, 38 AND 50). SN 85-430,766. PUB. 7-3-2012. FILED 9-23-2011.
- 4,208,979 (*See Class 12 for this trademark*).
- 4,208,991. **STRING THINGS (STANDARD CHARACTER)**. AMS, LLC, DBA AMS BOWFISHING, (U.S. CLS. 22, 23, 38 AND 50). SN 85-447,690. PUB. 7-3-2012. FILED 10-14-2011.
- 4,209,040. **CROSTONER (STANDARD CHARACTER)**. FREY, DAVID W., (U.S. CLS. 22, 23, 38 AND 50). SN 85-468,990. PUB. 7-3-2012. FILED 11-10-2011.
- 4,209,065 (*See Class 16 for this trademark*).
- 4,209,070 (*See Class 9 for this trademark*).
- 4,209,074. **EDGE AND DESIGN**. SPROMISE INT'L INC., (U.S. CLS. 22, 23, 38 AND 50). SN 85-480,917. PUB. 7-3-2012. FILED 11-25-2011.
- 4,209,093. **COACH CLIFF'S (STANDARD CHARACTER)**.

- KARAJEN CORP., (U.S. CLS. 22, 23, 38 AND 50). SN 85-489,165. PUB. 7-3-2012. FILED 12-7-2011.
- 4,209,334. **ANGEL EYE (STANDARD CHARACTER)**. ANGEL PLAYING CARDS CO., LTD., (U.S. CLS. 22, 23, 38 AND 50). SN 85-523,655. PUB. 7-3-2012. FILED 1-24-2012.
- 4,209,419. **FLOUNDER FANATIC (STANDARD CHARACTER)**. BETTS TACKLE, LTD., (U.S. CLS. 22, 23, 38 AND 50). SN 85-526,704. PUB. 7-3-2012. FILED 1-27-2012.
- 4,209,499. **TANGKOU (STANDARD CHARACTER)**. SIMARD LAURIE, DBA TANGKOU DOLL, AND CLOUTIER JEAN-MICHEL, (U.S. CLS. 22, 23, 38 AND 50). SN 85-537,218. PUB. 7-3-2012. FILED 2-8-2012.
- 4,209,506. **HEX (STANDARD CHARACTER)**. INNOVATION FIRST, INC., (U.S. CLS. 22, 23, 38 AND 50). SN 85-537,578. PUB. 7-3-2012. FILED 2-8-2012.
- 4,209,514. **MISCELLANEOUS DESIGN**. DAVID A. BERNHARDT, (U.S. CLS. 22, 23, 38 AND 50). SN 85-537,953. PUB. 7-3-2012. FILED 2-9-2012.
- 4,209,519. **PUREDUCK (STANDARD CHARACTER)**. BANDED BRANDS, LLC, (U.S. CLS. 22, 23, 38 AND 50). SN 85-538,540. PUB. 7-3-2012. FILED 2-9-2012.
- 4,209,520. **FAT BROTHER (STANDARD CHARACTER)**. BANDED BRANDS, LLC, (U.S. CLS. 22, 23, 38 AND 50). SN 85-538,561. PUB. 7-3-2012. FILED 2-9-2012.
- 4,209,521. **CAP'N (STANDARD CHARACTER)**. BANDED BRANDS, LLC, (U.S. CLS. 22, 23, 38 AND 50). SN 85-538,567. PUB. 7-3-2012. FILED 2-9-2012.
- 4,209,523. **TKO (STANDARD CHARACTER)**. BANDED BRANDS, LLC, (U.S. CLS. 22, 23, 38 AND 50). SN 85-538,579. PUB. 7-3-2012. FILED 2-9-2012.
- 4,209,544. **EVIL TWIN AND DESIGN**. BANDED BRANDS, LLC, (U.S. CLS. 22, 23, 38 AND 50). SN 85-539,612. PUB. 7-3-2012. FILED 2-10-2012.
- 4,209,545. **CINDERELLA AND DESIGN**. BANDED BRANDS, LLC, (U.S. CLS. 22, 23, 38 AND 50). SN 85-539,642. PUB. 7-3-2012. FILED 2-10-2012.
- 4,209,642. **WAVELINE AND DESIGN**. SUNSPECS OF OCEAN CITY, INC., (U.S. CLS. 22, 23, 38 AND 50). SN 85-541,788. PUB. 7-3-2012. FILED 2-14-2012.
- 4,209,722. **HOOP JAM STADIUM (STANDARD CHARACTER)**. JACK GUARNIERI SERVICE CO., INC., (U.S. CLS. 22, 23, 38 AND 50). SN 85-543,209. PUB. 7-3-2012. FILED 2-15-2012.
- 4,209,807. **PUCK-IT (STANDARD CHARACTER)**. DARDEN, GRANT, (U.S. CLS. 22, 23, 38 AND 50). SN 85-544,470. PUB. 7-3-2012. FILED 2-16-2012.
- 4,209,854. **BACKBULL BY CARDIN (STYLIZED)**. BLUE DIAMONDS GROUP LLC, (U.S. CLS. 22, 23, 38 AND 50). SN 85-545,312. PUB. 7-3-2012. FILED 2-16-2012.
- 4,209,856. **ROVIC (STANDARD CHARACTER)**. CLICGEAR INDUSTRIES LIMITED, (U.S. CLS. 22, 23, 38 AND 50). SN 85-545,349. PUB. 7-3-2012. FILED 2-16-2012.
- 4,209,880 (*See Class 16 for this trademark*).
- 4,209,916. **TONGZO (STANDARD CHARACTER)**. PLAY VISIONS INC., (U.S. CLS. 22, 23, 38 AND 50). SN 85-546,583. PUB. 7-3-2012. FILED 2-17-2012.
- 4,209,997. **KRE-O TRANSFORMERS AND DESIGN**. HASBRO, INC., (U.S. CLS. 22, 23, 38 AND 50). SN 85-553,180. PUB. 7-3-2012. FILED 2-27-2012.
- 4,210,004. **DRB DRIBBLING AND DESIGN**. ABDALA, GERARDO PABLO, (U.S. CLS. 22, 23, 38 AND 50). SN 85-553,930. PUB. 7-3-2012. FILED 2-27-2012.
- 4,210,073. **MISCELLANEOUS DESIGN**. MERCHSOURCE, LLC, (U.S. CLS. 22, 23, 38 AND 50). SN 85-570,334. PUB. 7-3-2012. FILED 3-15-2012.
- 4,210,075. **GOLD FEVER (STANDARD CHARACTER)**. ARISTOCRAT TECHNOLOGIES AUSTRALIA PTY LTD., (U.S. CLS. 22, 23, 38 AND 50). SN 85-570,553. PUB. 7-3-2012. FILED 3-15-2012.
- 4,210,083. **MUTT-PUTT (STANDARD CHARACTER)**. CUDDEWEAR, INC., (U.S. CLS. 22, 23, 38 AND 50). SN 85-574,032. PUB. 7-3-2012. FILED 3-20-2012.
- 4,210,226 (*See Class 16 for this trademark*).
- CLASS 29—MEATS AND PROCESSED FOODS**
- 4,208,187 (*See Class 3 for this trademark*).
- 4,208,214. **GROVE 45 EXTRA VIRGIN OLIVE OIL (STANDARD CHARACTER)**. GROVE 45 EXTRA VIRGIN OLIVE OIL, (U.S. CL. 46). SN 77-934,222. PUB. 7-3-2012. FILED 2-12-2010.
- 4,208,243 (*See Class 3 for this trademark*).
- 4,208,326 (*See Class 1 for this trademark*).
- 4,208,339. **CPN CAMPONÍJAR AND DESIGN**. COPROHNIJAR S. COOP. AND, MULTIPLE CLASS, (INT. CLS. 29, 30 AND 31), (U.S. CLS. 1 AND 46). SN 79-102,711. PUB. 7-3-2012. FILED 9-12-2011.
- 4,208,359 (*See Class 5 for this trademark*).
- 4,208,416. **TUKAS DOGAYA HEP ÖZEN GÖSTERDİK AND DESIGN**. TUKAS GIDA; SANAYİ VE TİCARET ANONİM ŞİRKETİ, MULTIPLE CLASS, (INT. CLS. 29 AND 30), (U.S. CL. 46). SN 79-108,437. PUB. 7-3-2012. FILED 10-19-2011.
- 4,208,522. **BANANA LEAF AND DESIGN**. MANZOOR, ZAHIR, (U.S. CL. 46). SN 85-195,774. PUB. 7-3-2012. FILED 12-10-2010.
- 4,208,558. **TORTILLA CRUNCH (STANDARD CHARACTER)**. MAS MARKETING HOLDING COMPANY LLC, (U.S. CL. 46). SN 85-246,913. PUB. 1-17-2012. FILED 2-19-2011.
- 4,208,651. **VENTISQUEROS (STYLIZED)**. PRODUCTOS DEL MAR VENTISQUEROS S.A., (U.S. CL. 46). SN 85-346,726. PUB. 7-3-2012. FILED 6-15-2011.
- 4,208,679. **PIGGYBACKS (STANDARD CHARACTER)**. BUBBAQUE'S, LLC, (U.S. CL. 46). SN 85-357,761. PUB. 7-3-2012. FILED 6-28-2011.
- 4,208,795. **GN AND DESIGN**. PANADERIA SAN JORGE S.A., MULTIPLE CLASS, (INT. CLS. 29 AND 30), (U.S. CL. 46). SN 85-381,508. PUB. 7-3-2012. FILED 7-26-2011.
- 4,208,815. **G&R (STANDARD CHARACTER)**. BLEVIN & LEWIS ENTERPRISES, (U.S. CL. 46). SN 85-387,301. PUB. 7-3-2012. FILED 8-2-2011.
- 4,208,912. **HICKORY HOUSE (STANDARD CHARACTER)**. GLOBAL SMOKED FOODS LIMITED FOUNDATION, (U.S. CL. 46). SN 85-414,225. PUB. 7-3-2012. FILED 9-2-2011.
- 4,208,935. **HIGHLAND RESERVE (STANDARD CHARACTER)**. GLOBAL SMOKED FOODS LIMITED FOUNDATION, (U.S. CL. 46). SN 85-422,347. PUB. 7-3-2012. FILED 9-14-2011.
- 4,209,044. **A ARMA ENERGY SNX AND DESIGN**. JOHN B. SANFILIPPO & SON, INC., (U.S. CL. 46). SN 85-469,733. PUB. 7-3-2012. FILED 11-10-2011.
- 4,209,072. **BLUE OX (STANDARD CHARACTER)**. AWE-COMM TECHNOLOGIES, LLC, DBA THE BLUE OX JERKY COMPANY, (U.S. CL. 46). SN 85-479,323. PUB. 7-3-2012. FILED 11-22-2011.
- 4,209,137. **MISCELLANEOUS DESIGN**. ZHONGSHAN KAXING INDUSTRY & TRADE CO., LTD., (U.S. CL. 46). SN 85-499,370. PUB. 7-3-2012. FILED 12-19-2011.
- 4,209,326. **EPICUREX (STANDARD CHARACTER)**. EPICUREX LLC, MULTIPLE CLASS, (INT. CLS. 29, 30 AND 32), (U.S. CLS. 45, 46 AND 48). SN 85-523,094. PUB. 7-3-2012. FILED 1-23-2012.
- 4,209,332. **CRISPY CURLS (STANDARD CHARACTER)**. HARDEE'S FOOD SYSTEMS, INC., (U.S. CL. 46). SN 85-523,611. PUB. 7-3-2012. FILED 1-24-2012.
- 4,209,387. **SALTY AT ITS SWEETEST (STANDARD CHARACTER)**. POTOFFEE, (U.S. CL. 46). SN 85-525,858. PUB. 7-3-2012. FILED 1-26-2012.
- 4,209,400. **ALL AMERICAN MEATS (STANDARD CHARACTER)**. ALL AMERICAN MEATS, INC., (U.S. CL. 46). SN 85-526,016. PUB. 7-3-2012. FILED 1-26-2012.
- 4,209,470. **MISCELLANEOUS DESIGN**. BENEVOLENCE FOOD PRODUCTS, LLC, AKA BENEVOLENCE NESTS, LONG PHUNG YEN, (U.S. CL. 46). SN 85-532,125. PUB. 7-3-2012. FILED 2-2-2012.
- 4,209,486. **DUH! TASTES SO GOOD IT'S STUPID... (STANDARD CHARACTER)**. HOUSTON, JEFF, MULTIPLE CLASS, (INT. CLS. 29 AND 30), (U.S. CL. 46). SN 85-534,609. PUB. 7-3-2012. FILED 2-6-2012.
- 4,209,558. **NORTHERN CROSS (STANDARD CHARACTER)**. BALLARD FISH & OYSTER CO., INC., TA CHERRYSTONE AQUA-FARMS, MULTIPLE CLASS, (INT. CLS. 29 AND 31), (U.S. CLS. 1 AND 46). SN 85-540,163. PUB. 7-3-2012. FILED 2-10-2012.

- 4,209,597. **GRADUATES GRABBERS (STANDARD CHARACTER)**. SOCIÉTÉ DES PRODUITS NESTLÉ S.A., (U.S. CL. 46). SN 85-541,109. PUB. 7-3-2012. FILED 2-13-2012.
- 4,209,942. **SIGNATURE SERIES (STANDARD CHARACTER)**. SUNKIST GROWERS, INC., MULTIPLE CLASS, (INT. CLS. 29 AND 31), (U.S. CLS. 1 AND 46). SN 85-547,468. PUB. 7-3-2012. FILED 2-20-2012.
- 4,209,943. **SUNKIST SIGNATURE SERIES (STANDARD CHARACTER)**. SUNKIST GROWERS, INC., MULTIPLE CLASS, (INT. CLS. 29 AND 31), (U.S. CLS. 1 AND 46). SN 85-547,485. PUB. 7-3-2012. FILED 2-20-2012.
- 4,210,032. **LIPARI OLD TYME AND DESIGN**. LIPARI FOODS OPERATING COMPANY, LLC, MULTIPLE CLASS, (INT. CLS. 29 AND 30), (U.S. CL. 46). SN 85-558,849. PUB. 7-3-2012. FILED 3-2-2012.
- 4,210,052. **NATURE'S BASIN (STANDARD CHARACTER)**. SAVOR BRANDS, INC., (U.S. CL. 46). SN 85-565,412. PUB. 7-3-2012. FILED 3-9-2012.
- 4,210,064. **COCOZIA (STANDARD CHARACTER)**. EPICUREX LLC, MULTIPLE CLASS, (INT. CLS. 29, 30 AND 32), (U.S. CLS. 45, 46 AND 48). SN 85-568,248. PUB. 7-3-2012. FILED 3-13-2012.
- 4,210,099. **BISTRO AND DESIGN**. READY PAC PRODUCE, INC., (U.S. CL. 46). SN 85-577,292. PUB. 7-3-2012. FILED 3-22-2012.
- 4,210,144. **EGG MATES (STANDARD CHARACTER)**. MICHAEL FOODS OF DELAWARE, INC., (U.S. CL. 46). SN 85-589,053. PUB. 7-3-2012. FILED 4-4-2012.
- 4,210,219. **SUNKIST (STANDARD CHARACTER)**. SUNKIST GROWERS, INC., (U.S. CL. 46). SN 85-626,288. PUB. 7-3-2012. FILED 5-15-2012.

CLASS 30—STAPLE FOODS

- 4,208,121. **TOTAL TZATZIKI AUTHENTIC GREEK AND DESIGN**. FAGE DAIRY INDUSTRIES S.A., (U.S. CL. 46). SN 76-016,809. PUB. 12-25-2001. FILED 4-4-2000.
- 4,208,131. **LEE KUM KEE HONG KONG AND DESIGN**. LEE KUM KEE COMPANY LIMITED, (U.S. CL. 46). SN 76-696,700. PUB. 11-23-2010. FILED 4-6-2009.
- 4,208,148. **BARISTA BAKING COMPANY (STANDARD CHARACTER)**. CHAMPION FOODS, L.L.C., (U.S. CL. 46). SN 76-709,092. PUB. 7-3-2012. FILED 9-16-2011.
- 4,208,153. **FIBERGEL LC (STANDARD CHARACTER)**. FLORIDA FOOD PRODUCTS, INC., (U.S. CL. 46). SN 76-710,126. PUB. 7-3-2012. FILED 12-28-2011.
- 4,208,163. **BAMBU AND DESIGN**. TFI FOODS LTD., (U.S. CL. 46). SN 77-131,065. PUB. 10-18-2011. FILED 3-14-2007.
- 4,208,173. **LAPPERT'S HAWAII (STANDARD CHARACTER)**. LAPPERT'S, INC., MULTIPLE CLASS, (INT. CLS. 30 AND 35), (U.S. CLS. 46, 100, 101 AND 102). SN 77-406,655. PUB. 12-9-2008. FILED 2-26-2008.
- 4,208,184. **PLANET COFFEE ROASTERS, INC. (STANDARD CHARACTER)**. PLANET COFFEE ROASTERS, INC., (U.S. CL. 46). SN 77-660,508. PUB. 4-20-2010. FILED 1-30-2009.
- 4,208,185. **PLANET COFFEE ROASTERS, INC. FRESH COFFEE AND DESIGN**. PLANET COFFEE ROASTERS, INC., (U.S. CL. 46). SN 77-660,525. PUB. 4-13-2010. FILED 1-30-2009.
- 4,208,187 (*See Class 3 for this trademark*).
- 4,208,243 (*See Class 3 for this trademark*).
- 4,208,263 (*See Class 3 for this trademark*).
- 4,208,296 (*See Class 21 for this trademark*).
- 4,208,299. **P PARIS CHOCOLAT AND DESIGN**. E.M DEVELOPEMENT, (U.S. CL. 46). SN 79-101,523. PUB. 7-3-2012. FILED 7-22-2011.
- 4,208,326 (*See Class 1 for this trademark*).
- 4,208,339 (*See Class 29 for this trademark*).
- 4,208,345. **PETER'S YARD (STANDARD CHARACTER)**. PETER'S YARD LIMITED, MULTIPLE CLASS, (INT. CLS. 30 AND 43), (U.S. CLS. 46, 100 AND 101). SN 79-102,824. PUB. 7-3-2012. FILED 6-3-2011.
- 4,208,347 (*See Class 5 for this trademark*).
- 4,208,358 (*See Class 11 for this trademark*).
- 4,208,359 (*See Class 5 for this trademark*).
- 4,208,416 (*See Class 29 for this trademark*).
- 4,208,573. **VB PROGRAM AND DESIGN**. AMOREPACIFIC CORPORATION, (U.S. CL. 46). SN 85-274,145. PUB. 7-3-2012. FILED 3-23-2011.
- 4,208,607. **BONFIRE (STANDARD CHARACTER)**. SALTWORKS, INC., (U.S. CL. 46). SN 85-318,270. PUB. 7-3-2012. FILED 5-11-2011.
- 4,208,650. **MAMA COLA'S SAUCE HOMEMADE THE FINEST SPAGHETTI SAUCE "WE MAKE A SAUCE YOU CAN'T REFUSE" AND DESIGN**. TLC ENTERPRISES INC., (U.S. CL. 46). SN 85-345,588. PUB. 7-3-2012. FILED 6-14-2011.
- 4,208,714. **ESPECIAS DON JULIO (STANDARD CHARACTER)**. FABRICA ESPECIAS DON JULIO, S. DE R. L., (U.S. CL. 46). SN 85-366,704. PUB. 3-27-2012. FILED 7-8-2011.
- 4,208,770. **PASTIOLOT AND DESIGN**. PA ARTESA OLOT, S.L., MULTIPLE CLASS, (INT. CLS. 30 AND 35), (U.S. CLS. 46, 100, 101 AND 102). SN 85-376,561. PUB. 7-3-2012. FILED 7-20-2011.
- 4,208,795 (*See Class 29 for this trademark*).
- 4,208,799. **SMOKY MOUNTAIN HERITAGE PRODUCTS (STANDARD CHARACTER)**. SMOKY MOUNTAIN NATIVE PLANTS ASSOCIATION, (U.S. CL. 46). SN 85-383,152. PUB. 7-3-2012. FILED 7-28-2011.
- 4,208,928. **COFFEE LEGENDS (STANDARD CHARACTER)**. EIEIO, INC., (U.S. CL. 46). SN 85-419,770. PUB. 7-3-2012. FILED 9-11-2011.
- 4,208,989. **LA PEÑITA (STANDARD CHARACTER)**. FLORES GARCIA, FRANCISCO JAVIER, (U.S. CL. 46). SN 85-447,437. PUB. 3-27-2012. FILED 10-14-2011.
- 4,209,076. **AROMA & TASTE (STANDARD CHARACTER)**. SEVEN STAR TRADING, INC., (U.S. CL. 46). SN 85-481,152. PUB. 7-3-2012. FILED 11-27-2011.
- 4,209,081. **ANGEL'S BAKERY (STANDARD CHARACTER)**. ANGEL'S BAKERIES, INC., MULTIPLE CLASS, (INT. CLS. 30 AND 40), (U.S. CLS. 46, 100, 103 AND 106). SN 85-484,778. PUB. 7-3-2012. FILED 12-1-2011.
- 4,209,207. **SOUTHERN YUM (STANDARD CHARACTER)**. FORD'S PRODUCE CO., INC., (U.S. CL. 46). SN 85-512,784. PUB. 7-3-2012. FILED 1-10-2012.
- 4,209,212. **SUGAR CHALET (STANDARD CHARACTER)**. BISSELL MAPLE FARM, LLP, (U.S. CL. 46). SN 85-514,384. PUB. 7-3-2012. FILED 1-11-2012.
- 4,209,306. **ROYAL ROSE AND DESIGN**. ROYAL ROSE SYRUPS, LLC, (U.S. CL. 46). SN 85-522,375. PUB. 7-3-2012. FILED 1-23-2012.
- 4,209,326 (*See Class 29 for this trademark*).
- 4,209,329. **JUICE CRAFTERS (STANDARD CHARACTER)**. INNOCREATIVE SOLUTIONS, INC., MULTIPLE CLASS, (INT. CLS. 30 AND 32), (U.S. CLS. 45, 46 AND 48). SN 85-523,207. PUB. 7-3-2012. FILED 1-23-2012.
- 4,209,346. **COCK BRAND MARQUE DEPOSEE AND DESIGN**. THAI WORLD IMPORT & EXPORT CO., LTD., (U.S. CL. 46). SN 85-523,864. PUB. 7-3-2012. FILED 1-24-2012.
- 4,209,436. **THE COOKIE DEPARTMENT (STANDARD CHARACTER)**. THE COOKIE DEPARTMENT, INC., (U.S. CL. 46). SN 85-528,495. PUB. 7-3-2012. FILED 1-30-2012.
- 4,209,472. **ESIO HOT & COLD BEVERAGE SYSTEM AND DESIGN**. ESIO BEVERAGE COMPANY LLC, (U.S. CL. 46). SN 85-532,336. PUB. 7-3-2012. FILED 2-2-2012.
- 4,209,486 (*See Class 29 for this trademark*).
- 4,209,503. **YOUR OVENS BEST (STANDARD CHARACTER)**. ZESCAS INCORPORATED, TA ZESCAS, (U.S. CL. 46). SN 85-537,406. PUB. 7-3-2012. FILED 2-8-2012.
- 4,209,535. **GRANDE KAFFÉ COLLECTION (STANDARD CHARACTER)**. KAFFE MAGNUM OPUS, INC., (U.S. CL. 46). SN 85-539,313. PUB. 7-3-2012. FILED 2-10-2012.
- 4,209,538. **EKONG! SECONDS AND THIRDS... GUARANTEED AND DESIGN**. PUPLAMPU, ADITEL, (U.S. CL. 46). SN 85-539,339. PUB. 7-3-2012. FILED 2-10-2012.
- 4,209,546. **POOFY SHEEP (STANDARD CHARACTER)**. WAXMAN, RACHEL F, (U.S. CL. 46). SN 85-539,679. PUB. 7-3-2012. FILED 2-10-2012.
- 4,209,547. **PATRIOT ROCKET (STANDARD CHARACTER)**. RICH ICE CREAM COMPANY, INC., (U.S. CL. 46). SN 85-539,831. PUB. 7-3-2012. FILED 2-10-2012.
- 4,209,557. **ROCKET (STANDARD CHARACTER)**. RICH ICE CREAM COMPANY, INC., (U.S. CL. 46). SN 85-540,111. PUB. 7-3-2012. FILED 2-10-2012.
- 4,209,589. **SMOKESHACK (STANDARD CHARACTER)**. SSE

IP, LLC, (U.S. CL. 46). SN 85-541,039. PUB. 7-3-2012. FILED 2-13-2012.

4,209,653. **MARICH AND DESIGN**. MARICH CONFECTIONERY COMPANY, INC., (U.S. CL. 46). SN 85-541,965. PUB. 7-3-2012. FILED 2-14-2012.

4,209,714. **SNACKFAST (STANDARD CHARACTER)**. MELLO SMELLO LLC, DBA NOTABLES, (U.S. CL. 46). SN 85-543,032. PUB. 7-3-2012. FILED 2-15-2012.

4,209,724. **THE MEADOW (STYLIZED)**. THE MEADOW MARCHE, INC., (U.S. CL. 46). SN 85-543,219. PUB. 7-3-2012. FILED 2-15-2012.

4,209,777. **CHAPARRAL GARDENS AND DESIGN**. CHAPARRAL GARDENS VINEGAR, (U.S. CL. 46). SN 85-543,899. PUB. 7-3-2012. FILED 2-15-2012.

4,209,778. **"DON'T GIVE UP THE SHIP" AND DESIGN**. LAKE ERIE ISLANDS TRADING COMPANY LLC, (U.S. CL. 46). SN 85-543,904. PUB. 7-3-2012. FILED 2-15-2012.

4,209,792. **MOTEATO (STANDARD CHARACTER)**. R. TWINING AND COMPANY LIMITED, (U.S. CL. 46). SN 85-544,138. PUB. 7-3-2012. FILED 2-16-2012.

4,209,864. **LARRY THE CABLE GUY (STANDARD CHARACTER)**. GIT-R-DONE PRODUCTIONS, INC., (U.S. CL. 46). SN 85-545,555. PUB. 7-3-2012. FILED 2-17-2012.

4,209,865. **LARRY THE CABLE GUY (STANDARD CHARACTER)**. GIT-R-DONE PRODUCTIONS, INC., (U.S. CL. 46). SN 85-545,571. PUB. 7-3-2012. FILED 2-17-2012.

4,210,032 (*See Class 29 for this trademark*).

4,210,035. **SAVANNAH SMILES (STANDARD CHARACTER)**. KELLOGG NORTH AMERICA COMPANY, (U.S. CL. 46). SN 85-560,425. PUB. 7-3-2012. FILED 3-5-2012.

4,210,048. **CHEEZ-IT AND DESIGN**. KELLOGG NORTH AMERICA COMPANY, (U.S. CL. 46). SN 85-564,828. PUB. 7-3-2012. FILED 3-9-2012.

4,210,055. **AUNT MILLIE'S BAKEHOUSE (STANDARD CHARACTER)**. PERFECTION BAKERIES, INC., (U.S. CL. 46). SN 85-566,391. PUB. 7-3-2012. FILED 3-12-2012.

4,210,057. **LARRY THE CABLE GUY (STANDARD CHARACTER)**. GIT-R-DONE PRODUCTIONS, INC., (U.S. CL. 46). SN 85-566,678. PUB. 7-3-2012. FILED 3-12-2012.

4,210,064 (*See Class 29 for this trademark*).

4,210,081. **TONY (STANDARD CHARACTER)**. KELLOGG NORTH AMERICA COMPANY, (U.S. CL. 46). SN 85-573,355. PUB. 7-3-2012. FILED 3-19-2012.

4,210,101. **MOTEATO AND DESIGN**. R. TWINING AND COMPANY LIMITED, (U.S. CL. 46). SN 85-577,902. PUB. 7-3-2012. FILED 3-23-2012.

4,210,102. **MELON REMIX (STANDARD CHARACTER)**. WM. WRIGLEY JR. COMPANY, (U.S. CL. 46). SN 85-578,067. PUB. 7-3-2012. FILED 3-23-2012.

4,210,145. **LARRY THE CABLE GUY (STANDARD CHARACTER)**. GIT-R-DONE PRODUCTIONS, INC., (U.S. CL. 46). SN 85-589,358. PUB. 7-3-2012. FILED 4-4-2012.

4,210,184. **HARD BODIES (STANDARD CHARACTER)**. JONES, DONOVAN O, DBA HARD BODIES(TM) FITNESS COOKIE, (U.S. CL. 46). SN 85-604,776. PUB. 7-3-2012. FILED 4-22-2012.

4,210,186. **UENO DORA AND DESIGN**. RICHIN TRADING INC., (U.S. CL. 46). SN 85-605,663. PUB. 7-3-2012. FILED 4-23-2012.

4,210,199. **BREAKFAST IN A CUP (STANDARD CHARACTER)**. KAFFE MAGNUM OPUS, INC., (U.S. CL. 46). SN 85-611,569. PUB. 7-3-2012. FILED 4-30-2012.

CLASS 31—NATURAL AGRICULTURAL PRODUCTS

4,208,326 (*See Class 1 for this trademark*).

4,208,339 (*See Class 29 for this trademark*).

4,208,449 (*See Class 5 for this trademark*).

4,208,524. **WILLOW & BLOOM (STANDARD CHARACTER)**. WILLOW & BLOOM LLC, (U.S. CLS. 1 AND 46). SN 85-196,858. PUB. 7-3-2012. FILED 12-13-2010.

4,208,549. **CANNA BUS (STANDARD CHARACTER)**. RINCK, MICHAEL, (U.S. CLS. 1 AND 46). SN 85-230,104. PUB. 7-3-2012. FILED 1-31-2011.

4,208,734. **VIVID AQUARIUMS (STYLIZED)**. DAVID BURR,

MULTIPLE CLASS, (INT. CLS. 31 AND 37), (U.S. CLS. 1, 46, 100, 103 AND 106). SN 85-372,031. PUB. 7-3-2012. FILED 7-14-2011.

4,209,203. **SANTA CRUZ BERRY FARMING CO AND DESIGN**. SANTA CRUZ BERRY FARMING CO., LLC, (U.S. CLS. 1 AND 46). SN 85-511,807. PUB. 7-3-2012. FILED 1-9-2012.

4,209,316. **SAVE THE SONG BIRDS AND DESIGN**. SMG BRANDS, INC., (U.S. CLS. 1 AND 46). SN 85-522,674. PUB. 7-3-2012. FILED 1-23-2012.

4,209,325. **SELECT GRILLE (STANDARD CHARACTER)**. TABCOM, LLC, (U.S. CLS. 1 AND 46). SN 85-523,055. PUB. 7-3-2012. FILED 1-23-2012.

4,209,416. **BENCHMARK GROWERS AND DESIGN**. THE QUEEN'S FLOWERS, INC., (U.S. CLS. 1 AND 46). SN 85-526,650. PUB. 7-3-2012. FILED 1-26-2012.

4,209,417. **BENCHMARK GROWERS (STANDARD CHARACTER)**. THE QUEEN'S FLOWERS, INC., (U.S. CLS. 1 AND 46). SN 85-526,653. PUB. 7-3-2012. FILED 1-26-2012.

4,209,428. **MISCELLANEOUS DESIGN**. EXTERIOR DESIGN, INC., TA THE PERENNIAL FARM, (U.S. CLS. 1 AND 46). SN 85-527,628. PUB. 7-3-2012. FILED 1-27-2012.

4,209,558 (*See Class 29 for this trademark*).

4,209,580. **MISCELLANEOUS DESIGN**. DUTCH VALLEY PARTNERS, LLC, (U.S. CLS. 1 AND 46). SN 85-540,946. PUB. 7-3-2012. FILED 2-13-2012.

4,209,656. **DUTCH VALLEY (STANDARD CHARACTER)**. DUTCH VALLEY PARTNERS, LLC, (U.S. CLS. 1 AND 46). SN 85-542,057. PUB. 7-3-2012. FILED 2-14-2012.

4,209,788. **AMERIZORB (STANDARD CHARACTER)**. WRIGHT BROTHERS INVESTMENTS, INC., DBA AMERIZORB, (U.S. CLS. 1 AND 46). SN 85-544,088. PUB. 7-3-2012. FILED 2-15-2012.

4,209,889. **BLOOMTASTIC! (STANDARD CHARACTER)**. HINES GROWERS LLC, (U.S. CLS. 1 AND 46). SN 85-546,107. PUB. 7-3-2012. FILED 2-17-2012.

4,209,891. **FANTASTIC BLOOMS...EVERY TIME (STANDARD CHARACTER)**. HINES GROWERS LLC, (U.S. CLS. 1 AND 46). SN 85-546,110. PUB. 7-3-2012. FILED 2-17-2012.

4,209,902. **PREY DRIVE (STANDARD CHARACTER)**. HEYWARD, MARK, (U.S. CLS. 1 AND 46). SN 85-546,309. PUB. 7-3-2012. FILED 2-17-2012.

4,209,942 (*See Class 29 for this trademark*).

4,209,943 (*See Class 29 for this trademark*).

4,209,992. **SMITH & HAWKEN AND DESIGN**. TARGET BRANDS, INC., (U.S. CLS. 1 AND 46). SN 85-552,271. PUB. 7-3-2012. FILED 2-24-2012.

4,210,022. **BRAUTS-N-TOTS (STANDARD CHARACTER)**. MERRICK PET CARE, INC., (U.S. CLS. 1 AND 46). SN 85-556,590. PUB. 7-3-2012. FILED 2-29-2012.

4,210,213. **BLOOMTASTIC! AND DESIGN**. HINES GROWERS LLC, (U.S. CLS. 1 AND 46). SN 85-620,618. PUB. 7-3-2012. FILED 5-9-2012.

4,210,221 (*See Class 22 for this trademark*).

CLASS 32—LIGHT BEVERAGES

4,208,187 (*See Class 3 for this trademark*).

4,208,192. **DRAGON JUICE (STANDARD CHARACTER)**. VARIOUS BEVERAGES LLC, (U.S. CLS. 45, 46 AND 48). SN 77-838,374. PUB. 7-3-2012. FILED 9-30-2009.

4,208,227. **XL ENERGY (STANDARD CHARACTER)**. XL ENERGY DRINK CORP., (U.S. CLS. 45, 46 AND 48). SN 78-673,257. PUB. 7-3-2012. FILED 7-19-2005.

4,208,243 (*See Class 3 for this trademark*).

4,208,263 (*See Class 3 for this trademark*).

4,208,284 (*See Class 5 for this trademark*).

4,208,302. **THE INTERNATIONAL EXHIBITION LONDON 1884 AND DESIGN**. CHIVAS HOLDINGS (IP) LIMITED, MULTIPLE CLASS, (INT. CLS. 32, 33 AND 43), (U.S. CLS. 45, 46, 47, 48, 49, 100 AND 101). SN 79-101,679. PUB. 7-3-2012. FILED 7-4-2011.

4,208,316. **MISCELLANEOUS DESIGN**. CHIVAS HOLDINGS (IP) LIMITED, MULTIPLE CLASS, (INT. CLS. 32, 33 AND 43), (U.S. CLS. 45, 46, 47, 48, 49, 100 AND 101). SN 79-102,021. PUB. 7-3-2012. FILED 7-4-2011.

- 4,208,317. **MISCELLANEOUS DESIGN**. CHIVAS HOLDINGS (IP) LIMITED, MULTIPLE CLASS, (INT. CLS. 32, 33 AND 43), (U.S. CLS. 45, 46, 47, 48, 49, 100 AND 101). SN 79-102,022. PUB. 7-3-2012. FILED 7-4-2011.
- 4,208,326 (*See Class 1 for this trademark*).
- 4,208,335. **CHUONG DUONG AND DESIGN**. CONG TY CO PHAN NUOC GIAI KHAT CHUONG DUONG, (U.S. CLS. 45, 46 AND 48). SN 79-102,677. PUB. 7-3-2012. FILED 8-12-2011.
- 4,208,359 (*See Class 5 for this trademark*).
- 4,208,446 (*See Class 16 for this trademark*).
- 4,208,773. **BOSCO MOCHA (STANDARD CHARACTER)**. BOSCO PRODUCTS INC., (U.S. CLS. 45, 46 AND 48). SN 85-376,817. PUB. 7-3-2012. FILED 7-20-2011.
- 4,208,797. **ANTOINETTE (STANDARD CHARACTER)**. GREEN ARCH LIMITED, MULTIPLE CLASS, (INT. CLS. 32, 33 AND 43), (U.S. CLS. 45, 46, 47, 48, 49, 100 AND 101). SN 85-381,905. PUB. 7-3-2012. FILED 7-27-2011.
- 4,208,803 (*See Class 5 for this trademark*).
- 4,208,887. **HOPE THRU WATER (STANDARD CHARACTER)**. COMMUNITY DISTRIBUTION CENTER, MULTIPLE CLASS, (INT. CLS. 32 AND 36), (U.S. CLS. 45, 46, 48, 100, 101 AND 102). SN 85-405,375. PUB. 7-3-2012. FILED 8-23-2011.
- 4,208,908. **HOPE IN EVERY DROP (STANDARD CHARACTER)**. COMMUNITY DISTRIBUTION CENTER, MULTIPLE CLASS, (INT. CLS. 32 AND 36), (U.S. CLS. 45, 46, 48, 100, 101 AND 102). SN 85-413,638. PUB. 7-3-2012. FILED 9-1-2011.
- 4,208,954. **GREAT LAKES BREWING CO. OKTOBERFEST A HANDCRAFTED AMBER LAGER CLEVELAND, OHIO AND DESIGN**. THE GREAT LAKES BREWING CO., (U.S. CLS. 45, 46 AND 48). SN 85-435,241. PUB. 3-20-2012. FILED 9-29-2011.
- 4,208,956. **KARL STRAUSS BREWING '89 COMPANY BOARDWALK BLACK RYE AND DESIGN**. ASSOCIATED MICROBREWERIES, LTD., DBA KARL STRAUSS BREWING COMPANY, (U.S. CLS. 45, 46 AND 48). SN 85-435,849. PUB. 7-3-2012. FILED 9-29-2011.
- 4,208,990. **DEVIANT DALE'S (STANDARD CHARACTER)**. OSKAR BLUES BREWERY LLC, DBA OSKAR BLUES BREWERY, (U.S. CLS. 45, 46 AND 48). SN 85-447,560. PUB. 7-3-2012. FILED 10-14-2011.
- 4,209,038. **YARDS ALES OF THE REVOLUTION AUTHENTIC RECIPE THOMAS JEFFERSON'S TAVERN ALE AND DESIGN**. YARDS BREWING COMPANY, LLC, (U.S. CLS. 45, 46 AND 48). SN 85-467,640. PUB. 5-29-2012. FILED 11-8-2011.
- 4,209,078. **WILDCAT (STANDARD CHARACTER)**. SABER-TOOTH MOTORCYCLES, LLC, (U.S. CLS. 45, 46 AND 48). SN 85-481,502. PUB. 3-27-2012. FILED 11-28-2011.
- 4,209,121. **LEANLEAF (STANDARD CHARACTER)**. TASTI DLITE LLC, (U.S. CLS. 45, 46 AND 48). SN 85-495,437. PUB. 7-3-2012. FILED 12-14-2011.
- 4,209,205. **SMOG CITY BREWING CO. AND DESIGN**. BEER LAB INC., (U.S. CLS. 45, 46 AND 48). SN 85-512,559. PUB. 7-3-2012. FILED 1-10-2012.
- 4,209,326 (*See Class 29 for this trademark*).
- 4,209,329 (*See Class 30 for this trademark*).
- 4,209,555. **BARRANDOV (STANDARD CHARACTER)**. THE BARRANDOV OPERA COMPANY LIMITED, (U.S. CLS. 45, 46 AND 48). SN 85-539,947. PUB. 7-3-2012. FILED 2-10-2012.
- 4,209,808 (*See Class 5 for this trademark*).
- 4,209,818. **DRINK UP & DOWNLOAD (STANDARD CHARACTER)**. SUNNY DELIGHT BEVERAGES CO., (U.S. CLS. 45, 46 AND 48). SN 85-544,568. PUB. 7-3-2012. FILED 2-16-2012.
- 4,209,878. **CRYSTAL CREEK (STANDARD CHARACTER)**. PREMIUM WATERS, INC., (U.S. CLS. 45, 46 AND 48). SN 85-545,944. PUB. 7-3-2012. FILED 2-17-2012.
- 4,210,024. **MISCELLANEOUS DESIGN**. WORLDWIDE WATER, INC., (U.S. CLS. 45, 46 AND 48). SN 85-556,613. PUB. 7-3-2012. FILED 2-29-2012.
- 4,210,054. **SIES GOYA TIENE QUE SER BUENO (STANDARD CHARACTER)**. GOYA FOODS, INC., (U.S. CLS. 45, 46 AND 48). SN 85-566,098. PUB. 7-3-2012. FILED 3-10-2012.
- 4,210,064 (*See Class 29 for this trademark*).
- 4,210,135. **IT'S WORTH THE EFFORT (STANDARD CHARACTER)**. CHURCHKEY CAN COMPANY, INC., (U.S. CLS. 45, 46 AND 48). SN 85-584,702. PUB. 7-3-2012. FILED 3-30-2012.
- 4,210,150. **RIM ZIM (STANDARD CHARACTER)**. MEENAXI ENTERPRISE, INC., DBA MEENAXI ENTERPRISE, INC., (U.S. CLS. 45, 46 AND 48). SN 85-592,003. PUB. 7-3-2012. FILED 4-8-2012.
- 4,210,151. **JUICYLITE (STANDARD CHARACTER)**. MEENAXI ENTERPRISE, INC., DBA MEENAXI ENTERPRISE, INC., (U.S. CLS. 45, 46 AND 48). SN 85-593,072. PUB. 7-3-2012. FILED 4-10-2012.

CLASS 33—WINES AND SPIRITS

- 4,208,156. **ROBERT JOHN VINEYARDS (STANDARD CHARACTER)**. ROBERT JOHN VINEYARDS, LLC, (U.S. CLS. 47 AND 49). SN 76-710,221. PUB. 7-3-2012. FILED 1-10-2012.
- 4,208,174. **GLEN CLYDE (STANDARD CHARACTER)**. GLEN CLYDE WHISKY LIMITED, (U.S. CLS. 47 AND 49). SN 77-435,981. PUB. 3-20-2012. FILED 3-31-2008.
- 4,208,187 (*See Class 3 for this trademark*).
- 4,208,213. **JOHN BARR (STANDARD CHARACTER)**. WHYTE AND MACKAY LIMITED, (U.S. CLS. 47 AND 49). SN 77-931,913. PUB. 1-11-2011. FILED 2-9-2010.
- 4,208,263 (*See Class 3 for this trademark*).
- 4,208,302 (*See Class 32 for this trademark*).
- 4,208,311. **MEMORO (STANDARD CHARACTER)**. GESTIONI PICCINI S.R.L., (U.S. CLS. 47 AND 49). SN 79-101,913. PUB. 7-3-2012. FILED 8-17-2011.
- 4,208,315. **KEPE AND DESIGN**. BODEGAS LUIS ALEGRE, S.A., (U.S. CLS. 47 AND 49). SN 79-102,006. PUB. 7-3-2012. FILED 8-24-2011.
- 4,208,316 (*See Class 32 for this trademark*).
- 4,208,317 (*See Class 32 for this trademark*).
- 4,208,352. **HEINRICH LORCH TRADITION IM WEIN AND DESIGN**. ZIMMERMANN-GRAEFF & MÜLLER GMBH & CO. KG, (U.S. CLS. 47 AND 49). SN 79-102,935. PUB. 7-3-2012. FILED 8-16-2011.
- 4,208,400. **CENTONZE AND DESIGN**. CENTONZE S.R.L., (U.S. CLS. 47 AND 49). SN 79-107,114. PUB. 7-3-2012. FILED 9-30-2011.
- 4,208,427. **THE FLYING DUTCHMAN RUM (STANDARD CHARACTER)**. ZUIDAM DISTILLERS BV, (U.S. CLS. 47 AND 49). SN 79-109,768. PUB. 7-3-2012. FILED 1-31-2012.
- 4,208,432. **GLENGLOSSAUGH (STANDARD CHARACTER)**. THE GLENGLOSSAUGH DISTILLERY COMPANY LIMITED, (U.S. CLS. 47 AND 49). SN 79-110,467. PUB. 7-3-2012. FILED 2-16-2012.
- 4,208,434. **DAUVERGNE RANVIER - D&R (STANDARD CHARACTER)**. R&D VINS, S.A.R.L., (U.S. CLS. 47 AND 49). SN 79-110,704. PUB. 7-3-2012. FILED 2-10-2012.
- 4,208,442. **IL BACIO DELLE MUSE AND DESIGN**. GAGLIANO MARCATI DI PIETRO MARCATO; E C. S.N.C., (U.S. CLS. 47 AND 49). SN 79-112,324. PUB. 7-3-2012. FILED 2-9-2012.
- 4,208,443. **LFP (STANDARD CHARACTER)**. S.C. DU CHATEAU LA FLEUR PETRUS, (U.S. CLS. 47 AND 49). SN 79-112,433. PUB. 7-3-2012. FILED 3-19-2012.
- 4,208,446 (*See Class 16 for this trademark*).
- 4,208,476. **GRADUATE LUXURY VODKA B 1928 AND DESIGN**. CEDC INTERNATIONAL SP. Z O.O., (U.S. CLS. 47 AND 49). SN 85-108,091. PUB. 7-3-2012. FILED 8-16-2010.
- 4,208,551. **SERENA'S VINEYARD (STANDARD CHARACTER)**. FRIEDMAN, SERENA M., DBA FOUR SISTERS RANCH, AND DRUCKER, MICHAEL, DBA FOUR SISTERS RANCH, (U.S. CLS. 47 AND 49). SN 85-235,269. PUB. 7-3-2012. FILED 2-7-2011.
- 4,208,615. **LA CLE SAINT-PIERRE (STANDARD CHARACTER)**. BOISSET - LA FAMILLE DES GRANDS VINS, (U.S. CLS. 47 AND 49). SN 85-323,897. PUB. 3-20-2012. FILED 5-18-2011.
- 4,208,687. **HEREDAD DE JUDIMA (STANDARD CHARACTER)**. QUIROGA DE PABLO JUAN LUIS, DBA BODEGA JUAN LUIS QUIROGA DE PABLO, (U.S. CLS. 47 AND 49). SN 85-360,092. PUB. 7-3-2012. FILED 6-29-2011.

- 4,208,797 (*See Class 32 for this trademark*).
- 4,208,809. **A MOMENT IN WINE (STANDARD CHARACTER)**. BURGDORF'S WINERY LLC, (U.S. CLS. 47 AND 49). SN 85-386,091. PUB. 7-3-2012. FILED 8-1-2011.
- 4,208,885. **CAPPELLA (STANDARD CHARACTER)**. ABREU, DAVID, (U.S. CLS. 47 AND 49). SN 85-405,160. PUB. 7-3-2012. FILED 8-23-2011.
- 4,208,886. **ABREU CAPPELLA (STANDARD CHARACTER)**. ABREU, DAVID, (U.S. CLS. 47 AND 49). SN 85-405,167. PUB. 7-3-2012. FILED 8-23-2011.
- 4,208,961. **CHATEAU POMARI (STANDARD CHARACTER)**. SAZERAC COMPANY, INC., (U.S. CLS. 47 AND 49). SN 85-437,411. PUB. 3-27-2012. FILED 10-3-2011.
- 4,209,004. **VERA CUBA AND DESIGN**. HAVANA CLUB HOLDING, S.A., (U.S. CLS. 47 AND 49). SN 85-449,670. PUB. 7-3-2012. FILED 10-18-2011.
- 4,209,005. **VERA CUBA (STANDARD CHARACTER)**. HAVANA CLUB HOLDING, S.A., (U.S. CLS. 47 AND 49). SN 85-449,699. PUB. 7-3-2012. FILED 10-18-2011.
- 4,209,021. **CROWN VALLEY DISTILLING (STANDARD CHARACTER)**. CROWN VALLEY WINERY, INC., (U.S. CLS. 47 AND 49). SN 85-459,688. PUB. 7-3-2012. FILED 10-29-2011.
- 4,209,083. **MISCELLANEOUS DESIGN**. CK3 LLC, (U.S. CLS. 47 AND 49). SN 85-485,642. PUB. 7-3-2012. FILED 12-2-2011.
- 4,209,097 (*See Class 3 for this trademark*).
- 4,209,143. **EG EDINBURGH GIN PRODUCED & BOTTLED IN EDINBURGH AND DESIGN**. SPENCERFIELD SPIRIT COMPANY LIMITED, (U.S. CLS. 47 AND 49). SN 85-501,502. PUB. 7-3-2012. FILED 12-21-2011.
- 4,209,224. **CINCO PERROS (STANDARD CHARACTER)**. ARIOTO, JOHN J., (U.S. CLS. 47 AND 49). SN 85-516,595. PUB. 7-3-2012. FILED 1-13-2012.
- 4,209,237. **J JOANGINÉ AND DESIGN**. BUIL & GINE SL., (U.S. CLS. 47 AND 49). SN 85-518,082. PUB. 7-3-2012. FILED 1-17-2012.
- 4,209,411. **NIKITA AND DESIGN**. LEUCANA INVEST, SL., (U.S. CLS. 47 AND 49). SN 85-526,419. PUB. 7-3-2012. FILED 1-26-2012.
- 4,209,559. **FLASHBANG (STANDARD CHARACTER)**. FLASHBANG INC., (U.S. CLS. 47 AND 49). SN 85-540,173. PUB. 7-3-2012. FILED 2-10-2012.
- 4,209,779. **BEAUCHEMIN (STANDARD CHARACTER)**. SONOMA WINE COMPANY, (U.S. CLS. 47 AND 49). SN 85-543,910. PUB. 7-3-2012. FILED 2-15-2012.
- 4,209,809. **DEALER'S CHOICE (STANDARD CHARACTER)**. JACKSON FAMILY FARMS, LLC, (U.S. CLS. 47 AND 49). SN 85-544,494. PUB. 7-3-2012. FILED 2-16-2012.
- 4,209,934. **QUEEN OF IBERIA (STANDARD CHARACTER)**. LAKE NORMAN INDUSTRIES, LLC, (U.S. CLS. 47 AND 49). SN 85-546,877. PUB. 7-3-2012. FILED 2-19-2012.
- 4,209,935. **OLD FRIENDS (STANDARD CHARACTER)**. LAKE NORMAN INDUSTRIES, LLC, (U.S. CLS. 47 AND 49). SN 85-546,880. PUB. 7-3-2012. FILED 2-19-2012.
- 4,209,993. **MATANZAS CREEK (STANDARD CHARACTER)**. JACKSON FAMILY FARMS, LLC, (U.S. CLS. 47 AND 49). SN 85-552,390. PUB. 7-3-2012. FILED 2-24-2012.
- 4,210,008. **UV CAKE (STANDARD CHARACTER)**. PHILLIPS PRODUCTS COMPANY, LLC, (U.S. CLS. 47 AND 49). SN 85-554,507. PUB. 7-3-2012. FILED 2-28-2012.
- 4,210,009. **UV ESPRESSO (STANDARD CHARACTER)**. PHILLIPS PRODUCTS COMPANY, LLC, (U.S. CLS. 47 AND 49). SN 85-554,519. PUB. 7-3-2012. FILED 2-28-2012.
- 4,210,065. **MILADY (STANDARD CHARACTER)**. MEXCOR, INC., (U.S. CLS. 47 AND 49). SN 85-568,433. PUB. 7-3-2012. FILED 3-13-2012.
- 4,210,072. **TOM SIMS (STANDARD CHARACTER)**. ABC LIQUORS, INC., (U.S. CLS. 47 AND 49). SN 85-570,113. PUB. 7-3-2012. FILED 3-15-2012.
- 4,210,084 (*See Class 21 for this trademark*).
- 4,210,097. **SPIRIT OF THE SHAMAN (STANDARD CHARACTER)**. JAVIER MARTINEZ, (U.S. CLS. 47 AND 49). SN 85-576,855. PUB. 7-3-2012. FILED 3-22-2012.
- 4,210,130. **LUCKY PLAYER (STANDARD CHARACTER)**. LUCKY PLAYER VODKA, INC., (U.S. CLS. 47 AND 49). SN 85-583,478. PUB. 7-3-2012. FILED 3-29-2012.
- 4,210,131. **UPPERCUT AND DESIGN**. DIAGEO CHATEAU & ESTATE WINES COMPANY, (U.S. CLS. 47 AND 49). SN 85-583,519. PUB. 7-3-2012. FILED 3-29-2012.
- 4,210,134. **MISCELLANEOUS DESIGN**. TAKARA HOLDINGS INC., (U.S. CLS. 47 AND 49). SN 85-584,538. PUB. 7-3-2012. FILED 3-30-2012.
- 4,210,190. **NINE BARREL (STANDARD CHARACTER)**. LC TM HOLDING, LLC, (U.S. CLS. 47 AND 49). SN 85-607,696. PUB. 7-3-2012. FILED 4-25-2012.
- 4,210,191. **YANGARRA (STANDARD CHARACTER)**. JACKSON WINE ESTATES INTERNATIONAL LIMITED, (U.S. CLS. 47 AND 49). SN 85-609,838. PUB. 7-3-2012. FILED 4-26-2012.
- 4,210,192. **NINE BARREL 9 (STYLIZED)**. LC TM HOLDING, LLC, (U.S. CLS. 47 AND 49). SN 85-609,865. PUB. 7-3-2012. FILED 4-26-2012.
- 4,210,197. **LA JOTA (STANDARD CHARACTER)**. JACKSON WINE ESTATES INTERNATIONAL LIMITED, (U.S. CLS. 47 AND 49). SN 85-611,042. PUB. 7-3-2012. FILED 4-27-2012.
- 4,210,217. **TENUTA DI ARCENO (STANDARD CHARACTER)**. JACKSON WINE ESTATES INTERNATIONAL LIMITED, (U.S. CLS. 47 AND 49). SN 85-623,627. PUB. 7-3-2012. FILED 5-11-2012.

CLASS 34—SMOKERS' ARTICLES

- 4,208,155. **DJARUM MILD AND DESIGN**. P.T. DJARUM, (U.S. CLS. 2, 8, 9 AND 17). SN 76-710,198. PUB. 7-3-2012. FILED 1-6-2012.
- 4,208,201. **MIDDLETON'S BLACK & MILD PIPE-TOBACCO CIGARS AND DESIGN**. JOHN MIDDLETON CO., (U.S. CLS. 2, 8, 9 AND 17). SN 77-904,293. PUB. 7-3-2012. FILED 1-4-2010.
- 4,208,202. **BLACK & MILD MIDDLETON'S PIPE-TOBACCO CIGARS AND DESIGN**. JOHN MIDDLETON CO., (U.S. CLS. 2, 8, 9 AND 17). SN 77-904,304. PUB. 7-3-2012. FILED 1-4-2010.
- 4,208,203. **BLACK & MILD WINE MIDDLETON'S WINE PIPE-TOBACCO CIGARS AND DESIGN**. JOHN MIDDLETON CO., (U.S. CLS. 2, 8, 9 AND 17). SN 77-904,323. PUB. 7-3-2012. FILED 1-4-2010.
- 4,208,204. **BLACK & MILD WINE MIDDLETON'S PIPE-TOBACCO CIGARS AND DESIGN**. JOHN MIDDLETON CO., (U.S. CLS. 2, 8, 9 AND 17). SN 77-904,329. PUB. 7-3-2012. FILED 1-4-2010.
- 4,208,205. **BLACK & MILD APPLE MIDDLETON'S PIPE-TOBACCO CIGARS AND DESIGN**. JOHN MIDDLETON CO., (U.S. CLS. 2, 8, 9 AND 17). SN 77-904,335. PUB. 7-3-2012. FILED 1-4-2010.
- 4,208,206. **BLACK & MILD APPLE MIDDLETON'S PIPE-TOBACCO CIGARS AND DESIGN**. JOHN MIDDLETON CO., (U.S. CLS. 2, 8, 9 AND 17). SN 77-904,341. PUB. 7-3-2012. FILED 1-4-2010.
- 4,208,207. **BLACK & MILD CREAM MIDDLETON'S PIPE-TOBACCO CIGARS AND DESIGN**. JOHN MIDDLETON CO., (U.S. CLS. 2, 8, 9 AND 17). SN 77-904,403. PUB. 7-3-2012. FILED 1-4-2010.
- 4,208,208. **BLACK & MILD CREAM MIDDLETON'S PIPE-TOBACCO CIGARS AND DESIGN**. JOHN MIDDLETON CO., (U.S. CLS. 2, 8, 9 AND 17). SN 77-904,412. PUB. 7-3-2012. FILED 1-4-2010.
- 4,208,209. **BLACK & MILD MILD MIDDLETON'S PIPE-TOBACCO CIGARS AND DESIGN**. JOHN MIDDLETON CO., (U.S. CLS. 2, 8, 9 AND 17). SN 77-904,419. PUB. 7-3-2012. FILED 1-4-2010.
- 4,208,210. **BLACK & MILD MILD MIDDLETON'S PIPE-TOBACCO CIGARS AND DESIGN**. JOHN MIDDLETON CO., (U.S. CLS. 2, 8, 9 AND 17). SN 77-904,427. PUB. 7-3-2012. FILED 1-4-2010.
- 4,208,289 (*See Class 3 for this trademark*).
- 4,208,362. **DON (STYLIZED)**. EDNOLITCHNO DRUJESTVO S OGRANITCHENA OTGOVORNOST "FINANSKONSULT", (U.S. CLS. 2, 8, 9 AND 17). SN 79-103,428. PUB. 7-3-2012. FILED 8-29-2011.
- 4,208,375. **CORSAIR AND DESIGN**. EDNOLITCHNO DRUJESTVO S OGRANITCHENA OTGOVORNOST "FINANSKONSULT", (U.S. CLS. 2, 8, 9 AND 17). SN 79-104,441. PUB. 7-3-2012. FILED 9-13-2011.

- 4,208,393 (*See Class 4 for this trademark*).
 4,208,459. **MAI TAI (STANDARD CHARACTER)**. FANTASIA DISTRIBUTION, INC., (U.S. CLS. 2, 8, 9 AND 17). SN 85-052,510. PUB. 6-14-2011. FILED 6-2-2010.
 4,208,595 (*See Class 11 for this trademark*).
 4,208,952. **RED BUCK (STANDARD CHARACTER)**. IP, LLC, (U.S. CLS. 2, 8, 9 AND 17). SN 85-435,142. PUB. 7-3-2012. FILED 9-29-2011.
 4,208,955. **MISCELLANEOUS DESIGN**. IP, LLC, (U.S. CLS. 2, 8, 9 AND 17). SN 85-435,518. PUB. 7-3-2012. FILED 9-29-2011.
 4,209,049. **EONSMOKE ELECTRONIC CIGARETTES AND DESIGN**. EONSMOKE, LLC., DBA EONSMOKE ELECTRONIC CIGARETTES, (U.S. CLS. 2, 8, 9 AND 17). SN 85-471,742. PUB. 7-3-2012. FILED 11-14-2011.
 4,209,068. **XEN BY NISH PATEL (STANDARD CHARACTER)**. ROCKY PATEL PREMIUM CIGARS, INC., (U.S. CLS. 2, 8, 9 AND 17). SN 85-477,430. PUB. 6-26-2012. FILED 11-21-2011.
 4,209,461. **RUTHLESS CIGARS (STANDARD CHARACTER)**. HIGH GRADE HERBAL INC., DBA NATURAL LEAF INC., (U.S. CLS. 2, 8, 9 AND 17). SN 85-531,310. PUB. 7-3-2012. FILED 2-1-2012.
 4,209,479. **PLOOM (STYLIZED)**. PLOOM, INC., (U.S. CLS. 2, 8, 9 AND 17). SN 85-533,707. PUB. 7-3-2012. FILED 2-3-2012.
 4,209,654. **HUDSON (STANDARD CHARACTER)**. PT SUMATRA TOBACCO TRADING COMPANY, (U.S. CLS. 2, 8, 9 AND 17). SN 85-541,969. PUB. 7-3-2012. FILED 2-14-2012.
 4,209,708 (*See Class 16 for this trademark*).
 4,210,106. **ANILLOS DE PLATA (STANDARD CHARACTER)**. THOMPSON & CO. OF TAMPA, INC., (U.S. CLS. 2, 8, 9 AND 17). SN 85-578,586. PUB. 7-3-2012. FILED 3-23-2012.
 4,210,108. **HIS DUDENESS (STANDARD CHARACTER)**. THOMPSON & CO. OF TAMPA, INC., (U.S. CLS. 2, 8, 9 AND 17). SN 85-579,541. PUB. 7-3-2012. FILED 3-26-2012.

SERVICE MARKS

CLASS 35—ADVERTISING AND BUSINESS

- 4,208,120. **ORANGE**. ORANGE BRAND SERVICES, LTD., (U.S. CLS. 100, 101 AND 102). SN 75-982,035. PUB. 3-30-2010. FILED 2-23-2001.
 4,208,122 (*See Class 12 for this trademark*).
 4,208,124 (*See Class 9 for this trademark*).
 4,208,129. **EROS TRANSEXUAL ESCORTS (STANDARD CHARACTER)**. GROUP KAITU, LLC, (U.S. CLS. 100, 101 AND 102). SN 76-683,791. PUB. 7-3-2012. FILED 11-7-2007.
 4,208,134. **E EVOLUTION ENTERPRISE AND DESIGN**. EVOLUTION ENTERPRISE, LLC, (U.S. CLS. 100, 101 AND 102). SN 76-707,534. PUB. 7-3-2012. FILED 5-9-2011.
 4,208,135. **FEDERAL LAW REQUIRES UNDER 27 WE CARD LAW PROHIBITS THE SALE OF TOBACCO TO MINORS EVERY TIME PLEASE HAVE ID READY AND DESIGN**. WE CARD PROGRAM, INC., THE, MULTIPLE CLASS, (INT. CLS. 35 AND 41), (U.S. CLS. 100, 101, 102 AND 107). SN 76-707,651. PUB. 7-3-2012. FILED 5-18-2011.
 4,208,142. **A ALLAN KNIGHT AND DESIGN**. ALLAN KNIGHT & ASSOCIATES, INC., (U.S. CLS. 100, 101 AND 102). SN 76-708,549. PUB. 7-3-2012. FILED 8-1-2011.
 4,208,143. **APPLE ENERGY GROUP (STANDARD CHARACTER)**. APPLE ENERGY GROUP, L.L.C., MULTIPLE CLASS, (INT. CLS. 35 AND 41), (U.S. CLS. 100, 101, 102 AND 107). SN 76-708,558. PUB. 1-24-2012. FILED 8-1-2011.
 4,208,146. **CONSORTIUM OF PAPERS (STANDARD CHARACTER)**. CONSORTIUM OF PAPERS, INC., (U.S. CLS. 100, 101 AND 102). SN 76-708,731. PUB. 7-3-2012. FILED 8-15-2011.
 4,208,152. **PARA- GEAR (STANDARD CHARACTER)**. BACHMAN ENTERPRISES, INC., (U.S. CLS. 100, 101 AND 102). SN 76-710,068. PUB. 7-3-2012. FILED 12-19-2011.
 4,208,165 (*See Class 5 for this trademark*).
 4,208,171. **RE THINK AND DESIGN**. GREENSENDER, LLC, (U.S. CLS. 100, 101 AND 102). SN 77-381,814. PUB. 7-3-2012. FILED 1-28-2008.
 4,208,173 (*See Class 30 for this trademark*).
 4,208,179. **PERMIRA AND DESIGN**. PERMIRA I.P. LIMITED, MULTIPLE CLASS, (INT. CLS. 35 AND 36), (U.S. CLS. 100, 101 AND 102). SN 77-529,879. PUB. 7-3-2012. FILED 7-23-2008.
 4,208,190. **METS AND DESIGN**. MICHIGAN EDUCATIONAL TRANSPORTATION SERVICES, INC., DBA METS, (U.S. CLS. 100, 101 AND 102). SN 77-808,995. PUB. 1-19-2010. FILED 8-20-2009.
 4,208,199 (*See Class 9 for this trademark*).
 4,208,211. **ACI BRANDS AND DESIGN**. ACI BRANDS INC., MULTIPLE CLASS, (INT. CLS. 35, 39 AND 42), (U.S. CLS. 100, 101, 102 AND 105). SN 77-914,130. PUB. 7-3-2012. FILED 1-18-2010.
 4,208,215. **MIDWEST (STANDARD CHARACTER)**. MIDWEST TILE SUPPLY CO., (U.S. CLS. 100, 101 AND 102). SN 77-939,227. PUB. 7-3-2012. FILED 2-18-2010.
 4,208,216. **MIDWEST AND DESIGN**. MIDWEST TILE SUPPLY CO., (U.S. CLS. 100, 101 AND 102). SN 77-939,230. PUB. 7-3-2012. FILED 2-18-2010.
 4,208,217. **BOXING 360 (STANDARD CHARACTER)**. BOXING 360 PROMOTIONS LLC, (U.S. CLS. 100, 101 AND 102). SN 77-946,680. PUB. 7-3-2012. FILED 2-27-2010.
 4,208,235 (*See Class 17 for this trademark*).
 4,208,238. **SKEMA SCHOOL OF KNOWLEDGE ECONOMY AND MANAGEMENT (STYLIZED)**. ASSOCIATION SKEMA BUSINESS SCHOOL, MULTIPLE CLASS, (INT. CLS. 35, 41 AND 42), (U.S. CLS. 100, 101, 102 AND 107). SN 79-084,107. PUB. 2-28-2012. FILED 4-13-2010.
 4,208,240. **REVENDEX. (STYLIZED)**. VANESSA KESSLER, MULTIPLE CLASS, (INT. CLS. 35 AND 36), (U.S. CLS. 100, 101 AND 102). SN 79-085,386. PUB. 7-3-2012. FILED 6-29-2010.
 4,208,242 (*See Class 16 for this trademark*).
 4,208,247 (*See Class 9 for this trademark*).
 4,208,256 (*See Class 25 for this trademark*).
 4,208,258 (*See Class 9 for this trademark*).
 4,208,275 (*See Class 9 for this trademark*).
 4,208,281. **ECS (STANDARD CHARACTER)**. EUROPEAN CARGO SERVICES (SOCIÉTÉ ANONYME), MULTIPLE CLASS, (INT. CLS. 35 AND 39), (U.S. CLS. 100, 101, 102 AND 105). SN 79-100,388. PUB. 7-3-2012. FILED 6-17-2011.
 4,208,288 (*See Class 25 for this trademark*).
 4,208,291 (*See Class 9 for this trademark*).
 4,208,295. **A-WORLD (STANDARD CHARACTER)**. ALDEASA, S.A., (U.S. CLS. 100, 101 AND 102). SN 79-101,346. PUB. 7-3-2012. FILED 2-16-2011.
 4,208,303 (*See Class 9 for this trademark*).
 4,208,319 (*See Class 7 for this trademark*).
 4,208,321 (*See Class 16 for this trademark*).
 4,208,329. **NOVA EXTERNAL VENTURING AND DESIGN**. COMPAGNIE DE SAINT-GOBAIN, MULTIPLE CLASS, (INT. CLS. 35, 38, 41 AND 42), (U.S. CLS. 100, 101, 102, 104 AND 107). SN 79-102,386. PUB. 7-3-2012. FILED 7-4-2011.
 4,208,331. **FOTON (STANDARD CHARACTER)**. BEIQI FOTON MOTOR CO., LTD., MULTIPLE CLASS, (INT. CLS. 35 AND 37), (U.S. CLS. 100, 101, 102, 103 AND 106). SN 79-102,612. PUB. 7-3-2012. FILED 4-21-2011.
 4,208,332. **GICON (STANDARD CHARACTER)**. GICON-GROBMANN INGENIEUR CONSULT GMBH, MULTIPLE CLASS, (INT. CLS. 35, 37 AND 42), (U.S. CLS. 100, 101, 102, 103 AND 106). SN 79-102,621. PUB. 7-3-2012. FILED 5-26-2011.
 4,208,337 (*See Class 9 for this trademark*).
 4,208,341. **MISOLO (STANDARD CHARACTER)**. STARTMAP B.V., MULTIPLE CLASS, (INT. CLS. 35, 38 AND 42), (U.S. CLS. 100, 101, 102 AND 104). SN 79-102,734. PUB. 7-3-2012. FILED 6-17-2011.
 4,208,346 (*See Class 16 for this trademark*).
 4,208,364 (*See Class 9 for this trademark*).
 4,208,365 (*See Class 7 for this trademark*).
 4,208,367 (*See Class 2 for this trademark*).
 4,208,382 (*See Class 9 for this trademark*).
 4,208,389 (*See Class 7 for this trademark*).
 4,208,401 (*See Class 1 for this trademark*).
 4,208,407 (*See Class 9 for this trademark*).
 4,208,446 (*See Class 16 for this trademark*).
 4,208,447 (*See Class 7 for this trademark*).
 4,208,448 (*See Class 7 for this trademark*).

- 4,208,449 (*See Class 5 for this trademark*).
 4,208,452 (*See Class 25 for this trademark*).
 4,208,456. **RELEVATE (STANDARD CHARACTER)**. TELEMATCH, INC., MULTIPLE CLASS, (INT. CLS. 35, 38 AND 39), (U.S. CLS. 100, 101, 102, 104 AND 105). SN 85-043,379. PUB. 7-3-2012. FILED 5-20-2010.
 4,208,462. **GREEN MONSTER (STANDARD CHARACTER)**. ST. JOHNS RIVERKEEPER, INC., (U.S. CLS. 100, 101 AND 102). SN 85-058,440. PUB. 5-17-2011. FILED 6-9-2010.
 4,208,471. **ROCK & REPUBLIC (STANDARD CHARACTER)**. R&R APPAREL COMPANY, LLC, (U.S. CLS. 100, 101 AND 102). SN 85-093,272. PUB. 7-3-2012. FILED 7-26-2010.
 4,208,480. **B BRADY AND DESIGN**. ERNST, NANCY-TYNNA BRADY, DBA THE BRADY GROUP LLC, AND ERNST, STEPHEN PHILIP, (U.S. CLS. 100, 101 AND 102). SN 85-123,439. PUB. 7-3-2012. FILED 9-5-2010.
 4,208,496. **SWEET ASYLUM BOUTIQUE AND DESIGN**. BASILE STACEY, (U.S. CLS. 100, 101 AND 102). SN 85-164,148. PUB. 7-3-2012. FILED 10-28-2010.
 4,208,497. **TEMASEK OPERATING PARTNERS (STANDARD CHARACTER)**. TEMASEK HOLDINGS (PRIVATE) LIMITED, MULTIPLE CLASS, (INT. CLS. 35, 36 AND 41), (U.S. CLS. 100, 101, 102 AND 107). SN 85-165,345. PUB. 7-3-2012. FILED 10-29-2010.
 4,208,498. **LONGREADS (STANDARD CHARACTER)**. ARMSTRONG, MARK W., MULTIPLE CLASS, (INT. CLS. 35 AND 41), (U.S. CLS. 100, 101, 102 AND 107). SN 85-166,163. PUB. 7-3-2012. FILED 11-1-2010.
 4,208,508. **NEED A USED CAR? (STANDARD CHARACTER)**. OFF LEASE ONLY, INC., DBA OFFLEASEONLY.COM, (U.S. CLS. 100, 101 AND 102). SN 85-173,996. PUB. 1-24-2012. FILED 11-10-2010.
 4,208,509. **HUEY HIPPO AND DESIGN**. JEROME J. PINCKNEY, DBA HUEY HIPPO ENTERPRISES, (U.S. CLS. 100, 101 AND 102). SN 85-175,591. PUB. 7-3-2012. FILED 11-12-2010.
 4,208,515. **DESIGNSHOP (STANDARD CHARACTER)**. MG TAYLOR CORPORATION, (U.S. CLS. 100, 101 AND 102). SN 85-188,448. PUB. 7-3-2012. FILED 12-1-2010.
 4,208,527. **PEARL (STANDARD CHARACTER)**. PILLSBURY WINTHROP SHAW PITTMAN LLP, MULTIPLE CLASS, (INT. CLS. 35, 39 AND 42), (U.S. CLS. 100, 101, 102 AND 105). SN 85-197,708. PUB. 7-3-2012. FILED 12-14-2010.
 4,208,543. **DATAQDIRECT (STANDARD CHARACTER)**. DATAQ INTERNET EQUIPMENT CORPORATION, (U.S. CLS. 100, 101 AND 102). SN 85-223,435. PUB. 7-3-2012. FILED 1-21-2011.
 4,208,550 (*See Class 25 for this trademark*).
 4,208,560. **HALLOWEEN OUTLET (STANDARD CHARACTER)**. PAPERKING INC., (U.S. CLS. 100, 101 AND 102). SN 85-247,826. PUB. 3-27-2012. FILED 2-22-2011.
 4,208,568. **HOPBIT (STANDARD CHARACTER)**. HOPSCOTCH GROUP, LLC, (U.S. CLS. 100, 101 AND 102). SN 85-264,035. PUB. 7-3-2012. FILED 3-10-2011.
 4,208,570. **ALEVASTORES.COM (STANDARD CHARACTER)**. AMERICAN MEDICAL SERVICES, (U.S. CLS. 100, 101 AND 102). SN 85-266,860. PUB. 8-2-2011. FILED 3-15-2011.
 4,208,576. **SALES HONING (STANDARD CHARACTER)**. BTI GROWTH ADVISORS, INC., (U.S. CLS. 100, 101 AND 102). SN 85-278,526. PUB. 7-3-2012. FILED S.R. 3-28-2011; AM. P.R. 8-16-2011.
 4,208,589. **WIND2SHARE (STYLIZED)**. WINDMILLS CAPITAL INC, MULTIPLE CLASS, (INT. CLS. 35, 36, 38 AND 45), (U.S. CLS. 100, 101, 102 AND 104). SN 85-295,584. PUB. 7-3-2012. FILED 4-14-2011.
 4,208,592. **INVENTORY SOURCE (STANDARD CHARACTER)**. INVENTORY SOURCE, LLC, DBA INVENTORY SOURCE, (U.S. CLS. 100, 101 AND 102). SN 85-296,540. PUB. 7-3-2012. FILED 4-15-2011.
 4,208,594. **TECHNEKES (STANDARD CHARACTER)**. TECHNEKES, LLC, (U.S. CLS. 100, 101 AND 102). SN 85-298,576. PUB. 7-3-2012. FILED 4-19-2011.
 4,208,598 (*See Class 3 for this trademark*).
 4,208,606. **INSPIRULINA AND DESIGN**. INSPIRAMA LLC, MULTIPLE CLASS, (INT. CLS. 35 AND 41), (U.S. CLS. 100, 101, 102 AND 107). SN 85-317,247. PUB. 7-3-2012. FILED 5-10-2011.
 4,208,623. **5050BMX (STANDARD CHARACTER)**. THUNDER HILL, LLC, (U.S. CLS. 100, 101 AND 102). SN 85-329,976. PUB. 7-3-2012. FILED 5-25-2011.
 4,208,625. **YOUR BEST SALESMAN (STANDARD CHARACTER)**. FATHOM SEO, LLC, AKA FATHOM, (U.S. CLS. 100, 101 AND 102). SN 85-333,082. PUB. 7-3-2012. FILED 5-28-2011.
 4,208,629. **A&E (STANDARD CHARACTER)**. AE JEWELERS, INC., (U.S. CLS. 100, 101 AND 102). SN 85-335,544. PUB. 7-3-2012. FILED 6-1-2011.
 4,208,641. **BLOOPN (STANDARD CHARACTER)**. BLOOPN S.A.C., (U.S. CLS. 100, 101 AND 102). SN 85-341,416. PUB. 7-3-2012. FILED 6-8-2011.
 4,208,644 (*See Class 4 for this trademark*).
 4,208,653. **A POWERFUL PARTNER IN A CHANGING WORLD (STANDARD CHARACTER)**. MCENERGY, INC., (U.S. CLS. 100, 101 AND 102). SN 85-346,930. PUB. 7-3-2012. FILED 6-15-2011.
 4,208,654. **FLYZIK AND DESIGN**. EMGS CONSULTING, S.L., MULTIPLE CLASS, (INT. CLS. 35 AND 41), (U.S. CLS. 100, 101, 102 AND 107). SN 85-347,265. PUB. 7-3-2012. FILED 6-15-2011.
 4,208,660. **JS ROYAL HOME AND DESIGN**. JIANGSU ROYAL HOME USA, INC., (U.S. CLS. 100, 101 AND 102). SN 85-350,375. PUB. 7-3-2012. FILED 6-20-2011.
 4,208,669. **THE CHILDREN'S HOUR (STANDARD CHARACTER)**. THE CHILDREN'S HOUR, LLC, (U.S. CLS. 100, 101 AND 102). SN 85-352,924. PUB. 7-3-2012. FILED 6-22-2011.
 4,208,690 (*See Class 22 for this trademark*).
 4,208,691. **E GOLF INSTRUCTION AND DESIGN**. WILLIAM A. CONSULTING, INC., (U.S. CLS. 100, 101 AND 102). SN 85-360,811. PUB. 7-3-2012. FILED 6-30-2011.
 4,208,693. **JIRAFE (STANDARD CHARACTER)**. JIRAFE INC., MULTIPLE CLASS, (INT. CLS. 35 AND 42), (U.S. CLS. 100, 101 AND 102). SN 85-361,101. PUB. 7-3-2012. FILED 6-30-2011.
 4,208,696. **DW TICKETS (STANDARD CHARACTER)**. CENTRAFI, INC., MULTIPLE CLASS, (INT. CLS. 35 AND 41), (U.S. CLS. 100, 101, 102 AND 107). SN 85-361,999. PUB. 7-3-2012. FILED 7-1-2011.
 4,208,698. **MIDDLE EAST INVESTMENT INITIATIVE (STANDARD CHARACTER)**. MIDDLE EAST INVESTMENT INITIATIVE (MEII), (U.S. CLS. 100, 101 AND 102). SN 85-362,925. PUB. 7-3-2012. FILED 7-5-2011.
 4,208,700 (*See Class 18 for this trademark*).
 4,208,703. **A BETTER WAY TO SEE THE WORLD (STANDARD CHARACTER)**. SVO TRADEMARK, INC., (U.S. CLS. 100, 101 AND 102). SN 85-363,875. PUB. 7-3-2012. FILED 7-6-2011.
 4,208,710 (*See Class 16 for this trademark*).
 4,208,718. **DIGITRONICO (STANDARD CHARACTER)**. DIGITRONICO CORPORATION, DBA DIGITRONICO, (U.S. CLS. 100, 101 AND 102). SN 85-368,063. PUB. 7-3-2012. FILED 7-11-2011.
 4,208,726. **ACMP ASSOCIATION OF CHANGE MANAGEMENT PROFESSIONALS AND DESIGN**. ASSOCIATION OF CHANGE MANAGEMENT PROFESSIONALS, (U.S. CLS. 100, 101 AND 102). SN 85-368,991. PUB. 7-3-2012. FILED 7-12-2011.
 4,208,746. **VERTIFI (STANDARD CHARACTER)**. VERTIFI SOFTWARE, LLC, MULTIPLE CLASS, (INT. CLS. 35, 36, 38, 39, 41 AND 45), (U.S. CLS. 100, 101, 102, 104, 105 AND 107). SN 85-373,465. PUB. 7-3-2012. FILED 7-18-2011.
 4,208,755. **CLEAR 4 ONE (STANDARD CHARACTER)**. TWENTY-NINE PALMS BAND OF MISSION INDIANS, MULTIPLE CLASS, (INT. CLS. 35 AND 42), (U.S. CLS. 100, 101 AND 102). SN 85-374,381. PUB. 12-13-2011. FILED 7-18-2011.
 4,208,756. **MYSTERY GUILD (STANDARD CHARACTER)**. DOUBLEDAY DIRECT, INC., (U.S. CLS. 100, 101 AND 102). SN 85-374,567. PUB. 7-3-2012. FILED 7-19-2011.
 4,208,768. **DREAM IT . PLAN IT . DO IT . SHARE IT (STANDARD CHARACTER)**. I2ASOLUTIONS, (U.S. CLS. 100, 101 AND 102). SN 85-376,322. PUB. 7-3-2012. FILED 7-20-2011.
 4,208,770 (*See Class 30 for this trademark*).
 4,208,777. **EDISABILITYUNIVERSITY (STANDARD CHARACTER)**. EDISABILITY, INC., (U.S. CLS. 100, 101 AND 102). SN 85-376,901. PUB. 7-3-2012. FILED 7-21-2011.

- 4,208,779. **CRUISE CAPITAL OF THE WORLD (STANDARD CHARACTER)**. MIAMI-DADE COUNTY, FLORIDA, DBA PORT OF MIAMI, MULTIPLE CLASS, (INT. CLS. 35 AND 39), (U.S. CLS. 100, 101, 102 AND 105). SN 85-377,157. PUB. 7-3-2012. FILED 7-21-2011.
- 4,208,781. **NATIONAL PAWNBROKERS ASSOCIATION PAWN EXPO AND DESIGN**. NATIONAL PAWNBROKERS ASSOCIATION, INC., (U.S. CLS. 100, 101 AND 102). SN 85-377,679. PUB. 7-3-2012. FILED 7-21-2011.
- 4,208,791 (*See Class 25 for this trademark*).
- 4,208,805. **EASTLAND FOOD CORPORATION (STANDARD CHARACTER)**. EASTLAND FOOD CORPORATION, (U.S. CLS. 100, 101 AND 102). SN 85-384,776. PUB. 7-3-2012. FILED 7-29-2011.
- 4,208,808. **GETTING SMART (STANDARD CHARACTER)**. EDUCATIONAL & PROFESSIONAL SERVICES INT., INC., (U.S. CLS. 100, 101 AND 102). SN 85-385,808. PUB. 7-3-2012. FILED 8-1-2011.
- 4,208,822. **CREDIT UNION NATIONAL ASSOCIATION (STANDARD CHARACTER)**. CREDIT UNION NATIONAL ASSOCIATION, INC., (U.S. CLS. 100, 101 AND 102). SN 85-388,705. PUB. 3-27-2012. FILED 8-3-2011.
- 4,208,825. **YOUNG LIVING ESSENTIAL OILS AND DESIGN**. YL HOLDINGS, INC., (U.S. CLS. 100, 101 AND 102). SN 85-388,853. PUB. 7-3-2012. FILED 8-3-2011.
- 4,208,833. **CARLO'S BAKERY (STANDARD CHARACTER)**. BUDDY V ENTERTAINMENT LLC, (U.S. CLS. 100, 101 AND 102). SN 85-391,526. PUB. 7-3-2012. FILED 8-6-2011.
- 4,208,843. **ASSOCIA ON CALL (STANDARD CHARACTER)**. ASSOCIATIONS, INC., MULTIPLE CLASS, (INT. CLS. 35 AND 37), (U.S. CLS. 100, 101, 102, 103 AND 106). SN 85-394,334. PUB. 7-3-2012. FILED 8-10-2011.
- 4,208,849. **GALVAN GROUP AND DESIGN**. GALVAN FINANCIAL CORP. (U.S. CLS. 100, 101 AND 102). SN 85-396,055. PUB. 7-3-2012. FILED 8-11-2011.
- 4,208,854. **LONG LIVE HAPPY HOMES (STANDARD CHARACTER)**. HOME BUYERS WARRANTY CORPORATION, MULTIPLE CLASS, (INT. CLS. 35 AND 36), (U.S. CLS. 100, 101 AND 102). SN 85-397,075. PUB. 7-3-2012. FILED 8-12-2011.
- 4,208,857. **MISCELLANEOUS DESIGN**. SKY DIGITAL (SHENZHEN) CO., LTD., (U.S. CLS. 100, 101 AND 102). SN 85-398,535. PUB. 7-3-2012. FILED 8-15-2011.
- 4,208,859. **MISCELLANEOUS DESIGN**. THAT-A-WAY, LLC, (U.S. CLS. 100, 101 AND 102). SN 85-399,184. PUB. 7-3-2012. FILED 8-16-2011.
- 4,208,863. **NETWORK FOR GOOD (STANDARD CHARACTER)**. NETWORK FOR GOOD, INC., MULTIPLE CLASS, (INT. CLS. 35, 36 AND 45), (U.S. CLS. 100, 101 AND 102). SN 85-400,289. PUB. 7-3-2012. FILED 8-17-2011.
- 4,208,874. **CATALYST CONNECTION (STANDARD CHARACTER)**. CATALYST CONNECTION, INC., MULTIPLE CLASS, (INT. CLS. 35 AND 41), (U.S. CLS. 100, 101, 102 AND 107). SN 85-402,488. PUB. 7-3-2012. FILED 8-19-2011.
- 4,208,896. **APPLE ENERGY GROUP (STANDARD CHARACTER)**. APPLE ENERGY GROUP LLC, (U.S. CLS. 100, 101 AND 102). SN 85-411,330. PUB. 1-24-2012. FILED 8-31-2011.
- 4,208,897. **CASH CONNECT (STANDARD CHARACTER)**. WILMINGTON SAVINGS FUND SOCIETY, FSB, MULTIPLE CLASS, (INT. CLS. 35 AND 42), (U.S. CLS. 100, 101 AND 102). SN 85-411,424. PUB. 7-3-2012. FILED 8-31-2011.
- 4,208,903 (*See Class 9 for this trademark*).
- 4,208,913. **PAYLESS PIPES (STANDARD CHARACTER)**. NEW ORLEANS CIGAR COMPANY, (U.S. CLS. 100, 101 AND 102). SN 85-414,392. PUB. 2-21-2012. FILED 9-2-2011.
- 4,208,919. **OFFER ALLIANCE AND DESIGN**. PMA MEDIA GROUP, (U.S. CLS. 100, 101 AND 102). SN 85-415,760. PUB. 7-3-2012. FILED 9-6-2011.
- 4,208,923. **ORCHARD ADVISORS (STANDARD CHARACTER)**. ORCHARD ADVISORS, LLC, (U.S. CLS. 100, 101 AND 102). SN 85-417,922. PUB. 7-3-2012. FILED 9-8-2011.
- 4,208,925. **IMPACT STAFFING "WORKFORCE SOLUTIONS" (STYLIZED)**. IMPACT STAFFING, LLC, DBA IMPACT STAFFING, (U.S. CLS. 100, 101 AND 102). SN 85-419,305. PUB. 7-3-2012. FILED 9-9-2011.
- 4,208,930. **LV2BFIT AND DESIGN**. LV2BFIT, INC., (U.S. CLS. 100, 101 AND 102). SN 85-420,889. PUB. 7-3-2012. FILED 9-12-2011.
- 4,208,931 (*See Class 4 for this trademark*).
- 4,208,932. **FEELS GOOD TO BEAT IT. (STANDARD CHARACTER)**. GAMEWRECKERS, LLC, (U.S. CLS. 100, 101 AND 102). SN 85-421,550. PUB. 7-3-2012. FILED 9-13-2011.
- 4,208,934. **I-AGUIRRE (STANDARD CHARACTER)**. ROBOAM AGUIRRE, (U.S. CLS. 100, 101 AND 102). SN 85-422,022. PUB. 7-3-2012. FILED 9-14-2011.
- 4,208,939 (*See Class 14 for this trademark*).
- 4,208,940. **EXECUTIVE LINKS AND DESIGN**. EXECUTIVE LINKS, LLC, (U.S. CLS. 100, 101 AND 102). SN 85-428,167. PUB. 3-27-2012. FILED 9-21-2011.
- 4,208,948 (*See Class 9 for this trademark*).
- 4,208,957. **ANTIQUÉ MALLS COM AND DESIGN**. VINTAGE SOFTWARE, LLC, (U.S. CLS. 100, 101 AND 102). SN 85-435,920. PUB. 7-3-2012. FILED 9-29-2011.
- 4,208,958. **ESTATE SALES NET AND DESIGN**. VINTAGE SOFTWARE, LLC, (U.S. CLS. 100, 101 AND 102). SN 85-435,929. PUB. 7-3-2012. FILED 9-29-2011.
- 4,208,966. **LIQUOR LICENSE CONNECTION AND DESIGN**. CONNECTWARE TECHNOLOGIES, LLC, DBA LIQUOR-LICENSECONNECTION.COM, MULTIPLE CLASS, (INT. CLS. 35 AND 38), (U.S. CLS. 100, 101, 102 AND 104). SN 85-441,138. PUB. 7-3-2012. FILED S.R. 10-6-2011; AM. P.R. 3-14-2012.
- 4,208,967. **ANOTHER CHANCEE, INC "HELPING PEOPLE EXPERIENCE LIFE MORE ABUNDANTLY" ANOTHER CHANCEE, INC. AND DESIGN**. ANOTHER CHANCEE INCORPORATED, DBA ANOTHER CHANCEE INC, (U.S. CLS. 100, 101 AND 102). SN 85-441,645. PUB. 7-3-2012. FILED 10-7-2011.
- 4,208,968. **BLACK DOG SALVAGE AND DESIGN**. BLACK DOG SALVAGE, INC., (U.S. CLS. 100, 101 AND 102). SN 85-441,984. PUB. 7-3-2012. FILED 10-7-2011.
- 4,208,973. **SPORTSMANSLIQUIDATION.COM AND DESIGN**. SPORTSMANSLIQUIDATION.COM LLC, (U.S. CLS. 100, 101 AND 102). SN 85-443,386. PUB. 7-3-2012. FILED 10-10-2011.
- 4,208,974. **AMRI (STANDARD CHARACTER)**. LOANSIFTER, INC., (U.S. CLS. 100, 101 AND 102). SN 85-443,874. PUB. 7-3-2012. FILED 10-10-2011.
- 4,208,975. **BLACK DOG SALVAGE (STANDARD CHARACTER)**. BLACK DOG SALVAGE, INC., (U.S. CLS. 100, 101 AND 102). SN 85-444,015. PUB. 7-3-2012. FILED 10-11-2011.
- 4,208,986. **ONE FOR ONE (STANDARD CHARACTER)**. MY-COSKIE, LLC, (U.S. CLS. 100, 101 AND 102). SN 85-447,150. PUB. 3-27-2012. FILED 10-13-2011.
- 4,208,988. **LEADING EDGE AUTO REFINISHES, INC. AND DESIGN**. LEADING EDGE AUTO REFINISHES, INC., (U.S. CLS. 100, 101 AND 102). SN 85-447,402. PUB. 7-3-2012. FILED 10-14-2011.
- 4,208,995. **VANGUARD ENERGY PARTNERS, LLC AND DESIGN**. VANGUARD ENERGY PARTNERS, LLC, MULTIPLE CLASS, (INT. CLS. 35, 36, 37 AND 42), (U.S. CLS. 100, 101, 102, 103 AND 106). SN 85-448,604. PUB. 7-3-2012. FILED 10-17-2011.
- 4,208,996. **DESIGN FINANCE MAINTAIN BUILD EDUCATE MONITOR AND DESIGN**. VANGUARD ENERGY PARTNERS, LLC, MULTIPLE CLASS, (INT. CLS. 35, 36, 37 AND 42), (U.S. CLS. 100, 101, 102, 103 AND 106). SN 85-448,608. PUB. 7-3-2012. FILED 10-17-2011.
- 4,209,002. **DOMINGO'S ITALIAN DELI (STANDARD CHARACTER)**. CARLO GHAILIAN, MULTIPLE CLASS, (INT. CLS. 35 AND 43), (U.S. CLS. 100, 101 AND 102). SN 85-449,296. PUB. 7-3-2012. FILED 10-17-2011.
- 4,209,006. **THE WHOLESALE GIANT (STANDARD CHARACTER)**. THE B&F SYSTEM, INC., (U.S. CLS. 100, 101 AND 102). SN 85-449,915. PUB. 3-27-2012. FILED 10-18-2011.
- 4,209,008. **MELISSA WHITAKER INTERNATIONAL (STANDARD CHARACTER)**. MELISSA WHITAKER INTERNATIONAL, LLC, (U.S. CLS. 100, 101 AND 102). SN 85-451,342. PUB. 7-3-2012. FILED 10-19-2011.
- 4,209,010. **FLEETEYES (STANDARD CHARACTER)**. INTER-MEDIX CORPORATION, MULTIPLE CLASS, (INT. CLS. 35, 42 AND 45), (U.S. CLS. 100, 101 AND 102). SN 85-451,729. PUB. 7-3-2012. FILED 10-20-2011.
- 4,209,014. **MOONSHINE UNIVERSITY (STANDARD CHARACTER)**. DISTILLED SPIRITS EPICENTER, LLC, MULTIPLE CLASS, (INT. CLS. 35 AND 41), (U.S. CLS. 100, 101, 102

- AND 107). SN 85-452,997. PUB. 7-3-2012. FILED 10-21-2011.
- 4,209,033. **RISQUÉ VIDEO AND DESIGN. RISQUE VIDEO CORP.**, MULTIPLE CLASS, (INT. CLS. 35 AND 41), (U.S. CLS. 100, 101, 102 AND 107). SN 85-464,453. PUB. 7-3-2012. FILED 11-4-2011.
- 4,209,034. **RISQUE VIDEO (STANDARD CHARACTER). RISQUE VIDEO CORP.**, MULTIPLE CLASS, (INT. CLS. 35 AND 41), (U.S. CLS. 100, 101, 102 AND 107). SN 85-464,537. PUB. 7-3-2012. FILED 11-4-2011.
- 4,209,041. **CONVIO AND DESIGN. CONVIO, INC.**, MULTIPLE CLASS, (INT. CLS. 35 AND 42), (U.S. CLS. 100, 101 AND 102). SN 85-469,351. PUB. 7-3-2012. FILED 11-10-2011.
- 4,209,043. **CONVIO AND DESIGN. CONVIO, INC.**, MULTIPLE CLASS, (INT. CLS. 35 AND 42), (U.S. CLS. 100, 101 AND 102). SN 85-469,462. PUB. 7-3-2012. FILED 11-10-2011.
- 4,209,045. **MISCELLANEOUS DESIGN. SCOOTERS COFFEE, LLC**, MULTIPLE CLASS, (INT. CLS. 35 AND 43), (U.S. CLS. 100, 101 AND 102). SN 85-470,216. PUB. 7-3-2012. FILED 11-11-2011.
- 4,209,046 (*See Class 1 for this trademark*).
- 4,209,060. **STORIED DIAMONDS (STANDARD CHARACTER). AVILAN, LLC**, (U.S. CLS. 100, 101 AND 102). SN 85-473,393. PUB. 7-3-2012. FILED 11-15-2011.
- 4,209,069. **OCS (STYLIZED). OMNI COMPUTER SERVICES, INC.**, AKA OCS, MULTIPLE CLASS, (INT. CLS. 35 AND 40), (U.S. CLS. 100, 101, 102, 103 AND 106). SN 85-478,516. PUB. 5-8-2012. FILED 11-22-2011.
- 4,209,084. **MGAC MARK G ANDERSON CONSULTANTS, INC. AND DESIGN. MARK G. ANDERSON CONSULTANTS, INC.**, MULTIPLE CLASS, (INT. CLS. 35 AND 37), (U.S. CLS. 100, 101, 102, 103 AND 106). SN 85-486,058. PUB. 7-3-2012. FILED 12-2-2011.
- 4,209,087. **ANNE V (STANDARD CHARACTER). VYALITSYNA, ANNE**, MULTIPLE CLASS, (INT. CLS. 35 AND 41), (U.S. CLS. 100, 101, 102 AND 107). SN 85-487,618. PUB. 7-3-2012. FILED 12-5-2011.
- 4,209,091. **PUBLIC HEALTH CAREERMART (STANDARD CHARACTER). AMERICAN PUBLIC HEALTH ASSOCIATION**, (U.S. CLS. 100, 101 AND 102). SN 85-489,124. PUB. 7-3-2012. FILED 12-7-2011.
- 4,209,094. **ALL YOU NEED TO REACH THE BEACH (STANDARD CHARACTER). L&L WINGS, INC.**, (U.S. CLS. 100, 101 AND 102). SN 85-489,630. PUB. 7-3-2012. FILED 12-7-2011.
- 4,209,103. **ARDX (STANDARD CHARACTER). A. REDDIX & ASSOCIATES**, (U.S. CLS. 100, 101 AND 102). SN 85-491,144. PUB. 7-3-2012. FILED 12-8-2011.
- 4,209,126. **SIMPLI (STANDARD CHARACTER). TECMARK, INC.**, MULTIPLE CLASS, (INT. CLS. 35 AND 42), (U.S. CLS. 100, 101 AND 102). SN 85-497,336. PUB. 7-3-2012. FILED 12-16-2011.
- 4,209,130. **BASKETTES (STANDARD CHARACTER). AYS ORGANIZATION, INC.**, (U.S. CLS. 100, 101 AND 102). SN 85-498,239. PUB. 7-3-2012. FILED 12-18-2011.
- 4,209,150. **WHITSONS (STANDARD CHARACTER). WHITSONS FOOD SERVICE CORP.**, MULTIPLE CLASS, (INT. CLS. 35, 39, 43 AND 44), (U.S. CLS. 100, 101, 102 AND 105). SN 85-502,530. PUB. 7-3-2012. FILED 12-22-2011.
- 4,209,152 (*See Class 9 for this trademark*).
- 4,209,157. **TURBOCHARGERPROS.COM (STANDARD CHARACTER). MERIDIAN RACK & PINION, DBA TURBOCHARGERPROS.COM**, (U.S. CLS. 100, 101 AND 102). SN 85-504,110. PUB. 7-3-2012. FILED 12-27-2011.
- 4,209,158. **DISCOUNTAPARTS.COM (STANDARD CHARACTER). MERIDIAN RACK & PINION, DBA DISCOUNTAPARTS.COM**, (U.S. CLS. 100, 101 AND 102). SN 85-504,158. PUB. 7-3-2012. FILED 12-27-2011.
- 4,209,167. **FORTCOLLINSACCOUNTING.COM (STANDARD CHARACTER). ANDREA J. SMITH & ASSOCIATES, INC.**, (U.S. CLS. 100, 101 AND 102). SN 85-505,488. PUB. 7-3-2012. FILED 12-29-2011.
- 4,209,175. **URBAN PIONEER (STANDARD CHARACTER). URBAN PIONEER PROPERTY MANAGEMENT, INC.**, MULTIPLE CLASS, (INT. CLS. 35 AND 36), (U.S. CLS. 100, 101 AND 102). SN 85-506,026. PUB. 7-3-2012. FILED 12-29-2011.
- 4,209,179. **DREYER MOTORSPORTS (STANDARD CHARACTER). DREYER, MICHAEL**, (U.S. CLS. 100, 101 AND 102). SN 85-507,526. PUB. 7-3-2012. FILED 1-3-2012.
- 4,209,182. **THE GLOBAL REPORT CARD (STANDARD CHARACTER). GEORGE W. BUSH FOUNDATION**, MULTIPLE CLASS, (INT. CLS. 35 AND 41), (U.S. CLS. 100, 101, 102 AND 107). SN 85-508,388. PUB. 7-3-2012. FILED 1-4-2012.
- 4,209,197. **LEGALAIDERS (STYLIZED). PROBELGIN, INC.**, (U.S. CLS. 100, 101 AND 102). SN 85-511,019. PUB. 7-3-2012. FILED 1-6-2012.
- 4,209,200. **TAX LOVIN' (STANDARD CHARACTER). COOPER, JOSHUA I.**, (U.S. CLS. 100, 101 AND 102). SN 85-511,244. PUB. 7-3-2012. FILED 1-8-2012.
- 4,209,215. **JAMMER CYCLE PRODUCTS AND DESIGN. DAEIL USA, INC.**, (U.S. CLS. 100, 101 AND 102). SN 85-514,710. PUB. 7-3-2012. FILED 1-12-2012.
- 4,209,229. **AMERICA CHINA SOCIETY OF INDIANA AND DESIGN. AMERICA CHINA SOCIETY OF INDIANA, INC.**, (U.S. CLS. 100, 101 AND 102). SN 85-517,161. PUB. 7-3-2012. FILED 1-16-2012.
- 4,209,239. **EE INFINITELEVATION AND DESIGN. INFINITE ELEVATION, LLC**, (U.S. CLS. 100, 101 AND 102). SN 85-518,158. PUB. 7-3-2012. FILED 1-17-2012.
- 4,209,242. **STAIRPARTSNOW (STANDARD CHARACTER). STAIR PARTS NOW LLC**, (U.S. CLS. 100, 101 AND 102). SN 85-518,555. PUB. 7-3-2012. FILED 1-17-2012.
- 4,209,247. **SAFECAST (STANDARD CHARACTER). MOMOKO ITO FOUNDATION**, (U.S. CLS. 100, 101 AND 102). SN 85-519,045. PUB. 7-3-2012. FILED 1-18-2012.
- 4,209,248. **MISCELLANEOUS DESIGN. MOMOKO ITO FOUNDATION**, (U.S. CLS. 100, 101 AND 102). SN 85-519,062. PUB. 7-3-2012. FILED 1-18-2012.
- 4,209,255. **TRUCKSTOPS OF IOWA AND DESIGN. IOWA 80 TRUCKSTOP, INC.**, (U.S. CLS. 100, 101 AND 102). SN 85-519,445. PUB. 7-3-2012. FILED 1-18-2012.
- 4,209,273 (*See Class 25 for this trademark*).
- 4,209,275. **A-LIST STAFF (STANDARD CHARACTER). THE A GROUP, LLC**, (U.S. CLS. 100, 101 AND 102). SN 85-520,877. PUB. 7-3-2012. FILED 1-20-2012.
- 4,209,279. **WCW WERNER CYCLE WORKS (STYLIZED). WERNER MANAGEMENT, INC.**, MULTIPLE CLASS, (INT. CLS. 35 AND 37), (U.S. CLS. 100, 101, 102, 103 AND 106). SN 85-521,017. PUB. 7-3-2012. FILED 1-20-2012.
- 4,209,282. **MONEYVOTE (STANDARD CHARACTER). EVOLVING STRATEGIES, LLC**, (U.S. CLS. 100, 101 AND 102). SN 85-521,138. PUB. 7-3-2012. FILED 1-20-2012.
- 4,209,288. **THE MATTRESS GUYS (STANDARD CHARACTER). UNCLAIMED SURPLUS LIQUIDATIONS LLC**, (U.S. CLS. 100, 101 AND 102). SN 85-521,255. PUB. 7-3-2012. FILED 1-20-2012.
- 4,209,299. **COOPER LLC FOCUSES ON BUSINESS ISSUES THAT DRIVE GROWTH, PROFITABILITY AND VALUE (STANDARD CHARACTER). F H COOPER LLC**, (U.S. CLS. 100, 101 AND 102). SN 85-521,978. PUB. 7-3-2012. FILED 1-21-2012.
- 4,209,300. **MISCELLANEOUS DESIGN. INTEGRATED PAYROLL SYSTEMS, INC.**, MULTIPLE CLASS, (INT. CLS. 35 AND 36), (U.S. CLS. 100, 101 AND 102). SN 85-521,983. PUB. 7-3-2012. FILED 1-21-2012.
- 4,209,303. **MOBILE WEB UP (STANDARD CHARACTER). MOBILE WEB UP**, MULTIPLE CLASS, (INT. CLS. 35 AND 42), (U.S. CLS. 100, 101 AND 102). SN 85-522,286. PUB. 7-3-2012. FILED 1-23-2012.
- 4,209,305. **COMPASS ROSE EVENTS AND DESIGN. COMPASS ROSE EVENTS, INC.**, (U.S. CLS. 100, 101 AND 102). SN 85-522,336. PUB. 7-3-2012. FILED 1-23-2012.
- 4,209,314. **KAPRUKA (STANDARD CHARACTER). KAPRUKA.COM LLC**, (U.S. CLS. 100, 101 AND 102). SN 85-522,631. PUB. 7-3-2012. FILED 1-23-2012.
- 4,209,319. **LA AUTO SHOW (STANDARD CHARACTER). ANSA PRODUCTIONS, INC.**, DBA LA AUTO SHOW, (U.S. CLS. 100, 101 AND 102). SN 85-522,836. PUB. 7-3-2012. FILED 1-23-2012.
- 4,209,327. **TANDEM THE APPLIED SCIENCE OF TEAMING AND DESIGN. DLK CONSULTANTS LLC**, (U.S. CLS. 100, 101 AND 102). SN 85-523,136. PUB. 7-3-2012. FILED 1-23-2012.
- 4,209,336. **USA FAST TAX AND DESIGN. GIBSON, PANDWE, AND NALLS, NATASHA**, (U.S. CLS. 100, 101 AND 102). SN 85-523,700. PUB. 7-3-2012. FILED 1-24-2012.

- 4,209,344. **MY SOLO PLAN (STANDARD CHARACTER)**. ROBERT G BRUECHERT ATTORNEY AT LAW PC, DBA THE BRUECHERT LAW FIRM, MULTIPLE CLASS, (INT. CLS. 35 AND 45), (U.S. CLS. 100, 101 AND 102). SN 85-523,848. PUB. 7-3-2012. FILED 1-24-2012.
- 4,209,360. **FROM INCEPTION TO COMPLETION (STANDARD CHARACTER)**. PRESIDIUM AVIATION, INC., (U.S. CLS. 100, 101 AND 102). SN 85-524,685. PUB. 7-3-2012. FILED 1-25-2012.
- 4,209,373. **REAL ESTATE...ALWAYS A WISE MOVE! (STANDARD CHARACTER)**. GREATER TAMPA ASSOCIATION OF REALTORS, INC., AKA GTAR, (U.S. CLS. 100, 101 AND 102). SN 85-525,125. PUB. 7-3-2012. FILED 1-25-2012.
- 4,209,374. **PLATT AND DESIGN. HARMONY INVESTMENTS LIMITED PARTNERSHIP**, (U.S. CLS. 100, 101 AND 102). SN 85-525,214. PUB. 7-3-2012. FILED 1-25-2012.
- 4,209,381. **FUSIONFLOW MEDIA (STANDARD CHARACTER)**. FUSION FLOW MEDIA, (U.S. CLS. 100, 101 AND 102). SN 85-525,563. PUB. 7-3-2012. FILED 1-26-2012.
- 4,209,386. **GALAXY ARMY NAVY (STANDARD CHARACTER)**. HJ DISTRIBUTION LLC, (U.S. CLS. 100, 101 AND 102). SN 85-525,850. PUB. 7-3-2012. FILED 1-26-2012.
- 4,209,404 (*See Class 18 for this trademark*).
- 4,209,405. **FRANCHISE GATOR .COM AND DESIGN. FRANCHISE GATOR, LLC**, (U.S. CLS. 100, 101 AND 102). SN 85-526,285. PUB. 7-3-2012. FILED 1-26-2012.
- 4,209,408. **POP! BOUTIQUE GIFTS & ACCESSORIES AND DESIGN. DERRIK WEST**, (U.S. CLS. 100, 101 AND 102). SN 85-526,362. PUB. 7-3-2012. FILED 1-26-2012.
- 4,209,410. **CASTLE & COOKE (STANDARD CHARACTER)**. CASTLE & COOKE, INC., MULTIPLE CLASS, (INT. CLS. 35, 36, 37 AND 39), (U.S. CLS. 100, 101, 102, 103, 105 AND 106). SN 85-526,403. PUB. 7-3-2012. FILED 1-26-2012.
- 4,209,412. **ARMY UNIVERSE (STANDARD CHARACTER)**. HJ DISTRIBUTION LLC, (U.S. CLS. 100, 101 AND 102). SN 85-526,439. PUB. 7-3-2012. FILED 1-26-2012.
- 4,209,413. **EMMALINE BRIDE (STANDARD CHARACTER)**. ARENDOSKI, EMMA, (U.S. CLS. 100, 101 AND 102). SN 85-526,444. PUB. 7-3-2012. FILED 1-26-2012.
- 4,209,420. **TABS WORLDVIEW (STANDARD CHARACTER)**. TABS GROUP, INC., (U.S. CLS. 100, 101 AND 102). SN 85-526,865. PUB. 7-3-2012. FILED 1-27-2012.
- 4,209,424. **IT'S ALL ABOUT THE STUFF! (STANDARD CHARACTER)**. BUD STYER AND ASSOCIATES, LLC, MULTIPLE CLASS, (INT. CLS. 35 AND 43), (U.S. CLS. 100, 101 AND 102). SN 85-527,441. PUB. 7-3-2012. FILED 1-27-2012.
- 4,209,425. **CAMPING FOR THE FUN OF IT (STANDARD CHARACTER)**. BUD STYER AND ASSOCIATES, LLC, MULTIPLE CLASS, (INT. CLS. 35 AND 43), (U.S. CLS. 100, 101 AND 102). SN 85-527,514. PUB. 7-3-2012. FILED 1-27-2012.
- 4,209,429. **FABULOUSITY INTERNATIONAL, INC (STANDARD CHARACTER)**. AKINLOYE, TANISHA E., (U.S. CLS. 100, 101 AND 102). SN 85-527,782. PUB. 7-3-2012. FILED 1-27-2012.
- 4,209,437. **NEWTON CONSULTING (STANDARD CHARACTER)**. NEWTON CONSULTING, LLC, MULTIPLE CLASS, (INT. CLS. 35, 36 AND 42), (U.S. CLS. 100, 101 AND 102). SN 85-528,689. PUB. 7-3-2012. FILED 1-30-2012.
- 4,209,438. **PRECIOUSTEES (STANDARD CHARACTER)**. GOTTSMAN, AKEMI, DBA PRECIOUSTEES, (U.S. CLS. 100, 101 AND 102). SN 85-528,797. PUB. 7-3-2012. FILED 1-30-2012.
- 4,209,446. **DFI MAIL (STYLIZED)**. DFI TECHNOLOGIES, INC., (U.S. CLS. 100, 101 AND 102). SN 85-529,159. PUB. 7-3-2012. FILED 1-30-2012.
- 4,209,448. **MIDDAY DASH (STANDARD CHARACTER)**. NM NEVADA TRUST, (U.S. CLS. 100, 101 AND 102). SN 85-529,736. PUB. 7-3-2012. FILED 1-31-2012.
- 4,209,449. **PERFUME CHALET (STANDARD CHARACTER)**. LOAISIGA GROUP, INC., DBA PERFUME CHALET, (U.S. CLS. 100, 101 AND 102). SN 85-529,770. PUB. 7-3-2012. FILED 1-31-2012.
- 4,209,452. **LUV HOMES (STANDARD CHARACTER)**. CMH HOMES, INC., (U.S. CLS. 100, 101 AND 102). SN 85-530,097. PUB. 7-3-2012. FILED 1-31-2012.
- 4,209,453. **PREMIER COLLECTIBLES (STANDARD CHARACTER)**. NEW YORK MINT, LLC, (U.S. CLS. 100, 101 AND 102). SN 85-530,130. PUB. 7-3-2012. FILED 1-31-2012.
- 4,209,456 (*See Class 16 for this trademark*).
- 4,209,480. **VEGUARY (STANDARD CHARACTER)**. ANDREW UDELL, (U.S. CLS. 100, 101 AND 102). SN 85-533,715. PUB. 7-3-2012. FILED 2-3-2012.
- 4,209,485. **COUPNET (STANDARD CHARACTER)**. RICK T. HAMMOND, (U.S. CLS. 100, 101 AND 102). SN 85-534,562. PUB. 7-3-2012. FILED 2-6-2012.
- 4,209,488. **DFY (STANDARD CHARACTER)**. DORMIFY, INC., (U.S. CLS. 100, 101 AND 102). SN 85-534,777. PUB. 7-3-2012. FILED 2-6-2012.
- 4,209,502. **THE FOUR LENSES OF INNOVATION (STANDARD CHARACTER)**. ROWAN GIBSON, (U.S. CLS. 100, 101 AND 102). SN 85-537,404. PUB. 7-3-2012. FILED 2-8-2012.
- 4,209,518. **P AND DESIGN. THE FRANCIS E. PARKER MEMORIAL HOME, INC., AKA PARKER HOME, MULTIPLE CLASS, (INT. CLS. 35 AND 44), (U.S. CLS. 100, 101 AND 102)**. SN 85-538,426. PUB. 7-3-2012. FILED 2-9-2012.
- 4,209,525. **PTS AND DESIGN. CLP RESOURCES, INC., (U.S. CLS. 100, 101 AND 102)**. SN 85-538,637. PUB. 7-3-2012. FILED 2-9-2012.
- 4,209,541. **TROP ADVANTAGE AND DESIGN. NEW TROPICANA HOLDINGS, INC., MULTIPLE CLASS, (INT. CLS. 35 AND 41), (U.S. CLS. 100, 101, 102 AND 107)**. SN 85-539,453. PUB. 7-3-2012. FILED 2-10-2012.
- 4,209,543. **SUBWAY PARTNERS (STANDARD CHARACTER)**. DOCTOR'S ASSOCIATES INC., MULTIPLE CLASS, (INT. CLS. 35 AND 42), (U.S. CLS. 100, 101 AND 102). SN 85-539,596. PUB. 7-3-2012. FILED 2-10-2012.
- 4,209,548. **SUBWAY (STANDARD CHARACTER)**. DOCTOR'S ASSOCIATES INC., MULTIPLE CLASS, (INT. CLS. 35 AND 42), (U.S. CLS. 100, 101 AND 102). SN 85-539,838. PUB. 7-3-2012. FILED 2-10-2012.
- 4,209,554. **LIVE UP (STANDARD CHARACTER)**. CITY OF TEHACHAPI, (U.S. CLS. 100, 101 AND 102). SN 85-539,928. PUB. 7-3-2012. FILED 2-10-2012.
- 4,209,576. **ONE CLEAR PRICE (STANDARD CHARACTER)**. KUNI WEST SLOPE MOTORS, L.L.C., (U.S. CLS. 100, 101 AND 102). SN 85-540,900. PUB. 7-3-2012. FILED 2-13-2012.
- 4,209,577. **ONE CLEAR PRICE AND DESIGN. KUNI WEST SLOPE MOTORS, L.L.C., (U.S. CLS. 100, 101 AND 102)**. SN 85-540,906. PUB. 7-3-2012. FILED 2-13-2012.
- 4,209,578 (*See Class 18 for this trademark*).
- 4,209,579. **PARKER (STANDARD CHARACTER)**. THE FRANCIS E. PARKER MEMORIAL HOME, INC., MULTIPLE CLASS, (INT. CLS. 35 AND 44), (U.S. CLS. 100, 101 AND 102). SN 85-540,944. PUB. 7-3-2012. FILED 2-13-2012.
- 4,209,591. **O9 (STANDARD CHARACTER)**. O9 SOLUTIONS, INC., MULTIPLE CLASS, (INT. CLS. 35 AND 42), (U.S. CLS. 100, 101 AND 102). SN 85-541,087. PUB. 7-3-2012. FILED 2-13-2012.
- 4,209,592. **O9 SMART.SIMPLE (STANDARD CHARACTER)**. O9 SOLUTIONS, INC., MULTIPLE CLASS, (INT. CLS. 35 AND 42), (U.S. CLS. 100, 101 AND 102). SN 85-541,092. PUB. 7-3-2012. FILED 2-13-2012.
- 4,209,593. **WHAT WILL THEY DO NEXT? (STANDARD CHARACTER)**. WHAT WILL THEY DO NEXT, LLC, (U.S. CLS. 100, 101 AND 102). SN 85-541,098. PUB. 7-3-2012. FILED 2-13-2012.
- 4,209,594. **ROWAN GIBSON AND DESIGN. ROWAN GIBSON**, (U.S. CLS. 100, 101 AND 102). SN 85-541,100. PUB. 7-3-2012. FILED 2-13-2012.
- 4,209,604. **UPTILO (STANDARD CHARACTER)**. UPTILO INC., MULTIPLE CLASS, (INT. CLS. 35 AND 42), (U.S. CLS. 100, 101 AND 102). SN 85-541,189. PUB. 7-3-2012. FILED 2-13-2012.
- 4,209,616 (*See Class 14 for this trademark*).
- 4,209,619. **PERMAFLYER (STANDARD CHARACTER)**. INQWORKS, INC., (U.S. CLS. 100, 101 AND 102). SN 85-541,394. PUB. 7-3-2012. FILED 2-13-2012.
- 4,209,629. **IBODY (STANDARD CHARACTER)**. IBODY, LLC, DBA IBODY DIRECTORY, (U.S. CLS. 100, 101 AND 102). SN 85-541,578. PUB. 7-3-2012. FILED 2-13-2012.
- 4,209,632. **YOUR SUCCESS IS OUR GREATEST CONCERN (STANDARD CHARACTER)**. STASHKIW, ROBERT M., DBA AMERICAN MARKETING EXCHANGE, MULTIPLE CLASS, (INT. CLS. 35 AND 42), (U.S. CLS. 100, 101 AND

- 102). SN 85-541,613. PUB. 7-3-2012. FILED 2-13-2012.
- 4,209,640. **DI (STYLIZED)**. LOGI D INC., (U.S. CLS. 100, 101 AND 102). SN 85-541,755. PUB. 7-3-2012. FILED 2-14-2012.
- 4,209,657. **IMAGINE NATION (STANDARD CHARACTER)**. FREEMAN + LEONARD LLC, (U.S. CLS. 100, 101 AND 102). SN 85-542,059. PUB. 7-3-2012. FILED 2-14-2012.
- 4,209,658. **ADULTREV (STANDARD CHARACTER)**. ADULTREV LLC, (U.S. CLS. 100, 101 AND 102). SN 85-542,065. PUB. 7-3-2012. FILED 2-14-2012.
- 4,209,659. **BOUNTYBUY (STANDARD CHARACTER)**. SABUNO, LLC, (U.S. CLS. 100, 101 AND 102). SN 85-542,112. PUB. 7-3-2012. FILED 2-14-2012.
- 4,209,660. **BEGREENREADY (STANDARD CHARACTER)**. M. L. BENJAMIN ENTERPRISES, INC., DBA BENJAMIN ENTERPRISES, (U.S. CLS. 100, 101 AND 102). SN 85-542,121. PUB. 7-3-2012. FILED 2-14-2012.
- 4,209,670. **420NURSES (STANDARD CHARACTER)**. SILVA, JIMMY, (U.S. CLS. 100, 101 AND 102). SN 85-542,268. PUB. 7-3-2012. FILED 2-14-2012.
- 4,209,672. **MASCON (STYLIZED)**. ADVANCED EXPOS LLC, (U.S. CLS. 100, 101 AND 102). SN 85-542,311. PUB. 7-3-2012. FILED 2-14-2012.
- 4,209,676. **ÈPEUS (STANDARD CHARACTER)**. Ecorp LIMITED, MULTIPLE CLASS, (INT. CLS. 35, 36 AND 37), (U.S. CLS. 100, 101, 102, 103 AND 106). SN 85-542,399. PUB. 7-3-2012. FILED 2-14-2012.
- 4,209,677. **È AND DESIGN**. Ecorp LIMITED, MULTIPLE CLASS, (INT. CLS. 35, 36 AND 37), (U.S. CLS. 100, 101, 102, 103 AND 106). SN 85-542,411. PUB. 7-3-2012. FILED 2-14-2012.
- 4,209,680. **CUSTOMERCALLERS AND DESIGN**. CUSTOMER CALLERS, (U.S. CLS. 100, 101 AND 102). SN 85-542,437. PUB. 7-3-2012. FILED 2-14-2012.
- 4,209,689. **TELL 'EM THE BONE SENT YA (STANDARD CHARACTER)**. NORTHWEST MOTORSPORT, INC., (U.S. CLS. 100, 101 AND 102). SN 85-542,565. PUB. 7-3-2012. FILED 2-14-2012.
- 4,209,697. **MISCELLANEOUS DESIGN**. MARRIOTT INTERNATIONAL, INC., (U.S. CLS. 100, 101 AND 102). SN 85-542,713. PUB. 7-3-2012. FILED 2-14-2012.
- 4,209,712. **I WANT TO BE PRESIDENT (STANDARD CHARACTER)**. DAVID HUGHES, MULTIPLE CLASS, (INT. CLS. 35, 38 AND 41), (U.S. CLS. 100, 101, 102, 104 AND 107). SN 85-542,925. PUB. 7-3-2012. FILED 2-15-2012.
- 4,209,713. **SOCIUS (STANDARD CHARACTER)**. SOCIUS1, LLC, DBA SOCIUS, MULTIPLE CLASS, (INT. CLS. 35, 41 AND 42), (U.S. CLS. 100, 101, 102 AND 107). SN 85-543,005. PUB. 7-3-2012. FILED 2-15-2012.
- 4,209,720. **APPENDATA (STANDARD CHARACTER)**. ONLINE COMMUNICATIONS, INC., DBA OLC GLOBAL, (U.S. CLS. 100, 101 AND 102). SN 85-543,177. PUB. 7-3-2012. FILED 2-15-2012.
- 4,209,725. **SAY NO TO REPO (STANDARD CHARACTER)**. JASANDA CAPITAL LLC, (U.S. CLS. 100, 101 AND 102). SN 85-543,222. PUB. 7-3-2012. FILED 2-15-2012.
- 4,209,727. **IBPO (STANDARD CHARACTER)**. BANCTEC, INC., (U.S. CLS. 100, 101 AND 102). SN 85-543,234. PUB. 7-3-2012. FILED 2-15-2012.
- 4,209,729 (*See Class 9 for this trademark*).
- 4,209,734. **DAILY WAFFLE DW AND DESIGN**. LUFTWAFLE SUBORBITALS, (U.S. CLS. 100, 101 AND 102). SN 85-543,295. PUB. 7-3-2012. FILED 2-15-2012.
- 4,209,738. **IMPROVE GROUP (STANDARD CHARACTER)**. IMPROVE GROUP, INC., (U.S. CLS. 100, 101 AND 102). SN 85-543,385. PUB. 7-3-2012. FILED 2-15-2012.
- 4,209,745 (*See Class 9 for this trademark*).
- 4,209,751. **LIGHTING SMILE (STANDARD CHARACTER)**. LIGHTING SMILE, INC., (U.S. CLS. 100, 101 AND 102). SN 85-543,549. PUB. 7-3-2012. FILED 2-15-2012.
- 4,209,754. **DRINKINGTICKET (STANDARD CHARACTER)**. DRINKINGTICKET LLC, (U.S. CLS. 100, 101 AND 102). SN 85-543,562. PUB. 7-3-2012. FILED 2-15-2012.
- 4,209,759. **CULTUREFIX (STANDARD CHARACTER)**. ADCAS L.L.C., DBA CULTUREFIX, MULTIPLE CLASS, (INT. CLS. 35 AND 43), (U.S. CLS. 100, 101 AND 102). SN 85-543,595. PUB. 7-3-2012. FILED 2-15-2012.
- 4,209,762. **TECHHUB (STANDARD CHARACTER)**. TECHHUB EUROPE LIMITED, (U.S. CLS. 100, 101 AND 102). SN 85-543,688. PUB. 7-3-2012. FILED 2-15-2012.
- 4,209,765. **REVERE (STANDARD CHARACTER)**. REVERE ELECTRIC SUPPLY COMPANY, (U.S. CLS. 100, 101 AND 102). SN 85-543,712. PUB. 7-3-2012. FILED 2-15-2012.
- 4,209,770. **A AND DESIGN**. AURORA REYES, LLC, (U.S. CLS. 100, 101 AND 102). SN 85-543,784. PUB. 7-3-2012. FILED 2-15-2012.
- 4,209,773. **YOZIO (STANDARD CHARACTER)**. REYES-SMITHLEY, LLC, (U.S. CLS. 100, 101 AND 102). SN 85-543,809. PUB. 7-3-2012. FILED 2-15-2012.
- 4,209,775. **LUXEYARD (STANDARD CHARACTER)**. LUXEYARD, INC., (U.S. CLS. 100, 101 AND 102). SN 85-543,838. PUB. 7-3-2012. FILED 2-15-2012.
- 4,209,784. **REVERE ELECTRIC (STANDARD CHARACTER)**. REVERE ELECTRIC SUPPLY COMPANY, (U.S. CLS. 100, 101 AND 102). SN 85-543,998. PUB. 7-3-2012. FILED 2-15-2012.
- 4,209,795. **INTERVIEW ROULETTE (STANDARD CHARACTER)**. SKILLFUL COMMUNICATIONS, LLC, (U.S. CLS. 100, 101 AND 102). SN 85-544,198. PUB. 7-3-2012. FILED 2-16-2012.
- 4,209,800. **RR AND DESIGN**. REALITIES FOR CHILDREN, INC., MULTIPLE CLASS, (INT. CLS. 35 AND 36), (U.S. CLS. 100, 101 AND 102). SN 85-544,293. PUB. 7-3-2012. FILED 2-16-2012.
- 4,209,804. **GOT NATURAL GAS? (STANDARD CHARACTER)**. REGIONAL INTERNATIONAL CORP., (U.S. CLS. 100, 101 AND 102). SN 85-544,410. PUB. 7-3-2012. FILED 2-16-2012.
- 4,209,830. **LANGUAGE ON DEMAND (STANDARD CHARACTER)**. LANGUAGE ON DEMAND, INC., MULTIPLE CLASS, (INT. CLS. 35 AND 41), (U.S. CLS. 100, 101, 102 AND 107). SN 85-544,706. PUB. 7-3-2012. FILED 2-16-2012.
- 4,209,833 (*See Class 25 for this trademark*).
- 4,209,855. **KEEN (STANDARD CHARACTER)**. KEEN, INC., (U.S. CLS. 100, 101 AND 102). SN 85-545,336. PUB. 7-3-2012. FILED 2-16-2012.
- 4,209,860. **WE'RE JUST NOT ANNOYING (STANDARD CHARACTER)**. NORTHWEST REGISTERED AGENT, LLC, (U.S. CLS. 100, 101 AND 102). SN 85-545,399. PUB. 7-3-2012. FILED 2-16-2012.
- 4,209,871. **CAUGHT COLD (STANDARD CHARACTER)**. DD IP HOLDER LLC, (U.S. CLS. 100, 101 AND 102). SN 85-545,658. PUB. 7-3-2012. FILED 2-17-2012.
- 4,209,872. **NEED A GOODACCOUNTANT? (STANDARD CHARACTER)**. GOODACCOUNTANTS.COM, INC., (U.S. CLS. 100, 101 AND 102). SN 85-545,709. PUB. 7-3-2012. FILED 2-17-2012.
- 4,209,881. **IMPLICIT (STANDARD CHARACTER)**. LIEBERMAN RESEARCH WORLDWIDE, INC., (U.S. CLS. 100, 101 AND 102). SN 85-545,996. PUB. 7-3-2012. FILED 2-17-2012.
- 4,209,882. **NFF (STANDARD CHARACTER)**. THE NATIONAL FOOTBALL FOUNDATION AND COLLEGE HALL OF FAME, INC., (U.S. CLS. 100, 101 AND 102). SN 85-546,019. PUB. 7-3-2012. FILED 2-17-2012.
- 4,209,893. **LEANSIGMA (STANDARD CHARACTER)**. TBM CONSULTING GROUP, INC., (U.S. CLS. 100, 101 AND 102). SN 85-546,176. PUB. 7-3-2012. FILED 2-17-2012.
- 4,209,898. **PAEA (STANDARD CHARACTER)**. PHYSICIAN ASSISTANT EDUCATION ASSOCIATION, (U.S. CLS. 100, 101 AND 102). SN 85-546,210. PUB. 7-3-2012. FILED 2-17-2012.
- 4,209,900. **SOCKS ADDICT (STANDARD CHARACTER)**. AMERICAN MEDICAL SERVICES, INC., (U.S. CLS. 100, 101 AND 102). SN 85-546,301. PUB. 7-3-2012. FILED 2-17-2012.
- 4,209,905. **VERIFY (STANDARD CHARACTER)**. VERIFY, INC., (U.S. CLS. 100, 101 AND 102). SN 85-546,404. PUB. 7-3-2012. FILED 2-17-2012.
- 4,209,908. **HAMSTERS USA AND DESIGN**. HHCUS, LLC, (U.S. CLS. 100, 101 AND 102). SN 85-546,491. PUB. 7-3-2012. FILED 2-17-2012.
- 4,209,912. **HAMSTERS USA (STANDARD CHARACTER)**. HHCUS, LLC, (U.S. CLS. 100, 101 AND 102). SN 85-546,506. PUB. 7-3-2012. FILED 2-17-2012.
- 4,209,919. **QUAINT ESSENTIAL (STANDARD CHARACTER)**. KIEHL, DONNA L., (U.S. CLS. 100, 101 AND 102). SN 85-546,604. PUB. 7-3-2012. FILED 2-17-2012.
- 4,209,950. **LABEL ROW (STANDARD CHARACTER)**. LABEL

- ROW, (U.S. CLS. 100, 101 AND 102). SN 85-547,661. PUB. 7-3-2012. FILED 2-20-2012.
- 4,209,953. **HI-HEALTH (STANDARD CHARACTER)**. HI-HEALTH SUPERMART CORPORATION, (U.S. CLS. 100, 101 AND 102). SN 85-547,716. PUB. 7-3-2012. FILED 2-20-2012.
- 4,209,957. **STEEL TUBE INSTITUTE OF NORTH AMERICA AND DESIGN**. STEEL TUBE INSTITUTE OF NORTH AMERICA, (U.S. CLS. 100, 101 AND 102). SN 85-547,867. PUB. 7-3-2012. FILED 2-21-2012.
- 4,209,959. **HI-HEALTH LIVING HEALTHY (STANDARD CHARACTER)**. HI-HEALTH SUPERMART CORPORATION, (U.S. CLS. 100, 101 AND 102). SN 85-548,246. PUB. 7-3-2012. FILED 2-21-2012.
- 4,209,973. **HI-HEALTH AND DESIGN**. HI-HEALTH SUPERMART CORPORATION, (U.S. CLS. 100, 101 AND 102). SN 85-549,993. PUB. 7-3-2012. FILED 2-22-2012.
- 4,209,975. **CRAMRECOVERY (STANDARD CHARACTER)**. CRAMBLOCK L.C., (U.S. CLS. 100, 101 AND 102). SN 85-550,017. PUB. 7-3-2012. FILED 2-22-2012.
- 4,209,981 (*See Class 9 for this trademark*).
- 4,210,017. **750 COMMERCE (STANDARD CHARACTER)**. 750 GROUP, LLC, MULTIPLE CLASS, (INT. CLS. 35 AND 42), (U.S. CLS. 100, 101 AND 102). SN 85-555,446. PUB. 7-3-2012. FILED 2-28-2012.
- 4,210,018. **VTR (STANDARD CHARACTER)**. VERIFY, INC., (U.S. CLS. 100, 101 AND 102). SN 85-555,646. PUB. 7-3-2012. FILED 2-28-2012.
- 4,210,030. **IAVA IRAQ AND AFGHANISTAN VETERANS OF AMERICA (STYLIZED)**. IRAQ AND AFGHANISTAN VETERANS OF AMERICA, INC., (U.S. CLS. 100, 101 AND 102). SN 85-558,709. PUB. 7-3-2012. FILED 3-2-2012.
- 4,210,033. **VSC (STANDARD CHARACTER)**. VERIFY, INC., (U.S. CLS. 100, 101 AND 102). SN 85-558,935. PUB. 7-3-2012. FILED 3-2-2012.
- 4,210,041. **O9 SOLUTIONS AND DESIGN**. O9 SOLUTIONS, INC., MULTIPLE CLASS, (INT. CLS. 35 AND 42), (U.S. CLS. 100, 101 AND 102). SN 85-561,442. PUB. 7-3-2012. FILED 3-6-2012.
- 4,210,050. **PLANETBARGAINS (STANDARD CHARACTER)**. EXPONENTIAL INTERACTIVE, INC., (U.S. CLS. 100, 101 AND 102). SN 85-565,266. PUB. 7-3-2012. FILED 3-9-2012.
- 4,210,051 (*See Class 12 for this trademark*).
- 4,210,056. **EWONDERWORLD (STANDARD CHARACTER)**. AMERICAN CREATIVE TEAM, INC., (U.S. CLS. 100, 101 AND 102). SN 85-566,640. PUB. 7-3-2012. FILED 3-12-2012.
- 4,210,066. **MISCELLANEOUS DESIGN**. THE NATIONAL FOOTBALL FOUNDATION AND COLLEGE HALL OF FAME, INC., (U.S. CLS. 100, 101 AND 102). SN 85-568,553. PUB. 7-3-2012. FILED 3-13-2012.
- 4,210,069. **WHERE ACADEMICS AND INNOVATION CONVERGE (STANDARD CHARACTER)**. DELTAK EDU, INC., MULTIPLE CLASS, (INT. CLS. 35, 41 AND 42), (U.S. CLS. 100, 101, 102 AND 107). SN 85-569,289. PUB. 7-3-2012. FILED 3-14-2012.
- 4,210,098 (*See Class 14 for this trademark*).
- 4,210,100. **ROWAN GIBSON (STANDARD CHARACTER)**. ROWAN GIBSON, (U.S. CLS. 100, 101 AND 102). SN 85-577,859. PUB. 7-3-2012. FILED 3-23-2012.
- 4,210,120 (*See Class 9 for this trademark*).
- 4,210,121 (*See Class 9 for this trademark*).
- 4,210,129. **MISCELLANEOUS DESIGN**. THE FOUR 9'S GROUP, LLC, (U.S. CLS. 100, 101 AND 102). SN 85-583,439. PUB. 7-3-2012. FILED 3-29-2012.
- 4,210,136. **GAIL'S TOBACCO & GAS OUTLET (STANDARD CHARACTER)**. GAIL A. HALIM, DBA GAIL'S TOBACCO & GAS OUTLET, (U.S. CLS. 100, 101 AND 102). SN 85-585,939. PUB. 7-3-2012. FILED 4-1-2012.
- 4,210,140. **QUANTIVIEW AND DESIGN**. PANSINO, GARY, (U.S. CLS. 100, 101 AND 102). SN 85-586,980. PUB. 7-3-2012. FILED 4-2-2012.
- 4,210,146. **MOMMYUNPLUGGED (STANDARD CHARACTER)**. UNPLUGGED VENTURES LLC, (U.S. CLS. 100, 101 AND 102). SN 85-590,068. PUB. 7-3-2012. FILED 4-5-2012.
- 4,210,147. **MOMMYUNPLUGGED AND DESIGN**. UNPLUGGED VENTURES, (U.S. CLS. 100, 101 AND 102). SN 85-590,111. PUB. 7-3-2012. FILED 4-5-2012.
- 4,210,167. **FELIX AND DESIGN**. FELIX CALLS, LLC, (U.S. CLS. 100, 101 AND 102). SN 85-597,287. PUB. 7-3-2012. FILED 4-13-2012.
- 4,210,177. **FASHION STEPS FOR A CAUSE (STANDARD CHARACTER)**. NINE WEST DEVELOPMENT CORPORATION, (U.S. CLS. 100, 101 AND 102). SN 85-602,368. PUB. 7-3-2012. FILED 4-19-2012.
- 4,210,180. **FREEDOM HOMES AND DESIGN**. CMH HOMES, INC., (U.S. CLS. 100, 101 AND 102). SN 85-602,792. PUB. 7-3-2012. FILED 4-19-2012.
- 4,210,187. **FRANCESCA'S (STYLIZED)**. FRANCESCA'S COLLECTIONS, INC., (U.S. CLS. 100, 101 AND 102). SN 85-606,591. PUB. 7-3-2012. FILED 4-24-2012.
- 4,210,195. **PRAGMATIC BRAIN SCIENCE (STANDARD CHARACTER)**. LIEBERMAN RESEARCH WORLDWIDE, INC., (U.S. CLS. 100, 101 AND 102). SN 85-610,431. PUB. 7-3-2012. FILED 4-27-2012.
- 4,210,204. **MISCELLANEOUS DESIGN**. LOCOCO SPORTS, INC., (U.S. CLS. 100, 101 AND 102). SN 85-615,226. PUB. 7-3-2012. FILED 5-3-2012.
- 4,210,205. **CLEARVISION (STANDARD CHARACTER)**. CLEAR CHANNEL OUTDOOR, INC., MULTIPLE CLASS, (INT. CLS. 35 AND 38), (U.S. CLS. 100, 101, 102 AND 104). SN 85-615,311. PUB. 7-3-2012. FILED 5-3-2012.
- 4,210,222. **WE ENGINEER SUCCESS (STANDARD CHARACTER)**. NATIONAL TECHNICAL SYSTEMS, INC., (U.S. CLS. 100, 101 AND 102). SN 85-976,787. PUB. 7-3-2012. FILED 11-11-2011.

CLASS 36—INSURANCE AND FINANCIAL

- 4,208,122 (*See Class 12 for this trademark*).
- 4,208,124 (*See Class 9 for this trademark*).
- 4,208,139. **ENDURANCE AND DESIGN**. ENDURANCE WARRANTY SERVICES, LLC, (U.S. CLS. 100, 101 AND 102). SN 76-708,500. PUB. 7-3-2012. FILED 7-26-2011.
- 4,208,140. **EMPOWERING CONFIDENCE FOR THE ROAD AHEAD (STANDARD CHARACTER)**. ENDURANCE WARRANTY SERVICES, LLC, (U.S. CLS. 100, 101 AND 102). SN 76-708,501. PUB. 7-3-2012. FILED 7-26-2011.
- 4,208,141. **EMPOWERING CONFIDENCE (STANDARD CHARACTER)**. ENDURANCE WARRANTY SERVICES, LLC, (U.S. CLS. 100, 101 AND 102). SN 76-708,502. PUB. 7-3-2012. FILED 7-26-2011.
- 4,208,149. **THE SOUL OF EAST AUSTIN AND DESIGN**. MINISTRY OF CHALLENGE, (U.S. CLS. 100, 101 AND 102). SN 76-709,149. PUB. 7-3-2012. FILED 9-19-2011.
- 4,208,150. **UMPQUA BANK MORTGAGE (STANDARD CHARACTER)**. UMPQUA BANK, (U.S. CLS. 100, 101 AND 102). SN 76-709,483. PUB. 7-3-2012. FILED 10-21-2011.
- 4,208,178. **PAYNGO AND DESIGN**. COLUMBUS DATA SERVICES, L.L.C., (U.S. CLS. 100, 101 AND 102). SN 77-529,308. PUB. 7-3-2012. FILED 7-23-2008.
- 4,208,179 (*See Class 35 for this trademark*).
- 4,208,240 (*See Class 35 for this trademark*).
- 4,208,247 (*See Class 9 for this trademark*).
- 4,208,290 (*See Class 12 for this trademark*).
- 4,208,297. **CUBE INFRASTRUCTURE FUND AND DESIGN**. NATIXIS, (U.S. CLS. 100, 101 AND 102). SN 79-101,358. PUB. 7-3-2012. FILED 7-12-2011.
- 4,208,319 (*See Class 7 for this trademark*).
- 4,208,330. **MISCELLANEOUS DESIGN**. TRIODOS BANK N.V., (U.S. CLS. 100, 101 AND 102). SN 79-102,580. PUB. 7-3-2012. FILED 7-13-2011.
- 4,208,364 (*See Class 9 for this trademark*).
- 4,208,446 (*See Class 16 for this trademark*).
- 4,208,497 (*See Class 35 for this trademark*).
- 4,208,519. **WFC (STANDARD CHARACTER)**. WEST FACE CAPITAL INC., (U.S. CLS. 100, 101 AND 102). SN 85-191,293. PUB. 7-3-2012. FILED 12-6-2010.
- 4,208,525. **MIDDLESEX FINANCIAL GROUP AND DESIGN**. MIDDLESEX SAVINGS BANK, (U.S. CLS. 100, 101 AND 102). SN 85-197,297. PUB. 7-3-2012. FILED S.R. 12-14-2010; AM. P.R. 4-26-2012.
- 4,208,535. **IMONTHFEES.COM (STANDARD CHARACTER)**. AVIDAR, DORIT, (U.S. CLS. 100, 101 AND 102). SN 85-208,607. PUB. 7-3-2012. FILED 12-31-2010.

- 4,208,536. **JEWISH FEDERATION AND DESIGN**. THE JEWISH FEDERATIONS OF NORTH AMERICA, INC., (U.S. CLS. 100, 101 AND 102). SN 85-210,901. PUB. 7-3-2012. FILED 1-5-2011.
- 4,208,583. **COMPTON FOUNDATION (STANDARD CHARACTER)**. COMPTON FOUNDATION, INC., (U.S. CLS. 100, 101 AND 102). SN 85-286,194. PUB. 7-3-2012. FILED 4-5-2011.
- 4,208,589 (*See Class 35 for this trademark*).
- 4,208,597. **EMPLOYEE NAVIGATOR (STANDARD CHARACTER)**. EMPLOYEE NAVIGATOR, LLC, (U.S. CLS. 100, 101 AND 102). SN 85-304,326. PUB. 3-20-2012. FILED 4-25-2011.
- 4,208,638. **CPDIRECT.COM (STANDARD CHARACTER)**. CDOC, INC., MULTIPLE CLASS, (INT. CLS. 36 AND 42), (U.S. CLS. 100, 101 AND 102). SN 85-339,892. PUB. 7-3-2012. FILED 6-7-2011.
- 4,208,644 (*See Class 4 for this trademark*).
- 4,208,661. **\$ FXRENEW AND DESIGN**. FX RENEW, LLC, (U.S. CLS. 100, 101 AND 102). SN 85-350,932. PUB. 7-3-2012. FILED 6-20-2011.
- 4,208,662. **MSF MULTIPLE SCLEROSIS FOUNDATION AND DESIGN**. MULTIPLE SCLEROSIS FOUNDATION, (U.S. CLS. 100, 101 AND 102). SN 85-351,710. PUB. 7-3-2012. FILED 6-21-2011.
- 4,208,746 (*See Class 35 for this trademark*).
- 4,208,747. **UNICO (STANDARD CHARACTER)**. UNICO NATIONAL, (U.S. CLS. 100, 101 AND 102). SN 85-373,533. PUB. 7-3-2012. FILED 7-18-2011.
- 4,208,798. **RED CARPET (STANDARD CHARACTER)**. RED CARPET INTERNATIONAL, INC., (U.S. CLS. 100, 101 AND 102). SN 85-383,109. PUB. 7-3-2012. FILED 7-28-2011.
- 4,208,813. **MISCELLANEOUS DESIGN**. CREO GROUP LLC, (U.S. CLS. 100, 101 AND 102). SN 85-386,396. PUB. 1-31-2012. FILED 8-1-2011.
- 4,208,854 (*See Class 35 for this trademark*).
- 4,208,863 (*See Class 35 for this trademark*).
- 4,208,887 (*See Class 32 for this trademark*).
- 4,208,891. **GRUBER FOUNDATION AND DESIGN**. THE PETER AND PATRICIA GRUBER FOUNDATION, (U.S. CLS. 100, 101 AND 102). SN 85-405,984. PUB. 7-3-2012. FILED 8-24-2011.
- 4,208,908 (*See Class 32 for this trademark*).
- 4,208,911. **HEART & HAND FUND AND DESIGN**. PHI MU FRATERNITY, (U.S. CLS. 100, 101 AND 102). SN 85-414,157. PUB. 3-20-2012. FILED 9-2-2011.
- 4,208,926. **WOMEN'S FUNDING NETWORK (STANDARD CHARACTER)**. WOMEN'S FUNDING NETWORK, (U.S. CLS. 100, 101 AND 102). SN 85-419,460. PUB. 7-3-2012. FILED 9-9-2011.
- 4,208,933. **LINK COWORKING (STANDARD CHARACTER)**. EME ENTERPRISES, LLC, DBA LINK COWORKING, (U.S. CLS. 100, 101 AND 102). SN 85-421,716. PUB. 7-3-2012. FILED 9-13-2011.
- 4,208,995 (*See Class 35 for this trademark*).
- 4,208,996 (*See Class 35 for this trademark*).
- 4,209,003. **FRESH WORKS AND DESIGN**. THE CALIFORNIA ENDOWMENT, (U.S. CLS. 100, 101 AND 102). SN 85-449,334. PUB. 7-3-2012. FILED 10-17-2011.
- 4,209,027. **VINING SPARKS (STANDARD CHARACTER)**. VINING-SPARKS IBG, LIMITED PARTNERSHIP, (U.S. CLS. 100, 101 AND 102). SN 85-462,087. PUB. 7-3-2012. FILED 11-2-2011.
- 4,209,028. **VINING SPARKS AND DESIGN**. VINING-SPARKS IBG, LIMITED PARTNERSHIP, (U.S. CLS. 100, 101 AND 102). SN 85-462,094. PUB. 7-3-2012. FILED 11-2-2011.
- 4,209,030. **MEGATRON (STANDARD CHARACTER)**. MEGATRON EQUITY PARTNERS, INC., MULTIPLE CLASS, (INT. CLS. 36 AND 41), (U.S. CLS. 100, 101, 102 AND 107). SN 85-462,758. PUB. 7-3-2012. FILED 11-2-2011.
- 4,209,066. **REALTY MOMENTUM (STANDARD CHARACTER)**. DIAS PROPERTIES, LLC., DBA REALTY MOMENTUM, (U.S. CLS. 100, 101 AND 102). SN 85-475,863. PUB. 7-3-2012. FILED 11-17-2011.
- 4,209,115. **MISCELLANEOUS DESIGN**. FESTFARE, INC., (U.S. CLS. 100, 101 AND 102). SN 85-493,556. PUB. 7-3-2012. FILED 12-13-2011.
- 4,209,128. **ALCO INSURANCE (STANDARD CHARACTER)**. ALABAMA INSURANCE AGENCY, INC., (U.S. CLS. 100, 101 AND 102). SN 85-497,495. PUB. 7-3-2012. FILED 12-16-2011.
- 4,209,131. **IQ RISK INSURANCE SERVICES, LLC AND DESIGN**. IQ RISK INSURANCE SERVICES, LLC, (U.S. CLS. 100, 101 AND 102). SN 85-498,313. PUB. 7-3-2012. FILED 12-18-2011.
- 4,209,148. **CLINTON FOUNDATION (STANDARD CHARACTER)**. WILLIAM J. CLINTON FOUNDATION, MULTIPLE CLASS, (INT. CLS. 36 AND 41), (U.S. CLS. 100, 101, 102 AND 107). SN 85-502,382. PUB. 7-3-2012. FILED 12-22-2011.
- 4,209,149. **CLINTON FOUNDATION AND DESIGN**. WILLIAM J. CLINTON FOUNDATION, MULTIPLE CLASS, (INT. CLS. 36 AND 41), (U.S. CLS. 100, 101, 102 AND 107). SN 85-502,402. PUB. 7-3-2012. FILED 12-22-2011.
- 4,209,175 (*See Class 35 for this trademark*).
- 4,209,184. **THE MAGNOLIA COUNCIL (STANDARD CHARACTER)**. TOWER CANCER RESEARCH FOUNDATION, (U.S. CLS. 100, 101 AND 102). SN 85-508,840. PUB. 7-3-2012. FILED 1-4-2012.
- 4,209,185. **THE MAGNOLIA COUNCIL AND DESIGN**. TOWER CANCER RESEARCH FOUNDATION, (U.S. CLS. 100, 101 AND 102). SN 85-508,845. PUB. 7-3-2012. FILED 1-4-2012.
- 4,209,211 (*See Class 16 for this trademark*).
- 4,209,228. **WISH LIST CHICAGO AND DESIGN**. THE WISH LIST AUXILIARY BOARD, DBA WISH LIST CHICAGO, (U.S. CLS. 100, 101 AND 102). SN 85-517,085. PUB. 7-3-2012. FILED 1-16-2012.
- 4,209,230. **A AMANDA HOWARD REAL ESTATE AND DESIGN**. AMANDA HOWARD REAL ESTATE, L.L.C., (U.S. CLS. 100, 101 AND 102). SN 85-517,239. PUB. 7-3-2012. FILED 1-16-2012.
- 4,209,259. **ECU BEYOND FREE CHECKING (STANDARD CHARACTER)**. EASTMAN CREDIT UNION, (U.S. CLS. 100, 101 AND 102). SN 85-519,973. PUB. 7-3-2012. FILED 1-19-2012.
- 4,209,270. **ECU BESIDE YOU (STANDARD CHARACTER)**. EASTMAN CREDIT UNION, (U.S. CLS. 100, 101 AND 102). SN 85-520,482. PUB. 7-3-2012. FILED 1-19-2012.
- 4,209,274. **TANGRAM INSURANCE SERVICES AND DESIGN**. TANGRAM INSURANCE SERVICES, (U.S. CLS. 100, 101 AND 102). SN 85-520,756. PUB. 7-3-2012. FILED 1-19-2012.
- 4,209,285. **DNA BAIL BONDS (STANDARD CHARACTER)**. DNA BAIL BONDS, LLC, (U.S. CLS. 100, 101 AND 102). SN 85-521,221. PUB. 7-3-2012. FILED 1-20-2012.
- 4,209,297. **SECOND DAY EVENTS (STANDARD CHARACTER)**. KATTLER KUPETZ, DEBORAH, (U.S. CLS. 100, 101 AND 102). SN 85-521,819. PUB. 7-3-2012. FILED 1-20-2012.
- 4,209,300 (*See Class 35 for this trademark*).
- 4,209,312. **REALDIRECT (STANDARD CHARACTER)**. REALDIRECT, INC., AKA REALDIRECT, MULTIPLE CLASS, (INT. CLS. 36 AND 42), (U.S. CLS. 100, 101 AND 102). SN 85-522,589. PUB. 7-3-2012. FILED 1-23-2012.
- 4,209,338. **CRABTREE FUND (STANDARD CHARACTER)**. CRABTREE ASSET MANAGEMENT, (U.S. CLS. 100, 101 AND 102). SN 85-523,716. PUB. 7-3-2012. FILED 1-24-2012.
- 4,209,345. **ACEM AND DESIGN**. ACCELERATED CHRISTIAN EDUCATION, INC., (U.S. CLS. 100, 101 AND 102). SN 85-523,855. PUB. 7-3-2012. FILED 1-24-2012.
- 4,209,354. **SOLARITY AND DESIGN**. SOLARITY CREDIT UNION, (U.S. CLS. 100, 101 AND 102). SN 85-524,427. PUB. 7-3-2012. FILED 1-24-2012.
- 4,209,361. **AE2S N E X U THE FINANCIAL LINK AND DESIGN**. ADVANCED ENGINEERING AND ENVIRONMENTAL SERVICES, INC., (U.S. CLS. 100, 101 AND 102). SN 85-524,695. PUB. 7-3-2012. FILED 1-25-2012.
- 4,209,365. **TANNER'S TEAM FOUNDATION TEAMING UP TO HELP FAMILIES AND DESIGN**. TANNER'S TEAM FOUNDATION, (U.S. CLS. 100, 101 AND 102). SN 85-524,906. PUB. 7-3-2012. FILED 1-25-2012.
- 4,209,369. **MISCELLANEOUS DESIGN**. CAROLINA FINANCIAL CORPORATION, INC., (U.S. CLS. 100, 101 AND 102). SN 85-525,073. PUB. 7-3-2012. FILED 1-25-2012.
- 4,209,410 (*See Class 35 for this trademark*).
- 4,209,426. **BDA CARES FOUNDATION (STANDARD CHARACTER)**. BDA CARES FOUNDATION, (U.S. CLS. 100, 101 AND 102). SN 85-527,535. PUB. 7-3-2012. FILED 1-27-2012.
- 4,209,437 (*See Class 35 for this trademark*).
- 4,209,484. **PAYWELL (STANDARD CHARACTER)**. URGENT

CARES OF AMERICA HOLDINGS, LLC, (U.S. CLS. 100, 101 AND 102). SN 85-534,462. PUB. 7-3-2012. FILED 2-6-2012.

4,209,526. **BUST OUTTA JAIL ASK ME ABOUT BAIL BONDS BAIL BONDS BAIL BONDS SUPERBONDGIRL.COM AND DESIGN**, TISCARENO, NANCY, (U.S. CLS. 100, 101 AND 102). SN 85-538,787. PUB. 7-3-2012. FILED 2-9-2012.

4,209,573. **STRIDES AGAINST STIGMA (STANDARD CHARACTER)**, FAMILIES FOR DEPRESSION AWARENESS, INC., (U.S. CLS. 100, 101 AND 102). SN 85-540,866. PUB. 7-3-2012. FILED 2-13-2012.

4,209,586 (*See Class 16 for this trademark*).

4,209,624. **PERMISSION TO START DREAMING (STANDARD CHARACTER)**, MAYNE, LESLIE, (U.S. CLS. 100, 101 AND 102). SN 85-541,474. PUB. 7-3-2012. FILED 2-13-2012.

4,209,676 (*See Class 35 for this trademark*).

4,209,677 (*See Class 35 for this trademark*).

4,209,746. **RUN 10 FEED 10 (STANDARD CHARACTER)**, RODALE INC., MULTIPLE CLASS, (INT. CLS. 36 AND 41), (U.S. CLS. 100, 101, 102 AND 107). SN 85-543,434. PUB. 7-3-2012. FILED 2-15-2012.

4,209,800 (*See Class 35 for this trademark*).

4,209,834. **NEW JERSEY HEALTH FOUNDATION (STANDARD CHARACTER)**, NEW JERSEY HEALTH FOUNDATION, INC., (U.S. CLS. 100, 101 AND 102). SN 85-544,868. PUB. 7-3-2012. FILED 2-16-2012.

4,209,842. **SHORE MORTGAGE AND DESIGN**, UNITED SHORE FINANCIAL SERVICES, LLC, (U.S. CLS. 100, 101 AND 102). SN 85-544,937. PUB. 7-3-2012. FILED 2-16-2012.

4,209,868. **BOST (STANDARD CHARACTER)**, BOST BENEFITS CORP., (U.S. CLS. 100, 101 AND 102). SN 85-545,604. PUB. 7-3-2012. FILED 2-17-2012.

4,209,883. **NFF (STANDARD CHARACTER)**, THE NATIONAL FOOTBALL FOUNDATION AND COLLEGE HALL OF FAME, INC., (U.S. CLS. 100, 101 AND 102). SN 85-546,024. PUB. 7-3-2012. FILED 2-17-2012.

4,209,890. **CITYLIGHT HOMES (STANDARD CHARACTER)**, CITYLIGHT HOMES, LLC, (U.S. CLS. 100, 101 AND 102). SN 85-546,109. PUB. 7-3-2012. FILED 2-17-2012.

4,209,907. **MCOMMAND (STANDARD CHARACTER)**, FIRST COMMAND FINANCIAL SERVICES, INC., (U.S. CLS. 100, 101 AND 102). SN 85-546,479. PUB. 7-3-2012. FILED 2-17-2012.

4,209,979. **FANDANGO (STANDARD CHARACTER)**, LUTHERAN FAMILY SERVICES OF NEBRASKA, INC., AKA LFS, (U.S. CLS. 100, 101 AND 102). SN 85-551,086. PUB. 7-3-2012. FILED 2-23-2012.

4,209,990. **EAGLE TRACE (STANDARD CHARACTER)**, GREAT EASTERN RESORT MANAGEMENT, INC., (U.S. CLS. 100, 101 AND 102). SN 85-552,213. PUB. 7-3-2012. FILED 2-24-2012.

4,209,991. **WOODSTONE MEADOWS (STANDARD CHARACTER)**, GREAT EASTERN RESORT MANAGEMENT, INC., MULTIPLE CLASS, (INT. CLS. 36 AND 41), (U.S. CLS. 100, 101, 102 AND 107). SN 85-552,238. PUB. 7-3-2012. FILED 2-24-2012.

4,209,999. **EAGLE TRACE AT KILLY COURT (STANDARD CHARACTER)**, GREAT EASTERN RESORT MANAGEMENT, INC., (U.S. CLS. 100, 101 AND 102). SN 85-553,481. PUB. 7-3-2012. FILED 2-27-2012.

4,210,037. **M AND DESIGN**, GREAT EASTERN RESORT MANAGEMENT, INC., MULTIPLE CLASS, (INT. CLS. 36 AND 41), (U.S. CLS. 100, 101, 102 AND 107). SN 85-561,104. PUB. 7-3-2012. FILED 3-6-2012.

4,210,062. **MISCELLANEOUS DESIGN**, THE NATIONAL FOOTBALL FOUNDATION AND COLLEGE HALL OF FAME, INC., (U.S. CLS. 100, 101 AND 102). SN 85-568,152. PUB. 7-3-2012. FILED 3-13-2012.

4,210,086. **YOU SUCCEED. WE SUCCEED. (STANDARD CHARACTER)**, SOUTHCITY BANK, (U.S. CLS. 100, 101 AND 102). SN 85-575,472. PUB. 7-3-2012. FILED 3-21-2012.

4,210,113. **GFT MARKETS (STANDARD CHARACTER)**, GLOBAL FUTURES & FOREX, LTD., (U.S. CLS. 100, 101 AND 102). SN 85-579,856. PUB. 7-3-2012. FILED 3-26-2012.

4,210,153. **APMEXCLUSIVE (STANDARD CHARACTER)**, APMEX, INC., (U.S. CLS. 100, 101 AND 102). SN 85-593,764. PUB. 7-3-2012. FILED 4-10-2012.

4,210,168. **PEER TO PEER (STANDARD CHARACTER)**, THE

ANNENBERG FOUNDATION, MULTIPLE CLASS, (INT. CLS. 36 AND 41), (U.S. CLS. 100, 101, 102 AND 107). SN 85-597,586. PUB. 7-3-2012. FILED 4-13-2012.

4,210,198 (*See Class 9 for this trademark*).

4,210,207. **DONATE WITH A KISS (STANDARD CHARACTER)**, ULTA SALON, COSMETICS & FRAGRANCE, INC., (U.S. CLS. 100, 101 AND 102). SN 85-617,260. PUB. 7-3-2012. FILED 5-4-2012.

4,210,211. **CORNERSTONE (STANDARD CHARACTER)**, UTAH STATE BOARD OF REGENTS, C/O THE OFFICE OF THE COMMISSIONER OF HIGHER EDUCATION, (U.S. CLS. 100, 101 AND 102). SN 85-618,892. PUB. 7-3-2012. FILED 5-7-2012.

4,210,212. **PEER2PEER (STANDARD CHARACTER)**, THE ANNENBERG FOUNDATION, MULTIPLE CLASS, (INT. CLS. 36 AND 41), (U.S. CLS. 100, 101, 102 AND 107). SN 85-619,526. PUB. 7-3-2012. FILED 5-8-2012.

CLASS 37—CONSTRUCTION AND REPAIR

4,208,124 (*See Class 9 for this trademark*).

4,208,157. **QUICK NO SANDING SOLUTION FOR BEAUTIFUL WOOD FLOORS (STANDARD CHARACTER)**, MR. SANDLESS FRANCHISE, LLC, (U.S. CLS. 100, 103 AND 106). SN 76-710,613. PUB. 7-3-2012. FILED 2-13-2012.

4,208,229. **TIVIT (STANDARD CHARACTER)**, TIVIT TERCEIRIZACAO DE PROCESSOS SERVICOS E TECNOLOGIA S/A, (U.S. CLS. 100, 103 AND 106). SN 78-981,380. PUB. 6-12-2012. FILED 10-14-2005.

4,208,245 (*See Class 9 for this trademark*).

4,208,250 (*See Class 9 for this trademark*).

4,208,252 (*See Class 9 for this trademark*).

4,208,272 (*See Class 7 for this trademark*).

4,208,285 (*See Class 9 for this trademark*).

4,208,286 (*See Class 7 for this trademark*).

4,208,287 (*See Class 19 for this trademark*).

4,208,303 (*See Class 9 for this trademark*).

4,208,319 (*See Class 7 for this trademark*).

4,208,331 (*See Class 35 for this trademark*).

4,208,332 (*See Class 35 for this trademark*).

4,208,337 (*See Class 9 for this trademark*).

4,208,367 (*See Class 2 for this trademark*).

4,208,407 (*See Class 9 for this trademark*).

4,208,408 (*See Class 9 for this trademark*).

4,208,414 (*See Class 6 for this trademark*).

4,208,447 (*See Class 7 for this trademark*).

4,208,448 (*See Class 7 for this trademark*).

4,208,502 (*See Class 1 for this trademark*).

4,208,504 (*See Class 1 for this trademark*).

4,208,506 (*See Class 1 for this trademark*).

4,208,507 (*See Class 1 for this trademark*).

4,208,510 (*See Class 9 for this trademark*).

4,208,540. **BPOD (STANDARD CHARACTER)**, BUILDPOD INTERNATIONAL LTD, (U.S. CLS. 100, 103 AND 106). SN 85-219,643. PUB. 7-3-2012. FILED 1-18-2011.

4,208,562. **FIBREBOND (STANDARD CHARACTER)**, FIBREBOND CORPORATION, (U.S. CLS. 100, 103 AND 106). SN 85-250,561. PUB. 7-3-2012. FILED 2-24-2011.

4,208,602. **C P AND DESIGN**, CHANNEL PLUMBING, INC., (U.S. CLS. 100, 103 AND 106). SN 85-311,329. PUB. 7-3-2012. FILED 5-3-2011.

4,208,644 (*See Class 4 for this trademark*).

4,208,720 (*See Class 27 for this trademark*).

4,208,734 (*See Class 31 for this trademark*).

4,208,767. **JW POWERLINE AND DESIGN**, JIM F. WEBB, DBA JW POWERLINE, (U.S. CLS. 100, 103 AND 106). SN 85-376,214. PUB. 7-3-2012. FILED 7-20-2011.

4,208,842. **THE FIRE STOPS HERE! (STANDARD CHARACTER)**, APEX CONSOLIDATED, INC., DBA APEX FIRESTOP, (U.S. CLS. 100, 103 AND 106). SN 85-393,873. PUB. 7-3-2012. FILED 8-9-2011.

4,208,843 (*See Class 35 for this trademark*).

4,208,965. **BATES TROY HEALTHCARE LINEN SERVICES (STANDARD CHARACTER)**, BATES TROY, INC., MULTIPLE CLASS, (INT. CLS. 37 AND 43), (U.S. CLS. 100, 101, 103 AND 106). SN 85-440,903. PUB. 7-3-2012. FILED 10-6-2011.

- 4,208,995 (*See Class 35 for this trademark.*)
 4,208,996 (*See Class 35 for this trademark.*)
 4,209,046 (*See Class 1 for this trademark.*)
 4,209,054. **TOWN & COUNTRY (STANDARD CHARACTER).** TOWN & COUNTRY DEVELOPMENT, INC., (U.S. CLS. 100, 103 AND 106). SN 85-472,839. PUB. 7-3-2012. FILED 11-15-2011.
 4,209,055. **TOWN & COUNTRY OFFICE CLEANING AND DESIGN.** TOWN & COUNTRY DEVELOPMENT, INC., (U.S. CLS. 100, 103 AND 106). SN 85-472,854. PUB. 7-3-2012. FILED 11-15-2011.
 4,209,084 (*See Class 35 for this trademark.*)
 4,209,090. **ONESOURCEFIRESOLUTIONS (STYLIZED).** B & D FIRE PROTECTION LLC, (U.S. CLS. 100, 103 AND 106). SN 85-489,116. PUB. 7-3-2012. FILED 12-7-2011.
 4,209,134. **EMPOWER SOLAR AND DESIGN.** EMPOWER CES, LLC, MULTIPLE CLASS, (INT. CLS. 37 AND 42), (U.S. CLS. 100, 101, 103 AND 106). SN 85-498,793. PUB. 7-3-2012. FILED 12-19-2011.
 4,209,161. **CRITTER & PEST DEFENSE AND DESIGN.** SHAW, CARL G., AND SHAW, STEPHANIE L., (U.S. CLS. 100, 103 AND 106). SN 85-504,712. PUB. 7-3-2012. FILED 12-28-2011.
 4,209,163. **CRITTER & PEST DEFENSE.COM AND DESIGN.** SHAW, CARL G., AND SHAW, STEPHANIE L., (U.S. CLS. 100, 103 AND 106). SN 85-504,828. PUB. 7-3-2012. FILED 12-28-2011.
 4,209,169. **WW WALTERS & WOLF AND DESIGN.** WALTERS & WOLF GLASS COMPANY, DBA WALTERS & WOLF, (U.S. CLS. 100, 103 AND 106). SN 85-505,561. PUB. 7-3-2012. FILED 12-29-2011.
 4,209,188. **THE SPOILED HORSE (STANDARD CHARACTER).** THE SPOILED HORSE, LLC, (U.S. CLS. 100, 103 AND 106). SN 85-509,324. PUB. 7-3-2012. FILED 1-5-2012.
 4,209,204. **KEEPING IT KLEEN AND DESIGN.** RESTAURANT RESULTS, INC., (U.S. CLS. 100, 103 AND 106). SN 85-512,424. PUB. 7-3-2012. FILED 1-10-2012.
 4,209,218 (*See Class 11 for this trademark.*)
 4,209,225. **CHECKERED FLAG PLUMBING (STANDARD CHARACTER).** SOUTHWORTH, TYSON, DBA CHECKERED FLAG PLUMBING, (U.S. CLS. 100, 103 AND 106). SN 85-516,749. PUB. 7-3-2012. FILED 1-14-2012.
 4,209,244. **MISCELLANEOUS DESIGN.** F. LOPRESTI, INC., DBA BUDGET TIRE AND AUTO SERVICES, (U.S. CLS. 100, 103 AND 106). SN 85-518,679. PUB. 7-3-2012. FILED 1-18-2012.
 4,209,252. **CONSTRUCTIONPLACE.COM (STANDARD CHARACTER).** PONTA, INC., DBA CONSTRUCTIONPLACE.COM, (U.S. CLS. 100, 103 AND 106). SN 85-519,387. PUB. 7-3-2012. FILED 1-18-2012.
 4,209,261 (*See Class 9 for this trademark.*)
 4,209,264. **THE LETTERS K AND C AND DESIGN.** KISER CONSTRUCTION, INC., (U.S. CLS. 100, 103 AND 106). SN 85-520,136. PUB. 7-3-2012. FILED 1-19-2012.
 4,209,279 (*See Class 35 for this trademark.*)
 4,209,389. **STERI-CLEAN AND DESIGN.** STERI-CLEAN, INC., (U.S. CLS. 100, 103 AND 106). SN 85-525,886. PUB. 7-3-2012. FILED 1-26-2012.
 4,209,410 (*See Class 35 for this trademark.*)
 4,209,434. **CAVELL MERTZ & ASSOCIATES, INC. AND DESIGN.** CAVELL, MERTZ & ASSOCIATES, INC., MULTIPLE CLASS, (INT. CLS. 37, 38 AND 42), (U.S. CLS. 100, 101, 103, 104 AND 106). SN 85-528,334. PUB. 7-3-2012. FILED 1-30-2012.
 4,209,443. **DENT CONCEPTS (STANDARD CHARACTER).** DENT CONCEPTS, INC., (U.S. CLS. 100, 103 AND 106). SN 85-528,986. PUB. 7-3-2012. FILED 1-30-2012.
 4,209,451. **MISCELLANEOUS DESIGN.** RESTORECORE, INC., MULTIPLE CLASS, (INT. CLS. 37 AND 40), (U.S. CLS. 100, 103 AND 106). SN 85-530,070. PUB. 7-3-2012. FILED 1-31-2012.
 4,209,462. **UWIN (STANDARD CHARACTER).** CLOCKWORK IP, LLC, (U.S. CLS. 100, 103 AND 106). SN 85-531,335. PUB. 7-3-2012. FILED 2-1-2012.
 4,209,473. **U . WIN AND DESIGN.** CLOCKWORK IP, LLC, (U.S. CLS. 100, 103 AND 106). SN 85-532,376. PUB. 7-3-2012. FILED 2-2-2012.
 4,209,500. **TECHS ON TOUR (STANDARD CHARACTER).** GTE FEDERAL CREDIT UNION, MULTIPLE CLASS, (INT. CLS. 37 AND 42), (U.S. CLS. 100, 101, 103 AND 106). SN 85-537,298. PUB. 7-3-2012. FILED 2-8-2012.
 4,209,501. **TECHS ON TOUR AND DESIGN.** GTE FEDERAL CREDIT UNION, MULTIPLE CLASS, (INT. CLS. 37 AND 42), (U.S. CLS. 100, 101, 103 AND 106). SN 85-537,303. PUB. 7-3-2012. FILED 2-8-2012.
 4,209,511. **ONE NAME SAYS IT ALL! (STANDARD CHARACTER).** MICHAEL NASH CUSTOM KITCHENS, INC., MULTIPLE CLASS, (INT. CLS. 37 AND 42), (U.S. CLS. 100, 101, 103 AND 106). SN 85-537,864. PUB. 7-3-2012. FILED 2-9-2012.
 4,209,524. **TYTAL AND DESIGN.** TRAILERS Y TANQUES DE ALUMINIO, S.A. DE C.V., (U.S. CLS. 100, 103 AND 106). SN 85-538,636. PUB. 7-3-2012. FILED 2-9-2012.
 4,209,567. **TRUBERRY (STANDARD CHARACTER).** WOOD RUN PARTNERS, DBA TRUBERRY CUSTOM HOMES, (U.S. CLS. 100, 103 AND 106). SN 85-540,669. PUB. 7-3-2012. FILED 2-13-2012.
 4,209,581. **LEAK WHISPERER (STANDARD CHARACTER).** TYSON SOUTHWORTH, AKA LEAK WHISPERER, (U.S. CLS. 100, 103 AND 106). SN 85-540,982. PUB. 7-3-2012. FILED 2-13-2012.
 4,209,582. **NEXTGEN COLLECTIONS (STANDARD CHARACTER).** NEXTGEN COLLECTIONS, LLC, (U.S. CLS. 100, 103 AND 106). SN 85-540,987. PUB. 7-3-2012. FILED 2-13-2012.
 4,209,676 (*See Class 35 for this trademark.*)
 4,209,677 (*See Class 35 for this trademark.*)
 4,209,705. **MISCELLANEOUS DESIGN.** UNIVERSAL CITY STUDIOS LLC, (U.S. CLS. 100, 103 AND 106). SN 85-542,830. PUB. 7-3-2012. FILED 2-14-2012.
 4,209,707. **DRY-B-LO (STANDARD CHARACTER).** MOORE, GRANT M., (U.S. CLS. 100, 103 AND 106). SN 85-542,867. PUB. 7-3-2012. FILED 2-14-2012.
 4,209,715. **DUBAK ELECTRICAL MAINTENANCE CORP. INDUSTRIAL ELECTRICAL CONTRACTORS AND DESIGN.** DUBAK ELECTRICAL MAINTENANCE CORP., (U.S. CLS. 100, 103 AND 106). SN 85-543,067. PUB. 7-3-2012. FILED 2-15-2012.
 4,209,739. **IMPROVE GROUP (STANDARD CHARACTER).** IMPROVE GROUP, INC., (U.S. CLS. 100, 103 AND 106). SN 85-543,400. PUB. 7-3-2012. FILED 2-15-2012.
 4,209,768. **YOU RUN YOUR BUSINESS. WE'LL RUN YOUR NETWORK. (STANDARD CHARACTER).** FULL SERVICE NETWORK LP, MULTIPLE CLASS, (INT. CLS. 37, 38 AND 42), (U.S. CLS. 100, 101, 103, 104 AND 106). SN 85-543,755. PUB. 7-3-2012. FILED 2-15-2012.
 4,209,947. **SNAP!INSTALL AND DESIGN.** SNAP INSTALL, INC., (U.S. CLS. 100, 103 AND 106). SN 85-547,629. PUB. 7-3-2012. FILED 2-20-2012.
 4,210,003. **BECAUSE PAINTING IS PERSONAL (STANDARD CHARACTER).** CERTA PROPAINTEERS, LTD., (U.S. CLS. 100, 103 AND 106). SN 85-553,809. PUB. 7-3-2012. FILED 2-27-2012.
 4,210,019. **LECHASE. BUILDING PARTNERSHIPS. (STANDARD CHARACTER).** LECHASE CONSTRUCTION SERVICES, LLC, (U.S. CLS. 100, 103 AND 106). SN 85-555,873. PUB. 7-3-2012. FILED 2-29-2012.
 4,210,185 (*See Class 10 for this trademark.*)

CLASS 38—COMMUNICATION

- 4,208,124 (*See Class 9 for this trademark.*)
 4,208,233 (*See Class 9 for this trademark.*)
 4,208,234 (*See Class 9 for this trademark.*)
 4,208,245 (*See Class 9 for this trademark.*)
 4,208,261 (*See Class 9 for this trademark.*)
 4,208,262 (*See Class 9 for this trademark.*)
 4,208,264 (*See Class 9 for this trademark.*)
 4,208,274 (*See Class 9 for this trademark.*)
 4,208,303 (*See Class 9 for this trademark.*)
 4,208,329 (*See Class 35 for this trademark.*)
 4,208,333 (*See Class 5 for this trademark.*)
 4,208,337 (*See Class 9 for this trademark.*)
 4,208,341 (*See Class 35 for this trademark.*)
 4,208,349 (*See Class 5 for this trademark.*)

4,208,364 (*See Class 9 for this trademark.*)
 4,208,382 (*See Class 9 for this trademark.*)
 4,208,456 (*See Class 35 for this trademark.*)
 4,208,589 (*See Class 35 for this trademark.*)
 4,208,657. **CINE MEXICANO (STANDARD CHARACTER).** OLYMPUSAT, INC., MULTIPLE CLASS, (INT. CLS. 38 AND 41), (U.S. CLS. 100, 101, 104 AND 107). SN 85-349,195. PUB. 7-3-2012. FILED 6-17-2011.
 4,208,663. **LEARNABLE (STANDARD CHARACTER).** LEARNABLE PTY LTD, (U.S. CLS. 100, 101 AND 104). SN 85-351,714. PUB. 7-3-2012. FILED 6-21-2011.
 4,208,711. **SOUTH CAROLINA RADIO NETWORK (STANDARD CHARACTER).** LEARFIELD COMMUNICATIONS, INC., (U.S. CLS. 100, 101 AND 104). SN 85-366,427. PUB. 7-3-2012. FILED 7-8-2011.
 4,208,712. **NEBRASKA RADIO NETWORK (STANDARD CHARACTER).** LEARFIELD COMMUNICATIONS, INC., (U.S. CLS. 100, 101 AND 104). SN 85-366,642. PUB. 7-3-2012. FILED 7-8-2011.
 4,208,746 (*See Class 35 for this trademark.*)
 4,208,817 (*See Class 9 for this trademark.*)
 4,208,903 (*See Class 9 for this trademark.*)
 4,208,948 (*See Class 9 for this trademark.*)
 4,208,966 (*See Class 35 for this trademark.*)
 4,209,051. **ZIMRIDE (STANDARD CHARACTER).** ZIMRIDE, INC., MULTIPLE CLASS, (INT. CLS. 38 AND 39), (U.S. CLS. 100, 101, 104 AND 105). SN 85-472,326. PUB. 7-3-2012. FILED 11-14-2011.
 4,209,061. **ADIOS (STANDARD CHARACTER).** TOTAL CALL INTERNATIONAL, INC., (U.S. CLS. 100, 101 AND 104). SN 85-473,528. PUB. 7-3-2012. FILED 11-15-2011.
 4,209,062. **ADIOS AND DESIGN.** TOTAL CALL INTERNATIONAL, INC., (U.S. CLS. 100, 101 AND 104). SN 85-474,247. PUB. 7-3-2012. FILED 11-16-2011.
 4,209,165. **WANTBASKET (STANDARD CHARACTER).** WANTBASKET, INC., (U.S. CLS. 100, 101 AND 104). SN 85-505,214. PUB. 7-3-2012. FILED 12-28-2011.
 4,209,261 (*See Class 9 for this trademark.*)
 4,209,434 (*See Class 37 for this trademark.*)
 4,209,458. **LIBRARY IDEAS (STANDARD CHARACTER).** LIBRARY IDEAS, LLC, (U.S. CLS. 100, 101 AND 104). SN 85-531,068. PUB. 7-3-2012. FILED 2-1-2012.
 4,209,459. **FREADING (STANDARD CHARACTER).** LIBRARY IDEAS, LLC, (U.S. CLS. 100, 101 AND 104). SN 85-531,100. PUB. 7-3-2012. FILED 2-1-2012.
 4,209,460. **FREGAL (STANDARD CHARACTER).** LIBRARY IDEAS, LLC, (U.S. CLS. 100, 101 AND 104). SN 85-531,113. PUB. 7-3-2012. FILED 2-1-2012.
 4,209,614 (*See Class 9 for this trademark.*)
 4,209,712 (*See Class 35 for this trademark.*)
 4,209,740. **IMPROVE GROUP (STANDARD CHARACTER).** IMPROVE GROUP, INC., (U.S. CLS. 100, 101 AND 104). SN 85-543,408. PUB. 7-3-2012. FILED 2-15-2012.
 4,209,768 (*See Class 37 for this trademark.*)
 4,209,806. **TELEBROAD (STANDARD CHARACTER).** SPITZ, YISRAEL, AND SCHWARTZ, YITZCHOK, (U.S. CLS. 100, 101 AND 104). SN 85-544,460. PUB. 7-3-2012. FILED 2-16-2012.
 4,210,014. **IT'S NOT MAGIC (STANDARD CHARACTER).** MITEL NETWORKS CORPORATION, (U.S. CLS. 100, 101 AND 104). SN 85-555,297. PUB. 7-3-2012. FILED 2-28-2012.
 4,210,036. **JAMOOZ (STANDARD CHARACTER).** SPITZ, YISRAEL, (U.S. CLS. 100, 101 AND 104). SN 85-560,521. PUB. 7-3-2012. FILED 3-5-2012.
 4,210,071. **GH (STYLIZED).** REALNETWORKS, INC., (U.S. CLS. 100, 101 AND 104). SN 85-569,828. PUB. 7-3-2012. FILED 3-14-2012.
 4,210,124. **CHL TV (STANDARD CHARACTER).** WESTERN PROFESSIONAL HOCKEY LEAGUE INC., AND CENTRAL HOCKEY LEAGUE, INC., (U.S. CLS. 100, 101 AND 104). SN 85-582,772. PUB. 7-3-2012. FILED 3-28-2012.
 4,210,205 (*See Class 35 for this trademark.*)

CLASS 39—TRANSPORTATION AND STORAGE

4,208,124 (*See Class 9 for this trademark.*)
 4,208,211 (*See Class 35 for this trademark.*)
 4,208,254 (*See Class 12 for this trademark.*)
 4,208,280. **STAR FRIENDS BY IBEROSTAR AND DESIGN.** IBEROSTAR HOTELES Y APARTAMENTOS, S.L., MULTIPLE CLASS, (INT. CLS. 39, 41 AND 43), (U.S. CLS. 100, 101, 105 AND 107). SN 79-100,025. PUB. 7-3-2012. FILED 5-6-2011.
 4,208,281 (*See Class 35 for this trademark.*)
 4,208,286 (*See Class 7 for this trademark.*)
 4,208,290 (*See Class 12 for this trademark.*)
 4,208,337 (*See Class 9 for this trademark.*)
 4,208,353 (*See Class 10 for this trademark.*)
 4,208,355 (*See Class 9 for this trademark.*)
 4,208,364 (*See Class 9 for this trademark.*)
 4,208,401 (*See Class 1 for this trademark.*)
 4,208,456 (*See Class 35 for this trademark.*)
 4,208,527 (*See Class 35 for this trademark.*)
 4,208,537. **SPIRIT.COM (STANDARD CHARACTER).** SPIRIT AIRLINES, INC., (U.S. CLS. 100 AND 105). SN 85-211,140. PUB. 7-3-2012. FILED 1-5-2011.
 4,208,636. **EXPERIENCE LIFE (STANDARD CHARACTER).** MOODY GARDENS, INC., MULTIPLE CLASS, (INT. CLS. 39, 41 AND 43), (U.S. CLS. 100, 101, 105 AND 107). SN 85-338,439. PUB. 7-3-2012. FILED 6-6-2011.
 4,208,644 (*See Class 4 for this trademark.*)
 4,208,645. **OUTSIDE | LINES AND DESIGN.** JACK ELVIS PRODUCTIONS, LLC, AKA JACK-ELVIS PRODUCTIONS, LLC, (U.S. CLS. 100 AND 105). SN 85-343,949. PUB. 7-3-2012. FILED 6-11-2011.
 4,208,680. **FLIGHTPASS (STANDARD CHARACTER).** FLIGHTWORKS INCORPORATED, (U.S. CLS. 100 AND 105). SN 85-357,906. PUB. 7-3-2012. FILED 6-28-2011.
 4,208,685. **HIP TRAVEL MAMA (STANDARD CHARACTER).** ANNE TAYLOR COMMUNICATIONS, LLC, MULTIPLE CLASS, (INT. CLS. 39 AND 45), (U.S. CLS. 100, 101 AND 105). SN 85-359,466. PUB. 7-3-2012. FILED 6-29-2011.
 4,208,700 (*See Class 18 for this trademark.*)
 4,208,739. **KID ON VACATION (STANDARD CHARACTER).** KID ON VACATION, LLC, (U.S. CLS. 100 AND 105). SN 85-372,891. PUB. 7-3-2012. FILED 7-15-2011.
 4,208,746 (*See Class 35 for this trademark.*)
 4,208,779 (*See Class 35 for this trademark.*)
 4,208,780. **TP (STYLIZED).** TRANSIT PROS, LLC, (U.S. CLS. 100 AND 105). SN 85-377,592. PUB. 7-3-2012. FILED 7-21-2011.
 4,208,817 (*See Class 9 for this trademark.*)
 4,209,024. **COMPOST OFFICE (STANDARD CHARACTER).** THE COMPOST OFFICE, INC., (U.S. CLS. 100 AND 105). SN 85-461,420. PUB. 7-3-2012. FILED 11-1-2011.
 4,209,051 (*See Class 38 for this trademark.*)
 4,209,109. **CUSTOM COMMODITIES AND DESIGN.** CUSTOM COMMODITIES, INC., (U.S. CLS. 100 AND 105). SN 85-492,006. PUB. 7-3-2012. FILED 12-9-2011.
 4,209,150 (*See Class 35 for this trademark.*)
 4,209,301. **RD 2 SUCCESS EXPRESS LMT "THE RD 2 SUCCESS IS ALWAYS THE BEST" LMT AND DESIGN.** RD 2 SUCCESS EXPRESS, INC, (U.S. CLS. 100 AND 105). SN 85-522,191. PUB. 7-3-2012. FILED 1-22-2012.
 4,209,409. **R AND DESIGN.** RELIANCE RENT-A-CAR, LLC, (U.S. CLS. 100 AND 105). SN 85-526,372. PUB. 7-3-2012. FILED 1-26-2012.
 4,209,410 (*See Class 35 for this trademark.*)
 4,209,466. **PIXIE VACATIONS (STANDARD CHARACTER).** VLM LLC, (U.S. CLS. 100 AND 105). SN 85-531,557. PUB. 7-3-2012. FILED 2-1-2012.
 4,209,469. **DRINK KING DISTRIBUTING AND DESIGN.** NTH DEGREE INNOVATIONS, INC., (U.S. CLS. 100 AND 105). SN 85-531,913. PUB. 7-3-2012. FILED 2-2-2012.
 4,209,622. **CHOPPHEARSE (STANDARD CHARACTER).** CHOPPHEARSE INC, (U.S. CLS. 100 AND 105). SN 85-541,427. PUB. 7-3-2012. FILED 2-13-2012.
 4,209,627. **THE LAST RUN (STANDARD CHARACTER).** CHOPPHEARSE INC, (U.S. CLS. 100 AND 105). SN 85-541,518. PUB. 7-3-2012. FILED 2-13-2012.
 4,209,728. **S-TRIP! (STANDARD CHARACTER).** HANDA

TRAVEL STUDENT TRIP LTD., DBA S-TRIP! AND EDGE ACADEMY, (U.S. CLS. 100 AND 105). SN 85-543,248. PUB. 7-3-2012. FILED 2-15-2012.

4,209,731. **S-TRIP! AND DESIGN**. HANDA TRAVEL STUDENT TRIP LTD., DBA S-TRIP! AND EDGE ACADEMY, (U.S. CLS. 100 AND 105). SN 85-543,266. PUB. 7-3-2012. FILED 2-15-2012.

4,209,741. **IMPROVE GROUP (STANDARD CHARACTER)**. IMPROVE GROUP, INC., (U.S. CLS. 100 AND 105). SN 85-543,412. PUB. 7-3-2012. FILED 2-15-2012.

4,209,756. **PETSTREAK (STANDARD CHARACTER)**. ALASKA AIRLINES, INC., (U.S. CLS. 100 AND 105). SN 85-543,575. PUB. 7-3-2012. FILED 2-15-2012.

4,209,810. **BEERCYCLING (STANDARD CHARACTER)**. COHAN, EVAN M, (U.S. CLS. 100 AND 105). SN 85-544,498. PUB. 7-3-2012. FILED 2-16-2012.

4,209,816. **CIRCA '64 (STANDARD CHARACTER)**. JACKSON FAMILY FARMS, LLC, (U.S. CLS. 100 AND 105). SN 85-544,561. PUB. 7-3-2012. FILED 2-16-2012.

4,209,850. **IAPARTMENTS (STANDARD CHARACTER)**. CULBERSON, BOBBIE, (U.S. CLS. 100 AND 105). SN 85-545,187. PUB. 7-3-2012. FILED 2-16-2012.

4,209,964. **MISCELLANEOUS DESIGN**. CHOPPHEARSE INC, (U.S. CLS. 100 AND 105). SN 85-548,679. PUB. 7-3-2012. FILED 2-21-2012.

4,209,984 (*See Class 9 for this trademark*).

4,210,016. **IN SEARCH OF ROOTS (STANDARD CHARACTER)**. CHINESE CULTURE FOUNDATION OF SAN FRANCISCO, (U.S. CLS. 100 AND 105). SN 85-555,388. PUB. 7-3-2012. FILED 2-28-2012.

4,210,155. **MISCELLANEOUS DESIGN**. U-HAUL INTERNATIONAL, INC., (U.S. CLS. 100 AND 105). SN 85-594,434. PUB. 7-3-2012. FILED 4-11-2012.

CLASS 40—MATERIAL TREATMENT

4,208,286 (*See Class 7 for this trademark*).

4,208,319 (*See Class 7 for this trademark*).

4,208,336 (*See Class 23 for this trademark*).

4,208,367 (*See Class 2 for this trademark*).

4,208,405 (*See Class 10 for this trademark*).

4,208,407 (*See Class 9 for this trademark*).

4,208,414 (*See Class 6 for this trademark*).

4,208,453 (*See Class 20 for this trademark*).

4,208,481 (*See Class 1 for this trademark*).

4,208,510 (*See Class 9 for this trademark*).

4,208,590 (*See Class 7 for this trademark*).

4,208,591 (*See Class 7 for this trademark*).

4,208,603. **HELICAL PRODUCT LIFECYCLE OPTIMIZATION AND DESIGN**. HELGESEN INDUSTRIES, INC., (U.S. CLS. 100, 103 AND 106). SN 85-312,342. PUB. 7-3-2012. FILED 5-4-2011.

4,208,628 (*See Class 6 for this trademark*).

4,208,644 (*See Class 4 for this trademark*).

4,208,869. **E AND DESIGN**. EVOLVE SOLUTIONS HOLDINGS, LLC, (U.S. CLS. 100, 103 AND 106). SN 85-401,621. PUB. 7-3-2012. FILED 8-18-2011.

4,208,875. **CCL LABEL (STANDARD CHARACTER)**. CCL INDUSTRIES INC., MULTIPLE CLASS, (INT. CLS. 40 AND 42), (U.S. CLS. 100, 101, 103 AND 106). SN 85-402,681. PUB. 7-3-2012. FILED 8-19-2011.

4,208,876. **CCL LABEL AND DESIGN**. CCL INDUSTRIES INC., MULTIPLE CLASS, (INT. CLS. 40 AND 42), (U.S. CLS. 100, 101, 103 AND 106). SN 85-402,686. PUB. 7-3-2012. FILED 8-19-2011.

4,208,951. **360 IMAGING INC. AND DESIGN**. 360 IMAGING, INC., MULTIPLE CLASS, (INT. CLS. 40 AND 41), (U.S. CLS. 100, 101, 103, 106 AND 107). SN 85-434,892. PUB. 7-3-2012. FILED 9-29-2011.

4,209,009. **CHAMELEON HI-FI COLOR SEPARATION (STANDARD CHARACTER)**. 360 IMAGING, INC., (U.S. CLS. 100, 103 AND 106). SN 85-451,642. PUB. 7-3-2012. FILED 10-20-2011.

4,209,011. **HIVISION (STANDARD CHARACTER)**. HOYA CORPORATION, (U.S. CLS. 100, 103 AND 106). SN 85-451,833. PUB. 7-3-2012. FILED 10-20-2011.

4,209,069 (*See Class 35 for this trademark*).

4,209,081 (*See Class 30 for this trademark*).

4,209,088. **ROLLING BONES HOT ROD SHOP AND DESIGN**. CORNELL, KEITH, (U.S. CLS. 100, 103 AND 106). SN 85-488,091. PUB. 7-3-2012. FILED 12-6-2011.

4,209,106. **GPI PROTOTYPE & MANUFACTURING SERVICES (STANDARD CHARACTER)**. GALLOWAY PLASTICS, INC., (U.S. CLS. 100, 103 AND 106). SN 85-491,835. PUB. 7-3-2012. FILED 12-9-2011.

4,209,107. **PROTOTYPE TODAY (STANDARD CHARACTER)**. LAKE BLUFF CONSULTING, INC., (U.S. CLS. 100, 103 AND 106). SN 85-491,923. PUB. 7-3-2012. FILED 12-9-2011.

4,209,208 (*See Class 16 for this trademark*).

4,209,261 (*See Class 9 for this trademark*).

4,209,304. **ADVANTACLEAN (STANDARD CHARACTER)**. ADVANTACLEAN SYSTEMS, INC., (U.S. CLS. 100, 103 AND 106). SN 85-522,310. PUB. 7-3-2012. FILED 1-23-2012.

4,209,451 (*See Class 37 for this trademark*).

4,209,478. **J&A FOODS, INC. (STANDARD CHARACTER)**. J&A FOODS, INC., (U.S. CLS. 100, 103 AND 106). SN 85-533,512. PUB. 7-3-2012. FILED 2-3-2012.

4,209,644. **DESIGN PROOF (STANDARD CHARACTER)**. YOUSEIGNIT, LLC, (U.S. CLS. 100, 103 AND 106). SN 85-541,862. PUB. 7-3-2012. FILED 2-14-2012.

4,209,690. **VICO (STANDARD CHARACTER)**. RSI HOME PRODUCTS MANAGEMENT, INC., (U.S. CLS. 100, 103 AND 106). SN 85-542,577. PUB. 7-3-2012. FILED 2-14-2012.

4,209,848. **SAY IT WITH SUGAR (STANDARD CHARACTER)**. SAY IT WITH SUGAR CAKE SHOP LLC, (U.S. CLS. 100, 103 AND 106). SN 85-545,114. PUB. 7-3-2012. FILED 2-16-2012.

4,209,927. **FLASH (STANDARD CHARACTER)**. SFP WORKS, LLC, (U.S. CLS. 100, 103 AND 106). SN 85-546,735. PUB. 7-3-2012. FILED 2-18-2012.

4,210,051 (*See Class 12 for this trademark*).

4,210,193. **ELAPSS (STANDARD CHARACTER)**. G2 REVOLUTION, LLC, (U.S. CLS. 100, 103 AND 106). SN 85-610,050. PUB. 7-3-2012. FILED 4-27-2012.

CLASS 41—EDUCATION AND ENTERTAINMENT

4,208,123 (*See Class 9 for this trademark*).

4,208,124 (*See Class 9 for this trademark*).

4,208,133. **POWER UP (STANDARD CHARACTER)**. NEILL TECHNOLOGIES, (U.S. CLS. 100, 101 AND 107). SN 76-705,399. PUB. 7-3-2012. FILED 11-18-2010.

4,208,135 (*See Class 35 for this trademark*).

4,208,136. **THE MELLO-KINGS (STANDARD CHARACTER)**. SCHOLL, GERALD, AND MANSUETO, MICHAEL, AND MAGNETICO, JOSEPH M., (U.S. CLS. 100, 101 AND 107). SN 76-708,340. PUB. 7-3-2012. FILED 7-14-2011.

4,208,138. **THE OTHER SIDE OF GRIEF (STANDARD CHARACTER)**. SMITH, CANDIS, (U.S. CLS. 100, 101 AND 107). SN 76-708,484. PUB. 7-3-2012. FILED 7-26-2011.

4,208,143 (*See Class 35 for this trademark*).

4,208,158. **DEJA VU SHOWGIRLS (STANDARD CHARACTER)**. GLOBAL LICENSING, INC., MULTIPLE CLASS, (INT. CLS. 41 AND 43), (U.S. CLS. 100, 101 AND 107). SN 76-710,615. PUB. 7-3-2012. FILED 2-14-2012.

4,208,159. **DE JA VU (STANDARD CHARACTER)**. GLOBAL LICENSING, INC, MULTIPLE CLASS, (INT. CLS. 41 AND 43), (U.S. CLS. 100, 101 AND 107). SN 76-710,616. PUB. 7-3-2012. FILED 2-14-2012.

4,208,172. **LIVING BUILDING LEADER (STANDARD CHARACTER)**. CASCADIA REGIONAL GREEN BUILDING COUNCIL, (U.S. CLS. 100, 101 AND 107). SN 77-405,393. PUB. 7-3-2012. FILED 2-25-2008.

4,208,181 (*See Class 9 for this trademark*).

4,208,189. **WILD MAGNOLIAS (STANDARD CHARACTER)**. BIG CHIEF THEODORE BO DOLLIS, TA THE WILD MAGNOLIAS, (U.S. CLS. 100, 101 AND 107). SN 77-795,310. PUB. 7-3-2012. FILED 8-3-2009.

4,208,195. **GREEN DOOR (STANDARD CHARACTER)**. MUS, INC., DBA THE GREEN DOOR, (U.S. CLS. 100, 101 AND 107). SN 77-865,028. PUB. 7-3-2012. FILED 11-4-2009.

- 4,208,196 (*See Class 18 for this trademark*).
- 4,208,197. **YBF (STANDARD CHARACTER)**. YOUNG, BLACK AND FABULOUS, L.L.C., DBA YBF, (U.S. CLS. 100, 101 AND 107). SN 77-872,428. PUB. 7-3-2012. FILED 11-13-2009.
- 4,208,199 (*See Class 9 for this trademark*).
- 4,208,212. **THE PARKETTES (STANDARD CHARACTER)**. GREENWOOD GAMING & ENTERTAINMENT, INC., DBA PARX CASINO, (U.S. CLS. 100, 101 AND 107). SN 77-925,910. PUB. 7-3-2012. FILED 2-2-2010.
- 4,208,218. **MS. FITNESS WORLD (STANDARD CHARACTER)**. WALLY BOYKO PRODUCTIONS, INC., (U.S. CLS. 100, 101 AND 107). SN 77-947,644. PUB. 5-10-2011. FILED 3-1-2010.
- 4,208,238 (*See Class 35 for this trademark*).
- 4,208,243 (*See Class 3 for this trademark*).
- 4,208,246 (*See Class 9 for this trademark*).
- 4,208,247 (*See Class 9 for this trademark*).
- 4,208,260 (*See Class 9 for this trademark*).
- 4,208,261 (*See Class 9 for this trademark*).
- 4,208,262 (*See Class 9 for this trademark*).
- 4,208,274 (*See Class 9 for this trademark*).
- 4,208,278 (*See Class 9 for this trademark*).
- 4,208,280 (*See Class 39 for this trademark*).
- 4,208,291 (*See Class 9 for this trademark*).
- 4,208,298 (*See Class 16 for this trademark*).
- 4,208,305 (*See Class 25 for this trademark*).
- 4,208,306. **VMZ PRO-ZINC (STANDARD CHARACTER)**. UMICORE BUILDING PRODUCTS FRANCE, SOCIÉTÉ PAR ACTION SIMPLIFIÉE, (U.S. CLS. 100, 101 AND 107). SN 79-101,826. PUB. 7-3-2012. FILED 7-8-2011.
- 4,208,321 (*See Class 16 for this trademark*).
- 4,208,329 (*See Class 35 for this trademark*).
- 4,208,333 (*See Class 5 for this trademark*).
- 4,208,342 (*See Class 9 for this trademark*).
- 4,208,346 (*See Class 16 for this trademark*).
- 4,208,349 (*See Class 5 for this trademark*).
- 4,208,364 (*See Class 9 for this trademark*).
- 4,208,381 (*See Class 3 for this trademark*).
- 4,208,405 (*See Class 10 for this trademark*).
- 4,208,407 (*See Class 9 for this trademark*).
- 4,208,408 (*See Class 9 for this trademark*).
- 4,208,429 (*See Class 9 for this trademark*).
- 4,208,446 (*See Class 16 for this trademark*).
- 4,208,458 (*See Class 9 for this trademark*).
- 4,208,479. **DJ REKHA BOLLYWOOD DISCO (STANDARD CHARACTER)**. SANGAMENT, INC., (U.S. CLS. 100, 101 AND 107). SN 85-117,642. PUB. 7-3-2012. FILED 8-27-2010.
- 4,208,494 (*See Class 9 for this trademark*).
- 4,208,495 (*See Class 9 for this trademark*).
- 4,208,497 (*See Class 35 for this trademark*).
- 4,208,498 (*See Class 35 for this trademark*).
- 4,208,516. **SWIM FASTER AND DESIGN**. TRI FASTER, LLC, (U.S. CLS. 100, 101 AND 107). SN 85-188,539. PUB. 7-3-2012. FILED 12-1-2010.
- 4,208,521. **THEURBANFLY THE URBANFLY.COM AND DESIGN**. GEORGE LETNESS ILLUSTRATION, DBA GRAPHICS440, (U.S. CLS. 100, 101 AND 107). SN 85-192,665. PUB. 7-3-2012. FILED 12-7-2010.
- 4,208,555 (*See Class 9 for this trademark*).
- 4,208,559. **HAMBURG CASINO AT THE FAIRGROUNDS AND DESIGN**. BUFFALO TROTTER ASSOCIATION, INC., MULTIPLE CLASS, (INT. CLS. 41 AND 43), (U.S. CLS. 100, 101 AND 107). SN 85-246,931. PUB. 7-3-2012. FILED 2-19-2011.
- 4,208,564. **YOUTH CARE (STANDARD CHARACTER)**. ASPEN EDUCATION GROUP, INC., MULTIPLE CLASS, (INT. CLS. 41 AND 44), (U.S. CLS. 100, 101 AND 107). SN 85-253,966. PUB. 7-3-2012. FILED 2-28-2011.
- 4,208,566 (*See Class 16 for this trademark*).
- 4,208,574. **SENATE'S END (STANDARD CHARACTER)**. CONGAREE HOLDINGS AND DEVELOPMENT GROUP, LLC, (U.S. CLS. 100, 101 AND 107). SN 85-276,264. PUB. 7-3-2012. FILED 3-24-2011.
- 4,208,579 (*See Class 9 for this trademark*).
- 4,208,590 (*See Class 7 for this trademark*).
- 4,208,591 (*See Class 7 for this trademark*).
- 4,208,604. **JEIGH B. RECORDS (STANDARD CHARACTER)**. FAMJAM, INC., (U.S. CLS. 100, 101 AND 107). SN 85-312,994. PUB. 7-3-2012. FILED 5-5-2011.
- 4,208,606 (*See Class 35 for this trademark*).
- 4,208,613. **SHE LEADS (STANDARD CHARACTER)**. DR. CHRISTINA T. SCHLACHTER, PHD, DBA SHE LEADS, (U.S. CLS. 100, 101 AND 107). SN 85-323,090. PUB. 7-3-2012. FILED 5-17-2011.
- 4,208,630. **PHYSICAL SECURITY PROFESSIONAL (STANDARD CHARACTER)**. ASIS INTERNATIONAL, INC., MULTIPLE CLASS, (INT. CLS. 41 AND 42), (U.S. CLS. 100, 101 AND 107). SN 85-335,967. PUB. 7-3-2012. FILED 6-2-2011.
- 4,208,636 (*See Class 39 for this trademark*).
- 4,208,643. **TWENTYFORSEVEN (STANDARD CHARACTER)**. LIVE THE MUSIC GROUP, AKA LIVETMG, (U.S. CLS. 100, 101 AND 107). SN 85-342,709. PUB. 7-3-2012. FILED 6-9-2011.
- 4,208,654 (*See Class 35 for this trademark*).
- 4,208,656. **THE MASON BROTHERS QUINTET (STANDARD CHARACTER)**. MASON BROTHERS BAND, (U.S. CLS. 100, 101 AND 107). SN 85-348,300. PUB. 7-3-2012. FILED 6-16-2011.
- 4,208,657 (*See Class 38 for this trademark*).
- 4,208,668 (*See Class 16 for this trademark*).
- 4,208,696 (*See Class 35 for this trademark*).
- 4,208,697. **RONNIE RAY (STANDARD CHARACTER)**. RENE HERNANDEZ, DBA RONNIE RAY, (U.S. CLS. 100, 101 AND 107). SN 85-362,287. PUB. 7-3-2012. FILED 7-1-2011.
- 4,208,701. **NICK SAGLIMBENI'S MASTERING RETOUCHING AND DESIGN**. SLICKFORCE, INC., (U.S. CLS. 100, 101 AND 107). SN 85-363,714. PUB. 7-3-2012. FILED 7-6-2011.
- 4,208,706. **ARME BIBLE CAMP (STANDARD CHARACTER)**. ARME MINISTRIES, (U.S. CLS. 100, 101 AND 107). SN 85-365,406. PUB. 7-3-2012. FILED 7-7-2011.
- 4,208,708. **ALEXIS JORDAN (STANDARD CHARACTER)**. ALEXIS JORDAN, (U.S. CLS. 100, 101 AND 107). SN 85-365,854. PUB. 7-3-2012. FILED 7-7-2011.
- 4,208,710 (*See Class 16 for this trademark*).
- 4,208,719. **SWEET PEA EVENTS (STANDARD CHARACTER)**. SIMANTS, KELLY A., DBA SWEET PEA EVENTS, (U.S. CLS. 100, 101 AND 107). SN 85-368,220. PUB. 7-3-2012. FILED 7-11-2011.
- 4,208,729 (*See Class 9 for this trademark*).
- 4,208,730. **THE RIGHT PREP THE RIGHT FUTURE AND DESIGN**. THE RIGHT PREP, LLC, (U.S. CLS. 100, 101 AND 107). SN 85-371,113. PUB. 7-3-2012. FILED 7-14-2011.
- 4,208,732. **FRISCO GUN CLUB AND DESIGN**. FRISCO GUN CLUB, INC., (U.S. CLS. 100, 101 AND 107). SN 85-371,605. PUB. 7-3-2012. FILED 7-14-2011.
- 4,208,741. **NYCSUBWAYGIRL (STANDARD CHARACTER)**. GRIER, CATHY, (U.S. CLS. 100, 101 AND 107). SN 85-373,119. PUB. 7-3-2012. FILED 7-16-2011.
- 4,208,746 (*See Class 35 for this trademark*).
- 4,208,748. **SOUTH FLORIDA PRIDE MARCHING BAND AND DESIGN**. SOUTH FLORIDA PRIDE WIND ENSEMBLE, INC., (U.S. CLS. 100, 101 AND 107). SN 85-373,580. PUB. 7-3-2012. FILED 7-18-2011.
- 4,208,749. **SOUTH FLORIDA PRIDE WIND ENSEMBLE AND DESIGN**. SOUTH FLORIDA PRIDE WIND ENSEMBLE, INC., (U.S. CLS. 100, 101 AND 107). SN 85-373,646. PUB. 7-3-2012. FILED 7-18-2011.
- 4,208,750. **SOUTH FLORIDA PRIDE JAZZ ENSEMBLE AND DESIGN**. SOUTH FLORIDA PRIDE WIND ENSEMBLE, INC., (U.S. CLS. 100, 101 AND 107). SN 85-373,684. PUB. 7-3-2012. FILED 7-18-2011.
- 4,208,752. **INDYFRINGE (STANDARD CHARACTER)**. INDIANAPOLIS THEATRE FRINGE FESTIVAL, INC., MULTIPLE CLASS, (INT. CLS. 41 AND 43), (U.S. CLS. 100, 101 AND 107). SN 85-374,151. PUB. 7-3-2012. FILED 7-18-2011.
- 4,208,754. **MISCELLANEOUS DESIGN**. CHARLOTTE ANDERSON, (U.S. CLS. 100, 101 AND 107). SN 85-374,296. PUB. 7-3-2012. FILED 7-18-2011.
- 4,208,758. **FREAK CITY (STANDARD CHARACTER)**. JUSTIN ROMERO, (U.S. CLS. 100, 101 AND 107). SN 85-374,952. PUB. 12-13-2011. FILED 7-19-2011.
- 4,208,762. **NOURISH NUTRITION SUPPORT PROGRAM (STYLIZED)**. CORAM LLC, (U.S. CLS. 100, 101 AND 107). SN 85-375,475. PUB. 7-3-2012. FILED 7-19-2011.
- 4,208,764. **NOURISH NUTRITION SUPPORT PROGRAM**

- (STANDARD CHARACTER). CORAM LLC, (U.S. CLS. 100, 101 AND 107). SN 85-375,493. PUB. 7-3-2012. FILED 7-19-2011.
- 4,208,766. **TREATMENT ROOM (STANDARD CHARACTER)**. HIGHLINE DIGITAL MEDIA, LLC, (U.S. CLS. 100, 101 AND 107). SN 85-376,115. PUB. 7-3-2012. FILED 7-20-2011.
- 4,208,776. **LOVE YOUR BOOBIES (STANDARD CHARACTER)**. YABLON, ERIC, (U.S. CLS. 100, 101 AND 107). SN 85-376,874. PUB. 3-27-2012. FILED 7-21-2011.
- 4,208,778 (*See Class 9 for this trademark*).
- 4,208,783. **COUSTEAU DIVERS (STANDARD CHARACTER)**. THE COUSTEAU SOCIETY, INC., (U.S. CLS. 100, 101 AND 107). SN 85-378,576. PUB. 7-3-2012. FILED 7-22-2011.
- 4,208,787. **ADVENTURCISE (STANDARD CHARACTER)**. GORDON, MICHELE E, DBA CHIEF EXECUTIVE OFFICER, (U.S. CLS. 100, 101 AND 107). SN 85-379,332. PUB. 7-3-2012. FILED S.R. 7-24-2011; AM. P.R. 5-3-2012.
- 4,208,790. **MISSISSIPPI COMMUNITY COLLEGE BOARD M AND DESIGN**. MISSISSIPPI COMMUNITY COLLEGE BOARD, (U.S. CLS. 100, 101 AND 107). SN 85-379,804. PUB. 7-3-2012. FILED 7-25-2011.
- 4,208,792. **THE COMEDY GARAGE (STANDARD CHARACTER)**. GREEN, SEAN, AND DANKE, PAUL, AND REID, CORNELL, AND LEISTIKOW, LOGAN, AND FEIGH, CASEY, (U.S. CLS. 100, 101 AND 107). SN 85-380,471. PUB. 7-3-2012. FILED 7-25-2011.
- 4,208,801. **BENCHPREP (STANDARD CHARACTER)**. WATERMELON EXPRESS, INC., (U.S. CLS. 100, 101 AND 107). SN 85-383,852. PUB. 7-3-2012. FILED 7-28-2011.
- 4,208,804. **JOHNSON BIBLE COLLEGE FOUNDED 1893 FAITH PRAYER WORK AND DESIGN**. JOHNSON UNIVERSITY, FORMERLY JOHNSON BIBLE COLLEGE, (U.S. CLS. 100, 101 AND 107). SN 85-384,706. PUB. 7-3-2012. FILED 7-29-2011.
- 4,208,814. **GOLDEN RASPBERRY (RAZZIE) AWARDS (STANDARD CHARACTER)**. WILSON, JOHN JB, DBA GOLDEN RASPBERRY (RAZZIE) AWARD FOUNDATION, (U.S. CLS. 100, 101 AND 107). SN 85-387,292. PUB. 7-3-2012. FILED 8-2-2011.
- 4,208,818 (*See Class 9 for this trademark*).
- 4,208,821. **CREDIT UNION NATIONAL ASSOCIATION (STANDARD CHARACTER)**. CREDIT UNION NATIONAL ASSOCIATION, INC., (U.S. CLS. 100, 101 AND 107). SN 85-388,700. PUB. 3-27-2012. FILED 8-3-2011.
- 4,208,826. **ALL-VOLLEY TENNIS (STANDARD CHARACTER)**. BEACH TENNIS USA, LLC, (U.S. CLS. 100, 101 AND 107). SN 85-389,508. PUB. 7-3-2012. FILED 8-4-2011.
- 4,208,828 (*See Class 9 for this trademark*).
- 4,208,831. **MILK COW BLUES FESTIVAL AT FAIR OAKS FARMS FAIR OAKS FARMS AND DESIGN**. FAIR OAKS DAIRY PRODUCTS, LLC, (U.S. CLS. 100, 101 AND 107). SN 85-390,942. PUB. 7-3-2012. FILED 8-5-2011.
- 4,208,837. **SOUTHERN PIGSKIN (STANDARD CHARACTER)**. SOUTHERNPIGSKIN.COM LLC, (U.S. CLS. 100, 101 AND 107). SN 85-392,907. PUB. 7-3-2012. FILED 8-9-2011.
- 4,208,856. **HCDE 1889 HARRIS COUNTY DEPARTMENT OF EDUCATION AND DESIGN**. HARRIS COUNTY DEPARTMENT OF EDUCATION, (U.S. CLS. 100, 101 AND 107). SN 85-398,413. PUB. 7-3-2012. FILED 8-15-2011.
- 4,208,867. **ARCHERY TAG (STANDARD CHARACTER)**. DEERSPACE LLC, DBA ARCHERY TAG, (U.S. CLS. 100, 101 AND 107). SN 85-401,217. PUB. 7-3-2012. FILED 8-18-2011.
- 4,208,874 (*See Class 35 for this trademark*).
- 4,208,878 (*See Class 16 for this trademark*).
- 4,208,890. **BUSTED BUSTEDCOP.COM AND DESIGN**. MONTEPERTUSO, INC., (U.S. CLS. 100, 101 AND 107). SN 85-405,665. PUB. 7-3-2012. FILED 8-24-2011.
- 4,208,901. **CLUB AUSSIE (STANDARD CHARACTER)**. BOWTIE, INC., (U.S. CLS. 100, 101 AND 107). SN 85-412,385. PUB. 7-3-2012. FILED 8-31-2011.
- 4,208,902. **CLUB BOSTON (STANDARD CHARACTER)**. BOWTIE, INC., (U.S. CLS. 100, 101 AND 107). SN 85-412,394. PUB. 7-3-2012. FILED 8-31-2011.
- 4,208,903 (*See Class 9 for this trademark*).
- 4,208,904. **CATALYST (STANDARD CHARACTER)**. CATALYST INC., (U.S. CLS. 100, 101 AND 107). SN 85-412,687. PUB. 7-3-2012. FILED 9-1-2011.
- 4,208,910. **MISS POLE DANCE OKLAHOMA (STANDARD CHARACTER)**. POLE ZONE, L.L.C., (U.S. CLS. 100, 101 AND 107). SN 85-414,070. PUB. 7-3-2012. FILED 9-2-2011.
- 4,208,927 (*See Class 16 for this trademark*).
- 4,208,936. **AUTOCAD (STANDARD CHARACTER)**. AUTO-DESK, INC., MULTIPLE CLASS, (INT. CLS. 41 AND 42), (U.S. CLS. 100, 101 AND 107). SN 85-422,922. PUB. 7-3-2012. FILED 9-14-2011.
- 4,208,941 (*See Class 9 for this trademark*).
- 4,208,948 (*See Class 9 for this trademark*).
- 4,208,951 (*See Class 40 for this trademark*).
- 4,208,962. **JENNY WILEY THEATRE AND DESIGN**. JENNY WILEY DRAMA ASSOCIATION, (U.S. CLS. 100, 101 AND 107). SN 85-437,880. PUB. 7-3-2012. FILED 10-3-2011.
- 4,208,969. **BECOMING ONE (STANDARD CHARACTER)**. BECOMING ONE LLC, (U.S. CLS. 100, 101 AND 107). SN 85-442,039. PUB. 3-20-2012. FILED 10-7-2011.
- 4,208,970. **INQUIRE WITHIN (STANDARD CHARACTER)**. BECOMING ONE LLC, (U.S. CLS. 100, 101 AND 107). SN 85-442,058. PUB. 3-20-2012. FILED 10-7-2011.
- 4,208,972. **PITTSBURGH KETTLEBELLS PGH KB AND DESIGN**. PITTSBURGH KETTLEBELLS, LLC, (U.S. CLS. 100, 101 AND 107). SN 85-443,146. PUB. 7-3-2012. FILED 10-10-2011.
- 4,208,976. **CROSS SKILLS WHERE FAITH MEETS EVERYDAY AND DESIGN**. DELOACH, ROBIN, (U.S. CLS. 100, 101 AND 107). SN 85-444,025. PUB. 7-3-2012. FILED 10-11-2011.
- 4,208,978. **LE LYCEE FRANCAIS DE LOS ANGELES WE TEACH THE WORLD (STANDARD CHARACTER)**. LE LYCEE FRANCAIS DE LOS ANGELES, (U.S. CLS. 100, 101 AND 107). SN 85-444,318. PUB. 7-3-2012. FILED 10-11-2011.
- 4,208,980 (*See Class 9 for this trademark*).
- 4,208,983. **AMERICAN BOARD OF MEDICAL PSYCHOLOGY AND DESIGN**. AMERICAN BOARD OF MEDICAL PSYCHOLOGY, (U.S. CLS. 100, 101 AND 107). SN 85-446,286. PUB. 7-3-2012. FILED 10-13-2011.
- 4,208,984. **MISCELLANEOUS DESIGN**. BECOMING ONE, LLC, (U.S. CLS. 100, 101 AND 107). SN 85-446,543. PUB. 3-27-2012. FILED 10-13-2011.
- 4,208,994. **AMERICAN MAFIA (STANDARD CHARACTER)**. IT DATAWORKS, LLC, (U.S. CLS. 100, 101 AND 107). SN 85-448,497. PUB. 3-27-2012. FILED 10-17-2011.
- 4,208,998. **HODOMANIACS (STANDARD CHARACTER)**. CV III, L.L.C., (U.S. CLS. 100, 101 AND 107). SN 85-448,908. PUB. 7-3-2012. FILED 10-17-2011.
- 4,208,999 (*See Class 9 for this trademark*).
- 4,209,001. **CBI (STANDARD CHARACTER)**. CHICAGO BAPTIST INSTITUTE, (U.S. CLS. 100, 101 AND 107). SN 85-449,157. PUB. 7-3-2012. FILED 10-17-2011.
- 4,209,013. **PIFL PROFESSIONAL INDOOR FOOTBALL LEAGUE AND DESIGN**. THE PROFESSIONAL INDOOR FOOTBALL LEAGUE, (U.S. CLS. 100, 101 AND 107). SN 85-452,296. PUB. 7-3-2012. FILED 10-20-2011.
- 4,209,014 (*See Class 35 for this trademark*).
- 4,209,015. **FF FORMATIVE FITNESS AND DESIGN**. BUSINESS AND CONCIERGE SERVICES, LLC, DBA FORMATIVE FITNESS, (U.S. CLS. 100, 101 AND 107). SN 85-456,267. PUB. 7-3-2012. FILED 10-26-2011.
- 4,209,016. **SS LAKE TAHOE SUMMERFEST (STYLIZED)**. LAKE TAHOE SUMMERFEST, (U.S. CLS. 100, 101 AND 107). SN 85-457,127. PUB. 7-3-2012. FILED 10-26-2011.
- 4,209,026. **MISCELLANEOUS DESIGN**. GOLFING FORE HIM, LLC, (U.S. CLS. 100, 101 AND 107). SN 85-461,893. PUB. 7-3-2012. FILED 11-1-2011.
- 4,209,030 (*See Class 36 for this trademark*).
- 4,209,033 (*See Class 35 for this trademark*).
- 4,209,034 (*See Class 35 for this trademark*).
- 4,209,042. **INTERPREBOT (STANDARD CHARACTER)**. LANGUAGE SERVICES ASSOCIATES, INC., (U.S. CLS. 100, 101 AND 107). SN 85-469,406. PUB. 7-3-2012. FILED 11-10-2011.
- 4,209,058. **AMERICAN DIPLOMA PROJECT (STANDARD CHARACTER)**. ACHIEVE, INC., (U.S. CLS. 100, 101 AND 107). SN 85-473,320. PUB. 7-3-2012. FILED 11-15-2011.
- 4,209,064. **MISCELLANEOUS DESIGN**. SALISH KOOTENAI COLLEGE, INC., (U.S. CLS. 100, 101 AND 107). SN 85-474,588. PUB. 7-3-2012. FILED 11-16-2011.
- 4,209,070 (*See Class 9 for this trademark*).

- 4,209,073. **TACTICOG (STANDARD CHARACTER)**. MAIER, HERBERT N., (U.S. CLS. 100, 101 AND 107). SN 85-479,417. PUB. 7-3-2012. FILED 11-22-2011.
- 4,209,077. **CARTHAGE (STANDARD CHARACTER)**. CARTHAGE COLLEGE, (U.S. CLS. 100, 101 AND 107). SN 85-481,428. PUB. 7-3-2012. FILED 11-28-2011.
- 4,209,080. **THE MARRIAGE BOOTCAMP (STANDARD CHARACTER)**. THE MARRIAGE BOOT CAMP INC., (U.S. CLS. 100, 101 AND 107). SN 85-484,402. PUB. 7-3-2012. FILED 11-30-2011.
- 4,209,087 (*See Class 35 for this trademark*).
- 4,209,104 (*See Class 9 for this trademark*).
- 4,209,105 (*See Class 16 for this trademark*).
- 4,209,114. **HOOPSTERTOTS (STANDARD CHARACTER)**. SOCCERTOTS INCORPORATED, (U.S. CLS. 100, 101 AND 107). SN 85-493,508. PUB. 5-29-2012. FILED 12-12-2011.
- 4,209,119. **IDAEXPO AND DESIGN**. INTERNATIONAL DOOR ASSOCIATION, INC., (U.S. CLS. 100, 101 AND 107). SN 85-494,885. PUB. 7-3-2012. FILED 12-14-2011.
- 4,209,123. **DISEASE TECHNIQUE TECHNOLOGY DTT (STANDARD CHARACTER)**. RAMSAY, CHRISTOPHER, (U.S. CLS. 100, 101 AND 107). SN 85-495,844. PUB. 7-3-2012. FILED 12-15-2011.
- 4,209,140. **PREP (STANDARD CHARACTER)**. MASSACHUSETTS DEPARTMENT OF MENTAL HEALTH, MULTIPLE CLASS, (INT. CLS. 41, 44 AND 45), (U.S. CLS. 100, 101 AND 107). SN 85-499,695. PUB. 7-3-2012. FILED 12-20-2011.
- 4,209,148 (*See Class 36 for this trademark*).
- 4,209,149 (*See Class 36 for this trademark*).
- 4,209,151. **E EXCELLENCE PHOTO BOOTHS AND DESIGN**. WESTERFIELD, JACOB J, DBA EXCELLENCE PHOTO BOOTHS, (U.S. CLS. 100, 101 AND 107). SN 85-502,791. PUB. 7-3-2012. FILED 12-23-2011.
- 4,209,162. **QUIK-HELP (STANDARD CHARACTER)**. QUIK-HELP, MULTIPLE CLASS, (INT. CLS. 41 AND 42), (U.S. CLS. 100, 101 AND 107). SN 85-504,784. PUB. 7-3-2012. FILED 12-28-2011.
- 4,209,164. **CAPTIVATING CINEMA (STANDARD CHARACTER)**. BLACKWELL, DEVANTE, (U.S. CLS. 100, 101 AND 107). SN 85-505,003. PUB. 7-3-2012. FILED 12-28-2011.
- 4,209,174. **CADDIE CONCIERGE (STANDARD CHARACTER)**. GOLDEN BELL MANAGEMENT, INC., MULTIPLE CLASS, (INT. CLS. 41 AND 45), (U.S. CLS. 100, 101 AND 107). SN 85-505,921. PUB. 7-3-2012. FILED 12-29-2011.
- 4,209,176. **BARBERSHOP FUNNY AND DESIGN**. FELDER, FREDERICK, (U.S. CLS. 100, 101 AND 107). SN 85-506,141. PUB. 7-3-2012. FILED 12-30-2011.
- 4,209,181. **ANDRAE MICHAELS NATIONAL PORTRAIT COMPANY, LLC AND DESIGN**. ANDRAE MICHAELS NATIONAL PORTRAIT COMPANY, (U.S. CLS. 100, 101 AND 107). SN 85-508,206. PUB. 7-3-2012. FILED 1-4-2012.
- 4,209,182 (*See Class 35 for this trademark*).
- 4,209,206. **TIAA-CREF UNIVERSITY (STANDARD CHARACTER)**. TEACHERS INSURANCE AND ANNUITY ASSOCIATION OF AMERICA, (U.S. CLS. 100, 101 AND 107). SN 85-512,752. PUB. 7-3-2012. FILED 1-10-2012.
- 4,209,210. **MATRIMONIO DINÁMICO AND DESIGN**. FAMILY DYNAMICS INSTITUTE, INC., AKA FAMILY DYNAMICS, (U.S. CLS. 100, 101 AND 107). SN 85-514,079. PUB. 7-3-2012. FILED 1-11-2012.
- 4,209,211 (*See Class 16 for this trademark*).
- 4,209,216. **BE A HERO PLAY BIGGER (STANDARD CHARACTER)**. ORANGE, DAVID, DBA QUESTS AND SUMMITS LLC, (U.S. CLS. 100, 101 AND 107). SN 85-515,045. PUB. 7-3-2012. FILED 1-12-2012.
- 4,209,222. **IDENTIFY ANALYZE DESIGN IMPLEMENT OBSERVE SUPPORT REVISIT REFRESH AND DESIGN**. NORTHSTAR EDUCATIONAL CONSULTING GROUP, LLC, (U.S. CLS. 100, 101 AND 107). SN 85-516,359. PUB. 7-3-2012. FILED 1-13-2012.
- 4,209,223. **THE ACE BAND (STANDARD CHARACTER)**. TULLIO, JIM, AND TULLIO, BOB, (U.S. CLS. 100, 101 AND 107). SN 85-516,538. PUB. 7-3-2012. FILED 1-13-2012.
- 4,209,233. **FEARLESS (STANDARD CHARACTER)**. PRODIGY EVENTS INC., (U.S. CLS. 100, 101 AND 107). SN 85-517,579. PUB. 7-3-2012. FILED 1-16-2012.
- 4,209,241. **CYCLELATES BY HBHM STUDIOS (STANDARD CHARACTER)**. SPINLATE WELLNESS CENTER, FORMERLY SPINLATES BY HBHM STUDIOS, (U.S. CLS. 100, 101 AND 107). SN 85-518,377. PUB. 7-3-2012. FILED 1-17-2012.
- 4,209,243. **TRADESHOW BOOTCAMP AND DESIGN**. HUNT, KATHLEEN E., (U.S. CLS. 100, 101 AND 107). SN 85-518,581. PUB. 7-3-2012. FILED 1-17-2012.
- 4,209,256. **OREGON MANIFEST (STANDARD CHARACTER)**. OREGON MANIFEST, (U.S. CLS. 100, 101 AND 107). SN 85-519,638. PUB. 7-3-2012. FILED 1-18-2012.
- 4,209,260. **CREDENTIALS UNLEASHED (STANDARD CHARACTER)**. PARCHMENT INC., (U.S. CLS. 100, 101 AND 107). SN 85-519,984. PUB. 7-3-2012. FILED 1-19-2012.
- 4,209,262. **RVP STUDIOS (STANDARD CHARACTER)**. RVP STUDIOS, LLC, (U.S. CLS. 100, 101 AND 107). SN 85-519,995. PUB. 7-3-2012. FILED 1-19-2012.
- 4,209,280. **HOT YOGA. HOT BODY (STANDARD CHARACTER)**. TWIN TOWERS, INC., (U.S. CLS. 100, 101 AND 107). SN 85-521,071. PUB. 7-3-2012. FILED 1-20-2012.
- 4,209,283. **X FELON CLUB REDEEMING THE TIME FOR EX-OFFENDERS (STYLIZED)**. BRYANT, CARL, DBA X-FELON CLUB, (U.S. CLS. 100, 101 AND 107). SN 85-521,160. PUB. 7-3-2012. FILED 1-20-2012.
- 4,209,286 (*See Class 25 for this trademark*).
- 4,209,289. **5280 ANGLER (STANDARD CHARACTER)**. J & J FLYFISHING, DBA 5280 ANGLER, (U.S. CLS. 100, 101 AND 107). SN 85-521,267. PUB. 7-3-2012. FILED 1-20-2012.
- 4,209,315. **SAVE THE SONG BIRDS AND DESIGN**. SMG BRANDS, INC., (U.S. CLS. 100, 101 AND 107). SN 85-522,658. PUB. 7-3-2012. FILED 1-23-2012.
- 4,209,318. **LEDET TRAINING (STANDARD CHARACTER)**. LEDET, STERLING JOSEPH, (U.S. CLS. 100, 101 AND 107). SN 85-522,790. PUB. 7-3-2012. FILED 1-23-2012.
- 4,209,321. **POHP (STANDARD CHARACTER)**. UNIVERSITY OF NORTH CAROLINA AT CHAPEL HILL, (U.S. CLS. 100, 101 AND 107). SN 85-522,959. PUB. 7-3-2012. FILED 1-23-2012.
- 4,209,330. **WORLD CHOCOLATE AWARDS AND DESIGN**. WORLD CHOCOLATE AWARDS, (U.S. CLS. 100, 101 AND 107). SN 85-523,270. PUB. 7-3-2012. FILED 1-23-2012.
- 4,209,347. **HOW TO BE A REDHEAD AND DESIGN**. HOW TO BE A REDHEAD LLC, (U.S. CLS. 100, 101 AND 107). SN 85-523,877. PUB. 7-3-2012. FILED 1-24-2012.
- 4,209,356. **BREATHE REPEAT (STANDARD CHARACTER)**. BREATHE REPEAT LLC, (U.S. CLS. 100, 101 AND 107). SN 85-524,584. PUB. 7-3-2012. FILED 1-25-2012.
- 4,209,357. **PUT A LITTLE EAST IN YOUR WEST (STANDARD CHARACTER)**. BREATHE REPEAT LLC, (U.S. CLS. 100, 101 AND 107). SN 85-524,590. PUB. 7-3-2012. FILED 1-25-2012.
- 4,209,359. **MISCELLANEOUS DESIGN**. ADDICTIVE HUNTING LLC, (U.S. CLS. 100, 101 AND 107). SN 85-524,661. PUB. 7-3-2012. FILED S.R. 1-25-2012; AM. P.R. 5-4-2012.
- 4,209,382. **RED JOKER PRODUCTIONS AND DESIGN**. GRANT-HARVEY, SHALISSA DIONE, (U.S. CLS. 100, 101 AND 107). SN 85-525,600. PUB. 7-3-2012. FILED 1-26-2012.
- 4,209,383 (*See Class 16 for this trademark*).
- 4,209,390. **MOUNTAIN EDGE RACEWAY (STANDARD CHARACTER)**. GREAT LAKES SERVICES, LLC, (U.S. CLS. 100, 101 AND 107). SN 85-525,889. PUB. 7-3-2012. FILED 1-26-2012.
- 4,209,394. **PHYSIX TRAIN YOUR MATTER INTO ENERGY AND DESIGN**. PHYSIX, LLC, (U.S. CLS. 100, 101 AND 107). SN 85-525,953. PUB. 7-3-2012. FILED 1-26-2012.
- 4,209,401. **THE WATERY RAVE (STANDARD CHARACTER)**. CROSS OPTICAL GROUP, INC., (U.S. CLS. 100, 101 AND 107). SN 85-526,113. PUB. 7-3-2012. FILED 1-26-2012.
- 4,209,407. **KINDERLAND INDOOR PLAY & CAFE AND DESIGN**. KINDERLAND CAFE LTD., MULTIPLE CLASS, (INT. CLS. 41 AND 43), (U.S. CLS. 100, 101 AND 107). SN 85-526,355. PUB. 7-3-2012. FILED 1-26-2012.
- 4,209,415. **TREADMARK STUDIOS (STANDARD CHARACTER)**. TREADMARK STUDIOS, (U.S. CLS. 100, 101 AND 107). SN 85-526,648. PUB. 7-3-2012. FILED 1-26-2012.
- 4,209,418. **SPINGUIN (STANDARD CHARACTER)**. GAIN, ELIZABETH S., DBA SPINGUIN MUSIC, (U.S. CLS. 100, 101 AND 107). SN 85-526,654. PUB. 7-3-2012. FILED 1-26-2012.
- 4,209,445. **MENTOR FACTOR (STANDARD CHARACTER)**.

- THE MENTOR FACTOR LLC, (U.S. CLS. 100, 101 AND 107). SN 85-529,155. PUB. 7-3-2012. FILED 1-30-2012.
- 4,209,455. **HIGH CLASS NO CASH (STYLIZED)**. SMITH, JEFFRY, (U.S. CLS. 100, 101 AND 107). SN 85-530,288. PUB. 7-3-2012. FILED 1-31-2012.
- 4,209,465. **DEEP MEMORY PROCESS DMP (STANDARD CHARACTER)**. WALSH, PATRICIA L., DBA WOOLGER TRAINING, (U.S. CLS. 100, 101 AND 107). SN 85-531,537. PUB. 7-3-2012. FILED 2-1-2012.
- 4,209,467. **DIVAS IN DEFENSE (STANDARD CHARACTER)**. DIVAS IN DEFENSE, INC., (U.S. CLS. 100, 101 AND 107). SN 85-531,676. PUB. 7-3-2012. FILED 2-2-2012.
- 4,209,474. **A. PHILIP RANDOLPH PULLMAN PORTER MUSEUM AND DESIGN. A. PHILIP RANDOLPH PULLMAN PORTER MUSEUM**, (U.S. CLS. 100, 101 AND 107). SN 85-532,471. PUB. 7-3-2012. FILED 2-2-2012.
- 4,209,477. **LEATHERWOOD OUTDOORS (STANDARD CHARACTER)**. LEATHERWOOD OUTDOORS, LLC, (U.S. CLS. 100, 101 AND 107). SN 85-533,399. PUB. 7-3-2012. FILED 2-3-2012.
- 4,209,490. **NO PERMISSION TO FORGET AND DESIGN. FROM L TO J CONSULTING GROUP, INC.**, (U.S. CLS. 100, 101 AND 107). SN 85-535,600. PUB. 7-3-2012. FILED 2-7-2012.
- 4,209,494. **THE PRAISEOLOGIST (STANDARD CHARACTER)**. TODD M HALL ENTERPRISES LLC, (U.S. CLS. 100, 101 AND 107). SN 85-536,622. PUB. 7-3-2012. FILED 2-8-2012.
- 4,209,517. **THE WORLD'S BIGGEST VIRTUAL TAILGATE (STANDARD CHARACTER)**. NEW ENGLAND PATRIOTS LLC, (U.S. CLS. 100, 101 AND 107). SN 85-538,370. PUB. 7-3-2012. FILED 2-9-2012.
- 4,209,528 (*See Class 9 for this trademark*).
- 4,209,540. **DECADES (STANDARD CHARACTER)**. JACKSON FAMILY FARMS, LLC, (U.S. CLS. 100, 101 AND 107). SN 85-539,446. PUB. 7-3-2012. FILED 2-10-2012.
- 4,209,541 (*See Class 35 for this trademark*).
- 4,209,542. **KULA FOR KARMA (STANDARD CHARACTER)**. KULA FOR KARMA, (U.S. CLS. 100, 101 AND 107). SN 85-539,534. PUB. 7-3-2012. FILED 2-10-2012.
- 4,209,562. **GEEKGIRLCON (STANDARD CHARACTER)**. GEEKGIRLCON, (U.S. CLS. 100, 101 AND 107). SN 85-540,532. PUB. 7-3-2012. FILED 2-12-2012.
- 4,209,565. **MERCY BEACH (STANDARD CHARACTER)**. MICHAEL ROLAND, (U.S. CLS. 100, 101 AND 107). SN 85-540,633. PUB. 7-3-2012. FILED 2-13-2012.
- 4,209,566. **WHAT SMART WOMEN NEED TO KNOW ABOUT BREAST CANCER (STANDARD CHARACTER)**. STACEY VITIELLO, (U.S. CLS. 100, 101 AND 107). SN 85-540,655. PUB. 7-3-2012. FILED 2-13-2012.
- 4,209,569. **MAPPING CHANGE (STANDARD CHARACTER)**. SINEQUANON GROUP INC., (U.S. CLS. 100, 101 AND 107). SN 85-540,687. PUB. 7-3-2012. FILED 2-13-2012.
- 4,209,570. **THEATRE-PLUS (STANDARD CHARACTER)**. ROUNDABOUT THEATRE COMPANY, INC., (U.S. CLS. 100, 101 AND 107). SN 85-540,693. PUB. 7-3-2012. FILED 2-13-2012.
- 4,209,583. **JUKEBOX JUNCTION (STANDARD CHARACTER)**. DIAMOND PRODUCTIONS, INC., (U.S. CLS. 100, 101 AND 107). SN 85-540,988. PUB. 7-3-2012. FILED 2-13-2012.
- 4,209,584. **YOU'LL KNOW AT THE FINISH LINE (STANDARD CHARACTER)**. SPARTAN RACE, INC., (U.S. CLS. 100, 101 AND 107). SN 85-541,001. PUB. 7-3-2012. FILED 2-13-2012.
- 4,209,586 (*See Class 16 for this trademark*).
- 4,209,603. **THE BEAUTIFUL WORLD (STYLIZED)**. LIVING OUR REAL DREAMS PRODUCTIONS, (U.S. CLS. 100, 101 AND 107). SN 85-541,178. PUB. 7-3-2012. FILED 2-13-2012.
- 4,209,607. **T TEN (STANDARD CHARACTER)**. TOYOTA MOTOR SALES, U.S.A., INC., (U.S. CLS. 100, 101 AND 107). SN 85-541,229. PUB. 7-3-2012. FILED 2-13-2012.
- 4,209,612. **LOVE BRUNCH (STANDARD CHARACTER)**. DODGE, NATALIE A., (U.S. CLS. 100, 101 AND 107). SN 85-541,292. PUB. 7-3-2012. FILED 2-13-2012.
- 4,209,613. **ARTSTREAM (STANDARD CHARACTER)**. ARTSTREAM, INC., (U.S. CLS. 100, 101 AND 107). SN 85-541,302. PUB. 7-3-2012. FILED 2-13-2012.
- 4,209,615. **PERFORM YOUR ART OUT (STANDARD CHARACTER)**. ARTSTREAM, INC., (U.S. CLS. 100, 101 AND 107). SN 85-541,336. PUB. 7-3-2012. FILED 2-13-2012.
- 4,209,647. **MAMA TIME (STANDARD CHARACTER)**. MAMA TIME, LLC, (U.S. CLS. 100, 101 AND 107). SN 85-541,903. PUB. 7-3-2012. FILED 2-14-2012.
- 4,209,648. **BASEBALL HEAVEN (STANDARD CHARACTER)**. BASEBALL HEAVEN INC., (U.S. CLS. 100, 101 AND 107). SN 85-541,906. PUB. 7-3-2012. FILED 2-14-2012.
- 4,209,652. **HEROES & COOL KIDS (STANDARD CHARACTER)**. BRUNAN, INC., (U.S. CLS. 100, 101 AND 107). SN 85-541,961. PUB. 7-3-2012. FILED 2-14-2012.
- 4,209,661 (*See Class 9 for this trademark*).
- 4,209,662 (*See Class 16 for this trademark*).
- 4,209,668. **EARLYACT FIRSTKNIGHT (STANDARD CHARACTER)**. THE RANDALL PARR ORGANIZATION, INC., (U.S. CLS. 100, 101 AND 107). SN 85-542,211. PUB. 7-3-2012. FILED 2-14-2012.
- 4,209,675. **BETCRIS (STANDARD CHARACTER)**. TOWNVIEW TRADING, LTD, (U.S. CLS. 100, 101 AND 107). SN 85-542,388. PUB. 7-3-2012. FILED 2-14-2012.
- 4,209,682 (*See Class 25 for this trademark*).
- 4,209,686 (*See Class 16 for this trademark*).
- 4,209,688. **TRAVELBALL (STANDARD CHARACTER)**. TOP PROSPECTS, INC., (U.S. CLS. 100, 101 AND 107). SN 85-542,560. PUB. 7-3-2012. FILED 2-14-2012.
- 4,209,692. **EDUNEERING (STANDARD CHARACTER)**. EDUNEERING HOLDINGS, INC., (U.S. CLS. 100, 101 AND 107). SN 85-542,593. PUB. 7-3-2012. FILED 2-14-2012.
- 4,209,709. **TOOFFIE (STANDARD CHARACTER)**. CONSTANT, MARIE, AND CONSTANT, MANOUSHKA, MULTIPLE CLASS, (INT. CLS. 41 AND 43), (U.S. CLS. 100, 101 AND 107). SN 85-542,895. PUB. 7-3-2012. FILED 2-14-2012.
- 4,209,710. **WHERE THE LINE ORIGINATES (STANDARD CHARACTER)**. SABANA INVESTMENTS INC., (U.S. CLS. 100, 101 AND 107). SN 85-542,905. PUB. 7-3-2012. FILED 2-15-2012.
- 4,209,711. **OLD SCHOOL MEETS NEW SCHOOL (STANDARD CHARACTER)**. SABANA INVESTMENTS INC., (U.S. CLS. 100, 101 AND 107). SN 85-542,906. PUB. 7-3-2012. FILED 2-15-2012.
- 4,209,712 (*See Class 35 for this trademark*).
- 4,209,713 (*See Class 35 for this trademark*).
- 4,209,729 (*See Class 9 for this trademark*).
- 4,209,742. **IMPROVE GROUP (STANDARD CHARACTER)**. IMPROVE GROUP, INC., (U.S. CLS. 100, 101 AND 107). SN 85-543,417. PUB. 7-3-2012. FILED 2-15-2012.
- 4,209,746 (*See Class 36 for this trademark*).
- 4,209,749. **JUST SWEAT (STANDARD CHARACTER)**. WORLD OYAMA KARATE, INC., (U.S. CLS. 100, 101 AND 107). SN 85-543,471. PUB. 7-3-2012. FILED 2-15-2012.
- 4,209,750. **MOTAC (STANDARD CHARACTER)**. MUSEUM OF THE AMERICAN COCKTAIL, INC., (U.S. CLS. 100, 101 AND 107). SN 85-543,501. PUB. 7-3-2012. FILED 2-15-2012.
- 4,209,752. **NATIONAL CATTLED OG FINALS (STANDARD CHARACTER)**. U. S. BORDER COLLIE HANDLER'S ASSOCIATION, INC., AKA USBCHA, (U.S. CLS. 100, 101 AND 107). SN 85-543,556. PUB. 7-3-2012. FILED 2-15-2012.
- 4,209,761. **A AND DESIGN. AURORA REYES, LLC**, (U.S. CLS. 100, 101 AND 107). SN 85-543,639. PUB. 7-3-2012. FILED 2-15-2012.
- 4,209,787. **NO MILE LEFT BEHIND (STANDARD CHARACTER)**. NGUYEN, THANG M, AKA ANDY NGUYEN, (U.S. CLS. 100, 101 AND 107). SN 85-544,081. PUB. 7-3-2012. FILED 2-15-2012.
- 4,209,799. **QUILLY (STANDARD CHARACTER)**. D&N IPROPERTIES LLC, (U.S. CLS. 100, 101 AND 107). SN 85-544,287. PUB. 7-3-2012. FILED 2-16-2012.
- 4,209,820. **IRONVAN (STANDARD CHARACTER)**. VANICHKACHORN, GREG, (U.S. CLS. 100, 101 AND 107). SN 85-544,577. PUB. 7-3-2012. FILED 2-16-2012.
- 4,209,821. **DRINK UP & DOWNLOAD (STANDARD CHARACTER)**. SUNNY DELIGHT BEVERAGES CO., (U.S. CLS. 100, 101 AND 107). SN 85-544,578. PUB. 7-3-2012. FILED 2-16-2012.
- 4,209,822. **LUCHAMANIA (STANDARD CHARACTER)**. LUCHA LIBRE USA LLC, (U.S. CLS. 100, 101 AND 107). SN 85-544,600. PUB. 7-3-2012. FILED 2-16-2012.
- 4,209,830 (*See Class 35 for this trademark*).

- 4,209,832. **BLAZE (STANDARD CHARACTER)**. HISTORIC HUDSON VALLEY, (U.S. CLS. 100, 101 AND 107). SN 85-544,746. PUB. 7-3-2012. FILED 2-16-2012.
- 4,209,835. **SURVIVOR ONE WORLD OUTWIT OUTPLAY OUTLAST AND DESIGN**. SURVIVOR PRODUCTIONS LLC, (U.S. CLS. 100, 101 AND 107). SN 85-544,891. PUB. 7-3-2012. FILED 2-16-2012.
- 4,209,837. **FLUID LEARNING UNIQUELY EXECUTED (STANDARD CHARACTER)**. FLUID LEARNING UNIQUELY EXECUTED LLC, (U.S. CLS. 100, 101 AND 107). SN 85-544,894. PUB. 7-3-2012. FILED 2-16-2012.
- 4,209,841. **PLANET GRANITE (STANDARD CHARACTER)**. PLANET GRANITE BELMONT LLC, (U.S. CLS. 100, 101 AND 107). SN 85-544,935. PUB. 7-3-2012. FILED 2-16-2012.
- 4,209,843. **BIG BOARD LITTLE UNIVERSE (STANDARD CHARACTER)**. CAMBER, BRUCE, (U.S. CLS. 100, 101 AND 107). SN 85-544,947. PUB. 7-3-2012. FILED 2-16-2012.
- 4,209,844. **FLUX (STANDARD CHARACTER)**. FLUID LEARNING UNIQUELY EXECUTED LLC, (U.S. CLS. 100, 101 AND 107). SN 85-544,954. PUB. 7-3-2012. FILED 2-16-2012.
- 4,209,849. **IDARE INTEGRITY OF DIVERSITY - ADAPTATION RESILIENCE - EMPOWERMENT AND DESIGN**. EDDY, NICKY, (U.S. CLS. 100, 101 AND 107). SN 85-545,148. PUB. 7-3-2012. FILED 2-16-2012.
- 4,209,852. **GIOGO (STANDARD CHARACTER)**. BROWN, TIANA CHANEL, AND WATERS, JULIANNE MARIE, (U.S. CLS. 100, 101 AND 107). SN 85-545,239. PUB. 7-3-2012. FILED 2-16-2012.
- 4,209,866. **NORTHERN MOTION (STANDARD CHARACTER)**. GRAND TRAVERSE MOUNTAIN BIKE ASSOCIATION, LLC, (U.S. CLS. 100, 101 AND 107). SN 85-545,594. PUB. 7-3-2012. FILED 2-17-2012.
- 4,209,869. **PPC IAN (STANDARD CHARACTER)**. IJL PRODUCTIONS LLC, (U.S. CLS. 100, 101 AND 107). SN 85-545,625. PUB. 7-3-2012. FILED 2-17-2012.
- 4,209,870. **POPCHANGE (STANDARD CHARACTER)**. MORRISON, ELEANOR GRACE, (U.S. CLS. 100, 101 AND 107). SN 85-545,638. PUB. 7-3-2012. FILED 2-17-2012.
- 4,209,879. **FOSTERING A LOVE OF LEARNING WITH A PASSION FOR JESUS CHRIST (STANDARD CHARACTER)**. THE CAMBRIDGE SCHOOL OF DALLAS, (U.S. CLS. 100, 101 AND 107). SN 85-545,973. PUB. 7-3-2012. FILED 2-17-2012.
- 4,209,884. **NFF (STANDARD CHARACTER)**. THE NATIONAL FOOTBALL FOUNDATION AND COLLEGE HALL OF FAME, INC., (U.S. CLS. 100, 101 AND 107). SN 85-546,032. PUB. 7-3-2012. FILED 2-17-2012.
- 4,209,903. **LOONEY GOONS (STANDARD CHARACTER)**. WALKER, COREY, (U.S. CLS. 100, 101 AND 107). SN 85-546,343. PUB. 7-3-2012. FILED 2-17-2012.
- 4,209,906. **P'KNOCKS P'KNOCKS A NEW KID THAT ROCKS! AND DESIGN**. RAGAS, NELSON, (U.S. CLS. 100, 101 AND 107). SN 85-546,466. PUB. 7-3-2012. FILED 2-17-2012.
- 4,209,921. **HANDS ON... AND DESIGN**. BIRKENHEUER, DOUG, DBA BIRKENHEUER PHOTOGRAPHY, (U.S. CLS. 100, 101 AND 107). SN 85-546,635. PUB. 7-3-2012. FILED 2-18-2012.
- 4,209,923. **BROKEN TONGUES (STANDARD CHARACTER)**. BROKEN TONGUES, LLC, (U.S. CLS. 100, 101 AND 107). SN 85-546,691. PUB. 7-3-2012. FILED 2-18-2012.
- 4,209,924. **THE JERNI COLLECTION (STANDARD CHARACTER)**. GERALD R. GREENE, AND NINA A. GREENE, (U.S. CLS. 100, 101 AND 107). SN 85-546,708. PUB. 7-3-2012. FILED 2-18-2012.
- 4,209,936. **MYDAILYTUTOR (STANDARD CHARACTER)**. MYDAILYTUTOR INCORPORATED, DBA MYDAILYTUTOR.COM, (U.S. CLS. 100, 101 AND 107). SN 85-546,889. PUB. 7-3-2012. FILED 2-19-2012.
- 4,209,938. **ZEN TRANSLATION (STANDARD CHARACTER)**. FOREIGN CREDITS, INC., DBA ZEN TRANSLATION, INC., (U.S. CLS. 100, 101 AND 107). SN 85-546,955. PUB. 7-3-2012. FILED 2-19-2012.
- 4,209,951. **TEAMELITES.COM WORLD CLASS SYSTEM. WORLDWIDE SUCCESS AND DESIGN**. SCHUMACHER, MONTE L., (U.S. CLS. 100, 101 AND 107). SN 85-547,673. PUB. 7-3-2012. FILED 2-20-2012.
- 4,209,952. **BARI (STANDARD CHARACTER)**. BARI COLLECTION CORP, (U.S. CLS. 100, 101 AND 107). SN 85-547,675. PUB. 7-3-2012. FILED 2-20-2012.
- 4,209,963. **VIRTUAL TRAINING AND DESIGN**. LEVI, RAY & SHOUP, INC., (U.S. CLS. 100, 101 AND 107). SN 85-548,541. PUB. 7-3-2012. FILED 2-21-2012.
- 4,209,965. **URBANSHOPTALK.COM (STANDARD CHARACTER)**. CHRISTOPHER LEE HUNTER, (U.S. CLS. 100, 101 AND 107). SN 85-548,690. PUB. 7-3-2012. FILED 2-21-2012.
- 4,209,971. **THE TOUR VAN (STANDARD CHARACTER)**. TURNSTILE PUBLISHING COMPANY, (U.S. CLS. 100, 101 AND 107). SN 85-549,546. PUB. 7-3-2012. FILED 2-22-2012.
- 4,209,988. **TORYPEDIA (STANDARD CHARACTER)**. RIVER LIGHT V, L.P., (U.S. CLS. 100, 101 AND 107). SN 85-552,129. PUB. 7-3-2012. FILED 2-24-2012.
- 4,209,991 (*See Class 36 for this trademark*).
- 4,210,011. **SHARE.LIKE.BUY (STANDARD CHARACTER)**. BARKLEY, INC., (U.S. CLS. 100, 101 AND 107). SN 85-554,853. PUB. 7-3-2012. FILED 2-28-2012.
- 4,210,027. **EMARINE (STANDARD CHARACTER)**. U.S. MARINE CORPS, A COMPONENT OF THE U.S. DEPARTMENT OF THE NAVY, (U.S. CLS. 100, 101 AND 107). SN 85-557,529. PUB. 7-3-2012. FILED 3-1-2012.
- 4,210,037 (*See Class 36 for this trademark*).
- 4,210,038. **BUNT (STANDARD CHARACTER)**. THE TOPPS COMPANY, INC., (U.S. CLS. 100, 101 AND 107). SN 85-561,287. PUB. 7-3-2012. FILED 3-6-2012.
- 4,210,042. **MISCELLANEOUS DESIGN**. SPARTAN RACE, INC., (U.S. CLS. 100, 101 AND 107). SN 85-562,725. PUB. 7-3-2012. FILED 3-7-2012.
- 4,210,044. **TEAMELITES.COM (STANDARD CHARACTER)**. SCHUMACHER, MONTE L., (U.S. CLS. 100, 101 AND 107). SN 85-563,324. PUB. 7-3-2012. FILED 3-7-2012.
- 4,210,049. **HOUSE HUNTERS ON VACATION (STANDARD CHARACTER)**. SCRIPPS NETWORKS, LLC, (U.S. CLS. 100, 101 AND 107). SN 85-564,885. PUB. 7-3-2012. FILED 3-9-2012.
- 4,210,063. **MISCELLANEOUS DESIGN**. THE NATIONAL FOOTBALL FOUNDATION AND COLLEGE HALL OF FAME, INC., (U.S. CLS. 100, 101 AND 107). SN 85-568,165. PUB. 7-3-2012. FILED 3-13-2012.
- 4,210,069 (*See Class 35 for this trademark*).
- 4,210,076. **BARI (STYLIZED)**. BARI COLLECTION CORP, (U.S. CLS. 100, 101 AND 107). SN 85-570,980. PUB. 7-3-2012. FILED 3-15-2012.
- 4,210,088. **PATAGONIA (STANDARD CHARACTER)**. PATAGONIA, INC., (U.S. CLS. 100, 101 AND 107). SN 85-575,837. PUB. 7-3-2012. FILED 3-21-2012.
- 4,210,103. **I WANT THAT (STANDARD CHARACTER)**. SCRIPPS NETWORKS, LLC, (U.S. CLS. 100, 101 AND 107). SN 85-578,180. PUB. 7-3-2012. FILED 3-23-2012.
- 4,210,109 (*See Class 16 for this trademark*).
- 4,210,110. **MISCELLANEOUS DESIGN**. HARNESSING HAPPINESS, INC., (U.S. CLS. 100, 101 AND 107). SN 85-579,633. PUB. 7-3-2012. FILED 3-26-2012.
- 4,210,114. **OPEN ZION (STANDARD CHARACTER)**. THE NEWSWEEK/DAILY BEAST COMPANY LLC, (U.S. CLS. 100, 101 AND 107). SN 85-579,967. PUB. 7-3-2012. FILED 3-26-2012.
- 4,210,125. **THE CENTER OF HOCKEY (STANDARD CHARACTER)**. WESTERN PROFESSIONAL HOCKEY LEAGUE INC., AND CENTRAL HOCKEY LEAGUE, INC., (U.S. CLS. 100, 101 AND 107). SN 85-582,773. PUB. 7-3-2012. FILED 3-28-2012.
- 4,210,126. **CHL CENTRAL HOCKEY LEAGUE AND DESIGN**. WESTERN PROFESSIONAL HOCKEY LEAGUE INC., AND CENTRAL HOCKEY LEAGUE, INC., (U.S. CLS. 100, 101 AND 107). SN 85-582,776. PUB. 7-3-2012. FILED 3-28-2012.
- 4,210,128. **FEEL GOOD, DO GOOD! (STANDARD CHARACTER)**. AYOUB, MICHELE, (U.S. CLS. 100, 101 AND 107). SN 85-583,274. PUB. 7-3-2012. FILED 3-29-2012.
- 4,210,132. **ESAP (STANDARD CHARACTER)**. THE ENDOCRINE SOCIETY, (U.S. CLS. 100, 101 AND 107). SN 85-583,638. PUB. 7-3-2012. FILED 3-29-2012.
- 4,210,168 (*See Class 36 for this trademark*).
- 4,210,170. **IRIS NIGHTS (STANDARD CHARACTER)**. THE ANNENBERG FOUNDATION, (U.S. CLS. 100, 101 AND 107). SN 85-597,695. PUB. 7-3-2012. FILED 4-13-2012.

4,210,194. **MAKE LIFE GRAND (STANDARD CHARACTER)**. INDIANAPOLIS DOWNS, LLC, (U.S. CLS. 100, 101 AND 107). SN 85-610,085. PUB. 7-3-2012. FILED 4-27-2012.

4,210,196. **MYSTIC ICE BLAST (STANDARD CHARACTER)**. REALNETWORKS, INC., (U.S. CLS. 100, 101 AND 107). SN 85-611,029. PUB. 7-3-2012. FILED 4-27-2012.

4,210,212 (*See Class 36 for this trademark*).

4,210,223. **BODY LAB (STANDARD CHARACTER)**. RICHELLE MELDE, (U.S. CLS. 100, 101 AND 107). SN 85-977,216. PUB. 9-13-2011. FILED 3-18-2011.

4,210,227. **BOXWORKS (STANDARD CHARACTER)**. BOX, INC., (U.S. CLS. 100, 101 AND 107). SN 85-977,267. PUB. 4-3-2012. FILED 9-22-2011.

CLASS 42—SCIENTIFIC AND COMPUTER SERVICES

4,208,124 (*See Class 9 for this trademark*).

4,208,127. **EROS SHEMALE ESCORTS (STANDARD CHARACTER)**. GROUP KAITU, LLC, (U.S. CLS. 100 AND 101). SN 76-683,741. PUB. 7-3-2012. FILED 11-7-2007.

4,208,128. **EROS TRANSEXUAL ESCORTS (STANDARD CHARACTER)**. GROUP KAITU, LLC, (U.S. CLS. 100 AND 101). SN 76-683,789. PUB. 7-3-2012. FILED 11-7-2007.

4,208,132 (*See Class 5 for this trademark*).

4,208,176. **AXONTECH (STANDARD CHARACTER)**. AXONTECH, LLC, (U.S. CLS. 100 AND 101). SN 77-451,330. PUB. 7-3-2012. FILED 4-17-2008.

4,208,181 (*See Class 9 for this trademark*).

4,208,182. **SEARCH MEDICA PROFESSIONAL MEDICAL SEARCH AND DESIGN**. UBM MEDICA LLC, (U.S. CLS. 100 AND 101). SN 77-602,111. PUB. 5-31-2011. FILED 10-28-2008.

4,208,211 (*See Class 35 for this trademark*).

4,208,230. **TIVIT (STANDARD CHARACTER)**. TIVIT TERCEIRIZACAO DE PROCESSOS SERVICOS E TECNOLOGIA S/A, (U.S. CLS. 100 AND 101). SN 78-981,381. PUB. 6-12-2012. FILED 10-14-2005.

4,208,233 (*See Class 9 for this trademark*).

4,208,234 (*See Class 9 for this trademark*).

4,208,238 (*See Class 35 for this trademark*).

4,208,251 (*See Class 1 for this trademark*).

4,208,257 (*See Class 7 for this trademark*).

4,208,258 (*See Class 9 for this trademark*).

4,208,261 (*See Class 9 for this trademark*).

4,208,262 (*See Class 9 for this trademark*).

4,208,264 (*See Class 9 for this trademark*).

4,208,265 (*See Class 7 for this trademark*).

4,208,274 (*See Class 9 for this trademark*).

4,208,275 (*See Class 9 for this trademark*).

4,208,285 (*See Class 9 for this trademark*).

4,208,286 (*See Class 7 for this trademark*).

4,208,303 (*See Class 9 for this trademark*).

4,208,322 (*See Class 9 for this trademark*).

4,208,329 (*See Class 35 for this trademark*).

4,208,332 (*See Class 35 for this trademark*).

4,208,333 (*See Class 5 for this trademark*).

4,208,337 (*See Class 9 for this trademark*).

4,208,341 (*See Class 35 for this trademark*).

4,208,346 (*See Class 16 for this trademark*).

4,208,349 (*See Class 5 for this trademark*).

4,208,353 (*See Class 10 for this trademark*).

4,208,355 (*See Class 9 for this trademark*).

4,208,360 (*See Class 7 for this trademark*).

4,208,364 (*See Class 9 for this trademark*).

4,208,366 (*See Class 6 for this trademark*).

4,208,367 (*See Class 2 for this trademark*).

4,208,382 (*See Class 9 for this trademark*).

4,208,384 (*See Class 5 for this trademark*).

4,208,389 (*See Class 7 for this trademark*).

4,208,401 (*See Class 1 for this trademark*).

4,208,407 (*See Class 9 for this trademark*).

4,208,408 (*See Class 9 for this trademark*).

4,208,425 (*See Class 9 for this trademark*).

4,208,438. **MYOBSERVER (STANDARD CHARACTER)**. THE GUIDANCE SL, (U.S. CLS. 100 AND 101). SN 79-111,422. PUB. 7-3-2012. FILED 2-9-2012.

4,208,449 (*See Class 5 for this trademark*).

4,208,450. **TAP LAKESHORE AND DESIGN**. PETERSON, DON, (U.S. CLS. 100 AND 101). SN 85-007,971. PUB. 7-3-2012. FILED 4-7-2010.

4,208,451. **TAP QA AND DESIGN**. PETERSON, DON, (U.S. CLS. 100 AND 101). SN 85-009,019. PUB. 7-3-2012. FILED 4-8-2010.

4,208,453 (*See Class 20 for this trademark*).

4,208,474. **CAREER PORTFOLIO CENTRAL (STANDARD CHARACTER)**. COLLEGE CENTRAL NETWORK, INC., (U.S. CLS. 100 AND 101). SN 85-097,506. PUB. 7-3-2012. FILED 7-31-2010.

4,208,487. **SORCA (STANDARD CHARACTER)**. SORCA DESIGN INCORPORATED, (U.S. CLS. 100 AND 101). SN 85-142,569. PUB. 7-3-2012. FILED 9-30-2010.

4,208,527 (*See Class 35 for this trademark*).

4,208,563 (*See Class 9 for this trademark*).

4,208,577 (*See Class 9 for this trademark*).

4,208,586. **EC MEDICAID ASSET PROTECTION TRUST (STANDARD CHARACTER)**. ELDER COUNSEL LLC, MULTIPLE CLASS, (INT. CLS. 42 AND 45), (U.S. CLS. 100 AND 101). SN 85-289,248. PUB. 7-3-2012. FILED 4-7-2011.

4,208,590 (*See Class 7 for this trademark*).

4,208,591 (*See Class 7 for this trademark*).

4,208,616. **HELISPOT AND DESIGN**. DASGALOS INTERACTIVE SOLUTIONS, INC., (U.S. CLS. 100 AND 101). SN 85-324,487. PUB. 7-3-2012. FILED 5-19-2011.

4,208,619 (*See Class 1 for this trademark*).

4,208,628 (*See Class 6 for this trademark*).

4,208,630 (*See Class 41 for this trademark*).

4,208,633. **COMMAND HUB (STANDARD CHARACTER)**. COMMANDHUB PTY LTD., (U.S. CLS. 100 AND 101). SN 85-337,646. PUB. 7-3-2012. FILED 6-3-2011.

4,208,638 (*See Class 36 for this trademark*).

4,208,674. **DOMINO'S TRACKER (STANDARD CHARACTER)**. DOMINO'S IP HOLDER LLC, (U.S. CLS. 100 AND 101). SN 85-355,270. PUB. 7-3-2012. FILED 6-24-2011.

4,208,686. **EMIL VICALE (STANDARD CHARACTER)**. EMIL VICALE, FORMERLY EMIL VICALE, (U.S. CLS. 100 AND 101). SN 85-359,551. PUB. 7-3-2012. FILED 6-29-2011.

4,208,692 (*See Class 9 for this trademark*).

4,208,693 (*See Class 35 for this trademark*).

4,208,720 (*See Class 27 for this trademark*).

4,208,737. **SOUTHWIRE SOLUTIONS - ENERGIZE (STANDARD CHARACTER)**. SOUTHWIRE COMPANY, (U.S. CLS. 100 AND 101). SN 85-372,652. PUB. 7-3-2012. FILED 7-15-2011.

4,208,755 (*See Class 35 for this trademark*).

4,208,810 (*See Class 9 for this trademark*).

4,208,835. **HEALTH RESEARCH, INC. (STANDARD CHARACTER)**. HEALTH RESEARCH, INC., (U.S. CLS. 100 AND 101). SN 85-392,306. PUB. 7-3-2012. FILED 8-8-2011.

4,208,844. **GTS (STANDARD CHARACTER)**. MBA FOCUS, LLC, (U.S. CLS. 100 AND 101). SN 85-394,454. PUB. 7-3-2012. FILED 8-10-2011.

4,208,860. **THANK DIFFERENT (STANDARD CHARACTER)**. KUDOS INC., (U.S. CLS. 100 AND 101). SN 85-399,317. PUB. 7-3-2012. FILED 8-16-2011.

4,208,870. **PRIMIMOD (STANDARD CHARACTER)**. FENTRESS, BARBARA, AKA BARBARA HOCHSTETLER, (U.S. CLS. 100 AND 101). SN 85-401,833. PUB. 7-3-2012. FILED 8-18-2011.

4,208,875 (*See Class 40 for this trademark*).

4,208,876 (*See Class 40 for this trademark*).

4,208,881. **CYANOMICS (STANDARD CHARACTER)**. CYANOMICS, INC., MULTIPLE CLASS, (INT. CLS. 42 AND 44), (U.S. CLS. 100 AND 101). SN 85-404,415. PUB. 7-3-2012. FILED 8-23-2011.

4,208,889. **CYNOGEN AND DESIGN**. ABBOTT LABORATORIES, (U.S. CLS. 100 AND 101). SN 85-405,649. PUB. 7-3-2012. FILED 8-24-2011.

4,208,897 (*See Class 35 for this trademark*).

4,208,903 (*See Class 9 for this trademark*).

4,208,909. **DATUM SOFTWARE AND DESIGN**. DATUM SOFTWARE, INC., (U.S. CLS. 100 AND 101). SN 85-413,707. PUB. 7-3-2012. FILED 9-2-2011.

4,208,936 (*See Class 41 for this trademark*).

- 4,208,948 (*See Class 9 for this trademark*).
- 4,208,963. **HEALTH PLAN ASSIST AND DESIGN**. MILLIMAN, INC., (U.S. CLS. 100 AND 101). SN 85-438,542. PUB. 7-3-2012. FILED 10-4-2011.
- 4,208,985. **COMPLEAT (STANDARD CHARACTER)**. GDSX, LTD., (U.S. CLS. 100 AND 101). SN 85-447,105. PUB. 7-3-2012. FILED 10-13-2011.
- 4,208,995 (*See Class 35 for this trademark*).
- 4,208,996 (*See Class 35 for this trademark*).
- 4,209,010 (*See Class 35 for this trademark*).
- 4,209,025. **MOBI2CLOUDS MOBILITY REDEFINED AND DESIGN**. SOFTCLOUDS LLC, (U.S. CLS. 100 AND 101). SN 85-461,473. PUB. 7-3-2012. FILED 11-1-2011.
- 4,209,031. **EVENTSCAN LEAD RETRIEVAL REDEFINED AND DESIGN**. SOFTCLOUDS LLC, (U.S. CLS. 100 AND 101). SN 85-463,756. PUB. 7-3-2012. FILED 11-3-2011.
- 4,209,039. **(C2FO) (STANDARD CHARACTER)**. POLLEN, INC., (U.S. CLS. 100 AND 101). SN 85-467,864. PUB. 7-3-2012. FILED 11-9-2011.
- 4,209,041 (*See Class 35 for this trademark*).
- 4,209,043 (*See Class 35 for this trademark*).
- 4,209,047. **CHANNEL ISLANDS (STANDARD CHARACTER)**. CHANNEL ISLANDS MEDIA GROUP, INC., (U.S. CLS. 100 AND 101). SN 85-470,726. PUB. 7-3-2012. FILED 11-11-2011.
- 4,209,071. **BOCAVOX (STANDARD CHARACTER)**. SABAT, JOSE H, (U.S. CLS. 100 AND 101). SN 85-478,671. PUB. 7-3-2012. FILED 11-22-2011.
- 4,209,089. **TECHWISE GROUP (STANDARD CHARACTER)**. FARRAGO LLC, DBA TECHWISE GROUP, (U.S. CLS. 100 AND 101). SN 85-488,156. PUB. 7-3-2012. FILED 12-6-2011.
- 4,209,095 (*See Class 6 for this trademark*).
- 4,209,096. **REACH ENGINE (STANDARD CHARACTER)**. LEVELS BEYOND, LLC, (U.S. CLS. 100 AND 101). SN 85-489,921. PUB. 7-3-2012. FILED 12-7-2011.
- 4,209,101. **WHY + HOW = ZERO (STANDARD CHARACTER)**. G.T.S. CORPORATION PTY LTD, MULTIPLE CLASS, (INT. CLS. 42 AND 45), (U.S. CLS. 100 AND 101). SN 85-490,681. PUB. 5-15-2012. FILED 12-8-2011.
- 4,209,120. **CIRCULENT (STANDARD CHARACTER)**. CIRCULENT, (U.S. CLS. 100 AND 101). SN 85-495,348. PUB. 7-3-2012. FILED 12-14-2011.
- 4,209,126 (*See Class 35 for this trademark*).
- 4,209,132. **DCSNEXT (STANDARD CHARACTER)**. MAVERICK TECHNOLOGIES HOLDINGS, LLC, (U.S. CLS. 100 AND 101). SN 85-498,574. PUB. 7-3-2012. FILED 12-19-2011.
- 4,209,133. **DCSNEXT AND DESIGN**. MAVERICK TECHNOLOGIES HOLDINGS, LLC, (U.S. CLS. 100 AND 101). SN 85-498,582. PUB. 7-3-2012. FILED 12-19-2011.
- 4,209,134 (*See Class 37 for this trademark*).
- 4,209,144. **SOILLFU X AND DESIGN**. STANLEY N. UMOH, DBA SOILLFU, (U.S. CLS. 100 AND 101). SN 85-501,533. PUB. 7-3-2012. FILED 12-21-2011.
- 4,209,147. **LABWORKS (STANDARD CHARACTER)**. ATLAS DATABASE SOFTWARE CORP., (U.S. CLS. 100 AND 101). SN 85-502,184. PUB. 7-3-2012. FILED 12-22-2011.
- 4,209,155. **INNEREYE STUDIOS (STANDARD CHARACTER)**. INNEREYE STUDIOS, LLC, (U.S. CLS. 100 AND 101). SN 85-503,921. PUB. 7-3-2012. FILED 12-27-2011.
- 4,209,156. **INNEREYE STUDIOS AND DESIGN**. INNEREYE STUDIOS, LLC, (U.S. CLS. 100 AND 101). SN 85-503,977. PUB. 7-3-2012. FILED 12-27-2011.
- 4,209,159. **TRADINGVIEW AND DESIGN**. MULTICHARTS, LLC, (U.S. CLS. 100 AND 101). SN 85-504,379. PUB. 7-3-2012. FILED 12-27-2011.
- 4,209,162 (*See Class 41 for this trademark*).
- 4,209,173. **TSM WATCHDOG ALWAYS ON GUARD LRS IT SOLUTIONS AND DESIGN**. LEVI, RAY & SHOUP, INC., (U.S. CLS. 100 AND 101). SN 85-505,914. PUB. 7-3-2012. FILED 12-29-2011.
- 4,209,177. **SYNCHRON (STANDARD CHARACTER)**. SYNCHRON MANAGEMENT, LLC, (U.S. CLS. 100 AND 101). SN 85-507,298. PUB. 7-3-2012. FILED 1-2-2012.
- 4,209,183. **TECHASPECT (STANDARD CHARACTER)**. TECHASPECT SOLUTIONS, INC., FORMERLY TECHASPECT SOLUTIONS, LLC, (U.S. CLS. 100 AND 101). SN 85-508,680. PUB. 7-3-2012. FILED 1-4-2012.
- 4,209,186. **EXPLORATION SUPPORT SERVICES INC. AND DESIGN**. EXPLORATION SUPPORT SERVICES, INC., (U.S. CLS. 100 AND 101). SN 85-509,000. PUB. 7-3-2012. FILED 1-5-2012.
- 4,209,202. **COMMERX (STANDARD CHARACTER)**. COMMERX CORPORATION, (U.S. CLS. 100 AND 101). SN 85-511,599. PUB. 7-3-2012. FILED 1-9-2012.
- 4,209,211 (*See Class 16 for this trademark*).
- 4,209,227. **LEBANESE WORLD . ORG AND DESIGN**. LEBANESE WORLD, (U.S. CLS. 100 AND 101). SN 85-517,013. PUB. 7-3-2012. FILED 1-16-2012.
- 4,209,231. **750 GROUP (STANDARD CHARACTER)**. 750 GROUP, LLC, (U.S. CLS. 100 AND 101). SN 85-517,418. PUB. 7-3-2012. FILED 1-16-2012.
- 4,209,245. **SURDOC (STYLIZED)**. SURDOC CORP., DBA PRODUCTION AND SALES OR SERVICE, (U.S. CLS. 100 AND 101). SN 85-518,704. PUB. 7-3-2012. FILED 1-18-2012.
- 4,209,257. **INTECH AND DESIGN**. INTEGRATION TECHNOLOGIES, INC., AKA INTECH, (U.S. CLS. 100 AND 101). SN 85-519,699. PUB. 7-3-2012. FILED 1-18-2012.
- 4,209,261 (*See Class 9 for this trademark*).
- 4,209,268. **ZIPPYKID AND DESIGN**. ZIPPYKID, (U.S. CLS. 100 AND 101). SN 85-520,294. PUB. 7-3-2012. FILED 1-19-2012.
- 4,209,281. **YOUR IMMIGRATION MATTERS! (STANDARD CHARACTER)**. LAW OFFICES OF SHEELA MURTHY, P.C., (U.S. CLS. 100 AND 101). SN 85-521,088. PUB. 7-3-2012. FILED 1-20-2012.
- 4,209,295. **ENTIA BIOSCIENCES (STANDARD CHARACTER)**. ENTIA BIOSCIENCES INC., FORMERLY TOTAL NUTRACEUTICAL SOLUTIONS INC., (U.S. CLS. 100 AND 101). SN 85-521,583. PUB. 7-3-2012. FILED 1-20-2012.
- 4,209,303 (*See Class 35 for this trademark*).
- 4,209,309. **YELLOW DOG NETWORKS, INC. UNCONDITIONAL SERVICE AND DESIGN**. YELLOW DOG NETWORKS, INC., (U.S. CLS. 100 AND 101). SN 85-522,560. PUB. 7-3-2012. FILED 1-23-2012.
- 4,209,312 (*See Class 36 for this trademark*).
- 4,209,322. **XEMED (STANDARD CHARACTER)**. XEMED LLC, MULTIPLE CLASS, (INT. CLS. 42 AND 44), (U.S. CLS. 100 AND 101). SN 85-522,977. PUB. 7-3-2012. FILED 1-23-2012.
- 4,209,324. **BLACK SWAN CONSULTING (STANDARD CHARACTER)**. WONG, AARON, (U.S. CLS. 100 AND 101). SN 85-523,037. PUB. 7-3-2012. FILED 1-23-2012.
- 4,209,337. **PRACTICAL HELP FOR YOUR DIGITAL LIFE (STANDARD CHARACTER)**. POSITEK.NET LLC, (U.S. CLS. 100 AND 101). SN 85-523,712. PUB. 7-3-2012. FILED 1-24-2012.
- 4,209,339. **IDEA MONSTER (STANDARD CHARACTER)**. DIAZ, LUIS, (U.S. CLS. 100 AND 101). SN 85-523,729. PUB. 7-3-2012. FILED 1-24-2012.
- 4,209,340. **AMERICAN BOARD OF WILDERNESS MEDICINE-ORGANIZED 2011 AND DESIGN**. AMERICAN ASSOCIATION OF PHYSICIAN SPECIALISTS, INC., (U.S. CLS. 100 AND 101). SN 85-523,740. PUB. 7-3-2012. FILED 1-24-2012.
- 4,209,343. **POSITEK.NET (STANDARD CHARACTER)**. POSITEK.NET LLC, (U.S. CLS. 100 AND 101). SN 85-523,780. PUB. 7-3-2012. FILED 1-24-2012.
- 4,209,353. **SOLOWAY SOLUTIONS INC (STYLIZED)**. SOLOWAY SOLUTIONS, INC., (U.S. CLS. 100 AND 101). SN 85-524,280. PUB. 7-3-2012. FILED 1-24-2012.
- 4,209,362. **MEIJUN (STANDARD CHARACTER)**. MEIJUN LLC, (U.S. CLS. 100 AND 101). SN 85-524,816. PUB. 7-3-2012. FILED 1-25-2012.
- 4,209,379. **PROMITOR TECHNOLOGY (STANDARD CHARACTER)**. PROMITOR TECHNOLOGY LLC, (U.S. CLS. 100 AND 101). SN 85-525,421. PUB. 7-3-2012. FILED 1-25-2012.
- 4,209,384. **APRENTICA (STANDARD CHARACTER)**. APRENTICA, LLC, (U.S. CLS. 100 AND 101). SN 85-525,763. PUB. 7-3-2012. FILED 1-26-2012.
- 4,209,414. **IT. OUTSOURCING @ PEACE OF MIND (STANDARD CHARACTER)**. KHEMKA, SHAMIT, (U.S. CLS. 100 AND 101). SN 85-526,554. PUB. 7-3-2012. FILED 1-26-2012.
- 4,209,421. **SIMPLEGIVE (STANDARD CHARACTER)**. SIMPLEGIVE LLC, (U.S. CLS. 100 AND 101). SN 85-526,967. PUB. 7-3-2012. FILED 1-27-2012.
- 4,209,422. **INNOFACTOR (STANDARD CHARACTER)**. INNOFACTOR PLC, (U.S. CLS. 100 AND 101). SN 85-527,221. PUB. 7-3-2012. FILED 1-27-2012.

- 4,209,434 (*See Class 37 for this trademark*).
- 4,209,437 (*See Class 35 for this trademark*).
- 4,209,441. **APPLICATION BLUEPRINT (STYLIZED)**. THE SOFTWARE REVOLUTION, INC., AKA TSRI, (U.S. CLS. 100 AND 101). SN 85-528,922. PUB. 7-3-2012. FILED 1-30-2012.
- 4,209,447. **COREFLEX (STANDARD CHARACTER)**. QUALITYTECH, LP, (U.S. CLS. 100 AND 101). SN 85-529,355. PUB. 7-3-2012. FILED 1-31-2012.
- 4,209,464. **NETIZEN SOLUTIONS (STANDARD CHARACTER)**. NETIZEN SOLUTIONS, LLC, (U.S. CLS. 100 AND 101). SN 85-531,484. PUB. 7-3-2012. FILED 2-1-2012.
- 4,209,489. **FAITHLINKED AND DESIGN**. FAITHLINKED CHRISTIAN MEDIA GROUP, LLC, (U.S. CLS. 100 AND 101). SN 85-535,444. PUB. 7-3-2012. FILED 2-7-2012.
- 4,209,491. **PATENTSTATUS (STANDARD CHARACTER)**. PATENTSTATUS LLC, (U.S. CLS. 100 AND 101). SN 85-535,683. PUB. 7-3-2012. FILED 2-7-2012.
- 4,209,500 (*See Class 37 for this trademark*).
- 4,209,501 (*See Class 37 for this trademark*).
- 4,209,507. **VERPOND (STANDARD CHARACTER)**. VERPOND, INC., (U.S. CLS. 100 AND 101). SN 85-537,623. PUB. 7-3-2012. FILED 2-8-2012.
- 4,209,511 (*See Class 37 for this trademark*).
- 4,209,527. **ANYPLACE WORKSPACE (STANDARD CHARACTER)**. MCPC, INC., (U.S. CLS. 100 AND 101). SN 85-538,816. PUB. 7-3-2012. FILED 2-9-2012.
- 4,209,529. **STYLEPRINT (STANDARD CHARACTER)**. POWELL INVESTORS GROUP, LLC, (U.S. CLS. 100 AND 101). SN 85-539,071. PUB. 7-3-2012. FILED 2-10-2012.
- 4,209,533. **MINDLINKS (STANDARD CHARACTER)**. CENGAGE LEARNING, INC., (U.S. CLS. 100 AND 101). SN 85-539,231. PUB. 7-3-2012. FILED 2-10-2012.
- 4,209,536. **CCMS AND DESIGN**. ARGENT CONSULTING SERVICES, INC., (U.S. CLS. 100 AND 101). SN 85-539,329. PUB. 7-3-2012. FILED 2-10-2012.
- 4,209,537. **MATRICES AND DESIGN**. ARGENT CONSULTING SERVICES, INC., (U.S. CLS. 100 AND 101). SN 85-539,330. PUB. 7-3-2012. FILED 2-10-2012.
- 4,209,543 (*See Class 35 for this trademark*).
- 4,209,548 (*See Class 35 for this trademark*).
- 4,209,588. **CLAIM MY RUN (STANDARD CHARACTER)**. CLAIM IT PRODUCTIONS, LLC, (U.S. CLS. 100 AND 101). SN 85-541,037. PUB. 7-3-2012. FILED 2-13-2012.
- 4,209,591 (*See Class 35 for this trademark*).
- 4,209,592 (*See Class 35 for this trademark*).
- 4,209,596. **WE SEE THE WORLD THROUGH YOUR EYES. (STANDARD CHARACTER)**. CLAIM IT PRODUCTIONS, LLC, (U.S. CLS. 100 AND 101). SN 85-541,103. PUB. 7-3-2012. FILED 2-13-2012.
- 4,209,604 (*See Class 35 for this trademark*).
- 4,209,632 (*See Class 35 for this trademark*).
- 4,209,646 (*See Class 2 for this trademark*).
- 4,209,661 (*See Class 9 for this trademark*).
- 4,209,674. **APPSFREEDOM DRIVING BUSINESS PRODUCTIVITY (STYLIZED)**. SEAL INNOTECH, LLC, DBA APPSFREEDOM, (U.S. CLS. 100 AND 101). SN 85-542,350. PUB. 7-3-2012. FILED 2-14-2012.
- 4,209,693. **HEALTHCARE ANALYTICS SOLUTION (STANDARD CHARACTER)**. RGI INFORMATICS, LLC, (U.S. CLS. 100 AND 101). SN 85-542,594. PUB. 7-3-2012. FILED 2-14-2012.
- 4,209,713 (*See Class 35 for this trademark*).
- 4,209,726. **EGOWORKS (STANDARD CHARACTER)**. ENVISIONIER MEDICAL TECHNOLOGIES, INC., (U.S. CLS. 100 AND 101). SN 85-543,226. PUB. 7-3-2012. FILED 2-15-2012.
- 4,209,743. **IMPROVE GROUP (STANDARD CHARACTER)**. IMPROVE GROUP, INC., (U.S. CLS. 100 AND 101). SN 85-543,419. PUB. 7-3-2012. FILED 2-15-2012.
- 4,209,764. **CUZUCO (STANDARD CHARACTER)**. CUZUCO, INC., (U.S. CLS. 100 AND 101). SN 85-543,695. PUB. 7-3-2012. FILED 2-15-2012.
- 4,209,766. **DATATIS (STANDARD CHARACTER)**. STORAGE ASSESSMENTS, LLC, (U.S. CLS. 100 AND 101). SN 85-543,720. PUB. 7-3-2012. FILED 2-15-2012.
- 4,209,768 (*See Class 37 for this trademark*).
- 4,209,811. **LEVERAGING TECHNOLOGIES TO ENHANCE YOUR BUSINESS (STANDARD CHARACTER)**. BUSINESS DATA SERVICES, CORP, DBA BDS, (U.S. CLS. 100 AND 101). SN 85-544,509. PUB. 7-3-2012. FILED 2-16-2012.
- 4,209,814. **CROWDLY (STANDARD CHARACTER)**. APPSWELL, INC., (U.S. CLS. 100 AND 101). SN 85-544,545. PUB. 7-3-2012. FILED 2-16-2012.
- 4,209,845. **PORNGANIZER (STANDARD CHARACTER)**. PORNGANIZER LLC, (U.S. CLS. 100 AND 101). SN 85-545,016. PUB. 7-3-2012. FILED 2-16-2012.
- 4,209,861. **METROPOLITAN CLOUD (STANDARD CHARACTER)**. CITYSTRUCTURE, LLC, (U.S. CLS. 100 AND 101). SN 85-545,440. PUB. 7-3-2012. FILED 2-17-2012.
- 4,209,862 (*See Class 9 for this trademark*).
- 4,209,863 (*See Class 9 for this trademark*).
- 4,209,867. **JOINGO (STANDARD CHARACTER)**. JOINGO, LLC, (U.S. CLS. 100 AND 101). SN 85-545,595. PUB. 7-3-2012. FILED 2-17-2012.
- 4,209,897. **UNICODE (STANDARD CHARACTER)**. UNICODER, INC., AKA THE UNICODER CONSORTIUM, (U.S. CLS. 100 AND 101). SN 85-546,207. PUB. 7-3-2012. FILED 2-17-2012.
- 4,209,899. **ALERTRA AND DESIGN**. ALERTRA, INC., (U.S. CLS. 100 AND 101). SN 85-546,227. PUB. 7-3-2012. FILED 2-17-2012.
- 4,209,909. **ADVANCED TEST EQUIPMENT (STANDARD CHARACTER)**. ADVANCED TEST EQUIPMENT CORPORATION, (U.S. CLS. 100 AND 101). SN 85-546,492. PUB. 7-3-2012. FILED 2-17-2012.
- 4,209,922. **DIVORCEWRITER (STANDARD CHARACTER)**. PRO SE PLANNING, INC., DBA DIVORCEWRITER, (U.S. CLS. 100 AND 101). SN 85-546,667. PUB. 7-3-2012. FILED 2-18-2012.
- 4,209,939. **INVITRAN (STANDARD CHARACTER)**. ENIMANTRANS, DBA INVITRAN, (U.S. CLS. 100 AND 101). SN 85-546,961. PUB. 7-3-2012. FILED 2-19-2012.
- 4,209,940. **OUR FLORIDA. OUR FUTURE. (STANDARD CHARACTER)**. THE COLLINS CENTER FOR PUBLIC POLICY, INC., (U.S. CLS. 100 AND 101). SN 85-547,151. PUB. 7-3-2012. FILED 2-20-2012.
- 4,209,966. **MISCELLANEOUS DESIGN**. CLAIM IT PRODUCTIONS, LLC, (U.S. CLS. 100 AND 101). SN 85-548,742. PUB. 7-3-2012. FILED 2-21-2012.
- 4,209,969. **TEAPPLIX (STANDARD CHARACTER)**. TEAPPLIX INC, (U.S. CLS. 100 AND 101). SN 85-548,971. PUB. 7-3-2012. FILED 2-21-2012.
- 4,209,977. **LEGACYWRITER (STANDARD CHARACTER)**. PRO SE PLANNING, INC., DBA LEGACYWRITER, (U.S. CLS. 100 AND 101). SN 85-550,517. PUB. 7-3-2012. FILED 2-23-2012.
- 4,209,994. **FROM THE SAFELY FAMILY (STANDARD CHARACTER)**. WAVEMARKET, INC., (U.S. CLS. 100 AND 101). SN 85-552,487. PUB. 7-3-2012. FILED 2-24-2012.
- 4,210,002. **VISITING NURSE SERVICE OF NEW YORK (STANDARD CHARACTER)**. VISITING NURSE SERVICE OF NEW YORK, (U.S. CLS. 100 AND 101). SN 85-553,720. PUB. 7-3-2012. FILED 2-27-2012.
- 4,210,017 (*See Class 35 for this trademark*).
- 4,210,021. **WELL IQ (STANDARD CHARACTER)**. PETROPOWER LLC, (U.S. CLS. 100 AND 101). SN 85-556,550. PUB. 7-3-2012. FILED 2-29-2012.
- 4,210,025. **MISCELLANEOUS DESIGN**. MONSTER WORLDWIDE, INC., (U.S. CLS. 100 AND 101). SN 85-556,649. PUB. 7-3-2012. FILED 2-29-2012.
- 4,210,041 (*See Class 35 for this trademark*).
- 4,210,051 (*See Class 12 for this trademark*).
- 4,210,069 (*See Class 35 for this trademark*).
- 4,210,111. **CARE (STANDARD CHARACTER)**. DONLEN CORPORATION, (U.S. CLS. 100 AND 101). SN 85-579,779. PUB. 7-3-2012. FILED 3-26-2012.
- 4,210,133. **FRIENDLY FIRE (STANDARD CHARACTER)**. ADIZU, LLC, (U.S. CLS. 100 AND 101). SN 85-584,486. PUB. 7-3-2012. FILED 3-30-2012.
- 4,210,165. **PAYCHECKCITY (STANDARD CHARACTER)**. TEKNON CORPORATION, DBA SYMMETRY SOFTWARE, (U.S. CLS. 100 AND 101). SN 85-596,567. PUB. 7-3-2012. FILED 4-12-2012.
- 4,210,166. **PAYCHECKCITY AND DESIGN**. TEKNON CORPORATION, DBA SYMMETRY SOFTWARE, (U.S. CLS. 100 AND 101). SN 85-596,612. PUB. 7-3-2012. FILED 4-12-

2012.
4,210,206. **REMOFIX (STANDARD CHARACTER)**. DAVIS, DAVID, (U.S. CLS. 100 AND 101). SN 85-616,248. PUB. 7-3-2012. FILED 5-3-2012.

CLASS 43—HOTEL AND RESTAURANT SERVICES

- 4,208,158 (*See Class 41 for this trademark*).
4,208,159 (*See Class 41 for this trademark*).
4,208,194. **TORO BURGER . BAR AND DESIGN**. MOSTAFA RIFAI, (U.S. CLS. 100 AND 101). SN 77-859,698. PUB. 7-3-2012. FILED 10-28-2009.
4,208,221. **THE BUBBLE LOUNGE CHAMPAGNE BAR AND COMPANY (STANDARD CHARACTER)**. THE BUBBLE LOUNGE SAN FRANCISCO, INC, DBA THE BUBBLE LOUNGE CHAMPAGNE BAR AND COMPANY, (U.S. CLS. 100 AND 101). SN 77-962,835. PUB. 8-24-2010. FILED 3-18-2010.
4,208,243 (*See Class 3 for this trademark*).
4,208,280 (*See Class 39 for this trademark*).
4,208,289 (*See Class 3 for this trademark*).
4,208,302 (*See Class 32 for this trademark*).
4,208,305 (*See Class 25 for this trademark*).
4,208,316 (*See Class 32 for this trademark*).
4,208,317 (*See Class 32 for this trademark*).
4,208,342 (*See Class 9 for this trademark*).
4,208,345 (*See Class 30 for this trademark*).
4,208,376. **HANLASAN AND DESIGN**. BEIJING HANLASAN HOMETOWN RESTAURANT CO., LTD., (U.S. CLS. 100 AND 101). SN 79-104,464. PUB. 7-3-2012. FILED 10-10-2011.
4,208,446 (*See Class 16 for this trademark*).
4,208,465. **5 STAR BURGERS (STANDARD CHARACTER)**. 5 STAR BURGERS, INC., DBA 5 STAR BURGERS, (U.S. CLS. 100 AND 101). SN 85-079,122. PUB. 2-15-2011. FILED 7-7-2010.
4,208,489. **ROTI MEDITERRANEAN GRILL - FOOD THAT LOVES YOU BACK (STANDARD CHARACTER)**. ROTI RESTAURANTS, LLC, (U.S. CLS. 100 AND 101). SN 85-145,592. PUB. 7-3-2012. FILED 10-5-2010.
4,208,492. **ROTI REWARDS (STANDARD CHARACTER)**. ROTI RESTAURANTS, LLC, (U.S. CLS. 100 AND 101). SN 85-150,676. PUB. 7-3-2012. FILED 10-12-2010.
4,208,512. **NU-WAY (STANDARD CHARACTER)**. NU-WAY WEINERS, INC., (U.S. CLS. 100 AND 101). SN 85-185,976. PUB. 7-3-2012. FILED 11-29-2010.
4,208,513. **NU-WAY SINCE 1916 AND DESIGN**. NU-WAY WEINERS, INC., (U.S. CLS. 100 AND 101). SN 85-186,198. PUB. 7-3-2012. FILED 11-29-2010.
4,208,526. **FORNO 400° AND DESIGN**. PROVEEDORES DE INGENIERIA ALIMENTARIA, SA. DE CV., (U.S. CLS. 100 AND 101). SN 85-197,492. PUB. 7-3-2012. FILED 12-14-2010.
4,208,539. **PUTTANESCA (STANDARD CHARACTER)**. MIDWEST TOMATO, INC., (U.S. CLS. 100 AND 101). SN 85-213,871. PUB. 7-3-2012. FILED 1-10-2011.
4,208,544. **LOTUS OF SIAM (STANDARD CHARACTER)**. TCHUTIMA INC., DBA LOTUS OF SIAM, (U.S. CLS. 100 AND 101). SN 85-226,069. PUB. 7-3-2012. FILED 1-25-2011.
4,208,559 (*See Class 41 for this trademark*).
4,208,609. **WANNA PLAY (STANDARD CHARACTER)**. WANNA PLAY, LLC, (U.S. CLS. 100 AND 101). SN 85-318,865. PUB. 7-3-2012. FILED 5-12-2011.
4,208,614. **TA'CARBON THE REAL MEXICAN GRILL (STYLIZED)**. TA CARBON THE REAL MEXICAN GRILL, (U.S. CLS. 100 AND 101). SN 85-323,491. PUB. 7-3-2012. FILED 5-18-2011.
4,208,636 (*See Class 39 for this trademark*).
4,208,646. **LIL' SAINT PIGNIC FOR A SMOKIN' TIME CATERING FROM PARTIES TO CORPORATE EVENTS 732-612-3077 AND DESIGN**. SANTULLI, MARIA, SUE, DBA LIL' SAINT PIGNIC, (U.S. CLS. 100 AND 101). SN 85-344,451. PUB. 7-3-2012. FILED 6-13-2011.
4,208,699. **VORACIOUS MEATHEADS (STANDARD CHARACTER)**. JED REICHL INVESTMENTS, LLC, (U.S. CLS. 100 AND 101). SN 85-363,298. PUB. 7-3-2012. FILED 7-5-2011.
4,208,745. **PARADISE BIRYANI POINTE AND DESIGN**. BIRYANI POINTE PARADISE LLC, (U.S. CLS. 100 AND 101). SN 85-373,450. PUB. 7-3-2012. FILED 7-18-2011.
4,208,752 (*See Class 41 for this trademark*).
4,208,761. **EDIETS (STANDARD CHARACTER)**. EDIETS.-COM, INC., (U.S. CLS. 100 AND 101). SN 85-375,415. PUB. 7-3-2012. FILED 7-19-2011.
4,208,788. **STK OUT AND DESIGN**. THE ONE GROUP LLC, (U.S. CLS. 100 AND 101). SN 85-379,387. PUB. 7-3-2012. FILED 7-24-2011.
4,208,797 (*See Class 32 for this trademark*).
4,208,816. **PAPA'S PIZZA PP & BBQ EST. 2000 AND DESIGN**. PAPA'S PIZZA, INC., (U.S. CLS. 100 AND 101). SN 85-387,868. PUB. 7-3-2012. FILED 8-3-2011.
4,208,845. **WAG CLUB AND DESIGN**. BROOKLYN BRIDGE BARK, INC., DBA WAG CLUB, (U.S. CLS. 100 AND 101). SN 85-395,146. PUB. 7-3-2012. FILED 8-11-2011.
4,208,847. **DOM DEMARCO'S PIZZERIA & BAR (STANDARD CHARACTER)**. GUSTO ENTERTAINMENT, LLC, (U.S. CLS. 100 AND 101). SN 85-396,000. PUB. 7-3-2012. FILED 8-11-2011.
4,208,848. **DOM DEMARCO'S PIZZERIA & BAR (STYLIZED)**. GUSTO ENTERTAINMENT, LLC, (U.S. CLS. 100 AND 101). SN 85-396,018. PUB. 7-3-2012. FILED 8-11-2011.
4,208,877. **CBG CALIFORNIA BURRITO GRILL AND DESIGN**. DANIEL LOPEZ, (U.S. CLS. 100 AND 101). SN 85-402,886. PUB. 7-3-2012. FILED 8-19-2011.
4,208,965 (*See Class 37 for this trademark*).
4,208,982. **ELI CANNONS (STANDARD CHARACTER)**. ELI CANNON'S L.L.C., (U.S. CLS. 100 AND 101). SN 85-446,208. PUB. 7-3-2012. FILED 10-13-2011.
4,209,002 (*See Class 35 for this trademark*).
4,209,022. **MISCELLANEOUS DESIGN**. CHOICES CAFE, INC., (U.S. CLS. 100 AND 101). SN 85-460,258. PUB. 7-3-2012. FILED 10-31-2011.
4,209,045 (*See Class 35 for this trademark*).
4,209,057. **MARTINS RUN (STANDARD CHARACTER)**. MARTINS RUN, (U.S. CLS. 100 AND 101). SN 85-473,133. PUB. 7-3-2012. FILED 11-15-2011.
4,209,063. **KIDS R KIDS SCHOOLS OF QUALITY LEARNING AND DESIGN**. KIDS 'R' KIDS, INC., (U.S. CLS. 100 AND 101). SN 85-474,389. PUB. 7-3-2012. FILED 11-16-2011.
4,209,138. **JING SI BOOKS & CAFE AND DESIGN**. JING SI PUBLICATIONS CO., LTD., (U.S. CLS. 100 AND 101). SN 85-499,524. PUB. 7-3-2012. FILED 12-20-2011.
4,209,150 (*See Class 35 for this trademark*).
4,209,180. **PAELLA AT YOUR PLACE (STANDARD CHARACTER)**. PAELLA AT YOUR PLACE, LLC, (U.S. CLS. 100 AND 101). SN 85-507,636. PUB. 7-3-2012. FILED 1-3-2012.
4,209,232. **URBAN PICNIC GOURMET EATERY AND DESIGN**. MARCELLE, (U.S. CLS. 100 AND 101). SN 85-517,473. PUB. 7-3-2012. FILED 1-16-2012.
4,209,249. **WING . STOP . S . P . O . R . T . S AND DESIGN**. WINGSTOP RESTAURANTS, INC., (U.S. CLS. 100 AND 101). SN 85-519,069. PUB. 7-3-2012. FILED 1-18-2012.
4,209,253. **MISCELLANEOUS DESIGN**. WOUNDED WARRIOR HOMES, INC., (U.S. CLS. 100 AND 101). SN 85-519,399. PUB. 7-3-2012. FILED 1-18-2012.
4,209,287. **LAND THAI KITCHEN (STANDARD CHARACTER)**. D AND D THAI RESTAURANT CORP., (U.S. CLS. 100 AND 101). SN 85-521,231. PUB. 7-3-2012. FILED 1-20-2012.
4,209,293. **WOW CAFE . AMERICAN GRILL & WINGERY . AND DESIGN**. WOW CAFE & WINGERY FRANCHISING ACCOUNT, LLC, (U.S. CLS. 100 AND 101). SN 85-521,507. PUB. 7-3-2012. FILED 1-20-2012.
4,209,294. **IOWA CAFE (STANDARD CHARACTER)**. ALEMAP LLC, (U.S. CLS. 100 AND 101). SN 85-521,548. PUB. 7-3-2012. FILED 1-20-2012.
4,209,302. **JUICE ON THE LOOSE (STANDARD CHARACTER)**. URNOVITZ, ABBY LAUREN, (U.S. CLS. 100 AND 101). SN 85-522,246. PUB. 7-3-2012. FILED 1-22-2012.
4,209,310. **EDDIE'S PIZZA HOME OF THE BAR PIE AND DESIGN**. 2048 HILLSIDE RESTAURANT CORP., DBA EDDIES, (U.S. CLS. 100 AND 101). SN 85-522,584. PUB. 7-3-2012. FILED 1-23-2012.
4,209,313. **THE EDDIE'S PIZZA TRUCK HOME OF THE BAR PIE AND DESIGN**. 2048 HILLSIDE RESTAURANT CORP., DBA EDDIES, (U.S. CLS. 100 AND 101). SN 85-522,598. PUB.

- 7-3-2012. FILED 1-23-2012.
- 4,209,331. **OCUX AND DESIGN**. NGUYEN, DAVID, (U.S. CLS. 100 AND 101). SN 85-523,400. PUB. 7-3-2012. FILED 1-24-2012.
- 4,209,335. **MIGHT AS WELL BAR AND GRILL (STANDARD CHARACTER)**. MANJACKSON INC., (U.S. CLS. 100 AND 101). SN 85-523,696. PUB. 7-3-2012. FILED 1-24-2012.
- 4,209,352. **THAI BASIL (STANDARD CHARACTER)**. THAI SWEET BASIL, INC., DBA THAI BASIL, (U.S. CLS. 100 AND 101). SN 85-524,240. PUB. 7-3-2012. FILED 1-24-2012.
- 4,209,391. **CAMP CRITTER BAR & GRILLE (STANDARD CHARACTER)**. GREAT LAKES SERVICES, LLC, (U.S. CLS. 100 AND 101). SN 85-525,903. PUB. 7-3-2012. FILED 1-26-2012.
- 4,209,392. **THE FRANKLIN GRILL & TAVERN (STANDARD CHARACTER)**. KOCHENSPIRGER, RUTH, DBA FRANKLIN GRILL & TAVERN, (U.S. CLS. 100 AND 101). SN 85-525,912. PUB. 7-3-2012. FILED 1-26-2012.
- 4,209,393. **WOLF DEN SUITE (STANDARD CHARACTER)**. GREAT LAKES SERVICES, LLC, (U.S. CLS. 100 AND 101). SN 85-525,916. PUB. 7-3-2012. FILED 1-26-2012.
- 4,209,397. **ROYAL BEAR SUITE (STANDARD CHARACTER)**. GREAT LAKES SERVICES, LLC, (U.S. CLS. 100 AND 101). SN 85-526,004. PUB. 7-3-2012. FILED 1-26-2012.
- 4,209,398. **MAJESTIC BEAR SUITE (STANDARD CHARACTER)**. GREAT LAKES SERVICES, LLC, (U.S. CLS. 100 AND 101). SN 85-526,009. PUB. 7-3-2012. FILED 1-26-2012.
- 4,209,399. **KIDKAMP (STANDARD CHARACTER)**. GREAT LAKES SERVICES, LLC, (U.S. CLS. 100 AND 101). SN 85-526,015. PUB. 7-3-2012. FILED 1-26-2012.
- 4,209,407 (*See Class 41 for this trademark*).
- 4,209,424 (*See Class 35 for this trademark*).
- 4,209,425 (*See Class 35 for this trademark*).
- 4,209,522. **MICHEL'S CORNER (STANDARD CHARACTER)**. MICHEL'S CORNER, LLC, (U.S. CLS. 100 AND 101). SN 85-538,570. PUB. 7-3-2012. FILED 2-9-2012.
- 4,209,561. **ELISE CONSTANTINE (STANDARD CHARACTER)**. PODO, LLC, (U.S. CLS. 100 AND 101). SN 85-540,359. PUB. 7-3-2012. FILED 2-11-2012.
- 4,209,563. **YUMPTY (STANDARD CHARACTER)**. YUMPTY, LLC, (U.S. CLS. 100 AND 101). SN 85-540,556. PUB. 7-3-2012. FILED 2-12-2012.
- 4,209,602. **WE'LL DO DINNER (STANDARD CHARACTER)**. WE'LL DO DINNER LLC, (U.S. CLS. 100 AND 101). SN 85-541,173. PUB. 7-3-2012. FILED 2-13-2012.
- 4,209,609. **AMERICANS FEEDING AMERICANS A PROJECT OF FEED THE CHILDREN AND DESIGN**. FEED THE CHILDREN, INC., (U.S. CLS. 100 AND 101). SN 85-541,272. PUB. 7-3-2012. FILED 2-13-2012.
- 4,209,611. **SLEEP 4 ALL (STANDARD CHARACTER)**. SLEEP SHOPPE, INC., (U.S. CLS. 100 AND 101). SN 85-541,283. PUB. 7-3-2012. FILED 2-13-2012.
- 4,209,633. **SAY NO TO DRUGS AND SAY YES TO PIZZA! (STANDARD CHARACTER)**. THE PIZZA-RANT, INC., (U.S. CLS. 100 AND 101). SN 85-541,631. PUB. 7-3-2012. FILED 2-13-2012.
- 4,209,679. **THE WOOF ROOM (STANDARD CHARACTER)**. THE WOOF ROOM, LLC, (U.S. CLS. 100 AND 101). SN 85-542,425. PUB. 7-3-2012. FILED 2-14-2012.
- 4,209,709 (*See Class 41 for this trademark*).
- 4,209,717. **AREPABOX (STANDARD CHARACTER)**. AREPABOX LLC, (U.S. CLS. 100 AND 101). SN 85-543,118. PUB. 7-3-2012. FILED 2-15-2012.
- 4,209,759 (*See Class 35 for this trademark*).
- 4,209,767. **CASA VEGA (STANDARD CHARACTER)**. CV CONCEPTS, LLC, (U.S. CLS. 100 AND 101). SN 85-543,746. PUB. 7-3-2012. FILED 2-15-2012.
- 4,209,780. **BEAR CREEK COFFEE AND DESIGN**. SUMMIT BUILDERS, INC., DBA BEAR CREEK COFFEE COMPANY, (U.S. CLS. 100 AND 101). SN 85-543,956. PUB. 7-3-2012. FILED 2-15-2012.
- 4,209,875. **ESCAPE THE CRATE (STANDARD CHARACTER)**. ESCAPE THE CRATE, (U.S. CLS. 100 AND 101). SN 85-545,736. PUB. 7-3-2012. FILED 2-17-2012.
- 4,209,930. **THE PIZZA-RANT (STANDARD CHARACTER)**. THE PIZZA-RANT, INC., (U.S. CLS. 100 AND 101). SN 85-546,794. PUB. 7-3-2012. FILED 2-18-2012.
- 4,210,045. **THE HUNGRY HOUSEWIFE AND DESIGN**. THE HUNGRY HOUSEWIFE, INC., (U.S. CLS. 100 AND 101). SN 85-563,328. PUB. 7-3-2012. FILED 3-7-2012.
- 4,210,078. **CAFELADOS COFFEE SHOP (STANDARD CHARACTER)**. PEREZ, LEMUEL, (U.S. CLS. 100 AND 101). SN 85-572,835. PUB. 7-3-2012. FILED 3-19-2012.
- 4,210,118. **TRYP BY WYNDHAM (STANDARD CHARACTER)**. TRYP HOTELS WORLDWIDE, INC., AND WYNDHAM TM CORP., (U.S. CLS. 100 AND 101). SN 85-580,561. PUB. 7-3-2012. FILED 3-27-2012.
- 4,210,202. **RIGHT ON 'CUE (STANDARD CHARACTER)**. RALEIGH PITMASTER EMPIRE, LLC, (U.S. CLS. 100 AND 101). SN 85-614,216. PUB. 7-3-2012. FILED 5-2-2012.
- 4,210,220. **GRILLEBRATION (STANDARD CHARACTER)**. DIETZ & WATSON, INC., (U.S. CLS. 100 AND 101). SN 85-976,726. PUB. 7-3-2012. FILED 6-30-2011.

CLASS 44—MEDICAL, BEAUTY AND AGRICULTURAL SERVICES

- 4,208,183 (*See Class 10 for this trademark*).
- 4,208,228. **WHEN SECONDS COUNT...COUNT ON US! (STANDARD CHARACTER)**. CYPRESS CREEK EMERGENCY MEDICAL SERVICES ASSOCIATION, (U.S. CLS. 100 AND 101). SN 78-848,209. PUB. 11-7-2006. FILED 3-28-2006.
- 4,208,260 (*See Class 9 for this trademark*).
- 4,208,273 (*See Class 10 for this trademark*).
- 4,208,305 (*See Class 25 for this trademark*).
- 4,208,322 (*See Class 9 for this trademark*).
- 4,208,333 (*See Class 5 for this trademark*).
- 4,208,342 (*See Class 9 for this trademark*).
- 4,208,349 (*See Class 5 for this trademark*).
- 4,208,381 (*See Class 3 for this trademark*).
- 4,208,384 (*See Class 5 for this trademark*).
- 4,208,444 (*See Class 3 for this trademark*).
- 4,208,449 (*See Class 5 for this trademark*).
- 4,208,464. **APOTHECARY (STANDARD CHARACTER)**. BOGUE, BRET, (U.S. CLS. 100 AND 101). SN 85-077,477. PUB. 7-3-2012. FILED 7-2-2010.
- 4,208,495 (*See Class 9 for this trademark*).
- 4,208,552. **DOR YESHORIM (STANDARD CHARACTER)**. DOR YESHURIM, INC., DBA DOR YESHORIM, (U.S. CLS. 100 AND 101). SN 85-238,749. PUB. 7-3-2012. FILED 2-10-2011.
- 4,208,564 (*See Class 41 for this trademark*).
- 4,208,584. **RAPID RESOLUTION THERAPY AND DESIGN**. INSTITUTE FOR RAPID RESOLUTION THERAPY, INC., (U.S. CLS. 100 AND 101). SN 85-286,285. PUB. 7-3-2012. FILED 4-5-2011.
- 4,208,617 (*See Class 8 for this trademark*).
- 4,208,626. **BABYVISION ULTRASOUND AND DESIGN**. BABYVISION ULTRASOUND, (U.S. CLS. 100 AND 101). SN 85-333,462. PUB. 7-3-2012. FILED 5-30-2011.
- 4,208,642 (*See Class 5 for this trademark*).
- 4,208,690 (*See Class 22 for this trademark*).
- 4,208,720 (*See Class 27 for this trademark*).
- 4,208,744 (*See Class 16 for this trademark*).
- 4,208,759. **WENDLING (STANDARD CHARACTER)**. ARDZROONI VINEYARD MANAGEMENT, LLC, (U.S. CLS. 100 AND 101). SN 85-375,389. PUB. 7-3-2012. FILED 7-19-2011.
- 4,208,760. **EDIETS (STANDARD CHARACTER)**. EDIETS-COM, INC., (U.S. CLS. 100 AND 101). SN 85-375,406. PUB. 7-3-2012. FILED 7-19-2011.
- 4,208,763. **NOURISH NUTRITION SUPPORT PROGRAM (STANDARD CHARACTER)**. CORAM LLC, MULTIPLE CLASS, (INT. CLS. 44 AND 45), (U.S. CLS. 100 AND 101). SN 85-375,484. PUB. 7-3-2012. FILED 7-19-2011.
- 4,208,765. **NOURISH NUTRITION SUPPORT PROGRAM (STYLIZED)**. CORAM LLC, MULTIPLE CLASS, (INT. CLS. 44 AND 45), (U.S. CLS. 100 AND 101). SN 85-375,498. PUB. 7-3-2012. FILED 7-19-2011.
- 4,208,866. **ACUARIOTERAPIA AND DESIGN**. REY IGLESIAS, ANTONIO RAMON, (U.S. CLS. 100 AND 101). SN 85-400,888. PUB. 6-12-2012. FILED 8-18-2011.
- 4,208,879. **VOICE COLORS (STANDARD CHARACTER)**. EVE MEGARGEL, (U.S. CLS. 100 AND 101). SN 85-403,800. PUB.

- 7-3-2012. FILED 8-22-2011.
 4,208,881 (*See Class 42 for this trademark*).
 4,208,899. **DEJA VU TATTOO & PIERCING (STANDARD CHARACTER)**. MITCHELL K. BROWN, (U.S. CLS. 100 AND 101). SN 85-412,005. PUB. 7-3-2012. FILED 8-31-2011.
 4,208,949. **PASS IT ON UNTIL EVERY WOMAN KNOWS (STANDARD CHARACTER)**. GENOMIC HEALTH, INC., (U.S. CLS. 100 AND 101). SN 85-434,393. PUB. 7-3-2012. FILED 9-28-2011.
 4,209,035 (*See Class 3 for this trademark*).
 4,209,110. **NEW HAIR SYSTEM AND DESIGN**. NEW HAIR SYSTEM, INC., (U.S. CLS. 100 AND 101). SN 85-492,036. PUB. 7-3-2012. FILED 12-9-2011.
 4,209,113. **SERENITY SIREN (STANDARD CHARACTER)**. ROUMBOS, BERNADETTE, (U.S. CLS. 100 AND 101). SN 85-493,281. PUB. 7-3-2012. FILED 12-12-2011.
 4,209,140 (*See Class 41 for this trademark*).
 4,209,150 (*See Class 35 for this trademark*).
 4,209,220. **GOGA JET AND DESIGN**. GOGA STUDIOS, INC., (U.S. CLS. 100 AND 101). SN 85-516,166. PUB. 7-3-2012. FILED 1-13-2012.
 4,209,221. **MY BODY & ME (STANDARD CHARACTER)**. PERNELL, CHRIS, T, (U.S. CLS. 100 AND 101). SN 85-516,250. PUB. 7-3-2012. FILED 1-13-2012.
 4,209,226. **E ECOURBAN DESIGNS, INC. AND DESIGN**. ECOURBAN DESIGNS, INC., (U.S. CLS. 100 AND 101). SN 85-516,793. PUB. 7-3-2012. FILED S.R. 1-14-2012; AM. P.R. 4-27-2012.
 4,209,238. **MEDIG IMAGING AND DESIGN**. MEDIG PROPRIETARY HOLDINGS, L.L.C., (U.S. CLS. 100 AND 101). SN 85-518,138. PUB. 7-3-2012. FILED 1-17-2012.
 4,209,265. **BAYADA PEDIATRICS A SPECIALTY OF BAYADA HOME HEALTH CARE AND DESIGN**. BAYADA HOME HEALTH CARE, INC., FORMERLY BAYADA NURSES, INC., (U.S. CLS. 100 AND 101). SN 85-520,151. PUB. 7-3-2012. FILED 1-19-2012.
 4,209,278 (*See Class 9 for this trademark*).
 4,209,307. **SO CLIMBING IAL (STYLIZED)**. PORTNOY ABEMAYOR, DONNA, (U.S. CLS. 100 AND 101). SN 85-522,489. PUB. 7-3-2012. FILED 1-23-2012.
 4,209,322 (*See Class 42 for this trademark*).
 4,209,341. **SWEET 185 AND DESIGN**. SUGAR GENIUS LLC, DBA SWEET 185, (U.S. CLS. 100 AND 101). SN 85-523,768. PUB. 7-3-2012. FILED 1-24-2012.
 4,209,342. **SWEET 185 (STANDARD CHARACTER)**. SUGAR GENIUS LLC, DBA SWEET 185, (U.S. CLS. 100 AND 101). SN 85-523,776. PUB. 7-3-2012. FILED 1-24-2012.
 4,209,349. **SCHEDULENOW AND DESIGN**. MEMORIAL HERMANN HOSPITAL SYSTEM, (U.S. CLS. 100 AND 101). SN 85-524,078. PUB. 7-3-2012. FILED 1-24-2012.
 4,209,351. **HEARTWATCH (STANDARD CHARACTER)**. PRODUCTIVEMD, LLC, (U.S. CLS. 100 AND 101). SN 85-524,181. PUB. 7-3-2012. FILED 1-24-2012.
 4,209,380. **RECOVERY HELP NOW (STANDARD CHARACTER)**. RECOVERY HELP NOW, INC., (U.S. CLS. 100 AND 101). SN 85-525,553. PUB. 7-3-2012. FILED 1-26-2012.
 4,209,403. **MISCELLANEOUS DESIGN**. BRAKE LANDSCAPING AND LAWNCARE, INC., (U.S. CLS. 100 AND 101). SN 85-526,237. PUB. 7-3-2012. FILED 1-26-2012.
 4,209,406. **YOUR WEIGHT IS FINALLY OVER (STANDARD CHARACTER)**. DIET AND WEIGHT LOSS CENTERS, LLC, (U.S. CLS. 100 AND 101). SN 85-526,331. PUB. 7-3-2012. FILED 1-26-2012.
 4,209,430. **LUMIERE DENTAL SPA AND DESIGN**. HOVAIZI, NEDA, DBA LUMIERE DENTAL SPA, LLC, (U.S. CLS. 100 AND 101). SN 85-527,929. PUB. 7-3-2012. FILED 1-28-2012.
 4,209,433. **LANRACORP (STANDARD CHARACTER)**. LANRACORP, INC., (U.S. CLS. 100 AND 101). SN 85-528,275. PUB. 7-3-2012. FILED 1-30-2012.
 4,209,457. **BEALE STREET BARBER SHOP (STANDARD CHARACTER)**. BEALE STREET BARBER SHOP INC., (U.S. CLS. 100 AND 101). SN 85-530,457. PUB. 7-3-2012. FILED 1-31-2012.
 4,209,483. **NIKI MOON SALON (STANDARD CHARACTER)**. NIKI MOON SALON, (U.S. CLS. 100 AND 101). SN 85-534,221. PUB. 7-3-2012. FILED 2-5-2012.
 4,209,495. **NURSENOW (STANDARD CHARACTER)**. COM-PRESULTS, L.L.C., (U.S. CLS. 100 AND 101). SN 85-536,754. PUB. 7-3-2012. FILED 2-8-2012.
 4,209,505. **TUNE-UPS A CHIROPRACTIC PLACE (STANDARD CHARACTER)**. AWENDER, JEFFERY E., (U.S. CLS. 100 AND 101). SN 85-537,488. PUB. 7-3-2012. FILED 2-8-2012.
 4,209,518 (*See Class 35 for this trademark*).
 4,209,579 (*See Class 35 for this trademark*).
 4,209,590. **MISCELLANEOUS DESIGN**. JACK L. GREIDER, JR., (U.S. CLS. 100 AND 101). SN 85-541,044. PUB. 7-3-2012. FILED 2-13-2012.
 4,209,695. **IT'S NOT JUST THEIR PROBLEM. (STANDARD CHARACTER)**. RECOVERY CARE MATTERS, LLC, (U.S. CLS. 100 AND 101). SN 85-542,683. PUB. 7-3-2012. FILED 2-14-2012.
 4,209,737. **CARL RAY MAKEUP ARTIST (STANDARD CHARACTER)**. CARL RAY MAKEUP ARTIST, (U.S. CLS. 100 AND 101). SN 85-543,366. PUB. 7-3-2012. FILED 2-15-2012.
 4,209,819. **SOUND OPTIONS (STANDARD CHARACTER)**. SOUND OPTIONS, INC., (U.S. CLS. 100 AND 101). SN 85-544,570. PUB. 7-3-2012. FILED 2-16-2012.
 4,209,932. **HC HOLLAND AND DESIGN**. HOLLAND, MARK JOHN, DBA HOLLAND CLINIC, (U.S. CLS. 100 AND 101). SN 85-546,828. PUB. 7-3-2012. FILED 2-19-2012.
 4,209,970. **WE'RE ALL VIPS (STANDARD CHARACTER)**. VICTORIA PARTNERS, (U.S. CLS. 100 AND 101). SN 85-549,500. PUB. 7-3-2012. FILED 2-22-2012.
 4,210,040. **EQUINOX (STANDARD CHARACTER)**. EQUINOX HOLDINGS, INC., (U.S. CLS. 100 AND 101). SN 85-561,342. PUB. 7-3-2012. FILED 3-6-2012.
 4,210,068. **GET IN THE GAME. SAVE A LIFE (STANDARD CHARACTER)**. NATIONAL MARROW DONOR PROGRAM, (U.S. CLS. 100 AND 101). SN 85-569,005. PUB. 7-3-2012. FILED 3-14-2012.
 4,210,178. **EXPERIENCE OUR PASSION FOR PEOPLE (STANDARD CHARACTER)**. UHS OF DELAWARE, INC., (U.S. CLS. 100 AND 101). SN 85-602,389. PUB. 7-3-2012. FILED 4-19-2012.
 4,210,221 (*See Class 22 for this trademark*).

CLASS 45—PERSONAL AND LEGAL SERVICES

- 4,208,247 (*See Class 9 for this trademark*).
 4,208,346 (*See Class 16 for this trademark*).
 4,208,425 (*See Class 9 for this trademark*).
 4,208,586 (*See Class 42 for this trademark*).
 4,208,589 (*See Class 35 for this trademark*).
 4,208,624 (*See Class 9 for this trademark*).
 4,208,685 (*See Class 39 for this trademark*).
 4,208,700 (*See Class 18 for this trademark*).
 4,208,746 (*See Class 35 for this trademark*).
 4,208,763 (*See Class 44 for this trademark*).
 4,208,765 (*See Class 44 for this trademark*).
 4,208,818 (*See Class 9 for this trademark*).
 4,208,863 (*See Class 35 for this trademark*).
 4,208,907. **H AND DESIGN**. KERIAN, CHRISTINE L., (U.S. CLS. 100 AND 101). SN 85-413,475. PUB. 7-3-2012. FILED 9-1-2011.
 4,208,948 (*See Class 9 for this trademark*).
 4,209,010 (*See Class 35 for this trademark*).
 4,209,017. **QUEERLY ORGANIZED (STANDARD CHARACTER)**. ALL KINDS OF CLIENTS ORGANIZING LLC, DBA QUEERLY ORGANIZED, (U.S. CLS. 100 AND 101). SN 85-457,689. PUB. 7-3-2012. FILED 10-27-2011.
 4,209,101 (*See Class 42 for this trademark*).
 4,209,140 (*See Class 41 for this trademark*).
 4,209,174 (*See Class 41 for this trademark*).
 4,209,187. **ETHEMIS (STANDARD CHARACTER)**. ETHEMIS, (U.S. CLS. 100 AND 101). SN 85-509,168. PUB. 5-29-2012. FILED 1-5-2012.
 4,209,201. **RTYM RESTORING THE YEARS MINISTRIES AND DESIGN**. RESTORING THE YEARS MINISTRIES INCORPORATED, (U.S. CLS. 100 AND 101). SN 85-511,289. PUB. 7-3-2012. FILED 1-8-2012.
 4,209,254. **DECK PRISM (STANDARD CHARACTER)**. STEVEN A. CASH, TA DECK PRISM, LLC, AND DECK

- PRISM, LLC, DBA DECK PRISM, LLC, (U.S. CLS. 100 AND 101). SN 85-519,434. PUB. 7-3-2012. FILED 1-18-2012.
- 4,209,269. **YOKED FOR A CAUSE (STANDARD CHARACTER)**. BUFFARD, JENNIFER, (U.S. CLS. 100 AND 101). SN 85-520,468. PUB. 7-3-2012. FILED 1-19-2012.
- 4,209,291. **WATER RIGHTS (STANDARD CHARACTER)**. JEFFERY KEITH HORNBAKER, AND VIRGINIE FRANCE MIRAMON, (U.S. CLS. 100 AND 101). SN 85-521,341. PUB. 7-3-2012. FILED 1-20-2012.
- 4,209,344 (*See Class 35 for this trademark*).
- 4,209,372. **ORGANIZE AND ENERGIZE (STANDARD CHARACTER)**. ORGANIZED 4 LIFE, LLC, DBA MAJOR MOM, (U.S. CLS. 100 AND 101). SN 85-525,087. PUB. 7-3-2012. FILED 1-25-2012.
- 4,209,432. **PASSION FOR PLANNING (STANDARD CHARACTER)**. AMAYESING PRODUCTIONS, INC., (U.S. CLS. 100 AND 101). SN 85-528,183. PUB. 7-3-2012. FILED 1-30-2012.
- 4,209,439. **CN (STYLIZED)**. J. THOMPSON CRAVENS & ASSOCIATES, P.C., DBA CRAVENS & NOLL P.C., (U.S. CLS. 100 AND 101). SN 85-528,835. PUB. 7-3-2012. FILED 1-30-2012.
- 4,209,444. **TEAMCASUAL (STANDARD CHARACTER)**. ARAMARK UNIFORM & CAREER APPAREL, LLC, (U.S. CLS. 100 AND 101). SN 85-529,126. PUB. 7-3-2012. FILED 1-30-2012.
- 4,209,463. **CONNECT 2 CHRIST CHURCH AND DESIGN**. CONNECT 2 CHRIST CHURCH, INC., (U.S. CLS. 100 AND 101). SN 85-531,433. PUB. 7-3-2012. FILED 2-1-2012.
- 4,209,487. **KING SURVEY TRACKER AND DESIGN**. KING PRODUCTS AND EQUIPMENT LLC., (U.S. CLS. 100 AND 101). SN 85-534,743. PUB. 7-3-2012. FILED 2-6-2012.
- 4,209,650. **JOEDATE.COM (STANDARD CHARACTER)**. GLOBAL MARKETING RESOURCES, INC., (U.S. CLS. 100 AND 101). SN 85-541,936. PUB. 7-3-2012. FILED 2-14-2012.
- 4,209,703. **IN SEARCH OF ROOTS (STANDARD CHARACTER)**. CHINESE CULTURE FOUNDATION OF SAN FRANCISCO, (U.S. CLS. 100 AND 101). SN 85-542,814. PUB. 7-3-2012. FILED 2-14-2012.
- 4,209,721. **LIFETHRUDIVORCE (STANDARD CHARACTER)**. KIDS MATTER, LLC, (U.S. CLS. 100 AND 101). SN 85-543,193. PUB. 7-3-2012. FILED 2-15-2012.
- 4,209,733. **WHERE JUSTICE IS SERVED (STANDARD CHARACTER)**. BERNHEIM & DOLINSKY, (U.S. CLS. 100 AND 101). SN 85-543,284. PUB. 7-3-2012. FILED 2-15-2012.
- 4,209,829. **ASAT (STANDARD CHARACTER)**. ORBIS OPERATIONS, LLC, (U.S. CLS. 100 AND 101). SN 85-544,705. PUB. 7-3-2012. FILED 2-16-2012.
- 4,209,895. **GOT2GO (STANDARD CHARACTER)**. HOME WATCH AND PET CARE SERVICES, LLC, DBA GOT2GO PET SITTING, (U.S. CLS. 100 AND 101). SN 85-546,198. PUB. 7-3-2012. FILED 2-17-2012.
- 4,209,896. **KEEPING YOUR LIABILITIES UNDER CONTROL (STANDARD CHARACTER)**. INSPARISK, LLC, (U.S. CLS. 100 AND 101). SN 85-546,206. PUB. 7-3-2012. FILED 2-17-2012.
- 4,209,931. **KITWAKE (STANDARD CHARACTER)**. KITWAKE IP, INC., (U.S. CLS. 100 AND 101). SN 85-546,811. PUB. 7-3-2012. FILED 2-19-2012.
- 4,209,937. **LEXERO (STANDARD CHARACTER)**. MENHART, ERIC, (U.S. CLS. 100 AND 101). SN 85-546,929. PUB. 7-3-2012. FILED 2-19-2012.
- 4,209,974. **FUNVITE (STANDARD CHARACTER)**. BELLAMY, STEVE, (U.S. CLS. 100 AND 101). SN 85-549,994. PUB. 7-3-2012. FILED 2-22-2012.
- 4,210,112. **PASSION FOR PLANNING IMAGINE LIFE SIMPLIFIED. (STANDARD CHARACTER)**. AMAYESING PRODUCTIONS, INC. (U.S. CLS. 100 AND 101). SN 85-579,796. PUB. 7-3-2012. FILED 3-26-2012.
- 4,210,179. **YOUR LIFE. YOUR WAY. YOUR HOME. (STANDARD CHARACTER)**. WILD KARMA, INC., DBA DIVINE HOME CARE, (U.S. CLS. 100 AND 101). SN 85-602,466. PUB. 7-3-2012. FILED 4-19-2012.
- 4,210,225 (*See Class 8 for this trademark*).

SECTION 2.—PRIOR UNITED STATES CLASSIFICATION

COLLECTIVE MEMBERSHIP MARKS

CLASS 200—COLLECTIVE MEMBERSHIP

4,209,012. **SIX POINT RIDERS (STANDARD CHARACTER).**
MORRIS, MELVYN G., SN 85-452,083. PUB. 7-3-2012.
FILED 10-20-2011.

4,209,496. **BMC AND DESIGN.** PIKE, JEFFFREY, SN 85-
536,888. PUB. 7-3-2012. FILED 2-8-2012.

4,208,561. **APPROVED AMERICAN NATIONAL STANDARD
ANSI AND DESIGN.** AMERICAN NATIONAL STANDARDS
INSTITUTE, INCORPORATED, SN 85-248,137. PUB. 7-3-
2012. FILED 2-22-2011.

4,208,864. **HAYYA HALAL (STANDARD CHARACTER).**
SHAMBRA, MUHAMMAD, SN 85-400,345. PUB. 7-3-2012.
FILED 8-17-2011.

4,209,736. **OFFICIAL LICENSED PRODUCT AND DESIGN.**
AFFINITY MARKETING CONSULTANTS, INC., DBA
AFFINITY CONSULTANTS, SN 85-543,323. PUB. 7-3-2012.
FILED 2-15-2012.

CERTIFICATION MARKS

CLASS A—GOODS

4,209,812. **K AND DESIGN.** TRIANGLE K, INC., SN 85-
544,513. PUB. 7-3-2012. FILED 2-16-2012.

* * * * *

TRADEMARK REGISTRATIONS ISSUED UNDER SECTION 1(d)

The following marks have registered on the Principal Register pursuant to the intent-to-use provisions of Section 1(d) of the Trademark Act of 1946, as amended.

SECTION 1.— INTERNATIONAL CLASSIFICATION

The short titles associated below with the international class numbers are terms designed merely for quick identification and are not an official part of the international classification. The full names of international classes are given in section 6.1 of the trademark rules of practice.

The designation "U.S. Cl." appearing in this section refers to the U.S. class in effect prior to Sep. 1, 1973 rather than the international class which applies to applications filed on or after that date. For adoption of international classification see notice in the OFFICIAL GAZETTE of Jun. 26, 1973 (911 O.G. TM 210).

Application in more than one class

4,210,230. FIAT GROUP MARKETING & CORPORATE COMMUNICATION S.P.A., TORINO, ITALY. SN 76-654,512. PUB. 5-12-2009, FILED 2-2-2006.

4,210,231. SAFEWAY INC., PLEASANTON, CA. SN 76-690,158. PUB. 4-28-2009, FILED 5-30-2008.



OWNER OF ITALY REG. NO. 52003, DATED 10-14-1935, RENEWED AS REG. NO. 0001158340, DATED 11-27-2008, EXPIRES 3-29-2015.

CLASS 12—VEHICLES

FOR AUTOMOBILES AND TRUCKS; AUTOMOBILE BODIES, TRUCK BODIES, MOTOR LAND VEHICLE BODIES, TRACTOR BODIES, ENGINES, CLUTCHES, BRAKES, SAFETY BELTS, ALL FOR MOTOR LAND VEHICLES; STRUCTURAL PARTS FOR MOTOR LAND VEHICLES; TRACTORS; ELECTRIC LOCOMOTIVES (U.S. CLS. 19, 21, 23, 31, 35 AND 44).

CLASS 25—CLOTHING

FOR T-SHIRTS, SWEAT SHIRTS, POLO-SHIRTS, CAPS, WIND RESISTANT JACKETS, WATERPROOF JACKETS, PULLOVERS, COATS, SWEATERS, SHIRTS (U.S. CLS. 22 AND 39).
FIRST USE 4-0-2011; IN COMMERCE 4-0-2011.

CLASS 35—ADVERTISING AND BUSINESS

FOR RETAIL STORE SERVICES FEATURING AUTOMOBILES AND TRUCKS, BODIES, ENGINES, CLUTCHES, BRAKES, SAFETY BELTS, ALL FOR MOTOR LAND VEHICLES, STRUCTURAL PARTS FOR MOTOR LAND VEHICLES, T-SHIRTS, SWEAT SHIRTS, POLO-SHIRTS, CAPS, WIND RESISTANT JACKETS, WATERPROOF JACKETS, PULLOVERS, COATS, SWEATERS, SHIRTS (U.S. CLS. 100, 101 AND 102).
FIRST USE 4-0-2011; IN COMMERCE 4-0-2011.



THE MARK CONSISTS OF STANDARD CHARACTERS WITHOUT CLAIM TO ANY PARTICULAR FONT, STYLE, SIZE, OR COLOR.

OWNER OF U.S. REG. NO. 3,477,124.

CLASS 3—COSMETICS AND CLEANING PREPARATIONS

FOR SUNSCREEN LOTIONS (U.S. CLS. 1, 4, 6, 50, 51 AND 52).
FIRST USE 9-13-2009; IN COMMERCE 9-13-2009.

CLASS 5—PHARMACEUTICALS

FOR OVER THE COUNTER MEDICATIONS FOR BABIES AND CHILDREN, NAMELY, MEDICATED DIAPER RASH OINTMENT; PEDIATRIC ELECTROLYTE DRINKS, PEDIATRIC NUTRITION DRINKS, NAMELY, LIQUID NUTRITIONAL SUPPLEMENTS (U.S. CLS. 6, 18, 44, 46, 51 AND 52).
FIRST USE 9-13-2009; IN COMMERCE 9-13-2009.

4,210,247. TOSHIBA MEDICAL SYSTEMS CORPORATION, TOCHIGI 324-8550, JAPAN. SN 76-709,701. PUB. 1-3-2012, FILED 5-21-2008.

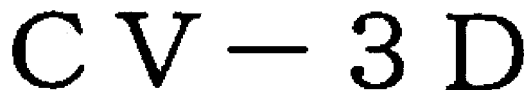

PRIORITY CLAIMED UNDER SEC. 44(D) ON JAPAN APPLICATION NO. 2008-033144, FILED 4-28-2008.

CLASS 9—ELECTRICAL AND SCIENTIFIC APPARATUS

FOR IMAGE GENERATING COMPUTER PROGRAMS FOR X-RAY CARDIOVASCULAR DIAGNOSTIC SYSTEMS FOR MEDICAL USE, QUANTITATIVE CORONARY ARTERIOGRAPHY COMPUTER PROGRAMS FOR X-RAY CARDIOVASCULAR DIAGNOSTIC SYSTEMS FOR MEDICAL USE (U.S. CLS. 21, 23, 26, 36 AND 38).
FIRST USE 1-25-2006; IN COMMERCE 1-25-2006.

CLASS 10—MEDICAL APPARATUS

FOR X-RAY DIAGNOSTIC APPARATUS FOR MEDICAL USE, NAMELY, X-RAY CARDIOVASCULAR DIAGNOSTIC SYSTEMS FOR MEDICAL USE, IMAGE GENERATING SYSTEMS FOR X-RAY CARDIOVASCULAR DIAGNOSTIC SYSTEMS FOR MEDICAL USE, AND QUANTITATIVE CORONARY ARTERIOGRAPHY SYSTEMS FOR X-RAY CARDIOVASCULAR DIAGNOSTIC SYSTEMS FOR MEDICAL USE (U.S. CLS. 26, 39 AND 44).
FIRST USE 1-25-2006; IN COMMERCE 1-25-2006.

4,210,248. SAFEWAY INC., PLEASANTON, CA. SN 76-978,915. PUB. 3-17-2009, FILED 11-21-2006.



THE COLOR(S) GREEN AND WHITE IS/ARE CLAIMED AS A FEATURE OF THE MARK.

THE COLOR GREEN APPEARS IN THE BACKGROUND OF THE ENTIRE MARK, AND IN THE WORDING "EATING" AND "UNITING FLAVOR & NUTRITION"; THE COLOR WHITE APPEARS IN THE WORDING "RIGHT".

CLASS 29—MEATS AND PROCESSED FOODS

FOR MEATS; POULTRY; PROCESSED VEGETABLES; FROZEN, PREPARED OR PACKAGED ENTREES AND MEALS CONSISTING PRIMARILY OF MEAT, POULTRY OR VEGETABLES; DAIRY PRODUCTS EXCLUDING ICE CREAM, ICE MILK AND FROZEN YOGURT; DAIRY-BASED BEVERAGES; FISH NOT LIVE; FRUIT-BASED ORGANIC FOOD BARS, SNACK FOODS AND SPREADS; POTATO CRISPS; SNACK DIPS EXCLUDING SALSA AND OTHER SAUCES USED AS DIPS; SOUPS; HUMMUS; SOY, TURKEY AND VEGGIE BURGER PATTIES; CHILI (U.S. CL. 46).

FIRST USE 9-13-2009; IN COMMERCE 9-13-2009.

CLASS 32—LIGHT BEVERAGES

FOR FRUIT BEVERAGES AND JUICES; WATER BEVERAGES (U.S. CLS. 45, 46 AND 48).
FIRST USE 9-13-2009; IN COMMERCE 9-13-2009.

4,210,252. THE BRITISH BROADCASTING CORPORATION, LONDON, UNITED KINGDOM. SN 77-274,524. PUB. 3-31-2009, FILED 9-7-2007.



NO CLAIM IS MADE TO THE EXCLUSIVE RIGHT TO USE "PLANET EARTH", APART FROM THE MARK AS SHOWN.

CLASS 9—ELECTRICAL AND SCIENTIFIC APPARATUS

FOR AUDIO, VIDEO, STILL AND MOVING IMAGES, AND DATA RECORDINGS IN COMPRESSED AND UNCOMPRESSED FORM, NAMELY, DVDS FEATURING MUSIC, ENTERTAINMENT IN THE NATURE OF FILMS AND TELEVISION PROGRAMS, AND INSTRUCTION, AND EDUCATION RELATING TO NATURAL HISTORY AND THE ENVIRONMENT; COMPUTER, ELECTRONIC AND VIDEO GAMES PROGRAMS AND EQUIPMENT, NAMELY, DISCS, DVDS (U.S. CLS. 21, 23, 26, 36 AND 38).

FIRST USE 9-0-2008; IN COMMERCE 9-0-2008.

CLASS 16—PAPER GOODS AND PRINTED MATTER

FOR PRINTED PUBLICATIONS, NAMELY, BOOKS PROVIDING INSTRUCTION, ENTERTAINMENT, AND EDUCATION RELATING TO THE ENVIRONMENT; POSTERS; GREETINGS CARDS; CALENDARS (U.S. CLS. 2, 5, 22, 23, 29, 37, 38 AND 50).

FIRST USE 6-0-2010; IN COMMERCE 6-0-2010.

CLASS 18—LEATHER GOODS

FOR BAGS AND ACCESSORIES, NAMELY, WHEELED BACKPACKS, MESSENGER BAGS, TOTE BAGS, AND LUGGAGE (U.S. CLS. 1, 2, 3, 22 AND 41).

FIRST USE 12-0-2010; IN COMMERCE 12-0-2010.

CLASS 28—TOYS AND SPORTING GOODS

FOR TOYS, GAMES AND PLAYTHINGS, NAMELY, PLUSH TOYS, JIGSAW PUZZLES, AND BOARD GAMES (U.S. CLS. 22, 23, 38 AND 50).

FIRST USE 12-0-2007; IN COMMERCE 12-0-2007.

4,210,254. ORACLE AMERICA, INC., REDWOOD SHORES, CA. SN 77-322,393. PUB. 9-15-2009, FILED 11-6-2007.

JAVAFX

THE MARK CONSISTS OF STANDARD CHARACTERS WITHOUT CLAIM TO ANY PARTICULAR FONT, STYLE, SIZE, OR COLOR.

PRIORITY CLAIMED UNDER SEC. 44(D) ON ERP N CMNTY TM OFC APPLICATION NO. 5878616, FILED 5-7-2007.

OWNER OF U.S. REG. NOS. 1,516,265, 2,178,784, AND 2,921,013.

CLASS 9—ELECTRICAL AND SCIENTIFIC APPARATUS

FOR COMPUTER PROGRAMS FOR USE IN COMPUTER NETWORKING; COMPUTER PROGRAMS FOR USE IN COMPUTER EMULATION; COMPUTER PROGRAMS FOR CREATING GRAPHICAL INTERFACES; COMPUTER PROGRAMS FOR USE IN THE DEVELOPMENT OF COMPUTER PROGRAMS, PROGRAMMING LANGUAGES, TOOLKITS AND COMPILERS; COMPUTER PROGRAMS FOR USE IN DEVELOPING, COMPILING AND EXECUTING OTHER COMPUTER PROGRAMS ON COMPUTERS, COMPUTER NETWORKS, AND GLOBAL COMMUNICATIONS NETWORKS; COMPUTER PROGRAMS FOR USE IN NAVIGATING, BROWSING, TRANSFERRING INFORMATION, AND DISTRIBUTING AND VIEWING OTHER COMPUTER PROGRAMS ON COMPUTERS, COMPUTER NETWORKS AND GLOBAL COMMUNICATIONS NETWORKS; COMPUTER PROGRAMS FOR RECORDING, PROCESSING, RECEIVING, REPRODUCING, TRANSMITTING, MODIFYING, COMPRESSING, DECOMPRESSING, BROADCASTING, MERGING, AND/OR ENHANCING SOUND, VIDEO, IMAGES, GRAPHICS, AND/OR DATA; COMPUTER OPERATING SYSTEM PROGRAMS; COMPUTER UTILITY PROGRAMS; COMPUTER PROGRAMS FOR USE WITH COMPUTER SERVERS; AND INSTRUCTIONAL MANUALS IN ELECTRONIC FORMAT SOLD WITH THE AFOREMENTIONED GOODS (U.S. CLS. 21, 23, 26, 36 AND 38).

FIRST USE 12-4-2008; IN COMMERCE 12-4-2008.

CLASS 41—EDUCATION AND ENTERTAINMENT

FOR EDUCATION SERVICES, NAMELY, PROVIDING CLASSES, WORKSHOPS AND SEMINARS IN THE FIELDS OF COMPUTERS, COMPUTER SOFTWARE, COMPUTER NETWORKS, INFORMATION TECHNOLOGY, AND GLOBAL COMPUTER NETWORK TECHNOLOGY, AND RELATED SERVICES; PROVIDING OF TRAINING IN THE FIELDS OF COMPUTERS, COMPUTER SOFTWARE, COMPUTER NETWORKS, INFORMATION TECHNOLOGY, AND GLOBAL COMPUTER NETWORK TECHNOLOGY, AND RELATED SERVICES (U.S. CLS. 100, 101 AND 107).

FIRST USE 12-4-2008; IN COMMERCE 12-4-2008.

CLASS 42—SCIENTIFIC AND COMPUTER SERVICES

FOR TECHNICAL CONSULTATION IN THE TECHNOLOGY FIELDS OF COMPUTER SOFTWARE, COMPUTER NETWORKS, AND GLOBAL COMMUNICATION NETWORKS; COMPUTER CONSULTATION SERVICES; DESIGN AND DEVELOPMENT OF COMPUTER SOFTWARE; COMPUTER PROGRAMMING; PROVIDING ONLINE INFORMATION AND NEWS IN THE FIELD OF COMPUTER SOFTWARE AND INFORMATION TECHNOLOGY (U.S. CLS. 100 AND 101).

FIRST USE 12-4-2008; IN COMMERCE 12-4-2008.

4,210,255. HOWCAST MEDIA, INC., NEW YORK, NY. SN 77-324,011. PUB. 3-31-2009, FILED 11-7-2007.

**CLASS 9—ELECTRICAL AND SCIENTIFIC APPARATUS**

FOR DOWNLOADABLE VIDEOS FEATURING EDUCATIONAL AND ENTERTAINMENT CONTENT ON TOPICS OF GENERAL INTEREST IN THE FIELDS OF ARTS AND MEDIA, BUSINESS AND FINANCE, CAREERS AND EDUCATION, CARS AND TRANSPORTATION, CRAFTS AND HOBBIES, ENVIRONMENT, FIRST AID AND SAFETY, FOOD AND DRINK, GAMES, HEALTH AND NUTRITION, HOLIDAYS AND CELEBRATIONS, HOUSE AND GARDEN, KIDS, LANGUAGE AND REFERENCE, MIND AND BODY, PARENTING AND FAMILY, PERFORMING ARTS, PERSONAL CARE AND STYLE, PETS, RELIGION AND SPIRITUALITY, SEX AND RELATIONSHIPS, SPORTS AND FITNESS, TECHNOLOGY, TEENS, OR TRAVEL (U.S. CLS. 21, 23, 26, 36 AND 38).

FIRST USE 2-6-2008; IN COMMERCE 2-6-2008.

CLASS 41—EDUCATION AND ENTERTAINMENT

FOR DEVELOPMENT OF EDUCATIONAL AND INSTRUCTIONAL MATERIALS FOR OTHERS ABOUT TOPICS OF GENERAL INTEREST, NEWS, AND DOCUMENTARIES ON TOPICS OF GENERAL INTEREST IN THE FIELDS OF ARTS AND MEDIA, BUSINESS AND FINANCE, CAREERS AND EDUCATION, CARS AND TRANSPORTATION, CRAFTS AND HOBBIES, ENVIRONMENT, FIRST AID AND SAFETY, FOOD AND DRINK, GAMES, HEALTH AND NUTRITION, HOLIDAYS AND CELEBRATIONS, HOUSE AND GARDEN, KIDS, LANGUAGE AND REFERENCE, MIND AND BODY, PARENTING AND FAMILY, PERFORMING ARTS, PERSONAL CARE AND STYLE, PETS, RELIGION AND SPIRITUALITY, SEX AND RELATIONSHIPS, SPORTS AND FITNESS, TECHNOLOGY, TEENS, OR TRAVEL; PROVIDING A WEBSITE THAT FEATURES INFORMAL INSTRUCTION ON CREATING, COLLABORATING, AND DEVELOPING VIDEOS; EDUCATIONAL SERVICES, NAMELY, AN ON-LINE SOCIAL NETWORK FOR USERS TO CREATE, COLLABORATE AND DEVELOP THEIR OWN EDUCATIONAL AND ENTERTAINMENT VIDEOS; MULTIMEDIA PUBLISHING FOR OTHERS OF ONLINE ELECTRONIC PUBLICATIONS; MULTI-MEDIA PRODUCTION SERVICES, NAMELY, PRODUCTION OF MUSIC, VIDEOS, TELEVISION PROGRAMS, MOVIES, TRAILERS, REALITY VIDEOS, INTERVIEWS, AND DOCUMENTARIES ON TOPICS OF GENERAL INTEREST IN THE FIELDS OF ARTS AND MEDIA, BUSINESS AND FINANCE, CAREERS AND EDUCATION, CARS AND TRANSPORTATION, CRAFTS AND HOBBIES, ENVIRONMENT, FIRST AID AND SAFETY, FOOD AND DRINK, GAMES, HEALTH AND NUTRITION, HOLIDAYS AND CELEBRATIONS, HOUSE AND GARDEN, KIDS, LANGUAGE AND REFERENCE, MIND AND BODY, PARENTING AND FAMILY, PERFORMING ARTS, PERSONAL CARE AND STYLE, PETS, RELIGION AND SPIRITUALITY, SEX AND RELATIONSHIPS, SPORTS AND FITNESS, TECHNOLOGY, TEENS, OR TRAVEL; EDITING OF

AUDIO AND VIDEO CONTENT; AUDIO AND DIGITAL VIDEO FILM PRODUCTION (U.S. CLS. 100, 101 AND 107).

FIRST USE 2-6-2008; IN COMMERCE 2-6-2008.

4,210,256. HOWCAST MEDIA, INC., NEW YORK, NY. SN 77-324,028. PUB. 3-31-2009, FILED 11-7-2007.



CLASS 9—ELECTRICAL AND SCIENTIFIC APPARATUS

FOR DOWNLOADABLE VIDEOS FEATURING EDUCATIONAL AND ENTERTAINMENT CONTENT ON TOPICS OF GENERAL INTEREST IN THE FIELDS OF ARTS AND MEDIA, BUSINESS AND FINANCE, CAREERS AND EDUCATION, CARS AND TRANSPORTATION, CRAFTS AND HOBBIES, ENVIRONMENT, FIRST AID AND SAFETY, FOOD AND DRINK, GAMES, HEALTH AND NUTRITION, HOLIDAYS AND CELEBRATIONS, HOUSE AND GARDEN, KIDS, LANGUAGE AND REFERENCE, MIND AND BODY, PARENTING AND FAMILY, PERFORMING ARTS, PERSONAL CARE AND STYLE, PETS, RELIGION AND SPIRITUALITY, SEX AND RELATIONSHIPS, SPORTS AND FITNESS, TECHNOLOGY, TEENS, OR TRAVEL (U.S. CLS. 21, 23, 26, 36 AND 38).

FIRST USE 2-6-2008; IN COMMERCE 2-6-2008.

CLASS 41—EDUCATION AND ENTERTAINMENT

FOR DEVELOPMENT OF EDUCATIONAL AND INSTRUCTIONAL MATERIALS FOR OTHERS ABOUT TOPICS OF GENERAL INTEREST, NEWS, AND DOCUMENTARIES ON TOPICS OF GENERAL INTEREST IN THE FIELDS OF ARTS AND MEDIA, BUSINESS AND FINANCE, CAREERS AND EDUCATION, CARS AND TRANSPORTATION, CRAFTS AND HOBBIES, ENVIRONMENT, FIRST AID AND SAFETY, FOOD AND DRINK, GAMES, HEALTH AND NUTRITION, HOLIDAYS AND CELEBRATIONS, HOUSE AND GARDEN, KIDS, LANGUAGE AND REFERENCE, MIND AND BODY, PARENTING AND FAMILY, PERFORMING ARTS, PERSONAL CARE AND STYLE, PETS, RELIGION AND SPIRITUALITY, SEX AND RELATIONSHIPS, SPORTS AND FITNESS, TECHNOLOGY, TEENS, OR TRAVEL; PROVIDING A WEBSITE THAT FEATURES INFORMAL INSTRUCTION ON CREATING, COLLABORATING, AND DEVELOPING VIDEOS; EDUCATIONAL SERVICES, NAMELY, AN ON-LINE SOCIAL NETWORK FOR USERS TO CREATE, COLLABORATE AND DEVELOP THEIR OWN EDUCATIONAL AND ENTERTAINMENT VIDEOS; MULTIMEDIA PUBLISHING FOR OTHERS OF ONLINE ELECTRONIC PUBLICATIONS; MULTI-MEDIA PRODUCTION SERVICES, NAMELY, PRODUCTION OF MUSIC, VIDEOS, TELEVISION PROGRAMS, MOVIES, TRAILERS, REALITY VIDEOS, INTERVIEWS, AND DOCUMENTARIES ON TOPICS OF GENERAL INTEREST IN THE FIELDS OF ARTS AND MEDIA, BUSINESS AND FINANCE, CAREERS AND EDUCATION, CARS AND TRANSPORTATION, CRAFTS AND HOBBIES, ENVIRONMENT, FIRST AID AND SAFETY, FOOD AND DRINK, GAMES, HEALTH AND NUTRITION, HOLIDAYS AND CELEBRATIONS, HOUSE AND GARDEN, KIDS, LANGUAGE AND REFERENCE, MIND AND BODY, PARENTING AND FAMILY, PERFORMING ARTS, PERSONAL CARE AND STYLE, PETS, RELIGION AND SPIRITUALITY, SEX AND RELATIONSHIPS, SPORTS AND FITNESS, TECHNOLOGY, TEENS, OR TRAVEL; EDITING OF AUDIO AND VIDEO CONTENT; AUDIO AND DIGITAL VIDEO FILM PRODUCTION (U.S. CLS. 100, 101 AND 107).

FIRST USE 2-6-2008; IN COMMERCE 2-6-2008.

4,210,261. TAKASAGO INTERNATIONAL CORPORATION, ROCKLEIGH, NJ. SN 77-369,852. PUB. 5-19-2009, FILED 1-11-2008.

AROMAHYGIENE

THE MARK CONSISTS OF STANDARD CHARACTERS WITHOUT CLAIM TO ANY PARTICULAR FONT, STYLE, SIZE, OR COLOR.

CLASS 1—CHEMICALS

FOR CHEMICALS, CHEMICAL ADDITIVES, BOTANICAL EXTRACTS, FRAGRANCES AND AROMA CHEMICALS FOR USE IN MANUFACTURING PHARMACEUTICAL PREPARATIONS, DERMATOLOGICAL PREPARATIONS, PERSONAL CARE PRODUCTS, HOUSEHOLD PRODUCTS, ODORANTS, DEODORANTS, INDUSTRIAL PRODUCTS, CLEANING PRODUCTS, SOAPS, PERFUMES, LOTIONS, COSMETICS, AND CANDLES; CHEMICALS, CHEMICAL ADDITIVES, BOTANICAL EXTRACTS, FLAVOR CHEMICALS AND AROMA CHEMICALS FOR USE IN THE MANUFACTURE AND PRESERVATION OF BEVERAGES, FOODSTUFFS, FOOD INGREDIENTS, FOODS, FOOD EXTRACTS, NATURAL, ARTIFICIAL AND SYNTHETIC FLAVORING AND CONCENTRATES FOR FOODS (U.S. CLS. 1, 5, 6, 10, 26 AND 46).

FIRST USE 8-3-2012; IN COMMERCE 8-3-2012.

CLASS 3—COSMETICS AND CLEANING PREPARATIONS

FOR ESSENTIAL OILS; COSMETIC AND CLEANING PREPARATIONS, NAMELY, PERFUMES, ESSENTIAL OILS FOR PERSONAL USE, DENTIFRICES, SUNSCREEN PREPARATIONS, SKIN SOAP, PERSONAL DEODORANTS, HAIR AND SKIN EMOLLIENTS, HAIR SHAMPOOS AND CONDITIONERS, SKIN CLEANSING LOTION, SKIN CONDITIONERS, AND SKIN CREAM FOR COLORING AND CONDITIONING SKIN, AND MOUTHWASHES (U.S. CLS. 1, 4, 6, 50, 51 AND 52).

FIRST USE 8-3-2012; IN COMMERCE 8-3-2012.

CLASS 5—PHARMACEUTICALS

FOR PHARMACEUTICAL SUBSTANCES, NAMELY, PROPHYLACTIC PREPARATIONS FOR THE TREATMENT OF DERMATOLOGICAL CONDITIONS, DIETARY SUPPLEMENTS, ALL PURPOSE DISINFECTANTS, MEDICATED LOTIONS FOR TREATMENT OF DERMATOLOGICAL CONDITIONS, AND MEDICATED SKIN CARE PREPARATIONS (U.S. CLS. 6, 18, 44, 46, 51 AND 52).

FIRST USE 8-3-2012; IN COMMERCE 8-3-2012.

4,210,266. POLYPLASTICS CO., LTD., TOKYO, JAPAN. SN 77-422,017. PUB. 5-12-2009, FILED 3-14-2008.



THE NON-LATIN CHARACTERS IN THE MARK TRANSLITERATE TO "JURAFAYDO" AND THIS HAS NO MEANING IN A FOREIGN LANGUAGE.

CLASS 1—CHEMICALS

FOR UNPROCESSED PLASTICS (U.S. CLS. 1, 5, 6, 10, 26 AND 46).
FIRST USE 7-23-2012; IN COMMERCE 7-23-2012.

CLASS 17—RUBBER GOODS

FOR SEMI-PROCESSED PLASTICS (U.S. CLS. 1, 5, 12, 13, 35 AND 50).
FIRST USE 7-23-2012; IN COMMERCE 7-23-2012.

4,210,268. SCIENTIFIC FOOD SOLUTIONS, LLC, FAIRFIELD, CA. SN 77-445,589. PUB. 4-21-2009, FILED 4-10-2008.

ALKEMY

THE MARK CONSISTS OF STANDARD CHARACTERS WITHOUT CLAIM TO ANY PARTICULAR FONT, STYLE, SIZE, OR COLOR.

CLASS 5—PHARMACEUTICALS

FOR VITAMIN ENRICHED SPORTS DRINKS (U.S. CLS. 6, 18, 44, 46, 51 AND 52).
FIRST USE 3-5-2012; IN COMMERCE 3-5-2012.

CLASS 29—MEATS AND PROCESSED FOODS

FOR PROCESSED GARLIC FOR USE IN THE MANUFACTURE OF NUTRITIONAL SUPPLEMENTS (U.S. CL. 46).
FIRST USE 3-5-2012; IN COMMERCE 3-5-2012.

4,210,270. AMERICAN TACTICAL IMPORTS INC., ROCHESTER, NY. SN 77-453,340. PUB. 7-26-2011, FILED 4-21-2008.

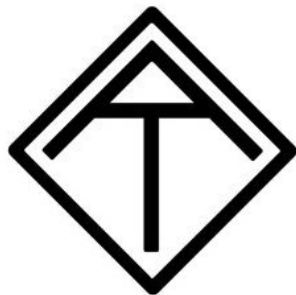

AMERICAN TACTICAL

NO CLAIM IS MADE TO THE EXCLUSIVE RIGHT TO USE "AMERICAN TACTICAL", APART FROM THE MARK AS SHOWN.

THE MARK CONSISTS OF A DIAMOND SHAPED BORDER THAT IS THE SAME LENGTH ON ALL SIDES WITH THE LETTERS "A" & "T" IN THE CENTER OF THE DIAMOND SHAPE. THE TWO SIDES OF THE LETTER "A" ARE PARALLEL TO THE UPPER RIGHT AND LEFT SLOPED SIDES OF THE DIAMOND WITH THE HORIZON-

TAL LINE OF THE LETTER "A" THAT CONNECTS THE TWO SIDES FORMING THE TOP LINE OF THE LETTER "T" AND HAVING A PERPENDICULAR LINE STARTING IN THE CENTER MOVING DOWN TOWARDS THE BOTTOM CORNER OF THE DIAMOND BORDER FORMING THE LETTER "T" AND STOPS SHORT OF MAKING CONTACT WITH THE BOTTOM CORNER OF THE DIAMOND BELOW THE MARK IS THE WORDS "AMERICAN TACTICAL".

CLASS 8—HAND TOOLS

FOR BAGEL SLICERS; BIODEGRADABLE CUTLERY, NAMELY, KNIVES, FORKS AND SPOONS; BLADES FOR HUNTING, FISHING AND MILITARY KNIVES; BUTCHER KNIVES; CARPET KNIVES; CARVING KNIVES; CHEF KNIVES; CUTLERY, NAMELY, KNIVES; DIVING KNIVES; FISH SLICING KITCHEN KNIVES; FISHING KNIVES; FLATWARE, NAMELY, FORKS, KNIVES, AND SPOONS; FOLDING KNIVES; HAND TOOLS FOR USE IN CARVING OR DECORATING PUMPKINS, MINI-PUMPKINS, GOURDS, AND OTHER FRUITS AND VEGETABLES, NAMELY, KNIVES, SAWS, SCOOPS, CHISELS AND DRILLS; HAND TOOLS, NAMELY, PUTTY KNIVES; HOUSEHOLD KNIVES; HUNTING KNIVES; JACK KNIVES; JAPANESE CHOPPING KITCHEN KNIVES; KNIVES; KNIVES FOR HOBBY USE; KNIVES MADE OF PRECIOUS METAL; KNIVES, FORKS AND SPOONS; LEATHER SHEATHS FOR KNIVES; MULTI-FUNCTION HAND TOOLS COMPRISED OF KNIVES, SAWS, SCREWDRIVERS, PLIERS; PALETTE KNIVES; PARING KNIVES; PEN KNIVES; POCKET KNIVES; PRUNING KNIVES; PUTTY KNIVES; RAZOR KNIVES; SCALING KNIVES; SHARPENING WHEELS FOR KNIVES AND BLADES; SIDE ARMS, NOT INCLUDING FIREARMS, NAMELY, HUNTING KNIVES; SPORT KNIVES; STAINLESS STEEL TABLE KNIVES, FORKS AND SPOONS; STERLING SILVER TABLE KNIVES; STERLING SILVER TABLE KNIVES, FORKS AND SPOONS; TABLE KNIVES; TABLEWARE NAMELY, KNIVES, FORKS AND SPOONS; TABLEWARE, NAMELY, KNIVES, FORKS AND SPOONS MADE OF PRECIOUS METAL; THIN-BLADED KITCHEN KNIVES; THROWING KNIVES; UTILITY KNIVES; VEGETABLE KNIVES; WHITTLING KNIVES; WORKING KNIVES (U.S. CLS. 23, 28 AND 44).
FIRST USE 8-1-2011; IN COMMERCE 11-1-2011.

CLASS 13—FIREARMS

FOR AMMUNITION FOR FIREARMS; BARREL REFLECTORS FOR FIREARMS; BREECHES OF FIREARMS; CASE COVERS FOR FIREARMS; CLEANING IMPLEMENTS FOR FIREARMS, NAMELY, CLEANING AND MAINTENANCE KITS COMPRISED OF BRUSHES, CLOTHS, PATCHES AND RODS; CLEANING RODS FOR FIREARMS; COVERS FOR FIREARMS; FIREARM HAND GUARDS; FIREARM SIGHTS; FIREARM SLINGS; FIREARMS; FIREARMS, NAMELY, MORTARS; FORESIGHTS FOR FIREARMS; GUNSIGHTS FOR FIREARMS; MORTARS; MUZZLE-LOADING FIREARMS; NON-TELESCOPIC GUN SIGHTS FOR FIREARMS; POWDER FLASKS FOR FIREARMS; SIGHT PROTECTORS FOR FIREARMS; SIGHTS, NAMELY, OPEN SIGHTS FOR USE ON FIREARMS; SILENCERS FOR FIREARMS; SLING STRAPS FOR FIREARMS; SUPPLEMENTAL CHAMBERS FOR FIREARMS; TRIPODS AND STANDS FOR FIREARMS (U.S. CLS. 2 AND 9).
FIRST USE 8-1-2011; IN COMMERCE 7-1-2012.

4,210,273. THE INSIGHTS GROUP LIMITED, DUNDEE, UNITED KINGDOM. SN 77-464,322. PUB. 9-1-2009, FILED 5-2-2008.



THE MARK CONSISTS OF STYLIZED CIRCLE WITH VARIOUS SHADED BANDS TO THE LEFT OF THE WORDS "INSIGHTS DISCOVERY".

CLASS 9—ELECTRICAL AND SCIENTIFIC APPARATUS

FOR DOWNLOADABLE ELECTRONIC PUBLICATIONS IN THE NATURE OF PERIODICAL PUBLICATIONS, MAGAZINES, BOOKS AND NEWSLETTERS IN THE FIELD OF EMPLOYEE, PERSONAL AND ORGANIZATIONAL ASSESSMENT AND/OR DEVELOPMENT, AND COMPUTER SOFTWARE FOR USE IN EMPLOYEE AND PERSONAL ASSESSMENT AND ORGANIZATIONAL DEVELOPMENT; ALL THE FOREMENTIONED IN THE FIELD OF EMPLOYEE, PERSONAL, TEAM, LEADERSHIP AND ORGANIZATIONAL DEVELOPMENT (U.S. CLS. 21, 23, 26, 36 AND 38).

FIRST USE 4-0-2006; IN COMMERCE 4-0-2006.

CLASS 16—PAPER GOODS AND PRINTED MATTER

FOR PRINTED MATTER IN THE NATURE OF PERIODICAL PUBLICATIONS, MAGAZINES, BOOKS, BOOKLETS AND CATALOGUES IN THE FIELD OF EMPLOYEE, PERSONAL AND ORGANIZATIONAL ASSESSMENT AND/OR DEVELOPMENT, BLANK CARDS, BUSINESS CARDS, STATIONERY, OFFICE REQUISITES IN THE NATURE OF FOLDERS, CALENDARS, DIARIES, NOTEPADS, PENS, PENCILS, ERASERS, PENCIL SHARPENERS, PENCIL CASES, RULERS, BOXES FOR PENS, BOOK MARKERS, DRAWING MATERIALS FOR BLACKBOARDS, PRINTED INSTRUCTIONAL, EDUCATIONAL TEACHING MATERIALS IN THE FIELD OF EMPLOYEE, PERSONAL AND ORGANIZATIONAL ASSESSMENT AND/OR DEVELOPMENT (U.S. CLS. 2, 5, 22, 23, 29, 37, 38 AND 50).

FIRST USE 4-0-2006; IN COMMERCE 4-0-2006.

CLASS 35—ADVERTISING AND BUSINESS

FOR BUSINESS CONSULTATION, BUSINESS MANAGEMENT CONSULTING IN THE FIELD OF TEAM DEVELOPMENT, PROVIDING CAREER CONSULTATION AND CONFLICT MANAGEMENT; PSYCHOLOGICAL TESTING FOR THE SELECTION OF PERSONNEL, PSYCHOMETRIC TESTING SERVICES, NAMELY, DEVELOPMENT AND APPLICATION OF STANDARDIZED, STATISTICALLY BASED PROTOCOLS FOR THE QUANTITATIVE MEASUREMENT, PROFILING AND ANALYSIS OF COGNITIVE AND PROBLEM SOLVING ABILITY, PSYCHOLOGICAL AND PERSONALITY TRAITS, OCCUPATIONAL COMPETENCIES, APTITUDE AND WORK PREFERENCES, ALL FOR USE IN THE RECRUITMENT, SELECTION, PLACEMENT, RETENTION AND PROFESSIONAL DEVELOPMENT AND ENHANCEMENT OF PERSONNEL, AND BUSINESS MANAGEMENT CONSULTING WITH RELATION TO STRATEGY AND SALES, PARTICULARLY SPECIALIZING IN THE USE OF ANALYTIC AND STATISTIC MODELS FOR THE UNDERSTANDING AND PREDICTING OF CONSUMERS, BUSINESSES AND MARKET TRENDS AND ACTIONS (U.S. CLS. 100, 101 AND 102).

FIRST USE 2-26-1998; IN COMMERCE 2-26-1998.

CLASS 41—EDUCATION AND ENTERTAINMENT

FOR ORGANIZATION AND ARRANGING OF EDUCATIONAL SEMINARS, WORKSHOPS, TRAINING SESSIONS, CONFERENCES, SYMPOSIUMS, CONGRESSES AND COLLOQUIUMS, PROVIDING EDUCATIONAL INFORMATION IN THE FIELD OF EMPLOYEE, PERSONAL AND ORGANIZATIONAL ASSESSMENT AND/OR DEVELOPMENT, PUBLICATION OF BOOKS AND TEXTS, ALL THE AFOREMENTIONED IN THE FIELD OF EMPLOYEE, PERSONAL AND ORGANIZATIONAL ASSESSMENT AND/OR DEVELOPMENT, BUT NOT PERSONAL RELATIONSHIP, AND BUSINESS TRAINING; ALL THE FOREMENTIONED IN THE FIELD OF EMPLOYEE, PERSONAL, TEAM, LEADERSHIP AND ORGANIZATIONAL DEVELOPMENT (U.S. CLS. 100, 101 AND 107).

FIRST USE 2-26-1998; IN COMMERCE 2-26-1998.

4,210,275. MICHAELS STORES PROCUREMENT COMPANY, INC., IRVING, TX. SN 77-470,473. PUB. 4-7-2009, FILED 5-9-2008.

LOOPS & THREADS

THE MARK CONSISTS OF STANDARD CHARACTERS WITHOUT CLAIM TO ANY PARTICULAR FONT, STYLE, SIZE, OR COLOR.

NO CLAIM IS MADE TO THE EXCLUSIVE RIGHT TO USE "THREADS", APART FROM THE MARK AS SHOWN.

CLASS 16—PAPER GOODS AND PRINTED MATTER

FOR CROSS-STITCH AND EMBROIDERY KITS CONSISTING OF EMBROIDERY DESIGN PATTERNS, QUILT PATTERNS AND QUILT FABRIC (U.S. CLS. 2, 5, 22, 23, 29, 37, 38 AND 50).

FIRST USE 2-0-2010; IN COMMERCE 2-0-2010.

CLASS 26—FANCY GOODS

FOR NEEDLEPOINT KITS CONSISTING OF NEEDLES, THREAD AND PATTERNS; KNITTING, CROCHET AND EMBROIDERY NEEDLES; HOOK AND LOOP FASTENING TAPE; KNITTING IMPLEMENTS, NAMELY, STITCH MARKERS, STITCH GAUGES, STITCH HOLDERS, YARN BOBBINS; NEEDLE THREADERS; PIN AND NEEDLE CUSHIONS; RUBBER POINT PROTECTORS FOR KNITTING NEEDLES; CROCHET HOOKS; QUILTING AND SEWING MATERIALS AND SUPPLIES, NAMELY, FINGER GUARDS, HOOPS AND KITS USED TO MAKE NEEDLEWORK COMPRISING NEEDLES, THREAD AND PATTERNS; NEEDLE CASES NOT OF PRECIOUS METAL; SEWING BASKETS AND BOXES (U.S. CLS. 37, 39, 40, 42 AND 50).

FIRST USE 2-0-2010; IN COMMERCE 2-0-2010.

4,210,276. SEIDMAN, DOV, LOS ANGELES, CA. SN 77-470,734. PUB. 4-14-2009, FILED 5-9-2008.

HOW

THE MARK CONSISTS OF STANDARD CHARACTERS WITHOUT CLAIM TO ANY PARTICULAR FONT, STYLE, SIZE, OR COLOR.

CLASS 16—PAPER GOODS AND PRINTED MATTER

FOR PUBLICATIONS, NAMELY, HAND-OUTS IN THE FIELDS OF LAW, ETHICS, BUSINESS REGULATORY COMPLIANCE, LEGAL COMPLIANCE, BUSINESS CONDUCT AND GOVERNANCE; PRINTED CORRESPONDENCE COURSE MATERIALS IN THE FIELD OF LAW, ETHICS, BUSINESS REGULATORY COMPLIANCE, LEGAL COMPLIANCE, BUSINESS CONDUCT AND GOVERNANCE; COURSE MATERIALS IN THE FIELDS OF LAW, ETHICS, BUSINESS REGULATORY COMPLIANCE, LEGAL COMPLIANCE, BUSINESS CONDUCT AND GOVERNANCE (U.S. CLS. 2, 5, 22, 23, 29, 37, 38 AND 50).

FIRST USE 9-29-2011; IN COMMERCE 9-29-2011.

CLASS 41—EDUCATION AND ENTERTAINMENT

FOR EDUCATIONAL SERVICES, NAMELY, CONDUCTING CLASSES, SEMINARS, CONFERENCES AND WORKSHOPS IN THE FIELDS OF LAW, ETHICS, BUSINESS REGULATORY COMPLIANCE, LEGAL COMPLIANCE, BUSINESS CONDUCT AND GOVERNANCE AND DISTRIBUTION OF COURSE MATERIAL IN CONNECTION THEREWITH; PROVIDING ON-LINE TRAINING COURSES, SEMINARS, WORKSHOPS IN THE FIELDS OF LAW, ETHICS, BUSINESS REGULATORY COMPLIANCE, LEGAL COMPLIANCE, BUSINESS CONDUCT AND GOVERNANCE (U.S. CLS. 100, 101 AND 107).

FIRST USE 9-21-2011; IN COMMERCE 9-21-2011.

4,210,286. SILVESTRE LABS QUIMICA E FARMACEUTICA LTDA., RIO DE JANEIRO, R.J., BRAZIL. SN 77-499,701. PUB. 4-28-2009, FILED 6-16-2008.



NO CLAIM IS MADE TO THE EXCLUSIVE RIGHT TO USE "GRAFT", APART FROM THE MARK AS SHOWN.

THE MARK CONSISTS OF THE WORDS "EXTRA GRAFT" IN BLACK WITH A BLACK LINE ABOVE AND BELOW THIS WORDING TO THE LEFT OF AND IMMEDIATELY ADJACENT TO THE LETTER NUMBER COMBINATION "XG-13" IN WHITE ALL IN CAPITAL LETTERS OVER A BLACK RECTANGULAR BACKGROUND.

CLASS 9—ELECTRICAL AND SCIENTIFIC APPARATUS

FOR CELLULAR PROLIFERATION MATRIX FOR CULTIVATION OF BIOLOGICAL CELLS (U.S. CLS. 21, 23, 26, 36 AND 38).

FIRST USE 10-21-2009; IN COMMERCE 6-18-2012.

CLASS 10—MEDICAL APPARATUS

FOR BIOMATERIAL, NAMELY, BONE SUBSTITUTES AND BONE GRAFT FOR ODONTOLOGICAL AND ORTHOPEDIC APPLICATIONS; ARTIFICIAL LIMBS, EYES AND TEETH; SUTURE MATERIALS (U.S. CLS. 26, 39 AND 44).

FIRST USE 10-21-2009; IN COMMERCE 6-18-2012.

4,210,287. PAPA BEAR ENTERPRISES, LLC, WILMINGTON, DE. SN 77-499,758. PUB. 11-11-2008, FILED 6-16-2008.

GEORGE HALAS

THE MARK CONSISTS OF STANDARD CHARACTERS WITHOUT CLAIM TO ANY PARTICULAR FONT, STYLE, SIZE, OR COLOR.

THE NAME "GEORGE HALAS" DOES NOT IDENTIFY A LIVING INDIVIDUAL.

CLASS 9—ELECTRICAL AND SCIENTIFIC APPARATUS

FOR MOUSE PADS (U.S. CLS. 21, 23, 26, 36 AND 38).

FIRST USE 7-11-2011; IN COMMERCE 7-11-2011.

CLASS 16—PAPER GOODS AND PRINTED MATTER

FOR PENS, NOTEBOOKS (U.S. CLS. 2, 5, 22, 23, 29, 37, 38 AND 50).

FIRST USE 7-11-2011; IN COMMERCE 7-11-2011.

CLASS 25—CLOTHING

FOR SHIRTS; T-SHIRTS; JERSEYS; HATS; VISORS (U.S. CLS. 22 AND 39).

FIRST USE 7-11-2011; IN COMMERCE 7-11-2011.

CLASS 28—TOYS AND SPORTING GOODS

FOR FOOTBALLS (U.S. CLS. 22, 23, 38 AND 50).

FIRST USE 7-11-2011; IN COMMERCE 7-11-2011.

4,210,288. KCD IP, LLC, HOFFMAN ESTATES, IL. SN 77-503,381. PUB. 5-12-2009, FILED 6-19-2008.



OWNER OF U.S. REG. NOS. 517,739, 3,470,307, AND OTHERS.

NO CLAIM IS MADE TO THE EXCLUSIVE RIGHT TO USE "PRO", APART FROM THE MARK AS SHOWN.

THE MARK CONSISTS OF A ROUNDED SQUARE SHAPE DIVIDED BY TWO WAVY HORIZONTAL LINES TO THE LEFT OF THE WORDING "KENMORE PRO". THE ENTIRE MARK IS IN A ROUNDED RECTANGULAR SHAPED CARRIER.

CLASS 7—MACHINERY

FOR DISHWASHING MACHINES; REPAIR AND REPLACEMENT PARTS FOR DISHWASHERS (U.S. CLS. 13, 19, 21, 23, 31, 34 AND 35).

FIRST USE 10-0-2006; IN COMMERCE 10-0-2006.

CLASS 11—ENVIRONMENTAL CONTROL APPARATUS

FOR DOMESTIC AND COMMERCIAL COOKING OVENS, GAS AND ELECTRIC STOVES; GAS AND ELECTRIC RANGES; GAS AND ELECTRIC COOKTOPS; REFRIGERATORS; RANGE HOODS, OVEN RANGE HOODS; REPAIR AND REPLACEMENT PARTS FOR HOME APPLIANCES, NAMELY, DOMESTIC AND COMMERCIAL COOKING OVENS, REFRIGERATORS, GAS AND ELECTRIC STOVES, GAS AND ELECTRIC RANGES, AND GAS AND ELECTRIC COOKTOPS (U.S. CLS. 13, 21, 23, 31 AND 34).

FIRST USE 10-0-2006; IN COMMERCE 10-0-2006.

4,210,291. EIGEN DEVELOPMENT LTD., VANCOUVER, BC, CANADA. SN 77-515,112. PUB. 1-26-2010, FILED 7-4-2008.

MIRAPOS

THE MARK CONSISTS OF STANDARD CHARACTERS WITHOUT CLAIM TO ANY PARTICULAR FONT, STYLE, SIZE, OR COLOR.

PRIORITY CLAIMED UNDER SEC. 44(D) ON CANADA APPLICATION NO. 1399215, FILED 6-11-2008, REG. NO. TMA749364, DATED 10-2-2009, EXPIRES 10-2-2024.

CLASS 9—ELECTRICAL AND SCIENTIFIC APPARATUS

FOR COMPUTER SOFTWARE FOR TRANSACTION PROCESSING, NAMELY, ENCRYPTING AND TRANSPORTING DEBIT, CREDIT CARD AND GIFT CARD TRANSACTION INFORMATION BETWEEN MERCHANTS AND CREDIT AND DEBIT CARD PROCESSORS IN A SECURE ENVIRONMENT; COMPUTER HARDWARE (U.S. CLS. 21, 23, 26, 36 AND 38).

FIRST USE 6-11-2008; IN COMMERCE 10-19-2011.

CLASS 36—INSURANCE AND FINANCIAL

FOR TRANSACTION PROCESSING SERVICES, NAMELY, ELECTRONIC PROCESSING OF DEBIT, CREDIT CARD AND GIFT CARD TRANSACTION INFORMATION BETWEEN MERCHANTS AND CREDIT AND DEBIT CARD PROCESSORS IN A SECURE ENVIRONMENT (U.S. CLS. 100, 101 AND 102).

FIRST USE 6-11-2008; IN COMMERCE 10-19-2011.

4,210,295. DHANA, INC., MILL VALLEY, CA. SN 77-529,379. PUB. 4-21-2009, FILED 7-23-2008.

DHANA

THE MARK CONSISTS OF STANDARD CHARACTERS WITHOUT CLAIM TO ANY PARTICULAR FONT, STYLE, SIZE, OR COLOR.

THE ENGLISH TRANSLATION OF "DHANA" IN THE MARK IS TREASURES, A TERM FOR THE FOLLOWING SEVEN QUALITIES: FAITH, MORALITY, MORAL SHAME, MORAL DREAD, LEARNING, LIBERALITY, AND WISDOM.

CLASS 25—CLOTHING

FOR CHILDREN'S CLOTHES, NAMELY, T-SHIRTS, SHIRTS, DRESSES, TANK TOPS (U.S. CLS. 22 AND 39).

FIRST USE 9-8-2011; IN COMMERCE 10-26-2011.

CLASS 35—ADVERTISING AND BUSINESS

FOR ONLINE RETAIL STORE SERVICES FEATURING CLOTHING (U.S. CLS. 100, 101 AND 102).

FIRST USE 9-8-2011; IN COMMERCE 10-26-2011.

4,210,297. OPTIONMONSTER HOLDINGS, INC., CHICAGO, IL. SN 77-552,011. PUB. 11-25-2008, FILED 8-20-2008.

INVEST LIKE A MONSTER

THE MARK CONSISTS OF STANDARD CHARACTERS WITHOUT CLAIM TO ANY PARTICULAR FONT, STYLE, SIZE, OR COLOR.

CLASS 36—INSURANCE AND FINANCIAL

FOR PROVIDING FINANCIAL INFORMATION (U.S. CLS. 100, 101 AND 102).
FIRST USE 9-5-2008; IN COMMERCE 11-8-2008.

4,210,311. STRANGE INVISIBLE PERFUMES, LLC, VENICE, CA. SN 77-607,830. PUB. 3-31-2009, FILED 11-5-2008.

CLASS 41—EDUCATION AND ENTERTAINMENT

FOR EDUCATIONAL SERVICES, NAMELY, CONDUCTING SEMINARS, WORKSHOPS, COURSES AND CLASSES IN THE FIELDS OF THE ANALYSIS AND THE DEVELOPMENT OF INVESTMENT STRATEGIES FOR STOCKS, OPTIONS, FUTURES, BONDS, COMMODITIES AND CURRENCIES AND DISTRIBUTION OF COURSE MATERIAL IN CONNECTION THEREWITH (U.S. CLS. 100, 101 AND 107).
FIRST USE 9-5-2008; IN COMMERCE 11-8-2008.

DAUGHTERS OF CHAOS

THE MARK CONSISTS OF STANDARD CHARACTERS WITHOUT CLAIM TO ANY PARTICULAR FONT, STYLE, SIZE, OR COLOR.

4,210,307. AGRIVIDA, INC., MEDFORD, MA. SN 77-602,155. PUB. 9-29-2009, FILED 10-28-2008.

AGRIVIDA

THE MARK CONSISTS OF STANDARD CHARACTERS WITHOUT CLAIM TO ANY PARTICULAR FONT, STYLE, SIZE, OR COLOR.

THE WORDING "AGRIVIDA" HAS NO MEANING IN A FOREIGN LANGUAGE.

CLASS 3—COSMETICS AND CLEANING PREPARATIONS

FOR HOME FRAGRANCES, NAMELY, ROOM FRAGRANCES (U.S. CLS. 1, 4, 6, 50, 51 AND 52).
FIRST USE 6-14-2012; IN COMMERCE 6-14-2012.

CLASS 25—CLOTHING

FOR T-SHIRTS (U.S. CLS. 22 AND 39).
FIRST USE 6-14-2012; IN COMMERCE 6-14-2012.

CLASS 31—NATURAL AGRICULTURAL PRODUCTS

FOR GENETICALLY ENGINEERED PLANTS FOR USE IN PRODUCING ALTERNATIVE FUEL, ETHANOL, PHARMACEUTICALS, BIOCHEMICALS, CHEMICALS, BIOCHEMICALS FOR FOOD PROCESSING, AGRICHEMICALS, AND ANIMAL FEEDS (U.S. CLS. 1 AND 46).
FIRST USE 3-15-2012; IN COMMERCE 3-15-2012.

4,210,314. PURPLE LABS S.A., 73375 LE BOURGET DU LA, FRANCE. SN 77-614,414. PUB. 4-26-2011, FILED 11-14-2008.

myriad

CLASS 42—SCIENTIFIC AND COMPUTER SERVICES

FOR SCIENTIFIC RESEARCH, DEVELOPMENT, AND TESTING IN THE FIELDS OF PRODUCING GENETICALLY ENGINEERED PLANTS FOR USE IN PRODUCING ALTERNATIVE FUEL, ETHANOL, PHARMACEUTICALS, BIOCHEMICALS, CHEMICALS, BIOCHEMICALS FOR FOOD PROCESSING, AGRICHEMICALS, AND ANIMAL FEEDS; INDUSTRIAL SERVICES IN THE NATURE OF INDUSTRIAL RESEARCH IN THE FIELDS OF PRODUCING GENETICALLY ENGINEERED PLANTS FOR USE IN PRODUCING ALTERNATIVE FUEL, ETHANOL, PHARMACEUTICALS, BIOCHEMICALS, CHEMICALS, BIOCHEMICALS FOR FOOD PROCESSING, AGRICHEMICALS, AND ANIMAL FEEDS (U.S. CLS. 100 AND 101).
FIRST USE 12-22-2011; IN COMMERCE 12-22-2011.

PRIORITY CLAIMED UNDER SEC. 44(D) ON SWITZERLAND APPLICATION NO. 63729/2008, FILED 11-7-2008, REG. NO. 584433, DATED 3-19-2009, EXPIRES 11-7-2018.

THE MARK CONSISTS OF THE WORD "MYRIAD".

CLASS 45—PERSONAL AND LEGAL SERVICES

FOR LICENSING OF INTELLECTUAL PROPERTY FOR OTHERS TO USE GENETICALLY ENGINEERED PLANTS FOR USE IN PRODUCING ALTERNATIVE FUEL, ETHANOL, PHARMACEUTICALS, BIOCHEMICALS, CHEMICALS, BIOCHEMICALS FOR FOOD PROCESSING, AGRICHEMICALS, AND ANIMAL FEEDS (U.S. CLS. 100 AND 101).
FIRST USE 12-22-2011; IN COMMERCE 12-22-2011.

CLASS 9—ELECTRICAL AND SCIENTIFIC APPARATUS

FOR COMPUTER SOFTWARE, NAMELY, SOFTWARE FOR INTERNET BROWSING, MESSAGING, SEARCH ENGINES, MOBILE SOCIAL NETWORKING AND FOR USER INTERFACE DESIGN FOR USE IN MOBILE TELEPHONE COMMUNICATIONS (U.S. CLS. 21, 23, 26, 36 AND 38).
FIRST USE 3-19-2009; IN COMMERCE 3-19-2009.

CLASS 42—SCIENTIFIC AND COMPUTER SERVICES

FOR COMPUTER SOFTWARE DESIGN AND COMPUTER SYSTEMS INTEGRATION SERVICES IN THE FIELD OF MOBILE COMMUNICATIONS (U.S. CLS. 100 AND 101).
FIRST USE 3-19-2009; IN COMMERCE 3-19-2009.

4,210,317. FUTURE US, INC., SOUTH SAN FRANCISCO, CA. SN 77-618,887. PUB. 3-31-2009, FILED 11-20-2008.

4,210,321. GARCIA, SERGIO, CLEVELAND, OH. SN 77-623,117. PUB. 4-7-2009, FILED 11-28-2008.

TRIRADAR

THE MARK CONSISTS OF STANDARD CHARACTERS WITHOUT CLAIM TO ANY PARTICULAR FONT, STYLE, SIZE, OR COLOR.

CLASS 35—ADVERTISING AND BUSINESS

FOR ADVERTISING AND DIRECTORY SERVICES, NAMELY, PROMOTING THE SERVICES OF OTHERS BY PROVIDING A WEB PAGE FEATURING LINKS TO THE WEBSITES OF OTHERS; PROMOTING SPORTS COMPETITIONS AND/OR EVENTS OF OTHERS; PROVIDING CONSUMER PRODUCT INFORMATION VIA THE INTERNET (U.S. CLS. 100, 101 AND 102).
FIRST USE 9-9-2010; IN COMMERCE 9-9-2010.

CLASS 41—EDUCATION AND ENTERTAINMENT

FOR PROVIDING INFORMATION AND INSTRUCTION IN THE FIELD OF TRIATHLON EVENTS (U.S. CLS. 100, 101 AND 107).
FIRST USE 9-9-2010; IN COMMERCE 9-9-2010.

CLASS 44—MEDICAL, BEAUTY AND AGRICULTURAL SERVICES

FOR PROVIDING A WEB SITE FEATURING INFORMATION ON HEALTH AND NUTRITION; PROVIDING INFORMATION ABOUT DIETARY SUPPLEMENTS AND NUTRITION (U.S. CLS. 100 AND 101).
FIRST USE 9-9-2010; IN COMMERCE 9-9-2010.

4,210,319. CAREPARTNERS PLUS LLC, HORSHAM, PA. SN 77-621,349. PUB. 4-7-2009, FILED 11-25-2008.

IF EVERY PATIENT COUNTS,
YOU CAN COUNT ON WELLBY

THE MARK CONSISTS OF STANDARD CHARACTERS WITHOUT CLAIM TO ANY PARTICULAR FONT, STYLE, SIZE, OR COLOR.

CLASS 35—ADVERTISING AND BUSINESS

FOR ELECTRONIC DATA COLLECTION AND DATA SUBMISSION SERVICES FOR BUSINESS PURPOSES IN THE FIELDS OF MEDICINE AND HEALTHCARE (U.S. CLS. 100, 101 AND 102).
FIRST USE 5-1-2012; IN COMMERCE 5-1-2012.

CLASS 42—SCIENTIFIC AND COMPUTER SERVICES

FOR DATA AUTOMATION AND COLLECTION SERVICE USING PROPRIETARY SOFTWARE TO EVALUATE, ANALYZE AND COLLECT SERVICE DATA (U.S. CLS. 100 AND 101).
FIRST USE 5-1-2012; IN COMMERCE 5-1-2012.



THE COLOR(S) GOLDENROD AND BRICK RED IS/ARE CLAIMED AS A FEATURE OF THE MARK.

THE MARK CONSISTS OF A STYLIZED LETTER WITH THE UPPER HALF OF GOLDENROD AND THE LOWER HALF OF BRICK RED.

CLASS 25—CLOTHING

FOR HEADWEAR (U.S. CLS. 22 AND 39).
FIRST USE 0-0-2009; IN COMMERCE 0-0-2009.

CLASS 28—TOYS AND SPORTING GOODS

FOR GOLF BAGS; GOLF BALLS (U.S. CLS. 22, 23, 38 AND 50).
FIRST USE 3-21-2012; IN COMMERCE 3-21-2012.

4,210,331. FRED W. GRETSCH ENTERPRISES, LTD., POOLER, GA. SN 77-640,663. PUB. 4-28-2009, FILED 12-29-2008.

AJAHA

THE MARK CONSISTS OF STANDARD CHARACTERS WITHOUT CLAIM TO ANY PARTICULAR FONT, STYLE, SIZE, OR COLOR.

CLASS 15—MUSICAL INSTRUMENTS

FOR PERCUSSION INSTRUMENTS (U.S. CLS. 2, 21 AND 36).
FIRST USE 6-0-2012; IN COMMERCE 6-0-2012.

CLASS 25—CLOTHING

FOR CLOTHING, NAMELY, SHIRTS (U.S. CLS. 22 AND 39).
FIRST USE 5-30-2011; IN COMMERCE 5-30-2011.

4,210,332. MOLECULAR IMPRINTS, INC., AUSTIN, TX. SN 77-641,604. PUB. 11-10-2009, FILED 12-30-2008.

4,210,360. ROCHE DIAGNOSTICS OPERATIONS, INC., INDIANAPOLIS, IN. SN 77-741,912. PUB. 10-6-2009, FILED 5-21-2009.

J-FIL

THE MARK CONSISTS OF STANDARD CHARACTERS WITHOUT CLAIM TO ANY PARTICULAR FONT, STYLE, SIZE, OR COLOR.

CLASS 7—MACHINERY

FOR MACHINES TO MANUFACTURE MICRO AND NANO-SCALE STRUCTURES BY SOLIDIFYING A FLUID COMPOUND TO CONFORM TO A SHAPE OF A MOLD (U.S. CLS. 13, 19, 21, 23, 31, 34 AND 35).
FIRST USE 9-2-2011; IN COMMERCE 9-2-2011.

CLASS 9—ELECTRICAL AND SCIENTIFIC APPARATUS

FOR COMPUTER OPERATING SOFTWARE FOR CONTROLLING MACHINES FOR MANUFACTURING MICRO AND NANO-SCALE STRUCTURES BY SOLIDIFYING A FLUID COMPOUND TO CONFORM TO A SHAPE OF A MOLD (U.S. CLS. 21, 23, 26, 36 AND 38).
FIRST USE 6-28-2012; IN COMMERCE 6-28-2012.

4,210,350. TASER INTERNATIONAL, INC., SCOTTSDALE, AZ. SN 77-686,925. PUB. 3-2-2010, FILED 3-9-2009.



THE MARK CONSISTS OF AN IMAGE OF A STYLIZED LIGHTNING BOLT WITHIN A CIRCLE.

CLASS 42—SCIENTIFIC AND COMPUTER SERVICES

FOR COMPUTER SERVICES, NAMELY, CREATING AND MAINTAINING WEB SITES THAT ALLOW STREAMING SELECTED VIDEO, AUDIO, AND PHOTOGRAPHIC DATA FOR OTHERS (U.S. CLS. 100 AND 101).
FIRST USE 3-18-2011; IN COMMERCE 3-18-2011.

CLASS 45—PERSONAL AND LEGAL SERVICES

FOR PROVIDING AN ON-LINE COMPUTER DATABASE IN THE FIELD OF LAW ENFORCEMENT, PROFESSIONAL SECURITY SERVICES, SELF-DEFENSE, AND PRISONS (U.S. CLS. 100 AND 101).
FIRST USE 3-18-2011; IN COMMERCE 3-18-2011.

COBAS Z

THE MARK CONSISTS OF STANDARD CHARACTERS WITHOUT CLAIM TO ANY PARTICULAR FONT, STYLE, SIZE, OR COLOR.

OWNER OF U.S. REG. NOS. 1,251,382, 3,256,885, AND OTHERS.

THE WORDING "COBAS" HAS NO MEANING IN A FOREIGN LANGUAGE.

CLASS 9—ELECTRICAL AND SCIENTIFIC APPARATUS

FOR LABORATORY INSTRUMENTS, NAMELY, CLINICAL CHEMISTRY ANALYZERS AND IMMUNOCHEMISTRY ANALYZERS FOR THE ANALYSIS OF BIOLOGICAL SAMPLES FOR SCIENTIFIC OR MEDICAL RESEARCH PURPOSES; COMPUTER HARDWARE AND SOFTWARE FOR USE WITH LABORATORY INSTRUMENTS, NAMELY, FOR USE IN DATA ANALYSIS AND DATABASE MANAGEMENT; DOWNLOADABLE ELECTRONIC PUBLICATIONS IN THE NATURE OF INSTRUCTION SHEETS AND INSTRUCTION MANUALS IN THE FIELD OF MEDICINE AND DIAGNOSTICS (U.S. CLS. 21, 23, 26, 36 AND 38).
FIRST USE 10-31-2011; IN COMMERCE 10-31-2011.

CLASS 10—MEDICAL APPARATUS

FOR MEDICAL APPARATUS, NAMELY, CLINICAL CHEMISTRY ANALYZERS AND IMMUNOCHEMISTRY ANALYZERS FOR THE ANALYSIS OF BIOLOGICAL SAMPLES FOR CLINICAL MEDICAL DIAGNOSTIC PURPOSES (U.S. CLS. 26, 39 AND 44).
FIRST USE 10-31-2011; IN COMMERCE 10-31-2011.

4,210,365. LIGHTHOUSE INTERNATIONAL, NEW YORK, NY. SN 77-750,323. PUB. 10-13-2009, FILED 6-2-2009.

SAVVYSIGHT

THE MARK CONSISTS OF STANDARD CHARACTERS WITHOUT CLAIM TO ANY PARTICULAR FONT, STYLE, SIZE, OR COLOR.

CLASS 35—ADVERTISING AND BUSINESS

FOR PROMOTING PUBLIC AWARENESS OF ISSUES RELATED TO VISION HEALTH (U.S. CLS. 100, 101 AND 102).
FIRST USE 2-0-2012; IN COMMERCE 2-0-2012.

CLASS 44—MEDICAL, BEAUTY AND AGRICULTURAL SERVICES

FOR PROVIDING INFORMATION VIA THE INTERNET REGARDING VISION HEALTH (U.S. CLS. 100 AND 101).
FIRST USE 2-0-2012; IN COMMERCE 2-0-2012.

4,210,374. SOUTHEAST ANESTHESIOLOGY CONSULTANTS, P.A., CHARLOTTE, NC. SN 77-774,078. PUB. 6-1-2010, FILED 7-3-2009.

QUANTUM CNS

THE MARK CONSISTS OF STANDARD CHARACTERS WITHOUT CLAIM TO ANY PARTICULAR FONT, STYLE, SIZE, OR COLOR.

OWNER OF U.S. REG. NO. 3,612,989.

CLASS 9—ELECTRICAL AND SCIENTIFIC APPARATUS

FOR COMPUTER SOFTWARE FOR MONITORING, REPORTING, AND IMPROVING QUALITY OUTCOMES, EFFICIENCY, AND PATIENT SATISFACTION IN MEDICAL ENVIRONMENTS AND MANUALS SOLD THEREWITH (U.S. CLS. 21, 23, 26, 36 AND 38).

FIRST USE 1-31-2008; IN COMMERCE 1-31-2008.

CLASS 35—ADVERTISING AND BUSINESS

FOR BUSINESS CONSULTATION SERVICES IN THE FIELD OF IMPROVING BILLING SERVICES, EFFICIENCY, AND PATIENT SATISFACTION IN MEDICAL ENVIRONMENTS; BUSINESS RESEARCH IN THE FIELD OF IMPROVING EFFICIENCY, BILLING, AND PATIENT SATISFACTION IN MEDICAL ENVIRONMENTS (U.S. CLS. 100, 101 AND 102).

FIRST USE 1-31-2008; IN COMMERCE 1-31-2008.

CLASS 42—SCIENTIFIC AND COMPUTER SERVICES

FOR RESEARCH IN THE FIELD OF IMPROVING QUALITY CONTROL IN MEDICAL ENVIRONMENTS; CONSULTATION SERVICES IN THE FIELD OF IMPROVING QUALITY CONTROL IN MEDICAL ENVIRONMENTS (U.S. CLS. 100 AND 101).

FIRST USE 1-31-2008; IN COMMERCE 1-31-2008.

4,210,376. REPUBLIC OF FRIENDS, INC., ENCINITAS, CA. SN 77-783,202. PUB. 3-9-2010, FILED 7-16-2009.

REPUBLIC OF FRIENDS

THE MARK CONSISTS OF STANDARD CHARACTERS WITHOUT CLAIM TO ANY PARTICULAR FONT, STYLE, SIZE, OR COLOR.

CLASS 9—ELECTRICAL AND SCIENTIFIC APPARATUS

FOR ELECTRONICS, NAMELY, HEAD PHONES; AUDIO EQUIPMENT, NAMELY, SPEAKERS; EYEWEAR, NAMELY, AND SNOW GOGGLES (U.S. CLS. 21, 23, 26, 36 AND 38).

FIRST USE 10-1-2010; IN COMMERCE 10-1-2010.

CLASS 18—LEATHER GOODS

FOR LUGGAGE, INCLUDING BACKPACKS (U.S. CLS. 1, 2, 3, 22 AND 41).

FIRST USE 10-1-2010; IN COMMERCE 10-1-2010.

CLASS 25—CLOTHING

FOR APPAREL, NAMELY, T-SHIRTS, SWEATSHIRTS, PULLOVERS, AND HATS (U.S. CLS. 22 AND 39).

FIRST USE 10-1-2010; IN COMMERCE 10-1-2010.

4,210,381. RECKITT BENCKISER (SWITZERLAND) AG, ZURICH, SWITZERLAND. SN 77-800,510. PUB. 4-19-2011, FILED 8-10-2009.

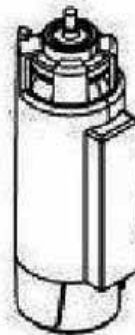

PRIORITY CLAIMED UNDER SEC. 44(D) ON ERPN CMNTY TM OFC APPLICATION NO. 7592281, FILED 2-10-2009.

THE MARK CONSISTS OF A THREE-DIMENSIONAL CONFIGURATION OF THE PACKAGING FOR REFILLS FOR THE AIR WICK BRAND AIR FRESHENER COMPRISED OF A CYLINDRICAL CARTRIDGE ELEMENT WITH A RECTANGULAR PROTRUSION IN THE BOTTOM THIRD AND VARIOUS OTHER PROTRUSIONS, NAMELY, FOUR RECTANGULAR CLIPS NEAR THE CARTRIDGE'S TOP AND TWO ROUNDED SQUARE FLAPS AROUND THE BOTTOM OF THE CARTRIDGE.

CLASS 3—COSMETICS AND CLEANING PREPARATIONS

FOR PERFUMING PREPARATIONS FOR THE ATMOSPHERE; ROOM PERFUME SPRAYS; PREPARATIONS FOR PERFUMING OR FRAGRANCING THE AIR (U.S. CLS. 1, 4, 6, 50, 51 AND 52).

FIRST USE 4-0-2007; IN COMMERCE 4-0-2007.

CLASS 5—PHARMACEUTICALS

FOR AIR FRESHENING PREPARATIONS; AIR PURIFYING PREPARATIONS; ROOM AIR FRESHENERS; HOUSEHOLD AND ROOM DEODORANTS; PREPARATIONS FOR NEUTRALIZING ODORS FOR USE IN THE AIR (U.S. CLS. 6, 18, 44, 46, 51 AND 52).

FIRST USE 4-0-2007; IN COMMERCE 4-0-2007.

CLASS 11—ENVIRONMENTAL CONTROL APPARATUS

FOR APPARATUS AND INSTRUMENTS, ALL FOR SCENTING, PURIFYING OR FRESHENING THE ATMOSPHERE, NAMELY, ELECTRIC AND BATTERY OPERATED DISPENSERS, DISPENSING UNITS, AND DIFFUSERS FOR AIR FRESHENERS, HOUSEHOLD AND ROOM DEODORANTS AND PREPARATIONS FOR NEUTRALIZING ODORS; PARTS AND FITTINGS FOR ALL THE AFORESAID GOODS (U.S. CLS. 13, 21, 23, 31 AND 34).

FIRST USE 4-0-2007; IN COMMERCE 4-0-2007.

4,210,389. GEA FARM TECHNOLOGIES, INC., NAPERVILLE, IL. SN 77-841,311. PUB. 4-26-2011, FILED 10-5-2009.

GEA FARM TECHNOLOGIES

THE MARK CONSISTS OF STANDARD CHARACTERS WITHOUT CLAIM TO ANY PARTICULAR FONT, STYLE, SIZE, OR COLOR.

NO CLAIM IS MADE TO THE EXCLUSIVE RIGHT TO USE "FARM TECHNOLOGIES", APART FROM THE MARK AS SHOWN.

CLASS 1—CHEMICALS

FOR CHLORINATED CHEMICAL PREPARATIONS FOR CLEANING PURPOSES FOR MILKING SYSTEMS; BORIC ACID AND CLEAN-IN-PLACE (CIP) WATER CONDITIONERS WITH CHEMICAL AGENTS ALL FOR USE IN SANITIZING DAIRY MILKING SYSTEMS; SULFURIC, NITRIC, CITRIC AND PHOSPHORIC ACIDS FOR CLEANING AND SANITIZING MILKING SYSTEMS ON DAIRY FARMS; DAIRY SANITATION PRODUCTS, NAMELY, INDUSTRIAL DETERGENT AND SULFURIC, NITRIC, CITRIC AND PHOSPHORIC ACIDS USED TO CLEAN, RINSE AND SANITIZE DAIRY FARM MILKING EQUIPMENT AND FOAMING TEAT DIP APPLICATORS; WATER CONDITIONERS (U.S. CLS. 1, 5, 6, 10, 26 AND 46).

FIRST USE 1-1-2012; IN COMMERCE 1-1-2012.

CLASS 3—COSMETICS AND CLEANING PREPARATIONS

FOR ALL-PURPOSE CLEANING PREPARATIONS FOR USE IN THE DAIRY INDUSTRY; ACID-BASED CLEANING PREPARATIONS FOR REMOVING MILKSTONE, WATER SCALE AND RUST FROM PIPELINES, BULK TANKS, MILKING MACHINES, AND INFLATIONS IN THE DAIRY INDUSTRY; CLEANING PREPARATIONS FOR USE IN CONNECTION WITH DAIRY MILK PIPELINES AND MILK TANKS; LAUNDRY DETERGENT AND ALL-PURPOSE LIQUID DETERGENT, BOTH FOR GENERAL HOUSEHOLD USE; UDDER WASHING DETERGENTS; CLEANING PREPARATIONS FOR MILKERS, MILK-HANDLING EQUIPMENT AND SYSTEMS FOR DAIRY FARMS AND FOOD CONTACT SURFACES; ANTI-MICROBIAL HAND SOAPS (U.S. CLS. 1, 4, 6, 50, 51 AND 52).

FIRST USE 1-1-2012; IN COMMERCE 1-1-2012.

CLASS 4—LUBRICANTS AND FUELS

FOR LUBRICATING OIL; NON-MINERAL OIL FOR INDUSTRIAL PURPOSES, NAMELY, FOR VACUUM PUMPS AND MILKING SYSTEM PARTS (U.S. CLS. 1, 6 AND 15).

FIRST USE 1-1-2012; IN COMMERCE 1-1-2012.

CLASS 5—PHARMACEUTICALS

FOR GERMICIDAL SANITIZERS FOR USE ON DAIRY EQUIPMENT; SANITIZERS FOR MILKERS, MILK-HANDLING EQUIPMENT AND SYSTEMS FOR DAIRY FARMS; GERMICIDAL TEAT DIPS; SANITIZING UDDER WASHES; MEDICATED UDDER SALVE; SANITIZING TEAT DIPS; SANITIZING FOAMING TEAT DIPS; VETERINARY PREPARATIONS, NAMELY, TOPICAL TEAT DIPS FOR TISSUE TONING; MEDICATED SKIN CONDITIONERS FOR DAIRY ANIMALS; MEDICATED HOOF CARE PREPARATIONS IN THE FORM OF FOOT BATH CONCENTRATES AND TOPICAL SOLUTIONS; SANITIZERS FOR HOOF TRIMMING EQUIPMENT AND UTENSILS; CONCENTRATED GERMICIDAL DETERGENT FOR CLEANING MILKING SYSTEMS ON DAIRY FARMS, CONCENTRATED GERMICIDAL DETERGENT FOR SANITIZING MILKING SYSTEMS ON DAIRY FARMS; INDUSTRIAL SANITIZERS, NAMELY, ACID DETERGENT WITH GERMICIDE FOR CLEAN-IN-PLACE (CIP) SYSTEMS ON DAIRY FARMS; DAIRY SANITATION PRODUCTS, NAMELY, INDUSTRIAL SANITIZER TABLETS USED TO CLEAN, RINSE AND SANITIZE DAIRY FARM MILKING EQUIPMENT AND FOAMING TEAT DIP APPLICATORS (U.S. CLS. 6, 18, 44, 46, 51 AND 52).

FIRST USE 1-1-2012; IN COMMERCE 1-1-2012.

CLASS 6—METAL GOODS

FOR BULK MILK STORAGE TANKS, MILKING PARLOR STALLS AND STANCHIONS, MILK RESERVOIR VATS, ALL MADE PRIMARILY OF METAL; COMPONENT PARTS FOR MILKING MACHINES, NAMELY, MANUALLY ACTIVATED METAL VALVES; METAL MILKING PARLOR EQUIPMENT, NAMELY, SEQUENCE GATES, ENTRY GATES, EXIT GATES, SPLASH SHIELDS, CURBS, BRISKET BOARDS, AND DAIRY BARN EQUIPMENT, NAMELY, FREESTALLS, TIESTALLS, HEAD SELFLOCKS, KEDER TUBES USED AS HEM PIPES, WATERERS, CATTLE TRAFFIC CONTROL GATES, NAMELY, TELESCOPING GATES, SWING GATES, AND TIP GATES, ALL MADE OF METAL; METAL GUTTER GRATES; METAL COW HANDLING; STEEL TRUSSES FOR LIVESTOCK BARN; PARTITIONS AND PARTITION FITTINGS AND CLAMPS OF METAL; METAL BARRIERS FOR LIVESTOCK; METAL EAR TAGS FOR LIVESTOCK; TREATMENT STALLS AND GATES MADE OF METAL; ISOLATION STALLS AND GATES MADE OF METAL (U.S. CLS. 2, 12, 13, 14, 23, 25 AND 50).

FIRST USE 1-1-2012; IN COMMERCE 1-1-2012.

CLASS 7—MACHINERY

FOR ROTARY AND LINEAR MILKING PARLOR INSTALLATIONS, NAMELY, MILKING MACHINES, VACUUM PUMPS AND PULSATORS; COMPONENT PARTS FOR MILKING MACHINES, NAMELY, MILK STIMULATORS, FILTERS FOR MILKING MACHINES, VACUUM PUMPS, MILK PUMPS, AIR COMPRESSING PUMPS, WATER PUMPS, CHEMICAL DISPENSING PUMPS, POWER-OPERATED TEAT SPRAYERS, POWER-OPERATED UDDER WASHERS, AERATORS, MILKING SYSTEM WASHERS, INDUSTRIAL MILKING ROBOTS; MACHINES FOR SUPPLYING FODDER CONCENTRATE IN FODDER TROUGH; AUTOMATIC CONVEYORS FOR STABLE CLEANING; STABLE CLEANING MACHINES; STATIONARY MACHINES FOR AUTOMATICALLY SPRAYING COWS WITH LIQUID INSECTICIDES AND GERMICIDES; VACUUM REGULATORS AS PARTS OF MILKING MACHINES; MILKING MACHINE RETRACTORS; TEAT DISINFECTING MACHINES; UDDER SPRAYING APPARATUS, NAMELY, SPRAY WANDS; DAIRY BARN AND MILKING PARLOR EQUIPMENT, NAMELY, POWER-OPERATED VENTILATION CURTAINS THAT OPEN AND CLOSE, POWER-OPERATED VENTILATION SYSTEM FOR THE ROOF OF LIVESTOCK BARN, POWER-OPERATED MANURE SCRAPERS; ROBOTIC AND POWER-OPERATED MANURE SCRAPERS; TRACTOR-TOWED FARM IMPLEMENTS, NAMELY, MANURE SPREADERS; ANIMAL WASTE MANAGEMENT SYSTEM, NAMELY, SOLID AND LIQUID MANURE HANDLING PUMPS; MECHANIZED LIVESTOCK FEEDERS; MANURE AUGERS, MANURE AGITATORS, MANURE SEPARATORS (U.S. CLS. 13, 19, 21, 23, 31, 34 AND 35).

FIRST USE 1-1-2012; IN COMMERCE 1-1-2012.

CLASS 9—ELECTRICAL AND SCIENTIFIC APPARATUS

FOR LIGHT SCANNERS, OPTICAL SENSORS, ANIMAL SCALES AND ELECTRONIC ANIMAL COUNTING DEVICES; ELECTRONIC MILK FLOW MONITORING DEVICES AND MILK METERS; ELECTRONIC NECK TAGS AND RESPONDERS FOR LIVESTOCK; ELECTRONIC DATA PROCESSING UNITS, TRANSMITTERS, RECEIVERS AND TRANSPONDERS ATTACHED TO COWS FOR AUTOMATIC RECOGNITION OF ANIMALS, FOR SUPPLY OF FEED AND FODDER CONCENTRATE, FOR COW CALENDAR, FOR DETERMINATION OF MILK QUANTITIES AND QUALITY, FOR DETERMINATION OF MILK TEMPERATURES, AND FOR DETERMINATION OF WASHING TEMPERATURES; DAIRY HERD MANAGEMENT SOFTWARE AND COMPUTER HARDWARE; ELECTRIC CONTROL PANELS FOR MONITORING AND OPERATING MILKING SYSTEMS; REMOTE CONTROLS FOR AUTOMATICALLY DISPENSING ANIMAL FEED; VACUUM GAUGES; AUTOMATIC DISPENSERS FOR SUPPLYING LIQUIDS IN DRINKING BOWLS; ELECTRONIC CONTROLLERS FOR MILK PIPELINE WASHERS; AUTOMATIC DISPENSERS FOR SUPPLYING CHEMICALS FOR MILK PIPELINE WASHERS; TIME AND TEMPERATURE RECORDERS; AND CLOSED-CIRCUIT VIDEO OBSERVATION SYSTEMS COMPRISED OF CLOSED CIRCUIT TELEVISION CAMERA AND VIDEO MONITOR; PROTECTIVE BOOTS, PROTECTIVE GLOVES AND PROTECTIVE CLOTHING FOR FARM WORKERS; MILKING MONITORS, AUTOMATIC LIQUID-FLOW CONTROLS FOR MILKING MACHINES, AUTOMATIC FEED DISPENSERS FOR DAIRY ANIMALS; FLOW SENSORS FOR MILKERS; DAIRY BARN EQUIPMENT, NAMELY, ELECTRONIC CLIMATE CONTROL DEVICE (U.S. CLS. 21, 23, 26, 36 AND 38).

FIRST USE 1-1-2012; IN COMMERCE 1-1-2012.

CLASS 11—ENVIRONMENTAL CONTROL APPARATUS

FOR MILK COOLING APPARATUS, NAMELY, REFRIGERATED MILK STORAGE TANKS, HEAT EXCHANGERS, REFRIGERATION CONDENSING UNITS, WATER COOLERS AND ICE MACHINES; WATER CONDITIONING UNITS; DAIRY CATTLE EQUIPMENT FOR USE IN STABLES AND PASTURES, NAMELY, NON-MEDICAL STERILIZERS; MILK COOLERS, NAMELY, A CHILLER IN THE NATURE OF A REFRIGERATION UNIT USED TO COOL A HEAT TRANSFER MEDIUM AND A HEAT EXCHANGER IN WHICH THE HEAT TRANSFER MEDIUM COOLS MILK AS IT COMES FROM COWS BEING MILKED; DAIRY BARN AND MILKING PARLOR EQUIPMENT, NAMELY, ELECTRIC CIRCULATING FANS; MECHANIZED LIVESTOCK WATERERS; SLURRY TREATMENT UNITS FOR STABILIZING AND SANITIZING SLURRY; WASTE MILK PURIFYING APPARATUS FOR FEEDING WASTE MILK TO CALVES; WATER CONDITIONING UNITS (U.S. CLS. 13, 21, 23, 31 AND 34).

FIRST USE 1-1-2012; IN COMMERCE 1-1-2012.

CLASS 17—RUBBER GOODS

FOR MILKING MACHINE INFLATIONS, RUBBER AND SILICONE MILKING LINERS; PIPE GASKETS; AND NON-METALLIC HOSES; ALL OF THE ABOVE FOR USE IN MILKING SYSTEMS (U.S. CLS. 1, 5, 12, 13, 35 AND 50).

FIRST USE 1-1-2012; IN COMMERCE 1-1-2012.

CLASS 18—LEATHER GOODS

FOR LIVESTOCK PRODUCTS IN THE NATURE OF A RESTRAINING DEVICE, NAMELY, RESTRAINING CHAINS, STRAPS AND FASTENERS (U.S. CLS. 1, 2, 3, 22 AND 41).

FIRST USE 1-1-2012; IN COMMERCE 1-1-2012.

CLASS 19—NON-METALLIC BUILDING MATERIALS

FOR LIVESTOCK BARN EQUIPMENT, NAMELY, CUSHIONED FLOORING FOR WALKWAYS (U.S. CLS. 1, 12, 33 AND 50).

FIRST USE 1-1-2012; IN COMMERCE 1-1-2012.

CLASS 20—FURNITURE AND ARTICLES NOT OTHERWISE CLASSIFIED

FOR CABINETS FOR HOUSING MILKING EQUIPMENT (U.S. CLS. 2, 13, 22, 25, 32 AND 50).

FIRST USE 1-1-2012; IN COMMERCE 1-1-2012.

CLASS 21—HOUSEWARES AND GLASS

FOR WATER TROUGHS; MANGERS FOR ANIMALS; METAL TROUGHS AND PANS FOR LIVESTOCK; NON-MECHANIZED LIVESTOCK WATERERS; ROTATING CYLINDRICAL BRUSH FOR LIVESTOCK (U.S. CLS. 2, 13, 23, 29, 30, 33, 40 AND 50).

FIRST USE 1-1-2012; IN COMMERCE 1-1-2012.

CLASS 25—CLOTHING

FOR CLOTHING, NAMELY, SHIRTS, T-SHIRTS, JACKETS, WIND-RESISTANT JACKETS, HATS, CAPS, SWEATSHIRTS, VESTS, SWEATERS, SWEAT PANTS, TIES, GLOVES AND OVERALLS (U.S. CLS. 22 AND 39).

FIRST USE 1-1-2012; IN COMMERCE 1-1-2012.

CLASS 27—FLOOR COVERINGS

FOR BARN STALL EQUIPMENT, NAMELY, STALL MATS, BEDDING MATS AND CUSHIONED BEDDING MATS FOR LIVESTOCK WHICH ARE LAID ON THE FLOOR OF ANIMAL STALLS (U.S. CLS. 19, 20, 37, 42 AND 50).

FIRST USE 1-1-2012; IN COMMERCE 1-1-2012.

CLASS 35—ADVERTISING AND BUSINESS

FOR BUSINESS CONSULTING SERVICES FOR DEALERS AND DEALERSHIP PERSONNEL IN THE DAIRY PRODUCTION INDUSTRY IN THE FIELD OF DEALERSHIP ROUTE MANAGEMENT, NAMELY, SALES TERRITORY DEVELOPMENT PLANNING, SALES AND MARKETING PLANNING, SALES TECHNIQUES, SALES ROUTE MANAGEMENT PLANNING, BUSINESS MANPOWER MANAGEMENT, AND BUSINESS OPERATIONS MANAGEMENT; INDIVIDUAL CONSULTATION IN THE FIELD OF GENERAL BUSINESS MANAGEMENT FOR DEALERS AND DEALERSHIP PERSONNEL IN THE DAIRY PRODUCTION AND HERD HEALTH INDUSTRY; DAIRY FACILITY BUSINESS PLANNING SERVICES CONSISTING OF FEED MANAGEMENT; DAIRY PARLOR AND DAIRY FACILITIES DESIGN SERVICES IN THE NATURE OF PROVIDING CONSULTATION ON BUSINESS MANAGEMENT AND DATA PROCESSING (U.S. CLS. 100, 101 AND 102).

FIRST USE 1-1-2012; IN COMMERCE 1-1-2012.

CLASS 36—INSURANCE AND FINANCIAL

FOR CONSULTING SERVICES FOR DEALERS AND DEALERSHIP PERSONNEL IN THE DAIRY PRODUCTION INDUSTRY IN THE FIELD OF DEALERSHIP ROUTE MANAGEMENT, NAMELY, FINANCIAL PLANNING AND MANAGEMENT (U.S. CLS. 100, 101 AND 102).

FIRST USE 1-1-2012; IN COMMERCE 1-1-2012.

CLASS 37—CONSTRUCTION AND REPAIR

FOR DAIRY FACILITY PLANNING SERVICES, NAMELY, LAYING OUT OF MILKING PARLORS AND HOLDING AREAS, DAIRY HOUSING, CALF AND MATERNITY HOUSING, AND COW COMFORT AND TRAFFIC PATTERNS; INSTALLATION AND MAINTENANCE OF DAIRY PARLOR EQUIPMENT; PLUMBING CONSULTING (U.S. CLS. 100, 103 AND 106).

FIRST USE 1-1-2012; IN COMMERCE 1-1-2012.

CLASS 39—TRANSPORTATION AND STORAGE

FOR DELIVERY OF DAIRY FARM EQUIPMENT; DELIVERY OF DAIRY FARM HYGIENE PRODUCTS, NAMELY, DAIRY FARM EQUIPMENT HYGIENE PRODUCTS AND ANIMAL HYGIENE PRODUCTS; DELIVERY OF ANIMAL HEALTH PRODUCTS; DELIVERY OF DAIRY FARM SUPPLIES, AND REPAIR AND REPLACEMENT PARTS FOR DAIRY FARM EQUIPMENT (U.S. CLS. 100 AND 105).

FIRST USE 1-1-2012; IN COMMERCE 1-1-2012.

CLASS 41—EDUCATION AND ENTERTAINMENT

FOR TRAINING SERVICES FOR DAIRY PRODUCERS AND DEALERS AND DEALERSHIP PERSONNEL IN THE DAIRY PRODUCTION INDUSTRY, NAMELY, CONDUCTING WORKSHOPS, SEMINARS AND CLASSES, AND INDIVIDUALIZED TRAINING IN THE FIELD OF DAIRY FARM HYGIENE, NAMELY, DAIRY FARM EQUIPMENT HYGIENE AND ANIMAL HYGIENE, ANIMAL HEALTH, MILKING SYSTEM ANALYSIS, AND MILKING MANAGEMENT; TRAINING SERVICES FOR DEALERS AND DEALERSHIP PERSONNEL IN THE DAIRY PRODUCTION INDUSTRY, NAMELY, CONDUCTING WORKSHOPS, SEMINARS AND CLASSES IN THE FIELD OF DEALERSHIP ROUTE MANAGEMENT AND GENERAL BUSINESS MANAGEMENT, NAMELY, FINANCIAL PLANNING AND MANAGEMENT, TERRITORY DEVELOPMENT PLANNING, SALES AND MARKETING PLANNING, SALES TECHNIQUES, ROUTE MANAGEMENT PLANNING, MANPOWER MANAGEMENT, AND OPERATIONS MANAGEMENT; EDUCATIONAL SERVICES, NAMELY, CONDUCTING CLASSES, SEMINARS, CONFERENCES, AND WORKSHOPS IN THE FIELD OF GENERAL BUSINESS MANAGEMENT FOR DEALERS AND DEALERSHIP PERSONNEL IN THE DAIRY PRODUCTION AND HERD HEALTH INDUSTRY (U.S. CLS. 100, 101 AND 107).

FIRST USE 1-1-2012; IN COMMERCE 1-1-2012.

CLASS 42—SCIENTIFIC AND COMPUTER SERVICES

FOR CONSULTING SERVICES FOR DAIRY PRODUCERS IN THE FIELD OF WATER QUALITY TESTING AND ANALYSIS AND MAINTENANCE ASSESSMENT OF THE PERFORMANCE AND RELIABILITY OF MILKING AND COOLING SYSTEMS AND UDDER WASHING SYSTEM FUNCTION; PROVIDING CHEMICAL ANALYSIS FOR THE OPTIMIZATION OF HYGIENE ON DAIRY FARMS; CONSULTING SERVICES TO ASSIST DAIRY PRODUCERS IN OPTIMIZING MILK PRODUCTION PERFORMANCE AND IN MAXIMIZING MILKING EFFICIENCY BY ANALYZING DATA, NAMELY, MILKING VACUUM LEVELS, PULSATION RATES, RATIOS AND CHARACTERISTICS, LINER DESIGN AND COMPOSITION, MILK PRODUCTION AND DAIRY OPERATOR ROUTINES; DAIRY PARLOR AND DAIRY FACILITIES DESIGN SERVICES IN THE NATURE OF PROVIDING TECHNICAL CONSULTATION ON MILKING TIME AND PROCEDURES; MILKING SYSTEM DESIGN SERVICES, NAMELY, PROVIDING CONSULTATION TO DAIRY PRODUCERS ON VACUUM PUMPS, CONTROLLERS AND PULSATORS USED WITH MILKING MACHINES, MILKING UNITS, PIPE LINES, DAIRY OPERATOR PERFORMANCE, SANITATION AND SUPPLIES, MILK STORAGE AND COOLING, SERVICE SCHEDULES, MILK PUMPS AND MILK FILTERING, TIMING AND FLOW CONTROL DEVICES; CONSULTING SERVICES FOR DAIRY PARLOR AND DAIRY FACILITIES BY PROVIDING TECHNOLOGICAL CONSULTATION ON MILKING EQUIPMENT, LEVEL OF AUTOMATION, TECHNICAL EQUIPMENT MONITORING MEASURES, ELECTRICAL EQUIPMENT NEEDS, WATER QUALITY MONITORING (U.S. CLS. 100 AND 101).

FIRST USE 1-1-2012; IN COMMERCE 1-1-2012.

CLASS 44—MEDICAL, BEAUTY AND AGRICULTURAL SERVICES

FOR CONSULTING SERVICES FOR DAIRY PRODUCERS IN THE FIELD OF DAIRY FARM HYGIENE, NAMELY, DAIRY FARM EQUIPMENT HYGIENE AND ANIMAL HYGIENE, ANIMAL HEALTH, AND TOTAL FARM HYGIENE; PROVIDING CONSULTATION AND INFORMATION REGARDING THE TREATMENT AND PREVENTION OF FOOT DISEASES IN COWS AND RELATED FOOT CARE SERVICES FOR COWS (U.S. CLS. 100 AND 101).

FIRST USE 1-1-2012; IN COMMERCE 1-1-2012.

4,210,399. ST. JAMES PLACE OF BATON ROUGE, BATON ROUGE, LA. SN 77-866,723. PUB. 6-15-2010, FILED 11-6-2009.

DINEWELL

THE MARK CONSISTS OF STANDARD CHARACTERS WITHOUT CLAIM TO ANY PARTICULAR FONT, STYLE, SIZE, OR COLOR.

CLASS 43—HOTEL AND RESTAURANT SERVICES

FOR CONTRACT FOOD SERVICES FEATURING HEALTHFUL NUTRITION OPTIONS FOR SENIORS (U.S. CLS. 100 AND 101).

FIRST USE 3-22-2012; IN COMMERCE 3-22-2012.

CLASS 44—MEDICAL, BEAUTY AND AGRICULTURAL SERVICES

FOR PROVIDING HEALTHY LIFESTYLE AND NUTRITION SERVICES, NAMELY, PERSONAL ASSESSMENTS, PERSONALIZED ROUTINES, MAINTENANCE SCHEDULES AND COUNSELING FOR SENIORS; COUNSELING SERVICES IN THE FIELDS OF HEALTH, NUTRITION AND LIFESTYLE WELLNESS FOR SENIORS (U.S. CLS. 100 AND 101).

FIRST USE 3-22-2012; IN COMMERCE 3-22-2012.

4,210,402. THE NEBRASKA MEDICAL CENTER, OMAHA, NE. SN 77-869,140. PUB. 10-12-2010, FILED 11-10-2009.



NO CLAIM IS MADE TO THE EXCLUSIVE RIGHT TO USE "ACCOUNTABLE CARE ALLIANCE", APART FROM THE MARK AS SHOWN.

THE MARK CONSISTS OF THE WORDS "ACCOUNTABLE CARE ALLIANCE" WITH A SWIRL DESIGN.

CLASS 35—ADVERTISING AND BUSINESS

FOR HEALTH CARE UTILIZATION AND REVIEW SERVICES; BUSINESS CONSULTING, NAMELY, ANALYZING AND COMPILING DATA FOR EVALUATING THE PERFORMANCE OF HOSPITALS AND PHYSICIANS TO IDENTIFY OPPORTUNITIES FOR IMPROVED PATIENT SAFETY, CLINICAL EFFICIENCY AND PATIENT OUTCOMES (U.S. CLS. 100, 101 AND 102).

FIRST USE 7-21-2010; IN COMMERCE 7-21-2010.

CLASS 44—MEDICAL, BEAUTY AND AGRICULTURAL SERVICES

FOR MANAGED HEALTH CARE SERVICES, NAMELY, ASSISTING PHYSICIANS WITH MONITORING AND IMPROVING PATIENT COMPLIANCE WITH DESIGNATED HEALTHY BEHAVIORS (U.S. CLS. 100 AND 101).

FIRST USE 7-21-2010; IN COMMERCE 7-21-2010.

4,210,407. FAMILY DOLLAR STORES OF MICHIGAN, INC., MATTHEWS, NC. SN 77-876,017. PUB. 11-9-2010, FILED 11-19-2009.

EXTREMELY ME

THE MARK CONSISTS OF STANDARD CHARACTERS WITHOUT CLAIM TO ANY PARTICULAR FONT, STYLE, SIZE, OR COLOR.

CLASS 14—JEWELRY

FOR JEWELRY, NAMELY, EARRINGS, BRACELETS, NECKLACES, WATCHES, AND JEWELRY SETS COMPRISED OF NECKLACES AND EARRINGS (U.S. CLS. 2, 27, 28 AND 50).

FIRST USE 1-31-2012; IN COMMERCE 1-31-2012.

CLASS 18—LEATHER GOODS

FOR TOTE BAGS (U.S. CLS. 1, 2, 3, 22 AND 41).

FIRST USE 6-9-2012; IN COMMERCE 6-9-2012.

4,210,410. KIDDESIGNS, INC., RAHWAY, NJ. SN 77-880,056. PUB. 5-3-2011, FILED 11-24-2009.

EKIDS

THE MARK CONSISTS OF STANDARD CHARACTERS WITHOUT CLAIM TO ANY PARTICULAR FONT, STYLE, SIZE, OR COLOR.

OWNER OF U.S. REG. NOS. 3,042,106, 3,042,107, AND 3,042,108.

CLASS 9—ELECTRICAL AND SCIENTIFIC APPARATUS

FOR ELECTRONIC PRODUCTS, NAMELY, RADIOS, RADIOS INCORPORATING CLOCKS, AUDIO SPEAKERS WITH MP3 DOCKING AND CONNECTIVITY, BOOM BOXES, NAMELY, PERSONAL STEREOS, WALKIE-TALKIES, HEADPHONES, AUDIO SPEAKERS; PROTECTIVE CARRYING CASES SPECIALLY ADAPTED FOR AUDIO SPEAKERS; COMPUTER AND LAPTOP ACCESSORIES, NAMELY, HEADSETS FOR USE WITH COMPUTERS; PROTECTIVE CARRYING CASES FOR PORTABLE MEDIA PLAYERS, NAMELY, PORTABLE MEDIA PLAYERS, SMARTPHONES AND MP3 PLAYERS; CELL PHONE ACCESSORIES, NAMELY, PROTECTIVE CARRYING CASES SPECIALLY ADAPTED FOR CELL PHONES FOR USE IN VEHICLES (U.S. CLS. 21, 23, 26, 36 AND 38).

FIRST USE 5-0-2011; IN COMMERCE 5-0-2011.

CLASS 28—TOYS AND SPORTING GOODS

FOR ELECTRONIC LEARNING TOYS; ROLE PLAYING GAMES; INTERACTIVE ELECTRONIC TOYS, NAMELY, TOY CELL PHONES, TOY MP3 PLAYERS, TOY CD PLAYERS, TOY WALKIE-TALKIES, TOY KARAOKE PLAYERS (U.S. CLS. 22, 23, 38 AND 50).

FIRST USE 5-0-2011; IN COMMERCE 5-0-2011.

4,210,412. DIRECT CONSUMER CONTACT, INC., PALM HARBOR, FL. SN 77-885,102. PUB. 5-24-2011, FILED 12-3-2009.

YOU ARE HOLLYWOOD

THE MARK CONSISTS OF STANDARD CHARACTERS WITHOUT CLAIM TO ANY PARTICULAR FONT, STYLE, SIZE, OR COLOR.

CLASS 35—ADVERTISING AND BUSINESS

FOR PROVIDING ADVERTISING SPACE AT A WEBSITE FOR ADVERTISEMENTS OF THE GOODS AND SERVICES OF OTHERS (U.S. CLS. 100, 101 AND 102).

FIRST USE 4-19-2012; IN COMMERCE 4-19-2012.

CLASS 38—COMMUNICATION

FOR PROVIDING MULTIPLE USER-ACCESS TO THE INTERNET FEATURING INFORMATION, AUDIO AND VIDEO OVER THE INTERNET IN THE FIELD OF GENERAL INTEREST; PROVIDING ONLINE INTERACTIVE ELECTRONIC BULLETIN BOARDS AND CHAT ROOMS FOR TRANSMISSION OF MESSAGES AMONG USERS IN THE FIELD OF GENERAL INTEREST (U.S. CLS. 100, 101 AND 104).

FIRST USE 4-19-2012; IN COMMERCE 4-19-2012.

CLASS 41—EDUCATION AND ENTERTAINMENT

FOR ENTERTAINMENT SERVICES, NAMELY, PROVIDING A WEBSITE AT WHICH INDIVIDUALS CAN SUBMIT FOR JUDGING IN A CONTEST USER GENERATED AUDIO AND VIDEO SHOWCASING THEIR TALENTS IN ARTISTIC FIELDS (U.S. CLS. 100, 101 AND 107).

FIRST USE 4-19-2012; IN COMMERCE 4-19-2012.

4,210,414. YGS, INC., ORLAND PARK, IL. SN 77-891,044.
PUB. 1-18-2011, FILED 12-10-2009.

GLOG

THE MARK CONSISTS OF STANDARD CHARACTERS WITHOUT CLAIM TO ANY PARTICULAR FONT, STYLE, SIZE, OR COLOR.

CLASS 42—SCIENTIFIC AND COMPUTER SERVICES

FOR PROVIDING A WEBSITE FEATURING INFORMATION ABOUT WEATHER; COMPUTER SERVICES, NAMELY, CREATING AN ON-LINE COMMUNITY FOR REGISTERED USERS TO PARTICIPATE IN DISCUSSIONS, GET FEEDBACK FROM THEIR PEERS, FORM VIRTUAL COMMUNITIES, AND ENGAGE IN SOCIAL NETWORKING; PROVIDING A WEBSITE FEATURING CLIMATE-RELATED DATA FOR USE BY OTHERS IN SCIENTIFIC STUDIES (U.S. CLS. 100 AND 101).

FIRST USE 5-0-2010; IN COMMERCE 5-0-2010.

CLASS 44—MEDICAL, BEAUTY AND AGRICULTURAL SERVICES

FOR PROVIDING A WEBSITE FEATURING GARDENING-RELATED DATA FOR USE BY OTHERS IN SCIENTIFIC STUDIES (U.S. CLS. 100 AND 101).

FIRST USE 5-0-2010; IN COMMERCE 5-0-2010.

CLASS 45—PERSONAL AND LEGAL SERVICES

FOR ONLINE SOCIAL NETWORKING IN THE FIELD OF GARDENING (U.S. CLS. 100 AND 101).

FIRST USE 5-0-2010; IN COMMERCE 5-0-2010.

4,210,415. IFA EDUCATIONAL FOUNDATION, WASHINGTON, DC. SN 77-891,836. PUB. 5-4-2010, FILED 12-11-2009.

IFA FRAN-GUARD

THE MARK CONSISTS OF STANDARD CHARACTERS WITHOUT CLAIM TO ANY PARTICULAR FONT, STYLE, SIZE, OR COLOR.

OWNER OF U.S. REG. NOS. 1,908,437, 2,186,317, AND OTHERS.

CLASS 35—ADVERTISING AND BUSINESS

FOR PROVIDING A WEBSITE ABOUT FRANCHISING OPPORTUNITIES; PROVIDING INFORMATION REGARDING FRANCHISING TO COMPANIES IN THE FRANCHISE INDUSTRY (U.S. CLS. 100, 101 AND 102).

FIRST USE 2-5-2010; IN COMMERCE 2-5-2010.

CLASS 41—EDUCATION AND ENTERTAINMENT

FOR EDUCATIONAL SERVICES, NAMELY, CONDUCTING CONFERENCES, SEMINARS, WORKSHOPS AND ONLINE COURSES IN THE FIELD OF FRANCHISING; PROVIDING ONLINE MAGAZINES, NEWSLETTERS, HANDBOOKS AND BOOKS IN THE FIELD OF FRANCHISING (U.S. CLS. 100, 101 AND 107).

FIRST USE 2-5-2010; IN COMMERCE 2-5-2010.

4,210,429. BANK OF AMERICA CORPORATION, CHARLOTTE, NC. SN 77-910,930. PUB. 5-3-2011, FILED 1-13-2010.

BOFA

THE MARK CONSISTS OF STANDARD CHARACTERS WITHOUT CLAIM TO ANY PARTICULAR FONT, STYLE, SIZE, OR COLOR.

PRIORITY CLAIMED UNDER SEC. 44(D) ON ICELAND APPLICATION NO. 1911/2009, FILED 7-16-2009.

OWNER OF U.S. REG. NO. 847,761.

CLASS 36—INSURANCE AND FINANCIAL

FOR FINANCIAL AFFAIRS AND MONETARY AFFAIRS, NAMELY, FINANCIAL INFORMATION, MANAGEMENT AND ANALYSIS SERVICES; BANKING SERVICES; FINANCIAL SERVICES, NAMELY, WEALTH MANAGEMENT SERVICES, MANAGEMENT AND BROKERAGE IN THE FIELDS OF STOCKS, BONDS, OPTIONS, COMMODITIES, FUTURES AND OTHER SECURITIES, AND THE INVESTMENT OF FUNDS OF OTHERS; FINANCIAL ANALYSIS; FINANCIAL MANAGEMENT AND CONSULTING; CAPITAL INVESTMENT SERVICES; PROVIDING FINANCIAL INFORMATION; FINANCIAL SERVICES IN THE NATURE OF INVESTMENT SERVICES; CREDIT AND DEBIT CARD SERVICES; FINANCIAL RESEARCH; AND PROVISION OF THESE SERVICES THROUGH AN ONLINE GLOBAL COMPUTER NETWORK; INVESTMENT AND FINANCIAL BANKING RESEARCH AND ANALYSIS (U.S. CLS. 100, 101 AND 102).

FIRST USE 3-21-2008; IN COMMERCE 3-21-2008.

CLASS 42—SCIENTIFIC AND COMPUTER SERVICES

FOR PROVISION OF NON-DOWNLOADABLE ONLINE COMPUTER SOFTWARE FOR ACCESSING FINANCIAL INFORMATION AND SERVICES THROUGH AN ONLINE GLOBAL COMPUTER NETWORK (U.S. CLS. 100 AND 101).

FIRST USE 3-21-2008; IN COMMERCE 3-21-2008.

4,210,434. SUN LIFE ASSURANCE COMPANY OF CANADA, TORONTO, ONTARIO, CANADA. SN 77-915,093. PUB. 11-16-2010, FILED 1-19-2010.



NO CLAIM IS MADE TO THE EXCLUSIVE RIGHT TO USE "STADIUM", APART FROM THE MARK AS SHOWN. THE MARK CONSISTS OF THE WORDS "SUN LIFE STADIUM" WITH A STYLIZED GLOBE ABOVE.

CLASS 16—PAPER GOODS AND PRINTED MATTER

FOR PAPER GOODS, NAMELY, POSTERS AND PRINTED EVENT PROGRAMS; NOTEPADS (U.S. CLS. 2, 5, 22, 23, 29, 37, 38 AND 50). FIRST USE 1-20-2010; IN COMMERCE 1-20-2010.

CLASS 35—ADVERTISING AND BUSINESS

FOR PROMOTING SPORTS COMPETITIONS, CONCERTS AND/OR EVENTS OF OTHERS; PROMOTING EXHIBITIONS AND TRADESHOWS FOR BUSINESS PURPOSES (U.S. CLS. 100, 101 AND 102). FIRST USE 1-20-2010; IN COMMERCE 1-20-2010.

CLASS 41—EDUCATION AND ENTERTAINMENT

FOR PROVIDING ONLINE INFORMATION AND VIA ELECTRONIC MAIL REGARDING ENTERTAINMENT AND SPORTING EVENTS; PROVIDING FACILITIES FOR EDUCATIONAL CONVENTIONS (U.S. CLS. 100, 101 AND 107). FIRST USE 1-20-2010; IN COMMERCE 1-20-2010.

CLASS 43—HOTEL AND RESTAURANT SERVICES

FOR ARENA SERVICES, NAMELY, PROVIDING FACILITIES FOR SPORTS, CONCERTS, CONVENTIONS AND EXHIBITIONS (U.S. CLS. 100 AND 101). FIRST USE 1-20-2010; IN COMMERCE 1-20-2010.

4,210,435. SUN LIFE ASSURANCE COMPANY OF CANADA, TORONTO, ONTARIO, CANADA. SN 77-915,399. PUB. 11-23-2010, FILED 1-19-2010.

SUN LIFE STADIUM

THE MARK CONSISTS OF STANDARD CHARACTERS

WITHOUT CLAIM TO ANY PARTICULAR FONT, STYLE, SIZE, OR COLOR.

NO CLAIM IS MADE TO THE EXCLUSIVE RIGHT TO USE "STADIUM", APART FROM THE MARK AS SHOWN.

CLASS 9—ELECTRICAL AND SCIENTIFIC APPARATUS

FOR DECORATIVE REFRIGERATOR MAGNETS (U.S. CLS. 21, 23, 26, 36 AND 38). FIRST USE 1-20-2010; IN COMMERCE 1-20-2010.

CLASS 16—PAPER GOODS AND PRINTED MATTER

FOR PAPER GOODS, NAMELY, POSTERS AND PRINTED EVENT PROGRAMS; NOTEPADS; PENS; PENCILS (U.S. CLS. 2, 5, 22, 23, 29, 37, 38 AND 50). FIRST USE 1-20-2010; IN COMMERCE 1-20-2010.

CLASS 18—LEATHER GOODS

FOR UMBRELLAS (U.S. CLS. 1, 2, 3, 22 AND 41). FIRST USE 1-20-2010; IN COMMERCE 1-20-2010.

CLASS 28—TOYS AND SPORTING GOODS

FOR SPORTING GOODS, NAMELY, FOOTBALLS (U.S. CLS. 22, 23, 38 AND 50). FIRST USE 1-20-2010; IN COMMERCE 1-20-2010.

CLASS 35—ADVERTISING AND BUSINESS

FOR PROMOTING SPORTS COMPETITIONS, CONCERTS AND/OR EVENTS OF OTHERS; PROMOTING EXHIBITIONS AND TRADESHOWS FOR BUSINESS PURPOSES (U.S. CLS. 100, 101 AND 102). FIRST USE 1-20-2010; IN COMMERCE 1-20-2010.

CLASS 41—EDUCATION AND ENTERTAINMENT

FOR PROVIDING ONLINE INFORMATION AND VIA ELECTRONIC MAIL REGARDING ENTERTAINMENT AND SPORTING EVENTS; PROVIDING FACILITIES FOR EDUCATIONAL CONVENTIONS (U.S. CLS. 100, 101 AND 107). FIRST USE 1-20-2010; IN COMMERCE 1-20-2010.

CLASS 43—HOTEL AND RESTAURANT SERVICES

FOR ARENA SERVICES, NAMELY, PROVIDING FACILITIES FOR SPORTS, CONCERTS, CONVENTIONS AND EXHIBITIONS (U.S. CLS. 100 AND 101). FIRST USE 1-20-2010; IN COMMERCE 1-20-2010.

4,210,440. WILDCARE, SAN RAFAEL, CA. SN 77-917,796. PUB. 6-7-2011, FILED 1-22-2010.

Live Well with Wildlife

THE MARK CONSISTS OF STANDARD CHARACTERS WITHOUT CLAIM TO ANY PARTICULAR FONT, STYLE, SIZE, OR COLOR.

NO CLAIM IS MADE TO THE EXCLUSIVE RIGHT TO USE "WILDLIFE", APART FROM THE MARK AS SHOWN.

CLASS 35—ADVERTISING AND BUSINESS

FOR CHARITABLE SERVICES, NAMELY, PUBLIC ADVOCACY TO PROMOTE AWARENESS OF WILD ANIMAL LIFE AND THE ENVIRONMENT, AND TO PROMOTE EDUCATION IN THE FIELD OF NATURE, WILDLIFE, AND ENVIRONMENTAL PRESERVATION; CHARITABLE SERVICES, NAMELY, PROMOTING PUBLIC AWARENESS OF ISSUES CONCERNING WILD ANIMAL LIFE AND THE ENVIRONMENT THROUGH A HOTLINE PHONE SERVICE (U.S. CLS. 100, 101 AND 102).

FIRST USE 1-15-2010; IN COMMERCE 1-15-2010.

CLASS 37—CONSTRUCTION AND REPAIR

FOR PEST CONTROL SERVICES, NAMELY, CAPTURING AND TRAPPING OF ANIMALS (U.S. CLS. 100, 103 AND 106).

FIRST USE 1-15-2010; IN COMMERCE 1-15-2010.

CLASS 39—TRANSPORTATION AND STORAGE

FOR HUMANE REMOVAL AND EFFECTIVE EXCLUSION OF NUISANCE ANIMALS; RESCUE OF WILD ANIMALS (U.S. CLS. 100 AND 105).

FIRST USE 1-15-2010; IN COMMERCE 1-15-2010.

CLASS 41—EDUCATION AND ENTERTAINMENT

FOR EDUCATIONAL SERVICES, NAMELY, ONSITE AND OUTREACH EDUCATIONAL PROGRAMS IN THE FIELDS OF WILD ANIMAL LIFE AND THE ENVIRONMENT; FIELD TRIPS CONDUCTED TO EDUCATE ABOUT ECOSYSTEMS, WILD ANIMAL LIFE, AND THE ENVIRONMENT, NAMELY, TAKING STUDENTS TO VARIOUS ECOSYSTEMS AND EDUCATING THEM ABOUT THE ENVIRONMENT; CONDUCTING OFFSITE EDUCATION PRESENTATIONS AT HIGH SCHOOL, MIDDLE AND ELEMENTARY SCHOOLS IN THE FIELDS OF WILD ANIMAL LIFE AND THE ENVIRONMENT; CONDUCTING OFFSITE EDUCATION PRESENTATIONS FOR ADULTS IN THE FIELDS OF WILD ANIMAL LIFE AND THE ENVIRONMENT; ANIMAL TRAINING (U.S. CLS. 100, 101 AND 107).

FIRST USE 1-15-2010; IN COMMERCE 1-15-2010.

4,210,447. DIRTY BEATS, LLC, WHITE PLAINS, NY. SN 77-922,054. PUB. 6-15-2010, FILED 1-28-2010.

DIRTY BEATS

THE MARK CONSISTS OF STANDARD CHARACTERS WITHOUT CLAIM TO ANY PARTICULAR FONT, STYLE, SIZE, OR COLOR.

CLASS 9—ELECTRICAL AND SCIENTIFIC APPARATUS

FOR PRERECORDED CDS AND DVDS FEATURING MUSIC (U.S. CLS. 21, 23, 26, 36 AND 38).

FIRST USE 12-5-2009; IN COMMERCE 12-5-2009.

CLASS 35—ADVERTISING AND BUSINESS

FOR RETAIL MUSIC AND RECORD STORE SERVICES; PROMOTING LIVE MUSIC CONCERTS AND DISC JOCKEY SERVICES FOR PARTIES AND SPECIAL EVENTS FOR OTHERS (U.S. CLS. 100, 101 AND 102).

FIRST USE 3-1-2008; IN COMMERCE 3-1-2008.

CLASS 41—EDUCATION AND ENTERTAINMENT

FOR ENTERTAINMENT, NAMELY, PROVIDING LIVE MUSIC CONCERTS AND DISC JOCKEY SERVICES FOR PARTIES AND SPECIAL EVENTS; PROVIDING INFORMATION RELATING TO LIVE PERFORMANCES, ROAD SHOWS, LIVE STAGE EVENTS, LIVE MUSIC CONCERTS AND AUDIENCE PARTICIPATION IN SUCH EVENTS; MULTI-MEDIA ENTERTAINMENT AND MUSIC PRODUCTION SERVICES IN THE NATURE OF RECORDING, PRODUCTION AND POST PRODUCTION SERVICES IN THE FIELDS OF MUSIC, VIDEO AND FILM (U.S. CLS. 100, 101 AND 107).

FIRST USE 3-1-2008; IN COMMERCE 3-1-2008.

CLASS 42—SCIENTIFIC AND COMPUTER SERVICES

FOR PROVIDING A WEB SITE ALLOWING USERS TO UPLOAD AND DOWNLOAD MUSIC (U.S. CLS. 100 AND 101).

FIRST USE 3-1-2008; IN COMMERCE 3-1-2008.

4,210,451. NEW VIEW GIFTS & ACCESSORIES, LTD., MEDIA, PA. SN 77-925,467. PUB. 11-30-2010, FILED 2-1-2010.

Front Street

THE MARK CONSISTS OF THE PHRASE "FRONT STREET" IN STYLIZED FORM.

CLASS 4—LUBRICANTS AND FUELS

FOR CANDLES; SCENTED CANDLES; FILLED CANDLES; TEA LIGHT CANDLES (U.S. CLS. 1, 6 AND 15).

FIRST USE 6-0-2011; IN COMMERCE 6-0-2011.

CLASS 16—PAPER GOODS AND PRINTED MATTER

FOR WALL DÉCOR, NAMELY, PHOTO COLLAGES; PHOTO ALBUMS (U.S. CLS. 2, 5, 22, 23, 29, 37, 38 AND 50).

FIRST USE 3-0-2010; IN COMMERCE 3-0-2010.

CLASS 19—NON-METALLIC BUILDING MATERIALS

FOR WALL PLAQUES MADE OF STONE, CONCRETE, OR MARBLE (U.S. CLS. 1, 12, 33 AND 50).

FIRST USE 8-0-2010; IN COMMERCE 8-0-2010.

CLASS 20—FURNITURE AND ARTICLES NOT OTHERWISE CLASSIFIED

FOR WALL DÉCOR, NAMELY, PHOTO FRAMES; WALL PLAQUES MADE OF PLASTER, WAX OR WOOD; MIRRORS; MIRROR FRAMES; PILLOWS; DISPLAY BOARDS FOR PICTURES, PHOTOGRAPHS, MEMOS, NOTE CARDS, OR OTHER PAPER-LIKE PRODUCTS (U.S. CLS. 2, 13, 22, 25, 32 AND 50).

FIRST USE 3-0-2010; IN COMMERCE 3-0-2010.

4,210,459. HUNTER DEFENSE TECHNOLOGIES, INC., DBA HDT ENGINEERED TECHNOLOGIES, SOLON, OH. SN 77-943,909. PUB. 3-15-2011, FILED 2-24-2010.

4,210,468. ALPHANET, INC., COCONUT GROVE, FL. SN 77-960,336. PUB. 8-3-2010, FILED 3-16-2010.

COPD BIG FAT REFERENCE GUIDE (BFRG)

HDT ENGINEERED TECHNOLOGIES

THE MARK CONSISTS OF STANDARD CHARACTERS WITHOUT CLAIM TO ANY PARTICULAR FONT, STYLE, SIZE, OR COLOR.

NO CLAIM IS MADE TO THE EXCLUSIVE RIGHT TO USE "ENGINEERED TECHNOLOGIES", APART FROM THE MARK AS SHOWN.

CLASS 11—ENVIRONMENTAL CONTROL APPARATUS

FOR MULTI FUEL BURNING HEATERS (DIESEL FUEL OR KEROSENE) FOR SHELTERS AND VEHICLES; POWERED, SELF-POWERED AND NON-POWERED HEATERS; FILTERS AND FILTERING DEVICES FOR AIR AND GAS CONDITIONING; AIR CONDITIONING APPARATUS; AIR COOLING APPARATUS; VENTILATION APPARATUS ENVIRONMENTAL CONTROL UNITS, NAMELY, HEATING, COOLING AND AIR FILTRATION UNITS (U.S. CLS. 13, 21, 23, 31 AND 34).

FIRST USE 7-31-2009; IN COMMERCE 7-31-2009.

CLASS 19—NON-METALLIC BUILDING MATERIALS

FOR NON-METAL SHELTER STRUCTURES; NON-METAL BUILDING MATERIALS, NAMELY, RIGID PIPES USED AS BEAMS IN BUILDINGS OR SHELTERS (U.S. CLS. 1, 12, 33 AND 50).

FIRST USE 7-31-2009; IN COMMERCE 7-31-2009.

CLASS 22—CORDAGE AND FIBERS

FOR TENTS; FABRIC SHELTERS; CAMOUFLAGE EQUIPMENT, NAMELY, NETS, TENTS, TEXTILE STORAGE BAGS NOT FOR TRAVEL PURPOSES, AND NON METAL STRAPS AND HARNESSSES FOR HANDLING LOADS; FABRICS SOLD AS AN INTEGRAL COMPONENT OF CAMOUFLAGE EQUIPMENT IN THE NATURE OF NETS, TENTS, TEXTILE STORAGE BAGS NOT FOR TRAVEL PURPOSES AND NON METAL STRAPS AND HARNESSSES FOR HANDLING LOADS (U.S. CLS. 1, 2, 7, 19, 22, 42 AND 50).

FIRST USE 7-31-2009; IN COMMERCE 7-31-2009.

CLASS 40—MATERIAL TREATMENT

FOR CUSTOM MANUFACTURE OF SHELTERS (U.S. CLS. 100, 103 AND 106).

FIRST USE 7-31-2010; IN COMMERCE 7-31-2010.

CLASS 42—SCIENTIFIC AND COMPUTER SERVICES

FOR ENGINEERING AND CUSTOM DESIGN SERVICES IN THE FIELDS OF MILITARY EQUIPMENT AND SPACE FLIGHT EQUIPMENT, NAMELY, ROBOTS AND ROBOTIC MANIPULATORS, RAPIDLY DEPLOYABLE SHELTER SYSTEMS, AIR FILTRATION AND ENVIRONMENTAL CONDITIONING SYSTEMS (U.S. CLS. 100 AND 101).

FIRST USE 7-31-2010; IN COMMERCE 7-31-2010.

THE MARK CONSISTS OF STANDARD CHARACTERS WITHOUT CLAIM TO ANY PARTICULAR FONT, STYLE, SIZE, OR COLOR.

OWNER OF U.S. REG. NOS. 3,093,616 AND 3,507,672.

NO CLAIM IS MADE TO THE EXCLUSIVE RIGHT TO USE "COPD" AND "REFERENCE GUIDE", APART FROM THE MARK AS SHOWN.

CLASS 9—ELECTRICAL AND SCIENTIFIC APPARATUS

FOR ELECTRONIC PUBLICATIONS, NAMELY, EDUCATIONAL GUIDES TARGETED TO INDIVIDUALS AFFECTED BY CHRONIC OBSTRUCTIVE PULMONARY DISEASE, RECORDED ON COMPUTER MEDIA (U.S. CLS. 21, 23, 26, 36 AND 38).

FIRST USE 12-0-2009; IN COMMERCE 12-0-2009.

CLASS 16—PAPER GOODS AND PRINTED MATTER

FOR PRINTED EDUCATIONAL GUIDES TARGETED TO INDIVIDUALS AFFECTED BY CHRONIC OBSTRUCTIVE PULMONARY DISEASE (U.S. CLS. 2, 5, 22, 23, 29, 37, 38 AND 50).

FIRST USE 1-0-2010; IN COMMERCE 1-0-2010.

CLASS 41—EDUCATION AND ENTERTAINMENT

FOR PROVIDING ON-LINE EDUCATIONAL GUIDES TARGETED TO INDIVIDUALS AFFECTED BY CHRONIC OBSTRUCTIVE PULMONARY DISEASE (U.S. CLS. 100, 101 AND 107).

FIRST USE 3-16-2009; IN COMMERCE 3-16-2009.

4,210,480. LAKOSKY, LEE, SALEM, IA. AND LAKOSKY, TIFFANY, SALEM, IA. SN 77-983,336. PUB. 9-8-2009, FILED 10-10-2008.

The Crush

THE MARK CONSISTS OF STANDARD CHARACTERS WITHOUT CLAIM TO ANY PARTICULAR FONT, STYLE, SIZE, OR COLOR.

CLASS 9—ELECTRICAL AND SCIENTIFIC APPARATUS

FOR PRE-RECORDED CDS, VIDEO TAPES, LASER DISKS AND DVDS FEATURING LIVE GAME HUNTING (U.S. CLS. 21, 23, 26, 36 AND 38).

FIRST USE 12-15-2009; IN COMMERCE 12-15-2009.

CLASS 14—JEWELRY

FOR JEWELRY AND IMITATION JEWELRY (U.S. CLS. 2, 27, 28 AND 50).
FIRST USE 1-30-2010; IN COMMERCE 1-30-2010.

CLASS 25—CLOTHING

FOR HATS; HEADGEAR IN THE NATURE OF TOBOGGAN HATS, SKULL CAPS AND SNOW CAPS; SHIRTS; SWEATSHIRTS (U.S. CLS. 22 AND 39).
FIRST USE 1-0-2009; IN COMMERCE 1-0-2009.

4,210,490. SMARTLIDAR INC, AUSTIN, TX. SN 85-012,057.
PUB. 9-7-2010, FILED 4-12-2010.

SmartLiDAR

THE MARK CONSISTS OF STANDARD CHARACTERS WITHOUT CLAIM TO ANY PARTICULAR FONT, STYLE, SIZE, OR COLOR.

CLASS 9—ELECTRICAL AND SCIENTIFIC APPARATUS

FOR SOFTWARE SYSTEM FOR LIDAR GEOSPATIAL DATA PROCESSING VISUALIZATION, MANIPULATION AND INTEGRATION OF GEOGRAPHIC INFORMATION WITH GRAPHICAL USER INTERFACE (U.S. CLS. 21, 23, 26, 36 AND 38).
FIRST USE 9-1-2010; IN COMMERCE 1-3-2011.

CLASS 42—SCIENTIFIC AND COMPUTER SERVICES

FOR DESIGN AND DEVELOPMENT OF COMPUTER SOFTWARE; DEVELOPING COMPUTER SOFTWARE; IMAGE PROCESSING SOFTWARE DESIGN; SOFTWARE DEVELOPMENT AND PRODUCT DEVELOPMENT IN THE FIELD LIDAR AND POINT CLOUD DATA PROCESSING (U.S. CLS. 100 AND 101).
FIRST USE 9-1-2010; IN COMMERCE 1-3-2011.

4,210,495. NIKE, INC., BEAVERTON, OR. SN 85-012,215.
PUB. 7-27-2010, FILED 4-12-2010.

T90

THE MARK CONSISTS OF STANDARD CHARACTERS WITHOUT CLAIM TO ANY PARTICULAR FONT, STYLE, SIZE, OR COLOR.

OWNER OF U.S. REG. NO. 3,618,407.

CLASS 18—LEATHER GOODS

FOR BAGS, NAMELY, ALL-PURPOSE SPORTS BAGS, TOTE BAGS, DUFFLE BAGS, MESSENGER BAGS AND BACKPACKS (U.S. CLS. 1, 2, 3, 22 AND 41).
FIRST USE 7-31-2008; IN COMMERCE 7-31-2008.

CLASS 25—CLOTHING

FOR FOOTWEAR; APPAREL, NAMELY, SHIRTS, T-SHIRTS, JERSEYS, JACKETS (U.S. CLS. 22 AND 39).
FIRST USE 1-31-2001; IN COMMERCE 1-31-2001.

4,210,496. NIKE, INC., BEAVERTON, OR. SN 85-012,218.
PUB. 7-27-2010, FILED 4-12-2010.

MERCURIAL

THE MARK CONSISTS OF STANDARD CHARACTERS WITHOUT CLAIM TO ANY PARTICULAR FONT, STYLE, SIZE, OR COLOR.

CLASS 18—LEATHER GOODS

FOR BAGS, NAMELY, ALL-PURPOSE SPORTS BAGS, TOTE BAGS, DUFFLE BAGS, MESSENGER BAGS AND BACKPACKS (U.S. CLS. 1, 2, 3, 22 AND 41).
FIRST USE 7-31-2001; IN COMMERCE 7-31-2001.

CLASS 25—CLOTHING

FOR FOOTWEAR (U.S. CLS. 22 AND 39).
FIRST USE 3-31-1998; IN COMMERCE 3-31-1998.

4,210,507. SUMMER INFANT (USA), INC., WOONSOCKET, RI. SN 85-023,079. PUB. 10-26-2010, FILED 4-26-2010.

Kiddopotamus

THE MARK CONSISTS OF STANDARD CHARACTERS WITHOUT CLAIM TO ANY PARTICULAR FONT, STYLE, SIZE, OR COLOR.

OWNER OF U.S. REG. NO. 2,414,463.

CLASS 12—VEHICLES

FOR COVERS FOR BABY STROLLERS AND CHILDREN'S CAR SEATS; WATERPROOF LINERS AND PADS FOR LINING CHILDREN'S CAR SEATS AND STROLLERS; WATERPROOF VEHICLE SEAT LINERS; SHADE COVERS FOR BABY STROLLERS; VEHICLE SEAT COVER IN THE NATURE OF A PROTECTIVE MAT THAT COVERS THE SEAT FOR USE WITH AN INFANT OR CHILD CAR SEAT; INFANT/CHILD PROTECTIVE BARRIER, NAMELY, AN ADJUSTABLE FITTED COVERING FOR SHOPPING CARTS (U.S. CLS. 19, 21, 23, 31, 35 AND 44).
FIRST USE 7-3-2003; IN COMMERCE 7-3-2003.

CLASS 20—FURNITURE AND ARTICLES NOT OTHERWISE CLASSIFIED

FOR ADJUSTABLE, REMOVABLE INFANT BODY SUPPORT MATS NOT FOR MEDICAL PURPOSES FOR USE WITH INFANT CARRIERS, STROLLERS, AND CAR SEATS; HEAD SUPPORT CUSHION FOR USE WITH INFANT AND TODDLER CAR SEATS AND STROLLERS; WATERPROOF BOOSTER SEAT LINERS; PORTABLE INFANT CHANGING KIT CONSISTING PRIMARILY OF PADDED DIAPER-CHANGING MAT AND ATTACHED STORAGE POCKETS; INFANT/CHILD PROTECTIVE BARRIER, NAMELY, AN ADJUSTABLE FITTED COVERING FOR HIGH CHAIRS; PADDED COVERS FOR USE ON VARIOUS STRAPS (U.S. CLS. 2, 13, 22, 25, 32 AND 50).

FIRST USE 8-31-2000; IN COMMERCE 8-31-2000.

CLASS 24—FABRICS

FOR CONTOURED BABY BLANKET, WHICH SECURELY SLIPS AROUND BABY; DIAPER-CHANGING PADS NOT OF PAPER; CHILD'S PORTABLE PLASTIC, VINYL AND TEXTILE PLACEMATS; PLACEMATS MADE OF PLASTIC; CHILDREN'S BLANKETS; CHILDREN'S SECURITY BLANKETS; FABRIC COVERS FOR USE ON VARIOUS STRAPS (U.S. CLS. 42 AND 50).

FIRST USE 9-26-2011; IN COMMERCE 9-26-2011.

CLASS 25—CLOTHING

FOR SWADDLING CLOTHES, NAMELY, ADJUSTABLE WRAP FOR USE WITH BABY; CLOTHING, NAMELY, WRAP-AROUNDS; INFANT AND TODDLER ONE-PIECE CLOTHING; INFANT SLEEPERS; INFANT WEAR; ONE-PIECE GARMENT FOR INFANTS AND TODDLERS; SLEEP PRODUCTS FOR INFANTS, NAMELY, ADJUSTABLE WRAP FOR USE WITH AN INFANT; INFANT-WEARABLE BLANKETS, NAMELY, BABY BUNTINGS; INFANTS' OR CHILDREN'S BIBS, NAMELY, PLASTIC BIBS; SLEEPING GARMENTS (U.S. CLS. 22 AND 39).

FIRST USE 2-28-2002; IN COMMERCE 2-28-2002.

4,210,516. SMARTPOOL, INCORPORATED, LAKEWOOD, NJ. SN 85-033,865. PUB. 5-3-2011, FILED 5-10-2010.

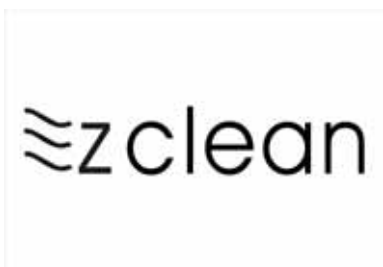

NO CLAIM IS MADE TO THE EXCLUSIVE RIGHT TO USE "CLEAN", APART FROM THE MARK AS SHOWN.

THE MARK CONSISTS OF THE WORD "E Z CLEAN" WITH THE LETTER "E" APPEARING AS THREE STYLIZED WAVY HORIZONTAL LINES.

CLASS 1—CHEMICALS

FOR CHEMICALS FOR THE PURIFICATION OF WATER USED IN SWIMMING POOLS; WATER SOFTENING CHEMICALS FOR USE IN SWIMMING POOLS; WATER PURIFYING CHEMICALS FOR SWIMMING POOLS; WATER TREATMENT CHEMICALS FOR USE IN SWIMMING POOLS AND SPAS (U.S. CLS. 1, 5, 6, 10, 26 AND 46).

FIRST USE 9-1-2011; IN COMMERCE 9-1-2011.

CLASS 7—MACHINERY

FOR AUTOMATIC SWIMMING POOL CLEANERS; AUTOMATIC SWIMMING POOL SWEEPERS; BOTTOM CLEANING MACHINES IN THE NATURE OF VACUUMS FOR SWIMMING POOLS; SKIMMERS, NAMELY, DIVERTERS, FOR CLEANING SWIMMING POOLS; WATER PUMPS FOR RECYCLING WATER IN SWIMMING POOLS; ROBOTIC SWIMMING POOL VACUUM CLEANING MACHINES; SWIMMING POOL SWEEPING MACHINES; AUTOMATIC SWIMMING POOL CLEANING APPARATUS IN THE NATURE OF SWEEPERS; AUTOMATIC SWIMMING POOL CLEANING MACHINES (U.S. CLS. 13, 19, 21, 23, 31, 34 AND 35).

FIRST USE 9-1-2011; IN COMMERCE 9-1-2011.

CLASS 11—ENVIRONMENTAL CONTROL APPARATUS

FOR WATER FILTERS FOR USE WITH SWIMMING POOLS; INSTALLATIONS FOR THE TREATMENT OF WATER USED IN SWIMMING POOLS, NAMELY, WATER CLEANING AND FILTERING UNITS; FILTERS FOR WATER PURIFIERS; WATER PURIFIERS (U.S. CLS. 13, 21, 23, 31 AND 34).

FIRST USE 9-1-2011; IN COMMERCE 9-1-2011.

4,210,528. DREAMTRAP COMMERCIALS LTD., LIMASSOL, CYPRUS. SN 85-047,171. PUB. 10-19-2010, FILED 5-25-2010.

Dreamtrap

THE MARK CONSISTS OF STYLIZED WORDING "DREAMTRAP".

CLASS 42—SCIENTIFIC AND COMPUTER SERVICES

FOR DEVELOPING COMPUTER SOFTWARE FOR COMPREHENSIVE RESOURCE-INTENSIVE ANALYSIS OF BIOMETRIC DATA ON A SERVER; DESIGN AND DEVELOPMENT OF COMPUTER HARDWARE AND SOFTWARE; DESIGN AND DEVELOPMENT OF SOFTWARE FOR EMBEDDED SYSTEMS; DESIGN AND DEVELOPMENT OF BIOMETRIC SENSORS FOR NON-MEDICAL USE (U.S. CLS. 100 AND 101).

FIRST USE 12-20-2009; IN COMMERCE 10-5-2011.

CLASS 44—MEDICAL, BEAUTY AND AGRICULTURAL SERVICES

FOR PROVIDING A WEBSITE FEATURING INFORMATION ABOUT HEALTH, SLEEP, AND WELLNESS; PROVIDING ONLINE DATABASE VIA A WEBSITE ABOUT USER'S ACTIVITY AND SLEEP AS COLLECTED BY WEARABLE SENSORS; PROVIDING ADVICE REGARDING SLEEP AND HEALTH VIA WEBSITE, EMAIL, INSTANT MESSAGING AND OTHER ELECTRONIC COMMUNICATION MEANS (U.S. CLS. 100 AND 101).

FIRST USE 12-20-2009; IN COMMERCE 10-5-2011.

4,210,530. SCOTT, CORTNEY, SAN DIEGO, CA. SN 85-048,775. PUB. 10-26-2010, FILED 5-26-2010.

4,210,535. ABBOTT DIABETES CARE INC., ALAMEDA, CA. SN 85-053,194. PUB. 5-3-2011, FILED 6-2-2010.

Exodus Army

THE MARK CONSISTS OF STANDARD CHARACTERS WITHOUT CLAIM TO ANY PARTICULAR FONT, STYLE, SIZE, OR COLOR.

CLASS 9—ELECTRICAL AND SCIENTIFIC APPARATUS

FOR DIGITAL MATERIALS, NAMELY, CDS, DVDS FEATURING MUSIC (U.S. CLS. 21, 23, 26, 36 AND 38). FIRST USE 3-3-2009; IN COMMERCE 3-3-2009.

CLASS 25—CLOTHING

FOR HATS; SWEAT SHIRTS; T-SHIRTS (U.S. CLS. 22 AND 39). FIRST USE 4-1-2010; IN COMMERCE 4-1-2010.

CLASS 41—EDUCATION AND ENTERTAINMENT

FOR ENTERTAINMENT IN THE NATURE OF LIVE PERFORMANCES BY MUSICAL BAND; MUSIC PRODUCTION SERVICES (U.S. CLS. 100, 101 AND 107). FIRST USE 3-3-2010; IN COMMERCE 3-3-2010.

4,210,532. HORNY TOAD ACTIVEWEAR, INC., SANTA BARBARA, CA. SN 85-050,716. PUB. 10-26-2010, FILED 5-28-2010.

LIVE TOADALLY

THE MARK CONSISTS OF STANDARD CHARACTERS WITHOUT CLAIM TO ANY PARTICULAR FONT, STYLE, SIZE, OR COLOR.

CLASS 25—CLOTHING

FOR SHIRTS, CAPRIS, COATS, SWEATERS, SWEAT-SHIRTS, JACKETS, PULLOVERS, VESTS, PANTS, SHORTS, BELTS, HATS, GLOVES, SCARVES, FLEECE CLOTHING, NAMELY, SHIRTS, VESTS, PANTS, GLOVES, AND SCARVES, AND OUTERWEAR, NAMELY, PARKAS, OVERCOATS, RAIN AND WEATHER RESISTANT JACKETS, AND RAIN AND WEATHER RESISTANT PANTS (U.S. CLS. 22 AND 39). FIRST USE 2-15-2011; IN COMMERCE 2-15-2011.

CLASS 35—ADVERTISING AND BUSINESS

FOR RETAIL STORE SERVICES, AND ONLINE RETAIL STORE SERVICES FEATURING CLOTHING AND ACCESSORIES (U.S. CLS. 100, 101 AND 102). FIRST USE 4-8-2011; IN COMMERCE 4-8-2011.



THE COLOR(S) BLACK, BLUE, WHITE, YELLOW, ORANGE AND SILVER IS/ARE CLAIMED AS A FEATURE OF THE MARK.

THE MARK CONSISTS OF A BUTTERFLY WITH A SILVER BODY, BLACK WINGS, YELLOW AND ORANGE OBLONG SHAPES ON THE WINGS WITH TWO ROWS OF WHITE SPOTS GOING AROUND THE OBLONG SHAPES AND WITH BLUE SHADING.

CLASS 5—PHARMACEUTICALS

FOR MEDICAL DIAGNOSTIC TEST STRIPS FOR USE IN THE FIELD OF MONITORING BLOOD GLUCOSE LEVELS (U.S. CLS. 6, 18, 44, 46, 51 AND 52). FIRST USE 3-8-2012; IN COMMERCE 3-8-2012.

CLASS 10—MEDICAL APPARATUS

FOR MEDICAL MACHINES AND APPARATUS, NAMELY, GLUCOSE METERS (U.S. CLS. 26, 39 AND 44). FIRST USE 4-18-2012; IN COMMERCE 4-18-2012.

4,210,550. PHAROS HOSPITALITY, LLC, CHARLOTTE, NC. SN 85-065,210. PUB. 11-15-2011, FILED 6-17-2010.

PHAROS HOSPITALITY

THE MARK CONSISTS OF STANDARD CHARACTERS WITHOUT CLAIM TO ANY PARTICULAR FONT, STYLE, SIZE, OR COLOR.

NO CLAIM IS MADE TO THE EXCLUSIVE RIGHT TO USE "HOSPITALITY", APART FROM THE MARK AS SHOWN.

CLASS 36—INSURANCE AND FINANCIAL

FOR REAL ESTATE ACQUISITION SERVICES; REAL ESTATE AND HOSPITALITY SERVICES, NAMELY, IN MANAGEMENT OF HOTELS, MOTELS, INNS AND RESORTS FOR OTHERS (U.S. CLS. 100, 101 AND 102). FIRST USE 5-21-2010; IN COMMERCE 5-21-2010.

CLASS 43—HOTEL AND RESTAURANT SERVICES

FOR HOTEL AND RESTAURANT SERVICES (U.S. CLS. 100 AND 101).
FIRST USE 5-21-2010; IN COMMERCE 5-21-2010.

4,210,551. LIBERTY GLOBAL LOGISTICS LLC, LAKE SUCCESS, NY. SN 85-066,207. PUB. 6-14-2011, FILED 6-18-2010.



THE COLOR(S) BLACK, BLUE AND RED IS/ARE CLAIMED AS A FEATURE OF THE MARK.

THE MARK CONSISTS OF THE BLACK WORDING "LGL" BENEATH A BLUE GLOBE WITH A RED CURVED LINE.

CLASS 16—PAPER GOODS AND PRINTED MATTER

FOR PASSPORT COVERS; SELF-ADHESIVE STICKERS; BUSINESS CARDS; LETTERHEAD PAPER AND ENVELOPES (U.S. CLS. 2, 5, 22, 23, 29, 37, 38 AND 50).
FIRST USE 9-21-2010; IN COMMERCE 9-21-2010.

CLASS 21—HOUSEWARES AND GLASS

FOR COFFEE MUGS (U.S. CLS. 2, 13, 23, 29, 30, 33, 40 AND 50).
FIRST USE 12-6-2010; IN COMMERCE 12-6-2010.

CLASS 25—CLOTHING

FOR T-SHIRTS; HATS; COVERALLS AND POLO SHIRTS (U.S. CLS. 22 AND 39).
FIRST USE 12-6-2010; IN COMMERCE 12-6-2010.

CLASS 28—TOYS AND SPORTING GOODS

FOR GOLF BALLS AND GOLF BALL MARKERS (U.S. CLS. 22, 23, 38 AND 50).
FIRST USE 1-9-2012; IN COMMERCE 1-9-2012.

4,210,555. LIFE + GEAR, INC., DEL MAR, CA. SN 85-068,617. PUB. 11-16-2010, FILED 6-22-2010.

PREPARE FOR LIFE

THE MARK CONSISTS OF STANDARD CHARACTERS WITHOUT CLAIM TO ANY PARTICULAR FONT, STYLE, SIZE, OR COLOR.

CLASS 8—HAND TOOLS

FOR HAND TOOLS, NAMELY, EMERGENCY AUTO GLASS BREAKERS AND SEAT BELT CUTTERS (U.S. CLS. 23, 28 AND 44).
FIRST USE 3-1-2012; IN COMMERCE 3-1-2012.

CLASS 9—ELECTRICAL AND SCIENTIFIC APPARATUS

FOR SAFETY EQUIPMENT, NAMELY, CRANK POWERED CELL PHONE CHARGER; CRANK POWERED RADIO; COMPASS; EMERGENCY FLASHER, NAMELY, EMERGENCY BEACON LIGHT; SIGNALING WHISTLE; EMERGENCY PREPAREDNESS KITS CONTAINING SIGNALING WHISTLE WITH BUILT-IN COMPASS AND MAGNIFYING GLASS, EMERGENCY REFLECTIVE MIRROR, A FIRST AID KIT, PROTECTIVE PONCHO, THERMAL BLANKET, PAPER PAD, PEN, LEATHER GLOVES, MULTIFUNCTION TOOL COMPRISED OF A COMPASS, RADIO, SIREN, AND FLASHLIGHT, WATERPROOF DOCUMENT BAG, PERSONAL HYGIENE KIT, AND EMERGENCY PACKS OF WATER (U.S. CLS. 21, 23, 26, 36 AND 38).
FIRST USE 11-1-2011; IN COMMERCE 11-1-2011.

CLASS 11—ENVIRONMENTAL CONTROL APPARATUS

FOR FLASHLIGHTS, LANTERNS, CRANK POWERED PORTABLE LAMPS, CRANK POWERED FLASHLIGHTS, KEYCHAIN FLASHLIGHTS (U.S. CLS. 13, 21, 23, 31 AND 34).
FIRST USE 12-1-2011; IN COMMERCE 12-1-2011.

CLASS 18—LEATHER GOODS

FOR BACKPACKS (U.S. CLS. 1, 2, 3, 22 AND 41).
FIRST USE 11-1-2011; IN COMMERCE 11-1-2011.

4,210,560. CENTRAL FIBER LLC, WELLSVILLE, KS. SN 85-074,201. PUB. 11-23-2010, FILED 6-29-2010.



OWNER OF U.S. REG. NOS. 2,192,071 AND 2,192,072.
NO CLAIM IS MADE TO THE EXCLUSIVE RIGHT TO USE "FIBER", APART FROM THE MARK AS SHOWN.
THE MARK CONSISTS OF THE WORDS "CENTRAL" AND "FIBER" WITH A CIRCLE BETWEEN THE WORDS, AND WITH RANDOM INTERSECTING LINES PRESENTED WITHIN THE CIRCLE.

CLASS 1—CHEMICALS

FOR FIBER AND CHEMICAL COMPOUNDS FOR APPLYING A COATING TO SOIL OR THE LIKE FOR EROSION CONTROL PURPOSES (U.S. CLS. 1, 5, 6, 10, 26 AND 46).
FIRST USE 11-11-2011; IN COMMERCE 11-11-2011.

CLASS 17—RUBBER GOODS

FOR FIBER PRODUCTS MADE FROM VIRGIN AND RECYCLED MATERIALS, NAMELY, FIBER INSULATION FOR BUILDINGS AND OTHER INSULATION APPLICATIONS (U.S. CLS. 1, 5, 12, 13, 35 AND 50).
FIRST USE 11-2-2011; IN COMMERCE 11-2-2011.

CLASS 22—CORDAGE AND FIBERS

FOR FIBER PRODUCTS MADE FROM VIRGIN AND RECYCLED MATERIALS, NAMELY, INDUSTRIAL FIBER PRODUCTS INTENDED FOR USE AS INGREDIENTS FOR PLASTICS, COATINGS, CAULKS, PAINTS, ASPHALTS, AND THE LIKE; AND TEMPORARY PROTECTIVE COVER IN THE NATURE OF VIRGIN OR RECYCLED FIBERS IMPREGNATED WITH A CHEMICAL FORMULATION TO BE MIXED WITH WATER TO FORM A SLURRY FOR LANDFILLS AND THE LIKE (U.S. CLS. 1, 2, 7, 19, 22, 42 AND 50).

FIRST USE 12-5-2011; IN COMMERCE 12-5-2011.

CLASS 31—NATURAL AGRICULTURAL PRODUCTS

FOR FIBER PRODUCTS MADE FROM VIRGIN AND RECYCLED MATERIALS, NAMELY, MULCH PRODUCTS FOR HYDROSEEDING APPLICATIONS (U.S. CLS. 1 AND 46).

FIRST USE 11-11-2011; IN COMMERCE 11-11-2011.

4,210,566. FORTINET, INC., SUNNYVALE, CA. SN 85-076,574. PUB. 11-22-2011, FILED 7-1-2010.

FORTICARE

THE MARK CONSISTS OF STANDARD CHARACTERS WITHOUT CLAIM TO ANY PARTICULAR FONT, STYLE, SIZE, OR COLOR.

CLASS 35—ADVERTISING AND BUSINESS

FOR PROVIDING RETURN MERCHANDISE AUTHORIZATION SERVICES, NAMELY, MANAGEMENT OF RETURNED MERCHANDISE AND ARRANGEMENT OF REPAIR AND REPLACEMENT OF GOODS FOR CUSTOMERS, NAMELY, COMPUTER SOFTWARE, FIRMWARE, HARDWARE, AND NETWORK SYSTEMS PRODUCTS; ARRANGING FOR OTHERS THE REPLACEMENT OF COMPUTER SOFTWARE, FIRMWARE, HARDWARE AND NETWORK SYSTEMS PRODUCTS (U.S. CLS. 100, 101 AND 102).

FIRST USE 3-0-2005; IN COMMERCE 3-0-2005.

CLASS 37—CONSTRUCTION AND REPAIR

FOR TECHNICAL SUPPORT SERVICES, NAMELY, TROUBLESHOOTING IN THE NATURE OF THE REPAIR OF COMPUTER HARDWARE AND COMPUTER NETWORKING HARDWARE; PROVIDING ON-SITE MAINTENANCE IN CONNECTION WITH COMPUTER HARDWARE AND COMPUTER NETWORKING HARDWARE; INSTALLATION, MAINTENANCE AND REPAIR OF COMPUTER HARDWARE AND COMPUTER NETWORKING HARDWARE (U.S. CLS. 100, 103 AND 106).

FIRST USE 3-0-2005; IN COMMERCE 3-0-2005.

CLASS 42—SCIENTIFIC AND COMPUTER SERVICES

FOR COMPUTER CONSULTING SERVICES, NAMELY, COMPUTER SOFTWARE, HARDWARE, FIRMWARE, AND NETWORK CONSULTING SERVICES; COMPUTER CONSULTING SERVICES, NAMELY, COMPUTER SOFTWARE, HARDWARE, FIRMWARE, AND NETWORK SECURITY CONSULTING SERVICES; TECHNICAL SUPPORT SERVICES RELATED TO THE PROVISION OF ANTIVIRUS, ANTI-SPAM, ANTI-SPYWARE, ANTI-MALWARE, WEB-CONTENT FILTERING AND/OR INTRUSION DETECTION AND PREVENTION FOR NETWORK AND COMPUTER SECURITY; TROUBLESHOOTING OF COMPUTER SOFTWARE, FIRMWARE, AND HARDWARE PROBLEMS AND TECHNICAL MONITORING OF NETWORK SYSTEMS; COMPUTER SERVICES, NAMELY, PROVIDING A WEB-BASED SYSTEM AND ONLINE PORTAL FOR USERS TO ACCESS AND TRACK CUSTOMER SUPPORT REQUEST TICKETS, TO ACCESS REAL-TIME CUSTOMER SUPPORT SERVICE, TO ACCESS TECHNICAL DOCUMENTATION, TO ACCESS TROUBLESHOOTING GUIDES, TO REQUEST TECHNICAL SUPPORT, AND TO TROUBLESHOOT SOFTWARE, FIRMWARE, HARDWARE, AND NETWORK ISSUES; UPGRADING AND UPDATING OF COMPUTER SOFTWARE; TECHNICAL SUPPORT SERVICES, NAMELY, PROVIDING REPORTS IN THE FIELDS OF COMPUTER SOFTWARE, FIRMWARE, HARDWARE, AND NETWORK SYSTEMS FOR DIAGNOSING COMPUTER HARDWARE AND SOFTWARE PROBLEMS; TECHNICAL SUPPORT SERVICES, NAMELY, PROVIDING A WEBSITE FEATURING INFORMATION FOR DIAGNOSING COMPUTER SOFTWARE, FIRMWARE, HARDWARE, AND NETWORK SYSTEMS PROBLEMS; TECHNICAL SUPPORT SERVICES, NAMELY, ENGINEERING SERVICES IN CONNECTION WITH COMPUTER SOFTWARE, FIRMWARE, HARDWARE, AND NETWORK SYSTEMS; TECHNICAL SUPPORT SERVICES, NAMELY, TROUBLESHOOTING IN THE NATURE OF THE REPAIR OF COMPUTER SOFTWARE AND FIRMWARE; PROVIDING ON-SITE MAINTENANCE IN CONNECTION WITH COMPUTER SOFTWARE AND FIRMWARE; INSTALLATION, MAINTENANCE AND REPAIR OF COMPUTER SOFTWARE AND FIRMWARE (U.S. CLS. 100 AND 101).

FIRST USE 3-0-2005; IN COMMERCE 3-0-2005.

4,210,570. HLT DOMESTIC IP LLC, MCLEAN, VA. SN 85-079,490. PUB. 11-2-2010, FILED 7-7-2010.

STAY CONNECTED @ DOUBLETREE

THE MARK CONSISTS OF STANDARD CHARACTERS WITHOUT CLAIM TO ANY PARTICULAR FONT, STYLE, SIZE, OR COLOR.

OWNER OF U.S. REG. NOS. 1,094,809, 3,365,776, AND OTHERS.

CLASS 38—COMMUNICATION

FOR PROVIDING HIGH SPEED ACCESS TO AREA NETWORKS AND GLOBAL COMPUTER INFORMATION NETWORKS (U.S. CLS. 100, 101 AND 104).

FIRST USE 6-30-2011; IN COMMERCE 6-30-2011.

CLASS 43—HOTEL AND RESTAURANT SERVICES

FOR HOTEL SERVICES (U.S. CLS. 100 AND 101).

FIRST USE 6-30-2011; IN COMMERCE 6-30-2011.

4,210,571. STEVENSON UNIVERSITY, INC., STEVENSON, MD. SN 85-080,029. PUB. 5-3-2011, FILED 7-8-2010.



THE MARK CONSISTS OF A STYLIZED LETTER "S" WITH CURVED LINED AREAS ON EACH SIDE.

CLASS 25—CLOTHING

FOR CLOTHING, NAMELY, SHIRTS, T-SHIRTS, BLOUSES, PANTS, SHORTS, SWEATSHIRTS, SWEAT-PANTS, WARM-UP SUITS, SLEEPWEAR, SWEATERS, JACKETS, COATS, HATS, VISORS, UNIFORMS, UNDERGARMENTS, SCARVES, SOCKS, TIES, INFANTWEAR, ALL OF THE FORESAID GOODS SPECIFICALLY EXCLUDING ITEMS DESIGNED FOR, OR TARGETED TO, BICYCLISTS (U.S. CLS. 22 AND 39). FIRST USE 9-0-2010; IN COMMERCE 9-0-2010.

CLASS 41—EDUCATION AND ENTERTAINMENT

FOR ARRANGING AND CONDUCTING ATHLETIC EVENTS IN THE NATURE OF BASEBALL, BASKETBALL, CHEER, CROSS COUNTRY, FIELD HOCKEY, FOOTBALL, GOLF, LACROSSE, SOFTBALL, SOCCER, TENNIS, TRACK AND FIELD, AND VOLLEYBALL, AND SPECIFICALLY EXCLUDING ATHLETIC EVENTS OR RACES RELATED TO CYCLING, RECREATION PROGRAMS IN THE NATURE OF ATHLETIC TRAINING, INTRAMURALS AND SPORTS CAMPS, AND BASEBALL, BASKETBALL, CHEER, CROSS COUNTRY, FIELD HOCKEY, FOOTBALL, GOLF, LACROSSE, SOFTBALL, SOCCER, TENNIS, TRACK AND FIELD, AND VOLLEYBALL TOURNAMENTS, AND SPECIFICALLY EXCLUDING PROGRAMS RELATED TO CYCLING; ARRANGING AND CONDUCTING EDUCATIONAL CONFERENCES; ENTERTAINMENT SERVICES, NAMELY, ATHLETIC PERFORMANCES IN THE NATURE OF COMPETITIONS IN THE FIELD OF ATHLETICS, SPECIFICALLY EXCLUDING COMPETITIONS RELATED TO CYCLING, CULTURAL EVENTS IN THE NATURE OF DANCE PERFORMANCES AND LIVE MUSICAL AND LIVE DRAMATIC PERFORMANCES (U.S. CLS. 100, 101 AND 107).

FIRST USE 5-0-2011; IN COMMERCE 5-0-2011.

4,210,572. STEVENSON UNIVERSITY, INC., STEVENSON, MD. SN 85-080,039. PUB. 5-3-2011, FILED 7-8-2010.



THE MARK CONSISTS OF A PROFILE OF THE HEAD AND NECK OF A MUSTANG HORSE WITH A STYLIZED LETTER "S" INSIDE THE HORSE'S HEAD AND NECK AREA.

CLASS 25—CLOTHING

FOR CLOTHING, NAMELY, SHIRTS, T-SHIRTS, BLOUSES, PANTS, SHORTS, SWEATSHIRTS, SWEAT-PANTS, WARM-UP SUITS, SLEEPWEAR, SWEATERS, JACKETS, COATS, HATS, VISORS, UNIFORMS, UNDERGARMENTS, SCARVES, SOCKS, TIES, INFANTWEAR (U.S. CLS. 22 AND 39).

FIRST USE 9-0-2010; IN COMMERCE 9-0-2010.

CLASS 41—EDUCATION AND ENTERTAINMENT

FOR ARRANGING AND CONDUCTING ATHLETIC EVENTS IN THE NATURE OF BASEBALL, BASKETBALL, CHEER, CROSS COUNTRY, FIELD HOCKEY, FOOTBALL, GOLF, LACROSSE, SOFTBALL, SOCCER, TENNIS, TRACK AND FIELD, AND VOLLEYBALL, RECREATION PROGRAMS IN THE NATURE OF ATHLETIC TRAINING, INTRAMURALS AND SPORTS CAMPS, AND BASEBALL, BASKETBALL, CHEER, CROSS COUNTRY, FIELD HOCKEY, FOOTBALL, GOLF, LACROSSE, SOFTBALL, SOCCER, TENNIS, TRACK AND FIELD, AND VOLLEYBALL TOURNAMENTS; ARRANGING AND CONDUCTING EDUCATIONAL CONFERENCES; ENTERTAINMENT SERVICES, NAMELY, ATHLETIC PERFORMANCES IN THE NATURE OF COMPETITIONS IN THE FIELD OF ATHLETICS, CULTURAL EVENTS IN THE NATURE OF DANCE PERFORMANCES AND LIVE MUSICAL PERFORMANCES, LIVE MUSICAL AND LIVE DRAMATIC PERFORMANCES (U.S. CLS. 100, 101 AND 107).

FIRST USE 5-0-2011; IN COMMERCE 5-0-2011.

4,210,573. JOHNSON, HANS C, RANCHO SANTA FE, CA. SN 85-080,815. PUB. 11-23-2010, FILED 7-8-2010.



THE COLOR(S) WHITE, RED, BLUE, BLACK, BROWN, GOLD, GREY IS/ARE CLAIMED AS A FEATURE OF THE MARK.

THE MARK CONSISTS OF WHITE BACKGROUND "USA-MEN" STYLIZED LETTERS RED WITH BLUE OUTLINE BALD EAGLE BLACK BROWN WINGS WHITE TAIL AND HEAD, GOLD BEAK AND GOLD CLAWS.

CLASS 16—PAPER GOODS AND PRINTED MATTER

FOR ALBUMS FOR STICKERS; BUMPER STICKERS; CHILDREN'S WALL STICKERS AND MURALS; DECORATIVE STICKERS FOR HELMETS; STICKER ALBUMS; STICKERS; STICKERS AND DECALCOMANIAS; STICKERS AND STICKER ALBUMS; STICKERS AND TRANSFERS (U.S. CLS. 2, 5, 22, 23, 29, 37, 38 AND 50).

FIRST USE 6-1-2011; IN COMMERCE 6-1-2011.

CLASS 26—FANCY GOODS

FOR EMBROIDERED EMBLEMS; EMBROIDERED PATCHES FOR CLOTHING (U.S. CLS. 37, 39, 40, 42 AND 50).

FIRST USE 6-1-2011; IN COMMERCE 6-1-2011.

4,210,577. RSL FIBER SYSTEMS, LLC, EAST HARTFORD, CT. SN 85-084,371. PUB. 6-7-2011, FILED 7-14-2010.

RSL

THE MARK CONSISTS OF STANDARD CHARACTERS WITHOUT CLAIM TO ANY PARTICULAR FONT, STYLE, SIZE, OR COLOR.

CLASS 11—ENVIRONMENTAL CONTROL APPARATUS

FOR FIBER OPTIC LIGHTING FIXTURES FOR ILLUMINATION, SIGNALING, AND INSPECTION FOR USE IN MILITARY, GOVERNMENT, COMMERCIAL, INDUSTRIAL AND NAUTICAL APPLICATIONS; FIBER OPTIC ILLUMINATION SYSTEMS FOR USE IN MILITARY, GOVERNMENT, COMMERCIAL, INDUSTRIAL, AND NAUTICAL APPLICATIONS COMPRISED OF ELECTRICAL ILLUMINATORS FOR USE WITH FIBER OPTIC LIGHTING FIXTURES, FIBER OPTIC CABLES, FIBER OPTICS, FIBER OPTIC LIGHTING FIXTURES, FIBER OPTIC CONNECTORS; ALL OF THE AFORESAID NOT FOR USE WITH LANDSCAPE LIGHTING (U.S. CLS. 13, 21, 23, 31 AND 34).
FIRST USE 6-3-2012; IN COMMERCE 6-3-2012.

CLASS 37—CONSTRUCTION AND REPAIR

FOR INSTALLATION, MAINTENANCE AND REPAIR OF FIBER OPTIC ILLUMINATION SYSTEMS FOR USE IN MILITARY, GOVERNMENT, COMMERCIAL, INDUSTRIAL, AND NAUTICAL APPLICATIONS, ALL OF THE AFORESAID NOT FOR USE WITH LANDSCAPE LIGHTING (U.S. CLS. 100, 103 AND 106).
FIRST USE 7-2-2012; IN COMMERCE 7-2-2012.

CLASS 42—SCIENTIFIC AND COMPUTER SERVICES

FOR DESIGN FOR OTHERS OF FIBER OPTIC LIGHTING SYSTEMS FOR ILLUMINATION, SIGNALING AND INSPECTION FOR USE IN MILITARY, GOVERNMENT, COMMERCIAL, INDUSTRIAL, AND NAUTICAL APPLICATIONS; CUSTOM DESIGN AND ENGINEERING OF FIBER OPTIC ILLUMINATION SYSTEMS FOR USE IN MILITARY, GOVERNMENT, COMMERCIAL, INDUSTRIAL, AND NAUTICAL APPLICATIONS; ALL OF THE AFORESAID NOT FOR USE WITH LANDSCAPE LIGHTING (U.S. CLS. 100 AND 101).
FIRST USE 7-2-2012; IN COMMERCE 7-2-2012.

4,210,580. OCHC LLC, SHAKER HEIGHTS, OH. SN 85-085,217. PUB. 6-14-2011, FILED 7-15-2010.

OASIS

THE MARK CONSISTS OF STANDARD CHARACTERS WITHOUT CLAIM TO ANY PARTICULAR FONT, STYLE, SIZE, OR COLOR.

CLASS 3—COSMETICS AND CLEANING PREPARATIONS

FOR NON-MEDICATED MOUTH AND ORAL CARE PRODUCTS, NAMELY, TOOTHPASTE, TEETH WHITENING STRIPS IMPREGNATED WITH TEETH WHITENING PREPARATIONS, BREATH FRESHENING SPRAYS; NON-MEDICATED MOUTH AND ORAL BREATH FRESHENING CONFECTIONARY, NAMELY, DISSOLVABLE BREATH GUM, AND, DENTIFRICES IN THE FORM OF CHEWING GUM; NON-MEDICATED MOUTH AND ORAL LOZENGES; NON-MEDICATED MOUTH AND ORAL RINSES AND WASHES, NAMELY, ANTI-CAVITY MOUTH RINSES, COSMETIC PREPARATIONS FOR THE CARE OF MOUTH AND TEETH, NON-MEDICATED MOUTH RINSE, MOUTH WASHES, NON-MEDICATED MOUTH WASH AND RINSE, NON-MEDICATED MOUTH WASHES; NON-MEDICATED BREATH MINTS AND MOUTH AND ORAL MINTS, NAMELY, BREATH MINTS FOR USE AS A BREATH FRESHENER; NON-MEDICATED MOUTH OR ORAL GELS, NAMELY, TOOTHGELS, TOOTH WHITENERS FOR COSMETIC PURPOSES COMPRISED OF NEUTRAL SODIUM FLUORIDE SUSTAINED RELEASE GEL, TOOTH WHITENING GELS; NON-MEDICATED MOUTH AND ORAL MOISTURIZERS FOR COSMETIC USES, NAMELY, LIP REPAIRERS (U.S. CLS. 1, 4, 6, 50, 51 AND 52).
FIRST USE 6-1-2012; IN COMMERCE 6-1-2012.

CLASS 5—PHARMACEUTICALS

FOR MEDICATED MOUTH AND ORAL CARE PRODUCTS, NAMELY, MEDICATED TOOTHPASTE, DISSOLVABLE STRIPS TO STOP BLEEDING IN THE MOUTH FROM MINOR CUTS, ORAL SPRAY FOR BOOSTING ENERGY, ORAL SPRAY FOR THE CESSATION OF SMOKING, MEDICINAL PREPARATIONS FOR THE MOUTH AND AS SPRAYS; MEAL REPLACEMENT POWDERS FOR MAKING DRINKS, MEDICATED CHEWING GUM; MOUTH AND ORAL LOZENGES, NAMELY, COUGH LOZENGES, MEDICATED LOZENGES, THROAT LOZENGES, ZINC SUPPLEMENT LOZENGES; MEDICATED MOUTH WASHES; MEDICATED MOUTH AND ORAL SANITIZER, NAMELY, MOUTH CAVITY CLEANSERS; MEDICATED CANDY; MEDICATED MOUTH CARE PRODUCTS, NAMELY, MOUTH AND ORAL ANTISEPTICS; MEDICATED MOUTH CARE PRODUCTS, NAMELY, ORALLY INGESTED GEL FOR BOOSTING ENERGY, AND, MEDICATED BRUSH-ON ORAL CARE GELS; MEDICATED PREPARATIONS AND MOISTURIZING MOUTH WASHES FOR RELIEF OF DRY MOUTH AND ASSOCIATED SYMPTOMS AND CONDITIONS (U.S. CLS. 6, 18, 44, 46, 51 AND 52).
FIRST USE 6-1-2012; IN COMMERCE 6-1-2012.

4,210,585. SCHRATTER FOODS INCORPORATED, FAIRFIELD, NJ. SN 85-090,473. PUB. 1-11-2011, FILED 7-22-2010.



NO CLAIM IS MADE TO THE EXCLUSIVE RIGHT TO USE "AFFINAGE" FOR INTERNATIONAL CLASS 29 AND "UNIQUE CHEESES FROM AROUND THE WORLD", APART FROM THE MARK AS SHOWN.

THE MARK CONSISTS OF THE DEPICTION OF A STYLIZED "A" ABOVE THE WORD "AFFINAGE" WITH

THE WORDS "UNIQUE CHEESES FROM AROUND THE WORLD" BELOW "AFFINAGE".

4,210,600. NANOFORGE CORP., CARY, NC. SN 85-098,760. PUB. 10-4-2011, FILED 8-3-2010.

CLASS 29—MEATS AND PROCESSED FOODS

FOR CHEESE (U.S. CL. 46).
FIRST USE 11-5-2010; IN COMMERCE 11-5-2010.

CLASS 35—ADVERTISING AND BUSINESS

FOR RETAIL CHEESE STORES; ON-LINE RETAIL STORE SERVICES FEATURING CHEESE (U.S. CLS. 100, 101 AND 102).
FIRST USE 11-5-2010; IN COMMERCE 11-5-2010.

NanoForge

THE MARK CONSISTS OF STANDARD CHARACTERS WITHOUT CLAIM TO ANY PARTICULAR FONT, STYLE, SIZE, OR COLOR.

CLASS 1—CHEMICALS

FOR NANOSTRANDS, NAMELY, SUB-MICRON DIAMETER, HIGH ASPECT RATIO METAL STRANDS/FILAMENTS, WHETHER LINEAR OR BRANCHED, FOR USES THAT ADVANTAGEOUSLY BENEFIT FROM THE INHERENT PROPERTIES OF THESE METAL STRANDS/FILAMENTS FOR USE IN THE MANUFACTURE OF OTHER GOODS (U.S. CLS. 1, 5, 6, 10, 26 AND 46).

FIRST USE 3-17-2011; IN COMMERCE 5-1-2011.

CLASS 2—PAINTS

FOR NANO-PARTICLE AND NANO-WIRE BASED METAL POWDERS FOR USE IN CONDUCTIVE INKS, CONDUCTIVE COATINGS, CONDUCTIVE FILMS AND CONDUCTIVE EMULSIONS (U.S. CLS. 6, 11 AND 16).
FIRST USE 3-17-2011; IN COMMERCE 5-1-2011.

4,210,597. CUSTOM LEATHERCRAFT MANUFACTURING CO., INC., SOUTH GATE, CA. SN 85-097,520. PUB. 10-25-2011, FILED 7-31-2010.

CLIMATE GEAR

THE MARK CONSISTS OF STANDARD CHARACTERS WITHOUT CLAIM TO ANY PARTICULAR FONT, STYLE, SIZE, OR COLOR.

NO CLAIM IS MADE TO THE EXCLUSIVE RIGHT TO USE "GEAR", APART FROM THE MARK AS SHOWN.

CLASS 8—HAND TOOLS

FOR WEATHER RESISTANT APRONS FOR CARRYING TOOLS, WEATHER RESISTANT UTILITY BELTS FOR CARRYING TOOLS, WEATHER RESISTANT SUSPENDERS FOR HOLDING UTILITY TOOL BELTS, WEATHER RESISTANT TOOL HOLDING POUCHES FOR ATTACHMENT TO UTILITY TOOL BELTS (U.S. CLS. 23, 28 AND 44).

FIRST USE 6-30-2010; IN COMMERCE 1-11-2011.

CLASS 9—ELECTRICAL AND SCIENTIFIC APPARATUS

FOR WEATHER RESISTANT SAFETY EQUIPMENT, NAMELY, PROTECTIVE WORK GLOVES, PROTECTIVE WORK VESTS, WORK PROTECTIVE JUMPSUITS, PROTECTIVE RAINWEAR AND PROTECTIVE KNEEPADS (U.S. CLS. 21, 23, 26, 36 AND 38).

FIRST USE 6-30-2010; IN COMMERCE 1-11-2011.

CLASS 18—LEATHER GOODS

FOR WEATHER RESISTANT TOOL BAGS AND TOOL CARRYING BAGS, ALL SOLD EMPTY (U.S. CLS. 1, 2, 3, 22 AND 41).

FIRST USE 6-30-2010; IN COMMERCE 1-11-2011.

4,210,612. LIMITED STORES, LLC, NEW ALBANY, OH. SN 85-110,560. PUB. 5-10-2011, FILED 8-18-2010.

THE LIMITED

THE MARK CONSISTS OF STANDARD CHARACTERS WITHOUT CLAIM TO ANY PARTICULAR FONT, STYLE, SIZE, OR COLOR.

OWNER OF U.S. REG. NOS. 1,020,794, 1,062,519, AND OTHERS.

CLASS 3—COSMETICS AND CLEANING PREPARATIONS

FOR COLOGNE AND PERFUME (U.S. CLS. 1, 4, 6, 50, 51 AND 52).

FIRST USE 5-30-2011; IN COMMERCE 5-30-2011.

CLASS 9—ELECTRICAL AND SCIENTIFIC APPARATUS

FOR EYE WEAR (U.S. CLS. 21, 23, 26, 36 AND 38).
FIRST USE 4-30-2012; IN COMMERCE 4-30-2012.

4,210,615. OLD DUTCH FOODS, INC., ST. PAUL, MN. SN 85-112,349. PUB. 6-7-2011, FILED 8-20-2010.



NO CLAIM IS MADE TO THE EXCLUSIVE RIGHT TO USE "SNACK", APART FROM THE MARK AS SHOWN.

THE MARK CONSISTS OF A STYLIZED STICK FIGURE WITH TORSO, LEGS AND ARMS AND A CIRCLE FOR A HEAD, ALL IN A DOUBLE CIRCLE BACKGROUND, WITH THE WORDS "SNACK WISE" ON THE LOWER BOTTOM EDGE OF THE OUTSIDE BACKGROUND CIRCLE.

CLASS 29—MEATS AND PROCESSED FOODS

FOR SNACK FOODS, NAMELY, POTATO CHIPS (U.S. CL. 46).
FIRST USE 5-2-2011; IN COMMERCE 5-2-2011.

CLASS 30—STAPLE FOODS

FOR SNACK FOODS, NAMELY, TORTILLA CHIPS (U.S. CL. 46).
FIRST USE 5-7-2012; IN COMMERCE 5-7-2012.

4,210,618. MIGHTYKARMA, LLC, DENVER, CO. SN 85-114,577. PUB. 1-18-2011, FILED 8-24-2010.

Zeppatamus

THE MARK CONSISTS OF STANDARD CHARACTERS WITHOUT CLAIM TO ANY PARTICULAR FONT, STYLE, SIZE, OR COLOR.

CLASS 25—CLOTHING

FOR CLOTH BIBS; INFANT AND TODDLER ONE PIECE CLOTHING; ROMPERS; SWEAT SHIRTS; T-SHIRTS (U.S. CLS. 22 AND 39).
FIRST USE 8-1-2011; IN COMMERCE 8-1-2011.

CLASS 41—EDUCATION AND ENTERTAINMENT

FOR PROVIDING A WEBSITE FEATURING INFORMATION IN THE FIELDS OF EDUCATION AND ENTERTAINMENT FOR CHILDREN (U.S. CLS. 100, 101 AND 107).
FIRST USE 9-1-2011; IN COMMERCE 9-1-2011.

4,210,619. MIGHTYKARMA, LLC, DENVER, CO. SN 85-114,686. PUB. 1-18-2011, FILED 8-24-2010.

Squirtle

THE MARK CONSISTS OF STANDARD CHARACTERS WITHOUT CLAIM TO ANY PARTICULAR FONT, STYLE, SIZE, OR COLOR.

CLASS 25—CLOTHING

FOR BIBS NOT OF CLOTH OR PAPER; CLOTH BIBS; INFANT AND TODDLER ONE PIECE CLOTHING; ROMPERS; SWEAT SHIRTS; T-SHIRTS (U.S. CLS. 22 AND 39).
FIRST USE 8-1-2011; IN COMMERCE 8-1-2011.

CLASS 41—EDUCATION AND ENTERTAINMENT

FOR PROVIDING A WEBSITE FEATURING INFORMATION IN THE FIELDS OF EDUCATION AND ENTERTAINMENT FOR CHILDREN (U.S. CLS. 100, 101 AND 107).
FIRST USE 9-1-2011; IN COMMERCE 9-1-2011.

4,210,620. MIGHTYKARMA, LLC, DENVER, CO. SN 85-114,688. PUB. 1-18-2011, FILED 8-24-2010.

Woolybear

THE MARK CONSISTS OF STANDARD CHARACTERS WITHOUT CLAIM TO ANY PARTICULAR FONT, STYLE, SIZE, OR COLOR.

CLASS 25—CLOTHING

FOR BABY BIBS NOT OF PAPER; CLOTH BIBS; INFANT AND TODDLER ONE PIECE CLOTHING; ROMPERS; SWEAT SHIRTS; T-SHIRTS (U.S. CLS. 22 AND 39).
FIRST USE 8-1-2011; IN COMMERCE 8-1-2011.

CLASS 41—EDUCATION AND ENTERTAINMENT

FOR PROVIDING A WEBSITE FEATURING INFORMATION IN THE FIELDS OF EDUCATION AND ENTERTAINMENT FOR CHILDREN (U.S. CLS. 100, 101 AND 107).
FIRST USE 9-1-2011; IN COMMERCE 9-1-2011.

4,210,621. MIGHTYKARMA, LLC, DENVER, CO. SN 85-114,692. PUB. 1-18-2011, FILED 8-24-2010.

4,210,623. MIGHTYKARMA, LLC, DENVER, CO. SN 85-114,704. PUB. 1-18-2011, FILED 8-24-2010.

Alliox

THE MARK CONSISTS OF STANDARD CHARACTERS WITHOUT CLAIM TO ANY PARTICULAR FONT, STYLE, SIZE, OR COLOR.

CLASS 25—CLOTHING

FOR BABY BIBS NOT OF PAPER; CLOTH BIBS; INFANT AND TODDLER ONE PIECE CLOTHING; ROMPERS; SWEAT SHIRTS; T-SHIRTS (U.S. CLS. 22 AND 39).

FIRST USE 8-1-2011; IN COMMERCE 8-1-2011.

CLASS 41—EDUCATION AND ENTERTAINMENT

FOR PROVIDING A WEBSITE FEATURING INFORMATION IN THE FIELDS OF EDUCATION AND ENTERTAINMENT FOR CHILDREN (U.S. CLS. 100, 101 AND 107).

FIRST USE 9-1-2011; IN COMMERCE 9-1-2011.

Butterbully

THE MARK CONSISTS OF STANDARD CHARACTERS WITHOUT CLAIM TO ANY PARTICULAR FONT, STYLE, SIZE, OR COLOR.

CLASS 25—CLOTHING

FOR BABY BIBS NOT OF PAPER; CLOTH BIBS; INFANT AND TODDLER ONE PIECE CLOTHING; ROMPERS; SWEAT SHIRTS; T-SHIRTS (U.S. CLS. 22 AND 39).

FIRST USE 8-1-2011; IN COMMERCE 8-1-2011.

CLASS 41—EDUCATION AND ENTERTAINMENT

FOR PROVIDING A WEBSITE FEATURING INFORMATION IN THE FIELDS OF EDUCATION AND ENTERTAINMENT FOR CHILDREN (U.S. CLS. 100, 101 AND 107).

FIRST USE 9-1-2011; IN COMMERCE 9-1-2011.

4,210,622. MIGHTYKARMA, LLC, DENVER, CO. SN 85-114,695. PUB. 1-18-2011, FILED 8-24-2010.

4,210,624. DISRUPTIVEAPPS, INCORPORATED, BEVERLY, MA. SN 85-115,770. PUB. 4-12-2011, FILED 8-25-2010.

Owlion

THE MARK CONSISTS OF STANDARD CHARACTERS WITHOUT CLAIM TO ANY PARTICULAR FONT, STYLE, SIZE, OR COLOR.

CLASS 25—CLOTHING

FOR BABY BIBS NOT OF PAPER; CLOTH BIBS; INFANT AND TODDLER ONE PIECE CLOTHING; ROMPERS; SWEAT SHIRTS; T-SHIRTS (U.S. CLS. 22 AND 39).

FIRST USE 8-1-2011; IN COMMERCE 8-1-2011.

CLASS 41—EDUCATION AND ENTERTAINMENT

FOR PROVIDING A WEBSITE FEATURING INFORMATION IN THE FIELDS OF EDUCATION AND ENTERTAINMENT FOR CHILDREN (U.S. CLS. 100, 101 AND 107).

FIRST USE 9-1-2011; IN COMMERCE 9-1-2011.

WHAT'S YOUR REQUEST?

THE MARK CONSISTS OF STANDARD CHARACTERS WITHOUT CLAIM TO ANY PARTICULAR FONT, STYLE, SIZE, OR COLOR.

CLASS 38—COMMUNICATION

FOR UNICAST STREAMING OF AUDIO AND VISUAL MATERIAL VIA A GLOBAL COMPUTER NETWORK; PROVIDING ACCESS TO AUDIO AND VIDEO DATABASES FOR REAL-TIME SELECTION AND PLAYING OF AUDIO AND VIDEO RECORDINGS (U.S. CLS. 100, 101 AND 104).

FIRST USE 4-1-2012; IN COMMERCE 4-1-2012.

CLASS 41—EDUCATION AND ENTERTAINMENT

FOR ENTERTAINMENT SERVICES, NAMELY, PROVIDING ACCESS TO AUDIO AND VIDEO LIBRARIES FOR REAL-TIME SELECTION AND PLAY OF AUDIO AND VIDEO RECORDINGS IN A PARTICULAR VENUE (U.S. CLS. 100, 101 AND 107).

FIRST USE 4-1-2012; IN COMMERCE 4-1-2012.

CLASS 42—SCIENTIFIC AND COMPUTER SERVICES

FOR COMPUTER SERVICE, NAMELY, ACTING AS AN APPLICATION SERVICE PROVIDER IN THE FIELD OF DIGITAL AUDIO AND VIDEO RECORDING TO HOST COMPUTER APPLICATION SOFTWARE VIA SMARTPHONES OR OTHER WIRELESS DEVICES FOR DISTRIBUTING, SELECTING, PURCHASING AND PLAYING AUDIO AND VIDEO RECORDINGS; COMPUTER SERVICE, NAMELY, ACTING AS AN APPLICATION SERVICE PROVIDER UTILIZING GLOBAL POSITIONING SATELLITES (GPS) IN THE FIELD OF DISTRIBUTION OF AUDIO AND VIDEO RECORDING TO HOST COMPUTER APPLICATION SOFTWARE FOR IDENTIFYING THE LOCATION OF PROVIDERS THAT OFFER THE SELECTION, PURCHASE, AND PLAY OF AUDIO AND VIDEO RECORDING; PROVIDING ONLINE TEMPORARY USE OF NON-DOWNLOADABLE COMPUTER SOFTWARE FOR DISTRIBUTING, SELECTING, PRICING, SELLING AND PLAYING AUDIO AND VIDEO RECORDINGS IN A PARTICULAR VENUE; PROVIDING ONLINE TEMPORARY USE OF NON-DOWNLOADABLE COMPUTER SOFTWARE FOR PROVIDING DEMOGRAPHIC DATA OF PAST AND PRESENT USERS OF AFFILIATED COMPUTER SOFTWARE APPLICATION AT A PARTICULAR VENUE; PROVIDING ONLINE TEMPORARY USE OF NON-DOWNLOADABLE COMPUTER SOFTWARE FOR IDENTIFYING A LIST OF AVAILABLE AUDIO AND VIDEO RECORDINGS FOR SELECTION BY THE VENUE IN WHICH THOSE AUDIO AND VIDEO RECORDINGS WILL BE SELECTED, PURCHASED AND PLAYED BY USERS OF AN AFFILIATED COMPUTER SOFTWARE APPLICATION; PROVIDING ONLINE TEMPORARY USE OF NON-DOWNLOADABLE COMPUTER SOFTWARE FOR ENABLING THE DESIGNATION OF AND DISTRIBUTION TO CHARITIES OF PROFITS MADE FROM THE SALE OF AUDIO AND VIDEO RECORDINGS VIA AFFILIATED COMPUTER SOFTWARE APPLICATION (U.S. CLS. 100 AND 101).

FIRST USE 4-1-2012; IN COMMERCE 4-1-2012.

4,210,635. BSH HOME APPLIANCES CORPORATION, HUNTINGTON BEACH, CA. SN 85-122,510. PUB. 3-22-2011, FILED 9-3-2010.

HOTTER COOLER FASTER BETTER

THE MARK CONSISTS OF STANDARD CHARACTERS WITHOUT CLAIM TO ANY PARTICULAR FONT, STYLE, SIZE, OR COLOR.

CLASS 7—MACHINERY

FOR HOUSEHOLD AND KITCHEN MACHINES AND EQUIPMENT, NAMELY, ELECTRIC KITCHEN MACHINES AND EQUIPMENT, NAMELY, DISHWASHERS; STRUCTURAL PARTS FOR DISHWASHERS (U.S. CLS. 13, 19, 21, 23, 31, 34 AND 35).

FIRST USE 11-1-2010; IN COMMERCE 11-1-2010.

CLASS 11—ENVIRONMENTAL CONTROL APPARATUS

FOR HOUSEHOLD AND KITCHEN MACHINES AND EQUIPMENT, NAMELY, HEATING, STEAM PRODUCING, AND COOKING DEVICES, NAMELY, COOKING, BAKING, FRYING, GRILLING, TOASTING, THAWING, AND HOT-KEEPING APPARATUS, NAMELY, DOMESTIC COOKING OVENS, ELECTRIC AND GAS RANGES, COOKTOPS, WARMING DRAWERS SOLD AS PARTS OF OVENS, RANGES AND COOKTOPS, MICROWAVE APPLIANCES, NAMELY, MICROWAVE OVENS, BEVERAGE MAKING APPARATUS, NAMELY, ELECTRIC ESPRESSO MACHINES, ELECTRIC TEMPERATURE-CONTROLLED BEVERAGE DISPENSERS; COOLING DEVICES, NAMELY, REFRIGERATORS, FREEZERS, COMBINATION REFRIGERATOR-FREEZERS, DEEP FREEZERS, ICE MAKING MACHINES, ELECTRIC ICE-CREAM MAKING MACHINES; VENTILATION DEVICES, NAMELY, VENTILATORS SOLD AS PARTS OF HOODS FOR RANGES, OVENS AND COOKTOPS, GREASE FILTER DEVICES SOLD AS PARTS OF HOODS FOR RANGES, OVENS AND COOKTOPS; EXTRACTOR DEVICES, NAMELY, EXTRACTOR HOODS FOR USE WITH OVENS, RANGES AND COOKTOPS; AIR CONDITIONING DEVICES AND DEVICES TO IMPROVE AIR QUALITY, NAMELY, AIR HUMIDIFIERS, PIPES BEING PARTS OF SANITARY FACILITIES; WARM WATER DEVICES, NAMELY, STORAGE WATER HEATERS AND CONTINUOUS FLOW WATER HEATERS; KITCHEN SINKS; HEAT PUMPS; STRUCTURAL PARTS OF ALL AFOREMENTIONED GOODS (U.S. CLS. 13, 21, 23, 31 AND 34).

FIRST USE 11-1-2010; IN COMMERCE 11-1-2010.

4,210,636. GRADY RESTAURANT GROUP, LLC, HOMEWOOD, IL. SN 85-124,311. PUB. 2-15-2011, FILED 9-7-2010.



THE MARK CONSISTS OF TWO LOWERCASE "G"'S WITHIN RANDOM CIRCLES.

CLASS 21—HOUSEWARES AND GLASS

FOR BEVERAGE GLASSWARE (U.S. CLS. 2, 13, 23, 29, 30, 33, 40 AND 50).

FIRST USE 6-4-2010; IN COMMERCE 6-4-2010.

CLASS 25—CLOTHING

FOR T-SHIRTS (U.S. CLS. 22 AND 39).

FIRST USE 6-4-2010; IN COMMERCE 6-4-2010.

CLASS 28—TOYS AND SPORTING GOODS

FOR TOY MODELING DOUGH (U.S. CLS. 22, 23, 38 AND 50).

FIRST USE 6-4-2010; IN COMMERCE 6-4-2010.

CLASS 29—MEATS AND PROCESSED FOODS

FOR SOUPS (U.S. CL. 46).

FIRST USE 6-4-2010; IN COMMERCE 6-4-2010.

CLASS 30—STAPLE FOODS

FOR BARBECUE SAUCE; SALAD DRESSINGS (U.S. CL. 46).
FIRST USE 6-4-2010; IN COMMERCE 6-4-2010.

CLASS 43—HOTEL AND RESTAURANT SERVICES

FOR BAR AND RESTAURANT SERVICES (U.S. CLS. 100 AND 101).
FIRST USE 6-4-2010; IN COMMERCE 6-4-2010.

4,210,638. PRICEMETRIX INC., TORONTO, ON, CANADA.
SN 85-126,939. PUB. 9-6-2011, FILED 9-10-2010.

FEECHECK

THE MARK CONSISTS OF STANDARD CHARACTERS WITHOUT CLAIM TO ANY PARTICULAR FONT, STYLE, SIZE, OR COLOR.

PRIORITY CLAIMED UNDER SEC. 44(D) ON CANADA APPLICATION NO. 1485303, FILED 6-16-2010.

CLASS 9—ELECTRICAL AND SCIENTIFIC APPARATUS

FOR PROVIDING ONLINE NON-DOWNLOADABLE SOFTWARE TO ACQUIRE, STORE, ANALYZE, MANIPULATE, COMPARE, STUDY, DISSEMINATE AND PRESENT STATISTICS AND PRICING INFORMATION REGARDING FINANCIAL PRODUCTS AND TO ASSIST IN CALCULATING THE PRICING AND VALUE OF FINANCIAL PRODUCTS (U.S. CLS. 21, 23, 26, 36 AND 38).

FIRST USE 3-1-2012; IN COMMERCE 3-1-2012.

CLASS 35—ADVERTISING AND BUSINESS

FOR BUSINESS CONSULTATION, NAMELY, ANALYZING BUSINESS INFORMATION IN THE NATURE OF STATISTICS AND PRICING INFORMATION TO RECOMMEND APPROPRIATE PRICING STRATEGIES (U.S. CLS. 100, 101 AND 102).

FIRST USE 3-1-2012; IN COMMERCE 3-1-2012.

CLASS 36—INSURANCE AND FINANCIAL

FOR FINANCIAL ANALYSIS OF STATISTICS AND PRICING INFORMATION REGARDING FINANCIAL PRODUCTS (U.S. CLS. 100, 101 AND 102).

FIRST USE 3-1-2012; IN COMMERCE 3-1-2012.

4,210,644. BASF SE, LUDWIGSHAFEN AM RHEIN, FED REP GERMANY. SN 85-136,352. PUB. 12-28-2010, FILED 9-23-2010.

PRIAXOR

THE MARK CONSISTS OF STANDARD CHARACTERS WITHOUT CLAIM TO ANY PARTICULAR FONT, STYLE,

SIZE, OR COLOR.

CLASS 1—CHEMICALS

FOR CHEMICALS USED IN AGRICULTURE, NAMELY, PLANT FORTIFYING PREPARATIONS, PLANT GROWTH REGULATING PREPARATIONS, CHEMICAL PREPARATIONS FOR THE TREATMENT OF SEEDS, SURFACTANTS (U.S. CLS. 1, 5, 6, 10, 26 AND 46).

FIRST USE 6-13-2012; IN COMMERCE 6-13-2012.

CLASS 5—PHARMACEUTICALS

FOR FUNGICIDES (U.S. CLS. 6, 18, 44, 46, 51 AND 52).
FIRST USE 6-13-2012; IN COMMERCE 6-13-2012.

4,210,648. SMA SOLAR TECHNOLOGY AG, NIESTETAL, FED REP GERMANY. SN 85-138,597. PUB. 5-10-2011, FILED 9-27-2010.

BE A SOLAR EXPERT

THE MARK CONSISTS OF STANDARD CHARACTERS WITHOUT CLAIM TO ANY PARTICULAR FONT, STYLE, SIZE, OR COLOR.

CLASS 16—PAPER GOODS AND PRINTED MATTER

FOR PRINTED INSTRUCTION MANUALS AND TEACHING MATERIALS IN THE FIELD OF SOLAR TECHNOLOGY: OFFICE REQUISITES, NAMELY, DOCUMENT FILES, LETTER FILES AND WRITING FILES (U.S. CLS. 2, 5, 22, 23, 29, 37, 38 AND 50).

FIRST USE 7-12-2010; IN COMMERCE 7-27-2010.

CLASS 41—EDUCATION AND ENTERTAINMENT

FOR EDUCATIONAL SERVICES, NAMELY, CLASSES, SEMINARS, INSTRUCTIONAL COURSES, AND TRAINING IN THE FIELD OF SOLAR TECHNOLOGY (U.S. CLS. 100, 101 AND 107).

FIRST USE 7-12-2010; IN COMMERCE 7-25-2010.

4,210,653. JOHN LOWE, METAMORA, IN. SN 85-148,201. PUB. 3-15-2011, FILED 10-8-2010.

RAN WITH THE WRONG CROWD

THE MARK CONSISTS OF STANDARD CHARACTERS WITHOUT CLAIM TO ANY PARTICULAR FONT, STYLE, SIZE, OR COLOR.

CLASS 16—PAPER GOODS AND PRINTED MATTER

FOR BUMPER STICKERS; CALENDARS; POSTERS (U.S. CLS. 2, 5, 22, 23, 29, 37, 38 AND 50).
FIRST USE 11-3-2011; IN COMMERCE 11-3-2011.

CLASS 20—FURNITURE AND ARTICLES NOT OTHERWISE CLASSIFIED

FOR PICTURE FRAMES (U.S. CLS. 2, 13, 22, 25, 32 AND 50).
FIRST USE 11-3-2011; IN COMMERCE 11-3-2011.

CLASS 21—HOUSEWARES AND GLASS

FOR PORTABLE BEVERAGE COOLERS (U.S. CLS. 2, 13, 23, 29, 30, 33, 40 AND 50).
FIRST USE 11-3-2011; IN COMMERCE 11-3-2011.

CLASS 25—CLOTHING

FOR HATS; T-SHIRTS (U.S. CLS. 22 AND 39).
FIRST USE 11-3-2011; IN COMMERCE 11-3-2011.

4,210,655. AMERICAN DOCUMENT SYSTEMS LLC, FORT WORTH, TX. SN 85-149,624. PUB. 2-28-2012, FILED 10-11-2010.



NO CLAIM IS MADE TO THE EXCLUSIVE RIGHT TO USE "AMERICAN DOCUMENT SYSTEMS LLC", APART FROM THE MARK AS SHOWN.

THE MARK CONSISTS OF A STYLIZED "ADS AMERICAN DOCUMENT SYSTEMS LLC" WITH BANNERS FLOWING FROM AND TO THE LEFT OF THE LETTER "A", AND A VERTICAL BAR BETWEEN "ADS" AND "AMERICAN DOCUMENT SYSTEMS, LLC".

CLASS 35—ADVERTISING AND BUSINESS

FOR PREPARING BUSINESS AND FINANCIAL DOCUMENTS IN THE FIELD OF RESIDENTIAL AND COMMERCIAL REAL ESTATE TRANSACTIONS (U.S. CLS. 100, 101 AND 102).
FIRST USE 8-5-2011; IN COMMERCE 8-5-2011.

CLASS 45—PERSONAL AND LEGAL SERVICES

FOR PREPARING LEGAL DOCUMENTS IN THE FIELD OF RESIDENTIAL AND COMMERCIAL REAL ESTATE TRANSACTIONS; PREPARING AND ORGANIZING LOAN CLOSING DOCUMENTS IN THE FIELD OF RESIDENTIAL AND COMMERCIAL REAL ESTATE TRANSACTIONS (U.S. CLS. 100 AND 101).
FIRST USE 8-5-2011; IN COMMERCE 8-5-2011.

4,210,656. SMISEK, WAYNE, COLORADO SPRINGS, CO. SN 85-150,069. PUB. 5-10-2011, FILED 10-11-2010.

Chocolate Mountaineers

THE MARK CONSISTS OF STANDARD CHARACTERS WITHOUT CLAIM TO ANY PARTICULAR FONT, STYLE, SIZE, OR COLOR.

CLASS 9—ELECTRICAL AND SCIENTIFIC APPARATUS

FOR CDS, DVDS AND VIDEOS THAT PROMOTE CHARACTER DEVELOPMENT IN CHILDREN (U.S. CLS. 21, 23, 26, 36 AND 38).
FIRST USE 6-28-2012; IN COMMERCE 6-28-2012.

CLASS 16—PAPER GOODS AND PRINTED MATTER

FOR PUBLICATIONS AND PRINTED MATERIALS, NAMELY, CHILDREN'S BOOKS, ACTIVITY BOOKS, PICTURE BOOKS, PRINTED LESSON BOOKS IN THE FIELD OF EDUCATION AND CHARACTER DEVELOPMENT, COLORING BOOKS, POSTERS, CARTOON PRINTS, CARTOON STRIPS (U.S. CLS. 2, 5, 22, 23, 29, 37, 38 AND 50).
FIRST USE 6-28-2012; IN COMMERCE 6-28-2012.

CLASS 18—LEATHER GOODS

FOR BACKPACKS, BOOK BAGS, SPORTS BAGS (U.S. CLS. 1, 2, 3, 22 AND 41).
FIRST USE 6-28-2012; IN COMMERCE 6-28-2012.

CLASS 21—HOUSEWARES AND GLASS

FOR HOUSE WARES, NAMELY, CUPS, MUGS, PLATES (U.S. CLS. 2, 13, 23, 29, 30, 33, 40 AND 50).
FIRST USE 6-28-2012; IN COMMERCE 6-28-2012.

CLASS 22—CORDAGE AND FIBERS

FOR CAMPING GEAR, NAMELY, CAMPING TENTS (U.S. CLS. 1, 2, 7, 19, 22, 42 AND 50).
FIRST USE 6-28-2012; IN COMMERCE 6-28-2012.

CLASS 24—FABRICS

FOR BABY BEDDING, NAMELY, CRIB BUMPER, FITTED CRIB SHEETS; BEDDING, NAMELY, BED SHEETS, BED SPREADS, PILLOW CASES, BED BLANKETS, COMFORTERS, TOWELS (U.S. CLS. 42 AND 50).
FIRST USE 6-28-2012; IN COMMERCE 6-28-2012.

CLASS 25—CLOTHING

FOR CHILDREN'S AND BABY CLOTHING, NAMELY, SHIRTS, PANTS, SHORTS, ROMPERS, PAJAMAS, CLOTH BIBS, SOCKS, UNDERWEAR, JACKETS; SPORTSWEAR, NAMELY, T-SHIRTS, SWEATSHIRTS, SHIRTS, HATS, SOCKS, CAPS, PANTS, SHORTS, SHOES, BOOTS (U.S. CLS. 22 AND 39).
FIRST USE 6-28-2012; IN COMMERCE 6-28-2012.

CLASS 28—TOYS AND SPORTING GOODS

FOR TOYS, NAMELY, BATH TOYS, PLASTIC ACTION FIGURES, STUFFED DOLLS AND ANIMALS, FANTASY CHARACTER TOYS, BOARD GAMES, PUZZLES (U.S. CLS. 22, 23, 38 AND 50).
FIRST USE 6-28-2012; IN COMMERCE 6-28-2012.

CLASS 35—ADVERTISING AND BUSINESS

FOR ONLINE RETAIL STORE SERVICES FEATURING CLOTHING, PUBLICATIONS AND PRINTED MATERIAL, TOYS, DOLLS, STUFFED ANIMALS, BACKPACKS, BOOK BAGS, SPORTS BAGS, HOUSE WARES, CUPS, MUGS, PLATES; BEDDING, BABY BEDDING, BED SHEETS, BED SPREADS, PILLOW CASES, BLANKETS, COMFORTERS, TOWELS; PROMOTING PUBLIC AWARENESS OF THE NEED FOR CHARACTER DEVELOPMENT IN CHILDREN, PROMOTING PUBLIC AWARENESS OF THE NEED FOR CHILDREN TO BE AWARE OF THE NEEDS OF OTHER CHILDREN (U.S. CLS. 100, 101 AND 102).

FIRST USE 6-28-2012; IN COMMERCE 6-28-2012.

CLASS 36—INSURANCE AND FINANCIAL

FOR CHARITABLE FOUNDATION SERVICES, NAMELY, PROVIDING FUNDRAISING ACTIVITIES, SCHOLARSHIPS AND FINANCIAL ASSISTANCE FOR EDUCATION AND CHARACTER DEVELOPMENT OF CHILDREN; CHARITABLE FUNDRAISING SERVICES FOR CHILDREN'S CHARITIES (U.S. CLS. 100, 101 AND 102).

FIRST USE 6-28-2012; IN COMMERCE 6-28-2012.

CLASS 41—EDUCATION AND ENTERTAINMENT

FOR EDUCATION AND ENTERTAINMENT SERVICES FOR CHILDREN AND FAMILIES, NAMELY, ANIMATED TELEVISION SERIES, LIVE PERFORMANCES, STORYTELLING EVENTS, PROVIDING A WEB SITE FEATURING INTERACTIVE EDUCATIONAL GAMES, ANIMATED CARTOONS, VIDEOS AND LITERATURE THAT PROMOTE CHARACTER DEVELOPMENT IN CHILDREN; CHARITABLE SERVICES FOR CHILDREN AND FAMILIES, NAMELY, PROVIDING TOYS FOR NEEDY CHILDREN (U.S. CLS. 100, 101 AND 107).

FIRST USE 6-28-2012; IN COMMERCE 6-28-2012.

4,210,659. LINE SHIFT MANAGEMENT GROUP, INC., CENTENNIAL, CO. SN 85-152,216. PUB. 5-10-2011, FILED 10-13-2010.

CLASS 35—ADVERTISING AND BUSINESS

FOR ADVERTISING AND INFORMATION DISTRIBUTION SERVICES, NAMELY, PROVIDING ADVERTISING SPACE ONLINE VIA THE GLOBAL COMPUTER NETWORK; PROMOTING THE GOODS AND SERVICES OF OTHERS OVER THE INTERNET OR OTHER COMMUNICATION NETWORKS; PROVIDING AN ON-LINE DIRECTORY INFORMATION SERVICE FEATURING INFORMATION REGARDING USER'S EXPERIENCES AND PERSONAL PREFERENCES IN THE FIELD OF SOCIAL EVENTS, RESTAURANTS, SHOPPING AND TRAVEL; PROVIDING AN ON-LINE DIRECTORY INFORMATION SERVICE FEATURING INFORMATION REGARDING SOCIAL EVENTS, RESTAURANTS, SHOPPING AND TRAVEL IN THE NATURE OF CLASSIFIED ADVERTISEMENTS; PROVIDING AN ON-LINE DIRECTORY INFORMATION SERVICE FEATURING INFORMATION REGARDING LOCATING OTHER USERS TO DISCUSS SOCIAL EVENTS, RESTAURANTS, SHOPPING AND TRAVEL; ADVERTISING AND INFORMATION DISTRIBUTION SERVICES, NAMELY, PROVIDING CLASSIFIED ADVERTISING SPACE VIA THE GLOBAL COMPUTER NETWORK; PROVIDING ON-LINE COMPUTER DATABASES AND ON-LINE SEARCHABLE DATABASES IN THE FIELD OF SHOPPING CLASSIFIEDS (U.S. CLS. 100, 101 AND 102).

FIRST USE 6-0-2010; IN COMMERCE 1-0-2011.

CLASS 45—PERSONAL AND LEGAL SERVICES

FOR ONLINE SOCIAL NETWORKING SERVICES; PROVIDING A WEBSITE ON THE INTERNET FOR THE PURPOSE OF SOCIAL NETWORKING; PROVIDING ON-LINE COMPUTER DATABASES AND ON-LINE SEARCHABLE DATABASES IN THE FIELD OF SOCIAL NETWORKING (U.S. CLS. 100 AND 101).

FIRST USE 6-0-2010; IN COMMERCE 1-0-2011.

4,210,663. BRITISH POLYTHENE LIMITED, LONDON, UNITED KINGDOM. SN 85-155,489. PUB. 11-29-2011, FILED 10-18-2010.

I WAS THERE

POLYCROP

THE MARK CONSISTS OF STANDARD CHARACTERS WITHOUT CLAIM TO ANY PARTICULAR FONT, STYLE, SIZE, OR COLOR.

THE MARK CONSISTS OF STANDARD CHARACTERS WITHOUT CLAIM TO ANY PARTICULAR FONT, STYLE, SIZE, OR COLOR.

OWNER OF ERPN CMNTY TM OFC REG. NO. 004705711, DATED 10-10-2006, EXPIRES 10-25-2015.

CLASS 9—ELECTRICAL AND SCIENTIFIC APPARATUS

FOR COMPUTER APPLICATION SOFTWARE FOR MOBILE PHONES, NAMELY, SOFTWARE FOR USE IN PROVIDING INFORMATION FOR THE PURPOSES OF SOCIAL NETWORKING (U.S. CLS. 21, 23, 26, 36 AND 38).

FIRST USE 6-0-2010; IN COMMERCE 1-0-2011.

CLASS 16—PAPER GOODS AND PRINTED MATTER

FOR SILAGE BALE WRAP IN THE NATURE OF PLASTIC FILM FOR NON-COMMERCIAL USE FOR WRAPPING SILAGE BALE (U.S. CLS. 2, 5, 22, 23, 29, 37, 38 AND 50).

FIRST USE 5-1-2010; IN COMMERCE 5-1-2010.

CLASS 17—RUBBER GOODS

FOR SILAGE BALE WRAP IN THE NATURE OF PLASTIC FILM FOR COMMERCIAL USE FOR WRAPPING SILAGE BALES; SHEET PLASTICS IN THE NATURE OF PLASTIC IN THE FORM OF SHEETS FOR USE IN MANUFACTURING AND FOR GENERAL INDUSTRIAL USE; PLASTICS IN SHEET FORM AND FILM FORM FOR LAYING ON THE GROUND FOR GENERAL CONSTRUCTION USE, FOR AGRICULTURAL AND HORTICULTURAL USE, FOR GENERAL COMMERCIAL USE IN COVERING SOIL AND PLANTS, AND FOR GENERAL COMMERCIAL USE IN COVERING MATERIALS LYING ON THE GROUND; PLASTICS IN SHEET FORM, FILM FORM, PERFORATED SHEET FORM, PERFORATED FILM FORM, IN THE FORM OF SHEETS WITH APERTURES, AND IN THE FORM OF FILMS WITH APERTURES, ALL FOR USE IN AGRICULTURE AND HORTICULTURE; MULCHES MADE OF PLASTICS FOR USE IN AGRICULTURE AND HORTICULTURE (U.S. CLS. 1, 5, 12, 13, 35 AND 50).

FIRST USE 5-1-2010; IN COMMERCE 5-1-2010.

4,210,669. AUGUST HAT COMPANY, INC., OXNARD, CA. SN 85-157,580. PUB. 10-25-2011, FILED 10-20-2010.

HEX

THE MARK CONSISTS OF STANDARD CHARACTERS WITHOUT CLAIM TO ANY PARTICULAR FONT, STYLE, SIZE, OR COLOR.

CLASS 9—ELECTRICAL AND SCIENTIFIC APPARATUS

FOR BANDS WORN ON THE BODY FOR CARRYING PERSONAL ELECTRONIC DEVICES; ARM AND WRIST BANDS FOR CARRYING PERSONAL ELECTRONIC DEVICES; BANDS WORN ON THE BODY FOR CARRYING PORTABLE, DIGITAL ELECTRONIC DEVICES; CASES, STRAPS, WRIST AND ARM BANDS FOR DIGITAL ELECTRONIC DEVICES FOR RECORDING, ORGANIZING, TRANSMITTING, MANIPULATING AND REVIEWING TEXT, DATA AND AUDIO FILES, TIME-KEEPING AND PLAYING MUSIC; WRIST BANDS AND STRAPS FOR HOLDING PERSONAL ELECTRONIC DEVICES (U.S. CLS. 21, 23, 26, 36 AND 38).

FIRST USE 12-0-2010; IN COMMERCE 12-0-2010.

CLASS 14—JEWELRY

FOR WATCH BANDS AND STRAPS; BANDS AND STRAPS FOR CHRONOMETRIC INSTRUMENTS (U.S. CLS. 2, 27, 28 AND 50).

FIRST USE 12-0-2010; IN COMMERCE 12-0-2010.

CLASS 18—LEATHER GOODS

FOR BACK PACKS, TOTE BAGS, SATCHELS, WALLET, WAIST PACKS (U.S. CLS. 1, 2, 3, 22 AND 41).

FIRST USE 8-0-2011; IN COMMERCE 8-0-2011.

4,210,671. ALEXANDRIA REAL ESTATE EQUITIES, INC., PASADENA, CA. SN 85-158,498. PUB. 11-15-2011, FILED 10-21-2010.

ALEXANDRIA: AN INVESTMENT
GRADE REIT FOR THE LIFE
SCIENCE INDUSTRY

THE MARK CONSISTS OF STANDARD CHARACTERS WITHOUT CLAIM TO ANY PARTICULAR FONT, STYLE, SIZE, OR COLOR.

CLASS 35—ADVERTISING AND BUSINESS

FOR BUSINESS ADMINISTRATION AND MANAGEMENT; BUSINESS MANAGEMENT CONSULTING; BUSINESS INCUBATOR SERVICES, NAMELY, BUSINESS MARKETING, BUSINESS MANAGEMENT, AND BUSINESS DEVELOPMENT SERVICES IN THE FORM OF START-UP SUPPORT FOR BUSINESSES OF OTHERS; BUSINESS NETWORKING SERVICES; BUSINESS COMMUNICATIONS SERVICES, NAMELY, PUBLIC RELATIONS, ADVERTISING, MARKETING AND PUBLICITY SERVICES; RENTAL AND LEASING OF OFFICE MACHINERY AND EQUIPMENT (U.S. CLS. 100, 101 AND 102).

FIRST USE 5-0-2012; IN COMMERCE 5-0-2012.

CLASS 36—INSURANCE AND FINANCIAL

FOR REAL ESTATE MANAGEMENT; FINANCIAL SERVICES, NAMELY, FINANCIAL CONSULTATION, FINANCIAL ANALYSIS, FINANCIAL PLANNING, FINANCIAL MANAGEMENT, FINANCING SERVICES, PROVIDING WORKING CAPITAL, NAMELY, DEBT AND EQUITY CAPITAL, TANGIBLE AND INTANGIBLE ASSET FINANCING, AND FINANCIAL PORTFOLIO MANAGEMENT; BUSINESS INCUBATOR SERVICES, NAMELY, PROVIDING DEBT AND EQUITY FINANCING TO EMERGING AND START-UP COMPANIES (U.S. CLS. 100, 101 AND 102).

FIRST USE 5-0-2012; IN COMMERCE 5-0-2012.

CLASS 37—CONSTRUCTION AND REPAIR

FOR REAL ESTATE DEVELOPMENT; BUILDING CONSTRUCTION AND REPAIR; MAINTENANCE AND REPAIR OF BUILDINGS, ELECTRICAL SYSTEMS, HEATING AND AIR CONDITIONING SYSTEMS AND PLUMBING SYSTEMS (U.S. CLS. 100, 103 AND 106).

FIRST USE 5-0-2012; IN COMMERCE 5-0-2012.

CLASS 42—SCIENTIFIC AND COMPUTER SERVICES

FOR ARCHITECTURAL DESIGN SERVICES; ENGINEERING SERVICES; RENTAL AND LEASING OF COMPUTERS (U.S. CLS. 100 AND 101).

FIRST USE 5-0-2012; IN COMMERCE 5-0-2012.

4,210,672. CHOCOLAFABRIKEN LINDT & SPRÜNGLI AG, CH-8802 KILCHBERG, SWITZERLAND. SN 85-159,014. PUB. 11-8-2011, FILED 10-22-2010.

LINDT CHOCOLATE R.S.V.P.

THE MARK CONSISTS OF STANDARD CHARACTERS

WITHOUT CLAIM TO ANY PARTICULAR FONT, STYLE, SIZE, OR COLOR.

OWNER OF U.S. REG. NOS. 87,306, 3,462,853, AND OTHERS.

NO CLAIM IS MADE TO THE EXCLUSIVE RIGHT TO USE "CHOCOLATE", APART FROM THE MARK AS SHOWN.

CLASS 16—PAPER GOODS AND PRINTED MATTER

FOR PRINTED BUSINESS SUPPLIES AND SALES AIDS FOR THOSE ENGAGED IN THE PROMOTION AND SALE OF CHOCOLATE AND CONFECTIONERY PRODUCTS, NAMELY, BUSINESS ORGANIZER FOLDERS, ADHESIVE LABELS, PRINTED PAPER LABELS, DECALS, PRINTED GUIDES, INSTRUCTIONAL BROCHURES, PAMPHLETS, LEAFLETS AND BROCHURES, ALL IN THE FIELD OF CHOCOLATE TASTING AND CHOCOLATE SALES (U.S. CLS. 2, 5, 22, 23, 29, 37, 38 AND 50).

FIRST USE 9-2-2011; IN COMMERCE 9-2-2011.

CLASS 21—HOUSEWARES AND GLASS

FOR PORTABLE COOLERS FOR THE TRANSPORT AND SALE OF CHOCOLATE; HOUSEHOLD CONTAINERS FOR THE TRANSPORT AND SALE OF CHOCOLATE (U.S. CLS. 2, 13, 23, 29, 30, 33, 40 AND 50).

FIRST USE 9-2-2011; IN COMMERCE 9-2-2011.

CLASS 35—ADVERTISING AND BUSINESS

FOR SHOP AT HOME PARTIES FEATURING CHOCOLATE PRODUCTS; PREPARING AUDIOVISUAL PRESENTATIONS FOR USE IN THE PROMOTION AND SALE OF CHOCOLATE (U.S. CLS. 100, 101 AND 102).

FIRST USE 9-2-2011; IN COMMERCE 9-2-2011.

4,210,674. BIO-LAB, INC., MIDDLEBURY, CT. SN 85-159,499. PUB. 4-19-2011, FILED 10-22-2010.

POOL ESSENTIALS

THE MARK CONSISTS OF STANDARD CHARACTERS WITHOUT CLAIM TO ANY PARTICULAR FONT, STYLE, SIZE, OR COLOR.

OWNER OF U.S. REG. NOS. 2,241,811, 3,030,345, AND 3,151,890.

NO CLAIM IS MADE TO THE EXCLUSIVE RIGHT TO USE "POOL", APART FROM THE MARK AS SHOWN.

CLASS 1—CHEMICALS

FOR WATER TREATMENT CHEMICALS AND CHEMICAL BLENDS, NAMELY, BIOCIDES, CHLORINE AND CHLORINE COMPOUNDS, OXIDIZERS, STABILIZERS, SHOCK TREATMENT CHEMICALS, CLARIFIERS (U.S. CLS. 1, 5, 6, 10, 26 AND 46).

FIRST USE 1-31-2012; IN COMMERCE 1-31-2012.

CLASS 5—PHARMACEUTICALS

FOR DISINFECTING AND SANITIZING PREPARATIONS FOR SWIMMING POOL USE; BACTERICIDES AND ALGAECIDES FOR SWIMMING POOLS (U.S. CLS. 6, 18, 44, 46, 51 AND 52).

FIRST USE 1-31-2012; IN COMMERCE 1-31-2012.

4,210,687. METROPOLITAN LIFE INSURANCE COMPANY, NEW YORK, NY. SN 85-175,791. PUB. 5-31-2011, FILED 11-12-2010.

METLIFE CENTER FOR WORKPLACE BENEFITS

THE MARK CONSISTS OF STANDARD CHARACTERS WITHOUT CLAIM TO ANY PARTICULAR FONT, STYLE, SIZE, OR COLOR.

OWNER OF U.S. REG. NOS. 1,415,273, 3,799,545, AND OTHERS.

NO CLAIM IS MADE TO THE EXCLUSIVE RIGHT TO USE "CENTER FOR WORKPLACE BENEFITS", APART FROM THE MARK AS SHOWN.

CLASS 36—INSURANCE AND FINANCIAL

FOR ADMINISTRATION OF EMPLOYEE BENEFIT PLANS CONCERNING INSURANCE AND FINANCE (U.S. CLS. 100, 101 AND 102).

FIRST USE 3-31-2010; IN COMMERCE 3-31-2010.

CLASS 41—EDUCATION AND ENTERTAINMENT

FOR EDUCATION SERVICES, NAMELY, PROVIDING ON-LINE POD CASTS, VIDEO, AND RESEARCH REPORTS AND OTHER ON-LINE CONTENT IN THE FIELD OF EMPLOYEE BENEFITS (U.S. CLS. 100, 101 AND 107).

FIRST USE 3-31-2010; IN COMMERCE 3-31-2010.

4,210,688. SCHMIDT, BRIAN M., NAZARETH, PA. SN 85-177,112. PUB. 10-25-2011, FILED 11-15-2010.

IEXPECT

THE MARK CONSISTS OF STANDARD CHARACTERS WITHOUT CLAIM TO ANY PARTICULAR FONT, STYLE, SIZE, OR COLOR.

CLASS 25—CLOTHING

FOR CLOTHING, NAMELY, SHIRTS, PANTS AND HEADWEAR (U.S. CLS. 22 AND 39).

FIRST USE 9-20-2011; IN COMMERCE 9-20-2011.

CLASS 35—ADVERTISING AND BUSINESS

FOR ON-LINE RETAIL STORE SERVICES FEATURING CLOTHING, AND GENERAL CONSUMER MERCHANDISE (U.S. CLS. 100, 101 AND 102).

FIRST USE 9-20-2011; IN COMMERCE 9-20-2011.

4,210,693. GARAGISTRY, LLC, ALPHARETTA, GA. SN 85-181,093. PUB. 5-17-2011, FILED 11-19-2010.

PRESERVING AUTOMOTIVE HISTORY ... ONE CAR AT A TIME

THE MARK CONSISTS OF STANDARD CHARACTERS WITHOUT CLAIM TO ANY PARTICULAR FONT, STYLE, SIZE, OR COLOR.

CLASS 35—ADVERTISING AND BUSINESS

FOR PROVIDING A WEB SITE WHERE USERS CAN POST ITEMS FOR SALE THROUGH ON-LINE CLASSIFIED ADVERTISEMENTS; PROVIDING ON-LINE SEARCHABLE DATABASES FEATURING CLASSIFIED AD LISTINGS IN THE FIELD OF CLASSIC VEHICLES, NAMELY, MUSCLE CARS, HOT RODS, AUTOMOBILES, TRUCKS, BOATS, PLANES, AND MOTORCYCLES; PROVIDING AN INTERNET WEB SITE TO PROMOTE EVENTS RELATING TO CLASSIC VEHICLES, NAMELY, MUSCLE CARS, HOT RODS, AUTOMOBILES, TRUCKS, BOATS, PLANES, AND MOTORCYCLES, BY MEANS OF AN ONLINE EVENTS CALENDAR; PROVIDING AN ON-LINE DIRECTORY INFORMATION SERVICE FEATURING INFORMATION REGARDING CLASSIC VEHICLES, NAMELY, MUSCLE CARS, HOT RODS, AUTOMOBILES, TRUCKS, BOATS, PLANES, AND MOTORCYCLES (U.S. CLS. 100, 101 AND 102).

FIRST USE 10-22-2010; IN COMMERCE 7-3-2012.

CLASS 38—COMMUNICATION

FOR PROVIDING ELECTRONIC BULLETIN BOARDS FOR TRANSMISSION OF MESSAGES AMONG USERS IN THE FIELD OF CLASSIC VEHICLES, NAMELY, MUSCLE CARS, HOT RODS, AUTOMOBILES, TRUCKS, BOATS, PLANES, AND MOTORCYCLES (U.S. CLS. 100, 101 AND 104).

FIRST USE 10-22-2010; IN COMMERCE 7-3-2012.

CLASS 41—EDUCATION AND ENTERTAINMENT

FOR PROVIDING HISTORICAL AND ENTERTAINMENT INFORMATION IN THE FIELD OF CLASSIC VEHICLES, NAMELY, MUSCLE CARS, HOT RODS, AUTOMOBILES, TRUCKS, BOATS, PLANES, AND MOTORCYCLES; PROVIDING ON-LINE ELECTRONIC DATABASES IN THE FIELD OF CLASSIC VEHICLES, NAMELY, MUSCLE CARS, HOT RODS, AUTOMOBILES, TRUCKS, BOATS, PLANES, AND MOTORCYCLES, FEATURING HISTORICAL RECORDS, HISTORICAL PUBLICATIONS, PHOTOGRAPHS, VEHICLE OWNERSHIP RECORDS, VEHICLE OWNERS' NARRATIVES, VEHICLE MAINTENANCE HISTORIES, AND VEHICLE RESTORATION HISTORIES SUBMITTED BY USERS, PROVIDED ON THE GLOBAL COMPUTER NETWORK (U.S. CLS. 100, 101 AND 107).

FIRST USE 10-22-2010; IN COMMERCE 7-3-2012.

CLASS 42—SCIENTIFIC AND COMPUTER SERVICES

FOR COMPUTER SERVICES, NAMELY, CREATING AN ON-LINE COMMUNITY FOR REGISTERED USERS TO PARTICIPATE IN DISCUSSIONS, RECEIVE FEEDBACK FROM THEIR PEERS, SOLICIT ADVICE, FORM VIRTUAL COMMUNITIES, AND ENGAGE IN SOCIAL NETWORKING IN THE FIELD OF CLASSIC VEHICLES, NAMELY, MUSCLE CARS, HOT RODS, AUTOMOBILES, TRUCKS, BOATS, PLANES, AND MOTORCYCLES; COMPUTER SERVICES, NAMELY, CREATING AN ON-LINE COMMUNITY FOR REGISTERED USERS TO PARTICIPATE IN DISCUSSIONS, GET FEEDBACK FROM THEIR PEERS, FORM VIRTUAL COMMUNITIES, AND ENGAGE IN SOCIAL NETWORKING;

COMPUTER SERVICES, NAMELY, HOSTING CUSTOMIZED WEB PAGES AND DATA FEEDS FEATURING USER-DEFINED INFORMATION, NAMELY, BLOG POSTS, PERSONAL PROFILES, NEW MEDIA CONTENT, AND ON-LINE CONTENT, ALL IN THE FIELD OF CLASSIC VEHICLES, NAMELY, MUSCLE CARS, HOT RODS, AUTOMOBILES, TRUCKS, BOATS, PLANES, AND MOTORCYCLES; COMPUTER SERVICES, NAMELY, HOSTING AN INTERACTIVE WEB SITE FOR USE IN CREATING, DISPLAYING, SHARING AND STORING MULTIMEDIA PRESENTATIONS THAT INCLUDE TEXT, PHOTOGRAPHS AND SOUND, ALL IN THE FIELD OF CLASSIC VEHICLES, NAMELY, MUSCLE CARS, HOT RODS, AUTOMOBILES, TRUCKS, BOATS, PLANES, AND MOTORCYCLES; HOSTING OF DIGITAL CONTENT ON THE INTERNET, NAMELY, HOSTING OF ON-LINE ARTICLES, JOURNALS, BULLETIN BOARDS, AND BLOGS IN THE FIELD OF CLASSIC VEHICLES, NAMELY, MUSCLE CARS, HOT RODS, AUTOMOBILES, TRUCKS, BOATS, PLANES, AND MOTORCYCLES; COMPUTER SERVICES, NAMELY, HOSTING AND MAINTAINING AN ONLINE WEBSITE FOR OTHERS TO ACCESS PHOTO ALBUMS AND CALENDARS; PROVIDING TEMPORARY USE OF NON-DOWNLOADABLE COMPUTER SOFTWARE FOR USE IN THE CREATION AND PUBLICATION OF ON-LINE JOURNALS, BLOGS, AND MULTI-MEDIA PRESENTATIONS IN THE FIELD OF CLASSIC VEHICLES, NAMELY, MUSCLE CARS, HOT RODS, AUTOMOBILES, TRUCKS, BOATS, PLANES, AND MOTORCYCLES (U.S. CLS. 100 AND 101).

FIRST USE 10-22-2010; IN COMMERCE 7-3-2012.

4,210,704. BING HAN PHARMACEUTICAL FACTORY CO., LTD., KUAN-TYEN HSIANG, TAIWAN. SN 85-185,432. PUB. 1-31-2012, FILED 11-26-2010.



THE MARK CONSISTS OF THE OVERLAPPING LETTERS "Q" AND "S" UNDER A CROWN.

CLASS 3—COSMETICS AND CLEANING PREPARATIONS

FOR FACE AND BODY CREAMS; FACE AND BODY BEAUTY CREAMS; COSMETICS; COSMETIC PREPARATIONS FOR BODY AND SKIN CARE; COSMETIC PREPARATIONS FOR THE HAIR AND SCALP; HAIRSPRAY; SHAMPOO; NON-MEDICATED SKIN CARE PREPARATIONS, NAMELY, CREAMS, LOTIONS, GELS, TONERS, CLEANERS AND PEELS; NON-MEDICATED SKIN CARE CREAMS AND LOTIONS (U.S. CLS. 1, 4, 6, 50, 51 AND 52).

FIRST USE 11-26-2011; IN COMMERCE 11-26-2011.

CLASS 5—PHARMACEUTICALS

FOR MEDICINAL GINSENG POWDER; MINERAL FOOD-SUPPLEMENTS; DIETARY SUPPLEMENTS; FOOD SUPPLEMENTS; GINSENG FOR MEDICINAL USE; HERBAL SUPPLEMENTS; AND NATURAL HERBAL SUPPLEMENTS (U.S. CLS. 6, 18, 44, 46, 51 AND 52).
FIRST USE 11-26-2011; IN COMMERCE 11-26-2011.

CLASS 30—STAPLE FOODS

FOR BEVERAGES, NAMELY, TEA INCLUDING GINSENG TEA, COFFEE, COCOA; TEA LEAVES; TEA BAGS; MIXES IN THE NATURE OF CONCENTRATES, SYRUPS OR POWDERS USED IN THE PREPARATION OF TEA BASED BEVERAGES; CHOCOLATE; ICE AND ITS PRODUCTS, NAMELY, FLAVORED ICES AND ICE CUBES; FOOD AND BEVERAGE SEASONINGS, FOODS, NAMELY, SUGAR, HONEY, BREAD, TOAST, PUDDINGS, GLUTINOUS RICE CAKE, PROCESSED GRAIN POWDER, NAMELY, RICE MIX AND FLOUR MIX; NOODLES, INSTANT COOKING NOODLES, PROCESSED GRAIN DESSERTS, NAMELY, RICE CAKES; DUMPLINGS; RICE AND COOKED RICE (U.S. CL. 46).
FIRST USE 11-26-2011; IN COMMERCE 11-26-2011.

4,210,708. SCHOLAREEDGE COLLEGE CONSULTING, LLC, ST. PAUL, MN. SN 85-188,509. PUB. 11-8-2011, FILED 12-1-2010.



NO CLAIM IS MADE TO THE EXCLUSIVE RIGHT TO USE "COLLEGE CONSULTING", APART FROM THE MARK AS SHOWN.

THE COLOR(S) WHITE, NAVY BLUE, GRAY AND LIGHT GRAY IS/ARE CLAIMED AS A FEATURE OF THE MARK.

THE MARK CONSISTS OF A BLUE RECTANGLE BACKGROUND. WITHIN THE BACKGROUND IS A NAVY BLUE BOOK THAT IS OPEN WITH A HALF-TURNED PAGE CREATING A WHITE SHADOW, ALL OF WHICH IS SURROUNDED BY A WHITE TILTED SQUARE, AND ALL OF WHICH IS FOLLOWED BY THE WORD "SCHOLAREEDGE" IN CAPITAL LETTERS IN A BLOCK-STYLE FONT WITH THE WORD "SCHOLAR" APPEARING IN WHITE AND THE WORD "EDGE" APPEARING IN LIGHT GRAY. THE WORD "SCHOLAREEDGE", AS DESCRIBED, APPEARS ABOVE THE WORDS "COLLEGE CONSULTING" IN WHITE CAPITAL LETTERS IN A BLOCK-STYLE FONT. BOTH THE WORDS "SCHOLAREEDGE" AND "COLLEGE CONSULTING" APPEAR OVER THE WORDS "APPLY. COMPETE. SUCCEED." IN UPPER AND LOWER CASE GRAY LETTERS IN A BLOCK-STYLE FONT.

CLASS 16—PAPER GOODS AND PRINTED MATTER

FOR PRINTED EDUCATIONAL MATERIALS IN THE FIELD OF PLANNING AND PREPARING FOR FURTHER EDUCATION (U.S. CLS. 2, 5, 22, 23, 29, 37, 38 AND 50).

FIRST USE 1-1-2012; IN COMMERCE 1-1-2012.

CLASS 41—EDUCATION AND ENTERTAINMENT

FOR EDUCATION SERVICES, NAMELY, PROVIDING SEMINARS AND WORKSHOPS IN THE FIELDS OF PLANNING AND PREPARING FOR FURTHER EDUCATION; EDUCATIONAL COUNSELING SERVICES TO ASSIST STUDENTS IN PLANNING AND PREPARING FOR FURTHER EDUCATION (U.S. CLS. 100, 101 AND 107).

FIRST USE 8-19-2010; IN COMMERCE 8-19-2010.

4,210,715. QUALITY NEW MEXICO, ALBUQUERQUE, NM. SN 85-189,557. PUB. 11-1-2011, FILED 12-2-2010.

NMEXL

THE MARK CONSISTS OF STANDARD CHARACTERS WITHOUT CLAIM TO ANY PARTICULAR FONT, STYLE, SIZE, OR COLOR.

CLASS 35—ADVERTISING AND BUSINESS

FOR HUMAN RESOURCES SERVICES IN THE FIELD OF BUSINESS MANAGEMENT, NAMELY, OFFERING ASSESSMENTS AND SURVEYS IN THE FIELD OF EMPLOYEE TRAINING AND PERFORMANCE FOR THE PUBLIC AND PRIVATE EDUCATION SECTOR (U.S. CLS. 100, 101 AND 102).

FIRST USE 6-9-2011; IN COMMERCE 6-9-2011.

CLASS 41—EDUCATION AND ENTERTAINMENT

FOR BUSINESS EDUCATION AND TRAINING SERVICES, NAMELY, OFFERING ASSESSMENTS AND DEVELOPING AND FACILITATING CUSTOMIZED PROFESSIONAL DEVELOPMENT AND PERFORMANCE IMPROVEMENT PROGRAMS FOR THE PUBLIC AND PRIVATE EDUCATION SECTOR; PROVIDING COACHING, TRAINING AND MENTORING IN THE FIELD OF EMPLOYEE PERFORMANCE IMPROVEMENT FOR THE PUBLIC AND PRIVATE EDUCATION SECTOR; EDUCATIONAL SERVICES, NAMELY, CONDUCTING CONFERENCES IN THE FIELD OF EMPLOYEE TRAINING AND PERFORMANCE FOR THE PUBLIC AND PRIVATE EDUCATION SECTOR (U.S. CLS. 100, 101 AND 107).

FIRST USE 6-9-2011; IN COMMERCE 6-9-2011.

4,210,719. UNITED LABORATORIES INTERNATIONAL, LLC, HOUSTON, TX. SN 85-191,351. PUB. 11-22-2011, FILED 12-6-2010.



THE MARK CONSISTS OF THE LETTERING "ULI", WITH "U" AND "I" STYLIZED, AND WITH A CONVEX

CURVE OF INCREASING DIAMETER EXTENDING FROM ABOVE THE "U" TO ABOVE THE "I".

4,210,730. MILLER, TRUDY WEAVER, SHEFFIELD, MA. SN 85-194,058. PUB. 11-8-2011, FILED 12-9-2010.

CLASS 1—CHEMICALS

FOR CHEMICALS FOR INDUSTRIAL USE, NAMELY, CHEMICALS FOR OXIDIZING SULFIDES AND PYROPHORICS, CHEMICALS FOR TREATING BENZENE, CHEMICALS FOR EMULSIFYING AND DEMULSIFYING HYDROCARBONS, CHEMICALS FOR DE-OILING SOLIDS, CHEMICALS FOR LIBERATING VOLATILE ORGANIC COMPOUNDS, CHEMICALS FOR ABSORPTION OF HYDROCARBON VAPORS INTO LIQUIDS, CHEMICALS FOR DEGASSING OF INDUSTRIAL EQUIPMENT, CHEMICALS FOR USE IN ODOR CONTROL, ENZYME AND SURFACTANT BASED CHEMICAL COMPOSITIONS, CHEMICALS FOR NEUTRALIZING CONTAMINANTS, NAMELY, AMMONIA; CHEMICAL ADDITIVES, NAMELY, ADDITIVES FOR REFINERY SOLVENTS, ADDITIVES FOR HYDROCARBON SOLVENTS, AND ADDITIVES FOR PETROCHEMICAL SOLVENTS; CHEMICAL COMPOSITIONS AND CHEMICAL SOLVENT ADDITIVES FOR INDUSTRIAL USE FOR DEGASSING OF TANKS, VESSELS, REACTORS, PIPING AND OTHER INDUSTRIAL EQUIPMENT (U.S. CLS. 1, 5, 6, 10, 26 AND 46).

FIRST USE 3-31-2011; IN COMMERCE 3-31-2011.

CLASS 3—COSMETICS AND CLEANING PREPARATIONS

FOR CLEANING PREPARATIONS FOR INDUSTRIAL USE, NAMELY, CHEMICAL CLEANERS AND SOLVENT ADDITIVES FOR CLEANING AND DECONTAMINATING TANKS, VESSELS, REACTORS, PIPING AND OTHER INDUSTRIAL EQUIPMENT (U.S. CLS. 1, 4, 6, 50, 51 AND 52).

FIRST USE 3-31-2011; IN COMMERCE 3-31-2011.

CLASS 37—CONSTRUCTION AND REPAIR

FOR MAINTENANCE OF INDUSTRIAL EQUIPMENT, NAMELY, TANK, VESSEL, PIPING, AND REACTOR CLEANING SERVICES; CONSULTANCY REGARDING INDUSTRIAL EQUIPMENT MAINTENANCE; CONSULTANCY REGARDING ENVIRONMENTAL REMEDIATION, NAMELY, CONSULTANCY REGARDING WASTE DISPOSAL; CLEANING OF INDUSTRIAL EQUIPMENT, NAMELY, CLEANING OF TANKS, VESSELS, PIPING, AND REACTORS; CONSULTANCY REGARDING CLEANING OF INDUSTRIAL EQUIPMENT, NAMELY, CONSULTANCY REGARDING CLEANING OF TANKS, VESSELS, PIPING, AND REACTORS (U.S. CLS. 100, 103 AND 106).

FIRST USE 3-31-2011; IN COMMERCE 3-31-2011.

CLASS 40—MATERIAL TREATMENT

FOR TREATMENT OF MATERIALS, NAMELY, TREATMENT OF SULFIDES, HYDROCARBONS, PYROPHORICS, AND BENZENE; DECONTAMINATION OF INDUSTRIAL EQUIPMENT, NAMELY, DECONTAMINATION OF TANKS, VESSELS, PIPING, AND REACTORS; CONSULTANCY REGARDING DECONTAMINATION OF INDUSTRIAL EQUIPMENT, NAMELY, CONSULTANCY REGARDING DECONTAMINATION OF TANKS, VESSELS, PIPING, AND REACTORS; CONSULTANCY REGARDING TREATMENT OF CHEMICALS, GAS, AND WASTE MATERIALS; CONSULTANCY REGARDING ENVIRONMENTAL REMEDIATION, NAMELY, CONSULTANCY REGARDING SOIL, WASTE AND WATER TREATMENT SERVICES (U.S. CLS. 100, 103 AND 106).

FIRST USE 3-31-2011; IN COMMERCE 3-31-2011.

CLASS 42—SCIENTIFIC AND COMPUTER SERVICES

FOR ENGINEERING SERVICES; CONSULTANCY REGARDING ENGINEERING ACTIVITY (U.S. CLS. 100 AND 101).

FIRST USE 3-31-2011; IN COMMERCE 3-31-2011.

SINGERSBABEL

THE MARK CONSISTS OF STANDARD CHARACTERS WITHOUT CLAIM TO ANY PARTICULAR FONT, STYLE, SIZE, OR COLOR.

CLASS 41—EDUCATION AND ENTERTAINMENT

FOR EDUCATION SERVICES, NAMELY, PROVIDING ONLINE TEXT, IMAGES, AUDIO AND VIDEO RECORDINGS AND OTHER MULTIMEDIA MATERIALS, FEATURING DEMONSTRATIONS, INSTRUCTION, TRANSLATION, TRANSLITERATION AND PERFORMANCES IN THE FIELD OF MUSIC (U.S. CLS. 100, 101 AND 107).

FIRST USE 4-18-2012; IN COMMERCE 4-18-2012.

CLASS 42—SCIENTIFIC AND COMPUTER SERVICES

FOR PROVIDING TEMPORARY USE OF ON-LINE NON-DOWNLOADABLE DEVELOPMENT SOFTWARE FOR PROVIDING A PRONUNCIATION SYSTEM ALLOWING SINGERS, MUSIC SCHOOLS AND OTHER ENTERTAINMENT AND EDUCATIONAL CENTERS TO TRANSLATE MUSIC INTO AN INTERNATIONAL LANGUAGE (U.S. CLS. 100 AND 101).

FIRST USE 4-18-2012; IN COMMERCE 4-18-2012.

4,210,733. MARWARE, INC., HOLLYWOOD, FL. SN 85-196,479. PUB. 5-10-2011, FILED 12-13-2010.

THE LEADING WAVE OF THE MOBILE COMMUNITY

THE MARK CONSISTS OF STANDARD CHARACTERS WITHOUT CLAIM TO ANY PARTICULAR FONT, STYLE, SIZE, OR COLOR.

NO CLAIM IS MADE TO THE EXCLUSIVE RIGHT TO USE "MOBILE COMMUNITY", APART FROM THE MARK AS SHOWN.

CLASS 9—ELECTRICAL AND SCIENTIFIC APPARATUS

FOR BUSINESS MANAGEMENT SOFTWARE FOR USE IN PROJECT MANAGEMENT; CASES FOR MP3 PLAYERS, PDAS, PORTABLE PHONES AND PORTABLE COMPUTERS; FITTED CASES FOR PORTABLE WEB CAMERAS; SCREEN PROTECTOR FILTERS AND SCREEN GLARE REDUCERS FOR ELECTRONIC DEVICES (U.S. CLS. 21, 23, 26, 36 AND 38).

FIRST USE 12-1-2010; IN COMMERCE 12-1-2010.

CLASS 25—CLOTHING

FOR WEARING APPAREL IN THE NATURE OF CLOTHING ACCESSORIES, NAMELY, BANDANAS, BELTS, GLOVES, SCARVES, SWEAT BANDS, SUSPENDERS AND TIES; CLOTHING, NAMELY, APRONS, BLOUSES, BOTTOMS, GYM SHORTS, GYM SUITS, JERSEYS, JUMP SUITS, PANTS, PULLOVERS, SHIRTS, SHORTS, SKIRTS, SWEATERS, SWEAT PANTS, SWEAT SHIRTS, SWEAT SUITS, TANK TOPS, AND T-SHIRTS; HEAD WEAR, NAMELY, CAPS, EAR MUFFS, HATS AND VISORS (U.S. CLS. 22 AND 39).

FIRST USE 12-1-2010; IN COMMERCE 12-1-2010.

CLASS 35—ADVERTISING AND BUSINESS

FOR ONLINE, MAIL ORDER, CATALOG, RETAIL AND WHOLESALE STORE SERVICES FEATURING COMMUNICATIONS APPARATUS ACCESSORIES, NAMELY, CASES FOR MP3 PLAYERS, PDAS, PORTABLE PHONES AND PORTABLE COMPUTERS, FITTED CASES FOR PORTABLE WEB CAMERAS, SCREEN PROTECTORS AND SCREEN GLARE REDUCERS, AND WEARING APPAREL AND CLOTHING ACCESSORIES (U.S. CLS. 100, 101 AND 102).

FIRST USE 12-1-2010; IN COMMERCE 12-1-2010.

4,210,734. MARWARE, INC., HOLLYWOOD, FL. SN 85-196,547. PUB. 5-10-2011, FILED 12-13-2010.

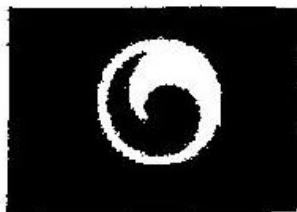

OWNER OF U.S. REG. NO. 2,951,589.

THE MARK CONSISTS OF A SINGLE WAVE SUPERIMPOSED ON A DARK BACKGROUND ENCAPSULATED IN A CIRCLE.

CLASS 9—ELECTRICAL AND SCIENTIFIC APPARATUS

FOR BUSINESS MANAGEMENT SOFTWARE FOR USE IN PROJECT MANAGEMENT; CASES FOR MP3 PLAYERS, PDAS, PORTABLE PHONES AND PORTABLE COMPUTERS; FITTED CASES FOR PORTABLE WEB CAMERAS; SCREEN PROTECTOR FILTERS AND SCREEN GLARE REDUCERS FOR ELECTRONIC DEVICES (U.S. CLS. 21, 23, 26, 36 AND 38).

FIRST USE 1-1-2000; IN COMMERCE 1-1-2000.

CLASS 25—CLOTHING

FOR WEARING APPAREL IN THE NATURE OF CLOTHING ACCESSORIES, NAMELY, BANDANAS, BELTS, GLOVES, SCARVES, SWEAT BANDS, SUSPENDERS AND TIES; CLOTHING, NAMELY, APRONS, BLOUSES, BOTTOMS, GYM SHORTS, GYM SUITS, JERSEYS, JUMP SUITS, PANTS, PULLOVERS, SHIRTS, SHORTS, SKIRTS, SWEATERS, SWEAT PANTS, SWEAT SHIRTS, SWEAT SUITS, TANK TOPS, AND T-SHIRTS; HEAD WEAR, NAMELY, CAPS, EAR MUFFS, HATS AND VISORS (U.S. CLS. 22 AND 39).

FIRST USE 1-1-2000; IN COMMERCE 1-1-2000.

CLASS 35—ADVERTISING AND BUSINESS

FOR ONLINE, MAIL ORDER, CATALOG, RETAIL AND WHOLESALE STORE SERVICES FEATURING COMMUNICATIONS APPARATUS ACCESSORIES, NAMELY, CASES FOR MP3 PLAYERS, PDAS, PORTABLE PHONES AND PORTABLE COMPUTERS, FITTED CASES FOR PORTABLE WEB CAMERAS, SCREEN PROTECTORS AND SCREEN GLARE REDUCERS, AND WEARING APPAREL AND CLOTHING ACCESSORIES (U.S. CLS. 100, 101 AND 102).

FIRST USE 1-1-2000; IN COMMERCE 1-1-2000.

CLASS 41—EDUCATION AND ENTERTAINMENT

FOR EDUCATIONAL AND INSTRUCTIONAL SERVICES, NAMELY, CONDUCTING SEMINARS AND WORKSHOPS IN THE FIELDS OF BUSINESS DEVELOPMENT AND BUSINESS MANAGEMENT; ENTERTAINMENT SERVICES, NAMELY, LIVE SPEAKING ENGAGEMENTS IN THE FIELD OF BUSINESS DEVELOPMENT AND BUSINESS MANAGEMENT, AND PUBLICATION OF ACCOMPANYING MATERIALS IN THE FORM OF BOOKS, HANDOUTS, MAGAZINES AND NEWSLETTERS; COACHING SERVICES IN THE FIELDS OF BUSINESS DEVELOPMENT AND BUSINESS MANAGEMENT (U.S. CLS. 100, 101 AND 107).

FIRST USE 1-1-2000; IN COMMERCE 1-1-2000.

4,210,737. PORTRAIT CITY, LLC, OVERLAND PARK, KS. SN 85-197,714. PUB. 5-10-2011, FILED 12-14-2010.

NO CLAIM IS MADE TO THE EXCLUSIVE RIGHT TO USE "STUDIOS", APART FROM THE MARK AS SHOWN.

THE COLOR(S) GRAY, RED, ORANGE, BLUE, GREEN, YELLOW, PURPLE IS/ARE CLAIMED AS A FEATURE OF THE MARK.

THE MARK CONSISTS OF THE WORDS "PICTURE DAY STUDIOS" WITH THE LETTERS BEING DIFFERENT COLORS AS FOLLOWS: A RED "P", ORANGE "I", BLUE "C", GREEN "T", RED "U", YELLOW "R" AND PURPLE "E" MAKE UP THE WORD "PICTURE"; A BLUE "D", RED "A" AND GREEN "Y" MAKE UP THE WORD "DAY"; A YELLOW "S", RED "T", ORANGE "U", PURPLE "D", GREEN "I", BLUE "O" AND RED "S" MAKE UP THE WORD "STUDIOS". ALL LETTERS HAVE A LIGHT GRAY SHADOWING.

CLASS 35—ADVERTISING AND BUSINESS

FOR BUSINESS SUPPORT SERVICES, NAMELY, BUSINESS CONSULTING TO PROFESSIONAL PHOTOGRAPHERS (U.S. CLS. 100, 101 AND 102).

FIRST USE 6-29-2012; IN COMMERCE 6-29-2012.

CLASS 40—MATERIAL TREATMENT

FOR PHOTOGRAPHIC PROCESSING SERVICES (U.S. CLS. 100, 103 AND 106).

FIRST USE 6-29-2012; IN COMMERCE 6-29-2012.

CLASS 41—EDUCATION AND ENTERTAINMENT

FOR PHOTOGRAPHY SERVICES (U.S. CLS. 100, 101 AND 107).

FIRST USE 6-29-2012; IN COMMERCE 6-29-2012.

4,210,738. INTERDESIGN, INC., SOLON, OH. SN 85-198,705.
PUB. 11-15-2011, FILED 12-15-2010.

4,210,744. THE NET2 GROUP, INC., NEW YORK, NY. SN 85-
201,886. PUB. 11-22-2011, FILED 12-20-2010.

iFORM

THE MARK CONSISTS OF STANDARD CHARACTERS WITHOUT CLAIM TO ANY PARTICULAR FONT, STYLE, SIZE, OR COLOR.

CLASS 9—ELECTRICAL AND SCIENTIFIC APPARATUS

FOR RADIOS; HANGING RADIOS (U.S. CLS. 21, 23, 26, 36 AND 38).
FIRST USE 2-1-2012; IN COMMERCE 2-1-2012.

CLASS 11—ENVIRONMENTAL CONTROL APPARATUS

FOR ELECTRIC BATHROOM NIGHTLIGHTS; ELECTRIC NIGHT LIGHTS; SENSOR LIGHTS; TUBE LIGHTS IN THE NATURE OF TUBE-SHAPED LIGHTS MOUNTABLE TO A SURFACE HAVING A FLEXIBLE LIGHTED ARM (U.S. CLS. 13, 21, 23, 31 AND 34).
FIRST USE 2-10-2012; IN COMMERCE 2-10-2012.

CLASS 20—FURNITURE AND ARTICLES NOT OTHERWISE CLASSIFIED

FOR ILLUMINATED MIRRORS; MIRRORS INCORPORATING A FLEXIBLE OR MOVABLE ARM HAVING A LIGHT; ELECTRONIC LED MIRRORS AND SUCTION MOUNTED ELECTRONIC LED MIRRORS, FOR HOUSEHOLD USE (U.S. CLS. 2, 13, 22, 25, 32 AND 50).
FIRST USE 2-10-2012; IN COMMERCE 2-10-2012.

4,210,741. GELLER, JORDAN, LAS VEGAS, NV. SN 85-
200,833. PUB. 4-26-2011, FILED 12-17-2010.

SHOEZEUM

THE MARK CONSISTS OF STANDARD CHARACTERS WITHOUT CLAIM TO ANY PARTICULAR FONT, STYLE, SIZE, OR COLOR.

CLASS 25—CLOTHING

FOR ATHLETIC APPAREL, NAMELY, SHIRTS, PANTS, JACKETS, FOOTWEAR, HATS AND CAPS, ATHLETIC UNIFORMS; ATHLETIC SHOES; CAPS; GYM SUITS; HATS; HEADWEAR; HOODED SWEAT-SHIRTS; JACKETS; JOGGING SUITS; SHIRTS; SHIRTS; SHORTS; SWEAT SHIRTS; SWEAT SHORTS; SWEAT SUITS; T-SHIRTS; TANK TOPS (U.S. CLS. 22 AND 39).
FIRST USE 6-15-2012; IN COMMERCE 6-15-2012.

CLASS 41—EDUCATION AND ENTERTAINMENT

FOR MUSEUM SERVICES (U.S. CLS. 100, 101 AND 107).
FIRST USE 11-15-2010; IN COMMERCE 11-15-2010.

YOUR CONNECTION TO THE WORLD OF LUXURY JEWELS

THE MARK CONSISTS OF STANDARD CHARACTERS WITHOUT CLAIM TO ANY PARTICULAR FONT, STYLE, SIZE, OR COLOR.

NO CLAIM IS MADE TO THE EXCLUSIVE RIGHT TO USE "LUXURY JEWELS", APART FROM THE MARK AS SHOWN.

CLASS 35—ADVERTISING AND BUSINESS

FOR ONLINE ADVERTISING AND PROVIDING ONLINE INFORMATION ABOUT JEWELRY FOR SALE; ONLINE MARKETPLACES FEATURING JEWELRY (U.S. CLS. 100, 101 AND 102).
FIRST USE 2-5-2012; IN COMMERCE 2-5-2012.

CLASS 41—EDUCATION AND ENTERTAINMENT

FOR PROVIDING AN ONLINE NONDOWNLOADABLE MAGAZINE FEATURING NEWS AND INFORMATION RELATING TO JEWELRY (U.S. CLS. 100, 101 AND 107).
FIRST USE 2-5-2012; IN COMMERCE 2-5-2012.

4,210,752. AGENCY EA, L.L.C., CHICAGO, IL. SN 85-203,779.
PUB. 11-22-2011, FILED 12-22-2010.

AGENCYEA

THE MARK CONSISTS OF STANDARD CHARACTERS WITHOUT CLAIM TO ANY PARTICULAR FONT, STYLE, SIZE, OR COLOR.

OWNER OF U.S. REG. NO. 3,441,143.

CLASS 35—ADVERTISING AND BUSINESS

FOR BUSINESS MEETING PLANNING; BUSINESS MANAGEMENT PLANNING; AND LOCATING AND PROVIDING VENUES FOR BUSINESS RELATED EVENTS; SPECIAL EVENT PLANNING FOR BUSINESS PURPOSES; ADMINISTRATION OF PROMOTIONAL AND FULFILLMENT PROGRAMS AND PROMOTIONAL EVENTS FOR THE EMPLOYEES OF OTHERS, NAMELY, ADMINISTRATION OF EMPLOYEE RECOGNITION PROGRAMS AND EMPLOYEE INCENTIVE PROGRAMS TO PROMOTE EMPLOYEE PRODUCTIVITY, PERFORMANCE, RECOGNITION AND MORALE (U.S. CLS. 100, 101 AND 102).
FIRST USE 4-15-2011; IN COMMERCE 4-15-2011.

CLASS 41—EDUCATION AND ENTERTAINMENT

FOR ENTERTAINMENT SERVICES, NAMELY, PROVIDING LIVE ENTERTAINMENT PERFORMANCES FOR LATER BROADCASTS FEATURING PUBLIC SPEAKERS, PERFORMING ARTS, MUSICAL AND THEATRICAL PERFORMANCES; SPECIAL EVENT PLANNING FOR SOCIAL ENTERTAINMENT PURPOSES; PROVIDING LIVE MUSICAL PERFORMANCES THAT ALSO FEATURE SECTIONS OF PRERECORDED MUSIC; EDUCATIONAL AND ENTERTAINMENT SERVICES, NAMELY, PROVIDING MOTIVATIONAL AND EDUCATIONAL SPEAKERS; PROVIDING FACILITIES FOR BUSINESS MEETINGS; MULTIMEDIA PRODUCTION SERVICES, NAMELY, DESIGNING MULTIMEDIA SHOWS FOR CONVENTIONS, TRADE SHOWS, KEY NOTE ADDRESSES AND AWARD CEREMONIES (U.S. CLS. 100, 101 AND 107).

FIRST USE 4-15-2011; IN COMMERCE 4-15-2011.

CLASS 42—SCIENTIFIC AND COMPUTER SERVICES

FOR GRAPHIC ART DESIGN SERVICES, NAMELY, DESIGNING INVITATION CARDS FOR OTHERS; DESIGNING THEME GRAPHICS AND MULTIMEDIA SHOWS FOR CONVENTIONS TRADE SHOWS, KEY NOTE ADDRESSES AND AWARD CEREMONIES FOR OTHERS (U.S. CLS. 100 AND 101).

FIRST USE 4-15-2011; IN COMMERCE 4-15-2011.

CLASS 43—HOTEL AND RESTAURANT SERVICES

FOR CATERING SERVICES; CONSULTING SERVICES IN THE FIELD OF HOSPITALITY (U.S. CLS. 100 AND 101).

FIRST USE 4-15-2011; IN COMMERCE 4-15-2011.

CLASS 35—ADVERTISING AND BUSINESS

FOR BUSINESS MEETING PLANNING; BUSINESS MANAGEMENT PLANNING; AND LOCATING AND PROVIDING VENUES FOR BUSINESS RELATED EVENTS; SPECIAL EVENT PLANNING FOR BUSINESS PURPOSES; ADMINISTRATION OF PROMOTIONAL AND FULFILLMENT PROGRAMS AND PROMOTIONAL EVENTS FOR THE EMPLOYEES OF OTHERS, NAMELY, ADMINISTRATION OF EMPLOYEE RECOGNITION PROGRAMS AND EMPLOYEE INCENTIVE PROGRAMS TO PROMOTE EMPLOYEE PRODUCTIVITY, PERFORMANCE, RECOGNITION AND MORALE (U.S. CLS. 100, 101 AND 102).

FIRST USE 4-15-2011; IN COMMERCE 4-15-2011.

CLASS 41—EDUCATION AND ENTERTAINMENT

FOR ENTERTAINMENT SERVICES, NAMELY, PROVIDING LIVE ENTERTAINMENT PERFORMANCES FOR LATER BROADCASTS FEATURING PUBLIC SPEAKERS, PERFORMING ARTS, MUSICAL AND THEATRICAL PERFORMANCES; SPECIAL EVENT PLANNING FOR SOCIAL ENTERTAINMENT PURPOSES; PROVIDING LIVE MUSICAL PERFORMANCES THAT ALSO FEATURE SECTIONS OF PRERECORDED MUSIC; EDUCATIONAL AND ENTERTAINMENT SERVICES, NAMELY, PROVIDING MOTIVATIONAL AND EDUCATIONAL SPEAKERS; PROVIDING FACILITIES FOR BUSINESS MEETINGS; MULTIMEDIA PRODUCTION SERVICES, NAMELY, DESIGNING MULTIMEDIA SHOWS FOR CONVENTIONS, TRADE SHOWS, KEY NOTE ADDRESSES AND AWARD CEREMONIES (U.S. CLS. 100, 101 AND 107).

FIRST USE 4-15-2011; IN COMMERCE 4-15-2011.

4,210,758. MAGNACARD, INC., DUBOIS, PA. SN 85-204,630. PUB. 11-1-2011, FILED 12-23-2010.

4,210,753. AGENCY EA, L.L.C., CHICAGO, IL. SN 85-203,788. PUB. 11-22-2011, FILED 12-22-2010.



OWNER OF U.S. REG. NO. 3,441,143.
THE MARK CONSISTS OF THE WORDING "EA AGENCY EA" IN STYLIZED FORM.

ALL ABOUT YOUR LOCKER

THE MARK CONSISTS OF STANDARD CHARACTERS WITHOUT CLAIM TO ANY PARTICULAR FONT, STYLE, SIZE, OR COLOR.

NO CLAIM IS MADE TO THE EXCLUSIVE RIGHT TO USE "LOCKER", APART FROM THE MARK AS SHOWN.

CLASS 9—ELECTRICAL AND SCIENTIFIC APPARATUS

FOR DECORATIVE MAGNETS (U.S. CLS. 21, 23, 26, 36 AND 38).

FIRST USE 4-30-2011; IN COMMERCE 4-30-2011.

CLASS 11—ENVIRONMENTAL CONTROL APPARATUS

FOR PORTABLE BATTERY-OPERATED LIGHTS (U.S. CLS. 13, 21, 23, 31 AND 34).

FIRST USE 4-30-2011; IN COMMERCE 4-30-2011.

4,210,765. WEGO CO., LTD., TOKYO, JAPAN. SN 85-206,586.
PUB. 6-14-2011, FILED 12-28-2010.

WC JAPAN

PRIORITY CLAIMED UNDER SEC. 44(D) ON JAPAN APPLICATION NO. 2010-096879, FILED 12-14-2010.
NO CLAIM IS MADE TO THE EXCLUSIVE RIGHT TO USE "JAPAN", APART FROM THE MARK AS SHOWN.
THE MARK CONSISTS OF THE LETTERS "WC" AND THE WORD "JAPAN".

CLASS 18—LEATHER GOODS

FOR BACKPACKS; GARMENT BAGS FOR TRAVEL; CARD CASES, NAMELY, BUSINESS CARD CASES; HANDBAGS; POCKET WALLETS; PURSES; RUCKSACKS; BAGS FOR SPORTS (U.S. CLS. 1, 2, 3, 22 AND 41).
FIRST USE 1-1-2012; IN COMMERCE 1-1-2012.

CLASS 25—CLOTHING

FOR SHORTS; COATS; TOP COATS; JACKETS; JUMPERS; LEGGINGS; OVERALLS; OVERCOATS; PARKAS; SKIRTS; SUITS; TROUSERS; PANTS; LAYETTES; PAPER UNDERWEAR; JACKETS OF IMITATIONS OF LEATHER; JACKETS OF LEATHER; JACKETS OF FUR; JACKETS OF GABARDINE; JERSEYS; SPORTS JERSEYS; BATHING SUITS; BODICES; CAMISOLES; UNDERGARMENTS, NAMELY, DRAWERS; FISHING VESTS; PAJAMAS; PETTICOATS; PULLOVERS; SHIRTS; PERSPIRATION ABSORBENT UNDERWEAR CLOTHING; SWEATERS; SWIMSUITS; T-SHIRTS; UNDERWEAR; ANTI-SWEAT-UNDERWEAR; VESTS; WAISTCOATS; BABIES' PANTS; BANDANAS; BIBS, NOT OF PAPER; BOAS; COLLAR PROTECTORS; EAR MUFFS; FUR STOLE; GLOVES; SLEEP MASKS; NECKTIES; SCARVES; SHAWLS; SOCKS; GAITER STRAPS; SPATS IN THE NATURE OF LEGGINGS; BERETS; CAP PEAKS; CAPS; HATS; PAPER HATS FOR USE AS CLOTHING ITEMS; SUN VISORS; TURBANS; VISORS; BELTS; BRACES FOR CLOTHING; GARTER; SUSPENDERS; TROUSER STRAPS; BEACH SHOES; BOOTS; HEELPIECES FOR BOOTS AND SHOES; INNER SOLES; LACE BOOTS; SPORTS SHOES; FOOTWEAR; ESPADRILLES; SOLES FOR FOOTWEAR; SHOES; SLIPPERS; MASQUERADE COSTUMES; FOOTBALL BOOTS; GYMNASIUM SHOES; HEADBANDS; BOOTS FOR SPORTS (U.S. CLS. 22 AND 39).

FIRST USE 1-1-2012; IN COMMERCE 1-1-2012.

4,210,794. RED BLUE VOICE, LLC, PITTSBURGH, PA. SN 85-215,568. PUB. 12-27-2011, FILED 1-12-2011.

REDBLUEVOICE

THE MARK CONSISTS OF STANDARD CHARACTERS WITHOUT CLAIM TO ANY PARTICULAR FONT, STYLE, SIZE, OR COLOR.

CLASS 14—JEWELRY

FOR JEWELRY; PINS BEING JEWELRY (U.S. CLS. 2, 27, 28 AND 50).
FIRST USE 7-3-2012; IN COMMERCE 7-3-2012.

CLASS 16—PAPER GOODS AND PRINTED MATTER

FOR STICKERS (U.S. CLS. 2, 5, 22, 23, 29, 37, 38 AND 50).
FIRST USE 7-3-2012; IN COMMERCE 7-3-2012.

CLASS 25—CLOTHING

FOR CLOTHING, NAMELY, HEADWEAR, UNDERWEAR, CAPS, JACKETS, GYM SUITS, JOGGING OUTFITS, SPORTS JERSEYS, SPORTS SHIRTS WITH SHORT SLEEVES, HOODED SWEAT SHIRTS, SWEAT SHIRTS, SWEAT SUITS, TRACK SUITS, TRACKSUITS, TEE SHIRTS, T-SHIRTS (U.S. CLS. 22 AND 39).
FIRST USE 7-3-2012; IN COMMERCE 7-3-2012.

CLASS 26—FANCY GOODS

FOR NOVELTY PINS (U.S. CLS. 37, 39, 40, 42 AND 50).
FIRST USE 7-3-2012; IN COMMERCE 7-3-2012.

CLASS 35—ADVERTISING AND BUSINESS

FOR ADVERTISING AND PROMOTION SERVICES; PUBLIC RELATIONS; DISTRIBUTION OF ADVERTISEMENTS; PRODUCTION OF ADVERTISEMENTS AND COMMERCIALS INCLUDING PRINT, MULTI-MEDIA, VIDEO, MOBILE AND AUDIO; ADVERTISING CONSULTING SERVICES; POLITICAL ADVERTISING CONSULTING SERVICES; ADVERTISING SERVICES FOR POLITICAL CAMPAIGNS; BUSINESS AND CORPORATE IDENTITY SERVICES; REPORTING SERVICES FOR INDIVIDUALS AND BUSINESSES WITH REPORTS CONTAINING A COLLECTION AND CONSOLIDATION OF PUBLIC ANNOUNCEMENTS, NEWS AND MEDIA CONTENT REGARDING SUCH INDIVIDUALS AND BUSINESSES, AS THE CASE MAY BE (U.S. CLS. 100, 101 AND 102).
FIRST USE 7-3-2012; IN COMMERCE 7-3-2012.

4,210,805. JOHNSON, RESARANI D, NORTH LAS VEGAS, NV. SN 85-217,203. PUB. 5-31-2011, FILED 1-13-2011.



NO CLAIM IS MADE TO THE EXCLUSIVE RIGHT TO USE "PIX.COM", "INDEPENDENT", AND "VINTAGE", APART FROM THE MARK AS SHOWN.

THE COLOR(S) BRONZE, GOLD, BLACK, ORANGE, AND BROWN IS/ARE CLAIMED AS A FEATURE OF THE MARK.

THE MARK CONSISTS OF THE TERM "THE AFRO PIX.COM" IN ORANGE WITH BLACK SHADOWING ABOVE THE TERMS "INDEPENDENT. VINTAGE. UNDER-

GROUND." IN GOLD WITH BLACK SHADOWING. BEHIND THE WORDING APPEARS A STYLIZED DEPICTION OF AN AFRO COMB IN BRONZE WITH BROWN ACCENTS AND SHADOWING INCORPORATING THE DESIGN OF TWO STYLIZED FILM REELS IN BRONZE WITH BROWN ACCENTS, AND A STYLIZED DEPICTION OF A FIST IN BRONZE WITH BROWN ACCENTS AND GOLD HIGHLIGHTING. THE BACKGROUND OF THE ENTIRE MARK IS TRANSLUCENT.

CLASS 35—ADVERTISING AND BUSINESS

FOR ADVERTISING AND MARKETING SERVICES PROVIDED BY MEANS OF INDIRECT METHODS OF MARKETING COMMUNICATIONS, NAMELY, SOCIAL MEDIA, SEARCH ENGINE MARKETING, INQUIRY MARKETING, INTERNET MARKETING, MOBILE MARKETING, BLOGGING AND OTHER FORMS OF PASSIVE, SHARABLE OR VIRAL COMMUNICATIONS CHANNELS (U.S. CLS. 100, 101 AND 102).

FIRST USE 1-13-2011; IN COMMERCE 1-13-2011.

CLASS 38—COMMUNICATION

FOR VIDEO STREAMING SERVICES VIA THE INTERNET, FEATURING INDEPENDENT FILMS AND MOVIES (U.S. CLS. 100, 101 AND 104).

FIRST USE 1-13-2011; IN COMMERCE 1-13-2011.

4,210,812. JNC CORPORATION, TOKYO, JAPAN. SN 85-219,813. PUB. 12-6-2011, FILED 1-18-2011.



OWNER OF JAPAN REG. NO. 5330473, DATED 6-18-2010, EXPIRES 6-18-2020.

THE COLOR(S) BROWN, PINK, ORANGE, YELLOW AND WHITE IS/ARE CLAIMED AS A FEATURE OF THE MARK.

THE MARK CONSISTS OF BROWN JAPANESE CHARACTERS CENTERED OVER THE BROWN STYLIZED WORD "PURE" WHICH IS CENTERED OVER THE BROWN STYLIZED WORD "COLLA". A GRAPHIC ELEMENT RESEMBLING A PINWHEEL IS CENTERED ABOVE THE JAPANESE CHARACTERS. THE GRAPHIC ELEMENT CONTAINS THREE LEAF-LIKE SECTIONS AND A WHITE CIRCLE APPEARS IN THE CENTER OF EACH SECTION. THE OUTERMOST PART OF EACH SECTION IS PINK, GRADUALLY CHANGING TO ORANGE AND THEN YELLOW WHERE THE THREE SECTIONS MEET. TOGETHER, ALL OF THE DIFFERENT PORTIONS OF THIS MARK FORM A TRIANGLE.

THE NON-LATIN CHARACTERS IN THE MARK TRANSLITERATE TO "PURECOLLA" AND THIS HAS NO MEANING IN A FOREIGN LANGUAGE.

CLASS 1—CHEMICALS

FOR BIOCHEMICALS, NAMELY, SYNTHETIC POLYPEPTIDES MADE FROM AMINO ACIDS THAT DO NOT DERIVE FROM ANIMALS FOR USE IN COSMETICS (U.S. CLS. 1, 5, 6, 10, 26 AND 46).

FIRST USE 2-21-2011; IN COMMERCE 2-21-2011.

CLASS 3—COSMETICS AND CLEANING PREPARATIONS

FOR COSMETICS (U.S. CLS. 1, 4, 6, 50, 51 AND 52).

FIRST USE 2-21-2011; IN COMMERCE 2-21-2011.

4,210,825. MYHOMEEQ, LLC, CHICAGO, IL. SN 85-228,210. PUB. 1-10-2012, FILED 1-27-2011.

MyHomeEQ

THE MARK CONSISTS OF STANDARD CHARACTERS WITHOUT CLAIM TO ANY PARTICULAR FONT, STYLE, SIZE, OR COLOR.

CLASS 35—ADVERTISING AND BUSINESS

FOR PROVIDING REFERRAL INFORMATION ONLINE CONCERNING HOME BUILDING CONTRACTORS AND RENOVATORS THAT WORK IN THE FIELD OF ENERGY EFFICIENCY; PROVIDING INFORMATION ONLINE CONCERNING TAX REBATES AND TAX CREDITS IN THE FIELD OF HOME RENOVATIONS RELATING TO ENERGY EFFICIENCY (U.S. CLS. 100, 101 AND 102).

FIRST USE 10-31-2011; IN COMMERCE 10-31-2011.

CLASS 36—INSURANCE AND FINANCIAL

FOR PROVIDING FINANCING INFORMATION ONLINE IN THE FIELD OF HOME RENOVATIONS RELATING TO ENERGY EFFICIENCY (U.S. CLS. 100, 101 AND 102).

FIRST USE 10-31-2011; IN COMMERCE 10-31-2011.

CLASS 37—CONSTRUCTION AND REPAIR

FOR PROVIDING INFORMATION ONLINE CONCERNING HOME RENOVATION RELATING TO ENERGY EFFICIENCY (U.S. CLS. 100, 103 AND 106).

FIRST USE 10-31-2011; IN COMMERCE 10-31-2011.

CLASS 42—SCIENTIFIC AND COMPUTER SERVICES

FOR PROVIDING NON DOWNLOADABLE SOFTWARE ONLINE FOR ASSESSING HOME ENERGY EFFICIENCY AND PROVIDING SPECIFIC HOME IMPROVEMENT RECOMMENDATIONS (U.S. CLS. 100 AND 101).

FIRST USE 10-31-2011; IN COMMERCE 10-31-2011.

4,210,834. NEW PENDULUM CORP., WILMINGTON, DE.
SN 85-235,344. PUB. 11-29-2011, FILED 2-7-2011.

LEAKTRAPPER

THE MARK CONSISTS OF STANDARD CHARACTERS WITHOUT CLAIM TO ANY PARTICULAR FONT, STYLE, SIZE, OR COLOR.

CLASS 16—PAPER GOODS AND PRINTED MATTER

FOR GENERAL PURPOSE PLASTIC BAGS FOR HOUSEHOLD USE, NAMELY, BAGS WITH ABSORBENT LININGS USED TO ABSORB LIQUIDS WHEN SECURED ADJACENT TO LEAKING ARTICLES (U.S. CLS. 2, 5, 22, 23, 29, 37, 38 AND 50).

FIRST USE 5-17-2011; IN COMMERCE 5-17-2011.

CLASS 17—RUBBER GOODS

FOR ABSORBENT PILLOWS USED IN COMMERCIAL, INDUSTRIAL AND RESIDENTIAL SETTINGS TO ABSORB LIQUIDS WHEN SECURED ADJACENT TO LEAKING ARTICLES (U.S. CLS. 1, 5, 12, 13, 35 AND 50).

FIRST USE 8-9-2011; IN COMMERCE 8-9-2011.

CLASS 22—CORDAGE AND FIBERS

FOR GENERAL UTILITY BAGS FOR COMMERCIAL USE, NAMELY, BAGS WITH ABSORBENT LININGS USED IN COMMERCIAL AND INDUSTRIAL SETTINGS TO ABSORB LIQUIDS WHEN SECURED ADJACENT TO LEAKING ARTICLES (U.S. CLS. 1, 2, 7, 19, 22, 42 AND 50).

FIRST USE 5-6-2011; IN COMMERCE 5-6-2011.

CLASS 27—FLOOR COVERINGS

FOR ABSORBENT MATS USED IN COMMERCIAL, INDUSTRIAL AND RESIDENTIAL SETTINGS TO ABSORB LIQUIDS WHEN SECURED ADJACENT TO LEAKING ARTICLES (U.S. CLS. 19, 20, 37, 42 AND 50).

FIRST USE 5-15-2011; IN COMMERCE 2-15-2011.

4,210,835. IPSEN BIOPHARM LIMITED, WREXHAM, UNITED KINGDOM. SN 85-235,457. PUB. 11-1-2011, FILED 2-7-2011.

DYSPORT ANSWERS

THE MARK CONSISTS OF STANDARD CHARACTERS WITHOUT CLAIM TO ANY PARTICULAR FONT, STYLE, SIZE, OR COLOR.

OWNER OF U.S. REG. NOS. 1,624,403, 3,941,865, AND OTHERS.

CLASS 38—COMMUNICATION

FOR ELECTRONIC TRANSMISSION OF INFORMATION AND IMAGES RELATING TO PHARMACEUTICALS, MEDICINE AND HYGIENE (U.S. CLS. 100, 101 AND 104).

FIRST USE 4-18-2011; IN COMMERCE 4-18-2011.

CLASS 44—MEDICAL, BEAUTY AND AGRICULTURAL SERVICES

FOR PROVIDING INFORMATION RELATING TO DIAGNOSTIC, PROPHYLACTIC AND THERAPEUTIC PROPERTIES OF PHARMACEUTICALS; PROVIDING A WEBSITE FEATURING INFORMATION IN THE FIELD OF THE DIAGNOSIS AND TREATMENT OF NEUROLOGICAL AND NEUROMUSCULAR DISORDERS; PROVIDING A WEBSITE FEATURING INFORMATION IN THE FIELD OF THE DIAGNOSIS AND TREATMENT OF CERVICAL DYSTONIA, CEREBRAL PALSY AND SPASTICITY (U.S. CLS. 100 AND 101).

FIRST USE 4-18-2011; IN COMMERCE 4-18-2011.

4,210,842. USA FINANCIAL DISTRIBUTION CORPORATION, ADA, MI. SN 85-237,023. PUB. 1-17-2012, FILED 2-8-2011.

AnnuAssure

THE MARK CONSISTS OF STANDARD CHARACTERS WITHOUT CLAIM TO ANY PARTICULAR FONT, STYLE, SIZE, OR COLOR.

CLASS 35—ADVERTISING AND BUSINESS

FOR BUSINESS CONSULTING SERVICES, NAMELY, BUSINESS CONSULTING SERVICES TO INSURANCE AGENTS, FINANCIAL PLANNERS AND FINANCIAL ADVISORS; MARKETING SERVICES, NAMELY, BUSINESS MARKETING SERVICES TO INSURANCE AGENTS, FINANCIAL PLANNERS, AND FINANCIAL AID ADVISORS AND PROMOTING FINANCIAL PRODUCTS OF OTHERS TO INSURANCE AGENTS AND FINANCIAL PLANNERS THROUGH THE DISTRIBUTION OF MARKETING BROCHURES, FLYERS AND ADVERTISEMENTS (U.S. CLS. 100, 101 AND 102).

FIRST USE 3-22-2011; IN COMMERCE 3-22-2011.

CLASS 36—INSURANCE AND FINANCIAL

FOR FINANCIAL PLANNING STRATEGY SERVICES; INSURANCE BROKERAGE SERVICES (U.S. CLS. 100, 101 AND 102).

FIRST USE 3-22-2011; IN COMMERCE 3-22-2011.

CLASS 41—EDUCATION AND ENTERTAINMENT

FOR EDUCATIONAL SERVICES, NAMELY, PROVIDING TRAINING COURSES IN FINANCIAL PLANNING AND MARKETING (U.S. CLS. 100, 101 AND 107).

FIRST USE 3-22-2011; IN COMMERCE 3-22-2011.

4,210,846. TECH IS GOOD, LLC, RENO, NV. SN 85-238,825. PUB. 2-7-2012, FILED 2-10-2011.

4,210,854. SCHERDEL INNOTECH, MARKTREDWITZ, FED REP GERMANY. SN 85-240,370. PUB. 11-1-2011, FILED 2-11-2011.

Tech is good.



THE MARK CONSISTS OF STANDARD CHARACTERS WITHOUT CLAIM TO ANY PARTICULAR FONT, STYLE, SIZE, OR COLOR.

OWNER OF U.S. REG. NO. 4,013,845.

THE MARK CONSISTS OF A STYLIZED LETTER "S" INSIDE OF A SQUARE.

CLASS 9—ELECTRICAL AND SCIENTIFIC APPARATUS

FOR COMPUTER BAGS; SUNGLASSES (U.S. CLS. 21, 23, 26, 36 AND 38).
FIRST USE 5-1-2011; IN COMMERCE 5-1-2011.

CLASS 16—PAPER GOODS AND PRINTED MATTER

FOR BUMPER STICKERS; DECORATIVE STICKERS FOR HELMETS; MAGNETIC BUMPER STICKERS; STICKERS; STICKERS AND DECALCOMANIAS; STICKERS AND TRANSFERS (U.S. CLS. 2, 5, 22, 23, 29, 37, 38 AND 50).

FIRST USE 5-1-2011; IN COMMERCE 5-1-2011.

CLASS 18—LEATHER GOODS

FOR ALL PURPOSE SPORT BAGS; ALL-PURPOSE ATHLETIC BAGS; ALL-PURPOSE CARRYING BAGS; ALL-PURPOSE REUSABLE CARRYING BAGS; BACKPACKS; BAGS FOR SPORTS; MESSENGER BAGS (U.S. CLS. 1, 2, 3, 22 AND 41).

FIRST USE 5-1-2011; IN COMMERCE 5-1-2011.

CLASS 21—HOUSEWARES AND GLASS

FOR ALUMINUM WATER BOTTLES SOLD EMPTY; COFFEE CUPS; COFFEE CUPS, TEA CUPS AND MUGS; CUPS; CUPS AND MUGS; DRINKING CUPS; MUGS; PLASTIC WATER BOTTLES SOLD EMPTY; REUSABLE PLASTIC WATER BOTTLES SOLD EMPTY; REUSABLE STAINLESS STEEL WATER BOTTLES SOLD EMPTY; SPORTS BOTTLES SOLD EMPTY; SQUEEZE BOTTLE SOLD EMPTY (U.S. CLS. 2, 13, 23, 29, 30, 33, 40 AND 50).

FIRST USE 5-1-2011; IN COMMERCE 5-1-2011.

CLASS 25—CLOTHING

FOR HATS; JACKETS; PANTS; SCARFS; SWEATSHIRTS; T-SHIRTS (U.S. CLS. 22 AND 39).

FIRST USE 5-1-2011; IN COMMERCE 5-1-2011.

CLASS 6—METAL GOODS

FOR COMMON METALS AND THEIR ALLOYS; METAL BUILDING MATERIALS, NAMELY, CONCRETE DOWEL PINS; NON-ELECTRIC CABLES AND WIRES OF COMMON METALS; PIPES AND TUBES OF METAL; GOODS OF COMMON METAL, AS FAR AS INCLUDED IN THIS CLASS, NAMELY, HARDWARE SPRINGS, HOSE CLAMPS, AND ARM REST AND HEAD SUPPORT COMPONENTS, NAMELY, SPRINGS, WIRE, STRIPS AND TUBES; ADJUSTING AND ACTUATING MECHANISMS IN THE NATURE OF NON-POWERED DOOR AND TRUNK ACTUATORS, NON-POWERED SEAT ADJUSTMENT MECHANISMS, NAMELY, METAL HARDWARE RUNNERS, LATCHES AND HINGES, FITTING COMPONENTS FOR UPHOLSTERY IN THE NATURE OF METAL WIRE SPRINGS AND WIRES; METAL HARDWARE, NAMELY, SPRINGS; METAL PULLEYS, SPRINGS AND VALVES; SPRING-RETRACTED METAL HOSE REELS (U.S. CLS. 2, 12, 13, 14, 23, 25 AND 50).

FIRST USE 12-31-1995; IN COMMERCE 4-30-2000.

CLASS 7—MACHINERY

FOR MACHINES FOR TREATMENT OF METAL, NAMELY, METAL WORKING MACHINES; MACHINE COUPLING AND TRANSMISSION COMPONENTS EXCEPT FOR LAND VEHICLES; METALWORKING MACHINE TOOLS (U.S. CLS. 13, 19, 21, 23, 31, 34 AND 35).

FIRST USE 12-31-1995; IN COMMERCE 4-30-2000.

CLASS 12—VEHICLES

FOR AIR SPRINGS FOR VEHICLE SUSPENSION COMPONENTS FOR CUSHIONING DRIVER'S SEATS AND CABS; AUTOMOBILE SUSPENSION SYSTEM COMPONENTS, NAMELY, SPRING PERCHES; LAND VEHICLE SUSPENSION PARTS, NAMELY, COIL SPRINGS; LAND VEHICLE SUSPENSION PARTS, NAMELY, LEAF SPRINGS; SHOCK ABSORBING SPRINGS FOR MOTOR CARS; SUSPENSION SPRINGS FOR MOTOR CARS; NON-POWERED SEAT ADJUSTMENT MECHANISMS, NAMELY, RUNNERS, SLIDES AND LATCHES INCORPORATED INTO A VEHICLE SEAT (U.S. CLS. 19, 21, 23, 31, 35 AND 44).

FIRST USE 12-31-1995; IN COMMERCE 4-30-2000.

4,210,871. ANAND, MAHESH, FREMONT, CA. SN 85-246,677. PUB. 8-2-2011, FILED 2-18-2011.

Olive Financial Services

THE MARK CONSISTS OF STANDARD CHARACTERS WITHOUT CLAIM TO ANY PARTICULAR FONT, STYLE, SIZE, OR COLOR.

NO CLAIM IS MADE TO THE EXCLUSIVE RIGHT TO USE "FINANCIAL SERVICES", APART FROM THE MARK AS SHOWN.

CLASS 35—ADVERTISING AND BUSINESS

FOR ACCOUNTING SERVICES; BOOKKEEPING; PAYROLL PREPARATION; TAX PREPARATION (U.S. CLS. 100, 101 AND 102).

FIRST USE 7-1-2011; IN COMMERCE 7-31-2011.

CLASS 36—INSURANCE AND FINANCIAL

FOR INSURANCE BROKERAGE; INVESTMENT ADVISORY SERVICES; INVESTMENT CONSULTANCY; INVESTMENT MANAGEMENT (U.S. CLS. 100, 101 AND 102).

FIRST USE 7-1-2011; IN COMMERCE 7-31-2011.

4,210,890. CHROMADDEX, INC., IRVINE, CA. SN 85-254,515. PUB. 7-19-2011, FILED 3-1-2011.



THE COLOR(S) BLACK AND RED IS/ARE CLAIMED AS A FEATURE OF THE MARK.

THE MARK CONSISTS OF AN INCOMPLETE OVAL WITH THE LEFT HALF OF THE OVAL BLACK AND THE RIGHT HALF OF THE OVAL RED.

CLASS 1—CHEMICALS

FOR CHEMICAL REAGENTS FOR NON-MEDICAL PURPOSES; CHEMICAL TEST KITS FOR ANALYTICAL MEASUREMENT OF RAW MATERIAL IDENTITY, POTENCY AND FORMULATION CONSISTENCY FOR LABORATORY OR RESEARCH USE; CHEMICALS FOR USE IN INDUSTRY AND SCIENCE; CHEMICALS FOR USE IN THE BIOCHEMICAL AND CHEMICAL INDUSTRY; ASSAYS FOR RESEARCH PURPOSES (U.S. CLS. 1, 5, 6, 10, 26 AND 46).

FIRST USE 10-0-1999; IN COMMERCE 10-0-1999.

CLASS 42—SCIENTIFIC AND COMPUTER SERVICES

FOR CHEMICAL, BIOCHEMICAL, BIOLOGICAL AND BACTERIOLOGICAL RESEARCH AND ANALYSIS; CONSULTING IN THE FIELD OF PRODUCT DEVELOPMENT IN THE FIELD OF CHEMICALS; DEVELOPMENT AND ESTABLISHMENT OF TESTING SPECIFICATIONS AND PROCEDURES IN THE FIELD OF CHEMICALS; DEVELOPMENT AND TEST OF CHEMICAL PRODUCTION METHODS; DEVELOPMENT OF VOLUNTARY STANDARDS FOR CHEMICALS; EXECUTING OF CHEMICAL ANALYSES; INDUSTRIAL RESEARCH IN THE FIELD OF CHEMICALS; PHARMACEUTICAL RESEARCH AND DEVELOPMENT; PRODUCT RESEARCH AND DEVELOPMENT; RESEARCH AND DEVELOPMENT AND CONSULTATION RELATED THERETO IN THE FIELD OF CHEMICALS; TESTING OF RAW MATERIALS (U.S. CLS. 100 AND 101).

FIRST USE 6-0-2000; IN COMMERCE 6-0-2000.

4,210,895. COATING EXCELLENCE INTERNATIONAL LLC, WRIGHTSTOWN, WI. SN 85-256,545. PUB. 11-1-2011, FILED 3-3-2011.



OWNER OF U.S. REG. NOS. 2,158,714 AND 2,835,959.
THE MARK CONSISTS OF THE WORDING "CEI" AND "CONVERTING IDEAS INTO INNOVATION" AND TO THE LEFT APPEARS A STYLIZED PAPER ROLL DESIGN DEPICTED INSIDE A RECTANGLE CARRIER.

CLASS 16—PAPER GOODS AND PRINTED MATTER

FOR PAPER CONTAINERS AND BAGS FOR PACKAGING; LAMINATED PAPER FOR USE IN WRAPPING AND PACKAGING; PLASTIC BAGS FOR PACKAGING; PLASTIC BUBBLE PACKS FOR WRAPPING AND PACKAGING; ENVELOPES; FOOD PACKAGING CONTAINERS COMPRISED PRIMARILY OF PAPER; PLASTIC FILM FOR CONSUMER PACKAGING USE, NOT FOR COMMERCIAL OR INDUSTRIAL PURPOSES; LAMINATED PAPER; PACKAGING MATERIALS, NAMELY, INDUSTRIAL PACKAGING CONTAINERS COMPRISED PRIMARILY OF PAPER (U.S. CLS. 2, 5, 22, 23, 29, 37, 38 AND 50).

FIRST USE 9-23-2010; IN COMMERCE 9-23-2010.

CLASS 17—RUBBER GOODS

FOR PLASTIC FLEXIBLE PACKAGING FILM FOR INDUSTRIAL PACKING USE; PLASTIC FILMS USED AS PACKAGING FOR FOOD; PLASTIC WRAPPING FILM FOR INDUSTRIAL USE, NAMELY, CONSUMER PRODUCT PACKAGING; METALIZED PLASTIC BARRIER FILMS USED AS PACKAGING FOR FOOD AND USED AS INDUSTRIAL OR COMMERCIAL NON-FOOD PACKAGING; PLASTIC FILM FOR INDUSTRIAL OR COMMERCIAL NON-FOOD PACKAGING; PLASTIC FILM FOR INDUSTRIAL PACKING USE (U.S. CLS. 1, 5, 12, 13, 35 AND 50).

FIRST USE 9-23-2010; IN COMMERCE 9-23-2010.

4,210,896. RMO, INC., DENVER, CO. SN 85-256,990. PUB. 1-10-2012, FILED 3-3-2011.



OWNER OF U.S. REG. NOS. 659,435, 1,488,072, AND OTHERS.

NO CLAIM IS MADE TO THE EXCLUSIVE RIGHT TO USE "ORTHODONTICS", APART FROM THE MARK AS SHOWN.

THE MARK CONSISTS OF THE WORDS "SYNERGISTIC SOLUTIONS FOR PROGRESSIVE ORTHODONTICS RMO ROCKY MOUNTAIN ORTHODONTICS" IN FRONT OF THE OUTLINE OF MOUNTAINS.

SEC. 2(F) AS TO "ROCKY MOUNTAIN".

CLASS 10—MEDICAL APPARATUS

FOR ORTHODONTIC APPLIANCES (U.S. CLS. 26, 39 AND 44).

FIRST USE 3-0-2011; IN COMMERCE 3-0-2011.

CLASS 35—ADVERTISING AND BUSINESS

FOR RETAIL STORE SERVICES AND CATALOG ORDERING SERVICES FEATURING ORTHODONTIC APPLIANCES (U.S. CLS. 100, 101 AND 102).

FIRST USE 3-0-2011; IN COMMERCE 3-0-2011.

CLASS 41—EDUCATION AND ENTERTAINMENT

FOR EDUCATIONAL SERVICES, NAMELY, PROVIDING CLASSES, SEMINARS AND WORKSHOPS IN THE FIELD OF DENTISTRY AND ORTHODONTICS (U.S. CLS. 100, 101 AND 107).

FIRST USE 3-0-2011; IN COMMERCE 3-0-2011.

CLASS 44—MEDICAL, BEAUTY AND AGRICULTURAL SERVICES

FOR PROVIDING A WEBSITE IN THE FIELD OF ORTHODONTICS; PROVIDING DIAGNOSIS AND TREATMENT PLANS IN THE FIELD OF ORTHODONTIA; PROVIDING COMPUTERIZED DIAGNOSTIC ANALYSIS SERVICES IN THE FIELD OF ORTHODONTIA; FACIAL GROWTH FORECASTING SERVICES IN THE ORTHODONTIC FIELD; UTILIZING FORECASTING COMPUTER SOFTWARE; PROVIDING A WEBSITE FOR USE BY DENTAL PROFESSIONALS FOR DIAGNOSIS, ANALYSIS AND TREATMENT PLANS IN THE FIELD OF ORTHODONTIA; PROVIDING A WEBSITE FEATURING EDUCATIONAL MATERIALS IN THE FIELD OF ORTHODONTIA (U.S. CLS. 100 AND 101).

FIRST USE 3-0-2011; IN COMMERCE 3-0-2011.

4,210,906. FORMBY, GEARY, PORTLAND, OR. AND FORMBY, MARTHA PIGG, VANCOUVER, WA. SN 85-262,917. PUB. 2-28-2012, FILED 3-10-2011.



NO CLAIM IS MADE TO THE EXCLUSIVE RIGHT TO

USE "MOLD SEAL" AND "THE GREEN SEAL", APART FROM THE MARK AS SHOWN.

THE COLOR(S) BLACK AND GREEN IS/ARE CLAIMED AS A FEATURE OF THE MARK.

THE MARK CONSISTS OF THE LITERAL ELEMENTS "MOLD SEAL THE GREEN SEAL" WHEREIN THE WORD "MOLD" IS IN GREEN COLOR AND THE WORD "SEAL" IS IN BLACK COLOR BOTH IN A BOLD FORM AND AN IMAGE OF A SEAL IN GREEN COLOR WITH A BLACK BORDER IS PLACED BESIDE THE WORD "MOLD SEAL". THE WORDS "THE GREEN SEAL" APPEARS IN BLACK INSIDE BLACK QUOTATION MARKS UNDER THE WORDS "MOLD SEAL".

CLASS 1—CHEMICALS

FOR CHEMICALS USED IN INDUSTRY, NAMELY, SEALANTS USED FOR BUILDINGS WHICH PENETRATE THROUGH WALLS, FLOORS AND CEILINGS FOR MOLD PREVENTION (U.S. CLS. 1, 5, 6, 10, 26 AND 46).

FIRST USE 3-1-2011; IN COMMERCE 3-1-2011.

CLASS 2—PAINTS

FOR PAINT COATINGS USED IN INDUSTRY, NAMELY, COATINGS IN THE NATURE OF PRIMER FOR USE ON SURFACES, SUCH AS WALLS, FLOORS, CEILINGS, AND VARIOUS STRUCTURAL BUILDING COMPONENTS, BOTH INTERIOR AND EXTERIOR (U.S. CLS. 6, 11 AND 16).

FIRST USE 3-1-2011; IN COMMERCE 3-1-2011.

CLASS 19—NON-METALLIC BUILDING MATERIALS

FOR BUILDING MATERIALS USED IN INDUSTRY, NAMELY, VINYL WINDOWS, NON-METAL SKYLIGHTS (U.S. CLS. 1, 12, 33 AND 50).

FIRST USE 3-1-2011; IN COMMERCE 3-1-2011.

4,210,909. LEHIGH CONSUMER PRODUCTS LLC, MACUNGIE, PA. SN 85-263,576. PUB. 10-4-2011, FILED 3-10-2011.



OWNER OF U.S. REG. NO. 2,387,160.

THE MARK CONSISTS OF A DARK SQUARE WITH THE LETTER "C" CENTERED WITHIN THE SQUARE AND WITH A TRIANGLE CENTERED ABOVE THE "C" WITH THE LITERAL ELEMENT "CRAWFORD" HORIZONTALLY ADJACENT TO THE RIGHT SIDE OF THE SQUARE AND CENTERED TO THE HEIGHT OF THE SQUARE.

CLASS 6—METAL GOODS

FOR METAL HARDWARE, NAMELY, WALL MOUNTED TOOL ORGANIZERS IN THE NATURE OF BRACKETS, HOOKS AND HANGERS FOR HOLDING AND HANGING TOOLS ADJACENT A WALL, SHELF BRACKETS, STORAGE HOOKS, CEILING MOUNTED BIKE PULLEYS, SPRING CLIPS, NAMELY, METAL CLIPS FOR HOLDING TOOLS AND HARDWARE IN PLACE ADJACENT A WALL (U.S. CLS. 2, 12, 13, 14, 23, 25 AND 50).

FIRST USE 5-1-2012; IN COMMERCE 5-1-2012.

CLASS 20—FURNITURE AND ARTICLES NOT OTHERWISE CLASSIFIED

FOR WALL AND CEILING MOUNTED STORAGE SHELVES; WALL MOUNTED TOOL RACKS; PLASTIC SUCTION CUPS (U.S. CLS. 2, 13, 22, 25, 32 AND 50).
FIRST USE 5-22-2012; IN COMMERCE 5-22-2012.

4,210,910. ZECCO HOLDINGS, INC., SAN FRANCISCO, CA. SN 85-264,459. PUB. 11-1-2011, FILED 3-11-2011.

ZECCO MOBILE

THE MARK CONSISTS OF STANDARD CHARACTERS WITHOUT CLAIM TO ANY PARTICULAR FONT, STYLE, SIZE, OR COLOR.

OWNER OF U.S. REG. NOS. 3,346,206, 3,696,934, AND OTHERS.

NO CLAIM IS MADE TO THE EXCLUSIVE RIGHT TO USE "MOBILE", APART FROM THE MARK AS SHOWN.

CLASS 36—INSURANCE AND FINANCIAL

FOR FINANCIAL INVESTMENT ADVICE IN THE FIELD OF SECURITIES, NAMELY, STOCKS, BONDS, MUTUAL FUNDS, FUTURES, OPTIONS AND FOREIGN EXCHANGE TRANSACTIONS; BANKING SERVICES; FINANCE AND INVESTMENT INFORMATION NEWS REPORTING IN THE FIELD OF STOCKS, BONDS, MUTUAL FUNDS, FUTURES, OPTIONS, FOREIGN EXCHANGE TRANSACTIONS AND BANKING (U.S. CLS. 100, 101 AND 102).

FIRST USE 2-0-2011; IN COMMERCE 2-0-2011.

CLASS 42—SCIENTIFIC AND COMPUTER SERVICES

FOR PROVIDING TEMPORARY USE OF ON-LINE NON-DOWNLOADABLE COMPUTER SOFTWARE, NAMELY, AN APPLICATION ALLOWING CUSTOMERS TO UPDATE AND RECEIVE DATA STORED IN AN ENTERPRISE'S COMPUTER DATABASES IN REAL TIME, USING A MOBILE DEVICE, WITH FULL TELEPHONY INTEGRATION WITH THE TELEPHONE AND/OR SOFTWARE FEATURES OF THE MOBILE DEVICE IN THE FIELD OF FINANCIAL AND INVESTMENT SERVICES, NAMELY, BROKERAGE OF SHARES OR STOCKS, BONDS, MUTUAL FUNDS, FUTURES, OPTIONS, AND FOREIGN EXCHANGE TRANSACTIONS (U.S. CLS. 100 AND 101).

FIRST USE 2-0-2011; IN COMMERCE 2-0-2011.

4,210,914. ALUMINART PRODUCTS LIMITED, BRAMPTON, ONTARIO, CANADA. SN 85-266,776. PUB. 11-22-2011, FILED 3-14-2011.

ALUMINART

THE MARK CONSISTS OF STANDARD CHARACTERS WITHOUT CLAIM TO ANY PARTICULAR FONT, STYLE, SIZE, OR COLOR.

PRIORITY CLAIMED UNDER SEC. 44(D) ON CANADA

APPLICATION NO. 1497964, FILED 9-30-2010.
OWNER OF U.S. REG. NO. 2,657,556.

CLASS 6—METAL GOODS

FOR METAL DOORS FOR BUILDINGS, NAMELY, ENTRY DOORS, STORM DOORS, SCREEN DOORS AND PATIO DOORS; RETRACTABLE METAL SCREENS FOR DOORS FOR BUILDINGS (U.S. CLS. 2, 12, 13, 14, 23, 25 AND 50).

FIRST USE 5-0-2006; IN COMMERCE 5-0-2006.

CLASS 19—NON-METALLIC BUILDING MATERIALS

FOR NON-METAL WINDOWS FOR BUILDINGS; NON-METAL DOORS FOR BUILDINGS, NAMELY, ENTRY SCREEN DOORS FOR BUILDINGS (U.S. CLS. 1, 12, 33 AND 50).

FIRST USE 5-0-2006; IN COMMERCE 5-0-2006.

4,210,919. MICHAEL ADAMS, QUAKERTOWN, PA. SN 85-272,383. PUB. 2-28-2012, FILED 3-21-2011.

FIREHOUSE COFFEE

THE MARK CONSISTS OF STANDARD CHARACTERS WITHOUT CLAIM TO ANY PARTICULAR FONT, STYLE, SIZE, OR COLOR.

NO CLAIM IS MADE TO THE EXCLUSIVE RIGHT TO USE "COFFEE", APART FROM THE MARK AS SHOWN.

CLASS 21—HOUSEWARES AND GLASS

FOR COFFEE CUPS, TEA CUPS AND MUGS; COFFEE MUGS; CUPS AND MUGS; MUGS (U.S. CLS. 2, 13, 23, 29, 30, 33, 40 AND 50).

FIRST USE 3-8-2012; IN COMMERCE 4-1-2012.

CLASS 30—STAPLE FOODS

FOR COFFEE; COFFEE BEANS; GROUND COFFEE BEANS; ROASTED COFFEE BEANS (U.S. CL. 46).

FIRST USE 3-8-2012; IN COMMERCE 4-1-2012.

4,210,921. BRETT SICILIANO, IRVINE, CA. SN 85-276,046. PUB. 10-25-2011, FILED 3-24-2011.



THE MARK CONSISTS OF THE WORDS "WRAP WRENCH" WITH A TORNADO.

CLASS 7—MACHINERY

FOR POWER OPERATED HAND HELD TOOL FOR THE PURPOSE OF ROLLING UP CLOTH OR ELASTIC WRAPS, RIBBON, STRING, ROPE, WIRE OR OTHER MATERIAL BY POSITIONING THE MATERIAL INSIDE THE BIT (U.S. CLS. 13, 19, 21, 23, 31, 34 AND 35).
FIRST USE 1-1-2012; IN COMMERCE 1-1-2012.

CLASS 8—HAND TOOLS

FOR BITS FOR HAND DRILLS; HAND TOOLS, NAMELY, HAND-OPERATED REACHING DEVICES FOR PICKING UP AND REMOVING TRASH, LITTER AND OBJECTS; HAND TOOLS, NAMELY, TOOLS FOR PLACING A ROPE OR OTHER FLEXIBLE MEMBER THROUGH AN EYE OR AROUND A TARGET OBJECT; HAND TOOLS, NAMELY, MANUALLY OPERATED HAND HELD TOOL FOR THE PURPOSE OF ROLLING UP CLOTH OR ELASTIC WRAPS, RIBBON, STRING, ROPE, WIRE OR OTHER MATERIAL BY POSITIONING THE MATERIAL INSIDE THE BIT (U.S. CLS. 23, 28 AND 44).

FIRST USE 1-1-2012; IN COMMERCE 1-1-2012.

4,210,928. LANDI NAILS LLC, HINSDALE, IL. SN 85-280,345.
PUB. 3-13-2012, FILED 3-29-2011.

Landi Nails

THE MARK CONSISTS OF STANDARD CHARACTERS WITHOUT CLAIM TO ANY PARTICULAR FONT, STYLE, SIZE, OR COLOR.

NO CLAIM IS MADE TO THE EXCLUSIVE RIGHT TO USE "NAILS", APART FROM THE MARK AS SHOWN.

CLASS 3—COSMETICS AND CLEANING PREPARATIONS

FOR COSMETIC PREPARATIONS FOR NAIL DRYING; NAIL ART STICKERS; NAIL CARE KITS COMPRISING NAIL POLISH; NAIL ENAMEL; NAIL GEL; NAIL HARDENERS; NAIL POLISH; NAIL POLISH TOP COAT; NAIL STRENGTHENERS; NAIL VARNISH FOR COSMETIC PURPOSES (U.S. CLS. 1, 4, 6, 50, 51 AND 52).
FIRST USE 9-26-2011; IN COMMERCE 9-26-2011.

CLASS 11—ENVIRONMENTAL CONTROL APPARATUS

FOR ULTRAVIOLET LAMPS NOT FOR MEDICAL PURPOSES (U.S. CLS. 13, 21, 23, 31 AND 34).
FIRST USE 9-26-2011; IN COMMERCE 9-26-2011.

4,210,936. COGNATE NUTRITIONALS, INC., BLOOMFIELD, CT. SN 85-283,860. PUB. 2-28-2012, FILED 4-1-2011.

FUEL FOR THOUGHT

THE MARK CONSISTS OF STANDARD CHARACTERS WITHOUT CLAIM TO ANY PARTICULAR FONT, STYLE,

SIZE, OR COLOR.

CLASS 5—PHARMACEUTICALS

FOR NUTRITIONAL BEVERAGES BASED UPON COCONUT OIL FORTIFIED WITH KETOGENIC MEDIUM CHAIN TRIGLYCERIDES; DRIED POWDER USED AS A NUTRITIONAL SUPPLEMENT BASED UPON COCONUT OIL FORTIFIED WITH KETOGENIC MEDIUM CHAIN TRIGLYCERIDES FOR MIXING INTO BEVERAGES OR SOUPS; NUTRITIONAL SNACK BARS FOR USE AS A MEAL REPLACEMENT, BASED UPON COCONUT OIL FORTIFIED WITH KETOGENIC MEDIUM CHAIN TRIGLYCERIDES (U.S. CLS. 6, 18, 44, 46, 51 AND 52).

FIRST USE 4-24-2012; IN COMMERCE 4-24-2012.

CLASS 29—MEATS AND PROCESSED FOODS

FOR EDIBLE PROCESSED COCONUT OIL AND FOODS CONTAINING PROCESSED COCONUT OIL, NAMELY, COCONUT OIL FORTIFIED WITH KETOGENIC MEDIUM CHAIN TRIGLYCERIDES (U.S. CL. 46).

FIRST USE 4-24-2012; IN COMMERCE 4-24-2012.

4,210,937. QUAVERMUSIC.COM, LLC, NASHVILLE, TN. SN 85-284,583. PUB. 3-20-2012, FILED 4-2-2011.



NO CLAIM IS MADE TO THE EXCLUSIVE RIGHT TO USE "MUSIC", APART FROM THE MARK AS SHOWN.

THE MARK CONSISTS OF THE WORDS "QUAVER'S MARVELOUS WORLD OF MUSIC" OVER THE DESIGN OF A PIANO KEYBOARD.

CLASS 25—CLOTHING

FOR CLOTHING, NAMELY, T-SHIRTS, JACKETS; PANTS, PONCHOS, SHIRTS, SHORTS; HEADWEAR, NAMELY, HATS AND CAPS (U.S. CLS. 22 AND 39).

FIRST USE 1-27-2011; IN COMMERCE 1-27-2011.

CLASS 41—EDUCATION AND ENTERTAINMENT

FOR EDUCATIONAL AND ENTERTAINMENT SERVICES, NAMELY, PROVIDING EDUCATIONAL WEBSITES IN THE FIELDS OF MUSIC AND ENTERTAINMENT; EDUCATIONAL SERVICES, NAMELY, CONDUCTING INFORMAL PROGRAMS IN THE FIELDS OF MUSIC, MUSICAL INSTRUCTION, MUSICAL TECHNIQUE AND MUSIC THEORY USING WEB-BASED INTERACTIVE EXHIBITS AND PRINTABLE MATERIALS DISTRIBUTED THEREWITH; EDUCATIONAL AND ENTERTAINMENT SERVICES, NAMELY, PROVIDING ON-LINE INTERACTIVE VIRTUAL ENVIRONMENTS IN WHICH USERS CAN INTERACT FOR RECREATIONAL, LEISURE, EDUCATIONAL AND ENTERTAINMENT PURPOSES; ENTERTAINMENT SERVICES, NAMELY, PROVIDING ONLINE, NON-DOWNLOADABLE VIRTUAL ITEMS IN THE NATURE OF CHARACTERS, MUSICAL INSTRUMENTS AND CLOTHING FOR USE IN VIRTUAL ENVIRONMENTS; EDUCATIONAL AND ENTERTAINMENT SERVICES, NAMELY, PROVIDING ONLINE INTERACTIVE AND EDUCATIONAL COMPUTER GAMES IN SINGLE AND MULTI-USER FORMATS FEATURING FICTIONAL CHARACTERS; ENTERTAINMENT SERVICES, NAMELY, PROVIDING TEMPORARY USE OF NON-DOWNLOADABLE INTERACTIVE GAMES; EDUCATIONAL AND ENTERTAINMENT SERVICES, NAMELY, PROVIDING NON-DOWNLOADABLE AUDIO AND VIDEO FILES FEATURING ENTERTAINMENT, EDUCATION, MUSIC, AND STORIES FOR CHILDREN; EDUCATIONAL AND ENTERTAINMENT SERVICES, NAMELY, PROVIDING A NON-DOWNLOADABLE INTERACTIVE WEBSITE PROVIDING PLAYBACK OF MUSIC, MUSIC INSTRUCTION AND INSTRUCTION IN MUSIC COMPOSITION AND MUSIC THEORY; ENTERTAINMENT SERVICES, NAMELY, PROVIDING LIVE ENTERTAINMENT PERFORMANCES IN THE NATURE OF INSTRUMENTAL, MUSICAL, COMEDY AND DRAMA; LIVE PERFORMANCES BY COSTUMED ENTERTAINERS; EDUCATIONAL AND ENTERTAINMENT SERVICES, NAMELY, CONDUCTING WORKSHOPS, CONVENTIONS, SEMINARS, AND LECTURES IN THE FIELD OF MUSIC, MUSICAL INSTRUCTION, MUSICAL TECHNIQUE AND MUSIC THEORY (U.S. CLS. 100, 101 AND 107).

FIRST USE 11-5-2010; IN COMMERCE 1-27-2011.

4,210,951. S.A.M. ITALIA S.R.L., 50059 VINCI (FIRENZE), ITALY. SN 85-292,914. PUB. 11-22-2011, FILED 4-12-2011.



CAVALLERIA
TOSCANA

NO CLAIM IS MADE TO THE EXCLUSIVE RIGHT TO USE "TOSCANA", APART FROM THE MARK AS SHOWN.

THE MARK CONSISTS OF THE WORDS "CAVALLERIA TOSCANA" SET BENEATH A STYLIZED LETTER "T" ABOVE THE LETTER "C" ON ITS SIDE.

THE ENGLISH TRANSLATION OF "CAVALLERIA TOSCANA" IN THE MARK IS "TUSCAN CAVALRY".

CLASS 18—LEATHER GOODS

FOR HORSE BLANKETS, HANDBAGS, TRAVELLING BAGS, BAGS FOR SPORTS (U.S. CLS. 1, 2, 3, 22 AND 41). FIRST USE 2-0-2010; IN COMMERCE 2-0-2010.

CLASS 25—CLOTHING

FOR BELTS FOR CLOTHING, CAPS, JACKETS, COATS, JERSEY, NECKTIES, PANTS, TROUSERS, SCARVES, SHIRTS AND DRESSES, TEE SHIRTS (U.S. CLS. 22 AND 39).

FIRST USE 2-0-2010; IN COMMERCE 2-0-2010.

4,210,972. ONE TOUCH INTELLIGENCE, LLC, GREENWOOD VILLAGE, CO. SN 85-307,430. PUB. 12-6-2011, FILED 4-28-2011.

APPSTRAK

THE MARK CONSISTS OF STANDARD CHARACTERS WITHOUT CLAIM TO ANY PARTICULAR FONT, STYLE, SIZE, OR COLOR.

OWNER OF U.S. REG. NOS. 3,590,156, 3,853,159, AND OTHERS.

CLASS 35—ADVERTISING AND BUSINESS

FOR MARKET ANALYSIS, NAMELY, MONITORING, ANALYSIS AND REPORTING OF COMPETITIVE ACTIVITY IN THE CABLE, DIRECT BROADCAST SATELLITE, TELECOMMUNICATIONS, WIRELESS AND PROGRAMMER BUSINESS SECTORS, IN PARTICULAR REGARDING THEIR APPLICATIONS FOR DIGITAL ELECTRONIC DEVICES, COMPUTERS AND OTHER MOBILE DEVICES (U.S. CLS. 100, 101 AND 102).

FIRST USE 5-12-2011; IN COMMERCE 6-0-2011.

CLASS 42—SCIENTIFIC AND COMPUTER SERVICES

FOR COMPUTER MONITORING SERVICE WHICH TRACKS THE PERFORMANCE OF APPLICATION SOFTWARE OF CABLE COMPANIES, DIRECT BROADCAST SATELLITE COMPANIES, TELECOMMUNICATIONS COMPANIES, WIRELESS COMPANIES AND PROGRAMMERS, PERFORMS PERIODIC MAINTENANCE AND PROVIDES REPORTS AND ALERTS CONCERNING SUCH PERFORMANCE (U.S. CLS. 100 AND 101).

FIRST USE 5-12-2011; IN COMMERCE 6-0-2011.

4,210,979. IMPERIAL USA LTD, CHARLOTTE, NC. SN 85-310,113. PUB. 9-27-2011, FILED 5-2-2011.

EZGrab

THE MARK CONSISTS OF STANDARD CHARACTERS WITHOUT CLAIM TO ANY PARTICULAR FONT, STYLE, SIZE, OR COLOR.

CLASS 6—METAL GOODS

FOR METAL BATHTUB GRAB BARS; METAL SHOWER GRAB BARS (U.S. CLS. 2, 12, 13, 14, 23, 25 AND 50).

FIRST USE 9-25-2011; IN COMMERCE 2-27-2012.

CLASS 20—FURNITURE AND ARTICLES NOT OTHERWISE CLASSIFIED

FOR BATHTUB GRAB BARS NOT MADE OF METAL; SHOWER GRAB BARS NOT OF METAL (U.S. CLS. 2, 13, 22, 25, 32 AND 50).

FIRST USE 9-25-2011; IN COMMERCE 2-27-2012.

CLASS 5—PHARMACEUTICALS

FOR VITAMINS; FOOD SUPPLEMENTS; PROTEIN SUPPLEMENTS; MINERAL SUPPLEMENTS; NUTRITIONAL SUPPLEMENTS; NUTRIENTS; NUTRACEUTICALS FOR USE AS A DIETARY SUPPLEMENT; VITAMIN SUPPLEMENT BEVERAGES (U.S. CLS. 6, 18, 44, 46, 51 AND 52).

FIRST USE 6-11-2012; IN COMMERCE 6-11-2012.

CLASS 32—LIGHT BEVERAGES

FOR SPORTS DRINKS (U.S. CLS. 45, 46 AND 48).

FIRST USE 6-11-2012; IN COMMERCE 6-11-2012.

4,210,983. CLINICAL TRIALS OF TEXAS, INC., SAN ANTONIO, TX. SN 85-313,855. PUB. 10-25-2011, FILED 5-5-2011.

ADAPTIX CLINICAL SOLUTIONS

THE MARK CONSISTS OF STANDARD CHARACTERS WITHOUT CLAIM TO ANY PARTICULAR FONT, STYLE, SIZE, OR COLOR.

NO CLAIM IS MADE TO THE EXCLUSIVE RIGHT TO USE "CLINICAL SOLUTIONS", APART FROM THE MARK AS SHOWN.

CLASS 35—ADVERTISING AND BUSINESS

FOR BUSINESS MANAGEMENT IN THE FIELD OF CLINICAL TRIALS, NAMELY, CLINICAL DATA AND REGULATORY SUBMISSION MANAGEMENT ON BEHALF OF MEDICAL, BIOPHARMACEUTICAL AND BIOTECHNOLOGY COMPANIES TO ASSIST THEM WITH CLINICAL RESEARCH, CLINICAL TRIALS AND APPLICATIONS FOR DRUG APPROVAL (U.S. CLS. 100, 101 AND 102).

FIRST USE 11-1-2011; IN COMMERCE 11-1-2011.

CLASS 42—SCIENTIFIC AND COMPUTER SERVICES

FOR CLINICAL RESEARCH PROGRAM DEVELOPMENT SERVICES (U.S. CLS. 100 AND 101).

FIRST USE 11-1-2011; IN COMMERCE 11-1-2011.

4,210,987. PROFESSIONAL HEALTH AND NUTRITION, INC., TROY, MI. SN 85-317,366. PUB. 11-1-2011, FILED 5-10-2011.

PROVEN4 CERTIFIED SPORT

THE MARK CONSISTS OF STANDARD CHARACTERS WITHOUT CLAIM TO ANY PARTICULAR FONT, STYLE, SIZE, OR COLOR.

NO CLAIM IS MADE TO THE EXCLUSIVE RIGHT TO USE "CERTIFIED SPORT", APART FROM THE MARK AS SHOWN.

4,210,988. GREEN EXCHANGE LLC, NEW YORK, NY. SN 85-317,904. PUB. 10-11-2011, FILED 5-11-2011.



THE MARK CONSISTS OF TWO ANGLED LINES FORMING THE SHAPE OF A STYLIZED "X".

CLASS 36—INSURANCE AND FINANCIAL

FOR FINANCIAL SERVICES IN THE NATURE OF TRADING COMMODITIES; PROVIDING FINANCIAL INFORMATION (U.S. CLS. 100, 101 AND 102).

FIRST USE 1-24-2011; IN COMMERCE 1-24-2011.

CLASS 41—EDUCATION AND ENTERTAINMENT

FOR CONDUCTING SEMINARS AND WORKSHOPS IN THE FIELD OF ENVIRONMENTAL MARKETS (U.S. CLS. 100, 101 AND 107).

FIRST USE 3-12-2010; IN COMMERCE 3-12-2012.

4,210,996. CRYSTAL ART IMPORTS, INC., COLUMBUS, OH. SN 85-320,034. PUB. 11-1-2011, FILED 5-13-2011.

CASHS

THE MARK CONSISTS OF STANDARD CHARACTERS WITHOUT CLAIM TO ANY PARTICULAR FONT, STYLE, SIZE, OR COLOR.

OWNER OF U.S. REG. NO. 1,288,972.

CLASS 21—HOUSEWARES AND GLASS

FOR STATUES AND STATUETTES MADE OF CRYSTAL; CRYSTAL SCULPTURES; DESKTOP STATUARY MADE OF CRYSTAL; CRYSTAL FIGURES AND FIGURINES; ORNAMENTS OF CRYSTAL; HOLIDAY ORNAMENTS OF CRYSTAL; WORKS OF ART MADE OF CRYSTAL; HOUSEHOLD CONTAINERS OF CRYSTAL; BARWARE, BEVERAGE GLASSWARE, BEVERAGEWARE, BOWLS, CANDLE HOLDERS, CANDLESTICKS, CHAMPAGNE FLUTES, COOLING BUCKETS FOR WINE, CUPS AND MUGS, DISHWARE, DRINKING CUPS AND SAUCERS, DRINKING GLASSES, DRINKING VESSELS, FLOWER BOWLS, FLOWER VASES, FRUIT BOWLS, STEMWARE, VASES, WINE GLASSES, ALL MADE OF CRYSTAL (U.S. CLS. 2, 13, 23, 29, 30, 33, 40 AND 50).

FIRST USE 0-0-2009; IN COMMERCE 0-0-2009.

CLASS 35—ADVERTISING AND BUSINESS

FOR CATALOG ORDERING SERVICE FEATURING CRYSTAL; MAIL ORDER SERVICES FEATURING CRYSTAL; ONLINE RETAIL STORE SERVICES FEATURING CRYSTAL (U.S. CLS. 100, 101 AND 102).

FIRST USE 0-0-1902; IN COMMERCE 0-0-1975.

CLASS 11—ENVIRONMENTAL CONTROL APPARATUS

FOR LIGHT BULBS; LIGHTING TUBES (U.S. CLS. 13, 21, 23, 31 AND 34).

FIRST USE 1-0-2012; IN COMMERCE 1-0-2012.

CLASS 35—ADVERTISING AND BUSINESS

FOR ON-LINE RETAIL STORE SERVICES FEATURING LIGHTING FIXTURES, LIGHTING TUBES AND LIGHT BULBS; RETAIL STORE SERVICES FEATURING LIGHTING FIXTURES, LIGHTING TUBES AND LIGHT BULBS (U.S. CLS. 100, 101 AND 102).

FIRST USE 12-29-2011; IN COMMERCE 12-29-2011.

4,210,998. HOEGEMEYER HYBRIDS, INC., HOOPER, NE. SN 85-320,185. PUB. 10-25-2011, FILED 5-13-2011.

Right Stand

THE MARK CONSISTS OF STANDARD CHARACTERS WITHOUT CLAIM TO ANY PARTICULAR FONT, STYLE, SIZE, OR COLOR.

CLASS 31—NATURAL AGRICULTURAL PRODUCTS

FOR AGRICULTURAL SEED (U.S. CLS. 1 AND 46).
FIRST USE 12-31-2011; IN COMMERCE 12-31-2011.

CLASS 40—MATERIAL TREATMENT

FOR AGRICULTURAL SERVICES, NAMELY, SEED TREATMENT (U.S. CLS. 100, 103 AND 106).
FIRST USE 12-31-2011; IN COMMERCE 12-31-2011.

4,210,999. LIGHT DREAMS, LLC, PUYALLUP, WA. SN 85-320,914. PUB. 10-11-2011, FILED 5-13-2011.

LIGHT DREAMS

THE MARK CONSISTS OF STANDARD CHARACTERS WITHOUT CLAIM TO ANY PARTICULAR FONT, STYLE, SIZE, OR COLOR.

NO CLAIM IS MADE TO THE EXCLUSIVE RIGHT TO USE "LIGHT", APART FROM THE MARK AS SHOWN.

4,211,000. JAVAN, SHADAAN, PISCATAWAY, NJ. SN 85-321,358. PUB. 10-4-2011, FILED 5-15-2011.

SUNTUITY

THE MARK CONSISTS OF STANDARD CHARACTERS WITHOUT CLAIM TO ANY PARTICULAR FONT, STYLE, SIZE, OR COLOR.

CLASS 37—CONSTRUCTION AND REPAIR

FOR INSTALLATION AND MAINTENANCE OF PHOTOVOLTAIC INSTALLATIONS; INSTALLATION AND MAINTENANCE OF PHOTOVOLTAIC/SOLAR THERMAL HYBRID INSTALLATIONS; INSTALLATION AND MAINTENANCE OF SOLAR ENERGY BASED POWER PLANTS; INSTALLATION AND MAINTENANCE OF SOLAR THERMAL INSTALLATIONS; INSTALLATION OF ELECTRICAL AND GENERATING MACHINERY; INSTALLATION OF GEOTHERMAL ENERGY BASED POWER PLANTS; INSTALLATION OF RENEWABLE ENERGY GENERATION EQUIPMENT; INSTALLATION OF SOLAR ENERGY SYSTEMS AND ALTERNATIVE ENERGY PRODUCTS FOR RESIDENTIAL AND COMMERCIAL USE; INSTALLATION OF WIRING AND POWER SUPPLY EQUIPMENT FOR TRANSMISSION AND DISTRIBUTION OF ELECTRICITY SUITABLE FOR ELECTRIC VEHICLE RECHARGING STATIONS (U.S. CLS. 100, 103 AND 106).

FIRST USE 8-3-2011; IN COMMERCE 8-3-2011.

CLASS 42—SCIENTIFIC AND COMPUTER SERVICES

FOR DESIGN OF SOLAR PHOTOVOLTAIC SYSTEMS; DESIGN, DEVELOPMENT, INSTALLATION AND MAINTENANCE OF COMPUTER SOFTWARE; ENVIRONMENTAL ENGINEERING, TESTING AND INSPECTION SERVICES; ENVIRONMENTAL SERVICES, NAMELY, TECHNICAL CONSULTATION IN THE FIELD OF ENVIRONMENTAL SCIENCE, ENGINEERING SERVICES AND DESIGN FOR OTHERS IN THE FIELD OF ENVIRONMENTAL ENGINEERING; QUALITY EVALUATION FOR OTHERS IN THE FIELD OF MAINTENANCE, REPAIR AND INSTALLATION OF SOLAR INSTALLATIONS AND PHOTOVOLTAIC INSTALLATIONS; RESEARCH AND DEVELOPMENT OF ENVIRONMENTALLY FRIENDLY FORMS OF ENERGY AND POWER (U.S. CLS. 100 AND 101).

FIRST USE 8-3-2011; IN COMMERCE 8-3-2011.

4,211,004. SHERWOOD, THOMAS W., PENN'S PARK, PA. SN 85-322,991. PUB. 10-11-2011, FILED 5-17-2011.

4,211,026. SPLUNK INC., SAN FRANCISCO, CA. SN 85-327,870. PUB. 11-8-2011, FILED 5-23-2011.

DIVE IN · DINE · UNWIND

THE MARK CONSISTS OF STANDARD CHARACTERS WITHOUT CLAIM TO ANY PARTICULAR FONT, STYLE, SIZE, OR COLOR.

CLASS 41—EDUCATION AND ENTERTAINMENT

FOR ADULT ENTERTAINMENT SERVICES, NAMELY, NIGHT CLUB SERVICES FEATURING EXOTIC DANCING (U.S. CLS. 100, 101 AND 107).
FIRST USE 5-31-2011; IN COMMERCE 5-31-2011.

CLASS 43—HOTEL AND RESTAURANT SERVICES

FOR BAR AND RESTAURANT SERVICES (U.S. CLS. 100 AND 101).
FIRST USE 5-31-2011; IN COMMERCE 5-31-2011.

4,211,025. DEMCO, INC., MADISON, WI. SN 85-327,254. PUB. 11-1-2011, FILED 5-23-2011.

DEMCO INTERIORS

THE MARK CONSISTS OF STANDARD CHARACTERS WITHOUT CLAIM TO ANY PARTICULAR FONT, STYLE, SIZE, OR COLOR.

OWNER OF U.S. REG. NOS. 2,721,302, 3,026,750, AND OTHERS.

NO CLAIM IS MADE TO THE EXCLUSIVE RIGHT TO USE "INTERIORS", APART FROM THE MARK AS SHOWN.

CLASS 35—ADVERTISING AND BUSINESS

FOR DISTRIBUTORSHIPS IN THE FIELD OF FURNITURE; RETAIL DISTRIBUTORSHIP SERVICES FEATURING FURNITURE; AND PROCUREMENT, NAMELY, PURCHASING FURNITURE FOR OTHERS (U.S. CLS. 100, 101 AND 102).
FIRST USE 6-25-2010; IN COMMERCE 6-25-2010.

CLASS 37—CONSTRUCTION AND REPAIR

FOR INSTALLATION OF LIBRARY AND MEDIA DESIGN CENTER EQUIPMENT AND FURNISHINGS (U.S. CLS. 100, 103 AND 106).
FIRST USE 6-25-2010; IN COMMERCE 6-25-2010.

CLASS 42—SCIENTIFIC AND COMPUTER SERVICES

FOR INTERIOR DESIGN CONSULTATION IN THE FIELD OF LIBRARY AND MEDIA CENTER DESIGN, EQUIPMENT AND FURNISHINGS (U.S. CLS. 100 AND 101).
FIRST USE 6-25-2010; IN COMMERCE 6-25-2010.

SPLUNK STORM

THE MARK CONSISTS OF STANDARD CHARACTERS WITHOUT CLAIM TO ANY PARTICULAR FONT, STYLE, SIZE, OR COLOR.

CLASS 9—ELECTRICAL AND SCIENTIFIC APPARATUS

FOR COMPUTER HARDWARE; COMPUTER SERVER SOFTWARE FOR PROVIDING SEARCH, TROUBLESHOOTING, OPERATIONAL INTELLIGENCE AND BUSINESS ANALYTICS USING CLIENTS DATA; COMPUTER SEARCH ENGINE SOFTWARE; AND INSTRUCTIONAL MANUALS SOLD AS A UNIT THEREWITH (U.S. CLS. 21, 23, 26, 36 AND 38).
FIRST USE 8-16-2011; IN COMMERCE 8-16-2011.

CLASS 16—PAPER GOODS AND PRINTED MATTER

FOR PRINTED MATTER, NAMELY, MANUALS, WHITE PAPERS, BOOKS, MAGAZINES, NEWSLETTERS AND USER GUIDES ON THE SUBJECT OF INFORMATION TECHNOLOGY (U.S. CLS. 2, 5, 22, 23, 29, 37, 38 AND 50).
FIRST USE 8-16-2011; IN COMMERCE 8-16-2011.

CLASS 35—ADVERTISING AND BUSINESS

FOR BUSINESS CONSULTING SERVICES IN THE FIELD OF CLOUD COMPUTING (U.S. CLS. 100, 101 AND 102).
FIRST USE 8-16-2011; IN COMMERCE 8-16-2011.

CLASS 38—COMMUNICATION

FOR PROVIDING MULTIPLE USER ACCESS TO GLOBAL COMPUTER NETWORKS FOR THE TRANSFER AND DISSEMINATION OF A WIDE RANGE OF INFORMATION, PROVIDING ON-LINE ELECTRONIC BULLETIN BOARDS FOR TRANSMISSION OF MESSAGES AMONG COMPUTER USERS IN THE FIELDS OF COMPUTER OPERATION AND NETWORKING AND INFORMATION TECHNOLOGY IN THE FIELD OF CLOUD COMPUTING (U.S. CLS. 100, 101 AND 107).
FIRST USE 8-16-2011; IN COMMERCE 8-16-2011.

CLASS 41—EDUCATION AND ENTERTAINMENT

FOR EDUCATIONAL SERVICES, NAMELY, PROVIDING TRAINING, TUTORIALS, CLASSES AND SEMINARS IN THE FIELD OF COMPUTERS, COMPUTER SOFTWARE AND COMPUTER NETWORKS AND THE DEVELOPMENT AND OPERATION OF CLOUD COMPUTING NETWORKS (U.S. CLS. 100, 101 AND 107).
FIRST USE 8-16-2011; IN COMMERCE 8-16-2011.

CLASS 42—SCIENTIFIC AND COMPUTER SERVICES

FOR CLOUD COMPUTING FEATURING SOFTWARE FOR INDEXING AND MAKING SEARCHABLE DATA FROM ANY APPLICATION, SERVER OR NETWORK DEVICE; COMPUTER SERVICES, NAMELY, REMOTE AND ON-SITE MANAGEMENT OF CLOUD COMPUTING SYSTEMS AND APPLICATIONS FOR OTHERS; CONSULTING SERVICES IN THE FIELD OF CLOUD COMPUTING; TECHNICAL CONSULTING SERVICES IN THE FIELDS OF DATACENTER ARCHITECTURE, PUBLIC AND PRIVATE CLOUD COMPUTING SOLUTIONS, AND EVALUATION AND IMPLEMENTATION OF INTERNET TECHNOLOGY AND SERVICES; TECHNICAL SUPPORT SERVICES, NAMELY, REMOTE AND ON-SITE INFRASTRUCTURE MANAGEMENT SERVICES FOR MONITORING, ADMINISTRATION AND MANAGEMENT OF PUBLIC AND PRIVATE CLOUD COMPUTING IT AND APPLICATION SYSTEMS (U.S. CLS. 100 AND 101).

FIRST USE 8-16-2011; IN COMMERCE 8-16-2011.

4,211,028. CHAN & ZEN LLC, NEW YORK, NY. SN 85-328,428. PUB. 10-18-2011, FILED 5-24-2011.

CHAN & ZEN

THE MARK CONSISTS OF STANDARD CHARACTERS WITHOUT CLAIM TO ANY PARTICULAR FONT, STYLE, SIZE, OR COLOR.

THE NAME(S), PORTRAIT(S), AND/OR SIGNATURE(S) SHOWN IN THE MARK DOES NOT IDENTIFY A PARTICULAR LIVING INDIVIDUAL.

CLASS 14—JEWELRY

FOR JEWELRY (U.S. CLS. 2, 27, 28 AND 50).
FIRST USE 3-1-2012; IN COMMERCE 3-1-2012.

CLASS 35—ADVERTISING AND BUSINESS

FOR WHOLESALE ORDERING SERVICES IN THE FIELD OF JEWELRY; WHOLESALE STORES FEATURING JEWELRY (U.S. CLS. 100, 101 AND 102).
FIRST USE 3-1-2012; IN COMMERCE 3-1-2012.

4,211,034. FLYGRIP INC., MELVILLE, NY. SN 85-329,305. PUB. 4-24-2012, FILED 5-24-2011.

FLYGRIP

THE MARK CONSISTS OF STANDARD CHARACTERS WITHOUT CLAIM TO ANY PARTICULAR FONT, STYLE, SIZE, OR COLOR.

CLASS 9—ELECTRICAL AND SCIENTIFIC APPARATUS

FOR SPECIALIZED FINGER GRIPS FOR HOLDING AND CARRYING HAND HELD ELECTRONIC DIGITAL DEVICES, SMART PHONES, TABLET COMPUTERS AND E-BOOK READERS (U.S. CLS. 21, 23, 26, 36 AND 38).

FIRST USE 9-1-2011; IN COMMERCE 9-1-2011.

CLASS 21—HOUSEWARES AND GLASS

FOR SPECIALIZED FINGER GRIPS FOR HOLDING AND CARRYING CUPS, MUGS AND SPORTS BOTTLES (U.S. CLS. 2, 13, 23, 29, 30, 33, 40 AND 50).

FIRST USE 9-1-2011; IN COMMERCE 9-1-2011.

4,211,036. FLEX ENERGY, INC., IRVINE, CA. SN 85-329,603. PUB. 11-8-2011, FILED 5-25-2011.

FLEX RECUPERATOR

THE MARK CONSISTS OF STANDARD CHARACTERS WITHOUT CLAIM TO ANY PARTICULAR FONT, STYLE, SIZE, OR COLOR.

NO CLAIM IS MADE TO THE EXCLUSIVE RIGHT TO USE "RECUPERATOR", APART FROM THE MARK AS SHOWN.

CLASS 7—MACHINERY

FOR HEAT EXCHANGERS BEING PARTS OF ENGINES NOT FOR LAND VEHICLES; HEAT EXCHANGERS BEING PARTS OF MACHINES (U.S. CLS. 13, 19, 21, 23, 31, 34 AND 35).

FIRST USE 6-20-2012; IN COMMERCE 6-20-2012.

CLASS 11—ENVIRONMENTAL CONTROL APPARATUS

FOR HEAT EXCHANGERS NOT BEING PARTS OF MACHINES; HEAT GENERATORS (U.S. CLS. 13, 21, 23, 31 AND 34).

FIRST USE 6-20-2012; IN COMMERCE 6-20-2012.

4,211,044. MONSCIERGE, LLC, OKLAHOMA CITY, OK. SN 85-331,315. PUB. 12-6-2011, FILED 5-26-2011.



THE COLOR(S) BLUE AND LIGHT BLUE IS/ARE CLAIMED AS A FEATURE OF THE MARK.

THE MARK CONSISTS OF A STYLIZED LETTER "M" IN BLUE, SURROUNDED BY TWO CIRCLES OF BROKEN LINES FADING FROM BLUE TO LIGHT BLUE.

CLASS 9—ELECTRICAL AND SCIENTIFIC APPARATUS

FOR COMPUTER HARDWARE; COMPUTER OPERATING SYSTEM SOFTWARE; INTERACTIVE COMPUTER KIOSKS COMPRISING COMPUTERS, COMPUTER HARDWARE AND COMPUTER SOFTWARE FOR PROCESSING DATA, NAMELY, INFORMATION ON TRAVEL, TRANSPORTATION, LODGING, LOCAL ATTRACTIONS, DINING, ENTERTAINMENT, RECREATION AND CULTURAL EVENTS (U.S. CLS. 21, 23, 26, 36 AND 38).

FIRST USE 9-21-2011; IN COMMERCE 9-21-2011.

CLASS 38—COMMUNICATION

FOR PROVIDING ACCESS TO DATABASES OF INFORMATION ON TRAVEL, TRANSPORTATION, LODGING, LOCAL ATTRACTIONS, DINING, ENTERTAINMENT, RECREATION AND CULTURAL EVENTS (U.S. CLS. 100, 101 AND 104).

FIRST USE 9-21-2011; IN COMMERCE 9-21-2011.

4,211,067. ZYNGA INC., SAN FRANCISCO, CA. SN 85-335,790. PUB. 4-3-2012, FILED 6-1-2011.

EMPIRES & ALLIES

THE MARK CONSISTS OF STANDARD CHARACTERS WITHOUT CLAIM TO ANY PARTICULAR FONT, STYLE, SIZE, OR COLOR.

PRIORITY CLAIMED UNDER SEC. 44(D) ON TRINIDAD/TOBAGO APPLICATION NO. 43465, FILED 3-4-2011.

CLASS 9—ELECTRICAL AND SCIENTIFIC APPARATUS

FOR COMPUTER GAME SOFTWARE; VIDEO GAME PROGRAMS; AND COMPUTER SOFTWARE PLATFORMS FOR SOCIAL NETWORKING; INTERACTIVE VIDEO GAME PROGRAMS; DOWNLOADABLE ELECTRONIC GAME PROGRAMS AND COMPUTER SOFTWARE PLATFORMS FOR SOCIAL NETWORKING THAT MAY BE ACCESSED VIA THE INTERNET, COMPUTERS AND WIRELESS DEVICES; COMPUTER SOFTWARE TO ENABLE UPLOADING, POSTING, SHOWING, DISPLAYING, TAGGING, BLOGGING, SHARING OR OTHERWISE PROVIDING ELECTRONIC MEDIA OR INFORMATION IN THE FIELDS OF VIRTUAL COMMUNITIES, ELECTRONIC GAMING, ENTERTAINMENT, AND GENERAL INTEREST VIA THE INTERNET OR OTHER COMMUNICATIONS NETWORKS WITH THIRD PARTIES (U.S. CLS. 21, 23, 26, 36 AND 38).

FIRST USE 6-1-2011; IN COMMERCE 6-1-2011.

CLASS 41—EDUCATION AND ENTERTAINMENT

FOR COMPUTER AND ELECTRONIC GAMES PROVIDED ONLINE, ENHANCEMENTS WITHIN ONLINE COMPUTER AND ELECTRONIC GAMES, AND GAME APPLICATIONS WITHIN ONLINE COMPUTER AND ELECTRONIC GAMES; ENTERTAINMENT REVIEWS OF COMPUTER GAMES PROVIDED ONLINE; INFORMATION RELATING TO COMPUTER GAMES PROVIDED ONLINE; VIRTUAL ENVIRONMENTS IN WHICH USERS CAN INTERACT THROUGH SOCIAL GAMES FOR RECREATIONAL, LEISURE OR ENTERTAINMENT PURPOSES (U.S. CLS. 100, 101 AND 107).

FIRST USE 6-1-2011; IN COMMERCE 6-1-2011.

4,211,076. KLUTZ, PALO ALTO, CA. SN 85-337,370. PUB. 11-8-2011, FILED 6-3-2011.

TWIRLY Q'S

THE MARK CONSISTS OF STANDARD CHARACTERS WITHOUT CLAIM TO ANY PARTICULAR FONT, STYLE, SIZE, OR COLOR.

CLASS 16—PAPER GOODS AND PRINTED MATTER

FOR BOOK KITS COMPRISED OF PRINTED INSTRUCTIONS FOR CREATING 3-DIMENSIONAL CREATURES AND FLOWERS (U.S. CLS. 2, 5, 22, 23, 29, 37, 38 AND 50).

FIRST USE 5-8-2012; IN COMMERCE 5-8-2012.

CLASS 28—TOYS AND SPORTING GOODS

FOR HOBBY CRAFT KITS COMPRISED OF CORRUGATED CARDBOARD, GLUE, AND CUSTOM SHAPING TOOLS FOR MAKING 3-DIMENSIONAL CREATURES AND FLOWERS (U.S. CLS. 22, 23, 38 AND 50).

FIRST USE 5-8-2012; IN COMMERCE 5-8-2012.

4,211,082. PIERRE-LOUIS, MONA, NEW YORK, NY. SN 85-337,878. PUB. 10-25-2011, FILED 6-3-2011.

Triumph Begins With U

THE MARK CONSISTS OF STANDARD CHARACTERS WITHOUT CLAIM TO ANY PARTICULAR FONT, STYLE, SIZE, OR COLOR.

CLASS 14—JEWELRY

FOR BRACELETS; JEWELRY; RINGS; RINGS BEING JEWELRY; STAINLESS STEEL JEWELRY BRACELETS (U.S. CLS. 2, 27, 28 AND 50).

FIRST USE 5-25-2011; IN COMMERCE 5-25-2011.

CLASS 25—CLOTHING

FOR SHORT-SLEEVED OR LONG-SLEEVED T-SHIRTS; T-SHIRTS; T-SHIRTS FOR BABIES, CHILDREN, ADULTS, WOMEN, MEN (U.S. CLS. 22 AND 39).
FIRST USE 5-1-2012; IN COMMERCE 5-1-2012.

4,211,094. SAGAX PRODUCTS, INC., KENNESAW, GA. SN 85-339,662. PUB. 11-22-2011, FILED 6-7-2011.



NO CLAIM IS MADE TO THE EXCLUSIVE RIGHT TO USE "CLEAN", APART FROM THE MARK AS SHOWN.

THE MARK CONSISTS OF THE STYLIZED TEXT "H CLEAN".

CLASS 1—CHEMICALS

FOR CHEMICALS FOR THE TREATMENT OF COOLING WATER SYSTEMS; CHEMICALS FOR THE TREATMENT OF WATER AND WASTEWATER; WASTE WATER TREATMENT CHEMICALS FOR INDUSTRIAL USE; WATER TREATMENT CHEMICALS FOR USE IN SWIMMING POOLS AND SPAS (U.S. CLS. 1, 5, 6, 10, 26 AND 46).

FIRST USE 6-1-2012; IN COMMERCE 6-28-2012.

CLASS 22—CORDAGE AND FIBERS

FOR SWIMMING POOL SKIMMING NETS (U.S. CLS. 1, 2, 7, 19, 22, 42 AND 50).

FIRST USE 6-1-2012; IN COMMERCE 6-28-2012.

4,211,098. PREMIER IVF, LLC, LONE TREE, CO. SN 85-340,177. PUB. 1-24-2012, FILED 6-7-2011.



NO CLAIM IS MADE TO THE EXCLUSIVE RIGHT TO USE "IVF", APART FROM THE MARK AS SHOWN.

THE COLOR(S) BLACK AND GOLD IS/ARE CLAIMED AS A FEATURE OF THE MARK.

THE MARK CONSISTS OF A BLACK CROWN DESIGN ABOVE THE BLACK STYLIZED WORDING "PREMIER" IN ALL CAPITAL LETTERS, WHICH IS IN TURN ABOVE THE BLACK STYLIZED CAPITAL LETTERS "IVF"; ALL OF THE AFOREMENTIONED WORDING AND DESIGNS APPEAR ON A GOLD BACKGROUND.

CLASS 35—ADVERTISING AND BUSINESS

FOR HEALTHCARE MANAGEMENT SERVICE ORGANIZATIONS (MSO) SERVICES, NAMELY, PROVIDING PRACTICE ORGANIZATION, MANAGEMENT AND ADMINISTRATIVE SUPPORT SERVICES TO INDIVIDUAL OR SMALL GROUP PRACTICES (U.S. CLS. 100, 101 AND 102).

FIRST USE 4-30-2012; IN COMMERCE 4-30-2012.

CLASS 44—MEDICAL, BEAUTY AND AGRICULTURAL SERVICES

FOR IN VITRO FERTILIZATION PHYSICIAN SERVICES (U.S. CLS. 100 AND 101).

FIRST USE 4-30-2012; IN COMMERCE 4-30-2012.

4,211,104. THE PROCTER & GAMBLE COMPANY, CINCINNATI, OH. SN 85-341,217. PUB. 5-15-2012, FILED 6-8-2011.

SWIFFER PROFESSIONAL

THE MARK CONSISTS OF STANDARD CHARACTERS WITHOUT CLAIM TO ANY PARTICULAR FONT, STYLE, SIZE, OR COLOR.

OWNER OF U.S. REG. NOS. 2,296,103, 3,007,962, AND OTHERS.

NO CLAIM IS MADE TO THE EXCLUSIVE RIGHT TO USE "PROFESSIONAL", APART FROM THE MARK AS SHOWN.

CLASS 16—PAPER GOODS AND PRINTED MATTER

FOR DISPOSABLE PAPER WIPES FOR HOUSEHOLD CLEANING NOT IMPREGNATED WITH CHEMICALS OR COMPOUNDS (U.S. CLS. 2, 5, 22, 23, 29, 37, 38 AND 50).

FIRST USE 12-12-2011; IN COMMERCE 12-12-2011.

CLASS 21—HOUSEWARES AND GLASS

FOR MOPS (U.S. CLS. 2, 13, 23, 29, 30, 33, 40 AND 50).
FIRST USE 12-12-2011; IN COMMERCE 12-12-2011.

4,211,113. BEIJING ELOOMOBILE CO. LTD., HAIDIAN DIST., BEIJING, CHINA. SN 85-342,288. PUB. 11-1-2011, FILED 6-9-2011.

OPENFACE

THE MARK CONSISTS OF STANDARD CHARACTERS WITHOUT CLAIM TO ANY PARTICULAR FONT, STYLE, SIZE, OR COLOR.

CLASS 9—ELECTRICAL AND SCIENTIFIC APPARATUS

FOR COMPUTER APPLICATION SOFTWARE FOR MOBILE PHONES, PORTABLE MEDIA PLAYERS, HANDHELD COMPUTERS, NAMELY, SOFTWARE FOR USE IN DATABASE MANAGEMENT, USE IN ELECTRONIC STORAGE OF DATA, COMPUTER GAMES; COMPUTER APPLICATION SOFTWARE FOR MOBILE PHONES, PORTABLE MEDIA PLAYERS, HANDHELD COMPUTERS, NAMELY, SOFTWARE FOR THE COLLECTION, EDITING, ORGANIZING, MODIFYING, BOOK MARKING, TRANSMISSION, STORAGE AND SHARING OF DATA AND INFORMATION (U.S. CLS. 21, 23, 26, 36 AND 38).

FIRST USE 10-8-2008; IN COMMERCE 7-8-2011.

CLASS 35—ADVERTISING AND BUSINESS

FOR RETAIL STORE SERVICES FEATURING COMPUTER SOFTWARE PROVIDED VIA THE INTERNET AND OTHER COMPUTER AND ELECTRONIC COMMUNICATION NETWORKS; RETAIL STORE SERVICES FEATURING COMPUTER SOFTWARE FOR USE ON HANDHELD MOBILE DIGITAL ELECTRONIC DEVICES AND OTHER CONSUMER ELECTRONICS (U.S. CLS. 100, 101 AND 102).

FIRST USE 10-8-2008; IN COMMERCE 7-8-2011.

4,211,117. RED E PRODUCTIONS LLC, PROSPECT, KY. SN 85-342,978. PUB. 11-15-2011, FILED 6-10-2011.



NO CLAIM IS MADE TO THE EXCLUSIVE RIGHT TO USE "APP", APART FROM THE MARK AS SHOWN.

THE MARK CONSISTS OF A CONVERSATION BALLOON CONTAINING THE LETTERS "REDE" WITH TAIL OF SECOND "E" TERMINATING IN THE POINT OF AN ARROW, AND WITH THE WORD "APP" DISPLAYED VERTICALLY ALONG ONE SIDE OF THE ARROW POINT.

CLASS 9—ELECTRICAL AND SCIENTIFIC APPARATUS

FOR COMPUTER SOFTWARE FOR SENDING, RECEIVING, AND MANAGING ELECTRONIC MESSAGES (U.S. CLS. 21, 23, 26, 36 AND 38).

FIRST USE 5-0-2012; IN COMMERCE 5-0-2012.

CLASS 38—COMMUNICATION

FOR ELECTRONIC TRANSMISSION OF MESSAGES (U.S. CLS. 100, 101 AND 104).

FIRST USE 5-0-2012; IN COMMERCE 5-0-2012.

4,211,140. POSH PUMPKINS, LLC, LUGOFF, SC. SN 85-345,694. PUB. 11-1-2011, FILED 6-14-2011.

POSH PUMPKINS

THE MARK CONSISTS OF STANDARD CHARACTERS WITHOUT CLAIM TO ANY PARTICULAR FONT, STYLE, SIZE, OR COLOR.

CLASS 22—CORDAGE AND FIBERS

FOR WATERPROOF BAGS, NAMELY, WET BAGS FOR TEMPORARY STORAGE OF WET AND/OR SOILED CLOTH DIAPERS (U.S. CLS. 1, 2, 7, 19, 22, 42 AND 50).

FIRST USE 5-27-2011; IN COMMERCE 5-27-2011.

CLASS 25—CLOTHING

FOR CLOTH DIAPERS (U.S. CLS. 22 AND 39).

FIRST USE 5-27-2011; IN COMMERCE 5-27-2011.

4,211,146. MILLICOM INTERNATIONAL CELLULAR S.A., LU-3372 LEUDELANGE, LUXEMBOURG. SN 85-346,481. PUB. 11-29-2011, FILED 6-15-2011.

TIGO

THE MARK CONSISTS OF STANDARD CHARACTERS WITHOUT CLAIM TO ANY PARTICULAR FONT, STYLE, SIZE, OR COLOR.

OWNER OF U.S. REG. NO. 3,542,571.

CLASS 16—PAPER GOODS AND PRINTED MATTER

FOR PREPAID TELEPHONE CALLING CARDS, NOT MAGNETICALLY ENCODED (U.S. CLS. 2, 5, 22, 23, 29, 37, 38 AND 50).

FIRST USE 8-24-2007; IN COMMERCE 8-24-2007.

CLASS 36—INSURANCE AND FINANCIAL

FOR ELECTRONIC TRANSFERS OF MONEY AND FUNDS; PRE-PAID TELECOMMUNICATIONS CALLING CARD SERVICES; MAKING PAYMENTS FOR RECHARGING MINUTES FOR OTHERS IN CONNECTION WITH PRE-PAID MOBILE AIR-TIME PLANS; FINANCIAL SERVICES, NAMELY, RECEIVING OR SENDING MONEY TRANSFERS, DEPOSITING AND WITHDRAWING MONEY, PAYING BILLS AND BUYING AIRTIME CREDIT; MOBILE PHONE MONEY EXCHANGE; MOBILE PHONE CASH ACCOUNT SERVICES (U.S. CLS. 100, 101 AND 102).

FIRST USE 8-24-2007; IN COMMERCE 8-24-2007.

4,211,149. PRECIDIAN INVESTMENTS LLC, BEDMINSTER, NJ. SN 85-346,773. PUB. 11-15-2011, FILED 6-15-2011.



NO CLAIM IS MADE TO THE EXCLUSIVE RIGHT TO USE "INVESTMENTS", APART FROM THE MARK AS SHOWN.

THE MARK CONSISTS OF A STYLIZED REPRESENTATION OF A SHIELD INTERSECTED BY A CURVED LINE; DIRECTLY TO THE RIGHT OF THE SHIELD IS THE WORD "PRECIDIAN" STACKED ON TOP OF THE WORD "INVESTMENTS".

CLASS 36—INSURANCE AND FINANCIAL

FOR FINANCIAL MANAGEMENT SERVICES, NAMELY, PROVIDING CONSTRUCTION OF INVESTMENT PORTFOLIOS COMPRISED OF CERTAIN FINANCIAL INSTRUMENTS; DEVELOPMENT OF FINANCIAL INSTRUMENTS, NAMELY, EXCHANGE TRADED PRODUCTS (ETPS), MUTUAL FUNDS AND DERIVATIVES FOR OTHERS, NAMELY, RETAIL INVESTORS, REGISTERED INVESTMENT ADVISERS (RIAS), INSTITUTIONAL, PENSION AND ENDOWMENT INVESTORS; FINANCIAL CONSULTATION SERVICES, NAMELY, PROVIDING FINANCIAL ANALYSIS SERVICES TO OTHERS; FINANCIAL AND INVESTMENT CONSULTATION SERVICES, NAMELY, PROVIDING ANALYSIS OF POTENTIAL ASSET AND INVESTMENT ACQUISITIONS (U.S. CLS. 100, 101 AND 102).

FIRST USE 6-7-2011; IN COMMERCE 6-7-2011.

CLASS 42—SCIENTIFIC AND COMPUTER SERVICES

FOR DEVELOPMENT OF TECHNOLOGIES IN THE FIELD OF TRADING OF FINANCIAL INSTRUMENTS, NAMELY, SCIENTIFIC RESEARCH FOR MATH ALGORITHMS AND DEVELOPING COMPUTER SOFTWARE IN CONNECTION WITH TRADING OR OTHER ACTIVITIES RELATED TO TRADING OF FINANCIAL INSTRUMENTS (U.S. CLS. 100 AND 101).

FIRST USE 6-7-2011; IN COMMERCE 6-7-2011.

CLASS 45—PERSONAL AND LEGAL SERVICES

FOR LICENSING OF INTELLECTUAL PROPERTY USED IN THE CREATION OF FINANCIAL INSTRUMENTS (U.S. CLS. 100 AND 101).

FIRST USE 6-7-2011; IN COMMERCE 6-7-2011.

4,211,158. VIEGA LLC, WICHITA, KS. SN 85-347,691. PUB. 4-10-2012, FILED 6-16-2011.

SMART CONNECT

THE MARK CONSISTS OF STANDARD CHARACTERS WITHOUT CLAIM TO ANY PARTICULAR FONT, STYLE, SIZE, OR COLOR.

OWNER OF U.S. REG. NO. 3,319,494.

NO CLAIM IS MADE TO THE EXCLUSIVE RIGHT TO

USE "CONNECT", APART FROM THE MARK AS SHOWN.

CLASS 11—ENVIRONMENTAL CONTROL APPARATUS

FOR PLASTIC PRESS FITTINGS AND CONNECTORS, NAMELY, COUPLERS, VALVES FOR COMMERCIAL, INDUSTRIAL AND RESIDENTIAL PLUMBING AND HEATING SYSTEMS (U.S. CLS. 13, 21, 23, 31 AND 34).

FIRST USE 2-3-2012; IN COMMERCE 2-3-2012.

CLASS 19—NON-METALLIC BUILDING MATERIALS

FOR PLASTIC PIPE FITTINGS FOR COMMERCIAL, INDUSTRIAL AND RESIDENTIAL PLUMBING AND HEATING SYSTEMS; PLASTIC ELBOWS AND TEES FOR PIPES FOR COMMERCIAL, INDUSTRIAL AND RESIDENTIAL PLUMBING AND HEATING SYSTEMS (U.S. CLS. 1, 12, 33 AND 50).

FIRST USE 2-3-2012; IN COMMERCE 2-3-2012.

4,211,165. FLIP FLOP DOGS, LLC, MARCO ISLAND, FL. SN 85-348,135. PUB. 5-22-2012, FILED 6-16-2011.



THE MARK CONSISTS OF THE HEAD OF A DOG WEARING SUNGLASSES AND HOLDING A BAG WITH THE WORD "FLIPFLOP".

CLASS 35—ADVERTISING AND BUSINESS

FOR RETAIL STORE SERVICES FEATURING PET SUPPLIES; WHOLESALE DISTRIBUTORSHIPS FEATURING PET SUPPLIES; FRANCHISE SERVICES, NAMELY, OFFERING BUSINESS MANAGEMENT ASSISTANCE IN THE ESTABLISHMENT AND OPERATION OF RETAIL STORES AND WHOLESALE DISTRIBUTORSHIPS IN THE FIELDS OF PET SUPPLIES AND IN THE ESTABLISHMENT AND OPERATION OF BUSINESSES IN THE FIELDS OF PET BOARDING, PET GROOMING AND PET CARE (U.S. CLS. 100, 101 AND 102).

FIRST USE 10-31-2011; IN COMMERCE 10-31-2011.

CLASS 43—HOTEL AND RESTAURANT SERVICES

FOR TEMPORARY PET BOARDING AND DAY CARE SERVICES (U.S. CLS. 100 AND 101).

FIRST USE 10-31-2011; IN COMMERCE 10-31-2011.

CLASS 44—MEDICAL, BEAUTY AND AGRICULTURAL SERVICES

FOR PET GROOMING SERVICES; PET CARE SERVICES, NAMELY, DOG WALKING, DOG BATHING, NON-MEDICATED PET GROOMING AND IN-HOME MEDICAL CARE (U.S. CLS. 100 AND 101).

FIRST USE 10-31-2011; IN COMMERCE 10-31-2011.

CLASS 45—PERSONAL AND LEGAL SERVICES

FOR PET CARE SERVICES, NAMELY, PET SITTING (U.S. CLS. 100 AND 101).
FIRST USE 10-31-2011; IN COMMERCE 10-31-2011.

4,211,204. NEXT PRODUCTS (USA) LLC, NEW YORK, NY. SN 85-353,039. PUB. 12-6-2011, FILED 6-22-2011.

ARCHSTONE

THE MARK CONSISTS OF STANDARD CHARACTERS WITHOUT CLAIM TO ANY PARTICULAR FONT, STYLE, SIZE, OR COLOR.

CLASS 8—HAND TOOLS

FOR ELECTRIC RAZORS AND ELECTRIC HAIR CLIPPERS; NON-ELECTRIC RAZORS; PEDICURE IMPLEMENTS, NAMELY, NAIL FILES, NAIL CLIPPERS, CUTICLE PUSHERS, TWEEZERS, NAIL AND CUTICLE SCISSORS (U.S. CLS. 23, 28 AND 44).
FIRST USE 11-0-2011; IN COMMERCE 11-0-2011.

CLASS 9—ELECTRICAL AND SCIENTIFIC APPARATUS

FOR BINOCULARS; ELECTRIC IRONS; ELECTRICALLY-HEATED MUGS; FLAT IRONS, ELECTRIC (U.S. CLS. 21, 23, 26, 36 AND 38).
FIRST USE 11-0-2011; IN COMMERCE 11-0-2011.

CLASS 21—HOUSEWARES AND GLASS

FOR CUPS AND MUGS; DRINKING FLASKS; INSULATED VACUUM FLASKS (U.S. CLS. 2, 13, 23, 29, 30, 33, 40 AND 50).
FIRST USE 11-0-2011; IN COMMERCE 11-0-2011.

4,211,207. CREDIT INFONET, INC., DAYTON, OH. SN 85-354,043. PUB. 11-15-2011, FILED 6-23-2011.

INFORMATION. INNOVATED.

THE MARK CONSISTS OF STANDARD CHARACTERS WITHOUT CLAIM TO ANY PARTICULAR FONT, STYLE, SIZE, OR COLOR.

CLASS 36—INSURANCE AND FINANCIAL

FOR CREDIT REPORTING SERVICES (U.S. CLS. 100, 101 AND 102).
FIRST USE 10-27-2011; IN COMMERCE 10-27-2011.

CLASS 45—PERSONAL AND LEGAL SERVICES

FOR LEGAL DUE DILIGENCE SERVICES, NAMELY, PROVIDING CUSTOMIZED RESEARCH AND FINANCIAL INFORMATION FOR USE BY ATTORNEYS IN THE INVESTIGATION OF CONSUMERS' FINANCIAL AFFAIRS AND IN THE PREPARATION OF CONSUMER BANKRUPTCY SCHEDULES AND OTHER DOCUMENTS FOR PRESENTATION TO COURTS (U.S. CLS. 100 AND 101).
FIRST USE 10-27-2011; IN COMMERCE 10-27-2011.

4,211,208. THE MCGRAW-HILL COMPANIES, INC., NEW YORK, NY. SN 85-354,055. PUB. 11-22-2011, FILED 6-23-2011.

MCGRAW-HILL READING WONDERS

THE MARK CONSISTS OF STANDARD CHARACTERS WITHOUT CLAIM TO ANY PARTICULAR FONT, STYLE, SIZE, OR COLOR.

OWNER OF U.S. REG. NOS. 1,350,345, 3,988,680, AND OTHERS.

NO CLAIM IS MADE TO THE EXCLUSIVE RIGHT TO USE "READING", APART FROM THE MARK AS SHOWN.

CLASS 16—PAPER GOODS AND PRINTED MATTER

FOR SERIES OF TEXTBOOKS, WORKBOOKS, TESTS, ANSWER SHEETS, AND TEACHER'S GUIDES IN THE FIELD OF READING FOR GRADES PREK- 6 (U.S. CLS. 2, 5, 22, 23, 29, 37, 38 AND 50).
FIRST USE 4-0-2012; IN COMMERCE 4-0-2012.

CLASS 41—EDUCATION AND ENTERTAINMENT

FOR PROVIDING EDUCATIONAL INFORMATION IN THE ACADEMIC FIELD OF READING FOR GRADES PREKINDERGARTEN THROUGH 6TH GRADE FOR THE PURPOSE OF ACADEMIC STUDY; ENTERTAINMENT SERVICES, NAMELY, PROVIDING ONLINE COMPUTER GAMES IN THE FIELD OF READING FOR GRADES PREKINDERGARTEN THROUGH 6TH GRADE (U.S. CLS. 100, 101 AND 107).
FIRST USE 4-0-2012; IN COMMERCE 4-0-2012.

4,211,214. ZYNGA INC., SAN FRANCISCO, CA. SN 85-354,857. PUB. 3-20-2012, FILED 6-23-2011.

HANGING WITH FRIENDS

THE MARK CONSISTS OF STANDARD CHARACTERS WITHOUT CLAIM TO ANY PARTICULAR FONT, STYLE, SIZE, OR COLOR.

PRIORITY CLAIMED UNDER SEC. 44(D) ON TRINIDAD/TOBAGO APPLICATION NO. 43787, FILED 5-10-2011.

PRIORITY CLAIMED UNDER SEC. 44(D) ON TRINIDAD/TOBAGO APPLICATION NO. 43784, FILED 5-10-2011.

CLASS 9—ELECTRICAL AND SCIENTIFIC APPARATUS

FOR COMPUTER GAME SOFTWARE; VIDEO GAME PROGRAMS; AND COMPUTER SOFTWARE PLATFORMS FOR SOCIAL NETWORKING; INTERACTIVE VIDEO GAME PROGRAMS; DOWNLOADABLE ELECTRONIC GAME PROGRAMS AND COMPUTER SOFTWARE PLATFORMS FOR SOCIAL NETWORKING THAT MAY BE ACCESSED VIA THE INTERNET, COMPUTERS AND WIRELESS DEVICES; COMPUTER SOFTWARE TO ENABLE UPLOADING, POSTING, SHOWING, DISPLAYING, TAGGING, BLOGGING, SHARING OR OTHERWISE PROVIDING ELECTRONIC MEDIA OR INFORMATION IN THE FIELDS OF VIRTUAL COMMUNITIES, ELECTRONIC GAMING, ENTERTAINMENT, AND GENERAL INTEREST VIA THE INTERNET OR OTHER COMMUNICATIONS NETWORKS WITH THIRD PARTIES (U.S. CLS. 21, 23, 26, 36 AND 38).

FIRST USE 6-9-2011; IN COMMERCE 6-9-2011.

CLASS 41—EDUCATION AND ENTERTAINMENT

FOR COMPUTER AND ELECTRONIC GAMES PROVIDED ONLINE, ENHANCEMENTS WITHIN ONLINE COMPUTER AND ELECTRONIC GAMES, AND GAME APPLICATIONS WITHIN ONLINE COMPUTER AND ELECTRONIC GAMES; VIRTUAL ENVIRONMENTS IN WHICH USERS CAN INTERACT THROUGH SOCIAL GAMES FOR RECREATIONAL, LEISURE OR ENTERTAINMENT PURPOSES (U.S. CLS. 100, 101 AND 107).

FIRST USE 6-9-2011; IN COMMERCE 6-9-2011.

4,211,233. 1467118 ONTARIO INC., BEAVERTON, ONTARIO, CANADA. SN 85-356,696. PUB. 11-22-2011, FILED 6-27-2011.

STUFF4

THE MARK CONSISTS OF STANDARD CHARACTERS WITHOUT CLAIM TO ANY PARTICULAR FONT, STYLE, SIZE, OR COLOR.

CLASS 35—ADVERTISING AND BUSINESS

FOR ON-LINE RETAIL STORE SERVICES IN THE FIELD OF SCRAPBOOKING SUPPLIES, CRAFT SUPPLIES, STENCILING SUPPLIES, QUILTING SUPPLIES, NEEDLE ART, FOOD CRAFTS, EMBROIDERY, TEXTILES FOR CLOTHING AND CRAFTS, GLASS ETCHING SUPPLIES, CLOCK MAKING SUPPLIES, SUPPLIES FOR ENGRAVING GOODS, POTTERY SUPPLIES, CANDLE AND SOAP MAKING SUPPLIES, MACRAMÉ SUPPLIES, PURSE MAKING AND BASKETRY SUPPLIES, CAKE AND CANDY MAKING AND DECORATION SUPPLIES, PAINTING SUPPLIES, HOBBY AND ART ITEMS AND SUPPLIES, SUPPLIES FOR SEWING, KNITTING, CROCHETING, CROSS-STITCHING AND EMBROIDERY, SUPPLIES FOR MAKING JEWELRY, SILK AND DRIED FLOWERS AND SUPPLIES TO MAKE SILK AND DRIED FLOWERS, QUILTING AND DECOUPAGE SUPPLIES, HOME AND WALL DÉCOR ITEMS, PARTY SUPPLIES, TOYS, GAMES AND PUZZLES FOR CHILDREN, DOLLS, PARTY FAVORS AND DECORATIONS, AND OFFICE SUPPLIES; PROVIDING A WEBSITE FEATURING DISCOUNT VOUCHERS, COUPONS, REBATES, PRODUCT RENEWS, AND DISCOUNT INFORMATION IN THE FIELDS OF ARTS AND CRAFTS, SCRAPBOOKING, HOME DÉCOR, HOBBY SUPPLIES, PARTY SUPPLIES, AND OFFICE SUPPLIES (U.S. CLS. 100, 101 AND 102).

FIRST USE 5-15-2012; IN COMMERCE 5-15-2012.

CLASS 41—EDUCATION AND ENTERTAINMENT

FOR ON-LINE ELECTRONIC NEWSLETTERS DELIVERED BY E-MAIL IN THE FIELDS OF ARTS AND CRAFTS, SCRAPBOOKING, HOME DÉCOR, HOBBY SUPPLIES, PARTY SUPPLIES, AND OFFICE SUPPLIES (U.S. CLS. 100, 101 AND 107).

FIRST USE 5-15-2012; IN COMMERCE 5-15-2012.

4,211,237. PRIDESTAFF, INC., FRESNO, CA. SN 85-357,316. PUB. 3-27-2012, FILED 6-27-2011.

INNOVATIONS

THE MARK CONSISTS OF STANDARD CHARACTERS WITHOUT CLAIM TO ANY PARTICULAR FONT, STYLE, SIZE, OR COLOR.

CLASS 16—PAPER GOODS AND PRINTED MATTER

FOR PRINT NEWSLETTERS COVERING TOPICS OF INTEREST TO EMPLOYERS IN THE FIELD OF HUMAN RESOURCES, INCLUDING BUT NOT LIMITED TO STAFFING, TRAINING, RECRUITING, LEGAL COMPLIANCE, AND PERSONNEL MANAGEMENT (U.S. CLS. 2, 5, 22, 23, 29, 37, 38 AND 50).

FIRST USE 8-0-2006; IN COMMERCE 8-0-2006.

CLASS 41—EDUCATION AND ENTERTAINMENT

FOR NON-DOWNLOADABLE ELECTRONIC NEWSLETTERS COVERING TOPICS OF INTEREST TO EMPLOYERS IN THE FIELD OF HUMAN RESOURCES, INCLUDING BUT NOT LIMITED TO STAFFING, TRAINING, RECRUITING, LEGAL COMPLIANCE, AND PERSONNEL MANAGEMENT; EDUCATIONAL SERVICES IN THE FORM OF WEBINARS COVERING TOPICS OF INTEREST TO EMPLOYERS IN THE FIELD OF HUMAN RESOURCES, INCLUDING BUT NOT LIMITED TO STAFFING, TRAINING, RECRUITING, LEGAL COMPLIANCE, AND PERSONNEL MANAGEMENT (U.S. CLS. 100, 101 AND 107).

FIRST USE 8-0-2006; IN COMMERCE 8-0-2006.

4,211,251. AMERICAN INSTITUTE OF CERTIFIED PUBLIC ACCOUNTANTS, NEW YORK, NY. SN 85-358,849. PUB. 10-25-2011, FILED 6-28-2011.



International Qualification Examination

NO CLAIM IS MADE TO THE EXCLUSIVE RIGHT TO USE "QUALIFICATION EXAMINATION", APART FROM THE MARK AS SHOWN.

THE MARK CONSISTS OF A STYLIZED DEPICTION OF THE LETTERS "IQEX" ADJACENT TO A CURVED DESIGN AND ALSO TO THE WORDS "INTERNATIONAL QUALIFICATION EXAMINATION".

SEC. 2(F) AS TO "INTERNATIONAL QUALIFICATION

EXAMINATION" .

4,211,253. EVEREST GLOBAL, INC., DALLAS, TX. SN 85-359,181. PUB. 1-3-2012, FILED 6-29-2011.

CLASS 16—PAPER GOODS AND PRINTED MATTER

FOR PRINTED MATTER, NAMELY, PRACTICE ACCOUNTING EXAMINATIONS, ACCOUNTING EXAMS, ACCOUNTING EXAM INFORMATION BOOKLETS, AND PRIOR ACCOUNTING EXAMINATION QUESTIONS AND ANSWERS (U.S. CLS. 2, 5, 22, 23, 29, 37, 38 AND 50).

FIRST USE 8-30-2011; IN COMMERCE 8-30-2011.

CLASS 41—EDUCATION AND ENTERTAINMENT

FOR EDUCATIONAL TESTING SERVICES, NAMELY, PREPARING, DISSEMINATING AND GRADING COMPUTER BASED ACCOUNTING EXAMINATIONS; ADMINISTERING COMPUTER BASED ACCOUNTING EXAMINATIONS VIA THE INTERNET; PROVIDING PRACTICE ACCOUNTING EXAMINATIONS VIA THE INTERNET (U.S. CLS. 100, 101 AND 107).

FIRST USE 8-30-2011; IN COMMERCE 8-30-2011.

4,211,252. AMERICAN INSTITUTE OF CERTIFIED PUBLIC ACCOUNTANTS, NEW YORK, NY. SN 85-358,853. PUB. 11-29-2011, FILED 6-28-2011.

IQEX

THE MARK CONSISTS OF STANDARD CHARACTERS WITHOUT CLAIM TO ANY PARTICULAR FONT, STYLE, SIZE, OR COLOR.

CLASS 16—PAPER GOODS AND PRINTED MATTER

FOR PRINTED MATTER, NAMELY, PRACTICE ACCOUNTING EXAMINATIONS; ACCOUNTING EXAMS; ACCOUNTING EXAM INFORMATION BOOKLETS; AND PRIOR ACCOUNTING EXAMINATION QUESTIONS AND ANSWERS (U.S. CLS. 2, 5, 22, 23, 29, 37, 38 AND 50).

FIRST USE 4-30-1997; IN COMMERCE 11-6-1997.

CLASS 41—EDUCATION AND ENTERTAINMENT

FOR EDUCATIONAL TESTING SERVICES, NAMELY, PREPARING, DISSEMINATING AND GRADING COMPUTER BASED ACCOUNTING EXAMINATIONS; ADMINISTERING COMPUTER BASED ACCOUNTING EXAMINATIONS VIA THE INTERNET; PROVIDING PRACTICE ACCOUNTING EXAMINATIONS VIA THE INTERNET (U.S. CLS. 100, 101 AND 107).

FIRST USE 4-30-1997; IN COMMERCE 11-6-1997.

EVEREST GROUP

THE MARK CONSISTS OF STANDARD CHARACTERS WITHOUT CLAIM TO ANY PARTICULAR FONT, STYLE, SIZE, OR COLOR.

OWNER OF U.S. REG. NOS. 3,459,967 AND 3,464,910.

NO CLAIM IS MADE TO THE EXCLUSIVE RIGHT TO USE "GROUP", APART FROM THE MARK AS SHOWN.

CLASS 35—ADVERTISING AND BUSINESS

FOR PROVIDING BUSINESS RESEARCH AND ANALYSIS SERVICES IN THE FIELDS OF SOURCING AND OUTSOURCING; THE MANAGEMENT OF BUSINESS PROCESS, BUSINESS MANAGEMENT, AND DEVELOPMENT OF BUSINESS SOLUTIONS, PROVIDING SOURCING AND OUTSOURCING CONSULTATION SERVICES IN THE FIELD OF BUSINESS PROCESSES; PROVIDING SOURCING AND OUTSOURCING CONSULTATION SERVICES IN THE FIELDS OF INFORMATION TECHNOLOGY (U.S. CLS. 100, 101 AND 102).

FIRST USE 9-5-2011; IN COMMERCE 9-5-2011.

CLASS 42—SCIENTIFIC AND COMPUTER SERVICES

FOR PROVIDING RESEARCH AND ANALYSIS SERVICES IN THE FIELD OF INFORMATION TECHNOLOGY (U.S. CLS. 100 AND 101).

FIRST USE 9-2-2011; IN COMMERCE 9-5-2011.

4,211,254. EVEREST GLOBAL, INC., DALLAS, TX. SN 85-359,183. PUB. 1-3-2012, FILED 6-29-2011.



OWNER OF U.S. REG. NOS. 3,459,967 AND 3,464,910.
NO CLAIM IS MADE TO THE EXCLUSIVE RIGHT TO USE "GROUP", APART FROM THE MARK AS SHOWN.

THE MARK CONSISTS OF TWO LINES FORMING AN ANGLE ABOVE THE WORDS "EVEREST GROUP".

CLASS 35—ADVERTISING AND BUSINESS

FOR PROVIDING BUSINESS RESEARCH AND ANALYSIS SERVICES IN THE FIELDS OF SOURCING AND OUTSOURCING; THE MANAGEMENT OF BUSINESS PROCESS, BUSINESS MANAGEMENT, AND DEVELOPMENT OF BUSINESS SOLUTIONS, PROVIDING SOURCING AND OUTSOURCING CONSULTATION SERVICES IN THE FIELD OF BUSINESS PROCESSES; PROVIDING SOURCING AND OUTSOURCING CONSULTATION SERVICES IN THE FIELDS OF INFORMATION TECHNOLOGY (U.S. CLS. 100, 101 AND 102).

FIRST USE 9-5-2011; IN COMMERCE 9-5-2011.

CLASS 42—SCIENTIFIC AND COMPUTER SERVICES

FOR PROVIDING RESEARCH AND ANALYSIS SERVICES IN THE FIELD OF INFORMATION TECHNOLOGY (U.S. CLS. 100 AND 101).

FIRST USE 9-5-2011; IN COMMERCE 9-5-2011.

4,211,267. VIBRACODE, LLC, NASHVILLE, TN. SN 85-362,000. PUB. 12-20-2011, FILED 7-1-2011.

SIGSITES

THE MARK CONSISTS OF STANDARD CHARACTERS WITHOUT CLAIM TO ANY PARTICULAR FONT, STYLE, SIZE, OR COLOR.

CLASS 35—ADVERTISING AND BUSINESS

FOR PROMOTIONAL SERVICES, NAMELY, PROVIDING A WEBSITE AT WHICH USERS CAN SHOWCASE THEIR GOODS AND SERVICES VIA AN ONLINE MULTI-MEDIA PORTFOLIO (U.S. CLS. 100, 101 AND 102).

FIRST USE 11-1-2011; IN COMMERCE 11-1-2011.

CLASS 42—SCIENTIFIC AND COMPUTER SERVICES

FOR PROVIDING A WEBSITE THAT GIVES USERS THE ABILITY TO CREATE CUSTOMIZED WEB PAGES FEATURING USER-DEFINED INFORMATION AND PROFILES (U.S. CLS. 100 AND 101).

FIRST USE 11-1-2011; IN COMMERCE 11-1-2011.

CLASS 45—PERSONAL AND LEGAL SERVICES

FOR PROVIDING A WEBSITE ON THE INTERNET FOR THE PURPOSE OF SOCIAL NETWORKING (U.S. CLS. 100 AND 101).

FIRST USE 11-1-2011; IN COMMERCE 11-1-2011.

4,211,269. KING, ALEX, ROSEVILLE, CA. SN 85-362,600. PUB. 1-17-2012, FILED 7-4-2011.

DEVILLAN BLACK

THE MARK CONSISTS OF STANDARD CHARACTERS WITHOUT CLAIM TO ANY PARTICULAR FONT, STYLE, SIZE, OR COLOR.

THE NAME(S) "DEVILLAN BLACK" SHOWN IN THE MARK IDENTIFIES ALEX KING, WHOSE CONSENT(S) TO REGISTER IS MADE OF RECORD.

CLASS 25—CLOTHING

FOR CLOTHING, NAMELY, TOPS, BOTTOMS, JACKETS, COATS, SHIRTS, PANTS, FOOTWEAR, SHOES, HEADWEAR, HATS, DRESSES, CLOTHING ACCESSORIES NAMELY, BANDANAS (U.S. CLS. 22 AND 39).

FIRST USE 5-5-2011; IN COMMERCE 6-2-2011.

CLASS 35—ADVERTISING AND BUSINESS

FOR PROMOTION SERVICES, NAMELY, PROVIDING MARKETING AND PROMOTION OF SPECIAL EVENTS (U.S. CLS. 100, 101 AND 102).

FIRST USE 5-5-2011; IN COMMERCE 6-2-2011.

CLASS 41—EDUCATION AND ENTERTAINMENT

FOR ENTERTAINMENT SERVICES IN THE NATURE OF RECORDING, PRODUCTION AND POST-PRODUCTION SERVICES IN THE FIELD OF MUSIC; PRODUCTION OF SOUND AND MUSIC VIDEO RECORDINGS; MULTIMEDIA ENTERTAINMENT SERVICES IN THE NATURE OF RECORDING, PRODUCTION AND POST-PRODUCTION SERVICES IN THE FIELDS OF TELEVISION, MUSIC, VIDEO, AND FILMS; PHOTOGRAPHY (U.S. CLS. 100, 101 AND 107).

FIRST USE 5-5-2011; IN COMMERCE 6-2-2011.

4,211,278. UNIQUE GLOBAL DESIGNS, LLC, POTOMAC, MD. SN 85-364,023. PUB. 12-20-2011, FILED 7-6-2011.



THE NAME(S), PORTRAIT(S), AND/OR SIGNATURE(S) SHOWN IN THE MARK DOES NOT IDENTIFY A PARTICULAR LIVING INDIVIDUAL.

THE MARK CONSISTS OF A STYLIZED LETTER "A" ABOVE THE TERMS "ADAM ALEXIS".

CLASS 18—LEATHER GOODS

FOR HANDBAGS; TOTE BAGS; SATCHELS; TRAVEL BAGS; WALLETS (U.S. CLS. 1, 2, 3, 22 AND 41).

FIRST USE 6-25-2011; IN COMMERCE 7-30-2011.

CLASS 25—CLOTHING

FOR CLOTHING, NAMELY, BLOUSES, SHIRTS, JACKETS, BELTS, SCARVES, T-SHIRTS, TOPS (U.S. CLS. 22 AND 39).

FIRST USE 6-25-2011; IN COMMERCE 7-30-2011.

4,211,362. SBYKE USA LLC, LAS VEGAS, NV. SN 85-382,331.
PUB. 12-6-2011, FILED 7-27-2011.



THE MARK CONSISTS OF THE LETTER "S" IN STY-
LIZED FONT AND PLACED AT AN ANGLE.

CLASS 12—VEHICLES

FOR REAR-WHEELED STEERING NON-POWER
SCOOTERS (U.S. CLS. 19, 21, 23, 31, 35 AND 44).
FIRST USE 5-13-2010; IN COMMERCE 12-19-2011.

CLASS 25—CLOTHING

FOR WEARING APPAREL, NAMELY, SHIRTS, T-
SHIRTS, SWEATSHIRTS, JACKETS, PANTS, SHORTS,
AND HATS (U.S. CLS. 22 AND 39).
FIRST USE 4-8-2010; IN COMMERCE 2-21-2011.

4,211,369. COLOR WHEEL PAINTS & COATINGS, INC.,
ORLANDO, FL. SN 85-384,155. PUB. 4-3-2012, FILED 7-
28-2011.

MULTISOLUTIONS

THE MARK CONSISTS OF STANDARD CHARACTERS
WITHOUT CLAIM TO ANY PARTICULAR FONT, STYLE,
SIZE, OR COLOR.

CLASS 35—ADVERTISING AND BUSINESS

FOR BUSINESS CONSULTATION SERVICES IN THE
FIELD OF PAINTS AND PAINTING SERVICES; PRO-
VIDING PURCHASING INFORMATION IN THE FIELD
OF PAINTS; CONSULTING SERVICES IN THE FIELD
OF PURCHASING PAINTS (U.S. CLS. 100, 101 AND 102).
FIRST USE 7-5-2011; IN COMMERCE 7-5-2011.

CLASS 37—CONSTRUCTION AND REPAIR

FOR PROVIDING INFORMATION IN THE FIELD OF
PAINTING SERVICES; CONSULTING SERVICES IN THE
FIELD OF PAINTING SERVICES (U.S. CLS. 100, 103
AND 106).
FIRST USE 7-5-2011; IN COMMERCE 7-5-2011.

CLASS 42—SCIENTIFIC AND COMPUTER SERVICES

FOR DESIGN AND DEVELOPMENT OF PAINT; PRO-
VIDING INTERIOR DECORATING INFORMATION IN
THE FIELD OF PAINTS; CONSULTING SERVICES IN
THE FIELD OF INTERIOR DECORATING, NAMELY,
PAINT SELECTION (U.S. CLS. 100 AND 101).
FIRST USE 7-5-2011; IN COMMERCE 7-5-2011.

4,211,376. VOKE TAB, INC., BOZEMAN, MT. SN 85-385,540.
PUB. 12-27-2011, FILED 7-31-2011.



THE MARK CONSISTS OF AN IMAGE OF A LION'S
HEAD IN THE SHAPE OF A CIRCLE WITH THE TOP OF
THE LION'S MANE FORMING A LETTER "V".

CLASS 5—PHARMACEUTICALS

FOR DIETARY SUPPLEMENTS (U.S. CLS. 6, 18, 44, 46,
51 AND 52).
FIRST USE 8-17-2011; IN COMMERCE 8-17-2011.

CLASS 30—STAPLE FOODS

FOR NON- MEDICATED LOZENGES (U.S. CL. 46).
FIRST USE 8-17-2011; IN COMMERCE 8-17-2011.

4,211,386. GOOD HEALTH NATURALLY, INC., LAS VE-
GAS, NV. SN 85-390,818. PUB. 1-31-2012, FILED 8-5-2011.

BECAUSE IT WORKS!

THE MARK CONSISTS OF STANDARD CHARACTERS
WITHOUT CLAIM TO ANY PARTICULAR FONT, STYLE,
SIZE, OR COLOR.

CLASS 5—PHARMACEUTICALS

FOR VITAMINS; MINERAL SUPPLEMENTS; NUTRI-
TIONAL SUPPLEMENTS; DIETARY SUPPLEMENTS
(U.S. CLS. 6, 18, 44, 46, 51 AND 52).
FIRST USE 6-18-2012; IN COMMERCE 6-18-2012.

CLASS 35—ADVERTISING AND BUSINESS

FOR ON-LINE WHOLESALE AND RETAIL STORE SERVICES FEATURING VITAMIN, MINERAL, NUTRITIONAL AND DIETARY SUPPLEMENTS (U.S. CLS. 100, 101 AND 102).

FIRST USE 6-18-2012; IN COMMERCE 6-18-2012.

4,211,401. GREER LABORATORIES, INC., LENOIR, NC. SN 85-395,252. PUB. 2-28-2012, FILED 8-11-2011.



4,211,400. WINE TABLE, LLC, MOUND, MN. SN 85-395,157. PUB. 1-17-2012, FILED 8-11-2011.



THE MARK CONSISTS OF TWO RECTANGULAR BOXES WITH ONE OVERLAPPING THE OTHER WITH A "W" IN THE CENTER OF THE TWO RECTANGLES AS WELL AS A "T" IN THE FORM OF A CORK SCREW JUST BELOW THE "W".

CLASS 43—HOTEL AND RESTAURANT SERVICES

FOR PROVIDING A WEBSITE WHERE GENERAL USERS AND SOMMELIERS CAN POST RATINGS, REVIEWS AND RECOMMENDATIONS ON WINES FOR WINE APPRECIATION PURPOSES (U.S. CLS. 100 AND 101).

FIRST USE 7-18-2011; IN COMMERCE 7-18-2011.

CLASS 45—PERSONAL AND LEGAL SERVICES

FOR ONLINE SOCIAL NETWORKING SERVICES (U.S. CLS. 100 AND 101).

FIRST USE 7-18-2011; IN COMMERCE 7-18-2011.

OWNER OF U.S. REG. NOS. 917,452, 3,147,131, AND 3,875,682.

NO CLAIM IS MADE TO THE EXCLUSIVE RIGHT TO USE "CUSTOMER RESOURCE CENTER", APART FROM THE MARK AS SHOWN.

THE MARK CONSISTS OF THE WORD "GREER" ABOVE CONCENTRIC CIRCLES WITH THE LETTERS "CRC" IN THE MIDDLE AND BELOW THE CIRCLES THE WORDS "CUSTOMER RESOURCE CENTER" AGAINST A DARK BACKGROUND.

CLASS 35—ADVERTISING AND BUSINESS

FOR BUSINESS CONSULTING SERVICES IN THE FIELD OF ALLERGY IMMUNOTHERAPY MEDICAL AND VETERINARY PRACTICES (U.S. CLS. 100, 101 AND 102).

FIRST USE 8-31-2011; IN COMMERCE 8-31-2011.

CLASS 42—SCIENTIFIC AND COMPUTER SERVICES

FOR PROVIDING MEDICAL AND SCIENTIFIC RESEARCH INFORMATION IN THE FIELD OF ALLERGY IMMUNOTHERAPY FOR HUMANS AND ANIMALS (U.S. CLS. 100 AND 101).

FIRST USE 8-31-2011; IN COMMERCE 8-31-2011.

CLASS 44—MEDICAL, BEAUTY AND AGRICULTURAL SERVICES

FOR MEDICAL AND PHARMACEUTICAL CONSULTATION SERVICES (U.S. CLS. 100 AND 101).

FIRST USE 8-31-2011; IN COMMERCE 8-31-2011.

4,211,411. NATURAL SUPPLEMENT ASSOCIATION, INCORPORATED, DBA EXPERIMENTAL AND APPLIED SCIENCES, INC., ABBOTT PARK, IL. SN 85-399,339. PUB. 11-8-2011, FILED 8-16-2011.

EAS LEAN 15

THE MARK CONSISTS OF STANDARD CHARACTERS WITHOUT CLAIM TO ANY PARTICULAR FONT, STYLE, SIZE, OR COLOR.

OWNER OF U.S. REG. NOS. 2,817,504, 2,886,499, AND OTHERS.

CLASS 5—PHARMACEUTICALS

FOR NUTRITIONAL AND DIETARY SUPPLEMENTS; LIQUID OR POWDER NUTRITIVE SUPPLEMENTS FOR HUMAN USE; NUTRITIONALLY FORTIFIED BEVERAGES AND POWDERS FOR MEAL REPLACEMENT (U.S. CLS. 6, 18, 44, 46, 51 AND 52).

FIRST USE 12-28-2011; IN COMMERCE 12-28-2011.

CLASS 29—MEATS AND PROCESSED FOODS

FOR PROTEIN BASED, NUTRIENT-DENSE SNACK BARS (U.S. CL. 46).

FIRST USE 3-31-2012; IN COMMERCE 3-31-2012.

4,211,415. TATCHA LLC, SAN FRANCISCO, CA. SN 85-400,308. PUB. 1-17-2012, FILED 8-17-2011.



THE MARK CONSISTS OF A STYLIZED GEOMETRIC DEPICTION OF A FLOWER CONTAINED WITHIN A CIRCLE.

CLASS 3—COSMETICS AND CLEANING PREPARATIONS

FOR COSMETICS (U.S. CLS. 1, 4, 6, 50, 51 AND 52).
FIRST USE 10-19-2011; IN COMMERCE 10-19-2011.

CLASS 35—ADVERTISING AND BUSINESS

FOR ONLINE RETAIL STORE SERVICES IN THE FIELD OF COSMETICS AND BEAUTY PRODUCTS (U.S. CLS. 100, 101 AND 102).

FIRST USE 2-1-2012; IN COMMERCE 2-1-2012.

4,211,418. C.H. ROBINSON WORLDWIDE, INC., EDEN PRAIRIE, MN. SN 85-400,758. PUB. 11-8-2011, FILED 8-17-2011.

ChemSolutions

THE MARK CONSISTS OF STANDARD CHARACTERS WITHOUT CLAIM TO ANY PARTICULAR FONT, STYLE, SIZE, OR COLOR.

CLASS 35—ADVERTISING AND BUSINESS

FOR TRANSPORTATION MANAGEMENT CONSULTING SERVICES, NAMELY, PLANNING AND COORDINATING TRANSPORTATION OF CHEMICALS FOR OTHERS; TRANSPORTATION LOGISTICS SERVICES, NAMELY, PLANNING AND SCHEDULING SHIPMENTS FOR USERS OF TRANSPORTATION SERVICES; OUTSOURCING IN THE TRANSPORTATION FIELD; BUSINESS MANAGEMENT SERVICES, NAMELY, SUPPLY CHAIN LOGISTICS, LEAD LOGISTICS, INBOUND AND REVERSE LOGISTICS OF OTHERS; CONSULTING SERVICES RELATED TO SHIPMENT TRACKING (U.S. CLS. 100, 101 AND 102).

FIRST USE 11-30-2011; IN COMMERCE 11-30-2011.

CLASS 39—TRANSPORTATION AND STORAGE

FOR CONSULTING SERVICES RELATED TO STORAGE, TRANSPORTATION AND DELIVERY OF CHEMICALS BY AIR, RAIL, SHIP OR TRUCK (U.S. CLS. 100 AND 105).

FIRST USE 11-30-2011; IN COMMERCE 11-30-2011.

4,211,428. THE PERMANENTE MEDICAL GROUP, INC., OAKLAND, CA. SN 85-405,019. PUB. 2-28-2012, FILED 8-23-2011.



NO CLAIM IS MADE TO THE EXCLUSIVE RIGHT TO USE "1948", APART FROM THE MARK AS SHOWN.

THE MARK CONSISTS OF A CIRCULAR DESIGN SURROUNDING A DESIGN OF A CADUCEUS AND "1948" SUPERIMPOSED ON AN OPEN BOOK, AND WITH THE LETTERS "TPMG" ENCLOSED IN A BANNER SUPERIMPOSED OVER THE LOWER PART OF THE CIRCULAR DESIGN.

CLASS 39—TRANSPORTATION AND STORAGE

FOR PROVIDING ELECTRONIC DATA STORAGE SERVICES, NAMELY, STORAGE OF HEALTHCARE-RELATED PATIENT DATA; ONLINE STORAGE OF HEALTHCARE-RELATED PATIENT DATA (U.S. CLS. 100 AND 105).

FIRST USE 4-30-2012; IN COMMERCE 4-30-2012.

CLASS 41—EDUCATION AND ENTERTAINMENT

FOR ONLINE PUBLICATION OF BOOKLETS, NEWSPAPERS, PAMPHLETS, NEWSLETTERS, REPORTS, MAGAZINES, ARTICLES AND RESEARCH STUDY REPORTS, ALL IN THE FIELD OF HEALTHCARE, MEDICINE AND MEDICAL RESEARCH; EDUCATIONAL SERVICES, NAMELY, ON-LINE AND WEB-BASED WORKSHOPS, LEARNING MODULES, COURSES AND SEMINARS AND TRAINING IN THE FIELDS OF MEDICAL ANALYSIS, DIAGNOSIS AND RESEARCH AND CLINICAL ANALYSIS, DIAGNOSIS AND RESEARCH; TRAINING SERVICES, NAMELY, DEVELOPMENT AND DISSEMINATION OF EDUCATIONAL MATERIALS OF OTHERS IN THE FIELDS OF MEDICINE, HEALTHCARE AND MEDICAL RESEARCH; ARRANGING AND CONDUCTING EDUCATIONAL COLLOQUIUMS, CONFERENCES, LECTURES, SEMINARS AND WORKSHOPS IN THE FIELDS OF MEDICINE, HEALTHCARE, AND MEDICAL RESEARCH; ONLINE PUBLICATION OF REPORTS, ARTICLES AND STUDIES IN THE FIELDS OF MEDICINE, HEALTHCARE, AND MEDICAL RESEARCH (U.S. CLS. 100, 101 AND 107).

FIRST USE 4-30-2012; IN COMMERCE 4-30-2012.

CLASS 42—SCIENTIFIC AND COMPUTER SERVICES

FOR PROVIDING AN INTERACTIVE WEBSITE FEATURING TECHNOLOGY THAT ENABLES USERS TO INPUT DATA FOR HEALTHCARE MANAGEMENT PURPOSES; PROVIDING THE TEMPORARY USE OF ONLINE NONDOWNLOADABLE SOFTWARE AND COMPUTER PROGRAMS FOR HEALTH CARE AND HEALTH MANAGEMENT, NAMELY, FOR OBTAINING MEDICAL DATA AND HEALTH CARE INFORMATION, AND FOR MANAGING CHRONIC DISEASES, MEDICAL CONDITIONS, AND HEALTH RISKS; PROVIDING AN INTERACTIVE WEBSITE THAT ENABLES USERS TO ENTER, ACCESS, TRACK, MONITOR AND GENERATE HEALTH AND MEDICAL INFORMATION AND REPORTS, AND TO MANAGE CHRONIC DISEASES, MEDICAL CONDITIONS, AND HEALTH RISKS; PROVIDING AN INTERACTIVE WEBSITE FEATURING TECHNOLOGY ALLOWING USERS TO MANAGE AND ADMINISTER MEDICAL DATA; PROVIDING A WEBSITE FEATURING THE TEMPORARY USE OF ONLINE NONDOWNLOADABLE SOFTWARE FOR MANAGING AND ADMINISTERING MEDICAL DATA; PLATFORM AS A SERVICE (PAAS) FEATURING COMPUTER SOFTWARE PLATFORMS FOR HEALTHCARE AND HEALTH MANAGEMENT, NAMELY, FOR OBTAINING MEDICAL DATA AND HEALTHCARE INFORMATION, AND FOR MANAGING CHRONIC DISEASES, MEDICAL CONDITIONS AND HEALTH RISKS (U.S. CLS. 100 AND 101).

FIRST USE 4-30-2012; IN COMMERCE 4-30-2012.

CLASS 44—MEDICAL, BEAUTY AND AGRICULTURAL SERVICES

FOR MEDICAL SERVICES, NAMELY, PROVIDING MEDICAL INFORMATION, CONSULTANCY AND ADVISORY SERVICES, AND DIAGNOSIS AND TREATMENT IN THE FIELDS OF MEDICINE AND HEALTHCARE, IN-PERSON AND VIA TELEPHONE AND THE INTERNET; PROVIDING AN ONLINE COMPUTER DATABASE FEATURING INFORMATION REGARDING HEALTH AND NUTRITION, HEALTHCARE SERVICES, AND TREATMENT OF CHRONIC DISEASES, MEDICAL CONDITIONS, AND HEALTH RISKS; HEALTH CARE SERVICES, NAMELY, PROVIDING A DATABASE IN THE FIELD OF MEDICAL AND HEALTHCARE INFORMATION AND MANAGING CHRONIC DISEASES, MEDICAL CONDITIONS AND HEALTH RISKS AND FEATURING INPUTTING AND COLLECTION OF DATA AND INFORMATION, ALL FOR INFORMATIONAL AND TREATMENT PURPOSES; WEB-BASED HEALTH ASSESSMENT SERVICES, NAMELY, HEALTH-RELATED QUESTIONNAIRES FOR RESPONSE FROM THE USERS THAT RESULT IN

REPORTS THAT PROVIDE HEALTH-RELATED INFORMATION IN THE FORM OF RECOMMENDED EDUCATIONAL RESOURCES AND TREATMENT INFORMATION; MEDICAL SERVICES, NAMELY, PROVIDING MEDICAL INFORMATION, CONSULTANCY AND ADVISORY SERVICES, AND DIAGNOSIS AND TREATMENT IN THE FIELDS OF MEDICINE AND HEALTHCARE, IN-PERSON AND VIA TELEPHONE AND THE INTERNET; MANAGEMENT AND ADMINISTRATION OF PATIENT MEDICAL DATA, NAMELY, MAINTAINING PATIENT MEDICAL RECORDS AND FILES (U.S. CLS. 100 AND 101).

FIRST USE 4-30-2012; IN COMMERCE 4-30-2012.

4,211,429. NYLOK LLC, MACOMB, MI. SN 85-405,156. PUB. 11-8-2011, FILED 8-23-2011.



OWNER OF U.S. REG. NOS. 439,351, 907,426, AND 2,738,411.

THE MARK CONSISTS OF THE WORD "NYLOK" IN THREE-DIMENSIONAL FORMAT WITH THREE CURVED LINES IN THREE DIMENSIONAL FORMAT ABOVE AND BELOW THE WORD "NYLOK".

CLASS 6—METAL GOODS

FOR METAL THREADED FASTENERS HAVING SELF-LOCKING, SEALING, MASKING, RETENTIVE, ANTI-SEIZE PROTECTIVE AND LUBRICATING COATINGS APPLIED THERETO (U.S. CLS. 2, 12, 13, 14, 23, 15 AND 50).

FIRST USE 9-27-2011; IN COMMERCE 9-27-2011.

CLASS 40—MATERIAL TREATMENT

FOR SERVICE OF APPLYING SELF-LOCKING, SEALING, MASKING, RETENTIVE, ANTI-SEIZE PROTECTIVE AND LUBRICATING COATINGS TO METAL FASTENERS (U.S. CLS. 100, 103 AND 106).

FIRST USE 10-7-2011; IN COMMERCE 10-7-2011.

4,211,440. PLANETREE, INC., DERBY, CT. SN 85-409,547. PUB. 3-6-2012, FILED 8-29-2011.

PATIENT CENTERED LEAN

THE MARK CONSISTS OF STANDARD CHARACTERS WITHOUT CLAIM TO ANY PARTICULAR FONT, STYLE, SIZE, OR COLOR.

NO CLAIM IS MADE TO THE EXCLUSIVE RIGHT TO USE "PATIENT CENTERED", APART FROM THE MARK AS SHOWN.

CLASS 35—ADVERTISING AND BUSINESS

FOR BUSINESS MANAGEMENT AND CONSULTING SERVICES FOR THE HEALTH CARE INDUSTRY, NAMELY, CUSTOMER SERVICE, ORGANIZATIONAL STRATEGIC PLANNING AND QUALITY IMPROVEMENT METHODS; BUSINESS MANAGEMENT CONSULTING, STRATEGIC PLANNING AND BUSINESS ADVISORY SERVICES PROVIDED TO HEALTH CARE PROVIDERS (U.S. CLS. 100, 101 AND 102).

FIRST USE 2-14-2011; IN COMMERCE 2-14-2011.

CLASS 41—EDUCATION AND ENTERTAINMENT

FOR TRAINING SERVICES IN THE FIELD OF PATIENT-CENTERED CARE APPROACHES WITH ORGANIZATIONAL STRATEGIC PLANNING AND QUALITY IMPROVEMENT METHODS FOR HEALTH CARE PROVIDERS (U.S. CLS. 100, 101 AND 107).

FIRST USE 2-14-2011; IN COMMERCE 2-14-2011.

CLASS 44—MEDICAL, BEAUTY AND AGRICULTURAL SERVICES

FOR CONSULTING SERVICES TO HEALTH CARE PROVIDERS IN THE FIELD OF MEDICAL CARE FOR PATIENTS AND RESIDENTS IN PATIENT-CENTERED HEALTH CARE FACILITIES (U.S. CLS. 100 AND 101).

FIRST USE 2-14-2011; IN COMMERCE 2-14-2011.

4,211,446. SOPHISTICATED BUSINESS SYSTEMS, INC., DBA ATERAS, DALLAS, TX. SN 85-410,903. PUB. 12-13-2011, FILED 8-30-2011.

ATP

THE MARK CONSISTS OF STANDARD CHARACTERS WITHOUT CLAIM TO ANY PARTICULAR FONT, STYLE, SIZE, OR COLOR.

CLASS 9—ELECTRICAL AND SCIENTIFIC APPARATUS

FOR COMPUTER SOFTWARE FOR MIGRATION AND MODERNIZATION OF EXISTING ELECTRONIC DATA AND APPLICATIONS (U.S. CLS. 21, 23, 26, 36 AND 38).

FIRST USE 7-29-2011; IN COMMERCE 7-29-2011.

CLASS 42—SCIENTIFIC AND COMPUTER SERVICES

FOR COMPUTER SERVICES, NAMELY, PROVIDING MIGRATION AND MODERNIZATION OF EXISTING ELECTRONIC DATA AND APPLICATIONS (U.S. CLS. 100 AND 101).

FIRST USE 7-29-2011; IN COMMERCE 7-29-2011.

4,211,442. PUNK ROCK HOOPS, LLC, DALLAS, TX. SN 85-410,282. PUB. 2-21-2012, FILED 8-30-2011.

PUNK ROCK HOOPS

THE MARK CONSISTS OF STANDARD CHARACTERS WITHOUT CLAIM TO ANY PARTICULAR FONT, STYLE, SIZE, OR COLOR.

NO CLAIM IS MADE TO THE EXCLUSIVE RIGHT TO USE "HOOPS", APART FROM THE MARK AS SHOWN.

CLASS 28—TOYS AND SPORTING GOODS

FOR PLASTIC TOY HOOPS (U.S. CLS. 22, 23, 38 AND 50).

FIRST USE 8-30-2011; IN COMMERCE 8-30-2011.

CLASS 41—EDUCATION AND ENTERTAINMENT

FOR EDUCATION SERVICES, NAMELY, PROVIDING CLASSES, WORKSHOPS, TEACHER CERTIFICATION IN THE FIELD OF HULA HOOP FITNESS (U.S. CLS. 100, 101 AND 107).

FIRST USE 8-30-2011; IN COMMERCE 8-30-2011.

4,211,447. ASIAN ART MUSEUM FOUNDATION OF SAN FRANCISCO, SAN FRANCISCO, CA. SN 85-411,010. PUB. 2-14-2012, FILED 8-30-2011.



THE MARK CONSISTS OF AN INVERTED LETTER "A".

CLASS 35—ADVERTISING AND BUSINESS

FOR RETAIL STORE AND ON-LINE RETAIL STORE SERVICES FEATURING GOODS IN THE FIELD OF ART, NAMELY, ARTWORK, BOOKS, GIFTS AND OTHER GENERAL MERCHANDISE (U.S. CLS. 100, 101 AND 102).

FIRST USE 10-0-2011; IN COMMERCE 10-0-2011.

CLASS 41—EDUCATION AND ENTERTAINMENT

FOR EDUCATION SERVICES, NAMELY, PROVIDING TOURS, PROGRAMS, RESOURCES, VIDEOS, BOOKS, CURRICULUM GUIDES, AND MATERIALS IN THE FIELD OF ART; MUSEUM SERVICES; MUSEUMS; PROVIDING ON-LINE NEWSLETTERS IN THE FIELD OF ART (U.S. CLS. 100, 101 AND 107).

FIRST USE 10-0-2011; IN COMMERCE 10-0-2011.

4,211,449. ABBOTT LABORATORIES, ABBOTT PARK, IL. SN 85-411,415. PUB. 11-29-2011, FILED 8-31-2011.

4,211,471. SENSEONET, INC., CENTENNIAL, CO. SN 85-419,757. PUB. 3-6-2012, FILED 9-11-2011.

PEDIASURE SIDEKICKS

THE MARK CONSISTS OF STANDARD CHARACTERS WITHOUT CLAIM TO ANY PARTICULAR FONT, STYLE, SIZE, OR COLOR.

OWNER OF U.S. REG. NOS. 3,858,192 AND 3,862,056.

CLASS 5—PHARMACEUTICALS

FOR LIQUID NUTRITIVE SUPPLEMENTS FOR HUMAN USE; NUTRITIONALLY FORTIFIED BEVERAGES AND POWDERS FOR MEAL REPLACEMENT (U.S. CLS. 6, 18, 44, 46, 51 AND 52).

FIRST USE 7-26-2010; IN COMMERCE 7-26-2010.

CLASS 32—LIGHT BEVERAGES

FOR FRUIT DRINKS AND FRUIT JUICES (U.S. CLS. 45, 46 AND 48).

FIRST USE 3-19-2012; IN COMMERCE 3-19-2012.

4,211,464. HAPO COMMUNITY CREDIT UNION, RICHLAND, WA. SN 85-418,116. PUB. 3-20-2012, FILED 9-8-2011.

THE OFFICIAL SPONSOR OF SUMMER

THE MARK CONSISTS OF STANDARD CHARACTERS WITHOUT CLAIM TO ANY PARTICULAR FONT, STYLE, SIZE, OR COLOR.

NO CLAIM IS MADE TO THE EXCLUSIVE RIGHT TO USE "SPONSOR", APART FROM THE MARK AS SHOWN.

CLASS 35—ADVERTISING AND BUSINESS

FOR PROMOTIONAL SPONSORSHIP OF COMMUNITY EVENTS, NAMELY, CAR SHOWS, AIR SHOWS, AND COMMUNITY CELEBRATIONS INCLUDING FOURTH OF JULY FIREWORKS (U.S. CLS. 100, 101 AND 102).

FIRST USE 6-12-2012; IN COMMERCE 6-12-2012.

CLASS 36—INSURANCE AND FINANCIAL

FOR FINANCIAL SPONSORSHIP OF COMMUNITY EVENTS, NAMELY, CAR SHOWS, AIR SHOWS, AND COMMUNITY CELEBRATIONS INCLUDING FOURTH OF JULY FIREWORKS (U.S. CLS. 100, 101 AND 102).

FIRST USE 6-12-2012; IN COMMERCE 6-12-2012.

Hey Honey

THE MARK CONSISTS OF STANDARD CHARACTERS WITHOUT CLAIM TO ANY PARTICULAR FONT, STYLE, SIZE, OR COLOR.

CLASS 3—COSMETICS AND CLEANING PREPARATIONS

FOR BODY AND BEAUTY CARE COSMETICS; COSMETIC PREPARATIONS FOR BATH AND SHOWER; COSMETIC PREPARATIONS FOR SKIN CARE (U.S. CLS. 1, 4, 6, 50, 51 AND 52).

FIRST USE 4-20-2012; IN COMMERCE 4-20-2012.

CLASS 35—ADVERTISING AND BUSINESS

FOR THE BRINGING TOGETHER, FOR THE BENEFIT OF OTHERS, OF A VARIETY OF GOODS, ENABLING CUSTOMERS TO CONVENIENTLY VIEW AND PURCHASE THOSE GOODS FROM AN INTERNET WEB SITE, SPECIALIZING IN THE MARKETING OF COSMETICS AND TOILETRIES (U.S. CLS. 100, 101 AND 102).

FIRST USE 4-20-2012; IN COMMERCE 5-29-2012.

CLASS 44—MEDICAL, BEAUTY AND AGRICULTURAL SERVICES

FOR COMPUTER SERVICES, NAMELY, PROVIDING ONLINE INFORMATION AND CONSULTATION SERVICES ON BEAUTY, NUTRITION, AND IN THE SELECTION AND USE OF COSMETICS, HAIR CARE AND SKIN CARE PRODUCTS (U.S. CLS. 100 AND 101).

FIRST USE 4-20-2012; IN COMMERCE 4-20-2012.

4,211,484. BARHORST INSURANCE GROUP LTD, HOUSTON, TX. SN 85-425,898. PUB. 2-21-2012, FILED 9-19-2011.

iscential

THE MARK CONSISTS OF STANDARD CHARACTERS WITHOUT CLAIM TO ANY PARTICULAR FONT, STYLE, SIZE, OR COLOR.

CLASS 35—ADVERTISING AND BUSINESS

FOR MANAGING THE OPERATIONS OF INSURANCE AGENCIES AND BROKERS ON AN OUTSOURCING BASIS; PROMOTION OF FINANCIAL AND INSURANCE SERVICES, ON BEHALF OF THIRD PARTIES (U.S. CLS. 100, 101 AND 102).

FIRST USE 2-15-2012; IN COMMERCE 2-15-2012.

CLASS 36—INSURANCE AND FINANCIAL

FOR CONSULTING AND INFORMATION CONCERNING INSURANCE; FINANCIAL CONSULTANCY AND INSURANCE CONSULTANCY; FINANCIAL EVALUATION FOR INSURANCE PURPOSES; INSURANCE AGENCIES; INSURANCE AGENCY AND BROKERAGE; INSURANCE AND FINANCIAL INFORMATION AND CONSULTANCY SERVICES; INSURANCE BROKERAGE; INSURANCE BROKERAGE SERVICES; INSURANCE CONSULTANCY; INSURANCE CONSULTANCY SERVICES, NAMELY, PROVIDING ADVICE IN THE FIELD OF PROPERTY AND CASUALTY INSURANCE; INSURANCE CONSULTATION; INSURANCE INFORMATION; INSURANCE INFORMATION AND CONSULTANCY; INSURANCE SERVICES, NAMELY, WRITING PROPERTY AND CASUALTY INSURANCE; LIFE INSURANCE BROKERAGE; PROVIDING DETAILED INFORMATION REGARDING AVAILABLE INSURANCE PRODUCTS FOR COMMERCIAL PROPERTY AND CASUALTY, PROFESSIONAL AND PERSONAL LINES; PROVIDING INFORMATION IN INSURANCE MATTERS; PROVIDING VEHICLE INSURANCE RATE QUOTES (U.S. CLS. 100, 101 AND 102).

FIRST USE 2-15-2012; IN COMMERCE 2-15-2012.

4,211,498. GENABILITY INC., SAN FRANCISCO, CA. SN 85-436,687. PUB. 3-13-2012, FILED 9-30-2011.



THE COLOR(S) BLACK AND BLUE IS/ARE CLAIMED AS A FEATURE OF THE MARK.

THE MARK CONSISTS OF THE WORD "GENABILITY" IN BLACK WITH A STYLIZED BLUE SQUARE ABOVE THE WORDING AND TO THE RIGHT.

CLASS 9—ELECTRICAL AND SCIENTIFIC APPARATUS

FOR DOWNLOADABLE INTERNET-BASED COMPUTER SOFTWARE FOR ENERGY PRICING, FORECASTING, MONITORING, MANAGEMENT AND OPTIMIZATION FOR INDIVIDUALS AND BUSINESS (U.S. CLS. 21, 23, 26, 36 AND 38).

FIRST USE 9-30-2011; IN COMMERCE 9-30-2011.

CLASS 35—ADVERTISING AND BUSINESS

FOR RETAIL ELECTRICITY PROVIDER SERVICES, NAMELY, PROVIDING A SERVICE THAT ALLOWS CUSTOMERS TO PURCHASE ENERGY, NAMELY, ELECTRICITY (U.S. CLS. 100, 101 AND 102).

FIRST USE 2-6-2012; IN COMMERCE 2-6-2012.

CLASS 36—INSURANCE AND FINANCIAL

FOR BROKERAGE OF ENERGY, NAMELY, ELECTRICITY (U.S. CLS. 100, 101 AND 102).

FIRST USE 2-6-2012; IN COMMERCE 2-6-2012.

CLASS 42—SCIENTIFIC AND COMPUTER SERVICES

FOR RESEARCH IN THE FIELD OF ENERGY; ELECTRICITY METERING SERVICES; CONSULTING SERVICES IN CONNECTION WITH SOFTWARE IMPLEMENTATION, INTEGRATION AND UTILIZATION (U.S. CLS. 100 AND 101).

FIRST USE 9-30-2011; IN COMMERCE 9-30-2011.

4,211,534. VENTEGRA, LLC, GLENDALE, CA. SN 85-452,779. PUB. 4-10-2012, FILED 10-21-2011.



OWNER OF U.S. REG. NO. 3,105,275.

NO CLAIM IS MADE TO THE EXCLUSIVE RIGHT TO USE "RX SAVINGS", APART FROM THE MARK AS SHOWN.

THE COLOR(S) BLUE IS/ARE CLAIMED AS A FEATURE OF THE MARK.

THE MARK CONSISTS OF A BLUE RECTANGULAR SHAPE WITH ROUNDED CORNERS CONTAINING THE LETTERS "VRXSP" PLACED ABOVE THE WORDS "VENTEGRA RX SAVINGS PLUS" IN BLUE. THE COLOR WHITE IN THE DRAWING REPRESENTS BACKGROUND AND IS NOT A FEATURE OF THE MARK.

CLASS 35—ADVERTISING AND BUSINESS

FOR ADMINISTRATION OF A PROGRAM FOR ENABLING PARTICIPANTS TO OBTAIN DISCOUNTS AND REBATES ON PRODUCTS AND SERVICES SOLD THROUGH PHARMACIES (U.S. CLS. 100, 101 AND 102).

FIRST USE 4-0-2012; IN COMMERCE 4-0-2012.

CLASS 42—SCIENTIFIC AND COMPUTER SERVICES

FOR PROVIDING A WEBSITE FEATURING NON-DOWNLOADABLE SOFTWARE FOR SEARCHING FOR ELIGIBLE DRUGS IN DISCOUNT AND REBATE PROGRAM AND PARTICIPATING PHARMACIES IN DISCOUNT AND REBATE PROGRAM (U.S. CLS. 100 AND 101).

FIRST USE 3-0-2012; IN COMMERCE 3-0-2012.

4,211,549. THE RED FLAG GROUP LIMITED, SHEUNG WAN, HONG KONG. SN 85-459,965. PUB. 4-10-2012, FILED 10-31-2011.

IntegraTeach

THE MARK CONSISTS OF STANDARD CHARACTERS WITHOUT CLAIM TO ANY PARTICULAR FONT, STYLE, SIZE, OR COLOR.

CLASS 9—ELECTRICAL AND SCIENTIFIC APPARATUS

FOR COMPUTER SOFTWARE FOR THE DISSEMINATION OF ETHICS AND COMPLIANCE COMPUTER BASED TRAINING THAT MAY BE DOWNLOADED FROM A GLOBAL COMPUTER NETWORK (U.S. CLS. 21, 23, 26, 36 AND 38).

FIRST USE 1-1-2011; IN COMMERCE 1-1-2011.

CLASS 41—EDUCATION AND ENTERTAINMENT

FOR DEVELOPING TRAINING SYSTEMS AND LEARNING METHODOLOGIES FOR OTHERS; EDUCATIONAL SERVICES, NAMELY, PROVIDING ONLINE INSTRUCTION IN THE FIELD OF ETHICS AND COMPLIANCE VIA AN ONLINE WEBSITE; PROVIDING EDUCATION COURSES IN THE FIELD OF ETHICS AND COMPLIANCE OFFERED THROUGH ONLINE, NON-DOWNLOADABLE VIDEOS AND INSTRUCTOR ASSISTANCE (U.S. CLS. 100, 101 AND 107).

FIRST USE 1-1-2011; IN COMMERCE 1-1-2011.

4,211,576. J&Z INTERNATIONAL LLC, TROY, MI. SN 85-472,738. PUB. 4-24-2012, FILED 11-15-2011.



THE MARK CONSISTS OF A HOUSE WITH THE STYLIZED TEXT "J&Z".

CLASS 7—MACHINERY

FOR ELECTRIC FOOD GRINDERS; ELECTRIC JUICERS (U.S. CLS. 13, 19, 21, 23, 31, 34 AND 35).

FIRST USE 3-9-2012; IN COMMERCE 6-20-2012.

CLASS 11—ENVIRONMENTAL CONTROL APPARATUS

FOR ELECTRIC COFFEE MAKERS; ELECTRIC COOKING OVENS; ELECTRIC COOKTOPS; ELECTRIC DEEP FRYERS; ELECTRIC DEHYDRATORS; ELECTRIC FOOD STEAMER; ELECTRIC GRILLS; ELECTRIC KETTLES; ELECTRIC PRESSURE COOKERS; ELECTROMAGNETIC INDUCTION COOKERS (U.S. CLS. 13, 21, 23, 31 AND 34).

FIRST USE 3-9-2012; IN COMMERCE 6-20-2012.

4,211,555. TERRIO PHYSICAL THERAPY-FITNESS, INC, BAKERSFIELD, CA. SN 85-462,328. PUB. 4-17-2012, FILED 11-2-2011.

GET INFORMED. GET
MOVING. GET BETTER!

THE MARK CONSISTS OF STANDARD CHARACTERS WITHOUT CLAIM TO ANY PARTICULAR FONT, STYLE, SIZE, OR COLOR.

CLASS 41—EDUCATION AND ENTERTAINMENT

FOR EDUCATIONAL SERVICES, NAMELY, CONDUCTING SEMINARS, CLINICS, COURSES AND CONTINUING EDUCATION CLASSES IN THE FIELD OF PHYSICAL THERAPY, MANUAL THERAPY, EXERCISE, DIAGNOSIS AND TREATMENT OF ORTHOPEDIC INJURIES, AND INJURY PREVENTION BY USING STRENGTH ASSESSMENT, FUNCTIONAL ASSESSMENT, RANGE OF MOTION ASSESSMENT, MANUAL THERAPY, PATIENT EDUCATION AND EXERCISE PRESCRIPTION AND DISTRIBUTION OF COURSE MATERIAL IN CONNECTION THEREWITH; ONLINE PHYSICAL FITNESS INSTRUCTION, NAMELY, PROVIDING INSTRUCTION REGARDING PHYSICAL FITNESS VIA AN INTERNET WEBSITE (U.S. CLS. 100, 101 AND 107).

FIRST USE 9-0-2011; IN COMMERCE 9-0-2011.

CLASS 44—MEDICAL, BEAUTY AND AGRICULTURAL SERVICES

FOR PHYSICAL THERAPY SERVICES; PROVIDING AN ONLINE COMPUTER DATABASE IN THE FIELD OF MEDICINE AND PHYSICAL THERAPY FOR MEDICAL AND PHYSICAL THERAPY PATIENTS (U.S. CLS. 100 AND 101).

FIRST USE 9-0-2011; IN COMMERCE 9-0-2011.

4,211,598. 654 MEDIA, LLC, DENVER, CO. SN 85-483,131. PUB. 5-8-2012, FILED 11-29-2011.

Shacked

THE MARK CONSISTS OF STANDARD CHARACTERS WITHOUT CLAIM TO ANY PARTICULAR FONT, STYLE, SIZE, OR COLOR.

CLASS 35—ADVERTISING AND BUSINESS

FOR PROVIDING A WEBSITE WHERE OWNERS CAN POST ITEMS AND SERVICES AVAILABLE FOR RENT BY OTHERS (U.S. CLS. 100, 101 AND 102).

FIRST USE 4-23-2012; IN COMMERCE 4-23-2012.

CLASS 36—INSURANCE AND FINANCIAL

FOR PROVIDING REAL ESTATE LISTINGS AND REAL ESTATE INFORMATION VIA THE INTERNET (U.S. CLS. 100, 101 AND 102).

FIRST USE 4-23-2012; IN COMMERCE 4-23-2012.

4,211,659. AMERICAN PERFORMANCE TECHNOLOGIES, LLC, KANSAS CITY, MO. SN 85-976,885. PUB. 9-27-2011, FILED 3-3-2011.

BETTER BY DESIGN

THE MARK CONSISTS OF STANDARD CHARACTERS WITHOUT CLAIM TO ANY PARTICULAR FONT, STYLE, SIZE, OR COLOR.

CLASS 7—MACHINERY

FOR MOTORCYCLE ENGINE PARTS, NAMELY, AIR CLEANERS, AIR CONDENSERS, AIR FILTERS, BRUSHES AND CAM SHAFTS ALL FOR USE WITH MOTORCYCLES; MOTORCYCLE ENGINE PARTS, NAMELY, CARBURETORS, COILS, CONTACT POINTS, CYLINDERS, CYLINDER HEADS, ENGINE CASES, EXHAUST PIPES AND FAN BELTS ALL FOR USE WITH MOTORCYCLES; MOTORCYCLE ENGINE PARTS, NAMELY, GAS FILTERS, GASKETS, GENERATORS, IGNITION CONDENSERS, IGNITION POINTS, IGNITION WIRES, INTAKE MANIFOLDS AND KICK STARTERS ALL FOR USE WITH MOTORCYCLES; MOTORCYCLE ENGINE PARTS, NAMELY, MUFFLERS, OIL FILTERS, OIL TANKS, PISTONS, RADIATORS, SPARK PLUGS, SPARK PLUG WIRES, AND VALVES ALL FOR USE WITH MOTORCYCLES (U.S. CLS. 13, 19, 21, 23, 31, 34 AND 35).

FIRST USE 6-1-2011; IN COMMERCE 6-1-2011.

CLASS 9—ELECTRICAL AND SCIENTIFIC APPARATUS

FOR MOTORCYCLE HELMETS; PROTECTIVE FACE-SHIELDS FOR MOTORCYCLE HELMETS; MOTORCYCLE GOGGLES; PROTECTIVE EYEWEAR (U.S. CLS. 21, 23, 26, 36 AND 38).

FIRST USE 6-1-2011; IN COMMERCE 6-1-2011.

CLASS 12—VEHICLES

FOR MOTORIZED VEHICLES, NAMELY, GO-CARTS, MINI-BIKES AND DIRT BIKES FOR MOTORCROSS; MOTORCYCLES AND STRUCTURAL PARTS THEREFOR; MOTOR SCOOTERS AND STRUCTURAL PARTS THEREFOR; MOTORCYCLE ENGINES (U.S. CLS. 19, 21, 23, 31, 35 AND 44).

FIRST USE 6-1-2011; IN COMMERCE 6-1-2011.

4,211,664. LEADER TECHNOLOGIES INCORPORATED, LEWIS CENTER, OH. SN 85-977,051. PUB. 10-18-2011, FILED 1-14-2011.

LEADER NEWS

THE MARK CONSISTS OF STANDARD CHARACTERS WITHOUT CLAIM TO ANY PARTICULAR FONT, STYLE, SIZE, OR COLOR.

OWNER OF U.S. REG. NOS. 2,743,662, 2,867,183, AND OTHERS.

NO CLAIM IS MADE TO THE EXCLUSIVE RIGHT TO USE "NEWS", APART FROM THE MARK AS SHOWN.

CLASS 9—ELECTRICAL AND SCIENTIFIC APPARATUS

FOR COMPUTER SOFTWARE FOR INTERACTIVE AUDIO, IMAGE, VIDEO, GRAPHICS, AND DATA TRANSFER FOR USE IN TELECOMMUNICATIONS; COMPUTER SOFTWARE FOR USE IN PREPAID LICENSURES (U.S. CLS. 21, 23, 26, 36 AND 38).

FIRST USE 7-22-1999; IN COMMERCE 7-22-1999.

CLASS 38—COMMUNICATION

FOR TELECOMMUNICATIONS SERVICES, NAMELY, ELECTRONIC TRANSMISSION OF VOICE, DATA, INFORMATION AND IMAGES (U.S. CLS. 100, 101 AND 104).

FIRST USE 7-22-1999; IN COMMERCE 7-22-1999.

CLASS 42—SCIENTIFIC AND COMPUTER SERVICES

FOR COMPUTER SERVICES, NAMELY, PROVIDING AN ONLINE NON-DOWNLOADABLE SUITE OF COMPUTER SOFTWARE FOR USE IN TELECOMMUNICATIONS THAT ENABLES COLLABORATION THROUGH TRACKING, CONTEXT, AND STORAGE COMPONENTS OF TECHNOLOGY WITHIN A WEB-BASED SYSTEM, ENABLES MANAGEMENT OF TASKS, ENABLE MANAGEMENT OF COMMUNICATIONS, NAMELY, TRACKING OF INCOMING AND OUTGOING WRITTEN, ELECTRONIC, AND TELEPHONIC COMMUNICATIONS, ENABLES FILE TRANSFERS, ENABLES USE OF USER-DEFINED TOOLS, NAMELY, NEWS INTERFACES, AND ESCALATIONS OF ALERT NOTIFICATION THAT ENHANCE THE PRODUCTIVITY OF THE USER, ENABLE TEAMWORK AMONG THE USERS, ENABLE ACCESS TO USER-GENERATED DATA, AND ENABLE THE USER TO LEVERAGE ENTERPRISE KNOWLEDGE; APPLICATION SERVICE PROVIDER (ASP) FEATURING NON-DOWNLOADABLE SOFTWARE TO ENABLE OR FACILITATE THE UPLOADING, DOWNLOADING, STREAMING, POSTING, DISPLAYING, BLOGGING, LINKING, SHARING OR OTHERWISE PROVIDING ELECTRONIC MEDIA OR INFORMATION OVER COMMUNICATION NETWORKS; PROVIDING A WEB SITE FEATURING NON-DOWNLOADABLE SOFTWARE TECHNOLOGY THAT ENABLES ONLINE USERS TO CREATE PERSONAL PROFILES FEATURING SOCIAL NETWORKING INFORMATION AND TO TRANSFER AND SHARE SUCH INFORMATION AMONG MULTIPLE WEBSITES (U.S. CLS. 100 AND 101).

FIRST USE 7-22-1999; IN COMMERCE 7-22-1999.

4,211,666. LEADER TECHNOLOGIES INCORPORATED, LEWIS CENTER, OH. SN 85-977,076. PUB. 10-18-2011, FILED 1-14-2011.

LEADER MEETING

THE MARK CONSISTS OF STANDARD CHARACTERS WITHOUT CLAIM TO ANY PARTICULAR FONT, STYLE, SIZE, OR COLOR.

OWNER OF U.S. REG. NOS. 2,743,662, 2,807,278, AND OTHERS.

NO CLAIM IS MADE TO THE EXCLUSIVE RIGHT TO USE "MEETING", APART FROM THE MARK AS SHOWN.

CLASS 9—ELECTRICAL AND SCIENTIFIC APPARATUS

FOR COMPUTER SOFTWARE FOR INTERACTIVE AUDIO, IMAGE, VIDEO, GRAPHICS, AND DATA TRANSFER FOR USE IN TELECOMMUNICATIONS; COMPUTER SOFTWARE FOR USE IN PREPAID LICENSURES (U.S. CLS. 21, 23, 26, 36 AND 38).

FIRST USE 7-22-1999; IN COMMERCE 7-22-1999.

CLASS 38—COMMUNICATION

FOR TELECOMMUNICATIONS SERVICES, NAMELY, ELECTRONIC TRANSMISSION OF VOICE, DATA, INFORMATION AND IMAGES (U.S. CLS. 100, 101 AND 104).

FIRST USE 7-22-1999; IN COMMERCE 7-22-1999.

CLASS 42—SCIENTIFIC AND COMPUTER SERVICES

FOR COMPUTER SERVICES, NAMELY, PROVIDING AN ONLINE NON-DOWNLOADABLE SUITE OF COMPUTER SOFTWARE FOR USE IN TELECOMMUNICATIONS THAT ENABLES COLLABORATION THROUGH TRACKING, CONTEXT, AND STORAGE COMPONENTS OF TECHNOLOGY WITHIN A WEB-BASED SYSTEM, ENABLES MANAGEMENT OF TASKS, ENABLE MANAGEMENT OF COMMUNICATIONS, NAMELY, TRACKING OF INCOMING AND OUTGOING WRITTEN, ELECTRONIC, AND TELEPHONIC COMMUNICATIONS, ENABLES FILE TRANSFERS, ENABLES USE OF USER-DEFINED TOOLS, NAMELY, NEWS INTERFACES, AND ESCALATIONS OF ALERT NOTIFICATION THAT ENHANCE THE PRODUCTIVITY OF THE USER, ENABLE TEAMWORK AMONG THE USERS, ENABLE ACCESS TO USER-GENERATED DATA, AND ENABLE THE USER TO LEVERAGE ENTERPRISE KNOWLEDGE; APPLICATION SERVICE PROVIDER (ASP) FEATURING NON-DOWNLOADABLE SOFTWARE TO ENABLE OR FACILITATE THE UPLOADING, DOWNLOADING, STREAMING, POSTING, DISPLAYING, BLOGGING, LINKING, SHARING OR OTHERWISE PROVIDING ELECTRONIC MEDIA OR INFORMATION OVER COMMUNICATION NETWORKS; PROVIDING A WEB SITE FEATURING NON-DOWNLOADABLE TECHNOLOGY THAT ENABLES ONLINE USERS TO CREATE PERSONAL PROFILES FEATURING SOCIAL NETWORKING INFORMATION AND TO TRANSFER AND SHARE SUCH INFORMATION AMONG MULTIPLE WEBSITES (U.S. CLS. 100 AND 101).

FIRST USE 7-22-1999; IN COMMERCE 7-22-1999.

4,211,667. WALGREEN CO., DEERFIELD, IL. SN 85-977,101. PUB. 12-13-2011, FILED 7-13-2011.

SMART. QUALITY. EVERYDAY.

THE MARK CONSISTS OF STANDARD CHARACTERS WITHOUT CLAIM TO ANY PARTICULAR FONT, STYLE, SIZE, OR COLOR.

NO CLAIM IS MADE TO THE EXCLUSIVE RIGHT TO USE "QUALITY", APART FROM THE MARK AS SHOWN.

CLASS 20—FURNITURE AND ARTICLES NOT OTHERWISE CLASSIFIED

FOR DRINKING STRAWS (U.S. CLS. 2, 13, 22, 25, 32 AND 50).

FIRST USE 10-27-2011; IN COMMERCE 10-27-2011.

CLASS 24—FABRICS

FOR PLASTIC TABLE COVERS (U.S. CLS. 42 AND 50). FIRST USE 7-30-2011; IN COMMERCE 7-30-2011.

4,211,669. MUST WIN, INC., LOS ANGELES, CA. SN 85-977,138. PUB. 3-20-2012, FILED 10-12-2011.

URBAN EXPRESSIONS

THE MARK CONSISTS OF STANDARD CHARACTERS WITHOUT CLAIM TO ANY PARTICULAR FONT, STYLE, SIZE, OR COLOR.

OWNER OF U.S. REG. NO. 3,878,378.

CLASS 9—ELECTRICAL AND SCIENTIFIC APPARATUS

FOR CARRYING CASES FOR CELL PHONES; CARRYING CASES FOR MOBILE COMPUTERS; CELL PHONE CASES; CELL PHONE COVERS; PROTECTIVE COVERS AND CASES FOR CELL PHONES, LAPTOPS AND PORTABLE MEDIA PLAYERS; PROTECTIVE COVERS FOR ELECTRONIC READING DEVICES (U.S. CLS. 21, 23, 26, 36 AND 38).

FIRST USE 4-1-2005; IN COMMERCE 5-1-2005.

CLASS 18—LEATHER GOODS

FOR CLUTCH BAGS; COSMETIC BAGS SOLD EMPTY; EVENING HANDBAGS; FASHION HANDBAGS; HANDBAGS; HANDBAGS FOR LADIES; HANDBAGS, PURSES AND WALLETS; HIP BAGS; KNITTED BAGS, NOT OF PRECIOUS METALS; LEATHER BAGS AND WALLETS; SATCHELS; SHOULDER BAGS; TOTE BAGS (U.S. CLS. 1, 2, 3, 22 AND 41).

FIRST USE 5-1-2005; IN COMMERCE 5-1-2005.

4,211,671. PLAYMATES TOYS INC., EL SEGUNDO, CA. SN 85-977,185. PUB. 11-30-2010, FILED 6-29-2010.



THE MARK CONSISTS OF TWO SOLID CIRCULAR DISCS SUGGESTING TWO HEADS HOVERING ABOVE TWO BODY SHAPES ALL TOGETHER COMPRISING THE SILHOUETTE OF TWO FEMALE FIGURES NEARLY ADJOINING HANDS BENEATH A HEART SHAPE.

CLASS 28—TOYS AND SPORTING GOODS

FOR PLAYSETS FOR DOLLS AND DOLL ACCESSORIES; CHILDREN'S DRESS-UP SETS FOR TOYS, NAMELY, DRESS-UP CLOTHING FOR TOYS, COSTUMES FOR TOYS, HATS FOR TOYS, SHOES FOR TOYS, HAIR PIECES FOR TOYS, HAIR RIBBONS FOR TOYS, HAIR BARRETTES FOR TOYS AND JEWELRY FOR TOYS (U.S. CLS. 22, 23, 38 AND 50).

FIRST USE 10-28-2010; IN COMMERCE 10-28-2010.

CLASS 41—EDUCATION AND ENTERTAINMENT

FOR INTERACTIVE VIRTUAL CHARACTER DOLLS AND ANIMALS, NAMELY, PROVIDING ON-LINE, NON-DOWNLOADABLE VIRTUAL CHARACTER DOLLS AND ANIMALS FOR USE IN ENVIRONMENTS CREATED FOR ENTERTAINMENT PURPOSES (U.S. CLS. 100, 101 AND 107).

FIRST USE 10-28-2010; IN COMMERCE 10-28-2010.

4,211,672. NEW BIRTH COMPANY, L3C, OVERLAND PARK, KS. SN 85-977,191. PUB. 11-22-2011, FILED 12-22-2010.

NEW BIRTH COMPANY

THE MARK CONSISTS OF STANDARD CHARACTERS WITHOUT CLAIM TO ANY PARTICULAR FONT, STYLE, SIZE, OR COLOR.

NO CLAIM IS MADE TO THE EXCLUSIVE RIGHT TO USE "COMPANY", APART FROM THE MARK AS SHOWN.

CLASS 3—COSMETICS AND CLEANING PREPARATIONS

FOR NON-MEDICATED HERBAL BATH PRODUCTS; NON-MEDICATED TOPICAL SUTURING AIDS; NON-MEDICATED PERINEAL TOPICAL OIL FOR BIRTH AND AFTER BIRTH; NON-MEDICATED BREAST TOPICAL OIL (U.S. CLS. 1, 4, 6, 50, 51 AND 52).

FIRST USE 4-0-2011; IN COMMERCE 4-0-2011.

CLASS 41—EDUCATION AND ENTERTAINMENT

FOR EDUCATIONAL SERVICES IN THE MEDICAL AND WELLNESS FIELDS OF MATERNITY CARE, LABOR AND DELIVERY, MIDWIFERY, AND PRIMARY CARE WOMEN'S WELLNESS (U.S. CLS. 100, 101 AND 107).

FIRST USE 9-17-2011; IN COMMERCE 9-17-2011.

CLASS 44—MEDICAL, BEAUTY AND AGRICULTURAL SERVICES

FOR MEDICAL SERVICES DIRECTED PRIMARILY TO MATERNITY CARE, LABOR AND DELIVERY, MIDWIFERY, AND PRIMARY CARE WOMEN'S WELLNESS (U.S. CLS. 100 AND 101).

FIRST USE 9-17-2011; IN COMMERCE 9-17-2011.

4,211,673. MARTY COOPER PRODUCTIONS, INC., MALIBU, CA. SN 85-977,193. PUB. 10-18-2011, FILED 6-23-2011.



THE COLOR(S) RED, BLUE, WHITE, BLACK, GRAY AND TAN IS/ARE CLAIMED AS A FEATURE OF THE MARK.

THE MARK CONSISTS OF "A LITTLE BIT COUNTRY" (WITH "A LITTLE BIT" IN RED AND "COUNTRY" IN BLUE) ABOVE A FILLED IN BLUE AND BLACK OVAL CARRYING A DIAGONAL G CLEF WITH MULTIPLE NOTES ON IT IN BLUE AND ONE NOTE ON IT IN WHITE AND OVER THAT, TWO GUITARS, A TAN AND BLACK COLORED ACOUSTIC GUITAR ON THE LEFT AND A RED, GRAY AND TAN COLORED ELECTRIC GUITAR ON THE RIGHT, CROSSED AT THE NECKS, WITH "A LITTLE BIT ROCK'N ROLL" UNDERNEATH (WITH "A LITTLE BIT" IN RED AND "ROCK'N ROLL" IN BLUE AND STYLIZED SO IT LOOKS AS IF IT IS MOVING QUICKLY), ALL OVER A WHITE BACKGROUND.

CLASS 16—PAPER GOODS AND PRINTED MATTER

FOR PRINTED MATTER, NAMELY, POSTERS, STATIONERY (U.S. CLS. 2, 5, 22, 23, 29, 37, 38 AND 50).

FIRST USE 6-11-2012; IN COMMERCE 6-11-2012.

CLASS 21—HOUSEWARES AND GLASS

FOR MUGS (U.S. CLS. 2, 13, 23, 29, 30, 33, 40 AND 50).

FIRST USE 6-11-2012; IN COMMERCE 6-11-2012.

CLASS 25—CLOTHING

FOR SPORTS AND CASUAL WEAR FOR MEN, WOMEN AND CHILDREN, NAMELY, TOPS, BOTTOMS, OUTER WEAR BEING JACKETS, COATS, SWEATSHIRTS, SWEATERS, AND HEADWEAR (U.S. CLS. 22 AND 39).

FIRST USE 6-11-2012; IN COMMERCE 6-11-2012.

CLASS 28—TOYS AND SPORTING GOODS

FOR TOYS, NAMELY, PLUSH TOY ANIMALS (U.S. CLS. 22, 23, 38 AND 50).

FIRST USE 6-11-2012; IN COMMERCE 6-11-2012.

4,211,676. SLISH ENTERPRISES, INC., MARINA DEL REY, CA. SN 85-977,235. PUB. 11-29-2011, FILED 2-17-2011.

SANDRA BY SANDRA LEE

THE MARK CONSISTS OF STANDARD CHARACTERS

WITHOUT CLAIM TO ANY PARTICULAR FONT, STYLE, SIZE, OR COLOR.

THE NAME(S), PORTRAIT(S), AND/OR SIGNATURE(S) SHOWN IN THE MARK IDENTIFIES "SANDRA LEE", WHOSE CONSENT(S) TO REGISTER IS MADE OF RECORD.

CLASS 7—MACHINERY

FOR SMALL KITCHEN APPLIANCES FOR DOMESTIC USE, NAMELY, ELECTRIC MIXERS AND ELECTRIC BLENDERS (U.S. CLS. 13, 19, 21, 23, 31, 34 AND 35).
FIRST USE 4-15-2012; IN COMMERCE 4-15-2012.

CLASS 11—ENVIRONMENTAL CONTROL APPARATUS

FOR ELECTRIC COOKWARE FOR DOMESTIC USE, NAMELY, ELECTRIC SLOW COOKERS, ELECTRIC GRILLS, ELECTRIC ICE CREAM MAKERS (U.S. CLS. 13, 21, 23, 31 AND 34).
FIRST USE 4-15-2012; IN COMMERCE 4-15-2012.

CLASS 20—FURNITURE AND ARTICLES NOT OTHERWISE CLASSIFIED

FOR KITCHEN FURNITURE (U.S. CLS. 2, 13, 22, 25, 32 AND 50).
FIRST USE 5-1-2012; IN COMMERCE 5-1-2012.

CLASS 21—HOUSEWARES AND GLASS

FOR KITCHEN ACCESSORIES, NAMELY, CUTTING BOARDS, CONTAINERS FOR FOOD STORAGE, CAKE AND PIE CARRIERS AND CHOPPING MATS; DINNERWARE; BAKE WARE; COOKWARE, NAMELY, POTS AND PANS, NON-ELECTRIC SKILLETS, MIXING BOWLS, SAUTE PANS, SOUP POTS, ULTIMATE PANS, EGG PANS, LASAGNA PANS, RAMEKINS, NON-ELECTRIC GRIDDLES, COLANDERS; COOKING UTENSILS, NAMELY, SPATULAS, TURNERS, GRATERS, KITCHEN TONGS, GARLIC PRESSES, SILICONE BRUSHES FOR COOKING, MIXING SPOONS, PASTA SPOONS, BASTING SPOONS, FOOD BASTER; SERVING SPOONS; SLOTTED SPOONS, LADLES, POTATO MASHERS, NON-ELECTRIC PASTRY BLENDER, SERVING TONGS, WHISKS AND HAND COLANDERS (U.S. CLS. 2, 13, 23, 29, 30, 33, 40 AND 50).
FIRST USE 4-15-2012; IN COMMERCE 4-15-2012.

CLASS 24—FABRICS

FOR KITCHEN AND TABLE LINENS (U.S. CLS. 42 AND 50).
FIRST USE 4-15-2012; IN COMMERCE 4-15-2012.

4,211,677. UNIVERSITYNOW, INC., SAN FRANCISCO, CA. SN 85-977,237. PUB. 4-17-2012, FILED 7-10-2011.

UniversityNow

THE MARK CONSISTS OF STANDARD CHARACTERS WITHOUT CLAIM TO ANY PARTICULAR FONT, STYLE, SIZE, OR COLOR.

CLASS 41—EDUCATION AND ENTERTAINMENT

FOR EDUCATIONAL SERVICES, NAMELY, PROVIDING COURSES OF INSTRUCTION AT THE UNIVERSITY, GRADUATE, AND POST-GRADUATE LEVEL; PROVIDING ON-LINE COURSES OF INSTRUCTION AT THE UNIVERSITY, GRADUATE, AND POST-GRADUATE LEVEL FOR STUDENTS VIA THE INTERNET (U.S. CLS. 100, 101 AND 107).
FIRST USE 6-1-2010; IN COMMERCE 9-1-2011.

CLASS 42—SCIENTIFIC AND COMPUTER SERVICES

FOR PROVIDING ONLINE NON-DOWNLOADABLE SOFTWARE TO ASSESS STUDENTS' LEARNING, FOR TEACHER TRAINING, AND FOR CURRICULUM DEVELOPMENT AND MANAGEMENT; PROVIDING ONLINE NON-DOWNLOADABLE EDUCATIONAL SOFTWARE FOR STUDENTS FEATURING UNIVERSITY, GRADUATE, AND POST-GRADUATE LEVEL ACADEMIC SUBJECTS; PROVIDING ON-LINE NON-DOWNLOADABLE SOFTWARE FOR GENERATING ONLINE COURSES OF INSTRUCTION, PARTICULARLY FOR MANAGEMENT AND ADMINISTRATION OF ONLINE COURSES OF INSTRUCTION, BULLETIN BOARDS, CHAT ROOMS AND DATABASE RESOURCES AND SEARCHING, BROWSING, INDEXING, FILTERING AND RETRIEVAL OF DATA AND CONTENT OF COMPUTERS, COMPUTER NETWORKS AND THE INTERNET, AND MANAGEMENT OF ADMINISTRATIVE AND COMMUNITY FUNCTIONS FOR UNIVERSITY AND CORPORATE ENVIRONMENTS (U.S. CLS. 100 AND 101).
FIRST USE 6-1-2010; IN COMMERCE 9-1-2011.

4,211,678. SOLUTIA INC., ST. LOUIS, MO. SN 85-977,252. PUB. 5-24-2011, FILED 9-13-2010.



OWNER OF U.S. REG. NOS. 2,578,976, 3,029,580, AND OTHERS.

THE COLOR(S) BLACK, BLUE AND GREEN IS/ARE CLAIMED AS A FEATURE OF THE MARK.

THE MARK CONSISTS OF THE WORD "SOLUTIA" IN BLACK WITH BLUE AND GREEN LINES RADIATING OUT IN A SEMI-CIRCULAR PATTERN FROM THE LETTER "S".

CLASS 1—CHEMICALS

FOR INDUSTRIAL CHEMICALS; HYDRAULIC FLUIDS; HEAT TRANSFER FLUIDS FOR INDUSTRIAL USE; HEAT TRANSFER FLUIDS FOR USE IN BOILERS, IN FURNACES, IN CHEMICAL PROCESS REACTORS; CHEMICALS AND CHEMICAL COMPOSITIONS, NAMELY, SOLVENTS, COALESCING AIDS, COUPLING AGENTS AND PLASTICIZERS, FOR USE IN THE MANUFACTURE OF COATINGS, PLASTIC FILMS AND PLASTIC-BASED COATINGS, PAINTS, VARNISHES, LACQUERS, ADHESIVES, SEALANTS, AND INKS; ARTIFICIAL RESINS; SYNTHETIC RESINS; CHEMICAL PREPARATIONS FOR SCIENTIFIC PURPOSES; SULFUR; INSOLUBLE SULFUR; CHEMICAL PREPARATIONS, NAMELY, DEGREASING AND CLEANING SOLVENTS; CHEMICALS FOR RUBBER AND PLASTIC PROCESSING APPLICATIONS; CHEMICALS FOR RUBBER PROCESSING, BEING VULCANIZATION AGENTS, VULCANIZATION ACCELERATORS, ANTI-OXIDANTS, ANTI-DEGRADANTS AND ANTI-OZONANTS, ANTI-REVERSION AGENTS, POST-VULCANIZATION STABILIZERS, REINFORCING AGENTS, AND CURING AGENTS, ALL FOR USE IN THE TIRE AND RUBBER PROCESSING INDUSTRIES; SYNTHETIC RESINOUS PLASTIC MATERIALS AND SYNTHETIC RESINS FOR USE IN THE INDUSTRIAL ARTS AND FOR FURTHER MANUFACTURE; SYNTHETIC RESIN ADHESIVES FOR LAMINATING PURPOSES; ETHYLENE VINYL ACETATE FILMS FOR PHOTOVOLTAIC MODULE ENCAPSULATION (U.S. CLS. 1, 5, 6, 10, 26 AND 46).

FIRST USE 11-8-2010; IN COMMERCE 11-8-2010.

CLASS 17—RUBBER GOODS

FOR RESINS IN BARS, BLOCKS, PELLETS, RODS, FOR GENERAL INDUSTRIAL USE; PLASTIC INSULATING AND PROTECTIVE INTERLAYER FOR USE IN THE ARCHITECTURAL AND AUTOMOTIVE LAMINATED GLASS INDUSTRIES; PLASTIC INSULATING AND PROTECTIVE INTERLAYER FOR SAFETY GLASS; PLASTIC INSULATING AND PROTECTIVE INTERLAYER FOR USE IN LAMINATING SAFETY GLASS; SYNTHETIC RESIN SHEETING FOR USE IN THE MANUFACTURE OF LAMINATED GLASS; POLYVINYL BUTYRAL FILM FOR USE IN GLASS LAMINATIONS; COLORED, METALLIC, IMAGED, LAMINATED, SOUND INSULATING, SOLAR PROTECTIVE, SOLAR ABSORBING, REFLECTIVE AND ELECTROMAGNETIC FILTERING PLASTIC FILMS AND INSULATING AND PROTECTIVE INTERLAYERS FOR USE IN ARCHITECTURAL OR VEHICLE GLASS AND WINDOWS; LAMINATED PLASTIC FILM FOR USE IN HOME OR AUTO WINDOWS FOR SUN CONTROL; POLYURETHANE FILM FOR USE IN GLASS LAMINATIONS FOR RESIDENTIAL AND COMMERCIAL WINDOWS AND DOORS; SOLAR PLASTIC FILM, NAMELY, TINTED, LAMINATED OR REFLECTIVE, FOR USE IN RESIDENTIAL AND COMMERCIAL WINDOWS; SOLAR PLASTIC FILM, NAMELY, LAMINATED OR REFLECTIVE, FOR USE IN AUTOMOTIVE WINDOWS; SOLAR POLYURETHANE FILM FOR USE IN GLASS LAMINATIONS; HEAT REFLECTIVE PLASTIC FILM TO BE APPLIED TO WINDOWS; PLASTIC FILM FOR INDUSTRIAL AND COMMERCIAL USE; PLASTIC FILM FOR APPLICATION TO AUTOMOBILES AS A PAINT PROTECTION LAYER; SEMI-FINISHED PLASTIC FILMS AND SHEETS TO BE USED IN SOLAR OR PHOTOVOLTAIC MODULES; THIN PLASTIC FILM, FOR USE AS A COMPONENT OF FLEXIBLE THIN FILM PHOTOVOLTAIC MODULES; BARRIER THIN PLASTIC FILMS FOR USE WITHIN SUCH THIN FILM PHOTOVOLTAIC MODULES; THIN PLASTIC FILMS WITH DEPOSITED TRANSPARENT CONDUCTIVE OXIDE FOR USE IN THIN FILM PLASTIC PHOTOVOLTAIC MODULES; TRANSPARENT CONDUCTIVE PLASTIC FILM FOR USE AS A COMPONENT WITHIN THE SENSORS OF TOUCH SCREEN DISPLAYS; TRANSPARENT CONDUCTIVE FILMS FOR USE IN MANUFACTURE OF E-READERS AND OTHER ELECTRONIC INK AND ELECTRONIC PAPER DISPLAYS; PLASTIC DISPOSABLE RELEASE FILMS, PLASTIC CARRIER FILMS AND PLASTIC LINERS FOR COMPONENTS OF THIN FILM PHOTOVOLTAIC MODULES, TOUCH SCREENS, DIS-

PLAYS, ADJUSTABLE TINT WINDOWS, SOLAR CONCENTRATORS HARD DISK DRIVES, ELECTROLUMINESCENT LAMPS, BATTERIES AND MEDICAL DIAGNOSTIC DEVICES; ADHERENT PLASTIC FILMS, LAMINATES MADE OF PLASTIC FILMS AND LAYERED FIBERS FORMING PART OF THE LAMINATE FOR USE AS EMBEDDING MATERIALS TO ENCAPSULATE OR COVER A COMPONENT IN THE PRODUCTION OF GLASS/GLASS LAMINATES AND/OR GLASS/FILM LAMINATES, IN PARTICULAR FOR PHOTOVOLTAIC AND DISPLAY SCREEN USES (U.S. CLS. 1, 5, 12, 13, 35 AND 50).

FIRST USE 11-8-2010; IN COMMERCE 11-8-2010.

4,211,679. VONAGE MARKETING LLC, HOLMDEL, NJ. SN 85-977,255. PUB. 3-27-2012, FILED 5-23-2011.



OWNER OF U.S. REG. NOS. 3,440,689, 3,681,594, AND 3,687,598.

THE MARK CONSISTS OF A STYLIZED "V" WITH A DOT.

CLASS 9—ELECTRICAL AND SCIENTIFIC APPARATUS

FOR COMPUTER TELEPHONY SOFTWARE, NAMELY, SOFTWARE APPLICATIONS FOR ESTABLISHING AND PERFORMING PHONE CALLS, OVER A VARIETY OF NETWORKS IN THE NATURE OF THE INTERNET; DOWNLOADABLE SOFTWARE FOR USE WITH WIRELESS TELECOMMUNICATIONS DEVICES TO PROVIDE WIRELESS TRANSMISSION OF E-MAIL, TEXT, VOICE, STILL IMAGES, INFORMATION, DATA AND OTHER CONTENT VIA THE INTERNET AND VIA WIRELESS LOCAL AREA NETWORK DEVICES; COMPUTER AND TELECOMMUNICATIONS NETWORK HUBS, SWITCHES AND ROUTERS; COMPUTER HARDWARE AND COMMUNICATIONS SOFTWARE FOR USE IN CONNECTING TELECOMMUNICATIONS EQUIPMENT, TELEPHONES, COMPUTERS, WIRED AND WIRELESS COMPUTER NETWORKS; COMPUTER SOFTWARE AND HARDWARE FOR PROVIDING TRANSMISSION AND EXCHANGE OF VOICE, DATA, IMAGES AND GRAPHICS IN THE FIELDS OF TELECOMMUNICATIONS; HARDWARE FOR TELECOMMUNICATIONS FOR CONNECTING DEVICES VIA IN-HOME PHONE AND ELECTRICAL WIRING, NAMELY, COMPUTER NETWORK HUBS, COMPUTER SWITCHES AND COMPUTER ROUTERS DESIGNED TO PROVIDE IN-HOME VOICE OVER INTERNET PROTOCOL (VOIP) COMMUNICATIONS (U.S. CLS. 21, 23, 26, 36 AND 38).

FIRST USE 6-29-2006; IN COMMERCE 6-29-2006.

CLASS 38—COMMUNICATION

FOR TELEPHONY COMMUNICATIONS SERVICES (U.S. CLS. 100, 101 AND 104).

FIRST USE 6-29-2006; IN COMMERCE 6-29-2006.

4,211,680. PROMETHEUS GLOBAL MEDIA, LLC, NEW YORK, NY. SN 85-977,278. PUB. 11-1-2011, FILED 12-3-2010.

CLASS 43—HOTEL AND RESTAURANT SERVICES

FOR RESTAURANT SERVICES (U.S. CLS. 100 AND 101).
FIRST USE 8-31-1996; IN COMMERCE 8-31-1996.

BILLBOARD

THE MARK CONSISTS OF STANDARD CHARACTERS WITHOUT CLAIM TO ANY PARTICULAR FONT, STYLE, SIZE, OR COLOR.

OWNER OF U.S. REG. NOS. 606,753, 1,528,168, AND OTHERS.

CLASS 9—ELECTRICAL AND SCIENTIFIC APPARATUS

FOR DOWNLOADABLE ELECTRONIC PUBLICATIONS IN THE NATURE OF MAGAZINES, NEWSLETTERS, AND INFORMATION FLYERS IN THE FIELD OF MUSIC AND ENTERTAINMENT; COMPUTER SOFTWARE AND COMPUTER MOBILE APPLICATION SOFTWARE FOR DOWNLOADING MUSIC, PLAYING GAMES, PERFORMING SOCIAL MEDIA FUNCTIONS, RECEIVING MUSIC AND ENTERTAINMENT NEWS ALERTS AND RECEIVING INFORMATION REGARDING MUSIC AND ENTERTAINMENT; MOBILE PHONES; ELECTRONIC DEVICES, NAMELY, MOBILE COMPUTERS, MOBILE DATA RECEIVERS, HAND-HELD COMPUTERS, PERSONAL DATA ASSISTANTS, AND VIDEO GAME PLAYERS, NAMELY, HAND HELD UNITS FOR PLAYING ELECTRONIC VIDEO GAMES FOR USE WITH EXTERNAL DISPLAY SCREEN OR MONITOR; SUNGLASSES (U.S. CLS. 21, 23, 26, 36 AND 38).

FIRST USE 5-31-1994; IN COMMERCE 5-31-1994.

CLASS 16—PAPER GOODS AND PRINTED MATTER

FOR PRINTED PUBLICATIONS IN THE NATURE OF MAGAZINES, BOOKS, NEWSLETTERS, AND INFORMATION FLYERS IN THE FIELD OF MUSIC AND ENTERTAINMENT, PRINTED MATTER, NAMELY, NEWSPAPERS, CATALOGS, PHOTOGRAPHS, MAGAZINES, BOOKS, PRINTED PERIODICALS, NEWSLETTERS, AND BROCHURES ALL IN THE FIELDS MUSIC AND ENTERTAINMENT; POSTERS, STATIONERY, NOTEBOOKS, BOOK COVERS, STICKERS, DECALS (U.S. CLS. 2, 5, 22, 23, 29, 37, 38 AND 50).

FIRST USE 1-1-1900; IN COMMERCE 1-1-1900.

CLASS 25—CLOTHING

FOR CLOTHING, NAMELY, TOPS, BOTTOMS, DRESSES, SKIRTS, JACKETS, GLOVES, BELTS, SOCKS; FOOTWEAR, HEADWEAR (U.S. CLS. 22 AND 39).

FIRST USE 9-30-1996; IN COMMERCE 9-30-1996.

CLASS 41—EDUCATION AND ENTERTAINMENT

FOR ONLINE WEBSITES FEATURING INFORMATION IN THE FIELD OF MUSIC AND ENTERTAINMENT; ONLINE MAGAZINES IN THE FIELD OF MUSIC AND ENTERTAINMENT; ENTERTAINMENT SERVICES IN THE NATURE OF PROVIDING LIVE MUSICAL PERFORMANCES; NIGHT CLUBS (U.S. CLS. 100, 101 AND 107).

FIRST USE 12-10-1990; IN COMMERCE 12-10-1990.

4,211,681. TREETOP SOFTWARE COMPANY, LLC, LAKE-LAND, FL. SN 85-977,301. PUB. 7-12-2011, FILED 1-14-2011.



THE MARK CONSISTS OF A DESIGN OF A CROWN POSITIONED ABOVE A CLOCK FACE.

CLASS 35—ADVERTISING AND BUSINESS

FOR PROVIDING AN ON-LINE DIRECTORY INFORMATION SERVICE AND ON-LINE SEARCHABLE DATABASE BOTH REGARDING EMPLOYMENT OPPORTUNITIES AND VOLUNTEER OPPORTUNITIES AVAILABLE AT VOLUNTEER PROGRAMS, COMMUNITY SERVICE PROJECTS, CHARITIES, FUNDRAISING EVENTS, SCHOOLS, BUSINESSES, AND JOB FAIRS; PROVIDING A WEBSITE FEATURING ON-LINE BUSINESS INFORMATION IN THE FIELDS OF VOLUNTEER PROGRAMS, COMMUNITY SERVICE PROJECTS, CHARITIES, FUNDRAISING EVENTS, SCHOOLS, BUSINESSES, JOB FAIRS, EMPLOYMENT AND CAREER PLANNING; PROVIDING ONLINE RESUME PREPARATION SERVICES (U.S. CLS. 100, 101 AND 102).

FIRST USE 1-16-2012; IN COMMERCE 1-16-2012.

CLASS 42—SCIENTIFIC AND COMPUTER SERVICES

FOR PROVIDING A MEANS TO TRACK VOLUNTEER HOURS, JOB TRAINING HOURS AND OTHER HOURS OF WORK AND EDUCATION BY COMPANIES, CHARITIES, ORGANIZATIONS AND INDIVIDUALS, NAMELY, PROVIDING ONLINE NON-DOWNLOADABLE SOFTWARE FOR TRACKING VOLUNTEER HOURS, JOB TRAINING HOURS AND OTHER HOURS OF WORK AND EDUCATION BY COMPANIES, CHARITIES, ORGANIZATIONS AND INDIVIDUALS (U.S. CLS. 100 AND 101).

FIRST USE 1-16-2012; IN COMMERCE 1-16-2012.

SECTION 2.— INTERNATIONAL CLASSIFICATION

The short titles associated below with the international class numbers are terms designed merely for quick identification and are not an official part of the international classification. The full names of international classes are given in section 6.1 of the trademark rules of practice.

The designation "U.S. Cl." appearing in this section refers to the U.S. class in effect prior to Sep. 1, 1973 rather than the international class which applies to applications filed on or after that date. For adoption of international classification see notice in the OFFICIAL GAZETTE of Jun. 26, 1973 (911 O.G. TM 210).

Application in one class

CLASS 1—CHEMICALS

4,210,375. IOGENETICS, LLC, MADISON, WI. SN 77-774,257.
PUB. 6-15-2010, FILED 7-3-2009.

CLASS 1—(Continued).

4,210,420. MEDTRAIN TECHNOLOGIES, LLC, HILLSBOROUGH, NC. SN 77-900,345. PUB. 7-13-2010, FILED 12-23-2009.

DIRECTED BIOCIDES

THE MARK CONSISTS OF STANDARD CHARACTERS WITHOUT CLAIM TO ANY PARTICULAR FONT, STYLE, SIZE, OR COLOR.

NO CLAIM IS MADE TO THE EXCLUSIVE RIGHT TO USE "BIOCIDES", APART FROM THE MARK AS SHOWN. FOR REAGENTS FOR SCIENTIFIC AND RESEARCH USE (U.S. CLS. 1, 5, 6, 10, 26 AND 46).
FIRST USE 12-1-2002; IN COMMERCE 1-30-2012.

ThermaCol

THE MARK CONSISTS OF STANDARD CHARACTERS WITHOUT CLAIM TO ANY PARTICULAR FONT, STYLE, SIZE, OR COLOR.

FOR PROTEIN MATERIAL USED AS A SCAFFOLD OR FRAMEWORK FOR THE DEVELOPMENT OF THREE DIMENSIONAL CELL CULTURES IN CELL AND TISSUE ENGINEERING RESEARCH (U.S. CLS. 1, 5, 6, 10, 26 AND 46).
FIRST USE 3-7-2012; IN COMMERCE 3-7-2012.

4,210,393. NORANDA ALUMINUM, INC., FRANKLIN, TN. SN 77-857,385. PUB. 3-30-2010, FILED 10-26-2009.

4,210,448. NANO VAPOR FUELS GROUP, INC., CYPRESS, TX. SN 77-922,226. PUB. 6-15-2010, FILED 1-28-2010.



THE MARK CONSISTS OF THE LETTER "N" IN A STYLIZED FORM.
FOR BAUXITE (U.S. CLS. 1, 5, 6, 10, 26 AND 46).
FIRST USE 7-11-2011; IN COMMERCE 7-11-2011.



NO CLAIM IS MADE TO THE EXCLUSIVE RIGHT TO USE "FUELS GROUP", APART FROM THE MARK AS SHOWN.

THE COLOR(S) GREEN, LIGHT BLUE, DARK BLUE, AND BLACK IS/ARE CLAIMED AS A FEATURE OF THE MARK.

THE MARK CONSISTS OF A LARGE "V" THAT IS DESIGNED TO PROVIDE THE VISUAL EFFECT OF VA-

CLASS 1—(Continued).

PORS. THIS "V" IS HALF GREEN, AND HALF DARK BLUE FADING TO LIGHT BLUE ON TOP. THE "NANO" IN THE NAME "NANOVAPOR" IS IN GREEN, WITH THE FIRST HALF OF THE "V" ALSO GREEN. THE LATTER HALF OF THE "V" APPEARS IN DARK BLUE FADING TO LIGHT BLUE ON TOP AND THE LETTERS "APOR" ARE IN DARK BLUE. THE WORDS "FUELS GROUP" IS LOCATED DIRECTLY UNDERNEATH IN BLACK, SEPARATED SLIGHTLY BY THE "V". ALL LETTERS ARE CAPITALIZED.

FOR ABSORBING CARBONS FOR SAFELY DEGASING AND CLEANING LARGE STORAGE TANKS IN THE PETROCHEMICAL INDUSTRIES; CHEMICALS FOR USE IN INDUSTRY AND SCIENCE (U.S. CLS. 1, 5, 6, 10, 26 AND 46).

FIRST USE 6-1-2006; IN COMMERCE 12-15-2011.

CLASS 1—(Continued).

4,210,673. FLORATINE PRODUCTS GROUP, INC., AKA FPG, FLORATINE, COLLIERVILLE, TN. SN 85-159,460. PUB. 9-27-2011, FILED 10-22-2010.

Glycosyn Induction

THE MARK CONSISTS OF STANDARD CHARACTERS WITHOUT CLAIM TO ANY PARTICULAR FONT, STYLE, SIZE, OR COLOR.

FOR CHEMICAL FERTILIZERS; CHEMICALS FOR USE IN AGRICULTURE, EXCEPT FUNGICIDES, HERBICIDES, INSECTICIDES AND PARASITICIDES; CHEMICALS FOR USE IN AGRICULTURE, HORTICULTURE AND FORESTRY EXCEPT FUNGICIDES, HERBICIDES, INSECTICIDES AND PARASITICIDES; COMPLEX FERTILIZER; COMPLEX FERTILIZERS; FERTILIZERS; FERTILIZERS FOR AGRICULTURAL USE; FERTILIZERS FOR DOMESTIC USE; HORTICULTURAL PRODUCTS, NAMELY, SOIL AMENDMENTS THAT ARE INCORPORATED INTO OR ONTO A TURF, LAWN OR SOIL PROFILE FOR CREATING A HEALTH MEDIUM FOR INCREASED ROOT GROWTH AND/OR A SMOOTHER TURF OR LAWN SURFACE CUT OR APPEARANCE; MIXED FERTILIZERS; NON-CHEMICAL BIO-FERTILIZERS (U.S. CLS. 1, 5, 6, 10, 26 AND 46).

FIRST USE 8-8-2011; IN COMMERCE 8-8-2011.

4,210,514. CRANSTON PRINT WORKS COMPANY, CRANSTON, RI. SN 85-031,701. PUB. 10-19-2010, FILED 5-6-2010.

BERCEN INC. WHERE INNOVATIVE SOLUTIONS BEGIN

THE MARK CONSISTS OF STANDARD CHARACTERS WITHOUT CLAIM TO ANY PARTICULAR FONT, STYLE, SIZE, OR COLOR.

OWNER OF U.S. REG. NO. 2,076,941.

NO CLAIM IS MADE TO THE EXCLUSIVE RIGHT TO USE "INC.", APART FROM THE MARK AS SHOWN.

FOR INDUSTRIAL CHEMICALS FOR USE IN PAPER AND PAPERBOARD MANUFACTURING, COATING AND CONVERTING, NAMELY, PAPER COATING INSOLUBILIZERS; POLYMERIC SIZING COMPOUNDS FOR SURFACE AND INTERNAL SIZING OF PAPER PRODUCTS; WET CHEMICALS AND CHEMICAL ADDITIVES ALL FOR USE IN THE MANUFACTURING OF PAPER PRODUCTS (U.S. CLS. 1, 5, 6, 10, 26 AND 46).

FIRST USE 7-0-2010; IN COMMERCE 7-0-2010.

4,211,040. WINFIELD SOLUTIONS, LLC, SHOREVIEW, MN. SN 85-330,889. PUB. 11-8-2011, FILED 5-26-2011.

GOLDCOTE

4,210,660. CALGON CARBON CORPORATION, PITTSBURGH, PA. SN 85-152,441. PUB. 3-1-2011, FILED 10-14-2010.

PEROXCARB

THE MARK CONSISTS OF STANDARD CHARACTERS WITHOUT CLAIM TO ANY PARTICULAR FONT, STYLE, SIZE, OR COLOR.

FOR GRANULAR ACTIVATED CARBON USED TO TREAT MUNICIPAL DRINKING WATER (U.S. CLS. 1, 5, 6, 10, 26 AND 46).

FIRST USE 4-9-2012; IN COMMERCE 4-9-2012.

THE MARK CONSISTS OF STANDARD CHARACTERS WITHOUT CLAIM TO ANY PARTICULAR FONT, STYLE, SIZE, OR COLOR.

FOR FERTILIZERS (U.S. CLS. 1, 5, 6, 10, 26 AND 46).

FIRST USE 5-31-2012; IN COMMERCE 5-31-2012.

CLASS 1—(Continued).

4,211,275. INNOPHOS, INC., CRANBURY, NJ. SN 85-363,780.
PUB. 11-8-2011, FILED 7-6-2011.

TEXTUR-MELT

THE MARK CONSISTS OF STANDARD CHARACTERS WITHOUT CLAIM TO ANY PARTICULAR FONT, STYLE, SIZE, OR COLOR.

FOR CHEMICAL COMPOSITIONS USED IN THE PROCESSING OF CHEESE AND CHEESE PRODUCTS TO IMPROVE MELT PROPERTIES (U.S. CLS. 1, 5, 6, 10, 26 AND 46).

FIRST USE 7-14-2011; IN COMMERCE 7-14-2011.

4,211,390. LOVELAND PRODUCTS, INC., LOVELAND, CO.
SN 85-392,508. PUB. 11-1-2011, FILED 8-8-2011.

EQUITY

THE MARK CONSISTS OF STANDARD CHARACTERS WITHOUT CLAIM TO ANY PARTICULAR FONT, STYLE, SIZE, OR COLOR.

FOR SEED TREATMENT PREPARATIONS, NAMELY, CHEMICAL PREPARATIONS FOR USE IN AGRICULTURE, NAMELY, CHEMICAL PREPARATIONS FOR THE TREATMENT OF SEEDS (U.S. CLS. 1, 5, 6, 10, 26 AND 46).

FIRST USE 3-19-2012; IN COMMERCE 3-19-2012.

4,211,394. LOVELAND PRODUCTS, INC., LOVELAND, CO.
SN 85-393,290. PUB. 11-1-2011, FILED 8-9-2011.

CONSENSUS

THE MARK CONSISTS OF STANDARD CHARACTERS WITHOUT CLAIM TO ANY PARTICULAR FONT, STYLE, SIZE, OR COLOR.

FOR SEED TREATMENT PREPARATIONS, NAMELY, CHEMICAL PREPARATIONS FOR USE IN AGRICULTURE, NAMELY, CHEMICAL PREPARATIONS FOR THE TREATMENT OF SEEDS (U.S. CLS. 1, 5, 6, 10, 26 AND 46).

FIRST USE 4-2-2012; IN COMMERCE 4-2-2012.

CLASS 1—(Continued).

4,211,403. AMERICAN AGRITECH, L.L.C., CHANDLER, AZ.
SN 85-395,587. PUB. 11-1-2011, FILED 8-11-2011.

STRAPPED

THE MARK CONSISTS OF STANDARD CHARACTERS WITHOUT CLAIM TO ANY PARTICULAR FONT, STYLE, SIZE, OR COLOR.

FOR PLANT NUTRIENTS AND SUPPLEMENTS IN THE NATURE OF PLANT FOOD FOR THE HORTICULTURAL INDUSTRY (U.S. CLS. 1, 5, 6, 10, 26 AND 46).

FIRST USE 8-31-2011; IN COMMERCE 8-31-2011.

4,211,409. PHOCATOX TECHNOLOGIES, LLC, INDIANAPOLIS, IN. SN 85-397,911. PUB. 2-7-2012, FILED 8-15-2011.

BIOSWEEP SURFACE DEFENSE

THE MARK CONSISTS OF STANDARD CHARACTERS WITHOUT CLAIM TO ANY PARTICULAR FONT, STYLE, SIZE, OR COLOR.

OWNER OF U.S. REG. NO. 3,351,509.

NO CLAIM IS MADE TO THE EXCLUSIVE RIGHT TO USE "SURFACE", APART FROM THE MARK AS SHOWN.

FOR SURFACE AND TEXTILE PROTECTANT IN THE NATURE OF A SPRAY-ON POLYMER FOR PROVIDING ANTIMICROBIAL PROTECTION FOR POROUS AND NON-POROUS SURFACES (U.S. CLS. 1, 5, 6, 10, 26 AND 46).

FIRST USE 10-1-2011; IN COMMERCE 10-1-2011.

4,211,475. INVISTA NORTH AMERICA S.A. R.L., WICHITA, KS. SN 85-423,780. PUB. 2-21-2012, FILED 9-15-2011.

TORZEN

THE MARK CONSISTS OF STANDARD CHARACTERS WITHOUT CLAIM TO ANY PARTICULAR FONT, STYLE, SIZE, OR COLOR.

FOR POLYMERS AND POLYMER COMPOSITIONS USED IN THE MANUFACTURE OF AUTOMOTIVE, ELECTRICAL, ELECTRONIC, INDUSTRIAL AND CONSUMER PRODUCTS; CHEMICALS AND UNPROCESSED PLASTICS USED IN THE MANUFACTURE OF AUTOMOTIVE, ELECTRICAL, ELECTRONIC, INDUSTRIAL AND CONSUMER PRODUCTS (U.S. CLS. 1, 5, 6, 10, 26 AND 46).

FIRST USE 9-15-2011; IN COMMERCE 6-30-2012.

CLASS 1—(Continued).

4,211,577. W. F. TAYLOR CO., INC., FONTANA, CA. SN 85-473,382. PUB. 5-1-2012, FILED 11-15-2011.

MBA

THE MARK CONSISTS OF STANDARD CHARACTERS WITHOUT CLAIM TO ANY PARTICULAR FONT, STYLE, SIZE, OR COLOR.
FOR ADHESIVE FOR FLOORING (U.S. CLS. 1, 5, 6, 10, 26 AND 46).
FIRST USE 4-3-2012; IN COMMERCE 4-3-2012.

4,211,651. POTTERS INDUSTRIES, LLC, WILMINGTON, DE. SN 85-517,909. PUB. 5-1-2012, FILED 1-17-2012.

ONG

THE MARK CONSISTS OF STANDARD CHARACTERS WITHOUT CLAIM TO ANY PARTICULAR FONT, STYLE, SIZE, OR COLOR.
FOR SODIUM SILICATE IN THE FORM OF HOLLOW SPHERES (U.S. CLS. 1, 5, 6, 10, 26 AND 46).
FIRST USE 4-29-2009; IN COMMERCE 4-29-2009.

CLASS 2—PAINTS

4,210,315. THE SHERWIN-WILLIAMS COMPANY, CLEVELAND, OH. SN 77-614,637. PUB. 3-31-2009, FILED 11-14-2008.

GEOSHADES

THE MARK CONSISTS OF STANDARD CHARACTERS WITHOUT CLAIM TO ANY PARTICULAR FONT, STYLE, SIZE, OR COLOR.
FOR COLORANT DISPERSIONS FOR USE IN SURFACE COATING COMPOSITIONS (U.S. CLS. 6, 11 AND 16).
FIRST USE 4-23-2012; IN COMMERCE 4-23-2012.

CLASS 2—(Continued).

4,210,508. USA AOBOMA INTERNATIONAL CHEMICAL LLC, WALNUT, NV. SN 85-025,870. PUB. 11-8-2011, FILED 4-28-2010.



THE MARK CONSISTS OF THE WORD "AOBOMA" ABOVE THREE CHINESE CHARACTERS, ALL BELOW THE DESIGN OF A SHIELD COMPRISED OF A LION, A GAZELLE, A BIG BIRD AND A FLAG WITH THE WORDS "AOBOMA PAINT" RESTING ON AN OPEN BOOK.

THE WORDING "AOBOMA" HAS NO MEANING IN A FOREIGN LANGUAGE.

THE NON-LATIN CHARACTERS IN THE MARK TRANSLITERATE TO "AOBOMA" AND THIS HAS NO MEANING IN A FOREIGN LANGUAGE.

FOR PAINTS; ACRYLIC PAINTS; ENAMEL PAINTS; ALUMINUM PAINTS; ACRYLIC PAINTS FOR ARTISTS; ACRYLIC COATINGS BEING PAINTS, NAMELY, COATING PREPARATIONS IN THE NATURE OF PAINTS HAVING WATER REPELLENT PROPERTIES; COATING COMPOSITIONS IN THE NATURE OF PAINT FOR INDUSTRIAL APPLICATIONS; GLAZES IN THE NATURE OF PAINTS AND LACQUERS; LUMINESCENT PAINTS; PAINTS FOR USE IN THE PRINTING INDUSTRY, NAMELY, DECORATION, FURNITURE AND INTERIOR PRINTING USE; FABRIC PAINTS; PAINTS COMPRISED OF PHOSPHORESCENT COLOR PIGMENTS AND DISPERSIONS; PAINT THICKENERS; PAINT THINNERS; VARNISHES; SPRAY PAINTS FOR WOOD, PLASTIC, METAL, CERAMICS AND AUTOMOBILES; ENGRAVING INKS; OFFSET PRINTING INKS; INK FOR LINOTYPE PRINTING; INK FOR MONOTYPE PRINTING; INK FOR PRINTING BLOCKS; INKS FOR USE IN SILK SCREEN PRINTING; SCREEN PRINTING INKS; DRY INKS; METALLIC INKS; MIMEOGRAPHING INK (U.S. CLS. 6, 11 AND 16).

FIRST USE 6-1-2010; IN COMMERCE 6-1-2010.

CLASS 2—(Continued).

4,210,918. BTD WOOD POWDER COATING INC., BRAINERD, MN. SN 85-271,178. PUB. 8-2-2011, FILED 3-18-2011.

T.FUSION

THE MARK CONSISTS OF STANDARD CHARACTERS WITHOUT CLAIM TO ANY PARTICULAR FONT, STYLE, SIZE, OR COLOR.

FOR COATINGS FOR WOOD AS PAINTS; COATINGS FOR WOOD IN THE NATURE OF A PAINT, NAMELY, WOOD POWDER COATED FINISHES; COATINGS FOR WOOD IN THE NATURE OF A PRESERVATIVE, NAMELY, WOOD POWDER COATED FINISHES (U.S. CLS. 6, 11 AND 16).

FIRST USE 6-30-2011; IN COMMERCE 6-30-2011.

4,210,932. HUNTSMAN ADVANCED MATERIALS (SWITZERLAND) GMBH, BASEL, SWITZERLAND. SN 85-282,582. PUB. 11-8-2011, FILED 3-31-2011.

LANASOL

THE MARK CONSISTS OF STANDARD CHARACTERS WITHOUT CLAIM TO ANY PARTICULAR FONT, STYLE, SIZE, OR COLOR.

OWNER OF U.S. REG. NO. 138,516.
FOR DYES FOR USE IN THE MANUFACTURE OF WOOL, NYLON AND SILK FIBERS (U.S. CLS. 6, 11 AND 16).

FIRST USE 0-0-1966; IN COMMERCE 0-0-1968.

CLASS 2—(Continued).

4,211,061. THE VALSPAR CORPORATION, MINNEAPOLIS, MN. SN 85-334,894. PUB. 10-25-2011, FILED 6-1-2011.



THE MARK CONSISTS OF A STYLIZED "X" AND THE WORD "MAX".
FOR AEROSOL SPRAY PAINTS (U.S. CLS. 6, 11 AND 16).

FIRST USE 10-0-2011; IN COMMERCE 10-0-2011.

4,211,112. WINFIELD SOLUTIONS, LLC, SHOREVIEW, MN. SN 85-342,254. PUB. 11-8-2011, FILED 6-9-2011.

MYSTIC

THE MARK CONSISTS OF STANDARD CHARACTERS WITHOUT CLAIM TO ANY PARTICULAR FONT, STYLE, SIZE, OR COLOR.

OWNER OF U.S. REG. NO. 3,083,877.
FOR AGRICULTURAL DYE MARKER (U.S. CLS. 6, 11 AND 16).

FIRST USE 3-29-2012; IN COMMERCE 3-29-2012.

4,211,198. GUANGDONG YATU CHEMICAL CO., LTD, GUANGDONG, CHINA. SN 85-352,411. PUB. 11-15-2011, FILED 6-22-2011.



THE MARK CONSISTS OF A FLOWER DESIGN ON THE LEFT, AND THE STYLIZED WORD "YATU" ON THE RIGHT.

CLASS 2—(Continued).

THE WORDING "YATU" HAS NO MEANING IN A FOREIGN LANGUAGE.

FOR BINDING AGENTS FOR PAINTS; COATINGS COMPRISED OF CEMENT; FIXATIVES IN SPRAY FORM FOR INDUSTRIAL USE IN THE NATURE OF AN ACRYLIC PROTECTIVE COATING; PAINTS; PIGMENTS; PRIMERS; PRINTING INK; RAW NATURAL RESINS; SICCATIVES FOR USE AS A DRYING AGENT FOR COATINGS AND INKS; VARNISH (U.S. CLS. 6, 11 AND 16).

FIRST USE 5-1-2010; IN COMMERCE 4-26-2011.

4,211,199. GUANGDONG YATU CHEMICAL CO., LTD, GUANGDONG, CHINA. SN 85-352,415. PUB. 11-15-2011, FILED 6-22-2011.

Maxytone

THE MARK CONSISTS OF STANDARD CHARACTERS WITHOUT CLAIM TO ANY PARTICULAR FONT, STYLE, SIZE, OR COLOR.

THE WORDING "MAXYTONE" HAS NO MEANING IN A FOREIGN LANGUAGE.

FOR BINDING AGENTS FOR PAINTS; COATINGS COMPRISED OF CEMENT; FIXATIVES IN SPRAY FORM FOR INDUSTRIAL USE IN THE NATURE OF AN ACRYLIC PROTECTIVE COATING; PAINTS; PIGMENTS; PRIMERS; PRINTING INK; RAW NATURAL RESINS; SICCATIVES FOR USE AS A DRYING AGENT FOR COATINGS AND INKS; VARNISH (U.S. CLS. 6, 11 AND 16).

FIRST USE 5-1-2010; IN COMMERCE 4-26-2011.

4,211,648. IMPERIAL PAINTS, LLC, FAIRFOREST, SC. SN 85-514,662. PUB. 5-15-2012, FILED 1-12-2012.

LULLABY

THE MARK CONSISTS OF STANDARD CHARACTERS WITHOUT CLAIM TO ANY PARTICULAR FONT, STYLE, SIZE, OR COLOR.

FOR PAINTS (U.S. CLS. 6, 11 AND 16).

FIRST USE 5-31-2012; IN COMMERCE 5-31-2012.

CLASS 3—COSMETICS AND CLEANING PREPARATIONS

CLASS 3—(Continued).

4,210,234. IT'S A 10, INC., FORT LAUDERDALE, FL. SN 76-703,186. PUB. 4-26-2011, FILED 6-1-2010.

MIRACLE FIRM HOLD GEL

THE MARK CONSISTS OF STANDARD CHARACTERS WITHOUT CLAIM TO ANY PARTICULAR FONT, STYLE, SIZE, OR COLOR.

OWNER OF U.S. REG. NOS. 3,760,933, 3,760,956, AND 3,761,012.

NO CLAIM IS MADE TO THE EXCLUSIVE RIGHT TO USE "FIRM HOLD GEL", APART FROM THE MARK AS SHOWN.

FOR HAIR CARE STYLING AIDS, NAMELY, HAIR GELS (U.S. CLS. 1, 4, 6, 50, 51 AND 52).

FIRST USE 8-4-2010; IN COMMERCE 8-4-2010.

4,210,237. LOUDER, MARY, TRAVERSE CITY, MI. SN 76-704,914. PUB. 2-21-2012, FILED 10-15-2010.

CHEEKY MONKEY CREAM

THE MARK CONSISTS OF STANDARD CHARACTERS WITHOUT CLAIM TO ANY PARTICULAR FONT, STYLE, SIZE, OR COLOR.

NO CLAIM IS MADE TO THE EXCLUSIVE RIGHT TO USE "CREAM", APART FROM THE MARK AS SHOWN.

FOR NON-MEDICATED SKIN CARE PREPARATIONS (U.S. CLS. 1, 4, 6, 50, 51 AND 52).

FIRST USE 8-1-2010; IN COMMERCE 8-1-2010.

4,210,301. BRUNO SANTERRE INC., RIVIÈRE-DU-LOUP QUEBEC, CANADA. SN 77-563,356. PUB. 11-15-2011, FILED 9-5-2008.

À LA UNE

THE MARK CONSISTS OF STANDARD CHARACTERS WITHOUT CLAIM TO ANY PARTICULAR FONT, STYLE, SIZE, OR COLOR.

PRIORITY CLAIMED UNDER SEC. 44(D) ON CANADA APPLICATION NO. 1404198, FILED 7-22-2008, REG. NO. TMA803,598, DATED 8-4-2011, EXPIRES 8-4-2026.

THE WORDING "A LA UNE" HAS NO MEANING IN A FOREIGN LANGUAGE.

FOR SUN TANNING LOTIONS (U.S. CLS. 1, 4, 6, 50, 51 AND 52).

FIRST USE 8-31-2010; IN COMMERCE 8-31-2010.

CLASS 3—(Continued).

4,210,339. SPARITUAL, L.L.C., VAN NUYS, CA. SN 77-645,567. PUB. 5-11-2010, FILED 1-8-2009.

FOOTPRINT

THE MARK CONSISTS OF STANDARD CHARACTERS WITHOUT CLAIM TO ANY PARTICULAR FONT, STYLE, SIZE, OR COLOR.

FOR NON-MEDICATED FOOT LOTION (U.S. CLS. 1, 4, 6, 50, 51 AND 52).

FIRST USE 7-23-2012; IN COMMERCE 7-23-2012.

4,210,342. MSA CONSULTING CORPORATION, SUFFERN, NY. SN 77-649,175. PUB. 5-5-2009, FILED 1-14-2009.

KARFASHION

THE MARK CONSISTS OF STANDARD CHARACTERS WITHOUT CLAIM TO ANY PARTICULAR FONT, STYLE, SIZE, OR COLOR.

FOR BLUSH; COSMETICS AND MAKE-UP; EYE LINER; EYE SHADOW; EYEBROW COSMETICS; FACE POWDER; FACIAL CONCEALER; FOUNDATION MAKE-UP; FRAGRANCES; HAIR CARE PREPARATIONS; LIP GLOSS; LIP LINER; LIPSTICK; MAKE-UP REMOVER; MASCARA; NAIL CARE PREPARATIONS; NAIL POLISH; NON-MEDICATED SKIN CARE PREPARATIONS, NAMELY, CREAMS, LOTIONS, GELS, TONERS, CLEANSERS AND PEELS; PERFUMED POWDER; PERFUMES AND COLOGNES; ROUGE (U.S. CLS. 1, 4, 6, 50, 51 AND 52).

FIRST USE 7-20-2012; IN COMMERCE 7-20-2012.

CLASS 3—(Continued).

4,210,403. SALES & PRODUCT SOLUTIONS, INC., NORTH-BROOK, IL. SN 77-870,941. PUB. 10-19-2010, FILED 11-12-2009.



THE MARK CONSISTS OF THE WORD "SNAPRODUCTS" IN A RECTANGLE WITH AN EXCLAMATION MARK OVER THE LETTER "P" WITH THREE DOTS BELOW THE EXCLAMATION MARK.

FOR BATH AND BODY CARE PRODUCTS AND ACCESSORIES, NAMELY, HOT AND COLD REUSABLE EYE COMPRESSES FOR BEAUTY AND COSMETIC USES, COSMETICS, COSMETIC PADS, BUBBLE BATHS, BATH GELS, BATH LOTIONS, NON-MEDICATED BATH SALTS, BATH PEARLS, SKIN SOAPS, BODY LOTIONS, SKIN CREAMS, BODY WASHES, BODY SPRAYS, PUMICE STONES FOR PERSONAL USE, BODY SCRUBS (U.S. CLS. 1, 4, 6, 50, 51 AND 52).

FIRST USE 12-0-2007; IN COMMERCE 12-0-2007.

4,210,454. MURAD, INC., EL SEGUNDO, CA. SN 77-927,841. PUB. 6-22-2010, FILED 2-4-2010.

EYE LUSCIOUS

THE MARK CONSISTS OF STANDARD CHARACTERS WITHOUT CLAIM TO ANY PARTICULAR FONT, STYLE, SIZE, OR COLOR.

NO CLAIM IS MADE TO THE EXCLUSIVE RIGHT TO USE "EYE", APART FROM THE MARK AS SHOWN.

FOR NON-MEDICATED SKIN CARE PREPARATIONS, NAMELY, CREAMS, LOTIONS, GELS, TONERS, CLEANSERS AND PEELS (U.S. CLS. 1, 4, 6, 50, 51 AND 52).

FIRST USE 1-0-2012; IN COMMERCE 1-0-2012.

CLASS 3—(Continued).

4,210,476. MG ICON LLC, NEW YORK, NY. SN 77-983,206.
PUB. 3-8-2011, FILED 12-9-2009.

TRUTH OR DARE

THE MARK CONSISTS OF STANDARD CHARACTERS WITHOUT CLAIM TO ANY PARTICULAR FONT, STYLE, SIZE, OR COLOR.

FOR BODY LOTION; LIQUID SOAPS FOR BODY; PERFUME (U.S. CLS. 1, 4, 6, 50, 51 AND 52).
FIRST USE 4-6-2012; IN COMMERCE 4-6-2012.

4,210,512. SPARITUAL, LLC, VAN NUYS, CA. SN 85-029,386.
PUB. 5-3-2011, FILED 5-4-2010.

SLOW

THE MARK CONSISTS OF STANDARD CHARACTERS WITHOUT CLAIM TO ANY PARTICULAR FONT, STYLE, SIZE, OR COLOR.

FOR PERFUME (U.S. CLS. 1, 4, 6, 50, 51 AND 52).
FIRST USE 7-23-2012; IN COMMERCE 7-23-2012.

4,210,541. COREBEAUTY, LLC, SAN DIEGO, CA. SN 85-058,346. PUB. 11-9-2010, FILED 6-9-2010.

MY

THE MARK CONSISTS OF STANDARD CHARACTERS WITHOUT CLAIM TO ANY PARTICULAR FONT, STYLE, SIZE, OR COLOR.

FOR SKIN CREAMS, SKIN LOTIONS, NON-MEDICATED SKIN SERUMS (U.S. CLS. 1, 4, 6, 50, 51 AND 52).
FIRST USE 3-15-2012; IN COMMERCE 3-15-2012.

CLASS 3—(Continued).

4,210,565. JOHNSON & JOHNSON, NEW BRUNSWICK, NJ. SN 85-075,982. PUB. 5-31-2011, FILED 7-1-2010.

FAB BUBBLE GUM

THE MARK CONSISTS OF STANDARD CHARACTERS WITHOUT CLAIM TO ANY PARTICULAR FONT, STYLE, SIZE, OR COLOR.

NO CLAIM IS MADE TO THE EXCLUSIVE RIGHT TO USE "BUBBLE GUM", APART FROM THE MARK AS SHOWN.

FOR NON-MEDICATED MOUTHRINSE (U.S. CLS. 1, 4, 6, 50, 51 AND 52).
FIRST USE 2-11-2011; IN COMMERCE 2-11-2011.

4,210,650. FARÉCLA PRODUCTS LIMITED, HERTFORDSHIRE, UNITED KINGDOM. SN 85-143,269. PUB. 3-15-2011, FILED 10-1-2010.

FAST TRACK

THE MARK CONSISTS OF STANDARD CHARACTERS WITHOUT CLAIM TO ANY PARTICULAR FONT, STYLE, SIZE, OR COLOR.

FOR SURFACE TREATMENT PREPARATIONS AND COMPOUNDS IN THE NATURE OF ABRASIVE, RUBBING AND POLISHING COMPOUNDS FOR USE ON METAL, FIBERGLASS AND PAINTED SURFACES; CLEANING AND SCOURING PREPARATIONS AND COMPOUNDS; GENERAL PURPOSE ABRASIVE LIQUIDS AND POWDERS AND GENERAL PURPOSE POLISHING PREPARATIONS; GLAZES IN THE NATURE OF BUFFING COMPOUNDS FOR USE ON METAL, FIBERGLASS AND PAINTED SURFACES AND POLISHING WAXES (U.S. CLS. 1, 4, 6, 50, 51 AND 52).
FIRST USE 8-0-2008; IN COMMERCE 9-0-2008.

4,210,668. TRISH MCEVOY, LTD., NEW YORK, NY. SN 85-157,400. PUB. 10-25-2011, FILED 10-20-2010.

**Trish McEvoy Intense
Coverage Concealer**

THE MARK CONSISTS OF STANDARD CHARACTERS WITHOUT CLAIM TO ANY PARTICULAR FONT, STYLE, SIZE, OR COLOR.

NO CLAIM IS MADE TO THE EXCLUSIVE RIGHT TO USE "COVERAGE CONCEALER", APART FROM THE MARK AS SHOWN.

CLASS 3—(Continued).

THE NAME(S), PORTRAIT(S), AND/OR SIGNATURE(S) SHOWN IN THE MARK IDENTIFIES "TRISH MCEVOY", WHOSE CONSENT(S) TO REGISTER IS MADE OF RECORD.

FOR COSMETIC GOODS, NAMELY, SKIN CONCEALER (U.S. CLS. 1, 4, 6, 50, 51 AND 52).

FIRST USE 10-20-2010; IN COMMERCE 10-20-2010.

4,210,713. WILKIE, MARTHA, KINGWOOD, TX. SN 85-189,087. PUB. 5-3-2011, FILED 12-2-2010.



THE MARK CONSISTS OF THE STYLIZED TEXT "BATHOLOGY THE SCIENCE OF RELAXATION" AND A VINE DESIGN.

FOR AFTER-SHAVE; ALL-PURPOSE CLEANERS; ANTIBACTERIAL SOAP; AROMATIC BODY CARE PRODUCTS, NAMELY, BODY LOTION, SHOWER GEL, CUTICLE CREAM, SHAMPOO, CONDITIONER, NON-MEDICATED LIP BALM, SOAP, BODY POLISH, BODY AND FOOT SCRUB AND NON-MEDICATED FOOT CREAM; AROMATIC EVAPORATING BATH AND SHOWER BALLS IN THE NATURE OF SCENTED BATH FIZZIES; BATH AND SHOWER GELS AND SALTS NOT FOR MEDICAL PURPOSES; BATH OILS AND BATH SALTS; BATH SOAPS IN LIQUID, SOLID OR GEL FORM; BODY BUTTER; HAND AND BODY CREAM; GLITTER FOR COSMETIC PURPOSES; LOTIONS FOR SKIN, FACE, BODY; BODY SPRAY USED AS A PERSONAL DEODORANT AND AS FRAGRANCE; BUBBLE BATH; COLOGNES, PERFUMES AND COSMETICS; DETERGENTS FOR HOUSEHOLD USE; FOOT DEODORANT SPRAY; FOOT POWDER; FOOT SCRUBS; FOOT SMOOTHING STONES; GIFT BASKETS CONTAINING NON-MEDICATED BATH PREPARATIONS AND COSMETIC PREPARATIONS; LIQUID SOAPS FOR HANDS, FACE AND BODY; PET CARE KITS COMPRISING SHAMPOO, CONDITIONER, BODY SPRAY; ROOM FRAGRANCES (U.S. CLS. 1, 4, 6, 50, 51 AND 52).

FIRST USE 11-1-2010; IN COMMERCE 11-1-2010.

4,210,717. BON VITAL INCORPORATED, HARTLAND, WI. SN 85-190,167. PUB. 10-25-2011, FILED 12-3-2010.

P.T. PRO

THE MARK CONSISTS OF STANDARD CHARACTERS WITHOUT CLAIM TO ANY PARTICULAR FONT, STYLE, SIZE, OR COLOR.

NO CLAIM IS MADE TO THE EXCLUSIVE RIGHT TO USE "P.T.", APART FROM THE MARK AS SHOWN.

FOR SKIN CARE PREPARATIONS, NAMELY, SKIN CREAMS, OILS, BALMS, NON-MEDICATED OINTMENTS, LOTIONS, GELS, AND BODY POLISH (U.S. CLS. 1, 4, 6, 50, 51 AND 52).

FIRST USE 7-31-2011; IN COMMERCE 7-31-2011.

CLASS 3—(Continued).

4,210,747. BRANDED LLC, DALLAS, TX. SN 85-202,429. PUB. 5-10-2011, FILED 12-21-2010.

Jamaica Joe

THE MARK CONSISTS OF STANDARD CHARACTERS WITHOUT CLAIM TO ANY PARTICULAR FONT, STYLE, SIZE, OR COLOR.

THE NAME(S), PORTRAIT(S), AND/OR SIGNATURE(S) SHOWN IN THE MARK DOES NOT IDENTIFY A PARTICULAR LIVING INDIVIDUAL.

FOR SUNBLOCK PREPARATIONS; SUNSCREEN PREPARATIONS; SKIN LOTIONS; NON-MEDICATED LIP BALM (U.S. CLS. 1, 4, 6, 50, 51 AND 52).

FIRST USE 7-5-2012; IN COMMERCE 7-5-2012.

4,210,780. IT COSMETICS, JERSEY CITY, NJ. SN 85-211,951. PUB. 5-17-2011, FILED 1-6-2011.

Celebration Foundation

THE MARK CONSISTS OF STANDARD CHARACTERS WITHOUT CLAIM TO ANY PARTICULAR FONT, STYLE, SIZE, OR COLOR.

NO CLAIM IS MADE TO THE EXCLUSIVE RIGHT TO USE "FOUNDATION", APART FROM THE MARK AS SHOWN.

FOR COSMETIC PREPARATIONS; COSMETIC PREPARATIONS FOR BODY CARE; COSMETIC PREPARATIONS FOR SKIN CARE; COSMETIC WHITE FACE POWDER; COSMETICS; COSMETICS AND COSMETIC PREPARATIONS; COSMETICS AND MAKE-UP; SOLID POWDER FOR COMPACTS; WRINKLE-MINIMIZING COSMETIC PREPARATIONS FOR TOPICAL FACIAL USE (U.S. CLS. 1, 4, 6, 50, 51 AND 52).

FIRST USE 4-0-2012; IN COMMERCE 4-0-2012.

4,210,785. INDUSTRIAS ALEN, S.A. DE C.V., N.L., MEXICO. SN 85-212,874. PUB. 5-24-2011, FILED 1-7-2011.

ULTRA ENSUEÑO MAX

THE MARK CONSISTS OF STANDARD CHARACTERS WITHOUT CLAIM TO ANY PARTICULAR FONT, STYLE, SIZE, OR COLOR.

OWNER OF U.S. REG. NOS. 2,094,530, 3,331,728, AND OTHERS.

CLASS 3—(Continued).

THE ENGLISH TRANSLATION OF THE WORD "ENSUE-
NO" IN THE MARK IS DREAM OR DAYDREAM.
FOR FABRIC SOFTENERS (U.S. CLS. 1, 4, 6, 50, 51
AND 52).
FIRST USE 7-31-2012; IN COMMERCE 7-31-2012.

4,210,796. IT'S A 10, INC., FORT LAUDERDALE, FL. SN 85-
216,013. PUB. 11-1-2011, FILED 1-12-2011.

MIRACLE STYLING CREAM

THE MARK CONSISTS OF STANDARD CHARACTERS
WITHOUT CLAIM TO ANY PARTICULAR FONT, STYLE,
SIZE, OR COLOR.
NO CLAIM IS MADE TO THE EXCLUSIVE RIGHT TO
USE "STYLING CREAM", APART FROM THE MARK AS
SHOWN.
FOR HAIR CARE STYLING AIDS, NAMELY, HAIR
CREAMS (U.S. CLS. 1, 4, 6, 50, 51 AND 52).
FIRST USE 3-29-2011; IN COMMERCE 3-29-2011.

4,210,830. THE PROCTER & GAMBLE COMPANY, CINCIN-
NATI, OH. SN 85-231,961. PUB. 6-7-2011, FILED 2-2-2011.

SPRING COTTON

THE MARK CONSISTS OF STANDARD CHARACTERS
WITHOUT CLAIM TO ANY PARTICULAR FONT, STYLE,
SIZE, OR COLOR.
FOR ANTIPERSPIRANTS, DEODORANTS AND FRA-
GRANT BODY SPRAY (U.S. CLS. 1, 4, 6, 50, 51 AND 52).
FIRST USE 2-5-2012; IN COMMERCE 2-5-2012.

4,210,865. IT'S A 10, INC., FORT LAUDERDALE, FL. SN 85-
243,477. PUB. 11-1-2011, FILED 2-16-2011.

MIRACLE FINISHING SPRAY

THE MARK CONSISTS OF STANDARD CHARACTERS
WITHOUT CLAIM TO ANY PARTICULAR FONT, STYLE,
SIZE, OR COLOR.
OWNER OF U.S. REG. NOS. 3,760,933, 3,760,956, AND
3,761,012.

CLASS 3—(Continued).

NO CLAIM IS MADE TO THE EXCLUSIVE RIGHT TO USE
"FINISHING SPRAY", APART FROM THE MARK AS
SHOWN.
FOR HAIR CARE PRODUCTS, NAMELY, STYLING
SPRAYS (U.S. CLS. 1, 4, 6, 50, 51 AND 52).
FIRST USE 3-25-2011; IN COMMERCE 3-25-2011.

4,210,866. IT'S A 10, INC., FORT LAUDERDALE, FL. SN 85-
243,483. PUB. 11-1-2011, FILED 2-16-2011.

MIRACLE OIL PLUS KERATIN

THE MARK CONSISTS OF STANDARD CHARACTERS
WITHOUT CLAIM TO ANY PARTICULAR FONT, STYLE,
SIZE, OR COLOR.
OWNER OF U.S. REG. NOS. 3,760,933, 3,760,956, AND
3,761,012.
NO CLAIM IS MADE TO THE EXCLUSIVE RIGHT TO
USE "OIL PLUS KERATIN", APART FROM THE MARK AS
SHOWN.
FOR HAIR CARE PRODUCTS, NAMELY, OIL PRE-
PARATION FOR HAIR (U.S. CLS. 1, 4, 6, 50, 51 AND 52).
FIRST USE 12-2-2011; IN COMMERCE 12-2-2011.

4,210,867. IT'S A 10, INC., FORT LAUDERDALE, FL. SN 85-
243,490. PUB. 10-25-2011, FILED 2-16-2011.

MIRACLE VOLUME SHAMPOO

THE MARK CONSISTS OF STANDARD CHARACTERS
WITHOUT CLAIM TO ANY PARTICULAR FONT, STYLE,
SIZE, OR COLOR.
OWNER OF U.S. REG. NOS. 3,760,933, 3,760,956, AND
3,761,012.
NO CLAIM IS MADE TO THE EXCLUSIVE RIGHT TO
USE "VOLUME SHAMPOO", APART FROM THE MARK AS
SHOWN.
FOR HAIR CARE PRODUCTS, NAMELY, SHAMPOOS
(U.S. CLS. 1, 4, 6, 50, 51 AND 52).
FIRST USE 2-16-2012; IN COMMERCE 2-16-2012.

CLASS 3—(Continued).

4,210,868. IT'S A 10, INC., FORT LAUDERDALE, FL. SN 85-243,515. PUB. 10-25-2011, FILED 2-16-2011.

MIRACLE SHAMPOO PLUS KERATIN

THE MARK CONSISTS OF STANDARD CHARACTERS WITHOUT CLAIM TO ANY PARTICULAR FONT, STYLE, SIZE, OR COLOR.

OWNER OF U.S. REG. NOS. 3,760,933, 3,760,956, AND 3,761,012.

NO CLAIM IS MADE TO THE EXCLUSIVE RIGHT TO USE "SHAMPOO PLUS KERATIN", APART FROM THE MARK AS SHOWN.

FOR HAIR CARE PRODUCTS, NAMELY, SHAMPOOS (U.S. CLS. 1, 4, 6, 50, 51 AND 52).

FIRST USE 12-2-2011; IN COMMERCE 12-2-2011.

4,210,911. L'OREAL USA CREATIVE, INC., NEW YORK, NY. SN 85-264,521. PUB. 7-26-2011, FILED 3-11-2011.

MEGA PLUSH

THE MARK CONSISTS OF STANDARD CHARACTERS WITHOUT CLAIM TO ANY PARTICULAR FONT, STYLE, SIZE, OR COLOR.

FOR MASCARA (U.S. CLS. 1, 4, 6, 50, 51 AND 52).

FIRST USE 5-1-2012; IN COMMERCE 5-1-2012.

4,210,912. PRODUCT INNOVATIONS RESEARCH LLC, DALLAS, TX. SN 85-264,751. PUB. 1-31-2012, FILED 3-11-2011.

Winning!

THE MARK CONSISTS OF STANDARD CHARACTERS WITHOUT CLAIM TO ANY PARTICULAR FONT, STYLE, SIZE, OR COLOR.

FOR INDOOR TANNING PRODUCTS, NAMELY, NON-MEDICATED SKIN TAN DARKENING LOTIONS AND MOISTURIZERS (U.S. CLS. 1, 4, 6, 50, 51 AND 52).

FIRST USE 10-15-2011; IN COMMERCE 11-1-2011.

CLASS 3—(Continued).

4,210,913. GLOBAL BEAUTY CARE INC., BROOKLYN, NY. SN 85-266,575. PUB. 2-21-2012, FILED 3-14-2011.

DEAD SEA ELEMENTS

THE MARK CONSISTS OF STANDARD CHARACTERS WITHOUT CLAIM TO ANY PARTICULAR FONT, STYLE, SIZE, OR COLOR.

NO CLAIM IS MADE TO THE EXCLUSIVE RIGHT TO USE "DEAD SEA", APART FROM THE MARK AS SHOWN.

FOR BODY AND BEAUTY CARE COSMETICS; BODY LOTIONS; CLEANSING CREAMS; COSMETIC CREAMS FOR SKIN CARE; COSMETIC PADS; COSMETIC SKIN FRESHENERS; COSMETIC TANNING PREPARATIONS; COSMETICS; EYE MAKE-UP REMOVER; FACIAL LOTION; HAIR CARE LOTIONS; HAIR COLOR REMOVERS; HAIR REMOVING CREAM; HAND LOTIONS; LIQUID SOAPS; MAKE UP REMOVING PREPARATIONS; MAKE-UP REMOVER; MAKE-UP REMOVING LOTIONS; NAIL POLISH REMOVER; PRE-MOISTENED COSMETIC WIPES; SELF-TANNING PREPARATIONS; SKIN BRONZING CREAMS; SKIN CLARIFIERS; SKIN CLEANSERS; SKIN CLEANSING CREAM; SKIN CLEANSING LOTION; SKIN CREAMS; SKIN MOISTURIZER; SKIN TONERS; SUN BLOCK; WIPES IMPREGNATED WITH A SKIN CLEANSER; WRINKLE REMOVING SKIN CARE PREPARATIONS; ALL THE FOREGOING CONSISTING OF DEAD SEA SALTS AND MINERALS (U.S. CLS. 1, 4, 6, 50, 51 AND 52).

FIRST USE 1-1-2012; IN COMMERCE 1-1-2012.

4,210,923. SASI HOLDINGS PTY LTD, ENGLISHTOWN, NJ. SN 85-276,106. PUB. 11-15-2011, FILED 3-24-2011.



OWNER OF U.S. REG. NO. 3,980,389.
THE MARK CONSISTS OF THE STYLIZED WORDING "O&M".

FOR NON-MEDICATED HAIR CARE PREPARATIONS, NAMELY, HAIR BLEACHES, COLORANTS, DYES, AND COLOR REMOVERS, CONDITIONERS, STYLING FIXATIVES IN THE NATURE OF HAIR WAX, GELS, GLAZE, HAIR RESTORATION PREPARATIONS, LACQUERS, HAIR WAX, LOTIONS, MASKS, MOUSSE, OILS, RELAXERS, HAIR STRAIGHTENING PREPARATION, RINSES, SHAMPOOS, SHINE SERUMS, SPRAYS, STYLING PREPARATIONS, THICKENING CONTROL CREAMS, TONICS, AND TREATMENT PREPARATIONS FOR COSMETIC PURPOSES; HAIR KITS COMPRISING OF NON-MEDICATED HAIR CARE PREPARATIONS (U.S. CLS. 1, 4, 6, 50, 51 AND 52).

FIRST USE 1-16-2012; IN COMMERCE 1-16-2012.

CLASS 3—(Continued).

4,210,955. SHIRAN PTY LTD, HALLAM, AUSTRALIA. SN 85-297,259. PUB. 10-25-2011, FILED 4-17-2011.



PRIORITY CLAIMED UNDER SEC. 44(D) ON AUSTRALIA APPLICATION NO. 1408880, FILED 2-24-2011.

THE MARK CONSISTS OF THE WORDING "ISTAR" AND AN IMAGE OF A STAR.

THE WORDING "ISTAR" HAS NO MEANING IN A FOREIGN LANGUAGE.

FOR NON-MEDICATED HAIR CARE PREPARATIONS; NON-MEDICATED PREPARATIONS FOR THE CARE OF HAIR AND SCALP; HAIR WAX; COSMETIC HAIR DRESSING PREPARATIONS; FRAGRANCES AND PERFUMERY (U.S. CLS. 1, 4, 6, 50, 51 AND 52).

FIRST USE 9-15-2010; IN COMMERCE 2-1-2012.

4,211,027. NRCOMMUNICATION CO., LTD., SEOUL, REPUBLIC OF KOREA. SN 85-327,981. PUB. 4-17-2012, FILED 5-23-2011.



THE MARK CONSISTS OF A STYLIZED CHINESE CHARACTER PLACED ABOVE A STYLIZED KOREAN CHARACTER.

THE NON-LATIN CHARACTERS IN THE MARK TRANSLITERATE TO SOOYAN AND THIS HAS NO MEANING IN A FOREIGN LANGUAGE.

FOR AFTER-SUN LOTIONS; BAR SOAP; BEAUTY LOTIONS; BEAUTY SOAP; COSMETIC PREPARATIONS FOR SLIMMING PURPOSES; COSMETIC PREPARATIONS, NAMELY, FIRING LOTIONS; COSMETIC SOAPS; COSMETIC SUNSCREEN PREPARATIONS; FACE AND BODY LOTIONS; FACIAL CLEANSERS; FACIAL CREAMS; FACIAL MASKS; FACIAL MOISTURIZER WITH SPF; FACIAL SCRUBS; FACIAL WASHES; HAND SOAPS; LIQUID SOAP; LOTIONS FOR CELLULITE REDUCTION; LOTIONS FOR COSMETIC PURPOSES; LOTIONS FOR FACE AND BODY CARE; MAKE-UP REMOVING LOTIONS; MASK PACK FOR COSMETIC PURPOSES; PERFUMES AND TOILET WATERS; SUN CARE LOTIONS; SUN TAN LOTION; SUN-BLOCK LOTIONS; SUN-TANNING OILS AND LOTIONS; SUNSCREEN CREAMS; TOILET WATER; TONING LOTION, FOR THE FACE, BODY AND HANDS (U.S. CLS. 1, 4, 6, 50, 51 AND 52).

FIRST USE 6-20-2011; IN COMMERCE 6-20-2011.

CLASS 3—(Continued).

4,211,045. BEE-ALIVE, INC., VALLEY COTTAGE, NY. SN 85-331,563. PUB. 11-1-2011, FILED 5-26-2011.

BEEALIVE SPA ESSENTIALS

THE MARK CONSISTS OF STANDARD CHARACTERS WITHOUT CLAIM TO ANY PARTICULAR FONT, STYLE, SIZE, OR COLOR.

OWNER OF U.S. REG. NOS. 1,529,237, 2,491,323, AND OTHERS.

NO CLAIM IS MADE TO THE EXCLUSIVE RIGHT TO USE "SPA", APART FROM THE MARK AS SHOWN.

FOR NON-MEDICATED SKIN CARE PRODUCTS, NAMELY, SKIN CLEANSER, SKIN TONER, SKIN MOISTURIZER, HAND LOTION, AND NON-MEDICATED PROFESSIONAL SKIN CARE PRODUCTS, NAMELY, AGE SPOT AND PIGMENT LIGHTENING GELS, EXFOLIATING CREAMS, MOISTURIZING AND ACNE PRONE SKIN FORMULA, NAMELY, LOTIONS, SERUMS, AND MOISTURIZERS; LOTIONS FOR BODY, FACE, AND HAIR; PERFUMERY PRODUCTS, NAMELY, PERFUMES, EAU DE COLOGNE, PERFUMED WATER, SKIN LOTIONS, SOAPS, BATH AND SHOWER FOAMING COMPOSITIONS AND GELS; COSMETICS, NAMELY, CREAMS, GELS, MILKS, POWDERS AND LOTIONS FOR THE FACE AND BODY (U.S. CLS. 1, 4, 6, 50, 51 AND 52).

FIRST USE 1-16-2012; IN COMMERCE 1-16-2012.

4,211,049. VICTORIA'S SECRET STORES BRAND MANAGEMENT, INC., REYNOLDSBURG, OH. SN 85-332,436. PUB. 11-1-2011, FILED 5-27-2011.

COLOR LUST

THE MARK CONSISTS OF STANDARD CHARACTERS WITHOUT CLAIM TO ANY PARTICULAR FONT, STYLE, SIZE, OR COLOR.

NO CLAIM IS MADE TO THE EXCLUSIVE RIGHT TO USE "COLOR", APART FROM THE MARK AS SHOWN.

FOR LIP GLOSS (U.S. CLS. 1, 4, 6, 50, 51 AND 52).

FIRST USE 10-31-2011; IN COMMERCE 10-31-2011.

CLASS 3—(Continued).

4,211,068. PC DESIGN, TANGER, MOROCCO. SN 85-335,899. PUB. 11-29-2011, FILED 6-2-2011.



NO CLAIM IS MADE TO THE EXCLUSIVE RIGHT TO USE "NEW BRAND PERFUMES", APART FROM THE MARK AS SHOWN.

THE MARK CONSISTS OF TWO CONCENTRIC CIRCLES THE INITIALS "NBP" WITHIN A CIRCLE WITH THE WORDING "NEW BRAND PERFUMES" APPEARING AT THE TOP AND BOTTOM OF ANOTHER CIRCLE ENCASING THE FIRST CIRCLE AND THERE ARE TWO DOTS APPEARING DIRECTLY ACROSS FROM EACH OTHER SEPARATING THE WORDING.

FOR PERFUMERY PRODUCTS IN THE NATURE OF PERFUME; ESSENTIAL OILS; COSMETIC PRODUCTS IN THE NATURE OF COSMETICS, COSMETIC CREAMS, COSMETIC MILKS AND COSMETIC PREPARATIONS FOR BODY CARE; HAIR LOTIONS (U.S. CLS. 1, 4, 6, 50, 51 AND 52).

FIRST USE 1-31-2012; IN COMMERCE 1-31-2012.

4,211,077. INTERNATIONAL PERFUME PALACE INCORPORATED, PLAINVIEW, NY. SN 85-337,383. PUB. 10-25-2011, FILED 6-3-2011.

TR TONY RAKANA

THE MARK CONSISTS OF STANDARD CHARACTERS WITHOUT CLAIM TO ANY PARTICULAR FONT, STYLE, SIZE, OR COLOR.

THE NAME "TONY RAKANA" DOES NOT IDENTIFY A LIVING INDIVIDUAL.

FOR AFTERSHAVE; BAR SOAP; BATH SOAPS; BATH SOAPS IN LIQUID, SOLID OR GEL FORM; BEAUTY CREAMS; BODY CREAM; BODY DEODORANTS; BODY LOTIONS; BODY SPRAY USED AS A PERSONAL DEODORANT AND AS FRAGRANCE; COLOGNE; COLOGNE WATER; EAU DE COLOGNE; FACIAL LOTION; FRAGRANCES; NON-MEDICATED SKIN CARE PREPARATION, NAMELY, BODY MIST; PERFUMED SOAP; PERFUMES AND COLOGNES; PERFUMES, AFTERSHAVES AND COLOGNES; SHOWER AND BATH GEL; SHOWER GEL; TOILET WATER (U.S. CLS. 1, 4, 6, 50, 51 AND 52).

FIRST USE 1-0-2012; IN COMMERCE 1-0-2012.

CLASS 3—(Continued).

4,211,087. INTERNATIONAL PERFUME PALACE INCORPORATED, PLAINVIEW, NY. SN 85-338,218. PUB. 10-25-2011, FILED 6-4-2011.

TONY RAKANA

THE MARK CONSISTS OF STANDARD CHARACTERS WITHOUT CLAIM TO ANY PARTICULAR FONT, STYLE, SIZE, OR COLOR.

THE NAME "TONY RAKANA" DOES NOT IDENTIFY A LIVING INDIVIDUAL.

FOR AFTERSHAVE; BAR SOAP; BATH SOAPS; BATH SOAPS IN LIQUID, SOLID OR GEL FORM; BEAUTY CREAMS; BODY CREAM; BODY DEODORANTS; BODY LOTIONS; BODY SPRAY USED AS A PERSONAL DEODORANT AND AS FRAGRANCE; COLOGNE; COLOGNE WATER; EAU DE COLOGNE; FACIAL LOTION; FRAGRANCES; NON-MEDICATED SKIN CARE PREPARATION, NAMELY, BODY MIST; PERFUMED SOAP; PERFUMES AND COLOGNES; PERFUMES, AFTERSHAVES AND COLOGNES; SHOWER AND BATH GEL; SHOWER GEL; TOILET WATER (U.S. CLS. 1, 4, 6, 50, 51 AND 52).

FIRST USE 1-0-2012; IN COMMERCE 1-0-2012.

4,211,088. INTERNATIONAL PERFUME PALACE INCORPORATED, PLAINVIEW, NY. SN 85-338,219. PUB. 10-25-2011, FILED 6-4-2011.

HAMPTON GIRLS

THE MARK CONSISTS OF STANDARD CHARACTERS WITHOUT CLAIM TO ANY PARTICULAR FONT, STYLE, SIZE, OR COLOR.

FOR BODY DEODORANTS; BODY SPRAY USED AS A PERSONAL DEODORANT AND AS FRAGRANCE; COLOGNE; COLOGNE WATER; EAU DE COLOGNE; FRAGRANCES; NON-MEDICATED SKIN CARE PREPARATION, NAMELY, BODY MIST; PERFUMES AND COLOGNES; TOILET WATER (U.S. CLS. 1, 4, 6, 50, 51 AND 52).

FIRST USE 5-0-2012; IN COMMERCE 5-0-2012.

CLASS 3—(Continued).

4,211,089. INTERNATIONAL PERFUME PALACE INCORPORATED, PLAINVIEW, NY. SN 85-338,223. PUB. 10-25-2011, FILED 6-4-2011.

TONY RAKANA DYNAMIC

THE MARK CONSISTS OF STANDARD CHARACTERS WITHOUT CLAIM TO ANY PARTICULAR FONT, STYLE, SIZE, OR COLOR.

THE NAME "TONY RAKANA" DOES NOT IDENTIFY A LIVING INDIVIDUAL.

FOR AFTERSHAVE; BAR SOAP; BATH SOAPS; BATH SOAPS IN LIQUID, SOLID OR GEL FORM; BEAUTY CREAMS; BODY CREAM; BODY DEODORANTS; BODY LOTIONS; BODY SPRAY USED AS A PERSONAL DEODORANT AND AS FRAGRANCE; COLOGNE; COLOGNE WATER; EAU DE COLOGNE; FACIAL LOTION; FRAGRANCES; NON-MEDICATED SKIN CARE PREPARATION, NAMELY, BODY MIST; PERFUMED SOAP; PERFUMES AND COLOGNES; PERFUMES, AFTERSHAVES AND COLOGNES; SHOWER AND BATH GEL; SHOWER GEL; TOILET WATER (U.S. CLS. 1, 4, 6, 50, 51 AND 52).

FIRST USE 2-0-2012; IN COMMERCE 2-0-2012.

4,211,100. DR. RYAMOND LABORATORIES, INC., RUMSON, NJ. SN 85-340,456. PUB. 10-25-2011, FILED 6-7-2011.

PSORIAPALM

THE MARK CONSISTS OF STANDARD CHARACTERS WITHOUT CLAIM TO ANY PARTICULAR FONT, STYLE, SIZE, OR COLOR.

FOR SKIN CREAMS, SKIN LOTIONS, SHAMPOOS (U.S. CLS. 1, 4, 6, 50, 51 AND 52).

FIRST USE 2-10-2010; IN COMMERCE 2-10-2010.

CLASS 3—(Continued).

4,211,106. HOMAX PRODUCTS, INC., BELLINGHAM, WA. SN 85-341,639. PUB. 11-1-2011, FILED 6-8-2011.

WITH STAY CLEAN TECHNOLOGY

THE MARK CONSISTS OF STANDARD CHARACTERS WITHOUT CLAIM TO ANY PARTICULAR FONT, STYLE, SIZE, OR COLOR.

FOR CLEANING PREPARATIONS; CLEANING PREPARATIONS FOR HOUSEHOLD PURPOSES; HOUSEHOLD CLEANING PREPARATIONS; CLEANING PREPARATIONS FOR HARD SURFACES; CLEANING PREPARATIONS FOR METAL SURFACES SUCH AS STAINLESS STEEL, CHROME, BRONZE, AND COPPER; CLEANING PREPARATIONS FOR RANGE AND STOVE SURFACES; CLEANING PREPARATIONS FOR COUNTER SURFACES; CLEANING PREPARATIONS FOR CABINET SURFACES; CLEANING PREPARATIONS FOR EATING AND COOKING IMPLEMENTS AND UTENSILS SUCH AS SILVERWARE, DISHES, POTS, AND PANS; CLEANING PREPARATIONS FOR WOOD; CLEANING PREPARATIONS FOR LEATHER; CLEANING PREPARATIONS FOR STONE SURFACES SUCH AS MARBLE SURFACES AND GRANITE SURFACES; CLEANING PREPARATIONS FOR TILE AND GROUT; CLEANING PREPARATIONS FOR CLEANING, PROTECTING, AND PRESERVING VEHICLE SURFACES; ALL PURPOSE CLEANING PREPARATIONS; AUTOMOTIVE CLEANING PREPARATIONS; GENERAL PURPOSE CLEANING AND POLISHING LIQUIDS; CLEANING PREPARATIONS FOR CARPETS; STAIN REMOVERS; PET STAIN REMOVERS; STAIN REMOVERS FOR REMOVING STAINS CAUSED BY MOLD; STAIN REMOVERS FOR REMOVING STAINS CAUSED BY MILDEW (U.S. CLS. 1, 4, 6, 50, 51 AND 52).

FIRST USE 12-31-2011; IN COMMERCE 12-31-2011.

4,211,139. INTERNATIONAL PERFUME PALACE INCORPORATED, PLAINVIEW, NY. SN 85-345,578. PUB. 10-25-2011, FILED 6-14-2011.

TONY RAKANA BLACK

THE MARK CONSISTS OF STANDARD CHARACTERS WITHOUT CLAIM TO ANY PARTICULAR FONT, STYLE, SIZE, OR COLOR.

THE NAME "TONY RAKANA" DOES NOT IDENTIFY A LIVING INDIVIDUAL.

FOR BODY DEODORANTS; BODY SPRAY USED AS A PERSONAL DEODORANT AND AS FRAGRANCE; COLOGNE; COLOGNE WATER; EAU DE COLOGNE; FRAGRANCES; NON-MEDICATED SKIN CARE PREPARATION, NAMELY, BODY MIST; PERFUMES AND COLOGNES; TOILET WATER (U.S. CLS. 1, 4, 6, 50, 51 AND 52).

FIRST USE 5-0-2012; IN COMMERCE 5-0-2012.

CLASS 3—(Continued).

4,211,144. D' CINQUE HAIR SCIENCE, LLC, NEWPORT BEACH, CA. SN 85-346,195. PUB. 11-1-2011, FILED 6-14-2011.

COLORCONSTRUCT

THE MARK CONSISTS OF STANDARD CHARACTERS WITHOUT CLAIM TO ANY PARTICULAR FONT, STYLE, SIZE, OR COLOR.
FOR HAIR CARE PREPARATIONS (U.S. CLS. 1, 4, 6, 50, 51 AND 52).
FIRST USE 7-31-2011; IN COMMERCE 7-31-2011.

4,211,170. PACHOPOS, GEORGIOS, ATHENS, GREECE. SN 85-348,722. PUB. 11-8-2011, FILED 6-17-2011.



**YELLOW
ROSE**

OWNER OF GREECE REG. NO. 1046628, DATED 12-21-2009, EXPIRES 12-21-2019.
THE MARK CONSISTS OF THE DESIGN OF A ROSE INSIDE A ROUNDED CORNER SQUARE WITH THE STYLIZED WORD "YELLOW" BELOW THE DESIGN AND THE STYLIZED WORD "ROSE" BELOW THE WORD "YELLOW".
FOR COSMETICS; BEAUTY PRODUCTS, NAMELY, FACE, BODY AND HAND LOTIONS, CREAMS, GELS, MASKS, SERUMS, SCRUBS AND GELS (U.S. CLS. 1, 4, 6, 50, 51 AND 52).
FIRST USE 4-25-1968; IN COMMERCE 5-10-1974.

CLASS 3—(Continued).

4,211,216. BURT'S BEES, INC., DURHAM, CA. SN 85-355,522. PUB. 4-17-2012, FILED 6-24-2011.



NO CLAIM IS MADE TO THE EXCLUSIVE RIGHT TO USE "HYACINTH" AND "BLOOD ORANGE", APART FROM THE MARK AS SHOWN.
THE COLOR(S) DARK ORANGE, LIGHT ORANGE AND WHITE IS/ARE CLAIMED AS A FEATURE OF THE MARK.
THE MARK CONSISTS OF THE PHRASE "SOFT HYACINTH. BLOOD ORANGE. THAT'S WHAT LAUGHTER SMELLS LIKE." IN WHITE LETTERING, APPEARING ON AN IMAGE THAT RESEMBLES THE CROSS SECTION OF AN ORANGE SLICE. EACH ORANGE SEGMENT OF THE SLICE IS DARK ORANGE AND OUTLINED IN LIGHT ORANGE. TWO OF THE SEGMENTS ON THE BOTTOM RIGHT CONTAIN PATTERNS: ONE IS JUICE DROPS AND THE OTHER IS FLORAL.
FOR BODY MIST AND PERFUME (U.S. CLS. 1, 4, 6, 50, 51 AND 52).
FIRST USE 12-8-2011; IN COMMERCE 12-8-2011.

4,211,218. BURT'S BEES, INC., DURHAM, NC. SN 85-355,594. PUB. 4-17-2012, FILED 6-24-2011.



NO CLAIM IS MADE TO THE EXCLUSIVE RIGHT TO USE "RICE MILK AND VANILLA", APART FROM THE MARK AS SHOWN.
THE COLOR(S) BROWN, GOLD, LIGHT YELLOW, ORANGE AND WHITE IS/ARE CLAIMED AS A FEATURE OF THE MARK.

CLASS 3—(Continued).

THE MARK CONSISTS OF THE PHRASE "RICE MILK AND VANILLA. INTOXICATING. AND LEGAL." IN WHITE LETTERING, APPEARING ON A STAR-SHAPED FLOWER OUTLINED IN BROWN AND FILLED WITH A GOLD AND ORANGE WASH. AT THE CENTER OF THE FLOWER IS A BROWN CIRCLE WITH A LIGHT YELLOW STAR RADIATING FROM IT. THE LEFT AND TOP PETALS HAVE TWO DIFFERENT FLORAL PATTERNS APPEARING WITHIN THEM.

FOR BODY MIST AND PERFUME (U.S. CLS. 1, 4, 6, 50, 51 AND 52).
FIRST USE 12-8-2011; IN COMMERCE 12-8-2011.

4,211,224. CONOPCO, INC., ENGLEWOOD CLIFFS, NJ. SN 85-355,893. PUB. 10-25-2011, FILED 6-24-2011.

PASSIONATE SPELL

THE MARK CONSISTS OF STANDARD CHARACTERS WITHOUT CLAIM TO ANY PARTICULAR FONT, STYLE, SIZE, OR COLOR.

FOR BODY CLEANSING WASH AND SOAP BARS (U.S. CLS. 1, 4, 6, 50, 51 AND 52).
FIRST USE 5-0-2012; IN COMMERCE 5-0-2012.

4,211,244. BURT'S BEES, INC., DURHAM, NC. SN 85-358,035. PUB. 4-17-2012, FILED 6-28-2011.

SOFT HYACINTH. BLOOD ORANGE. THAT'S WHAT LAUGHTER SMELLS LIKE.

THE MARK CONSISTS OF STANDARD CHARACTERS WITHOUT CLAIM TO ANY PARTICULAR FONT, STYLE, SIZE, OR COLOR.

NO CLAIM IS MADE TO THE EXCLUSIVE RIGHT TO USE "HYACINTH" AND "BLOOD ORANGE", APART FROM THE MARK AS SHOWN.
FOR BODY MIST AND PERFUME (U.S. CLS. 1, 4, 6, 50, 51 AND 52).
FIRST USE 12-8-2011; IN COMMERCE 12-8-2011.

CLASS 3—(Continued).

4,211,245. BURT'S BEES, INC., DURHAM, NC. SN 85-358,061. PUB. 2-28-2012, FILED 6-28-2011.

PEAR MEETS ACAI BERRY. NOSES EVERYWHERE ARE SMELLBOUND.

THE MARK CONSISTS OF STANDARD CHARACTERS WITHOUT CLAIM TO ANY PARTICULAR FONT, STYLE, SIZE, OR COLOR.

NO CLAIM IS MADE TO THE EXCLUSIVE RIGHT TO USE "PEAR" AND "ACAI BERRY", APART FROM THE MARK AS SHOWN.

FOR BODY MIST AND PERFUME (U.S. CLS. 1, 4, 6, 50, 51 AND 52).
FIRST USE 12-20-2011; IN COMMERCE 12-20-2011.

4,211,246. BURT'S BEES, INC., DURHAM, NC. SN 85-358,072. PUB. 4-17-2012, FILED 6-28-2011.

RICE MILK AND VANILLA. INTOXICATING. AND LEGAL.

THE MARK CONSISTS OF STANDARD CHARACTERS WITHOUT CLAIM TO ANY PARTICULAR FONT, STYLE, SIZE, OR COLOR.

NO CLAIM IS MADE TO THE EXCLUSIVE RIGHT TO USE "RICE MILK AND VANILLA", APART FROM THE MARK AS SHOWN.

FOR NON-MEDICATED SKIN CARE PREPARATION, NAMELY, BODY MIST; PERFUME (U.S. CLS. 1, 4, 6, 50, 51 AND 52).
FIRST USE 12-8-2011; IN COMMERCE 12-8-2011.

4,211,248. D'CINQUE HAIR SCIENCE, LLC, NEWPORT BEACH, CA. SN 85-358,486. PUB. 11-1-2011, FILED 6-28-2011.



OWNER OF U.S. REG. NO. 3,842,668.

CLASS 3—(Continued).

THE MARK CONSISTS OF A CIRCULAR MEDALLION WITH 5 EVENLY SPACED DOTS INTERSECTING THE OUTER RING ALIGNED WITH AN INNER CIRCLE OF 5 STYLIZED FLOWER BUDS CENTERED IN TRIANGULAR WHITE SPACES.

FOR HAIR CARE PREPARATIONS (U.S. CLS. 1, 4, 6, 50, 51 AND 52).

FIRST USE 7-31-2011; IN COMMERCE 7-31-2011.

4,211,264. WALGREEN CO., DEERFIELD, IL. SN 85-361,070. PUB. 11-22-2011, FILED 6-30-2011.

OCEAN SKY

THE MARK CONSISTS OF STANDARD CHARACTERS WITHOUT CLAIM TO ANY PARTICULAR FONT, STYLE, SIZE, OR COLOR.

FOR LAUNDRY DETERGENTS; FABRIC SOFTENERS; ANTI-STATIC DRYER SHEETS (U.S. CLS. 1, 4, 6, 50, 51 AND 52).

FIRST USE 10-11-2011; IN COMMERCE 10-11-2011.

4,211,265. WALGREEN CO., DEERFIELD, IL. SN 85-361,081. PUB. 11-22-2011, FILED 6-30-2011.

LAKE BREEZE

THE MARK CONSISTS OF STANDARD CHARACTERS WITHOUT CLAIM TO ANY PARTICULAR FONT, STYLE, SIZE, OR COLOR.

FOR LAUNDRY DETERGENTS; FABRIC SOFTENERS; ANTI-STATIC DRYER SHEETS (U.S. CLS. 1, 4, 6, 50, 51 AND 52).

FIRST USE 10-11-2011; IN COMMERCE 10-11-2011.

CLASS 3—(Continued).

4,211,276. THE PROCTER & GAMBLE COMPANY, CINCINNATI, OH. SN 85-363,787. PUB. 11-29-2011, FILED 7-6-2011.

WHAT COURAGE SMELLS LIKE

THE MARK CONSISTS OF STANDARD CHARACTERS WITHOUT CLAIM TO ANY PARTICULAR FONT, STYLE, SIZE, OR COLOR.

FOR ANTIPERSPIRANT AND DEODORANTS, FRAGRANCES, SOAPS, BODY WASH AND SHOWER GEL (U.S. CLS. 1, 4, 6, 50, 51 AND 52).

FIRST USE 1-31-2012; IN COMMERCE 1-31-2012.

4,211,286. ALL STAR FOODS, INC., MT. PROSPECT, IL. SN 85-365,920. PUB. 11-29-2011, FILED 7-7-2011.

Cell-u-logic

THE MARK CONSISTS OF STANDARD CHARACTERS WITHOUT CLAIM TO ANY PARTICULAR FONT, STYLE, SIZE, OR COLOR.

FOR BODY AND BEAUTY CARE COSMETICS; COLOGNES, PERFUMES AND COSMETICS; COSMETIC CREAMS; COSMETIC CREAMS FOR SKIN CARE; COSMETIC HAND CREAMS; COSMETICS; FACE AND BODY BEAUTY CREAMS (U.S. CLS. 1, 4, 6, 50, 51 AND 52).

FIRST USE 4-14-2012; IN COMMERCE 4-14-2012.

4,211,288. GENERAL NUTRITION INVESTMENT COMPANY, PHOENIX, AZ. SN 85-366,074. PUB. 11-22-2011, FILED 7-7-2011.

GNC PETS

THE MARK CONSISTS OF STANDARD CHARACTERS WITHOUT CLAIM TO ANY PARTICULAR FONT, STYLE, SIZE, OR COLOR.

OWNER OF U.S. REG. NOS. 2,180,647, 3,941,916, AND OTHERS.

NO CLAIM IS MADE TO THE EXCLUSIVE RIGHT TO USE "PETS", APART FROM THE MARK AS SHOWN.

FOR PET SHAMPOO AND CONDITIONER (U.S. CLS. 1, 4, 6, 50, 51 AND 52).

FIRST USE 3-1-2012; IN COMMERCE 3-1-2012.

CLASS 3—(Continued).

4,211,292. PRODUCT INNOVATION RESEARCH LLC, DALLAS, TX. SN 85-366,990. PUB. 1-31-2012, FILED 7-8-2011.

Gimme More

THE MARK CONSISTS OF STANDARD CHARACTERS WITHOUT CLAIM TO ANY PARTICULAR FONT, STYLE, SIZE, OR COLOR.

FOR INDOOR TANNING PRODUCTS, NAMELY, NON-MEDICATED SKIN TAN DARKENING LOTIONS AND SKIN MOISTURIZERS (U.S. CLS. 1, 4, 6, 50, 51 AND 52).

FIRST USE 10-15-2011; IN COMMERCE 11-1-2011.

4,211,293. PRODUCT INNOVATION RESEARCH LLC, DALLAS, TX. SN 85-367,075. PUB. 4-24-2012, FILED 7-8-2011.

Hemplessly in love

THE MARK CONSISTS OF STANDARD CHARACTERS WITHOUT CLAIM TO ANY PARTICULAR FONT, STYLE, SIZE, OR COLOR.

FOR INDOOR TANNING PRODUCTS, NAMELY, NON-MEDICATED SKIN TAN DARKENING LOTIONS AND SKIN MOISTURIZERS (U.S. CLS. 1, 4, 6, 50, 51 AND 52).

FIRST USE 10-15-2011; IN COMMERCE 11-15-2011.

4,211,294. AVID SKIN CARE, LLC, CUMMING, GA. SN 85-367,581. PUB. 12-6-2011, FILED 7-11-2011.

Avid Skin Care

THE MARK CONSISTS OF STANDARD CHARACTERS WITHOUT CLAIM TO ANY PARTICULAR FONT, STYLE, SIZE, OR COLOR.

CLASS 3—(Continued).

NO CLAIM IS MADE TO THE EXCLUSIVE RIGHT TO USE "SKIN CARE", APART FROM THE MARK AS SHOWN.

FOR CLEANSING CREAMS; COLOGNES, PERFUMES AND COSMETICS; CONCEALERS; COSMETIC CREAMS; COSMETIC CREAMS FOR SKIN CARE; COSMETIC HAND CREAMS; COSMETIC NOURISHING CREAMS; COSMETIC OILS; COSMETIC PREPARATIONS FOR BODY CARE; COSMETIC PREPARATIONS FOR SKIN CARE; COSMETIC PREPARATIONS FOR SKIN RENEWAL; COSMETIC SKIN FRESHENERS; COSMETIC SOAPS; COSMETICS AND COSMETIC PREPARATIONS; COSMETICS AND MAKE-UP; COSMETICS IN GENERAL, INCLUDING PERFUMES (U.S. CLS. 1, 4, 6, 50, 51 AND 52).

FIRST USE 9-1-2011; IN COMMERCE 4-1-2012.

4,211,330. MARIA TEREZA CAREY, DBA PARFUM BY TRUDIE, MIDLAND, GA. SN 85-374,461. PUB. 11-8-2011, FILED 7-18-2011.

RNTUAQT :)

THE MARK CONSISTS OF STANDARD CHARACTERS WITHOUT CLAIM TO ANY PARTICULAR FONT, STYLE, SIZE, OR COLOR.

FOR PERFUME; PERFUME OILS (U.S. CLS. 1, 4, 6, 50, 51 AND 52).

FIRST USE 11-11-2011; IN COMMERCE 11-11-2011.

4,211,353. INTERNATIONAL PERFUME PALACE INCORPORATED, PLAINVIEW, NY. SN 85-379,109. PUB. 10-25-2011, FILED 7-22-2011.

TONY RAKANA ELECTRIC NIGHT

THE MARK CONSISTS OF STANDARD CHARACTERS WITHOUT CLAIM TO ANY PARTICULAR FONT, STYLE, SIZE, OR COLOR.

THE NAME "TONY RAKANA" DOES NOT IDENTIFY A LIVING INDIVIDUAL.

FOR BEAUTY CREAMS; BODY CREAM; BODY DEODORANTS; BODY LOTIONS; BODY SPRAY USED AS A PERSONAL DEODORANT AND AS FRAGRANCE; COLOGNE; COLOGNE WATER; EAU DE COLOGNE; FACIAL LOTION; FRAGRANCES; HAIR SHAMPOOS AND CONDITIONERS; NON-MEDICATED SKIN CARE PREPARATION, NAMELY, BODY MIST; PERFUMES AND COLOGNES; TOILET WATER (U.S. CLS. 1, 4, 6, 50, 51 AND 52).

FIRST USE 1-0-2012; IN COMMERCE 1-0-2012.

CLASS 3—(Continued).

4,211,355. BURT'S BEES, INC., DURHAM, NC. SN 85-380,384. PUB. 11-22-2011, FILED 7-25-2011.

WHEN DOES GÜD HAPPEN? JUST OPEN THE CAP.

THE MARK CONSISTS OF STANDARD CHARACTERS WITHOUT CLAIM TO ANY PARTICULAR FONT, STYLE, SIZE, OR COLOR.

FOR BODY LOTIONS; BODY WASH; HAND CREAMS; HAND SOAPS; NON-MEDICATED SKIN CARE PREPARATION, NAMELY, BODY MIST; PERFUME (U.S. CLS. 1, 4, 6, 50, 51 AND 52).

FIRST USE 12-31-2011; IN COMMERCE 12-31-2011.

4,211,372. SANTE SEMPRINI CESARI, UNION CITY, NJ. SN 85-385,123. PUB. 11-15-2011, FILED 7-29-2011.

ARGANWAY

THE MARK CONSISTS OF STANDARD CHARACTERS WITHOUT CLAIM TO ANY PARTICULAR FONT, STYLE, SIZE, OR COLOR.

FOR HAIR BLEACHING PREPARATIONS; HAIR CARE CREAMS; HAIR CARE LOTIONS; HAIR GEL AND HAIR MOUSSE; HAIR LACQUERS; HAIR OILS; HAIR SHAMPOOS AND CONDITIONERS; HAIR SHEEN SPRAY; HAIR SPRAY; HAIR WAVING LOTION; HAIR WAX; NON-MEDICATED HAIR SERUMS (U.S. CLS. 1, 4, 6, 50, 51 AND 52).

FIRST USE 3-8-2011; IN COMMERCE 3-8-2011.

4,211,385. L'OREAL USA CREATIVE, INC., NEW YORK, NY. SN 85-390,374. PUB. 12-6-2011, FILED 8-5-2011.

DUO SHIELD

THE MARK CONSISTS OF STANDARD CHARACTERS WITHOUT CLAIM TO ANY PARTICULAR FONT, STYLE, SIZE, OR COLOR.

FOR HAIR STYLING PREPARATION (U.S. CLS. 1, 4, 6, 50, 51 AND 52).

FIRST USE 5-0-2012; IN COMMERCE 5-0-2012.

CLASS 3—(Continued).

4,211,474. JOHN PAUL MITCHELL SYSTEMS, SANTA CLARITA, CA. SN 85-422,378. PUB. 2-14-2012, FILED 9-14-2011.

FOREVER BLONDE

THE MARK CONSISTS OF STANDARD CHARACTERS WITHOUT CLAIM TO ANY PARTICULAR FONT, STYLE, SIZE, OR COLOR.

NO CLAIM IS MADE TO THE EXCLUSIVE RIGHT TO USE "BLONDE", APART FROM THE MARK AS SHOWN.

FOR HAIR SHAMPOOS AND CONDITIONERS (U.S. CLS. 1, 4, 6, 50, 51 AND 52).

FIRST USE 3-8-2012; IN COMMERCE 3-8-2012.

4,211,500. JOHN PAUL MITCHELL SYSTEMS, SANTA CLARITA, CA. SN 85-438,051. PUB. 2-14-2012, FILED 10-3-2011.

DRAMATIC REPAIR

THE MARK CONSISTS OF STANDARD CHARACTERS WITHOUT CLAIM TO ANY PARTICULAR FONT, STYLE, SIZE, OR COLOR.

NO CLAIM IS MADE TO THE EXCLUSIVE RIGHT TO USE "REPAIR", APART FROM THE MARK AS SHOWN.

FOR HAIR CONDITIONERS (U.S. CLS. 1, 4, 6, 50, 51 AND 52).

FIRST USE 5-31-2012; IN COMMERCE 5-31-2012.

4,211,530. M & G PARTNERS, LLP, DBA FASHION ANGELS ENTERPRISES, MILWAUKEE, WI. SN 85-450,367. PUB. 3-20-2012, FILED 10-18-2011.

COLOR ROX HAIR CHOX

THE MARK CONSISTS OF STANDARD CHARACTERS WITHOUT CLAIM TO ANY PARTICULAR FONT, STYLE, SIZE, OR COLOR.

NO CLAIM IS MADE TO THE EXCLUSIVE RIGHT TO USE "COLOR" AND "HAIR", APART FROM THE MARK AS SHOWN.

FOR TEMPORARY HAIR COLORING KITS CONSISTING OF HAIR COLORANTS AND DYES (U.S. CLS. 1, 4, 6, 50, 51 AND 52).

FIRST USE 7-17-2012; IN COMMERCE 7-17-2012.

CLASS 3—(Continued).

4,211,533. WEXFORD INDUSTRIAL CORPORATION, DBA WEXFORD CORPORATION, SANTA BARBARA, CA. SN 85-452,251. PUB. 4-3-2012, FILED 10-20-2011.

OCEANSPA

THE MARK CONSISTS OF STANDARD CHARACTERS WITHOUT CLAIM TO ANY PARTICULAR FONT, STYLE, SIZE, OR COLOR.

FOR AROMATIC BODY CARE PRODUCTS, NAMELY, BODY LOTION, SHOWER GEL, CUTICLE CREAM, SHAMPOO, CONDITIONER, NON-MEDICATED LIP BALM, SOAP, BODY POLISH, BODY AND FOOT SCRUB AND NON-MEDICATED FOOT CREAM (U.S. CLS. 1, 4, 6, 50, 51 AND 52).

FIRST USE 3-15-2012; IN COMMERCE 5-3-2012.

CLASS 3—(Continued).

4,211,565. U.S. SOAPS MANUFACTURING COMPANY, RALEIGH, NC. SN 85-469,668. PUB. 4-24-2012, FILED 11-10-2011.

Maxx

THE MARK CONSISTS OF OUTLINED BLOCK LETTERS, RISING FROM LEFT TO RIGHT, FORMING THE WORD "MAXX".

FOR DETERGENTS FOR HOUSEHOLD USE (U.S. CLS. 1, 4, 6, 50, 51 AND 52).

FIRST USE 3-7-2012; IN COMMERCE 3-7-2012.

4,211,558. BIAO, HOUSTON, TX. SN 85-463,691. PUB. 4-17-2012, FILED 11-3-2011.

 biao

THE MARK CONSISTS OF A STYLIZED FLOWER CONSISTING OF FOUR PETALS. TO THE RIGHT IS THE STYLIZED TEXT "BIAO".

FOR COSMETICS; NON-MEDICATED SKIN CARE PREPARATIONS (U.S. CLS. 1, 4, 6, 50, 51 AND 52).

FIRST USE 6-1-2012; IN COMMERCE 6-1-2012.

4,211,567. MONITEX INDUSTRIAL CO., LTD., NEW TAIPEI CITY, TAIWAN. SN 85-469,788. PUB. 5-1-2012, FILED 11-10-2011.

Kerenna
凱倫娜

THE MARK CONSISTS OF A STYLIZED "K" WITHIN A CIRCLE ABOVE THE STYLIZED WORD "KERENNA" WHICH HAS A PLUS SYMBOL INSIDE THE LETTER "A" ALL OF WHICH IS ABOVE THREE NON-LATIN CHARACTERS.

THE NON-LATIN CHARACTERS IN THE MARK TRANSLITERATE TO KAI LUN NA AND THIS MEANS VICTORIOUS, MORAL RELATIONSHIP AND GRACEFUL IN ENGLISH.

FOR BREATH FRESHENING SPRAYS; CLEANING PREPARATIONS; COSMETICS; DENTAL BLEACHING GELS; DENTIFRICES; DENTURE POLISHES; NON-MEDICATED MOUTH WASHES; PREPARATION FOR CLEANING DENTURES (U.S. CLS. 1, 4, 6, 50, 51 AND 52).

FIRST USE 5-11-2012; IN COMMERCE 5-11-2012.

CLASS 3—(Continued).

4,211,588. BJORKNERT, VICKY A, LOS ANGELES, CA. SN 85-477,298. PUB. 5-1-2012, FILED 11-20-2011.

WTR

THE MARK CONSISTS OF STANDARD CHARACTERS WITHOUT CLAIM TO ANY PARTICULAR FONT, STYLE, SIZE, OR COLOR.

FOR BAR SOAP; BATH GELS; BATH OILS; BATH SALTS; BATH SOAPS IN LIQUID, SOLID OR GEL FORM; BODY BUTTER; BODY LOTIONS; BODY MILKS; BODY OILS; COLOGNE; DEODORANTS FOR PERSONAL USE; EAU DE PARFUM; EAU DE TOILETTE; FACE AND BODY LOTIONS; FRAGRANCES; HAND CREAMS; HAND LOTIONS; HAND SOAPS; LIQUID SOAPS FOR HANDS, FACE AND BODY; PERFUME OILS; PERFUMES; SCENTED OILS (U.S. CLS. 1, 4, 6, 50, 51 AND 52).

FIRST USE 5-1-2012; IN COMMERCE 5-1-2012.

CLASS 4—LUBRICANTS AND FUELS

4,210,471. REMET PIC, INC., UTICA, NY. SN 77-966,939. PUB. 2-8-2011, FILED 3-24-2010.

FastForm

THE MARK CONSISTS OF STANDARD CHARACTERS WITHOUT CLAIM TO ANY PARTICULAR FONT, STYLE, SIZE, OR COLOR.

FOR PASTE INJECTABLE PATTERN WAX, LIQUID INJECTABLE PATTERN WAX, NON-FILLED CASTING WAX, AND CASTING WAX, ALL OF THE FOREGOING CONSISTING OF BLENDS OF WAXES, RESINS, ROSINS, THAT IS, ENGINEERED WAX FORMULATIONS, SUITABLE FOR INDUSTRIAL APPLICATION (U.S. CLS. 1, 6 AND 15).

FIRST USE 4-12-2012; IN COMMERCE 4-13-2012.

4,211,120. CHRISTIAN LACROIX, PARIS, FRANCE. SN 85-343,179. PUB. 10-18-2011, FILED 6-10-2011.

CHRISTIAN LACROIX

THE MARK CONSISTS OF STANDARD CHARACTERS WITHOUT CLAIM TO ANY PARTICULAR FONT, STYLE, SIZE, OR COLOR.

OWNER OF U.S. REG. NOS. 1,499,154, 3,547,594, AND OTHERS.

CLASS 4—(Continued).

THE NAME SHOWN IN THE MARK IDENTIFIES "CHRISTIAN LACROIX" WHOSE CONSENT IS MADE OF RECORD.

FOR CANDLES (U.S. CLS. 1, 6 AND 15).
FIRST USE 10-1-2011; IN COMMERCE 6-30-2012.

4,211,300. LIST COMPANY, INC., PIEDMONT, SC. SN 85-369,183. PUB. 12-6-2011, FILED 7-12-2011.

RICHLAND

THE MARK CONSISTS OF STANDARD CHARACTERS WITHOUT CLAIM TO ANY PARTICULAR FONT, STYLE, SIZE, OR COLOR.

FOR CANDLES; CANDLES FOR LIGHTING; SCENTED CANDLES; PERFUMED CANDLES; VOTIVE CANDLES; FLOATING CANDLES; PILLAR CANDLES; TEALIGHT CANDLES; LUMINARY CANDLES; TAPER CANDLES; SPHERE CANDLES; WEDDING CANDLES; RESTAURANT CANDLES; JAR CANDLES (U.S. CLS. 1, 6 AND 15).

FIRST USE 5-0-2012; IN COMMERCE 5-0-2012.

CLASS 5—PHARMACEUTICALS

4,210,257. EDOM LABORATORIES, INC., DEER PARK, NY. SN 77-345,974. PUB. 5-6-2008, FILED 12-6-2007.

Skinny Me

THE MARK CONSISTS OF STANDARD CHARACTERS WITHOUT CLAIM TO ANY PARTICULAR FONT, STYLE, SIZE, OR COLOR.

FOR HERBAL NUTRITIONAL SUPPLEMENTS (U.S. CLS. 6, 18, 44, 46, 51 AND 52).
FIRST USE 5-31-2012; IN COMMERCE 5-31-2012.

CLASS 5—(Continued).

4,210,274. GO BODY NUTRITION LLC, ANDERSON, SC. SN 77-470,344. PUB. 2-24-2009, FILED 5-9-2008.

GO BODY

THE MARK CONSISTS OF STANDARD CHARACTERS WITHOUT CLAIM TO ANY PARTICULAR FONT, STYLE, SIZE, OR COLOR.

FOR MEAL REPLACEMENT SHAKES AND DRINKS; NUTRITIONAL SUPPLEMENTS IN THE NATURE OF PROTEIN-BASED SHAKES AND DRINKS (U.S. CLS. 6, 18, 44, 46, 51 AND 52).

FIRST USE 11-18-2011; IN COMMERCE 11-18-2011.

CLASS 5—(Continued).

4,210,351. MERCK SHARP & DOHME CORP., WHITEHOUSE STATION, NJ. SN 77-687,395. PUB. 7-14-2009, FILED 3-10-2009.

GRATECT

THE MARK CONSISTS OF STANDARD CHARACTERS WITHOUT CLAIM TO ANY PARTICULAR FONT, STYLE, SIZE, OR COLOR.

FOR PHARMACEUTICALS FOR THE PREVENTION AND TREATMENT OF ALLERGIES (U.S. CLS. 6, 18, 44, 46, 51 AND 52).

FIRST USE 5-23-2012; IN COMMERCE 5-23-2012.

4,210,293. ORASURE TECHNOLOGIES, INC., BETHLEHEM, PA. SN 77-519,932. PUB. 12-23-2008, FILED 7-11-2008.

FREEZE 'N CLEAR SKIN CLINIC

THE MARK CONSISTS OF STANDARD CHARACTERS WITHOUT CLAIM TO ANY PARTICULAR FONT, STYLE, SIZE, OR COLOR.

NO CLAIM IS MADE TO THE EXCLUSIVE RIGHT TO USE "SKIN CLINIC", APART FROM THE MARK AS SHOWN.

FOR WART AND SKIN TAG REMOVING PREPARATIONS (U.S. CLS. 6, 18, 44, 46, 51 AND 52).

FIRST USE 2-12-2009; IN COMMERCE 2-12-2009.

4,210,352. MERCK SHARP & DOHME CORP., WHITEHOUSE STATION, NJ. SN 77-687,437. PUB. 7-14-2009, FILED 3-10-2009.

GRAZEVE

THE MARK CONSISTS OF STANDARD CHARACTERS WITHOUT CLAIM TO ANY PARTICULAR FONT, STYLE, SIZE, OR COLOR.

FOR PHARMACEUTICALS FOR THE PREVENTION AND TREATMENT OF ALLERGIES (U.S. CLS. 6, 18, 44, 46, 51 AND 52).

FIRST USE 5-23-2012; IN COMMERCE 5-23-2012.

4,210,334. THE THERAPLEX COMPANY, MEMPHIS, TN. SN 77-642,033. PUB. 4-28-2009, FILED 12-31-2008.

Clean 'N Treat

THE MARK CONSISTS OF STANDARD CHARACTERS WITHOUT CLAIM TO ANY PARTICULAR FONT, STYLE, SIZE, OR COLOR.

FOR MEDICATED LOTIONS FOR SKIN AND BODY (U.S. CLS. 6, 18, 44, 46, 51 AND 52).

FIRST USE 7-12-2012; IN COMMERCE 7-12-2012.

4,210,353. MERCK SHARP & DOHME CORP., WHITEHOUSE STATION, NJ. SN 77-687,447. PUB. 7-7-2009, FILED 3-10-2009.

GRASTEK

THE MARK CONSISTS OF STANDARD CHARACTERS WITHOUT CLAIM TO ANY PARTICULAR FONT, STYLE, SIZE, OR COLOR.

FOR PHARMACEUTICALS FOR THE PREVENTION AND TREATMENT OF ALLERGIES (U.S. CLS. 6, 18, 44, 46, 51 AND 52).

FIRST USE 5-23-2012; IN COMMERCE 6-28-2012.

CLASS 5—(Continued).

4,210,396. NATURE'S SHIELD, INC., PALM, PA. SN 77-860,669. PUB. 5-3-2011, FILED 10-29-2009.

NATURE'S SHIELD

THE MARK CONSISTS OF STANDARD CHARACTERS WITHOUT CLAIM TO ANY PARTICULAR FONT, STYLE, SIZE, OR COLOR.

FOR DIETARY SUPPLEMENTS, FOOD SUPPLEMENTS, HERBAL SUPPLEMENTS, HOMEOPATHIC SUPPLEMENTS, MINERAL SUPPLEMENTS, NATUROPATHIC DIETARY SUPPLEMENTS, NUTRACEUTICAL DIETARY SUPPLEMENTS, NUTRITIONAL SUPPLEMENTS, AND VITAMIN SUPPLEMENTS; HERBAL PREPARATIONS FOR MEDICINAL USE, HOMEOPATHIC PREPARATIONS, NAMELY, HOMEOPATHIC SUPPLEMENTS FOR MEDICINAL USE, AND MINERAL PREPARATIONS FOR MEDICINAL USE (U.S. CLS. 6, 18, 44, 46, 51 AND 52).

FIRST USE 1-4-2010; IN COMMERCE 1-6-2010.

4,210,405. PORTNOLOGY, INC., SAN DIEGO, CA. SN 77-871,642. PUB. 4-20-2010, FILED 11-12-2009.

BLUEDROP

THE MARK CONSISTS OF STANDARD CHARACTERS WITHOUT CLAIM TO ANY PARTICULAR FONT, STYLE, SIZE, OR COLOR.

FOR PROPHYLACTIC AND THERAPEUTIC PREPARATIONS TO PREVENT AND TREAT INFECTIOUS DISEASES AND RELATED DISORDERS, HOMEOPATHIC COMMON COLD PREPARATION WHICH REDUCES THE DURATION AND SEVERITY OF THE COMMON COLD, NATURAL HEALTH FOOD SUPPLEMENTS, NAMELY, HEALTH FOOD SUPPLEMENTS FROM HERBAL SOURCES WHICH ARE IN THE FORM OF GROUND OR DRY PRODUCT, IN SOLUTION OR AS AN EXTRACT OF HERBAL SOURCES DIETARY SUPPLEMENTS, HERBAL SUPPLEMENTS, MINERAL SUPPLEMENTS, VITAMINS AND VITAMIN FORMULATIONS, VITAMIN SUPPLEMENT FOR PEOPLE IN CROWDED ENVIRONMENTS, WHICH ARE POTENTIALLY GERM-INFESTED, VITAMIN AND MINERAL PREPARATIONS FOR USE AS INGREDIENTS IN THE FOOD AND PHARMACEUTICAL INDUSTRY, VITAMINS AND MINERAL, HERBAL, AND NUTRITION SUPPLEMENTS, NATURAL PHARMACEUTICAL PREPARATIONS FOR THE TREATMENT OF VITAMIN DEFICIENCIES AND FOOD SUPPLEMENTS PRIMARILY BASED ON ACTIVE INGREDIENTS AND EXTRACTS FOR NUTRITIONAL PURPOSES (U.S. CLS. 6, 18, 44, 46, 51 AND 52).

FIRST USE 1-18-2011; IN COMMERCE 1-18-2011.

CLASS 5—(Continued).

4,210,442. GOWAN COMPANY, L.L.C., YUMA, AZ. SN 77-919,254. PUB. 6-8-2010, FILED 1-25-2010.

TORINO

THE MARK CONSISTS OF STANDARD CHARACTERS WITHOUT CLAIM TO ANY PARTICULAR FONT, STYLE, SIZE, OR COLOR.

FOR AGRICULTURAL PESTICIDES (U.S. CLS. 6, 18, 44, 46, 51 AND 52).

FIRST USE 7-10-2012; IN COMMERCE 7-10-2012.

4,210,449. INFINITELABS, LLC, ORLANDO, FL. SN 77-923,241. PUB. 5-11-2010, FILED 1-29-2010.

FINAL FORM

THE MARK CONSISTS OF STANDARD CHARACTERS WITHOUT CLAIM TO ANY PARTICULAR FONT, STYLE, SIZE, OR COLOR.

FOR VITAMINS AND NUTRITIONAL SUPPLEMENTS FOR HUMAN CONSUMPTION (U.S. CLS. 6, 18, 44, 46, 51 AND 52).

FIRST USE 7-6-2012; IN COMMERCE 7-6-2012.

CLASS 5—(Continued).

4,210,467. NATURAL ORGANICS, INC., MELVILLE, NY. SN 77-955,887. PUB. 1-18-2011, FILED 3-10-2010.

UBIQUIMAX

THE MARK CONSISTS OF STANDARD CHARACTERS WITHOUT CLAIM TO ANY PARTICULAR FONT, STYLE, SIZE, OR COLOR.

FOR ABSORPTION ENHANCING INGREDIENT SOLD AS AN INTEGRAL COMPONENT OF INGESTIBLE DIETARY SUPPLEMENTS IN THE NATURE OF WHOLE FOOD CONCENTRATES, WHOLE FOOD EXTRACTS, VITAMINS, MINERALS, HERBS, HERBAL EXTRACTS, HERBAL CONCENTRATES, BIOFLAVONOIDS, LIPIDS, BOTANICAL EXTRACTS, AMINO ACIDS, NUCLEIC ACIDS, ENZYMES AND ANTIOXIDANTS IN THE FORM OF CAPSULES, TABLETS, LOZENGES, SOFT GELS, LIQUIDS, TINCTURES, DRINK MIXES, COLLOIDAL SUSPENSIONS, ENERGY SHAKE MIXES, MEAL REPLACEMENT DRINK MIXES, READY-TO-DRINK BEVERAGES, CHEWABLE TABLETS, CONFECTIONERIES, GUMMY CONFECTIONERIES, POWDERS, TABLETED DRINK MIXES, EFFERVESCENT DRINK MIXES, AND ENERGY BOOSTING BARS FOR USE AS A MEAL SUBSTITUTE (U.S. CLS. 6, 18, 44, 46, 51 AND 52).

FIRST USE 5-24-2010; IN COMMERCE 5-24-2010.

4,210,474. COLGATE-PALMOLIVE COMPANY, NEW YORK, NY. SN 77-982,897. PUB. 10-20-2009, FILED 12-23-2008.

PRO-ARGIN

THE MARK CONSISTS OF STANDARD CHARACTERS WITHOUT CLAIM TO ANY PARTICULAR FONT, STYLE, SIZE, OR COLOR.

FOR MEDICATED ORAL CARE PRODUCTS, NAMELY, MEDICATED TOOTHPASTE, MEDICATED MOUTHWASH, MEDICATED DENTAL RINSES, PROPHY PASTE (U.S. CLS. 6, 18, 44, 46, 51 AND 52).

FIRST USE 10-1-2009; IN COMMERCE 10-1-2009.

4,210,487. YOLI, INC., SANDY, UT. SN 85-003,739. PUB. 11-1-2011, FILED 3-31-2010.

YOLI LIVE ACTIVE INGREDIENTS

THE MARK CONSISTS OF STANDARD CHARACTERS WITHOUT CLAIM TO ANY PARTICULAR FONT, STYLE, SIZE, OR COLOR.

CLASS 5—(Continued).

OWNER OF U.S. REG. NOS. 3,710,363 AND 3,817,729.

NO CLAIM IS MADE TO THE EXCLUSIVE RIGHT TO USE "LIVE ACTIVE INGREDIENTS", APART FROM THE MARK AS SHOWN.

THE WORDING "YOLI" HAS NO MEANING IN A FOREIGN LANGUAGE.

FOR DIETARY AND NUTRITIONAL SUPPLEMENTS; DIETARY SUPPLEMENTAL DRINKS; DIETARY SUPPLEMENTAL DRINKS IN THE NATURE OF VITAMIN AND MINERAL BEVERAGES; LIQUID NUTRITIONAL SUPPLEMENT; ALL OF THE AFOREMENTIONED GOODS CONTAINING LIVE ACTIVE BACTERIA CULTURES (U.S. CLS. 6, 18, 44, 46, 51 AND 52).

FIRST USE 5-0-2012; IN COMMERCE 5-0-2012.

4,210,522. WHEAT, JARED R., NORCROSS, GA. SN 85-040,005. PUB. 10-19-2010, FILED 5-17-2010.

RIPPED UP

THE MARK CONSISTS OF STANDARD CHARACTERS WITHOUT CLAIM TO ANY PARTICULAR FONT, STYLE, SIZE, OR COLOR.

FOR DIETARY SUPPLEMENTS (U.S. CLS. 6, 18, 44, 46, 51 AND 52).

FIRST USE 9-1-2010; IN COMMERCE 9-1-2010.

4,210,534. DREAM MASTERS, LLC, CHANDLER, AZ. SN 85-053,131. PUB. 5-10-2011, FILED 6-2-2010.

TELOMERASE FOR LIFE

THE MARK CONSISTS OF STANDARD CHARACTERS WITHOUT CLAIM TO ANY PARTICULAR FONT, STYLE, SIZE, OR COLOR.

NO CLAIM IS MADE TO THE EXCLUSIVE RIGHT TO USE "TELOMERASE", APART FROM THE MARK AS SHOWN.

FOR NUTRITIONAL SUPPLEMENTS (U.S. CLS. 6, 18, 44, 46, 51 AND 52).

FIRST USE 8-15-2011; IN COMMERCE 8-15-2011.

CLASS 5—(Continued).

4,210,583. ULTIMA NUTRITION, LLC, LAS VEGAS, NV. SN 85-090,002. PUB. 12-28-2010, FILED 7-21-2010.

MigraMedic

THE MARK CONSISTS OF STANDARD CHARACTERS WITHOUT CLAIM TO ANY PARTICULAR FONT, STYLE, SIZE, OR COLOR.

FOR DIETARY AND NUTRITIONAL SUPPLEMENTS; HEADACHE TREATMENT PREPARATIONS; HERBAL SUPPLEMENTS; MEDICINAL HERBAL EXTRACTS FOR MEDICAL PURPOSES; MEDICINAL HERBAL PREPARATIONS; MIGRAINE TREATMENT PREPARATIONS; NATURAL HERBAL SUPPLEMENTS; NUTRITIONAL SUPPLEMENTS (U.S. CLS. 6, 18, 44, 46, 51 AND 52).

FIRST USE 7-21-2010; IN COMMERCE 6-12-2012.

4,210,595. W.F. YOUNG, INCORPORATED, EAST LONGMEADOW, MA. SN 85-096,001. PUB. 1-18-2011, FILED 7-29-2010.

ANTIPHLOGISTINE

THE MARK CONSISTS OF STANDARD CHARACTERS WITHOUT CLAIM TO ANY PARTICULAR FONT, STYLE, SIZE, OR COLOR.

FOR MEDICATED POULTICE (U.S. CLS. 6, 18, 44, 46, 51 AND 52).

FIRST USE 1-1-1976; IN COMMERCE 1-1-1976.

4,210,629. INSIGHT PHARMACEUTICALS LLC, LANGHORNE, PA. SN 85-117,174. PUB. 11-8-2011, FILED 8-27-2010.



OWNER OF U.S. REG. NO. 3,928,890.

CLASS 5—(Continued).

NO CLAIM IS MADE TO THE EXCLUSIVE RIGHT TO USE "TRIPLE ACTION SYSTEM", APART FROM THE MARK AS SHOWN.

THE COLOR(S) WHITE AND PINK IS/ARE CLAIMED AS A FEATURE OF THE MARK.

THE MARK CONSISTS OF THE STYLIZED PHRASE "TRIPLE ACTION SYSTEM" IN WHITE IN A PINK CIRCLE WITH WHITE RINGS.

FOR VAGINAL CARE PREPARATIONS; FUNGICIDAL AGENTS IN THE FORM OF SUPPOSITORIES AND CREAMS SOLD OTHER THAN THROUGH INDEPENDENT SALES CONSULTANTS (U.S. CLS. 6, 18, 44, 46, 51 AND 52).

FIRST USE 10-1-2011; IN COMMERCE 10-1-2011.

4,210,630. INSIGHT PHARMACEUTICALS LLC, LANGHORNE, PA. SN 85-117,181. PUB. 11-8-2011, FILED 8-27-2010.



NO CLAIM IS MADE TO THE EXCLUSIVE RIGHT TO USE "DUAL ACTION SYSTEM", APART FROM THE MARK AS SHOWN.

THE COLOR(S) WHITE AND YELLOW IS/ARE CLAIMED AS A FEATURE OF THE MARK.

THE MARK CONSISTS OF THE STYLIZED PHRASE "DUAL ACTION SYSTEM" IN WHITE IN A YELLOW CIRCLE WITH TWO WHITE RINGS.

FOR VAGINAL CARE PREPARATIONS; FUNGICIDAL AGENTS IN THE FORM OF SUPPOSITORIES AND CREAMS SOLD OTHER THAN THROUGH INDEPENDENT SALES CONSULTANTS (U.S. CLS. 6, 18, 44, 46, 51 AND 52).

FIRST USE 10-1-2011; IN COMMERCE 10-1-2011.

CLASS 5—(Continued).

4,210,649. RICARDO ALVAREZ, CHULA VISTA, CA. SN 85-139,447. PUB. 3-8-2011, FILED 9-28-2010.

Mamisan

THE MARK CONSISTS OF STANDARD CHARACTERS WITHOUT CLAIM TO ANY PARTICULAR FONT, STYLE, SIZE, OR COLOR.

FOR ANTI-INFLAMMATORY OINTMENTS; HEMORRHOIDAL OINTMENTS; HERBAL ANTI-ITCH AND SORE SKIN OINTMENT FOR PETS; HERBAL TOPICAL CREAMS, GELS, SALVES, BALMS, LINIMENT AND OINTMENTS FOR THE RELIEF OF ACHE AND PAIN; MENTHOLATED OINTMENT FOR MEDICAL USE; SORE SKIN OINTMENT FOR PETS (U.S. CLS. 6, 18, 44, 46, 51 AND 52).

FIRST USE 12-1-2008; IN COMMERCE 12-1-2008.

4,210,684. NATUREX, INC., SOUTH HACKENSACK, NJ. SN 85-171,817. PUB. 12-6-2011, FILED 11-8-2010.

BILBERRYPURE

THE MARK CONSISTS OF STANDARD CHARACTERS WITHOUT CLAIM TO ANY PARTICULAR FONT, STYLE, SIZE, OR COLOR.

FOR PHARMACEUTICAL PRODUCTS CONTAINING BILBERRY EXTRACTS FOR MEDICAL PURPOSES, NAMELY, PHARMACEUTICALS FOR THE PREVENTION AND TREATMENT OF EYE DISEASES AND CONDITIONS, FOR THE PREVENTION AND TREATMENT OF EYESTRAIN, FOR THE PREVENTION AND TREATMENT OF SKIN AGING SIGNS, DAMAGED SKIN AND TISSUES AND FOR THE PREVENTION AND TREATMENT OF EYE AGING TROUBLES; PHYTOTHERAPEUTIC PRODUCTS CONTAINING BILBERRY EXTRACTS FOR MEDICAL PURPOSES, NAMELY, HERBAL SUPPLEMENTS; NUTRITIONAL AND DIETETIC SUPPLEMENTS CONTAINING BILBERRY EXTRACTS FOR MEDICAL PURPOSES; NUTRITIONAL AND DIETETIC SUPPLEMENTS COMPRISED OF BILBERRY EXTRACTS IN THE FORM OF CAPSULES, TABLETS, MEDICATED CHEWING GUM, EDIBLE LIQUID AND SOLID PREPARATIONS, MILK PREPARATIONS, POWDERS, POWDERS FOR EDIBLE PREPARATIONS, POWDERS FOR BEVERAGE PREPARATIONS, AND MEDICATED BEVERAGES; PHARMACEUTICAL PRODUCTS CONTAINING BILBERRY EXTRACTS, NAMELY, MEDICINES AND PHYTOMEDICINES FOR THE PREVENTION AND TREATMENT OF EYE DISEASES AND CONDITIONS, FOR THE PREVENTION AND TREATMENT OF EYESTRAIN, FOR THE PREVENTION AND TREATMENT OF SKIN AGING SIGNS, DAMAGED SKIN AND TISSUES AND FOR THE PREVENTION AND TREATMENT OF EYE AGING TROUBLES (U.S. CLS. 6, 18, 44, 46, 51 AND 52).

FIRST USE 7-22-2011; IN COMMERCE 7-22-2011.

CLASS 5—(Continued).

4,210,699. DR. KNOLL PRODUCTS, INC., DBA BIOWELL NATURAL HEALTH, CANFIELD, OH. SN 85-182,527. PUB. 4-12-2011, FILED 11-22-2010.

InternaCleanse

THE MARK CONSISTS OF STANDARD CHARACTERS WITHOUT CLAIM TO ANY PARTICULAR FONT, STYLE, SIZE, OR COLOR.

FOR DIETARY SUPPLEMENTS; DIETARY SUPPLEMENTS TO PROMOTE DIGESTIVE HEALTH (U.S. CLS. 6, 18, 44, 46, 51 AND 52).

FIRST USE 6-11-2012; IN COMMERCE 6-11-2012.

4,210,763. SUSTAINA BEVERAGE GROUP LLC, CARMEL, CA. SN 85-206,269. PUB. 5-3-2011, FILED 12-27-2010.

Sustaina

THE MARK CONSISTS OF THE STYLIZED MARK "SUSTAINA" WITH A LEAF IMAGE OVER THE "I".

FOR VITAMIN SUPPLEMENTS (U.S. CLS. 6, 18, 44, 46, 51 AND 52).

FIRST USE 2-1-2012; IN COMMERCE 2-1-2012.

4,210,872. SABINSA CORPORATION, EAST WINDSOR, NJ. SN 85-247,037. PUB. 6-28-2011, FILED 2-20-2011.

Capsallyl

THE MARK CONSISTS OF STANDARD CHARACTERS WITHOUT CLAIM TO ANY PARTICULAR FONT, STYLE, SIZE, OR COLOR.

FOR DIETARY SUPPLEMENT CONTAINING A BOTANICAL EXTRACT AND SPECIFICALLY EXCLUDING ANY STARCH OR STARCH RELATED INGREDIENTS (U.S. CLS. 6, 18, 44, 46, 51 AND 52).

FIRST USE 8-5-2011; IN COMMERCE 8-5-2011.

CLASS 5—(Continued).

4,210,873. PERFECT CROSS, LLC, NASHOTAH, WI. SN 85-247,259. PUB. 6-28-2011, FILED 2-21-2011.

STAY STRONG. MOVE ON.

THE MARK CONSISTS OF STANDARD CHARACTERS WITHOUT CLAIM TO ANY PARTICULAR FONT, STYLE, SIZE, OR COLOR.

FOR ADHESIVE APPLIANCES OF VARIOUS SHAPES AND CONFIGURATIONS FOR MEDICAL PURPOSES, NAMELY, FOR MUSCLE SUPPORT AND PAIN REDUCTION (U.S. CLS. 6, 18, 44, 46, 51 AND 52).

FIRST USE 5-31-2012; IN COMMERCE 5-31-2012.

4,210,884. MEDOP, INC., OLDSMAR, FL. SN 85-251,420. PUB. 7-5-2011, FILED 2-25-2011.

EYEVISION

THE MARK CONSISTS OF STANDARD CHARACTERS WITHOUT CLAIM TO ANY PARTICULAR FONT, STYLE, SIZE, OR COLOR.

FOR DIETARY AND NUTRITIONAL SUPPLEMENTS (U.S. CLS. 6, 18, 44, 46, 51 AND 52).

FIRST USE 6-2-2012; IN COMMERCE 6-14-2012.

4,210,899. GNR SPORTS INNOVATIONS LLC, SCOTTS-DALE, AZ. SN 85-260,155. PUB. 7-26-2011, FILED 3-7-2011.

ENERGY

THE MARK CONSISTS OF STANDARD CHARACTERS WITHOUT CLAIM TO ANY PARTICULAR FONT, STYLE, SIZE, OR COLOR.

FOR DISPOSABLE WIPES OR CLOTHS IMPREGNATED WITH DILUTE SMELLING SALT SOLUTION; MEDICATED TOWELS FOR PERSONAL COOLING OR RESPIRATORY STIMULATION (U.S. CLS. 6, 18, 44, 46, 51 AND 52).

FIRST USE 4-25-2011; IN COMMERCE 4-25-2011.

CLASS 5—(Continued).

4,210,943. GOOD HEALTH NATURALLY, INC., LAS VEGAS, NV. SN 85-286,193. PUB. 11-29-2011, FILED 4-5-2011.

THEMIRACLEENZYME

THE MARK CONSISTS OF STANDARD CHARACTERS WITHOUT CLAIM TO ANY PARTICULAR FONT, STYLE, SIZE, OR COLOR.

FOR DIETARY AND NUTRITIONAL SUPPLEMENTS; ENZYME FOOD SUPPLEMENTS; FOOD SUPPLEMENTS; MINERAL SUPPLEMENTS; AND VITAMINS WITH ALL OF THE FOREGOING FOR HUMAN USE (U.S. CLS. 6, 18, 44, 46, 51 AND 52).

FIRST USE 3-0-2009; IN COMMERCE 3-0-2009.

4,210,944. ANGONE, JENNIFER, BERWYN, IL. SN 85-286,516. PUB. 8-30-2011, FILED 4-5-2011.

SWERVE

THE MARK CONSISTS OF STANDARD CHARACTERS WITHOUT CLAIM TO ANY PARTICULAR FONT, STYLE, SIZE, OR COLOR.

NO CLAIM IS MADE TO THE EXCLUSIVE RIGHT TO USE "PEST REPELLENT", APART FROM THE MARK AS SHOWN.

FOR INSECT REPELLENTS (U.S. CLS. 6, 18, 44, 46, 51 AND 52).

FIRST USE 4-30-2011; IN COMMERCE 5-30-2011.

4,210,947. NPS PHARMACEUTICALS, INC., BEDMINSTER, NJ. SN 85-289,949. PUB. 3-6-2012, FILED 4-8-2011.

NATPARA

THE MARK CONSISTS OF STANDARD CHARACTERS WITHOUT CLAIM TO ANY PARTICULAR FONT, STYLE, SIZE, OR COLOR.

FOR PHARMACEUTICAL PREPARATIONS FOR THE TREATMENT OR PREVENTION OF GASTROINTESTINAL DISORDERS, DISEASES INVOLVING VARYING LEVELS OF CALCIUM IN CELLS AND OUTSIDE CELLS, NEUROLOGICAL OR OTHER CENTRAL NERVOUS SYSTEM DISORDERS, ENDOCRINE DISORDERS, AND BONE METABOLISM DISORDERS (U.S. CLS. 6, 18, 44, 46, 51 AND 52).

FIRST USE 11-7-2011; IN COMMERCE 11-7-2011.

CLASS 5—(Continued).

4,210,949. NEW WORLD IMPORTS, NASHVILLE, TN. SN 85-291,487. PUB. 8-23-2011, FILED 4-11-2011.



THE COLOR(S) WHITE, BLACK, AND BLUE IS/ARE CLAIMED AS A FEATURE OF THE MARK.

THE MARK CONSISTS OF THE WORDING "CAREALL" AND ASSOCIATED DESIGN ELEMENTS. THE WORDING "CAREALL" APPEARS AS ONE COMPOUND WORD, WITH "CARE" IN THE COLOR BLACK AND "ALL" IN THE COLOR BLUE. THE DESIGN IS LOCATED TO THE LEFT OF THE WORDING AND CONSISTS OF A WHITE SQUARE WITH BLACK DOTS AROUND ITS PERIMETER, WITH WHITE AND BLUE DOTS EXTENDING FROM THE WHITE SQUARE BOTH HORIZONTALLY AND VERTICALLY TO CREATE A CROSS WITH EQUAL SIZED LINES, WITHIN A BLUE SHADED SQUARE WITH SLIGHTLY CURVED EDGES.

FOR ACETAMINOPHEN; ANTIBIOTIC CREAMS; ANTIBIOTIC OINTMENTS; ANTIFUNGAL CREAMS FOR MEDICAL USE; ARTIFICIAL TEARS; ASPIRIN; HYDROCORTISONE CREAM; IBUPROFEN FOR USE AS AN ORAL ANALGESIC; MUSCLE RELAXANTS (U.S. CLS. 6, 18, 44, 46, 51 AND 52).

FIRST USE 1-13-2011; IN COMMERCE 7-5-2012.

4,210,952. SCENTSIBLE, LLC, ADDISON, TX. SN 85-296,064. PUB. 8-30-2011, FILED 4-15-2011.

Crap Shooter

THE MARK CONSISTS OF STANDARD CHARACTERS WITHOUT CLAIM TO ANY PARTICULAR FONT, STYLE, SIZE, OR COLOR.

FOR AIR DEODORIZER; AIR FRESHENER SPRAYS; AIR FRESHENERS (U.S. CLS. 6, 18, 44, 46, 51 AND 52).

FIRST USE 6-1-2011; IN COMMERCE 6-1-2011.

4,210,974. WILBUR-ELLIS COMPANY, SAN FRANCISCO, CA. SN 85-307,689. PUB. 12-6-2011, FILED 4-28-2011.

GOLDEN MICRONIZED SULFUR

THE MARK CONSISTS OF STANDARD CHARACTERS WITHOUT CLAIM TO ANY PARTICULAR FONT, STYLE, SIZE, OR COLOR.

OWNER OF U.S. REG. NOS. 1,076,782 AND 3,463,399.

NO CLAIM IS MADE TO THE EXCLUSIVE RIGHT TO USE "MICRONIZED SULFUR", APART FROM THE MARK AS SHOWN.

FOR PESTICIDES CONTAINING SULFUR FOR AGRICULTURAL USE, NAMELY, FUNGICIDES AND INSECTICIDES (U.S. CLS. 6, 18, 44, 46, 51 AND 52).

FIRST USE 4-30-2012; IN COMMERCE 4-30-2012.

CLASS 5—(Continued).

4,211,003. MUSCLEPHARM CORPORATION, DENVER, CO. SN 85-322,101. PUB. 11-8-2011, FILED 5-16-2011.

Armor V Advanced Multi Nutrient Complex

THE MARK CONSISTS OF STANDARD CHARACTERS WITHOUT CLAIM TO ANY PARTICULAR FONT, STYLE, SIZE, OR COLOR.

NO CLAIM IS MADE TO THE EXCLUSIVE RIGHT TO USE "ADVANCED MULTI NUTRIENT COMPLEX", APART FROM THE MARK AS SHOWN.

FOR DIETARY AND NUTRITIONAL SUPPLEMENTS CONTAINING VITAMINS AND MINERALS (U.S. CLS. 6, 18, 44, 46, 51 AND 52).

FIRST USE 4-18-2009; IN COMMERCE 7-15-2011.

4,211,015. THE HONEST KITCHEN, INC., SAN DIEGO, CA. SN 85-325,539. PUB. 11-8-2011, FILED 5-20-2011.

EASY PEESY TEA

THE MARK CONSISTS OF STANDARD CHARACTERS WITHOUT CLAIM TO ANY PARTICULAR FONT, STYLE, SIZE, OR COLOR.

NO CLAIM IS MADE TO THE EXCLUSIVE RIGHT TO USE "TEA", APART FROM THE MARK AS SHOWN.

FOR HERBAL TEAS FOR MEDICINAL PURPOSES FOR USE BY ANIMALS, NAMELY, DOGS AND CATS (U.S. CLS. 6, 18, 44, 46, 51 AND 52).

FIRST USE 6-23-2011; IN COMMERCE 6-23-2011.

4,211,016. THE HONEST KITCHEN, INC., SAN DIEGO, CA. SN 85-325,543. PUB. 11-8-2011, FILED 5-20-2011.

QUIET TEA

THE MARK CONSISTS OF STANDARD CHARACTERS WITHOUT CLAIM TO ANY PARTICULAR FONT, STYLE, SIZE, OR COLOR.

NO CLAIM IS MADE TO THE EXCLUSIVE RIGHT TO USE "TEA", APART FROM THE MARK AS SHOWN.

FOR HERBAL TEAS FOR MEDICINAL PURPOSES FOR USE BY ANIMALS, NAMELY, DOGS AND CATS (U.S. CLS. 6, 18, 44, 46, 51 AND 52).

FIRST USE 6-23-2011; IN COMMERCE 6-23-2011.

CLASS 5—(Continued).

4,211,019. GLANBIA NUTRITIONALS (IRELAND) LIMITED, KILKENNY, IRELAND. SN 85-325,681. PUB. 8-23-2011, FILED 5-20-2011.

AMINO X

THE MARK CONSISTS OF STANDARD CHARACTERS WITHOUT CLAIM TO ANY PARTICULAR FONT, STYLE, SIZE, OR COLOR.

NO CLAIM IS MADE TO THE EXCLUSIVE RIGHT TO USE "AMINO", APART FROM THE MARK AS SHOWN.

FOR DIETARY SUPPLEMENTS (U.S. CLS. 6, 18, 44, 46, 51 AND 52).

FIRST USE 8-19-2011; IN COMMERCE 8-19-2011.

4,211,059. LEVEL ENTERPRISES, LLC, BOYNTON BEACH, FL. SN 85-334,784. PUB. 10-25-2011, FILED 6-1-2011.

THE SCIENCE OF WEIGHT LOSS, SIMPLIFIED

THE MARK CONSISTS OF STANDARD CHARACTERS WITHOUT CLAIM TO ANY PARTICULAR FONT, STYLE, SIZE, OR COLOR.

FOR NUTRITIONAL SUPPLEMENTS (U.S. CLS. 6, 18, 44, 46, 51 AND 52).

FIRST USE 5-18-2012; IN COMMERCE 5-18-2012.

4,211,060. LEVEL ENTERPRISES, LLC, BOYNTON BEACH, FL. SN 85-334,870. PUB. 10-25-2011, FILED 6-1-2011.

LEVEL

THE MARK CONSISTS OF THE WORD "LEVEL" ENDING WITH THE LETTER "L" WHICH IS A MIRRORED IMAGE OF THE FIRST LETTER "L", THE LETTERS "E" HAVING NO VERTICAL LINE AND THE LETTER "V" HAVING HORIZONTAL LINES EXTENDING BOTH DIRECTIONS OVER THE "L"'S AND "E"'S.

FOR NUTRITIONAL SUPPLEMENTS (U.S. CLS. 6, 18, 44, 46, 51 AND 52).

FIRST USE 5-18-2012; IN COMMERCE 5-18-2012.

CLASS 5—(Continued).

4,211,081. DEN-MAT HOLDINGS, LLC, SANTA MARIA, CA. SN 85-337,866. PUB. 12-6-2011, FILED 6-3-2011.

CERINATE ONE-HOUR

THE MARK CONSISTS OF STANDARD CHARACTERS WITHOUT CLAIM TO ANY PARTICULAR FONT, STYLE, SIZE, OR COLOR.

OWNER OF U.S. REG. NO. 1,362,864.

NO CLAIM IS MADE TO THE EXCLUSIVE RIGHT TO USE "ONE-HOUR", APART FROM THE MARK AS SHOWN.

FOR DENTAL RESTORATIVES, NAMELY, PORCELAIN LAMINATES AND PORCELAIN VENEERS (U.S. CLS. 6, 18, 44, 46, 51 AND 52).

FIRST USE 5-31-2011; IN COMMERCE 5-31-2011.

4,211,137. AGAN CHEMICAL MANUFACTURERS LTD., ASHDOD, ISRAEL. SN 85-345,306. PUB. 11-1-2011, FILED 6-14-2011.

DEFY

THE MARK CONSISTS OF STANDARD CHARACTERS WITHOUT CLAIM TO ANY PARTICULAR FONT, STYLE, SIZE, OR COLOR.

FOR HERBICIDES (U.S. CLS. 6, 18, 44, 46, 51 AND 52).

FIRST USE 11-10-2011; IN COMMERCE 11-10-2011.

CLASS 5—(Continued).

4,211,166. DRVITA, INC., LAS VEGAS, NV. SN 85-348,184. PUB. 11-1-2011, FILED 6-16-2011.

DrVita

THE MARK CONSISTS OF STANDARD CHARACTERS WITHOUT CLAIM TO ANY PARTICULAR FONT, STYLE, SIZE, OR COLOR.

FOR DIETARY AND NUTRITIONAL SUPPLEMENTS FOR ENDURANCE SPORTS; DIETARY AND NUTRITIONAL SUPPLEMENTS USED FOR WEIGHT LOSS; DIETARY SUPPLEMENTS FOR PETS; DIETARY SUPPLEMENTS FOR PETS IN THE NATURE OF A POWDERED DRINK MIX; GUMMY VITAMINS; HERB TEAS FOR MEDICINAL PURPOSES; HERBS FOR MEDICINAL PURPOSES; LIQUID VITAMIN SUPPLEMENTS; MULTI-VITAMIN PREPARATIONS; NUTRACEUTICALS FOR USE AS A DIETARY SUPPLEMENT; NUTRITIONAL AND DIETARY SUPPLEMENTS FORMED AND PACKAGED AS BARS; NUTRITIONAL DRINKS USED FOR MEAL REPLACEMENT; NUTRITIONAL ENERGY BARS FOR USE AS A MEAL SUBSTITUTE; NUTRITIONAL SUPPLEMENTS, NAMELY, PROBIOTIC COMPOSITIONS; PLANT AND HERB EXTRACTS SOLD AS COMPONENTS OF MEDICATED COSMETICS; PRENATAL VITAMINS; VITAMIN SUPPLEMENTS; VITAMINS AND DIETARY FOOD SUPPLEMENTS FOR ANIMALS (U.S. CLS. 6, 18, 44, 46, 51 AND 52).

FIRST USE 5-9-2012; IN COMMERCE 5-9-2012.

4,211,180. AVEDRO, INC., WALTHAM, MA. SN 85-349,759. PUB. 11-1-2011, FILED 6-17-2011.

PARACEL

THE MARK CONSISTS OF STANDARD CHARACTERS WITHOUT CLAIM TO ANY PARTICULAR FONT, STYLE, SIZE, OR COLOR.

FOR PHARMACEUTICAL PREPARATIONS FOR TREATMENT OF EYE CONDITIONS AND DISEASES (U.S. CLS. 6, 18, 44, 46, 51 AND 52).

FIRST USE 11-0-2011; IN COMMERCE 11-0-2011.

CLASS 5—(Continued).

4,211,190. NATURAL SUPPLEMENT ASSOCIATION, INCORPORATED, DBA EXPERIMENTAL AND APPLIED SCIENCES, INC., ABBOTT PARK, IL. SN 85-350,736. PUB. 11-8-2011, FILED 6-20-2011.

EAS RECOVERY

THE MARK CONSISTS OF STANDARD CHARACTERS WITHOUT CLAIM TO ANY PARTICULAR FONT, STYLE, SIZE, OR COLOR.

OWNER OF U.S. REG. NOS. 2,817,504, 2,886,499, AND OTHERS.

FOR NUTRITIONAL AND DIETARY SUPPLEMENTS; LIQUID OR POWDER NUTRITIVE SUPPLEMENTS FOR HUMAN USE; NUTRITIONALLY FORTIFIED BEVERAGES AND POWDERS FOR MEAL REPLACEMENT (U.S. CLS. 6, 18, 44, 46, 51 AND 52).

FIRST USE 4-30-2012; IN COMMERCE 4-30-2012.

4,211,222. PROCLAIM NUTRITION LLC, HENDERSON, NV. SN 85-355,793. PUB. 11-15-2011, FILED 6-24-2011.

FITPRO

THE MARK CONSISTS OF STANDARD CHARACTERS WITHOUT CLAIM TO ANY PARTICULAR FONT, STYLE, SIZE, OR COLOR.

FOR DIETARY AND NUTRITIONAL SUPPLEMENTS CONTAINING MILK (U.S. CLS. 6, 18, 44, 46, 51 AND 52).

FIRST USE 7-3-2012; IN COMMERCE 7-3-2012.

4,211,262. ASTRAZENECA AB, SÖDERTÄLJE, SWEDEN. SN 85-360,880. PUB. 11-22-2011, FILED 6-30-2011.



OWNER OF U.S. REG. NO. 3,092,679.

THE MARK CONSISTS OF GEOMETRIC SHAPES FORMING A HUMAN FIGURE APPEARING ABOVE THE WORD "CAPRELSA".

FOR PHARMACEUTICAL PREPARATIONS AND SUBSTANCES FOR THE TREATMENT OF CANCER (U.S. CLS. 6, 18, 44, 46, 51 AND 52).

FIRST USE 7-25-2011; IN COMMERCE 7-25-2011.

CLASS 5—(Continued).

4,211,280. KIMBERLY-CLARK WORLDWIDE, INC., NEE-NAH, WI. SN 85-364,253. PUB. 9-6-2011, FILED 7-6-2011.

MEMORYFLEX

THE MARK CONSISTS OF STANDARD CHARACTERS WITHOUT CLAIM TO ANY PARTICULAR FONT, STYLE, SIZE, OR COLOR.

FOR FEATURE OF FEMININE CARE PRODUCTS, NAMELY, FEMININE PADS, IN THE NATURE OF AN ABSORBENT CENTER LAYER (U.S. CLS. 6, 18, 44, 46, 51 AND 52).

FIRST USE 3-28-2010; IN COMMERCE 3-28-2010.

4,211,359. BAYER AKTIENGESELLSCHAFT, 51373 LEVERKUSEN, FED REP GERMANY. SN 85-381,533. PUB. 11-15-2011, FILED 7-26-2011.

SOBERAN

THE MARK CONSISTS OF STANDARD CHARACTERS WITHOUT CLAIM TO ANY PARTICULAR FONT, STYLE, SIZE, OR COLOR.

FOR HERBICIDES (U.S. CLS. 6, 18, 44, 46, 51 AND 52).

FIRST USE 12-31-2008; IN COMMERCE 2-6-2012.

4,211,370. TIANJUN WANG, SHREWSBURY, MA. SN 85-384,559. PUB. 1-31-2012, FILED 7-29-2011.



NO CLAIM IS MADE TO THE EXCLUSIVE RIGHT TO USE "NATIONAL ASSOCIATION OF HEALTH AND WELLNESS", APART FROM THE MARK AS SHOWN.

THE MARK CONSISTS OF A DESIGN OF A PLANT WITH THE SUN BEHIND IT AND THE WORDING "NATIONAL ASSOCIATION OF HEALTH AND WELLNESS" WRAPPED UNDERNEATH THE DESIGN.

FOR DIETARY AND NUTRITIONAL SUPPLEMENTS (U.S. CLS. 6, 18, 44, 46, 51 AND 52).

FIRST USE 6-28-2011; IN COMMERCE 6-28-2011.

CLASS 5—(Continued).

4,211,379. AGAN CHEMICAL MANUFACTURERS LTD., ASHDOD, ISRAEL. SN 85-387,297. PUB. 11-1-2011, FILED 8-2-2011.

PARROT

THE MARK CONSISTS OF STANDARD CHARACTERS WITHOUT CLAIM TO ANY PARTICULAR FONT, STYLE, SIZE, OR COLOR.

FOR HERBICIDES FOR AGRICULTURAL USE; HERBICIDES FOR DOMESTIC USE (U.S. CLS. 6, 18, 44, 46, 51 AND 52).

FIRST USE 11-10-2011; IN COMMERCE 11-10-2011.

4,211,380. TAYLOR, JERRY, DAYTONA BEACH, FL. SN 85-387,486. PUB. 2-21-2012, FILED 8-2-2011.



NO CLAIM IS MADE TO THE EXCLUSIVE RIGHT TO USE "POTTY PAK" AND "PERSONAL HYGIENE", APART FROM THE MARK AS SHOWN.

THE STIPPLING IS FOR SHADING PURPOSES ONLY.

THE MARK CONSISTS OF THE WORDS "POTTY PAK" WITH AN OPEN COMMODE SEAT THAT FIT IN AT THE "O" IN "POTTY" AND THE "A" IN "PAK", ON THE HOOK OF THE "K" IN "PAK" IS A ROLL OF TOILET TISSUES, AND WORDS "PERSONAL HYGIENE TO GO!" AT THE BOTTOM.

FOR KITS COMPRISING SANITIZER GEL, DISINFECTING SPRAY, SANITARY MASKS, SANITARY NAPKINS, PAPER TOWELS, TISSUE, PLASTIC GLOVES AND HAND CREAM USED FOR GERM PREVENTION (U.S. CLS. 6, 18, 44, 46, 51 AND 52).

FIRST USE 6-14-2007; IN COMMERCE 9-20-2011.

CLASS 5—(Continued).

4,211,382. WHOLE PRODUCTS GROUP, HIGHLAND, NJ. SN 85-389,203. PUB. 1-24-2012, FILED 8-4-2011.

Bikini Ready

FOR AMINO ACIDS FOR NUTRITIONAL PURPOSES; DIETARY AND NUTRITIONAL SUPPLEMENTS; DIETARY AND NUTRITIONAL SUPPLEMENTS FOR ENDURANCE SPORTS; DIETARY AND NUTRITIONAL SUPPLEMENTS USED FOR WEIGHT LOSS; DIETARY BEVERAGE SUPPLEMENTS FOR HUMAN CONSUMPTION IN LIQUID AND DRY MIX FORM FOR THERAPEUTIC PURPOSES; DIETARY FOOD SUPPLEMENTS; DIETARY SUPPLEMENT FOR ELIMINATING TOXINS FROM THE INTESTINAL TRACT; DIETARY SUPPLEMENTAL DRINKS; DIETARY SUPPLEMENTAL DRINKS IN THE NATURE OF VITAMIN AND MINERAL BEVERAGES; DIETARY SUPPLEMENTS; DIETARY SUPPLEMENTS FOR CONTROLLING CHOLESTEROL; DIETARY SUPPLEMENTS FOR HUMAN CONSUMPTION; DIETARY SUPPLEMENTS IN THE NATURE OF WEIGHT LOSS POWDERS; ENZYME FOOD SUPPLEMENTS; FOOD SUPPLEMENTS; FOOD SUPPLEMENTS, NAMELY, ANTI-OXIDANTS; GROUND FLAXSEED FIBER FOR USE AS A DIETARY SUPPLEMENT; HEALTH FOOD SUPPLEMENTS; HERBAL SUPPLEMENTS; HOMEOPATHIC SUPPLEMENTS; LECITHIN FOR USE AS A DIETARY SUPPLEMENT; LIQUID NUTRITIONAL SUPPLEMENT; LIQUID PROTEIN SUPPLEMENTS; LIQUID VITAMIN SUPPLEMENTS; MEAL REPLACEMENT AND DIETARY SUPPLEMENT DRINK MIXES; MINERAL NUTRITIONAL SUPPLEMENTS; MINERAL SUPPLEMENTS; NATURAL HERBAL SUPPLEMENTS; NUTRACEUTICALS FOR USE AS A DIETARY SUPPLEMENT; NUTRITIONAL AND DIETARY SUPPLEMENTS FORMED AND PACKAGED AS BARS; NUTRITIONAL DRINK MIX FOR USE AS A MEAL REPLACEMENT; NUTRITIONAL ENERGY BARS FOR USE AS A MEAL SUBSTITUTE; NUTRITIONAL FOOD BARS FOR USE AS A MEAL REPLACEMENT; NUTRITIONAL OILS NOT FOR FOOD OR COSMETIC PURPOSES; NUTRITIONAL SHAKES FOR USE AS A MEAL SUBSTITUTE; NUTRITIONAL SUPPLEMENT FOR ELIMINATING TOXINS FROM THE BODY; NUTRITIONAL SUPPLEMENT FOR ELIMINATING TOXINS FROM THE INTESTINAL TRACT; NUTRITIONAL SUPPLEMENTS; NUTRITIONAL SUPPLEMENTS IN LOTION FORM SOLD AS A COMPONENT OF NUTRITIONAL SKIN CARE PRODUCTS; NUTRITIONAL SUPPLEMENTS IN THE NATURE OF NUTRITIONALLY FORTIFIED SOFT CHEWS; NUTRITIONAL SUPPLEMENTS, NAMELY, CARBOHYDRATES IN POWDERED FORM; NUTRITIONAL SUPPLEMENTS, NAMELY, PROBIOTIC COMPOSITIONS; POWDERED FRUIT-FLAVORED DIETARY SUPPLEMENT DRINK MIX; POWDERED NUTRITIONAL SUPPLEMENT DRINK MIX; POWDERED NUTRITIONAL SUPPLEMENT DRINK MIX AND CONCENTRATE; PROTEIN SUPPLEMENTS; VITAMIN AND MINERAL SUPPLEMENTS; VITAMIN SUPPLEMENT IN TABLET FORM FOR USE IN MAKING AN EFFERVESCENT BEVERAGE WHEN ADDED TO WATER; VITAMIN SUPPLEMENTS; VITAMINS AND DIETARY FOOD SUPPLEMENTS FOR ANIMALS; WEIGHT MANAGEMENT SUPPLEMENTS; WHEY PROTEIN SUPPLE (U.S. CLS. 6, 18, 44, 46, 51 AND 52).

FIRST USE 2-1-2009; IN COMMERCE 7-1-2011.

CLASS 5—(Continued).

4,211,419. FERNDALE IP, INC., FERNDALE, MI. SN 85-401,185. PUB. 1-17-2012, FILED 8-18-2011.

RECTICARE

THE MARK CONSISTS OF STANDARD CHARACTERS WITHOUT CLAIM TO ANY PARTICULAR FONT, STYLE, SIZE, OR COLOR.

FOR TOPICAL ANESTHETIC PREPARATIONS (U.S. CLS. 6, 18, 44, 46, 51 AND 52).

FIRST USE 3-8-2012; IN COMMERCE 3-8-2012.

4,211,487. MONAVIE LLC, SOUTH JORDAN, UT. SN 85-426,436. PUB. 3-27-2012, FILED 9-19-2011.

NUTRITIONAL CHEMISTRY

THE MARK CONSISTS OF STANDARD CHARACTERS WITHOUT CLAIM TO ANY PARTICULAR FONT, STYLE, SIZE, OR COLOR.

NO CLAIM IS MADE TO THE EXCLUSIVE RIGHT TO USE "NUTRITIONAL", APART FROM THE MARK AS SHOWN.

FOR POWDERED FRUIT-FLAVORED DIETARY SUPPLEMENT DRINK MIX; POWDERED NUTRITIONAL SUPPLEMENT DRINK MIX; POWDERED NUTRITIONAL SUPPLEMENT DRINK MIX AND CONCENTRATE (U.S. CLS. 6, 18, 44, 46, 51 AND 52).

FIRST USE 1-13-2012; IN COMMERCE 1-13-2012.

4,211,526. BIOLIFE, LLC, SARASOTA, FL. SN 85-449,674. PUB. 3-27-2012, FILED 10-18-2011.

StatSeal

THE MARK CONSISTS OF STANDARD CHARACTERS WITHOUT CLAIM TO ANY PARTICULAR FONT, STYLE, SIZE, OR COLOR.

FOR NON-PRESCRIPTION PHARMACEUTICAL PREPARATIONS, NAMELY, NON-ABSORBABLE TOPICAL POWDER APPLIED EXTERNALLY TO SEAL AND PROTECT VASCULAR ACCESS SITES AND OTHER EXTERNAL WOUNDS (U.S. CLS. 6, 18, 44, 46, 51 AND 52).

FIRST USE 7-13-2012; IN COMMERCE 7-13-2012.

CLASS 5—(Continued).

4,211,544. ABBOTT DIABETES CARE INC., ALAMEDA, CA. SN 85-457,075. PUB. 4-3-2012, FILED 10-26-2011.

FREESTYLE INSULINX

THE MARK CONSISTS OF STANDARD CHARACTERS WITHOUT CLAIM TO ANY PARTICULAR FONT, STYLE, SIZE, OR COLOR.

OWNER OF U.S. REG. NOS. 2,670,744, 3,111,863, AND OTHERS.

FOR MEDICAL DIAGNOSTIC TEST STRIPS FOR USE IN THE FIELD OF MONITORING BLOOD GLUCOSE LEVELS (U.S. CLS. 6, 18, 44, 46, 51 AND 52).

FIRST USE 3-8-2012; IN COMMERCE 3-8-2012.

4,211,547. YOGAEARTH GROUP LLC, DBA YOGAEARTH, VENICE, CA. SN 85-459,015. PUB. 1-10-2012, FILED 10-28-2011.

Intelligent Indulgence

THE MARK CONSISTS OF STANDARD CHARACTERS WITHOUT CLAIM TO ANY PARTICULAR FONT, STYLE, SIZE, OR COLOR.

FOR NUTRITIONAL FOOD BARS FOR USE AS A MEAL REPLACEMENT (U.S. CLS. 6, 18, 44, 46, 51 AND 52).

FIRST USE 6-1-2011; IN COMMERCE 11-15-2011.

4,211,582. ULTIMATE WELLNESS SYSTEMS INC., NORTH PALM BEACH, FL. SN 85-476,226. PUB. 5-1-2012, FILED 11-18-2011.

PR7

THE MARK CONSISTS OF STANDARD CHARACTERS WITHOUT CLAIM TO ANY PARTICULAR FONT, STYLE, SIZE, OR COLOR.

FOR NUTRITIONAL SUPPLEMENTS; DIETARY SUPPLEMENTS, NAMELY, LIQUID DRINK WHICH PROMOTES AND SUPPORTS TRAINING-INDUCED INCREASE IN MUSCULAR STRENGTH, POWER, AND STAMINA AND INTENDED TO DECREASE PERCEIVED RATE OF EXERTION FOR A GIVEN INTENSITY AND DURATION OF PHYSICAL AND MENTAL ACTIVITY (U.S. CLS. 6, 18, 44, 46, 51 AND 52).

FIRST USE 3-28-2012; IN COMMERCE 3-28-2012.

CLASS 5—(Continued).

4,211,602. ULTIMATE WELLNESS SYSTEMS, INC., NORTH PALM BEACH, FL. SN 85-484,421. PUB. 5-8-2012, FILED 11-30-2011.



THE COLOR(S) BLACK, RED, AND WHITE. IS/ARE CLAIMED AS A FEATURE OF THE MARK.

THE MARK CONSISTS OF STYLIZED VERSION OF THE LETTERS "PR" AND NUMBER "7" IN WHITE WITH A DIAGONAL "/" IN WHITE SEPARATING THE "PR" AND "7". A LARGER "7" IN RED BEHIND THE SMALLER "7" IN WHITE, AND ALL WITH A SOLID BLACK BACKGROUND.

FOR NUTRITIONAL SUPPLEMENTS; DIETARY SUPPLEMENTS, NAMELY, LIQUID DRINK WHICH PROMOTES AND SUPPORTS TRAINING-INDUCED INCREASE IN MUSCULAR STRENGTH, POWER, AND STAMINA AND INTENDED TO DECREASE PERCEIVED RATE OF EXERTION FOR A GIVEN INTENSITY AND DURATION OF PHYSICAL AND MENTAL ACTIVITY (U.S. CLS. 6, 18, 44, 46, 51 AND 52).

FIRST USE 3-28-2012; IN COMMERCE 3-28-2012.

4,211,652. TERRAMERA, INC., VANCOUVER, BC, CANADA. SN 85-524,278. PUB. 5-22-2012, FILED 1-24-2012.

CIRKIL

THE MARK CONSISTS OF STANDARD CHARACTERS WITHOUT CLAIM TO ANY PARTICULAR FONT, STYLE, SIZE, OR COLOR.

FOR PESTICIDES, BIOPESTICIDES, INSECTICIDES, AND OVICIDES (U.S. CLS. 6, 18, 44, 46, 51 AND 52).

FIRST USE 6-25-2012; IN COMMERCE 6-25-2012.

CLASS 5—(Continued).

4,211,653. PRIMARY INVESTMENTS GROUP LIMITED, ROAD TOWN, TORTOLA, BR.VIRGIN ISLANDS. SN 85-538,449. PUB. 5-22-2012, FILED 2-9-2012.

T-STRONG

THE MARK CONSISTS OF STANDARD CHARACTERS WITHOUT CLAIM TO ANY PARTICULAR FONT, STYLE, SIZE, OR COLOR.

FOR DIETARY SUPPLEMENTS; FOOD SUPPLEMENTS; HERBAL SUPPLEMENTS; NUTRITIONAL SUPPLEMENTS; VITAMIN SUPPLEMENTS; MINERAL SUPPLEMENTS; MULTI-VITAMIN AND MINERAL SUPPLEMENTS (U.S. CLS. 6, 18, 44, 46, 51 AND 52).
FIRST USE 6-22-2012; IN COMMERCE 6-22-2012.

4,211,670. PRIMUS PHARMACEUTICALS, INC., SCOTTS-DALE, AZ. SN 85-977,170. PUB. 5-10-2011, FILED 6-11-2010.

VASCULERA

THE MARK CONSISTS OF STANDARD CHARACTERS WITHOUT CLAIM TO ANY PARTICULAR FONT, STYLE, SIZE, OR COLOR.

FOR MEDICAL FOODS FOR THE DIETARY MANAGEMENT OF CHRONIC VENOUS INSUFFICIENCY, COMPROMISED VASCULATURE, AND POOR CIRCULATION INCLUDING THEIR MANIFESTATIONS AND ASSOCIATED CONDITIONS SUCH AS VARICOSE VEINS, SPIDER VEINS, EDEMA, DEEP VEIN THROMBOSIS, STASIS DERMATITIS, SKIN ULCERS, AND HEMORRHOIDS; PHARMACEUTICAL PREPARATIONS FOR TREATMENT, PREVENTION, MITIGATION, CURE, OR DIAGNOSIS OF CHRONIC VENOUS INSUFFICIENCY, COMPROMISED VASCULATURE, AND POOR CIRCULATION INCLUDING THEIR MANIFESTATIONS AND ASSOCIATED CONDITIONS SUCH AS VARICOSE VEINS, SPIDER VEINS, EDEMA, DEEP VEIN THROMBOSIS, STASIS DERMATITIS, SKIN ULCERS, AND HEMORRHOIDS (U.S. CLS. 6, 18, 44, 46, 51 AND 52).
FIRST USE 10-28-2010; IN COMMERCE 10-28-2010.

CLASS 6—METAL GOODS

CLASS 6—(Continued).

4,210,281. HALEX/SCOTT FETZER COMPANY, BEDFORD HEIGHTS, OH. SN 77-485,887. PUB. 4-14-2009, FILED 5-29-2008.



THE MARK CONSISTS OF AN OVAL INTERSECTING TWO VERTICAL BARS.

FOR METAL FASTENERS, NAMELY, METAL STAPLES, AND METAL STAPLES HAVING NON-METAL INSULATION PORTIONS (U.S. CLS. 2, 12, 13, 14, 23, 25 AND 50).
FIRST USE 6-5-2012; IN COMMERCE 6-5-2012.

4,210,431. CGI WINDOWS AND DOORS, INC., DORAL, FL. SN 77-911,469. PUB. 12-7-2010, FILED 1-13-2010.



ESTATE ENTRANCES

Peace of mind has never looked so good

OWNER OF U.S. REG. NOS. 3,055,449, 4,035,607, AND OTHERS.

THE COLOR(S) RED, WHITE AND BLACK IS/ARE CLAIMED AS A FEATURE OF THE MARK.

THE MARK CONSISTS OF THE LETTERS "CGI" IN WHITE STYLIZED FONT ON A RED CIRCLE BACKGROUND WITH A WHITE BORDER WITH SHADING, CENTERED ABOVE THE WORDS "ESTATE ENTRANCES" IN BLACK STYLIZED FONT CENTERED ABOVE A BLACK LINE AND BELOW THAT BLACK LINE THE WORDS "PEACE OF MIND HAS NEVER LOOKED SO GOOD" IN RED STYLIZED FONT.

FOR IMPACT RESISTANT WINDOWS AND DOORS MADE OF ALUMINUM FOR RESIDENTIAL AND COMMERCIAL APPLICATION (U.S. CLS. 2, 12, 13, 14, 23, 25 AND 50).

FIRST USE 10-29-2010; IN COMMERCE 10-29-2010.

CLASS 6—(Continued).

4,210,616. INFASTECH DECORAH, LLC, WILMINGTON, DE. SN 85-113,735. PUB. 8-2-2011, FILED 8-23-2010.

ENGINEERED STANDARDS

THE MARK CONSISTS OF STANDARD CHARACTERS WITHOUT CLAIM TO ANY PARTICULAR FONT, STYLE, SIZE, OR COLOR.

FOR METAL FASTENERS, NAMELY, SCREWS, NUTS, BOLTS, THREAD-FORMING SCREWS; METAL WASHERS FOR USE IN FASTENER ASSEMBLIES; METAL THREADED FASTENERS; THREAD-ROLLING FASTENERS, THREAD-FORMING FASTENERS, SELF-DRILLING FASTENERS, SELF-TAPPING FASTENERS, ALL MADE OF METAL (U.S. CLS. 2, 12, 13, 14, 23, 25 AND 50).

FIRST USE 12-31-2001; IN COMMERCE 12-31-2001.

4,210,691. MOBILE SHELTER SYSTEMS, INC., HELOTES, TX. SN 85-180,448. PUB. 11-22-2011, FILED 11-18-2010.



OWNER OF U.S. REG. NOS. 2,852,533 AND 2,956,662.
NO CLAIM IS MADE TO THE EXCLUSIVE RIGHT TO USE "MODULAR STORAGE & TRANSPORT FRAME", APART FROM THE MARK AS SHOWN.

THE MARK CONSISTS OF THE LETTERS "MSTF", EACH LETTER LOCATED WITHIN A CHEVRON, AND BELOW A BAND WITH THE WORDS "MODULAR STORAGE & TRANSPORT FRAME".

FOR METAL CONTAINERS FOR THE STORAGE AND TRANSPORTATION OF GOODS; GENERAL PURPOSE METAL STORAGE CONTAINERS; PORTABLE STEEL BUILDINGS (U.S. CLS. 2, 12, 13, 14, 23, 25 AND 50).

FIRST USE 3-15-2012; IN COMMERCE 3-15-2012.

CLASS 6—(Continued).

4,210,823. BLUESCOPE STEEL LIMITED, MELBOURNE, AUSTRALIA. SN 85-225,264. PUB. 5-24-2011, FILED 1-25-2011.

BH HIGHLINE

THE MARK CONSISTS OF STANDARD CHARACTERS WITHOUT CLAIM TO ANY PARTICULAR FONT, STYLE, SIZE, OR COLOR.

FOR WATER STORAGE TANKS OF METAL FOR RESIDENTIAL, COMMERCIAL AND INDUSTRIAL PURPOSES (U.S. CLS. 2, 12, 13, 14, 23, 25 AND 50).

FIRST USE 1-1-2012; IN COMMERCE 1-1-2012.

4,210,879. NASATKA BARRIER, INC., CLINTON, MD. SN 85-249,236. PUB. 9-20-2011, FILED 2-23-2011.

NO CLAIM IS MADE TO THE EXCLUSIVE RIGHT TO USE "SECURITY", APART FROM THE MARK AS SHOWN.

THE MARK CONSISTS OF THE WORD "NASATKA" HAVING A STAR IN THE SECOND "A" IN THE WORD "NASATKA" OVER A LINE AND THE WORD "SECURITY" BELOW THE LINE.

THE WORDING "NASATKA" HAS NO MEANING IN A FOREIGN LANGUAGE.

FOR CRASH BARRIERS OF METAL (U.S. CLS. 2, 12, 13, 14, 23, 25 AND 50).

FIRST USE 9-0-2010; IN COMMERCE 9-0-2010.

4,210,898. RIDING PARTNERS, INC., ASHEVILLE, NC. SN 85-259,370. PUB. 11-22-2011, FILED 3-7-2011.

BRIGHTFIELD

THE MARK CONSISTS OF STANDARD CHARACTERS WITHOUT CLAIM TO ANY PARTICULAR FONT, STYLE, SIZE, OR COLOR.

FOR FREE STANDING METAL SHELTER STRUCTURES UTILIZING A PHOTOVOLTAIC PANELIZED ROOF SYSTEM (U.S. CLS. 2, 12, 13, 14, 23, 25 AND 50).

FIRST USE 3-7-2011; IN COMMERCE 9-5-2011.

CLASS 6—(Continued).

4,210,930. GLOBE PIPE HANGER PRODUCTS INC., CLEVELAND, OH. SN 85-281,004. PUB. 2-14-2012, FILED 3-30-2011.



NO CLAIM IS MADE TO THE EXCLUSIVE RIGHT TO USE "LIGHTER. STRONGER. MADE IN USA.", APART FROM THE MARK AS SHOWN.

THE MARK CONSISTS OF THE WORDS "SILVER HAWK" IN CAPITALIZED BLOCK LETTERING, WITH THE WORD "SILVER" ABOVE AND THE WORD "HAWK" BELOW; TO THE LEFT OF THESE WORDS IS A DESIGN THAT RESEMBLES A STYLIZED HAWK LANDING; THE DESIGN IS COMPRISED OF A SOLID DARK SQUARE WITH TWO LIGHTER SHAPES INSIDE IT THAT RESEMBLE THE HAWK'S TALONS, AND ABOVE THE SQUARE ARE A SERIES OF JAGGED LINES RESEMBLING THE HAWK'S WINGS, TAIL, AND HEAD; UNDERNEATH ALL OF THE FOREGOING ARE THE FOLLOWING WORDS, IN SMALLER, CAPITALIZED BLOCK LETTERING: "LIGHTER. STRONGER. MADE IN USA."

FOR METAL CLAMPS (U.S. CLS. 2, 12, 13, 14, 23, 25 AND 50).

FIRST USE 6-1-2011; IN COMMERCE 6-1-2011.

4,211,404. HAMPTON PRODUCTS INTERNATIONAL CORPORATION, FOOTHILL RANCH, CA. SN 85-395,972. PUB. 12-13-2011, FILED 8-11-2011.



OWNER OF U.S. REG. NOS. 2,106,212 AND 3,026,742.
THE MARK CONSISTS OF THE STYLIZED LETTER "K" FORMED BY THREE TRIANGLES AND THE STYLIZED WORD "KEEPER".

FOR METAL DEVICES FOR HANDLING, SECURING, AND STOWING CARGO, NAMELY, METAL HOOKS, METAL ANCHOR POINTS, AND METAL EYES (U.S. CLS. 2, 12, 13, 14, 23, 25 AND 50).

FIRST USE 10-30-2011; IN COMMERCE 10-30-2011.

CLASS 6—(Continued).

4,211,527. QUALITY EDGE, INC., WALKER, MI. SN 85-450,011. PUB. 3-27-2012, FILED 10-18-2011.

TRULEGACY

THE MARK CONSISTS OF STANDARD CHARACTERS WITHOUT CLAIM TO ANY PARTICULAR FONT, STYLE, SIZE, OR COLOR.

FOR METAL FASCIA ASSEMBLY FOR BUILDINGS (U.S. CLS. 2, 12, 13, 14, 23, 25 AND 50).

FIRST USE 2-0-2012; IN COMMERCE 2-0-2012.

CLASS 7—MACHINERY

4,210,242. VAREL INTERNATIONAL IND., L.P., CARROLLTON, TX. SN 76-707,399. PUB. 1-3-2012, FILED 4-26-2011.

HIGH ROLLER

THE MARK CONSISTS OF STANDARD CHARACTERS WITHOUT CLAIM TO ANY PARTICULAR FONT, STYLE, SIZE, OR COLOR.

FOR ROLLER CONE DRILL BITS, PDC DRILL BITS AND DOWN HOLE EQUIPMENT, NAMELY, EARTH BORING DRILLING REAMERS AND TORQUE REDUCTION UNITS (U.S. CLS. 13, 19, 21, 23, 31, 34 AND 35).

FIRST USE 5-25-2012; IN COMMERCE 5-25-2012.

4,210,259. KABUSHIKI KAISHA KOBE SEIKO SHO, TA KOBE STEEL, LTD., KOBE-SHI, HYOGO, JAPAN. SN 77-361,189. PUB. 4-28-2009, FILED 12-28-2007.

ARCMAN

THE MARK CONSISTS OF STANDARD CHARACTERS WITHOUT CLAIM TO ANY PARTICULAR FONT, STYLE, SIZE, OR COLOR.

OWNER OF U.S. REG. NOS. 2,196,200 AND 2,239,152.
FOR ELECTRIC WELDING MACHINES; ELECTRIC ARC WELDING MACHINES; GAS-OPERATED WELDING MACHINES; INDUSTRIAL ROBOTS, NAMELY, WELDING ROBOT MACHINES; ELECTRIC ARC CUTTING APPARATUS, NAMELY, CUTTING TORCHES (U.S. CLS. 13, 19, 21, 23, 31, 34 AND 35).

FIRST USE 5-22-1996; IN COMMERCE 5-22-1996.

CLASS 7—(Continued).

4,210,502. JAMES POLLOCK, OZONA, FL. SN 85-018,006. PUB. 12-21-2010, FILED 4-20-2010.

DRYTEK

THE MARK CONSISTS OF STANDARD CHARACTERS WITHOUT CLAIM TO ANY PARTICULAR FONT, STYLE, SIZE, OR COLOR.

FOR VACUUM PUMPS, SEMICONDUCTOR PROCESSING EQUIPMENT, NAMELY, VACUUM DESIGNED LOAD LOCKS FOR MANUFACTURED WAFERS, CARRIER MODULES, CHAMBERS, VACUUM MODULES FOR PLASMA ETCHING, VACUUM MODULES FOR PLASMA VAPOR DEPOSITION, VACUUM MODULES FOR PLASMA ENHANCED VAPOR DEPOSITION, CHEMICALLY POWERED ASSISTED ELECTROMECHANICAL PLASMA INDUCTION SYSTEMS, CHEMICALLY AND RF POWERED ASSISTED ELECTROMECHANICAL PLASMA INDUCTION SYSTEMS, VACUUM ENHANCED PROCESSING CHAMBERS; EQUIPMENT USED IN THE STORAGE AND TRANSPORTATION OF SEMICONDUCTOR SUBSTRATE MATERIALS, NAMELY, SMIF PODS, MASK PACKAGES, EUV PODS, WAFER CASSETTES, FRONT OPENING UNIFIED POD (FOUP) AND FRAMES (U.S. CLS. 13, 19, 21, 23, 31, 34 AND 35).

FIRST USE 1-31-2011; IN COMMERCE 1-31-2011.

CLASS 7—(Continued).

4,210,539. NILFISK-ADVANCE, INC., PLYMOUTH, MN. SN 85-056,373. PUB. 10-4-2011, FILED 6-7-2010.

REV

THE MARK CONSISTS OF STANDARD CHARACTERS WITHOUT CLAIM TO ANY PARTICULAR FONT, STYLE, SIZE, OR COLOR.

FOR FLOOR SCRUBBING MACHINES FOR COMMERCIAL AND INDUSTRIAL USE, AND REPLACEMENT PARTS THEREFOR; ACCESSORIES DESIGNED FOR USE ONLY WITH FLOOR SCRUBBING MACHINES FOR COMMERCIAL AND INDUSTRIAL USE, NAMELY, SCRUB DECKS (U.S. CLS. 13, 19, 21, 23, 31, 34 AND 35).

FIRST USE 3-10-2011; IN COMMERCE 3-10-2011.

4,210,511. SEARS BRANDS, LLC, HOFFMAN ESTATES, IL. SN 85-028,602. PUB. 5-31-2011, FILED 5-3-2010.

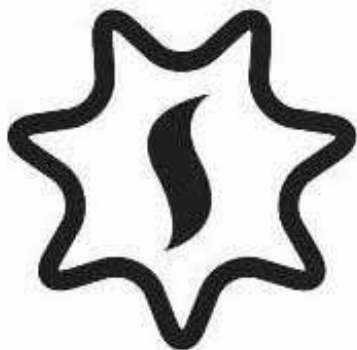

THE MARK CONSISTS OF A STARBURST DESIGN, IN WHICH THE INTERIOR OF THE STARBURST ELEMENT CONTAINS A WAVY LINE.

FOR WASHING CYCLE OPTION TO SANITIZE AND REMOVE BACTERIA, SOLD AS AN INTEGRATED PART OF CLOTHES WASHING MACHINES, DISPLAYED ON AN LCD PANEL (U.S. CLS. 13, 19, 21, 23, 31, 34 AND 35).

FIRST USE 1-0-2011; IN COMMERCE 1-0-2011.

4,210,562. INDUSTRIAL ENVIRONMENTAL CARBON, HUNTINGTON, VT. SN 85-074,711. PUB. 1-18-2011, FILED 6-30-2010.

ECOxHAUST 

THE MARK CONSISTS OF THE STYLIZED TEXT "ECOxHAUST" WITH A PORTION OF THE LETTER "X" EXTENDING BENEATH THE LETTER "O" AND A LIZARD AT THE RIGHT OF THE TEXT.

FOR VEHICLE EXHAUST PIPE ADD-ON DEVICE THAT CAPTURES CARBON DIOXIDE FROM FUEL COMBUSTION PRODUCT WASTE GASES (U.S. CLS. 13, 19, 21, 23, 31, 34 AND 35).

FIRST USE 6-1-2009; IN COMMERCE 6-1-2009.

CLASS 7—(Continued).

4,210,652. HYTORC DIVISION UNEX CORPORATION, MAHWAH, NJ. SN 85-147,283. PUB. 8-30-2011, FILED 10-7-2010.

ICE

THE MARK CONSISTS OF STANDARD CHARACTERS WITHOUT CLAIM TO ANY PARTICULAR FONT, STYLE, SIZE, OR COLOR.

FOR WORKING MACHINES AND TOOLS FOR INDUSTRIAL USE, NAMELY, HYDRAULIC OPERATED TORQUE AND TENSION WRENCHES; PUMPS FOR INDUSTRIAL USE, NAMELY, HYDRAULIC OPERATED PUMPS FOR USE WITH SUCH MACHINES AND TOOLS; BOLTING MACHINES AND BOLTING MACHINE PARTS FOR USE WITH BOLTING MACHINES, TOOLS AND PUMPS, NAMELY, SOCKETS, REACTION FIXTURES, ADAPTERS, REDUCERS, RINGS, CONNECTORS, EXTENDERS, OFF-SET LINKS AND SILENCERS; AND ASSOCIATED METALLIC OPERATIONAL, STRUCTURAL AND REPLACEMENT PARTS THEREOF, NAMELY, HOUSINGS, HANDLES, PAWLS, SHIFTERS, MOTORS, GEARS, SPACERS, BUSHINGS, CAPS, FORCE TRANSMITTERS, PLUGS, COVERS, SCREWS, SPRINGS, PINS, BUTTONS, SLEEVES, DRIVES, PLUNGERS, RATCHETS, DRIVE PLATES, DRIVE SEGMENTS, O-RING, RINGS, PLUGS, SEALS, PISTON RODS, GLANDS, SHROUDS, SWIVELS, COUPLERS, RETAINERS, CLIPS, DRIVES, BEARINGS, VALVES, HOSES, AND CONTROLLERS (U.S. CLS. 13, 19, 21, 23, 31, 34 AND 35).

FIRST USE 1-1-2012; IN COMMERCE 1-1-2012.

4,210,716. FIELDPIECE INSTRUMENTS, INC., ANAHEIM, CA. SN 85-189,771. PUB. 4-19-2011, FILED 12-2-2010.

LER

THE MARK CONSISTS OF STANDARD CHARACTERS WITHOUT CLAIM TO ANY PARTICULAR FONT, STYLE, SIZE, OR COLOR.

FOR ELECTRIC MOTORS FOR MACHINES (U.S. CLS. 13, 19, 21, 23, 31, 34 AND 35).

FIRST USE 5-14-2012; IN COMMERCE 5-14-2012.

4,210,722. AI ENTERPRISES, INC., YANKTON, SD. SN 85-192,109. PUB. 6-28-2011, FILED 12-7-2010.



OWNER OF U.S. REG. NOS. 1,027,027, 1,946,261, AND OTHERS.

CLASS 7—(Continued).

NO CLAIM IS MADE TO THE EXCLUSIVE RIGHT TO USE "A DIVISION OF" AND "INC.", APART FROM THE MARK AS SHOWN.

THE MARK CONSISTS OF THE STYLIZED CAPITAL LETTER "A" AND LOWERCASE "I" OVERLAPPING EACH OTHER TO THE LEFT OF THE WORDING "DILLMAN" AND "A DIVISION OF ASTEC INC."

FOR MACHINES, NAMELY, ASPHALT MANUFACTURING AND PROCESSING EQUIPMENT IN THE NATURE OF PORTABLE AND STATIONARY ASPHALT PLANTS, DRUM DRYERS, MIXERS, COLDFEED SYSTEMS COMPRISED OF BINS, CONVEYORS, SHAKER SCREENS AND STANDS THEREFOR, SOLD AS A UNIT, RECYCLE SYSTEMS COMPRISED OF BINS, CONVEYORS, SHAKER SCREENS AND STANDS THEREFOR, SOLD AS A UNIT, BAGHOUSES, AIR POLLUTION CONTROL SYSTEMS COMPRISED OF REVERSE PULSE BAGHOUSES, PRIMARY COLLECTORS AND CYCLONES, SOLD AS A UNIT, DRAG SLATS, TRANSFER CONVEYORS, PLANT CONTROLS AND CONTROL HOUSES (U.S. CLS. 13, 19, 21, 23, 31, 34 AND 35).

FIRST USE 6-0-2012; IN COMMERCE 6-0-2012.

4,210,739. CONN-WELD INDUSTRIES, INC., PRINCETON, WV. SN 85-200,766. PUB. 10-25-2011, FILED 12-17-2010.

TUFFLOK

THE MARK CONSISTS OF STANDARD CHARACTERS WITHOUT CLAIM TO ANY PARTICULAR FONT, STYLE, SIZE, OR COLOR.

OWNER OF U.S. REG. NOS. 1,293,918, 3,175,828, AND OTHERS.

FOR SCREEN PANELS FOR VIBRATING MACHINES (U.S. CLS. 13, 19, 21, 23, 31, 34 AND 35).

FIRST USE 3-11-2011; IN COMMERCE 3-11-2011.

4,210,891. DANA MOSMAN, BOULDER, CO. SN 85-254,595. PUB. 7-19-2011, FILED 3-1-2011.

Trinator

THE MARK CONSISTS OF STANDARD CHARACTERS WITHOUT CLAIM TO ANY PARTICULAR FONT, STYLE, SIZE, OR COLOR.

FOR AGRICULTURAL MACHINES, NAMELY, LEAF TRIMMERS CAPABLE OF HARVESTING AND PROCESSING VARIOUS PLANTS AND HERBS (U.S. CLS. 13, 19, 21, 23, 31, 34 AND 35).

FIRST USE 2-1-2011; IN COMMERCE 6-1-2012.

CLASS 7—(Continued).

4,210,959. OUTDOOR UNLIMITED LLC, ORLANDO, OK. SN 85-300,963. PUB. 9-13-2011, FILED 4-21-2011.

OMNILIFT

THE MARK CONSISTS OF STANDARD CHARACTERS WITHOUT CLAIM TO ANY PARTICULAR FONT, STYLE, SIZE, OR COLOR.

FOR POWER-OPERATED LIFTS FOR RAISING AND LOWERING TROLLING MOTORS ON FISHING BOATS (U.S. CLS. 13, 19, 21, 23, 31, 34 AND 35).

FIRST USE 5-4-2012; IN COMMERCE 5-4-2012.

CLASS 7—(Continued).

4,211,346. REDUCTION ENGINEERING, INC., KENT, OH. SN 85-377,647. PUB. 11-8-2011, FILED 7-21-2011.



THE COLOR(S) RED AND WHITE IS/ARE CLAIMED AS A FEATURE OF THE MARK.

THE MARK CONSISTS OF CONNECTED BLOCK-STYLE CAPITAL LETTERS "SF" IN WHITE CIRCLED IN WHITE WITH THE BLOCK-STYLE CAPITAL LETTERS "SCHEER" BELOW, ALL ON A RED SQUARED BACKGROUND.

FOR MACHINES FOR PLASTIC WORKING AND PLASTICS PROCESSING EQUIPMENT, NAMELY, PELLETIZERS (U.S. CLS. 13, 19, 21, 23, 31, 34 AND 35).

FIRST USE 10-24-2008; IN COMMERCE 10-24-2008.

4,211,188. TELSMITH, INC., MEQUON, WI. SN 85-350,489. PUB. 12-20-2011, FILED 6-20-2011.



OWNER OF U.S. REG. NOS. 515,271 AND 1,715,039. NO CLAIM IS MADE TO THE EXCLUSIVE RIGHT TO USE "INDUSTRIES CO.", APART FROM THE MARK AS SHOWN.

THE MARK CONSISTS OF THE DESIGN ELEMENT OF THE CAPITAL LETTER "A" AND LOWERCASE "I" OVERLAPPING EACH OTHER APPEARING TO THE LEFT OF THE STYLIZED WORDING "TELSMITH" ABOVE THE STYLIZED WORDING "AN ASTEC INDUSTRIES CO." IN SMALLER LETTERING.

FOR ROCK, ORE, SAND AND GRAVEL HANDLING MACHINES FOR INDUSTRIAL AND COMMERCIAL APPLICATIONS, NAMELY, GYRATORY CRUSHERS AND BREAKERS, JAW CRUSHERS AND BREAKERS, ROLL CRUSHERS AND BREAKERS, VIBRATORY SCREENS, ROTARY SCREENS, GRIZZLIES, WASHERS, SCRUBBERS, CLASSIFIERS, BELT CONVEYORS, CHAIN BUCKET CONVEYORS, FLIGHT CONVEYORS, SCREW CONVEYORS, SCREW ELEVATORS, BIN GATES AND PLATE FEEDERS, APRON FEEDERS AND SCREW FEEDERS (U.S. CLS. 13, 19, 21, 23, 31, 34 AND 35).

FIRST USE 1-0-2012; IN COMMERCE 1-0-2012.

4,211,420. ORECK HOLDINGS, LLC, NASHVILLE, TN. SN 85-401,221. PUB. 11-15-2011, FILED 8-18-2011.

GRAB-IT & STEAM-IT

THE MARK CONSISTS OF STANDARD CHARACTERS WITHOUT CLAIM TO ANY PARTICULAR FONT, STYLE, SIZE, OR COLOR.

OWNER OF U.S. REG. NO. 3,808,097.

FOR MULTIPURPOSE ELECTRIC STEAM CLEANING MACHINE AND ELECTRIC BROOM FOR CLEANING ALL FLOOR SURFACES (U.S. CLS. 13, 19, 21, 23, 31, 34 AND 35).

FIRST USE 11-4-2011; IN COMMERCE 11-4-2011.

CLASS 7—(Continued).

4,211,467. WIRE BELT COMPANY OF AMERICA, LONDON-DERRY, NH. SN 85-418,529. PUB. 2-21-2012, FILED 9-9-2011.

VERSA-LINK

THE MARK CONSISTS OF STANDARD CHARACTERS WITHOUT CLAIM TO ANY PARTICULAR FONT, STYLE, SIZE, OR COLOR.

FOR FLAT RIBBON METAL CONVEYOR BELTS (U.S. CLS. 13, 19, 21, 23, 31, 34 AND 35).

FIRST USE 3-1-2012; IN COMMERCE 3-1-2012.

4,211,521. BSH HOME APPLIANCES CORPORATION, IRVINE, CA. SN 85-447,520. PUB. 3-27-2012, FILED 10-14-2011.

DUOPOWER

THE MARK CONSISTS OF STANDARD CHARACTERS WITHOUT CLAIM TO ANY PARTICULAR FONT, STYLE, SIZE, OR COLOR.

FOR DOUBLE SPRAY ARM FEATURE OF A DISHWASHER; STRUCTURAL PARTS OF ALL AFOREMENTIONED GOODS (U.S. CLS. 13, 19, 21, 23, 31, 34 AND 35).

FIRST USE 12-1-2011; IN COMMERCE 12-1-2011.

4,211,542. P & P POWER INC., KINCHELOE, MI. SN 85-456,659. PUB. 5-8-2012, FILED 10-26-2011.

P & P POWER

THE MARK CONSISTS OF STANDARD CHARACTERS WITHOUT CLAIM TO ANY PARTICULAR FONT, STYLE, SIZE, OR COLOR.

NO CLAIM IS MADE TO THE EXCLUSIVE RIGHT TO USE "POWER", APART FROM THE MARK AS SHOWN.

FOR POWER TOOLS, NAMELY, CUTTING MACHINES (U.S. CLS. 13, 19, 21, 23, 31, 34 AND 35).

FIRST USE 2-22-2012; IN COMMERCE 2-22-2012.

CLASS 8—HAND TOOLS

CLASS 8—(Continued).

4,210,470. SOG SPECIALTY KNIVES & TOOLS, LLC, LYNNWOOD, WA. SN 77-966,578. PUB. 5-10-2011, FILED 3-23-2010.

BLADELIGHT

THE MARK CONSISTS OF STANDARD CHARACTERS WITHOUT CLAIM TO ANY PARTICULAR FONT, STYLE, SIZE, OR COLOR.

FOR KNIVES, NAMELY, POCKET KNIVES, SPORT KNIVES, CAMPING KNIVES AND SURVIVAL KNIVES; SHEATHS FOR KNIVES AND SHEATHS FOR MULTI-FUNCTION HAND TOOLS; MULTI-FUNCTION HAND TOOLS COMPRISED OF POCKET KNIVES, AND ONE OR MORE OF THE FOLLOWING COMPONENTS: SCREWDRIVERS, AWL, BOTTLE OPENER, WIRE CUTTERS, SAWS, FLASHLIGHT, AND WINE KEY (U.S. CLS. 23, 28 AND 44).

FIRST USE 1-3-2012; IN COMMERCE 1-3-2012.

4,211,356. PEI LICENSING, INC., MIAMI, FL. SN 85-380,634. PUB. 10-18-2011, FILED 7-26-2011.

PERRY ELLIS PORTFOLIO

THE MARK CONSISTS OF STANDARD CHARACTERS WITHOUT CLAIM TO ANY PARTICULAR FONT, STYLE, SIZE, OR COLOR.

OWNER OF U.S. REG. NOS. 2,612,007, 3,674,935, AND OTHERS.

NO CLAIM IS MADE TO THE EXCLUSIVE RIGHT TO USE "PORTFOLIO", APART FROM THE MARK AS SHOWN.

THE NAME(S), PORTRAIT(S), AND/OR SIGNATURE(S) SHOWN IN THE MARK DOES NOT IDENTIFY A PARTICULAR LIVING INDIVIDUAL.

FOR ELECTRIC AND NON-ELECTRIC SHAVERS; NON-ELECTRIC RAZORS AND RAZOR BLADES; RAZOR CASES AND RAZOR STROPS; HAIRCUTTING SCISSORS; NOSE TRIMMERS, NAIL CLIPPERS; NAIL FILES; NAIL BUFFERS; MANICURE AND PEDICURE SETS CONTAINING TWEEZERS, CUTICLE SCISSORS, CUTICLE FILES, AND CUTICLE PUSHERS; HAND TOOLS AND IMPLEMENTS FOR PERSONAL CARE, GROOMING, AND HYGIENE, NAMELY, ELECTRIC HAIR, BEARD AND MUSTACHE CUTTERS (U.S. CLS. 23, 28 AND 44).

FIRST USE 5-30-2012; IN COMMERCE 5-30-2012.

CLASS 8—(Continued).

4,211,366. FISH TALES, LLC, TUCSON, AZ. SN 85-383,423.
PUB. 10-25-2011, FILED 7-28-2011.

ONE CUT AND YOU'RE THROUGH

THE MARK CONSISTS OF STANDARD CHARACTERS WITHOUT CLAIM TO ANY PARTICULAR FONT, STYLE, SIZE, OR COLOR.

FOR KNIFE (U.S. CLS. 23, 28 AND 44).
FIRST USE 9-15-2011; IN COMMERCE 9-15-2011.

4,211,405. HAMPTON PRODUCTS INTERNATIONAL CORPORATION, FOOTHILL RANCH, CA. SN 85-395,980. PUB. 12-13-2011, FILED 8-11-2011.



OWNER OF U.S. REG. NOS. 2,106,212 AND 3,026,742.
THE MARK CONSISTS OF THE STYLIZED LETTER "K" FORMED BY THREE TRIANGLES AND THE STYLIZED WORD "KEEPER".

FOR HAND-OPERATED IMPLEMENTS FOR HANDLING, SECURING, AND STOWING CARGO, NAMELY, CAM-BUCKLE TIE-DOWNS, CARGO BARS, AND ADJUSTABLE ROPE TIE-DOWNS (U.S. CLS. 23, 28 AND 44).
FIRST USE 10-30-2011; IN COMMERCE 10-30-2011.

4,211,439. JERRY MILLER, WEST JEFFERSON, MD. SN 85-409,114. PUB. 2-28-2012, FILED 8-28-2011.

BLADE BULL

THE MARK CONSISTS OF STANDARD CHARACTERS WITHOUT CLAIM TO ANY PARTICULAR FONT, STYLE, SIZE, OR COLOR.

NO CLAIM IS MADE TO THE EXCLUSIVE RIGHT TO USE "BLADE", APART FROM THE MARK AS SHOWN.

FOR HAND OPERATED CUTTING EDGE HANDLERS FOR PLOWS AND GRADERS (U.S. CLS. 23, 28 AND 44).
FIRST USE 3-31-2012; IN COMMERCE 3-31-2012.

CLASS 9—ELECTRICAL AND SCIENTIFIC APPARATUS

4,210,245. UNIVERSAL LIGHTING TECHNOLOGIES, INC., NASHVILLE, TN. SN 76-709,562. PUB. 4-24-2012, FILED 10-27-2011.

VARIPRO

THE MARK CONSISTS OF STANDARD CHARACTERS WITHOUT CLAIM TO ANY PARTICULAR FONT, STYLE, SIZE, OR COLOR.

FOR ELECTRONIC LIGHTING BALLASTS AND CONTROLS (U.S. CLS. 21, 23, 26, 36 AND 38).
FIRST USE 4-0-2012; IN COMMERCE 4-0-2012.

4,210,260. KABUSHIKI KAISHA KOBE SEIKO SHO, TA KOBE STEEL, LTD., KOBE-SHI, HYOGO, JAPAN. SN 77-361,211. PUB. 4-28-2009, FILED 12-28-2007.

SENSARC

THE MARK CONSISTS OF STANDARD CHARACTERS WITHOUT CLAIM TO ANY PARTICULAR FONT, STYLE, SIZE, OR COLOR.

OWNER OF U.S. REG. NO. 2,201,792.
FOR ELECTRIC WELDING APPARATUS; WELDING POWER SOURCES (U.S. CLS. 21, 23, 26, 36 AND 38).
FIRST USE 5-22-1996; IN COMMERCE 5-22-1996.

4,210,263. ROSENBAUER INTERNATIONAL AKTIENGESELLSCHAFT, LEONADING, AUSTRIA. SN 77-390,949. PUB. 1-13-2009, FILED 2-7-2008.

HEROS

THE MARK CONSISTS OF STANDARD CHARACTERS WITHOUT CLAIM TO ANY PARTICULAR FONT, STYLE, SIZE, OR COLOR.

FOR PROTECTIVE HELMETS, IN PARTICULAR FIRE FIGHTING HELMETS; PROTECTIVE CLOTHING, IN PARTICULAR CLOTHING FOR PROTECTION AGAINST HEAT AND CLOTHING FOR PROTECTION AGAINST HAZARDOUS SUBSTANCES FOR FIRE FIGHTERS (U.S. CLS. 21, 23, 26, 36 AND 38).

FIRST USE 3-16-2006; IN COMMERCE 3-16-2006.

CLASS 9—(Continued).

4,210,267. CENTRACCO, ZAHIA, DBA CENTRACCO, COOKIE, OKLAHOMA CITY, OK. AND BATCHELOR, DANIELLE, HOUSTON, TX. SN 77-426,972. PUB. 3-31-2009, FILED 3-20-2008.



THE MARK CONSISTS OF A CHILD POSITIONED IN A SEAT APPARATUS.

FOR COMPUTER GAME SOFTWARE, COMPUTER ANIMATION SOFTWARE, NAMELY, COMPUTER SOFTWARE FOR USE IN RELATION TO ANIMATION AND SPECIAL EFFECTS OF IMAGES (U.S. CLS. 21, 23, 26, 36 AND 38).

FIRST USE 4-15-2012; IN COMMERCE 4-15-2012.

4,210,269. PARISE, CHRISTOPHER, SAN DIMAS, CA. SN 77-448,409. PUB. 5-5-2009, FILED 4-15-2008.

DOMMIN

THE MARK CONSISTS OF STANDARD CHARACTERS WITHOUT CLAIM TO ANY PARTICULAR FONT, STYLE, SIZE, OR COLOR.

FOR DIGITAL MATERIALS, NAMELY, PRERECORDED AUDIO CD'S FEATURING MUSIC; DOWNLOADABLE RING TONES AND RING BACK TONES (U.S. CLS. 21, 23, 26, 36 AND 38).

FIRST USE 4-14-2009; IN COMMERCE 4-14-2009.

4,210,272. ARTIFICIALLY NATURAL, LLC, BEL AIR, MD. SN 77-460,392. PUB. 4-28-2009, FILED 4-29-2008.

ElectroVine

THE MARK CONSISTS OF STANDARD CHARACTERS WITHOUT CLAIM TO ANY PARTICULAR FONT, STYLE, SIZE, OR COLOR.

FOR DECORATIVE ELECTRICAL CORDS AND CABLES (U.S. CLS. 21, 23, 26, 36 AND 38).

FIRST USE 4-24-2009; IN COMMERCE 7-20-2012.

CLASS 9—(Continued).

4,210,282. NATIONAL AUTOMATED CLEARING HOUSE ASSOCIATION, HERNDON, VA. SN 77-490,930. PUB. 11-4-2008, FILED 6-4-2008.

pay·ol·o·gie

THE MARK CONSISTS OF THE WORD "PAY", FOLLOWED BY A DOT, FOLLOWED BY THE LETTERS "OL", FOLLOWED BY A DOT, FOLLOWED BY THE LETTER "O", AND FOLLOWED BY THE LETTERS "GIE".

FOR AUDIO RECORDINGS FEATURING INFORMATION IN THE FIELD OF ELECTRONIC BILLING AND PAYMENT RULES, OPTIONS, SERVICES, NETWORKS, AND RISKS; DOWNLOADABLE ELECTRONIC NEWSLETTERS IN THE FIELD OF ELECTRONIC BILLING AND PAYMENT RULES, OPTIONS, SERVICES, NETWORKS, AND RISKS; VIDEO RECORDINGS FEATURING INFORMATION IN THE FIELD OF ELECTRONIC BILLING AND PAYMENT RULES, OPTIONS, SERVICES, NETWORKS, AND RISKS (U.S. CLS. 21, 23, 26, 36 AND 38).

FIRST USE 3-29-2011; IN COMMERCE 3-29-2011.

4,210,283. NATIONAL AUTOMATED CLEARING HOUSE ASSOCIATION, HERNDON, VA. SN 77-490,942. PUB. 11-4-2008, FILED 6-4-2008.

PAYOLOGIST

THE MARK CONSISTS OF STANDARD CHARACTERS WITHOUT CLAIM TO ANY PARTICULAR FONT, STYLE, SIZE, OR COLOR.

FOR DOWNLOADABLE ELECTRONIC NEWSLETTERS IN THE FIELD OF ELECTRONIC BILLING AND PAYMENT RULES, OPTIONS, SERVICES, NETWORKS, AND RISKS (U.S. CLS. 21, 23, 26, 36 AND 38).

FIRST USE 12-29-2011; IN COMMERCE 12-29-2011.

4,210,290. SULLIVAN, NADINE M., SPOKANE, WA. SN 77-504,648. PUB. 4-21-2009, FILED 6-20-2008.

ECO DEPOT

THE MARK CONSISTS OF STANDARD CHARACTERS WITHOUT CLAIM TO ANY PARTICULAR FONT, STYLE, SIZE, OR COLOR.

OWNER OF U.S. REG. NO. 3,234,510.

FOR SOLAR ELECTRIC PANELS, NAMELY, PHOTOVOLTAIC SOLAR MODULES AND PHOTOVOLTAIC SOLAR MODULE ARRAYS (U.S. CLS. 21, 23, 26, 36 AND 38).

FIRST USE 7-5-2012; IN COMMERCE 7-5-2012.

CLASS 9—(Continued).

4,210,299. FUSION-IO, INC., SALT LAKE CITY, UT. SN 77-555,313. PUB. 3-2-2010, FILED 8-25-2008.

Flashback

THE MARK CONSISTS OF STANDARD CHARACTERS WITHOUT CLAIM TO ANY PARTICULAR FONT, STYLE, SIZE, OR COLOR.

FOR HARDWARE IN THE NATURE OF ELECTRONIC CIRCUITS, AND RELATED SOFTWARE, USED FOR DATA PROTECTION; COMPUTER CHIPS AND ELECTRONIC CIRCUITS USED TO PROTECT FROM DATA STORAGE FAILURE; ELECTRONIC CIRCUITS, AND RELATED SOFTWARE, USED TO PROTECT FROM MEMORY CHIP FAILURE; ELECTRONIC CIRCUITS, AND RELATED SOFTWARE, USED TO PROTECT FROM NAND FLASH MEMORY CHIP FAILURE (U.S. CLS. 21, 23, 26, 36 AND 38).

FIRST USE 5-17-2012; IN COMMERCE 5-17-2012.

4,210,325. GLOBALSCAPE, INC., SAN ANTONIO, TX. SN 77-634,642. PUB. 4-21-2009, FILED 12-16-2008.

MAIL EXPRESS

THE MARK CONSISTS OF STANDARD CHARACTERS WITHOUT CLAIM TO ANY PARTICULAR FONT, STYLE, SIZE, OR COLOR.

NO CLAIM IS MADE TO THE EXCLUSIVE RIGHT TO USE "MAIL", APART FROM THE MARK AS SHOWN.

FOR COMPUTER SOFTWARE FOR USE IN DELIVERY OF E-MAIL ATTACHMENTS AND WITH FUNCTIONALITY APPLICABLE TO OTHER INTER-COMPUTER FILE TRANSFER SOLUTIONS (U.S. CLS. 21, 23, 26, 36 AND 38).

FIRST USE 12-31-2008; IN COMMERCE 12-31-2008.

CLASS 9—(Continued).

4,210,326. GLOBALSCAPE, INC., SAN ANTONIO, TX. SN 77-634,643. PUB. 4-21-2009, FILED 12-16-2008.



NO CLAIM IS MADE TO THE EXCLUSIVE RIGHT TO USE "MAIL", APART FROM THE MARK AS SHOWN.

THE MARK CONSISTS OF THE LITERAL ELEMENT "MAIL EXPRESS" WITH A PICTURE OF AN ENVELOPE.

FOR COMPUTER SOFTWARE FOR USE IN DELIVERY OF E-MAIL ATTACHMENTS AND WITH FUNCTIONALITY APPLICABLE TO OTHER INTER-COMPUTER FILE TRANSFER SOLUTIONS (U.S. CLS. 21, 23, 26, 36 AND 38).

FIRST USE 12-31-2008; IN COMMERCE 12-31-2008.

4,210,328. FRESNEL TECHNOLOGIES, INC., FORT WORTH, TX. SN 77-636,311. PUB. 6-30-2009, FILED 12-18-2008.

SOLAROPTIX

THE MARK CONSISTS OF STANDARD CHARACTERS WITHOUT CLAIM TO ANY PARTICULAR FONT, STYLE, SIZE, OR COLOR.

FOR SPECIALTY AND CUSTOM-DESIGNED OPTICAL LENSES FOR INDUSTRIAL USE (U.S. CLS. 21, 23, 26, 36 AND 38).

FIRST USE 12-18-2008; IN COMMERCE 12-18-2008.

4,210,344. COMPUTER SCIENCES CORPORATION, FALLS CHURCH, VA. SN 77-651,101. PUB. 5-5-2009, FILED 1-16-2009.

CRR CLINICAL ROUNDS REPORT

THE MARK CONSISTS OF STANDARD CHARACTERS WITHOUT CLAIM TO ANY PARTICULAR FONT, STYLE, SIZE, OR COLOR.

CLASS 9—(Continued).

NO CLAIM IS MADE TO THE EXCLUSIVE RIGHT TO USE "CLINICAL ROUNDS REPORT", APART FROM THE MARK AS SHOWN.

FOR COMPUTER PROGRAMS FOR USE BY HOSPITALS, CLINICS, MEDICAL OFFICES, AND OTHER HEALTH CARE FACILITIES AND HEALTH CARE PROFESSIONALS FOR INPUT, DISPLAY, AND PROCESSING OF CLINICAL DATA (U.S. CLS. 21, 23, 26, 36 AND 38).

FIRST USE 5-22-2008; IN COMMERCE 5-22-2008.

CLASS 9—(Continued).

4,210,382. DEFOND NORTH AMERICA, INC., DBA DNA GROUP, INC., RALEIGH, NC. SN 77-807,902. PUB. 2-21-2012, FILED 8-19-2009.

OMNI-BUS

THE MARK CONSISTS OF STANDARD CHARACTERS WITHOUT CLAIM TO ANY PARTICULAR FONT, STYLE, SIZE, OR COLOR.

FOR DIGITAL SWITCHING SYSTEMS COMPRISED OF INTERCONNECTED ELECTROMECHANICAL AND SOLID-STATE POWER MANAGEMENT ENCLOSURES WITH STANDARD AND CUSTOM KEYPADS FOR USER REMOTE CONTROL, THE FOREGOING FOR USE ON MARINE HELMS AND LAND-BASED VEHICLE DASHBOARDS; HUMAN-TO-MACHINE INTERFACES FOR AUXILIARY POWER AND LOGIC CONTROLS ON INDUSTRIAL EQUIPMENT (U.S. CLS. 21, 23, 26, 36 AND 38).

FIRST USE 8-31-2009; IN COMMERCE 10-12-2009.

4,210,357. RUDOLPH TECHNOLOGIES, INC., BLOOMINGTON, MN. SN 77-720,775. PUB. 9-22-2009, FILED 4-23-2009.

DISCOVER SOLAR

THE MARK CONSISTS OF STANDARD CHARACTERS WITHOUT CLAIM TO ANY PARTICULAR FONT, STYLE, SIZE, OR COLOR.

OWNER OF U.S. REG. NO. 3,496,573.

NO CLAIM IS MADE TO THE EXCLUSIVE RIGHT TO USE "SOLAR", APART FROM THE MARK AS SHOWN.

FOR COMPUTER SOFTWARE FOR DATA AND YIELD MANAGEMENT AND ANALYSIS IN SEMICONDUCTOR MANUFACTURING (U.S. CLS. 21, 23, 26, 36 AND 38).

FIRST USE 6-18-2012; IN COMMERCE 6-18-2012.

4,210,413. SENTIENT ENERGY, INC., BURLINGAME, CA. SN 77-886,799. PUB. 4-27-2010, FILED 12-4-2009.

**The Eyes and the Ears of
the Smart Grid**

4,210,361. IGT, RENO, NV. SN 77-743,572. PUB. 9-29-2009, FILED 5-22-2009.

KEEPIN' IT HOT

THE MARK CONSISTS OF STANDARD CHARACTERS WITHOUT CLAIM TO ANY PARTICULAR FONT, STYLE, SIZE, OR COLOR.

FOR GAMING MACHINES, NAMELY, DEVICES WHICH ACCEPT A WAGER (U.S. CLS. 21, 23, 26, 36 AND 38).

FIRST USE 12-1-2011; IN COMMERCE 5-24-2012.

THE MARK CONSISTS OF STANDARD CHARACTERS WITHOUT CLAIM TO ANY PARTICULAR FONT, STYLE, SIZE, OR COLOR.

NO CLAIM IS MADE TO THE EXCLUSIVE RIGHT TO USE "SMART GRID", APART FROM THE MARK AS SHOWN.

FOR ELECTRIC OR ELECTRONIC SENSORS FOR MEDIUM VOLTAGE ELECTRICITY DISTRIBUTION CURRENT, VOLTAGE, TEMPERATURE, AND OTHER CRITICAL PARAMETERS (U.S. CLS. 21, 23, 26, 36 AND 38).

FIRST USE 1-12-2011; IN COMMERCE 1-1-2012.

CLASS 9—(Continued).

4,210,416. VIBRATION TECHNOLOGIES, LLC, SAN RAFAEL, CA. SN 77-893,487. PUB. 5-18-2010, FILED 12-15-2009.



THE MARK CONSISTS OF A VIBRATION WAVE DESIGN SIMULATING A "V" ON TOP OF A SOLID "T"-SHAPE FORM.

FOR COMPUTER HARDWARE AND COMPUTER SOFTWARE ALL FOR USE IN MONITORING, TESTING AND VERIFYING THE DESIGNS OF MANUFACTURED GOODS (U.S. CLS. 21, 23, 26, 36 AND 38).

FIRST USE 7-2-2012; IN COMMERCE 7-2-2012.

4,210,417. ANDA, INC., WESTON, FL. SN 77-895,127. PUB. 11-30-2010, FILED 12-16-2009.

CSOS ENTERPRISE

THE MARK CONSISTS OF STANDARD CHARACTERS WITHOUT CLAIM TO ANY PARTICULAR FONT, STYLE, SIZE, OR COLOR.

NO CLAIM IS MADE TO THE EXCLUSIVE RIGHT TO USE "CSOS", APART FROM THE MARK AS SHOWN.

FOR SOFTWARE FOR QUOTING AND ORDERING PHARMACEUTICALS FOR USE BY LICENSED REPRESENTATIVES OF AN APPROVED PHARMACY (U.S. CLS. 21, 23, 26, 36 AND 38).

FIRST USE 10-21-2006; IN COMMERCE 10-21-2006.

CLASS 9—(Continued).

4,210,419. HONEYWELL INTERNATIONAL INC., MORRISTOWN, NJ. SN 77-897,802. PUB. 4-13-2010, FILED 12-21-2009.

SMARTTRAFFIC

THE MARK CONSISTS OF STANDARD CHARACTERS WITHOUT CLAIM TO ANY PARTICULAR FONT, STYLE, SIZE, OR COLOR.

FOR AIRCRAFT NAVIGATION AND LANDING GUIDANCE SYSTEM COMPRISED OF COMPUTER SOFTWARE, COMPUTER DATABASES, DISPLAYS, AND GLOBAL POSITIONING INFORMATION (U.S. CLS. 21, 23, 26, 36 AND 38).

FIRST USE 9-30-2010; IN COMMERCE 9-30-2010.

4,210,421. SUSTAINABLE GROUP HOLDINGS LLC, SEATTLE, WA. SN 77-900,487. PUB. 5-4-2010, FILED 12-23-2009.

NO LANDFILL REQUIRED

THE MARK CONSISTS OF STANDARD CHARACTERS WITHOUT CLAIM TO ANY PARTICULAR FONT, STYLE, SIZE, OR COLOR.

FOR CD AND DVD SLEEVES AND CASES (U.S. CLS. 21, 23, 26, 36 AND 38).

FIRST USE 4-30-2010; IN COMMERCE 4-30-2010.

4,210,432. ZERO CHROMA, LLC, SYKESVILLE, MD. SN 77-912,866. PUB. 12-7-2010, FILED 1-15-2010.

ZEROCHROMA

THE MARK CONSISTS OF STANDARD CHARACTERS WITHOUT CLAIM TO ANY PARTICULAR FONT, STYLE, SIZE, OR COLOR.

FOR PROTECTIVE CARRYING CASES AND COVERS SPECIFICALLY DESIGNED FOR MOBILE ELECTRONIC DEVICES, NAMELY, COMPUTERS, MOBILE PHONES, PORTABLE MUSIC DEVICES, PORTABLE GAMING DEVICES, TOUCH SCREEN DEVICES, COMPUTER MONITORS, CAMERAS, AND PERSONAL DIGITAL ASSISTANTS (U.S. CLS. 21, 23, 26, 36 AND 38).

FIRST USE 11-1-2009; IN COMMERCE 11-1-2009.

CLASS 9—(Continued).

4,210,433. GILL, CHANDRA, PHD., CHICAGO, IL. SN 77-914,484. PUB. 6-1-2010, FILED 1-19-2010.

BLACKADEMICALLY SPEAKING

THE MARK CONSISTS OF STANDARD CHARACTERS WITHOUT CLAIM TO ANY PARTICULAR FONT, STYLE, SIZE, OR COLOR.

OWNER OF U.S. REG. NO. 3,927,537.

FOR DIGITAL MATERIALS, NAMELY, CDS, DVDS, DOWNLOADABLE AUDIO AND VIDEO RECORDINGS FEATURING EDUCATIONAL AND ENTERTAINMENT MATERIALS FEATURING AN ACADEMIC TOOL AND FRAMEWORK TO SOCIALLY ASSESS, PERSONALLY EMPOWER, POLITICALLY CHALLENGE, SPIRITUALLY UPLIFT AND CULTURALLY ENGAGE THE MASSES (U.S. CLS. 21, 23, 26, 36 AND 38).
FIRST USE 8-22-2011; IN COMMERCE 8-22-2011.

4,210,463. D3PUBLISHER OF AMERICA, INC., LOS ANGELES, CA. SN 77-948,307. PUB. 7-27-2010, FILED 3-2-2010.

KID ADVENTURES

THE MARK CONSISTS OF STANDARD CHARACTERS WITHOUT CLAIM TO ANY PARTICULAR FONT, STYLE, SIZE, OR COLOR.

NO CLAIM IS MADE TO THE EXCLUSIVE RIGHT TO USE "KID", APART FROM THE MARK AS SHOWN.

FOR SOFTWARE AND ELECTRONIC GAMES, NAMELY, GAME SOFTWARE RECORDED ON CD-ROM AND DIGITAL VIDEO DISCS FOR COMPUTERS; GAME SOFTWARE RECORDED ON CD-ROMS, DIGITAL VIDEO DISCS, AND CARTRIDGES FOR CONSOLE AND INDIVIDUAL PORTABLE GAMING SYSTEMS; GAME SOFTWARE THAT IS DOWNLOADABLE FROM A REMOTE COMPUTER SITE; DOWNLOADABLE GAME SOFTWARE FOR MOBILE PHONES, PERSONAL DIGITAL ASSISTANTS, CONSOLE GAMING SYSTEMS, AND HANDHELD COMPUTERS (U.S. CLS. 21, 23, 26, 36 AND 38).
FIRST USE 6-0-2010; IN COMMERCE 6-0-2010.

CLASS 9—(Continued).

4,210,478. SUNLIGHT PHOTONICS INC., SOUTH PLAINFIELD, NJ. SN 77-983,296. PUB. 7-13-2010, FILED 2-25-2008.

SUNLIGHT PHOTONICS

THE MARK CONSISTS OF STANDARD CHARACTERS WITHOUT CLAIM TO ANY PARTICULAR FONT, STYLE, SIZE, OR COLOR.

NO CLAIM IS MADE TO THE EXCLUSIVE RIGHT TO USE "PHOTONICS", APART FROM THE MARK AS SHOWN.

FOR ELECTRICAL DEVICES FOR CONVERTING ELECTROMAGNETIC RADIATION INTO ELECTRICAL ENERGY, ABSORBERS, EXCLUDING BATTERIES (U.S. CLS. 21, 23, 26, 36 AND 38).
FIRST USE 2-25-2008; IN COMMERCE 2-24-2011.

4,210,481. INQUISITIVE MINDS, INC., MOUNTAIN VIEW, CA. SN 77-983,337. PUB. 6-22-2010, FILED 6-23-2009.

ZOODLES

THE MARK CONSISTS OF STANDARD CHARACTERS WITHOUT CLAIM TO ANY PARTICULAR FONT, STYLE, SIZE, OR COLOR.

FOR COMPUTER SOFTWARE FOR SEARCHING, LOCATING AND TRANSFERRING INFORMATION ACROSS GLOBAL COMPUTER COMMUNICATIONS NETWORKS; EDUCATIONAL SOFTWARE FOR CHILDREN; COMPUTER SOFTWARE IN THE NATURE OF A WEB BROWSER FOR BROWSING GLOBAL COMPUTER NETWORKS AND SECURE PRIVATE NETWORKS, AND SOFTWARE PROGRAMS TO CONNECT COMPUTERS TO THE GLOBAL COMPUTER NETWORK AND TO SECURE PRIVATE NETWORKS; COMPUTER SOFTWARE IN THE NATURE OF A WEB BROWSER FOR USE BY CHILDREN, PARENTS, FAMILIES, EDUCATORS AND INDIVIDUALS CARING FOR CHILDREN IN BROWSING GLOBAL COMPUTER NETWORKS AND SECURE PRIVATE NETWORKS AND LOCATING AGE-APPROPRIATE CONTENT FOR CHILDREN; COMPUTER SOFTWARE IN THE NATURE OF A WEB BROWSER THAT ENABLES PARENTS, FAMILIES, EDUCATORS AND INDIVIDUALS CARING FOR CHILDREN TO MONITOR AND CONTROL THE ONLINE CONTENT CHILDREN HAVE ACCESS TO, CUSTOMIZE THE TYPES OF CONTENT CHILDREN CAN ACCESS IN ORDER TO PROMOTE SPECIFIC EDUCATIONAL OR ENTERTAINMENT GOALS, AND EVALUATE THE EDUCATIONAL VALUE OF THE ONLINE CONTENT CHILDREN ARE INTERACTING WITH; COMPUTER GAME SOFTWARE FOR CHILDREN AND CHILDREN'S EDUCATIONAL SOFTWARE FEATURING GAMES, PUZZLES, EDUCATIONAL CHALLENGES AND ACTIVITIES, DOWNLOADABLE VIA A GLOBAL COMPUTER NETWORK AND WIRELESS DEVICES, NAMELY, MOBILE COMPUTERS AND COMMUNICATION DEVICES, ELECTRONIC HAND-HELD AND STATIONARY GAME UNITS (U.S. CLS. 21, 23, 26, 36 AND 38).
FIRST USE 4-16-2009; IN COMMERCE 4-16-2009.

CLASS 9—(Continued).

4,210,527. SMULE, INC., PALO ALTO, CA. SN 85-047,089. PUB. 10-12-2010, FILED 5-25-2010.

AUTORAP

THE MARK CONSISTS OF STANDARD CHARACTERS WITHOUT CLAIM TO ANY PARTICULAR FONT, STYLE, SIZE, OR COLOR.

FOR COMPUTER GAME SOFTWARE; COMMUNICATIONS SOFTWARE FOR CONNECTING MOBILE USERS; COMPUTER APPLICATION SOFTWARE FOR MOBILE PHONES; COMPUTER GRAPHICS SOFTWARE; COMPUTER SOFTWARE PROGRAMS FOR THE INTEGRATION OF TEXT, AUDIO, GRAPHICS, STILL IMAGES AND MOVING PICTURES INTO AN INTERACTIVE DELIVERY FOR MULTIMEDIA APPLICATIONS; COMPUTER SOFTWARE FOR PROCESSING DIGITAL MUSIC FILES; COMPUTER SOFTWARE FEATURING MUSICAL SOUND RECORDINGS OR MUSICAL VIDEO RECORDINGS; COMPUTER SOFTWARE FOR COMMUNICATING WITH USERS OF HAND-HELD COMPUTERS; COMPUTER SOFTWARE FOR MANIPULATING DIGITAL AUDIO INFORMATION FOR USE IN AUDIO MEDIA APPLICATIONS; COMPUTER SOFTWARE FOR PROCESSING DIGITAL MUSIC FILES; COMPUTER SOFTWARE FOR USE IN RELATION TO DIGITAL ANIMATION AND SPECIAL EFFECTS OF IMAGES; COMPUTER SOFTWARE FOR WIRELESS CONTENT DELIVERY; COMPUTER SOFTWARE PLATFORMS FOR DEVELOPMENT OF INTERACTIVE AUDIO APPLICATIONS FOR USE WITH MOBILE AUDIO PLATFORMS; COMPUTER SOFTWARE TO CONTROL AND IMPROVE COMPUTER AND AUDIO EQUIPMENT SOUND QUALITY; COMPUTER SOFTWARE, NAMELY, SOFTWARE DEVELOPMENT TOOLS FOR THE CREATION OF MOBILE INTERNET APPLICATIONS AND CLIENT INTERFACES; DOWNLOADABLE COMPUTER SOFTWARE EXECUTABLE TO CAUSE MOBILE DEVICES TO FUNCTION AS MUSICAL INSTRUMENTS; DOWNLOADABLE COMPUTER SOFTWARE FOR MOBILE DEVICES THAT ENABLES USERS TO TRANSFORM AND ENHANCE THE VIDEO AND AUDIO CAPABILITIES OF THEIR MOBILE DEVICES; DOWNLOADABLE COMPUTER SOFTWARE EXECUTABLE TO COMMUNICATE AMONGST MOBILE DEVICES USING AUDIO ENCODINGS OF INFORMATION; DOWNLOADABLE COMPUTER SOFTWARE EXECUTABLE TO PROVIDE MOBILE DEVICES WITH SIGNAL PROCESSING CAPABILITIES; DOWNLOADABLE COMPUTER SOFTWARE THAT CREATES A VOICE CHANGER FEATURE ON A MOBILE DEVICE; DOWNLOADABLE COMPUTER SOFTWARE FOR MOBILE DEVICES THAT ENABLES USERS TO INTERACTIVELY PERFORM INDIVIDUALIZED AUDIO AND VIDEO; DOWNLOADABLE COMPUTER SOFTWARE FOR MOBILE DEVICES THAT ENABLES USERS TO SEND MUSIC, TEXT, AUDIO, VIDEO, AND GRAPHICS INFORMATION TO OTHER USERS OF MOBILE DEVICES; DOWNLOADABLE COMPUTER SOFTWARE FOR MOBILE DEVICES FOR ENABLING USERS TO DOWNLOAD AND SHARE INTERACTIVE AUDIO AND MUSIC USING MOBILE PHONES; DOWNLOADABLE COMPUTER SOFTWARE FOR MOBILE DEVICES FOR ENHANCING AUDIO AND VIDEO CAPABILITIES FOR ENTERTAINMENT PURPOSES; DOWNLOADABLE COMPUTER SOFTWARE FOR MOBILE DEVICES FOR PERSONALIZING AUDIO PERFORMANCES ON A MOBILE DEVICE BASED ON INTERACTION OF USER; ELECTRONIC GAME SOFTWARE FOR CELLULAR TELEPHONES; ELECTRONIC GAME SOFTWARE FOR HANDHELD ELECTRONIC DEVICES; ELECTRONIC GAME SOFTWARE FOR WIRELESS DEVICES (U.S. CLS. 21, 23, 26, 36 AND 38).

FIRST USE 7-17-2012; IN COMMERCE 7-17-2012.

CLASS 9—(Continued).

4,210,537. LOPEZ, R. DAN, WATERVILLE, WA. SN 85-055,510. PUB. 5-17-2011, FILED 6-5-2010.

MORAL COMPASS

THE MARK CONSISTS OF STANDARD CHARACTERS WITHOUT CLAIM TO ANY PARTICULAR FONT, STYLE, SIZE, OR COLOR.

FOR DIRECTIONAL COMPASSES (U.S. CLS. 21, 23, 26, 36 AND 38).

FIRST USE 10-19-2010; IN COMMERCE 5-28-2012.

4,210,542. ECHIDNA, INC., MINNEAPOLIS, MN. SN 85-060,985. PUB. 6-7-2011, FILED 6-11-2010.

PROLIPHIQ

THE MARK CONSISTS OF STANDARD CHARACTERS WITHOUT CLAIM TO ANY PARTICULAR FONT, STYLE, SIZE, OR COLOR.

FOR COMPUTER APPLICATION SOFTWARE FOR MOBILE PHONES, NAMELY, SOFTWARE FOR SEARCHING FOR AND MANAGING SOCIAL MEDIA INFORMATION AND PROFILES; COMPUTER SOFTWARE FOR SEARCHING FOR AND MANAGING SOCIAL MEDIA INFORMATION AND PROFILES (U.S. CLS. 21, 23, 26, 36 AND 38).

FIRST USE 4-30-2012; IN COMMERCE 4-30-2012.

4,210,543. WAVECONNEX, INC., WESTLAKE VILLAGE, CA. SN 85-061,967. PUB. 11-9-2010, FILED 6-14-2010.

WAVECONNEX

THE MARK CONSISTS OF STANDARD CHARACTERS WITHOUT CLAIM TO ANY PARTICULAR FONT, STYLE, SIZE, OR COLOR.

FOR SEMICONDUCTOR DEVICES; CONNECTORS FOR ELECTRONIC CIRCUITS AND ELECTRONIC CONNECTORS; SEMICONDUCTOR CHIPS (U.S. CLS. 21, 23, 26, 36 AND 38).

FIRST USE 6-10-2011; IN COMMERCE 6-10-2011.

CLASS 9—(Continued).

4,210,552. DREAMTRAP COMMERCIALS LTD., LIMASSOL, CYPRUS. SN 85-067,250. PUB. 10-19-2010, FILED 6-21-2010.



THE MARK CONSISTS OF WORDING "DREAMWARE" WITH A STICK FIGURE DESIGN OF HUMAN AND HANDS RAISED UP.

FOR COMPUTER SOFTWARE FOR MOBILE PHONES AND OTHER PORTABLE DEVICES, NAMELY, SOFTWARE THAT WORKS WITH BIOMETRIC SENSOR AND FUNCTIONS AS ALARM CLOCK; DOWNLOADABLE SOFTWARE AND SOFTWARE UPDATES FOR WORKING WITH BIOMETRIC SENSORS AND ALARM CLOCKS (U.S. CLS. 21, 23, 26, 36 AND 38).
FIRST USE 1-14-2010; IN COMMERCE 3-13-2012.

4,210,559. MEDIAMOUNTS, LTD., CAMBRIDGE, ONTARIO, CANADA. SN 85-073,982. PUB. 6-14-2011, FILED 6-29-2010.

FUSION

THE MARK CONSISTS OF STANDARD CHARACTERS WITHOUT CLAIM TO ANY PARTICULAR FONT, STYLE, SIZE, OR COLOR.

FOR COMPUTER ACCESSORIES, NAMELY, MONITOR MOUNTS, KEYBOARD SUPPORTS AND WALL TRACKS (U.S. CLS. 21, 23, 26, 36 AND 38).
FIRST USE 3-10-2010; IN COMMERCE 3-10-2010.

4,210,576. SECRET LABS LLC, NEW YORK, NY. SN 85-083,996. PUB. 1-10-2012, FILED 7-14-2010.

NETDUINO

THE MARK CONSISTS OF STANDARD CHARACTERS WITHOUT CLAIM TO ANY PARTICULAR FONT, STYLE, SIZE, OR COLOR.

FOR COMPUTER HARDWARE; COMPUTER HARDWARE FOR ASSEMBLING CUSTOM ELECTRICAL AND ELECTRONIC DEVICES; MICROCONTROLLERS; MICROCONTROLLER MODULES CONSISTING PRIMARILY OF MICROCONTROLLERS; ELECTRONIC CIRCUIT BOARDS (U.S. CLS. 21, 23, 26, 36 AND 38).
FIRST USE 8-31-2010; IN COMMERCE 8-31-2010.

CLASS 9—(Continued).

4,210,586. FINGERPRINT DIGITAL, INC., NEW YORK, NY. SN 85-090,639. PUB. 6-7-2011, FILED 7-22-2010.

FINGERPRINT DIGITAL

THE MARK CONSISTS OF STANDARD CHARACTERS WITHOUT CLAIM TO ANY PARTICULAR FONT, STYLE, SIZE, OR COLOR.

NO CLAIM IS MADE TO THE EXCLUSIVE RIGHT TO USE "DIGITAL", APART FROM THE MARK AS SHOWN.
FOR CHILDREN'S EDUCATIONAL SOFTWARE (U.S. CLS. 21, 23, 26, 36 AND 38).
FIRST USE 7-13-2012; IN COMMERCE 7-13-2012.

4,210,589. CORRELATED MAGNETICS RESEARCH, LLC, NEW HOPE, AL. SN 85-091,658. PUB. 1-4-2011, FILED 7-23-2010.

MAGLATCH

THE MARK CONSISTS OF STANDARD CHARACTERS WITHOUT CLAIM TO ANY PARTICULAR FONT, STYLE, SIZE, OR COLOR.

FOR MAGNETS (U.S. CLS. 21, 23, 26, 36 AND 38).
FIRST USE 9-1-2010; IN COMMERCE 7-2-2012.

4,210,590. SECRET LABS LLC, NEW YORK, NY. SN 85-091,685. PUB. 1-10-2012, FILED 7-23-2010.

netduino

THE MARK CONSISTS OF THE WORD "NETDUINO" IN STYLIZED FONT.

FOR COMPUTER HARDWARE; COMPUTER HARDWARE FOR ASSEMBLING CUSTOM ELECTRICAL AND ELECTRONIC DEVICES; MICROCONTROLLERS; MICROCONTROLLER MODULES CONSISTING PRIMARILY OF MICROCONTROLLERS; ELECTRONIC CIRCUIT BOARDS (U.S. CLS. 21, 23, 26, 36 AND 38).
FIRST USE 8-31-2010; IN COMMERCE 8-31-2010.

CLASS 9—(Continued).

4,210,594. KURIYAMA OF AMERICA, INC., SCHAUMBURG, IL. SN 85-095,622. PUB. 3-29-2011, FILED 7-29-2010.

LIFESTAR

THE MARK CONSISTS OF STANDARD CHARACTERS WITHOUT CLAIM TO ANY PARTICULAR FONT, STYLE, SIZE, OR COLOR.

FOR NON-METAL AIR BREATHING HOSE FOR UNDERWATER DIVING (U.S. CLS. 21, 23, 26, 36 AND 38).

FIRST USE 5-1-2012; IN COMMERCE 5-1-2012.

4,210,596. ELBIT SYSTEMS OF AMERICA, LLC, FORT WORTH, TX. SN 85-097,220. PUB. 1-18-2011, FILED 7-30-2010.

SOSTAR

THE MARK CONSISTS OF STANDARD CHARACTERS WITHOUT CLAIM TO ANY PARTICULAR FONT, STYLE, SIZE, OR COLOR.

FOR HAND HELD OR TRIPOD MOUNTED LONG RANGE DAY AND NIGHT HIGH RESOLUTION TARGETING SYSTEM CONSISTING OF A DAY CAMERA AND INFRARED CAMERA, LASER RANGE FINDER, DIGITAL MAGNETIC COMPASS AND GLOBAL POSITIONING SYSTEM COMPONENTS HAVING SNAPSHOT IMPORT AND EXPORT AND IMAGE DATA STORAGE CAPABILITY (U.S. CLS. 21, 23, 26, 36 AND 38).

FIRST USE 12-16-2010; IN COMMERCE 12-16-2010.

4,210,602. BLUE HORSESHOE SOLUTIONS, INC., CARMEL, IN. SN 85-101,101. PUB. 9-27-2011, FILED 8-5-2010.



TRAX
TRANSPORTATION FOR AX

NO CLAIM IS MADE TO THE EXCLUSIVE RIGHT TO USE "TRANSPORTATION" AND "AX", APART FROM THE MARK AS SHOWN.

THE COLOR(S) BLUE AND GOLD IS/ARE CLAIMED AS A FEATURE OF THE MARK.

CLASS 9—(Continued).

THE MARK CONSISTS OF THE WORD "TRAX" IN CAPITAL LETTERS, WITH "TR" IN BLUE AND "AX" IN GOLD, WITH PART OF THE "X" EXTENDING BELOW THE REMAINING LETTERS, WITH THE WORD "TRANSPORTATION" IN BLUE AND LOCATED BENEATH THE LETTERS "TRA", AND THE WORDS "FOR AX" IN BLUE AND LOCATED BENEATH THE "X".

FOR COMPUTER SOFTWARE FOR USE IN FREIGHT TRANSPORTATION PLANNING, SPECIFICALLY, RATING AND ROUTING, AND SPECIFICALLY EXCLUDING SOFTWARE THAT TRACKS FREIGHT AFTER SHIPMENT (U.S. CLS. 21, 23, 26, 36 AND 38).

FIRST USE 5-31-2010; IN COMMERCE 5-31-2010.

4,210,608. HUNDEMER, JAMES, BATON ROUGE, LA. SN 85-106,856. PUB. 11-15-2011, FILED 8-13-2010.

FORGET THEE NOT

THE MARK CONSISTS OF STANDARD CHARACTERS WITHOUT CLAIM TO ANY PARTICULAR FONT, STYLE, SIZE, OR COLOR.

FOR PRE-RECORDED CDS FEATURING A CALENDAR AND PERSONAL DAY PLANNER FOR NOTING IMPORTANT HOLIDAYS AND PERSONAL DAYS OF IMPORTANCE (U.S. CLS. 21, 23, 26, 36 AND 38).

FIRST USE 7-9-2012; IN COMMERCE 7-9-2012.

4,210,640. FORD, GARY, ROGERS, AR. AND FORD, YVONNE, ROGERS, AR. SN 85-132,233. PUB. 3-1-2011, FILED 9-17-2010.



THE MARK CONSISTS OF THE DESIGN OF AN OIL QUART CONTAINER POURING OIL BEARING THE WORDING "CEO4GOD" IN BROADWAY TYPE FACE.

FOR COMPUTER GAME SOFTWARE; DIGITAL MATERIALS, NAMELY, CDS AND DVDS FEATURING RELIGIOUS CONTENT (U.S. CLS. 21, 23, 26, 36 AND 38).

FIRST USE 8-31-2010; IN COMMERCE 12-15-2010.

CLASS 9—(Continued).

4,210,642. IGT, RENO, NV. SN 85-132,510. PUB. 1-11-2011, FILED 9-17-2010.

DOUBLE INFERNO

THE MARK CONSISTS OF STANDARD CHARACTERS WITHOUT CLAIM TO ANY PARTICULAR FONT, STYLE, SIZE, OR COLOR.

FOR GAMING MACHINES, NAMELY, DEVICES WHICH ACCEPT A WAGER (U.S. CLS. 21, 23, 26, 36 AND 38).

FIRST USE 10-12-2011; IN COMMERCE 5-29-2012.

CLASS 9—(Continued).

4,210,696. BOSE CORPORATION, FRAMINGHAM, MA. SN 85-182,170. PUB. 3-29-2011, FILED 11-22-2010.

SMARTSOURCE

THE MARK CONSISTS OF STANDARD CHARACTERS WITHOUT CLAIM TO ANY PARTICULAR FONT, STYLE, SIZE, OR COLOR.

FOR LOUDSPEAKER SYSTEMS; LOUDSPEAKERS (U.S. CLS. 21, 23, 26, 36 AND 38).

FIRST USE 9-30-2011; IN COMMERCE 9-30-2011.

4,210,654. BIONIC TRADER SYSTEMS, LLC, CHICAGO, IL. SN 85-149,201. PUB. 8-9-2011, FILED 10-10-2010.

BIONIC TRADER SYSTEMS

THE MARK CONSISTS OF STANDARD CHARACTERS WITHOUT CLAIM TO ANY PARTICULAR FONT, STYLE, SIZE, OR COLOR.

NO CLAIM IS MADE TO THE EXCLUSIVE RIGHT TO USE "TRADER SYSTEMS", APART FROM THE MARK AS SHOWN.

FOR COMPUTER SOFTWARE PROGRAMS AND COMPUTER HARDWARE FOR TRADING FUTURES, COMMODITIES, STOCKS, BONDS, OPTIONS, FOREX, CURRENCIES, FIXED INCOME INSTRUMENTS, EXCHANGE TRADED FUNDS, CREDIT INSTRUMENTS, INTEREST RATE INSTRUMENTS, INDEX FUNDS, SWAPS AND DERIVATIVES (U.S. CLS. 21, 23, 26, 36 AND 38).

FIRST USE 8-12-2011; IN COMMERCE 6-12-2012.

4,210,698. BOSE CORPORATION, FRAMINGHAM, MA. SN 85-182,196. PUB. 3-29-2011, FILED 11-22-2010.

FLEXMOUNT

THE MARK CONSISTS OF STANDARD CHARACTERS WITHOUT CLAIM TO ANY PARTICULAR FONT, STYLE, SIZE, OR COLOR.

FOR LOUDSPEAKER SYSTEMS; LOUDSPEAKERS (U.S. CLS. 21, 23, 26, 36 AND 38).

FIRST USE 9-30-2011; IN COMMERCE 9-30-2011.

4,210,675. JUNIPER NETWORKS, INC., SUNNYVALE, CA. SN 85-159,980. PUB. 3-15-2011, FILED 10-25-2010.

JUNOS SPACE

THE MARK CONSISTS OF STANDARD CHARACTERS WITHOUT CLAIM TO ANY PARTICULAR FONT, STYLE, SIZE, OR COLOR.

FOR COMPUTER SOFTWARE, NAMELY, OPEN NETWORK APPLICATION PLATFORM FOR THE DEVELOPMENT, DEPLOYMENT, TESTING, CONFIGURATION, MONITORING, AND HOSTING OF NETWORK APPLICATIONS (U.S. CLS. 21, 23, 26, 36 AND 38).

FIRST USE 10-22-2009; IN COMMERCE 10-22-2009.

4,210,701. AUSTRALIAN WOOL INNOVATION LIMITED, SYDNEY, AUSTRALIA. SN 85-183,709. PUB. 11-1-2011, FILED 11-23-2010.

SAM THE LAMB

THE MARK CONSISTS OF STANDARD CHARACTERS WITHOUT CLAIM TO ANY PARTICULAR FONT, STYLE, SIZE, OR COLOR.

FOR CHILDREN'S EDUCATIONAL COMPUTER SOFTWARE FOR USE ON MOBILE PHONES; ELECTRONIC GAME PROGRAMS FOR EDUCATIONAL PURPOSES, FOR USE ON MOBILE PHONES; EDUCATIONAL SOFTWARE PRODUCTS, NAMELY, CHILDREN'S EDUCATIONAL COMPUTER SOFTWARE; ELECTRONIC AND RECORDED MULTIMEDIA PUBLICATIONS, NAMELY, CHILDREN'S EDUCATIONAL CDS, DVDS, BOOKS AND MAGAZINES; DOWNLOADABLE ELECTRONIC PUBLICATIONS IN THE NATURE OF CHILDREN'S EDUCATIONAL BOOKS AND MAGAZINES (U.S. CLS. 21, 23, 26, 36 AND 38).

FIRST USE 12-3-2010; IN COMMERCE 12-3-2010.

CLASS 9—(Continued).

4,210,711. RECKITT BENCKISER N.V., 2132 WT HOOFD-DORP, NETHERLANDS. SN 85-188,996. PUB. 5-17-2011, FILED 12-2-2010.



PRIORITY CLAIMED UNDER SEC. 44(D) ON ERPN CMNTY TM OFC APPLICATION NO. 009172651, FILED 6-14-2010, REG. NO. 9172651, DATED 11-29-2010, EXPIRES 6-14-2020.

THE COLOR(S) PINK BLUE AND WHITE IS/ARE CLAIMED AS A FEATURE OF THE MARK.

THE MARK CONSISTS OF THE WORD "POWERBRANDS" IN PINK, OUTLINED IN WHITE AND BLUE, SUPERIMPOSED OVER AN ILLUSTRATION OF THREE EXECUTIVES DEPICTED IN SHADOW IN BLUE AND WHITE ALL ON A WHITE BACKGROUND SURROUNDED BY A THIN BLUE LINE.

FOR DOWNLOADABLE ELECTRONIC GAME PROGRAMS; COMPUTER GAME SOFTWARE (U.S. CLS. 21, 23, 26, 36 AND 38).

FIRST USE 7-0-2010; IN COMMERCE 7-0-2010.

4,210,721. SCALE COMPUTING, INC., INDIANAPOLIS, IN. SN 85-191,864. PUB. 11-8-2011, FILED 12-7-2010.



NO CLAIM IS MADE TO THE EXCLUSIVE RIGHT TO USE "TECHNOLOGY", APART FROM THE MARK AS SHOWN.

THE MARK CONSISTS OF THE STYLIZED, OUTLINED LETTERS "ICOS". TO THE LEFT OF THESE LETTERS ARE TWO OUTLINED QUADRILATERALS STACKED ON TOP OF EACH OTHER, THE TOP ONE IS SMALLER. A THIRD LONG, OUTLINED QUADRILATERAL UNDERLINES ALL OF THESE ELEMENTS AND CONTAINS THE WORD "TECHNOLOGY".

FOR COMPUTER STORAGE DEVICES, NAMELY, STORAGE SUBSYSTEMS FOR STORAGE AND BACKUP OF ELECTRONIC DATA THAT INCORPORATE A DATA STORAGE OPERATING SYSTEM (U.S. CLS. 21, 23, 26, 36 AND 38).

FIRST USE 10-15-2009; IN COMMERCE 10-15-2009.

CLASS 9—(Continued).

4,210,728. SCALE COMPUTING, INC., INDIANAPOLIS, IN. SN 85-193,813. PUB. 11-8-2011, FILED 12-9-2010.

ICOS

THE MARK CONSISTS OF STANDARD CHARACTERS WITHOUT CLAIM TO ANY PARTICULAR FONT, STYLE, SIZE, OR COLOR.

FOR COMPUTER STORAGE DEVICES, NAMELY, STORAGE SUBSYSTEMS FOR STORAGE AND BACKUP OF ELECTRONIC DATA THAT INCORPORATE A DATA STORAGE OPERATING SYSTEM (U.S. CLS. 21, 23, 26, 36 AND 38).

FIRST USE 10-15-2009; IN COMMERCE 10-15-2009.

4,210,729. CONAIR CORPORATION, STAMFORD, CT. SN 85-193,866. PUB. 11-8-2011, FILED 12-9-2010.

CUISINART PROVANTAGE

THE MARK CONSISTS OF STANDARD CHARACTERS WITHOUT CLAIM TO ANY PARTICULAR FONT, STYLE, SIZE, OR COLOR.

OWNER OF U.S. REG. NOS. 1,048,889, 2,313,580, AND OTHERS.

FOR FOOD WEIGHING SCALES AND MEASUREMENT DEVICES, NAMELY, SCALES, BALANCES AND MEASURING CUPS (U.S. CLS. 21, 23, 26, 36 AND 38).

FIRST USE 6-0-2011; IN COMMERCE 6-0-2011.

4,210,777. SAMSUNG ELECTRONICS CO., LTD., SUWON-SI, GYEONGGI-DO, REPUBLIC OF KOREA. SN 85-211,239. PUB. 4-26-2011, FILED 1-5-2011.

SAMSUNG EXHILARATE

THE MARK CONSISTS OF STANDARD CHARACTERS WITHOUT CLAIM TO ANY PARTICULAR FONT, STYLE, SIZE, OR COLOR.

OWNER OF U.S. REG. NOS. 2,929,519, 3,503,660, AND OTHERS.

THE ENGLISH TRANSLATION OF "SAMSUNG" IN THE MARK IS THREE STARS.

FOR MOBILE PHONES; SMARTPHONES (U.S. CLS. 21, 23, 26, 36 AND 38).

FIRST USE 6-10-2012; IN COMMERCE 6-10-2012.

CLASS 9—(Continued).

4,210,778. OPTOMA TECHNOLOGY, INC., FREMONT, CA. SN 85-211,836. PUB. 1-24-2012, FILED 1-6-2011.



NO CLAIM IS MADE TO THE EXCLUSIVE RIGHT TO USE "PROJECT", APART FROM THE MARK AS SHOWN. THE MARK CONSISTS OF "PROJECT GREEN" IN A BOX WITH A LEAF PATTERN.
FOR DIGITAL VIDEO PROJECTORS; DIGITAL LIGHT PROCESSING PROJECTORS; DIGITAL MULTIMEDIA PROJECTORS (U.S. CLS. 21, 23, 26, 36 AND 38).
FIRST USE 4-29-2011; IN COMMERCE 8-1-2011.

4,210,792. ARBOR NETWORKS, INC., CHELMSFORD, MA. SN 85-214,605. PUB. 5-24-2011, FILED 1-11-2011.

PRAVAIL

THE MARK CONSISTS OF STANDARD CHARACTERS WITHOUT CLAIM TO ANY PARTICULAR FONT, STYLE, SIZE, OR COLOR.
FOR ANTI-SPYWARE SOFTWARE; COMPUTER ANTI-VIRUS SOFTWARE; COMPUTER HARDWARE AND SOFTWARE SYSTEMS FOR USE IN NETWORK SECURITY, MONITORING AND OPTIMIZATION; COMPUTER OPERATING SOFTWARE; COMPUTER PROGRAMS FOR USE IN NETWORK SECURITY, MONITORING AND OPTIMIZATION; COMPUTER SOFTWARE FOR USE IN NETWORK SECURITY, MONITORING AND OPTIMIZATION; COMPUTER SOFTWARE PLATFORMS FOR USE IN NETWORK SECURITY, MONITORING AND OPTIMIZATION (U.S. CLS. 21, 23, 26, 36 AND 38).
FIRST USE 12-1-2011; IN COMMERCE 12-1-2011.

CLASS 9—(Continued).

4,210,797. GUESS? IP HOLDER L.P., LOS ANGELES, CA. SN 85-216,149. PUB. 5-24-2011, FILED 1-12-2011.

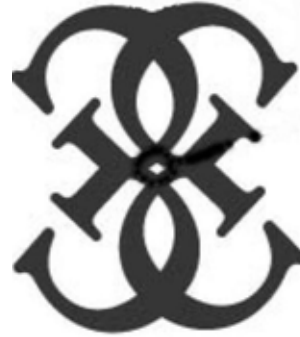

OWNER OF U.S. REG. NOS. 3,261,860 AND 3,308,152.
THE MARK CONSISTS OF 4 LETTER "G"'S. A PAIR OF INTERLOCKING "G"'S ARE FACING OUTWARD ABOVE A SECOND PART OF INVERTED INTERLOCKING "G"'S FACING OUTWARDS.
FOR DECORATIVE AND PROTECTIVE COVERS AND CASES FOR PORTABLE ELECTRONIC DEVICES, NAMELY, PERSONAL ELECTRONIC DEVICES, CELL PHONES, MOBILE PHONES, TELEPHONES, COMPUTERS, LAPTOP COMPUTERS, TABLET COMPUTERS, NOTEBOOK COMPUTERS, MP3 PLAYERS, PORTABLE MUSIC PLAYERS, PERSONAL DIGITAL ASSISTANTS, ELECTRONIC READING DEVICES, DIGITAL CAMERAS, AND CAMERAS; EYEWEAR (U.S. CLS. 21, 23, 26, 36 AND 38).
FIRST USE 0-0-2003; IN COMMERCE 0-0-2003.

4,210,798. GUESS? IP HOLDER L.P., LOS ANGELES, CA. SN 85-216,171. PUB. 5-24-2011, FILED 1-12-2011.

GUESS

THE MARK CONSISTS OF STANDARD CHARACTERS WITHOUT CLAIM TO ANY PARTICULAR FONT, STYLE, SIZE, OR COLOR.
OWNER OF U.S. REG. NOS. 1,704,002, 3,573,181, AND OTHERS.
FOR DECORATIVE AND PROTECTIVE COVERS AND CASES FOR PORTABLE ELECTRONIC DEVICES, NAMELY, PERSONAL ELECTRONIC DEVICES, CELL PHONES, MOBILE PHONES, TELEPHONES, COMPUTERS, LAPTOP COMPUTERS, TABLET COMPUTERS, NOTEBOOK COMPUTERS, MP3 PLAYERS, PORTABLE MUSIC PLAYERS, PERSONAL DIGITAL ASSISTANTS, ELECTRONIC READING DEVICES, DIGITAL CAMERAS, AND CAMERAS; EYEWEAR (U.S. CLS. 21, 23, 26, 36 AND 38).
FIRST USE 0-0-1984; IN COMMERCE 0-0-1984.

CLASS 9—(Continued).

4,210,799. GUESS? IP HOLDER L.P., LOS ANGELES, CA. SN 85-216,179. PUB. 5-24-2011, FILED 1-12-2011.

GUESS BY MARCIANO

THE MARK CONSISTS OF STANDARD CHARACTERS WITHOUT CLAIM TO ANY PARTICULAR FONT, STYLE, SIZE, OR COLOR.

OWNER OF U.S. REG. NOS. 1,704,002, 3,015,017, AND OTHERS.

FOR DECORATIVE AND PROTECTIVE COVERS AND CASES FOR PORTABLE ELECTRONIC DEVICES, NAMELY, PERSONAL ELECTRONIC DEVICES, CELL PHONES, MOBILE PHONES, TELEPHONES, COMPUTERS, LAPTOP COMPUTERS, TABLET COMPUTERS, NOTEBOOK COMPUTERS, MP3 PLAYERS, PORTABLE MUSIC PLAYERS, PERSONAL DIGITAL ASSISTANTS, ELECTRONIC READING DEVICES, DIGITAL CAMERAS, AND CAMERAS; EYEWEAR (U.S. CLS. 21, 23, 26, 36 AND 38).

FIRST USE 0-0-2008; IN COMMERCE 0-0-2008.

4,210,800. GUESS? IP HOLDER L.P., LOS ANGELES, CA. SN 85-216,187. PUB. 5-24-2011, FILED 1-12-2011.

G BY GUESS

THE MARK CONSISTS OF STANDARD CHARACTERS WITHOUT CLAIM TO ANY PARTICULAR FONT, STYLE, SIZE, OR COLOR.

OWNER OF U.S. REG. NOS. 3,112,898 AND 3,573,181.

FOR DECORATIVE AND PROTECTIVE COVERS AND CASES FOR PORTABLE ELECTRONIC DEVICES, NAMELY, PERSONAL ELECTRONIC DEVICES, CELL PHONES, MOBILE PHONES, TELEPHONES, COMPUTERS, LAPTOP COMPUTERS, TABLET COMPUTERS, NOTEBOOK COMPUTERS, MP3 PLAYERS, PORTABLE MUSIC PLAYERS, PERSONAL DIGITAL ASSISTANTS, ELECTRONIC READING DEVICES, DIGITAL CAMERAS, AND CAMERAS; EYEWEAR (U.S. CLS. 21, 23, 26, 36 AND 38).

FIRST USE 0-0-2007; IN COMMERCE 0-0-2007.

CLASS 9—(Continued).

4,210,801. GUESS? IP HOLDER L.P., LOS ANGELES, CA. SN 85-216,198. PUB. 5-24-2011, FILED 1-12-2011.

GUESS?

THE MARK CONSISTS OF STANDARD CHARACTERS WITHOUT CLAIM TO ANY PARTICULAR FONT, STYLE, SIZE, OR COLOR.

OWNER OF U.S. REG. NOS. 1,704,002 AND 2,308,468.

FOR DECORATIVE AND PROTECTIVE COVERS AND CASES FOR PORTABLE ELECTRONIC DEVICES, NAMELY, PERSONAL ELECTRONIC DEVICES, CELL PHONES, MOBILE PHONES, TELEPHONES, COMPUTERS, LAPTOP COMPUTERS, TABLET COMPUTERS, NOTEBOOK COMPUTERS, MP3 PLAYERS, PORTABLE MUSIC PLAYERS, PERSONAL DIGITAL ASSISTANTS, ELECTRONIC READING DEVICES, DIGITAL CAMERAS, AND CAMERAS; EYEWEAR (U.S. CLS. 21, 23, 26, 36 AND 38).

FIRST USE 0-0-1984; IN COMMERCE 0-0-1984.

4,210,802. GUESS? IP HOLDER L.P., LOS ANGELES, CA. SN 85-216,398. PUB. 5-24-2011, FILED 1-12-2011.



OWNER OF U.S. REG. NO. 1,712,645.

THE MARK CONSISTS OF AN EQUILATERAL, INVERTED TRIANGLE WITH THE WORD "GUESS" INSIDE THE TRIANGLE. BELOW THE WORD "GUESS" AND WITHIN THE TRIANGLE IS A QUESTION MARK SYMBOL.

FOR DECORATIVE AND PROTECTIVE COVERS AND CASES FOR PORTABLE ELECTRONIC DEVICES, NAMELY, PERSONAL ELECTRONIC DEVICES, CELL PHONES, MOBILE PHONES, TELEPHONES, COMPUTERS, LAPTOP COMPUTERS, TABLET COMPUTERS, NOTEBOOK COMPUTERS, MP3 PLAYERS, PORTABLE MUSIC PLAYERS, PERSONAL DIGITAL ASSISTANTS, ELECTRONIC READING DEVICES, DIGITAL CAMERAS, AND CAMERAS; EYEWEAR (U.S. CLS. 21, 23, 26, 36 AND 38).

FIRST USE 0-0-1984; IN COMMERCE 0-0-1984.

CLASS 9—(Continued).

4,210,811. RED DOT SECURITY INC., SANDY, UT. SN 85-219,275. PUB. 5-31-2011, FILED 1-17-2011.

RED DOT SECURITY

THE MARK CONSISTS OF STANDARD CHARACTERS WITHOUT CLAIM TO ANY PARTICULAR FONT, STYLE, SIZE, OR COLOR.

NO CLAIM IS MADE TO THE EXCLUSIVE RIGHT TO USE "SECURITY", APART FROM THE MARK AS SHOWN.

FOR SECURITY ALARM SYSTEM COMPONENTS, NAMELY, SECURITY CONTROL PANELS, ELECTRONIC KEYPADS, SECURITY MOTION SENSORS, ELECTRONIC DOOR AND WINDOW INTRUSION SENSORS, SIRENS, ELECTRONIC GLASS-BREAK SENSORS, ELECTRONIC TEMPERATURE, FREEZE, AND HEAT SENSORS, FLOOD DETECTORS AND SMOKE DETECTORS (U.S. CLS. 21, 23, 26, 36 AND 38).

FIRST USE 7-5-2012; IN COMMERCE 7-5-2012.

CLASS 9—(Continued).

4,210,836. FAIRVIEW IMPORT CORPORATION, SANTA FE SPRINGS, CA. SN 85-236,112. PUB. 4-19-2011, FILED 2-7-2011.



THE MARK CONSISTS OF THE LETTERS "B" AND "G" WITH THE WORDS "BAD GIRL", ALL IN STYLIZED LETTERING.

FOR CASES FOR EYEGLASSES AND SUNGLASSES; CASES FOR SPECTACLES AND SUNGLASSES; EYEWEAR, NAMELY, SUNGLASSES, EYEGLASSES AND OPHTHALMIC FRAMES AND CASES THEREFOR; FRAMES FOR SPECTACLES AND SUNGLASSES; LENSES FOR SUNGLASSES; SPECTACLES AND SUNGLASSES; SUNGLASS LENSES; SUNGLASSES; SUNGLASSES AND SPECTACLES (U.S. CLS. 21, 23, 26, 36 AND 38).

FIRST USE 3-19-2011; IN COMMERCE 3-19-2011.

4,210,827. VIRTUAL FIELD TRIPS LLC, PITTSBURGH, PA. SN 85-228,957. PUB. 6-21-2011, FILED 1-28-2011.

The Virtual Trillium Trail

THE MARK CONSISTS OF STANDARD CHARACTERS WITHOUT CLAIM TO ANY PARTICULAR FONT, STYLE, SIZE, OR COLOR.

NO CLAIM IS MADE TO THE EXCLUSIVE RIGHT TO USE "VIRTUAL" OR "TRAIL", APART FROM THE MARK AS SHOWN.

FOR CHILDREN'S EDUCATIONAL SOFTWARE; COMPUTER GAME SOFTWARE; VIDEO GAME SOFTWARE; VIRTUAL REALITY GAME SOFTWARE (U.S. CLS. 21, 23, 26, 36 AND 38).

FIRST USE 5-1-2007; IN COMMERCE 2-27-2011.

4,210,851. TEXAS TECH UNIVERSITY SYSTEM, LUBBOCK, TX. SN 85-239,721. PUB. 5-3-2011, FILED 2-11-2011.



THE COLOR(S) PURPLE, GRAY, AND GREEN IS/ARE CLAIMED AS A FEATURE OF THE MARK.

THE MARK CONSISTS OF "MOMMY MEDS" IN PURPLE WITH AN OUTLINE OF A PERSON IN GRAY FOLLOWED BY A GREEN CHECK MARK.

FOR MEDICAL SOFTWARE FOR STORING DRUG INFORMATION (U.S. CLS. 21, 23, 26, 36 AND 38).

FIRST USE 12-0-2011; IN COMMERCE 12-0-2011.

CLASS 9—(Continued).

4,210,852. TEXAS TECH UNIVERSITY SYSTEM, LUBBOCK, TX. SN 85-239,734. PUB. 5-3-2011, FILED 2-11-2011.

MOMMY MEDS

THE MARK CONSISTS OF STANDARD CHARACTERS WITHOUT CLAIM TO ANY PARTICULAR FONT, STYLE, SIZE, OR COLOR.

FOR MEDICAL SOFTWARE FOR STORING DRUG INFORMATION (U.S. CLS. 21, 23, 26, 36 AND 38).
FIRST USE 12-0-2011; IN COMMERCE 12-0-2011.

4,210,883. NEVADA RESTAURANT SERVICES, INC., LAS VEGAS, NV. SN 85-250,897. PUB. 6-7-2011, FILED 2-24-2011.

SUIT YOURSELF

THE MARK CONSISTS OF STANDARD CHARACTERS WITHOUT CLAIM TO ANY PARTICULAR FONT, STYLE, SIZE, OR COLOR.

FOR INTERACTIVE VIDEO GAME PROGRAMS FOR USE WITH GAMING MACHINES (U.S. CLS. 21, 23, 26, 36 AND 38).

FIRST USE 6-14-2012; IN COMMERCE 6-14-2012.

4,210,908. NEC BIGLOBE, LTD., TOKYO, JAPAN. SN 85-263,315. PUB. 7-19-2011, FILED 3-10-2011.

SMAPHO-MELODY

THE MARK CONSISTS OF STANDARD CHARACTERS WITHOUT CLAIM TO ANY PARTICULAR FONT, STYLE, SIZE, OR COLOR.

FOR COMPUTER APPLICATION SOFTWARE FOR MOBILE PHONES, CELLULAR PHONES, SMART PHONES AND MOBILE HAND HELD DEVICES, NAMELY, COMPUTER SOFTWARE FOR SEARCHING, TRANSMITTING, SHARING, RECEIVING, DOWNLOADING, AND TRANSFERRING AUDIO, MUSIC AND VIDEO FILES (U.S. CLS. 21, 23, 26, 36 AND 38).

FIRST USE 4-12-2011; IN COMMERCE 4-12-2011.

CLASS 9—(Continued).

4,210,922. LANG-MEKRA NORTH AMERICA, LLC, RIDGEWAY, SC. SN 85-276,078. PUB. 8-23-2011, FILED 3-24-2011.

IDEAL VIEW

THE MARK CONSISTS OF STANDARD CHARACTERS WITHOUT CLAIM TO ANY PARTICULAR FONT, STYLE, SIZE, OR COLOR.

FOR VEHICLE VISION SYSTEMS COMPRISING SENSORS, CAMERAS, MONITORS AND MIRROR ASSEMBLIES, FOR OBSERVING AREAS ADJACENT THE VEHICLE (U.S. CLS. 21, 23, 26, 36 AND 38).

FIRST USE 6-5-2012; IN COMMERCE 6-5-2012.

4,210,927. ADVANCED RESPONSE CONCEPTS CORPORATION, FAIRFAX, VA. SN 85-279,482. PUB. 8-16-2011, FILED 3-29-2011.



THE COLOR(S) DARK BLUE, LIGHT BLUE, GRAY IS/ ARE CLAIMED AS A FEATURE OF THE MARK.

THE MARK CONSISTS OF A DARK BLUE GRADIENT SPHERE WITH A GRAY HAWK'S HEAD WRAPPING AROUND IT. THE WORD "CONDOR" WITH A STYLIZED "N" WRITTEN BACKWARDS IN LIGHT BLUE BELOW THE SPHERE.

FOR HAND HELD COMPUTER DEVICE FOR FORENSIC DATA COLLECTION; COMPUTER HARDWARE AND SOFTWARE SYSTEM FOR COLLECTING AND TRACKING EVIDENCE AND DATA AT CRIME SCENES USING A HAND HELD DEVICE (U.S. CLS. 21, 23, 26, 36 AND 38).

FIRST USE 10-1-2010; IN COMMERCE 10-1-2010.

CLASS 9—(Continued).

4,210,931. RAYMARINE UK LTD., PORTSMOUTH, HAMPSHIRE, UNITED KINGDOM. SN 85-281,993. PUB. 10-18-2011, FILED 3-31-2011.

CLEARPULSE

THE MARK CONSISTS OF STANDARD CHARACTERS WITHOUT CLAIM TO ANY PARTICULAR FONT, STYLE, SIZE, OR COLOR.

FOR MARINE EQUIPMENT, NAMELY, SONAR, ECHO SOUNDERS, FISH FINDERS, AND DEPTH FINDERS (U.S. CLS. 21, 23, 26, 36 AND 38).

FIRST USE 2-16-2012; IN COMMERCE 2-16-2012.

4,210,933. LU, YUEH-CHUAN, TAIPEI CITY, TAIWAN. SN 85-282,892. PUB. 8-9-2011, FILED 3-31-2011.

Dapad

THE MARK CONSISTS OF STANDARD CHARACTERS WITHOUT CLAIM TO ANY PARTICULAR FONT, STYLE, SIZE, OR COLOR.

FOR CELL PHONE ORNAMENT; MEMORY CARD READER; MEMORY CARD; EARPHONE; HAND-FREE HANDSET; CELL PHONE BATTERY CHARGER; CELL PHONE CASE; CELL PHONE BAG; CELL PHONE BATTERY; AND LEATHER SHEATH FOR PERSONAL ELECTRONIC DEVICE (U.S. CLS. 21, 23, 26, 36 AND 38).

FIRST USE 4-14-2006; IN COMMERCE 5-8-2012.

CLASS 9—(Continued).

4,210,950. NORTHWEST ANALYTICS, INC., PORTLAND, OR. SN 85-292,316. PUB. 8-23-2011, FILED 4-11-2011.

**Manufacturing Intelligence
for Intelligent
Manufacturing**

THE MARK CONSISTS OF STANDARD CHARACTERS WITHOUT CLAIM TO ANY PARTICULAR FONT, STYLE, SIZE, OR COLOR.

FOR COMPUTER SOFTWARE FOR STATISTICAL PROCESS CONTROL AND QUALITY CONTROL IN THE MANUFACTURING, ENGINEERING AND SCIENTIFIC FIELDS AND FOR THE COLLECTION, ANALYSIS AND REPORTING OF MANUFACTURING DATA; COMPUTER SOFTWARE FOR STATISTICAL PROCESS CONTROL AND QUALITY CONTROL IN THE MANUFACTURING, ENGINEERING AND SCIENTIFIC FIELDS AND FOR THE COLLECTION, ANALYSIS AND REPORTING OF MANUFACTURING DATA THAT MAY BE DOWNLOADED FROM A GLOBAL COMPUTER NETWORK (U.S. CLS. 21, 23, 26, 36 AND 38).

FIRST USE 10-31-2011; IN COMMERCE 10-31-2011.

4,210,962. WEI WANG, SHANGHAI, CHINA. SN 85-302,724. PUB. 12-6-2011, FILED 4-22-2011.

ELESONIC

THE MARK CONSISTS OF STANDARD CHARACTERS WITHOUT CLAIM TO ANY PARTICULAR FONT, STYLE, SIZE, OR COLOR.

FOR AUDIO ELECTRONICS PRODUCTS, NAMELY, AUDIO SPEAKERS AND AMPLIFIERS; AUDIO SPEAKERS; RECORDING STUDIO AND AUDIO STUDIO APPARATUS AND INSTRUMENTS, NAMELY, SPEAKERS, SPEAKER DRIVERS AND AMPLIFIERS; AND SOUND AND AUDIO RECORDING AND REPRODUCING APPARATUS AND INSTRUMENTS, NAMELY, SPEAKERS, SPEAKER DRIVERS AND AMPLIFIERS (U.S. CLS. 21, 23, 26, 36 AND 38).

FIRST USE 4-20-2012; IN COMMERCE 4-20-2012.

4,210,967. BORR & DECKER ENTERPRISES, LLC, PORTAGE, MI. SN 85-304,306. PUB. 9-27-2011, FILED 4-25-2011.

TEXTING TACO

THE MARK CONSISTS OF STANDARD CHARACTERS WITHOUT CLAIM TO ANY PARTICULAR FONT, STYLE, SIZE, OR COLOR.

CLASS 9—(Continued).

NO CLAIM IS MADE TO THE EXCLUSIVE RIGHT TO USE "TEXTING", APART FROM THE MARK AS SHOWN.

FOR COMPUTER APPLICATION SOFTWARE FOR MOBILE PHONES, NAMELY, SOFTWARE FOR CONTROLLING THE TEXT MESSAGE FUNCTION OF MOBILE PHONES (U.S. CLS. 21, 23, 26, 36 AND 38).

FIRST USE 5-0-2011; IN COMMERCE 5-0-2012.

CLASS 9—(Continued).

4,210,982. RANKIN INDUSTRIES, INC., RANCHO CUCAMONGA, CA. SN 85-313,626. PUB. 9-27-2011, FILED 5-5-2011.

RANTRAK

THE MARK CONSISTS OF STANDARD CHARACTERS WITHOUT CLAIM TO ANY PARTICULAR FONT, STYLE, SIZE, OR COLOR.

FOR COMPUTER SOFTWARE FOR USE IN THE FIELD OF WELDING, NAMELY, FOR DATA LOGGING AND DATA MAPPING OF WELDING INFORMATION AND WELDED PRODUCTS INFORMATION (U.S. CLS. 21, 23, 26, 36 AND 38).

FIRST USE 3-0-2012; IN COMMERCE 3-0-2012.

4,210,973. CHEM-AQUA, INC., IRVING, TX. SN 85-307,609. PUB. 9-13-2011, FILED 4-28-2011.

aquaDART

THE MARK CONSISTS OF STANDARD CHARACTERS WITHOUT CLAIM TO ANY PARTICULAR FONT, STYLE, SIZE, OR COLOR.

FOR ELECTRONIC-BASED INSTRUMENT FOR MEASURING AND CONTROLLING TRACED PRODUCTS IN INDUSTRIAL COOLING WATER SYSTEMS USING A FLUORESCENT LIGHT TO MONITOR LEVELS OF A TAGGED INHIBITOR, NAMELY, CORROSION, MINERAL SCALE, AND MICROBIOLOGICAL FOULING. ELECTRONIC-BASED INSTRUMENT TO TRIGGER A PROGRAMMED RESPONSE WHEN LEVELS OF A TAGGED INHIBITOR, NAMELY, CORROSION, MINERAL SCALE, AND MICROBIOLOGICAL FOULING PASSES A PREDETERMINED LEVEL (U.S. CLS. 21, 23, 26, 36 AND 38).

FIRST USE 3-0-2011; IN COMMERCE 3-0-2011.

4,210,990. CHAUVIN ARNOUX, INC., DOVER, NH. SN 85-318,311. PUB. 4-24-2012, FILED 5-11-2011.

True InRush

THE MARK CONSISTS OF STANDARD CHARACTERS WITHOUT CLAIM TO ANY PARTICULAR FONT, STYLE, SIZE, OR COLOR.

NO CLAIM IS MADE TO THE EXCLUSIVE RIGHT TO USE "INRUSH", APART FROM THE MARK AS SHOWN.

FOR ELECTRICAL INSTRUMENTS FOR MEASURING CURRENT, VOLTAGE, AND ASSOCIATED SIGNALS SUCH AS POWER, ENERGY AND POWER QUALITY (U.S. CLS. 21, 23, 26, 36 AND 38).

FIRST USE 6-13-2012; IN COMMERCE 6-13-2012.

4,210,976. PAULSSON, INC., VAN NUYS, CA. SN 85-309,116. PUB. 8-23-2011, FILED 4-30-2011.

OpticSeis

THE MARK CONSISTS OF STANDARD CHARACTERS WITHOUT CLAIM TO ANY PARTICULAR FONT, STYLE, SIZE, OR COLOR.

FOR SEISMIC EXPLORATION MACHINES AND APPARATUS (U.S. CLS. 21, 23, 26, 36 AND 38).

FIRST USE 9-1-2011; IN COMMERCE 9-1-2011.

4,210,992. VTECH ELECTRONICS NORTH AMERICA, LLC, ARLINGTON HEIGHTS, IL. SN 85-319,105. PUB. 11-15-2011, FILED 5-12-2011.

KIDIZOOM SPIN & SMILE CAMERA

THE MARK CONSISTS OF STANDARD CHARACTERS WITHOUT CLAIM TO ANY PARTICULAR FONT, STYLE, SIZE, OR COLOR.

OWNER OF U.S. REG. NO. 3,894,062.

NO CLAIM IS MADE TO THE EXCLUSIVE RIGHT TO USE "SPIN" AND "CAMERA", APART FROM THE MARK AS SHOWN.

FOR CAMERA CASES; CAMERAS (U.S. CLS. 21, 23, 26, 36 AND 38).

FIRST USE 8-8-2011; IN COMMERCE 8-8-2011.

CLASS 9—(Continued).

4,210,994. LUMA ARCADE, LLC, SALEM, OR. SN 85-319,939. PUB. 10-4-2011, FILED 5-13-2011.

Bladeslinger

THE MARK CONSISTS OF STANDARD CHARACTERS WITHOUT CLAIM TO ANY PARTICULAR FONT, STYLE, SIZE, OR COLOR.

FOR COMPUTER GAME SOFTWARE FOR PERSONAL COMPUTERS AND HOME VIDEO GAME CONSOLES; COMPUTER GAME SOFTWARE FOR USE ON MOBILE AND CELLULAR PHONES (U.S. CLS. 21, 23, 26, 36 AND 38).

FIRST USE 12-1-2011; IN COMMERCE 7-12-2012.

4,211,011. COPPERHEAD INDUSTRIES, LLC, MONTICELLO, MN. SN 85-324,731. PUB. 10-18-2011, FILED 5-19-2011.

SECUREFENCE

THE MARK CONSISTS OF STANDARD CHARACTERS WITHOUT CLAIM TO ANY PARTICULAR FONT, STYLE, SIZE, OR COLOR.

FOR ELECTRONIC SIGNAL CARRYING WIRE FOR UNDERGROUND BOUNDARY PET CONTAINMENT SYSTEMS (U.S. CLS. 21, 23, 26, 36 AND 38).

FIRST USE 6-12-2012; IN COMMERCE 6-12-2012.

4,211,014. AINSWORTH GAME TECHNOLOGY LIMITED, NEWINGTON, AUSTRALIA. SN 85-325,525. PUB. 10-25-2011, FILED 5-20-2011.



THE COLOR(S) YELLOW, GOLD, ORANGE, RED, BLUE, BLACK AND WHITE IS/ARE CLAIMED AS A FEATURE OF THE MARK.

CLASS 9—(Continued).

THE MARK CONSISTS OF THE WORDING "RAPID STRIKE" WITH THE WORD "RAPID" IN WHITE, BLUE AND BLACK WITH WHITE AND GOLD OUTLINE WITH EACH LETTER. TO THE RIGHT THE WORDING "STRIKE" IN WHITE, ORANGE, RED AND BLACK WITH WHITE AND GOLD OUTLINE WITH EACH LETTER. IN BETWEEN THE WORDING IS A ORANGE AND RED BOWLING BALL. BEHIND THE BOWLING BALL IS A YELLOW AND BLACK "X" OR CROSS. BEHIND THE WORDING AND CROSS IS ANOTHER BLACK AND YELLOW BORDER.

FOR COMPUTER SOFTWARE AND FIRMWARE FOR GAMES OF CHANCE ON ANY COMPUTERIZED PLATFORM, INCLUDING DEDICATED GAMING CONSOLES, VIDEO BASED SLOT MACHINES, REEL BASED SLOT MACHINES, AND VIDEO LOTTERY TERMINALS (U.S. CLS. 21, 23, 26, 36 AND 38).

FIRST USE 5-7-2012; IN COMMERCE 5-7-2012.

4,211,021. THE PATH OF WELLNESS AND HEALING, LLC, LOS ANGELES, CA. SN 85-325,823. PUB. 11-8-2011, FILED 5-20-2011.

THE PATH OF WELLNESS & HEALING

THE MARK CONSISTS OF STANDARD CHARACTERS WITHOUT CLAIM TO ANY PARTICULAR FONT, STYLE, SIZE, OR COLOR.

NO CLAIM IS MADE TO THE EXCLUSIVE RIGHT TO USE "WELLNESS & HEALING", APART FROM THE MARK AS SHOWN.

FOR PRE-RECORDED DVDS FEATURING AUDIO AND VISUAL INFORMATION ON CANCER (U.S. CLS. 21, 23, 26, 36 AND 38).

FIRST USE 11-1-2009; IN COMMERCE 11-1-2009.

4,211,033. 1ST DETECT CORPORATION, HOUSTON, TX. SN 85-329,159. PUB. 3-27-2012, FILED 5-24-2011.

1st Detect

THE MARK CONSISTS OF STANDARD CHARACTERS WITHOUT CLAIM TO ANY PARTICULAR FONT, STYLE, SIZE, OR COLOR.

NO CLAIM IS MADE TO THE EXCLUSIVE RIGHT TO USE "DETECT", APART FROM THE MARK AS SHOWN.

FOR PORTABLE CHEMICAL DETECTOR CAPABLE OF DETECTING RESIDUES AND VAPORS FROM A WIDE RANGE OF CHEMICALS INCLUDING EXPLOSIVES, CHEMICAL WARFARE AGENTS, TOXIC CHEMICALS, AND VOLATILE ORGANIC COMPOUNDS (U.S. CLS. 21, 23, 26, 36 AND 38).

FIRST USE 5-28-2009; IN COMMERCE 11-1-2011.

CLASS 9—(Continued).

4,211,037. JOHNSON, HARALD, AKA HARALD JOHNSON COMMUNICATIONS, CHARLOTTESVILLE, VA. SN 85-330,037. PUB. 11-22-2011, FILED 5-25-2011.

Photo IQ

THE MARK CONSISTS OF STANDARD CHARACTERS WITHOUT CLAIM TO ANY PARTICULAR FONT, STYLE, SIZE, OR COLOR.

NO CLAIM IS MADE TO THE EXCLUSIVE RIGHT TO USE "PHOTO", APART FROM THE MARK AS SHOWN.

FOR COMPUTER GAMES AND QUIZZES ABOUT THE ART AND SCIENCE OF PHOTOGRAPHY FOR USE ON MOBILE DEVICES NAMELY, PHONES, TABLET COMPUTERS AND PERSONAL COMPUTERS; ELECTRONIC GAME PROGRAMS; DOWNLOADABLE ELECTRONIC GAME PROGRAMS; ELECTRONIC GAME SOFTWARE; COMPUTER GAME PROGRAMS; DOWNLOADABLE COMPUTER GAME PROGRAMS; COMPUTER GAME SOFTWARE; INTERACTIVE GAME PROGRAMS; INTERACTIVE GAME SOFTWARE; AND VIDEO GAME PROGRAMS (U.S. CLS. 21, 23, 26, 36 AND 38).

FIRST USE 4-12-2010; IN COMMERCE 5-10-2010.

4,211,048. SEABLOOM & ASSOCIATES INC, ROSEVILLE, MN. SN 85-332,369. PUB. 11-15-2011, FILED 5-27-2011.

UBOC

THE MARK CONSISTS OF STANDARD CHARACTERS WITHOUT CLAIM TO ANY PARTICULAR FONT, STYLE, SIZE, OR COLOR.

FOR BATTERY CHARGERS (U.S. CLS. 21, 23, 26, 36 AND 38).

FIRST USE 10-0-2011; IN COMMERCE 10-0-2011.

4,211,050. MYLANGUAGE, SAN JOSE, CA. SN 85-332,628. PUB. 5-15-2012, FILED 5-27-2011.

VOCRE

THE MARK CONSISTS OF STANDARD CHARACTERS WITHOUT CLAIM TO ANY PARTICULAR FONT, STYLE, SIZE, OR COLOR.

CLASS 9—(Continued).

THE WORDING "VOCRE" HAS NO MEANING IN A FOREIGN LANGUAGE.

FOR COMPUTER APPLICATION SOFTWARE FOR MOBILE PHONES, HANDHELD COMPUTERS AND PERSONAL COMPUTERS, NAMELY, SOFTWARE FOR AUTOMATED LANGUAGE TRANSLATION (U.S. CLS. 21, 23, 26, 36 AND 38).

FIRST USE 9-13-2011; IN COMMERCE 9-13-2011.

4,211,056. PACINIAN CORPORATION, SPOKANE, WA. SN 85-333,373. PUB. 10-25-2011, FILED 5-30-2011.

ThinTouch

THE MARK CONSISTS OF STANDARD CHARACTERS WITHOUT CLAIM TO ANY PARTICULAR FONT, STYLE, SIZE, OR COLOR.

FOR COMPUTER PERIPHERALS, NAMELY, KEYBOARDS, TOUCHPADS, CONTROL PANELS, BUTTONS, TOUCHSCREENS, KEYPADS, AND MICE; MULTI-FUNCTION KEYBOARDS; KEYBOARDS; COMPUTER KEYBOARDS; KEYBOARDS FOR MOBILE PHONES; KEYBOARDS FOR TABLET COMPUTERS; KEYBOARDS FOR LAPTOPS, NOTEBOOKS, AND OTHER COMPUTERS; WIRELESS COMPUTER PERIPHERALS; WIRED COMPUTER PERIPHERALS; COMPONENTS INTEGRATED INTO A COMPUTER SYSTEM, NAMELY, KEYBOARDS, TOUCHPADS, CONTROL PANELS, BUTTONS, TOUCHSCREENS, KEYPADS, AND MICE; HUMAN-MACHINE INTERFACE DEVICES; COMPUTERS HAVING HUMAN-MACHINE INTERFACE DEVICES OR COMPONENTS; LAPTOP OR NOTEBOOK COMPUTERS; INPUT DEVICES FOR COMPUTERS; COMPUTER HARDWARE AND COMPUTER PERIPHERAL DEVICES; COMPUTER PERIPHERAL DEVICES; COMPUTER PERIPHERAL EQUIPMENT; INTERFACES AND PERIPHERAL DEVICES FOR COMPUTERS (U.S. CLS. 21, 23, 26, 36 AND 38).

FIRST USE 11-1-2011; IN COMMERCE 11-1-2011.

4,211,065. MILESTONE AV TECHNOLOGIES LLC, SAVAGE, MN. SN 85-335,309. PUB. 11-1-2011, FILED 6-1-2011.

ECOSYSTEM

THE MARK CONSISTS OF STANDARD CHARACTERS WITHOUT CLAIM TO ANY PARTICULAR FONT, STYLE, SIZE, OR COLOR.

FOR MOUNTING RACKS FOR COMPUTER HARDWARE; RACKS FOR AMPLIFIERS (U.S. CLS. 21, 23, 26, 36 AND 38).

FIRST USE 12-20-2010; IN COMMERCE 9-1-2011.

CLASS 9—(Continued).

4,211,078. LIFETIME BRANDS, INC., GARDEN CITY, NY.
SN 85-337,544. PUB. 10-11-2011, FILED 6-3-2011.

ULTRAPRO

THE MARK CONSISTS OF STANDARD CHARACTERS WITHOUT CLAIM TO ANY PARTICULAR FONT, STYLE, SIZE, OR COLOR.

OWNER OF U.S. REG. NO. 2,040,952.
FOR MEASURING CUPS; MEASURING SPOONS (U.S. CLS. 21, 23, 26, 36 AND 38).
FIRST USE 12-31-2011; IN COMMERCE 12-31-2011.

4,211,092. MATCOR, INC., DOYLESTOWN, PA. SN 85-338,789. PUB. 11-1-2011, FILED 6-6-2011.

KYNEX

THE MARK CONSISTS OF STANDARD CHARACTERS WITHOUT CLAIM TO ANY PARTICULAR FONT, STYLE, SIZE, OR COLOR.

FOR CONNECTORS FOR ANODE AND CABLE CONNECTIONS USED IN THE CORROSION PROTECTION INDUSTRY (U.S. CLS. 21, 23, 26, 36 AND 38).
FIRST USE 6-11-2012; IN COMMERCE 6-11-2012.

4,211,123. MINE SAFETY APPLIANCES COMPANY, CRANBERRY TOWNSHIP, PA. SN 85-343,303. PUB. 12-6-2011, FILED 6-10-2011.

V-GARD

THE MARK CONSISTS OF STANDARD CHARACTERS WITHOUT CLAIM TO ANY PARTICULAR FONT, STYLE, SIZE, OR COLOR.

OWNER OF U.S. REG. NO. 1,037,320.
FOR PROTECTIVE HELMET ACCESSORIES THAT ATTACH TO THE HELMET OR THAT ARE WORN INSIDE THE HELMET TO COVER THE HEAD AND NECK, NAMELY, HELMET FRAMES, HELMET VISORS, HELMET WINTER LINERS, CHIN STRAPS AND HELMET SAFETY LIGHTS (U.S. CLS. 21, 23, 26, 36 AND 38).
FIRST USE 9-6-2011; IN COMMERCE 9-6-2011.

CLASS 9—(Continued).

4,211,125. BEATPORT, LLC, DENVER, CO. SN 85-343,701.
PUB. 12-13-2011, FILED 6-10-2011.

MASHBOX

THE MARK CONSISTS OF STANDARD CHARACTERS WITHOUT CLAIM TO ANY PARTICULAR FONT, STYLE, SIZE, OR COLOR.

FOR COMPUTER APPLICATION SOFTWARE FOR MOBILE ELECTRONIC DEVICES, WHICH ALLOWS A USER TO MIX AND BLEND TWO DIFFERENT TRACKS INTO A NEW MIX TO MANIPULATE DIFFERENT PRESELECTED PIECES OF MUSIC, TO ADD SOUND EFFECTS, AND TO SYNCHRONIZE THE BEAT AND TONE (U.S. CLS. 21, 23, 26, 36 AND 38).
FIRST USE 12-8-2011; IN COMMERCE 12-8-2011.

4,211,126. NOBLE JESTER, INC., DALLAS, TX. SN 85-343,749.
PUB. 11-1-2011, FILED 6-10-2011.

GOLD GRABBER

THE MARK CONSISTS OF STANDARD CHARACTERS WITHOUT CLAIM TO ANY PARTICULAR FONT, STYLE, SIZE, OR COLOR.

FOR COMPUTER GAME PROGRAMS; COMPUTER GAME SOFTWARE; ELECTRONIC GAME PROGRAMS; ELECTRONIC GAME SOFTWARE; INTERACTIVE VIDEO GAME PROGRAMS; DOWNLOADABLE ELECTRONIC GAME PROGRAMS AND COMPUTER SOFTWARE PLATFORMS FOR SOCIAL NETWORKING THAT MAY BE ACCESSED VIA THE INTERNET, COMPUTERS AND WIRELESS DEVICES; DOWNLOADABLE ELECTRONIC GAMES VIA THE INTERNET AND WIRELESS DEVICES (U.S. CLS. 21, 23, 26, 36 AND 38).
FIRST USE 5-0-2012; IN COMMERCE 5-0-2012.

CLASS 9—(Continued).

4,211,131. BROWN & YELLOW INTERNATIONAL HOLDINGS LLC, NEW YORK, NY. SN 85-344,775. PUB. 4-3-2012, FILED 6-13-2011.

PEE & POO

THE MARK CONSISTS OF STANDARD CHARACTERS WITHOUT CLAIM TO ANY PARTICULAR FONT, STYLE, SIZE, OR COLOR.

FOR COMPUTER GAME SOFTWARE FOR PERSONAL COMPUTERS AND HOME VIDEO GAME CONSOLES; COMPUTER GAME SOFTWARE FOR USE WITH PERSONAL COMPUTERS, HOME VIDEO GAME CONSOLES USED WITH TELEVISIONS AND ARCADE-BASED VIDEO GAME CONSOLES; COMPUTER PROGRAMS FOR VIDEO AND COMPUTER GAMES; COMPUTER SOFTWARE AND FIRMWARE FOR GAMES OF CHANCE ON ANY COMPUTERIZED PLATFORM, INCLUDING DEDICATED GAMING CONSOLES, VIDEO BASED SLOT MACHINES, REEL BASED SLOT MACHINES, AND VIDEO LOTTERY TERMINALS; COMPUTER SOFTWARE, NAMELY, GAME ENGINE SOFTWARE FOR VIDEO GAME DEVELOPMENT AND OPERATION; DOWNLOADABLE MULTIMEDIA FILE CONTAINING ARTWORK, TEXT, AUDIO, VIDEO, GAMES, AND INTERNET WEB LINKS RELATING TO VARIOUS ANIMATED CHARACTERS; INTERACTIVE VIDEO GAME PROGRAMS; VIDEO AND COMPUTER GAME PROGRAMS (U.S. CLS. 21, 23, 26, 36 AND 38).

FIRST USE 11-1-2011; IN COMMERCE 11-1-2011.

4,211,132. BROWN & YELLOW INTERNATIONAL HOLDINGS LLC, NEW YORK, NY. SN 85-344,838. PUB. 3-27-2012, FILED 6-13-2011.



THE COLOR(S) YELLOW, BROWN, WHITE, BLACK, GRAY AND ORANGE IS/ARE CLAIMED AS A FEATURE OF THE MARK.

CLASS 9—(Continued).

THE MARK CONSISTS OF A CHARACTER WITH A YELLOW BODY OUTLINED IN ORANGE, A CHARACTER WITH A BROWN BODY OUTLINED IN BLACK, SIDE BY SIDE, WITH THE WORDS "PEE & POO SAVE THE WORLD!" BELOW THEIR FIGURES, "PEE" AND "POO" AND "SAVE THE WORLD!" IN WHITE OUTLINED IN BROWN AND SURROUNDED BY A GRAY CLOUD, AND THE "&" SYMBOL IN ORANGE.

FOR COMPUTER GAME PROGRAMMES DOWNLOADABLE VIA THE INTERNET; COMPUTER GAME SOFTWARE; COMPUTER GAME SOFTWARE FOR USE WITH PERSONAL COMPUTERS, HOME VIDEO GAME CONSOLES USED WITH TELEVISIONS AND ARCADE-BASED VIDEO GAME CONSOLES; COMPUTER SOFTWARE AND FIRMWARE FOR GAMES OF CHANCE ON ANY COMPUTERIZED PLATFORM, INCLUDING DEDICATED GAMING CONSOLES, VIDEO BASED SLOT MACHINES, REEL BASED SLOT MACHINES, AND VIDEO LOTTERY TERMINALS; COMPUTER SOFTWARE, NAMELY, GAME ENGINE SOFTWARE FOR VIDEO GAME DEVELOPMENT AND OPERATION; DOWNLOADABLE COMPUTER GAME PROGRAMS; DOWNLOADABLE ELECTRONIC GAME PROGRAMS; DOWNLOADABLE MULTIMEDIA FILE CONTAINING ARTWORK, TEXT, AUDIO, VIDEO, GAMES, AND INTERNET WEB LINKS RELATING TO VARIOUS ANIMATED CHARACTERS (U.S. CLS. 21, 23, 26, 36 AND 38).

FIRST USE 11-1-2011; IN COMMERCE 11-1-2011.

4,211,143. GYRODATA INCORPORATED, HOUSTON, TX. SN 85-345,984. PUB. 11-29-2011, FILED 6-14-2011.

GYRODATA

THE MARK CONSISTS OF STANDARD CHARACTERS WITHOUT CLAIM TO ANY PARTICULAR FONT, STYLE, SIZE, OR COLOR.

OWNER OF U.S. REG. NO. 1,338,471.

FOR DIRECTIONAL DRILLING CONTROL TOOL INCORPORATING A GYROSCOPE WHEREIN THE TOOL CONTROLS THE DIRECTION OF OIL AND GAS WELL DRILLING PROCESS; GYROSCOPIC WELLBORE MEASUREMENT TOOL, NAMELY, GYROSCOPE TOOL FOR MEASURING DIRECTION AND ORIENTATION OF A WELLBORE FOR THE OIL AND GAS, ENERGY, MINING, ENVIRONMENTAL AND CONSTRUCTION INDUSTRIES; DOWN HOLE GYROSCOPIC MEASUREMENT TOOL FOR OBTAINING DIRECTIONAL DRILLING CONTROL DATA FOR USE BY OTHERS FOR CONTROLLING THE DIRECTION OF WELLBORE DRILLING IN THE OIL AND GAS, ENERGY, MINING, ENVIRONMENTAL AND CONSTRUCTION INDUSTRIES; DIRECTIONAL DRILLING DATA COLLECTION AND ANALYSIS SOFTWARE FOR THE OIL AND GAS, ENERGY, MINING, ENVIRONMENTAL AND CONSTRUCTION INDUSTRIES; SOFTWARE FOR USE IN CONTROLLING THE DIRECTION OF WELLBORE DRILLING, NAMELY, SOFTWARE FOR COLLECTING AND ANALYZING WELLBORE DEPTH, ORIENTATION, AND DRILLING DIRECTION DATA FOR USE IN CONTROLLING DIRECTIONAL DRILLING OF A WELLBORE; AND ELECTRONIC WELLBORE DATA COLLECTOR, NAMELY, AN ELECTRONIC DEVICE FOR COLLECTION OF WELLBORE DIRECTION AND ORIENTATION DATA FROM WELLBORE MEASUREMENT DEVICES OF OTHERS IN THE OIL AND GAS, ENERGY, MINING, ENVIRONMENTAL AND CONSTRUCTION INDUSTRIES (U.S. CLS. 21, 23, 26, 36 AND 38).

FIRST USE 7-20-1983; IN COMMERCE 7-20-1983.

CLASS 9—(Continued).

4,211,160. T-MOBILE USA, INC., BELLEVUE, WA. SN 85-347,907. PUB. 1-3-2012, FILED 6-16-2011.

SPRINGBOARD

THE MARK CONSISTS OF STANDARD CHARACTERS WITHOUT CLAIM TO ANY PARTICULAR FONT, STYLE, SIZE, OR COLOR.

FOR TABLET COMPUTERS FOR RETAIL CONSUMERS (U.S. CLS. 21, 23, 26, 36 AND 38).
FIRST USE 11-16-2011; IN COMMERCE 11-16-2011.

4,211,162. BDSRCO, INC., BRADENTON, FL. SN 85-347,996. PUB. 11-29-2011, FILED 6-16-2011.

IZARO

THE MARK CONSISTS OF STANDARD CHARACTERS WITHOUT CLAIM TO ANY PARTICULAR FONT, STYLE, SIZE, OR COLOR.

OWNER OF U.S. REG. NO. 3,895,097.
FOR SUNGLASSES (U.S. CLS. 21, 23, 26, 36 AND 38).
FIRST USE 1-1-2012; IN COMMERCE 1-1-2012.

4,211,169. INTERVENTION DEVELOPMENT LLC, CARY, IL. SN 85-348,540. PUB. 11-22-2011, FILED 6-16-2011.

augie AAC

THE MARK CONSISTS OF STANDARD CHARACTERS WITHOUT CLAIM TO ANY PARTICULAR FONT, STYLE, SIZE, OR COLOR.

NO CLAIM IS MADE TO THE EXCLUSIVE RIGHT TO USE "AAC", APART FROM THE MARK AS SHOWN.

FOR COMPUTER APPLICATION SOFTWARE FOR TABLET COMPUTERS, NAMELY, SOFTWARE FOR USE IN PERSONAL COMMUNICATION BY INDIVIDUALS WITH DISABILITIES, SPECIFICALLY, FOR AUGMENTATIVE ALTERNATIVE COMMUNICATION (U.S. CLS. 21, 23, 26, 36 AND 38).
FIRST USE 6-1-2010; IN COMMERCE 6-15-2011.

CLASS 9—(Continued).

4,211,176. SONRISA ENTERPRISES, INC., VAN NUYS, CA. SN 85-349,352. PUB. 11-8-2011, FILED 6-17-2011.

REVGEAR

OWNER OF U.S. REG. NOS. 2,153,482 AND 3,546,389.
THE MARK CONSISTS OF THE WORD "REVGEAR" STYLIZED.

FOR SPORTS EQUIPMENT FOR BOXING AND MARTIAL ARTS, NAMELY, PROTECTIVE HEADGEAR (U.S. CLS. 21, 23, 26, 36 AND 38).

FIRST USE 11-0-2011; IN COMMERCE 11-0-2011.

4,211,182. SIMON MILNER, SAN JOSE, CA. SN 85-350,045. PUB. 11-8-2011, FILED 6-20-2011.

FEEDAIR

THE MARK CONSISTS OF STANDARD CHARACTERS WITHOUT CLAIM TO ANY PARTICULAR FONT, STYLE, SIZE, OR COLOR.

FOR ELECTRONIC ADVERTISEMENT AND MESSAGING DISPLAY UNIT WITH MULTI-NETWORKING (TCP/IP) CAPABILITIES AND REMOTE CONNECTIVITY (U.S. CLS. 21, 23, 26, 36 AND 38).

FIRST USE 5-9-2012; IN COMMERCE 5-9-2012.

4,211,193. PARKTEL, FZE, DUBAI, UNITED ARAB EMIR.. SN 85-350,948. PUB. 11-8-2011, FILED 6-20-2011.



THE COLOR(S) LILAC, PURPLE, BLACK, YELLOW, BLUE, GREEN, PINK, ORANGE IS/ARE CLAIMED AS A FEATURE OF THE MARK.

CLASS 9—(Continued).

THE MARK CONSISTS OF THE STYLIZED WORDING "UNNECTO" IN BLACK UNDERNEATH A SERIES OF LILAC, PURPLE, BLACK, YELLOW, BLUE, GREEN, PINK AND ORANGE TRIANGLES. THE LETTER "O" IN "UNNECTO" HAS A BLACK ARROW POINTING TO THE LEFT.

FOR MOBILE TELEPHONES; SMART TELEPHONES, NAMELY, TELEPHONES WITH CAPABILITY OF TRANSMITTING DATA VOICE AND IMAGES AND ACCESSING THE INTERNET, SENDING AND RECEIVING E-MAIL; BATTERIES, BATTERY CHARGERS, POWER SUPPLIES, HOUSINGS OR CASINGS OR COVERS, CLIPS, CARRYING CASES FOR MOBILE TELEPHONES; HOLDERS, DESKTOP STANDS, MOBILE TELEPHONE ACCESSORIES IN THE NATURE OF HANDS FREE HOLDERS, HEADSETS, MICROPHONES AND SPEAKERS FOR MOBILE TELEPHONES; CAR KITS FOR THE ADAPTATION OF PORTABLE COMMUNICATION APPARATUS AND INSTRUMENTS FOR VEHICULAR USE, COMPRISING CABLES, EARPHONES, HANDSFREE MICROPHONES, PHONE HOLDERS, SPEAKERS, CAR CHARGERS, DATA CABLES AND ELECTRICAL WIRES; MOBILE COMPUTERS, COMPUTER SOFTWARE AND PROGRAMS FEATURING MUSIC, MOVIES, ANIMATION, ELECTRONIC BOOKS, AND GAMES IN THE FIELD OF GENERAL ENTERTAINMENT; USER INTERFACE UNITS, NAMELY, KEYBOARDS, KEYPADS, KEY ROLLS, BUTTONS, AND SCREENS; COMPUTER SOFTWARE AND PROGRAMS FOR MANAGEMENT AND OPERATION OF MOBILE TELEPHONES; COMPUTER SOFTWARE FOR ACCESSING, SEARCHING, INDEXING AND RETRIEVING INFORMATION AND DATA FROM GLOBAL COMPUTER NETWORKS AND GLOBAL COMMUNICATION NETWORKS, AND FOR BROWSING AND NAVIGATING THROUGH WEB SITES ON SAID NETWORKS, AND COMPUTER SOFTWARE FOR SENDING AND RECEIVING SHORT MESSAGES AND ELECTRONIC MAIL; ANALOG AND DIGITAL RADIO TRANSCEIVERS OR RECEIVERS FOR DATA, VOICE, IMAGE AND VIDEO COMMUNICATION SOLD AS A COMPONENT PARTS OF MOBILE TELEPHONES; ELECTRONIC GAME SOFTWARE FOR MOBILE TELEPHONES; CAMERAS, NAMELY, DIGITAL CAMERAS, AND VIDEO CAMERAS SOLD AS COMPONENT PARTS OF MOBILE TELEPHONES; CALCULATORS SOLD AS COMPONENT PARTS OF MOBILE TELEPHONES; STEREO EQUIPMENT, NAMELY, MP3 PLAYERS AND SPEAKERS SOLD AS COMPONENT PARTS OF MOBILE TELEPHONES (U.S. CLS. 21, 23, 26, 36 AND 38).

FIRST USE 5-1-2012; IN COMMERCE 5-1-2012.

4,211,201. WATCHME 911, INC., SUN VALLEY, CA. SN 85-352,877. PUB. 1-31-2012, FILED 6-22-2011.



THE COLOR GRAY REPRESENTS SHADING AND IS NOT A FEATURE OF THE MARK

CLASS 9—(Continued).

THE MARK CONSISTS OF THE SILHOUETTE OF A PERSON IN A BEAM OF LIGHT, IN FRONT OF THE SILHOUETTE OF A CITY SKYLINE.

FOR COMPUTER SOFTWARE APPLICATIONS FOR MOBILE ELECTRONIC DEVICES TO GENERATE ALERTS AND NOTIFICATIONS DELIVERED VIA WIRELESS NETWORKS, COMPUTER NETWORKS, TELEPHONE NETWORKS, USED TO NOTIFY OTHER INDIVIDUALS AND LAW ENFORCEMENT PERSONNEL OF EMERGENCY SITUATIONS, THE NEED FOR AID, LOCATION OF THE SENDER, ARRIVAL AT A DESTINATION OR OTHER INFORMATION DETERMINED BY THE SENDER (U.S. CLS. 21, 23, 26, 36 AND 38).

FIRST USE 9-23-2011; IN COMMERCE 9-23-2011.

4,211,206. ZETTASET, INC., MOUNTAIN VIEW, CA. SN 85-353,941. PUB. 11-8-2011, FILED 6-23-2011.

Zettaset

THE MARK CONSISTS OF "ZETTASET" WITH A DOT WITHIN THE LETTER "Z".

FOR COMPUTER SOFTWARE FOR DATA COLLECTION, DATA ANALYTICS, AND DATA VISUALIZATION (U.S. CLS. 21, 23, 26, 36 AND 38).

FIRST USE 10-1-2011; IN COMMERCE 10-1-2011.

4,211,210. PEARLSWAN COMMUNICATIONS LLC, BEVERLY HILLS, MI. SN 85-354,167. PUB. 12-13-2011, FILED 6-23-2011.

MEDITOONS

THE MARK CONSISTS OF STANDARD CHARACTERS WITHOUT CLAIM TO ANY PARTICULAR FONT, STYLE, SIZE, OR COLOR.

FOR COMPUTER SOFTWARE IN THE NATURE OF MOBILE APPLICATIONS FOR PROVIDING MEDICAL INFORMATION (U.S. CLS. 21, 23, 26, 36 AND 38).

FIRST USE 3-0-2012; IN COMMERCE 3-0-2012.

CLASS 9—(Continued).

4,211,215. LIVEDATA, INC., CAMBRIDGE, MA. SN 85-355,514. PUB. 12-13-2011, FILED 6-24-2011.

OR CHECKPOINT

THE MARK CONSISTS OF STANDARD CHARACTERS WITHOUT CLAIM TO ANY PARTICULAR FONT, STYLE, SIZE, OR COLOR.

NO CLAIM IS MADE TO THE EXCLUSIVE RIGHT TO USE "OR", APART FROM THE MARK AS SHOWN.

FOR COMPUTER SOFTWARE FOR TRACKING AND DISPLAYING CHECKLISTS AND OTHER INFORMATION DURING MEDICAL, CRITICAL, OR OTHER URGENT PROCEDURES (U.S. CLS. 21, 23, 26, 36 AND 38).

FIRST USE 4-18-2012; IN COMMERCE 4-18-2012.

4,211,220. HAPPY HOUR EYEWEAR LLC, LONG BEACH, CA. SN 85-355,777. PUB. 11-15-2011, FILED 6-24-2011.

HAPPY HOUR

THE MARK CONSISTS OF STANDARD CHARACTERS WITHOUT CLAIM TO ANY PARTICULAR FONT, STYLE, SIZE, OR COLOR.

FOR EYEWEAR (U.S. CLS. 21, 23, 26, 36 AND 38).

FIRST USE 9-11-2011; IN COMMERCE 9-11-2011.

4,211,225. BALLY GAMING, INC., DBA BALLY TECHNOLOGIES, LAS VEGAS, NV. SN 85-356,046. PUB. 10-18-2011, FILED 6-24-2011.

SUPER PHOENIX

THE MARK CONSISTS OF STANDARD CHARACTERS WITHOUT CLAIM TO ANY PARTICULAR FONT, STYLE, SIZE, OR COLOR.

FOR GAMING MACHINES, NAMELY, DEVICES WHICH ACCEPT A WAGER AND GAMING SOFTWARE THAT GENERATES OR DISPLAYS OUTCOMES FOR GAMING MACHINES (U.S. CLS. 21, 23, 26, 36 AND 38).

FIRST USE 4-1-2012; IN COMMERCE 4-1-2012.

CLASS 9—(Continued).

4,211,226. BALLY GAMING, INC., DBA BALLY TECHNOLOGIES, LAS VEGAS, NV. SN 85-356,060. PUB. 11-15-2011, FILED 6-24-2011.

WILD SWEEP

THE MARK CONSISTS OF STANDARD CHARACTERS WITHOUT CLAIM TO ANY PARTICULAR FONT, STYLE, SIZE, OR COLOR.

FOR GAMING MACHINES, NAMELY, DEVICES WHICH ACCEPT A WAGER AND GAMING SOFTWARE THAT GENERATES OR DISPLAYS OUTCOMES FOR GAMING MACHINES (U.S. CLS. 21, 23, 26, 36 AND 38).

FIRST USE 1-1-2012; IN COMMERCE 1-1-2012.

4,211,227. BALLY GAMING, INC., DBA BALLY TECHNOLOGIES, LAS VEGAS, NV. SN 85-356,072. PUB. 11-15-2011, FILED 6-24-2011.

MERMAID KINGDOM

THE MARK CONSISTS OF STANDARD CHARACTERS WITHOUT CLAIM TO ANY PARTICULAR FONT, STYLE, SIZE, OR COLOR.

FOR GAMING MACHINES, NAMELY, DEVICES WHICH ACCEPT A WAGER AND GAMING SOFTWARE THAT GENERATES OR DISPLAYS OUTCOMES FOR GAMING MACHINES (U.S. CLS. 21, 23, 26, 36 AND 38).

FIRST USE 4-1-2012; IN COMMERCE 4-1-2012.

4,211,249. MELITA L. HARLEY, AKA OWNER, CAMBRIDGE, MD. SN 85-358,774. PUB. 11-15-2011, FILED 6-28-2011.

LITTLE BENNY

THE MARK CONSISTS OF STANDARD CHARACTERS WITHOUT CLAIM TO ANY PARTICULAR FONT, STYLE, SIZE, OR COLOR.

FOR AUDIO AND VIDEO RECORDINGS FEATURING MUSIC AND ARTISTIC PERFORMANCES (U.S. CLS. 21, 23, 26, 36 AND 38).

FIRST USE 9-26-1963; IN COMMERCE 11-14-1974.

CLASS 9—(Continued).

4,211,263. SAKURA & ASSOCIATES GROUP, INC., MIAMI, FL. SN 85-360,989. PUB. 1-10-2012, FILED 6-30-2011.



THE MARK CONSISTS OF A DESIGN OF A FLOWER INSIDE A SHADED CIRCLE. THE WORD "SAKURA" IS TO THE RIGHT OF THE CIRCLE WITH JAPANESE SYMBOLS APPEARING BELOW THE TERM "SAKURA".

THE NON-LATIN CHARACTERS IN THE MARK TRANSLITERATE TO "SAKURA", AND THIS MEANS "CHERRY BLOSSOM" IN ENGLISH.

FOR HAND HELD JOY STICK UNITS FOR VIDEO GAMES, MEMORY CARDS FOR VIDEO GAMES, MICROPHONES FOR VIDEO GAMES, HAND HELD WIRED CONTROLS FOR PLAYING ELECTRONIC GAMES, EARPHONES, EARPHONES FOR ELECTRONIC GAMES, ELECTRIC CHARGERS FOR ELECTRONIC GAMES, BATTERIES FOR ELECTRONIC GAMES, ELECTRIC CABLES FOR VIDEO GAMES CONSOLES, SCREEN PROTECTORS IN THE NATURE OF DISPLAY PROTECTOR TO PROVIDE SHADE AND PRIVACY FOR ELECTRONIC DEVICES HAVING SCREENS, COMPUTER STYLUS PEN, COOLING SYSTEMS IN THE NATURE OF INTERNAL COOLING FANS FOR HAND HELD UNITS; SILICONE PROTECTIVE COVERS SPECIALLY ADAPTED FOR HAND HELD PERSONAL ELECTRONIC DEVICES (U.S. CLS. 21, 23, 26, 36 AND 38).

FIRST USE 7-31-2009; IN COMMERCE 1-31-2012.

4,211,279. CAMTROL L.L.C., OXNARD, CA. SN 85-364,187. PUB. 12-6-2011, FILED 7-6-2011.

FREE SHOOTING

THE MARK CONSISTS OF STANDARD CHARACTERS WITHOUT CLAIM TO ANY PARTICULAR FONT, STYLE, SIZE, OR COLOR.

FOR CAMERA STANDS AND PLATFORMS FOR STILL, VIDEO AND MOVIE CAMERAS, NAMELY, STABILIZING STANDS AND PLATFORMS FOR ADJUSTABLE POSITIONING OF CAMERAS FOR TAKING STILL AND MOVING IMAGES AND FOR CAMERA PLACEMENT FOR EDITING IMAGES AND FOR STABILIZING CAMERAS WHEN STORED, AND PARTS AND ACCESSORIES THEREFOR (U.S. CLS. 21, 23, 26, 36 AND 38).

FIRST USE 6-0-2011; IN COMMERCE 6-0-2011.

CLASS 9—(Continued).

4,211,301. MELISSA HEUSER, NEWPORT, CA. SN 85-369,335. PUB. 12-13-2011, FILED 7-12-2011.

INVENT A TALE

THE MARK CONSISTS OF STANDARD CHARACTERS WITHOUT CLAIM TO ANY PARTICULAR FONT, STYLE, SIZE, OR COLOR.

FOR ELECTRONIC PUBLICATIONS, NAMELY, CHILDREN'S INTERACTIVE BOOKS FEATURING FICTIONAL STORIES RECORDED ON COMPUTER MEDIA; DOWNLOADABLE COMPUTER SOFTWARE FOR READING CHILDREN'S INTERACTIVE BOOKS (U.S. CLS. 21, 23, 26, 36 AND 38).

FIRST USE 1-26-2012; IN COMMERCE 1-26-2012.

4,211,302. CAPE EVOLUTION LTD, CENTRAL, HONG KONG, CHINA. SN 85-369,493. PUB. 12-13-2011, FILED 7-12-2011.

PIVOTHEAD

THE MARK CONSISTS OF STANDARD CHARACTERS WITHOUT CLAIM TO ANY PARTICULAR FONT, STYLE, SIZE, OR COLOR.

FOR HIGH DEFINITION, POINT OF VIEW, HANDS FREE DIGITAL VIDEO WEARABLE RECORDING APPARATUS FOR VIDEO AND STILL IMAGE CAPTURE FOR PROFESSIONAL USE, RECREATIONAL USE, DRIVING, SPORTS, AND INDOOR USE (U.S. CLS. 21, 23, 26, 36 AND 38).

FIRST USE 7-12-2011; IN COMMERCE 6-4-2012.

4,211,319. GENII, INC., WOODBURY, MN. SN 85-372,837. PUB. 1-10-2012, FILED 7-15-2011.

Tap a Tool

THE MARK CONSISTS OF STANDARD CHARACTERS WITHOUT CLAIM TO ANY PARTICULAR FONT, STYLE, SIZE, OR COLOR.

NO CLAIM IS MADE TO THE EXCLUSIVE RIGHT TO USE "TOOL", APART FROM THE MARK AS SHOWN.

FOR COMPUTER SOFTWARE IN THE NATURE OF TEXT AND GRAPHICS FOR THE TOUCH SCREEN INTERFACE OF AN ELECTROSURGICAL GENERATOR THAT ALLOWS THE USER TO SELECT PRESET POWER SETTINGS MATCHED TO SPECIFIC ELECTROSURGICAL ACCESSORIES, FOR MEDICAL APPLICATIONS (U.S. CLS. 21, 23, 26, 36 AND 38).

FIRST USE 2-1-2012; IN COMMERCE 5-21-2012.

CLASS 9—(Continued).

4,211,332. ELECTRONIC ARTS INC., REDWOOD CITY, CA. SN 85-374,978. PUB. 12-13-2011, FILED 7-19-2011.

SPY MOUSE

THE MARK CONSISTS OF STANDARD CHARACTERS WITHOUT CLAIM TO ANY PARTICULAR FONT, STYLE, SIZE, OR COLOR.

FOR COMPUTER GAME SOFTWARE; DOWNLOADABLE COMPUTER GAME SOFTWARE VIA A GLOBAL COMPUTER NETWORK AND WIRELESS DEVICES; VIDEO GAME SOFTWARE (U.S. CLS. 21, 23, 26, 36 AND 38).

FIRST USE 8-25-2011; IN COMMERCE 8-25-2011.

CLASS 9—(Continued).

4,211,337. BALLY GAMING, INC., DBA BALLY TECHNOLOGIES, LAS VEGAS, NV. SN 85-375,532. PUB. 12-13-2011, FILED 7-19-2011.

CHIMNEY STACKS

THE MARK CONSISTS OF STANDARD CHARACTERS WITHOUT CLAIM TO ANY PARTICULAR FONT, STYLE, SIZE, OR COLOR.

FOR GAMING MACHINES, NAMELY, DEVICES WHICH ACCEPT A WAGER AND GAMING SOFTWARE THAT GENERATES OR DISPLAYS OUTCOMES FOR GAMING MACHINES (U.S. CLS. 21, 23, 26, 36 AND 38).

FIRST USE 6-4-2012; IN COMMERCE 6-4-2012.

4,211,335. IGT, RENO, NV. SN 85-375,092. PUB. 12-13-2011, FILED 7-19-2011.

THE ROYAL PROMISE

THE MARK CONSISTS OF STANDARD CHARACTERS WITHOUT CLAIM TO ANY PARTICULAR FONT, STYLE, SIZE, OR COLOR.

FOR GAMING MACHINES, NAMELY, DEVICES WHICH ACCEPT A WAGER (U.S. CLS. 21, 23, 26, 36 AND 38).

FIRST USE 2-29-2012; IN COMMERCE 2-29-2012.

4,211,338. BALLY GAMING, INC., DBA BALLY TECHNOLOGIES, LAS VEGAS, NV. SN 85-375,546. PUB. 12-13-2011, FILED 7-19-2011.

GODDESS OF WEALTH

THE MARK CONSISTS OF STANDARD CHARACTERS WITHOUT CLAIM TO ANY PARTICULAR FONT, STYLE, SIZE, OR COLOR.

FOR GAMING MACHINES, NAMELY, DEVICES WHICH ACCEPT A WAGER AND GAMING SOFTWARE THAT GENERATES OR DISPLAYS OUTCOMES FOR GAMING MACHINES (U.S. CLS. 21, 23, 26, 36 AND 38).

FIRST USE 4-1-2012; IN COMMERCE 4-1-2012.

4,211,336. IGT, RENO, NV. SN 85-375,095. PUB. 12-13-2011, FILED 7-19-2011.

THE LOVELY OUTLAWS

THE MARK CONSISTS OF STANDARD CHARACTERS WITHOUT CLAIM TO ANY PARTICULAR FONT, STYLE, SIZE, OR COLOR.

FOR GAMING MACHINES, NAMELY, DEVICES WHICH ACCEPT A WAGER (U.S. CLS. 21, 23, 26, 36 AND 38).

FIRST USE 4-18-2012; IN COMMERCE 4-18-2012.

4,211,341. N.E.T. ENTERTAINMENT TECHNOLOGY LLC, HINCKLEY, OH. SN 85-376,133. PUB. 12-20-2011, FILED 7-20-2011.

NETSTAR

THE MARK CONSISTS OF STANDARD CHARACTERS WITHOUT CLAIM TO ANY PARTICULAR FONT, STYLE, SIZE, OR COLOR.

FOR ELECTRONIC GAMING MACHINES (U.S. CLS. 21, 23, 26, 36 AND 38).

FIRST USE 8-1-2011; IN COMMERCE 8-1-2011.

CLASS 9—(Continued).

4,211,349. BALLY GAMING, INC., DBA BALLY TECHNOLOGIES, LAS VEGAS, NV. SN 85-377,862. PUB. 12-13-2011, FILED 7-21-2011.

PHARAOH'S DREAM

THE MARK CONSISTS OF STANDARD CHARACTERS WITHOUT CLAIM TO ANY PARTICULAR FONT, STYLE, SIZE, OR COLOR.

FOR GAMING MACHINES, NAMELY, DEVICES WHICH ACCEPT A WAGER AND GAMING SOFTWARE THAT GENERATES OR DISPLAYS OUTCOMES FOR GAMING MACHINES (U.S. CLS. 21, 23, 26, 36 AND 38).
FIRST USE 6-4-2012; IN COMMERCE 6-4-2012.

4,211,357. PEI LICENSING, INC., MIAMI, FL. SN 85-380,636. PUB. 11-1-2011, FILED 7-26-2011.

PRO PLAYER

THE MARK CONSISTS OF STANDARD CHARACTERS WITHOUT CLAIM TO ANY PARTICULAR FONT, STYLE, SIZE, OR COLOR.

OWNER OF U.S. REG. NO. 2,901,823.
FOR EYEWEAR AND EYEWEAR ACCESSORIES, NAMELY, FRAMES FOR PRESCRIPTION AND NON-PRESCRIPTION EYEGLASSES AND SUNGLASSES, PRESCRIPTION AND NON-PRESCRIPTION SUNGLASSES, EYEGLASS AND SUNGLASS CHAINS, EYEGLASS AND SUNGLASS LENSES, GOGGLES FOR SPORTS AND CASES FOR ALL THE AFOREMENTIONED GOODS (U.S. CLS. 21, 23, 26, 36 AND 38).
FIRST USE 1-26-2012; IN COMMERCE 1-26-2012.

4,211,363. BALLY GAMING, INC., DBA BALLY TECHNOLOGIES, LAS VEGAS, NV. SN 85-382,835. PUB. 12-27-2011, FILED 7-27-2011.

TAHITIAN QUEEN

THE MARK CONSISTS OF STANDARD CHARACTERS WITHOUT CLAIM TO ANY PARTICULAR FONT, STYLE, SIZE, OR COLOR.

FOR GAMING MACHINES, NAMELY, DEVICES WHICH ACCEPT A WAGER AND GAMING SOFTWARE THAT GENERATES OR DISPLAYS OUTCOMES FOR GAMING MACHINES (U.S. CLS. 21, 23, 26, 36 AND 38).
FIRST USE 6-1-2012; IN COMMERCE 6-1-2012.

CLASS 9—(Continued).

4,211,371. TOSHIBA AMERICA INFORMATION SYSTEMS, INC., IRVINE, CA. SN 85-384,950. PUB. 1-17-2012, FILED 7-29-2011.

CAMILEO CLIP

THE MARK CONSISTS OF STANDARD CHARACTERS WITHOUT CLAIM TO ANY PARTICULAR FONT, STYLE, SIZE, OR COLOR.

OWNER OF U.S. REG. NO. 3,902,017.
NO CLAIM IS MADE TO THE EXCLUSIVE RIGHT TO USE "CLIP", APART FROM THE MARK AS SHOWN.
THE WORDING "CAMILEO" HAS NO MEANING IN A FOREIGN LANGUAGE.
FOR CAMERAS AND CAMCORDERS (U.S. CLS. 21, 23, 26, 36 AND 38).
FIRST USE 6-16-2012; IN COMMERCE 6-16-2012.

4,211,377. RETAIL ROYALTY COMPANY, LAS VEGAS, NV. SN 85-386,751. PUB. 11-15-2011, FILED 8-2-2011.



OWNER OF U.S. REG. NOS. 3,657,727, 3,878,197, AND OTHERS.

THE MARK CONSISTS OF A FLYING EAGLE.
FOR EAR BUDS (U.S. CLS. 21, 23, 26, 36 AND 38).
FIRST USE 10-0-2011; IN COMMERCE 10-0-2011.

CLASS 9—(Continued).

4,211,384. MIAMI TRIBE OF OKLAHOMA BUSINESS DEVELOPMENT AUTHORITY, A TRIBAL ENTERPRISE OF THE MIAMI TRIBE OF OKLAHOMA, MIAMI, OK. SN 85-390,132. PUB. 10-11-2011, FILED 8-4-2011.

CAJUN FEVER

THE MARK CONSISTS OF STANDARD CHARACTERS WITHOUT CLAIM TO ANY PARTICULAR FONT, STYLE, SIZE, OR COLOR.

FOR GAMING MACHINES, NAMELY, BINGO-RELATED GAMES AND SLOT MACHINES (U.S. CLS. 21, 23, 26, 36 AND 38).

FIRST USE 1-25-2012; IN COMMERCE 1-25-2012.

CLASS 9—(Continued).

4,211,402. TWO TECHNOLOGIES, INC., HORSHAM, PA. SN 85-395,436. PUB. 1-17-2012, FILED 8-11-2011.

UPSAFETY

THE MARK CONSISTS OF STANDARD CHARACTERS WITHOUT CLAIM TO ANY PARTICULAR FONT, STYLE, SIZE, OR COLOR.

FOR COMPUTER HARDWARE AND SOFTWARE, NAMELY, A HAND-HELD OPERATOR INTERFACE WITH BUILT-IN CAMERA, AND COMPUTER HARDWARE AND SOFTWARE, NAMELY, A HAND-HELD DATA PROCESSOR WITH BUILT-IN CAMERA, ALL OF THE PRECEDING FOR USE IN THE FIELD OF ENFORCING PARKING REGULATIONS AND THE ISSUANCE OF CITATIONS FOR PARKING REGULATION VIOLATIONS (U.S. CLS. 21, 23, 26, 36 AND 38).

FIRST USE 0-0-2011; IN COMMERCE 0-0-2011.

4,211,389. PEI LICENSING, INC., MIAMI, FL. SN 85-392,146. PUB. 1-10-2012, FILED 8-8-2011.

4,211,432. GPSMYCITY.COM INC., LAS VEGAS, NV. SN 85-406,235. PUB. 2-14-2012, FILED 8-24-2011.



OWNER OF U.S. REG. NO. 2,401,979.

THE MARK CONSISTS OF THE LETTER "P" WRITTEN IN STYLIZED FONT WITH A CURVED LINE OR BAND IN FRONT OF THE "P".

FOR EYEWEAR AND EYEWEAR ACCESSORIES, NAMELY, FRAMES FOR PRESCRIPTION AND NON-PRESCRIPTION EYEGLASSES AND SUNGLASSES, PRESCRIPTION AND NON-PRESCRIPTION SUNGLASSES, EYEGLASS AND SUNGLASS CHAINS, EYEGLASS AND SUNGLASS LENSES, AND CASES FOR ALL THE AFOREMENTIONED GOODS (U.S. CLS. 21, 23, 26, 36 AND 38).

FIRST USE 1-26-2012; IN COMMERCE 1-26-2012.

TRIPSUITE

THE MARK CONSISTS OF STANDARD CHARACTERS WITHOUT CLAIM TO ANY PARTICULAR FONT, STYLE, SIZE, OR COLOR.

FOR DOWNLOADABLE SOFTWARE FEATURING SELF GUIDED TOURS THAT OFFER COMPREHENSIVE INFORMATION, PICTURES AND DIRECTIONS FOR SPECIFIED PLACES OF INTEREST, DINING, SHOPPING AND ENTERTAINMENT, ALL PLAYABLE ON ELECTRONIC DEVICES; COMPUTER APPLICATION SOFTWARE FOR MOBILE PHONES, NAMELY, SOFTWARE FOR USE IN DATA PROCESSING AND GRAPHIC DISPLAY; DOWNLOADABLE SOFTWARE IN THE NATURE OF A MOBILE APPLICATION FOR USE IN DATA PROCESSING AND GRAPHIC DISPLAY; DOWNLOADABLE SOFTWARE FOR USE IN DATA PROCESSING AND GRAPHIC DISPLAY (U.S. CLS. 21, 23, 26, 36 AND 38).

FIRST USE 7-10-2012; IN COMMERCE 7-10-2012.

CLASS 9—(Continued).

4,211,437. BIG BLUE AUDIO LLC, DBA BIG BLUE AUDIO, MERRIMACK, NH. SN 85-407,476. PUB. 10-25-2011, FILED 8-25-2011.



NO CLAIM IS MADE TO THE EXCLUSIVE RIGHT TO USE "AUDIO", APART FROM THE MARK AS SHOWN. THE COLOR(S) BLUE IS/ARE CLAIMED AS A FEATURE OF THE MARK.

THE MARK CONSISTS OF THE WORDS "BIG BLUE AUDIO" IN A BLUE STYLIZED FONT AND STACKED IN A LEFT-JUSTIFIED CONFIGURATION WHEREIN THE LETTER "L" IN THE WORD "BLUE" AND THE "I" IN THE WORD "BIG" ARE PLACED WITH A SINGLE ANTENNAE WITH SOUND WAVES EMANATING UPWARDS.

FOR AUDIO SPEAKERS; DIGITAL AUDIO PLAYERS; EARPHONES AND HEADPHONES; PERSONAL STEREO; PORTABLE LISTENING DEVICES, NAMELY, MP3 PLAYERS (U.S. CLS. 21, 23, 26, 36 AND 38). FIRST USE 10-25-2011; IN COMMERCE 10-25-2011.

4,211,461. CAPE EVOLUTION LTD, CENTRAL, HONG KONG, CHINA. SN 85-416,983. PUB. 12-13-2011, FILED 9-7-2011.



THE MARK CONSISTS OF A RESEMBLANCE TO A HEAD WHICH IS TURNED AND HAS A SET OF GOGGLES/EYEGLASSES WITH A BASEBALL CAP ON BACKWARDS.

FOR HIGH DEFINITION, POINT OF VIEW, HANDS FREE DIGITAL VIDEO WEARABLE RECORDING APPARATUS FOR VIDEO AND STILL IMAGE CAPTURE FOR PROFESSIONAL USE, RECREATIONAL USE, DRIVING, SPORTS, AND INDOOR USE (U.S. CLS. 21, 23, 26, 36 AND 38).

FIRST USE 9-7-2011; IN COMMERCE 6-4-2012.

CLASS 9—(Continued).

4,211,472. D-TA SYSTEMS INC., OTTAWA, ONTARIO, CANADA. SN 85-420,324. PUB. 2-21-2012, FILED 9-12-2011.

SigInspector

THE MARK CONSISTS OF STANDARD CHARACTERS WITHOUT CLAIM TO ANY PARTICULAR FONT, STYLE, SIZE, OR COLOR.

FOR SOFTWARE FOR RADIO FREQUENCY SPECTRUM MONITORING AND SURVEILLANCE (U.S. CLS. 21, 23, 26, 36 AND 38).

FIRST USE 9-1-2011; IN COMMERCE 9-1-2011.

4,211,478. MEI, INC., WEST CHESTER, PA. SN 85-423,967. PUB. 3-6-2012, FILED 9-15-2011.

MEI EASITRAX ADVANCE 5000

THE MARK CONSISTS OF STANDARD CHARACTERS WITHOUT CLAIM TO ANY PARTICULAR FONT, STYLE, SIZE, OR COLOR.

OWNER OF U.S. REG. NO. 2,805,442.

FOR ELECTRONIC HARDWARE SYSTEMS COMPRISED OF HANDHELD COMPUTERS, DATA PORTS, REMOTE ACCESS DEVICES, NAMELY, RF AND WIRELESS TELEMETRY, AND CODE SCANNERS, USED FOR THE ENTERPRISE RESOURCE MANAGEMENT OF BUSINESSES WHO USE UNATTENDED TRANSACTION EQUIPMENT WHICH SUPPORT THE TRANSPORTATION, RETAIL, GAMING AND VENDING MARKETS (U.S. CLS. 21, 23, 26, 36 AND 38).

FIRST USE 1-0-2012; IN COMMERCE 1-0-2012.

4,211,489. SECURITY SOLUTIONS TECHNOLOGY GROUP, LLC, BUFFALO GROVE, IL. SN 85-430,872. PUB. 3-6-2012, FILED 9-23-2011.

PANTASCENE

THE MARK CONSISTS OF STANDARD CHARACTERS WITHOUT CLAIM TO ANY PARTICULAR FONT, STYLE, SIZE, OR COLOR.

OWNER OF U.S. REG. NO. 3,931,954.

FOR COMPUTER SOFTWARE FOR GATHERING AND INTEGRATING INFORMATION COLLECTED FROM DISPARATE SENSOR AND SURVEILLANCE SYSTEMS (U.S. CLS. 21, 23, 26, 36 AND 38).

FIRST USE 2-0-2012; IN COMMERCE 2-0-2012.

CLASS 9—(Continued).

4,211,491. BOLD RED ENTERTAINMENT GROUP LLC, SELMA, TX. SN 85-432,626. PUB. 3-6-2012, FILED 9-27-2011.

BOLD RED

THE MARK CONSISTS OF STANDARD CHARACTERS WITHOUT CLAIM TO ANY PARTICULAR FONT, STYLE, SIZE, OR COLOR.

FOR DIGITAL MUSIC DOWNLOADABLE FROM THE INTERNET (U.S. CLS. 21, 23, 26, 36 AND 38). FIRST USE 11-11-2011; IN COMMERCE 11-11-2011.

CLASS 9—(Continued).

4,211,522. ETRAVEL APPLICATIONS, LLC, PLEASANTON, CA. SN 85-448,947. PUB. 5-8-2012, FILED 10-17-2011.

HOTELTAP

THE MARK CONSISTS OF STANDARD CHARACTERS WITHOUT CLAIM TO ANY PARTICULAR FONT, STYLE, SIZE, OR COLOR.

FOR SOFTWARE APPLICATIONS FOR ELECTRONIC MOBILE DEVICES FEATURING INFORMATION AND REVIEWS ABOUT HOTELS, TRAVEL DIRECTIONS TO HOTELS, AND INFORMATION REGARDING THE ATTRACTIONS, RESTAURANTS, AND SHOPPING LOCATED NEAR HOTELS (U.S. CLS. 21, 23, 26, 36 AND 38). FIRST USE 5-15-2012; IN COMMERCE 5-15-2012.

4,211,561. CE BROKER, INC., JACKSONVILLE, FL. SN 85-464,820. PUB. 4-17-2012, FILED 11-4-2011.

EverCheck

THE MARK CONSISTS OF STANDARD CHARACTERS WITHOUT CLAIM TO ANY PARTICULAR FONT, STYLE, SIZE, OR COLOR.

FOR COMPUTER SOFTWARE FOR AUTOMATING PROFESSIONAL LICENSE VERIFICATION (U.S. CLS. 21, 23, 26, 36 AND 38). FIRST USE 1-1-2012; IN COMMERCE 3-1-2012.

4,211,566. AMERICAN MILLENNIUM CORP. INC., GOLDEN, CO. SN 85-469,674. PUB. 4-24-2012, FILED 11-10-2011.

METEREYE

THE MARK CONSISTS OF STANDARD CHARACTERS WITHOUT CLAIM TO ANY PARTICULAR FONT, STYLE, SIZE, OR COLOR.

FOR ELECTRONIC MONITORS FOR MONITORING FLOWMETERS (U.S. CLS. 21, 23, 26, 36 AND 38). FIRST USE 6-1-2012; IN COMMERCE 6-1-2012.

4,211,503. IVIU TECHNOLOGIES, LLC, ANAHEIM, CA. SN 85-439,322. PUB. 3-20-2012, FILED 10-5-2011.



NO CLAIM IS MADE TO THE EXCLUSIVE RIGHT TO USE "TECHNOLOGIES", APART FROM THE MARK AS SHOWN.

THE MARK CONSISTS OF THE WORDING "IVIU TECHNOLOGIES" WITH "IVIU" APPEARING ABOVE "TECHNOLOGIES". THE FIRST "I" IN "IVIU" APPEARS TO HAVE AN EYE AS THE DOT IN THE "I", AND THIS EYE IS SURROUNDED BY CONCENTRIC SEMI-CIRCULAR ELEMENTS CENTERED ABOUT THE EYE THAT REPRESENT RADIO AND SOUND WAVES.

FOR INTEROPERABLE COMMUNICATION SYSTEM DESIGNED TO PROVIDE RADIO, STREAMING VIDEO, WIRELESS INTERNET, AND VOIP PHONE; WIRELESS ADAPTERS USED TO LINK COMPUTERS TO A TELECOMMUNICATIONS NETWORK; WIRELESS TRANSMITTERS WITH COLLECTION AND DISPLAY TECHNOLOGY FOR THE STATUS AND TRACKING OF RETAIL GOODS FROM THE BACKDOOR TO THE SHELF; WIRELESS TRANSMITTERS AND RECEIVERS (U.S. CLS. 21, 23, 26, 36 AND 38).

FIRST USE 10-10-2011; IN COMMERCE 5-10-2012.

CLASS 9—(Continued).

4,211,584. SEMTECH CORPORATION, CAMARILLO, CA. SN 85-476,449. PUB. 5-1-2012, FILED 11-18-2011.

X-EMI

THE MARK CONSISTS OF STANDARD CHARACTERS WITHOUT CLAIM TO ANY PARTICULAR FONT, STYLE, SIZE, OR COLOR.

FOR INDUCTORS AND INTEGRATED CIRCUITS USED TO CONVERT ONE VOLTAGE TO ANOTHER (U.S. CLS. 21, 23, 26, 36 AND 38).

FIRST USE 2-8-2012; IN COMMERCE 2-8-2012.

CLASS 9—(Continued).

4,211,606. COHN, SCOTT, WOODSIDE, NY. SN 85-487,061. PUB. 5-22-2012, FILED 12-5-2011.

PARADYME 1.0

THE MARK CONSISTS OF STANDARD CHARACTERS WITHOUT CLAIM TO ANY PARTICULAR FONT, STYLE, SIZE, OR COLOR.

FOR DOWNLOADABLE ELECTRONIC PUBLICATIONS, NAMELY, COMIC BOOKS AND BOOKS AND MAGAZINES IN ILLUSTRATED FORM IN THE NATURE OF GRAPHIC NOVELS AND RELATED COMIC BOOK SUBJECT MATTER (U.S. CLS. 21, 23, 26, 36 AND 38).

FIRST USE 7-1-2012; IN COMMERCE 7-1-2012.

4,211,590. JACKSON SYSTEMS, LLC, INDIANAPOLIS, IN. SN 85-478,583. PUB. 5-1-2012, FILED 11-22-2011.

CONTROLS DONE RIGHT

THE MARK CONSISTS OF STANDARD CHARACTERS WITHOUT CLAIM TO ANY PARTICULAR FONT, STYLE, SIZE, OR COLOR.

NO CLAIM IS MADE TO THE EXCLUSIVE RIGHT TO USE "CONTROLS", APART FROM THE MARK AS SHOWN.

FOR CLIMATE CONTROL SYSTEMS CONSISTING OF DIGITAL THERMOSTATS FOR COOLING EQUIPMENT, AND A PROGRAMMABLE LOGIC CONTROLLER (PLC) WITH INPUT AND OUTPUT FEATURES FOR TEMPERATURE AND HUMIDITY, WHICH WORKS WITH A REMOTE DIGITAL READ OUT CONTROLLER; CLIMATE CONTROL SYSTEMS CONSISTING OF DIGITAL THERMOSTATS, AIR CONDITIONING, HEATING, VENTILATION AND DRYING CONTROL DEVICES; TEMPERATURE SENSORS (U.S. CLS. 21, 23, 26, 36 AND 38).

FIRST USE 1-31-2012; IN COMMERCE 1-31-2012.

4,211,607. RICHARD KINCAID, CHICAGO, IL. SN 85-487,593. PUB. 5-15-2012, FILED 12-5-2011.



THE COLOR(S) RED AND BLACK IS/ARE CLAIMED AS A FEATURE OF THE MARK.

THE MARK CONSISTS OF THE BLACK STYLIZED LETTERS "RK" AGAINST A RED SQUARE BACKGROUND.

FOR SERIES OF MUSICAL SOUND RECORDINGS (U.S. CLS. 21, 23, 26, 36 AND 38).

FIRST USE 12-1-2011; IN COMMERCE 12-1-2011.

CLASS 9—(Continued).

4,211,611. MEGUMI O LLC, LOS ANGELES, CA. SN 85-490,084. PUB. 4-24-2012, FILED 12-7-2011.



THE COLOR(S) FLESH TONE, AUBURN, RED AND BLACK IS/ARE CLAIMED AS A FEATURE OF THE MARK. THE MARK CONSISTS OF GIRL'S HEAD WITH AUBURN HAIR, WEARING ROUND BLACK SUNGLASSES WITH RED "O" SHAPED MOUTH. THE GIRL'S FACE IS FLESH TONED. THE OUTLINE OF THE GIRL'S FACE IS BLACK.

FOR AUDIO HEADPHONES; BAGS AND CASES SPECIALLY ADAPTED FOR HOLDING OR CARRYING ELECTRIC HAIR CURLING IRONS; BAGS AND CASES SPECIALLY ADAPTED FOR HOLDING OR CARRYING PORTABLE TELEPHONES AND TELEPHONE EQUIPMENT AND ACCESSORIES; BATTERY CASES; BEEPER CARRYING CASES; CAMERA CASES; CARRYING CASES AND CONTAINERS FOR CONTACT LENSES; CARRYING CASES FOR CELL PHONES; CARRYING CASES FOR MOBILE COMPUTERS; CARRYING CASES FOR RADIO PAGERS; CARRYING CASES SPECIALLY ADAPTED FOR POCKET CALCULATORS AND CELLPHONES; CARRYING CASES, HOLDERS, PROTECTIVE CASES AND STANDS FEATURING POWER SUPPLY CONNECTORS, ADAPTORS, SPEAKERS AND BATTERY CHARGING DEVICES, SPECIALLY ADAPTED FOR USE WITH HANDHELD DIGITAL ELECTRONIC DEVICES; CASES FOR CHILDREN'S EYE GLASSES; CASES FOR CONTACT LENSES; CASES FOR DISKETTES AND COMPACT DISKS; CASES FOR ELECTRONIC DIARIES; CASES FOR EYEGLASSES AND SUNGLASSES; CASES FOR MOBILE PHONES; CASES FOR MUSIC, AUDIO AND RELATED ELECTRONIC EQUIPMENT, NAMELY, CASES FOR AUDIO TUNERS, AUDIO RECEIVERS, AMPLIFIERS, TAPE PLAYERS, COMPACT DISC PLAYERS, MP3 CONTROLLERS/PLAYERS, AUDIO MIXERS, AUDIO SPEAKERS IN THE NATURE OF MUSIC STUDIO MONITORS, MICROPHONES, AUDIO SPEAKERS, COMPACT DISCS, AUDIO TAPES, PORTABLE COMPUTERS, ANTENNAS, PHONOGRAPHIC RECORD PLAYERS, AUDIO RECORDING EQUIPMENT, AND THE CABLES ASSOCIATED WITH ALL OF THE FOREGOING EQUIPMENT; CASES FOR PHOTOGRAPHIC APPARATUS; CASES FOR POCKET CALCULATORS; CASES FOR SPECTACLES AND SUNGLASSES; CASES FOR SPECTACLES, FOR PINCE-NEZ AND FOR CONTACT LENSES; CASES FOR TELEPHONES; CASINGS AND CASING PARTS FOR ELECTRICAL EQUIPMENT, NAMELY, HOUSING FOR SWITCHING APPARATUS; CD CASES; CELL PHONE BACKPLATES; CELL PHONE BATTERY CHARGERS; CELL PHONE BATTERY CHARGERS FOR USE IN VEHICLES; CELL PHONE CASES; CELL PHONE COVERS; CELL PHONE FACEPLATES; COMPACT DISC CASES; COMPUTER CARRYING CASES; CONTACT LENS CASES; DVD CASES; EAR PHONES; EARPHONE ACCESSORIES, NAMELY, EARPHONE CUSHIONS, EARPHONE PADS, CORD MANAGEMENT SYSTEMS, EARPHONE CASES, AND EARPHONE EXTENSION CORDS; EARPHONES AND HEADPHONES; EYE GLASS CASES; EYEGLASS CASES; EYEWEAR CASES; EYEWEAR, NAMELY, SUNGLASSES, EYEGLASSES AND OPHTHALMIC FRAMES AND CASES THEREFOR; HEADPHONES; HEADSETS

CLASS 9—(Continued).

FOR CELLULAR OR MOBILE PHONES; LAPTOP CARRYING CASES; MUSIC HEADPHONES; NOTEBOOK COMPUTER CARRYING CASES; PLASTIC AND CARDBOARD CASES FOR STORING RECORD ALBUMS; PLASTIC CASE USED AS A SECURITY DEVICE FOR PROTECTING AND SECURING DVDS AND OTHER MAGNETIC AND ELECTRONIC MEDIA FROM THEFT; PLASTIC CASES SPECIALLY ADAPTED HOLDING COMPACT DISCS, DVDS AND OTHER ELECTRONIC MEDIA; PRINTER CARRYING CASES; PROTECTIVE CARRYING CASES FOR PORTABLE MUSIC PLAYERS, NAMELY, MP3 PLAYERS; PROTECTIVE CARRYING CASES SPECIALLY ADAPTED FOR GLOBAL POSITIONING SYSTEM (GPS) APPARATUS; PROTECTIVE CARRYING CASES SPECIALLY ADAPTED FOR PERSONAL DIGITAL ASSISTANTS (PDA); PROTECTIVE CARRYING CASES SPECIALLY ADAPTED FOR VIDEO GAME CONSOLES FOR USE WITH AN EXTERNAL DISPLAY SCREEN OR MONITOR; PROTECTIVE COVERS AND CASES FOR CELL PHONES, LAPTOPS AND PORTABLE MEDIA PLAYERS; ROLLING CASES ESPECIALLY ADAPTED FOR HOLDING LAPTOPS AND NOTEBOOK COMPUTERS; SHIELD CASES FOR MAGNETIC DISKS; SPECTACLE CASES; SPECTACLES, FRAMES AND CASES; STEREO HEADPHONES; VIBRATING ALARM INCORPORATED INTO PLASTIC MEDICATION CASES SOLD EMPTY AS A REMINDER TO TAKE MEDICATION; VINYL COVERS SPECIALLY ADAPTED FOR CELL PHONES, MP3 PLAYERS, LAPTOPS, COMPUTERS, PORTABLE SATELLITE RADIOS, PERSONAL DIGITAL ASSISTANTS, REMOTE CONTROLS, AND TELEVISION SATELLITE RECORDERS; WIRELESS CELLULAR PHONE HEADSETS (U.S. CLS. 21, 23, 26, 36 AND 38).

FIRST USE 6-20-2012; IN COMMERCE 6-20-2012.

4,211,614. MIAMI TRIBE OF OKLAHOMA BUSINESS DEVELOPMENT AUTHORITY, A TRIBAL ENTERPRISE OF THE MIAMI TRIBE OF OKLAHOMA, MIAMI, OK. SN 85-491,047. PUB. 1-31-2012, FILED 12-8-2011.

PANDAMONIUM

THE MARK CONSISTS OF STANDARD CHARACTERS WITHOUT CLAIM TO ANY PARTICULAR FONT, STYLE, SIZE, OR COLOR.

FOR GAMING MACHINES, NAMELY, BINGO-RELATED GAMES AND SLOT MACHINES (U.S. CLS. 21, 23, 26, 36 AND 38).

FIRST USE 2-10-2012; IN COMMERCE 2-10-2012.

CLASS 9—(Continued).

4,211,618. METRYX LLC, PROVIDENCE, RI. SN 85-493,118. PUB. 5-15-2012, FILED 12-12-2011.

METRYX

THE MARK CONSISTS OF STANDARD CHARACTERS WITHOUT CLAIM TO ANY PARTICULAR FONT, STYLE, SIZE, OR COLOR.

FOR COMPUTER SOFTWARE FOR USE BY EDUCATORS TO CONDUCT EDUCATIONAL ASSESSMENTS, TO MONITOR STUDENT PROGRESS, TO TRACK STUDENTS' INDIVIDUAL NEEDS, SKILLS AND CHALLENGES AND TO PREPARE REPORTS AND GRAPHIC DISPLAYS OF STUDENT AND CLASS PERFORMANCE; DOWNLOADABLE SOFTWARE IN THE NATURE OF A MOBILE APPLICATION FOR USE BY EDUCATORS TO CONDUCT EDUCATIONAL ASSESSMENTS, TO MONITOR STUDENT PROGRESS, TO TRACK STUDENTS' INDIVIDUAL NEEDS, SKILLS AND CHALLENGES AND TO PREPARE REPORTS AND GRAPHIC DISPLAYS OF STUDENT AND CLASS PERFORMANCE (U.S. CLS. 21, 23, 26, 36 AND 38).

FIRST USE 2-0-2012; IN COMMERCE 2-0-2012.

CLASS 9—(Continued).

4,211,625. PANTECH CO., LTD., MAPO-GU, SEOUL, REPUBLIC OF KOREA. SN 85-495,439. PUB. 4-10-2012, FILED 12-14-2011.



The logo for PANTECH BURST features the word "PANTECH" in a bold, sans-serif font with a horizontal line underneath. To the right, the word "BURST" is written in a stylized, italicized, bold font.

FOR AUDIO-RECEIVERS AND VIDEO-RECEIVERS; BATTERIES; BATTERY CHARGERS; CELLULAR TELEPHONES; COMPUTER OPERATING RECORDED PROGRAMS; COMPUTER PROGRAMS FOR USE IN DATA COMMUNICATION BETWEEN MOBILE TELEPHONES AND COMPUTERS; EARPHONES; HEADPHONES; MOBILE TELEPHONE BATTERIES; MOBILE TELEPHONES; MP3 PLAYERS; NAVIGATION APPARATUS FOR VEHICLES IN THE NATURE OF ON-BOARD COMPUTERS; NOTEBOOK AND LAPTOP COMPUTERS; PERSONAL DIGITAL ASSISTANTS; RECHARGEABLE ELECTRIC BATTERIES; PORTABLE MULTIMEDIA PLAYERS (PMP); SATELLITE NAVIGATIONAL SYSTEM, NAMELY, A GLOBAL POSITIONING SYSTEM (GPS); SMARTPHONES; TABLET COMPUTERS; TELECOMMUNICATIONS CABLES; TELEPHONE RECEIVERS; TELEPHONE TRANSMITTERS; TELEPHONES; USB (UNIVERSAL SERIAL BUS) HARDWARE; USB CABLES; VIDEO CAMERAS; VIDEO TELEPHONES; WIRELESS CELLULAR PHONE HEADSETS; WIRELESS TELEPHONES (U.S. CLS. 21, 23, 26, 36 AND 38).

FIRST USE 1-22-2012; IN COMMERCE 1-22-2012.

4,211,631. FACTYLE INC., MONTREAL, QUEBEC, CANADA. SN 85-497,204. PUB. 3-6-2012, FILED 12-16-2011.

CINEMAGRAM

THE MARK CONSISTS OF STANDARD CHARACTERS WITHOUT CLAIM TO ANY PARTICULAR FONT, STYLE, SIZE, OR COLOR.

FOR COMPUTER SOFTWARE AND COMPUTER APPLICATION SOFTWARE FOR EDITING DIGITAL IMAGES AND PHOTOGRAPHS; COMPUTER SOFTWARE AND COMPUTER APPLICATION SOFTWARE FOR CREATING ANIMATED IMAGES AND FOR CONVERTING DIGITAL IMAGES AND PHOTOGRAPHS TO ANIMATED IMAGES; DOWNLOADABLE SOFTWARE IN THE NATURE OF A MOBILE APPLICATION FOR EDITING DIGITAL IMAGES AND PHOTOGRAPHS; DOWNLOADABLE SOFTWARE IN THE NATURE OF A MOBILE APPLICATION FOR CREATING ANIMATED IMAGES AND FOR CONVERTING DIGITAL IMAGES AND PHOTOGRAPHS TO ANIMATED IMAGES (U.S. CLS. 21, 23, 26, 36 AND 38).

FIRST USE 2-9-2012; IN COMMERCE 2-9-2012.

4,211,620. IGT, RENO, NV. SN 85-493,390. PUB. 5-15-2012, FILED 12-12-2011.

FIESTA CHIHUAHUA

THE MARK CONSISTS OF STANDARD CHARACTERS WITHOUT CLAIM TO ANY PARTICULAR FONT, STYLE, SIZE, OR COLOR.

FOR GAMING MACHINES, NAMELY, DEVICES WHICH ACCEPT A WAGER (U.S. CLS. 21, 23, 26, 36 AND 38).

FIRST USE 6-19-2012; IN COMMERCE 6-26-2012.

CLASS 9—(Continued).

4,211,639. LASALLE SYSTEMS LEASING, INC., DBA LASALLE SOLUTIONS, ROSEMONT, IL. SN 85-500,813. PUB. 5-1-2012, FILED 12-21-2011.

LAMP Scan

THE MARK CONSISTS OF STANDARD CHARACTERS WITHOUT CLAIM TO ANY PARTICULAR FONT, STYLE, SIZE, OR COLOR.

OWNER OF U.S. REG. NO. 3,334,494.

NO CLAIM IS MADE TO THE EXCLUSIVE RIGHT TO USE "SCAN", APART FROM THE MARK AS SHOWN.

FOR COMPUTER APPLICATION SOFTWARE FOR MOBILE PHONES, TABLET COMPUTERS, AND MOBILE ELECTRONIC DEVICES, NAMELY, SOFTWARE FOR USE IN SCANNING BARCODES OR ENTERING PRODUCT NUMBERS (U.S. CLS. 21, 23, 26, 36 AND 38).
FIRST USE 2-1-2012; IN COMMERCE 3-6-2012.

4,211,650. DIGI INTERNATIONAL INC., MINNETONKA, MN. SN 85-517,459. PUB. 4-24-2012, FILED 1-16-2012.



THE COLOR(S) GREEN, LIGHT GREEN, WHITE AND PALE YELLOW IS/ARE CLAIMED AS A FEATURE OF THE MARK.

THE MARK CONSISTS OF THE LETTER "S" SURROUNDED BY STYLIZED RADIATING RAYS IN THE FORM OF EIGHT RECTANGULAR SHAPES WITH ROUNDED ENDS, ALL FORMING A BURST DESIGN AROUND THE LETTER "S". THE LETTER "S" APPEARS IN WHITE AT THE TOP AND PALE YELLOW AT THE BOTTOM. THE "RAYS" SURROUNDING THE LETTER "S" APPEAR IN WHITE. THE LETTER "S" AND THE "RAYS" ARE ENCLOSED INSIDE A GREEN SQUARE SHAPE WITH ROUNDED CORNERS. THE BOTTOM HALF OF THE SQUARE SHAPE IS GREEN AND THE TOP HALF OF THE SQUARE SHAPE IS LIGHT GREEN.

FOR COMPUTER HARDWARE AND COMPUTER SOFTWARE, NAMELY, SOFTWARE AND MIDDLEWARE ALLOWING USERS TO MANAGE ENERGY USE (U.S. CLS. 21, 23, 26, 36 AND 38).

FIRST USE 1-20-2012; IN COMMERCE 1-20-2012.

CLASS 9—(Continued).

4,211,654. INVICTA WATCH COMPANY OF AMERICA, INC., HOLLYWOOD, FL. SN 85-541,979. PUB. 5-1-2012, FILED 2-14-2012.

POWERPATCH

THE MARK CONSISTS OF STANDARD CHARACTERS WITHOUT CLAIM TO ANY PARTICULAR FONT, STYLE, SIZE, OR COLOR.

FOR CELL PHONE BATTERY CHARGERS; CELL PHONE CASES; CELL PHONE COVERS (U.S. CLS. 21, 23, 26, 36 AND 38).

FIRST USE 2-0-2012; IN COMMERCE 2-0-2012.

4,211,655. HONEYWELL INTERNATIONAL INC., MORRISTOWN, NJ. SN 85-543,100. PUB. 4-24-2012, FILED 2-15-2012.

ONRAMP

THE MARK CONSISTS OF STANDARD CHARACTERS WITHOUT CLAIM TO ANY PARTICULAR FONT, STYLE, SIZE, OR COLOR.

FOR COMPUTER SOFTWARE FOR USE IN CONTROLLING INTERNAL COMBUSTION ENGINES (U.S. CLS. 21, 23, 26, 36 AND 38).

FIRST USE 4-26-2012; IN COMMERCE 5-21-2012.

4,211,660. PCS WIRELESS LLC, FLORHAM PARK, NJ. SN 85-976,999. PUB. 10-4-2011, FILED 2-16-2011.

HANDCANDY

THE MARK CONSISTS OF STANDARD CHARACTERS WITHOUT CLAIM TO ANY PARTICULAR FONT, STYLE, SIZE, OR COLOR.

FOR EAR BUDS; ELECTRONIC TRANSMITTERS AND RECEIVERS FOR USE IN FASHION ACCESSORIES DEVELOPED FOR WIRELESS COMMUNICATION, NAMELY, SPECIALIZED HEADPHONES AND HEADSETS IN THE FORM OF EARRINGS AND NECKLACES FOR CELLULAR PHONES, MP3 PLAYERS AND PERSONAL ELECTRONIC DEVICES (U.S. CLS. 21, 23, 26, 36 AND 38).

FIRST USE 5-21-2012; IN COMMERCE 5-21-2012.

CLASS 10—MEDICAL APPARATUS

CLASS 10—(Continued).

4,210,313. NUORTHO SURGICAL, INC., FALL RIVER, MA.
SN 77-614,150. PUB. 5-26-2009, FILED 11-13-2008.



THE COLOR(S) WHITE, GRAY, AND BLUE IS/ARE CLAIMED AS A FEATURE OF THE MARK.

THE MARK CONSISTS OF A WATER MOLECULE. THE TWO HYDROGEN ATOMS ARE BLUE WITH WHITE REFLECTIONS. THE OXYGEN ATOM IS GRAY WITH WHITE REFLECTIONS.

FOR ELECTROSURGERY MEDICAL DEVICE SYSTEM COMPRISED PRIMARILY OF PROBES FOR MEDICAL PURPOSES, CATHETERS, MEDICAL ELECTRODES, CONTAINERS CONTAINING SOLUTIONS IN LIQUID FORM FOR MEDICAL USE, INTERFACES FOR MEDICAL DEVICES, AND POWER SUPPLIES FOR THE MEDICAL ELECTRODES (U.S. CLS. 26, 39 AND 44).

FIRST USE 11-13-2008; IN COMMERCE 7-22-2012.

4,210,323. NEOTECH PRODUCTS, INC., VALENCIA, CA. SN 77-627,739. PUB. 4-28-2009, FILED 12-5-2008.

NeoSeal

THE MARK CONSISTS OF STANDARD CHARACTERS WITHOUT CLAIM TO ANY PARTICULAR FONT, STYLE, SIZE, OR COLOR.

FOR CANNULA FOR RESPIRATORY THERAPY (U.S. CLS. 26, 39 AND 44).

FIRST USE 5-1-2012; IN COMMERCE 5-1-2012.

CLASS 10—(Continued).

4,210,346. THORNHILL RESEARCH INC., TORONTO, CANADA. SN 77-672,009. PUB. 6-9-2009, FILED 2-17-2009.

MOVES

THE MARK CONSISTS OF STANDARD CHARACTERS WITHOUT CLAIM TO ANY PARTICULAR FONT, STYLE, SIZE, OR COLOR.

FOR HEART MONITORS; MEDICAL APPARATUS, NAMELY, LUNG VENTILATORS WITH MONITORING CAPABILITY; MEDICAL VENTILATORS; OXYGEN CONCENTRATORS FOR MEDICAL APPLICATIONS; OXYGEN MONITORS; PATIENT BREATHING SYSTEM COMPRISING A BREATHING CIRCUIT, CONNECTIONS TO PATIENT, VENTILATOR, FRESH GAS DELIVERY CIRCUIT AND CARBON DIOXIDE ABSORBER; PATIENT MONITORING SENSORS AND ALARMS; PATIENT MONITORS FOR CRITICAL CARE AND ANESTHESIA; PULSE RATE MONITORS; RESPIRATION MONITORS; VENTILATORS AND ANESTHESIA MACHINES FOR USE IN PATIENT CARE; WOUND SUCTION APPARATUS (U.S. CLS. 26, 39 AND 44).

FIRST USE 7-1-2010; IN COMMERCE 7-1-2010.

4,210,347. SPINE VIEW, INC., FREMONT, CA. SN 77-672,333. PUB. 4-28-2009, FILED 2-17-2009.

ENPOWERING SPINAL CARE

THE MARK CONSISTS OF STANDARD CHARACTERS WITHOUT CLAIM TO ANY PARTICULAR FONT, STYLE, SIZE, OR COLOR.

NO CLAIM IS MADE TO THE EXCLUSIVE RIGHT TO USE "SPINAL CARE", APART FROM THE MARK AS SHOWN.

FOR RIGID AND FLEXIBLE MEDICAL ENDOSCOPES; MEDICAL INSTRUMENTS FOR USE IN SPINAL SURGERY, NAMELY, BONE CUTTING INSTRUMENTS (U.S. CLS. 26, 39 AND 44).

FIRST USE 10-0-2011; IN COMMERCE 10-0-2011.

CLASS 10—(Continued).

4,210,364. STRYKER TRAUMA AG, SELZACH, SWITZERLAND. SN 77-749,984. PUB. 10-20-2009, FILED 6-2-2009.

SONICPIN

THE MARK CONSISTS OF STANDARD CHARACTERS WITHOUT CLAIM TO ANY PARTICULAR FONT, STYLE, SIZE, OR COLOR.

FOR ORTHOPEDIC IMPLANTS, NAMELY, A PIN CONFIGURED TO BE IMPLANTED ADJACENT FRACTURED BONE AND TO WHICH ULTRASOUND IS TRANSMITTED FOR MEDICAL USE AND FOR THE PURPOSE OF EXPEDITING THE HEALING PROCESS OF BONE FRACTURES (U.S. CLS. 26, 39 AND 44).
FIRST USE 4-30-2012; IN COMMERCE 4-30-2012.

4,210,373. ROCHE DIAGNOSTICS OPERATIONS, INC., INDIANAPOLIS, IN. SN 77-773,396. PUB. 10-6-2009, FILED 7-2-2009.

COBAS X

THE MARK CONSISTS OF STANDARD CHARACTERS WITHOUT CLAIM TO ANY PARTICULAR FONT, STYLE, SIZE, OR COLOR.

OWNER OF U.S. REG. NOS. 1,251,382, 2,001,778, AND OTHERS.
THE WORDING "COBAS" HAS NO MEANING IN A FOREIGN LANGUAGE.
FOR MEDICAL APPARATUS IN THE NATURE OF CLINICAL CHEMISTRY ANALYZERS AND IMMUNOCHEMISTRY ANALYZERS FOR USE IN THE ANALYSIS OF BIOLOGICAL SAMPLES FOR CLINICAL MEDICAL DIAGNOSTIC PURPOSES (U.S. CLS. 26, 39 AND 44).
FIRST USE 10-31-2011; IN COMMERCE 10-31-2011.

4,210,388. BGS MEDICAL PRODUCTS, INC., VENICE, FL. SN 77-832,088. PUB. 5-17-2011, FILED 9-22-2009.

SQUEEZE TEST THE GOLD STANDARD FOR FECAL ANALYSIS

THE MARK CONSISTS OF STANDARD CHARACTERS WITHOUT CLAIM TO ANY PARTICULAR FONT, STYLE, SIZE, OR COLOR.

CLASS 10—(Continued).

NO CLAIM IS MADE TO THE EXCLUSIVE RIGHT TO USE "FECAL ANALYSIS", APART FROM THE MARK AS SHOWN.

FOR VETERINARY DIAGNOSTIC TEST KITS COMPRISING A COLLECTING AND MIXING CONTAINER FOR FECAL MATTER, A UTENSIL FOR MANIPULATING THE FECAL MATTER AND A STRAINER FOR FILTERING THE MATERIAL (U.S. CLS. 26, 39 AND 44).
FIRST USE 12-1-2010; IN COMMERCE 12-1-2010.

4,210,418. ARTHROCARE CORPORATION, AUSTIN, TX. SN 77-895,638. PUB. 3-23-2010, FILED 12-17-2009.

MegaVac

THE MARK CONSISTS OF STANDARD CHARACTERS WITHOUT CLAIM TO ANY PARTICULAR FONT, STYLE, SIZE, OR COLOR.

FOR MEDICAL DEVICE FOR USE IN ORTHOPEDIC SURGICAL PROCEDURES, NAMELY, ELECTROSURGICAL PROBES FOR CONTROLLED ABLATION OF TISSUE (U.S. CLS. 26, 39 AND 44).
FIRST USE 5-29-2012; IN COMMERCE 5-29-2012.

4,210,548. SYNTHES USA, LLC, WEST CHESTER, PA. SN 85-063,919. PUB. 11-2-2010, FILED 6-16-2010.

XRL

THE MARK CONSISTS OF STANDARD CHARACTERS WITHOUT CLAIM TO ANY PARTICULAR FONT, STYLE, SIZE, OR COLOR.

FOR EXPANDABLE CAGES FOR USE IN VERTEBRAL BODY REPLACEMENT AND INSTRUMENTS FOR USE IN EXPANDING EXPANDABLE CAGES; SPREADER AND ASSOCIATED COMPONENTS, LOCKING INSTRUMENTATION, ENDPLATE ASSEMBLY AND DISASSEMBLY TOOLS, VARIOUS TRIALS, IMPLANT HOLDER, AND GRAFT PACKING TAMPS; ALL FOR USE IN SURGICAL PROCEDURES RELATING TO VERTEBRAL BODY REPLACEMENT (U.S. CLS. 26, 39 AND 44).
FIRST USE 12-27-2011; IN COMMERCE 12-27-2011.

CLASS 10—(Continued).

4,210,553. ALPHATEC SPINE, INC., CARLSBAD, CA. SN 85-067,926. PUB. 5-10-2011, FILED 6-21-2010.

BRIDGEPOINT

THE MARK CONSISTS OF STANDARD CHARACTERS WITHOUT CLAIM TO ANY PARTICULAR FONT, STYLE, SIZE, OR COLOR.

FOR SPINAL IMPLANTS MADE FROM ARTIFICIAL MATERIALS FOR ATTACHMENT TO THE SPINOUS PROCESSES, SCREWS, CLAMPS, NUTS, HOOKS AND ASSOCIATED SURGICAL APPARATUS AND INSTRUMENTS (U.S. CLS. 26, 39 AND 44).

FIRST USE 3-15-2012; IN COMMERCE 3-15-2012.

4,210,700. LINVATEC CORPORATION, LARGO, FL. SN 85-182,632. PUB. 4-12-2011, FILED 11-22-2010.

ECOFLOW

THE MARK CONSISTS OF STANDARD CHARACTERS WITHOUT CLAIM TO ANY PARTICULAR FONT, STYLE, SIZE, OR COLOR.

FOR SURGICAL DEVICES, NAMELY, TUBING SYSTEMS USED DURING SURGICAL PROCEDURES FOR CONVEYING IRRIGATING AND/OR DISTENTION FLUIDS FROM A FLUID SOURCE TO A SURGICAL WORK SITE WHEREIN THE TUBING SYSTEMS COMPRISE A RE-USABLE FIRST PORTION EXTENDING BETWEEN THE FLUID SOURCE AND A PREDETERMINED POINT, THE FIRST PORTION BEING SELECTIVELY ATTACHABLE TO AND DETACHABLE FROM THE FLUID SOURCE AND REUSABLE DURING A PLURALITY OF SUCCESSIVE SURGICAL CASES, AND A SINGLE-USE SECOND PORTION EXTENDING BETWEEN THE PREDETERMINED POINT AND THE SURGICAL WORK SITE, THE SECOND PORTION BEING SELECTIVELY ATTACHABLE TO AND DETACHABLE FROM THE FIRST PORTION, AND USABLE ONLY FOR A SINGLE SURGICAL CASE (U.S. CLS. 26, 39 AND 44).

FIRST USE 10-4-2011; IN COMMERCE 10-4-2011.

CLASS 10—(Continued).

4,210,775. MECTRA LABS, INC., BLOOMFIELD, IN. SN 85-210,707. PUB. 5-3-2011, FILED 1-5-2011.

ALIEN

THE MARK CONSISTS OF STANDARD CHARACTERS WITHOUT CLAIM TO ANY PARTICULAR FONT, STYLE, SIZE, OR COLOR.

FOR MEDICAL DEVICES, NAMELY, ENDOSCOPIC NEEDLES (U.S. CLS. 26, 39 AND 44).

FIRST USE 11-20-2011; IN COMMERCE 11-20-2011.

4,210,795. ORASURE TECHNOLOGIES, INC., BETHLEHEM, PA. SN 85-215,984. PUB. 12-13-2011, FILED 1-12-2011.

ORASURE QUICKFLU

THE MARK CONSISTS OF STANDARD CHARACTERS WITHOUT CLAIM TO ANY PARTICULAR FONT, STYLE, SIZE, OR COLOR.

OWNER OF U.S. REG. NOS. 1,658,132 AND 2,102,169. FOR MEDICAL DIAGNOSTIC RAPID TEST KITS (U.S. CLS. 26, 39 AND 44).

FIRST USE 3-31-2011; IN COMMERCE 3-31-2011.

4,210,833. MIZUHO ORTHOPEDIC SYSTEMS, INC., SACRAMENTO, CA. SN 85-234,822. PUB. 6-14-2011, FILED 2-4-2011.

TAKE THE PRESSURE OFF YOUR PATIENTS

THE MARK CONSISTS OF STANDARD CHARACTERS WITHOUT CLAIM TO ANY PARTICULAR FONT, STYLE, SIZE, OR COLOR.

FOR SUPPORTS FOR GENERAL MEDICAL USE (U.S. CLS. 26, 39 AND 44).

FIRST USE 7-1-2011; IN COMMERCE 8-31-2011.

CLASS 10—(Continued).

4,210,882. TRACTOR SUPPLY CO. OF TEXAS, LP, BRENTWOOD, TN. SN 85-250,241. PUB. 7-19-2011, FILED 2-24-2011.

DUMOR

THE MARK CONSISTS OF STANDARD CHARACTERS WITHOUT CLAIM TO ANY PARTICULAR FONT, STYLE, SIZE, OR COLOR.

OWNER OF U.S. REG. NO. 1,471,155.
FOR ANIMAL CARE SUPPLIES, NAMELY, CALVING BOTTLES AND NIPPLES FOR FEEDING BOTTLES (U.S. CLS. 26, 39 AND 44).
FIRST USE 5-30-2011; IN COMMERCE 5-30-2011.

CLASS 10—(Continued).

4,211,031. XR. LLC, HUNTINGTON BEACH, CA. SN 85-328,824. PUB. 10-18-2011, FILED 5-24-2011.

VELVAFEEL

THE MARK CONSISTS OF STANDARD CHARACTERS WITHOUT CLAIM TO ANY PARTICULAR FONT, STYLE, SIZE, OR COLOR.

FOR ADULT SEXUAL STIMULATION AIDS, NAMELY, VIBRATORS (U.S. CLS. 26, 39 AND 44).
FIRST USE 4-29-2011; IN COMMERCE 4-29-2011.

4,211,008. ACACIA, INC., BREA, CA. SN 85-324,200. PUB. 3-27-2012, FILED 5-18-2011.



OWNER OF U.S. REG. NO. 3,797,178.
THE MARK CONSISTS OF THREE CIRCLES TO THE LEFT OF THE WORD "ACACIA".

FOR NEONATAL MEDICAL PRODUCTS, NAMELY, FEEDING SYRINGES, INTRAVENOUS (I.V.) DRUG DELIVERY SETS COMPRISED OF MEDICAL TUBING AND CONNECTORS AND TUBING VALVES; MULTI-ACCESS DRUG DELIVERY SETS COMPRISED OF MEDICAL TUBING AND CONNECTORS AND TUBING VALVES; EXTENSION SETS COMPRISED OF MEDICAL TUBING AND CONNECTORS AND TUBING VALVES; AND NICU SPECIALTY TUBING (U.S. CLS. 26, 39 AND 44).

FIRST USE 3-1-2011; IN COMMERCE 3-1-2011.

4,211,064. O2OOL LLC, FORT COLLINS, CO. SN 85-335,182. PUB. 10-25-2011, FILED 6-1-2011.

O2OOL

THE MARK CONSISTS OF STANDARD CHARACTERS WITHOUT CLAIM TO ANY PARTICULAR FONT, STYLE, SIZE, OR COLOR.

FOR NASAL CANNULA POSITIONING DEVICE (U.S. CLS. 26, 39 AND 44).
FIRST USE 4-19-2012; IN COMMERCE 4-19-2012.

4,211,013. NUVASIVE INC., SAN DIEGO, CA. SN 85-325,453. PUB. 11-1-2011, FILED 5-19-2011.

EasyScreen

THE MARK CONSISTS OF STANDARD CHARACTERS WITHOUT CLAIM TO ANY PARTICULAR FONT, STYLE, SIZE, OR COLOR.

FOR FLUID SEPARATION APPARATUS FOR SEPARATION OF LIQUID FROM MATERIALS FOR MEDICAL USE (U.S. CLS. 26, 39 AND 44).
FIRST USE 10-3-2011; IN COMMERCE 10-3-2011.

4,211,084. TCM SUPPLY CORP, DBA WORLDWIDE TATTOO SUPPLY, CITY OF INDUSTRY, CA. SN 85-338,136. PUB. 5-15-2012, FILED 6-4-2011.

Black Bear

THE MARK CONSISTS OF STANDARD CHARACTERS WITHOUT CLAIM TO ANY PARTICULAR FONT, STYLE, SIZE, OR COLOR.

FOR DISPOSABLE LATEX AND NITRILE EXAM GLOVES FOR MEDICAL USE (U.S. CLS. 26, 39 AND 44).
FIRST USE 12-0-2011; IN COMMERCE 12-0-2011.

CLASS 10—(Continued).

4,211,103. MIZUHO ORTHOPEDIC SYSTEMS INC., SACRAMENTO, CA. SN 85-341,011. PUB. 11-29-2011, FILED 6-8-2011.



THE MARK CONSISTS THE OF THE TERM "AXIS" WITH A CIRCLE SURROUNDING THE "X" IN "AXIS". THE TERM "PRO" IS SUPERIMPOSED OVER THE CENTER OF THE "X". WITHIN THE CIRCLE, THERE ARE SEVEN THIN LINES EXTENDING OUTWARD AND TO THE LEFT FROM THE CENTER OF THE "X".

FOR OPERATING TABLES; PATIENT EXAMINATION AND/OR TREATMENT TABLES (U.S. CLS. 26, 39 AND 44).

FIRST USE 6-3-2011; IN COMMERCE 3-26-2012.

4,211,133. MIZUHO ORTHOPEDIC SYSTEMS, INC, SACRAMENTO, CA. SN 85-344,934. PUB. 11-29-2011, FILED 6-13-2011.



THE MARK CONSISTS OF THE WORD "PRO" SUPERIMPOSED OVER THE CENTER OF AN "X" WITHIN A CIRCLE. WITHIN THE CIRCLE, THERE ARE SEVEN THIN LINES EXTENDING OUTWARD AND TO THE LEFT FROM THE CENTER OF THE "X".

FOR OPERATING TABLES; PATIENT EXAMINATION AND/OR TREATMENT TABLES (U.S. CLS. 26, 39 AND 44).

FIRST USE 6-3-2011; IN COMMERCE 3-25-2012.

CLASS 10—(Continued).

4,211,152. RHAUSLER, INC., SAN CARLOS, CA. SN 85-346,914. PUB. 11-1-2011, FILED 6-15-2011.

PL-AGE

THE MARK CONSISTS OF STANDARD CHARACTERS WITHOUT CLAIM TO ANY PARTICULAR FONT, STYLE, SIZE, OR COLOR.

FOR SPINAL IMPLANTS COMPOSED OF ARTIFICIAL MATERIAL (U.S. CLS. 26, 39 AND 44).

FIRST USE 3-9-2012; IN COMMERCE 3-9-2012.

4,211,305. MOBHEALTH, EL MONTE, CA. SN 85-369,734. PUB. 5-1-2012, FILED 7-12-2011.

MobCardio

THE MARK CONSISTS OF STANDARD CHARACTERS WITHOUT CLAIM TO ANY PARTICULAR FONT, STYLE, SIZE, OR COLOR.

FOR ELECTRONIC DEVICE THAT SUGGESTS THE RISK LEVEL OF CARDIOVASCULAR CONDITIONS, NAMELY, AN ELECTROCARDIOGRAM THAT ACQUIRES DATA USING 12-LEAD EKG, AND MAY BE CONNECTED TO PROPRIETARY CARDIOVASCULAR ANALYSIS PROGRAM (U.S. CLS. 26, 39 AND 44).

FIRST USE 3-15-2012; IN COMMERCE 5-25-2012.

4,211,315. EYE CARE AND CURE CORP., TUCSON, AZ. SN 85-371,924. PUB. 10-4-2011, FILED 7-14-2011.

VU-FILTERZ

THE MARK CONSISTS OF STANDARD CHARACTERS WITHOUT CLAIM TO ANY PARTICULAR FONT, STYLE, SIZE, OR COLOR.

FOR MEDICAL APPARATUS, NAMELY, VISUAL OCCLUSION DEVICE (U.S. CLS. 26, 39 AND 44).

FIRST USE 8-21-2008; IN COMMERCE 8-21-2008.

CLASS 10—(Continued).

4,211,316. EYE CARE AND CURE CORP., TUCSON, AZ. SN 85-371,928. PUB. 10-4-2011, FILED 7-14-2011.

THE MARK CONSISTS OF THE WORDING "FIXISTIX" IN BLACK LETTERING WITH A PICTURE OF A BUTTERFLY, FLOWER AND GRASS DISPLAYED ON FIRST "I", WITH A PICTURE OF A MONKEY, GRASS AND TREES DISPLAYED ON THE SECOND "I", AND WITH A PICTURE OF A PUPPY AND GRASS DISPLAYED ON THE THIRD "I".
FOR MEDICAL APPARATUS, NAMELY, EYE TESTING CARDS DESIGNED FOR DETAILED ACCOMMODATION STIMULATING TARGETS (U.S. CLS. 26, 39 AND 44).

FIRST USE 2-6-2009; IN COMMERCE 2-6-2009.

4,211,414. MEDLINE INDUSTRIES, INC., MUNDELEIN, IL. SN 85-400,257. PUB. 1-17-2012, FILED 8-17-2011.

THE MARK CONSISTS OF STANDARD CHARACTERS WITHOUT CLAIM TO ANY PARTICULAR FONT, STYLE, SIZE, OR COLOR.
FOR MEDICAL SCRUBS (U.S. CLS. 26, 39 AND 44).
FIRST USE 5-23-2012; IN COMMERCE 5-23-2012.

4,211,633. MERIT MEDICAL SYSTEMS, INC., SOUTH JORDAN, UT. SN 85-497,224. PUB. 4-10-2012, FILED 12-16-2011.

THE MARK CONSISTS OF STANDARD CHARACTERS WITHOUT CLAIM TO ANY PARTICULAR FONT, STYLE, SIZE, OR COLOR.

OWNER OF U.S. REG. NO. 3,541,404.
FOR MEDICAL DEVICES, NAMELY, DIALYSIS CATHETERS (U.S. CLS. 26, 39 AND 44).
FIRST USE 5-22-2012; IN COMMERCE 5-22-2012.

CLASS 10—(Continued).

4,211,649. NICO CORPORATION, INDIANAPOLIS, IN. SN 85-516,158. PUB. 5-1-2012, FILED 1-13-2012.

THE MARK CONSISTS OF STANDARD CHARACTERS WITHOUT CLAIM TO ANY PARTICULAR FONT, STYLE, SIZE, OR COLOR.

FOR MEDICAL APPARATUS AND INSTRUMENTS FOR USE IN SURGERY; SURGICAL INSTRUMENTS FOR USE IN NEUROSURGERY, BRAIN SURGERY AND SPINAL SURGERY (U.S. CLS. 26, 39 AND 44).
FIRST USE 6-0-2012; IN COMMERCE 6-0-2012.

CLASS 11—ENVIRONMENTAL CONTROL APPARATUS

4,210,241. REV-A-SHELF COMPANY, LLC, JEFFERSON-TOWN, KY. SN 76-707,354. PUB. 12-27-2011, FILED 4-21-2011.

THE MARK CONSISTS OF STANDARD CHARACTERS WITHOUT CLAIM TO ANY PARTICULAR FONT, STYLE, SIZE, OR COLOR.

OWNER OF U.S. REG. NOS. 1,978,924, 1,984,678, AND 3,557,941.

FOR LOW VOLTAGE LED LIGHTING SYSTEMS, NAMELY, LED MODULES, POWER SUPPLIES AND WIRING (U.S. CLS. 13, 21, 23, 31 AND 34).
FIRST USE 11-30-2009; IN COMMERCE 11-30-2009.

4,210,316. MAYTAG PROPERTIES, LLC, ST. JOSEPH, MI. SN 77-618,763. PUB. 4-7-2009, FILED 11-20-2008.



OWNER OF U.S. REG. NOS. 868,637, 2,365,749, AND OTHERS.

CLASS 11—(Continued).

THE MARK CONSISTS OF THE WORD MAYTAG WITHIN A SHIELD.

FOR AIR CONDITIONERS; AIR FILTERS FOR AIR CONDITIONING UNITS; AIR FILTERS FOR DOMESTIC USE; AIR PURIFIERS; AIR-CONDITIONING, AIR COOLING AND VENTILATION APPARATUS AND INSTRUMENTS; APPARATUS FOR COOKING, NAMELY, COOKTOPS; DOMESTIC COOKING OVENS; ELECTRIC COOKING OVENS; ELECTRIC RANGES; FREEZERS; FURNACES; GAS COOKING OVENS; GAS RANGES; HOODS FOR RANGES; HUMIDIFIERS; HVAC UNITS; MICROWAVE OVENS FOR COOKING; REFRIGERATORS (U.S. CLS. 13, 21, 23, 31 AND 34).

FIRST USE 9-1-2009; IN COMMERCE 9-1-2009.

4,210,391. ENVION, INC., WASHINGTON, DC. SN 77-850,714. PUB. 6-8-2010, FILED 10-16-2009.

Envion

THE MARK CONSISTS OF STANDARD CHARACTERS WITHOUT CLAIM TO ANY PARTICULAR FONT, STYLE, SIZE, OR COLOR.

FOR WASTE CONVERSION MACHINES USING THERMAL CRACKING TO CONVERT WASTE PLASTIC TO HYDROCARBONS (U.S. CLS. 13, 21, 23, 31 AND 34).
FIRST USE 9-23-2009; IN COMMERCE 7-17-2012.

4,210,425. ROHL, LLC, IRVINE, CA. SN 77-909,891. PUB. 5-25-2010, FILED 1-12-2010.

VIAGGIO

THE MARK CONSISTS OF STANDARD CHARACTERS WITHOUT CLAIM TO ANY PARTICULAR FONT, STYLE, SIZE, OR COLOR.

THE ENGLISH TRANSLATION OF "VIAGGIO" IN THE MARK IS "TRAVEL" OR "TRIP".

FOR PLUMBING AND SHOWER FIXTURES, NAMELY, FAUCETS, SHOWER HEADS, RESTS FOR SHOWER HEADS, HAND SHOWERS, THERMOSTATIC CONTROL VALVES FOR SHOWERS, AND SHOWER MIXERS (U.S. CLS. 13, 21, 23, 31 AND 34).

FIRST USE 12-31-2009; IN COMMERCE 12-31-2009.

CLASS 11—(Continued).

4,210,426. ROHL, LLC, IRVINE, CA. SN 77-909,901. PUB. 5-25-2010, FILED 1-12-2010.

VOCCA

THE MARK CONSISTS OF STANDARD CHARACTERS WITHOUT CLAIM TO ANY PARTICULAR FONT, STYLE, SIZE, OR COLOR.

FOR PLUMBING AND SHOWER FIXTURES, NAMELY, FAUCETS, SHOWER HEADS, RESTS FOR SHOWER HEADS, HAND SHOWERS, THERMOSTATIC CONTROL VALVES FOR SHOWERS, AND SHOWER MIXERS (U.S. CLS. 13, 21, 23, 31 AND 34).

FIRST USE 12-31-2009; IN COMMERCE 12-31-2009.

4,210,561. NJUN LLC, ATLANTA, GA. SN 85-074,373. PUB. 11-30-2010, FILED 6-29-2010.

NJUN

THE MARK CONSISTS OF STANDARD CHARACTERS WITHOUT CLAIM TO ANY PARTICULAR FONT, STYLE, SIZE, OR COLOR.

FOR SEWAGE TREATMENT MINI-PLANTS INTENDED FOR INSTALLATION AT LOCAL SOURCES OF WASTEWATER GENERATION, NAMELY, RESIDENTIAL HOMES (U.S. CLS. 13, 21, 23, 31 AND 34).

FIRST USE 11-0-2011; IN COMMERCE 11-0-2011.

4,210,683. MINDEN GRILL COMPANY, INC., MINDEN, NV. SN 85-171,347. PUB. 5-10-2011, FILED 11-8-2010.

Anytime Grill

THE MARK CONSISTS OF STANDARD CHARACTERS WITHOUT CLAIM TO ANY PARTICULAR FONT, STYLE, SIZE, OR COLOR.

NO CLAIM IS MADE TO THE EXCLUSIVE RIGHT TO USE "GRILL", APART FROM THE MARK AS SHOWN.

FOR BARBECUE GRILLS (U.S. CLS. 13, 21, 23, 31 AND 34).

FIRST USE 4-23-2011; IN COMMERCE 4-23-2011.

CLASS 11—(Continued).

4,211,017. FIELDS, FRANKLIN, LODI, CA. SN 85-325,549. PUB. 10-18-2011, FILED 5-20-2011.

FLASHSTRAP

THE MARK CONSISTS OF STANDARD CHARACTERS WITHOUT CLAIM TO ANY PARTICULAR FONT, STYLE, SIZE, OR COLOR.
FOR FLASHLIGHT HOLDERS (U.S. CLS. 13, 21, 23, 31 AND 34).
FIRST USE 1-1-2012; IN COMMERCE 1-1-2012.

4,211,035. FLEXENERGY, INC., IRVINE, CA. SN 85-329,551. PUB. 11-8-2011, FILED 5-25-2011.

FLEX OXIDIZER

THE MARK CONSISTS OF STANDARD CHARACTERS WITHOUT CLAIM TO ANY PARTICULAR FONT, STYLE, SIZE, OR COLOR.
NO CLAIM IS MADE TO THE EXCLUSIVE RIGHT TO USE "OXIDIZER", APART FROM THE MARK AS SHOWN.
FOR HEAT GENERATORS; STEAM GENERATORS (U.S. CLS. 13, 21, 23, 31 AND 34).
FIRST USE 6-20-2012; IN COMMERCE 6-20-2012.

CLASS 11—(Continued).

4,211,042. THE AGENCY ACBH, INC., LINCOLN UNIVERSITY, PA. SN 85-331,046. PUB. 10-25-2011, FILED 5-26-2011.

PartsmasterPro

THE MARK CONSISTS OF STANDARD CHARACTERS WITHOUT CLAIM TO ANY PARTICULAR FONT, STYLE, SIZE, OR COLOR.
FOR PLUMBING FITTINGS, NAMELY, AERATORS FOR FAUCETS; PLUMBING FITTINGS, NAMELY, BAFFLES; PLUMBING FITTINGS, NAMELY, BIBBS; PLUMBING FITTINGS, NAMELY, COCKS; PLUMBING FITTINGS, NAMELY, COUPLERS; PLUMBING FITTINGS, NAMELY, DRAINS; PLUMBING FITTINGS, NAMELY, FAUCET FILTERS; PLUMBING FITTINGS, NAMELY, SHOWER CONTROL VALVES; PLUMBING FITTINGS, NAMELY, SINK STRAINERS; PLUMBING FITTINGS, NAMELY, SPOUTS; PLUMBING FITTINGS, NAMELY, TRAPS; PLUMBING FITTINGS, NAMELY, TUB CONTROL VALVES; PLUMBING FITTINGS, NAMELY, VALVES; PLUMBING FIXTURES, NAMELY, SHOWER MIXERS; PLUMBING FIXTURES, NAMELY, SHOWER SPRAYERS; PLUMBING FIXTURES, NAMELY, SINK SPRAYERS; PLUMBING FIXTURES, NAMELY, SINK TRAPS; PLUMBING SUPPLIES, NAMELY, SINK STRAINERS; STRAINERS FOR PLUMBING DRAINS (U.S. CLS. 13, 21, 23, 31 AND 34).
FIRST USE 3-0-2011; IN COMMERCE 3-0-2011.

4,211,043. THE AGENCY ACBH, INC., LINCOLN UNIVERSITY, PA. SN 85-331,140. PUB. 10-25-2011, FILED 5-26-2011.



THE MARK CONSISTS OF THE SMALL LETTERS "P" AND "M" IN PARENTHESIS FOLLOWED BY THE SMALL LETTER "P" AS A SUPERSCRIPIT.
FOR FLEXIBLE PIPES BEING PARTS OF BASIN PLUMBING INSTALLATIONS; FLEXIBLE PIPES BEING PARTS OF BATH PLUMBING INSTALLATIONS; FLEXIBLE PIPES BEING PARTS OF SHOWER PLUMBING INSTALLATIONS; FLEXIBLE PIPES BEING PARTS OF SINK PLUMBING INSTALLATIONS; MANUALLY-OPERATED PLUMBING VALVES; PLUMBING FITTINGS, NAMELY, AERATORS FOR FAUCETS; PLUMBING FITTINGS, NAMELY, BAFFLES; PLUMBING FITTINGS, NAMELY, BIBBS; PLUMBING FITTINGS, NAMELY, COCKS; PLUMBING FITTINGS, NAMELY, COUPLERS; PLUMBING FITTINGS, NAMELY, DRAINS; PLUMBING FITTINGS, NAMELY, FAUCET FILTERS; PLUMBING FITTINGS, NAMELY, SHOWER CONTROL VALVES; PLUMBING FITTINGS, NAMELY, SINK STRAINERS; PLUMBING FITTINGS, NAMELY, SPOUTS; PLUMBING FITTINGS, NAMELY, TRAPS; PLUMBING FITTINGS, NAMELY, TUB CONTROL VALVES; PLUMBING FITTINGS, NAMELY, VALVES; PLUMBING FIXTURES, NAMELY, SHOWER MIXERS; PLUMBING FIXTURES, NAMELY, SHOWER SPRAYERS; PLUMBING FIXTURES, NAMELY, SINK SPRAYERS; PLUMBING FIXTURES, NAMELY, SINK TRAPS; PLUMBING SUPPLIES, NAMELY, SINK STRAINERS; STRAINERS FOR PLUMBING DRAINS (U.S. CLS. 13, 21, 23, 31 AND 34).
FIRST USE 3-0-2011; IN COMMERCE 3-0-2011.

CLASS 11—(Continued).

4,211,238. ORECK HOLDINGS, LLC, NASHVILLE, TN. SN 85-357,427. PUB. 11-15-2011, FILED 6-27-2011.

AIRINSTINCT

THE MARK CONSISTS OF STANDARD CHARACTERS WITHOUT CLAIM TO ANY PARTICULAR FONT, STYLE, SIZE, OR COLOR.

FOR AIR PURIFIERS (U.S. CLS. 13, 21, 23, 31 AND 34).
FIRST USE 10-17-2011; IN COMMERCE 10-17-2011.

4,211,290. FAR EAST BROKERS AND CONSULTANTS, INC., JACKSONVILLE, FL. SN 85-366,376. PUB. 12-27-2011, FILED 7-8-2011.

FABULOUS HOME

THE MARK CONSISTS OF STANDARD CHARACTERS WITHOUT CLAIM TO ANY PARTICULAR FONT, STYLE, SIZE, OR COLOR.

NO CLAIM IS MADE TO THE EXCLUSIVE RIGHT TO USE "HOMES", APART FROM THE MARK AS SHOWN.

FOR ELECTRIC FANS; ELECTRIC HEATING FANS; ELECTRIC LIGHT BULBS; ELECTRIC LIGHTS FOR CHRISTMAS TREES; ELECTRIC WINDOW FANS; LIGHTED PARTY-THEMED DECORATIONS, ELECTRIC LIGHT DECORATIVE STRINGS (U.S. CLS. 13, 21, 23, 31 AND 34).

FIRST USE 9-1-2010; IN COMMERCE 9-1-2010.

4,211,347. CLARCOR AIR FILTRATION PRODUCTS, INC., JEFFERSONVILLE, IN. SN 85-377,666. PUB. 12-20-2011, FILED 7-21-2011.

AIRGUARD ADVANTAGE

THE MARK CONSISTS OF STANDARD CHARACTERS WITHOUT CLAIM TO ANY PARTICULAR FONT, STYLE, SIZE, OR COLOR.

OWNER OF U.S. REG. NOS. 1,507,019 AND 1,534,162.
FOR COMMERCIAL AND INDUSTRIAL AIR FILTERS FOR HVAC SYSTEMS (U.S. CLS. 13, 21, 23, 31 AND 34).
FIRST USE 4-5-2012; IN COMMERCE 4-5-2012.

CLASS 11—(Continued).

4,211,399. ORECK HOLDINGS, LLC, NASHVILLE, TN. SN 85-394,742. PUB. 11-15-2011, FILED 8-10-2011.

TURN IT ON AND WALK AWAY

THE MARK CONSISTS OF STANDARD CHARACTERS WITHOUT CLAIM TO ANY PARTICULAR FONT, STYLE, SIZE, OR COLOR.

FOR AIR PURIFIERS (U.S. CLS. 13, 21, 23, 31 AND 34).
FIRST USE 10-17-2011; IN COMMERCE 10-17-2011.

4,211,416. ORECK HOLDINGS, LLC, NASHVILLE, TN. SN 85-400,458. PUB. 11-15-2011, FILED 8-17-2011.



THE MARK CONSISTS OF FOUR SWIRLS ENCIRCLING EACH OTHER IN A CIRCULAR DESIGN.
FOR AIR PURIFIERS (U.S. CLS. 13, 21, 23, 31 AND 34).
FIRST USE 10-17-2011; IN COMMERCE 10-17-2011.

CLASS 11—(Continued).

4,211,455. ORECK HOLDINGS, LLC, NASHVILLE, TN. SN 85-414,588. PUB. 11-15-2011, FILED 9-2-2011.



THE MARK CONSISTS OF THE WORD "DUALMAX" WITH THE "X" BEING A STYLIZED FAN COMPOSED OF A CIRCLE IN THE CENTER WITH FOUR PROPELLERS AND A BOWED SWIRL DESIGN BELOW THE "DUAL" COMPONENT AND A BOWED SWIRL DESIGN ABOVE THE "MAX" COMPONENT.
FOR AIR PURIFIERS (U.S. CLS. 13, 21, 23, 31 AND 34).
FIRST USE 8-31-2011; IN COMMERCE 8-31-2011.

4,211,492. EMSCO, INC., MASSILLON, OH. SN 85-433,205. PUB. 3-27-2012, FILED 9-27-2011.



THE MARK CONSISTS OF THE LETTERS "HYPRCOOL" WITH A WAVY LINE RUNNING THROUGH THE LETTERS.
FOR COOLING TOWERS USED IN LIQUID COOLING SYSTEMS FOR INDUSTRIAL PROCESS EQUIPMENT, INCLUDING INDUCTION FURNACES, THAT REQUIRE REMOVAL OF PROCESS HEAT BY CIRCULATING COOLING LIQUID (U.S. CLS. 13, 21, 23, 31 AND 34).
FIRST USE 11-30-2010; IN COMMERCE 11-30-2010.

CLASS 11—(Continued).

4,211,556. 2K INNOVATIONS INC, OLYMPIA, WA. SN 85-462,882. PUB. 4-24-2012, FILED 11-2-2011.

VOLT

THE MARK CONSISTS OF STANDARD CHARACTERS WITHOUT CLAIM TO ANY PARTICULAR FONT, STYLE, SIZE, OR COLOR.
FOR HEATING CUSHIONS NOT FOR MEDICAL PURPOSES; HEATING PILLOWS NOT FOR MEDICAL PURPOSES (U.S. CLS. 13, 21, 23, 31 AND 34).
FIRST USE 1-0-2012; IN COMMERCE 1-0-2012.

4,211,604. CARRIER ENTERPRISES, LLC, ORLANDO, FL. SN 85-484,656. PUB. 5-15-2012, FILED 12-1-2011.

E-TAC

THE MARK CONSISTS OF STANDARD CHARACTERS WITHOUT CLAIM TO ANY PARTICULAR FONT, STYLE, SIZE, OR COLOR.
FOR AIR CONDITIONING UNITS AND HEATING UNITS FOR INDUSTRIAL AND DOMESTIC PURPOSES (U.S. CLS. 13, 21, 23, 31 AND 34).
FIRST USE 1-2-2012; IN COMMERCE 1-2-2012.

CLASS 12—VEHICLES

4,210,233. CVG ALABAMA, LLC, NEW ABANY, OH. SN 76-700,770. PUB. 8-3-2010, FILED 12-10-2009.

BOSTROM PRO RIDE

OWNER OF U.S. REG. NOS. 638,335, 875,351, AND OTHERS.
FOR SEATS FOR COMMERCIAL TRUCKS (U.S. CLS. 19, 21, 23, 31, 35 AND 44).
FIRST USE 3-0-2010; IN COMMERCE 3-0-2010.

CLASS 12—(Continued).

4,210,289. STRYKER CORPORATION, KALAMAZOO, MI. SN 77-504,518. PUB. 3-24-2009, FILED 6-20-2008.

Power Load

THE MARK CONSISTS OF STANDARD CHARACTERS WITHOUT CLAIM TO ANY PARTICULAR FONT, STYLE, SIZE, OR COLOR.

FOR FASTENING SYSTEM, ESPECIALLY ADAPTED FOR USE WITH AMBULANCES AND AIRCRAFT, COMPRISED OF A TRACK AND A MOVABLE CARRIAGE WITH A COUPLER TO SECURE MEDICAL COTS AND STRETCHERS TO AN AMBULANCE OR AN AIRCRAFT FLOOR DURING PATIENT TRANSPORT (U.S. CLS. 19, 21, 23, 31, 35 AND 44).

FIRST USE 5-15-2012; IN COMMERCE 5-15-2012.

CLASS 12—(Continued).

4,210,498. SPBI, DOMPIERRE-SUR-YON, FRANCE. SN 85-013,270. PUB. 11-1-2011, FILED 4-13-2010.

SENSE

THE MARK CONSISTS OF STANDARD CHARACTERS WITHOUT CLAIM TO ANY PARTICULAR FONT, STYLE, SIZE, OR COLOR.

PRIORITY CLAIMED UNDER SEC. 44(D) ON FRANCE APPLICATION NO. 10/3727611, FILED 4-6-2010, REG. NO. 103727611, DATED 4-6-2010, EXPIRES 4-6-2020.

FOR VEHICLES AND APPARATUS FOR LOCOMOTION BY WATER, NAMELY, BOATS, SAILING-POWERED AND/OR MOTORIZED SHIPS, BOATS, WATERCRAFTS, NAMELY, WATER SCOOTERS; SAIL-POWERED AND/OR MOTORIZED PLEASURE BOATS; FISHING BOATS, SERVICE BOATS (U.S. CLS. 19, 21, 23, 31, 35 AND 44).

FIRST USE 8-5-2010; IN COMMERCE 8-5-2010.

4,210,387. HYUNDAI MOTOR AMERICA, FOUNTAIN VALLEY, CA. SN 77-827,811. PUB. 2-16-2010, FILED 9-16-2009.

ECOSHIFT

THE MARK CONSISTS OF STANDARD CHARACTERS WITHOUT CLAIM TO ANY PARTICULAR FONT, STYLE, SIZE, OR COLOR.

FOR TRANSMISSIONS FOR LAND VEHICLES (U.S. CLS. 19, 21, 23, 31, 35 AND 44).

FIRST USE 10-1-2011; IN COMMERCE 10-1-2011.

4,210,517. AIR CUSHION DESIGNS, INC., CHILLICOTHE, OH. SN 85-034,581. PUB. 10-5-2010, FILED 5-10-2010.

VOODOO

THE MARK CONSISTS OF STANDARD CHARACTERS WITHOUT CLAIM TO ANY PARTICULAR FONT, STYLE, SIZE, OR COLOR.

FOR AIR-CUSHION VEHICLES (U.S. CLS. 19, 21, 23, 31, 35 AND 44).

FIRST USE 5-10-2010; IN COMMERCE 1-1-2012.

4,210,390. AMERICAN OMNI TRADING COMPANY, HOUSTON, TX. SN 77-848,478. PUB. 3-23-2010, FILED 10-14-2009.

OMNI

THE MARK CONSISTS OF STANDARD CHARACTERS WITHOUT CLAIM TO ANY PARTICULAR FONT, STYLE, SIZE, OR COLOR.

OWNER OF U.S. REG. NO. 1,121,800.

FOR TIRES (U.S. CLS. 19, 21, 23, 31, 35 AND 44).

FIRST USE 7-13-2012; IN COMMERCE 7-13-2012.

4,210,651. OBX BOATWORKS LLC, DBA OBX BOATWORKS, HIGH POINT, NC. SN 85-145,848. PUB. 4-5-2011, FILED 10-5-2010.

OBX Boatworks

THE MARK CONSISTS OF STANDARD CHARACTERS WITHOUT CLAIM TO ANY PARTICULAR FONT, STYLE, SIZE, OR COLOR.

NO CLAIM IS MADE TO THE EXCLUSIVE RIGHT TO USE "BOATWORKS", APART FROM THE MARK AS SHOWN.

FOR BOAT HULLS; BOATS AND STRUCTURAL PARTS THEREFOR; FISHING BOATS (U.S. CLS. 19, 21, 23, 31, 35 AND 44).

FIRST USE 1-1-2011; IN COMMERCE 1-15-2012.

CLASS 12—(Continued).

4,210,814. SUN NATION CORP, POMPANO BEACH, FL. SN 85-220,871. PUB. 5-31-2011, FILED 1-19-2011.

MotorKing

THE MARK CONSISTS OF STANDARD CHARACTERS WITHOUT CLAIM TO ANY PARTICULAR FONT, STYLE, SIZE, OR COLOR.

FOR AIR SUSPENSION VALVES FOR CONTROLLING SUSPENSION HEIGHT FOR VEHICLES; AUTOMOBILE DOOR HANDLES; AUTOMOBILE SUSPENSION DEVICES, NAMELY, COILOVERS; AUTOMOBILE SUSPENSION SYSTEM COMPONENTS, NAMELY, SPRING PERCHES; AUTOMOTIVE ENGINE MOUNTS; AUTOMOTIVE PARTS, NAMELY, TRANSMISSION SEALS; LAND VEHICLE PARTS, NAMELY, TRANSMISSIONS; LAND VEHICLE SUSPENSION PARTS, NAMELY, COIL SPRINGS; LAND VEHICLE SUSPENSION PARTS, NAMELY, EQUALIZERS; LAND VEHICLE SUSPENSION PARTS, NAMELY, LEAF SPRINGS; LAND VEHICLE SUSPENSION PARTS, NAMELY, TORSION/SWAY BARS; REAR VIEW MIRRORS; REARVIEW MIRRORS; SUSPENSION ARMS FOR CABLE CARS; SUSPENSION SPRINGS FOR MOTOR CARS; SUSPENSION SYSTEMS FOR AUTOMOBILES; VEHICLE PARTS, NAMELY, SUSPENSION STRUTS; VEHICLE PARTS, NAMELY, REARVIEW MIRRORS; VEHICLE SIDE VIEW MIRROR COVER (U.S. CLS. 19, 21, 23, 31, 35 AND 44).
FIRST USE 1-19-2011; IN COMMERCE 2-1-2011.

4,210,845. KARSTEN MANUFACTURING CORPORATION, PHOENIX, AZ. SN 85-238,732. PUB. 5-24-2011, FILED 2-10-2011.

PLAY YOUR BEST

THE MARK CONSISTS OF STANDARD CHARACTERS WITHOUT CLAIM TO ANY PARTICULAR FONT, STYLE, SIZE, OR COLOR.

OWNER OF U.S. REG. NOS. 2,476,383, 2,853,525, AND 3,268,236.
FOR LICENSE PLATE FRAMES (U.S. CLS. 19, 21, 23, 31, 35 AND 44).
FIRST USE 7-17-2012; IN COMMERCE 7-17-2012.

CLASS 12—(Continued).

4,210,855. OMNI UNITED (S) PTE LTD, SINGAPORE 048616, SINGAPORE. SN 85-240,472. PUB. 6-21-2011, FILED 2-11-2011.

ARGONITE

THE MARK CONSISTS OF STANDARD CHARACTERS WITHOUT CLAIM TO ANY PARTICULAR FONT, STYLE, SIZE, OR COLOR.

FOR TRUCK AND BUS RADIAL TIRES AND INNER TUBES; LIGHT TRUCK RADIAL TIRES AND INNER TUBES; PASSENGER CAR RADIAL TIRES AND INNER TUBES; RADIAL TIRES AND INNER TUBES FOR OFF-ROAD VEHICLES (U.S. CLS. 19, 21, 23, 31, 35 AND 44).
FIRST USE 2-27-2012; IN COMMERCE 2-27-2012.

4,210,863. HOWARD BERREY, PUNTA GORDA, FL. SN 85-242,797. PUB. 6-21-2011, FILED 2-15-2011.

STOR N BOAT

THE MARK CONSISTS OF STANDARD CHARACTERS WITHOUT CLAIM TO ANY PARTICULAR FONT, STYLE, SIZE, OR COLOR.

NO CLAIM IS MADE TO THE EXCLUSIVE RIGHT TO USE "BOAT", APART FROM THE MARK AS SHOWN.
FOR BOATS AND STRUCTURAL PARTS THEREFOR; ROOF RACK STORAGE CONTAINERS FOR LAND VEHICLES (U.S. CLS. 19, 21, 23, 31, 35 AND 44).
FIRST USE 2-15-2011; IN COMMERCE 7-6-2012.

4,210,926. JOINT RESOURCES, INC., GLENDALE HEIGHTS, IL. SN 85-278,812. PUB. 3-27-2012, FILED 3-28-2011.



THE COLOR(S) BLACK, RED AND WHITE IS/ARE CLAIMED AS A FEATURE OF THE MARK.

THE MARK CONSISTS OF THE STYLIZED WORDS "I TOW" IN BLACK WITH A RED DOT IN THE LETTER "I" ENCIRCLED IN A BLACK CIRCLE, ALL OF THE ABOVE ON A WHITE BACKGROUND.

FOR AUTOMOTIVE TOW HITCHES AND ACCESSORIES, NAMELY, BALL MOUNTS, TRAILER COUPLINGS, HITCH PINS FOR TRAILER HITCHES AND METAL LOCKING DEVICES FOR TRAILER HITCH COUPLERS; TRAILERS AND PARTS THEREFOR (U.S. CLS. 19, 21, 23, 31, 35 AND 44).
FIRST USE 5-31-2012; IN COMMERCE 5-31-2012.

CLASS 12—(Continued).

4,211,200. NIRVE SPORTS, LTD., HUNTINGTON BEACH, CA. SN 85-352,775. PUB. 11-15-2011, FILED 6-22-2011.

BROOKHURST

THE MARK CONSISTS OF STANDARD CHARACTERS WITHOUT CLAIM TO ANY PARTICULAR FONT, STYLE, SIZE, OR COLOR.
FOR BICYCLES AND BICYCLE STRUCTURAL PARTS (U.S. CLS. 19, 21, 23, 31, 35 AND 44).
FIRST USE 8-15-2008; IN COMMERCE 8-15-2008.

4,211,202. NIRVE SPORTS, LTD., HUNTINGTON BEACH, CA. SN 85-352,878. PUB. 11-15-2011, FILED 6-22-2011.

WILSHIRE

THE MARK CONSISTS OF STANDARD CHARACTERS WITHOUT CLAIM TO ANY PARTICULAR FONT, STYLE, SIZE, OR COLOR.
FOR BICYCLES AND BICYCLE STRUCTURAL PARTS (U.S. CLS. 19, 21, 23, 31, 35 AND 44).
FIRST USE 8-15-2008; IN COMMERCE 8-15-2008.

4,211,343. KANEI, INC., DBA ACE ALLOY WHEELS, CHINO, CA. SN 85-376,265. PUB. 12-20-2011, FILED 7-20-2011.

AMF

THE MARK CONSISTS OF STANDARD CHARACTERS WITHOUT CLAIM TO ANY PARTICULAR FONT, STYLE, SIZE, OR COLOR.
FOR WHEELS FOR AUTOMOBILES (U.S. CLS. 19, 21, 23, 31, 35 AND 44).
FIRST USE 9-30-2011; IN COMMERCE 9-30-2011.

CLASS 12—(Continued).

4,211,427. AMERICAN SEATING COMPANY, GRAND RAPIDS, MI. SN 85-404,856. PUB. 11-8-2011, FILED 8-23-2011.

RELIANT

THE MARK CONSISTS OF STANDARD CHARACTERS WITHOUT CLAIM TO ANY PARTICULAR FONT, STYLE, SIZE, OR COLOR.
FOR SAFETY RESTRAINTS FOR SECURING WHEELCHAIRS AND WHEELCHAIR PASSENGERS IN BUSES, MOTOR COACHES, TRAINS, TRANSITS, AND SHUTTLES (U.S. CLS. 19, 21, 23, 31, 35 AND 44).
FIRST USE 5-8-2012; IN COMMERCE 5-8-2012.

4,211,445. DYNACRAFT BSC, INC., AMERICAN CANYON, CA. SN 85-410,718. PUB. 2-14-2012, FILED 8-30-2011.

DOROTHY

THE MARK CONSISTS OF STANDARD CHARACTERS WITHOUT CLAIM TO ANY PARTICULAR FONT, STYLE, SIZE, OR COLOR.
FOR BICYCLES (U.S. CLS. 19, 21, 23, 31, 35 AND 44).
FIRST USE 10-0-2011; IN COMMERCE 10-0-2011.

4,211,448. DOUBLECROSS BIKES, LLC, PIEDMONT, OK. SN 85-411,306. PUB. 2-14-2012, FILED 8-31-2011.

DOUBLECROSS

THE MARK CONSISTS OF STANDARD CHARACTERS WITHOUT CLAIM TO ANY PARTICULAR FONT, STYLE, SIZE, OR COLOR.
FOR BICYCLE FRAMES; BICYCLE PARTS, NAMELY, TUBES AND CONNECTORS FOR BICYCLE FRAMES (U.S. CLS. 19, 21, 23, 31, 35 AND 44).
FIRST USE 11-25-2011; IN COMMERCE 11-25-2011.

CLASS 12—(Continued).

4,211,454. HEARTLAND RECREATIONAL VEHICLES, LLC, ELKART, IN. SN 85-414,556. PUB. 3-13-2012, FILED 9-2-2011.

LYNX

THE MARK CONSISTS OF STANDARD CHARACTERS WITHOUT CLAIM TO ANY PARTICULAR FONT, STYLE, SIZE, OR COLOR.
FOR RECREATIONAL VEHICLES, NAMELY, TRAVEL TRAILERS (U.S. CLS. 19, 21, 23, 31, 35 AND 44).
FIRST USE 0-0-2011; IN COMMERCE 0-0-2011.

CLASS 13—FIREARMS

4,210,397. MIDWAY ARMS, INC., COLUMBIA, MO. SN 77-863,292. PUB. 10-26-2010, FILED 11-2-2009.

NEARLY-PERFECT

THE MARK CONSISTS OF STANDARD CHARACTERS WITHOUT CLAIM TO ANY PARTICULAR FONT, STYLE, SIZE, OR COLOR.
FOR FIREARMS, INCLUDING RIFLES (U.S. CLS. 2 AND 9).
FIRST USE 1-31-2010; IN COMMERCE 1-20-2012.

4,211,118. TRUGLO, INC., RICHARDSON, TX. SN 85-343,141. PUB. 10-25-2011, FILED 6-10-2011.

SMACKDOWN

THE MARK CONSISTS OF STANDARD CHARACTERS WITHOUT CLAIM TO ANY PARTICULAR FONT, STYLE, SIZE, OR COLOR.
FOR GUN CHOKES (U.S. CLS. 2 AND 9).
FIRST USE 12-12-2011; IN COMMERCE 12-12-2011.

CLASS 13—(Continued).

4,211,318. DYNNO NOBEL INC., SALT LAKE CITY, UT. SN 85-372,675. PUB. 12-6-2011, FILED 7-15-2011.

TROJAN SPARTAN

THE MARK CONSISTS OF STANDARD CHARACTERS WITHOUT CLAIM TO ANY PARTICULAR FONT, STYLE, SIZE, OR COLOR.
OWNER OF U.S. REG. NOS. 2,204,841 AND 2,266,902.
FOR EXPLOSIVES (U.S. CLS. 2 AND 9).
FIRST USE 11-14-2011; IN COMMERCE 11-14-2011.

4,211,323. SELLIER & BELLOT J.S.C., 258 13 VLASIM, CZECH REPUBLIC. SN 85-373,694. PUB. 12-13-2011, FILED 7-18-2011.

WILD WEST

THE MARK CONSISTS OF STANDARD CHARACTERS WITHOUT CLAIM TO ANY PARTICULAR FONT, STYLE, SIZE, OR COLOR.
FOR AMMUNITION (U.S. CLS. 2 AND 9).
FIRST USE 6-29-2011; IN COMMERCE 8-5-2011.

4,211,541. ROCK RIVER ARMS, INC., COLONA, IL. SN 85-455,256. PUB. 4-3-2012, FILED 10-25-2011.

HOG HUNTER

THE MARK CONSISTS OF STANDARD CHARACTERS WITHOUT CLAIM TO ANY PARTICULAR FONT, STYLE, SIZE, OR COLOR.
NO CLAIM IS MADE TO THE EXCLUSIVE RIGHT TO USE "HUNTER", APART FROM THE MARK AS SHOWN.
FOR FIREARMS, NAMELY, RIFLES AND PISTOLS AND SPARE PARTS AND REPLACEMENT PARTS FOR RIFLES AND PISTOLS (U.S. CLS. 2 AND 9).
FIRST USE 11-0-2011; IN COMMERCE 11-0-2011.

CLASS 14—JEWELRY

CLASS 14—(Continued).

4,210,250. SWISS LUXURY BRANDS LLC, LONG ISLAND CITY, NY. SN 77-203,908. PUB. 9-13-2011, FILED 6-12-2007.

STALLION

THE MARK CONSISTS OF STANDARD CHARACTERS WITHOUT CLAIM TO ANY PARTICULAR FONT, STYLE, SIZE, OR COLOR.

FOR WATCHES (U.S. CLS. 2, 27, 28 AND 50).
FIRST USE 6-30-2007; IN COMMERCE 6-30-2007.



4,210,320. HIGHLIGHTS FOR CHILDREN, INC., COLUMBUS, OH. SN 77-622,722. PUB. 4-7-2009, FILED 11-26-2008.

HIGHLIGHTS

THE MARK CONSISTS OF STANDARD CHARACTERS WITHOUT CLAIM TO ANY PARTICULAR FONT, STYLE, SIZE, OR COLOR.

FOR CHARMS; KEY CHAINS OF PRECIOUS METAL (U.S. CLS. 2, 27, 28 AND 50).
FIRST USE 7-0-2011; IN COMMERCE 7-0-2011.



4,210,348. MARELJ, JELISAVETA, OAKVILLE, ON, CANADA. SN 77-677,241. PUB. 6-23-2009, FILED 2-24-2009.



THE MARK CONSISTS OF A MISCELLANEOUS DESIGN. FOR JEWELRY, NAMELY, NECKLACES, EARRINGS, BRACELETS, BROACHES, PENDANTS, AND RINGS (U.S. CLS. 2, 27, 28 AND 50).
FIRST USE 12-31-2010; IN COMMERCE 12-31-2011.

CLASS 14—(Continued).

4,210,400. SALES & PRODUCT SOLUTIONS, INC., NORTH-BROOK, IL. SN 77-868,546. PUB. 4-13-2010, FILED 11-9-2009.

SNAPRODUCTS

THE MARK CONSISTS OF STANDARD CHARACTERS WITHOUT CLAIM TO ANY PARTICULAR FONT, STYLE, SIZE, OR COLOR.

FOR COSTUME JEWELRY (U.S. CLS. 2, 27, 28 AND 50).
FIRST USE 8-0-2008; IN COMMERCE 8-0-2008.



4,210,409. GDP IMPORTS, LLC, DESTIN, FL. SN 77-879,855. PUB. 4-20-2010, FILED 11-24-2009.

WATCHDOG

THE MARK CONSISTS OF STANDARD CHARACTERS WITHOUT CLAIM TO ANY PARTICULAR FONT, STYLE, SIZE, OR COLOR.

FOR WATCHES (U.S. CLS. 2, 27, 28 AND 50).
FIRST USE 7-2-2012; IN COMMERCE 7-2-2012.



4,210,422. GDP IMPORTS, LLC, DESTIN, FL. SN 77-901,044. PUB. 6-1-2010, FILED 12-26-2009.

Weather Watch

THE MARK CONSISTS OF STANDARD CHARACTERS WITHOUT CLAIM TO ANY PARTICULAR FONT, STYLE, SIZE, OR COLOR.

NO CLAIM IS MADE TO THE EXCLUSIVE RIGHT TO USE "WATCH", APART FROM THE MARK AS SHOWN. FOR CLOCKS AND WATCHES (U.S. CLS. 2, 27, 28 AND 50).
FIRST USE 7-2-2012; IN COMMERCE 7-2-2012.

CLASS 14—(Continued).

4,210,628. ADVANCE WATCH COMPANY LTD., NEW YORK, NY. SN 85-116,591. PUB. 2-8-2011, FILED 8-26-2010.

JULES + JAMES

THE MARK CONSISTS OF STANDARD CHARACTERS WITHOUT CLAIM TO ANY PARTICULAR FONT, STYLE, SIZE, OR COLOR.

FOR WATCHES (U.S. CLS. 2, 27, 28 AND 50).
FIRST USE 10-25-2010; IN COMMERCE 10-25-2010.

CLASS 14—(Continued).

4,210,786. SAMUEL AARON, INC., LONG ISLAND CITY, NY. SN 85-212,981. PUB. 5-3-2011, FILED 1-7-2011.

ROCK N' ICE

THE MARK CONSISTS OF STANDARD CHARACTERS WITHOUT CLAIM TO ANY PARTICULAR FONT, STYLE, SIZE, OR COLOR.

FOR JEWELRY (U.S. CLS. 2, 27, 28 AND 50).
FIRST USE 9-0-2011; IN COMMERCE 9-0-2011.

4,210,637. ROCKIN' BELLES, LLC, DENTON, TX. SN 85-125,667. PUB. 6-21-2011, FILED 9-9-2010.



THE MARK CONSISTS OF THE STYLIZED TEXT "JUJU-BELLE" WITH A BIRDCAGE. ON TOP OF THE LETTER "U" THERE IS A BIRD.

FOR JEWELRY (U.S. CLS. 2, 27, 28 AND 50).
FIRST USE 9-16-2011; IN COMMERCE 9-16-2011.

4,210,824. NEW YORK YANKEES PARTNERSHIP, BRONX, NY. SN 85-226,491. PUB. 12-20-2011, FILED 1-26-2011.

YANKEES UNIVERSE

THE MARK CONSISTS OF STANDARD CHARACTERS WITHOUT CLAIM TO ANY PARTICULAR FONT, STYLE, SIZE, OR COLOR.

OWNER OF U.S. REG. NOS. 1,032,767, 3,326,224, AND OTHERS.

FOR JEWELRY, NAMELY, BRACELETS, COSTUME JEWELRY, RUBBER AND SILICONE BRACELETS; RUBBER AND SILICONE WRISTBANDS IN THE NATURE OF BRACELETS (U.S. CLS. 2, 27, 28 AND 50).
FIRST USE 12-7-2011; IN COMMERCE 12-7-2011.

4,210,759. SCOTT KAY, INC., TEANECK, NJ. SN 85-204,957. PUB. 10-25-2011, FILED 12-23-2010.

SCOTT KAY GUARDIAN

THE MARK CONSISTS OF STANDARD CHARACTERS WITHOUT CLAIM TO ANY PARTICULAR FONT, STYLE, SIZE, OR COLOR.

OWNER OF U.S. REG. NOS. 2,827,785 AND 3,060,827.

THE NAME(S), PORTRAIT(S), AND/OR SIGNATURE(S) SHOWN IN THE MARK IDENTIFIES "SCOTT KAY", WHOSE CONSENT(S) TO REGISTER IS MADE OF RECORD.

FOR JEWELRY (U.S. CLS. 2, 27, 28 AND 50).
FIRST USE 11-0-2008; IN COMMERCE 11-0-2008.

4,211,052. EASEPAL ENTERPRISES LTD, FUJIAN PROVINCE, CHINA. SN 85-333,310. PUB. 10-25-2011, FILED 5-30-2011.



THE MARK CONSISTS OF THE STYLIZED WORD "KNINK" ON THE LEFT, AND TWO CHINESE CHARACTERS WHICH TRANSLITERATE INTO YIN KE ON THE RIGHT.

THE WORDING "KNINK" HAS NO MEANING IN A FOREIGN LANGUAGE.

CLASS 14—(Continued).

THE NON-LATIN CHARACTERS IN THE MARK TRANSLITERATE TO YIN; KE AND THIS MEANS STAMP; GUEST IN ENGLISH.

FOR ALARM CLOCKS; CLOCKS; INGOTS OF PRECIOUS METAL; JADE; JEWELLERY; KEY RINGS OF PRECIOUS METAL; ORNAMENTS OF PRECIOUS METAL IN THE NATURE OF JEWELRY; WATCHES; WORKS OF ART OF PRECIOUS METAL; WRISTWATCHES (U.S. CLS. 2, 27, 28 AND 50).

FIRST USE 2-1-2010; IN COMMERCE 9-1-2010.

4,211,163. BDSRSCO, INC., BRADENTON, FL. SN 85-348,012.
PUB. 11-29-2011, FILED 6-16-2011.

IZARO

THE MARK CONSISTS OF STANDARD CHARACTERS WITHOUT CLAIM TO ANY PARTICULAR FONT, STYLE, SIZE, OR COLOR.

OWNER OF U.S. REG. NO. 3,895,097.
FOR JEWELRY (U.S. CLS. 2, 27, 28 AND 50).
FIRST USE 10-1-2011; IN COMMERCE 10-1-2011.

4,211,259. KOBİ KATZ, INC., LOS ANGELES, CA. SN 85-359,974. PUB. 12-27-2011, FILED 6-29-2011.

NITEZ N DAZE

THE MARK CONSISTS OF STANDARD CHARACTERS WITHOUT CLAIM TO ANY PARTICULAR FONT, STYLE, SIZE, OR COLOR.

FOR JEWELRY (U.S. CLS. 2, 27, 28 AND 50).
FIRST USE 1-3-2012; IN COMMERCE 1-3-2012.

CLASS 14—(Continued).

4,211,361. CRUISE COINS, LLC, SARASOTA, FL. SN 85-382,274. PUB. 1-17-2012, FILED 7-27-2011.



NO CLAIM IS MADE TO THE EXCLUSIVE RIGHT TO USE "CRUISE COINS", APART FROM THE MARK AS SHOWN.

THE MARK CONSISTS OF A STYLIZED IMAGE OF A SHIP IN MOTION WITHIN A CIRCLE ALL APPEARING ABOVE THE WORDS "CRUISE COINS" IS STYLIZED SCRIPT.

FOR COLLECTIBLE COMMEMORATIVE COINS WITH NO MONETARY VALUE (U.S. CLS. 2, 27, 28 AND 50).

FIRST USE 7-7-2012; IN COMMERCE 7-7-2012.

4,211,422. STRAUSS MARKETING, INC., ENGLEWOOD, NJ. SN 85-402,577. PUB. 11-29-2011, FILED 8-19-2011.

Emma Skye

THE MARK CONSISTS OF STANDARD CHARACTERS WITHOUT CLAIM TO ANY PARTICULAR FONT, STYLE, SIZE, OR COLOR.

THE NAME SHOWN IN THE MARK IDENTIFIES A LIVING INDIVIDUAL WHOSE CONSENT TO REGISTER IS MADE OF RECORD.

FOR JEWELRY (U.S. CLS. 2, 27, 28 AND 50).
FIRST USE 11-22-2011; IN COMMERCE 11-22-2011.

CLASS 14—(Continued).

4,211,424. ULTIMATE SPARKLE, INC., THE, LAFAYETTE, CA. SN 85-403,583. PUB. 1-17-2012, FILED 8-22-2011.

THE ULTIMATE SPARKLE

THE MARK CONSISTS OF STANDARD CHARACTERS WITHOUT CLAIM TO ANY PARTICULAR FONT, STYLE, SIZE, OR COLOR.
FOR JEWELRY (U.S. CLS. 2, 27, 28 AND 50).
FIRST USE 6-11-2011; IN COMMERCE 6-11-2011.



4,211,425. AEGEAN BLUE, INC., NORTH PALM BEACH, FL. SN 85-403,609. PUB. 12-6-2011, FILED 8-22-2011.



THE COLOR(S) BLACK AND BLUE AND SILVER IS/ARE CLAIMED AS A FEATURE OF THE MARK.
THE MARK CONSISTS OF A BLACK CURSIVE STYLE LETTER "A" WITH A BLUE GEMSTONE AND THREE SILVER LINES EXTENDING OUT FROM THE BLUE GEMSTONE TO DENOTE A SPARKLE EMITTING FROM THE BLUE GEMSTONE.
FOR JEWELRY (U.S. CLS. 2, 27, 28 AND 50).
FIRST USE 5-18-2012; IN COMMERCE 5-18-2012.



4,211,435. AIRPLANE WATCH CORP., NEW YORK, NY. SN 85-407,220. PUB. 2-7-2012, FILED 8-25-2011.

ACCUTIME

THE MARK CONSISTS OF STANDARD CHARACTERS WITHOUT CLAIM TO ANY PARTICULAR FONT, STYLE, SIZE, OR COLOR.
FOR WATCHES AND CLOCKS (U.S. CLS. 2, 27, 28 AND 50).
FIRST USE 6-1-2005; IN COMMERCE 6-1-2005.

CLASS 14—(Continued).

4,211,468. ROMANCE & CO., INC., REGO PARK, NY. SN 85-418,552. PUB. 5-1-2012, FILED 9-9-2011.



NO CLAIM IS MADE TO THE EXCLUSIVE RIGHT TO USE "CO.", APART FROM THE MARK AS SHOWN.
THE MARK CONSISTS OF THE STYLIZED WORDING "R & CO. ROMANCE & CO."
FOR JEWELRY (U.S. CLS. 2, 27, 28 AND 50).
FIRST USE 7-20-2010; IN COMMERCE 7-20-2010.



4,211,497. CROREY, DAVID J., CLINTON TOWNSHIP, MI. SN 85-436,543. PUB. 4-24-2012, FILED 9-30-2011.

MY IMAGE BRACELET MAKER

THE MARK CONSISTS OF STANDARD CHARACTERS WITHOUT CLAIM TO ANY PARTICULAR FONT, STYLE, SIZE, OR COLOR.
OWNER OF U.S. REG. NOS. 3,785,767 AND 4,061,456.
NO CLAIM IS MADE TO THE EXCLUSIVE RIGHT TO USE "IMAGE BRACELET MAKER", APART FROM THE MARK AS SHOWN.
FOR JEWELRY MAKING KITS (U.S. CLS. 2, 27, 28 AND 50).
FIRST USE 6-25-2011; IN COMMERCE 6-25-2012.



4,211,508. BUCKLEY, WILLIAM L, TOKYO, JAPAN. SN 85-441,951. PUB. 3-20-2012, FILED 10-7-2011.

WILLIAM BUCKLEY

THE MARK CONSISTS OF STANDARD CHARACTERS WITHOUT CLAIM TO ANY PARTICULAR FONT, STYLE, SIZE, OR COLOR.

CLASS 14—(Continued).

THE NAME(S), PORTRAIT(S), AND/OR SIGNATURE(S) SHOWN IN THE MARK IDENTIFIES "WILLIAM L BUCKLEY", WHOSE CONSENT(S) TO REGISTER IS MADE OF RECORD.

FOR BRACELETS; BROACHES; BROOCHES; CHARMS; CHARMS FOR COLLAR JEWELRY AND BRACELET; COSTUME JEWELRY; DIAMOND JEWELRY; GEMSTONE JEWELRY; JEWELRY; JEWELRY AND IMITATION JEWELRY; JEWELRY BOXES; JEWELRY BROOCHES; JEWELRY CASES; JEWELRY CHAINS; JEWELRY FOR ATTACHMENT TO CLOTHING; JEWELRY FOR THE HEAD; JEWELRY, NAMELY, STONE PENDANTS; PRECIOUS AND SEMI-PRECIOUS CRYSTAL STONES AND BEADS FOR USE IN JEWELRY; RINGS; WATCHES AND JEWELRY; WOMEN'S JEWELRY (U.S. CLS. 2, 27, 28 AND 50).

FIRST USE 6-18-2012; IN COMMERCE 6-18-2012.

CLASS 14—(Continued).

4,211,579. INVICTA WATCH COMPANY OF AMERICA, INC., HOLLYWOOD, FL. SN 85-475,334. PUB. 5-1-2012, FILED 11-17-2011.

SEABASE

THE MARK CONSISTS OF STANDARD CHARACTERS WITHOUT CLAIM TO ANY PARTICULAR FONT, STYLE, SIZE, OR COLOR.

FOR WATCHES (U.S. CLS. 2, 27, 28 AND 50).
FIRST USE 4-5-2012; IN COMMERCE 4-5-2012.

4,211,518. SOERGEL, RICH C., SAN DIEGO, CA. SN 85-446,634. PUB. 4-3-2012, FILED 10-13-2011.

UZAPPIT

4,211,635. FAIR TRADE JEWELLERY COMPANY LTD., TORONTO, ONTARIO, CANADA. SN 85-498,157. PUB. 5-22-2012, FILED 12-17-2011.

THE MARK CONSISTS OF STANDARD CHARACTERS WITHOUT CLAIM TO ANY PARTICULAR FONT, STYLE, SIZE, OR COLOR.

FOR JEWELRY, NAMELY, DOG TAGS FOR WEAR BY HUMANS FOR DECORATIVE PURPOSES, KEY CHAINS AS JEWELRY, NAMELY, KEY FOBS AND NECKLACES WITH A QUICK RESPONSE CODE ENGRAVED OR PRINTED ON THEM THAT WHEN SCANNED WILL DIRECT THE SCANNED CODE TO A DEFINED FUNCTION OR SITE ON THE INTERNET (U.S. CLS. 2, 27, 28 AND 50).

FIRST USE 2-22-2012; IN COMMERCE 2-27-2012.



4,211,548. MARCO POLO DESIGNS, PORTLAND, OR. SN 85-459,624. PUB. 4-10-2012, FILED 10-29-2011.

FOR THE WOMAN WHO KNOWS

THE MARK CONSISTS OF PEACOCK LOOKING OVER ITS BACK WITH FOUR TAIL FEATHERS ON THE RIGHT SIDE.

FOR JEWELRY, DIAMONDS AND GEMS OBTAINED FROM, AND MANUFACTURED WITH, ECOLOGICALLY FRIENDLY METHODS AND SOURCES; RECYCLED PRECIOUS METALS AND PRECIOUS METAL ALLOYS (U.S. CLS. 2, 27, 28 AND 50).

FIRST USE 2-11-2011; IN COMMERCE 2-11-2011.

THE MARK CONSISTS OF STANDARD CHARACTERS WITHOUT CLAIM TO ANY PARTICULAR FONT, STYLE, SIZE, OR COLOR.

FOR JEWELRY (U.S. CLS. 2, 27, 28 AND 50).
FIRST USE 10-25-2011; IN COMMERCE 3-1-2012.

CLASS 15—MUSICAL INSTRUMENTS

CLASS 15—(Continued).

4,210,904. RAJAH MUSICAL INSTRUMENTS CO., LTD.,
TAIPEI, TAIWAN. SN 85-262,226. PUB. 11-29-2011, FILED
3-9-2011.



THE MARK CONSISTS OF STYLIZED WRITING OF
WORD "WENCHIA" WITH THE ENDING OF LETTER "A"
CONNECTED TO LETTER "W".

FOR MUSIC INSTRUMENTS, NAMELY, WOOD WIND
AND BRASS WIND INSTRUMENTS AND ALL PARTS
AND ACCESSORIES THEREFOR, NAMELY, REEDS
FOR USE IN WOODWIND MOUTHPIECES; WIND IN-
STRUMENTS, NAMELY, FLUTES, SAXOPHONES, SO-
PRANOS, ALTOS, BASSES, CLARINETS, OBOES, REED
WIND INSTRUMENTS, AND BASSOONS; OBOE BAR-
REL; OBOE BELL; CLARINET BARREL; CLARINET
BELL (U.S. CLS. 2, 21 AND 36).

FIRST USE 5-10-2002; IN COMMERCE 7-15-2004.

CLASS 16—(Continued).

4,210,279. CORTES, MARTHA, NEW YORK, NY. SN 77-
479,076. PUB. 4-28-2009, FILED 5-20-2008.

Your Smile Your Health

THE MARK CONSISTS OF STANDARD CHARACTERS
WITHOUT CLAIM TO ANY PARTICULAR FONT, STYLE,
SIZE, OR COLOR.

FOR BOOKS IN THE FIELD OF DENTIST SERVICES,
NAMELY, COSMETIC, ESTHETIC, LASER, PERIODON-
TAL, ENDODONTIC, NEUROMUSCULAR, SURGICAL,
NATURAL, HOLISTIC AND ALTERNATIVE DENTIS-
TRY (U.S. CLS. 2, 5, 22, 23, 29, 37, 38 AND 50).

FIRST USE 6-20-2012; IN COMMERCE 6-20-2012.

**CLASS 16—PAPER GOODS AND PRINTED
MATTER**

4,210,246. PENTEL OF AMERICA, LTD., TORRANCE, CA.
SN 76-709,570. PUB. 3-27-2012, FILED 10-28-2011.



FOR WRITING INSTRUMENTS (U.S. CLS. 2, 5, 22, 23,
29, 37, 38 AND 50).
FIRST USE 7-0-2011; IN COMMERCE 3-0-2012.

4,210,354. WASHBURN UNIVERSITY, TOPEKA, KS. SN 77-
707,553. PUB. 9-22-2009, FILED 4-6-2009.



THE MARK CONSISTS OF THE LETTER "W" WITH
"WASHBURN" WRITTEN ACROSS THE "W".

FOR DECALS, BUMPER STICKERS, NOTEBOOKS,
BINDERS, WRITING PADS, WRITING PAD HOLDERS,
PENS, PENCILS, STATIONERY FOLDERS, PLANNING
AND APPOINTMENT BOOKS, WRITING PAPER, EN-
VELOPES, AND ACADEMIC AND ENTERTAINMENT
PUBLICATIONS, NAMELY, EVENT PROGRAMS, AND
BROCHURES, CATALOGS, PAMPHLETS, AND YEAR-
BOOKS ALL IN THE FIELD OF EDUCATION, SPORTS
AND THEATRE, POSTCARDS (U.S. CLS. 2, 5, 22, 23, 29,
37, 38 AND 50).

FIRST USE 12-0-2010; IN COMMERCE 12-0-2010.

CLASS 16—(Continued).

4,210,355. ARCHIE COMIC PUBLICATIONS, INC., MARONECK, NY. SN 77-714,347. PUB. 5-11-2010, FILED 4-15-2009.

BETTY AND ME

THE MARK CONSISTS OF STANDARD CHARACTERS WITHOUT CLAIM TO ANY PARTICULAR FONT, STYLE, SIZE, OR COLOR.

FOR COMIC MAGAZINE (U.S. CLS. 2, 5, 22, 23, 29, 37, 38 AND 50).
FIRST USE 8-1-1965; IN COMMERCE 5-1-2012.

4,210,368. MCGUIGAN, ANTHONY, SEBASTOPOL, CA. SN 77-757,882. PUB. 10-27-2009, FILED 6-11-2009.

SPORE LORE

THE MARK CONSISTS OF STANDARD CHARACTERS WITHOUT CLAIM TO ANY PARTICULAR FONT, STYLE, SIZE, OR COLOR.

FOR BOOKS IN THE FIELD OF LANDSCAPING DESIGN AND ANIMAL HABITATS (U.S. CLS. 2, 5, 22, 23, 29, 37, 38 AND 50).

FIRST USE 7-6-2012; IN COMMERCE 7-6-2012.

4,210,427. AHOLD LICENSING SARL, GENEVA, SWITZERLAND. SN 77-910,121. PUB. 11-2-2010, FILED 1-12-2010.

SMART LIVING

THE MARK CONSISTS OF STANDARD CHARACTERS WITHOUT CLAIM TO ANY PARTICULAR FONT, STYLE, SIZE, OR COLOR.

CLASS 16—(Continued).

OWNER OF U.S. REG. NO. 3,228,459.

FOR ADHESIVE TAPES FOR STATIONERY OR HOUSEHOLD PURPOSES; DISPENSERS FOR ADHESIVE TAPES FOR STATIONERY PURPOSES; ADHESIVE NOTE PAPER; CORRECTING TAPE FOR TYPE; CORRECTION FLUID FOR DOCUMENTS; ENVELOPES; PENS; PENCILS; GIFT BAGS; GIFT WRAP PAPER; PAPER GIFT WRAP BOWS; TISSUE PAPER; HIGHLIGHTER PENS; MARKERS; WRITING GRIPS; ERASERS; PENCIL SHARPENERS; PENCIL BOXES; GLUE STICKS FOR STATIONERY OR HOUSEHOLD USE; CLIP BOARDS; PAPER HOLE PUNCHES; STAPLES; PAPER STAPLERS; RUBBER BANDS; PUSH PINS; PAPER CLIPS; BINDER CLIPS; PRESENTATION FOLDERS; PAPER REPORT COVERS; INDEX CARDS; NOTEBOOKS; LEGAL PADS; MEMO PADS; WRITING PAPER; PAPER LABELS (U.S. CLS. 2, 5, 22, 23, 29, 37, 38 AND 50).
FIRST USE 11-28-2010; IN COMMERCE 11-28-2010.

4,210,428. MEAD PRODUCTS LLC, DAYTON, OH. SN 77-910,293. PUB. 5-25-2010, FILED 1-12-2010.

ACT RESPONSIBLY

THE MARK CONSISTS OF STANDARD CHARACTERS WITHOUT CLAIM TO ANY PARTICULAR FONT, STYLE, SIZE, OR COLOR.

FOR NOTEBOOKS, BINDERS, STATIONERY-TYPE PORTFOLIOS, PAPER EXPANDING FILES, WRITING PAPER, DAILY PLANNERS, WALL AND DESK CALENDARS, PERSONAL ORGANIZERS (U.S. CLS. 2, 5, 22, 23, 29, 37, 38 AND 50).

FIRST USE 7-0-2010; IN COMMERCE 7-0-2010.

4,210,430. MEREDITH CORPORATION, DES MOINES, IA. SN 77-910,961. PUB. 4-20-2010, FILED 1-13-2010.

BHGRE COMMERCIAL

THE MARK CONSISTS OF STANDARD CHARACTERS WITHOUT CLAIM TO ANY PARTICULAR FONT, STYLE, SIZE, OR COLOR.

NO CLAIM IS MADE TO THE EXCLUSIVE RIGHT TO USE "COMMERCIAL", APART FROM THE MARK AS SHOWN.

FOR PRINTED MATERIALS, NAMELY, MANUALS, MAGAZINES, BROCHURES, PAMPHLETS, NEWSLETTERS, LEAFLETS AND PRINTED INSTRUCTIONAL MATERIALS IN THE FIELD OF REAL ESTATE BROKERAGE; STATIONERY; BUSINESS CARDS; BUSINESS FORMS; POSTERS; DECALS; PUBLICATIONS, NAMELY, BROCHURES, BOOKLETS AND PRINTED INSTRUCTIONAL AND TEACHING MATERIALS RELATING TO REAL ESTATE BROKERAGE SERVICES, ESCROW, TITLE INSURANCE AND REAL ESTATE FINANCING (U.S. CLS. 2, 5, 22, 23, 29, 37, 38 AND 50).

FIRST USE 6-0-2011; IN COMMERCE 6-0-2011.

CLASS 16—(Continued).

4,210,439. BULLINGTON, J.D., SANTA FE, NM. SN 77-916,672. PUB. 6-8-2010, FILED 1-21-2010.

Racquet Tattoos

THE MARK CONSISTS OF STANDARD CHARACTERS WITHOUT CLAIM TO ANY PARTICULAR FONT, STYLE, SIZE, OR COLOR.

NO CLAIM IS MADE TO THE EXCLUSIVE RIGHT TO USE "RACQUET", APART FROM THE MARK AS SHOWN.

FOR STENCILS USED TO APPLY DESIGNS ONTO TENNIS RACKETS (U.S. CLS. 2, 5, 22, 23, 29, 37, 38 AND 50).

FIRST USE 1-12-2012; IN COMMERCE 1-12-2012.

4,210,443. OASIS BRANDS INC., WINCHESTER, VA. SN 77-919,434. PUB. 6-8-2010, FILED 1-25-2010.

LOCOR

THE MARK CONSISTS OF STANDARD CHARACTERS WITHOUT CLAIM TO ANY PARTICULAR FONT, STYLE, SIZE, OR COLOR.

FOR CLEANING PAPER TISSUE, NAMELY, PAPER TOWELS FOR CLEANING; BATHROOM TISSUE; TOILET PAPER; PAPER TISSUE TO BE USED IN BATHROOM, NAMELY, FACIAL TISSUE; PAPER TOWELS; KITCHEN ROLL PAPER TOWELS; ROLL PAPER TOWELS; FOLDED PAPER TOWELS; PAPER TOWELS INTENDED FOR USE IN CLEANING HUMAN BODIES AND SURFACES IN A BATHROOM (U.S. CLS. 2, 5, 22, 23, 29, 37, 38 AND 50).

FIRST USE 2-1-2011; IN COMMERCE 2-1-2011.

4,210,479. CACIQUE, INC., CITY OF INDUSTRY, CA. SN 77-983,316. PUB. 4-20-2010, FILED 10-20-2009.

MARIA'S COCINA

THE MARK CONSISTS OF STANDARD CHARACTERS WITHOUT CLAIM TO ANY PARTICULAR FONT, STYLE, SIZE, OR COLOR.

OWNER OF U.S. REG. NO. 3,310,043.

CLASS 16—(Continued).

THE ENGLISH TRANSLATION OF "COCINA" IN THE MARK IS KITCHEN.

FOR PRINTED MATERIALS, NAMELY, PAMPHLETS, BROCHURES, BOOKS, MAGAZINES, AND NEWSLETTERS IN THE FIELD OF MEXICAN-STYLE FOOD, COOKING AND RECIPES (U.S. CLS. 2, 5, 22, 23, 29, 37, 38 AND 50).

FIRST USE 3-0-2011; IN COMMERCE 3-0-2011.

4,210,488. VELAR-GASKILL, DAVID S, OAK PARK, MI. SN 85-006,434. PUB. 8-31-2010, FILED 4-5-2010.

The Enhanced

THE MARK CONSISTS OF STANDARD CHARACTERS WITHOUT CLAIM TO ANY PARTICULAR FONT, STYLE, SIZE, OR COLOR.

FOR COMIC BOOKS (U.S. CLS. 2, 5, 22, 23, 29, 37, 38 AND 50).

FIRST USE 8-1-2011; IN COMMERCE 8-1-2012.

4,210,499. FIELDS, ALAN, DBA WINDSOR PEAK PRESS, BOULDER, CO. AND FIELDS, DENISE, DBA WINDSOR PEAK PRESS, BOULDER, CO. SN 85-013,648. PUB. 12-7-2010, FILED 4-14-2010.

EXPECTING 411

THE MARK CONSISTS OF STANDARD CHARACTERS WITHOUT CLAIM TO ANY PARTICULAR FONT, STYLE, SIZE, OR COLOR.

NO CLAIM IS MADE TO THE EXCLUSIVE RIGHT TO USE "EXPECTING", APART FROM THE MARK AS SHOWN.

FOR SERIES OF NON-FICTION BOOKS ON VARIOUS TOPICS IN THE FIELDS OF PRENATAL AND POSTPARTUM MEDICAL CARE FOR WOMEN AND MEDICAL CARE FOR INFANTS (U.S. CLS. 2, 5, 22, 23, 29, 37, 38 AND 50).

FIRST USE 4-16-2012; IN COMMERCE 4-16-2012.

CLASS 16—(Continued).

4,210,529. ARTE GRAFICO EDITORIAL ARGENTINO S.A., BUENOS AIRES, ARGENTINA. SN 85-048,016. PUB. 4-5-2011, FILED 5-26-2010.



OWNER OF U.S. REG. NOS. 2,130,172, 2,130,173, AND 2,130,175.

THE COLOR(S) RED IS/ARE CLAIMED AS A FEATURE OF THE MARK.

THE MARK CONSISTS OF THE WORD "CLARIN" IN STYLIZED RED LETTERS FOLLOWED BY THE SILHOUETTE OF MAN PLAYING THE BUGLE ALL APPEARING IN THE COLOR RED.

THE ENGLISH TRANSLATION OF "CLARIN" IN THE MARK IS "BUGLE".

FOR NEWSPAPERS OF GENERAL CIRCULATION (U.S. CLS. 2, 5, 22, 23, 29, 37, 38 AND 50).

FIRST USE 8-28-1945; IN COMMERCE 9-9-1969.

CLASS 16—(Continued).

4,210,626. INSPERITY, INC., KINGWOOD, TX. SN 85-116,162. PUB. 5-3-2011, FILED 8-26-2010.

INSPIRING BUSINESS PERFORMANCE

THE MARK CONSISTS OF STANDARD CHARACTERS WITHOUT CLAIM TO ANY PARTICULAR FONT, STYLE, SIZE, OR COLOR.

NO CLAIM IS MADE TO THE EXCLUSIVE RIGHT TO USE "BUSINESS PERFORMANCE", APART FROM THE MARK AS SHOWN.

FOR PRE-PRINTED BUSINESS HUMAN RESOURCES FORMS (U.S. CLS. 2, 5, 22, 23, 29, 37, 38 AND 50).

FIRST USE 3-3-2011; IN COMMERCE 3-3-2011.

4,210,705. TRALY (U.S.A.) INC., BOCA RATON, FL. SN 85-185,782. PUB. 7-19-2011, FILED 11-28-2010.

FROMBIE

THE MARK CONSISTS OF STANDARD CHARACTERS WITHOUT CLAIM TO ANY PARTICULAR FONT, STYLE, SIZE, OR COLOR.

FOR ART PRINTS, PRINTED MATERIALS, NAMELY, POSTERS, COMIC BOOKS (U.S. CLS. 2, 5, 22, 23, 29, 37, 38 AND 50).

FIRST USE 10-13-2011; IN COMMERCE 10-13-2011.

4,210,707. TERESA THOMAS, PELHAM, AL. AND SAM JONES, PELHAM, AL. SN 85-187,461. PUB. 5-3-2011, FILED 11-30-2010.

Scripture Tree

THE MARK CONSISTS OF STANDARD CHARACTERS WITHOUT CLAIM TO ANY PARTICULAR FONT, STYLE, SIZE, OR COLOR.

NO CLAIM IS MADE TO THE EXCLUSIVE RIGHT TO USE "SCRIPTURE", APART FROM THE MARK AS SHOWN.

FOR PERSONALIZED WRITTEN OR PRINTED BIBLE SCRIPTURES, ON PAPER STATIONERY WITH INSPIRATIONAL OR CHRISTIAN MESSAGES IMPRINTED THEREON INCLUDED IN DECORATIVE FLOWER ARRANGEMENTS; PERSONALIZED WRITTEN OR PRINTED BIBLE SCRIPTURES, ON PAPER STATIONERY WITH INSPIRATIONAL OR CHRISTIAN MESSAGES ARRANGED AND HELD IN DECORATIVE WOODEN, METAL, OR PLASTIC HOLDERS (U.S. CLS. 2, 5, 22, 23, 29, 37, 38 AND 50).

FIRST USE 3-1-2011; IN COMMERCE 3-1-2011.

4,210,604. WORTHY HEN PRODUCTIONS, LLC, BEVERLY HILLS, CA. SN 85-101,542. PUB. 6-21-2011, FILED 8-5-2010.



NO CLAIM IS MADE TO THE EXCLUSIVE RIGHT TO USE "GUIDE" AND "3+", APART FROM THE MARK AS SHOWN.

THE MARK CONSISTS OF THE WORDS "TRAVELTIVITY GUIDE 3+", STYLIZED, CONTAINED IN A CIRCLE, AND A DRAWING OF A PLANE WITH A BODY SIMILAR TO A CRAYON SHAPE, AND THREE STARS AROUND THE AIRPLANE DESIGN, ALL INSIDE THE CIRCLE.

FOR A SERIES OF BOOKS, NAMELY, CHILDREN'S BOOKS, CHILDREN'S ACTIVITY BOOKS, COLORING BOOKS, CITY GUIDE BOOKS FEATURING TRAVEL INFORMATION, CITY DIRECTORIES, TOUR GUIDE BOOKS IN THE FIELD OF TRAVEL; DECALS; STICKERS (U.S. CLS. 2, 5, 22, 23, 29, 37, 38 AND 50).

FIRST USE 7-25-2011; IN COMMERCE 7-25-2011.

CLASS 16—(Continued).

4,210,985. BONVENTRE, BARBARA, DBA PIZZA PALETTE PUBLICATIONS, NEW YORK, NY. SN 85-315,999. PUB. 11-8-2011, FILED 5-9-2011.

YourPizzaPalette

THE MARK CONSISTS OF STANDARD CHARACTERS WITHOUT CLAIM TO ANY PARTICULAR FONT, STYLE, SIZE, OR COLOR.

FOR PIZZA COOKBOOK (U.S. CLS. 2, 5, 22, 23, 29, 37, 38 AND 50).

FIRST USE 1-3-2012; IN COMMERCE 3-3-2012.

4,211,085. LAVENDER THIEF LLC, SEATTLE, WA. SN 85-338,162. PUB. 10-25-2011, FILED 6-4-2011.



THE MARK CONSISTS OF THE WORDING "LAVENDER" ALL CAPITAL LETTERS, "THIEF" IN SMALL LETTERS BELOW "LAVENDER THIEF" APPEARS A TAG LINE "LIFE IS FLEETING—CAPTURE THE ESSENCE" TO THE RIGHT IF THE WORDS APPEARS TWO SPRIGS OF STYLIZED LAVENDER BLOSSOM THAT IS ARCHED AND A BUTTERFLY IN SIDE VIEW OR PROFILE VIEW TO THE RIGHT OF THE LAVENDER SPRIG.

FOR GREETINGS CARDS AND POSTCARDS; PRINTED CALENDARS; PUBLICATIONS, NAMELY, BROCHURES, BOOKLETS, AND TEACHING MATERIALS IN THE FIELD OF TRAVEL AND ROMANCE (U.S. CLS. 2, 5, 22, 23, 29, 37, 38 AND 50).

FIRST USE 7-10-2011; IN COMMERCE 7-10-2011.

CLASS 16—(Continued).

4,211,129. CITY OF TULSA, TULSA, OK. SN 85-344,298. PUB. 12-13-2011, FILED 6-13-2011.



THE MARK CONSISTS OF A LARGE CIRCLE, CONNECTED WITH A SMALL CIRCLE (SITUATED NORTH-EAST), WITH THE NUMBER "2", ALSO RESEMBLING A STYLIZED LETTER "E", SITUATED IN THE CENTER OF THE LARGE CIRCLE.

FOR PRINTED VISUALS IN THE NATURE OF ADVERTISING AND MARKETING MATERIALS TO PROMOTE THE CITY OF TULSA AND ITS CITIZENS (U.S. CLS. 2, 5, 22, 23, 29, 37, 38 AND 50).

FIRST USE 8-18-2011; IN COMMERCE 8-18-2011.

4,211,142. JOS. E. MARCH INVESTMENTS, INC., FAIRVIEW, NC. SN 85-345,781. PUB. 11-8-2011, FILED 6-14-2011.

VIRTUAL E-CIGARETTES
PERMITTED

THE MARK CONSISTS OF STANDARD CHARACTERS WITHOUT CLAIM TO ANY PARTICULAR FONT, STYLE, SIZE, OR COLOR.

FOR DECALS, NAMELY, WINDOW DECALS AND DOOR DECALS (U.S. CLS. 2, 5, 22, 23, 29, 37, 38 AND 50).

FIRST USE 5-12-2012; IN COMMERCE 5-12-2012.

CLASS 16—(Continued).

4,211,255. STEVEN P. DEMME, LITITZ, PA. SN 85-359,357.
PUB. 11-22-2011, FILED 6-29-2011.

CLASS 16—(Continued).

4,211,271. LF, LLC, MOUNT MOURNE, NC. SN 85-362,911.
PUB. 11-15-2011, FILED 7-5-2011.

Decimal Street

THE MARK CONSISTS OF STANDARD CHARACTERS WITHOUT CLAIM TO ANY PARTICULAR FONT, STYLE, SIZE, OR COLOR.

FOR EDUCATIONAL KITS SOLD AS A UNIT IN THE FIELD OF MATHEMATICS CONSISTING PRIMARILY OF EDUCATIONAL BOOKS, FLASH CARDS AND WORKSHEETS, AND ALSO INCLUDING AN EDUCATIONAL DVD (U.S. CLS. 2, 5, 22, 23, 29, 37, 38 AND 50).
FIRST USE 6-21-2012; IN COMMERCE 6-21-2012.

NEVER STOP IMPROVING

THE MARK CONSISTS OF STANDARD CHARACTERS WITHOUT CLAIM TO ANY PARTICULAR FONT, STYLE, SIZE, OR COLOR.

FOR PRINTED MATERIALS, NAMELY, MAGAZINES RELATING TO HOME IMPROVEMENT, CONSTRUCTION, DECORATING, GARDENING, LANDSCAPING AND RELATED ACTIVITIES (U.S. CLS. 2, 5, 22, 23, 29, 37, 38 AND 50).
FIRST USE 2-0-2012; IN COMMERCE 2-0-2012.

4,211,258. WORKMAN PUBLISHING CO., INC., NEW YORK, NY. SN 85-359,840. PUB. 11-22-2011, FILED 6-29-2011.

4,211,274. CONCORDIA PUBLISHING HOUSE, ST. LOUIS, MO. SN 85-363,431. PUB. 11-29-2011, FILED 7-5-2011.

Unlikely Friendships

THE MARK CONSISTS OF STANDARD CHARACTERS WITHOUT CLAIM TO ANY PARTICULAR FONT, STYLE, SIZE, OR COLOR.

FOR CALENDARS; SERIES OF NON-FICTION BOOKS IN THE FIELD OF ANIMALS AND NATURE (U.S. CLS. 2, 5, 22, 23, 29, 37, 38 AND 50).
FIRST USE 5-0-2011; IN COMMERCE 5-0-2011.

CROSS EXPLORATIONS

THE MARK CONSISTS OF STANDARD CHARACTERS WITHOUT CLAIM TO ANY PARTICULAR FONT, STYLE, SIZE, OR COLOR.

FOR RELIGIOUS TEACHING MATERIALS, NAMELY, STUDY GUIDES, TEACHERS' GUIDES, LEAFLETS, POSTERS AND PAPER-CRAFT ACTIVITY PACKETS (U.S. CLS. 2, 5, 22, 23, 29, 37, 38 AND 50).
FIRST USE 7-2-2012; IN COMMERCE 7-2-2012.

4,211,260. DPE LABEL HOLDING CORP., BROOKLYN, NY. SN 85-360,044. PUB. 11-8-2011, FILED 6-29-2011.

4,211,314. XEROX CORPORATION, NORWALK, CT. SN 85-371,758. PUB. 12-6-2011, FILED 7-14-2011.

EL JARRITO

THE MARK CONSISTS OF STANDARD CHARACTERS WITHOUT CLAIM TO ANY PARTICULAR FONT, STYLE, SIZE, OR COLOR.

THE ENGLISH TRANSLATION OF "EL JARRITO" IN THE MARK IS "THE LITTLE JUG".

FOR PRE-PAID TELEPHONE CALLING CARDS, NOT MAGNETICALLY ENCODED (U.S. CLS. 2, 5, 22, 23, 29, 37, 38 AND 50).
FIRST USE 6-29-2012; IN COMMERCE 6-29-2012.

PLANET 4+

THE MARK CONSISTS OF STANDARD CHARACTERS WITHOUT CLAIM TO ANY PARTICULAR FONT, STYLE, SIZE, OR COLOR.

FOR PAPER (U.S. CLS. 2, 5, 22, 23, 29, 37, 38 AND 50).
FIRST USE 4-1-2012; IN COMMERCE 4-1-2012.

CLASS 16—(Continued).

4,211,340. DEBTMOLITON, LLC, LANTANA, TX. SN 85-375,658. PUB. 12-20-2011, FILED 7-20-2011.

MereProsperity

THE MARK CONSISTS OF STANDARD CHARACTERS WITHOUT CLAIM TO ANY PARTICULAR FONT, STYLE, SIZE, OR COLOR.

FOR NEWSLETTERS IN THE FIELD OF DEBT REDUCTION, CHARITABLE GIVING, AND FINANCIAL FREEDOM (U.S. CLS. 2, 5, 22, 23, 29, 37, 38 AND 50).
FIRST USE 6-1-2012; IN COMMERCE 6-1-2012.

4,211,480. EVRIHOLDER PRODUCTS LLC, ANAHEIM, CA. SN 85-425,351. PUB. 2-21-2012, FILED 9-17-2011.

SWEET-TREATS

THE MARK CONSISTS OF STANDARD CHARACTERS WITHOUT CLAIM TO ANY PARTICULAR FONT, STYLE, SIZE, OR COLOR.

FOR PLASTIC OR PAPER BAGS FOR HOUSEHOLD USE (U.S. CLS. 2, 5, 22, 23, 29, 37, 38 AND 50).
FIRST USE 8-22-2011; IN COMMERCE 9-21-2011.

4,211,509. EDIBLE COMMUNITIES, INC., SANTA BARBARA, CA. SN 85-442,201. PUB. 3-20-2012, FILED 10-7-2011.

EDIBLE CLEVELAND

THE MARK CONSISTS OF STANDARD CHARACTERS WITHOUT CLAIM TO ANY PARTICULAR FONT, STYLE, SIZE, OR COLOR.

OWNER OF U.S. REG. NOS. 3,281,408, 3,440,817, AND OTHERS.

NO CLAIM IS MADE TO THE EXCLUSIVE RIGHT TO USE "CLEVELAND", APART FROM THE MARK AS SHOWN.

FOR MAGAZINES FEATURING TOURISM, CULINARY AND AGRICULTURE INDUSTRIES AND PUBLICATIONS, NAMELY, MAGAZINES AND NEWSLETTERS DEALING WITH CONNECTING CONSUMERS WITH LOCAL GROWERS, FOOD RETAILERS, CHEFS AND FOOD ARTISANS (U.S. CLS. 2, 5, 22, 23, 29, 37, 38 AND 50).

FIRST USE 1-1-2012; IN COMMERCE 1-1-2012.

CLASS 16—(Continued).

4,211,510. EDIBLE COMMUNITIES, INC., SANTA BARBARA, CA. SN 85-442,225. PUB. 3-20-2012, FILED 10-7-2011.

EDIBLE OMAHA

THE MARK CONSISTS OF STANDARD CHARACTERS WITHOUT CLAIM TO ANY PARTICULAR FONT, STYLE, SIZE, OR COLOR.

OWNER OF U.S. REG. NOS. 3,281,408, 3,440,817, AND OTHERS.

NO CLAIM IS MADE TO THE EXCLUSIVE RIGHT TO USE "OMAHA", APART FROM THE MARK AS SHOWN.

FOR MAGAZINES FEATURING TOURISM, CULINARY AND AGRICULTURE INDUSTRIES AND PUBLICATIONS, NAMELY, MAGAZINES AND NEWSLETTERS DEALING WITH CONNECTING CONSUMERS WITH LOCAL GROWERS, FOOD RETAILERS, CHEFS AND FOOD ARTISANS (U.S. CLS. 2, 5, 22, 23, 29, 37, 38 AND 50).

FIRST USE 1-1-2012; IN COMMERCE 1-1-2012.

4,211,513. KEEP IN MIND, INC., INDIAN LAND, SC. SN 85-443,193. PUB. 3-13-2012, FILED 10-10-2011.

KEEP IN MIND

THE MARK CONSISTS OF STANDARD CHARACTERS WITHOUT CLAIM TO ANY PARTICULAR FONT, STYLE, SIZE, OR COLOR.

FOR PRINTED PERIODICALS IN THE FIELD OF ALZHEIMER'S DISEASE AND DEMENTIA (U.S. CLS. 2, 5, 22, 23, 29, 37, 38 AND 50).

FIRST USE 11-8-2011; IN COMMERCE 11-8-2011.

4,211,520. THE ARISTOTLE CORPORATION, STAMFORD, CT. SN 85-447,508. PUB. 3-27-2012, FILED 10-14-2011.

ARTASTIC

THE MARK CONSISTS OF STANDARD CHARACTERS WITHOUT CLAIM TO ANY PARTICULAR FONT, STYLE, SIZE, OR COLOR.

FOR ART PADS, ART PAPER, DRAWING PADS, DRAWING PAPER, SKETCH BOOKS, SKETCH PADS, DRAWING PENCILS, ERASERS (U.S. CLS. 2, 5, 22, 23, 29, 37, 38 AND 50).

FIRST USE 12-31-2011; IN COMMERCE 12-31-2011.

CLASS 16—(Continued).

4,211,537. RETTER, DANIEL, NEW YORK, NY. SN 85-454,478. PUB. 4-10-2012, FILED 10-24-2011.

Talmud Bavli Indexed Reference Guide

NO CLAIM IS MADE TO THE EXCLUSIVE RIGHT TO USE "TALMUD BAVLI INDEXED REFERENCE GUIDE", APART FROM THE MARK AS SHOWN.

THE MARK CONSISTS OF THE TITLE TO A BOOK WHICH IS AN INDEXED REFERENCE GUIDE TO THE TALMUD BAVLI AND WHICH FEATURES THE WORD "HAMAFTEACH" IN LARGE, DISTINCTIVE, ICONIC FONT, WHICH MEANS THE KEY IN HEBREW. ABOVE THE ENGLISH WORD "HAMAFTEACH" IS WRITTEN ITS HEBREW LANGUAGE EQUIVALENT WORD. ABOVE THE HEBREW WORD FOR "HAMAFTEACH" IS WRITTEN "TALMUD BAVLI INDEXED REFERENCE GUIDE" IN ENGLISH.

THE ENGLISH TRANSLATION OF THE WORD "BAVLI" IN THE MARK IS "BABYLONIAN".

THE NON-LATIN CHARACTERS IN THE MARK TRANSLITERATE TO "HAMAFTEACH" AND THIS MEANS "THE KEY" IN ENGLISH.

FOR REFERENCE BOOKS IN THE FIELD OF THE BABYLONIAN TALMUD (U.S. CLS. 2, 5, 22, 23, 29, 37, 38 AND 50).

FIRST USE 11-24-2011; IN COMMERCE 11-24-2011.

4,211,538. RETTER, DANIEL, NEW YORK, NY. SN 85-454,529. PUB. 4-10-2012, FILED 10-24-2011.



NO CLAIM IS MADE TO THE EXCLUSIVE RIGHT TO USE "TALMUD BAVLI", APART FROM THE MARK AS SHOWN.

THE MARK CONSISTS OF THE TITLE TO A BOOK WHICH IS AN INDEXED REFERENCE GUIDE TO THE TALMUD BAVLI (BABYLONIAN TALMUD) AND WHICH FEATURES THE TRANSLITERATED HEBREW WORDS, "HAMAFTEACH LEH TALMUD BAVLI" WHICH TRANSLATED INTO ENGLISH MEANS "THE KEY TO THE BABYLONIAN TALMUD".

THE NON-LATIN CHARACTERS IN THE MARK TRANSLITERATE TO "HAMAFTEACH LETALMUD BAVLI" AND THIS MEANS "THE KEY TO THE BABYLONIAN TALMUD" IN ENGLISH.

FOR REFERENCE BOOKS IN THE FIELD OF THE BABYLONIAN TALMUD (U.S. CLS. 2, 5, 22, 23, 29, 37, 38 AND 50).

FIRST USE 11-24-2011; IN COMMERCE 11-24-2011.

CLASS 16—(Continued).

4,211,559. KIT USA CO LTD, DBA KIT USA CO LTD, HONOLULU, HI. SN 85-464,127. PUB. 4-17-2012, FILED 11-3-2011.

Fascinating Hawaii

THE MARK CONSISTS OF STANDARD CHARACTERS WITHOUT CLAIM TO ANY PARTICULAR FONT, STYLE, SIZE, OR COLOR.

NO CLAIM IS MADE TO THE EXCLUSIVE RIGHT TO USE "HAWAII", APART FROM THE MARK AS SHOWN.

FOR MAGAZINES IN THE FIELD OF TRAVEL (U.S. CLS. 2, 5, 22, 23, 29, 37, 38 AND 50).

FIRST USE 10-7-2011; IN COMMERCE 10-7-2011.

4,211,585. NATUR UND TIER - VERLAG GMBH, MUNSTER, FED REP GERMANY. SN 85-476,520. PUB. 5-1-2012, FILED 11-18-2011.

AMAZONAS

THE MARK CONSISTS OF STANDARD CHARACTERS WITHOUT CLAIM TO ANY PARTICULAR FONT, STYLE, SIZE, OR COLOR.

FOR MAGAZINES IN THE FIELD OF FRESHWATER AQUARIUMS (U.S. CLS. 2, 5, 22, 23, 29, 37, 38 AND 50).

FIRST USE 8-1-2005; IN COMMERCE 12-27-2011.

4,211,601. NBTV MEDIA, TROY, MI. SN 85-484,207. PUB. 5-8-2012, FILED 11-30-2011.



THE MARK CONSISTS OF THE WORD "REmind" WITH THE LETTERS "RE" UNDERLINED AND THE LOWER PORTION OF THE "I" EXTENDING BELOW THE OTHER LETTERS TO FORM A POINT RESEMBLING A PENCIL AND THE WORDS "HOURS OF PUZZLES, VINTAGE COMICS &" TO THE LEFT OF THAT POINT AND BELOW THE LETTERS "REM" AND THE WORDS "BLASTS FROM THE PAST!" TO THE RIGHT OF THAT POINT AND BELOW THE LETTERS "ND".

FOR MAGAZINES FEATURING PUZZLES AND COMICS (U.S. CLS. 2, 5, 22, 23, 29, 37, 38 AND 50).

FIRST USE 12-16-2011; IN COMMERCE 12-16-2011.

CLASS 16—(Continued).

4,211,608. SNAP LEARNING, INC., FRESNO, CA. SN 85-488,844. PUB. 5-15-2012, FILED 12-6-2011.

SNAP LEARNING

THE MARK CONSISTS OF STANDARD CHARACTERS WITHOUT CLAIM TO ANY PARTICULAR FONT, STYLE, SIZE, OR COLOR.

NO CLAIM IS MADE TO THE EXCLUSIVE RIGHT TO USE "LEARNING", APART FROM THE MARK AS SHOWN.

FOR EDUCATIONAL AND LEARNING PUBLICATIONS, NAMELY, BOOKS, WORKBOOKS, TEXT BOOKS, ACTIVITY BOOKS, TEACHERS GUIDES AND MANUALS IN THE FIELDS OF READING, WRITING, MATHEMATICS, SOCIAL STUDIES, SCIENCE AND ENGLISH AS A SECOND LANGUAGE (U.S. CLS. 2, 5, 22, 23, 29, 37, 38 AND 50).

FIRST USE 4-5-2012; IN COMMERCE 4-19-2012.

4,211,610. SNAP LEARNING, INC., FRESNO, CA. SN 85-489,157. PUB. 5-15-2012, FILED 12-7-2011.



NO CLAIM IS MADE TO THE EXCLUSIVE RIGHT TO USE "LEARNING", APART FROM THE MARK AS SHOWN.

THE MARK CONSISTS OF THE WORD "SNAP" FOLLOWED BY AN EXCLAMATION POINT, THE WORD "LEARNING" IS CONTAINED WITHIN A PAINTBRUSH STROKE-LIKE DESIGN, A GLOVED HAND WITH FOUR (4) FINGERS EXTENDS LEFT FROM THE BOTTOM OF THE LETTER "S" IN THE WORD "SNAP" WITH THE TOP TWO (2) FINGERS MAKING A REVERSE "L" SHAPE AND THE BOTTOM TWO (2) FINGERS FOLDED IN, SPARKS RADIATE FROM THE TOP TWO (2) FINGERS IN THE GLOVED HAND.

FOR EDUCATIONAL AND LEARNING PUBLICATIONS, NAMELY, BOOKS, WORKBOOKS, TEXT BOOKS, ACTIVITY BOOKS, TEACHERS GUIDES AND MANUALS IN THE FIELDS OF READING, WRITING, MATHEMATICS, SOCIAL STUDIES, SCIENCE AND ENGLISH AS A SECOND LANGUAGE (U.S. CLS. 2, 5, 22, 23, 29, 37, 38 AND 50).

FIRST USE 4-5-2012; IN COMMERCE 4-19-2012.

CLASS 16—(Continued).

4,211,665. TRION WORLDS, INC., REDWOOD CITY, CA. SN 85-977,073. PUB. 9-27-2011, FILED 12-7-2010.

RIFT

THE MARK CONSISTS OF STANDARD CHARACTERS WITHOUT CLAIM TO ANY PARTICULAR FONT, STYLE, SIZE, OR COLOR.

FOR PAPER GOODS, NAMELY, COMIC BOOKS, STRATEGY GUIDES FOR PLAYING ENTERTAINMENT COMPUTER GAMES; POSTERS; INSTRUCTIONAL LEAFLETS, MANUALS FOR COMPUTER GAMES (U.S. CLS. 2, 5, 22, 23, 29, 37, 38 AND 50).

FIRST USE 1-4-2011; IN COMMERCE 1-4-2011.

4,211,674. BERRY PLASTICS CORPORATION, EVANSVILLE, IN. SN 85-977,224. PUB. 6-21-2011, FILED 11-22-2010.

A NO NONSENSE CHOICE

THE MARK CONSISTS OF STANDARD CHARACTERS WITHOUT CLAIM TO ANY PARTICULAR FONT, STYLE, SIZE, OR COLOR.

FOR PLASTIC FOOD STORAGE BAGS FOR HOUSEHOLD USE; PLASTIC WRAP; TRASH BAGS (U.S. CLS. 2, 5, 22, 23, 29, 37, 38 AND 50).

FIRST USE 1-19-2012; IN COMMERCE 1-19-2012.

CLASS 17—RUBBER GOODS

4,210,497. GREEN COMFORT SAFE, INC., SOUTH BRISTOL, ME. SN 85-012,450. PUB. 9-14-2010, FILED 4-13-2010.

GREEN COMFORT SAFE

THE MARK CONSISTS OF STANDARD CHARACTERS WITHOUT CLAIM TO ANY PARTICULAR FONT, STYLE, SIZE, OR COLOR.

NO CLAIM IS MADE TO THE EXCLUSIVE RIGHT TO USE "GREEN" OR "SAFE", APART FROM THE MARK AS SHOWN.

FOR BUILDING INSULATION; PROCESSED CELLULOSE FOR USE AS INSULATION (U.S. CLS. 1, 5, 12, 13, 35 AND 50).

FIRST USE 4-26-2012; IN COMMERCE 4-26-2012.

CLASS 17—(Continued).

4,211,277. RAIN TREE ESSIX INC., WILMINGTON, DE. SN 85-363,806. PUB. 3-6-2012, FILED 7-6-2011.



THE COLOR(S) BLUE AND WHITE IS/ARE CLAIMED AS A FEATURE OF THE MARK.

THE MARK CONSISTS OF A BLUE DIAMOND WITH A STYLIZED CAPITAL LETTER "E" INSIDE IN WHITE COLOR.

FOR PRE-CUT THERMOPLASTIC SHEET MATERIALS FOR MAKING DENTAL APPLIANCES, NAMELY, RETAINERS, ORTHODONTIC RETAINERS, BLEACHING TRAYS, TEMPORAL MANDIBULAR JOINT SPLINTS, AND MOUTHGUARDS (U.S. CLS. 1, 5, 12, 13, 35 AND 50).

FIRST USE 6-25-2012; IN COMMERCE 6-25-2012.

4,211,450. JPS ELASTOMERICS, DBA STEVENS URETHANE, EASTHAMPTON, MA. SN 85-412,902. PUB. 2-21-2012, FILED 9-1-2011.

CAPROCOVER

THE MARK CONSISTS OF STANDARD CHARACTERS WITHOUT CLAIM TO ANY PARTICULAR FONT, STYLE, SIZE, OR COLOR.

FOR PROTECTIVE PLASTIC FILM FOR PAINTED SURFACES (U.S. CLS. 1, 5, 12, 13, 35 AND 50).

FIRST USE 5-22-2012; IN COMMERCE 5-22-2012.

CLASS 17—(Continued).

4,211,451. JPS ELASTOMERICS, DBA STEVENS URETHANE, EASTHAMPTON, MA. SN 85-412,932. PUB. 2-21-2012, FILED 9-1-2011.

GLOSS GUARD

THE MARK CONSISTS OF STANDARD CHARACTERS WITHOUT CLAIM TO ANY PARTICULAR FONT, STYLE, SIZE, OR COLOR.

NO CLAIM IS MADE TO THE EXCLUSIVE RIGHT TO USE "GLOSS", APART FROM THE MARK AS SHOWN.

FOR PROTECTIVE PLASTIC FILM FOR PAINTED SURFACES (U.S. CLS. 1, 5, 12, 13, 35 AND 50).

FIRST USE 6-14-2012; IN COMMERCE 6-14-2012.

4,211,495. NEW PENDULUM CORP., WILMINGTON, DE. SN 85-435,543. PUB. 3-6-2012, FILED 9-29-2011.

GRIPPY

THE MARK CONSISTS OF STANDARD CHARACTERS WITHOUT CLAIM TO ANY PARTICULAR FONT, STYLE, SIZE, OR COLOR.

OWNER OF U.S. REG. NO. 3,948,571.

FOR ABSORBENT MATS, PADS, SOCKS AND PILLOWS HAVING ADHESIVE BACKINGS USED IN INDUSTRIAL, COMMERCIAL AND RESIDENTIAL SETTINGS TO ABSORB LEAKS AND SPILLS (U.S. CLS. 1, 5, 12, 13, 35 AND 50).

FIRST USE 8-18-2011; IN COMMERCE 8-18-2011.

CLASS 18—LEATHER GOODS

CLASS 18—(Continued).

4,210,258. RAE, KAREN L., RIDGEFIELD, WA. SN 77-347,795. PUB. 5-25-2010, FILED 12-10-2007.

Good Enough

THE MARK CONSISTS OF STANDARD CHARACTERS WITHOUT CLAIM TO ANY PARTICULAR FONT, STYLE, SIZE, OR COLOR.

FOR OVERNIGHT BAGS; ALL PURPOSE SPORT BAGS; ALL-PURPOSE ATHLETIC BAGS; ALL-PURPOSE CARRYING BAGS; ATHLETIC BAGS; BACKPACKS; BACKPACKS; BACKPACKS, BOOK BAGS, SPORTS BAGS, BUM BAGS, WALLETS AND HANDBAGS; BAGS AND HOLDALLS FOR SPORTS CLOTHING; BAGS FOR CARRYING BABIES' ACCESSORIES; BAGS FOR SPORTS; BARREL BAGS; BEACH BAGS; BOOK BAGS; CANVAS SHOPPING BAGS; CARRY-ALL BAGS; CARRY-ON BAGS; CLUTCH BAGS; COSMETIC BAGS SOLD EMPTY; DIAPER BAGS; DUFFEL BAGS; DUFFEL BAGS FOR TRAVEL; DUFFLE BAGS; GENERAL PURPOSE BAGS FOR CARRYING YOGA EQUIPMENT; MAKE-UP BAGS SOLD EMPTY; SCHOOL BAGS; SCHOOL BOOK BAGS; SCHOOLCHILDREN'S BACKPACKS; SHOULDER BAGS; SPORTS BAGS; TEXTILE SHOPPING BAGS; TOILETRY BAGS SOLD EMPTY; TOTE BAGS; BUM-BAGS; BILLFOLDS; POCKETBOOKS; CARRYALLS; CARRYING CASES; CHANGE PURSES; CLUTCH PURSES; CLUTCHES; COIN PURSES; HANDBAGS, PURSES AND WALLETS; PURSES; PURSES AND WALLETS; SMALL CLUTCH PURSES; SMALL PURSES; BEACHBAGS; WALLETS; KEYCASES (U.S. CLS. 1, 2, 3, 22 AND 41).

FIRST USE 4-20-2011; IN COMMERCE 4-20-2011.

4,210,367. MACKENZIE, CAROLYN HELEN, MS, AVON, CT. SN 77-756,487. PUB. 11-3-2009, FILED 6-10-2009.

Coral Candy

THE MARK CONSISTS OF STANDARD CHARACTERS WITHOUT CLAIM TO ANY PARTICULAR FONT, STYLE, SIZE, OR COLOR.

FOR LEATHER HANDBAGS, LEATHER PURSES, LEATHER WALLETS, LEATHER CLUTCH BAGS, LEATHER TOTE BAGS, LEATHER TRAVEL BAGS, LEATHER BRIEFCASES, LEATHER BRIEFCASE-TYPE PORTFOLIOS; TEXTILE HANDBAGS, TEXTILE PURSES, TEXTILE WALLETS, TEXTILE CLUTCH BAGS, TEXTILE TOTE BAGS, TEXTILE TRAVEL BAGS, TEXTILE COSMETIC BAGS SOLD EMPTY, TEXTILE MAKE-UP BAGS SOLD EMPTY, AND TEXTILE TOILETRY BAGS SOLD EMPTY, TEXTILE BEACH BAGS, TEXTILE ALL-PURPOSE ATHLETIC BAGS, TEXTILE SHOPPING BAGS (U.S. CLS. 1, 2, 3, 22 AND 41).

FIRST USE 1-1-2010; IN COMMERCE 7-17-2012.

CLASS 18—(Continued).

4,210,453. JONES INVESTMENT CO. INC., WILMINGTON, DE. SN 77-927,698. PUB. 6-8-2010, FILED 2-4-2010.



OWNER OF U.S. REG. NOS. 1,155,671, 1,606,340, AND OTHERS.

THE MARK CONSISTS OF SILHOUETTE OF A SWAN, FOR HANDBAGS; TOTE BAGS; WALLETS (U.S. CLS. 1, 2, 3, 22 AND 41).
FIRST USE 2-28-2010; IN COMMERCE 2-28-2010.

4,210,533. NEUBRAF TEXTILES LIMITED, WANCHAI, HONG KONG. SN 85-052,622. PUB. 5-17-2011, FILED 6-2-2010.



THE NAME SHOWN IN THE MARK IDENTIFIES "STÉPHANE CREMIEUX", WHOSE CONSENT IS MADE RECORD.

THE MARK CONSISTS OF THE WORD "CREMIEUX" APPEARING ABOVE A SHIELD DESIGN THAT CONTAINS THE NUMBER "38" IN THE UPPER LEFT-HAND CORNER. THE SHIELD IS SEPARATED INTO THREE SECTIONS WITH A DIVIDING LINE GOING FROM UPPER RIGHT TO LOWER LEFT.

FOR HANDBAGS, LEATHER BAGS, LEATHER AND IMITATIONS OF LEATHER, TRAVELLING BAGS, RUCKSACKS, LEATHER SHOPPING BAGS, CLUTCH BAGS, SHOULDER BAGS, LEATHER COIN BAGS, PURSES, WALLETS, LEATHER POUCHES, PERFUME POUCHES MADE OF LEATHER SOLD EMPTY, POUCHES MADE OF LEATHER, LEATHER SHOULDER BELTS, GOODS MADE OF LEATHER AND NOT INCLUDED IN OTHER CLASSES, NAMELY, LEATHER BRIEF CASES; ANIMAL SKINS, HIDES; TRUNKS; UMBRELLAS, PARASOLS AND WALKING STICKS; WHIPS, HARNESSES AND SADDLERY (U.S. CLS. 1, 2, 3, 22 AND 41).

FIRST USE 11-0-2009; IN COMMERCE 3-0-2010.

CLASS 18—(Continued).

4,210,581. EAGLE OTTAWA, LLC, AUBURN HILLS, MI. SN 85-086,826. PUB. 12-21-2010, FILED 7-16-2010.



NO CLAIM IS MADE TO THE EXCLUSIVE RIGHT TO USE "COMPOSITION LEATHER", "GREEN", AND "LIGHTWEIGHT", APART FROM THE MARK AS SHOWN.

THE MARK CONSISTS OF A FILLED RECTANGLE WITH THE LETTER "N" APPEARING INSIDE THE RECTANGLE IN RELIEF; A LEAF APPEARS IN RELIEF AT THE BOTTOM OF RECTANGLE TO THE LEFT OF THE DIAGONAL LINE OF THE LETTER "N"; A DROPLET OF LIQUID APPEARS IN RELIEF AT THE TOP OF THE RECTANGLE TO THE RIGHT OF THE DIAGONAL LINE OF THE LETTER "N"; THE WORD "NATALLE" APPEARS TO THE RIGHT OF THE RECTANGLE; THE WORDING "COMPOSITION LEATHER" APPEARS TO THE RIGHT OF THE RECTANGLE AND DIRECTLY BENEATH THE WORD "NATALLE"; A SOLID LINE RUNS ACROSS THE MARK BENEATH THE RECTANGLE AND THE WORDING "COMPOSITION LEATHER"; THE WORDING "INNOVATIVE. GREEN. LIGHTWEIGHT." APPEARS BENEATH THE SOLID LINE ALONG THE BOTTOM OF THE MARK.

THE WORDING "NATALLE" HAS NO MEANING IN A FOREIGN LANGUAGE.

FOR COMPOSITION LEATHER COMPOSED OF GENUINE LEATHER FIBERS AND RESIN THAT IS FINISHED AND EMBOSSED TO HAVE THE LOOK AND FEEL OF GENUINE LEATHER (U.S. CLS. 1, 2, 3, 22 AND 41).

FIRST USE 7-29-2010; IN COMMERCE 8-30-2010.

4,210,748. BRANDED, LLC, DALLAS, TX. SN 85-202,434. PUB. 5-10-2011, FILED 12-21-2010.

Jamaica Joe

THE MARK CONSISTS OF STANDARD CHARACTERS WITHOUT CLAIM TO ANY PARTICULAR FONT, STYLE, SIZE, OR COLOR.

THE NAME(S), PORTRAIT(S), AND/OR SIGNATURE(S) SHOWN IN THE MARK DOES NOT IDENTIFY A PARTICULAR LIVING INDIVIDUAL.

FOR ALL PURPOSE SPORT BAGS; ALL-PURPOSE ATHLETIC BAGS; ALL-PURPOSE CARRYING BAGS; BACK PACKS; SPORTS PACKS; TOTE BAGS; WAIST PACKS (U.S. CLS. 1, 2, 3, 22 AND 41).

FIRST USE 7-5-2012; IN COMMERCE 7-5-2012.

CLASS 18—(Continued).

4,210,847. BJ ACQUISITION LLC, LONG ISLAND, NY. SN 85-239,073. PUB. 12-6-2011, FILED 2-10-2011.

BETSEYVILLE BY BETSEY JOHNSON

THE MARK CONSISTS OF STANDARD CHARACTERS WITHOUT CLAIM TO ANY PARTICULAR FONT, STYLE, SIZE, OR COLOR.

OWNER OF U.S. REG. NOS. 1,509,247, 3,210,939, AND OTHERS.

THE NAME(S), PORTRAIT(S), AND/OR SIGNATURE(S) SHOWN IN THE MARK IDENTIFIES "BETSEY JOHNSON", WHOSE CONSENT(S) TO REGISTER IS MADE OF RECORD.

FOR SMALL LEATHER GOODS, NAMELY, KEY CHAINS, WALLETS, COSMETIC PURSES SOLD EMPTY, AND CHANGE PURSES (U.S. CLS. 1, 2, 3, 22 AND 41).

FIRST USE 1-1-2006; IN COMMERCE 1-1-2006.

4,210,934. SILLY CREATION, INC., LOS ANGELES, CA. SN 85-283,303. PUB. 8-9-2011, FILED 4-1-2011.

SUNDAE SKY

THE MARK CONSISTS OF STANDARD CHARACTERS WITHOUT CLAIM TO ANY PARTICULAR FONT, STYLE, SIZE, OR COLOR.

FOR BACKPACKS, BOOK BAGS, SPORTS BAGS, BUM BAGS, WALLETS AND HANDBAGS; EVENING HANDBAGS; FASHION HANDBAGS; GENTLEMEN'S HANDBAGS; HANDBAGS; HANDBAGS FOR LADIES; HANDBAGS FOR MEN; HANDBAGS, PURSES AND WALLETS; LEATHER HANDBAGS (U.S. CLS. 1, 2, 3, 22 AND 41).

FIRST USE 5-1-2011; IN COMMERCE 5-1-2011.

4,211,039. RAWLINGS SPORTING GOODS COMPANY, INC., ST. LOUIS, MO. SN 85-330,750. PUB. 11-22-2011, FILED 5-26-2011.

RAWLINGS

THE MARK CONSISTS OF STANDARD CHARACTERS WITHOUT CLAIM TO ANY PARTICULAR FONT, STYLE, SIZE, OR COLOR.

OWNER OF U.S. REG. NOS. 412,343, 1,337,914, AND OTHERS.

CLASS 18—(Continued).

SEC. 2(F).

FOR LEATHER LUGGAGE; LUGGAGE NOT OF LEATHER; LEATHER DUFFLE BAGS; DUFFLE BAGS, NOT OF LEATHER; LEATHER HANDBAGS; LEATHER BRIEFCASE-TYPE PORTFOLIOS; LEATHER WALLETS; LEATHER BRIEFCASES; LEATHER BACKPACKS; LEATHER SHAVE BAGS SOLD EMPTY; LEATHER LUGGAGE TAGS; LEATHER MESSENGER BAGS; LEATHER JOTTERS, NAMELY, BRIEF-CASE TYPE BUSINESS FOLDERS; LEATHER SPORT BAGS; ATTACHE CASES; ATTACHE CASES MADE OF LEATHER; ATHLETIC BAGS; BACKPACKS; BAGS AND HOLLERS FOR SPORTING CLOTHING; UMBRELLAS (U.S. CLS. 1, 2, 3, 22 AND 41).

FIRST USE 11-0-2011; IN COMMERCE 11-0-2011.

4,211,053. EASEPAL ENTERPRISES LTD, FUJIAN PROVINCE, CHINA. SN 85-333,311. PUB. 10-25-2011, FILED 5-30-2011.



THE MARK CONSISTS OF THE STYLIZED WORD "KNINK" ON THE LEFT, AND TWO CHINESE CHARACTERS WHICH TRANSLITERATE INTO YIN KE ON THE RIGHT.

THE WORDING "KNINK" HAS NO MEANING IN A FOREIGN LANGUAGE.

THE NON-LATIN CHARACTERS IN THE MARK TRANSLITERATE TO YIN; KE AND THIS MEANS STAMP; GUEST IN ENGLISH.

FOR ALL-PURPOSE CARRYING BAGS; BACKPACKS; BRIEFCASE-TYPE LEATHER BUSINESS FOLDERS; BRIEFCASES; CARRYING CASES; HANDBAGS; HAVESACKS; PURSES; REUSABLE SHOPPING BAGS; SCHOOL SATCHELS; TRAVELLING BAGS; UNFITTED VANITY CASES; VALISES (U.S. CLS. 1, 2, 3, 22 AND 41).

FIRST USE 2-1-2010; IN COMMERCE 9-1-2010.

4,211,354. COLLEGE READY, LLC, MIAMI, FL. SN 85-379,226. PUB. 1-31-2012, FILED 7-23-2011.

College App Sack

THE MARK CONSISTS OF STANDARD CHARACTERS WITHOUT CLAIM TO ANY PARTICULAR FONT, STYLE, SIZE, OR COLOR.

NO CLAIM IS MADE TO THE EXCLUSIVE RIGHT TO USE "COLLEGE" AND "SACK", APART FROM THE MARK AS SHOWN.

FOR DOCUMENT CASES (U.S. CLS. 1, 2, 3, 22 AND 41).

FIRST USE 7-6-2012; IN COMMERCE 7-6-2012.

CLASS 18—(Continued).

4,211,417. HELENA CHRAIME, DBA HELENA AND TROY, BROOKLYN, NY. SN 85-400,524. PUB. 1-10-2012, FILED 8-17-2011.

LUNCHBOX

THE MARK CONSISTS OF STANDARD CHARACTERS WITHOUT CLAIM TO ANY PARTICULAR FONT, STYLE, SIZE, OR COLOR.

FOR HANDBAGS; EVENING HANDBAGS; FASHION HANDBAGS; HANDBAGS FOR LADIES; LEATHER HANDBAGS (U.S. CLS. 1, 2, 3, 22 AND 41).

FIRST USE 9-0-2011; IN COMMERCE 9-0-2011.

CLASS 19—NON-METALLIC BUILDING MATERIALS

4,210,370. AVIHOME, LLC, SALISBURY, MD. SN 77-762,267. PUB. 5-25-2010, FILED 6-17-2009.

AVIHOME

THE MARK CONSISTS OF STANDARD CHARACTERS WITHOUT CLAIM TO ANY PARTICULAR FONT, STYLE, SIZE, OR COLOR.

FOR VENTILATED MODULAR FLOOR TILES MADE OF PLASTIC FOR USE AS A FLOOR COVERING IN POULTRY HOUSES (U.S. CLS. 1, 12, 33 AND 50).

FIRST USE 2-10-2012; IN COMMERCE 2-10-2012.

4,210,464. SHIGEKI KANAO, HYOGO, JAPAN. SN 77-949,049. PUB. 11-16-2010, FILED 3-3-2010.

Kanastone

THE MARK CONSISTS OF STANDARD CHARACTERS WITHOUT CLAIM TO ANY PARTICULAR FONT, STYLE, SIZE, OR COLOR.

FOR BUILDING MATERIALS NOT OF METAL, NAMELY, COMPOSITE PANELS CONSISTING OF NON-FLAMMABLE LIGHTWEIGHT BOARD AND STONE PLATES; NON-METAL BUILDING PANELS FOR INTERIOR DECORATING; CONSTRUCTION MATERIAL, NAMELY, NONMETAL EXTERIOR PANELS; AND BUILDING PANELS NOT OF METAL (U.S. CLS. 1, 12, 33 AND 50).

FIRST USE 1-20-2010; IN COMMERCE 1-12-2011.

CLASS 19—(Continued).

4,210,544. MASONITE INTERNATIONAL CORPORATION, MISSISSAUGA, CANADA. SN 85-063,614. PUB. 12-27-2011, FILED 6-15-2010.

SALERNO

THE MARK CONSISTS OF STANDARD CHARACTERS WITHOUT CLAIM TO ANY PARTICULAR FONT, STYLE, SIZE, OR COLOR.

FOR DOOR LITES, SIDE LITES AND TRANSOM LITES, ALL IN THE NATURE OF GLASS AND PLASTIC PANELS FOR DOORS AND DOOR ENTRANCEWAYS; DOOR LITES, SIDE LITES, TRANSOM LITES IN THE NATURE OF GLASS AND PLASTIC PANELS WHICH ARE SOLD AS AN INTEGRAL COMPONENT OF NON-METAL ENTRY DOORS AND DOOR ENTRANCEWAYS (U.S. CLS. 1, 12, 33 AND 50).
FIRST USE 9-30-2010; IN COMMERCE 2-29-2012.

CLASS 19—(Continued).

4,210,546. MASONITE INTERNATIONAL CORPORATION, MISSISSAUGA, CANADA. SN 85-063,626. PUB. 12-27-2011, FILED 6-15-2010.

LEMANS

THE MARK CONSISTS OF STANDARD CHARACTERS WITHOUT CLAIM TO ANY PARTICULAR FONT, STYLE, SIZE, OR COLOR.

FOR DOOR LITES, SIDE LITES AND TRANSOM LITES, ALL IN THE NATURE OF GLASS AND PLASTIC PANELS FOR DOORS AND DOOR ENTRANCEWAYS; DOOR LITES, SIDE LITES, TRANSOM LITES IN THE NATURE OF GLASS AND PLASTIC PANELS WHICH ARE SOLD AS AN INTEGRAL COMPONENT OF NON-METAL ENTRY DOORS AND DOOR ENTRANCEWAYS (U.S. CLS. 1, 12, 33 AND 50).
FIRST USE 12-31-2010; IN COMMERCE 2-29-2012.

4,210,582. COLUMBIA INSURANCE COMPANY, OMAHA, NE. SN 85-089,180. PUB. 10-25-2011, FILED 7-21-2010.

STA TITE

THE MARK CONSISTS OF STANDARD CHARACTERS WITHOUT CLAIM TO ANY PARTICULAR FONT, STYLE, SIZE, OR COLOR.

FOR LOCKING SYSTEM SOLD AS A FEATURE OF VINYL FLOORING COMPRISING SELF LOCKING EDGE COMPONENTS MOLDED AS PART OF THE FLOORING (U.S. CLS. 1, 12, 33 AND 50).
FIRST USE 1-13-2011; IN COMMERCE 1-13-2011.

4,210,545. MASONITE INTERNATIONAL CORPORATION, MISSISSAUGA, CANADA. SN 85-063,620. PUB. 12-27-2011, FILED 6-15-2010.

DUBLIN

THE MARK CONSISTS OF STANDARD CHARACTERS WITHOUT CLAIM TO ANY PARTICULAR FONT, STYLE, SIZE, OR COLOR.

OWNER OF U.S. REG. NOS. 3,373,824, 3,764,852, AND OTHERS.

FOR DOOR LITES, SIDE LITES AND TRANSOM LITES, ALL IN THE NATURE OF GLASS AND PLASTIC PANELS FOR DOORS AND DOOR ENTRANCEWAYS; DOOR LITES, SIDE LITES, TRANSOM LITES IN THE NATURE OF GLASS AND PLASTIC PANELS WHICH ARE SOLD AS AN INTEGRAL COMPONENT OF NON-METAL ENTRY DOORS AND DOOR ENTRANCEWAYS (U.S. CLS. 1, 12, 33 AND 50).
FIRST USE 2-24-2011; IN COMMERCE 2-24-2011.

4,210,610. CULTEC, INC., BROOKFIELD, CT. SN 85-107,211. PUB. 2-15-2011, FILED 8-13-2010.

CRRH

THE MARK CONSISTS OF STANDARD CHARACTERS WITHOUT CLAIM TO ANY PARTICULAR FONT, STYLE, SIZE, OR COLOR.

FOR STORM WATER MANAGEMENT DEVICES, NAMELY, NON-METAL STORM WATER DRY WELLS FEATURING ARCH SHAPED CHAMBERS, AND NON-METAL CATCHMENT CHAMBERS, AND NON-METAL WATER PIPES, AND PARTS AND FITTINGS FOR ALL OF THE FOREGOING (U.S. CLS. 1, 12, 33 AND 50).
FIRST USE 5-10-2010; IN COMMERCE 7-2-2012.

CLASS 19—(Continued).

4,210,776. THE TILE SHOP, LLC, PLYMOUTH, MN. SN 85-211,111. PUB. 5-17-2011, FILED 1-5-2011.



OWNER OF U.S. REG. NOS. 3,442,292 AND 3,661,965.
NO CLAIM IS MADE TO THE EXCLUSIVE RIGHT TO USE "FIRED EARTH CERAMICS" OR "DURABLE HAND-CRAFTED QUALITY PORCELAIN BATHWARE", APART FROM THE MARK AS SHOWN.

THE MARK CONSISTS OF THREE KILNS, BELOW WHICH IS THE WORDING "FIRED EARTH CERAMICS". BELOW THAT IS THE WORDING "DURABLE HAND-CRAFTED QUALITY PORCELAIN BATHWARE" WITH A HORIZONTAL LINE ON EITHER SIDE. ALL OF THE FOREGOING IS SURROUNDED BY A RECTANGLE.

FOR EARTHENWARE TILES; NON-METAL ROOFING TILES; NON-METAL TILES (U.S. CLS. 1, 12, 33 AND 50).
FIRST USE 7-14-2008; IN COMMERCE 7-14-2008.

4,210,803. SAFEWALL, LLC, ORANGE PARK, FL. SN 85-216,653. PUB. 8-9-2011, FILED 1-13-2011.

SAFESUITE

THE MARK CONSISTS OF STANDARD CHARACTERS WITHOUT CLAIM TO ANY PARTICULAR FONT, STYLE, SIZE, OR COLOR.

FOR MANUFACTURED HOUSING, NAMELY, PANELIZED HOMES (U.S. CLS. 1, 12, 33 AND 50).
FIRST USE 1-31-2011; IN COMMERCE 2-3-2012.

4,210,858. PERGO (EUROPE) AB, TRELLEBORG, SWEDEN. SN 85-240,801. PUB. 7-19-2011, FILED 2-12-2011.

PERMAMAX

THE MARK CONSISTS OF STANDARD CHARACTERS WITHOUT CLAIM TO ANY PARTICULAR FONT, STYLE, SIZE, OR COLOR.

FOR PROTECTIVE, WEAR-RESISTANT OVERLAY BONDED ONTO AND SOLD AS A FEATURE OF LAMINATE FLOORING (U.S. CLS. 1, 12, 33 AND 50).
FIRST USE 9-30-2010; IN COMMERCE 9-30-2010.

CLASS 19—(Continued).

4,211,183. KEYSTONE RETAINING WALL SYSTEMS, INC., EDINA, MN. SN 85-350,113. PUB. 11-8-2011, FILED 6-20-2011.

INSIGNIA

THE MARK CONSISTS OF STANDARD CHARACTERS WITHOUT CLAIM TO ANY PARTICULAR FONT, STYLE, SIZE, OR COLOR.

FOR MODULAR CONCRETE BLOCKS USED IN LANDSCAPING APPLICATIONS; CONCRETE BLOCKS USED IN LANDSCAPING APPLICATIONS (U.S. CLS. 1, 12, 33 AND 50).

FIRST USE 2-15-2012; IN COMMERCE 2-15-2012.

4,211,229. KEYSTONE RETAINING WALL SYSTEMS, INC., EDINA, MN. SN 85-356,557. PUB. 11-8-2011, FILED 6-27-2011.

ALAMEDA

THE MARK CONSISTS OF STANDARD CHARACTERS WITHOUT CLAIM TO ANY PARTICULAR FONT, STYLE, SIZE, OR COLOR.

FOR MODULAR CONCRETE BLOCKS USED IN LANDSCAPING APPLICATIONS; CONCRETE BLOCKS USED IN LANDSCAPING APPLICATIONS; PAVING BLOCKS; PAVING STONES; PATIO STONES (U.S. CLS. 1, 12, 33 AND 50).

FIRST USE 3-1-2012; IN COMMERCE 3-1-2012.

4,211,306. TOTAL CONTAINMENT SOLUTIONS, INC., FT MYERS, FL. SN 85-369,927. PUB. 12-13-2011, FILED 7-13-2011.

RoboLiner

THE MARK CONSISTS OF STANDARD CHARACTERS WITHOUT CLAIM TO ANY PARTICULAR FONT, STYLE, SIZE, OR COLOR.

FOR CONTAINMENT SYSTEMS FOR LARGE SCALE LIQUID SPILLS OR RELEASES, NAMELY, BERMS MADE OF POLYMER CONCRETE, VINYL, OR FIBER-GLASS (U.S. CLS. 1, 12, 33 AND 50).

FIRST USE 6-1-2011; IN COMMERCE 8-1-2011.

CLASS 19—(Continued).

4,211,463. SOUTHFIELD CORPORATION, DBA ILLINOIS BRICK COMPANY, PALOS HILLS, IL. SN 85-417,807. PUB. 4-10-2012, FILED 9-8-2011.



THE COLOR(S) YELLOW, BLACK, AND WHITE IS/ARE CLAIMED AS A FEATURE OF THE MARK.

THE MARK CONSISTS OF A RECTANGLE ARRANGED VERTICALLY, CONTAINING A BLACK BORDER WITH A WHITE INTERIOR AND DIVIDED INTO THREE EQUALLY-SIZED INTERNAL SQUARES, CONTIGUOUSLY ARRANGED FROM TOP TO BOTTOM. THE TOP SQUARE CONTAINING THE LETTER "I" WRITTEN IN BLACK AGAINST A YELLOW BACKGROUND, THE MIDDLE SQUARE CONTAINING THE LETTER "B" WRITTEN IN WHITE AGAINST A BLACK BACKGROUND, AND THE BOTTOM SQUARE CONTAINS THE LETTER "C" WRITTEN IN BLACK AGAINST A YELLOW BACKGROUND.

FOR BRICKS; BUILDING MATERIALS, NAMELY, MANUFACTURED BRICK VENEER FOR USE ON INTERIOR AND EXTERIOR WALLS, FLOORS AND SURFACES, PATIOS, POOLSIDES AND DRIVEWAYS; BUILDING STONE; CONCRETE; CONCRETE BUILDING MATERIALS, NAMELY, BRICK AND STONE; FIRED BRICKS; FIREPLACE BRICKS; GRAVEL; LIMESTONE; LIMESTONE; NATURAL STONE; NATURAL STONE AND STONE TILE; NATURAL STONE SLABS AND TILES; NATURAL STONES THAT ARE INSCRIBED WITH A NAME, QUOTATION AND/OR PHRASE; NON-AGRICULTURAL LIME FOR USE IN CONSTRUCTION; PAVING STONE; PAVING STONES; POTTERY STONE; SANDSTONE; SLABS OF STONE AND CONCRETE; SLAG STONE; STONE FOR BUILDING AND CONSTRUCTION; STONE FOR CARVING MANTELS, COLUMNS AND BANISTERS; STONE SLATES; STONES (U.S. CLS. 1, 12, 33 AND 50).

FIRST USE 2-22-2012; IN COMMERCE 2-22-2012.

CLASS 19—(Continued).

4,211,506. KEDING ENTERPRISES CO., LTD., NEW TAIPEI CITY, TAIWAN. SN 85-440,783. PUB. 3-20-2012, FILED 10-6-2011.



THE MARK CONSISTS OF THE LETTERS "K" AND "D", WHICH ARE PLACED NEXT TO EACH OTHER, AND THE CIRCULAR PART OF THE "D" IS SOLID. TO THE LEFT OF THE "K" IS A SMALL EQUILATERAL TRIANGLE THAT POINTS TO THE "K". BENEATH THE TWO LETTERS IS THE WORD "KEDING" IN ALL CAPITALS.

FOR BUILDING MATERIALS, NAMELY, WALL BOARDS, HARDWOOD BOARDS, WOOD BOARDS, PARTICLE BOARDS; BUILDING MATERIALS, NAMELY, COMPOSITE PANELS COMPOSED PRIMARILY OF NONMETAL MATERIALS; CHEMICALLY TREATED WOOD, NAMELY, WOOD BEAMS, WOOD BOARDS, WOOD JOISTS, WOOD RAFTERS, WOOD SIDING, WOOD TILE FLOORS AND FLOORING, WOOD TRIM, WOODEN BEAMS, WOODEN FLOORING, WOODEN RAILINGS, AND WOODEN WAINSCOTING, ALL OF THE ABOVE CONTAINING A FIRE RETARDANT CHEMICAL; FLOOR BOARDS OF WOOD; GLUE-LAMINATED WOOD; HARD WOOD FLOORING; MULTI-LAYERED WOOD; PARQUET WOOD FLOORING; WOOD PANELING; WOOD VENEERS; VENEER WOOD; WOODEN VENEERS; ENGINEERED HARDWOOD FLOORING; WOODEN FLOORING; NON-METAL BUILDING MATERIALS, NAMELY, MATERIALS FOR INTERIOR FIT OUT (U.S. CLS. 1, 12, 33 AND 50).

FIRST USE 8-5-2002; IN COMMERCE 1-31-2012.

CLASS 20—FURNITURE AND ARTICLES NOT OTHERWISE CLASSIFIED

4,210,238. PROVIDENT MARKETING, INC, DOYLESTOWN, PA. SN 76-705,190. PUB. 3-22-2011, FILED 11-1-2010.



NO CLAIM IS MADE TO THE EXCLUSIVE RIGHT TO USE "BAGTIE", APART FROM THE MARK AS SHOWN.

THE MARK IS CHARACTERIZED BY AN ELONGATE ELEMENT EXTENDING BEHIND THE WORD "BAGTIE" AND HAVING CAPPED END PORTIONS WRAPPED PARTIALLY IN FRONT OF IT.

FOR NON-METAL BAG CLOSURES (U.S. CLS. 2, 13, 22, 25, 32 AND 50).

FIRST USE 2-28-2011; IN COMMERCE 2-28-2011.

CLASS 20—(Continued).

4,210,438. SUSTAINABLE GROUP HOLDINGS LLC, SEATTLE, WA. SN 77-916,056. PUB. 5-4-2010, FILED 1-20-2010.



THE MARK CONSISTS OF LEAVES IN A CIRCULAR PATTERN AND THE WORD "REBADGE".
FOR RECYCLABLE CLEAR PLASTIC NAME BADGE HOLDERS (U.S. CLS. 2, 13, 22, 25, 32 AND 50).
FIRST USE 5-31-2008; IN COMMERCE 5-31-2008.

CLASS 20—(Continued).

4,210,689. FURNITURE MARKETING ASSOCIATES, INC., FARMINGDALE, NY. SN 85-178,928. PUB. 10-18-2011, FILED 11-17-2010.



THE MARK CONSISTS OF STANDARD CHARACTERS WITHOUT CLAIM TO ANY PARTICULAR FONT, STYLE, SIZE, OR COLOR.
FOR YOUTH FURNITURE (U.S. CLS. 2, 13, 22, 25, 32 AND 50).
FIRST USE 4-1-2011; IN COMMERCE 4-1-2011.

4,210,556. SRITHAI AUTO SEATS INDUSTRY CO., LTD., SAMUTPRAKARN, THAILAND. SN 85-070,344. PUB. 12-7-2010, FILED 6-24-2010.



THE MARK CONSISTS OF THE WORD "LIMPAITOON" WITH THE LETTERS "LIM" ILLUSTRATED WITH LINES HAVING GREATER THICKNESS THAN THE LETTERS "PAITOON"; A CIRCLE IS LOCATED OVER A PORTION OF THE LETTER "N".
THE WORDING "LIMPAITOON" HAS NO MEANING IN A FOREIGN LANGUAGE.
FOR PORTABLE BACK SUPPORTS NOT FOR MEDICAL PURPOSES FOR USE WITH CHAIRS; BACK SUPPORT CUSHIONS NOT FOR MEDICAL PURPOSES; SEATS (U.S. CLS. 2, 13, 22, 25, 32 AND 50).
FIRST USE 7-20-2012; IN COMMERCE 7-20-2012.

4,210,710. TOTAL RESOURCES INTERNATIONAL, WALNUT, CA. SN 85-188,900. PUB. 9-27-2011, FILED 12-2-2010.



THE MARK CONSISTS OF STANDARD CHARACTERS WITHOUT CLAIM TO ANY PARTICULAR FONT, STYLE, SIZE, OR COLOR.
NO CLAIM IS MADE TO THE EXCLUSIVE RIGHT TO USE "FAN", APART FROM THE MARK AS SHOWN.
FOR HAND-HELD NON-ELECTRIC, NON-METALLIC FANS FOR PERSONAL USE (U.S. CLS. 2, 13, 22, 25, 32 AND 50).
FIRST USE 1-0-2012; IN COMMERCE 1-0-2012.

4,210,667. FIT FOR LIFE SLEEP, INC., NORFOLK, VA. SN 85-156,717. PUB. 10-18-2011, FILED 10-20-2010.



NO CLAIM IS MADE TO THE EXCLUSIVE RIGHT TO USE "LAVENDER", APART FROM THE MARK AS SHOWN.
THE MARK CONSISTS OF THE WORDS "SIMPLY LAVENDER" WITH A PLANT DESIGN BELOW IT.
FOR MATTRESSES, MATTRESS FOUNDATIONS; BOX SPRINGS; MATTRESS TOPPERS; PILLOWS (U.S. CLS. 2, 13, 22, 25, 32 AND 50).
FIRST USE 12-31-2011; IN COMMERCE 12-31-2011.

4,210,755. THE TILE SHOP, LLC, PLYMOUTH, MN. SN 85-203,990. PUB. 5-17-2011, FILED 12-22-2010.



OWNER OF U.S. REG. NOS. 2,413,607, 3,108,881, AND 3,290,690.
NO CLAIM IS MADE TO THE EXCLUSIVE RIGHT TO USE "STONE STUDIOS", APART FROM THE MARK AS SHOWN.

CLASS 20—(Continued).

THE MARK CONSISTS OF THE WORDS "RUSH RIVER" OVER THE LETTERS "R" AND "R" REVERSED. BELOW THAT IS AN IMAGE OF A RIVER FLOWING FROM THE LETTER "R". ALL OF THE FOREGOING APPEARS ON A RECTANGULAR BACKGROUND. BELOW THE RECTANGLE IS THE WORDING "STONE STUDIOS".

SEC. 2(F) AS TO "RUSH RIVER".
FOR SHELVES; AND TOWEL RACKS (U.S. CLS. 2, 13, 22, 25, 32 AND 50).
FIRST USE 8-25-2005; IN COMMERCE 8-25-2005.

4,210,831. DREAMWELL, LTD., LAS VEGAS, NV. SN 85-233,195. PUB. 5-31-2011, FILED 2-3-2011.

ST. DOMINICK

THE MARK CONSISTS OF STANDARD CHARACTERS WITHOUT CLAIM TO ANY PARTICULAR FONT, STYLE, SIZE, OR COLOR.

FOR MATTRESSES AND BOX SPRINGS (U.S. CLS. 2, 13, 22, 25, 32 AND 50).
FIRST USE 11-30-2011; IN COMMERCE 11-30-2011.

4,210,881. DREAMWELL, LTD., LAS VEGAS, NV. SN 85-249,909. PUB. 5-31-2011, FILED 2-23-2011.

REACTION MATERIAL

THE MARK CONSISTS OF STANDARD CHARACTERS WITHOUT CLAIM TO ANY PARTICULAR FONT, STYLE, SIZE, OR COLOR.

NO CLAIM IS MADE TO THE EXCLUSIVE RIGHT TO USE "MATERIAL", APART FROM THE MARK AS SHOWN.
FOR MATTRESS FOUNDATIONS; MATTRESSES (U.S. CLS. 2, 13, 22, 25, 32 AND 50).

FIRST USE 1-31-2011; IN COMMERCE 1-31-2011.

CLASS 20—(Continued).

4,211,018. DE RUCCI BEDDINGS CO., LTD., DONGGUAN CITY, CHINA. SN 85-325,565. PUB. 10-25-2011, FILED 5-20-2011.



THE MARK CONSISTS OF STYLIZED LETTERS "DR", WORD "DE RUCCI" AND CHINESE CHARACTERS.

THE ENGLISH TRANSLATION OF "MU SI" IN THE MARK IS ADMIRE THOUGHT.

THE NON-LATIN CHARACTERS IN THE MARK TRANSLITERATE TO "MU SI" AND THIS MEANS ADMIRE THOUGHT IN ENGLISH.

FOR BEDS; BENCHES; BOLSTERS; CHAIRS; COTS; CUSHIONS; FITTED FURNITURE COVER NOT OF FABRIC; FURNITURE; MATTRESSES; PILLOWS; SOFAS; SPRING MATTRESSES; WOOD BEDSTEADS (U.S. CLS. 2, 13, 22, 25, 32 AND 50).

FIRST USE 1-15-2012; IN COMMERCE 1-15-2012.

4,211,135. VERATEX, INC., PANORAMA CITY, CA. SN 85-345,156. PUB. 11-1-2011, FILED 6-13-2011.

SCHMOOZI

THE MARK CONSISTS OF STANDARD CHARACTERS WITHOUT CLAIM TO ANY PARTICULAR FONT, STYLE, SIZE, OR COLOR.

FOR BED PILLOWS; FLOOR PILLOWS; HEAD SUPPORTING PILLOWS; MATERNITY PILLOWS; NECK-SUPPORTING PILLOWS; NURSING PILLOWS; PILLOWS (U.S. CLS. 2, 13, 22, 25, 32 AND 50).

FIRST USE 5-13-2011; IN COMMERCE 3-23-2012.

CLASS 20—(Continued).

4,211,328. MCNEELY, KEVIN, ARLINGTON, TX. SN 85-374,036. PUB. 12-13-2011, FILED 7-18-2011.

DoseMinder

THE MARK CONSISTS OF STANDARD CHARACTERS WITHOUT CLAIM TO ANY PARTICULAR FONT, STYLE, SIZE, OR COLOR.

FOR NON-METAL BOTTLE CAPS FOR PRESCRIPTION BOTTLE CAPS FOR DOSAGE REMINDERS (U.S. CLS. 2, 13, 22, 25, 32 AND 50).

FIRST USE 6-1-2012; IN COMMERCE 6-1-2012.

4,211,410. CENTURYLINK, INC., MONROE, LA. SN 85-398,928. PUB. 11-8-2011, FILED 8-16-2011.

CENTURYLINK

THE MARK CONSISTS OF STANDARD CHARACTERS WITHOUT CLAIM TO ANY PARTICULAR FONT, STYLE, SIZE, OR COLOR.

FOR NON-METAL KEY FOBs; NON-METAL KEY-RINGS; NON-METAL RETRACTABLE BADGE HOLDERS; CHAIRS FOR GENERAL RECREATIONAL USE AND NOT FOR COMMERCIAL USE, NAMELY, CHAIRS FOR USE AT SPORTING MEETS AND WHILE CAMPING (U.S. CLS. 2, 13, 22, 25, 32 AND 50).

FIRST USE 8-9-2011; IN COMMERCE 8-9-2011.

4,211,465. ELAM, TIM, BOISE, ID. SN 85-418,320. PUB. 4-17-2012, FILED 9-9-2011.

PAK-RAT

THE MARK CONSISTS OF STANDARD CHARACTERS WITHOUT CLAIM TO ANY PARTICULAR FONT, STYLE, SIZE, OR COLOR.

FOR SPORTING GOODS, NAMELY, AN APPARATUS IN THE NATURE OF A PLASTIC CARABINER WITH A RUBBER LOCKING MECHANISM THAT ATTACHES TO BACKPACKS AND OTHER SHOULDERS STRAPS TO ENABLE SUPPORT OF A SLING OF A RIFLE, CAMERA BAG, OR ANOTHER ITEMS CONTAINING A SLING, IN ORDER TO HOLD OBJECTS IN A MORE SECURE FASHION (U.S. CLS. 2, 13, 22, 25, 32 AND 50).

FIRST USE 8-1-2011; IN COMMERCE 1-17-2012.

CLASS 20—(Continued).

4,211,550. NOWPAK, INC., BURLINGAME, CA. SN 85-461,295. PUB. 4-10-2012, FILED 11-1-2011.



The logo for 'take-out now' features the words 'take-out' in a bold, lowercase sans-serif font, followed by 'now' in a smaller, lowercase sans-serif font. The 'now' is contained within a solid black square.

THE MARK CONSISTS OF THE TEXT "TAKE-OUT NOW" WITH "NOW" INSIDE A SQUARE WITH ROUNDED CORNERS.

FOR PLASTIC CONTAINERS AND COVERS FOR THE FOOD INDUSTRY (U.S. CLS. 2, 13, 22, 25, 32 AND 50).

FIRST USE 4-2-2012; IN COMMERCE 4-2-2012.

4,211,630. ZINUS INC., HAYWARD, CA. SN 85-496,835. PUB. 5-15-2012, FILED 12-15-2011.

Geltex

THE MARK CONSISTS OF STANDARD CHARACTERS WITHOUT CLAIM TO ANY PARTICULAR FONT, STYLE, SIZE, OR COLOR.

FOR MATTRESS CUSHIONS; MATTRESS TOPPERS; MATTRESSES AND PILLOWS (U.S. CLS. 2, 13, 22, 25, 32 AND 50).

FIRST USE 3-15-2012; IN COMMERCE 4-1-2012.

CLASS 21—HOUSEWARES AND GLASS

4,210,280. THE TRANZONIC COMPANIES, CLEVELAND, OH. SN 77-479,357. PUB. 12-2-2008, FILED 5-20-2008.

TOOLWORKS

THE MARK CONSISTS OF STANDARD CHARACTERS WITHOUT CLAIM TO ANY PARTICULAR FONT, STYLE, SIZE, OR COLOR.

FOR WIPING CLOTHS FOR THE INDUSTRIAL AND INSTITUTIONAL FIELDS (U.S. CLS. 2, 13, 23, 29, 30, 33, 40 AND 50).

FIRST USE 2-10-2012; IN COMMERCE 2-10-2012.

CLASS 21—(Continued).

4,210,303. FERGUSON ENTERPRISES, INC., NEWPORT NEWS, VA. SN 77-565,783. PUB. 2-3-2009, FILED 9-9-2008.

BOCA RATON

THE MARK CONSISTS OF STANDARD CHARACTERS WITHOUT CLAIM TO ANY PARTICULAR FONT, STYLE, SIZE, OR COLOR.

OWNER OF U.S. REG. NO. 3,535,255.

FOR BATHROOM ACCESSORIES, NAMELY, TOWEL BARS, TOWEL RINGS, TOILET TISSUE HOLDERS, TOOTHBRUSH HOLDERS, CUP HOLDERS, SOAP DISHES AND SOAP DISPENSERS (U.S. CLS. 2, 13, 23, 29, 30, 33, 40 AND 50).

FIRST USE 2-0-2008; IN COMMERCE 2-0-2008.

4,210,406. PACTIV LLC, LAKE FOREST, IL. SN 77-874,056. PUB. 5-4-2010, FILED 11-17-2009.

CLEAR ADVANTAGE

THE MARK CONSISTS OF STANDARD CHARACTERS WITHOUT CLAIM TO ANY PARTICULAR FONT, STYLE, SIZE, OR COLOR.

FOR DISPOSABLE PLASTIC HINGED LID FOOD CONTAINERS (U.S. CLS. 2, 13, 23, 29, 30, 33, 40 AND 50).

FIRST USE 3-22-2010; IN COMMERCE 3-22-2010.

4,210,749. QUICKIE MANUFACTURING CORPORATION, CINNAMINSON, NJ. SN 85-202,448. PUB. 5-17-2011, FILED 12-21-2010.



NO CLAIM IS MADE TO THE EXCLUSIVE RIGHT TO USE "DRY SHINE SPONGE", APART FROM THE MARK AS SHOWN.

THE COLOR(S) DARK BLUE, LIGHT BLUE, RED AND WHITE IS/ARE CLAIMED AS A FEATURE OF THE MARK.

CLASS 21—(Continued).

THE MARK CONSISTS OF THE WORDS "DRY SHINE SPONGE" IN WHITE CAPITAL LETTERS. THE WORDS APPEAR ONE UNDER THE OTHER IN AN UPWARDS DIAGONAL DIRECTION. TO THE RIGHT OF THE WORD "DRY" THERE APPEARS A WHITE STARBURST. THE WORDS AND STARBURST ARE CONTAINED WITHIN A DARK BLUE BACKGROUND. BEHIND THE WORDING THERE APPEARS A LIGHT BLUE CIRCLE OUTLINED IN DARK BLUE AND RED CONCENTRIC CIRCLES.

FOR MOPS (U.S. CLS. 2, 13, 23, 29, 30, 33, 40 AND 50).

FIRST USE 1-0-2011; IN COMMERCE 1-0-2011.

4,210,888. PILL PICK UP, LLC, DOWNERS GROVE, IL. SN 85-251,938. PUB. 7-5-2011, FILED 2-25-2011.

SKIO

THE MARK CONSISTS OF STANDARD CHARACTERS WITHOUT CLAIM TO ANY PARTICULAR FONT, STYLE, SIZE, OR COLOR.

FOR PERSONAL DISPENSERS FOR PILLS OR CAPSULES FOR DOMESTIC USE (U.S. CLS. 2, 13, 23, 29, 30, 33, 40 AND 50).

FIRST USE 5-31-2012; IN COMMERCE 5-31-2012.

4,210,995. CRYSTAL ART IMPORTS, INC., COLUMBUS, OH. SN 85-320,032. PUB. 11-1-2011, FILED 5-13-2011.

CASHS IRELAND

THE MARK CONSISTS OF STANDARD CHARACTERS WITHOUT CLAIM TO ANY PARTICULAR FONT, STYLE, SIZE, OR COLOR.

OWNER OF U.S. REG. NO. 1,288,972.

NO CLAIM IS MADE TO THE EXCLUSIVE RIGHT TO USE "IRELAND", APART FROM THE MARK AS SHOWN.

FOR STATUES AND STATUETTES MADE OF CRYSTAL; CRYSTAL SCULPTURES; DESKTOP STATUARY MADE OF CRYSTAL; CRYSTAL FIGURES AND FIGURINES; ORNAMENTS OF CRYSTAL; HOLIDAY ORNAMENTS OF CRYSTAL; WORKS OF ART MADE OF CRYSTAL; HOUSEHOLD CONTAINERS OF CRYSTAL; BARWARE, BEVERAGE GLASSWARE, BEVERAGEWARE, BOWLS, CANDLE HOLDERS, CANDLESTICKS, CHAMPAGNE FLUTES, COOLING BUCKETS FOR WINE, CUPS AND MUGS, DISHWARE, DRINKING CUPS AND SAUCERS, DRINKING GLASSES, DRINKING VESSELS, FLOWER BOWLS, FLOWER VASES, FRUIT BOWLS, STEMWARE, VASES, WINE GLASSES, ALL MADE OF CRYSTAL (U.S. CLS. 2, 13, 23, 29, 30, 33, 40 AND 50).

FIRST USE 0-0-2009; IN COMMERCE 0-0-2009.

CLASS 21—(Continued).

4,211,054. EASEPAL ENTERPRISES LTD, FUJIAN PROVINCE, CHINA. SN 85-333,314. PUB. 10-25-2011, FILED 5-30-2011.



THE MARK CONSISTS OF THE STYLIZED WORD "KNINK" ON THE LEFT, AND TWO CHINESE CHARACTERS WHICH TRANSLITERATE INTO YIN KE ON THE RIGHT.

THE WORDING "KNINK" HAS NO MEANING IN A FOREIGN LANGUAGE.

THE NON-LATIN CHARACTERS IN THE MARK TRANSLITERATE TO YIN; KE AND THIS MEANS STAMP; GUEST IN ENGLISH.

FOR BEER MUGS; BEVERAGE GLASSWARE; BOWLS; CERAMIC SCULPTURES, VASES, VESSELS, BOWLS, PLATES AND POTS; CONTAINERS FOR HOUSEHOLD OR KITCHEN USE; CUPS; DISHES; DRINKING GLASSES; ENAMELLED GLASS; GOBLETS; PAPER AND PLASTIC CUPS; WATERING POTS (U.S. CLS. 2, 13, 23, 29, 30, 33, 40 AND 50).

FIRST USE 2-1-2010; IN COMMERCE 9-1-2010.

4,211,058. TIGHTPAC AMERICA INC., INGLEWOOD, CA. SN 85-334,542. PUB. 10-25-2011, FILED 5-31-2011.

SNACKVAC

THE MARK CONSISTS OF STANDARD CHARACTERS WITHOUT CLAIM TO ANY PARTICULAR FONT, STYLE, SIZE, OR COLOR.

FOR PLASTIC STORAGE CONTAINERS FOR HOUSEHOLD USE (U.S. CLS. 2, 13, 23, 29, 30, 33, 40 AND 50).

FIRST USE 5-1-2011; IN COMMERCE 1-1-2012.

CLASS 21—(Continued).

4,211,066. PILL PICK UP, LLC, DOWNERS GROVE, IL. SN 85-335,518. PUB. 10-25-2011, FILED 6-1-2011.

THE MARK CONSISTS OF THE STYLIZED WORD "SKIO".

FOR PERSONAL PILL DISPENSERS FOR PILLS OR CAPSULES FOR DOMESTIC USE (U.S. CLS. 2, 13, 23, 29, 30, 33, 40 AND 50).

FIRST USE 5-31-2012; IN COMMERCE 5-31-2012.

4,211,153. CAMELBAK PRODUCTS, LLC, PETALUMA, CA. SN 85-346,979. PUB. 11-1-2011, FILED 6-15-2011.

EDDY

THE MARK CONSISTS OF STANDARD CHARACTERS WITHOUT CLAIM TO ANY PARTICULAR FONT, STYLE, SIZE, OR COLOR.

FOR WATER BOTTLES, SOLD EMPTY; SPORTS BOTTLES, SOLD EMPTY; WATER BOTTLES WITH BITE-ACTUATED MOUTHPIECES, SOLD EMPTY; THERMAL INSULATED WATER BOTTLES, SOLD EMPTY; REUSABLE STAINLESS STEEL WATER BOTTLES, SOLD EMPTY (U.S. CLS. 2, 13, 23, 29, 30, 33, 40 AND 50).

FIRST USE 2-1-2012; IN COMMERCE 2-1-2012.

4,211,242. SKT PRODUCTIONS, INC., NEW YORK, NY. SN 85-358,012. PUB. 11-29-2011, FILED 6-28-2011.

iRoller

THE MARK CONSISTS OF STANDARD CHARACTERS WITHOUT CLAIM TO ANY PARTICULAR FONT, STYLE, SIZE, OR COLOR.

FOR HOUSEHOLD CLEANING DEVICE, NAMELY, CLEANING ROLLER FOR REMOVING DUST FROM TV, VCR, VIDEO AND COMPUTER SCREENS (U.S. CLS. 2, 13, 23, 29, 30, 33, 40 AND 50).

FIRST USE 7-12-2012; IN COMMERCE 7-12-2012.

CLASS 21—(Continued).

4,211,444. DENTEK ORAL CARE, INC., MARYVILLE, TN. SN 85-410,644. PUB. 5-15-2012, FILED 8-30-2011.

FRESH CLEAN

THE MARK CONSISTS OF STANDARD CHARACTERS WITHOUT CLAIM TO ANY PARTICULAR FONT, STYLE, SIZE, OR COLOR.

OWNER OF U.S. REG. NOS. 2,974,417, 3,782,487, AND 3,914,550.

NO CLAIM IS MADE TO THE EXCLUSIVE RIGHT TO USE "CLEAN", APART FROM THE MARK AS SHOWN.

FOR HOME DENTAL CLEANING DEVICE FOR CONSUMER USE CONSISTING OF A COMBINATION DENTAL FLOSS AND PICK FOR CLEANING TEETH, AND NOT FOR USE FOR CLEANING DENTURES (U.S. CLS. 2, 13, 23, 29, 30, 33, 40 AND 50).

FIRST USE 5-1-2012; IN COMMERCE 5-1-2012.

4,211,481. EVRIHOLDER PRODUCTS LLC, ANAHEIM, CA. SN 85-425,369. PUB. 2-21-2012, FILED 9-17-2011.

SOPHISTI-CLEAN

THE MARK CONSISTS OF STANDARD CHARACTERS WITHOUT CLAIM TO ANY PARTICULAR FONT, STYLE, SIZE, OR COLOR.

FOR CLOTHS FOR CLEANING (U.S. CLS. 2, 13, 23, 29, 30, 33, 40 AND 50).

FIRST USE 9-26-2011; IN COMMERCE 10-26-2011.

CLASS 21—(Continued).

4,211,535. FLP, LLC, TEMPE, AZ. SN 85-453,282. PUB. 4-3-2012, FILED 10-21-2011.

Great Ideas

THE MARK CONSISTS OF STANDARD CHARACTERS WITHOUT CLAIM TO ANY PARTICULAR FONT, STYLE, SIZE, OR COLOR.

FOR DRINKING CUPS FOR BABIES AND CHILDREN AND PARTS AND FITTINGS THEREFOR, NAMELY, CUPS FOR BABIES AND CHILDREN SOLD AS A UNIT WITH VALVES AND LIDS; DRINKING CUPS FOR CHILDREN AND PARTS AND FITTINGS THEREFOR, NAMELY, DRINKING CUPS FOR CHILDREN SOLD AS A UNIT WITH NON-INSULATED LIDS; DRINKING CUPS SOLD WITH LIDS THEREFOR; HOUSEHOLD UTENSILS, NAMELY, ICE CUBE MOLDS, POPSICLE MOLDS, PLASTIC LIDS FOR OPENED CANS, AND ICE CREAM CONE HOLDERS; REUSABLE SELF-SEALING LIDS FOR HOUSEHOLD USE FOR BOWLS, CUPS, CONTAINERS AND THE STORAGE OF FOOD (U.S. CLS. 2, 13, 23, 29, 30, 33, 40 AND 50).

FIRST USE 1-1-2012; IN COMMERCE 1-1-2012.

4,211,545. SMALDONE, JAMES, BROOKLYN, NY. SN 85-457,197. PUB. 4-3-2012, FILED 10-26-2011.

STANDS TALL WON'T FALL

THE MARK CONSISTS OF STANDARD CHARACTERS WITHOUT CLAIM TO ANY PARTICULAR FONT, STYLE, SIZE, OR COLOR.

FOR BEER MUGS; COFFEE CUPS, TEA CUPS AND MUGS; COFFEE MUGS; COMPOSTABLE AND BIODEGRADABLE PLATES, BOWLS, CUPS AND TRAYS; CROCKERY, NAMELY, POTS, DISHES, DRINKING CUPS AND SAUCERS, BOWLS, SERVING BOWLS AND TRAYS; CUPS; CUPS AND MUGS; CUPS, NOT OF PRECIOUS METAL; DRINKING GLASSES; DRINKING GLASSES MADE FROM RECYCLED PLASTIC/GLASS; DRINKING GLASSES, NAMELY, TUMBLERS; EARTH-WARE MUGS; GLASS BEVERAGeware; GLASS CARAFES; GLASS DISHES; GLASS FLOOR VASES; GLASS MUGS; GLASS STORAGE JARS; MUG TREES; MUGS; MUGS, NOT OF PRECIOUS METAL; PAPER AND PLASTIC CUPS; PILSNER DRINKING GLASSES; PORCELAIN MUGS; SAKE CUPS; SHOT GLASSES; TRAINING CUPS FOR BABIES AND CHILDREN; WINE GLASSES (U.S. CLS. 2, 13, 23, 29, 30, 33, 40 AND 50).

FIRST USE 6-27-2011; IN COMMERCE 2-7-2012.

CLASS 22—CORDAGE AND FIBERS

CLASS 22—(Continued).

4,210,920. GAINES, RICHARD, BRECKENRIDGE, MI. SN 85-273,247. PUB. 8-23-2011, FILED 3-22-2011.



NO CLAIM IS MADE TO THE EXCLUSIVE RIGHT TO USE "LOCK", APART FROM THE MARK AS SHOWN.

THE MARK CONSISTS OF THE STYLIZED TEXT "LOCK SOCK" WITH A LOCK IN THE MIDDLE.

FOR WATERPROOF AND WIND-RESISTANT UNFITTED NYLON FABRIC COVER FOR PADLOCKS TO PREVENT RUST AND FREEZING AND EXPOSURE TO RAIN AND SNOW (U.S. CLS. 1, 2, 7, 19, 22, 42 AND 50). FIRST USE 4-1-2011; IN COMMERCE 4-15-2011.

4,210,953. INVISTA NORTH AMERICA S.A. R.L., WICHITA, KS. SN 85-296,461. PUB. 7-5-2011, FILED 4-15-2011.

DUALFX

THE MARK CONSISTS OF STANDARD CHARACTERS WITHOUT CLAIM TO ANY PARTICULAR FONT, STYLE, SIZE, OR COLOR.

FOR RAW TEXTILE FIBERS; SYNTHETIC FIBERS AND FILAMENTS FOR USE IN THE MANUFACTURE OF FABRICS, TEXTILES, YARNS, AND CARPETS; YARN FIBERS (U.S. CLS. 1, 2, 7, 19, 22, 42 AND 50). FIRST USE 4-15-2011; IN COMMERCE 7-31-2011.

4,211,406. HAMPTON PRODUCTS INTERNATIONAL CORPORATION, FOOTHILL RANCH, CA. SN 85-395,986. PUB. 12-13-2011, FILED 8-11-2011.



OWNER OF U.S. REG. NOS. 2,106,212 AND 3,026,742.

CLASS 22—(Continued).

THE MARK CONSISTS OF THE STYLIZED LETTER "K" FORMED BY THREE TRIANGLES AND THE STYLIZED WORD "KEEPER".

FOR NON-METAL DEVICES FOR HANDLING, SECURING, AND STOWING CARGO, NAMELY, TIE-DOWNS, CARGO SECURING AND TOWING STRAPS, STRETCH STRAPS, ALL-PURPOSE STRAPS, AND CARGO BAGS AND NETS FOR USE ON MOTOR VEHICLES AND TRAILERS (U.S. CLS. 1, 2, 7, 19, 22, 42 AND 50). FIRST USE 10-30-2011; IN COMMERCE 10-30-2011.

CLASS 23—YARNS AND THREADS

4,211,457. J. & P. COATS, LIMITED, GLASGOW, UNITED KINGDOM. SN 85-415,283. PUB. 1-24-2012, FILED 9-6-2011.

CUPID

THE MARK CONSISTS OF STANDARD CHARACTERS WITHOUT CLAIM TO ANY PARTICULAR FONT, STYLE, SIZE, OR COLOR.

OWNER OF U.S. REG. NO. 3,121,956. FOR YARNS FOR KNITTING AND CROCHETING (U.S. CL. 43). FIRST USE 7-6-2012; IN COMMERCE 7-6-2012.

CLASS 24—FABRICS

4,211,020. ELLERY HOLDINGS LLC, NEW YORK, NY. SN 85-325,733. PUB. 10-11-2011, FILED 5-20-2011.

TOP IT OFF

THE MARK CONSISTS OF STANDARD CHARACTERS WITHOUT CLAIM TO ANY PARTICULAR FONT, STYLE, SIZE, OR COLOR.

FOR CURTAINS (U.S. CLS. 42 AND 50). FIRST USE 1-28-2011; IN COMMERCE 1-28-2011.

CLASS 24—(Continued).

4,211,091. TRINITY GUARDION, LLC, BATESVILLE, IN. SN 85-338,787. PUB. 10-25-2011, FILED 6-6-2011.



THE MARK CONSISTS OF A CIRCLE, LIGHTENING FROM ITS CIRCUMFERENCE TO ITS CENTER, SURROUNDED BY, BUT NOT CONTACTING, A RING DIVIDED INTO THREE EQUAL-SIZED SECTIONS, THE LEFT SECTION DARKER THAN THE UPPER RIGHT SECTION, DARKER THAN THE LOWER RIGHT SECTION.

FOR BED COVERS; MATTRESS COVERS; COVERS FOR HOSPITAL BEDS AND NURSING HOME BEDS (U.S. CLS. 42 AND 50).

FIRST USE 6-27-2011; IN COMMERCE 6-27-2011.

4,211,191. SVETLANA HALL, WAYLAND, MA. SN 85-350,836. PUB. 11-8-2011, FILED 6-20-2011.

SIMPLY LANA

THE MARK CONSISTS OF STANDARD CHARACTERS WITHOUT CLAIM TO ANY PARTICULAR FONT, STYLE, SIZE, OR COLOR.

FOR FACE TOWELS; HAND TOWELS; TOWELS (U.S. CLS. 42 AND 50).

FIRST USE 11-1-2011; IN COMMERCE 11-1-2011.

CLASS 24—(Continued).

4,211,230. SOUTHERN FELT COMPANY, INC., NORTH AUGUSTA, SC. SN 85-356,604. PUB. 11-15-2011, FILED 6-27-2011.

POWERTECH

THE MARK CONSISTS OF STANDARD CHARACTERS WITHOUT CLAIM TO ANY PARTICULAR FONT, STYLE, SIZE, OR COLOR.

FOR NON-WOVEN FABRICS AND FELTS (U.S. CLS. 42 AND 50).

FIRST USE 7-22-2011; IN COMMERCE 7-22-2011.

4,211,232. SOUTHERN FELT COMPANY, INC., NORTH AUGUSTA, SC. SN 85-356,607. PUB. 11-15-2011, FILED 6-27-2011.

POWERLOX

THE MARK CONSISTS OF STANDARD CHARACTERS WITHOUT CLAIM TO ANY PARTICULAR FONT, STYLE, SIZE, OR COLOR.

FOR NON-WOVEN FABRICS AND FELTS (U.S. CLS. 42 AND 50).

FIRST USE 7-22-2011; IN COMMERCE 7-22-2011.

4,211,383. ONE SOURCE APPAREL, PORTSMOUTH, NH. SN 85-389,488. PUB. 1-3-2012, FILED 8-4-2011.

THERMA LOFT-PRO

THE MARK CONSISTS OF STANDARD CHARACTERS WITHOUT CLAIM TO ANY PARTICULAR FONT, STYLE, SIZE, OR COLOR.

FOR FABRICS FOR THE MANUFACTURE OF JACKETS, VESTS, PULLOVERS, ROBES, HATS, GLOVES, SOCKS, UNDERWEAR, THROWS, AND BLANKETS; TEXTILE FABRICS FOR THE MANUFACTURE OF CLOTHING (U.S. CLS. 42 AND 50).

FIRST USE 8-4-2011; IN COMMERCE 8-4-2011.

CLASS 24—(Continued).

4,211,593. WEST CHESTER HOLDINGS, INC., MONROE, OH. SN 85-479,357. PUB. 5-8-2012, FILED 11-22-2011.

IRONTEX

THE MARK CONSISTS OF STANDARD CHARACTERS WITHOUT CLAIM TO ANY PARTICULAR FONT, STYLE, SIZE, OR COLOR.

FOR FABRICS FOR THE MANUFACTURE OF JACKETS, APRONS AND SLEEVES (U.S. CLS. 42 AND 50).
FIRST USE 2-21-2012; IN COMMERCE 2-21-2012.

4,211,597. GRACE HOME FASHIONS, LLC, NEW YORK, NY. SN 85-482,888. PUB. 5-8-2012, FILED 11-29-2011.

COLORFUL DREAMS

THE MARK CONSISTS OF STANDARD CHARACTERS WITHOUT CLAIM TO ANY PARTICULAR FONT, STYLE, SIZE, OR COLOR.

FOR BED SHEETS, AND PILLOWCASES (U.S. CLS. 42 AND 50).
FIRST USE 3-25-2012; IN COMMERCE 3-25-2012.

CLASS 25—CLOTHING

4,210,232. JOZETTE PTY LTD., POTTS POINT NSW 2011, AUSTRALIA. SN 76-690,479. PUB. 6-2-2009, FILED 6-11-2008.

JOZETTE HAZZOURI

THE MARK CONSISTS OF STANDARD CHARACTERS WITHOUT CLAIM TO ANY PARTICULAR FONT, STYLE, SIZE, OR COLOR.

THE NAME "JOZETTE HAZZOURI" IDENTIFIES A LIVING INDIVIDUAL WHOSE CONSENT IS OF RECORD.

FOR SHOES AND CLOTHING FOR WEAR IN THE PRACTICE AND PERFORMANCE OF DANCE, NAMELY, LEOTARDS AND TIGHTS (U.S. CLS. 22 AND 39).
FIRST USE 7-0-2012; IN COMMERCE 7-0-2012.

CLASS 25—(Continued).

4,210,235. SELLMAN, PASQUALE, UPPER MARLBORO, MD. AND SELLMAN, TAWANA, UPPER MARLBORO, MD. SN 76-703,253. PUB. 12-14-2010, FILED 6-7-2010.



Wrought Iron

FOR CLOTHING, NAMELY, SHIRTS, PANTS, SOCKS, BELTS, AND UNDERWEAR (U.S. CLS. 22 AND 39).
FIRST USE 7-23-2012; IN COMMERCE 7-23-2012.

4,210,236. AOM HOLDING, L.L.C., NEW YORK, NY. SN 76-703,703. PUB. 11-22-2011, FILED 7-8-2010.

ISLAND WAVES

THE MARK CONSISTS OF STANDARD CHARACTERS WITHOUT CLAIM TO ANY PARTICULAR FONT, STYLE, SIZE, OR COLOR.

FOR CLOTHING, NAMELY, SWIMWEAR, SHIRTS, TOPS, COVER-UPS, TANK TOPS, PANTS, TSHIRTS, HEADWEAR, FOOTWEAR, JACKETS, AND SOCKS (U.S. CLS. 22 AND 39).
FIRST USE 11-1-2011; IN COMMERCE 11-1-2011.

4,210,239. IN MOCEAN GROUP, L.L.C., NEW YORK, NY. SN 76-705,914. PUB. 7-26-2011, FILED 2-1-2011.

WITH IN MOCEAN YOU'RE NEVER SWIMMING ALONE

THE MARK CONSISTS OF STANDARD CHARACTERS WITHOUT CLAIM TO ANY PARTICULAR FONT, STYLE, SIZE, OR COLOR.

OWNER OF U.S. REG. NO. 3,909,598.
FOR CLOTHING, NAMELY, SWIMWEAR, BEACHWEAR, BATHING SUITS, SHIRTS, SHORTS, COVER-UPS, SWIM DRESSES, COVER DRESSES, TOPS, AND BOARD SHORTS; AND BODYWEAR, NAMELY, TIGHTS, BODYSUITS, LEOTARDS, BIKE SHORTS, BRA TOPS, LEGGINGS, BIKETARDS, UNITARDS, T-SHIRTS, SWEATSHIRTS, SWEATPANTS, TANK TOPS, JOGGING SUITS, ATHLETIC SHOES, FLIP FLOPS, SANDALS, SOCKS, HATS, HEADBANDS, AND UNDERWEAR (U.S. CLS. 22 AND 39).
FIRST USE 12-0-2010; IN COMMERCE 12-0-2010.

CLASS 25—(Continued).

4,210,240. KEM ROUNDS, MEMPHIS, TN. AND BRENDA ROUNDS, MEMPHIS, TN. SN 76-706,065. PUB. 10-25-2011, FILED 1-18-2011.



THE COLOR(S) RED, GREEN, AND BLACK IS/ARE CLAIMED AS A FEATURE OF THE MARK.

THE MARK CONSISTS OF THE STYLIZED LETTERS AND NUMERAL "TO4E" INTERTWINED IN THE COLOR RED, WITH A GREEN OUTLINE, AND THE STYLIZED WORDING "THUGGED OUT 4 EVER" IN THE COLOR BLACK.

FOR T-SHIRT (U.S. CLS. 22 AND 39).

FIRST USE 3-25-2012; IN COMMERCE 3-25-2012.

4,210,251. HURLEY INTERNATIONAL LLC, COSTA MESA, CA. SN 77-235,284. PUB. 6-14-2011, FILED 7-20-2007.

SALVATION

THE MARK CONSISTS OF STANDARD CHARACTERS WITHOUT CLAIM TO ANY PARTICULAR FONT, STYLE, SIZE, OR COLOR.

OWNER OF U.S. REG. NOS. 2,363,365 AND 3,699,709.

FOR CLOTHING, NAMELY, T-SHIRTS AND TOPS (U.S. CLS. 22 AND 39).

FIRST USE 8-31-2011; IN COMMERCE 8-31-2011.

CLASS 25—(Continued).

4,210,265. MILLER, PHILLIP, BROOKLYN, NY. SN 77-411,181. PUB. 7-22-2008, FILED 3-3-2008.



THE MARK CONSISTS OF A HUMMING BIRD, FOR CLOTHING, NAMELY, T-SHIRTS, PULLOVERS, SWEATERS, JERSEYS, JEANS, SHORTSETS, TOPS (U.S. CLS. 22 AND 39).

FIRST USE 11-15-2011; IN COMMERCE 11-15-2011.

4,210,278. NINJAI GANG, LLC, KAILUA, HI. SN 77-476,117. PUB. 4-28-2009, FILED 5-15-2008.

NINJAI THE LITTLE NINJA

THE MARK CONSISTS OF STANDARD CHARACTERS WITHOUT CLAIM TO ANY PARTICULAR FONT, STYLE, SIZE, OR COLOR.

OWNER OF U.S. REG. NOS. 2,872,444 AND 3,042,123.

FOR HEADWEAR, JACKETS, POLO SHIRTS, SHORTS, SWEATSHIRTS (U.S. CLS. 22 AND 39).

FIRST USE 7-18-2012; IN COMMERCE 7-18-2012.

4,210,298. SUNNY BANKS INC., FULLERTON, CA. SN 77-552,015. PUB. 3-24-2009, FILED 8-20-2008.

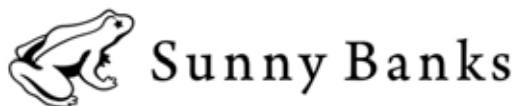

THE MARK CONSISTS OF THE DESIGN OF A FROG WITH A STAR AS ITS EYE NEXT TO THE WORDING "SUNNY BANKS".

FOR SHIRTS; SHORT-SLEEVED OR LONG-SLEEVED T-SHIRTS; T-SHIRTS (U.S. CLS. 22 AND 39).

FIRST USE 8-3-2011; IN COMMERCE 1-11-2012.

CLASS 25—(Continued).

4,210,310. PDC LICENSING, LLC, NEW YORK, NY. SN 77-607,816. PUB. 2-10-2009, FILED 11-5-2008.

RESIN

THE MARK CONSISTS OF STANDARD CHARACTERS WITHOUT CLAIM TO ANY PARTICULAR FONT, STYLE, SIZE, OR COLOR.
FOR PANTS, SWEATERS, JACKETS, COATS, SHIRTS, T-SHIRTS, SKIRTS, VESTS, TOPS (U.S. CLS. 22 AND 39).
FIRST USE 1-0-2011; IN COMMERCE 1-0-2011.

4,210,329. COURAGE SPORTS, INC., FAIRACRES, NM. SN 77-637,291. PUB. 11-3-2009, FILED 12-19-2008.

CRIMSON COURAGE

THE MARK CONSISTS OF STANDARD CHARACTERS WITHOUT CLAIM TO ANY PARTICULAR FONT, STYLE, SIZE, OR COLOR.
FOR CLOTHING, NAMELY, MEN'S, WOMEN'S AND CHILDREN'S FITNESS, ATHLETIC AND CASUAL CLOTHING, NAMELY, PANTS, SHIRTS, T-SHIRTS, SWEATSHIRTS, SOCKS, TROUSERS, SHORTS, SWEAT-PANTS, JOGGING SUITS, WIND AND/OR RAIN RESISTANT JACKETS, JACKETS, COATS AND PARKAS; SHOES; HEADGEAR, NAMELY, HATS AND CAPS (U.S. CLS. 22 AND 39).
FIRST USE 4-11-2012; IN COMMERCE 4-11-2012.

4,210,330. AUTRY CONSULTING SERVICES, LLC, MERIDIAN, MS. SN 77-639,478. PUB. 4-21-2009, FILED 12-23-2008.

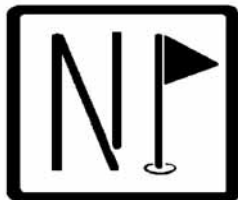

THE MARK CONSISTS OF THE STYLIZED TEXT "NIP" FOLLOWED BY A GOLF FLAGSTICK IN THE CUP FORMING THE STYLIZED TEXT "P".
FOR BASEBALL CAPS; PANTS; SHIRTS; SKIRTS; T-SHIRTS (U.S. CLS. 22 AND 39).
FIRST USE 1-1-2010; IN COMMERCE 2-1-2010.

CLASS 25—(Continued).

4,210,336. PUNKSTAR, LLC, LOS ANGELES, CA. SN 77-642,496. PUB. 4-28-2009, FILED 1-2-2009.

PUNKSTAR

THE MARK CONSISTS OF STANDARD CHARACTERS WITHOUT CLAIM TO ANY PARTICULAR FONT, STYLE, SIZE, OR COLOR.
FOR MEN'S AND WOMEN'S CLOTHING, NAMELY, T-SHIRTS (U.S. CLS. 22 AND 39).
FIRST USE 7-11-2012; IN COMMERCE 7-11-2012.

4,210,358. UPTON, JULIE, LAYTONSVILLE, MD. SN 77-726,337. PUB. 10-27-2009, FILED 4-30-2009.

TANKEE

THE MARK CONSISTS OF STANDARD CHARACTERS WITHOUT CLAIM TO ANY PARTICULAR FONT, STYLE, SIZE, OR COLOR.
FOR FOUNDATION GARMENTS, NAMELY, MID-RIF F TOPS, TANK TOPS AND TEE SHIRTS; WOMEN'S UNDERCLOTHING (U.S. CLS. 22 AND 39).
FIRST USE 7-12-2012; IN COMMERCE 7-12-2012.

4,210,384. TASER INTERNATIONAL, INC., SCOTTSDALE, AZ. SN 77-813,122. PUB. 7-13-2010, FILED 8-26-2009.



THE MARK CONSISTS OF AN IMAGE OF A STYLIZED LIGHTNING BOLT WITHIN A CIRCLE.
FOR SHIRTS AND CAPS (U.S. CLS. 22 AND 39).
FIRST USE 1-9-2009; IN COMMERCE 1-9-2009.

CLASS 25—(Continued).

4,210,392. WEST, WILLIAM, HENDERSON, NV. AND TROUPE, NEIL, HENDERSON, NV. AND RUSNAK, MICHAEL, HENDERSON, NV. SN 77-855,554. PUB. 9-7-2010, FILED 10-22-2009.

**DIRTY WHITE BOY RACING
D.W.B.R.**

THE MARK CONSISTS OF STANDARD CHARACTERS WITHOUT CLAIM TO ANY PARTICULAR FONT, STYLE, SIZE, OR COLOR.

NO CLAIM IS MADE TO THE EXCLUSIVE RIGHT TO USE "RACING", APART FROM THE MARK AS SHOWN.

FOR CLOTHING, NAMELY, MALE AND FEMALE SHORTS AND PANTS, MALE AND FEMALE SWIMWEAR, MALE AND FEMALE UNDERWEAR, MALE AND FEMALE JACKETS, HOODED SWEATSHIRTS, SWEAT SHIRTS, LONG SLEEVE SHIRTS, SHORT SLEEVE SHIRTS, TANK TOPS, HATS, SOCKS, BELTS, BEANIES, SHOES, AND BANDANAS (U.S. CLS. 22 AND 39).

FIRST USE 1-1-1998; IN COMMERCE 4-1-2011.

4,210,401. SALES & PRODUCT SOLUTIONS, INC., NORTHBROOK, IL. SN 77-868,555. PUB. 4-13-2010, FILED 11-9-2009.

SNAPRODUCTS

THE MARK CONSISTS OF STANDARD CHARACTERS WITHOUT CLAIM TO ANY PARTICULAR FONT, STYLE, SIZE, OR COLOR.

FOR ADULT APPAREL, NAMELY, SCARVES, MITTENS AND HOSIERY; CHILDREN'S APPAREL, NAMELY, SLIPPERS AND HOSIERY; ADULT AND CHILDREN'S CASUAL FOOTWEAR; COTTON GLOVES FOR USE AFTER APPLYING MOISTURIZING LOTIONS, COTTON BOOTIES FOR USE AFTER APPLYING MOISTURIZING LOTIONS AND SLEEP MASKS (U.S. CLS. 22 AND 39).

FIRST USE 5-0-2010; IN COMMERCE 5-0-2010.

4,210,408. SPEEDO INTERNATIONAL LIMITED, LONDON, UNITED KINGDOM. SN 77-878,620. PUB. 4-13-2010, FILED 11-23-2009.

**SPEEDO ENGINEERED FROM THE
INSIDE OUT**

THE MARK CONSISTS OF STANDARD CHARACTERS WITHOUT CLAIM TO ANY PARTICULAR FONT, STYLE, SIZE, OR COLOR.

CLASS 25—(Continued).

OWNER OF U.S. REG. NOS. 1,011,585, 1,647,484, AND OTHERS.

FOR CLOTHING, NAMELY, SWIMWEAR AND FOOTWEAR (U.S. CLS. 22 AND 39).

FIRST USE 0-0-2011; IN COMMERCE 0-0-2011.

4,210,424. RODRIGUEZ PINEDA, MIGUEL ANGEL, TLALNEPANTLA, ESTADO DE MEXICO, MEXICO. SN 77-909,347. PUB. 5-25-2010, FILED 1-11-2010.

AY GÜEY

THE MARK CONSISTS OF STANDARD CHARACTERS WITHOUT CLAIM TO ANY PARTICULAR FONT, STYLE, SIZE, OR COLOR.

THE ENGLISH TRANSLATION OF "AY GÜEY" IN THE MARK IS OH DEAR OR OH DUDE.

FOR BELTS; BERMUDA SHORTS; BLOUSES; BOXER SHORTS; CAPS; DRESSES; HATS; JACKETS; JEANS; SHIRTS; SHORTS; SWEAT SHIRTS; T-SHIRTS (U.S. CLS. 22 AND 39).

FIRST USE 2-3-2008; IN COMMERCE 5-21-2012.

4,210,441. BIG IDEA BRANDS, LLC, NEW YORK, NY. SN 77-918,047. PUB. 11-2-2010, FILED 1-22-2010.



NO CLAIM IS MADE TO THE EXCLUSIVE RIGHT TO USE "AUTHENTIC LACROSSE GEAR", APART FROM THE MARK AS SHOWN.

THE MARK CONSISTS OF THE WORDS "FLOW SOCIETY AUTHENTIC LACROSSE GEAR" WITH A STYLIZED EAGLE TO THE LEFT OF THE WORDS.

FOR COATS; FOOTWEAR; GLOVES; HEADWEAR; JACKETS; LOUNGEWEAR; PANTS; SCARVES; SHIRTS; SHORTS; SOCKS; SWEAT BANDS; SWIMWEAR; UNDERWEAR (U.S. CLS. 22 AND 39).

FIRST USE 2-3-2012; IN COMMERCE 2-3-2012.

CLASS 25—(Continued).

4,210,445. COHEN, STEPHEN J., UPPER SADDLE RIVER, NJ. SN 77-921,602. PUB. 6-15-2010, FILED 1-27-2010.

CWAJGA

THE MARK CONSISTS OF STANDARD CHARACTERS WITHOUT CLAIM TO ANY PARTICULAR FONT, STYLE, SIZE, OR COLOR.

THE WORDING "CWAJGA" HAS NO MEANING IN A FOREIGN LANGUAGE.

FOR APPAREL, NAMELY, T-SHIRTS AND SHIRTS (U.S. CLS. 22 AND 39).

FIRST USE 7-30-2012; IN COMMERCE 7-30-2012.

CLASS 25—(Continued).

4,210,491. NIKE, INC., BEAVERTON, OR. SN 85-012,185. PUB. 3-15-2011, FILED 4-12-2010.

TIEMPO

THE MARK CONSISTS OF STANDARD CHARACTERS WITHOUT CLAIM TO ANY PARTICULAR FONT, STYLE, SIZE, OR COLOR.

FOR FOOTWEAR FOR SOCCER (U.S. CLS. 22 AND 39). FIRST USE 12-31-1984; IN COMMERCE 12-31-1984.

4,210,466. GEORGEMARC LLC, NEW YORK, NY. SN 77-955,641. PUB. 8-3-2010, FILED 3-10-2010.

 **Descendant of Thieves**
By: Dres Ladro

THE NAME(S), PORTRAIT(S), AND/OR SIGNATURE(S) SHOWN IN THE MARK DOES NOT IDENTIFY A PARTICULAR LIVING INDIVIDUAL.

THE MARK CONSISTS OF A STYLIZED TREE NEXT TO THE LITERAL ELEMENT.

FOR BELTS; BLAZERS; BLOUSES; CAMISOLES; CAPS; COATS; DRESSES; FOOTWEAR; HALTER TOPS; HATS; JACKETS; JEANS; KNIT SHIRTS; LINGERIE; LOUNGEWEAR; PANTS; POLO KNIT TOPS; SCARVES; SHIRTS; SHOES; SHORTS; SKIRTS; SLACKS; SOCKS; SWEAT PANTS; SWEAT SHIRTS; SWEATERS; T-SHIRTS; TANK TOPS; UNDERSHIRTS; UNDERWEAR; VESTS (U.S. CLS. 22 AND 39).

FIRST USE 7-1-2010; IN COMMERCE 7-1-2010.

4,210,492. NIKE, INC., BEAVERTON, OR. SN 85-012,191. PUB. 7-27-2010, FILED 4-12-2010.

CTR360

THE MARK CONSISTS OF STANDARD CHARACTERS WITHOUT CLAIM TO ANY PARTICULAR FONT, STYLE, SIZE, OR COLOR.

FOR FOOTWEAR (U.S. CLS. 22 AND 39). FIRST USE 8-31-2009; IN COMMERCE 8-31-2009.

4,210,472. CUSHMAN, VANESSA A., NEW ROCHELLE, NY. SN 77-968,300. PUB. 8-17-2010, FILED 3-25-2010.

Lov Me Lov My Boy

THE MARK CONSISTS OF STANDARD CHARACTERS WITHOUT CLAIM TO ANY PARTICULAR FONT, STYLE, SIZE, OR COLOR.

FOR DRESSES; JACKETS; PANTS; SHIRTS (U.S. CLS. 22 AND 39).

FIRST USE 9-1-2006; IN COMMERCE 9-21-2006.

4,210,493. NIKE, INC., BEAVERTON, OR. SN 85-012,211. PUB. 7-27-2010, FILED 4-12-2010.

NIKE5

THE MARK CONSISTS OF STANDARD CHARACTERS WITHOUT CLAIM TO ANY PARTICULAR FONT, STYLE, SIZE, OR COLOR.

OWNER OF U.S. REG. NOS. 2,024,717, 3,192,901, AND OTHERS.

FOR FOOTWEAR (U.S. CLS. 22 AND 39). FIRST USE 1-31-2009; IN COMMERCE 1-31-2009.

CLASS 25—(Continued).

4,210,494. NIKE, INC., BEAVERTON, OR. SN 85-012,213. PUB. 7-27-2010, FILED 4-12-2010.

TOTAL 90

THE MARK CONSISTS OF STANDARD CHARACTERS WITHOUT CLAIM TO ANY PARTICULAR FONT, STYLE, SIZE, OR COLOR.

FOR FOOTWEAR (U.S. CLS. 22 AND 39).
FIRST USE 1-31-2000; IN COMMERCE 1-31-2000.

4,210,526. SOUL AND SPIRIT, LLC, DBA SOUL AND SPIRIT, PHOENIX, AZ. SN 85-045,739. PUB. 10-19-2010, FILED 5-22-2010.



THE MARK CONSISTS OF TWO STYLIZED BULLHORNS FORMING TWO INVERTED LETTER "S" AND THE WORDING "SOUL&SPIRIT."

FOR FABRIC BELTS; HATS; HOODS; JACKETS; LEATHER BELTS; PANTS; SHIRTS; SWEAT JACKETS; T-SHIRTS; WAIST BELTS (U.S. CLS. 22 AND 39).
FIRST USE 7-1-2010; IN COMMERCE 7-1-2010.

4,210,531. PEREZ, JEAN MARC, PARIS, FRANCE. SN 85-050,239. PUB. 5-24-2011, FILED 5-28-2010.

ESCORT GIRL

THE MARK CONSISTS OF STANDARD CHARACTERS WITHOUT CLAIM TO ANY PARTICULAR FONT, STYLE, SIZE, OR COLOR.

FOR LADIES UNDERWEAR (U.S. CLS. 22 AND 39).
FIRST USE 3-17-2011; IN COMMERCE 3-17-2011.

CLASS 25—(Continued).

4,210,538. FORD, BRIAN J., MEBANE, NC. SN 85-056,211. PUB. 11-30-2010, FILED 6-7-2010.

PRIDEFULTEES

THE MARK CONSISTS OF STANDARD CHARACTERS WITHOUT CLAIM TO ANY PARTICULAR FONT, STYLE, SIZE, OR COLOR.

FOR CLOTHING, NAMELY, SHIRTS, AND SWEAT-SHIRTS (U.S. CLS. 22 AND 39).
FIRST USE 7-6-2012; IN COMMERCE 7-6-2012.

4,210,554. GAYNOR MINDEN, INC., NEW YORK, NY. SN 85-068,507. PUB. 11-16-2010, FILED 6-22-2010.

MINIMINDEN

THE MARK CONSISTS OF STANDARD CHARACTERS WITHOUT CLAIM TO ANY PARTICULAR FONT, STYLE, SIZE, OR COLOR.

OWNER OF U.S. REG. NOS. 1,915,123 AND 3,191,936.
FOR BALLET SLIPPERS; DANCE SHOES; LEG WARMERS; LEOTARDS; TIGHTS (U.S. CLS. 22 AND 39).
FIRST USE 5-31-2008; IN COMMERCE 5-31-2008.

4,210,557. DRIFTING SPIRIT SONGS, LLC, STRONGSVILLE, OH. SN 85-072,889. PUB. 5-10-2011, FILED 6-28-2010.



THE COLOR(S) RED, WHITE AND BLUE IS/ARE CLAIMED AS A FEATURE OF THE MARK.

THE MARK CONSISTS OF AN IMAGE OF A LION, SPLIT ALONG A HORIZONTAL AXIS AND HAVING THREE STARS IN THE LOWER PART. THE UPPER PART OF THE LION IS IN RED AND THE LOWER PART IS IN BLUE. THE STARS ARE IN WHITE.

FOR BASEBALL CAPS AND HATS; CAPS; GOLF SHIRTS; HATS; HOODED PULLOVERS; HOODED SWEAT SHIRTS; JACKETS; SHIRTS; SPORTS CAPS AND HATS; SWEAT SHIRTS; T-SHIRTS (U.S. CLS. 22 AND 39).

FIRST USE 6-20-2012; IN COMMERCE 6-20-2012.

CLASS 25—(Continued).

4,210,568. BEN ELIAS INDUSTRIES CORP., NEW YORK, NY. SN 85-076,955. PUB. 12-7-2010, FILED 7-2-2010.

VALERIE OF MALIBU

THE MARK CONSISTS OF STANDARD CHARACTERS WITHOUT CLAIM TO ANY PARTICULAR FONT, STYLE, SIZE, OR COLOR.

FOR LADIES' CLOTHING, NAMELY, SUITS, BLOUSES, SHIRTS, T-SHIRTS, DRESSES, SKIRTS, CULOTTES, SHORTS, PANTS, JEANS, LEGGINGS, BODY-SUITS, SOCKS, SWEATERS, VESTS, SCARVES, BELTS, JACKETS AND COATS (U.S. CLS. 22 AND 39).

FIRST USE 1-1-2012; IN COMMERCE 1-1-2012.

4,210,588. 2023321 ONTARIO LIMITED, CAMBRIDGE, ONTARIO, CANADA. SN 85-090,844. PUB. 5-10-2011, FILED 7-22-2010.

LEG SAVERS

THE MARK CONSISTS OF STANDARD CHARACTERS WITHOUT CLAIM TO ANY PARTICULAR FONT, STYLE, SIZE, OR COLOR.

NO CLAIM IS MADE TO THE EXCLUSIVE RIGHT TO USE "LEG", APART FROM THE MARK AS SHOWN.

FOR HOSIERY, NAMELY, SOCKS FOR DIABETIC AND OTHER HEALTH PURPOSES (U.S. CLS. 22 AND 39).

FIRST USE 11-15-2010; IN COMMERCE 11-15-2010.

4,210,601. T&C MARKETING MIAMI, LLC, NORTH MIAMI, FL. SN 85-098,981. PUB. 4-3-2012, FILED 8-3-2010.



THE MARK CONSISTS OF THE WORD "FLIPOUT", WITH A FLOWER APPEARING OVER THE LETTER "I", WITH THE LETTER "O" APPEARING AS A SPIRAL AND BEING FORMED BY THE STEM OF THE FLOWER.

FOR SANDALS (U.S. CLS. 22 AND 39).
FIRST USE 11-9-2010; IN COMMERCE 11-9-2010.

CLASS 25—(Continued).

4,210,605. SIX-VICTOR LTD., TAICHUNG, TAIWAN. SN 85-102,203. PUB. 5-10-2011, FILED 8-6-2010.

Ecovina

THE MARK CONSISTS OF STANDARD CHARACTERS WITHOUT CLAIM TO ANY PARTICULAR FONT, STYLE, SIZE, OR COLOR.

FOR SHOES, BOOTS, SHOE SOLES, SHOE SOLES FOR REPAIR, INSOLES FOR SHOES AND BOOTS, SHOE-UPPERS, SHOE PADS IN THE NATURE OF INSOLES AND RUNNING PADS THAT STRAP ONTO SHOES, SPORTING SHOES, ATHLETIC SHOES, SKI BOOTS, GOLF SHOES (U.S. CLS. 22 AND 39).

FIRST USE 8-6-2010; IN COMMERCE 2-0-2012.

4,210,606. SIX-VICTOR LTD., TAICHUNG, TAIWAN. SN 85-102,288. PUB. 5-10-2011, FILED 8-6-2010.

HyMat

THE MARK CONSISTS OF STANDARD CHARACTERS WITHOUT CLAIM TO ANY PARTICULAR FONT, STYLE, SIZE, OR COLOR.

FOR SHOES, BOOTS, SHOE SOLES, SHOE SOLES FOR REPAIR, INSOLES FOR SHOES AND BOOTS, SHOE-UPPERS, SHOE PADS IN THE NATURE OF INSOLES AND RUNNING PADS THAT STRAP ONTO SHOES, SPORTING SHOES, ATHLETIC SHOES, SKI BOOTS, GOLF SHOES (U.S. CLS. 22 AND 39).

FIRST USE 8-6-2010; IN COMMERCE 2-0-2012.

4,210,625. ROCK AND ROLL RELIGION, INC., LOS ANGELES, CA. SN 85-116,003. PUB. 2-8-2011, FILED 8-25-2010.

JESUS THE ORIGINAL ROCKSTAR

THE MARK CONSISTS OF STANDARD CHARACTERS WITHOUT CLAIM TO ANY PARTICULAR FONT, STYLE, SIZE, OR COLOR.

FOR SHIRTS; T-SHIRTS (U.S. CLS. 22 AND 39).
FIRST USE 8-31-2010; IN COMMERCE 8-31-2010.

CLASS 25—(Continued).

4,210,631. RUNNING OUT LOUD LLC, JACKSONVILLE, FL. SN 85-119,510. PUB. 2-15-2011, FILED 8-31-2010.



THE MARK CONSISTS OF A RIBBON FOLDED OVER ITSELF IN SUCH A WAY AS TO FORM A HEART SHAPE AT THE TOP WITH THE WORDS "ROCK THE CAUSE" IMPRINTED ACROSS ONE END OF THE RIBBON.

FOR APRONS; ATHLETIC TIGHTS; CHEF'S COATS; CLOTHING, NAMELY, ATHLETIC SLEEVES; HATS; HEADBANDS; LONG-SLEEVED SHIRTS; SCARVES; SCRUBS NOT FOR MEDICAL PURPOSES; SHORT-SLEEVED OR LONG-SLEEVED T-SHIRTS; SHORT-SLEEVED SHIRTS; SHORTS; SWEATBANDS; TANK TOPS (U.S. CLS. 22 AND 39).

FIRST USE 9-24-2010; IN COMMERCE 2-11-2011.

4,210,632. VALERI, DINO O., DBA HITLIST OUTDOORS, NEENAH, WI. SN 85-119,860. PUB. 2-15-2011, FILED 8-31-2010.

Hitlist Outdoors

THE MARK CONSISTS OF STANDARD CHARACTERS WITHOUT CLAIM TO ANY PARTICULAR FONT, STYLE, SIZE, OR COLOR.

NO CLAIM IS MADE TO THE EXCLUSIVE RIGHT TO USE "OUTDOORS", APART FROM THE MARK AS SHOWN.

FOR ATHLETIC APPAREL, NAMELY, SHIRTS, PANTS, JACKETS, FOOTWEAR, HATS AND CAPS, ATHLETIC UNIFORMS (U.S. CLS. 22 AND 39).

FIRST USE 12-1-2010; IN COMMERCE 12-1-2010.

CLASS 25—(Continued).

4,210,677. SAFARI GIRL, LLC, RICHFIELD, WI. SN 85-161,412. PUB. 5-3-2011, FILED 10-26-2010.

SAFARI GIRL

THE MARK CONSISTS OF STANDARD CHARACTERS WITHOUT CLAIM TO ANY PARTICULAR FONT, STYLE, SIZE, OR COLOR.

NO CLAIM IS MADE TO THE EXCLUSIVE RIGHT TO USE "GIRL", APART FROM THE MARK AS SHOWN.

FOR SANDALS AND BEACH SHOES; FLIP FLOPS; BELTS FOR CLOTHING (U.S. CLS. 22 AND 39).

FIRST USE 11-1-2010; IN COMMERCE 11-1-2010.

4,210,690. SAMUEL A YOUNG, DBA NATTHEKAT ENTERPRISES LLC, ACWORTH, GA. SN 85-179,928. PUB. 5-24-2011, FILED 11-18-2010.



THE MARK CONSISTS OF THE WORDING "INNERMAN" WITH STIPPLING UNDER A DESIGN OF A SILHOUETTE OF A PERSON JUMPING AND OVER A DESIGN OF A TRIANGULAR SHAPE WITH STIPPLING.

FOR ATHLETIC APPAREL, NAMELY, SHIRTS, PANTS, JACKETS, FOOTWEAR, HATS AND CAPS, ATHLETIC UNIFORMS; HOODED SWEATSHIRTS; SMALL HATS; SPORTS CAPS AND HATS; SWEATSHIRTS; WOMEN'S HATS AND HOODS (U.S. CLS. 22 AND 39).

FIRST USE 3-14-2012; IN COMMERCE 5-7-2012.

4,210,692. KATIA LIMOLI SILVA AZULAY, SINTRA, PORTUGAL. SN 85-180,815. PUB. 4-12-2011, FILED 11-19-2010.

GALIBELLE

THE MARK CONSISTS OF STANDARD CHARACTERS WITHOUT CLAIM TO ANY PARTICULAR FONT, STYLE, SIZE, OR COLOR.

CLASS 25—(Continued).

THE WORDING "GALIBELLE" HAS NO MEANING IN A FOREIGN LANGUAGE.

FOR BEACH SHOES; BOOTS; CLOGS; FOOTWEAR; LEATHER SHOES; RAIN BOOTS; SANDALS; SLIPPERS (U.S. CLS. 22 AND 39).

FIRST USE 0-0-2007; IN COMMERCE 0-0-2011.

CLASS 25—(Continued).

4,210,709. BILLION GENIUS LIMITED, ROAD TOWN, TORTOLA, BR. VIRGIN ISLANDS. SN 85-188,870. PUB. 5-24-2011, FILED 12-2-2010.

4,210,703. MEAN MUGZ, LLC, CHICAGO, IL. SN 85-184,902. PUB. 4-12-2011, FILED 11-24-2010.

JAS. COX

MEAN MUGZ

THE MARK CONSISTS OF STANDARD CHARACTERS WITHOUT CLAIM TO ANY PARTICULAR FONT, STYLE, SIZE, OR COLOR.

FOR BASEBALL CAPS; HATS; HOODED SWEAT SHIRTS; SHIRTS; SWEAT SHIRTS; T-SHIRTS (U.S. CLS. 22 AND 39).

FIRST USE 2-1-2010; IN COMMERCE 12-15-2011.

OWNER OF U.S. REG. NO. 3,573,431.

THE NAME(S), PORTRAIT(S), AND/OR SIGNATURE(S) SHOWN IN THE MARK DOES NOT IDENTIFY A PARTICULAR LIVING INDIVIDUAL.

THE MARK CONSISTS OF THE STYLIZED WORDING "JAS. COX" FORMING AN ARCH WITH THE S BEING SUPERSCRIPT OVER THE PERIOD.

FOR CLOTHING, NAMELY, SHIRTS, SWEATERS, COATS AND CAPS (U.S. CLS. 22 AND 39).

FIRST USE 3-9-2012; IN COMMERCE 3-9-2012.

4,210,706. THE GET IN TOUCH FOUNDATION, INC., MILFORD, CT. SN 85-187,361. PUB. 4-19-2011, FILED 11-30-2010.

GIT PINKIFIED

THE MARK CONSISTS OF STANDARD CHARACTERS WITHOUT CLAIM TO ANY PARTICULAR FONT, STYLE, SIZE, OR COLOR.

FOR SHIRTS, T-SHIRTS (U.S. CLS. 22 AND 39). FIRST USE 10-31-2010; IN COMMERCE 10-31-2010.

4,210,718. THE AQUA LAB LTD., CINCINNATI, OH. SN 85-190,777. PUB. 4-26-2011, FILED 12-4-2010.



THE MARK CONSISTS OF A SKI MASK WITH AN ANGRY EXPRESSION.

FOR T-SHIRTS (U.S. CLS. 22 AND 39). FIRST USE 2-1-2010; IN COMMERCE 5-10-2011.

CLASS 25—(Continued).

4,210,746. BRANDED, LLC, DALLAS, TX. SN 85-202,421.
PUB. 5-10-2011, FILED 12-21-2010.

Jamaica Joe

THE MARK CONSISTS OF STANDARD CHARACTERS WITHOUT CLAIM TO ANY PARTICULAR FONT, STYLE, SIZE, OR COLOR.

THE NAME(S), PORTRAIT(S), AND/OR SIGNATURE(S) SHOWN IN THE MARK DOES NOT IDENTIFY A PARTICULAR LIVING INDIVIDUAL.

FOR CLOTHING, NAMELY, T-SHIRTS, SHIRTS, SWEATERS, PANTS, SHORTS, JACKETS, COATS, SWEATSHIRTS, SOCKS, BELTS, SCARVES; FOOTWEAR, HEADWEAR (U.S. CLS. 22 AND 39).

FIRST USE 7-5-2012; IN COMMERCE 7-5-2012.

4,210,762. PERMAUL, JENNIFER, CITRUS HEIGHTS, CA.
SN 85-206,219. PUB. 5-17-2011, FILED 12-27-2010.

SWEET MELONS

THE MARK CONSISTS OF STANDARD CHARACTERS WITHOUT CLAIM TO ANY PARTICULAR FONT, STYLE, SIZE, OR COLOR.

FOR CLOTHING, NAMELY, T-SHIRTS, TANK TOPS, AND SWEAT SHIRTS (U.S. CLS. 22 AND 39).

FIRST USE 6-30-2012; IN COMMERCE 6-30-2012.

4,210,769. NATIONAL FISHERIES INSTITUTE, MCLEAN, VA. SN 85-208,333. PUB. 5-10-2011, FILED 12-30-2010.

TUNATHEWONDERFISH

THE MARK CONSISTS OF STANDARD CHARACTERS WITHOUT CLAIM TO ANY PARTICULAR FONT, STYLE, SIZE, OR COLOR.

FOR T-SHIRTS, SHIRTS, SHORT-SLEEVED SHIRTS, LONG-SLEEVED SHIRTS, SWEAT SHIRTS WITH AND WITHOUT HOODS, APRONS, BABY BIBS NOT OF PAPER, HATS AND CAPS, TANK TOPS, TIES (U.S. CLS. 22 AND 39).

FIRST USE 7-1-2011; IN COMMERCE 7-1-2011.

CLASS 25—(Continued).

4,210,772. STATON, LISA, WHITESTOWN, IN. SN 85-209,248.
PUB. 5-3-2011, FILED 1-3-2011.

CLEAR MINDS ROCK!

THE MARK CONSISTS OF STANDARD CHARACTERS WITHOUT CLAIM TO ANY PARTICULAR FONT, STYLE, SIZE, OR COLOR.

FOR HATS; PANTS; SHIRTS; SHORTS; SWEATSHIRTS; TANK-TOPS (U.S. CLS. 22 AND 39).

FIRST USE 5-0-2012; IN COMMERCE 5-0-2012.

4,210,791. HICOBOY, INC., DBA HICOBOY, DALLAS, TX. SN 85-214,198. PUB. 5-31-2011, FILED 1-10-2011.

Sakanuki

THE MARK CONSISTS OF STANDARD CHARACTERS WITHOUT CLAIM TO ANY PARTICULAR FONT, STYLE, SIZE, OR COLOR.

THE WORDING "SAKANUKI" HAS NO MEANING IN A FOREIGN LANGUAGE.

FOR WOMEN'S UNDERGARMENTS, NAMELY, PANTIES, BRAS, LEGGINGS AND STOCKINGS (U.S. CLS. 22 AND 39).

FIRST USE 6-1-2012; IN COMMERCE 6-1-2012.

4,210,839. GLOBAL TRADEMARKS INC., STOCKERTOWN, PA. SN 85-236,622. PUB. 5-17-2011, FILED 2-8-2011.

ECO INTIMATES

THE MARK CONSISTS OF STANDARD CHARACTERS WITHOUT CLAIM TO ANY PARTICULAR FONT, STYLE, SIZE, OR COLOR.

NO CLAIM IS MADE TO THE EXCLUSIVE RIGHT TO USE "INTIMATES", APART FROM THE MARK AS SHOWN. FOR BODY SHAPERS; BRAS; CAMISOLES; PANTIES; TANK TOPS (U.S. CLS. 22 AND 39).

FIRST USE 4-25-2012; IN COMMERCE 4-25-2012.

CLASS 25—(Continued).

4,210,857. THOMPSON, DENNIS K, DBA TRUCE & SANTUARY GANG AND DRUG FREE KIDS & TEENS STOP BULLYING, LAUREL, MD. SN 85-240,798. PUB. 7-19-2011, FILED 2-11-2011.

Truce &
Sanctuary
Gang and Drug
Free
Kids & Teens
Stop Bullying

THE MARK CONSISTS OF STANDARD CHARACTERS WITHOUT CLAIM TO ANY PARTICULAR FONT, STYLE, SIZE, OR COLOR.

FOR ATHLETIC APPAREL, NAMELY, SHIRTS, PANTS, JACKETS, FOOTWEAR, HATS AND CAPS, ATHLETIC UNIFORMS (U.S. CLS. 22 AND 39).
FIRST USE 1-12-2011; IN COMMERCE 1-12-2011.

4,210,862. HERLOOM, LLC, SEATTLE, WA. SN 85-242,007. PUB. 12-13-2011, FILED 2-14-2011.

HERLOOM

THE MARK CONSISTS OF STANDARD CHARACTERS WITHOUT CLAIM TO ANY PARTICULAR FONT, STYLE, SIZE, OR COLOR.

FOR WOMEN'S CLOTHING, NAMELY, SHIRTS, BLOUSES, TANK TOPS, TEE SHIRTS, PANTS, UNDERWEAR (U.S. CLS. 22 AND 39).
FIRST USE 5-15-2011; IN COMMERCE 5-15-2011.

4,210,869. COTTON & ELSE, INC., LAUDERDALE LAKES, FL. SN 85-244,912. PUB. 11-22-2011, FILED 2-17-2011.

COTTON CRAZE

THE MARK CONSISTS OF STANDARD CHARACTERS WITHOUT CLAIM TO ANY PARTICULAR FONT, STYLE, SIZE, OR COLOR.

NO CLAIM IS MADE TO THE EXCLUSIVE RIGHT TO USE "COTTON", APART FROM THE MARK AS SHOWN.
FOR COTTON T-SHIRTS (U.S. CLS. 22 AND 39).
FIRST USE 5-16-2012; IN COMMERCE 5-16-2012.

CLASS 25—(Continued).

4,210,878. PINNACLE ENTERTAINMENT, INC., LAS VEGAS, NV. SN 85-248,813. PUB. 5-3-2011, FILED 2-22-2011.

RIVER DOWNS

THE MARK CONSISTS OF STANDARD CHARACTERS WITHOUT CLAIM TO ANY PARTICULAR FONT, STYLE, SIZE, OR COLOR.

FOR HEADGEAR, NAMELY, HATS AND CAPS; JACKETS; SHIRTS; SWEAT SHIRTS; T-SHIRTS; TANK TOPS (U.S. CLS. 22 AND 39).
FIRST USE 1-28-2011; IN COMMERCE 1-28-2011.

4,210,885. GINLACK, SAA TAMBA, KAPAA, HI. SN 85-251,568. PUB. 5-3-2011, FILED 2-25-2011.



THE MARK CONSISTS OF A DESIGN OF A WARRIOR. FOR CLOTHING, NAMELY, SHORTS, HATS, JEANS, PANTS, DRESS SHIRTS, SHIRTS, FOOTWEAR (U.S. CLS. 22 AND 39).
FIRST USE 12-15-2011; IN COMMERCE 12-15-2011.

4,210,905. GRASS COLLECTION, LLC, CAVE CREEK, AZ. SN 85-262,445. PUB. 11-15-2011, FILED 3-9-2011.

HATCH & CLOAK

THE MARK CONSISTS OF STANDARD CHARACTERS WITHOUT CLAIM TO ANY PARTICULAR FONT, STYLE, SIZE, OR COLOR.

CLASS 25—(Continued).

NO CLAIM IS MADE TO THE EXCLUSIVE RIGHT TO USE "CLOAK", APART FROM THE MARK AS SHOWN.

FOR CLOTHING, APPAREL AND ACCESSORIES, NAMELY, DRESSES, SKIRTS, SHORT SLEEVED AND LONG SLEEVED SHIRTS, BLOUSES, TOPS, T-SHIRTS, SWEATERS, VESTS, SHORTS, PANTS, JEANS, JACKETS, COATS, OVERALLS, TIGHTS, SOCKS, SWEATSHIRTS, SWEAT PANTS, FOOTWEAR, HEADWEAR, SLEEPWEAR, SWIM WEAR, ROBES, SCARVES, HEADBANDS, CAPS AND BELTS (U.S. CLS. 22 AND 39).

FIRST USE 10-24-2011; IN COMMERCE 10-24-2011.

4,210,938. EXCLUSIVELY.IN INC., NEW YORK, NY. SN 85-284,867. PUB. 9-6-2011, FILED 4-4-2011.

Sher Singh

THE MARK CONSISTS OF STANDARD CHARACTERS WITHOUT CLAIM TO ANY PARTICULAR FONT, STYLE, SIZE, OR COLOR.

THE NAME "SHER SINGH" DOES NOT IDENTIFY A LIVING INDIVIDUAL.

FOR BLOUSES; CLOTHING, NAMELY, BASE LAYERS; JACKETS; JERSEYS; MEN'S AND WOMEN'S JACKETS, COATS, TROUSERS, VESTS; POLO SHIRTS; SHORT-SLEEVED OR LONG-SLEEVED T-SHIRTS; SHORTS; WEARABLE GARMENTS AND CLOTHING, NAMELY, SHIRTS; WOMEN'S CLOTHING, NAMELY, SHIRTS, DRESSES, SKIRTS, BLOUSES (U.S. CLS. 22 AND 39).

FIRST USE 3-1-2011; IN COMMERCE 8-11-2011.

4,210,939. EXCLUSIVELY.IN INC., NEW YORK, NY. SN 85-284,872. PUB. 9-6-2011, FILED 4-4-2011.

Cricket By Sher Singh

THE MARK CONSISTS OF STANDARD CHARACTERS WITHOUT CLAIM TO ANY PARTICULAR FONT, STYLE, SIZE, OR COLOR.

THE NAME "SHER SINGH" DOES NOT IDENTIFY A LIVING INDIVIDUAL.

FOR BLOUSES; CLOTHING, NAMELY, BASE LAYERS; JACKETS; JERSEYS; MEN'S AND WOMEN'S JACKETS, COATS, TROUSERS, VESTS; POLO SHIRTS; SHORT-SLEEVED OR LONG-SLEEVED T-SHIRTS; SHORTS; WEARABLE GARMENTS AND CLOTHING, NAMELY, SHIRTS; WOMEN'S CLOTHING, NAMELY, SHIRTS, DRESSES, SKIRTS, BLOUSES (U.S. CLS. 22 AND 39).

FIRST USE 3-1-2011; IN COMMERCE 8-11-2011.

CLASS 25—(Continued).

4,210,956. KINETIC OOMPH, LLC, BROOKLYN, NY. SN 85-298,533. PUB. 12-27-2011, FILED 4-19-2011.

VISORGT

THE MARK CONSISTS OF STANDARD CHARACTERS WITHOUT CLAIM TO ANY PARTICULAR FONT, STYLE, SIZE, OR COLOR.

FOR APPAREL, NAMELY, HATS AND VISORS (U.S. CLS. 22 AND 39).

FIRST USE 8-8-2011; IN COMMERCE 2-5-2012.

4,210,963. POWERS, CALI, SAN MATEO, CA. AND DREW, BRENEE, SAN MATEO, CA. SN 85-302,821. PUB. 8-16-2011, FILED 4-23-2011.

365FEMME

THE MARK CONSISTS OF STANDARD CHARACTERS WITHOUT CLAIM TO ANY PARTICULAR FONT, STYLE, SIZE, OR COLOR.

FOR CLOTHING, NAMELY, T-SHIRTS, TROUSERS, JACKETS, TOPS, TANK TOPS, HOODED T-SHIRTS; HEADWEAR, FOOTWEAR (U.S. CLS. 22 AND 39).

FIRST USE 3-15-2011; IN COMMERCE 12-22-2011.

4,210,966. TOMI OTEE, NEW YORK, NY. SN 85-303,489. PUB. 12-27-2011, FILED 4-25-2011.

TOMI OTEE

THE MARK CONSISTS OF STANDARD CHARACTERS WITHOUT CLAIM TO ANY PARTICULAR FONT, STYLE, SIZE, OR COLOR.

THE NAME(S), PORTRAIT(S), AND/OR SIGNATURE(S) SHOWN IN THE MARK DOES NOT IDENTIFY A PARTICULAR LIVING INDIVIDUAL.

FOR ATHLETIC APPAREL, NAMELY, SHIRTS, PANTS, JACKETS, FOOTWEAR, HATS AND CAPS, ATHLETIC UNIFORMS; GOLF PANTS, SHIRTS AND SKIRTS (U.S. CLS. 22 AND 39).

FIRST USE 1-27-2012; IN COMMERCE 6-27-2012.

CLASS 25—(Continued).

4,210,986. GERS, JEREMY, BAYOONE, NJ. SN 85-316,316.
PUB. 10-25-2011, FILED 5-9-2011.

East Coast Hooked

THE MARK CONSISTS OF STANDARD CHARACTERS WITHOUT CLAIM TO ANY PARTICULAR FONT, STYLE, SIZE, OR COLOR.

NO CLAIM IS MADE TO THE EXCLUSIVE RIGHT TO USE "EAST COAST", APART FROM THE MARK AS SHOWN.

FOR HATS; JACKETS; T-SHIRTS (U.S. CLS. 22 AND 39).

FIRST USE 6-1-2011; IN COMMERCE 1-1-2012.

CLASS 25—(Continued).

4,211,032. JONATHAN ABEL MENDIOLA, SAN DIEGO, CA.
SN 85-329,010. PUB. 10-25-2011, FILED 5-24-2011.

Freshly Baked

THE MARK CONSISTS OF STANDARD CHARACTERS WITHOUT CLAIM TO ANY PARTICULAR FONT, STYLE, SIZE, OR COLOR.

FOR BABY TOPS; BANDEAU TOPS; BASEBALL CAPS AND HATS; BEANIES; BODY SHIRTS; BUTTON DOWN SHIRTS; CLOTHING FOR BABIES, TODDLERS AND CHILDREN, NAMELY, PAJAMAS, JACKETS, SHIRTS, PANTS, JUMPERS; COLLARED SHIRTS; CREW NECK SWEATERS; CROP TOPS; DRESS SHIRTS; HATS; HATS FOR INFANTS, BABIES, TODDLERS AND CHILDREN; HOODED SWEAT SHIRTS; KNIT SHIRTS; KNIT TOPS; LONG-SLEEVED SHIRTS; POLO KNIT TOPS; POLO SHIRTS; SHIRTS; SHIRTS AND SHORT-SLEEVED SHIRTS; SHIRTS FOR INFANTS, BABIES, TODDLERS AND CHILDREN; SHORT-SLEEVED OR LONG-SLEEVED T-SHIRTS; SHORT-SLEEVED SHIRTS; SNAP CROTCH SHIRTS FOR INFANTS AND TODDLERS; SPORTS CAPS AND HATS; SWEAT SHIRTS; SWEATERS; T-SHIRTS; TANK TOPS; TANK-TOPS; V-NECK SWEATERS; WOMEN'S HATS AND HOODS; WOMEN'S TOPS, NAMELY, CAMIS (U.S. CLS. 22 AND 39).

FIRST USE 6-22-2011; IN COMMERCE 6-22-2011.

4,211,030. SKUNKBUNKER,LLC, MEDFORD, NJ. SN 85-328,619. PUB. 10-18-2011, FILED 5-24-2011.

Skunkbunker

THE MARK CONSISTS OF STANDARD CHARACTERS WITHOUT CLAIM TO ANY PARTICULAR FONT, STYLE, SIZE, OR COLOR.

FOR HATS; SHIRTS; SHORTS; SWEAT SHIRTS (U.S. CLS. 22 AND 39).

FIRST USE 11-5-2011; IN COMMERCE 6-12-2012.

4,211,055. EASEPAL ENTERPRISES LTD, FUJIAN PROVINCE, CHINA. SN 85-333,315. PUB. 10-25-2011, FILED 5-30-2011.



THE MARK CONSISTS OF THE STYLIZED WORD "KNINK" ON THE LEFT, AND TWO CHINESE CHARACTERS WHICH TRANSLITERATE INTO YIN KE ON THE RIGHT.

THE WORDING "KNINK" HAS NO MEANING IN A FOREIGN LANGUAGE.

THE NON-LATIN CHARACTERS IN THE MARK TRANSLITERATE TO YIN; KE AND THIS MEANS STAMP; GUEST IN ENGLISH.

FOR APRONS; BATH SLIPPERS; BOOTS; CAMISOLES; CAPS; COATS; FOOTWEAR; GLOVES; HOSIERY; LEATHER BELTS; SANDALS; SCARVES; SHOULDER WRAPS; SPORTS JERSEYS; SWIMSUITS; TEE SHIRTS; TURBANS; UNDER GARMENTS (U.S. CLS. 22 AND 39).

FIRST USE 2-1-2010; IN COMMERCE 9-1-2010.

CLASS 25—(Continued).

4,211,057. SKUNKBUNKER, LLC, MEDFORD, NJ. SN 85-333,688. PUB. 10-18-2011, FILED 5-31-2011.



THE MARK CONSISTS OF AN ELONGATED OVAL OUTLINE OF ROPE LOOKING MATERIAL WITH AN "S" IN THE MIDDLE MIMICKING A FISH HOOK.

FOR HATS; JACKETS; PANTS; SHIRTS (U.S. CLS. 22 AND 39).

FIRST USE 11-5-2011; IN COMMERCE 6-12-2012.

4,211,069. GREENSTEIN, RENEE, NEW YORK, NY. SN 85-336,383. PUB. 11-22-2011, FILED 6-2-2011.

ATTITUDES BY WOMEN WITH
CONTROL

THE MARK CONSISTS OF STANDARD CHARACTERS WITHOUT CLAIM TO ANY PARTICULAR FONT, STYLE, SIZE, OR COLOR.

OWNER OF U.S. REG. NOS. 3,146,037 AND 3,702,430.
FOR KNIT CLOTHING, NAMELY, TOPS (U.S. CLS. 22 AND 39).

FIRST USE 9-2-2011; IN COMMERCE 9-2-2011.

4,211,080. ATOMSCHIRM CORPORATION, DURHAM, NC. SN 85-337,849. PUB. 11-1-2011, FILED 6-3-2011.

AMERICAN SIN BIN

THE MARK CONSISTS OF STANDARD CHARACTERS WITHOUT CLAIM TO ANY PARTICULAR FONT, STYLE, SIZE, OR COLOR.

FOR CLOTHING, NAMELY, T-SHIRTS, SHORTS, PANTS, SWEAT SHIRTS, SWEAT PANTS, JERSEYS, POLO SHIRTS, JACKETS, HEADWEAR, ATHLETIC SHIRTS, ATHLETIC SHORTS (U.S. CLS. 22 AND 39).

FIRST USE 10-1-2011; IN COMMERCE 10-1-2011.

CLASS 25—(Continued).

4,211,083. GAP (APPAREL), LLC, SAN FRANCISCO, CA. SN 85-337,907. PUB. 11-8-2011, FILED 6-3-2011.



OWNER OF U.S. REG. NOS. 3,438,371, 3,633,314, AND OTHERS.

THE COLOR(S) WHITE AND LIME GREEN IS/ARE CLAIMED AS A FEATURE OF THE MARK.

THE MARK CONSISTS OF THE COLORS WHITE AND LIME GREEN IN THE STYLIZED LIME CROSS-SECTION DESIGN.

FOR DRESSES, SHIRTS, TOPS, SWEATERS, SKIRTS, COATS AND JACKETS, SHORTS, PANTS, VESTS (U.S. CLS. 22 AND 39).

FIRST USE 2-23-2011; IN COMMERCE 2-23-2011.

4,211,107. SINGLOGEN, SOLANA BEACH, CA. SN 85-341,667. PUB. 11-1-2011, FILED 6-8-2011.

SingloSPORT

THE MARK CONSISTS OF STANDARD CHARACTERS WITHOUT CLAIM TO ANY PARTICULAR FONT, STYLE, SIZE, OR COLOR.

FOR ATHLETIC APPAREL, NAMELY, SHIRTS, PANTS, JACKETS, FOOTWEAR, HATS AND CAPS, ATHLETIC UNIFORMS (U.S. CLS. 22 AND 39).

FIRST USE 8-10-2011; IN COMMERCE 8-10-2011.

4,211,116. JUST SO...DESIGNS LLC, ASHEVILLE, NC. SN 85-342,851. PUB. 11-22-2011, FILED 6-10-2011.

SO...ASHEVILLE

THE MARK CONSISTS OF STANDARD CHARACTERS WITHOUT CLAIM TO ANY PARTICULAR FONT, STYLE, SIZE, OR COLOR.

CLASS 25—(Continued).

NO CLAIM IS MADE TO THE EXCLUSIVE RIGHT TO USE "ASHEVILLE", APART FROM THE MARK AS SHOWN.
FOR T-SHIRTS AND SHIRTS (U.S. CLS. 22 AND 39).
FIRST USE 1-23-2012; IN COMMERCE 1-23-2012.

4,211,127. INC INTERNATIONAL COMPANY, KENNETT SQUARE, PA. SN 85-344,007. PUB. 11-8-2011, FILED 6-12-2011.

FEEL INVINCIBLE

THE MARK CONSISTS OF STANDARD CHARACTERS WITHOUT CLAIM TO ANY PARTICULAR FONT, STYLE, SIZE, OR COLOR.
FOR SHIRTS (U.S. CLS. 22 AND 39).
FIRST USE 7-1-2012; IN COMMERCE 7-1-2012.

4,211,130. GILMORE, DANIEL V, HACKENSACK, NJ. SN 85-344,403. PUB. 12-13-2011, FILED 6-13-2011.



THE MARK CONSISTS OF A STYLIZED IMAGE OF AN ADIRONDACK CHAIR VIEWED AT AN ANGLE
FOR ATHLETIC APPAREL, NAMELY, SHIRTS, PANTS, JACKETS, FOOTWEAR, HATS AND CAPS, ATHLETIC UNIFORMS; BUTTON DOWN SHIRTS; COLARED SHIRTS; DRESS SHIRTS; GOLF PANTS, SHIRTS AND SKIRTS; GOLF SHIRTS; HATS; HOODED SWEAT SHIRTS; KNIT SHIRTS; LONG-SLEEVED SHIRTS; MOISTURE-WICKING SPORTS SHIRTS; PIQUE SHIRTS; POLO SHIRTS; RUGBY SHIRTS; SHIRTS; SHIRTS AND SHORT-SLEEVED SHIRTS; SHORT-SLEEVED OR LONG-SLEEVED T-SHIRTS; SHORT-SLEEVED SHIRTS; SPORT SHIRTS; SPORTS SHIRTS; SPORTS SHIRTS WITH SHORT SLEEVES; SWEAT SHIRTS; T-SHIRTS; TEE SHIRTS; TIES; WEARABLE GARMENTS AND CLOTHING, NAMELY, SHIRTS; WIND SHIRTS (U.S. CLS. 22 AND 39).
FIRST USE 8-1-2011; IN COMMERCE 8-1-2011.

CLASS 25—(Continued).

4,211,136. CRESTONE, LLC, VERNON, CA. SN 85-345,159. PUB. 11-1-2011, FILED 6-13-2011.

1 . 3 c m a

THE MARK CONSISTS OF THE NUMERAL "1", FOLLOWED BY A SMALL SQUARE PERIOD, FOLLOWED BY THE NUMERAL "3", FOLLOWED BY THE LETTERS "C", "M", "A".
FOR BELTS; BLOUSES; COATS; DRESSES; HATS; JACKETS; PANTS; SCARVES; SHIRTS; SHORTS; SKIRTS; SUITS; SWEATERS; T-SHIRTS; TOPS (U.S. CLS. 22 AND 39).
FIRST USE 11-1-2011; IN COMMERCE 11-1-2011.

4,211,145. CARTER, FREDERICK DAVID, DBA DRAFT HOUSE STUDIOS, MESA, AZ. SN 85-346,289. PUB. 11-1-2011, FILED 6-14-2011.

DRAFT HOUSE STUDIOS

THE MARK CONSISTS OF STANDARD CHARACTERS WITHOUT CLAIM TO ANY PARTICULAR FONT, STYLE, SIZE, OR COLOR.
FOR T-SHIRTS (U.S. CLS. 22 AND 39).
FIRST USE 8-20-2011; IN COMMERCE 2-1-2012.

4,211,155. COON, DOUGLAS, SEMINOLE, FL. SN 85-347,146. PUB. 11-1-2011, FILED 6-15-2011.

EAST COAST WEST SIDE

THE MARK CONSISTS OF STANDARD CHARACTERS WITHOUT CLAIM TO ANY PARTICULAR FONT, STYLE, SIZE, OR COLOR.
FOR CLOTHING, NAMELY, T-SHIRTS, HATS (U.S. CLS. 22 AND 39).
FIRST USE 6-11-2011; IN COMMERCE 6-19-2012.

CLASS 25—(Continued).

4,211,175. SONRISA ENTERPRISES, INC., VAN NUYS, CA.
SN 85-349,336. PUB. 11-8-2011, FILED 6-17-2011.



OWNER OF U.S. REG. NOS. 2,153,482 AND 3,546,389.
THE MARK CONSISTS OF THE WORD "REVGEAR"
STYLIZED.

FOR HATS; HEADWEAR; HOODED PULLOVERS;
HOODED SWEATSHIRTS; JACKETS; MARTIAL ARTS
UNIFORMS, NAMELY, GIs; PANTS; SHIRTS; SHORTS;
SPORTS BRAS; SWEATSHIRTS; T-SHIRTS; TANK TOPS;
UNIFORMS (U.S. CLS. 22 AND 39).

FIRST USE 11-0-2011; IN COMMERCE 11-0-2011.

4,211,177. SONRISA ENTERPRISES, INC., VAN NUYS, CA.
SN 85-349,384. PUB. 11-8-2011, FILED 6-17-2011.



THE MARK CONSISTS OF THE LETTER "R" STYLIZED.
FOR HATS; HEADWEAR; HOODED PULLOVERS;
HOODED SWEATSHIRTS; JACKETS; MARTIAL ARTS
UNIFORMS, NAMELY, GIs; PANTS; SHIRTS; SHORTS;
SPORTS BRAS; SWEATSHIRTS; T-SHIRTS; TANK TOPS;
UNIFORMS (U.S. CLS. 22 AND 39).

FIRST USE 11-0-2011; IN COMMERCE 11-0-2011.

CLASS 25—(Continued).

4,211,217. JACOB, RAMSIN, SANTA BARBARA, CA. SN 85-
355,568. PUB. 11-15-2011, FILED 6-24-2011.



THE COLOR(S) BLACK, YELLOW IS/ARE CLAIMED AS
A FEATURE OF THE MARK.

THE MARK CONSISTS OF "A", "R" LETTERING BLACK
OUTLINED WITH YELLOW. ATOP A CROWN WITH A
SLIGHT TILT TO THE RIGHT, OPPOSITE COLORS OF THE
"AR".

FOR BUTTON DOWN SHIRTS; DRESS SHIRTS;
SHORT-SLEEVED OR LONG-SLEEVED T-SHIRTS; WO-
MEN'S CLOTHING, NAMELY, SHIRTS, DRESSES,
SKIRTS, BLOUSES (U.S. CLS. 22 AND 39).

FIRST USE 1-1-2010; IN COMMERCE 2-1-2012.

4,211,250. MOOS, JONATHAN, PLEASANTON, CA. SN 85-
358,797. PUB. 11-22-2011, FILED 6-28-2011.

NAKED HEAD

THE MARK CONSISTS OF STANDARD CHARACTERS
WITHOUT CLAIM TO ANY PARTICULAR FONT, STYLE,
SIZE, OR COLOR.

FOR CLOTHING, NAMELY, HATS, BEANIES, VISORS,
SHIRTS, T-SHIRTS, TANK TOPS, PANTS, SHORTS,
SWEATSHIRTS, HOODED SWEATSHIRTS, SWEAT-
PANTS, JACKETS, UNDERWEAR, BANDANNAS,
WRISTBANDS, HEADBANDS (U.S. CLS. 22 AND 39).

FIRST USE 3-17-2010; IN COMMERCE 6-15-2012.

CLASS 25—(Continued).

4,211,281. SBYKE USA LLC, LAS VEGAS, NV. SN 85-365,299.
PUB. 12-6-2011, FILED 7-7-2011.

SBYKE

THE MARK CONSISTS OF STANDARD CHARACTERS WITHOUT CLAIM TO ANY PARTICULAR FONT, STYLE, SIZE, OR COLOR.

FOR WEARING APPAREL, NAMELY, SHIRTS, T-SHIRTS, SWEATSHIRTS, JACKETS, PANTS, SHORTS, AND HATS (U.S. CLS. 22 AND 39).

FIRST USE 4-8-2010; IN COMMERCE 2-21-2011.

4,211,311. JACEY HANSON, AMSTERDAM, NY. SN 85-371,108. PUB. 12-13-2011, FILED 7-14-2011.

SMILIN' JACK

THE MARK CONSISTS OF STANDARD CHARACTERS WITHOUT CLAIM TO ANY PARTICULAR FONT, STYLE, SIZE, OR COLOR.

FOR FOOTWEAR; ATHLETIC FOOTWEAR; BEACH FOOTWEAR; FOOTWEAR; FOOTWEAR FOR MEN; FOOTWEAR FOR MEN AND WOMEN (U.S. CLS. 22 AND 39).

FIRST USE 2-1-2012; IN COMMERCE 6-1-2012.

4,211,334. SPEED ACTION CORP., COMMERCE, CA. SN 85-375,018. PUB. 12-13-2011, FILED 7-19-2011.

Islandia

THE MARK CONSISTS OF STANDARD CHARACTERS WITHOUT CLAIM TO ANY PARTICULAR FONT, STYLE, SIZE, OR COLOR.

FOR CARGO PANTS; DENIMS; JEANS; KNIT SHIRTS; PANTS; SHIRTS; SHORTS; SWEATERS; T-SHIRTS; TOPS (U.S. CLS. 22 AND 39).

FIRST USE 10-15-2011; IN COMMERCE 2-27-2012.

CLASS 25—(Continued).

4,211,367. REYNOSO, JUAN SALVADOR, HIDALGO, TX. SN 85-383,631. PUB. 3-27-2012, FILED 7-28-2011.



THE MARK CONSISTS OF THE WORDS "ROYAL BEXAR". OVERLAPPING THE LETTER "B" THERE IS A THREE POINT CROWN ON TOP OF A HEART WHICH HAS A CUT OUT OF A TEDDY BEAR.

THE WORD(S) "BEXAR" HAS NO MEANING IN A FOREIGN LANGUAGE.

FOR WEARING APPAREL, CLOTHING, AND CLOTHING ACCESSORIES, NAMELY, TOPS, BOTTOMS, COATS, JACKETS, TIES, BELTS, HEADWEAR, FOOTWEAR, SWIMWEAR, SWEAT PANTS, SHORTS, SHIRTS, HATS AND CAPS (U.S. CLS. 22 AND 39).

FIRST USE 6-20-2012; IN COMMERCE 6-21-2012.

4,211,392. RACONTEUR, INC., BOCA RATON, FL. SN 85-392,845. PUB. 1-10-2012, FILED 8-9-2011.

NOSTRUM CONSILIUM

THE MARK CONSISTS OF STANDARD CHARACTERS WITHOUT CLAIM TO ANY PARTICULAR FONT, STYLE, SIZE, OR COLOR.

FOR CLOTHING, NAMELY, FOOTWEAR, SHOES, HEADWEAR, HATS, TOPS, BOTTOMS, SHIRTS, POLO SHIRTS, T-SHIRTS, JACKETS, SWEATERS, COATS, SHORTS, DENIMS, PANTS, AND UNDERWEAR (U.S. CLS. 22 AND 39).

FIRST USE 6-1-2011; IN COMMERCE 1-1-2012.

4,211,413. KENNETH CHAMBERS, HARKER HEIGHTS, TX. SN 85-400,200. PUB. 1-17-2012, FILED 8-17-2011.

TEAM BELIEVER

THE MARK CONSISTS OF STANDARD CHARACTERS WITHOUT CLAIM TO ANY PARTICULAR FONT, STYLE, SIZE, OR COLOR.

FOR HATS; SHORT-SLEEVED OR LONG-SLEEVED T-SHIRTS; T-SHIRTS (U.S. CLS. 22 AND 39).

FIRST USE 8-17-2011; IN COMMERCE 4-15-2012.

CLASS 25—(Continued).

4,211,421. ANGELA ROWELL, PHOENIX, AZ. SN 85-402,477.
PUB. 11-8-2011, FILED 8-19-2011.

BEZU

THE MARK CONSISTS OF STANDARD CHARACTERS WITHOUT CLAIM TO ANY PARTICULAR FONT, STYLE, SIZE, OR COLOR.
FOR SWIMWEAR (U.S. CLS. 22 AND 39).
FIRST USE 7-14-2011; IN COMMERCE 7-14-2011.

4,211,423. ANGELA ROWELL, PHOENIX, AZ. SN 85-402,716.
PUB. 11-8-2011, FILED 8-19-2011.



THE MARK CONSISTS OF LIPS.
FOR SWIMWEAR (U.S. CLS. 22 AND 39).
FIRST USE 7-14-2011; IN COMMERCE 7-14-2011.

4,211,431. S. GOLDBERG & CO., INC. HACKENSACK, NJ. SN 85-406,118. PUB. 2-7-2012, FILED 8-24-2011.

AQUAFLO

THE MARK CONSISTS OF "AQUAFLO" WITH WATER DROP SHAPE IN "O".
FOR FOOTWEAR (U.S. CLS. 22 AND 39).
FIRST USE 2-24-2012; IN COMMERCE 2-24-2012.

CLASS 25—(Continued).

4,211,473. ELSHAW, VINCENT, MENTOR, OH. SN 85-420,891.
PUB. 2-21-2012, FILED 9-12-2011.

U Mad Bro?

THE MARK CONSISTS OF STANDARD CHARACTERS WITHOUT CLAIM TO ANY PARTICULAR FONT, STYLE, SIZE, OR COLOR.
FOR HATS; SWEATSHIRTS; T-SHIRTS (U.S. CLS. 22 AND 39).
FIRST USE 11-23-2011; IN COMMERCE 1-1-2012.

4,211,476. ENTERPRISES J&C, INC., KEY WEST, FL. SN 85-423,835. PUB. 2-21-2012, FILED 9-15-2011.

LIFE IN PARADISE

THE MARK CONSISTS OF STANDARD CHARACTERS WITHOUT CLAIM TO ANY PARTICULAR FONT, STYLE, SIZE, OR COLOR.
FOR BATHING SUITS, BEACHWEAR, BIKINIS, BLAZERS, BLOUSES, BOARDSHORTS, BODYSUITS, BOXER SHORTS, COATS, DRESSES, FOOTWEAR, GYM SHORTS, HALTER TOPS, HATS, HEAD WEAR, JACKETS, JEANS, KNIT SHIRTS, LINGERIE, PAJAMAS, PANTIES, PANTS, POLO SHIRTS, PULLOVERS, RAINWEAR, SARONGS, SHIRTS, SHORTS, SKIRTS, SLACKS, SPORT SHIRTS, SOCKS, SWEAT SHIRTS, SWEATERS, SWIM TRUNKS, SWIMWEAR, T-SHIRTS, TANK TOPS, TIGHTS, UNDER SHIRTS, VESTS (U.S. CLS. 22 AND 39).
FIRST USE 3-0-2012; IN COMMERCE 3-0-2012.

4,211,482. LIU, BOJIA, NORTH QUINCY, MA. SN 85-425,372.
PUB. 4-10-2012, FILED 9-17-2011.

Mr.ing

THE NAME(S), PORTRAIT(S), AND/OR SIGNATURE(S) SHOWN IN THE MARK DOES NOT IDENTIFY A PARTICULAR LIVING INDIVIDUAL.

CLASS 25—(Continued).

THE MARK CONSISTS OF A BLACK LITERAL ELEMENT "MR. ING" ON A WHITE BACKGROUND.

FOR ANGLERS' SHOES; APRES-SKI SHOES; AQUA SHOES; ATHLETIC SHOES; BALLET SHOES; BALL-ROOM DANCING SHOES; BASEBALL SHOES; BEACH SHOES; BOAT SHOES; BOWLING SHOES; BOXING SHOES; CANVAS SHOES; CLEATS FOR ATTACHMENT TO SPORTS SHOES; CLIMBING SHOES; CYCLING SHOES; DANCE SHOES; DECK-SHOES; DRIVERS; FITTED SHOE OR BOOT COVERING TO PROTECT THE SHOES OR BOOT FROM WATER OR OTHER DAMAGE; FOOTBALL SHOES; GOLF SHOES; GYMNAS-TIC SHOES; HANDBALL SHOES; HEEL PIECES FOR SHOES; HOCKEY SHOES; INFANTS' SHOES AND BOOTS; INSOLES; LEATHER SHOES; LEISURE SHOES; MOUNTAINEERING SHOES; PAPER SHOES USED WHEN GOING THROUGH METAL DETECTORS TO KEEP FEET AND SOCKS CLEAN; POLYMER CUSTOM CUSHIONED SHOE INSERTS FOR PRIMARILY NON-ORTHOPEDIC PURPOSES; PROTECTIVE METAL MEM-BERS FOR SHOES AND BOOTS; RIDING SHOES; RUBBER SHOES; RUGBY SHOES; RUNNING PADS THAT STRAP ONTO SHOES; RUNNING SHOES; SAN-DALS AND BEACH SHOES; SHOE COVERS FOR USE WHEN WEARING SHOES; SHOE DOWELS; SHOE IN-SERTS FOR PRIMARILY NON-ORTHOPEDIC PUR-POSES; SHOE PEGS; SHOE SOLES; SHOE STRAPS; SHOES; SHOES FEATURING CUSHIONING; SHOES SOLES FOR REPAIR; SHOES WITH HOOK AND PILE FASTENING TAPES; SKI AND SNOWBOARD SHOES AND PARTS THEREOF; SKIING SHOES; SOCCER SHOES; TAP SHOES; TENNIS SHOES; TONGUE OR PULLSTRAP FOR SHOES AND BOOTS; TRACK AND FIELD SHOES; TRAINING SHOES; VOLLEYBALL SHOES; WATER REPELLING LEATHER SHOES AND BOOTS; WATERPROOF LEATHER SHOES; WATER-PROOF LEATHER SHOES AND BOOTS; WELTS FOR BOOTS AND SHOES; WOMEN'S SHOES; WOMEN'S SHOES, NAMELY, FOLDABLE FLATS; WOODEN SHOES; WORK SHOES AND BOOTS (U.S. CLS. 22 AND 39).

FIRST USE 7-1-2012; IN COMMERCE 7-1-2012.

4,211,483. LIU, BOJIA, NORTH QUINCY, MA. SN 85-425,373. PUB. 4-17-2012, FILED 9-17-2011.



THE MARK CONSISTS OF A LITERAL ELEMENT OF A STYLIZED "V" ABOVE THE WORD "OLUNPO".

THE WORDING "V OLUNPO" HAS NO MEANING IN A FOREIGN LANGUAGE.

FOR ANGLERS' SHOES; APRES-SKI SHOES; AQUA SHOES; ATHLETIC SHOES; BALLET SHOES; BALL-ROOM DANCING SHOES; BASEBALL SHOES; BEACH SHOES; BOAT SHOES; BOWLING SHOES; BOXING SHOES; CANVAS SHOES; CLEATS FOR ATTACHMENT TO SPORTS SHOES; CLIMBING SHOES; CYCLING SHOES; DANCE SHOES; DECK-SHOES; DRIVERS; FITTED SHOE OR BOOT COVERING TO PROTECT THE SHOES OR BOOT FROM WATER OR OTHER DAMAGE; FOOTBALL SHOES; GOLF SHOES; GYMNAS-TIC SHOES; HANDBALL SHOES; HEEL PIECES FOR SHOES; HOCKEY SHOES; INFANTS' SHOES AND BOOTS; INSOLES; LEATHER SHOES; LEISURE SHOES; MOUNTAINEERING SHOES; PAPER SHOES USED WHEN GOING THROUGH METAL DETECTORS TO KEEP FEET AND SOCKS CLEAN; POLYMER CUSTOM CUSHIONED SHOE INSERTS FOR PRIMARILY NON-ORTHOPEDIC PURPOSES; PROTECTIVE METAL MEM-

CLASS 25—(Continued).

BERS FOR SHOES AND BOOTS; RIDING SHOES; RUBBER SHOES; RUGBY SHOES; RUNNING PADS THAT STRAP ONTO SHOES; RUNNING SHOES; SAN-DALS AND BEACH SHOES; SHOE COVERS FOR USE WHEN WEARING SHOES; SHOE DOWELS; SHOE IN-SERTS FOR PRIMARILY NON-ORTHOPEDIC PUR-POSES; SHOE PEGS; SHOE SOLES; SHOE STRAPS; SHOES; SHOES FEATURING CUSHIONING; SHOES SOLES FOR REPAIR; SHOES WITH HOOK AND PILE FASTENING TAPES; SKI AND SNOWBOARD SHOES AND PARTS THEREOF; SKIING SHOES; SOCCER SHOES; TAP SHOES; TENNIS SHOES; TONGUE OR PULLSTRAP FOR SHOES AND BOOTS; TRACK AND FIELD SHOES; TRAINING SHOES; VOLLEYBALL SHOES; WATER REPELLING LEATHER SHOES AND BOOTS; WATERPROOF LEATHER SHOES; WATER-PROOF LEATHER SHOES AND BOOTS; WELTS FOR BOOTS AND SHOES; WOMEN'S SHOES; WOMEN'S SHOES, NAMELY, FOLDABLE FLATS; WOODEN SHOES; WORK SHOES AND BOOTS (U.S. CLS. 22 AND 39).

FIRST USE 7-1-2012; IN COMMERCE 7-1-2012.

4,211,504. STEINHOFF, PATRICIA, MANSFIELD, MA. SN 85-440,444. PUB. 3-13-2012, FILED 10-6-2011.



THE MARK CONSISTS OF A SHADOW OF AN ELLIP-TICAL FIGURE WITH A SHADOW OF AN ELLIPTICAL FIGURE ATTACHED TO IT.

FOR BANDANAS; BASEBALL CAPS; BASEBALL CAPS AND HATS; BERMUDA SHORTS; BOXER SHORTS; CAPS; CAPS WITH VISORS; CLOTH BIBS; CYCLISTS' JERSEYS; EAR BANDS; EAR MUFFS; EAR WARMERS; EARBANDS; FLEECE BOTTOMS; FLEECE PULLOVERS; FLEECE SHORTS; FLEECE TOPS; FLEECE VESTS; FLIP FLOPS; FOOTWEAR; FOOTWEAR; GLOVES; HATS; HEAD SCARVES; HEAD SWEATBANDS; HEAD WEAR; HEADBANDS; HEADBANDS AGAINST SWEATING; HEADWEAR; HOODED PULLOVERS; HOODED SWEAT SHIRTS; HOODED SWEATSHIRTS; INFANT AND TOD-DLER ONE PIECE CLOTHING; INFANT WEAR; IN-FANT WEARABLE BLANKETS; INFANTWEAR; JERSEYS; LONG SLEEVE PULLOVERS; LONG SLEEVED VESTS; LONG UNDERWEAR; LONG-SLEEVED SHIRTS; LOUNGE PANTS; LOUNGEWEAR; NIGHT GOWNS; NIGHT SHIRTS; NIGHTDRESSES; NIGHTGOWNS; NIGHTIES; ONE PIECE GARMENT FOR INFANTS AND TODDLERS; ONE-PIECE GAR-MENTS FOR CHILDREN; ONE-PIECE PLAY SUITS; PAJAMA BOTTOMS; PAJAMAS; PAJAMAS TREATED WITH FIRE AND HEAT RETARDANTS; PONCHOS; PULLOVERS; SHIRTS; SHIRTS AND SHORT-SLEEVED SHIRTS; SHIRTS FOR INFANTS, BABIES, TODDLERS AND CHILDREN; SHORT-SLEEVED OR LONG-SLEEVED T-SHIRTS; SHORT-SLEEVED SHIRTS; SHORTS; SINGLET; SLEEP PANTS; SLEEP SHIRTS; SLEEVED OR SLEEVELESS JACKETS; SLEEVELESS JERSEYS; SUN VISORS; SWEAT BANDS; SWEAT PANTS; SWEAT SHIRTS; SWEAT SHORTS; SWEAT-BANDS; SWEATPANTS; SWEATSHIRTS; SWEATSUITS; T-SHIRTS; TANK TOPS; TANK-TOPS; TANKINIS; TEE SHIRTS; TUBE TOPS; VISORS; WAISTBANDS; WARM UP SUITS; WRIST BANDS; WRISTBANDS; YOGA PANTS; YOGA SHIRTS (U.S. CLS. 22 AND 39).

FIRST USE 6-30-2012; IN COMMERCE 6-30-2012.

CLASS 25—(Continued).

4,211,517. MILLER INTERNATIONAL, INC., DENVER, CO.
SN 85-444,511. PUB. 3-20-2012, FILED 10-11-2011.



THE MARK CONSISTS OF BACKWARD "C" IN BLOCK FONT JOINED TO A FORWARD FACING "E" IN BLOCK FONT.

FOR FOOTWEAR (U.S. CLS. 22 AND 39).
FIRST USE 6-20-2012; IN COMMERCE 6-20-2012.

CLASS 25—(Continued).

4,211,552. JANCRISS CORPORATION, CHULA VISTA, CA.
SN 85-461,429. PUB. 4-24-2012, FILED 11-1-2011.

JANCRISS

THE MARK CONSISTS OF STANDARD CHARACTERS WITHOUT CLAIM TO ANY PARTICULAR FONT, STYLE, SIZE, OR COLOR.

FOR BODY SHAPERS; UNDERGARMENTS; SHAPEWEAR, NAMELY, GIRDLES, PANTS WITH ABDOMINAL CONTROL, AND CORSETS; PANTIES; UNDERCLOTHES; APPAREL, NAMELY, PANTS AND SHIRTS (U.S. CLS. 22 AND 39).

FIRST USE 11-11-2011; IN COMMERCE 11-11-2011.

4,211,532. CRAZY MOMMA PRODUCTIONS, INC., SANTA MONICA, CA. SN 85-451,077. PUB. 4-10-2012, FILED 10-19-2011.

HOLLY ROBINSON PEETE

THE MARK CONSISTS OF STANDARD CHARACTERS WITHOUT CLAIM TO ANY PARTICULAR FONT, STYLE, SIZE, OR COLOR.

THE NAME(S), PORTRAIT(S), AND/OR SIGNATURE(S) SHOWN IN THE MARK IDENTIFIES "HOLLY ROBINSON PEETE", WHOSE CONSENT(S) TO REGISTER IS MADE OF RECORD.

FOR CLOTHING, NAMELY, PANTS, SLACKS, SHORTS, SHIRTS, BLOUSES, T-SHIRTS, PULLOVERS, SWEAT SHIRTS, SKIRTS, DRESSES, SWEATERS, JERSEYS, KNIT TOPS AND KNIT PANTS, JACKETS, BLAZERS, COATS, SOCKS, PANTYHOSE, PAJAMAS, NIGHTGOWNS, ROBES, GLOVES, BELTS, HATS, CAPS; FOOTWEAR AND HEADWEAR (U.S. CLS. 22 AND 39).
FIRST USE 6-1-2012; IN COMMERCE 6-1-2012.

4,211,563. BUMBUMS, INC., FORMERLY LITTLE BUMBUM, INC., LA JOLLA, CA. SN 85-465,513. PUB. 4-17-2012, FILED 11-6-2011.

bumbums

THE MARK CONSISTS OF STANDARD CHARACTERS WITHOUT CLAIM TO ANY PARTICULAR FONT, STYLE, SIZE, OR COLOR.

FOR CHILDREN'S FOOTWEAR (U.S. CLS. 22 AND 39).
FIRST USE 7-7-2011; IN COMMERCE 2-15-2012.

CLASS 25—(Continued).

4,211,570. RAE, KAREN L., RIDGEFIELD, WA. SN 85-470,315. PUB. 5-1-2012, FILED 11-11-2011.



THE MARK CONSISTS OF A STYLIZED "G" WITHIN A CIRCLE WITH THREE DOTS LINED TOGETHER ALONG EDGE INSIDE THE CIRCLE AT UPPER LEFT AND THE IMAGE INCLUDES TWO HORIZONTAL BLACK LINES AT HALFWAY POINT COMING FROM OUTER EDGE OF CIRCLE INWARD BUT NOT MEETING "G" IN CENTER.

FOR HEADWEAR; HOODED SWEATSHIRTS; NIGHT SHIRTS; SHIRTS; SLEEPING GARMENTS; SWEATSHIRTS; T-SHIRTS (U.S. CLS. 22 AND 39).
FIRST USE 5-20-2011; IN COMMERCE 5-20-2011.

4,211,589. B2TD, LLC, WINTERVILLE, NC. SN 85-478,443. PUB. 5-1-2012, FILED 11-21-2011.

B2TD

THE MARK CONSISTS OF STANDARD CHARACTERS WITHOUT CLAIM TO ANY PARTICULAR FONT, STYLE, SIZE, OR COLOR.

FOR HATS; SHIRTS (U.S. CLS. 22 AND 39).
FIRST USE 12-9-2011; IN COMMERCE 12-9-2011.

4,211,613. SUPPLIER DIRECT LLC, SAN FRANCISCO, CA. SN 85-490,968. PUB. 5-1-2012, FILED 12-8-2011.

Saru

THE MARK CONSISTS OF STANDARD CHARACTERS WITHOUT CLAIM TO ANY PARTICULAR FONT, STYLE, SIZE, OR COLOR.

FOR DRESSES; SHIRTS; SKIRTS (U.S. CLS. 22 AND 39).
FIRST USE 2-1-2012; IN COMMERCE 2-20-2012.

CLASS 25—(Continued).

4,211,619. BROGDEN, RICHARD, GALLOWAY, NJ. SN 85-493,372. PUB. 5-22-2012, FILED 12-12-2011.



THE MARK CONSISTS OF THE STYLIZED TEXT "W" FOLLOWED BY AN ANCHOR DESIGN WITH A ROPE WRAPPED AROUND THE ANCHOR, AND FOLLOWED BY A STYLIZED TEXT "S" ALL INSIDE A CIRCLE. THERE IS A LINE ACROSS THE ANCHOR SYMBOL.

FOR BASEBALL CAPS; DRESS SHIRTS; HOODED SWEATSHIRTS; POLO SHIRTS; SOCKS; SWEATERS; SWEATSHIRTS; T-SHIRTS; TIES; UNDERPANTS (U.S. CLS. 22 AND 39).
FIRST USE 1-1-2012; IN COMMERCE 1-1-2012.

4,211,640. SAVES BY B, INC., NEW YORK, NY. SN 85-501,100. PUB. 5-15-2012, FILED 12-21-2011.

SAVES B

THE MARK CONSISTS OF STANDARD CHARACTERS WITHOUT CLAIM TO ANY PARTICULAR FONT, STYLE, SIZE, OR COLOR.

FOR SNEAKERS (U.S. CLS. 22 AND 39).
FIRST USE 2-23-2012; IN COMMERCE 2-23-2012.

4,211,645. SKECHERS U.S.A., INC. II, MANHATTAN BEACH, CA. SN 85-510,001. PUB. 5-1-2012, FILED 1-5-2012.

M STRIKE

THE MARK CONSISTS OF STANDARD CHARACTERS WITHOUT CLAIM TO ANY PARTICULAR FONT, STYLE, SIZE, OR COLOR.

FOR FOOTWEAR (U.S. CLS. 22 AND 39).
FIRST USE 5-15-2012; IN COMMERCE 5-15-2012.

CLASS 25—(Continued).

4,211,661. BRIAN DEEGAN.COM, LOS ANGELES, CA. SN 85-977,008. PUB. 10-4-2011, FILED 9-28-2010.

DANGER BOY

THE MARK CONSISTS OF STANDARD CHARACTERS WITHOUT CLAIM TO ANY PARTICULAR FONT, STYLE, SIZE, OR COLOR.

FOR APPAREL PRODUCTS, NAMELY, T-SHIRTS, SHIRTS, PANTS, SHORTS, SWIMWEAR, SKIRTS, DRESSES, BLOUSES, HOODED SWEATSHIRTS, SWEATERS, SOCKS, FOOTWEAR, HATS, AND BASEBALL CAPS (U.S. CLS. 22 AND 39).

FIRST USE 0-0-2009; IN COMMERCE 0-0-2009.

4,211,662. BRIAN DEEGAN.COM, LOS ANGELES, CA. SN 85-977,009. PUB. 9-27-2011, FILED 9-28-2010.

DIRT PRINCESS

THE MARK CONSISTS OF STANDARD CHARACTERS WITHOUT CLAIM TO ANY PARTICULAR FONT, STYLE, SIZE, OR COLOR.

FOR APPAREL PRODUCTS, NAMELY, T-SHIRTS, SHIRTS, PANTS, SHORTS, SWIMWEAR, SKIRTS, DRESSES, BLOUSES, HOODED SWEATSHIRTS, SWEATERS, SOCKS, FOOTWEAR, HATS, AND BASEBALL CAPS (U.S. CLS. 22 AND 39).

FIRST USE 0-0-2009; IN COMMERCE 0-0-2009.

CLASS 26—FANCY GOODS

4,210,757. BEAUTY PLUS TRADING CO., INC., MOON-ACHIE, NJ. SN 85-204,536. PUB. 11-15-2011, FILED 12-22-2010.

BLING WOLING

THE MARK CONSISTS OF STANDARD CHARACTERS WITHOUT CLAIM TO ANY PARTICULAR FONT, STYLE, SIZE, OR COLOR.

FOR HAIR EXTENSIONS (U.S. CLS. 37, 39, 40, 42 AND 50).

FIRST USE 1-21-2011; IN COMMERCE 1-21-2011.

CLASS 26—(Continued).

4,210,832. HIGH VOLTAGE GRAPHICS, INC., FT. COLLINS, CO. SN 85-234,662. PUB. 4-19-2011, FILED 2-4-2011.

TACKLEKNIT

THE MARK CONSISTS OF STANDARD CHARACTERS WITHOUT CLAIM TO ANY PARTICULAR FONT, STYLE, SIZE, OR COLOR.

FOR FABRIC APPLIQUES AND FABRIC TRANSFERS APPLIED TO CLOTHING AND OTHER SURFACES (U.S. CLS. 37, 39, 40, 42 AND 50).

FIRST USE 6-10-2011; IN COMMERCE 6-10-2011.

4,211,101. SNIK LLC, BERKELEY, CA. SN 85-340,480. PUB. 11-1-2011, FILED 6-7-2011.

SNIK

THE MARK CONSISTS OF STANDARD CHARACTERS WITHOUT CLAIM TO ANY PARTICULAR FONT, STYLE, SIZE, OR COLOR.

FOR ZIPPERS; ZIPPER PULLS; AND ZIPPER FASTENERS (U.S. CLS. 37, 39, 40, 42 AND 50).

FIRST USE 4-25-2012; IN COMMERCE 4-25-2012.

4,211,241. BARCE, SUSAN MICHELLE, BURKE, VA. AND NYSTROM, KEITH MICHAEL, BURKE, VA. SN 85-357,867. PUB. 12-13-2011, FILED 6-28-2011.

SNAZZITS

THE MARK CONSISTS OF STANDARD CHARACTERS WITHOUT CLAIM TO ANY PARTICULAR FONT, STYLE, SIZE, OR COLOR.

FOR CLOTHING ACCESSORIES, NAMELY, DECORATIVE COVERS FOR ATTACHMENT TO BUTTONS, SNAPS AND PRESS STUDS (U.S. CLS. 37, 39, 40, 42 AND 50).

FIRST USE 12-12-2011; IN COMMERCE 12-12-2011.

CLASS 27—FLOOR COVERINGS

CLASS 27—(Continued).

4,210,593. MOHAWK CARPET DISTRIBUTION, INC., CHATSWORTH, GA. SN 85-094,447. PUB. 12-14-2010, FILED 7-28-2010.

EVERSMART

THE MARK CONSISTS OF STANDARD CHARACTERS WITHOUT CLAIM TO ANY PARTICULAR FONT, STYLE, SIZE, OR COLOR.

OWNER OF U.S. REG. NO. 2,787,533.
FOR CARPETING (U.S. CLS. 19, 20, 37, 42 AND 50).
FIRST USE 2-15-2012; IN COMMERCE 2-15-2012.

4,210,766. WP IP, LLC, NEW YORK, NY. SN 85-206,764. PUB. 12-6-2011, FILED 12-28-2010.

COLOR SOLUTIONS

THE MARK CONSISTS OF STANDARD CHARACTERS WITHOUT CLAIM TO ANY PARTICULAR FONT, STYLE, SIZE, OR COLOR.

NO CLAIM IS MADE TO THE EXCLUSIVE RIGHT TO USE "COLOR", APART FROM THE MARK AS SHOWN.
FOR CARPETS, RUGS AND BATH MATS (U.S. CLS. 19, 20, 37, 42 AND 50).
FIRST USE 4-30-2011; IN COMMERCE 4-30-2011.

4,211,122. OFFICIAL PILLOWTEX LLC, NEW YORK, NY. SN 85-343,232. PUB. 11-29-2011, FILED 6-10-2011.

ROYAL VELVET

THE MARK CONSISTS OF STANDARD CHARACTERS WITHOUT CLAIM TO ANY PARTICULAR FONT, STYLE, SIZE, OR COLOR.

OWNER OF U.S. REG. NOS. 2,325,800, 3,646,693, AND OTHERS.
FOR AREA RUGS; ACCENT RUGS (U.S. CLS. 19, 20, 37, 42 AND 50).
FIRST USE 5-1-2012; IN COMMERCE 5-1-2012.

CLASS 27—(Continued).

4,211,326. MESSMATZ LLC, DBA MESSMATZ, HIGHLANDS RANCH, CO. SN 85-373,849. PUB. 12-13-2011, FILED 7-18-2011.

MessMatz

THE MARK CONSISTS OF STANDARD CHARACTERS WITHOUT CLAIM TO ANY PARTICULAR FONT, STYLE, SIZE, OR COLOR.

FOR RUBBER MATS (U.S. CLS. 19, 20, 37, 42 AND 50).
FIRST USE 3-21-2012; IN COMMERCE 3-21-2012.

CLASS 28—TOYS AND SPORTING GOODS

4,210,243. KENNEDY, JOHN, KALAMAZOO, MI. SN 76-707,671. PUB. 11-1-2011, FILED 5-20-2011.

DIRTY LITTLE DOE

THE MARK CONSISTS OF STANDARD CHARACTERS WITHOUT CLAIM TO ANY PARTICULAR FONT, STYLE, SIZE, OR COLOR.

NO CLAIM IS MADE TO THE EXCLUSIVE RIGHT TO USE "DOE", APART FROM THE MARK AS SHOWN.
FOR HUNTING GAME CALLS (U.S. CLS. 22, 23, 38 AND 50).
FIRST USE 12-1-2011; IN COMMERCE 12-1-2011.

4,210,285. MAINARDI, JOHN V, WARREN, MI. SN 77-499,322. PUB. 4-14-2009, FILED 6-15-2008.

SPORTTE

THE MARK CONSISTS OF STANDARD CHARACTERS WITHOUT CLAIM TO ANY PARTICULAR FONT, STYLE, SIZE, OR COLOR.

OWNER OF U.S. REG. NO. 3,386,178.
THE WORDING "SPORTTE" HAS NO MEANING IN A FOREIGN LANGUAGE.
FOR TOY MODEL AIRPLANE KITS AND RELATED ACCESSORIES SOLD AS A UNIT (U.S. CLS. 22, 23, 38 AND 50).
FIRST USE 12-19-2011; IN COMMERCE 12-19-2011.

CLASS 28—(Continued).

4,210,337. COMPERDA, SCOTT MICHAEL, ST. CHARLES, IL. SN 77-645,167. PUB. 4-28-2009, FILED 1-7-2009.

GRIDMANIA

THE MARK CONSISTS OF STANDARD CHARACTERS WITHOUT CLAIM TO ANY PARTICULAR FONT, STYLE, SIZE, OR COLOR.

FOR BOARD GAMES; DICE GAMES; EQUIPMENT SOLD AS A UNIT FOR PLAYING BOARD GAMES; PRINTED POSITIONABLE TOYS FOR USE IN CHILDREN'S BOARD GAMES; TABLETOP GAMES (U.S. CLS. 22, 23, 38 AND 50).

FIRST USE 7-18-2012; IN COMMERCE 7-18-2012.

4,210,343. PUNKSTAR, LLC, LOS ANGELES, CA. SN 77-649,807. PUB. 11-3-2009, FILED 1-14-2009.

PUNKSTAR

THE MARK CONSISTS OF STANDARD CHARACTERS WITHOUT CLAIM TO ANY PARTICULAR FONT, STYLE, SIZE, OR COLOR.

FOR VINYL TOYS, NAMELY, VINYL CHARACTER TOYS; PLUSH TOYS; PLASTIC TOYS, NAMELY, PLASTIC CHARACTER TOYS (U.S. CLS. 22, 23, 38 AND 50).

FIRST USE 5-0-2012; IN COMMERCE 5-0-2012.

4,210,359. MIAMI MARLINS, L.P., MIAMI, FL. SN 77-729,977. PUB. 9-22-2009, FILED 5-6-2009.

MIAMI MARLINS

THE MARK CONSISTS OF STANDARD CHARACTERS WITHOUT CLAIM TO ANY PARTICULAR FONT, STYLE, SIZE, OR COLOR.

OWNER OF U.S. REG. NOS. 1,807,380, 2,084,194, AND OTHERS.

CLASS 28—(Continued).

NO CLAIM IS MADE TO THE EXCLUSIVE RIGHT TO USE "MIAMI", APART FROM THE MARK AS SHOWN.

FOR TOYS AND SPORTING GOODS, NAMELY, STUFFED TOYS, PLUSH TOYS, BALLOONS, PARLOR GAMES, PUZZLES, TOY BANKS, TOY FIGURES, DOLLS, BOBBING HEAD DOLLS, MINIATURE BASEBALL BATS, BASEBALL BATS, MINI BATTING HELMET REPLICAS, BASEBALLS, HOLDERS FOR BASEBALLS, AUTOGRAPHED BASEBALLS, PLAYGROUND BALLS, CHRISTMAS TREE ORNAMENTS AND DECORATIONS, ACTION FIGURES, BALLS FOR GAMES (U.S. CLS. 22, 23, 38 AND 50).

FIRST USE 3-1-2012; IN COMMERCE 3-1-2012.

4,210,378. SPIN MASTER LTD., TORONTO, CANADA. SN 77-788,596. PUB. 11-30-2010, FILED 7-23-2009.

PAPERONI

THE MARK CONSISTS OF STANDARD CHARACTERS WITHOUT CLAIM TO ANY PARTICULAR FONT, STYLE, SIZE, OR COLOR.

OWNER OF U.S. REG. NO. 3,479,277.

FOR TOYS, GAMES AND PLAYTHINGS, NAMELY, HOBBY CRAFT KITS COMPRISING PLASTIC AND FABRIC FORMS OF ANIMALS, CREATURES AND BIRDS TO WHICH CREPE PAPER ROLLS ARE ATTACHED, AND ACCESSORIES THEREFOR (U.S. CLS. 22, 23, 38 AND 50).

FIRST USE 8-31-2009; IN COMMERCE 8-31-2009.

4,210,380. CROWNS & ANDREWS PTY LIMITED, RYDALMERE, AUSTRALIA. SN 77-793,037. PUB. 9-20-2011, FILED 7-30-2009.

BILLIONAIRE

THE MARK CONSISTS OF STANDARD CHARACTERS WITHOUT CLAIM TO ANY PARTICULAR FONT, STYLE, SIZE, OR COLOR.

FOR CARD GAMES (U.S. CLS. 22, 23, 38 AND 50).

FIRST USE 0-0-2001; IN COMMERCE 0-0-2001.

CLASS 28—(Continued).

4,210,383. SADOWSKI, STANLEY, PROVO, UT. SN 77-810,586. PUB. 1-19-2010, FILED 8-21-2009.

TailgateFootball

THE MARK CONSISTS OF STANDARD CHARACTERS WITHOUT CLAIM TO ANY PARTICULAR FONT, STYLE, SIZE, OR COLOR.

FOR BOARD GAMES; EQUIPMENT SOLD AS A UNIT FOR PLAYING BOARD GAMES; GAME EQUIPMENT SET SOLD AS A UNIT COMPRISED PRIMARILY OF A PLAYING BOARD AND PLAYING CARDS AND ALSO INCLUDING RULES OF PLAY, DRY ERASE BOARDS AND ERASERS, MARKERS, A TIMER AND T-SHIRTS; POSITIONABLE THREE DIMENSIONAL TOYS FOR USE IN GAMES; PROMOTIONAL GAME MATERIALS; TABLETOP GAMES (U.S. CLS. 22, 23, 38 AND 50).
FIRST USE 3-2-2009; IN COMMERCE 12-13-2011.

CLASS 28—(Continued).

4,210,404. SALES & PRODUCT SOLUTIONS, INC., NORTH-BROOK, IL. SN 77-870,966. PUB. 10-19-2010, FILED 11-12-2009.



THE MARK CONSISTS OF THE WORD "SNAPRODUCTS" IN A RECTANGLE WITH AN EXCLAMATION MARK OVER THE LETTER "P" WITH THREE DOTS BELOW THE EXCLAMATION MARK.

FOR CHRISTMAS TREE DECORATIONS AND ORNAMENTS (U.S. CLS. 22, 23, 38 AND 50).
FIRST USE 8-0-2008; IN COMMERCE 8-0-2008.

4,210,457. MATTEL, INC., EL SEGUNDO, CA. SN 77-934,340. PUB. 6-29-2010, FILED 2-12-2010.

CLAMP CHAMP

THE MARK CONSISTS OF STANDARD CHARACTERS WITHOUT CLAIM TO ANY PARTICULAR FONT, STYLE, SIZE, OR COLOR.

FOR TOYS, GAMES AND PLAYTHINGS, NAMELY, TOY ACTION FIGURES AND ACCESSORIES THEREFOR (U.S. CLS. 22, 23, 38 AND 50).
FIRST USE 6-30-2012; IN COMMERCE 6-30-2012.

4,210,482. BRIAN FITZPATRICK, LADERA RANCH, CA. AND CHASE FITZPATRICK, LADERA RANCH, CA. SN 78-648,612. PUB. 11-23-2010, FILED 6-10-2005.

PERFECTOS

THE MARK CONSISTS OF A FURRY STUFFED ANIMAL AND THE WORD "FURGIVABLES".

SEC. 2(F).
FOR STUFFED TOY ANIMALS (U.S. CLS. 22, 23, 38 AND 50).
FIRST USE 5-30-2011; IN COMMERCE 5-30-2011.



THE MARK CONSISTS OF STANDARD CHARACTERS WITHOUT CLAIM TO ANY PARTICULAR FONT, STYLE, SIZE, OR COLOR.

CLASS 28—(Continued).

THE FOREIGN WORDING IN THE MARK TRANSLATES INTO ENGLISH AS "PERFECT".
FOR MOLDED PLASTIC TOY FIGURINES AND ACTION FIGURES (U.S. CLS. 22, 23, 38 AND 50).
FIRST USE 6-28-2012; IN COMMERCE 6-28-2012.

POLAR GRIP

4,210,524. TECH 4 KIDS INC., MISSISSAUGA, ONTARIO, CANADA. SN 85-044,212. PUB. 11-22-2011, FILED 5-20-2010.

THE MARK CONSISTS OF STANDARD CHARACTERS WITHOUT CLAIM TO ANY PARTICULAR FONT, STYLE, SIZE, OR COLOR.

FOR SNOW SLEDS FOR RECREATIONAL USE; TOBOGGANS; RIDE-ON TOYS FOR USE ON SNOW; SNOW BOARDS; SKI BOBS, SKI BIKES AND SNOW BIKES ALL IN THE NATURE OF NON-POWERED RIDE-ON DEVICES SET UPON SNOW SKIS FOR RECREATIONAL USE (U.S. CLS. 22, 23, 38 AND 50).

FIRST USE 10-31-2010; IN COMMERCE 10-31-2010.

OUTER EDGE

THE MARK CONSISTS OF STANDARD CHARACTERS WITHOUT CLAIM TO ANY PARTICULAR FONT, STYLE, SIZE, OR COLOR.

FOR TOYS, NAMELY, CHILDREN'S OUTDOOR ACTIVITY TOYS FOR USE IN SNOW; SNOW SLEDS FOR RECREATIONAL USE; TOY SCOOTERS AND SKATEBOARDS; NON-POWERED RIDE-ON TOYS FOR RECREATIONAL USE IN SNOW; TOBOGGANS; SKI BOBS AND SKI BIKES BOTH IN THE NATURE OF NON-POWERED RIDE-ON DEVICES SET UPON SNOW SKIS FOR RECREATIONAL USE; SNOWBOARDS (U.S. CLS. 22, 23, 38 AND 50).

FIRST USE 10-31-2010; IN COMMERCE 10-31-2010.

CLASS 28—(Continued).

4,210,547. SHRUNKEN HEAD STUDIOS, NORTH HOLLYWOOD, CA. SN 85-063,880. PUB. 8-23-2011, FILED 6-16-2010.

SHRUNKEN HEAD STUDIOS

THE MARK CONSISTS OF STANDARD CHARACTERS WITHOUT CLAIM TO ANY PARTICULAR FONT, STYLE, SIZE, OR COLOR.

NO CLAIM IS MADE TO THE EXCLUSIVE RIGHT TO USE "STUDIOS", APART FROM THE MARK AS SHOWN.

FOR ACTION FIGURES; ACTION FIGURES AND ACCESSORIES THEREFOR; COLLECTABLE TOY FIGURES; MOLDED TOY FIGURES; PLAY FIGURES; PLAY SETS FOR ACTION FIGURES; POSITIONABLE TOY FIGURES; TOY ACTION FIGURES; TOY ACTION FIGURES AND ACCESSORIES THEREFOR; TOY FIGURES (U.S. CLS. 22, 23, 38 AND 50).

FIRST USE 1-24-2011; IN COMMERCE 1-24-2011.

4,210,806. MARCO, PETER, DBA MARCOART, NEW YORK, NY. SN 85-217,722. PUB. 5-31-2011, FILED 1-14-2011.



THE COLOR(S) PINK, BLACK, ROYAL BLUE, WHITE, GREEN, GOLDEN YELLOW, RED AND SKY BLUE IS/ARE CLAIMED AS A FEATURE OF THE MARK.

THE MARK CONSISTS OF A PINK, BLACK, ROYAL BLUE AND WHITE AQUATIC DINOSAUR WITH GREEN POLKA DOTS OUTLINED IN BLACK WEARING A GOLDEN YELLOW CROWN OUTLINED IN BLACK TOPPED WITH THREE RED GLOBES OUTLINED IN BLACK ON A SKY BLUE BACKGROUND SPANGLED WITH WHITE BUBBLES OUTLINED IN BLACK ABOVE THE WORDS "MY GOOD NESS" WITH THE WORD "MY" IN BLACK, THE WORD "GOOD" IN GOLDEN YELLOW AND OUTLINED IN BLACK, AND THE WORD "NESS" IN ROYAL BLUE OUTLINED IN BLACK.

FOR BATH TOYS; BATHTUB TOYS; BENDABLE TOYS; CAT TOYS; COLLECTABLE TOY FIGURES; INFLATABLE BATH TOYS; INFLATABLE RIDE-ON TOYS; INFLATABLE TOYS; MODELED PLASTIC TOY FIGURINES; MOLDED TOY FIGURES; PET TOYS; PLUSH TOYS; PULL TOYS; PUNCHING TOYS; PUSH TOYS; RUBBER CHARACTER TOYS; SOFT SCULPTURE PLUSH TOYS; SOFT SCULPTURE TOYS; SQUEEZE TOYS; STUFFED AND PLUSH TOYS; STUFFED TOY ANIMALS; STUFFED TOYS; TOY ANIMALS (U.S. CLS. 22, 23, 38 AND 50).

FIRST USE 2-14-2002; IN COMMERCE 6-15-2010.

CLASS 28—(Continued).

4,210,849. DAVID BRODRICK ENTERPRISES, LLC, PLANO, TX. SN 85-239,481. PUB. 7-5-2011, FILED 2-10-2011.

SCOSSA

THE MARK CONSISTS OF STANDARD CHARACTERS WITHOUT CLAIM TO ANY PARTICULAR FONT, STYLE, SIZE, OR COLOR.

THE ENGLISH TRANSLATION OF THE ITALIAN WORD "SCOSSA" IN THE MARK IS "TOSS".
FOR GAMING TABLES (U.S. CLS. 22, 23, 38 AND 50).
FIRST USE 5-20-2011; IN COMMERCE 5-20-2011.

CLASS 28—(Continued).

4,211,007. LUCKY CRAFT CO., LTD., OYABE-SHI, TOYAMA, JAPAN. SN 85-323,846. PUB. 10-11-2011, FILED 5-18-2011.

RTO

THE MARK CONSISTS OF STANDARD CHARACTERS WITHOUT CLAIM TO ANY PARTICULAR FONT, STYLE, SIZE, OR COLOR.

FOR FISHING LURES (U.S. CLS. 22, 23, 38 AND 50).
FIRST USE 1-1-2012; IN COMMERCE 1-1-2012.

4,210,893. AMERICAN SPORTS LICENSING, INC., WILMINGTON, DE. SN 85-254,703. PUB. 11-8-2011, FILED 3-1-2011.



THE MARK CONSISTS OF AN INTERLOCKING TRIANGULAR DESIGN SURROUNDED BY A BROKEN CIRCLE TO THE LEFT OF THE WORDING "OMEN".
FOR GOLF PUTTERS (U.S. CLS. 22, 23, 38 AND 50).
FIRST USE 5-10-2011; IN COMMERCE 5-10-2011.

4,211,010. GOLFSMITH INTERNATIONAL, INC., AUSTIN, TX. SN 85-324,602. PUB. 10-11-2011, FILED 5-19-2011.

SILVERCAT

THE MARK CONSISTS OF STANDARD CHARACTERS WITHOUT CLAIM TO ANY PARTICULAR FONT, STYLE, SIZE, OR COLOR.

FOR GOLF CLUBS (U.S. CLS. 22, 23, 38 AND 50).
FIRST USE 10-0-2011; IN COMMERCE 10-0-2011.

4,210,900. HAUKEAHOE VENTURES, SALT LAKE CITY, UT. SN 85-261,466. PUB. 7-26-2011, FILED 3-8-2011.

SNOW SHIFT

THE MARK CONSISTS OF STANDARD CHARACTERS WITHOUT CLAIM TO ANY PARTICULAR FONT, STYLE, SIZE, OR COLOR.

NO CLAIM IS MADE TO THE EXCLUSIVE RIGHT TO USE "SNOW", APART FROM THE MARK AS SHOWN.
FOR SNOWBOARDS (U.S. CLS. 22, 23, 38 AND 50).
FIRST USE 1-22-2011; IN COMMERCE 1-22-2011.

4,211,012. TRIBUNE MEDIA SERVICES, INC., CHICAGO, IL. SN 85-325,108. PUB. 10-11-2011, FILED 5-19-2011.

JUMBLE

THE MARK CONSISTS OF STANDARD CHARACTERS WITHOUT CLAIM TO ANY PARTICULAR FONT, STYLE, SIZE, OR COLOR.

FOR PLAYING CARDS, PLAYING CARD SETS, PLAYING CARD GAMES, CARD GAMES, DICE, DICE GAMES AND POKER CHIPS (U.S. CLS. 22, 23, 38 AND 50).
FIRST USE 11-1-2011; IN COMMERCE 11-1-2011.

CLASS 28—(Continued).

4,211,086. 3G CARDIO, LLC, SCOTTSDALE, AZ. SN 85-338,216. PUB. 11-22-2011, FILED 6-4-2011.

AVT accelerated vibration training

THE MARK CONSISTS OF STANDARD CHARACTERS WITHOUT CLAIM TO ANY PARTICULAR FONT, STYLE, SIZE, OR COLOR.

NO CLAIM IS MADE TO THE EXCLUSIVE RIGHT TO USE "ACCELERATED VIBRATION TRAINING", APART FROM THE MARK AS SHOWN.

FOR VIBRATING APPARATUS USED IN FITNESS AND EXERCISE PROGRAMS TO STIMULATE MUSCLES AND INCREASE STRENGTH AND PHYSICAL PERFORMANCE (U.S. CLS. 22, 23, 38 AND 50).

FIRST USE 1-15-2012; IN COMMERCE 1-15-2012.

4,211,108. EATON CORPORATION, CLEVELAND, OH. SN 85-341,875. PUB. 2-7-2012, FILED 6-9-2011.

MULTICOMPOUND 360

THE MARK CONSISTS OF STANDARD CHARACTERS WITHOUT CLAIM TO ANY PARTICULAR FONT, STYLE, SIZE, OR COLOR.

NO CLAIM IS MADE TO THE EXCLUSIVE RIGHT TO USE "MULTICOMPOUND", APART FROM THE MARK AS SHOWN.

FOR HAND GRIPS FOR SPORTING IMPLEMENTS, GOLF CLUB GRIPS (U.S. CLS. 22, 23, 38 AND 50).

FIRST USE 9-28-2011; IN COMMERCE 9-28-2011.

4,211,110. KEYS PUBLISHING CO., INC., SARASOTA, FL. SN 85-342,212. PUB. 11-1-2011, FILED 6-9-2011.

SMELL-O-RAMA!

THE MARK CONSISTS OF STANDARD CHARACTERS WITHOUT CLAIM TO ANY PARTICULAR FONT, STYLE, SIZE, OR COLOR.

FOR CARD GAMES; EQUIPMENT SOLD AS A UNIT FOR PLAYING CARD GAMES (U.S. CLS. 22, 23, 38 AND 50).

FIRST USE 6-18-2012; IN COMMERCE 6-18-2012.

CLASS 28—(Continued).

4,211,168. THE HARTZ MOUNTAIN CORPORATION, SECAUCUS, NJ. SN 85-348,336. PUB. 10-11-2011, FILED 6-16-2011.

THREE BLIND MICE

THE MARK CONSISTS OF STANDARD CHARACTERS WITHOUT CLAIM TO ANY PARTICULAR FONT, STYLE, SIZE, OR COLOR.

FOR PET TOYS (U.S. CLS. 22, 23, 38 AND 50).

FIRST USE 3-5-2012; IN COMMERCE 3-5-2012.

4,211,174. GORDON RIDES, LLC, WHITE PLAINS, NY. SN 85-349,249. PUB. 11-8-2011, FILED 6-17-2011.

MEGA WHIRL

THE MARK CONSISTS OF STANDARD CHARACTERS WITHOUT CLAIM TO ANY PARTICULAR FONT, STYLE, SIZE, OR COLOR.

FOR AMUSEMENT PARK RIDES (U.S. CLS. 22, 23, 38 AND 50).

FIRST USE 7-1-2012; IN COMMERCE 7-1-2012.

4,211,185. MCCLEAN ENTERPRISES LLC, DELMAR, IA. SN 85-350,174. PUB. 12-6-2011, FILED 6-20-2011.

RELISH THE MOMENT

THE MARK CONSISTS OF STANDARD CHARACTERS WITHOUT CLAIM TO ANY PARTICULAR FONT, STYLE, SIZE, OR COLOR.

FOR PARLOUR GAMES (U.S. CLS. 22, 23, 38 AND 50).

FIRST USE 11-14-2011; IN COMMERCE 11-14-2011.

CLASS 28—(Continued).

4,211,228. TRUGLO, INC., RICHARDSON, TX. SN 85-356,402.
PUB. 10-25-2011, FILED 6-26-2011.

GAME CHANGER

THE MARK CONSISTS OF STANDARD CHARACTERS WITHOUT CLAIM TO ANY PARTICULAR FONT, STYLE, SIZE, OR COLOR.

FOR ARCHERY EQUIPMENT, NAMELY, NON-TELESCOPIC BOW SIGHTS; ARCHERY EQUIPMENT, NAMELY, OPEN BOW SIGHTS; ARCHERY QUIVERS (U.S. CLS. 22, 23, 38 AND 50).

FIRST USE 11-16-2011; IN COMMERCE 11-16-2011.

CLASS 28—(Continued).

4,211,283. MATTEL, INC., EL SEGUNDO, CA. SN 85-365,651.
PUB. 12-6-2011, FILED 7-7-2011.

MISSION FORCE

THE MARK CONSISTS OF STANDARD CHARACTERS WITHOUT CLAIM TO ANY PARTICULAR FONT, STYLE, SIZE, OR COLOR.

FOR TOY VEHICLES AND ACCESSORIES THEREFOR (U.S. CLS. 22, 23, 38 AND 50).

FIRST USE 3-29-2012; IN COMMERCE 3-29-2012.

4,211,243. GRIFFIN TECHNOLOGY, INC., NASHVILLE, TN.
SN 85-358,020. PUB. 11-1-2011, FILED 6-28-2011.

HELO TC

THE MARK CONSISTS OF STANDARD CHARACTERS WITHOUT CLAIM TO ANY PARTICULAR FONT, STYLE, SIZE, OR COLOR.

NO CLAIM IS MADE TO THE EXCLUSIVE RIGHT TO USE "HELO", APART FROM THE MARK AS SHOWN.

FOR REMOTE CONTROL TOYS, NAMELY, HELICOPTERS (U.S. CLS. 22, 23, 38 AND 50).

FIRST USE 3-23-2012; IN COMMERCE 3-23-2012.

4,211,284. MATTEL, INC., EL SEGUNDO, CA. SN 85-365,655.
PUB. 12-6-2011, FILED 7-7-2011.

QUICKTEK

THE MARK CONSISTS OF STANDARD CHARACTERS WITHOUT CLAIM TO ANY PARTICULAR FONT, STYLE, SIZE, OR COLOR.

FOR TOY VEHICLES AND ACCESSORIES THEREFOR; TOY FIGURES AND ACCESSORIES THEREFOR (U.S. CLS. 22, 23, 38 AND 50).

FIRST USE 6-6-2012; IN COMMERCE 6-6-2012.

4,211,257. HOLMAN, TIM, OCEANSIDE, CA. SN 85-359,544.
PUB. 12-20-2011, FILED 6-29-2011.

MAGIC PUTTER

THE MARK CONSISTS OF STANDARD CHARACTERS WITHOUT CLAIM TO ANY PARTICULAR FONT, STYLE, SIZE, OR COLOR.

NO CLAIM IS MADE TO THE EXCLUSIVE RIGHT TO USE "PUTTER", APART FROM THE MARK AS SHOWN.

FOR GOLF PUTTER COVERS; GOLF PUTTERS (U.S. CLS. 22, 23, 38 AND 50).

FIRST USE 4-1-2012; IN COMMERCE 4-1-2012.

4,211,285. MATTEL, INC., EL SEGUNDO, CA. SN 85-365,663.
PUB. 12-6-2011, FILED 7-7-2011.

TURBO HAULER

THE MARK CONSISTS OF STANDARD CHARACTERS WITHOUT CLAIM TO ANY PARTICULAR FONT, STYLE, SIZE, OR COLOR.

FOR TOY VEHICLES AND ACCESSORIES THEREFOR (U.S. CLS. 22, 23, 38 AND 50).

FIRST USE 12-6-2011; IN COMMERCE 12-6-2011.

CLASS 28—(Continued).

4,211,298. MATTEL, INC., EL SEGUNDO, CA. SN 85-368,840.
PUB. 12-6-2011, FILED 7-12-2011.

TAMIKA

THE MARK CONSISTS OF STANDARD CHARACTERS WITHOUT CLAIM TO ANY PARTICULAR FONT, STYLE, SIZE, OR COLOR.

FOR DOLLS, DOLL CLOTHING AND DOLL ACCESSORIES (U.S. CLS. 22, 23, 38 AND 50).

FIRST USE 6-6-2012; IN COMMERCE 6-6-2012.

4,211,358. CHELSEA & SCOTT, LTD, LAKE BLUFF, IL. SN 85-380,744. PUB. 1-10-2012, FILED 7-26-2011.

MY GEO GYM

THE MARK CONSISTS OF STANDARD CHARACTERS WITHOUT CLAIM TO ANY PARTICULAR FONT, STYLE, SIZE, OR COLOR.

NO CLAIM IS MADE TO THE EXCLUSIVE RIGHT TO USE "GYM", APART FROM THE MARK AS SHOWN.

FOR INFLATABLE TOYS; TOY BUILDING BLOCKS (U.S. CLS. 22, 23, 38 AND 50).

FIRST USE 10-1-2011; IN COMMERCE 10-1-2011.

CLASS 28—(Continued).

4,211,434. CHENG, KUO HUNG, KAOHSIUNG CITY, TAIWAN, TAIWAN. SN 85-406,978. PUB. 2-7-2012, FILED 8-25-2011.

WELLHOPE

THE MARK CONSISTS OF THE WORDING "WELLHOPE" IN STYLIZED LETTERING, WITH THE LOWEST HORIZONTAL LINE OF BOTH "E'S," THE LETTER "W," AND BOTH "L'S" IN A DARKER SHADE THAN THE TOP TWO HORIZONTAL LINES OF THE "E'S" AND THE LETTERS "H," "O," AND "P".

FOR ARTIFICIAL FISHING BAIT; BITE SENSORS; FISH HOOKS; FISHING CREELS; FISHING LURES; FISHING ROD RACKS; FISHING TACKLE; FISHING TACKLE BAGS; FISHING TACKLE, NAMELY, BOBBERS; FLOATS FOR FISHING; HUNTING GAME CALLS; LANDING NETS FOR ANGLERS; LINES FOR FISHING; REELS FOR FISHING; RODS FOR FISHING; STRUCTURAL PARTS OF FISHING RODS, NAMELY, CONDUCTOR COILS FOR FISHING RODS BEING RINGS ATTACHED TO THE ROD THROUGH WHICH THE FISHING LINE PASSES (U.S. CLS. 22, 23, 38 AND 50).

FIRST USE 12-25-2011; IN COMMERCE 12-25-2011.

4,211,443. INDIAN INDUSTRIES, INC., EVANSVILLE, IN. SN 85-410,397. PUB. 1-10-2012, FILED 8-30-2011.

ALL SEASON TRAINER

THE MARK CONSISTS OF STANDARD CHARACTERS WITHOUT CLAIM TO ANY PARTICULAR FONT, STYLE, SIZE, OR COLOR.

NO CLAIM IS MADE TO THE EXCLUSIVE RIGHT TO USE "TRAINER", APART FROM THE MARK AS SHOWN.

FOR SPORTS TRAINING APPARATUS FOR REBOUNDING AND CATCHING BALLS (U.S. CLS. 22, 23, 38 AND 50).

FIRST USE 2-1-2012; IN COMMERCE 2-1-2012.

CLASS 28—(Continued).

4,211,466. WINNING MOVES INC., DANVERS, MA. SN 85-418,399. PUB. 2-21-2012, FILED 9-9-2011.

PASTIME PUZZLES

THE MARK CONSISTS OF STANDARD CHARACTERS WITHOUT CLAIM TO ANY PARTICULAR FONT, STYLE, SIZE, OR COLOR.

NO CLAIM IS MADE TO THE EXCLUSIVE RIGHT TO USE "PUZZLES", APART FROM THE MARK AS SHOWN, FOR JIGSAW PUZZLES; PUZZLES (U.S. CLS. 22, 23, 38 AND 50).

FIRST USE 2-1-2012; IN COMMERCE 5-15-2012.

4,211,524. MJ PARTNERS LLC, NORTH HOLLYWOOD, CA. SN 85-449,016. PUB. 4-3-2012, FILED 10-17-2011.

MAHJ MANIA

THE MARK CONSISTS OF STANDARD CHARACTERS WITHOUT CLAIM TO ANY PARTICULAR FONT, STYLE, SIZE, OR COLOR.

FOR GAME PLAYING EQUIPMENT, NAMELY, TILE MIXERS (U.S. CLS. 22, 23, 38 AND 50).

FIRST USE 10-15-2011; IN COMMERCE 10-15-2011.

4,211,525. MJ PARTNERS LLC, NORTH HOLLYWOOD, CA. SN 85-449,034. PUB. 4-3-2012, FILED 10-17-2011.



THE MARK CONSISTS OF WOMAN HOLDING UMBRELLA.

FOR GAME PLAYING EQUIPMENT, NAMELY, TILE MIXERS (U.S. CLS. 22, 23, 38 AND 50).

FIRST USE 10-15-2011; IN COMMERCE 10-15-2011.

CLASS 28—(Continued).

4,211,551. CEPIA, LLC, SAINT LOUIS, MO. SN 85-461,416. PUB. 4-17-2012, FILED 11-1-2011.

DING-E

THE MARK CONSISTS OF STANDARD CHARACTERS WITHOUT CLAIM TO ANY PARTICULAR FONT, STYLE, SIZE, OR COLOR.

FOR BATTERY OPERATED ACTION TOYS; ELECTRONIC ACTION TOYS; MOLDED TOY FIGURES; PLAYSETS FOR ACTION TOYS; PLUSH TOYS; TALKING TOYS; TOY ACTION FIGURES AND ACCESSORIES THEREFOR; TOY BUILDINGS AND ACCESSORIES THEREFOR; TOY VEHICLES (U.S. CLS. 22, 23, 38 AND 50).

FIRST USE 3-9-2012; IN COMMERCE 3-9-2012.

4,211,553. CEPIA, LLC, SAINT LOUIS, MO. SN 85-461,430. PUB. 4-17-2012, FILED 11-1-2011.

DING-E DING-E BABIES

THE MARK CONSISTS OF STANDARD CHARACTERS WITHOUT CLAIM TO ANY PARTICULAR FONT, STYLE, SIZE, OR COLOR.

FOR BATTERY OPERATED ACTION TOYS; ELECTRONIC ACTION TOYS; MOLDED TOY FIGURES; PLAYSETS FOR ACTION TOYS; PLUSH TOYS; TALKING TOYS; TOY ACTION FIGURES AND ACCESSORIES THEREFOR; TOY BUILDINGS AND ACCESSORIES THEREFOR; TOY VEHICLES (U.S. CLS. 22, 23, 38 AND 50).

FIRST USE 3-9-2012; IN COMMERCE 3-9-2012.

4,211,609. VOLITION LLC, VEAZIE, ME. SN 85-489,086. PUB. 2-14-2012, FILED 12-7-2011.

Volition

THE MARK CONSISTS OF STANDARD CHARACTERS WITHOUT CLAIM TO ANY PARTICULAR FONT, STYLE, SIZE, OR COLOR.

FOR SKIS (U.S. CLS. 22, 23, 38 AND 50).

FIRST USE 11-14-2011; IN COMMERCE 11-14-2011.

CLASS 29—MEATS AND PROCESSED FOODS

CLASS 29—(Continued).

4,210,284. JONMOR INVESTMENTS, INC., WILMINGTON, DE. SN 77-493,211. PUB. 11-16-2010, FILED 6-6-2008.

1827 BRAND PIT HAM

THE MARK CONSISTS OF STANDARD CHARACTERS WITHOUT CLAIM TO ANY PARTICULAR FONT, STYLE, SIZE, OR COLOR.

NO CLAIM IS MADE TO THE EXCLUSIVE RIGHT TO USE "BRAND PIT HAM", APART FROM THE MARK AS SHOWN.

FOR PIT HAM (U.S. CL. 46).

FIRST USE 11-30-2008; IN COMMERCE 11-30-2008.

4,210,294. CACIQUE INC., INDUSTRY, CA. SN 77-525,512. PUB. 4-14-2009, FILED 7-18-2008.

SUNNY STATE FARMS

THE MARK CONSISTS OF STANDARD CHARACTERS WITHOUT CLAIM TO ANY PARTICULAR FONT, STYLE, SIZE, OR COLOR.

NO CLAIM IS MADE TO THE EXCLUSIVE RIGHT TO USE "FARMS", APART FROM THE MARK AS SHOWN.

FOR DAIRY PRODUCTS EXCLUDING ICE CREAM, ICE MILK AND FROZEN YOGURT (U.S. CL. 46).

FIRST USE 1-0-2010; IN COMMERCE 1-0-2010.

4,210,304. FAMILY FOOD DISTRIBUTORS, INC., KEARNY, NJ. SN 77-571,031. PUB. 4-28-2009, FILED 9-16-2008.

QUETZAL

THE MARK CONSISTS OF STANDARD CHARACTERS WITHOUT CLAIM TO ANY PARTICULAR FONT, STYLE, SIZE, OR COLOR.

FOR FRUIT AND VEGETABLES PRESERVES; DRIED BEANS (U.S. CL. 46).

FIRST USE 7-1-2012; IN COMMERCE 7-1-2012.

CLASS 29—(Continued).

4,210,335. FORK IN THE ROAD FOODS, LLC, SAN FRANCISCO, CA. SN 77-642,101. PUB. 5-5-2009, FILED 12-31-2008.

FORK IN THE ROAD

THE MARK CONSISTS OF STANDARD CHARACTERS WITHOUT CLAIM TO ANY PARTICULAR FONT, STYLE, SIZE, OR COLOR.

FOR FRESH, REFRIGERATED AND PROCESSED MEAT, NAMELY, BEEF, PORK, POULTRY, VEAL, LAMB AND GAME; FRESH, REFRIGERATED AND PROCESSED MEATS; PROCESSED MEATS, NAMELY, SAUSAGE AND SMOKED MEATS; PROCESSED MEATS; PROCESSED MEATS, NAMELY, SAUSAGE AND SMOKED MEATS WITH ADDED FRUITS, VEGETABLES, HERBS AND SPICES; FRESH, REFRIGERATED, PACKAGED ENTREES CONSISTING PRIMARILY OF BEEF, PORK, POULTRY, VEAL, LAMB OR GAME; FRESH, REFRIGERATED APPETIZERS CONSISTING PRIMARILY OF BEEF, PORK, POULTRY, VEAL, LAMB OR GAME; FRANKFURTERS; HOT DOGS; LUNCHEON MEATS; PRESERVED MEATS AND SAUSAGES (U.S. CL. 46).

FIRST USE 1-15-2009; IN COMMERCE 1-15-2009.

4,210,395. JONMOR INVESTMENTS, INC., WILMINGTON, DE. SN 77-859,394. PUB. 4-13-2010, FILED 10-28-2009.



NO CLAIM IS MADE TO THE EXCLUSIVE RIGHT TO USE "FOOD ALLERGY RECOGNITION", APART FROM THE MARK AS SHOWN.

THE COLOR(S) BLUE, YELLOW AND WHITE IS/ARE CLAIMED AS A FEATURE OF THE MARK.

THE MARK CONSISTS OF A BLUE, LOOPED, AWARENESS RIBBON OUTLINED IN YELLOW WITH THE WORDS "FOOD ALLERGY RECOGNITION" IN STYLIZED WHITE LETTERS DOWN THE OUTER PORTION OF THE LOOP.

FOR MEAT; HOT DOGS; LUNCHEON MEATS; SMOKED SAUSAGES (U.S. CL. 46).

FIRST USE 9-30-2009; IN COMMERCE 9-30-2009.

CLASS 29—(Continued).

4,210,505. REDWOOD HILL FARM & CREAMERY, INC., SEBASTOPOL, CA. SN 85-021,883. PUB. 6-14-2011, FILED 4-23-2010.

GREEN VALLEY ORGANICS

THE MARK CONSISTS OF STANDARD CHARACTERS WITHOUT CLAIM TO ANY PARTICULAR FONT, STYLE, SIZE, OR COLOR.

NO CLAIM IS MADE TO THE EXCLUSIVE RIGHT TO USE "ORGANICS", APART FROM THE MARK AS SHOWN. FOR ORGANIC DAIRY PRODUCTS, NAMELY, YOGURT, KEFIR, SOUR CRÈME AND YOGURT DRINKS (U.S. CL. 46).

FIRST USE 7-1-2010; IN COMMERCE 7-1-2010.

4,210,808. THE NEWPORT KITCHEN LLC, NEWPORT BEACH, CA. SN 85-218,260. PUB. 5-31-2011, FILED 1-14-2011.

SIMPLY TOMATO

THE MARK CONSISTS OF STANDARD CHARACTERS WITHOUT CLAIM TO ANY PARTICULAR FONT, STYLE, SIZE, OR COLOR.

NO CLAIM IS MADE TO THE EXCLUSIVE RIGHT TO USE "TOMATO", APART FROM THE MARK AS SHOWN. FOR PREPARED ENTREES CONSISTING PRIMARILY OF VEGETABLES; SOUPS (U.S. CL. 46).

FIRST USE 7-23-2012; IN COMMERCE 7-23-2012.

4,210,809. THE NEWPORT KITCHEN LLC, NEWPORT BEACH, CA. SN 85-218,277. PUB. 5-31-2011, FILED 1-14-2011.

SIMPLY VEGETABLE

THE MARK CONSISTS OF STANDARD CHARACTERS WITHOUT CLAIM TO ANY PARTICULAR FONT, STYLE, SIZE, OR COLOR.

NO CLAIM IS MADE TO THE EXCLUSIVE RIGHT TO USE "VEGETABLE", APART FROM THE MARK AS SHOWN.

FOR PREPARED ENTREES CONSISTING PRIMARILY OF VEGETABLES; SOUPS (U.S. CL. 46).

FIRST USE 7-23-2012; IN COMMERCE 7-23-2012.

CLASS 29—(Continued).

4,210,810. THE NEWPORT KITCHEN LLC, NEWPORT BEACH, CA. SN 85-218,296. PUB. 5-31-2011, FILED 1-14-2011.

SIMPLY MUSHROOM

THE MARK CONSISTS OF STANDARD CHARACTERS WITHOUT CLAIM TO ANY PARTICULAR FONT, STYLE, SIZE, OR COLOR.

NO CLAIM IS MADE TO THE EXCLUSIVE RIGHT TO USE "MUSHROOM", APART FROM THE MARK AS SHOWN.

FOR PREPARED ENTREES CONSISTING PRIMARILY OF VEGETABLES; SOUPS (U.S. CL. 46).

FIRST USE 7-23-2012; IN COMMERCE 7-23-2012.

4,210,815. THE NEWPORT KITCHEN LLC, NEWPORT BEACH, CA. SN 85-220,975. PUB. 12-13-2011, FILED 1-19-2011.

SIMPLY BEEF

THE MARK CONSISTS OF STANDARD CHARACTERS WITHOUT CLAIM TO ANY PARTICULAR FONT, STYLE, SIZE, OR COLOR.

NO CLAIM IS MADE TO THE EXCLUSIVE RIGHT TO USE "BEEF", APART FROM THE MARK AS SHOWN.

FOR SOUP (U.S. CL. 46).

FIRST USE 7-23-2012; IN COMMERCE 7-23-2012.

4,210,818. BUNGE OILS, INC., ST. LOUIS, MO. SN 85-223,064. PUB. 5-31-2011, FILED 1-21-2011.



THE MARK CONSISTS OF THE WORDING "AVM" IN A STYLIZED FONT AND A DESIGN THAT CONSISTS OF A SHADED RECTANGULAR POLYGON THAT IS OUTLINED AND WITH THE LETTERS "A", "V" AND "M" LOCATED IN THE CENTER.

FOR EDIBLE FATS; EDIBLE OILS; MARGARINE (U.S. CL. 46).

FIRST USE 1-0-2011; IN COMMERCE 1-0-2011.

CLASS 29—(Continued).

4,210,935. JANES FAMILY FOODS LTD., MISSISSAUGA, ONTARIO, CANADA. SN 85-283,436. PUB. 10-4-2011, FILED 4-1-2011.

THANK GOODNESS

THE MARK CONSISTS OF STANDARD CHARACTERS WITHOUT CLAIM TO ANY PARTICULAR FONT, STYLE, SIZE, OR COLOR.

FOR FROZEN POULTRY (U.S. CL. 46).
FIRST USE 10-15-2011; IN COMMERCE 10-15-2011.

4,210,941. CHIQUITA BRANDS L.L.C., CINCINNATI, OH. SN 85-285,446. PUB. 6-14-2011, FILED 4-4-2011.



OWNER OF U.S. REG. NOS. 670,320, 2,424,101, AND OTHERS.

THE COLOR(S) YELLOW, WHITE AND BLUE IS/ARE CLAIMED AS A FEATURE OF THE MARK.

THE MARK CONSISTS OF A DESIGN OF A LADY WITH FRUITED HAT ABOVE THE WORDING "CHIQUITA", ALL WITHIN AN OVAL, WHERE THE DESIGN OF THE LADY AND THE INSIDE BORDER OF THE OVAL IS IN THE COLOR YELLOW, THE WORDING "CHIQUITA" IS IN THE COLOR WHITE, AND THE BACKGROUND OF THE OVAL IS IN THE COLOR BLUE.

THE ENGLISH TRANSLATION OF "CHIQUITA" IN THE MARK IS "LITTLE GIRL".

FOR PRESERVED, DRIED AND COOKED FRUIT AND VEGETABLES (U.S. CL. 46).
FIRST USE 4-14-2012; IN COMMERCE 4-14-2012.

CLASS 29—(Continued).

4,210,965. HQM LTD., WILMINGTON, DE. SN 85-303,131. PUB. 9-13-2011, FILED 4-24-2011.



OWNER OF U.S. REG. NOS. 1,250,561, 2,381,877, AND OTHERS.

THE COLOR(S) YELLOW, WHITE, BLUE, AND RED IS/ARE CLAIMED AS A FEATURE OF THE MARK.

THE MARK CONSISTS OF THE WORD "HATFIELD" WHICH APPEARS IN WHITE, OUTLINED IN RED, ON A YELLOW SUNBURST DESIGN SURROUNDING A BLUE OVAL WITH WHITE RAYS. BELOW THE SUNBURST IS A RED BANNER OUTLINED IN YELLOW, BEARING THE PHRASE "CHEF CHOICE" IN WHITE, WITH A WHITE CHEF'S HAT.

FOR PORK (U.S. CL. 46).
FIRST USE 1-16-2012; IN COMMERCE 1-16-2012.

4,211,022. CLOCK SHADOW CREAMERY, LLC, PLAIN, WI. SN 85-325,858. PUB. 12-6-2011, FILED 5-20-2011.

CLOCK SHADOW CREAMERY

THE MARK CONSISTS OF STANDARD CHARACTERS WITHOUT CLAIM TO ANY PARTICULAR FONT, STYLE, SIZE, OR COLOR.

NO CLAIM IS MADE TO THE EXCLUSIVE RIGHT TO USE "CREAMERY", APART FROM THE MARK AS SHOWN.

FOR CHEESE (U.S. CL. 46).
FIRST USE 6-21-2012; IN COMMERCE 6-21-2012.

CLASS 29—(Continued).

4,211,157. LITTLE FARM FROZEN FOODS, INC., AKA LA HUERTA, BROWNSVILLE, TX. SN 85-347,415. PUB. 11-1-2011, FILED 6-15-2011.

Cosecha una vida
saludable...

THE MARK CONSISTS OF STANDARD CHARACTERS WITHOUT CLAIM TO ANY PARTICULAR FONT, STYLE, SIZE, OR COLOR.

THE ENGLISH TRANSLATION OF "COSECHA UNA VIDA SALUDABLE" IN THE MARK IS HARVEST A HEALTHY LIFE.

FOR FROZEN VEGETABLES (U.S. CL. 46).
FIRST USE 2-1-2011; IN COMMERCE 2-1-2011.

4,211,289. E.W. GROBBEL SONS, INC., DETROIT, MI. SN 85-366,257. PUB. 12-13-2011, FILED 7-8-2011.

ON THE GRILL

THE MARK CONSISTS OF STANDARD CHARACTERS WITHOUT CLAIM TO ANY PARTICULAR FONT, STYLE, SIZE, OR COLOR.

FOR MEAT (U.S. CL. 46).
FIRST USE 5-0-2012; IN COMMERCE 5-0-2012.

4,211,374. SUNSHINE RAISIN CORPORATION, DBA NATIONAL RAISIN CO., FOWLER, CA. SN 85-385,276. PUB. 1-31-2012, FILED 7-29-2011.



OWNER OF U.S. REG. NOS. 914,094, 996,879, AND 1,190,845.

NO CLAIM IS MADE TO THE EXCLUSIVE RIGHT TO USE "DRIED FRUIT", APART FROM THE MARK AS SHOWN.

CLASS 29—(Continued).

THE MARK CONSISTS OF THE WORD "CHAMPION" IN CAPITAL LETTERS IN A DOUBLE LINED RECTANGLE ABOVE THE WORDS "DRIED FRUIT" IN CAPITAL LETTERS IN A SMALLER BLACK RECTANGLE OUTLINED BY A SECOND RECTANGLE. AN ARC AND CURVED TUBE OF BROAD STRIPES RISES FROM BEHIND THE TOP RECTANGLE.

FOR DRIED FRUITS (U.S. CL. 46).

FIRST USE 9-0-2011. THE MARK WAS FIRST USED ANYWHERE IN A DIFFERENT FORM OTHER THAN THAT SOUGHT TO BE REGISTERED AT LEAST AS EARLY AS 11/12/1969; IN COMMERCE 9-0-2011, THE MARK WAS FIRST USED IN COMMERCE IN A DIFFERENT FORM OTHER THAN THAT SOUGHT TO BE REGISTERED AT LEAST AS EARLY AS 11/12/1969.

4,211,398. WILDBRINE LLC, WINDSOR, CA. SN 85-393,816. PUB. 1-3-2012, FILED 8-9-2011.

WILDBRINE

THE MARK CONSISTS OF STANDARD CHARACTERS WITHOUT CLAIM TO ANY PARTICULAR FONT, STYLE, SIZE, OR COLOR.

FOR FERMENTED VEGETABLES; VEGETABLE SALADS (U.S. CL. 46).

FIRST USE 4-26-2012; IN COMMERCE 4-26-2012.

4,211,469. NATURAL SELECTION FOODS, LLC, SAN JUAN BAUTISTA, CA. SN 85-418,739. PUB. 12-20-2011, FILED 9-9-2011.

DIPPIN' DOUBLES

THE MARK CONSISTS OF STANDARD CHARACTERS WITHOUT CLAIM TO ANY PARTICULAR FONT, STYLE, SIZE, OR COLOR.

FOR PACKAGED CUT FRUIT WITH DIP; PACKAGED CUT VEGETABLES WITH DIP (U.S. CL. 46).

FIRST USE 2-1-2012; IN COMMERCE 2-1-2012.

CLASS 30—STAPLE FOODS

CLASS 30—(Continued).

4,210,302. THE SAUL ZAENTZ COMPANY, BERKELEY, CA.
SN 77-563,681. PUB. 7-21-2009, FILED 9-5-2008.

BILBO

THE MARK CONSISTS OF STANDARD CHARACTERS WITHOUT CLAIM TO ANY PARTICULAR FONT, STYLE, SIZE, OR COLOR.
OWNER OF U.S. REG. NOS. 2,772,530, 3,505,019, AND OTHERS.
FOR COOKIES (U.S. CL. 46).
FIRST USE 6-22-2011; IN COMMERCE 6-22-2011.

4,210,333. COMOBAR, LLC, MIAMI GARDENS, FL. SN 77-641,664. PUB. 4-28-2009, FILED 12-30-2008.

ComoCup

THE MARK CONSISTS OF STANDARD CHARACTERS WITHOUT CLAIM TO ANY PARTICULAR FONT, STYLE, SIZE, OR COLOR.
FOR COFFEE; ESPRESSO (U.S. CL. 46).
FIRST USE 6-22-2012; IN COMMERCE 6-22-2012.

4,210,411. U.S. ROASTERIE, INC., DES MOINES, IA. SN 77-880,432. PUB. 11-2-2010, FILED 11-24-2009.

The Bean Stop

THE MARK CONSISTS OF STANDARD CHARACTERS WITHOUT CLAIM TO ANY PARTICULAR FONT, STYLE, SIZE, OR COLOR.
NO CLAIM IS MADE TO THE EXCLUSIVE RIGHT TO USE "BEAN", APART FROM THE MARK AS SHOWN.
FOR CAPPUCCINO; COFFEE (U.S. CL. 46).
FIRST USE 5-18-2012; IN COMMERCE 5-18-2012.

CLASS 30—(Continued).

4,210,460. SNOWIZARD, INC., JEFFERSON, LA. SN 77-945,364. PUB. 5-25-2010, FILED 2-25-2010.

PUCKER

THE MARK CONSISTS OF STANDARD CHARACTERS WITHOUT CLAIM TO ANY PARTICULAR FONT, STYLE, SIZE, OR COLOR.
FOR FLAVORING CONCENTRATE FOR NON-NUTRITIONAL PURPOSES, NAMELY, FLAVORING CONCENTRATE FOR SHAVED ICE CONFECTIONS (U.S. CL. 46).
FIRST USE 7-16-2012; IN COMMERCE 7-16-2012.

4,210,484. FRITO-LAY NORTH AMERICA, INC., PLANO, TX. SN 78-981,442. PUB. 6-12-2007, FILED 4-25-2005.

SUN

THE MARK CONSISTS OF STANDARD CHARACTERS WITHOUT CLAIM TO ANY PARTICULAR FONT, STYLE, SIZE, OR COLOR.
OWNER OF U.S. REG. NOS. 986,097 AND 2,686,169.
FOR MULTIGRAIN CHIPS; CORN-BASED SNACK FOODS; CRACKERS; SNACK MIX CONSISTING PRIMARILY OF GRAIN-BASED SNACK FOODS; RICE-BASED SNACK FOODS, ALL OF THE AFOREMENTIONED EXCLUDING BREAKFAST CEREAL (U.S. CL. 46).
FIRST USE 8-6-2011; IN COMMERCE 8-6-2011.

4,210,515. ELIZA'S QUEST FOODS, LLC, CHARLOTTE, NC. SN 85-032,166. PUB. 1-4-2011, FILED 5-6-2010.

POSTUM

THE MARK CONSISTS OF STANDARD CHARACTERS WITHOUT CLAIM TO ANY PARTICULAR FONT, STYLE, SIZE, OR COLOR.
FOR PREPARED BEVERAGE ITEMS, NAMELY, COFFEE SUBSTITUTE BEVERAGES (U.S. CL. 46).
FIRST USE 7-13-2012; IN COMMERCE 7-13-2012.

CLASS 30—(Continued).

4,210,523. THAI HA PUBLIC COMPANY LTD., BANGKOK, THAILAND. SN 85-042,700. PUB. 11-8-2011, FILED 5-19-2010.

THE MARK CONSISTS OF THE WORDS "FIRST LADY" IN STYLIZED SCRIPT.

FOR JASMINE RICE (U.S. CL. 46).
FIRST USE 6-24-2009; IN COMMERCE 6-24-2009.

CLASS 30—(Continued).

4,210,643. KABUSHIKI KAISHA YAKULT HONSHA, TA YAKULT HONSHA CO., LTD., TOKYO, JAPAN. SN 85-134,294. PUB. 6-21-2011, FILED 9-21-2010.

YAKULT

THE MARK CONSISTS OF STANDARD CHARACTERS WITHOUT CLAIM TO ANY PARTICULAR FONT, STYLE, SIZE, OR COLOR.

OWNER OF JAPAN REG. NO. 1252232, DATED 2-21-1977, EXPIRES 2-21-2017.

OWNER OF U.S. REG. NOS. 1,140,460, 3,215,883, AND 3,571,904.

FOR SEASONINGS; NATURAL SWEETENERS; NATURAL SWEETENERS CONTAINING OLIGOSACCHARIDES; SUGAR (U.S. CL. 46).

FIRST USE 10-5-2005; IN COMMERCE 7-9-2012.

4,210,664. MARY A. VAUGHT, CRANE, MO. AND GREGORY L. VAUGHT, CRANE, MO. SN 85-155,706. PUB. 4-12-2011, FILED 10-19-2010.

Angel's Coney Sauce

THE MARK CONSISTS OF STANDARD CHARACTERS WITHOUT CLAIM TO ANY PARTICULAR FONT, STYLE, SIZE, OR COLOR.

NO CLAIM IS MADE TO THE EXCLUSIVE RIGHT TO USE "CONEY SAUCE", APART FROM THE MARK AS SHOWN.

FOR READY-MADE SAUCES (U.S. CL. 46).

FIRST USE 6-30-2011; IN COMMERCE 7-31-2011.

4,210,685. HAITI ORIGINALE, LLC, CORAL GABLES, FL. SN 85-173,108. PUB. 9-27-2011, FILED 11-10-2010.



NO CLAIM IS MADE TO THE EXCLUSIVE RIGHT TO USE "HAITI ORIGINALE", APART FROM THE MARK AS SHOWN.

4,210,599. PACHAMAMA COFFEE COOPERATIVE OF SMALL SCALE COFFEE PRODUCERS, DAVIS, CA. SN 85-098,097. PUB. 11-22-2011, FILED 8-2-2010.

NO CLAIM IS MADE TO THE EXCLUSIVE RIGHT TO USE "COFFEECSA.ORG", APART FROM THE MARK AS SHOWN.

THE COLOR(S) BROWN IS/ARE CLAIMED AS A FEATURE OF THE MARK.

THE MARK CONSISTS OF THE WORD "COFFEE" IN ALL CAPS AND BROWN LETTERS WITH THE LETTERS "CSA" IN ALL CAPS AND BROWN LETTERS UNDERNEATH THE WORD "COFFEE" WITH A PICTURE OF A BROWN COFFEE BEAN BELOW THE DOUBLE "E" IN THE WORD "COFFEE" WITH THE WORD "ORG" IN BROWN, CAPITAL LETTERS UNDERNEATH THE PICTURE OF THE COFFEE BEAN. THE COFFEE BEAN REPRESENTS THE "I" IN "ORG".

FOR COFFEE (U.S. CL. 46).

FIRST USE 4-1-2011; IN COMMERCE 4-1-2011.

CLASS 30—(Continued).

THE MARK CONSISTS OF AN IRREGULAR OVAL FIELD WITH THE LITERAL ELEMENT "HAITI ORIGINALE" SUPERIMPOSED OVER A PALM TREE DESIGN.

THE ENGLISH TRANSLATION OF "ORIGINALE" IN THE MARK IS "ORIGINAL", "NOVEL", OR "INVENTIVE". FOR COFFEE (U.S. CL. 46).
FIRST USE 2-24-2012; IN COMMERCE 2-24-2012.

4,210,725. SNAX IN PAX, INC., TOPEKA, IN. SN 85-192,846.
PUB. 11-8-2011, FILED 12-8-2010.

CAMO CORN

THE MARK CONSISTS OF STANDARD CHARACTERS WITHOUT CLAIM TO ANY PARTICULAR FONT, STYLE, SIZE, OR COLOR.

NO CLAIM IS MADE TO THE EXCLUSIVE RIGHT TO USE "CORN", APART FROM THE MARK AS SHOWN. FOR CARAMEL POPCORN (U.S. CL. 46).
FIRST USE 4-5-2012; IN COMMERCE 4-5-2012.

4,210,732. X AND X2, LLC, NEW YORK, NY. SN 85-196,412.
PUB. 4-26-2011, FILED 12-13-2010.



THE COLOR(S) ORANGE AND DARK GREY IS/ARE CLAIMED AS A FEATURE OF THE MARK.

THE MARK CONSISTS OF THE WORD "MEHTAPHOR" CONTAINING A LOWER CASE LETTER "H" IN STYLIZED ORANGE LETTERING. THE REMAINING LETTERS IN THE WORD "MEHTAPHOR" ARE IN DARK GREY CAPITAL LETTERS.

FOR SAUCES; SPICES; SEASONINGS; RICE; TEA; COFFEE; COCOA; FROZEN, PREPARED AND PACKAGED ENTREES CONSISTING PRIMARILY OF PASTA OR RICE; FROZEN, PREPARED AND PACKAGED MEALS CONSISTING PRIMARILY OF PASTA OR RICE; FROZEN BREADS; FROZEN CONFECTIONS; FROZEN FOODS, NAMELY, GRAIN AND BREAD BASED APPETIZERS, HORS D'OEUVRES, AND CANAPES; FROZEN SOY-BASED DESSERTS; NON-DAIRY FROZEN CONFECTIONS; FROZEN DESSERT CONSISTING OF FRUIT AND CREAM OR CREAM SUBSTITUTES; ICE CREAM DESSERTS (U.S. CL. 46).
FIRST USE 6-19-2012; IN COMMERCE 6-19-2012.

CLASS 30—(Continued).

4,210,735. EAST SIDE TRADING CO., TORONTO, CANADA.
SN 85-196,974. PUB. 11-8-2011, FILED 12-13-2010.

Arghawan

THE MARK CONSISTS OF STANDARD CHARACTERS WITHOUT CLAIM TO ANY PARTICULAR FONT, STYLE, SIZE, OR COLOR.

THE ENGLISH TRANSLATION OF "ARGHAWAN" IN THE MARK IS "RED BUD FLOWER". FOR GREEN TEA AND BLACK TEA (U.S. CL. 46).
FIRST USE 2-1-2010; IN COMMERCE 6-6-2010.

4,210,844. MOM BRANDS COMPANY, MINNEAPOLIS, MN.
SN 85-237,969. PUB. 4-19-2011, FILED 2-9-2011.

TUMBLE WHEATS

THE MARK CONSISTS OF STANDARD CHARACTERS WITHOUT CLAIM TO ANY PARTICULAR FONT, STYLE, SIZE, OR COLOR.

NO CLAIM IS MADE TO THE EXCLUSIVE RIGHT TO USE "WHEATS", APART FROM THE MARK AS SHOWN. FOR BREAKFAST CEREAL (U.S. CL. 46).
FIRST USE 3-1-2012; IN COMMERCE 3-1-2012.

4,210,887. WM. WRIGLEY JR. COMPANY, CHICAGO, IL. SN 85-251,878. PUB. 5-17-2011, FILED 2-25-2011.

RIDDLES

THE MARK CONSISTS OF STANDARD CHARACTERS WITHOUT CLAIM TO ANY PARTICULAR FONT, STYLE, SIZE, OR COLOR.

FOR CANDY (U.S. CL. 46).
FIRST USE 12-4-2011; IN COMMERCE 12-4-2011.

CLASS 30—(Continued).

4,210,946. DECAVALCANTI, RONALD, NEW YORK, NY. SN 85-288,784. PUB. 9-6-2011, FILED 4-7-2011.



NO CLAIM IS MADE TO THE EXCLUSIVE RIGHT TO USE "POPS", APART FROM THE MARK AS SHOWN.

THE MARK CONSISTS OF THE STYLIZED TEXT "TROP POPS" WITH A PINEAPPLE IN PLACE OF THE LETTER "O" IN "TROP".

FOR CHOCOLATE COVERED FRUIT (U.S. CL. 46).
FIRST USE 6-19-2011; IN COMMERCE 6-19-2011.

4,210,960. PEPSICO, INC., PURCHASE, NY. SN 85-301,517.
PUB. 2-28-2012, FILED 4-21-2011.

A BETTER WAY TO ROCK

THE MARK CONSISTS OF STANDARD CHARACTERS WITHOUT CLAIM TO ANY PARTICULAR FONT, STYLE, SIZE, OR COLOR.

FOR LOLLIPOPS, CANDY COVERED GUM AND CONFECTIONERY (U.S. CL. 46).
FIRST USE 6-0-2011; IN COMMERCE 6-0-2011.

4,211,024. PENA, NAIROBY G, BROOKLYN, NY. SN 85-326,775. PUB. 11-1-2011, FILED 5-21-2011.

Peach's & Penny

THE MARK CONSISTS OF STANDARD CHARACTERS WITHOUT CLAIM TO ANY PARTICULAR FONT, STYLE, SIZE, OR COLOR.

THE NAMES SHOWN IN THE MARK DO NOT IDENTIFY PARTICULAR LIVING INDIVIDUALS.

FOR CUP CAKES (U.S. CL. 46).
FIRST USE 6-27-2011; IN COMMERCE 6-27-2011.

CLASS 30—(Continued).

4,211,029. SHAPES OF FAITH, LLC, MCDONOUGH, GA. SN 85-328,458. PUB. 10-18-2011, FILED 5-24-2011.

Shapes of Faith

THE MARK CONSISTS OF STANDARD CHARACTERS WITHOUT CLAIM TO ANY PARTICULAR FONT, STYLE, SIZE, OR COLOR.

FOR COOKIES (U.S. CL. 46).
FIRST USE 5-10-2011; IN COMMERCE 8-15-2011.

4,211,079. KRAFT FOODS SCHWEIZ HOLDING GMBH, 6301 ZUG, SWITZERLAND. SN 85-337,705. PUB. 10-18-2011, FILED 6-3-2011.



OWNER OF U.S. REG. NOS. 3,030,372, 3,168,052, AND OTHERS.

THE MARK CONSISTS OF SIX IDENTICAL TEARDROP SHAPES FORMING A CIRCLE WITH THE POINTED ENDS MEETING IN THE MIDDLE. THE BOTTOM MOST IMAGE IS FILLED IN AND IS BLACK AND THE OTHER FIVE SHAPES ARE OUTLINE DRAWINGS. THE WORD "TASSIMO" IS WRITTEN ABOVE THE BLACK SHAPE AND IS CONTAINED WITHIN THE TEARDROP SHAPES.

FOR COFFEE; HOT CHOCOLATE; TEA (U.S. CL. 46).
FIRST USE 7-31-2011; IN COMMERCE 7-31-2011.

4,211,134. GRIFFIN, THRESA H., ZION, IL. SN 85-345,111.
PUB. 11-22-2011, FILED 6-13-2011.



NO CLAIM IS MADE TO THE EXCLUSIVE RIGHT TO USE "TEA CO.", APART FROM THE MARK AS SHOWN.

CLASS 30—(Continued).

THE MARK CONSISTS OF THE ARTISTIC RENDERING OF THREE HUMAN BEINGS, TWO OF WHICH ARE CARRYING BASKETS, APPEARING ABOVE THE STYLIZED WORDS "NAPOLEONA TEA CO." APPEARING BELOW THE AFOREMENTIONED STYLIZED WORDS ARE THE STYLIZED WORDS "DISCOVER OUR WORLD".

FOR TEA (U.S. CL. 46).

FIRST USE 0-0-2011; IN COMMERCE 0-0-2011.

4,211,138. PENGFEI ENTERPRISES INC., DBA OKEYOGII, BALTIMORE, MD. SN 85-345,401. PUB. 11-29-2011, FILED 6-14-2011.



THE COLOR(S) RED, LIME, CYAN, YELLOW, PINK, AMETHYST, BLUE-VIOLET, ORANGE, AND WHITE IS/ARE CLAIMED AS A FEATURE OF THE MARK.

THE MARK CONSISTS OF 8 LETTERS AND 1 HEART-SHAPED PATTERN. THE FIRST LETTER "O" IS UPPER CASE IN RED, SECOND LETTER "K" IS LOWER CASE IN LIME, THIRD LETTER "E" IS LOWER CASE IN CYAN, 4TH LETTER "Y" IS UPPER CASE IN YELLOW, 5TH LETTER "O" IS LOWER CASE IN PINK, 6TH LETTER "G" IS LOWER CASE IN AMETHYST, 7TH LETTER "I" IS LOWER CASE IN BLUE-VIOLET, 8TH LETTER "I" IS LOWER CASE IN ORANGE. THE HEART-SHAPED PATTERN IS PINK AND WHITE AND ABOVE THE 7TH AND 8TH LETTERS.

FOR FROZEN YOGURT (U.S. CL. 46).

FIRST USE 6-10-2012; IN COMMERCE 6-10-2012.

4,211,172. SWEET EARTH BAKERS LLC, BOSTON, MA. SN 85-349,133. PUB. 11-1-2011, FILED 6-17-2011.

A.K.A. MARVELICIOUS

THE MARK CONSISTS OF STANDARD CHARACTERS WITHOUT CLAIM TO ANY PARTICULAR FONT, STYLE, SIZE, OR COLOR.

FOR COOKIES (U.S. CL. 46).

FIRST USE 9-0-2011; IN COMMERCE 9-0-2011.

CLASS 30—(Continued).

4,211,186. HOMRA, BRIAN, HENDERSONVILLE, TN. SN 85-350,295. PUB. 12-6-2011, FILED 6-20-2011.

Memphis Magic

THE MARK CONSISTS OF STANDARD CHARACTERS WITHOUT CLAIM TO ANY PARTICULAR FONT, STYLE, SIZE, OR COLOR.

NO CLAIM IS MADE TO THE EXCLUSIVE RIGHT TO USE "MEMPHIS", APART FROM THE MARK AS SHOWN.

FOR BARBEQUE SAUCE (U.S. CL. 46).

FIRST USE 7-17-2012; IN COMMERCE 7-17-2012.

4,211,209. R. TWINING AND COMPANY LIMITED, LONDON, UNITED KINGDOM. SN 85-354,113. PUB. 11-8-2011, FILED 6-23-2011.

TEAS THAT FIT YOUR EVERY MOOD

THE MARK CONSISTS OF STANDARD CHARACTERS WITHOUT CLAIM TO ANY PARTICULAR FONT, STYLE, SIZE, OR COLOR.

FOR TEAS AND HERBAL TEAS (U.S. CL. 46).

FIRST USE 10-31-2010; IN COMMERCE 9-5-2011.

4,211,266. CLASSIC FOODS INTERNATIONAL CORP., DBA CLASSIC FOODS, INC., IRVINE, CA. SN 85-361,939. PUB. 10-11-2011, FILED 7-1-2011.

POPTILLAS

THE MARK CONSISTS OF STANDARD CHARACTERS WITHOUT CLAIM TO ANY PARTICULAR FONT, STYLE, SIZE, OR COLOR.

FOR CORN-BASED SNACK FOODS, NAMELY, PRESSURE EXPANDED CORN TORTILLA CHIPS (U.S. CL. 46).

FIRST USE 6-1-2012; IN COMMERCE 6-1-2012.

CLASS 30—(Continued).

4,211,268. DONG WHA PHARM. CO., LTD, SEOUL, REPUBLIC OF KOREA. SN 85-362,358. PUB. 12-27-2011, FILED 7-2-2011.



THE COLOR(S) RED IS/ARE CLAIMED AS A FEATURE OF THE MARK.
THE MARK CONSISTS OF A RED OPENED FAN.
FOR HERBAL FOOD BEVERAGE (U.S. CL. 46).
FIRST USE 11-1-1981; IN COMMERCE 11-1-1981.

CLASS 30—(Continued).

4,211,307. H. J. HEINZ COMPANY, PITTSBURGH, PA. SN 85-370,219. PUB. 12-13-2011, FILED 7-13-2011.

TODDS

THE MARK CONSISTS OF STANDARD CHARACTERS WITHOUT CLAIM TO ANY PARTICULAR FONT, STYLE, SIZE, OR COLOR.
OWNER OF U.S. REG. NO. 1,364,729.
FOR OATMEAL (U.S. CL. 46).
FIRST USE 1-5-2012; IN COMMERCE 1-5-2012.

4,211,320. GENGHIS GRILL FRANCHISE CONCEPTS, LP, DALLAS, TX. SN 85-372,887. PUB. 11-15-2011, FILED 7-15-2011.

KHANZU

THE MARK CONSISTS OF STANDARD CHARACTERS WITHOUT CLAIM TO ANY PARTICULAR FONT, STYLE, SIZE, OR COLOR.
FOR SAUCES FOR CONSUMPTION ON OR OFF PREMISES (U.S. CL. 46).
FIRST USE 9-29-2010; IN COMMERCE 10-30-2010.

4,211,296. KING'S HAWAIIAN HOLDING COMPANY, INC., TORRANCE, CA. SN 85-368,184. PUB. 4-17-2012, FILED 7-11-2011.



OWNER OF U.S. REG. NOS. 1,228,641, 2,823,976, AND 2,888,718.

NO CLAIM IS MADE TO THE EXCLUSIVE RIGHT TO USE "THE ORIGINAL", "HAWAIIAN", "EST 1950" OR "HILO HI", APART FROM THE MARK AS SHOWN.

THE MARK CONSISTS OF THE STYLIZED WORDS "THE ORIGINAL KING'S HAWAIIAN EST 1950 HILO HI" ON FOUR LINES WITHIN A RECTANGLE WITH SLIGHTLY CURVED BORDERS, WITH ABSTRACT DESIGNS WITHIN THE RECTANGLE ALONG THE TOP AND BOTTOM BORDERS, WITH TWO LINES IMMEDIATELY ABOVE AND BELOW THE WORDS "EST 1950 HILO HI", AND WITH A CROWN DESIGN BETWEEN THE WORDS "EST 1950" AND "HILO HI" SUPERIMPOSED OVER THE TWO LINES.

FOR BAKERY GOODS, BAKERY PRODUCTS, BREAD, ROLLS (U.S. CL. 46).
FIRST USE 6-0-2011; IN COMMERCE 6-0-2011.

4,211,378. DL FOODS, LLC, CHANDLER, AZ. SN 85-386,841. PUB. 1-17-2012, FILED 8-2-2011.

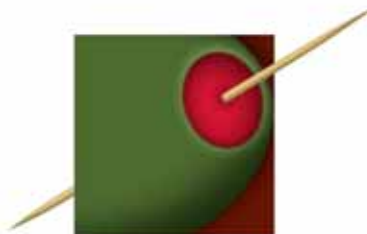

THE COLOR(S) LIGHT BROWN, BROWN, GREEN, AND RED IS/ARE CLAIMED AS A FEATURE OF THE MARK.

CLASS 30—(Continued).

THE MARK CONSISTS OF THE IMAGE OF AN OLIVE PARTIALLY FILLING A SQUARE. THE OLIVE IS GREEN WITH A RED CENTER AND HAS A LIGHT BROWN TOOTHPICK GOING THROUGH THE CENTER OF THE OLIVE. THE SQUARE IS ALSO SHADED IN BROWN ON THE UPPER RIGHT AND LOWER RIGHT CORNERS.

FOR BARBECUE DRY RUB; DRY SPICE RUB FOR MEATS AND FISH; EDIBLE SPICES; FOOD SEASONINGS; SEASONING MIXES; SEASONINGS; SPICE BLENDS; SPICE RUBS; SPICES; STEAK SEASONING (U.S. CL. 46).

FIRST USE 10-11-2011; IN COMMERCE 10-11-2011.

4,211,452. KRAFT FOODS GLOBAL BRANDS LLC, NORTH-FIELD, IL. SN 85-413,090. PUB. 12-6-2011, FILED 9-1-2011.

FLAVOR YOU CAN FEEL

THE MARK CONSISTS OF STANDARD CHARACTERS WITHOUT CLAIM TO ANY PARTICULAR FONT, STYLE, SIZE, OR COLOR.

FOR CHEWING GUM (U.S. CL. 46).
FIRST USE 3-31-2011; IN COMMERCE 3-31-2011.

4,211,528. WELLS ENTERPRISES, INC., LE MARS, IA. SN 85-450,065. PUB. 4-3-2012, FILED 10-18-2011.

24 KARAT CARROT CAKE

THE MARK CONSISTS OF STANDARD CHARACTERS WITHOUT CLAIM TO ANY PARTICULAR FONT, STYLE, SIZE, OR COLOR.

NO CLAIM IS MADE TO THE EXCLUSIVE RIGHT TO USE "CARROT CAKE", APART FROM THE MARK AS SHOWN.

FOR FROZEN CONFECTIONS (U.S. CL. 46).
FIRST USE 1-9-2012; IN COMMERCE 1-9-2012.

CLASS 30—(Continued).

4,211,572. JCD BRANDS LLC, OLD BRIDGE, NJ. SN 85-470,683. PUB. 4-24-2012, FILED 11-11-2011.

START

THE MARK CONSISTS OF STANDARD CHARACTERS WITHOUT CLAIM TO ANY PARTICULAR FONT, STYLE, SIZE, OR COLOR.

FOR HOT SAUCE (U.S. CL. 46).
FIRST USE 3-7-2012; IN COMMERCE 3-7-2012.

4,211,605. WESTERN BAGEL BAKING CORPORATION, VAN NUYS, CA. SN 85-484,993. PUB. 5-8-2012, FILED 12-1-2011.

ALTERNATIVE 2.0 BAGELS

THE MARK CONSISTS OF STANDARD CHARACTERS WITHOUT CLAIM TO ANY PARTICULAR FONT, STYLE, SIZE, OR COLOR.

NO CLAIM IS MADE TO THE EXCLUSIVE RIGHT TO USE "BAGELS", APART FROM THE MARK AS SHOWN.
FOR BAGELS (U.S. CL. 46).
FIRST USE 5-8-2012; IN COMMERCE 5-8-2012.

4,211,647. STACY'S PITA CHIP COMPANY, INC., RANDOLPH, MA. SN 85-511,821. PUB. 4-10-2012, FILED 1-9-2012.

PERFECTLY THYMED

THE MARK CONSISTS OF STANDARD CHARACTERS WITHOUT CLAIM TO ANY PARTICULAR FONT, STYLE, SIZE, OR COLOR.

FOR FLOUR-BASED CHIPS; PITA CHIPS; WHEAT-BASED SNACK FOODS (U.S. CL. 46).
FIRST USE 4-0-2012; IN COMMERCE 4-0-2012.

CLASS 31—NATURAL AGRICULTURAL PRODUCTS

CLASS 31—(Continued).

4,210,322. ELMY, STEVEN M., ROSLIN, ON, CANADA. SN 77-624,242. PUB. 4-7-2009, FILED 12-1-2008.

Mineral Fountain

THE MARK CONSISTS OF STANDARD CHARACTERS WITHOUT CLAIM TO ANY PARTICULAR FONT, STYLE, SIZE, OR COLOR.

NO CLAIM IS MADE TO THE EXCLUSIVE RIGHT TO USE "MINERAL", APART FROM THE MARK AS SHOWN. FOR SALT LICKS (U.S. CLS. 1 AND 46). FIRST USE 8-11-2008; IN COMMERCE 6-22-2012.

4,210,362. GIORGIFRED COMPANY, WILMINGTON, DE. SN 77-746,282. PUB. 10-13-2009, FILED 5-28-2009.

GIORGIO D'LIGHTFUL

THE MARK CONSISTS OF STANDARD CHARACTERS WITHOUT CLAIM TO ANY PARTICULAR FONT, STYLE, SIZE, OR COLOR.

OWNER OF U.S. REG. NOS. 1,183,132, 3,344,186, AND OTHERS.

THE ENGLISH TRANSLATION OF "GIORGIO" IN THE MARK IS GEORGE.

FOR FRESH MUSHROOMS (U.S. CLS. 1 AND 46). FIRST USE 12-26-2011; IN COMMERCE 12-26-2011.

4,210,870. MARS, INCORPORATED, MCLEAN, VA. SN 85-245,493. PUB. 5-3-2011, FILED 2-17-2011.

EVERY DOG DESERVES

THE MARK CONSISTS OF STANDARD CHARACTERS WITHOUT CLAIM TO ANY PARTICULAR FONT, STYLE, SIZE, OR COLOR.

FOR PET FOOD (U.S. CLS. 1 AND 46). FIRST USE 1-31-2012; IN COMMERCE 1-31-2012.

CLASS 31—(Continued).

4,210,876. TRIPLE CROWN NUTRITION, INC., WAYZATA, MN. SN 85-247,947. PUB. 6-28-2011, FILED 2-22-2011.

TLC TOTAL LIFETIME CARE

THE MARK CONSISTS OF STANDARD CHARACTERS WITHOUT CLAIM TO ANY PARTICULAR FONT, STYLE, SIZE, OR COLOR.

FOR ANIMAL FEED (U.S. CLS. 1 AND 46).

FIRST USE 11-0-2011; IN COMMERCE 12-12-2011.

4,210,901. CHIQUITA BRANDS L.L.C., CINCINNATI, OH. SN 85-261,856. PUB. 6-14-2011, FILED 3-9-2011.



OWNER OF U.S. REG. NOS. 670,320, 2,424,101, AND OTHERS.

THE MARK CONSISTS OF LADY WITH FRUITED HAT IN AN OVAL.

THE ENGLISH TRANSLATION OF "CHIQUITA" IN THE MARK IS "LITTLE GIRL".

FOR FRESH FRUIT AND VEGETABLES (U.S. CLS. 1 AND 46).

FIRST USE 7-31-2011; IN COMMERCE 7-31-2011.

4,210,970. PROFESSOR CONNOR'S, INC., DBA FRESHPET, SECAUCUS, NJ. SN 85-306,384. PUB. 5-1-2012, FILED 4-27-2011.

VITAL COMPLETE MEALS

THE MARK CONSISTS OF STANDARD CHARACTERS WITHOUT CLAIM TO ANY PARTICULAR FONT, STYLE, SIZE, OR COLOR.

CLASS 31—(Continued).

NO CLAIM IS MADE TO THE EXCLUSIVE RIGHT TO USE "COMPLETE MEALS", APART FROM THE MARK AS SHOWN.

FOR PET FOOD (U.S. CLS. 1 AND 46).
FIRST USE 7-11-2011; IN COMMERCE 7-11-2011.

4,211,073. HOUWELING NURSERIES OXNARD, INC., CAMARILLO, CA. SN 85-336,831. PUB. 2-7-2012, FILED 6-2-2011.

THE INDOOR ADVANTAGE

THE MARK CONSISTS OF STANDARD CHARACTERS WITHOUT CLAIM TO ANY PARTICULAR FONT, STYLE, SIZE, OR COLOR.

NO CLAIM IS MADE TO THE EXCLUSIVE RIGHT TO USE "INDOOR", APART FROM THE MARK AS SHOWN.

FOR GREENHOUSE VEGETABLES, NAMELY, FRESH TOMATOES, FRESH CUCUMBERS AND FRESH PEPPERS (U.S. CLS. 1 AND 46).

FIRST USE 10-16-2006; IN COMMERCE 10-16-2006.

4,211,074. HOUWELING NURSERIES OXNARD, INC., CAMARILLO, CA. SN 85-336,843. PUB. 2-7-2012, FILED 6-2-2011.

HOUWELING'S HOT HOUSE

THE MARK CONSISTS OF STANDARD CHARACTERS WITHOUT CLAIM TO ANY PARTICULAR FONT, STYLE, SIZE, OR COLOR.

OWNER OF U.S. REG. NO. 3,246,127.

NO CLAIM IS MADE TO THE EXCLUSIVE RIGHT TO USE "HOT HOUSE", APART FROM THE MARK AS SHOWN.

FOR GREENHOUSE VEGETABLES, NAMELY, FRESH TOMATOES, FRESH CUCUMBERS AND FRESH PEPPERS (U.S. CLS. 1 AND 46).

FIRST USE 10-16-2006; IN COMMERCE 10-16-2006.

CLASS 31—(Continued).

4,211,295. DLF INTERNATIONAL SEEDS, INC., HALSEY, OR. SN 85-367,797. PUB. 11-15-2011, FILED 7-11-2011.

MASTERGREEN

THE MARK CONSISTS OF STANDARD CHARACTERS WITHOUT CLAIM TO ANY PARTICULAR FONT, STYLE, SIZE, OR COLOR.

FOR GRASS SEED (U.S. CLS. 1 AND 46).
FIRST USE 2-0-2012; IN COMMERCE 2-0-2012.

4,211,327. LIPINSKI, STEVEN J., STREAMWOOD, IL. SN 85-373,852. PUB. 12-13-2011, FILED 7-18-2011.

Wagables

THE MARK CONSISTS OF STANDARD CHARACTERS WITHOUT CLAIM TO ANY PARTICULAR FONT, STYLE, SIZE, OR COLOR.

FOR DOG FOOD (U.S. CLS. 1 AND 46).
FIRST USE 3-1-2012; IN COMMERCE 4-1-2012.

4,211,351. SOCIETE DES PRODUITS NESTLE S.A., VEVEY, SWITZERLAND. SN 85-378,724. PUB. 12-20-2011, FILED 7-22-2011.

MORNINGS

THE MARK CONSISTS OF STANDARD CHARACTERS WITHOUT CLAIM TO ANY PARTICULAR FONT, STYLE, SIZE, OR COLOR.

FOR CANNED CAT FOOD (U.S. CLS. 1 AND 46).
FIRST USE 6-0-2012; IN COMMERCE 6-0-2012.

CLASS 31—(Continued).

4,211,477. JERRY KOHLI, SUN CITY WEST, AZ. SN 85-423,875. PUB. 2-21-2012, FILED 9-15-2011.

GNAWLERS

THE MARK CONSISTS OF STANDARD CHARACTERS WITHOUT CLAIM TO ANY PARTICULAR FONT, STYLE, SIZE, OR COLOR.

FOR CONSUMABLE PET CHEWS; DOG BISCUITS; EDIBLE FOOD FOR ANIMALS FOR CHEWING; PET FOOD; PROTEIN FOR ANIMAL CONSUMPTION (U.S. CLS. 1 AND 46).

FIRST USE 3-16-2012; IN COMMERCE 3-16-2012.

4,211,494. WM. F. PUCKETT, INC., BARBERVILLE, FL. SN 85-435,514. PUB. 3-6-2012, FILED 9-29-2011.



NO CLAIM IS MADE TO THE EXCLUSIVE RIGHT TO USE "GILDED & FROSTED FLORAL FOLIAGES", APART FROM THE MARK AS SHOWN.

THE COLOR(S) GREEN, GOLD, SILVER, AND WHITE IS/ARE CLAIMED AS A FEATURE OF THE MARK.

THE MARK CONSISTS OF REPLICA OF A GREEN FLORAL FOLIAGE LEAF WITH THE STYLIZED WORDING "GILDED & FROSTED FLORAL FOLIAGES". THE WORD "FROSTED" IS SILVER AND THE REMAINING TEXT IS GOLD. A WHITE STRIPE SEPARATES THE LEAF IN TWO PARTS. THE COLOR WHITE IN THE BACKGROUND REPRESENTS A TRANSPARENT AREA THAT IS NOT PART OF THE MARK.

FOR LIVE CUT FOLIAGE (U.S. CLS. 1 AND 46).
FIRST USE 6-27-2012; IN COMMERCE 6-27-2012.

CLASS 31—(Continued).

4,211,578. SOCIETE DES PRODUITS NESTLE S.A., VEVEY, SWITZERLAND. SN 85-475,023. PUB. 4-17-2012, FILED 11-17-2011.

BE HAPPY

THE MARK CONSISTS OF STANDARD CHARACTERS WITHOUT CLAIM TO ANY PARTICULAR FONT, STYLE, SIZE, OR COLOR.

FOR PET FOOD (U.S. CLS. 1 AND 46).
FIRST USE 6-18-2012; IN COMMERCE 6-18-2012.

CLASS 32—LIGHT BEVERAGES

4,210,229. RUBEN, MARSHALL S., HARTFORD, CT. SN 76-654,165. PUB. 1-5-2010, FILED 1-27-2006.

BLUE STATE BEER

THE MARK CONSISTS OF STANDARD CHARACTERS WITHOUT CLAIM TO ANY PARTICULAR FONT, STYLE, SIZE, OR COLOR.

NO CLAIM IS MADE TO THE EXCLUSIVE RIGHT TO USE "BEER", APART FROM THE MARK AS SHOWN.

FOR BEERS; ALES; AND BEER-BASED AND ALE-BASED BEVERAGES, NAMELY, BEER, ALE, LAGER, STOUT AND PORTER (U.S. CLS. 45, 46 AND 48).

FIRST USE 2-15-2012; IN COMMERCE 2-15-2012.

4,210,489. BRICKTOWN CANDY COMPANY, DBA BRICKTOWN CANDY CO., OKLAHOMA CITY, OK. SN 85-010,011. PUB. 11-23-2010, FILED 4-8-2010.



THE MARK CONSISTS OF THREE CONCENTRIC POLYGONS WITH THE WORD "TRIPLE" ABOVE THE LETTERS "AAA" WITHIN THE POLYGONS.

FOR POP; SOFT DRINKS (U.S. CLS. 45, 46 AND 48).
FIRST USE 6-1-2012; IN COMMERCE 6-1-2012.

CLASS 32—(Continued).

4,210,609. JONES SODA CO. (USA) INC., SEATTLE, WA. SN 85-107,074. PUB. 11-8-2011, FILED 8-13-2010.

OPEN A CAN!

THE MARK CONSISTS OF STANDARD CHARACTERS WITHOUT CLAIM TO ANY PARTICULAR FONT, STYLE, SIZE, OR COLOR.

FOR ENERGY DRINKS (U.S. CLS. 45, 46 AND 48).
FIRST USE 10-5-2010; IN COMMERCE 10-5-2010.

4,210,617. JONES SODA CO. (USA) INC., SEATTLE, WA. SN 85-113,923. PUB. 11-8-2011, FILED 8-23-2010.



OWNER OF U.S. REG. NO. 3,066,216.
THE MARK CONSISTS OF GRAPHIC REPRESENTATION OF A YOUNG PERSON HOLDING A FIST.
FOR ENERGY DRINKS (U.S. CLS. 45, 46 AND 48).
FIRST USE 10-5-2010; IN COMMERCE 10-5-2010.

4,210,754. STONY CREEK BREWERY, LLC, BRANFORD, CT. SN 85-203,832. PUB. 5-3-2011, FILED 12-22-2010.

860

THE MARK CONSISTS OF STANDARD CHARACTERS WITHOUT CLAIM TO ANY PARTICULAR FONT, STYLE, SIZE, OR COLOR.

FOR BEER (U.S. CLS. 45, 46 AND 48).
FIRST USE 4-30-2012; IN COMMERCE 5-26-2012.

CLASS 32—(Continued).

4,210,764. V GROUP, INC., CARLSBAD, CA. SN 85-206,283. PUB. 11-15-2011, FILED 12-28-2010.

AND

THE MARK CONSISTS OF STANDARD CHARACTERS WITHOUT CLAIM TO ANY PARTICULAR FONT, STYLE, SIZE, OR COLOR.

FOR READY TO DRINK, WATER-BASED, NON-ALCOHOLIC FLAVORED BEVERAGE PRODUCTS, NAMELY, DRINKING WATER, FRUIT-FLAVORED BEVERAGES, FRUIT JUICES AND ENERGY DRINKS CONTAINING NUTRITIONAL SUPPLEMENTS, CARBONATED BEVERAGES, NON-ALCOHOLIC BEVERAGES WITH TEA FLAVOR (U.S. CLS. 45, 46 AND 48).
FIRST USE 8-30-2011; IN COMMERCE 8-30-2011.

4,210,774. STONY CREEK BREWERY, LLC, BRANFORD, CT. SN 85-209,966. PUB. 5-3-2011, FILED 1-4-2011.

SIMPLY GREAT BEER, FROM GREAT PEOPLE, FOR GREAT PEOPLE

THE MARK CONSISTS OF STANDARD CHARACTERS WITHOUT CLAIM TO ANY PARTICULAR FONT, STYLE, SIZE, OR COLOR.

FOR BEER (U.S. CLS. 45, 46 AND 48).
FIRST USE 4-30-2012; IN COMMERCE 5-26-2012.

4,210,819. STONY CREEK BREWERY, LLC, BRANFORD, CT. SN 85-223,177. PUB. 5-3-2011, FILED 1-21-2011.

617

THE MARK CONSISTS OF STANDARD CHARACTERS WITHOUT CLAIM TO ANY PARTICULAR FONT, STYLE, SIZE, OR COLOR.

FOR BEER (U.S. CLS. 45, 46 AND 48).
FIRST USE 4-30-2012; IN COMMERCE 5-26-2012.

CLASS 32—(Continued).

4,210,820. STONY CREEK BREWERY, LLC, BRANFORD, CT. SN 85-223,183. PUB. 5-3-2011, FILED 1-21-2011.

CLASS 32—(Continued).

4,211,105. SEISMIC BREWING COMPANY, LLC, SAN DIEGO, CA. SN 85-341,312. PUB. 11-22-2011, FILED 6-8-2011.

401

ROUGH DRAFT BREWING COMPANY

THE MARK CONSISTS OF STANDARD CHARACTERS WITHOUT CLAIM TO ANY PARTICULAR FONT, STYLE, SIZE, OR COLOR.
FOR BEER (U.S. CLS. 45, 46 AND 48).
FIRST USE 4-30-2012; IN COMMERCE 5-26-2012.

THE MARK CONSISTS OF STANDARD CHARACTERS WITHOUT CLAIM TO ANY PARTICULAR FONT, STYLE, SIZE, OR COLOR.
NO CLAIM IS MADE TO THE EXCLUSIVE RIGHT TO USE "BREWING COMPANY", APART FROM THE MARK AS SHOWN.
FOR BEER, ALE, LAGER, STOUT (U.S. CLS. 45, 46 AND 48).
FIRST USE 3-9-2012; IN COMMERCE 3-9-2012.

4,210,821. STONY CREEK BREWERY, LLC, BRANFORD, CT. SN 85-223,189. PUB. 5-3-2011, FILED 1-21-2011.

4,211,325. MUTIARA FOOD & DRINKS (M) SDN. BHD., JOHOR, MALAYSIA. SN 85-373,793. PUB. 1-10-2012, FILED 7-18-2011.

917

THE MARK CONSISTS OF STANDARD CHARACTERS WITHOUT CLAIM TO ANY PARTICULAR FONT, STYLE, SIZE, OR COLOR.
FOR BEER (U.S. CLS. 45, 46 AND 48).
FIRST USE 4-30-2012; IN COMMERCE 5-26-2012.



4,210,822. STONY CREEK BREWERY, LLC, BRANFORD, CT. SN 85-223,192. PUB. 5-3-2011, FILED 1-21-2011.

NO CLAIM IS MADE TO THE EXCLUSIVE RIGHT TO USE "ENERGY DRINK", APART FROM THE MARK AS SHOWN.
THE MARK CONSISTS OF THE WORDING "DRIVE" IN STYLIZED HOLLOW FONT ON THE TOP LINE AND ON THE SECOND LINE THE WORDING "M7" IN STYLIZED AND HOLLOW FONT WITHIN A BLACK SQUARE BLOCK. GOING ACROSS THE SECOND LINE IS A BLACK WITH A WHITE LINE GOING ACROSS IT ABOUT A QUARTER OF THE WAY DOWN THE BAR AND THE WORDING "ENERGY DRINK" IS WRITTEN INSIDE THE BLACK BAR TO THE RIGHT OF THE SQUARE BLOCK.
FOR NON-ALCOHOLIC BEVERAGES, NAMELY, REFRESHING DRINKS IN THE NATURE OF ENERGY DRINKS ENHANCED WITH VITAMINS, MINERALS, AND NUTRIENTS, ENERGY DRINKS, ISOTONIC DRINKS, NAMELY, HYPERTONIC AND HYPOTONIC DRINKS, SOFT DRINKS, SPORT DRINKS, MINERAL WATER, AERATED WATER, FRUIT DRINKS AND FRUIT JUICES (U.S. CLS. 45, 46 AND 48).
FIRST USE 9-21-2011; IN COMMERCE 9-21-2011.

516

THE MARK CONSISTS OF STANDARD CHARACTERS WITHOUT CLAIM TO ANY PARTICULAR FONT, STYLE, SIZE, OR COLOR.
FOR BEER (U.S. CLS. 45, 46 AND 48).
FIRST USE 4-30-2012; IN COMMERCE 5-26-2012.

CLASS 32—(Continued).

4,211,516. SUNKIST GROWERS, INC., SHERMAN OAKS, CA. SN 85-444,307. PUB. 3-20-2012, FILED 10-11-2011.

SUNKIST FRUIT ULTIMATES

THE MARK CONSISTS OF STANDARD CHARACTERS WITHOUT CLAIM TO ANY PARTICULAR FONT, STYLE, SIZE, OR COLOR.

OWNER OF U.S. REG. NOS. 301,278, 1,215,135, AND OTHERS.

NO CLAIM IS MADE TO THE EXCLUSIVE RIGHT TO USE "FRUIT ULTIMATES", APART FROM THE MARK AS SHOWN.

FOR FRUIT CONCENTRATES AND PUREES USED AS INGREDIENTS OF BEVERAGES; FRUIT DRINKS AND FRUIT JUICES (U.S. CLS. 45, 46 AND 48).

FIRST USE 1-24-2012; IN COMMERCE 1-24-2012.

4,211,592. A&W CONCENTRATE COMPANY, PLANO, TX. SN 85-479,130. PUB. 5-8-2012, FILED 11-22-2011.

SQUIRT

THE MARK CONSISTS OF STANDARD CHARACTERS WITHOUT CLAIM TO ANY PARTICULAR FONT, STYLE, SIZE, OR COLOR.

OWNER OF U.S. REG. NOS. 771,971, 2,917,521, AND 3,111,963.

FOR CONCENTRATES AND POWDERS FOR MAKING NON-ALCOHOLIC BEVERAGES (U.S. CLS. 45, 46 AND 48).

FIRST USE 2-0-2012; IN COMMERCE 2-0-2012.

CLASS 33—WINES AND SPIRITS**CLASS 33—(Continued).**

4,210,277. JOSE CANEPA Y CIA. LTDA., CERRILLOS SANTIAGO, CHILE. SN 77-474,810. PUB. 3-31-2009, FILED 5-15-2008.



OWNER OF U.S. REG. NOS. 1,421,380, 1,488,759, AND OTHERS.

NO CLAIM IS MADE TO THE EXCLUSIVE RIGHT TO USE "FINISIMO", APART FROM THE MARK AS SHOWN.

THE MARK CONSISTS OF THREE RECTANGLES. THE UPPER RECTANGLE HAS AN EXTERIOR BORDER, A HASHED BORDER, A THIN BORDER, AND AN INTERIOR SPACE, UPON WHICH A CASTLE, A KEY, AND THE WORD "CANEPA" APPEAR. THE MIDDLE RECTANGLE LIES BETWEEN THE UPPER AND LOWER RECTANGLES. THE LOWER RECTANGLE CONSISTS OF AN EXTERIOR BORDER, A HASHED BORDER, A THIN BORDER, AND AN INTERIOR SPACE, UPON WHICH THE WORD "FINISIMO" APPEARS.

THE ENGLISH TRANSLATION OF "FINISIMO" IN THE MARK IS "SUPERB".

FOR WINE (U.S. CLS. 47 AND 49).

FIRST USE 12-0-1990; IN COMMERCE 4-23-2012.

4,210,296. HENRY, JAMES C, FLINT HILL, VA. SN 77-544,476. PUB. 5-5-2009, FILED 8-12-2008.

TEAVINE

THE MARK CONSISTS OF STANDARD CHARACTERS WITHOUT CLAIM TO ANY PARTICULAR FONT, STYLE, SIZE, OR COLOR.

FOR ALCOHOLIC BEVERAGES EXCEPT BEERS; ALCOHOLIC BEVERAGES, NAMELY, WINE; ALCOHOLIC COCKTAIL MIXES; ALCOHOLIC ESSENCES; ALCOHOLIC EXTRACTS; ALCOHOLIC PUNCH; ALCOHOLIC TEA-BASED BEVERAGE; PREPARED ALCOHOLIC COCKTAIL (U.S. CLS. 47 AND 49).

FIRST USE 11-15-2011; IN COMMERCE 2-17-2012.

CLASS 33—(Continued).

4,210,318. SAZERAC COMPANY, INC., METAIRIE, LA. SN 77-620,148. PUB. 4-5-2011, FILED 11-22-2008.

HDW CLIX

THE MARK CONSISTS OF STANDARD CHARACTERS WITHOUT CLAIM TO ANY PARTICULAR FONT, STYLE, SIZE, OR COLOR.

FOR VODKA (U.S. CLS. 47 AND 49).
FIRST USE 11-0-2011; IN COMMERCE 11-0-2011.

4,210,446. SIXTYWINE, INC., CORONA, CA. SN 77-921,883. PUB. 6-15-2010, FILED 1-27-2010.



THE MARK CONSISTS OF THE STYLIZED TEXT "SIXTYWINE" WITH TWO WINE GLASSES.
FOR WINE (U.S. CLS. 47 AND 49).
FIRST USE 1-1-2012; IN COMMERCE 1-1-2012.

4,210,450. E. & J. GALLO WINERY, MODESTO, CA. SN 77-924,036. PUB. 5-11-2010, FILED 1-29-2010.

BODEGA ELENA

THE MARK CONSISTS OF STANDARD CHARACTERS WITHOUT CLAIM TO ANY PARTICULAR FONT, STYLE, SIZE, OR COLOR.

NO CLAIM IS MADE TO THE EXCLUSIVE RIGHT TO USE "BODEGA", APART FROM THE MARK AS SHOWN.
FOR WINES (U.S. CLS. 47 AND 49).
FIRST USE 4-30-2012; IN COMMERCE 4-30-2012.

CLASS 33—(Continued).

4,210,462. AGAVE LOCO LLC, DEERFIELD, IL. SN 77-947,669. PUB. 4-3-2012, FILED 3-1-2010.

CHATA

THE MARK CONSISTS OF STANDARD CHARACTERS WITHOUT CLAIM TO ANY PARTICULAR FONT, STYLE, SIZE, OR COLOR.

FOR MIXED ALCOHOLIC BEVERAGES, NAMELY, A CREAM-BASED HORCHATA-FLAVORED ALCOHOLIC BEVERAGE MADE WITH RUM (U.S. CLS. 47 AND 49).
FIRST USE 11-11-2011; IN COMMERCE 11-11-2011.

4,210,614. DGB (PROPRIETARY) LIMITED, GAUTENG, SOUTH AFRICA. SN 85-111,792. PUB. 2-1-2011, FILED 8-19-2010.

HONEY BADGER

THE MARK CONSISTS OF STANDARD CHARACTERS WITHOUT CLAIM TO ANY PARTICULAR FONT, STYLE, SIZE, OR COLOR.

FOR ALCOHOLIC BEVERAGES EXCEPT BEERS; WINES (U.S. CLS. 47 AND 49).
FIRST USE 12-14-2010; IN COMMERCE 12-14-2010.

4,210,661. PALM BAY INTERNATIONAL, INC., PORT WASHINGTON, NY. SN 85-153,358. PUB. 3-8-2011, FILED 10-15-2010.

MIO ROSCATO

THE MARK CONSISTS OF STANDARD CHARACTERS WITHOUT CLAIM TO ANY PARTICULAR FONT, STYLE, SIZE, OR COLOR.

FOR ALCOHOLIC BEVERAGES, NAMELY, WINES (U.S. CLS. 47 AND 49).
FIRST USE 7-17-2012; IN COMMERCE 7-17-2012.

CLASS 33—(Continued).

4,210,662. PALM BAY INTERNATIONAL, INC., PORT WASHINGTON, NY. SN 85-153,362. PUB. 3-8-2011, FILED 10-15-2010.

IL ROSCATO

THE MARK CONSISTS OF STANDARD CHARACTERS WITHOUT CLAIM TO ANY PARTICULAR FONT, STYLE, SIZE, OR COLOR.

FOR ALCOHOLIC BEVERAGES, NAMELY, WINES (U.S. CLS. 47 AND 49).

FIRST USE 6-26-2012; IN COMMERCE 6-26-2012.

4,210,678. PALM BAY INTERNATIONAL, INC., PORT WASHINGTON, NY. SN 85-161,498. PUB. 3-8-2011, FILED 10-26-2010.

MIA ROSCATA

THE MARK CONSISTS OF STANDARD CHARACTERS WITHOUT CLAIM TO ANY PARTICULAR FONT, STYLE, SIZE, OR COLOR.

FOR ALCOHOLIC BEVERAGES, NAMELY, WINES (U.S. CLS. 47 AND 49).

FIRST USE 7-17-2012; IN COMMERCE 7-17-2012.

4,210,686. HAITI ORIGINALE, LLC, CORAL GABLES, FL. SN 85-173,866. PUB. 10-11-2011, FILED 11-10-2010.



NO CLAIM IS MADE TO THE EXCLUSIVE RIGHT TO USE "HAITI", APART FROM THE MARK AS SHOWN.

THE MARK CONSISTS OF A RECTANGULAR FIELD WITH THE LITERAL ELEMENT "PAR HAITI" ON THE TOP, THE LITERAL ELEMENT "POUR HAITI" ON THE BOTTOM, AND A STYLIZED BUILDING AND LEAF DESIGN IN THE MIDDLE.

CLASS 33—(Continued).

THE ENGLISH TRANSLATION OF "PAR HAITI POUR HAITI" IN THE MARK IS "BY HAITI FOR HAITI".
FOR SPIRITS AND LIQUEURS (U.S. CLS. 47 AND 49).
FIRST USE 4-2-2012; IN COMMERCE 4-2-2012.

4,210,712. NEW ARTISAN SPIRITS, INC., HOUSTON, TX. SN 85-189,031. PUB. 4-19-2011, FILED 12-2-2010.

ROXOR

THE MARK CONSISTS OF STANDARD CHARACTERS WITHOUT CLAIM TO ANY PARTICULAR FONT, STYLE, SIZE, OR COLOR.

FOR GIN (U.S. CLS. 47 AND 49).

FIRST USE 11-17-2011; IN COMMERCE 11-17-2011.

4,210,743. AYLIN ALGAN, NEW YORK, NY. SN 85-201,459. PUB. 12-13-2011, FILED 12-19-2010.

VieVité

THE MARK CONSISTS OF STANDARD CHARACTERS WITHOUT CLAIM TO ANY PARTICULAR FONT, STYLE, SIZE, OR COLOR.

FOR STILL WINES (U.S. CLS. 47 AND 49).

FIRST USE 5-1-2011; IN COMMERCE 5-1-2011.

4,210,771. KRUPP BROTHERS WINERY LLC, NAPA, CA. SN 85-209,169. PUB. 5-3-2011, FILED 1-3-2011.

WATER WITCH

THE MARK CONSISTS OF STANDARD CHARACTERS WITHOUT CLAIM TO ANY PARTICULAR FONT, STYLE, SIZE, OR COLOR.

FOR ALCOHOLIC BEVERAGES EXCEPT BEERS (U.S. CLS. 47 AND 49).

FIRST USE 6-28-2012; IN COMMERCE 6-28-2012.

CLASS 33—(Continued).

4,210,807. ENGARRAFAMENTO PITU LTDA., VITORIA DE SANTO ANTAO, BRAZIL. SN 85-218,036. PUB. 12-13-2011, FILED 1-14-2011.



OWNER OF U.S. REG. NOS. 1,621,543 AND 1,625,133.
NO CLAIM IS MADE TO THE EXCLUSIVE RIGHT TO USE "GOLD", APART FROM THE MARK AS SHOWN.
THE COLOR(S) GOLD AND BLACK IS/ARE CLAIMED AS A FEATURE OF THE MARK.
THE MARK CONSISTS OF A BLACK OVAL SHAPED DESIGN, FEATURING THE STYLIZED WORDS "PITU GOLD" IN GOLD LETTERS AND THE DESIGN OF A GOLD PRAWN ABOVE THE WORDS, ALL ON A GOLD BACKGROUND.
THE ENGLISH TRANSLATION OF THE WORD "PITU" IN THE MARK IS "LARGE SHRIMP OR PRAWN".
FOR ALCOHOLIC DISTILLED BEVERAGES, NAMELY, SUGAR CANE SPIRITS, NAMELY, CACHACA (U.S. CLS. 47 AND 49).
FIRST USE 12-0-2006; IN COMMERCE 12-0-2006.

4,210,957. OLD TAHOE DISTILLERY, LLC, SPOKANE, WA. SN 85-300,510. PUB. 9-13-2011, FILED 4-20-2011.

OLD TAHOE

THE MARK CONSISTS OF STANDARD CHARACTERS WITHOUT CLAIM TO ANY PARTICULAR FONT, STYLE, SIZE, OR COLOR.
FOR ALCOHOLIC BEVERAGES, NAMELY, FLAVOR-INFUSED WHISKEY; ALCOHOLIC BEVERAGES, NAMELY, RYE WHISKEY, STRAIGHT RYE WHISKEY, AMERICAN RYE WHISKEY, FLAVORED RYE WHISKEY, INFUSED RYE WHISKEY AND HONEY-FLAVORED RYE WHISKEY; WHISKEY (U.S. CLS. 47 AND 49).
FIRST USE 6-0-2012; IN COMMERCE 6-0-2012.

CLASS 33—(Continued).

4,210,975. PACIFIC RIM WINEMAKERS, INC., DBA VINMOTION, PORTLAND, OR. SN 85-308,872. PUB. 9-13-2011, FILED 4-29-2011.

RAINSTORM

THE MARK CONSISTS OF STANDARD CHARACTERS WITHOUT CLAIM TO ANY PARTICULAR FONT, STYLE, SIZE, OR COLOR.
FOR WINE (U.S. CLS. 47 AND 49).
FIRST USE 12-19-2011; IN COMMERCE 12-19-2011.

4,211,023. CAVE DE TAIN L'HERMITAGE, UNION DES PROPRIETAIRES, TAIN L'HERMITAGE, FRANCE. SN 85-326,046. PUB. 1-3-2012, FILED 5-20-2011.

LES DEUX CÔTES

THE MARK CONSISTS OF STANDARD CHARACTERS WITHOUT CLAIM TO ANY PARTICULAR FONT, STYLE, SIZE, OR COLOR.
THE ENGLISH TRANSLATION OF "LES DEUX CÔTES" IN THE MARK IS "TWO COASTS".
FOR WINES (U.S. CLS. 47 AND 49).
FIRST USE 7-0-2011; IN COMMERCE 7-0-2011.

4,211,046. MOUNTAIN LAUREL SPIRITS, LLC, NEW HOPE, PA. SN 85-331,638. PUB. 10-18-2011, FILED 5-26-2011.

DAD'S HAT

THE MARK CONSISTS OF STANDARD CHARACTERS WITHOUT CLAIM TO ANY PARTICULAR FONT, STYLE, SIZE, OR COLOR.
FOR DISTILLED SPIRITS (U.S. CLS. 47 AND 49).
FIRST USE 2-10-2012; IN COMMERCE 6-12-2012.

CLASS 33—(Continued).

4,211,072. MUERTO SPIRITS, INC., GOLD RIVER, CA. SN 85-336,726. PUB. 11-22-2011, FILED 6-2-2011.

VIVA MUERTO

THE MARK CONSISTS OF STANDARD CHARACTERS WITHOUT CLAIM TO ANY PARTICULAR FONT, STYLE, SIZE, OR COLOR.

THE ENGLISH TRANSLATION OF "VIVA MUERTO" IS "LIVING DEAD".

FOR ALCOHOLIC BEVERAGES, NAMELY, TEQUILA (U.S. CLS. 47 AND 49).

FIRST USE 3-14-2012; IN COMMERCE 4-19-2012.

CLASS 33—(Continued).

4,211,171. SX BRAND TRIBE, INC., FORT LAUDERDALE, FL. SN 85-348,999. PUB. 10-25-2011, FILED 6-17-2011.

SEXIER

THE MARK CONSISTS OF STANDARD CHARACTERS WITHOUT CLAIM TO ANY PARTICULAR FONT, STYLE, SIZE, OR COLOR.

FOR DISTILLED SPIRITS; SPIRITS AND LIQUEURS (U.S. CLS. 47 AND 49).

FIRST USE 7-31-2011; IN COMMERCE 7-31-2011.

4,211,075. BIAGIO CRU & ESTATE WINES, LLC, ROSLYN HEIGHTS, NY. SN 85-337,161. PUB. 10-25-2011, FILED 6-3-2011.

JUST PEACHY

THE MARK CONSISTS OF STANDARD CHARACTERS WITHOUT CLAIM TO ANY PARTICULAR FONT, STYLE, SIZE, OR COLOR.

FOR SPIRITS; WINES (U.S. CLS. 47 AND 49).

FIRST USE 12-20-2011; IN COMMERCE 12-20-2011.

4,211,178. LOLA'S LIBATIONS, LLC, COLLEYVILLE, TX. SN 85-349,586. PUB. 3-27-2012, FILED 6-17-2011.

SMARTINI

THE MARK CONSISTS OF STANDARD CHARACTERS WITHOUT CLAIM TO ANY PARTICULAR FONT, STYLE, SIZE, OR COLOR.

FOR PREPARED ALCOHOLIC COCKTAIL MIXES (U.S. CLS. 47 AND 49).

FIRST USE 6-22-2012; IN COMMERCE 6-22-2012.

4,211,154. CRUSHPAD, INC., SONOMA, CA. SN 85-347,122. PUB. 11-1-2011, FILED 6-15-2011.

DOGPATCH

THE MARK CONSISTS OF STANDARD CHARACTERS WITHOUT CLAIM TO ANY PARTICULAR FONT, STYLE, SIZE, OR COLOR.

FOR ALCOHOLIC BEVERAGES EXCEPT BEERS (U.S. CLS. 47 AND 49).

FIRST USE 12-31-2008; IN COMMERCE 12-31-2008.

4,211,184. CAPITAL BRANDS, LLC, CLEARWATER, FL. SN 85-350,173. PUB. 10-11-2011, FILED 6-20-2011.

JAILERS

THE MARK CONSISTS OF THE WORD "JAILERS" IN A STYLIZED RECTANGULAR BACKGROUND.

FOR WHISKEY (U.S. CLS. 47 AND 49).

FIRST USE 12-21-2011; IN COMMERCE 12-21-2011.

CLASS 33—(Continued).

4,211,321. GENGHIS GRILL FRANCHISE CONCEPTS, LP, DALLAS, TX. SN 85-372,959. PUB. 11-15-2011, FILED 7-15-2011.

GONG ISLAND ICED TEA

THE MARK CONSISTS OF STANDARD CHARACTERS WITHOUT CLAIM TO ANY PARTICULAR FONT, STYLE, SIZE, OR COLOR.

NO CLAIM IS MADE TO THE EXCLUSIVE RIGHT TO USE "ICED TEA", APART FROM THE MARK AS SHOWN. FOR PREPARED ALCOHOLIC COCKTAIL (U.S. CLS. 47 AND 49).

FIRST USE 9-29-2010; IN COMMERCE 10-30-2010.

4,211,322. GENGHIS GRILL FRANCHISE CONCEPTS, LP, DALLAS, TX. SN 85-372,963. PUB. 11-15-2011, FILED 7-15-2011.

KHAN'S MOJITO

THE MARK CONSISTS OF STANDARD CHARACTERS WITHOUT CLAIM TO ANY PARTICULAR FONT, STYLE, SIZE, OR COLOR.

OWNER OF U.S. REG. NOS. 3,364,286, 3,364,299, AND OTHERS.

NO CLAIM IS MADE TO THE EXCLUSIVE RIGHT TO USE "MOJITO", APART FROM THE MARK AS SHOWN.

FOR PREPARED ALCOHOLIC COCKTAIL (U.S. CLS. 47 AND 49).

FIRST USE 9-29-2010; IN COMMERCE 10-30-2010.

4,211,329. DEUTSCH NANTZ ALLIANCE, LLC, WHITE PLAINS, NY. SN 85-374,172. PUB. 12-13-2011, FILED 7-18-2011.

THE CALLING

THE MARK CONSISTS OF STANDARD CHARACTERS WITHOUT CLAIM TO ANY PARTICULAR FONT, STYLE, SIZE, OR COLOR.

FOR WINES (U.S. CLS. 47 AND 49).

FIRST USE 5-7-2012; IN COMMERCE 5-7-2012.

CLASS 33—(Continued).

4,211,412. VERMONT HARD CIDER COMPANY, LLC, MIDDLEBURY, VT. SN 85-400,107. PUB. 2-7-2012, FILED 8-17-2011.



OWNER OF U.S. REG. NOS. 1,731,480, 3,195,593, AND OTHERS.

NO CLAIM IS MADE TO THE EXCLUSIVE RIGHT TO USE "CRAFTED IN VERMONT FARMHOUSE SELECT HARD CIDER ORIGINAL '91", APART FROM THE MARK AS SHOWN.

THE MARK CONSISTS OF AN APPLE TREE WITH A WOODCHUCK SITTING UNDERNEATH THE TREE TO THE LOWER RIGHT EATING AN APPLE. UNDER THE TREE AND WOODCHUCK AND WITHIN A SHADED AREA ARE THE WORDS "FARMHOUSE SELECT HARD CIDER". TO THE LEFT OF THESE WORDS IN THE SHADED AREA IS A DESIGN CONSISTING OF DARK CONCENTRIC OVALS CONTAINING THE WORDS "WOODCHUCK HARD CIDER", SURROUNDING A LIGHTER INNER OVAL, SURROUNDING A WOODCHUCK STANDING ON A ROCK AND HOLDING AN APPLE. IN THE BACKGROUND OF THE WOODCHUCK ARE ROWS OF TREES AND MOUNTAINS, AND IN THE FOREGROUND OF THE WOODCHUCK ARE PLANTS. ABOVE THE TREE ARE DISPLAYED THE WORDS "CRAFTED IN VERMONT" IN A SEMI-CIRCULAR DESIGN. BENEATH THE MARK OUTSIDE THE SHADED AREA ARE THE WORDS "ORIGINAL '91".

FOR HARD CIDER (U.S. CLS. 47 AND 49).

FIRST USE 11-2-2011; IN COMMERCE 11-2-2011.

4,211,453. MARTITA'S MIXERS, MILWAUKEE, WI. SN 85-413,706. PUB. 2-21-2012, FILED 9-2-2011.

guiltless

THE MARK CONSISTS OF STANDARD CHARACTERS WITHOUT CLAIM TO ANY PARTICULAR FONT, STYLE, SIZE, OR COLOR.

OWNER OF U.S. REG. NO. 3,858,283.

FOR WINE COOLERS (U.S. CLS. 47 AND 49).

FIRST USE 5-22-2011; IN COMMERCE 6-8-2012.

CLASS 33—(Continued).

4,211,458. DIAGEO NORTH AMERICA, INC., NORWALK, CT. SN 85-415,561. PUB. 5-1-2012, FILED 9-6-2011.

**CAPTAIN MORGAN BLACK
SPICED RUM**

THE MARK CONSISTS OF STANDARD CHARACTERS WITHOUT CLAIM TO ANY PARTICULAR FONT, STYLE, SIZE, OR COLOR.

OWNER OF U.S. REG. NOS. 3,016,339, 3,159,948, AND OTHERS.

NO CLAIM IS MADE TO THE EXCLUSIVE RIGHT TO USE "BLACK SPICED RUM", APART FROM THE MARK AS SHOWN.

FOR DISTILLED SPIRITS (U.S. CLS. 47 AND 49).
FIRST USE 2-15-2012; IN COMMERCE 2-15-2012.

4,211,479. VERMONT SPIRITS DISTILLING COMPANY, QUECHEE, VT. SN 85-424,915. PUB. 2-21-2012, FILED 9-16-2011.

THE SPIRIT OF VERMONT

THE MARK CONSISTS OF STANDARD CHARACTERS WITHOUT CLAIM TO ANY PARTICULAR FONT, STYLE, SIZE, OR COLOR.

FOR VODKA (U.S. CLS. 47 AND 49).
FIRST USE 2-23-2012; IN COMMERCE 2-27-2012.

4,211,486. WHISKEY RESTAURANTS INC., SCOTTSDALE, AZ. SN 85-426,135. PUB. 3-13-2012, FILED 9-19-2011.

LINCOLN WHISKEY

THE MARK CONSISTS OF STANDARD CHARACTERS WITHOUT CLAIM TO ANY PARTICULAR FONT, STYLE, SIZE, OR COLOR.

NO CLAIM IS MADE TO THE EXCLUSIVE RIGHT TO USE "WHISKEY", APART FROM THE MARK AS SHOWN.

FOR ALCOHOLIC BEVERAGES EXCEPT BEERS; SPIRITS (U.S. CLS. 47 AND 49).
FIRST USE 5-7-2012; IN COMMERCE 5-7-2012.

CLASS 33—(Continued).

4,211,543. MICHAEL STARR, CANYON COUNTRY, CA. SN 85-456,695. PUB. 4-3-2012, FILED 10-26-2011.

Blacklight

THE MARK CONSISTS OF STANDARD CHARACTERS WITHOUT CLAIM TO ANY PARTICULAR FONT, STYLE, SIZE, OR COLOR.

OWNER OF U.S. REG. NOS. 2,826,409, 3,097,956, AND OTHERS.

FOR FROZEN PREPARED COCKTAILS AND PREPARED ALCOHOLIC COCKTAILS (U.S. CLS. 47 AND 49).

FIRST USE 10-26-2011; IN COMMERCE 4-14-2012.

4,211,568. DEAR, INC., ATLANTA, GA. SN 85-470,246. PUB. 4-24-2012, FILED 11-11-2011.

BIASINI

THE MARK CONSISTS OF STANDARD CHARACTERS WITHOUT CLAIM TO ANY PARTICULAR FONT, STYLE, SIZE, OR COLOR.

FOR WINES (U.S. CLS. 47 AND 49).

FIRST USE 5-30-2012; IN COMMERCE 5-30-2012.

4,211,616. SAN ANTONIO WINERY, LOS ANGELES, CA. SN 85-492,638. PUB. 5-8-2012, FILED 12-12-2011.

STELLA BERRY

THE MARK CONSISTS OF STANDARD CHARACTERS WITHOUT CLAIM TO ANY PARTICULAR FONT, STYLE, SIZE, OR COLOR.

OWNER OF U.S. REG. NOS. 3,663,013 AND 4,000,417.

NO CLAIM IS MADE TO THE EXCLUSIVE RIGHT TO USE "BERRY", APART FROM THE MARK AS SHOWN.

THE ENGLISH TRANSLATION OF "STELLA" IN THE MARK IS "STAR".

FOR WINE (U.S. CLS. 47 AND 49).
FIRST USE 2-2-2012; IN COMMERCE 2-6-2012.

CLASS 33—(Continued).

4,211,617. SAN ANTONIO WINERY, LOS ANGELES, CA. SN 85-492,654. PUB. 5-8-2012, FILED 12-12-2011.

STELLA PINK

THE MARK CONSISTS OF STANDARD CHARACTERS WITHOUT CLAIM TO ANY PARTICULAR FONT, STYLE, SIZE, OR COLOR.

OWNER OF U.S. REG. NOS. 3,663,013 AND 4,000,417.

NO CLAIM IS MADE TO THE EXCLUSIVE RIGHT TO USE "PINK", APART FROM THE MARK AS SHOWN.

THE ENGLISH TRANSLATION OF "STELLA" IN THE MARK IS "STAR".

FOR WINE (U.S. CLS. 47 AND 49).

FIRST USE 2-2-2012; IN COMMERCE 2-6-2012.

CLASS 34—(Continued).

4,210,558. VINTAGE ENTERPRISES, INC., EAST STROUDSBURG, PA. SN 85-072,975. PUB. 11-16-2010, FILED 6-28-2010.

Dona Patricia

THE MARK CONSISTS OF STANDARD CHARACTERS WITHOUT CLAIM TO ANY PARTICULAR FONT, STYLE, SIZE, OR COLOR.

THE NAME "DONA PATRICIA" DOES NOT IDENTIFY A LIVING INDIVIDUAL.

THE ENGLISH TRANSLATION OF THE WORD "DONA" IN THE MARK IS "LADY".

FOR CIGARS (U.S. CLS. 2, 8, 9 AND 17).

FIRST USE 11-14-2010; IN COMMERCE 11-14-2010.

4,211,641. SONOMA WINE COMPANY, GRATON, CA. SN 85-501,530. PUB. 5-22-2012, FILED 12-21-2011.

Bison Ridge

THE MARK CONSISTS OF STANDARD CHARACTERS WITHOUT CLAIM TO ANY PARTICULAR FONT, STYLE, SIZE, OR COLOR.

FOR WINE; WINES (U.S. CLS. 47 AND 49).

FIRST USE 4-28-2012; IN COMMERCE 4-28-2012.

4,210,679. REMBERTO ESTRELLA, SANTIAGO, DOMINICAN REP. SN 85-163,321. PUB. 3-29-2011, FILED 10-28-2010.

33 MINERS

THE MARK CONSISTS OF STANDARD CHARACTERS WITHOUT CLAIM TO ANY PARTICULAR FONT, STYLE, SIZE, OR COLOR.

FOR CIGAR BOXES; CIGAR CASES; CIGAR CUTTERS; CIGAR HOLDERS; CIGAR LIGHTERS; CIGAR WRAPS; CIGARILLOS; CIGARS; HOOKAH TOBACCO; MOLASSES TOBACCO; PIPE TOBACCO; SMOKING TOBACCO; TOBACCO; TOBACCO, CIGARS AND CIGARETTES (U.S. CLS. 2, 8, 9 AND 17).

FIRST USE 2-9-2011; IN COMMERCE 5-2-2011.

CLASS 34—SMOKERS' ARTICLES

4,210,549. VINTAGE ENTERPRISES, INC., EAST STROUDSBURG, PA. SN 85-064,430. PUB. 11-16-2010, FILED 6-16-2010.

BIG DOG

THE MARK CONSISTS OF STANDARD CHARACTERS WITHOUT CLAIM TO ANY PARTICULAR FONT, STYLE, SIZE, OR COLOR.

FOR CIGARS (U.S. CLS. 2, 8, 9 AND 17).

FIRST USE 11-14-2010; IN COMMERCE 11-14-2010.

4,210,840. FAMOUS SMOKE SHOP-PA, INC., EASTON, PA. SN 85-236,871. PUB. 6-14-2011, FILED 2-8-2011.

IRON HORSE

THE MARK CONSISTS OF STANDARD CHARACTERS WITHOUT CLAIM TO ANY PARTICULAR FONT, STYLE, SIZE, OR COLOR.

FOR CIGARS (U.S. CLS. 2, 8, 9 AND 17).

FIRST USE 12-1-2011; IN COMMERCE 12-1-2011.

CLASS 34—(Continued).

4,210,841. FAMOUS SMOKE SHOP-PA, INC., EASTON, PA.
SN 85-236,885. PUB. 6-14-2011, FILED 2-8-2011.

INFERNO

THE MARK CONSISTS OF STANDARD CHARACTERS
WITHOUT CLAIM TO ANY PARTICULAR FONT, STYLE,
SIZE, OR COLOR.

FOR CIGARS (U.S. CLS. 2, 8, 9 AND 17).
FIRST USE 4-1-2012; IN COMMERCE 4-1-2012.

4,211,173. ROMAR UNIVERSAL, INC., FORT LAUDER-
DALE, FL. SN 85-349,245. PUB. 11-8-2011, FILED 6-17-2011.

ROXWELL

THE MARK CONSISTS OF STANDARD CHARACTERS
WITHOUT CLAIM TO ANY PARTICULAR FONT, STYLE,
SIZE, OR COLOR.

FOR TOBACCO, CIGARS AND CIGARETTES (U.S.
CLS. 2, 8, 9 AND 17).
FIRST USE 5-21-2012; IN COMMERCE 5-21-2012.

4,211,580. EPC IP CO. LLC, MIAMI, FL. SN 85-475,369. PUB. 5-
1-2012, FILED 11-17-2011.

INCH

THE MARK CONSISTS OF STANDARD CHARACTERS
WITHOUT CLAIM TO ANY PARTICULAR FONT, STYLE,
SIZE, OR COLOR.

FOR CIGARS (U.S. CLS. 2, 8, 9 AND 17).
FIRST USE 7-9-2012; IN COMMERCE 7-9-2012.

SERVICE MARKS

CLASS 35—ADVERTISING AND BUSINESS

CLASS 35—(Continued).

4,210,249. 1-800-FLOWERS.COM, INC., CARLE PLACE, NY.
SN 76-979,184. PUB. 5-1-2012, FILED 5-9-2003.

CELEBRATIONS.COM

OWNER OF U.S. REG. NO. 2,605,451.
FOR ON-LINE RETAIL STORE SERVICES FEATUR-
ING PARTY SUPPLIES (U.S. CLS. 100, 101 AND 102).
FIRST USE 7-13-2012; IN COMMERCE 7-13-2012.

4,210,305. MARSH, PAUL FRANKLIN, PARK CITY, UT. SN
77-585,687. PUB. 4-21-2009, FILED 10-4-2008.

TREAT RESPONSIBLY

THE MARK CONSISTS OF STANDARD CHARACTERS
WITHOUT CLAIM TO ANY PARTICULAR FONT, STYLE,
SIZE, OR COLOR.

FOR ORGANIZING AND PROMOTING THE PUBLIC
AWARENESS OF PERSONAL RESPONSIBILITY OF
PARENTS, TEACHERS, COMMUNITY MEMBERS AND
STUDENTS RELATING TO THE SAFETY AND RESPON-
SIBLE DECISIONS REGARDING THE DISTRIBUTION
OF HALLOWEEN CANDY AND TREATS (U.S. CLS. 100,
101 AND 102).

FIRST USE 1-1-2009; IN COMMERCE 1-1-2009.

4,210,338. WEINBERG, BRUCE, DENVER, CO. SN 77-645,454.
PUB. 4-28-2009, FILED 1-8-2009.

DO IT KNOWLEDGEABLY

THE MARK CONSISTS OF STANDARD CHARACTERS
WITHOUT CLAIM TO ANY PARTICULAR FONT, STYLE,
SIZE, OR COLOR.

FOR ON-LINE RETAIL STORE SERVICES FEATUR-
ING CLOTHING, CONDOMS, MASSAGE OIL, AND
GELS FOR USE AS PERSONAL LUBRICANT (U.S. CLS.
100, 101 AND 102).

FIRST USE 1-16-2012; IN COMMERCE 1-16-2012.

CLASS 35—(Continued).

4,210,341. SUPERMEDIA LLC, DALLAS/FORT WORTH AIRPORT, TX. SN 77-649,034. PUB. 5-12-2009, FILED 1-14-2009.

SUPERCALLS

THE MARK CONSISTS OF STANDARD CHARACTERS WITHOUT CLAIM TO ANY PARTICULAR FONT, STYLE, SIZE, OR COLOR.

OWNER OF U.S. REG. NOS. 2,022,484, 3,086,056, AND OTHERS.

FOR ELECTRONIC TELEPHONE DIRECTORY SERVICES, NAMELY, ON-LINE TELEPHONE DIRECTORY INFORMATION; ADVERTISING SERVICES, NAMELY, PROMOTING THE GOODS AND SERVICES OF OTHERS VIA THE INTERNET AND DISSEMINATION OF ADVERTISING FOR OTHERS VIA THE INTERNET; PAY PER CALL ADVERTISING SERVICES; SEARCH ENGINE MARKETING SERVICES (U.S. CLS. 100, 101 AND 102).
FIRST USE 8-0-2011; IN COMMERCE 8-0-2011.

CLASS 35—(Continued).

4,210,371. CENTER FOR FOOD INTEGRITY, KANSAS CITY, MO. SN 77-769,902. PUB. 12-13-2011, FILED 6-29-2009.

FARMERS FEED US

THE MARK CONSISTS OF STANDARD CHARACTERS WITHOUT CLAIM TO ANY PARTICULAR FONT, STYLE, SIZE, OR COLOR.

FOR PROMOTING PUBLIC AWARENESS OF AGRICULTURAL PRODUCERS (U.S. CLS. 100, 101 AND 102).
FIRST USE 6-0-2009; IN COMMERCE 6-0-2009.

4,210,345. PALLADIUM GROUP, INC., LINCOLN, MA. SN 77-658,587. PUB. 12-29-2009, FILED 1-28-2009.

KAPLAN & NORTON

THE MARK CONSISTS OF STANDARD CHARACTERS WITHOUT CLAIM TO ANY PARTICULAR FONT, STYLE, SIZE, OR COLOR.

FOR BUSINESS MANAGEMENT CONSULTING SERVICES, NAMELY, DESIGNING AND IMPLEMENTING MANAGEMENT PROCESSES FOR OTHERS; PROVIDING INFORMATION IN THE FIELD OF BUSINESS MANAGEMENT BY MEANS OF A LINK TO A DIRECTORY OF BUSINESS MANAGEMENT SERVICES AND PRODUCTS AVAILABLE OVER THE INTERNET, INCLUDING ROADMAPS TO IMPLEMENT STRATEGY, REPORTS, NEWSLETTERS, WEBCASTS, EDUCATION AND TRAINING; CONSULTING SERVICES IN THE FIELD OF BUSINESS ORGANIZATION, STRATEGY AND MANAGEMENT; BEST PRACTICES BUSINESS CONSULTING SERVICES DEVELOPING RESEARCH SERVICES AND BENCHMARKS (U.S. CLS. 100, 101 AND 102).

FIRST USE 1-0-2009; IN COMMERCE 1-0-2009.

4,210,377. INFLECTION POINT RETAIL, LLC, WINDERMERE, FL. SN 77-786,408. PUB. 6-15-2010, FILED 7-21-2009.

INFLECTION POINT RETAIL

THE MARK CONSISTS OF STANDARD CHARACTERS WITHOUT CLAIM TO ANY PARTICULAR FONT, STYLE, SIZE, OR COLOR.

NO CLAIM IS MADE TO THE EXCLUSIVE RIGHT TO USE "RETAIL", APART FROM THE MARK AS SHOWN.

FOR RETAIL MANAGEMENT SERVICES PROVIDED TO RETAIL STORES FOR CONTROLLING INVENTORY THROUGH THE USE OF COMPUTER SOFTWARE THAT EXPEDITES THE SALE OF PERISHABLE GOODS, TIME-SENSITIVE GOODS AND OVERSTOCKED GOODS (U.S. CLS. 100, 101 AND 102).

FIRST USE 5-27-2009; IN COMMERCE 5-27-2009.

CLASS 35—(Continued).

4,210,385. JUST MARKETING, INC., ZIONSVILLE, IN. SN 77-824,619. PUB. 5-15-2012, FILED 9-11-2009.



THE MARK CONSISTS OF FOUR CURVED, BROAD LINES OR STROKES TO THE LEFT OF THE LETTERS "JMI".

FOR ADVERTISING SERVICES, PUBLIC RELATIONS AND MARKETING SERVICES, NAMELY, PROMOTING AND MARKETING THE GOODS AND SERVICES OF OTHERS THROUGH ALL PUBLIC COMMUNICATION MEANS; COMMERCIAL ADMINISTRATION OF THE LICENSING OF THE GOODS AND SERVICES OF OTHERS; CORPORATE EVENT MANAGEMENT SERVICES; PROMOTING THE GOODS AND SERVICES OF OTHERS BY ARRANGING FOR SPONSORS TO AFFILIATE THEIR GOODS AND SERVICES WITH MOTORSPORTS COMPETITIONS; SERVICES WITH REGARD TO PRODUCT PRESENTATION TO THE PUBLIC (U.S. CLS. 100, 101 AND 102).

FIRST USE 12-1-2009; IN COMMERCE 12-1-2009.

4,210,461. CYBERWIZE.COM, INC., SARASOTA, FL. SN 77-946,420. PUB. 3-15-2011, FILED 2-26-2010.

LiveSmart 360

THE MARK CONSISTS OF STANDARD CHARACTERS WITHOUT CLAIM TO ANY PARTICULAR FONT, STYLE, SIZE, OR COLOR.

FOR DISTRIBUTORSHIP SERVICES IN THE FIELD OF DIETARY AND NUTRITIONAL SUPPLEMENTS, MEAL REPLACEMENT PREPARATIONS, WEIGHT LOSS SUPPLEMENTS AND PREPARATIONS, COSMETIC AND PERSONAL CARE PREPARATIONS, TRAVEL PACKAGES, TAX ADVISORY PRODUCTS, WEBSITE DEVELOPMENT PRODUCTS, PET CARE PREPARATIONS, AND HOUSEHOLD AND AUTOMOTIVE CLEANING PREPARATIONS; MULTI-LEVEL MARKETING BUSINESS SERVICES; ON-LINE ORDERING SERVICES FEATURING DIETARY AND NUTRITIONAL SUPPLEMENTS, MEAL REPLACEMENT PREPARATIONS, WEIGHT LOSS SUPPLEMENTS AND PREPARATIONS, COSMETIC AND PERSONAL CARE PREPARATIONS, TRAVEL PACKAGES, TAX ADVISORY PRODUCTS, WEBSITE DEVELOPMENT PRODUCTS, SEARCH ENGINE OPTIMIZATION SERVICES, PET CARE PREPARATIONS, AND HOUSEHOLD AND

CLASS 35—(Continued).

AUTOMOTIVE CLEANING PREPARATIONS; ON-LINE RETAIL STORE SERVICES FEATURING DIETARY AND NUTRITIONAL SUPPLEMENTS, MEAL REPLACEMENT PREPARATIONS, WEIGHT LOSS SUPPLEMENTS AND PREPARATIONS, COSMETIC AND PERSONAL CARE PREPARATIONS, TRAVEL PACKAGES, TAX ADVISORY PRODUCTS, WEBSITE DEVELOPMENT PRODUCTS, SEARCH ENGINE OPTIMIZATION SERVICES, PET CARE PREPARATIONS, AND HOUSEHOLD AND AUTOMOTIVE CLEANING PREPARATIONS; RETAIL SERVICES BY DIRECT SOLICITATION BY SALES AGENTS IN THE FIELD OF DIETARY AND NUTRITIONAL SUPPLEMENTS, MEAL REPLACEMENT PREPARATIONS, WEIGHT LOSS SUPPLEMENTS AND PREPARATIONS, COSMETIC AND PERSONAL CARE PREPARATIONS, TRAVEL PACKAGES, TAX ADVISORY PRODUCTS, WEBSITE DEVELOPMENT PRODUCTS, SEARCH ENGINE OPTIMIZATION SERVICES, PET CARE PREPARATIONS, AND HOUSEHOLD AND AUTOMOTIVE CLEANING PREPARATIONS (U.S. CLS. 100, 101 AND 102).

FIRST USE 4-1-2010; IN COMMERCE 4-1-2010.

4,210,469. STHREE IP LIMITED, LONDON, UNITED KINGDOM. SN 77-965,897. PUB. 1-10-2012, FILED 3-23-2010.



NO CLAIM IS MADE TO THE EXCLUSIVE RIGHT TO USE "RECOGNIZING TALENT", APART FROM THE MARK AS SHOWN.

THE COLOR(S) PURPLE IS/ARE CLAIMED AS A FEATURE OF THE MARK.

CLASS 35—(Continued).

THE MARK CONSISTS OF A LARGE LETTER "R" IN UPPER CASE MOSTLY SURROUNDED BY A CIRCULAR DESIGN INCLUDING A STAR DESIGN ON THE UPPER RIGHT OF THE CIRCULAR DESIGN; AND BENEATH THE "R" APPEARS "REAL RECOGNISING TALENT" IN LOWER CASE WITH A STAR DESIGN TO THE LEFT OF "RECOGNISING" AND ALL OF WHICH ARE IN THE COLOR PURPLE.

FOR PERSONNEL EMPLOYMENT AND RECRUITMENT SERVICES; RECRUITMENT CONSULTANCY SERVICES; PERSONNEL RECRUITMENT SERVICES; PERSONNEL SELECTION SERVICES; HUMAN RESOURCE MANAGEMENT SERVICES; EMPLOYMENT AND RECRUITMENT AGENCY SERVICES; EMPLOYMENT AND RECRUITMENT SERVICES RELATING TO THE FINANCIAL, MANAGEMENT CONSULTANCY AND IT SECTORS; PROJECT MANAGEMENT SERVICES IN THE FIELD OF EMPLOYMENT AND RECRUITMENT; ADVERTISING SERVICES RELATING TO RECRUITMENT AND EMPLOYMENT; MARKET RESEARCH SERVICES IN THE FIELDS OF EMPLOYMENT RECRUITMENT, EMPLOYEE AND JOB PROFILING; EMPLOYEE AND JOB PROFILING SERVICES; ONLINE RECRUITING SERVICES, NAMELY, SEARCHABLE JOB POSTINGS AND RESUMES; EXECUTIVE RECRUITMENT SERVICES; PSYCHOMETRIC TESTING RELATING TO EMPLOYMENT AND PERSONNEL SELECTION; ADVISORY, CONSULTANCY AND INFORMATION SERVICES RELATING TO ALL THE AFORESAID (U.S. CLS. 100, 101 AND 102).

FIRST USE 6-0-2010; IN COMMERCE 6-0-2010.

4,210,486. NAPOLEON, ANDRA, LANOKA HARBOR, NJ. SN 85-003,169. PUB. 8-31-2010, FILED 3-31-2010.

GOT GLOW?

THE MARK CONSISTS OF STANDARD CHARACTERS WITHOUT CLAIM TO ANY PARTICULAR FONT, STYLE, SIZE, OR COLOR.

FOR CLUB SERVICES, NAMELY, PROMOTING THE INTERESTS OF SINGLE PERSONS (U.S. CLS. 100, 101 AND 102).

FIRST USE 3-9-2011; IN COMMERCE 3-9-2011.

4,210,501. LATHER, INC., PASADENA, CA. SN 85-015,338. PUB. 9-7-2010, FILED 4-15-2010.

ELEVATE THE EXPERIENCE

THE MARK CONSISTS OF STANDARD CHARACTERS WITHOUT CLAIM TO ANY PARTICULAR FONT, STYLE, SIZE, OR COLOR.

FOR ONLINE RETAIL STORE SERVICES FEATURING HEALTH AND BEAUTY AID PRODUCTS (U.S. CLS. 100, 101 AND 102).

FIRST USE 10-1-2005; IN COMMERCE 10-1-2005.

CLASS 35—(Continued).

4,210,519. SAN PASQUAL CASINO DEVELOPMENT GROUP INC., VALLEY CENTER, CA. SN 85-039,289. PUB. 4-17-2012, FILED 5-14-2010.

CONNECTIONS VALLEY VIEW CASINO & HOTEL

THE MARK CONSISTS OF STANDARD CHARACTERS WITHOUT CLAIM TO ANY PARTICULAR FONT, STYLE, SIZE, OR COLOR.

OWNER OF U.S. REG. NO. 3,542,867.

NO CLAIM IS MADE TO THE EXCLUSIVE RIGHT TO USE "CASINO & HOTEL", APART FROM THE MARK AS SHOWN.

FOR ADVERTISING AND MARKETING; COOPERATIVE ADVERTISING AND MARKETING (U.S. CLS. 100, 101 AND 102).

FIRST USE 7-0-2010; IN COMMERCE 7-0-2010.

4,210,540. ROSS-SIMONS OF WARWICK, INC., CRANSTON, RI. SN 85-057,266. PUB. 9-28-2010, FILED 6-8-2010.

GOTTA HAVE BLING

THE MARK CONSISTS OF STANDARD CHARACTERS WITHOUT CLAIM TO ANY PARTICULAR FONT, STYLE, SIZE, OR COLOR.

NO CLAIM IS MADE TO THE EXCLUSIVE RIGHT TO USE "BLING", APART FROM THE MARK AS SHOWN.

FOR PROVIDING A WEBSITE USED TO PLACE ONLINE COMMERCIAL ORDERS IN THE FIELD OF JEWELRY, GEMSTONES, PRECIOUS METALS, WATCHES AND CLOCKS; RETAIL SERVICES BY DIRECT SOLICITATION BY SALES AGENTS IN THE FIELD OF JEWELRY, GEMSTONES, PRECIOUS METALS, WATCHES AND CLOCKS; RETAIL STORE AND ON-LINE RETAIL STORE SERVICES FEATURING JEWELRY, GEMSTONES, PRECIOUS METALS, WATCHES AND CLOCKS (U.S. CLS. 100, 101 AND 102).

FIRST USE 1-2-2011; IN COMMERCE 1-2-2011.

CLASS 35—(Continued).

4,210,569. BIOPHARM COMMUNICATIONS, LLC, NEW HOPE, PA. SN 85-079,285. PUB. 11-2-2010, FILED 7-7-2010.

ClinTags

THE MARK CONSISTS OF STANDARD CHARACTERS WITHOUT CLAIM TO ANY PARTICULAR FONT, STYLE, SIZE, OR COLOR.

FOR ADVERTISING AND MARKETING; ADVERTISING AND MARKETING SERVICES, NAMELY, PROMOTING THE GOODS AND SERVICES OF OTHERS; BUSINESS MARKETING SERVICES; MARKETING AND CONSULTING SERVICES IN THE FIELD OF PROMOTING AND TRACKING THE GOODS, SERVICES, AND BRANDS OF OTHERS THROUGH ALL PUBLIC COMMUNICATION MEANS, PARTICULARLY SPECIALIZING IN THE USE OF MOBILE, SOCIAL, AND PRINT MEDIA TO DRIVE CONSUMER INTEREST, ENGAGEMENT AND ACTION; MARKETING, PROMOTIONAL AND ADVERTISING SERVICES PROVIDED BY MOBILE TELEPHONE CONNECTIONS; PROMOTING THE GOODS AND SERVICES OF OTHERS BY DISTRIBUTING ADVERTISING MATERIALS THROUGH A VARIETY OF METHODS; PROVIDING ADVERTISING, MARKETING AND PROMOTIONAL SERVICES FOR THE PHARMACEUTICAL AND MEDICAL INDUSTRY (U.S. CLS. 100, 101 AND 102).

FIRST USE 7-0-2011; IN COMMERCE 7-0-2011.

4,210,591. MONACHUS, LLC, SAN JUAN CAPISTRANO, CA. SN 85-092,582. PUB. 1-4-2011, FILED 7-26-2010.

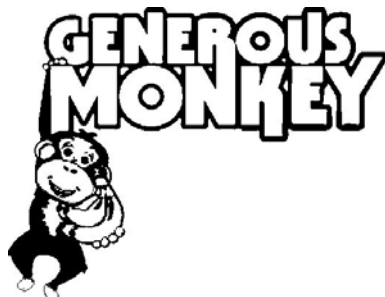

THE MARK CONSISTS OF THE STYLIZED WORDS "GENEROUS MONKEY". AN IMAGE OF A MONKEY HANGING FROM THE LETTER "M" IN THE WORD "MONKEY".

FOR PROMOTING THE CHARITABLE SERVICES OF OTHERS, NAMELY, PROVIDING INDIVIDUALS WITH INFORMATION FOR THE PURPOSE OF MAKING DONATIONS TO CHARITIES (U.S. CLS. 100, 101 AND 102).

FIRST USE 6-0-2006; IN COMMERCE 6-0-2006.

CLASS 35—(Continued).

4,210,627. THE NATIONAL BOARD OF CERTIFICATION FOR COMMUNITY ASSOCIATION MANAGERS, FALLS CHURCH, VA. SN 85-116,242. PUB. 2-15-2011, FILED 8-26-2010.

THE ESSENTIAL CREDENTIAL

THE MARK CONSISTS OF STANDARD CHARACTERS WITHOUT CLAIM TO ANY PARTICULAR FONT, STYLE, SIZE, OR COLOR.

FOR ASSOCIATION SERVICES, NAMELY, PROMOTING THE INTERESTS OF COMMUNITY ASSOCIATION MANAGERS AND PROTECTING CONSUMERS LIVING IN COMMUNITY ASSOCIATIONS SERVED BY PROFESSIONAL MANAGERS (U.S. CLS. 100, 101 AND 102).

FIRST USE 9-0-2010; IN COMMERCE 9-0-2010.

4,210,633. FINANCIAL FITNESS, LLC, LUTZ, FL. SN 85-121,864. PUB. 4-24-2012, FILED 9-2-2010.

YOURHOME1SOURCE

THE MARK CONSISTS OF STANDARD CHARACTERS WITHOUT CLAIM TO ANY PARTICULAR FONT, STYLE, SIZE, OR COLOR.

FOR PROVIDING AN INTERNET WEBSITE PORTAL FEATURING PROMOTION AND ADVERTISING FOR HOME SERVICE PROVIDERS AND PRODUCT MANUFACTURERS (U.S. CLS. 100, 101 AND 102).

FIRST USE 11-30-2010; IN COMMERCE 11-30-2010.

4,210,634. TEMPTATION SWEETS INC., GLEN BURNIE, MD. SN 85-122,286. PUB. 8-30-2011, FILED 9-2-2010.

TEMPTATION CANDY

THE MARK CONSISTS OF STANDARD CHARACTERS WITHOUT CLAIM TO ANY PARTICULAR FONT, STYLE, SIZE, OR COLOR.

NO CLAIM IS MADE TO THE EXCLUSIVE RIGHT TO USE "CANDY", APART FROM THE MARK AS SHOWN.

FOR ONLINE RETAIL CANDY STORE SERVICES (U.S. CLS. 100, 101 AND 102).

FIRST USE 9-1-2010; IN COMMERCE 9-1-2010.

CLASS 35—(Continued).

4,210,666. FIRSTCHOICE ADMINISTRATORS, LLC, SPRINGFIELD, MO. SN 85-155,979. PUB. 5-17-2011, FILED 10-19-2010.

PROMERIS

THE MARK CONSISTS OF STANDARD CHARACTERS WITHOUT CLAIM TO ANY PARTICULAR FONT, STYLE, SIZE, OR COLOR.

FOR ONLINE MANAGEMENT OF EMPLOYEE BENEFITS CONCERNING INSURANCE (U.S. CLS. 100, 101 AND 102).

FIRST USE 9-5-2011; IN COMMERCE 9-5-2011.

4,210,682. JOINT APPAREL ASSOCIATION FORUM, COLOMBO, SRI LANKA. SN 85-169,240. PUB. 11-29-2011, FILED 11-4-2010.



PRIORITY CLAIMED UNDER SEC. 44(D) ON SRI LANKA APPLICATION NO. 158557, FILED 10-14-2010.

NO CLAIM IS MADE TO THE EXCLUSIVE RIGHT TO USE "SRILANKA APPAREL GARMENTS", APART FROM THE MARK AS SHOWN.

THE COLOR(S) GRAY, MAROON AND OLIVE GREEN IS/ARE CLAIMED AS A FEATURE OF THE MARK.

THE MARK CONSISTS OF THE WORDS "SRILANKA APPAREL" IN GRAY LETTERS UNDERLINED WITH A GRAY LINE OVER THE WORDS "GARMENTS WITHOUT GUILT" IN GRAY LETTERS WITH GRAY LINES ABOVE AND BELOW THE WORDS. A STYLIZED HUMANOID FIGURE IN MAROON OVER THE WORD "SRILANKA" AND EIGHT STYLIZED HUMANOID FIGURES IN OLIVE GREEN FANNING OUT FROM THE CENTER.

FOR PROMOTING THE AWARENESS OF THE BENEFITS OF SRI LANKAN APPAREL AND THE COMMITMENT OF ITS PRODUCERS TO ETHICAL PRINCIPLES, PARTICULARLY ETHICAL EMPLOYMENT AND ENVIRONMENTAL ACCOUNTABILITY; ADVERTISING SERVICES (U.S. CLS. 100, 101 AND 102).

FIRST USE 0-0-2009; IN COMMERCE 0-0-2009.

CLASS 35—(Continued).

4,210,723. WALDEN BACKYARDS LLC, EDINA, MN. SN 85-192,158. PUB. 11-1-2011, FILED 12-7-2010.

WALDEN

THE MARK CONSISTS OF STANDARD CHARACTERS WITHOUT CLAIM TO ANY PARTICULAR FONT, STYLE, SIZE, OR COLOR.

FOR ONLINE RETAIL STORE FEATURING BACKYARD LIVING AND LEISURE EQUIPMENT, NAMELY, SHEPHERD HOOKS, STORAGE RACKS, BARBECUE GRILLING RACKS FOR USE WITH PORTABLE FIREPLACES, PORTABLE FIREPLACES AND PARTS AND INSERTS THEREFOR, AND PARTS AND ACCESSORIES FOR PORTABLE FIREPLACES, NAMELY, CATCH BASINS, FIREPLACE SCREENS, FIREPLACE SNUFFER LIDS, FIREPLACE COVERS (U.S. CLS. 100, 101 AND 102).

FIRST USE 6-27-2012; IN COMMERCE 6-27-2012.

4,210,724. WALDEN BACKYARDS LLC, EDINA, MN. SN 85-192,426. PUB. 11-1-2011, FILED 12-7-2010.

WALDEN BACKYARDS

THE MARK CONSISTS OF STANDARD CHARACTERS WITHOUT CLAIM TO ANY PARTICULAR FONT, STYLE, SIZE, OR COLOR.

NO CLAIM IS MADE TO THE EXCLUSIVE RIGHT TO USE "BACKYARDS", APART FROM THE MARK AS SHOWN.

FOR ONLINE RETAIL STORE FEATURING BACKYARD LIVING AND LEISURE EQUIPMENT, NAMELY, SHEPHERD HOOKS, STORAGE RACKS, BARBECUE GRILLING RACKS FOR USE WITH PORTABLE FIREPLACES, PORTABLE FIREPLACES AND PARTS AND INSERTS THEREFOR, AND PARTS AND ACCESSORIES FOR PORTABLE FIREPLACES, NAMELY, CATCH BASINS, FIREPLACE SCREENS, FIREPLACE SNUFFER LIDS, FIREPLACE COVERS (U.S. CLS. 100, 101 AND 102).

FIRST USE 6-27-2012; IN COMMERCE 6-27-2012.

CLASS 35—(Continued).

4,210,740. OMNICO MEDIA GROUP HOLDINGS INC., NEW YORK, NY. SN 85-200,802. PUB. 11-29-2011, FILED 12-17-2010.

CLASS 35—(Continued).

4,210,768. LAVDAS JEWELRY, LTD., WARREN, MI. SN 85-208,087. PUB. 11-1-2011, FILED 12-30-2010.

CONTENT COLLECTIVE

THE MARK CONSISTS OF STANDARD CHARACTERS WITHOUT CLAIM TO ANY PARTICULAR FONT, STYLE, SIZE, OR COLOR.

NO CLAIM IS MADE TO THE EXCLUSIVE RIGHT TO USE "CONTENT", APART FROM THE MARK AS SHOWN.

FOR ADVERTISING MANAGEMENT SERVICES, NAMELY, THE SERVICES OF MANAGING THE INTEGRATION OF BRANDS IN ADVERTISING AND MARKETING CONTENT (U.S. CLS. 100, 101 AND 102).

FIRST USE 2-10-2011; IN COMMERCE 2-10-2011.

**LAVDAS JEWELERS THE
CLOSEST PRICE TO WHOLESALE**

4,210,756. SKULLCANDY, INC., PARK CITY, UT. SN 85-204,110. PUB. 5-17-2011, FILED 12-22-2010.

THE MARK CONSISTS OF STANDARD CHARACTERS WITHOUT CLAIM TO ANY PARTICULAR FONT, STYLE, SIZE, OR COLOR.

NO CLAIM IS MADE TO THE EXCLUSIVE RIGHT TO USE "JEWELERS", APART FROM THE MARK AS SHOWN.

FOR RETAIL JEWELRY STORES (U.S. CLS. 100, 101 AND 102).

FIRST USE 4-29-2012; IN COMMERCE 4-29-2012.

**EVERY REVOLUTION NEEDS A
SOUNDTRACK**

THE MARK CONSISTS OF STANDARD CHARACTERS WITHOUT CLAIM TO ANY PARTICULAR FONT, STYLE, SIZE, OR COLOR.

FOR RETAIL STORE SERVICES AND ONLINE RETAIL STORE SERVICES FEATURING EARPHONES, HEADPHONES, MOBILE PHONE ACCESSORIES, PORTABLE MEDIA PLAYER ACCESSORIES (U.S. CLS. 100, 101 AND 102).

FIRST USE 1-5-2011; IN COMMERCE 1-5-2011.

4,210,783. BRAINPIK, ATHENS, GA. SN 85-212,747. PUB. 5-17-2011, FILED 1-7-2011.

4,210,761. KOPPMAN, KIM, VICKSBURG, MS. SN 85-206,071. PUB. 5-3-2011, FILED 12-27-2010.

KIM KOPPMAN**BRAINPIK**

THE MARK CONSISTS OF STANDARD CHARACTERS WITHOUT CLAIM TO ANY PARTICULAR FONT, STYLE, SIZE, OR COLOR.

THE NAME(S), PORTRAIT(S), AND/OR SIGNATURE(S) SHOWN IN THE MARK IDENTIFIES "KIM KOPPMAN", WHOSE CONSENT(S) TO REGISTER IS MADE OF RECORD.

FOR ON-LINE ART GALLERIES; ON-LINE RETAIL STORE SERVICES FEATURING ARTWORK, NAMELY, PAINTINGS, PHOTOGRAPHS, DRAWINGS, SKETCHES, SCULPTURE AND WORKS OF CREATIVE WRITING (U.S. CLS. 100, 101 AND 102).

FIRST USE 0-0-2011; IN COMMERCE 6-25-2012.

THE MARK CONSISTS OF STANDARD CHARACTERS WITHOUT CLAIM TO ANY PARTICULAR FONT, STYLE, SIZE, OR COLOR.

FOR BUSINESS CONSULTING AND BUSINESS INFORMATION FOR ENTERPRISES (U.S. CLS. 100, 101 AND 102).

FIRST USE 10-31-2010; IN COMMERCE 3-28-2012.

CLASS 35—(Continued).

4,210,787. HEWITT ASSOCIATES LLC, LINCOLNSHIRE, IL. SN 85-213,857. PUB. 5-24-2011, FILED 1-10-2011.



THE MARK CONSISTS OF THE WORDING "VIA VOICE, INSIGHT, ACTION" TO THE RIGHT OF A RECTANGLE WITH INTERIOR WAVE LENGTH OR STYLIZED "V" DESIGN.

FOR BUSINESS MANAGEMENT CONSULTATION, NAMELY, CONSULTING BUSINESSES IN IMPROVING THE QUALITY OF THE WORKPLACE, AND WORKPLACE SATISFACTION; BUSINESS RESEARCH SERVICES IN THE FIELDS OF HUMAN RESOURCES, WORKPLACE ISSUES AND EMPLOYEE AND CUSTOMER ENGAGEMENT, PROVIDING INFORMATION VIA AN INTERNET PORTAL RELATING TO HUMAN RESOURCE ISSUES, EMPLOYEE AND CUSTOMER ENGAGEMENT AND WORKPLACE IMPROVEMENT; CONDUCTING ON-LINE BUSINESS QUESTIONNAIRES AND SURVEYS WHICH ENABLE EMPLOYERS TO GATHER AND INTERPRET DATA HUMAN RESOURCE INFORMATION AND TO HELP MEASURE THE QUALITY OF THE WORKPLACE, AND WORKPLACE AND EMPLOYEE SATISFACTION (U.S. CLS. 100, 101 AND 102).

FIRST USE 6-30-2012; IN COMMERCE 6-30-2012.

4,210,813. MANAGEMENT CONSULTING GROUP PLC, LONDON, GREAT BRITAIN. SN 85-220,834. PUB. 5-31-2011, FILED 1-19-2011.



THE MARK CONSISTS OF THE TERM "CLEVERSYS" WITH A DEPICTION OF A HIGHLY STYLIZED LETTER "S" CONSISTING OF TWO INTERLOCKING LINKS.

FOR BUSINESS MANAGEMENT CONSULTING SERVICES (U.S. CLS. 100, 101 AND 102).
FIRST USE 1-28-2011; IN COMMERCE 1-28-2011.

CLASS 35—(Continued).

4,210,828. ARGUS MANAGEMENT, LLC, BEVERLY, MA. SN 85-230,288. PUB. 12-27-2011, FILED 1-31-2011.

Argus Management, LLC

THE MARK CONSISTS OF STANDARD CHARACTERS WITHOUT CLAIM TO ANY PARTICULAR FONT, STYLE, SIZE, OR COLOR.

OWNER OF U.S. REG. NOS. 1,748,817 AND 1,748,818.

NO CLAIM IS MADE TO THE EXCLUSIVE RIGHT TO USE "MANAGEMENT, LLC", APART FROM THE MARK AS SHOWN.

FOR BUSINESS MANAGEMENT CONSULTING SERVICES, NAMELY, PROVIDING MANAGEMENT AND CONSULTING SERVICES FOR FINANCIALLY TROUBLED BUSINESSES (U.S. CLS. 100, 101 AND 102).
FIRST USE 2-1-2011; IN COMMERCE 2-1-2011.

4,210,829. KACHLER, KARIN, LOS ANGELES, CA. SN 85-231,297. PUB. 7-5-2011, FILED 2-1-2011.

VEVOLUTION

THE MARK CONSISTS OF STANDARD CHARACTERS WITHOUT CLAIM TO ANY PARTICULAR FONT, STYLE, SIZE, OR COLOR.

FOR WHOLESALE AND RETAIL STORE SERVICES FEATURING A WIDE VARIETY OF CONSUMER GOODS OF OTHERS (U.S. CLS. 100, 101 AND 102).

FIRST USE 1-1-2008; IN COMMERCE 1-1-2008.

4,210,843. STANCORP FINANCIAL GROUP, INC., PORTLAND, OR. SN 85-237,787. PUB. 1-24-2012, FILED 2-9-2011.

WORKPLACE POSSIBILITIES

THE MARK CONSISTS OF STANDARD CHARACTERS WITHOUT CLAIM TO ANY PARTICULAR FONT, STYLE, SIZE, OR COLOR.

CLASS 35—(Continued).

NO CLAIM IS MADE TO THE EXCLUSIVE RIGHT TO USE "WORKPLACE", APART FROM THE MARK AS SHOWN.

FOR CUSTOMER SERVICES, NAMELY, RESPONDING TO CUSTOMERS' INQUIRIES FOR OTHERS IN THE FIELD OF DISABILITY CASE MANAGEMENT; RESUME PREPARATION AND REVIEW SERVICES; PROCUREMENT, NAMELY, PURCHASING FURNITURE AND ERGONOMIC EQUIPMENT FOR OTHERS; REFERRALS IN THE FIELD OF HEALTH AND WELLNESS PROVIDERS; PROVIDING INFORMATION SERVICES TO ASSIST EMPLOYERS IN FACILITATING THE WORKPLACE TO FUNCTION FOR WORKERS RECOVERING FROM ON-THE-JOB INJURIES; VOCATIONAL REHABILITATION SERVICES, NAMELY, CONDUCTING WORK ANALYSIS TO DETERMINE WORKER SKILL SETS AND OTHER WORK REQUIREMENTS AND CONSULTATION RELATED THERETO (U.S. CLS. 100, 101 AND 102).

FIRST USE 2-28-2011; IN COMMERCE 2-28-2011.

4,210,856. F. L. LIMA CAVALCANTE DE OLIVEIRA, MANAUS, AMAZONAS, BRAZIL. SN 85-240,667. PUB. 11-29-2011, FILED 2-11-2011.



NO CLAIM IS MADE TO THE EXCLUSIVE RIGHT TO USE "AMAZON FOREST", APART FROM THE MARK AS SHOWN.

THE COLOR(S) AMBER, DARK ORANGE, RED, REDDISH BROWN, MAGENTA, ORANGE, DARK AND LIGHT GREEN IS/ARE CLAIMED AS A FEATURE OF THE MARK.

THE MARK CONSISTS OF THE LITERAL ELEMENT "AMAZON FOREST" DISPLAYED IN SHADES OF AMBER AND OUTLINED IN DARK ORANGE. A CUP IN RED FEATURING TWO REDDISH BROWN CURVED STRIPES FILLED WITH A DRINK FEATURING A MAGENTA AND AMBER SWIRL AND A STRAW IN AMBER OUTLINED IN ORANGE APPEARS ON THE LEFT OF THE TEXTUAL PORTION. TWO STYLIZED DARK AND LIGHT GREEN LEAVES APPEAR AT THE BOTTOM OF THE CUP, ONE IN FRONT AND THE OTHER ON THE BACK OF THE CUP.

FOR ARRANGING OF CONTRACTUAL TRADE SERVICES WITH THIRD PARTIES; ARRANGING OF TRADING TRANSACTIONS AND COMMERCIAL CONTRACTS; IMPORT AND EXPORT AGENCIES SERVICES IN THE FOOD/BEVERAGE INDUSTRIES; FRANCHISING, NAMELY, CONSULTATION AND ASSISTANCE IN BUSINESS MANAGEMENT, ORGANIZATION, ADMINISTRATION AND PROMOTION (U.S. CLS. 100, 101 AND 102).

FIRST USE 9-24-2008; IN COMMERCE 8-8-2010.

CLASS 35—(Continued).

4,210,864. FAO SCHWARZ FAMILY FOUNDATION, NEW YORK, NY. SN 85-242,858. PUB. 1-10-2012, FILED 2-15-2011.

ACTION PACKED AT FAO

THE MARK CONSISTS OF STANDARD CHARACTERS WITHOUT CLAIM TO ANY PARTICULAR FONT, STYLE, SIZE, OR COLOR.

OWNER OF U.S. REG. NOS. 2,278,187, 2,446,326, AND OTHERS.

FOR RETAIL STORE AND ONLINE RETAIL STORE SERVICES FEATURING TOYS, GAMES, PLAYTHINGS, CLOTHING, ELECTRONICS AND GIFTS (U.S. CLS. 100, 101 AND 102).

FIRST USE 11-15-2011; IN COMMERCE 11-15-2011.

4,210,874. HUSONG, RICK, LOS ANGELES, CA. SN 85-247,710. PUB. 7-19-2011, FILED 2-21-2011.

Ideas Alive

THE MARK CONSISTS OF STANDARD CHARACTERS WITHOUT CLAIM TO ANY PARTICULAR FONT, STYLE, SIZE, OR COLOR.

NO CLAIM IS MADE TO THE EXCLUSIVE RIGHT TO USE "IDEAS", APART FROM THE MARK AS SHOWN.

FOR ADVERTISING AND MARKETING CONSULTANCY (U.S. CLS. 100, 101 AND 102).

FIRST USE 1-31-2011; IN COMMERCE 1-31-2011.

4,210,877. WPP PROPERTIES, NEW YORK, NY. SN 85-248,211. PUB. 6-14-2011, FILED 2-22-2011.

KANTAR SHOPCOM

THE MARK CONSISTS OF STANDARD CHARACTERS WITHOUT CLAIM TO ANY PARTICULAR FONT, STYLE, SIZE, OR COLOR.

CLASS 35—(Continued).

OWNER OF U.S. REG. NOS. 2,149,876 AND 3,692,181.
 FOR BUSINESS MARKETING CONSULTING SERVICES IN THE FIELD OF MARKETING, ADVERTISING, CONSUMER PURCHASE BEHAVIOR AND BRAND INVESTMENT; MARKET RESEARCH SERVICES; MARKET ANALYSIS SERVICES; MARKET RESEARCH IN THE NATURE OF AUDIENCE MEASUREMENT, AUDIENCE RESEARCH AND AUDIENCE ANALYSIS SERVICES; CONDUCTING MARKETING STUDIES AND SURVEYS; BUSINESS MARKETING CONSULTING SERVICES USING MARKETING AND ADVERTISING CONTENT, SHOPPER PURCHASE BEHAVIOR DATA AND ONLINE PANELS TO EVALUATE CONSUMER ATTITUDINAL AND BEHAVIORAL RESPONSE; STATISTICAL INFORMATION SERVICES, NAMELY, PROVIDING STATISTICAL INFORMATION FOR BUSINESS PURPOSES; TRADE INFORMATION SERVICES, NAMELY, PROVIDING TRADE INFORMATION; PUBLIC OPINION POLLING SERVICES; DATA PROCESSING SERVICES AND MARKET DATA ANALYSIS SERVICES (U.S. CLS. 100, 101 AND 102).
 FIRST USE 3-20-2012; IN COMMERCE 3-20-2012.

4,210,892. JAGUAR CARS LIMITED, COVENTRY, UNITED KINGDOM. SN 85-254,601. PUB. 7-19-2011, FILED 3-1-2011.

DRIVE IT FORWARD

THE MARK CONSISTS OF STANDARD CHARACTERS WITHOUT CLAIM TO ANY PARTICULAR FONT, STYLE, SIZE, OR COLOR.
 FOR ADVERTISING AND PROMOTIONAL SERVICES FOR OTHERS RELATING TO MOTOR VEHICLES (U.S. CLS. 100, 101 AND 102).
 FIRST USE 11-15-2010; IN COMMERCE 11-15-2010.

4,210,897. I GOLF LIKE A GIRL, LLC, FORT WORTH, TX. SN 85-258,032. PUB. 7-19-2011, FILED 3-4-2011.



THE COLOR(S) WHITE, BLACK, BLUE, GREEN, YELLOW, TAN AND GRAY IS/ARE CLAIMED AS A FEATURE OF THE MARK.
 THE MARK CONSISTS OF FEMALE GOLFER OUTLINED IN BLACK WITH BLUE EYES, WHITE SMILE, YELLOW HAIR IN A PONYTAIL WITH A WHITE HAIR BAND, WEARING A WHITE AND GRAY HAT, BLACK

CLASS 35—(Continued).

SHIRT, WHITE AND GRAY SKIRT, WHITE SHOES, WHITE AND GRAY GLOVES ON HANDS, SKIN IS TAN; SHE IS STANDING WITH HER RIGHT HAND ON HER HIP AND LEFT HAND HOLDING A BLACK GOLF CLUB OVER HER LEFT SHOULDER. TWO GRAY CURVED LINES THAT GRADUALLY FADE EXTEND FROM THE EDGE OF THE SKIRT TO THE GOLFER'S RIGHT ARM. THE GOLFER IS SUPERIMPOSED ON THE LEFT EDGE OF AN OVAL. THE OVAL IS GREEN, FADING TO YELLOW IN THE CENTER, AND OUTLINED IN BLACK. INSIDE THE OVAL IS THE WORDING "I GOLF LIKE A GIRL" IN WHITE OUTLINED IN BLACK, WITH THE LETTER "O" IN "GOLF" STYLIZED TO LOOK LIKE A GOLF BALL. THERE IS A WHITE GOLF HOLE WITH A BLACK FLAGSTICK AND WHITE FLAG ABOVE THE LETTER "L" IN "GIRL" AND TWO BLACK CURVED LINES THAT BEING NEAR THE LEFT CENTER EDGE OF THE OVAL AND CURVE UNDER THE LETTERS "LI" IN "LIKE" AND INTERSECT THE "O" IN "GOLF".
 FOR ON-LINE RETAIL STORE SERVICES FEATURING GOLF ACCESSORIES AND APPAREL (U.S. CLS. 100, 101 AND 102).
 FIRST USE 1-1-2012; IN COMMERCE 1-1-2012.

4,210,902. NEW ENGLAND SPORTS ENTERPRISES, LLC, BOSTON, MA. SN 85-262,120. PUB. 2-21-2012, FILED 3-9-2011.

FENWAY SPORTS MANAGEMENT

THE MARK CONSISTS OF STANDARD CHARACTERS WITHOUT CLAIM TO ANY PARTICULAR FONT, STYLE, SIZE, OR COLOR.
 OWNER OF U.S. REG. NOS. 3,548,173, 3,859,220, AND 3,859,325.

NO CLAIM IS MADE TO THE EXCLUSIVE RIGHT TO USE "SPORTS MANAGEMENT", APART FROM THE MARK AS SHOWN.

FOR BUSINESS MARKETING; SPORTS AND ENTERTAINMENT BUSINESS RELATED REPRESENTATION, NAMELY, PUBLICITY AGENTS FOR SPORTS AND ENTERTAINMENT; MANAGEMENT AND CONSULTING SERVICES TO BUSINESSES AND PROFESSIONAL AND COLLEGIATE SPORTS ORGANIZATIONS WITH RESPECT TO SALES, MARKETING AND ADVERTISING OF THEIR PRODUCTS AND SERVICES; BUSINESS ACQUISITION AND BUSINESS MANAGEMENT, NAMELY, ACQUIRING AND OPERATING SPORTS TEAMS AND SPORTS-RELATED BUSINESSES; MANAGEMENT OF PROFESSIONAL ATHLETES; ADVERTISING AND SELLING MEDIA RIGHTS AND SPONSORSHIP RIGHTS OF PROFESSIONAL AND COLLEGIATE SPORTS ORGANIZATIONS TO SPONSORS; COORDINATION OF PUBLIC RELATIONS; MANAGEMENT OF TALENT AGENCIES, CELEBRITIES, PERFORMING ARTISTS (U.S. CLS. 100, 101 AND 102).
 FIRST USE 3-22-2011; IN COMMERCE 3-22-2011.

CLASS 35—(Continued).

4,210,925. BTI GROWTH ADVISORS, INC., CARLSBAD, CA. SN 85-278,546. PUB. 11-1-2011, FILED S.R. 3-28-2011; AM. P.R. 8-16-2011.

High Performance Tuning for the Trained Sales Force

THE MARK CONSISTS OF STANDARD CHARACTERS WITHOUT CLAIM TO ANY PARTICULAR FONT, STYLE, SIZE, OR COLOR.

FOR BUSINESS DEVELOPMENT CONSULTING SERVICES, NAMELY, PROVIDING MINOR AND MAJOR ADJUSTMENTS TO THE STRATEGIES, SYSTEMS AND PROCESSES THAT CONTRIBUTE TO THE PERFORMANCE OF AN ENTERPRISE IN THE FIELDS OF FINANCE, BANKING, BUSINESS MANAGEMENT, BUSINESS OPERATIONS, HUMAN RESOURCES, SALES, MARKETING, AND LEADERSHIP (U.S. CLS. 100, 101 AND 102).

FIRST USE 2-0-2012; IN COMMERCE 2-0-2012.

4,210,954. GRAPE TECHNOLOGY GROUP, INC., BETHLEHEM, PA. SN 85-296,835. PUB. 4-10-2012, FILED 4-15-2011.

WE'VE GOT KGB DEAL APPEAL

THE MARK CONSISTS OF STANDARD CHARACTERS WITHOUT CLAIM TO ANY PARTICULAR FONT, STYLE, SIZE, OR COLOR.

OWNER OF U.S. REG. NO. 3,872,653.

NO CLAIM IS MADE TO THE EXCLUSIVE RIGHT TO USE "DEAL", APART FROM THE MARK AS SHOWN.

FOR ADVERTISING AND PROMOTING THE GOODS AND SERVICES OF OTHERS VIA THE INTERNET AND MOBILE COMMUNICATIONS NETWORKS BY PROVIDING A WEBSITE FEATURING COUPONS, REBATES, PRICE-COMPARISON INFORMATION, PRODUCT REVIEWS, LINKS TO RETAIL WEBSITES OF OTHERS, AND DISCOUNT INFORMATION (U.S. CLS. 100, 101 AND 102).

FIRST USE 5-10-2011; IN COMMERCE 5-10-2011.

4,210,958. ROCK SQUARE, INC., LOS ANGELES, CA. SN 85-300,690. PUB. 11-22-2011, FILED 4-21-2011.

ROCK SQUARE

THE MARK CONSISTS OF STANDARD CHARACTERS WITHOUT CLAIM TO ANY PARTICULAR FONT, STYLE, SIZE, OR COLOR.

CLASS 35—(Continued).

NO CLAIM IS MADE TO THE EXCLUSIVE RIGHT TO USE "ROCK", APART FROM THE MARK AS SHOWN.

FOR OPERATING A SHOPPING WEBSITE AND ON-LINE MARKETPLACE FEATURING A WIDE VARIETY OF CONSUMER GOODS AND SERVICES; PROVIDING CONSUMER PRODUCT AND SERVICE INFORMATION VIA THE INTERNET OR OTHER COMMUNICATIONS NETWORKS; COMPUTERIZED ONLINE ORDERING SERVICES FEATURING A WIDE VARIETY OF CONSUMER GOODS AND SERVICES; PROVIDING A SEARCHABLE DATABASE IN THE FIELD OF BUSINESS INFORMATION VIA THE INTERNET OR OTHER COMMUNICATIONS NETWORKS; ADVERTISING SERVICES, NAMELY, PROVIDING ADVERTISING IN THE NATURE OF ON-LINE AND ELECTRONIC CLASSIFIED DIRECTORIES; ELECTRONIC AUCTION SERVICES VIA THE INTERNET; ON-LINE AUCTION SERVICES; PROVIDING A WEBSITE FEATURING EVALUATIVE FEEDBACK AND PRODUCT RATINGS OF CONSUMER GOODS AND SERVICES OF OTHERS IN THE FIELD OF MUSIC (U.S. CLS. 100, 101 AND 102).

FIRST USE 6-26-2012; IN COMMERCE 6-26-2012.

4,210,969. JAMES, GEORGE R., TAMPA, FL. AND NORLIN, BETTY, TAMPA, FL. SN 85-305,054. PUB. 9-20-2011, FILED 4-26-2011.

Pitchin In The Kitchen

THE MARK CONSISTS OF STANDARD CHARACTERS WITHOUT CLAIM TO ANY PARTICULAR FONT, STYLE, SIZE, OR COLOR.

NO CLAIM IS MADE TO THE EXCLUSIVE RIGHT TO USE "KITCHEN", APART FROM THE MARK AS SHOWN.

FOR ONLINE RETAIL SERVICES THROUGH DIRECT SOLICITATION BY SALESPERSONS DIRECTED TO END-USERS FEATURING A WIDE VARIETY OF PRODUCTS RELATED TO THE HOME AND KITCHEN, AND TO LIFESTYLE, FOOD, HEALTH AND WELLNESS (U.S. CLS. 100, 101 AND 102).

FIRST USE 5-1-2011; IN COMMERCE 9-1-2011.

4,210,971. YOUADATA, INC., HOUSTON, TX. SN 85-306,572. PUB. 9-13-2011, FILED 4-27-2011.

YOUADATA

THE MARK CONSISTS OF STANDARD CHARACTERS WITHOUT CLAIM TO ANY PARTICULAR FONT, STYLE, SIZE, OR COLOR.

FOR ON-LINE ADVERTISING AND MARKETING SERVICES (U.S. CLS. 100, 101 AND 102).

FIRST USE 10-1-2008; IN COMMERCE 10-1-2008.

CLASS 35—(Continued).

4,210,977. ROBERTS, VALERIE TAYLOR, BOSTON, MA. SN 85-309,254. PUB. 11-29-2011, FILED 5-1-2011.

THE UPSIDE CLUB

THE MARK CONSISTS OF STANDARD CHARACTERS WITHOUT CLAIM TO ANY PARTICULAR FONT, STYLE, SIZE, OR COLOR.

NO CLAIM IS MADE TO THE EXCLUSIVE RIGHT TO USE "CLUB", APART FROM THE MARK AS SHOWN.

FOR ADMINISTRATION OF A GROUP BUYING DISCOUNT PROGRAM WHICH ALLOWS MEMBERS TO OBTAIN GOODS AND SERVICES AT A DISCOUNT RATE; PROMOTING THE GOODS AND SERVICES OF OTHERS BY MEANS OF OFFERING MEMBERSHIP TO AN ON-LINE COMMUNITY THAT PROVIDES SPECIAL DISCOUNTS AND SERVICES TO MEMBERS (U.S. CLS. 100, 101 AND 102).

FIRST USE 6-0-2012; IN COMMERCE 6-0-2012.

4,211,005. ROMERO, JOHN R., EDGEWOOD, NM. SN 85-323,373. PUB. 11-1-2011, FILED 5-17-2011.

Gargantuan Gear

THE MARK CONSISTS OF STANDARD CHARACTERS WITHOUT CLAIM TO ANY PARTICULAR FONT, STYLE, SIZE, OR COLOR.

NO CLAIM IS MADE TO THE EXCLUSIVE RIGHT TO USE "GEAR", APART FROM THE MARK AS SHOWN.

FOR RETAIL STORE SERVICES FEATURING CLOTHING, CAMPING EQUIPMENT, FOOTWEAR, AND FOUL WEATHER GEAR (U.S. CLS. 100, 101 AND 102).

FIRST USE 2-5-2011; IN COMMERCE 8-20-2011.

4,211,047. ALI, ABDULFATAH, LEWISTON, ME. SN 85-332,157. PUB. 4-17-2012, FILED 5-27-2011.

JaaGiT

THE MARK CONSISTS OF STANDARD CHARACTERS WITHOUT CLAIM TO ANY PARTICULAR FONT, STYLE, SIZE, OR COLOR.

CLASS 35—(Continued).

THE WORDING "JAAGIT" HAS NO MEANING IN A FOREIGN LANGUAGE.

FOR ONLINE CLASSIFIED ADVERTISEMENT SERVICES AND BUSINESS DIRECTORY SERVICES, NAMELY, PROVIDING A WEBSITE WHERE USERS CAN POST AND FIND PRODUCTS AND SERVICES FOR SALE AND PROVIDING A WEBSITE FEATURING HYPERLINKS TO RETAILERS OF THE PRODUCTS FOR SALE AND PROVIDERS OF THE AVAILABLE SERVICES (U.S. CLS. 100, 101 AND 102).

FIRST USE 4-15-2012; IN COMMERCE 4-15-2012.

4,211,071. DARKHORSE MULTIMEDIA, INC., SAVANNAH, GA. SN 85-336,523. PUB. 10-25-2011, FILED 6-2-2011.

CRIMESCAPE

THE MARK CONSISTS OF STANDARD CHARACTERS WITHOUT CLAIM TO ANY PARTICULAR FONT, STYLE, SIZE, OR COLOR.

FOR RETAIL BOOK STORE SERVICES (U.S. CLS. 100, 101 AND 102).

FIRST USE 7-19-2011; IN COMMERCE 7-19-2011.

4,211,093. GARFF ENTERPRISES, INC., SALT LAKE CITY, UT. SN 85-339,208. PUB. 10-18-2011, FILED 6-6-2011.

DRIVE THE EXPERIENCE

THE MARK CONSISTS OF STANDARD CHARACTERS WITHOUT CLAIM TO ANY PARTICULAR FONT, STYLE, SIZE, OR COLOR.

FOR BUSINESS INFORMATION IN THE FIELD OF CUSTOMER SERVICE AND CUSTOMER RELATIONS; CONDUCTING EMPLOYEE INCENTIVE AWARD PROGRAMS TO PROMOTE CUSTOMER SERVICE AND CUSTOMER RELATIONS (U.S. CLS. 100, 101 AND 102).

FIRST USE 6-11-2012; IN COMMERCE 6-11-2012.

CLASS 35—(Continued).

4,211,096. XANTI MEDIA LLC, RUTHERFORD, NJ. SN 85-339,788. PUB. 10-25-2011, FILED 6-7-2011.

FIZZIN

THE MARK CONSISTS OF STANDARD CHARACTERS WITHOUT CLAIM TO ANY PARTICULAR FONT, STYLE, SIZE, OR COLOR.

FOR PROMOTING THE GOODS AND SERVICES OF OTHERS BY PROVIDING A WEBSITE FEATURING COUPONS, REBATES, PRICE-COMPARISON INFORMATION, PRODUCT REVIEWS, LINKS TO THE RETAIL WEBSITES OF OTHERS, AND DISCOUNT INFORMATION; PROMOTING THE GOODS OF OTHERS, NAMELY, PROVIDING COUPONS, REBATES AND VOUCHERS FOR THE GOODS OF OTHERS; PROMOTING THE GOODS OF OTHERS, NAMELY, PROVIDING INFORMATION REGARDING DISCOUNTS, COUPONS, REBATES, VOUCHERS AND SPECIAL OFFERS FOR THE GOODS OF OTHERS; PROMOTIONAL SERVICES, NAMELY, PROMOTING THE GOODS OF OTHERS BY MEANS OF PROVIDING ONLINE COUPONS (U.S. CLS. 100, 101 AND 102).

FIRST USE 3-20-2012; IN COMMERCE 3-22-2012.

CLASS 35—(Continued).

4,211,109. DOUGLAS JOHN HILTZ, HAMILTON ONTARIO, CANADA. SN 85-342,176. PUB. 11-1-2011, FILED 6-9-2011.

PASSION PROPS

THE MARK CONSISTS OF STANDARD CHARACTERS WITHOUT CLAIM TO ANY PARTICULAR FONT, STYLE, SIZE, OR COLOR.

FOR COMPUTERIZED ON-LINE RETAIL STORE SERVICES IN THE FIELD OF ADULT SEXUAL GOODS; ON-LINE RETAIL STORE SERVICES FEATURING PRODUCTS CONCERNING HUMAN SEXUALITY OR THAT ARE PRIMARILY SEXUAL, SENSUAL OR EROTIC IN NATURE (U.S. CLS. 100, 101 AND 102).

FIRST USE 6-6-2012; IN COMMERCE 6-6-2012.

4,211,119. HARMS, KATHERINE, BREINIGSVILLE, PA. SN 85-343,161. PUB. 11-29-2011, FILED 6-10-2011.

4,211,099. DONEGAL MUTUAL INSURANCE COMPANY, MARIETTA, PA. SN 85-340,214. PUB. 12-13-2011, FILED 6-7-2011.



NO CLAIM IS MADE TO THE EXCLUSIVE RIGHT TO USE "WORKERS COMPENSATION", APART FROM THE MARK AS SHOWN.

THE MARK CONSISTS OF THE WORDING "COMPAY WORKERS COMPENSATION" BENEATH A CURVED BAND WITH TAPERED ENDS.

FOR ADMINISTRATION SERVICES FOR PREMIUM PAYROLL DEDUCTIONS FOR WORKERS COMPENSATION POLICIES OF OTHERS, AND PREMIUM PAYMENT SERVICES (U.S. CLS. 100, 101 AND 102).

FIRST USE 10-7-2011; IN COMMERCE 10-7-2011.



THE MARK CONSISTS OF THE STYLIZED TEXT "SYC" IN WHICH THE LETTER "Y" RESEMBLES A TREE TRUNK, NINE LEAVES ARE SCATTERED AROUND THE "Y" REPRESENTING LEAVES ON A TREE. UNDER THIS TEXT IS THE STYLIZED TEXT "START YOUR CHANGE."

FOR CHARITABLE SERVICES, NAMELY, PROMOTING PUBLIC AWARENESS OF THE NEED FOR CONSERVATION AND SUSTAINABILITY (U.S. CLS. 100, 101 AND 102).

FIRST USE 9-1-2011; IN COMMERCE 9-1-2011.

CLASS 35—(Continued).

4,211,141. JOS. E. MARCH INVESTMENTS, INC., FAIRVIEW, NC. SN 85-345,763. PUB. 11-8-2011, FILED 6-14-2011.

VIRTUAL E-CIGARETTES PERMITTED

THE MARK CONSISTS OF STANDARD CHARACTERS WITHOUT CLAIM TO ANY PARTICULAR FONT, STYLE, SIZE, OR COLOR.

FOR PROMOTING THE USE OF ELECTRONIC CIGARETTES AT PUBLIC, PRIVATE AND BUSINESS VENUES AND ESTABLISHMENTS; PROVIDING A WEBSITE WHICH PROMOTES THE USE OF ELECTRONIC CIGARETTES AT PUBLIC, PRIVATE AND BUSINESS VENUES AND ESTABLISHMENTS; AND LICENSING OF MATERIALS, ITEMS, AND DECALS WHICH PROMOTE THE USE OF ELECTRONIC CIGARETTES AT PUBLIC, PRIVATE AND BUSINESS VENUES AND ESTABLISHMENTS (U.S. CLS. 100, 101 AND 102).

FIRST USE 9-0-2011; IN COMMERCE 9-0-2011.

4,211,151. MAEBON, LLC, JERSEY CITY, NJ. SN 85-346,811. PUB. 11-29-2011, FILED 6-15-2011.

MAEBON

THE MARK CONSISTS OF STANDARD CHARACTERS WITHOUT CLAIM TO ANY PARTICULAR FONT, STYLE, SIZE, OR COLOR.

FOR ONLINE RETAIL STORE SERVICES FEATURING A WIDE VARIETY OF CONSUMER GOODS OF OTHERS (U.S. CLS. 100, 101 AND 102).

FIRST USE 7-12-2012; IN COMMERCE 7-12-2012.

4,211,156. SANDOW MEDIA, LLC, BOCA RATON, FL. SN 85-347,311. PUB. 12-13-2011, FILED 6-15-2011.

WONDER VISUALIZING BRANDS

THE MARK CONSISTS OF STANDARD CHARACTERS WITHOUT CLAIM TO ANY PARTICULAR FONT, STYLE, SIZE, OR COLOR.

NO CLAIM IS MADE TO THE EXCLUSIVE RIGHT TO USE "BRANDS", APART FROM THE MARK AS SHOWN.

FOR ADVERTISING AGENCIES, NAMELY, PROMOTING THE GOODS AND SERVICES OF OTHERS; ADVERTISING SERVICES (U.S. CLS. 100, 101 AND 102).

FIRST USE 5-1-2012; IN COMMERCE 5-1-2012.

CLASS 35—(Continued).

4,211,159. INTRACK TIRES, RICHMOND HILL, NY. SN 85-347,813. PUB. 1-31-2012, FILED 6-16-2011.



NO CLAIM IS MADE TO THE EXCLUSIVE RIGHT TO USE "TIRES", APART FROM THE MARK AS SHOWN.

THE MARK CONSISTS OF A CHECKERED FLAG, INTRACK TIRES, WHEEL, AND THE TEXT "INTRACK TIRES" ON A RECTANGULAR BACKGROUND WITH ROUNDED EDGES.

FOR RETAIL TIRE STORES (U.S. CLS. 100, 101 AND 102).

FIRST USE 10-13-2007; IN COMMERCE 10-13-2007.

4,211,181. INTELLECTUAL EYES, LLC, MCLEAN, VA. SN 85-349,957. PUB. 12-13-2011, FILED 6-19-2011.

FRANCHISOR FOLIO

THE MARK CONSISTS OF STANDARD CHARACTERS WITHOUT CLAIM TO ANY PARTICULAR FONT, STYLE, SIZE, OR COLOR.

NO CLAIM IS MADE TO THE EXCLUSIVE RIGHT TO USE "FRANCHISOR", APART FROM THE MARK AS SHOWN.

FOR PROVIDING AN INTERNET WEBSITE FEATURING BUSINESS INFORMATION RELATED TO THE FIELD OF FRANCHISING AND FRANCHISE COMPANIES; PROVIDING BUSINESS INFORMATION RELATED TO THE FIELD OF FRANCHISING, NAMELY, A LISTING OF PUBLICLY TRADED FRANCHISORS AND PUBLICLY TRADED COMPANIES THAT OWN FRANCHISORS, AND THEIR STOCK PRICES (U.S. CLS. 100, 101 AND 102).

FIRST USE 6-14-2012; IN COMMERCE 6-14-2012.

CLASS 35—(Continued).

4,211,194. PARKTEL, FZE, DUBAI, UNITED ARAB EMIR..
SN 85-350,951. PUB. 11-8-2011, FILED 6-20-2011.



THE COLOR(S) LILAC, PURPLE, BLACK, YELLOW, BLUE, GREEN, PINK, ORANGE IS/ARE CLAIMED AS A FEATURE OF THE MARK.

THE MARK CONSISTS OF THE STYLIZED WORDING "UNNECTO" IN BLACK UNDERNEATH A SERIES OF LILAC, PURPLE, BLACK, YELLOW, BLUE, GREEN, PINK, AND ORANGE TRIANGLES. THE LETTER "O" IN "UNNECTO" HAS A BLACK ARROW POINTING TO THE LEFT.

FOR DISTRIBUTORSHIP SERVICES FOR TELEPHONES, TELEPHONE HANDSETS AND TELEPHONE HANDSETS ACCESSORIES (U.S. CLS. 100, 101 AND 102).
FIRST USE 5-1-2012; IN COMMERCE 5-1-2012.

4,211,205. NAPA VALLEY CONFERENCE & VISITORS BUREAU, NAPA, CA. SN 85-353,637. PUB. 12-13-2011, FILED 6-22-2011.

TERROIR TO TABLE

THE MARK CONSISTS OF STANDARD CHARACTERS WITHOUT CLAIM TO ANY PARTICULAR FONT, STYLE, SIZE, OR COLOR.

CLASS 35—(Continued).

THE ENGLISH TRANSLATION OF "TERROIR" IN THE MARK IS "A FRENCH WINEMAKING TERM THAT REFERS TO THE COMBINATION OF FACTORS, INCLUDING SOIL, CLIMATE AND ENVIRONMENT THAT GIVE WINE ITS DISTINCTIVE CHARACTER".

FOR CHAMBER OF COMMERCE SERVICES, NAMELY, PROMOTING BUSINESS AND TOURISM IN THE NAPA VALLEY AREA IN RELATION TO THE PROMOTION OF WINE TOURISM AND WINE/CULINARY-RELATED CONSUMER ACTIVITIES; ARRANGING AND CONDUCTING BUSINESS CONFERENCES; ARRANGING AND CONDUCTING OF FAIRS AND EXHIBITIONS FOR BUSINESS AND ADVERTISING PURPOSES; PROVIDING A LIVE FORUM FOR COMPANIES TO SHOWCASE, DISPLAY, DEMONSTRATE AND PROMOTE NEW AND INNOVATIVE IDEAS, PRODUCTS AND SERVICES IN THE CONVENTION/MEETING MANAGEMENT ARENA; ADVERTISING AND COMMERCIAL INFORMATION SERVICES, VIA THE INTERNET; ADVERTISING AND MARKETING; ADVERTISING AND PUBLICITY SERVICES; ADVERTISING AND PUBLICITY SERVICES, NAMELY, PROMOTING THE GOODS, SERVICES, BRAND IDENTITY AND COMMERCIAL INFORMATION AND NEWS OF THIRD PARTIES THROUGH PRINT, AUDIO, VIDEO, DIGITAL AND ON-LINE MEDIUM; ADVERTISING FLYER DISTRIBUTION; ADVERTISING, MARKETING AND PROMOTION SERVICES; PROMOTING TOURISM IN NAPA VALLEY AREA; DISSEMINATION OF ADVERTISING FOR OTHERS VIA AN ON-LINE COMMUNICATIONS NETWORK ON THE INTERNET; ADVERTISING SERVICES, NAMELY, PROMOTING AND MARKETING THE GOODS AND SERVICES OF OTHERS THROUGH ALL PUBLIC COMMUNICATION MEANS (U.S. CLS. 100, 101 AND 102).

FIRST USE 7-1-2012; IN COMMERCE 7-1-2012.

4,211,219. SENERGENT, INC., LAS VEGAS, NV. SN 85-355,612. PUB. 11-15-2011, FILED 6-24-2011.

SMART ENERGY REVOLUTION

THE MARK CONSISTS OF STANDARD CHARACTERS WITHOUT CLAIM TO ANY PARTICULAR FONT, STYLE, SIZE, OR COLOR.

NO CLAIM IS MADE TO THE EXCLUSIVE RIGHT TO USE "ENERGY", APART FROM THE MARK AS SHOWN.

FOR ENERGY MANAGEMENT SERVICES, NAMELY, PROVIDING A SERVICE THAT ALLOWS CUSTOMERS TO PURCHASE ENERGY, NAMELY, ELECTRICITY, NATURAL GAS AND RENEWABLE ENERGY, AT A FIXED PRICE (U.S. CLS. 100, 101 AND 102).

FIRST USE 7-8-2012; IN COMMERCE 7-8-2012.

CLASS 35—(Continued).

4,211,236. RETAIL MEDIA NOW, LLC, OVERLAND PARK, KS. SN 85-357,044. PUB. 12-13-2011, FILED 6-27-2011.

RETAIL MEDIA NOW

THE MARK CONSISTS OF STANDARD CHARACTERS WITHOUT CLAIM TO ANY PARTICULAR FONT, STYLE, SIZE, OR COLOR.

NO CLAIM IS MADE TO THE EXCLUSIVE RIGHT TO USE "RETAIL MEDIA", APART FROM THE MARK AS SHOWN.

FOR ON-LINE ADVERTISING AND MARKETING SERVICES; DEVELOPMENT OF MARKETING STRATEGIES, PROGRAMS, CONCEPTS AND TACTICS, NAMELY, AUDIENCE DEVELOPMENT, BRAND AWARENESS, ONLINE COMMUNITY BUILDING AND DIGITAL WORD OF MOUTH COMMUNICATIONS; PLANNING, DESIGN, DEVELOPMENT, MAINTENANCE, TRACKING AND REPORTING OF ONLINE MARKETING ACTIVITIES FOR THIRD PARTIES (U.S. CLS. 100, 101 AND 102).
FIRST USE 9-9-2011; IN COMMERCE 9-9-2011.

4,211,291. TRANSPORTATION SAFETY EQUIPMENT INSTITUTE, WASHINGTON, DC. SN 85-366,736. PUB. 12-27-2011, FILED 7-8-2011.



OWNER OF U.S. REG. NOS. 1,094,101, 1,546,894, AND OTHERS.

THE MARK CONSISTS OF THE CAPITAL LETTERS "TSEI" WITHIN THE SHAPE OF AN UP-SIDE-DOWN TRIANGLE.

FOR TRADE ASSOCIATION SERVICES, NAMELY, PROMOTING THE INTERESTS OF MANUFACTURERS OF VEHICLE LIGHTING, REFLECTIVE, MIRROR, AND WARNING DEVICES (U.S. CLS. 100, 101 AND 102).
FIRST USE 4-1-2011; IN COMMERCE 7-15-2011.

CLASS 35—(Continued).

4,211,303. COMPETITOR GROUP, INC., SAN DIEGO, CA. SN 85-369,557. PUB. 1-10-2012, FILED 7-12-2011.

KIDS ROCK

THE MARK CONSISTS OF STANDARD CHARACTERS WITHOUT CLAIM TO ANY PARTICULAR FONT, STYLE, SIZE, OR COLOR.

OWNER OF U.S. REG. NO. 3,026,185.
FOR ORGANIZING, PROMOTING AND CONDUCTING EXHIBITIONS AND TRADESHOWS FOR BUSINESS PURPOSES FEATURING BOOTHS AND DISPLAYS RELATING TO COMPETITIVE-SPORTS EVENTS (U.S. CLS. 100, 101 AND 102).
FIRST USE 1-0-2005; IN COMMERCE 1-0-2005.

4,211,339. FREDA, CARMINE, WASHINGTON, NJ. SN 85-375,572. PUB. 12-20-2011, FILED 7-19-2011.

CoupPuzzle.com

THE MARK CONSISTS OF STANDARD CHARACTERS WITHOUT CLAIM TO ANY PARTICULAR FONT, STYLE, SIZE, OR COLOR.

FOR PROMOTING THE GOODS AND SERVICES OF OTHERS BY PROVIDING A WEBSITE FEATURING COUPONS, REBATES, PRICE-COMPARISON INFORMATION, PRODUCT REVIEWS, LINKS TO THE RETAIL WEBSITES OF OTHERS, AND DISCOUNT INFORMATION (U.S. CLS. 100, 101 AND 102).
FIRST USE 5-5-2012; IN COMMERCE 5-5-2012.

4,211,344. CENTURYLINK, INC., MONROE, LA. SN 85-376,275. PUB. 11-15-2011, FILED 7-20-2011.



THE MARK CONSISTS OF CONNECTING LINES.
FOR PROMOTING BUSINESS, SPORTS AND ENTERTAINMENT EVENTS OF OTHERS (U.S. CLS. 100, 101 AND 102).
FIRST USE 7-15-2011; IN COMMERCE 7-15-2011.

CLASS 35—(Continued).

4,211,360. WAL-MART STORES, INC., BENTONVILLE, AR. SN 85-381,908. PUB. 11-1-2011, FILED 7-27-2011.

WALMART MARKET

THE MARK CONSISTS OF STANDARD CHARACTERS WITHOUT CLAIM TO ANY PARTICULAR FONT, STYLE, SIZE, OR COLOR.

OWNER OF U.S. REG. NOS. 1,783,039, 3,612,345, AND OTHERS.

NO CLAIM IS MADE TO THE EXCLUSIVE RIGHT TO USE "MARKET", APART FROM THE MARK AS SHOWN.

FOR RETAIL DEPARTMENT STORE SERVICES; RETAIL GROCERY STORES; RETAIL STORE SERVICES FEATURING A WIDE VARIETY OF CONSUMER GOODS OF OTHERS (U.S. CLS. 100, 101 AND 102).

FIRST USE 5-18-2011; IN COMMERCE 5-18-2011.

4,211,373. TEXAS NATIONAL OUTFITTERS, KATY, TX. SN 85-385,241. PUB. 1-24-2012, FILED 7-29-2011.



NO CLAIM IS MADE TO THE EXCLUSIVE RIGHT TO USE "TEXAS NATIONAL OUTFITTERS", APART FROM THE MARK AS SHOWN.

THE STIPPLING IS FOR SHADING PURPOSES ONLY.

THE MARK CONSISTS OF THE STYLIZED TEXT "TEXAS NATIONAL OUTFITTERS" WITH A TEXAS STAR WITH AND A WESTERN SCROLL IN THE BACKGROUND.

FOR ON-LINE RETAIL STORE SERVICES FEATURING BOOTS, SHIRTS, AND CLOTHING ACCESSORIES (U.S. CLS. 100, 101 AND 102).

FIRST USE 7-22-2012; IN COMMERCE 7-22-2012.

CLASS 35—(Continued).

4,211,375. XAD, INC., NEW YORK, NY. SN 85-385,497. PUB. 1-3-2012, FILED 7-31-2011.



THE MARK CONSISTS OF THE WORDS "XAD" WITH A DESIGN OF AN "X".

FOR ADVERTISING AND MARKETING SERVICES, NAMELY, PROMOTING THE GOODS AND SERVICES OF OTHERS, AND PROVIDING PAY FOR PERFORMANCE ADVERTISING MANAGEMENT SERVICES; DISSEMINATION OF ADVERTISING FOR OTHERS VIA PUBLIC AND PRIVATE WIRELESS NETWORKS FOR DISPLAY ON MOBILE DEVICES; ADVERTISING AND MARKETING SERVICES PROVIDED BY MEANS OF INDIRECT METHODS OF MARKETING COMMUNICATIONS, NAMELY, SOCIAL MEDIA, SEARCH ENGINE MARKETING, INQUIRY MARKETING, INTERNET MARKETING, MOBILE MARKETING, BLOGGING, AND OTHER FORMS OF PASSIVE, SHARABLE OR VIRAL COMMUNICATIONS CHANNELS (U.S. CLS. 100, 101 AND 102).

FIRST USE 8-1-2011; IN COMMERCE 8-1-2011.

4,211,387. WORKWEAR ON WHEELS, INC., AURORA, CO. SN 85-391,300. PUB. 1-24-2012, FILED 8-5-2011.

Wow Scrubs

THE MARK CONSISTS OF STANDARD CHARACTERS WITHOUT CLAIM TO ANY PARTICULAR FONT, STYLE, SIZE, OR COLOR.

NO CLAIM IS MADE TO THE EXCLUSIVE RIGHT TO USE "SCRUBS", APART FROM THE MARK AS SHOWN.

FOR MOBILE RETAIL STORE SERVICES FEATURING CLOTHING FOR MEDICAL PURPOSES, NAMELY, SCRUBS TOPS, SCRUBS BOTTOMS, NURSING SHOES, NURSING UNIFORMS, MEDICAL SHOES FOR USE IN THE HOSPITAL, AND MEDICAL EXAMINATION SUITS AND GOWNS, SHIRTS, PANTS, TUNICS AND JACKETS FOR USE DURING PATIENT EXAMINATION (U.S. CLS. 100, 101 AND 102).

FIRST USE 6-1-2006; IN COMMERCE 6-1-2006.

CLASS 35—(Continued).

4,211,485. THE POOL FACTORY INC., BROOKLYN, NY. SN 85-426,051. PUB. 2-28-2012, FILED 9-19-2011.



NO CLAIM IS MADE TO THE EXCLUSIVE RIGHT TO USE "THE POOL FACTORY", APART FROM THE MARK AS SHOWN.

THE COLOR(S) BLUE, LIGHT BLUE, YELLOW, BLACK AND WHITE IS/ARE CLAIMED AS A FEATURE OF THE MARK.

THE MARK CONSISTS OF DIAMOND LOGO OUTLINED IN DARK BLUE WITH A LIGHT BLUE INTERIOR AND BACK WALL THAT IS BLACK AND BLUE TILES. "THE POOL FACTORY" IN YELLOW STYLIZED FONT OUTLINED IN BLACK WITH WHITE AND BLUE WAVES.

FOR ON-LINE WHOLESALE AND RETAIL STORE SERVICES FEATURING POOLS AND POOL SUPPLIES (U.S. CLS. 100, 101 AND 102).

FIRST USE 10-0-2011; IN COMMERCE 10-0-2011.

4,211,496. GALYA, SCOTT, MIAMI, FL. SN 85-435,895. PUB. 3-13-2012, FILED 9-29-2011.

Glitz City

THE MARK CONSISTS OF STANDARD CHARACTERS WITHOUT CLAIM TO ANY PARTICULAR FONT, STYLE, SIZE, OR COLOR.

FOR PROMOTIONAL SERVICES, NAMELY, PROMOTING THE GOODS OF OTHERS BY MEANS OF PROVIDING ONLINE COUPONS (U.S. CLS. 100, 101 AND 102).

FIRST USE 9-1-2011; IN COMMERCE 11-1-2011.

CLASS 35—(Continued).

4,211,501. JANA MOBILE, INC., BOSTON, MA. SN 85-438,928. PUB. 3-13-2012, FILED 10-4-2011.

JANA

THE MARK CONSISTS OF STANDARD CHARACTERS WITHOUT CLAIM TO ANY PARTICULAR FONT, STYLE, SIZE, OR COLOR.

FOR MARKETING, PROMOTIONAL AND ADVERTISING SERVICES PROVIDED BY MOBILE TELEPHONE CONNECTIONS; DIRECT MARKETING ADVERTISING FOR OTHERS; MARKETING, ADVERTISING, AND PROMOTING THE RETAIL GOODS AND SERVICES OF OTHERS THROUGH WIRELESS ELECTRONIC DEVICES; DISSEMINATION OF ADVERTISING FOR OTHERS VIA THE INTERNET; DISSEMINATION OF ADVERTISING FOR OTHERS VIA PUBLIC AND PRIVATE WIRELESS NETWORKS FOR DISPLAY ON MOBILE DEVICES; ELECTRONIC COMMERCE SERVICES, NAMELY, PROVIDING INFORMATION ABOUT PRODUCTS VIA TELECOMMUNICATION NETWORKS FOR ADVERTISING AND SALES PURPOSES; PROMOTING THE GOODS AND SERVICES OF OTHERS BY MEANS OF DISTRIBUTING ADVERTISING ON THE INTERNET; SPECIALTY MERCHANDISING SERVICES, NAMELY, PROMOTING THE GOODS AND SERVICES OF OTHERS THROUGH THE DISTRIBUTION OF CUSTOMIZED ADVERTISING MATERIALS, NAMELY, INCENTIVES TO USERS OF WIRELESS ELECTRONIC DEVICES IN THE FORM OF FREE MOBILE PHONE TALK TIME OR REDUCED COST MOBILE PHONE SERVICES IN EXCHANGE FOR USER RESPONSE TO SURVEYS OR PURCHASE OF THE GOODS AND SERVICES OF OTHERS; PROMOTING THE GOODS OF OTHERS, NAMELY, PROVIDING COUPONS, REBATES AND VOUCHERS FOR THE GOODS OF OTHERS; PROMOTING THE GOODS OF OTHERS, NAMELY, PROVIDING INFORMATION REGARDING DISCOUNTS, COUPONS, REBATES, VOUCHERS AND SPECIAL OFFERS FOR THE GOODS OF OTHERS; PROMOTING THE GOODS AND SERVICES OF OTHERS BY PROVIDING A WEBSITE FEATURING COUPONS, REBATES, AND DISCOUNT INFORMATION; PROVIDING INCENTIVE AWARD PROGRAMS FOR USERS OF WIRELESS ELECTRONIC DEVICES IN THE FORM OF FREE MOBILE PHONE TALK TIME OR REDUCED COST MOBILE PHONE SERVICES IN EXCHANGE FOR USER RESPONSE TO SURVEYS OR PURCHASE OF THE GOODS AND SERVICES OF OTHERS; ADMINISTRATION OF A PROGRAM FOR ENABLING PARTICIPANTS TO OBTAIN DISCOUNTS ON THE COST OF SERVICES OR RECEIVE IMPROVED SERVICES; ADMINISTRATION OF A PROGRAM FOR ENABLING PARTICIPANT USERS OF WIRELESS ELECTRONIC DEVICES TO OBTAIN DISCOUNTS ON THE COST OF MOBILE PHONE SERVICES, FREE OR LOWER COST MOBILE PHONE SERVICES OR RECEIVE IMPROVED MOBILE PHONE SERVICES; PROMOTING AND MARKETING THE GOODS AND SERVICES OF OTHERS BY DISTRIBUTING ADVERTISING MATERIAL, COUPONS AND DISCOUNT OFFERS VIA WIRELESS ELECTRONIC DEVICES; BUSINESS MARKETING SERVICES; CONDUCTING MARKETING STUDIES; CONSUMER MARKETING RESEARCH AND CONSULTING RELATED THERETO; MARKETING ANALYSIS SERVICES; MARKETING RESEARCH SERVICES; MARKETING SERVICES, NAMELY, CONDUCTING CONSUMER TRACKING BEHAVIOR RESEARCH AND CONSUMER TREND ANALYSIS; ONLINE BUSINESS RESEARCH SERVICES THAT ALLOW USERS TO SHARE OPINIONS WITH A MARKETING RESEARCH COMPANY RELATED TO EVERYDAY CONSUMER PRODUCTS AND SERVICES; PROVIDING BUSINESS

CLASS 35—(Continued).

MARKETING INFORMATION; SOCIAL MEDIA STRATEGY AND MARKETING CONSULTANCY FOCUSING ON HELPING CLIENTS CREATE AND EXTEND THEIR PRODUCT AND BRAND STRATEGIES BY BUILDING VIRALLY ENGAGING MARKETING SOLUTIONS; STATISTICAL EVALUATIONS OF MARKETING DATA; COLLECTION OF MARKET RESEARCH INFORMATION; COLLECTION OF CONSUMER DATA, ENABLING REPEAT INTERACTIONS AND CONSUMER RELATIONSHIP MANAGEMENT (CRM); CONDUCTING BUSINESS AND MARKET RESEARCH SURVEYS; MARKET RESEARCH AND MARKET INTELLIGENCE SERVICES; INCENTIVE AWARD PROGRAMS TO PROMOTE THE SALE OF PRODUCTS AND SERVICES OF OTHERS; PROVIDING INCENTIVE AWARD PROGRAMS FOR CUSTOMERS THROUGH THE ISSUANCE AND PROCESSING OF LOYALTY COUPONS FOR FREQUENT USE OF PARTICIPATING BUSINESSES; PROVIDING INCENTIVE AWARD PROGRAMS FOR USERS OF WIRELESS ELECTRONIC DEVICES IN THE FORM OF FREE MOBILE PHONE TALK TIME OR REDUCED COST MOBILE PHONE SERVICES IN EXCHANGE FOR USER RESPONSE TO SURVEYS OR PURCHASE OF THE GOODS AND SERVICES OF OTHER (U.S. CLS. 100, 101 AND 102).

FIRST USE 7-1-2011; IN COMMERCE 7-1-2011.

4,211,502. IVIU TECHNOLOGIES, LLC., ANAHEIM, CA. SN 85-439,297. PUB. 3-13-2012, FILED 10-4-2011.

iviu

THE MARK CONSISTS OF STANDARD CHARACTERS WITHOUT CLAIM TO ANY PARTICULAR FONT, STYLE, SIZE, OR COLOR.

FOR DISSEMINATION OF ADVERTISING FOR OTHERS VIA PUBLIC AND PRIVATE WIRELESS NETWORKS FOR DISPLAY ON MOBILE DEVICES; MARKETING SERVICES, NAMELY, PROMOTING OR ADVERTISING THE GOODS AND SERVICES OF OTHERS; MARKETING, ADVERTISING, AND PROMOTING THE RETAIL GOODS AND SERVICES OF OTHERS THROUGH WIRELESS ELECTRONIC DEVICES (U.S. CLS. 100, 101 AND 102).

FIRST USE 10-10-2011; IN COMMERCE 5-10-2012.

4,211,512. GILLESPIE, SCOTT, PARKER, CO. SN 85-442,389. PUB. 3-20-2012, FILED 10-7-2011.

TRANSAD PARTNERS

THE MARK CONSISTS OF STANDARD CHARACTERS WITHOUT CLAIM TO ANY PARTICULAR FONT, STYLE, SIZE, OR COLOR.

CLASS 35—(Continued).

NO CLAIM IS MADE TO THE EXCLUSIVE RIGHT TO USE "PARTNERS", APART FROM THE MARK AS SHOWN.

FOR BUSINESS CONSULTING TO TRANSFORM OPERATING PRACTICES; BUSINESS MANAGEMENT CONSULTING WITH RELATION TO OPERATIONS (U.S. CLS. 100, 101 AND 102).

FIRST USE 11-15-2011; IN COMMERCE 1-17-2012.

4,211,531. SORT ORDER SPACE, LOS ANGELES, CA. SN 85-451,057. PUB. 4-3-2012, FILED 10-19-2011.



THE COLOR(S) GRAY AND ORANGE IS/ARE CLAIMED AS A FEATURE OF THE MARK.

THE MARK CONSISTS OF AN ORANGE SQUARE TO THE LEFT OF THE WORDS "SORT ORDER SPACE" IN GRAY LETTERS. THE SQUARE IS SEPARATED INTO PARTS THAT FORM THE LETTERS "SOS."

FOR BUSINESS ORGANIZATION CONSULTING FEATURING TIME AND PAPER MANAGEMENT (U.S. CLS. 100, 101 AND 102).

FIRST USE 10-19-2011; IN COMMERCE 10-19-2011.

4,211,539. STATE FARM MUTUAL AUTOMOBILE INSURANCE COMPANY, BLOOMINGTON, IL. SN 85-454,561. PUB. 4-3-2012, FILED 10-24-2011.

Celebrate My Drive

THE MARK CONSISTS OF STANDARD CHARACTERS WITHOUT CLAIM TO ANY PARTICULAR FONT, STYLE, SIZE, OR COLOR.

FOR PROMOTING PUBLIC AWARENESS OF THE IMPORTANCE OF AUTOMOBILE AND TEEN DRIVER SAFETY (U.S. CLS. 100, 101 AND 102).

FIRST USE 4-9-2012; IN COMMERCE 4-9-2012.

CLASS 35—(Continued).

4,211,575. TEAM TAKEOVER MARKETING, LLC, TAMPA, FL. SN 85-472,445. PUB. 4-24-2012, FILED 11-14-2011.

Team Takeover Marketing

THE MARK CONSISTS OF STANDARD CHARACTERS WITHOUT CLAIM TO ANY PARTICULAR FONT, STYLE, SIZE, OR COLOR.

NO CLAIM IS MADE TO THE EXCLUSIVE RIGHT TO USE "MARKETING", APART FROM THE MARK AS SHOWN.

FOR MARKETING SERVICES (U.S. CLS. 100, 101 AND 102).
FIRST USE 5-24-2007; IN COMMERCE 6-1-2007.

CLASS 35—(Continued).

4,211,586. SMART MONKEY MARKETING, COLUMBUS, GA. SN 85-477,103. PUB. 5-1-2012, FILED 11-19-2011.

2SURVIVE

THE MARK CONSISTS OF STANDARD CHARACTERS WITHOUT CLAIM TO ANY PARTICULAR FONT, STYLE, SIZE, OR COLOR.

FOR CHARITABLE SERVICES, NAMELY, PROMOTING PUBLIC AWARENESS OF CANCER SURVIVAL, CANCER REMISSION AND THE NEED FOR CANCER RESEARCH (U.S. CLS. 100, 101 AND 102).

FIRST USE 11-1-2011; IN COMMERCE 11-1-2011.

4,211,595. ACE HARDWARE CORPORATION, OAK BROOK, IL. SN 85-482,592. PUB. 5-1-2012, FILED 11-29-2011.

PRIMO BRANDS

THE MARK CONSISTS OF STANDARD CHARACTERS WITHOUT CLAIM TO ANY PARTICULAR FONT, STYLE, SIZE, OR COLOR.

NO CLAIM IS MADE TO THE EXCLUSIVE RIGHT TO USE "BRANDS", APART FROM THE MARK AS SHOWN.

FOR RETAIL STORE SERVICES IN THE FIELD OF HARDWARE AND RELATED GOODS (U.S. CLS. 100, 101 AND 102).

FIRST USE 2-0-2012; IN COMMERCE 2-0-2012.

4,211,599. E*CONCIERGELIVE LLC, ALEXANDRIA, VA. SN 85-483,402. PUB. 5-15-2012, FILED 11-30-2011.

Padvertisement

THE MARK CONSISTS OF STANDARD CHARACTERS WITHOUT CLAIM TO ANY PARTICULAR FONT, STYLE, SIZE, OR COLOR.

FOR ADVERTISING AGENCIES, NAMELY, PROMOTING THE GOODS AND SERVICES OF OTHERS (U.S. CLS. 100, 101 AND 102).

FIRST USE 1-1-2012; IN COMMERCE 5-1-2012.

4,211,581. SPACEFOOD 11, LLC, LOS ANGELES, CA. SN 85-475,527. PUB. 5-1-2012, FILED 11-17-2011.



THE COLOR(S) LIGHT GREEN, BLACK AND WHITE IS/ ARE CLAIMED AS A FEATURE OF THE MARK.

THE MARK CONSISTS OF THE STYLIZED WORD "BUCCELLA" IN BLACK BENEATH A DESIGN OF A PIECE OF BREAD CONTAINING A SMILING FACE. THE BREAD IS OUTLINED IN LIGHT GREEN WITH A WHITE INTERIOR, AND THE EYES, NOSE AND MOUTH OF THE FACE ARE LIGHT GREEN.

FOR RETAIL BAKERY SHOPS (U.S. CLS. 100, 101 AND 102).
FIRST USE 2-1-2012; IN COMMERCE 2-1-2012.

CLASS 35—(Continued).

4,211,600. FORHAN, MARK, SAINT CHARLES, MO. SN 85-483,598. PUB. 5-8-2012, FILED 11-30-2011.

Forturn Solutions

THE MARK CONSISTS OF STANDARD CHARACTERS WITHOUT CLAIM TO ANY PARTICULAR FONT, STYLE, SIZE, OR COLOR.

FOR BUSINESS CONSULTATION (U.S. CLS. 100, 101 AND 102).

FIRST USE 4-1-2012; IN COMMERCE 4-1-2012.

4,211,615. AGRIMUM INC., CALGARY, ALBERTA, CANADA. SN 85-491,624. PUB. 4-17-2012, FILED 12-9-2011.

COMMITTED TO GROWTH

THE MARK CONSISTS OF STANDARD CHARACTERS WITHOUT CLAIM TO ANY PARTICULAR FONT, STYLE, SIZE, OR COLOR.

FOR DIRECT MARKETING AND DIRECT MARKETING CONSULTING FOR FERTILIZER, SEEDS, CHEMICALS, LANDSCAPE SUPPLIES, NAMELY, COMPOST, MANURE, POTTING SOIL, PEAT, HUMUS AND SOIL CONDITIONER, CEDAR CHIPS, CEDAR MULCH, TINTED MULCH, PINE BARK MULCH, PINE BARK NUGGETS, CYPRESS MULCH, BLACK HARDWOOD MULCH AND TOPSOIL FOR USE IN AGRICULTURE, HORTICULTURE AND TURF (U.S. CLS. 100, 101 AND 102).

FIRST USE 1-3-2012; IN COMMERCE 1-3-2012.

CLASS 35—(Continued).

4,211,624. GEOTRADEMARKS LLC, HOLLYWOOD, FL. SN 85-495,051. PUB. 5-22-2012, FILED 12-14-2011.

GEOPON

THE MARK CONSISTS OF STANDARD CHARACTERS WITHOUT CLAIM TO ANY PARTICULAR FONT, STYLE, SIZE, OR COLOR.

FOR PROMOTING THE GOODS AND SERVICES OF OTHERS BY PROVIDING AN ELECTRONIC CUSTOMER RETAIL COUPON PROGRAM, NAMELY, A RETAIL MONEY SAVING PROGRAM THAT PROVIDES CUSTOMERS WITH COUPONS SENT VIA THE INTERNET OR SHORT MESSAGING SYSTEM (SMS) WHERE SUCH COUPONS ARE TRIGGERED BASED UPON THE GEOGRAPHIC LOCATION OF THE ELECTRONIC DEVICE RECEIVING THE COUPONS; CUSTOMER INCENTIVE AWARD PROGRAM, NAMELY, A CUSTOMER LOYALTY PROGRAM THAT PROVIDES DISCOUNTS AND RELATED BENEFITS TO REWARD CUSTOMERS WHO OPT IN TO RECEIVE SUCH DISCOUNTS AND BENEFITS; BUSINESS SERVICES IN THE NATURE OF DEVELOPMENT, ADMINISTRATION, PROMOTION, MARKETING, IMPLEMENTATION, ANALYZING BUSINESS DATA, AND MONITORING OF CUSTOMER LOYALTY PROGRAMS AND CUSTOMER REWARD PROGRAMS; PROVIDING INCENTIVE AWARD PROGRAMS FOR CUSTOMERS THROUGH THE DISTRIBUTION OF PREPAID STORED VALUE CARDS FOR THE PURPOSE OF PROMOTING AND REWARDING LOYALTY; DEVELOPMENT AND DISSEMINATION OF ADVERTISEMENTS BY ELECTRONIC MEANS, NAMELY, OVER THE INTERNET OR BY USE OF THE SHORT MESSAGING SYSTEM (SMS) (U.S. CLS. 100, 101 AND 102).

FIRST USE 5-7-2012; IN COMMERCE 5-7-2012.

4,211,634. ACE HARDWARE CORPORATION, OAK BROOK, IL. SN 85-497,675. PUB. 4-24-2012, FILED 12-16-2011.

FIND YOUR SOUL PAINT

THE MARK CONSISTS OF STANDARD CHARACTERS WITHOUT CLAIM TO ANY PARTICULAR FONT, STYLE, SIZE, OR COLOR.

FOR RETAIL STORE SERVICES IN THE FIELD OF HARDWARE AND RELATED GOODS (U.S. CLS. 100, 101 AND 102).

FIRST USE 2-0-2012; IN COMMERCE 2-0-2012.

CLASS 35—(Continued).

4,211,638. ACE HARDWARE CORPORATION, OAK BROOK, IL. SN 85-500,183. PUB. 4-24-2012, FILED 12-20-2011.

THE BEST TOOLS FOR SAVING
MONEY

THE MARK CONSISTS OF STANDARD CHARACTERS WITHOUT CLAIM TO ANY PARTICULAR FONT, STYLE, SIZE, OR COLOR.

FOR RETAIL HARDWARE STORE SERVICES (U.S. CLS. 100, 101 AND 102).
FIRST USE 3-0-2012; IN COMMERCE 3-0-2012.

CLASS 36—INSURANCE AND FINANCIAL

4,210,369. THE BANK OF NEW YORK MELLON CORPORATION, NEW YORK, NY. SN 77-760,748. PUB. 1-19-2010, FILED 6-16-2009.

TREASURYEDGE

THE MARK CONSISTS OF STANDARD CHARACTERS WITHOUT CLAIM TO ANY PARTICULAR FONT, STYLE, SIZE, OR COLOR.

FOR FINANCIAL SERVICES, NAMELY, PROVIDING BANKING SERVICES, CASH MANAGEMENT SERVICES, AND MANAGEMENT OF PORT FOLIOS COMPRISING SECURITIES AND CURRENCIES, ALL VIA A GLOBAL COMMUNICATION NETWORK (U.S. CLS. 100, 101 AND 102).

FIRST USE 11-5-2010; IN COMMERCE 11-5-2010.

4,210,372. SANDALS RESORTS INTERNATIONAL 2000 LIMITED, WEST BAY ST, NASSAU, BAHAMAS. SN 77-772,213. PUB. 5-10-2011, FILED 7-1-2009.



OWNER OF U.S. REG. NOS. 1,614,295, 3,326,218, AND OTHERS.

NO CLAIM IS MADE TO THE EXCLUSIVE RIGHT TO USE "SANDALS" AS TO FOOTWEAR, "FOUNDATION" AND "EDUCATING, BUILDING AND PROTECTING THE CARIBBEAN", APART FROM THE MARK AS SHOWN.

CLASS 36—(Continued).

THE COLOR(S) YELLOW, ORANGE, LIGHT BLUE, DARK BLUE, WHITE AND BLACK IS/ARE CLAIMED AS A FEATURE OF THE MARK.

THE MARK CONSISTS OF A STYLIZED IMAGE OF A YELLOW STARFISH WITH ORANGE OUTLINING AND DETAILING, SURROUNDED BY A WATER SPLASH DESIGN IN LIGHT BLUE AND DARK BLUE WITH WHITE HIGHLIGHTING. BELOW APPEARS THE WORD "SANDALS" IN STYLIZED SCRIPT, CHANGING IN COLOR FROM LIGHT BLUE TO DARK BLUE WITH WHITE HIGHLIGHTING. BELOW THAT APPEARS THE WORD "FOUNDATION" IN BLACK BLOCK LETTERS BETWEEN TWO BLACK LINES, AND "EDUCATING", "BUILDING AND PROTECTING THE CARIBBEAN" IN BLACK BLOCK LETTERS, UNDERLINED IN BLACK.

FOR CHARITABLE FUNDRAISING (U.S. CLS. 100, 101 AND 102).

FIRST USE 3-18-2009; IN COMMERCE 3-18-2009.

4,210,398. KEYCORP, CLEVELAND, OH. SN 77-865,197. PUB. 4-6-2010, FILED 11-4-2009.



OWNER OF U.S. REG. NOS. 1,722,378, 2,175,115, AND OTHERS.

THE MARK CONSISTS OF THE WORD "KEYBANK" WITH THE DESIGN OF A KEY PLACED BENEATH THE WORD "KEYBANK".

FOR BANKING AND FINANCING SERVICES (U.S. CLS. 100, 101 AND 102).

FIRST USE 8-10-2011; IN COMMERCE 8-10-2011.

4,210,444. YESKE BUIE INC., SAN FRANCISCO, CA. SN 77-920,221. PUB. 4-27-2010, FILED 1-26-2010.

YEBU

THE MARK CONSISTS OF STANDARD CHARACTERS WITHOUT CLAIM TO ANY PARTICULAR FONT, STYLE, SIZE, OR COLOR.

FOR FINANCIAL PLANNING AND INVESTMENT MANAGEMENT SERVICES (U.S. CLS. 100, 101 AND 102).

FIRST USE 6-6-2012; IN COMMERCE 6-6-2012.

CLASS 36—(Continued).

4,210,509. APOLLO INSURANCE SERVICES, INC., LADERA RANCH, CA. SN 85-027,273. PUB. 12-28-2010, FILED 4-30-2010.

APOLLO INSURANCE SERVICES

THE MARK CONSISTS OF STANDARD CHARACTERS WITHOUT CLAIM TO ANY PARTICULAR FONT, STYLE, SIZE, OR COLOR.

NO CLAIM IS MADE TO THE EXCLUSIVE RIGHT TO USE "INSURANCE SERVICES", APART FROM THE MARK AS SHOWN.

FOR FINANCIAL AND INSURANCE SERVICES PROVIDED BY MOBILE TELEPHONE CONNECTIONS, NAMELY, PROVIDING PERSONAL FINANCIAL AND INSURANCE INFORMATION AND ADVICE, PROVIDING INFORMATION TO MEMBERS IN THE FIELDS OF FINANCIAL SERVICES AND INSURANCE, PROVIDING NONDOWNLOADABLE INSTRUCTIONAL VIDEOS IN THE FIELDS OF FINANCIAL SERVICES AND INSURANCE, PROVIDING FINANCIAL ADVICE AND CONSULTANCY SERVICES, AND WRITING PROPERTY, CAR, CASUALTY AND LIFE INSURANCE; BROKERAGE IN THE FIELD OF INSURANCE; FINANCIAL ADVICE AND CONSULTANCY SERVICES; INSURANCE ADMINISTRATION; INSURANCE AGENCIES; INSURANCE ADVICE AND CONSULTANCY SERVICES; INSURANCE SERVICES, NAMELY, WRITING PROPERTY AND CASUALTY INSURANCE; MEMBERSHIP CLUB SERVICES, NAMELY, PROVIDING INFORMATION TO MEMBERS IN THE FIELDS OF FINANCIAL SERVICES AND INSURANCE; PROVIDING A WEBSITE FEATURING FINANCIAL AND INSURANCE INFORMATION AND ADVICE; PROVIDING A WEBSITE FEATURING PERSONAL FINANCIAL AND INSURANCE INFORMATION AND ADVICE; PROVIDING A WEBSITE FEATURING NON-DOWNLOADABLE INSTRUCTIONAL VIDEOS IN THE FIELDS OF FINANCIAL SERVICES AND INSURANCE; PROVIDING INFORMATION AND NEWS IN THE FIELDS OF FINANCIAL SERVICES AND INSURANCE (U.S. CLS. 100, 101 AND 102).

FIRST USE 9-30-2010; IN COMMERCE 9-30-2010.

4,210,567. HUNTING HILL GLOBAL CAPITAL, LLC, NEW YORK, NY. SN 85-076,904. PUB. 11-30-2010, FILED 7-2-2010.

HUNTING HILL

THE MARK CONSISTS OF STANDARD CHARACTERS WITHOUT CLAIM TO ANY PARTICULAR FONT, STYLE, SIZE, OR COLOR.

FOR INVESTMENT MANAGEMENT; FINANCIAL SERVICES IN THE NATURE OF INVESTMENT ADVISORY (U.S. CLS. 100, 101 AND 102).

FIRST USE 2-14-2012; IN COMMERCE 2-14-2012.

CLASS 36—(Continued).

4,210,578. OPEN CIRCLE ADVISORS, LLC, WOODBRIDGE, CT. SN 85-084,527. PUB. 11-23-2010, FILED 7-14-2010.



THE MARK CONSISTS OF A SWIRL HAVING A CIRCULAR PERIMETER WITH TONE GIVING AN APPEARANCE OF DEPTH.

FOR INVESTMENT ADVISORY SERVICES (U.S. CLS. 100, 101 AND 102).

FIRST USE 11-0-2011; IN COMMERCE 6-12-2012.

4,210,598. APOLLO INSURANCE SERVICES, INC., LADERA RANCH, CA. SN 85-098,031. PUB. 2-8-2011, FILED 8-2-2010.



THE MARK CONSISTS OF THE LETTER "O" FORMED BY TWO CRESCENTS THAT DO NOT TOUCH.

FOR FINANCIAL AND INSURANCE SERVICES PROVIDED BY MOBILE TELEPHONE CONNECTIONS, NAMELY, PROVIDING PERSONAL FINANCIAL AND INSURANCE INFORMATION AND ADVICE, PROVIDING INFORMATION TO MEMBERS IN THE FIELDS OF FINANCIAL SERVICES AND INSURANCE, PROVIDING NONDOWNLOADABLE INSTRUCTIONAL VIDEOS IN THE FIELDS OF FINANCIAL SERVICES AND INSURANCE, PROVIDING FINANCIAL ADVICE AND CONSULTANCY SERVICES, AND WRITING PROPERTY, CAR, CASUALTY AND LIFE INSURANCE; BROKERAGE IN THE FIELD OF INSURANCE; FINANCIAL ADVICE AND CONSULTANCY SERVICES; PROVIDING A WEBSITE FEATURING NON-DOWNLOADABLE INSTRUCTIONAL VIDEOS IN THE FIELDS OF FINANCIAL SERVICES AND INSURANCE (U.S. CLS. 100, 101 AND 102).

FIRST USE 5-1-2012; IN COMMERCE 5-1-2012.

CLASS 36—(Continued).

4,210,645. BENEMAX, INC., MEDFIELD, MA. SN 85-136,624.
PUB. 11-29-2011, FILED 9-23-2010.

Benemex-The Benefits Exchange

THE MARK CONSISTS OF STANDARD CHARACTERS WITHOUT CLAIM TO ANY PARTICULAR FONT, STYLE, SIZE, OR COLOR.

OWNER OF U.S. REG. NO. 3,537,026.

NO CLAIM IS MADE TO THE EXCLUSIVE RIGHT TO USE "THE BENEFITS EXCHANGE", APART FROM THE MARK AS SHOWN.

FOR PROCESSING, ADMINISTERING AND MANAGING EMPLOYEE BENEFIT PLANS, INCLUDING PLAN CONSULTATION AND CLAIMS ADMINISTRATION (U.S. CLS. 100, 101 AND 102).

FIRST USE 6-6-2011; IN COMMERCE 5-23-2012.

4,210,726. YOST, ERIKA, DENVER, CO. SN 85-193,056. PUB. 5-17-2011, FILED 12-8-2010.

A Girl's Best Fund

THE MARK CONSISTS OF STANDARD CHARACTERS WITHOUT CLAIM TO ANY PARTICULAR FONT, STYLE, SIZE, OR COLOR.

FOR CHARITABLE FUNDRAISING SERVICES, NAMELY, RAISING FUNDS FOR GIRLS' EDUCATION AND HEALTH GLOBALLY (U.S. CLS. 100, 101 AND 102).

FIRST USE 7-11-2012; IN COMMERCE 7-11-2012.

4,210,727. INTEGRITY LIFE INSURANCE COMPANY, CINCINNATI, OH. SN 85-193,793. PUB. 4-26-2011, FILED 12-9-2010.

MultiVantage

THE MARK CONSISTS OF STANDARD CHARACTERS WITHOUT CLAIM TO ANY PARTICULAR FONT, STYLE, SIZE, OR COLOR.

FOR UNDERWRITING, ISSUANCE AND ADMINISTRATION OF ANNUITIES (U.S. CLS. 100, 101 AND 102).

FIRST USE 8-18-2011; IN COMMERCE 8-18-2011.

CLASS 36—(Continued).

4,210,736. ZENO CONSULTING GROUP, LLC, BETHESDA, MD. SN 85-197,120. PUB. 5-3-2011, FILED 12-14-2010.



THE COLOR(S) BLUE AND WHITE IS/ARE CLAIMED AS A FEATURE OF THE MARK.

THE MARK CONSISTS OF A WHITE AND BLUE ICEBERG, AGAINST A BLUE AND WHITE SKY, IN A SMOOTH BLUE SEA.

FOR INSTITUTIONAL INVESTMENT CONSULTANT SERVICES TO PENSION FUNDS, MUTUAL FUND BOARDS AND INSTITUTIONS EXERCISING OVERSIGHT OVER THIRD PARTY ASSET MANAGERS IN THE FIELD OF MONITORING AND EXERCISING OVERSIGHT OVER EXTERNAL ASSET MANAGERS TO INSURE ADHERENCE TO BEST FINANCIAL PRACTICES AND APPROPRIATE FIDUCIARY STANDARDS AND THE FIELD OF DEVELOPING APPROPRIATE STRATEGIES FOR SUCH PENSION FUNDS, MUTUAL FUND BOARDS AND INSTITUTIONS EXERCISING OVERSIGHT OVER THIRD PARTY ASSET MANAGERS TO TRANSFER INVESTMENT PORTFOLIOS FROM AN EXISTING INVESTMENT MANAGER TO ANOTHER INVESTMENT MANAGER IN ADHERENCE TO BEST FINANCIAL PRACTICES AND APPROPRIATE FIDUCIARY STANDARDS (U.S. CLS. 100, 101 AND 102).

FIRST USE 1-16-2010; IN COMMERCE 1-16-2010.

4,210,745. HEADLAND CAPITAL PARTNERS LIMITED, HONG KONG, HONG KONG. SN 85-201,916. PUB. 1-24-2012, FILED 12-20-2010.

滙睿資本

NO CLAIM IS MADE TO THE EXCLUSIVE RIGHT TO USE THE NON-LATIN CHARACTERS THAT TRANSLITERATE TO ZI BEN, APART FROM THE MARK AS SHOWN.

THE MARK CONSISTS OF FOUR CHINESE CHARACTERS.

CLASS 36—(Continued).

THE ENGLISH TRANSLATION OF THE CHINESE CHARACTERS IN THE MARK IS HEADLAND CAPITAL. THE NON-LATIN CHARACTERS IN THE MARK TRANSLITERATE TO HUI RUI ZI BEN, AND THIS HAS NO MEANING IN A FOREIGN LANGUAGE.

FOR VENTURE CAPITAL FUND AND PRIVATE EQUITY FUND MANAGEMENT; FINANCIAL RESEARCH IN THE FIELD OF VENTURE CAPITAL FUNDS AND PRIVATE EQUITY FUNDS; FINANCIAL ANALYSES IN THE FIELD OF VENTURE CAPITAL FUNDS AND PRIVATE EQUITY FUNDS; FINANCIAL CONSULTANCY IN THE FIELD OF VENTURE CAPITAL FUNDS AND PRIVATE EQUITY FUNDS; FUND CREATION, NAMELY, ESTABLISHING MUTUAL FUNDS FOR OTHERS; FUNDRAISING SERVICES, NAMELY, SOLICITATION OF FUNDS FOR PRIVATE EQUITY AND VENTURE CAPITAL INVESTMENTS; FUND INVESTMENT CONSULTATION; FUND ADMINISTRATION, NAMELY, MANAGEMENT OF A CAPITAL INVESTMENT FUND; PRIVATE EQUITY FINANCING; PRIVATE EQUITY CAPITAL STRUCTURING; PRIVATE EQUITY CAPITAL AND DEBT INVESTMENT SERVICES; PRIVATE EQUITY FUND MANAGEMENT; ARRANGING EQUITY SHARING AGREEMENTS FOR OTHERS; FINANCIAL ADVISORY SERVICES IN THE FIELD OF PRIVATE EQUITY FINANCIAL INVESTMENTS, PRIVATE EQUITY INVESTMENT FUNDS, AND PRIVATE EQUITY FINANCING; VENTURE CAPITAL FINANCING, NAMELY, VENTURE CAPITAL STRUCTURING; VENTURE CAPITAL AND DEBT INVESTMENT SERVICES; FINANCIAL ADVISORY SERVICES RELATING TO VENTURE CAPITAL INVESTMENTS (U.S. CLS. 100, 101 AND 102).

FIRST USE 12-1-2010; IN COMMERCE 1-6-2011.

4,210,760. NEW YORK LIFE INSURANCE COMPANY, NEW YORK, NY. SN 85-205,099. PUB. 10-25-2011, FILED 12-23-2010.

ADVANCED INCOME SOLUTIONS

THE MARK CONSISTS OF STANDARD CHARACTERS WITHOUT CLAIM TO ANY PARTICULAR FONT, STYLE, SIZE, OR COLOR.

NO CLAIM IS MADE TO THE EXCLUSIVE RIGHT TO USE "INCOME SOLUTIONS", APART FROM THE MARK AS SHOWN.

FOR INVESTMENT ADVISORY SERVICES; INVESTMENT ADVISORY SERVICES RELATED TO THE EFFICIENT WITHDRAWAL OF ASSETS DURING RETIREMENT; INVESTMENT CONSULTATION; INVESTMENT MANAGEMENT (U.S. CLS. 100, 101 AND 102).

FIRST USE 1-0-2011; IN COMMERCE 1-0-2011.

CLASS 36—(Continued).

4,210,767. EVERY TRIBE ENTERTAINMENT LLC, OKLAHOMA CITY, OK. SN 85-207,423. PUB. 5-3-2011, FILED 12-29-2010.

EVERY TRIBE EVERY NATION

THE MARK CONSISTS OF STANDARD CHARACTERS WITHOUT CLAIM TO ANY PARTICULAR FONT, STYLE, SIZE, OR COLOR.

OWNER OF U.S. REG. NO. 3,228,515.

FOR CHARITABLE FUNDRAISING SERVICES FOR PROMOTING RESEARCH, EDUCATION AND OTHER ACTIVITIES RELATING TO THE TRANSLATION AND DISSEMINATION OF THE HOLY BIBLE IN VARIOUS MEDIA (U.S. CLS. 100, 101 AND 102).

FIRST USE 5-16-2012; IN COMMERCE 5-16-2012.

4,210,773. NEXT STEP CAPITAL PARTNERS LLC, AUSTIN, TX. SN 85-209,688. PUB. 11-8-2011, FILED 1-4-2011.

NEXT STEP CAPITAL PARTNERS

THE MARK CONSISTS OF STANDARD CHARACTERS WITHOUT CLAIM TO ANY PARTICULAR FONT, STYLE, SIZE, OR COLOR.

NO CLAIM IS MADE TO THE EXCLUSIVE RIGHT TO USE "CAPITAL PARTNERS", APART FROM THE MARK AS SHOWN.

FOR VENTURE CAPITAL FUNDING SERVICES TO EMERGING AND START-UP COMPANIES (U.S. CLS. 100, 101 AND 102).

FIRST USE 2-3-2011; IN COMMERCE 2-3-2011.

4,210,788. NATIONAL SOLAR POWER PARTNERS, MELBOURNE, FL. SN 85-214,067. PUB. 12-20-2011, FILED 1-10-2011.

DECARBONIZE

THE MARK CONSISTS OF STANDARD CHARACTERS WITHOUT CLAIM TO ANY PARTICULAR FONT, STYLE, SIZE, OR COLOR.

FOR BROKERAGE OF CARBON OFFSET CREDITS AND RENEWABLE ENERGY CERTIFICATES (U.S. CLS. 100, 101 AND 102).

FIRST USE 3-0-2011; IN COMMERCE 3-0-2011.

CLASS 36—(Continued).

4,210,804. PARTNERS FEDERAL CREDIT UNION, BURBANK, CA. SN 85-217,109. PUB. 12-20-2011, FILED 1-13-2011.



OWNER OF U.S. REG. NO. 2,414,006.
NO CLAIM IS MADE TO THE EXCLUSIVE RIGHT TO USE "FEDERAL CREDIT UNION", APART FROM THE MARK AS SHOWN.

THE MARK CONSISTS OF THE WORDING "PARTNERS! FEDERAL CREDIT UNION" WITH A SERIES OF STARS AND DOTS ABOVE SUCH MARK IN AN ARCH FORM.

FOR FINANCIAL AND MONETARY AFFAIRS, NAMELY, BANKING SERVICES CONDUCTED ACROSS-THE-COUNTER, BY TELEPHONE AND TELECOPY, BY MAIL, AND BY MEANS OF A GLOBAL COMPUTER NETWORK (U.S. CLS. 100, 101 AND 102).

FIRST USE 5-1-2011; IN COMMERCE 5-1-2011.

4,210,838. APOLLO HEALTHCARE LLC, ATLANTA, GA. SN 85-236,296. PUB. 11-8-2011, FILED 2-8-2011.



THE MARK CONSISTS OF TWO PARALLEL CONCAVE CURVED LINES TO THE LEFT OF, AND CURVING IN THE DIRECTION OF, TEXT READING "WELLCAP." THE INTERIOR CURVED LINE IS DARKER THAN THE EXTERIOR AND CONNECTS TO THE UPPER LEFT CORNER OF THE LETTER "W" IN THE TEXT.

FOR REINSURANCE SERVICES, NAMELY, ISSUANCE AND ADMINISTRATION OF SELF-FUNDED GROUP HEALTH REINSURANCE DESIGNED TO SUPPORT A WELLNESS RISK POOLING ARRANGEMENT (U.S. CLS. 100, 101 AND 102).

FIRST USE 2-2-2011; IN COMMERCE 2-2-2011.

CLASS 36—(Continued).

4,210,853. THE PROCTER & GAMBLE COMPANY, CINCINNATI, OH. SN 85-240,089. PUB. 6-21-2011, FILED 2-11-2011.

SCHOOL THE NATION

THE MARK CONSISTS OF STANDARD CHARACTERS WITHOUT CLAIM TO ANY PARTICULAR FONT, STYLE, SIZE, OR COLOR.

FOR CHARITABLE FUNDRAISING SERVICES, NAMELY, SHARING PROFITS FROM SALE OF CONSUMER PRODUCTS WITH EDUCATIONAL NON-PROFIT ORGANIZATIONS (U.S. CLS. 100, 101 AND 102).

FIRST USE 7-1-2011; IN COMMERCE 7-1-2011.

4,210,859. VANTIV, LLC, CINCINNATI, OH. SN 85-241,733. PUB. 12-13-2011, FILED 2-14-2011.

VANTIV

THE MARK CONSISTS OF STANDARD CHARACTERS WITHOUT CLAIM TO ANY PARTICULAR FONT, STYLE, SIZE, OR COLOR.

FOR FINANCIAL SERVICES, NAMELY, TRANSACTION AND DATA PROCESSING SERVICES; PAYMENT TRANSACTION PROCESSING SERVICES; NAMELY, CREDIT CARD, DEBIT CARD, BANK CARD, STORED VALUE CARD, LOYALTY CARD, GIFT CARD, ELECTRONIC BENEFITS TRANSFER, CHECK, ONLINE, MOBILE AND ELECTRONIC FUNDS TRANSFER TRANSACTION PROCESSING SERVICES; CREDIT CARD SERVICES AND CREDIT CARD TRANSACTION PROCESSING SERVICES; DEBIT CARD SERVICES AND DEBIT CARD TRANSACTION PROCESSING SERVICES; BANK CARD SERVICES AND BANK CARD TRANSACTION PROCESSING SERVICES; STORED VALUE CARD SERVICES AND STORED VALUE CARD TRANSACTION PROCESSING SERVICES; GIFT CARD SERVICES AND GIFT CARD TRANSACTION PROCESSING SERVICES; LOYALTY CARD SERVICES AND LOYALTY CARD TRANSACTION PROCESSING SERVICES; ELECTRONIC PAYMENT SERVICES, NAMELY, ELECTRONIC PROCESSING AND TRANSMISSION OF CREDIT CARD, DEBIT CARD, BANK CARD, STORED VALUE CARD, GIFT CARD, LOYALTY CARD, ELECTRONIC BENEFITS, CHECK, MOBILE, ONLINE, ELECTRONIC FUNDS, AND BILL PAYMENT DATA VIA A GLOBAL COMPUTER NETWORK; ELECTRONIC FUNDS TRANSFER AND BANK ACCOUNT SETTLEMENT SERVICES VIA A GLOBAL COMPUTER NETWORK; INFORMATION SECURITY SERVICES NAMELY, ENCRYPTION AND TOKENIZATION SERVICES; CREDIT CARD, DEBIT CARD, BANK CARD, STORED VALUE CARD, LOYALTY CARD, AND GIFT CARD DESIGN AND PRODUCTION SERVICES; AUTOMATED TELLER MACHINE (ATM), POINT-OF-SALE TERMINAL, COMPUTER PAYMENT TERMINAL, AND MOBILE PAYMENT ACCEPTANCE TERMINAL OPERATION SERVICES, NAMELY, CONNECTING AUTOMATED TELLER MACHINE (ATM), POINT-OF-SALE TERMINAL, COMPU-

CLASS 36—(Continued).

TER PAYMENT TERMINAL, AND MOBILE PAYMENT ACCEPTANCE TERMINALS TO BANKCARD ASSOCIATION NETWORKS, MERCHANTS AND FINANCIAL INSTITUTIONS VIA A GLOBAL COMPUTER NETWORK; CREDIT CARD, DEBIT CARD, BANK CARD, STORED VALUE CARD, GIFT CARD, AND LOYALTY CARD PROGRAM DESIGN AND IMPLEMENTATION; FIRST-PARTY DEBT COLLECTIONS SERVICES RELATED TO PROCESSED CREDIT CARD PROGRAMS; PROVIDING CUSTOMER SUPPORT SERVICES RELATED TO CREDIT CARD, DEBIT CARD, BANK CARD, STORED VALUE CARD, GIFT CARD, ELECTRONIC BENEFITS, CHECK, MOBILE, ONLINE, ELECTRONIC FUNDS, AND BILL PAYMENT TRANSACTIONS IN THE NATURE OF CALL CENTER SUPPORT AND CUSTOMER ASSISTANT ACCOUNT INFORMATION; LEASING AND RENTING OF POINT-OF-SALE TERMINALS, COMPUTER PAYMENT TERMINALS, MOBILE PAYMENT ACCEPTANCE TERMINALS, AND OTHER PAYMENT FACILITATING DEVICES (U.S. CLS. 100, 101 AND 102).

FIRST USE 6-15-2011; IN COMMERCE 6-15-2011.

4,210,875. DON B. GILL, JR., ROCHESTER, MI. SN 85-247,907. PUB. 7-12-2011, FILED 2-22-2011.

SALARY

THE MARK CONSISTS OF STANDARD CHARACTERS WITHOUT CLAIM TO ANY PARTICULAR FONT, STYLE, SIZE, OR COLOR.

FOR INVESTMENT ADVISORY SERVICES CONCERNING RETIREMENT, LONG-TERM SAVINGS AND WEALTH MANAGEMENT (U.S. CLS. 100, 101 AND 102). FIRST USE 5-1-2011; IN COMMERCE 5-1-2011.

4,210,880. MOORE, TIMOTHY MICHAEL, GRAND PRAIRIE, TX. SN 85-249,783. PUB. 10-4-2011, FILED 2-23-2011.



NO CLAIM IS MADE TO THE EXCLUSIVE RIGHT TO USE "ASSET PROTECTION RESPONSE TEAM", APART FROM THE MARK AS SHOWN.

THE MARK CONSISTS OF THE WORDS "ASSET PROTECTION" ABOVE THE WORD "RESPONSE", ABOVE THE WORD "TEAM", ABOVE THE LETTERS "(A.P.R.T.)".

FOR ASSET PROTECTION CONSULTING (U.S. CLS. 100, 101 AND 102). FIRST USE 3-1-2010; IN COMMERCE 3-1-2010.

CLASS 36—(Continued).

4,210,903. MEMONEYS, LLC, SARASOTA, FL. SN 85-262,179. PUB. 11-8-2011, FILED 3-9-2011.

MeMoneys

THE MARK CONSISTS OF STANDARD CHARACTERS WITHOUT CLAIM TO ANY PARTICULAR FONT, STYLE, SIZE, OR COLOR.

FOR FINANCIAL SERVICES, NAMELY, PROVIDING SAVINGS ACCUMULATION SERVICES FOR TRAVEL IN THE NATURE OF PROVIDING ON-LINE STORED VALUE ACCOUNTS IN AN ELECTRONIC ENVIRONMENT FOR TRAVEL PURPOSES; FINANCIAL SERVICES, NAMELY, ADMINISTRATION OF SAVINGS ACCOUNTS FOR TRAVEL FUNDS PURPOSES, FINANCIAL ADMINISTRATION OF A DEBIT CARD SAVINGS PROGRAM FOR GIFT GIVING, SAVINGS ACCOUNT SERVICES, AND SAVINGS ACCOUNT SERVICES FOR PURCHASE OF MUTUAL FUNDS; CHARITABLE CONTRIBUTION SERVICES PROVIDED THROUGH ELECTRONIC MEANS, NAMELY, ACCEPTING MONETARY CHARITABLE CONTRIBUTIONS THROUGH ELECTRONIC MEANS (U.S. CLS. 100, 101 AND 102).

FIRST USE 4-15-2011; IN COMMERCE 4-15-2011.

4,210,907. LEXICON LENDING CORPORATION, FORT MILL, SC. SN 85-262,980. PUB. 11-1-2011, FILED 3-10-2011.

SET FINANCIAL

THE MARK CONSISTS OF STANDARD CHARACTERS WITHOUT CLAIM TO ANY PARTICULAR FONT, STYLE, SIZE, OR COLOR.

NO CLAIM IS MADE TO THE EXCLUSIVE RIGHT TO USE "FINANCIAL", APART FROM THE MARK AS SHOWN.

FOR CREDIT AND LOAN SERVICES; ELECTRONIC LOAN PREPARATION SERVICES; FINANCIAL SERVICES, NAMELY, MONEY LENDING; INSTALLMENT LOANS (U.S. CLS. 100, 101 AND 102).

FIRST USE 1-1-2012; IN COMMERCE 1-1-2012.

CLASS 36—(Continued).

4,210,915. ALLOYA CORPORATE FCU, ALBANY, NY. SN 85-266,947. PUB. 11-8-2011, FILED 3-15-2011.



NO CLAIM IS MADE TO THE EXCLUSIVE RIGHT TO USE "CORPORATE FEDERAL CREDIT UNION", APART FROM THE MARK AS SHOWN.

THE MARK CONSISTS OF A LARGE TRIANGLE MADE OF THREE SMALLER TRIANGLES TO THE LEFT OF THE WORD "ALLOYA" ALL CENTERED OVER THE WORDING "CORPORATE FEDERAL CREDIT UNION".

FOR CREDIT UNION SERVICES; CREDIT UNIONS (U.S. CLS. 100, 101 AND 102).

FIRST USE 10-24-2011; IN COMMERCE 10-24-2011.

4,210,978. ARCH CAPITAL GROUP (U.S.) INC., NEW YORK, NY. SN 85-310,009. PUB. 10-25-2011, FILED 5-2-2011.

ARCH ESSENTIAL ENHANCEMENT
ENDORSEMENT

THE MARK CONSISTS OF STANDARD CHARACTERS WITHOUT CLAIM TO ANY PARTICULAR FONT, STYLE, SIZE, OR COLOR.

OWNER OF U.S. REG. NOS. 3,116,619, 3,784,744, AND OTHERS.

NO CLAIM IS MADE TO THE EXCLUSIVE RIGHT TO USE "ENHANCEMENT ENDORSEMENT", APART FROM THE MARK AS SHOWN.

FOR INSURANCE UNDERWRITING SERVICES IN THE FIELD OF DIRECTORS AND OFFICERS LIABILITY (U.S. CLS. 100, 101 AND 102).

FIRST USE 7-24-2012; IN COMMERCE 7-24-2012.

4,210,991. NEPSIS CAPITAL MANAGEMENT, INC., SAVAGE, MN. SN 85-318,533. PUB. 1-10-2012, FILED 5-11-2011.

Nepsis Capital Management,
Inc.

THE MARK CONSISTS OF STANDARD CHARACTERS WITHOUT CLAIM TO ANY PARTICULAR FONT, STYLE, SIZE, OR COLOR.

CLASS 36—(Continued).

NO CLAIM IS MADE TO THE EXCLUSIVE RIGHT TO USE "CAPITAL MANAGEMENT, INC.", APART FROM THE MARK AS SHOWN.

THE ENGLISH TRANSLATION OF "NEPSIS" IN THE MARK IS TO BE WATCHFUL, ALERT, DISCERNING, PRUDENT, AND VIGILANT.

FOR FINANCIAL AND INVESTMENT SERVICES, NAMELY, MANAGEMENT AND BROKERAGE IN THE FIELDS OF STOCKS, BONDS, OPTIONS, COMMODITIES, FUTURES AND OTHER SECURITIES, AND THE INVESTMENT OF FUNDS OF OTHERS; FINANCIAL PORTFOLIO MANAGEMENT; FINANCIAL SERVICES, NAMELY, COORDINATION, WITHIN A SINGLE ACCOUNT, OF AN INVESTMENT PORTFOLIO'S MAINTENANCE, TRADING, REBALANCING, AND TAX MANAGEMENT NEEDS; FINANCIAL SERVICES, NAMELY, INVESTMENT ADVICE, INVESTMENT MANAGEMENT, INVESTMENT CONSULTATION AND INVESTMENT OF FUNDS FOR OTHERS, INCLUDING PRIVATE AND PUBLIC EQUITY AND DEBT INVESTMENT SERVICES; FINANCIAL SERVICES, NAMELY, WEALTH MANAGEMENT SERVICES (U.S. CLS. 100, 101 AND 102).

FIRST USE 10-1-2011; IN COMMERCE 10-1-2011.

4,210,997. STURMAK, LINDSAY, NEW YORK, NY. SN 85-320,173. PUB. 10-4-2011, FILED 5-13-2011.

Sustaining What Matters

THE MARK CONSISTS OF STANDARD CHARACTERS WITHOUT CLAIM TO ANY PARTICULAR FONT, STYLE, SIZE, OR COLOR.

FOR FINANCIAL ASSET MANAGEMENT; FINANCIAL PLANNING; FINANCIAL PLANNING FOR RETIREMENT; FINANCIAL SERVICES, NAMELY, WEALTH MANAGEMENT SERVICES; INVESTMENT CONSULTATION (U.S. CLS. 100, 101 AND 102).

FIRST USE 3-1-2012; IN COMMERCE 3-1-2012.

4,211,038. SAFE AUTO INSURANCE COMPANY, COLUMBUS, OH. SN 85-330,208. PUB. 11-1-2011, FILED 5-25-2011.

MORENIMUM COVERAGE

THE MARK CONSISTS OF STANDARD CHARACTERS WITHOUT CLAIM TO ANY PARTICULAR FONT, STYLE, SIZE, OR COLOR.

OWNER OF U.S. REG. NO. 3,000,483.

NO CLAIM IS MADE TO THE EXCLUSIVE RIGHT TO USE "COVERAGE", APART FROM THE MARK AS SHOWN.

FOR INSURANCE BROKERAGE SERVICES, NAMELY, PROVIDING LAND VEHICLE INSURANCE; INSURANCE UNDERWRITING AND ADMINISTRATION SERVICES IN THE FIELD OF LAND VEHICLE INSURANCE (U.S. CLS. 100, 101 AND 102).

FIRST USE 5-0-2012; IN COMMERCE 5-0-2012.

CLASS 36—(Continued).

4,211,051. HARBORONE CREDIT UNION, BROCKTON, MA. SN 85-333,122. PUB. 10-25-2011, FILED 5-28-2011.

Embrace the Difference

THE MARK CONSISTS OF STANDARD CHARACTERS WITHOUT CLAIM TO ANY PARTICULAR FONT, STYLE, SIZE, OR COLOR.

FOR CREDIT UNION SERVICES; CONSUMER AND MORTGAGE LENDING SERVICES; DEPOSIT ACCOUNT SERVICES; BANKING SERVICES; INSURANCE BROKERAGE SERVICES IN THE FIELDS OF LIFE, LONG-TERM CARE AND FIXED ANNUITIES; INVESTMENT MANAGEMENT SERVICES; AND FINANCIAL PLANNING SERVICES (U.S. CLS. 100, 101 AND 102).
FIRST USE 5-21-2012; IN COMMERCE 5-21-2012.

4,211,070. CAPRETZ, TAYLOR, LAGUNA BEACH, CA. AND CAPRETZ, RYAN, LAGUNA BEACH, CA. AND CAPRETZ, CINDY, LAGUNA BEACH, CA. SN 85-336,482. PUB. 10-25-2011, FILED 6-2-2011.

RED for Life

THE MARK CONSISTS OF STANDARD CHARACTERS WITHOUT CLAIM TO ANY PARTICULAR FONT, STYLE, SIZE, OR COLOR.

FOR CHARITABLE FUNDRAISING SERVICES FOR THE SUPPORT OF WOMEN AND CHILDREN INFECTED WITH HIV AIDS (U.S. CLS. 100, 101 AND 102).
FIRST USE 8-0-2011; IN COMMERCE 8-0-2011.

4,211,111. KAM-SOUTH, LLC, ATLANTA, GA. SN 85-342,232. PUB. 11-1-2011, FILED 6-9-2011.

FPLF

THE MARK CONSISTS OF STANDARD CHARACTERS WITHOUT CLAIM TO ANY PARTICULAR FONT, STYLE, SIZE, OR COLOR.

FOR ESTATE PLANNING; FINANCIAL PLANNING AND INVESTMENT ADVISORY SERVICES (U.S. CLS. 100, 101 AND 102).
FIRST USE 8-1-2011; IN COMMERCE 8-1-2011.

CLASS 36—(Continued).

4,211,150. PRECIDIAN INVESTMENTS LLC, BEDMINSTER, NJ. SN 85-346,808. PUB. 11-15-2011, FILED 6-15-2011.



The logo for Precidian Funds features a stylized shield icon on the left, composed of a curved line intersecting a vertical line. To the right of the shield, the word "Precidian" is written in a large, bold, serif font, and the word "Funds" is written below it in a smaller, bold, sans-serif font.

NO CLAIM IS MADE TO THE EXCLUSIVE RIGHT TO USE "FUNDS", APART FROM THE MARK AS SHOWN.

THE MARK CONSISTS OF A STYLIZED REPRESENTATION OF A SHIELD INTERSECTED BY A CURVED LINE; DIRECTLY TO THE RIGHT OF THE SHIELD IS THE WORD "PRECIDIAN" STACKED ON TOP OF THE WORD "FUNDS".

FOR FINANCIAL ADVISORY SERVICES FOR EXCHANGE TRADED PRODUCTS (ETPS) (U.S. CLS. 100, 101 AND 102).

FIRST USE 6-7-2011; IN COMMERCE 6-7-2011.

4,211,187. KING, FELICIA, NASHVILLE, TN. AND MONTES, LISA, NASHVILLE, TN. SN 85-350,297. PUB. 11-15-2011, FILED 6-20-2011.



THE MARK CONSISTS OF AN INVERTED HEART DESIGN WITH A TWISTED LOOP AT ITS APEX.

FOR CHARITABLE FUNDRAISING SERVICES; CHARITABLE FUNDRAISING SERVICES BY MEANS OF THE SALE OF CLOTHING ITEMS AND FASHION ACCESSORIES (U.S. CLS. 100, 101 AND 102).

FIRST USE 6-1-2011; IN COMMERCE 6-1-2011.

CLASS 36—(Continued).

4,211,203. GEORGIA CENTRAL CORPORATE FEDERAL CREDIT UNION, DULUTH, GA. SN 85-352,971. PUB. 11-8-2011, FILED 6-22-2011.



THE COLOR(S) RED, BLUE, AND YELLOW IS/ARE CLAIMED AS A FEATURE OF THE MARK.

THE MARK CONSISTS OF A RED STYLIZED LETTER "C" AND A YELLOW CHEVRON DISPOSED TO THE RIGHT OF THE RED STYLIZED LETTER "C" AND EXTENDING WITHIN THE OPENING OF THE RED STYLIZED LETTER "C" AND A SOLID YELLOW DOT DISPOSED ABOVE THE YELLOW CHEVRON AND THREE BLUE CURVED HORIZONTAL BARS DISPOSED WITHIN THE RED STYLIZED LETTER "C" AND EXTENDING TO THE YELLOW CHEVRON WHEREIN THE THREE BLUE CURVED HORIZONTAL BARS ARE SHADED ALONG A GRADIENT FROM LEFT TO RIGHT AND ARE VERTICALLY STACKED IN RELATION TO ONE ANOTHER.

FOR BANKING SERVICES; CREDIT UNION SERVICES; CREDIT UNIONS (U.S. CLS. 100, 101 AND 102). FIRST USE 9-6-2011; IN COMMERCE 9-6-2011.

4,211,212. FIRST FOUNDATION, INC., IRVINE, CA. SN 85-354,808. PUB. 11-8-2011, FILED 6-23-2011.

DIRECT2FFB

THE MARK CONSISTS OF STANDARD CHARACTERS WITHOUT CLAIM TO ANY PARTICULAR FONT, STYLE, SIZE, OR COLOR.

FOR BANKING SERVICES, NAMELY, PROVIDING ONLINE BUSINESS AND PERSONAL SAVINGS AND CHECKING ACCOUNTS; BUSINESS AND PERSONAL LENDING; ELECTRONIC PROCESSING AND TRANSMISSION OF BILL PAYMENT DATA AND BILL PAYMENT; ONLINE ACCESS TO BANK ACCOUNTS; AND ELECTRONIC PROCESSING OF CHECKS FOR DEPOSIT AND LOCKBOX SERVICES (U.S. CLS. 100, 101 AND 102). FIRST USE 7-27-2011; IN COMMERCE 7-27-2011.

CLASS 36—(Continued).

4,211,213. FIRST FOUNDATION, INC., IRVINE, CA. SN 85-354,809. PUB. 11-8-2011, FILED 6-23-2011.



THE MARK CONSISTS OF THE WORD "DIRECT" AND THE LETTERS "FFB" WITH THE NUMBER "2" IN THE MIDDLE OF AN ARROW.

FOR BANKING SERVICES, NAMELY, PROVIDING ONLINE BUSINESS AND PERSONAL SAVINGS AND CHECKING ACCOUNTS; BUSINESS AND PERSONAL LENDING; ELECTRONIC PROCESSING AND TRANSMISSION OF BILL PAYMENT DATA AND BILL PAYMENT; ONLINE ACCESS TO BANK ACCOUNTS; AND ELECTRONIC PROCESSING OF CHECKS FOR DEPOSIT AND LOCKBOX SERVICES (U.S. CLS. 100, 101 AND 102). FIRST USE 7-27-2011; IN COMMERCE 7-27-2011.

4,211,221. OCEAN COLONY LLC, BAY HARBOR ISLANDS, FL. SN 85-355,784. PUB. 11-15-2011, FILED 6-24-2011.

Ocean Colony

THE MARK CONSISTS OF STANDARD CHARACTERS WITHOUT CLAIM TO ANY PARTICULAR FONT, STYLE, SIZE, OR COLOR.

FOR FINANCIAL SERVICES, NAMELY, IN INVESTMENT FUNDS (U.S. CLS. 100, 101 AND 102). FIRST USE 1-31-2012; IN COMMERCE 1-31-2012.

4,211,234. XLIT LTD, DUBLIN, IRELAND. SN 85-356,785. PUB. 11-22-2011, FILED 6-27-2011.

XL IT

THE MARK CONSISTS OF STANDARD CHARACTERS WITHOUT CLAIM TO ANY PARTICULAR FONT, STYLE, SIZE, OR COLOR.

OWNER OF U.S. REG. NOS. 2,167,223, 2,645,626, AND OTHERS.

FOR INSURANCE UNDERWRITING SERVICES IN THE FIELDS OF PROPERTY AND CASUALTY; REINSURANCE UNDERWRITING SERVICES (U.S. CLS. 100, 101 AND 102).

FIRST USE 11-30-2011; IN COMMERCE 11-30-2011.

CLASS 36—(Continued).

4,211,235. RBS CITIZENS FINANCIAL GROUP, INC., PROVIDENCE, RI. SN 85-357,005. PUB. 10-18-2011, FILED 6-27-2011.

BUSINESS ADVISOR CHECKING

THE MARK CONSISTS OF STANDARD CHARACTERS WITHOUT CLAIM TO ANY PARTICULAR FONT, STYLE, SIZE, OR COLOR.

NO CLAIM IS MADE TO THE EXCLUSIVE RIGHT TO USE "BUSINESS" AND "CHECKING", APART FROM THE MARK AS SHOWN.

FOR BANKING SERVICES (U.S. CLS. 100, 101 AND 102).

FIRST USE 4-23-2012; IN COMMERCE 4-23-2012.

4,211,240. DEYAR LLC, DUBAI, UNITED ARAB EMIR... SN 85-357,658. PUB. 12-20-2011, FILED 6-28-2011.



THE COLOR(S) BLUE, LIGHT BLUE, GREEN AND YELLOW IS/ARE CLAIMED AS A FEATURE OF THE MARK.

THE MARK CONSISTS OF LETTER "D" IN YELLOW COLOR WRITTEN INSIDE A BLUE COLOR RECTANGLE WITH TWO HORIZONTAL WAVE-LIKE IMAGES IN LIGHT BLUE AND GREEN COLOR POSITIONED ACROSS THE RECTANGLE. THE WORD "DEYAR" IS WRITTEN IN BLUE, IN PERSIAN/ARABIC LANGUAGE ABOVE THE RECTANGLE AND IN ENGLISH LANGUAGE BELOW THE RECTANGLE, ALSO IN BLUE.

THE ENGLISH TRANSLATION OF "DEYAR" IN THE MARK IS "COUNTRY OF CITIZENSHIP".

THE NON-LATIN CHARACTERS IN THE MARK TRANSLITERATE TO "DEYAR" AND THIS MEANS "COUNTRY OF CITIZENSHIP" IN ENGLISH.

FOR ISSUING PREPAID DEBIT CARDS; ISSUING PREPAID CREDIT CARDS; ON-LINE PREPAID CARD SERVICES; PRE-PAID PURCHASE CARD SERVICES, NAMELY, PROCESSING ELECTRONIC PAYMENTS MADE THROUGH PREPAID CARDS; FINANCIAL ANALYSIS AND CONSULTATION; ELECTRONIC TRANSFER OF MONEY; MONEY TRANSFER; CREDIT CARD AND PAYMENT CARD SERVICES; DEBIT AND CREDIT CARD SERVICES; PROCESSING OF ELECTRONIC PAYMENTS ONLINE (U.S. CLS. 100, 101 AND 102).

FIRST USE 1-3-2006; IN COMMERCE 1-3-2006.

CLASS 36—(Continued).

4,211,272. AMERISTRAC, INC., GREAT NECK, NY. SN 85-363,077. PUB. 11-8-2011, FILED 7-5-2011.



THE MARK CONSISTS OF A SHAPE THAT APPEARS TO RESEMBLE A QUILL PEN, WHICH IS LOCATED ABOVE A DESIGN THAT APPEARS TO RESEMBLE AN INKWELL, BOTH OF WHICH APPEAR OVER A DESIGN ELEMENT THAT APPEARS AS TRIANGULAR IN SHAPE WITH CURVED EDGES.

FOR INSURANCE AGENCIES IN THE FIELD OF TITLE INSURANCE; REAL ESTATE TITLE INSURANCE UNDERWRITING SERVICES (U.S. CLS. 100, 101 AND 102).

FIRST USE 1-18-2012; IN COMMERCE 1-18-2012.

4,211,313. BANKS STREET PARTNERS, LLC, ATLANTA, GA. SN 85-371,608. PUB. 1-10-2012, FILED 7-14-2011.



NO CLAIM IS MADE TO THE EXCLUSIVE RIGHT TO USE "SECURITIES", APART FROM THE MARK AS SHOWN.

THE MARK CONSISTS OF A STYLIZED LETTER "B", FOLLOWED BY A VERTICAL LINE, FOLLOWED BY A STYLIZED "S", FOLLOWED BY A VERTICAL LINE, FOLLOWED BY THE LETTER "P", WITH THE WORD "SECURITIES" DIRECTLY BELOW THE STYLIZED LETTERS.

FOR FINANCIAL SERVICES, NAMELY, RAISING DEBT AND EQUITY CAPITAL FOR OTHERS; INVESTMENT BANKING SERVICES (U.S. CLS. 100, 101 AND 102).

FIRST USE 12-18-2011; IN COMMERCE 12-18-2011.

CLASS 36—(Continued).

4,211,324. RBS CITIZENS FINANCIAL GROUP, INC., PROVIDENCE, RI. SN 85-373,727. PUB. 10-18-2011, FILED 7-18-2011.

**TRUFIT GOOD CITIZEN
SCHOLARSHIP**

THE MARK CONSISTS OF STANDARD CHARACTERS WITHOUT CLAIM TO ANY PARTICULAR FONT, STYLE, SIZE, OR COLOR.

OWNER OF U.S. REG. NOS. 3,703,109, 3,826,238, AND 3,963,027.

NO CLAIM IS MADE TO THE EXCLUSIVE RIGHT TO USE "SCHOLARSHIP", APART FROM THE MARK AS SHOWN.

FOR FINANCIAL ADMINISTRATION OF SCHOLARSHIP PROGRAMS (U.S. CLS. 100, 101 AND 102).

FIRST USE 8-1-2011; IN COMMERCE 8-1-2011.

4,211,364. SUNTRUST BANKS, INC. ATLANTA, GA. SN 85-383,068. PUB. 12-27-2011, FILED 7-28-2011.

Signature Advantage Banking

THE MARK CONSISTS OF STANDARD CHARACTERS WITHOUT CLAIM TO ANY PARTICULAR FONT, STYLE, SIZE, OR COLOR.

NO CLAIM IS MADE TO THE EXCLUSIVE RIGHT TO USE "BANKING", APART FROM THE MARK AS SHOWN.

FOR CHECKING ACCOUNT SERVICES (U.S. CLS. 100, 101 AND 102).

FIRST USE 6-18-2011; IN COMMERCE 6-18-2011.

4,211,365. DISCOVER FINANCIAL SERVICES, RIVERWOODS, IL. SN 85-383,288. PUB. 1-3-2012, FILED 7-28-2011.

DISCOVER

OWNER OF U.S. REG. NOS. 1,620,369, 3,760,567, AND OTHERS.

CLASS 36—(Continued).

THE MARK CONSISTS OF THE WORD "DISCOVER" IN BLOCK LETTERS WITH THE LETTER "O" PARTIALLY SHADED.

FOR FINANCIAL SERVICES, NAMELY, PAYMENT CARD SERVICES, CREDIT CARD SERVICES; PREPAID CARD SERVICES OFFERED THROUGH CARDS WITH STORED VALUE; DEBIT CARD SERVICES; ELECTRONIC CREDIT AND DEBIT TRANSACTION SERVICES; CASH DISBURSEMENT AND CASH REPLACEMENT SERVICES RENDERED BY CREDIT CARD; ELECTRONIC CASH TRANSACTIONS; CHECK VERIFICATION SERVICES; CHECK CASHING SERVICES; POINT OF SALE AND POINT OF TRANSACTION SERVICES; TRANSACTION AUTHORIZATION AND SETTLEMENT SERVICES, ELECTRONIC PAYMENT PROCESSING SERVICES; CREDIT CARD AND PAYMENT TRANSACTION AUTHENTICATION AND VERIFICATION SERVICES; BANKING SERVICES; BILL PAYMENT AND PRESENTMENT SERVICES; FACILITATING PAYMENT SERVICES THROUGH ELECTRONIC MEANS VIA A GLOBAL COMPUTER NETWORK; ELECTRONIC FUNDS TRANSFER; PROVIDING FINANCIAL INFORMATION, NAMELY, CREDIT AND DEBIT CARD DATA AND REPORTS, FINANCIAL RECORDS MANAGEMENT; ELECTRONIC FUNDS TRANSFER SERVICES; CREDIT MANAGEMENT SERVICES; DISSEMINATION OF FINANCIAL INFORMATION VIA A GLOBAL COMPUTER NETWORK; AND ADVISORY SERVICES REGARDING ALL OF THE FOREGOING SERVICES; BANKING SERVICES; INSURANCE ADMINISTRATION IN THE FIELD OF VEHICLE, LIFE AND ACCIDENT INSURANCE; CERTIFICATE OF DEPOSIT ACCOUNT SERVICES AND SAVINGS ACCOUNT SERVICES; CONSUMER LENDING SERVICES; MORTGAGE LENDING; CREDIT AND LOAN SERVICES; PROVIDING PERSONAL LOANS AND LINES OF CREDIT (U.S. CLS. 100, 101 AND 102).

FIRST USE 2-20-1985; IN COMMERCE 2-20-1985.

4,211,396. MERACORD LLC, TACOMA, WA. SN 85-393,693. PUB. 1-3-2012, FILED 8-9-2011.

MERACORD

THE MARK CONSISTS OF STANDARD CHARACTERS WITHOUT CLAIM TO ANY PARTICULAR FONT, STYLE, SIZE, OR COLOR.

OWNER OF U.S. REG. NO. 3,657,059.

THE WORDING "MERACORD" HAS NO MEANING IN A FOREIGN LANGUAGE.

FOR REAL ESTATE ESCROW SERVICES, MAINTAINING MORTGAGE ESCROW ACCOUNTS, AND MAINTAINING ESCROW ACCOUNTS FOR INVESTMENTS, NAMELY, MAINTAINING ESCROW ACCOUNTS FOR ALL TYPES OF CONTRACTS REQUIRING INSTALLMENT PAYMENTS, NAMELY, PRIVATE MORTGAGES, PERSONAL LOANS, PROMISSORY NOTES, LEASE AGREEMENTS, APARTMENT RENTALS, INSTALLMENT CONTRACTS, UNSECURED LOANS, UNSECURED DEBT OBLIGATIONS, TAX AND INSURANCE OBLIGATIONS, MEMBERSHIP FEES, AND ASSOCIATION DUES; PAYMENT PROCESSING SERVICES, NAMELY, CREDIT CARD AND DEBIT CARD TRANSACTION PROCESSING SERVICES; PROVIDING FINANCIAL INFORMATION RELATED TO SELLER-FINANCED REAL ESTATE TRANSACTIONS, PRIVATE MORTGAGES AND ESCROW ACCOUNTS OVER THE TELEPHONE OR BY MEANS OF A GLOBAL COMPUTER NETWORK (U.S. CLS. 100, 101 AND 102).

FIRST USE 1-9-2012; IN COMMERCE 1-9-2012.

CLASS 36—(Continued).

4,211,397. MERACORD LLC, TACOMA, WA. SN 85-393,700. PUB. 1-3-2012, FILED 8-9-2011.

CLASS 36—(Continued).

4,211,441. EAST STROUDSBURG SAVINGS ASSOCIATION, STROUDSBURG, PA. SN 85-409,874. PUB. 11-15-2011, FILED 8-29-2011.

PROTECTING THE PROMISE

THE MARK CONSISTS OF STANDARD CHARACTERS WITHOUT CLAIM TO ANY PARTICULAR FONT, STYLE, SIZE, OR COLOR.

OWNER OF U.S. REG. NO. 3,657,059.

FOR REAL ESTATE ESCROW SERVICES, MAINTAINING MORTGAGE ESCROW ACCOUNTS, AND MAINTAINING ESCROW ACCOUNTS FOR INVESTMENTS, NAMELY, MAINTAINING ESCROW ACCOUNTS FOR ALL TYPES OF CONTRACTS REQUIRING INSTALLMENT PAYMENTS, NAMELY, PRIVATE MORTGAGES, PERSONAL LOANS, PROMISSORY NOTES, LEASE AGREEMENTS, APARTMENT RENTALS, INSTALLMENT CONTRACTS, UNSECURED LOANS, UNSECURED DEBT OBLIGATIONS, TAX AND INSURANCE OBLIGATIONS, MEMBERSHIP FEES, AND ASSOCIATION DUES; PAYMENT PROCESSING SERVICES, NAMELY, CREDIT CARD AND DEBIT CARD TRANSACTION PROCESSING SERVICES; PROVIDING FINANCIAL INFORMATION RELATED TO SELLER-FINANCED REAL ESTATE TRANSACTIONS, PRIVATE MORTGAGES AND ESCROW ACCOUNTS OVER THE TELEPHONE OR BY MEANS OF A GLOBAL COMPUTER NETWORK (U.S. CLS. 100, 101 AND 102).

FIRST USE 1-9-2012; IN COMMERCE 1-9-2012.

eDeposit@ESSA

THE MARK CONSISTS OF STANDARD CHARACTERS WITHOUT CLAIM TO ANY PARTICULAR FONT, STYLE, SIZE, OR COLOR.

FOR BANKING; BANKING SERVICES; FINANCIAL SERVICES, NAMELY, ELECTRONIC REMOTE CHECK DEPOSIT SERVICES; ON-LINE BANKING SERVICES (U.S. CLS. 100, 101 AND 102).

FIRST USE 6-8-2011; IN COMMERCE 6-8-2011.

4,211,438. NEPSIS CAPITAL MANAGEMENT, INC., SAVAGE, MN. SN 85-409,095. PUB. 1-10-2012, FILED 8-28-2011.

4,211,470. THL CREDIT ADVISORS LLC, BOSTON, MA. SN 85-418,986. PUB. 2-21-2012, FILED 9-9-2011.

ROAD TO NEPSIS

THE MARK CONSISTS OF STANDARD CHARACTERS WITHOUT CLAIM TO ANY PARTICULAR FONT, STYLE, SIZE, OR COLOR.

FOR FINANCIAL AND INVESTMENT SERVICES, NAMELY, MANAGEMENT AND BROKERAGE IN THE FIELDS OF STOCKS, BONDS, OPTIONS, COMMODITIES, FUTURES AND OTHER SECURITIES, AND THE INVESTMENT OF FUNDS OF OTHERS; FINANCIAL ASSET MANAGEMENT; FINANCIAL INVESTMENT BROKERAGE; FINANCIAL INVESTMENT BROKERAGE SERVICES; FINANCIAL PLANNING AND INVESTMENT ADVISORY SERVICES; FINANCIAL PORTFOLIO ANALYSIS SERVICES; FINANCIAL PORTFOLIO MANAGEMENT; FINANCIAL RESEARCH AND EQUITY RESEARCH BROKERAGE SERVICES; FINANCIAL RISK MANAGEMENT; FINANCIAL RISK MANAGEMENT CONSULTATION; FINANCIAL SERVICES, NAMELY, INVESTMENT ADVICE, INVESTMENT MANAGEMENT, INVESTMENT CONSULTATION AND INVESTMENT OF FUNDS FOR OTHERS, INCLUDING PRIVATE AND PUBLIC EQUITY AND DEBT INVESTMENT SERVICES (U.S. CLS. 100, 101 AND 102).

FIRST USE 1-5-2012; IN COMMERCE 1-5-2012.



THE COLOR(S) BLUE, GREEN, AND WHITE IS/ARE CLAIMED AS A FEATURE OF THE MARK.

THE MARK CONSISTS OF CHESS PIECE DESIGNS SUPERIMPOSED ON FIVE SQUARES FORMING A RECTANGLE. THE COLOR BLUE APPEARS IN THE SHADING OF THREE SQUARES ENCOMPASSING THE THREE WHITE CHESS DESIGN PIECES AND THE COLOR WHITE APPEARS IN THE SHADING OF THE TWO GREEN CHESS DESIGN PIECES.

FOR COMMERCIAL LENDING SERVICES; EQUITY CAPITAL INVESTMENT; FINANCIAL SERVICES, NAMELY, MONEY LENDING; INVESTMENT ADVICE; INVESTMENT ADVISORY SERVICES; INVESTMENT MANAGEMENT (U.S. CLS. 100, 101 AND 102).

FIRST USE 8-16-2011; IN COMMERCE 8-16-2011.

CLASS 36—(Continued).

4,211,488. REWARDSPAY, INC., MILPITAS, CA. SN 85-430,413. PUB. 2-28-2012, FILED 9-23-2011.

REWARDSPAY

THE MARK CONSISTS OF STANDARD CHARACTERS WITHOUT CLAIM TO ANY PARTICULAR FONT, STYLE, SIZE, OR COLOR.

FOR ELECTRONIC COMMERCE PAYMENT SERVICE THAT ENABLES CONSUMERS TO USE LOYALTY POINTS, REWARD POINTS, CASH BACK OFFERS AND COUPONS, TOKENS, MILES AND OTHER FORMS OF REWARDS TO MAKE ONLINE PURCHASES, IN WHOLE OR IN PART, OF VIRTUAL, DIGITAL AND PHYSICAL GOODS (U.S. CLS. 100, 101 AND 102).
FIRST USE 6-17-2012; IN COMMERCE 6-17-2012.

4,211,490. FIDELITY FINANCIAL CORPORATION, DBA FIDELITY BANK, WICHITA, KS. SN 85-431,832. PUB. 3-6-2012, FILED 9-26-2011.

BRAVELY ONWARD

THE MARK CONSISTS OF STANDARD CHARACTERS WITHOUT CLAIM TO ANY PARTICULAR FONT, STYLE, SIZE, OR COLOR.

FOR BANKING SERVICES (U.S. CLS. 100, 101 AND 102).
FIRST USE 6-25-2012; IN COMMERCE 6-25-2012.

4,211,591. EVERBANK, JACKSONVILLE, FL. SN 85-478,809. PUB. 4-10-2012, FILED 11-22-2011.

SIMPLIFY. ORGANIZE. INFORM.

THE MARK CONSISTS OF STANDARD CHARACTERS WITHOUT CLAIM TO ANY PARTICULAR FONT, STYLE, SIZE, OR COLOR.

FOR BANKING SERVICES; FINANCIAL INVESTMENT BROKERAGE; FINANCIAL INVESTMENT IN THE FIELD OF CERTIFICATES OF DEPOSIT, MONEY MARKET FUNDS, METALS AND FOREIGN CURRENCIES; FUND INVESTMENT CONSULTATION; PROVIDING INFORMATION AND RESEARCH IN THE FIELD OF FINANCE AND FINANCIAL INVESTMENTS (U.S. CLS. 100, 101 AND 102).
FIRST USE 1-18-2012; IN COMMERCE 1-18-2012.

CLASS 36—(Continued).

4,211,626. STATE FARM MUTUAL AUTOMOBILE INSURANCE COMPANY, BLOOMINGTON, IL. SN 85-496,258. PUB. 4-10-2012, FILED 12-15-2011.



OWNER OF U.S. REG. NOS. 834,461, 1,979,585, AND OTHERS.

THE MARK CONSISTS OF THREE OVALS TOUCHING FORMING AN OVERALL TRIANGULAR SHAPE WHERE ONE OVAL APPEARS CENTERED ABOVE THE OTHER TWO OVALS TO THE LEFT OF THE WORDING "STATE FARM".

FOR INSURANCE UNDERWRITING SERVICES IN THE FIELDS OF AUTO, HOME, HEALTH, LIFE, AND FIRE; PROVIDING BANKING SERVICES; MUTUAL FUND INVESTMENTS; FINANCIAL ANALYSIS AND CONSULTATION (U.S. CLS. 100, 101 AND 102).
FIRST USE 1-1-2012; IN COMMERCE 1-1-2012.

4,211,627. STATE FARM MUTUAL AUTOMOBILE INSURANCE COMPANY, BLOOMINGTON, IL. SN 85-496,345. PUB. 4-10-2012, FILED 12-15-2011.



OWNER OF U.S. REG. NOS. 1,087,834, 2,749,909, AND OTHERS.

THE MARK CONSISTS OF THREE OVALS TOUCHING FORMING AN OVERALL TRIANGULAR SHAPE WHERE ONE OVAL APPEARS CENTERED ABOVE THE OTHER TWO OVALS.

FOR INSURANCE UNDERWRITING SERVICES IN THE FIELDS OF AUTO, HOME, HEALTH, LIFE, AND FIRE; PROVIDING BANKING SERVICES; MUTUAL FUND INVESTMENTS; FINANCIAL ANALYSIS AND CONSULTATION (U.S. CLS. 100, 101 AND 102).
FIRST USE 1-1-2012; IN COMMERCE 1-1-2012.

4,211,628. STATE FARM MUTUAL AUTOMOBILE INSURANCE COMPANY, BLOOMINGTON, IL. SN 85-496,405. PUB. 4-3-2012, FILED 12-15-2011.



OWNER OF U.S. REG. NOS. 1,087,834, 2,749,909, AND OTHERS.

CLASS 36—(Continued).

NO CLAIM IS MADE TO THE EXCLUSIVE RIGHT TO USE "BANK", APART FROM THE MARK AS SHOWN.

THE MARK CONSISTS OF THREE OVALS TOUCHING FORMING AN OVERALL TRIANGULAR SHAPE WHERE ONE OVAL APPEARS CENTERED ABOVE THE OTHER TWO OVALS TO THE LEFT OF THE WORDING "STATE FARM BANK".

FOR PROVIDING BANKING SERVICES TO OTHERS (U.S. CLS. 100, 101 AND 102).

FIRST USE 1-1-2012; IN COMMERCE 1-1-2012.

4,211,629. STATE FARM MUTUAL AUTOMOBILE INSURANCE COMPANY, BLOOMINGTON, IL. SN 85-496,457. PUB. 4-3-2012, FILED 12-15-2011.

StateFarmBank



OWNER OF U.S. REG. NOS. 1,087,834, 2,749,909, AND OTHERS.

NO CLAIM IS MADE TO THE EXCLUSIVE RIGHT TO USE "BANK", APART FROM THE MARK AS SHOWN.

THE MARK CONSISTS OF THE WORDING "STATE FARM BANK" CENTERED ABOVE THREE OVALS TOUCHING FORMING AN OVERALL TRIANGULAR SHAPE WHERE ONE OVAL APPEARS CENTERED ABOVE THE OTHER TWO OVALS.

FOR PROVIDING BANKING SERVICES TO OTHERS (U.S. CLS. 100, 101 AND 102).

FIRST USE 1-1-2012; IN COMMERCE 1-1-2012.

4,211,632. GLOBAL MARKET HOLDINGS, LLC, ARLINGTON, VA. SN 85-497,218. PUB. 5-8-2012, FILED 12-16-2011.

Inglobal

THE MARK CONSISTS OF STANDARD CHARACTERS WITHOUT CLAIM TO ANY PARTICULAR FONT, STYLE, SIZE, OR COLOR.

FOR ELECTRONIC FINANCIAL TRADING SERVICES (U.S. CLS. 100, 101 AND 102).

FIRST USE 11-1-2011; IN COMMERCE 11-2-2011.

CLASS 36—(Continued).

4,211,656. AKITA, INC., WILMINGTON, DE. SN 85-556,467. PUB. 5-15-2012, FILED 2-29-2012.

CYBEREDGE

THE MARK CONSISTS OF STANDARD CHARACTERS WITHOUT CLAIM TO ANY PARTICULAR FONT, STYLE, SIZE, OR COLOR.

FOR INSURANCE UNDERWRITING IN THE FIELD OF INTERNET LIABILITY, CYBER EXTORTION, BUSINESS INTERRUPTION AND PROPERTY AND CASUALTY INSURANCE (U.S. CLS. 100, 101 AND 102).

FIRST USE 3-28-2012; IN COMMERCE 3-28-2012.

4,211,658. GIFTS THAT GIVE, INC., SOUTH ORANGE, NJ. SN 85-976,110. PUB. 3-6-2012, FILED 3-17-2011.

**GIFTS THAT
GIVE**

THE MARK CONSISTS OF THE MARK "GIFTS THAT GIVE" WITH THE LETTER "V" IN "GIVE" BEING REPLACED WITH A HEART THAT HAS ANOTHER HEART INSIDE IT.

FOR CHARITABLE FUNDRAISING (U.S. CLS. 100, 101 AND 102).

FIRST USE 5-0-2011; IN COMMERCE 5-0-2011.

CLASS 37—CONSTRUCTION AND REPAIR

4,210,563. THE TRUSTEES OF THE WHITESTONE REIT, A MARYLAND BUSINESS TRUST, HOUSTON, TX. SN 85-075,434. PUB. 11-23-2010, FILED 6-30-2010.

**COMMUNITY CENTERED
PROPERTIES**

THE MARK CONSISTS OF STANDARD CHARACTERS WITHOUT CLAIM TO ANY PARTICULAR FONT, STYLE, SIZE, OR COLOR.

NO CLAIM IS MADE TO THE EXCLUSIVE RIGHT TO USE "PROPERTIES", APART FROM THE MARK AS SHOWN.

FOR REAL ESTATE DEVELOPMENT AND CONSTRUCTION OF COMMERCIAL PROPERTY (U.S. CLS. 100, 103 AND 106).

FIRST USE 1-15-2009; IN COMMERCE 1-15-2009.

CLASS 37—(Continued).

4,210,564. THE TRUSTEES OF THE WHITESTONE REIT, HOUSTON, TX. SN 85-075,442. PUB. 11-30-2010, FILED 6-30-2010.

DRIVING TRAFFIC DRIVING
VALUE

THE MARK CONSISTS OF STANDARD CHARACTERS WITHOUT CLAIM TO ANY PARTICULAR FONT, STYLE, SIZE, OR COLOR.

FOR REAL ESTATE DEVELOPMENT AND CONSTRUCTION OF COMMERCIAL PROPERTY (U.S. CLS. 100, 103 AND 106).

FIRST USE 1-15-2009; IN COMMERCE 1-15-2009.

4,210,695. MERRITT PROPERTIES, LLC, BALTIMORE, MD. SN 85-182,108. PUB. 6-14-2011, FILED 11-22-2010.



NO CLAIM IS MADE TO THE EXCLUSIVE RIGHT TO USE "BUILDING GREEN", APART FROM THE MARK AS SHOWN.

THE MARK CONSISTS OF THE LETTER "M" WITH A VERTICAL LINE DIRECTLY TO THE RIGHT OF THE LETTER "M". A FIGURE THAT IS A LEAF ON THE BOTTOM AND THREE BUILDINGS ON THE TOP APPEARS DIRECTLY TO THE RIGHT OF THE VERTICAL LINE. THE WORDS "BUILDING GREEN" APPEAR BELOW THE "M" AND THE LEAF/BUILDING FIGURE.

FOR BUILDING CONSTRUCTION SERVICES; REAL ESTATE DEVELOPMENT (U.S. CLS. 100, 103 AND 106). FIRST USE 6-21-2012; IN COMMERCE 6-21-2012.

CLASS 37—(Continued).

4,210,697. MERRITT PROPERTIES, LLC, BALTIMORE, MD. SN 85-182,184. PUB. 6-14-2011, FILED 11-22-2010.



NO CLAIM IS MADE TO THE EXCLUSIVE RIGHT TO USE "BUILDING GREEN", APART FROM THE MARK AS SHOWN.

THE MARK CONSISTS OF A FIGURE THAT IS A LEAF ON THE BOTTOM AND THREE BUILDINGS ON THE TOP, WITH THE WORDS "BUILDING GREEN" DIRECTLY BELOW THE FIGURE AND A HORIZONTAL LINE BENEATH THE WORDS "BUILDING GREEN". THE LETTER "M" APPEARS DIRECTLY BELOW THE HORIZONTAL LINE.

FOR BUILDING CONSTRUCTION SERVICES; REAL ESTATE DEVELOPMENT (U.S. CLS. 100, 103 AND 106). FIRST USE 7-12-2011; IN COMMERCE 7-12-2011.

4,210,779. CLEAN CURRENTS, LLC, SILVER SPRING, MD. SN 85-211,921. PUB. 11-15-2011, FILED 1-6-2011.



OWNER OF U.S. REG. NOS. 3,487,020, 3,487,022, AND OTHERS.

NO CLAIM IS MADE TO THE EXCLUSIVE RIGHT TO USE "CLEAN" AND "SOLAR", APART FROM THE MARK AS SHOWN.

THE MARK CONSISTS OF THE WORDING "CLEAN CURRENTS" WITH A DEPICTION OF A SUN WITH A PLUG IN THE MIDDLE AND THE WORD "SOLAR" UNDER THE WORD "CURRENTS".

FOR INSTALLATION AND MAINTENANCE OF ON-SITE RENEWABLE SOLAR ENERGY GENERATION SYSTEMS FOR RESIDENTIAL AND COMMERCIAL USE (U.S. CLS. 100, 103 AND 106). FIRST USE 10-17-2008; IN COMMERCE 10-17-2008.

CLASS 37—(Continued).

4,210,781. CLEAN CURRENTS, LLC, SILVER SPRING, MD. SN 85-211,993. PUB. 11-15-2011, FILED 1-6-2011.



OWNER OF U.S. REG. NOS. 3,487,020, 3,487,022, AND OTHERS.

NO CLAIM IS MADE TO THE EXCLUSIVE RIGHT TO USE "CLEAN" AND "SOLAR", APART FROM THE MARK AS SHOWN.

THE MARK CONSISTS OF THE WORDING "POWERED BY CLEAN CURRENTS SOLAR" SURROUNDING A DEPICTION OF A SUN WITH A PLUG IN THE MIDDLE.

FOR INSTALLATION AND MAINTENANCE OF ON-SITE RENEWABLE SOLAR ENERGY GENERATION SYSTEMS FOR RESIDENTIAL AND COMMERCIAL USE (U.S. CLS. 100, 103 AND 106).

FIRST USE 10-17-2008; IN COMMERCE 10-17-2008.

4,210,924. TRI STATE RESTORATIONS, LLC, ROCKVILLE, MD. SN 85-276,946. PUB. 8-9-2011, FILED 3-25-2011.

Turning Disaster into Peace of Mind

THE MARK CONSISTS OF STANDARD CHARACTERS WITHOUT CLAIM TO ANY PARTICULAR FONT, STYLE, SIZE, OR COLOR.

FOR RESTORATION SERVICES IN THE FIELD OF WATER, SMOKE AND FIRE DAMAGE (U.S. CLS. 100, 103 AND 106).

FIRST USE 5-31-2011; IN COMMERCE 5-31-2011.

CLASS 37—(Continued).

4,210,984. EUROPEAN GREEN RUG SERVICES, LLC, SOUTH HACKENSACK, NJ. SN 85-315,405. PUB. 9-27-2011, FILED 5-9-2011.

RevitaRUGS

THE MARK CONSISTS OF STANDARD CHARACTERS WITHOUT CLAIM TO ANY PARTICULAR FONT, STYLE, SIZE, OR COLOR.

FOR OFF-SITE CLEANING SERVICES FOR TRANSPORTABLE, NON-PERMANENT AREA RUGS (U.S. CLS. 100, 103 AND 106).

FIRST USE 9-1-2011; IN COMMERCE 9-1-2011.

4,211,368. IBROKE LLC, PALM BEACH GARDENS, FL. SN 85-383,953. PUB. 12-27-2011, FILED 7-28-2011.

iBroke

THE MARK CONSISTS OF THE STYLIZED WORD "IBROKE".

FOR REPAIR OF SMARTPHONES (U.S. CLS. 100, 103 AND 106).

FIRST USE 3-15-2011; IN COMMERCE 3-15-2011.

4,211,622. BODINE, JAMES, CENTERVILLE, OH. SN 85-494,657. PUB. 5-1-2012, FILED 12-14-2011.

NIGHT OR DAY...NO OVER TIME TO PAY

THE MARK CONSISTS OF STANDARD CHARACTERS WITHOUT CLAIM TO ANY PARTICULAR FONT, STYLE, SIZE, OR COLOR.

FOR MAINTENANCE, REPAIR AND REPLACEMENT OF HEATING AND AIR CONDITIONING UNITS (U.S. CLS. 100, 103 AND 106).

FIRST USE 2-13-2012; IN COMMERCE 2-27-2012.

CLASS 37—(Continued).

4,211,675. TUFF DECKS, INC., ENGLEWOOD, CO. SN 85-977,225. PUB. 5-17-2011, FILED 1-6-2011.



NO CLAIM IS MADE TO THE EXCLUSIVE RIGHT TO USE "DECKS", APART FROM THE MARK AS SHOWN.

THE MARK CONSISTS OF THE WORD "TUFF" WITH THE LETTER "T" IN THE IMAGE OF A PIECE OF WOOD OR LUMBER APPEARING HORIZONTALLY ABOVE THE LETTERS "UFF", THE WORD "DECKS" WRITTEN VERTICALLY FROM THE BOTTOM GOING UP BEHIND THE WORD "TUFF", AND THE WORDS "COAT IT - DON'T REPLACE IT" WRITTEN BELOW THE WORDS "TUFF DECKS".

FOR APPLICATION OF COATINGS AND SEALERS; APPLICATION OF COATINGS FOR OTHERS, NAMELY, APPLYING PROTECTIVE COATING; APPLICATION OF PROTECTIVE COATINGS; APPLYING PROTECTIVE COATINGS TO DECKS; INSTALLATION AND MAINTENANCE OF DECKS; INSTALLATION OF DECKS; INSTALLATION, MAINTENANCE AND REPAIR OF DECKS; PAINTING AND APPLYING COATINGS TO BUILDING INTERIORS AND BUILDING EXTERIORS (U.S. CLS. 100, 103 AND 106).

FIRST USE 4-19-2011; IN COMMERCE 4-19-2011.

CLASS 38—COMMUNICATION

4,210,423. SUNSHINE ELECTRONIC DISPLAY CORPORATION, ST. JOSEPH, MO. SN 77-908,536. PUB. 6-8-2010, FILED 1-10-2010.

SmartSign

THE MARK CONSISTS OF THE WORD "SMARTSIGN" HAVING THE LETTERS "S" CAPITALIZED.

FOR RADIO FREQUENCY TRANSMISSION OF DATA AND CONTROL SIGNALS TO REMOTE DISPLAY SIGNS FOR PRESENTATION OF INFORMATION ON REMOTE DISPLAY SIGNS (U.S. CLS. 100, 101 AND 104).
FIRST USE 5-1-2012; IN COMMERCE 5-1-2012.

CLASS 38—(Continued).

4,210,575. FIORE, MERCEDES, CORAL GABLES, FL. SN 85-081,904. PUB. 7-12-2011, FILED 7-10-2010.

TELE-ROMANTICA

THE MARK CONSISTS OF STANDARD CHARACTERS WITHOUT CLAIM TO ANY PARTICULAR FONT, STYLE, SIZE, OR COLOR.

THE ENGLISH TRANSLATION OF "ROMANTICA" IN THE MARK IS "ROMANTIC".

FOR TELEVISION BROADCASTING, NAMELY, SPANISH CABLE TELEVISION NETWORK SERVICES IN THE NATURE OF CABLE TELEVISION BROADCASTING (U.S. CLS. 100, 101 AND 104).

FIRST USE 1-19-2012; IN COMMERCE 1-19-2012.

4,210,680. TOKBOX, INC., SAN FRANCISCO, CA. SN 85-164,879. PUB. 3-29-2011, FILED 10-29-2010.

OPENTOK

THE MARK CONSISTS OF STANDARD CHARACTERS WITHOUT CLAIM TO ANY PARTICULAR FONT, STYLE, SIZE, OR COLOR.

FOR COMMUNICATION SERVICES, NAMELY, TRANSMISSION OF VOICE, AUDIO, VIDEO, AND DATA VIA THE INTERNET OR OTHER COMMUNICATIONS NETWORK (U.S. CLS. 100, 101 AND 104).

FIRST USE 11-15-2010; IN COMMERCE 11-15-2010.

4,210,860. VANTIV, LLC, CINCINNATI, OH. SN 85-241,778. PUB. 12-13-2011, FILED 2-14-2011.

VANTIV

THE MARK CONSISTS OF STANDARD CHARACTERS WITHOUT CLAIM TO ANY PARTICULAR FONT, STYLE, SIZE, OR COLOR.

FOR ELECTRONIC TRANSMISSION OF CREDIT CARD, DEBIT CARD, BANK CARD, STORED VALUE CARD, LOYALTY CARD, GIFT CARD, ELECTRONIC BENEFITS, CHECK, MOBILE, ELECTRONIC FUNDS, AND BILL PAYMENT AND TRANSACTION DATA VIA A GLOBAL COMPUTER NETWORK (U.S. CLS. 100, 101 AND 104).

FIRST USE 6-15-2011; IN COMMERCE 6-15-2011.

CLASS 38—(Continued).

4,210,889. I-WIRELESS LLC, NEWPORT, KY. SN 85-254,289. PUB. 5-15-2012, FILED S.R. 3-1-2011; AM. P.R. 7-19-2011.



NO CLAIM IS MADE TO THE EXCLUSIVE RIGHT TO USE "ACCESSWIRELESS", APART FROM THE MARK AS SHOWN.

THE COLOR(S) GREEN AND BLACK IS/ARE CLAIMED AS A FEATURE OF THE MARK.

THE MARK CONSISTS OF THE WORD "ACCESS" IN GREEN, "WIRELESS" IN BLACK AND THREE GREEN ARCS ABOVE A BLACK DOT OVER THE "I" IN "WIRELESS".

FOR TELECOMMUNICATION SERVICES, NAMELY, LOCAL AND LONG DISTANCE TRANSMISSION OF VOICE, DATA, GRAPHICS AND VIDEO BY MEANS OF BROADBAND OPTICAL OR WIRELESS NETWORKS; TELECOMMUNICATION SERVICES, NAMELY, WIRELESS TELEPHONE SERVICES; WIRELESS TELEPHONE TELECOMMUNICATIONS SERVICES, NAMELY, WIRELESS MOBILE TELEPHONE CALLING PLANS (U.S. CLS. 100, 101 AND 104).

FIRST USE 5-31-2011; IN COMMERCE 5-31-2011.

4,210,894. TROUP, JAMES U., WASHINGTON, DC. SN 85-254,925. PUB. 7-5-2011, FILED 3-1-2011.

TeleStride

THE MARK CONSISTS OF STANDARD CHARACTERS WITHOUT CLAIM TO ANY PARTICULAR FONT, STYLE, SIZE, OR COLOR.

FOR COMMUNICATION SERVICES, NAMELY, TRANSMISSION OF VOICE, AUDIO, VISUAL IMAGES AND DATA BY TELECOMMUNICATIONS NETWORKS, WIRELESS COMMUNICATION NETWORKS, THE INTERNET, INFORMATION SERVICES NETWORKS AND DATA NETWORKS; PROVIDING ACCESS TO TELECOMMUNICATION NETWORKS; PROVIDING THIRD PARTY USERS WITH ACCESS TO TELECOMMUNICATION INFRASTRUCTURE; TELECOMMUNICATION ACCESS SERVICES; TELECOMMUNICATION SERVICES, NAMELY, LOCAL AND LONG DISTANCE TRANSMISSION OF VOICE, DATA, GRAPHICS AND VIDEO BY MEANS OF BROADBAND, COPPER AND OPTICAL OR WIRELESS NETWORKS; TELECOMMUNICATION SERVICES, NAMELY, PROVIDING ADVANCED CALLING FEATURES (U.S. CLS. 100, 101 AND 104).

FIRST USE 1-5-2012; IN COMMERCE 1-5-2012.

CLASS 38—(Continued).

4,210,917. FUTURE MEDIA ARCHITECTS, INC., ROAD TOWN, BR. VIRGIN ISLANDS. SN 85-271,084. PUB. 11-1-2011, FILED 3-18-2011.



NO CLAIM IS MADE TO THE EXCLUSIVE RIGHT TO USE THE NON-LATIN CHARACTERS THAT TRANSLITERATE TO "AL MOUNTADA ASSIYASSI AL ARABI" AND "ARABS.COM", APART FROM THE MARK AS SHOWN.

THE MARK CONSISTS OF THE WORDING "FREEDOM OF SPEECH IS A HUMAN RIGHT" BENEATH THE ARABIC WORDING ON THE LEFT; THE WORDING "ARABS.COM" ABOVE THE ARABIC WORDING ON THE RIGHT, ALL OF WHICH IS ENCLOSED WITHIN A RECTANGULAR BOX WITH CURVED CORNERS FEATURING A LIGHT COLORED LEFT PORTION AND DARKER COLORED RIGHT PORTION.

THE ENGLISH TRANSLATION OF THE ARABIC IN THE MARK IS "FREEDOM OF SPEECH IS A HUMAN RIGHT" ON THE LEFT AND THE ARAB POLITICAL FORUM ON THE RIGHT.

THE NON-LATIN CHARACTERS IN THE MARK TRANSLITERATE TO HOURIAT AL RAI HAKON LIKOULI INSAN AND AL MOUNTADA ASSIYASSI AL ARABI AND THIS MEANS "FREEDOM OF SPEECH IS A HUMAN RIGHT" AND ARAB POLITICAL FORUM IN ENGLISH.

FOR ELECTRONIC MAIL SERVICES; ON-LINE CHAT ROOM SERVICES FOR TRANSMISSION OF MESSAGES AMONG COMPUTER USERS ON A WIDE VARIETY OF TOPICS; TRANSMITTING AND STREAMING OF AUDIO AND VIDEO VIA THE INTERNET (U.S. CLS. 100, 101 AND 104).

FIRST USE 5-3-2011; IN COMMERCE 5-3-2011.

4,210,945. RINGCENTRAL, INC., SAN MATEO, CA. SN 85-288,340. PUB. 3-13-2012, FILED 4-6-2011.



NO CLAIM IS MADE TO THE EXCLUSIVE RIGHT TO USE "NO HARDWARE", APART FROM THE MARK AS SHOWN.

CLASS 38—(Continued).

THE MARK CONSISTS OF THE WORDS "NO HARDWARE!" WRITTEN WITHIN A CLOUD.

FOR AUTOMATED TELEPHONE CALL SCREENING SERVICES; AUTOMATED TELEPHONE VOICE MESSAGE SERVICES; CALL BARRING SERVICES; CALL FORWARDING SERVICES; CALL RECORDING SERVICES; CALL SCREENING SERVICES; CELLULAR TELEPHONE SERVICES; COMMUNICATION SERVICES, NAMELY, ELECTRONIC TRANSMISSION OF DATA AND DOCUMENTS AMONG USERS OF COMPUTERS; COMMUNICATION SERVICES, NAMELY, PROVIDING ELECTRONIC TRANSMISSION OF INFORMATION STORED IN A DATABASE VIA INTERACTIVELY COMMUNICATING COMPUTER SYSTEMS; COMMUNICATION SERVICES, NAMELY, TRANSMISSION OF VOICE, AUDIO, VISUAL IMAGES AND DATA BY TELECOMMUNICATIONS NETWORKS, WIRELESS COMMUNICATION NETWORKS, THE INTERNET, INFORMATION SERVICES NETWORKS AND DATA NETWORKS; COMMUNICATIONS SERVICES, NAMELY, TRANSMITTING STREAMED SOUND AND AUDIOVISUAL RECORDINGS VIA THE INTERNET; COMMUNICATIONS VIA MULTINATIONAL TELECOMMUNICATION NETWORKS; COMPUTER NETWORK ACCESS SERVICES BY MEANS OF A METRO ETHERNET; COMPUTER SERVICES, NAMELY, PROVIDING ON-LINE FACILITIES FOR REAL-TIME INTERACTION WITH OTHER COMPUTER USERS CONCERNING TOPICS OF EDUCATION; COMPUTER TELEPHONY SERVICES; COMPUTER TRANSMISSION OF ONLINE BASED SERVICES ACCESSED VIA A NETWORK REFERENCE, NAMELY, A URI, VISUAL CODE, NAMELY, BARCODES, TAG, NAMELY, RFID, TERMINAL, NAMELY, PC OR MOBILE DEVICE, OR ANY COMBINATION THEREOF; COMPUTERIZED TELEPHONY SERVICES; DIGITAL NETWORK TELECOMMUNICATIONS SERVICES; E-MAIL DATA SERVICES; E-MAIL FORWARDING SERVICES; ELECTRONIC MAIL AND MESSAGING SERVICES; ELECTRONIC MAIL SERVICES; ELECTRONIC MAIL SERVICES FOR DATA AND VOICE; ELECTRONIC MESSAGING SYSTEM, NAMELY, ELECTRONIC QUEUING SERVICES; ELECTRONIC ORDER TRANSMISSION SERVICES; ELECTRONIC TRANSMISSION FOR OTHERS OF SECURITIES AND FINANCIAL INFORMATION VIA COMPUTER LINKING SERVICES, NAMELY, COMMUNICATING AND ROUTING TRADE INFORMATION INVOLVING ORDERS, ENTRY AND EXECUTION SERVICES, TO OTHERS VIA A GLOBAL COMPUTER NETWORK; FACSIMILE TRANSMISSION AND RETRIEVAL SERVICES; FIXED AND MOBILE TELEPHONE SERVICES; HOSTED PBX SERVICES; INFORMATION TRANSMISSION SERVICES VIA DIGITAL NETWORKS; INSTANT MESSAGING SERVICES; INTERNET BASED PAGING AND ALERTING SERVICES, NAMELY, PROVIDING A WEB SITE AT WHICH USERS CAN SEND MESSAGES TO ELECTRONIC PAGING DEVICES; INTERNET SERVICES, NAMELY, PROVIDING MULTIPLE-USER ACCESS TO INFORMATION ON THE INTERNET CONCERNING THE DEVELOPMENT AND GENERATION OF COMPUTER SOFTWARE FOR USE IN BUSINESSES AS WELL AS THE FUNCTIONS AND APPLICATION OF SUCH BUSINESS SOFTWARE; INTERNET TELEPHONY SERVICES; LOCAL AND LONG DISTANCE TELEPHONE SERVICES; LONG DISTANCE TELEPHONE COMMUNICATION SERVICES; MESSAGE SENDING AND RECEIVING SERVICES; MOBILE RADIO TELEPHONE SERVICES (U.S. CLS. 100, 101 AND 104).

FIRST USE 4-30-2011; IN COMMERCE 4-30-2011.

CLASS 38—(Continued).

4,211,001. WEINTRAUB TELECOMM, LLC, KING OF PRUSSIA, PA. SN 85-321,398. PUB. 10-11-2011, FILED 5-16-2011.

HEALTHSIGNALS

THE MARK CONSISTS OF STANDARD CHARACTERS WITHOUT CLAIM TO ANY PARTICULAR FONT, STYLE, SIZE, OR COLOR.

FOR COMMUNICATION SERVICES, NAMELY, TRANSMISSION OF VOICE, AUDIO, VISUAL IMAGES AND DATA BY TELECOMMUNICATIONS NETWORKS, WIRELESS COMMUNICATION NETWORKS, THE INTERNET, INFORMATION SERVICES NETWORKS AND DATA NETWORKS; COMMUNICATIONS VIA FIBEROPTIC NETWORKS; ELECTRONIC DELIVERY OF IMAGES AND PHOTOGRAPHS VIA A GLOBAL COMPUTER NETWORK; ELECTRONIC EXCHANGE OF DATA STORED IN DATABASES ACCESSIBLE VIA TELECOMMUNICATION NETWORKS; ELECTRONIC EXCHANGE OF MEDICAL RECORDS ACROSS A NATIONWIDE HEALTH INFORMATION NETWORK; INFORMATION TRANSMISSION SERVICES VIA DIGITAL NETWORKS; INTERACTIVE DELIVERY OF VIDEO OVER DIGITAL NETWORKS; INTERNET SERVICE PROVIDER SERVICES, NAMELY, TRANSMITTING INFORMATION VIA THE INTERNET CONCERNING GLOBAL COMPUTER NETWORK DATA IN THE FIELD OF TELEMEDICINE, TELEHEALTH, VOICE, INTERNET AND TELEVISION SERVICES; PROVIDING A WEB SITE FOR SYNCHRONOUS AND ASYNCHRONOUS COMMUNICATION AND FOR CONNECTION OF PHYSICIANS WITH THEIR PATIENTS REGARDLESS OF MEDICAL ORGANIZATION OR GEOGRAPHIC LOCATION (U.S. CLS. 100, 101 AND 104).

FIRST USE 6-6-2011; IN COMMERCE 6-6-2011.

4,211,164. WIDEOPENWEST FINANCE, LLC, ENGLEWOOD, CO. SN 85-348,036. PUB. 11-1-2011, FILED 6-16-2011.

WOW! ULTRA TV

THE MARK CONSISTS OF STANDARD CHARACTERS WITHOUT CLAIM TO ANY PARTICULAR FONT, STYLE, SIZE, OR COLOR.

NO CLAIM IS MADE TO THE EXCLUSIVE RIGHT TO USE "ULTRA TV", APART FROM THE MARK AS SHOWN. FOR INTERACTIVE DELIVERY OF VIDEO OVER DIGITAL NETWORKS (U.S. CLS. 100, 101 AND 104).

FIRST USE 11-30-2011; IN COMMERCE 11-30-2011.

CLASS 38—(Continued).

4,211,195. PARKTEL, FZE, DUBAI, UNITED ARAB EMIR.
SN 85-350,955. PUB. 11-8-2011, FILED 6-20-2011.



THE COLOR(S) LILAC, PURPLE, BLACK, YELLOW, BLUE, GREEN, PINK, ORANGE IS/ARE CLAIMED AS A FEATURE OF THE MARK.

THE MARK CONSISTS OF THE STYLIZED WORDING "UNNECTO" IN BLACK UNDERNEATH A SERIES OF LILAC, PURPLE, BLACK, YELLOW, BLUE, GREEN, PINK, AND ORANGE TRIANGLES. THE LETTER "O" IN "UNNECTO" HAS A BLACK ARROW POINTING TO THE LEFT.

FOR TELECOMMUNICATION AND WIRELESS COMMUNICATION SERVICES, NAMELY, SATELLITE TRANSMISSION, TELEPHONE COMMUNICATION, TELEGRAM TRANSMISSION, TELETEXT, FACSIMILES AND TELEVISION BROADCASTING, ELECTRONIC VOICE MESSAGING, NAMELY, RECORDING, STORAGE AND SUBSEQUENT TRANSMISSION OF VOICE MESSAGES BY TELEPHONE, VIDEO TELECONFERENCING, ELECTRONIC TRANSMISSION OF VOICE, VOICE TRANSMISSION, VOICE MAIL, DIGITAL TEXT MESSAGING, FACSIMILE MAIL AND PAGING SERVICES; PROVIDING ACCESS TO A FIBER-OPTIC TELECOMMUNICATIONS NETWORK, PROVIDING TELECOMMUNICATION CONNECTIONS TO A GLOBAL COMPUTER NETWORK; PROVIDING MULTIPLE-USER ACCESS TO A GLOBAL COMPUTER INFORMATION NETWORK VIA COMPUTERS, WIRELESS DEVICES, RADIO PAGERS, CELLULAR TELEPHONES AND PERSONAL DIGITAL ASSISTANTS (U.S. CLS. 100, 101 AND 104).

FIRST USE 5-1-2012; IN COMMERCE 5-1-2012.

4,211,644. SHOPITPROFIT.COM, LLC, HYANNIS, MA. SN 85-507,825. PUB. 5-15-2012, FILED 1-3-2012.

REALTY EXCHANGE HUB

THE MARK CONSISTS OF STANDARD CHARACTERS WITHOUT CLAIM TO ANY PARTICULAR FONT, STYLE, SIZE, OR COLOR.

NO CLAIM IS MADE TO THE EXCLUSIVE RIGHT TO USE "REALTY EXCHANGE", APART FROM THE MARK AS SHOWN.

FOR PROVIDING PASSWORD-PROTECTED ONLINE ELECTRONIC BULLETIN BOARDS FOR REGISTERED USERS WHO ARE PARTIES TO A REAL ESTATE TRANSACTION FOR TRANSMISSION OF MESSAGES AND DOCUMENTS RELATING TO THE TRANSACTION AND ITS PROGRESS TO A CLOSING (U.S. CLS. 100, 101 AND 104).

FIRST USE 6-7-2012; IN COMMERCE 6-7-2012.

CLASS 39—TRANSPORTATION AND STORAGE

4,210,363. INTERNATIONAL PLAZA GROUP, INC., MIAMI, FL. SN 77-748,668. PUB. 10-13-2009, FILED 6-1-2009.

PLAZA

THE MARK CONSISTS OF STANDARD CHARACTERS WITHOUT CLAIM TO ANY PARTICULAR FONT, STYLE, SIZE, OR COLOR.

FOR TRANSPORTATION OF PASSENGERS AND LUGGAGE BY BUS (U.S. CLS. 100 AND 105).

FIRST USE 1-1-2012; IN COMMERCE 4-1-2012.

4,210,513. GLOBAL MAIL, INC., WESTON, FL. SN 85-029,692. PUB. 10-25-2011, FILED 5-4-2010.

DHL SMARTMAIL PHARMA SELECT

THE MARK CONSISTS OF STANDARD CHARACTERS WITHOUT CLAIM TO ANY PARTICULAR FONT, STYLE, SIZE, OR COLOR.

NO CLAIM IS MADE TO THE EXCLUSIVE RIGHT TO USE "PHARMA SELECT", APART FROM THE MARK AS SHOWN.

FOR TRANSPORTATION AND DELIVERY SERVICES BY AIR, ROAD, RAIL AND SEA (U.S. CLS. 100 AND 105).

FIRST USE 3-1-2010; IN COMMERCE 3-1-2010.

4,210,639. U-HAUL INTERNATIONAL, INC., PHOENIX, AZ. SN 85-130,983. PUB. 7-5-2011, FILED 9-16-2010.

RAPID SHARE

THE MARK CONSISTS OF STANDARD CHARACTERS WITHOUT CLAIM TO ANY PARTICULAR FONT, STYLE, SIZE, OR COLOR.

FOR RENTAL, MOVING AND STORAGE SERVICES, NAMELY, RENTAL OF MOVING TRUCKS, TRAILERS AND VANS; AND RENTAL, MOVING AND STORAGE OF PORTABLE STORAGE UNITS IN THE NATURE OF STORAGE PODS (U.S. CLS. 100 AND 105).

FIRST USE 7-17-2012; IN COMMERCE 7-17-2012.

CLASS 39—(Continued).

4,210,646. LIFE WITHOUT LAUNDRY, LLC, SOUTH BOSTON, MA. SN 85-137,517. PUB. 3-8-2011, FILED 9-24-2010.

Life Without Laundry

THE MARK CONSISTS OF STANDARD CHARACTERS WITHOUT CLAIM TO ANY PARTICULAR FONT, STYLE, SIZE, OR COLOR.

FOR LAUNDRY PICK-UP AND DELIVERY SERVICES (U.S. CLS. 100 AND 105).

FIRST USE 10-12-2009; IN COMMERCE 10-12-2009.

CLASS 39—(Continued).

4,210,790. BACKSTAGE MOUSE, LLC, PORTLAND, ME. SN 85-214,094. PUB. 5-31-2011, FILED 1-10-2011.



THE MARK CONSISTS OF TWO CIRCLES BETWEEN WHICH ARE THE TERMS "BACKSTAGE" AND "MOUSE.COM" AND TWO STAR DESIGNS AND WITHIN THE INNER CIRCLE IS THE DEPICTION OF A MOUSE WEARING A TIE PEAKING ITS HEAD OUT FROM BEHIND A CURTAIN.

FOR PROVIDING A WEB SITE FEATURING TRAVEL DESTINATION INFORMATION AND COMMENTARY (U.S. CLS. 100 AND 105).

FIRST USE 6-6-2012; IN COMMERCE 6-6-2012.

4,211,090. RIGHT ASCENSION, INC., WARRENDALE, PA. SN 85-338,573. PUB. 11-8-2011, FILED 6-6-2011.

BITBUNKER

THE MARK CONSISTS OF STANDARD CHARACTERS WITHOUT CLAIM TO ANY PARTICULAR FONT, STYLE, SIZE, OR COLOR.

FOR COMPUTER SERVICES, NAMELY, THE PROVISION OF ELECTRONIC LONG-TERM DATA STORAGE SERVICES (U.S. CLS. 100 AND 105).

FIRST USE 5-1-2012; IN COMMERCE 5-1-2012.

BACKSTAGEMOUSE.COM

4,211,261. HERTZ SYSTEM, INC., PARK RIDGE, NJ. SN 85-360,446. PUB. 4-24-2012, FILED 6-30-2011.

HERTZ BUSINESS REWARDS

THE MARK CONSISTS OF STANDARD CHARACTERS WITHOUT CLAIM TO ANY PARTICULAR FONT, STYLE, SIZE, OR COLOR.

FOR PROVIDING A WEB SITE FEATURING TRAVEL DESTINATION INFORMATION AND COMMENTARY (U.S. CLS. 100 AND 105).

FIRST USE 6-6-2012; IN COMMERCE 6-6-2012.

THE MARK CONSISTS OF STANDARD CHARACTERS WITHOUT CLAIM TO ANY PARTICULAR FONT, STYLE, SIZE, OR COLOR.

CLASS 39—(Continued).

OWNER OF U.S. REG. NOS. 614,123, 3,826,294, AND OTHERS.

NO CLAIM IS MADE TO THE EXCLUSIVE RIGHT TO USE "BUSINESS REWARDS", APART FROM THE MARK AS SHOWN.

FOR VEHICLE RENTAL SERVICES (U.S. CLS. 100 AND 105).

FIRST USE 8-15-2011; IN COMMERCE 8-15-2011.

4,211,511. ASTA PARKING, FORT LAUDERDALE, FL. SN 85-442,266. PUB. 3-27-2012, FILED 10-7-2011.



NO CLAIM IS MADE TO THE EXCLUSIVE RIGHT TO USE "PARKING", APART FROM THE MARK AS SHOWN.

THE MARK CONSISTS OF THE LETTERS "AP", BLENDED AS ONE INSIDE A CIRCLE THAT IS OPEN AT THE BOTTOM, AND THE WORDS "ASTA PARKING" TO THE RIGHT OF THE CIRCLE WITH THE WORD "PARKING" BELOW THE WORD "ASTA".

FOR PARKING LOT SERVICES (U.S. CLS. 100 AND 105).

FIRST USE 10-1-2011; IN COMMERCE 10-1-2011.

4,211,560. TABOSKY, ALEJANDRO, WESTON, FL. SN 85-464,611. PUB. 4-24-2012, FILED 11-4-2011.



NO CLAIM IS MADE TO THE EXCLUSIVE RIGHT TO USE "TUCRUCERO.COM", APART FROM THE MARK AS SHOWN.

THE COLOR(S) NAVY BLUE, WHITE, BLUE, AND YELLOW IS/ARE CLAIMED AS A FEATURE OF THE MARK.

THE MARK CONSISTS OF THE WORDS "TUCRUCERO.COM" IN A NAVY BLUE FONT. THE TOP OF THE MARK PRESENTS THE IMAGE OF A CRUISE SHIP. THERE ARE FOUR STRIPE LIKE IMAGES COMPRISING THE TOP OF THE SHIP. AT THE VERY TOP OF THE SHIP ARE TWO SQUARE LIKE IMAGES THAT ARE NAVY BLUE. THE TOP THREE STRIPES ARE NAVY BLUE AND THE FOURTH STRIPE IS BLUE. IN BETWEEN THE STRIPES ARE WHITE SPACES. THE MAIN BODY OF THE SHIP IS NAVY BLUE. TO THE RIGHT OF THE SHIP IS THE IMAGE OF A YELLOW SUN. ON THE FRONT RIGHT OF THE SHIP IS THE IMAGE OF A YELLOW STAR WITH A RAY BEHIND IT. THE ".COM" IS PRESENTED IN A WHITE FONT IN A BLUE SHADED CIRCLE. BELOW THE WORD "TUCRUCERO" ARE TWO STYLIZED LINES A LARGER NAVY BLUE LINE AND SMALLER BLUE LINE UNDERNEATH THE NAVY BLUE LINE.

CLASS 39—(Continued).

THE ENGLISH TRANSLATION OF "TUCRUCERO" IN THE MARK IS "YOUR CRUISE".

FOR TRAVEL, EXCURSION AND CRUISE ARRANGEMENT (U.S. CLS. 100 AND 105).

FIRST USE 10-1-2011; IN COMMERCE 10-1-2011.

4,211,562. FIRST CHOICE MEDICAL SUPPLY, RICHLAND, MS. SN 85-465,060. PUB. 4-17-2012, FILED 11-4-2011.



NO CLAIM IS MADE TO THE EXCLUSIVE RIGHT TO USE "HOME DELIVERY", APART FROM THE MARK AS SHOWN.

THE MARK CONSISTS OF THE WORDS "PATIENT DIRECT" AND "HOME DELIVERY" WITH A LINE SEPARATING "PATIENT DIRECT" AND "HOME DELIVERY" AND A CIRCLE ARROW STARTING AT THE LETTER "H" IN "HOME" AND POINTING TO THE "D" IN "DIRECT". FOR HOME DELIVERY OF MEDICAL SUPPLIES (U.S. CLS. 100 AND 105).

FIRST USE 6-15-2004; IN COMMERCE 6-15-2004.

CLASS 40—MATERIAL TREATMENT

4,210,503. VOYAGER OIL & GAS, INC., BILLINGS, MT. SN 85-019,023. PUB. 11-1-2011, FILED 4-21-2010.

VOYAGER OIL & GAS

THE MARK CONSISTS OF STANDARD CHARACTERS WITHOUT CLAIM TO ANY PARTICULAR FONT, STYLE, SIZE, OR COLOR.

NO CLAIM IS MADE TO THE EXCLUSIVE RIGHT TO USE "OIL & GAS", APART FROM THE MARK AS SHOWN.

FOR OIL AND GAS PRODUCTION SERVICES (U.S. CLS. 100, 103 AND 106).

FIRST USE 4-16-2010; IN COMMERCE 4-16-2010.

CLASS 40—(Continued).

4,210,504. VOYAGER OIL & GAS, INC., BILLINGS, MT. SN 85-019,027. PUB. 11-1-2011, FILED 4-21-2010.



NO CLAIM IS MADE TO THE EXCLUSIVE RIGHT TO USE "OIL & GAS", APART FROM THE MARK AS SHOWN. THE MARK CONSISTS OF A STYLIZED IMAGE OF A FLAME NEXT TO THE WORD "VOYAGER" WITH THE WORDS "OIL & GAS" BELOW.

FOR OIL AND GAS PRODUCTION SERVICES (U.S. CLS. 100, 103 AND 106).
FIRST USE 4-16-2010; IN COMMERCE 4-16-2010.

4,211,331. ARROW SHED, LLC, WAYNE, NJ. SN 85-374,843. PUB. 11-22-2011, FILED 7-19-2011.

EXPLORE YOUR OUTER SPACE

THE MARK CONSISTS OF STANDARD CHARACTERS WITHOUT CLAIM TO ANY PARTICULAR FONT, STYLE, SIZE, OR COLOR.

FOR MANUFACTURING SERVICES FOR OTHERS IN THE FIELD OF STORAGE SHEDS, BUILDINGS, AWNINGS AND GREENHOUSES, REINFORCING MATERIALS FOR SHEDS AND BUILDINGS, CARPORTS, SHELVING, TOOL AND STORAGE RACKS (U.S. CLS. 100, 103 AND 106).

FIRST USE 9-0-2011; IN COMMERCE 9-0-2011.

4,211,574. TURBINE ENGINE COMPONENTS TECHNOLOGIES CORPORATION, THOMASVILLE, GA. SN 85-471,795. PUB. 5-1-2012, FILED 11-14-2011.

TECT POWERPLEX

THE MARK CONSISTS OF STANDARD CHARACTERS WITHOUT CLAIM TO ANY PARTICULAR FONT, STYLE, SIZE, OR COLOR.

OWNER OF U.S. REG. NOS. 2,762,591, 3,957,130, AND OTHERS.

FOR MANUFACTURING SERVICES FOR OTHERS OF ENGINE COMPONENTS, NAMELY, BLISKS AND INTEGRALLY BLADED ROTORS (U.S. CLS. 100, 103 AND 106).

FIRST USE 7-0-2010; IN COMMERCE 6-0-2012.

CLASS 41—EDUCATION AND ENTERTAINMENT

4,210,244. MURPHY, ANNE NILAND, PLANTSVILLE, CT. SN 76-708,013. PUB. 11-22-2011, FILED 6-16-2011.

GRANDMOTHER STORYTELLER

THE MARK CONSISTS OF STANDARD CHARACTERS WITHOUT CLAIM TO ANY PARTICULAR FONT, STYLE, SIZE, OR COLOR.

FOR CONDUCTING SEMINARS IN THE FIELD OF PUBLIC SPEAKING AND WRITING (U.S. CLS. 100, 101 AND 107).

FIRST USE 10-27-2010; IN COMMERCE 10-27-2010.

4,210,253. VOLVO TRADEMARK HOLDING AB, GÖTEBORG, SWEDEN. SN 77-318,170. PUB. 4-21-2009, FILED 10-31-2007.

LIFE AT THE EXTREME

THE MARK CONSISTS OF STANDARD CHARACTERS WITHOUT CLAIM TO ANY PARTICULAR FONT, STYLE, SIZE, OR COLOR.

FOR ORGANIZATION OF SPORT COMPETITIONS AND SPORT EVENTS ARRANGEMENT OF PRIZE COMPETITIONS IN THE FIELD OF YACHT RACING AND SAILING; SPORTING AND CULTURAL ACTIVITIES AND EVENTS SERVICES IN THE NATURE OF ORGANIZING, AND CONDUCTING SPORTS, COMPETITIONS IN THE FIELD OF YACHT RACES AND SAILING (U.S. CLS. 100, 101 AND 107).

FIRST USE 7-0-2010; IN COMMERCE 7-0-2010.

4,210,264. AGELESS ENTERTAINMENT, LLC, WEST PALM BEACH, FL. SN 77-405,265. PUB. 4-28-2009, FILED 2-25-2008.

MOM VS ME

THE MARK CONSISTS OF STANDARD CHARACTERS WITHOUT CLAIM TO ANY PARTICULAR FONT, STYLE, SIZE, OR COLOR.

FOR ENTERTAINMENT SERVICES, NAMELY, PROVIDING A WEBSITE AT WHICH THE GENERAL PUBLIC CAN RECEIVE ADVICE FROM AN INDIVIDUAL CONCERNING RELATIONSHIPS, SUCH ADVICE FOR ENTERTAINMENT PURPOSES ONLY (U.S. CLS. 100, 101 AND 107).

FIRST USE 4-0-2008; IN COMMERCE 4-0-2008.

CLASS 41—(Continued).

4,210,324. EXPLORE ANNENBERG LLC, LOS ANGELES, CA. SN 77-629,028. PUB. 11-10-2009, FILED 12-8-2008.

DOG BLESS YOU

THE MARK CONSISTS OF STANDARD CHARACTERS WITHOUT CLAIM TO ANY PARTICULAR FONT, STYLE, SIZE, OR COLOR.

FOR ENTERTAINMENT SERVICES, NAMELY, PRODUCTION AND DISTRIBUTION OF A SERIES OF PUBLIC SERVICE MULTI-MEDIA PROGRAMS AND MOTION PICTURES DISTRIBUTED VIA VARIOUS PLATFORMS ACROSS MULTIPLE FORMS OF TRANSMISSION MEDIA FEATURING TOPICS CONCERNING PETS (U.S. CLS. 100, 101 AND 107).

FIRST USE 1-0-2005; IN COMMERCE 1-0-2005.

4,210,327. HILL COUNTRY IP, LLC, NEW YORK, NY. SN 77-635,159. PUB. 4-21-2009, FILED 12-17-2008.

HILL COUNTRY

THE MARK CONSISTS OF STANDARD CHARACTERS WITHOUT CLAIM TO ANY PARTICULAR FONT, STYLE, SIZE, OR COLOR.

OWNER OF U.S. REG. NO. 3,325,750.

FOR MUSIC PRODUCTION SERVICES; AUDIO RECORDING AND PRODUCTION; ENTERTAINMENT IN THE NATURE OF LIVE PERFORMANCES BY A MUSICAL ARTIST, MUSICAL GROUP OR MUSICAL BAND; ENTERTAINMENT IN THE NATURE OF VISUAL AND AUDIO PERFORMANCES BY A MUSICAL ARTIST, MUSICAL GROUP AND MUSICAL BAND; ENTERTAINMENT, NAMELY, LIVE MUSIC CONCERTS; ENTERTAINMENT, NAMELY, PERSONAL APPEARANCES BY A MUSICIAN, MUSICAL GROUP OR MUSICAL BAND; ENTERTAINMENT SERVICES, NAMELY, PROVIDING A WEB SITE FEATURING MUSICAL PERFORMANCES, MUSICAL VIDEOS, RELATED FILM CLIPS, PHOTOGRAPHS, AND OTHER MULTIMEDIA MATERIALS (U.S. CLS. 100, 101 AND 107).

FIRST USE 6-0-2007; IN COMMERCE 6-0-2007.

CLASS 41—(Continued).

4,210,340. PIXIE STUFF, L.L.C., ST LOUIS, MO. SN 77-647,837. PUB. 5-5-2009, FILED 1-12-2009.

THE ADVENTURES OF THUMBS UP JOHNNIE

THE MARK CONSISTS OF STANDARD CHARACTERS WITHOUT CLAIM TO ANY PARTICULAR FONT, STYLE, SIZE, OR COLOR.

FOR EDUCATIONAL AND ENTERTAINMENT SERVICES FOR CHILDREN, NAMELY, PERSONAL APPEARANCES BY A COSTUMED CHARACTER; BOOK PUBLISHING; CHARITABLE SERVICES, NAMELY, PROVIDING BOOKS TO PEOPLE; CUSTOM WRITING SERVICES; PROVISION OF EDUCATION AND ENTERTAINMENT FOR CHILDREN BY MEANS OF THE INTERNET, NAMELY, PROVIDING A WEBSITE FEATURING MUSICAL PERFORMANCES, MUSICAL VIDEOS, RELATED FILM CLIPS, PHOTOGRAPHS, AND OTHER MULTIMEDIA MATERIALS FEATURING ANIMATED CHARACTERS, COSTUMED CHARACTERS AND CHILDREN'S STORIES; FAN CLUBS (U.S. CLS. 100, 101 AND 107).

FIRST USE 6-5-2004; IN COMMERCE 10-16-2001.

4,210,349. MINNESOTA VIKINGS FOOTBALL, LLC, EDEN PRAIRIE, MN. SN 77-685,857. PUB. 1-19-2010, FILED 3-6-2009.

MINNESOTA VIKINGS' PURPLE FRIDAY

THE MARK CONSISTS OF STANDARD CHARACTERS WITHOUT CLAIM TO ANY PARTICULAR FONT, STYLE, SIZE, OR COLOR.

OWNER OF U.S. REG. NOS. 997,182, 3,351,349, AND OTHERS.

NO CLAIM IS MADE TO THE EXCLUSIVE RIGHT TO USE "MINNESOTA" AND "FRIDAY", APART FROM THE MARK AS SHOWN.

FOR ENTERTAINMENT SERVICES, NAMELY, PRESENTATIONS IN THE NATURE OF PROFESSIONAL FOOTBALL GAMES AND EXHIBITIONS (U.S. CLS. 100, 101 AND 107).

FIRST USE 7-0-2008; IN COMMERCE 7-0-2008.

CLASS 41—(Continued).

4,210,366. 3:1 CINEMA, LLC, VAIL, CO. SN 77-752,813. PUB. 10-20-2009, FILED 6-5-2009.

3:1 CINEMA

THE MARK CONSISTS OF STANDARD CHARACTERS WITHOUT CLAIM TO ANY PARTICULAR FONT, STYLE, SIZE, OR COLOR.

NO CLAIM IS MADE TO THE EXCLUSIVE RIGHT TO USE "CINEMA", APART FROM THE MARK AS SHOWN.

FOR CINEMATOGRAPHIC ADAPTATION AND EDITING; FILM EDITING; MOVIE STUDIOS; MULTIMEDIA ENTERTAINMENT SERVICES IN THE NATURE OF RECORDING, PRODUCTION AND POST-PRODUCTION SERVICES IN THE FIELDS OF MUSIC, VIDEO, AND FILMS; OPERATING OF FILM STUDIOS; POST-PRODUCTION EDITING SERVICES IN THE FIELD OF MUSIC, VIDEOS AND FILMS; PRODUCTION AND DISTRIBUTION OF MOTION PICTURES; PRODUCTION OF FILMS; PRODUCTION OF TELEVISION PROGRAMS; PROVIDING FACILITIES FOR PRODUCING VIDEO, CINEMA AND PHOTOGRAPHY PRODUCTIONS; WRITTEN TEXT EDITING (U.S. CLS. 100, 101 AND 107).

FIRST USE 5-1-2012; IN COMMERCE 5-1-2012.

CLASS 41—(Continued).

4,210,386. NUNLEY, VANESSA, WHEATON, IL. SN 77-827,159. PUB. 4-13-2010, FILED 9-15-2009.

MORE IS MORE MOM

THE MARK CONSISTS OF STANDARD CHARACTERS WITHOUT CLAIM TO ANY PARTICULAR FONT, STYLE, SIZE, OR COLOR.

FOR PROVIDING A WEBSITE VIA A GLOBAL COMPUTER NETWORK FEATURING INFORMATION AND COMPREHENSIVE CONTENT IN THE FIELDS OF PARENTING CONCERNING EDUCATION AND ENTERTAINMENT OF CHILDREN; PROVIDING A WEBSITE THAT FEATURES INFORMAL INSTRUCTION ON HOME CARE AND HOMEMAKING, DECORATING, COOKING, MANNERS AND ETIQUETTE; ON-LINE JOURNALS, NAMELY, BLOGS FEATURING INFORMATION AND CONTENT IN THE FIELDS OF PARENTING, CHILD CARE, CHILD RAISING AND FAMILIES, HOME CARE AND HOMEMAKING, DECORATING, COOKING, MANNERS, ETIQUETTE, COMMUNITY SERVICE, SUB-URBAN LIFESTYLES, AND WOMEN'S ISSUES (U.S. CLS. 100, 101 AND 107).

FIRST USE 12-2-2009; IN COMMERCE 12-2-2009.

4,210,452. UNG, LAM, SUNNYVALE, CA. SN 77-927,642. PUB. 6-22-2010, FILED 2-4-2010.

ALGER

THE MARK CONSISTS OF STANDARD CHARACTERS WITHOUT CLAIM TO ANY PARTICULAR FONT, STYLE, SIZE, OR COLOR.

FOR EDUCATIONAL SERVICES, NAMELY, CONDUCTING CLASSES, WORKSHOPS, SEMINARS AND LECTURES IN THE FIELD OF FINANCE AND FINANCIAL PLANNING (U.S. CLS. 100, 101 AND 107).

FIRST USE 6-0-2011; IN COMMERCE 6-0-2011.

THE MARK CONSISTS OF THE WORD "MERKAKIS" WITH A STYLIZED MONKEY REPRESENTING THE LETTER "K" AND A STYLIZED BANANA REPRESENTING A CEDILLA BELOW THE "K".

FOR EDITING OR RECORDING OF SOUNDS AND IMAGES; MOVIE STUDIOS; MULTIMEDIA PUBLISHING OF BOOKS, MAGAZINES, JOURNALS, SOFTWARE, GAMES, MUSIC, AND ELECTRONIC PUBLICATIONS; PRODUCTION AND DISTRIBUTION OF MOTION PICTURES; PRODUCTION AND DISTRIBUTION OF TELEVISION SHOWS AND MOVIES; PRODUCTION OF VIDEO AND COMPUTER GAME SOFTWARE; PUBLISHING OF BOOKS, E-BOOKS, AUDIO BOOKS, MUSIC AND ILLUSTRATIONS (U.S. CLS. 100, 101 AND 107).

FIRST USE 1-7-2012; IN COMMERCE 1-7-2012.

CLASS 41—(Continued).

4,210,456. PSYCH-TECH INC., RIVERDALE, NY. SN 77-930,024. PUB. 6-29-2010, FILED 2-7-2010.

Empathy Games

THE MARK CONSISTS OF STANDARD CHARACTERS WITHOUT CLAIM TO ANY PARTICULAR FONT, STYLE, SIZE, OR COLOR.

NO CLAIM IS MADE TO THE EXCLUSIVE RIGHT TO USE "GAMES", APART FROM THE MARK AS SHOWN.

FOR INTERACTIVE ON-LINE TRAINING SERVICES IN THE FIELD OF PERSONAL GROWTH AND RELATIONSHIP ENHANCEMENT (U.S. CLS. 100, 101 AND 107).

FIRST USE 7-19-2012; IN COMMERCE 7-19-2012.

4,210,465. GRAMRO, LLC, NISKAYUNA, NY. SN 77-950,671. PUB. 7-27-2010, FILED 3-4-2010.

Gender Defenders

THE MARK CONSISTS OF STANDARD CHARACTERS WITHOUT CLAIM TO ANY PARTICULAR FONT, STYLE, SIZE, OR COLOR.

FOR ENTERTAINMENT SERVICES IN THE NATURE OF COMEDY SHOWS (U.S. CLS. 100, 101 AND 107).

FIRST USE 1-1-2008; IN COMMERCE 1-1-2008.

4,210,477. INTERNATIONAL LEGAL TECHNOLOGY ASSOCIATION, AUSTIN, TX. SN 77-983,260. PUB. 5-31-2011, FILED 1-8-2010.

LAW2020

THE MARK CONSISTS OF STANDARD CHARACTERS WITHOUT CLAIM TO ANY PARTICULAR FONT, STYLE, SIZE, OR COLOR.

FOR EDUCATIONAL SERVICES, NAMELY, CONDUCTING SEMINARS AND ON-LINE SEMINARS IN THE FIELDS OF FEE STRUCTURE, RISK MITIGATION, TECHNOLOGY, MANAGEMENT, AND BEST PRACTICES FOR THE LEGAL PROFESSION (U.S. CLS. 100, 101 AND 107).

FIRST USE 7-30-2010; IN COMMERCE 7-30-2010.

CLASS 41—(Continued).

4,210,574. ALZHEIMER'S DISEASE AND RELATED DISORDERS ASSOCIATION, INC., CHICAGO, IL. SN 85-080,998. PUB. 12-14-2010, FILED 7-9-2010.

ESSENTIALZ

THE MARK CONSISTS OF STANDARD CHARACTERS WITHOUT CLAIM TO ANY PARTICULAR FONT, STYLE, SIZE, OR COLOR.

FOR EDUCATION SERVICES, NAMELY, PROVIDING CLASSES, SEMINARS AND WORKSHOPS IN THE FIELD OF ALZHEIMER'S DISEASE AND RELATED DISORDERS (U.S. CLS. 100, 101 AND 107).

FIRST USE 10-11-2011; IN COMMERCE 10-11-2011.

4,210,579. SHIPLEY BUSINESS DEVELOPMENT SERVICES, INC., DBA SHIPLEY ASSOCIATES, KAYSVILLE, UT. SN 85-085,004. PUB. 5-24-2011, FILED 7-15-2010.

WE EMPOWER LEARNING

THE MARK CONSISTS OF STANDARD CHARACTERS WITHOUT CLAIM TO ANY PARTICULAR FONT, STYLE, SIZE, OR COLOR.

NO CLAIM IS MADE TO THE EXCLUSIVE RIGHT TO USE "LEARNING", APART FROM THE MARK AS SHOWN.

FOR DEVELOPMENT AND DISSEMINATION OF EDUCATIONAL MATERIALS OF OTHERS IN THE FIELD OF BUSINESS DEVELOPMENT, SALES, COMMUNICATION SKILLS, PROPOSAL DEVELOPMENT, AND CAPTURE PLANNING; EDUCATION SERVICES, NAMELY, PROVIDING ON-LINE WEBINARS, COURSES, AND DISCUSSIONS IN THE FIELD OF PROPOSAL DEVELOPMENT, PROPOSAL WRITING, CAPTURE PLANNING, AND SELLING TO THE GOVERNMENT; EDUCATION SERVICES, NAMELY, CONDUCTING CLASSES, SEMINARS, CONFERENCES, AND WORKSHOPS IN THE FIELD OF PROPOSAL DEVELOPMENT, SALES, CAPTURE PLANNING, BUSINESS DEVELOPMENT, AND PRICE TO WIN IN THE FIELD OF BUSINESS DEVELOPMENT; EDUCATIONAL SERVICES, NAMELY, CONDUCTING ONLINE AND CLASSROOM CLASSES, WORKSHOPS, SEMINARS, AND WEB-BASED TRAINING COURSES IN THE FIELD OF PROPOSAL DEVELOPMENT, SALES, CAPTURE PLANNING, WRITING AND MANAGING PROPOSALS, BUSINESS DEVELOPMENT, PROCESS IMPROVEMENT AND DISTRIBUTION OF PRINTED MATERIALS IN CONNECTION THEREWITH IN HARD COPY OR ELECTRONIC FORMAT ON THE SAME TOPICS (U.S. CLS. 100, 101 AND 107).

FIRST USE 10-4-2009; IN COMMERCE 10-1-2009.

CLASS 41—(Continued).

4,210,592. TRICKSTAR INNOVATIONS LLC, FORMERLY TRICKSTAR INC., WOODMERE, NY. SN 85-094,159. PUB. 1-4-2011, FILED 7-27-2010.

TRICKOMATICS

THE MARK CONSISTS OF STANDARD CHARACTERS WITHOUT CLAIM TO ANY PARTICULAR FONT, STYLE, SIZE, OR COLOR.

FOR EDUCATION SERVICES, NAMELY, PROVIDING ON-LINE INTERACTIVE TUTORIAL SESSIONS AND TUTORIAL SESSIONS FEATURING TEST QUESTIONS IN THE FIELD OF MATHEMATICS; PROVIDING EDUCATIONAL INFORMATION AND TEST QUESTIONS IN THE ACADEMIC FIELD OF MATHEMATICS (U.S. CLS. 100, 101 AND 107).

FIRST USE 10-6-2011; IN COMMERCE 10-6-2011.

4,210,611. RICHEY, KELLY, J, DBA POWERED BY INTENTION, CINCINNATI, OH. SN 85-109,933. PUB. 2-8-2011, FILED 8-18-2010.

Powered By Intention

THE MARK CONSISTS OF STANDARD CHARACTERS WITHOUT CLAIM TO ANY PARTICULAR FONT, STYLE, SIZE, OR COLOR.

FOR PERSONAL COACHING SERVICES IN THE FIELDS OF PERSONAL IMPROVEMENT, SELF-FULFILLMENT AND HEALTHY LIFESTYLES (U.S. CLS. 100, 101 AND 107).

FIRST USE 1-1-2009; IN COMMERCE 1-1-2009.

4,210,613. ARGILA, LINDA, NEW YORK, NY. SN 85-110,901. PUB. 2-15-2011, FILED 8-19-2010.

CHALLENGE TO TRIUMPH

THE MARK CONSISTS OF STANDARD CHARACTERS WITHOUT CLAIM TO ANY PARTICULAR FONT, STYLE, SIZE, OR COLOR.

FOR EDUCATIONAL AND ENTERTAINMENT SERVICES, NAMELY, ORGANIZING AND CONDUCTING MOTIVATIONAL EVENTS FEATURING MOTIVATIONAL AND EDUCATIONAL SPEAKERS; ENTERTAINMENT, NAMELY, A CONTINUING MOTIVATIONAL AND EMPOWERMENT SHOW BROADCAST OVER TELEVISION, SATELLITE, AUDIO, AND VIDEO MEDIA (U.S. CLS. 100, 101 AND 107).

FIRST USE 8-10-2010; IN COMMERCE 8-20-2010.

CLASS 41—(Continued).

4,210,641. HOLMES, THADDEUS J, AKA THADDEUS REX, PORTLAND, IN. SN 85-132,492. PUB. 11-22-2011, FILED 9-17-2010.

Sell it Like a Rock Star

THE MARK CONSISTS OF STANDARD CHARACTERS WITHOUT CLAIM TO ANY PARTICULAR FONT, STYLE, SIZE, OR COLOR.

OWNER OF U.S. REG. NO. 3,897,528.

FOR EDUCATIONAL AND ENTERTAINMENT SERVICES, NAMELY, PROVIDING MOTIVATIONAL AND EDUCATIONAL SPEAKERS (U.S. CLS. 100, 101 AND 107).

FIRST USE 1-31-2011; IN COMMERCE 7-12-2012.

4,210,647. SUMMIT SALON BUSINESS CENTER, PLYMOUTH, MN. SN 85-138,230. PUB. 8-16-2011, FILED 9-25-2010.

Summit Salon

THE MARK CONSISTS OF STANDARD CHARACTERS WITHOUT CLAIM TO ANY PARTICULAR FONT, STYLE, SIZE, OR COLOR.

NO CLAIM IS MADE TO THE EXCLUSIVE RIGHT TO USE "SALON", APART FROM THE MARK AS SHOWN.

FOR EDUCATION AND TRAINING SERVICES IN THE BEAUTY INDUSTRY, NAMELY, PROVIDING CLASSES, SEMINARS, WORKSHOPS AND TUTORIAL SESSIONS REGARDING BEAUTY INDUSTRY BUSINESS OPERATIONS AND SERVICES AND DISTRIBUTION OF COURSE MATERIAL AND WRITTEN CURRICULUM IN CONNECTION THEREWITH (U.S. CLS. 100, 101 AND 107).

FIRST USE 4-30-2012; IN COMMERCE 4-30-2012.

4,210,670. SUPLES, LTD., BOISE, ID. SN 85-158,270. PUB. 2-8-2011, FILED 10-21-2010.

Suples Training Systems

THE MARK CONSISTS OF STANDARD CHARACTERS WITHOUT CLAIM TO ANY PARTICULAR FONT, STYLE, SIZE, OR COLOR.

OWNER OF U.S. REG. NO. 3,132,109.

NO CLAIM IS MADE TO THE EXCLUSIVE RIGHT TO USE "TRAINING SYSTEMS", APART FROM THE MARK AS SHOWN.

CLASS 41—(Continued).

THE WORD(S) "SUPLES" HAS NO MEANING IN A FOREIGN LANGUAGE.

FOR PROVIDING INSTRUCTION AND EQUIPMENT IN THE FIELD OF PHYSICAL EXERCISE AND FITNESS, NAMELY, EXERCISE EQUIPMENT SEMINARS, WORKSHOPS AND GUIDANCE CONSULTATIONS (U.S. CLS. 100, 101 AND 107).

FIRST USE 3-1-2011; IN COMMERCE 3-1-2011.

4,210,681. LIBERTY MEDIA HOLDINGS, LLC, DBA CORBIN FISHER, MIAMI, CA. SN 85-165,330. PUB. 4-19-2011, FILED 10-29-2010.



OWNER OF U.S. REG. NOS. 3,196,073 AND 3,200,827.
NO CLAIM IS MADE TO THE EXCLUSIVE RIGHT TO USE "COEDS", APART FROM THE MARK AS SHOWN.

THE NAME "CORBIN" DOES NOT IDENTIFY A LIVING INDIVIDUAL.

THE COLOR(S) BLUE AND GRAY IS/ARE CLAIMED AS A FEATURE OF THE MARK.

THE MARK CONSISTS OF THE WORDS "CORBIN'S COEDS" WITH A BLUE HUE AT THE TOP OF THE LETTERS FADING TO GRAY AT THE BOTTOM.

FOR PRODUCTION OF DVDS, VIDEOTAPES AND TELEVISION PROGRAMS FEATURING ADULT ENTERTAINMENT; PROVIDING AN ONLINE ADULT WEBSITE FEATURING PHOTOGRAPHS AND VIDEOS IN THE FIELD OF ADULT ENTERTAINMENT; ENTERTAINMENT SERVICES IN THE NATURE OF PROVIDING A WEBSITE ON THE GLOBAL COMPUTER NETWORKS FEATURING INFORMATION IN THE FIELD OF ADULT ENTERTAINMENT; PROVIDING AN ONLINE WEBSITE OF INFORMATION COMPRISING ADULT MATERIAL AND VIEWING THEREOF, AND OTHER ADULT ENTERTAINMENT RELATED MATERIAL (U.S. CLS. 100, 101 AND 107).

FIRST USE 5-31-2011; IN COMMERCE 1-31-2012.

4,210,694. CREDERE ENTERPRISES, LLC, IRVINE, CA. SN 85-181,497. PUB. 6-21-2011, FILED 11-19-2010.



THE MARK CONSISTS OF STANDARD CHARACTERS WITHOUT CLAIM TO ANY PARTICULAR FONT, STYLE, SIZE, OR COLOR.

FOR PROVIDING ONLINE EDUCATIONAL INFORMATION IN THE AREAS OF COLLEGE ADMISSIONS, COLLEGE LOCATIONS, COLLEGE CURRICULUMS OFFERED, AND COLLEGE CONTACT INFORMATION (U.S. CLS. 100, 101 AND 107).

FIRST USE 3-30-2012; IN COMMERCE 3-30-2012.

CLASS 41—(Continued).

4,210,702. TRAVIS, MARK E, DBA CAERUS DEVELOPMENTS, ALBUQUERQUE, NM. SN 85-184,829. PUB. 6-28-2011, FILED S.R. 11-24-2010; AM. P.R. 4-11-2011.

The Dirty Bourbon Dance Hall & Saloon

THE MARK CONSISTS OF STANDARD CHARACTERS WITHOUT CLAIM TO ANY PARTICULAR FONT, STYLE, SIZE, OR COLOR.

NO CLAIM IS MADE TO THE EXCLUSIVE RIGHT TO USE "DANCE HALL & SALOON" FOR CLASS 41, APART FROM THE MARK AS SHOWN.

FOR ARRANGING AND CONDUCTING NIGHTCLUB ENTERTAINMENT EVENTS (U.S. CLS. 100, 101 AND 107).

FIRST USE 3-0-2012; IN COMMERCE 3-0-2012.

4,210,731. MACY'S, INC., CINCINNATI, OH. SN 85-194,548. PUB. 5-10-2011, FILED 12-9-2010.

MILLION DOLLAR MAKEOVER

THE MARK CONSISTS OF STANDARD CHARACTERS WITHOUT CLAIM TO ANY PARTICULAR FONT, STYLE, SIZE, OR COLOR.

NO CLAIM IS MADE TO THE EXCLUSIVE RIGHT TO USE "MAKEOVER", APART FROM THE MARK AS SHOWN.

FOR MAKEOVER CONTESTS (U.S. CLS. 100, 101 AND 107).

FIRST USE 12-0-2010; IN COMMERCE 12-0-2010.

4,210,750. INTERNATIONAL CHURCH OF THE FOUR-SQUARE GOSPEL, LOS ANGELES, CA. SN 85-202,659. PUB. 11-22-2011, FILED 12-21-2010.

IGNITE ACADEMY

THE MARK CONSISTS OF STANDARD CHARACTERS WITHOUT CLAIM TO ANY PARTICULAR FONT, STYLE, SIZE, OR COLOR.

OWNER OF U.S. REG. NO. 3,882,566.

CLASS 41—(Continued).

NO CLAIM IS MADE TO THE EXCLUSIVE RIGHT TO USE "ACADEMY", APART FROM THE MARK AS SHOWN.

FOR EDUCATIONAL SERVICES, NAMELY, LEADERSHIP TRAINING FOR MINISTRY IN GLOBAL MISSIONS AND LOCAL CHURCH OUTREACH; EDUCATIONAL SERVICES, NAMELY, CLASSES, SEMINARS, ON-LINE INSTRUCTION, LOCAL AND FOREIGN FIELD PRACTICUM IN DISCIPLESHIP AND ACADEMIC TRAINING IN THE FIELDS OF BIBLE, CHRISTIAN DOCTRINE, EVANGELISM, CROSS-CULTURAL MINISTRY AND MISSIOLOGY (U.S. CLS. 100, 101 AND 107).

FIRST USE 8-29-2011; IN COMMERCE 8-29-2011.

4,210,784. CALIFORNIA ONLINE POKER ASSOCIATION LLC, LOS ANGELES, CA. SN 85-212,807. PUB. 5-17-2011, FILED 1-7-2011.

COPA

THE MARK CONSISTS OF STANDARD CHARACTERS WITHOUT CLAIM TO ANY PARTICULAR FONT, STYLE, SIZE, OR COLOR.

FOR PROVIDING INSTRUCTIONAL INFORMATION ON POKER; PROVIDING ON-LINE POKER GAMES (U.S. CLS. 100, 101 AND 107).

FIRST USE 11-29-2010; IN COMMERCE 11-29-2010.

4,210,793. MOULENE, KATE, LOS ANGELES, CA. SN 85-215,560. PUB. 6-7-2011, FILED 1-12-2011.

GLOBAL CREATIVE FORUM

THE MARK CONSISTS OF STANDARD CHARACTERS WITHOUT CLAIM TO ANY PARTICULAR FONT, STYLE, SIZE, OR COLOR.

NO CLAIM IS MADE TO THE EXCLUSIVE RIGHT TO USE "GLOBAL" AND "FORUM", APART FROM THE MARK AS SHOWN.

FOR EDUCATION SERVICES, NAMELY, CONDUCTING CLASSES, SEMINARS, WORKSHOPS, PANEL DISCUSSIONS AND FORUMS FEATURING GLOBAL ISSUES IN THE FIELDS OF ENVIRONMENT, EDUCATION, GENDER EQUALITY, HUMAN RIGHTS, PEACE AND SECURITY, HEALTH CARE, DISASTER RELIEF, POVERTY, WORLD HUNGER, CLEAN WATER AND PEACE AND SECURITY; ENTERTAINMENT SERVICES, NAMELY, CONDUCTING CONTESTS (U.S. CLS. 100, 101 AND 107).

FIRST USE 9-1-2010; IN COMMERCE 9-1-2010.

CLASS 41—(Continued).

4,210,826. BRIAN TRAINOR, DBA VECTOR EDUCATION, YORK, ME. SN 85-228,352. PUB. 11-29-2011, FILED 1-27-2011.

vector
education

NO CLAIM IS MADE TO THE EXCLUSIVE RIGHT TO USE "EDUCATION", APART FROM THE MARK AS SHOWN.

THE MARK CONSISTS OF THE WORD, "VECTOR" IN A LOWER CASE, SANS SERIF FONT POSITIONED ABOVE THE WORD "EDUCATION", WHICH IS IN THE SAME, SANS SERIF FONT, BUT OF A PROPORTIONATELY SMALLER POINT SIZE SO THAT THE TWO WORDS ARE APPROXIMATELY EQUAL IN WIDTH.

FOR EDUCATIONAL SERVICES, NAMELY, DEVELOPING AND CONDUCTING TRAINING COURSES AND DISTRIBUTION OF TRAINING MATERIALS IN CONNECTION THEREWITH FOR SUBJECT MATTERS AS REQUESTED BY CUSTOMERS (U.S. CLS. 100, 101 AND 107).

FIRST USE 1-18-2012; IN COMMERCE 1-18-2012.

4,210,848. MISHKEL, GREGORY, SPRINGFIELD, IL. AND KOLLURI, RAGHU, SPRINGFIELD, IL. SN 85-239,368. PUB. 5-8-2012, FILED 2-10-2011.

The
VEINS
VENOUS ENDOVASCULAR
INTERVENTIONAL STRATEGIES

NO CLAIM IS MADE TO THE EXCLUSIVE RIGHT TO USE "THE VEINS VENOUS ENDOVASCULAR INTERVENTIONAL STRATEGIES", APART FROM THE MARK AS SHOWN.

THE MARK CONSISTS OF THE WORDING "THE VEINS VENOUS ENDOVASCULAR INTERVENTIONAL STRATEGIES" AND A SERIES OF THREE CRESCENTS OF VARIOUS DIAMETERS.

FOR ORGANISATION OF CONFERENCES AND SYMPOSIA IN THE FIELD OF MEDICAL SCIENCE (U.S. CLS. 100, 101 AND 107).

FIRST USE 3-1-2011; IN COMMERCE 3-1-2011.

CLASS 41—(Continued).

4,210,886. VIACOM INTERNATIONAL INC., NEW YORK, NY. SN 85-251,734. PUB. 7-5-2011, FILED 2-25-2011.

AWKWARD

THE MARK CONSISTS OF STANDARD CHARACTERS WITHOUT CLAIM TO ANY PARTICULAR FONT, STYLE, SIZE, OR COLOR.

FOR ENTERTAINMENT SERVICES IN THE NATURE OF CONTINUING PROGRAM SERIES ABOUT A TEEN-AGE GIRL COPING WITH THE AFTERMATH OF AN ACCIDENT, FEATURING LIVE ACTION, COMEDY AND DRAMA PROVIDED THROUGH CABLE TELEVISION, BROADCAST TELEVISION, AND THROUGH OTHER DISTRIBUTION PLATFORMS (U.S. CLS. 100, 101 AND 107).

FIRST USE 7-19-2011; IN COMMERCE 7-19-2011.

4,210,916. SCHIRALDI, GLENN R., PH.D., ASHBURN, VA. SN 85-267,282. PUB. 3-20-2012, FILED 3-15-2011.

RESILIENCE TRAINING INTERNATIONAL (RTI)

THE MARK CONSISTS OF STANDARD CHARACTERS WITHOUT CLAIM TO ANY PARTICULAR FONT, STYLE, SIZE, OR COLOR.

NO CLAIM IS MADE TO THE EXCLUSIVE RIGHT TO USE "RESILIENCE TRAINING INTERNATIONAL", APART FROM THE MARK AS SHOWN.

FOR TRAINING SERVICES IN THE FIELD OF MENTAL HEALTH AND PERFORMANCE, RECOVERY, PREVENTION OF STRESS-RELATED MENTAL AND MEDICAL DISORDERS, SELF ESTEEM, AND STRENGTH OF MIND AND BODY, AND DISTRIBUTION OF TRAINING PUBLICATIONS IN CONNECTION THEREWITH (U.S. CLS. 100, 101 AND 107).

FIRST USE 3-17-2011; IN COMMERCE 3-17-2011.

CLASS 41—(Continued).

4,210,940. DEELS, INC., BEVERLY HILLS, CA. SN 85-284,966. PUB. 1-31-2012, FILED 4-4-2011.



NO CLAIM IS MADE TO THE EXCLUSIVE RIGHT TO USE "INC", APART FROM THE MARK AS SHOWN.

THE PORTRAIT IN THE MARK DOES NOT IDENTIFY A LIVING INDIVIDUAL.

THE MARK CONSISTS OF A POSTAGE STAMP WITH A SILHOUETTE OF A WOMAN WITH THE WORDING "DEELS INC" SUPERIMPOSED OVER THE SILHOUETTE.

FOR FILM AND VIDEO PRODUCTION; PRODUCTION AND DISTRIBUTION OF TELEVISION SHOWS AND MOVIES; PRODUCTION OF RADIO AND TELEVISION PROGRAMS (U.S. CLS. 100, 101 AND 107).

FIRST USE 5-27-2012; IN COMMERCE 5-27-2012.

4,210,942. THE ELDER INSIDER, BRADFORD, MA. SN 85-285,813. PUB. 9-20-2011, FILED 4-4-2011.

The Elder Insider

THE MARK CONSISTS OF STANDARD CHARACTERS WITHOUT CLAIM TO ANY PARTICULAR FONT, STYLE, SIZE, OR COLOR.

NO CLAIM IS MADE TO THE EXCLUSIVE RIGHT TO USE "ELDER", APART FROM THE MARK AS SHOWN.

FOR EDUCATION SERVICES, NAMELY, PROVIDING PRESENTATIONS IN THE FIELD OF AGING INDEPENDENTLY (U.S. CLS. 100, 101 AND 107).

FIRST USE 9-1-2011; IN COMMERCE 9-1-2011.

CLASS 41—(Continued).

4,210,961. AGRO-CULTURE LIQUID FERTILIZERS, ST. JOHNS, MI. SN 85-302,546. PUB. 8-23-2011, FILED 4-22-2011.

Nutrients Not Numbers

THE MARK CONSISTS OF STANDARD CHARACTERS WITHOUT CLAIM TO ANY PARTICULAR FONT, STYLE, SIZE, OR COLOR.

NO CLAIM IS MADE TO THE EXCLUSIVE RIGHT TO USE "NUTRIENTS", APART FROM THE MARK AS SHOWN.

FOR EDUCATION SERVICES, NAMELY, PROVIDING LIVE AND ON-LINE WORKSHOPS, SEMINARS, BLOGS IN THE FIELD OF FERTILIZERS, AND PLANT NUTRITION PREPARATIONS (U.S. CLS. 100, 101 AND 107).

FIRST USE 8-0-2011; IN COMMERCE 8-0-2011.

CLASS 41—(Continued).

4,211,097. IMAGE QUEST WORLDWIDE, INC., LAS VEGAS, NV. SN 85-339,792. PUB. 11-15-2011, FILED 6-7-2011.

SCORE!

THE MARK CONSISTS OF STANDARD CHARACTERS WITHOUT CLAIM TO ANY PARTICULAR FONT, STYLE, SIZE, OR COLOR.

FOR MUSEUM SERVICES, NAMELY, EXHIBITING AND DISPLAYING SPORTS MEMORABILIA AND ARTIFACTS, IN THE NATURE OF SPORTS EQUIPMENT, UNIFORMS AND AUTOGRAPHS, AS WELL AS EXHIBITING AND DISPLAYING SPORTS HIGHLIGHTS AND SPORTS HISTORY THROUGH VIDEO AND SOUND RECORDINGS (U.S. CLS. 100, 101 AND 107).

FIRST USE 1-1-2012; IN COMMERCE 1-1-2012.

4,210,993. ANDERSON, LARRY, EDMONTON ALBERTA, CANADA. SN 85-319,901. PUB. 11-22-2011, FILED 5-13-2011.

Live Your MAGIC!

THE MARK CONSISTS OF STANDARD CHARACTERS WITHOUT CLAIM TO ANY PARTICULAR FONT, STYLE, SIZE, OR COLOR.

FOR EDUCATION SERVICES, NAMELY, CONDUCTING SEMINARS, WORKSHOPS, AND COACHING IN THE FIELD OF SELF-HELP AND PERSONAL DEVELOPMENT AND PROVIDING PRINTED MATERIALS THEREWITH (U.S. CLS. 100, 101 AND 107).

FIRST USE 6-1-2011; IN COMMERCE 6-1-2011.

4,211,041. MICHAEL SENA ENTERPRISES INC., DYER, IN. SN 85-330,956. PUB. 11-29-2011, FILED 5-26-2011.

**MICHAEL SENA'S PRO-FIT
PROGRAM FITNESS FOR RESULTS**

THE MARK CONSISTS OF STANDARD CHARACTERS WITHOUT CLAIM TO ANY PARTICULAR FONT, STYLE, SIZE, OR COLOR.

THE NAME(S), PORTRAIT(S), AND/OR SIGNATURE(S) SHOWN IN THE MARK IDENTIFIES "MICHAEL SENA", WHOSE CONSENT(S) TO REGISTER IS MADE OF RECORD.

FOR GROUP TRAINING PROVIDED IN CONNECTION WITH EXERCISE AND WEIGHT LOSS PROGRAMS (U.S. CLS. 100, 101 AND 107).

FIRST USE 10-17-2011; IN COMMERCE 10-17-2011.

4,211,102. FLEMING, RYAN, CARLSBAD, CA. SN 85-340,665. PUB. 11-1-2011, FILED 6-8-2011.

RISE Basketball Systems

THE MARK CONSISTS OF STANDARD CHARACTERS WITHOUT CLAIM TO ANY PARTICULAR FONT, STYLE, SIZE, OR COLOR.

NO CLAIM IS MADE TO THE EXCLUSIVE RIGHT TO USE "BASKETBALL SYSTEMS", APART FROM THE MARK AS SHOWN.

FOR BASKETBALL CAMPS; COACHING IN THE FIELD OF SPORTS; PHYSICAL FITNESS TRAINING SERVICES; SPORTS TRAINING SERVICES (U.S. CLS. 100, 101 AND 107).

FIRST USE 5-20-2012; IN COMMERCE 5-20-2012.

4,211,114. NATHAN GILBERT, CHICAGO, IL. SN 85-342,492. PUB. 11-1-2011, FILED 6-9-2011.

Surround Sound of Fashion

THE MARK CONSISTS OF STANDARD CHARACTERS WITHOUT CLAIM TO ANY PARTICULAR FONT, STYLE, SIZE, OR COLOR.

FOR ENTERTAINMENT IN THE NATURE OF FASHION SHOWS (U.S. CLS. 100, 101 AND 107).

FIRST USE 6-1-2011; IN COMMERCE 6-1-2011.

CLASS 41—(Continued).

4,211,128. TUBLIN, MITCHELL E., STAMFORD, CT. SN 85-344,226. PUB. 11-1-2011, FILED 6-13-2011.

MASTER YOUR MOMENTS

THE MARK CONSISTS OF STANDARD CHARACTERS WITHOUT CLAIM TO ANY PARTICULAR FONT, STYLE, SIZE, OR COLOR.

FOR EDUCATION SERVICES, NAMELY, PROVIDING PUBLIC SPEAKING EVENTS, WORKSHOPS AND SEMINARS IN THE FIELDS OF PERSONAL DEVELOPMENT, SELF-HELP, INSPIRATION AND MOTIVATION AND DISTRIBUTION OF TRAINING MATERIAL IN CONNECTION THEREWITH; LIFE COACHING SERVICES IN THE FIELD OF PERSONAL DEVELOPMENT, SELF-HELP, INSPIRATION AND MOTIVATION; PERSONAL COACHING SERVICES IN THE FIELD OF PERSONAL DEVELOPMENT, SELF-HELP, INSPIRATION AND MOTIVATION; PUBLICATION OF AN E-ZINE; PROVIDING ON-LINE NONDOWNLOADABLE E-ZINES IN THE FIELD OF PERSONAL DEVELOPMENT, SELF-HELP, INSPIRATION AND MOTIVATION (U.S. CLS. 100, 101 AND 107).

FIRST USE 11-0-2011; IN COMMERCE 11-0-2011.

4,211,147. THE MCGRAW-HILL COMPANIES, INC., NEW YORK, NY. SN 85-346,643. PUB. 11-22-2011, FILED 6-15-2011.

MCGRAW-HILL LEARNSMART

THE MARK CONSISTS OF STANDARD CHARACTERS WITHOUT CLAIM TO ANY PARTICULAR FONT, STYLE, SIZE, OR COLOR.

CLASS 41—(Continued).

OWNER OF U.S. REG. NOS. 1,350,345, 3,988,680, AND OTHERS.

FOR PROVIDING EDUCATIONAL INFORMATION FOR THE PURPOSE OF ACADEMIC STUDY, NAMELY, PROVIDING A WEBSITE FEATURING AN INTERACTIVE SELF-ASSESSMENT STUDENT DIAGNOSTIC TOOL FOR STUDENTS IN VARIOUS DISCIPLINES TAUGHT IN THE HIGHER EDUCATION CURRICULUM IN THE ACADEMIC FIELDS OF AMERICAN GOVERNMENT, ANATOMY AND PHYSIOLOGY, DEVELOPMENTAL PSYCHOLOGY, EMR, EMT, FINANCIAL ACCOUNTING, FITNESS AND WELLNESS, PSYCHOLOGY, SOCIOLOGY, BUSINESS, MANAGEMENT, MARKETING, BIOLOGY, MEDICAL ASSISTING, MEDICAL TERMINOLOGY, MICROBIOLOGY, NUTRITION, ORGANIC CHEMISTRY, PERSONAL HEALTH, PHARMACOLOGY, PHYSICAL GEOLOGY; WEBSITE CONTAINING NON-DOWNLOADABLE EDUCATIONAL CONTENT FOR STUDENTS IN VARIOUS DISCIPLINES TAUGHT IN THE HIGHER EDUCATION CURRICULUM, INCLUDING WITHOUT LIMITATION THE FIELDS OF AMERICAN GOVERNMENT, ANATOMY AND PHYSIOLOGY, DEVELOPMENTAL PSYCHOLOGY, EMR, EMT, FINANCIAL ACCOUNTING, FITNESS AND WELLNESS, PSYCHOLOGY, SOCIOLOGY, BUSINESS, MANAGEMENT, MARKETING, BIOLOGY, MEDICAL ASSISTING, MEDICAL TERMINOLOGY, MICROBIOLOGY, NUTRITION, ORGANIC CHEMISTRY, PERSONAL HEALTH, PHARMACOLOGY, PHYSICAL GEOLOGY (U.S. CLS. 100, 101 AND 107).

FIRST USE 8-0-2009; IN COMMERCE 8-0-2009.

4,211,167. GUTIERREZ MENDEZ, GILDARDO, QUERETARO, MEXICO. SN 85-348,188. PUB. 9-13-2011, FILED 6-16-2011.

CEPADE

THE MARK CONSISTS OF STANDARD CHARACTERS WITHOUT CLAIM TO ANY PARTICULAR FONT, STYLE, SIZE, OR COLOR.

FOR EDUCATING AT UNIVERSITY OR COLLEGES; EDUCATION SERVICES IN THE NATURE OF COURSES AT THE UNIVERSITY LEVEL; EDUCATIONAL SERVICES, NAMELY, PROVIDING COURSES OF INSTRUCTION AT THE COLLEGIATE AND POSTGRADUATE LEVEL AND DISTRIBUTION OF COURSE MATERIAL IN CONNECTION THEREWITH; PROVIDING CONTINUING BUSINESS EDUCATION COURSES (U.S. CLS. 100, 101 AND 107).

FIRST USE 5-1-2011; IN COMMERCE 5-1-2011.

CLASS 41—(Continued).

4,211,231. GIBBON, ZACHARY S., GREAT MEADOWS, NJ. SN 85-356,606. PUB. 12-13-2011, FILED 6-27-2011.

ZS Fitness

THE MARK CONSISTS OF STANDARD CHARACTERS WITHOUT CLAIM TO ANY PARTICULAR FONT, STYLE, SIZE, OR COLOR.

NO CLAIM IS MADE TO THE EXCLUSIVE RIGHT TO USE "FITNESS", APART FROM THE MARK AS SHOWN.

FOR PERSONAL FITNESS TRAINING SERVICES AND CONSULTANCY; PHYSICAL FITNESS STUDIO SERVICES, NAMELY, PROVIDING EXERCISE CLASSES, BODY SCULPTING CLASSES, AND GROUP FITNESS CLASSES (U.S. CLS. 100, 101 AND 107).

FIRST USE 12-2-2011; IN COMMERCE 12-2-2011.

4,211,247. SIEBERT, EDWARD J., CULVER CITY, CA. SN 85-358,171. PUB. 5-1-2012, FILED 6-28-2011.



NO CLAIM IS MADE TO THE EXCLUSIVE RIGHT TO USE "NETWORK", APART FROM THE MARK AS SHOWN. THE COLOR(S) WHITE, YELLOW, AND BLACK IS/ARE CLAIMED AS A FEATURE OF THE MARK.

THE MARK CONSISTS OF THE WORDING "IN NETWORK" WITH THE LETTERS "I" & "N" IN WHITE WITH THE DOT IN THE "I" IN YELLOW INSIDE A YELLOW RECTANGLE WITH ROUNDED CORNERS BLENDED INTO A WHITE BACKGROUND AND THE WORDING "NETWORK" IN BLACK.

FOR PROVIDING INFORMATION, NEWS AND COMMENTARY IN THE FIELD OF CURRENT EVENTS RELATING TO JESUIT WORKS (U.S. CLS. 100, 101 AND 107).

FIRST USE 6-14-2011; IN COMMERCE 11-7-2011.

4,211,256. JOHNSON & JOHNSON, NEW BRUNSWICK, NJ. SN 85-359,437. PUB. 10-25-2011, FILED 6-29-2011.

SEE WHAT COULD BE

THE MARK CONSISTS OF STANDARD CHARACTERS WITHOUT CLAIM TO ANY PARTICULAR FONT, STYLE, SIZE, OR COLOR.

CLASS 41—(Continued).

OWNER OF U.S. REG. NO. 3,781,896.

FOR HEALTH EDUCATION PROGRAM REGARDING EYE CARE AND EYE HEALTH (U.S. CLS. 100, 101 AND 107).

FIRST USE 8-31-2011; IN COMMERCE 8-31-2011.

4,211,282. THE MCGRAW-HILL COMPANIES, INC., NEW YORK, NY. SN 85-365,555. PUB. 11-22-2011, FILED 7-7-2011.

PRELAS OBSERVATIONAL ASSESSMENT

THE MARK CONSISTS OF STANDARD CHARACTERS WITHOUT CLAIM TO ANY PARTICULAR FONT, STYLE, SIZE, OR COLOR.

NO CLAIM IS MADE TO THE EXCLUSIVE RIGHT TO USE "OBSERVATIONAL ASSESSMENT", APART FROM THE MARK AS SHOWN.

FOR WEB SITE CONTAINING NON-DOWNLOADABLE STUDENT ASSESSMENT TESTS AND TEACHER TRAINING INFORMATION; TEACHER TRAINING SERVICES IN THE FIELD OF ADMINISTERING TESTS; TEST SCORING SERVICES (U.S. CLS. 100, 101 AND 107).

FIRST USE 12-0-2011; IN COMMERCE 12-0-2011.

4,211,304. COMPETITOR GROUP, INC., SAN DIEGO, CA. SN 85-369,563. PUB. 12-6-2011, FILED 7-12-2011.

KIDS ROCK

THE MARK CONSISTS OF STANDARD CHARACTERS WITHOUT CLAIM TO ANY PARTICULAR FONT, STYLE, SIZE, OR COLOR.

FOR ENTERTAINMENT SERVICES, NAMELY, ARRANGING AND ORGANIZING A SPORTING EVENT IN THE NATURE OF A RUNNING RACE; PROVIDING ENTERTAINMENT EVENTS, NAMELY, ORGANIZING COMMUNITY FESTIVALS FEATURING VENDOR BOOTHS; PARTY PLANNING, NAMELY, PLANNING PARTIES AND SPECIAL-EVENT DINNERS (U.S. CLS. 100, 101 AND 107).

FIRST USE 1-0-2005; IN COMMERCE 1-0-2005.

CLASS 41—(Continued).

4,211,308. BERT RODGERS SCHOOLS OF REAL ESTATE, INC., SARASOTA, FL. SN 85-370,262. PUB. 12-13-2011, FILED 7-13-2011.

CLASS 41—(Continued).

4,211,310. EDUCATION INNOVATOR, LLC, DBA REEDY WOLF, BROOKLINE, MA. SN 85-370,328. PUB. 1-3-2012, FILED 7-13-2011.

YOUR LICENSE TO SUCCESS

THE MARK CONSISTS OF STANDARD CHARACTERS WITHOUT CLAIM TO ANY PARTICULAR FONT, STYLE, SIZE, OR COLOR.

FOR PROVIDING CONTINUING EDUCATION COURSES AND PROFESSIONAL LICENSING COURSES IN THE FIELDS OF REAL ESTATE AGENCY AND BROKERAGE, REAL PROPERTY APPRAISAL, MORTGAGE LENDING, AND COMMUNITY ASSOCIATION MANAGEMENT, AND DISTRIBUTION OF PRINTED MATERIALS IN CONNECTION THEREWITH IN HARD COPY OR ELECTRONIC FORMAT (U.S. CLS. 100, 101 AND 107).

FIRST USE 8-22-2011; IN COMMERCE 8-22-2011.

THE COLOR(S) ORANGE, BLUE, AND RED IS/ARE CLAIMED AS A FEATURE OF THE MARK.

THE MARK CONSISTS OF A RED SHADOW OF A WOLF STANDING ON TOP OF AN ORANGE BANNER. THE ORANGE BANNER ON WHICH THE WOLF IS STANDING CONTAINS THE BLUE WORDS, "REEDY WOLF".

FOR INFORMATION RELATING TO ENTERTAINMENT AND EDUCATION, PROVIDED ON-LINE FROM A COMPUTER DATABASE OR THE INTERNET; PROVIDING A WEBSITE FEATURING INFORMATION IN THE FIELDS OF EDUCATION AND ENTERTAINMENT FOR CHILDREN; PROVIDING INFORMATION ON-LINE RELATING TO EDUCATIONAL OPPORTUNITIES; PROVISION OF INFORMATION RELATING TO EDUCATION SERVICES FOR CHILDREN (U.S. CLS. 100, 101 AND 107).

FIRST USE 10-22-2011; IN COMMERCE 10-22-2011.

4,211,309. EDUCATION INNOVATOR, LLC, DBA REEDY WOLF, BROOKLINE, MA. SN 85-370,310. PUB. 1-3-2012, FILED 7-13-2011.

4,211,317. GENESIS IP, LLC, KENNETT SQUARE, PA. SN 85-372,243. PUB. 11-1-2011, FILED 7-15-2011.

Reedy Wolf**BALANCE IN ACTION**

THE MARK CONSISTS OF STANDARD CHARACTERS WITHOUT CLAIM TO ANY PARTICULAR FONT, STYLE, SIZE, OR COLOR.

FOR INFORMATION RELATING TO ENTERTAINMENT AND EDUCATION, PROVIDED ON-LINE FROM A COMPUTER DATABASE OR THE INTERNET; PROVIDING A WEBSITE FEATURING INFORMATION IN THE FIELDS OF EDUCATION AND ENTERTAINMENT FOR CHILDREN; PROVIDING INFORMATION ON-LINE RELATING TO EDUCATIONAL OPPORTUNITIES; PROVISION OF INFORMATION RELATING TO EDUCATION SERVICES FOR CHILDREN (U.S. CLS. 100, 101 AND 107).

FIRST USE 10-22-2011; IN COMMERCE 10-22-2011.

THE MARK CONSISTS OF STANDARD CHARACTERS WITHOUT CLAIM TO ANY PARTICULAR FONT, STYLE, SIZE, OR COLOR.

FOR PROVIDING EXERCISE SERVICES, NAMELY, STRENGTH TRAINING TO REDUCE THE RISK OF FALLING FOR PHYSICAL REHABILITATION PATIENTS AND RESIDENTS OF ASSISTED LIVING FACILITIES (U.S. CLS. 100, 101 AND 107).

FIRST USE 4-0-2011; IN COMMERCE 4-0-2011.

CLASS 41—(Continued).

4,211,333. ELECTRONIC ARTS INC., REDWOOD CITY, CA. SN 85-374,982. PUB. 12-13-2011, FILED 7-19-2011.

SPY MOUSE

THE MARK CONSISTS OF STANDARD CHARACTERS WITHOUT CLAIM TO ANY PARTICULAR FONT, STYLE, SIZE, OR COLOR.

FOR ENTERTAINMENT SERVICES, NAMELY, PROVIDING AN ON-LINE COMPUTER GAME; PROVISION OF INFORMATION RELATING TO ELECTRONIC COMPUTER GAMES PROVIDED VIA THE INTERNET (U.S. CLS. 100, 101 AND 107).

FIRST USE 8-25-2011; IN COMMERCE 8-25-2011.

4,211,381. THE MO' MUSIC PROJECT LLC, LOS ANGELES, CA. SN 85-388,747. PUB. 1-3-2012, FILED 8-3-2011.

Fresh Boy

THE MARK CONSISTS OF STANDARD CHARACTERS WITHOUT CLAIM TO ANY PARTICULAR FONT, STYLE, SIZE, OR COLOR.

FOR ENTERTAINMENT SERVICES IN THE NATURE OF RECORDING, PRODUCTION AND POST-PRODUCTION SERVICES IN THE FIELD OF MUSIC; ENTERTAINMENT, NAMELY, LIVE PERFORMANCES BY A MUSICAL BAND (U.S. CLS. 100, 101 AND 107).

FIRST USE 1-0-2005; IN COMMERCE 1-0-2005.

4,211,393. WISE, BRANDON M, LAWRENCEVILLE, NJ. SN 85-393,056. PUB. 1-31-2012, FILED 8-9-2011.

Open Shutter Studios

THE MARK CONSISTS OF STANDARD CHARACTERS WITHOUT CLAIM TO ANY PARTICULAR FONT, STYLE, SIZE, OR COLOR.

NO CLAIM IS MADE TO THE EXCLUSIVE RIGHT TO USE "STUDIOS", APART FROM THE MARK AS SHOWN.

FOR AERIAL PHOTOGRAPHY; DIGITAL IMAGING SERVICES; PHOTOGRAPHY; PHOTOGRAPHY SERVICES; PORTRAIT PHOTOGRAPHY; PROVIDING FACILITIES FOR PRODUCING VIDEO, CINEMA AND PHOTOGRAPHY PRODUCTIONS; WEDDING PHOTOGRAPHY SERVICES (U.S. CLS. 100, 101 AND 107).

FIRST USE 4-1-2012; IN COMMERCE 4-15-2012.

CLASS 41—(Continued).

4,211,395. REAVES, RAY, AUSTIN, TX. SN 85-393,598. PUB. 3-27-2012, FILED 8-9-2011.



NO CLAIM IS MADE TO THE EXCLUSIVE RIGHT TO USE "AUSTIN MIND & BODY", APART FROM THE MARK AS SHOWN.

THE COLOR(S) LIGHT BLUE AND NAVY BLUE IS/ARE CLAIMED AS A FEATURE OF THE MARK.

THE MARK CONSISTS OF THE WORDING "AUSTINMB.COM", WHERE THE LETTER "T" IS FORMED BY STYLIZED REPRESENTATION OF A PERSON, AND THE STYLIZED PERSON AND THE LETTERS "MB" APPEAR IN NAVY BLUE, WHILE THE LETTERS "AUS IN" AND ".COM" APPEAR IN LIGHT BLUE. UNDERNEATH, THE WORDING "AUSTIN MIND & BODY" APPEARS IN LIGHT BLUE.

FOR PROVIDING ON-LINE E-ZINES IN THE FIELD OF MIND AND BODY (U.S. CLS. 100, 101 AND 107).

FIRST USE 1-1-2012; IN COMMERCE 1-1-2012.

4,211,407. VIACOM INTERNATIONAL INC., NEW YORK, NY. SN 85-397,675. PUB. 1-10-2012, FILED 8-15-2011.

HOW TO ROCK

THE MARK CONSISTS OF STANDARD CHARACTERS WITHOUT CLAIM TO ANY PARTICULAR FONT, STYLE, SIZE, OR COLOR.

FOR ENTERTAINMENT SERVICES IN THE NATURE OF CONTINUING PROGRAM SERIES, FEATURING LIVE ACTION, COMEDY AND DRAMA PROVIDED THROUGH CABLE TELEVISION, BROADCAST TELEVISION, INTERNET, VIDEO-ON-DEMAND, AND THROUGH OTHER DISTRIBUTION PLATFORMS; PROVIDING ONLINE INFORMATION IN THE FIELD OF ENTERTAINMENT CONCERNING TELEVISION PROGRAMS (U.S. CLS. 100, 101 AND 107).

FIRST USE 2-4-2012; IN COMMERCE 2-4-2012.

CLASS 41—(Continued).

4,211,408. BALAGNA, MARY C., FORSYTH, IL. SN 85-397,804. PUB. 1-17-2012, FILED 8-15-2011.



NO CLAIM IS MADE TO THE EXCLUSIVE RIGHT TO USE "MARATHON", "FINISHING" AND "WINNING", APART FROM THE MARK AS SHOWN.

THE STIPPLING IS FOR SHADING PURPOSES ONLY.

THE MARK CONSISTS OF A STICK FIGURED RUNNER ON THE LEFT, ON THE RIGHT OF THE IMAGE IS THE TEXT "MOVING FORWARD" IN EXTRA-LARGE SIZED FONT AND ITALICIZED, THE TEXT "MARY-THON" CENTERED UNDER ABOVE LINE IN A MEDIUM SIZED FONT, A WAVY LINE CENTERED, AND THE TEXT "FINISHING = WINNING" IN SMALL SIZED FONT AND CENTERED UNDER ABOVE LINES.

FOR PHYSICAL FITNESS CONSULTATION; PROVIDING INFORMATION ON PHYSICAL EXERCISE (U.S. CLS. 100, 101 AND 107).

FIRST USE 7-20-2011; IN COMMERCE 7-20-2011.

4,211,426. MAUZY, PERRY, PAWLEYS ISLAND, SC. SN 85-404,325. PUB. 2-7-2012, FILED 8-23-2011.

PERRYLATES

THE MARK CONSISTS OF STANDARD CHARACTERS WITHOUT CLAIM TO ANY PARTICULAR FONT, STYLE, SIZE, OR COLOR.

FOR CONDUCTING FITNESS CLASSES; PERSONAL FITNESS TRAINING SERVICES AND CONSULTANCY; PROVIDING FITNESS AND EXERCISE STUDIO SERVICES, NAMELY, PILATES INSTRUCTION AND TRAINING; PERSONAL TRAINING SERVICES, NAMELY, STRENGTH AND CONDITIONING TRAINING AND SPEED TRAINING (U.S. CLS. 100, 101 AND 107).

FIRST USE 9-1-2011; IN COMMERCE 9-1-2011.

CLASS 41—(Continued).

4,211,456. MULTISPORTS.COM, LLC, ENCINITAS, CA. SN 85-414,991. PUB. 2-14-2012, FILED 9-5-2011.

DIRT FONDO

THE MARK CONSISTS OF STANDARD CHARACTERS WITHOUT CLAIM TO ANY PARTICULAR FONT, STYLE, SIZE, OR COLOR.

FOR ENTERTAINMENT SERVICES, NAMELY, ARRANGING AND CONDUCTING ATHLETIC COMPETITIONS (U.S. CLS. 100, 101 AND 107).

FIRST USE 8-1-2011; IN COMMERCE 8-1-2011.

4,211,460. EMMIS PUBLISHING, L.P., INDIANAPOLIS, IN. SN 85-416,261. PUB. 3-13-2012, FILED 9-7-2011.

TM DAILY POST

THE MARK CONSISTS OF STANDARD CHARACTERS WITHOUT CLAIM TO ANY PARTICULAR FONT, STYLE, SIZE, OR COLOR.

OWNER OF U.S. REG. NOS. 3,587,889 AND 3,592,016.

NO CLAIM IS MADE TO THE EXCLUSIVE RIGHT TO USE "DAILY POST", APART FROM THE MARK AS SHOWN.

FOR ON-LINE MAGAZINE COLUMN DEALING WITH MATTERS OF GENERAL INTEREST, NAMELY, POPULAR CULTURE, MUSIC, FASHION, THEATER, FILM, FOOD, TRAVEL, SPORTS, POLITICS, ADVENTURE, HUMOR, HEALTH, AND NEWS (U.S. CLS. 100, 101 AND 107).

FIRST USE 12-1-2011; IN COMMERCE 12-1-2011.

4,211,493. MOGAN, CHELSIE, FONTANA, CA. SN 85-433,491. PUB. 3-6-2012, FILED 9-27-2011.

Proud and Pretty in Pink

THE MARK CONSISTS OF STANDARD CHARACTERS WITHOUT CLAIM TO ANY PARTICULAR FONT, STYLE, SIZE, OR COLOR.

FOR EDUCATION SERVICES, NAMELY, PROVIDING SEMINARS, FOCUS GROUPS, AND WORKSHOPS IN THE FIELD OF SEXUAL HEALTH EDUCATION, SELF ESTEEM AND BODY IMAGE (U.S. CLS. 100, 101 AND 107).

FIRST USE 12-10-2011; IN COMMERCE 12-10-2011.

CLASS 41—(Continued).

4,211,505. MAIN SEQUENCE, LTD., ROCHESTER, NY. SN 85-440,498. PUB. 3-20-2012, FILED 10-6-2011.

CARLIN'S CORNER

THE MARK CONSISTS OF STANDARD CHARACTERS WITHOUT CLAIM TO ANY PARTICULAR FONT, STYLE, SIZE, OR COLOR.

THE NAME(S), PORTRAIT(S), AND/OR SIGNATURE(S) SHOWN IN THE MARK DOES NOT IDENTIFY A PARTICULAR LIVING INDIVIDUAL.

FOR ENTERTAINMENT SERVICES, NAMELY, PROVIDING ONGOING AUDIO PROGRAMS FEATURING COMEDY VIA SATELLITE, A GLOBAL COMMUNICATIONS NETWORK, MOBILE TELEPHONE, OR OTHER ELECTRONIC OR DIGITAL COMMUNICATIONS NETWORK OR DEVICE (U.S. CLS. 100, 101 AND 107).

FIRST USE 10-13-2011; IN COMMERCE 10-13-2011.

4,211,519. DISCOVERY COMMUNICATIONS, LLC, SILVER SPRING, MD. SN 85-446,918. PUB. 3-27-2012, FILED 10-13-2011.

REEL CRIME/REAL STORY

THE MARK CONSISTS OF STANDARD CHARACTERS WITHOUT CLAIM TO ANY PARTICULAR FONT, STYLE, SIZE, OR COLOR.

FOR ENTERTAINMENT AND EDUCATIONAL SERVICES IN THE NATURE OF TELEVISION AND MULTIMEDIA PROGRAM SERIES FEATURING SUBJECTS OF GENERAL HUMAN INTEREST DISTRIBUTED VIA VARIOUS PLATFORMS ACROSS MULTIPLE FORMS OF TRANSMISSION MEDIA; PROVIDING ENTERTAINMENT INFORMATION TO OTHERS VIA A GLOBAL COMPUTER NETWORK (U.S. CLS. 100, 101 AND 107).

FIRST USE 5-29-2012; IN COMMERCE 5-29-2012.

4,211,529. EDUCATION CONTINUUM, LLC, ANDOVER, MN. SN 85-450,239. PUB. 3-27-2012, FILED 10-18-2011.

Higher Plain Learning

THE MARK CONSISTS OF STANDARD CHARACTERS WITHOUT CLAIM TO ANY PARTICULAR FONT, STYLE, SIZE, OR COLOR.

CLASS 41—(Continued).

NO CLAIM IS MADE TO THE EXCLUSIVE RIGHT TO USE "LEARNING", APART FROM THE MARK AS SHOWN.

FOR EDUCATIONAL SERVICES, NAMELY, PROVIDING CONTINUING PROFESSIONAL EDUCATION COURSES IN THE FIELD OF TEACHER EDUCATION (U.S. CLS. 100, 101 AND 107).

FIRST USE 1-10-2012; IN COMMERCE 1-23-2012.

4,211,540. ROC RACING INC., DBA NATIONAL HOT ROD DIESEL ASSOCIATION, MARYSVILLE, WA. SN 85-454,796. PUB. 5-8-2012, FILED 10-24-2011.



NO CLAIM IS MADE TO THE EXCLUSIVE RIGHT TO USE "DIESEL" FOR ENTERTAINMENT SERVICES IN THE NATURE OF AUTOMOBILE RACING AND EXHIBITIONS OR "TV" FOR TELEVISION SHOW PRODUCTION, APART FROM THE MARK AS SHOWN.

THE COLOR(S) BLACK, RED AND GRAY IS/ARE CLAIMED AS A FEATURE OF THE MARK.

THE MARK CONSISTS OF THE WORD "DIESEL" IN STYLIZED BLOCK LETTERS IN GRAY AND BLACK WITH A GRAY DROP SHADOW. THE STYLIZED WORD "TV" IN RED AND OUTLINED IN BLACK APPEARS TO THE RIGHT.

FOR ENTERTAINMENT SERVICES IN THE NATURE OF AUTOMOBILE RACING AND EXHIBITIONS; TELEVISION SHOW PRODUCTION (U.S. CLS. 100, 101 AND 107).

FIRST USE 2-1-2012; IN COMMERCE 2-20-2012.

4,211,554. DETROIT ZOOLOGICAL SOCIETY, THE, ROYAL OAK, MI. SN 85-462,083. PUB. 4-17-2012, FILED 11-2-2011.



THE COLOR(S) GREEN IS/ARE CLAIMED AS A FEATURE OF THE MARK.

THE MARK CONSISTS OF A COLLAGE OF LEAVES OF VARIOUS SHADES OF GREEN IN THE SHAPE OF A POLAR BEAR WITH THE WORDS "JOIN US ON THE GREEN JOURNEY" WRITTEN OVER THE BACK OF THE POLAR BEAR IN VARIOUS SHADES OF GREEN.

FOR ANIMAL EXHIBITIONS; EDUCATIONAL SERVICES, NAMELY, CONDUCTING CLASSES, SEMINARS AND WORKSHOPS IN THE FIELD OF ECOLOGY AND ZOOLOGY; RECREATIONAL PARK SERVICES; ZOOS (U.S. CLS. 100, 101 AND 107).

FIRST USE 2-24-2012; IN COMMERCE 2-24-2012.

CLASS 41—(Continued).

4,211,557. HOME INSTEAD, INC., OMAHA, NE. SN 85-462,951. PUB. 3-6-2012, FILED 11-2-2011.

SENIOR HEROES

THE MARK CONSISTS OF STANDARD CHARACTERS WITHOUT CLAIM TO ANY PARTICULAR FONT, STYLE, SIZE, OR COLOR.

NO CLAIM IS MADE TO THE EXCLUSIVE RIGHT TO USE "SENIOR", APART FROM THE MARK AS SHOWN.

FOR PROVIDING RECOGNITION AND INCENTIVES BY THE WAY OF AWARDS AND CONTESTS TO SENIOR CITIZENS WHO DEMONSTRATE EXCELLENCE IN THE FIELD OF COMMUNITY SERVICE (U.S. CLS. 100, 101 AND 107).

FIRST USE 1-8-2012; IN COMMERCE 1-8-2012.

4,211,564. XIST FITNESS LICENSING, LLC, FENTON, MO. SN 85-467,373. PUB. 4-24-2012, FILED 11-8-2011.

XIST

THE MARK CONSISTS OF STANDARD CHARACTERS WITHOUT CLAIM TO ANY PARTICULAR FONT, STYLE, SIZE, OR COLOR.

FOR GYMNASIUMS, NAMELY, PROVIDING PHYSICAL FITNESS AND EXERCISE FACILITIES, PERSONAL FITNESS TRAINING AND CONSULTATION SERVICES, AND EXERCISE, BODY SCULPTING AND GROUP FITNESS CLASSES (U.S. CLS. 100, 101 AND 107).

FIRST USE 1-15-2012; IN COMMERCE 1-15-2012.

4,211,583. THREE ANGELS BROADCASTING NETWORK, INC., WEST FRANKFORT, IL. SN 85-476,376. PUB. 5-1-2012, FILED 11-18-2011.

A Sharper Focus

THE MARK CONSISTS OF STANDARD CHARACTERS WITHOUT CLAIM TO ANY PARTICULAR FONT, STYLE, SIZE, OR COLOR.

FOR EDUCATIONAL AND ENTERTAINMENT SERVICES, NAMELY, A CONTINUING PROGRAM ABOUT RELIGION, NAMELY, A CHRISTIAN PRAYER MEETING AND BIBLE STUDY PROGRAM ACCESSIBLE BY RADIO, TELEVISION, SATELLITE, AUDIO, VIDEO AND COMPUTER NETWORKS (U.S. CLS. 100, 101 AND 107).

FIRST USE 5-1-2012; IN COMMERCE 5-1-2012.

CLASS 41—(Continued).

4,211,603. CARLOS ABREU, BEVERLY HILLS, CA. SN 85-484,431. PUB. 5-15-2012, FILED 11-30-2011.

HOLLYWOOD GIVES BACK AWARDS

THE MARK CONSISTS OF STANDARD CHARACTERS WITHOUT CLAIM TO ANY PARTICULAR FONT, STYLE, SIZE, OR COLOR.

OWNER OF U.S. REG. NO. 3,640,823.

NO CLAIM IS MADE TO THE EXCLUSIVE RIGHT TO USE "HOLLYWOOD AND AWARDS", APART FROM THE MARK AS SHOWN.

FOR PROVIDING RECOGNITION AND INCENTIVES BY THE WAY OF AWARDS TO DEMONSTRATE EXCELLENCE IN THE FIELD OF MOTION PICTURES, TELEVISION, MUSIC, RADIO, AND MULTIMEDIA (U.S. CLS. 100, 101 AND 107).

FIRST USE 3-13-2012; IN COMMERCE 3-13-2012.

4,211,612. KIM, RACHEL, MORGANVILLE, NJ. SN 85-490,791. PUB. 5-15-2012, FILED 12-8-2011.

LET'S LEARN BABY

THE MARK CONSISTS OF STANDARD CHARACTERS WITHOUT CLAIM TO ANY PARTICULAR FONT, STYLE, SIZE, OR COLOR.

FOR EDUCATIONAL SERVICES, NAMELY, PROVIDING A WEBSITE FEATURING NON-DOWNLOADABLE VIDEO CLIPS OF EDUCATIONAL FLASH CARDS IN THE FIELD OF EARLY CHILDHOOD EDUCATION; EDUCATIONAL SERVICES, NAMELY, PROVIDING ONLINE INSTRUCTION IN THE FIELD OF EARLY CHILDHOOD EDUCATION VIA AN ONLINE WEBSITE; PROVIDING A WEBSITE FEATURING INFORMATION IN THE FIELDS OF EDUCATION AND ENTERTAINMENT FOR CHILDREN (U.S. CLS. 100, 101 AND 107).

FIRST USE 4-25-2012; IN COMMERCE 4-25-2012.

4,211,636. BYON, TAE, IRVINE, CA. SN 85-498,597. PUB. 5-22-2012, FILED 12-19-2011.

LOCK AND ROLL TENNIS

THE MARK CONSISTS OF STANDARD CHARACTERS WITHOUT CLAIM TO ANY PARTICULAR FONT, STYLE, SIZE, OR COLOR.

CLASS 41—(Continued).

NO CLAIM IS MADE TO THE EXCLUSIVE RIGHT TO USE "TENNIS", APART FROM THE MARK AS SHOWN.

FOR ENTERTAINMENT AND EDUCATIONAL SERVICES, NAMELY, PROVIDING A WEBSITE THAT FEATURES ARTICLES, NON-DOWNLOADABLE INSTRUCTIONAL VIDEOS AND PHOTOGRAPHS IN THE FIELD OF TENNIS; PROVIDING NON-DOWNLOADABLE ELECTRONIC NEWSLETTERS FEATURING INFORMATION ON TENNIS; ON-LINE JOURNALS, NAMELY, BLOGS FEATURING TENNIS (U.S. CLS. 100, 101 AND 107).

FIRST USE 6-2-2011; IN COMMERCE 12-15-2011.

CLASS 41—(Continued).

4,211,663. GILLOURY INSTITUTE, CHICAGO, IL. SN 85-977,039. PUB. 10-11-2011, FILED 5-4-2011.

SILK ROAD RISING

4,211,637. VISIONARY MOVEMENTS, LLC., HOUSTON, TX. SN 85-499,098. PUB. 5-22-2012, FILED 12-19-2011.



THE MARK CONSISTS OF A CONCRETE SLAB WITH THE WORD "G.R.U.S.T.L.E." ENGRAVED; THE SLAB IS SLIGHTLY SLANTED TO THE LEFT, THE DOLLAR SIGN IS THE CENTER OF THE WORD, AND THE WORD "DIARIES" IS TO THE BOTTOM RIGHT HAND CORNER OF THE SLAB OF CONCRETE CONTAINING "G.R.U.S.T.L.E."

FOR ENTERTAINMENT SERVICES, NAMELY, AN ON-GOING SERIES FEATURING DRAMA PROVIDED THROUGH TELEVISION AND INTERNET (U.S. CLS. 100, 101 AND 107).

FIRST USE 11-21-2011; IN COMMERCE 7-4-2012.

THE MARK CONSISTS OF STANDARD CHARACTERS WITHOUT CLAIM TO ANY PARTICULAR FONT, STYLE, SIZE, OR COLOR.

OWNER OF U.S. REG. NO. 2,987,158.

FOR ENTERTAINMENT, NAMELY, LIVE THEATRICAL PRODUCTIONS, AND ENTERTAINMENT AND EDUCATIONAL SERVICES, NAMELY, A WEB SITE FEATURING VIDEO AND FILMED PERFORMANCES OF THEATRICAL WORKS, VIDEO BLOGS, AND ON-LINE VIDEO AND TEXT TOOLS FOR DEVELOPMENT OF NEW THEATRICAL WORKS (U.S. CLS. 100, 101 AND 107).

FIRST USE 7-1-2011; IN COMMERCE 7-1-2011.

4,211,682. GREGG RITZ IP, LLC, STRATHAM, NH. SN 85-977,310. PUB. 5-17-2011, FILED 5-6-2010.

4,211,646. BUFFALO CHIP CAMPGROUND, LLC, STURGIS, SD. SN 85-511,735. PUB. 4-10-2012, FILED 1-9-2012.

**CROSSROADS AT THE BUFFALO
CHIP**

THE MARK CONSISTS OF STANDARD CHARACTERS WITHOUT CLAIM TO ANY PARTICULAR FONT, STYLE, SIZE, OR COLOR.

OWNER OF U.S. REG. NOS. 3,825,985, 4,007,124, AND OTHERS.

FOR ENTERTAINMENT SERVICES IN THE NATURE OF PRESENTING LIVE MUSICAL PERFORMANCES; PRESENTATION OF LIVE COMEDY SHOWS (U.S. CLS. 100, 101 AND 107).

FIRST USE 2-1-2012; IN COMMERCE 2-1-2012.

PRIMITIVE INSTINCT

THE MARK CONSISTS OF STANDARD CHARACTERS WITHOUT CLAIM TO ANY PARTICULAR FONT, STYLE, SIZE, OR COLOR.

FOR ENTERTAINMENT SERVICES IN THE NATURE OF ONGOING TELEVISION SHOWS, PROGRAMS AND SERIES ABOUT HUNTING; ENTERTAINMENT SERVICES, NAMELY, PROVIDING ONGOING VIDEO SHOWS, PROGRAMS AND SERIES ABOUT HUNTING VIA SATELLITE TELEVISION, TELEVISION BROADCAST, AND CABLE TELEVISION; ENTERTAINMENT SERVICES, NAMELY, PROVIDING NON-DOWNLOADABLE VIDEOS ABOUT HUNTING VIA THE INTERNET; ENTERTAINMENT SERVICES, NAMELY, PROVIDING A WEB SITE FEATURING PHOTOGRAPHIC, AUDIO AND VIDEO PRESENTATIONS FEATURING HUNTING (U.S. CLS. 100, 101 AND 107).

FIRST USE 6-27-2011; IN COMMERCE 6-27-2011.

CLASS 41—(Continued).

4,211,683. KNOWLEDGE ADVENTURE, INC., TORRANCE, CA 90501, CA. SN 85-977,314. PUB. 4-24-2012, FILED 11-14-2011.

Eat my Dust

THE MARK CONSISTS OF STANDARD CHARACTERS WITHOUT CLAIM TO ANY PARTICULAR FONT, STYLE, SIZE, OR COLOR.

FOR ENTERTAINMENT SERVICES, NAMELY, CONDUCTING ALTERNATE REALITY GAMES VIA THE INTERNET; ENTERTAINMENT SERVICES, NAMELY, PROVIDING AN ON-LINE COMPUTER GAME; ENTERTAINMENT SERVICES, NAMELY, PROVIDING ONLINE VIDEO GAMES (U.S. CLS. 100, 101 AND 107).

FIRST USE 10-31-2011; IN COMMERCE 1-11-2012.

CLASS 42—SCIENTIFIC AND COMPUTER SERVICES

4,210,262. ADOBE SYSTEMS INCORPORATED, SAN JOSE, CA. SN 77-381,125. PUB. 10-18-2011, FILED 1-25-2008.

CLICKMAP

THE MARK CONSISTS OF STANDARD CHARACTERS WITHOUT CLAIM TO ANY PARTICULAR FONT, STYLE, SIZE, OR COLOR.

PRIORITY CLAIMED UNDER SEC. 44(D) ON ERPN CMNTY TM OFC APPLICATION NO. 006144265, FILED 7-27-2007.

FOR COMPUTER SERVICES, NAMELY, MANAGEMENT, GATHERING, AND REPORTING WEB ANALYTIC INFORMATION; CONSULTATION RELATED TO WEBSITE DESIGN AND IMPLEMENTATION FOR OTHERS; MONITORING THE WEBSITES OF OTHERS TO OPTIMIZE WEBSITE PROCESSES; WEBSITE DIAGNOSTIC SERVICES; PROVIDING TEMPORARY USE OF NON-DOWNLOADABLE COMPUTER SOFTWARE OVER A GLOBAL COMPUTER NETWORK THAT ALLOWS USERS TO BROWSE THEIR WEBSITES AND VISUALLY UNDERSTAND ANALYTIC DATA DETAILING THE VALUE OF EACH PIECE OF CONTENT ON THE SITE; APPLICATION SERVICE PROVIDER (ASP) SERVICES FEATURING SOFTWARE FOR THAT ALLOWS USERS TO BROWSE THEIR WEBSITES AND VISUALLY UNDERSTAND ANALYTIC DATA DETAILING THE VALUE OF EACH PIECE OF CONTENT ON THE SITE; APPLICATION SERVICE PROVIDER (ASP) SERVICES FEATURING WEB ANALYTICS SOFTWARE; APPLICATION SERVICE PROVIDER (ASP) SERVICES FEATURING SOFTWARE FOR MANAGING, MONITORING, OPTIMIZING, AND DISPLAYING THE PERFORMANCE AND EFFECTIVENESS OF WEBSITES AND WEBSITE CONTENT; APPLICATION SERVICE PROVIDER (ASP) SERVICES FEATURING SOFTWARE FOR COLLECTING, MANAGING, INTEGRATING, AND MONITORING THE PERFORMANCE OF WEBSITES THROUGH WEB USER BEHAVIOR; PROVIDING HOSTED INTERFACES FEATURING WEB ANALYTIC INFORMATION DESIGNED FOR WEBSITE OWNERS; TECHNICAL SUPPORT SERVICES FOR THE AFOREMENTIONED SOFTWARE, NAMELY, MONITORING OF NETWORK

CLASS 42—(Continued).

SYSTEMS AND TROUBLESHOOTING OF COMPUTER SOFTWARE PROBLEMS; COMPUTER CONSULTING SERVICES IN THE FIELDS OF WEB ANALYTICS; PROVIDING TEMPORARY USE OF ONLINE NON-DOWNLOADABLE WEB ANALYTICS SOFTWARE; PROVIDING TEMPORARY USE OF ONLINE NON-DOWNLOADABLE SOFTWARE FOR MANAGING, MONITORING, OPTIMIZING, AND DISPLAYING THE PERFORMANCE AND EFFECTIVENESS OF WEBSITES AND WEBSITE CONTENT; PROVIDING TEMPORARY USE OF ONLINE NON-DOWNLOADABLE SOFTWARE FOR COLLECTING, MANAGING, INTEGRATING, AND MONITORING THE PERFORMANCE OF WEBSITES THROUGH WEB USER BEHAVIOR; COMPUTER PROGRAMMING SERVICES; COMPUTER SERVICES, NAMELY, COMPUTER DIAGNOSTIC SERVICES FOR WEBSITES; COMPUTER SOFTWARE DESIGN, ENGINEERING AND TESTING; UPDATING OF COMPUTER SOFTWARE; APPLICATION SERVICE PROVIDER (ASP), NAMELY, HOSTING SOFTWARE FOR OTHERS (U.S. CLS. 100 AND 101).

FIRST USE 3-10-2003; IN COMMERCE 3-10-2003.

4,210,306. SCISBO, LLC., WILMINGTON, DE. SN 77-599,254. PUB. 4-14-2009, FILED 10-23-2008.

SCISBO

THE MARK CONSISTS OF STANDARD CHARACTERS WITHOUT CLAIM TO ANY PARTICULAR FONT, STYLE, SIZE, OR COLOR.

FOR PROVIDING TEMPORARY USE OF NON-DOWNLOADABLE COMPUTER SOFTWARE FOR WIRELESS DEVICES THAT ALLOWS USERS TO ACCESS INFORMATION (U.S. CLS. 100 AND 101).

FIRST USE 3-30-2012; IN COMMERCE 3-30-2012.

4,210,308. SFE INVESTMENTS, LLC, SAN ANTONIO, TX. SN 77-605,834. PUB. 4-28-2009, FILED 11-3-2008.

MYFACESHEET

THE MARK CONSISTS OF STANDARD CHARACTERS WITHOUT CLAIM TO ANY PARTICULAR FONT, STYLE, SIZE, OR COLOR.

FOR PROVIDING THE TEMPORARY USE OF NON-DOWNLOADABLE SOFTWARE FOR CONNECTING INTERNET-BASED COMPUTER NETWORK USERS IN THE FIELD OF CONNECTING CONSUMERS, INSURANCE CARRIERS, AND EMPLOYERS WITH MEDICAL PROVIDERS, INCLUDING PHYSICIANS OF ALL SPECIALTY TYPES, ANCILLARY PHYSICIAN PROVIDERS OF ALL TYPES, HOSPITALS, AND HEALTHCARE FACILITIES, AND TO INFORMATION ABOUT PHARMACEUTICALS, AND MEDICAL PRODUCTS OF ALL TYPES (U.S. CLS. 100 AND 101).

FIRST USE 7-19-2012; IN COMMERCE 7-19-2012.

CLASS 42—(Continued).

4,210,356. EX LIBRIS (USA) INC., DES PLAINES, IL. SN 77-718,205. PUB. 5-31-2011, FILED 4-21-2009.

CLASS 42—(Continued).

4,210,455. SILVER SPRING NETWORKS, INC., REDWOOD CITY, CA. SN 77-928,455. PUB. 7-19-2011, FILED 2-4-2010.

bX

THE MARK CONSISTS OF STANDARD CHARACTERS WITHOUT CLAIM TO ANY PARTICULAR FONT, STYLE, SIZE, OR COLOR.
FOR COMPUTER SERVICES, NAMELY, PROVIDING SEARCH ENGINES FOR OBTAINING DATA FROM JOURNALS AND OTHER PUBLICATIONS ON A GLOBAL COMPUTER NETWORK, AND FOR PROVIDING PUBLICATION RECOMMENDATIONS (U.S. CLS. 100 AND 101).
FIRST USE 5-1-2009; IN COMMERCE 5-1-2009.

4,210,436. THE BAPTIST STANDARD PUBLISHING COMPANY, DBA FAITHVILLAGE, PLANO, TX. SN 77-915,623. PUB. 6-8-2010, FILED 1-20-2010.

FAITHVILLAGE

THE MARK CONSISTS OF STANDARD CHARACTERS WITHOUT CLAIM TO ANY PARTICULAR FONT, STYLE, SIZE, OR COLOR.
FOR COMPUTER SERVICES, NAMELY, CREATING AN ON-LINE FAITH-BASED COMMUNITY FOR REGISTERED USERS TO PARTICIPATE IN SOCIAL NETWORKING, ENGAGE IN DISCUSSIONS, COLLABORATE WITH PEERS IN VIRTUAL GROUPS, ACCESS RELIGIOUS NEWS, EDUCATION AND ENTERTAINMENT RESOURCES, AND SHARE USER-GENERATED MINISTRY RESOURCES (U.S. CLS. 100 AND 101).
FIRST USE 2-27-2012; IN COMMERCE 2-27-2012.

CUSTOMERIQ

THE MARK CONSISTS OF STANDARD CHARACTERS WITHOUT CLAIM TO ANY PARTICULAR FONT, STYLE, SIZE, OR COLOR.
FOR COMPUTER SERVICES FOR OTHERS, NAMELY, IMPLEMENTING AND OPERATING COMPUTER NETWORKS COMPRISED OF COMPUTER SOFTWARE FOR MONITORING CUSTOMER UTILITY USAGE; SOFTWARE AS A SERVICE (SAAS) SERVICES, NAMELY, HOSTING SOFTWARE FOR USE BY OTHERS FOR MONITORING CUSTOMER UTILITY USAGE; SOFTWARE AS A SERVICE (SAAS) SERVICES, NAMELY, HOSTING SOFTWARE THAT ALLOWS ENERGY CONSUMERS, INCLUDING PUBLIC UTILITY CUSTOMERS, TO VIEW AND MONITOR ENERGY CONSUMPTION; PROVIDING ONLINE NON-DOWNLOADABLE SOFTWARE FOR ENABLING ENERGY CONSUMERS, INCLUDING PUBLIC UTILITY CUSTOMERS, TO TRACK, VIEW, AND MONITOR ENERGY CONSUMPTION INFORMATION, NAMELY, INFORMATION RELATED TO USAGE ANALYSIS, COST ANALYSIS, BILL ANALYSIS, BILL ESTIMATION, ENERGY BUDGETING, NEIGHBORHOOD COMPARISONS, COMMUNITY ANALYSIS, ENVIRONMENTAL ANALYSIS, RATE COMPARISONS, WEATHER MODELING, AND HVAC MODELING, AS WELL AS TO RECEIVE ENERGY-RELATED REPORTS (U.S. CLS. 100 AND 101).
FIRST USE 4-0-2010; IN COMMERCE 4-0-2010.

4,210,475. TRUE FIT CORPORATION, WOBURN, MA. SN 77-983,198. PUB. 9-28-2010, FILED 10-23-2009.

TRUE FIT

THE MARK CONSISTS OF STANDARD CHARACTERS WITHOUT CLAIM TO ANY PARTICULAR FONT, STYLE, SIZE, OR COLOR.
FOR PROVIDING ONLINE NON-DOWNLOADABLE SOFTWARE FOR MATCHING USERS TO APPAREL BASED ON BODY MEASUREMENTS AND HEURISTICS (U.S. CLS. 100 AND 101).
FIRST USE 12-0-2006; IN COMMERCE 12-0-2006.

CLASS 42—(Continued).

4,210,485. LRM INDUSTRIES INTERNATIONAL, INC., ROCKLEDGE, FL. SN 78-981,538. PUB. 5-17-2011, FILED 9-15-2005.

TPF THERMOPLASTIC FLOWFORMING

THE MARK CONSISTS OF STANDARD CHARACTERS WITHOUT CLAIM TO ANY PARTICULAR FONT, STYLE, SIZE, OR COLOR.

NO CLAIM IS MADE TO THE EXCLUSIVE RIGHT TO USE "THERMOPLASTIC FLOWFORMING", APART FROM THE MARK AS SHOWN.

FOR LICENSING OF INTELLECTUAL PROPERTY; DESIGN AND DEVELOPMENT FOR OTHERS OF REINFORCED AND UNREINFORCED PLASTIC PRODUCTS (U.S. CLS. 100 AND 101).

FIRST USE 6-0-2012; IN COMMERCE 6-0-2012.

CLASS 42—(Continued).

4,210,584. SALESFORCE.COM, INC., SAN FRANCISCO, CA. SN 85-090,053. PUB. 10-26-2010, FILED 7-21-2010.

APPQUEST

THE MARK CONSISTS OF STANDARD CHARACTERS WITHOUT CLAIM TO ANY PARTICULAR FONT, STYLE, SIZE, OR COLOR.

FOR PROVIDING TEMPORARY USE OF ONLINE NON-DOWNLOADABLE COMPUTER SOFTWARE APPLICATION DEVELOPMENT TOOLS, EXPRESSLY EXCLUDING MAPPING AND NAVIGATION SERVICES; ONLINE HOSTED COMPUTER SERVICES, NAMELY, DESIGNING, DEVELOPING, AND MAINTAINING COMPUTER SOFTWARE APPLICATIONS FOR OTHERS AND CONSULTING SERVICES RELATED THERETO, EXPRESSLY EXCLUDING MAPPING AND NAVIGATION SERVICES (U.S. CLS. 100 AND 101).

FIRST USE 4-20-2009; IN COMMERCE 4-20-2009.

4,210,657. VIANI, PAUL L., SAN DIEGO, CA. SN 85-151,154. PUB. 3-22-2011, FILED 10-13-2010.

Plans Tonight

THE MARK CONSISTS OF STANDARD CHARACTERS WITHOUT CLAIM TO ANY PARTICULAR FONT, STYLE, SIZE, OR COLOR.

FOR COMPUTER SERVICES, NAMELY, HOSTING ON-LINE INTERACTIVE PUBLIC CALENDARS THAT ALLOW MULTIPLE PARTICIPANTS TO SHARE EVENT SCHEDULES, FACILITY RESERVATIONS, AND TRANSPORTATION REQUESTS; COMPUTER SOFTWARE DEVELOPMENT IN THE FIELD OF MOBILE APPLICATIONS; CUSTOMIZED SOFTWARE DEVELOPMENT IN THE FIELD OF TRAFFIC AND TRANSPORTATION; ENGINEERING SERVICES IN THE FIELDS OF TRAFFIC AND TRANSPORTATION; PROVIDING A SECURE, WEB-BASED SERVICE ENABLING INDIVIDUALS TO REMOTELY CREATE AND MANAGE THEIR OWN ACCOUNTS SO THAT WHATEVER PRIVATE CONTENT THEY UPLOAD NOW CAN BE ENCRYPTED, THEN DELIVERED TO THEIR INTENDED RECIPIENTS, AT THE TIME AND IN THE MANNER REQUESTED; PROVIDING A WEB SITE FEATURING TECHNOLOGY THAT ENABLES INTERNET USERS TO BOOK TRAVEL; TRANSPORTATION AND TRAFFIC PLANNING SERVICES (U.S. CLS. 100 AND 101).

FIRST USE 1-1-2008; IN COMMERCE 1-1-2008.

4,210,506. XO GROUP INC., NEW YORK, NY. SN 85-022,102. PUB. 11-22-2011, FILED 4-23-2010.

SEMPELST

THE MARK CONSISTS OF STANDARD CHARACTERS WITHOUT CLAIM TO ANY PARTICULAR FONT, STYLE, SIZE, OR COLOR.

FOR PROVIDING A WEBSITE FEATURING ON-LINE NON-DOWNLOADABLE SOFTWARE TOOLS FOR CREATING AND OPTIMIZING THIRD PARTY ADVERTISING APPEARING IN A SEARCH ENGINE ENVIRONMENT (U.S. CLS. 100 AND 101).

FIRST USE 6-30-2012; IN COMMERCE 6-30-2012.

CLASS 42—(Continued).

4,210,676. BARNESANDNOBLE.COM LLC, NEW YORK, NY.
SN 85-160,969. PUB. 11-29-2011, FILED 10-26-2010.



The logo for 'nook developer' features the word 'nook' in a lowercase, sans-serif font. The letters 'n', 'o', and 'o' are colored light green, dark green, and purple respectively. The word 'developer' is in a smaller, gray, lowercase, sans-serif font to the right of 'nook'.

NO CLAIM IS MADE TO THE EXCLUSIVE RIGHT TO USE "DEVELOPER", APART FROM THE MARK AS SHOWN.

THE COLOR(S) LIGHT GREEN, DARK GREEN, PURPLE, YELLOW AND GRAY IS/ARE CLAIMED AS A FEATURE OF THE MARK.

THE MARK CONSISTS OF THE WORDS "NOOK" AND "DEVELOPER" IN LOWERCASE LETTERS WITH THE LETTER "N" IN LIGHT GREEN, THE LETTER "O" IN DARK GREEN, THE LETTER "O" IN PURPLE, THE LETTER "K" IN YELLOW AND THE WORD "DEVELOPER" IN GRAY.

FOR COMPUTER SOFTWARE DEVELOPMENT IN THE FIELDS OF PORTABLE ELECTRONIC BOOK READERS AND MOBILE APPLICATIONS; COMPUTER SOFTWARE DEVELOPMENT, COMPUTER PROGRAMMING DEVELOPMENT AND COMPUTER APPLICATION DEVELOPMENT FOR PORTABLE ELECTRONIC BOOK READERS AND MOBILE APPLICATIONS FOR OTHERS; CUSTOMIZED SOFTWARE, SOFTWARE DEVELOPMENT PROGRAMS, APPLICATIONS, ACCESSORIES AND MULTIMEDIA CONTENT DEVELOPMENT IN THE FIELDS OF PORTABLE ELECTRONIC BOOK READERS AND MOBILE APPLICATIONS; PROVIDING TEMPORARY USE OF COMPUTER SOFTWARE, ONLINE FACILITIES AND SOFTWARE DEVELOPMENT PROGRAMS, TOOLS AND APPLICATIONS TO ENABLE USERS TO ACCESS AND DOWNLOAD COMPUTER SOFTWARE, SOFTWARE DEVELOPMENT PROGRAMS AND APPLICATIONS IN THE FIELDS OF PORTABLE ELECTRONIC BOOK READERS AND MOBILE APPLICATIONS; PROVIDING ACCESS TO DOWNLOADABLE COMPUTER SOFTWARE, SOFTWARE DEVELOPMENT PROGRAMS, TOOLS AND APPLICATIONS IN THE FIELDS OF PORTABLE ELECTRONIC BOOK READERS AND MOBILE APPLICATIONS; MAINTENANCE AND UPDATING OF COMPUTER SOFTWARE AND APPLICATIONS; PROVIDING INFORMATION, KNOWLEDGE BASE AND CUSTOMER SUPPORT CONCERNING COMPUTER SOFTWARE, COMPUTER SOFTWARE DEVELOPMENT, COMPUTER PROGRAMMING DEVELOPMENT, PORTABLE ELECTRONIC BOOK READERS AND MOBILE COMPUTER APPLICATIONS VIA THE INTERNET AND OTHER COMPUTER AND ELECTRONIC COMMUNICATION NETWORKS; PROVIDING ONLINE NON-DOWNLOADABLE COMPUTER SOFTWARE THAT GENERATES CUSTOMIZED RECOMMENDATIONS OF SOFTWARE APPLICATIONS BASED ON USER PREFERENCES; PROVIDING SEARCH ENGINES FOR OBTAINING INFORMATION ON COMPUTER SOFTWARE, SOFTWARE DEVELOPMENT PROGRAMS, APPLICATIONS, ACCESSORIES AND DOWNLOADABLE MULTIMEDIA CONTENT VIA ONLINE COMMUNICATIONS NETWORKS (U.S. CLS. 100 AND 101).

FIRST USE 7-23-2012; IN COMMERCE 7-23-2012.

CLASS 42—(Continued).

4,210,742. APPLE INC., CUPERTINO, CA. SN 85-200,964. PUB. 4-17-2012, FILED 12-17-2010.

VOICEPASS

THE MARK CONSISTS OF STANDARD CHARACTERS WITHOUT CLAIM TO ANY PARTICULAR FONT, STYLE, SIZE, OR COLOR.

PRIORITY CLAIMED UNDER SEC. 44(D) ON TRINIDAD/TOBAGO APPLICATION NO. 42396, FILED 6-28-2010.

FOR COMPUTER SERVICES, NAMELY, PROVIDING ONLINE PORTAL FOR TROUBLESHOOTING IN THE NATURE OF DIAGNOSING PROBLEMS RELATING TO COMPUTER HARDWARE, COMPUTER PERIPHERALS, CONSUMER ELECTRONIC DEVICES, COMPUTER SOFTWARE AND COMPUTER NETWORKS; PROVIDING TECHNICAL SUPPORT AND TROUBLESHOOTING INFORMATION VIA THE INTERNET AND VOICE TELECOMMUNICATIONS NETWORKS FOR FIXING PROBLEMS RELATING TO COMPUTER SOFTWARE AND COMPUTER NETWORKS (U.S. CLS. 100 AND 101).
FIRST USE 9-12-2010; IN COMMERCE 9-12-2010.

4,210,817. FIDELITY NATIONAL CARD SERVICES, INC., JACKSONVILLE, FL. SN 85-222,650. PUB. 12-20-2011, FILED 1-20-2011.

EPIX

THE MARK CONSISTS OF STANDARD CHARACTERS WITHOUT CLAIM TO ANY PARTICULAR FONT, STYLE, SIZE, OR COLOR.

FOR COMPUTER SERVICES, NAMELY, CUSTOM ELECTRONIC IMAGING OF PHOTOGRAPHS, ARTWORK, IMAGES, OR OTHER VISUAL MEDIA ONTO CUSTOMIZED CREDIT, DEBIT, INCENTIVE, LOYALTY, GIFT, AND GREETING CARDS, AND ELECTRONIC IMAGING OF PHOTOGRAPHS, ARTWORK, IMAGES, OR OTHER VISUAL MEDIA ONTO CARRIERS FOR ALL OF THE FOREGOING; PHOTOGRAPHIC COMPUTER IMAGING SERVICES FOR COMMERCIAL USE (U.S. CLS. 100 AND 101).

FIRST USE 12-1-2010; IN COMMERCE 12-1-2010.

CLASS 42—(Continued).

4,210,837. MEDIA LINK, INC., DAVENPORT, IA. SN 85-236,227. PUB. 8-30-2011, FILED 2-7-2011.

Media Link Software

THE MARK CONSISTS OF STANDARD CHARACTERS WITHOUT CLAIM TO ANY PARTICULAR FONT, STYLE, SIZE, OR COLOR.

NO CLAIM IS MADE TO THE EXCLUSIVE RIGHT TO USE "MEDIA" AND "SOFTWARE", APART FROM THE MARK AS SHOWN.

FOR PROVIDING TEMPORARY USE OF ON-LINE NON-DOWNLOADABLE COMPUTER SOFTWARE ENABLING AN END USER TO PURCHASE OR PLACE AN ADVERTISEMENT ACROSS MULTIPLE MEDIA FORMATS, PARTICULARLY, CABLE, MAGAZINES, NEWSPAPERS, OUTDOOR, RADIO, TELEVISION AND THE INTERNET; PROVIDING TEMPORARY USE OF ON-LINE NON-DOWNLOADABLE COMPUTER SOFTWARE ENABLING AN END USER TO PRODUCE, GENERATE AND ANALYZE ORDERS FOR PLACEMENT OF ADVERTISEMENTS ACROSS MULTIPLE MEDIA FORMATS, PARTICULARLY, CABLE, MAGAZINES, NEWSPAPERS, OUTDOOR, RADIO, TELEVISION AND THE INTERNET; PROVIDING TEMPORARY USE OF ON-LINE NON-DOWNLOADABLE COMPUTER SOFTWARE ENABLING DATA ANALYSIS, COMPARISON OF DIFFERENT MEDIA OPTIONS AND REPORT GENERATION IN PROPOSAL FORMAT FOR PLACEMENT AND DISSEMINATION OF ADVERTISEMENTS ACROSS MULTIPLE MEDIA FORMATS, PARTICULARLY, CABLE, MAGAZINES, NEWSPAPERS, OUTDOOR, RADIO, TELEVISION AND THE INTERNET (U.S. CLS. 100 AND 101).

FIRST USE 2-8-2011; IN COMMERCE 10-1-2011.

4,210,861. VANTIV, LLC, CINCINNATI, OH. SN 85-241,792. PUB. 12-13-2011, FILED 2-14-2011.

VANTIV

THE MARK CONSISTS OF STANDARD CHARACTERS WITHOUT CLAIM TO ANY PARTICULAR FONT, STYLE, SIZE, OR COLOR.

FOR COMPUTER SERVICES, NAMELY, DESIGNING AND MAINTAINING COMPUTER PROGRAMS FOR OTHERS IN THE AREA OF PAYMENT PROCESSING SERVICES THAT FACILITATE ELECTRONIC PROCESSING, TRANSMISSION, TRANSFER AND BANK ACCOUNT SETTLEMENT OF CREDIT CARD, DEBIT CARD, BANK CARD, STORED VALUE CARD, LOYALTY CARD, GIFT CARD, ELECTRONIC BENEFITS, CHECK, MOBILE, ONLINE, ELECTRONIC FUNDS, AND BILL PAYMENT AND TRANSACTION DATA VIA A GLOBAL COMPUTER NETWORK; DATA ENCRYPTION AND DATA SECURITY SERVICES, NAMELY, PROVIDING SECURITY AND ANONYMITY FOR ELECTRONICALLY TRANSMITTED CREDIT CARD, DEBIT CARD, BANK CARD, STORED VALUE CARD, LOYALTY CARD, GIFT CARD, ELECTRONIC BENEFITS, CHECK, MOBILE, ONLINE, ELECTRONIC FUNDS, AND BILL PAYMENT DATA AND TRANSACTIONS VIA A GLOBAL COMPUTER NETWORK; PROVIDING USE OF ON-LINE, NON-DOWNLOADABLE SOFTWARE FOR USE

CLASS 42—(Continued).

BY ENTITIES, NAMELY, FINANCIAL INSTITUTIONS, MERCHANTS, VALUE-ADDED RESELLERS, SOFTWARE DEALERS AND OTHER PAYMENT PROCESSORS, IN ORDER TO PROCESS CREDIT CARD, DEBIT CARD, BANK CARD, STORED VALUE CARD, LOYALTY CARD, GIFT CARD, ELECTRONIC BENEFITS, CHECK, MOBILE, ONLINE, ELECTRONIC FUNDS, AND BILL PAYMENT TRANSACTIONS VIA A GLOBAL COMPUTER NETWORK; PROVIDING TEMPORARY USE OF ON-LINE NON-DOWNLOADABLE SOFTWARE FOR USE IN ANALYZING CREDIT AND DEBIT CARD EXPENDITURES AND GENERATING REPORTS RELATING THERETO; EQUIPMENT LEASING, NAMELY, LEASING OF COMPUTER HARDWARE AND PERIPHERAL EQUIPMENT FOR USE IN POINT OF SALE TRANSACTIONS; GRAPHIC DESIGN AND ELECTRONIC OR DOWNLOADABLE DELIVERY OF CREDIT CARD, DEBIT CARD, BANK CARD, STORED VALUE CARD, LOYALTY CARD, GIFT CARD TRANSACTION AND PAYMENT PROCESSING REPORTS; GRAPHIC DESIGN OF CREDIT CARD, DEBIT CARD, BANK CARD, STORED VALUE CARD, LOYALTY CARD, GIFT CARDS FOR OTHERS; DELIVERY AND INSTALLATION OF POINT-OF-SALE-TERMINALS AND COMPUTER PAYMENT TERMINALS, AND MOBILE PAYMENT ACCEPTANCE TERMINALS, NAMELY, THROUGH MAILING AND COURIER (U.S. CLS. 100 AND 101).

FIRST USE 6-15-2011; IN COMMERCE 6-15-2011.

4,210,980. HILLS-KAHN, INC., DBA PRMCONNECT, LAS VEGAS, NV. SN 85-310,425. PUB. 11-22-2011, FILED 5-2-2011.

PRMCONNECT

THE MARK CONSISTS OF STANDARD CHARACTERS WITHOUT CLAIM TO ANY PARTICULAR FONT, STYLE, SIZE, OR COLOR.

FOR PROVIDING ONLINE NON-DOWNLOADABLE SOFTWARE THAT MANAGES INFORMATION GATHERED FROM TRADE SHOWS AND OTHER EVENTS, SUCH AS CONFERENCE BADGE AND LEAD INFORMATION, AND DELIVERS AND TRACKS RELEVANT ELECTRONIC LITERATURE (U.S. CLS. 100 AND 101).

FIRST USE 3-11-2009; IN COMMERCE 3-11-2009.

4,211,009. WILLIAM AGEE, SAINT HELENA, CA. SN 85-324,218. PUB. 10-11-2011, FILED 5-18-2011.

HISTORY GUARDIAN

THE MARK CONSISTS OF STANDARD CHARACTERS WITHOUT CLAIM TO ANY PARTICULAR FONT, STYLE, SIZE, OR COLOR.

CLASS 42—(Continued).

NO CLAIM IS MADE TO THE EXCLUSIVE RIGHT TO USE "HISTORY", APART FROM THE MARK AS SHOWN.

FOR CONVERSION OF DATA OR DOCUMENTS FROM PHYSICAL TO ELECTRONIC MEDIA; ELECTRONIC DIGITIZING OF PHOTOGRAPHS INTO A COMPUTER READABLE MEDIA; MEDIA DUPLICATION OF DATA AND DIGITAL INFORMATION; RECORDING DATA FOR OTHERS ON OPTICAL, DIGITAL AND MAGNETIC MEDIA FOR ELECTRONIC STORAGE (U.S. CLS. 100 AND 101).

FIRST USE 11-2-2011; IN COMMERCE 11-2-2011.

4,211,062. INNOVATRIX MARKETING LLC, LONG GROVE, IL. SN 85-335,030. PUB. 10-25-2011, FILED 6-1-2011.

MEMORY-ART-PRINT

THE MARK CONSISTS OF STANDARD CHARACTERS WITHOUT CLAIM TO ANY PARTICULAR FONT, STYLE, SIZE, OR COLOR.

FOR COMPUTER GRAPHICS DESIGN SERVICES, NAMELY, CREATING OF CUSTOM AND NON-CUSTOM PHOTOGRAPHS, PAINTINGS, COLLAGES, PRINTS, WORKS OF ART, GIFTS; COMPUTER SERVICES, NAMELY, ELECTRONIC DIGITIZING OF CUSTOM AND NON-CUSTOM PHOTOGRAPHS, PAINTINGS, COLLAGES, PRINTS, WORKS OF ART, GIFTS; COMPUTER SERVICES, NAMELY, ELECTRONIC IMAGING OF CUSTOM AND NON-CUSTOM PHOTOGRAPHS, PAINTINGS, COLLAGES, PRINTS, WORKS OF ART, GIFTS; CUSTOM DESIGN AND DEVELOPMENT OF CUSTOM AND NON-CUSTOM PHOTOGRAPHS, PAINTINGS, COLLAGES, PRINTS, WORKS OF ART, GIFTS; CUSTOM DESIGN AND ENGINEERING OF CUSTOM AND NON-CUSTOM PHOTOGRAPHS, PAINTINGS, COLLAGES, PRINTS, WORKS OF ART, GIFTS; CUSTOM DESIGN OF CUSTOM AND NON-CUSTOM PHOTOGRAPHS, PAINTINGS, COLLAGES, PRINTS, WORKS OF ART, GIFTS BASED ON PERSONAL SELECTIONS MADE BY THE CUSTOMER; GRAPHIC DESIGN SERVICES FOR CUSTOM AND NON-CUSTOM PHOTOGRAPHS, PAINTINGS, COLLAGES, PRINTS, WORKS OF ART, GIFTS; GRAPHIC ILLUSTRATION AND DRAWING SERVICES, NAMELY, CUSTOM AND NON-CUSTOM PHOTOGRAPHS, PAINTINGS, COLLAGES, PRINTS, WORKS OF ART, GIFTS; GRAPHIC ILLUSTRATION SERVICES FOR OTHERS (U.S. CLS. 100 AND 101).

FIRST USE 6-10-2012; IN COMMERCE 6-10-2012.

4,211,063. INNOVATRIX MARKETING LLC, LONG GROVE, IL. SN 85-335,107. PUB. 10-25-2011, FILED 6-1-2011.

HAPPINESS GUARANTEE

THE MARK CONSISTS OF STANDARD CHARACTERS WITHOUT CLAIM TO ANY PARTICULAR FONT, STYLE, SIZE, OR COLOR.

CLASS 42—(Continued).

NO CLAIM IS MADE TO THE EXCLUSIVE RIGHT TO USE "GUARANTEE", APART FROM THE MARK AS SHOWN.

FOR COMPUTER GRAPHICS DESIGN SERVICES, NAMELY, CREATING OF CUSTOM AND NON-CUSTOM PHOTOGRAPHS, PAINTINGS, COLLAGES, PRINTS, WORKS OF ART, GIFTS; CUSTOM DESIGN AND ENGINEERING OF PHOTOGRAPHS, PAINTINGS, COLLAGES, PRINTS, WORKS OF ART, GIFTS; CUSTOM DESIGN OF PHOTOGRAPHS, PAINTINGS, COLLAGES, PRINTS, WORKS OF ART, GIFTS BASED ON PERSONAL SELECTIONS MADE BY THE CUSTOMER (U.S. CLS. 100 AND 101).

FIRST USE 6-10-2012; IN COMMERCE 6-10-2012.

4,211,115. BRACKET RACKET LLC, RICHMOND, VA. SN 85-342,645. PUB. 11-1-2011, FILED 6-9-2011.

Bracket Racket

THE MARK CONSISTS OF STANDARD CHARACTERS WITHOUT CLAIM TO ANY PARTICULAR FONT, STYLE, SIZE, OR COLOR.

FOR COMPUTER SERVICES, NAMELY, CREATING AN ON-LINE COMMUNITY FOR REGISTERED USERS TO PARTICIPATE IN QUIZZES, CREATE QUIZZES, SEND/RECEIVE FEEDBACK FROM THEIR PEERS (U.S. CLS. 100 AND 101).

FIRST USE 6-26-2012; IN COMMERCE 6-26-2012.

4,211,121. YOUFINITY, LLC, ATLANTA, GA. SN 85-343,202. PUB. 11-1-2011, FILED 6-10-2011.

YouFinity

THE MARK CONSISTS OF STANDARD CHARACTERS WITHOUT CLAIM TO ANY PARTICULAR FONT, STYLE, SIZE, OR COLOR.

FOR COMPUTER SERVICES, NAMELY, CREATING AN ON-LINE COMMUNITY FOR REGISTERED USERS TO POST EXTENSIVE INFORMATION ABOUT THEMSELVES, CONNECT WITH THEIR FRIENDS, AND THEN SEE GIFT-GIVING RECOMMENDATIONS FOR THEMSELVES AND THEIR CONNECTIONS (U.S. CLS. 100 AND 101).

FIRST USE 12-29-2006; IN COMMERCE 9-1-2011.

CLASS 42—(Continued).

4,211,124. HUBSPAN, INC., SEATTLE, WA. SN 85-343,365. PUB. 11-8-2011, FILED 6-10-2011.

WEBSpan SNAPSHOT

THE MARK CONSISTS OF STANDARD CHARACTERS WITHOUT CLAIM TO ANY PARTICULAR FONT, STYLE, SIZE, OR COLOR.

FOR COMPUTER SERVICES, NAMELY, A HOSTED COLLABORATION INFRASTRUCTURE TO ENABLE THE AUTOMATED COLLECTION, TRANSFORMATION AND TRANSMISSION OF DATA AND INFORMATION VIA A COMMUNICATIONS NETWORK (U.S. CLS. 100 AND 101).

FIRST USE 8-23-2011; IN COMMERCE 8-23-2011.

4,211,161. OTX SYSTEMS LTD., CALGARY, ALBERTA, CANADA. SN 85-347,953. PUB. 11-8-2011, FILED 6-16-2011.

OTXGIS

THE MARK CONSISTS OF STANDARD CHARACTERS WITHOUT CLAIM TO ANY PARTICULAR FONT, STYLE, SIZE, OR COLOR.

FOR ENGINEERING SERVICES IN THE FIELD OF THE CUSTOM DESIGN AND DEVELOPMENT OF MAPPING SOFTWARE FOR OTHERS (U.S. CLS. 100 AND 101).

FIRST USE 4-23-2012; IN COMMERCE 4-23-2012.

4,211,196. PROXIBID, INC., OMAHA, NE. SN 85-351,547. PUB. 11-8-2011, FILED 6-21-2011.

AUCTIONGUARD

THE MARK CONSISTS OF STANDARD CHARACTERS WITHOUT CLAIM TO ANY PARTICULAR FONT, STYLE, SIZE, OR COLOR.

FOR APPLICATION SERVICE PROVIDER FEATURING SOFTWARE FOR USE BY ONLINE AUCTION COMPANIES TO DETERMINE THE RISK ASSOCIATED WITH A POTENTIAL BIDDER (U.S. CLS. 100 AND 101).

FIRST USE 11-15-2011; IN COMMERCE 11-15-2011.

CLASS 42—(Continued).

4,211,197. HARPO, INC., CHICAGO, IL. SN 85-351,691. PUB. 11-1-2011, FILED 6-21-2011.

HARPOSTUDIOS

THE MARK CONSISTS OF STANDARD CHARACTERS WITHOUT CLAIM TO ANY PARTICULAR FONT, STYLE, SIZE, OR COLOR.

FOR ORGANIZING AND CONDUCTING ONLINE MEETINGS, GATHERINGS, AND INTERACTIVE DISCUSSIONS ABOUT FOOD, NUTRITION, HEALTH, FITNESS, VOLUNTEERISM, CHARITABLE WORK, HOME DECORATING, AND LIFESTYLE ISSUES (U.S. CLS. 100 AND 101).

FIRST USE 10-10-2011; IN COMMERCE 10-10-2011.

4,211,211. PROXIBID, INC., OMAHA, NE. SN 85-354,531. PUB. 11-8-2011, FILED 6-23-2011.

AUCTIONBUILDER

THE MARK CONSISTS OF STANDARD CHARACTERS WITHOUT CLAIM TO ANY PARTICULAR FONT, STYLE, SIZE, OR COLOR.

FOR TEMPORARY USE OF NON-DOWNLOADABLE COMPUTER SOFTWARE THAT ALLOWS AUCTION COMPANIES THE ABILITY TO SET UP AND MANAGE THEIR AUCTIONS, CATALOGS AND ADVERTISING THROUGH THE HOST SYSTEM (U.S. CLS. 100 AND 101).

FIRST USE 6-5-2002; IN COMMERCE 11-11-2011.

4,211,223. LABBLER, INC., MIAMI, FL. SN 85-355,890. PUB. 11-15-2011, FILED 6-24-2011.

LABBLER

THE MARK CONSISTS OF STANDARD CHARACTERS WITHOUT CLAIM TO ANY PARTICULAR FONT, STYLE, SIZE, OR COLOR.

FOR PROVIDING A WEBSITE THAT GIVES COMPUTER USERS THE ABILITY TO AUTOMATIZE THE BUSINESS OF MUSIC AND CONDUCT THEIR MUSIC BUSINESS, FOR ARTISTS, LABELS, CLUBS, FANS, PROMOTERS AND BOOKING AGENCIES; SOFTWARE AS A SERVICE (SAAS) SERVICES FEATURING SOFTWARE FOR BUSINESS AUTOMATIZATION AND SOCIAL NETWORKING, IN THE FIELD OF MUSIC (U.S. CLS. 100 AND 101).

FIRST USE 6-1-2012; IN COMMERCE 6-1-2012.

CLASS 42—(Continued).

4,211,239. PERSOCIETY, INC., SAN FRANCISCO, CA. SN 85-357,539. PUB. 11-15-2011, FILED 6-27-2011.

PERSOCIETY

THE MARK CONSISTS OF STANDARD CHARACTERS WITHOUT CLAIM TO ANY PARTICULAR FONT, STYLE, SIZE, OR COLOR.

FOR APPLICATION SERVICE PROVIDER (ASP) FEATURING SOFTWARE FOR USE IN CONTACT MANAGEMENT, DATABASE MANAGEMENT, AND KNOWLEDGE MANAGEMENT.; COMPUTER SERVICES, NAMELY, CREATING AN ON-LINE COMMUNITY FOR REGISTERED USERS TO EDIT AND MAINTAIN CONTACT, PERSONAL, AND BUSINESS INFORMATION, AND SEARCH AND VIEW THE CONTACT, PERSONAL, AND BUSINESS INFORMATION OF OTHERS.; PROVIDING A WEBSITE FEATURING NON-DOWNLOADABLE SOFTWARE FOR USERS TO UPLOAD, DOWNLOAD, RESEARCH, SHOW, SEND, DISPLAY, TAG, SHARE AND COMMENT MESSAGES, VIDEOS, PICTURES, PHOTOGRAPHIC IMAGES, AUDIO CLIPS, TEXTS AND OTHER USER-DEFINED CONTENT (U.S. CLS. 100 AND 101).

FIRST USE 2-15-2011; IN COMMERCE 6-1-2012.

4,211,273. THINKFUSE INC., SEATTLE, WA. SN 85-363,090. PUB. 12-6-2011, FILED 7-5-2011.

THINKFUSE

THE MARK CONSISTS OF STANDARD CHARACTERS WITHOUT CLAIM TO ANY PARTICULAR FONT, STYLE, SIZE, OR COLOR.

FOR SOFTWARE AS A SERVICE (SAAS) SERVICES FEATURING SOFTWARE FOR MANAGING BUSINESS COMMUNICATIONS (U.S. CLS. 100 AND 101).

FIRST USE 8-10-2011; IN COMMERCE 8-10-2011.

CLASS 42—(Continued).

4,211,299. ANDREW R. SPRIEGEL, HUDSON, OH. SN 85-369,176. PUB. 11-8-2011, FILED 7-12-2011.

Think Outside The Bulb

THE MARK CONSISTS OF STANDARD CHARACTERS WITHOUT CLAIM TO ANY PARTICULAR FONT, STYLE, SIZE, OR COLOR.

FOR COMPUTER AIDED DESIGN FOR OTHERS; COMPUTER AIDED GRAPHIC DESIGN; COMPUTER HARDWARE AND SOFTWARE DESIGN; CONSULTATION IN THE FIELD OF GAS TURBINE AND COMBUSTION ENGINE DESIGN; CONSULTING IN THE FIELD OF ENGINEERING; CONSULTING IN THE FIELD OF STRUCTURAL ENGINEERING; CONSULTING IN THE FIELD OF MECHANICAL ENGINEERING; CONSULTING IN THE FIELDS OF ENGINEERING AND ARCHITECTURE; CONSULTING SERVICES IN THE FIELD OF ARCHITECTURAL DESIGN; CONSULTING SERVICES IN THE FIELD OF DESIGNING ENGINES TO BE MORE EFFICIENT; CONSULTING SERVICES IN THE FIELD OF INDUSTRIAL ENGINEERING; CONSULTING SERVICES IN THE FIELD OF MEDICAL PHYSICS; DESIGN OF ENGINEERING PRODUCTS; DESIGN, ENGINEERING, RESEARCH, DEVELOPMENT AND TESTING SERVICES IN THE FIELD OF POLYMERIC MATERIALS, POLYMER SYNTHESIS, AND MATERIALS CUSTOMIZATION FOR MEDICAL, SCIENTIFIC, AND TECHNOLOGICAL APPLICATIONS; DESIGN/PLANNING AND ENGINEERING OF COMPRESSED-AIR STATIONS; DRAFTING OF PLANS AND ENGINEERING DRAWINGS FOR OTHERS; GRAPHIC DESIGN SERVICES; GRAPHIC ILLUSTRATION SERVICES FOR OTHERS; HAUNTED ATTRACTION DESIGN SERVICES; HYDRAULIC ENGINEERING AND DESIGN; HYDROLOGIC ENGINEERING SERVICES; INDUSTRIAL DESIGN SERVICES; INNOVATION CONSULTING SERVICES, NAMELY, ADVISING OTHERS IN THE AREAS OF PRODUCT DEVELOPMENT; MECHANICAL ENGINEERING; NEW PRODUCT DESIGN SERVICES; NON-LAND VEHICLES DESIGN SERVICES; PRODUCT DEVELOPMENT AND ENGINEERING SERVICES FOR OTHERS; PRODUCT RESEARCH AND DEVELOPMENT SERVICES FOR OTHERS IN THE FIELDS OF FOOD PRODUCTS AND MENUS; PROFESSIONAL CONSULTING SERVICES AND ADVICE ABOUT AGRICULTURAL CHEMISTRY; PROVIDING PLANNING AND ENGINEERING SERVICES IN THE FIELD OF INFORMATION AND COMMUNICATIONS NETWORKS; RESEARCH AND DEVELOPMENT OF COMPUTER SOFTWARE; RESEARCH AND DEVELOPMENT SERVICES IN CONNECTION WITH PHYSICS; RESEARCH RELATING TO MECHANICAL ENGINEERING; RESEARCH SERVICES IN THE FIELD OF FORENSIC SCIENCE, NAMELY, ANALYSIS, DETECTION AND ISOLATION OF BIOLOGICAL SUBSTANCES IN FORENSIC SAMPLES; RESEARCH SERVICES IN THE FIELD OF INFORMATION AND TELECOMMUNICATIONS TECHNOLOGY; RESEARCH, DEVELOPMENT AND ENGINEERING SERVICES IN THE FIELDS OF ISOTOPE SEPARATION AND ENRICHMENT OF URANIUM; RESEARCH, DEVELOPMENT, ENGINEERING AND TESTING SERVICES IN THE FIELDS OF IMMUNOPHARMACEUTICALS AND VACCINES; RESEARCH, DEVELOPMENT, ENGINEERING AND TESTING SERVICES IN THE FIELDS OF WELDING AND MATERIAL JOINING; STRUCTURAL ENGINEERING DESIGN SERVICES (U.S. CLS. 100 AND 101).

FIRST USE 7-2-2012; IN COMMERCE 7-2-2012.

CLASS 42—(Continued).

4,211,345. GLODON SOFTWARE CO., LTD., HAIDIAN DIST, BEIJING, CHINA. SN 85-376,894. PUB. 12-20-2011, FILED 7-21-2011.

广联达

THE MARK CONSISTS OF THREE CHINESE CHARACTERS WHICH TRANSLITERATE INTO "GUANG LIAN DA".

THE NON-LATIN CHARACTERS IN THE MARK TRANSLITERATE TO "GUANG"; "LIAN"; "DA" AND THIS MEANS "WIDE"; "JOIN"; "REACH" IN ENGLISH.

FOR COMPUTER PROGRAMMING; COMPUTER SOFTWARE CONSULTANCY; COMPUTER SOFTWARE DESIGN FOR OTHERS; CONSTRUCTION DRAFTING; DRAFTING OF PLANS AND ENGINEERING DRAWINGS FOR OTHERS; MAINTENANCE OF COMPUTER SOFTWARE; PERIODIC UPGRADING OF COMPUTER SOFTWARE FOR OTHERS; PLANNING OF BUILDINGS AND INFRASTRUCTURE SYSTEMS FOR BUILDINGS; RENTAL OF COMPUTER SOFTWARE; UPDATING OF COMPUTER SOFTWARE FOR OTHERS (U.S. CLS. 100 AND 101).

FIRST USE 5-7-1996; IN COMMERCE 1-10-2010.

4,211,348. ARCHES & ANGLES, LLC, FARMINGTON, CT. SN 85-377,743. PUB. 1-24-2012, FILED 7-21-2011.

ARCHES & ANGLES

THE MARK CONSISTS OF STANDARD CHARACTERS WITHOUT CLAIM TO ANY PARTICULAR FONT, STYLE, SIZE, OR COLOR.

FOR APARTMENT, CONDOMINIUM AND HOME STAGING SERVICES FOR THE PURPOSE OF INCREASING THE APPEAL OF THE PROPERTY TO PROSPECTIVE BUYERS AND/OR RENTERS; COLOR ANALYSIS FOR PURPOSES OF INTERIOR DESIGN; INTERIOR DESIGN SERVICES, NAMELY, INTERIOR DESIGN CONSULTATIONS, FURNITURE SELECTION, MATERIAL AND SURFACE SELECTION, HOME ACCESSORIES SELECTION, ROOM DESIGN AND DÉCOR TRANSFORMATIONS (U.S. CLS. 100 AND 101).

FIRST USE 2-1-2012; IN COMMERCE 5-5-2012.

CLASS 42—(Continued).

4,211,350. GERHARDT & ASSOCIATES, LLC, SPRINGFIELD, LA. SN 85-378,331. PUB. 2-14-2012, FILED 7-22-2011.

G&A

THE MARK CONSISTS OF LARGE CAPITAL "G" & "A" AND SMALLER CAPITAL "A" WITH LINE UNDERNEATH ALL AND PARTIAL LINE ABOVE "& A" LINE IS BROKEN AT TIP OF "A".

FOR PROVIDING TECHNOLOGY INFORMATION IN THE OIL AND GAS INDUSTRY (U.S. CLS. 100 AND 101). FIRST USE 7-1-2011; IN COMMERCE 7-1-2011.

4,211,388. ESYS CORPORATION, AUBURN HILLS, MI. SN 85-392,090. PUB. 11-29-2011, FILED 8-8-2011.



THE COLOR(S) BLUE, GREEN AND WHITE IS/ARE CLAIMED AS A FEATURE OF THE MARK.

THE MARK CONSISTS OF A BALL WITH GREEN AND WHITE SHADING SURROUND BY TWO BLUE SHADED HALF CIRCLES.

FOR CUSTOM DESIGN AND ENGINEERING OF AUTOMATION AND ROBOTIC SYSTEMS FOR MANUFACTURING (U.S. CLS. 100 AND 101).

FIRST USE 6-28-2011; IN COMMERCE 7-1-2011.

4,211,430. CARINGBRIDGE, EAGAN, MN. SN 85-405,769. PUB. 3-6-2012, FILED 8-24-2011.

CARING BRIDGE.ORG

OWNER OF U.S. REG. NOS. 2,983,335 AND 4,012,589.

CLASS 42—(Continued).

THE MARK CONSISTS OF THE TERMS "CARING" AND "BRIDGE.ORG" CONNECTED BY A HEART WITH 3 LINES ABOVE IT REPRESENTING A BRIDGE.

FOR COMPUTER SERVICES, NAMELY, CREATING, DESIGNING, IMPLEMENTING, MANAGING, MAINTAINING AND HOSTING INTERACTIVE WEB SITES FOR OTHERS (U.S. CLS. 100 AND 101).

FIRST USE 6-7-2012; IN COMMERCE 6-7-2012.

CLASS 42—(Continued).

4,211,569. MCCREADIE GROUP, INC., ANN ARBOR, MI. SN 85-470,258. PUB. 4-24-2012, FILED 11-11-2011.

4,211,459. CENTAURI STRATEGIC SERVICES, MARIETTA, GA. SN 85-416,075. PUB. 2-14-2012, FILED 9-6-2011.

VESTIGO

Centauri Strategic Services

THE MARK CONSISTS OF STANDARD CHARACTERS WITHOUT CLAIM TO ANY PARTICULAR FONT, STYLE, SIZE, OR COLOR.

NO CLAIM IS MADE TO THE EXCLUSIVE RIGHT TO USE "STRATEGIC SERVICES", APART FROM THE MARK AS SHOWN.

FOR COMPUTER DISASTER RECOVERY PLANNING; COMPUTER FORENSIC SERVICES; COMPUTER SECURITY CONSULTANCY; COMPUTER SECURITY CONSULTANCY IN THE FIELD OF SCANNING AND PENETRATION TESTING OF COMPUTERS AND NETWORKS TO ASSESS INFORMATION SECURITY VULNERABILITY; UPDATING OF COMPUTER SOFTWARE RELATING TO COMPUTER SECURITY AND PREVENTION OF COMPUTER RISKS (U.S. CLS. 100 AND 101).

FIRST USE 9-1-2011; IN COMMERCE 10-26-2011.

THE MARK CONSISTS OF STANDARD CHARACTERS WITHOUT CLAIM TO ANY PARTICULAR FONT, STYLE, SIZE, OR COLOR.

FOR APPLICATION SERVICE PROVIDER (ASP) FEATURING SOFTWARE FOR USE IN THE MANAGEMENT OF PHARMACIES ENGAGED IN CLINICAL RESEARCH (U.S. CLS. 100 AND 101).

FIRST USE 1-1-2012; IN COMMERCE 1-1-2012.

4,211,507. ICONECT DEVELOPMENT, LLC, REDONDO BEACH, CA. SN 85-441,066. PUB. 4-10-2012, FILED 10-6-2011.

XERA

THE MARK CONSISTS OF STANDARD CHARACTERS WITHOUT CLAIM TO ANY PARTICULAR FONT, STYLE, SIZE, OR COLOR.

THE ENGLISH TRANSLATION OF "XERA" IS "GENERATES".

FOR PROVIDING TEMPORARY USE OF NON-DOWNLOADABLE COMPUTER BROWSER SOFTWARE FOR USE ON A GLOBAL NETWORK USED TO ACCESS, VIEW AND TRANSMIT INFORMATION AND DATA FROM A DATABASE USED IN THE FIELDS OF LAW, GOVERNMENT, INSURANCE, CORPORATION AND STOCK INFORMATION (U.S. CLS. 100 AND 101).

FIRST USE 3-9-2012; IN COMMERCE 3-9-2012.

4,211,571. GILMORE, SAMANTHA, TUCSON, AZ. SN 85-470,608. PUB. 5-8-2012, FILED 11-11-2011.

Anticage Design

THE MARK CONSISTS OF STANDARD CHARACTERS WITHOUT CLAIM TO ANY PARTICULAR FONT, STYLE, SIZE, OR COLOR.

NO CLAIM IS MADE TO THE EXCLUSIVE RIGHT TO USE "DESIGN", APART FROM THE MARK AS SHOWN.

FOR GRAPHIC DESIGN SERVICES (U.S. CLS. 100 AND 101).

FIRST USE 2-1-2008; IN COMMERCE 6-1-2008.

CLASS 42—(Continued).

4,211,596. TRIALGRAPHIX, INC., MIRAMAR, FL. SN 85-482,627. PUB. 4-24-2012, FILED 11-29-2011.



THE MARK CONSISTS OF "LEGALRADIUS" IN A STYLIZED FORMAT, WITH A CIRCULAR ARC SHAPE APPEARING OVER THE LETTERS "ADIU".

FOR WEB-BASED NON-DOWNLOADABLE SOFTWARE FOR USE BY LAW FIRMS AND CORPORATIONS THAT ENABLES USERS TO JOINTLY ACCESS DOCUMENTS AND TRANSCRIPTS, ASSEMBLE AND COLLABORATE WITH WORKING GROUPS, AND MANAGE CASE MATERIALS FOR INVESTIGATIONS, MERGERS, TRIALS, HEARINGS, MEDIATIONS OR OTHER MATTERS (U.S. CLS. 100 AND 101).

FIRST USE 1-24-2012; IN COMMERCE 1-24-2012.

4,211,621. DIGI INTERNATIONAL INC., MINNETONKA, MN. SN 85-494,478. PUB. 4-24-2012, FILED 12-13-2011.

WHERE WIRELESS HAPPENS

THE MARK CONSISTS OF STANDARD CHARACTERS WITHOUT CLAIM TO ANY PARTICULAR FONT, STYLE, SIZE, OR COLOR.

FOR ENGINEERING DESIGN SERVICES IN CONNECTION WITH COMPUTER HARDWARE, COMPUTER SOFTWARE, ELECTRICAL AND ELECTRONIC CIRCUITS; PROVIDING CONSULTING SERVICES IN CONNECTION WITH THE DESIGN AND INTEGRATION OF COMPUTER HARDWARE, COMPUTER SOFTWARE, SEMICONDUCTOR DEVICES ALONG WITH WIRED AND WIRELESS CONNECTIVITY DEVICES (U.S. CLS. 100 AND 101).

FIRST USE 3-30-2012; IN COMMERCE 3-30-2012.

CLASS 42—(Continued).

4,211,623. SEEDONK, INC., FREMONT, CA. SN 85-495,005. PUB. 4-10-2012, FILED 12-14-2011.

Protect What Matters

THE MARK CONSISTS OF STANDARD CHARACTERS WITHOUT CLAIM TO ANY PARTICULAR FONT, STYLE, SIZE, OR COLOR.

FOR APPLICATION SERVICE PROVIDER (ASP) FEATURING SOFTWARE FOR USE IN RECEIVING, STORING AND ANALYZING DIGITAL PHOTO AND VIDEO IMAGES, AND NOTIFYING USERS OF IMAGE AVAILABILITY AND SCREENED RESULTS (U.S. CLS. 100 AND 101).

FIRST USE 11-30-2011; IN COMMERCE 11-30-2011.

4,211,642. CELGENE CORPORATION, SUMMIT, NJ. SN 85-502,965. PUB. 5-22-2012, FILED 12-23-2011.

MATRIX: MEDICAL AFFAIRS TRACKING REPORTING AND INFORMATION XCHANGE

THE MARK CONSISTS OF STANDARD CHARACTERS WITHOUT CLAIM TO ANY PARTICULAR FONT, STYLE, SIZE, OR COLOR.

NO CLAIM IS MADE TO THE EXCLUSIVE RIGHT TO USE "MEDICAL AFFAIRS TRACKING REPORTING AND INFORMATION EXCHANGE", APART FROM THE MARK AS SHOWN.

FOR APPLICATION SERVICE PROVIDER (ASP) FEATURING SOFTWARE FOR MEDICAL AFFAIR MANAGEMENT AND INFORMATION EXCHANGE; PROVIDING A WEBSITE FEATURING NON-DOWNLOADABLE SOFTWARE FOR MEDICAL AFFAIR MANAGEMENT AND INFORMATION EXCHANGE; PROVIDING AN ON-LINE COMPUTER DATABASE FEATURING MEDICAL AND SCIENTIFIC RESEARCH INFORMATION IN THE FIELD OF CANCER AND IMMUNOLOGICAL DISORDERS THAT ALLOWS FOR THE INPUT AND COLLECTION OF SCIENTIFIC AND RESEARCH DATA AND INFORMATION (U.S. CLS. 100 AND 101).

FIRST USE 3-0-2012; IN COMMERCE 5-0-2012.

4,211,643. CELGENE CORPORATION, SUMMIT, NJ. SN 85-502,979. PUB. 5-22-2012, FILED 12-23-2011.

CELGENE MATRIX

THE MARK CONSISTS OF STANDARD CHARACTERS WITHOUT CLAIM TO ANY PARTICULAR FONT, STYLE, SIZE, OR COLOR.

CLASS 42—(Continued).

OWNER OF U.S. REG. NOS. 2,375,599, 2,888,517, AND OTHERS.

FOR APPLICATION SERVICE PROVIDER (ASP) FEATURING SOFTWARE FOR MEDICAL AFFAIR MANAGEMENT AND INFORMATION EXCHANGE; PROVIDING A WEBSITE FEATURING NON-DOWNLOADABLE SOFTWARE FOR MEDICAL AFFAIR MANAGEMENT AND INFORMATION EXCHANGE; PROVIDING AN ON-LINE COMPUTER DATABASE FEATURING MEDICAL AND SCIENTIFIC RESEARCH INFORMATION IN THE FIELD OF CANCER AND IMMUNOLOGICAL DISORDERS THAT ALLOWS FOR THE INPUT AND COLLECTION OF SCIENTIFIC AND RESEARCH DATA AND INFORMATION (U.S. CLS. 100 AND 101).

FIRST USE 3-0-2012; IN COMMERCE 5-0-2012.

4,211,657. CELGENE CORPORATION, SUMMIT, NJ. SN 85-561,665. PUB. 5-8-2012, FILED 3-6-2012.



NO CLAIM IS MADE TO THE EXCLUSIVE RIGHT TO USE "MEDICAL AFFAIRS TRACKING REPORTING AND INFORMATION EXCHANGE", APART FROM THE MARK AS SHOWN.

THE COLOR(S) BLUE AND GREY IS/ARE CLAIMED AS A FEATURE OF THE MARK.

THE MARK CONSISTS OF THE WORD "MATRIX" IN BLUE WITH FOUR BLUE SQUARES TO THE RIGHT OVER A GREY DIAMOND WITH A BLUE ARROW UNDERNEATH AND THE WORDS "MEDICAL AFFAIRS TRACKING REPORTING AND INFORMATION EXCHANGE" UNDER THE ARROW IN BLUE.

FOR APPLICATION SERVICE PROVIDER (ASP) FEATURING SOFTWARE FOR MEDICAL AFFAIR MANAGEMENT AND INFORMATION EXCHANGE; PROVIDING A WEBSITE FEATURING NON-DOWNLOADABLE SOFTWARE FOR MEDICAL AFFAIR MANAGEMENT AND INFORMATION EXCHANGE; PROVIDING AN ON-LINE COMPUTER DATABASE FEATURING MEDICAL AND SCIENTIFIC RESEARCH INFORMATION IN THE FIELD OF CANCER AND IMMUNOLOGICAL DISORDERS THAT ALLOWS FOR INPUT AND COLLECTION OF SCIENTIFIC AND RESEARCH DATA AND INFORMATION (U.S. CLS. 100 AND 101).

FIRST USE 3-0-2012; IN COMMERCE 5-0-2012.

4,211,668. AUDIO & VIDEO LABS, INC., PENNSAUKEN, NJ. SN 85-977,123. PUB. 11-9-2010, FILED 5-28-2010.

OWNER OF U.S. REG. NOS. 3,467,602, 3,551,953, AND OTHERS.

CLASS 42—(Continued).

THE MARK CONSISTS OF THREE VERTICAL RECTANGLES OF VARYING SIZE REPRESENTING BOOKS, WITH THE SECOND AND THIRD RECTANGLES LEANING TOWARD THE LEFT, FOLLOWED BY THE WORD "BOOK-BABY" IN A LOWER CASE, STYLIZED FONT.

FOR DIGITAL FORMATTING OF ELECTRONIC BOOKS (EBOOKS) INTO DOWNLOADABLE PRODUCTS; GRAPHIC DESIGN SERVICES, NAMELY, COVER DESIGN FOR ELECTRONIC BOOKS (U.S. CLS. 100 AND 101).

FIRST USE 5-1-2010; IN COMMERCE 5-1-2010.

CLASS 43—HOTEL AND RESTAURANT SERVICES

4,210,292. HOTEL GENPAR, LTD., MIAMI, FL. SN 77-515,459. PUB. 5-19-2009, FILED 7-7-2008.



NO CLAIM IS MADE TO THE EXCLUSIVE RIGHT TO USE "LOUNGE", APART FROM THE MARK AS SHOWN.

THE COLOR(S) ORANGE AND WHITE IS/ARE CLAIMED AS A FEATURE OF THE MARK.

THE MARK CONSISTS OF THE WORDS "NAU LOUNGE" IN THE COLOR WHITE WITHIN AN ORANGE CIRCLE.

THE ENGLISH TRANSLATION OF "NAU" IN THE MARK IS "TRENDY" IN JAPANESE.

FOR RESTAURANT AND BAR SERVICES (U.S. CLS. 100 AND 101).

FIRST USE 3-2-2012; IN COMMERCE 3-2-2012.

4,210,473. SMOKIN D'S CATERING & ENTERPRISE, LLC, LANDOVER, MD. SN 77-968,616. PUB. 8-9-2011, FILED 3-25-2010.

THE MARK CONSISTS OF STANDARD CHARACTERS WITHOUT CLAIM TO ANY PARTICULAR FONT, STYLE, SIZE, OR COLOR.

FOR CATERING SERVICES (U.S. CLS. 100 AND 101). FIRST USE 1-0-2009; IN COMMERCE 7-0-2011.

CLASS 43—(Continued).

4,210,510. WHG COMPANIES, LLC LIMITED LIABILITY COMPANY WISCONSIN, OSHKOSH, WI. SN 85-027,575. PUB. 4-12-2011, FILED 4-30-2010.



OWNER OF U.S. REG. NO. 3,412,423.

NO CLAIM IS MADE TO THE EXCLUSIVE RIGHT TO USE "HOTEL & SUITES", APART FROM THE MARK AS SHOWN.

THE COLOR(S) WHITE, BLUE, GREEN AND GRAY IS/ARE CLAIMED AS A FEATURE OF THE MARK.

THE MARK CONSISTS OF A WHITE OUTLINED OVAL WITH A WHITE LETTER "C" IN THE MIDDLE; WITHIN THE OVAL THE FIELD TO THE LEFT OF THE LETTER "C" IS FILLED IN WITH GRAY, AND THE FIELD TO THE RIGHT OF THE LETTER "C" IS FILLED IN WITH GREEN. UNDERNEATH THE OVAL, "COBBLESTONE HOTEL & SUITES" IS WRITTEN IN WHITE LETTERING. ALL OF THIS IS ON A BLUE BACKGROUND, THE BOTTOM AND SIDES ARE SQUARED WITH A ROUNDED TOP.

FOR HOTEL SERVICES (U.S. CLS. 100 AND 101).
FIRST USE 5-4-2012; IN COMMERCE 5-4-2012.

4,210,520. RAVIOLI OLI COMPANY, PALOS HEIGHTS, IL. SN 85-039,475. PUB. 3-8-2011, FILED 5-14-2010.

RAVIOLI OLI

THE MARK CONSISTS OF STANDARD CHARACTERS WITHOUT CLAIM TO ANY PARTICULAR FONT, STYLE, SIZE, OR COLOR.

NO CLAIM IS MADE TO THE EXCLUSIVE RIGHT TO USE "RAVIOLI", APART FROM THE MARK AS SHOWN.

THE ENGLISH TRANSLATION OF "OLI" IN THE MARK IS "OILS".

FOR CATERING; RESTAURANT SERVICES; TAKE-OUT RESTAURANT SERVICES (U.S. CLS. 100 AND 101).
FIRST USE 7-1-2012; IN COMMERCE 7-1-2012.

CLASS 43—(Continued).

4,210,521. RAVIOLI OLI COMPANY, PALOS HEIGHTS, IL. SN 85-039,477. PUB. 3-8-2011, FILED 5-15-2010.



NO CLAIM IS MADE TO THE EXCLUSIVE RIGHT TO USE "RAVIOLI", APART FROM THE MARK AS SHOWN.

THE COLOR(S) RED, DARK RED, YELLOW AND BLACK IS/ARE CLAIMED AS A FEATURE OF THE MARK.

THE MARK CONSISTS OF A YELLOW ROUNDED RECTANGLE BORDERED IN RED AND CONTAINING THE PHRASE "RAVIOLI OLI" IN BLACK. BETWEEN THE WORDS "RAVIOLI" AND "OLI" IS A DARK RED ROUNDED SQUARE BORDERED IN RED. THE LETTERING OF THE PHRASE INCLUDES UPPER CASE LETTERS "R", "V", "O" AND "L" AND LOWER CASE LETTERS "A" AND "I".

THE ENGLISH TRANSLATION OF "OLI" IN THE MARK IS "OILS".

FOR CATERING; RESTAURANT SERVICES; TAKE-OUT RESTAURANT SERVICES (U.S. CLS. 100 AND 101).
FIRST USE 7-1-2012; IN COMMERCE 7-1-2012.

4,210,603. S M & N HOSPITALITY GROUP LLC, DBA PUBBELLY, MIAMI BEACH, FL. SN 85-101,448. PUB. 7-12-2011, FILED 8-5-2010.



THE STIPPLING IS FOR SHADING PURPOSES ONLY. THE COLOR(S) RED, WHITE, YELLOW AND TAN IS/ARE CLAIMED AS A FEATURE OF THE MARK.

THE MARK CONSISTS OF A PIG'S HEAD IN RED AND TAN WITH A WOODLIKE BACKGROUND IN TAN, A YELLOW STAR IN THE UPPER RIGHT HAND CORNER, AND THE STYLIZED TEXT "PUBBELLY" IN WHITE APPEARING ACROSS THE IMAGE OF THE PIG AND BELOW THE YELLOW STAR.

FOR RESTAURANT AND BAR SERVICES (U.S. CLS. 100 AND 101).
FIRST USE 9-1-2010; IN COMMERCE 9-1-2010.

CLASS 43—(Continued).

4,210,607. A TASTE OF SEAFOOD, MANHATTAN, NY. SN 85-102,411. PUB. 1-25-2011, FILED 8-6-2010.

A TASTE OF SEAFOOD

THE MARK CONSISTS OF STANDARD CHARACTERS WITHOUT CLAIM TO ANY PARTICULAR FONT, STYLE, SIZE, OR COLOR.
NO CLAIM IS MADE TO THE EXCLUSIVE RIGHT TO USE "SEAFOOD", APART FROM THE MARK AS SHOWN.
FOR RESTAURANT (U.S. CLS. 100 AND 101).
FIRST USE 4-1-1993; IN COMMERCE 4-1-1993.

CLASS 43—(Continued).

4,210,720. NINO ANTUZZI, HUNTINGTON, NY. SN 85-191,525. PUB. 4-19-2011, FILED 12-6-2010.

SAPSUCKERS

THE MARK CONSISTS OF STANDARD CHARACTERS WITHOUT CLAIM TO ANY PARTICULAR FONT, STYLE, SIZE, OR COLOR.
FOR RESTAURANT AND BAR SERVICES (U.S. CLS. 100 AND 101).
FIRST USE 9-30-2010; IN COMMERCE 9-30-2010.

4,210,782. BRUNSWICK CORPORATION, LAKE FOREST, IL. SN 85-212,164. PUB. 10-18-2011, FILED 1-6-2011.



NO CLAIM IS MADE TO THE EXCLUSIVE RIGHT TO USE "BAR & GRILL", APART FROM THE MARK AS SHOWN.
THE MARK CONSISTS OF "STRIKERZ" IN STYLIZED FORM WITH THE "I" IN THE SHAPE OF A PARTIAL BOWLING PIN AND "STRIKERZ" LOCATED ABOVE THE WORDS "BAR & GRILL" WITH A LINE SEPARATING THEM.
FOR RESTAURANT AND BAR SERVICES (U.S. CLS. 100 AND 101).
FIRST USE 10-31-2010; IN COMMERCE 10-31-2010.

4,210,714. THE PROCTER & GAMBLE COMPANY, CINCINNATI, OH. SN 85-189,448. PUB. 9-6-2011, FILED 12-2-2010.



OWNER OF U.S. REG. NOS. 2,883,114, 3,138,056, AND OTHERS.
THE MARK CONSISTS OF AN OPEN CIRCLE CONTAINING THE PARTIAL OUTLINE OF A WATER DROPLET WITH THE WORDS "SK-II CLEAR FOR LIFE" TO THE RIGHT OF THE OUTLINE.
FOR CHARITABLE SERVICES, NAMELY, PROVIDING POTABLE WATER TO NEEDY PERSONS (U.S. CLS. 100 AND 101).
FIRST USE 3-31-2011; IN COMMERCE 3-31-2011.

4,210,816. BOERNE BUEN PROVECHO LLC, BOERNE, TX. SN 85-222,310. PUB. 6-7-2011, FILED 1-20-2011.



NO CLAIM IS MADE TO THE EXCLUSIVE RIGHT TO USE "RESTAURANT", APART FROM THE MARK AS SHOWN.
THE COLOR(S) DARK BROWN FADING TO A LIGHTER BROWN AND NON-METALLIC GOLD IS/ARE CLAIMED AS A FEATURE OF THE MARK.

CLASS 43—(Continued).

THE MARK CONSISTS OF A DECAGON IN WHICH A DARK BROWN BACKGROUND IS AROUND THE EDGES OF THE DECAGON WHICH FADES TO A LIGHTER BROWN IN THE MIDDLE OF THE MARK; GOLD COLOR IVY AND VINES ARE AROUND THE BORDER OF THE MARK; THE WORDS "THE CREEK RESTAURANT" IN THE CENTER OF THE MARK ARE A GOLD COLOR.

FOR RESTAURANT SERVICES (U.S. CLS. 100 AND 101).

FIRST USE 6-1-2012; IN COMMERCE 6-1-2012.

4,210,968. HO-CHUNK NATION, BLACK RIVER FALLS, WI. SN 85-304,880. PUB. 6-14-2011, FILED 4-26-2011.

HO-CHUNK HOSPITALITY

THE MARK CONSISTS OF STANDARD CHARACTERS WITHOUT CLAIM TO ANY PARTICULAR FONT, STYLE, SIZE, OR COLOR.

OWNER OF U.S. REG. NOS. 2,666,349, 2,741,323, AND 2,741,327.

NO CLAIM IS MADE TO THE EXCLUSIVE RIGHT TO USE "HOSPITALITY", APART FROM THE MARK AS SHOWN.

FOR HOTEL SERVICES (U.S. CLS. 100 AND 101).

FIRST USE 4-0-2011; IN COMMERCE 4-0-2011.

4,210,989. GRAB & GOURMET, INC., LOS ANGELES, CA. SN 85-318,051. PUB. 11-22-2011, FILED 5-11-2011.

MOD FRESH

THE MARK CONSISTS OF STANDARD CHARACTERS WITHOUT CLAIM TO ANY PARTICULAR FONT, STYLE, SIZE, OR COLOR.

CLASS 43—(Continued).

NO CLAIM IS MADE TO THE EXCLUSIVE RIGHT TO USE "FRESH", APART FROM THE MARK AS SHOWN.

FOR CATERING SERVICES; FOOD PREPARATION SERVICES; FOOD PREPARATION SERVICES FEATURING FRESH, CHILLED, FROZEN, PREPARED, AND PACKAGED ENTREES CONSISTING PRIMARILY OF MEAT, FISH, POULTRY OR VEGETABLES, FRESH, CHILLED, FROZEN, PREPARED, AND PACKAGED MEALS CONSISTING PRIMARILY OF MEAT, FISH, POULTRY OR VEGETABLES, FRESH, CHILLED, FROZEN, PREPARED, AND PACKAGED VEGETABLE-BASED ENTREES, PREPARED SNACKS MADE FROM FRUIT, PREPARED SNACKS MADE FROM COOKED VEGETABLES, PREPARED SNACKS MADE FROM NUTS, REFRIGERATED FOOD PACKAGE COMBINATIONS CONSISTING PRIMARILY OF MEAT, CHEESE, LUNCHEON MEATS, CUT VEGETABLES, FRUIT-BASED SNACK FOODS, VEGETABLE BASED SNACK FOODS, PREPARED AND PACKAGED SANDWICHES, PREPARED AND PACKAGED FOOD, NAMELY, PASTAS, SOUPS, CHILI, DIPS, PROTEIN BASED, NUTRIENT-DENSE SNACK BARS, PROTEIN BASED, NUTRIENT-DENSE SNACK FOODS, PREPARED ENTREES CONSISTING PRIMARILY OF VEGETABLES, SOUPS, FRUIT SALADS AND VEGETABLE SALADS, DEHYDRATED FRUIT SNACKS, DRIED FRUIT-BASED SNACKS, FRUIT AND SOY BASED SNACK FOOD, MEAT-BASED SNACK FOODS, NUT AND SEED-BASED SNACK BARS, NUT-BASED SNACK FOODS; MOBILE CAFE SERVICES FOR PROVIDING FOOD AND DRINK; PROVIDING OF FOOD AND DRINK; PROVIDING OF FOOD AND DRINK VIA A MOBILE TRUCK; SERVING FOOD AND DRINKS (U.S. CLS. 100 AND 101).

FIRST USE 3-1-2012; IN COMMERCE 3-1-2012.

4,211,002. ESPRIT DE CORPS GROUP, INC., WILLOW, NY. SN 85-321,529. PUB. 10-11-2011, FILED 5-16-2011.

ESPRIT DE CORPS

THE MARK CONSISTS OF STANDARD CHARACTERS WITHOUT CLAIM TO ANY PARTICULAR FONT, STYLE, SIZE, OR COLOR.

FOR CONSULTING SERVICES IN THE FIELD OF HOSPITALITY PROVISION (U.S. CLS. 100 AND 101).

FIRST USE 5-25-2012; IN COMMERCE 5-25-2012.

CLASS 43—(Continued).

4,211,006. GRAFFIT USA, LLC, NEW YORK, NY. SN 85-323,813. PUB. 10-11-2011, FILED 5-18-2011.

GASTROARTE

THE MARK CONSISTS OF STANDARD CHARACTERS WITHOUT CLAIM TO ANY PARTICULAR FONT, STYLE, SIZE, OR COLOR.

FOR BAR AND RESTAURANT SERVICES; BAR SERVICES; CAFE AND RESTAURANT SERVICES; CAFE-RESTAURANTS; CAFETERIA AND RESTAURANT SERVICES; CARRY-OUT RESTAURANTS; DELICATESSENS; RESTAURANT; RESTAURANT AND BAR SERVICES; RESTAURANT AND BAR SERVICES, INCLUDING RESTAURANT CARRYOUT SERVICES; RESTAURANT AND CAFE SERVICES; RESTAURANT AND CATERING SERVICES; RESTAURANT SERVICES; RESTAURANT SERVICES, INCLUDING SIT-DOWN SERVICE OF FOOD AND TAKE-OUT RESTAURANT SERVICES; RESTAURANT SERVICES, NAMELY, PROVIDING OF FOOD AND BEVERAGES FOR CONSUMPTION ON AND OFF THE PREMISES; RESTAURANT, BAR AND CATERING SERVICES; RESTAURANTS; RESTAURANTS FEATURING HOME DELIVERY; TAKE-OUT RESTAURANT SERVICES; WINE BARS (U.S. CLS. 100 AND 101).
FIRST USE 6-15-2011; IN COMMERCE 6-15-2011.

4,211,095. BURON, INC., BELLINGHAM, WA. SN 85-339,729. PUB. 4-10-2012, FILED 6-7-2011.

EACH DAY TO THE FULLEST

THE MARK CONSISTS OF STANDARD CHARACTERS WITHOUT CLAIM TO ANY PARTICULAR FONT, STYLE, SIZE, OR COLOR.

FOR PROVIDING INDEPENDENT LIVING RESIDENCES AND LIVING FACILITIES, ASSISTED LIVING FACILITIES; AND LIVING FACILITIES FOR PERSONS WITH ADVANCING MEMORY DECLINE (U.S. CLS. 100 AND 101).
FIRST USE 6-0-2011; IN COMMERCE 6-0-2011.

CLASS 43—(Continued).

4,211,270. MALLOW MUNCHIES LLC, BALTIMORE, MD. SN 85-362,629. PUB. 1-31-2012, FILED 7-4-2011.



NO CLAIM IS MADE TO THE EXCLUSIVE RIGHT TO USE "MALLOW BAR" AND "DESSERT CAFE", APART FROM THE MARK AS SHOWN.

THE COLOR(S) BROWN, CREAM, OFF WHITE, AND WHITE IS/ARE CLAIMED AS A FEATURE OF THE MARK.

THE MARK CONSISTS OF THE BROWN WORDING "THE MALLOW" WITH A CREAM AND OFF WHITE MARSHMALLOW REPLACING THE "O" AND THE WHITE WORDING "BAR" OUTLINED IN BROWN AND BELOW IS THE BROWN WORDING "A MALLOW CRUNCHIES DESERT CAFE".

FOR CAFE; CAFE AND RESTAURANT SERVICES; CAFE-RESTAURANTS; CAFES; RESTAURANT AND CAFE SERVICES (U.S. CLS. 100 AND 101).
FIRST USE 11-1-2011; IN COMMERCE 2-18-2012.

4,211,342. CENTURYLINK, INC., MONROE, LA. SN 85-376,201. PUB. 11-15-2011, FILED 7-20-2011.



THE MARK CONSISTS OF CONNECTING LINES. FOR ARENA SERVICES, NAMELY, PROVIDING FACILITIES FOR BUSINESS EVENTS, CONSUMER SHOWS, TRADE SHOWS, ARTISTIC ACTIVITIES, COMMUNITY ACTIVITIES, ENTERTAINMENT EVENTS, PUBLIC EVENTS, SPORTING EVENTS AND TOURNAMENTS, EDUCATIONAL EVENTS, CONVENTIONS AND EXHIBITIONS (U.S. CLS. 100 AND 101).
FIRST USE 7-15-2011; IN COMMERCE 7-15-2011.

4,211,352. JGC MANAGEMENT, LLC, DALLAS, TX. SN 85-378,856. PUB. 4-17-2012, FILED 7-22-2011.

POMPIS SPORTS CANTINA

THE MARK CONSISTS OF STANDARD CHARACTERS WITHOUT CLAIM TO ANY PARTICULAR FONT, STYLE, SIZE, OR COLOR.

CLASS 43—(Continued).

NO CLAIM IS MADE TO THE EXCLUSIVE RIGHT TO USE "SPORTS CANTINA", APART FROM THE MARK AS SHOWN.

THE ENGLISH TRANSLATION OF "POMPIS" IN THE MARK IS "BOTTOM".

FOR RESTAURANT AND BAR SERVICES, INCLUDING RESTAURANT CARRYOUT SERVICES; RESTAURANT AND CATERING SERVICES; RESTAURANT SERVICES; RESTAURANT SERVICES, INCLUDING SIT-DOWN SERVICE OF FOOD AND TAKE-OUT RESTAURANT SERVICES; RESTAURANT SERVICES, NAMELY, PROVIDING OF FOOD AND BEVERAGES FOR CONSUMPTION ON AND OFF THE PREMISES; RESTAURANT, BAR AND CATERING SERVICES; RESTAURANTS; TAKE-OUT RESTAURANT SERVICES (U.S. CLS. 100 AND 101).

FIRST USE 12-1-2011; IN COMMERCE 12-1-2011.

4,211,433. BACK TO THE TABLE, INC., LAFAYETTE, CA. SN 85-406,294. PUB. 2-7-2012, FILED 8-24-2011.

Back To The Table

THE MARK CONSISTS OF STANDARD CHARACTERS WITHOUT CLAIM TO ANY PARTICULAR FONT, STYLE, SIZE, OR COLOR.

NO CLAIM IS MADE TO THE EXCLUSIVE RIGHT TO USE "TABLE", APART FROM THE MARK AS SHOWN.

FOR PROVIDING TEMPORARY KITCHEN FACILITIES (U.S. CLS. 100 AND 101).

FIRST USE 8-1-2011; IN COMMERCE 6-1-2012.

4,211,436. CAR BAR, LLC, CLARKSTON, MI. SN 85-407,384. PUB. 2-7-2012, FILED 8-25-2011.

Vinsetta Garage

THE MARK CONSISTS OF STANDARD CHARACTERS WITHOUT CLAIM TO ANY PARTICULAR FONT, STYLE, SIZE, OR COLOR.

FOR BAR AND RESTAURANT SERVICES; CARRY-OUT RESTAURANTS (U.S. CLS. 100 AND 101).

FIRST USE 6-7-2012; IN COMMERCE 6-7-2012.

CLASS 43—(Continued).

4,211,462. GREEKTOWN CASINO, L.L.C., DETROIT, MI. SN 85-417,484. PUB. 1-10-2012, FILED 9-8-2011.

ASTERIA

THE MARK CONSISTS OF STANDARD CHARACTERS WITHOUT CLAIM TO ANY PARTICULAR FONT, STYLE, SIZE, OR COLOR.

FOR BAR AND COCKTAIL LOUNGE SERVICES (U.S. CLS. 100 AND 101).

FIRST USE 10-0-2011; IN COMMERCE 10-0-2011.

4,211,515. FUSE MANAGEMENT, LLC, LOS ANGELES, CA. SN 85-443,843. PUB. 4-10-2012, FILED 10-10-2011.



ARTISAN HOUSE

NO CLAIM IS MADE TO THE EXCLUSIVE RIGHT TO USE "ARTISAN", APART FROM THE MARK AS SHOWN.

THE MARK CONSISTS OF THE LETTERS "AH" ENCLOSED BY A HEXAGON DESIGN WITH THE WORDS "ARTISAN HOUSE" UNDERNEATH.

FOR RESTAURANT SERVICES (U.S. CLS. 100 AND 101).

FIRST USE 11-29-2011; IN COMMERCE 11-29-2011.

CLASS 44—MEDICAL, BEAUTY AND AGRICULTURAL SERVICES

4,210,271. GOULD, MICHAEL, SHERMAN OAKS, CA. SN 77-458,046. PUB. 10-21-2008, FILED 4-25-2008.



NO CLAIM IS MADE TO THE EXCLUSIVE RIGHT TO USE "LANDSCAPE MAINTENANCE", APART FROM THE MARK AS SHOWN.

THE COLOR(S) BLACK, RED, LIGHT BLUE, LIGHT GREEN AND GREEN IS/ARE CLAIMED AS A FEATURE OF THE MARK.

CLASS 44—(Continued).

THE MARK CONSISTS OF BLACK AND RED ON THE BODY AND HEAD OF THE LADY BUG; THE WING IN MOTION ARE IN LIGHT BLUE, LIGHT GREEN AND; THE WORDS "EARTH CONSCIOUS, COMMUNITY KIND" ARE IN GREEN; AND THE WORDS "WHISPER LANDSCAPE MAINTENANCE" ARE IN BLACK.

FOR LANDSCAPE GARDENING (U.S. CLS. 100 AND 101).

FIRST USE 1-1-2011; IN COMMERCE 3-31-2012.

4,210,483. IMI INTELLIGENT MEDICAL IMPLANTS AG, ZUG, SWITZERLAND. SN 78-708,891. PUB. 4-21-2009, FILED 9-8-2005.

INTELLIGENT RETINAL IMPLANT SYSTEM

THE MARK CONSISTS OF STANDARD CHARACTERS WITHOUT CLAIM TO ANY PARTICULAR FONT, STYLE, SIZE, OR COLOR.

PRIORITY CLAIMED UNDER SEC. 44(D) ON ERP N CMNTY TM OFC APPLICATION NO. 004329975, FILED 3-9-2005, REG. NO. 004329975, DATED 6-5-2008, EXPIRES 3-9-2015.

NO CLAIM IS MADE TO THE EXCLUSIVE RIGHT TO USE "RETINAL IMPLANT SYSTEM", APART FROM THE MARK AS SHOWN.

FOR RENTAL OF MEDICAL EQUIPMENT; INTERNET SERVICES, NAMELY, PROVIDING MEDICAL DATA RELATING TO PATIENTS AND/OR IMPLANTS; INTERNET SERVICES, NAMELY, PROVIDING TECHNICAL MEDICAL DATA RELATING TO PATIENTS AND/OR IMPLANTS (U.S. CLS. 100 AND 101).

FIRST USE 3-16-2007; IN COMMERCE 3-16-2007.

4,210,500. FIELDS, ALAN, DBA WINDSOR PEAK PRESS, BOULDER, CO. AND FIELDS, DENISE, DBA WINDSOR PEAK PRESS, BOULDER, CO. SN 85-013,662. PUB. 12-7-2010, FILED 4-14-2010.

EXPECTING 411

THE MARK CONSISTS OF STANDARD CHARACTERS WITHOUT CLAIM TO ANY PARTICULAR FONT, STYLE, SIZE, OR COLOR.

NO CLAIM IS MADE TO THE EXCLUSIVE RIGHT TO USE "EXPECTING", APART FROM THE MARK AS SHOWN.

FOR PROVIDING AN ONLINE RESOURCE GUIDE AND INFORMATION IN THE FIELDS OF PRENATAL AND POSTPARTUM MEDICAL CARE FOR WOMEN AND MEDICAL CARE FOR INFANTS (U.S. CLS. 100 AND 101).

FIRST USE 6-1-2011; IN COMMERCE 6-1-2011.

CLASS 44—(Continued).

4,210,518. D & D BEAUTY CARE COMPANY, INC., CHICAGO, IL. SN 85-034,989. PUB. 4-26-2011, FILED 5-11-2010.

SHE BAR

THE MARK CONSISTS OF STANDARD CHARACTERS WITHOUT CLAIM TO ANY PARTICULAR FONT, STYLE, SIZE, OR COLOR.

NO CLAIM IS MADE TO THE EXCLUSIVE RIGHT TO USE "BAR", APART FROM THE MARK AS SHOWN.

FOR BEAUTY SPA SERVICES, NAMELY, COSMETIC BODY CARE; HEALTH SPA SERVICES FOR HEALTH AND WELLNESS OF THE BODY AND SPIRIT; HEALTH SPA SERVICES FOR HEALTH AND WELLNESS OF THE BODY AND SPIRIT, NAMELY, PROVIDING MASSAGE, FACIAL AND BODY TREATMENT SERVICES, COSMETIC BODY CARE SERVICES; HEALTH SPA SERVICES, NAMELY, COSMETIC BODY CARE SERVICES (U.S. CLS. 100 AND 101).

FIRST USE 4-1-2011; IN COMMERCE 4-1-2011.

4,210,536. INVIVOSCRIBE TECHNOLOGIES, INC., SAN DIEGO, CA. SN 85-055,410. PUB. 5-3-2011, FILED 6-4-2010.



NO CLAIM IS MADE TO THE EXCLUSIVE RIGHT TO USE "AML ALLIANCE", APART FROM THE MARK AS SHOWN.

THE MARK CONSISTS OF A RIBBON FORMED INTO A TEAR-DROP SHAPE WITH A SOLID CIRCLE PLACED ABOVE SO AS TO SUGGEST A STYLIZED PERSON WITH WORDS AND OR LETTERS "AML ALLIANCE" TO THE RIGHT OF THE RIBBON.

FOR PROVIDING INFORMATION SERVICES REGARDING THE DIAGNOSIS, MONITORING AND OPTIONS IN THE TREATMENT OF LEUKEMIA (U.S. CLS. 100 AND 101).

FIRST USE 8-1-2011; IN COMMERCE 8-1-2011.

4,210,587. CHILDREN'S HEARTLINK, MINNEAPOLIS, MN. SN 85-090,645. PUB. 1-24-2012, FILED 7-22-2010.

HEALING HEARTS WORLDWIDE

THE MARK CONSISTS OF STANDARD CHARACTERS WITHOUT CLAIM TO ANY PARTICULAR FONT, STYLE, SIZE, OR COLOR.

CLASS 44—(Continued).

NO CLAIM IS MADE TO THE EXCLUSIVE RIGHT TO USE "WORLDWIDE", APART FROM THE MARK AS SHOWN.

FOR MEDICAL AND HEALTHCARE CONSULTING SERVICES TO CARDIOVASCULAR HEALTHCARE PROVIDERS IN UNDERDEVELOPED COUNTRIES (U.S. CLS. 100 AND 101).

FIRST USE 1-30-2003; IN COMMERCE 1-30-2003.

CLASS 44—(Continued).

4,210,751. SAINT LUKE'S HEALTH SYSTEM, INC, KANSAS CITY, MO. SN 85-203,697. PUB. 5-3-2011, FILED 12-22-2010.

NEVER SETTLE

4,210,658. PEDERSEN, JOHN CARL, AKRON, OH. SN 85-151,623. PUB. 4-5-2011, FILED 10-13-2010.

THE MARK CONSISTS OF STANDARD CHARACTERS WITHOUT CLAIM TO ANY PARTICULAR FONT, STYLE, SIZE, OR COLOR.

FOR HOSPITALS; MEDICAL SERVICES; HEALTHCARE SERVICES (U.S. CLS. 100 AND 101).

FIRST USE 1-0-2011; IN COMMERCE 1-0-2011.

BREAST OASIS

4,210,770. ATLANTICARE NURSING SERVICES, INC., DELRAY BEACH, FL. SN 85-209,167. PUB. 10-25-2011, FILED 1-3-2011.

THE MARK CONSISTS OF STANDARD CHARACTERS WITHOUT CLAIM TO ANY PARTICULAR FONT, STYLE, SIZE, OR COLOR.

OWNER OF U.S. REG. NO. 3,834,464.

NO CLAIM IS MADE TO THE EXCLUSIVE RIGHT TO USE "BREAST", APART FROM THE MARK AS SHOWN.

FOR HEALTH INFORMATION PROGRAMS, NAMELY, PROVIDING HEALTH INFORMATION; PROVIDING INFORMATION ON GENERAL HEALTH, WELLNESS AND ILLNESS PREVENTION TOPICS (U.S. CLS. 100 AND 101).

FIRST USE 5-23-2012; IN COMMERCE 5-23-2012.



NO CLAIM IS MADE TO THE EXCLUSIVE RIGHT TO USE "SENIOR HOME CARE", APART FROM THE MARK AS SHOWN.

THE MARK CONSISTS OF THE STYLIZED WORD "NAUTILUS" AND THE WORDING "SENIOR HOME CARE" UNDERNEATH WITH THE DESIGN OF A SPIRAL CONSISTING OF DOTS STARTING FROM THE "N" CIRCLING THROUGH THE CENTER OF THE WORDS.

FOR SENIOR HOME HEALTH CARE SERVICES (U.S. CLS. 100 AND 101).

FIRST USE 1-7-2011; IN COMMERCE 1-7-2011.

4,210,665. 99 PERCENTILE. GRAND RAPIDS, MI. SN 85-155,939. PUB. 9-20-2011, FILED 10-19-2010.

Discharge Box

4,210,948. MEDSTAR HEALTH, INC., COLUMBIA, MD. SN 85-290,749. PUB. 9-6-2011, FILED 4-8-2011.

THE MARK CONSISTS OF STANDARD CHARACTERS WITHOUT CLAIM TO ANY PARTICULAR FONT, STYLE, SIZE, OR COLOR.

NO CLAIM IS MADE TO THE EXCLUSIVE RIGHT TO USE "DISCHARGE", APART FROM THE MARK AS SHOWN.

FOR MEDICAL SERVICES, NAMELY, EXPLAINING HOSPITAL DISCHARGE INSTRUCTIONS TO PATIENTS (U.S. CLS. 100 AND 101).

FIRST USE 4-18-2012; IN COMMERCE 4-18-2012.

MEDSTAR EHR

THE MARK CONSISTS OF STANDARD CHARACTERS WITHOUT CLAIM TO ANY PARTICULAR FONT, STYLE, SIZE, OR COLOR.

OWNER OF U.S. REG. NOS. 1,327,545, 3,009,989, AND OTHERS.

CLASS 44—(Continued).

NO CLAIM IS MADE TO THE EXCLUSIVE RIGHT TO USE "EHR", APART FROM THE MARK AS SHOWN.

FOR ELECTRONIC HEALTH RECORD SERVICES, NAMELY, MAINTAINING PATIENT MEDICAL RECORDS AND FILES AND PROVIDING THOSE RECORDS TO PATIENTS VIA A WEBSITE (U.S. CLS. 100 AND 101).

FIRST USE 8-24-2011; IN COMMERCE 8-24-2011.

CLASS 44—(Continued).

4,211,179. AVEDRO, INC., WALTHAM, MA. SN 85-349,744. PUB. 11-1-2011, FILED 6-17-2011.

KXL

4,210,981. PLASTIC SURGERY NORTHWEST PLLC, SPOKANE, WA. SN 85-311,342. PUB. 1-24-2012, FILED 5-3-2011.

THE MARK CONSISTS OF STANDARD CHARACTERS WITHOUT CLAIM TO ANY PARTICULAR FONT, STYLE, SIZE, OR COLOR.

FOR SURGERY; LASER VISION SURGERY SERVICES; TREATMENT OF EYE CONDITIONS AND DISEASES (U.S. CLS. 100 AND 101).

FIRST USE 12-0-2010; IN COMMERCE 12-0-2010.

Plastic Surgery Northwest

4,211,297. GEORGE IBACH, MINNEAPOLIS, MN. SN 85-368,736. PUB. 12-6-2011, FILED 7-12-2011.

EARTH, WE'RE ON HER SIDE.

THE MARK CONSISTS OF STANDARD CHARACTERS WITHOUT CLAIM TO ANY PARTICULAR FONT, STYLE, SIZE, OR COLOR.

NO CLAIM IS MADE TO THE EXCLUSIVE RIGHT TO USE "PLASTIC SURGERY", APART FROM THE MARK AS SHOWN.

FOR COSMETIC AND RECONSTRUCTIVE SURGERY (U.S. CLS. 100 AND 101).

FIRST USE 8-1-2010; IN COMMERCE 8-1-2010.

THE MARK CONSISTS OF STANDARD CHARACTERS WITHOUT CLAIM TO ANY PARTICULAR FONT, STYLE, SIZE, OR COLOR.

FOR VINEYARD SERVICES FOR OTHERS, NAMELY, GROWING GRAPES FOR MAKING WINE (U.S. CLS. 100 AND 101).

FIRST USE 5-0-2012; IN COMMERCE 5-0-2012.

4,211,148. ESNF, LLC, STRATFORD, CT. SN 85-346,661. PUB. 11-1-2011, FILED 6-15-2011.

eSNF

WEALTH FROM HEALTH

THE MARK CONSISTS OF STANDARD CHARACTERS WITHOUT CLAIM TO ANY PARTICULAR FONT, STYLE, SIZE, OR COLOR.

FOR MEDICAL SERVICES, NAMELY, PROVIDING TELEHEALTH SERVICES FOR LONG TERM CARE FACILITIES (U.S. CLS. 100 AND 101).

FIRST USE 6-1-2011; IN COMMERCE 8-1-2011.

THE MARK CONSISTS OF STANDARD CHARACTERS WITHOUT CLAIM TO ANY PARTICULAR FONT, STYLE, SIZE, OR COLOR.

FOR HEALTH CARE SERVICES, NAMELY, HEALTH AND WELLNESS PROGRAMS IN THE FIELD OF CHRONIC DISEASE MANAGEMENT (U.S. CLS. 100 AND 101).

FIRST USE 1-1-1991; IN COMMERCE 1-1-1991.

CLASS 44—(Continued).

4,211,391. ABY-LOPEZ, CORINNE, STUDIO CITY, CA. SN 85-392,746. PUB. 1-31-2012, FILED 8-8-2011.



THE STIPLING IS FOR SHADING PURPOSES ONLY. THE MARK CONSISTS OF THREE CARTOON ILLUSTRATIONS OF LADIES WITH THREE DIFFERENT HAIRSTYLES. THE GIRL ON THE LEFT IS HOLDING A COMB, THE GIRL IN THE MIDDLE IS HOLDING A BLOW DRYER AND THE ONE ON THE RIGHT IS HOLDING A PAIR OF SCISSORS.

FOR BEAUTY SALONS (U.S. CLS. 100 AND 101).
FIRST USE 8-15-2011; IN COMMERCE 8-15-2011.

4,211,499. COMMUNITY PET OUTREACH, P.A., ARLINGTON, TX. SN 85-436,828. PUB. 4-10-2012, FILED 9-30-2011.

COMMUNITY PET OUTREACH

THE MARK CONSISTS OF STANDARD CHARACTERS WITHOUT CLAIM TO ANY PARTICULAR FONT, STYLE, SIZE, OR COLOR.

NO CLAIM IS MADE TO THE EXCLUSIVE RIGHT TO USE "PET", APART FROM THE MARK AS SHOWN.

FOR VETERINARY SERVICES (U.S. CLS. 100 AND 101).

FIRST USE 3-1-2012; IN COMMERCE 3-1-2012.

4,211,514. KEEP IN MIND, INC., INDIAN LAND, SC. SN 85-443,458. PUB. 3-13-2012, FILED 10-10-2011.

KEEP IN MIND

THE MARK CONSISTS OF STANDARD CHARACTERS WITHOUT CLAIM TO ANY PARTICULAR FONT, STYLE, SIZE, OR COLOR.

FOR CONSULTING SERVICES IN THE FIELD OF ALZHEIMER'S DISEASE AND DEMENTIA (U.S. CLS. 100 AND 101).

FIRST USE 11-8-2011; IN COMMERCE 11-8-2011.

CLASS 44—(Continued).

4,211,536. WONG, TOA, STATEN ISLAND, NY. SN 85-453,683. PUB. 4-3-2012, FILED 10-21-2011.

ACUPHYSIO

THE MARK CONSISTS OF STANDARD CHARACTERS WITHOUT CLAIM TO ANY PARTICULAR FONT, STYLE, SIZE, OR COLOR.

FOR PHYSICAL THERAPY AND ACUPUNCTURE SERVICES (U.S. CLS. 100 AND 101).

FIRST USE 3-10-2003; IN COMMERCE 3-10-2003.

4,211,573. SUPERCUTS, INC., MINNEAPOLIS, MN. SN 85-471,614. PUB. 5-1-2012, FILED 11-14-2011.

ROCK THE CUT

THE MARK CONSISTS OF STANDARD CHARACTERS WITHOUT CLAIM TO ANY PARTICULAR FONT, STYLE, SIZE, OR COLOR.

FOR HAIR CUTTING SERVICES; HAIR STYLING (U.S. CLS. 100 AND 101).

FIRST USE 3-0-2012; IN COMMERCE 3-0-2012.

4,211,594. SUNSHINE INFUSION SERVICES, INC., ELMWOOD PARK, IL. SN 85-480,366. PUB. 5-8-2012, FILED 11-23-2011.

**HOME HEALTH & INFUSION, WE
HAVE IT COVERED!**

THE MARK CONSISTS OF STANDARD CHARACTERS WITHOUT CLAIM TO ANY PARTICULAR FONT, STYLE, SIZE, OR COLOR.

NO CLAIM IS MADE TO THE EXCLUSIVE RIGHT TO USE "HOME HEALTH & INFUSION", APART FROM THE MARK AS SHOWN.

FOR PROFESSIONAL, IN HOME NURSING CARE FOR HUMAN BEINGS; HEALTH CARE SERVICES IN THE NATURE OF IN HOME INFUSION THERAPY SERVICES; OCCUPATIONAL THERAPY SERVICES; PHYSICAL THERAPY SERVICES; AND SPEECH THERAPY SERVICES (U.S. CLS. 100 AND 101).

FIRST USE 5-0-2011; IN COMMERCE 6-0-2012.

CLASS 44—(Continued).

4,211,684. MD DELIVERED INC., SEAL BEACH, CA. SN 85-977,333. PUB. 12-13-2011, FILED 2-2-2011.

MD DELIVERED

THE MARK CONSISTS OF STANDARD CHARACTERS WITHOUT CLAIM TO ANY PARTICULAR FONT, STYLE, SIZE, OR COLOR.

NO CLAIM IS MADE TO THE EXCLUSIVE RIGHT TO USE "MD", APART FROM THE MARK AS SHOWN.

FOR MEDICAL SERVICES (U.S. CLS. 100 AND 101).
FIRST USE 5-31-2010; IN COMMERCE 1-0-2011.

CLASS 45—PERSONAL AND LEGAL SERVICES

4,210,312. KIMBROUGH, VALERIE, PEMBROKE PINES, FL. SN 77-608,666. PUB. 3-31-2009, FILED 11-6-2008.

Sporgo

THE MARK CONSISTS OF STANDARD CHARACTERS WITHOUT CLAIM TO ANY PARTICULAR FONT, STYLE, SIZE, OR COLOR.

FOR PROVIDING A SOCIAL NETWORKING WEBSITE FOR ENTERTAINMENT PURPOSES (U.S. CLS. 100 AND 101).

FIRST USE 4-3-2012; IN COMMERCE 4-3-2012.

4,210,437. THE BAPTIST STANDARD PUBLISHING COMPANY, DBA FAITHVILLAGE, PLANO, TX. SN 77-915,640. PUB. 6-1-2010, FILED 1-20-2010.

FAITHVILLAGE

THE MARK CONSISTS OF STANDARD CHARACTERS WITHOUT CLAIM TO ANY PARTICULAR FONT, STYLE, SIZE, OR COLOR.

FOR ONLINE SOCIAL NETWORKING SERVICES (U.S. CLS. 100 AND 101).

FIRST USE 2-27-2012; IN COMMERCE 2-27-2012.

CLASS 45—(Continued).

4,210,458. TASER INTERNATIONAL, INC., SCOTTSDALE, AZ. SN 77-934,542. PUB. 6-29-2010, FILED 2-12-2010.

TASER

THE MARK CONSISTS OF STANDARD CHARACTERS WITHOUT CLAIM TO ANY PARTICULAR FONT, STYLE, SIZE, OR COLOR.

FOR PROVIDING AN ON-LINE COMPUTER DATABASE IN THE FIELD OF LAW ENFORCEMENT, PROFESSIONAL SECURITY SERVICES, SELF DEFENSE, AND PRISONS (U.S. CLS. 100 AND 101).

FIRST USE 3-18-2011; IN COMMERCE 3-18-2011.

4,210,929. ROBERTSON, LYNN, SEATTLE, WA. SN 85-280,557. PUB. 8-30-2011, FILED 3-29-2011.

Secure Show

THE MARK CONSISTS OF STANDARD CHARACTERS WITHOUT CLAIM TO ANY PARTICULAR FONT, STYLE, SIZE, OR COLOR.

NO CLAIM IS MADE TO THE EXCLUSIVE RIGHT TO USE "SECURE", APART FROM THE MARK AS SHOWN.

FOR IDENTIFICATION VERIFICATION SERVICES, NAMELY, PROVIDING AUTHENTICATION OF PERSONAL IDENTIFICATION INFORMATION (U.S. CLS. 100 AND 101).

FIRST USE 3-25-2011; IN COMMERCE 5-1-2011.

4,210,964. RIKOCHET LIMITED, OAKLAND, CA. SN 85-302,929. PUB. 9-13-2011, FILED 4-23-2011.

Trendsmitt

THE MARK CONSISTS OF STANDARD CHARACTERS WITHOUT CLAIM TO ANY PARTICULAR FONT, STYLE, SIZE, OR COLOR.

FOR ON-LINE SOCIAL NETWORKING SERVICES (U.S. CLS. 100 AND 101).

FIRST USE 11-11-2011; IN COMMERCE 11-11-2011.

CLASS 45—(Continued).

4,211,189. CICHON, JOSEPH, TRUMBULL, CT. SN 85-350,721. PUB. 11-8-2011, FILED 6-20-2011.

CLASS 45—(Continued).

4,211,523. THE PLANNING AND ZONING RESOURCE CORPORATION, AKA PZR, OKLAHOMA CITY, OK. SN 85-448,990. PUB. 3-27-2012, FILED 10-17-2011.

The Heart of Technology

PZR

THE MARK CONSISTS OF STANDARD CHARACTERS WITHOUT CLAIM TO ANY PARTICULAR FONT, STYLE, SIZE, OR COLOR.

FOR CHRISTIAN MINISTRY SERVICES (U.S. CLS. 100 AND 101).

FIRST USE 1-15-2011; IN COMMERCE 1-15-2011.

THE MARK CONSISTS OF STANDARD CHARACTERS WITHOUT CLAIM TO ANY PARTICULAR FONT, STYLE, SIZE, OR COLOR.

OWNER OF U.S. REG. NO. 3,507,345.

FOR PERMITTING, NAMELY, OBTAINING ENVIRONMENTAL, DESIGN, ZONING AND OTHER GOVERNMENTAL PERMITS FOR DEVELOPMENT PROJECTS; REVIEWING STANDARDS AND PRACTICES TO ASSURE COMPLIANCE WITH ZONING LAWS AND REGULATIONS (U.S. CLS. 100 AND 101).

FIRST USE 7-3-2012; IN COMMERCE 7-3-2012.

4,211,192. VIASOFT, LLC, MONTREAL, QUEBEC, CANADA. SN 85-350,856. PUB. 11-8-2011, FILED 6-20-2011.

4,211,546. COMPUTERLAW GROUP, PALO ALTO, CA. SN 85-458,361. PUB. 5-15-2012, FILED 10-27-2011.

ITOP10

Every Lasting Agreement
Starts With Trust

THE MARK CONSISTS OF STANDARD CHARACTERS WITHOUT CLAIM TO ANY PARTICULAR FONT, STYLE, SIZE, OR COLOR.

FOR ONLINE SOCIAL NETWORKING SERVICES IN THE FIELD OF SHARING PERSONAL INTERESTS FOR PLEASURE OR BUSINESS (U.S. CLS. 100 AND 101).

FIRST USE 3-15-2012; IN COMMERCE 3-15-2012.

THE MARK CONSISTS OF STANDARD CHARACTERS WITHOUT CLAIM TO ANY PARTICULAR FONT, STYLE, SIZE, OR COLOR.

FOR LEGAL SERVICES (U.S. CLS. 100 AND 101).

FIRST USE 7-11-2012; IN COMMERCE 7-11-2012.

* * * * *

PRIOR UNITED STATES CLASSIFICATION

APPLICATION IN ONE CLASS

CERTIFICATION MARKS

4,210,309. TÜV SÜD AMERICA INC., PEABODY, MA. SN 77-607,107. PUB. 3-31-2009, FILED 11-4-2008.

CLASS A—GOODS

4,210,300. CONTINUA HEALTH ALLIANCE, BEAVERTON, OR. SN 77-558,460. PUB. 4-7-2009, FILED 8-28-2008.



OWNER OF U.S. REG. NOS. 3,284,483 AND 3,284,484.
NO CLAIM IS MADE TO THE EXCLUSIVE RIGHT TO USE "CERTIFIED", APART FROM THE MARK AS SHOWN.
THE MARK CONSISTS OF FOUR PARTIALLY SHADED, OVERLAPPING CIRCLES. THE OVERLAPPING PARTS OF THE CIRCLES CREATE GEOMETRIC SHAPES RESEMBLING A STICK FIGURE. THE DESIGN IS LOCATED ABOVE AND TO THE RIGHT OF THE STYLIZED WORD "CONTINUA", LOCATED DIRECTLY BELOW THE WORD "CONTINUA" AND JUSTIFIED RIGHT IS THE STYLIZED WORD "CERTIFIED".

THE CERTIFICATION MARK, AS INTENDED TO BE USED BY AUTHORIZED PERSONS, IS INTENDED TO CERTIFY THAT GOODS MANUFACTURED OR DISTRIBUTED BY AUTHORIZED PERSONS HAVE BEEN EVALUATED AND MEET STANDARDS SET BY THE CERTIFIER FOR INTEROPERABILITY, COMPATIBILITY, FUNCTIONALITY, RELIABILITY AND USABILITY OF COMPUTER HARDWARE AND SOFTWARE, DIGITAL MOBILE AND WIRELESS ELECTRONIC PRODUCTS, WIRELESS COMMUNICATION DEVICES, AND DIGITAL NETWORKING EQUIPMENT, ALL FOR MEDICAL AND HEALTH MONITORING PURPOSES.

FOR COMPUTER HARDWARE AND SOFTWARE, DIGITAL MOBILE AND WIRELESS ELECTRONIC PRODUCTS, WIRELESS COMMUNICATION DEVICES, AND DIGITAL NETWORKING EQUIPMENT, ALL FOR MEDICAL AND HEALTH MONITORING PURPOSES (U.S. CL. A).

FIRST USE 12-1-2009; IN COMMERCE 12-1-2009.



OWNER OF U.S. REG. NOS. 1,648,416, 3,562,714, AND OTHERS.

THE MARK CONSISTS OF THE STYLIZED WORDING "TÜV" LOCATED ABOVE THE STYLIZED WORDING "SÜD". THERE IS A HORIZONTAL LINE LOCATED BETWEEN THE TERMS "TÜV" AND "SÜD".

THE CERTIFICATION MARK, AS INTENDED TO BE USED BY AUTHORIZED PERSONS, IS INTENDED TO CERTIFY THAT THE RESPECTIVE PRODUCTS, WHEN THE MARK IS AFFIXED, COMPLY WITH ENFORCED PRODUCT SAFETY STANDARDS.

FOR MACHINERY (U.S. CL. A).

FIRST USE 3-0-2010; IN COMMERCE 3-0-2010.

4,210,850. BENT CREEK INSTITUTE, INC., ASHEVILLE, NC. SN 85-239,665. PUB. 10-4-2011, FILED 2-11-2011.



THE MARK CONSISTS OF OPEN SPHERE OVER THE IMAGE OF A GINKGO LEAF WITH THE LETTERS "USBSL" IN THE FOREGROUND HAVING "BSL" INSIDE THE CIRCLE AND "US" OUTSIDE THE CIRCLE.

THE CERTIFICATION MARK, AS USED OR INTENDED TO BE USED BY PERSONS AUTHORIZED BY THE CERTIFIER, CERTIFIES OR IS INTENDED TO CERTIFY THAT THE GOODS PROVIDED HAVE THE CORRECT BOTANICAL IDENTITY, PURITY OR COMPOSITION. FOR BOTANICALS AND HERBALS USED AS INGREDIENTS IN MANUFACTURED PRODUCTS (U.S. CL. A). FIRST USE 5-14-2012; IN COMMERCE 5-14-2012.

CERTIFICATION MARKS

CLASS B—SERVICES

4,211,587. NATIONAL BOARD FOR CERTIFIED COUNSELORS, INC. (NBCC), GREENSBORO, NC. SN 85-477,192. PUB. 5-1-2012, FILED 11-19-2011.

4,211,287. SIX COLUMNS, LLC, CARROLLTON, MO. SN 85-366,023. PUB. 12-6-2011, FILED 7-7-2011.

CCMHC

AWIS

THE MARK CONSISTS OF THE LETTERS "AWIS" WITH THE "A" AND "W" CONNECTED TO EACH OTHER. THE CERTIFICATION MARK, AS INTENDED TO BE USED BY AUTHORIZED PERSONS, IS INTENDED TO CERTIFY THAT THE WOOD PACKAGING MATERIALS CONFORM TO APPLICABLE INTERNATIONAL STANDARDS. FOR WOOD PACKAGING MATERIALS (U.S. CL. A). FIRST USE 2-0-2012; IN COMMERCE 2-0-2012.

THE MARK CONSISTS OF STANDARD CHARACTERS WITHOUT CLAIM TO ANY PARTICULAR FONT, STYLE, SIZE, OR COLOR. THE CERTIFICATION MARK, AS INTENDED TO BE USED BY AUTHORIZED PERSONS, IS INTENDED TO CERTIFY THAT AUTHORIZED PERSONS PERFORMING COUNSELING SERVICES HAVE DEMONSTRATED PROFESSIONAL KNOWLEDGE COMPETENCY IN THE FIELD OF MENTAL HEALTH COUNSELING, IN ACCORDANCE WITH THE REQUIREMENTS ESTABLISHED BY THE CERTIFIER, INCLUDING THE COMPLETION OF EDUCATIONAL AND PROFESSIONAL EXPERIENCE REQUIREMENTS, SUCCESSFUL COMPLETION OF A KNOWLEDGE-BASED EXAMINATION, AND CONTINUING EDUCATION REQUIREMENTS. FOR MENTAL HEALTH COUNSELING SERVICES (U.S. CL. B). FIRST USE 10-23-1993; IN COMMERCE 10-23-1993.

* * * * *

SUPPLEMENTAL REGISTER

These registrations are not subject to opposition.

SECTION 1.— INTERNATIONAL CLASSIFICATION

The short titles associated below with the international class numbers are terms designed merely for quick identification and are not an official part of the international classification. The full names of international classes are given in section 6.1 of the trademark rules of practice.

The designation "U.S. Cl." appearing in this section refers to the U.S. class in effect prior to Sep. 1, 1973 rather than the international class which applies to applications filed on or after that date. For adoption of international classification see notice in the OFFICIAL GAZETTE of Jun. 26, 1973 (911 O.G. TM 210).

Application in more than one class

4,211,685. DESIGN WORKS INTERNATIONAL, INC., NEW YORK, NY. SN 76-709,193. FILED 9-23-2011.

NO CLAIM IS MADE TO THE EXCLUSIVE RIGHT TO USE "FAT LOSS", APART FROM THE MARK AS SHOWN.

CREATIVE CORPORATE

CLASS 9—ELECTRICAL AND SCIENTIFIC APPARATUS

THE MARK CONSISTS OF STANDARD CHARACTERS WITHOUT CLAIM TO ANY PARTICULAR FONT, STYLE, SIZE, OR COLOR.

FOR PRE-RECORDED VIDEOTAPES, DIGITAL VIDEO DISCS AND DVD'S FEATURING EXERCISE, NUTRITION AND WEIGHT LOSS (U.S. CLS. 21, 23, 26, 36 AND 38).

FIRST USE 1-6-2012; IN COMMERCE 1-6-2012.

CLASS 35—ADVERTISING AND BUSINESS

FOR BUSINESS MANAGEMENT CONSULTATION TO BUSINESS; MARKETING RESEARCH; MARKETING STUDIES; PRODUCT MERCHANDISING; MERCHANDISING SERVICES IN THE NATURE OF PREPARATION OF CUSTOMIZED MERCHANDISING PACKAGING FOR OTHERS; MERCHANDISING DISPLAY SERVICES (U.S. CLS. 100, 101 AND 102).

FIRST USE 1-1-2011; IN COMMERCE 1-1-2011.

CLASS 16—PAPER GOODS AND PRINTED MATTER

FOR PRINTED MATERIALS, NAMELY, BOOKS, MAGAZINES, PERIODICALS AND NEWSLETTERS IN THE FIELDS OF HEALTH, NUTRITION AND WEIGHT LOSS, AND RELATED PRODUCTS AND SERVICES (U.S. CLS. 2, 5, 22, 23, 29, 37, 38 AND 50).

FIRST USE 1-6-2012; IN COMMERCE 1-6-2012.

CLASS 42—SCIENTIFIC AND COMPUTER SERVICES

FOR DESIGN AND TESTING FOR NEW PRODUCT DEVELOPMENT; DESIGN OF PACKAGING FOR OTHERS; DEVELOPMENT CONSULTATION ON PRODUCT DESIGN; PRODUCT DEVELOPMENT FOR OTHERS (U.S. CLS. 100 AND 101).

FIRST USE 1-1-2011; IN COMMERCE 1-1-2011.

CLASS 41—EDUCATION AND ENTERTAINMENT

FOR ENTERTAINMENT IN THE NATURE OF ONGOING TELEVISION PROGRAMS IN THE FIELD OF EXERCISE, NUTRITION AND WEIGHT LOSS (U.S. CLS. 100, 101 AND 107).

FIRST USE 1-6-2012; IN COMMERCE 1-6-2012.

4,211,689. ALCHEMY WORLDWIDE, LLC, SHERMAN OAKS, CA. SN 77-803,241. FILED P.R. 8-12-2009; AM. S.R. 1-11-2012.

4,211,691. AMB I.T. B.V., HAARLEM, NETHERLANDS. SN 85-027,098. FILED P.R. 4-30-2010; AM. S.R. 2-25-2011.

BIBTAG

AMERICA'S FAT LOSS COACH

THE MARK CONSISTS OF STANDARD CHARACTERS WITHOUT CLAIM TO ANY PARTICULAR FONT, STYLE, SIZE, OR COLOR.

THE MARK CONSISTS OF STANDARD CHARACTERS WITHOUT CLAIM TO ANY PARTICULAR FONT, STYLE, SIZE, OR COLOR.

PRIORITY CLAIMED UNDER SEC. 44(D) ON ERPN CMNTY TM OFC APPLICATION NO. 008655425, FILED 11-2-2009, REG. NO. 008655425, DATED 8-24-2010, EXPIRES 11-2-2019.

CLASS 9—ELECTRICAL AND SCIENTIFIC APPARATUS

FOR EQUIPMENT FOR TIMING AND IDENTIFICATION OF PARTICIPANTS IN SPORTING EVENTS AND PRACTICE SESSIONS, COMPRISED OF COMPUTER HARDWARE HAVING A TRANSMITTER AND A RECEIVER OF ELECTRICAL SIGNALS, AND TIMING CHIPS TO BE ATTACHED TO PARTICIPANTS IN SPORTING EVENTS AND PRACTICE SESSIONS TO BE USED AS A UNIT (U.S. CLS. 21, 23, 26, 36 AND 38).
FIRST USE 1-17-2010; IN COMMERCE 1-17-2010.

CLASS 41—EDUCATION AND ENTERTAINMENT

FOR (BASED ON 44(D) PRIORITY APPLICATION) (BASED ON 44(E)) TIMING OF SPORTS EVENTS (U.S. CLS. 100, 101 AND 107).

4,211,696. FIERCELY LOYAL MERCHANDISE CO., LLC, MALIBU, CA. SN 85-254,859. FILED P.R. 3-1-2011; AM. S.R. 7-10-2012.

LIGHTER SKINZ

THE MARK CONSISTS OF STANDARD CHARACTERS WITHOUT CLAIM TO ANY PARTICULAR FONT, STYLE, SIZE, OR COLOR.

NO CLAIM IS MADE TO THE EXCLUSIVE RIGHT TO USE "SKINZ" FOR INTERNATIONAL CLASS 21, APART FROM THE MARK AS SHOWN.

CLASS 21—HOUSEWARES AND GLASS

FOR CANDLE HOLDERS (U.S. CLS. 2, 13, 23, 29, 30, 33, 40 AND 50).
FIRST USE 2-0-2011; IN COMMERCE 2-0-2011.

CLASS 34—SMOKERS' ARTICLES

FOR CIGARETTE LIGHTER HOLDERS (U.S. CLS. 2, 8, 9 AND 17).
FIRST USE 2-0-2011; IN COMMERCE 2-0-2011.

CLASS 35—ADVERTISING AND BUSINESS

FOR ONLINE RETAIL STORE SERVICES FEATURING CIGARETTE LIGHTER HOLDERS AND CANDLE HOLDERS (U.S. CLS. 100, 101 AND 102).
FIRST USE 2-0-2011; IN COMMERCE 2-0-2011.

4,211,701. JIMENEZ, XABIER URIBE-ETXEBARRIA, ERANDIO 48950, SPAIN. SN 85-279,667. FILED P.R. 3-29-2011; AM. S.R. 8-7-2012.

WEB SUMMIT

THE MARK CONSISTS OF STANDARD CHARACTERS WITHOUT CLAIM TO ANY PARTICULAR FONT, STYLE, SIZE, OR COLOR.

PRIORITY CLAIMED UNDER SEC. 44(D) ON ERP CMNTY TM OFC APPLICATION NO. 9776031, FILED 3-1-2011, REG. NO. 9776031, DATED 7-13-2011, EXPIRES 3-1-2021.

NO CLAIM IS MADE TO THE EXCLUSIVE RIGHT TO USE "WEB" WITH RESPECT TO CLASSES 35 AND 41, APART FROM THE MARK AS SHOWN.

CLASS 25—CLOTHING

FOR T-SHIRTS, SWEAT SHIRTS, CAPS (U.S. CLS. 22 AND 39).

CLASS 35—ADVERTISING AND BUSINESS

FOR PROMOTING THE INTERESTS OF COMPANIES AND PEOPLE DOING BUSINESS OR ENTREPRENEURSHIP ON THE WORLD WIDE WEB AND INTERNET (U.S. CLS. 100, 101 AND 102).

CLASS 41—EDUCATION AND ENTERTAINMENT

FOR EDUCATIONAL SERVICES, NAMELY, CONDUCTING SEMINARS, WORKSHOPS AND CONGRESSES IN THE FIELD OF DOING BUSINESS OR ENTREPRENEURSHIP ON THE WORLD WIDE WEB AND INTERNET; ORGANIZING AND CONDUCTING EVENTS FOR CULTURAL PURPOSES; ORGANIZING AND CONDUCTING SOCIAL ENTERTAINMENT EVENTS; ENTERTAINMENT SERVICES, NAMELY, PROVIDING RECOGNITION AND INCENTIVES BY THE WAY OF AWARDS TO DEMONSTRATE EXCELLENCE IN THE FIELD OF WORLD WIDE WEB AND INTERNET DEVELOPMENT (U.S. CLS. 100, 101 AND 107).

4,211,706. KUNTZ ELECTROPLATING INC., KITCHENER, CANADA. SN 85-292,654. FILED P.R. 4-12-2011; AM. S.R. 7-30-2012.



NO CLAIM IS MADE TO THE EXCLUSIVE RIGHT TO USE "PLATED PRODUCTS", APART FROM THE MARK AS SHOWN.

THE MARK CONSISTS OF A SQUARE CONTAINING THE NUMBER "24" AND THE WORDING "CR". THIS SQUARE APPEARS TO THE LEFT OF THE WORDING "REAL CHROME". THE WORDING "REALCHROME" APPEARS ABOVE THE WORDING "PREMIUM PLATED PRODUCTS".

CLASS 1—CHEMICALS

FOR CHROME METAL ELECTROPLATING CHEMICAL COMPOSITIONS (U.S. CLS. 1, 5, 6, 10, 26 AND 46). FIRST USE 5-19-2010; IN COMMERCE 5-19-2010.

CLASS 12—VEHICLES

FOR CHROME METAL PARTS FOR VEHICLES, NAMELY, METAL-PLATED AUTOMOTIVE EXTERIOR AND INTERIOR DECORATIVE AND PROTECTIVE TRIM, ENGINE COVERS, VEHICLE WHEELS, RIMS FOR VEHICLE WHEELS, RUNNING BOARDS, DOOR HANDLES, AND STRUCTURAL PARTS THEREFOR; CHROME METAL-PLATED VEHICLE SUSPENSION COMPONENTS, NAMELY, SUSPENSION SPRINGS, STRUTS AND SHOCKS AND STRUCTURAL PARTS THEREFOR (U.S. CLS. 19, 21, 23, 31, 35 AND 44). FIRST USE 5-19-2010; IN COMMERCE 5-19-2010.

4,211,707. JOHNSON & JOHNSON, NEW BRUNSWICK, NJ. SN 85-303,275. FILED P.R. 4-25-2011; AM. S.R. 7-20-2012.

NO CLAIM IS MADE TO THE EXCLUSIVE RIGHT TO USE "SAAS", APART FROM THE MARK AS SHOWN.

CLASS 9—ELECTRICAL AND SCIENTIFIC APPARATUS

FOR COMPUTER SOFTWARE THAT PROVIDES WEB-BASED ACCESS TO APPLICATIONS THROUGH A WEB OPERATING SYSTEM FOR STORING, DISTRIBUTING, MANIPULATING AND MANAGING DIGITAL ASSETS (U.S. CLS. 21, 23, 26, 36 AND 38). FIRST USE 6-10-2011; IN COMMERCE 6-10-2011.

CLASS 42—SCIENTIFIC AND COMPUTER SERVICES

FOR WEB AND CLOUD BASED, NON-DOWNLOADABLE COMPUTER APPLICATION SOFTWARE STORING, DISTRIBUTING, MANIPULATING AND MANAGING DIGITAL ASSETS, AND NON-DOWNLOADABLE COMPUTER DATABASE SOFTWARE FOR STORING, DISTRIBUTING, MANIPULATING AND MANAGING DIGITAL ASSETS (U.S. CLS. 100 AND 101). FIRST USE 6-10-2011; IN COMMERCE 6-10-2011.



THE MARK CONSISTS OF A BOX WITHIN A BOX.

CLASS 3—COSMETICS AND CLEANING PREPARATIONS

FOR NON-MEDICATED MOUTHWASH (U.S. CLS. 1, 4, 6, 50, 51 AND 52). FIRST USE 11-3-1994; IN COMMERCE 11-3-1994.

CLASS 5—PHARMACEUTICALS

FOR MEDICATED MOUTHWASH (U.S. CLS. 6, 18, 44, 46, 51 AND 52). FIRST USE 11-3-1994; IN COMMERCE 11-3-1994.

4,211,715. ORTERY TECHNOLOGIES, INC., IRVINE, CA. SN 85-322,897. FILED P.R. 5-17-2011; AM. S.R. 7-23-2012.

SAAS PHOTO

THE MARK CONSISTS OF STANDARD CHARACTERS WITHOUT CLAIM TO ANY PARTICULAR FONT, STYLE, SIZE, OR COLOR.

4,211,716. TRIP ALERTZ, INC., CHESTNUT HILL, MA. SN 85-327,500. FILED P.R. 5-23-2011; AM. S.R. 7-22-2012.

TRIPALERTZ

THE MARK CONSISTS OF STANDARD CHARACTERS WITHOUT CLAIM TO ANY PARTICULAR FONT, STYLE, SIZE, OR COLOR.

CLASS 39—TRANSPORTATION AND STORAGE

FOR ARRANGING AND COORDINATING TRAVEL ARRANGEMENTS FOR INDIVIDUALS, ASSOCIATIONS, NAMELY, VACATIONS; TRAVEL AGENCY SERVICES, NAMELY, MAKING RESERVATIONS AND BOOKINGS FOR TRANSPORTATION; PROVIDING A WEBSITE AND WEBSITE LINKS TO TRAVEL INFORMATION, GEOGRAPHIC INFORMATION, MAPS, MAP IMAGES AND TRIP ROUTING; PROVIDING INFORMATION ABOUT TOURS AND TRAVEL TO EVENTS AND ATTRACTIONS; PROVIDING A WEBSITE WHERE USERS CAN SELECT, VOTE ON OR CREATE TRAVEL ARRANGEMENTS, TRANSPORTATION, PROVIDE ONLINE REVIEWS, COMMUNICATE AND INVITE PEERS REGARDING TRANSPORTATION AND TRAVEL ACTIVITIES (U.S. CLS. 100 AND 105). FIRST USE 10-25-2010; IN COMMERCE 10-25-2010.

CLASS 43—HOTEL AND RESTAURANT SERVICES

FOR TRAVEL AGENCY SERVICES, NAMELY, MAKING RESERVATIONS AND BOOKINGS FOR TEMPORARY ACCOMMODATIONS, HOTELS, MOTELS, VILLAS, CONDOMINIUMS, RESORTS; RESERVATION OF HOTEL ROOMS FOR TRAVELERS; HOTEL AND LODGING SERVICES PROVIDING AND RELAYING INFORMATION, NAMELY, PROVIDING INFORMATION REGARDING HOTEL ACCOMMODATIONS AND RESERVATIONS; PROVIDING A WEBSITE WHERE USERS CAN SELECT, VOTE ON OR CREATE HOTEL VACATION PACKAGES, PROVIDE ON-LINE REVIEWS, COMMUNICATE AND INVITE PEERS, AND OBTAIN RESERVATIONS FOR HOTELS, RESORTS, AND TRAVEL ACCOMMODATIONS (U.S. CLS. 100 AND 101).

FIRST USE 10-25-2010; IN COMMERCE 10-25-2010.

CLASS 42—SCIENTIFIC AND COMPUTER SERVICES

FOR COMPUTER SERVICE, NAMELY, ACTING AS AN APPLICATION SERVICE PROVIDER IN THE FIELD OF KNOWLEDGE MANAGEMENT TO HOST COMPUTER APPLICATION SOFTWARE FOR THE COLLECTION, EDITING, ORGANIZING, MODIFYING, BOOK MARKING, TRANSMISSION, STORAGE AND SHARING OF DATA AND INFORMATION TO OTHERS VIA AN ONLINE WEB SITE ACCESSED THROUGH A GLOBAL COMPUTER NETWORK; COMPUTER SERVICES, NAMELY, OPERATING COMPUTER SYSTEMS AND COMPUTER NETWORKS FEATURING BROADBAND TRANSMISSION SOFTWARE FOR TELECOMMUTERS; PROVIDING A SECURE ELECTRONIC ONLINE SYSTEM FEATURING TECHNOLOGY WHICH ALLOWS BUSINESSES TO MANAGE THEIR BUSINESS AND WORKFORCE FROM ANY LOCATION; PROVIDING ON-LINE, NON-DOWNLOADABLE, INTERNET-BASED SOFTWARE APPLICATION FOR BUSINESS TO BILL THEIR CUSTOMERS; TECHNICAL SUPPORT, NAMELY, MONITORING OF BROADBAND COMMUNICATION NETWORKS TO ENABLE TELECOMMUTERS TO WORK EFFICIENTLY FROM ANY REMOTE LOCATION; TELECOMMUNICATIONS SERVICES, NAMELY, DESIGN OF UNIFIED COMMUNICATIONS SERVICES CONSOLIDATING ALL COMMUNICATION SERVICES FOR BUSINESSES; TELECOMMUNICATIONS SERVICES, NAMELY, PROVIDING AN INTERNET PORTAL FOR BUSINESSES TO EFFECTIVELY MANAGE UNIFIED BUSINESS COMMUNICATIONS BY PROVIDING INFORMATION IN THE FIELDS OF TECHNOLOGY AND SOFTWARE DEVELOPMENT; COMPUTER SERVICES, NAMELY, DOMAIN FORWARDING SERVICES (U.S. CLS. 100 AND 101).

FIRST USE 8-2-2010; IN COMMERCE 8-2-2010.

4,211,718. OFFICESCAPE, INC., INDIANAPOLIS, IN. SN 85-329,883. FILED P.R. 5-25-2011; AM. S.R. 11-25-2011.

Business in a Cloud

4,211,726. HOG SLAT, INC., NEWTON GROVE, NC. SN 85-361,469. FILED P.R. 7-1-2011; AM. S.R. 7-26-2012.

THE MARK CONSISTS OF STANDARD CHARACTERS WITHOUT CLAIM TO ANY PARTICULAR FONT, STYLE, SIZE, OR COLOR.

CLASS 35—ADVERTISING AND BUSINESS

FOR MANAGING BROADBAND COMMUNICATION NETWORKS FOR OTHERS TO ENABLE BUSINESSES TO OPERATE EFFICIENTLY WITH EMPLOYEES IN DIFFERENT LOCATIONS; PROVIDING A WEB-BASED ONLINE PORTAL THAT PROVIDES FOR BUSINESS OPERATIONS AND ONLINE BUSINESS MANAGEMENT, NAMELY, USER ACCESS/EMPLOYEE MANAGEMENT, SERVICE MANAGEMENT, HUMAN RESOURCE MANAGEMENT, DEPARTMENTAL MANAGEMENT, COST TRACKING, CORPORATE COMMUNICATIONS AND COLLABORATION (U.S. CLS. 100, 101 AND 102).

FIRST USE 8-2-2010; IN COMMERCE 8-2-2010.

CLASS 38—COMMUNICATION

FOR VIDEO, AUDIO, AND WEB CONFERENCING SERVICES; PERSONALIZED FAX AND VOICE ELECTRONIC MAIL SERVICES; WEB MESSAGING; VIRTUAL PBX DIALING SERVICE; ELECTRONIC TRANSMISSION OF VOICE SIGNALS, DATA, FACSIMILES, IMAGES, AND INFORMATION VIA A GLOBAL COMPUTER NETWORK (U.S. CLS. 100, 101 AND 104).

FIRST USE 8-2-2010; IN COMMERCE 8-2-2010.

GROWER SELECT

THE MARK CONSISTS OF STANDARD CHARACTERS WITHOUT CLAIM TO ANY PARTICULAR FONT, STYLE, SIZE, OR COLOR.

CLASS 7—MACHINERY

FOR ELECTRONIC FEEDERS FOR ANIMALS AND PARTS THEREFOR; ELECTRIC MOTORS FOR MACHINES; BELTS FOR MACHINES (U.S. CLS. 13, 19, 21, 23, 31, 34 AND 35).

FIRST USE 5-31-2007; IN COMMERCE 5-31-2007.

CLASS 10—MEDICAL APPARATUS

FOR MEDICAL FLUID INJECTORS (U.S. CLS. 26, 39 AND 44).

FIRST USE 11-23-2007; IN COMMERCE 11-23-2007.

4,211,736. THE SOLID WOOD CABINET COMPANY LLC, SOUTHAMPTON, PA. SN 85-395,853. FILED P.R. 8-11-2011; AM. S.R. 5-31-2012.

CloseoutCabinets.com

THE MARK CONSISTS OF STANDARD CHARACTERS WITHOUT CLAIM TO ANY PARTICULAR FONT, STYLE, SIZE, OR COLOR.

CLASS 20—FURNITURE AND ARTICLES NOT OTHERWISE CLASSIFIED

FOR CABINET DOORS FOR FURNITURE CABINETS; CABINET DRAWERS FOR FURNITURE CABINETS; CABINETS; KITCHEN CABINETS; KITCHEN FURNITURE, NAMELY, READY TO ASSEMBLE MOBILE KITCHEN ISLANDS (U.S. CLS. 2, 13, 22, 25, 32 AND 50). FIRST USE 6-30-2009; IN COMMERCE 6-30-2009.

CLASS 35—ADVERTISING AND BUSINESS

FOR COMPUTERIZED ON-LINE RETAIL STORE SERVICES IN THE FIELD OF KITCHEN CABINETS; DISCOUNT STORES IN THE FIELD OF KITCHEN CABINETS; ON-LINE RETAIL STORE SERVICES FEATURING KITCHEN CABINETS; ON-LINE WHOLESALE AND RETAIL STORE SERVICES FEATURING KITCHEN CABINETS; RETAIL BUILDING SUPPLY STORE SERVICES FEATURING KITCHEN CABINETS; RETAIL FURNITURE STORES; RETAIL STORES FEATURING KITCHEN CABINETS; WHOLESALE AND RETAIL STORE SERVICES FEATURING KITCHEN CABINETS; WHOLESALE DISTRIBUTORSHIPS FEATURING KITCHEN CABINETS; WHOLESALE STORES FEATURING KITCHEN CABINETS (U.S. CLS. 100, 101 AND 102). FIRST USE 6-30-2009; IN COMMERCE 6-30-2009.

CLASS 40—MATERIAL TREATMENT

FOR CABINET MAKING (U.S. CLS. 100, 103 AND 106). FIRST USE 6-30-2009; IN COMMERCE 6-30-2009.

4,211,745. COVANTA ENERGY CORPORATION, MORRISTOWN, NJ. SN 85-417,332. FILED P.R. 9-8-2011; AM. S.R. 6-20-2012.

4RECOVERY

THE MARK CONSISTS OF STANDARD CHARACTERS WITHOUT CLAIM TO ANY PARTICULAR FONT, STYLE, SIZE, OR COLOR.

CLASS 37—CONSTRUCTION AND REPAIR

FOR WASTE DISPOSAL FOR OTHERS (U.S. CLS. 100, 103 AND 106). FIRST USE 11-1-2011; IN COMMERCE 11-1-2011.

CLASS 39—TRANSPORTATION AND STORAGE

FOR WASTE TRANSPORTATION FOR OTHERS (U.S. CLS. 100 AND 105). FIRST USE 11-1-2011; IN COMMERCE 11-1-2011.

CLASS 40—MATERIAL TREATMENT

FOR OPERATION OF WASTE TRANSFER STATIONS FOR OTHERS (U.S. CLS. 100, 103 AND 106). FIRST USE 11-1-2011; IN COMMERCE 11-1-2011.

4,211,755. HI-LINE ELECTRIC COMPANY, AKA HI-LINE, INC., DALLAS, TX. SN 85-429,599. FILED 9-22-2011.

America's Mobile
Industrial Hardware Store

THE MARK CONSISTS OF STANDARD CHARACTERS WITHOUT CLAIM TO ANY PARTICULAR FONT, STYLE, SIZE, OR COLOR.

NO CLAIM IS MADE TO THE EXCLUSIVE RIGHT TO USE "INDUSTRIAL HARDWARE" FOR INTERNATIONAL CLASS 6, "INDUSTRIAL" FOR INTERNATIONAL CLASS 9, OR "MOBILE INDUSTRIAL HARDWARE STORE" FOR INTERNATIONAL CLASS 35, APART FROM THE MARK AS SHOWN.

CLASS 6—METAL GOODS

FOR METAL FASTENERS, NAMELY, STANDARD AND METRIC BOLTS AND SHEET METAL AND SELF-TAPING SCREWS (U.S. CLS. 2, 12, 13, 14, 23, 25 AND 50). FIRST USE 9-19-2011; IN COMMERCE 9-19-2011.

CLASS 9—ELECTRICAL AND SCIENTIFIC APPARATUS

FOR ELECTRIC CABLES, WIRES, CONDUCTORS AND CONNECTION FITTINGS THEREFOR (U.S. CLS. 21, 23, 26, 36 AND 38). FIRST USE 9-19-2011; IN COMMERCE 9-19-2011.

CLASS 35—ADVERTISING AND BUSINESS

FOR MOBILE RETAIL STORE SERVICES FEATURING A FULL LINE OF INDUSTRIAL, ELECTRICAL AND AUTOMOTIVE MAINTENANCE AND REPAIR PARTS AND SUPPLIES; DISTRIBUTORSHIP SERVICES IN THE FIELD OF INDUSTRIAL, ELECTRICAL AND AUTOMOTIVE MAINTENANCE REPAIR PARTS AND SUPPLIES; INVENTORY MANAGEMENT SERVICES IN THE FIELD OF INDUSTRIAL, ELECTRICAL AND AUTOMOTIVE MAINTENANCE REPAIR PARTS AND SUPPLIES; ON-LINE WHOLESALE AND RETAIL STORE SERVICES FEATURING A FULL LINE OF INDUSTRIAL, ELECTRICAL AND AUTOMOTIVE MAINTENANCE AND REPAIR PARTS AND SUPPLIES; DISTRIBUTORSHIP SERVICES IN THE FIELD OF INDUSTRIAL, ELECTRICAL AND AUTOMOTIVE MAINTENANCE REPAIR PARTS AND SUPPLIES; INVENTORY MANAGEMENT SERVICES IN THE FIELD OF INDUSTRIAL, ELECTRICAL AND AUTOMOTIVE MAINTENANCE REPAIR PARTS AND SUPPLIES (U.S. CLS. 100, 101 AND 102). FIRST USE 9-19-2011; IN COMMERCE 1-26-2012.

4,211,758. FREE CONFERENCING CORPORATION, LONG BEACH, CA. SN 85-433,137. FILED P.R. 9-27-2011; AM. S.R. 7-23-2012.

FREECONFERENCECALL

THE MARK CONSISTS OF STANDARD CHARACTERS WITHOUT CLAIM TO ANY PARTICULAR FONT, STYLE, SIZE, OR COLOR.

OWNER OF U.S. REG. NOS. 3,131,428, 3,522,474, AND 3,541,823.

CLASS 16—PAPER GOODS AND PRINTED MATTER

FOR CALLING CARDS FOR USE IN TELECONFERENCING SERVICES NOT MAGNETICALLY ENCODED (U.S. CLS. 2, 5, 22, 23, 29, 37, 38 AND 50).

FIRST USE 8-6-2003; IN COMMERCE 8-6-2003.

CLASS 38—COMMUNICATION

FOR TELECOMMUNICATION SERVICES, NAMELY, TELEPHONE AND VIDEO CONFERENCE CALLING SERVICES; WEB CONFERENCING SERVICES; PROVIDING ELECTRONIC TELECOMMUNICATION CONNECTIONS FOR ONLINE MEETINGS; ELECTRONIC VOICE MESSAGING SERVICES, NAMELY, THE RECORDING AND SUBSEQUENT TRANSMISSION OF VOICE MESSAGES BY TELEPHONE; WEB MESSAGING SERVICES; INTERNET BASED CONFERENCING SERVICES, NAMELY, VIDEO AND WEB CONFERENCING VIA THE INTERNET (U.S. CLS. 100, 101 AND 104).

FIRST USE 10-26-2001; IN COMMERCE 11-1-2001.

4,211,759. FREE CONFERENCING CORPORATION, LONG BEACH, CA. SN 85-433,292. FILED P.R. 9-27-2011; AM. S.R. 7-23-2012.

FREECONFERENCECALL.COM

THE MARK CONSISTS OF STANDARD CHARACTERS WITHOUT CLAIM TO ANY PARTICULAR FONT, STYLE, SIZE, OR COLOR.

OWNER OF U.S. REG. NOS. 3,131,428, 3,522,474, AND 3,541,823.

CLASS 16—PAPER GOODS AND PRINTED MATTER

FOR CALLING CARDS FOR USE IN TELECONFERENCING SERVICES NOT MAGNETICALLY ENCODED (U.S. CLS. 2, 5, 22, 23, 29, 37, 38 AND 50).

FIRST USE 8-6-2003; IN COMMERCE 8-6-2003.

CLASS 38—COMMUNICATION

FOR TELECOMMUNICATION SERVICES, NAMELY, TELEPHONE AND VIDEO CONFERENCE CALLING SERVICES; WEB CONFERENCING SERVICES; PROVIDING ELECTRONIC TELECOMMUNICATION CONNECTIONS FOR ONLINE MEETINGS; ELECTRONIC VOICE MESSAGING SERVICES, NAMELY, THE RECORDING AND SUBSEQUENT TRANSMISSION OF VOICE MESSAGES BY TELEPHONE; WEB MESSAGING SERVICES; INTERNET BASED CONFERENCING SERVICES, NAMELY, VIDEO AND WEB CONFERENCING VIA THE INTERNET (U.S. CLS. 100, 101 AND 104).

FIRST USE 10-26-2001; IN COMMERCE 11-1-2001.

4,211,762. KERR HEALTH, LLC, RALEIGH, NC. SN 85-435,006. FILED P.R. 9-29-2011; AM. S.R. 7-23-2012.

KERR HEALTH

THE MARK CONSISTS OF STANDARD CHARACTERS WITHOUT CLAIM TO ANY PARTICULAR FONT, STYLE, SIZE, OR COLOR.

NO CLAIM IS MADE TO THE EXCLUSIVE RIGHT TO USE "HEALTH", APART FROM THE MARK AS SHOWN.

CLASS 35—ADVERTISING AND BUSINESS

FOR PHARMACY SERVICES, NAMELY, PROVIDING PRESCRIPTION DRUG FULFILLMENT SERVICES FOR OTHERS; PROVIDING PRESCRIPTION DRUG FULFILLMENT SERVICES AND INFORMATION MANAGEMENT SERVICES FOR SPECIALIZED DISEASE MANAGEMENT; PROVIDING PRESCRIPTION DRUG FULFILLMENT SERVICES FOR RESIDENTS OF LONG-TERM CARE FACILITIES AND GROUP HOMES (U.S. CLS. 100, 101 AND 102).

FIRST USE 12-11-2009; IN COMMERCE 12-11-2009.

CLASS 41—EDUCATION AND ENTERTAINMENT

FOR EDUCATION SERVICES, NAMELY, PROVIDING COURSES IN THE FIELDS OF HEALTH AND WELLNESS; PROVIDING MEDICATION ADMINISTRATION AND HEALTH AND WELLNESS EDUCATION SERVICES THROUGH LIVE, PRINTED, TELEPHONIC, AND ONLINE CLASSES AND INSTRUCTION (U.S. CLS. 100, 101 AND 107).

FIRST USE 12-11-2009; IN COMMERCE 12-11-2009.

CLASS 44—MEDICAL, BEAUTY AND AGRICULTURAL SERVICES

FOR HEALTHCARE SERVICES, NAMELY, PROVIDING MEDICATION THERAPY MANAGEMENT SERVICES; ADMINISTERING INFLUENZA, PNEUMONIA, SHINGLES, AND OTHER VACCINATIONS TO HUMANS; PROVIDING SCREENING SERVICES AND PREVENTATIVE CARE FOR DIABETES, HIGH CHOLESTEROL, AND HIGH BLOOD PRESSURE; PROVIDING MONITORING AND REMINDER SERVICES FOR ADHERENCE TO PRESCRIBED DRUG THERAPY; CUSTOM COMPOUNDING OF PRESCRIPTION DRUGS FOR OTHERS (U.S. CLS. 100 AND 101).

FIRST USE 12-11-2009; IN COMMERCE 12-11-2009.

4,211,764. FOREX CAPITAL MARKETS LLC, NEW YORK, NY. SN 85-437,941. FILED P.R. 10-3-2011; AM. S.R. 7-30-2012.

Trading Station

THE MARK CONSISTS OF STANDARD CHARACTERS WITHOUT CLAIM TO ANY PARTICULAR FONT, STYLE, SIZE, OR COLOR.

NO CLAIM IS MADE TO THE EXCLUSIVE RIGHT TO USE "TRADING", APART FROM THE MARK AS SHOWN.

CLASS 9—ELECTRICAL AND SCIENTIFIC APPARATUS

FOR COMPUTER SOFTWARE, NAMELY, ELECTRONIC FINANCIAL PLATFORM THAT ACCOMMODATES MULTIPLE TYPES OF PAYMENT AND DEBT TRANSACTIONS IN AN INTEGRATED MOBILE PHONE, PDA AND WEB-BASED ENVIRONMENT (U.S. CLS. 21, 23, 26, 36 AND 38).

FIRST USE 2-1-2012; IN COMMERCE 2-1-2012.

CLASS 36—INSURANCE AND FINANCIAL

FOR FINANCIAL SERVICES, NAMELY, ASSISTING OTHERS WITH THE COMPLETION OF FINANCIAL TRANSACTIONS FOR STOCKS, BONDS, SECURITIES AND EQUITIES; ELECTRONIC FOREIGN EXCHANGE PAYMENT PROCESSING; FINANCIAL SERVICES, NAMELY, PROVIDING INFORMATION IN THE FIELDS OF FOREIGN CURRENCY, COMMODITIES, FINANCIAL DERIVATIVES, INTEREST RATE PRODUCTS, AND EQUITIES VIA THE INTERNET AND INTRANET SYSTEMS; CURRENCY TRANSFER SERVICES; ELECTRONIC FINANCIAL TRADING SERVICES (U.S. CLS. 100, 101 AND 102).

FIRST USE 9-28-2011; IN COMMERCE 9-28-2011.

CLASS 42—SCIENTIFIC AND COMPUTER SERVICES

FOR PROVIDING A WEB HOSTING PLATFORM FOR FOREIGN CURRENCY EXCHANGE AND OTHER FINANCIAL TRANSACTIONS (U.S. CLS. 100 AND 101).

FIRST USE 9-28-2011; IN COMMERCE 9-28-2011.

4,211,775. CAINES HILL PARTNERS, LLC, ATLANTA, GA. SN 85-441,574. FILED P.R. 10-7-2011; AM. S.R. 7-30-2012.

Official Kickoff Block Party

THE MARK CONSISTS OF STANDARD CHARACTERS WITHOUT CLAIM TO ANY PARTICULAR FONT, STYLE, SIZE, OR COLOR.

NO CLAIM IS MADE TO THE EXCLUSIVE RIGHT TO USE "BLOCK PARTY", APART FROM THE MARK AS SHOWN.

CLASS 25—CLOTHING

FOR WEARABLE GARMENTS AND CLOTHING, NAMELY, SHIRTS (U.S. CLS. 22 AND 39).

FIRST USE 7-14-2011; IN COMMERCE 7-14-2011.

CLASS 41—EDUCATION AND ENTERTAINMENT

FOR ENTERTAINMENT SERVICES, NAMELY, CONDUCTING PARTIES (U.S. CLS. 100, 101 AND 107).

FIRST USE 7-14-2011; IN COMMERCE 7-14-2011.

4,211,783. ALPHAMETRIX GROUP, LLC, CHICAGO, IL. SN 85-445,688. FILED P.R. 10-12-2011; AM. S.R. 6-13-2012.

THE MARKETPLACE FOR PRIVATE INVESTMENTS

THE MARK CONSISTS OF STANDARD CHARACTERS WITHOUT CLAIM TO ANY PARTICULAR FONT, STYLE, SIZE, OR COLOR.

CLASS 36—INSURANCE AND FINANCIAL

FOR FINANCIAL SERVICES, NAMELY, PROVIDING FINANCIAL INFORMATION IN THE FIELD OF FINANCIAL DATA; PROVIDING INVESTORS AND CLIENTS WITH FINANCIAL INFORMATION CONCERNING SECURITIES, OPTIONS, FUTURES, FOREIGN EXCHANGES, MANAGED FUTURES, DERIVATIVES AND RELATED FINANCIAL PRODUCTS; INVESTMENT SERVICES, NAMELY, OPERATION AND MANAGEMENT OF HEDGE FUNDS, COMMODITY POOLS AND COLLECTIVE INVESTMENT VEHICLES AND TRADING FOR OTHERS OF SECURITIES, OPTIONS, FUTURES, DERIVATIVES, DEBT INSTRUMENTS AND COMMODITIES; FINANCIAL RESEARCH (U.S. CLS. 100, 101 AND 102).

FIRST USE 12-5-2011; IN COMMERCE 12-5-2011.

CLASS 42—SCIENTIFIC AND COMPUTER SERVICES

FOR PROVIDING TEMPORARY USE OF ONLINE NON-DOWNLOADABLE COMPUTER SOFTWARE FOR THE PURPOSE OF PROVIDING THE USER WITH FINANCIAL DATA TO CONSTRUCT AND MONITOR SECURITIES, OPTIONS, FUTURES, DERIVATIVES, FOREIGN EXCHANGE AND RELATED FINANCIAL PRODUCTS, ALTERNATIVE INVESTMENTS AND MANAGED FUTURES PORTFOLIOS; PROVIDING TEMPORARY USE OF ONLINE NON-DOWNLOADABLE COMPUTER SOFTWARE FEATURING INTERACTIVE FINANCIAL RESEARCH DATABASES THAT ASSIST USERS IN IDENTIFYING AVAILABLE ALTERNATIVE INVESTMENT PORTFOLIOS, CONDUCTS FUND MANAGER SCREENINGS, RESEARCHES INVESTMENT PERFORMANCES AND TRACKS THE PERFORMANCE OF VARIOUS ALTERNATIVE INVESTMENT VEHICLES (U.S. CLS. 100 AND 101).

FIRST USE 12-5-2011; IN COMMERCE 12-5-2011.

4,211,792. SNCC LEGACY PROJECT, INC., WASHINGTON, DC. SN 85-456,292. FILED P.R. 10-26-2011; AM. S.R. 8-1-2012.

STUDENT NONVIOLENT COORDINATING COMMITTEE

THE MARK CONSISTS OF STANDARD CHARACTERS WITHOUT CLAIM TO ANY PARTICULAR FONT, STYLE, SIZE, OR COLOR.

NO CLAIM IS MADE TO THE EXCLUSIVE RIGHT TO USE "STUDENT" AND "NONVIOLENT", APART FROM THE MARK AS SHOWN.

CLASS 35—ADVERTISING AND BUSINESS

FOR PUBLIC ADVOCACY SERVICES TO PROMOTE AWARENESS OF CIVIL RIGHTS, HUMAN RIGHTS, AND INTERNATIONAL STRUGGLES FOR LIBERATION AND PEACE (U.S. CLS. 100, 101 AND 102).

FIRST USE 4-15-2009; IN COMMERCE 4-15-2010.

CLASS 36—INSURANCE AND FINANCIAL

FOR CHARITABLE FUNDRAISING SERVICES, NAMELY, RAISING FUNDS TO PROMOTE CAUSES RELATED TO CIVIL RIGHTS, HUMAN RIGHTS, AND INTERNATIONAL STRUGGLES FOR LIBERATION AND PEACE (U.S. CLS. 100, 101 AND 102).

FIRST USE 4-15-2009; IN COMMERCE 4-15-2010.

CLASS 41—EDUCATION AND ENTERTAINMENT

FOR EDUCATION SERVICES, NAMELY, PROVIDING CLASSES, SEMINARS, CONFERENCES, WORKSHOPS, EXHIBITIONS, DISPLAYS, WEB SITES, AND INTERACTIVE EXHIBITS IN THE FIELD OF CIVIL RIGHTS, HUMAN RIGHTS, AND INTERNATIONAL STRUGGLES FOR LIBERATION AND PEACE (U.S. CLS. 100, 101 AND 107).

FIRST USE 4-15-2009; IN COMMERCE 4-15-2010.

4,211,800. RUTLIN, THOMAS H., MADISON, WI. SN 85-475,489. FILED P.R. 11-17-2011; AM. S.R. 8-2-2012.

TOTAL BODY WALKING

THE MARK CONSISTS OF STANDARD CHARACTERS WITHOUT CLAIM TO ANY PARTICULAR FONT, STYLE, SIZE, OR COLOR.

CLASS 28—TOYS AND SPORTING GOODS

FOR EXERCISE EQUIPMENT, NAMELY, HAND HELD POLES USED TO ENHANCE THE EXERCISE BENEFITS OF WALKING OR RUNNING (U.S. CLS. 22, 23, 38 AND 50).

FIRST USE 12-0-2010; IN COMMERCE 12-0-2010.

CLASS 41—EDUCATION AND ENTERTAINMENT

FOR EDUCATIONAL SERVICES, NAMELY, CONDUCTING CLASSES, WORKSHOPS AND SEMINARS IN THE FIELD OF RECREATIONAL FITNESS; PROVIDING A WEBSITE FEATURING INFORMATION ON EXERCISE AND FITNESS; PROVIDING INFORMATION IN THE FIELD OF EXERCISE TRAINING; PROVIDING INFORMATION ON PHYSICAL EXERCISE (U.S. CLS. 100, 101 AND 107).

FIRST USE 12-0-2010; IN COMMERCE 12-0-2010.

4,211,823. SERVPRO INTELLECTUAL PROPERTY, INC., GALLATIN, TN. SN 85-547,119. FILED P.R. 2-20-2012; AM. S.R. 7-30-2012.

EMERGENCY READY PROFILE

THE MARK CONSISTS OF STANDARD CHARACTERS WITHOUT CLAIM TO ANY PARTICULAR FONT, STYLE, SIZE, OR COLOR.

CLASS 37—CONSTRUCTION AND REPAIR

FOR SERVICES FOR BOTH INDOORS AND OUTDOORS RESTORATION OF COMMERCIAL AND RESIDENTIAL STRUCTURES AND/OR CONTENTS DAMAGED BY FIRE, WATER, AND WATER CATASTROPHES; CARPET, FURNITURE, AND DRAPERY CLEANING SERVICES (U.S. CLS. 100, 103 AND 106).

FIRST USE 7-0-2011; IN COMMERCE 7-0-2011.

CLASS 40—MATERIAL TREATMENT

FOR MOLD REMEDIATION SERVICES (U.S. CLS. 100, 103 AND 106).

FIRST USE 7-0-2011; IN COMMERCE 7-0-2011.

4,211,827. SUSTAINABLE BUSINESS PARTNERSHIPS, LLC, HUNTINGTON BEACH, CA. SN 85-552,733. FILED 2-24-2012.

SUSTAINABILITY NEWS & ENTERTAINMENT

THE MARK CONSISTS OF STANDARD CHARACTERS WITHOUT CLAIM TO ANY PARTICULAR FONT, STYLE, SIZE, OR COLOR.

NO CLAIM IS MADE TO THE EXCLUSIVE RIGHT TO USE "NEWS & ENTERTAINMENT", APART FROM THE MARK AS SHOWN.

CLASS 9—ELECTRICAL AND SCIENTIFIC APPARATUS

FOR DOWNLOADABLE MP3 FILES, MP3 RECORDINGS, ON-LINE DISCUSSION BOARDS, WEBCASTS, WEBINARS AND PODCASTS FEATURING MUSIC AND INFORMATION IN THE FIELD OF HEALTH, COMMUNITY AND SUSTAINABILITY ISSUES (U.S. CLS. 21, 23, 26, 36 AND 38).

FIRST USE 10-1-2011; IN COMMERCE 2-4-2012.

CLASS 35—ADVERTISING AND BUSINESS

FOR PROVIDING A WEB SITE PROMOTING THE INTERESTS OF PEOPLE CONCERNED WITH HEALTH, COMMUNITY AND ENVIRONMENTAL SUSTAINABILITY ISSUES; BUSINESS MANAGEMENT AND CONSULTATION IN THE FIELD OF HEALTH, COMMUNITY, ENVIRONMENT AND SUSTAINABILITY; PROFESSIONAL BUSINESS CONSULTATION; ADVERTISING AND MARKETING SERVICES PROVIDED BY MEANS OF INDIRECT METHODS OF MARKETING COMMUNICATIONS, NAMELY, SOCIAL MEDIA, SEARCH ENGINE MARKETING, INQUIRY MARKETING, INTERNET MARKETING, MOBILE MARKETING, BLOGGING AND OTHER FORMS OF PASSIVE, SHARABLE OR VIRAL COMMUNICATIONS CHANNELS (U.S. CLS. 100, 101 AND 102).

FIRST USE 10-1-2011; IN COMMERCE 2-4-2012.

CLASS 38—COMMUNICATION

FOR TELECOMMUNICATION SERVICES, NAMELY, TRANSMISSION OF PODCASTS; RADIO BROADCASTING CONSULTATION; BROADCASTING OF RADIO PROGRAMS; TELEVISION PROGRAMME BROADCASTING (U.S. CLS. 100, 101 AND 104).

FIRST USE 10-1-2011; IN COMMERCE 2-4-2012.

CLASS 41—EDUCATION AND ENTERTAINMENT

FOR ENTERTAINMENT SERVICES, NAMELY, AN ON-GOING SERIES FEATURING HEALTH, COMMUNITY, ENVIRONMENTAL AND SUSTAINABILITY NEWS PROVIDED THROUGH CABLE TELEVISION, WEBCASTS, RADIO BROADCASTS, PODCASTS, AUDIO AND VIDEO MEDIA; PROVIDING INFORMATION RELATING TO ORGANIZING COMMUNITY SPORTING AND CULTURAL EVENTS (U.S. CLS. 100, 101 AND 107).

FIRST USE 10-1-2011; IN COMMERCE 2-4-2012.

4,211,830. BETHANY MAYER CONSULTING LLC, BROOKLYN, NY. SN 85-557,573. FILED P.R. 3-1-2012; AM. S.R. 7-11-2012.

SURF BAZAAR

THE MARK CONSISTS OF STANDARD CHARACTERS WITHOUT CLAIM TO ANY PARTICULAR FONT, STYLE, SIZE, OR COLOR.

NO CLAIM IS MADE TO THE EXCLUSIVE RIGHT TO USE "BAZAAR", APART FROM THE MARK AS SHOWN.

CLASS 25—CLOTHING

FOR CLOTHING, NAMELY, DRESSES, TUNICS, SHIRTS, BLOUSES, SHORTS, SKIRTS, PANTS, COATS, JACKETS, CAPES, SCARVES, SARONGS, TEE SHIRTS, SWEATSHIRTS, LINGERIE, SWEATERS, AND BELTS (U.S. CLS. 22 AND 39).

FIRST USE 5-31-2010; IN COMMERCE 5-31-2010.

CLASS 35—ADVERTISING AND BUSINESS

FOR RETAIL APPAREL STORES (U.S. CLS. 100, 101 AND 102).

FIRST USE 5-31-2010; IN COMMERCE 5-31-2010.

4,211,832. TRAINING & E-TRACKING SOLUTIONS, LLC, HUNT VALLEY, MD. SN 85-561,851. FILED P.R. 3-6-2012; AM. S.R. 7-12-2012.

Training & eTracking Solutions

THE MARK CONSISTS OF STANDARD CHARACTERS WITHOUT CLAIM TO ANY PARTICULAR FONT, STYLE, SIZE, OR COLOR.

CLASS 35—ADVERTISING AND BUSINESS

FOR DATA COMPILING AND ANALYZING FOR BUSINESS MANAGEMENT PURPOSES, NAMELY, COMPUTERIZED TRACKING OF EMPLOYEE EDUCATION AND TRAINING DATA (U.S. CLS. 100, 101 AND 102).

FIRST USE 7-1-2011; IN COMMERCE 7-1-2011.

CLASS 41—EDUCATION AND ENTERTAINMENT

FOR EDUCATIONAL SERVICES, NAMELY, PROVIDING ONLINE TRAINING FOR EMPLOYEES OF NON-PROFIT BUSINESSES AND SOCIAL SERVICE AGENCIES IN THE FIELD OF CAREER AND PROFESSIONAL DEVELOPMENT (U.S. CLS. 100, 101 AND 107).

FIRST USE 7-1-2011; IN COMMERCE 7-1-2011.

4,211,834. STUDIO MANHATTAN PRODUCTIONS, INC., LONG ISLAND CITY, NY. SN 85-566,954. FILED P.R. 3-12-2012; AM. S.R. 8-3-2012.

STUDIO MANHATTAN ART+DESIGN

NO CLAIM IS MADE TO THE EXCLUSIVE RIGHT TO USE ART + DESIGN, APART FROM THE MARK AS SHOWN.

THE MARK CONSISTS OF THE WORD "STUDIO" ABOVE THE WORD "MANHATTAN" WHICH IS ABOVE THE WORDS "ART + DESIGN", ALL STACKED ON TOP OF EACH OTHER TO BE THE SAME WIDTH AND TO APPEAR AS A SINGLE BOX. THE WORDS "STUDIO" AND "MANHATTAN" BOTH APPEAR IN A STENCIL FONT HAVING A DISTRESSED APPEARANCE.

CLASS 9—ELECTRICAL AND SCIENTIFIC APPARATUS

FOR DECORATIVE MAGNETS (U.S. CLS. 21, 23, 26, 36 AND 38).

FIRST USE 4-1-2011; IN COMMERCE 4-1-2011.

CLASS 16—PAPER GOODS AND PRINTED MATTER

FOR ART PRINTS; ART PRINTS COMPRISED OF DIGITAL ILLUSTRATIONS ORIGINATING FROM PHOTOGRAPHS; ART PRINTS ON CANVAS; CARDS BEARING UNIVERSAL GREETINGS; FRAMED ART PRINTS; GREETING CARDS; PASSPORT CASES; PASSPORT COVERS; PASSPORT HOLDERS; PHOTOGRAPHIC OR ART MOUNTS; PHOTOGRAPHS; POSTCARDS AND GREETING CARDS; STATIONERY; UNMOUNTED AND MOUNTED PHOTOGRAPHS (U.S. CLS. 2, 5, 22, 23, 29, 37, 38 AND 50).

FIRST USE 1-1-2010; IN COMMERCE 1-1-2010.

CLASS 18—LEATHER GOODS

FOR COIN PURSES; CREDIT CARD CASES; CREDIT CARD HOLDERS; HANDBAGS; LEATHER CASES; LEATHER KEY CHAINS; LUGGAGE TAGS; MAKE-UP BAGS SOLD EMPTY; MESSENGER BAGS; WALLETS; WALLETS MADE OF LEATHER OR OTHER MATERIALS (U.S. CLS. 1, 2, 3, 22 AND 41).

FIRST USE 10-1-2010; IN COMMERCE 10-1-2010.

CLASS 25—CLOTHING

FOR BELTS; BELTS FOR CLOTHING; T-SHIRTS (U.S. CLS. 22 AND 39).

FIRST USE 4-1-2010; IN COMMERCE 4-1-2010.

CLASS 9—ELECTRICAL AND SCIENTIFIC APPARATUS

FOR COMMUNICATIONS SOFTWARE FOR CONNECTING CONTENT MANAGEMENT DATABASE SYSTEMS; COMPUTER SOFTWARE FOR ACCESSING INFORMATION DIRECTORIES THAT MAY BE DOWNLOADED FROM THE GLOBAL COMPUTER NETWORK; COMPUTER SOFTWARE FOR APPLICATION AND DATABASE INTEGRATION; COMPUTER SOFTWARE ALLOWING USERS TO TAG, FILTER, DELIVER, TRACK AND CONNECT DATA FROM ONE CONTENT MANAGEMENT SYSTEM TO ANOTHER (U.S. CLS. 21, 23, 26, 36 AND 38).

FIRST USE 2-14-2012; IN COMMERCE 2-14-2012.

CLASS 42—SCIENTIFIC AND COMPUTER SERVICES

FOR COMPUTER SERVICES, NAMELY, PROVIDING AN INTERACTIVE WEB SITE FEATURING TECHNOLOGY THAT ALLOWS USERS TO COLLECT, STORE, MANAGE, DELIVER AND SHOWCASE ELECTRONIC AND PAPER-BASED CONTENT; HOSTING OF DIGITAL CONTENT ON THE INTERNET; PLATFORM AS A SERVICE (PAAS) FEATURING COMPUTER SOFTWARE PLATFORMS FOR IDENTIFYING, COLLECTING, TAGGING, FILTERING, DELIVERING AND TRACKING CONTENT; PROVIDING A WEBSITE FEATURING RESOURCES, NAMELY, NON-DOWNLOADABLE SOFTWARE FOR THE PURPOSE OF IDENTIFYING, COLLECTING, TAGGING, FILTERING, DELIVERING AND TRACKING CONTENT; PROVIDING TEMPORARY USE OF A WEB-BASED SOFTWARE APPLICATION FOR THE PURPOSE OF IDENTIFYING, COLLECTING, TAGGING, FILTERING, DELIVERING AND TRACKING CONTENT; PROVIDING TEMPORARY USE OF ONLINE NON-DOWNLOADABLE SOFTWARE AND APPLICATIONS FOR THE PURPOSE OF IDENTIFYING, COLLECTING, TAGGING, FILTERING, DELIVERING AND TRACKING CONTENT; SOFTWARE AS A SERVICE (SAAS) SERVICES FEATURING SOFTWARE FOR THE SELECTION, SYNDICATION AND DELIVERY OF TARGETED CONTENT FOR INCLUSION IN A THIRD-PARTY CONTENT MANAGEMENT SYSTEM OR FOR DISPLAY ON A THIRD-PARTY WEB SITE; SOFTWARE AS A SERVICE (SAAS) SERVICES FEATURING SOFTWARE FOR THE CREATION OF CONTENT FEEDS AND RETRIEVAL OF QUEUED CONTENT; COMPUTER SERVICES, NAMELY, ACTING AS AN APPLICATION SERVICE PROVIDER IN THE FIELD OF INFORMATION MANAGEMENT TO HOST COMPUTER APPLICATION SOFTWARE FOR THE PURPOSE OF IDENTIFYING, COLLECTING, TAGGING, FILTERING, DELIVERING AND TRACKING CONTENT; ONLINE SERVICES IN THE NATURE OF PROVIDING ONLINE NON-DOWNLOADABLE SOFTWARE WHICH DELIVERS CUSTOMER-SPECIFIED, TARGETED CONTENT IN A VARIETY OF FORMATS TO A CUSTOMER'S CONTENT MANAGEMENT SYSTEM AND WEBSITES FOR BUSINESS PURPOSES; PROVIDING ONLINE NON-DOWNLOADABLE SOFTWARE FOR SYNDICATING ONLINE CONTENT THROUGH A NETWORK FOR MARKETING PURPOSES, TO BE USED BY SOCIAL MEDIA AND ONLINE MARKETING PROFESSIONALS; PROVIDING ONLINE NON-DOWNLOADABLE SOFTWARE ALLOWING USERS TO TAG, FILTER, DELIVER, TRACK AND CONNECT DATA FROM ONE CONTENT MANAGEMENT SYSTEM TO ANOTHER (U.S. CLS. 100 AND 101).

FIRST USE 2-14-2012; IN COMMERCE 2-14-2012.

4,211,836. CFE MEDIA LLC, OAK BROOK, IL. SN 85-569,871.
FILED P.R. 3-14-2012; AM. S.R. 7-9-2012.

CONTENTSTREAM

THE MARK CONSISTS OF STANDARD CHARACTERS WITHOUT CLAIM TO ANY PARTICULAR FONT, STYLE, SIZE, OR COLOR.

4,211,862. TRUST ASSOCIATES, DBA TRUST ASSOCIATES SERVICES TRUST, TUCKER, GA. SN 85-597,852. FILED P.R. 4-13-2012; AM. S.R. 7-31-2012.

4,211,872. DOUGHERTY'S PHARMACY, INC., DALLAS, TX. SN 85-977,143. FILED P.R. 7-5-2011; AM. S.R. 4-30-2012.

Certified Affordable Housing Provider

THE MARK CONSISTS OF STANDARD CHARACTERS WITHOUT CLAIM TO ANY PARTICULAR FONT, STYLE, SIZE, OR COLOR.

DOUGHERTY'S PHARMACY

CLASS 16—PAPER GOODS AND PRINTED MATTER

FOR PUBLICATIONS, NAMELY, MARKETING MATERIALS, GUIDEBOOKS, DIRECTORIES, NEWSLETTERS, MANUALS, PRINTED INSTRUCTIONAL AND TEACHING MATERIALS, IN THE FIELD OF REAL ESTATE INVESTMENTS, NAMELY, HOME STUDY INSTRUCTION AND TRAINING IN BUYING AND SELLING REAL ESTATE FOR ACHIEVING PERSONAL WEALTH AND IN THE FIELD OF INTERNET MARKETING OF NEW PRODUCTS, AND PRODUCT LICENSING AND IN OFFERING REAL ESTATE TO THE PUBLIC THROUGH RENT, RENT TO OWN, OWNER (SELLER) FINANCING AND/OR SALE (U.S. CLS. 2, 5, 22, 23, 29, 37, 38 AND 50).
FIRST USE 6-13-2010; IN COMMERCE 6-13-2010.

THE MARK CONSISTS OF STANDARD CHARACTERS WITHOUT CLAIM TO ANY PARTICULAR FONT, STYLE, SIZE, OR COLOR.

NO CLAIM IS MADE TO THE EXCLUSIVE RIGHT TO USE "PHARMACY", APART FROM THE MARK AS SHOWN.

CLASS 5—PHARMACEUTICALS

FOR VITAMINS AND VITAMIN SUPPLEMENTS (U.S. CLS. 6, 18, 44, 46, 51 AND 52).
FIRST USE 4-0-2009; IN COMMERCE 4-0-2009.

CLASS 41—EDUCATION AND ENTERTAINMENT

FOR EDUCATIONAL SERVICES, PROVIDING LIVE AND RECORDED WORKSHOPS, SEMINARS, LECTURES, CLASSES, CONFERENCES, AND COURSES OF INSTRUCTION AND TRAINING IN THE FIELD OF REAL ESTATE INVESTMENTS, NAMELY, BUYING AND SELLING REAL ESTATE FOR ACHIEVING PERSONAL WEALTH, INFORMATION AND INTERNET MARKETING ON NEW PRODUCTS, AND PRODUCT LICENSING; AND PROVIDING HOME STUDY INSTRUCTION COURSES AND TRAINING IN THE FIELD OF REAL ESTATE INVESTMENTS, NAMELY, BUYING AND SELLING REAL ESTATE FOR ACHIEVING PERSONAL WEALTH INFORMATION AND INTERNET MARKETING OF NEW PRODUCTS, AND PRODUCT LICENSING (U.S. CLS. 100, 101 AND 107).
FIRST USE 6-13-2010; IN COMMERCE 6-13-2010.

CLASS 10—MEDICAL APPARATUS

FOR COMPRESSION SOCKS AND HOSIERY FOR MEDICAL OR THERAPEUTIC USE (U.S. CLS. 26, 39 AND 44).
FIRST USE 5-0-2010; IN COMMERCE 5-0-2010.

CLASS 44—MEDICAL, BEAUTY AND AGRICULTURAL SERVICES

FOR PROVIDING HEALTHCARE INFORMATION (U.S. CLS. 100 AND 101).
FIRST USE 5-0-2011; IN COMMERCE 5-0-2011.

* * * * *

SECTION 2.— INTERNATIONAL CLASSIFICATION

The short titles associated below with the international class numbers are terms designed merely for quick identification and are not an official part of the international classification. The full names of international classes are given in section 6.1 of the trademark rules of practice.

The designation "U.S. Cl." appearing in this section refers to the U.S. class in effect prior to Sep. 1, 1973 rather than the international class which applies to applications filed on or after that date. For adoption of international classification see notice in the OFFICIAL GAZETTE of Jun. 26, 1973 (911 O.G. TM 210).

Application in one class

CLASS 1—CHEMICALS

4,211,735. TUTTLE, DEXTER, FORT WORTH, TX. SN 85-388,681. FILED P.R. 8-3-2011; AM. S.R. 7-25-2012.

LIQUID MPG

THE MARK CONSISTS OF STANDARD CHARACTERS WITHOUT CLAIM TO ANY PARTICULAR FONT, STYLE, SIZE, OR COLOR.

FOR CHEMICAL ADDITIVES FOR FUEL TREATMENT; CHEMICAL ADDITIVES FOR USE WITH INTERNAL COMBUSTION ENGINE FUELS; CHEMICAL ADDITIVES FOR ENHANCING THE PERFORMANCE OF LUBRICATING OILS, GREASES AND INTERNAL COMBUSTION ENGINE FUELS; CHEMICAL ADDITIVES FOR MOTOR FUELS; CHEMICAL ENGINE TREATMENTS AND ADDITIVES FOR ENGINE OILS, GASOLINE AND DIESEL FUELS, TRANSMISSION FLUIDS AND COOLING SYSTEMS; CHEMICALS, NAMELY, STABILITY ADDITIVES, COLD FLOW IMPROVERS, DEHAZERS, ACID REDUCTION AIDS, CORROSION INHIBITORS, AND COMBUSTION IMPROVERS USED IN BIODIESEL, BIODIESEL BLENDS, AND BIOREFINED FUELS; FUEL INJECTION CLEANER CHEMICAL ADDITIVE (U.S. CLS. 1, 5, 6, 10, 26 AND 46).

FIRST USE 1-1-2011; IN COMMERCE 1-1-2011.

CLASS 3—COSMETICS AND CLEANING PREPARATIONS

4,211,695. V BEAUTE LLC, NEW YORK, NY. SN 85-241,097. FILED P.R. 2-13-2011; AM. S.R. 7-27-2012.

RUB OFF

THE MARK CONSISTS OF STANDARD CHARACTERS WITHOUT CLAIM TO ANY PARTICULAR FONT, STYLE, SIZE, OR COLOR.

FOR COSMETICS; NON-MEDICATED SKIN CARE PREPARATIONS (U.S. CLS. 1, 4, 6, 50, 51 AND 52).
FIRST USE 11-1-2011; IN COMMERCE 11-1-2011.

CLASS 3—(Continued).

4,211,770. BEENA BEAUTY HOLDING, INC., COSTA MESA, CA. SN 85-439,675. FILED P.R. 10-5-2011; AM. S.R. 7-24-2012.

COLORISTA

THE MARK CONSISTS OF STANDARD CHARACTERS WITHOUT CLAIM TO ANY PARTICULAR FONT, STYLE, SIZE, OR COLOR.

THE ENGLISH TRANSLATION OF "COLORISTA" IN THE MARK IS "COLORIST".

FOR HAIR CARE PREPARATIONS; HAIR OILS; HAIR STYLING PREPARATIONS; NON-MEDICATED HAIR SERUMS; HAIR CONDITIONER (U.S. CLS. 1, 4, 6, 50, 51 AND 52).

FIRST USE 3-1-2012; IN COMMERCE 3-28-2012.

CLASS 4—LUBRICANTS AND FUELS

4,211,772. COX OIL, LLC, DALLAS, TX. SN 85-440,976. FILED P.R. 10-6-2011; AM. S.R. 7-26-2012.

COX

THE MARK CONSISTS OF STANDARD CHARACTERS WITHOUT CLAIM TO ANY PARTICULAR FONT, STYLE, SIZE, OR COLOR.

FOR FUEL FOR MOTOR VEHICLES, NAMELY, GASOLINE AND DIESEL (U.S. CLS. 1, 6 AND 15).
FIRST USE 6-0-2012; IN COMMERCE 6-0-2012.

CLASS 4—(Continued).

4,211,773. COX OIL, LLC, DALLAS, TX. SN 85-440,994. FILED P.R. 10-6-2011; AM. S.R. 7-26-2012.



THE MARK CONSISTS OF THE WORD "COX", WHEREIN THE LEFT SIDE OF THE "X" IS HIGHLIGHTED TO INDICATE A DIRECTION TO THE RIGHT.

FOR FUEL FOR MOTOR VEHICLES, NAMELY, GASOLINE AND DIESEL (U.S. CLS. 1, 6 AND 15).
FIRST USE 6-0-2012; IN COMMERCE 6-0-2012.

CLASS 5—(Continued).

4,211,761. MANUKAMED LIMITED, MASTERTON, NEW ZEALAND. SN 85-434,486. FILED P.R. 9-28-2011; AM. S.R. 7-26-2012.

MANUKABALM

THE MARK CONSISTS OF STANDARD CHARACTERS WITHOUT CLAIM TO ANY PARTICULAR FONT, STYLE, SIZE, OR COLOR.

OWNER OF U.S. REG. NO. 3,847,286.
FOR MEDICATED LIP BALM CONTAINING MEDICAL GRADE MANUKA HONEY (U.S. CLS. 6, 18, 44, 46, 51 AND 52).
FIRST USE 3-1-2010; IN COMMERCE 3-1-2010.

CLASS 5—PHARMACEUTICALS

4,211,756. MANUKAMED LIMITED, MASTERTON, NEW ZEALAND. SN 85-432,899. FILED P.R. 9-27-2011; AM. S.R. 7-26-2012.

MANUKALOZENGES

THE MARK CONSISTS OF STANDARD CHARACTERS WITHOUT CLAIM TO ANY PARTICULAR FONT, STYLE, SIZE, OR COLOR.

OWNER OF U.S. REG. NO. 3,847,286.
FOR THROAT LOZENGES CONTAINING MEDICAL GRADE MANUKA HONEY (U.S. CLS. 6, 18, 44, 46, 51 AND 52).
FIRST USE 3-1-2010; IN COMMERCE 3-1-2010.

4,211,837. WELLSTONE LABS, INC., HICKSVILLE, NY. SN 85-569,893. FILED P.R. 3-14-2012; AM. S.R. 7-31-2012.

MOLECULARAF

THE MARK CONSISTS OF STANDARD CHARACTERS WITHOUT CLAIM TO ANY PARTICULAR FONT, STYLE, SIZE, OR COLOR.

FOR ANTIFUNGAL PREPARATIONS (U.S. CLS. 6, 18, 44, 46, 51 AND 52).
FIRST USE 11-0-2011; IN COMMERCE 11-0-2011.

4,211,757. MANUKAMED LIMITED, MASTERTON, NEW ZEALAND. SN 85-432,901. FILED P.R. 9-27-2011; AM. S.R. 7-26-2012.

MANUKACAPS

THE MARK CONSISTS OF STANDARD CHARACTERS WITHOUT CLAIM TO ANY PARTICULAR FONT, STYLE, SIZE, OR COLOR.

OWNER OF U.S. REG. NO. 3,847,286.
FOR DIETARY SUPPLEMENTS IN THE NATURE OF GEL CAPSULES CONTAINING MEDICAL GRADE MANUKA HONEY (U.S. CLS. 6, 18, 44, 46, 51 AND 52).
FIRST USE 3-1-2010; IN COMMERCE 3-1-2010.

4,211,844. COVALENT MEDICAL, LLC, GREENBELT, MD. SN 85-584,822. FILED P.R. 3-30-2012; AM. S.R. 7-24-2012.

THE STANDARD OF CARE IN
OCULAR NUTRITION

THE MARK CONSISTS OF STANDARD CHARACTERS WITHOUT CLAIM TO ANY PARTICULAR FONT, STYLE, SIZE, OR COLOR.

FOR VITAMIN AND MINERAL SUPPLEMENTS (U.S. CLS. 6, 18, 44, 46, 51 AND 52).
FIRST USE 1-15-2012; IN COMMERCE 1-15-2012.

CLASS 6—METAL GOODS

CLASS 6—(Continued).

4,211,812. SOLAR INNOVATIONS, INC., PINE GROVE, PA. SN 85-519,628. FILED P.R. 1-18-2012; AM. S.R. 7-27-2012.

UNIVERSAL CLAMP

THE MARK CONSISTS OF STANDARD CHARACTERS WITHOUT CLAIM TO ANY PARTICULAR FONT, STYLE, SIZE, OR COLOR.

NO CLAIM IS MADE TO THE EXCLUSIVE RIGHT TO USE "CLAMP", APART FROM THE MARK AS SHOWN.

FOR METAL FASTENERS, NAMELY, ROOF CLAMPS (U.S. CLS. 2, 12, 13, 14, 23, 25 AND 50).

FIRST USE 1-14-2012; IN COMMERCE 1-14-2012.

CLASS 7—MACHINERY

4,211,728. OMID USA, INC., TERRACE PARK, OH. SN 85-362,328. FILED P.R. 7-2-2011; AM. S.R. 7-26-2012.

Portable Renewable Energy Platform

THE MARK CONSISTS OF STANDARD CHARACTERS WITHOUT CLAIM TO ANY PARTICULAR FONT, STYLE, SIZE, OR COLOR.

NO CLAIM IS MADE TO THE EXCLUSIVE RIGHT TO USE "RENEWABLE ENERGY", APART FROM THE MARK AS SHOWN.

FOR SOLAR-POWERED ELECTRICITY GENERATORS (U.S. CLS. 13, 19, 21, 23, 31, 34 AND 35).

FIRST USE 2-17-2011; IN COMMERCE 4-1-2012.

4,211,835. AFTERMARKET DOCK PARTS, INC., LOS ANGELES, CA. SN 85-569,067. FILED P.R. 3-14-2012; AM. S.R. 7-31-2012.

Ellis Multi-line Products

THE MARK CONSISTS OF STANDARD CHARACTERS WITHOUT CLAIM TO ANY PARTICULAR FONT, STYLE, SIZE, OR COLOR.

NO CLAIM IS MADE TO THE EXCLUSIVE RIGHT TO USE "MULTI-LINE PRODUCTS", APART FROM THE MARK AS SHOWN.

FOR MECHANIZED UNITS MOUNTED ON LOADING DOCKS TO SECURE TRUCKS TO THE LOADING DOCK DURING LOADING AND UNLOADING, ELEVATING DOCKS AND LIFT TABLES (U.S. CLS. 13, 19, 21, 23, 31, 34 AND 35).

FIRST USE 1-22-2010; IN COMMERCE 1-22-2010.

CLASS 9—ELECTRICAL AND SCIENTIFIC APPARATUS

4,211,712. F5 NETWORKS, INC., SEATTLE, WA. SN 85-308,453. FILED P.R. 4-29-2011; AM. S.R. 2-2-2012.

IAPPS

THE MARK CONSISTS OF STANDARD CHARACTERS WITHOUT CLAIM TO ANY PARTICULAR FONT, STYLE, SIZE, OR COLOR.

FOR COMPUTER NETWORK INTERFACE DEVICES, NAMELY, A NETWORK CONFIGURATION MANAGEMENT INTERFACE FOR A NETWORK APPLICATION DELIVERY CONTROLLER DEVICE THAT ALLOWS ITS OPERATORS TO CONFIGURE AND MONITOR NETWORK OBJECTS, NODES, SERVERS, AND DEVICES MANAGED BY THE CONTROLLER DEVICE (U.S. CLS. 21, 23, 26, 36 AND 38).

FIRST USE 7-25-2011; IN COMMERCE 7-25-2011.

4,211,721. TEXAS-NEW MEXICO NEWSPAPERS PARTNERSHIP, EL PASO, TX. SN 85-335,248. FILED P.R. 6-1-2011; AM. S.R. 8-9-2012.

CARS & TRUCKS

THE MARK CONSISTS OF STANDARD CHARACTERS WITHOUT CLAIM TO ANY PARTICULAR FONT, STYLE, SIZE, OR COLOR.

FOR DOWNLOADABLE ELECTRONIC PUBLICATIONS IN THE NATURE OF MAGAZINES FEATURING AUTOMOBILES AND ADVERTISEMENTS (U.S. CLS. 21, 23, 26, 36 AND 38).

FIRST USE 2-1-2001; IN COMMERCE 2-1-2001.

4,211,725. DUACARRIER ELECTRONICS TECHNOLOGY, INC., KNOXVILLE, TN. SN 85-354,424. FILED P.R. 6-23-2011; AM. S.R. 1-27-2012.

CABLING AND COMMUNICATION SOLUTIONS

THE MARK CONSISTS OF STANDARD CHARACTERS WITHOUT CLAIM TO ANY PARTICULAR FONT, STYLE, SIZE, OR COLOR.

CLASS 9—(Continued).

NO CLAIM IS MADE TO THE EXCLUSIVE RIGHT TO USE "CABLING", APART FROM THE MARK AS SHOWN.

FOR AUDIO CABLES; CABLE CONNECTORS; CABLES AND FIBRES FOR THE TRANSMISSION OF SOUNDS AND IMAGES; CABLES FOR ELECTRICAL AND OPTICAL SIGNAL TRANSMISSION SYSTEMS; CABLES FOR ELECTRICAL OR OPTICAL SIGNAL TRANSMISSION; CABLES FOR OPTICAL SIGNAL TRANSMISSION; CABLES, ELECTRIC; COAXIAL CABLES; COAXIAL CABLES INCORPORATING FILTERS; COMPONENT VIDEO CABLES; COMPUTER CABLES; CONNECTING ELECTRICAL CABLES; CONNECTION CABLES; DUCTING FOR ELECTRIC CABLES; ELECTRIC CABLES AND WIRES; ELECTRIC CABLES, WIRES, CONDUCTORS AND CONNECTION FITTINGS THEREFOR; ELECTRIC WIRE AND CABLE; ELECTRIC WIRES AND CABLES; ELECTRICAL AND OPTICAL CABLES; ELECTRICAL CABLES; ELECTRICAL CABLES AND CORDSETS; ELECTRICAL CABLES FOR MUSICAL INSTRUMENTS; ELECTRICAL CABLES FOR USE IN CONNECTIONS; ELECTRICAL CABLES WITH INTEGRATED FITTINGS, NAMELY, CORDSETS; ELECTRICAL INTERCONNECT CABLES; ELECTRICAL PLUG DEVICE ENABLING CONNECTION AND DISCONNECTION OF POWER AND/OR CONTROL CABLES; ELECTRONIC CABLES; ETHERNET CABLES; EXTENSION CABLES; FIBER OPTIC CABLES; FIBRE-OPTIC CABLES; GUITAR CABLES; HIGH-DEFINITION MULTIMEDIA INTERFACE APPARATUS AND COMPONENT CABLES SOLD AS A UNIT; HIGH-DEFINITION MULTIMEDIA INTERFACE CABLES; JUMPER CABLES; METAL CABINETS SPECIALLY ADAPTED TO PROTECT TELECOMMUNICATIONS EQUIPMENT IN THE NATURE OF FIBER OPTIC CABLES.; MICROPHONE CABLES; MODEM CABLES; OPTICAL CABLES; OPTICAL FIBER CABLES; OPTICAL FIBERS SOLD AS A COMPONENT OF FIBER OPTICAL CABLES; POWER CABLES; PRINTER CABLES; PROTECTIVE SHEATHS FOR FIBER OPTICAL CABLES; PUBLIC ADDRESS (PA) AND SOUND SYSTEM ACCESSORIES, NAMELY, MICROPHONE STANDS, SPEAKER STANDS, MICROPHONE CABLES, SPEAKER CABLES, SPEAKER BOXES AND SOUND MIXERS; SHEATHS FOR ELECTRIC CABLES; STEREO CABLES; TELECOMMUNICATION CABLES; TELECOMMUNICATIONS CABLES; THREADED CABLE CONNECTORS OF METAL; USB CABLES; VIDEO CABLES (U.S. CLS. 21, 23, 26, 36 AND 38).

FIRST USE 12-0-2009; IN COMMERCE 12-0-2009.

CLASS 9—(Continued).

4,211,766. JOHNSON MATTHEY PLC, LONDON, UNITED KINGDOM. SN 85-438,846. FILED P.R. 10-4-2011; AM. S.R. 7-27-2012.

SOOT ALERT

THE MARK CONSISTS OF STANDARD CHARACTERS WITHOUT CLAIM TO ANY PARTICULAR FONT, STYLE, SIZE, OR COLOR.

FOR ENGINE EXHAUST ANALYZERS; ENGINE EXHAUST ANALYZERS THAT MONITOR EXHAUST PRESSURE AND TEMPERATURE; ENGINE EXHAUST ANALYZERS THAT MONITOR EXHAUST PRESSURE AND TEMPERATURE TO DETERMINE CONDITION OF PARTICULATE FILTERS; PARTICULATE FILTER MONITORING SYSTEM COMPRISED PRIMARILY OF ENGINE EXHAUST ANALYZERS AND ELECTRONIC DISPLAYS; PARTICULATE FILTER MONITORING SYSTEM COMPRISED PRIMARILY OF ENGINE EXHAUST ANALYZERS AND ELECTRONIC DISPLAYS PROVIDING DATA REGARDING EXHAUST AND FILTER CONDITIONS; PARTICULATE FILTER MONITORING SYSTEM COMPRISED PRIMARILY OF ENGINE EXHAUST ANALYZERS, ELECTRONIC DISPLAYS PROVIDING DATA REGARDING EXHAUST AND FILTER CONDITIONS, AND PARTICULATE FILTERS; PARTICULATE FILTER MONITORING SYSTEM COMPRISED PRIMARILY OF ENGINE EXHAUST ANALYZERS AND ELECTRONIC DISPLAYS PROVIDING DATA REGARDING EXHAUST AND FILTER CONDITIONS AND NOTIFYING WHEN FILTER CLEANING IS WARRANTED (U.S. CLS. 21, 23, 26, 36 AND 38).

FIRST USE 4-20-2012; IN COMMERCE 4-20-2012.

4,211,816. BRIGHT IDEAS, INC., AGOURA HILLS, CA. SN 85-527,724. FILED P.R. 1-27-2012; AM. S.R. 7-3-2012.

ReStore

THE MARK CONSISTS OF STANDARD CHARACTERS WITHOUT CLAIM TO ANY PARTICULAR FONT, STYLE, SIZE, OR COLOR.

FOR BATTERY PACKS; BATTERY CHARGING ADAPTORS FOR ELECTRONIC DEVICES, NAMELY, SMART PHONES, CELL PHONES, TABLETS, COMPUTERS, MP3 PLAYERS AND CAMERAS; SOLAR CHARGING BATTERY PACKS FOR ELECTRONIC DEVICES SUCH AS SMART PHONES, CELL PHONES, TABLETS, COMPUTERS, MP3 PLAYERS AND CAMERAS; SOLAR CHARGING ADAPTORS FOR ELECTRONIC DEVICES, NAMELY, SMART PHONES, CELL PHONES, TABLETS, COMPUTERS, MP3 PLAYERS AND CAMERAS (U.S. CLS. 21, 23, 26, 36 AND 38).

FIRST USE 1-1-2010; IN COMMERCE 1-1-2010.

CLASS 9—(Continued).

4,211,838. DYAX CORP., BURLINGTON, MA. SN 85-570,263. FILED P.R. 3-15-2012; AM. S.R. 7-26-2012.

HAE ATTACK TRACKER

THE MARK CONSISTS OF STANDARD CHARACTERS WITHOUT CLAIM TO ANY PARTICULAR FONT, STYLE, SIZE, OR COLOR.

NO CLAIM IS MADE TO THE EXCLUSIVE RIGHT TO USE "TRACKER", APART FROM THE MARK AS SHOWN.

FOR COMPUTER SOFTWARE FOR USE BY HEREDITARY ANGIOEDEMA PATIENTS TO RECORD AND MONITOR INFORMATION ABOUT THEIR SYMPTOMS AND TO OBTAIN INFORMATION ABOUT THE DISEASE; DOWNLOADABLE SOFTWARE IN THE NATURE OF A MOBILE APPLICATION FOR USE BY HEREDITARY ANGIOEDEMA PATIENTS TO RECORD AND MONITOR INFORMATION ABOUT THEIR SYMPTOMS AND TO OBTAIN INFORMATION ABOUT THE DISEASE (U.S. CLS. 21, 23, 26, 36 AND 38).

FIRST USE 4-23-2012; IN COMMERCE 4-23-2012.

4,211,840. MISOFIT, LLC, BURR RIDGE, IL. SN 85-572,297. FILED P.R. 3-16-2012; AM. S.R. 7-13-2012.

MOBILE I SOFTWARE

THE MARK CONSISTS OF STANDARD CHARACTERS WITHOUT CLAIM TO ANY PARTICULAR FONT, STYLE, SIZE, OR COLOR.

NO CLAIM IS MADE TO THE EXCLUSIVE RIGHT TO USE "SOFTWARE", APART FROM THE MARK AS SHOWN.

FOR COMPUTER SOFTWARE, NAMELY, DEVICE APPLICATION SOFTWARE FOR DESIGNING PRINT PRODUCTS, POST AND GREETING CARD CREATION AND SHARING, WORD PROCESSING, PAINTING, GRAPHIC DESIGN AND EDITING, DOCUMENT CREATION, CLIP ART AND IMAGE STORAGE, MUSIC PRODUCTION, DIGITAL PRINTING AND PRODUCTION, SLIDE SHOW CREATION, TWO AND THREE DIMENSIONAL CREATION AND GAMING, CREATIVE EXPRESSION, NAMELY, FOR RECORDING AND EDITING AUDIO AND VIDEO, CONTAINING EDUCATIONAL PROGRAMS FOR LEARNING MATHEMATICS, ENGLISH, WRITING AND GRAMMAR, AND FOR ENTERTAINMENT, NAMELY, COMPUTER GAME SOFTWARE FOR USE BY MOBILE DEVICE USERS OF ALL AGES (U.S. CLS. 21, 23, 26, 36 AND 38).

FIRST USE 12-1-2009; IN COMMERCE 1-1-2010.

CLASS 9—(Continued).

4,211,845. EAGAN, TODD, DBA MAIN STREET RECORDS, SANTA MONICA, CA. SN 85-587,094. FILED P.R. 4-2-2012; AM. S.R. 8-6-2012.

Main Street Records

THE MARK CONSISTS OF STANDARD CHARACTERS WITHOUT CLAIM TO ANY PARTICULAR FONT, STYLE, SIZE, OR COLOR.

NO CLAIM IS MADE TO THE EXCLUSIVE RIGHT TO USE "RECORDS", APART FROM THE MARK AS SHOWN.

FOR AUDIO AND VIDEO RECORDINGS FEATURING MUSIC AND ARTISTIC PERFORMANCES; DOWNLOADABLE MUSICAL SOUND RECORDINGS (U.S. CLS. 21, 23, 26, 36 AND 38).

FIRST USE 3-1-2012; IN COMMERCE 3-1-2012.

CLASS 10—MEDICAL APPARATUS

4,211,699. NEOS SURGERY, S.L., CERDANYOLA DEL VALLÉS, SPAIN. SN 85-270,675. FILED P.R. 3-18-2011; AM. S.R. 7-24-2012.



THE COLOR(S) BLACK AND YELLOW IS/ARE CLAIMED AS A FEATURE OF THE MARK.

THE MARK CONSISTS OF THE STYLIZED WORDS "CRANIAL" IN THE COLOR BLACK WITH "LOOP" IN THE COLOR YELLOW.

FOR SURGICAL, DENTAL, MEDICAL, VETERINARY APPARATUS AND INSTRUMENTS, NAMELY, SURGICAL IMPLANTS COMPRISED OF ARTIFICIAL MATERIAL; FIXATION SYSTEMS, COMPRISED OF IMPLANTS MADE OF ARTIFICIAL MATERIAL, PARTICULARLY FIXATION SYSTEMS FOR FIXATION OF CRANIAL BONES; PROSTHESES FOR BREAST, HAND, LEG, EYES AND SKULL BONES FOR USE IN GENERAL SURGERY, NEUROSURGERY, ORTHOPEDIC SURGERY AND CARDIOVASCULAR SURGERY; ARTIFICIAL LIMBS, EYES, TEETH AND BONES; ORTHOPEDIC ARTICLES MADE OF ARTIFICIAL MATERIALS, NAMELY, SURGICAL IMPLANTS, PROSTHESES FOR BREAST, HAND, LEG, EYES AND SKULL BONES; SUTURE MATERIALS (U.S. CLS. 26, 39 AND 44).

FIRST USE 9-2-2009; IN COMMERCE 2-25-2011.

CLASS 10—(Continued).

4,211,730. FIUS DISTRIBUTORS LLC, DBA INADA MASSAGE CHAIRS, BOULDER, CO. SN 85-364,801. FILED 7-6-2011.

**The World's Best Massage
Chair**

THE MARK CONSISTS OF STANDARD CHARACTERS WITHOUT CLAIM TO ANY PARTICULAR FONT, STYLE, SIZE, OR COLOR.

NO CLAIM IS MADE TO THE EXCLUSIVE RIGHT TO USE "MASSAGE CHAIR", APART FROM THE MARK AS SHOWN.

FOR ELECTRIC MASSAGE APPARATUS FOR HOUSEHOLD USE; MASSAGE CHAIRS; MASSAGE CHAIRS WITH BUILT-IN MASSAGE APPARATUS (U.S. CLS. 26, 39 AND 44).

FIRST USE 6-1-2009; IN COMMERCE 6-1-2010.



4,211,739. WILLIE CHEN, NORCROSS, GA. SN 85-408,862. FILED P.R. 8-27-2011; AM. S.R. 6-22-2012.

Bleph-pen

THE MARK CONSISTS OF STANDARD CHARACTERS WITHOUT CLAIM TO ANY PARTICULAR FONT, STYLE, SIZE, OR COLOR.

FOR MEDICAL DEVICES AND APPARATUS FOR OPHTHALMIC TREATMENTS, NAMELY, HAND-HELD MEDICAL EQUIPMENT FOR BLEPHARITIS SURGERY AND TREATMENT OF BLEPHARITIS AND MEIBOMIAN GLAND DYSFUNCTION AND OPHTHALMIC ILLNESS (U.S. CLS. 26, 39 AND 44).

FIRST USE 6-1-2011; IN COMMERCE 6-1-2011.

CLASS 10—(Continued).

4,211,753. MANDARIN ENTERPRISES LLC, DBA CLINICAL GUARD, ATLANTA, GA. SN 85-427,403. FILED P.R. 9-20-2011; AM. S.R. 7-5-2012.

Portablenebs

THE MARK CONSISTS OF STANDARD CHARACTERS WITHOUT CLAIM TO ANY PARTICULAR FONT, STYLE, SIZE, OR COLOR.

FOR MEDICAL SUPPLIES, NAMELY, NEBULIZERS FOR RESPIRATION THERAPY, ULTRASONIC MEDICATION NEBULIZERS, AEROSOL MASKS, PEAK EXPIRATORY AIR FLOW METERS, OXIMETERS, GLUCOMETERS, OTOSCOPIES, BLOOD PRESSURE MONITORS, THERMOMETERS, STETHOSCOPIES, FETAL DOPPLERS, HEART RATE MONITORS, PATIENT MONITORS FOR MONITORING AND MEASURING BLOOD PROPERTIES AND RESPIRATORY EVENTS, ELECTROCARDIOGRAPHS, INFUSION PUMPS FOR DELIVERING MEASURED AMOUNTS OF SOLUTIONS INTO THE BLOODSTREAM OVER TIME, VITAL SIGNS MONITORS, PEAK FLOW METERS, AEROSOL DISPENSERS FOR MEDICAL USE AND CUPS FOR DISPENSING MEDICINE, ENDOSCOPES, MASSAGE MACHINES, HEARING AIDS, OXYGEN CONCENTRATORS, BRONCHOSCOPIES, COLONOSCOPIES, CYTOSCOPIES, DUODENOSCOPIES, GASTROSCOPES, HYSTEROSCOPIES, MEDICAL INTUBATION EQUIPMENT, RHINOLARYNGOSCOPIES, SIGMOIDOSCOPIES, URETEROSCOPIES, DEFIBRILLATORS, HEARING AID DEVICES, AND BLOOD ALCOHOL TESTING APPARATUS IN THE NATURE OF ALCOHOL BREATH TESTING UNITS (U.S. CLS. 26, 39 AND 44).

FIRST USE 12-26-2006; IN COMMERCE 2-1-2007.

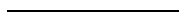

4,211,796. OWEN MUMFORD LIMITED, WOODSTOCK OXFORD, UNITED KINGDOM. SN 85-461,949. FILED P.R. 11-1-2011; AM. S.R. 7-3-2012.

TRAVEL LANCETS

THE MARK CONSISTS OF STANDARD CHARACTERS WITHOUT CLAIM TO ANY PARTICULAR FONT, STYLE, SIZE, OR COLOR.

NO CLAIM IS MADE TO THE EXCLUSIVE RIGHT TO USE "LANCETS", APART FROM THE MARK AS SHOWN.

FOR BLOOD SAMPLING APPARATUS AND INSTRUMENTS AND PARTS AND FITTINGS THEREFOR; LANCETS; LANCING DEVICES, NAMELY, APPARATUS AND INSTRUMENTS FOR USE WITH LANCETS (U.S. CLS. 26, 39 AND 44).

FIRST USE 8-0-2010; IN COMMERCE 8-0-2010.

CLASS 10—(Continued).

4,211,833. XHALE, INC., GAINESVILLE, FL. SN 85-562,043.
FILED P.R. 3-6-2012; AM. S.R. 7-5-2012.

SMART

THE MARK CONSISTS OF STANDARD CHARACTERS WITHOUT CLAIM TO ANY PARTICULAR FONT, STYLE, SIZE, OR COLOR.

FOR BREATH GAS ANALYZERS FOR MEDICAL DIAGNOSTICS, NAMELY, FOR VERIFYING INGESTION OF MEDICATIONS BY HUMAN PATIENTS USING PATIENT BIOMETRIC IDENTIFICATION (U.S. CLS. 26, 39 AND 44).

FIRST USE 5-14-2012; IN COMMERCE 5-14-2012.

CLASS 11—ENVIRONMENTAL CONTROL APPARATUS

4,211,771. HOT-CAN SDN. BHD., 6000 KUALA LUMPUR, MALAYSIA. SN 85-440,957. FILED P.R. 10-6-2011; AM. S.R. 7-26-2012.

HOT-CAN

THE MARK CONSISTS OF STANDARD CHARACTERS WITHOUT CLAIM TO ANY PARTICULAR FONT, STYLE, SIZE, OR COLOR.

OWNER OF U.S. REG. NOS. 3,212,019, 3,942,402, AND 3,959,624.

FOR SELF HEATING CONTAINERS MADE PRIMARILY OF METAL FOR FOOD (U.S. CLS. 13, 21, 23, 31 AND 34).

FIRST USE 7-25-2012; IN COMMERCE 7-25-2012.

CLASS 12—VEHICLES

4,211,702. EPOWER ENGINE SYSTEMS, FLORENCE, KY. SN 85-279,770. FILED P.R. 3-29-2011; AM. S.R. 7-18-2012.

ePower engine systems

THE MARK CONSISTS OF STANDARD CHARACTERS WITHOUT CLAIM TO ANY PARTICULAR FONT, STYLE, SIZE, OR COLOR.

CLASS 12—(Continued).

NO CLAIM IS MADE TO THE EXCLUSIVE RIGHT TO USE "ENGINE", APART FROM THE MARK AS SHOWN.
FOR ELECTRIC DRIVES FOR VEHICLES (U.S. CLS. 19, 21, 23, 31, 35 AND 44).
FIRST USE 7-17-2012; IN COMMERCE 7-17-2012.

4,211,782. JRM INTERNATIONAL PRODUCTS, INC., INDIANAPOLIS, IN. SN 85-445,441. FILED P.R. 10-12-2011; AM. S.R. 7-31-2012.

STOR-A-HITCH

THE MARK CONSISTS OF STANDARD CHARACTERS WITHOUT CLAIM TO ANY PARTICULAR FONT, STYLE, SIZE, OR COLOR.

FOR AUTOMOTIVE AFTERMARKET PARTS, NAMELY, A HIGH-STRENGTH PLASTIC RECTANGULAR TUBE WITH MULTIPLE HOLES FOR SECURING VEHICLE HITCH BALL MOUNTS (U.S. CLS. 19, 21, 23, 31, 35 AND 44).

FIRST USE 9-27-2011; IN COMMERCE 9-27-2011.

CLASS 14—JEWELRY

4,211,687. PHILADELPHIA DIAMOND COMPANY, PHILADELPHIA, PA. SN 77-288,176. FILED P.R. 9-25-2007; AM. S.R. 6-26-2012.

QUEEN CUT

THE MARK CONSISTS OF STANDARD CHARACTERS WITHOUT CLAIM TO ANY PARTICULAR FONT, STYLE, SIZE, OR COLOR.

NO CLAIM IS MADE TO THE EXCLUSIVE RIGHT TO USE "CUT", APART FROM THE MARK AS SHOWN.
FOR CUT DIAMONDS (U.S. CLS. 2, 27, 28 AND 50).
FIRST USE 11-9-2011; IN COMMERCE 11-9-2011.

CLASS 14—(Continued).

4,211,692. CROWN RING INC., SAINT LAURENT, QUEBEC, CANADA. SN 85-068,920. FILED P.R. 6-22-2010; AM. S.R. 8-6-2012.

CROWN RING

THE MARK CONSISTS OF STANDARD CHARACTERS WITHOUT CLAIM TO ANY PARTICULAR FONT, STYLE, SIZE, OR COLOR.

FOR WEDDING BANDS (U.S. CLS. 2, 27, 28 AND 50).
FIRST USE 8-28-2000; IN COMMERCE 8-28-2000.

4,211,870. COUSIN CORPORATION OF AMERICA, LARGO, FL. SN 85-623,136. FILED P.R. 5-11-2012; AM. S.R. 7-26-2012.

Jewelry Shop

THE MARK CONSISTS OF STANDARD CHARACTERS WITHOUT CLAIM TO ANY PARTICULAR FONT, STYLE, SIZE, OR COLOR.

NO CLAIM IS MADE TO THE EXCLUSIVE RIGHT TO USE "JEWELRY", APART FROM THE MARK AS SHOWN.

FOR BEADS FOR USE IN THE MANUFACTURE OF JEWELRY (U.S. CLS. 2, 27, 28 AND 50).
FIRST USE 5-11-2012; IN COMMERCE 5-11-2012.

CLASS 16—PAPER GOODS AND PRINTED MATTER

4,211,719. TEXAS-NEW MEXICO NEWSPAPERS PARTNERSHIP, EL PASO, TX. SN 85-332,342. FILED P.R. 5-27-2011; AM. S.R. 8-9-2012.

CARS & TRUCKS

THE MARK CONSISTS OF STANDARD CHARACTERS WITHOUT CLAIM TO ANY PARTICULAR FONT, STYLE, SIZE, OR COLOR.

FOR PRINTED MATTER, NAMELY, MAGAZINE FEATURING AUTOMOBILES AND ADVERTISEMENTS (U.S. CLS. 2, 5, 22, 23, 29, 37, 38 AND 50).
FIRST USE 1-14-2000; IN COMMERCE 1-14-2000.

CLASS 16—(Continued).

4,211,750. MACFADDEN BEVERAGE BUSINESS, LLC, NEW YORK, NY. SN 85-423,802. FILED P.R. 9-15-2011; AM. S.R. 6-29-2012.

BEVERAGE EXECUTIVE

THE MARK CONSISTS OF STANDARD CHARACTERS WITHOUT CLAIM TO ANY PARTICULAR FONT, STYLE, SIZE, OR COLOR.

FOR PRINTED PUBLICATIONS, NAMELY, MAGAZINES CONTAINING INFORMATION RELATED TO THE BEVERAGE INDUSTRY (U.S. CLS. 2, 5, 22, 23, 29, 37, 38 AND 50).

FIRST USE 9-15-2011; IN COMMERCE 9-15-2011.

4,211,752. CHARLES Y COGHLAN, DBA OFFICE EASEL, BLOOMINGTON, IN. SN 85-426,394. FILED P.R. 9-19-2011; AM. S.R. 7-25-2012.



THE MARK CONSISTS OF A PEACE SIGN, A HEART, AND A SMILEY FACE WITH BRACES ALL ARRANGED IN A ROW. BELOW THESE IMAGES IS THE STYLIZED TEXT "PEACE . LOVE . BRACES".

FOR GREETING CARDS; MEMO PADS; PENCILS; PENS; POSTCARDS; STICKERS (U.S. CLS. 2, 5, 22, 23, 29, 37, 38 AND 50).

FIRST USE 3-1-2000; IN COMMERCE 3-1-2000.

4,211,768. MODELE WEDDINGS, VENTURA, CA. SN 85-439,428. FILED P.R. 10-5-2011; AM. S.R. 7-23-2012.

modèle

THE MARK CONSISTS OF THE STYLIZED TEXT "MODÈLE".

THE ENGLISH TRANSLATION OF "MODÈLE" IN THE MARK IS "MODEL".

FOR MAGAZINES IN THE FIELD OF WEDDINGS AND FASHION (U.S. CLS. 2, 5, 22, 23, 29, 37, 38 AND 50).
FIRST USE 2-15-2011; IN COMMERCE 4-14-2011.

CLASS 17—RUBBER GOODS

4,211,868. FASTENATION, INC., CLIFTON, NJ. SN 85-605,671. FILED P.R. 4-23-2012; AM. S.R. 7-31-2012.

FASTENfoam

THE MARK CONSISTS OF THE WORD "FASTENFOAM" WHEREIN "FASTEN" IS CAPITAL LETTERS AND "FOAM" IS SMALL LETTERS.

FOR DOUBLE-SIDED PRESSURE SENSITIVE ADHESIVE TAPE FOR INDUSTRIAL AND COMMERCIAL USE (U.S. CLS. 1, 5, 12, 13, 35 AND 50).

FIRST USE 7-31-2008; IN COMMERCE 7-31-2008.

4,211,869. FASTENATION, INC., CLIFTON, NJ. SN 85-605,675. FILED P.R. 4-23-2012; AM. S.R. 7-31-2012.

FASTENfoam

THE COLOR(S) RED AND BLACK IS/ARE CLAIMED AS A FEATURE OF THE MARK.

THE MARK CONSISTS OF THE WORD "FASTENFOAM" WHEREIN "FASTEN" IS CAPITAL RED LETTERS AND "FOAM" IS SMALL BLACK LETTERS.

FOR DOUBLE-SIDED PRESSURE SENSITIVE ADHESIVE TAPE FOR INDUSTRIAL AND COMMERCIAL USE (U.S. CLS. 1, 5, 12, 13, 35 AND 50).

FIRST USE 7-31-2008; IN COMMERCE 7-31-2008.

CLASS 19—NON-METALLIC BUILDING MATERIALS

4,211,722. DORIC PRODUCTS, INC., MARSHALL, IL. SN 85-341,303. FILED P.R. 6-8-2011; AM. S.R. 7-17-2012.

INGALLS

THE MARK CONSISTS OF STANDARD CHARACTERS WITHOUT CLAIM TO ANY PARTICULAR FONT, STYLE, SIZE, OR COLOR.

FOR BURIAL VAULTS NOT OF METAL (U.S. CLS. 1, 12, 33 AND 50).

FIRST USE 8-25-2011; IN COMMERCE 8-25-2011.

CLASS 19—(Continued).

4,211,797. CARLISLE INTANGIBLE COMPANY, SYRACUSE, NY. SN 85-462,477. FILED P.R. 11-2-2011; AM. S.R. 1-19-2012.

PREMIER SIPS

THE MARK CONSISTS OF STANDARD CHARACTERS WITHOUT CLAIM TO ANY PARTICULAR FONT, STYLE, SIZE, OR COLOR.

NO CLAIM IS MADE TO THE EXCLUSIVE RIGHT TO USE "SIPS", APART FROM THE MARK AS SHOWN.

FOR CONSTRUCTION MATERIAL, NAMELY, NON-METAL EXTERIOR PANELS CONTAINING FOAM INSULATION (U.S. CLS. 1, 12, 33 AND 50).

FIRST USE 1-30-2011; IN COMMERCE 1-30-2011.

CLASS 20—FURNITURE AND ARTICLES NOT OTHERWISE CLASSIFIED

4,211,688. DAYSTAR PRODUCTS INTERNATIONAL, INC., PHOENIX, AZ. SN 77-793,524. FILED P.R. 7-30-2009; AM. S.R. 7-31-2012.

CAM CAN

THE MARK CONSISTS OF STANDARD CHARACTERS WITHOUT CLAIM TO ANY PARTICULAR FONT, STYLE, SIZE, OR COLOR.

NO CLAIM IS MADE TO THE EXCLUSIVE RIGHT TO USE "CAN", APART FROM THE MARK AS SHOWN.

FOR CONTAINERS FOR INDUSTRIAL AND COMMERCIAL LIQUIDS NOT MADE OF METAL (U.S. CLS. 2, 13, 22, 25, 32 AND 50).

FIRST USE 11-1-2011; IN COMMERCE 11-1-2011.

CLASS 21—HOUSEWARES AND GLASS

CLASS 21—(Continued).

4,211,708. NEXT FUTURE LLC, DUBLIN, OH. SN 85-304,995.
FILED P.R. 4-26-2011; AM. S.R. 7-25-2012.

SOAP SLEEVE

THE MARK CONSISTS OF STANDARD CHARACTERS WITHOUT CLAIM TO ANY PARTICULAR FONT, STYLE, SIZE, OR COLOR.

FOR DECORATIVE COVERING FOR A DISPENSING BOTTLE; REUSABLE COVER FOR LIQUID SOAP OR LOTION DISPENSERS (U.S. CLS. 2, 13, 23, 29, 30, 33, 40 AND 50).

FIRST USE 3-31-2012; IN COMMERCE 3-31-2012.

CLASS 25—(Continued).

4,211,693. JOHN P. CERVINI, DAVIE, FL. SN 85-106,159.
FILED P.R. 8-12-2010; AM. S.R. 7-25-2012.

Armed And Not Dangerous

THE MARK CONSISTS OF STANDARD CHARACTERS WITHOUT CLAIM TO ANY PARTICULAR FONT, STYLE, SIZE, OR COLOR.

FOR HATS; PANTS; SHORTS; T-SHIRTS (U.S. CLS. 22 AND 39).

FIRST USE 11-18-2011; IN COMMERCE 11-18-2011.

4,211,733. TONY SACCA, LAS VEGAS, NV. SN 85-374,141.
FILED P.R. 7-18-2011; AM. S.R. 8-3-2012.

LOS ANGELES ROCKS

THE MARK CONSISTS OF STANDARD CHARACTERS WITHOUT CLAIM TO ANY PARTICULAR FONT, STYLE, SIZE, OR COLOR.

OWNER OF U.S. REG. NOS. 3,424,113 AND 3,424,443.
NO CLAIM IS MADE TO THE EXCLUSIVE RIGHT TO USE "LOS ANGELES", APART FROM THE MARK AS SHOWN.

FOR COFFEE MUGS; DRINKING GLASSES; SHOT GLASSES (U.S. CLS. 2, 13, 23, 29, 30, 33, 40 AND 50).

FIRST USE 7-18-2011; IN COMMERCE 7-18-2011.

4,211,711. ZIMMERMAN, TERRESA L, SAGLE, ID. SN 85-307,800. FILED P.R. 4-28-2011; AM. S.R. 7-17-2012.

WOOD Underwear

THE MARK CONSISTS OF STANDARD CHARACTERS WITHOUT CLAIM TO ANY PARTICULAR FONT, STYLE, SIZE, OR COLOR.

NO CLAIM IS MADE TO THE EXCLUSIVE RIGHT TO USE "UNDERWEAR", APART FROM THE MARK AS SHOWN.

FOR BRIEFS; LADIES' UNDERWEAR; MEN'S UNDERWEAR; UNDERWEAR; UNDERWEAR, NAMELY, BOY SHORTS (U.S. CLS. 22 AND 39).

FIRST USE 11-1-2011; IN COMMERCE 11-1-2011.

CLASS 25—CLOTHING

4,211,690. EAGLE EARTHWORKS, INC., BETHEL, ME. SN 77-883,188. FILED P.R. 12-1-2009; AM. S.R. 8-7-2012.

Skid 'R Done

THE MARK CONSISTS OF STANDARD CHARACTERS WITHOUT CLAIM TO ANY PARTICULAR FONT, STYLE, SIZE, OR COLOR.

FOR CLOTHING, NAMELY, TEE SHIRTS, HATS, SWEATSHIRTS, JERSEYS, SHORTS, PANTS, JACKETS, SHIRTS, OVERALLS, COVERALLS, CHAPS, SCARVES, NECK-WARMING SCARVES, HEADBANDS, GLOVES, MITTENS, PAJAMAS, BOXER SHORTS, UNDERWEAR, LINGERIE, THERMAL UNDERWEAR, NECK TIES, SWIMWEAR, DRESSES, SKIRTS, TANK TOPS, SUSPENDERS, BANDANNAS AND BELTS (U.S. CLS. 22 AND 39).

FIRST USE 12-16-2011; IN COMMERCE 12-16-2011.

4,211,724. SPENCE, MIKE, DEKALB, IL. SN 85-349,693.
FILED P.R. 6-17-2011; AM. S.R. 8-3-2012.



THE STIPPLING IS FOR SHADING PURPOSES ONLY.
THE MARK CONSISTS OF A MARTINI GLASS WITH A SPIKE AND ONE OLIVE IN THE LIQUID. TO THE RIGHT THERE IS THE STYLIZED TEXT "LUCKY BACHELOR'S CLUB" WITH TWO OLIVES ON THE RIGHT. THERE IS A STAR ON TOP OF THE LETTER "Y".

FOR T-SHIRTS (U.S. CLS. 22 AND 39).

FIRST USE 3-11-2012; IN COMMERCE 3-18-2012.

CLASS 25—(Continued).

4,211,731. JENQ, KENNETH, BALTIMORE, MD. SN 85-372,233. FILED P.R. 7-15-2011; AM. S.R. 7-15-2011.

toughmuck

THE MARK CONSISTS OF STANDARD CHARACTERS WITHOUT CLAIM TO ANY PARTICULAR FONT, STYLE, SIZE, OR COLOR.

FOR APPAREL FOR DANCERS, NAMELY, TEE SHIRTS, SWEATSHIRTS, PANTS, LEGGINGS, SHORTS AND JACKETS; ATHLETIC APPAREL, NAMELY, SHIRTS, PANTS, JACKETS, FOOTWEAR, HATS AND CAPS, ATHLETIC UNIFORMS; CAMOUFLAGE SHIRTS; COLLARED SHIRTS; DRESS SHIRTS; HOODED SWEAT SHIRTS; POLO SHIRTS; RUGBY SHIRTS; SHIRTS; SHIRTS AND SHORT-SLEEVED SHIRTS; SWEAT SHIRTS; T-SHIRTS (U.S. CLS. 22 AND 39).

FIRST USE 8-29-2011; IN COMMERCE 1-7-2012.

4,211,734. TONY SACCA, LAS VEGAS, NV. SN 85-374,149. FILED P.R. 7-18-2011; AM. S.R. 8-3-2012.

LOS ANGELES ROCKS

THE MARK CONSISTS OF STANDARD CHARACTERS WITHOUT CLAIM TO ANY PARTICULAR FONT, STYLE, SIZE, OR COLOR.

OWNER OF U.S. REG. NOS. 3,424,113 AND 3,424,443.

NO CLAIM IS MADE TO THE EXCLUSIVE RIGHT TO USE "LOS ANGELES", APART FROM THE MARK AS SHOWN.

FOR CAPS; HATS; SHIRTS (U.S. CLS. 22 AND 39).

FIRST USE 7-18-2011; IN COMMERCE 7-18-2011.

4,211,779. BRAY, MICHAEL S., SOMERS POINT, NJ. SN 85-443,505. FILED P.R. 10-10-2011; AM. S.R. 7-25-2012.



OWNER OF U.S. REG. NO. 4,153,773.

CLASS 25—(Continued).

THE MARK CONSISTS OF THE STYLIZED WORDING "PASSION BREWS" AND THE STYLIZED LETTERS "PB" IN A CIRCULAR DESIGN WITH IRREGULAR EXTERIOR, WITH TWO FIVE-POINT STARS AND LAUREL LEAVES OR BRANCHES AROUND THE CIRCULAR DESIGN.

FOR CLOTHING, NAMELY, TEE-SHIRTS, SHIRTS AND HATS (U.S. CLS. 22 AND 39).

FIRST USE 10-29-2011; IN COMMERCE 10-29-2011.

4,211,789. CAROLINA HOSIERY MILLS, INC., BURLINGTON, NC. SN 85-452,006. FILED P.R. 10-20-2011; AM. S.R. 8-1-2012.

Ultra-Dri

THE MARK CONSISTS OF STANDARD CHARACTERS WITHOUT CLAIM TO ANY PARTICULAR FONT, STYLE, SIZE, OR COLOR.

FOR SOCKS SOLD AT RETAIL TO CONSUMERS (U.S. CLS. 22 AND 39).

FIRST USE 11-0-2011; IN COMMERCE 11-0-2011.

4,211,790. SURF COWBOY, INC., RIDGEFIELD, WA. SN 85-452,114. FILED P.R. 10-20-2011; AM. S.R. 8-1-2012.

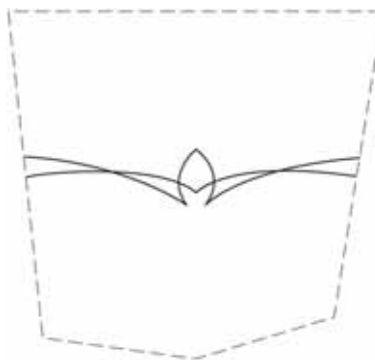

THE MARK CONSISTS OF A STITCHED STYLIZED DESIGN ON THE BACK POCKETS OF JEANS. THE STITCHING DESIGN CONSISTS OF TWO INTERSECTING CURVED LINES FORMING A SHAPE LIKE A PAIR OF WINGS ON THE BACK OF THE POCKET. THE DOTTED LINES ARE USED TO INDICATE THE POSITION OF THE MARK ON THE GOODS AND ARE NOT CLAIMED AS A FEATURE OF THE MARK.

FOR CLOTHING, NAMELY, JEANS (U.S. CLS. 22 AND 39).

FIRST USE 1-0-2003; IN COMMERCE 1-0-2003.

CLASS 25—(Continued).

4,211,794. BOOKHOLDERS, GAMBRILLS, MD. SN 85-460,366. FILED P.R. 10-31-2011; AM. S.R. 8-2-2012.



THE MARK CONSISTS OF THE WORDING "SUCKS TO BE U" INSIDE A SQUARE. THE MIDDLE OF THE "U" CONTAINS THE WORDS "TO BE".

FOR ATHLETIC APPAREL, NAMELY, SHIRTS, PANTS, JACKETS, FOOTWEAR, HATS AND CAPS, ATHLETIC UNIFORMS (U.S. CLS. 22 AND 39).
FIRST USE 5-1-2011; IN COMMERCE 5-1-2011.

4,211,798. BRAY, MICHAEL S., SOMERS POINT, NJ. SN 85-469,151. FILED 11-10-2011.

Drink different

THE MARK CONSISTS OF STANDARD CHARACTERS WITHOUT CLAIM TO ANY PARTICULAR FONT, STYLE, SIZE, OR COLOR.

FOR TEE-SHIRTS, HATS (U.S. CLS. 22 AND 39).
FIRST USE 10-29-2011; IN COMMERCE 10-29-2011.

4,211,813. VETRONE, MICHAEL, SAN JOSE, CA. SN 85-521,043. FILED P.R. 1-20-2012; AM. S.R. 8-2-2012.

CHOMP CHOMP CHOMP

THE MARK CONSISTS OF STANDARD CHARACTERS WITHOUT CLAIM TO ANY PARTICULAR FONT, STYLE, SIZE, OR COLOR.

FOR HATS; SWEATSHIRTS; T-SHIRTS (U.S. CLS. 22 AND 39).
FIRST USE 10-18-2011; IN COMMERCE 10-18-2011.

CLASS 25—(Continued).

4,211,825. WALTENBURG, JAMIE L., SHEPHERDSVILLE, KY. SN 85-548,812. FILED P.R. 2-21-2012; AM. S.R. 7-9-2012.

gotti fight gear

THE MARK CONSISTS OF STANDARD CHARACTERS WITHOUT CLAIM TO ANY PARTICULAR FONT, STYLE, SIZE, OR COLOR.

FOR ATHLETIC APPAREL, NAMELY, SHIRTS, PANTS, JACKETS, FOOTWEAR, HATS AND CAPS, ATHLETIC UNIFORMS (U.S. CLS. 22 AND 39).
FIRST USE 2-17-2012; IN COMMERCE 2-17-2012.

4,211,850. HOLMES, LARRY PETER, WEST SWANZEY, NH. SN 85-591,803. FILED P.R. 4-7-2012; AM. S.R. 7-25-2012.

Party Like A Pirate

THE MARK CONSISTS OF STANDARD CHARACTERS WITHOUT CLAIM TO ANY PARTICULAR FONT, STYLE, SIZE, OR COLOR.

FOR WEARABLE GARMENTS AND CLOTHING, NAMELY, SHIRTS (U.S. CLS. 22 AND 39).
FIRST USE 6-1-2010; IN COMMERCE 6-1-2010.

4,211,866. LOPE FOR HOPE, LLC, LAKE CITY, MI. SN 85-605,500. FILED P.R. 4-23-2012; AM. S.R. 7-9-2012.

Fight Like A Cowgirl

THE MARK CONSISTS OF STANDARD CHARACTERS WITHOUT CLAIM TO ANY PARTICULAR FONT, STYLE, SIZE, OR COLOR.

FOR BUTTON DOWN SHIRTS; COLLARED SHIRTS; DENIM JACKETS; DOWN JACKETS; DRESS SHIRTS; HATS; HEAVY JACKETS; HOODED SWEAT SHIRTS; JACKETS; LONG JACKETS; LONG-SLEEVED SHIRTS; NIGHT SHIRTS; OPEN-NECKED SHIRTS; OUTER JACKETS; POLO SHIRTS; RAIN JACKETS; RAINPROOF JACKETS; SHIRTS; SHORT-SLEEVED OR LONG-SLEEVED T-SHIRTS; SPORTS CAPS AND HATS; SWEAT SHIRTS; T-SHIRTS; TEE SHIRTS; TRACK JACKETS; WOMEN'S HATS AND HOODS (U.S. CLS. 22 AND 39).
FIRST USE 2-20-2012; IN COMMERCE 3-23-2012.

CLASS 25—(Continued).

4,211,867. LOPE FOR HOPE, LLC, LAKE CITY, MI. SN 85-605,558. FILED P.R. 4-23-2012; AM. S.R. 7-9-2012.

Buck Cancer

THE MARK CONSISTS OF STANDARD CHARACTERS WITHOUT CLAIM TO ANY PARTICULAR FONT, STYLE, SIZE, OR COLOR.

FOR BUTTON DOWN SHIRTS; COLLARED SHIRTS; DENIM JACKETS; DRESS SHIRTS; HATS; HOODED SWEAT SHIRTS; JACKETS; KNIT SHIRTS; POLO SHIRTS; RAINPROOF JACKETS; SHELL JACKETS; SHIRTS; SHIRTS AND SHORT-SLEEVED SHIRTS; SHORT-SLEEVED OR LONG-SLEEVED T-SHIRTS; SHORT-SLEEVED SHIRTS; SLEEVED OR SLEEVELESS JACKETS; SPORT SHIRTS; SPORTS CAPS AND HATS; SWEAT SHIRTS; T-SHIRTS; TEE SHIRTS; TRACK JACKETS; WATERPROOF JACKETS AND PANTS; WEARABLE GARMENTS AND CLOTHING, NAMELY, SHIRTS; WIND RESISTANT JACKETS; WOMEN'S HATS AND HOODS (U.S. CLS. 22 AND 39).

FIRST USE 12-12-2011; IN COMMERCE 1-25-2012.

CLASS 26—FANCY GOODS

4,211,818. INTERNATIONAL DESIGNS CORPORATION, HALLANDALE, FL. SN 85-531,989. FILED P.R. 2-2-2012; AM. S.R. 7-25-2012.

TRESS COUTURE

THE MARK CONSISTS OF STANDARD CHARACTERS WITHOUT CLAIM TO ANY PARTICULAR FONT, STYLE, SIZE, OR COLOR.

NO CLAIM IS MADE TO THE EXCLUSIVE RIGHT TO USE "TRESS", APART FROM THE MARK AS SHOWN.

FOR HAIR EXTENSIONS; WIGS (U.S. CLS. 37, 39, 40, 42 AND 50).

FIRST USE 5-31-2012; IN COMMERCE 5-31-2012.

CLASS 26—(Continued).

4,211,853. ARIZONA DEPARTMENT OF PUBLIC SAFETY, PHOENIX, AZ. SN 85-592,381. FILED P.R. 4-9-2012; AM. S.R. 7-24-2012.



OWNER OF U.S. REG. NO. 3,618,715.

NO CLAIM IS MADE TO THE EXCLUSIVE RIGHT TO USE "DEPARTMENT OF PUBLIC SAFETY" AND "ARIZONA HIGHWAY PATROL" AND THE DESIGN OF THE MAP OF ARIZONA, APART FROM THE MARK AS SHOWN.

THE COLOR(S) BLACK, SILVER IS/ARE CLAIMED AS A FEATURE OF THE MARK.

THE MARK CONSISTS OF SHAPE OF THE STATE OF ARIZONA. BLACK BACKGROUND ON THE TOP AND BOTTOM UNDER THE WORDING. BLACK IS FOR THE 1ST, 3RD, 5TH, 7TH, 9TH, 11TH, AND 13TH RAYS COMING OUT OF THE STAR. SILVER IS FOR THE LETTERING "DEPARTMENT OF PUBLIC SAFETY" "ARIZONA HIGHWAY PATROL", BORDER INSIDE OF BLACK BORDER AND THE 2ND, 4TH, 6TH, 8TH, 10TH, AND 12TH RAYS FROM THE STAR. BLACK IS THE BORDER. SILVER IS THE STAR IN THE CENTER.

FOR CLOTH PATCHES FOR CLOTHING; EMBROIDERED PATCHES FOR CLOTHING (U.S. CLS. 37, 39, 40, 42 AND 50).

FIRST USE 7-1-2011; IN COMMERCE 7-1-2011.

CLASS 28—TOYS AND SPORTING GOODS

4,211,871. COBRA GOLF INCORPORATED, CARLSBAD, CA. SN 85-626,381. FILED P.R. 5-15-2012; AM. S.R. 7-23-2012.



THE COLOR(S) ORANGE IS/ARE CLAIMED AS A FEATURE OF THE MARK.

CLASS 28—(Continued).

THE MARK CONSISTS OF THE COLOR ORANGE APPEARING ON THE CROWN OF THE GOLF CLUB HEAD. THE BROKEN OUTLINE OF THE GOODS IS INTENDED TO SHOW THE POSITION OF THE COLOR ON THE GOODS AND FORMS NO PART OF THE MARK, SERVING AS POSITIONAL REFERENCE ONLY.
FOR GOLF CLUB HEAD (U.S. CLS. 22, 23, 38 AND 50).
FIRST USE 7-11-2012; IN COMMERCE 7-11-2012.

CLASS 30—(Continued).

4,211,723. REMINGTON, INC., SANTA CLARITA, CA. SN 85-348,524. FILED P.R. 6-16-2011; AM. S.R. 8-9-2012.

FreshPak

THE MARK CONSISTS OF STANDARD CHARACTERS WITHOUT CLAIM TO ANY PARTICULAR FONT, STYLE, SIZE, OR COLOR.
FOR COFFEE AND TEA (U.S. CL. 46).
FIRST USE 5-1-2011; IN COMMERCE 6-1-2011.

CLASS 29—MEATS AND PROCESSED FOODS

4,211,828. OCEAN DUKE CORPORATION, TORRANCE, CA. SN 85-554,899. FILED P.R. 2-28-2012; AM. S.R. 7-26-2012.

Shrimp Snacks

4,211,802. SOUTHERN KNIFE, LLC, MAULDIN, SC. SN 85-485,972. FILED P.R. 12-2-2011; AM. S.R. 7-27-2012.

THE MARK CONSISTS OF STANDARD CHARACTERS WITHOUT CLAIM TO ANY PARTICULAR FONT, STYLE, SIZE, OR COLOR.
NO CLAIM IS MADE TO THE EXCLUSIVE RIGHT TO USE "SHRIMP", APART FROM THE MARK AS SHOWN.
FOR SEAFOOD (U.S. CL. 46).
FIRST USE 1-1-2012; IN COMMERCE 1-1-2012.

BLACK MAIZE

THE MARK CONSISTS OF STANDARD CHARACTERS WITHOUT CLAIM TO ANY PARTICULAR FONT, STYLE, SIZE, OR COLOR.
FOR DIPPING SAUCES; SALSA (U.S. CL. 46).
FIRST USE 1-0-2012; IN COMMERCE 5-0-2012.

4,211,847. JESSICA GILL, ARDENTOWN, DE. SN 85-588,348. FILED 4-3-2012.

Uniquely Greek

4,211,807. SWEET STREET DESSERTS, INC., READING, PA. SN 85-502,896. FILED P.R. 12-23-2011; AM. S.R. 8-6-2012.

**BLUEBERRY WHITE CHOCOLATE
CHEESE BRULEE**

THE MARK CONSISTS OF STANDARD CHARACTERS WITHOUT CLAIM TO ANY PARTICULAR FONT, STYLE, SIZE, OR COLOR.
FOR CHEESE SPREADS; DAIRY-BASED DIPS; DAIRY-BASED SPREADS; GARLIC-BASED SPREAD; HUMMUS CHICK PEA PASTE; SNACK DIPS; SNACK FOOD DIPS (U.S. CL. 46).
FIRST USE 9-30-2010; IN COMMERCE 9-30-2010.

THE MARK CONSISTS OF STANDARD CHARACTERS WITHOUT CLAIM TO ANY PARTICULAR FONT, STYLE, SIZE, OR COLOR.
OWNER OF U.S. REG. NOS. 3,284,011, 3,284,016, AND OTHERS.
THE ENGLISH TRANSLATION OF "BRULEE" IN THE MARK IS "BURNT".
FOR DESSERT PRODUCTS, NAMELY, BAKERY DESERTS (U.S. CL. 46).
FIRST USE 9-0-2011; IN COMMERCE 9-0-2011.

CLASS 30—STAPLE FOODS

CLASS 31—NATURAL AGRICULTURAL PRODUCTS

CLASS 31—(Continued).

4,211,686. ALL NATURAL CANINE, INC., SPICEWOOD, TX. SN 76-710,857. FILED P.R. 3-9-2012; AM. S.R. 3-9-2012.

ALL NATURAL CANINE

THE MARK CONSISTS OF STANDARD CHARACTERS WITHOUT CLAIM TO ANY PARTICULAR FONT, STYLE, SIZE, OR COLOR.

FOR DOG FOOD (U.S. CLS. 1 AND 46).
FIRST USE 1-1-2009; IN COMMERCE 1-1-2009.

4,211,709. WHEBLE, JOHN E., JR., KINGSTON, MA. AND TAYLOR, THOMAS W, II, KINGSTON, MA. AND BARKER, GREGORY C, KINGSTON, MA. SN 85-305,184. FILED P.R. 4-26-2011; AM. S.R. 7-26-2012.

Rocky Nook Oysters

THE MARK CONSISTS OF STANDARD CHARACTERS WITHOUT CLAIM TO ANY PARTICULAR FONT, STYLE, SIZE, OR COLOR.

NO CLAIM IS MADE TO THE EXCLUSIVE RIGHT TO USE "OYSTERS", APART FROM THE MARK AS SHOWN.
FOR OYSTERS (U.S. CLS. 1 AND 46).
FIRST USE 8-19-2010; IN COMMERCE 8-19-2010.

4,211,738. ALIAK KENNELS, LLC, MARENGO, IL. SN 85-403,916. FILED P.R. 8-22-2011; AM. S.R. 7-20-2012.

DArKK

THE MARK CONSISTS OF STANDARD CHARACTERS WITHOUT CLAIM TO ANY PARTICULAR FONT, STYLE, SIZE, OR COLOR.

FOR LIVE ANIMALS, NAMELY, DOGS AND PUPPIES (U.S. CLS. 1 AND 46).
FIRST USE 1-27-2005; IN COMMERCE 1-27-2005.

CLASS 31—(Continued).

4,211,795. REDPAW, INC., FRANKLIN, WI. SN 85-461,096. FILED P.R. 11-1-2011; AM. S.R. 7-20-2012.

**THE DOG FOOD FORMULATED
FOR CANINE FITNESS**

THE MARK CONSISTS OF STANDARD CHARACTERS WITHOUT CLAIM TO ANY PARTICULAR FONT, STYLE, SIZE, OR COLOR.

NO CLAIM IS MADE TO THE EXCLUSIVE RIGHT TO USE "DOG FOOD", APART FROM THE MARK AS SHOWN.
FOR FOOD FOR ANIMALS (U.S. CLS. 1 AND 46).
FIRST USE 4-23-2012; IN COMMERCE 5-3-2012.

CLASS 32—LIGHT BEVERAGES

4,211,815. CILURZO, VINNIE, SANTA ROSA, CA. AND CILURZO, NATALIE, SANTA ROSA, CA. SN 85-524,064. FILED P.R. 1-24-2012; AM. S.R. 7-25-2012.

DAUENHAUER

THE MARK CONSISTS OF STANDARD CHARACTERS WITHOUT CLAIM TO ANY PARTICULAR FONT, STYLE, SIZE, OR COLOR.

FOR BEER (U.S. CLS. 45, 46 AND 48).
FIRST USE 7-1-2012; IN COMMERCE 7-1-2012.

4,211,846. BAI BRANDS LLC, PRINCETON, NJ. SN 85-587,693. FILED P.R. 4-3-2012; AM. S.R. 7-27-2012.

ANTIOXIDANT INFUSIONS

THE MARK CONSISTS OF STANDARD CHARACTERS WITHOUT CLAIM TO ANY PARTICULAR FONT, STYLE, SIZE, OR COLOR.

FOR NON-ALCOHOLIC BEVERAGES CONTAINING FRUIT JUICES, FRUIT FLAVORED BEVERAGES, FRUIT FLAVORED SPORT DRINKS, FRUIT-FLAVORED DRINKS, FRUIT BASED BEVERAGES, ALL THE FOREGOING ENHANCED WITH ANTIOXIDANTS; FRUIT BASED BEVERAGES ENHANCED WITH ANTIOXIDANTS (U.S. CLS. 45, 46 AND 48).
FIRST USE 8-6-2009; IN COMMERCE 9-2-2009.

CLASS 33—WINES AND SPIRITS

CLASS 33—(Continued).

4,211,754. GWARDIA LLC, MIDDLETON, WI. SN 85-428,525.
FILED P.R. 9-21-2011; AM. S.R. 7-11-2012.

BELAYA RUS

THE MARK CONSISTS OF STANDARD CHARACTERS WITHOUT CLAIM TO ANY PARTICULAR FONT, STYLE, SIZE, OR COLOR.
FOR VODKA (U.S. CLS. 47 AND 49).
FIRST USE 8-12-2011; IN COMMERCE 8-12-2011.

4,211,842. GREEN BARREL, LLC, SAN FRANCISCO, CA. SN 85-581,498. FILED P.R. 3-27-2012; AM. S.R. 7-13-2012.



THE MARK CONSISTS OF THE STYLIZED WORDS "GREEN BARREL".
FOR WINE (U.S. CLS. 47 AND 49).
FIRST USE 2-0-2010; IN COMMERCE 2-0-2010.

SERVICE MARKS

CLASS 35—ADVERTISING AND BUSINESS

4,211,694. CAREQUEST, INC., DBA NAVGATE TECHNOLOGIES, PLYMOUTH, MN. SN 85-106,481. FILED P.R. 8-12-2010; AM. S.R. 6-18-2012.

CareOptions

THE MARK CONSISTS OF STANDARD CHARACTERS WITHOUT CLAIM TO ANY PARTICULAR FONT, STYLE, SIZE, OR COLOR.
FOR CONSULTING SERVICES, NAMELY, TO EMPLOYERS, COMMUNITY ORGANIZATIONS, BROKERS AND BENEFICIARIES, RELATED TO CONSUMER INFORMATION REGARDING HEALTH CARE PLAN OPTIONS, PRODUCTS AND PROGRAMS IN THE FIELD OF MANAGED CARE AND STATE AND FEDERAL MEDICAL CARE PROGRAMS (U.S. CLS. 100, 101 AND 102).
FIRST USE 2-22-2005; IN COMMERCE 2-22-2005.

CLASS 35—(Continued).

4,211,704. CHAINDRUGSTORE.NET INCORPORATED, ALEXANDRIA, VA. SN 85-281,041. FILED P.R. 3-30-2011; AM. S.R. 1-12-2012.

PREDICTIVE ACQUISITION COST

THE MARK CONSISTS OF STANDARD CHARACTERS WITHOUT CLAIM TO ANY PARTICULAR FONT, STYLE, SIZE, OR COLOR.
NO CLAIM IS MADE TO THE EXCLUSIVE RIGHT TO USE "ACQUISITION COST", APART FROM THE MARK AS SHOWN.
FOR PROVIDING DRUG PRICING STANDARDS AND ANALYSIS OF PHARMACEUTICAL PRODUCT PRICES BASED UPON STATISTICAL MODELING TO THE PHARMACEUTICAL INDUSTRY FOR BUSINESS OR COMMERCIAL PURPOSES (U.S. CLS. 100, 101 AND 102).
FIRST USE 12-23-2010; IN COMMERCE 1-18-2011.

4,211,729. DIRECT SWAP LLC, SEATTLE, WA. SN 85-363,729.
FILED P.R. 7-6-2011; AM. S.R. 4-24-2012.

DIRECT SWAP

THE MARK CONSISTS OF STANDARD CHARACTERS WITHOUT CLAIM TO ANY PARTICULAR FONT, STYLE, SIZE, OR COLOR.
FOR PROVIDING AN ONLINE MARKETPLACE, FOR CONNECTING PARTIES QUALIFIED UNDER THE END USER CLEARING EXCEPTION CONTAINED IN THE DODD FRANK WALL STREET REFORM AND CONSUMER PROTECTION ACT, IN THE FIELD OF COMMERCIAL HEDGING TRANSACTION SERVICES (U.S. CLS. 100, 101 AND 102).
FIRST USE 5-12-2011; IN COMMERCE 6-13-2011.

4,211,732. KRAUSS, GEOFF, KEWAUNEE, WI. SN 85-373,622.
FILED P.R. 7-18-2011; AM. S.R. 7-11-2012.

Cheese It Makes A Body Smile

THE MARK CONSISTS OF STANDARD CHARACTERS WITHOUT CLAIM TO ANY PARTICULAR FONT, STYLE, SIZE, OR COLOR.
FOR ADVERTISING AND PROMOTING THE SALE, USE, AND EVERYDAY CONSUMPTION OF CHEESE (U.S. CLS. 100, 101 AND 102).
FIRST USE 5-12-2011; IN COMMERCE 5-12-2011.

CLASS 35—(Continued).

4,211,741. BOXAD MEDIA, INC., IDAHO FALLS, ID. SN 85-412,336. FILED P.R. 8-31-2011; AM. S.R. 6-28-2012.

BOXAD

THE MARK CONSISTS OF STANDARD CHARACTERS WITHOUT CLAIM TO ANY PARTICULAR FONT, STYLE, SIZE, OR COLOR.

FOR ADVERTISING AND MARKETING SERVICES, NAMELY, PROMOTING THE GOODS AND SERVICES OF OTHERS; ADVERTISING, MARKETING AND PROMOTION SERVICES IN THE FIELD OF TRANSPORTATION, NAMELY, OVER-THE ROAD VEHICLES, COMMERCIAL TRAILERS, COMMERCIAL DELIVERY VEHICLES, AND SEMI-TRAILERS; OUT-OF-HOME ADVERTISING SERVICES, NAMELY, RENTAL OF ADVERTISING SPACE, AND PREPARING AND PLACING ADVERTISEMENTS FOR OTHERS; OUTDOOR ADVERTISING; PREPARING AND PLACING OF ADVERTISEMENTS (U.S. CLS. 100, 101 AND 102).

FIRST USE 9-1-2011; IN COMMERCE 4-1-2012.

4,211,747. DATA IMAGE, INC., NEWARK, OH. SN 85-418,781. FILED P.R. 9-9-2011; AM. S.R. 7-6-2012.

DataPreRegister

THE MARK CONSISTS OF STANDARD CHARACTERS WITHOUT CLAIM TO ANY PARTICULAR FONT, STYLE, SIZE, OR COLOR.

FOR ONLINE ELECTRONIC APPOINTMENT SCHEDULING SERVICE FOR HEALTHCARE ORGANIZATIONS (U.S. CLS. 100, 101 AND 102).

FIRST USE 11-30-2007; IN COMMERCE 11-30-2007.

CLASS 35—(Continued).

4,211,749. LDM GROUP, LLC, ST. LOUIS, MO. SN 85-419,713. FILED P.R. 9-11-2011; AM. S.R. 7-27-2012.

ECOPAY

THE MARK CONSISTS OF STANDARD CHARACTERS WITHOUT CLAIM TO ANY PARTICULAR FONT, STYLE, SIZE, OR COLOR.

FOR PROVIDING ADVERTISING SERVICES, NAMELY, PROMOTING THE GOODS AND SERVICES OF OTHERS BY AUTOMATICALLY DISTRIBUTING ELECTRONIC COUPONS, VOUCHERS, DISCOUNTS AND SPECIAL OFFERS FOR REDUCING OUT-OF-POCKET EXPENSES ON SELECTED PHARMACEUTICAL AND OVER THE COUNTER PRODUCTS TO IMPROVE PATIENT PRESCRIPTION COMPLIANCE (U.S. CLS. 100, 101 AND 102).

FIRST USE 7-1-2010; IN COMMERCE 7-1-2010.

4,211,760. JUDITH BRIGHT, LLC, NASHVILLE, TN. SN 85-434,403. FILED P.R. 9-28-2011; AM. S.R. 7-23-2012.

BAUBLE OF THE MONTH

THE MARK CONSISTS OF STANDARD CHARACTERS WITHOUT CLAIM TO ANY PARTICULAR FONT, STYLE, SIZE, OR COLOR.

FOR ONLINE AND RETAIL STORE SERVICES FEATURING JEWELRY (U.S. CLS. 100, 101 AND 102).

FIRST USE 1-18-2009; IN COMMERCE 1-18-2009.

4,211,767. ALLAN, T. ERIC, PITTSBURGH, PA. SN 85-438,974. FILED P.R. 10-4-2011; AM. S.R. 7-26-2012.

Detailer's Club

THE MARK CONSISTS OF STANDARD CHARACTERS WITHOUT CLAIM TO ANY PARTICULAR FONT, STYLE, SIZE, OR COLOR.

FOR RETAIL STORE AND ON-LINE RETAIL STORE SERVICES FEATURING AUTOMOTIVE CAR CARE PRODUCTS (U.S. CLS. 100, 101 AND 102).

FIRST USE 7-25-2012; IN COMMERCE 7-25-2012.

CLASS 35—(Continued).

4,211,769. DC WINE WEEK, LLC, ALEXANDRIA, VA. SN 85-439,543. FILED P.R. 10-5-2011; AM. S.R. 7-27-2012.

DC Wine Week

THE MARK CONSISTS OF STANDARD CHARACTERS WITHOUT CLAIM TO ANY PARTICULAR FONT, STYLE, SIZE, OR COLOR.

NO CLAIM IS MADE TO THE EXCLUSIVE RIGHT TO USE "WINE", APART FROM THE MARK AS SHOWN.

FOR ADVERTISING SERVICES, NAMELY, PROMOTING THE FOOD AND WINE OF OTHERS (U.S. CLS. 100, 101 AND 102).

FIRST USE 9-1-2011; IN COMMERCE 9-1-2011.

4,211,777. THE ACCOUNTING RESOURCE GROUP, LLC, KNOXVILLE, TN. SN 85-442,139. FILED P.R. 10-7-2011; AM. S.R. 8-2-2012.

StaffSource

THE COLOR(S) BLUE AND GREY IS/ARE CLAIMED AS A FEATURE OF THE MARK.

THE MARK CONSISTS OF A STYLIZED DEPICTION OF THE TERM "STAFFSOURCE" WITH THE LETTERS "STAFF" AND A LOWER PORTION OF THE FOLLOWING LETTER "S" APPEARING IN BLUE AND THE REMAINING LETTERS AND PORTIONS THEREOF APPEARING IN GREY.

FOR EMPLOYMENT STAFFING CONSULTATION SERVICES; EMPLOYMENT STAFFING IN THE FIELD OF ACCOUNTING AND FINANCE; PROFESSIONAL STAFFING AND RECRUITING SERVICES (U.S. CLS. 100, 101 AND 102).

FIRST USE 9-1-2011; IN COMMERCE 9-1-2011.

CLASS 35—(Continued).

4,211,780. SIMON YANG, INC., DBA HOURSMAP, PALO ALTO, CA. SN 85-443,823. FILED P.R. 10-10-2011; AM. S.R. 7-18-2012.

hoursmap

THE MARK CONSISTS OF STANDARD CHARACTERS WITHOUT CLAIM TO ANY PARTICULAR FONT, STYLE, SIZE, OR COLOR.

FOR ADVERTISING AND COMMERCIAL INFORMATION SERVICES, VIA THE INTERNET; DISSEMINATION OF ADVERTISING FOR OTHERS VIA THE INTERNET; PROVIDING A SEARCHABLE ONLINE ADVERTISING GUIDE FEATURING THE GOODS AND SERVICES OF OTHERS ON THE INTERNET; PROVIDING A WEB SITE WHICH FEATURES ADVERTISEMENTS FOR THE GOODS AND SERVICES OF OTHERS ON A GLOBAL COMPUTER NETWORK; PROVIDING AN ONLINE COMMERCIAL INFORMATION DIRECTORY ON THE INTERNET; PROVIDING AND RENTAL OF ADVERTISING SPACE ON THE INTERNET; PROVIDING INFORMATION ABOUT COMMERCIAL BUSINESS AND COMMERCIAL INFORMATION VIA THE GLOBAL COMPUTER NETWORK; PROVIDING INFORMATION ABOUT THE GOODS AND SERVICES OF OTHERS VIA THE GLOBAL COMPUTER NETWORK; PROVIDING ON-LINE DIRECTORY INFORMATION SERVICES ALSO FEATURING HYPERLINKS TO OTHER WEB SITES; PROVIDING SPACE AT A WEB SITE FOR THE ADVERTISEMENT OF THE GOODS AND SERVICES OF OTHERS; PROVIDING TELEPHONE DIRECTORY INFORMATION; PROMOTING GOODS AND SERVICES OF OTHERS THROUGH CREATING AND PLACING ADVERTISEMENTS AND LISTINGS BY MEANS OF A WEB SITE; PROVIDING A DIRECTORY OF THE HOURS OF OPERATION OF OTHERS; PROVIDING SPACE ON A MAP AT A WEB SITE FOR THE COMMERCIAL INFORMATION OF OTHERS; PROVIDING DIRECTORY INFORMATION SERVICES ALSO FEATURING GEOGRAPHIC INFORMATION AND MAP IMAGES FOR LOCATING BUSINESSES VIA THE INTERNET; ADVERTISEMENT VIA MOBILE PHONE NETWORKS; DISSEMINATION OF ADVERTISING FOR OTHERS VIA PUBLIC AND PRIVATE WIRELESS NETWORKS FOR DISPLAY ON MOBILE DEVICES; PROVIDING INFORMATION ABOUT THE GOODS AND SERVICES OF OTHERS ON MOBILE OR HANDHELD DEVICES (U.S. CLS. 100, 101 AND 102).

FIRST USE 12-1-2009; IN COMMERCE 12-1-2009.

4,211,781. ANVIL ACQUISITION CORP., LEXINGTON, IL. SN 85-445,342. FILED P.R. 10-12-2011; AM. S.R. 8-1-2012.

World's Best Hoofcare Store

THE MARK CONSISTS OF STANDARD CHARACTERS WITHOUT CLAIM TO ANY PARTICULAR FONT, STYLE, SIZE, OR COLOR.

CLASS 35—(Continued).

NO CLAIM IS MADE TO THE EXCLUSIVE RIGHT TO USE "STORE", APART FROM THE MARK AS SHOWN.

FOR ON-LINE RETAIL STORE SERVICES FEATURING A WIDE VARIETY OF HORSE AND FARRIER PRODUCTS OF OTHERS (U.S. CLS. 100, 101 AND 102).
FIRST USE 6-1-2011; IN COMMERCE 6-1-2011.

4,211,791. SAVILLE, DODGEN & COMPANY, PLCC, DALLAS, TX. SN 85-452,856. FILED P.R. 10-21-2011; AM. S.R. 7-20-2012.

SAVILLE

THE MARK CONSISTS OF STANDARD CHARACTERS WITHOUT CLAIM TO ANY PARTICULAR FONT, STYLE, SIZE, OR COLOR.

FOR ACCOUNTING SERVICES (U.S. CLS. 100, 101 AND 102).
FIRST USE 12-31-2003; IN COMMERCE 12-31-2003.

4,211,804. CENTRO MEDIA, INC., CHICAGO, IL. SN 85-493,009. FILED P.R. 12-12-2011; AM. S.R. 7-24-2012.

EXPERTS IN MEDIA LOGISTICS

THE MARK CONSISTS OF STANDARD CHARACTERS WITHOUT CLAIM TO ANY PARTICULAR FONT, STYLE, SIZE, OR COLOR.

FOR PROVIDING DIGITAL MEDIA SERVICES, NAMELY, SELECTING, TRACKING, AND BUYING DIGITAL MEDIA SPACE FOR OTHERS, AND ADVERTISING SERVICES, NAMELY, PROMOTING THE GOODS AND SERVICES OF OTHERS BY PLACING INTERNET ADVERTISEMENTS ON INTERNET WEB SITES (U.S. CLS. 100, 101 AND 102).
FIRST USE 2-23-2012; IN COMMERCE 2-23-2012.

CLASS 35—(Continued).

4,211,808. CENTRIS CONSULTING, INC., SCRANTON, PA. SN 85-505,390. FILED P.R. 12-29-2011; AM. S.R. 7-5-2012.

Calibration Review

THE MARK CONSISTS OF STANDARD CHARACTERS WITHOUT CLAIM TO ANY PARTICULAR FONT, STYLE, SIZE, OR COLOR.

FOR BUSINESS CONSULTING SERVICES IN THE FIELD OF EVALUATING THE EFFECTIVENESS OF ENTERPRISE SYSTEMS IMPLEMENTATIONS AND BUSINESS TRANSFORMATION PROJECTS (U.S. CLS. 100, 101 AND 102).
FIRST USE 11-0-2011; IN COMMERCE 11-0-2011.

4,211,809. CENTRIS CONSULTING, INC., SCRANTON, PA. SN 85-505,409. FILED P.R. 12-29-2011; AM. S.R. 7-5-2012.

**Organizational Value
Analysis**

THE MARK CONSISTS OF STANDARD CHARACTERS WITHOUT CLAIM TO ANY PARTICULAR FONT, STYLE, SIZE, OR COLOR.

FOR BUSINESS CONSULTING SERVICES IN THE FIELD OF COST REDUCTION AND EFFICIENCY INCREASE (U.S. CLS. 100, 101 AND 102).
FIRST USE 11-0-2011; IN COMMERCE 11-0-2011.

4,211,810. RESICOM CUSTOM PAINTING & MAINTENANCE, INC., LEMONT, IL. SN 85-509,630. FILED P.R. 1-5-2012; AM. S.R. 7-30-2012.

INQUIRY BASED CONSULTING

THE MARK CONSISTS OF STANDARD CHARACTERS WITHOUT CLAIM TO ANY PARTICULAR FONT, STYLE, SIZE, OR COLOR.

NO CLAIM IS MADE TO THE EXCLUSIVE RIGHT TO USE "CONSULTING", APART FROM THE MARK AS SHOWN.

FOR CONSULTING SERVICES RELATED TO PROVIDING ADVICE AND ASSISTANCE TO BUSINESS OWNERS REGARDING THE MORE EFFECTIVE OPERATION OF THEIR BUSINESS (U.S. CLS. 100, 101 AND 102).
FIRST USE 2-0-2010; IN COMMERCE 2-0-2010.

CLASS 35—(Continued).

4,211,819. ITALIAN CHOPPERS LLC, SOUTHBRIDGE, MA. SN 85-532,788. FILED P.R. 2-2-2012; AM. S.R. 7-12-2012.

ITALIAN CHOPPERS

THE MARK CONSISTS OF STANDARD CHARACTERS WITHOUT CLAIM TO ANY PARTICULAR FONT, STYLE, SIZE, OR COLOR.

NO CLAIM IS MADE TO THE EXCLUSIVE RIGHT TO USE "CHOPPERS", APART FROM THE MARK AS SHOWN. FOR RETAIL STORE SERVICES FEATURING MOTORCYCLES, MOTORCYCLES PARTS AND CLOTHING (U.S. CLS. 100, 101 AND 102).

FIRST USE 6-29-2011; IN COMMERCE 6-29-2011.

4,211,822. NATIONAL BILLING ASSOCIATES, INC., BIRMINGHAM, AL. SN 85-543,159. FILED P.R. 2-15-2012; AM. S.R. 8-2-2012.

RENAL BILLING

THE MARK CONSISTS OF STANDARD CHARACTERS WITHOUT CLAIM TO ANY PARTICULAR FONT, STYLE, SIZE, OR COLOR.

NO CLAIM IS MADE TO THE EXCLUSIVE RIGHT TO USE "BILLING", APART FROM THE MARK AS SHOWN. FOR MEDICAL BILLING OUTSOURCING SERVICES (U.S. CLS. 100, 101 AND 102).

FIRST USE 2-0-2012; IN COMMERCE 2-0-2012.

4,211,852. BACKPACK TRAVEL STORE, LLC, WASHINGTON, DC. SN 85-592,166. FILED P.R. 4-9-2012; AM. S.R. 7-26-2012.

Backpack Travel Store

THE MARK CONSISTS OF STANDARD CHARACTERS WITHOUT CLAIM TO ANY PARTICULAR FONT, STYLE, SIZE, OR COLOR.

NO CLAIM IS MADE TO THE EXCLUSIVE RIGHT TO USE "STORE", APART FROM THE MARK AS SHOWN.

FOR ON-LINE RETAIL STORE SERVICES FEATURING TRAVEL RELATED ACCESSORIES AND PRODUCTS (U.S. CLS. 100, 101 AND 102).

FIRST USE 4-1-2010; IN COMMERCE 4-1-2010.

CLASS 35—(Continued).

4,211,854. JULIAN MONTOYA, DBA ZEN OASIS HEALTH RETREATS, ARCATA, CA. SN 85-593,155. FILED P.R. 4-10-2012; AM. S.R. 7-25-2012.

Humboldt Garden Supply

THE MARK CONSISTS OF STANDARD CHARACTERS WITHOUT CLAIM TO ANY PARTICULAR FONT, STYLE, SIZE, OR COLOR.

OWNER OF U.S. REG. NOS. 3,855,259, 3,968,153, AND 3,999,948.

NO CLAIM IS MADE TO THE EXCLUSIVE RIGHT TO USE "GARDEN SUPPLY", APART FROM THE MARK AS SHOWN.

FOR ON-LINE RETAIL STORE SERVICES FEATURING GARDENING SUPPLIES, NAMELY, FERTILIZERS, SOIL AMENDMENTS, SOILS AND GROWING MEDIUMS, HORTICULTURE LIGHTING AND IRRIGATION (U.S. CLS. 100, 101 AND 102).

FIRST USE 5-1-2010; IN COMMERCE 5-1-2010.

4,211,856. KANSAS CITY FASHION WEEK, LLC, KANSAS CITY, MO. SN 85-593,981. FILED 4-10-2012.

Kansas City Fashion Week

THE MARK CONSISTS OF STANDARD CHARACTERS WITHOUT CLAIM TO ANY PARTICULAR FONT, STYLE, SIZE, OR COLOR.

NO CLAIM IS MADE TO THE EXCLUSIVE RIGHT TO USE "FASHION WEEK", APART FROM THE MARK AS SHOWN.

FOR FASHION SHOW EXHIBITIONS FOR COMMERCIAL PURPOSES; ORGANIZATION OF FASHION SHOWS FOR COMMERCIAL PURPOSES (U.S. CLS. 100, 101 AND 102).

FIRST USE 11-1-2010; IN COMMERCE 11-1-2010.

4,211,857. SOUTHERN PERSONNEL MANAGEMENT, INC., DBA MY HR PROFESSIONALS, VAN BUREN, AR. SN 85-594,447. FILED 4-11-2012.

My HR Professionals

THE MARK CONSISTS OF STANDARD CHARACTERS WITHOUT CLAIM TO ANY PARTICULAR FONT, STYLE, SIZE, OR COLOR.

CLASS 35—(Continued).

NO CLAIM IS MADE TO THE EXCLUSIVE RIGHT TO USE "HR", APART FROM THE MARK AS SHOWN.

FOR ADMINISTRATION OF BUSINESS PAYROLL FOR OTHERS; ADMINISTRATIVE ACCOUNTING; BUSINESS RISK MANAGEMENT; BUSINESS RISK MANAGEMENT CONSULTATION; HUMAN RESOURCE ANALYSIS AND CONSULTING SERVICES; HUMAN RESOURCE SERVICES, NAMELY, FACILITATING THE EMPLOYEE TERMINATION AND SEPARATION PROCESS BY EXECUTING THE REQUIRED ACTIVITY AND COMMUNICATION RELATED TO EMPLOYEE TERMINATION AND SEPARATION; HUMAN RESOURCES CONSULTANCY; HUMAN RESOURCES CONSULTATION; HUMAN RESOURCES MANAGEMENT; PAYROLL ADMINISTRATION AND MANAGEMENT SERVICES; PAYROLL PREPARATION; PAYROLL PROCESSING SERVICES; SERVING AS A HUMAN RESOURCES DEPARTMENT FOR OTHERS; WAGE PAYROLL PREPARATION (U.S. CLS. 100, 101 AND 102).
FIRST USE 1-1-2012; IN COMMERCE 1-1-2012.

4,211,865. HOME TEAM MARKETING, CLEVELAND,, OH. SN 85-602,203. FILED P.R. 4-19-2012; AM. S.R. 8-6-2012.

#1 High School Platform In America

THE MARK CONSISTS OF STANDARD CHARACTERS WITHOUT CLAIM TO ANY PARTICULAR FONT, STYLE, SIZE, OR COLOR.

FOR PROVIDING MARKETING SERVICES AT HIGH SCHOOL SPORTING EVENTS (U.S. CLS. 100, 101 AND 102).

FIRST USE 4-1-2001; IN COMMERCE 4-1-2001.

CLASS 36—INSURANCE AND FINANCIAL

4,211,710. PENNSYLVANIA STATE EMPLOYEES CREDIT UNION, HARRISBURG, PA. SN 85-307,527. FILED P.R. 4-28-2011; AM. S.R. 8-6-2012.

FinancingBiz

THE MARK CONSISTS OF STANDARD CHARACTERS WITHOUT CLAIM TO ANY PARTICULAR FONT, STYLE, SIZE, OR COLOR.

FOR CREDIT UNION SERVICES (U.S. CLS. 100, 101 AND 102).

FIRST USE 5-0-2009; IN COMMERCE 5-0-2009.

CLASS 36—(Continued).

4,211,727. OMNI FINANCIAL GROUP, INC., DBA THE OMNI GROUP, ROCHESTER, NY. SN 85-361,616. FILED P.R. 7-1-2011; AM. S.R. 8-9-2012.

PREFERRED PROVIDER PROGRAM

THE MARK CONSISTS OF STANDARD CHARACTERS WITHOUT CLAIM TO ANY PARTICULAR FONT, STYLE, SIZE, OR COLOR.

NO CLAIM IS MADE TO THE EXCLUSIVE RIGHT TO USE "PROGRAM", APART FROM THE MARK AS SHOWN.

FOR ADMINISTRATION OF EMPLOYER-SPONSORED FINANCIAL RETIREMENT PLANS (U.S. CLS. 100, 101 AND 102).

FIRST USE 6-29-2011; IN COMMERCE 6-29-2011.

4,211,743. TMFS HOLDINGS, LLC, OVERLAND PARK, KS. SN 85-414,304. FILED P.R. 9-2-2011; AM. S.R. 6-25-2012.

MARKET REENTRY PLAN

THE MARK CONSISTS OF STANDARD CHARACTERS WITHOUT CLAIM TO ANY PARTICULAR FONT, STYLE, SIZE, OR COLOR.

FOR INVESTMENT ADVISORY SERVICES; MUTUAL FUND MANAGEMENT SERVICES (U.S. CLS. 100, 101 AND 102).

FIRST USE 1-0-2009; IN COMMERCE 1-0-2009.

4,211,744. GOVERNMENT PAYMENTS LLC, FREMONT, CA. SN 85-414,627. FILED P.R. 9-2-2011; AM. S.R. 6-25-2012.

CONVENIENT PAYMENTS

THE MARK CONSISTS OF STANDARD CHARACTERS WITHOUT CLAIM TO ANY PARTICULAR FONT, STYLE, SIZE, OR COLOR.

CLASS 36—(Continued).

NO CLAIM IS MADE TO THE EXCLUSIVE RIGHT TO USE "PAYMENTS", APART FROM THE MARK AS SHOWN.

FOR PROVIDING SECURE FINANCIAL COMMERCIAL TRANSACTIONS AND PAYMENT OPTIONS FOR PROCESSING OF ELECTRONIC FUNDS TRANSFERS, ACH, CREDIT CARD, DEBIT CARD, ELECTRONIC CHECK, CONVENIENCE FEES, AND ELECTRONIC PAYMENTS; ELECTRONIC PAYMENT, NAMELY, ELECTRONIC PAYMENT PROCESSING OF BILL PAYMENT DATA VIA ELECTRONIC TRANSMISSION, WIRELESS TRANSMISSION, TELEPHONE AND A GLOBAL COMPUTER NETWORK (U.S. CLS. 100, 101 AND 102).

FIRST USE 4-23-2012; IN COMMERCE 4-23-2012.

4,211,748. DATA IMAGE, INC., NEWARK, OH. SN 85-418,799. FILED P.R. 9-9-2011; AM. S.R. 7-10-2012.

DataRegister

THE MARK CONSISTS OF STANDARD CHARACTERS WITHOUT CLAIM TO ANY PARTICULAR FONT, STYLE, SIZE, OR COLOR.

FOR PROVIDING POINT OF SALE PAYMENT INTERFACE PROCESSING SERVICES FOR HEALTHCARE (U.S. CLS. 100, 101 AND 102).

FIRST USE 11-30-2007; IN COMMERCE 11-30-2007.

4,211,776. AFFILIATES INSURANCE RECIPROCAL, A RISK RETENTION GROUP, BURLINGTON, VT. SN 85-441,714. FILED P.R. 10-7-2011; AM. S.R. 7-26-2012.

AFFILIATES INSURANCE RECIPROCAL, A RISK RETENTION GROUP

THE MARK CONSISTS OF STANDARD CHARACTERS WITHOUT CLAIM TO ANY PARTICULAR FONT, STYLE, SIZE, OR COLOR.

NO CLAIM IS MADE TO THE EXCLUSIVE RIGHT TO USE "INSURANCE RECIPROCAL, A RISK RETENTION GROUP", APART FROM THE MARK AS SHOWN.

FOR INSURANCE SERVICES, NAMELY, UNDERWRITING INSURANCE AND REINSURANCE POLICIES FOR ALL TYPES OF LIABILITY INSURANCE (U.S. CLS. 100, 101 AND 102).

FIRST USE 1-1-2010; IN COMMERCE 1-1-2010.

CLASS 36—(Continued).

4,211,787. PROCTOR, DAVID MICHAEL, NORTHBRIDGE, CA. SN 85-451,098. FILED P.R. 10-19-2011; AM. S.R. 7-26-2012.

1-800-SHORTSALE

THE MARK CONSISTS OF STANDARD CHARACTERS WITHOUT CLAIM TO ANY PARTICULAR FONT, STYLE, SIZE, OR COLOR.

FOR PROVIDING INFORMATION IN THE FIELD OF REAL ESTATE VIA THE INTERNET; PROVIDING REAL ESTATE LISTINGS AND REAL ESTATE INFORMATION VIA THE INTERNET; REAL ESTATE APPRAISAL AND VALUATION; REAL ESTATE BROKERAGE; REAL ESTATE CONSULTANCY; REAL ESTATE INVESTMENT SERVICES; REAL ESTATE PROCUREMENT FOR OTHERS; RESIDENTIAL REAL ESTATE AGENCY SERVICES (U.S. CLS. 100, 101 AND 102).

FIRST USE 11-0-2011; IN COMMERCE 11-0-2011.

4,211,788. PAYMENTCOLLECT, LLC, ARDEN, NC. SN 85-452,005. FILED P.R. 10-20-2011; AM. S.R. 8-1-2012.

PAYMENTCOLLECT

THE MARK CONSISTS OF STANDARD CHARACTERS WITHOUT CLAIM TO ANY PARTICULAR FONT, STYLE, SIZE, OR COLOR.

FOR PAYMENT TRANSACTION PROCESSING SERVICES; BILL PAYMENT SERVICES; BILL PAYMENT SERVICES PROVIDED THROUGH A WEBSITE; ELECTRONIC PAYMENT SERVICES, NAMELY, ELECTRONIC PROCESSING AND TRANSMISSION OF BILL PAYMENT DATA; MERCHANT SERVICES, NAMELY, PAYMENT TRANSACTION PROCESSING SERVICES; PROVIDING ELECTRONIC PROCESSING OF ACH AND CREDIT CARD TRANSACTIONS; AND ELECTRONIC PAYMENT SERVICES VIA A GLOBAL COMPUTER NETWORK (U.S. CLS. 100, 101 AND 102).

FIRST USE 12-0-2011; IN COMMERCE 12-0-2011.

CLASS 36—(Continued).

4,211,799. JOEL GREENBLATT, DBA GOTHAM ASSET MANAGEMENT, LLC, NEW YORK, NY. SN 85-473,048. FILED P.R. 11-15-2011; AM. S.R. 6-28-2012.

VALUE WEIGHTED INDEX

THE MARK CONSISTS OF STANDARD CHARACTERS WITHOUT CLAIM TO ANY PARTICULAR FONT, STYLE, SIZE, OR COLOR.

FOR FINANCIAL SERVICES, NAMELY, PROVIDING FINANCIAL AND INVESTMENT SERVICES RELATING TO THE SELECTION OF SECURITIES BASED ON A CALCULATION OF EACH SECURITY'S VALUE AS A MEASURE OF EARNINGS YIELD AND RETURN ON CAPITAL COMPARED WITH CERTAIN OTHER SECURITIES (U.S. CLS. 100, 101 AND 102).

FIRST USE 4-30-2011; IN COMMERCE 4-30-2011.

4,211,805. UNION BANK, NATIONAL ASSOCIATION, SAN FRANCISCO, CA. SN 85-493,135. FILED P.R. 12-12-2011; AM. S.R. 7-26-2012.

LIQUIDITYRESOURCE

THE MARK CONSISTS OF STANDARD CHARACTERS WITHOUT CLAIM TO ANY PARTICULAR FONT, STYLE, SIZE, OR COLOR.

FOR CONSULTING SERVICES IN THE FIELD OF FINANCIAL PORTFOLIO MANAGEMENT (U.S. CLS. 100, 101 AND 102).

FIRST USE 12-5-2011; IN COMMERCE 12-5-2011.

4,211,806. CHADBOURNE ROAD CAPITAL, RED BANK, NJ. SN 85-497,951. FILED P.R. 12-16-2011; AM. S.R. 7-6-2012.

Northeastern Financial Group

THE MARK CONSISTS OF STANDARD CHARACTERS WITHOUT CLAIM TO ANY PARTICULAR FONT, STYLE, SIZE, OR COLOR.

CLASS 36—(Continued).

NO CLAIM IS MADE TO THE EXCLUSIVE RIGHT TO USE "FINANCIAL GROUP", APART FROM THE MARK AS SHOWN.

FOR FINANCIAL ADVISORY AND CONSULTANCY SERVICES; FINANCIAL AND INVESTMENT SERVICES, NAMELY, ASSET AND INVESTMENT ACQUISITION, CONSULTATION, ADVISORY AND DEVELOPMENT; FINANCIAL PLANNING AND INVESTMENT ADVISORY SERVICES; INVESTMENT MANAGEMENT; INVESTMENT SERVICES, NAMELY, ASSET ACQUISITION, CONSULTATION, DEVELOPMENT AND MANAGEMENT SERVICES (U.S. CLS. 100, 101 AND 102).

FIRST USE 10-7-2011; IN COMMERCE 5-31-2012.

4,211,839. CRNA FINANCIAL PLANNING, INC., WINSTON-SALEM, NC. SN 85-572,027. FILED P.R. 3-16-2012; AM. S.R. 7-26-2012.

CRNA Financial Planning

THE MARK CONSISTS OF STANDARD CHARACTERS WITHOUT CLAIM TO ANY PARTICULAR FONT, STYLE, SIZE, OR COLOR.

NO CLAIM IS MADE TO THE EXCLUSIVE RIGHT TO USE "FINANCIAL PLANNING", APART FROM THE MARK AS SHOWN.

FOR FINANCIAL SERVICES, NAMELY, IDENTIFYING LONG-TERM FINANCIAL OBJECTIVES FOR INDIVIDUAL CERTIFIED REGISTERED NURSE ANESTHETISTS, PARTNERSHIPS, AND PRACTICE GROUPS AND DEVELOPING AND IMPLEMENTING TAX PLANNING, ASSET ALLOCATION, INVESTMENT PLANNING, INSURANCE PLANNING, RISK MANAGEMENT, RETIREMENT AND ESTATE PLANNING STRATEGIES IN ORDER TO MEET THE LONG-TERM FINANCIAL OBJECTIVES (U.S. CLS. 100, 101 AND 102).

FIRST USE 3-13-2008; IN COMMERCE 3-13-2008.

4,211,843. PACILIO, THOMAS, WESTPORT, CT. SN 85-583,266. FILED P.R. 3-29-2012; AM. S.R. 7-19-2012.

PACILIO WEALTH MANAGEMENT

THE MARK CONSISTS OF STANDARD CHARACTERS WITHOUT CLAIM TO ANY PARTICULAR FONT, STYLE, SIZE, OR COLOR.

CLASS 36—(Continued).

NO CLAIM IS MADE TO THE EXCLUSIVE RIGHT TO USE "WEALTH MANAGEMENT", APART FROM THE MARK AS SHOWN.

FOR FINANCIAL SERVICES, NAMELY, ASSISTING OTHERS WITH THE COMPLETION OF FINANCIAL TRANSACTIONS FOR STOCKS, BONDS, SECURITIES AND EQUITIES; FINANCIAL SERVICES, NAMELY, INVESTMENT ADVICE, INVESTMENT MANAGEMENT, INVESTMENT CONSULTATION AND INVESTMENT OF FUNDS FOR OTHERS, INCLUDING PRIVATE AND PUBLIC EQUITY AND DEBT INVESTMENT SERVICES; FINANCIAL SERVICES, NAMELY, WEALTH MANAGEMENT SERVICES (U.S. CLS. 100, 101 AND 102).

FIRST USE 12-9-2011; IN COMMERCE 12-9-2011.

CLASS 37—CONSTRUCTION AND REPAIR

4,211,746. DDRUS HOLDINGS INC., STONEY CREEK, ON, CANADA. SN 85-418,719. FILED P.R. 9-9-2011; AM. S.R. 6-21-2012.

LINT CHECK

THE MARK CONSISTS OF STANDARD CHARACTERS WITHOUT CLAIM TO ANY PARTICULAR FONT, STYLE, SIZE, OR COLOR.

PRIORITY CLAIMED UNDER SEC. 44(D) ON CANADA APPLICATION NO. 1525493, FILED 4-28-2011.

FOR AIR DUCT CLEANING SERVICES; INSTALLATION AND MAINTENANCE OF FIRE ALARM, DETECTION AND SUPPRESSION SYSTEMS (U.S. CLS. 100, 103 AND 106).

FIRST USE 4-11-2012; IN COMMERCE 4-11-2012.

4,211,824. BULWARK EXTERMINATING LLC, GILBERT, AZ. SN 85-548,161. FILED P.R. 2-21-2012; AM. S.R. 8-8-2012.

Nocturnal Treatments

THE MARK CONSISTS OF STANDARD CHARACTERS WITHOUT CLAIM TO ANY PARTICULAR FONT, STYLE, SIZE, OR COLOR.

NO CLAIM IS MADE TO THE EXCLUSIVE RIGHT TO USE "TREATMENTS", APART FROM THE MARK AS SHOWN.

FOR PEST CONTROL (U.S. CLS. 100, 103 AND 106).

FIRST USE 12-5-2011; IN COMMERCE 12-5-2011.

CLASS 38—COMMUNICATION**CLASS 38—(Continued).**

4,211,740. PRIVACY DATA SYSTEMS, LLC, GREENWOOD, IN. SN 85-411,654. FILED P.R. 8-31-2011; AM. S.R. 6-26-2012.

PRIVACY DATA SYSTEMS

THE MARK CONSISTS OF STANDARD CHARACTERS WITHOUT CLAIM TO ANY PARTICULAR FONT, STYLE, SIZE, OR COLOR.

OWNER OF U.S. REG. NO. 4,065,727.

FOR TRANSMISSION OF ENCRYPTED VOICE, VIDEO AND DATA FILES FOR SECURE MESSAGING DATA TRANSMISSION THROUGH A DIGITAL COURIER (U.S. CLS. 100, 101 AND 104).

FIRST USE 4-1-2010; IN COMMERCE 4-1-2010.

4,211,803. METROPCS WIRELESS, INC., RICHARDSON, TX. SN 85-487,883. FILED P.R. 12-6-2011; AM. S.R. 7-19-2012.

MEXICO UNLIMITED

THE MARK CONSISTS OF STANDARD CHARACTERS WITHOUT CLAIM TO ANY PARTICULAR FONT, STYLE, SIZE, OR COLOR.

FOR TELECOMMUNICATIONS SERVICES, NAMELY, WIRELESS TELEPHONY AND WIRELESS BROADBAND COMMUNICATIONS SERVICES FOR THE TRANSMISSION OF VOICE AND DATA (U.S. CLS. 100, 101 AND 104).

FIRST USE 4-0-2009; IN COMMERCE 4-0-2009.

CLASS 40—MATERIAL TREATMENT

4,211,858. VALMONT INDUSTRIES, INC., OMAHA, NE. SN 85-595,143. FILED P.R. 4-11-2012; AM. S.R. 8-3-2012.

MIAMI GALVANIZING

THE MARK CONSISTS OF STANDARD CHARACTERS WITHOUT CLAIM TO ANY PARTICULAR FONT, STYLE, SIZE, OR COLOR.

NO CLAIM IS MADE TO THE EXCLUSIVE RIGHT TO USE "GALVANIZING", APART FROM THE MARK AS SHOWN.

FOR GALVANIZING SERVICES (U.S. CLS. 100, 103 AND 106).

FIRST USE 3-16-2012; IN COMMERCE 3-28-2012.

CLASS 40—(Continued).

4,211,859. VALMONT INDUSTRIES, INC., OMAHA, NE. SN 85-595,170. FILED P.R. 4-11-2012; AM. S.R. 8-3-2012.

COLUMBIA GALVANIZING

THE MARK CONSISTS OF STANDARD CHARACTERS WITHOUT CLAIM TO ANY PARTICULAR FONT, STYLE, SIZE, OR COLOR.

NO CLAIM IS MADE TO THE EXCLUSIVE RIGHT TO USE "GALVANIZING", APART FROM THE MARK AS SHOWN.

FOR GALVANIZING SERVICES (U.S. CLS. 100, 103 AND 106).

FIRST USE 3-16-2012; IN COMMERCE 3-30-2012.

4,211,860. VALMONT INDUSTRIES, INC., OMAHA, NE. SN 85-595,175. FILED P.R. 4-11-2012; AM. S.R. 8-3-2012.

VIRGINIA GALVANIZING

THE MARK CONSISTS OF STANDARD CHARACTERS WITHOUT CLAIM TO ANY PARTICULAR FONT, STYLE, SIZE, OR COLOR.

NO CLAIM IS MADE TO THE EXCLUSIVE RIGHT TO USE "GALVANIZING", APART FROM THE MARK AS SHOWN.

FOR GALVANIZING SERVICES (U.S. CLS. 100, 103 AND 106).

FIRST USE 3-16-2012; IN COMMERCE 3-27-2012.

CLASS 41—EDUCATION AND ENTERTAINMENT

4,211,698. LITERARY LICENSING, LLC, WHITEFISH, MT. SN 85-258,101. FILED P.R. 3-4-2011; AM. S.R. 8-6-2012.

LITERARY LICENSING

THE MARK CONSISTS OF STANDARD CHARACTERS WITHOUT CLAIM TO ANY PARTICULAR FONT, STYLE, SIZE, OR COLOR.

FOR PUBLISHING OF BOOKS (U.S. CLS. 100, 101 AND 107).

FIRST USE 5-1-2011; IN COMMERCE 5-1-2011.

CLASS 41—(Continued).

4,211,700. BALL UP, LLC, FORT WORTH, TX. SN 85-271,482. FILED P.R. 3-19-2011; AM. S.R. 7-6-2012.

PROFESSIONAL STREETBALL LEAGUE

THE MARK CONSISTS OF STANDARD CHARACTERS WITHOUT CLAIM TO ANY PARTICULAR FONT, STYLE, SIZE, OR COLOR.

NO CLAIM IS MADE TO THE EXCLUSIVE RIGHT TO USE "STREETBALL", APART FROM THE MARK AS SHOWN.

FOR ENTERTAINMENT AND EDUCATIONAL SERVICES IN THE NATURE OF ONGOING TELEVISION AND RADIO PROGRAMS IN THE FIELD OF BASKETBALL AND RENDERING LIVE BASKETBALL GAMES AND BASKETBALL EXHIBITIONS; THE PRODUCTION AND DISTRIBUTION OF RADIO AND TELEVISION BROADCASTS OF BASKETBALL GAMES, BASKETBALL EVENTS AND PROGRAMS IN THE FIELD OF BASKETBALL; ENTERTAINMENT SERVICES, NAMELY, PROVIDING A WEBSITE FEATURING MULTIMEDIA MATERIAL IN THE NATURE OF TELEVISION HIGHLIGHTS, INTERACTIVE TELEVISION HIGHLIGHTS, VIDEO RECORDINGS, VIDEO STREAM RECORDINGS, INTERACTIVE VIDEO HIGHLIGHT SELECTIONS, RADIO PROGRAMS, RADIO HIGHLIGHTS, AND AUDIO RECORDINGS IN THE FIELD OF BASKETBALL, BASKETBALL NEWS IN THE NATURE OF INFORMATION, STATISTICS, AND TRIVIA ABOUT BASKETBALL, AND ON-LINE NON-DOWNLOADABLE PUBLICATIONS IN THE NATURE OF MAGAZINES, GUIDES, NEWSLETTERS, COLORING BOOKS, GAME SCHEDULES IN THE FIELD OF BASKETBALL THAT CAN BE PRINTED OVER THE INTERNET (U.S. CLS. 100, 101 AND 107).

FIRST USE 5-0-2011; IN COMMERCE 5-0-2011.

4,211,703. AMERICAN ASSOCIATION FOR THE ADVANCEMENT OF SCIENCE, WASHINGTON, DC, DC. SN 85-280,954. FILED P.R. 3-30-2011; AM. S.R. 7-31-2012.

SCIENCE & TECHNOLOGY POLICY FELLOWSHIPS

THE MARK CONSISTS OF STANDARD CHARACTERS WITHOUT CLAIM TO ANY PARTICULAR FONT, STYLE, SIZE, OR COLOR.

NO CLAIM IS MADE TO THE EXCLUSIVE RIGHT TO USE "FELLOWSHIPS", APART FROM THE MARK AS SHOWN.

FOR ARRANGING, ORGANIZING AND CONDUCTING FELLOWSHIP PROGRAMS FOR THE PLACEMENT OF FELLOWS IN POSITIONS WITH MEMBERS OF CONGRESS OR IN CONGRESSIONAL COMMITTEES IN THE AREAS OF SCIENCE, TECHNOLOGY AND PUBLIC POLICY; CONDUCTING SEMINARS, CONFERENCES AND TRAINING PROGRAMS IN THE FIELDS OF SCIENCE, TECHNOLOGY, AND PUBLIC POLICY (U.S. CLS. 100, 101 AND 107).

FIRST USE 1-1-1974; IN COMMERCE 1-1-1974.

CLASS 41—(Continued).

4,211,717. LAPOINT, GREGORY JOSEPH, PARKER, CO. SN 85-328,142. FILED P.R. 5-23-2011; AM. S.R. 12-27-2011.

Center for Natural Law

THE MARK CONSISTS OF STANDARD CHARACTERS WITHOUT CLAIM TO ANY PARTICULAR FONT, STYLE, SIZE, OR COLOR.

FOR EDUCATION SERVICES, NAMELY, MENTORING IN THE FIELD OF NATURAL LAW; EDUCATION SERVICES, NAMELY, PROVIDING CLASSES, SEMINARS, WORKSHOPS IN THE FIELD OF NATURAL LAW; EDUCATION SERVICES, NAMELY, PROVIDING LIVE AND ON-LINE CLASSES, SEMINARS, WORKSHOPS IN THE FIELD OF NATURAL LAW (U.S. CLS. 100, 101 AND 107).

FIRST USE 4-15-2011; IN COMMERCE 4-15-2011.

4,211,720. TEXAS-NEW MEXICO NEWSPAPERS PARTNERSHIP, EL PASO, TX. SN 85-332,427. FILED P.R. 5-27-2011; AM. S.R. 8-9-2012.

CARS & TRUCKS

THE MARK CONSISTS OF STANDARD CHARACTERS WITHOUT CLAIM TO ANY PARTICULAR FONT, STYLE, SIZE, OR COLOR.

FOR PROVIDING ON-LINE MAGAZINES FEATURING AUTOMOBILES AND ADVERTISEMENTS; PROVIDING A WEBSITE FEATURING NON-DOWNLOADABLE PUBLICATIONS IN THE NATURE OF MAGAZINES FEATURING AUTOMOBILES AND ADVERTISEMENTS (U.S. CLS. 100, 101 AND 107).

FIRST USE 2-1-2001; IN COMMERCE 2-1-2001.

4,211,737. BAYLOR COLLEGE OF MEDICINE, HOUSTON, TX. SN 85-399,484. FILED P.R. 8-16-2011; AM. S.R. 6-13-2012.

NATIONAL SCHOOL OF TROPICAL MEDICINE

THE MARK CONSISTS OF STANDARD CHARACTERS WITHOUT CLAIM TO ANY PARTICULAR FONT, STYLE, SIZE, OR COLOR.

CLASS 41—(Continued).

NO CLAIM IS MADE TO THE EXCLUSIVE RIGHT TO USE "SCHOOL", APART FROM THE MARK AS SHOWN.

FOR EDUCATING AT UNIVERSITY OR COLLEGES; EDUCATION SERVICES IN THE NATURE OF COURSES AT THE UNIVERSITY LEVEL; PROVIDING CONTINUING MEDICAL EDUCATION COURSES (U.S. CLS. 100, 101 AND 107).

FIRST USE 10-20-2011; IN COMMERCE 6-1-2012.

4,211,742. COMMUNITY NEWSPAPER HOLDINGS INC, MONTGOMERY, AL. SN 85-413,215. FILED P.R. 9-1-2011; AM. S.R. 5-30-2012.

North Shore 100

THE MARK CONSISTS OF STANDARD CHARACTERS WITHOUT CLAIM TO ANY PARTICULAR FONT, STYLE, SIZE, OR COLOR.

FOR AWARD PROGRAMS HONORING EXCELLENCE IN THE NORTH SHORE AREA OF MASSACHUSETTS, NAMELY, AWARD PROGRAMS FOR INDIVIDUALS WHO HAVE MADE SIGNIFICANT CHARITABLE CONTRIBUTIONS (U.S. CLS. 100, 101 AND 107).

FIRST USE 11-1-2008; IN COMMERCE 11-1-2008.

4,211,774. MARKETING GOO, INC., ALISO VIEJO, CA. SN 85-441,480. FILED P.R. 10-6-2011; AM. S.R. 8-1-2012.

DAILY PLUGIN

THE MARK CONSISTS OF STANDARD CHARACTERS WITHOUT CLAIM TO ANY PARTICULAR FONT, STYLE, SIZE, OR COLOR.

FOR ENTERTAINMENT, NAMELY, A CONTINUING VIDEO SHOW BROADCAST OVER THE INTERNET FEATURING INFORMATION AND NEWS ON BLOG TOOLS, PUBLISHING PLATFORMS, AND RELATED SOFTWARE APPLICATION ADD-ONS (U.S. CLS. 100, 101 AND 107).

FIRST USE 8-8-2011; IN COMMERCE 8-8-2011.

CLASS 41—(Continued).

4,211,778. EDUCATION MANAGEMENT LLC, PITTSBURGH, PA. SN 85-442,287. FILED P.R. 10-7-2011; AM. S.R. 6-19-2012.

TEXAS SCHOOL OF
PROFESSIONAL PSYCHOLOGY

THE MARK CONSISTS OF STANDARD CHARACTERS WITHOUT CLAIM TO ANY PARTICULAR FONT, STYLE, SIZE, OR COLOR.

NO CLAIM IS MADE TO THE EXCLUSIVE RIGHT TO USE "SCHOOL OF PROFESSIONAL PSYCHOLOGY", APART FROM THE MARK AS SHOWN.

FOR EDUCATION SERVICES, NAMELY, OFFERING COURSES OF INSTRUCTION AT THE POST-SECONDARY LEVEL (U.S. CLS. 100, 101 AND 107).

FIRST USE 4-15-2012; IN COMMERCE 4-15-2012.

4,211,785. EDUCATION MANAGEMENT LLC, PITTSBURGH, PA. SN 85-448,968. FILED P.R. 10-17-2011; AM. S.R. 6-19-2012.

MINNESOTA SCHOOL OF
PROFESSIONAL PSYCHOLOGY

THE MARK CONSISTS OF STANDARD CHARACTERS WITHOUT CLAIM TO ANY PARTICULAR FONT, STYLE, SIZE, OR COLOR.

NO CLAIM IS MADE TO THE EXCLUSIVE RIGHT TO USE "SCHOOL OF PROFESSIONAL PSYCHOLOGY", APART FROM THE MARK AS SHOWN.

FOR EDUCATION SERVICES, NAMELY, OFFERING COURSES OF INSTRUCTION AT THE POST-SECONDARY LEVEL (U.S. CLS. 100, 101 AND 107).

FIRST USE 4-15-2012; IN COMMERCE 4-15-2012.

4,211,786. EDUCATION MANAGEMENT LLC, PITTSBURGH, PA. SN 85-448,996. FILED P.R. 10-17-2011; AM. S.R. 6-19-2012.

GEORGIA SCHOOL OF
PROFESSIONAL PSYCHOLOGY

THE MARK CONSISTS OF STANDARD CHARACTERS WITHOUT CLAIM TO ANY PARTICULAR FONT, STYLE, SIZE, OR COLOR.

NO CLAIM IS MADE TO THE EXCLUSIVE RIGHT TO USE "SCHOOL OF PROFESSIONAL PSYCHOLOGY", APART FROM THE MARK AS SHOWN.

FOR EDUCATION SERVICES, NAMELY, OFFERING COURSES OF INSTRUCTION AT THE POST-SECONDARY LEVEL (U.S. CLS. 100, 101 AND 107).

FIRST USE 4-15-2012; IN COMMERCE 4-15-2012.

CLASS 41—(Continued).

4,211,793. DIRECTORS LIVE, LLC, MONTGOMERY, IL. SN 85-459,190. FILED P.R. 10-28-2011; AM. S.R. 7-30-2012.

DIRECTORS LIVE

THE MARK CONSISTS OF STANDARD CHARACTERS WITHOUT CLAIM TO ANY PARTICULAR FONT, STYLE, SIZE, OR COLOR.

FOR ENTERTAINMENT SERVICES, NAMELY, PROVIDING A WEB SITE FEATURING FILM, VIDEO, PHOTOGRAPHIC, AND AUDIO PRESENTATIONS FEATURING MOVIES, MOTION PICTURES, AND POPULAR CULTURE; PROVISION OF NON-DOWNLOADABLE MOTION PICTURES VIA A VIDEO-ON-DEMAND SERVICE (U.S. CLS. 100, 101 AND 107).

FIRST USE 1-31-2010; IN COMMERCE 1-31-2010.

4,211,801. ROB ZAPPULLA MUSIC, LLC, SOMERS, CT. SN 85-483,248. FILED P.R. 11-30-2011; AM. S.R. 7-16-2012.

COME FLY WITH ME

THE MARK CONSISTS OF STANDARD CHARACTERS WITHOUT CLAIM TO ANY PARTICULAR FONT, STYLE, SIZE, OR COLOR.

FOR ENTERTAINMENT SERVICES, NAMELY, THE PRESENTATION OF LIVE MUSICAL PERFORMANCES OF A MUSICAL ACT (U.S. CLS. 100, 101 AND 107).

FIRST USE 1-1-1995; IN COMMERCE 6-17-1995.

4,211,811. YVETTE MOORE, DBA CYCLEWORKS PROMOTIONS, OWENSBORO, KY. SN 85-515,553. FILED 1-12-2012.

Mid America Motorcycle Expo

THE MARK CONSISTS OF STANDARD CHARACTERS WITHOUT CLAIM TO ANY PARTICULAR FONT, STYLE, SIZE, OR COLOR.

FOR ENTERTAINMENT SERVICES IN THE NATURE OF MOTORCYCLE EXHIBITIONS (U.S. CLS. 100, 101 AND 107).

FIRST USE 1-1-2011; IN COMMERCE 1-1-2011.

CLASS 41—(Continued).

4,211,814. TELEVISA, S.A. DE C.V., SANTA FE, MEXICO. SN 85-521,363. FILED P.R. 1-20-2012; AM. S.R. 7-23-2012.

PARODIANDO

THE MARK CONSISTS OF STANDARD CHARACTERS WITHOUT CLAIM TO ANY PARTICULAR FONT, STYLE, SIZE, OR COLOR.

PRIORITY CLAIMED UNDER SEC. 44(D) ON MEXICO APPLICATION NO. 1228586, FILED 11-17-2011, REG. NO. 1279581, DATED 11-17-2011, EXPIRES 11-17-2021.

THE ENGLISH TRANSLATION OF "PARODIANDO" IN THE MARK IS "PARODYING".

FOR ENTERTAINMENT SERVICES IN THE NATURE OF A CONTINUING TALENT SHOW BROADCAST OVER THE INTERNET FEATURING AMATEUR PEOPLE MAKING HUMOROUS AND SATIRICAL IMITATIONS OF FAMOUS MEXICAN AND INTERNATIONAL ARTISTS AND A CONTINUING TALENT SHOW TELEVISION PROGRAM FEATURING AMATEUR PEOPLE MAKING A HUMOROUS AND SATIRICAL IMITATIONS OF FAMOUS MEXICAN AND INTERNATIONAL ARTISTS (U.S. CLS. 100, 101 AND 107).

4,211,817. LAUNCHLAB, PASADENA, CA. SN 85-527,978. FILED P.R. 1-29-2012; AM. S.R. 5-15-2012.

Pet Travel Experts

THE MARK CONSISTS OF STANDARD CHARACTERS WITHOUT CLAIM TO ANY PARTICULAR FONT, STYLE, SIZE, OR COLOR.

NO CLAIM IS MADE TO THE EXCLUSIVE RIGHT TO USE "PET TRAVEL", APART FROM THE MARK AS SHOWN.

FOR ON-LINE JOURNALS, NAMELY, BLOGS FEATURING INFORMATION ON PET TRAVEL (U.S. CLS. 100, 101 AND 107).

FIRST USE 11-4-2011; IN COMMERCE 11-4-2011.

CLASS 41—(Continued).

4,211,826. SWEET, DERRICK, FENELON FALLS, ONTARIO, CANADA. SN 85-549,530. FILED P.R. 2-22-2012; AM. S.R. 6-20-2012.

COGNITIVE REFLEX CONDITIONING

THE MARK CONSISTS OF STANDARD CHARACTERS WITHOUT CLAIM TO ANY PARTICULAR FONT, STYLE, SIZE, OR COLOR.

FOR SELF-IMPROVEMENT COURSES IN THE FOLLOWING FIELDS: LIFE COACH TRAINING, HYPNOSIS TRAINING, SELF-IMPROVEMENT TRAINING, AND PUBLIC SPEAKING TRAINING (U.S. CLS. 100, 101 AND 107).

FIRST USE 2-11-2012; IN COMMERCE 2-11-2012.

4,211,829. JHA, GIRISH, EAST BRUNSWICK, NJ. SN 85-556,882. FILED P.R. 2-29-2012; AM. S.R. 7-31-2012.

Authentic Yoga Tradition

THE MARK CONSISTS OF STANDARD CHARACTERS WITHOUT CLAIM TO ANY PARTICULAR FONT, STYLE, SIZE, OR COLOR.

NO CLAIM IS MADE TO THE EXCLUSIVE RIGHT TO USE "YOGA", APART FROM THE MARK AS SHOWN.

FOR EDUCATIONAL SERVICES, NAMELY, PROVIDING TRAINING FOR CERTIFICATION IN THE FIELD OF YOGA, REST, RELAXATION AND RESILIENCE, STRESS MANAGEMENT, PERSONAL DEVELOPMENT, PROFESSIONAL DEVELOPMENT, SOCIAL DEVELOPMENT AND A CONSCIOUSNESS BASED APPROACH TO LIFE AND LIVING; EDUCATIONAL SERVICES, NAMELY, PROVIDING CLASSES, SEMINARS, AND WORKSHOPS IN THE FIELD OF YOGA, TANTRA, SPIRITUALITY, AYURVEDA AND ALTERNATIVE MEDICINE, AND A CONSCIOUSNESS BASED APPROACH TO LIFE AND LIVING (U.S. CLS. 100, 101 AND 107).

FIRST USE 1-1-2011; IN COMMERCE 1-1-2011.

4,211,841. LOVE AUSTIN HOMES, LLC, AUSTIN, TX. SN 85-577,164. FILED P.R. 3-22-2012; AM. S.R. 7-26-2012.

ALL-IN-ONE REAL ESTATE TRAINING

THE MARK CONSISTS OF STANDARD CHARACTERS WITHOUT CLAIM TO ANY PARTICULAR FONT, STYLE, SIZE, OR COLOR.

CLASS 41—(Continued).

NO CLAIM IS MADE TO THE EXCLUSIVE RIGHT TO USE "REAL ESTATE TRAINING", APART FROM THE MARK AS SHOWN.

FOR EDUCATIONAL SERVICES, NAMELY, CONDUCTING ONLINE CLASSES, TRAINING, SEMINARS, CONFERENCES AND WORKSHOPS IN THE FIELD OF REAL ESTATE (U.S. CLS. 100, 101 AND 107).

FIRST USE 2-16-2012; IN COMMERCE 2-16-2012.

4,211,848. FAZZI ASSOCIATES INC., NORTHAMPTON, MA. SN 85-588,755. FILED P.R. 4-4-2012; AM. S.R. 7-25-2012.

THE INTERNATIONAL CODING
ACADEMY

THE MARK CONSISTS OF STANDARD CHARACTERS WITHOUT CLAIM TO ANY PARTICULAR FONT, STYLE, SIZE, OR COLOR.

OWNER OF U.S. REG. NO. 4.110.522.

NO CLAIM IS MADE TO THE EXCLUSIVE RIGHT TO USE "ACADEMY", APART FROM THE MARK AS SHOWN.

FOR EDUCATIONAL SERVICES, NAMELY, PROVIDING PROGRAMS OF INSTRUCTION AND TRAINING IN THE FORM OF CLASSES, SEMINARS AND WORKSHOPS IN THE FIELD OF HOME HEALTH CARE AND SPECIFICALLY RELATIVE TO MEDICAL CLASSIFICATION FOR THE CODING OF DISEASES, SIGNS AND SYMPTOMS IN THE TRACKING OF DIAGNOSES (U.S. CLS. 100, 101 AND 107).

FIRST USE 6-1-2012; IN COMMERCE 6-1-2012.

4,211,849. PHYSICIANS' EDUCATION RESOURCE, PLAINSBORO, NJ. SN 85-590,105. FILED P.R. 4-5-2012; AM. S.R. 7-26-2012.

WINTER HEMATOLOGY

THE MARK CONSISTS OF STANDARD CHARACTERS WITHOUT CLAIM TO ANY PARTICULAR FONT, STYLE, SIZE, OR COLOR.

FOR EDUCATION SERVICES, NAMELY, PROVIDING ANNUAL MEDICAL CONFERENCE, LECTURES, INTERACTIVE DISCUSSIONS, POSTER SESSIONS, HANDS-ON WORKSHOPS, AND BROADCAST SYMPOSIUM FOR ONCOLOGISTS AND SURGEONS IN THE FIELD OF ONCOLOGY (U.S. CLS. 100, 101 AND 107).

FIRST USE 5-1-2011; IN COMMERCE 5-1-2011.

CLASS 41—(Continued).

4,211,851. JACK QUINN SOLUTIONS, LLC, SATELLITE BEACH, FL. SN 85-591,951. FILED P.R. 4-7-2012; AM. S.R. 7-24-2012.

Supply Leaders Academy

THE MARK CONSISTS OF STANDARD CHARACTERS WITHOUT CLAIM TO ANY PARTICULAR FONT, STYLE, SIZE, OR COLOR.

NO CLAIM IS MADE TO THE EXCLUSIVE RIGHT TO USE "ACADEMY", APART FROM THE MARK AS SHOWN.

FOR EDUCATION SERVICES, NAMELY, PROVIDING SEMINARS, WEBINARS, AND ONLINE CLASSES IN THE FIELD OF PROCUREMENT (U.S. CLS. 100, 101 AND 107).

FIRST USE 6-27-2011; IN COMMERCE 6-27-2011.

4,211,855. AKKA SOCCER, MEDFORD, NJ. SN 85-593,970. FILED P.R. 4-10-2012; AM. S.R. 7-27-2012.

AKKA Soccer

THE MARK CONSISTS OF STANDARD CHARACTERS WITHOUT CLAIM TO ANY PARTICULAR FONT, STYLE, SIZE, OR COLOR.

NO CLAIM IS MADE TO THE EXCLUSIVE RIGHT TO USE "SOCCER", APART FROM THE MARK AS SHOWN.

FOR SOCCER INSTRUCTION; ENTERTAINMENT IN THE NATURE OF SOCCER GAMES AND SOCCER TOURNAMENTS; ORGANIZATION OF SOCCER GAMES; SOCCER CAMPS (U.S. CLS. 100, 101 AND 107).

FIRST USE 1-2-2008; IN COMMERCE 2-3-2009.

4,211,861. LYNCH, WILLIAM D., SPRINGFIELD, MO. SN 85-596,788. FILED P.R. 4-12-2012; AM. S.R. 7-28-2012.

Ozark Mountain Yoga

THE MARK CONSISTS OF STANDARD CHARACTERS WITHOUT CLAIM TO ANY PARTICULAR FONT, STYLE, SIZE, OR COLOR.

NO CLAIM IS MADE TO THE EXCLUSIVE RIGHT TO USE "YOGA", APART FROM THE MARK AS SHOWN.

FOR YOGA INSTRUCTION (U.S. CLS. 100, 101 AND 107).

FIRST USE 4-9-2012; IN COMMERCE 4-9-2012.

CLASS 42—SCIENTIFIC AND COMPUTER SERVICES

4,211,820. FREE HEALTH INC, ROYAL PALM BEACH, FL. SN 85-534,156. FILED P.R. 2-4-2012; AM. S.R. 6-8-2012.

Certified Global Benefits Specialist

THE MARK CONSISTS OF STANDARD CHARACTERS WITHOUT CLAIM TO ANY PARTICULAR FONT, STYLE, SIZE, OR COLOR.

NO CLAIM IS MADE TO THE EXCLUSIVE RIGHT TO USE "CERTIFIED", APART FROM THE MARK AS SHOWN.

FOR ACCREDITATION SERVICES, NAMELY, DEVELOPING AND ADMINISTERING STANDARDS AND PROCEDURES FOR CERTIFYING PROFESSIONALS IN THE FIELD OF HUMAN RESOURCES MANAGEMENT OF GLOBAL BENEFITS PLANS (U.S. CLS. 100 AND 101). FIRST USE 1-25-2012; IN COMMERCE 2-1-2012.

4,211,821. CERTIFIED VOLUNTARY BENEFITS PROVIDER, ROYAL PALM BEACH, FL. SN 85-534,160. FILED P.R. 2-4-2012; AM. S.R. 8-1-2012.

Certified Voluntary Benefits Provider

THE MARK CONSISTS OF STANDARD CHARACTERS WITHOUT CLAIM TO ANY PARTICULAR FONT, STYLE, SIZE, OR COLOR.

NO CLAIM IS MADE TO THE EXCLUSIVE RIGHT TO USE "CERTIFIED", APART FROM THE MARK AS SHOWN.

FOR ACCREDITATION SERVICES, NAMELY, DEVELOPING AND ADMINISTERING STANDARDS AND PROCEDURES FOR CERTIFYING PROFESSIONALS IN THE FIELD OF HUMAN RESOURCES MANAGEMENT OF GLOBAL BENEFITS PLANS (U.S. CLS. 100 AND 101). FIRST USE 1-25-2012; IN COMMERCE 2-1-2012.

CLASS 42—(Continued).

4,211,863. VOXSPINE LLC, ALLEN, TX. SN 85-599,328. FILED P.R. 4-16-2012; AM. S.R. 8-3-2012.

The Leader in Cloud Communication Solutions

THE MARK CONSISTS OF STANDARD CHARACTERS WITHOUT CLAIM TO ANY PARTICULAR FONT, STYLE, SIZE, OR COLOR.

FOR PROVIDING TEMPORARY USE OF NON-DOWNLOADABLE COMPUTER SOFTWARE FOR USE IN THE COMMUNICATIONS INDUSTRY, NAMELY, FOR SWITCHING, ROUTING, BILLING AND PROVIDING COMMUNICATIONS PRODUCTS DISTRIBUTION MANAGEMENT VIA THE INTERNET (U.S. CLS. 100 AND 101).

FIRST USE 9-11-2011; IN COMMERCE 9-13-2011.

CLASS 43—HOTEL AND RESTAURANT SERVICES

4,211,697. HALSTIN GROUP, LLC, DALLAS, TX. SN 85-254,910. FILED P.R. 3-1-2011; AM. S.R. 7-2-2012.

PRIVATE SOCIAL

THE MARK CONSISTS OF STANDARD CHARACTERS WITHOUT CLAIM TO ANY PARTICULAR FONT, STYLE, SIZE, OR COLOR.

FOR RESTAURANT AND BAR SERVICES (U.S. CLS. 100 AND 101).

FIRST USE 9-24-2011; IN COMMERCE 9-24-2011.

4,211,763. FISHMARKET, LLC, ST. HELENA, CA. SN 85-437,740. FILED P.R. 10-3-2011; AM. S.R. 7-18-2012.

BRASSICA mediterranean kitchen and wine bar

THE MARK CONSISTS OF STANDARD CHARACTERS WITHOUT CLAIM TO ANY PARTICULAR FONT, STYLE, SIZE, OR COLOR.

NO CLAIM IS MADE TO THE EXCLUSIVE RIGHT TO USE "KITCHEN AND WINE BAR", APART FROM THE MARK AS SHOWN.

FOR RESTAURANT AND CATERING SERVICES (U.S. CLS. 100 AND 101).

FIRST USE 9-1-2011; IN COMMERCE 9-1-2011.

CLASS 44—MEDICAL, BEAUTY AND AGRICULTURAL SERVICES

4,211,705. AMERICAN COTON CLUB, COLFAX, CA. SN 85-289,763. FILED P.R. 4-8-2011; AM. S.R. 7-20-2012.

RARE BREED COTON DE TULÉAR

THE MARK CONSISTS OF STANDARD CHARACTERS WITHOUT CLAIM TO ANY PARTICULAR FONT, STYLE, SIZE, OR COLOR.

FOR PROVIDING INFORMATION IN THE FIELDS OF ANIMALS AND PET BREEDING, SELECTION OF THE ANIMALS AND PETS, GROOMING, HEALTH AND NUTRITION (U.S. CLS. 100 AND 101).

FIRST USE 1-1-2000; IN COMMERCE 1-1-2000.

4,211,713. GENESIS IP, LLC, KENNETT SQUARE, PA. SN 85-309,770. FILED P.R. 5-2-2011; AM. S.R. 8-1-2012.

PATIENT CONTACT HOURS

THE MARK CONSISTS OF STANDARD CHARACTERS WITHOUT CLAIM TO ANY PARTICULAR FONT, STYLE, SIZE, OR COLOR.

FOR PHYSICAL REHABILITATION SERVICES, NAMELY, METRICS USED TO MEASURE THERAPIST EFFICIENCY (U.S. CLS. 100 AND 101).

FIRST USE 3-0-2011; IN COMMERCE 3-0-2011.

4,211,714. GENESIS IP, LLC, KENNETT SQUARE, PA. SN 85-309,779. FILED P.R. 5-2-2011; AM. S.R. 8-1-2012.

PATIENT CARE HOURS

THE MARK CONSISTS OF STANDARD CHARACTERS WITHOUT CLAIM TO ANY PARTICULAR FONT, STYLE, SIZE, OR COLOR.

FOR PHYSICAL REHABILITATION SERVICES, NAMELY, METRICS USED TO MEASURE THERAPIST EFFICIENCY (U.S. CLS. 100 AND 101).

FIRST USE 3-0-2011; IN COMMERCE 3-0-2011.

CLASS 44—(Continued).

4,211,765. JENNIFER GUINAN, RENO, NV. SN 85-438,756. FILED P.R. 10-4-2011; AM. S.R. 7-27-2012.

Anodyne Massage Therapy

THE MARK CONSISTS OF STANDARD CHARACTERS WITHOUT CLAIM TO ANY PARTICULAR FONT, STYLE, SIZE, OR COLOR.

NO CLAIM IS MADE TO THE EXCLUSIVE RIGHT TO USE "MASSAGE THERAPY", APART FROM THE MARK AS SHOWN.

FOR MASSAGE THERAPY SERVICES (U.S. CLS. 100 AND 101).

FIRST USE 1-26-2001; IN COMMERCE 1-26-2001.

4,211,784. PROFESSIONAL RESEARCH CONSULTANTS, INC., OMAHA, NE. SN 85-448,583. FILED P.R. 10-17-2011; AM. S.R. 7-26-2012.

healthforecast.net

THE MARK CONSISTS OF STANDARD CHARACTERS WITHOUT CLAIM TO ANY PARTICULAR FONT, STYLE, SIZE, OR COLOR.

FOR PROVIDING INTERNET WEBSITES FEATURING COMMUNITY HEALTH ASSESSMENT AND RELATED HEALTH CARE INFORMATION (U.S. CLS. 100 AND 101).

FIRST USE 10-11-2011; IN COMMERCE 10-11-2011.

CLASS 45—(Continued).

4,211,831. CENTER FOR INTERVENTIONAL MEDICINE LLC, WHITE PLAINS, MD. SN 85-559,507. FILED P.R. 3-4-2012; AM. S.R. 6-28-2012.

Center for Interventional
Medicine

THE MARK CONSISTS OF STANDARD CHARACTERS WITHOUT CLAIM TO ANY PARTICULAR FONT, STYLE, SIZE, OR COLOR.

FOR MEDICAL CLINIC PROVIDING DIAGNOSIS AND MINIMALLY INVASIVE INTERVENTIONAL TREATMENTS AND MEDICAL SERVICES, NAMELY, DIAGNOSIS AND TREATMENT OF DISEASES OF THE ARTERIES AND VEINS SUCH AS VARICOSE VEINS, SPIDER VEINS, DEEP VEIN REFLUX, DEEP VENOUS THROMBOSIS AND PERIPHERAL ARTERIAL DISEASE, DIAGNOSIS AND TREATMENT OF UTERINE FIBROID EMBOLIZATION, DIALYSIS ACCESS PROCEDURES, PERCUTANEOUS BIOPSIES, AND MEDICAL MANAGEMENT OF ACUTE AND CHRONIC BACK PAIN (U.S. CLS. 100 AND 101).

FIRST USE 4-29-2011; IN COMMERCE 4-29-2011.

CLASS 45—(Continued).

4,211,864. NO DENTURES, LLC, CHICAGO, IL. SN 85-599,445. FILED P.R. 4-17-2012; AM. S.R. 8-2-2012.

TEETH - NO DENTURES!

THE MARK CONSISTS OF STANDARD CHARACTERS WITHOUT CLAIM TO ANY PARTICULAR FONT, STYLE, SIZE, OR COLOR.

OWNER OF U.S. REG. NO. 4,123,252.
FOR DENTISTRY SERVICES; AND DENTAL IMPLANT SERVICES (U.S. CLS. 100 AND 101).
FIRST USE 10-1-2011; IN COMMERCE 10-1-2011.

CLASS 45—PERSONAL AND LEGAL SERVICES

4,211,751. DIGITAL PARALEGAL SERVICES, LLC, GUTHRIE, OK. SN 85-426,166. FILED P.R. 9-19-2011; AM. S.R. 7-12-2012.

E-PARALEGALS

THE MARK CONSISTS OF STANDARD CHARACTERS WITHOUT CLAIM TO ANY PARTICULAR FONT, STYLE, SIZE, OR COLOR.

FOR PARALEGAL SERVICES (U.S. CLS. 100 AND 101).
FIRST USE 7-8-2012; IN COMMERCE 7-8-2012.

* * * * *

TRADEMARK REGISTRATIONS RENEWED

The designation "U.S. Cl." appearing in this section refers to the U.S. class in effect prior to Sep. 1, 1973 rather than the international class which applies to applications filed on or after that date. For adoption of international classification see notice in the OFFICIAL GAZETTE of Jun. 26, 1973 (911 O.G. TM 210).

- 157,846. MISCELLANEOUS DESIGN. U.S. CL. 49. (INT. CL. 33). REG. 8-22-1922.
- 293,368. ILLIUM. U.S. CL. 14. (INT. CL. 6). REG. 4-19-1932.
- 297,594. LV AND DESIGN. U.S. CL. 3. (INT. CL. 18). REG. 9-20-1932.
- 396,975. KODAK (STYLIZED). U.S. CL. 6. (INT. CLS. 1, 2, 3, 4 AND 5). REG. 8-11-1942.
- 557,037. BLUE SHIELD (STYLIZED). U.S. CL. 100. (INT. CL. 42). REG. 4-1-1952.
- 561,960. CRATER. U.S. CL. 15. (INT. CL. 4). REG. 7-22-1952.
- 562,509. LIFEGUARD (STYLIZED). U.S. CL. 39. (INT. CL. 25). REG. 8-5-1952.
- 562,814. ELEVATORS. U.S. CL. 39. (INT. CL. 25). REG. 8-12-1952.
- 564,393. SOLDER SEAL AND DESIGN. U.S. CL. 35. (INT. CLS. 7, 12 AND 17). REG. 9-23-1952.
- 564,480. STRATOFLEX (STYLIZED). U.S. CL. 13. (INT. CL. 6). REG. 9-23-1952.
- 727,110. HETRAPHENE (STYLIZED). U.S. CL. 52. (INT. CL. 3). REG. 1-30-1962.
- 727,200. SCALEXTRIC. U.S. CL. 22. (INT. CL. 28). REG. 2-6-1962.
- 727,220. LUK AND DESIGN. U.S. CL. 23. (INT. CLS. 6, 7, 8, 9, 11, 12, 16, 21 AND 28). REG. 2-6-1962.
- 727,382. PROTECTONE. U.S. CL. 12. (INT. CL. 19). REG. 2-13-1962.
- 734,840. TENSOR. U.S. CL. 21. (INT. CLS. 7, 9, 11, 12 AND 15). REG. 7-24-1962.
- 735,348. VISCOTESTER. U.S. CL. 26. (INT. CL. 9). REG. 7-31-1962.
- 735,851. LEVAFIX. U.S. CL. 6. (INT. CL. 2). REG. 8-14-1962.
- 735,930. KLARON. U.S. CL. 18. (INT. CL. 5). REG. 8-14-1962.
- 735,961. FRINK (STYLIZED). U.S. CL. 23. (INT. CL. 7). REG. 8-14-1962.
- 735,984. SR. U.S. CL. 26. (INT. CL. 9). REG. 8-14-1962.
- 736,342. L AND DESIGN. U.S. CL. 22. (INT. CL. 28). REG. 8-21-1962.
- 736,568. NALS AND DESIGN. U.S. CL. 200. REG. 8-21-1962.
- 737,703. BPL. U.S. CL. 6. (INT. CL. 1). REG. 9-18-1962.
- 737,704. CAL. U.S. CL. 6. (INT. CL. 1). REG. 9-18-1962.
- 738,441. MIRANOL. U.S. CL. 6. (INT. CL. 1). REG. 10-2-1962.
- 740,287. BRACH'S PICK-A-MIX. U.S. CL. 46. (INT. CL. 30). REG. 11-6-1962.
- 741,434. STARKSPUR. U.S. CL. 1. (INT. CL. 31). REG. 12-4-1962.
- 745,717. PARA-SAIL. U.S. CL. 19. (INT. CL. 12). REG. 2-26-1963.
- 750,768. GRIFFIN. U.S. CL. 14. (INT. CL. 6). REG. 6-11-1963.
- 937,070. UNILUX. U.S. CL. 26. (INT. CL. 9). REG. 7-4-1972.
- 938,069. PUMPEX. U.S. CL. 23. (INT. CL. 7). REG. 7-18-1972.
- 938,451. A AND DESIGN. U.S. CLS. 13 AND 23. (INT. CLS. 6 AND 8). REG. 7-25-1972.
- 938,483. GAPASIL. U.S. CL. 14. (INT. CL. 6). REG. 7-25-1972.
- 939,294. KERMEL. INT. CL. 1. (U.S. CL. 1). REG. 8-1-1972.
- 939,320. MICROWARE (STYLIZED). U.S. CL. 2. (INT. CL. 21). REG. 8-1-1972.
- 939,456. SUPERFINE. U.S. CL. 13. (INT. CL. 6). REG. 8-1-1972.
- 939,980. FORTNUM & MASON. U.S. CL. 46. (INT. CLS. 1, 5, 29, 30, 31 AND 32). REG. 8-1-1972.
- 940,028. MISCELLANEOUS DESIGN. U.S. CL. 47. (INT. CL. 33). REG. 8-1-1972.
- 940,211. SUMMERFEST. U.S. CL. 107. (INT. CL. 41). REG. 8-1-1972.
- 940,779. MARTINEZ. U.S. CL. 47. (INT. CL. 33). REG. 8-8-1972.
- 940,870. MODULOAD. U.S. CL. 21. (INT. CL. 9). REG. 8-15-1972.
- 941,228. THOROSEAL. U.S. CL. 12. (INT. CL. 19). REG. 8-22-1972.
- 941,851. PHILLIPS'. U.S. CL. 18. (INT. CL. 5). REG. 8-29-1972.
- 941,856. VERIDATE. U.S. CL. 18. (INT. CL. 5). REG. 8-29-1972.
- 942,107. W WILLIAMS AND DESIGN. U.S. CL. 100. (INT. CL. 42). REG. 8-29-1972.
- 942,333. MARAND. U.S. CL. 23. (INT. CL. 7). REG. 9-5-1972.
- 942,613. AQUASOL A. U.S. CL. 18. (INT. CL. 5). REG. 9-12-1972.
- 943,354. PETERS DELICIOUS AND DESIGN. U.S. CL. 46. (INT. CL. 29). REG. 9-19-1972.
- 944,941. THE GAP. INT. CL. 35. (U.S. CLS. 100, 101 AND 102). REG. 10-10-1972.
- 945,029. SUPERSOFT. U.S. CL. 6. (INT. CL. 1). REG. 10-17-1972.
- 945,465. DASH. U.S. CL. 105. (INT. CL. 39). REG. 10-17-1972.
- 946,879. MALTLAG. U.S. CL. 46. (INT. CL. 31). REG. 11-7-1972.
- 947,683. IDENTOLINE. U.S. CL. 50. (INT. CL. 17). REG. 11-21-1972.
- 949,313. ANSWER. INT. CL. 5. (U.S. CLS. 6, 18, 44, 46, 51 AND 52). REG. 12-26-1972.
- 951,528. DQ. U.S. CL. 101. (INT. CL. 35). REG. 1-23-1973.
- 958,042. PAK-LINE. U.S. CLS. 2, 50, 100 AND 103. (INT. CLS. 17, 20, 37 AND 42). REG. 5-1-1973.
- 961,838. GOOD-RITE. U.S. CL. 6. (INT. CL. 1). REG. 6-26-1973.
- 963,325. SOCK IT (STYLIZED). U.S. CL. 6. (INT. CL. 1). REG. 7-10-1973.
- 964,021. AUREO S-P 250. U.S. CL. 18. (INT. CL. 5). REG. 7-17-1973.
- 964,532. THERMALINE. U.S. CL. 13. (INT. CL. 6). REG. 7-24-1973.
- 1,169,714. A & F. INT. CL. 42. (U.S. CLS. 100 AND 101). REG. 9-15-1981.
- 1,187,443. DEMON DIALER. INT. CL. 9. (U.S. CL. 21). REG. 1-26-1982.
- 1,189,424. SHIMMERS. INT. CL. 25. (U.S. CL. 39). REG. 2-9-1982.
- 1,190,144. DEEP BLUE. INT. CL. 29. (U.S. CL. 46). REG. 2-16-1982.
- 1,190,602. POLAR FLEX. INT. CL. 11. (U.S. CL. 31). REG. 2-23-1982.
- 1,197,499. KEEP CLAM. INT. CL. 42. (U.S. CL. 100). REG. 6-8-1982.
- 1,198,889. MISCELLANEOUS DESIGN. INT. CL. 28. (U.S. CL. 22). REG. 6-22-1982.
- 1,201,149. S AND DESIGN. INT. CL. 21. (U.S. CLS. 2, 13, 23, 29, 30, 33, 40 AND 50). REG. 7-13-1982.
- 1,201,784. QIX. INT. CLS. 7, 9 AND 11. (U.S. CLS. 23, 26 AND 31). REG. 7-20-1982.
- 1,201,900. MINIM. INT. CL. 10. (U.S. CL. 44). REG. 7-20-1982.
- 1,202,216. EL ALMENDRO. INT. CL. 30. (U.S. CL. 46). REG. 7-20-1982.
- 1,202,517. MISCELLANEOUS DESIGN. INT. CL. 6. (U.S. CLS. 13 AND 25). REG. 7-27-1982.
- 1,203,324. BILTRICIDE. INT. CL. 5. (U.S. CL. 18). REG. 8-3-1982.
- 1,203,346. BAG-A-BUG. INT. CL. 5. (U.S. CL. 6). REG. 8-3-1982.

- 1,203,408. TURBOLOG. INT. CL. 9. (U.S. CL. 26). REG. 8-3-1982.
- 1,203,474. ENERGY-JET. INT. CL. 11. (U.S. CL. 34). REG. 8-3-1982.
- 1,203,572. PANZER. INT. CL. 19. (U.S. CL. 12). REG. 8-3-1982.
- 1,204,314. DIAMOND AND DESIGN. INT. CL. 8 ONLY. (U.S. CLS. 23, 28 AND 44). REG. 8-10-1982.
- 1,204,812. TRC (STYLIZED). INT. CL. 36. (U.S. CL. 102). REG. 8-10-1982.
- 1,204,923. YESTERDOG. INT. CL. 42. (U.S. CL. 100). REG. 8-10-1982.
- 1,205,011. SWEST (STYLIZED). INT. CL. 42. (U.S. CL. 101). REG. 8-10-1982.
- 1,205,349. CARROUSEL. INT. CL. 11. (U.S. CL. 23). REG. 8-17-1982.
- 1,205,457. KEN-SHELTER. INT. CL. 19. (U.S. CL. 12). REG. 8-17-1982.
- 1,205,724. YOU GIVE US 22 MINUTES. WE'LL GIVE YOU THE WORLD.. INT. CL. 38. (U.S. CL. 104). REG. 8-17-1982.
- 1,205,871. GOLF HANDICAP & INFORMATION NETWORK. INT. CL. 41. (U.S. CL. 107). REG. 8-17-1982.
- 1,206,191. DELPHI. INT. CL. 19. (U.S. CLS. 12 AND 33). REG. 8-24-1982.
- 1,206,442. CAS. INT. CLS. 35 AND 41. (U.S. CLS. 101 AND 107). REG. 8-24-1982.
- 1,206,443. BASES. INT. CL. 35. (U.S. CL. 101). REG. 8-24-1982.
- 1,207,133. ARAYA. INT. CL. 12. (U.S. CL. 19). REG. 9-7-1982.
- 1,209,100. NITA. INT. CL. 41. (U.S. CLS. 100, 101 AND 107). REG. 9-14-1982.
- 1,209,104. LOCHINVAR AND DESIGN. INT. CL. 41. (U.S. CL. 107). REG. 9-14-1982.
- 1,209,627. MISCELLANEOUS DESIGN. INT. CL. 12. (U.S. CL. 19). REG. 9-21-1982.
- 1,210,391. SOUNPAK. INT. CL. 11. (U.S. CL. 34). REG. 9-28-1982.
- 1,212,076. TEI-FU. INT. CL. 3. (U.S. CL. 51). REG. 10-12-1982.
- 1,212,209. IDENTICARD. INT. CLS. 9 AND 35. (U.S. CLS. 23, 26, 101 AND 103). REG. 10-12-1982.
- 1,212,959. HEDCON. INT. CL. 7. (U.S. CL. 23). REG. 10-19-1982.
- 1,215,157. HEITZ CELLAR AND DESIGN. INT. CL. 33. (U.S. CL. 47). REG. 11-2-1982.
- 1,218,065. CLIPPER. INT. CLS. 6, 7 AND 8 ONLY. (U.S. CLS. 13 AND 23). REG. 11-30-1982.
- 1,218,717. MISCELLANEOUS DESIGN. INT. CL. 42. (U.S. CL. 100). REG. 11-30-1982.
- 1,219,693. TAN STRAND. INT. CL. 6. (U.S. CL. 7). REG. 12-14-1982.
- 1,219,871. FREEZGARD. INT. CL. 11. (U.S. CLS. 13, 21, 23, 31 AND 34). REG. 12-14-1982.
- 1,220,196. MEMMI. INT. CL. 29. (U.S. CL. 46). REG. 12-14-1982.
- 1,223,508. SOX (STYLIZED). INT. CL. 25. (U.S. CL. 39). REG. 1-11-1983.
- 1,223,942. FSK AND DESIGN. INT. CLS. 7 AND 8. (U.S. CL. 4). REG. 1-18-1983.
- 1,224,414. ASTEROIDS. INT. CL. 28. (U.S. CL. 22). REG. 1-18-1983.
- 1,224,783. FEELIN' FRESH (STYLIZED). INT. CL. 3. (U.S. CLS. 1, 4, 6, 50, 51 AND 52). REG. 1-25-1983.
- 1,225,053. RX. INT. CL. 17. (U.S. CLS. 1 AND 39). REG. 1-25-1983.
- 1,229,279. CHAMPION. INT. CL. 7. (U.S. CL. 23). REG. 3-8-1983.
- 1,233,175. SUPER GEL-X. INT. CL. 1. (U.S. CL. 1). REG. 4-5-1983.
- 1,235,957. MIX-N-FINE. INT. CL. 1. (U.S. CLS. 1, 6 AND 10). REG. 5-3-1983.
- 1,236,637. BRIARCREST. INT. CL. 33. (U.S. CL. 47). REG. 5-3-1983.
- 1,238,523. UNIVERSITY OF WASHINGTON. INT. CL. 25. (U.S. CL. 39). REG. 5-17-1983.
- 1,239,200. MAXTEMP. INT. CL. 7. (U.S. CL. 23). REG. 5-24-1983.
- 1,239,821. THE RECORDING ACADEMY. INT. CL. 35. (U.S. CLS. 100, 101 AND 102). REG. 5-24-1983.
- 1,247,033. YEAR BOOK. INT. CL. 16. (U.S. CL. 38). REG. 8-2-1983.
- 1,247,070. UNIVERSITY CASEBOOK SERIES. INT. CL. 16. (U.S. CL. 38). REG. 8-2-1983.
- 1,247,071. UNIVERSITY TEXTBOOK SERIES. INT. CL. 16. (U.S. CLS. 2, 5, 22, 23, 29, 37, 38 AND 50). REG. 8-2-1983.
- 1,247,072. UNITED STATES SUPREME COURT DIGEST. INT. CL. 16. (U.S. CL. 38). REG. 8-2-1983.
- 1,247,356. BUMPER TO BUMPER. INT. CL. 42. (U.S. CL. 101). REG. 8-2-1983.
- 1,247,704. SPORTWOOD. INT. CL. 19. (U.S. CL. 12). REG. 8-9-1983.
- 1,647,453. PENRHYN. INT. CL. 19. (U.S. CL. 12). REG. 6-11-1991.
- 1,670,025. FAT PEAK. INT. CL. 5. (U.S. CLS. 18 AND 46). REG. 12-31-1991.
- 1,672,115. AES. INT. CL. 39. (U.S. CLS. 100 AND 105). REG. 1-14-1992.
- 1,674,335. EXETER AND DESIGN. INT. CL. 25. (U.S. CLS. 22 AND 39). REG. 2-4-1992.
- 1,674,631. ATHLETES & ENTERTAINERS FOR KIDS AND DESIGN. INT. CL. 42. (U.S. CL. 100). REG. 2-4-1992.
- 1,675,007. STURDI. INT. CL. 16. (U.S. CL. 2). REG. 2-11-1992.
- 1,675,634. FAST LOCK. INT. CL. 1. (U.S. CLS. 1, 5, 6, 10, 26 AND 46). REG. 2-18-1992.
- 1,680,098. THE TRAGICALLY HIP. INT. CLS. 9 AND 41. (U.S. CLS. 21, 23, 26, 36, 38, 100, 101 AND 107). REG. 3-24-1992.
- 1,683,768. MISCELLANEOUS DESIGN. INT. CL. 16. (U.S. CLS. 31 AND 50). REG. 4-21-1992.
- 1,687,978. THE DELI NUTRITION EXPERTS. INT. CL. 29. (U.S. CL. 46). REG. 5-19-1992.
- 1,688,052. IMAGEBANK STANDARD CHARACTER MARK. INT. CL. 35. (U.S. CLS. 100, 101 AND 102). REG. 5-19-1992.
- 1,691,237. DC NIKKOR. INT. CL. 9. (U.S. CL. 26). REG. 6-9-1992.
- 1,694,335. M AND DESIGN. INT. CL. 16. (U.S. CLS. 37 AND 38). REG. 6-16-1992.
- 1,694,977. WOMAN WITHIN. INT. CL. 41. (U.S. CLS. 100, 101 AND 107). REG. 6-16-1992.
- 1,698,129. HEALTHWARD BOUND. INT. CL. 41. (U.S. CL. 107). REG. 6-30-1992.
- 1,699,565. MISSING A PIECE OF YOUR PATTERN?. INT. CL. 42. (U.S. CL. 101). REG. 7-7-1992.
- 1,699,832. LLOYD LOOM. INT. CL. 20. (U.S. CL. 32). REG. 7-7-1992.
- 1,700,895. NO DRAWING-SENSORY MARK. INT. CL. 41. (U.S. CL. 107). REG. 7-14-1992.
- 1,701,629. HOLIDAY. INT. CL. 11. (U.S. CLS. 13, 21, 23, 31 AND 34). REG. 7-21-1992.
- 1,702,676. PURASPEC. INT. CLS. 1 AND 42. (U.S. CLS. 6 AND 100). REG. 7-28-1992.
- 1,702,802. SILHOUETTE. INT. CL. 5. (U.S. CL. 18). REG. 7-28-1992.
- 1,702,804. SECRET. INT. CL. 5. (U.S. CL. 44). REG. 7-28-1992.
- 1,702,890. CHEMSTATION. INT. CLS. 9 AND 16. (U.S. CLS. 2, 5, 21, 22, 23, 26, 29, 36, 37, 38 AND 50). REG. 7-28-1992.
- 1,702,894. SOFTEST DESIGNS. INT. CLS. 9, 40 AND 42. (U.S. CLS. 21, 23, 26, 36, 38, 100, 101, 103 AND 106). REG. 7-28-1992.
- 1,702,940. SYNERGIS NETWORK FILEMANAGER. INT. CL. 9. (U.S. CL. 38). REG. 7-28-1992.
- 1,702,979. MISCELLANEOUS DESIGN. INT. CL. 9 ONLY. (U.S. CL. 21). REG. 7-28-1992.
- 1,703,005. KINGSTON. INT. CL. 9. (U.S. CL. 26). REG. 7-28-1992.
- 1,703,037. ERICSSON AND E AND DESIGN. INT. CLS. 9, 37 AND 42. (U.S. CLS. 21, 26, 100 AND 103). REG. 7-28-1992.
- 1,703,260. E-A-RLOG AND DESIGN. INT. CL. 16. (U.S. CL. 38). REG. 7-28-1992.
- 1,703,288. MOUNTAINSMITH GOLDEN COLORADO U.S.A. AND DESIGN. INT. CL. 18. (U.S. CL. 3). REG. 7-28-1992.
- 1,703,530. LIAN HOW (STYLIZED). INT. CLS. 29 AND 30. (U.S. CL. 46). REG. 7-28-1992.
- 1,703,571. COWBONES. INT. CL. 31. (U.S. CL. 46). REG. 7-28-1992.
- 1,703,625. THE FOOD MATRIX AND DESIGN. INT. CL. 35. (U.S. CL. 101). REG. 7-28-1992.
- 1,703,825. FITNESS AMERICA PAGEANT. INT. CL. 41. (U.S. CL. 107). REG. 7-28-1992.
- 1,703,854. YOGAMOTION. INT. CL. 41. (U.S. CL. 107). REG. 7-28-1992.
- 1,704,063. OVERTURE. INT. CL. 3. (U.S. CLS. 51 AND 52). REG. 7-28-1992.
- 1,704,202. LETTERMAN. INT. CL. 14. (U.S. CL. 28). REG. 7-28-1992.

- 1,704,457. DRY-PAK. INT. CL. 1. (U.S. CL. 6). REG. 8-4-1992.
- 1,704,462. IPS (STYLIZED). INT. CL. 1. (U.S. CL. 5). REG. 8-4-1992.
- 1,704,471. 1881 NINO CERRUTI AND DESIGN. INT. CL. 3. (U.S. CLS. 1, 4, 6, 50, 51 AND 52). REG. 8-4-1992.
- 1,704,545. KWIK KERB AND DESIGN. INT. CL. 7. (U.S. CL. 23). REG. 8-4-1992.
- 1,704,646. EASYCLERK. INT. CL. 9. (U.S. CL. 38). REG. 8-4-1992.
- 1,704,656. FOTO/FORCE. INT. CL. 9. (U.S. CL. 21). REG. 8-4-1992.
- 1,704,663. TIME-ALIGN. INT. CL. 9. (U.S. CL. 21). REG. 8-4-1992.
- 1,704,767. POROFLEX. INT. CL. 10. (U.S. CL. 44). REG. 8-4-1992.
- 1,704,807. ROCK SHOX AND DESIGN. INT. CL. 12. (U.S. CL. 19). REG. 8-4-1992.
- 1,704,907. DOVER NEEDLEWORK SERIES AND DESIGN. INT. CL. 16. (U.S. CL. 38). REG. 8-4-1992.
- 1,704,986. TYPAR. INT. CLS. 17 AND 24. (U.S. CLS. 1 AND 42). REG. 8-4-1992.
- 1,704,988. TESA AND DESIGN. INT. CL. 17. (U.S. CLS. 1 AND 5). REG. 8-4-1992.
- 1,705,019. FORMICA AND DESIGN. INT. CL. 20. (U.S. CL. 32). REG. 8-4-1992.
- 1,705,075. GOLDENTEX. INT. CL. 24 ONLY. (U.S. CL. 42). REG. 8-4-1992.
- 1,705,121. XMI. INT. CL. 25. (U.S. CL. 39). REG. 8-4-1992.
- 1,705,137. M.R. DUCKLINGS. INT. CL. 25. (U.S. CL. 39). REG. 8-4-1992.
- 1,705,230. ACT II AND DESIGN. INT. CL. 31 ONLY. (U.S. CLS. 1 AND 46). REG. 8-4-1992.
- 1,705,721. PERMEOX. INT. CL. 1. (U.S. CLS. 6 AND 10). REG. 8-4-1992.
- 1,705,757. CP AND DESIGN. INT. CL. 7. (U.S. CLS. 13, 19, 21, 23, 31, 34 AND 35). REG. 8-4-1992.
- 1,705,916. MISCELLANEOUS DESIGN. INT. CL. 28. (U.S. CL. 22). REG. 8-4-1992.
- 1,706,100. WESTERN FAMILY. INT. CL. 1. (U.S. CL. 6). REG. 8-11-1992.
- 1,706,196. VITALITY PAK. INT. CL. 5. (U.S. CL. 18). REG. 8-11-1992.
- 1,706,281. AIR LINK. INT. CL. 7. (U.S. CL. 23). REG. 8-11-1992.
- 1,706,312. MICRO-FLAPPER. INT. CL. 9. (U.S. CL. 26). REG. 8-11-1992.
- 1,706,315. GIANT. INT. CL. 9. (U.S. CLS. 21, 23, 26, 36 AND 38). REG. 8-11-1992.
- 1,706,334. MEMEX. INT. CL. 9. (U.S. CL. 38). REG. 8-11-1992.
- 1,706,402. TELLER ASSIST. INT. CL. 9. (U.S. CL. 26). REG. 8-11-1992.
- 1,706,538. ULTRA-TEK (STYLIZED). INT. CL. 11. (U.S. CLS. 31 AND 34). REG. 8-11-1992.
- 1,706,558. PRO TECTA. INT. CL. 12 ONLY. (U.S. CL. 19). REG. 8-11-1992.
- 1,706,666. DOVER CLIP-ART SERIES AND DESIGN. INT. CL. 16. (U.S. CL. 38). REG. 8-11-1992.
- 1,706,755. X-OLENE. INT. CL. 17. (U.S. CLS. 1 AND 12). REG. 8-11-1992.
- 1,706,812. FAIRY DUST AND DESIGN. INT. CL. 20. (U.S. CL. 50). REG. 8-11-1992.
- 1,706,847. NOMEX. INT. CL. 24. (U.S. CL. 42). REG. 8-11-1992.
- 1,706,924. ROCKPORT. INT. CL. 25. (U.S. CLS. 22 AND 39). REG. 8-11-1992.
- 1,706,929. DRIVING FORCE. INT. CL. 25. (U.S. CLS. 22 AND 39). REG. 8-11-1992.
- 1,707,078. KIBBLES'N BITS. INT. CL. 31. (U.S. CL. 46). REG. 8-11-1992.
- 1,707,106. CAFFE LOLITA. INT. CL. 33. (U.S. CL. 49). REG. 8-11-1992.
- 1,707,115. CHRISTMAS CHEER. INT. CL. 34. (U.S. CL. 17). REG. 8-11-1992.
- 1,707,144. 1-800-BAHAMAS. INT. CL. 35. (U.S. CLS. 101 AND 105). REG. 8-11-1992.
- 1,707,146. THE SOCCER POST AMERICA'S SOCCER STORE AND DESIGN. INT. CL. 35. (U.S. CL. 101). REG. 8-11-1992.
- 1,707,279. DUDA. INT. CL. 40. (U.S. CLS. 100, 103 AND 106). REG. 8-11-1992.
- 1,707,396. RYAN'S (STYLIZED). INT. CL. 42. (U.S. CL. 100). REG. 8-11-1992.
- 1,707,418. SAVE THE SEED MINISTRY. INT. CL. 42. (U.S. CL. 100). REG. 8-11-1992.
- 1,707,524. GUS. INT. CL. 42. (U.S. CLS. 100 AND 101). REG. 8-11-1992.
- 1,707,552. A2LA ACCREDITED AND DESIGN. U.S. CL. B. REG. 8-11-1992.
- 1,707,694. ZEREX. INT. CL. 3. (U.S. CL. 6). REG. 8-18-1992.
- 1,707,800. WESTERN FAMILY. INT. CLS. 8, 11 AND 21. (U.S. CLS. 3, 21, 23 AND 29). REG. 8-18-1992.
- 1,707,831. LAWSON. INT. CL. 9. (U.S. CL. 38). REG. 8-18-1992.
- 1,707,938. FOXY. INT. CL. 9. (U.S. CL. 44). REG. 8-18-1992.
- 1,707,990. LOCK & GO. INT. CL. 11. (U.S. CL. 34). REG. 8-18-1992.
- 1,708,035. RAVELLO BEVERLY HILLS. INT. CL. 14. (U.S. CL. 28). REG. 8-18-1992.
- 1,708,039. RING A DAY (STYLIZED). INT. CL. 14. (U.S. CL. 28). REG. 8-18-1992.
- 1,708,066. AMERICAN ALLIANCE FOR HEALTH, PHYSICAL EDUCATION, RECREATION AND DANCE. INT. CLS. 16 AND 41. (U.S. CLS. 37, 38 AND 107). REG. 8-18-1992.
- 1,708,167. PONTIAC. INT. CL. 16. (U.S. CL. 38). REG. 8-18-1992.
- 1,708,168. PARK AVENUE. INT. CL. 16. (U.S. CL. 38). REG. 8-18-1992.
- 1,708,225. USMKITOS (STYLIZED). INT. CL. 20. (U.S. CL. 32). REG. 8-18-1992.
- 1,708,257. GALAXY. INT. CL. 22. (U.S. CL. 1). REG. 8-18-1992.
- 1,708,372. COCOTUFF. INT. CL. 27. (U.S. CL. 50). REG. 8-18-1992.
- 1,708,562. CANHELP. INT. CLS. 35 AND 42. (U.S. CLS. 100 AND 101). REG. 8-18-1992.
- 1,708,776. IT'S THE LAW. INT. CLS. 41 AND 42. (U.S. CLS. 100 AND 107). REG. 8-18-1992.
- 1,708,794. PLEASE TOUCH. INT. CLS. 41 AND 42. (U.S. CLS. 101 AND 107). REG. 8-18-1992.
- 1,709,234. FOTO/ANALYST. INT. CL. 9. (U.S. CL. 26). REG. 8-18-1992.
- 1,709,953. GOYARD (STYLIZED). INT. CLS. 16 AND 18. (U.S. CLS. 1, 2, 3, 5, 22, 23, 29, 37, 38, 41 AND 50). REG. 8-25-1992.
- 1,710,028. BELONGING. INT. CL. 16. (U.S. CL. 38). REG. 8-25-1992.
- 1,710,077. CLODAGH. INT. CL. 21. (U.S. CLS. 2 AND 33). REG. 8-25-1992.
- 1,710,234. TWISTER. INT. CL. 29. (U.S. CL. 46). REG. 8-25-1992.
- 1,710,380. INCLUSIVITY. INT. CL. 41 ONLY. (U.S. CL. 107). REG. 8-25-1992.
- 1,710,488. I.D. PLEASE. INT. CLS. 41 AND 42. (U.S. CLS. 100 AND 107). REG. 8-25-1992.
- 1,710,506. FIREWORKS BY GRUCCI. INT. CL. 41. (U.S. CL. 107). REG. 8-25-1992.
- 1,710,631. YEAR ONE. INT. CL. 42. (U.S. CL. 101). REG. 8-25-1992.
- 1,710,638. C Y C C L G AND DESIGN. U.S. CL. 200. REG. 8-25-1992.
- 1,710,689. FPI (STYLIZED). INT. CL. 7. (U.S. CL. 23). REG. 8-25-1992.
- 1,711,067. NABC PLUS IV AND DESIGN. INT. CL. 3. (U.S. CL. 52). REG. 9-1-1992.
- 1,711,202. RED STREAK. INT. CL. 7. (U.S. CL. 23). REG. 9-1-1992.
- 1,711,377. KEYPHASOR. INT. CL. 9. (U.S. CL. 26). REG. 9-1-1992.
- 1,711,613. MISCELLANEOUS DESIGN. INT. CL. 16. (U.S. CL. 38). REG. 9-1-1992.
- 1,711,810. MISCELLANEOUS DESIGN. INT. CL. 25. (U.S. CL. 39). REG. 9-1-1992.
- 1,711,843. CAMP MYSTIC (STYLIZED). INT. CL. 25. (U.S. CL. 39). REG. 9-1-1992.
- 1,711,908. TRIVIAL PURSUIT AND DESIGN. INT. CL. 28. (U.S. CL. 22). REG. 9-1-1992.
- 1,711,976. GARDEN OF EATIN'. INT. CL. 30. (U.S. CL. 46). REG. 9-1-1992.
- 1,712,245. RENOVISIONS. INT. CL. 37. (U.S. CL. 103). REG. 9-1-1992.
- 1,712,269. THE CUSTOM COMPANIES AND DESIGN. INT. CL. 39. (U.S. CL. 105). REG. 9-1-1992.
- 1,712,947. SHEER PROTECTION. INT. CL. 3. (U.S. CL. 51). REG. 9-8-1992.
- 1,713,390. GRIPPER. INT. CL. 10. (U.S. CL. 44). REG. 9-8-1992.
- 1,713,448. MAREMONT (STYLIZED). INT. CL. 12. (U.S. CLS. 19, 21, 23, 31, 35 AND 44). REG. 9-8-1992.

- 1,713,642. THE GUIDEWAY. INT. CL. 16. (U.S. CL. 38). REG. 9-8-1992.
- 1,713,733. SELF-STAK. INT. CL. 20. (U.S. CL. 2). REG. 9-8-1992.
- 1,713,734. SELF-LOK. INT. CL. 20. (U.S. CL. 50). REG. 9-8-1992.
- 1,713,847. DURASHOCKS. INT. CL. 25. (U.S. CL. 39). REG. 9-8-1992.
- 1,714,169. PORTERS NECK PLANTATION. INT. CL. 37. (U.S. CL. 103). REG. 9-8-1992.
- 1,714,170. PN (STYLIZED). INT. CL. 37. (U.S. CL. 103). REG. 9-8-1992.
- 1,714,589. MISCELLANEOUS DESIGN. INT. CL. 5. (U.S. CLS. 18 AND 52). REG. 9-8-1992.
- 1,714,863. MOR-ESTER. INT. CL. 1. (U.S. CLS. 1 AND 6). REG. 9-15-1992.
- 1,715,392. DUO-CAP. INT. CL. 10. (U.S. CL. 44). REG. 9-15-1992.
- 1,716,788. CONCRETE EVIDENCE. INT. CL. 42. (U.S. CL. 100). REG. 9-15-1992.
- 1,717,852. TUTTNAUER. INT. CL. 10. (U.S. CLS. 34 AND 44). REG. 9-22-1992.
- 1,717,878. CLEANFIRE. INT. CL. 11. (U.S. CL. 34). REG. 9-22-1992.
- 1,717,909. RAIL KING AND DESIGN. INT. CL. 12. (U.S. CL. 19). REG. 9-22-1992.
- 1,718,715. GIFT OF HOPE AND DESIGN. INT. CL. 36. (U.S. CL. 102). REG. 9-22-1992.
- 1,718,818. NATIONAL. INT. CL. 39. (U.S. CL. 105). REG. 9-22-1992.
- 1,719,587. MAJOR LEAGUE BASEBALL ALL-STAR FANFEST. INT. CL. 35. (U.S. CL. 101). REG. 9-22-1992.
- 1,719,803. MY FAVORITE MULTIPLE. INT. CL. 5. (U.S. CL. 18). REG. 9-29-1992.
- 1,720,539. COOL GRAPE. INT. CL. 30. (U.S. CL. 46). REG. 9-29-1992.
- 1,720,575. MISCELLANEOUS DESIGN. INT. CL. 32. (U.S. CLS. 45, 46 AND 48). REG. 9-29-1992.
- 1,721,104. MILLENNIUM. INT. CL. 20. (U.S. CL. 32). REG. 9-29-1992.
- 1,721,152. DAKOTA BAKERS-YEAST (STYLIZED). INT. CL. 30. (U.S. CL. 46). REG. 9-29-1992.
- 1,722,244. GREEN'S. INT. CL. 30. (U.S. CL. 46). REG. 10-6-1992.
- 1,722,431. THE STAUBACH COMPANY. INT. CL. 36. (U.S. CLS. 101 AND 102). REG. 10-6-1992.
- 1,722,583. REID NINE STEPS OF INTERROGATION. INT. CL. 41. (U.S. CL. 107). REG. 10-6-1992.
- 1,722,672. TOURNAMENT PAIRING PROGRAM. INT. CL. 42. (U.S. CLS. 100 AND 101). REG. 10-6-1992.
- 1,722,870. QEI AND DESIGN. U.S. CL. B. REG. 10-6-1992.
- 1,722,946. AMERICAN GIRL. INT. CL. 16. (U.S. CLS. 2, 5, 22, 23, 29, 37, 38 AND 50). REG. 10-6-1992.
- 1,723,355. IOA. INT. CL. 9. (U.S. CLS. 26 AND 38). REG. 10-13-1992.
- 1,723,564. BETA V. INT. CL. 11. (U.S. CL. 34). REG. 10-13-1992.
- 1,723,669. TRADITIONAL MARTINIST ORDER. INT. CLS. 16 AND 41. (U.S. CLS. 38 AND 107). REG. 10-13-1992.
- 1,723,825. FLORAL-PAK. INT. CL. 20. (U.S. CLS. 2 AND 50). REG. 10-13-1992.
- 1,724,613. TRIAD. INT. CL. 11. (U.S. CL. 31). REG. 10-13-1992.
- 1,724,853. FLEXICLAD. INT. CL. 1. (U.S. CLS. 1, 5, 6, 10, 26 AND 46). REG. 10-20-1992.
- 1,725,148. C AND DESIGN. INT. CL. 9. (U.S. CLS. 21, 23, 26, 36 AND 38). REG. 10-20-1992.
- 1,726,103. AIRMATE. INT. CL. 35. (U.S. CL. 101). REG. 10-20-1992.
- 1,726,307. CUSTOM AND DESIGN. INT. CL. 39. (U.S. CL. 105). REG. 10-20-1992.
- 1,726,514. THE COLLECTOR'S FRIEND. INT. CL. 42. (U.S. CL. 101). REG. 10-20-1992.
- 1,726,996. STAR. INT. CL. 6. (U.S. CL. 13). REG. 10-27-1992.
- 1,727,112. BULLARD AND DESIGN. INT. CL. 9 ONLY. (U.S. CLS. 21, 23, 26, 36 AND 38). REG. 10-27-1992.
- 1,727,191. NINJA. INT. CL. 9. (U.S. CLS. 21 AND 23). REG. 10-27-1992.
- 1,727,285. SEACURE (STYLIZED). INT. CL. 9. (U.S. CLS. 26 AND 44). REG. 10-27-1992.
- 1,728,287. 8 BOSTON BILLIARD CLUB AND DESIGN. INT. CLS. 41 AND 42. (U.S. CLS. 100 AND 107). REG. 10-27-1992.
- 1,728,760. LITE-DRI. INT. CL. 1. (U.S. CL. 1). REG. 11-3-1992.
- 1,728,922. SCRUGRAB. INT. CL. 7. (U.S. CL. 23). REG. 11-3-1992.
- 1,729,158. COMET FLASH. INT. CL. 11. (U.S. CL. 21). REG. 11-3-1992.
- 1,729,616. KARLSBURGER AND DESIGN. INT. CLS. 29 AND 30. (U.S. CL. 46). REG. 11-3-1992.
- 1,729,633. PEPPERS UNLIMITED INC.. INT. CL. 29. (U.S. CL. 46). REG. 11-3-1992.
- 1,730,627. CAMPBELL HAUSFELD. INT. CLS. 6 AND 7. (U.S. CLS. 2, 13 AND 23). REG. 11-10-1992.
- 1,730,630. UNC CHARLOTTE AND DESIGN. INT. CLS. 6, 16, 21, 25 AND 41. (U.S. CLS. 2, 5, 13, 22, 23, 25, 29, 33, 37, 38, 39, 50 AND 107). REG. 11-10-1992.
- 1,731,439. CHIQUITA AND DESIGN. INT. CL. 31. (U.S. CL. 46). REG. 11-10-1992.
- 1,731,675. VICTORIA CLIPPER. INT. CL. 39. (U.S. CL. 105). REG. 11-10-1992.
- 1,731,986. TECTYL. INT. CL. 4. (U.S. CL. 15). REG. 11-10-1992.
- 1,732,096. WALLBAGGER. INT. CL. 20. (U.S. CLS. 2 AND 32). REG. 11-10-1992.
- 1,732,309. PDC. INT. CL. 2. (U.S. CL. 16). REG. 11-17-1992.
- 1,732,859. MISCELLANEOUS DESIGN. INT. CLS. 12 AND 17. (U.S. CLS. 19, 23 AND 35). REG. 11-17-1992.
- 1,734,243. XP2. INT. CL. 1. (U.S. CLS. 6 AND 26). REG. 11-24-1992.
- 1,734,565. SIMPLIS. INT. CL. 9. (U.S. CLS. 21, 23, 26, 36 AND 38). REG. 11-24-1992.
- 1,734,601. ENDOMAT. INT. CL. 10. (U.S. CL. 44). REG. 11-24-1992.
- 1,734,723. SOUTHWEST MISSOURI STATE UNIVERSITY. INT. CLS. 16, 21, 25 AND 41. (U.S. CLS. 2, 5, 13, 22, 23, 29, 30, 33, 37, 38, 39, 40, 50, 100, 101 AND 107). REG. 11-24-1992.
- 1,734,980. SOLETECH. INT. CL. 25. (U.S. CL. 39). REG. 11-24-1992.
- 1,735,409. IMAGINE (STYLIZED). INT. CL. 41. (U.S. CL. 107). REG. 11-24-1992.
- 1,736,075. BB AND DESIGN. INT. CL. 7. (U.S. CL. 23). REG. 12-1-1992.
- 1,736,404. CHINOOK. INT. CL. 12. (U.S. CL. 19). REG. 12-1-1992.
- 1,736,679. BOSTON (STYLIZED). INT. CL. 25. (U.S. CL. 39). REG. 12-1-1992.
- 1,736,703. MISCELLANEOUS DESIGN. INT. CL. 25. (U.S. CL. 39). REG. 12-1-1992.
- 1,737,083. LAYNE. INT. CLS. 37, 40 AND 42. (U.S. CLS. 100, 103 AND 106). REG. 12-1-1992.
- 1,738,371. COPPER BLOCK. INT. CL. 21. (U.S. CL. 2). REG. 12-8-1992.
- 1,738,670. SOUTHWEST AIRLINES. INT. CL. 39. (U.S. CL. 105). REG. 12-8-1992.
- 1,738,673. ADVANTAGE RENT-A-CAR. INT. CL. 39. (U.S. CLS. 100 AND 105). REG. 12-8-1992.
- 1,738,703. TMEA. INT. CL. 41. (U.S. CL. 107). REG. 12-8-1992.
- 1,740,280. TMEA (STYLIZED). INT. CL. 41. (U.S. CL. 107). REG. 12-15-1992.
- 1,740,485. GLYNASE. INT. CL. 5. (U.S. CL. 18). REG. 12-15-1992.
- 1,741,086. MICROSOFT ACCESS. INT. CL. 9. (U.S. CL. 38). REG. 12-22-1992.
- 1,741,187. MATCHKING. INT. CL. 13. (U.S. CL. 9). REG. 12-22-1992.
- 1,741,188. SPORTS MASTER. INT. CL. 13. (U.S. CL. 9). REG. 12-22-1992.
- 1,741,404. PRISON BLUES. INT. CL. 25. (U.S. CLS. 22 AND 39). REG. 12-22-1992.
- 1,741,805. TEXAS MUSIC EDUCATORS ASSOCIATION. INT. CL. 41. (U.S. CL. 100). REG. 12-22-1992.
- 1,741,827. CITY LIGHT FILMS AND DESIGN. INT. CL. 41. (U.S. CL. 107). REG. 12-22-1992.
- 1,742,751. ACCU-DRIL. INT. CL. 7. (U.S. CL. 23). REG. 12-29-1992.
- 1,743,598. WHEREVER YOU GO. INT. CL. 38. (U.S. CL. 104). REG. 12-29-1992.
- 1,743,921. PACIFIC ENERGY CENTER. INT. CL. 16. (U.S. CLS. 2, 5, 22, 23, 29, 37, 38 AND 50). REG. 12-29-1992.
- 1,744,777. TCA. INT. CL. 35. (U.S. CL. 101). REG. 1-5-1993.
- 1,745,705. MURRAY. INT. CL. 12. (U.S. CL. 19). REG. 1-12-1993.
- 1,746,294. DRAIN-GARD. INT. CL. 6. (U.S. CL. 13). REG. 1-12-1993.
- 1,746,995. KINETEC. INT. CL. 10. (U.S. CL. 44). REG. 1-19-1993.

- 1,747,796. ENERGY ADVANTAGE. INT. CL. 19. (U.S. CLS. 12 AND 33). REG. 1-19-1993.
- 1,747,906. BENECARD. INT. CL. 36. (U.S. CLS. 101 AND 102). REG. 1-19-1993.
- 1,750,247. LAMIGLAS. INT. CL. 28. (U.S. CLS. 22, 23, 38 AND 50). REG. 2-2-1993.
- 1,751,234. THE AMERICAN POETRY REVIEW AND DESIGN. INT. CL. 16. (U.S. CL. 38). REG. 2-9-1993.
- 1,751,683. NSSA AND DESIGN. INT. CL. 42. (U.S. CL. 100). REG. 2-9-1993.
- 1,751,893. BOSELON. INT. CL. 17. (U.S. CL. 1). REG. 2-9-1993.
- 1,754,240. SEA GENIE. INT. CL. 39. (U.S. CL. 105). REG. 2-23-1993.
- 1,754,567. TIVALL. INT. CL. 29. (U.S. CL. 46). REG. 2-23-1993.
- 1,754,765. PROSAT. INT. CL. 3. (U.S. CLS. 1, 4, 6, 50, 51 AND 52). REG. 3-2-1993.
- 1,757,679. FX. INT. CL. 28. (U.S. CL. 22). REG. 3-9-1993.
- 1,757,686. CONVERGENCE. INT. CL. 28. (U.S. CL. 22). REG. 3-9-1993.
- 1,758,359. TAM-GLASS PREMIUM (STYLIZED). INT. CL. 19. (U.S. CL. 12). REG. 3-16-1993.
- 1,758,616. ROOZENGAARDE. INT. CL. 31. (U.S. CL. 46). REG. 3-16-1993.
- 1,759,498. GO-FER. INT. CL. 7. (U.S. CLS. 23 AND 34). REG. 3-23-1993.
- 1,760,442. NATIONAL SKEET SHOOTING ASSOCIATION. INT. CL. 42. (U.S. CL. 100). REG. 3-23-1993.
- 1,762,313. CES CHEVEUX. INT. CL. 3. (U.S. CLS. 51 AND 52). REG. 4-6-1993.
- 1,766,329. ACTION COMMITTEE FOR RURAL ELECTRIFICATION. INT. CL. 42. (U.S. CL. 100). REG. 4-20-1993.
- 1,766,501. COOL WAVE. INT. CL. 3. (U.S. CLS. 1, 4, 6, 50, 51 AND 52). REG. 4-20-1993.
- 1,767,699. PROTECTING THOSE WHO PROTECT. INT. CL. 41. (U.S. CL. 107). REG. 4-27-1993.
- 1,769,684. LEG SAVER. INT. CL. 6. (U.S. CL. 13). REG. 5-11-1993.
- 1,772,027. NATIONAL SPORTING CLAYS ASSOCIATION. INT. CL. 42. (U.S. CL. 100). REG. 5-18-1993.
- 1,772,916. SPILLMASTER. INT. CL. 12. (U.S. CL. 19). REG. 5-25-1993.
- 1,773,101. TRES ESTRELLAS AND DESIGN. INT. CL. 30. (U.S. CL. 46). REG. 5-25-1993.
- 1,773,973. PINNACLE. INT. CL. 2. (U.S. CL. 16). REG. 6-1-1993.
- 1,774,715. WAVE RACE. INT. CL. 28. (U.S. CL. 22). REG. 6-1-1993.
- 1,775,397. ROOZENGAARDE FLOWERS & BULBS AND DESIGN. INT. CL. 31. (U.S. CL. 1). REG. 6-8-1993.
- 1,775,888. 6125. INT. CL. 19. (U.S. CL. 12). REG. 6-8-1993.
- 1,776,407. KOAX. INT. CL. 11. (U.S. CL. 34). REG. 6-15-1993.
- 1,777,631. SPECTRA. INT. CL. 6. (U.S. CL. 12). REG. 6-22-1993.
- 1,777,652. BRENCO. INT. CLS. 7 AND 12. (U.S. CLS. 19 AND 23). REG. 6-22-1993.
- 1,777,721. CIAA. INT. CLS. 14, 16, 25 AND 28 ONLY. (U.S. CLS. 2, 5, 22, 23, 27, 28, 29, 37, 38, 39 AND 50). REG. 6-22-1993.
- 1,778,062. TRISTAR FULFILLMENT SERVICES, INC.. INT. CL. 35. (U.S. CLS. 100 AND 101). REG. 6-22-1993.
- 1,778,244. PLUS. INT. CLS. 36, 37 AND 39. (U.S. CLS. 102, 103 AND 105). REG. 6-22-1993.
- 1,778,301. MICROLINE. INT. CL. 9. (U.S. CL. 21). REG. 6-22-1993.
- 1,779,319. SPORTS & MARINE PARAFUNALIA (STYLIZED). INT. CL. 42. (U.S. CL. 101). REG. 6-29-1993.
- 1,779,812. DOMAINE SERENE. INT. CL. 33. (U.S. CL. 47). REG. 6-29-1993.
- 1,779,841. CRUISE 800. INT. CL. 39. (U.S. CL. 105). REG. 6-29-1993.
- 1,779,998. MIERO FIBER (STYLIZED). INT. CL. 32 ONLY. (U.S. CLS. 45 AND 48). REG. 7-6-1993.
- 1,780,972. PLANET FRIENDLY. INT. CL. 3. (U.S. CLS. 4 AND 52). REG. 7-13-1993.
- 1,781,080. TIFCO AND DESIGN. INT. CL. 6. (U.S. CL. 13). REG. 7-13-1993.
- 1,781,251. LVS. INT. CL. 9. (U.S. CL. 21). REG. 7-13-1993.
- 1,781,337. STARBURST. INT. CL. 16. (U.S. CL. 37). REG. 7-13-1993.
- 1,782,650. DOT CARDS. INT. CL. 16. (U.S. CL. 38). REG. 7-20-1993.
- 1,782,651. BIT OF INTELLIGENCE. INT. CL. 16. (U.S. CL. 38). REG. 7-20-1993.
- 1,782,683. BULLET GUARD AND DESIGN. INT. CLS. 17 AND 19. (U.S. CL. 12). REG. 7-20-1993.
- 1,783,321. VALENTINE ONE. INT. CL. 9. (U.S. CL. 26). REG. 7-20-1993.
- 1,783,852. DAYTIN. INT. CL. 7. (U.S. CLS. 16 AND 23). REG. 7-27-1993.
- 1,784,177. BALL (STYLIZED). INT. CL. 21. (U.S. CLS. 13 AND 23). REG. 7-27-1993.
- 1,784,290. BALL (STYLIZED). INT. CL. 29. (U.S. CL. 46). REG. 7-27-1993.
- 1,784,734. HEAT GUARD. INT. CL. 5. (U.S. CL. 18). REG. 7-27-1993.
- 1,785,980. MISCELLANEOUS DESIGN. INT. CL. 42. (U.S. CL. 100). REG. 8-3-1993.
- 1,786,633. BTREIVEE. INT. CL. 9. (U.S. CL. 38). REG. 8-10-1993.
- 1,787,059. RESCUE ROOTER. INT. CL. 37. (U.S. CL. 103). REG. 8-10-1993.
- 2,369,935. HUNTSMAN AND DESIGN. INT. CL. 1. (U.S. CLS. 1, 5, 6, 10, 26 AND 46). REG. 7-25-2000.
- 2,442,874. SUAVE AND DESIGN. INT. CL. 3. (U.S. CLS. 1, 4, 6, 50, 51 AND 52). REG. 4-10-2001.
- 2,466,111. MISCELLANEOUS DESIGN. INT. CLS. 2, 16 AND 35. (U.S. CLS. 2, 5, 6, 11, 16, 22, 23, 29, 37, 38, 50, 100, 101 AND 102). REG. 7-3-2001.
- 2,471,737. BAND-AID. INT. CL. 5 ONLY. (U.S. CLS. 6, 18, 44, 46, 51 AND 52). REG. 7-24-2001.
- 2,509,907. LOMAS. INT. CL. 35. (U.S. CLS. 100, 101 AND 102). REG. 11-20-2001.
- 2,517,949. DQC. INT. CL. 9. (U.S. CLS. 21, 23, 26, 36 AND 38). REG. 12-11-2001.
- 2,521,212. ALASKA. INT. CL. 9. (U.S. CLS. 21, 23, 26, 36 AND 38). REG. 12-18-2001.
- 2,531,415. I.D.D.L. INTERNATIONAL DOCUMENT DECODING LABORATORY AND TESTING FACILITY AND DESIGN. INT. CL. 42. (U.S. CLS. 100 AND 101). REG. 1-22-2002.
- 2,533,974. DCI. INT. CL. 10. (U.S. CLS. 26, 39 AND 44). REG. 1-29-2002.
- 2,534,382. A NEW SCIENCE IN SKIN CARE. INT. CL. 10. (U.S. CLS. 26, 39 AND 44). REG. 1-29-2002.
- 2,534,436. PARADOCX VINEYARD. INT. CLS. 29 AND 31. (U.S. CLS. 1 AND 46). REG. 1-29-2002.
- 2,534,438. MISCELLANEOUS DESIGN. INT. CLS. 41 AND 42. (U.S. CLS. 100, 101 AND 107). REG. 1-29-2002.
- 2,535,559. ULTRAHD. INT. CL. 1. (U.S. CLS. 1, 5, 6, 10, 26 AND 46). REG. 2-5-2002.
- 2,535,888. TULCINGO. INT. CL. 42. (U.S. CLS. 100 AND 101). REG. 2-5-2002.
- 2,537,150. PLAYERS CHOICE. INT. CL. 16. (U.S. CLS. 2, 5, 22, 23, 29, 37, 38 AND 50). REG. 2-5-2002.
- 2,537,270. DAN THE SAFETY MAN. INT. CL. 41. (U.S. CLS. 100, 101 AND 107). REG. 2-5-2002.
- 2,538,009. TURKEY. INT. CL. 30. (U.S. CL. 46). REG. 2-12-2002.
- 2,538,632. WEEKEND WARRIORS. INT. CL. 41. (U.S. CLS. 100, 101 AND 107). REG. 2-12-2002.
- 2,539,746. 1788 ROPEWALK A FEDERAL HILL TAVERN AND DESIGN. INT. CL. 42. (U.S. CLS. 100 AND 101). REG. 2-19-2002.
- 2,544,682. BULITEX. INT. CL. 12. (U.S. CLS. 19, 21, 23, 31, 35 AND 44). REG. 3-5-2002.
- 2,544,996. MISCELLANEOUS DESIGN. INT. CL. 37. (U.S. CLS. 100, 103 AND 106). REG. 3-5-2002.
- 2,548,191. UNI-GASKET. INT. CL. 11. (U.S. CLS. 13, 21, 23, 31 AND 34). REG. 3-12-2002.
- 2,549,281. PREFERRED PROVIDER PARTNERSHIPS. INT. CL. 35. (U.S. CLS. 100, 101 AND 102). REG. 3-19-2002.
- 2,549,282. LOCAL TRAVEL. INT. CL. 35. (U.S. CLS. 100, 101 AND 102). REG. 3-19-2002.
- 2,549,886. BYTEWRITE. INT. CL. 41. (U.S. CLS. 100, 101 AND 107). REG. 3-19-2002.
- 2,550,054. ALLIANCE. INT. CL. 37. (U.S. CLS. 100, 103 AND 106). REG. 3-19-2002.
- 2,554,404. CATALOG DIRECT. INT. CL. 35. (U.S. CLS. 100, 101 AND 102). REG. 3-26-2002.
- 2,554,817. MULTI LINK. INT. CL. 9. (U.S. CLS. 21, 23, 26, 36 AND 38). REG. 4-2-2002.
- 2,556,597. DEAD STRAIGHT. INT. CL. 28. (U.S. CLS. 22, 23, 38 AND 50). REG. 4-2-2002.

- 2,559,602. LOCATOR. INT. CL. 10. (U.S. CLS. 26, 39 AND 44). REG. 4-9-2002.
- 2,565,383. AMERICA'S SAVINGS MAGAZINE. INT. CL. 16. (U.S. CLS. 2, 5, 22, 23, 29, 37, 38 AND 50). REG. 4-30-2002.
- 2,568,403. SOXYGEN. INT. CL. 25. (U.S. CLS. 22 AND 39). REG. 5-7-2002.
- 2,571,765. CYBERBASE. INT. CL. 9 ONLY. (U.S. CLS. 21, 23, 26, 36 AND 38). REG. 5-21-2002.
- 2,574,122. PERFORMANCE TIRE AND DESIGN. INT. CL. 35. (U.S. CLS. 100, 101 AND 102). REG. 5-28-2002.
- 2,576,930. ISOFUSION. INT. CL. 6. (U.S. CLS. 2, 12, 13, 14, 23, 25 AND 50). REG. 6-11-2002.
- 2,579,075. PREMIER SERVICE NETWORK AND DESIGN. INT. CL. 39. (U.S. CLS. 100 AND 105). REG. 6-11-2002.
- 2,579,140. THE ROAD TO OMAHA. INT. CL. 41. (U.S. CLS. 100, 101 AND 107). REG. 6-11-2002.
- 2,582,197. ALAMARK. INT. CL. 35. (U.S. CLS. 100, 101 AND 102). REG. 6-18-2002.
- 2,584,952. LANDMARK PARKING P AND DESIGN. INT. CL. 39. (U.S. CLS. 100 AND 105). REG. 6-25-2002.
- 2,586,015. BOOSTER COMPLEX. INT. CL. 3. (U.S. CLS. 1, 4, 6, 50, 51 AND 52). REG. 6-25-2002.
- 2,588,523. TEAMPATH. INT. CL. 35. (U.S. CLS. 100, 101 AND 102). REG. 7-2-2002.
- 2,589,540. MISCELLANEOUS DESIGN. INT. CL. 42. (U.S. CLS. 100 AND 101). REG. 7-2-2002.
- 2,589,541. COPPERWYND. INT. CL. 42. (U.S. CLS. 100 AND 101). REG. 7-2-2002.
- 2,589,542. COPPERWYND. INT. CL. 41. (U.S. CLS. 100, 101 AND 107). REG. 7-2-2002.
- 2,589,544. MISCELLANEOUS DESIGN. INT. CL. 41. (U.S. CLS. 100, 101 AND 107). REG. 7-2-2002.
- 2,594,884. EPM ONLINE. INT. CLS. 35 AND 36. (U.S. CLS. 100, 101 AND 102). REG. 7-16-2002.
- 2,595,330. INSTANT WINNER. INT. CL. 13. (U.S. CLS. 2 AND 9). REG. 7-16-2002.
- 2,596,064. ALLIANCE. INT. CL. 18. (U.S. CLS. 1, 2, 3, 22 AND 41). REG. 7-16-2002.
- 2,596,268. CTI SERVER. INT. CL. 42. (U.S. CLS. 100 AND 101). REG. 7-16-2002.
- 2,596,739. FROG. INT. CL. 35. (U.S. CLS. 100, 101 AND 102). REG. 7-23-2002.
- 2,596,896. MICROFRESH. INT. CL. 7. (U.S. CLS. 13, 19, 21, 23, 31, 34 AND 35). REG. 7-23-2002.
- 2,596,958. SITRAIN. INT. CLS. 9, 16 AND 41. (U.S. CLS. 2, 5, 21, 22, 23, 26, 29, 36, 37, 38, 50, 100, 101 AND 107). REG. 7-23-2002.
- 2,596,966. VIMAL AND DESIGN. INT. CL. 32. (U.S. CLS. 45, 46 AND 48). REG. 7-23-2002.
- 2,597,996. STATE OF HOCKEY STANDARD CHARACTER MARK. INT. CL. 16. (U.S. CLS. 2, 5, 22, 23, 29, 37, 38 AND 50). REG. 7-23-2002.
- 2,598,536. ROFL. INT. CLS. 18, 21, 24 AND 25 ONLY. (U.S. CLS. 1, 2, 3, 13, 22, 23, 29, 30, 33, 39, 40, 41, 42 AND 50). REG. 7-23-2002.
- 2,598,630. BELL'O. INT. CL. 20. (U.S. CLS. 2, 13, 22, 25, 32 AND 50). REG. 7-23-2002.
- 2,598,743. BLACKJACK. INT. CL. 28. (U.S. CLS. 22, 23, 38 AND 50). REG. 7-23-2002.
- 2,599,066. MISCELLANEOUS DESIGN. INT. CL. 41. (U.S. CLS. 100, 101 AND 107). REG. 7-23-2002.
- 2,599,118. EXECUTIVE DEFENDER. INT. CL. 1. (U.S. CLS. 1, 5, 6, 10, 26 AND 46). REG. 7-23-2002.
- 2,599,330. TURBO DOUGH. INT. CL. 28. (U.S. CLS. 22, 23, 38 AND 50). REG. 7-23-2002.
- 2,599,622. SYNCHRO. INT. CL. 10. (U.S. CLS. 26, 39 AND 44). REG. 7-23-2002.
- 2,599,781. SANIBEL AND CAPTIVA ACCOMMODATIONS. INT. CL. 36. (U.S. CLS. 100, 101 AND 102). REG. 7-23-2002.
- 2,599,796. CERTIFIED HOUSEHOLD MANAGER. INT. CL. 41. (U.S. CLS. 100, 101 AND 107). REG. 7-23-2002.
- 2,599,797. CERTIFIED ESTATE MANAGER. INT. CL. 41. (U.S. CLS. 100, 101 AND 107). REG. 7-23-2002.
- 2,599,889. SILVER FERN. INT. CL. 29. (U.S. CL. 46). REG. 7-30-2002.
- 2,599,908. CONSTELLATION. INT. CL. 16. (U.S. CLS. 2, 5, 22, 23, 29, 37, 38 AND 50). REG. 7-30-2002.
- 2,599,920. MEAG. INT. CLS. 35 AND 36 ONLY. (U.S. CLS. 100, 101 AND 102). REG. 7-30-2002.
- 2,600,021. THE SOLUTION FOUNDRY AND DESIGN. INT. CLS. 9 AND 35. (U.S. CLS. 21, 23, 26, 36, 38, 100, 101 AND 102). REG. 7-30-2002.
- 2,600,028. DIGIMARK. INT. CL. 42. (U.S. CLS. 100 AND 101). REG. 7-30-2002.
- 2,600,044. COMMUNITY KITCHEN. INT. CL. 41. (U.S. CLS. 100, 101 AND 107). REG. 7-30-2002.
- 2,600,047. AMERICAN COLLEGE OF VETERINARY INTERNAL MEDICINE. U.S. CL. 200. REG. 7-30-2002.
- 2,600,048. AMERICAN COLLEGE VETERINARY INTERNAL MEDICINE MCMLXXII AND DESIGN. U.S. CL. 200. REG. 7-30-2002.
- 2,600,082. ON SEMICONDUCTOR ON AND DESIGN. INT. CL. 9. (U.S. CLS. 21, 23, 26, 36 AND 38). REG. 7-30-2002.
- 2,600,112. AT495. INT. CL. 12. (U.S. CLS. 19, 21, 23, 31, 35 AND 44). REG. 7-30-2002.
- 2,600,113. FLOTEC, INC. AND DESIGN. INT. CL. 10. (U.S. CLS. 26, 39 AND 44). REG. 7-30-2002.
- 2,600,238. WORKING VALUES. INT. CLS. 35 AND 41. (U.S. CLS. 100, 101, 102 AND 107). REG. 7-30-2002.
- 2,600,248. ANSORG. INT. CLS. 9, 11 AND 42 ONLY. (U.S. CLS. 13, 21, 23, 26, 31, 34, 36, 38, 100 AND 101). REG. 7-30-2002.
- 2,600,285. PROPRIETOR'S SERIES. INT. CL. 33. (U.S. CLS. 47 AND 49). REG. 7-30-2002.
- 2,600,288. GURU LABS. INT. CLS. 41 AND 42. (U.S. CLS. 100, 101 AND 107). REG. 7-30-2002.
- 2,600,367. SFML. INT. CL. 9. (U.S. CLS. 21, 23, 26, 36 AND 38). REG. 7-30-2002.
- 2,600,432. MATHPAD. INT. CL. 9. (U.S. CLS. 21, 23, 26, 36 AND 38). REG. 7-30-2002.
- 2,600,458. DIGITAL VIGILANCE. INT. CL. 35. (U.S. CLS. 100, 101 AND 102). REG. 7-30-2002.
- 2,600,485. SUPER CA-HD RAPID. INT. CL. 17. (U.S. CLS. 1, 5, 12, 13, 35 AND 50). REG. 7-30-2002.
- 2,600,551. BOOMER. INT. CL. 13. (U.S. CLS. 2 AND 9). REG. 7-30-2002.
- 2,600,555. MAXIM. INT. CL. 7. (U.S. CLS. 13, 19, 21, 23, 31, 34 AND 35). REG. 7-30-2002.
- 2,600,574. EXITEXCHANGE. INT. CLS. 35 AND 42. (U.S. CLS. 100, 101 AND 102). REG. 7-30-2002.
- 2,600,598. THE UNIVERSITY OF SOUTHERN MISSISSIPPI 1910 AND DESIGN. INT. CLS. 16, 20, 21 AND 25. (U.S. CLS. 2, 5, 13, 22, 23, 25, 29, 30, 32, 33, 37, 38, 39, 40 AND 50). REG. 7-30-2002.
- 2,600,599. ROAD TO THE FINAL FOUR. INT. CL. 25. (U.S. CLS. 22 AND 39). REG. 7-30-2002.
- 2,600,667. WESTGARD QC W AND DESIGN. INT. CL. 41. (U.S. CLS. 100, 101 AND 107). REG. 7-30-2002.
- 2,600,682. VOLTSOURCE. INT. CLS. 35, 36 AND 42. (U.S. CLS. 100, 101 AND 102). REG. 7-30-2002.
- 2,600,707. KIDSPACE. INT. CL. 16. (U.S. CLS. 2, 5, 22, 23, 29, 37, 38 AND 50). REG. 7-30-2002.
- 2,600,729. EXECUTIVE COACHING CONNECTIONS AND DESIGN. INT. CL. 35. (U.S. CLS. 100, 101 AND 102). REG. 7-30-2002.
- 2,600,739. STEVIE WONDER. INT. CL. 41. (U.S. CLS. 100, 101 AND 107). REG. 7-30-2002.
- 2,600,760. THE BONITA BAY GROUP. INT. CL. 37. (U.S. CLS. 100, 103 AND 106). REG. 7-30-2002.
- 2,600,778. REAL COACHING. INT. CL. 41. (U.S. CLS. 100, 101 AND 107). REG. 7-30-2002.
- 2,600,804. EQUILIBRIO. INT. CL. 25. (U.S. CLS. 22 AND 39). REG. 7-30-2002.
- 2,600,826. DANTE CONSULTING. INT. CLS. 35 AND 42 ONLY. (U.S. CLS. 100, 101 AND 102). REG. 7-30-2002.
- 2,600,835. MAKES TAP WATER TASTE GREAT. INT. CL. 11. (U.S. CLS. 13, 21, 23, 31 AND 34). REG. 7-30-2002.
- 2,600,842. TERMIGNONI AND DESIGN. INT. CL. 7. (U.S. CLS. 13, 19, 21, 23, 31, 34 AND 35). REG. 7-30-2002.
- 2,600,848. R RAYSTONE RECORDS AND DESIGN. INT. CL. 9. (U.S. CLS. 21, 23, 26, 36 AND 38). REG. 7-30-2002.
- 2,600,864. PATIO PAK. INT. CL. 19. (U.S. CLS. 1, 12, 33 AND 50). REG. 7-30-2002.
- 2,600,881. MENSJOURNAL (STYLIZED). INT. CL. 42. (U.S. CLS. 100 AND 101). REG. 7-30-2002.
- 2,600,895. AVERY DENNISON. INT. CL. 16. (U.S. CLS. 2, 5, 22, 23, 29, 37, 38 AND 50). REG. 7-30-2002.
- 2,600,988. PONCHO SANCHEZ. INT. CL. 41. (U.S. CLS. 100, 101 AND 107). REG. 7-30-2002.
- 2,601,057. LUXOR CABS. INT. CL. 39. (U.S. CLS. 100 AND 105). REG. 7-30-2002.

- 2,601,101. GREENS ARE GREAT FOR GROWING KIDS. INT. CL. 31. (U.S. CLS. 1 AND 46). REG. 7-30-2002.
- 2,601,125. INFINITYQS. INT. CL. 9. (U.S. CLS. 21, 23, 26, 36 AND 38). REG. 7-30-2002.
- 2,601,178. ROAM-TO-HOME. INT. CL. 38. (U.S. CLS. 100, 101 AND 104). REG. 7-30-2002.
- 2,601,215. MOUNTAIN PLEASURE HORSE. U.S. CL. A. REG. 7-30-2002.
- 2,601,219. ADANDE. INT. CL. 11 ONLY. (U.S. CLS. 13, 21, 23, 31 AND 34). REG. 7-30-2002.
- 2,601,300. RENAISSANCE EXECUTIVE FORUMS AND DESIGN. INT. CL. 41. (U.S. CLS. 100, 101 AND 107). REG. 7-30-2002.
- 2,601,373. HAM GRAM. INT. CL. 35. (U.S. CLS. 100, 101 AND 102). REG. 7-30-2002.
- 2,601,411. AUTO SAVER. INT. CL. 9. (U.S. CLS. 21, 23, 26, 36 AND 38). REG. 7-30-2002.
- 2,601,449. 444. INT. CL. 7. (U.S. CLS. 13, 19, 21, 23, 31, 34 AND 35). REG. 7-30-2002.
- 2,601,450. INDEPENDENT LIVING POWER. INT. CL. 35. (U.S. CLS. 100, 101 AND 102). REG. 7-30-2002.
- 2,601,457. MULTIDECK. INT. CLS. 9 AND 42. (U.S. CLS. 21, 23, 26, 36, 38, 100 AND 101). REG. 7-30-2002.
- 2,601,493. VENTURE MEASUREMENT. INT. CL. 9. (U.S. CLS. 21, 23, 26, 36 AND 38). REG. 7-30-2002.
- 2,601,502. KEVAN HALL. INT. CL. 25. (U.S. CLS. 22 AND 39). REG. 7-30-2002.
- 2,601,504. RED ROSE MUSIC. INT. CL. 9. (U.S. CLS. 21, 23, 26, 36 AND 38). REG. 7-30-2002.
- 2,601,565. MOLD HANDLER. INT. CL. 6. (U.S. CLS. 2, 12, 13, 14, 23, 25 AND 50). REG. 7-30-2002.
- 2,601,585. THE ROYAL STORE. INT. CL. 35. (U.S. CLS. 100, 101 AND 102). REG. 7-30-2002.
- 2,601,593. QUALITY THAT GROWS. INT. CL. 31. (U.S. CLS. 1 AND 46). REG. 7-30-2002.
- 2,601,598. VENTAIRE. INT. CL. 10. (U.S. CLS. 26, 39 AND 44). REG. 7-30-2002.
- 2,601,602. TIJUANA CITRUS PUNCH AND DESIGN. INT. CL. 32. (U.S. CLS. 45, 46 AND 48). REG. 7-30-2002.
- 2,601,604. BRIDGE OF WEIR FINE SCOTTISH LEATHER AND DESIGN. INT. CL. 18. (U.S. CLS. 1, 2, 3, 22 AND 41). REG. 7-30-2002.
- 2,601,615. B BREATH THERMO AND DESIGN. INT. CL. 25. (U.S. CLS. 22 AND 39). REG. 7-30-2002.
- 2,601,682. MIRACLE-GRO POUR & FEED. INT. CL. 1. (U.S. CLS. 1, 5, 6, 10, 26 AND 46). REG. 7-30-2002.
- 2,601,766. RADIAL-TAP. INT. CL. 6. (U.S. CLS. 2, 12, 13, 14, 23, 25 AND 50). REG. 7-30-2002.
- 2,601,811. FURNITURE FOR THE WAY YOU LIVE. INT. CL. 20. (U.S. CLS. 2, 13, 22, 25, 32 AND 50). REG. 7-30-2002.
- 2,601,820. CREATIVE CARRYOUTS. INT. CL. 21. (U.S. CLS. 2, 13, 23, 29, 30, 33, 40 AND 50). REG. 7-30-2002.
- 2,601,858. CHACMOL. INT. CL. 33. (U.S. CLS. 47 AND 49). REG. 7-30-2002.
- 2,601,876. TEENSCREEN. INT. CL. 42. (U.S. CLS. 100 AND 101). REG. 7-30-2002.
- 2,601,882. VIZGUARD. INT. CLS. 9 AND 25. (U.S. CLS. 21, 22, 23, 26, 36, 38 AND 39). REG. 7-30-2002.
- 2,601,930. INDESTRUCTABLE. INT. CL. 20. (U.S. CLS. 2, 13, 22, 25, 32 AND 50). REG. 7-30-2002.
- 2,601,964. DUMB BLONDE. INT. CL. 3. (U.S. CLS. 1, 4, 6, 50, 51 AND 52). REG. 7-30-2002.
- 2,601,990. COLD WEATHER CENTER. INT. CL. 20. (U.S. CLS. 2, 13, 22, 25, 32 AND 50). REG. 7-30-2002.
- 2,602,056. XG300. INT. CL. 12. (U.S. CLS. 19, 21, 23, 31, 35 AND 44). REG. 7-30-2002.
- 2,602,064. BIRDZOFF AND DESIGN. INT. CL. 6. (U.S. CLS. 2, 12, 13, 14, 23, 25 AND 50). REG. 7-30-2002.
- 2,602,162. SOFTAP. INT. CL. 42. (U.S. CLS. 100 AND 101). REG. 7-30-2002.
- 2,602,176. ULTRA-GRIP. INT. CL. 17. (U.S. CLS. 1, 5, 12, 13, 35 AND 50). REG. 7-30-2002.
- 2,602,215. CTC ORIGINAL AUTHENTIC 2000 AND DESIGN. INT. CLS. 29 AND 35 ONLY. (U.S. CLS. 46, 100, 101 AND 102). REG. 7-30-2002.
- 2,602,353. VIBRATRANSLATOR. INT. CL. 9. (U.S. CLS. 21, 23, 26, 36 AND 38). REG. 7-30-2002.
- 2,602,415. SUP FROM THE CUP THAT KEEPS YOU UP. INT. CL. 30. (U.S. CL. 46). REG. 7-30-2002.
- 2,602,416. TODAY 2 TOMORROW. INT. CL. 42. (U.S. CLS. 100 AND 101). REG. 7-30-2002.
- 2,602,478. LAXATROL. INT. CL. 5. (U.S. CLS. 6, 18, 44, 46, 51 AND 52). REG. 7-30-2002.
- 2,602,543. MAKE PET ADOPTION YOUR FIRST OPTION. INT. CL. 42. (U.S. CLS. 100 AND 101). REG. 7-30-2002.
- 2,602,547. ANNEX. INT. CL. 20. (U.S. CLS. 2, 13, 22, 25, 32 AND 50). REG. 7-30-2002.
- 2,602,553. SEPSA AND DESIGN. INT. CL. 9. (U.S. CLS. 21, 23, 26, 36 AND 38). REG. 7-30-2002.
- 2,602,605. GIGABAND. INT. CL. 9. (U.S. CLS. 21, 23, 26, 36 AND 38). REG. 7-30-2002.
- 2,602,630. MISCELLANEOUS DESIGN. INT. CL. 42. (U.S. CLS. 100 AND 101). REG. 7-30-2002.
- 2,602,658. TRADEMASTER. INT. CL. 12. (U.S. CLS. 19, 21, 23, 31, 35 AND 44). REG. 7-30-2002.
- 2,602,682. EYE-ONE. INT. CL. 9. (U.S. CLS. 21, 23, 26, 36 AND 38). REG. 7-30-2002.
- 2,602,687. PROPARA. INT. CL. 5. (U.S. CLS. 6, 18, 44, 46, 51 AND 52). REG. 7-30-2002.
- 2,602,710. CHECKPOINT. INT. CL. 11. (U.S. CLS. 13, 21, 23, 31 AND 34). REG. 7-30-2002.
- 2,602,727. MISS ME. INT. CL. 25. (U.S. CLS. 22 AND 39). REG. 7-30-2002.
- 2,602,758. TYCOR GUIDANCE SYSTEM STANDARD CHARACTER MARK. INT. CL. 36. (U.S. CLS. 100, 101 AND 102). REG. 7-30-2002.
- 2,602,860. ERGO-PRO. INT. CL. 10. (U.S. CLS. 26, 39 AND 44). REG. 7-30-2002.
- 2,602,892. EXCURSION. INT. CL. 21. (U.S. CLS. 2, 13, 23, 29, 30, 33, 40 AND 50). REG. 7-30-2002.
- 2,603,046. ATTORNEYGUIDE.COM. INT. CLS. 35 AND 42. (U.S. CLS. 100, 101 AND 102). REG. 7-30-2002.
- 2,603,049. INTEGRATED MEDIA SYSTEMS. INT. CLS. 37 AND 42. (U.S. CLS. 100, 101, 103 AND 106). REG. 7-30-2002.
- 2,603,055. ACCOUNTABILITY FRAMEWORK. INT. CL. 16. (U.S. CLS. 2, 5, 22, 23, 29, 37, 38 AND 50). REG. 7-30-2002.
- 2,603,063. ASIATRAVEL.COM. INT. CL. 42. (U.S. CLS. 100 AND 101). REG. 7-30-2002.
- 2,603,115. BABY CHINESE. INT. CLS. 9, 16, 28 AND 41. (U.S. CLS. 2, 5, 21, 22, 23, 26, 29, 36, 37, 38, 50, 100, 101 AND 107). REG. 7-30-2002.
- 2,603,116. BABY SPANISH. INT. CLS. 9, 16, 28 AND 41. (U.S. CLS. 2, 5, 21, 22, 23, 26, 29, 36, 37, 38, 50, 100, 101 AND 107). REG. 7-30-2002.
- 2,603,117. BABY POLISH. INT. CLS. 9, 16, 28 AND 41. (U.S. CLS. 2, 5, 21, 22, 23, 26, 29, 36, 37, 38, 50, 100, 101 AND 107). REG. 7-30-2002.
- 2,603,118. BABY ARABIC. INT. CLS. 9, 16, 28 AND 41. (U.S. CLS. 2, 5, 21, 22, 23, 26, 29, 36, 37, 38, 50, 100, 101 AND 107). REG. 7-30-2002.
- 2,603,119. MOVER'S GUIDE. INT. CLS. 35 AND 39. (U.S. CLS. 100, 101, 102 AND 105). REG. 7-30-2002.
- 2,603,228. AK AND DESIGN. INT. CL. 19. (U.S. CLS. 1, 12, 33 AND 50). REG. 7-30-2002.
- 2,603,235. COMFORTWEAR. INT. CL. 10. (U.S. CLS. 26, 39 AND 44). REG. 7-30-2002.
- 2,603,300. RX DIRECT. INT. CL. 35. (U.S. CLS. 100, 101 AND 102). REG. 8-6-2002.
- 2,603,318. NEW ROCK AND DESIGN. INT. CL. 25. (U.S. CLS. 22 AND 39). REG. 8-6-2002.
- 2,603,326. RENT ROLL. INT. CL. 9. (U.S. CLS. 21, 23, 26, 36 AND 38). REG. 8-6-2002.
- 2,603,429. HYOSUNG. INT. CLS. 16 AND 17. (U.S. CLS. 1, 2, 5, 12, 13, 22, 23, 29, 35, 37, 38 AND 50). REG. 8-6-2002.
- 2,603,447. STAGETEC AND DESIGN. INT. CL. 9. (U.S. CLS. 21, 23, 26, 36 AND 38). REG. 8-6-2002.
- 2,603,467. PARTEK AND DESIGN. INT. CL. 9. (U.S. CLS. 21, 23, 26, 36 AND 38). REG. 8-6-2002.
- 2,603,599. ISOFLUX. INT. CLS. 1, 7 AND 11. (U.S. CLS. 1, 5, 6, 10, 13, 19, 21, 23, 26, 31, 34, 35 AND 46). REG. 8-6-2002.
- 2,603,745. MOUNT PLEASANT WINERY AND DESIGN. INT. CL. 35. (U.S. CLS. 100, 101 AND 102). REG. 8-6-2002.
- 2,603,821. GEXOL. INT. CLS. 9 AND 17. (U.S. CLS. 1, 5, 12, 13, 21, 23, 26, 35, 36, 38 AND 50). REG. 8-6-2002.
- 2,603,882. THE FLORIDA HORSE. INT. CL. 16. (U.S. CLS. 2, 5, 22, 23, 29, 37, 38 AND 50). REG. 8-6-2002.
- 2,603,929. MISCELLANEOUS DESIGN. INT. CLS. 18, 25 AND 28. (U.S. CLS. 1, 2, 3, 22, 23, 38, 39, 41 AND 50). REG. 8-6-2002.

- 2,604,002. INNERDOT. INT. CL. 19. (U.S. CLS. 1, 12, 33 AND 50). REG. 8-6-2002.
- 2,604,022. POLY-VENT. INT. CL. 19. (U.S. CLS. 1, 12, 33 AND 50). REG. 8-6-2002.
- 2,604,070. MOLD-IT. INT. CL. 1. (U.S. CLS. 1, 5, 6, 10, 26 AND 46). REG. 8-6-2002.
- 2,604,212. ENDURA. INT. CL. 11. (U.S. CLS. 13, 21, 23, 31 AND 34). REG. 8-6-2002.
- 2,604,362. THE HINCKLEY COMPANY. INT. CL. 12. (U.S. CLS. 19, 21, 23, 31, 35 AND 44). REG. 8-6-2002.
- 2,604,363. GENKI SUSHI AND DESIGN. INT. CLS. 30 AND 42. (U.S. CLS. 46, 100 AND 101). REG. 8-6-2002.
- 2,604,455. B B R A D F O R D AND DESIGN. INT. CL. 40. (U.S. CLS. 100, 103 AND 106). REG. 8-6-2002.
- 2,604,492. TRILOKA (STYLIZED). INT. CL. 3. (U.S. CLS. 1, 4, 6, 50, 51 AND 52). REG. 8-6-2002.
- 2,604,627. LEVINE LEICHTMAN CAPITAL PARTNERS. INT. CL. 36. (U.S. CLS. 100, 101 AND 102). REG. 8-6-2002.
- 2,604,654. ENERGYGRAM. INT. CL. 41. (U.S. CLS. 100, 101 AND 107). REG. 8-6-2002.
- 2,604,692. SY-MED ONEAPP AND DESIGN. INT. CL. 9. (U.S. CLS. 21, 23, 26, 36 AND 38). REG. 8-6-2002.
- 2,604,715. MISCELLANEOUS DESIGN. INT. CL. 42. (U.S. CLS. 100 AND 101). REG. 8-6-2002.
- 2,604,755. STEEPLE MUSIC GROUP AND DESIGN. INT. CL. 9. (U.S. CLS. 21, 23, 26, 36 AND 38). REG. 8-6-2002.
- 2,604,797. THE FRIEZE. INT. CLS. 30 AND 42. (U.S. CLS. 46, 100 AND 101). REG. 8-6-2002.
- 2,604,824. MONEY IS ENERGY. INT. CL. 41. (U.S. CLS. 100, 101 AND 107). REG. 8-6-2002.
- 2,604,842. INDUSTRIAL PRESS. INT. CL. 34. (U.S. CLS. 2, 8, 9 AND 17). REG. 8-6-2002.
- 2,604,867. MEDRAD. INT. CL. 10 ONLY. (U.S. CLS. 26, 39 AND 44). REG. 8-6-2002.
- 2,604,956. KENTUCKY'S HERITAGE AND DESIGN. INT. CL. 42. (U.S. CLS. 100 AND 101). REG. 8-6-2002.
- 2,605,080. MISCELLANEOUS DESIGN. INT. CL. 18. (U.S. CLS. 1, 2, 3, 22 AND 41). REG. 8-6-2002.
- 2,605,127. MISCELLANEOUS DESIGN. INT. CLS. 35, 41 AND 42. (U.S. CLS. 100, 101, 102 AND 107). REG. 8-6-2002.
- 2,605,264. GMTA. INT. CLS. 18, 21, 24 AND 25 ONLY. (U.S. CLS. 1, 2, 3, 13, 22, 23, 29, 30, 33, 39, 40, 41, 42 AND 50). REG. 8-6-2002.
- 2,605,279. THE GUIDE TO THE MEANING OF LIFE. INT. CL. 16. (U.S. CLS. 2, 5, 22, 23, 29, 37, 38 AND 50). REG. 8-6-2002.
- 2,605,374. WHARFEDALE PRO. INT. CL. 9. (U.S. CLS. 21, 23, 26, 36 AND 38). REG. 8-6-2002.
- 2,605,393. ICM. INT. CL. 9. (U.S. CLS. 21, 23, 26, 36 AND 38). REG. 8-6-2002.
- 2,605,404. TELEFORMULA. INT. CLS. 38 AND 41. (U.S. CLS. 100, 101, 104 AND 107). REG. 8-6-2002.
- 2,605,433. FILTERSTREAM (STYLIZED). INT. CL. 7. (U.S. CLS. 13, 19, 21, 23, 31, 34 AND 35). REG. 8-6-2002.
- 2,605,476. EHPV. INT. CL. 9. (U.S. CLS. 21, 23, 26, 36 AND 38). REG. 8-6-2002.
- 2,605,531. GOOD SECURITY IS GOOD BUSINESS. INT. CL. 9. (U.S. CLS. 21, 23, 26, 36 AND 38). REG. 8-6-2002.
- 2,605,597. SEALAB 2021. INT. CL. 41. (U.S. CLS. 100, 101 AND 107). REG. 8-6-2002.
- 2,605,606. MISCELLANEOUS DESIGN. INT. CLS. 36 AND 38. (U.S. CLS. 100, 101, 102 AND 104). REG. 8-6-2002.
- 2,605,636. THERMA-CHARGE. INT. CL. 11. (U.S. CLS. 13, 21, 23, 31 AND 34). REG. 8-6-2002.
- 2,605,651. MISCELLANEOUS DESIGN. INT. CL. 42. (U.S. CLS. 100 AND 101). REG. 8-6-2002.
- 2,605,653. ARROWSIGHT. INT. CL. 42. (U.S. CLS. 100 AND 101). REG. 8-6-2002.
- 2,605,758. PROFILECOURIER. INT. CL. 9. (U.S. CLS. 21, 23, 26, 36 AND 38). REG. 8-6-2002.
- 2,605,760. EASEOUT. INT. CL. 9. (U.S. CLS. 21, 23, 26, 36 AND 38). REG. 8-6-2002.
- 2,605,796. ACUTEAR. INT. CL. 40. (U.S. CLS. 100, 103 AND 106). REG. 8-6-2002.
- 2,605,797. ACUTEAR. INT. CL. 9. (U.S. CLS. 21, 23, 26, 36 AND 38). REG. 8-6-2002.
- 2,605,861. TYCOR. INT. CL. 36. (U.S. CLS. 100, 101 AND 102). REG. 8-6-2002.
- 2,605,906. CLUTCH. INT. CL. 12. (U.S. CLS. 19, 21, 23, 31, 35 AND 44). REG. 8-6-2002.
- 2,605,973. VIRTELA. INT. CL. 38. (U.S. CLS. 100, 101 AND 104). REG. 8-6-2002.
- 2,606,009. VIEWPOINTE. INT. CL. 18. (U.S. CLS. 1, 2, 3, 22 AND 41). REG. 8-6-2002.
- 2,606,025. DIAMOND THUNDER. INT. CL. 28. (U.S. CLS. 22, 23, 38 AND 50). REG. 8-6-2002.
- 2,606,065. MISCELLANEOUS DESIGN. INT. CL. 5. (U.S. CLS. 6, 18, 44, 46, 51 AND 52). REG. 8-6-2002.
- 2,606,074. NMR-MOUSE. INT. CL. 9. (U.S. CLS. 21, 23, 26, 36 AND 38). REG. 8-6-2002.
- 2,606,084. BUONISSIMO. INT. CL. 29. (U.S. CL. 46). REG. 8-6-2002.
- 2,606,090. MISCELLANEOUS DESIGN. INT. CL. 7. (U.S. CLS. 13, 19, 21, 23, 31, 34 AND 35). REG. 8-6-2002.
- 2,606,136. BABY FINNISH. INT. CLS. 9, 16, 28 AND 41. (U.S. CLS. 2, 5, 21, 22, 23, 26, 29, 36, 37, 38, 50, 100, 101 AND 107). REG. 8-6-2002.
- 2,606,137. BABY FRENCH. INT. CLS. 9, 16, 28 AND 41. (U.S. CLS. 2, 5, 21, 22, 23, 26, 29, 36, 37, 38, 50, 100, 101 AND 107). REG. 8-6-2002.
- 2,606,138. BABY JAPANESE. INT. CLS. 9, 16, 28 AND 41. (U.S. CLS. 2, 5, 21, 22, 23, 26, 29, 36, 37, 38, 50, 100, 101 AND 107). REG. 8-6-2002.
- 2,606,139. BABY CZECH. INT. CLS. 9, 16, 28 AND 41. (U.S. CLS. 2, 5, 21, 22, 23, 26, 29, 36, 37, 38, 50, 100, 101 AND 107). REG. 8-6-2002.
- 2,606,140. BABY LATIN. INT. CLS. 9, 16, 28 AND 41. (U.S. CLS. 2, 5, 21, 22, 23, 26, 29, 36, 37, 38, 50, 100, 101 AND 107). REG. 8-6-2002.
- 2,606,146. MINIJET. INT. CL. 11. (U.S. CLS. 13, 21, 23, 31 AND 34). REG. 8-6-2002.
- 2,606,174. PHILLY ROAST. INT. CL. 30. (U.S. CL. 46). REG. 8-6-2002.
- 2,606,188. CONTENTCLEANUP. INT. CL. 9. (U.S. CLS. 21, 23, 26, 36 AND 38). REG. 8-6-2002.
- 2,606,237. MACKENZIE DECORATIVE BELTS, ETC. AND DESIGN. INT. CL. 25. (U.S. CLS. 22 AND 39). REG. 8-6-2002.
- 2,606,268. RHINO (STYLIZED). INT. CL. 1. (U.S. CLS. 1, 5, 6, 10, 26 AND 46). REG. 8-13-2002.
- 2,606,306. VISUAL. INT. CL. 9. (U.S. CLS. 21, 23, 26, 36 AND 38). REG. 8-13-2002.
- 2,606,528. STEMCO ESP. INT. CL. 17. (U.S. CLS. 1, 5, 12, 13, 35 AND 50). REG. 8-13-2002.
- 2,606,830. ELECTRICAL NUTRITION. INT. CL. 5. (U.S. CLS. 6, 18, 44, 46, 51 AND 52). REG. 8-13-2002.
- 2,606,865. MISCELLANEOUS DESIGN. INT. CL. 35. (U.S. CLS. 100, 101 AND 102). REG. 8-13-2002.
- 2,606,890. BHN. INT. CL. 31. (U.S. CLS. 1 AND 46). REG. 8-13-2002.
- 2,606,900. ELVIS PRESLEY. INT. CL. 34. (U.S. CLS. 2, 8, 9 AND 17). REG. 8-13-2002.
- 2,606,920. MIAMI HEAT AND DESIGN. INT. CL. 35. (U.S. CLS. 100, 101 AND 102). REG. 8-13-2002.
- 2,606,928. FLOR DE CANA EXTRA DRY (STYLIZED). INT. CL. 33. (U.S. CLS. 47 AND 49). REG. 8-13-2002.
- 2,607,017. AGRI-LOADER. INT. CL. 12. (U.S. CLS. 19, 21, 23, 31, 35 AND 44). REG. 8-13-2002.
- 2,607,094. TRIVANTIS.COM. INT. CL. 41. (U.S. CLS. 100, 101 AND 107). REG. 8-13-2002.
- 2,607,134. MISCELLANEOUS DESIGN. INT. CLS. 6 AND 7. (U.S. CLS. 2, 12, 13, 14, 19, 21, 23, 25, 31, 34, 35 AND 50). REG. 8-13-2002.
- 2,607,143. RESTAURATEUR. INT. CL. 16. (U.S. CLS. 2, 5, 22, 23, 29, 37, 38 AND 50). REG. 8-13-2002.
- 2,607,144. BUILDER + ARCHITECT STANDARD CHARACTER MARK. INT. CL. 16. (U.S. CLS. 2, 5, 22, 23, 29, 37, 38 AND 50). REG. 8-13-2002.
- 2,607,145. RESTAURANT FORUM. INT. CL. 16. (U.S. CLS. 2, 5, 22, 23, 29, 37, 38 AND 50). REG. 8-13-2002.
- 2,607,215. ASSEMBLEON. INT. CL. 9. (U.S. CLS. 21, 23, 26, 36 AND 38). REG. 8-13-2002.
- 2,607,236. DAKOTA DIGITAL. INT. CLS. 9 AND 35. (U.S. CLS. 21, 23, 26, 36, 38, 100, 101 AND 102). REG. 8-13-2002.
- 2,607,358. MISCELLANEOUS DESIGN. INT. CL. 39. (U.S. CLS. 100 AND 105). REG. 8-13-2002.
- 2,607,404. CREATAS. INT. CL. 42. (U.S. CLS. 100 AND 101). REG. 8-13-2002.
- 2,607,465. BRIDGESTONE (STYLIZED). INT. CL. 12. (U.S. CLS. 19, 21, 23, 31, 35 AND 44). REG. 8-13-2002.
- 2,607,589. PERSPECTA. INT. CL. 9. (U.S. CLS. 21, 23, 26, 36 AND 38). REG. 8-13-2002.
- 2,607,601. LIMESTONE. INT. CL. 36. (U.S. CLS. 100, 101 AND 102). REG. 8-13-2002.

- 2,607,623. SILVERADO VINEYARDS AND DESIGN. INT. CL. 33. (U.S. CLS. 47 AND 49). REG. 8-13-2002.
- 2,607,640. TOYS BY BREED. INT. CL. 42. (U.S. CLS. 100 AND 101). REG. 8-13-2002.
- 2,607,641. KLOV. INT. CLS. 35 AND 41. (U.S. CLS. 100, 101, 102 AND 107). REG. 8-13-2002.
- 2,608,042. POSITIVE COACHING ALLIANCE AND DESIGN. INT. CLS. 16 AND 41 ONLY. (U.S. CLS. 2, 5, 22, 23, 29, 37, 38, 50, 100, 101 AND 107). REG. 8-13-2002.
- 2,608,068. PAPA PRESTO AND DESIGN. INT. CL. 30. (U.S. CL. 46). REG. 8-13-2002.
- 2,608,130. PREPAIR. INT. CL. 5. (U.S. CLS. 6, 18, 44, 46, 51 AND 52). REG. 8-13-2002.
- 2,608,141. WOO GEAR (STYLIZED). INT. CL. 25. (U.S. CLS. 22 AND 39). REG. 8-13-2002.
- 2,608,215. GREEN VALLEY RANCH. INT. CL. 25. (U.S. CLS. 22 AND 39). REG. 8-13-2002.
- 2,608,235. TRUCAL AND DESIGN. INT. CL. 5. (U.S. CLS. 6, 18, 44, 46, 51 AND 52). REG. 8-13-2002.
- 2,608,243. BMC. INT. CLS. 9 AND 42. (U.S. CLS. 21, 23, 26, 36, 38, 100 AND 101). REG. 8-13-2002.
- 2,608,322. ATLANTIC CITY WEEKLY. INT. CL. 16. (U.S. CLS. 2, 5, 22, 23, 29, 37, 38 AND 50). REG. 8-13-2002.
- 2,608,375. HERONRIB. INT. CL. 27. (U.S. CLS. 19, 20, 37, 42 AND 50). REG. 8-20-2002.
- 2,608,474. SEAPOINTE VILLAGE. INT. CLS. 35 AND 36. (U.S. CLS. 100, 101 AND 102). REG. 8-20-2002.
- 2,608,489. TERACHEM. INT. CL. 1. (U.S. CLS. 1, 5, 6, 10, 26 AND 46). REG. 8-20-2002.
- 2,608,643. SUMMER BREEZE. INT. CL. 21. (U.S. CLS. 2, 13, 23, 29, 30, 33, 40 AND 50). REG. 8-20-2002.
- 2,608,731. VISTAPORTAL (STYLIZED). INT. CL. 9. (U.S. CLS. 21, 23, 26, 36 AND 38). REG. 8-20-2002.
- 2,608,747. ASX. INT. CLS. 16 AND 41 ONLY. (U.S. CLS. 2, 5, 22, 23, 29, 37, 38, 50, 100, 101 AND 107). REG. 8-20-2002.
- 2,608,762. PETLAC. INT. CL. 5. (U.S. CLS. 6, 18, 44, 46, 51 AND 52). REG. 8-20-2002.
- 2,608,836. ALTIO. INT. CLS. 9 AND 42. (U.S. CLS. 21, 23, 26, 36, 38, 100 AND 101). REG. 8-20-2002.
- 2,608,957. ROUTERMAX. INT. CL. 7. (U.S. CLS. 13, 19, 21, 23, 31, 34 AND 35). REG. 8-20-2002.
- 2,609,021. OMNILOG. INT. CL. 9. (U.S. CLS. 21, 23, 26, 36 AND 38). REG. 8-20-2002.
- 2,609,084. FLIP-TOP. INT. CL. 20. (U.S. CLS. 2, 13, 22, 25, 32 AND 50). REG. 8-20-2002.
- 2,609,116. THE SUKKAH CENTER AND DESIGN. INT. CL. 19. (U.S. CLS. 1, 12, 33 AND 50). REG. 8-20-2002.
- 2,609,301. ARTURO VALDEZ GUITAR. INT. CL. 15. (U.S. CLS. 2, 21 AND 36). REG. 8-20-2002.
- 2,609,363. UNICEL. INT. CL. 6. (U.S. CLS. 2, 12, 13, 14, 23, 25 AND 50). REG. 8-20-2002.
- 2,609,469. BOVINE HEALTHWATCH. INT. CL. 16. (U.S. CLS. 2, 5, 22, 23, 29, 37, 38 AND 50). REG. 8-20-2002.
- 2,609,547. PREP-COAT PLUS. INT. CL. 2. (U.S. CLS. 6, 11 AND 16). REG. 8-20-2002.
- 2,609,782. JODAN'S. INT. CL. 30. (U.S. CL. 46). REG. 8-20-2002.
- 2,609,957. SAFETY STOP. INT. CL. 9. (U.S. CLS. 21, 23, 26, 36 AND 38). REG. 8-20-2002.
- 2,610,001. AUDIBLEREADY. INT. CL. 9. (U.S. CLS. 21, 23, 26, 36 AND 38). REG. 8-20-2002.
- 2,610,044. BYT. INT. CL. 14. (U.S. CLS. 2, 27, 28 AND 50). REG. 8-20-2002.
- 2,610,196. CHOICE SAVINGS. INT. CL. 16. (U.S. CLS. 2, 5, 22, 23, 29, 37, 38 AND 50). REG. 8-20-2002.
- 2,610,197. CHOICE SAVINGS. INT. CL. 35. (U.S. CLS. 100, 101 AND 102). REG. 8-20-2002.
- 2,610,290. EXPEDIA. INT. CL. 35. (U.S. CLS. 100, 101 AND 102). REG. 8-20-2002.
- 2,610,333. EMERSON AND DESIGN. INT. CL. 9. (U.S. CLS. 21, 23, 26, 36 AND 38). REG. 8-20-2002.
- 2,610,398. PUBEASY. INT. CL. 35. (U.S. CLS. 100, 101 AND 102). REG. 8-20-2002.
- 2,610,469. B AND DESIGN. INT. CLS. 7, 9, 12, 14, 18, 25 AND 37. (U.S. CLS. 1, 2, 3, 13, 19, 21, 22, 23, 26, 27, 28, 31, 34, 35, 36, 38, 39, 41, 44, 50, 100, 103 AND 106). REG. 8-20-2002.
- 2,610,471. HDHPLUS. INT. CL. 42. (U.S. CLS. 100 AND 101). REG. 8-20-2002.
- 2,610,477. CRAZY HEARTS. INT. CL. 28. (U.S. CLS. 22, 23, 38 AND 50). REG. 8-20-2002.
- 2,610,479. POSIFIX. INT. CL. 10. (U.S. CLS. 26, 39 AND 44). REG. 8-20-2002.
- 2,610,542. ACCOUNTCARE (STYLIZED). INT. CL. 36. (U.S. CLS. 100, 101 AND 102). REG. 8-20-2002.
- 2,610,621. WHAT'S WHAT (STYLIZED). INT. CL. 25. (U.S. CLS. 22 AND 39). REG. 8-20-2002.
- 2,610,643. AUTOMUNDO. INT. CL. 41. (U.S. CLS. 100, 101 AND 107). REG. 8-20-2002.
- 2,610,755. QUADRATEK. INT. CL. 40. (U.S. CLS. 100, 103 AND 106). REG. 8-20-2002.
- 2,610,774. ONEMBA. INT. CL. 41. (U.S. CLS. 100, 101 AND 107). REG. 8-20-2002.
- 2,610,795. MIAMI AD SCHOOL. INT. CL. 41. (U.S. CLS. 100, 101 AND 107). REG. 8-20-2002.
- 2,610,825. MISCELLANEOUS DESIGN. INT. CL. 9. (U.S. CLS. 21, 23, 26, 36 AND 38). REG. 8-20-2002.
- 2,610,920. SUPERGRASSE. INT. CL. 27. (U.S. CLS. 19, 20, 37, 42 AND 50). REG. 8-20-2002.
- 2,610,970. PROBE POLISH. INT. CL. 3. (U.S. CLS. 1, 4, 6, 50, 51 AND 52). REG. 8-20-2002.
- 2,611,006. CLEVELAND FAUCET GROUP. INT. CL. 11. (U.S. CLS. 13, 21, 23, 31 AND 34). REG. 8-20-2002.
- 2,611,014. RUGGED WYPES. INT. CL. 21. (U.S. CLS. 2, 13, 23, 29, 30, 33, 40 AND 50). REG. 8-20-2002.
- 2,611,017. EYE FACTORS. INT. CL. 5. (U.S. CLS. 6, 18, 44, 46, 51 AND 52). REG. 8-20-2002.
- 2,611,262. KERABEN (STYLIZED). INT. CL. 19. (U.S. CLS. 1, 12, 33 AND 50). REG. 8-27-2002.
- 2,611,280. SNIPS. INT. CL. 21. (U.S. CLS. 2, 13, 23, 29, 30, 33, 40 AND 50). REG. 8-27-2002.
- 2,611,425. SCHEDONI AND DESIGN. INT. CLS. 14 AND 28 ONLY. (U.S. CLS. 2, 22, 23, 27, 28, 38 AND 50). REG. 8-27-2002.
- 2,611,438. "THE CHOICE OF FOODSERVICE PROFESSIONALS". INT. CL. 21. (U.S. CLS. 2, 13, 23, 29, 30, 33, 40 AND 50). REG. 8-27-2002.
- 2,611,681. PAK RAK. INT. CL. 9. (U.S. CLS. 21, 23, 26, 36 AND 38). REG. 8-27-2002.
- 2,611,897. FASTCAT. INT. CL. 1. (U.S. CLS. 1, 5, 6, 10, 26 AND 46). REG. 8-27-2002.
- 2,611,947. MISCELLANEOUS DESIGN. INT. CL. 19. (U.S. CLS. 1, 12, 33 AND 50). REG. 8-27-2002.
- 2,612,122. RVG AND DESIGN. INT. CLS. 9, 11, 30 AND 32. (U.S. CLS. 13, 21, 23, 26, 31, 34, 36, 38, 45, 46 AND 48). REG. 8-27-2002.
- 2,612,139. 1-800 AUTO LOAN. INT. CL. 36. (U.S. CLS. 100, 101 AND 102). REG. 8-27-2002.
- 2,612,155. MICRO-POP. INT. CLS. 11 AND 17. (U.S. CLS. 1, 5, 12, 13, 21, 23, 31, 34, 35 AND 50). REG. 8-27-2002.
- 2,612,187. CITYBREAK. INT. CL. 9. (U.S. CLS. 21, 23, 26, 36 AND 38). REG. 8-27-2002.
- 2,612,257. AVAILABILITY PLUS. INT. CL. 37. (U.S. CLS. 100, 103 AND 106). REG. 8-27-2002.
- 2,612,280. CHARTSCRIPTMD. INT. CL. 9. (U.S. CLS. 21, 23, 26, 36 AND 38). REG. 8-27-2002.
- 2,612,322. PASCHAL'S. INT. CL. 42. (U.S. CLS. 100 AND 101). REG. 8-27-2002.
- 2,612,400. CREATING PATHWAYS TO DIVERSITY. INT. CL. 41. (U.S. CLS. 100, 101 AND 107). REG. 8-27-2002.
- 2,612,489. TEXAS HOMEGROWN #1 AND DESIGN. INT. CL. 30. (U.S. CL. 46). REG. 8-27-2002.
- 2,612,761. FJN. INT. CL. 35. (U.S. CLS. 100, 101 AND 102). REG. 8-27-2002.
- 2,612,842. POLYGARD. INT. CL. 11. (U.S. CLS. 13, 21, 23, 31 AND 34). REG. 8-27-2002.
- 2,612,864. THORSONS. INT. CL. 16. (U.S. CLS. 2, 5, 22, 23, 29, 37, 38 AND 50). REG. 8-27-2002.
- 2,612,949. UTLX LINK-NET. INT. CL. 42. (U.S. CLS. 100 AND 101). REG. 8-27-2002.
- 2,612,988. HORIZON DISTRIBUTION. INT. CL. 35. (U.S. CLS. 100, 101 AND 102). REG. 8-27-2002.
- 2,613,183. ELECTRIC (STYLIZED). INT. CL. 28. (U.S. CLS. 22, 23, 38 AND 50). REG. 8-27-2002.
- 2,613,384. BAMBOO AND DESIGN. INT. CL. 16. (U.S. CLS. 2, 5, 22, 23, 29, 37, 38 AND 50). REG. 8-27-2002.
- 2,613,461. SPECIALISTS PLACING SPECIALISTS. INT. CL. 35. (U.S. CLS. 100, 101 AND 102). REG. 8-27-2002.
- 2,613,490. TYCOR AND DESIGN. INT. CL. 36. (U.S. CLS. 100, 101 AND 102). REG. 8-27-2002.
- 2,613,543. KNOWH2OW (STYLIZED). INT. CLS. 41 AND 42. (U.S. CLS. 100, 101 AND 107). REG. 8-27-2002.
- 2,613,584. NOAH'S ARK (STYLIZED). INT. CL. 41. (U.S. CLS. 100, 101 AND 107). REG. 9-3-2002.

- 2,613,818. TEKLOGIC. INT. CLS. 37 AND 42. (U.S. CLS. 100, 101, 103 AND 106). REG. 9-3-2002.
- 2,613,964. MISCELLANEOUS DESIGN. INT. CLS. 7 AND 12. (U.S. CLS. 13, 19, 21, 23, 31, 34, 35 AND 44). REG. 9-3-2002.
- 2,614,002. THE CHRISTMAS PALACE. INT. CL. 35. (U.S. CLS. 100, 101 AND 102). REG. 9-3-2002.
- 2,614,129. VAN DUZER. INT. CL. 33. (U.S. CLS. 47 AND 49). REG. 9-3-2002.
- 2,614,261. MISCELLANEOUS DESIGN. INT. CL. 1. (U.S. CLS. 1, 5, 6, 10, 26 AND 46). REG. 9-3-2002.
- 2,614,262. ENZYME MANUFACTURER TO THE WORLD. INT. CL. 1. (U.S. CLS. 1, 5, 6, 10, 26 AND 46). REG. 9-3-2002.
- 2,614,332. CIMA AND DESIGN. INT. CLS. 16 AND 35. (U.S. CLS. 2, 5, 22, 23, 29, 37, 38, 50, 100, 101 AND 102). REG. 9-3-2002.
- 2,614,333. CIMA. INT. CLS. 16 AND 35. (U.S. CLS. 2, 5, 22, 23, 29, 37, 38, 50, 100, 101 AND 102). REG. 9-3-2002.
- 2,614,435. DERMAZ. INT. CL. 1. (U.S. CLS. 1, 5, 6, 10, 26 AND 46). REG. 9-3-2002.
- 2,614,520. DOCTEUR VALNET. INT. CLS. 3, 5 AND 35. (U.S. CLS. 1, 4, 6, 18, 44, 46, 50, 51, 52, 100, 101 AND 102). REG. 9-3-2002.
- 2,614,525. FORMEX. INT. CL. 14. (U.S. CLS. 2, 27, 28 AND 50). REG. 9-3-2002.
- 2,614,904. BURDICK CUSTOM HOMES AND DESIGN. INT. CL. 37. (U.S. CLS. 100, 103 AND 106). REG. 9-3-2002.
- 2,614,952. MELBA. INT. CL. 33. (U.S. CLS. 47 AND 49). REG. 9-3-2002.
- 2,614,953. NOBLE ONE. INT. CL. 33. (U.S. CLS. 47 AND 49). REG. 9-3-2002.
- 2,614,954. BLACK NOBLE. INT. CL. 33. (U.S. CLS. 47 AND 49). REG. 9-3-2002.
- 2,615,018. NATIVE NEW YORKER RESTAURANT AND DESIGN. INT. CL. 43. (U.S. CLS. 100 AND 101). REG. 9-3-2002.
- 2,615,032. MAKE THE RIGHT CONNECTION. INT. CL. 37. (U.S. CLS. 100, 103 AND 106). REG. 9-3-2002.
- 2,615,091. TIP-UP TOWN U.S.A.. INT. CL. 41. (U.S. CLS. 100, 101 AND 107). REG. 9-3-2002.
- 2,615,233. SUCCESSFUL RECRUITMENT. INT. CL. 16. (U.S. CLS. 2, 5, 22, 23, 29, 37, 38 AND 50). REG. 9-3-2002.
- 2,615,415. EMERALD. INT. CL. 35. (U.S. CLS. 100, 101 AND 102). REG. 9-3-2002.
- 2,615,500. KIWI. INT. CL. 10. (U.S. CLS. 26, 39 AND 44). REG. 9-3-2002.
- 2,615,709. TTYL. INT. CLS. 18, 21, 24 AND 25 ONLY. (U.S. CLS. 1, 2, 3, 13, 22, 23, 29, 30, 33, 39, 40, 41, 42 AND 50). REG. 9-3-2002.
- 2,615,839. SKITTER WALK. INT. CL. 28. (U.S. CLS. 22, 23, 38 AND 50). REG. 9-3-2002.
- 2,616,023. PERI-GUM. INT. CL. 3. (U.S. CLS. 1, 4, 6, 50, 51 AND 52). REG. 9-3-2002.
- 2,616,170. MISCELLANEOUS DESIGN. INT. CL. 17. (U.S. CLS. 1, 5, 12, 13, 35 AND 50). REG. 9-10-2002.
- 2,616,674. NANOCUBE (STYLIZED). INT. CL. 9 ONLY. (U.S. CLS. 21, 23, 26, 36 AND 38). REG. 9-10-2002.
- 2,616,683. SHOCKBOARD. INT. CL. 12. (U.S. CLS. 19, 21, 23, 31, 35 AND 44). REG. 9-10-2002.
- 2,616,942. SECUREWORKS. INT. CL. 9. (U.S. CLS. 21, 23, 26, 36 AND 38). REG. 9-10-2002.
- 2,616,970. AIRCHAMP PRO. INT. CL. 12. (U.S. CLS. 19, 21, 23, 31, 35 AND 44). REG. 9-10-2002.
- 2,617,058. SIGMA POOL AND DESIGN. INT. CLS. 7 AND 9. (U.S. CLS. 13, 19, 21, 23, 26, 31, 34, 35, 36 AND 38). REG. 9-10-2002.
- 2,617,677. PERMA VAULT (STYLIZED). INT. CL. 6. (U.S. CLS. 2, 12, 13, 14, 23, 25 AND 50). REG. 9-10-2002.
- 2,617,679. MOSSY OAK PROPERTIES. INT. CL. 36. (U.S. CLS. 100, 101 AND 102). REG. 9-10-2002.
- 2,617,707. EMONSTER. INT. CL. 35. (U.S. CLS. 100, 101 AND 102). REG. 9-10-2002.
- 2,617,710. GOLDEN PYRAMIDS. INT. CL. 9. (U.S. CLS. 21, 23, 26, 36 AND 38). REG. 9-10-2002.
- 2,617,741. FARE AND DESIGN. INT. CL. 9. (U.S. CLS. 21, 23, 26, 36 AND 38). REG. 9-10-2002.
- 2,617,913. ECCOSHIELD. INT. CL. 17. (U.S. CLS. 1, 5, 12, 13, 35 AND 50). REG. 9-10-2002.
- 2,618,122. BIGMACHINES. INT. CL. 9. (U.S. CLS. 21, 23, 26, 36 AND 38). REG. 9-10-2002.
- 2,618,178. PURRFECTLY FRESH. INT. CL. 5. (U.S. CLS. 6, 18, 44, 46, 51 AND 52). REG. 9-10-2002.
- 2,618,665. SEPTIC PRO. INT. CL. 1. (U.S. CLS. 1, 5, 6, 10, 26 AND 46). REG. 9-10-2002.
- 2,618,701. HEAT FORCE. INT. CL. 4. (U.S. CLS. 1, 6 AND 15). REG. 9-10-2002.
- 2,618,954. CARLOS TORANO EXODUS 1959. INT. CL. 34. (U.S. CLS. 2, 8, 9 AND 17). REG. 9-10-2002.
- 2,619,002. EYECARECONNECT. INT. CL. 9. (U.S. CLS. 21, 23, 26, 36 AND 38). REG. 9-10-2002.
- 2,619,060. ENZYME WAVE STANDARD CHARACTER MARK. INT. CL. 16. (U.S. CLS. 2, 5, 22, 23, 29, 37, 38 AND 50). REG. 9-10-2002.
- 2,619,145. NUTRIENT CONTROL SYSTEM. INT. CL. 11. (U.S. CLS. 13, 21, 23, 31 AND 34). REG. 9-10-2002.
- 2,619,148. PORTABLE BUBBLES MACHINE. INT. CL. 28. (U.S. CLS. 22, 23, 38 AND 50). REG. 9-10-2002.
- 2,619,363. HOMEPORTAL. INT. CL. 9. (U.S. CLS. 21, 23, 26, 36 AND 38). REG. 9-17-2002.
- 2,619,456. CONCEPTS AND DESIGN. INT. CL. 35. (U.S. CLS. 100, 101 AND 102). REG. 9-17-2002.
- 2,619,531. NEW MEXICO AND DESIGN. INT. CL. 25. (U.S. CLS. 22 AND 39). REG. 9-17-2002.
- 2,619,564. IFE GROUP. INT. CL. 35. (U.S. CLS. 100, 101 AND 102). REG. 9-17-2002.
- 2,620,196. AMANDA WAKELEY. INT. CL. 25. (U.S. CLS. 22 AND 39). REG. 9-17-2002.
- 2,620,568. PRIMERA. INT. CL. 36. (U.S. CLS. 100, 101 AND 102). REG. 9-17-2002.
- 2,620,648. NATIONAL ELECTRIC COIL. INT. CL. 37. (U.S. CLS. 100, 103 AND 106). REG. 9-17-2002.
- 2,620,663. STARKEY INTERNATIONAL. INT. CLS. 16 AND 41. (U.S. CLS. 2, 5, 22, 23, 29, 37, 38, 50, 100, 101 AND 107). REG. 9-17-2002.
- 2,620,680. MISCELLANEOUS DESIGN. INT. CL. 41. (U.S. CLS. 100, 101 AND 107). REG. 9-17-2002.
- 2,621,138. RUBBER DUCKY. INT. CL. 3. (U.S. CLS. 1, 4, 6, 50, 51 AND 52). REG. 9-17-2002.
- 2,621,144. MISCELLANEOUS DESIGN. INT. CL. 36. (U.S. CLS. 100, 101 AND 102). REG. 9-17-2002.
- 2,621,255. KENDA AND DESIGN. INT. CL. 35. (U.S. CLS. 100, 101 AND 102). REG. 9-17-2002.
- 2,621,359. BEXT. INT. CL. 7. (U.S. CLS. 13, 19, 21, 23, 31, 34 AND 35). REG. 9-17-2002.
- 2,621,393. CAVEWALL. INT. CL. 35. (U.S. CLS. 100, 101 AND 102). REG. 9-17-2002.
- 2,621,497. 41IPAIN. INT. CLS. 35 AND 42. (U.S. CLS. 100, 101 AND 102). REG. 9-17-2002.
- 2,621,524. TRI-STATE GENERATION AND TRANSMISSION ASSOCIATION, INC.. INT. CLS. 39 AND 40. (U.S. CLS. 100, 103, 105 AND 106). REG. 9-17-2002.
- 2,621,575. Z TRIMMER AND DESIGN. INT. CL. 7. (U.S. CLS. 13, 19, 21, 23, 31, 34 AND 35). REG. 9-17-2002.
- 2,621,927. PIANOSOFT.PLUS AUDIO AND DESIGN. INT. CL. 9. (U.S. CLS. 21, 23, 26, 36 AND 38). REG. 9-17-2002.
- 2,622,256. AZATROL. INT. CL. 5. (U.S. CLS. 6, 18, 44, 46, 51 AND 52). REG. 9-17-2002.
- 2,622,455. THE WHITEBOARD SOURCE. INT. CL. 35. (U.S. CLS. 100, 101 AND 102). REG. 9-17-2002.
- 2,622,487. STOCK BUILDING SUPPLY. INT. CL. 37. (U.S. CLS. 100, 103 AND 106). REG. 9-17-2002.
- 2,622,658. MISCELLANEOUS DESIGN. INT. CLS. 40 AND 42. (U.S. CLS. 100, 101, 103 AND 106). REG. 9-24-2002.
- 2,622,846. BONTAZ CENTRE (STYLIZED). INT. CLS. 7 AND 12. (U.S. CLS. 13, 19, 21, 23, 31, 34, 35 AND 44). REG. 9-24-2002.
- 2,622,908. HOS AND DESIGN. INT. CL. 39. (U.S. CLS. 100 AND 105). REG. 9-24-2002.
- 2,622,910. HOS. INT. CL. 39. (U.S. CLS. 100 AND 105). REG. 9-24-2002.
- 2,623,001. TRU-START. INT. CL. 6. (U.S. CLS. 2, 12, 13, 14, 23, 25 AND 50). REG. 9-24-2002.
- 2,623,157. GOLF MINNESOTA. INT. CLS. 16 AND 42. (U.S. CLS. 2, 5, 22, 23, 29, 37, 38, 50, 100 AND 101). REG. 9-24-2002.
- 2,623,494. MISCELLANEOUS DESIGN. INT. CL. 41. (U.S. CLS. 100, 101 AND 107). REG. 9-24-2002.
- 2,623,720. TRITON INDUSTRIES AND DESIGN. INT. CLS. 37 AND 40. (U.S. CLS. 100, 103 AND 106). REG. 9-24-2002.

- 2,623,960. HAVING LIGHT WE PASS IT ON TO OTHERS WITTENBERG UNIVERSITY FOUNDED 1845 SPRINGFIELD, OHIO AND DESIGN. INT. CLS. 14, 16, 20, 21 AND 41 ONLY. (U.S. CLS. 2, 5, 13, 22, 23, 25, 27, 28, 29, 30, 32, 33, 37, 38, 40, 50, 100, 101 AND 107). REG. 9-24-2002.
- 2,624,317. VGS VISUAL GRAPHIC SYSTEMS INC. AND DESIGN. INT. CL. 20. (U.S. CLS. 2, 13, 22, 25, 32 AND 50). REG. 9-24-2002.
- 2,624,477. KRYPTOLYTE. INT. CL. 28. (U.S. CLS. 22, 23, 38 AND 50). REG. 9-24-2002.
- 2,624,580. RUG DOCTOR. INT. CL. 37. (U.S. CLS. 100, 103 AND 106). REG. 9-24-2002.
- 2,624,899. HOMESTEAD. INT. CL. 29. (U.S. CL. 46). REG. 9-24-2002.
- 2,624,938. THE ROYAL TOUR. INT. CL. 41. (U.S. CLS. 100, 101 AND 107). REG. 9-24-2002.
- 2,625,029. NU IMAGE. INT. CL. 16. (U.S. CLS. 2, 5, 22, 23, 29, 37, 38 AND 50). REG. 9-24-2002.
- 2,625,098. MOUNTAIN PLEASURE HORSE ASSOCIATION. INT. CL. 42. (U.S. CLS. 100 AND 101). REG. 9-24-2002.
- 2,625,153. FLEXMOUNT. INT. CL. 1. (U.S. CLS. 1, 5, 6, 10, 26 AND 46). REG. 9-24-2002.
- 2,625,368. TIME FOR TWO (STYLIZED). INT. CL. 35. (U.S. CLS. 100, 101 AND 102). REG. 9-24-2002.
- 2,625,410. SPEED BAG. INT. CL. 18. (U.S. CLS. 1, 2, 3, 22 AND 41). REG. 9-24-2002.
- 2,625,549. MISCELLANEOUS DESIGN. INT. CL. 11. (U.S. CLS. 13, 21, 23, 31 AND 34). REG. 9-24-2002.
- 2,625,550. VISTEON AND DESIGN. INT. CL. 11. (U.S. CLS. 13, 21, 23, 31 AND 34). REG. 9-24-2002.
- 2,625,551. VISTEON AND DESIGN. INT. CL. 11. (U.S. CLS. 13, 21, 23, 31 AND 34). REG. 9-24-2002.
- 2,625,596. ACOUSTIC MUSIC.ORG AND DESIGN. INT. CL. 35. (U.S. CLS. 100, 101 AND 102). REG. 9-24-2002.
- 2,625,742. MISCELLANEOUS DESIGN. INT. CL. 36. (U.S. CLS. 100, 101 AND 102). REG. 9-24-2002.
- 2,625,839. HGN (STYLIZED). INT. CL. 6. (U.S. CLS. 2, 12, 13, 14, 23, 25 AND 50). REG. 9-24-2002.
- 2,626,945. BUBBLES INSIDE BUBBLES. INT. CL. 28. (U.S. CLS. 22, 23, 38 AND 50). REG. 9-24-2002.
- 2,627,117. DIAMOND HARDWOODS AND DESIGN. INT. CL. 19. (U.S. CLS. 1, 12, 33 AND 50). REG. 10-1-2002.
- 2,627,272. CUSTOMER OPERATIONS SUPPORT CENTER. INT. CLS. 38 AND 41. (U.S. CLS. 100, 101, 104 AND 107). REG. 10-1-2002.
- 2,628,162. CHOMPI. INT. CL. 1. (U.S. CLS. 1, 5, 6, 10, 26 AND 46). REG. 10-1-2002.
- 2,629,240. BVX. INT. CL. 9. (U.S. CLS. 21, 23, 26, 36 AND 38). REG. 10-1-2002.
- 2,629,775. DIAMOND DECKING AND DESIGN. INT. CL. 19. (U.S. CLS. 1, 12, 33 AND 50). REG. 10-8-2002.
- 2,629,834. IEXPLORE AND DESIGN. INT. CL. 39 ONLY. (U.S. CLS. 100 AND 105). REG. 10-8-2002.
- 2,629,896. HOT MIX. INT. CL. 29. (U.S. CL. 46). REG. 10-8-2002.
- 2,629,989. IRLEN. INT. CLS. 41 AND 42. (U.S. CLS. 100, 101 AND 107). REG. 10-8-2002.
- 2,630,055. XWIN AND DESIGN. INT. CL. 7. (U.S. CLS. 13, 19, 21, 23, 31, 34 AND 35). REG. 10-8-2002.
- 2,630,073. TECHNERGY. INT. CL. 9. (U.S. CLS. 21, 23, 26, 36 AND 38). REG. 10-8-2002.
- 2,630,630. BEAT THE STREAK. INT. CL. 41. (U.S. CLS. 100, 101 AND 107). REG. 10-8-2002.
- 2,631,074. THE PATH OF A LIFETIME. INT. CL. 37. (U.S. CLS. 100, 103 AND 106). REG. 10-8-2002.
- 2,631,214. TEXAS HOMEGROWN. INT. CL. 30. (U.S. CL. 46). REG. 10-8-2002.
- 2,631,241. MARKETFRESH LA CARTE. INT. CL. 35. (U.S. CLS. 100, 101 AND 102). REG. 10-8-2002.
- 2,631,343. ROCK BOTTOM AUCTIONS. INT. CL. 35. (U.S. CLS. 100, 101 AND 102). REG. 10-8-2002.
- 2,631,365. VICTORIA ARDUINO. INT. CL. 11. (U.S. CLS. 13, 21, 23, 31 AND 34). REG. 10-8-2002.
- 2,631,484. CLAIMSQUEST. INT. CL. 36 ONLY. (U.S. CLS. 100, 101 AND 102). REG. 10-8-2002.
- 2,631,665. ASPEN. INT. CL. 30. (U.S. CL. 46). REG. 10-8-2002.
- 2,632,064. MISCELLANEOUS DESIGN. INT. CL. 33. (U.S. CLS. 47 AND 49). REG. 10-8-2002.
- 2,632,525. FASSI AND DESIGN. INT. CLS. 7 AND 12. (U.S. CLS. 13, 19, 21, 23, 31, 34, 35 AND 44). REG. 10-8-2002.
- 2,632,562. SAN COOLER. INT. CL. 9. (U.S. CLS. 21, 23, 26, 36 AND 38). REG. 10-8-2002.
- 2,632,821. GOATTHROAT. INT. CL. 7. (U.S. CLS. 13, 19, 21, 23, 31, 34 AND 35). REG. 10-8-2002.
- 2,632,861. WORKTUNES. INT. CLS. 9 AND 10. (U.S. CLS. 21, 23, 26, 36, 38, 39 AND 44). REG. 10-8-2002.
- 2,634,453. CHEMICAL SOURCES ASSOCIATION. INT. CL. 42. (U.S. CLS. 100 AND 101). REG. 10-15-2002.
- 2,634,516. QUALITY YOU CAN TASTE. INT. CLS. 35 AND 42. (U.S. CLS. 100, 101 AND 102). REG. 10-15-2002.
- 2,634,879. LL. INT. CL. 36. (U.S. CLS. 100, 101 AND 102). REG. 10-15-2002.
- 2,634,886. WORLD SELECT. INT. CL. 29. (U.S. CL. 46). REG. 10-15-2002.
- 2,635,422. PASTELLE. INT. CL. 16. (U.S. CLS. 2, 5, 22, 23, 29, 37, 38 AND 50). REG. 10-15-2002.
- 2,636,796. SILENTLINE. INT. CL. 6. (U.S. CLS. 2, 12, 13, 14, 23, 25 AND 50). REG. 10-15-2002.
- 2,636,799. INTERCOMPOSITE. INT. CL. 20. (U.S. CLS. 2, 13, 22, 25, 32 AND 50). REG. 10-15-2002.
- 2,637,042. SUMOTECH. INT. CL. 3. (U.S. CLS. 1, 4, 6, 50, 51 AND 52). REG. 10-15-2002.
- 2,638,190. INSULIN PUMPER. INT. CLS. 38 AND 42. (U.S. CLS. 100, 101 AND 104). REG. 10-22-2002.
- 2,638,256. WESTGARD. INT. CL. 41. (U.S. CLS. 100, 101 AND 107). REG. 10-22-2002.
- 2,638,445. LONG WINDOWS AND DESIGN. INT. CL. 37. (U.S. CLS. 100, 103 AND 106). REG. 10-22-2002.
- 2,638,446. LONG SIDING AND DESIGN. INT. CL. 37. (U.S. CLS. 100, 103 AND 106). REG. 10-22-2002.
- 2,638,447. LONG DOORS AND DESIGN. INT. CL. 37. (U.S. CLS. 100, 103 AND 106). REG. 10-22-2002.
- 2,638,982. STORAGE INNOVATIONS AND DESIGN. INT. CL. 20. (U.S. CLS. 2, 13, 22, 25, 32 AND 50). REG. 10-22-2002.
- 2,639,176. PIERMARIA. INT. CL. 15. (U.S. CLS. 2, 21 AND 36). REG. 10-22-2002.
- 2,639,439. RUG DOCTOR PRO. INT. CL. 7. (U.S. CLS. 13, 19, 21, 23, 31, 34 AND 35). REG. 10-22-2002.
- 2,639,522. PREMIO PRONTO. INT. CL. 29. (U.S. CL. 46). REG. 10-22-2002.
- 2,639,529. CLASSIC. INT. CL. 11. (U.S. CLS. 13, 21, 23, 31 AND 34). REG. 10-22-2002.
- 2,639,580. SOUNDEXCHANGE. INT. CL. 36. (U.S. CLS. 100, 101 AND 102). REG. 10-22-2002.
- 2,639,893. ASHTON. INT. CL. 34. (U.S. CLS. 2, 8, 9 AND 17). REG. 10-22-2002.
- 2,639,990. PURAPHARM. INT. CL. 5. (U.S. CLS. 6, 18, 44, 46, 51 AND 52). REG. 10-22-2002.
- 2,640,027. WAVEEASY. INT. CL. 9. (U.S. CLS. 21, 23, 26, 36 AND 38). REG. 10-22-2002.
- 2,640,047. NETBEACON. INT. CL. 9. (U.S. CLS. 21, 23, 26, 36 AND 38). REG. 10-22-2002.
- 2,641,590. INFOWORKSPACE. INT. CL. 9. (U.S. CLS. 21, 23, 26, 36 AND 38). REG. 10-29-2002.
- 2,641,682. KUBOTA SHOWROOM. INT. CL. 9. (U.S. CLS. 21, 23, 26, 36 AND 38). REG. 10-29-2002.
- 2,641,770. MOLD MAX. INT. CL. 1. (U.S. CLS. 1, 5, 6, 10, 26 AND 46). REG. 10-29-2002.
- 2,641,913. INSMARK. INT. CLS. 9, 35 AND 36. (U.S. CLS. 21, 23, 26, 36, 38, 100, 101 AND 102). REG. 10-29-2002.
- 2,642,266. EASYLIFT. INT. CL. 7. (U.S. CLS. 13, 19, 21, 23, 31, 34 AND 35). REG. 10-29-2002.
- 2,642,315. TOMCAT AND DESIGN. INT. CLS. 5 AND 21. (U.S. CLS. 2, 6, 13, 18, 23, 29, 30, 33, 40, 44, 46, 50, 51 AND 52). REG. 10-29-2002.
- 2,642,552. CLETOP. INT. CL. 9. (U.S. CLS. 21, 23, 26, 36 AND 38). REG. 10-29-2002.
- 2,643,012. INCASE. INT. CL. 9. (U.S. CLS. 21, 23, 26, 36 AND 38). REG. 10-29-2002.
- 2,643,248. ROYAL KING WUCHI BAIFENG WAN MULTIPLE HERB FORMULA WITH BONE MEAL AND OYSTER SHELL AND DESIGN. INT. CL. 5 ONLY. (U.S. CLS. 6, 18, 44, 46, 51 AND 52). REG. 10-29-2002.
- 2,644,639. FIDELITYCONNECT. INT. CL. 36. (U.S. CLS. 100, 101 AND 102). REG. 10-29-2002.
- 2,644,696. GRUPO POSADAS. INT. CL. 42. (U.S. CLS. 100 AND 101). REG. 10-29-2002.
- 2,645,049. XLSOFT. INT. CLS. 9 AND 42. (U.S. CLS. 21, 23, 26, 36, 38, 100 AND 101). REG. 11-5-2002.
- 2,645,123. FORTUNE 100 BEST COMPANIES TO WORK FOR. INT. CL. 16. (U.S. CLS. 2, 5, 22, 23, 29, 37, 38 AND 50). REG. 11-5-2002.

- 2,645,668. FIDELITY NETBENEFITS. INT. CL. 36. (U.S. CLS. 100, 101 AND 102). REG. 11-5-2002.
- 2,645,762. SILVERADO VINEYARDS (STYLIZED). INT. CL. 33. (U.S. CLS. 47 AND 49). REG. 11-5-2002.
- 2,645,974. INTERPACK (STYLIZED). INT. CL. 35. (U.S. CLS. 100, 101 AND 102). REG. 11-5-2002.
- 2,646,333. FIRST HOBBY. INT. CL. 35. (U.S. CLS. 100, 101 AND 102). REG. 11-5-2002.
- 2,646,384. MSN AND DESIGN. INT. CL. 36. (U.S. CLS. 100, 101 AND 102). REG. 11-5-2002.
- 2,646,459. URBAN TAILS. INT. CLS. 41 AND 42. (U.S. CLS. 100, 101 AND 107). REG. 11-5-2002.
- 2,648,204. MISCELLANEOUS DESIGN. INT. CLS. 5, 7, 8 AND 10 ONLY. (U.S. CLS. 6, 13, 18, 19, 21, 23, 26, 28, 31, 34, 35, 39, 44, 46, 51 AND 52). REG. 11-12-2002.
- 2,648,370. PTA (STYLIZED). INT. CL. 41. (U.S. CLS. 100, 101 AND 107). REG. 11-12-2002.
- 2,648,758. INTEGRITY. INT. CL. 7. (U.S. CLS. 13, 19, 21, 23, 31, 34 AND 35). REG. 11-12-2002.
- 2,649,569. METAMESA. INT. CL. 42. (U.S. CLS. 100 AND 101). REG. 11-12-2002.
- 2,650,602. ZOE. INT. CL. 42. (U.S. CLS. 100 AND 101). REG. 11-12-2002.
- 2,651,157. BLOMUS. INT. CLS. 14, 16, 20 AND 21. (U.S. CLS. 2, 5, 13, 22, 23, 25, 27, 28, 29, 30, 32, 33, 37, 38, 40 AND 50). REG. 11-19-2002.
- 2,651,945. CUTTINGEDGE.COM. INT. CL. 35. (U.S. CLS. 100, 101 AND 102). REG. 11-19-2002.
- 2,652,133. SPORTS ATTITUDE AND DESIGN. INT. CL. 25. (U.S. CLS. 22 AND 39). REG. 11-19-2002.
- 2,652,212. DEAD STRAIGHT. INT. CL. 25. (U.S. CLS. 22 AND 39). REG. 11-19-2002.
- 2,652,263. CONVERTING SOLUTIONS. INT. CL. 7. (U.S. CLS. 13, 19, 21, 23, 31, 34 AND 35). REG. 11-19-2002.
- 2,652,285. ELAMINATOR. INT. CL. 7. (U.S. CLS. 13, 19, 21, 23, 31, 34 AND 35). REG. 11-19-2002.
- 2,653,276. UNITED MARINE COMMUNICATIONS. INT. CL. 9. (U.S. CLS. 21, 23, 26, 36 AND 38). REG. 11-26-2002.
- 2,653,684. ONE-STEP. INT. CL. 16. (U.S. CLS. 2, 5, 22, 23, 29, 37, 38 AND 50). REG. 11-26-2002.
- 2,654,136. FIDELITY BILLPAY. INT. CL. 36. (U.S. CLS. 100, 101 AND 102). REG. 11-26-2002.
- 2,654,225. UNION LABOR LIFE. INT. CL. 36. (U.S. CLS. 100, 101 AND 102). REG. 11-26-2002.
- 2,654,425. TOM'S #1 WORLD FAMOUS CHILIBURGERS. INT. CL. 42. (U.S. CLS. 100 AND 101). REG. 11-26-2002.
- 2,654,532. T AND DESIGN. INT. CLS. 39 AND 40. (U.S. CLS. 100, 103, 105 AND 106). REG. 11-26-2002.
- 2,654,596. REAL MOMENTS. INT. CL. 41. (U.S. CLS. 100, 101 AND 107). REG. 11-26-2002.
- 2,655,162. COLORS & TEXTURES COLLECTION. INT. CL. 16. (U.S. CLS. 2, 5, 22, 23, 29, 37, 38 AND 50). REG. 11-26-2002.
- 2,656,084. DESIGN TWENTY THREE. INT. CL. 42. (U.S. CLS. 100 AND 101). REG. 12-3-2002.
- 2,656,115. SUPER POWER PAKS. INT. CL. 5. (U.S. CLS. 6, 18, 44, 46, 51 AND 52). REG. 12-3-2002.
- 2,656,775. BITORSION. INT. CLS. 7 AND 8. (U.S. CLS. 13, 19, 21, 23, 28, 31, 34, 35 AND 44). REG. 12-3-2002.
- 2,659,309. OLOGY. INT. CL. 41. (U.S. CLS. 100, 101 AND 107). REG. 12-10-2002.
- 2,659,438. TUXEGO (STYLIZED). INT. CL. 42 ONLY. (U.S. CLS. 100 AND 101). REG. 12-10-2002.
- 2,659,634. HUKI AND DESIGN. INT. CL. 12. (U.S. CLS. 19, 21, 23, 31, 35 AND 44). REG. 12-10-2002.
- 2,659,927. PANDEMIC AND DESIGN. INT. CL. 41. (U.S. CLS. 100, 101 AND 107). REG. 12-10-2002.
- 2,659,983. THE READING ROOM. INT. CL. 16. (U.S. CLS. 2, 5, 22, 23, 29, 37, 38 AND 50). REG. 12-10-2002.
- 2,660,292. CAIH. U.S. CL. B. REG. 12-10-2002.
- 2,660,348. FULL VIEW. INT. CL. 36. (U.S. CLS. 100, 101 AND 102). REG. 12-10-2002.
- 2,661,666. MOSQUITO GUARD. INT. CL. 9. (U.S. CLS. 21, 23, 26, 36 AND 38). REG. 12-17-2002.
- 2,662,230. SMASH! PLASTIC. INT. CL. 1. (U.S. CLS. 1, 5, 6, 10, 26 AND 46). REG. 12-17-2002.
- 2,662,236. HATCH MEDICAL AND DESIGN. INT. CL. 42. (U.S. CLS. 100 AND 101). REG. 12-17-2002.
- 2,662,278. EUCERIN AND DESIGN. INT. CLS. 3 AND 5. (U.S. CLS. 1, 4, 6, 18, 44, 46, 50, 51 AND 52). REG. 12-17-2002.
- 2,662,343. MISCELLANEOUS DESIGN. INT. CL. 6. (U.S. CLS. 2, 12, 13, 14, 23, 25 AND 50). REG. 12-17-2002.
- 2,662,451. DELTA AIRELITE. INT. CL. 39. (U.S. CLS. 100 AND 105). REG. 12-17-2002.
- 2,662,709. FIDELITY ADVISOR MONEY LINE. INT. CL. 36. (U.S. CLS. 100, 101 AND 102). REG. 12-17-2002.
- 2,662,838. PINCH.A.PENNY EXPRESS (STYLIZED). INT. CL. 35. (U.S. CLS. 100, 101 AND 102). REG. 12-17-2002.
- 2,662,842. ALGEBRA'SCOOL. INT. CL. 9. (U.S. CLS. 21, 23, 26, 36 AND 38). REG. 12-17-2002.
- 2,662,886. GRAY GHOST. INT. CL. 33. (U.S. CLS. 47 AND 49). REG. 12-17-2002.
- 2,662,899. BRIGHT FUTURES. INT. CL. 36. (U.S. CLS. 100, 101 AND 102). REG. 12-17-2002.
- 2,663,380. GOBLET. INT. CL. 35. (U.S. CLS. 100, 101 AND 102). REG. 12-17-2002.
- 2,663,529. CDMA2000. U.S. CLS. A AND B. REG. 12-17-2002.
- 2,663,880. XBOX. INT. CL. 9. (U.S. CLS. 21, 23, 26, 36 AND 38). REG. 12-17-2002.
- 2,664,296. ROADRAGS (STYLIZED). INT. CL. 11. (U.S. CLS. 13, 21, 23, 31 AND 34). REG. 12-17-2002.
- 2,664,623. RED RASPBERRY DOLLARS. INT. CL. 30. (U.S. CL. 46). REG. 12-17-2002.
- 2,664,669. FIDELITY CONNECT AND DESIGN. INT. CL. 36. (U.S. CLS. 100, 101 AND 102). REG. 12-17-2002.
- 2,665,879. TALBOT. INT. CL. 12. (U.S. CLS. 19, 21, 23, 31, 35 AND 44). REG. 12-24-2002.
- 2,665,965. WESTOW.COM CONTAINERS/OFFICE TRAILERS AND DESIGN. INT. CL. 39. (U.S. CLS. 100 AND 105). REG. 12-24-2002.
- 2,666,779. ENTERPRISE FINANCIAL. INT. CL. 36. (U.S. CLS. 100, 101 AND 102). REG. 12-24-2002.
- 2,666,994. LABMATES. INT. CL. 25. (U.S. CLS. 22 AND 39). REG. 12-24-2002.
- 2,667,149. MELARIS. INT. CL. 42. (U.S. CLS. 100 AND 101). REG. 12-24-2002.
- 2,667,375. THE SUDS PUMP. INT. CL. 21. (U.S. CLS. 2, 13, 23, 29, 30, 33, 40 AND 50). REG. 12-24-2002.
- 2,667,393. ELLSWORTH ADHESIVES. INT. CLS. 35 AND 42. (U.S. CLS. 100, 101 AND 102). REG. 12-24-2002.
- 2,668,150. WITTENBERG. INT. CLS. 16, 21, 25 AND 41 ONLY. (U.S. CLS. 2, 5, 13, 22, 23, 29, 30, 33, 37, 38, 39, 40, 50, 100, 101 AND 107). REG. 12-31-2002.
- 2,668,540. WE PACK LOGISTICS. INT. CL. 39. (U.S. CLS. 100 AND 105). REG. 12-31-2002.
- 2,668,542. WE PACK LOGISTICS AND DESIGN. INT. CL. 39. (U.S. CLS. 100 AND 105). REG. 12-31-2002.
- 2,668,579. DIXON AND DESIGN. INT. CLS. 9, 11, 15, 16 AND 20. (U.S. CLS. 2, 5, 13, 21, 22, 23, 25, 26, 29, 31, 32, 34, 36, 37, 38 AND 50). REG. 12-31-2002.
- 2,668,745. BESTQUEST TEACHING SYSTEMS. INT. CL. 41. (U.S. CLS. 100, 101 AND 107). REG. 12-31-2002.
- 2,668,873. THE JACKSON CITIZEN PATRIOT. INT. CL. 16. (U.S. CLS. 2, 5, 22, 23, 29, 37, 38 AND 50). REG. 12-31-2002.
- 2,669,553. THE WEB AND THE LADDER. INT. CLS. 9 AND 16. (U.S. CLS. 2, 5, 21, 22, 23, 26, 29, 36, 37, 38 AND 50). REG. 12-31-2002.
- 2,669,977. T-ZONE. INT. CL. 6 ONLY. (U.S. CLS. 2, 12, 13, 14, 23, 25 AND 50). REG. 12-31-2002.
- 2,670,218. ELITE. INT. CL. 11. (U.S. CLS. 13, 21, 23, 31 AND 34). REG. 12-31-2002.
- 2,670,244. PLATINUM BTE. INT. CL. 10. (U.S. CLS. 26, 39 AND 44). REG. 12-31-2002.
- 2,670,349. ICY COLD TO GO. INT. CLS. 29 AND 32. (U.S. CLS. 45, 46 AND 48). REG. 12-31-2002.
- 2,671,389. THE LAST COMMUNICATIONS COMPANY A SMALL BUSINESS WILL EVER NEED. INT. CLS. 38 AND 42. (U.S. CLS. 100, 101 AND 104). REG. 1-7-2003.
- 2,671,944. MINDBULGE. INT. CL. 35. (U.S. CLS. 100, 101 AND 102). REG. 1-7-2003.
- 2,671,977. MISCELLANEOUS DESIGN. INT. CL. 28. (U.S. CLS. 22, 23, 38 AND 50). REG. 1-7-2003.
- 2,671,984. MISCELLANEOUS DESIGN. INT. CL. 28. (U.S. CLS. 22, 23, 38 AND 50). REG. 1-7-2003.
- 2,672,018. CONESTOGA. INT. CL. 19. (U.S. CLS. 1, 12, 33 AND 50). REG. 1-7-2003.
- 2,672,019. MISCELLANEOUS DESIGN. INT. CL. 19. (U.S. CLS. 1, 12, 33 AND 50). REG. 1-7-2003.
- 2,673,077. ESP LOW-E. INT. CL. 17. (U.S. CLS. 1, 5, 12, 13, 35 AND 50). REG. 1-7-2003.

- 2,673,623. DIVE LAB. INT. CL. 42. (U.S. CLS. 100 AND 101). REG. 1-14-2003.
- 2,674,028. MARRIAGE BREAKTHROUGH. INT. CLS. 9, 16 AND 41. (U.S. CLS. 2, 5, 21, 22, 23, 26, 29, 36, 37, 38, 50, 100, 101 AND 107). REG. 1-14-2003.
- 2,674,203. DATE WITH THE STARS. INT. CL. 45. (U.S. CLS. 100 AND 101). REG. 1-14-2003.
- 2,674,445. NYSSA AND DESIGN. INT. CL. 31. (U.S. CLS. 1 AND 46). REG. 1-14-2003.
- 2,676,603. MLPA. INT. CLS. 1, 5 AND 42. (U.S. CLS. 1, 5, 6, 10, 18, 26, 44, 46, 51, 52, 100 AND 101). REG. 1-21-2003.
- 2,677,579. CREATE ENDLESS IMPRESSIONS. INT. CL. 40. (U.S. CLS. 100, 103 AND 106). REG. 1-21-2003.
- 2,677,596. FAITH AND JOY. INT. CL. 16. (U.S. CLS. 2, 5, 22, 23, 29, 37, 38 AND 50). REG. 1-21-2003.
- 2,677,851. D.C. WHITE AGENCY. INT. CL. 36. (U.S. CLS. 100, 101 AND 102). REG. 1-21-2003.
- 2,678,128. SMARTCET. INT. CL. 9. (U.S. CLS. 21, 23, 26, 36 AND 38). REG. 1-21-2003.
- 2,678,595. DIESEL KLEEN + CETANE BOOST AND DESIGN. INT. CL. 1. (U.S. CLS. 1, 5, 6, 10, 26 AND 46). REG. 1-21-2003.
- 2,679,447. POUND 4 POUND. INT. CL. 32. (U.S. CLS. 45, 46 AND 48). REG. 1-28-2003.
- 2,679,821. GEMPRINT. INT. CL. 42 ONLY. (U.S. CLS. 100 AND 101). REG. 1-28-2003.
- 2,679,896. ICDNET.COM. INT. CL. 42. (U.S. CLS. 100 AND 101). REG. 1-28-2003.
- 2,680,023. CO-ACTIVE COACH. INT. CL. 16. (U.S. CLS. 2, 5, 22, 23, 29, 37, 38 AND 50). REG. 1-28-2003.
- 2,680,138. HOPE PHARMACEUTICALS AND DESIGN. INT. CL. 5. (U.S. CLS. 6, 18, 44, 46, 51 AND 52). REG. 1-28-2003.
- 2,680,229. CAPTAIN INTEGRITY. INT. CL. 42. (U.S. CLS. 100 AND 101). REG. 1-28-2003.
- 2,680,237. GG AND DESIGN. INT. CL. 14. (U.S. CLS. 2, 27, 28 AND 50). REG. 1-28-2003.
- 2,680,372. MIDTRONICS. INT. CL. 9. (U.S. CLS. 21, 23, 26, 36 AND 38). REG. 1-28-2003.
- 2,680,466. ASHLEY FURNITURE HOMESTORE. INT. CL. 35. (U.S. CLS. 100, 101 AND 102). REG. 1-28-2003.
- 2,680,648. THE STANDARD FOR INFORMATION SECURITY. INT. CLS. 9 AND 42. (U.S. CLS. 21, 23, 26, 36, 38, 100 AND 101). REG. 1-28-2003.
- 2,680,789. WONDERFUL MEMORIES. INT. CL. 25. (U.S. CLS. 22 AND 39). REG. 1-28-2003.
- 2,680,797. AT HOME IN FRANCE. INT. CL. 43. (U.S. CLS. 100 AND 101). REG. 1-28-2003.
- 2,681,621. MAXIM. INT. CLS. 37 AND 39. (U.S. CLS. 100, 103, 105 AND 106). REG. 1-28-2003.
- 2,681,671. XI. INT. CL. 12. (U.S. CLS. 19, 21, 23, 31, 35 AND 44). REG. 1-28-2003.
- 2,683,264. I INTEGRITY NUTRIENT CONTROL SYSTEM AND DESIGN. INT. CL. 11. (U.S. CLS. 13, 21, 23, 31 AND 34). REG. 2-4-2003.
- 2,683,707. H AND DESIGN. INT. CL. 8. (U.S. CLS. 23, 28 AND 44). REG. 2-4-2003.
- 2,684,131. LITE HANDICAP. INT. CL. 13. (U.S. CLS. 2 AND 9). REG. 2-4-2003.
- 2,684,198. X AND DESIGN. INT. CLS. 37 AND 39. (U.S. CLS. 100, 103, 105 AND 106). REG. 2-4-2003.
- 2,684,199. MAXIM AND DESIGN. INT. CLS. 37 AND 39. (U.S. CLS. 100, 103, 105 AND 106). REG. 2-4-2003.
- 2,684,200. MAXIM CRANE WORKS AND DESIGN. INT. CLS. 37 AND 39. (U.S. CLS. 100, 103, 105 AND 106). REG. 2-4-2003.
- 2,684,203. MAXIM CRANE WORKS. INT. CLS. 37 AND 39. (U.S. CLS. 100, 103, 105 AND 106). REG. 2-4-2003.
- 2,685,844. SOUNDCLEAR. INT. CL. 9. (U.S. CLS. 21, 23, 26, 36 AND 38). REG. 2-11-2003.
- 2,686,141. H2O SUPPLY. INT. CL. 35. (U.S. CLS. 100, 101 AND 102). REG. 2-11-2003.
- 2,687,271. MISCELLANEOUS DESIGN. INT. CL. 25. (U.S. CLS. 22 AND 39). REG. 2-11-2003.
- 2,688,098. SELTMANN USA. INT. CL. 35. (U.S. CLS. 100, 101 AND 102). REG. 2-18-2003.
- 2,688,527. BUDGET BLINDS (STYLIZED). INT. CL. 35. (U.S. CLS. 100, 101 AND 102). REG. 2-18-2003.
- 2,688,660. JUNIATA COLLEGE. INT. CL. 41. (U.S. CLS. 100, 101 AND 107). REG. 2-18-2003.
- 2,690,259. TWEEDEE PRODUCTIONS. INT. CL. 41. (U.S. CLS. 100, 101 AND 107). REG. 2-25-2003.
- 2,690,938. CEN. INT. CL. 9. (U.S. CLS. 21, 23, 26, 36 AND 38). REG. 2-25-2003.
- 2,691,185. M AND DESIGN. INT. CL. 32. (U.S. CLS. 45, 46 AND 48). REG. 2-25-2003.
- 2,691,186. MISCELLANEOUS DESIGN. INT. CL. 32. (U.S. CLS. 45, 46 AND 48). REG. 2-25-2003.
- 2,691,438. AFCF. INT. CLS. 36, 41 AND 42. (U.S. CLS. 100, 101, 102 AND 107). REG. 2-25-2003.
- 2,692,427. ETIQUETTE HELL. INT. CL. 41. (U.S. CLS. 100, 101 AND 107). REG. 3-4-2003.
- 2,695,636. PATIO PLUS. INT. CL. 1. (U.S. CLS. 1, 5, 6, 10, 26 AND 46). REG. 3-11-2003.
- 2,695,905. YELLOW STUFF. INT. CL. 5. (U.S. CLS. 6, 18, 44, 46, 51 AND 52). REG. 3-11-2003.
- 2,695,929. WHERE KNOWLEDGE IS YOUR LIFELINE. INT. CL. 44. (U.S. CLS. 100 AND 101). REG. 3-11-2003.
- 2,697,011. I AND DESIGN. INT. CL. 44. (U.S. CLS. 100 AND 101). REG. 3-18-2003.
- 2,697,465. EVER-GLEEM. INT. CL. 6. (U.S. CLS. 2, 12, 13, 14, 23, 25 AND 50). REG. 3-18-2003.
- 2,697,546. MISCELLANEOUS DESIGN. INT. CL. 16. (U.S. CLS. 2, 5, 22, 23, 29, 37, 38 AND 50). REG. 3-18-2003.
- 2,697,809. SUPER POLIGRIP. INT. CL. 5. (U.S. CLS. 6, 18, 44, 46, 51 AND 52). REG. 3-18-2003.
- 2,698,160. PAWS AROUND THE WORLD. INT. CL. 16. (U.S. CLS. 2, 5, 22, 23, 29, 37, 38 AND 50). REG. 3-18-2003.
- 2,698,279. WINGNUTS. INT. CL. 42. (U.S. CLS. 100 AND 101). REG. 3-18-2003.
- 2,700,069. IRLAN SCREENER. INT. CL. 44. (U.S. CLS. 100 AND 101). REG. 3-25-2003.
- 2,700,489. ULTIMATE WHITE SHRIMP. INT. CL. 29. (U.S. CL. 46). REG. 3-25-2003.
- 2,700,648. TELETORIUM. INT. CLS. 38 AND 42. (U.S. CLS. 100, 101 AND 104). REG. 3-25-2003.
- 2,703,483. EVERFUSE. INT. CL. 9. (U.S. CLS. 21, 23, 26, 36 AND 38). REG. 4-8-2003.
- 2,704,221. US OPEN RACQUETBALL CHAMPIONSHIPS STANDARD CHARACTER MARK. INT. CL. 41. (U.S. CLS. 100, 101 AND 107). REG. 4-8-2003.
- 2,704,333. PF SELECT AND DESIGN. INT. CL. 30. (U.S. CL. 46). REG. 4-8-2003.
- 2,704,669. US SIGNAL AND DESIGN. INT. CLS. 36, 37 AND 38. (U.S. CLS. 100, 101, 102, 103, 104 AND 106). REG. 4-8-2003.
- 2,705,462. ASCEND. INT. CL. 20. (U.S. CLS. 2, 13, 22, 25, 32 AND 50). REG. 4-8-2003.
- 2,707,115. US SIGNAL. INT. CLS. 36, 37 AND 38. (U.S. CLS. 100, 101, 102, 103, 104 AND 106). REG. 4-15-2003.
- 2,707,314. CYBERDOME. INT. CL. 42. (U.S. CLS. 100 AND 101). REG. 4-15-2003.
- 2,708,153. SELF-CONNECTING IMAGERY. INT. CL. 41. (U.S. CLS. 100, 101 AND 107). REG. 4-15-2003.
- 2,708,223. TIFFANY & CO.. INT. CL. 25. (U.S. CLS. 22 AND 39). REG. 4-22-2003.
- 2,709,515. TCU. INT. CL. 10. (U.S. CLS. 26, 39 AND 44). REG. 4-22-2003.
- 2,709,633. E-SPONSE. INT. CL. 38. (U.S. CLS. 100, 101 AND 104). REG. 4-22-2003.
- 2,711,295. REOFLEX. INT. CL. 1. (U.S. CLS. 1, 5, 6, 10, 26 AND 46). REG. 4-29-2003.
- 2,711,917. AIRCAT. INT. CL. 28. (U.S. CLS. 22, 23, 38 AND 50). REG. 4-29-2003.
- 2,711,931. AIRCAT CONSISTENT AIR TECHNOLOGY AND DESIGN. INT. CL. 28. (U.S. CLS. 22, 23, 38 AND 50). REG. 4-29-2003.
- 2,711,998. BLUE ROSE SKIN CARE. INT. CL. 3. (U.S. CLS. 1, 4, 6, 50, 51 AND 52). REG. 4-29-2003.
- 2,712,690. ONE WORLD ONE GAME THE FOUNDATION AND DESIGN. INT. CL. 41. (U.S. CLS. 100, 101 AND 107). REG. 5-6-2003.
- 2,713,293. DEW KISS. INT. CL. 3. (U.S. CLS. 1, 4, 6, 50, 51 AND 52). REG. 5-6-2003.
- 2,713,969. TOMMY LEE JONES (STYLIZED). INT. CL. 16. (U.S. CLS. 2, 5, 22, 23, 29, 37, 38 AND 50). REG. 5-6-2003.
- 2,714,676. VOICE ADVENTURES. INT. CL. 16. (U.S. CLS. 2, 5, 22, 23, 29, 37, 38 AND 50). REG. 5-6-2003.
- 2,715,680. TOWER HILL RESOURCES. INT. CL. 35. (U.S. CLS. 100, 101 AND 102). REG. 5-13-2003.
- 2,715,979. QUALITY THAT GROWS. INT. CL. 42. (U.S. CLS. 100 AND 101). REG. 5-13-2003.
- 2,717,375. HE DOG. INT. CL. 28. (U.S. CLS. 22, 23, 38 AND 50). REG. 5-20-2003.
- 2,717,613. ON YOUR TOES. INT. CL. 5. (U.S. CLS. 6, 18, 44, 46, 51 AND 52). REG. 5-20-2003.

- 2,718,121. ANEW ULTIMATE. INT. CL. 3. (U.S. CLS. 1, 4, 6, 50, 51 AND 52). REG. 5-20-2003.
- 2,718,544. ATLANTA EDM. INT. CL. 40. (U.S. CLS. 100, 103 AND 106). REG. 5-27-2003.
- 2,718,629. MRS. HOCKEY. INT. CL. 36. (U.S. CLS. 100, 101 AND 102). REG. 5-27-2003.
- 2,718,855. CONOVER WORKSHOPS. INT. CL. 41. (U.S. CLS. 100, 101 AND 107). REG. 5-27-2003.
- 2,718,934. IRLIN FILTERS. INT. CL. 9. (U.S. CLS. 21, 23, 26, 36 AND 38). REG. 5-27-2003.
- 2,718,960. WE KEEP YOU FIT & BEAUTIFUL!. INT. CL. 35. (U.S. CLS. 100, 101 AND 102). REG. 5-27-2003.
- 2,719,023. LIP DEW. INT. CL. 3. (U.S. CLS. 1, 4, 6, 50, 51 AND 52). REG. 5-27-2003.
- 2,720,106. CAAP CLINICAL ASSESSMENT OF ARTICULATION AND PHONOLOGY. INT. CL. 16. (U.S. CLS. 2, 5, 22, 23, 29, 37, 38 AND 50). REG. 5-27-2003.
- 2,720,711. BOAT OWNERS ASSOCIATION OF THE UNITED STATES. INT. CL. 42. (U.S. CLS. 100 AND 101). REG. 6-3-2003.
- 2,721,513. SEABOY. INT. CL. 29. (U.S. CL. 46). REG. 6-3-2003.
- 2,721,551. PARADISE. INT. CL. 29. (U.S. CL. 46). REG. 6-3-2003.
- 2,721,633. BOWIENET. INT. CLS. 35 AND 41 ONLY. (U.S. CLS. 100, 101, 102 AND 107). REG. 6-3-2003.
- 2,722,344. MERRY THE CRANBERRY. INT. CL. 28. (U.S. CLS. 22, 23, 38 AND 50). REG. 6-3-2003.
- 2,723,728. SAFEVISION. INT. CL. 35. (U.S. CLS. 100, 101 AND 102). REG. 6-10-2003.
- 2,723,796. ILAND LURES AND DESIGN. INT. CL. 28. (U.S. CLS. 22, 23, 38 AND 50). REG. 6-10-2003.
- 2,723,838. DATAEXPRESS. INT. CL. 9. (U.S. CLS. 21, 23, 26, 36 AND 38). REG. 6-10-2003.
- 2,723,879. LATIN GRAMMY. INT. CLS. 9 AND 41. (U.S. CLS. 21, 23, 26, 36, 38, 100, 101 AND 107). REG. 6-10-2003.
- 2,724,031. IRIS. INT. CLS. 9 AND 16. (U.S. CLS. 2, 5, 21, 22, 23, 26, 29, 36, 37, 38 AND 50). REG. 6-10-2003.
- 2,724,423. MINDBULGE AND DESIGN. INT. CL. 35. (U.S. CLS. 100, 101 AND 102). REG. 6-10-2003.
- 2,724,526. INHALER COMPANIONS. INT. CL. 10. (U.S. CLS. 26, 39 AND 44). REG. 6-10-2003.
- 2,724,684. ELECTROLITE. INT. CL. 10. (U.S. CLS. 26, 39 AND 44). REG. 6-10-2003.
- 2,725,752. ULTIMAX. INT. CL. 11. (U.S. CLS. 13, 21, 23, 31 AND 34). REG. 6-10-2003.
- 2,725,934. HUMIRA. INT. CL. 5. (U.S. CLS. 6, 18, 44, 46, 51 AND 52). REG. 6-10-2003.
- 2,726,033. GO FOR THE DOUGH. INT. CL. 28. (U.S. CLS. 22, 23, 38 AND 50). REG. 6-10-2003.
- 2,726,658. ZABAR'S. INT. CLS. 29 AND 30. (U.S. CL. 46). REG. 6-17-2003.
- 2,726,747. EDL PACKAGING ENGINEERS. INT. CLS. 40 AND 42. (U.S. CLS. 100, 101, 103 AND 106). REG. 6-17-2003.
- 2,726,750. ROCKET DOUBLE. INT. CL. 30. (U.S. CL. 46). REG. 6-17-2003.
- 2,726,751. ROCKET SINGLE. INT. CL. 30. (U.S. CL. 46). REG. 6-17-2003.
- 2,726,886. CHAMPION'S EDGE. INT. CL. 41. (U.S. CLS. 100, 101 AND 107). REG. 6-17-2003.
- 2,726,909. WINNEMUCCA MUDD. INT. CL. 5. (U.S. CLS. 6, 18, 44, 46, 51 AND 52). REG. 6-17-2003.
- 2,727,115. IPCAPITAL GROUP. INT. CL. 35. (U.S. CLS. 100, 101 AND 102). REG. 6-17-2003.
- 2,727,715. MISCELLANEOUS DESIGN. INT. CL. 9. (U.S. CLS. 21, 23, 26, 36 AND 38). REG. 6-17-2003.
- 2,728,067. TOSTITOS AND DESIGN. INT. CL. 30. (U.S. CL. 46). REG. 6-17-2003.
- 2,728,526. UNIVERSITY PROPERTIES. INT. CLS. 36 AND 37. (U.S. CLS. 100, 101, 102, 103 AND 106). REG. 6-24-2003.
- 2,728,894. MDC ADVISOR. INT. CL. 16. (U.S. CLS. 2, 5, 22, 23, 29, 37, 38 AND 50). REG. 6-24-2003.
- 2,728,973. ALA EDITIONS. INT. CL. 16. (U.S. CLS. 2, 5, 22, 23, 29, 37, 38 AND 50). REG. 6-24-2003.
- 2,729,144. E-LMO FAST TRACK. INT. CL. 36. (U.S. CLS. 100, 101 AND 102). REG. 6-24-2003.
- 2,729,150. YIAYIA'S AND DESIGN. INT. CL. 30. (U.S. CL. 46). REG. 6-24-2003.
- 2,729,487. DRUMQUIK. INT. CL. 17. (U.S. CLS. 1, 5, 12, 13, 35 AND 50). REG. 6-24-2003.
- 2,730,110. CLEANPIX AND DESIGN. INT. CL. 35. (U.S. CLS. 100, 101 AND 102). REG. 6-24-2003.
- 2,730,477. MOUNTAIN GREENERY. INT. CL. 36. (U.S. CLS. 100, 101 AND 102). REG. 6-24-2003.
- 2,730,628. NIADA CMD NATIONAL INDEPENDENT AUTOMOBILE DEALERS ASSOCIATION CERTIFIED MASTER DEALER AND DESIGN. INT. CL. 41. (U.S. CLS. 100, 101 AND 107). REG. 6-24-2003.
- 2,731,648. LACROSSEGIANT. INT. CL. 35. (U.S. CLS. 100, 101 AND 102). REG. 7-1-2003.
- 2,732,633. ALTAIRE. INT. CL. 10. (U.S. CLS. 26, 39 AND 44). REG. 7-1-2003.
- 2,733,078. AN (STYLIZED). INT. CL. 28. (U.S. CLS. 22, 23, 38 AND 50). REG. 7-1-2003.
- 2,733,541. EDUCATION DECISION SUPPORT LIBRARY. INT. CL. 9. (U.S. CLS. 21, 23, 26, 36 AND 38). REG. 7-1-2003.
- 2,733,778. DATATUDE. INT. CL. 42. (U.S. CLS. 100 AND 101). REG. 7-8-2003.
- 2,733,803. STI SONOMA TECHNOLOGY, INC. (STYLIZED). INT. CLS. 9 AND 42. (U.S. CLS. 21, 23, 26, 36, 38, 100 AND 101). REG. 7-8-2003.
- 2,734,864. ATLANTIC ROSE. INT. CL. 29. (U.S. CL. 46). REG. 7-8-2003.
- 2,735,178. TECHNOLOGY THAT FITS. INT. CL. 25. (U.S. CLS. 22 AND 39). REG. 7-8-2003.
- 2,735,204. SENEARTHCO. INT. CL. 35. (U.S. CLS. 100, 101 AND 102). REG. 7-8-2003.
- 2,735,423. BLACKSMITH. INT. CL. 28. (U.S. CLS. 22, 23, 38 AND 50). REG. 7-8-2003.
- 2,735,580. FAC (STYLIZED). INT. CL. 9. (U.S. CLS. 21, 23, 26, 36 AND 38). REG. 7-8-2003.
- 2,736,350. ALA EDITIONS AND DESIGN. INT. CL. 16. (U.S. CLS. 2, 5, 22, 23, 29, 37, 38 AND 50). REG. 7-15-2003.
- 2,736,378. J.J. PEPPERS FOOD STORES AND DESIGN. INT. CL. 35. (U.S. CLS. 100, 101 AND 102). REG. 7-15-2003.
- 2,736,843. SARAP. INT. CL. 32. (U.S. CLS. 45, 46 AND 48). REG. 7-15-2003.
- 2,736,908. HISTORY ALIVE. INT. CL. 16. (U.S. CLS. 2, 5, 22, 23, 29, 37, 38 AND 50). REG. 7-15-2003.
- 2,737,143. THEBOOM STANDARD CHARACTER MARK. INT. CL. 9. (U.S. CLS. 21, 23, 26, 36 AND 38). REG. 7-15-2003.
- 2,737,361. TOMMY LEE JONES. INT. CL. 41. (U.S. CLS. 100, 101 AND 107). REG. 7-15-2003.
- 2,737,520. MLF. INT. CL. 9. (U.S. CLS. 21, 23, 26, 36 AND 38). REG. 7-15-2003.
- 2,738,124. MISCELLANEOUS DESIGN. INT. CL. 10. (U.S. CLS. 26, 39 AND 44). REG. 7-15-2003.
- 2,738,377. TED HENDRICKS DEFENSIVE END OF THE YEAR AWARD. INT. CL. 41. (U.S. CLS. 100, 101 AND 107). REG. 7-15-2003.
- 2,738,774. HOMESHOP AND DESIGN. INT. CL. 35. (U.S. CLS. 100, 101 AND 102). REG. 7-15-2003.
- 2,739,136. MBT AND DESIGN. INT. CL. 36. (U.S. CLS. 100, 101 AND 102). REG. 7-15-2003.
- 2,739,294. RHEUMATOLOGY NEWS. INT. CL. 44. (U.S. CLS. 100 AND 101). REG. 7-15-2003.
- 2,739,295. REALTYTOWEB.COM. INT. CL. 36. (U.S. CLS. 100, 101 AND 102). REG. 7-15-2003.
- 2,739,619. TRICITRASOL. INT. CL. 5. (U.S. CLS. 6, 18, 44, 46, 51 AND 52). REG. 7-22-2003.
- 2,739,690. FARMER GREEN. INT. CLS. 1 AND 31. (U.S. CLS. 1, 5, 6, 10, 26 AND 46). REG. 7-22-2003.
- 2,739,835. WSI SOLUTIONS AND DESIGN. INT. CL. 42. (U.S. CLS. 100 AND 101). REG. 7-22-2003.
- 2,739,928. DRAINSTICK. INT. CL. 8. (U.S. CLS. 23, 28 AND 44). REG. 7-22-2003.
- 2,739,946. WINCPP. INT. CL. 9. (U.S. CLS. 21, 23, 26, 36 AND 38). REG. 7-22-2003.
- 2,740,203. METEOR. INT. CL. 9. (U.S. CLS. 21, 23, 26, 36 AND 38). REG. 7-22-2003.
- 2,740,361. TACTICAL / 1ST RESPONSE RADIO INTEROPERABILITY AND DESIGN. INT. CL. 9. (U.S. CLS. 21, 23, 26, 36 AND 38). REG. 7-22-2003.
- 2,740,479. PAMELLA ROLAND. INT. CL. 25. (U.S. CLS. 22 AND 39). REG. 7-22-2003.
- 2,740,546. DUKE. INT. CL. 29. (U.S. CL. 46). REG. 7-22-2003.
- 2,740,594. UNDERBRUSH. INT. CL. 25. (U.S. CLS. 22 AND 39). REG. 7-22-2003.
- 2,740,715. TELISPIRE. INT. CL. 36. (U.S. CLS. 100, 101 AND 102). REG. 7-22-2003.

- 2,741,359. UNIFIED FIDUCIARY MONITORING INDEX. INT. CL. 36. (U.S. CLS. 100, 101 AND 102). REG. 7-29-2003.
- 2,741,401. CHIMICA. INT. CL. 42. (U.S. CLS. 100 AND 101). REG. 7-29-2003.
- 2,741,656. BUILDERS MUTUAL. INT. CL. 36. (U.S. CLS. 100, 101 AND 102). REG. 7-29-2003.
- 2,741,712. MINUS EIGHT. INT. CL. 30. (U.S. CL. 46). REG. 7-29-2003.
- 2,741,902. VERMONT COFFEE COMPANY. INT. CL. 30. (U.S. CL. 46). REG. 7-29-2003.
- 2,741,913. BUTADYL. INT. CL. 17. (U.S. CLS. 1, 5, 12, 13, 35 AND 50). REG. 7-29-2003.
- 2,742,034. D.C.. INT. CL. 29. (U.S. CL. 46). REG. 7-29-2003.
- 2,742,051. HSA. INT. CLS. 36 AND 37. (U.S. CLS. 100, 101, 102, 103 AND 106). REG. 7-29-2003.
- 2,742,061. CLARIDGE COURT. INT. CL. 43. (U.S. CLS. 100 AND 101). REG. 7-29-2003.
- 2,742,079. NEYERS AND DESIGN. INT. CL. 33. (U.S. CLS. 47 AND 49). REG. 7-29-2003.
- 2,742,085. FRESH MARKET SQUARE BUFFET. INT. CL. 43. (U.S. CLS. 100 AND 101). REG. 7-29-2003.
- 2,743,125. PURCHASE PERKS. INT. CL. 35. (U.S. CLS. 100, 101 AND 102). REG. 7-29-2003.
- 2,743,286. GROUP360. INT. CL. 42. (U.S. CLS. 100 AND 101). REG. 7-29-2003.
- 2,743,390. FIRST CHOICE COLORPRINT. INT. CL. 16. (U.S. CLS. 2, 5, 22, 23, 29, 37, 38 AND 50). REG. 7-29-2003.
- 2,743,834. SYMMETRE. INT. CL. 9. (U.S. CLS. 21, 23, 26, 36 AND 38). REG. 7-29-2003.
- 2,743,855. D23 AND DESIGN. INT. CL. 42. (U.S. CLS. 100 AND 101). REG. 7-29-2003.
- 2,744,022. PLANTTRIAGE. INT. CL. 9. (U.S. CLS. 21, 23, 26, 36 AND 38). REG. 7-29-2003.
- 2,744,025. DISPENSELINK. INT. CL. 9. (U.S. CLS. 21, 23, 26, 36 AND 38). REG. 7-29-2003.
- 2,744,098. SEQUENCE FOR KIDS. INT. CL. 28. (U.S. CLS. 22, 23, 38 AND 50). REG. 7-29-2003.
- 2,744,195. SUPRAVAR. INT. CL. 6. (U.S. CLS. 2, 12, 13, 14, 23, 25 AND 50). REG. 7-29-2003.
- 2,744,344. VPS/SECURE. INT. CL. 9. (U.S. CLS. 21, 23, 26, 36 AND 38). REG. 7-29-2003.
- 2,744,357. THINGS INT. CL. 28. (U.S. CLS. 22, 23, 38 AND 50). REG. 7-29-2003.
- 2,744,370. DENTAL PREFERENCE. INT. CL. 36. (U.S. CLS. 100, 101 AND 102). REG. 7-29-2003.
- 2,744,392. JPR. INT. CL. 25. (U.S. CLS. 22 AND 39). REG. 7-29-2003.
- 2,744,516. EX-RITE (STYLIZED). INT. CL. 7. (U.S. CLS. 13, 19, 21, 23, 31, 34 AND 35). REG. 7-29-2003.
- 2,744,615. FIDO FLIPZ. INT. CL. 31. (U.S. CLS. 1 AND 46). REG. 7-29-2003.
- 2,744,616. CATCHUM & CHEWUM. INT. CL. 31. (U.S. CLS. 1 AND 46). REG. 7-29-2003.
- 2,744,642. CELARA. INT. CL. 10. (U.S. CLS. 26, 39 AND 44). REG. 7-29-2003.
- 2,745,201. TRAVEL HEALTH SOLUTIONS. INT. CL. 44. (U.S. CLS. 100 AND 101). REG. 7-29-2003.
- 2,745,221. OMEGATIN. INT. CL. 31. (U.S. CLS. 1 AND 46). REG. 7-29-2003.
- 2,745,432. BIO-ENERGY SYSTEMS. INT. CLS. 5 AND 40. (U.S. CLS. 6, 18, 44, 46, 51, 52, 100, 103 AND 106). REG. 8-5-2003.
- 2,746,140. PHARMACEUTICAL APPROVALS MONTHLY. INT. CL. 16. (U.S. CLS. 2, 5, 22, 23, 29, 37, 38 AND 50). REG. 8-5-2003.
- 2,747,427. ACTIVEGIVING. INT. CL. 36. (U.S. CLS. 100, 101 AND 102). REG. 8-5-2003.
- 2,748,162. PFSWEB AND DESIGN. INT. CL. 35. (U.S. CLS. 100, 101 AND 102). REG. 8-5-2003.
- 2,749,729. SUNKIST. INT. CL. 35. (U.S. CLS. 100, 101 AND 102). REG. 8-12-2003.
- 2,749,993. AQUASEAL. INT. CL. 9. (U.S. CLS. 21, 23, 26, 36 AND 38). REG. 8-12-2003.
- 2,750,016. SASQUATCH!. INT. CL. 41. (U.S. CLS. 100, 101 AND 107). REG. 8-12-2003.
- 2,750,148. QUICK FINISH. INT. CL. 29. (U.S. CL. 46). REG. 8-12-2003.
- 2,750,286. TICKETWEB. INT. CL. 41. (U.S. CLS. 100, 101 AND 107). REG. 8-12-2003.
- 2,751,516. EINSULATION. INT. CL. 17. (U.S. CLS. 1, 5, 12, 13, 35 AND 50). REG. 8-12-2003.
- 3,494,342. TIME. INT. CL. 9. (U.S. CLS. 21, 23, 26, 36 AND 38). REG. 8-25-1992.
- 4,184,608. LANEROSI. INT. CL. 23. (U.S. CL. 43). REG. 7-30-2002.

* * * * *

TRADEMARK REGISTRATIONS CANCELED

The designation "U.S. Cl." appearing in this section refers to the U.S. class in effect prior to Sep. 1, 1973 rather than the international class which applies to applications filed on or after that date. For adoption of international classification see notice in the OFFICIAL GAZETTE of Jun. 26, 1973 (911 O.G. TM 210).

SECTION 7(D)

- 2,594,304. XODIAX. INT. CLS. 38 AND 42. REG. 7-16-2002.
3,009,587. TRUE CONTACT STANDARD CHARACTER MARK. INT. CL. 10. REG. 10-25-2005.
3,010,458. T-ZONE. INT. CLS. 9, 16, 35, 36, 38, 39, 41 AND 42. REG. 11-1-2005.
3,057,123. CALLTIME STANDARD CHARACTER MARK. INT. CL. 16. REG. 2-7-2006.
3,057,383. T-MOBILE NEWS EXPRESS STANDARD CHARACTER MARK. INT. CL. 9. REG. 2-7-2006.
3,059,165. ON-CAREERS STANDARD CHARACTER MARK. INT. CLS. 9, 16, 35, 36, 38 AND 42. REG. 2-14-2006.
3,059,955. T-GROUP STANDARD CHARACTER MARK. INT. CL. 35. REG. 2-21-2006.
3,061,438. T INFO AND DESIGN. INT. CLS. 9, 16, 35, 36, 38, 39, 41 AND 42. REG. 2-28-2006.
3,063,945. THERMAL SHUTTLE STANDARD CHARACTER MARK. INT. CL. 7. REG. 2-28-2006.
3,112,639. BIOVAXID STANDARD CHARACTER MARK. INT. CL. 5. REG. 7-4-2006.
3,124,456. BECOMPLIANT STANDARD CHARACTER MARK. INT. CL. 9. REG. 8-1-2006.
3,126,997. NOWWHAT.COM AND DESIGN. INT. CL. 36. REG. 8-8-2006.
3,212,639. SAFARI LTD AND DESIGN. INT. CL. 9 ONLY. REG. 2-27-2007.
3,409,056. PATIENTCONNECT STANDARD CHARACTER MARK. INT. CL. 38. REG. 4-8-2008.
3,494,932. SHOOTASAC BY JESSICA CLAIRE STANDARD CHARACTER MARK. INT. CL. 35. REG. 9-2-2008.
3,584,813. MISCELLANEOUS DESIGN. INT. CL. 28. REG. 3-3-2009.
3,937,072. WHITE WIDOW STANDARD CHARACTER MARK. INT. CL. 3. REG. 3-29-2011.
4,045,495. SUGARGROVE STANDARD CHARACTER MARK. INT. CL. 29. REG. 10-25-2011.
4,052,568. KANSAS CITY SENIORLIFE STANDARD CHARACTER MARK. INT. CL. 16. REG. 11-8-2011.
4,087,289. ONE FUN SUMMER AND DESIGN. INT. CL. 25. REG. 1-17-2012.
4,147,912. THE OMELETTE GUYS AND DESIGN. INT. CL. 43. REG. 5-22-2012.
4,154,230. MEDFOX STANDARD CHARACTER MARK. INT. CLS. 35, 41 AND 44. REG. 6-5-2012.
- 1,184,786. COMFY (STYLIZED). INT. CLS. 20 AND 25. REG. 1-5-1982.
1,185,200. PRICE CLUB (STYLIZED). INT. CL. 42. REG. 1-5-1982.
1,307,072. HOTEL RITZ. INT. CLS. 21 AND 33. REG. 11-27-1984.
1,460,115. METRO AND DESIGN. INT. CL. 25. REG. 10-6-1987.
1,600,355. UT (STYLIZED). INT. CL. 6. REG. 6-12-1990.
1,623,433. INNOVATION BY DESIGN. INT. CL. 9. REG. 11-20-1990.
1,670,984. COTEE AND DESIGN. INT. CLS. 8 AND 28. REG. 1-7-1992.
1,671,430. TELEWEATHER. INT. CL. 42. REG. 1-7-1992.
1,710,380. INCLUSIVITY. INT. CL. 35 ONLY. REG. 8-25-1992.
1,715,047. OPTIM. INT. CL. 7. REG. 9-15-1992.
1,727,112. BULLARD AND DESIGN. INT. CLS. 11 AND 25 ONLY. REG. 10-27-1992.
2,419,850. E-X CENTURY. INT. CL. 16. REG. 1-9-2001.
2,467,299. THE NEW AUTO TOY STORE. INT. CL. 35. REG. 7-10-2001.
2,484,475. BONAFIDE ENTERTAINMENT. INT. CL. 9. REG. 9-4-2001.
2,515,593. BILLY. INT. CL. 9. REG. 12-4-2001.
2,526,358. AUDIO CINEMA. INT. CL. 9. REG. 1-8-2002.
2,526,360. DYNAMIC COMPLETENESS FUND. INT. CL. 36. REG. 1-8-2002.
2,526,362. GHOST IN THE SHELL. INT. CL. 9. REG. 1-8-2002.
2,526,376. MT METALTEMPLE (STYLIZED). INT. CLS. 1, 4, 6, 7 AND 8. REG. 1-8-2002.
2,526,385. SONIC SOLUTIONS. INT. CLS. 9, 41 AND 42. REG. 1-8-2002.
2,526,390. PHOTO-ME AND DESIGN. INT. CLS. 9 AND 28. REG. 1-8-2002.
2,526,398. PREMONITION RECORDS. INT. CL. 9. REG. 1-8-2002.
2,526,408. LONGISTICS. INT. CL. 39. REG. 1-8-2002.
2,526,410. ROYAL ELASTICS (STYLIZED). INT. CL. 25. REG. 1-8-2002.
2,526,411. GRX HYDROGEL. INT. CL. 5. REG. 1-8-2002.
2,526,425. VECTOR. INT. CL. 6. REG. 1-8-2002.
2,526,455. CONFECTIONS & CREAM (STYLIZED). INT. CL. 30. REG. 1-8-2002.
2,526,458. KNOWLEDGE THAT WORKS. INT. CLS. 35 AND 42. REG. 1-8-2002.
2,526,459. ABEX. INT. CL. 20. REG. 1-8-2002.
2,526,461. SAK (STYLIZED). INT. CL. 36. REG. 1-8-2002.
2,526,469. CP 343-1 IT. INT. CL. 9. REG. 1-8-2002.
2,526,504. REED'S NAUTICAL ALMANAC. INT. CL. 16. REG. 1-8-2002.
2,526,509. URBANA AND DESIGN. INT. CL. 20. REG. 1-8-2002.
2,526,541. THE DOMINATOR AND DESIGN. INT. CLS. 9 AND 41. REG. 1-8-2002.
2,526,548. PSYCHIC FAIR ULTIMATE PSYCHIC FAIR. INT. CL. 42. REG. 1-8-2002.
2,526,560. A STEP AHEAD I.PARK AND DESIGN. INT. CL. 36. REG. 1-8-2002.
2,526,561. UP YOUR CASH FLOW. INT. CL. 9. REG. 1-8-2002.
2,526,563. RAIL PAK AND DESIGN. INT. CL. 19. REG. 1-8-2002.

SECTION 8

- 386,552. BEL PAESE CHEESE AND DESIGN. U.S. CL. 46. REG. 4-15-1941.
1,150,568. SWENSEN'S IN THE RICH TRADITION OF OLD SAN FRANCISCO AND DESIGN. INT. CLS. 30 AND 42. REG. 4-7-1981.
1,184,463. ROEDIGER AND DESIGN. INT. CLS. 7, 9 AND 11. REG. 1-5-1982.

- 2,526,576. CASCADE RECYCLE BIN. INT. CL. 21. REG. 1-8-2002.
- 2,526,586. ZAPT AND DESIGN. INT. CL. 3. REG. 1-8-2002.
- 2,526,599. QUICKLOCK. INT. CL. 11. REG. 1-8-2002.
- 2,526,619. AIRWEIGHT. INT. CL. 28. REG. 1-8-2002.
- 2,526,634. INTELLICHOICE. INT. CLS. 9 AND 42. REG. 1-8-2002.
- 2,526,635. LOS HURACANES DEL NORTE (STYLIZED). INT. CLS. 9 AND 41. REG. 1-8-2002.
- 2,526,636. QVIDEO. INT. CL. 35. REG. 1-8-2002.
- 2,526,638. MISCELLANEOUS DESIGN. INT. CLS. 31 AND 35. REG. 1-8-2002.
- 2,526,646. POCKET POWER. INT. CL. 9. REG. 1-8-2002.
- 2,526,649. THE LLC LINK. INT. CL. 42. REG. 1-8-2002.
- 2,526,663. 90PLUS. INT. CLS. 1, 4 AND 29. REG. 1-8-2002.
- 2,526,680. HEALTHCENTRALRX. INT. CLS. 35 AND 42. REG. 1-8-2002.
- 2,526,700. BIZGOLF. INT. CL. 35. REG. 1-8-2002.
- 2,526,706. CW COMPANION WEBSITE (STYLIZED). INT. CLS. 35, 41 AND 42. REG. 1-8-2002.
- 2,526,712. BUNNYDUCK. INT. CLS. 16, 25 AND 28. REG. 1-8-2002.
- 2,526,729. WINSTON. INT. CL. 35. REG. 1-8-2002.
- 2,526,732. ARMOR SCREEN. INT. CL. 22. REG. 1-8-2002.
- 2,526,735. A NEW CHOICE IN BANKING. INT. CL. 36. REG. 1-8-2002.
- 2,526,757. LIFECHAMPION. INT. CLS. 16 AND 41. REG. 1-8-2002.
- 2,526,764. MISCELLANEOUS DESIGN. INT. CL. 38. REG. 1-8-2002.
- 2,526,767. ACORN. INT. CLS. 37 AND 42. REG. 1-8-2002.
- 2,526,769. WINSPLUS. INT. CL. 9. REG. 1-8-2002.
- 2,526,775. MISCELLANEOUS DESIGN. INT. CLS. 36 AND 39. REG. 1-8-2002.
- 2,526,779. TEEXNET THE LEARNING NETWORK. INT. CL. 41. REG. 1-8-2002.
- 2,526,791. BABCOCK BORSIG. INT. CLS. 6, 7, 9, 11, 12, 35, 37, 40 AND 42. REG. 1-8-2002.
- 2,526,797. DENMAN. INT. CL. 12. REG. 1-8-2002.
- 2,526,800. SELECTSMART. INT. CL. 42. REG. 1-8-2002.
- 2,526,805. ASTROLOGICAL HEALTH. INT. CL. 5. REG. 1-8-2002.
- 2,526,816. CATER. INT. CL. 35. REG. 1-8-2002.
- 2,526,817. AGR PERFORMANCE POWER STEERING AND DESIGN. INT. CL. 12. REG. 1-8-2002.
- 2,526,829. CONACT AND DESIGN. INT. CL. 9. REG. 1-8-2002.
- 2,526,836. JJ COLLECTION (STYLIZED). INT. CL. 25. REG. 1-8-2002.
- 2,526,837. THREE CHEERS. INT. CLS. 6, 9, 20 AND 21. REG. 1-8-2002.
- 2,526,854. DELICIA'S ENGLISH TOFFEE. INT. CL. 30. REG. 1-8-2002.
- 2,526,859. BILL'S FRIENDS. INT. CL. 25. REG. 1-8-2002.
- 2,526,873. SPEEDTRADE ONLINE BROKERAGE AND DESIGN. INT. CL. 36. REG. 1-8-2002.
- 2,526,879. PARKTRONIC. INT. CL. 12. REG. 1-8-2002.
- 2,526,885. NTARGET. INT. CL. 42. REG. 1-8-2002.
- 2,526,893. MINI CARD AND DESIGN. INT. CLS. 9, 16 AND 24. REG. 1-8-2002.
- 2,526,894. MINI CARD AND DESIGN. INT. CLS. 9, 16 AND 24. REG. 1-8-2002.
- 2,526,896. TEDD E. TUNES AND DESIGN. INT. CLS. 9 AND 28. REG. 1-8-2002.
- 2,526,903. LIFECHART. INT. CL. 16. REG. 1-8-2002.
- 2,526,908. THE UTTERMOST CO. AND DESIGN. INT. CLS. 14, 16 AND 20. REG. 1-8-2002.
- 2,526,922. MAKING CORPORATE COMPUTING EASIER. INT. CLS. 35, 37 AND 42. REG. 1-8-2002.
- 2,526,924. MODULURE. INT. CL. 28. REG. 1-8-2002.
- 2,526,926. DIGISCRIP. INT. CL. 40. REG. 1-8-2002.
- 2,526,937. MISCELLANEOUS DESIGN. INT. CL. 41. REG. 1-8-2002.
- 2,526,949. PREMIUM VALUE AWARDS. INT. CL. 36. REG. 1-8-2002.
- 2,526,951. WIZARD CANDLES AND DESIGN. INT. CL. 40. REG. 1-8-2002.
- 2,526,952. A AND DESIGN. INT. CL. 28. REG. 1-8-2002.
- 2,526,955. HINSDALE ORTHOPAEDIC. INT. CL. 42. REG. 1-8-2002.
- 2,526,959. VIRTUAL IMMERSION. INT. CLS. 38 AND 41. REG. 1-8-2002.
- 2,526,968. EN-FORCE. INT. CLS. 1 AND 19. REG. 1-8-2002.
- 2,526,976. PENEDRILL (STYLIZED). INT. CL. 37. REG. 1-8-2002.
- 2,526,981. TELLME. (STYLIZED). INT. CL. 38. REG. 1-8-2002.
- 2,526,982. FOREM. INT. CLS. 9 AND 42. REG. 1-8-2002.
- 2,526,983. EXTREME LIMIT. INT. CL. 9. REG. 1-8-2002.
- 2,526,992. THE AMERICAN PENSION COMPANY. INT. CL. 36. REG. 1-8-2002.
- 2,527,001. MISCELLANEOUS DESIGN. INT. CLS. 41 AND 42. REG. 1-8-2002.
- 2,527,006. PARCEL@HOME. INT. CL. 39. REG. 1-8-2002.
- 2,527,023. THE CHARLESTON REPORT BUSINESS INSIGHTS INTO THE LIBRARY MARKET AND DESIGN. INT. CL. 16. REG. 1-8-2002.
- 2,527,024. TITAN. INT. CL. 7. REG. 1-8-2002.
- 2,527,031. NU-CAPE NU-LEASH & NU-COLLAR SET (STYLIZED). INT. CL. 18. REG. 1-8-2002.
- 2,527,038. MISCELLANEOUS DESIGN. INT. CLS. 9, 18 AND 25. REG. 1-8-2002.
- 2,527,052. GOOD HEALTH IS OUR BUSINESS. INT. CL. 5. REG. 1-8-2002.
- 2,527,057. MAX VAC. INT. CL. 7. REG. 1-8-2002.
- 2,527,061. STAY COOL IN SCHOOL. INT. CL. 42. REG. 1-8-2002.
- 2,527,071. LEMONADE FOR LIFE. INT. CL. 36. REG. 1-8-2002.
- 2,527,074. MOONDANCE CELLARS. INT. CL. 33. REG. 1-8-2002.
- 2,527,078. THE PET PLACE TELEVISION SHOW AND DESIGN. INT. CL. 41. REG. 1-8-2002.
- 2,527,084. VIRTUAL CLINIC. INT. CL. 9. REG. 1-8-2002.
- 2,527,085. FECS YOU YOUTH OPPORTUNITY CENTER AND DESIGN. INT. CL. 41. REG. 1-8-2002.
- 2,527,097. DELIVERING BETTER HEALTH. INT. CL. 35. REG. 1-8-2002.
- 2,527,098. TRINITY. INT. CL. 16. REG. 1-8-2002.
- 2,527,102. JANE TAYLOR. INT. CLS. 14 AND 42. REG. 1-8-2002.
- 2,527,103. ARCHITECTURAL COMMUNICATIONS (STYLIZED). INT. CL. 42. REG. 1-8-2002.
- 2,527,108. MUD'R TREAD PATTERN. INT. CL. 12. REG. 1-8-2002.
- 2,527,113. JESCRAFT. INT. CLS. 8 AND 12. REG. 1-8-2002.
- 2,527,114. MISCELLANEOUS DESIGN. INT. CL. 7. REG. 1-8-2002.
- 2,527,116. MAGNUM 360. INT. CL. 10. REG. 1-8-2002.
- 2,527,117. BRAKKIES AND DESIGN. INT. CL. 25. REG. 1-8-2002.
- 2,527,118. PLOP. INT. CLS. 41 AND 42. REG. 1-8-2002.
- 2,527,128. TETE DE COURSE. INT. CL. 12. REG. 1-8-2002.
- 2,527,134. T BLOCK. INT. CL. 11. REG. 1-8-2002.
- 2,527,143. TOTALVIEW (STYLIZED). INT. CL. 16. REG. 1-8-2002.
- 2,527,149. THE ONLY WAY TO TRAVEL GORDIE SURFBOARDS HUNTINGTON BEACH, CALIF.. INT. CL. 25. REG. 1-8-2002.
- 2,527,157. PLACE DES LICES. INT. CLS. 3, 4 AND 21. REG. 1-8-2002.
- 2,527,167. SILVER FACTORY (STYLIZED). INT. CL. 14. REG. 1-8-2002.
- 2,527,168. NATIONWIDE MATTRESS & FURNITURE WAREHOUSE. INT. CL. 35. REG. 1-8-2002.
- 2,527,176. LIFE INVESTORS. INT. CL. 36. REG. 1-8-2002.
- 2,527,196. STAR DECORATORS' WHOLESALE WAREHOUSE. INT. CL. 35. REG. 1-8-2002.
- 2,527,210. ULTRA CHOLESTEROL. INT. CL. 3. REG. 1-8-2002.
- 2,527,212. EMRE NEW YORK AND DESIGN. INT. CL. 14. REG. 1-8-2002.
- 2,527,218. JACKSON COLLECTION (STYLIZED). INT. CL. 35. REG. 1-8-2002.
- 2,527,219. CPS. INT. CL. 28. REG. 1-8-2002.

- 2,527,220. CHOOSEENERGY AND DESIGN. INT. CL. 35. REG. 1-8-2002.
- 2,527,227. LEXECON AND DESIGN. INT. CLS. 35 AND 42. REG. 1-8-2002.
- 2,527,228. DEEDUB. INT. CL. 25. REG. 1-8-2002.
- 2,527,229. PIC-A SEED. INT. CL. 21. REG. 1-8-2002.
- 2,527,232. SEARCHDOC. INT. CL. 42. REG. 1-8-2002.
- 2,527,235. MISCELLANEOUS DESIGN. INT. CL. 42. REG. 1-8-2002.
- 2,527,241. TEAMS. INT. CL. 9. REG. 1-8-2002.
- 2,527,255. MISCELLANEOUS DESIGN. INT. CL. 42. REG. 1-8-2002.
- 2,527,272. HOLLYWOOD DAILY MIRACLE DIET. INT. CL. 5. REG. 1-8-2002.
- 2,527,273. HOLLYWOOD MEGAMIRACLE 75. INT. CL. 5. REG. 1-8-2002.
- 2,527,275. GAIAM ORGANIX. INT. CLS. 24, 25 AND 35. REG. 1-8-2002.
- 2,527,286. PUBLIC LIVES. INT. CL. 41. REG. 1-8-2002.
- 2,527,287. PODIUM WATCH. INT. CL. 41. REG. 1-8-2002.
- 2,527,289. MARIAGE DE FLEURS. INT. CL. 3. REG. 1-8-2002.
- 2,527,290. RODMAN RODMAN & COMPANY, INC. AND DESIGN. INT. CL. 8. REG. 1-8-2002.
- 2,527,296. CRESTMONT COLLEGE. INT. CL. 41. REG. 1-8-2002.
- 2,527,298. HIGH 5 TICKETS TO THE ARTS AND DESIGN. INT. CL. 41. REG. 1-8-2002.
- 2,527,303. DRAKA ELEVATOR PRODUCTS. INT. CLS. 6 AND 9. REG. 1-8-2002.
- 2,527,304. PPW AND DESIGN. INT. CL. 35. REG. 1-8-2002.
- 2,527,320. TRI-ISO AND DESIGN. INT. CL. 35. REG. 1-8-2002.
- 2,527,326. PAWNBROKER PLUS. INT. CL. 9. REG. 1-8-2002.
- 2,527,337. "WE'VE GOT THE ANSWERS". INT. CL. 11. REG. 1-8-2002.
- 2,527,340. THE BIG DOWNTOWN. INT. CL. 42. REG. 1-8-2002.
- 2,527,351. MISCELLANEOUS DESIGN. INT. CL. 39. REG. 1-8-2002.
- 2,527,355. WILSONWEB. INT. CL. 9. REG. 1-8-2002.
- 2,527,358. PC PRINTERS COMPANY (STYLIZED). INT. CL. 42. REG. 1-8-2002.
- 2,527,361. WE BRING THE SHOWROOM TO YOU. INT. CL. 35. REG. 1-8-2002.
- 2,527,366. AIRTEX AND DESIGN. INT. CLS. 7 AND 9. REG. 1-8-2002.
- 2,527,370. ID-E AND DESIGN. INT. CL. 9. REG. 1-8-2002.
- 2,527,371. CRYSTAL MAGIC. INT. CL. 3. REG. 1-8-2002.
- 2,527,377. THE ILLUMINOLOGISTS. INT. CL. 37. REG. 1-8-2002.
- 2,527,385. ALWAYS DOUBLE MILES. INT. CL. 35. REG. 1-8-2002.
- 2,527,393. LONG GREEN LINE. U.S. CL. 200. REG. 1-8-2002.
- 2,527,396. SKILL/MAP. INT. CL. 42. REG. 1-8-2002.
- 2,527,403. WHEN IT COMES TO FLOORING...NOBODY DOESIT BETTER. INT. CL. 35. REG. 1-8-2002.
- 2,527,412. THE BEACON PROJECT AND DESIGN. INT. CL. 41. REG. 1-8-2002.
- 2,527,416. W AND DESIGN. INT. CL. 39. REG. 1-8-2002.
- 2,527,417. THE BEACON PROJECT. INT. CL. 41. REG. 1-8-2002.
- 2,527,424. DWT AND DESIGN. INT. CL. 42. REG. 1-8-2002.
- 2,527,448. BX-3. INT. CL. 7. REG. 1-8-2002.
- 2,527,459. SPLASH ISLAND. INT. CL. 28. REG. 1-8-2002.
- 2,527,480. FRECKLEFARM. INT. CL. 35. REG. 1-8-2002.
- 2,527,488. POLARPROP. INT. CL. 1. REG. 1-8-2002.
- 2,527,494. EMS AND DESIGN. INT. CL. 9. REG. 1-8-2002.
- 2,527,529. SOLID GROUND. INT. CL. 36. REG. 1-8-2002.
- 2,527,531. PRAKASHA. INT. CLS. 41 AND 42. REG. 1-8-2002.
- 2,527,535. SERENITY. INT. CL. 19. REG. 1-8-2002.
- 2,527,539. SATURNS. INT. CL. 36. REG. 1-8-2002.
- 2,527,540. OSTA. INT. CL. 42. REG. 1-8-2002.
- 2,527,541. EXPLO CAPS. INT. CL. 5. REG. 1-8-2002.
- 2,527,550. SHOW THE WORLD. INT. CL. 41. REG. 1-8-2002.
- 2,527,556. SUCCESS COMES IN CANS NOT IN CANNOTS AND DESIGN. INT. CL. 9. REG. 1-8-2002.
- 2,527,557. WESTON WOODS. INT. CL. 9. REG. 1-8-2002.
- 2,527,558. BIOCARTA. INT. CL. 1. REG. 1-8-2002.
- 2,527,561. MUELLER MUELLER MUELLER MUELLER AND DESIGN. INT. CL. 5. REG. 1-8-2002.
- 2,527,563. OKIFAX. INT. CL. 2. REG. 1-8-2002.
- 2,527,566. KRAHL CONSTRUCTION. INT. CL. 37. REG. 1-8-2002.
- 2,527,625. TRAINED 2 SURVIVE. INT. CL. 25. REG. 1-8-2002.
- 2,527,629. CHRONICLING THE FUTURE. INT. CL. 42. REG. 1-8-2002.
- 2,527,630. CHRISTIAN ANSWERS (STYLIZED). INT. CL. 42. REG. 1-8-2002.
- 2,527,636. MISCELLANEOUS DESIGN. INT. CL. 42. REG. 1-8-2002.
- 2,527,647. FAST ANSWERS FASTER SHOPPING. INT. CL. 35. REG. 1-8-2002.
- 2,527,649. ROYAL HIDE. INT. CL. 2. REG. 1-8-2002.
- 2,527,653. RUNT. INT. CL. 12. REG. 1-8-2002.
- 2,527,657. I: AND DESIGN. INT. CL. 9. REG. 1-8-2002.
- 2,527,659. UTFO. INT. CL. 41. REG. 1-8-2002.
- 2,527,662. PERFECTING PARADISE. INT. CL. 42. REG. 1-8-2002.
- 2,527,673. ASSETMARK FUNDS. INT. CL. 36. REG. 1-8-2002.
- 2,527,680. MR. RAY. INT. CL. 9. REG. 1-8-2002.
- 2,527,689. VELVET. INT. CL. 16. REG. 1-8-2002.
- 2,527,710. N AND DESIGN. INT. CL. 9. REG. 1-8-2002.
- 2,527,721. STEP INTO THE LIGHT. INT. CL. 11. REG. 1-8-2002.
- 2,527,722. MICRUS. INT. CL. 10. REG. 1-8-2002.
- 2,527,734. THE LAST OF THE MOHICANS. INT. CL. 25. REG. 1-8-2002.
- 2,527,736. BIO-IDENTICAL. INT. CL. 1. REG. 1-8-2002.
- 2,527,740. MIXPAP. INT. CL. 20. REG. 1-8-2002.
- 2,527,756. LOUISVILLE SLUGGER FIELD. INT. CL. 28. REG. 1-8-2002.
- 2,527,760. SQUIRREL NUT ZIPPERS. INT. CL. 41. REG. 1-8-2002.
- 2,527,761. SQUIRREL NUT ZIPPERS. INT. CL. 42. REG. 1-8-2002.
- 2,527,765. FOR THE BEST IN EQUINE HEALTH, COME TO LIFE. INT. CL. 5. REG. 1-8-2002.
- 2,527,766. CRILLO (STYLIZED). INT. CL. 16. REG. 1-8-2002.
- 2,527,782. TINTO ARZUAGA. INT. CL. 33. REG. 1-8-2002.
- 2,527,783. LOVE CUT. INT. CL. 14. REG. 1-8-2002.
- 2,527,788. HERBAL POWER. INT. CL. 5. REG. 1-8-2002.
- 2,527,789. SOCLEAR. INT. CL. 10. REG. 1-8-2002.
- 2,527,791. SPIRIT DATACINE. INT. CL. 9. REG. 1-8-2002.
- 2,527,792. APPSWITCH. INT. CL. 9. REG. 1-8-2002.
- 2,527,804. FOTOCONNECTED. INT. CL. 9. REG. 1-8-2002.
- 2,527,814. JUSTIN CHARLES. INT. CL. 20. REG. 1-8-2002.
- 2,527,822. CEDAR ELITE. INT. CL. 19. REG. 1-8-2002.
- 2,527,826. ICONIX. INT. CL. 42. REG. 1-8-2002.
- 2,527,828. OPTIMA. INT. CL. 12. REG. 1-8-2002.
- 2,527,832. C YOUR INTEGRATED OFFICE SYSTEM. INT. CL. 42. REG. 1-8-2002.
- 2,527,837. METATRACE. INT. CL. 5. REG. 1-8-2002.
- 2,527,857. GALLERY PLACE. INT. CL. 36. REG. 1-8-2002.
- 2,527,867. A AND DESIGN. INT. CL. 5. REG. 1-8-2002.
- 2,527,868. LUCTA AND DESIGN. INT. CL. 1. REG. 1-8-2002.
- 2,527,884. SAFE-T-RING. INT. CL. 7. REG. 1-8-2002.
- 2,527,897. ETA AND DESIGN. INT. CL. 7. REG. 1-8-2002.
- 2,527,918. PROMARK. INT. CL. 36. REG. 1-8-2002.
- 2,527,927. JOHN LYONS SIGNATURE. INT. CL. 31. REG. 1-8-2002.
- 2,527,954. COSMO GIRL. INT. CL. 16. REG. 1-8-2002.
- 2,527,955. URBAN ANIMALS. INT. CL. 28. REG. 1-8-2002.
- 2,527,956. GEOLIGHT. INT. CL. 42. REG. 1-8-2002.
- 2,527,961. MONDO'S. INT. CL. 30. REG. 1-8-2002.
- 2,527,966. FRONTIER DESERT RUNNER. INT. CL. 12. REG. 1-8-2002.
- 2,527,976. OC. INT. CL. 21. REG. 1-8-2002.
- 2,527,978. COLLEGIATE FRAMES STANDARD CHARACTER MARK. INT. CL. 20. REG. 1-8-2002.
- 2,527,980. FIBERNIDE. INT. CL. 6. REG. 1-8-2002.
- 2,527,987. EL INFORMADOR. INT. CL. 16. REG. 1-8-2002.
- 2,527,989. WHEN COFFEE DREAMS IT DREAMS OF CHOCOLATE. INT. CLS. 30 AND 35. REG. 1-8-2002.

- 2,527,991. SUPERIOR NUTRITION FOR THE LIFE OF YOUR PET. INT. CL. 31. REG. 1-8-2002.
- 2,527,992. DISCOVEREACTOR. INT. CL. 42. REG. 1-8-2002.
- 2,527,995. COMPLETE COURSE. INT. CL. 1. REG. 1-8-2002.
- 2,528,004. UA KINDERWORLD. INT. CL. 28. REG. 1-8-2002.
- 2,528,005. BOOK SENSE. INT. CL. 18. REG. 1-8-2002.
- 2,528,008. WINDOWS MEDIA AND DESIGN. INT. CL. 9. REG. 1-8-2002.
- 2,528,022. SLOW DOWN MASSAGE. INT. CL. 3. REG. 1-8-2002.
- 2,528,023. IT'S TIME FOR E*TRADE. INT. CL. 36. REG. 1-8-2002.
- 2,528,029. EARNFAIR. INT. CLS. 35, 36, 41 AND 42. REG. 1-8-2002.
- 2,528,037. BACCHUS VASCULAR. INT. CL. 10. REG. 1-8-2002.
- 2,528,044. AT FIRST BLUSH. INT. CL. 42. REG. 1-8-2002.
- 2,528,045. MISCELLANEOUS DESIGN. INT. CL. 42. REG. 1-8-2002.
- 2,528,055. BBB HOME LINE. INT. CL. 42. REG. 1-8-2002.
- 2,528,068. PRINT PRO. INT. CL. 7. REG. 1-8-2002.
- 2,528,069. PEOPLEMED. INT. CL. 42. REG. 1-8-2002.
- 2,528,083. HOLIDAY IMAGES. INT. CL. 16. REG. 1-8-2002.
- 2,528,090. SENSUS AND DESIGN. INT. CLS. 1 AND 5. REG. 1-8-2002.
- 2,528,098. ALL AMERICAN HOLIDAY GOOSE. INT. CL. 29. REG. 1-8-2002.
- 2,528,100. LENPUR. INT. CLS. 21, 23, 24, 25 AND 27. REG. 1-8-2002.
- 2,528,112. FASTVISION. INT. CL. 9. REG. 1-8-2002.
- 2,528,119. CRITERION. INT. CL. 10. REG. 1-8-2002.
- 2,528,122. MISCELLANEOUS DESIGN. INT. CLS. 3 AND 5. REG. 1-8-2002.
- 2,528,129. TVA. INT. CLS. 16 AND 42. REG. 1-8-2002.
- 2,528,132. SOMEONE TO LEAN ON. INT. CLS. 36 AND 42. REG. 1-8-2002.
- 2,528,139. VITEC. INT. CL. 30. REG. 1-8-2002.
- 2,528,140. NOSTALGIA. INT. CL. 3. REG. 1-8-2002.
- 2,528,149. E*WAY. INT. CL. 9. REG. 1-8-2002.
- 2,528,154. NANTUCKET WHALER AND DESIGN. INT. CLS. 16, 18, 21, 24, 25, 30, 35 AND 42. REG. 1-8-2002.
- 2,528,157. HOME ROW ADVANTAGE. INT. CL. 9. REG. 1-8-2002.
- 2,528,189. SCENT OF LOVE. INT. CL. 3. REG. 1-8-2002.
- 2,528,190. SCENT OF ROMANCE. INT. CL. 3. REG. 1-8-2002.
- 2,528,194. AGENTARTS. INT. CL. 35. REG. 1-8-2002.
- 2,528,196. SANSURFER. INT. CL. 9. REG. 1-8-2002.
- 2,528,207. SAMSONITE AND DESIGN. INT. CL. 18. REG. 1-8-2002.
- 2,528,213. MY BELOVED. INT. CLS. 9 AND 16. REG. 1-8-2002.
- 2,528,214. NOW YOU DRIVE. INT. CLS. 35 AND 37. REG. 1-8-2002.
- 2,528,227. CARFOLIA. INT. CL. 17. REG. 1-8-2002.
- 2,528,229. RESOLINE. INT. CL. 42. REG. 1-8-2002.
- 2,528,248. COMPLETING THE WORLDS CAPITAL MARKETS. INT. CL. 36. REG. 1-8-2002.
- 2,528,254. IT'S MY LIFE. INT. CL. 35. REG. 1-8-2002.
- 2,528,265. ANSWERMED.COM. INT. CL. 42. REG. 1-8-2002.
- 2,528,269. COLGATE PLATINUM DAYTIME. INT. CL. 3. REG. 1-8-2002.
- 2,528,270. FLEXTRA. INT. CL. 9. REG. 1-8-2002.
- 2,528,271. THE ULTIMATE EMPLOYEE BENEFIT (STYLIZED). INT. CL. 36. REG. 1-8-2002.
- 2,528,284. DETERMINATOR. INT. CL. 28. REG. 1-8-2002.
- 2,528,300. CLAIRE MURRAY. INT. CL. 24. REG. 1-8-2002.
- 2,528,308. STABLESOUND. INT. CL. 9. REG. 1-8-2002.
- 2,528,310. TREASURED CASTINGS. INT. CL. 28. REG. 1-8-2002.
- 2,528,315. POCKET PUCK. INT. CL. 9. REG. 1-8-2002.
- 2,528,321. FRONTIER REWARDS. INT. CL. 35. REG. 1-8-2002.
- 2,528,338. SOFTMIXER. INT. CL. 7. REG. 1-8-2002.
- 2,528,341. TUNA PERFECT. INT. CL. 8. REG. 1-8-2002.
- 2,528,344. XL. INT. CL. 9. REG. 1-8-2002.
- 2,528,350. ORGANICALLY GROWN AND DESIGN. INT. CL. 31. REG. 1-8-2002.
- 2,528,354. ORGANICALLY GROWN AND DESIGN. INT. CL. 31. REG. 1-8-2002.
- 2,528,361. COUNTRY CLASSICS. INT. CL. 4. REG. 1-8-2002.
- 2,528,370. DURABRAND. INT. CL. 9. REG. 1-8-2002.
- 2,528,373. SERIES II PRECISION AND DESIGN. INT. CL. 28. REG. 1-8-2002.
- 2,528,374. SQUARETRADE. INT. CL. 42. REG. 1-8-2002.
- 2,528,380. LOSE THE GLASSES, KEEP THE VISION. INT. CL. 42. REG. 1-8-2002.
- 2,528,395. HYDROSEAL. INT. CL. 3. REG. 1-8-2002.
- 2,528,397. JUST FOR DINNER. INT. CL. 11. REG. 1-8-2002.
- 2,528,403. GOD'S LITTLE ACRES. INT. CL. 41. REG. 1-8-2002.
- 2,528,410. TEI. INT. CL. 10. REG. 1-8-2002.
- 2,528,419. THOR. INT. CLS. 7 AND 11. REG. 1-8-2002.
- 2,528,431. ESAFE. INT. CL. 7. REG. 1-8-2002.
- 2,528,437. GIVE YOUR HOME A FACE LIFT. INT. CL. 37. REG. 1-8-2002.
- 2,528,451. SHINY BIG WAVES AND DESIGN. INT. CL. 9. REG. 1-8-2002.
- 2,528,453. SMART & EASY TOUCH SCREEN AND DESIGN. INT. CL. 11. REG. 1-8-2002.
- 2,528,457. DURA-CLEAN. INT. CL. 7. REG. 1-8-2002.
- 2,528,459. KAPUT. INT. CL. 5. REG. 1-8-2002.
- 2,528,460. AMERIFIT NUTRITION. INT. CL. 5. REG. 1-8-2002.
- 2,528,471. E LUXURY (STYLIZED). INT. CL. 35. REG. 1-8-2002.
- 2,528,472. E LUXURY (STYLIZED). INT. CL. 35. REG. 1-8-2002.
- 2,528,473. RESULTS MASTERS. INT. CLS. 35 AND 41. REG. 1-8-2002.
- 2,528,475. CHOICE PRIME. INT. CL. 5. REG. 1-8-2002.
- 2,528,478. TWISPS. INT. CL. 30. REG. 1-8-2002.
- 2,528,482. EVERLASTING IMPRESSIONS ROBIN CREATIONS AND DESIGN. INT. CL. 42. REG. 1-8-2002.
- 2,528,484. SHOPPER DNA. INT. CL. 35. REG. 1-8-2002.
- 2,528,491. FARENHEIT. INT. CL. 9. REG. 1-8-2002.
- 2,528,492. SUNSWEET FARMS. INT. CL. 29. REG. 1-8-2002.
- 2,528,498. QUAD SQUAD. INT. CL. 25. REG. 1-8-2002.
- 2,528,499. INFOCOMMERCE. INT. CL. 16. REG. 1-8-2002.
- 2,528,501. CRAZY HORSE. INT. CL. 25. REG. 1-8-2002.
- 2,528,507. SPECSOLUTIONS. INT. CL. 37. REG. 1-8-2002.
- 2,528,510. GREY HOME. INT. CL. 7. REG. 1-8-2002.
- 2,528,520. THE GREY PLACE. INT. CL. 35. REG. 1-8-2002.
- 2,528,521. THE TREND IS YOUR FRIEND EXPERT. INT. CL. 36. REG. 1-8-2002.
- 2,528,541. PHIL VASSAR. INT. CL. 41. REG. 1-8-2002.
- 2,528,543. FS FLOOR STYLE (STYLIZED). INT. CL. 35. REG. 1-8-2002.
- 2,528,558. BETTERBRICKS.COM. INT. CL. 35. REG. 1-8-2002.
- 2,528,564. DECORATING CENTS. INT. CL. 41. REG. 1-8-2002.
- 2,528,567. DNA. INT. CL. 9. REG. 1-8-2002.
- 2,528,568. HISTORY*FILE. INT. CLS. 9, 16 AND 35. REG. 1-8-2002.
- 2,528,570. EZ-HRIS. INT. CL. 9. REG. 1-8-2002.
- 2,528,593. SMOOTH THE WAY. INT. CL. 3. REG. 1-8-2002.
- 2,528,594. KALIX. INT. CL. 10. REG. 1-8-2002.
- 2,528,607. MISCELLANEOUS DESIGN. INT. CL. 36. REG. 1-8-2002.
- 2,528,608. ESTER-C BOOST. INT. CL. 5. REG. 1-8-2002.
- 2,528,621. GEROVISION. INT. CL. 41. REG. 1-8-2002.
- 2,528,629. CHOMPER. INT. CL. 28. REG. 1-8-2002.
- 2,528,634. CAPTAIN ISP. INT. CL. 42. REG. 1-8-2002.
- 2,528,647. TO A WINE GRAPE, IT'S EDEN. INT. CL. 42. REG. 1-8-2002.
- 2,528,651. ROTOSTEER. INT. CL. 7. REG. 1-8-2002.
- 2,528,654. MOSSCLOTH. INT. CL. 31. REG. 1-8-2002.
- 2,528,661. GREENDEALER (STYLIZED). INT. CL. 31. REG. 1-8-2002.
- 2,528,675. THE JAMERICAN FILM AND MUSIC FESTIVAL. INT. CL. 41. REG. 1-8-2002.
- 2,528,677. CANINE CARE. INT. CL. 5. REG. 1-8-2002.
- 2,528,681. THE SENIOR CHANNEL. INT. CL. 42. REG. 1-8-2002.

- 2,528,689. HEEL PAIN SHOE. INT. CL. 10. REG. 1-8-2002.
 2,528,709. CAPE COD MEDICAL CENTER. INT. CL. 42. REG. 1-8-2002.
 2,528,711. STONE SAVER. INT. CL. 19. REG. 1-8-2002.
 2,528,719. BRUNCH STIX. INT. CL. 30. REG. 1-8-2002.
 2,528,720. AUTO TRUCK BUYS. INT. CL. 16. REG. 1-8-2002.
 2,528,723. AUTHENTIC HAND-CARVED. INT. CL. 20. REG. 1-8-2002.
 2,528,742. TOTAL ENGAGEMENT MODEL. INT. CL. 35. REG. 1-8-2002.
 2,528,743. BEDSLIDE. INT. CL. 12. REG. 1-8-2002.
 2,528,750. NEW MEXICO SPINE. INT. CL. 42. REG. 1-8-2002.
 2,528,757. MISCELLANEOUS DESIGN. INT. CL. 30. REG. 1-8-2002.
 2,571,765. CYBERBASE. INT. CL. 16 ONLY. REG. 5-21-2002.
 2,598,536. ROFL. INT. CLS. 9, 16 AND 28 ONLY. REG. 7-23-2002.
 2,600,248. ANSORG. INT. CL. 37 ONLY. REG. 7-30-2002.
 2,600,826. DANTE CONSULTING. INT. CLS. 9 AND 41 ONLY. REG. 7-30-2002.
 2,602,215. CTC ORIGINAL AUTHENTIC 2000 AND DESIGN. INT. CL. 30 ONLY. REG. 7-30-2002.
 2,604,867. MEDRAD. INT. CL. 9 ONLY. REG. 8-6-2002.
 2,605,264. GMTA. INT. CLS. 9, 16 AND 28 ONLY. REG. 8-6-2002.
 2,608,042. POSITIVE COACHING ALLIANCE AND DESIGN. INT. CL. 9 ONLY. REG. 8-13-2002.
 2,611,425. SCHEDONI AND DESIGN. INT. CLS. 30 AND 34 ONLY. REG. 8-27-2002.
 2,615,709. TTYL. INT. CLS. 9 AND 28 ONLY. REG. 9-3-2002.
 2,616,674. NANOCUBE (STYLIZED). INT. CLS. 35 AND 42 ONLY. REG. 9-10-2002.
 2,631,484. CLAIMSQUEST. INT. CL. 9 ONLY. REG. 10-8-2002.
 2,659,438. TUXEGO (STYLIZED). INT. CL. 35 ONLY. REG. 12-10-2002.
 2,669,795. SOLAR-C RESCUE SERUM. INT. CLS. 3 AND 5. REG. 12-31-2002.
 2,706,879. MR. MARBLE CARE-TH INC.. INT. CL. 37. REG. 4-15-2003.
 2,721,633. BOWIENET. INT. CL. 38 ONLY. REG. 6-3-2003.
 2,874,581. ORBITZ FOR BUSINESS AND DESIGN. INT. CL. 39. REG. 8-17-2004.
 2,882,211. EXTRA JOSS AND DESIGN. INT. CL. 32. REG. 9-7-2004.
 2,912,044. NALERGIA. INT. CLS. 3 AND 5. REG. 12-21-2004.
 2,915,378. NURSING ORGANIZATIONS ALLIANCE. INT. CL. 35. REG. 12-28-2004.
 2,918,556. TORYS. INT. CL. 42. REG. 1-18-2005.
 2,921,921. DBT AND DESIGN. INT. CL. 41 ONLY. REG. 2-1-2005.
 2,922,410. ICENET STANDARD CHARACTER MARK. INT. CL. 38. REG. 2-1-2005.
 2,943,841. WHOLE PERSON HEALING ARTS (STYLIZED). INT. CL. 44. REG. 4-26-2005.
 2,948,658. SPORTS EARS. INT. CLS. 9 AND 38. REG. 5-10-2005.
 2,949,157. TRULEAN (STYLIZED). INT. CL. 5. REG. 5-10-2005.
 2,956,804. BOXPOOL STANDARD CHARACTER MARK. INT. CL. 9. REG. 5-31-2005.
 2,957,285. RIVERWOOD STANDARD CHARACTER MARK. INT. CL. 37. REG. 5-31-2005.
 2,962,113. MIDWESTONE FINANCIAL GROUP TIMELESS VALUES. ENDLESS POSSIBILITIES AND DESIGN. INT. CL. 36. REG. 6-14-2005.
 2,965,819. E-LUX. INT. CLS. 9, 40 AND 42. REG. 7-12-2005.
 2,968,615. QUILTED NORTHERN. INT. CL. 16. REG. 7-12-2005.
 2,989,096. LOF INACTIVE WEAR AND DESIGN. INT. CL. 25. REG. 8-30-2005.
 2,990,920. GOAL. INT. CL. 41. REG. 9-6-2005.
 2,992,137. BREAKING THE CYCLE BIKER RIDE AND DESIGN. INT. CL. 36. REG. 9-6-2005.
 3,005,803. SPECIALTY INJECTABLES FOR LIFE AND DESIGN. INT. CL. 5. REG. 10-11-2005.
 3,008,276. SUPREME REAL ESTATE INC. AND DESIGN. INT. CL. 36. REG. 10-25-2005.
 3,013,914. THE GREEN GODDESS. INT. CL. 25. REG. 11-8-2005.
 3,017,225. MOTHERSHIP ENTERTAINMENT. INT. CL. 41. REG. 11-22-2005.
 3,024,309. GATES WARE BY LAURIE GATES AND DESIGN. INT. CL. 21. REG. 12-6-2005.
 3,024,623. JULIET STANDARD CHARACTER MARK. INT. CL. 14. REG. 12-6-2005.
 3,025,813. FLAVA MEN STANDARD CHARACTER MARK. INT. CL. 16. REG. 12-13-2005.
 3,027,199. CELESTIAL CHURCH OF CHRIST AMERICAN DIOCESE EGLISE DU CHRISTIANISME CELESTE IJO AND DESIGN. INT. CL. 45. REG. 12-13-2005.
 3,027,610. PANEROF STANDARD CHARACTER MARK. INT. CL. 5. REG. 12-13-2005.
 3,029,598. TYCHIFORMATION. INT. CL. 35. REG. 12-13-2005.
 3,031,499. SONG VALERIE GREGORI MCKENZIE AND DESIGN. INT. CLS. 24 AND 25. REG. 12-20-2005.
 3,032,060. MEMORY LANE STANDARD CHARACTER MARK. INT. CLS. 9, 11 AND 14. REG. 12-20-2005.
 3,033,827. A C & A STANDARD CHARACTER MARK. INT. CL. 42. REG. 12-27-2005.
 3,036,989. FREE. INT. CL. 29. REG. 1-3-2006.
 3,036,990. S STARTER AND DESIGN. INT. CL. 18. REG. 1-3-2006.
 3,036,992. AMERICAN EAGLE RECORDS. INT. CL. 9. REG. 1-3-2006.
 3,036,994. U.S. SOUTH ONLINE. INT. CL. 42. REG. 1-3-2006.
 3,036,995. BAD DOG AND DESIGN. INT. CL. 25. REG. 1-3-2006.
 3,036,999. COMPLETEHOME. INT. CL. 9. REG. 1-3-2006.
 3,037,001. ACCEL HEALTHCARE COMMUNICATIONS. INT. CL. 35. REG. 1-3-2006.
 3,037,003. MISCELLANEOUS DESIGN. INT. CL. 32. REG. 1-3-2006.
 3,037,004. SUSTAINABLE CUISINE. INT. CLS. 16 AND 41. REG. 1-3-2006.
 3,037,007. GP SORENSEN. INT. CL. 6. REG. 1-3-2006.
 3,037,009. INFORMAX. INT. CL. 9. REG. 1-3-2006.
 3,037,015. FTRI AND DESIGN. INT. CL. 36. REG. 1-3-2006.
 3,037,028. WEE TALK. INT. CL. 16. REG. 1-3-2006.
 3,037,041. AIR SHOT. INT. CLS. 9 AND 13. REG. 1-3-2006.
 3,037,042. ROCA AND DESIGN. INT. CLS. 18, 22 AND 28. REG. 1-3-2006.
 3,037,044. DOUBLE CHEW. INT. CL. 18. REG. 1-3-2006.
 3,037,056. GLISTEN UP. INT. CL. 3. REG. 1-3-2006.
 3,037,066. SANA (STYLIZED). INT. CL. 8. REG. 1-3-2006.
 3,037,337. THE LANGUAGE KEY STANDARD CHARACTER MARK. INT. CL. 41. REG. 1-3-2006.
 3,037,460. IMMUNOCLIN. INT. CLS. 1, 5, 41 AND 42. REG. 1-3-2006.
 3,037,465. EZ REPORTER. INT. CL. 9. REG. 1-3-2006.
 3,037,468. THE CRANKY PRINCESS GIFTS AND HOME ACCENTS TO LIGHTEN THE HEART AND DESIGN. INT. CLS. 3 AND 25. REG. 1-3-2006.
 3,037,472. SIGNDOC. INT. CL. 42. REG. 1-3-2006.
 3,037,473. XIRO. INT. CLS. 2, 17 AND 22. REG. 1-3-2006.
 3,037,479. HANNIBAL, INC.. INT. CL. 9. REG. 1-3-2006.
 3,037,485. AMERICAN BABY FAIRE. INT. CL. 42. REG. 1-3-2006.
 3,037,491. BISCOTA. INT. CL. 33. REG. 1-3-2006.
 3,037,493. MICROBAND. INT. CL. 7. REG. 1-3-2006.
 3,037,502. TABIC. INT. CL. 5. REG. 1-3-2006.
 3,037,531. PROVIVACOR. INT. CL. 5. REG. 1-3-2006.
 3,038,122. LINCOLN FINANCIAL DIRECT. INT. CL. 36. REG. 1-3-2006.
 3,038,124. F/A-18F SUPER HORNET. INT. CL. 28. REG. 1-3-2006.
 3,038,127. LIQUIDFORMS (STYLIZED). INT. CL. 42. REG. 1-3-2006.
 3,038,130. STUDIO 512. INT. CL. 25. REG. 1-3-2006.
 3,038,132. MOMMY AND ME. INT. CLS. 24, 25, 27 AND 28. REG. 1-3-2006.
 3,038,136. GETTING OPTIMIZED. INT. CL. 38. REG. 1-3-2006.

- 3,038,137. SAN DIEGO SPIRIT. INT. CL. 41. REG. 1-3-2006.
 3,038,138. BRANDKEY CREATE. INT. CLS. 37 AND 42. REG. 1-3-2006.
 3,038,139. ENLACETEL. INT. CL. 38. REG. 1-3-2006.
 3,038,141. SECCURE. INT. CLS. 3, 41 AND 42. REG. 1-3-2006.
 3,038,142. METALINK. INT. CL. 9. REG. 1-3-2006.
 3,038,145. DEF POETRY. INT. CL. 41. REG. 1-3-2006.
 3,038,147. JUICY. INT. CL. 18. REG. 1-3-2006.
 3,038,149. VIDI MAIL. INT. CL. 38. REG. 1-3-2006.
 3,038,160. AL BAKER AND DESIGN. INT. CL. 30. REG. 1-3-2006.
 3,038,161. PIVOGY. INT. CL. 28. REG. 1-3-2006.
 3,038,165. LIGHT CHANGER AND DESIGN. INT. CL. 9. REG. 1-3-2006.
 3,038,167. WHERE A LOVE FOR LEARNING GROWS. INT. CL. 35. REG. 1-3-2006.
 3,038,169. WINERP (STYLIZED). INT. CLS. 9 AND 40. REG. 1-3-2006.
 3,038,170. THE POWER BEHIND THE PROMISE. INT. CL. 36. REG. 1-3-2006.
 3,038,171. GRAND CLASSICS STANDARD CHARACTER MARK. INT. CLS. 25 AND 41. REG. 1-3-2006.
 3,038,173. CENTERPOINTE COMMUNICATIONS. INT. CLS. 16 AND 41. REG. 1-3-2006.
 3,038,179. MR. TRICKY. INT. CL. 28. REG. 1-3-2006.
 3,038,180. CARMINA THE ART OF JEWELLING AND DESIGN. INT. CL. 14. REG. 1-3-2006.
 3,038,185. ALL THINGS OUTDOORS WITH CARL & CANDACE (STYLIZED). INT. CL. 41. REG. 1-3-2006.
 3,038,188. HOTScream. INT. CL. 30. REG. 1-3-2006.
 3,038,190. INNOVATION FIRST. INT. CL. 9. REG. 1-3-2006.
 3,038,197. CAFE Q. INT. CL. 30. REG. 1-3-2006.
 3,038,198. CREATE YOUR LEGACY NOT A MESS. INT. CL. 41. REG. 1-3-2006.
 3,038,203. XYCLEEN. INT. CL. 1. REG. 1-3-2006.
 3,038,205. EARTH & ELEMENTS. INT. CL. 20. REG. 1-3-2006.
 3,038,207. NEROLA. INT. CL. 3. REG. 1-3-2006.
 3,038,279. EVOGENE. INT. CL. 42. REG. 1-3-2006.
 3,038,281. ZIP-A-RUFFLE. INT. CL. 24. REG. 1-3-2006.
 3,038,283. MY WAY TO PAY. INT. CL. 36. REG. 1-3-2006.
 3,038,284. IRIS. INT. CL. 42. REG. 1-3-2006.
 3,038,286. THE TREND COMMANDMENTS. INT. CL. 41. REG. 1-3-2006.
 3,038,290. CHANGING THE WORLD THROUGH ENTERTAINMENT. INT. CL. 41. REG. 1-3-2006.
 3,038,293. PRINCIPAL SECRET HYDRAMOISTURE TECHNOLOGY. INT. CL. 3. REG. 1-3-2006.
 3,038,296. MISCELLANEOUS DESIGN. INT. CL. 9. REG. 1-3-2006.
 3,038,298. COLINA NEGRA. INT. CL. 33. REG. 1-3-2006.
 3,038,299. ORANGE BRITE. INT. CL. 3. REG. 1-3-2006.
 3,038,300. LINE OFF. INT. CL. 28. REG. 1-3-2006.
 3,038,301. MISCELLANEOUS DESIGN. INT. CLS. 7, 9, 17, 25 AND 41. REG. 1-3-2006.
 3,038,305. STILL WATERS RECORDINGS STANDARD CHARACTER MARK. INT. CL. 9. REG. 1-3-2006.
 3,038,306. SPEEDBAR. INT. CLS. 35 AND 42. REG. 1-3-2006.
 3,038,308. RAM. INT. CL. 25. REG. 1-3-2006.
 3,038,309. MISCELLANEOUS DESIGN. INT. CL. 38. REG. 1-3-2006.
 3,038,315. ERGOUSA. INT. CL. 20. REG. 1-3-2006.
 3,038,318. SEA AYRE. INT. CL. 44. REG. 1-3-2006.
 3,038,320. NRI NEURAL ROBOTICS INCORPORATED AND DESIGN. INT. CL. 12. REG. 1-3-2006.
 3,038,322. VIZON (STYLIZED). INT. CL. 9. REG. 1-3-2006.
 3,038,328. MANCHEGO REAL STANDARD CHARACTER MARK. INT. CL. 33. REG. 1-3-2006.
 3,038,329. RP SHIFT. INT. CL. 42. REG. 1-3-2006.
 3,038,330. FISHING GAME AND DESIGN. INT. CL. 9. REG. 1-3-2006.
 3,038,331. HEALS, RESTORES, RENEWS. INT. CL. 21. REG. 1-3-2006.
 3,038,334. ECORAD. INT. CL. 1. REG. 1-3-2006.
 3,038,335. EASY GRIP. INT. CL. 16. REG. 1-3-2006.
 3,038,336. CONTOUR GRIP. INT. CL. 16. REG. 1-3-2006.
 3,038,340. FOOHY. INT. CL. 25. REG. 1-3-2006.
 3,038,342. PE2GO STANDARD CHARACTER MARK. INT. CL. 25. REG. 1-3-2006.
 3,038,343. SAILWIND STANDARD CHARACTER MARK. INT. CL. 11. REG. 1-3-2006.
 3,038,344. ST. REGIS STANDARD CHARACTER MARK. INT. CL. 11. REG. 1-3-2006.
 3,038,345. EMPOWER (STYLIZED). INT. CL. 44. REG. 1-3-2006.
 3,038,349. CHEMICOLOUR STANDARD CHARACTER MARK. INT. CL. 2. REG. 1-3-2006.
 3,038,354. PETE STANDARD CHARACTER MARK. INT. CL. 25. REG. 1-3-2006.
 3,038,513. UNITED WE STAND UNITED WE PRAY. INT. CL. 25. REG. 1-3-2006.
 3,038,669. LULU GUINNESS. INT. CL. 8 ONLY. REG. 1-10-2006.
 3,043,130. VALUOMETRICS. INT. CLS. 35 AND 36. REG. 1-17-2006.
 3,044,258. SOLARFLAIR. INT. CL. 1 ONLY. REG. 1-17-2006.
 3,044,273. VIVIUS. INT. CL. 42 ONLY. REG. 1-17-2006.
 3,047,376. IRABA AND DESIGN. INT. CL. 6 ONLY. REG. 1-24-2006.
 3,047,621. GRAPHICS THAT MEAN BUSINESS STANDARD CHARACTER MARK. INT. CL. 16 ONLY. REG. 1-24-2006.
 3,048,786. WHAT PICKLE PEOPLE PREFER STANDARD CHARACTER MARK. INT. CL. 30 ONLY. REG. 1-24-2006.
 3,049,391. CANCUN.NET STANDARD CHARACTER MARK. INT. CL. 43 ONLY. REG. 1-24-2006.
 3,050,097. CANCUN ONLINE STANDARD CHARACTER MARK. INT. CLS. 39 AND 43 ONLY. REG. 1-24-2006.
 3,050,911. MISCELLANEOUS DESIGN. INT. CL. 18 ONLY. REG. 1-24-2006.
 3,052,546. THE DOG BAR AND DESIGN. INT. CLS. 21 AND 31 ONLY. REG. 1-31-2006.
 3,052,960. LOMBARD MEDICAL. INT. CLS. 9, 42 AND 44 ONLY. REG. 1-31-2006.
 3,053,055. TOLLTAG. INT. CL. 36 ONLY. REG. 1-31-2006.
 3,057,987. ACCESS7. INT. CLS. 35 AND 42 ONLY. REG. 2-7-2006.
 3,067,520. MISCELLANEOUS DESIGN. INT. CL. 32 ONLY. REG. 3-14-2006.
 3,072,034. PD AND DESIGN. INT. CL. 42 ONLY. REG. 3-21-2006.
 3,103,086. NCAA AND DESIGN. INT. CL. 14 ONLY. REG. 6-13-2006.
 3,106,692. PRECISION IN MOTION STANDARD CHARACTER MARK. INT. CL. 25 ONLY. REG. 6-20-2006.
 3,111,123. GNEOPTIMIZER. INT. CLS. 1 AND 5 ONLY. REG. 7-4-2006.
 3,111,377. MISCELLANEOUS DESIGN. INT. CL. 9 ONLY. REG. 7-4-2006.
 3,118,480. PANAMERICAN VENOUS FORUM STANDARD CHARACTER MARK. INT. CL. 35 ONLY. REG. 7-18-2006.
 3,118,822. EARTH COMMUNICATIONS OFFICE STANDARD CHARACTER MARK. INT. CL. 36 ONLY. REG. 7-25-2006.
 3,118,823. ECO EARTH COMMUNICATIONS OFFICE AND DESIGN. INT. CL. 36 ONLY. REG. 7-25-2006.
 3,119,027. MISCELLANEOUS DESIGN. INT. CLS. 38, 40 AND 43 ONLY. REG. 7-25-2006.
 3,120,574. MISCELLANEOUS DESIGN. INT. CLS. 30 AND 32 ONLY. REG. 7-25-2006.
 3,121,372. COCA-COLA AND DESIGN. INT. CL. 15 ONLY. REG. 7-25-2006.
 3,121,382. PLANETSHAKERS STANDARD CHARACTER MARK. INT. CL. 16 ONLY. REG. 7-25-2006.
 3,122,297. AW AND DESIGN. INT. CLS. 7, 40 AND 42 ONLY. REG. 8-1-2006.
 3,122,900. FEI STANDARD CHARACTER MARK. INT. CL. 9 ONLY. REG. 8-1-2006.
 3,122,905. MISCELLANEOUS DESIGN. INT. CL. 9 ONLY. REG. 8-1-2006.
 3,122,907. FEI (STYLIZED). INT. CL. 9 ONLY. REG. 8-1-2006.

- 3,124,008. STUDENT LOUNGE STANDARD CHARACTER MARK. INT. CL. 9 ONLY. REG. 8-1-2006.
 3,125,664. CONFLICT STANDARD CHARACTER MARK. INT. CLS. 28 AND 41 ONLY. REG. 8-8-2006.
 3,126,477. CINERGY STANDARD CHARACTER MARK. INT. CLS. 36 AND 38 ONLY. REG. 8-8-2006.
 3,128,033. SEMPHONIC STANDARD CHARACTER MARK. INT. CL. 9 ONLY. REG. 8-8-2006.
 3,128,488. ELIXIR STANDARD CHARACTER MARK. INT. CLS. 12 AND 17 ONLY. REG. 8-15-2006.
 3,132,519. IMMUNICON STANDARD CHARACTER MARK. INT. CLS. 1 AND 5 ONLY. REG. 8-22-2006.
 3,134,586. WILD UTAH. INT. CLS. 29 AND 39 ONLY. REG. 8-29-2006.
 3,200,745. PRIDE FOUNDATION AND DESIGN. INT. CL. 35 ONLY. REG. 1-23-2007.
 3,245,585. MISCELLANEOUS DESIGN. INT. CLS. 16 AND 18 ONLY. REG. 5-22-2007.

SECTION 18

- 2,083,447. ACRYLETHANE. INT. CL. 17. REG. 7-29-1997.
 3,232,665. TICKET2FAME STANDARD CHARACTER MARK. INT. CL. 35. REG. 4-24-2007.
 3,236,163. WING SPOT AND DESIGN. INT. CL. 43. REG. 5-1-2007.
 3,468,124. GATSBY (STYLIZED). INT. CL. 16. REG. 7-15-2008.
 3,552,141. REJECTS STANDARD CHARACTER MARK. INT. CL. 25. REG. 12-23-2008.
 3,604,148. GAZPROM STANDARD CHARACTER MARK. INT. CL. 4. REG. 4-7-2009.
 4,060,367. THE ELECTRIC BARBARELLAS STANDARD CHARACTER MARK. INT. CL. 41. REG. 11-22-2011.

SECTION 71

- 2,981,216. RETOC STANDARD CHARACTER MARK. INT. CL. 36. REG. 8-2-2005.

- 2,987,622. SENSOROR AN INFINEON TECHNOLOGIES COMPANY AND DESIGN. INT. CLS. 9, 35 AND 42. REG. 8-23-2005.
 2,992,655. ECHOBOY (STYLIZED). INT. CL. 38. REG. 9-6-2005.
 2,995,379. PROCORALAN (STYLIZED). INT. CL. 5. REG. 9-13-2005.
 3,002,049. B AND DESIGN. INT. CLS. 3, 5, 41 AND 44. REG. 9-27-2005.
 3,002,050. C AND DESIGN. INT. CLS. 3, 5, 41 AND 44. REG. 9-27-2005.
 3,007,553. MISCELLANEOUS DESIGN. INT. CL. 14. REG. 10-18-2005.
 3,008,982. TISSOT HIGH-T STANDARD CHARACTER MARK. INT. CL. 14. REG. 10-25-2005.
 3,011,535. A AND DESIGN. INT. CLS. 3, 5, 41 AND 44. REG. 11-1-2005.
 3,029,438. DENKAVIT (STYLIZED). INT. CL. 31. REG. 12-13-2005.
 3,032,407. CAFFÈ CUORAMÍ DECAFFEINIZZATO AND DESIGN. INT. CL. 30. REG. 12-20-2005.
 3,038,105. MISCELLANEOUS DESIGN. INT. CL. 33. REG. 1-3-2006.
 3,041,895. CREDITREFORM AND DESIGN. INT. CLS. 9, 16 AND 42 ONLY. REG. 1-10-2006.
 3,068,377. ISORALDEINE (STYLIZED). INT. CLS. 1 AND 3 ONLY. REG. 3-14-2006.
 3,109,418. AVO UVEZIAN AND DESIGN. INT. CL. 14. REG. 6-27-2006.
 3,112,152. MINGARDI AND DESIGN. INT. CLS. 7 AND 9 ONLY. REG. 7-4-2006.
 3,133,337. DURA STANDARD CHARACTER MARK. INT. CLS. 9, 37 AND 42 ONLY. REG. 8-22-2006.
 3,158,850. PEISELER (STYLIZED). INT. CLS. 8 AND 9 ONLY. REG. 10-17-2006.
 3,165,438. ATHOS STANDARD CHARACTER MARK. INT. CL. 11. REG. 10-31-2006.
 3,256,605. GTP AND DESIGN. INT. CLS. 7 AND 42 ONLY. REG. 6-26-2007.

INADVERTENTLY ISSUED REGISTRATION NUMBERS

- 3,853,982. ALONBRIGHT STANDARD CHARACTER MARK. INT. CL. 1. REG. 9-28-2010. RESTORED TO SN 79-081,165.

* * * * *

TRADEMARK REGISTRATIONS AMENDED, CORRECTED, ETC.

The designation "U.S. Cl." appearing in this section refers to the U.S. class in effect prior to Sep. 1, 1973 rather than the international class which applies to applications filed on or after that date. For adoption of international classification see notice in the OFFICIAL GAZETTE of Jun. 26, 1973 (911 O.G. TM 210).

Any change to the registration will be indicated at the bottom of each entry under ELEMENTS AMENDED, CORRECTED OR RESTRICTED. With the exception of changes to the goods and services, additions to the registration will appear in asterisks and deletions of the registration will appear in brackets. Elements which are only changed will be listed with no punctuation. As to the goods/services statement, amendments to the goods/services will appear in asterisks and deletions will appear in brackets. In addition if any change to the goods/services occurs, the element "Goods/Services" will be listed under ELEMENTS AMENDED, CORRECTED OR RESTRICTED.

945,380. REG. 10-17-1972. CAESARS WORLD, INC. (FLORIDA CORPORATION) ONE CAESARS PALACE DRIVE, LAS VEGAS, NV, 89109, SN 72-380,686. FILED 1-11-1971. PRINCIPAL REGISTER.

1,199,067. REG. 6-22-1982. HYDRAULIC COMPONENT SERVICES, INC. (WISCONSIN CORPORATION) 1760 S. SPRINGDALE RD., NEW BERLIN, WI, 53146, SN 73-308,806. FILED 5-4-1981. PRINCIPAL REGISTER.

GALLERIA

"GALLERIA" IS DEFINED AS "GALLERY, TUNNEL, (THEAT.) BALCONY."

INT. CLS. 35, 36, 37, 38, 39, 40, 41 AND 42/U.S. CL. 100
FOR RESTAURANT SERVICES *IN THE NATURE OF PROVIDING SNACKS AND DRINKS*.

FIRST USE 8-3-1966; IN COMMERCE 8-3-1966.

ELEMENTS AMENDED
GOODS/SERVICES

949,313. REG. 12-26-1972. CHURCH & DWIGHT CO., INC. (DELAWARE CORPORATION) 469 NORTH HARRISON STREET, PRINCETON, NJ, 085435297, SN 72-405,784. FILED 10-22-1971. PRINCIPAL REGISTER.

ANSWER

INT. CL. 5/U.S. CLS. 6, 18, 44, 46, 51 AND 52
FOR DIAGNOSTIC KIT TO TEST FOR THE PRESENCE OF HUMAN PREGNANCY HORMONE IN HUMANS.

FIRST USE 9-21-1971; IN COMMERCE 9-21-1971.

ELEMENTS AMENDED
GOODS/SERVICES
U.S. CLASS(ES)
DATE OF FIRST USE
DATE OF FIRST USE IN COMMERCE



HYDRAULIC COMPONENT SERVICES, INC.

THE TERMINOLOGY "HYDRAULIC COMPONENT SERVICES, INC." IS DISCLAIMED APART FROM THE MARK AS SHOWN, WITHOUT WAIVING ANY OF APPLICANTS COMMON LAW RIGHTS THEREIN.

INT. CL. 37/U.S. CL. 103
FOR REPAIR AND REBUILDING OF HYDRAULIC COMPONENTS.

FIRST USE 7-1-1975; IN COMMERCE 7-1-1975.

ELEMENTS AMENDED
MARK
DISCLAIMER

1,204,812. REG. 8-10-1982. TRANSATLANTIC HOLDINGS, INC. (DELAWARE CORPORATION) 80 PINE STREET, NEW YORK, NY, 10005, SN 73-282,519. FILED 10-20-1980. PRINCIPAL REGISTER.



THE LINING IS PART OF THE DESIGN AND IS NOT INTENDED TO INDICATE COLOR.

THE MARK CONSISTS OF THE LETTERS TRC IN STYLIZED FORM.

INT. CL. 36/U.S. CL. 102

FOR REINSURANCE SERVICES.
FIRST USE 9-4-1980; IN COMMERCE 9-4-1980.

1,745,875. REG. 1-12-1993. GAP (APPAREL), LLC (CALIFORNIA LIMITED LIABILITY COMPANY) 2 FOLSOM STREET, SAN FRANCISCO, CA, 94105, SN 74-239,382. FILED 1-22-1992. PRINCIPAL REGISTER.

ELEMENTS CORRECTED
OWNER NAME
OWNER ADDRESS
CITIZENSHIP

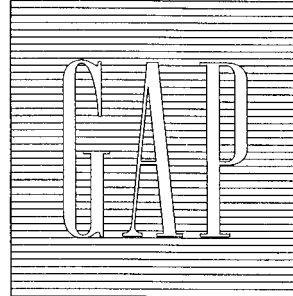

1,699,565. REG. 7-7-1992. BEVERLY BREMER'S SILVER SHOP, INC. (GEORGIA CORPORATION) 3164 PEACHTREE ROAD, N.E., ATLANTA, GA, 30305, SN 74-099,245. FILED 9-21-1990. PRINCIPAL REGISTER.

MISSING A PIECE OF YOUR PATTERN?

THE COLOR BLUE IS CLAIMED AS PART OF THE MARK.

INT. CL. 42/U.S. CL. 101
FOR RETAIL STORE SERVICES IN THE FIELD OF SILVERWARE.
FIRST USE 9-0-1976; IN COMMERCE 9-0-1976.

INT. CL. 25/U.S. CL. 39
FOR CLOTHING; NAMELY, SHIRTS, PANTS, SHORTS, VESTS, JACKETS, DRESSES, SKIRTS, SWEATERS, SWIMSUITS, HEADBANDS, BELTS, HATS, SCARVES, GLOVES, SOCKS, HOSIERY AND SHOES.
FIRST USE 12-0-1988; IN COMMERCE 12-0-1988.

ELEMENTS CORRECTED
OWNER NAME

INT. CL. 35/U.S. CLS. 100, 101 AND 102
FOR RETAIL CLOTHING STORE SERVICES.
FIRST USE 6-0-1987; IN COMMERCE 6-0-1987.

ELEMENTS AMENDED
GOODS/SERVICES
INTERNATIONAL CLASS(ES)
DATE OF FIRST USE
DATE OF FIRST USE IN COMMERCE

1,725,148. REG. 10-20-1992. CHICAGO CLASSICAL RECORDING FOUNDATION, THE (ILLINOIS NOT-FOR-PROFIT) 5255 NORTH LAKEWOOD AVENUE, CHICAGO, IL, 60640, SN 74-108,039. FILED 10-22-1990. PRINCIPAL REGISTER.

1,773,101. REG. 5-25-1993. SUPER BRANDS, LLC (DELAWARE LIMITED LIABILITY COMPANY) 121 MCKINNEY, 3600 ONE HOUSTON CENTER, HOUSTON, TX, 770102010, SN 74-082,763. FILED 7-30-1990. PRINCIPAL REGISTER.



NO CLAIM IS MADE TO THE EXCLUSIVE RIGHT TO USE THE DESIGN OF THE BASS CLEF, APART FROM THE MARK AS SHOWN.

OWNER OF MEXICO REG. NO. 338912, DATED 6-25-1987. THE MARK IS LINED FOR THE COLOR RED. THE COLOR(S) RED, WHITE, ORANGE, AND YELLOW IS/ARE CLAIMED AS A FEATURE OF THE MARK.

INT. CL. 9/U.S. CLS. 21, 23, 26, 36 AND 38
FOR SOUND RECORDINGS; NAMELY, [DISC PHONOGRAPH RECORDS, AUDIO CASSETTES,] COMPACT DISCS [AND VIDEO CASSETTES] CONTAINING MUSIC.
FIRST USE 11-1-1989; IN COMMERCE 11-1-1989.

THE MARK CONSISTS OF THE WORDING TRES IN WHITE OVER ESTRELLAS IN WHITE, ON A HOME PLATE SHAPED RED POLYGON BORDERED IN ORANGE, WITH WHITE FIVE-POINTED STARS ON A RED BANNER WITH YELLOW BORDERS CURLING AROUND THE POLYGON.

ELEMENTS AMENDED
MARK
DISCLAIMER

THE ENGLISH TRANSLATION OF THE WORDS "TRES ESTRELLAS" IN THE MARK IS "THREE STARS".
INT. CL. 30/U.S. CL. 46

FOR FOOD PRODUCTS AND INGREDIENTS; NAMELY, COOKIES, CAKE MIX, PREPARED CHURRO FLOUR, SWEETENED, FLAVORED GELATIN, COCOA, SUGAR, TAPIOCA, SAGO, CAKES, PASTRY AND FLAVORED ICES, AND CRACKERS.

ELEMENTS AMENDED
 ASSIGNMENT/NAME CHANGE
 DESCRIPTION OF MARK
 COLOR DESCRIPTION STATEMENT
 MARK

1,974,475. REG. 5-21-1996. ONEIDA INDIAN NATION OF NEW YORK, THE (UNITED STATES FEDERALLY RECOGNIZED SOVEREIGN INDIAN NATION), AKA THE ONEIDA INDIAN NATION OF NEW YORK, THE ONEIDA INDIAN NATION, ONEIDA INDIAN NATION, THE ONEIDA NATION OR ONEIDA NATION, 2037 DREAM CATCHER PLAZA, ONEIDA, NY, 13421, SN 74-420,046. FILED 8-3-1993. PRINCIPAL REGISTER.

TURNING STONE

THE MARK CONSISTS OF STANDARD CHARACTERS WITHOUT CLAIM TO ANY PARTICULAR FONT, STYLE, SIZE, OR COLOR.

INT. CL. 4/U.S. CLS. 1, 6 AND 15
 FOR [CANDLES].
 FIRST USE 7-17-1993; IN COMMERCE 7-17-1993.
 INT. CL. 16/U.S. CLS. 2, 5, 22, 23, 29, 37, 38 AND 50
 FOR DECALS, PAPERWEIGHTS.
 FIRST USE 7-17-1993; IN COMMERCE 7-17-1993.
 INT. CL. 20/U.S. CLS. 2, 13, 22, 25, 32 AND 50
 FOR KEY FOBS, NOT OF METAL.
 FIRST USE 7-17-1993; IN COMMERCE 7-17-1993.
 INT. CL. 21/U.S. CLS. 2, 13, 23, 29, 30, 33, 40 AND 50
 FOR DESK ORNAMENTS, NAMELY POTTERY AND CERAMIC WARE, NAMELY DECORATIVE CANDLE HOLDERS WITH CANDLES, MUGS, SOUVENIRS IN THE NATURE OF ALL PURPOSE PORTABLE CONTAINERS.
 FIRST USE 7-17-1993; IN COMMERCE 7-17-1993.
 INT. CL. 25/U.S. CL. 39
 FOR CLOTHING, NAMELY T-SHIRTS, HATS, SWEAT-SHIRTS, SPORTS SHIRTS.
 FIRST USE 7-17-1993; IN COMMERCE 7-17-1993.
 INT. CL. 30/U.S. CL. 46
 FOR [CANDIES].
 FIRST USE 7-17-1993; IN COMMERCE 7-17-1993.
 INT. CL. 34/U.S. CLS. 2, 8, 9 AND 17
 FOR [NON-METAL ASHTRAYS].
 FIRST USE 7-17-1993; IN COMMERCE 7-17-1993.
 INT. CL. 41/U.S. CL. 107
 FOR ENTERTAINMENT SERVICES, NAMELY CASINO SERVICES, AND LIVE ENTERTAINMENT SERVICES IN THE NATURE OF MUSICAL CONCERTS, VARIETY SHOWS, COMEDY SHOWS, AND CONDUCTING SPORTING EXHIBITIONS IN HOCKEY, BOCCE, GOLF AND BOXING.
 FIRST USE 7-17-1993; IN COMMERCE 7-17-1993.
 INT. CL. 42/U.S. CL. 100
 FOR RESTAURANT AND NON-ALCOHOLIC BAR SERVICES.
 FIRST USE 7-17-1993; IN COMMERCE 7-17-1993.

ELEMENTS AMENDED
 MARK

1,978,358. REG. 6-4-1996. BRAND DESIGN COMPANY, INC. (DELAWARE CORPORATION), DBA HOUSE INDUSTRIES, P. O. BOX 166, YORKLYN, DE, 19736, SN 74-694,080. FILED 6-26-1995. PRINCIPAL REGISTER.

HOUSE INDUSTRIES

NO CLAIM IS MADE TO THE EXCLUSIVE RIGHT TO USE "INDUSTRIES", APART FROM THE MARK AS SHOWN.
 INT. CL. 25/U.S. CLS. 22 AND 39

FOR CLOTHING, NAMELY T-SHIRTS, HATS, JACKETS, VESTS AND WORKSHIRTS.
 FIRST USE 11-1-1993; IN COMMERCE 11-1-1993.

ELEMENTS AMENDED
 DBA/AKA
 OWNER ADDRESS

2,086,957. REG. 8-12-1997. VISALIA CITRUS PACKING GROUP, L.P. (CALIFORNIA LIMITED PARTNERSHIP), DBA GOLDEN STATE CITRUS PACKERS, 500 NORTH SANTA FE STREET, VISALIA, CA, 93279, SN 75-030,293. FILED 12-11-1995. PRINCIPAL REGISTER.



NO CLAIM IS MADE TO THE EXCLUSIVE RIGHT TO USE "GOLDEN STATE", APART FROM THE MARK AS SHOWN.
 INT. CL. 31/U.S. CLS. 1 AND 46
 FOR FRESH CITRUS FRUITS.
 FIRST USE 6-12-1995; IN COMMERCE 6-12-1995.

ELEMENTS CORRECTED
 OWNER ADDRESS
 ENTITY

2,147,007. REG. 3-31-1998. HORIZON U.A.E. FZCO (UNITED ARAB EMIR. COMPANY) LOB 16 NO. 314, JEBEL ALI, DUBAI, UNITED ARAB EMIRATES, UNITED ARAB EMIR., SN 75-039,772. FILED 1-3-1996. PRINCIPAL REGISTER.

ABC

INT. CL. 29/U.S. CL. 46
 FOR [MILK, CANNED MUSHROOMS, RAMEN (NOODLES WITH SOUP MIX IN CUPS AND PACKETS), CANNED SARDINES, SOUP MIX].
 FIRST USE 0-0-1982; IN COMMERCE 0-0-1982.
 INT. CL. 30/U.S. CL. 46
 FOR CHILI SAUCE, [KETCHUP, NOODLES, PREPARED TEA, SEAFOOD SAUCE.] SOY SAUCE.
 FIRST USE 0-0-1975; IN COMMERCE 0-0-1978.

ELEMENTS AMENDED
 GOODS/SERVICES

2,458,663. REG. 6-5-2001. TRANSAMERICA CORPORATION (DELAWARE CORPORATION) 4333 EDGEWOOD ROAD N.E., CEDAR RAPIDS, IA, 524990010, SN 75-916,310. FILED 2-11-2000. PRINCIPAL REGISTER.

TRANSAMERICA ELITE

OWNER OF U.S. REG. NOS. 1,635,682, 2,246,732 AND OTHERS.
INT. CL. 36/U.S. CLS. 100, 101 AND 102
FOR LIFE INSURANCE UNDERWRITING AND ADMINISTRATION SERVICES.
FIRST USE 6-1-2000; IN COMMERCE 6-15-2000.

ELEMENTS CORRECTED
OWNER NAME

FOR REAL ESTATE MANAGEMENT AND LEASING OF REAL ESTATE.
FIRST USE 2-25-2000; IN COMMERCE 2-25-2000.

ELEMENTS AMENDED
OWNER ADDRESS
ENTITY
MARK

2,471,940. REG. 7-24-2001. POWER INTEGRATIONS, INC. (DELAWARE CORPORATION) 5245 HELLYER AVENUE, SAN JOSE, CA, 95138, SN 75-519,697. FILED 7-14-1998. PRINCIPAL REGISTER.

2,565,664. REG. 4-30-2002. SONY CORPORATION (JAPAN CORPORATION), TA SONY KABUSHIKI KAISHA, 1-7-1 KONAN, MINATO-KU, TOKYO, JAPAN., SN 75-710,922. FILED 5-19-1999. PRINCIPAL REGISTER.

TINY SWITCH

INT. CL. 9/U.S. CLS. 21, 23, 26, 36 AND 38
FOR INTEGRATED CIRCUITS, NAMELY AD/DC POWER CONVERTERS HAVING LOW CONSUMPTION OR POWER LOSS.
FIRST USE 7-0-1998; IN COMMERCE 9-0-1998.

ELEMENTS CORRECTED
CITIZENSHIP

2,472,252. REG. 7-24-2001. FEDERAL APD INCORPORATED (MICHIGAN CORPORATION) 28100 CABOT DRIVE, SUITE 200, NOVI, MI, 48377, SN 75-778,874. FILED 8-19-1999. PRINCIPAL REGISTER.

SCAN NET

INT. CL. 9/U.S. CLS. 21, 23, 26, 36 AND 38
FOR COMPUTER SOFTWARE FOR USE IN MONITORING PARKING, ACCESS AND REVENUE FOR PARKING FACILITIES.
FIRST USE 1-0-2000; IN COMMERCE 1-0-2000.

ELEMENTS CORRECTED
OWNER NAME
OWNER ADDRESS

2,555,115. REG. 4-2-2002. TOM HOM GROUP, LLC, THE (CALIFORNIA LIMITED LIABILITY COMPANY) 7660 FAY AVENUE, SUITE H-525, LA JOLLA, CA, 92037, SN 76-071,159. FILED 6-15-2000. PRINCIPAL REGISTER.

ROOM TO SAVE + ROOM TO GROW + ROOM FOR ALL YOU NEED

THE MARK CONSISTS OF STANDARD CHARACTERS WITHOUT CLAIM TO ANY PARTICULAR FONT, STYLE, SIZE, OR COLOR.
INT. CL. 35/U.S. CLS. 100, 101 AND 102
FOR BUSINESS MANAGEMENT, PLANNING AND SUPERVISION OF RESIDENTIAL PROPERTIES.
FIRST USE 2-25-2000; IN COMMERCE 2-25-2000.
INT. CL. 36/U.S. CLS. 100, 101 AND 102

OPENMG

INT. CL. 9/U.S. CLS. 21, 23, 26, 36 AND 38
FOR COMPUTERS, IC CHIP, STORAGE MEDIA FOR AUDIO/VISUAL/COMPUTER DATA, NAMELY, SEMI-CONDUCTORS PACKED STICK-LIKE, BLANK COMPUTER DISCS, BLANK FLOPPY DISCS, BLANK HARD DISCS, BLANK COMPACT DISCS, BLANK OPTICAL DISCS, BLANK MAGNETO-OPTICAL DISCS, BLANK AUDIO TAPES AND BLANK VIDEO TAPES FOR RECORDING AUDIO, VIDEO AND COMPUTER DATA, COMPUTER PRINTERS; APPARATUS FOR RECORDING, TRANSMISSION OR REPRODUCTION OF SOUND OR IMAGES, NAMELY, VIDEO CAMERAS, STILL CAMERAS, TELEVISIONS, AUDIO TAPE/DISC PLAYERS/RECORDERS, VIDEO TAPE/DISC PLAYERS/RECORDERS, HEADPHONES, EARPHONES, MICROPHONES, LOUDSPEAKERS, RADIOS.
FIRST USE 6-30-2001; IN COMMERCE 6-30-2001.

ELEMENTS AMENDED
OWNER NAME

2,573,398. REG. 5-28-2002. FEDERAL APD INCORPORATED (MICHIGAN CORPORATION) 28100 CABOT DRIVE, SUITE 200, NOVI, MI, 48377, SN 76-239,249. FILED 4-12-2001. PRINCIPAL REGISTER.



NO CLAIM IS MADE TO THE EXCLUSIVE RIGHT TO USE "DRIVE", APART FROM THE MARK AS SHOWN.
INT. CL. 9/U.S. CLS. 21, 23, 26, 36 AND 38
FOR MOTORIZED SECURITY GATE TO CONTROL VEHICLE ACCESS.
FIRST USE 11-0-2000; IN COMMERCE 11-0-2000.

ELEMENTS CORRECTED
OWNER NAME

2,578,687. REG. 6-11-2002. FEDERAL APD INCORPORATED (MICHIGAN CORPORATION) SUITE 200, 28100 CABOT DRIVE, NOVI, MI, 48377. SN 76-325,179. FILED 10-16-2001. PRINCIPAL REGISTER.

FEDERAL APD

INT. CL. 9/U.S. CLS. 21, 23, 26, 36 AND 38
 FOR MAGNETICALLY CODED PLASTIC CARDS; READERS FOR MAGNETICALLY CODED CARDS; ELECTRONIC LOCKS; AND MODULAR PARKING CONTROL DEVICES—NAMELY, TICKET DISPENSERS, PRINTERS AND DISPOSAL UNITS, VEHICLE DETECTORS, SPACE COUNTERS, FEE INDICATORS AND ACCEPTORS AND VEHICLE GATES ADAPTED TO BE ELECTRICALLY OPERATED BY SAID TICKET DISPENSERS, VEHICLE DETECTORS, FEE ACCEPTORS, ELECTRONIC LOCKS AND READERS FOR MAGNETICALLY CODED CARDS.
 FIRST USE 0-0-1982; IN COMMERCE 0-0-1982.

ELEMENTS CORRECTED
 OWNER NAME



2,601,604. REG. 7-30-2002. BRIDGE OF WEIR LEATHER COMPANY LIMITED (UNITED KINGDOM CORPORATION) BALTIC WORKS, KILBARCHAN ROAD, BRIDGE OF WEIR, RENFREWSHIRE, UNITED KINGDOM., SN 75-697,969. FILED 5-5-1999. PRINCIPAL REGISTER.



NO CLAIM IS MADE TO THE EXCLUSIVE RIGHT TO USE "FINE SCOTTISH LEATHER", APART FROM THE MARK AS SHOWN.

INT. CL. 18/U.S. CLS. 1, 2, 3, 22 AND 41
 FOR LEATHER AND IMITATIONS OF LEATHER, NAMELY, LEATHER SUPPLIED IN WHOLE HIDES OR CUT IN PIECES FOR FURNITURE OR AUTOMOTIVE, AIRCRAFT AND MARINE INTERIOR APPLICATIONS.
 FIRST USE 1-0-1986; IN COMMERCE 1-0-1986.

ELEMENTS AMENDED
 MARK



2,601,615. REG. 7-30-2002. MIZUNO KABUSHIKI KAISHA (MIZUNO CORPORATION) (JAPAN CORPORATION) CHUO-KU, OSAKA-SHI, NO. 1-23, KITAHAMA 4 CHOME, OSAKA, 541-8538, JAPAN., SN 75-706,921. FILED 5-14-1999. PRINCIPAL REGISTER.



INT. CL. 25/U.S. CLS. 22 AND 39

FOR CLOTHING -, NAMELY, BASEBALL UNIFORMS, BASEBALL STOCKINGS, BASEBALL UNDERSHIRTS, BASEBALL UNDER STOCKINGS, BASEBALL SLIDING PANTS, BADMINTON SHIRTS, BADMINTON PANTS AND SHORTS, BADMINTON SKIRTS, TENNIS JACKETS, TENNIS SHIRTS, TENNIS PANTS, TENNIS SHORTS AND SKIRTS, TABLE TENNIS JACKETS, TABLE TENNIS PANTS AND SHORTS, TABLE TENNIS SHIRTS, BASKETBALL SHIRTS, BASKETBALL PANTS, BASKETBALL JERSEYS, GOLF SHIRTS, GOLF VESTS, GOLF JACKETS, GOLF PANTS, GOLF SOCKS, GOLF RAINCOATS, GOLF RAIN JACKETS AND PANTS, GOLF SWEATERS, RUGBY SHIRTS, RUGBY PANTS, FOOTBALL JACKETS, FOOTBALL PANTS, FOOTBALL SHIRTS, FOOTBALL HOSE, NAMELY, SOCKS AND STOCKINGS, VOLLEYBALL JACKETS, VOLLEYBALL WARM-UP SHIRTS, VOLLEYBALL WARM-UP PANTS, VOLLEYBALL SHIRTS, VOLLEYBALL PANTS, SKI JACKETS, SKI PANTS, SKI ANORAK COATS, SKI JUMP SUITS, SKI STOCKINGS AND SOCKS; SKATE SUITS, BOXING TRUNKS, BOXING SHIRTS, WRESTLING UNIFORMS, TRACK AND FIELD SHIRTS, TRACK AND FIELD PANTS, TRACK AND FIELD WARM-UP SHIRTS, TRACK AND FIELD WARM-UP PANTS, GYMNAS TIC SHIRTS, GYMNAS TIC PANTS, MOUNTAINEERING JACKETS, MOUNTAINEERING SHIRTS, MOUNTAINEERING PANTS, MOUNTAINEERING SOCKS, MOUNTAINEERING BREECHES, MOUNTAINEERING ANORAKS, [BOWLING SHIRTS,] JUDO UNIFORMS, NAMELY, COATS, PANTS AND BELTS, JUDO UNDERWEAR FOR WOMEN, KARATE UNIFORMS, NAMELY, COATS, PANTS AND BELTS, KARATE UNDERWEAR FOR WOMEN, [KENDO UNIFORMS, NAMELY, COATS, PANTS AND BELTS,] SWIM PANTS, SWIM SUITS, HANDBALL SHIRTS, HANDBALL PANTS, SOCCER SHIRTS, SOCCER PANTS, WET SUITS, WATER SKI JACKETS, T-SHIRTS, SHORTS, SWEAT SHIRTS, SWEAT PANTS, GLOVES, POLO SHIRTS, BLOUSONS, VESTS, CARDIGANS, TROUSERS, SLACKS, SHORT PANTS, SOCKS AND HOSE, RAIN WEAR, SKIRTS, CULOTTES, WIND PROTECTION JACKETS AND UNDERWEAR; [FOOTWEAR, NAMELY, BASEBALL SHOES, SOFTBALL SHOES, BADMINTON SHOES, TENNIS SHOES, TABLE TENNIS SHOES, BASKETBALL SHOES, GOLF SHOES, FOOTBALL SHOES, VOLLEYBALL SHOES, HOCKEY SHOES, ARCHERY SHOES, HANDBALL SHOES, SKI BOOTS, AFTER SKI BOOTS, ICE SKATE BOOTS, WRESTLING SHOES, RUNNING SHOES, TRACK AND FIELD SHOES, WALKING AND CLIMBING FOOTWEAR, GYMNAS TIC SHOES, WEIGHT LIFTING SHOES, BOXING SHOES, SOCCER SHOES, RUGBY SHOES, CROSS TRAINING SHOES, CROSS COURT SHOES, RACKET BALL SHOES AND SQUASH SHOES;] CAPS AND HATS, NAMELY, BASEBALL CAPS, TENNIS CAPS, GOLF CAPS, GOLF SUN VISORS, SKI CAPS, SWIM CAPS, SUITS, SKIRTS, COATS, JACKETS, SHIRTS, BLOUSES, UNDERWEAR.
 FIRST USE 1-4-2002; IN COMMERCE 1-4-2002.

ELEMENTS AMENDED
 OWNER ADDRESS
 MARK



2,605,574. REG. 8-6-2002. EVERYDAY HEALTH, INC. (DELAWARE CORPORATION) 345 HUDSON STREET, NEW YORK, NY, 10014, SN 76-094,779. FILED 7-24-2000. PRINCIPAL REGISTER.

CAREPAGES

THE MARK CONSISTS OF STANDARD CHARACTERS WITHOUT CLAIM TO ANY PARTICULAR FONT, STYLE, SIZE, OR COLOR.

INT. CL. 38/U.S. CLS. 100, 101 AND 104

FOR PROVIDING ONLINE CHAT ROOMS AND ELECTRONIC BULLETIN BOARDS FOR TRANSMISSION OF MESSAGES AMONG COMPUTER USERS CONCERNING TOPICS OF GENERAL AND PERSONAL INTEREST VIA A GLOBAL COMPUTER NETWORK, INTERCONNECTING THE WEB SITES OF OTHERS REGARDING TOPICS OF GENERAL AND RELATED INTEREST VIA AN ONLINE ELECTRONIC COMMUNICATIONS NETWORK.

FIRST USE 5-1-2000; IN COMMERCE 8-11-2000.
INT. CL. 42/U.S. CLS. 100 AND 101
FOR COMPUTER SERVICES; NAMELY, HOSTING THE WEB SITES OF OTHERS ON A COMPUTER SERVER FOR A GLOBAL COMPUTER NETWORK; CREATING AND MAINTAINING WEB SITES OF OTHERS; PROVIDING NEWS AND CURRENT EVENTS INFORMATION VIA A GLOBAL COMPUTER NETWORK.

FIRST USE 5-1-2000; IN COMMERCE 8-13-2000.

ELEMENTS AMENDED
MARK

2,607,144. REG. 8-13-2002. SUNSHINE MEDIA I, INC. (DELAWARE CORPORATION) 735 BROAD STREET, CHATTANOOGA, TN, 37402, SN 76-224,947. FILED 3-12-2001. PRINCIPAL REGISTER.

BUILDER+ARCHITECT

THE MARK CONSISTS OF STANDARD CHARACTERS WITHOUT CLAIM TO ANY PARTICULAR FONT, STYLE, SIZE, OR COLOR.
SEC. 2(F).

INT. CL. 16/U.S. CLS. 2, 5, 22, 23, 29, 37, 38 AND 50
FOR PUBLICATIONS, NAMELY, MAGAZINES AND JOURNALS IN THE FIELD OF ARCHITECTURE.
FIRST USE 12-31-1937; IN COMMERCE 12-31-1937.

ELEMENTS AMENDED
MARK

2,608,850. REG. 8-20-2002. GENERAL COUNCIL ON FINANCE AND ADMINISTRATION OF THE UNITED METHODIST CHURCH (ILLINOIS NON-PROFIT CORPORATION) 1 MUSIC CIRCLE NORTH, NASHVILLE, TN, 37203, SN 76-131,752. FILED 9-20-2000. PRINCIPAL REGISTER.

UNITED METHODIST

SEC. 2(F).
INT. CL. 41/U.S. CLS. 100, 101 AND 107
FOR PUBLICATION OF EDUCATIONAL BOOKS, BROCHURES, MAGAZINES.

FIRST USE 0-0-1968; IN COMMERCE 0-0-1968.
INT. CL. 42/U.S. CLS. 100 AND 101
FOR CHARITABLE SERVICES, NAMELY PROVIDING AUDIO-VISUAL EQUIPMENT AND SUPPLIES TO CONGREGATIONS, CONFERENCES, BOARDS, OR OTHER AGENCIES.

FIRST USE 0-0-1968; IN COMMERCE 0-0-1968.
INT. CL. 200/U.S. CL. 200
FOR INDICATING MEMBERSHIP IN THE APPLICANT CHURCH.
FIRST USE 9-30-1968; IN COMMERCE 10-4-1968.

ELEMENTS CORRECTED
OWNER NAME

2,631,208. REG. 10-8-2002. GRUPO BIMBO, S.A. B. DE C.V. (MEXICO CORPORATION) NO. 1000, COL. PENA BLANCA SANTA FE, PROLONGACION PASEO DE LA REFORMA, MEXICO CITY, MEXICO, 01210, SN 76-307,741. FILED 8-30-2001. PRINCIPAL REGISTER.



OWNER OF U.S. REG. NOS. 962,937, 1,864,847 AND 1,970,348.

NO CLAIM IS MADE TO THE EXCLUSIVE RIGHT TO USE DESDE 1932, APART FROM THE MARK AS SHOWN.

THE MARK CONSISTS OF DESIGN OF THE UPPER PORTION OF A GOAT, SURROUNDED BY A CIRCLE OF THREE LINES, AND A BANNER WITH THE WORD CORONADO APPEARING ACROSS THE GOAT AND CIRCLE DESIGN. THE WORDING DESDE 1932 APPEARS INSIDE OF THE CIRCLE, UNDER THE CORONADO BANNER.

THE ENGLISH TRANSLATION OF "CORONADO" IS "CROWN". THE ENGLISH TRANSLATION OF "DESDE" IS "SINCE".
INT. CL. 30/U.S. CL. 46

FOR CANDY.
FIRST USE 9-0-1935; IN COMMERCE 3-3-1989.

ELEMENTS AMENDED
DESCRIPTION OF MARK
MARK
DISCLAIMER
TRANSLATION OF MARK

2,632,418. REG. 10-8-2002. OLDE SOUTH CANDLE COMPANY (KENTUCKY CORPORATION) 1031 LE GRAND BLVD, CHARELSTON, SC, 29492, SN 75-899,426. FILED 1-7-2000. PRINCIPAL REGISTER.



THE MARK CONSISTS IN PART OF A STYLIZED FLOWER.

INT. CL. 4/U.S. CLS. 1, 6 AND 15
FOR CANDLES, CANDLE WAXES, VOTIVE CANDLES, PILLAR CANDLES, JAR CANDLES, AROMATHERAPY CANDLES, CANDLES MADE FROM NATURAL PLANT AND ESSENTIAL OIL, CANDLES IN GLASS CONTAINERS, AND CANDLES IN METAL TINS, AND SCENTED WAX CANDLES.
FIRST USE 8-1-2000; IN COMMERCE 8-1-2000.

ELEMENTS CORRECTED
[DISCLAIMER]

2,647,148. REG. 11-5-2002. PBI-GORDON CORPORATION (MISSOURI CORPORATION) P.O. BOX 014090, KANSAS CITY, MO, 64101, SN 76-296,899. FILED 8-10-2001. PRINCIPAL REGISTER.

2,704,221. REG. 4-8-2003. UNITED STATES RACQUETBALL ASSOCIATION (COLORADO NON-PROFIT CORPORATION) 1685 WEST UINTAH, COLORADO SPRINGS, CO, 809042921, SN 76-389,412. FILED 3-28-2002. PRINCIPAL REGISTER.

SPEEDZONE

US OPEN RACQUETBALL CHAMPIONSHIPS

THE MARK CONSISTS OF STANDARD CHARACTERS WITHOUT CLAIM TO ANY PARTICULAR FONT, STYLE, SIZE, OR COLOR.

THE MARK CONSISTS OF STANDARD CHARACTERS WITHOUT CLAIM TO ANY PARTICULAR FONT, STYLE, SIZE, OR COLOR.

INT. CL. 5/U.S. CLS. 6, 18, 44, 46, 51 AND 52 FOR HERBICIDES FOR AGRICULTURAL, COMMERCIAL AND DOMESTIC USE.

OWNER OF U.S. REG. NOS. 2,039,546 AND 2,164,847. NO CLAIM IS MADE TO THE EXCLUSIVE RIGHT TO USE "OPEN RACQUETBALL CHAMPIONSHIPS", APART FROM THE MARK AS SHOWN.

FIRST USE 1-23-2002; IN COMMERCE 1-23-2002.

SEC. 2(F).
INT. CL. 41/U.S. CLS. 100, 101 AND 107

ELEMENTS AMENDED
OWNER NAME
OWNER ADDRESS
MARK

FOR ENTERTAINMENT SERVICES IN THE NATURE OF RACQUETBALL EXHIBITIONS AND TOURNAMENTS.
FIRST USE 2-17-1995; IN COMMERCE 2-17-1995.

ELEMENTS AMENDED
MARK

2,659,810. REG. 12-10-2002. POWER INTEGRATIONS, INC. (DELAWARE CORPORATION) 5245 HELLYER AVENUE, SAN JOSE, CA, 95138, SN 75-518,487. FILED 7-14-1998. PRINCIPAL REGISTER.

2,720,985. REG. 6-3-2003. STATE OF OREGON ACTING BY AND THROUGH THE STATE BOARD OF HIGHER EDUCATION ON BEHALF OF THE UNIVERSITY OF OREGON (UNITED STATES JURISTIC PERSON) 1238 UNIVERSITY OF OREGON, EUGENE, OR, 97403, SN 76-412,735. FILED 5-24-2002. PRINCIPAL REGISTER.

ECOSMART

OREGON QUARTERLY

INT. CL. 9/U.S. CLS. 21, 23, 26, 36 AND 38 FOR INTEGRATED CIRCUITS HAVING LOW POWER CONSUMPTION OR LOW POWER LOSS FOR USE IN ELECTRONIC DEVICES.

OWNER OF U.S. REG. NOS. 1,893,812 AND 2,127,171. NO CLAIM IS MADE TO THE EXCLUSIVE RIGHT TO USE "QUARTERLY", APART FROM THE MARK AS SHOWN.

FIRST USE 7-0-1998; IN COMMERCE 9-0-1998.

SEC. 2(F).
INT. CL. 16/U.S. CLS. 2, 5, 22, 23, 29, 37, 38 AND 50

ELEMENTS CORRECTED
CITIZENSHIP

FOR PERIODICAL FOR DISTRIBUTION AS A MAGAZINE TO AN AUDIENCE PRIMARILY CONSISTING OF ALUMNI, FACULTY, ADMINISTRATORS, UNIVERSITY OF OREGON FOUNDATION DONORS, OREGON LEGISLATORS AND NON-ALUMNI OREGON RESIDENTS.
FIRST USE 3-11-1994; IN COMMERCE 3-11-1994.

ELEMENTS CORRECTED
OWNER NAME
OWNER ADDRESS

2,687,046. REG. 2-11-2003. TIMAC SA (FRANCE CORPORATION) 27, AVENUE FRANKLIN ROOSEVELT, 35400 SAINT-MALO, FRANCE,, SN 76-039,928. FILED 5-3-2000. PRINCIPAL REGISTER.

2,737,143. REG. 7-15-2003. UMEVOICE, INC. (CALIFORNIA CORPORATION) 20 PIMENTEL COURT, SUITE C1, NOVATO, CA, 94949, SN 75-807,429. FILED 9-22-1999. PRINCIPAL REGISTER.

NUTRIBALANCE

THEBOOM

INT. CL. 1/U.S. CLS. 1 FOR FERTILIZERS FOR AGRICULTURAL, HORTICULTURAL, AND DOMESTIC USE, FERTILIZERS FOR USE IN GARDENING, GREENHOUSES, TREE NURSERIES, AND GOLF COURSES.

THE MARK CONSISTS OF STANDARD CHARACTERS WITHOUT CLAIM TO ANY PARTICULAR FONT, STYLE, SIZE, OR COLOR.

FIRST USE 7-31-2000; IN COMMERCE 7-31-2000.

INT. CL. 9/U.S. CLS. 21, 23, 26, 36 AND 38

ELEMENTS CORRECTED
OWNER NAME

FOR NOISE CANCELLATION DEVICES FOR USE WITH TELEPHONE HEADSETS AND MICROPHONE ACCESSORIES.
FIRST USE 12-1-2002; IN COMMERCE 12-1-2002.

FOR DOWNLOADABLE ELECTRONIC JOURNAL PERTAINING TO THE PSYCHOLOGICAL AND SOCIAL SCIENCES.
FIRST USE 4-0-1998; IN COMMERCE 4-0-1998.

ELEMENTS AMENDED
MARK

ELEMENTS CORRECTED
OWNER NAME
ENTITY

2,743,352. REG. 7-29-2003. AMERICAN PSYCHOLOGICAL ASSOCIATION, INC. (D.C. NON-PROFIT CORPORATION) 750 FIRST STREET, N.E., WASHINGTON, DC, 200024242, SN 76-210,439. FILED 2-15-2001. PRINCIPAL REGISTER.

2,743,355. REG. 7-29-2003. AMERICAN PSYCHOLOGICAL ASSOCIATION, INC. (D.C. NON-PROFIT CORPORATION) 750 FIRST STREET, N.E., WASHINGTON, DC, 200024242, SN 76-210,443. FILED 2-15-2001. PRINCIPAL REGISTER.

PSYCHOLOGY AND AGING

JOURNAL OF FAMILY PSYCHOLOGY

OWNER OF U.S. REG. NO. 1,840,511.
SEC. 2(F).
INT. CL. 9/U.S. CLS. 21, 23, 26, 36 AND 38
FOR DOWNLOADABLE ELECTRONIC JOURNAL PERTAINING TO THE PSYCHOLOGICAL AND SOCIAL SCIENCES.
FIRST USE 4-0-1998; IN COMMERCE 4-0-1998.

OWNER OF U.S. REG. NO. 1,590,340.
NO CLAIM IS MADE TO THE EXCLUSIVE RIGHT TO USE "JOURNAL", APART FROM THE MARK AS SHOWN.
SEC. 2(F).
INT. CL. 9/U.S. CLS. 21, 23, 26, 36 AND 38
FOR DOWNLOADABLE ELECTRONIC JOURNAL PERTAINING TO PSYCHOLOGICAL AND SOCIAL SCIENCE TOPICS.
FIRST USE 4-0-1998; IN COMMERCE 4-0-1998.

ELEMENTS CORRECTED
OWNER NAME
ENTITY

ELEMENTS CORRECTED
OWNER NAME
ENTITY

2,743,353. REG. 7-29-2003. AMERICAN PSYCHOLOGICAL ASSOCIATION, INC. (D.C. NON-PROFIT CORPORATION) 750 FIRST STREET, N.E., WASHINGTON, DC, 200024242, SN 76-210,440. FILED 2-15-2001. PRINCIPAL REGISTER.

2,743,363. REG. 7-29-2003. AMERICAN PSYCHOLOGICAL ASSOCIATION, INC. (D.C. NON-PROFIT CORPORATION) 750 FIRST STREET N.E., WASHINGTON, DC, 200024242, SN 76-211,186. FILED 2-16-2001. PRINCIPAL REGISTER.

PSYCHOLOGICAL ASSESSMENT

JOURNAL OF EXPERIMENTAL PSYCHOLOGY:
LEARNING, MEMORY, AND COGNITION

OWNER OF U.S. REG. NO. 1,860,896.
SEC. 2(F).
INT. CL. 9/U.S. CLS. 21, 23, 26, 36 AND 38
FOR DOWNLOADABLE ELECTRONIC JOURNAL PERTAINING TO THE PSYCHOLOGICAL AND SOCIAL SCIENCES.
FIRST USE 4-0-1998; IN COMMERCE 4-0-1998.

ELEMENTS CORRECTED
OWNER NAME
ENTITY

THE MARK CONSISTS OF STANDARD CHARACTERS WITHOUT CLAIM TO ANY PARTICULAR FONT, STYLE, SIZE, OR COLOR.

2,743,354. REG. 7-29-2003. AMERICAN PSYCHOLOGICAL ASSOCIATION, INC. (D.C. NON-PROFIT CORPORATION) 750 FIRST STREET, N.E., WASHINGTON, DC, 200024242, SN 76-210,442. FILED 2-15-2001. PRINCIPAL REGISTER.

OWNER OF U.S. REG. NO. 1,637,566.
NO CLAIM IS MADE TO THE EXCLUSIVE RIGHT TO USE "JOURNAL", APART FROM THE MARK AS SHOWN.
SEC. 2(F).
INT. CL. 9/U.S. CLS. 21, 23, 26, 36 AND 38
FOR DOWNLOADABLE ELECTRONIC JOURNAL PERTAINING TO PSYCHOLOGICAL TOPICS PERIODICALLY PUBLISHED AND DISTRIBUTED TO MEMBERS AND TO OTHER PERSONS IN THE PSYCHOLOGICAL AND SOCIAL SCIENCE COMMUNITIES.
FIRST USE 4-0-1998; IN COMMERCE 4-0-1998.

PSYCHOLOGICAL REVIEW

OWNER OF U.S. REG. NO. 1,856,732.
NO CLAIM IS MADE TO THE EXCLUSIVE RIGHT TO USE "REVIEW", APART FROM THE MARK AS SHOWN.
SEC. 2(F).
INT. CL. 9/U.S. CLS. 21, 23, 26, 36 AND 38

ELEMENTS CORRECTED
OWNER NAME
ENTITY

2,770,590. REG. 10-7-2003. DIAMOND CONSULTING SERVICES LIMITED (UNITED KINGDOM CORPORATION) ASTON SANDFORD, AYLESBURY, THE GRANARY, MANOR FARM COURTYARD, BUCKINGHAMSHIRE, HP17 8JB, UNITED KINGDOM., SN 76-022,536. FILED 4-11-2000. PRINCIPAL REGISTER.

3,079,128. REG. 4-11-2006. GORMAN, ROBIN A (UNITED STATES INDIVIDUAL), DBA SOLID IDEAS, W. 170 MARVIN WAY P.O. BOX 1518, SHELTON, WA, 98584, SN 78-566,364. FILED 2-13-2005. PRINCIPAL REGISTER.

IDRIS

PRIORITY CLAIMED UNDER SEC. 44(D) ON UNITED KINGDOM APPLICATION NO. 001542232, FILED 3-21-2000, REG. NO. 1542232, DATED 3-21-2000, EXPIRES 3-1-2010. INT. CL. 9/U.S. CLS. 21, 23, 26, 36 AND 38

FOR TRAFFIC MONITORING AND SUPERVISION SYSTEMS AND SPEED AND DISTANCE MEASURING APPARATUS FOR MONITORING ROADWAYS, ALL COMPRISING INDUCTIVE LOOP DETECTORS OR DETECTION SENSORS, TRAFFIC MONITORING AND SUPERVISION SYSTEM SOFTWARE FOR CONTROLLING THE TRAFFIC MONITORING AND SUPERVISION SYSTEMS, AND SPEED AND DISTANCE MEASURING APPARATUS SOFTWARE FOR CONTROLLING SPEED AND DISTANCE MEASURING APPARATUS; TRAFFIC SUPERVISION, SPEED MEASURING, AND DISTANCE MEASURING APPARATUS AND INSTALLATIONS, NAMELY- TRAFFIC MONITORING AND SUPERVISION SYSTEM ELECTRICAL AND ELECTRONIC CONTROLLERS; SPEED AND DISTANCE MEASURING APPARATUS ELECTRICAL AND ELECTRONIC CONTROLLERS; VEHICLE MOUNTED TRANSPONDERS.

FIRST USE : IN COMMERCE .

ELEMENTS CORRECTED
OWNER NAME
OWNER ADDRESS

3,033,871. REG. 12-27-2005. COX ENTERPRISES, INC. (DELAWARE CORPORATION) 6205 PEACHTREE DUNWOODY ROAD, ATLANTA, GA, 30328, SN 76-617,772. FILED 10-26-2004. PRINCIPAL REGISTER.



OWNER OF U.S. REG. NOS. 2,350,258, 2,781,346 AND OTHERS.

INT. CL. 16/U.S. CLS. 2, 5, 22, 23, 29, 37, 38 AND 50

FOR NEWSPAPERS FOR GENERAL CIRCULATION CONTAINING TOPICS OF GENERAL INTEREST.

FIRST USE 4-24-2003; IN COMMERCE 4-24-2003.

INT. CL. 35/U.S. CLS. 100, 101 AND 102

FOR DISSEMINATION OF ADVERTISING FOR OTHERS VIA THE INTERNET AND NEWSPAPERS.

FIRST USE 7-1-2003; IN COMMERCE 7-1-2003.

ELEMENTS AMENDED
MARK

Mare Magic

THE MARK CONSISTS OF STANDARD CHARACTERS WITHOUT CLAIM TO ANY PARTICULAR FONT, STYLE, SIZE, OR COLOR.

NO CLAIM IS MADE TO THE EXCLUSIVE RIGHT TO USE MARE, APART FROM THE MARK AS SHOWN.

INT. CL. 5/U.S. CLS. 6, 18, 44, 46, 51 AND 52

FOR NEUTRICUTICAL FOR USE AS A DIETARY SUPPLEMENT FOR LIVESTOCK.

FIRST USE 6-9-1999; IN COMMERCE 6-9-1999.

ELEMENTS AMENDED
DBA/AKA

3,086,074. REG. 4-25-2006. GOSPEL MUSIC ASSOCIATION, INC. (TENNESSEE CORPORATION), DBA GMA FOUNDATION, 1205 DIVISION STREET, NASHVILLE, TN, 37203, SN 78-226,845. FILED 3-18-2003. PRINCIPAL REGISTER.

GMA GOSPEL MUSIC HALL OF FAME

OWNER OF U.S. REG. NO. 2,734,234.

NO CLAIM IS MADE TO THE EXCLUSIVE RIGHT TO USE "GOSPEL MUSIC HALL OF FAME", APART FROM THE MARK AS SHOWN.

INT. CL. 41/U.S. CLS. 100, 101 AND 107

FOR EDUCATIONAL AND ENTERTAINMENT SERVICES, NAMELY, OPERATION OF A GOSPEL MUSIC MUSEUM; HALL OF FAME SERVICES, NAMELY, CONDUCTING INDUCTIONS AND RELATED CEREMONIES IN CONNECTION WITH THE FIELD OF GOSPEL MUSIC AND PERSONS AND GROUPS ASSOCIATED WITH SUCH MUSIC.

FIRST USE 2-22-2005; IN COMMERCE 2-22-2005.

ELEMENTS CORRECTED
OWNER NAME

3,101,966. REG. 6-6-2006. CENTRIC GROUP, LLC (DELAWARE LIMITED LIABILITY COMPANY) 1260 ANDES BOULEVARD, ST. LOUIS, MO, 63132, SN 78-467,317. FILED 8-13-2004. PRINCIPAL REGISTER.

3,121,848. REG. 7-25-2006. USA TAEKWONDO, INC. (COLORADO NON-PROFIT CORPORATION) ONE OLYMPIC PLAZA, COLORADO SPRINGS, CO, 80909, SN 78-488,064. FILED 9-22-2004. PRINCIPAL REGISTER.

PRO-TECTION



THE MARK CONSISTS OF STANDARD CHARACTERS WITHOUT CLAIM TO ANY PARTICULAR FONT, STYLE, SIZE, OR COLOR.

INT. CL. 3/U.S. CLS. 1, 4, 6, 50, 51 AND 52

FOR SHAVING CREAM, SHAVING GEL, AFTER-SHAVE LOTION, AFTER-SHAVE GEL, SHAVING POWDERS, BRUSHLESS SHAVING CREAMS, AND RAZORLESS SHAVING CREAMS.

FIRST USE 2-4-2005; IN COMMERCE 2-4-2005.

INT. CL. 8/U.S. CLS. 23, 28 AND 44

FOR DISPOSABLE RAZORS, RAZORS WITH REPLACEABLE RAZOR CARTRIDGES, AND RAZOR CARTRIDGES FOR RAZORS WITH REPLACEABLE RAZOR CARTRIDGES.

FIRST USE 2-4-2005; IN COMMERCE 2-4-2005.

ELEMENTS CORRECTED
CITIZENSHIP

NO CLAIM IS MADE TO THE EXCLUSIVE RIGHT TO USE "USA TAEKWONDO", APART FROM THE MARK AS SHOWN.

THE MARK CONSISTS OF THE WORDS USA TAEKWONDO WITH A STAR BELOW CONSISTING OF FIVE POINTS WITH THE TOP POINT FORMING PART OF THE LETTER "A" IN THE WORD USA.

INT. CL. 25/U.S. CLS. 22 AND 39

FOR MEN'S AND WOMEN'S CLOTHING, NAMELY, SHIRTS, PANTS, SHORTS, T-SHIRTS, POLO-STYLE SHIRTS, TANK TOPS, SWEATPANTS, SWEATSHIRTS, BASEBALL STYLE CAPS, SOCKS, JACKETS, TAEKWONDO UNIFORMS AND BELTS.

FIRST USE 3-31-2005; IN COMMERCE 3-31-2005.

ELEMENTS CORRECTED
ENTITY

3,103,766. REG. 6-13-2006. ASTER CUCINE S.P.A. (ITALY SOCIETA PER AZIONI (SPA)) VIA FERRARO MANLIO S.N., VILLA FASTIGGI (PESARO), ITALY, 61122, SN 78-653,437. FILED 6-17-2005. PRINCIPAL REGISTER.

3,121,868. REG. 7-25-2006. USA TAEKWONDO, INC. (COLORADO NON-PROFIT CORPORATION) ONE OLYMPIC PLAZA, COLORADO SPRINGS, CO, 80909, SN 78-493,372. FILED 10-1-2004. PRINCIPAL REGISTER.



NO CLAIM IS MADE TO THE EXCLUSIVE RIGHT TO USE CUCINE, APART FROM THE MARK AS SHOWN.

THE ENGLISH TRANSLATION OF CUCINE IS KITCHENS.

INT. CL. 20/U.S. CLS. 2, 13, 22, 25, 32 AND 50

FOR FURNITURE.

FIRST USE 12-31-2001; IN COMMERCE 12-31-2001.

ELEMENTS CORRECTED
OWNER NAME
OWNER ADDRESS
ENTITY

NO CLAIM IS MADE TO THE EXCLUSIVE RIGHT TO USE USA TAEKWONDO, APART FROM THE MARK AS SHOWN.

THE MARK CONSISTS OF THE WORDS USA TAEKWONDO WITH A STAR BELOW CONSISTING OF FIVE POINTS WITH THE TOP POINT FORMING PART OF THE LETTER "A" IN THE WORD USA.

INT. CL. 9/U.S. CLS. 21, 23, 26, 36 AND 38

FOR PRE-RECORDED COMPACT DISCS, AUDIO TAPES, VIDEO TAPES, AND DIGITAL VIDEO DISCS, ALL FEATURING CONTENT RELATING TO THE SPORT OF TAEKWONDO.

FIRST USE 6-30-2005; IN COMMERCE 6-30-2005.

ELEMENTS CORRECTED
ENTITY

3,132,759. REG. 8-22-2006. AWESOME BRANDS, INC. (FLORIDA CORPORATION) 1909 BANKS ROAD, MARGATE, FL, 33063, SN 78-709,631. FILED 9-9-2005. PRINCIPAL REGISTER.

ELEMENTS CORRECTED
ENTITY

WineStyles

OWNER OF U.S. REG. NO. 2,878,856.
INT. CL. 35/U.S. CLS. 100, 101 AND 102
FOR RETAIL STORE SERVICES FEATURING WINE,
WINE ACCESSORIES AND GIFT ITEMS.
FIRST USE 10-1-2002; IN COMMERCE 10-1-2002.

3,415,098. REG. 4-22-2008. BIOTANIC, S.A. DE C.V. (MEXICO CORPORATION) CLAUDIO ARCINIEGA 31-B, COL. MERCED GOMEZ, MEXICO, C.P.03910, SN 77-036,636. FILED 11-3-2006. PRINCIPAL REGISTER.

ELEMENTS AMENDED

OWNER NAME
OWNER ADDRESS
CITIZENSHIP
ENTITY
MARK



3,264,841. REG. 7-17-2007. RED BOX TOY FACTORY LTD. (CHINA CORPORATION) 7/F, TOWER 1, SOUTH SEAS CENTER, 75 MODY ROAD, TSIMSHATSUI EAST, KOWLOON, HONG KONG, CHINA., SN 78-962,938. FILED 8-29-2006. PRINCIPAL REGISTER.

THE WORD "FEMINELLE" HAS NO MEANING IN A FOREIGN LANGUAGE.

INT. CL. 5/U.S. CLS. 6, 18, 44, 46, 51 AND 52
FOR VITAMINS, MINERALS, DIETARY AND NUTRITIONAL SUPPLEMENTS; HOMEOPATHIC MEDICINES FOR THE RELIEF OF THE SYMPTOMS OF MENOPAUSE.

FIRST USE 0-0-2007; IN COMMERCE 0-0-2007.

ELEMENTS CORRECTED
OWNER NAME

INT. CL. 28/U.S. CLS. 22, 23, 38 AND 50
FOR CHILDREN'S MULTIPLE ACTIVITY TOYS;
ELECTRIC ACTION TOYS.
FIRST USE 3-31-2005; IN COMMERCE 11-30-2005.

3,434,822. REG. 5-27-2008. MONSTER ENERGY COMPANY (DELAWARE CORPORATION) 550 MONICA CIRCLE, STE. 201, CORONA, CA, 92880, SN 77-274,662. FILED 9-7-2007. PRINCIPAL REGISTER.

ELEMENTS CORRECTED
OWNER NAME



3,267,732. REG. 7-24-2007. CAMBRIDGE SENSORS LIMITED (UNITED KINGDOM LIMITED COMPANY (LTD.)) 9 CARDINAL PARK, GODMANCHESTER, HUNTINGDON, CAMBRIDGESHIRE, ENGLAND, PE29 2XG, SN 78-650,987. FILED 6-15-2005. PRINCIPAL REGISTER.

MICRO-DOT

THE MARK CONSISTS OF STANDARD CHARACTERS WITHOUT CLAIM TO ANY PARTICULAR FONT, STYLE, SIZE, OR COLOR.

PRIORITY CLAIMED UNDER SEC. 44(D) ON ERPNCMNTY TM OFC APPLICATION NO. 004492245, FILED 6-14-2005, REG. NO. 004492245, DATED 8-7-2006, EXPIRES 6-14-2015.

INT. CL. 10/U.S. CLS. 26, 39 AND 44
FOR SENSORS FOR MONITORING BLOOD SUGAR.

OWNER OF U.S. REG. NOS. 2,903,214 AND 3,134,841.
THE MARK CONSISTS OF THE LETTER "M" IN THE FORM OF A CLAW.

INT. CL. 32/U.S. CLS. 45, 46 AND 48
FOR NON-ALCOHOLIC BEVERAGES, NAMELY, ENERGY DRINKS, EXCLUDING PERISHABLE BEVERAGE PRODUCTS THAT CONTAIN FRUIT JUICE OR SOY.

FIRST USE 3-27-2002; IN COMMERCE 4-18-2002.

ELEMENTS AMENDED
OWNER NAME

3,676,145. REG. 9-1-2009. POTOMAC RIVER RUNNING, INC. (VIRGINIA CORPORATION), DBA POTOMAC RIVER RUNNING STORE, 1033 BROAD BRANCH COURT, MCLEAN, VA, 221012140, SN 77-672,268. FILED 2-17-2009. PRINCIPAL REGISTER.

3,840,906. REG. 8-31-2010. HUHTAMAKI FINANCE B.V. (NETHERLANDS LIMITED LIABILITY COMPANY) JUPITERSTRAAT 102, 2132 HE HOOFDDORP, NETHERLANDS., SN 77-921,002. FILED 1-27-2010. PRINCIPAL REGISTER.



NO CLAIM IS MADE TO THE EXCLUSIVE RIGHT TO USE "RUNNING", APART FROM THE MARK AS SHOWN. THE MARK CONSISTS OF SILHOUETTES OF A HUMAN MALE AND FEMALE DEPICTED RUNNING ON A CURVING ROAD; A CURVING RIVER; AND THE WORDS POTOMAC RIVER RUNNING, ALL PLACED WITHIN A SINGLE LINE OVAL BORDER.
 INT. CL. 35/U.S. CLS. 100, 101 AND 102
 FOR RETAIL STORE SERVICES FEATURING SHOES AND CLOTHING FOR RUNNERS.
 FIRST USE 3-11-2003; IN COMMERCE 3-11-2003.

ELEMENTS CORRECTED
 OWNER ADDRESS

3,709,967. REG. 11-10-2009. POWER PLATE NORTH AMERICA, INC. (DELAWARE CORPORATION) SUITE 125, 17900 VON KARMAN, IRVINE, IL, 92614, SN 77-536,415. FILED 7-31-2008. PRINCIPAL REGISTER.

MY BODY, MY TIME

THE MARK CONSISTS OF STANDARD CHARACTERS WITHOUT CLAIM TO ANY PARTICULAR FONT, STYLE, SIZE, OR COLOR.
 INT. CL. 10/U.S. CLS. 26, 39 AND 44
 FOR MEDICAL APPARATUS AND INSTRUMENTS, NAMELY, A MACHINE PRODUCING MECHANICAL VIBRATIONS FOR STIMULATION OF MUSCLES FOR USE IN CONNECTION WITH A MEDICAL TREATMENT PROGRAM.
 FIRST USE 9-0-2008; IN COMMERCE 9-0-2008.
 INT. CL. 28/U.S. CLS. 22, 23, 38 AND 50
 FOR FITNESS AND BODY BUILDING APPARATUS, NAMELY, A MACHINE PRODUCING MECHANICAL VIBRATIONS FOR STIMULATION OF MUSCLES FOR USE IN FITNESS OR BODYBUILDING PROGRAMS TO INCREASE STRENGTH AND MUSCLE FLEXIBILITY.
 FIRST USE 9-0-2008; IN COMMERCE 9-0-2008.

ELEMENTS CORRECTED
 MARK

HEATH

THE MARK CONSISTS OF STANDARD CHARACTERS WITHOUT CLAIM TO ANY PARTICULAR FONT, STYLE, SIZE, OR COLOR.
 OWNER OF U.S. REG. NOS. 1,404,302, 1,572,237 AND 3,309,793.
 INT. CL. 30/U.S. CL. 46
 FOR POPCORN.
 FIRST USE 11-30-2007; IN COMMERCE 11-30-2007.

ELEMENTS CORRECTED
 ENTITY

3,840,907. REG. 8-31-2010. HUHTAMAKI FINANCE B.V. (NETHERLANDS LIMITED LIABILITY COMPANY) JUPITERSTRAAT 102, 2132 HE HOOFDDORP, NETHERLANDS., SN 77-921,003. FILED 1-27-2010. PRINCIPAL REGISTER.

HEATH

THE MARK CONSISTS OF STANDARD CHARACTERS WITHOUT CLAIM TO ANY PARTICULAR FONT, STYLE, SIZE, OR COLOR.
 OWNER OF U.S. REG. NOS. 1,404,302, 1,572,237 AND 3,309,793.
 INT. CL. 30/U.S. CL. 46
 FOR CANDY FOR USE AS AN INGREDIENT IN ICE CREAM AND BAKED PRODUCTS.
 FIRST USE 1-23-1989; IN COMMERCE 1-23-1989.

ELEMENTS CORRECTED
 ENTITY

3,856,386. REG. 10-5-2010. AMERICAN DENTAL SUPPLY, INC. (PENNSYLVANIA CORPORATION) 1075 N. GILMORE STREET, ALLENTOWN, PA, 18109, SN 77-941,907. FILED 2-22-2010. PRINCIPAL REGISTER.

DIAMON-ALL

THE MARK CONSISTS OF STANDARD CHARACTERS WITHOUT CLAIM TO ANY PARTICULAR FONT, STYLE, SIZE, OR COLOR.
 INT. CL. 7/U.S. CLS. 13, 19, 21, 23, 31, 34 AND 35

FOR PRECISION MACHINE TOOLS, NAMELY, HARD METAL TOOLS, HIGH SPEED STEEL (HSS) TOOLS, CARBIDE TOOLS, CERAMIC TOOLS, POLY CRYSTAL-LINE DIAMOND (PCD) TOOLS, AND DIAMOND-COATED AND DIAMOND-UNCOATED TOOLS, AND HARD METAL TOOLS, ALL FOR USE IN THE CUTTING AND FORMING OF MATERIALS BY OTHERS.
FIRST USE 3-11-1990; IN COMMERCE 7-7-1993.

ELEMENTS CORRECTED
OWNER NAME

3,908,280. REG. 1-18-2011. AVALIGN TECHNOLOGIES, INC. (DELAWARE CORPORATION) 272 E. DEERPATH ROAD, SUITE 208, LAKE FOREST, IL, 60045, SN 77-120,077. FILED 3-1-2007. PRINCIPAL REGISTER.

AVALIGN TECHNOLOGIES

THE MARK CONSISTS OF STANDARD CHARACTERS WITHOUT CLAIM TO ANY PARTICULAR FONT, STYLE, SIZE, OR COLOR.

NO CLAIM IS MADE TO THE EXCLUSIVE RIGHT TO USE "TECHNOLOGIES", APART FROM THE MARK AS SHOWN.

THE WORDING "AVALIGN" HAS NO MEANING IN A FOREIGN LANGUAGE.

INT. CL. 10/U.S. CLS. 26, 39 AND 44

FOR SURGICAL INSTRUMENTS FOR USE IN A VARIETY OF SURGICAL FIELDS INCLUDING BUT NOT LIMITED TO CARDIOVASCULAR, THORACIC, ENT, ORTHOPAEDIC, OPHTHALMIC, ENDOSCOPIC, NEURO, SPINE, DENTAL, UROLOGICAL, PLASTIC SURGERY, SPORTS MEDICINE AND TRAUMA AND SUBASSEMBLIES AND COMPONENTS THEREFOR; ACCESSORIES FOR SURGICAL INSTRUMENTS, NAMELY, BRACKETS, CLAMPS, HANDLERS, EXTRACTORS AND RETRACTORS; SURGICAL IMPLANTS COMPRISING OF ARTIFICIAL MATERIAL AND COMPONENTS THEREFOR; SURGICAL SHARPS; SURGICAL PRECISION-GROUND GUIDE WIRES; STERILIZATION CONTAINERS AND TRAYS * FOR HOLDING IMPLANTS AND SURGICAL INSTRUMENTS FOR USE WITH STERILIZATION UNITS SPECIFICALLY EXCLUDING HAND AND SKIN SANITIZERS, ANTISEPTIC PREPARATIONS AND SURGICAL SCRUB AND PATIENT PREP SANITIZING PREPARATIONS *.

FIRST USE 3-29-2010; IN COMMERCE 3-29-2010.

ELEMENTS AMENDED
GOODS/SERVICES

3,916,049. REG. 2-8-2011. CHAMPION NATIONAL SECURITY, INC. (TEXAS CORPORATION) 1616 GATEWAY BLVD., RICHARDSON, TX, 75080, SN 77-960,573. FILED 3-16-2010. PRINCIPAL REGISTER.



NO CLAIM IS MADE TO THE EXCLUSIVE RIGHT TO USE "NATIONAL SECURITY", APART FROM THE MARK AS SHOWN.

THE MARK CONSISTS OF THE STYLIZED TEXT "CHAMPION NATIONAL SECURITY" IN BLOCK LETTERS.

INT. CL. 45/U.S. CLS. 100 AND 101

FOR CONTRACT SECURITY GUARD SERVICES.
FIRST USE 9-3-1997; IN COMMERCE 11-17-1998.

ELEMENTS CORRECTED
OWNER NAME

3,917,630. REG. 2-8-2011. PAKFLATT (UK) LIMITED (UNITED KINGDOM LIMITED COMPANY (LTD.)) SPRINGTOWN INDUSTRIAL ESTATE, 22 SPRINGTOWN PARK, COUNTY LONDONDERRY, UNITED KINGDOM, BT480LY, SN 77-727,375. FILED 5-1-2009. PRINCIPAL REGISTER.

PAKFLATT

THE MARK CONSISTS OF STANDARD CHARACTERS WITHOUT CLAIM TO ANY PARTICULAR FONT, STYLE, SIZE, OR COLOR.

INT. CL. 20/U.S. CLS. 2, 13, 22, 25, 32 AND 50

FOR FURNITURE, NAMELY, FURNITURE FOR USE AS VOTING STATIONS AND POLLING BOOTHS.

FIRST USE 6-30-1990; IN COMMERCE 6-30-1990.

ELEMENTS CORRECTED
OWNER NAME

3,919,999. REG. 2-15-2011. AVALIGN TECHNOLOGIES, INC. (DELAWARE CORPORATION) 272 E. DEERPATH ROAD, SUITE 208, LAKE FOREST, IL, 60045, SN 77-120,043. FILED 3-1-2007. PRINCIPAL REGISTER.



NO CLAIM IS MADE TO THE EXCLUSIVE RIGHT TO USE "TECHNOLOGIES", APART FROM THE MARK AS SHOWN.

THE MARK CONSISTS OF CURVED BANDS AND CIRCLES DESIGN APPEARING NEXT TO THE WORD "AVALIGN" WHICH APPEARS ABOVE THE WORD "TECHNOLOGY".

INT. CL. 10/U.S. CLS. 26, 39 AND 44

FOR SURGICAL INSTRUMENTS FOR USE IN A VARIETY OF SURGICAL FIELDS INCLUDING BUT NOT LIMITED TO CARDIOVASCULAR, THORACIC, ENT, ORTHOPAEDIC, OPHTHALMIC, ENDOSCOPIC, NEURO, SPINE, DENTAL, UROLOGICAL, PLASTIC SURGERY, SPORTS MEDICINE AND TRAUMA AND SUBASSEMBLIES AND COMPONENTS THEREFOR; ACCESSORIES FOR SURGICAL INSTRUMENTS, NAMELY, BRACKETS, CLAMPS, HANDLERS, EXTRACTORS AND RETRACTORS; SURGICAL IMPLANTS COMPRISING OF ARTIFICIAL MATERIAL AND COMPONENTS THEREFOR; SURGICAL SHARPS; SURGICAL PRECISION-GROUND GUIDE WIRES; STERILIZATION CONTAINERS AND TRAYS * FOR HOLDING IMPLANTS AND SURGICAL INSTRUMENTS FOR USE WITH STERILIZATION UNITS SPECIFICALLY EXCLUDING HAND AND SKIN SANITIZERS, ANTISEPTIC PREPARATIONS AND SURGICAL SCRUB AND PATIENT PREP SANITIZING PREPARATIONS *

FIRST USE 3-29-2010; IN COMMERCE 3-29-2010.

ELEMENTS AMENDED
GOODS/SERVICES

3,933,372. REG. 3-22-2011. AMBER-LEVONNE KOKO (UNITED STATES INDIVIDUAL), DBA BEACH BUNNY, 5225 CANYON CREST DR., SUITE 71-295, RIVERSIDE, CA, 92507, SN 77-840,421. FILED 10-2-2009. PRINCIPAL REGISTER.

BEACH BUNNY

THE MARK CONSISTS OF STANDARD CHARACTERS WITHOUT CLAIM TO ANY PARTICULAR FONT, STYLE, SIZE, OR COLOR.

INT. CL. 3/U.S. CLS. 1, 4, 6, 50, 51 AND 52

FOR FACE AND BODY LOTIONS.
FIRST USE 9-1-2007; IN COMMERCE 6-1-2008.

ELEMENTS AMENDED
DBA/KA

3,948,431. REG. 4-19-2011. FORYOU GROUP CO., LTD. (CHINA CORPORATION) 23RD-22ND FLOOR, FORYOU TOWER, YANDA YI ROAD, HUIZHOU, GUANGDONG, CHINA., SN 77-758,255. FILED 6-12-2009. PRINCIPAL REGISTER.

Adayo

THE MARK CONSISTS OF STANDARD CHARACTERS WITHOUT CLAIM TO ANY PARTICULAR FONT, STYLE, SIZE, OR COLOR.

THE WORDING "ADAYO" HAS NO MEANING IN A FOREIGN LANGUAGE.

INT. CL. 2/U.S. CLS. 6, 11 AND 16

FOR AUTOMOBILE PAINT; ANTI-FORGERY INK; PRINTING INK; ALUMINUM SILVER PASTE PIGMENTS; COATINGS, NAMELY, CLEAR AND PIGMENTED COATINGS USED IN THE NATURE OF PAINT; LACQUERS IN THE NATURE OF COATING; SILVER POWDER FOR PAINTING; UNDERCOATING FOR VEHICLE CHASSIS; PIGMENTS NOT FOR FOOD AND INSULATION PURPOSES; ALUMINUM POWDER FOR PAINTING; PIGMENTS, NAMELY, SILVER EMULSIONS; INK FOR LEATHER, NAMELY, LEATHER STAINS; DRY INK FOR LEATHER; PRINTING INK FOR LEATHER; INK PRINTING COMPOSITIONS; PAINTS, AND SUBSIDIARY MATERIALS EXCLUDING INSULATING PAINTS, NAMELY, THINNERS FOR PAINT, THICKENERS FOR PAINTS AND AGGLUTINATES FOR PAINTS; PAINTS; ALUMINUM PAINTS.

FIRST USE 3-15-2010; IN COMMERCE 3-15-2010.

INT. CL. 9/U.S. CLS. 21, 23, 26, 36 AND 38

FOR BLINKERS BEING SIGNALING LIGHTS; COMPUTERS; DATA PROCESSING APPARATUS; COMPUTER MEMORIES; LAPTOP COMPUTERS; DATA PROCESSING EQUIPMENT, NAMELY, COUPLERS; NOTEBOOK COMPUTERS; DOWNLOADABLE ELECTRONIC PUBLICATIONS IN THE NATURE OF BOOK, MAGAZINE AND MANUAL IN THE [FILED] *FIELD* OF AUTOMOBILE, CHEMICAL INDUSTRY AND MEDICINES; WALKIE-TALKIES; AMUSEMENT APPARATUS ADAPTED FOR USE WITH AN EXTERNAL DISPLAY SCREEN OR MONITOR; ELECTRIC ACCUMULATORS FOR VEHICLES; LITHIUM IRON PHOSPHATE BATTERIES; ELECTRONIC VIDEO SURVEILLANCE PRODUCTS FOR SECURITY AND GUARD PURPOSES, NAMELY, ELECTRONIC COMPONENTS OF SECURITY SYSTEMS; AUTOMATED SELF-CONTAINED ELECTRONIC SURVEILLANCE DEVICES THAT CAN BE DEPLOYED TO GATHER EVIDENCE OR INTELLIGENCE

3,927,814. REG. 3-8-2011. EASY-DO PRODUCTS LIMITED (UNITED KINGDOM LIMITED LIABILITY COMPANY) UNITEC HOUSE, 2 ALBERT PLACE FINCHLEY, LONDON N3 1QB, UNITED KINGDOM., SN 79-072,357. FILED 8-5-2009. PRINCIPAL REGISTER.

ECO FORCE

THE MARK CONSISTS OF STANDARD CHARACTERS WITHOUT CLAIM TO ANY PARTICULAR FONT, STYLE, SIZE, OR COLOR.

OWNER OF INTERNATIONAL REGISTRATION 0987336 DATED 8-29-2008, EXPIRES 8-29-2018.

INT. CL. 21/U.S. CLS. 2, 13, 23, 29, 30, 33, 40 AND 50

FOR FASTENING DEVICES AND CLIPS FOR SACHETS AND BAGS, ALL FOR HOUSEHOLD USE, NAMELY, CLOTHES PEGS, CLOTHES PINS; COMBS, CLEANING SPONGES AND BATH SPONGES; HAIR BRUSHES AND CLEANING BRUSHES FOR HOUSEHOLD USE; ARTICLES FOR CLEANING PURPOSES FOR HOUSEHOLD USE, NAMELY, HAND-HELD CLEANING UTENSILS WITH REMOVABLE SPONGE HEADS, CLEANING CLOTHS, DUSTERS, CLEANING SPONGES, CLEANING BRUSHES, SCOURERS FOR SAUCEPANS, WASH BOWLS; CLEANING INSTRUMENTS FOR HOUSEHOLD USE, NAMELY, HAND-HELD CLEANING UTENSILS WITH REMOVABLE SPONGE HEADS, CLEANING CLOTHS, DUSTERS, CLEANING SPONGES, CLEANING BRUSHES, SCOURERS FOR SAUCEPANS; BATHROOM UTENSILS AND CONTAINERS, NAMELY, TOOTHBRUSHES, BATH SPONGES, BATH BRUSHES AND BATHROOM PAILS; PLANTERS; FLOWER POTS; PARTS AND FITTINGS FOR ALL THE AFORESAID GOODS.

FIRST USE ; IN COMMERCE .

ELEMENTS CORRECTED
GOODS/SERVICES

IN REMOTE LOCATIONS FOR SECURITY OR GUARD PURPOSES; IDENTITY AUTHENTICATION SYSTEM, COMPRISED OF COMPUTER HARDWARE AND/OR SOFTWARE AND CARDS; LITHIUM-ION BATTERIES; OPTICAL COMMUNICATION EQUIPMENT, NAMELY, OPTICAL RECEIVERS AND OPTICAL TRANSMITTERS; CARRIER WAVE FACILITY, NAMELY, WAVEGUIDES FOR HIGH POWER BEAM DELIVERY; AERIALS; DISTANCE RECORDING APPARATUS, NAMELY, DISTANCE MEASURING APPARATUS; TELEMETERS; PETROL GAUGES FOR MEASURING LEVEL AND PRESSURE; CAR CD PLAYERS; CAR DVD PLAYERS.

FIRST USE 5-10-2010; IN COMMERCE 5-10-2010.
INT. CL. 11/U.S. CLS. 13, 21, 23, 31 AND 34

FOR LIGHT BULBS; ELECTRIC LIGHT BULBS; ELECTRIC LAMPS; LAMPS; LANTERNS FOR LIGHTING; POCKET SEARCHLIGHTS; ELECTRIC POCKET TORCHES FOR LIGHTING; PROJECTOR LAMPS; CHANDELIERS; CEILING LIGHTS; ELECTRIC LIGHTING FIXTURES, NAMELY, POWER FAILURE BACKUP SAFETY LIGHTING; LUMINOUS TUBES FOR LIGHTING; MINERS' LAMPS; FLASHLIGHTS; SEARCHLIGHTS; ELECTRIC TORCHES FOR LIGHTING; STANDARD LAMPS; STREET LAMPS; AQUARIUM LIGHTS; DIVING LIGHTS; ELECTRIC STAGE LIGHTING FIXTURE; STUDIO REFLECTING LAMPS; FLUORESCENT ELECTRIC LIGHT BULBS; FLUORESCENT LAMP AND LIGHTING TUBES; LIGHTS FOR VEHICLES; DYNAMO LAMPS FOR VEHICLES; HEADLIGHTS FOR AUTOMOBILES; BICYCLE LIGHTS; LIGHT BULBS FOR DIRECTIONAL SIGNALS FOR VEHICLES; CYCLE LIGHTS; VEHICLE HEADLIGHTS; LIGHTING APPARATUS FOR VEHICLES; LIGHTING APPARATUS FOR AUTOMOBILES; LAMPS FOR DIRECTIONAL SIGNALS OF AUTOMOBILES; LIGHTS FOR AUTOMOBILES.

FIRST USE 8-21-2010; IN COMMERCE 8-21-2010.

ELEMENTS CORRECTED
GOODS/SERVICES

3,951,671. REG. 4-26-2011. VOXEO CORPORATION (DELAWARE CORPORATION) SUITE 1000, 189 SOUTH ORANGE AVENUE, ORLANDO, FL. 32801, SN 77-820,143. FILED 9-4-2009. PRINCIPAL REGISTER.

MULTIPLY YOUR ROI

THE MARK CONSISTS OF STANDARD CHARACTERS WITHOUT CLAIM TO ANY PARTICULAR FONT, STYLE, SIZE, OR COLOR.

INT. CL. 9/U.S. CLS. 21, 23, 26, 36 AND 38

FOR COMPUTER TELEPHONY SOFTWARE; DOWNLOADABLE COMPUTER SOFTWARE FOR DEVELOPING OTHER COMPUTER PROGRAMS; DOWNLOADABLE COMPUTER SOFTWARE FOR ASSISTING DEVELOPERS IN CREATING PROGRAM CODE FOR COMMUNICATIONS APPLICATIONS, TELECOMMUNICATIONS SERVICES, INSTANT MESSAGING APPLICATIONS AND SMS APPLICATIONS; DOWNLOADABLE COMPUTER TELEPHONY SOFTWARE FOR THE CREATION, DEVELOPMENT AND DEPLOYMENT OF COMPUTER TELEPHONY APPLICATIONS, FOR INTEGRATION OF COMPUTER COMMUNICATIONS NETWORKS AND TELECOMMUNICATIONS NETWORKS, AND FOR ROUTING, MANAGEMENT, ENHANCEMENT, AND

CONFIGURATION OF COMMUNICATIONS OVER TELECOMMUNICATIONS AND COMPUTER COMMUNICATIONS NETWORKS; COMPUTER TELEPHONY SOFTWARE FOR THE CREATION, DEVELOPMENT AND DEPLOYMENT OF COMPUTER TELEPHONY APPLICATIONS, FOR INTEGRATION OF COMPUTER COMMUNICATIONS NETWORKS AND TELECOMMUNICATIONS NETWORKS, AND FOR ROUTING, MANAGEMENT, ENHANCEMENT, AND CONFIGURATION OF COMMUNICATIONS OVER TELECOMMUNICATIONS AND COMPUTER COMMUNICATIONS NETWORKS.

FIRST USE 10-1-2009; IN COMMERCE 10-1-2009.

INT. CL. 38/U.S. CLS. 100, 101 AND 104

FOR COMPUTER TELEPHONE COMMUNICATION SERVICES; INTERNET TELEPHONE COMMUNICATION SERVICES; TELECOMMUNICATION SERVICES, NAMELY, LOCAL AND LONG DISTANCE TRANSMISSION OF VOICE, DATA, GRAPHICS BY MEANS OF TELEPHONE, TELEGRAPHIC, CABLE, AND SATELLITE TRANSMISSIONS; VOICE OVER INTERNET PROTOCOL SERVICES; PROVIDING CO-LOCATION SERVICES FOR VOICE AND DATA COMMUNICATIONS APPLICATIONS; TELECOMMUNICATIONS RESELLER SERVICES, NAMELY, PROVIDING VALUE ADDED INTERACTIVE VOICE RESPONSE TELECOMMUNICATION SERVICES; PROVIDING TELEPHONE CONFERRING SERVICES AND PROVIDING TELEPHONE AUTO ATTENDANT SERVICES; COMMUNICATIONS AND TELECOMMUNICATIONS SERVICES IN THE AREA OF AUTOMATED VOICE APPLICATIONS AND COMMUNICATIONS SYSTEMS, NAMELY, PROVIDING TELEPHONE CALL ROUTING, INTERACTIVE VOICE RESPONSE, AND TELECONFERRING; TELEPHONE CALL MANAGEMENT SERVICES FOR OTHERS, NAMELY, TELEPHONE CALL BRIDGING, TELEPHONE CALL TRANSFERRING, AND TELEPHONE CALL CONFERRING; ELECTRONIC TRANSMISSION OF DATA, DOCUMENTS AND VOICE MAIL VIA COMPUTER TERMINALS; COMMUNICATIONS AND TELECOMMUNICATIONS SERVICES IN THE AREA OF AUTOMATED VOICE APPLICATIONS AND COMMUNICATIONS SYSTEMS, NAMELY, PROVIDING TELEPHONE CALL ROUTING, INTERACTIVE VOICE RESPONSE, AND TELECONFERRING.

FIRST USE 10-1-2009; IN COMMERCE 10-1-2009.

INT. CL. 42/U.S. CLS. 100 AND 101

FOR APPLICATION SERVICE PROVIDER FEATURING SOFTWARE IN THE FIELD OF INTERACTIVE VOICE RESPONSE; APPLICATION SERVICE PROVIDER, NAMELY, HOSTING COMPUTER SOFTWARE APPLICATIONS FOR THE USE OF OTHERS AND APPLICATIONS FEATURING SOFTWARE IN THE FIELD OF INTERACTIVE VOICE RESPONSE; PROVIDING ON-LINE NON-DOWNLOADABLE SOFTWARE FOR DEVELOPING OTHER COMPUTER PROGRAMS; PROVIDING ON-LINE NON-DOWNLOADABLE SOFTWARE FOR ASSISTING DEVELOPERS IN CREATING PROGRAM CODE FOR COMMUNICATIONS APPLICATIONS, TELECOMMUNICATIONS SERVICES, INSTANT MESSAGING APPLICATIONS AND SMS APPLICATIONS; HOSTING COMPUTER TELEPHONY APPLICATIONS OVER A NETWORK FOR OTHERS; HOSTING COMPUTER TELEPHONY APPLICATIONS AND AUTOMATED VOICE APPLICATIONS OVER COMMUNICATIONS NETWORK FOR OTHERS; CONSULTING SERVICES IN THE AREA OF AUTOMATED VOICE APPLICATIONS AND COMMUNICATION SYSTEMS; INTEGRATION OF TELECOMMUNICATION AND COMPUTER SYSTEMS; INTEGRATION OF TELEPHONE CALL CENTER SERVICES WITH COMPUTER AND COMMUNICATIONS SYSTEMS FOR OTHERS; INTEGRATION OF TELECOMMUNICATION AND COMPUTER SYSTEMS; INTEGRATION OF TELEPHONE CALL CENTER SERVICES WITH COMPUTERS AND COMMUNICATIONS SYSTEMS FOR OTHERS.

FIRST USE 10-1-2009; IN COMMERCE 10-1-2009.

ELEMENTS CORRECTED
OWNER ADDRESS
CITIZENSHIP

3,955,429. REG. 5-3-2011. VOXEO CORPORATION (DELAWARE CORPORATION) SUITE 1000, 189 SOUTH ORANGE AVENUE, ORLANDO, FL, 32801, SN 77-820,144. FILED 9-4-2009. PRINCIPAL REGISTER.

UNLOCKED COMMUNICATIONS

THE MARK CONSISTS OF STANDARD CHARACTERS WITHOUT CLAIM TO ANY PARTICULAR FONT, STYLE, SIZE, OR COLOR.

NO CLAIM IS MADE TO THE EXCLUSIVE RIGHT TO USE "COMMUNICATIONS", APART FROM THE MARK AS SHOWN.

INT. CL. 9/U.S. CLS. 21, 23, 26, 36 AND 38

FOR COMPUTER TELEPHONY SOFTWARE; DOWNLOADABLE COMPUTER SOFTWARE FOR DEVELOPING OTHER COMPUTER PROGRAMS; DOWNLOADABLE COMPUTER SOFTWARE FOR ASSISTING DEVELOPERS IN CREATING PROGRAM CODE FOR COMMUNICATIONS APPLICATIONS, TELECOMMUNICATIONS SERVICES, INSTANT MESSAGING APPLICATIONS AND SMS APPLICATIONS; DOWNLOADABLE COMPUTER TELEPHONY SOFTWARE FOR THE CREATION, DEVELOPMENT AND DEPLOYMENT OF COMPUTER TELEPHONY APPLICATIONS, FOR INTEGRATION OF COMPUTER COMMUNICATIONS NETWORKS AND TELECOMMUNICATIONS NETWORKS, AND FOR ROUTING, MANAGEMENT, ENHANCEMENT, AND CONFIGURATION OF COMMUNICATIONS OVER TELECOMMUNICATIONS AND COMPUTER COMMUNICATIONS NETWORKS; COMPUTER TELEPHONY SOFTWARE FOR THE CREATION, DEVELOPMENT AND DEPLOYMENT OF COMPUTER TELEPHONY APPLICATIONS, FOR INTEGRATION OF COMPUTER COMMUNICATIONS NETWORKS AND TELECOMMUNICATIONS NETWORKS, AND FOR ROUTING, MANAGEMENT, ENHANCEMENT, AND CONFIGURATION OF COMMUNICATIONS OVER TELECOMMUNICATIONS AND COMPUTER COMMUNICATIONS NETWORKS.

FIRST USE 10-1-2009; IN COMMERCE 10-1-2009.

INT. CL. 38/U.S. CLS. 100, 101 AND 104

FOR COMPUTER TELEPHONE COMMUNICATION SERVICES; INTERNET TELEPHONE COMMUNICATION SERVICES; TELECOMMUNICATION SERVICES, NAMELY, LOCAL AND LONG DISTANCE TRANSMISSION OF VOICE, DATA, GRAPHICS BY MEANS OF TELEPHONE, TELEGRAPHIC, CABLE, AND SATELLITE TRANSMISSIONS; VOICE OVER INTERNET PROTOCOL SERVICES; PROVIDING CO-LOCATION SERVICES FOR VOICE AND DATA COMMUNICATIONS APPLICATIONS; TELECOMMUNICATIONS RESELLER SERVICES, NAMELY, PROVIDING VALUE ADDED INTERACTIVE VOICE RESPONSE TELECOMMUNICATION SERVICES; PROVIDING TELEPHONE CONFERENCE SERVICES AND PROVIDING TELEPHONE AUTO ATTENDANT SERVICES; COMMUNICATIONS AND TELECOMMUNICATIONS SERVICES IN THE AREA OF AUTOMATED VOICE APPLICATIONS AND COMMUNICATIONS SYSTEMS, NAMELY, PROVIDING TELEPHONE CALL ROUTING, INTERACTIVE VOICE RESPONSE, AND TELECONFERENCING; TELEPHONE CALL MANAGEMENT SERVICES FOR OTHERS, NAMELY, TELEPHONE CALL BRIDGING, TELEPHONE CALL TRANSFERRING, AND TELEPHONE CALL CONFERENCE; ELECTRONIC TRANSMISSION OF DATA, DOCUMENTS AND VOICE MAIL VIA COMPUTER TERMINALS; COMMUNICATIONS AND TELECOMMUNICATIONS SERVICES IN THE AREA OF AUTOMATED VOICE APPLICATIONS AND COMMUNICATIONS SYSTEMS, NAMELY, PROVIDING TELEPHONE CALL ROUTING, INTERACTIVE VOICE RESPONSE, AND TELECONFERENCING.

FIRST USE 10-1-2009; IN COMMERCE 10-1-2009.

INT. CL. 42/U.S. CLS. 100 AND 101

FOR APPLICATION SERVICE PROVIDER FEATURING SOFTWARE IN THE FIELD OF INTERACTIVE VOICE RESPONSE; APPLICATION SERVICE PROVIDER, NAMELY, HOSTING COMPUTER SOFTWARE APPLICATIONS FOR THE USE OF OTHERS AND APPLICATIONS FEATURING SOFTWARE IN THE FIELD OF INTERACTIVE VOICE RESPONSE; PROVIDING ON-LINE NON-DOWNLOADABLE SOFTWARE FOR DEVELOPING OTHER COMPUTER PROGRAMS; PROVIDING ON-LINE NON-DOWNLOADABLE SOFTWARE FOR ASSISTING DEVELOPERS IN CREATING PROGRAM CODE FOR COMMUNICATIONS APPLICATIONS, TELECOMMUNICATIONS SERVICES, INSTANT MESSAGING APPLICATIONS AND SMS APPLICATIONS; HOSTING COMPUTER TELEPHONY APPLICATIONS OVER A NETWORK FOR OTHERS; HOSTING COMPUTER TELEPHONY APPLICATIONS AND AUTOMATED VOICE APPLICATIONS OVER COMMUNICATIONS NETWORK FOR OTHERS; CONSULTING SERVICES IN THE AREA OF AUTOMATED VOICE APPLICATIONS AND COMMUNICATION SYSTEMS; INTEGRATION OF TELECOMMUNICATION AND COMPUTER SYSTEMS; INTEGRATION OF TELEPHONE CALL CENTER SERVICES WITH COMPUTER AND COMMUNICATIONS SYSTEMS FOR OTHERS; INTEGRATION OF TELECOMMUNICATION AND COMPUTER SYSTEMS; INTEGRATION OF TELEPHONE CALL CENTER SERVICES WITH COMPUTERS AND COMMUNICATIONS SYSTEMS FOR OTHERS.

FIRST USE 10-1-2009; IN COMMERCE 10-1-2009.

ELEMENTS CORRECTED
OWNER ADDRESS
CITIZENSHIP

4,004,229. REG. 8-2-2011. NINTENDO OF AMERICA INC. (WASHINGTON CORPORATION) 4600 150TH AVENUE NE, REDMOND, WA, 98052, SN 77-583,745. FILED 10-2-2008. PRINCIPAL REGISTER.

NINTENDODSi

THE MARK CONSISTS OF STANDARD CHARACTERS WITHOUT CLAIM TO ANY PARTICULAR FONT, STYLE, SIZE, OR COLOR.

PRIORITY CLAIMED UNDER SEC. 44(D) ON JAPAN APPLICATION NO. 2008-079337, FILED 9-29-2008, REG. NO. 5323213, DATED 5-14-2010, EXPIRES 5-14-2020.

OWNER OF U.S. REG. NOS. 1,213,822, 1,628,966 AND OTHERS.

INT. CL. 14/U.S. CLS. 2, 27, 28 AND 50

FOR KEY HOLDERS OF PRECIOUS METALS, PRECIOUS METAL TROPHIES; PERSONAL ORNAMENTS OF PRECIOUS METAL; CLOCKS AND WATCHES; WATCHES CONTAINING A GAME FUNCTION.

FIRST USE ; IN COMMERCE .

ELEMENTS CORRECTED
FOREIGN APPLICATION NO.

4,055,170. REG. 11-15-2011. THE BLUEGREEN ALLIANCE, INC. (D.C. NON-PROFIT CORPORATION) 2828 UNIVERSITY AVE. SE, SUITE 200, MINNEAPOLIS, MN, 55414, SN 85-163,408. FILED 10-28-2010. PRINCIPAL REGISTER.



THE MARK CONSISTS OF THE PHRASE "THINC.-GREEN" WITH THE LETTERS "MSP" IN SUPERSCRIP TO THE RIGHT OF THE LETTER "N" IN "GREEN," OVER THE PHRASE "MANUFACTURING BETTER BUSINESS" WITH A DIAGONALLY DIVIDED CIRCULAR IMAGE TO THE LEFT OF THESE WORDS.

INT. CL. 35/U.S. CLS. 100, 101 AND 102

FOR PROVIDING INFORMATION ABOUT AND PROMOTING PUBLIC AWARENESS OF ENVIRONMENTALLY-CONSCIOUS AND GREEN INNOVATIONS, SUSTAINABLE ENERGY AND DEVELOPMENT OPPORTUNITIES, ALL OF THE FOREGOING FOR ENVIRONMENTALLY-CONSCIOUS AND GREEN-MANUFACTURING JOB CREATION.

FIRST USE 6-30-2010; IN COMMERCE 6-30-2010.

ELEMENTS CORRECTED
GOODS/SERVICES

4,058,153. REG. 11-22-2011. FOOTBALL CLUB SOCHAUX-MONTBELIARD (FRANCE GROUPEMENT D'INTERET ECONOMIQUE) STADE BONAL, F-25200 MONTBELIARD, FRANCE,, SN 79-090,025. FILED 9-13-2010. PRINCIPAL REGISTER.



PRIORITY DATE OF 9-9-2010 IS CLAIMED.

OWNER OF INTERNATIONAL REGISTRATION 1058396 DATED 9-13-2010, EXPIRES 9-13-2020.

NO CLAIM IS MADE TO THE EXCLUSIVE RIGHT TO USE "FOOTBALL CLUB SOCHAUX-MONTBELIARD", APART FROM THE MARK AS SHOWN.

THE COLOR(S) BLUE, YELLOW, GRAY AND BLACK IS/ARE CLAIMED AS A FEATURE OF THE MARK.

THE MARK CONSISTS OF A BLUE SHIELD WITH A YELLOW LINE AROUND THE INSIDE BORDER, THE WORDING "FCSM FOOTBALL CLUB SOCHAUX-MONTBELIARD" IN YELLOW, AND A GRAY LION RAMPANT OUTLINED IN BLACK.

INT. CL. 3/U.S. CLS. 1, 4, 6, 50, 51 AND 52

FOR BLEACHING PREPARATIONS FOR HOUSEHOLD USE, LAUNDRY USE, AND FOR THE HAIR; CLEANING; CLEANING, POLISHING, SCOURING AND ABRASIVE PREPARATIONS; PERFUMERY, ESSENTIAL OILS, COSMETICS, HAIR LOTIONS; SOAP.

FIRST USE ; IN COMMERCE .

INT. CL. 9/U.S. CLS. 21, 23, 26, 36 AND 38

FOR SPECTACLE CASES; SUNGLASSES; BLANK USB FLASH DRIVES; COMPACT DISCS FEATURING MUSIC; DVDS FEATURING SOCCER PROGRAMMING; VIDEOTAPES FEATURING SOCCER PROGRAMMING; CASES FOR TELEPHONES; INFLATABLE FLOTATION DEVICES; MAGNETS.

FIRST USE ; IN COMMERCE .

INT. CL. 10/U.S. CLS. 26, 39 AND 44

FOR FEEDING BOTTLES; TEATS.

FIRST USE ; IN COMMERCE .

INT. CL. 12/U.S. CLS. 19, 21, 23, 31, 35 AND 44

FOR LAND VEHICLES; APPARATUS FOR LOCOMOTION BY LAND AIR OR WATER, NAMELY, AUTOMOBILES, VANS, BICYCLES, MOTORIZED SCOOTERS, AND MOPEDS; MOTORCYCLES.

FIRST USE ; IN COMMERCE .

INT. CL. 14/U.S. CLS. 2, 27, 28 AND 50

FOR PRECIOUS METALS; ALLOYS OF PRECIOUS METAL; PINS BEING JEWELRY; BROOCHES BEING JEWELRY; MEDALS; CASES FOR WATCHES; KEY RINGS OF PRECIOUS METAL; JEWELRY; PRECIOUS STONES; HOROLOGICAL AND CHRONOMETRIC INSTRUMENTS; ALARM CLOCKS; WATCHES; WATCH STRAPS; CUFF LINKS; TIE PINS; TIE CLIPS.

FIRST USE ; IN COMMERCE .

INT. CL. 16/U.S. CLS. 2, 5, 22, 23, 29, 37, 38 AND 50

FOR PAPER; CARDBOARD; WRITING OR DRAWING BOOKS; PHOTOGRAPH ALBUMS; SCRAPBOOK ALBUMS; FOLDERS FOR PAPERS; FILE FOLDERS; PRINTED MATTER, NAMELY, SOUVENIR PROGRAMS CONCERNING SOCCER, POSTERS, POSTCARDS, AUTOGRAPH BOOKS, TRADING CARDS, STICKERS; BOOKBINDING MATERIALS; NEWSPAPERS; PRINTED PERIODICALS IN THE FIELD OF SOCCER; BOOKS ABOUT SOCCER; MAGAZINES IN THE FIELD OF SOCCER; CATALOGUES IN THE FIELD OF SPORTS APPAREL AND SPORTS EQUIPMENT; PHOTOGRAPHS; PHOTOGRAPH STANDS; STATIONERY; ADHESIVE GLUES FOR STATIONERY OR HOUSEHOLD PURPOSES; PAINTBRUSHES; TYPEWRITERS, ELECTRIC OR NON-ELECTRIC; ERASERS; PRINTED INSTRUCTIONAL AND TEACHING MATERIAL IN THE FIELD OF SOCCER; BAGS BEING ENVELOPES OR POUCHES OF PAPER OR PLASTICS, FOR PACKAGING; NON-MAGNETIC SUBSCRIPTION CARDS BEING ENTRY TICKETS; CREDIT CARDS WITHOUT MAGNETIC CODING; FOUNTAIN PENS; PADS BEING STATIONERY; PENCILS; PENCIL SHARPENERS, ELECTRIC OR NON-ELECTRIC; WRITING PADS; CARDS; DIARIES; ALMANACS; CALENDARS; FLAGS OF PAPER.

FIRST USE ; IN COMMERCE .

INT. CL. 18/U.S. CLS. 1, 2, 3, 22 AND 41

FOR LEATHER AND IMITATIONS OF LEATHER; UMBRELLAS; PARASOLS; WALKING STICKS; WHIPS; SADDLERY; LEATHER KEY CASES; HANDBAGS; TRUNKS BEING LUGGAGE; VALISES; TRAVELING BAGS; LUGGAGE; BRIEFCASES; BAGS IN THE NATURE OF ENVELOPES OR POUCHES OF LEATHER, FOR PACKAGING; LEATHER OR LEATHER-BOARD BOXES; IMITATION LEATHER; NAME CARD CASES; [CARD CASES FOR TRADING CARDS;] SUITCASES; TOILETRY CASES OF LEATHER SOLD EMPTY; TRAVELING TRUNKS; WALLETS, PURSES.

FIRST USE ; IN COMMERCE .

INT. CL. 20/U.S. CLS. 2, 13, 22, 25, 32 AND 50

FOR CUSHIONS BEING FURNITURE; PICTURE FRAMES; NON-METAL KEY RINGS.

FIRST USE ; IN COMMERCE .

INT. CL. 21/U.S. CLS. 2, 13, 23, 29, 30, 33, 40 AND 50

FOR TABLEWARE, OTHER THAN KNIVES, FORKS AND SPOONS, NAMELY, PLATES, CUPS, SAUCERS, BOWLS, DISHES, TRAYS, ICE BUCKETS, SALT SHAKERS, PEPPER SHAKERS; DRINKING FLASKS FOR TABLEWARE; THERMAL INSULATED BEVERAGE CONTAINERS; MUGS; BEVERAGE GLASSWARE.

FIRST USE ; IN COMMERCE .

INT. CL. 22/U.S. CLS. 1, 2, 7, 19, 22, 42 AND 50

FOR ROPES; STRING; TENTS; TARPAULINS; SAILS; CUSHIONING NOT OF RUBBER OR PLASTIC IN THE NATURE OF STUFFING; RAW FIBROUS TEXTILE; CABLES, NOT OF METAL; TEXTILE FIBERS; SACKS OR BAGS FOR THE TRANSPORT AND STORAGE OF MATERIALS IN BULK; TEXTILE BAGS, ENVELOPES AND POUCHES FOR PACKAGING.

FIRST USE ; IN COMMERCE .

INT. CL. 24/U.S. CLS. 42 AND 50

FOR FABRICS FOR TEXTILE USE; UPHOLSTERY FABRICS; BATH LINEN; CLOTH FLAGS; NYLON FLAGS; BED SHEETS; BED BLANKETS; PILLOWCASES; CURTAINS OF TEXTILE OR PLASTIC; HOUSEHOLD LINEN; TABLE LINEN, NOT OF PAPER; TOWELS OF TEXTILE; TRAVELING RUGS.

FIRST USE ; IN COMMERCE .

INT. CL. 25/U.S. CLS. 22 AND 39

FOR SCARVES; GLOVES; WRISTBANDS; SHIRTS; JACKETS; SWEATSHIRTS; TIES; PAJAMAS; PONCHOS; BATHROBES; JERSEYS; FOOTWEAR; HEADGEAR, NAMELY, HATS; CAPS; EARMUFFS.

FIRST USE ; IN COMMERCE .

INT. CL. 26/U.S. CLS. 37, 39, 40, 42 AND 50

FOR LACE AND EMBROIDERY; RIBBONS AND BRAID; BUTTONS; ORNAMENTAL NOVELTY PINS; ORNAMENTAL NOVELTY BADGES.

FIRST USE ; IN COMMERCE .

INT. CL. 27/U.S. CLS. 19, 20, 37, 42 AND 50

FOR CARPETS; RUGS; MATS AND MATTING; LINOLEUM; WALL HANGINGS, NOT OF TEXTILE.

INT. CL. 28/U.S. CLS. 22, 23, 38 AND 50

FOR BOARD GAMES; ARCADE GAMES; SOCCER TABLE TOP GAMES; CARD GAMES; COIN-OPERATED VIDEO GAMES; MODEL SOCCER STADIUMS; STUFFED TOYS; INFLATABLE MATTRESSES FOR RECREATIONAL USE; TOY NOISEMAKERS; ARCHERY BOWS; FENCING WEAPONS; STATIONARY EXERCISE BICYCLES; BOB-SLEIGHS; BALLS FOR GAMES; PLAY BALLOONS; BILLIARD EQUIPMENT; BILLIARD BALLS; BILLIARD TABLES; BILLIARD CUES; BOCCÉ BALLS; DISCUSSES FOR SPORTS; ORNAMENTS FOR CHRISTMAS TREES, EXCEPT ILLUMINATION ARTICLES AND CONFECTIONERY; SKATING BOOTS WITH SKATES ATTACHED; BOXING GLOVES; RODS FOR FISHING; GOLF CLUBS; KITES; TARGETS; MACHINES FOR PHYSICAL EXERCISES, NAMELY, EXERCISE BANDS, TRAINING BARS, ROWING MACHINES, ELLIPTICAL EXERCISE MACHINES, STAIR-STEPPING MACHINES, WEIGHT MACHINES, RESISTANCE MACHINES, STATIONARY CYCLES, TRAMPOLINES; QUOITS; PRACTICAL JOKE TOYS, NAMELY, FOAM FINGERS, FOAM HANDS, BUZZER RINGS, FACE MASKS, FAKE TEETH; DARTS; SKITTLES GAMES; SHUTTLECOCKS; GYMNASTICS APPARATUS; BODY-BUILDING APPARATUS; DUMB-BELLS; PARAGLIDERS; ICE SKATES; ROLLER SKATES; SKATEBOARDS; SAILBOARDS; SURFBOARDS; PROTECTIVE PADDING FOR PLAYING SOCCER; RACKETS FOR TENNIS, RACQUETBALL, AND SQUASH; SKIS; WATERSKIS; SURF SKIS; TABLES FOR INDOOR FOOTBALL AND SOCCER; TABLES FOR TABLE TENNIS; PLAYING CARDS.

FIRST USE ; IN COMMERCE .

INT. CL. 30/U.S. CL. 46

FOR COFFEE, TEA, COCOA, SUGAR, RICE, TAPIOCA, SAGO, ARTIFICIAL COFFEE; BREAKFAST CEREALS; BREAD; CANDY; ICES; HONEY, TREATLE; YEAST, BAKING-POWDER; SALT, MUSTARD; VINEGAR, SAUCES; SPICES; ICE FOR REFRESHMENT.

FIRST USE ; IN COMMERCE .

INT. CL. 32/U.S. CLS. 45, 46 AND 48

FOR BEER; MINERAL AND AERATED WATERS AND OTHER NON-ALCOHOLIC DRINKS, NAMELY, SOFT DRINKS, ENERGY DRINKS, ISOTONIC NON-ALCOHOLIC DRINKS; SPORTS DRINKS; FRUIT DRINKS AND FRUIT JUICES; CONCENTRATES, SYRUPS OR POWDERS USED IN THE PREPARATION OF SOFT DRINKS AND SPORTS AND ENERGY DRINKS.

FIRST USE ; IN COMMERCE .

INT. CL. 33/U.S. CLS. 47 AND 49

FOR ALCOHOLIC BEVERAGES, EXCEPT BEER.

FIRST USE ; IN COMMERCE .

INT. CL. 34/U.S. CLS. 2, 8, 9 AND 17

FOR TOBACCO; SMOKERS' ARTICLES, NAMELY, CIGARETTE LIGHTERS NOT FOR AUTOMOBILES, CIGAR CUTTERS; MATCHES; ASHTRAYS FOR SMOKERS; CIGARETTE CASES.

FIRST USE ; IN COMMERCE .

INT. CL. 35/U.S. CLS. 100, 101 AND 102

FOR RENTAL OF ADVERTISING SPACE.

FIRST USE ; IN COMMERCE .

INT. CL. 38/U.S. CLS. 100, 101 AND 104

FOR RENTAL OF SET-TOP BOXES FOR USE WITH TELEVISIONS; RENTAL OF ENCODING DEVICES FOR USE WITH TELEVISIONS.

FIRST USE ; IN COMMERCE .

INT. CL. 39/U.S. CLS. 100 AND 105

FOR TRANSPORTATION OF PEOPLE BY MEANS OF VEHICLES; PACKAGING OF GOODS FOR TRANSPORTATION AND STORAGE OF GOODS; ARRANGING OF TOURS; DELIVERY OF NEWSPAPERS; GARAGE RENTAL; BOOKING OF SEATS FOR TRAVEL; TOURIST OFFICE SERVICES; TRAVEL AGENCY SERVICES, NAMELY, MAKING RESERVATIONS AND BOOKINGS FOR TRANSPORTATION; VEHICLE RENTAL SERVICES; TRANSPORT VEHICLE AGENCIES, NAMELY, LOCAL, INTERSTATE AND INTERNATIONAL MOVING SERVICES.

FIRST USE ; IN COMMERCE .

INT. CL. 40/U.S. CLS. 100, 103 AND 106

FOR SILK SCREEN PRINTING.

INT. CL. 41/U.S. CLS. 100, 101 AND 107

FOR EDUCATION, NAMELY, PROVIDING SEMINARS IN THE FIELD OF SOCCER; PROVIDING OF TRAINING IN THE FIELD OF SOCCER; ENTERTAINMENT IN THE NATURE OF SOCCER GAMES; PUBLICATION OF BOOKS; LENDING LIBRARIES; PRODUCTION OF TELEVISION SHOWS; PRODUCTION OF FILMS; PRODUCTION OF TELEVISION FILMS; PRODUCTION OF TELEVISION PROGRAMS; PRODUCTION OF TELEVISED REPORTS; PRODUCTION OF TELEVISED DEBATES; PRODUCTION OF VIDEO RECORDINGS; RENTAL OF VIDEOTAPES; RENTAL OF SOUND RECORDINGS; RENTAL OF MOTION PICTURE FILMS; RENTAL OF PHONOGRAPH RECORDINGS; RENTAL OF MOVIE PROJECTORS AND ACCESSORIES; ORGANIZATION OF COMPETITIONS FOR EDUCATION OR ENTERTAINMENT PURPOSES, NAMELY, SPORTS COMPETITIONS; PRODUCTION OF RADIO AND TELEVISION PROGRAMMES; ORGANIZATION OF EXHIBITIONS FOR CULTURAL OR EDUCATIONAL PURPOSES; BOOKING OF SEATS FOR SHOWS; SPORT CAMP SERVICES; ORGANIZATION OF SPORTS COMPETITIONS; RENTAL OF SPORTS EQUIPMENT, EXCEPT VEHICLES; RENTAL OF STADIUM FACILITIES; SUPPORT SERVICES FOR MEMBERS OF A CLUB PRACTICING SPORTS AND CULTURAL ACTIVITIES, NAMELY, ARRANGING, ORGANIZING, AND HOSTING SOCIAL EVENTS, GET-TOGETHERS, AND PARTIES FOR CLUB MEMBERS.

INT. CL. 43/U.S. CLS. 100 AND 101

FOR RESTAURANT AND BAR SERVICES; SNACK BARS; PROVIDING TEMPORARY ACCOMMODATION.

ELEMENTS CORRECTED
GOODS/SERVICES

4,068,747. REG. 12-6-2011. PARKER SYNERGIES LLC (FLORIDA LIMITED LIABILITY COMPANY) 10670 RIVERSIDE DR. EAST, WINDSOR, ONTARIO, CANADA, N8P1A4, SN 85-975,730. FILED 9-22-2010. PRINCIPAL REGISTER.

COOL-CORE

THE MARK CONSISTS OF STANDARD CHARACTERS WITHOUT CLAIM TO ANY PARTICULAR FONT, STYLE, SIZE, OR COLOR.

INT. CL. 25/U.S. CLS. 22 AND 39

FOR JACKETS * GIVEN, INTENDED FOR SALE, OR ADVERTISED AND DIRECTED TO AND INTENDED TO BE USED BY RIDERS, MANUFACTURERS OR SELLERS OF MOTORCYCLES *; MOTORCYCLE JACKETS * JACKETS, EXCEPT THOSE GIVEN, INTENDED FOR SALE, OR ADVERTISED AND DIRECTED TO AND INTENDED TO BE USED BY RIDERS, MANUFACTURERS OR SELLERS OF MOTORCYCLES *.

FIRST USE 2-0-2011; IN COMMERCE 2-0-2011.

ELEMENTS AMENDED
GOODS/SERVICES

4,077,603. REG. 12-27-2011. IRIS OHYAMA, INC. (JAPAN CORPORATION) 2-12-1 ITSUTSUBASHI, AOBA-KU, SENDAI, MIYAGI, JAPAN., SN 77-980,050. FILED 12-1-2009. PRINCIPAL REGISTER.

IRIS

THE MARK CONSISTS OF STANDARD CHARACTERS WITHOUT CLAIM TO ANY PARTICULAR FONT, STYLE, SIZE, OR COLOR.

OWNER OF U.S. REG. NOS. 2,165,720, 2,992,732 AND OTHERS.

INT. CL. 9/U.S. CLS. 21, 23, 26, 36 AND 38

FOR PLASTIC COMPACT DISC HOLDERS.

FIRST USE 8-1-1996; IN COMMERCE 8-1-1996.

INT. CL. 12/U.S. CLS. 19, 21, 23, 31, 35 AND 44

FOR PLASTIC DRAWER-STORAGE CARTS; MOBILE PLASTIC DRAWER STORAGE CARTS FOR DOMESTIC OR COMMERCIAL USE.

FIRST USE 1-1-1997; IN COMMERCE 1-1-1997.

INT. CL. 18/U.S. CLS. 1, 2, 3, 22 AND 41

FOR STORAGE TRUNKS; PLASTIC TRUNK TRAYS; PLASTIC PET CARRIERS.

FIRST USE 7-1-1997; IN COMMERCE 7-1-1997.

INT. CL. 20/U.S. CLS. 2, 13, 22, 25, 32 AND 50

FOR PLASTIC STORAGE DRAWERS UNITS, PLASTIC STORAGE BOXES, CLEAR PLASTIC BOXES, MODULAR PLASTIC BOXES, BUCKLED CLEAR PLASTIC BOXES, WINGED-LID PLASTIC BOXES, NON-METAL CHESTS; CHESTS OF DRAWERS, NON-METAL FILE CHESTS; PLASTIC CHESTS OF DRAWERS AND MOBILE PLASTIC CHESTS OF DRAWERS FOR STORAGE; HIGH-GRADE NON-METAL CHESTS; STACKABLE DRAWERS; NON-METAL TOOL BOXES; PLASTIC BOXES FOR STORING HOBBY MATERIALS; PLASTIC STORAGE BOXES FOR SHOES; CANVAS STORAGE DRAWER ORGANIZERS FOR HOUSEHOLD, HOBBY, AND CRAFT ITEMS; PLASTIC RECYCLING BINS; WIRE SHELVES FOR STORAGE; PLASTIC PENS AND CRATES FOR PETS; READY-TO-ASSEMBLE FURNITURE.

FIRST USE 10-31-2010; IN COMMERCE 10-31-2010.

INT. CL. 21/U.S. CLS. 2, 13, 23, 29, 30, 33, 40 AND 50

FOR PLASTIC STORAGE BASKETS; PILL BOXES FOR PERSONAL USE; SHOWER CADDIES; PLASTIC MESH BASKETS AND PLASTIC MESH STACKABLE BINS FOR STORAGE FOR HOUSEHOLD USE; PET CAGES; PLASTIC PET FOOD SCOOPS AND PLASTIC LITTER BOXES; PLASTIC SMALL ANIMAL AND INSECT HABITATS; WIRE HOUSEHOLD STORAGE ORGANIZERS; PLASTIC UNDER-BED STORAGE CONTAINERS FOR DOMESTIC USE; RATTAN BASKETS; NON-MECHANIZED ELEVATED STORAGE FEEDERS FOR ANIMALS; STACKABLE PLASTIC BINS FOR HOUSEHOLD STORAGE; PLASTIC PET SUPPLY AND PET FOOD STORAGE CONTAINERS; RECEPTACLES USED FOR PET TRAINING PADS, NAMELY, TRAYS FOR DOMESTIC PURPOSES.

FIRST USE 1-1-1981; IN COMMERCE 1-1-1981.

ELEMENTS CORRECTED
GOODS/SERVICES

4,100,546. REG. 2-21-2012. CHASE DISTILLERY LIMITED (UNITED KINGDOM CORPORATION) PRESTON WYNNE, ROSAMAUND COTTAGE, HEREFORD, UNITED KINGDOM, HR13PG, SN 77-744,994. FILED 5-26-2009. PRINCIPAL REGISTER.

WILLIAMS CHASE

THE MARK CONSISTS OF STANDARD CHARACTERS WITHOUT CLAIM TO ANY PARTICULAR FONT, STYLE, SIZE, OR COLOR.

OWNER OF ERPN CMNTY TM OFC REG. NO. 6706221, DATED 1-28-2009, EXPIRES 2-28-2018.

INT. CL. 33/U.S. CLS. 47 AND 49

FOR ALCOHOLIC BEVERAGES EXCEPT BEERS.

FIRST USE ; IN COMMERCE .

ELEMENTS CORRECTED
OWNER ADDRESS

4,115,149. REG. 3-20-2012. CW FINANCIAL LLC (DELAWARE LIMITED LIABILITY COMPANY) 1436 NORTH CAROLINA AVE., NE, WASHINGTON, DC, 20002, SN 77-359,467. FILED 12-26-2007. PRINCIPAL REGISTER.

CASHWELL

THE MARK CONSISTS OF STANDARD CHARACTERS WITHOUT CLAIM TO ANY PARTICULAR FONT, STYLE, SIZE, OR COLOR.

PRIORITY CLAIMED UNDER SEC. 44(D) ON AUSTRALIA APPLICATION NO. 1183611, FILED 6-26-2007.

INT. CL. 36/U.S. CLS. 100, 101 AND 102

FOR FINANCIAL SERVICES IN THE FIELD OF MONEY LENDING; BANKING SERVICES; PROVIDING AUTOMATED TELLER MACHINES AND RELATED SERVICES, NAMELY, PROVIDING DEBIT AND CREDIT CARDS; CHECK CASHING SERVICES, CONSUMER LOAN SERVICES, PROVIDING MONEY ORDERS AND WIRE TRANSFER SERVICES; CASH ADVANCE SERVICES FOR INDIVIDUALS.

FIRST USE 1-31-2008; IN COMMERCE 3-31-2009.

ELEMENTS CORRECTED
OWNER NAME

4,120,173. REG. 4-3-2012. TOPSIL SEMICONDUCTOR MATERIALS A/S (DENMARK LIMITED COMPANY) LINDERUPVEJ 4, DK-3600 FREDERIKSSUND, DENMARK., SN 79-098,031. FILED 4-5-2011. PRINCIPAL REGISTER.

TOPSIL

THE MARK CONSISTS OF STANDARD CHARACTERS WITHOUT CLAIM TO ANY PARTICULAR FONT, STYLE, SIZE, OR COLOR.

PRIORITY DATE OF 12-6-2010 IS CLAIMED.

OWNER OF INTERNATIONAL REGISTRATION 1079147 DATED 4-5-2011, EXPIRES 4-5-2021.

INT. CL. 1/U.S. CLS. 1

FOR CHEMICALS USED IN INDUSTRY, SCIENCE, PHOTOGRAPHY AND THE ELECTRONIC INDUSTRY, SILICONE FLUIDS, SILICON, INCLUDING PURE SILICON [AND SILICON WAFERS FOR USE IN INDUSTRY, SCIENCE, PHOTOGRAPHY AND/OR THE ELECTRONIC INDUSTRY] .

FIRST USE ; IN COMMERCE .

INT. CL. 6/U.S. CLS. 2, 12, 13, 14, 23, 25 AND 50

FOR COMMON METALS AND THEIR ALLOYS, NON-ELECTRIC CABLES AND WIRES OF METAL; SILICON IRON; GOODS MADE OF METAL, INCLUDING SILICON MIXED METAL, NAMELY, ANGLE IRONS, DRAWER PULLS, CONDUIT, FLOORING.

INT. CL. 9/U.S. CLS. 21, 23, 26, 36 AND 38

FOR APPARATUS AND INSTRUMENTS FOR REGULATING OR CONTROLLING ELECTRICITY; SOLAR MODULES IN THE FORM OF SOLAR PANELS FOR GENERATING ELECTRICITY, SOLAR ELECTRIC TRANSFORMER, SOLAR CELLS FOR GENERATING ELECTRICITY; APPARATUS FOR RECORDING, TRANSMISSION OR REPRODUCTION OF SOUND OR IMAGES; BLANK MAGNETIC AND OPTICAL DATA CARRIERS, RECORDING DISCS, COMPACT DISCS; COMPUTERS; ELECTRIC CABLES; SEMICONDUCTORS; * SILICON WAFERS FOR USE IN INDUSTRY, SCIENCE, PHOTOGRAPHY AND/OR THE ELECTRONIC INDUSTRY * .

FIRST USE ; IN COMMERCE .

INT. CL. 11/U.S. CLS. 13, 21, 23, 31 AND 34

FOR SOLAR CELLS IN THE NATURE OF COLLECTION PANELS FOR SOLAR INSTALLATIONS TO COLLECT HEAT; SOLAR HEAT COLLECTION PANELS.

INT. CL. 35/U.S. CLS. 100, 101 AND 102

FOR RETAIL AND WHOLESALE STORE AND ON-LINE RETAIL AND WHOLESALE STORE SERVICES FEATURING SILICON SEMICONDUCTOR PRODUCTS AND PRODUCTS IN THE ELECTRONIC SEMICONDUCTOR INDUSTRY.

INT. CL. 40/U.S. CLS. 100, 103 AND 106

FOR PROCESSING AND TREATMENT OF SILICON SEMICONDUCTOR MATERIALS AND ARTICLES; GENERATING ELECTRICITY FROM SOLAR ENERGY.

ELEMENTS CORRECTED
GOODS/SERVICES

4,143,582. REG. 5-15-2012. FREEMAN CAPITAL COMPANY (DELAWARE LIMITED LIABILITY COMPANY) 6555 W. SUNSET ROAD, LAS VEGAS, NV, 89118, SN 85-163,681. FILED 10-28-2010. PRINCIPAL REGISTER.

EVENTRAC

THE MARK CONSISTS OF STANDARD CHARACTERS WITHOUT CLAIM TO ANY PARTICULAR FONT, STYLE, SIZE, OR COLOR.

INT. CL. 9/U.S. CLS. 21, 23, 26, 36 AND 38

FOR COMPUTER APPLICATION SOFTWARE FOR VIEWING AND DISPLAYING VIRTUAL TOURS OF FACILITIES FOR TRADE SHOWS, CONVENTIONS, EXPOSITIONS, CONFERENCES AND CORPORATE EVENTS.

FIRST USE 12-0-2010; IN COMMERCE 12-0-2010.

INT. CL. 42/U.S. CLS. 100 AND 101

FOR PROVIDING ON-LINE NON-DOWNLOADABLE COMPUTER APPLICATIONS USED BY SHOW ORGANIZERS AND EVENT MANAGERS TO ORGANIZE, PLAN AND MANAGE TRADE SHOWS, CONVENTIONS, CONFERENCES, AND CORPORATE EVENTS; PROVIDING ON-LINE NON-DOWNLOADABLE COMPUTER APPLICATIONS USED BY EXHIBITORS TO ORGANIZE AND PLAN EXHIBITS FOR TRADE SHOWS, CONVENTIONS, CONFERENCES, AND CORPORATE EVENTS; PROVIDING ON-LINE NON-DOWNLOADABLE COMPUTER APPLICATION FOR CUSTOMERS TO VIEW VIRTUAL TOURS OF FACILITIES FOR TRADE SHOWS, CONVENTIONS, CONFERENCES AND CORPORATE EVENTS; PROVIDING ON-LINE NON-DOWNLOADABLE COMPUTER APPLICATIONS FOR PROJECT MANAGEMENT AND VENDOR MANAGEMENT IN THE PLANNING AND PRODUCTION OF TRADE SHOWS, CONVENTIONS, CONFERENCES AND CORPORATE EVENTS.

FIRST USE 12-0-2010; IN COMMERCE 12-0-2010.

ELEMENTS CORRECTED
GOODS/SERVICES

4,152,971. REG. 6-5-2012. ROLAND DG CORPORATION (JAPAN CORPORATION) HAMAMATSU-SHI, 1-6-4 SHIN MIYAKODA, KITA-KU, SHIZUOKA-KEN, JAPAN, 431-2103, SN 85-338,077. FILED 6-3-2011. PRINCIPAL REGISTER.

VersaSTUDIO

OWNER OF JAPAN REG. NO. 5448307, DATED 11-4-2011, EXPIRES 11-4-2021.

OWNER OF U.S. REG. NOS. 2,987,031, 3,635,701 AND 3,635,702.

THE MARK CONSISTS OF THE WORD "VERSA" IN INITIAL CAPS, FOLLOWED BY THE WORD "STUDIO" IN ALL CAPS, WITH NO SPACING BETWEEN THE TWO WORDS. "VERSASTUDIO" IS IN AN ITALICIZED FONT.

INT. CL. 9/U.S. CLS. 21, 23, 26, 36 AND 38

FOR BASED ON 1(A) AND 44(E) APPARATUS CONTROLLED BY COMPUTERS, NAMELY, COMPUTER MONITOR DISPLAYS, PRINTERS AND X-Y PLOTTERS; PLOTTER PRINTERS; CUTTING PLOTTERS FOR USE AS SIGN MAKERS; COMBINATION INK JET PRINTER AND CUTTER; COMBINATION THERMAL PRINTER AND CUTTER; COMPUTER PRINTERS; BASED ON 44(E) X-Y PLOTTERS; THREE DIMENSIONAL SCANNERS; COMPUTER PROGRAMS FOR CONTROLLING CUTTING, DRILLING, GRINDING AND ENGRAVING MACHINES, POWER OPERATED COMPUTERIZED MACHINE CUTTERS, DRILLERS AND GRINDERS, ENGRAVING MACHINES, LASER ENGRAVING MACHINES, THREE DIMENSIONAL MODELING MACHINES, PLOTTER PRINTERS, CUTTING PLOTTERS FOR USE AS SIGN MAKERS, PRINTING AND CUTTING MACHINES, COMPUTER PRINTERS, X-Y PLOTTERS AND THREE-DIMENSIONAL SCANNERS.

FIRST USE 5-24-2011; IN COMMERCE 5-24-2011.

ELEMENTS CORRECTED
GOODS/SERVICES
OWNER ADDRESS

4,161,542. REG. 6-19-2012. NINTENDO OF AMERICA INC. (WASHINGTON CORPORATION) 4600 150TH AVENUE NE, REDMOND, WA, 98052, SN 77-583,767. FILED 10-2-2008. PRINCIPAL REGISTER.

4,161,670. REG. 6-19-2012. AMPELMANN GMBH (FED REP GERMANY GMBH) ROSENTHALER STRASSE 40, BERLIN, FED REP GERMANY, 10178, SN 78-953,855. FILED 8-16-2006. PRINCIPAL REGISTER.



PRIORITY CLAIMED UNDER SEC. 44(D) ON JAPAN APPLICATION NO. 2008-079339, FILED 9-29-2008, REG. NO. 5323215, DATED 5-14-2010, EXPIRES 5-14-2020.

OWNER OF U.S. REG. NOS. 1,213,822, 1,628,966 AND OTHERS.

THE MARK CONSISTS OF THE WORDING "NINTENDO", WITH THE LETTER "O" FORMING THE TOP BLOCK OF TWO VERTICALLY ALIGNED BLOCKS, FOLLOWED BY THE LETTERS "DS", FOLLOWED BY THE LETTER "I" WITHIN A CIRCLE AS A SUPERSCRIPIT, ALL OF THE LETTERING IN STYLIZED FONTS.

INT. CL. 38/U.S. CLS. 100, 101 AND 104

FOR COMMUNICATIONS BY COMPUTER VIDEO GAMES; PROVIDING INFORMATION ABOUT COMMUNICATIONS BY COMPUTER VIDEO GAMES; TELECOMMUNICATION SERVICES, NAMELY, TRANSMISSION OF DATA, GRAPHICS, IMAGES, AUDIO AND VIDEO BY MEANS OF WIRELESS COMMUNICATIONS NETWORKS AND THE INTERNET; COMMUNICATION SERVICES, NAMELY, ELECTRONIC TRANSMISSION OF DATA AND DOCUMENTS AMONG USERS OF VIDEO GAME COMPUTERS; TEXT AND NUMERIC WIRELESS DIGITAL MESSAGING SERVICES; WIRELESS DIGITAL MESSAGING SERVICES; WIRELESS ELECTRONIC TRANSMISSION OF DATA, IMAGES AND INFORMATION; ELECTRONIC TRANSMISSION OF DATA; INFORMATION AND DATA TRANSMISSION VIA ELECTRONIC COMMUNICATIONS NETWORKS; TELECOMMUNICATION SERVICES, NAMELY, TRANSMISSION OF VOICE BY MEANS OF WIRELESS COMMUNICATIONS NETWORKS AND THE INTERNET; PROVIDING INFORMATION ABOUT BROADCASTING OF TELEVISION PROGRAMS; VIDEO BROADCASTING SERVICES VIA THE INTERNET; ELECTRONIC MAIL SERVICES; PROVIDING ONLINE CHAT ROOMS AND ELECTRONIC BULLETIN BOARDS FOR TRANSMISSION OF MESSAGES AMONG USERS IN THE FIELD OF GENERAL INTEREST; PROVIDING ONLINE FORUMS FOR TRANSMISSION OF MESSAGES AMONG VIDEO GAME USERS; PROVIDING WIRELESS BROADBAND COMMUNICATION SERVICES FOR USE WITH VIDEO GAME COMPUTER NETWORKS AND THE INTERNET; STREAMING OF AUDIO AND VIDEO MATERIAL ON THE INTERNET; WEB MESSAGING SERVICES; WIRELESS BROADBAND COMMUNICATION SERVICES; ELECTRONIC TRANSMISSION OF HYPertext DOCUMENTS, STREAMING VIDEO, WEB HYPERLINKS, MUSIC AND DOCUMENTS; WEB MESSAGING SERVICES FOR THE ELECTRONIC EXCHANGE OF TEXT MESSAGES, NEWSLETTERS, PICTURES, NEWS, DATA AND VIDEOS; ELECTRONIC EXCHANGE OF NEWS, HYPertext DOCUMENTS, STREAMING VIDEO, WEB HYPERLINKS AND MUSIC DATA ALL STORED IN DATABASES ACCESSIBLE VIA TELECOMMUNICATION NETWORKS.

FIRST USE 4-5-2009; IN COMMERCE 4-5-2009.

ELEMENTS CORRECTED
GOODS/SERVICES

AMPELMANN

THE MARK CONSISTS OF STANDARD CHARACTERS WITHOUT CLAIM TO ANY PARTICULAR FONT, STYLE, SIZE, OR COLOR.

INT. CL. 16/U.S. CLS. 2, 5, 22, 23, 29, 37, 38 AND 50

FOR TOWELS OF PAPER; KITCHEN TOWELS OF PAPER; CARDBOARD AND GOODS MADE FROM PAPER AND CARDBOARD, NAMELY, BAGS OF PAPER FOR PACKAGING NOT INCLUDED IN OTHER CLASSES; PLASTIC MATERIALS FOR PACKAGING, NAMELY, PLASTIC BAGS; BAGS OF PLASTICS FOR PACKAGING NOT INCLUDED IN OTHER CLASSES, NAMELY, GARBAGE BAGS OF PAPER OR OF PLASTICS; PLASTIC OR PAPER BAGS; POSTCARDS, NAMELY, SHEET OF POSTCARDS; STATIONERY; BOOK MARKERS OF PAPER; POSTERS; STICKERS; BOOKENDS; SELF-ADHESIVE NOTE PADS; CALENDARS, NAMELY, TEAR-OFF CALENDARS; WRITING PADS; MAGNET PENS; PENCILS.

FIRST USE 0-0-1997; IN COMMERCE 0-0-1997.

INT. CL. 21/U.S. CLS. 2, 13, 23, 29, 30, 33, 40 AND 50

FOR ICE CUBE MOLDS.

FIRST USE 0-0-2002; IN COMMERCE 0-0-2007.

INT. CL. 25/U.S. CLS. 22 AND 39

FOR HEADGEAR FOR WEAR, NAMELY, HATS AND CAPS; CLOTHING, NAMELY, TEE-SHIRTS, SHIRTS, AND JACKETS; CLOTHES FOR CHILDREN, NAMELY, TEE-SHIRTS, SHIRTS, AND JACKETS; CYCLISTS' CLOTHING, NAMELY, TEE-SHIRTS AND JACKETS; MOTORISTS' CLOTHING, NAMELY, JACKETS.

FIRST USE 0-0-2002; IN COMMERCE 0-0-2007.

INT. CL. 28/U.S. CLS. 22, 23, 38 AND 50

FOR PLUSH TOYS; BALLS, NAMELY, FOOTBALLS; PLAYING CARDS; CARD GAMES, NAMELY, MEMORY CARD DECKS; BAGS ESPECIALLY DESIGNED FOR SKIS AND SURFBOARDS.

FIRST USE 0-0-2004; IN COMMERCE 0-0-2007.

ELEMENTS CORRECTED
GOODS/SERVICES

4,161,998. REG. 6-19-2012. FAYETTE COUNTY NAACP (GEORGIA CORPORATION), DBA FAYETTE COUNTY YOUTH COUNCIL NAACP, P.O. BOX 324, FAYETTEVILLE, GA, 30214, SN 85-257,216. FILED 3-3-2011. PRINCIPAL REGISTER.

I'M NOT A TEXT-A-HOLIC

THE MARK CONSISTS OF STANDARD CHARACTERS WITHOUT CLAIM TO ANY PARTICULAR FONT, STYLE, SIZE, OR COLOR.

INT. CL. 25/U.S. CLS. 22 AND 39

FOR ATHLETIC APPAREL, NAMELY, SHIRTS, PANTS, JACKETS, FOOTWEAR, HATS AND CAPS, ATHLETIC UNIFORMS; GOLF PANTS, SHIRTS AND SKIRTS; HOODED SWEAT SHIRTS; KNIT SHIRTS; OPEN-NECKED SHIRTS; POLO SHIRTS; SHORT-SLEEVED OR LONG-SLEEVED T-SHIRTS; TURTLE NECK SHIRTS; WEARABLE GARMENTS AND CLOTHING, NAMELY, SHIRTS; WRISTBANDS.

FIRST USE 3-1-2011; IN COMMERCE 4-1-2011.

ELEMENTS AMENDED
MARK

4,162,738. REG. 6-26-2012. ASAHI DENSO CO., LTD. (JAPAN CORPORATION) 1126 NAKAJO, HAMAKITA KU, HAMAMATSU CITY, SHIZUOKA, JAPAN., SN 77-459,644. FILED 4-28-2008. PRINCIPAL REGISTER.



PRIORITY CLAIMED UNDER SEC. 44(D) ON JAPAN APPLICATION NO. 2008-014279, FILED 2-27-2008, REG. NO. 5375982, DATED 12-10-2010, EXPIRES 12-10-2020.

THE MARK CONSISTS OF THE STYLIZED LETTERS "AD".

INT. CL. 6/U.S. CLS. 2, 12, 13, 14, 23, 25 AND 50

FOR LOCKS MADE OF METAL, NAMELY, HELMET LOCKS, SEAT LOCKS, TRUNK LOCKS, ANTI-THEFT LOCKS FOR MOTORCYCLES AND LOCKS FOR CHAINS; METAL LOCKS, ALL FOR VEHICLES; METAL KEY BLANKS; METAL JUNCTIONS FOR PIPES; METAL FLANGES; METAL PIPE JOINTS.

FIRST USE ; IN COMMERCE .

INT. CL. 7/U.S. CLS. 13, 19, 21, 23, 31, 34 AND 35

FOR PARTS FOR INTERNAL COMBUSTION ENGINES, NAMELY, FUEL PIPE JOINTS; AUTOMOTIVE PARTS, NAMELY, SEAL JOINTS FOR ENGINES.

FIRST USE ; IN COMMERCE .

INT. CL. 9/U.S. CLS. 21, 23, 26, 36 AND 38

FOR FUEL LEVEL GAUGES; OIL LEVEL GAUGES; ELECTRICAL FUSE BOXES; SOLENOID RELAY VALVES FOR VEHICLES; ELECTRIC SWITCHES FOR CASH REGISTERS; WEAR SENSORS FOR BRAKE PADS, BEING PARTS OF VEHICLES; ELECTRIC SWITCHES, ALL FOR VEHICLES FOR CONTROLLING ELECTRIC COMPONENTS, NAMELY, HEADLIGHTS, DIRECTION INDICATOR LAMPS, HORNS, WIPERS; METERS FOR VEHICLES, NAMELY, SPEEDOMETERS AND TACHOMETERS; ELECTRONIC INSTRUMENTS, NAMELY, KEYLESS ENTRY SYSTEM AND KEYLESS IGNITION SWITCH SYSTEM FOR AUTOMOTIVE VEHICLES COMPRISED OF A MICROPROCESSOR, ELECTRONIC SIGNAL RECEIVER, AND KEYFOB WITH ELECTRONIC SIGNAL TRANSPONDER; JOY STICKS FOR VEHICLES COMPRISING LEVERS, SHAFTS, HOUSING, SENSORS FOR CONTROLLING ELECTRIC COMPONENTS FOR VEHICLES; VEHICULAR ELECTRONIC CONTROL UNITS FOR CONTROLLING ELECTRIC COMPONENTS FOR VEHICLES; ELECTRICAL SOCKETS FOR VEHICLES; ELECTRONIC CONTROLS FOR LAND VEHICLES, NAMELY, ELECTRONIC CONTROLS FOR OPERATING HEATERS AND ELECTRONIC CONTROLS FOR OPERATING AIR CONDITIONERS.

FIRST USE ; IN COMMERCE .

INT. CL. 11/U.S. CLS. 13, 21, 23, 31 AND 34

FOR REAR TAIL LIGHTS FOR VEHICLES; LIGHTING APPARATUS FOR VEHICLES, AIR-CONDITIONING APPARATUS; ELECTRIC LAMPS AND OTHER LIGHTING APPARATUS, NAMELY, FLAT PANEL LIGHTING APPARATUS.

FIRST USE ; IN COMMERCE .

INT. CL. 12/U.S. CLS. 19, 21, 23, 31, 35 AND 44

FOR VEHICLE BRAKE LEVERS, VEHICLE CLUTCH LEVERS, VEHICLE SHIFT LEVERS; STEERING WHEEL LOCKS FOR VEHICLES; FUEL TANK CAPS FOR VEHICLES; ANTI-THEFT DEVICES FOR VEHICLES; ANTI-THEFT ALARM DEVICES FOR VEHICLES; MOTOR VEHICLE POWER LOCKS ANTI-THEFT ALARMS FOR VEHICLES; FUEL TANK CAPS WITH FUEL LEVEL GAUGES FOR MOTORCYCLES; TURN SIGNAL LIGHTS FOR VEHICLES; METAL HARDWARE PARTS OF MOTORCYCLES, NAMELY, SHIFT LEVERS, BRAKE LEVERS, AND CLUTCH LEVERS.

FIRST USE ; IN COMMERCE .

ELEMENTS CORRECTED
OWNER ADDRESS

4,168,017. REG. 7-3-2012. HERO DOGS, INC. (MARYLAND CORPORATION) P.O. BOX 64, BROOKEVILLE, MD, 208330064, SN 85-477,149. FILED 11-19-2011. PRINCIPAL REGISTER.

SERVICE DOGS FOR AMERICA'S HEROES

THE MARK CONSISTS OF STANDARD CHARACTERS WITHOUT CLAIM TO ANY PARTICULAR FONT, STYLE, SIZE, OR COLOR.

NO CLAIM IS MADE TO THE EXCLUSIVE RIGHT TO USE "SERVICE DOGS", APART FROM THE MARK AS SHOWN.

INT. CL. 44/U.S. CLS. 100 AND 101

FOR CHARITABLE SERVICES, NAMELY, PROVIDING TRAINED SERVICE DOGS FOR WOUNDED AND INJURED U.S. MILITARY VETERANS.

FIRST USE 2-1-2010; IN COMMERCE 2-1-2010.

ELEMENTS CORRECTED
MARK

4,172,341. REG. 7-10-2012. NINTENDO OF AMERICA INC. (WASHINGTON CORPORATION) 4600 150TH AVENUE NE, REDMOND, WA, 98052, SN 85-158,970. FILED 10-22-2010. PRINCIPAL REGISTER.

THE MARK CONSISTS OF THE WORD "NINTENDO" IN STYLIZED LETTERING FOLLOWED BY "3DS" IN A LARGER FONT OF THE SAME TYPE OF LETTERING. BENEATH THE LETTER "O" IN NINTENDO IS A BLOCK.

INT. CL. 9/U.S. CLS. 21, 23, 26, 36 AND 38

FOR CARTRIDGES AND MEMORY CARDS FEATURING ENTERTAINMENT, EDUCATIONAL AND INFORMATIONAL CONTENT, NAMELY, VIDEO GAMES; DOWNLOADABLE MULTIMEDIA FILES, NAMELY, VIDEO GAMES, DOWNLOADABLE ELECTRONIC GAME PROGRAMS; DOWNLOADABLE ELECTRONIC GAME SOFTWARE; ELECTRONIC GAME PROGRAMS; ELECTRONIC GAME SOFTWARE; VIDEO GAME CARTRIDGES; VIDEO GAME MEMORY CARDS; VIDEO GAME PROGRAMS; VIDEO GAME SOFTWARE; ACCESSORIES FOR ELECTRONIC VIDEO AND COMPUTER GAME SYSTEMS FOR USE WITH AN EXTERNAL DISPLAY SCREEN OR MONITOR, NAMELY, CARRYING CASES; OTHER PARTS AND FITTINGS FOR CONSUMER VIDEO GAMES, NAMELY, VIDEO GAME CARTRIDGE CASES; DOWNLOADABLE ELECTRONIC

MANUALS IN THE FIELD OF VIDEO GAMES; PEDOMETERS; PERIPHERALS FOR ELECTRONIC VIDEO AND COMPUTER GAME SYSTEMS, NAMELY, POWER SUPPLIES, BATTERY CHARGERS, HEADPHONES AND HEADSETS; VIDEO GAME MEMORY DEVICES, NAMELY, VIDEO GAME CARTRIDGES AND MEMORY CARDS; WRITING INSTRUMENTS FOR USE WITH COMPUTER VIDEO GAME MACHINES AND TOUCH SCREEN DISPLAYS, NAMELY, COMPUTER STYLUSES; PARTS AND FITTINGS FOR HAND-HELD GAME MACHINES WITH LIQUID CRYSTAL DISPLAYS, NAMELY, POWER SUPPLIES AND BATTERY CHARGERS.
FIRST USE 3-27-2011; IN COMMERCE 3-27-2011.

ELEMENTS CORRECTED
GOODS/SERVICES

4,172,342. REG. 7-10-2012. NINTENDO OF AMERICA INC. (WASHINGTON CORPORATION) 4600 150TH AVENUE NE, REDMOND, WA, 98052, SN 85-158,977. FILED 10-22-2010. PRINCIPAL REGISTER.

NINTENDO 3DS

THE MARK CONSISTS OF THE WORD "NINTENDO" IN STYLIZED LETTERING FOLLOWED BY "3DS" IN A LARGER FONT OF THE SAME TYPE OF LETTERING. BENEATH THE LETTER "O" IN "NINTENDO" IS A BLOCK.
INT. CL. 28/U.S. CLS. 22, 23, 38 AND 50

FOR CARRYING CASES FOR HAND-HELD VIDEO GAME SYSTEMS OTHER THAN THOSE ADAPTED FOR USE WITH AN EXTERNAL DISPLAY SCREEN OR MONITOR; ELECTRONIC GAME EQUIPMENT WITH A WATCH FUNCTION; HAND-HELD GAME MACHINES WITH LIQUID CRYSTAL DISPLAYS OTHER THAN THOSE ADAPTED FOR USE WITH AN EXTERNAL DISPLAY SCREEN OR MONITOR; HAND-HELD UNITS FOR PLAYING ELECTRONIC GAMES OTHER THAN THOSE ADAPTED FOR USE WITH AN EXTERNAL DISPLAY SCREEN OR MONITOR; HAND-HELD UNITS FOR PLAYING VIDEO GAMES OTHER THAN THOSE ADAPTED FOR USE WITH AN EXTERNAL DISPLAY SCREEN OR MONITOR; PRE-MADE WRAPS AND SKINS FOR HAND-HELD UNITS FOR PLAYING VIDEO GAMES OTHER THAN THOSE ADAPTED FOR USE WITH AN EXTERNAL DISPLAY SCREEN OR MONITOR; TOY KEY CHAINS WITH AND WITHOUT SOUND DEVICE; TRADING CARD GAMES; PROTECTIVE FILMS FOR LIQUID CRYSTAL DISPLAY OF HAND-HELD GAMES OTHER THAN THOSE ADAPTED FOR USE WITH AN EXTERNAL DISPLAY SCREEN OR MONITOR; ELECTRONIC GAME MACHINES OTHER THAN THOSE ADAPTED FOR USE WITH AN EXTERNAL DISPLAY SCREEN OR MONITOR; VIDEO GAME MACHINES OTHER THAN THOSE ADAPTED FOR USE WITH AN EXTERNAL DISPLAY SCREEN OR MONITOR; VIDEO GAME MACHINES OTHER THAN THOSE ADAPTED FOR USE WITH AN EXTERNAL DISPLAY SCREEN OR MONITOR FOR RECEIPT, STORAGE AND TRANSMISSION OF TEXT, GRAPHICS AND MULTIMEDIA CONTENT.
FIRST USE 3-27-2011; IN COMMERCE 3-27-2011.

ELEMENTS CORRECTED
GOODS/SERVICES

4,176,011. REG. 7-17-2012. THOMAS RAMIES (UNITED STATES INDIVIDUAL), DBA WEST 280, 143 CRESCENT AVE, PORTOLA VALLEY, CA, 94028, AND CLAY BAKER (UNITED STATES INDIVIDUAL), DBA WEST 280, 143 CRESCENT AVE, PORTOLA VALLEY, CA, 94028, SN 77-871,631. FILED 11-12-2009. PRINCIPAL REGISTER.

iopener

THE MARK CONSISTS OF STANDARD CHARACTERS WITHOUT CLAIM TO ANY PARTICULAR FONT, STYLE, SIZE, OR COLOR.

INT. CL. 9/U.S. CLS. 21, 23, 26, 36 AND 38

FOR CASES FOR SMARTPHONES AND PORTABLE MEDIA PLAYERS HAVING BEVERAGE CAP REMOVAL TOOLS INTEGRATED INTO THE CASES; CASES FOR SMARTPHONES AND PORTABLE MEDIA [LAYERS] * PLAYERS * HAVING WINE CORK REMOVAL TOOLS INTEGRATED INTO THE CASES.

FIRST USE 12-18-2010; IN COMMERCE 12-18-2010.

ELEMENTS CORRECTED
GOODS/SERVICES

4,176,097. REG. 7-17-2012. VISPLAY INTERNATIONAL AG (SWITZERLAND AKTIENGESELLSCHAFT) KLÜNENFELDSTRASSE 22, MUTTENZ, 4127 BIRSFELDEN, SWITZERLAND,, SN 77-982,968. FILED 1-22-2010. PRINCIPAL REGISTER.

INVISIBLE DESIGN

THE MARK CONSISTS OF STANDARD CHARACTERS WITHOUT CLAIM TO ANY PARTICULAR FONT, STYLE, SIZE, OR COLOR.

NO CLAIM IS MADE TO THE EXCLUSIVE RIGHT TO USE "DESIGN", APART FROM THE MARK AS SHOWN.

INT. CL. 6/U.S. CLS. 2, 12, 13, 14, 23, 25 AND 50

FOR METAL GOODS, NAMELY, METAL WALL SUPPORTS AND SHELF SUPPORTS WITH ATTACHED HOLDERS, SHELF HOLDERS AND CLOTHES RAILS FOR USE IN FASHION SHOPS; NON-LUMINOUS AND NON-MECHANICAL METAL PRICE AND SIZE SIGNS AND TAGS; METAL FRONT ARM HOLDERS AND PROFILE RAILS FOR USE IN FASHION SHOPS; METAL SHELF BRACKETS; METAL PLACARD WALLS AND PLACARD STANDS FOR USE IN FASHION SHOPS; METAL PLACARD COLUMNS; AND METAL PLACARD BOARDS; TRANSPORTABLE METAL BUILDING ELEMENTS, NAMELY, BACK WALLS AND PARTITION WALLS FOR SHOP INTERIORS.

FIRST USE 1-1-2011; IN COMMERCE 1-1-2011.

INT. CL. 37/U.S. CLS. 100, 103 AND 106

FOR CONSTRUCTION CONSULTANCY; CONSTRUCTION OF FURNITURE AND DISPLAY FIXTURES FOR SHOPS, WINDOWS DISPLAYS, TRADE SHOW BOOTHS, RECEPTION AREAS, OFFICES AND PRIVATE HOUSEHOLDS.

FIRST USE 1-1-2011; IN COMMERCE 1-1-2011.

ELEMENTS CORRECTED
OWNER ADDRESS

4,179,609. REG. 7-24-2012. APIVITA S.A. (GREECE CORPORATION) 3 KOLETTI STR., 144 52 METAMORPHOSI, ATHENS, GREECE., SN 77-225,175. FILED 7-9-2007. PRINCIPAL REGISTER.



INT. CL. 3/U.S. CLS. 1, 4, 6, 50, 51 AND 52
 FOR HAIR SHAMPOOS, HAIR CONDITIONERS, HAIR LOTIONS, HAIR CREAMS, HAIR GELS AND HAIR MASKS; FACIAL MASKS; FACIAL AND BODY MILKS, GELS, OILS, LOTIONS, CREAMS AND CLEANSERS; SHOWER AND BATH GELS; SKIN CLEANSING MILKS, CREAMS AND LOTIONS; SKIN MOISTURIZERS AND CREAMS; HAND CREAMS; EXFOLIANT CREAMS; EYE CREAMS AND GELS; EYE MAKE-UP REMOVER; SUNTAN AND SUNSCREEN CREAMS, MILKS, GELS, OILS AND LOTIONS; ESSENTIAL OILS FOR PERSONAL USE; MASSAGE OILS AND LOTIONS; NON-MEDICATED LIP BALMS; TOOTHPASTE; SKIN SOAPS; HAIR DYES; SHAVING CREAMS AND LOTIONS; EAU DE TOILETTE; BABY CREAM, NAMELY, NON-MEDICATED DIAPER RASH CREAM; BATH SALTS.
 FIRST USE 12-0-2006; IN COMMERCE 12-0-2006.

ELEMENTS CORRECTED
 GOODS/SERVICES

FOR ENTERTAINMENT SERVICES, NAMELY, PROVIDING NON-DOWNLOADABLE PLAYBACK OF MUSIC VIA GLOBAL COMMUNICATIONS NETWORKS.
 FIRST USE 6-22-2011; IN COMMERCE 6-22-2011.

ELEMENTS CORRECTED
 OWNER NAME

4,182,119. REG. 7-31-2012. COHEN, JASON (UNITED STATES INDIVIDUAL) 12726 54TH STREET, NORTH, ROYAL PALM BEACH, FL, 33411, AND COHEN, SUSAN (UNITED STATES INDIVIDUAL) 12726 54TH STREET NORTH, ROYAL PALM BEACH, FL, 33411, SN 85-386,894. FILED 8-2-2011. PRINCIPAL REGISTER.

O-SEA-D

THE MARK CONSISTS OF STANDARD CHARACTERS WITHOUT CLAIM TO ANY PARTICULAR FONT, STYLE, SIZE, OR COLOR.
 OWNER OF U.S. REG. NO. 3,927,013.
 INT. CL. 25/U.S. CLS. 22 AND 39
 FOR APPAREL, NAMELY, T-SHIRTS, HATS.
 FIRST USE 7-21-2011; IN COMMERCE 7-21-2011.

ELEMENTS CORRECTED
 GOODS/SERVICES

4,182,093. REG. 7-31-2012. CREATIVE RETAIL COMMUNICATIONS, LLC (PENNSYLVANIA LIMITED LIABILITY COMPANY), DBA UMIX MEDIA, 3477 CORPORATE PARKWAY, SUITE 100, CENTER VALLEY, PA, 18034, SN 85-381,529. FILED 7-26-2011. PRINCIPAL REGISTER.



NO CLAIM IS MADE TO THE EXCLUSIVE RIGHT TO USE "MEDIA", APART FROM THE MARK AS SHOWN.
 THE COLOR(S) BLUE, BLACK AND WHITE IS/ARE CLAIMED AS A FEATURE OF THE MARK.
 THE MARK CONSISTS OF THE LEFT ROUGHLY ONE THIRD OF THE MARK DISPLAYS THE LETTERS "U" AND "M" BLENDED TOGETHER TO FORM A SINGLE, WHITE DESIGN FEATURE, WITH THE COLOR BLUE ABOVE THE BLENDED LETTERS AND THE COLOR BLACK BELOW THE LETTERS. THE RIGHT TWO THIRDS OF THE MARK DISPLAYS THE WORDS "UMIX" AND "MEDIA". THE WORD "UMIX" APPEARS ABOVE THE WORD "MEDIA". THE WORD "UMIX" IS PRIMARILY BLUE AND WORD "MEDIA" IS PRIMARILY BLACK.
 INT. CL. 41/U.S. CLS. 100, 101 AND 107

4,182,147. REG. 7-31-2012. IMAGE ENTERTAINMENT, INC. (DELAWARE CORPORATION) 20525 NORDHOFF ST., SUITE 200, CHATSWORTH, CA, 91311, SN 85-399,612. FILED 8-16-2011. PRINCIPAL REGISTER.



NO CLAIM IS MADE TO THE EXCLUSIVE RIGHT TO USE "SERIES", APART FROM THE MARK AS SHOWN.
 THE MARK CONSISTS OF A DESIGN OF A MOON AND THE STYLIZED TERMS "MIDNIGHT MADNESS SERIES" WITH THE LETTER "M" OF "MIDNIGHT" APPEARING INSIDE OF THE MOON AND IN THE SAME COLOR AS THE BACKGROUND, WHILE THE OTHER LETTERS APPEAR IN THE SAME COLOR AS THE MOON.
 INT. CL. 9/U.S. CLS. 21, 23, 26, 36 AND 38
 FOR CINEMATOGRAPHIC MOVIES, MOTION PICTURE FILMS AND VIDEO DISCS, FILM ELEMENTS AND TAPES ON DIGITAL AND ANALOG MEDIA FEATURING ENTERTAINMENT IN THE FIELD OF HORROR.
 FIRST USE 6-20-2011; IN COMMERCE 8-16-2011.
 INT. CL. 35/U.S. CLS. 100, 101 AND 102

FOR WHOLESALE AND RETAIL ORDERING AND DISTRIBUTORSHIP SERVICES FEATURING MOTION PICTURES, TELEVISION PROGRAMS AND MULTIMEDIA PRODUCTS IN THE FIELD OF HORROR, ALL ON VIDEO DISCS AND DIGITAL AND ANALOG MEDIA; PUBLICITY, ADVERTISING, MARKETING AND PROMOTIONAL SERVICES RELATED TO MOTION PICTURES, TELEVISION PROGRAMS AND MULTIMEDIA PRODUCTS IN THE FIELD OF HORROR, ALL ON VIDEO DISCS AND DIGITAL AND ANALOG MEDIA; ONLINE WHOLESALE AND RETAIL ORDERING SERVICES FEATURING MOTION PICTURES, TELEVISION PROGRAMS AND MULTIMEDIA PRODUCTS IN THE FIELD OF HORROR, ALL ON VIDEO DISCS AND DIGITAL AND ANALOG MEDIA.

FIRST USE 6-20-2011; IN COMMERCE 8-16-2011.

ELEMENTS CORRECTED
GOODS/SERVICES

4,183,592. REG. 7-31-2012. RETRACTABLEDESIGNS, LLC (COLORADO LIMITED LIABILITY COMPANY) PO BOX 4419, BRECKENRIDGE, CO, 80424, SN 77-714,443. FILED 4-15-2009. PRINCIPAL REGISTER.

RetractableDesigns

THE MARK CONSISTS OF STANDARD CHARACTERS WITHOUT CLAIM TO ANY PARTICULAR FONT, STYLE, SIZE, OR COLOR.

INT. CL. 24/U.S. CLS. 42 AND 50

FOR QUILTING DESIGN WALL, NAMELY, A NON-WOVEN TEXTILE SURFACE FOR ARRANGEMENT OF QUILT MATERIAL.

FIRST USE 12-31-2008; IN COMMERCE 1-31-2012.

ELEMENTS CORRECTED
DATE OF FIRST USE

4,182,740. REG. 7-31-2012. DESTILADORA DEL VALLE DE TEQUILA, S.A. DE C.V. (MEXICO SOCIEDAD ANONIMA (SA DE CV)) CARRETERA INTERNACIONAL #102, CO. STA CRUZ, TEQUILA, JALISCO, MEXICO, 46400, SN 85-486,765. FILED 12-5-2011. PRINCIPAL REGISTER.

4,184,859. REG. 8-7-2012. FELT GMBH (FED REP GERMANY LIMITED LIABILITY COMPANY) INDUSTRIESTRASSE 39, 26188 EDEWECHT, FED REP GERMANY., SN 79-107,317. FILED 11-10-2011. PRINCIPAL REGISTER.

Krystal

THE MARK CONSISTS OF STANDARD CHARACTERS WITHOUT CLAIM TO ANY PARTICULAR FONT, STYLE, SIZE, OR COLOR.

PRIORITY DATE OF 9-30-2011 IS CLAIMED.

OWNER OF INTERNATIONAL REGISTRATION 1102025 DATED 11-10-2011, EXPIRES 11-10-2021.

INT. CL. 9/U.S. CLS. 21, 23, 26, 36 AND 38

FOR BICYCLE COMPUTERS; DEVICES FOR PROTECTION AGAINST ACCIDENTS, IN PARTICULAR, KNEE GUARDS, ARM PROTECTORS, AND BODY PROTECTORS SOLD AS AN INTEGRAL COMPONENT OF CLOTHING FOR PROTECTION AGAINST ACCIDENTS; PROTECTIVE HELMETS, IN PARTICULAR BICYCLE HELMETS; SPECTACLES, IN PARTICULAR CYCLING GOGGLES.

INT. CL. 12/U.S. CLS. 19, 21, 23, 31, 35 AND 44

FOR [LAND VEHICLES, IN PARTICULAR] BICYCLES * NOT INCLUDING MOTORIZED * [AND TWO-WHEELED MOTOR VEHICLES WITH AUXILIARY MOTORS]; PARTS AND * FITTINGS * COMPONENTS FOR BICYCLES [AND TWO-WHEELED VEHICLES WITH AUXILIARY MOTORS], IN PARTICULAR BICYCLE FRAMES, HANDLEBARS FOR BICYCLES, BICYCLE SADDLES, BICYCLE FORKS, BICYCLE BRAKES, BICYCLE BELLS, BICYCLE HANDLE BAR STEMS, [BICYCLE SEAT POSTS,] BICYCLE CRANKSETS, CONSISTING OF A SPROCKET AND A CRANKARM, BICYCLE PEDALS, BICYCLE GEAR SHIFTS, BICYCLE WHEEL HUBS [BICYCLE TIRES].

FIRST USE ; IN COMMERCE .

ELEMENTS CORRECTED
GOODS/SERVICES



THE MARK CONSISTS OF A SILHOUETTE OF A HORSE WITH THE WORDS "CASA MAESTRI" SITTING ABOVE THE HORSE'S HEAD.

THE ENGLISH TRANSLATION OF "CASA" IN THE MARK IS "HOUSE".

INT. CL. 33/U.S. CLS. 47 AND 49

FOR TEQUILA .

FIRST USE 1-13-2011; IN COMMERCE 1-13-2011.

ELEMENTS CORRECTED
OWNER NAME

TRADEMARK REGISTRATIONS—NEW CERTIFICATES

New Certificates issued under section 7(d) of the Trademark Act of 1946 for the unexpired term of the original registrations.

3,122,908. DOS NINER STANDARD CHARACTER MARK.
INT. CL. 12. QUALITY BICYCLE PRODUCTS, INC.,
BLOOMINGTON, MN. REG. 8-1-2006. NEW CERT. SEC.
7(D) TO REGISTRANT.

7(D) TO REGISTRANT.

3,254,457. MISCELLANEOUS DESIGN. INT. CL. 20. KOZY
PET, SAN MATEO, CA. REG. 6-26-2007. NEW CERT. SEC.

4,151,941. NAPA VALLEY BURGER COMPANY STAN-
DARD CHARACTER MARK. INT. CL. 43. NAPA VALLEY
BURGER COMPANY LTD, SAUSALITO, CA. REG. 5-29-
2012. NEW CERT. SEC. 7(D) TO REGISTRANT.

* * * * *

This page is intentionally blank

INDEX OF REGISTRANTS

SEPT. 18, 2012

(Registered; Renewed; Canceled; Amended, Corrected, etc.; New Certificates; 12c Publications.)

The designation "U.S. Cl." appearing in this section refers to the U.S. class in effect prior to Sep. 1, 1973 rather than the international class which applies to applications filed on or after that date. For adoption of international classification see notice in the OFFICIAL GAZETTE of Jun. 26, 1973 (911 O.G. TM 210).

- "MASK" MOTHERS AWARENESS ON SCHOOL AGE KIDS, SCOTTSDALE, AZ:
4,209,105, PUB. 7-3-2012. MULTIPLE CLASS, INT. CLS. 16 AND 41.
- A TASTE OF SEAFOOD, MANHATTAN, NY:
4,210,607, INT. CL. 43.
- A. DUDA & SONS, INC., OVIEDO, FL:
1,707,279. REN. 8-12-12. INT. CL. 40.
- A. G. THOMPSON PTY. LTD., MOORABBIN VICTORIA, AUSTRALIA:
1,198,889. REN. 8-14-12. INT. CL. 28.
- A. PHILIP RANDOLPH PULLMAN PORTER MUSEUM, CHICAGO, IL:
4,209,474, PUB. 7-3-2012. INT. CL. 41.
- A. REDDIX & ASSOCIATES, CHESAPEAKE, VA:
4,209,103, PUB. 7-3-2012. INT. CL. 35.
- A&E TELEVISION NETWORKS, LLC, NEW YORK, NY:
2,736,908. REN. 8-12-12. INT. CL. 16.
- A&I MANUFACTURING, INC., MONROE, WA:
4,208,733, PUB. 7-3-2012. INT. CL. 20.
- A&W CONCENTRATE COMPANY, PLANO, TX:
4,211,592, INT. CL. 32.
- ABBOTT BIOTECHNOLOGY LTD., HAMILTON, BERMUDA:
2,725,934. REN. 8-15-12. INT. CL. 5.
- ABBOTT DIABETES CARE INC., ALAMEDA, CA:
4,210,535, MULTIPLE CLASS, INT. CLS. 5 AND 10.
4,211,544, INT. CL. 5.
- ABBOTT LABORATORIES, ABBOTT PARK, IL:
4,208,889, PUB. 7-3-2012. INT. CL. 42.
4,211,449, MULTIPLE CLASS, INT. CLS. 5 AND 32.
- ABC LIQUORS, INC., ORLANDO, FL:
4,210,072, PUB. 7-3-2012. INT. CL. 33.
- ABDALA, GERARDO PABLO, 5000 CIUDAD DE CORDOBA, ARGENTINA:
4,210,004, PUB. 7-3-2012. INT. CL. 28.
- ABERCROMBIE & FITCH TRADING CO., NEW ALBANY, OH, OSHMAN'S SPORTING GOODS, INC., HOUSTON, TX:
1,169,714. REN. 8-10-12. INT. CL. 42.
- ABEX DISPLAY SYSTEMS, HOLLYWOOD, CA:
2,526,459, CANC. INT. CL. 20.
- ABIC BIOLOGICAL LABORATORIES LTD., BEIT SHEMESH POB 489, ISRAEL:
3,037,502, CANC. INT. CL. 5.
- ABL SA, LUXEMBOURG, LUXEMBOURG:
4,209,142, PUB. 7-3-2012. INT. CL. 9.
- ABM INTERNATIONAL, INC., THE WOODLANDS, TX:
4,209,901, PUB. 7-3-2012. INT. CL. 9.
- ABREU, DAVID, RUTHERFORD, CA:
4,208,885, PUB. 7-3-2012. INT. CL. 33.
4,208,886, PUB. 7-3-2012. INT. CL. 33.
- ABY-LOPEZ, CORINNE, STUDIO CITY, CA:
4,211,391, INT. CL. 44.
- ACACIA, INC., BREA, CA:
4,211,008, INT. CL. 10.
- ACCELERATED CHRISTIAN EDUCATION, INC., NASHVILLE, TN:
4,209,345, PUB. 7-3-2012. INT. CL. 36.
- ACCENSUM IBERICA, S.L., TERRASSA (BARCELONA), SPAIN:
4,208,605, PUB. 7-3-2012. INT. CL. 9.
- ACCUBUILT, INC., LIMA, OH:
4,210,051, PUB. 7-3-2012. MULTIPLE CLASS, INT. CLS. 12, 35, 40 AND 42.
- ACE HARDWARE CORPORATION, OAK BROOK, IL:
4,211,595, INT. CL. 35.
4,211,634, INT. CL. 35.
4,211,638, INT. CL. 35.
- ACHIEVE, INC., WASHINGTON, DC:
4,209,058, PUB. 7-3-2012. INT. CL. 41.
- ACI BRANDS INC., OAKVILLE, ONTARIO, CANADA:
4,208,211, PUB. 7-3-2012. MULTIPLE CLASS, INT. CLS. 35, 39 AND 42.
- ACLARA SOFTWARE INC., WELLESLEY, MA:
2,604,654. REN. 8-16-12. INT. CL. 41.
- ACORN CONSULTING GROUP CORPORATION, CONCORD, ONTARIO L4K 1 Y7, CANADA:
3,038,169, CANC. MULTIPLE CLASS, INT. CLS. 9 AND 40.
- ACOUSTIC TECHNOLOGIES, INC., MESA, AZ:
2,685,844. REN. 8-15-12. INT. CL. 9.
- ACTEK ENTERPRISES, INC., CITY OF INDUSTRY, CA:
2,601,565. REN. 8-12-12. INT. CL. 6.
- ADDICTIVE HUNTING LLC, YUKON, OK:
4,209,359, PUB. 7-3-2012. INT. CL. 41.
- ADDITIVE TECHNOLOGIES, LLC, SALT LAKE CITY, UT:
4,209,663, PUB. 7-3-2012. INT. CL. 3.
- ADHIKARI TECHNOLOGY, INC., LAKE ZURICH, IL:
2,629,240. REN. 8-15-12. INT. CL. 9.
- ADIZU, LLC, CHICAGO, IL:
4,210,133, PUB. 7-3-2012. INT. CL. 42.
- ADOBE SYSTEMS INCORPORATED, SAN JOSE, CA:
4,210,262, INT. CL. 42.
- ADSCAS L.L.C., NEW YORK, NY, DBA CULTUREFIX:
4,209,759, PUB. 7-3-2012. MULTIPLE CLASS, INT. CLS. 35 AND 43.
- ADULTREV LLC, LAS VEGAS, NV:
4,209,658, PUB. 7-3-2012. INT. CL. 35.
- ADVANCE WATCH COMPANY LTD., NEW YORK, NY:
4,210,628, INT. CL. 14.
- ADVANCED BIONICS AG, 8712 STAFA, SWITZERLAND:
2,670,244. REN. 8-16-12. INT. CL. 10.
- ADVANCED CHEMISTRY DEVELOPMENT INC., TORONTO, ONTARIO, CANADA:
4,208,469, PUB. 7-3-2012. INT. CL. 9.
- ADVANCED ENGINEERING AND ENVIRONMENTAL SERVICES, INC., GRAND FORKS, ND:
4,209,361, PUB. 7-3-2012. INT. CL. 36.
- ADVANCED EXPOS LLC, ELLINGTON, CT:
4,209,672, PUB. 7-3-2012. INT. CL. 35.
- ADVANCED KEYBOARD TECHNOLOGIES, INC., DAVIS, CA:
2,528,157, CANC. INT. CL. 9.
- ADVANCED RESPONSE CONCEPTS CORPORATION, FAIRFAX, VA:
4,210,927, INT. CL. 9.
- ADVANCED RESPONSE CORP., NEW YORK, NY:
4,209,108, PUB. 7-3-2012. INT. CL. 10.
- ADVANCED SOFTMATERIALS INC., CHIBA 277-0882, JAPAN:
4,208,420, PUB. 7-3-2012. INT. CL. 1.

- ADVANCED TEST EQUIPMENT CORPORATION, SAN DIEGO, CA:
4,209,909, PUB. 7-3-2012. INT. CL. 42.
- ADVANT MEDICAL LIMITED, IRELAND:
4,208,353, PUB. 7-3-2012. MULTIPLE CLASS, INT. CLS. 10, 39 AND 42.
- ADVANTACLEAN SYSTEMS, INC., HUNTERSVILLE, NC:
4,209,304, PUB. 7-3-2012. INT. CL. 40.
- ADVERTISING AND DESIGN EDUCATION CORP., MIAMI BEACH, FL:
2,610,795. REN. 8-10-12. INT. CL. 41.
- AE JEWELERS, INC., OSHKOSH, WI:
4,208,629, PUB. 7-3-2012. INT. CL. 35.
- AEGEAN BLUE, INC., NORTH PALM BEACH, FL:
4,211,425, INT. CL. 14.
- AEROCOOL ADVANCED TECHNOLOGIES CORPORATION, NEW TAIPEI CITY 221, TAIWAN:
4,209,079, PUB. 7-3-2012. INT. CL. 9.
- AEROGROUP INTERNATIONAL HOLDINGS LLC, EDISON, NJ:
2,610,621. REN. 8-15-12. INT. CL. 25.
- AES CORPORATION, THE, ARLINGTON, VA, APPLIED ENERGY SERVICES, INC., ARLINGTON, VA:
1,672,115. REN. 8-11-12. INT. CL. 39.
- AFFILIATES INSURANCE RECIPROCAL, A RISK RETENTION GROUP, BURLINGTON, VT:
4,211,776, INT. CL. 36.
- AFFINION PUBLISHING, INC., LAS VEGAS, NV:
3,036,999, CANC. INT. CL. 9.
- AFFINITY CLOUD MARKETING, LLC, LOS ANGELES, CA:
2,677,579. REN. 8-10-12. INT. CL. 40.
- AFFINITY MARKETING CONSULTANTS, INC., VISTA, CA. DBA AFFINITY CONSULTANTS:
4,209,736, PUB. 7-3-2012. U.S. CL. A.
- AFKA GROUP INTERNATIONAL, INC., WILDOMAR, CA:
4,209,311, PUB. 7-3-2012. INT. CL. 11.
- AFTERMARKET AUTO PARTS ALLIANCE, INC., SAN ANTONIO, TX, BUMPER TO BUMPER PROGRAM, INC., KANSAS CITY, KS:
1,247,356. REN. 8-10-12. INT. CL. 42.
- AFTERMARKET DOCK PARTS, INC., LOS ANGELES, CA:
4,211,835, INT. CL. 7.
- AGAN CHEMICAL MANUFACTURERS LTD., ASHDOD, ISRAEL:
4,211,137, INT. CL. 5.
4,211,379, INT. CL. 5.
- AGAVE LOCO LLC, DEERFIELD, IL:
4,210,462, INT. CL. 33.
- AGELESS ENTERTAINMENT, LLC, WEST PALM BEACH, FL:
4,210,264, INT. CL. 41.
- AGENCY EA, L.L.C., CHICAGO, IL:
4,210,752, MULTIPLE CLASS, INT. CLS. 35, 41, 42 AND 43.
4,210,753, MULTIPLE CLASS, INT. CLS. 35 AND 41.
- AGENTARTS, INC., SAN FRANCISCO, CA:
2,528,194, CANC. INT. CL. 35.
- AGILENT TECHNOLOGIES, INC., SANTA CLARA, CA:
1,702,890. REN. 8-11-12. MULTIPLE CLASS, INT. CLS. 9 AND 16.
- AGRI LABORATORIES, LTD., ST. JOSEPH, MO:
2,609,469. REN. 8-15-12. INT. CL. 16.
- AGRIUM INC., CALGARY, ALBERTA, CANADA:
4,211,615, INT. CL. 35.
- AGRIVIDA, INC., MEDFORD, MA:
4,210,307, MULTIPLE CLASS, INT. CLS. 31, 42 AND 45.
- AGRO-CULTURE LIQUID FERTILIZERS, ST. JOHNS, MI:
4,210,961, INT. CL. 41.
- AHMADI & SONS, INC., SCARSDALE, NY, DBA FOVAMA:
4,209,111, PUB. 7-3-2012. INT. CL. 27.
- AHOLD LICENSING SARL, GENEVA, SWITZERLAND:
4,210,427, INT. CL. 16.
- AI ENTERPRISES, INC., YANKTON, SD:
4,210,722, INT. CL. 7.
- AICELLO KAGAKU KABUSHIKI KAISHA, TOYOHASHI, AICHI, JAPAN, DBA AICELLO CHEMICAL CO., LTD.:
1,751,893. REN. 8-15-12. INT. CL. 17.
- AINSWORTH GAME TECHNOLOGY LIMITED, NEWINGTON, AUSTRALIA:
4,211,014, INT. CL. 9.
- AIR CUSHION DESIGNS, INC., CHILlicothe, OH:
4,210,517, INT. CL. 12.
- AIR PRODUCTS AND CHEMICALS, INC., ALLENTOWN, PA:
1,717,878. REN. 8-15-12. INT. CL. 11.
2,613,543. REN. 8-13-12. MULTIPLE CLASS, INT. CLS. 41 AND 42.
- AIRBORNE ATHLETICS, INC., BURNSVILLE, MN:
2,711,917. REN. 8-16-12. INT. CL. 28.
2,711,931. REN. 8-16-12. INT. CL. 28.
- AIRPLANE WATCH CORP., NEW YORK, NY:
4,211,435, INT. CL. 14.
- AIRTEX PRODUCTS, LLC, FAIRFIELD, IL:
2,527,366, CANC. MULTIPLE CLASS, INT. CLS. 7 AND 9.
- AIRTIES KABLOSUZ ILETISIM SANAYI VE DIS TICARET A.S., TURKEY:
4,208,264, PUB. 7-3-2012. MULTIPLE CLASS, INT. CLS. 9, 38 AND 42.
- AISAN KOGYO KABUSHIKI KAISHA, AICHI PREFECTURE, JAPAN:
1,710,689. REN. 8-11-12. INT. CL. 7.
- AISIN AW CO., LTD., ANJO-SHI, AICHI-KEN, 444-1192, JAPAN:
3,122,297, CANC. MULTIPLE CLASS, INT. CLS. 7, 40 AND 42.
- AKERS BIOSCIENCES, INC., THOROFARE, NJ, AKERS BIOSCIENCES, INC., THOROFARE, NJ:
2,738,124. REN. 8-14-12. INT. CL. 10.
- AKERUE INDUSTRIES, LLC., ANTIPOH, IL:
2,527,229, CANC. INT. CL. 21.
- AKINLOYE, TANISHA E., TRUMBULL, CT:
4,209,429, PUB. 7-3-2012. INT. CL. 35.
- AKITA, INC., WILMINGTON, DE:
4,211,656, INT. CL. 36.
- AKKA SOCCER, MEDFORD, NJ:
4,211,855, INT. CL. 41.
- ALABAMA INSURANCE AGENCY, INC., BIRMINGHAM, AL:
4,209,128, PUB. 7-3-2012. INT. CL. 36.
- ALACRON, INC., NASHUA, NH TO ALACRON, INC., NASHUA, NH:
2,528,112, CANC. INT. CL. 9.
- ALAMO DISTRIBUTION, LLC, SAN ANTONIO, TX:
2,582,197. REN. 8-16-12. INT. CL. 35.
- ALASKA AIRLINES, INC., SEATTLE, WA:
4,209,756, PUB. 7-3-2012. INT. CL. 39.
- ALASKA STRUCTURES, INC., ANCHORAGE, AK:
2,603,228. REN. 8-13-12. INT. CL. 19.
- ALBATROS ENERGY SA, SWITZERLAND:
4,208,319, PUB. 7-3-2012. MULTIPLE CLASS, INT. CLS. 7, 35, 36, 37 AND 40.
- ALCAN PACKAGING CANADA LIMITED/EMBALLAGES ALCAN CANADA LIMITEE, ETOBICOKE, ONTARIO, M8W 1T2, CANADA:
2,527,740, CANC. INT. CL. 20.
- ALCHEMY WORLDWIDE, LLC, SHERMAN OAKS, CA:
4,211,689, MULTIPLE CLASS, INT. CLS. 9, 16 AND 41.
- ALCON LABORATORIES, INC., FORT WORTH, TX:
4,210,185, PUB. 7-3-2012. MULTIPLE CLASS, INT. CLS. 10 AND 37.
- ALCON RESEARCH, LTD., FORT WORTH, TX, WESLEY-JESSEN CORPORATION, CHICAGO, IL:
1,714,589. REN. 8-12-12. INT. CL. 5.
- ALDEASA, S.A., SPAIN:
4,208,295, PUB. 7-3-2012. INT. CL. 35.
- ALEMAP LLC, MESA, AZ:
4,209,294, PUB. 7-3-2012. INT. CL. 43.
- ALENE CANDLES, LLC (F/K/A SBP ALENE ACQUISITION LLC), MILFORD, NH:
2,526,951, CANC. INT. CL. 40.
- ALERTNESS SOLUTIONS, CUPERTINO, CA:
2,605,127. REN. 8-15-12. MULTIPLE CLASS, INT. CLS. 35, 41 AND 42.
- ALERTRA, INC., STILLWATER, OK:
4,209,899, PUB. 7-3-2012. INT. CL. 42.

ALEXANDER BORODICH, MOSCOW, RUSSIAN FED., DBA WOWNRG LTD:
4,209,276, PUB. 7-3-2012. INT. CL. 9.

ALEXANDRIA REAL ESTATE EQUITIES, INC., PASADENA, CA:
4,210,671, MULTIPLE CLASS, INT. CLS. 35, 36, 37 AND 42.

ALEXIS JORDAN, NEW YORK, NY:
4,208,707, PUB. 7-3-2012. INT. CL. 9.
4,208,708, PUB. 7-3-2012. INT. CL. 41.

ALFRED MCALPINE SLATE PENRRHYN LIMITED, BANGOR, GWYNEDD, UNITED KINGDOM:
1,647,453. REN. 8-14-12. INT. CL. 19.

ALGER ASSOCIATES, INC., NEW YORK, NY:
4,210,379, INT. CL. 41.

ALI, ABDULFATAH, LEWISTON, ME:
4,211,047, INT. CL. 35.

ALIAK KENNELS, LLC, MARENGO, IL:
4,211,738, INT. CL. 31.

ALL AMERICAN MEATS, INC., OMAHA, NE:
4,209,400, PUB. 7-3-2012. INT. CL. 29.

ALL IN RETREATS LLC, RICHMOND, VA:
4,210,043, PUB. 7-3-2012. INT. CL. 14.

ALL KINDS OF CLIENTS ORGANIZING LLC, WOODINVILLE, WA, DBA QUEERLY ORGANIZED:
4,209,017, PUB. 7-3-2012. INT. CL. 45.

ALL NATURAL CANINE, INC., SPICEWOOD, TX:
4,211,686, INT. CL. 31.

ALL SEASONS IMPORTS, INC., HIALEAH GARDENS, FL:
2,614,002. REN. 8-16-12. INT. CL. 35.

ALL STAR FOODS, INC., MT. PROSPECT, IL:
4,211,286, INT. CL. 3.

ALLAN KNIGHT & ASSOCIATES, INC., DALLAS, TX:
4,208,142, PUB. 7-3-2012. INT. CL. 35.

ALLAN, T. ERIC, PITTSBURGH, PA:
4,211,767, INT. CL. 35.

ALLEN TELECOM LLC, WESTCHESTER, IL:
2,526,982, CANC. MULTIPLE CLASS, INT. CLS. 9 AND 42.

ALLERGY RESEARCH GROUP LLC, ALAMEDA, CA, DBA ALLERGY RESEARCH GROUP:
4,209,876, PUB. 7-3-2012. INT. CL. 5.

ALLFLEX EUROPE, FRANCE:
4,208,328, PUB. 7-3-2012. MULTIPLE CLASS, INT. CLS. 8 AND 10.

ALLIED WHEEL COMPONENTS, INC., GARDEN GROVE, CA:
4,209,730, PUB. 7-3-2012. INT. CL. 12.

ALLOYA CORPORATE FCU, ALBANY, NY:
4,210,915, INT. CL. 36.

ALOHA HOUSEWARES, INC., DALLAS, TX:
2,526,599, CANC. INT. CL. 11.

ALPHAMATRIX GROUP, LLC, CHICAGO, IL:
4,211,783, MULTIPLE CLASS, INT. CLS. 36 AND 42.

ALPHANET, INC., COCONUT GROVE, FL:
4,210,468, MULTIPLE CLASS, INT. CLS. 9, 16 AND 41.

ALPHARMA, LLC, MADISON, NJ, AMERICAN CYANAMID COMPANY, WAYNE, NJ:
964,021. REN. 8-16-12. U.S. CL. 18 (INT. CL. 5).

ALPHATEC SPINE, INC., CARLSBAD, CA:
4,210,553, INT. CL. 10.

ALTIBASE CO., LTD., SEOUL, REPUBLIC OF KOREA:
4,208,511, PUB. 7-3-2012. INT. CL. 9.

ALTO ENTERPRISES, INC., FREDERICK, MD:
562,814. REN. 8-10-12. U.S. CL. 39 (INT. CL. 25).

ALTUS INDUSTRIES, INC., GRAND RAPIDS, MI:
2,705,462. REN. 8-16-12. INT. CL. 20.

ALUMINART PRODUCTS LIMITED, BRAMPTON, ONTARIO, CANADA:
4,210,914, MULTIPLE CLASS, INT. CLS. 6 AND 19.

ALZHEIMER'S DISEASE AND RELATED DISORDERS ASSOCIATION, INC., CHICAGO, IL:
4,210,574, INT. CL. 41.

AM-GOLD PRODUCTS, INC., NEW YORK, NY TO AM-GOLD PRODUCTS, INC., NEW YORK, NY:
2,527,783, CANC. INT. CL. 14.

AMANDA HOWARD REAL ESTATE, L.L.C., HUNTSVILLE, AL:
4,209,230, PUB. 7-3-2012. INT. CL. 36.

AMANO ENZYME, INC., NAGOYA-SHI AICHI KEN 460-8630, JAPAN:
2,619,060. REN. 8-15-12. INT. CL. 16.

AMAYESING PRODUCTIONS, INC, CHICAGO, IL:
4,210,112, PUB. 7-3-2012. INT. CL. 45.

AMAYESING PRODUCTIONS, INC., CHICAGO, IL:
4,209,432, PUB. 7-3-2012. INT. CL. 45.

AMB I.T. B.V., HAARLEM, NETHERLANDS:
4,211,691, MULTIPLE CLASS, INT. CLS. 9 AND 41.

AMBER-LEVONNE KOKO, RIVERSIDE, CA, DBA BEACH BUNNY:
3,933,372, AM. INT. CL. 3.

AMCOL INTERNATIONAL CORPORATION, HOFFMAN ESTATES, IL:
1,233,175. REN. 8-11-12. INT. CL. 1.

AMENITY SERVICE CO., LTD., KANAGAWA, JAPAN:
4,208,183, PUB. 7-14-2009. MULTIPLE CLASS, INT. CLS. 10 AND 44.

AMEREX GROUP, LLC, NEW YORK, NY:
1,184,786, CANC. MULTIPLE CLASS, INT. CLS. 20 AND 25.

AMERICA CHINA SOCIETY OF INDIANA, INC., CARMEL, IN:
4,209,229, PUB. 7-3-2012. INT. CL. 35.

AMERICAN AGRITECH, L.L.C., CHANDLER, AZ:
4,211,403, INT. CL. 1.

AMERICAN ALLIANCE FOR HEALTH, PHYSICAL EDUCATION, RECREATION AND DANCE, RESTON, VA:
1,708,066. REN. 8-11-12. MULTIPLE CLASS, INT. CLS. 16 AND 41.

AMERICAN ASSOCIATION FOR LABORATORY ACCREDITATION, FREDERICK, MD:
1,707,552. REN. 8-12-12. U.S. CL. B.

AMERICAN ASSOCIATION FOR THE ADVANCEMENT OF SCIENCE, WASHINGTON, DC, DC:
4,211,703, INT. CL. 41.

AMERICAN ASSOCIATION OF PHYSICIAN SPECIALISTS, INC., TAMPA, FL:
4,209,340, PUB. 7-3-2012. INT. CL. 42.

AMERICAN AUTOMOBILE ASSOCIATION, INC., HEATHROW, FL:
1,778,244. REN. 8-16-12. MULTIPLE CLASS, INT. CLS. 36, 37 AND 39.

AMERICAN BIOSCIENCES, INC., BLAUVELT, NY:
4,209,258, PUB. 7-3-2012. INT. CL. 5.

AMERICAN BOARD OF INDUSTRIAL HYGIENE, LANSING, MI:
2,660,292. REN. 8-16-12. U.S. CL. B.

AMERICAN BOARD OF MEDICAL PSYCHOLOGY, NEVADA, MO:
4,208,983, PUB. 7-3-2012. INT. CL. 41.

AMERICAN BOOKSELLERS ASSOCIATION, TARRYTOWN, NY:
2,528,005, CANC. INT. CL. 18.

AMERICAN CHEMICAL SOCIETY, WASHINGTON, DC:
1,206,442. REN. 8-12-12. MULTIPLE CLASS, INT. CLS. 35 AND 41.

AMERICAN COLLEGE OF VETERINARY INTERNAL MEDICINE, INC., LAKEWOOD, CO:
2,600,047. REN. 8-10-12. U.S. CL. 200.
2,600,048. REN. 8-10-12. U.S. CL. 200.

AMERICAN COTON CLUB, COLFAX, CA:
4,211,705, INT. CL. 44.

AMERICAN CREATIVE TEAM, INC., SAN GABRIEL, CA:
4,210,056, PUB. 7-3-2012. INT. CL. 35.

AMERICAN DAIRY QUEEN CORPORATION, EDINA, MN:
951,528. REN. 8-15-12. U.S. CL. 101 (INT. CL. 35).

AMERICAN DENTAL SUPPLY, INC., ALLENTOWN, PA, AKA ADS, INC., LEACH & DILLON CO., MANSFIELD, MA:
1,702,802. REN. 8-14-12. INT. CL. 5.

AMERICAN DENTAL SUPPLY, INC., ALLENTOWN, PA, AKA ADS, INC.:
1,702,804. REN. 8-14-12. INT. CL. 5.

- AMERICAN DENTAL SUPPLY, INC., ALLENTOWN, PA:
3,856,386, COR. INT. CL. 7.
- AMERICAN DOCUMENT SYSTEMS LLC, FORT WORTH, TX:
4,210,655, MULTIPLE CLASS, INT. CLS. 35 AND 45.
- AMERICAN EXPRESS MARKETING & DEVELOPMENT CORP., NEW YORK, NY:
2,527,385, CANC. INT. CL. 35.
- AMERICAN FOOTBALL COACHES ASSOCIATION, WACO, TX:
2,620,680, REN. 8-15-12. INT. CL. 41.
- AMERICAN FOOTBALL COACHES FOUNDATION, WACO, TX:
2,691,438, REN. 8-15-12. MULTIPLE CLASS, INT. CLS. 36, 41 AND 42.
- AMERICAN FRUITS AND FLAVORS, PACOIMA, CA, DBA AMERICAN FRUIT PROCESSORS:
2,679,447, REN. 8-15-12. INT. CL. 32.
- AMERICAN GIRL, LLC, EL SEGUNDO, CA, PLEASANT COMPANY INCORPORATED, MIDDLETON, WI:
1,722,946, REN. 8-16-12. INT. CL. 16.
- AMERICAN GIRL, LLC, EL SIGUNDO, CA:
3,038,167, CANC. INT. CL. 35.
- AMERICAN HYDROTECH, INC., CHICAGO, IL:
1,775,888, REN. 8-16-12. INT. CL. 19.
- AMERICAN INSTITUTE OF CERTIFIED PUBLIC ACCOUNTANTS, NEW YORK, NY:
4,211,251, MULTIPLE CLASS, INT. CLS. 16 AND 41.
4,211,252, MULTIPLE CLASS, INT. CLS. 16 AND 41.
- AMERICAN INTERNATIONAL GROUP, INC., NEW YORK, NY TO LEXISNEXIS RISK SOLUTIONS INC., ALPHARETTA, GA:
2,526,769, CANC. INT. CL. 9.
- AMERICAN LIBRARY ASSOCIATION, CHICAGO, IL:
2,728,973, REN. 8-15-12. INT. CL. 16.
2,736,350, REN. 8-15-12. INT. CL. 16.
- AMERICAN MADE, LLC, CRANBERRY TOWNSHIP, PA, DBA U.S. LINER COMPANY:
2,544,682, REN. 8-11-12. INT. CL. 12.
- AMERICAN MEDICAL SERVICES, ROCHESTER HILLS, MI:
4,208,570, PUB. 8-2-2011. INT. CL. 35.
- AMERICAN MEDICAL SERVICES, INC., ROCHESTER HILLS, MI:
4,209,900, PUB. 7-3-2012. INT. CL. 35.
- AMERICAN MILLENNIUM CORP. INC., GOLDEN, CO:
4,211,566, INT. CL. 9.
- AMERICAN NATIONAL STANDARDS INSTITUTE, INCORPORATED, NEW YORK, NY:
4,208,561, PUB. 7-3-2012. U.S. CL. A.
- AMERICAN NEVADA COMPANY, LLC, LAS VEGAS, NV:
2,608,215, REN. 8-15-12. INT. CL. 25.
- AMERICAN OMNI TRADING COMPANY, HOUSTON, TX:
4,210,390, INT. CL. 12.
- AMERICAN PATENT GROUP, INC., ST. SIMONS ISLAND, GA:
1,704,457, REN. 8-12-12. INT. CL. 1.
- AMERICAN PENSION COMPANY, THE, SANTA BARBARA, CA:
2,526,992, CANC. INT. CL. 36.
- AMERICAN PERFORMANCE TECHNOLOGIES, LLC, KANSAS CITY, MO:
4,211,659, MULTIPLE CLASS, INT. CLS. 7, 9 AND 12.
- AMERICAN PSYCHOLOGICAL ASSOCIATION, INC., WASHINGTON, DC:
2,743,355, COR. INT. CL. 9.
- AMERICAN PSYCHOLOGICAL ASSOCIATION, INC., WASHINGTON, DC:
2,743,352, COR. INT. CL. 9.
2,743,353, COR. INT. CL. 9.
2,743,354, COR. INT. CL. 9.
2,743,363, COR. INT. CL. 9.
- AMERICAN PUBLIC HEALTH ASSOCIATION, WASHINGTON, DC:
4,209,091, PUB. 7-3-2012. INT. CL. 35.
- AMERICAN RESIDENTIAL SERVICES, L.L.C., MEMPHIS, TN, RESCUE INDUSTRIES, INC., SAN DIEGO, CA:
1,787,059, REN. 8-14-12. INT. CL. 37.
- AMERICAN SEATING COMPANY, GRAND RAPIDS, MI:
4,211,427, INT. CL. 12.
- AMERICAN SOCIETY FOR THE PREVENTION OF CRUELTY TO ANIMALS, THE, NEW YORK, NY:
2,602,543, REN. 8-11-12. INT. CL. 42.
2,695,929, REN. 8-11-12. INT. CL. 44.
- AMERICAN SOCIETY OF MECHANICAL ENGINEERS, THE, NEW YORK, NY:
1,722,870, REN. 8-14-12. U.S. CL. B.
- AMERICAN SPORTS LICENSING, INC., WILMINGTON, DE:
3,106,692, CANC. INT. CL. 25.
4,210,893, INT. CL. 28.
- AMERICAN SPORTS NETWORK, INC., ROSEMEAD, CA:
1,703,825, REN. 8-11-12. INT. CL. 41.
- AMERICAN TACTICAL IMPORTS INC., ROCHESTER, NY:
4,210,270, MULTIPLE CLASS, INT. CLS. 8 AND 13.
- AMERICAN TORCH TIP COMPANY, BRADENTON, FL:
4,208,924, PUB. 7-3-2012. INT. CL. 7.
- AMERICAN VELODUR METAL, INC., SCITUATE, MA:
2,600,485, REN. 8-16-12. INT. CL. 17.
- AMERICAN WEST FURNITURE MANUFACTURERS, INC., SANTA FE SPRINGS, CA, DBA URBANA:
2,526,509, CANC. INT. CL. 20.
- AMERICAS GOLD, INC., LOS ANGELES, CA:
4,208,470, PUB. 7-3-2012. INT. CL. 14.
- AMERISOURCEBERGEN DRUG CORPORATION, CHESTERBROOK, PA:
4,209,193, PUB. 7-3-2012. MULTIPLE CLASS, INT. CLS. 3, 5 AND 10.
- AMERISTRAC, INC., GREAT NECK, NY:
4,211,272, INT. CL. 36.
- AMERIWOOD INDUSTRIES, WRIGHT CITY, MO:
2,638,982, REN. 8-14-12. INT. CL. 20.
- AMI ENTERTAINMENT NETWORK, INC., BRISTOL, PA:
2,610,477, REN. 8-15-12. INT. CL. 28.
- AMINI INNOVATION CORP., PICO RIVERA, CA:
4,208,943, PUB. 7-3-2012. MULTIPLE CLASS, INT. CLS. 20 AND 24.
- AMKOR TECHNOLOGY, INC., CHANDLER, AZ:
2,737,520, REN. 8-16-12. INT. CL. 9.
- AMOREPACIFIC CORPORATION, SEOUL, REPUBLIC OF KOREA:
4,208,200, PUB. 7-3-2012. INT. CL. 3.
4,208,573, PUB. 7-3-2012. INT. CL. 30.
- AMPELMANN GMBH, BERLIN, FED REP GERMANY:
4,161,670, COR. MULTIPLE CLASS, INT. CLS. 16, 21, 25 AND 28.
- AMS, LLC, STRATFORD, WI, DBA AMS BOWFISHING:
4,208,991, PUB. 7-3-2012. INT. CL. 28.
- AMSTED RAIL COMPANY, INC., CHICAGO, IL:
750,768, REN. 8-11-12. U.S. CL. 14 (INT. CL. 6).
1,777,652, REN. 8-15-12. MULTIPLE CLASS, INT. CLS. 7 AND 12.
- AMTECH SYSTEMS, LLC., ALBUQUERQUE, NM:
3,053,055, CANC. INT. CL. 36.
- AMVAC AG, CH-6300 ZUG, SWITZERLAND:
4,208,231, PUB. 11-3-2009. INT. CL. 5.
- AMYRIS, INC., EMERYVILLE, CA:
4,209,630, PUB. 7-3-2012. MULTIPLE CLASS, INT. CLS. 1 AND 3.
- ANAND, MAHESH, FREMONT, CA:
4,210,871, MULTIPLE CLASS, INT. CLS. 35 AND 36.
- ANASTASIA BEVERLY HILLS, INC., BEVERLY HILLS, CA:
4,208,796, PUB. 7-3-2012. MULTIPLE CLASS, INT. CLS. 3, 8 AND 21.
- ANDA, INC., WESTON, FL:
4,210,417, INT. CL. 9.
- ANDERSEN, RAY, HIGHLAND PARK, NJ:
2,527,680, CANC. INT. CL. 9.
- ANDERSON ERICKSON DAIRY CO., DES MOINES, IA:
2,670,349, REN. 8-15-12. MULTIPLE CLASS, INT. CLS. 29 AND 32.
- ANDERSON-COOK INC, FRASER, MI, ANDERSON-COOK INCORPORATED, FRASER, MI:
942,333, REN. 8-15-12. U.S. CL. 23 (INT. CL. 7).

ANDERSON-MARTIN MACHINE COMPANY, FORT SMITH, AR:
2,527,024, CANC. INT. CL. 7.

ANDERSON, CURTIS, R/RICHARD, ASHLAND, OR:
2,526,800, CANC. INT. CL. 42.

ANDERSON, LARRY, EDMONTON ALBERTA, CANADA:
4,210,993, INT. CL. 41.

ANDERSON, MARK L., SPRING VALLEY, WI:
1,715,392, REN. 8-10-12. INT. CL. 10.

ANDERSONS, INC., THE, MAUMEE, OH:
2,527,995, CANC. INT. CL. 1.

ANDRAE MICHAELS NATIONAL PORTRAIT COMPANY, COLORADO SPRINGS, CO:
4,209,181, PUB. 7-3-2012. INT. CL. 41.

ANDREA J. SMITH & ASSOCIATES, INC., FORT COLLINS, CO:
4,209,167, PUB. 7-3-2012. INT. CL. 35.

ANDREW R. SPRIEGEL, HUDSON, OH:
4,211,299, INT. CL. 42.

ANDREW UDELL, NEW YORK, NY:
4,209,480, PUB. 7-3-2012. INT. CL. 35.

ANGEL PLAYING CARDS CO., LTD., CHUO-KU OSAKA, JAPAN:
4,209,334, PUB. 7-3-2012. INT. CL. 28.

ANGEL'S BAKERIES, INC., BROOKLYN, NY:
4,209,081, PUB. 7-3-2012. MULTIPLE CLASS, INT. CLS. 30 AND 40.

ANGELA ROWELL, PHOENIX, AZ:
4,211,421, INT. CL. 25.
4,211,423, INT. CL. 25.

ANGELANTONI LIFE SCIENCE S.R.L. IN BREVE ALS S.R.L., ITALY:
3,063,945, CANC. INT. CL. 7.

ANGONE, JENNIFER, BERWYN, IL:
4,210,944, INT. CL. 5.

ANHING CORPORATION, LOS ANGELES, CA:
2,736,843, REN. 8-11-12. INT. CL. 32.

ANIMAL SCIENCE PRODUCTS, INC., NACOGDOCHES, TX:
4,210,209, PUB. 7-3-2012. INT. CL. 5.

ANNABEL, JEFFREY CONRAD, BOYNTON BEACH, FL AND ANNABEL, BEVERLY MINOR, BOYNTON BEACH, FL:
3,038,300, CANC. INT. CL. 28.

ANNE TAYLOR COMMUNICATIONS, LLC, CHICAGO, IL:
4,208,685, PUB. 7-3-2012. MULTIPLE CLASS, INT. CLS. 39 AND 45.

ANOTHER CHANCEE INCORPORATED, DALLAS, TX, DBA ANOTHER CHANCEE INC:
4,208,967, PUB. 7-3-2012. INT. CL. 35.

ANSA PRODUCTIONS, INC., LOS ANGELES, CA, DBA LA AUTO SHOW:
4,209,319, PUB. 7-3-2012. INT. CL. 35.

ANTHONY & SYLVAN POOLS CORPORATION, MAYFIELD VILLAGE, OH, DBA ANTHONY & SYLVAN POOLS:
4,209,046, PUB. 7-3-2012. MULTIPLE CLASS, INT. CLS. 1, 5, 19, 35 AND 37.

ANVIL ACQUISITION CORP., LEXINGTON, IL:
4,211,781, INT. CL. 35.

AOM HOLDING, L.L.C., NEW YORK, NY:
4,210,236, INT. CL. 25.

APCO WORLDWIDE INC., WASHINGTON, DC, APCO WORLDWIDE INC., WASHINGTON, DC:
2,600,458, REN. 8-13-12. INT. CL. 35.

APEX BRANDS, INC., APEX, NC, DIAMOND TOOL AND HORSESHOE CO., DULUTH, MN:
1,204,314, REN. 8-11-12. INT. CL. 8.

APEX CONSOLIDATED, INC., HOUSTON, TX, DBA APEX FIRESTOP:
4,208,842, PUB. 7-3-2012. INT. CL. 37.

APIVITA S.A., ATHENS, GREECE:
4,179,609, COR. INT. CL. 3.

APMEX, INC., OKLAHOMA CITY, OK:
4,210,153, PUB. 7-3-2012. INT. CL. 36.

APOLLO HEALTHCARE LLC, ATLANTA, GA:
4,210,838, INT. CL. 36.

APOLLO INSURANCE SERVICES, INC., LADERA RANCH, CA:
4,210,509, INT. CL. 36.
4,210,598, INT. CL. 36.

APPLE ENERGY GROUP LLC, AUSTIN, TX:
4,208,896, PUB. 1-24-2012. INT. CL. 35.

APPLE ENERGY GROUP, L.L.C., AUSTIN, TX:
4,208,143, PUB. 1-24-2012. MULTIPLE CLASS, INT. CLS. 35 AND 41.

APPLE INC., CUPERTINO, CA:
4,209,614, PUB. 7-3-2012. MULTIPLE CLASS, INT. CLS. 9 AND 38.
4,210,742, INT. CL. 42.

APPLETREE AG, CH-8400 WINTERTHUR, SWITZERLAND:
4,208,384, PUB. 7-3-2012. MULTIPLE CLASS, INT. CLS. 5, 42 AND 44.

APPLIED DESIGN AND ENGINEERING LIMITED, LOWESTOFT, UNITED KINGDOM:
2,601,219, REN. 8-11-12. INT. CL. 11.

APPLIYA INC., TOKYO, JAPAN:
4,208,834, PUB. 7-3-2012. INT. CL. 28.

APPSWELL, INC., BOSTON, MA:
4,209,814, PUB. 7-3-2012. INT. CL. 42.

APPS4U2BU, INC., FARGO, ND, AKA ANDREW CHEN:
4,208,959, PUB. 7-3-2012. INT. CL. 9.

APRENTICA, LLC, BUENOS AIRES, ARGENTINA:
4,209,384, PUB. 7-3-2012. INT. CL. 42.

APT ACQUISITION CORP., HARMONY, PA:
2,610,920, REN. 8-15-12. INT. CL. 27.

AQUACULTURE SYSTEMS TECHNOLOGIES, LLC, NEW ORLEANS, LA:
4,208,688, PUB. 7-3-2012. INT. CL. 11.
4,208,689, PUB. 7-3-2012. INT. CL. 11.

AQUION, INC., ELK GROVE VILLAGE, IL:
4,208,977, PUB. 3-27-2012. MULTIPLE CLASS, INT. CLS. 3, 6, 7 AND 11.

ARAMARK UNIFORM & CAREER APPAREL, LLC, BURBANK, CA:
4,209,444, PUB. 7-3-2012. INT. CL. 45.

ARANDELL CORPORATION, MENOMONEE FALLS, WI:
2,554,404, REN. 8-10-12. INT. CL. 35.

ARAYA INDUSTRIAL CO., LTD., OSAKA, JAPAN:
1,207,133, REN. 8-14-12. INT. CL. 12.

ARBISER MACHINE, INC., TUCKER, GA:
2,718,544, REN. 8-10-12. INT. CL. 40.

ARBONNE INTERNATIONAL, LLC, IRVINE, CA:
4,210,094, PUB. 7-3-2012. INT. CL. 3.
4,210,095, PUB. 7-3-2012. INT. CL. 3.

ARBOR NETWORKS, INC., CHELMSFORD, MA:
4,210,792, INT. CL. 9.

ARCH CAPITAL GROUP (U.S.) INC., NEW YORK, NY:
4,210,978, INT. CL. 36.

ARCH CHEMICALS, INC., NORWALK, CT:
963,325, REN. 8-11-12. U.S. CL. 6 (INT. CL. 1).

ARCHES & ANGLES, LLC, FARMINGTON, CT:
4,211,348, INT. CL. 42.

ARCHIE COMIC PUBLICATIONS, INC., MAMARONECK, NY:
4,210,355, INT. CL. 16.

ARCTIC CAT INC., THIEF RIVER FALLS, MN:
4,208,167, PUB. 9-7-2010. MULTIPLE CLASS, INT. CLS. 7, 12 AND 25.

ARDERIU, JOAN ROCA, 08130 SANTA PERPETUA DE MOGODA, SPAIN:
3,037,042, CANC. MULTIPLE CLASS, INT. CLS. 18, 22 AND 28.

ARDZROONI VINEYARD MANAGEMENT, LLC, PHILO, CA:
4,208,759, PUB. 7-3-2012. INT. CL. 44.

ARENDOSKI, EMMA, ROMEO, MI:
4,209,413, PUB. 7-3-2012. INT. CL. 35.

AREPABOX LLC, MIAMI, FL:
4,209,717, PUB. 7-3-2012. INT. CL. 43.

ARGENT CONSULTING SERVICES, INC., HOUSTON, TX:
4,209,536, PUB. 7-3-2012. INT. CL. 42.
4,209,537, PUB. 7-3-2012. INT. CL. 42.

ARGILA, LINDA, NEW YORK, NY:
4,210,613, INT. CL. 41.

- ARGUS MANAGEMENT, LLC, BEVERLY, MA:
4,210,828, INT. CL. 35.
- ARIENS COMPANY, BRILLION, WI:
2,528,457, CANC. INT. CL. 7.
- ARIOTO, JOHN J, LOS GATOS, CA:
4,209,224, PUB. 7-3-2012. INT. CL. 33.
- ARISTOCRAT TECHNOLOGIES AUSTRALIA PTY LTD,
NORTH RYDE, NSW, AUSTRALIA:
2,617,710, REN. 8-16-12. INT. CL. 9.
- ARISTOCRAT TECHNOLOGIES AUSTRALIA PTY LTD.,
NORTH RYDE, NSW, AUSTRALIA:
4,208,637, PUB. 7-3-2012. INT. CL. 9.
4,210,075, PUB. 7-3-2012. INT. CL. 28.
- ARIVITA PRODUCTS USA LLC, LAS VEGAS, NV:
4,208,945, PUB. 7-3-2012. INT. CL. 5.
- ARIZONA DEPARTMENT OF PUBLIC SAFETY, PHOENIX,
AZ:
4,211,853, INT. CL. 26.
- ARLEN, MICHAEL W, LOS ANGELES, CA:
4,209,199, PUB. 3-27-2012. INT. CL. 5.
- ARLINGTON INDUSTRIES, INC., ARLINGTON, VT:
2,610,755, REN. 8-16-12. INT. CL. 40.
- ARMAMENT SYSTEMS AND PROCEDURES, INC., APPLE-
TON, WI:
1,767,699, REN. 8-15-12. INT. CL. 41.
2,599,118, REN. 8-16-12. INT. CL. 1.
2,639,529, REN. 8-15-12. INT. CL. 11.
2,670,218, REN. 8-15-12. INT. CL. 11.
- ARMATRON INTERNATIONAL, INC., MALDEN, MA:
2,661,666, REN. 8-14-12. INT. CL. 9.
- ARME MINISTRIES, ROSEVILLE, CA:
4,208,706, PUB. 7-3-2012. INT. CL. 41.
- ARMOR SCREEN CORP., RIVIERA BEACH, FL:
2,526,732, CANC. INT. CL. 22.
- ARMSTRONG, MARK W., NEW YORK, NY:
4,208,498, PUB. 7-3-2012. MULTIPLE CLASS, INT. CLS. 35
AND 41.
- ARNOLD, SHELLY SHIRLEY, SOUTH LAKE TAHOE, CA:
3,013,914, CANC. INT. CL. 25.
- ARROW INTERNATIONAL INVESTMENT CORP., WIL-
MINGTON, DE:
4,210,039, PUB. 7-3-2012. INT. CL. 9.
- ARROW SHED, LLC, WAYNE, NJ:
4,211,331, INT. CL. 40.
- ARROWHEAD MILLS, INC., UNIONDALE, NY, GARDEN
OF EATIN', INC., LOS ANGELES, CA:
1,711,976, REN. 8-10-12. INT. CL. 30.
- ARROWSIGHT, INC., MOUNT KISCO, NY, ARROWSIGHT,
INC., MOUNT KISCO, NY:
2,605,653, REN. 8-13-12. INT. CL. 42.
- ARTE GRAFICO EDITORIAL ARGENTINO S.A., BUENOS
AIRES, ARGENTINA:
4,210,529, INT. CL. 16.
- ARTHROCARE CORPORATION, AUSTIN, TX:
4,210,418, INT. CL. 10.
- ARTIFICIALLY NATURAL, LLC, BEL AIR, MD:
4,210,272, INT. CL. 9.
- ARTOGRAPH, INC., DELANO, MN:
4,208,917, PUB. 7-3-2012. INT. CL. 9.
- ARTSTREAM, INC., SILVER SPRING, MD:
4,209,613, PUB. 7-3-2012. INT. CL. 41.
4,209,615, PUB. 7-3-2012. INT. CL. 41.
- AR2 PRODUCTS, BUTLER, NJ:
4,209,851, PUB. 7-3-2012. INT. CL. 9.
- ASAHI DENSO CO., LTD., SHIZUOKA, JAPAN:
4,162,738, COR. MULTIPLE CLASS, INT. CLS. 6, 7, 9, 11
AND 12.
- ASAHI GLASS COMPANY, LIMITED, JAPAN:
4,208,388, PUB. 7-3-2012. MULTIPLE CLASS, INT. CLS. 9,
12, 19, 20 AND 21.
- ASCHER, ENRICO, BROOKLYN, NY:
3,118,480, CANC. INT. CL. 35.
- ASCO GROUP LIMITED, FREEPORT, BAHAMAS:
3,050,911, CANC. INT. CL. 18.
- ASERDIV, INC., SPRINGFIELD, PA:
2,526,922, CANC. MULTIPLE CLASS, INT. CLS. 35, 37
AND 42.
- ASHLAND LICENSING AND INTELLECTUAL PROPERTY
LLC, DUBLIN, OH:
1,707,694, REN. 8-11-12. INT. CL. 3.
- ASHLEY FURNITURE INDUSTRIES, INC., ARCADIA, WI:
1,721,104, REN. 8-10-12. INT. CL. 20.
2,680,466, REN. 8-14-12. INT. CL. 35.
- ASIA APPAREL COMPANY, LLC, CHARLOTTE, NC:
4,208,610, PUB. 7-3-2012. INT. CL. 25.
- ASIAN ART MUSEUM FOUNDATION OF SAN FRANCIS-
CO, SAN FRANCISCO, CA:
4,211,447, MULTIPLE CLASS, INT. CLS. 35 AND 41.
- ASIS INTERNATIONAL, INC., ALEXANDRIA, VA:
4,208,630, PUB. 7-3-2012. MULTIPLE CLASS, INT. CLS. 41
AND 42.
- ASKLEPION PHARMACEUTICALS, LLC, BALTIMORE,
MD:
4,209,840, PUB. 7-3-2012. INT. CL. 5.
- ASN GROUP CORPORATION, WALNUT, CA:
4,209,475, PUB. 7-3-2012. INT. CL. 5.
- ASPEN EDUCATION GROUP, INC., CERRITOS, CA:
4,208,564, PUB. 7-3-2012. MULTIPLE CLASS, INT. CLS. 41
AND 44.
- ASPEN PET PRODUCTS HOLDINGS, INC., DENVER, CO:
3,037,044, CANC. INT. CL. 18.
- ASSEMBLEON N.V., EINDHOVEN, NETHERLANDS:
2,607,215, REN. 8-11-12. INT. CL. 9.
- ASSETMARK INVESTMENT SERVICES INC., PLEASANT
HILL, CA:
2,527,673, CANC. INT. CL. 36.
- ASSISTANCE SOFTWARE GROUP B.V., NL-1411 AW
NAARDEN, NETHERLANDS:
4,208,307, PUB. 7-3-2012. INT. CL. 9.
- ASSOCIATED BRANDS LIMITED PARTNERSHIP, MISSIS-
SAUGA, ONTARIO, CANADA:
4,208,177, PUB. 7-3-2012. INT. CL. 21.
- ASSOCIATED MATERIALS INCORPORATED, EL DORA-
DO, AR:
2,603,821, REN. 8-16-12. MULTIPLE CLASS, INT. CLS. 9
AND 17.
- ASSOCIATED MICROBREWERIES, LTD., SAN DIEGO, CA,
DBA KARL STRAUSS BREWING COMPANY:
4,208,956, PUB. 7-3-2012. INT. CL. 32.
- ASSOCIATED RESEARCH, INC., LAKE FOREST, IL:
4,209,053, PUB. 7-3-2012. INT. CL. 9.
- ASSOCIATION OF CHANGE MANAGEMENT PROFES-
SIONALS, BOWIE, MD:
4,208,726, PUB. 7-3-2012. INT. CL. 35.
- ASSOCIATION SKEMA BUSINESS SCHOOL, FRANCE:
4,208,238, PUB. 2-28-2012. MULTIPLE CLASS, INT. CLS.
35, 41 AND 42.
- ASSOCIATIONS, INC., DALLAS, TX:
4,208,843, PUB. 7-3-2012. MULTIPLE CLASS, INT. CLS. 35
AND 37.
- AST ADVANCED SUSPENSION TECHNOLOGY B.V.,
NETHERLANDS:
4,208,402, PUB. 7-3-2012. INT. CL. 12.
- ASTA PARKING, FORT LAUDERDALE, FL:
4,211,511, INT. CL. 39.
- ASTER CUCINE S.P.A., VILLA FASTIGGI (PESARO),
ITALY:
3,103,766, COR. INT. CL. 20.
- ASTRAZENECA AB, SÖDERTÄLJE, SWEDEN:
4,211,262, INT. CL. 5.
- ASTRAZENECA UK LIMITED, LONDON W1Y 6LN, ENG,
UNITED KINGDOM:
3,037,531, CANC. INT. CL. 5.
- ASX OPERATIONS PTY LIMITED, SYDNEY NSW 2000,
AUSTRALIA:
2,608,747, REN. 8-16-12. MULTIPLE CLASS, INT. CLS. 16
AND 41.
- AT HOME IN FRANCE LLC, NORTH MIAMI, FL:
2,680,797, REN. 8-15-12. INT. CL. 43.
- AT RESERVATION NETWORK PTE, LTD, HOTEL GRAND
CENTRAL, SINGAPORE:
2,603,063, REN. 8-10-12. INT. CL. 42.
- AT&T INTELLECTUAL PROPERTY II, L.P., RENO, NV:
3,038,309, CANC. INT. CL. 38.

ATARI INTERACTIVE, INC., NEW YORK, NY, ATARI, INC., SUNNYVALE, CA:
1,224,414. REN. 8-13-12. INT. CL. 28.

ATHLETES & ENTERTAINERS FOR KIDS, LONG BEACH, CA:
1,674,631. REN. 8-15-12. INT. CL. 42.

ATLANTIC AUTOMOTIVE CORP., BALTIMORE, MD:
2,528,214. CANC. MULTIPLE CLASS, INT. CLS. 35 AND 37.

ATLANTICARE NURSING SERVICES, INC., DELRAY BEACH, FL:
4,210,770. INT. CL. 44.

ATLANTYCA SPA, I-20123 MILANO, ITALY:
4,208,243. PUB. 7-3-2012. MULTIPLE CLASS, INT. CLS. 3, 9, 16, 20, 24, 25, 28, 29, 30, 32, 41 AND 43.

ATLAS COPCO TOOLS AB, SWEDEN:
4,208,419. PUB. 7-3-2012. MULTIPLE CLASS, INT. CLS. 7 AND 9.

ATLAS DATABASE SOFTWARE CORP., CALABASAS, CA:
4,209,147. PUB. 7-3-2012. INT. CL. 42.

ATOMSCHIRM CORPORATION, DURHAM, NC:
4,211,080. INT. CL. 25.

ATTORNEYGUIDE.COM, LLC, RENO, NV:
2,603,046. REN. 8-12-12. MULTIPLE CLASS, INT. CLS. 35 AND 42.

AUDI AG, D-85045 INGOLSTADT, FED REP GERMANY:
2,526,879. CANC. INT. CL. 12.

AUDIBLE INC., NEWARK, NJ:
2,610,001. REN. 8-12-12. INT. CL. 9.

AUDIO & VIDEO LABS, INC., PENNSAUKEN, NJ:
4,211,668. INT. CL. 42.

AUDIO-TECHNICA U.S., INC., STOW, OH:
1,778,301. REN. 8-10-12. INT. CL. 9.

AUDIOCONTROL INC., MOUNTLAKE TERRACE, WA:
4,209,698. PUB. 7-3-2012. INT. CL. 9.

AUGUST HAT COMPANY, INC., OXNARD, CA:
4,210,669. MULTIPLE CLASS, INT. CLS. 9, 14 AND 18.

AURORA REYES, LLC, AUSTIN, TX:
4,209,761. PUB. 7-3-2012. INT. CL. 41.
4,209,770. PUB. 7-3-2012. INT. CL. 35.

AUSTRALIAN GOLD, LLC, INDIANAPOLIS, IN:
4,209,793. PUB. 7-3-2012. INT. CL. 3.

AUSTRALIAN WOOL INNOVATION LIMITED, SYDNEY, AUSTRALIA:
4,210,701. INT. CL. 9.

AUTODESK, INC., SAN RAFAEL, CA:
4,208,936. PUB. 7-3-2012. MULTIPLE CLASS, INT. CLS. 41 AND 42.

AUTOMOBILE PROTECTION CORPORATION-APCO, NORCROSS, GA:
4,209,617. PUB. 7-3-2012. INT. CL. 9.

AUTOMUNDO PRODUCTIONS, INC., MIAMI, FL:
2,610,643. REN. 8-10-12. INT. CL. 41.

AUTONOMOUS TRACTOR CORPORATION, FARGO, ND:
4,209,914. PUB. 7-3-2012. INT. CL. 12.

AUTRY CONSULTING SERVICES, LLC, MERIDIAN, MS:
4,210,330. INT. CL. 25.

AVALIGN TECHNOLOGIES, INC., LAKE FOREST, IL:
3,908,280. AM. INT. CL. 10.
3,919,999. AM. INT. CL. 10.

AVANT IMMUNOTHERAPEUTICS, INC., NEEDHAM, MA TO AVANT IMMUNOTHERAPEUTICS, INC., NEEDHAM, MA:
2,527,867. CANC. INT. CL. 5.

AVANTIS MEDICAL SYSTEMS, INC., SUNNYVALE, CA:
4,209,781. PUB. 7-3-2012. INT. CL. 10.
4,209,782. PUB. 7-3-2012. INT. CL. 10.

AVEDRO, INC., WALTHAM, MA:
4,211,179. INT. CL. 44.
4,211,180. INT. CL. 5.

AVENTIS REAL ESTATE GMBH & CO. KG, FED REP GERMANY:
2,981,216.

AVERY DENNISON CORPORATION, PASADENA, CA:
2,600,895. REN. 8-15-12. INT. CL. 16.

AVF GROUP LIMITED, SHROPSHIRE, TF1 4ET, ENGLAND:
2,526,425. CANC. INT. CL. 6.

AVIARA RESORT ASSOCIATES LIMITED PARTNERSHIP, LOS ANGELES, CA:
1,705,916. REN. 8-11-12. INT. CL. 28.

AVID SKIN CARE, LLC, CUMMING, GA:
4,211,294. INT. CL. 3.

AVIDAR, DORIT, BROOKLYN, NY:
4,208,535. PUB. 7-3-2012. INT. CL. 36.

AVIHOME, LLC, SALISBURY, MD:
4,210,370. INT. CL. 19.

AVILA THERAPEUTICS, INC., BEDFORD, MA:
4,208,806. PUB. 7-3-2012. INT. CL. 5.

AVILAN, LLC, SCOTTSDALE, AZ:
4,209,060. PUB. 7-3-2012. INT. CL. 35.

AVON PRODUCTS, INC., NEW YORK, NY:
1,224,783. REN. 8-10-12. INT. CL. 3.
2,528,395. CANC. INT. CL. 3.
2,713,293. REN. 8-16-12. INT. CL. 3.
2,718,121. REN. 8-16-12. INT. CL. 3.
2,719,023. REN. 8-16-12. INT. CL. 3.

AVRUPA İLAÇ VE KOZMETİK SANAYİ TİCARET ANONİM ŞİRKETİ, TURKEY:
4,208,308. PUB. 7-3-2012. MULTIPLE CLASS, INT. CLS. 3, 5 AND 10.

AW ATELIER LLP, LONDON, UNITED KINGDOM:
2,620,196. REN. 8-16-12. INT. CL. 25.

AWECOMM TECHNOLOGIES, LLC, TROY, MI, DBA THE BLUE OX JERKY COMPANY:
4,209,072. PUB. 7-3-2012. INT. CL. 29.

AWENDER, JEFFERY E., SAN CARLOS, CA:
4,209,505. PUB. 7-3-2012. INT. CL. 44.

AWESOME BRANDS, INC., MARGATE, FL:
3,132,759. AM. INT. CL. 35.

AXEL BLOOM, LOS ANGELES, CA:
4,208,664. PUB. 7-3-2012. INT. CL. 20.

AXONTECH, LLC, ROWLAND HEIGHTS, CA:
4,208,176. PUB. 7-3-2012. INT. CL. 42.

AYESHIRE LTD., SIERRA MADRE, CA:
2,604,824. REN. 8-11-12. INT. CL. 41.

AYLIN ALGAN, NEW YORK, NY:
4,210,743. INT. CL. 33.

AYOUB, MICHELE, NEW CANAAN, CT:
4,210,128. PUB. 7-3-2012. INT. CL. 41.

AYS ORGANIZATION, INC, LAS VEGAS, NV:
4,209,130. PUB. 7-3-2012. INT. CL. 35.

AZIENDA VINICOLA UMANI RONCHI S.P.A., OSIMO (AN), ITALY, FATTORIE DEI MARCHESI L. & P. ANTINORI S.A.S., FLORENCE, ITALY:
940,028. REN. 8-11-12. U.S. CL. 47 (INT. CL. 33).

AZOCAR, PATRICIA, HARTFORD, CT:
4,209,219. PUB. 7-3-2012. INT. CL. 16.

B & D FIRE PROTECTION LLC, CHARLOTTE, NC:
4,209,090. PUB. 7-3-2012. INT. CL. 37.

B-5, INC., WICHITA, KS:
4,209,791. PUB. 7-3-2012. INT. CL. 13.
4,210,028. PUB. 7-3-2012. INT. CL. 13.

BABCOCK BORSIG SERVICE GMBH, OBERHAUSEN, FED REP GERMANY:
2,526,791. CANC. MULTIPLE CLASS, INT. CLS. 6, 7, 9, 11, 12, 35, 37, 40 AND 42.

BABJAK, KIM, PHOENIX, AZ:
3,038,281. CANC. INT. CL. 24.

BABYVISION ULTRASOUND, SAN ANTONIO, TX:
4,208,626. PUB. 7-3-2012. INT. CL. 44.

BACCHUS VASCULAR, INC., SANTA CLARA, CA:
2,528,037. CANC. INT. CL. 10.

BACH TECHNOLOGY GMBH, FED REP GERMANY:
4,208,364. PUB. 7-3-2012. MULTIPLE CLASS, INT. CLS. 9, 15, 28, 35, 36, 38, 39, 41 AND 42.

BACHMAN ENTERPRISES, INC., SKOKIE, IL:
4,208,152. PUB. 7-3-2012. INT. CL. 35.

BACK TO THE TABLE, INC., LAFAYETTE, CA:
4,211,433. INT. CL. 43.

BACKPACK TRAVEL STORE, LLC, WASHINGTON, DC:
4,211,852. INT. CL. 35.

BACKSTAGE MOUSE, LLC, PORTLAND, ME:
4,210,789. INT. CL. 39.
4,210,790. INT. CL. 39.

- BADGLEY MISCHKA LICENSING LLC, NEW YORK, NY:
4,209,894, PUB. 7-3-2012. INT. CL. 25.
- BAI BRANDS LLC, PRINCETON, NJ:
4,211,846, INT. CL. 32.
- BAILLO S.P.A., PIEVE TESINO (TRENTO), ITALY:
2,527,038, CANC. MULTIPLE CLASS, INT. CLS. 9, 18
AND 25.
- BALAGNA, MARY C., FORSYTH, IL:
4,211,408, INT. CL. 41.
- BALL CORPORATION, BROOMFIELD, IN:
1,784,177, REN. 8-15-12. INT. CL. 21.
- BALL CORPORATION, BROOMFIELD, CO:
1,784,290, REN. 8-12-12. INT. CL. 29.
- BALL DYNAMICS INTERNATIONAL, LLC, LONGMONT,
CO:
2,671,977, REN. 8-10-12. INT. CL. 28.
2,671,984, REN. 8-10-12. INT. CL. 28.
2,697,546, REN. 8-10-12. INT. CL. 16.
- BALL UP, LLC, FORT WORTH, TX:
4,211,700, INT. CL. 41.
- BALLANTINES INTERVEST LTD, ROAD TOWN, TORTO-
LA, BR. VIRGIN ISLANDS:
4,208,365, PUB. 7-3-2012. MULTIPLE CLASS, INT. CLS. 7,
8, 9 AND 35.
- BALLARD FISH & OYSTER CO., INC., CHERITON, VA, TA
CHERRYSTONE AQUA-FARMS:
4,209,558, PUB. 7-3-2012. MULTIPLE CLASS, INT. CLS. 29
AND 31.
- BALLY GAMING, INC., LAS VEGAS, NV, DBA BALLY
TECHNOLOGIES:
4,211,225, INT. CL. 9.
4,211,226, INT. CL. 9.
4,211,227, INT. CL. 9.
4,211,337, INT. CL. 9.
4,211,338, INT. CL. 9.
4,211,349, INT. CL. 9.
4,211,363, INT. CL. 9.
- BANAFSHEHA, BEHROUZ, SHERMAN OAKS, CA AND
MOROVATI, MICHAEL, SAN MARINO, CA:
2,600,804, REN. 8-14-12. INT. CL. 25.
- BANCTEC, INC., IRVING, TX:
4,209,727, PUB. 7-3-2012. INT. CL. 35.
- BANDED BRANDS, LLC, SPARKS, NV:
4,209,519, PUB. 7-3-2012. INT. CL. 28.
4,209,520, PUB. 7-3-2012. INT. CL. 28.
4,209,521, PUB. 7-3-2012. INT. CL. 28.
4,209,523, PUB. 7-3-2012. INT. CL. 28.
4,209,544, PUB. 7-3-2012. INT. CL. 28.
4,209,545, PUB. 7-3-2012. INT. CL. 28.
- BANK OF AMERICA CORPORATION, CHARLOTTE, NC:
2,526,873, CANC. INT. CL. 36.
4,210,429, MULTIPLE CLASS, INT. CLS. 36 AND 42.
- BANKS STREET PARTNERS, LLC, ATLANTA, GA:
4,211,313, INT. CL. 36.
- BANSBACH EASYLIFT OF NORTH AMERICA, INC., MEL-
BOURNE, FL:
2,642,266, REN. 8-15-12. INT. CL. 7.
- BARAZZOTTO, ZOT, XENIA, OH, DBA TETON TECHNOL-
OGY:
2,527,789, CANC. INT. CL. 10.
- BARCANA, INC., WHITTIER, CA, DBA BARTHELMESS
U.S.A.:
3,038,165, CANC. INT. CL. 9.
- BARCE, SUSAN MICHELLE, BURKE, VA AND NYSTROM,
KEITH MICHAEL, BURKE, VA:
4,211,241, INT. CL. 26.
- BARHORST INSURANCE GROUP LTD, HOUSTON, TX:
4,211,484, MULTIPLE CLASS, INT. CLS. 35 AND 36.
- BARI COLLECTION CORP, NEW YORK, NY:
4,209,952, PUB. 7-3-2012. INT. CL. 41.
4,210,076, PUB. 7-3-2012. INT. CL. 41.
- BARKLEY, INC., KANSAS CITY, MO:
4,210,011, PUB. 7-3-2012. INT. CL. 41.
- BARNESANDNOBLE.COM LLC, NEW YORK, NY:
4,210,676, INT. CL. 42.
- BARTH, INGE, SCOTTSDALE, AZ:
2,526,805, CANC. INT. CL. 5.
- BARTKY, ROBIN, MANALAPAN, NJ, DBA EVERLASTING
IMPRESSIONS:
2,528,482, CANC. INT. CL. 42.
- BASEBALL HEAVEN INC., MILPITAS, CA:
4,209,648, PUB. 7-3-2012. INT. CL. 41.
- BASF SE, FED REP GERMANY:
4,208,439, PUB. 7-3-2012. INT. CL. 1.
- BASF SE, LUDWIGSHAFEN AM RHEIN, FED REP GER-
MANY:
4,210,644, MULTIPLE CLASS, INT. CLS. 1 AND 5.
- BASILE STACEY, APTOS, CA:
4,208,496, PUB. 7-3-2012. INT. CL. 35.
- BATES TROY, INC., BINGHAMTON, NY:
4,208,965, PUB. 7-3-2012. MULTIPLE CLASS, INT. CLS. 37
AND 43.
- BATTLEFRONT MINIATURES LIMITED, AUCKLAND
CENTRAL, NEW ZEALAND:
4,208,620, PUB. 7-3-2012. INT. CL. 16.
- BAUSCH & LOMB INCORPORATED, ROCHESTER, NY:
4,210,067, PUB. 7-3-2012. INT. CL. 9.
4,210,119, PUB. 7-3-2012. INT. CL. 5.
- BAXTER S.R.L., I-20821 MEDA (MONZA BRIANZA), ITALY:
4,208,259, PUB. 7-3-2012. MULTIPLE CLASS, INT. CLS. 18
AND 20.
- BAY STATE MILLING COMPANY, BOSTON, MA:
2,631,665, REN. 8-10-12. INT. CL. 30.
- BAY VALLEY FOODS, LLC, OAK BROOK, IL:
3,048,786, CANC. INT. CL. 30.
- BAYADA HOME HEALTH CARE, INC., MOORESTOWN,
NJ, FORMERLY BAYADA NURSES, INC.:
4,209,265, PUB. 7-3-2012. INT. CL. 44.
- BAYER AKTIENGESELLSCHAFT, 51373 LEVERKUSEN,
FED REP GERMANY:
1,203,324, REN. 8-15-12. INT. CL. 5.
4,211,359, INT. CL. 5.
- BAYER HEALTHCARE LLC, PITTSBURGH, PA, STERLING
DRUG INC., NEW YORK, NY:
941,851, REN. 8-15-12. U.S. CL. 18 (INT. CL. 5).
- BAYER HEALTHCARE LLC, PITTSBURGH, PA:
2,606,065, REN. 8-16-12. INT. CL. 5.
- BAYLOR COLLEGE OF MEDICINE, HOUSTON, TX:
4,211,737, INT. CL. 41.
- BC INTERNATIONAL COSMETICS & IMAGE SERVICES,
INC., ORLANDO, FL, BEAUTICONTROL COSMETICS,
INC., CARROLLTON, TX:
1,712,947, REN. 8-16-12. INT. CL. 3.
- BCATCO ARL, ST. HELLIER, JERSEY JE2 3JW, CHANNEL
ISLANDS:
2,527,108, CANC. INT. CL. 12.
- BDA CARES FOUNDATION, WOODINVILLE, WA:
4,209,426, PUB. 7-3-2012. INT. CL. 36.
- BDSRCO, INC., BRADENTON, FL:
4,211,162, INT. CL. 9.
4,211,163, INT. CL. 14.
- BEACH TENNIS USA, LLC, FRANKLIN SQUARE, NY:
4,208,826, PUB. 7-3-2012. INT. CL. 41.
- BEACON PICTURES, LLC, SANTA MONICA, CA:
4,208,622, PUB. 7-3-2012. INT. CL. 9.
- BEALE STREET BARBER SHOP INC., LAKE PEEKSKILL,
NY:
4,209,457, PUB. 7-3-2012. INT. CL. 44.
- BEATPORT, LLC, DENVER, CO:
4,211,125, INT. CL. 9.
- BEAUTY PLUS TRADING CO., INC., MOONACHIE, NJ:
4,210,757, INT. CL. 26.
- BEAUTY TREATS INTERNATIONAL CO., INC., LOS AN-
GELES, CA:
4,208,789, PUB. 7-3-2012. INT. CL. 3.
- BEAVER PAPER & GRAPHIC MEDIA, INC., LAWRENCE-
VILLE, GA:
4,209,684, PUB. 7-3-2012. INT. CL. 24.
- BEAVER PLASTICS LTD., EDMONTON, ALBERTA, CANA-
DA:
1,738,371, REN. 8-16-12. INT. CL. 21.
- BECK, THOMAS P., RIDGEFIELD, CT:
2,527,337, CANC. INT. CL. 11.
- BECKHAM, DAVID, LONDON, UNITED KINGDOM:
4,208,454, PUB. 7-3-2012. INT. CL. 3.

BECOMING ONE LLC, SEATTLE, WA:
4,208,969, PUB. 3-20-2012. INT. CL. 41.
4,208,970, PUB. 3-20-2012. INT. CL. 41.

BECOMING ONE, LLC, SEATTLE, WA:
4,208,984, PUB. 3-27-2012. INT. CL. 41.

BEE-ALIVE, INC., VALLEY COTTAGE, NY:
4,211,045, INT. CL. 3.

BEENA BEAUTY HOLDING, INC., COSTA MESA, CA:
4,211,770, INT. CL. 3.

BEER LAB INC., LOS ANGELES, CA:
4,209,205, PUB. 7-3-2012. INT. CL. 32.

BEI & NANNINI S.P.A., ITALY:
3,032,407.

BEIERSDORF AKTIENGESELLSCHAFT, 20253 HAMBURG,
FED REP GERMANY:
2,662,278. REN. 8-16-12. MULTIPLE CLASS, INT. CLS. 3
AND 5.

BEIJING ELOOMOBILE CO. LTD., HAIDIAN DIST., BEIJ-
ING, CHINA:
4,211,113, MULTIPLE CLASS, INT. CLS. 9 AND 35.

BEIJING HANLASAN HOMETOWN RESTAURANT CO.,
LTD., CHINA:
4,208,376, PUB. 7-3-2012. INT. CL. 43.

BEIQI FOTON MOTOR CO., LTD., CHINA:
4,208,331, PUB. 7-3-2012. MULTIPLE CLASS, INT. CLS. 35
AND 37.

BELIEVE THE HYPE, LLC, POTTSTOWN, PA:
4,209,564, PUB. 7-3-2012. INT. CL. 25.

BELL LABORATORIES, INC., MADISON, WI:
2,642,315. REN. 8-15-12. MULTIPLE CLASS, INT. CLS. 5
AND 21.

BELL'O INTERNATIONAL CORP., MORGANVILLE, NJ,
BELL'O INTERNATIONAL LLC, MORGANVILLE, NJ:
2,598,630. REN. 8-13-12. INT. CL. 20.

BELLAMY, MICHELLE, TESQUE, NM:
2,526,859, CANC. INT. CL. 25.

BELLAMY, STEVE, SUMMERLAND, CA:
4,209,974, PUB. 7-3-2012. INT. CL. 45.

BELLISSIMO FOODS COMPANY, LLC, WALNUT CREEK,
CA:
2,606,084. REN. 8-16-12. INT. CL. 29.

BEN ELIAS INDUSTRIES CORP., NEW YORK, NY:
4,210,568, INT. CL. 25.

BENECARD SERVICES, INC., LAWRENCEVILLE, NJ, BEN-
ECARD SERVICES, INC., LAWRENCEVILLE, NJ:
1,747,906. REN. 8-11-12. INT. CL. 36.

BENEMAX, INC., MEDFIELD, MA:
4,210,645, INT. CL. 36.

BENEVOLENCE FOOD PRODUCTS, LLC., LOS ANGELES,
CA, AKA BENEVOLENCE NESTS, LONG PHUNG YEN:
4,209,470, PUB. 7-3-2012. INT. CL. 29.

BENSON, RODRIQUE, CARDIFF, CA:
4,209,998, PUB. 7-3-2012. INT. CL. 25.

BENT CREEK INSTITUTE, INC., ASHEVILLE, NC:
4,210,850, U.S. CL. A.

BENTLY NEVADA, INC., MINDEN, NV:
1,711,377. REN. 8-15-12. INT. CL. 9.

BENTON, DUANE CALVIN, KANSAS CITY, MO, DBA
ROOSTER LABORATORIES:
1,780,972. REN. 8-10-12. INT. CL. 3.

BERGENDORFF, FRED, IRVINE, CA:
2,527,078, CANC. INT. CL. 41.

BERNHEIM & DOLINSKY, FORT LAUDERDALE, FL:
4,209,733, PUB. 7-3-2012. INT. CL. 45.

BERRY PLASTICS CORPORATION, EVANSVILLE, IN:
4,209,556, PUB. 7-3-2012. INT. CL. 21.
4,211,674, INT. CL. 16.

BERT RODGERS SCHOOLS OF REAL ESTATE, INC.,
SARASOTA, FL:
4,211,308, INT. CL. 41.

BETHANY MAYER CONSULTING LLC, BROOKLYN, NY:
4,211,830, MULTIPLE CLASS, INT. CLS. 25 AND 35.

BETTS TACKLE, LTD., FUQUAY VARINA, NC:
4,209,419, PUB. 7-3-2012. INT. CL. 28.

BEVERLY BREMER'S SILVER SHOP, INC., ATLANTA, GA:
1,699,565. REN. 8-14-12. INT. CL. 42.
1,699,565, COR. INT. CL. 42.

BEVRON LABS, INC., INDEPENDENCE, MO, CHEVEUX,
INC., DUARTE, CA:
1,762,313. REN. 8-10-12. INT. CL. 3.

BEZZINA, JOHN, ASTORIA, NY:
3,037,465, CANC. INT. CL. 9.

BG DESIGN SARL, CH-1294 GENTHOD, SWITZERLAND:
4,208,354, PUB. 7-3-2012. INT. CL. 25.

BGS MEDICAL PRODUCTS, INC., VENICE, FL:
4,210,388, INT. CL. 10.

BI NUTRACEUTICALS, INC., LONG BEACH, CA:
2,535,559. REN. 8-13-12. INT. CL. 1.

BI-LO, LLC, GREENVILLE, SC:
3,037,028, CANC. INT. CL. 16.

BIAGIO CRU & ESTATE WINES, LLC, ROSLYN HEIGHTS,
NY:
4,211,075, INT. CL. 33.

BIAO, HOUSTON, TX:
4,211,558, INT. CL. 3.

BICISUPPORT S.R.L., I-23880 CASATENOV (LECCO),
ITALY:
4,208,340, PUB. 7-3-2012. INT. CL. 12.

BICON, LLC, BOSTON, MA:
4,210,175, PUB. 7-3-2012. INT. CL. 10.

BIG BLUE AUDIO LLC, MERRIMACK, NH, DBA BIG BLUE
AUDIO:
4,211,437, INT. CL. 9.

BIG CHIEF THEODORE BO DOLLIS, NEW ORLEANS, LA,
TA THE WILD MAGNOLIAS:
4,208,189, PUB. 7-3-2012. INT. CL. 41.

BIG DUTCHMAN, INC., HOLLAND, MI, U.S. INDUSTRIES,
INC., NEW YORK, NY:
1,229,279. REN. 8-14-12. INT. CL. 7.

BIG IDEA BRANDS, LLC, NEW YORK, NY:
4,210,441, INT. CL. 25.

BIGMACHINES, INC., DEERFIELD, IL:
2,618,122. REN. 8-14-12. INT. CL. 9.

BILLION GENIUS LIMITED, ROAD TOWN, TORTOLA,
BR.VIRGIN ISLANDS:
4,210,709, INT. CL. 25.

BIMAL S.R.L., I-06135 PONTEVALLECEPPI (PERUGIA),
ITALY:
4,208,285, PUB. 7-3-2012. MULTIPLE CLASS, INT. CLS. 9,
37 AND 42.

BING HAN PHARMACEUTICAL FACTORY CO., LTD.,
KUAN-TYEN HSIANG, TAIWAN:
4,210,704, MULTIPLE CLASS, INT. CLS. 3, 5 AND 30.

BIO-ENERGY SYSTEMS, INC., KALISPELL, MT:
2,745,432. REN. 8-11-12. MULTIPLE CLASS, INT. CLS. 5
AND 40.

BIO-LAB, INC., MIDDLEBURY, CT:
4,210,674, MULTIPLE CLASS, INT. CLS. 1 AND 5.

BIO-ONE, INC., RICHARDSON, TX:
4,208,168, PUB. 7-3-2012. INT. CL. 1.

BIOCARTA, INC., SAN DIEGO, CA:
2,527,558, CANC. INT. CL. 1.

BIOFARMA, FRANCE:
2,995,379.

BIOFORTE USA LLC, DELRAY BEACH, FL:
4,209,885, PUB. 7-3-2012. INT. CL. 3.

BIOGRUND GMBH, FED REP GERMANY:
4,208,437, PUB. 7-3-2012. INT. CL. 1.

BIOLIFE, LLC, SARASOTA, FL:
4,211,526, INT. CL. 5.

BIOLOG, INC., HAYWARD, CA:
2,609,021. REN. 8-11-12. INT. CL. 9.

BIOMEDICAL DEVELOPMENT CORPORATION, BUR-
BANK, CA:
4,209,995, PUB. 7-3-2012. INT. CL. 10.
4,209,996, PUB. 7-3-2012. INT. CL. 10.

BIOMETRICOM, INC., LAKE OSWEGO, OR:
4,208,987, PUB. 7-3-2012. INT. CL. 9.

BIONIC TRADER SYSTEMS, LLC, CHICAGO, IL:
4,210,654, INT. CL. 9.

BIOPHARM COMMUNICATIONS, LLC, NEW HOPE, PA:
4,210,569, INT. CL. 35.

BIOPLANET CORP., KATY, TX:
4,209,976, PUB. 7-3-2012. MULTIPLE CLASS, INT. CLS. 16
AND 21.

- BIOSOUND ESAOTE, INC., INDIANAPOLIS, IN:
2,528,410, CANC. INT. CL. 10.
- BIOTANIC, S.A. DE C.V., COL. MERCED GOMEZ, MEXICO:
3,415,098, COR. INT. CL. 5.
- BIOTRONIK SE & CO. KG, BERLIN, FED REP GERMANY:
4,208,588, PUB. 2-14-2012. INT. CL. 10.
- BIOVEST INTERNATIONAL, INC., WORCESTER, MA:
3,112,639, CANC. INT. CL. 5.
- BIOVIGIL HYGIENE TECHNOLOGIES, LLC, ANN ARBOR, MI:
4,209,572, PUB. 7-3-2012. INT. CL. 9.
4,209,575, PUB. 7-3-2012. INT. CL. 9.
- BIRD TECHNOLOGIES GROUP, INC., CLEVELAND, OH,
BIRD ELECTRONIC CORPORATION, CLEVELAND, OH:
940,870, REN. 8-16-12. U.S. CL. 21 (INT. CL. 9).
- BIRD, HARRY, LONDON, ENGLAND AND BUGDEN,
ROY, EAST SUSSEX, ENGLAND:
2,526,712, CANC. MULTIPLE CLASS, INT. CLS. 16, 25
AND 28.
- BIRKENHEUER, DOUG, CHICAGO, IL, DBA BIRKEN-
HEUER PHOTOGRAPHY:
4,209,921, PUB. 7-3-2012. INT. CL. 41.
- BIRYANI POINTE PARADISE LLC, EDISON, NJ:
4,208,745, PUB. 7-3-2012. INT. CL. 43.
- BISSELL MAPLE FARM, LLP, ROCK CREEK, OH:
4,209,212, PUB. 7-3-2012. INT. CL. 30.
- BJ ACQUISITION LLC, LONG ISLAND, NY:
4,210,847, INT. CL. 18.
- BJORKNERT, VICKY A, LOS ANGELES, CA:
4,211,588, INT. CL. 3.
- BK GIULINI GMBH, 67065 LUDWIGSHAFEN, FED REP
GERMANY, RHENOFLEX GMBH FABRIK CHEMISCH-
TECHNISCHER ERZEUGNISSE, LUDWIGSHAFEN,
RHEIN, FED REP GERMANY:
1,225,053, REN. 8-14-12. INT. CL. 17.
- BKS NETWORKS, INC., STAMFORD, CT:
3,038,138, CANC. MULTIPLE CLASS, INT. CLS. 37 AND
42.
- BLACK DOG SALVAGE, INC., ROANOKE, VA:
4,208,968, PUB. 7-3-2012. INT. CL. 35.
4,208,975, PUB. 7-3-2012. INT. CL. 35.
- BLACKSTONE INVESTMENT GROUP, INC., AURORA,
MO:
1,703,288, REN. 8-15-12. INT. CL. 18.
- BLACKWELL, DEVANTE, LAKE CHARLES, LA:
4,209,164, PUB. 7-3-2012. INT. CL. 41.
- BLAZING WAHINE LLC, KIHEI, HI:
4,208,786, PUB. 7-3-2012. MULTIPLE CLASS, INT. CLS. 14
AND 18.
- BLEVIN & LEWIS ENTERPRISES, WALDO, OH:
4,208,815, PUB. 7-3-2012. INT. CL. 29.
- BLEVINS, BILL JOSEPH, MACKINAC ISLAND, MI, DBA
CAMERA SIGNATURE AND CARR, KAREN LENA,
MACKINAC ISLAND, MI, DBA CAMERA SIGNATURE
AND CARR, ROBERT, MACKINAC ISLAND, MI, DBA
CAMERA SIGNATURE:
4,208,950, PUB. 7-3-2012. INT. CL. 25.
- BLOMUS GMBH, SUNDERN, FED REP GERMANY:
2,651,157, REN. 8-10-12. MULTIPLE CLASS, INT. CLS. 14,
16, 20 AND 21.
- BLOOPN S.A.C., CALLAO, LIMA, PERU:
4,208,641, PUB. 7-3-2012. INT. CL. 35.
- BLUE CROSS AND BLUE SHIELD ASSOCIATION, CHICA-
GO, IL, BLUE SHIELD MEDICAL CARE PLANS, CHICA-
GO, IL:
557,037, REN. 8-11-12. U.S. CL. 100 (INT. CL. 42).
- BLUE CROSS LABORATORIES, SANTA CLARITA, CA:
4,209,534, PUB. 7-3-2012. INT. CL. 3.
- BLUE DIAMONDS GROUP LLC, WOODSTOCK, GA:
4,209,854, PUB. 7-3-2012. INT. CL. 28.
- BLUE GOOSE BIOREFINERIES INC., EDMONTON, AB,
CANADA:
4,208,481, PUB. 7-3-2012. MULTIPLE CLASS, INT. CLS. 1,
4 AND 40.
- BLUE HORSESHOE SOLUTIONS, INC., CARMEL, IN:
4,210,602, INT. CL. 9.
- BLUE RIBBON STAIRS, INC., SACRAMENTO, CA:
2,526,563, CANC. INT. CL. 19.
- BLUE ROSE SKIN CARE, INC., TOMS RIVER, NJ:
2,711,998, REN. 8-14-12. INT. CL. 3.
- BLUE SKY BIO LLC, CHICAGO, IL:
4,209,240, PUB. 7-3-2012. INT. CL. 10.
- BLUE SKY FACTORY, INC., BALTIMORE, MD:
2,526,885, CANC. INT. CL. 42.
- BLUEGRASS CELLULAR, INC., ELIZABETHTOWN, KY:
1,743,598, REN. 8-16-12. INT. CL. 38.
- BLUESCOPE STEEL LIMITED, MELBOURNE, AUSTRALIA:
4,210,823, INT. CL. 6.
- BLUFIN S.P.A., ITALY:
4,208,236, PUB. 7-3-2012. INT. CL. 3.
- BMC SOFTWARE, INC., HOUSTON, TX:
1,723,355, REN. 8-11-12. INT. CL. 9.
2,608,243, REN. 8-13-12. MULTIPLE CLASS, INT. CLS. 9
AND 42.
- BOARD OF DIRECTORS OF WITTENBERG COLLEGE,
THE, SPRINGFIELD, OH, DBA WITTENBERG UNIVER-
SITY:
2,623,960, REN. 8-16-12. MULTIPLE CLASS, INT. CLS. 14,
16, 20, 21 AND 41.
2,668,150, REN. 8-16-12. MULTIPLE CLASS, INT. CLS. 16,
21, 25 AND 41.
- BOARD OF GOVERNORS, MISSOURI STATE UNIVER-
SITY, SPRINGFIELD, MO:
1,734,723, REN. 8-16-12. MULTIPLE CLASS, INT. CLS. 16,
21, 25 AND 41.
- BOAT OWNERS ASSOCIATION OF THE UNITED STATES,
ALEXANDRIA, VA:
2,720,711, REN. 8-11-12. INT. CL. 42.
- BODEGAS LUIS ALEGRE, S.A., E-01300 LAGUARDIA
(ALAVA), SPAIN:
4,208,315, PUB. 7-3-2012. INT. CL. 33.
- BODINE, JAMES, CENTERVILLE, OH:
4,211,622, INT. CL. 37.
- BODYONICS, LTD., FARMINGDALE, NY:
2,527,541, CANC. INT. CL. 5.
- BOEING MANAGEMENT COMPANY, SEAL BEACH, CA:
3,038,124, CANC. INT. CL. 28.
- BOERNE BUEN PROVECHO LLC, BOERNE, TX:
4,210,816, INT. CL. 43.
- BOGUE, BRET, RANCHO SANTA MARGARITA, CA:
4,208,464, PUB. 7-3-2012. INT. CL. 44.
- BOI TRADING COMPANY LTD., MANCHESTER, LANCA-
SHIRE M8 8E, UNITED KINGDOM:
4,208,334, PUB. 7-3-2012. MULTIPLE CLASS, INT. CLS. 3,
18 AND 25.
- BOISSET - LA FAMILLE DES GRANDS VINS, NUIITS SAINT
GEORGES, FRANCE:
4,208,615, PUB. 3-20-2012. INT. CL. 33.
- BOLD RED ENTERTAINMENT GROUP LLC, SELMA, TX:
4,211,491, INT. CL. 9.
- BON VITAL INCORPORATED, HARTLAND, WI:
4,210,717, INT. CL. 3.
- BONAFIDE ENTERTAINMENT, LLC, PHILADELPHIA, PA:
2,484,475, CANC. INT. CL. 9.
- BONIDE PRODUCTS, INC., ORISKANY, NY:
4,208,125, PUB. 7-3-2012. INT. CL. 5.
- BONITA BAY GROUP, THE, BONITA SPRINGS, FL:
2,600,760, REN. 8-15-12. INT. CL. 37.
- BONTAZ CENTRE, 74460 MARNAZ, FRANCE:
2,613,964, REN. 8-13-12. MULTIPLE CLASS, INT. CLS. 7
AND 12.
2,622,846, REN. 8-10-12. MULTIPLE CLASS, INT. CLS. 7
AND 12.
- BONVENTRE, BARBARA, NEW YORK, NY, DBA PIZZA
PALETTE PUBLICATIONS:
4,210,985, INT. CL. 16.
- BOODA ORGANICS, INC., GOLDEN, CO:
4,209,620, PUB. 7-3-2012. INT. CL. 3.
- BOOKER, CHAKA, LOS ANGELES, CA:
2,527,228, CANC. INT. CL. 25.
- BOOKHOLDERS, GAMBRILLS, MD:
4,211,794, INT. CL. 25.
- BOOMERANGIT, INC., EMERYVILLE, CA:
2,605,651, REN. 8-16-12. INT. CL. 42.
- BOPRO ENTERPRISE CO., LTD., TAIPEI, TAIWAN:
4,208,829, PUB. 7-3-2012. INT. CL. 9.

BORR & DECKER ENTERPRISES, LLC, PORTAGE, MI:
4,210,967, INT. CL. 9.

BORTEK INDUSTRIES, INC., MECHANICSBURG, PA:
4,208,858, PUB. 7-3-2012. MULTIPLE CLASS, INT. CLS. 1,
2, 3, 5, 16, 20 AND 21.
4,208,862, PUB. 7-3-2012. MULTIPLE CLASS, INT. CLS. 1,
2, 3, 5, 16, 20 AND 21.

BOSCO PRODUCTS INC., TOWACO, NJ:
4,208,773, PUB. 7-3-2012. INT. CL. 32.

BOSE CORPORATION, FRAMINGHAM, MA:
4,210,696, INT. CL. 9.
4,210,698, INT. CL. 9.

BOST BENEFITS CORP., NEW CASTLE, PA:
4,209,868, PUB. 7-3-2012. INT. CL. 36.

BOSTON RED SOX BASEBALL CLUB LIMITED PARTNER-
SHIP, BOSTON, MA:
1,736,679, REN. 8-11-12. INT. CL. 25.

BOWTIE, INC., IRVINE, CA:
4,208,901, PUB. 7-3-2012. INT. CL. 41.
4,208,902, PUB. 7-3-2012. INT. CL. 41.

BOX, INC., PALO ALTO, CA:
4,210,227, PUB. 4-3-2012. INT. CL. 41.

BOXAD MEDIA, INC., IDAHO FALLS, ID:
4,211,741, INT. CL. 35.

BOXING 360 PROMOTIONS LLC, NEW YORK, NY:
4,208,217, PUB. 7-3-2012. INT. CL. 35.

BRABUS GMBH, 46240 BOTTROP, FED REP GERMANY:
2,610,469, REN. 8-13-12. MULTIPLE CLASS, INT. CLS. 7,
9, 12, 14, 18, 25 AND 37.

BRACKET RACKET LLC, RICHMOND, VA:
4,211,115, INT. CL. 42.

BRADY WORLDWIDE, INC., MILWAUKEE, WI, W. H.
BRADY CO., MILWAUKEE, WI:
947,683, REN. 8-15-12. U.S. CL. 50 (INT. CL. 17).

BRADY WORLDWIDE, INC., MILWAUKEE, WI:
2,653,684, REN. 8-15-12. INT. CL. 16.

BRAID, DENNIS, PALMDALE, CA:
2,598,743, REN. 8-10-12. INT. CL. 28.

BRAIN PARADE, LLC, STAMFORD, CT:
4,209,920, PUB. 7-3-2012. INT. CL. 9.

BRAINPIK, ATHENS, GA:
4,210,783, INT. CL. 35.

BRAKE LANDSCAPING AND LAWN CARE, INC., ST.
LOUIS, MO:
4,209,403, PUB. 7-3-2012. INT. CL. 44.

BRAND DESIGN COMPANY, INC., YORKLYN, DE, DBA
HOUSE INDUSTRIES:
1,978,358, AM. INT. CL. 25.

BRANDED LLC, DALLAS, TX:
4,210,747, INT. CL. 3.

BRANDED, LLC, DALLAS, TX:
4,210,746, INT. CL. 25.
4,210,748, INT. CL. 18.

BRANDON STACHEL, WARREN, MI:
4,208,794, PUB. 7-3-2012. INT. CL. 25.

BRAS TO HELP SAVE THE TA TAS, LLC, FT. LAUDER-
DALE, FL:
4,209,595, PUB. 7-3-2012. INT. CL. 10.

BRAUN, MARY J, NORTHVILLE, MI:
4,208,175, PUB. 7-3-2012. MULTIPLE CLASS, INT. CLS.
16, 21 AND 25.

BRAY, MICHAEL S., SOMERS POINT, NJ:
4,211,779, INT. CL. 25.
4,211,798, INT. CL. 25.

BREATHE REPEAT LLC, NEW YORK, NY:
4,209,356, PUB. 7-3-2012. INT. CL. 41.
4,209,357, PUB. 7-3-2012. INT. CL. 41.

BRESADOLA, THOMAS E., SKANEATELES, NY:
2,526,548, CANC. INT. CL. 42.

BRETT SICILIANO, IRVINE, CA:
4,210,921, MULTIPLE CLASS, INT. CLS. 7 AND 8.

BRIAN COX, UNITED KINGDOM:
4,208,278, PUB. 7-3-2012. MULTIPLE CLASS, INT. CLS. 9,
16, 28 AND 41.

BRIAN DEEGAN, LOS ANGELES, CA:
4,209,887, PUB. 7-3-2012. INT. CL. 25.

BRIAN DEEGAN.COM, LOS ANGELES, CA:
4,211,661, INT. CL. 25.
4,211,662, INT. CL. 25.

BRIAN FITZPATRICK, LADERA RANCH, CA AND CHASE
FITZPATRICK, LADERA RANCH, CA:
4,210,482, INT. CL. 28.

BRIAN TRAINOR, YORK, ME, DBA VECTOR EDUCATION:
4,210,826, INT. CL. 41.

BRICKTOWN CANDY COMPANY, OKLAHOMA CITY, OK,
DBA BRICKTOWN CANDY CO.:
4,210,489, INT. CL. 32.

BRIDGE OF WEIR LEATHER COMPANY LIMITED, RE-
NEREWSHIRE, UNITED KINGDOM:
2,601,604, REN. 8-16-12. INT. CL. 18.
2,601,604, AM. INT. CL. 18.

BRIDGESTONE CORPORATION, TOKYO, JAPAN:
2,607,465, REN. 8-16-12. INT. CL. 12.

BRIGGS NURSERY, LLC, WELLESLEY, MA:
2,601,593, REN. 8-10-12. INT. CL. 31.
2,715,979, REN. 8-10-12. INT. CL. 42.

BRIGHT IDEAS, INC., AGOURA HILLS, CA:
4,211,816, INT. CL. 9.

BRITA LP, NEUCHÂTEL, SWITZERLAND:
2,600,835, REN. 8-11-12. INT. CL. 11.

BRITISH POLYTHENE LIMITED, LONDON, UNITED
KINGDOM:
4,210,663, MULTIPLE CLASS, INT. CLS. 16 AND 17.

BROGDEN, RICHARD, GALLOWAY, NJ:
4,211,619, INT. CL. 25.

BROKEN TONGUES, LLC, DENVER, CO:
4,209,923, PUB. 7-3-2012. INT. CL. 41.

BROOKLYNNE DESIGNS LLC, BALDWINVILLE, NY,
HAM, AVA FORMO, FLORENCE, SC, DBA GOOD FAIRY
ENTERPRISES:
1,706,812, REN. 8-11-12. INT. CL. 20.

BROOKLYN BRIDGE BARK, INC., BROOKLYN, NY, DBA
WAG CLUB:
4,208,845, PUB. 7-3-2012. INT. CL. 43.

BROOKS, LINDA ROBERTSON, SHERMAN OAKS, CA:
2,612,761, REN. 8-10-12. INT. CL. 35.

BROTHER INDUSTRIES, LTD., NAGOYA-SHI 467-8561,
JAPAN:
4,208,223, PUB. 2-14-2012. INT. CL. 9.

BROWN & YELLOW INTERNATIONAL HOLDINGS LLC,
NEW YORK, NY:
4,211,131, INT. CL. 9.
4,211,132, INT. CL. 9.

BROWN BEAR CORPORATION, CORNING, IA, DBA
BROWN BEAR CORP.:
1,736,075, REN. 8-11-12. INT. CL. 7.

BROWN BEAR CORPORATION, CORNING, IA:
1,736,703, REN. 8-11-12. INT. CL. 25.

BROWN, JAMES E., JACKSON, MS:
4,208,147, PUB. 7-3-2012. INT. CL. 25.

BROWN, TIANA CHANEL, LOS ANGELES, CA AND
WATERS, JULIANNE MARIE, LOS ANGELES, CA:
4,209,852, PUB. 7-3-2012. INT. CL. 41.

BRUMIS IMPORTS INC., NEW YORK, NY, DBA CORE
BAMBOO:
4,208,556, PUB. 7-3-2012. INT. CL. 21.

BRUNAN, INC., NORWOOD, NJ:
4,209,652, PUB. 7-3-2012. INT. CL. 41.

BRUNING, KELLY L., ROGERS CITY, MI, DBA SOAPS
AND SUCH, L.L.C:
4,209,136, PUB. 7-3-2012. INT. CL. 3.

BRUNO SANTERRE INC., RIVIÈRE-DU-LOUP QUEBEC,
CANADA:
4,210,301, INT. CL. 3.

BRUNSWICK CORPORATION, LAKE FOREST, IL:
4,210,782, INT. CL. 43.

BRYANT, CARL, WEST PALM BEACH, FL, DBA X-FELON
CLUB:
4,209,283, PUB. 7-3-2012. INT. CL. 41.

BSH HOME APPLIANCES CORPORATION, HUNTINGTON
BEACH, CA:
4,210,635, MULTIPLE CLASS, INT. CLS. 7 AND 11.

BSH HOME APPLIANCES CORPORATION, IRVINE, CA:
4,211,521, INT. CL. 7.

- BSN MEDICAL, INC), CHARLOTTE, NC:
4,209,440, PUB. 7-3-2012. MULTIPLE CLASS, INT. CLS. 5 AND 10.
- BTD WOOD POWDER COATING INC., BRAINERD, MN:
4,210,918, INT. CL. 2.
- BTI GROWTH ADVISORS, INC., CARLSBAD, CA:
4,208,576, PUB. 7-3-2012. INT. CL. 35.
4,210,925, INT. CL. 35.
- BUBBAQUE'S, LLC, BRANDON, FL:
4,208,679, PUB. 7-3-2012. INT. CL. 29.
- BUCKET CLOTHING LLC, HONOLULU, HI:
4,209,508, PUB. 7-3-2012. INT. CL. 25.
- BUCKLEY, WILLIAM L, TOKYO, JAPAN:
4,211,508, INT. CL. 14.
- BUCYRUS EUROPE GMBH, 44534 LÜNEN, FED REP GERMANY:
4,208,255, PUB. 1-17-2012. MULTIPLE CLASS, INT. CLS. 7, 9 AND 12.
- BUD STYER AND ASSOCIATES, LLC, LODI, WI:
4,209,424, PUB. 7-3-2012. MULTIPLE CLASS, INT. CLS. 35 AND 43.
4,209,425, PUB. 7-3-2012. MULTIPLE CLASS, INT. CLS. 35 AND 43.
- BUDDY V ENTERTAINMENT LLC, EAST HANOVER, NJ:
4,208,833, PUB. 7-3-2012. INT. CL. 35.
- BUDGET BLINDS, INC., ORANGE, CA:
2,688,527. REN. 8-10-12. INT. CL. 35.
- BUFFALO CHIP CAMPGROUND, LLC, STURGIS, SD:
4,211,646, INT. CL. 41.
- BUFFALO TROTTER ASSOCIATION, INC., HAMBURG, NY:
4,208,559, PUB. 7-3-2012. MULTIPLE CLASS, INT. CLS. 41 AND 43.
- BUFFARD, JENNIFER, JUPITER, FL:
4,209,269, PUB. 7-3-2012. INT. CL. 45.
- BUGATTI HOLDING BRINKMANN GMBH & CO. KG, 32049 HERFORD, FED REP GERMANY:
4,208,292, PUB. 7-3-2012. INT. CL. 25.
- BUIL & GINE SL, FALSET, TARRAGONA, SPAIN:
4,209,237, PUB. 7-3-2012. INT. CL. 33.
- BUILDERS MUTUAL INSURANCE COMPANY, RALEIGH, NC:
2,741,656. REN. 8-16-12. INT. CL. 36.
- BUILDING CHAMPIONS, INC., LAKE OSWEGO, OR:
2,726,886. REN. 8-15-12. INT. CL. 41.
- BUILDPOD INTERNATIONAL LTD, CASTEL, GUERNSEY:
4,208,540, PUB. 7-3-2012. INT. CL. 37.
- BULL DOG TOOL, INC., HOBBS, NM:
1,728,922. REN. 8-11-12. INT. CL. 7.
- BULLET GUARD CORPORATION, WEST SACRAMENTO, CA, CURRENCY PROTECTION OF CALIFORNIA, INC., WEST SACRAMENTO, CA:
1,782,683. REN. 8-16-12. MULTIPLE CLASS, INT. CLS. 17 AND 19.
- BULLINGTON, J.D., SANTA FE, NM:
4,210,439, INT. CL. 16.
- BULWARK EXTERMINATING LLC, GILBERT, AZ:
4,211,824, INT. CL. 37.
- BUMBLE AND BUMBLE, LLC, NEW YORK, NY:
2,637,042. REN. 8-15-12. INT. CL. 3.
- BUMBUMS, INC., LA JOLLA, CA, FORMERLY LITTLE BUMBUM, INC.:
4,211,563, INT. CL. 25.
- BUNGE OILS, INC., ST. LOUIS, MO:
4,210,818, INT. CL. 29.
- BURAN SA, CH-2900 PORRENTREUY, SWITZERLAND:
4,208,293, PUB. 7-3-2012. INT. CL. 14.
- BURDICK CUSTOM HOMES, INC., SAN ANTONIO, TX:
2,614,904. REN. 8-16-12. INT. CL. 37.
- BURDMAN, GERALDENE MARR, PRESCOTT, AZ:
2,528,621, CANC. INT. CL. 41.
- BURGDORF'S WINERY LLC, HASLETT, MI:
4,208,809, PUB. 7-3-2012. INT. CL. 33.
- BURN MACHINE, LLC, REDFORD, MI:
4,208,704, PUB. 7-3-2012. INT. CL. 28.
- BURON, INC., BELLINGHAM, WA:
4,211,095, INT. CL. 43.
- BURT'S BEES, INC., DURHAM, CA:
4,211,216, INT. CL. 3.
- BURT'S BEES, INC., DURHAM, NC:
4,211,218, INT. CL. 3.
4,211,244, INT. CL. 3.
4,211,245, INT. CL. 3.
4,211,246, INT. CL. 3.
4,211,355, INT. CL. 3.
- BURTON CORPORATION, THE, BURLINGTON, VT:
2,733,078. REN. 8-16-12. INT. CL. 28.
- BUSH INDUSTRIES, INC., JAMESTOWN, NY:
2,601,811. REN. 8-13-12. INT. CL. 20.
- BUSINESS AND CONCIERGE SERVICES, LLC, TRAVERSE CITY, MI, DBA FORMATIVE FITNESS:
4,209,015, PUB. 7-3-2012. INT. CL. 41.
- BUSINESS DATA SERVICES, CORP, OVERLAND PARK, KS, DBA BDS:
4,209,811, PUB. 7-3-2012. INT. CL. 42.
- BUSINESS RADIOX, LLC, ATLANTA, GA:
4,208,903, PUB. 7-3-2012. MULTIPLE CLASS, INT. CLS. 9, 35, 38, 41 AND 42.
- BYD COMPANY LIMITED, SHENZHEN, 518119, CHINA:
4,208,893, PUB. 7-3-2012. INT. CL. 12.
- BYON, TAE, IRVINE, CA:
4,211,636, INT. CL. 41.
- B2TD, LLC, WINTERVILLE, NC:
4,211,589, INT. CL. 25.
- C B STRUCTURES, INC., NEW HOLLAND, PA:
2,672,018. REN. 8-10-12. INT. CL. 19.
2,672,019. REN. 8-10-12. INT. CL. 19.
- C.A.T. TOBACCO CORPORATION, MIAMI, FL:
2,618,954. REN. 8-14-12. INT. CL. 34.
- C.H. ROBINSON WORLDWIDE, INC., EDEN PRAIRIE, MN:
4,211,418, MULTIPLE CLASS, INT. CLS. 35 AND 39.
- CABA, STEVE, NEW YORK, NY:
4,209,235, PUB. 7-3-2012. INT. CL. 25.
- CABI, LLC, RANCHO DOMINGUEZ, CA:
4,208,666, PUB. 7-3-2012. INT. CL. 25.
- CACIQUE INC., INDUSTRY, CA:
4,210,294, INT. CL. 29.
- CACIQUE, INC., CITY OF INDUSTRY, CA:
4,210,479, INT. CL. 16.
- CAESARS LICENSE COMPANY, LLC, LAS VEGAS, NV:
2,742,085. REN. 8-15-12. INT. CL. 43.
- CAESARS WORLD, INC., LAS VEGAS, NV:
945,380, AM. U.S. CL. 100.
- CAINES HILL PARTNERS, LLC, ATLANTA, GA:
4,211,775, MULTIPLE CLASS, INT. CLS. 25 AND 41.
- CAL INDIA FOODS INTERNATIONAL, CHINO, CA, DBA SPECIALTY ENZYMES AND BIOCHEMICALS CO.:
2,614,261. REN. 8-15-12. INT. CL. 1.
2,614,262. REN. 8-15-12. INT. CL. 1.
- CALGON CARBON CORPORATION, PITTSBURGH, PA, PITTSBURGH CHEMICAL COMPANY, PITTSBURGH, PA:
737,703. REN. 8-10-12. U.S. CL. 6 (INT. CL. 1).
737,704. REN. 8-10-12. U.S. CL. 6 (INT. CL. 1).
- CALGON CARBON CORPORATION, PITTSBURGH, PA:
2,618,178. REN. 8-14-12. INT. CL. 5.
4,210,660, INT. CL. 1.
- CALIDAD AUTO TECH, INC., SAYLORSBURG, PA:
2,744,516. REN. 8-14-12. INT. CL. 7.
- CALIFORNIA ONLINE POKER ASSOCIATION LLC, LOS ANGELES, CA:
4,210,784, INT. CL. 41.
- CAMBER, BRUCE, NEW ORLEANS, LA:
4,209,843, PUB. 7-3-2012. INT. CL. 41.
- CAMBRIDGE SENSORS LIMITED, CAMBRIDGESHIRE, ENGLAND:
3,267,732. COR. INT. CL. 10.
- CAMELBAK PRODUCTS, LLC, PETALUMA, CA:
4,211,153, INT. CL. 21.
- CAMERICAN INTERNATIONAL, INC., PARAMUS, NJ:
1,190,144. REN. 8-15-12. INT. CL. 29.
- CAMP MYSTIC, INC., HUNT, TX:
1,711,843. REN. 8-16-12. INT. CL. 25.

CAMPBELL HAUSFELD/SCOTT FETZER COMPANY, HARRISON, OH:
1,730,627. REN. 8-15-12. MULTIPLE CLASS, INT. CLS. 6 AND 7.

CAMTROL L.L.C., OXNARD, CA:
4,211,279. INT. CL. 9.

CANADIAN ENERGY SERVICES L.P., CALGARY, AB, CANADA:
4,208,502. PUB. 5-8-2012. MULTIPLE CLASS, INT. CLS. 1 AND 37.
4,208,503. PUB. 5-8-2012. MULTIPLE CLASS, INT. CLS. 1 AND 4.
4,208,504. PUB. 5-8-2012. MULTIPLE CLASS, INT. CLS. 1 AND 37.
4,208,505. PUB. 5-8-2012. INT. CL. 1.
4,208,506. PUB. 5-8-2012. MULTIPLE CLASS, INT. CLS. 1 AND 37.
4,208,507. PUB. 5-8-2012. MULTIPLE CLASS, INT. CLS. 1 AND 37.

CANCUN ONLINE S.A. DE C.V., CANCUN, MEXICO:
3,049,391. CANC. INT. CL. 43.
3,050,097. CANC. MULTIPLE CLASS, INT. CLS. 39 AND 43.

CANHELP, LLC, LIVINGSTON, NJ:
1,708,562. REN. 8-16-12. MULTIPLE CLASS, INT. CLS. 35 AND 42.

CANNON, DEBORAH A., OLD BROOKVILLE, NY:
4,209,944. PUB. 7-3-2012. INT. CL. 16.

CANON KABUSHIKI KAISHA, TOKYO, JAPAN:
2,617,741. REN. 8-15-12. INT. CL. 9.

CANON KABUSHIKI KAISHA, JAPAN:
4,208,406. PUB. 7-3-2012. INT. CL. 2.

CANPLAS INDUSTRIES, LTD., BARRIE, ONTARIO, CANADA, CANPLAS INDUSTRIES, LTD., BARRIE, ONTARIO, CANADA:
2,604,212. REN. 8-15-12. INT. CL. 11.

CANTERBURY LIMITED, LANCASHIRE, UNITED KINGDOM:
4,208,478. PUB. 5-29-2012. MULTIPLE CLASS, INT. CLS. 3, 9 AND 28.

CAPE COD HOSPITAL, HYANNIS, MA:
2,528,709. CANC. INT. CL. 42.

CAPE EVOLUTION LTD, CENTRAL, HONG KONG, CHINA:
4,211,302. INT. CL. 9.
4,211,461. INT. CL. 9.

CAPITAL BRANDS, LLC, CLEARWATER, FL:
4,211,184. INT. CL. 33.

CAPITAL SYSTEMS, INC., NAPLES, FL:
2,527,326. CANC. INT. CL. 9.

CAPPS UK LIMITED, BODIAM, EAST SUSSEX, UNITED KINGDOM:
4,208,490. PUB. 7-3-2012. MULTIPLE CLASS, INT. CLS. 1 AND 2.

CAPRETZ, TAYLOR, LAGUNA BEACH, CA AND CAPRETZ, RYAN, LAGUNA BEACH, CA AND CAPRETZ, CINDY, LAGUNA BEACH, CA:
4,211,070. INT. CL. 36.

CAR BAR, LLC, CLARKSTON, MI:
4,211,436. INT. CL. 43.

CARA QUICI, NEW YORK, NY:
4,209,104. PUB. 7-3-2012. MULTIPLE CLASS, INT. CLS. 9 AND 41.

CAREFUSION 2200, INC., SAN DIEGO, CA:
4,209,892. PUB. 7-3-2012. INT. CL. 10.

CAREMED SUPPLY INC., NEW TAIPEI CITY, TAIWAN:
4,208,554. PUB. 7-3-2012. INT. CL. 10.

CAREPARTNERS PLUS LLC, HORSHAM, PA:
4,210,319. MULTIPLE CLASS, INT. CLS. 35 AND 42.

CAREQUEST, INC., PLYMOUTH, MN, DBA NAVGATE TECHNOLOGIES:
4,211,694. INT. CL. 35.

CARFOLIA INTERNATIONAL, INC., LAS VEGAS, NV:
2,528,227. CANC. INT. CL. 17.

CARGILL MEAT SOLUTIONS CORPORATION, WICHITA, KS:
1,670,025. REN. 8-14-12. INT. CL. 5.

CARGILL, INCORPORATED, WAYZATA, MN:
945,029. REN. 8-10-12. U.S. CL. 6 (INT. CL. 1).
1,235,957. REN. 8-14-12. INT. CL. 1.

CARIMAX CORPORATION, KWANGJU-CITY; KYUNGGIDO, REPUBLIC OF KOREA:
4,208,368. PUB. 7-3-2012. INT. CL. 18.

CARINGBRIDGE, EAGAN, MN:
4,211,430. INT. CL. 42.

CARL RAY MAKEUP ARTIST, WASHINGTON, DC:
4,209,737. PUB. 7-3-2012. INT. CL. 44.

CARLINGSWITCH, INC., PLAINVILLE, CT:
1,623,433. CANC. INT. CL. 9.

CARLISLE INTANGIBLE COMPANY, SYRACUSE, NY:
4,211,797. INT. CL. 19.

CARLO GHAILIAN, LOS ANGELES, CA:
4,209,002. PUB. 7-3-2012. MULTIPLE CLASS, INT. CLS. 35 AND 43.

CARLOS ABREU, BEVERLY HILLS, CA:
4,211,603. INT. CL. 41.

CARLSON MARKETING WORLDWIDE, INC., MINNEAPOLIS, MN:
2,528,742. CANC. INT. CL. 35.

CARMEN'S, INC., ABINGTON, MA:
2,527,636. CANC. INT. CL. 42.

CARMINA S.R.L., 00186 ROMA (IT), ITALY:
3,038,180. CANC. INT. CL. 14.

CAROLINA FINANCIAL CORPORATION, INC., CHARLESTON, SC:
4,209,369. PUB. 7-3-2012. INT. CL. 36.

CAROLINA HERRERA LTD, NEW YORK, NY:
4,208,378. PUB. 7-3-2012. INT. CL. 3.

CAROLINA HOSIERY MILLS, INC., BURLINGTON, NC:
4,211,789. INT. CL. 25.

CARRIER ENTERPRISES, LLC, ORLANDO, FL:
4,211,604. INT. CL. 11.

CARRILLO, DINO, SHERMAN OAKS, CA:
2,659,309. REN. 8-13-12. INT. CL. 41.

CARTER, FREDERICK DAVID, MESA, AZ, DBA DRAFT HOUSE STUDIOS:
4,211,145. INT. CL. 25.

CARTHAGE COLLEGE, KENOSHA, WI:
4,209,077. PUB. 7-3-2012. INT. CL. 41.

CARTIER INTERNATIONAL A.G., 6312 STEINHAUSEN, SWITZERLAND:
2,527,098. CANC. INT. CL. 16.

CARTOON NETWORK, INC., THE, ATLANTA, GA:
2,605,597. REN. 8-10-12. INT. CL. 41.

CASAPULLA, JOSEPH, NEWARK, DE:
2,528,341. CANC. INT. CL. 8.

CASCADE ENGINEERING, INC., GRAND RAPIDS, MI:
2,526,576. CANC. INT. CL. 21.

CASCADIA REGIONAL GREEN BUILDING COUNCIL, PORTLAND, OR:
4,208,172. PUB. 7-3-2012. INT. CL. 41.

CASHEL CORP., ANAHEIM, CA:
2,603,049. REN. 8-14-12. MULTIPLE CLASS, INT. CLS. 37 AND 42.

CASPERDAISY LTD CO., WICKLOW, IRELAND:
4,209,323. PUB. 7-3-2012. INT. CL. 9.

CASTLE & COOKE, INC., LOS ANGELES, CA:
4,209,410. PUB. 7-3-2012. MULTIPLE CLASS, INT. CLS. 35, 36, 37 AND 39.

CASTRO, CHERYL E, BENICIA, CA:
4,208,683. PUB. 7-3-2012. INT. CL. 25.

CATALYST APPLIED TECHNOLOGIES, INC., NEW YORK, NY:
2,625,410. REN. 8-10-12. INT. CL. 18.

CATALYST CONNECTION, INC., PITTSBURGH, PA:
4,208,874. PUB. 7-3-2012. MULTIPLE CLASS, INT. CLS. 35 AND 41.

CATALYST INC., NEW YORK, NY:
4,208,904. PUB. 7-3-2012. INT. CL. 41.

CATALYST PAPER CORPORATION, RICHMOND, BC, CANADA:
4,208,850. PUB. 1-17-2012. INT. CL. 16.
4,208,851. PUB. 1-17-2012. INT. CL. 16.

CATANIA-SPAGNA CORPORATION, AYER, MA:
2,734,864. REN. 8-16-12. INT. CL. 29.

- CATTIN, ROLAND, PARIS, FRANCE:
3,494,342. REN. 8-15-12. INT. CL. 9.
- CAUGHRAN, MARSHA, PORTLAND, TN:
4,208,802. PUB. 7-3-2012. INT. CL. 16.
- CAVALERA, GLORIA, PHOENIX, AZ:
2,527,734. CANC. INT. CL. 25.
- CAVE DE TAIN L'HERMITAGE, UNION DES PROPRIETAIRES, TAIN L'HERMITAGE, FRANCE:
4,211,023. INT. CL. 33.
- CAVELL, MERTZ & ASSOCIATES, INC., MANASSAS, VA:
4,209,434. PUB. 7-3-2012. MULTIPLE CLASS, INT. CLS. 37, 38 AND 42.
- CBeyond COMMUNICATIONS, LLC, ATLANTA, GA:
2,671,389. REN. 8-16-12. MULTIPLE CLASS, INT. CLS. 38 AND 42.
- CBS RADIO INC., NEW YORK, NY, WESTINGHOUSE BROADCASTING COMPANY INC., NEW YORK, NY:
1,205,724. REN. 8-16-12. INT. CL. 38.
- CCA GLOBAL PARTNERS, INC., EARTH CITY, MO:
2,527,403. CANC. INT. CL. 35.
- CCL INDUSTRIES INC., WILLOWDALE, ONTARIO, CANADA:
4,208,875. PUB. 7-3-2012. MULTIPLE CLASS, INT. CLS. 40 AND 42.
4,208,876. PUB. 7-3-2012. MULTIPLE CLASS, INT. CLS. 40 AND 42.
- CDOC, INC., CARMEL, IN:
4,208,638. PUB. 7-3-2012. MULTIPLE CLASS, INT. CLS. 36 AND 42.
- CE BROKER, INC., JACKSONVILLE, FL:
4,211,561. INT. CL. 9.
- CEDC INTERNATIONAL SP. Z O.O., OBORNIKI WIELKOPOLSKIE, POLAND:
4,208,476. PUB. 7-3-2012. INT. CL. 33.
- CELESTIAL CHURCH OF CHRIST AMERICAN DIOCESE, LANDOVER, MD:
3,027,199. CANC. INT. CL. 45.
- CELGENE CORPORATION, SUMMIT, NJ:
4,211,642. INT. CL. 42.
4,211,643. INT. CL. 42.
4,211,657. INT. CL. 42.
- CELINA ALUMINUM PRECISION TECHNOLOGY, INC., CELINA, OH:
4,208,735. PUB. 7-3-2012. MULTIPLE CLASS, INT. CLS. 7 AND 12.
- CELLULOSE INSULATION MANUFACTURERS ASSOCIATION, DAYTON, OH:
2,614,332. REN. 8-15-12. MULTIPLE CLASS, INT. CLS. 16 AND 35.
2,614,333. REN. 8-15-12. MULTIPLE CLASS, INT. CLS. 16 AND 35.
- CEN LINK CO., LTD., NEW TAIPEI CITY, TAIWAN:
2,690,938. REN. 8-16-12. INT. CL. 9.
- CENGAGE LEARNING, INC., STAMFORD, CT:
4,209,533. PUB. 7-3-2012. INT. CL. 42.
- CENTAURI STRATEGIC SERVICES, MARIETTA, GA:
4,211,459. INT. CL. 42.
- CENTER FOR FOOD INTEGRITY, KANSAS CITY, MO:
4,210,371. INT. CL. 35.
- CENTER FOR INTERVENTIONAL MEDICINE LLC, WHITE PLAINS, MD:
4,211,831. INT. CL. 44.
- CENTEX CORPORATION, DALLAS, TX:
2,957,285. CANC. INT. CL. 37.
- CENTONZE S.R.L., ITALY:
4,208,400. PUB. 7-3-2012. INT. CL. 33.
- CENTRACCO, ZAHIA, OKLAHOMA CITY, OK, DBA CENTRACCO, COOKIE AND BATCHELOR, DANIELLE, HOUSTON, TX:
4,210,267. INT. CL. 9.
- CENTRAFI, INC., BOSTON, MA:
4,208,696. PUB. 7-3-2012. MULTIPLE CLASS, INT. CLS. 35 AND 41.
- CENTRAL FIBER LLC, WELLSVILLE, KS:
4,210,560. MULTIPLE CLASS, INT. CLS. 1, 17, 22 AND 31.
- CENTRAL GARDEN & PET COMPANY, WALNUT CREEK, CA:
1,683,768. REN. 8-15-12. INT. CL. 16.
- CENTRAL INTERCOLLEGIATE ATHLETIC ASSOCIATION, THE, HAMPTON, VA:
1,777,721. REN. 8-16-12. MULTIPLE CLASS, INT. CLS. 14, 16, 25 AND 28.
- CENTRIC GROUP, LLC, ST. LOUIS, MO:
3,101,966. COR. MULTIPLE CLASS, INT. CLS. 3 AND 8.
- CENTRIS CONSULTING, INC., SCRANTON, PA:
4,211,808. INT. CL. 35.
4,211,809. INT. CL. 35.
- CENTRO MEDIA, INC., CHICAGO, IL:
4,211,804. INT. CL. 35.
- CENTURYLINK, INC., MONROE, LA:
4,211,342. INT. CL. 43.
4,211,344. INT. CL. 35.
4,211,410. INT. CL. 20.
- CEPIA, LLC, SAINT LOUIS, MO:
4,211,551. INT. CL. 28.
4,211,553. INT. CL. 28.
- CERAMIFIX LLC, MUNFORD, TN, DBA CERAMIFIX:
4,209,427. PUB. 7-3-2012. INT. CL. 2.
- CERRUTI 1881 S.A.S., PARIS, FRANCE:
1,704,471. REN. 8-16-12. INT. CL. 3.
- CERTA PROPAINTEERS, LTD., PHILADELPHIA, PA:
4,210,003. PUB. 7-3-2012. INT. CL. 37.
- CERTAINTEED CEILINGS CORPORATION, VALLEY FORGE, PA, CELOTEX CORPORATION, THE, CHICAGO, IL:
727,382. REN. 8-14-12. U.S. CL. 12 (INT. CL. 19).
- CERTIFIED VOLUNTARY BENEFITS PROVIDER, ROYAL PALM BEACH, FL:
4,211,821. INT. CL. 42.
- CFE MEDIA LLC, OAK BROOK, IL:
4,211,836. MULTIPLE CLASS, INT. CLS. 9 AND 42.
- CGI WINDOWS AND DOORS, INC., DORAL, FL:
4,210,431. INT. CL. 6.
- CG4 SOLUTIONS, INC., CENTERVILLE, UT TO CG4 SOLUTIONS, INC., CENTERVILLE, UT:
2,526,646. CANC. INT. CL. 9.
- CHABAD OF PARKLAND, INC., PARKLAND, FL:
2,609,116. REN. 8-15-12. INT. CL. 19.
- CHADBOURNE ROAD CAPITAL, RED BANK, NJ:
4,211,806. INT. CL. 36.
- CHAFER MACHINERY LTD., UPTON GAINSBOROUGH LINCOLNSHIRE, UNITED KINGDOM:
3,037,493. CANC. INT. CL. 7.
- CHAINDRUGSTORE.NET INCORPORATED, ALEXANDRIA, VA:
4,211,704. INT. CL. 35.
- CHAMPION FOODS, L.L.C., DETROIT, MI:
4,208,148. PUB. 7-3-2012. INT. CL. 30.
- CHAMPION NATIONAL SECURITY, INC., RICHARDSON, TX:
3,916,049. COR. INT. CL. 45.
- CHAN & ZEN LLC, NEW YORK, NY:
4,211,028. MULTIPLE CLASS, INT. CLS. 14 AND 35.
- CHAN, YEE HUNG DEBBY, NEW YORK, NY:
2,704,333. REN. 8-10-12. INT. CL. 30.
- CHANCE ENTERTAINMENT, LLC, DALLAS, TX:
3,232,665. CANC. INT. CL. 35.
- CHANNEL ISLANDS MEDIA GROUP, INC., DEL MAR, CA:
4,209,047. PUB. 7-3-2012. INT. CL. 42.
- CHANNEL PLUMBING, INC., SANTA BARBARA, CA:
4,208,602. PUB. 7-3-2012. INT. CL. 37.
- CHAPARRAL GARDENS VINEGAR, ATASCADERO, CA:
4,209,777. PUB. 7-3-2012. INT. CL. 30.
- CHARLES Y COGHLAN, BLOOMINGTON, IN, DBA OFFICE EASEL:
4,211,752. INT. CL. 16.
- CHARLESTON COMPANY FOR THE CHARLESTON REPORT, THE, DENVER, CO:
2,527,023. CANC. INT. CL. 16.
- CHARLOTTE ANDERSON, WILMINGTON, DE:
4,208,754. PUB. 7-3-2012. INT. CL. 41.
- CHASE DISTILLERY LIMITED, HEREFORD, UNITED KINGDOM:
4,100,546. COR. INT. CL. 33.

CHAUDEURGE, JEAN-MICHEL, FRANÇOIS, F-83170
 TOURVES, FRANCE:
 4,208,370, PUB. 7-3-2012. INT. CL. 12.
 CHAUVIN ARNOUX, INC., DOVER, NH:
 4,210,990, INT. CL. 9.
 CHECK SIX PRODUCTIONS, INC., STUDIO CITY, CA:
 2,624,938. REN. 8-11-12. INT. CL. 41.
 CHEIL INDUSTRIES, INC., KYOUNGSANGBUK-DO, RE-
 PUBLIC OF KOREA:
 1,705,075. REN. 8-10-12. INT. CL. 24.
 CHELSEA & SCOTT, LTD, LAKE BLUFF, IL:
 4,211,358, INT. CL. 28.
 CHEM-AQUA, INC., IRVING, TX:
 4,210,973, INT. CL. 9.
 CHEMCORP PTY LTD, TAREN POINT, AUSTRALIA:
 4,210,218, PUB. 7-3-2012. INT. CL. 16.
 CHEMICAL SOURCES ASSOCIATION, INC., LYNDHURST,
 NJ:
 2,634,453. REN. 8-11-12. INT. CL. 42.
 CHEMISCH THERMISCHE PROZESSTECHNIK GMBH,
 SCHMIEDLSTR. 10, AUSTRIA:
 4,208,567, PUB. 7-3-2012. INT. CL. 11.
 CHEMISCHES LABORATORIUM; DR. KURT RICHTER
 GMBH, FED REP GERMANY:
 4,208,398, PUB. 7-3-2012. INT. CL. 1.
 CHENG, KUO HUNG, KAOHSIUNG CITY, TAIWAN, TAI-
 WAN:
 4,211,434, INT. CL. 28.
 CHENSON INDUSTRIAL CO. LTD., INC., LOS ANGELES,
 CA:
 4,209,918, PUB. 7-3-2012. INT. CL. 18.
 CHEVRON INTELLECTUAL PROPERTY LLC, SAN RA-
 MON, CA:
 561,960. REN. 8-16-12. U.S. CL. 15 (INT. CL. 4).
 CHICAGO BAPTIST INSTITUTE, CHICAGO, IL:
 4,209,001, PUB. 7-3-2012. INT. CL. 41.
 CHICAGO CLASSICAL RECORDING FOUNDATION, THE,
 CHICAGO, IL:
 1,725,148. REN. 8-15-12. INT. CL. 9.
 1,725,148, AM. INT. CL. 9.
 CHICAGO PNEUMATIC TOOL COMPANY LLC, ROCK
 HILL, SC:
 1,705,757. REN. 8-16-12. INT. CL. 7.
 CHICAGO WHITE SOX, LTD., CHICAGO, IL:
 1,223,508. REN. 8-16-12. INT. CL. 25.
 CHICO'S BRANDS INVESTMENTS, INC., FORT MYERS,
 FL:
 2,527,071, CANC. INT. CL. 36.
 CHILDREN'S HEARTLINK, MINNEAPOLIS, MN:
 4,210,587, INT. CL. 44.
 CHILLER USA OUTFITTERS LLC, PROVIDENCE, RI:
 4,209,718, PUB. 7-3-2012. INT. CL. 25.
 CHINESE CULTURE FOUNDATION OF SAN FRANCISCO,
 SAN FRANCISCO, CA:
 4,209,703, PUB. 7-3-2012. INT. CL. 45.
 4,210,016, PUB. 7-3-2012. INT. CL. 39.
 CHING FENG HOME FASHIONS CO., LTD., CHANG-HWA
 HSIEN, TAIWAN:
 4,208,219, PUB. 4-17-2012. INT. CL. 20.
 CHIQUITA BRANDS L.L.C., CINCINNATI, OH:
 1,731,439. REN. 8-11-12. INT. CL. 31.
 4,210,901, INT. CL. 31.
 4,210,941, INT. CL. 29.
 CHIVAS HOLDINGS (IP) LIMITED, UNITED KINGDOM:
 4,208,302, PUB. 7-3-2012. MULTIPLE CLASS, INT. CLS.
 32, 33 AND 43.
 4,208,316, PUB. 7-3-2012. MULTIPLE CLASS, INT. CLS.
 32, 33 AND 43.
 4,208,317, PUB. 7-3-2012. MULTIPLE CLASS, INT. CLS.
 32, 33 AND 43.
 CHLOE & CO., LLC., CHARLOTTE, NC:
 4,209,585, PUB. 7-3-2012. INT. CL. 14.
 CHOCOLAFABRIKEN LINDT & SPRÜNGLI AG, CH-
 8802 KILCHBERG, SWITZERLAND:
 4,210,672, MULTIPLE CLASS, INT. CLS. 16, 21 AND 35.
 CHOICE SAVINGS FRANCHISING, INC., ROSWELL, GA:
 2,610,196. REN. 8-15-12. INT. CL. 16.
 2,610,197. REN. 8-16-12. INT. CL. 35.
 CHOICES CAFE, INC., MIAMI, FL:
 4,209,022, PUB. 7-3-2012. INT. CL. 43.
 CHOPPHEARSE INC, ALBUQUERQUE, NM:
 4,209,622, PUB. 7-3-2012. INT. CL. 39.
 4,209,627, PUB. 7-3-2012. INT. CL. 39.
 4,209,964, PUB. 7-3-2012. INT. CL. 39.
 CHRIS PEGULA, LOS ANGELES, CA:
 4,208,485, PUB. 7-3-2012. INT. CL. 25.
 CHRISTIAN LACROIX, PARIS, FRANCE:
 4,211,120, INT. CL. 4.
 CHRISTOPHER LEE HUNTER, NORCROSS, GA:
 4,209,965, PUB. 7-3-2012. INT. CL. 41.
 CHROMADDEX, INC., IRVINE, CA:
 4,210,890, MULTIPLE CLASS, INT. CLS. 1 AND 42.
 CHURCH & DWIGHT CO., INC., PRINCETON, NJ:
 949,313. REN. 8-14-12. U.S. CL. 5 (INT. CL. 5).
 949,313, AM. U.S. CL. 5.
 CHURCH WORLD SERVICE, INC., ELKHART, IN:
 2,621,144. REN. 8-15-12. INT. CL. 36.
 CHURCHKEY CAN COMPANY, INC., PLEASANTON, CA:
 4,210,135, PUB. 7-3-2012. INT. CL. 32.
 CICHON, JOSEPH, TRUMBULL, CT:
 4,211,189, INT. CL. 45.
 CILURZO, VINNIE, SANTA ROSA, CA AND CILURZO,
 NATALIE, SANTA ROSA, CA:
 4,211,815, INT. CL. 32.
 CINCINNATI INSURANCE COMPANY, THE, CINCINNATI,
 OH:
 2,739,946. REN. 8-10-12. INT. CL. 9.
 CINERGY CORP., CINCINNATI, OH:
 3,126,477, CANC. MULTIPLE CLASS, INT. CLS. 36 AND
 38.
 CIRCULENT, DARIEN, CT:
 4,209,120, PUB. 7-3-2012. INT. CL. 42.
 CITRA LABS, LLC, WARSAW, IN:
 2,739,619. REN. 8-15-12. INT. CL. 5.
 CITRUS DRINK VENTURES, INC., FT. LAUDERDALE, FL:
 2,601,602. REN. 8-11-12. INT. CL. 32.
 CITY GROUP, INC., JESSUP, MD:
 2,526,586, CANC. INT. CL. 3.
 CITY LIGHT FILMS, LTD., LOS ANGELES, CA:
 1,741,827. REN. 8-15-12. INT. CL. 41.
 CITY OF TEHACHAPI, CITY OF TEHACHAPI, CA:
 4,209,554, PUB. 7-3-2012. INT. CL. 35.
 CITY OF TULSA, TULSA, OK:
 4,211,129, INT. CL. 16.
 CITYLIGHT HOMES, LLC, PEABODY, MA:
 4,209,890, PUB. 7-3-2012. INT. CL. 36.
 CITYSTRUCTURE, LLC, SEATTLE, WA:
 4,209,861, PUB. 7-3-2012. INT. CL. 42.
 CIZETA MEDICALI S.P.A., ITALY:
 4,208,390, PUB. 7-3-2012. MULTIPLE CLASS, INT. CLS. 3
 AND 5.
 CK3 LLC, NEW YORK, NY:
 4,209,083, PUB. 7-3-2012. INT. CL. 33.
 CLAIM IT PRODUCTIONS, LLC, ALBUQUERQUE, NM:
 4,209,588, PUB. 7-3-2012. INT. CL. 42.
 4,209,596, PUB. 7-3-2012. INT. CL. 42.
 4,209,966, PUB. 7-3-2012. INT. CL. 42.
 CLARCOR AIR FILTRATION PRODUCTS, INC., JEFFER-
 SONVILLE, IN:
 4,211,347, INT. CL. 11.
 CLASSIC FOODS INTERNATIONAL CORP., IRVINE, CA,
 DBA CLASSIC FOODS, INC.:
 4,211,266, INT. CL. 30.
 CLAYTON COLLEGE OF NATURAL HEALTH, INC., BIR-
 MINGHAM, AL:
 2,526,937, CANC. INT. CL. 41.
 CLEAN CURRENTS, LLC, SILVER SPRING, MD:
 4,210,779, INT. CL. 37.
 4,210,781, INT. CL. 37.
 CLEAN ETHICS LLC, BURLINGTON, VT:
 4,209,839, PUB. 7-3-2012. INT. CL. 5.
 CLEAN PLUS INCORPORATED, WEST CONCORD, MN:
 2,611,014. REN. 8-16-12. INT. CL. 21.

- CLEANPIX CORPORATION, CALGARY, ALBERTA, CANADA, CLEANPIX CORPORATION, CALGARY, ALBERTA, CANADA:
2,730,110. REN. 8-11-12. INT. CL. 35.
- CLEAR CHANNEL OUTDOOR, INC., SAN ANTONIO, TX:
4,210,205. PUB. 7-3-2012. MULTIPLE CLASS, INT. CLS. 35 AND 38.
- CLEARY, ZOE, OXFORD, MS AND WOODYARD, PATRICK, OXFORD, MS:
4,209,146. PUB. 7-3-2012. INT. CL. 25.
- CLEAVER-BROOKS, INC., MILWAUKEE, WI:
4,209,982. PUB. 7-3-2012. INT. CL. 9.
- CLEMCO PRODUCTS, INC., WESTMINSTER, MD:
4,208,501. PUB. 7-3-2012. INT. CL. 18.
- CLEVELAND INDIANS BASEBALL COMPANY LIMITED PARTNERSHIP, CLEVELAND, OH:
1,711,810. REN. 8-11-12. INT. CL. 25.
- CLEVELAND MACK SALES, INC., CLEVELAND, TX:
2,574,122. REN. 8-15-12. INT. CL. 35.
- CLICGEAR INDUSTRIES LIMITED, KWAI CHUNG, N.T., HONG KONG:
4,209,856. PUB. 7-3-2012. INT. CL. 28.
- CLINICAL INNOVATIONS, LLC, LAKE FOREST, IL:
2,615,500. REN. 8-16-12. INT. CL. 10.
- CLINICAL TRIALS OF TEXAS, INC., SAN ANTONIO, TX:
4,210,983. MULTIPLE CLASS, INT. CLS. 35 AND 42.
- CLINIQUE LABORATORIES, LLC, NEW YORK, NY:
4,209,127. PUB. 7-3-2012. INT. CL. 3.
- CLIPPER NAVIGATION, INC., SEATTLE, WA:
1,731,675. REN. 8-16-12. INT. CL. 39.
- CLOCK SHADOW CREAMERY, LLC, PLAIN, WI:
4,211,022. INT. CL. 29.
- CLOCKWORK IP, LLC, SARASOTA, FL:
4,209,462. PUB. 7-3-2012. INT. CL. 37.
4,209,473. PUB. 7-3-2012. INT. CL. 37.
- CLONEX DEVELOPMENT, INC., CHICAGO, IL:
3,038,329. CANC. INT. CL. 42.
- CLP RESOURCES, INC., RENO, NV:
4,209,525. PUB. 7-3-2012. INT. CL. 35.
- CMD CORPORATION, APPLETON, WI:
2,652,263. REN. 8-13-12. INT. CL. 7.
- CMH HOMES, INC., MARYVILLE, TN:
4,209,452. PUB. 7-3-2012. INT. CL. 35.
4,210,180. PUB. 7-3-2012. INT. CL. 35.
- CNF INC., PALO ALTO, CA TO UNITED PARCEL SERVICE OF AMERICA, INC., ATLANTA, GA:
2,527,006. CANC. INT. CL. 39.
- COACHES TRAINING INSTITUTE, THE, SAN RAFAEL, CA:
2,680,023. REN. 8-11-12. INT. CL. 16.
- COATEX S.A.S., FRANCE:
4,208,445. PUB. 7-3-2012. INT. CL. 1.
- COATING EXCELLENCE INTERNATIONAL LLC, WRIGHTSTOWN, WI:
4,210,895. MULTIPLE CLASS, INT. CLS. 16 AND 17.
- COBRA ELECTRONICS CORPORATION, CHICAGO, IL, DYNASCAN CORPORATION, CHICAGO, IL:
1,702,979. REN. 8-11-12. INT. CL. 9.
- COBRA GOLF INCORPORATED, CARLSBAD, CA TO COBRA GOLF INCORPORATED, CARLSBAD, CA:
2,526,619. CANC. INT. CL. 28.
- COBRA GOLF INCORPORATED, CARLSBAD, CA:
4,211,871. INT. CL. 28.
- COCKBURN & CA., S.A., VILA NOVA DE GAIA, PORTUGAL:
940,779. REN. 8-12-12. U.S. CL. 47 (INT. CL. 33).
- COCOS ISLAND OKINAWA CORPORATION, JAPAN:
3,007,553.
- CODE OF ARMS LLC, NEW YORK, NY:
4,208,491. PUB. 9-13-2011. INT. CL. 25.
- COFFEE QUALITY INSTITUTE CHARITABLE TRUST, COMPRISING GERALD BALDWIN, DAVID BOYD, DOUGLAS CARPENTER, DAN COX, SALIM JANNA, HARRY KANGIS, TED LINGLE, MARY PETIT, ELLEN JORDAN REIDY, JOHN STILES, GEORGE VUKASIN, ALL US CITIZENS; HERBERT DE SOLA, A CITIZEN OF GUATEMALA AND EDUARDO A. ESTEVE, A CITIZEN OF MEXICO, LONG BEACH, CA:
3,038,197. CANC. INT. CL. 30.
- COGNATE NUTRITIONALS, INC., BLOOMFIELD, CT:
4,210,936. MULTIPLE CLASS, INT. CLS. 5 AND 29.
- COGNIS IP MANAGEMENT GMBH, DUESSELDORF, FED REP GERMANY:
2,614,435. REN. 8-13-12. INT. CL. 1.
- COHAN, EVAN M, VENTURA, CA:
4,209,810. PUB. 7-3-2012. INT. CL. 39.
- COHEN, DAVID C., SEBASTOPOL, CA:
2,527,074. CANC. INT. CL. 33.
- COHEN, JASON, ROYAL PALM BEACH, FL AND COHEN, SUSAN, ROYAL PALM BEACH, FL:
4,182,119. COR. INT. CL. 25.
- COHEN, STEPHEN J., UPPER SADDLE RIVER, NJ:
4,210,445. INT. CL. 25.
- COHN, SCOTT, WOODSIDE, NY:
4,211,606. INT. CL. 9.
- COLDER PRODUCTS COMPANY, ST. PAUL, MN:
2,729,487. REN. 8-15-12. INT. CL. 17.
- COLE, FREEDOM TOBIAS, NEVADA CITY, CA:
4,208,927. PUB. 7-3-2012. MULTIPLE CLASS, INT. CLS. 16 AND 41.
- COLEMAN COMPANY, INC., THE, WICHITA, KS:
2,602,892. REN. 8-10-12. INT. CL. 21.
- COLGATE-PALMOLIVE COMPANY, NEW YORK, NY:
2,528,269. CANC. INT. CL. 3.
4,210,474. INT. CL. 5.
- COLLANO SERVICES EXTRUSION AG, SCHMITTEN, SWITZERLAND:
3,037,473. CANC. MULTIPLE CLASS, INT. CLS. 2, 17 AND 22.
- COLLECTIVE HABIT, INC., SAN DIEGO, CA:
4,209,616. PUB. 7-3-2012. MULTIPLE CLASS, INT. CLS. 14, 25 AND 35.
- COLLEGE CENTRAL NETWORK, INC., NEW YORK, NY:
4,208,474. PUB. 7-3-2012. INT. CL. 42.
- COLLEGE READY, LLC, MIAMI, FL:
4,211,354. INT. CL. 18.
- COLLEGENET, INC., PORTLAND, OR:
2,709,633. REN. 8-12-12. INT. CL. 38.
- COLONIAL CIRCUITS, INC., FREDERICKSBURG, VA:
2,622,658. REN. 8-14-12. MULTIPLE CLASS, INT. CLS. 40 AND 42.
- COLOPLAST CORP., MARIETTA, GA TO COLOPLAST CORP., MARIETTA, GA:
2,528,122. CANC. MULTIPLE CLASS, INT. CLS. 3 AND 5.
- COLOR WHEEL PAINTS & COATINGS, INC., ORLANDO, FL:
4,211,369. MULTIPLE CLASS, INT. CLS. 35, 37 AND 42.
- COLORBOK, INC., DEXTER, MI:
2,528,310. CANC. INT. CL. 28.
- COLTENE/WHALEDENT INC., CUYAHOGA FALLS, OH, IPCO CORPORATION, NEW YORK, NY:
1,201,900. REN. 8-11-12. INT. CL. 10.
- COLUMBIA INSURANCE COMPANY, OMAHA, NE:
2,662,899. REN. 8-15-12. INT. CL. 36.
2,667,375. REN. 8-16-12. INT. CL. 21.
4,210,582. INT. CL. 19.
- COLUMBIA RIVER CARBONATES, WOODLAND, WA:
4,209,949. PUB. 7-3-2012. INT. CL. 1.
- COLUMBUS DATA SERVICES, L.L.C., DALLAS, TX:
4,208,178. PUB. 7-3-2012. INT. CL. 36.
- COMERCIALIZADORA MD, S.A. DE C.V., ZAPOPAN, JALISCO, MEXICO:
4,208,531. PUB. 8-23-2011. INT. CL. 5.
4,208,533. PUB. 4-24-2012. INT. CL. 5.
- COMMANDHUB PTY LTD., MELBOURNE, VICTORIA, AUSTRALIA:
4,208,633. PUB. 7-3-2012. INT. CL. 42.
- COMMEMORATIVE BRANDS, INC., AUSTIN, TX:
1,704,202. REN. 8-10-12. INT. CL. 14.
- COMMERX CORPOERATION, CALGARY, ALBERTA, CANADA:
4,209,202. PUB. 7-3-2012. INT. CL. 42.
- COMMISSO, ANTHONY J., LATHAM, NY:
2,659,438. REN. 8-13-12. INT. CL. 42.
2,659,438. CANC. INT. CL. 35.

COMMUNICATIONS-APPLIED TECHNOLOGY, RESTON, VA:
2,740,361. REN. 8-13-12. INT. CL. 9.

COMMUNITY DISTRIBUTION CENTER, SUN VALLEY, CA:
4,208,887. PUB. 7-3-2012. MULTIPLE CLASS, INT. CLS. 32 AND 36.
4,208,908. PUB. 7-3-2012. MULTIPLE CLASS, INT. CLS. 32 AND 36.

COMMUNITY NEWSPAPER HOLDINGS INC, MONTGOMERY, AL:
4,211,742. INT. CL. 41.

COMMUNITY PET OUTREACH, P.A., ARLINGTON, TX:
4,211,499. INT. CL. 44.

COMMUNITY UNIT SCHOOL DISTRICT 300, CARPENTERSVILLE, IL:
4,209,286. PUB. 7-3-2012. MULTIPLE CLASS, INT. CLS. 25 AND 41.

COMOBAR, LLC, MIAMI GARDENS, FL:
4,210,333. INT. CL. 30.

COMPAGNIE DE SAINT-GOBAIN, FRANCE:
4,208,329. PUB. 7-3-2012. MULTIPLE CLASS, INT. CLS. 35, 38, 41 AND 42.

COMPANIA LICORERA DE CENTROAMERICA, SA, MIAMI, FL:
2,606,928. REN. 8-10-12. INT. CL. 33.

COMPASS ROSE EVENTS, INC., BOOTHBAY HARBOR, ME:
4,209,305. PUB. 7-3-2012. INT. CL. 35.

COMPERDA, SCOTT MICHAEL, ST. CHARLES, IL:
4,210,337. INT. CL. 28.

COMPETITOR GROUP, INC., SAN DIEGO, CA:
4,211,303. INT. CL. 35.
4,211,304. INT. CL. 41.

COMPLEMENTARY COATINGS CORP., MONTVALE, NJ:
4,209,802. PUB. 7-3-2012. INT. CL. 2.
4,210,137. PUB. 7-3-2012. INT. CL. 2.

COMPRESULTS, L.L.C., FAIRWAY, KS:
4,209,495. PUB. 7-3-2012. INT. CL. 44.

COMPTON FOUNDATION, INC., REDWOOD CITY, CA:
4,208,583. PUB. 7-3-2012. INT. CL. 36.

COMPUTER SCIENCES CORPORATION, FALLS CHURCH, VA:
4,210,344. INT. CL. 9.

COMPUTERLAW GROUP, PALO ALTO, CA:
4,211,546. INT. CL. 45.

CONAGRA FOODS LAMB WESTON, INC., OMAHA, NE:
1,710,234. REN. 8-12-12. INT. CL. 29.

CONAGRA FOODS RDM, INC., OMAHA, NE, GOLDEN VALLEY MICROWAVE FOODS, INC., EDINA, MN:
1,705,230. REN. 8-10-12. INT. CL. 31.

CONAIR CORPORATION, STAMFORD, CT:
2,528,451. CANC. INT. CL. 9.
4,210,729. INT. CL. 9.

CONCEPT COMMUNICATION COMPANY, BOLINGBROOK, IL:
2,619,456. REN. 8-16-12. INT. CL. 35.

CONCEPT LABORATORIES, INC., CHICAGO, IL:
4,209,967. PUB. 7-3-2012. INT. CL. 3.
4,210,000. PUB. 7-3-2012. MULTIPLE CLASS, INT. CLS. 3 AND 5.

CONCORDIA PUBLISHING HOUSE, ST. LOUIS, MO:
4,211,274. INT. CL. 16.

CONDAX LLC., ROCKVILLE CENTER, NY:
4,208,681. PUB. 7-3-2012. INT. CL. 10.

CONG TY CO PHAN NUOC GIAI KHAT CHUONG DUONG, VIETNAM:
4,208,335. PUB. 7-3-2012. INT. CL. 32.

CONGAREE HOLDINGS AND DEVELOPMENT GROUP, LLC, COLUMBIA, SC:
4,208,574. PUB. 7-3-2012. INT. CL. 41.

CONKLIN OFFICE SERVICES, INC., HOLYOKE, MA:
4,209,945. PUB. 7-3-2012. INT. CL. 20.
4,209,946. PUB. 7-3-2012. INT. CL. 20.
4,210,156. PUB. 7-3-2012. INT. CL. 20.

CONN-WELD INDUSTRIES, INC., PRINCETON, WV:
4,210,739. INT. CL. 7.

CONNECT 2 CHRIST CHURCH, INC., SEMINOLE, FL:
4,209,463. PUB. 7-3-2012. INT. CL. 45.

CONNECTWARE TECHNOLOGIES, LLC, SAN FRANCISCO, CA, DBA LIQUORLICENSECONNECTION.COM:
4,208,966. PUB. 7-3-2012. MULTIPLE CLASS, INT. CLS. 35 AND 38.

CONOPCO, INC., ENGLEWOOD CLIFFS, NJ:
2,442,874. REN. 8-13-12. INT. CL. 3.
4,211,224. INT. CL. 3.

CONSORTIUM HEALTH PLANS INCORPORATED, COLUMBIA, MD:
2,631,484. REN. 8-14-12. INT. CL. 36.
2,631,484. CANC. INT. CL. 9.

CONSORTIUM OF PAPERS, INC., RENTON, WA:
4,208,146. PUB. 7-3-2012. INT. CL. 35.

CONSTANT, MARIE, ROSEDALE, NY AND CONSTANT, MANOUSHKA, ROSEDALE, NY:
4,209,709. PUB. 7-3-2012. MULTIPLE CLASS, INT. CLS. 41 AND 43.

CONSTELLATION WINES U.S., INC., CANANDAIGUA, NY, QUAKER HILL OF COLORADO INC., SAN RAFAEL, CA, DBA CLOS DU BOIS WINERY:
1,236,637. REN. 8-16-12. INT. CL. 33.

CONSTRUCTION RESEARCH & TECHNOLOGY GMBH, TROSTBERG, FED REP GERMANY:
941,228. REN. 8-11-12. U.S. CL. 12 (INT. CL. 19).

CONTEC, INC., SPARTANBURG, SC:
1,754,765. REN. 8-11-12. INT. CL. 3.

CONTENTWATCH, INC., MIDVALE, UT:
2,606,188. REN. 8-11-12. INT. CL. 9.

CONTINENTAL CONTROL SYSTEMS, LLC, BOULDER, CO:
4,209,599. PUB. 7-3-2012. INT. CL. 9.

CONTINENTAL REIFEN DEUTSCHLAND GMBH, 30165 HANNOVER, FED REP GERMANY:
4,208,267. PUB. 7-3-2012. INT. CL. 12.

CONTINUA HEALTH ALLIANCE, BEAVERTON, OR:
4,210,300. U.S. CL. A.

CONTRALCO, 34150 GIGNAC, FRANCE:
4,209,498. PUB. 7-3-2012. INT. CL. 10.

CONVIO, INC., AUSTIN, TX:
4,209,041. PUB. 7-3-2012. MULTIPLE CLASS, INT. CLS. 35 AND 42.
4,209,043. PUB. 7-3-2012. MULTIPLE CLASS, INT. CLS. 35 AND 42.

CONYMET DURATRAY PTY LIMITED, BAYSWATER, VIC, AUSTRALIA:
4,208,224. PUB. 10-4-2011. INT. CL. 12.

COOK, DIANA, CENTURY CITY, CA:
4,210,394. INT. CL. 28.

COON, DOUGLAS, SEMINOLE, FL:
4,211,155. INT. CL. 25.

COOPER, JOSHUA I, SAN RAFAEL, CA:
4,209,200. PUB. 7-3-2012. INT. CL. 35.

COOPER, MICHAEL K, GURNEE, IL, DBA LIGHTNING-SAW:
4,209,129. PUB. 7-3-2012. INT. CL. 7.

COPPERHEAD INDUSTRIES, LLC, MONTICELLO, MN:
4,211,011. INT. CL. 9.

COPROHNIJAR S. COOP. AND, SPAIN:
4,208,339. PUB. 7-3-2012. MULTIPLE CLASS, INT. CLS. 29, 30 AND 31.

CORAM LLC, WILMINGTON, DE:
4,208,762. PUB. 7-3-2012. INT. CL. 41.
4,208,763. PUB. 7-3-2012. MULTIPLE CLASS, INT. CLS. 44 AND 45.
4,208,764. PUB. 7-3-2012. INT. CL. 41.
4,208,765. PUB. 7-3-2012. MULTIPLE CLASS, INT. CLS. 44 AND 45.

CORBETT ACCEL HEALTHCARE GROUP CHICAGO INC., CHICAGO, IL:
3,038,284. CANC. INT. CL. 42.

CORBETT ACCEL HEALTHCARE GROUP NEW YORK LLC, NEW YORK, NY:
3,037,001. CANC. INT. CL. 35.

COREBEAUTY, LLC, SAN DIEGO, CA:
4,210,541. INT. CL. 3.

CORINTH PIPEWORKS S.A., ATHENS, GREECE:
4,209,704. PUB. 7-3-2012. INT. CL. 6.
4,209,706. PUB. 7-3-2012. INT. CL. 6.

- CORNELL, KEITH, GREENFIELD CENTER, NY:
4,209,088, PUB. 7-3-2012. INT. CL. 40.
- CORRADETTI, ROBERT CULLEN, BROOKLYN, NY:
4,209,431, PUB. 7-3-2012. MULTIPLE CLASS, INT. CLS. 16 AND 25.
- CORRELATED MAGNETICS RESEARCH, LLC, NEW HOPE, AL:
4,210,589, INT. CL. 9.
- CORTES, MARTHA, NEW YORK, NY:
4,210,279, INT. CL. 16.
- COSGROVE, MICHAEL T., ALBUQUERQUE, NM:
4,209,686, PUB. 7-3-2012. MULTIPLE CLASS, INT. CLS. 16 AND 41.
- COSTCO WHOLESALE MEMBERSHIP, INC., ISSAQUAH, WA:
1,185,200, CANC. INT. CL. 42.
- COSWAY COMPANY, INC., CARSON, CA:
4,210,224, PUB. 1-24-2012. INT. CL. 3.
- COTEE INDUSTRIES INC., PORT RICHEY, FL:
1,670,984, CANC. MULTIPLE CLASS, INT. CLS. 8 AND 28.
- COTTON & ELSE, INC., LAUDERDALE LAKES, FL:
4,210,869, INT. CL. 25.
- COUNCIL OF BETTER BUSINESS BUREAUS, INC., ARLINGTON, VA:
2,528,055, CANC. INT. CL. 42.
- COUNTRY LIFE OUTFITTERS INC, PANAMA CITY, FL:
4,209,000, PUB. 3-27-2012. MULTIPLE CLASS, INT. CLS. 16 AND 25.
- COURAGE SPORTS, INC., FAIRACRES, NM:
4,210,329, INT. CL. 25.
- COURION CORPORATION, WESTBOROUGH, MA:
2,605,758, REN. 8-13-12. INT. CL. 9.
- COUSIN CORPORATION OF AMERICA, LARGO, FL:
4,211,870, INT. CL. 14.
- COVALENT MEDICAL, LLC, GREENBELT, MD:
4,211,844, INT. CL. 5.
- COVANTA ENERGY CORPORATION, MORRISTOWN, NJ:
4,211,745, MULTIPLE CLASS, INT. CLS. 37, 39 AND 40.
- COX ENTERPRISES, INC., ATLANTA, GA:
3,033,871, AM. MULTIPLE CLASS, INT. CLS. 16 AND 35.
- COX OIL, LLC, DALLAS, TX:
4,211,772, INT. CL. 4.
4,211,773, INT. CL. 4.
- COX, DEBI, JACKSONVILLE, FL:
4,209,246, PUB. 7-3-2012. INT. CL. 25.
- CRABTREE ASSET MANAGEMENT, SAINT PAUL, MN:
4,209,338, PUB. 7-3-2012. INT. CL. 36.
- CRAFTING-A-LIFE, INC., TUCSON, AZ:
4,208,873, PUB. 7-3-2012. INT. CL. 16.
- CRAMBLOCK L.C., PHOENIX, AZ:
4,209,975, PUB. 7-3-2012. INT. CL. 35.
- CRANWARE, INC., ATLANTA, GA:
4,208,852, PUB. 7-3-2012. INT. CL. 9.
4,208,853, PUB. 7-3-2012. INT. CL. 9.
- CRANSTON PRINT WORKS COMPANY, CRANSTON, RI:
4,210,514, INT. CL. 1.
- CRAZY MOMMA PRODUCTIONS, INC., SANTA MONICA, CA:
4,211,532, INT. CL. 25.
- CREATIVE RETAIL COMMUNICATIONS, LLC, CENTER VALLEY, PA, DBA UMX MEDIA:
4,182,093, COR. INT. CL. 41.
- CREDERE ENTERPRISES, LLC, IRVINE, CA:
4,210,694, INT. CL. 41.
- CREDIT INFONET, INC., DAYTON, OH:
4,211,207, MULTIPLE CLASS, INT. CLS. 36 AND 45.
- CREDIT UNION NATIONAL ASSOCIATION, INC., MADISON, WI:
4,208,820, PUB. 3-27-2012. INT. CL. 16.
4,208,821, PUB. 3-27-2012. INT. CL. 41.
4,208,822, PUB. 3-27-2012. INT. CL. 35.
4,208,823, PUB. 3-27-2012. INT. CL. 16.
4,208,824, PUB. 3-27-2012. INT. CL. 9.
- CREO GROUP LLC, LOS ANGELES, CA:
4,208,813, PUB. 1-31-2012. INT. CL. 36.
- CRESTONE, LLC, VERNON, CA:
4,211,136, INT. CL. 25.
- CRETE-HEAT, LLC, FOND DU LAC, WI:
4,209,691, PUB. 7-3-2012. INT. CL. 17.
- CRIBIS CORPORATION, TAMPA, FL:
3,038,170, CANC. INT. CL. 36.
- CRNA FINANCIAL PLANNING, INC., WINSTON-SALEM, NC:
4,211,839, INT. CL. 36.
- CROREY, DAVID J., CLINTON TOWNSHIP, MI:
4,211,497, INT. CL. 14.
- CROSS OPTICAL GROUP, INC., DAYTONA BEACH, FL:
4,209,401, PUB. 7-3-2012. INT. CL. 41.
- CROW, SHARLA MARIE, LOS ANGELES, CA:
4,208,566, PUB. 7-3-2012. MULTIPLE CLASS, INT. CLS. 16 AND 41.
- CROWN RING INC., SAINT LAURENT, QUEBEC, CANADA:
4,211,692, INT. CL. 14.
- CROWN VALLEY WINERY, INC., STE. GENEVIEVE, MO:
4,209,021, PUB. 7-3-2012. INT. CL. 33.
- CROWNS & ANDREWS PTY LIMITED, RYDALMERE, AUSTRALIA:
4,210,380, INT. CL. 28.
- CRUISE COINS, LLC, SARASOTA, FL:
4,211,361, INT. CL. 14.
- CRUISE WORLD TRAVEL, INC., CINCINNATI, OH:
1,779,841, REN. 8-11-12. INT. CL. 39.
- CRUSHPAD, INC., SONOMA, CA:
4,211,154, INT. CL. 33.
- CRYSTAL ART IMPORTS, INC., COLUMBUS, OH:
4,210,995, INT. CL. 21.
4,210,996, MULTIPLE CLASS, INT. CLS. 21 AND 35.
- CRYSTAL BOHEMIA, A.S., CZECH REPUBLIC:
4,208,418, PUB. 7-3-2012. INT. CL. 21.
- CSC HOLDINGS, INC., BETHPAGE, NY:
3,038,136, CANC. INT. CL. 38.
- CUDDLEWEAR, INC., GLEN COVE, NY:
4,210,083, PUB. 7-3-2012. INT. CL. 28.
- CULBERSON, BOBBIE, DALLAS, TX:
4,209,850, PUB. 7-3-2012. INT. CL. 39.
- CULTEC, INC., BROOKFIELD, CT:
4,210,610, INT. CL. 19.
- CUNNINGHAM, CLARK W., NEWPORT BEACH, CA:
4,209,509, PUB. 7-3-2012. INT. CL. 25.
- CUOIO SCHEDONI MODENA DI SCHEDONI MAURO & C. S.N.C., 44, 41100 MODENA, ITALY:
2,611,425, REN. 8-15-12. MULTIPLE CLASS, INT. CLS. 14 AND 28.
2,611,425, CANC. MULTIPLE CLASS, INT. CLS. 30 AND 34.
- CUSHMAN, VANESSA A., NEW ROCHELLE, NY:
4,210,472, INT. CL. 25.
- CUSTOM COMMODITIES, INC., GILMER, TX:
4,209,109, PUB. 7-3-2012. INT. CL. 39.
- CUSTOM COMPANIES, INC., THE, NORTHLAKE, IL, CUSTOM CARTAGE, INC., BENSENVILLE, IL, DBA THE CUSTOM COMPANIES:
1,712,269, REN. 8-13-12. INT. CL. 39.
1,726,307, REN. 8-10-12. INT. CL. 39.
- CUSTOM LEATHERCRAFT MANUFACTURING CO., INC., SOUTH GATE, CA:
4,210,597, MULTIPLE CLASS, INT. CLS. 8, 9 AND 18.
- CUSTOM MOTORCYCLES MAMBA INC., CHIBA, JAPAN:
4,208,532, PUB. 7-3-2012. INT. CL. 12.
- CUSTOMER CALLERS, CHARLOTTE, NC:
4,209,680, PUB. 7-3-2012. INT. CL. 35.
- CUZUCO, INC., HOBOKEN, NJ:
4,209,764, PUB. 7-3-2012. INT. CL. 42.
- CV CONCEPTS, LLC, SHERMAN OAKS, CA:
4,209,767, PUB. 7-3-2012. INT. CL. 43.
- CV III, L.L.C., WATERLOO, IA:
4,208,998, PUB. 7-3-2012. INT. CL. 41.
- CVG ALABAMA, LLC, NEW ABANY, OH:
4,210,233, INT. CL. 12.
- CVS PHARMACY, INC., WOONSOCKET, RI, BAXTER INTERNATIONAL INC., DEERFIELD, IL:
1,710,028, REN. 8-10-12. INT. CL. 16.
- CW FINANCIAL LLC, WASHINGTON, DC:
4,115,149, COR. INT. CL. 36.

CYANOMICS, INC., LEXINGTON, KY:
4,208,881, PUB. 7-3-2012. MULTIPLE CLASS, INT. CLS. 42 AND 44.

CYBERWIZE.COM, INC., SARASOTA, FL:
4,210,461, INT. CL. 35.

CYFEON SOLUTIONS, INC., AUSTIN, TX:
4,209,671, PUB. 7-3-2012. INT. CL. 9.

CYIOS CORPORATION, WASHINGTON, DC TO CYIOS CORPORATION, WASHINGTON, DC:
2,527,832, CANC. INT. CL. 42.

CYPRESS CREEK EMERGENCY MEDICAL SERVICES ASSOCIATION, HOUSTON, TX:
4,208,228, PUB. 11-7-2006. INT. CL. 44.

D & B SUPPLY CORPORATION, ANAHEIM, CA, DBA AIR LINK INTERNATIONAL:
1,706,281. REN. 8-12-12. INT. CL. 7.

D & D BEAUTY CARE COMPANY, INC., CHICAGO, IL:
4,210,518, INT. CL. 44.

D AND D THAI RESTAURANT CORP., NEW YORK, NY:
4,209,287, PUB. 7-3-2012. INT. CL. 43.

D&N IPROPERTIES LLC, WINTER PARK, FL:
4,209,799, PUB. 7-3-2012. INT. CL. 41.

D-GENERATION, INC., DAYTONA BEACH, FL:
4,209,482, PUB. 7-3-2012. INT. CL. 6.
4,209,510, PUB. 7-3-2012. INT. CL. 16.
4,209,933, PUB. 7-3-2012. MULTIPLE CLASS, INT. CLS. 6 AND 20.

D-TA SYSTEMS INC., OTTAWA, ONTARIO, CANADA:
4,211,472, INT. CL. 9.

D' CINQUE HAIR SCIENCE, LLC, NEWPORT BEACH, CA:
4,211,144, INT. CL. 3.
4,211,248, INT. CL. 3.

DA LIAN YA TU TOU ZI ZI XUN YOU XIAN GONG SI, CHINA:
4,208,244, PUB. 7-3-2012. INT. CL. 21.

DA ROSA WARD, LLC, LOS ANGELES, CA:
3,552,141, CANC. INT. CL. 25.

DAE-IL USA, INC., MORGAN HILL, CA:
4,209,215, PUB. 7-3-2012. INT. CL. 35.

DAKOTA DIGITAL, INC., SIOUX FALLS, SD:
2,607,236. REN. 8-15-12. MULTIPLE CLASS, INT. CLS. 9 AND 35.

DALLMER GMBH & CO. KG, FED REP GERMANY:
4,208,436, PUB. 7-3-2012. INT. CL. 11.

DAMORE UNIVERSAL INC, LOS ANGELES, CA, DBA COLOR THREAD:
4,209,913, PUB. 7-3-2012. INT. CL. 25.

DANA MOSMAN, BOULDER, CO:
4,210,891, INT. CL. 7.

DANIEL BONEBRAKE, KEIZER, OR:
4,209,910, PUB. 7-3-2012. INT. CL. 16.

DANIEL LOPEZ, LOS ANGELES, CA:
4,208,877, PUB. 7-3-2012. INT. CL. 43.

DANTE CONSULTING, INC., ARLINGTON, VA:
2,600,826. REN. 8-11-12. MULTIPLE CLASS, INT. CLS. 35 AND 42.
2,600,826, CANC. MULTIPLE CLASS, INT. CLS. 9 AND 41.

DARDEN, GRANT, LITTLE ELM, TX:
4,209,807, PUB. 7-3-2012. INT. CL. 28.

DARKHORSE MULTIMEDIA, INC., SAVANNAH, GA:
4,211,071, INT. CL. 35.

DASGALOS INTERACTIVE SOLUTIONS, INC., BURBANK, CA:
4,208,616, PUB. 7-3-2012. INT. CL. 42.

DASHAMERICA, INC., LOUISVILLE, CO:
2,735,178. REN. 8-14-12. INT. CL. 25.

DASTERISK DEVELOPMENT GROUP LLC, VIRGINIA BEACH, VA:
4,209,783, PUB. 7-3-2012. INT. CL. 16.

DATA IMAGE, INC., NEWARK, OH:
4,211,747, INT. CL. 35.
4,211,748, INT. CL. 36.

DATAQ INTERNET EQUIPMENT CORPORATION, KING OF PRUSSIA, PA:
4,208,543, PUB. 7-3-2012. INT. CL. 35.

DATATUDE, INC., HOUSTON, TX:
2,733,778. REN. 8-16-12. INT. CL. 42.

DATAVANTAGE CORPORATION, CLEVELAND, OH:
4,209,667, PUB. 7-3-2012. INT. CL. 9.

DATUM SOFTWARE, INC., JOHNS CREEK, GA:
4,208,909, PUB. 7-3-2012. INT. CL. 42.

DAUBERT CHEMICAL COMPANY, INC., CHICAGO, IL:
1,731,986. REN. 8-15-12. INT. CL. 4.

DAVID A. BERNHARDT, CHESTERFIELD, MI:
4,209,514, PUB. 7-3-2012. INT. CL. 28.

DAVID BRODRICK ENTERPRISES, LLC, PLANO, TX:
4,210,849, INT. CL. 28.

DAVID BURR, CANOGA PARK, CA:
4,208,734, PUB. 7-3-2012. MULTIPLE CLASS, INT. CLS. 31 AND 37.

DAVID HUGHES, SHERMAN OAKS, CA:
4,209,712, PUB. 7-3-2012. MULTIPLE CLASS, INT. CLS. 35, 38 AND 41.

DAVID SHADE CORPORATION, BERKLEY, MI:
4,208,828, PUB. 7-3-2012. MULTIPLE CLASS, INT. CLS. 9, 16 AND 41.

DAVIS HOME IMPROVEMENTS, BAKERSFIELD, CA:
2,528,437, CANC. INT. CL. 37.

DAVIS WRIGHT TREMAINE LLP, SEATTLE, WA:
2,527,424, CANC. INT. CL. 42.

DAVIS, DAVID, LAKE CITY, TN:
4,210,206, PUB. 7-3-2012. INT. CL. 42.

DAY INTERNATIONAL, INC., DAYTON, OH:
2,528,068, CANC. INT. CL. 7.

DAYCO PRODUCTS, LLC, TULSA, OK:
4,210,020, PUB. 7-3-2012. INT. CL. 17.
4,210,171, PUB. 7-3-2012. INT. CL. 12.

DAYSTAR PRODUCTS INTERNATIONAL, INC., PHOENIX, AZ:
4,211,688, INT. CL. 20.

DAYTON PROGRESS CORPORATION, DAYTON, OH:
1,783,852. REN. 8-14-12. INT. CL. 7.

DB ORTHODONTICS LTD, SILSDEN, W. YORKSHIRE, UNITED KINGDOM:
4,209,100, PUB. 7-3-2012. INT. CL. 10.

DBT GMBH, 44534 LUNEN, FED REP GERMANY:
2,921,921, CANC. INT. CL. 41.

DC COMICS, NEW YORK, NY:
1,201,149. REN. 8-11-12. INT. CL. 21.

DC RMS LIMITED, UNITED KINGDOM:
4,208,327, PUB. 7-3-2012. INT. CL. 9.

DC ROLLERGIRLS, WASHINGTON, DC:
4,208,710, PUB. 7-3-2012. MULTIPLE CLASS, INT. CLS. 16, 25, 35 AND 41.

DC WINE WEEK, LLC, ALEXANDRIA, VA:
4,211,769, INT. CL. 35.

DD IP HOLDER LLC, CANTON, MA:
4,209,871, PUB. 7-3-2012. INT. CL. 35.

DDRUS HOLDINGS INC., STONEY CREEK, ON, CANADA:
4,211,746, INT. CL. 37.

DE BORTOLI WINES PTY LIMITED, NEW SOUTH WALES 2680, AUSTRALIA:
2,614,952. REN. 8-11-12. INT. CL. 33.
2,614,953. REN. 8-11-12. INT. CL. 33.
2,614,954. REN. 8-11-12. INT. CL. 33.

DE BOULLE DIAMOND & JEWELRY, INC., DALLAS, TX:
4,210,098, PUB. 7-3-2012. MULTIPLE CLASS, INT. CLS. 14 AND 35.

DE LUWE HOEK OCTROOIEN B.V., AMSTERDAM, NETHERLANDS:
2,676,603. REN. 8-16-12. MULTIPLE CLASS, INT. CLS. 1, 5 AND 42.

DE NEEF CONSTRUCTION CHEMICALS, INC., HOUSTON, TX:
2,526,968, CANC. MULTIPLE CLASS, INT. CLS. 1 AND 19.

DE ROBLIN, INC., CITY OF INDUSTRY, CA:
4,210,149, PUB. 7-3-2012. INT. CL. 3.

DE RUCCI BEDDINGS CO., LTD., DONGGUAN CITY, CHINA:
4,211,018, INT. CL. 20.

DEAD STRAIGHT, LLC, SAN FRANCISCO, CA:
2,556,597. REN. 8-15-12. INT. CL. 28.
2,652,212. REN. 8-15-12. INT. CL. 25.

- DEAF EYES BLIND EARS, GRAYSON, GA:
4,209,625, PUB. 7-3-2012. INT. CL. 25.
- DEAN EVANS & ASSOCIATES, INC., ENGLEWOOD, CO:
2,527,494, CANC. INT. CL. 9.
- DEAR, INC., ATLANTA, GA:
4,211,568, INT. CL. 33.
- DEBTMOLITON, LLC, LANTANA, TX:
4,211,340, INT. CL. 16.
- DECAVALCANTI, RONALD, NEW YORK, NY:
4,210,946, INT. CL. 30.
- DECK HOUSE, INC., ACTON, MA:
2,526,767, CANC. MULTIPLE CLASS, INT. CLS. 37 AND 42.
- DEELS, INC., BEVERLY HILLS, CA:
4,210,940, INT. CL. 41.
- DEEP FOODS, INC., UNION, NJ:
2,629,896, REN. 8-13-12. INT. CL. 29.
- DEERSPACE LLC, WATERLOO, IN, DBA ARCHERY TAG:
4,208,867, PUB. 7-3-2012. INT. CL. 41.
4,208,868, PUB. 7-3-2012. INT. CL. 28.
- DEFOND NORTH AMERICA, INC., RALEIGH, NC, DBA DNA GROUP, INC.:
4,210,382, INT. CL. 9.
- DEJOSIA, FRANCESCA, NYC, NY AND MANDRACCHIA, CHARLES, ROCKAWAY BEACH, NY:
4,208,941, PUB. 7-3-2012. MULTIPLE CLASS, INT. CLS. 9 AND 41.
- DEL MONTE CORPORATION, SAN FRANCISCO, CA, QUAKER OATS COMPANY, THE, CHICAGO, IL:
1,707,078, REN. 8-16-12. INT. CL. 31.
- DELASCO DERMATOLOGIC LAB & SUPPLY, INC., COUNCIL BLUFFS, IA, GEIGER MEDICAL TECHNOLOGIES, INC., MONARCH BEACH, CA:
2,724,684, REN. 8-15-12. INT. CL. 10.
- DELAWARE QUARRIES, INC., NEW HOPE, PA:
2,600,864, REN. 8-14-12. INT. CL. 19.
- DELICIA'S CANDIES LTD., ATLANTA, GA:
2,526,854, CANC. INT. CL. 30.
- DELL INC., ROUND ROCK, TX:
2,616,942, REN. 8-16-12. INT. CL. 9.
- DELOACH, ROBIN, SAVANNAH, GA:
4,208,976, PUB. 7-3-2012. INT. CL. 41.
- DELTA AIR LINES, INC., ATLANTA, GA:
945,465, REN. 8-15-12. U.S. CL. 105 (INT. CL. 39).
2,662,451, REN. 8-15-12. INT. CL. 39.
- DELTA MEDIA, LLC, JACKSON, WI:
4,208,596, PUB. 7-3-2012. INT. CL. 16.
- DELTAK EDU, INC., OAK BROOK, IL:
4,210,069, PUB. 7-3-2012. MULTIPLE CLASS, INT. CLS. 35, 41 AND 42.
- DELTATHREE, INC., HACKENSACK, NJ, DELTATHREE, INC., HACKENSACK, NJ:
2,605,606, REN. 8-10-12. MULTIPLE CLASS, INT. CLS. 36 AND 38.
- DEMARCO MAXVAC CORPORATION, MCHENRY, IL:
2,527,057, CANC. INT. CL. 7.
- DEMCO, INC., MADISON, WI:
4,211,025, MULTIPLE CLASS, INT. CLS. 35, 37 AND 42.
- DEN-MAT HOLDINGS, LLC, SANTA MARIA, CA:
4,211,081, INT. CL. 5.
- DENKAVIT INTERNATIONAAL B.V., NETHERLANDS:
3,029,438.
- DENKI KAGAKU KOGYO KABUSHIKI KAISHA, TOKYO, JAPAN:
3,853,982, CANC. IIRN. RESTORED TO S.N. 79-081,165.
- DENSO CORPORATION, KARIYA-CITY, JAPAN:
4,209,266, PUB. 7-3-2012. MULTIPLE CLASS, INT. CLS. 7 AND 9.
4,209,267, PUB. 7-3-2012. INT. CL. 11.
- DENT CONCEPTS, INC., NORTH PROVIDENCE, RI:
4,209,443, PUB. 7-3-2012. INT. CL. 37.
- DENTEK ORAL CARE, INC., MARYVILLE, TN:
4,211,444, INT. CL. 21.
- DENTOVATIONS, INC., BOSTON, MA:
2,744,642, REN. 8-14-12. INT. CL. 10.
- DERRIK WEST, WASHINGTON, DC:
4,209,408, PUB. 7-3-2012. INT. CL. 35.
- DESIGN WORKS INTERNATIONAL, INC., NEW YORK, NY:
4,211,685, MULTIPLE CLASS, INT. CLS. 35 AND 42.
- DESIGN WORKS STUDIOS, SCOTTSDALE, AZ, DBA DESIGN WORKS GAMING:
4,209,972, PUB. 7-3-2012. INT. CL. 9.
4,209,987, PUB. 7-3-2012. INT. CL. 9.
4,210,058, PUB. 7-3-2012. INT. CL. 9.
- DESIGNETICS, INC., HOLLAND, OH:
4,209,234, PUB. 7-3-2012. INT. CL. 9.
- DESTILADORA DEL VALLE DE TEQUILA, S.A. DE C.V., TEQUILA, JALISCO, MEXICO:
4,182,740, COR. INT. CL. 33.
- DETLEV N. HEINRICH, FED REP GERMANY:
2,528,568, CANC. MULTIPLE CLASS, INT. CLS. 9, 16 AND 35.
- DETROIT HYDROPONICS, INC., ST. CLAIRE SHORES, MI, DBA THE CULTIVATION STATION:
4,210,107, PUB. 7-3-2012. INT. CL. 25.
- DETROIT ZOOLOGICAL SOCIETY, THE, ROYAL OAK, MI:
4,211,554, INT. CL. 41.
- DEUTSCH NANTZ ALLIANCE, LLC, WHITE PLAINS, NY:
4,211,329, INT. CL. 33.
- DEUTSCHE TELEKOM AG, BONN, FED REP GERMANY:
3,010,458, CANC. MULTIPLE CLASS, INT. CLS. 9, 16, 35, 36, 38, 39, 41 AND 42.
3,057,123, CANC. INT. CL. 16.
3,057,383, CANC. INT. CL. 9.
- DEUTSCHE TELEKOM AG, D-53113 BONN, FED REP GERMANY:
3,059,165, CANC. MULTIPLE CLASS, INT. CLS. 9, 16, 35, 36, 38 AND 42.
- DEUTSCHE TELEKOM AG, BONN, FED REP GERMANY:
3,059,955, CANC. INT. CL. 35.
- DEUTSCHE TELEKOM AG, 53113 BONN, FED REP GERMANY:
3,061,438, CANC. MULTIPLE CLASS, INT. CLS. 9, 16, 35, 36, 38, 39, 41 AND 42.
- DEWINE SEEDS-SILVER DOLLAR BASEBALL, LLC, ASHEVILLE, NC:
4,208,920, PUB. 7-3-2012. INT. CL. 25.
- DEYAR LLC, DUBAI, UNITED ARAB EMIR.:
4,211,240, INT. CL. 36.
- DFI TECHNOLOGIES, INC., FAYETTEVILLE, AR:
4,209,446, PUB. 7-3-2012. INT. CL. 35.
- DGB (PROPRIETARY) LIMITED, GAUTENG, SOUTH AFRICA:
4,210,614, INT. CL. 33.
- DHANA, INC., MILL VALLEY, CA:
4,210,295, MULTIPLE CLASS, INT. CLS. 25 AND 35.
- DHAR, PATRICIA, GREENWICH, CT:
2,608,141, REN. 8-10-12. INT. CL. 25.
- DHV B.V., 3818 EK AMERSFOORT, NETHERLANDS, DHV RAADGEVEND INGENIEURSBUREAU B.V., AMERSFOORT, NETHERLANDS:
1,205,349, REN. 8-11-12. INT. CL. 11.
- DIAGEO CHATEAU & ESTATE WINES COMPANY, NAPA, CA:
4,210,131, PUB. 7-3-2012. INT. CL. 33.
- DIAGEO NORTH AMERICA, INC., NORWALK, CT:
4,211,458, INT. CL. 33.
- DIAMOND CONSULTING SERVICES LIMITED, BUCKS, HP17 8UG, UNITED KINGDOM:
2,770,590, COR. INT. CL. 9.
- DIAMOND HARDWOODS INC., METUCHEN, NJ:
2,627,117, REN. 8-14-12. INT. CL. 19.
- DIAMOND HARDWOODS, INC., METUCHEN, NJ:
2,629,775, REN. 8-10-12. INT. CL. 19.
- DIAMOND NATION, FLEMINGTON, NJ:
4,208,160, PUB. 7-3-2012. INT. CL. 25.
- DIAMOND PRODUCTIONS, INC., RENO, NV:
4,209,583, PUB. 7-3-2012. INT. CL. 41.
- DIAS PROPERTIES, LLC., COLLEGE STATION, TX, DBA REALTY MOMENTUM:
4,209,066, PUB. 7-3-2012. INT. CL. 36.
- DIAZ, LUIS, BARRINGTON, IL:
4,209,339, PUB. 7-3-2012. INT. CL. 42.

DIEBOLD, INCORPORATED, NORTH CANTON, OH:
 1,706,402. REN. 8-10-12. INT. CL. 9.
 DIET AND WEIGHT LOSS CENTERS, LLC, NORTH PALM BEACH, FL:
 4,209,406. PUB. 7-3-2012. INT. CL. 44.
 DIETZ & WATSON, INC., PHILADELPHIA, PA:
 4,210,220. PUB. 7-3-2012. INT. CL. 43.
 DIGI INTERNATIONAL INC., MINNETONKA, MN:
 4,211,621. INT. CL. 42.
 4,211,650. INT. CL. 9.
 DIGIScript, INC., NASHVILLE, TN:
 2,526,926. CANC. INT. CL. 40.
 DIGITAL CONCEALMENT SYSTEMS, LLC, PHENIX CITY, AL:
 4,210,225. PUB. 5-29-2012. MULTIPLE CLASS, INT. CLS. 8, 9, 13, 18, 25 AND 45.
 DIGITAL MARKETING, INC., BOWIE, MD:
 2,600,028. REN. 8-10-12. INT. CL. 42.
 DIGITAL PARALEGAL SERVICES, LLC, GUTHRIE, OK:
 4,211,751. INT. CL. 45.
 DIGITRONICO CORPORATION, POTOMAC, MD, DBA DIGITRONICO:
 4,208,718. PUB. 7-3-2012. INT. CL. 35.
 DILLON COMPANIES, INC., HUTCHINSON, KS:
 2,738,774. REN. 8-10-12. INT. CL. 35.
 DIMARZIO, INC., STATEN ISLAND, NY:
 4,209,801. PUB. 7-3-2012. INT. CL. 9.
 DIRECT CONSUMER CONTACT, INC., PALM HARBOR, FL:
 4,210,412. MULTIPLE CLASS, INT. CLS. 35, 38 AND 41.
 DIRECT ENERGY MARKETING LIMITED, TORONTO, CANADA:
 3,119,027. CANC. MULTIPLE CLASS, INT. CLS. 38, 40 AND 43.
 DIRECT SWAP LLC, SEATTLE, WA:
 4,211,729. INT. CL. 35.
 DIRECTORS LIVE, LLC, MONTGOMERY, IL:
 4,211,793. INT. CL. 41.
 DIRTY BEATS, LLC, WHITE PLAINS, NY:
 4,210,447. MULTIPLE CLASS, INT. CLS. 9, 35, 41 AND 42.
 DISCOVER FINANCIAL SERVICES, RIVERWOODS, IL:
 4,211,365. INT. CL. 36.
 DISCOVER MAGAZINE, INC., AVENTURA, FL:
 4,208,162. PUB. 7-3-2012. INT. CL. 16.
 DISCOVERY COMMUNICATIONS, LLC, SILVER SPRING, MD:
 4,211,519. INT. CL. 41.
 DISNEY ENTERPRISES, INC., BURBANK, CA:
 4,208,634. PUB. 7-3-2012. INT. CL. 26.
 DISORB SYSTEMS, INC., PHILADELPHIA, PA:
 4,208,538. PUB. 7-3-2012. INT. CL. 1.
 4,208,542. PUB. 7-3-2012. INT. CL. 1.
 DISRUPTIVEAPPS, INCORPORATED, BEVERLY, MA:
 4,210,624. MULTIPLE CLASS, INT. CLS. 38, 41 AND 42.
 DISTILLED SPIRITS EPICENTER, LLC, LOUISVILLE, KY:
 4,209,014. PUB. 7-3-2012. MULTIPLE CLASS, INT. CLS. 35 AND 41.
 DIVAS IN DEFENSE, INC., ATLANTA, GA:
 4,209,467. PUB. 7-3-2012. INT. CL. 41.
 DIVE LAB, INC., PANAMA CITY, FL:
 2,673,623. REN. 8-13-12. INT. CL. 42.
 DIVERS ALERT NETWORK, INC., DURHAM, NC:
 2,537,270. REN. 8-16-12. INT. CL. 41.
 DL FOODS, LLC, CHANDLER, AZ:
 4,211,378. INT. CL. 30.
 DL TECHNOLOGY, LLC, HAVERHILL, MA:
 2,744,025. REN. 8-15-12. INT. CL. 9.
 DLF INTERNATIONAL SEEDS, INC., HALSEY, OR:
 4,211,295. INT. CL. 31.
 DLK CONSULTANTS LLC, CORNELIUS, NC:
 4,209,327. PUB. 7-3-2012. INT. CL. 35.
 DMBGROUP, LLC., HIGHLAND VILLAGE, TX:
 2,723,838. REN. 8-11-12. INT. CL. 9.
 DNA (HOUSEMARKS) LIMITED, LONDON, UNITED KINGDOM:
 4,208,225. PUB. 7-3-2012. MULTIPLE CLASS, INT. CLS. 7, 12, 14, 18, 25 AND 28.
 DNA BAIL BONDS, LLC, SMITHFIELD, NC:
 4,209,285. PUB. 7-3-2012. INT. CL. 36.
 DOCMAGIC, INC., TORRANCE, CA:
 4,209,968. PUB. 7-3-2012. INT. CL. 9.
 DOCTOR'S ASSOCIATES INC., MILFORD, CT:
 4,209,543. PUB. 7-3-2012. MULTIPLE CLASS, INT. CLS. 35 AND 42.
 4,209,548. PUB. 7-3-2012. MULTIPLE CLASS, INT. CLS. 35 AND 42.
 4,210,120. PUB. 7-3-2012. MULTIPLE CLASS, INT. CLS. 9 AND 35.
 DOCTOR'S ASSOCIATES INC., MILFORD, DE:
 4,210,121. PUB. 7-3-2012. MULTIPLE CLASS, INT. CLS. 9 AND 35.
 DODGE, NATALIE A., LANCASTER, PA:
 4,209,612. PUB. 7-3-2012. INT. CL. 41.
 DODGE, TIMOTHY, HIGH RIDGE, MO:
 4,209,626. PUB. 7-3-2012. INT. CL. 25.
 DOHERTY, MARY ANN, COLUMBUS, MI:
 2,610,044. REN. 8-15-12. INT. CL. 14.
 DOLE REFRIGERATING COMPANY, LEWISBURG, TN:
 1,205,457. REN. 8-14-12. INT. CL. 19.
 DOLI ELEKTRONIK GMBH, MUNCHEN, FED REP GERMANY:
 4,208,529. PUB. 6-5-2012. INT. CL. 9.
 DOMAINE SERENE VINEYARDS AND WINERY, INC., MAPLE GROVE, MN:
 1,779,812. REN. 8-15-12. INT. CL. 33.
 DOMINION ENTERPRISES, NORFOLK, VA:
 2,612,139. REN. 8-15-12. INT. CL. 36.
 DOMINO'S IP HOLDER LLC, ANN ARBOR, MI:
 4,208,674. PUB. 7-3-2012. INT. CL. 42.
 DOMTAR PAPER COMPANY, LLC, FORT MILL, SC:
 2,743,390. REN. 8-16-12. INT. CL. 16.
 DON B. GILL, JR., ROCHESTER, MI:
 4,210,875. INT. CL. 36.
 DONALD S. MONOPOLI JR., MELBOURNE, FL, DBA TERABRITE:
 4,209,102. PUB. 7-3-2012. INT. CL. 9.
 DONALDSON COMPANY, INC., MINNEAPOLIS, MN:
 1,706,538. REN. 8-13-12. INT. CL. 11.
 DONEGAL MUTUAL INSURANCE COMPANY, MARIETTA, PA:
 4,211,099. INT. CL. 35.
 DONG WHA PHARM. CO., LTD, SEOUL, REPUBLIC OF KOREA:
 4,211,268. INT. CL. 30.
 DONG WHA PHARM. CO., LTD., SEOUL, REPUBLIC OF KOREA:
 4,208,803. PUB. 7-3-2012. MULTIPLE CLASS, INT. CLS. 5 AND 32.
 DONLEN CORPORATION, NORTHBROOK, IL:
 4,210,111. PUB. 7-3-2012. INT. CL. 42.
 DONNELLI, BEN O, RICHARDSON, TX:
 4,208,715. PUB. 7-3-2012. INT. CL. 16.
 DOR YESHURIM, INC., BROOKLYN, NY, DBA DOR YESHORIM:
 4,208,552. PUB. 7-3-2012. INT. CL. 44.
 DORIC PRODUCTS, INC., MARSHALL, IL:
 4,211,722. INT. CL. 19.
 DORMIFY, INC., ROCKVILLE, MD:
 4,209,488. PUB. 7-3-2012. INT. CL. 35.
 DOUBLECROSS BIKES, LLC, PIEDMONT, OK:
 4,211,448. INT. CL. 12.
 DOUBLEDAY DIRECT, INC., GARDEN CITY, NY:
 4,208,756. PUB. 7-3-2012. INT. CL. 35.
 DOUG MOCKETT & COMPANY, INC., MANHATTAN BEACH, CA:
 2,609,084. REN. 8-16-12. INT. CL. 20.
 DOUGHERTY'S PHARMACY, INC., DALLAS, TX:
 4,211,872. MULTIPLE CLASS, INT. CLS. 5, 10 AND 44.
 DOUGLAS JOHN HILTZ, HAMILTON ONTARIO, CANADA:
 4,211,109. INT. CL. 35.
 DOVER PUBLICATIONS INC, MINEOLA, NY:
 1,704,907. REN. 8-15-12. INT. CL. 16.
 1,706,666. REN. 8-15-12. INT. CL. 16.

- DOWNIE, GORDON, TORONTO, ONTARIO, CANADA AND SINCLAIR, R. GORDON, TORONTO, ONTARIO, CANADA AND BAKER, ROBERT, TORONTO, ONTARIO, CANADA AND LANGLOIS, PAUL, TORONTO, ONTARIO, CANADA AND FAY, JOHNNY, TORONTO, ONTARIO, CANADA, DBA THE TRAGICALLY HIP:
1,680,098. REN. 8-14-12. MULTIPLE CLASS, INT. CLS. 9 AND 41.
- DPE LABEL HOLDING CORP., BROOKLYN, NY:
4,211,260. INT. CL. 16.
- DR. CHRISTINA T. SCHLACHTER, PHD, BOULDER, CO, DBA SHE LEADS:
4,208,613. PUB. 7-3-2012. INT. CL. 41.
- DR. KNOLL PRODUCTS, INC., CANFIELD, OH, DBA BIOWELL NATURAL HEALTH:
4,210,699. INT. CL. 5.
- DR. RYAMOND LABORATORIES, INC., RUMSON, NJ:
4,211,100. INT. CL. 3.
- DR. ZIMMERMANN GES.M.B.H. & CO., AUSTRIA:
4,208,363. PUB. 7-3-2012. INT. CL. 3.
- DRAKA ELEVATOR PRODUCTS, INC., ROCKY MOUNT, NC:
2,527,303. CANC. MULTIPLE CLASS, INT. CLS. 6 AND 9.
- DRAKE UNIVERSITY, DES MOINES, IA:
2,600,778. REN. 8-13-12. INT. CL. 41.
- DREAM MASTERS, LLC, CHANDLER, AZ:
4,210,534. INT. CL. 5.
- DREAMTRAP COMMERCIALS LTD., LIMASSOL, CYPRUS:
4,210,528. MULTIPLE CLASS, INT. CLS. 42 AND 44.
4,210,552. INT. CL. 9.
- DREAMWELL, LTD., LAS VEGAS, NV:
4,210,831. INT. CL. 20.
4,210,881. INT. CL. 20.
- DRESSER-RAND CO., OLEAN, NY:
2,612,257. REN. 8-15-12. INT. CL. 37.
- DREW ESTATE HOLDING COMPANY LLC, MIAMI, FL:
2,604,842. REN. 8-14-12. INT. CL. 34.
- DREYER, MICHAEL, INDIANAPOLIS, IN:
4,209,179. PUB. 7-3-2012. INT. CL. 35.
- DRIFTING SPIRIT SONGS, LLC, STRONGSVILLE, OH:
4,210,557. INT. CL. 25.
- DRINKINGTICKET LLC, COLUMBIA, SC:
4,209,754. PUB. 7-3-2012. INT. CL. 35.
- DRVITA, INC, LAS VEGAS, NV:
4,211,166. INT. CL. 5.
- DRY LIKE ME LIMITED, WORCESTER, WORCESTER-SHIRE WR4 9FA, UNITED KINGDOM:
4,208,371. PUB. 7-3-2012. INT. CL. 5.
- DRYVIT SYSTEMS, INC., WEST WARWICK, RI, DRYVIT SYSTEM, INC., WEST WARWICK, RI:
1,203,572. REN. 8-10-12. INT. CL. 19.
- DSM IP ASSETS B.V., HEERLEN 6411 TE, NETHERLANDS:
2,528,460. CANC. INT. CL. 5.
- DTL CORPORACIÓN, S.L., SPAIN:
4,208,407. PUB. 7-3-2012. MULTIPLE CLASS, INT. CLS. 9, 11, 35, 37, 40, 41 AND 42.
- DUACARRIER ELECTRONICS TECHNOLOGY, INC., KNOXVILLE, TN:
4,211,725. INT. CL. 9.
- DUAL CORE LLC, LITIZE, PA:
1,212,209. REN. 8-15-12. MULTIPLE CLASS, INT. CLS. 9 AND 35.
- DUANE, GORDON P., HUNTINGTON BEACH, CA:
2,527,149. CANC. INT. CL. 25.
- DUBAK ELECTRICAL MAINTENANCE CORP., LA-GRANGE, IL:
4,209,715. PUB. 7-3-2012. INT. CL. 37.
- DUFF & PHELPS HOLDINGS LLC, CHICAGO, IL:
3,043,130. CANC. MULTIPLE CLASS, INT. CLS. 35 AND 36.
- DUNTON, DAVID A., CARY, NC:
2,527,625. CANC. INT. CL. 25.
- DURACARD, LLC, LAUREL, MD:
4,208,486. PUB. 1-24-2012. INT. CL. 16.
- DURBIN, DEREK L., SLIDELL, LA:
3,937,072. CANC. INT. CL. 3.
- DURKEE AMERICA INC., BELLINGHAM, WA:
4,209,911. PUB. 7-3-2012. MULTIPLE CLASS, INT. CLS. 11 AND 19.
- DUTCH VALLEY PARTNERS, LLC, BOURBONNAIS, IL:
4,209,580. PUB. 7-3-2012. INT. CL. 31.
4,209,656. PUB. 7-3-2012. INT. CL. 31.
- DVM SYSTEMS, LLC, GREELEY, CO:
4,208,563. PUB. 7-3-2012. MULTIPLE CLASS, INT. CLS. 9 AND 42.
- DYAX CORP., BURLINGTON, MA:
4,211,838. INT. CL. 9.
- DYNACRAFT BSC, INC., AMERICAN CANYON, CA:
2,605,906. REN. 8-15-12. INT. CL. 12.
4,211,445. INT. CL. 12.
- DYNO NOBEL INC., SALT LAKE CITY, UT:
4,211,318. INT. CL. 13.
- DYNOMAX DRILLING TOOLS INC., LEDUC, ALBERTA, CANADA:
4,208,460. PUB. 6-7-2011. INT. CL. 7.
- DYSTAR COLOURS DISTRIBUTION GMBH, 65926 FRANKFURT, FED REP GERMANY:
735,851. REN. 8-10-12. U.S. CL. 6 (INT. CL. 2).
- D2S PROPERTIES, LLC, LOS ANGELES, CA:
4,210,053. PUB. 7-3-2012. INT. CL. 25.
- D3PUBLISHER OF AMERICA, INC., LOS ANGELES, CA:
4,210,463. INT. CL. 9.
- E. & J. GALLO WINERY, MODESTO, CA:
4,210,450. INT. CL. 33.
- E. D. BULLARD COMPANY, CYNTHIANA, KY:
1,727,112. REN. 8-14-12. INT. CL. 9.
1,727,112. CANC. MULTIPLE CLASS, INT. CLS. 11 AND 25.
3,038,301. CANC. MULTIPLE CLASS, INT. CLS. 7, 9, 17, 25 AND 41.
- E. I. DU PONT DE NEMOURS AND COMPANY, WILMINGTON, DE:
1,706,847. REN. 8-16-12. INT. CL. 24.
- E. S. KLUFT & COMPANY, LLC, RANCHO CUCAMONGA, CA:
4,209,960. PUB. 7-3-2012. INT. CL. 20.
4,210,123. PUB. 7-3-2012. INT. CL. 20.
- E.M DEVELOPPEMENT, FRANCE:
4,208,299. PUB. 7-3-2012. INT. CL. 30.
- E.M. WINSTON BAND INSTRUMENTS CO. OF BOSTON, INC., NEW YORK, NY:
2,526,729. CANC. INT. CL. 35.
- E.W. GROBBEL SONS, INC., DETROIT, MI:
4,211,289. INT. CL. 29.
- E*CONCIERGE LIVE LLC, ALEXANDRIA, VA:
4,211,599. INT. CL. 35.
- E*TRADE SECURITIES, INC., PALO ALTO, CA:
2,528,023. CANC. INT. CL. 36.
- E-LUXURY.COM, INC., SAN FRANCISCO, CA:
2,528,471. CANC. INT. CL. 35.
2,528,472. CANC. INT. CL. 35.
- EAGAN, TODD, SANTA MONICA, CA, DBA MAIN STREET RECORDS:
4,211,845. INT. CL. 9.
- EAGLE EARTHWORKS, INC., BETHEL, ME:
4,211,690. INT. CL. 25.
- EAGLE OTTAWA, LLC, AUBURN HILLS, MI:
4,210,581. INT. CL. 18.
- EAR TECHNOLOGY CORPORATION, JOHNSON CITY, TN:
4,210,034. PUB. 7-3-2012. INT. CL. 10.
- EARTH COMMUNICATIONS OFFICE, LOS ANGELES, CA:
3,118,822. CANC. INT. CL. 36.
3,118,823. CANC. INT. CL. 36.
- EARTH PLEDGE FOUNDATION, NEW YORK, NY:
3,037,004. CANC. MULTIPLE CLASS, INT. CLS. 16 AND 41.
- EASEPAL ENTERPRISES LTD, FUJIAN PROVINCE, CHINA:
4,211,052. INT. CL. 14.
4,211,053. INT. CL. 18.
4,211,054. INT. CL. 21.
4,211,055. INT. CL. 25.
- EAST SIDE TRADING CO., TORONTO, CANADA:
4,210,735. INT. CL. 30.

EAST STROUDSBURG SAVINGS ASSOCIATION, STROUDSBURG, PA:
4,211,441, INT. CL. 36.

EASTLAND FOOD CORPORATION, JESSUP, MD:
4,208,805, PUB. 7-3-2012. INT. CL. 35.

EASTMAN CREDIT UNION, KINGSPORT, TN:
4,209,259, PUB. 7-3-2012. INT. CL. 36.
4,209,270, PUB. 7-3-2012. INT. CL. 36.

EASTMAN KODAK COMPANY, THE, ROCHESTER, NY:
396,975, REN. 8-16-12. U.S. CL. 6 (INT. CLS. 1, 2, 3, 4 AND 5).

EASY-DO PRODUCTS LIMITED, UNITED KINGDOM:
3,927,814, COR. INT. CL. 21.

EATON CORPORATION, CLEVELAND, OH:
4,211,108, INT. CL. 28.

ECHIDNA, INC., MINNEAPOLIS, MN:
4,210,542, INT. CL. 9.

ECHOQUIZ INC., FINLAND:
2,992,655.

ECHOXS ENTERTAINMENT, LLC, FORT LAUDERDALE, FL:
4,208,999, PUB. 7-3-2012. MULTIPLE CLASS, INT. CLS. 9 AND 41.

ECI, LLC, WEST ALLIS, WI:
4,208,618, PUB. 7-3-2012. INT. CL. 6.

ECO ANIMAL HEALTH LIMITED, LONDON, UNITED KINGDOM:
4,208,493, PUB. 7-3-2012. INT. CL. 5.

ECOLOGICAL FIBERS, INC., LUNENBURG, MA:
4,208,582, PUB. 8-30-2011. INT. CL. 16.

ECORP LIMITED, HOUSTON, TX:
4,209,676, PUB. 7-3-2012. MULTIPLE CLASS, INT. CLS. 35, 36 AND 37.
4,209,677, PUB. 7-3-2012. MULTIPLE CLASS, INT. CLS. 35, 36 AND 37.

ECOURBAN DESIGNS, INC., STOCKTON, CA:
4,209,226, PUB. 7-3-2012. INT. CL. 44.

EDDY, NICKY, SANTA CLARITA, CA:
4,209,849, PUB. 7-3-2012. INT. CL. 41.

EDGETEC INTERNATIONAL PTY LTD., BRISBANE, QUEENSLAND, 4074, AUSTRALIA:
1,704,545, REN. 8-10-12. INT. CL. 7.

EDIBLE COMMUNITIES, INC., SANTA BARBARA, CA:
4,211,509, INT. CL. 16.
4,211,510, INT. CL. 16.

EDIETS.COM, INC., FT. LAUDERDALE, FL:
4,208,760, PUB. 7-3-2012. INT. CL. 44.
4,208,761, PUB. 7-3-2012. INT. CL. 43.

EDISABILITY, INC., SAN DIEGO, CA:
4,208,777, PUB. 7-3-2012. INT. CL. 35.

EDISON LEARNING INTERNATIONAL LTD, UNITED KINGDOM:
4,208,298, PUB. 7-3-2012. MULTIPLE CLASS, INT. CLS. 16 AND 41.

EDL PACKAGING ENGINEERS, INC., GREEN BAY, WI:
2,726,747, REN. 8-11-12. MULTIPLE CLASS, INT. CLS. 40 AND 42.

EDNOLITCHNO DRUJESTVO S OGRANITCHENA OTGOVORNOST "FINANSKONSULT", BULGARIA:
4,208,362, PUB. 7-3-2012. INT. CL. 34.
4,208,375, PUB. 7-3-2012. INT. CL. 34.

EDOM LABORATORIES, INC., DEER PARK, NY:
4,210,257, INT. CL. 5.

EDUCATION CONTINUUM, LLC, ANDOVER, MN:
4,211,529, INT. CL. 41.

EDUCATION INNOVATOR, LLC, BROOKLINE, MA, DBA REEDY WOLF:
4,211,309, INT. CL. 41.
4,211,310, INT. CL. 41.

EDUCATION MANAGEMENT LLC, PITTSBURGH, PA:
4,211,778, INT. CL. 41.
4,211,785, INT. CL. 41.
4,211,786, INT. CL. 41.

EDUCATIONAL & PROFESSIONAL SERVICES INT., INC., FEDERAL WAY, WA:
4,208,808, PUB. 7-3-2012. INT. CL. 35.

EDUNEERING HOLDINGS, INC., PRINCETON, NJ:
4,209,692, PUB. 7-3-2012. INT. CL. 41.

EEGEO LIMITED, DUNDEE, SCOTLAND DD1 1NJ, UNITED KINGDOM:
4,208,274, PUB. 7-3-2012. MULTIPLE CLASS, INT. CLS. 9, 38, 41 AND 42.

EESKAY NH, INC., NASHUA, NH, BELOFF BILLIARDS, INC., BOSTON, MA:
1,728,287, REN. 8-10-12. MULTIPLE CLASS, INT. CLS. 41 AND 42.

EHRlich, SARAH, BEVERLY HILLS, CA:
4,210,189, PUB. 7-3-2012. MULTIPLE CLASS, INT. CLS. 3 AND 5.

EIEIO, INC., AUSTIN, TX:
4,208,928, PUB. 7-3-2012. INT. CL. 30.

EIGEN DEVELOPMENT LTD., VANCOUVER, BC, CANADA:
4,210,291, MULTIPLE CLASS, INT. CLS. 9 AND 36.

EINSULATION.COM, INC., FAIRFIELD, IA:
2,751,516, REN. 8-16-12. INT. CL. 17.

EL CHOLO, INC., LOS ANGELES, CA:
1,218,717, REN. 8-11-12. INT. CL. 42.

ELAM, TIM, BOISE, ID:
4,211,465, INT. CL. 20.

ELANTAS GMBH, FED REP GERMANY:
4,208,412, PUB. 7-3-2012. MULTIPLE CLASS, INT. CLS. 1, 2 AND 17.

ELBIT SYSTEMS OF AMERICA, LLC, FORT WORTH, TX:
4,210,596, INT. CL. 9.

ELDER COUNSEL LLC, ALBANY, NY:
4,208,586, PUB. 7-3-2012. MULTIPLE CLASS, INT. CLS. 42 AND 45.

ELECTRIC BODY, INC., LAS VEGAS, NV:
2,606,830, REN. 8-15-12. INT. CL. 5.

ELECTRIC VISUAL EVOLUTION, LLC, SAN CLEMENTE, CA:
2,613,183, REN. 8-15-12. INT. CL. 28.

ELECTRONIC ARTS INC., REDWOOD CITY, CA:
2,659,927, REN. 8-15-12. INT. CL. 41.
4,211,332, INT. CL. 9.
4,211,333, INT. CL. 41.

ELEGANT KIDS 2000 INC., LOS ANGELES, CA:
2,680,789, REN. 8-16-12. INT. CL. 25.

ELEPHANT TALK EUROPE HOLDING BV, NETHERLANDS:
4,208,303, PUB. 7-3-2012. MULTIPLE CLASS, INT. CLS. 9, 35, 37, 38 AND 42.

ELI CANNON'S L.L.C., MIDDLETOWN, CT:
4,208,982, PUB. 7-3-2012. INT. CL. 43.

ELITE SPORTS INC, EATONTOWN, NJ, DBA SOCCER POST:
1,707,146, REN. 8-10-12. INT. CL. 35.

ELIXIR INDUSTRIES, GARDENA, CA:
3,128,488, CANC. MULTIPLE CLASS, INT. CLS. 12 AND 17.

ELIZA'S QUEST FOODS, LLC, CHARLOTTE, NC:
4,210,515, INT. CL. 30.

ELLERY HOLDINGS LLC, NEW YORK, NY:
4,211,020, INT. CL. 24.

ELLIS COFFEE COMPANY, PHILADELPHIA, PA:
2,606,174, REN. 8-11-12. INT. CL. 30.

ELLSWORTH CORPORATION, GERMANTOWN, WI, DBA ELLSWORTH ADHESIVES, LLC:
2,667,393, REN. 8-11-12. MULTIPLE CLASS, INT. CLS. 35 AND 42.

ELMY, STEVEN M., ROSLIN, ON, CANADA:
4,210,322, INT. CL. 31.

ELSEVIER INC., WILMINGTON, DE, YEAR BOOK MEDICAL PUBLISHERS, INC., CHICAGO, IL:
1,247,033, REN. 8-16-12. INT. CL. 16.

ELSEVIER INC., WILMINGTON, DE:
2,739,294, REN. 8-15-12. INT. CL. 44.
2,741,401, REN. 8-14-12. INT. CL. 42.

ELSHAW, VINCENT, MENTOR, OH:
4,211,473, INT. CL. 25.

ELVIS PRESLEY ENTERPRISES, INC., MEMPHIS, TN:
2,606,900, REN. 8-13-12. INT. CL. 34.

EM'S 4 KIDS LLC, CULVER CITY, CA:
4,208,702, PUB. 7-3-2012. INT. CL. 9.

- EME ENTERPRISES, LLC, AUSTIN, TX, DBA LINK COW-
ORKING:
4,208,933, PUB. 7-3-2012. INT. CL. 36.
- EMERALD POLYMER ADDITIVES, LLC, AKRON, OH, B. F.
GOODRICH COMPANY, THE, AKRON, OH:
961,838. REN. 8-11-12. U.S. CL. 6 (INT. CL. 1).
- EMERSON & CUMING MICROWAVE PRODUCTS, N.V.,
GEEL, BELGIUM:
2,617,913. REN. 8-13-12. INT. CL. 17.
- EMERSON ELECTRIC CO., ST. LOUIS, MO:
2,601,449. REN. 8-12-12. INT. CL. 7.
- EMERSON RADIO CORP., HACKENSACK, NJ:
2,610,333. REN. 8-14-12. INT. CL. 9.
- EMGS CONSULTING, S.L., BARCELONA, SPAIN:
4,208,654, PUB. 7-3-2012. MULTIPLE CLASS, INT. CLS. 35
AND 41.
- EMIL VICALE, OXFORD, CT, FORMERLY EMIL VICALE:
4,208,686, PUB. 7-3-2012. INT. CL. 42.
- EMMI AG, SWITZERLAND:
4,208,359, PUB. 7-3-2012. MULTIPLE CLASS, INT. CLS. 5,
29, 30 AND 32.
- EMMI ROTH USA, INC., MONROE, WI:
2,624,899. REN. 8-15-12. INT. CL. 29.
- EMMIS PUBLISHING, L.P., INDIANAPOLIS, IN:
4,211,460, INT. CL. 41.
- EMPLOYEE BASED SYSTEMS LIMITED LIABILITY COM-
PANY, LITTLETON, CO:
2,528,570, CANC. INT. CL. 9.
- EMPLOYEE NAVIGATOR, LLC, GAITHERSBURG, MD:
4,208,597, PUB. 3-20-2012. INT. CL. 36.
- EMPOWER CES, LLC, ISLAND PARK, NY:
4,209,134, PUB. 7-3-2012. MULTIPLE CLASS, INT. CLS. 37
AND 42.
- EMREE ACCESSORIES, INC., NEW YORK, NY:
2,527,212, CANC. INT. CL. 14.
- EMSCO, INC., MASSILLON, OH:
4,211,492, INT. CL. 11.
- ENDURANCE WARRANTY SERVICES, LLC, NORTH-
BROOK, IL:
4,208,139, PUB. 7-3-2012. INT. CL. 36.
4,208,140, PUB. 7-3-2012. INT. CL. 36.
4,208,141, PUB. 7-3-2012. INT. CL. 36.
- ENECON CORPORATION, MEDFORD, NY:
1,724,853. REN. 8-13-12. INT. CL. 1.
- ENERGY JET INC., BRAMPTON, ONTARIO, CANADA:
1,203,474. REN. 8-16-12. INT. CL. 11.
- ENGARRAFAMENTO PITU LTDA., VITORIA DE SANTO
ANTAO, BRAZIL:
4,210,807, INT. CL. 33.
- ENIMANTRANS, PARLIN, NJ, DBA INVITRAN:
4,209,939, PUB. 7-3-2012. INT. CL. 42.
- ENOW, INC., LOS ANGELES, CA:
4,209,067, PUB. 7-3-2012. INT. CL. 9.
- ENQUATICS, INC., KIEL, WI:
2,725,752. REN. 8-11-12. INT. CL. 11.
- ENTERPRISE FINANCIAL SERVICES CORP., CLAYTON,
MO, ENTERPRISE FINANCIAL SERVICES CORP., CLAY-
TON, MO:
2,666,779. REN. 8-15-12. INT. CL. 36.
- ENTERPRISES J&C, INC., KEY WEST, FL:
4,211,476, INT. CL. 25.
- ENTIA BIOSCIENCES INC., SHERWOOD, OR, FORMERLY
TOTAL NUTRACEUTICAL SOLUTIONS INC.:
4,209,295, PUB. 7-3-2012. INT. CL. 42.
- ENVION, INC., WASHINGTON, DC:
4,210,391, INT. CL. 11.
- ENVIROCON TECHNOLOGIES, INC., MIDLAND, TX:
2,618,665. REN. 8-16-12. INT. CL. 1.
- ENVIRONMENTALLY SAFE PRODUCTS, INC., NEW OX-
FORD, PA:
2,673,077. REN. 8-15-12. INT. CL. 17.
- ENVISIONIER MEDICAL TECHNOLOGIES, INC., WOOD-
STOCK, GA:
4,209,726, PUB. 7-3-2012. INT. CL. 42.
- EONSMOKE, LLC., GARFIELD, NJ, DBA EONSMOKE
ELECTRONIC CIGARETTES:
4,209,049, PUB. 7-3-2012. INT. CL. 34.
- EORIGINAL, INC., BALTIMORE, MD:
4,208,817, PUB. 7-3-2012. MULTIPLE CLASS, INT. CLS. 9,
38 AND 39.
- EPC IP CO. LLC, MIAMI, FL:
4,211,580, INT. CL. 34.
- EPICORE BY LINDA ROSS, BEVERLY HILLS, CA:
4,209,035, PUB. 7-3-2012. MULTIPLE CLASS, INT. CLS. 3
AND 44.
- EPICUREX LLC, NORTH MIAMI BEACH, FL:
4,209,326, PUB. 7-3-2012. MULTIPLE CLASS, INT. CLS.
29, 30 AND 32.
4,210,064, PUB. 7-3-2012. MULTIPLE CLASS, INT. CLS.
29, 30 AND 32.
- EPOWER ENGINE SYSTEMS, FLORENCE, KY:
4,211,702, INT. CL. 12.
- EPSILON ELECTRONICS, INC., MONTEBELLO, CA:
2,528,491, CANC. INT. CL. 9.
- EPTRONICS, INC, LOS ANGELES, CA:
4,208,884, PUB. 7-3-2012. INT. CL. 9.
- EQUATORIAL GROUP LTD., PHOENIX, AZ:
2,528,520, CANC. INT. CL. 35.
- EQUINOX HOLDINGS, INC., NEW YORK, NY:
4,210,040, PUB. 7-3-2012. INT. CL. 44.
- ERGO VERSICHERUNGSGRUPPE AG, 40477 DUISSEL-
DORF, FED REP GERMANY:
2,599,920. REN. 8-10-12. MULTIPLE CLASS, INT. CLS. 35
AND 36.
- ERNST, NANCY-TYNNA BRADY, INDEPENDENCE, KY,
DBA THE BRADY GROUP LLC AND ERNST, STEPHEN
PHILIP, INDEPENDENCE, KY:
4,208,480, PUB. 7-3-2012. INT. CL. 35.
- ESCAPE THE CRATE, BOISE, ID:
4,209,875, PUB. 7-3-2012. INT. CL. 43.
- ESCHMANN HOLDINGS LIMITED, LANCING, UNITED
KINGDOM:
4,209,649, PUB. 7-3-2012. INT. CL. 10.
- ESCO BUCYRUS, INC., BUCYRUS, OH:
1,239,200. REN. 8-11-12. INT. CL. 7.
- ESHELMAN, CHARLES, NEW YORK, NY:
4,209,682, PUB. 7-3-2012. MULTIPLE CLASS, INT. CLS. 25
AND 41.
- ESIO BEVERAGE COMPANY LLC, MESA, AZ:
4,209,472, PUB. 7-3-2012. INT. CL. 30.
- ESNF, LLC, STRATFORD, CT:
4,211,148, INT. CL. 44.
- ESPRIT DE CORPS GROUP, INC., WILLOW, NY:
4,211,002, INT. CL. 43.
- ESSENTIAL NUTRACEUTICALS, LLC, BIRMINGHAM, AL:
4,209,292, PUB. 7-3-2012. INT. CL. 5.
- ESTATE ORGANIZATION AND RESOLUTION SERVICES,
INC., TAMPA, FL:
3,038,198, CANC. INT. CL. 41.
- ESYS CORPORATION, AUBURN HILLS, MI:
4,211,388, INT. CL. 42.
- ETAS ENTWICKLUNGS- UND APPLIKATIONSWERK-
ZEUGE FUER ELEKTRONISCHE SYSTEME GMBH,
STUTTGART, FED REP GERMANY:
4,208,810, PUB. 7-3-2012. MULTIPLE CLASS, INT. CLS. 9
AND 42.
- ETHEMIS, ENCINO, CA:
4,209,187, PUB. 5-29-2012. INT. CL. 45.
- ETIQUETTE HELL LLC, NEW HILL, NC:
2,692,427. REN. 8-11-12. INT. CL. 41.
- ETRAVEL APPLICATIONS, LLC, PLEASANTON, CA:
4,211,522, INT. CL. 9.
- EUROPEAN CARGO SERVICES (SOCIÉTÉ ANONYME),
FRANCE:
4,208,281, PUB. 7-3-2012. MULTIPLE CLASS, INT. CLS. 35
AND 39.
- EUROPEAN GREEN RUG SERVICES, LLC, SOUTH HACK-
ENSACK, NJ:
4,210,984, INT. CL. 37.
- EVANGELOS KARPOUZIS, MINDEN, NV:
2,654,425. REN. 8-15-12. INT. CL. 42.
- EVE MEGARGEL, WESTON, MA:
4,208,879, PUB. 7-3-2012. INT. CL. 44.
- EVENTBRITE, INC., SAN FRANCISCO, CA:
4,209,367, PUB. 7-3-2012. INT. CL. 9.

EVERBANK, JACKSONVILLE, FL:
 4,211,591, INT. CL. 36.
 EVERCORE PARTNERS SERVICES EAST LLC, NEW YORK,
 NY:
 4,209,586, PUB. 7-3-2012. MULTIPLE CLASS, INT. CLS.
 16, 36 AND 41.
 EVEREST EQUIPMENT CO., HALIFAX, NOVA SCOTIA B3J
 3N2, CANADA:
 735,961, REN. 8-14-12. U.S. CL. 23 (INT. CL. 7).
 EVEREST GLOBAL, INC., DALLAS, TX:
 4,211,253, MULTIPLE CLASS, INT. CLS. 35 AND 42.
 4,211,254, MULTIPLE CLASS, INT. CLS. 35 AND 42.
 EVERY TRIBE ENTERTAINMENT LLC, OKLAHOMA
 CITY, OK:
 4,210,767, INT. CL. 36.
 EVERYDAY HEALTH, INC., NEW YORK, NY:
 2,605,574, AM. MULTIPLE CLASS, INT. CLS. 38 AND 42.
 EVERYTHING OUTDOORS PRODUCTIONS, INC., INMAN,
 SC:
 3,038,185, CANC. INT. CL. 41.
 EVOGENIX PTY LIMITED, SYDNEY, NEW SOUTH WALES,
 AUSTRALIA:
 3,038,279, CANC. INT. CL. 42.
 EVOLUTION ENTERPRISE, LLC, SCOTTSDALE, AZ:
 4,208,134, PUB. 7-3-2012. INT. CL. 35.
 EVOLUTION LIGHTING, LLC, MIAMI LAKES, FL:
 734,840, REN. 8-11-12. U.S. CL. 21 (INT. CLS. 7, 9, 11, 12
 AND 15).
 EVOLUTION TECHNOLOGIES INTERNATIONAL, OG-
 DEN, UT:
 4,209,735, PUB. 7-3-2012. INT. CL. 3.
 EVOLVE SOLUTIONS HOLDINGS, LLC, SCOTTSDALE, AZ:
 4,208,869, PUB. 7-3-2012. INT. CL. 40.
 EVOLVING STRATEGIES, LLC, ARLINGTON, VA:
 4,209,282, PUB. 7-3-2012. INT. CL. 35.
 EVRIHOLDER PRODUCTS LLC, ANAHEIM, CA:
 4,211,480, INT. CL. 16.
 4,211,481, INT. CL. 21.
 EX LIBRIS (USA) INC., DES PLAINES, IL:
 4,210,356, INT. CL. 42.
 EX MORTIS, INC., BURBANK, CA:
 4,208,627, PUB. 7-3-2012. INT. CL. 3.
 EXADEL, INC., CONCORD, CA:
 4,209,317, PUB. 7-3-2012. INT. CL. 9.
 EXAMONE ENTERPRISES LTD, P.S. 3021, LIMASSOL,
 CYPRUS, CYPRUS:
 4,208,300, PUB. 7-3-2012. INT. CL. 3.
 EXCLUSIVE NUTRITION PRODUCTS, INC., CEDAR CITY,
 UT:
 4,210,173, PUB. 7-3-2012. INT. CL. 5.
 EXCLUSIVELY.IN INC., NEW YORK, NY:
 4,210,938, INT. CL. 25.
 4,210,939, INT. CL. 25.
 EXECUTIVE COACHING CONNECTIONS, LLC, WILM-
 ETTE, IL:
 2,600,729, REN. 8-13-12. INT. CL. 35.
 EXECUTIVE LINKS, LLC, CHARLOTTE, NC:
 4,208,940, PUB. 3-27-2012. INT. CL. 35.
 EXITEXCHANGE CORPORATION, PORTLAND, OR:
 2,600,574, REN. 8-10-12. MULTIPLE CLASS, INT. CLS. 35
 AND 42.
 EXOTIC CARS OF SOUTH FLORIDA, LLC, FORT LAUDER-
 DALE, FL:
 2,467,299, CANC. INT. CL. 35.
 EXPEDIA, INC., BELLEVUE, WA:
 2,610,290, REN. 8-15-12. INT. CL. 35.
 EXPERTUNE INC., HARTLAND, WI:
 2,744,022, REN. 8-14-12. INT. CL. 9.
 EXPLORATION SUPPORT SERVICES, INC., MISSOURI
 CITY, TX:
 4,209,186, PUB. 7-3-2012. INT. CL. 42.
 EXPLORE ANNENBERG LLC, LOS ANGELES, CA:
 4,210,324, INT. CL. 41.
 EXPONENTIAL INTERACTIVE, INC., EMERYVILLE, CA:
 4,210,050, PUB. 7-3-2012. INT. CL. 35.
 EXTERIOR DESIGN, INC., GLEN ARM, MD, TA THE
 PERENNIAL FARM:
 4,209,428, PUB. 7-3-2012. INT. CL. 31.
 EXTREME CULINARY OUTFITTERS, LOUISVILLE, KY:
 4,209,513, PUB. 7-3-2012. INT. CL. 25.
 EYE CARE AND CURE CORP., TUCSON, AZ:
 4,211,315, INT. CL. 10.
 4,211,316, INT. CL. 10.
 EZENIA! INC., GIG HARBOR, WA, EZENIA! INC., GIG
 HARBOR, WA:
 2,641,590, REN. 8-16-12. INT. CL. 9.
 F H COOPER LLC, CHICAGO, IL:
 4,209,299, PUB. 7-3-2012. INT. CL. 35.
 F. L. LIMA CAVALCANTE DE OLIVEIRA, MANAUS,
 AMAZONAS, BRAZIL:
 4,210,856, INT. CL. 35.
 F. LOPRESTI, INC., TEQUESTA, FL, DBA BUDGET TIRE
 AND AUTO SERVICES:
 4,209,244, PUB. 7-3-2012. INT. CL. 37.
 F-D-C REPORTS, INC., CHEVY CHASE, MD:
 2,746,140, REN. 8-13-12. INT. CL. 16.
 FABRICA ESPECIAS DON JULIO, S. DE R. L., S. PEDRO
 SULA, HONDURAS:
 4,208,714, PUB. 3-27-2012. INT. CL. 30.
 FACTYLE INC., MONTREAL, QUEBEC, CANADA:
 4,211,631, INT. CL. 9.
 FAGE DAIRY INDUSTRIES S.A, ATHENS 14452, GREECE:
 4,208,121, PUB. 12-25-2001. INT. CL. 30.
 FAIR INDIGO, LLC, MIDDLETON, WI:
 3,245,585, CANC. MULTIPLE CLASS, INT. CLS. 16 AND
 18.
 FAIR OAKS DAIRY PRODUCTS, LLC, FAIR OAKS, IN:
 4,208,831, PUB. 7-3-2012. INT. CL. 41.
 FAIR TRADE JEWELLERY COMPANY LTD., TORONTO,
 ONTARIO, CANADA:
 4,211,635, INT. CL. 14.
 FAIRFAX COUNTY SCHOOL BOARD, FALLS CHURCH,
 VA:
 2,733,541, REN. 8-14-12. INT. CL. 9.
 FAIRVIEW IMPORT CORPORATION, SANTA FE SPRINGS,
 CA:
 4,210,836, INT. CL. 9.
 FAIST CHEMTEC GMBH, FED REP GERMANY:
 4,208,343, PUB. 7-3-2012. MULTIPLE CLASS, INT. CLS. 1,
 7, 11, 12, 17 AND 19.
 FAITHLINKED CHRISTIAN MEDIA GROUP, LLC, DECA-
 TUR, GA:
 4,209,489, PUB. 7-3-2012. INT. CL. 42.
 FALCON INDUSTRIES, INC., MORIARTY, NM:
 4,209,605, PUB. 7-3-2012. INT. CL. 13.
 4,209,955, PUB. 7-3-2012. INT. CL. 13.
 4,209,956, PUB. 7-3-2012. INT. CL. 13.
 4,209,958, PUB. 7-3-2012. INT. CL. 21.
 4,210,183, PUB. 7-3-2012. INT. CL. 13.
 FAMILIES FOR DEPRESSION AWARENESS, INC., WAL-
 THAM, MA:
 4,209,573, PUB. 7-3-2012. INT. CL. 36.
 FAMILY DOLLAR STORES OF MICHIGAN, INC., MAT-
 THEWS, NC:
 4,210,407, MULTIPLE CLASS, INT. CLS. 14 AND 18.
 FAMILY DYNAMICS INSTITUTE, INC., FRANKLIN, TN,
 AKA FAMILY DYNAMICS:
 4,209,210, PUB. 7-3-2012. INT. CL. 41.
 FAMILY FOOD DISTRIBUTORS, INC., KEARNY, NJ:
 4,210,304, INT. CL. 29.
 FAMJAM, INC., FULLERTON, CA:
 4,208,604, PUB. 7-3-2012. INT. CL. 41.
 FAMOUS SMOKE SHOP-PA, INC., EASTON, PA:
 4,210,840, INT. CL. 34.
 4,210,841, INT. CL. 34.
 FANTASIA DISTRIBUTION, INC., ANAHEIM, CA:
 4,208,459, PUB. 6-14-2011. INT. CL. 34.
 FAO SCHWARZ FAMILY FOUNDATION, NEW YORK, NY:
 4,210,864, INT. CL. 35.
 FAR EAST BROKERS AND CONSULTANTS, INC., JACK-
 SONVILLE, FL:
 4,211,290, INT. CL. 11.
 FARAGO, MARGARET E., MESA, AZ AND FARAGO,
 STEPHEN A., MESA, AZ:
 4,209,618, PUB. 7-3-2012. INT. CL. 11.

- FARÉCLA PRODUCTS LIMITED, HERTFORDSHIRE, UNITED KINGDOM:
4,210,650, INT. CL. 3.
- FARLEY'S & SATHERS CANDY CO., INC., ROUND LAKE, MN:
1,720,539, REN. 8-13-12, INT. CL. 30.
- FARLEY'S & SATHERS CANDY COMPANY, INC., ROUND LAKE, MN, E. J. BRACH & SONS, CHICAGO, IL:
740,287, REN. 8-10-12, U.S. CL. 46 (INT. CL. 30).
- FARLEY'S & SATHERS CANDY COMPANY, INC., ROUND LAKE, MN:
2,664,623, REN. 8-11-12, INT. CL. 30.
- FARM FOUNDATION, NFP, OAK BROOK, IL:
4,209,211, PUB. 7-3-2012, MULTIPLE CLASS, INT. CLS. 16, 36, 41 AND 42.
- FARRAGO LLC, CONSHOHOCKEN, PA, DBA TECHWISE GROUP:
4,209,089, PUB. 7-3-2012, INT. CL. 42.
- FASHION SHOE LICENSING LLC, NEW HYDE PARK, NY:
1,460,115, CANC. INT. CL. 25.
- FASMA, LLC, OAK BROOK, IL:
3,037,056, CANC. INT. CL. 3.
- FASSI GRU S.P.A., ALBINO (BERGAMO), ITALY:
2,632,525, REN. 8-14-12, MULTIPLE CLASS, INT. CLS. 7 AND 12.
- FASTENATION, INC., CLIFTON, NJ:
4,211,868, INT. CL. 17.
4,211,869, INT. CL. 17.
- FATHOM SEO, LLC, VALLEY VIEW, OH, AKA FATHOM:
4,208,625, PUB. 7-3-2012, INT. CL. 35.
- FAYETTE COUNTY NAACP, FAYETTEVILLE, GA, DBA FAYETTE COUNTY YOUTH COUNCIL NAACP:
4,161,998, AM. INT. CL. 25.
- FAYSOB, LLC, SKIATOOK, OK:
4,208,772, PUB. 7-3-2012, INT. CL. 25.
- FAZZI ASSOCIATES INC., NORTHAMPTON, MA:
4,211,848, INT. CL. 41.
- FD MANAGEMENT, INC., STAMFORD, CT:
2,528,593, CANC. INT. CL. 3.
- FEDERAL APD INCORPORATED, OAK BROOK, IL:
2,472,252, COR. INT. CL. 9.
- FEDERAL APD INCORPORATED, NOVI, MI:
2,573,398, COR. INT. CL. 9.
2,578,687, COR. INT. CL. 9.
- FEDERATION EMPLOYMENT AND GUIDANCE SERVICES, INC., NEW YORK, NY:
2,527,085, CANC. INT. CL. 41.
- FEDRIGONI S.P.A., VERONA, ITALY:
2,599,908, REN. 8-12-12, INT. CL. 16.
- FEED THE CHILDREN, INC., OKLAHOMA CITY, OK:
4,209,609, PUB. 7-3-2012, INT. CL. 43.
- FEEDING AMERICA, CHICAGO, IL, AMERICA'S SECOND HARVEST, CHICAGO, IL:
2,600,044, REN. 8-10-12, INT. CL. 41.
- FEE GOOD PRODUCTS COMPANY, CASTLE ROCK, CO, DBA NUTRACEUTICAL PRODUCTS COMPANY:
2,602,687, REN. 8-11-12, INT. CL. 5.
- FELDER, FREDERICK, AUSTELL, GA:
4,209,176, PUB. 7-3-2012, INT. CL. 41.
- FELDNER, SARAH, FAYETTEVILLE, GA, DBA SIMPLY SARAH DESIGNS:
4,209,112, PUB. 7-3-2012, INT. CL. 20.
- FELIX CALLS, LLC, NEW YORK, NY:
4,210,167, PUB. 7-3-2012, INT. CL. 35.
- FELT GMBH, FED REP GERMANY:
4,184,859, COR. MULTIPLE CLASS, INT. CLS. 9 AND 12.
- FENTRESS, BARBARA, SCOTTSDALE, AZ, AKA BARBARA HOCHSTETLER:
4,208,870, PUB. 7-3-2012, INT. CL. 42.
- FEQUIRE, SHAUN, SAYLORSBURG, PA:
2,527,659, CANC. INT. CL. 41.
- FERGUSON ENTERPRISES, INC., NEWPORT NEWS, VA:
4,208,736, PUB. 7-3-2012, INT. CL. 17.
4,210,303, INT. CL. 21.
- FERNDALE IP, INC., FERNDALE, MI:
4,211,419, INT. CL. 5.
- FESTFARE, INC, LAS VEGAS, NV:
4,209,115, PUB. 7-3-2012, INT. CL. 36.
- FESTIVAL FUN PARKS, LLC, NEWPORT BEACH, CA:
2,613,584, REN. 8-10-12, INT. CL. 41.
- FIAT GROUP MARKETING & CORPORATE COMMUNICATION S.P.A., TORINO, ITALY:
4,210,230, MULTIPLE CLASS, INT. CLS. 12, 25 AND 35.
- FIBER COMPOSITES, LLC, NEW LONDON, NC:
4,208,652, PUB. 7-3-2012, MULTIPLE CLASS, INT. CLS. 6 AND 19.
- FIBERNIDE LTD., OAKVILLE, ONTARIO, CANADA:
2,527,980, CANC. INT. CL. 6.
- FIBERWEB, INC., OLD HICKORY, TN:
1,704,986, REN. 8-10-12, MULTIPLE CLASS, INT. CLS. 17 AND 24.
- FIBREBOND CORPORATION, MINDEN, LA:
4,208,562, PUB. 7-3-2012, INT. CL. 37.
- FICKES, WILLIAM H., JASPER, GA:
1,732,096, REN. 8-16-12, INT. CL. 20.
- FIDELITY FINANCIAL CORPORATION, WICHITA, KS, DBA FIDELITY BANK:
4,211,490, INT. CL. 36.
- FIDELITY NATIONAL CARD SERVICES, INC., JACKSONVILLE, FL:
4,210,817, INT. CL. 42.
- FIEDLER GENERAL STORE LTD., SAUSALITO, CA:
4,151,941, NEW CERT. 9-18-2012, INT. CL. 43.
- FIELDPIECE INSTRUMENTS, INC., ANAHEIM, CA:
4,210,716, INT. CL. 7.
- FIELDS, ALAN, BOULDER, CO, DBA WINDSOR PEAK PRESS AND FIELDS, DENISE, BOULDER, CO, DBA WINDSOR PEAK PRESS:
4,210,499, INT. CL. 16.
4,210,500, INT. CL. 44.
- FIELDS, FRANKLIN, LODI, CA:
4,211,017, INT. CL. 11.
- FIERCELY LOYAL MERCHANDISE CO., LLC, MALIBU, CA:
4,211,696, MULTIPLE CLASS, INT. CLS. 21, 34 AND 35.
- FIKE EUROPE BVBA, HERENTALS, BELGIUM:
4,209,023, PUB. 7-3-2012, INT. CL. 9.
- FILIVIVI S.R.L., MILANO, ITALY:
4,184,608, REN. 8-12-12, INT. CL. 23.
- FILMS FOR CHRIST, GILBERT, AZ:
2,527,630, CANC. INT. CL. 42.
- FINANCIAL EXECUTIVES INTERNATIONAL, MORRISTOWN, NJ:
3,122,900, CANC. INT. CL. 9.
3,122,905, CANC. INT. CL. 9.
3,122,907, CANC. INT. CL. 9.
- FINANCIAL FITNESS, LLC, LUTZ, FL:
4,210,633, INT. CL. 35.
- FINANCIAL TECHNOLOGY RESEARCH INSTITUTE, INC., TOKYO, JAPAN:
3,037,015, CANC. INT. CL. 36.
- FINGERPRINT DIGITAL, INC., NEW YORK, NY:
4,210,586, INT. CL. 9.
- FINLEY, LISHA, BUFORD, GA:
2,621,138, REN. 8-16-12, INT. CL. 3.
- FINULITE LLC, HENDERSON, NV:
4,209,917, PUB. 7-3-2012, INT. CL. 3.
- FIORE, MERCEDES, CORAL GABLES, FL:
4,210,575, INT. CL. 38.
- FIREWORKS BY GRUCCI, INC., BROOKHAVEN, NY:
1,710,506, REN. 8-16-12, INT. CL. 41.
- FIRST CHOICE MEDICAL SUPPLY, RICHLAND, MS:
4,211,562, INT. CL. 39.
- FIRST CHOICE MEDICAL SUPPLY LLC, RICHLAND, MS:
4,209,825, PUB. 7-3-2012, INT. CL. 20.
4,209,826, PUB. 7-3-2012, INT. CL. 20.
4,209,827, PUB. 7-3-2012, INT. CL. 20.
4,209,828, PUB. 7-3-2012, INT. CL. 20.
- FIRST COMMAND FINANCIAL SERVICES, INC., FORT WORTH, TX:
4,209,907, PUB. 7-3-2012, INT. CL. 36.
- FIRST FOUNDATION, INC., IRVINE, CA:
4,211,212, INT. CL. 36.
4,211,213, INT. CL. 36.

FIRSTCHOICE ADMINISTRATORS, LLC, SPRINGFIELD, MO:
4,210,666, INT. CL. 35.

FISH TALES, LLC, TUCSON, AZ:
4,211,366, INT. CL. 8.

FISHMARKET, LLC, ST. HELENA, CA:
4,211,763, INT. CL. 43.

FIT FOR LIFE SLEEP, INC., NORFOLK, VA:
4,210,667, INT. CL. 20.

FITUMI, LLC, VERNON, CA:
4,208,971, PUB. 7-3-2012. INT. CL. 25.

FIUS DISTRIBUTORS LLC, BOULDER, CO, DBA INADA MASSAGE CHAIRS:
4,211,730, INT. CL. 10.

FLAMINGO LAS VEGAS PROPCO, LLC, LAS VEGAS, NV:
4,210,176, PUB. 7-3-2012. INT. CL. 9.

FLANDERS INDUSTRIES, INC., FORT SMITH, AR:
1,699,832, REN. 8-15-12. INT. CL. 20.

FLASHBANG INC., FONTANA, CA:
4,209,559, PUB. 7-3-2012. INT. CL. 33.

FLAVA WORKS, INC., MIAMI, FL:
3,025,813, CANC. INT. CL. 16.

FLEER/SKYBOX INTERNATIONAL LP, MT. LAUREL, NJ TO THE UPPER DECK COMPANY, INC., CARLSBAD, CA:
2,419,850, CANC. INT. CL. 16.

FLEET WHOLESALE SUPPLY CO., INC., APPLETON, WI:
4,210,085, PUB. 7-3-2012. INT. CL. 5.
4,210,141, PUB. 7-3-2012. INT. CL. 10.
4,210,142, PUB. 7-3-2012. MULTIPLE CLASS, INT. CLS. 10 AND 16.
4,210,143, PUB. 7-3-2012. MULTIPLE CLASS, INT. CLS. 10 AND 16.

FLEMING, RYAN, CARLSBAD, CA:
4,211,102, INT. CL. 41.

FLEX ENERGY, INC., IRVINE, CA:
4,211,036, MULTIPLE CLASS, INT. CLS. 7 AND 11.

FLEXCON COMPANY, INC., SPENCER, MA:
2,625,153, REN. 8-15-12. INT. CL. 1.

FLEXENERGY, INC., IRVINE, CA:
4,211,035, INT. CL. 11.

FLEXIBLE STEEL LACING COMPANY, DOWNERS GROVE, IL:
1,218,065, REN. 8-16-12. MULTIPLE CLASS, INT. CLS. 6, 7 AND 8.

FLI MARKETING INC., POWAY, CA:
4,209,831, PUB. 7-3-2012. INT. CL. 9.

FLIGHTWORKS INCORPORATED, KENNESAW, GA:
4,208,680, PUB. 7-3-2012. INT. CL. 39.

FLING, RUSSELL, THOMAS, NAPERVILLE, IL:
2,649,569, REN. 8-15-12. INT. CL. 42.

FLIP FLOP DOGS, LLC, MARCO ISLAND, FL:
4,211,165, MULTIPLE CLASS, INT. CLS. 35, 43, 44 AND 45.

FLOOR STYLE PRODUCTS, INC., HASTINGS, MI:
2,528,543, CANC. INT. CL. 35.

FLORATINE PRODUCTS GROUP, INC., COLLIERVILLE, TN, AKA FPG, FLORATINE:
4,210,673, INT. CL. 1.

FLORES GARCIA, FRANCISCO JAVIER, MONTERREY, NUEVO LEON, MEXICO:
4,208,989, PUB. 3-27-2012. INT. CL. 30.

FLORIDA FOOD PRODUCTS, INC., EUSTIS, FL:
4,208,153, PUB. 7-3-2012. INT. CL. 30.

FLORIDA THOROUGHbred BREEDERS AND OWNERS ASSOCIATION, OCALA, FL:
2,603,882, REN. 8-15-12. INT. CL. 16.

FLOTEC, INC., INDIANAPOLIS, IN:
2,600,113, REN. 8-10-12. INT. CL. 10.

FLOWSERVE MANAGEMENT COMPANY, IRVING, TX:
938,451, REN. 8-14-12. MULTIPLE CLASS, U.S. CLS. 13 (INT. CL. 6) AND 23 (INT. CL. 8).

FLP, LLC, TEMPE, AZ:
4,211,535, INT. CL. 21.

FLUENT BABY, INC., PALO ALTO, CA:
2,603,115, REN. 8-10-12. MULTIPLE CLASS, INT. CLS. 9, 16, 28 AND 41.
2,603,116, REN. 8-10-12. MULTIPLE CLASS, INT. CLS. 9, 16, 28 AND 41.

2,603,117, REN. 8-10-12. MULTIPLE CLASS, INT. CLS. 9, 16, 28 AND 41.

2,603,118, REN. 8-10-12. MULTIPLE CLASS, INT. CLS. 9, 16, 28 AND 41.

2,606,136, REN. 8-10-12. MULTIPLE CLASS, INT. CLS. 9, 16, 28 AND 41.

2,606,137, REN. 8-10-12. MULTIPLE CLASS, INT. CLS. 9, 16, 28 AND 41.

2,606,138, REN. 8-10-12. MULTIPLE CLASS, INT. CLS. 9, 16, 28 AND 41.

2,606,139, REN. 8-10-12. MULTIPLE CLASS, INT. CLS. 9, 16, 28 AND 41.

2,606,140, REN. 8-10-12. MULTIPLE CLASS, INT. CLS. 9, 16, 28 AND 41.

FLUID LEARNING UNIQUELY EXECUTED LLC, WALLA WALLA, WA:
4,209,837, PUB. 7-3-2012. INT. CL. 41.
4,209,844, PUB. 7-3-2012. INT. CL. 41.

FLYGRIP INC., MELVILLE, NY:
4,211,034, MULTIPLE CLASS, INT. CLS. 9 AND 21.

FMC CORPORATION, PHILADELPHIA, PA:
1,705,721, REN. 8-10-12. INT. CL. 1.

FMR LLC, BOSTON, MA:
2,644,639, REN. 8-11-12. INT. CL. 36.
2,645,668, REN. 8-11-12. INT. CL. 36.
2,654,136, REN. 8-11-12. INT. CL. 36.

FMR LLC, BOSTON, MA, FMR CORP., BOSTON, MA:
2,660,348, REN. 8-13-12. INT. CL. 36.

FMR LLC, BOSTON, MA:
2,662,709, REN. 8-11-12. INT. CL. 36.
2,664,669, REN. 8-11-12. INT. CL. 36.

FOCELLA, SALVATORE, PARAMUS, NJ:
2,745,201, REN. 8-13-12. INT. CL. 44.

FOCUS 360, LAGUNA NIGUEL, CA:
2,527,103, CANC. INT. CL. 42.

FOOD MATRIX, INC., THE, TRAVERSE CITY, MI:
1,703,625, REN. 8-11-12. INT. CL. 35.

FOOTBALL CLUB SOCHAUX-MONTBELIARD, FRANCE:
4,058,153, COR. MULTIPLE CLASS, INT. CLS. 3, 9, 10, 12, 14, 16, 18, 20, 21, 22, 24, 25, 26, 27, 28, 30, 32, 33, 34, 35, 38, 39, 40, 41 AND 43.

FORD, BRIAN J., MEBANE, NC:
4,210,538, INT. CL. 25.

FORD, GARY, ROGERS, AR AND FORD, YVONNE, ROGERS, AR:
4,210,640, INT. CL. 9.

FORD'S PRODUCE CO., INC., RALEIGH, NC:
4,209,207, PUB. 7-3-2012. INT. CL. 30.

FOREIGN CREDITS, INC., WHEELING, IL, DBA ZEN TRANSLATION, INC.:
4,209,938, PUB. 7-3-2012. INT. CL. 41.

FOREVER18 RETAIL GMBH, AUSTRIA:
4,208,338, PUB. 7-3-2012. MULTIPLE CLASS, INT. CLS. 14, 18 AND 25.

FOREX CAPITAL MARKETS LLC, NEW YORK, NY:
4,211,764, MULTIPLE CLASS, INT. CLS. 9, 36 AND 42.

FORHAN, MARK, SAINT CHARLES, MO:
4,211,600, INT. CL. 35.

FORK IN THE ROAD FOODS, LLC, SAN FRANCISCO, CA:
4,210,335, INT. CL. 29.

FORMBY, GEARY, PORTLAND, OR AND FORMBY, MARTHA PIGG, VANCOUVER, WA:
4,210,906, MULTIPLE CLASS, INT. CLS. 1, 2 AND 19.

FORMEX WATCH SA, CH-2543 LENGNAU, SWITZERLAND:
2,614,525, REN. 8-16-12. INT. CL. 14.

FORT BOISE PRODUCE COMPANY, NYSSA, OR:
2,674,445, REN. 8-16-12. INT. CL. 31.

FORT JAMES OPERATING COMPANY, ATLANTA, GA:
2,968,615, CANC. INT. CL. 16.

FORTINET, INC., SUNNYVALE, CA:
4,210,566, MULTIPLE CLASS, INT. CLS. 35, 37 AND 42.

FORTNUM & MASON PUBLIC LIMITED COMPANY, LONDON, ENGLAND, FORTNUM & MASON LIMITED, LONDON W.1, ENGLAND:
939,980, REN. 8-14-12. U.S. CL. 46 (INT. CLS. 1, 5, 29, 30, 31 AND 32).

- FORTRUS LIMITED, UNITED KINGDOM:
4,208,355, PUB. 7-3-2012. MULTIPLE CLASS, INT. CLS. 9,
39 AND 42.
- FORTY FOUR GROUP LLC, CHICAGO, IL, DBA ORIGAU-
DIO:
4,209,574, PUB. 7-3-2012. INT. CL. 9.
- FORYOU GROUP CO., LTD., GUANGDONG, CHINA:
3,948,431, COR. MULTIPLE CLASS, INT. CLS. 2, 9 AND
11.
- FOSHAN AMSTRONG IMPORT & EXPORT CO., LTD.,
CHINA:
4,208,304, PUB. 7-3-2012. INT. CL. 11.
- FOTODYNE INCORPORATED, HARTLAND, WI:
1,704,656, REN. 8-16-12. INT. CL. 9.
1,709,234, REN. 8-15-12. INT. CL. 9.
- FOTONA D.D., SLOVENIA:
4,208,273, PUB. 7-3-2012. MULTIPLE CLASS, INT. CLS. 10
AND 44.
- FOUND MY ANIMAL, LLC, BROOKLYN, NY:
4,209,877, PUB. 7-3-2012. INT. CL. 18.
- FOX FACTORY, INC., WATSONVILLE, CA:
4,209,396, PUB. 7-3-2012. INT. CL. 12.
- FRANCESCA'S COLLECTIONS, INC., HOUSTON, TX:
4,210,187, PUB. 7-3-2012. INT. CL. 35.
- FRANCHISE GATOR, LLC, NORFOLK, VA:
4,209,405, PUB. 7-3-2012. INT. CL. 35.
- FRANKS & CO LIMITED, UNITED KINGDOM:
4,208,346, PUB. 7-3-2012. MULTIPLE CLASS, INT. CLS.
16, 35, 41, 42 AND 45.
- FRASER LABORATORIES, INC., STUDIO CITY, CA:
2,717,613, REN. 8-13-12. INT. CL. 5.
- FRAYER, KIMBERLY D, CRESTED BUTTE, CO:
4,209,350, PUB. 7-3-2012. INT. CL. 14.
- FRECKLEFARM CORPORATION, BRONXVILLE, NY:
2,527,480, CANC. INT. CL. 35.
- FRED W. GRETSCH ENTERPRISES, LTD., POOLER, GA:
4,210,331, MULTIPLE CLASS, INT. CLS. 15 AND 25.
- FREDA, CARMINE, WASHINGTON, NJ:
4,211,339, INT. CL. 35.
- FREE CONFERENCING CORPORATION, LONG BEACH,
CA:
4,211,758, MULTIPLE CLASS, INT. CLS. 16 AND 38.
4,211,759, MULTIPLE CLASS, INT. CLS. 16 AND 38.
- FREE HEALTH INC, ROYAL PALM BEACH, FL:
4,211,820, INT. CL. 42.
- FREEDOM BAG, PALM DESERT, CA, FEELING FREE,
INC., INCLINE VILLAGE, NV:
2,605,080, REN. 8-15-12. INT. CL. 18.
- FREEDOM DEVELOPMENT, LLC, SANTA MONICA, CA,
DBA INVISIBLE HAND STUDIOS:
4,208,180, PUB. 10-27-2009. INT. CL. 16.
- FREELIFE INTERNATIONAL HOLDINGS, LLC, PHOENIX,
AZ:
2,528,677, CANC. INT. CL. 5.
- FREEMAN + LEONARD LLC, DALLAS, TX:
4,209,657, PUB. 7-3-2012. INT. CL. 35.
- FREEMAN CAPITAL COMPANY, LAS VEGAS, NV:
4,143,582, COR. MULTIPLE CLASS, INT. CLS. 9 AND 42.
- FREMANTLEMEDIA LIMITED, LONDON, UNITED KING-
DOM:
4,209,070, PUB. 7-3-2012. MULTIPLE CLASS, INT. CLS. 9,
16, 25, 28 AND 41.
- FRESNEL TECHNOLOGIES, INC., FORT WORTH, TX:
4,210,328, INT. CL. 9.
- FRET FABRICS, LONG ISLAND CITY, NY:
4,208,855, PUB. 1-31-2012. INT. CL. 24.
- FREY, DAVID W, MILFORD, OH:
4,209,040, PUB. 7-3-2012. INT. CL. 28.
- FRIEDMAN, SERENA M., SIMI VALLEY, CA, DBA FOUR
SISTERS RANCH AND DRUCKER, MICHAEL, SIMI
VALLEY, CA, DBA FOUR SISTERS RANCH:
4,208,551, PUB. 7-3-2012. INT. CL. 33.
- FRIEDRICH, VICKI M., CHANHASSEN, MN, DBA IT'S
SMOKIN' HOT!
4,208,918, PUB. 7-3-2012. INT. CL. 25.
- FRIENDLY POINTS, LLC, ANN ARBOR, MI:
4,209,371, PUB. 7-3-2012. INT. CL. 9.
- FRISCO GUN CLUB, INC., PLANO, TX:
4,208,732, PUB. 7-3-2012. INT. CL. 41.
- FRITO-LAY NORTH AMERICA, INC., PLANO, TX:
2,728,067, REN. 8-10-12. INT. CL. 30.
4,210,484, INT. CL. 30.
- FROG DESIGN, INC., SAN FRANCISCO, CA:
2,596,739, REN. 8-14-12. INT. CL. 35.
- FROM L TO J CONSULTING GROUP, INC., SCOTTSDALE,
AZ:
4,209,490, PUB. 7-3-2012. INT. CL. 41.
- FROM WAR TO PEACE, SAN LUIS OBISPO, CA:
4,208,640, PUB. 7-3-2012. INT. CL. 21.
- FROST INCORPORATED, GRAND RAPIDS, MI:
2,607,134, REN. 8-11-12. MULTIPLE CLASS, INT. CLS. 6
AND 7.
- FRUIT OF THE LOOM, INC., BOWLING GREEN, KY:
4,209,213, PUB. 7-3-2012. INT. CL. 25.
- FRUTAROM SWITZERLAND LTD., SWITZERLAND:
4,208,347, PUB. 7-3-2012. MULTIPLE CLASS, INT. CLS. 5
AND 30.
- FSK INC., CHITA-CITY, AICHI, JAPAN, FUJI ABRASIVE
WORKS CO., LTD., SHINCHI, CHITA-CITY, AICHI,
JAPAN:
1,223,942, REN. 8-16-12. MULTIPLE CLASS, INT. CLS. 7
AND 8.
- FTS INTERNATIONAL SERVICES, LLC, FORT WORTH,
TX:
4,210,164, PUB. 7-3-2012. INT. CL. 7.
- FUJIFILM CORPORATION, MINATO-KU, TOKYO, JAPAN:
4,208,600, PUB. 1-31-2012. INT. CL. 10.
- FULL SERVICE NETWORK LP, PITTSBURGH, PA:
4,209,768, PUB. 7-3-2012. MULTIPLE CLASS, INT. CLS.
37, 38 AND 42.
- FULLER BRUSH COMPANY, THE, GREAT BEND, KS,
COLUMBIA WAX COMPANY, GLENDALE, CA:
727,110, REN. 8-11-12. U.S. CL. 52 (INT. CL. 3).
- FURNITURE MARKETING ASSOCIATES, INC., FARM-
INGDALE, NY:
4,210,689, INT. CL. 20.
- FUSE MANAGEMENT, LLC, LOS ANGELES, CA:
4,211,515, INT. CL. 43.
- FUSION CLOTHING COMPANY, MUMBAI, INDIA:
4,209,355, PUB. 7-3-2012. INT. CL. 25.
- FUSION FLOW MEDIA, DULUTH, GA:
4,209,381, PUB. 7-3-2012. INT. CL. 35.
- FUSION-IO, INC., SALT LAKE CITY, UT:
4,210,299, INT. CL. 9.
- FUTURE FOAM, INC., HIGH POINT, NC:
4,209,333, PUB. 7-3-2012. INT. CL. 17.
- FUTURE MEDIA ARCHITECTS, INC., ROAD TOWN,
BR.VIRGIN ISLANDS:
4,210,917, INT. CL. 38.
- FUTURE US, INC., SOUTH SAN FRANCISCO, CA:
4,210,317, MULTIPLE CLASS, INT. CLS. 35, 41 AND 44.
- FUTURESOFT, INC., HOUSTON, TX:
2,527,657, CANC. INT. CL. 9.
- FUZETEC TECHNOLOGY CO., LTD., HSINCHUANG CITY,
TAIPEI HSIEN, TAIWAN:
2,727,715, REN. 8-10-12. INT. CL. 9.
- FW ROBERTS MANUFACTURING CO., INC., LOCKPORT,
NY:
2,528,711, CANC. INT. CL. 19.
- FX RENEW, LLC, ORLANDO, FL:
4,208,661, PUB. 7-3-2012. INT. CL. 36.
- F5 NETWORKS, INC., SEATTLE, WA:
4,211,712, INT. CL. 9.
- G & ACOSTA, BENICA, CA:
4,209,790, PUB. 7-3-2012. INT. CL. 25.
- G PRIME MEDIA, LLC, ROYERSFORD, PA:
4,208,832, PUB. 7-3-2012. INT. CL. 9.
- G. POHL-BOSKAMP GMBH & CO. KG, FED REP GER-
MANY:
4,208,268, PUB. 2-7-2012. INT. CL. 5.
- G.T.S. CORPORATION PTY LTD, MIDVALE WA 6056,
AUSTRALIA:
4,209,101, PUB. 5-15-2012. MULTIPLE CLASS, INT. CLS.
42 AND 45.

G-III LEATHER FASHIONS, INC., NEW YORK, NY:
3,038,130, CANC. INT. CL. 25.

GABI CONCEPTS LTD., TORONTO, CANADA:
4,210,158, PUB. 7-3-2012. INT. CL. 21.

GAGLIANO MARCATI DI PIETRO MARCATO; E C. S.N.C., ITALY:
4,208,442, PUB. 7-3-2012. INT. CL. 33.

GAIAM, INC., BROOMFIELD, CO:
2,527,275, CANC. MULTIPLE CLASS, INT. CLS. 24, 25 AND 35.

GAIL A. HALIM, SANBORN, NY, DBA GAIL'S TOBACCO & GAS OUTLET:
4,210,136, PUB. 7-3-2012. INT. CL. 35.

GAIN, ELIZABETH S., GOLETA, CA, DBA SPINGUIN MUSIC:
4,209,418, PUB. 7-3-2012. INT. CL. 41.

GAINES, RICHARD, BRECKENRIDGE, MI:
4,210,920, INT. CL. 22.

GALASSI S.N.C. DI GALASSI ROBERTO & RENZO, OSIMO (AN), ITALY:
2,639,176. REN. 8-10-12. INT. CL. 15.

GALINDO, GUADALUPE J, LAS VEGAS, NV, AKA TRI LUNATICS:
4,209,189, PUB. 7-3-2012. INT. CL. 25.

GALLERY PLACE ASSOCIATES, LLC., WASHINGTON, DC:
2,527,857, CANC. INT. CL. 36.

GALLOWAY PLASTICS, INC., LAKE BLUFF, IL:
4,209,106, PUB. 7-3-2012. INT. CL. 40.

GALVAN FINANCIAL CORP, ORANGE, CA:
4,208,849, PUB. 7-3-2012. INT. CL. 35.

GALYA, SCOTT, MIAMI, FL:
4,211,496, INT. CL. 35.

GAMEWRECKERS, LLC, NOVATO, CA:
4,208,932, PUB. 7-3-2012. INT. CL. 35.

GANZ, WOODBRIDGE, CANADA:
4,208,717, PUB. 7-3-2012. INT. CL. 20.

GAP (APPAREL), LLC, SAN FRANCISCO, CA, GAP STORES, THE, BURLINGAME, CA:
944,941. REN. 8-16-12. U.S. CL. 35 (INT. CL. 35).

GAP (APPAREL), LLC, SAN FRANCISCO, CA:
4,211,083, INT. CL. 25.

GARAGISTRY, LLC, ALPHARETTA, GA:
4,210,693, MULTIPLE CLASS, INT. CLS. 35, 38, 41 AND 42.

GARCIA GROUP, INC., ATLANTA, GA:
1,713,733. REN. 8-16-12. INT. CL. 20.
1,713,734. REN. 8-16-12. INT. CL. 20.
1,723,825. REN. 8-15-12. INT. CL. 20.

GARCIA, RAYMUNDO MALDONADO, MONTERREY, MEXICO:
4,208,169, PUB. 7-3-2012. INT. CL. 17.

GARCIA, SERGIO, CLEVELAND, OH:
4,210,321, MULTIPLE CLASS, INT. CLS. 25 AND 28.

GARDEN OF DREAMS FOUNDATION, NEW YORK, NY:
2,527,529, CANC. INT. CL. 36.

GARFF ENTERPRISES, INC., SALT LAKE CITY, UT:
4,211,093, INT. CL. 35.

GARGIULO INC., NAPLES, FL:
2,606,890. REN. 8-10-12. INT. CL. 31.

GARICK, LLC, CLEVELAND, OH:
2,739,690. REN. 8-15-12. MULTIPLE CLASS, INT. CLS. 1 AND 31.

GARY D. LUKEHART, YAKIMA, WA:
1,736,404. REN. 8-10-12. INT. CL. 12.

GASTEL, DANIEL, 78370 PLAISIR, FRANCE:
2,636,796. REN. 8-10-12. INT. CL. 6.
2,636,799. REN. 8-10-12. INT. CL. 20.

GAT; GESELLSCHAFT FÜR ANTRIEBSTECHNIK MBH, FED REP GERMANY:
4,208,424, PUB. 7-3-2012. MULTIPLE CLASS, INT. CLS. 7, 9 AND 10.

GATES, LAWRENCE P., WILMINGTON, CA:
3,024,309, CANC. INT. CL. 21.

GAYNOR MINDEN, INC., NEW YORK, NY:
4,210,554, INT. CL. 25.

GDP IMPORTS, LLC, DESTIN, FL:
4,210,409, INT. CL. 14.
4,210,422, INT. CL. 14.

GDSX, LTD., ALLEN, TX:
4,208,985, PUB. 7-3-2012. INT. CL. 42.

GEA FARM TECHNOLOGIES GMBH, 59199 BÖNEN, FED REP GERMANY:
4,208,318, PUB. 7-3-2012. MULTIPLE CLASS, INT. CLS. 1, 3, 5 AND 7.

GEA FARM TECHNOLOGIES, INC., NAPERVILLE, IL:
4,210,389, MULTIPLE CLASS, INT. CLS. 1, 3, 4, 5, 6, 7, 9, 11, 17, 18, 19, 20, 21, 25, 27, 35, 36, 37, 39, 41, 42 AND 44.

GEBR. BRASELER GMBH & CO. KG, D-32675 LEMGO, FED REP GERMANY:
2,648,204. REN. 8-16-12. MULTIPLE CLASS, INT. CLS. 5, 7, 8 AND 10.

GEEKGIRLCON, SEATTLE, WA:
4,209,562, PUB. 7-3-2012. INT. CL. 41.

GEFRAN S.P.A., ITALY:
3,256,605.

GEHL COMPANY, INC., WEST BEND, WI:
2,607,017. REN. 8-11-12. INT. CL. 12.

GELLER, JORDAN, LAS VEGAS, NV:
4,210,741, MULTIPLE CLASS, INT. CLS. 25 AND 41.

GELLI ARTS LLC, SOUTH ORANGE, NJ:
4,209,019, PUB. 7-3-2012. INT. CL. 7.

GEMOLOGICAL APPRAISAL ASSOCIATION, INC., NEW YORK, NY:
2,679,821. REN. 8-10-12. INT. CL. 42.

GEN-PROBE INCORPORATED, SAN DIEGO, CA:
4,208,483, PUB. 7-3-2012. INT. CL. 9.

GENABILITY INC., SAN FRANCISCO, CA:
4,211,498, MULTIPLE CLASS, INT. CLS. 9, 35, 36 AND 42.

GENEART AG, REGENSBURG, FED REP GERMANY:
3,111,123, CANC. MULTIPLE CLASS, INT. CLS. 1 AND 5.

GENERAL AGRICULTURE, BUCKEYE, AZ:
4,210,221, PUB. 7-3-2012. MULTIPLE CLASS, INT. CLS. 22, 31 AND 44.

GENERAL AWARDS OF NEW YORK, INC., FLORIDA, NY:
2,526,837, CANC. MULTIPLE CLASS, INT. CLS. 6, 9, 20 AND 21.

GENERAL COUNCIL ON FINANCE AND ADMINISTRATION OF THE UNITED METHODIST CHURCH, EVANSTON, IL:
2,608,850. COR. MULTIPLE CLASS, U.S. CL. 200 INT. CLS. 41 AND 42.

GENERAL MOTORS ASSET MANAGEMENT CORPORATION, NEW YORK, NY:
2,527,918, CANC. INT. CL. 36.

GENERAL MOTORS LLC, DETROIT, MI:
1,708,167. REN. 8-15-12. INT. CL. 16.
1,708,168. REN. 8-15-12. INT. CL. 16.

GENERAL NUTRITION INVESTMENT COMPANY, PHOENIX, AZ:
4,211,288, INT. CL. 3.

GENESIS IP, LLC, KENNETT SQUARE, PA:
4,211,317, INT. CL. 41.
4,211,713, INT. CL. 44.
4,211,714, INT. CL. 44.

GENGHIS GRILL FRANCHISE CONCEPTS, LP, DALLAS, TX:
4,211,320, INT. CL. 30.
4,211,321, INT. CL. 33.
4,211,322, INT. CL. 33.

GENII, INC., WOODBURY, MN:
4,211,319, INT. CL. 9.

GENKI SUSHI CO., LTD., UTSUNOMIYA-SHI, TOCHIGI 320-0811, JAPAN:
2,604,363. REN. 8-14-12. MULTIPLE CLASS, INT. CLS. 30 AND 42.

GENOMIC HEALTH, INC., REDWOOD CITY, CA:
4,208,949, PUB. 7-3-2012. INT. CL. 44.

GENWORTH MORTGAGE HOLDINGS, LLC, RALEIGH, NC:
2,729,144. REN. 8-16-12. INT. CL. 36.

GEODIGITAL SOLUTIONS INC., MENDOTA HEIGHTS, MN:
2,605,760. REN. 8-16-12. INT. CL. 9.

GEORGE IBACH, MINNEAPOLIS, MN:
4,211,297, INT. CL. 44.

- GEORGE LETNESS ILLUSTRATION, MINNEAPOLIS, MN, DBA GRAPHICS440:
4,208,521, PUB. 7-3-2012. INT. CL. 41.
- GEORGE S. TAWHEEL, INC., STUDIO CITY, CA:
3,038,290, CANC. INT. CL. 41.
- GEORGE W. BUSH FOUNDATION, DALLAS, TX:
4,209,182, PUB. 7-3-2012. MULTIPLE CLASS, INT. CLS. 35 AND 41.
- GEORGEMARC LLC, NEW YORK, NY:
4,210,466, INT. CL. 25.
- GEORGIA CENTRAL CORPORATE FEDERAL CREDIT UNION, DULUTH, GA:
4,211,203, INT. CL. 36.
- GEOTHERMAL SUPPLY CO., INC., HORSE CAVE, KY:
4,209,098, PUB. 7-3-2012. INT. CL. 7.
- GEO TRADEMARKS LLC, HOLLYWOOD, FL:
4,211,624, INT. CL. 35.
- GERALD R. GREENE, ST. DAVIDS, PA AND NINA A. GREENE, ST. DAVIDS, PA:
4,209,924, PUB. 7-3-2012. INT. CL. 41.
- GERHARDT & ASSOCIATES, LLC, SPRINGFIELD, LA:
4,211,350, INT. CL. 42.
- GERITREX, CORP., MOUNT VERNON, NY:
2,526,411, CANC. INT. CL. 5.
- GERS, JEREMY, BAYOONE, NJ:
4,210,986, INT. CL. 25.
- GERSON & GERSON, INC., NEW YORK, NY:
4,209,797, PUB. 7-3-2012. INT. CL. 25.
4,209,824, PUB. 7-3-2012. INT. CL. 25.
- GESTIONI PICCINI S.R.L., ITALY:
4,208,311, PUB. 7-3-2012. INT. CL. 33.
- GETTY IMAGES (US), INC., NEW YORK, NY, IMAGE BANK, INC., THE, DALLAS, TX:
1,688,052, REN. 8-15-12. INT. CL. 35.
- GG&T CORPORATION, ASHEVILLE, NC:
2,729,150, REN. 8-15-12. INT. CL. 30.
- GIALIVE, INC, SAN ANTONIO, TX:
4,208,670, PUB. 7-3-2012. INT. CL. 5.
- GIANNA ROSE ATELIER, INC., SANTA ANA, CA:
2,527,289, CANC. INT. CL. 3.
- GIBBON, ZACHARY S., GREAT MEADOWS, NJ:
4,211,231, INT. CL. 41.
- GIBSON, PANDWE, WASHINGTON, DC AND NATASHA, WASHINGTON, DC:
4,209,336, PUB. 7-3-2012. INT. CL. 35.
- GICON-GROßMANN INGENIEUR CONSULT GMBH, FED REP GERMANY:
4,208,332, PUB. 7-3-2012. MULTIPLE CLASS, INT. CLS. 35, 37 AND 42.
- GIFTS THAT GIVE, INC., SOUTH ORANGE, NJ:
4,211,658, INT. CL. 36.
- GIGA-BYTE TECHNOLOGY CO., LTD., TAIPEI, TAIWAN:
4,208,658, PUB. 7-3-2012. INT. CL. 9.
4,208,659, PUB. 7-3-2012. INT. CL. 9.
- GILBARCO INC., GREENSBORO, NC:
4,208,518, PUB. 7-3-2012. INT. CL. 9.
- GILL, CHANDRA, PHD., CHICAGO, IL:
4,210,433, INT. CL. 9.
- GILLESPIE, SCOTT, PARKER, CO:
4,211,512, INT. CL. 35.
- GILLETTE COMPANY, THE, BOSTON, MA:
1,766,501, REN. 8-10-12. INT. CL. 3.
- GILLOURY INSTITUTE, CHICAGO, IL:
4,211,663, INT. CL. 41.
- GILMORE, DANIEL V, HACKENSACK, NJ:
4,211,130, INT. CL. 25.
- GILMORE, SAMANTHA, TUCSON, AZ:
4,211,571, INT. CL. 42.
- GIMOTA AG, CH-8954 GEROLDSWIL, SWITZERLAND:
4,208,348, PUB. 7-3-2012. MULTIPLE CLASS, INT. CLS. 9 AND 12.
- GINGO BILOBA S.A., BELGIUM:
4,208,314, PUB. 7-3-2012. MULTIPLE CLASS, INT. CLS. 9, 10 AND 11.
- GINLACK, SAA TAMBA, KAPAA, HI:
4,210,885, INT. CL. 25.
- GINO GASPARI & SONS, INC., TEMPLE, PA:
2,526,638, CANC. MULTIPLE CLASS, INT. CLS. 31 AND 35.
- GIORGIFRED COMPANY, WILMINGTON, DE:
4,210,362, INT. CL. 31.
- GIRL SCOUTS-ARIZONA CACTUS-PINE COUNCIL, INC., PHOENIX, AZ TO GIRL SCOUTS-ARIZONA CACTUS-PINE COUNCIL, INC., PHOENIX, AZ:
2,527,393, CANC. U.S. CL. 200.
- GIT-R-DONE PRODUCTIONS, INC., ATLANTA, GA:
4,209,864, PUB. 7-3-2012. INT. CL. 30.
4,209,865, PUB. 7-3-2012. INT. CL. 30.
4,210,031, PUB. 7-3-2012. INT. CL. 9.
4,210,057, PUB. 7-3-2012. INT. CL. 30.
4,210,138, PUB. 7-3-2012. INT. CL. 3.
4,210,145, PUB. 7-3-2012. INT. CL. 30.
- GIVAUDAN S.A., SWITZERLAND:
3,068,377.
- GIZZIO, INC., EXTON, PA:
2,607,640, REN. 8-14-12. INT. CL. 42.
- GL & LL OF O.C., LLC, OCEAN CITY, MD:
1,705,137, REN. 8-16-12. INT. CL. 25.
- GLANBIA NUTRITIONALS (IRELAND) LIMITED, KILKENNY, IRELAND:
4,211,019, INT. CL. 5.
- GLANBIA PLC, COUNTY KILKENNY, IRELAND:
2,608,235, REN. 8-15-12. INT. CL. 5.
- GLAXO GROUP LIMITED, GREENFORD, MIDDLESEX, UNITED KINGDOM:
3,027,610, CANC. INT. CL. 5.
- GLEN CLYDE WHISKY LIMITED, LONDON, UNITED KINGDOM:
4,208,174, PUB. 3-20-2012. INT. CL. 33.
- GLENCOE SOFTWARE INC., UNITED STATES:
4,208,258, PUB. 7-3-2012. MULTIPLE CLASS, INT. CLS. 9, 35 AND 42.
- GLOBAL BEAUTY CARE INC., BROOKLYN, NY:
4,210,913, INT. CL. 3.
- GLOBAL CROSSING NORTH AMERICA, INC., ROCHESTER, NY TO FRONTIER COMMUNICATIONS CORPORATION, STAMFORD, CT:
2,528,321, CANC. INT. CL. 35.
- GLOBAL FUTURES & FOREX, LTD., GRAND RAPIDS, MI:
4,210,113, PUB. 7-3-2012. INT. CL. 36.
- GLOBAL LICENSING, INC, DURAND, MI:
4,208,159, PUB. 7-3-2012. MULTIPLE CLASS, INT. CLS. 41 AND 43.
- GLOBAL LICENSING, INC., DURAND, MI:
4,208,158, PUB. 7-3-2012. MULTIPLE CLASS, INT. CLS. 41 AND 43.
- GLOBAL MAIL, INC., WESTON, FL:
4,210,513, INT. CL. 39.
- GLOBAL MARKET HOLDINGS, LLC, ARLINGTON, VA:
4,211,632, INT. CL. 36.
- GLOBAL MARKETING RESOURCES, INC., DUNEDIN, FL:
4,209,650, PUB. 7-3-2012. INT. CL. 45.
- GLOBAL QUALITY HEALTH, INC., YORKTOWN HEIGHTS, NY:
4,210,096, PUB. 7-3-2012. INT. CL. 5.
- GLOBAL SMOKED FOODS LIMITED FOUNDATION, CHARLESTOWN, ST.KITTS-NEVIS:
4,208,912, PUB. 7-3-2012. INT. CL. 29.
4,208,935, PUB. 7-3-2012. INT. CL. 29.
- GLOBAL TRADEMARKS INC., STOCKERTOWN, PA:
4,210,839, INT. CL. 25.
- GLOBALSCAPE, INC., SAN ANTONIO, TX:
4,210,325, INT. CL. 9.
4,210,326, INT. CL. 9.
- GLOBE PIPE HANGER PRODUCTS INC., CLEVELAND, OH:
4,210,930, INT. CL. 6.
- GLODON SOFTWARE CO., LTD., HAIDIAN DIST, BEIJING, CHINA:
4,211,345, INT. CL. 42.
- GLORY LTD., HIMEJI-SHI, HYOGO-KEN, JAPAN:
4,209,168, PUB. 7-3-2012. INT. CL. 9.
- GNASS, JEFF, JUNEAU, AK:
2,527,956, CANC. INT. CL. 42.
- GNR SPORTS INNOVATIONS LLC, SCOTTSDALE, AZ:
4,210,899, INT. CL. 5.

GNT LLC, MCLEAN, VA:
4,209,141, PUB. 7-3-2012. INT. CL. 16.

GO BODY NUTRITION LLC, ANDERSON, SC:
4,210,274, INT. CL. 5.

GO JUMP IN THE LAKE, LLC, ACWORTH, GA:
4,209,385, PUB. 7-3-2012. INT. CL. 21.

GOAL, INC., ATLANTA, GA:
2,990,920, CANC. INT. CL. 41.

GOD'S LITTLE ACRES, INC., COCONUT CREEK, FL:
2,528,403, CANC. INT. CL. 41.

GOGA STUDIOS, INC., HAMPTON, NH:
4,209,220, PUB. 7-3-2012. INT. CL. 44.

GOLDEN BELL MANAGEMENT, INC., JACKSONVILLE BEACH, FL:
4,209,174, PUB. 7-3-2012. MULTIPLE CLASS, INT. CLS. 41 AND 45.

GOLFING FORE HIM, LLC, LAS VEGAS, NV:
4,209,026, PUB. 7-3-2012. INT. CL. 41.

GOLFSMITH INTERNATIONAL, INC., AUSTIN, TX:
4,211,010, INT. CL. 28.

GONGSHOW GEAR INC., OTTAWA, ONTARIO, CANADA:
4,208,550, PUB. 7-3-2012. MULTIPLE CLASS, INT. CLS. 25 AND 35.

GOOD EARTH MINERALS, LLC, DENVER, CO:
4,209,789, PUB. 7-3-2012. MULTIPLE CLASS, INT. CLS. 1 AND 5.

GOOD FOOD, INC, HONEY BROOK, PA:
2,538,009, REN. 8-15-12. INT. CL. 30.

GOOD HEALTH NATURALLY, INC., LAS VEGAS, NV:
4,210,943, INT. CL. 5.
4,211,386, MULTIPLE CLASS, INT. CLS. 5 AND 35.

GOODACCOUNTANTS.COM, INC., LYNBROOK, NY:
4,209,872, PUB. 7-3-2012. INT. CL. 35.

GOODRIDGE UK LIMITED, UNITED KINGDOM:
4,208,361, PUB. 7-3-2012. MULTIPLE CLASS, INT. CLS. 6 AND 12.

GORDON RIDES, LLC, WHITE PLAINS, NY:
4,211,174, INT. CL. 28.

GORDON, MICHELE E, BELLMORE, NY, DBA CHIEF EXECUTIVE OFFICER:
4,208,787, PUB. 7-3-2012. INT. CL. 41.

GORHAM, ROBERT, UNITED KINGDOM AND HUGHES, JOHN, UNITED KINGDOM:
4,208,342, PUB. 7-3-2012. MULTIPLE CLASS, INT. CLS. 9, 16, 25, 41, 43 AND 44.

GORMAN, ROBIN A, SHELTON, WA, DBA SOLID IDEAS:
3,079,128, AM. INT. CL. 5.

GOSPEL MUSIC ASSOCIATION, INC., NASHVILLE, TN:
3,086,074, COR. INT. CL. 41.

GOTTSMAN, AKEMI, BROWNSBURG, IN, DBA PRECIOUS-TEES:
4,209,438, PUB. 7-3-2012. INT. CL. 35.

GOULD, MICHAEL, SHERMAN OAKS, CA:
4,210,271, INT. CL. 44.

GOURMET GRAM INTERNATIONAL, INC., CHICAGO, IL:
2,601,373, REN. 8-16-12. INT. CL. 35.

GOVERNMENT PAYMENTS LLC, FREMONT, CA:
4,211,744, INT. CL. 36.

GOWAN COMPANY, L.L.C., YUMA, AZ:
4,210,442, INT. CL. 5.

GOYA FOODS, INC., SECAUCUS, NJ:
4,210,054, PUB. 7-3-2012. INT. CL. 32.

GOYARD ST-HONORE, 75001 PARIS, FRANCE, GOYARD S.A.R.L., 75001 PARIS, FRANCE:
1,709,953, REN. 8-12-12. MULTIPLE CLASS, INT. CLS. 16 AND 18.

GPS (DELAWARE), INC., SAN BRUNO, CA TO GAP (APPAREL), LLC, SAN FRANCISCO, CA:
1,745,875, AM. MULTIPLE CLASS, INT. CLS. 25 AND 35.

GPSMYCITY.COM INC., LAS VEGAS, NV:
4,211,432, INT. CL. 9.

GRAB & GOURMET, INC., LOS ANGELES, CA:
4,210,989, INT. CL. 43.

GRACE HOME FASHIONS, LLC, NEW YORK, NY:
4,211,597, INT. CL. 24.

GRADY RESTAURANT GROUP, LLC, HOMEWOOD, IL:
4,210,636, MULTIPLE CLASS, INT. CLS. 21, 25, 28, 29, 30 AND 43.

GRAFELMAN, DEBORAH L., COUNCIL BLUFFS, IA:
2,709,515, REN. 8-16-12. INT. CL. 10.

GRAFFIT USA, LLC, NEW YORK, NY:
4,211,006, INT. CL. 43.

GRAHAM & BUFFETT, LTD., PLANO, TX:
4,209,808, PUB. 7-3-2012. MULTIPLE CLASS, INT. CLS. 5 AND 32.

GRAMRO, LLC, NISKAYUNA, NY:
4,210,465, INT. CL. 41.

GRAND LODGE F. AND A.M. OF MICHIGAN, THE, GRAND RAPIDS, MI:
2,527,412, CANC. INT. CL. 41.

GRAND LODGE F. AND A.M. OF MICHIGAN, THE, ALMA, MI:
2,527,417, CANC. INT. CL. 41.

GRAND TRAVERSE MOUNTAIN BIKE ASSOCIATION, LLC, ACME, MI:
4,209,866, PUB. 7-3-2012. INT. CL. 41.

GRANITE SECURITY PRODUCTS, INC., IRVING, TX:
4,209,678, PUB. 7-3-2012. INT. CL. 6.

GRANT-HARVEY, SHALISSA DIONE, DETROIT, MI:
4,209,382, PUB. 7-3-2012. INT. CL. 41.

GRANVILLE PUBLICATION SOFTWARE, LLC, LOS ANGELES, CA:
2,526,561, CANC. INT. CL. 9.

GRAPE TECHNOLOGY GROUP, INC., BETHLEHEM, PA:
4,210,954, INT. CL. 35.

GRAPHIC MANAGEMENT SPECIALTY PRODUCTS, INC., OCONTO, WI:
4,209,208, PUB. 7-3-2012. MULTIPLE CLASS, INT. CLS. 16, 21 AND 40.

GRASS COLLECTION, LLC, CAVE CREEK, AZ:
4,210,905, INT. CL. 25.

GRATEFUL DEAD PRODUCTIONS, LOS ANGELES, CA, GRATEFUL DEAD MERCHANDISING, SAN RAFAEL, CA:
1,711,613, REN. 8-11-12. INT. CL. 16.

GRAY GHOST VINEYARDS, AMISSVILLE, VA:
2,662,886, REN. 8-11-12. INT. CL. 33.

GREAT EASTERN RESORT MANAGEMENT, INC., MCGAHEYSVILLE, VA:
4,209,990, PUB. 7-3-2012. INT. CL. 36.
4,209,991, PUB. 7-3-2012. MULTIPLE CLASS, INT. CLS. 36 AND 41.
4,209,999, PUB. 7-3-2012. INT. CL. 36.
4,210,037, PUB. 7-3-2012. MULTIPLE CLASS, INT. CLS. 36 AND 41.

GREAT LAKES SERVICES, LLC, MADISON, WI:
4,209,390, PUB. 7-3-2012. INT. CL. 41.
4,209,391, PUB. 7-3-2012. INT. CL. 43.
4,209,393, PUB. 7-3-2012. INT. CL. 43.
4,209,397, PUB. 7-3-2012. INT. CL. 43.
4,209,398, PUB. 7-3-2012. INT. CL. 43.
4,209,399, PUB. 7-3-2012. INT. CL. 43.

GREAT NUMBERS! LLC, RED BANK, NJ:
2,528,473, CANC. MULTIPLE CLASS, INT. CLS. 35 AND 41.

GREATER TAMPA ASSOCIATION OF REALTORS, INC., TAMPA, FL, AKA GTAR:
4,209,373, PUB. 7-3-2012. INT. CL. 35.

GRECO, ELENA, NEW YORK, NY:
2,527,531, CANC. MULTIPLE CLASS, INT. CLS. 41 AND 42.

GREEKTOWN CASINO, L.L.C., DETROIT, MI:
4,211,462, INT. CL. 43.

GREEN & ACKERMAN BAKERY, INC., BROOKLYN, NY, DBA GREENS:
1,722,244, REN. 8-11-12. INT. CL. 30.

GREEN ARCH LIMITED, CENTRAL, HONG KONG:
4,208,797, PUB. 7-3-2012. MULTIPLE CLASS, INT. CLS. 32, 33 AND 43.

GREEN BARREL, LLC, SAN FRANCISCO, CA:
4,211,842, INT. CL. 33.

GREEN BROTHERS, FRANCE:
4,208,276, PUB. 7-3-2012. MULTIPLE CLASS, INT. CLS. 18, 25 AND 28.

GREEN COMFORT SAFE, INC., SOUTH BRISTOL, ME:
4,210,497, INT. CL. 17.

- GREEN EXCHANGE LLC, NEW YORK, NY:
4,210,988, MULTIPLE CLASS, INT. CLS. 36 AND 41.
- GREEN WHEAT LTD., NEW YORK, NY:
2,659,983, REN. 8-10-12. INT. CL. 16.
- GREEN, SEAN, LOS ANGELES, CA AND DANKE, PAUL,
LOS ANGELES, CA AND REID, CORNELL, LOS AN-
GELES, CA AND LEISTIKOW, LOGAN, LOS ANGELES,
CA AND FEIGH, CASEY, LOS FELIZ, CA:
4,208,792, PUB. 7-3-2012. INT. CL. 41.
- GREENONETEC SOLARINDUSTRIE GMBH, AUSTRIA:
4,208,366, PUB. 7-3-2012. MULTIPLE CLASS, INT. CLS. 6,
11 AND 42.
- GREENSENDER, LLC, MAPLEWOOD, NJ:
4,208,171, PUB. 7-3-2012. INT. CL. 35.
- GREENSTEIN, RENEE, NEW YORK, NY:
4,211,069, INT. CL. 25.
- GREENWOOD GAMING & ENTERTAINMENT, INC., BEN-
SALEM, PA, DBA PARX CASINO:
4,208,212, PUB. 7-3-2012. INT. CL. 41.
- GREER LABORATORIES, INC., LENOIR, NC:
4,211,401, MULTIPLE CLASS, INT. CLS. 35, 42 AND 44.
- GREGG RITZ IP, LLC, STRATHAM, NH:
4,211,682, INT. CL. 41.
- GRIER, CATHY, NEW YORK, NY:
4,208,741, PUB. 7-3-2012. INT. CL. 41.
- GRIFFIN TECHNOLOGY, INC., NASHVILLE, TN:
4,211,243, INT. CL. 28.
- GRIFFIN, THERESA H., ZION, IL:
4,211,134, INT. CL. 30.
- GRIT INC., LORETTO, ON, CANADA:
4,208,593, PUB. 7-3-2012. INT. CL. 28.
- GROGREEN, INC., PLANO, TX:
4,208,642, PUB. 7-3-2012. MULTIPLE CLASS, INT. CLS. 5
AND 44.
- GROUP KAITU, LLC, RICHMOND, VA:
4,208,127, PUB. 7-3-2012. INT. CL. 42.
4,208,128, PUB. 7-3-2012. INT. CL. 42.
4,208,129, PUB. 7-3-2012. INT. CL. 35.
- GROUPE UNIPLEX, F-92080 PARIS LA DÉFENSE CEDEX,
FRANCE:
4,208,401, PUB. 7-3-2012. MULTIPLE CLASS, INT. CLS. 1,
35, 39 AND 42.
- GROUP360, INC., ST. LOUIS, MO:
2,743,286, REN. 8-16-12. INT. CL. 42.
- GROVE 45 EXTRA VIRGIN OLIVE OIL, ST. HELENA, CA:
4,208,214, PUB. 7-3-2012. INT. CL. 29.
- GRUPO BIMBO, S.A. B. DE C.V., MEXICO CITY, MEXICO:
2,631,208, AM. INT. CL. 30.
- GSIMEDIA CORP., GRAND CAYMAN, CAYMAN IS-
LANDS:
4,208,534, PUB. 7-3-2012. INT. CL. 9.
- GTE FEDERAL CREDIT UNION, TAMPA, FL:
4,209,500, PUB. 7-3-2012. MULTIPLE CLASS, INT. CLS. 37
AND 42.
4,209,501, PUB. 7-3-2012. MULTIPLE CLASS, INT. CLS. 37
AND 42.
- GUANA ISLAND HOTEL CORP., RYE, NY:
2,527,001, CANC. MULTIPLE CLASS, INT. CLS. 41 AND
42.
- GUANGDONG YATU CHEMICAL CO., LTD, GUANG-
DONG, CHINA:
4,211,198, INT. CL. 2.
4,211,199, INT. CL. 2.
- GUANGJING CO., LTD., SANTA FE SPRINGS, CA:
4,210,005, PUB. 7-3-2012. INT. CL. 25.
- GUANGZHOU HENGFU TEA INDUSTRY CO., LTD., CHI-
NA:
4,208,296, PUB. 7-3-2012. MULTIPLE CLASS, INT. CLS. 21
AND 30.
- GUCCI AMERICA, INC., NEW YORK, NY:
2,680,237, REN. 8-14-12. INT. CL. 14.
- GUESS? IP HOLDER L.P., LOS ANGELES, CA:
4,210,797, INT. CL. 9.
4,210,798, INT. CL. 9.
4,210,799, INT. CL. 9.
4,210,800, INT. CL. 9.
4,210,801, INT. CL. 9.
4,210,802, INT. CL. 9.
- GUIDE DOG FOUNDATION FOR THE BLIND, INC.,
SMITHTOWN, NY:
1,713,642, REN. 8-11-12. INT. CL. 16.
- GUIST BROTHERS ENTERTAINMENT GROUP, LLC, GON-
ZALES, LA:
4,209,858, PUB. 7-3-2012. INT. CL. 25.
- GULF PACIFIC, INC., HOUSTON, TX:
2,612,489, REN. 8-16-12. INT. CL. 30.
2,631,214, REN. 8-16-12. INT. CL. 30.
- GURU LABS, L.C., WEST BOUNTIFUL, UT:
2,600,288, REN. 8-13-12. MULTIPLE CLASS, INT. CLS. 41
AND 42.
- GUSTO ENTERTAINMENT, LLC, LAS VEGAS, NV:
4,208,847, PUB. 7-3-2012. INT. CL. 43.
4,208,848, PUB. 7-3-2012. INT. CL. 43.
- GUTIERREZ MENDEZ, GILDARDO, QUERETARO, MEX-
ICO:
4,211,167, INT. CL. 41.
- GVARDIA LLC, MIDDLETON, WI:
4,211,754, INT. CL. 33.
- GYRODATA INCORPORATED, HOUSTON, TX:
4,211,143, INT. CL. 9.
- G2 REVOLUTION, LLC, HUNTLEY, IL:
4,209,805, PUB. 7-3-2012. INT. CL. 3.
4,210,193, PUB. 7-3-2012. INT. CL. 40.
- H. J. HEINZ COMPANY, PITTSBURGH, PA:
4,211,307, INT. CL. 30.
- H. S. WILLIAMS COMPANY, INCORPORATED, MARION,
VA:
942,107, REN. 8-15-12. U.S. CL. 100 (INT. CL. 42).
- H.W. WILSON COMPANY, THE, BRONX, NY:
2,527,355, CANC. INT. CL. 9.
- H&PP INTERNATIONAL INC., BALDWIN PARK, CA:
2,528,757, CANC. INT. CL. 30.
- HAAS OUTDOORS, INC., WEST POINT, MS:
2,617,679, REN. 8-11-12. INT. CL. 36.
- HAITI ORIGINALE, LLC, CORAL GABLES, FL:
4,210,685, INT. CL. 30.
4,210,686, INT. CL. 33.
- HALEX FLOORING CORPORATION, PORMONA, CA:
1,675,634, REN. 8-15-12. INT. CL. 1.
- HALEX/SCOTT FETZER COMPANY, BEDFORD HEIGHTS,
OH:
4,210,281, INT. CL. 6.
- HALL, KEVAN, ENCINO, CA:
2,601,502, REN. 8-12-12. INT. CL. 25.
- HALPIN, MARY ANN, LOS ANGELES, CA, DBA MARY
ANN HALPIN PHOTOGRAPHY:
4,208,895, PUB. 7-3-2012. INT. CL. 14.
- HALSTIN GROUP, LLC, DALLAS, TX:
4,211,697, INT. CL. 43.
- HAMPTON PRODUCTS INTERNATIONAL CORPORA-
TION, FOOTHILL RANCH, CA:
4,211,404, INT. CL. 6.
4,211,405, INT. CL. 8.
4,211,406, INT. CL. 22.
- HANDA TRAVEL STUDENT TRIP LTD., TORONTO, CA-
NADA, DBA S-TRIP! AND EDGE ACADEMY:
4,209,728, PUB. 7-3-2012. INT. CL. 39.
4,209,731, PUB. 7-3-2012. INT. CL. 39.
- HANGAR 14 SOLUTIONS, LLC, MOORESVILLE, NC:
4,208,678, PUB. 7-3-2012. INT. CL. 9.
- HANLONG INDUSTRIAL CO., LTD., NEW TAIPEI CITY,
TAIWAN:
2,683,707, REN. 8-16-12. INT. CL. 8.
- HANNIBAL INC., WILMINGTON, DE:
3,037,479, CANC. INT. CL. 9.
- HANSEL 'N GRETEL BRAND, INC., GLENDALE, NY:
1,687,978, REN. 8-15-12. INT. CL. 29.
- HANSELE, GUNTHER JOSEF, WHITTIER, CA:
2,665,879, REN. 8-14-12. INT. CL. 12.
- HAPO COMMUNITY CREDIT UNION, RICHLAND, WA:
4,211,464, MULTIPLE CLASS, INT. CLS. 35 AND 36.
- HAPPY HOUR EYEWEAR LLC, LONG BEACH, CA:
4,211,220, INT. CL. 9.
- HARBOR FURNITURE MANUFACTURING, INC., ELBER-
TA, AL:
4,208,161, PUB. 7-3-2012. INT. CL. 20.

HARBORONE CREDIT UNION, BROCKTON, MA:
4,211,051, INT. CL. 36.

HARDEE'S FOOD SYSTEMS, INC., ST. LOUIS, MO:
4,209,332, PUB. 7-3-2012. INT. CL. 29.

HARDING, SHERWOOD M., CUMBERLAND, ME:
2,528,140, CANC. INT. CL. 3.

HARLEM GLOBETROTTERS INTERNATIONAL, INC., PHOENIX, AZ:
1,700,895, REN. 8-14-12. INT. CL. 41.

HARLEY MURRAY, INC., STOCKTON, CA:
1,745,705, REN. 8-16-12. INT. CL. 12.

HARMAN TECHNOLOGY LIMITED, KNUTSFORD, CHESHIRE, UNITED KINGDOM, ILFORD LIMITED, CHESHIRE, WA16 7HA, ENGLAND:
1,734,243, REN. 8-10-12. INT. CL. 1.

HARMON STORES, INC., CEDAR GROVE, NJ:
2,718,960, REN. 8-15-12. INT. CL. 35.

HARMONY INVESTMENTS LIMITED PARTNERSHIP, BEAVERTON, OR:
4,209,374, PUB. 7-3-2012. INT. CL. 35.
4,209,375, PUB. 7-3-2012. INT. CL. 9.

HARMS, KATHERINE, BREINIGSVILLE, PA:
4,211,119, INT. CL. 35.

HARNESSING HAPPINESS, INC., MOUNT SHASTA, CA:
4,210,110, PUB. 7-3-2012. INT. CL. 41.

HARPERCOLLINS PUBLISHERS LIMITED, GLASGOW, UNITED KINGDOM:
2,612,864, REN. 8-11-12. INT. CL. 16.

HARPO, INC., CHICAGO, IL:
4,211,197, INT. CL. 42.

HARRIS CORPORATION, MELBOURNE, FL:
3,038,142, CANC. INT. CL. 9.

HARRIS COUNTY DEPARTMENT OF EDUCATION, HOUSTON, TX:
4,208,856, PUB. 7-3-2012. INT. CL. 41.

HARRIS PUBLICATIONS, INC., NEW YORK, NY:
4,209,978, PUB. 7-3-2012. INT. CL. 16.
4,209,980, PUB. 7-3-2012. INT. CL. 16.
4,209,983, PUB. 7-3-2012. INT. CL. 16.

HARRIS, JOANNE, WEST HOLLYWOOD, CA:
4,209,796, PUB. 7-3-2012. MULTIPLE CLASS, INT. CLS. 14 AND 26.

HART SOLUTIONS GROUP, INC., WOODBURN, KY:
4,208,793, PUB. 7-3-2012. INT. CL. 2.

HARTSTONE, INC., GLENVIEW, KY:
4,209,769, PUB. 7-3-2012. INT. CL. 19.

HASBRO, INC., PAWTUCKET, RI:
1,711,908, REN. 8-10-12. INT. CL. 28.
2,528,629, CANC. INT. CL. 28.
4,209,997, PUB. 7-3-2012. INT. CL. 28.

HATCH MEDICAL, L.L.C., DULUTH, GA:
2,662,236, REN. 8-14-12. INT. CL. 42.

HAUKEAHOE VENTURES, SALT LAKE CITY, UT:
4,210,900, INT. CL. 28.

HAVANA CLUB HOLDING, S.A, LUXEMBOURG L-2453, LUXEMBOURG:
4,209,004, PUB. 7-3-2012. INT. CL. 33.
4,209,005, PUB. 7-3-2012. INT. CL. 33.

HAWAIIAN JELLYS, LLC, WAIKOLOA, HI:
4,209,082, PUB. 7-3-2012. INT. CL. 25.

HAWKESWORTH ENTERPRISES, INC., BOYNTON BEACH, FL:
4,208,639, PUB. 7-3-2012. INT. CL. 18.

HAYABUSA FIGHTWEAR INC., KINGSTON, ONTARIO, CANADA:
3,584,813, CANC. INT. CL. 28.

HEADLAND CAPITAL PARTNERS LIMITED, HONG KONG, HONG KONG:
4,210,745, INT. CL. 36.

HEALTH EZ, LLC, ST. LOUIS, MO:
4,208,145, PUB. 7-3-2012. INT. CL. 21.

HEALTH RESEARCH, INC., MENANDS, NY:
4,208,835, PUB. 7-3-2012. INT. CL. 42.

HEARST COMMUNICATIONS, INC., NEW YORK, NY:
2,527,954, CANC. INT. CL. 16.

HEARTLAND BUILDING PRODUCTS, INC., BOONEVILLE, MS:
2,527,822, CANC. INT. CL. 19.

HEARTLAND RECREATIONAL VEHICLES, LLC, ELKART, IN:
4,211,454, INT. CL. 12.

HEARTMATH, LLC, BOULDER CREEK, CA:
4,209,528, PUB. 7-3-2012. MULTIPLE CLASS, INT. CLS. 9, 16 AND 41.

HEB GROCERY COMPANY, LP, SAN ANTONIO, TX:
4,209,874, PUB. 7-3-2012. INT. CL. 3.
4,209,888, PUB. 7-3-2012. INT. CL. 25.
4,209,961, PUB. 7-3-2012. INT. CL. 10.
4,209,962, PUB. 7-3-2012. INT. CL. 8.

HEBER BIOTEC, S.A.; (CONSEJO DE STADO), CUBA:
4,208,391, PUB. 7-3-2012. INT. CL. 5.

HEGWOOD, LINDA I., OSTEEN, FL:
4,209,192, PUB. 7-3-2012. INT. CL. 9.

HEITZ WINE CELLARS, ST. HELENA, CA:
1,215,157, REN. 8-15-12. INT. CL. 33.

HELENA CHRAIME, BROOKLYN, NY, DBA HELENA AND TROY:
4,211,417, INT. CL. 18.

HELGESEN INDUSTRIES, INC., HARTFORD, WI:
4,208,603, PUB. 7-3-2012. INT. CL. 40.

HELLERMANNTYTON CORPORATION, MILWAUKEE, WI:
2,602,605, REN. 8-13-12. INT. CL. 9.

HELSINN HEALTHCARE SA, LUGANO, SWITZERLAND:
4,210,228, PUB. 11-29-2011. MULTIPLE CLASS, INT. CLS. 5, 9 AND 16.

HENDRICKS, TED, ARLINGTON HEIGHTS, IL:
2,738,377, REN. 8-11-12. INT. CL. 41.

HENKEL AG & CO. KGAA, DUESSELDORF, FED REP GERMANY:
4,208,541, PUB. 4-26-2011. INT. CL. 3.

HENRY, JAMES C, FLINT HILL, VA:
4,210,296, INT. CL. 33.

HERAEUS KULZER GMBH, HANAU, FED REP GERMANY:
2,527,116, CANC. INT. CL. 10.

HERALD PUBLISHING COMPANY, LLC, THE, SYRACUSE, NY:
2,668,873, REN. 8-14-12. INT. CL. 16.

HERBA NATURAL PRODUCTS, INC., BROOKLYN, NY:
2,643,248, REN. 8-10-12. INT. CL. 5.

HERBERT GSCHWENDER, FED REP GERMANY:
4,208,232, PUB. 7-3-2012. MULTIPLE CLASS, INT. CLS. 25 AND 28.

HERCULES INCORPORATED, WILMINGTON, DE:
2,528,254, CANC. INT. CL. 35.

HERFF JONES, INC., INDIANAPOLIS, IN:
2,527,978, CANC. INT. CL. 20.

HERLOOM, LLC, SEATTLE, WA:
4,210,862, INT. CL. 25.

HERMAN, JOHN, BABYLON, NY:
2,527,629, CANC. INT. CL. 42.

HERO DOGS, INC., BROOKEVILLE, MD:
4,168,017, COR. INT. CL. 44.

HERTZ SYSTEM, INC., PARK RIDGE, NJ:
4,211,261, INT. CL. 39.

HEWITT ASSOCIATES LLC, LINCOLNSHIRE, IL:
4,210,787, INT. CL. 35.

HEXAGON INDUSTRIES, INC., CLEVELAND, OH:
2,625,839, REN. 8-16-12. INT. CL. 6.

HEYWARD, MARK, WINTER GARDEN, FL:
4,209,902, PUB. 7-3-2012. INT. CL. 31.

HFR, LLC, COVINGTON, LA:
2,622,908, REN. 8-13-12. INT. CL. 39.
2,622,910, REN. 8-13-12. INT. CL. 39.

HHCUS, LLC, RAPID CITY, SD:
4,209,908, PUB. 7-3-2012. INT. CL. 35.
4,209,912, PUB. 7-3-2012. INT. CL. 35.

HI-HEALTH SUPERMART CORPORATION, SCOTTSDALE, AZ:
4,209,549, PUB. 7-3-2012. INT. CL. 5.
4,209,552, PUB. 7-3-2012. INT. CL. 5.
4,209,953, PUB. 7-3-2012. INT. CL. 35.
4,209,959, PUB. 7-3-2012. INT. CL. 35.
4,209,973, PUB. 7-3-2012. INT. CL. 35.

- HI-LINE ELECTRIC COMPANY, DALLAS, TX, AKA HI-LINE, INC.:
4,211,755, MULTIPLE CLASS, INT. CLS. 6, 9 AND 35.
- HICOBOY, INC., DALLAS, TX, DBA HICOBOY:
4,210,791, INT. CL. 25.
- HIDDEN BEACH RECORDS, LLC, SANTA MONICA, CA:
3,038,305, CANC. INT. CL. 9.
- HIGH GRADE HERBAL INC., DANIA, FL, DBA NATURAL LEAF INC.:
4,209,461, PUB. 7-3-2012. INT. CL. 34.
- HIGH VOLTAGE GRAPHICS, INC., FT. COLLINS, CO:
4,210,832, INT. CL. 26.
- HIGH 5 TICKETS TO THE ARTS, INC., NEW YORK, NY:
2,527,298, CANC. INT. CL. 41.
- HIGHLIGHTS FOR CHILDREN, INC., COLUMBUS, OH:
4,210,320, INT. CL. 14.
- HIGHLINE DIGITAL MEDIA, LLC, TARRYTOWN, NY:
4,208,766, PUB. 7-3-2012. INT. CL. 41.
- HILL COUNTRY IP, LLC, NEW YORK, NY:
4,210,327, INT. CL. 41.
- HILL'S PET NUTRITION, INC., TOPEKA, KS:
2,527,991, CANC. INT. CL. 31.
4,208,684, PUB. 7-3-2012. INT. CL. 5.
- HILLERICH & BRADSBY CO., LOUISVILLE, KY:
2,527,756, CANC. INT. CL. 28.
- HILLS-KAHN, INC., LAS VEGAS, NV, DBA PRMCONNECT:
4,210,980, INT. CL. 42.
- HILLSIDE GROUP, INC., THE, KNOXVILLE, TN:
2,527,118, CANC. MULTIPLE CLASS, INT. CLS. 41 AND 42.
- HILLWOOD DEVELOPMENT COMPANY LLC, DALLAS, TX:
2,544,996, REN. 8-11-12. INT. CL. 37.
2,550,054, REN. 8-11-12. INT. CL. 37.
- HILLWOOD DEVELOPMENT COMPANY, LLC, DALLAS, TX:
2,631,074, REN. 8-16-12. INT. CL. 37.
- HILTAP FITTINGS, LTD., CALGARY, CANADA:
2,601,766, REN. 8-13-12. INT. CL. 6.
- HINES GROWERS LLC, LAGUNA HILLS, CA:
4,209,889, PUB. 7-3-2012. INT. CL. 31.
4,209,891, PUB. 7-3-2012. INT. CL. 31.
4,210,213, PUB. 7-3-2012. INT. CL. 31.
- HINKLE, ELIZABETH, NEW MARKET, MD:
4,209,497, PUB. 7-3-2012. INT. CL. 21.
- HINSDALE ORTHOPAEDIC ASSOCIATES, S.C., HINSDALE, IL:
2,526,955, CANC. INT. CL. 42.
- HINSHAW, EDWARD, CAMERON, SC AND HINSHAW, VICKI, CAMERON, SC:
3,038,318, CANC. INT. CL. 44.
- HIP HOP STOCK EXCHANGE & INVESTMENT INC., LEMON GROVE, CA:
4,208,126, PUB. 7-3-2012. INT. CL. 3.
- HISGADGET INC., UNION CITY, CA:
4,210,216, PUB. 7-3-2012. INT. CL. 9.
- HISTORIC HUDSON VALLEY, POCANTICO HILLS, NY:
4,209,832, PUB. 7-3-2012. INT. CL. 41.
- HITACHI MEDICAL CORPORATION, TOKYO, JAPAN:
2,732,633, REN. 8-13-12. INT. CL. 10.
- HJ DISTRIBUTION LLC, BROOKLYN, NY:
4,209,386, PUB. 7-3-2012. INT. CL. 35.
4,209,412, PUB. 7-3-2012. INT. CL. 35.
- HLT DOMESTIC IP LLC, MCLEAN, VA:
2,527,340, CANC. INT. CL. 42.
2,527,662, CANC. INT. CL. 42.
4,210,570, MULTIPLE CLASS, INT. CLS. 38 AND 43.
- HO-CHUNK NATION, BLACK RIVER FALLS, WI:
4,210,968, INT. CL. 43.
- HOB ENTERTAINMENT, LLC, BEVERLY HILLS, CA:
2,750,016, REN. 8-16-12. INT. CL. 41.
- HOBART BROTHERS COMPANY, TROY, OH:
2,615,032, REN. 8-10-12. INT. CL. 37.
- HOEGEMEYER HYBRIDS, INC., HOOPER, NE:
4,210,998, MULTIPLE CLASS, INT. CLS. 31 AND 40.
- HOG HAULERS INC., PORTLAND, OR:
2,527,351, CANC. INT. CL. 39.
- HOG SLAT, INC., NEWTON GROVE, NC:
4,211,726, MULTIPLE CLASS, INT. CLS. 7 AND 10.
- HOLDEN, PATRISE, WASHINGTON, DC:
3,037,337, CANC. INT. CL. 41.
- HOLLAND, MARK JOHN, ALBUQUERQUE, NM, DBA HOLLAND CLINIC:
4,209,932, PUB. 7-3-2012. INT. CL. 44.
- HOLLY M. RIDDEL, BEVERLY HILLS, CA:
4,209,363, PUB. 7-3-2012. INT. CL. 14.
- HOLMAN, TIM, OCEANSIDE, CA:
4,211,257, INT. CL. 28.
- HOLMES, LARRY PETER, WEST SWANZEY, NH:
4,211,850, INT. CL. 25.
- HOLMES, THADDEUS J, PORTLAND, IN, AKA THAD-DEUS REX:
4,210,641, INT. CL. 41.
- HOLT'S COMPANY, WILMINGTON, DE, HOLT'S COMPANY, WILMINGTON, DE:
2,639,893, REN. 8-10-12. INT. CL. 34.
- HOMASOTE COMPANY, WEST TRENTON, NJ:
958,042, REN. 8-14-12. MULTIPLE CLASS, U.S. CLS. 2 (INT. CL. 20), 50 (INT. CL. 17), 100 (INT. CL. 42) AND 103 (INT. CL. 37).
- HOMAX PRODUCTS, INC., BELLINGHAM, WA:
4,211,106, INT. CL. 3.
- HOME BUYERS WARRANTY CORPORATION, DENVER, CO:
4,208,854, PUB. 7-3-2012. MULTIPLE CLASS, INT. CLS. 35 AND 36.
- HOME HEALTHCARE CONNECTION, INC., WICHITA, KS:
3,038,345, CANC. INT. CL. 44.
- HOME INSTEAD, INC., OMAHA, NE:
4,211,557, INT. CL. 41.
- HOME TEAM MARKETING, CLEVELAND,, OH:
4,211,865, INT. CL. 35.
- HOME WATCH AND PET CARE SERVICES, LLC, CASTLE ROCK, CO, DBA GOT2GO PET SITTING:
4,209,895, PUB. 7-3-2012. INT. CL. 45.
- HOMEDICS, INC., COMMERCE TOWNSHIP, MI:
3,009,587, CANC. INT. CL. 10.
- HOMER TLC, INC., CLAYMONT, DE:
3,038,343, CANC. INT. CL. 11.
3,038,344, CANC. INT. CL. 11.
- HOMRA, BRIAN, HENDERSONVILLE, TN:
4,211,186, INT. CL. 30.
- HONEYWELL INTERNATIONAL INC., MORRISTOWN, NJ:
2,678,128, REN. 8-10-12. INT. CL. 9.
2,743,834, REN. 8-14-12. INT. CL. 9.
4,210,419, INT. CL. 9.
4,211,655, INT. CL. 9.
- HOOGVLIET, MARC J.H., HOOFDDORP, NETHERLANDS, DBA SCRIBBLY:
4,208,624, PUB. 7-3-2012. MULTIPLE CLASS, INT. CLS. 9 AND 45.
- HOOKED NATION, INC., VERO BEACH, FL:
4,208,647, PUB. 12-6-2011. INT. CL. 25.
4,208,675, PUB. 12-13-2011. INT. CL. 25.
- HOPE MEDICAL ENTERPRISES, INC., SCOTTSDALE, AZ, DBA HOPE PHARMACEUTICALS:
2,680,138, REN. 8-14-12. INT. CL. 5.
- HOPKINS MANUFACTURING CORPORATION, EMPORIA, KS, JONES, STEPHEN W., EMPORIA, KS:
1,772,916, REN. 8-16-12. INT. CL. 12.
- HOPSCOTCH GROUP, LLC, NEW YORK, NY:
4,208,568, PUB. 7-3-2012. INT. CL. 35.
- HORIZON DISTRIBUTION, INC., YAKIMA, WA, HORIZON DISTRIBUTION, INC., YAKIMA, WA:
2,612,988, REN. 8-15-12. INT. CL. 35.
- HORIZON U.A.E. FZCO, UNITED ARAB EMIRATES, UNITED ARAB EMIR.:
2,147,007, AM. INT. CL. 30.
- HORNBY HOBBIES LIMITED, KENT, CT9 4JX, GREAT BRITAIN, MINIMODELS LIMITED, NEW LANE HAVANT, ENGLAND:
727,200, REN. 8-10-12. U.S. CL. 22 (INT. CL. 28).
- HORNY TOAD ACTIVEWEAR, INC., SANTA BARBARA, CA:
4,210,532, MULTIPLE CLASS, INT. CLS. 25 AND 35.

HOSE-MCCANN TELEPHONE CO., INC., DEERFIELD BEACH, FL:
2,653,276. REN. 8-13-12. INT. CL. 9.

HOSPIRA BOULDER, INC., LAKE FOREST, IL, USV PHARMACEUTICAL CORPORATION, TUCKAHOE, NY:
942,613. REN. 8-16-12. U.S. CL. 18 (INT. CL. 5).

HOT-CAN SDN. BHD., 6000 KUALA LUMPUR, MALAYSIA:
4,211,771. INT. CL. 11.

HOTEL GENPAR, LTD., MIAMI, FL:
4,210,292. INT. CL. 43.

HOUGHTON LAKE CHAMBER OF COMMERCE, HOUGHTON LAKE, MI:
2,615,091. REN. 8-15-12. INT. CL. 41.

HOUSTON, JEFF, BALBOA ISLAND, CA:
4,209,486. PUB. 7-3-2012. MULTIPLE CLASS, INT. CLS. 29 AND 30.

HOUWELING NURSERIES OXNARD, INC., CAMARILLO, CA:
4,211,073. INT. CL. 31.
4,211,074. INT. CL. 31.

HOVAIZI, NEDA, QUINCY, MA, DBA LUMIERE DENTAL SPA, LLC:
4,209,430. PUB. 7-3-2012. INT. CL. 44.

HOW TO BE A REDHEAD LLC, HAINES CITY, FL:
4,209,347. PUB. 7-3-2012. INT. CL. 41.

HOWARD BERREY, PUNTA GORDA, FL:
4,210,863. INT. CL. 12.

HOWCAST MEDIA, INC., NEW YORK, NY:
4,210,255. MULTIPLE CLASS, INT. CLS. 9 AND 41.
4,210,256. MULTIPLE CLASS, INT. CLS. 9 AND 41.

HOYA CORPORATION, JAPAN:
4,208,373. PUB. 7-3-2012. INT. CL. 9.

HOYA CORPORATION, TOKYO, JAPAN:
4,208,861. PUB. 7-3-2012. INT. CL. 9.
4,209,011. PUB. 7-3-2012. INT. CL. 40.

HQM LTD., WILMINGTON, DE:
4,210,965. INT. CL. 29.

HRHH IP, LLC, NEW YORK, NY:
2,534,438. REN. 8-10-12. MULTIPLE CLASS, INT. CLS. 41 AND 42.

HSA COMMERCIAL, INC., CHICAGO, IL:
2,742,051. REN. 8-14-12. MULTIPLE CLASS, INT. CLS. 36 AND 37.

HUB GROUP, INC., DOWNERS GROVE, IL:
2,579,075. REN. 8-14-12. INT. CL. 39.

HUBBELL INCORPORATED, ORANGE, CT TO HUBBELL INCORPORATED, ORANGE, CT:
2,527,884. CANC. INT. CL. 7.

HUBERT BURDA; MEDIA HOLDING KOMMANDITGESELLSCHAFT, FED REP GERMANY:
4,208,429. PUB. 7-3-2012. MULTIPLE CLASS, INT. CLS. 9, 16 AND 41.

HUBSPAN, INC., SEATTLE, WA:
4,211,124. INT. CL. 42.

HUDSON VIEW ASSOCIATES L.L.C., GREENWICH, CT:
2,526,560. CANC. INT. CL. 36.

HUFFY SPORTS DELAWARE, INC., MIAMISBURG, OH:
3,038,308. CANC. INT. CL. 25.

HUHEM, MITCH, DANA POINT, CA:
4,210,208. PUB. 7-3-2012. INT. CL. 5.

HUHOT MONGOLIAN GRILLS, LLC, MISSOULA, MT:
2,602,630. REN. 8-13-12. INT. CL. 42.

HUHTAMAKI FINANCE B.V., 2132 HE HOOFDDORP, NETHERLANDS:
3,840,906. COR. INT. CL. 30.
3,840,907. COR. INT. CL. 30.

HUMAN RESOURCE DEVELOPMENT PRESS, INC., AMHERST, MA:
2,527,143. CANC. INT. CL. 16.

HUMBLE FISH, INC., SANTA FE SPRINGS, CA, DBA SKUNK JUICE EARBUDS:
4,209,853. PUB. 7-3-2012. INT. CL. 9.

HUNAN GREATDREAMS CARTOON MEDIA LIMITED COMPANY, XINGSHA TOWN, HUNAN, CHINA:
4,208,164. PUB. 7-3-2012. MULTIPLE CLASS, INT. CLS. 16, 20, 24, 25 AND 28.

HUNDEMER, JAMES, BATON ROUGE, LA:
4,210,608. INT. CL. 9.

HUNT, KATHLEEN E., EL SEGUNDO, CA:
4,209,243. PUB. 7-3-2012. INT. CL. 41.

HUNTER DEFENSE TECHNOLOGIES, INC., SOLON, OH, DBA HDT ENGINEERED TECHNOLOGIES:
4,210,459. MULTIPLE CLASS, INT. CLS. 11, 19, 22, 40 AND 42.

HUNTER FAN COMPANY, MEMPHIS, TN:
2,601,411. REN. 8-12-12. INT. CL. 9.

HUNTING HILL GLOBAL CAPITAL, LLC, NEW YORK, NY:
4,210,567. INT. CL. 36.

HUNTSMAN ADVANCED MATERIALS (SWITZERLAND) GMBH, BASEL, SWITZERLAND:
4,210,932. INT. CL. 2.

HUNTSMAN INTERNATIONAL, LLC, THE WOODLANDS, TX:
2,369,935. REN. 8-14-12. INT. CL. 1.

HURLEY INTERNATIONAL LLC, COSTA MESA, CA:
4,210,251. INT. CL. 25.

HUSCO INTERNATIONAL, INC., WAUKESHA, WI:
2,605,476. REN. 8-16-12. INT. CL. 9.

HUSH ENTERPRISES PTY LTD, AUSTRALIA AND STANDBY STAFF SERVICES AUSTRALIA PTY LTD, AUSTRALIA:
4,208,260. PUB. 7-3-2012. MULTIPLE CLASS, INT. CLS. 9, 41 AND 44.

HUSONG, RICK, LOS ANGELES, CA:
4,210,874. INT. CL. 35.

HYDRAULIC COMPONENT SERVICES, INC., NEW BERLIN, WI:
1,199,067. AM. INT. CL. 37.

HYOSUNG CORPORATION, MAPO-GU, SEOUL, REPUBLIC OF KOREA:
2,603,429. REN. 8-16-12. MULTIPLE CLASS, INT. CLS. 16 AND 17.

HYTORC DIVISION UNEX CORPORATION, MAHWAH, NJ:
4,210,652. INT. CL. 7.

HYUNDAI MOTOR AMERICA, FOUNTAIN VALLEY, CA:
2,602,056. REN. 8-13-12. INT. CL. 12.
4,210,387. INT. CL. 12.

HYUNDAI PHARM. CO., LTD., CHUNGCHEONGNAM-DO, REPUBLIC OF KOREA:
1,779,998. REN. 8-15-12. INT. CL. 32.

H2O POD, INC., ELKHART, IN:
4,208,457. PUB. 7-3-2012. INT. CL. 28.

H2O SUPPLY, INC., LEWISVILLE, TX:
2,686,141. REN. 8-16-12. INT. CL. 35.

I GOLF LIKE A GIRL, LLC, FORT WORTH, TX:
4,210,897. INT. CL. 35.

I. SPIEWAK & SONS, INC., NEW YORK, NY:
2,601,882. REN. 8-11-12. MULTIPLE CLASS, INT. CLS. 9 AND 25.

I.P. HOLDINGS, INC., GRAND PRAIRIE, TX:
3,037,041. CANC. MULTIPLE CLASS, INT. CLS. 9 AND 13.

I-WIRELESS LLC, NEWPORT, KY:
4,210,889. INT. CL. 38.

IBEROSTAR HOTELES Y APARTAMENTOS, S.L., SPAIN:
4,208,280. PUB. 7-3-2012. MULTIPLE CLASS, INT. CLS. 39, 41 AND 43.

IBODY, LLC, SPRINGFIELD, MO, DBA IBODY DIRECTORY:
4,209,629. PUB. 7-3-2012. INT. CL. 35.

IBROKE LLC, PALM BEACH GARDENS, FL:
4,211,368. INT. CL. 37.

ICD PUBLICATIONS, INC., EAST SATAUKET, NY:
2,679,896. REN. 8-16-12. INT. CL. 42.

ICEBERG ENTERPRISES LLC, PARK RIDGE, IL:
2,601,930. REN. 8-10-12. INT. CL. 20.

ICENET, LLC, EVANSVILLE, IN:
2,922,410. CANC. INT. CL. 38.

ICONECT DEVELOPMENT, LLC, REDONDO BEACH, CA:
4,208,585. PUB. 7-3-2012. INT. CL. 9.
4,211,507. INT. CL. 42.

IDEATRON PTY LTD, AUSTRALIA:
4,208,413. PUB. 7-3-2012. INT. CL. 9.

IDEAWEAR, INC., ONTARIO, CA:
2,598,536. REN. 8-11-12. MULTIPLE CLASS, INT. CLS. 18,

- 21, 24 AND 25.
2,598,536, CANC. MULTIPLE CLASS, INT. CLS. 9, 16 AND 28.
2,605,264, REN. 8-11-12. MULTIPLE CLASS, INT. CLS. 18, 21, 24 AND 25.
2,605,264, CANC. MULTIPLE CLASS, INT. CLS. 9, 16 AND 28.
2,615,709, REN. 8-11-12. MULTIPLE CLASS, INT. CLS. 18, 21, 24 AND 25.
2,615,709, CANC. MULTIPLE CLASS, INT. CLS. 9 AND 28.
- IDM GROUP LLC, NEW YORK, NY:
4,209,251, PUB. 7-3-2012. MULTIPLE CLASS, INT. CLS. 10, 24 AND 25.
- IDQ OPERATING, INC., GARLAND, TX:
3,038,203, CANC. INT. CL. 1.
- IEXPLORE, INC., CHICAGO, IL:
2,629,834, REN. 8-10-12. INT. CL. 39.
- IFA EDUCATIONAL FOUNDATION, WASHINGTON, DC:
4,210,415, MULTIPLE CLASS, INT. CLS. 35 AND 41.
- IFE GROUP, ENCINITAS, CA:
2,619,564, REN. 8-15-12. INT. CL. 35.
- IFW, INC., MEDFORD, OR:
2,528,743, CANC. INT. CL. 12.
- IGET IT FAST LLC, GILBERT, AZ, DBA IGET IT FAST:
4,208,894, PUB. 7-3-2012. INT. CL. 9.
- IGT, RENO, NV:
3,038,330, CANC. INT. CL. 9.
4,210,361, INT. CL. 9.
4,210,642, INT. CL. 9.
4,211,335, INT. CL. 9.
4,211,336, INT. CL. 9.
4,211,620, INT. CL. 9.
- IJL PRODUCTIONS LLC, FOSTER CITY, CA:
4,209,869, PUB. 7-3-2012. INT. CL. 41.
- ILLINOIS TOOL WORKS INC., GLENVIEW, IL:
2,083,447, CANC. INT. CL. 17.
2,517,949, REN. 8-14-12. INT. CL. 9.
- IMAGE ENTERTAINMENT, INC., CHATSWORTH, CA:
4,182,147, COR. MULTIPLE CLASS, INT. CLS. 9 AND 35.
- IMAGE QUEST WORLDWIDE, INC., LAS VEGAS, NV:
4,211,097, INT. CL. 41.
- IMAGINE FILMS ENTERTAINMENT LLC, UNIVERSAL CITY, CA, IMAGINE FILMS ENTERTAINMENT, INC., LOS ANGELES, CA:
1,735,409, REN. 8-10-12. INT. CL. 41.
- IMATION CORP., OAKDALE, MN:
3,124,456, CANC. INT. CL. 9.
- IMI INTELLIGENT MEDICAL IMPLANTS AG, ZUG, SWITZERLAND:
4,210,483, INT. CL. 44.
- IMMUNOCLIN LIMITED, LONDON, UNITED KINGDOM:
3,037,460, CANC. MULTIPLE CLASS, INT. CLS. 1, 5, 41 AND 42.
- IMPACT STAFFING, LLC, CHICAGO, IL, DBA IMPACT STAFFING:
4,208,925, PUB. 7-3-2012. INT. CL. 35.
- IMPERIAL PAINTS, LLC, FAIRFOREST, SC:
4,211,648, INT. CL. 2.
- IMPERIAL USA LTD, CHARLOTTE, NC:
4,210,979, MULTIPLE CLASS, INT. CLS. 6 AND 20.
- IMPROVE GROUP, INC., ALBUQUERQUE, NM:
4,209,738, PUB. 7-3-2012. INT. CL. 35.
4,209,739, PUB. 7-3-2012. INT. CL. 37.
4,209,740, PUB. 7-3-2012. INT. CL. 38.
4,209,741, PUB. 7-3-2012. INT. CL. 39.
- IMPROVE GROUP, INC., ALBUQUERQUE, CA:
4,209,742, PUB. 7-3-2012. INT. CL. 41.
- IMPROVE GROUP, INC., ALBUQUERQUE, NM:
4,209,743, PUB. 7-3-2012. INT. CL. 42.
- IN MOCEAN GROUP, L.L.C., NEW YORK, NY:
4,210,239, INT. CL. 25.
- IN-N-OUT BURGERS, IRVINE, CA:
2,634,516, REN. 8-15-12. MULTIPLE CLASS, INT. CLS. 35 AND 42.
- INC INTERNATIONAL COMPANY, KENNETT SQUARE, PA:
4,211,127, INT. CL. 25.
- INCASE DESIGNS CORP., CHINO, CA, INCASE DESIGNS CORP., CHINO, CA:
2,643,012, REN. 8-10-12. INT. CL. 9.
- INCEPTUS, INC., UXBRIDGE, MA, DBA BETTER REST SOLUTIONS:
4,209,423, PUB. 7-3-2012. INT. CL. 10.
- INCLUSIVITY LLC, GLENWOOD, WA:
1,710,380, REN. 8-12-12. INT. CL. 41.
1,710,380, CANC. INT. CL. 35.
- INDIAN INDUSTRIES, INC., EVANSVILLE, IN:
4,211,443, INT. CL. 28.
- INDIANAPOLIS DOWNS, LLC, SHELBYVILLE, IN:
4,210,194, PUB. 7-3-2012. INT. CL. 41.
- INDIANAPOLIS THEATRE FRINGE FESTIVAL, INC., INDIANAPOLIS, IN:
4,208,752, PUB. 7-3-2012. MULTIPLE CLASS, INT. CLS. 41 AND 43.
- INDUSTRIAL CONTROL DEVELOPMENT, INC, VANCOUVER, WA, DBA ICD HIGH PERFORMANCE COATING:
4,208,775, PUB. 7-3-2012. MULTIPLE CLASS, INT. CLS. 1 AND 2.
- INDUSTRIAL ENVIRONMENTAL CARBON, HUNTINGTON, VT:
4,210,562, INT. CL. 7.
- INDUSTRIAS ALEN, S.A. DE C.V., N.L., MEXICO:
4,210,785, INT. CL. 3.
- INDYSSEY ENTERTAINMENT, LLC, NEW YORK, NY:
3,038,171, CANC. MULTIPLE CLASS, INT. CLS. 25 AND 41.
- INFASTECH DECORAH, LLC, WILMINGTON, DE:
4,210,616, INT. CL. 6.
- INFIELD SALES PRO LLC, FAIRFIELD, NJ:
4,209,530, PUB. 7-3-2012. INT. CL. 9.
- INFINEON TECHNOLOGIES AG, FED REP GERMANY:
2,987,622.
- INFINITE ELEVATION, LLC, KENSINGTON, MD:
4,209,239, PUB. 7-3-2012. INT. CL. 35.
- INFINITE LABS, LLC, ORLANDO, FL:
4,210,449, INT. CL. 5.
- INFINITYQS INTERNATIONAL, INC., CHANTILLY, VA:
2,601,125, REN. 8-13-12. INT. CL. 9.
- INFLECTION POINT RETAIL, LLC, WINDERMERE, FL:
4,210,377, INT. CL. 35.
- INFOCOMMERCE GROUP, INC., BALA CYNWYD, PA:
2,528,499, CANC. INT. CL. 16.
- INFOR (US), INC., WILMINGTON, DE, LAWSON ASSOCIATES INC., MINNEAPOLIS, MN:
1,707,831, REN. 8-15-12. INT. CL. 9.
- INFOR (VEENENDAAL) B.V., BARNEVELD, NETHERLANDS:
2,606,306, REN. 8-11-12. INT. CL. 9.
- INFORMAX, INC., NORTH BETHESDA, MD:
3,037,009, CANC. INT. CL. 9.
- INFOUSE, BERKELEY, CA:
2,600,432, REN. 8-10-12. INT. CL. 9.
- INFOVISTA SA, 91940 LES ULIS, FRANCE:
2,608,731, REN. 8-15-12. INT. CL. 9.
- INNEREYE STUDIOS, LLC, WINSTON SALEM, NC:
4,209,155, PUB. 7-3-2012. INT. CL. 42.
4,209,156, PUB. 7-3-2012. INT. CL. 42.
- INNERFACE ARCHITECTURAL SIGNAGE, INC., ATLANTA, GA:
2,604,002, REN. 8-13-12. INT. CL. 19.
- INNOCREATIVE SOLUTIONS, INC., LOS ANGELES, CA:
4,209,329, PUB. 7-3-2012. MULTIPLE CLASS, INT. CLS. 30 AND 32.
- INNOFACTOR PLC, ESPOO, FINLAND:
4,209,422, PUB. 7-3-2012. INT. CL. 42.
- INNOPHOS, INC., CRANBURY, NJ:
4,211,275, INT. CL. 1.
- INNOVATION FIRST, INC., GREENVILLE, TX:
3,038,190, CANC. INT. CL. 9.
4,208,947, PUB. 7-3-2012. INT. CL. 28.
4,209,506, PUB. 7-3-2012. INT. CL. 28.
- INNOVATIVE KNOWLEDGE, INC., SAN JOSE, CA:
4,208,601, PUB. 7-3-2012. INT. CL. 9.

INNOVATIVE LEISURE, INC., LOS ANGELES, CA, AKA
 INNOVATIVE LEISURE RECORDS:
 4,209,954, PUB. 7-3-2012. INT. CL. 9.
 INNOVATIVE POLYMERS, INC., ST. JOHNS, MI:
 4,209,847, PUB. 7-3-2012. INT. CL. 1.
 4,210,026, PUB. 7-3-2012. INT. CL. 1.
 4,210,200, PUB. 7-3-2012. INT. CL. 1.
 INNOVATRIX MARKETING LLC, LONG GROVE, IL:
 4,211,062, INT. CL. 42.
 4,211,063, INT. CL. 42.
 INOS AUTOMATIONSSOFTWARE GMBH, STUTTGART,
 FED REP GERMANY:
 4,208,953, PUB. 7-3-2012. MULTIPLE CLASS, INT. CLS. 9
 AND 10.
 INOUE HIROKI, JAPAN AND ISHIZUKA HIROYUKI,
 JAPAN:
 4,208,247, PUB. 7-3-2012. MULTIPLE CLASS, INT. CLS. 9,
 16, 35, 36, 41 AND 45.
 INQUISITIVE MINDS, INC., MOUNTIAN VIEW, CA:
 4,210,481, INT. CL. 9.
 INQWORKS, INC., TIGARD, OR:
 4,209,619, PUB. 7-3-2012. INT. CL. 35.
 INSIGHT PHARMACEUTICALS LLC, LANGHORNE, PA:
 4,210,629, INT. CL. 5.
 4,210,630, INT. CL. 5.
 INSMARK, INC., SAN RAMON, CA:
 2,641,913. REN. 8-15-12. MULTIPLE CLASS, INT. CLS. 9,
 35 AND 36.
 INSPARISK, LLC, GLENDALE, CA:
 4,209,896, PUB. 7-3-2012. INT. CL. 45.
 INSPERITY, INC., KINGWOOD, TX:
 4,210,626, INT. CL. 16.
 INSPIRAMA LLC, MIAMI, FL:
 4,208,606, PUB. 7-3-2012. MULTIPLE CLASS, INT. CLS. 35
 AND 41.
 INSTITUTE FOR RAPID RESOLUTION THERAPY, INC.,
 JUPITER, FL:
 4,208,584, PUB. 7-3-2012. INT. CL. 44.
 INSTITUTES FOR THE ACHIEVEMENT OF HUMAN PO-
 TENTIAL, THE, WYNDMOOR, PA:
 1,782,650. REN. 8-11-12. INT. CL. 16.
 1,782,651. REN. 8-15-12. INT. CL. 16.
 INSULIN PUMPERS, INC., MILPITAS, CA:
 2,638,190. REN. 8-13-12. MULTIPLE CLASS, INT. CLS. 38
 AND 42.
 INTACT CONSULT GMBH, AUSTRIA:
 4,208,322, PUB. 7-3-2012. MULTIPLE CLASS, INT. CLS. 9,
 42 AND 44.
 INTEGRA SP LIMITED, LONDON W1G 9BR, UNITED
 KINGDOM:
 2,608,836. REN. 8-13-12. MULTIPLE CLASS, INT. CLS. 9
 AND 42.
 INTEGRATED BUSINESS SOLUTIONS GROUP, FEASTER-
 VILLE, PA, AKA IBSG:
 4,209,018, PUB. 7-3-2012. INT. CL. 9.
 INTEGRATED NETWORK CABLE, CHESTERFIELD, MO:
 4,208,649, PUB. 7-3-2012. INT. CL. 6.
 INTEGRATED PAYROLL SYSTEMS, INC., CALDWELL, NJ:
 4,209,300, PUB. 7-3-2012. MULTIPLE CLASS, INT. CLS. 35
 AND 36.
 INTEGRATED POOL PRODUCTS (PTY) LTD, MULDER-
 DRIFT, SOUTH AFRICA:
 4,209,550, PUB. 7-3-2012. INT. CL. 7.
 INTEGRATION TECHNOLOGIES, INC., HONOLULU, HI,
 AKA INTECH:
 4,209,257, PUB. 7-3-2012. INT. CL. 42.
 INTEGRITY LIFE INSURANCE COMPANY, CINCINNATI,
 OH:
 4,210,727, INT. CL. 36.
 INTELLECTUAL EYES, LLC, MCLEAN, VA:
 4,211,181, INT. CL. 35.
 INTELICHECK MOBILISA, INC., PORT TOWNSEND, WA:
 2,531,415. REN. 8-11-12. INT. CL. 42.
 INTELPROLIST LLC, MACEDON, NY:
 2,622,455. REN. 8-15-12. INT. CL. 35.
 INTER-EGO SYSTEMS INC., PLAINVIEW, NY:
 2,526,358, CANC. INT. CL. 9.
 INTERDESIGN, INC., SOLON, OH:
 4,210,738, MULTIPLE CLASS, INT. CLS. 9, 11 AND 20.
 INTERGRAPH CORPORATION, MADISON, AL:
 4,209,368, PUB. 7-3-2012. INT. CL. 9.
 INTERMEDIX CORPORATION, FT. LAUDERDALE, FL:
 4,209,010, PUB. 7-3-2012. MULTIPLE CLASS, INT. CLS.
 35, 42 AND 45.
 INTERMIX S.A., GRAND CAYMAN BWI, CAYMAN IS-
 LANDS:
 3,604,148, CANC. INT. CL. 4.
 INTERNATIONAL CHURCH OF THE FOURSQUARE GOS-
 PEL, LOS ANGELES, CA:
 4,210,750, INT. CL. 41.
 INTERNATIONAL DESIGNS CORPORATION, HALLAN-
 DALE, FL:
 4,211,818, INT. CL. 26.
 INTERNATIONAL DOOR ASSOCIATION, INC., WEST MIL-
 TON, OH:
 4,209,119, PUB. 7-3-2012. INT. CL. 41.
 INTERNATIONAL FOODSTUFFS CO, P.O. BOX 4115 SHAR-
 JAH, UNITED ARAB EMIR.:
 3,038,160, CANC. INT. CL. 30.
 INTERNATIONAL INTIMATES INC., NEW YORK, NY:
 2,568,403. REN. 8-13-12. INT. CL. 25.
 INTERNATIONAL LEGAL TECHNOLOGY ASSOCIATION,
 AUSTIN, TX:
 4,210,477, INT. CL. 41.
 INTERNATIONAL LUTHERAN LAYMEN'S LEAGUE, ST.
 LOUIS, MO:
 1,785,980. REN. 8-10-12. INT. CL. 42.
 INTERNATIONAL MUFFLER COMPANY, SCHULEN-
 BURG, TX, MAREMONT CORPORATION, CAROL
 STREAM, IL:
 1,713,448. REN. 8-11-12. INT. CL. 12.
 INTERNATIONAL PERFUME PALACE INCORPORATED,
 PLAINVIEW, NY:
 4,211,077, INT. CL. 3.
 4,211,087, INT. CL. 3.
 4,211,088, INT. CL. 3.
 4,211,089, INT. CL. 3.
 4,211,139, INT. CL. 3.
 4,211,353, INT. CL. 3.
 INTERNATIONAL PLAZA GROUP, INC., MIAMI, FL:
 4,210,363, INT. CL. 39.
 INTERNATIONAL POLICE TECHNOLOGIES, INC., TULSA,
 OK:
 3,038,296, CANC. INT. CL. 9.
 INTERNATIONAL SOCIAL PRINT PAPER LTD., NEW
 WESTMINSTER, BC, CANADA:
 4,209,456, PUB. 7-3-2012. MULTIPLE CLASS, INT. CLS. 16
 AND 35.
 INTERNATIONAL TALY COMMERCIAL GROUP (USA),
 INC., SOUTH EL MONTE, CA:
 2,528,100, CANC. MULTIPLE CLASS, INT. CLS. 21, 23, 24,
 25 AND 27.
 INTERNATIONAL TEST SOLUTIONS, INC., RENO, NV:
 2,610,970. REN. 8-14-12. INT. CL. 3.
 INTERVENTION DEVELOPMENT LLC, CARY, IL:
 4,211,169, INT. CL. 9.
 INTEVEP, S.A., CARACAS 1070A, VENEZUELA:
 2,610,471. REN. 8-15-12. INT. CL. 42.
 INTRACK TIRES, RICHMOND HILL, NY:
 4,211,159, INT. CL. 35.
 INVENTORY SOURCE, LLC, ATLANTIC BEACH, FL, DBA
 INVENTORY SOURCE:
 4,208,592, PUB. 7-3-2012. INT. CL. 35.
 INVICTA WATCH COMPANY OF AMERICA, INC., HOLLY-
 WOOD, FL:
 4,211,579, INT. CL. 14.
 4,211,654, INT. CL. 9.
 INVISTA NORTH AMERICA S.A R.L., WICHITA, KS:
 4,210,953, INT. CL. 22.
 4,211,475, INT. CL. 1.
 INVIVOSCRIBE TECHNOLOGIES, INC., SAN DIEGO, CA:
 4,210,536, INT. CL. 44.
 IOGENETICS, LLC, MADISON, WI:
 4,210,375, INT. CL. 1.

- ION-RAY COMPANY LTD., RICHMOND HILL, ONTARIO, CANADA:
4,208,461, PUB. 12-13-2011. INT. CL. 14.
- IOWA 80 TRUCKSTOP, INC., WALCOTT, IA:
4,209,255, PUB. 7-3-2012. INT. CL. 35.
- IP, LLC, RUSSELL SPRINGS, KY:
4,208,952, PUB. 7-3-2012. INT. CL. 34.
4,208,955, PUB. 7-3-2012. INT. CL. 34.
- IPARRAGUIRRE, FLORENTINO ARZUAGA, CTRA. MADRID-IRUN KM. 202. 5, SPAIN:
2,527,782, CANC. INT. CL. 33.
- IPCAPITAL GROUP, INC., WILLISTON, VT:
2,727,115. REN. 8-11-12. INT. CL. 35.
- IPS CORPORATION, GARDENA, CA:
1,704,462. REN. 8-10-12. INT. CL. 1.
- IPSEN BIOPHARM LIMITED, WREXHAM, UNITED KINGDOM:
4,210,835, MULTIPLE CLASS, INT. CLS. 38 AND 44.
- IQ RISK INSURANCE SERVICES, LLC, IRVINE, CA:
4,209,131, PUB. 7-3-2012. INT. CL. 36.
- IRAQ AND AFGHANISTAN VETERANS OF AMERICA, INC., NEW YORK, NY:
4,210,030, PUB. 7-3-2012. INT. CL. 35.
- IRBY, JOSEPH A., LITTLE ROCK, AR, DBA BESTQUEST TEACHING SYSTEMS:
2,662,842. REN. 8-11-12. INT. CL. 9.
2,668,745. REN. 8-11-12. INT. CL. 41.
- IRIS OHYAMA, INC., SENDAI, MIYAGI, JAPAN:
4,077,603, COR. MULTIPLE CLASS, INT. CLS. 9, 12, 18, 20 AND 21.
- ISABELLA & FERDINAND LLC, WASHINGTON, DC:
4,208,778, PUB. 7-3-2012. MULTIPLE CLASS, INT. CLS. 9, 16 AND 41.
- ISG2 TECHNOLOGIES, INC., NEW LENOX, IL:
2,509,907. REN. 8-14-12. INT. CL. 35.
- ISI BRANDS INC., GRAND RAPIDS, MI:
2,527,788, CANC. INT. CL. 5.
- ISLAND GIRL PRODUCTIONS, INC., LOS ANGELES, CA:
2,528,675, CANC. INT. CL. 41.
- IT COSMETICS, JERSEY CITY, NJ:
4,210,780, INT. CL. 3.
- IT DATAWORKS, LLC, TULSA, OK:
4,208,994, PUB. 3-27-2012. INT. CL. 41.
- IT'S A 10, INC., FORT LAUDERDALE, FL:
4,210,234, INT. CL. 3.
4,210,796, INT. CL. 3.
4,210,865, INT. CL. 3.
4,210,866, INT. CL. 3.
4,210,867, INT. CL. 3.
4,210,868, INT. CL. 3.
- ITALIAN CHOPPERS LLC, SOUTHBRIDGE, MA:
4,211,819, INT. CL. 35.
- ITT WATER & WASTEWATER AB, EMMABODA, SWEDEN:
2,527,897, CANC. INT. CL. 7.
- IVAR'S INC., SEATTLE, WA:
1,197,499. REN. 8-16-12. INT. CL. 42.
- IVIU TECHNOLOGIES, LLC, ANAHEIM, CA:
4,211,503, INT. CL. 9.
- IVIU TECHNOLOGIES, LLC., ANAHEIM, CA:
4,211,502, INT. CL. 35.
- I2ASOLUTIONS, SAN DIEGO, CA:
4,208,768, PUB. 7-3-2012. INT. CL. 35.
- 14 COMMERCE INC., TIMONIUM, MD:
3,038,283, CANC. INT. CL. 36.
- J & J FLYFISHING, ARVADA, CO, DBA 5280 ANGLER:
4,209,289, PUB. 7-3-2012. INT. CL. 41.
- J. & P. COATS, LIMITED, UNITED KINGDOM:
4,208,336, PUB. 7-3-2012. MULTIPLE CLASS, INT. CLS. 23, 26 AND 40.
- J. & P. COATS, LIMITED, GLASGOW, UNITED KINGDOM:
4,211,457, INT. CL. 23.
- J. RETTENMAIER & SÖHNE GMBH + CO. KG, FED REP GERMANY:
4,208,253, PUB. 7-3-2012. MULTIPLE CLASS, INT. CLS. 1 AND 5.
- J. THOMPSON CRAVENS & ASSOCIATES, P.C., RICHMOND, VA, DBA CRAVENS & NOLL P.C.:
4,209,439, PUB. 7-3-2012. INT. CL. 45.
- J.B. DIFFUSION, 13420 GEMENOS, FRANCE:
2,527,157, CANC. MULTIPLE CLASS, INT. CLS. 3, 4 AND 21.
- J.Y. RAYS, INC., SOUTH EL MONTE, CA, J.Y. RAYS, INC., SOUTH EL MONTE, CA:
2,652,133. REN. 8-10-12. INT. CL. 25.
- J&A FOODS, INC., MYERSTOWN, PA:
4,209,478, PUB. 7-3-2012. INT. CL. 40.
- J&J'S HOTSCREAM, CHESHIRE, CT:
3,038,188, CANC. INT. CL. 30.
- J&Z INTERNATIONAL LLC, TROY, MI:
4,211,576, MULTIPLE CLASS, INT. CLS. 7 AND 11.
- JACCOMA, HEATHER M., CUMBERLAND, ME:
2,606,237. REN. 8-13-12. INT. CL. 25.
- JACEY HANSON, AMSTERDAM, NY:
4,211,311, INT. CL. 25.
- JACK ELVIS PRODUCTIONS, LLC, VENICE, CA, AKA JACK-ELVIS PRODUCTIONS, LLC:
4,208,645, PUB. 7-3-2012. INT. CL. 39.
- JACK GUARNIERI SERVICE CO., INC., LAKEWOOD, NJ:
4,209,722, PUB. 7-3-2012. INT. CL. 28.
- JACK L. GREIDER, JR., ATLANTIC BEACH, FL:
4,209,590, PUB. 7-3-2012. INT. CL. 44.
- JACK QUINN SOLUTIONS, LLC, SATELLITE BEACH, FL:
4,211,851, INT. CL. 41.
- JACK'S MAGIC PRODUCTS, INC., LARGO, FL:
2,695,905. REN. 8-13-12. INT. CL. 5.
- JACKSON FAMILY FARMS, LLC, SANTA ROSA, CA:
4,209,540, PUB. 7-3-2012. INT. CL. 41.
4,209,809, PUB. 7-3-2012. INT. CL. 33.
4,209,816, PUB. 7-3-2012. INT. CL. 39.
4,209,993, PUB. 7-3-2012. INT. CL. 33.
- JACKSON SYSTEMS, LLC, INDIANAPOLIS, IN:
4,211,590, INT. CL. 9.
- JACKSON WINE ESTATES INTERNATIONAL LIMITED, SANTA ROSA, CA:
4,210,191, PUB. 7-3-2012. INT. CL. 33.
- JACKSON WINE ESTATES INTERNATIONAL LIMITED, COUNTY DUBLIN, IRELAND:
4,210,197, PUB. 7-3-2012. INT. CL. 33.
4,210,217, PUB. 7-3-2012. INT. CL. 33.
- JACOB, RAMSIN, SANTA BARBARA, CA:
4,211,217, INT. CL. 25.
- JACOBS, PAMELA J., OMAHA, NE:
3,038,173, CANC. MULTIPLE CLASS, INT. CLS. 16 AND 41.
- JACOBSPARTS INCORPORATED, INDIANAPOLIS, IN:
4,210,060, PUB. 7-3-2012. INT. CL. 9.
- JAGUAR CARS LIMITED, COVENTRY, UNITED KINGDOM:
2,681,671. REN. 8-16-12. INT. CL. 12.
4,210,892, INT. CL. 35.
- JAIN IRRIGATION INC., ONTARIO, CA, WADE MANUFACTURING CO., TUALATIN, OR:
1,706,312. REN. 8-10-12. INT. CL. 9.
- JAIN IRRIGATION INC., ONTARIO, CA:
2,612,155. REN. 8-14-12. MULTIPLE CLASS, INT. CLS. 11 AND 17.
- JAKE'S FIREWORKS, INC., PITTSBURG, KS:
2,595,330. REN. 8-11-12. INT. CL. 13.
- JAKE'S FIREWORKS, INC., PITTSBURG, KS:
2,600,551. REN. 8-13-12. INT. CL. 13.
- JAMES POLLOCK, OZONA, FL:
4,210,502, INT. CL. 7.
- JAMES, GEORGE R., TAMPA, FL AND NORLIN, BETTY, TAMPA, FL:
4,210,969, INT. CL. 35.
- JANA MOBILE, INC., BOSTON, MA:
4,211,501, INT. CL. 35.
- JANCRISSE CORPORATION, CHULA VISTA, CA:
4,211,552, INT. CL. 25.
- JANE TAYLOR, SOUTH HADLEY, MA:
2,527,102, CANC. MULTIPLE CLASS, INT. CLS. 14 AND 42.
- JANES FAMILY FOODS LTD., MISSISSAUGA, ONTARIO, CANADA:
4,210,935, INT. CL. 29.

JASANDA CAPITAL LLC, IRVINE, CA:
4,209,725, PUB. 7-3-2012. INT. CL. 35.

JAVAN, SHADAAN, PISCATAWAY, NJ:
4,211,000, MULTIPLE CLASS, INT. CLS. 37 AND 42.

JAVIER MARTINEZ, PASADENA, CA:
4,210,097, PUB. 7-3-2012. INT. CL. 33.

JAX LTD., INC., PLYMOUTH, MN:
2,744,098. REN. 8-14-12. INT. CL. 28.

JCD BRANDS LLC, OLD BRIDGE, NJ:
4,211,572, INT. CL. 30.

JDBASSOCIATES, LLC, WATERTOWN, MA:
4,209,370, PUB. 7-3-2012. INT. CL. 16.

JDS UNIPHASE CORPORATION, GERMANTOWN, MD:
3,057,987, CANC. MULTIPLE CLASS, INT. CLS. 35 AND 42.

JE PORTE MON BEBE, MONTREUIL, FRANCE:
4,209,178, PUB. 7-3-2012. MULTIPLE CLASS, INT. CLS. 18 AND 25.

JED REICHL INVESTMENTS, LLC, CHICAGO, IL:
4,208,699, PUB. 7-3-2012. INT. CL. 43.

JED TRADERS, INC., SANTA CRUZ, CA:
4,209,052, PUB. 7-3-2012. INT. CL. 25.

JEFFERY KEITH HORNBAKER, LAGUNA BEACH, CA AND VIRGINIE FRANCE MIRAMON, LAGUNA BEACH, CA:
4,209,291, PUB. 7-3-2012. INT. CL. 45.

JELS SAVVÆRK A/S, DK-6630 RØDDING, DENMARK:
4,208,287, PUB. 7-3-2012. MULTIPLE CLASS, INT. CLS. 19, 20 AND 37.

JEMELLA GROUP LIMITED C/O EVERSHEDES LLP, UNITED KINGDOM:
4,208,320, PUB. 7-3-2012. MULTIPLE CLASS, INT. CLS. 3, 9 AND 11.

JENESCO INDUSTRIES, INC., HOUSTON, TX:
2,741,913. REN. 8-13-12. INT. CL. 17.

JENNIFER GUINAN, RENO, NV:
4,211,765, INT. CL. 44.

JENNY WILEY DRAMA ASSOCIATION, PRESTONSBERG, KY:
4,208,962, PUB. 7-3-2012. INT. CL. 41.

JENQ, KENNETH, BALTIMORE, MD:
4,211,731, INT. CL. 25.

JEROME J. PINCKNEY, AUSTELL, GA, DBA HUEY HIPPO ENTERPRISES:
4,208,509, PUB. 7-3-2012. INT. CL. 35.

JERRY KOHLI, SUN CITY WEST, AZ:
4,211,477, INT. CL. 31.

JERRY MILLER, WEST JEFFERSON, MD:
4,211,439, INT. CL. 8.

JESCO IRON CRAFT, INC., BOGOTA, NJ:
2,527,113, CANC. MULTIPLE CLASS, INT. CLS. 8 AND 12.

JESSICA GILL, ARDENTOWN, DE:
4,211,847, INT. CL. 29.

JEWELPOP INC., DARTMOUTH, CANADA, DBA KAMELEON JEWELRY:
4,209,190, PUB. 7-3-2012. INT. CL. 14.
4,209,191, PUB. 7-3-2012. INT. CL. 14.

JGC MANAGEMENT, LLC, DALLAS, TX:
4,211,352, INT. CL. 43.

JHA, GIRISH, EAST BRUNSWICK, NJ:
4,211,829, INT. CL. 41.

JIANGSU ROYAL HOME USA, INC., CHARLOTTE, NC:
4,208,660, PUB. 7-3-2012. INT. CL. 35.

JIM F. WEBB, MIDLAND, TX, DBA JW POWERLINE:
4,208,767, PUB. 7-3-2012. INT. CL. 37.

JIMENEZ, XABIER URIBE-ETXEBARRIA, ERANDIO 48950, SPAIN:
4,211,701, MULTIPLE CLASS, INT. CLS. 25, 35 AND 41.

JING SI PUBLICATIONS CO., LTD., TAIPEI, TAIWAN:
4,209,138, PUB. 7-3-2012. INT. CL. 43.

JIRAFE INC., NEW YORK, NY:
4,208,693, PUB. 7-3-2012. MULTIPLE CLASS, INT. CLS. 35 AND 42.

JMM LEE PROPERTIES, LLC, BURBANK, CA:
2,528,419, CANC. MULTIPLE CLASS, INT. CLS. 7 AND 11.

JNC CORPORATION, TOKYO, JAPAN:
4,210,812, MULTIPLE CLASS, INT. CLS. 1 AND 3.

JOCHEN BENZEL, 55767 SONNENBERG-WINNENBERG, FED REP GERMANY:
4,208,410, PUB. 7-3-2012. INT. CL. 14.

JOEL GREENBLATT, NEW YORK, NY, DBA GOTHAM ASSET MANAGEMENT, LLC:
4,211,799, INT. CL. 36.

JOEL H. WELDON & ASSOCIATES, INC., SCOTTSDALE, AZ:
2,527,556, CANC. INT. CL. 9.

JOHN B. SANFILIPPO & SON, INC., ELGIN, IL:
4,209,044, PUB. 7-3-2012. INT. CL. 29.

JOHN E. REID & ASSOCIATES, INC., CHICAGO, IL:
1,722,583. REN. 8-15-12. INT. CL. 41.

JOHN LOWE, METAMORA, IN:
4,210,653, MULTIPLE CLASS, INT. CLS. 16, 20, 21 AND 25.

JOHN LYONS SYMPOSIUMS, INC., PARACHUTE, CO:
2,527,927, CANC. INT. CL. 31.

JOHN MIDDLETON CO., KING OF PRUSSIA, PA:
4,208,201, PUB. 7-3-2012. INT. CL. 34.
4,208,202, PUB. 7-3-2012. INT. CL. 34.
4,208,203, PUB. 7-3-2012. INT. CL. 34.
4,208,204, PUB. 7-3-2012. INT. CL. 34.
4,208,205, PUB. 7-3-2012. INT. CL. 34.
4,208,206, PUB. 7-3-2012. INT. CL. 34.
4,208,207, PUB. 7-3-2012. INT. CL. 34.
4,208,208, PUB. 7-3-2012. INT. CL. 34.
4,208,209, PUB. 7-3-2012. INT. CL. 34.
4,208,210, PUB. 7-3-2012. INT. CL. 34.

JOHN P. CERVINI, DAVIE, FL:
4,211,693, INT. CL. 25.

JOHN PAUL MITCHELL SYSTEMS, SANTA CLARITA, CA:
4,211,474, INT. CL. 3.
4,211,500, INT. CL. 3.

JOHN PAUL RICHARD, INC., CALABASAS, CA:
2,744,392. REN. 8-14-12. INT. CL. 25.

JOHNNY ROCKETS LICENSING, LLC, ALISO VIEJO, CA:
2,726,750. REN. 8-13-12. INT. CL. 30.
2,726,751. REN. 8-13-12. INT. CL. 30.

JOHNSON & JOHNSON, NEW BRUNSWICK, NJ:
941,856. REN. 8-16-12. U.S. CL. 18 (INT. CL. 5).
2,471,737. REN. 8-14-12. INT. CL. 5.
3,132,519, CANC. MULTIPLE CLASS, INT. CLS. 1 AND 5.
4,210,565, INT. CL. 3.
4,211,256, INT. CL. 41.
4,211,707, MULTIPLE CLASS, INT. CLS. 3 AND 5.

JOHNSON MATTHEY PLC, LONDON, UNITED KINGDOM:
4,211,766, INT. CL. 9.

JOHNSON MATTHEY PUBLIC LIMITED CO., LONDON, UNITED KINGDOM:
1,702,676. REN. 8-10-12. MULTIPLE CLASS, INT. CLS. 1 AND 42.

JOHNSON UNIVERSITY, KNOXVILLE, TN, FORMERLY JOHNSON BIBLE COLLEGE:
4,208,804, PUB. 7-3-2012. INT. CL. 41.

JOHNSON, HANS C, RANCHO SANTA FE, CA:
4,210,573, MULTIPLE CLASS, INT. CLS. 16 AND 26.

JOHNSON, HARALD, CHARLOTTESVILLE, VA, AKA HARALD JOHNSON COMMUNICATIONS:
4,211,037, INT. CL. 9.

JOHNSON, RESARANI D, NORTH LAS VEGAS, NV:
4,210,805, MULTIPLE CLASS, INT. CLS. 35 AND 38.

JOINGO, LLC, INCLINE VILLAGE, NV:
4,209,867, PUB. 7-3-2012. INT. CL. 42.

JOINT APPAREL ASSOCIATION FORUM, COLOMBO, SRI LANKA:
4,210,682, INT. CL. 35.

JOINT RESOURCES, INC., GLENDALE HEIGHTS, IL:
4,210,926, INT. CL. 12.

JONATHAN ABEL MENDIOLA, SAN DIEGO, CA:
4,211,032, INT. CL. 25.

JONES INTERNATIONAL, LTD., CENTENNIAL, CO:
2,707,314. REN. 8-15-12. INT. CL. 42.

JONES INVESTMENT CO. INC., WILMINGTON, DE:
4,210,453, INT. CL. 18.

- JONES SODA CO. (USA) INC., SEATTLE, WA:
4,210,609, INT. CL. 32.
4,210,617, INT. CL. 32.
- JONES, DONOVAN O, POST FALLS, ID, DBA HARD BODIES(TM) FITNESS COOKIE:
4,210,184, PUB. 7-3-2012. INT. CL. 30.
- JONES, TOMMY LEE, LOS ANGELES, CA:
2,713,969, REN. 8-13-12. INT. CL. 16.
2,737,361, REN. 8-11-12. INT. CL. 41.
- JONMOR INVESTMENTS, INC., WILMINGTON, DE:
2,750,148, REN. 8-15-12. INT. CL. 29.
4,210,284, INT. CL. 29.
4,210,395, INT. CL. 29.
- JORDAN, VENSON D., WASHINGTON, DC AND JORDAN, LAURA E., WASHINGTON, DC:
4,208,677, PUB. 7-3-2012. INT. CL. 16.
- JOS. E. MARCH INVESTMENTS, INC., FAIRVIEW, NC:
4,211,141, INT. CL. 35.
4,211,142, INT. CL. 16.
- JOSE CANEPA Y CIA. LTDA., CERRILLOS SANTIAGO, CHILE:
4,210,277, INT. CL. 33.
- JOSE DE JESUS GARCIA, EL PASO, TX:
4,209,209, PUB. 7-3-2012. INT. CL. 5.
- JOSE OLALDE, CARACAS, VENEZUELA:
4,208,838, PUB. 7-3-2012. INT. CL. 5.
- JOSEPH VÖGELE AG, LUDWIGSHAFEN, FED REP GERMANY:
4,208,447, PUB. 7-3-2012. MULTIPLE CLASS, INT. CLS. 7, 9, 35 AND 37.
4,208,448, PUB. 7-3-2012. MULTIPLE CLASS, INT. CLS. 7, 9, 35 AND 37.
- JOZETTE PTY LTD., POTTS POINT NSW 2011, AUSTRALIA:
4,210,232, INT. CL. 25.
- JPS ELASTOMERICS, EASTHAMPTON, MA, DBA STEVENS URETHANE:
4,211,450, INT. CL. 17.
4,211,451, INT. CL. 17.
- JR REALTY GROUP, INC., SANIBEL ISLAND, FL:
2,599,781, REN. 8-10-12. INT. CL. 36.
- JRM INTERNATIONAL PRODUCTS, INC., INDIANAPOLIS, IN:
4,211,782, INT. CL. 12.
- JSBD, LLC, LA JOLLA, CA:
4,209,481, PUB. 7-3-2012. INT. CL. 5.
- JUDITH BRIGHT, LLC, NASHVILLE, TN:
4,211,760, INT. CL. 35.
- JUICY COUTURE, INC., PACOIMA, CA:
3,038,147, CANC. INT. CL. 18.
- JULIAN MONTOYA, ARCATA, CA, DBA ZEN OASIS HEALTH RETREATS:
4,211,854, INT. CL. 35.
- JULIET CO., LTD., SEOUL, REPUBLIC OF KOREA:
3,024,623, CANC. INT. CL. 14.
- JULIUS CRONENBERG OH, ARNSBERG, FED REP GERMANY:
4,208,475, PUB. 12-6-2011. INT. CL. 6.
- JUNIATA COLLEGE, HUNTINGDON, PA:
2,688,660, REN. 8-15-12. INT. CL. 41.
- JUNIPER NETWORKS, INC., SUNNYVALE, CA:
4,210,675, INT. CL. 9.
- JUNK BRANDS LLC, BENTONVILLE, AR:
4,209,772, PUB. 7-3-2012. INT. CL. 26.
- JUPITERIMAGES CORPORATION, TUCSON, AZ:
2,607,404, REN. 8-15-12. INT. CL. 42.
- JUST MARKETING, INC., ZIONSVILLE, IN:
4,210,385, INT. CL. 35.
- JUST SO...DESIGNS LLC, ASHEVILLE, NC:
4,211,116, INT. CL. 25.
- JUSTIN ROMERO, ALHAMBRA, CA:
4,208,758, PUB. 12-13-2011. INT. CL. 41.
- JW PET COMPANY, INC., TETERBORO, NY:
4,208,738, PUB. 7-3-2012. INT. CL. 28.
- JW SALES, INC., PEARL CITY, HI:
4,209,628, PUB. 7-3-2012. INT. CL. 3.
- K&M ASSOCIATES L.P., PROVIDENCE, RI:
1,708,039, REN. 8-15-12. INT. CL. 14.
- KABUSHIKI KAISHA KOBE SEIKO SHO, KOBE-SHI, HYOGO, JAPAN, TA KOBE STEEL, LTD.:
4,210,259, INT. CL. 7.
4,210,260, INT. CL. 9.
- KABUSHIKI KAISHA PILOT CORPORATION A/T/A PILOT CORPORATION, CHUO-KU, TOKYO, JAPAN:
2,613,384, REN. 8-10-12. INT. CL. 16.
- KABUSHIKI KAISHA SONY COMPUTER ENTERTAINMENT; (ALSO TRADING AS; SONY COMPUTER ENTERTAINMENT INC.), JAPAN:
4,208,377, PUB. 7-3-2012. INT. CL. 9.
- KABUSHIKI KAISHA YAKULT HONSHA, TOKYO, JAPAN, TA YAKULT HONSHA CO., LTD.:
4,210,643, INT. CL. 30.
- KACHLER, KARIN, LOS ANGELES, CA:
4,210,829, INT. CL. 35.
- KAFFE MAGNUM OPUS, INC., MILLVILLE, NJ:
4,209,535, PUB. 7-3-2012. INT. CL. 30.
4,210,199, PUB. 7-3-2012. INT. CL. 30.
- KAI MEDICAL, INC., HONOLULU, HI:
4,209,050, PUB. 7-3-2012. INT. CL. 10.
- KALTENBACH & VOIGT GMBH, 88400 BIBERACH, FED REP GERMANY:
4,208,301, PUB. 7-3-2012. INT. CL. 10.
- KAM-SOUTH, LLC, ATLANTA, GA:
4,211,111, INT. CL. 36.
- KAMIL, ADIL, COSTA MESA, CA:
4,209,364, PUB. 7-3-2012. INT. CL. 25.
- KANEI, INC., CHINO, CA, DBA ACE ALLOY WHEELS:
4,211,343, INT. CL. 12.
- KANSAS CITY FASHION WEEK, LLC, KANSAS CITY, MO:
4,211,856, INT. CL. 35.
- KAPLAN EARLY LEARNING COMPANY, LEWISVILLE, NC:
4,209,794, PUB. 7-3-2012. INT. CL. 9.
- KAPRUKA.COM LLC, BEAVERTON, OR:
4,209,314, PUB. 7-3-2012. INT. CL. 35.
- KAR CHOON NG, SANTA ANA, CA:
3,038,315, CANC. INT. CL. 20.
- KARAJEN CORP., LIBERTYVILLE, IL:
4,209,093, PUB. 7-3-2012. INT. CL. 28.
- KARCHER NORTH AMERICA, INC., ENGLEWOOD, CO, CENTURY 400, INC., PUEBLO, CO:
1,727,191, REN. 8-10-12. INT. CL. 9.
- KAREN EGREN, LLC, BIRMINGHAM, MI:
4,209,904, PUB. 7-3-2012. INT. CL. 14.
- KARL STORZ GMBH & CO. KG, D-78532 TUTTLINGEN, FED REP GERMANY:
1,734,601, REN. 8-16-12. INT. CL. 10.
- KARLSBURGER FOODS, INC., MONTICELLO, MN:
1,729,616, REN. 8-10-12. MULTIPLE CLASS, INT. CLS. 29 AND 30.
- KARSTEN MANUFACTURING CORPORATION, PHOENIX, AZ:
4,210,845, INT. CL. 12.
- KATIA LIMOLI SILVA AZULAY, SINTRA, PORTUGAL:
4,210,692, INT. CL. 25.
- KATTLER KUPETZ, DEBORAH, LOS ANGELES, CA:
4,209,297, PUB. 7-3-2012. INT. CL. 36.
- KAWASAKI JUKOGYO KABUSHIKI KAISHA, CHUO-KU, KOBE, JAPAN, DBA KAWASAKI HEAVY INDUSTRIES, LTD.:
4,208,528, PUB. 7-3-2012. INT. CL. 12.
- KAYDON ACQUISITION XI, INC., ANN ARBOR, MI:
2,697,465, REN. 8-15-12. INT. CL. 6.
- KCD IP, LLC, HOFFMAN ESTATES, IL:
4,210,288, MULTIPLE CLASS, INT. CLS. 7 AND 11.
- KDT ENTERPRISES, LLC, PROSPECT, KY:
4,209,348, PUB. 7-3-2012. INT. CL. 3.
- KEDING ENTERPRISES CO., LTD., NEW TAIPEI CITY, TAIWAN:
4,211,506, INT. CL. 19.
- KEEN, INC., PORTLAND, OR:
4,209,855, PUB. 7-3-2012. INT. CL. 35.
- KEEP IN MIND, INC., INDIAN LAND, SC:
4,211,513, INT. CL. 16.
4,211,514, INT. CL. 44.

KELHEIM FIBRES GMBH, KELHEIM, FED REP GERMANY:
 1,708,257. REN. 8-10-12. INT. CL. 22.
 KELLOGG NORTH AMERICA COMPANY, BATTLE CREEK, MI:
 4,210,035, PUB. 7-3-2012. INT. CL. 30.
 4,210,048, PUB. 7-3-2012. INT. CL. 30.
 4,210,081, PUB. 7-3-2012. INT. CL. 30.
 KELLOGG SUPPLY, INC., CARSON, CA:
 2,695,636. REN. 8-10-12. INT. CL. 1.
 KEM ROUNDS, MEMPHIS, TN AND BRENDA ROUNDS, MEMPHIS, TN:
 4,210,240. INT. CL. 25.
 KEMERER GROUP INC., TORONTO, ONTARIO, CANADA:
 2,603,055. REN. 8-10-12. INT. CL. 16.
 KEMISTRE 8, LLC, NEW YORK, NY:
 4,209,606, PUB. 7-3-2012. INT. CL. 25.
 KENDA RUBBER INDUSTRIAL CO., LTD., YUANLIN JEN, CHANGHUA, TAIWAN:
 2,621,255. REN. 8-11-12. INT. CL. 35.
 KENNEDY, JOHN, KALAMAZOO, MI:
 4,210,243. INT. CL. 28.
 KENNETH CHAMBERS, HARKER HEIGHTS, TX:
 4,211,413. INT. CL. 25.
 KENNETH KNIGHT, UNITED KINGDOM:
 4,208,433, PUB. 7-3-2012. MULTIPLE CLASS, INT. CLS. 9, 12 AND 25.
 KENT FEEDS, INC., MUSCATINE, IA:
 2,745,221. REN. 8-14-12. INT. CL. 31.
 KERABEN GRUPO, S.A., NULES (CASTELLON), SPAIN:
 2,611,262. REN. 8-11-12. INT. CL. 19.
 2,611,947. REN. 8-11-12. INT. CL. 19.
 KERIAN, CHRISTINE L., LOS ANGELES, CA:
 4,208,907, PUB. 7-3-2012. INT. CL. 45.
 KERMEL COMPANY SAS, 68000 COLMAR, FRANCE, SOCIETE RHODIACETA, PARIS, FRANCE:
 939,294. REN. 8-14-12. U.S. CL. 1 (INT. CLS. 1 AND 17).
 KERR HEALTH, LLC, RALEIGH, NC:
 4,211,762, MULTIPLE CLASS, INT. CLS. 35, 41 AND 44.
 KEY CONTROL HOLDING, INC., HOUSTON, TX:
 2,610,825. REN. 8-15-12. INT. CL. 9.
 KEYANG ELECTRIC MACHINERY CO., LTD, REPUBLIC OF KOREA:
 4,208,279, PUB. 7-3-2012. MULTIPLE CLASS, INT. CLS. 6, 7, 8, 9, 17 AND 20.
 KEYCORP, CLEVELAND, OH:
 4,210,398. INT. CL. 36.
 KEYS PUBLISHING CO., INC., SARASOTA, FL:
 4,211,110. INT. CL. 28.
 KEYSTONE RETAINING WALL SYSTEMS, INC., EDINA, MN:
 4,211,183. INT. CL. 19.
 4,211,229. INT. CL. 19.
 KHEMKA, SHAMIT, NOIDA, INDIA:
 4,209,414, PUB. 7-3-2012. INT. CL. 42.
 KHS AMERICA, INC., MT. JULIET, TN:
 4,209,124, PUB. 7-3-2012. INT. CL. 15.
 KHS MUSICAL INSTRUMENTS LTD, NEW TAIPEI CITY, TAIWAN:
 4,209,217, PUB. 7-3-2012. INT. CL. 15.
 KID ON VACATION, LLC, LIVONIA, MI:
 4,208,739, PUB. 7-3-2012. INT. CL. 39.
 KIDDESIGNS, INC., RAHWAY, NJ:
 4,210,410, MULTIPLE CLASS, INT. CLS. 9 AND 28.
 KIDS 'R' KIDS, INC., DULUTH, GA:
 4,209,063, PUB. 7-3-2012. INT. CL. 43.
 KIDS MATTER, LLC, BOCA RATON, FL:
 4,209,721, PUB. 7-3-2012. INT. CL. 45.
 KIDSPACE CORPORATION, BETHLEHEM, PA:
 2,600,707. REN. 8-13-12. INT. CL. 16.
 KIDZOUT, INC., BUFFALO, WY:
 4,209,059, PUB. 3-27-2012. INT. CL. 9.
 KIEHL, DONNA L, LARGO, FL:
 4,209,919, PUB. 7-3-2012. INT. CL. 35.
 KIENMAYER, CHRISTOPH, A-2340 MODLING, AUSTRIA:
 4,209,095, PUB. 7-3-2012. MULTIPLE CLASS, INT. CLS. 6, 9 AND 42.
 KIKKOMAN CORPORATION, NODA CITY, CHIBA, JAPAN:
 1,220,196. REN. 8-11-12. INT. CL. 29.
 KIM, JOORI, LA MIRADA, CA:
 4,210,080, PUB. 7-3-2012. INT. CL. 25.
 KIM, RACHEL, MORGANVILLE, NJ:
 4,211,612. INT. CL. 41.
 KIMBERLY-CLARK WORLDWIDE, INC., NEENAH, WI:
 4,208,744, PUB. 7-3-2012. MULTIPLE CLASS, INT. CLS. 16 AND 44.
 4,211,280. INT. CL. 5.
 KIMBROUGH, VALERIE, PEMBROKE PINES, FL:
 4,210,312. INT. CL. 45.
 KINDERLAND CAFE LTD., LAS VEGAS, NV:
 4,209,407, PUB. 7-3-2012. MULTIPLE CLASS, INT. CLS. 41 AND 43.
 KINETIC OOMPH, LLC, BROOKLYN, NY:
 4,210,956. INT. CL. 25.
 KING PRODUCTS AND EQUIPMENT LLC., MIAMI, FL:
 4,209,277, PUB. 7-3-2012. INT. CL. 9.
 4,209,487, PUB. 7-3-2012. INT. CL. 45.
 KING, ALEX, ROSEVILLE, CA:
 4,211,269, MULTIPLE CLASS, INT. CLS. 25, 35 AND 41.
 KING, FELICIA, NASHVILLE, TN AND MONTES, LISA, NASHVILLE, TN:
 4,211,187. INT. CL. 36.
 KING, MICHAEL L., LOUISVILLE, KY:
 2,528,661. CANC. INT. CL. 31.
 KING'S HAWAIIAN HOLDING COMPANY, INC., TORRANCE, CA:
 4,211,296. INT. CL. 30.
 KINGSTON TECHNOLOGY CORPORATION, FOUNTAIN VALLEY, CA:
 1,703,005. REN. 8-10-12. INT. CL. 9.
 KISER CONSTRUCTION, INC., ELK RIVER, MN:
 4,209,264, PUB. 7-3-2012. INT. CL. 37.
 KIT USA CO LTD, HONOLULU, HI, DBA KIT USA CO LTD:
 4,211,559. INT. CL. 16.
 KITARU INNOVATIONS INC., LASCELLES, ST. JAMES, BARBADOS:
 4,208,827, PUB. 7-3-2012. INT. CL. 16.
 KITEO GMBH & CO. KG, FED REP GERMANY:
 4,208,275, PUB. 7-3-2012. MULTIPLE CLASS, INT. CLS. 9, 11, 35 AND 42.
 KITWAKE IP, INC., ALEXANDRIA, VA:
 4,209,931, PUB. 7-3-2012. INT. CL. 45.
 KK-YAS, CORPORATION, SOUTHFIELD, MI:
 4,209,758, PUB. 7-3-2012. INT. CL. 12.
 KLIVINGTON, EVA, FAIRFAX, VA, DBA REALTYTOWEB.COM:
 2,739,295. REN. 8-11-12. INT. CL. 36.
 KLUTZ, PALO ALTO, CA:
 4,211,076, MULTIPLE CLASS, INT. CLS. 16 AND 28.
 KNIFE COMPANY, INC., THE, ROGERS, AR, DBA A.G. RUSSELL KNIVES, INC.:
 2,651,945. REN. 8-14-12. INT. CL. 35.
 KNOWLEDGE ADVENTURE, INC., TORRANCE, CA 90501, CA:
 4,211,683. INT. CL. 41.
 KNURR AG, ARNSTORF, FED REP GERMANY:
 2,526,829. CANC. INT. CL. 9.
 KOAX CORP., OKLAHOMA CITY, OK:
 1,776,407. REN. 8-15-12. INT. CL. 11.
 KOBI KATZ, INC., LOS ANGELES, CA:
 4,211,259. INT. CL. 14.
 KOCHENSPIGGER, RUTH, FRANKLIN, MI, DBA FRANKLIN GRILL & TAVERN:
 4,209,392, PUB. 7-3-2012. INT. CL. 43.
 KODANSHA, LTD., BUNKYO-KU, TOKYO, JAPAN:
 2,526,362. CANC. INT. CL. 9.
 KOHL'S ILLINOIS, INC., AURORA, IL:
 3,124,008. CANC. INT. CL. 9.
 KOHLER CO., KOHLER, WI:
 4,210,148, PUB. 7-3-2012. INT. CL. 11.
 4,210,169, PUB. 7-3-2012. INT. CL. 11.
 KONETA, INC., WAPAKONETA, OH:
 1,706,558. REN. 8-10-12. INT. CL. 12.

- KONINKLIJKE COOPERATIE COSUN U.A., ND BREDA, NETHERLANDS TO SENSUS B.V., ROSENDAAL, NETHERLANDS:
2,528,090. CANC. MULTIPLE CLASS, INT. CLS. 1 AND 5.
- KOPPMAN, KIM, VICKSBURG, MS:
4,210,761, INT. CL. 35.
- KOWA COMPANY, LTD., JAPAN:
4,208,392, PUB. 7-3-2012. INT. CL. 11.
- KRAFT FOODS GLOBAL BRANDS LLC, NORTHFIELD, IL:
2,528,484, CANC. INT. CL. 35.
4,211,452, INT. CL. 30.
- KRAFT FOODS SCHWEIZ HOLDING GMBH, 6301 ZUG, SWITZERLAND:
4,211,079, INT. CL. 30.
- KRAFT FOODS, INC., NORTHFIELD, IL:
3,036,989, CANC. INT. CL. 29.
- KRAHL ASSOCIATES, INC., CHICAGO, IL, DBA KRAHL CONSTRUCTION:
2,527,566, CANC. INT. CL. 37.
- KRAUSS-MAFFEI WEGMANN GMBH & CO. KG, MÜNCHEN, FED REP GERMANY:
4,208,248, PUB. 7-3-2012. INT. CL. 9.
- KRAUSS, GEOFF, KEWAUNEE, WI:
4,211,732, INT. CL. 35.
- KRAVET INC., BETHPAGE, NY:
4,210,010, PUB. 7-3-2012. MULTIPLE CLASS, INT. CLS. 24, 26 AND 27.
- KRSPLIFE LLC, ASTORIA, NY:
4,209,873, PUB. 7-3-2012. INT. CL. 25.
- KRUPP BROTHERS WINERY LLC, NAPA, CA:
4,210,771, INT. CL. 33.
- KUBOTA CREDIT CORPORATION, U.S.A., TORRANCE, CA:
2,641,682. REN. 8-14-12. INT. CL. 9.
- KUDOS INC., CALGARY, CANADA:
4,208,860, PUB. 7-3-2012. INT. CL. 42.
- KUHNE ANLAGENBAU GMBH, FED REP GERMANY:
4,208,257, PUB. 7-3-2012. MULTIPLE CLASS, INT. CLS. 7, 9, 16 AND 42.
4,208,265, PUB. 7-3-2012. MULTIPLE CLASS, INT. CLS. 7, 9, 16 AND 42.
- KULA FOR KARMA, FRANKLIN LAKES, NJ:
4,209,542, PUB. 7-3-2012. INT. CL. 41.
- KULKAY, PATRICK, DAYTON, MN:
943,354. REN. 8-16-12. U.S. CL. 46 (INT. CL. 29).
- KULP, CHRISTOPHER G., YONKERS, NY:
4,209,880, PUB. 7-3-2012. MULTIPLE CLASS, INT. CLS. 16, 18, 25 AND 28.
- KUNI WEST SLOPE MOTORS, L.L.C., VANCOUVER, WA:
4,209,576, PUB. 7-3-2012. INT. CL. 35.
4,209,577, PUB. 7-3-2012. INT. CL. 35.
- KUNTZ ELECTROPLATING INC., KITCHENER, CANADA:
4,211,706, MULTIPLE CLASS, INT. CLS. 1 AND 12.
- KURIYAMA OF AMERICA, INC., SCHAUMBURG, IL:
4,210,594, INT. CL. 9.
- L & LEUNG HANDBAGS MFY. LTD., NEW TERRITORIES, HONG KONG:
4,208,694, PUB. 7-3-2012. MULTIPLE CLASS, INT. CLS. 18 AND 25.
- L.C. LICENSING, LLC, NEW YORK, NY:
2,528,501, CANC. INT. CL. 25.
- L&L WINGS, INC., NEW YORK, NY:
4,209,094, PUB. 7-3-2012. INT. CL. 35.
- L&P PROPERTY MANAGEMENT COMPANY, SOUTH GATE, CA:
4,210,154, PUB. 7-3-2012. INT. CL. 27.
4,210,157, PUB. 7-3-2012. INT. CL. 27.
- L&S BAIT COMPANY OF FLORIDA, INC., LARGO, FL:
2,717,375. REN. 8-14-12. INT. CL. 28.
2,723,796. REN. 8-14-12. INT. CL. 28.
- L-FASHION GROUP OY, 15501 LAHTI, FINLAND:
4,208,569, PUB. 2-7-2012. MULTIPLE CLASS, INT. CLS. 18 AND 25.
- L'OREAL USA CREATIVE, INC., NEW YORK, NY:
4,210,911, INT. CL. 3.
4,211,385, INT. CL. 3.
- LA COSTA CANDLE, FREEHOLD, NJ:
4,209,154, PUB. 7-3-2012. INT. CL. 4.
- LABBLER, INC., MIAMI, FL:
4,211,223, INT. CL. 42.
- LABEL ROW, IRVINE, CA:
4,209,950, PUB. 7-3-2012. INT. CL. 35.
- LABORATOIRE BIODERMA, F-69003 LYON, FRANCE:
4,208,417, PUB. 7-3-2012. INT. CL. 3.
- LACEBARK, INC., STILLWATER, OK:
4,209,139, PUB. 7-3-2012. INT. CL. 20.
- LADDAWN, INC., DEVENS, MA:
4,208,151, PUB. 7-3-2012. INT. CL. 16.
4,208,154, PUB. 7-3-2012. INT. CL. 16.
- LAKE BLUFF CONSULTING, INC., LAKE BLUFF, IL:
4,209,107, PUB. 7-3-2012. INT. CL. 40.
- LAKE ERIE ISLANDS TRADING COMPANY LLC, WESTERVILLE, OH:
4,209,778, PUB. 7-3-2012. INT. CL. 30.
- LAKE NORMAN INDUSTRIES, LLC, CORNELIUS, NC:
4,209,934, PUB. 7-3-2012. INT. CL. 33.
4,209,935, PUB. 7-3-2012. INT. CL. 33.
- LAKE TAHOE SUMMERFEST, INCLINE VILLAGE, NV:
4,209,016, PUB. 7-3-2012. INT. CL. 41.
- LAKELAND INCORPORATED, ISLE, MN:
2,606,025. REN. 8-11-12. INT. CL. 28.
- LAKOSKY, LEE, SALEM, IA AND LAKOSKY, TIFFANY, SALEM, IA:
4,210,480, MULTIPLE CLASS, INT. CLS. 9, 14 AND 25.
- LAMIGLAS, INC., WOODLAND, WA:
1,750,247. REN. 8-16-12. INT. CL. 28.
- LANCE, S.A. DE C.V., 07820 MEXICO D.F., MEXICO TO SUPER BRANDS, LLC, HOUSTON, TX:
1,773,101, AM. INT. CL. 30.
- LANCER MANAGEMENT COMPANY, INC., LONG BEACH, NY:
2,677,851. REN. 8-16-12. INT. CL. 36.
- LANDI NAILS LLC, HINSDALE, IL:
4,210,928, MULTIPLE CLASS, INT. CLS. 3 AND 11.
- LANDMARK PARKING, INC., BALTIMORE, MD:
2,584,952. REN. 8-11-12. INT. CL. 39.
- LANG-MEKRA NORTH AMERICA, LLC, RIDGEWAY, SC:
4,210,922, INT. CL. 9.
- LANGUAGE ON DEMAND, INC., FAIRFAX, VA:
4,209,830, PUB. 7-3-2012. MULTIPLE CLASS, INT. CLS. 35 AND 41.
- LANGUAGE SERVICES ASSOCIATES, INC., HORSHAM, PA:
4,209,042, PUB. 7-3-2012. INT. CL. 41.
- LANRACORP, INC., BROWNSTOWN, IL:
4,209,433, PUB. 7-3-2012. INT. CL. 44.
- LANYON, SAM G, FALMOUTH, UNITED KINGDOM, TA CONCEPT SHED:
4,209,638, PUB. 7-3-2012. INT. CL. 7.
- LAPOINT, GREGORY JOSEPH, PARKER, CO:
4,211,717, INT. CL. 41.
- LAPPERT'S, INC., HANAPEPE, HI:
4,208,173, PUB. 12-9-2008. MULTIPLE CLASS, INT. CLS. 30 AND 35.
- LARAMI LIMITED, PAWTUCKET, RI:
2,527,219, CANC. INT. CL. 28.
- LASALLE SYSTEMS LEASING, INC., ROSEMONT, IL, DBA LASALLE SOLUTIONS:
4,211,639, INT. CL. 9.
- LATHER, INC., PASADENA, CA:
4,210,501, INT. CL. 35.
- LAUNCHLAB, PASADENA, CA:
4,211,817, INT. CL. 41.
- LAUX, MARCUS, SAN RAMON, CA:
2,527,736, CANC. INT. CL. 1.
- LAVDAS JEWELRY, LTD., WARREN, MI:
4,210,768, INT. CL. 35.
- LAVENDER THIEF LLC, SEATTLE, WA:
4,211,085, INT. CL. 16.
- LAW OFFICES OF AGNES CHIU & ASSOCIATES, PLC, ROSEMead, CA:
3,033,827, CANC. INT. CL. 42.
- LAW OFFICES OF SHEELA MURTHY, P.C., OWINGS MILLS, MD:
4,209,281, PUB. 7-3-2012. INT. CL. 42.

LAWRENCE, MARK A., MCLEAN, VA:
2,708,153. REN. 8-11-12. INT. CL. 41.

LAWSON, ALEXIS A, PLEASANTON, CA AND LAWSON,
MICHAEL R, PLEASANTON, CA:
2,602,162. REN. 8-11-12. INT. CL. 42.

LAYNE CHRISTENSEN COMPANY, MISSION WOODS, KS,
LAYNE-WESTERN COMPANY, INC., MISSION WOODS,
KS:
1,737,083. REN. 8-10-12. MULTIPLE CLASS, INT. CLS. 37,
40 AND 42.

LAYNE CHRISTENSEN COMPANY, SHAWNEE MISSION,
KS, CHRISTENSEN BOYLES CORPORATION, SALT
LAKE CITY, UT:
1,742,751. REN. 8-10-12. INT. CL. 7.

LAZAR ENTERPRISES, INC., RED CREEK, NY:
3,236,163. CANC. INT. CL. 43.

LAZZARO CAR CARE PRODUCTS, MOUNTAIN GROVE,
MO:
4,209,600. PUB. 7-3-2012. INT. CL. 3.

LC TM HOLDING, LLC, SANTA ROSA, CA:
4,210,190. PUB. 7-3-2012. INT. CL. 33.
4,210,192. PUB. 7-3-2012. INT. CL. 33.

LCL ENTERPRISES, INC., EVERETT, WA:
4,210,203. PUB. 7-3-2012. INT. CL. 3.

LDM GROUP, LLC, ST. LOUIS, MO:
4,211,749. INT. CL. 35.

LE LYCEE FRANCAIS DE LOS ANGELES, LOS ANGELES,
CA:
4,208,978. PUB. 7-3-2012. INT. CL. 41.

LEADER TECHNOLOGIES INCORPORATED, LEWIS CEN-
TER, OH:
4,211,664. MULTIPLE CLASS, INT. CLS. 9, 38 AND 42.
4,211,666. MULTIPLE CLASS, INT. CLS. 9, 38 AND 42.

LEADING EDGE AUTO REFINISHES, INC., TEMPE, AZ:
4,208,988. PUB. 7-3-2012. INT. CL. 35.

LEARFIELD COMMUNICATIONS, INC., JEFFERSON
CITY, MO:
4,208,711. PUB. 7-3-2012. INT. CL. 38.
4,208,712. PUB. 7-3-2012. INT. CL. 38.

LEARNABLE PTY LTD, COLLINGWOOD VIC, AUSTRA-
LIA:
4,208,663. PUB. 7-3-2012. INT. CL. 38.

LEATHERWOOD OUTDOORS, LLC, FAIRMOUNT CITY,
PA:
4,209,477. PUB. 7-3-2012. INT. CL. 41.

LEBANESE WORLD, LAKE FOREST, CA:
4,209,227. PUB. 7-3-2012. INT. CL. 42.

LECHASE CONSTRUCTION SERVICES, LLC, ROCHESTER,
NY:
4,210,019. PUB. 7-3-2012. INT. CL. 37.

LEDET, STERLING JOSEPH, ATLANTA, GA:
4,209,318. PUB. 7-3-2012. INT. CL. 41.

LEDGEX SYSTEMS LLC, BOSTON, MA:
4,208,882. PUB. 7-3-2012. INT. CL. 9.
4,208,883. PUB. 7-3-2012. INT. CL. 9.

LEE KUM KEE COMPANY LIMITED, TAI PO, NEW
TERRITORIES, HONG KONG:
4,208,131. PUB. 11-23-2010. INT. CL. 30.

LEE, EUNCHANG, IRVINE, CA:
4,209,170. PUB. 7-3-2012. INT. CL. 21.

LEE, LISA JUSTINE KNAPP, SAN DIEGO, CA:
2,724,031. REN. 8-14-12. MULTIPLE CLASS, INT. CLS. 9
AND 16.

LEFLER, JOSEPH S., PAINESVILLE, OH:
3,038,179. CANC. INT. CL. 28.

LEHIGH CONSUMER PRODUCTS LLC, MACUNGIE, PA:
4,210,909. MULTIPLE CLASS, INT. CLS. 6 AND 20.

LES CONTENANTS I.M.L. D'AMÉRIQUE DU NORD INC.,
SAINT-PLACIDE, QUEBEC, CANADA:
4,208,453. PUB. 7-3-2012. MULTIPLE CLASS, INT. CLS.
20, 21, 40 AND 42.

LESKO-CARE, L.L.C., CRANFORD, NJ:
2,616,023. REN. 8-15-12. INT. CL. 3.

LESTER LAMPERT, INC., CHICAGO, IL:
2,526,816. CANC. INT. CL. 35.

LET IT FLY LLC, IRVINE, CA, LET IT FLY LLC, IRVINE,
CA:
2,698,279. REN. 8-15-12. INT. CL. 42.

LEUCANA INVEST, SL, 46688, VALENCIA, SPAIN:
4,209,411. PUB. 7-3-2012. INT. CL. 33.

LEVEL ENTERPRISES, LLC, BOYNTON BEACH, FL:
4,211,059. INT. CL. 5.
4,211,060. INT. CL. 5.

LEVELS BEYOND, LLC, DENVER, CO:
4,209,096. PUB. 7-3-2012. INT. CL. 42.

LEVERSET, INC., HAVERTOWN, PA, DBA LEVERSET,
INC.:
4,208,888. PUB. 7-3-2012. INT. CL. 14.

LEVI, RAY & SHOUP, INC., SPRINGFIELD, IL:
2,744,344. REN. 8-14-12. INT. CL. 9.
4,209,173. PUB. 7-3-2012. INT. CL. 42.
4,209,963. PUB. 7-3-2012. INT. CL. 41.

LEVINE LEICHTMAN CAPITAL PARTNERS, INC., BEV-
ERLY HILLS, CA:
2,604,627. REN. 8-16-12. INT. CL. 36.
2,634,879. REN. 8-16-12. INT. CL. 36.

LEVINSON, MARK, NEW YORK, NY:
2,601,504. REN. 8-12-12. INT. CL. 9.

LEVY SHAY ELIEZER, SHOUSON HILL, HONG KONG:
4,209,493. PUB. 7-3-2012. MULTIPLE CLASS, INT. CLS. 9
AND 18.

LEW, CHESTER, SAN MATEO, CA:
3,254,457 NEW CERT. 9-18-2012. INT. CL. 20.

LEWIS; WILLIAM, GRAND RAPIDS, MI, DBA YESTER-
DOG:
1,204,923. REN. 8-13-12. INT. CL. 42.

LEXECON, LLC, ANNAPOLIS, MD:
2,527,227. CANC. MULTIPLE CLASS, INT. CLS. 35 AND
42.

LEXICON LENDING CORPORATION, FORT MILL, SC:
4,210,907. INT. CL. 36.

LEXINGTON-ROWE FURNITURE, INC., BOCA RATON,
FL:
3,038,205. CANC. INT. CL. 20.

LEXIWYNN DESIGNS LLC, LIBERTYVILLE, IL:
4,209,404. PUB. 7-3-2012. MULTIPLE CLASS, INT. CLS. 18
AND 35.

LF, LLC, MOUNT MOURNE, NC, LF CORPORATION,
WILMINGTON, DE:
1,701,629. REN. 8-11-12. INT. CL. 11.

LF, LLC, MOUNT MOURNE, NC:
4,211,271. INT. CL. 16.

LFW DAIRY CORP, BROOKLYN, NY, DBA J&J DAIRY:
4,209,716. PUB. 7-3-2012. INT. CL. 5.

LG ELECTRONICS INC., SEOUL, REPUBLIC OF KOREA:
4,208,193. PUB. 7-3-2012. INT. CL. 9.

LG ELECTRONICS INC., SEOUL 150-721, REPUBLIC OF
KOREA:
4,208,484. PUB. 7-3-2012. INT. CL. 9.
4,208,545. PUB. 7-3-2012. INT. CL. 9.
4,208,546. PUB. 7-3-2012. INT. CL. 9.
4,208,547. PUB. 7-3-2012. INT. CL. 9.

LIBERTY GLOBAL LOGISTICS LLC, LAKE SUCCESS, NY:
4,210,551. MULTIPLE CLASS, INT. CLS. 16, 21, 25 AND
28.

LIBERTY MEDIA HOLDINGS, LLC, MIAMI, CA, DBA
CORBIN FISHER:
4,210,681. INT. CL. 41.

LIBRARY IDEAS, LLC, VIENNA, VA:
4,209,458. PUB. 7-3-2012. INT. CL. 38.
4,209,459. PUB. 7-3-2012. INT. CL. 38.
4,209,460. PUB. 7-3-2012. INT. CL. 38.

LICENSE PRODUCTS INC, NEW BERLIN, WI, DBA FIRST-
IME MANUFACTORY:
4,209,815. PUB. 7-3-2012. INT. CL. 14.

LIEBERMAN RESEARCH WORLDWIDE, INC., LOS AN-
GELES, CA:
4,209,881. PUB. 7-3-2012. INT. CL. 35.
4,210,195. PUB. 7-3-2012. INT. CL. 35.

LIEBHERR-INTERNATIONAL AG, CH-1630 BULLE/FR,
SWITZERLAND:
2,617,058. REN. 8-15-12. MULTIPLE CLASS, INT. CLS. 7
AND 9.

LIFE CARE RETIREMENT COMMUNITIES, INC., DES
MOINES, IA:
2,742,061. REN. 8-15-12. INT. CL. 43.

- LIFE DATA LABS, INC., CHEROKEE, AL:
2,527,765, CANC. INT. CL. 5.
- LIFE WITHOUT LAUNDRY, LLC, SOUTH BOSTON, MA:
4,210,646, INT. CL. 39.
- LIFE + GEAR, INC., DEL MAR, CA:
4,210,555, MULTIPLE CLASS, INT. CLS. 8, 9, 11 AND 18.
- LIFECHAMPION INTERNATIONAL, INC., BUCKNER, KY:
2,526,757, CANC. MULTIPLE CLASS, INT. CLS. 16 AND 41.
- LIFEGUARD LICENSING CORP, NEW YORK, NY, ROBERT REIS & CO., NEW YORK, NY:
562,509. REN. 8-15-12. U.S. CL. 39 (INT. CL. 25).
- LIFETIME BRANDS, INC., GARDEN CITY, NY:
4,211,078, INT. CL. 9.
- LIGHT DREAMS, LLC, PUYALLUP, WA:
4,210,999, MULTIPLE CLASS, INT. CLS. 11 AND 35.
- LIGHTHOUSE INTERNATIONAL, NEW YORK, NY:
4,210,365, MULTIPLE CLASS, INT. CLS. 35 AND 44.
- LIGHTING SMILE, INC., STATEN ISLAND, NY:
4,209,751, PUB. 7-3-2012. INT. CL. 35.
- LIMESTONE VENTURES MANAGEMENT, INC., AUSTIN, TX:
2,607,601. REN. 8-15-12. INT. CL. 36.
- LIMITED STORES, LLC, NEW ALBANY, OH:
4,210,612, MULTIPLE CLASS, INT. CLS. 3 AND 9.
- LINCOLN NATIONAL CORPORATION, PHILADELPHIA, PA:
3,038,122, CANC. INT. CL. 36.
- LINE SHIFT MANAGEMENT GROUP, INC., CENTENNIAL, CO:
4,210,659, MULTIPLE CLASS, INT. CLS. 9, 35 AND 45.
- LINVATEC CORPORATION, LARGO, FL:
4,210,700, INT. CL. 10.
- LIONEL TRADEMARK LLC, CHESTERFIELD, MI, LIONEL CORPORATION, THE, CHESTERFIELD, MI:
736,342. REN. 8-15-12. U.S. CL. 22 (INT. CL. 28).
- LIPARI FOODS OPERATING COMPANY, LLC, WARREN, MI:
4,210,032, PUB. 7-3-2012. MULTIPLE CLASS, INT. CLS. 29 AND 30.
- LIPINSKI, STEVEN J., STREAMWOOD, IL:
4,211,327, INT. CL. 31.
- LIPOTEC, S.A., SPAIN:
4,208,271, PUB. 3-20-2012. MULTIPLE CLASS, INT. CLS. 1, 3 AND 5.
- LIST COMPANY, INC., PIEDMONT, SC:
4,211,300, INT. CL. 4.
- LITERARY LICENSING, LLC, WHITEFISH, MT:
4,211,698, INT. CL. 41.
- LITTLE FARM FROZEN FOODS, INC., BROWNSVILLE, TX, AKA LA HUERTA:
4,211,157, INT. CL. 29.
- LITTLE RAPIDS CORPORATION, GREEN BAY, WI:
2,666,994. REN. 8-15-12. INT. CL. 25.
- LIU, JO S.P.A., ITALY:
4,208,423, PUB. 7-3-2012. INT. CL. 25.
- LIU, BOJIA, NORTH QUINCY, MA:
4,211,482, INT. CL. 25.
4,211,483, INT. CL. 25.
- LIU, JIAN, LEWISVILLE, TX:
4,209,571, PUB. 7-3-2012. INT. CL. 18.
- LIU, LILI, SUPRISE, AZ:
4,208,713, PUB. 7-3-2012. INT. CL. 5.
- LIVE NATION MOTOR SPORTS, INC., AURORA, IL:
2,735,423. REN. 8-11-12. INT. CL. 28.
- LIVE NATION WORDWIDE, INC., BEVERLY HILLS, CA:
2,721,633. REN. 8-15-12. MULTIPLE CLASS, INT. CLS. 35 AND 41.
2,721,633, CANC. INT. CL. 38.
- LIVE THE MUSIC GROUP, NOVI, MI, AKA LIVETMG:
4,208,643, PUB. 7-3-2012. INT. CL. 41.
- LIVEDATA, INC., CAMBRIDGE, MA:
4,211,215, INT. CL. 9.
- LIVING OUR REAL DREAMS PRODUCTIONS, CANOGA PARK, CA:
4,209,603, PUB. 7-3-2012. INT. CL. 41.
- LIVON LABORATORIES, INC., HENDERSON, NV:
4,154,230, CANC. MULTIPLE CLASS, INT. CLS. 35, 41 AND 44.
- LLOYD, SAMUEL H., GOLDSBORO, NC:
2,528,229, CANC. INT. CL. 42.
- LO SCARABEO S.R.L., ITALY:
4,208,309, PUB. 7-3-2012. INT. CL. 28.
- LO VI POR TV, LLC, HIALEAH, FL:
4,208,785, PUB. 7-3-2012. INT. CL. 5.
4,208,914, PUB. 7-3-2012. INT. CL. 9.
- LOAISIGA GROUP, INC., MONTCLAIR, CA, DBA PERFUME CHALET:
4,209,449, PUB. 7-3-2012. INT. CL. 35.
- LOANSIFTER, INC., LITTLE CHUTE, WI:
4,208,974, PUB. 7-3-2012. INT. CL. 35.
- LOC-AID TECHNOLOGIES, INC., SAN FRANCISCO, CA:
4,208,577, PUB. 7-3-2012. MULTIPLE CLASS, INT. CLS. 9, 16 AND 42.
- LOCHINVAR GOLF CLUB, HOUSTON, TX:
1,209,104. REN. 8-14-12. INT. CL. 41.
- LOCOCO SPORTS, INC., SAN DIEGO, CA:
4,210,204, PUB. 7-3-2012. INT. CL. 35.
- LODESTAR ANSTALT; (A LIECHTENSTEIN COMPANY), LIECHTENSTEIN:
4,208,393, PUB. 7-3-2012. MULTIPLE CLASS, INT. CLS. 4, 9, 14, 25 AND 34.
- LOF INTERNATIONAL, LLC, PITTSBURGH, PA:
2,989,096, CANC. INT. CL. 25.
- LOG OUT AND LIVE, LLC., FAIRFIELD, CT:
4,209,196, PUB. 7-3-2012. MULTIPLE CLASS, INT. CLS. 9, 16 AND 25.
- LOGI D INC., LAVAL, QC, CANADA:
4,209,639, PUB. 7-3-2012. INT. CL. 9.
4,209,640, PUB. 7-3-2012. INT. CL. 35.
- LOLA'S LIBATIONS, LLC, COLLEYVILLE, TX:
4,211,178, INT. CL. 33.
- LOMBARD MEDICAL TECHNOLOGIES PLC, ABINGDON, OXON, UNITED KINGDOM:
3,052,960, CANC. MULTIPLE CLASS, INT. CLS. 9, 42 AND 44.
- LONG FENCE AND HOME, LLLP, BELTSVILLE, MD:
2,638,445. REN. 8-15-12. INT. CL. 37.
2,638,446. REN. 8-15-12. INT. CL. 37.
2,638,447. REN. 8-15-12. INT. CL. 37.
- LONG, EDWARD M., SAN JOSE, CA:
1,704,663. REN. 8-14-12. INT. CL. 9.
- LONGISTICS, L.L.C., RESEARCH TRIANGLE PARK, NC:
2,526,408, CANC. INT. CL. 39.
- LONGITUDE LLC, NEW YORK, NY:
2,528,248, CANC. INT. CL. 36.
- LOOFAH ART, LLC, AVENEL, NJ:
4,208,665, PUB. 7-3-2012. INT. CL. 21.
- LOPE FOR HOPE, LLC, LAKE CITY, MI:
4,211,866, INT. CL. 25.
4,211,867, INT. CL. 25.
- LOPEZ, R. DAN, WATERVILLE, WA:
4,210,537, INT. CL. 9.
- LOS HURACANES DEL NORTE, PORTALES, NM:
2,526,635, CANC. MULTIPLE CLASS, INT. CLS. 9 AND 41.
- LOUDER, MARY, TRAVERSE CITY, MI:
4,210,237, INT. CL. 3.
- LOUIS ROYER S.A., JARNAC, FRANCE:
3,037,491, CANC. INT. CL. 33.
- LOUIS VUITTON MALLETIER, PARIS, FRANCE, VUITTON & VUITTON, SOCIETE A RESPONSABILITE LIMITEE, PARIS, FRANCE:
297,594. REN. 8-16-12. U.S. CL. 3 (INT. CL. 18).
- LOVE AUSTIN HOMES, LLC, AUSTIN, TX:
4,211,841, INT. CL. 41.
- LOVELAND PRODUCTS, INC., LOVELAND, CO:
4,211,390, INT. CL. 1.
4,211,394, INT. CL. 1.
- LOVESQUE, DENVER, CO:
4,209,702, PUB. 7-3-2012. INT. CL. 25.
- LOWEN CORPORATION, HUTCHINSON, KS, DBA LOWEN COLOR GRAPHICS:
3,047,621, CANC. INT. CL. 16.

LPS IP HOLDING COMPANY, LLC, JACKSONVILLE, FL, DATAMAP, INC., EDEN PRAIRIE, MN:
1,707,524. REN. 8-11-12. INT. CL. 42.

LRM INDUSTRIES INTERNATIONAL, INC., ROCKLEDGE, FL:
4,210,485. INT. CL. 42.

LSP PRODUCTS GROUP, INC., IRVING, TX:
4,208,921. PUB. 7-3-2012. INT. CL. 11.

LU, YUEH-CHUAN, TAIPEI CITY, TAIWAN:
4,210,933. INT. CL. 9.

LUCHA LIBRE USA LLC, NEW YORK, NY:
4,209,822. PUB. 7-3-2012. INT. CL. 41.

LUCKY CRAFT CO., LTD., OYABE-SHI, TOYAMA, JAPAN:
4,211,007. INT. CL. 28.

LUCKY PLAYER VODKA, INC., AVENTURA, FL:
4,210,130. PUB. 7-3-2012. INT. CL. 33.

LUCTA, S.A., BARCELONA, SPAIN:
2,527,868. CANC. INT. CL. 1.

LUFTHANSA TECHNIK AG, FED REP GERMANY:
4,208,337. PUB. 7-3-2012. MULTIPLE CLASS, INT. CLS. 9, 11, 12, 35, 37, 38, 39 AND 42.

LUFTWAFFLE SUBORBITALS, ISSAQUAH, WA:
4,209,734. PUB. 7-3-2012. INT. CL. 35.

LUGOSCH DESIGNS, INC., EDGEComb, ME:
4,209,125. PUB. 7-3-2012. INT. CL. 14.

LULU GUINNESS LIMITED, LONDON W10 5BZ, UNITED KINGDOM:
3,038,669. CANC. INT. CL. 8.

LUMA ARCADE, LLC, SALEM, OR:
4,210,994. INT. CL. 9.

LUMENE OY, FINLAND:
4,208,444. PUB. 7-3-2012. MULTIPLE CLASS, INT. CLS. 3 AND 44.

LUMINOVA AG, SCHWEIZ, SWITZERLAND:
4,208,269. PUB. 7-3-2012. INT. CL. 2.

LUTHERAN FAMILY SERVICES OF NEBRASKA, INC., OMAHA, NE, AKA LFS:
4,209,979. PUB. 7-3-2012. INT. CL. 36.

LUXCO, INC., ST. LOUIS, MO:
1,707,106. REN. 8-10-12. INT. CL. 33.

LUXEYARD, INC., LOS ANGELES, CA:
4,209,775. PUB. 7-3-2012. INT. CL. 35.

LUXOR CABS, INC., SAN FRANCISCO, CA:
2,601,057. REN. 8-14-12. INT. CL. 39.

LUXOTTICA NORTH AMERICA DISTRIBUTION LLC, MASON, OH:
2,528,567. CANC. INT. CL. 9.

LUXOTTICA RETAIL NORTH AMERICA INC., MASON, OH:
2,607,589. REN. 8-15-12. INT. CL. 9.

LVS, INC., SAN LEANDRO, CA:
1,781,251. REN. 8-14-12. INT. CL. 9.

LV2BFIT, INC., BEDFORD, NY:
4,208,930. PUB. 7-3-2012. INT. CL. 35.

LYNCH, WILLIAM D., SPRINGFIELD, MO:
4,211,861. INT. CL. 41.

M & G PARTNERS, LLP, MILWAUKEE, WI, DBA FASHION ANGELS ENTERPRISES:
4,211,530. INT. CL. 3.

M. L. BENJAMIN ENTERPRISES, INC., BRONX, NY, DBA BENJAMIN ENTERPRISES:
4,209,660. PUB. 7-3-2012. INT. CL. 35.

M.M.G. COMMUNICATIONS, INC., SAN ANTONIO, TX:
4,208,938. PUB. 7-3-2012. INT. CL. 16.

MACDONALD, MURRAY G., VANCOUVER, B.C. V6B 4Y4, CANADA:
2,600,367. REN. 8-14-12. INT. CL. 9.

MACFADDEN BEVERAGE BUSINESS, LLC, NEW YORK, NY:
4,211,750. INT. CL. 16.

MACKENZIE, CAROLYN HELEN, MS, AVON, CT:
4,210,367. INT. CL. 18.

MACPRO DISTRIBUTORS, YUBA CITY, CA:
4,208,137. PUB. 7-3-2012. INT. CL. 3.

MACY'S, INC., CINCINNATI, OH:
4,210,731. INT. CL. 41.

MADDEN, PAUL DANIEL, MANSFIELD, OH:
4,209,846. PUB. 7-3-2012. INT. CL. 9.

MADISON PLANNING GROUP, INC., WHITE PLAINS, NY:
2,599,066. REN. 8-14-12. INT. CL. 41.

MADRUGA, MARSHALL, SAN DIEGO, CA:
4,210,105. PUB. 7-3-2012. INT. CL. 25.

MAEBON, LLC, JERSEY CITY, NJ:
4,211,151. INT. CL. 35.

MAGI ASSOCIATES, INC, THE, MURRAY HILL STATION, NY:
2,674,203. REN. 8-14-12. INT. CL. 45.

MAGIC PLASTICS, INC., VALENICIA, CA:
4,209,118. PUB. 7-3-2012. INT. CL. 19.

MAGIC-FLIGHT GENERAL MANUFACTURING, INC., RANCHO SANTA FE, CA:
4,208,595. PUB. 7-3-2012. MULTIPLE CLASS, INT. CLS. 11 AND 34.

MAGNACARD, INC., DUBOIS, PA:
4,210,758. MULTIPLE CLASS, INT. CLS. 9 AND 11.

MAGOTTEAUX INTERNATIONAL, B-4051 VAUX-SOUS-CHEVREMONT, BELGIUM:
2,630,055. REN. 8-13-12. INT. CL. 7.

MAHAMED BASAMH, SAEED, JEDDAH 21464, SAUDI ARABIA:
3,067,520. CANC. INT. CL. 32.

MAHARRY, AYANNA, LOS ANGELES, CA:
4,209,700. PUB. 7-3-2012. INT. CL. 25.

MAIER, HERBERT N., SALISBURY, NC:
4,209,073. PUB. 7-3-2012. INT. CL. 41.

MAIN SEQUENCE, LTD., ROCHESTER, NY:
4,211,505. INT. CL. 41.

MAINARDI, JOHN V, WARREN, MI:
4,210,285. INT. CL. 28.

MAINSTREAM RENEWABLE POWER LIMITED, GLASTHULE, CO DUBLIN, IRELAND:
4,208,286. PUB. 7-3-2012. MULTIPLE CLASS, INT. CLS. 7, 9, 37, 39, 40 AND 42.

MAJOR LEAGUE BASEBALL PLAYERS ASSOCIATION, NEW YORK, NY:
2,537,150. REN. 8-13-12. INT. CL. 16.

MAJOR LEAGUE BASEBALL PROPERTIES, INC., NEW YORK, NY:
1,719,587. REN. 8-15-12. INT. CL. 35.

MALLOW MUNCHIES LLC, BALTIMORE, MD:
4,211,270. INT. CL. 43.

MAMA TIME, LLC, POOLER, GA:
4,209,647. PUB. 7-3-2012. INT. CL. 41.

MAMBO GRAPHICS PTY LIMITED, SYDNEY NSW 2000, AUSTRALIA:
4,208,428. PUB. 7-3-2012. MULTIPLE CLASS, INT. CLS. 9, 14, 16, 18 AND 25.

MAN DIESEL & TURBO SE, AUGSBURG, FED REP GERMANY, GUTEHOFFNUNGSHUTTE STERKRADE A.G., OBERHAUSEN 11, FED REP GERMANY:
1,203,408. REN. 8-16-12. INT. CL. 9.

MANAGEMENT CONSULTING GROUP PLC, LONDON, GREAT BRITAIN:
4,210,813. INT. CL. 35.

MANCHEGO REAL, LLC, GRANDVIEW, WA:
3,038,328. CANC. INT. CL. 33.

MANDARIN ENTERPRISES LLC, ATLANTA, GA, DBA CLINICAL GUARD:
4,211,753. INT. CL. 10.

MANGNALL, LLOYD W, ARGYLE, TX:
4,209,928. PUB. 7-3-2012. INT. CL. 9.

MANJACKSON INC., MYRTLE BEACH, SC:
4,209,335. PUB. 7-3-2012. INT. CL. 43.

MANSION PUBLISHING, INC., DENVER, CO:
2,599,796. REN. 8-10-12. INT. CL. 41.
2,599,797. REN. 8-10-12. INT. CL. 41.
2,620,663. REN. 8-11-12. MULTIPLE CLASS, INT. CLS. 16 AND 41.

MANUKAMED LIMITED, MASTERTON, NEW ZEALAND:
4,211,756. INT. CL. 5.
4,211,757. INT. CL. 5.
4,211,761. INT. CL. 5.

MANZOOR, ZAHIR, JERSEY CITY, NJ:
4,208,522. PUB. 7-3-2012. INT. CL. 29.

- MAPAL FABRIK FÜR PRÄZISIONSWERKZEUGE DR. KRESS KG, FED REP GERMANY:
4,208,272, PUB. 7-3-2012. MULTIPLE CLASS, INT. CLS. 7, 9 AND 37.
- MARANATHA! MUSIC, SAN CLEMENTE, CA:
2,528,213, CANC. MULTIPLE CLASS, INT. CLS. 9 AND 16.
- MARCELLE, SAN FRANCISCO, CA:
4,209,232, PUB. 7-3-2012. INT. CL. 43.
- MARCHON EYEWEAR, INC., MELVILLE, NY:
2,528,270, CANC. INT. CL. 9.
- MARCO POLO DESIGNS, PORTLAND, OR:
4,211,548, INT. CL. 14.
- MARCO, PETER, NEW YORK, NY, DBA MARCOART:
4,210,806, INT. CL. 28.
- MARCUS, BRIAN, SANTA FE, NM, DBA HIP MERMAID PRODUCTIONS:
4,209,836, PUB. 7-3-2012. INT. CL. 9.
- MARELJ, JELISAVETA, OAKVILLE, ON, CANADA:
4,210,348, INT. CL. 14.
- MAREYDT, RAY G., ST. CLAIR SHORES, MI:
2,656,084, REN. 8-16-12. INT. CL. 42.
- MAREYDT, RAY G., ST. CLAIR SHORES, MI, DBA DESIGN TWENTY THREE AND D23:
2,743,855, REN. 8-16-12. INT. CL. 42.
- MARIA TEREZA CAREY, MIDLAND, GA, DBA PARFUM BY TRUDIE:
4,211,330, INT. CL. 3.
- MARICH CONFECTIONERY COMPANY, INC., HOLLISTER, CA:
4,209,653, PUB. 7-3-2012. INT. CL. 30.
- MARÍA LUISA ADÁNEZ BARBA, E-28034 MADRID, SPAIN:
4,208,374, PUB. 7-3-2012. INT. CL. 18.
- MARK G. ANDERSON CONSULTANTS, INC., WASHINGTON, DC:
4,209,084, PUB. 7-3-2012. MULTIPLE CLASS, INT. CLS. 35 AND 37.
- MARK SISSON, MALIBU, CA:
4,208,226, PUB. 7-3-2012. INT. CL. 5.
- MARKETING GOO, INC., ALISO VIEJO, CA:
4,211,774, INT. CL. 41.
- MARLENA INTERNATIONAL, LLC, LAWRENCEVILLE, GA, MARLENA INTERNATIONAL, LLC, LAWRENCEVILLE, GA:
2,603,235, REN. 8-15-12. INT. CL. 10.
- MARRIOTT INTERNATIONAL, INC., BETHESDA, MD:
4,209,697, PUB. 7-3-2012. INT. CL. 35.
4,210,087, PUB. 7-3-2012. INT. CL. 16.
- MARS HILL CHURCH, SEATTLE, WA:
4,208,818, PUB. 7-3-2012. MULTIPLE CLASS, INT. CLS. 9, 41 AND 45.
- MARS, INCORPORATED, MCLEAN, VA:
4,210,870, INT. CL. 31.
- MARSH, PAUL FRANKLIN, PARK CITY, UT:
4,210,305, INT. CL. 35.
- MARTELL & CO, F-16100 COGNAC, FRANCE:
3,038,105.
- MARTIN FLYER JEWELRY, LLC., NEW YORK, NY:
4,208,571, PUB. 7-3-2012. INT. CL. 14.
- MARTIN, JOHN A., BEACH HAVEN CREST, NJ:
4,209,236, PUB. 7-3-2012. INT. CL. 9.
- MARTINA GEBHARDT NATURKOSMETIK GMBH, D-86935 ROTT-PESSENHAUSEN, FED REP GERMANY:
3,134,586, CANC. MULTIPLE CLASS, INT. CLS. 29 AND 39.
- MARTINGALE & COMPANY, BOTHELL, WA:
4,209,152, PUB. 7-3-2012. MULTIPLE CLASS, INT. CLS. 9, 16 AND 35.
- MARTINS RUN, MEDIA, PA:
4,209,057, PUB. 7-3-2012. INT. CL. 43.
- MARTITA'S MIXERS, MILWAUKEE, WI:
4,211,453, INT. CL. 33.
- MARTY COOPER PRODUCTIONS, INC., MALIBU, CA:
4,211,673, MULTIPLE CLASS, INT. CLS. 16, 21, 25 AND 28.
- MARVELL INTERNATIONAL LTD., HAMILTON HM 12, BERMUDA:
2,521,212, REN. 8-13-12. INT. CL. 9.
- MARVIN TEST SYSTEMS, INC., IRVINE, CA:
2,640,027, REN. 8-15-12. INT. CL. 9.
- MARWARE, INC., HOLLYWOOD, FL:
4,210,733, MULTIPLE CLASS, INT. CLS. 9, 25 AND 35.
4,210,734, MULTIPLE CLASS, INT. CLS. 9, 25, 35 AND 41.
- MARY A. VAUGHT, CRANE, MO AND GREGORY L. VAUGHT, CRANE, MO:
4,210,664, INT. CL. 30.
- MAS MARKETING HOLDING COMPANY LLC, DAWSONVILLE, GA:
4,208,558, PUB. 1-17-2012. INT. CL. 29.
- MASIMO CORPORATION, IRVINE, CA:
2,533,974, REN. 8-13-12. INT. CL. 10.
- MASON BROTHERS BAND, ASTORIA, NY:
4,208,656, PUB. 7-3-2012. INT. CL. 41.
- MASONITE INTERNATIONAL CORPORATION, MISSISSAUGA, CANADA:
4,210,544, INT. CL. 19.
4,210,545, INT. CL. 19.
4,210,546, INT. CL. 19.
- MASSACHUSETTS DEPARTMENT OF MENTAL HEALTH, BOSTON, MA:
4,209,140, PUB. 7-3-2012. MULTIPLE CLASS, INT. CLS. 41, 44 AND 45.
- MASTER HALCO, INC., IRVING, TX:
1,777,631, REN. 8-11-12. INT. CL. 6.
- MASTERLINK MARKETING INC., PRINCE GEORGE, B.C., CANADA:
4,209,020, PUB. 7-3-2012. INT. CL. 20.
- MATCOR, INC., DOYLESTOWN, PA:
4,211,092, INT. CL. 9.
- MATEK PERFORMANCE, INC., FORT WORTH, TX:
2,526,817, CANC. INT. CL. 12.
- MATRIX IMPORTS, INC., POMPANO BEACH, FL:
4,209,681, PUB. 7-3-2012. INT. CL. 20.
- MATTEL, INC., EL SEGUNDO, CA:
4,208,819, PUB. 7-3-2012. INT. CL. 28.
4,210,457, INT. CL. 28.
4,211,283, INT. CL. 28.
4,211,284, INT. CL. 28.
4,211,285, INT. CL. 28.
4,211,298, INT. CL. 28.
- MATTERDADDY LLC, ENCINITAS, CA:
4,209,551, PUB. 7-3-2012. INT. CL. 9.
- MATTHEWS STUDIO EQUIPMENT, INC., BURBANK, CA:
2,664,296, REN. 8-13-12. INT. CL. 11.
- MATTHIAS RATH, SANTA CLARA, CA:
4,208,333, PUB. 7-3-2012. MULTIPLE CLASS, INT. CLS. 5, 16, 38, 41, 42 AND 44.
4,208,349, PUB. 7-3-2012. MULTIPLE CLASS, INT. CLS. 5, 16, 38, 41, 42 AND 44.
- MATTIOLI ENGINEERING LTD., LONDON, UNITED KINGDOM, MATTIOLI ENGINEERING LTD., LONDON, UNITED KINGDOM:
2,534,382, REN. 8-10-12. INT. CL. 10.
- MAUZY, PERRY, PAWLEYS ISLAND, SC:
4,211,426, INT. CL. 41.
- MAVERICK TECHNOLOGIES HOLDINGS, LLC, COLUMBIA, IL:
4,209,132, PUB. 7-3-2012. INT. CL. 42.
4,209,133, PUB. 7-3-2012. INT. CL. 42.
- MAXIM CRANE WORKS, L.P., BRIDGEVILLE, PA:
2,681,621, REN. 8-11-12. MULTIPLE CLASS, INT. CLS. 37 AND 39.
2,684,198, REN. 8-11-12. MULTIPLE CLASS, INT. CLS. 37 AND 39.
2,684,199, REN. 8-11-12. MULTIPLE CLASS, INT. CLS. 37 AND 39.
2,684,200, REN. 8-11-12. MULTIPLE CLASS, INT. CLS. 37 AND 39.
2,684,203, REN. 8-11-12. MULTIPLE CLASS, INT. CLS. 37 AND 39.
- MAXIM SILENCERS, INC., STAFFORD, TX:
2,600,555, REN. 8-13-12. INT. CL. 7.
- MAYER-BERKSHIRE CORPORATION, WAYNE, NJ, MAYER-BEATON CORPORATION, WAYNE, NJ:
1,189,424, REN. 8-16-12. INT. CL. 25.

MAYNE PHARMA INTERNATIONAL PTY LTD, MELBOURNE VIC 3000, AUSTRALIA:
4,208,403, PUB. 7-3-2012. INT. CL. 5.

MAYNE, LESLIE, TACOMA, WA:
4,209,624, PUB. 7-3-2012. INT. CL. 36.

MAYTAG PROPERTIES, LLC, ST. JOSEPH, MI:
4,210,316, INT. CL. 11.

MBA FOCUS, LLC, DUBLIN, OH:
4,208,844, PUB. 7-3-2012. INT. CL. 42.

MCCANN, JOHN, POINT PLEASANT, NJ:
2,956,804, CANC. INT. CL. 9.

MCCLEAN ENTERPRISES LLC, DELMAR, IA:
4,211,185, INT. CL. 28.

MCCLELLAND TOBACCO CO., KANSAS CITY, MO:
1,707,115. REN. 8-10-12. INT. CL. 34.

MCCREADIE GROUP, INC., ANN ARBOR, MI:
4,211,569, INT. CL. 42.

MCENERGY, INC., VALHALLA, NY:
4,208,653, PUB. 7-3-2012. INT. CL. 35.

MCFAUL, MARC M., BALTIMORE, MD:
2,539,746. REN. 8-11-12. INT. CL. 42.

MCGUIGAN, ANTHONY, SEBASTOPOL, CA:
4,210,368, INT. CL. 16.

MCNEELY, KEVIN, ARLINGTON, TX:
4,211,328, INT. CL. 20.

MCP IP, LLC, SPARTA, WI:
2,527,814, CANC. INT. CL. 20.

MCPC, INC., CLEVELAND, OH:
4,209,527, PUB. 7-3-2012. INT. CL. 42.

MD DELIVERED INC., SEAL BEACH, CA:
4,211,684, INT. CL. 44.

MDC SYSTEMS OF DELAWARE, INC., PAOLI, PA:
2,728,894. REN. 8-15-12. INT. CL. 16.

MEAD PRODUCTS LLC, DAYTON, OH:
3,111,377, CANC. INT. CL. 9.
4,210,428, INT. CL. 16.

MEADOWS CREDIT UNION, ARLINGTON HEIGHTS, IL:
2,526,735, CANC. INT. CL. 36.

MEAN MUGZ, LLC, CHICAGO, IL:
4,210,703, INT. CL. 25.

MECO CORPORATION, GREENEVILLE, TN:
1,707,990. REN. 8-11-12. INT. CL. 11.

MECO PAK AB, ALINGSAS, SWEDEN:
2,527,114, CANC. INT. CL. 7.

MECTRA LABS, INC., BLOOMFIELD, IN:
4,210,775, INT. CL. 10.

MEDELA HOLDING AG, 6341 BAAR, SWITZERLAND:
4,208,165, PUB. 8-16-2011. MULTIPLE CLASS, INT. CLS. 5 AND 35.

MEDENTIKA GMBH, FED REP GERMANY:
4,208,405, PUB. 7-3-2012. MULTIPLE CLASS, INT. CLS. 10, 40 AND 41.

MEDIA LINK, INC., DAVENPORT, IA:
4,210,837, INT. CL. 42.

MEDIAMOUNTS, LTD., CAMBRIDGE, ONTARIO, CANADA:
4,210,559, INT. CL. 9.

MEDIG PROPRIETARY HOLDINGS, L.L.C., GAINESVILLE, FL:
4,209,238, PUB. 7-3-2012. INT. CL. 44.

MEDINOX, INC., CARLSBAD, CA:
2,527,052, CANC. INT. CL. 5.

MEDISANA AG, NEUSS, FED REP GERMANY:
4,208,617, PUB. 2-28-2012. MULTIPLE CLASS, INT. CLS. 8, 10, 11, 12 AND 44.

MEDIXMEDIA, INC., NEW YORK, NY:
2,697,011. REN. 8-13-12. INT. CL. 44.

MEDLINE INDUSTRIES, INC., MUNDELEIN, IL:
4,211,414, INT. CL. 10.

MEDOP, INC., OLDSMAR, FL:
4,210,884, INT. CL. 5.

MEDRAD, INC., INDIANOLA, PA:
2,604,867. REN. 8-16-12. INT. CL. 10.
2,604,867, CANC. INT. CL. 9.

MEDSTAR HEALTH, INC., COLUMBIA, MD:
4,210,948, INT. CL. 44.

MEDTRAIN TECHNOLOGIES, LLC, HILLSBOROUGH, NC:
4,210,420, INT. CL. 1.

MEDVEAL, LLC, FREMONT, CA:
4,209,673, PUB. 7-3-2012. INT. CL. 5.

MEENAXI ENTERPRISE, INC., SOUTH PLAINFIELD, NJ, DBA MEENAXI ENTERPRISE, INC.:
4,210,150, PUB. 7-3-2012. INT. CL. 32.
4,210,151, PUB. 7-3-2012. INT. CL. 32.

MEGATRON EQUITY PARTNERS, INC., MIAMI, FL:
4,209,030, PUB. 7-3-2012. MULTIPLE CLASS, INT. CLS. 36 AND 41.

MEGUMI O LLC, LOS ANGELES, CA:
4,211,611, INT. CL. 9.

MEL, INC., WEST CHESTER, PA:
4,211,478, INT. CL. 9.

MEIJUN LLC, SAN DIEGO, CA:
4,209,362, PUB. 7-3-2012. INT. CL. 42.

MELALEUCA, INC., IDAHO FALLS, ID:
1,706,196. REN. 8-12-12. INT. CL. 5.

MELISSA HEUSER, NEWPORT, CA:
4,211,301, INT. CL. 9.

MELISSA WHITAKER INTERNATIONAL, LLC, SCHAMBURG, IL:
4,209,008, PUB. 7-3-2012. INT. CL. 35.

MELITA L. HARLEY, CAMBRIDGE, MD, AKA OWNER:
4,211,249, INT. CL. 9.

MELLO SMELLO LLC, MINNEAPOLIS, MN, DBA NOTABLES:
4,209,714, PUB. 7-3-2012. INT. CL. 30.

MELVITA, LAGORCE, FRANCE:
4,208,411, PUB. 7-3-2012. INT. CL. 3.

MEMONEYS, LLC, SARASOTA, FL:
4,210,903, INT. CL. 36.

MEMORIAL HERMANN HOSPITAL SYSTEM, HOUSTON, TX:
4,209,349, PUB. 7-3-2012. INT. CL. 44.

MEN'S JOURNAL LLC, NEW YORK, NY:
2,600,881. REN. 8-14-12. INT. CL. 42.

MENHART, ERIC, WASHINGTON, DC:
4,209,937, PUB. 7-3-2012. INT. CL. 45.

MERACORD LLC, TACOMA, WA:
4,211,396, INT. CL. 36.
4,211,397, INT. CL. 36.

MERCADO CALOCA DIEGO GEOVANNI, GUADALAJARA, MEXICO:
4,208,473, PUB. 7-3-2012. INT. CL. 9.

MERCHSOURCE, LLC, FOOTHILL RANCH, CA:
4,210,073, PUB. 7-3-2012. INT. CL. 28.

MERCK KGAA, D-64293 DARMSTADT, FED REP GERMANY:
2,612,842. REN. 8-15-12. INT. CL. 11.
3,044,258, CANC. INT. CL. 1.

MERCK SHARP & DOHME CORP., WHITEHOUSE STATION, NJ:
4,210,351, INT. CL. 5.
4,210,352, INT. CL. 5.
4,210,353, INT. CL. 5.

MEREDITH CORPORATION, DES MOINES, IA:
3,037,485, CANC. INT. CL. 42.
4,210,430, INT. CL. 16.

MERIDIAN RACK & PINION, SAN DIEGO, CA, DBA TURBOCHARGERPROS.COM:
4,209,157, PUB. 7-3-2012. INT. CL. 35.

MERIDIAN RACK & PINION, SAN DIEGO, CA, DBA DISCOUNTACPARTS.COM:
4,209,158, PUB. 7-3-2012. INT. CL. 35.

MERIT MEDICAL SYSTEMS, INC., SOUTH JORDAN, UT:
4,211,633, INT. CL. 10.

MERRICK PET CARE, INC., AMARILLO, TX:
4,210,022, PUB. 7-3-2012. INT. CL. 31.

MERRITT PROPERTIES, LLC, BALTIMORE, MD:
4,210,695, INT. CL. 37.
4,210,697, INT. CL. 37.

MERRY THE CRANBERRY, L.L.C., PHOENIX, AZ:
2,722,344. REN. 8-10-12. INT. CL. 28.

MERX GLOBAL LLC, BELMONT, CA:
4,209,194, PUB. 7-3-2012. INT. CL. 9.
4,209,195, PUB. 7-3-2012. INT. CL. 9.

- MESSE DUESSELDORF GMBH, DUESSELDORF, FED REP GERMANY, MESSE DUESSELDORF GMBH, DUESSELDORF, FED REP GERMANY:
2,645,974. REN. 8-10-12. INT. CL. 35.
- MESSMATZ LLC, HIGHLANDS RANCH, CO, DBA MESSMATZ:
4,211,326. INT. CL. 27.
- MET-RX SUBSTRATE TECHNOLOGY, INC., RONKONKOMA, NY:
2,949,157. CANC. INT. CL. 5.
- METALLURGIQUE DU TEMPLE "METALTEMPLE", 73140 SAINT-MICHEL-DE-MAURIENNE, FRANCE:
2,526,376. CANC. MULTIPLE CLASS, INT. CLS. 1, 4, 6, 7 AND 8.
- METROBILITY OPTICAL SYSTEMS, INC., MANSFIELD, MA, METROBILITY OPTICAL SYSTEMS, INC., MANSFIELD, MA:
2,640,047. REN. 8-12-12. INT. CL. 9.
- METROPDS WIRELESS, INC., RICHARDSON, TX:
4,211,803. INT. CL. 38.
- METROPOLITAN AIR TECHNOLOGY LLC, CHICAGO, IL:
4,209,685. PUB. 7-3-2012. INT. CL. 11.
4,209,732. PUB. 7-3-2012. INT. CL. 11.
- METROPOLITAN LIFE INSURANCE COMPANY, NEW YORK, NY:
4,210,687. MULTIPLE CLASS, INT. CLS. 36 AND 41.
- METRYX LLC, PROVIDENCE, RI:
4,211,618. INT. CL. 9.
- MEX LATIN IMPORTS, LTD., AUSTIN, TX:
2,601,858. REN. 8-10-12. INT. CL. 33.
- MEXCOR, INC., HOUSTON, TX:
4,210,065. PUB. 7-3-2012. INT. CL. 33.
- MEYER, ANGELA L., CHINCOTEAGUE, VA, DBA COAST TEE'S:
4,209,378. PUB. 7-3-2012. INT. CL. 25.
- MG ICON LLC, NEW YORK, NY:
4,210,476. INT. CL. 3.
- MG TAYLOR CORPORATION, LOUISVILLE, KY:
4,208,515. PUB. 7-3-2012. INT. CL. 35.
- MGA ENTERTAINMENT, INC., VAN NUYS, CA:
4,210,115. PUB. 7-3-2012. INT. CL. 9.
4,210,116. PUB. 7-3-2012. INT. CL. 9.
- MGC CONSULTING LLC, WESTPORT, CT:
4,208,671. PUB. 7-3-2012. INT. CL. 19.
- MHO AG, CH-6055 ALPNACH-DORF, SWITZERLAND:
4,208,325. PUB. 7-3-2012. INT. CL. 14.
- MIAMI HEAT LIMITED PARTNERSHIP, THE, MIAMI, FL:
2,606,920. REN. 8-16-12. INT. CL. 35.
- MIAMI MARLINS, L.P., MIAMI, FL:
4,210,359. INT. CL. 28.
- MIAMI TRIBE OF OKLAHOMA BUSINESS DEVELOPMENT AUTHORITY, A TRIBAL ENTERPRISE OF THE MIAMI TRIBE OF OKLAHOMA, MIAMI, OK:
4,211,384. INT. CL. 9.
4,211,614. INT. CL. 9.
- MIAMI-DADE COUNTY, FLORIDA, MIAMI, FL, DBA PORT OF MIAMI:
4,208,779. PUB. 7-3-2012. MULTIPLE CLASS, INT. CLS. 35 AND 39.
- MICHAEL A. CERNIGLIA, SLIDELL, LA:
4,208,144. PUB. 7-3-2012. INT. CL. 25.
- MICHAEL ADAMS, QUAKERTOWN, PA:
4,210,919. MULTIPLE CLASS, INT. CLS. 21 AND 30.
- MICHAEL FOODS OF DELAWARE, INC., MINNETONKA, MN:
4,210,144. PUB. 7-3-2012. INT. CL. 29.
- MICHAEL HILL FRANCHISE PTY LIMITED, QUEENSLAND 4172, AUSTRALIA:
4,208,939. PUB. 7-3-2012. MULTIPLE CLASS, INT. CLS. 14 AND 35.
- MICHAEL NASH CUSTOM KITCHENS, INC., FAIRFAX, VA:
4,209,511. PUB. 7-3-2012. MULTIPLE CLASS, INT. CLS. 37 AND 42.
- MICHAEL ROLAND, LENNON, MI:
4,209,565. PUB. 7-3-2012. INT. CL. 41.
- MICHAEL ROTHBARD, CARPINTERIA, CA:
4,209,290. PUB. 7-3-2012. INT. CL. 20.
4,209,817. PUB. 7-3-2012. INT. CL. 20.
- MICHAEL SENA ENTERPRISES INC., DYER, IN:
4,211,041. INT. CL. 41.
- MICHAEL STARR, CANYON COUNTRY, CA:
4,211,543. INT. CL. 33.
- MICHAELS STORES PROCUREMENT COMPANY, INC., GRAND PRAIRIE, TX:
2,527,196. CANC. INT. CL. 35.
- MICHAELS STORES PROCUREMENT COMPANY, INC., IRVING, TX:
4,210,275. MULTIPLE CLASS, INT. CLS. 16 AND 26.
- MICHEL LAROCHE & JORGE CODERCH S.A., TALCA, CHILE:
3,038,298. CANC. INT. CL. 33.
- MICHEL MERCIER LIMITED, ISRAEL:
4,208,387. PUB. 7-3-2012. INT. CL. 21.
- MICHEL SABOURIN PORTRAIT DESIGN, INC., JUPITER, FL:
2,654,596. REN. 8-15-12. INT. CL. 41.
- MICHEL'S CORNER, LLC, DURANGO, CO:
4,209,522. PUB. 7-3-2012. INT. CL. 43.
- MICHIGAN EDUCATIONAL TRANSPORTATION SERVICES, INC., PORTLAND, MI, DBA METS:
4,208,190. PUB. 1-19-2010. INT. CL. 35.
- MICRO POWDERS, INC., TARRYTOWN, NY:
4,209,568. PUB. 7-3-2012. INT. CL. 4.
- MICROSOFT CORPORATION, REDMOND, WA:
1,741,086. REN. 8-15-12. INT. CL. 9.
2,526,981. CANC. INT. CL. 38.
2,528,008. CANC. INT. CL. 9.
2,625,742. REN. 8-10-12. INT. CL. 36.
2,646,384. REN. 8-10-12. INT. CL. 36.
2,663,880. REN. 8-10-12. INT. CL. 9.
- MICRUS ENDOVASCULAR LLC, SAN JOSE, CA:
2,527,722. CANC. INT. CL. 10.
- MIDDLE EAST INVESTMENT INITIATIVE (MEII), WASHINGTON, DC:
4,208,698. PUB. 7-3-2012. INT. CL. 35.
- MIDDLESEX SAVINGS BANK, NATICK, MA:
4,208,525. PUB. 7-3-2012. INT. CL. 36.
- MIDLAND PRODUCTS LLC, TINLEY PARK, IL:
4,209,601. PUB. 7-3-2012. INT. CL. 3.
- MIDPOINT INTERNATIONAL INC., AURORA, CANADA:
4,208,520. PUB. 7-3-2012. MULTIPLE CLASS, INT. CLS. 6 AND 20.
- MIDTRONICS, INC., WILLOWBROOK, IL:
2,680,372. REN. 8-14-12. INT. CL. 9.
- MIDWAY ARMS, INC., COLUMBIA, MO:
4,210,397. INT. CL. 13.
- MIDWEST TILE SUPPLY CO., LINCOLN, NE:
4,208,215. PUB. 7-3-2012. INT. CL. 35.
4,208,216. PUB. 7-3-2012. INT. CL. 35.
- MIDWEST TOMATO, INC., NEW YORK, NY:
4,208,539. PUB. 7-3-2012. INT. CL. 43.
- MIDWESTONE FINANCIAL GROUP, INC., OSKALOOSA, IA:
2,962,113. CANC. INT. CL. 36.
- MIGGINS, LAWRENCE E., HOUSTON, TX:
2,528,284. CANC. INT. CL. 28.
- MIGHTYKARMA, LLC, DENVER, CO:
4,210,618. MULTIPLE CLASS, INT. CLS. 25 AND 41.
4,210,619. MULTIPLE CLASS, INT. CLS. 25 AND 41.
4,210,620. MULTIPLE CLASS, INT. CLS. 25 AND 41.
4,210,621. MULTIPLE CLASS, INT. CLS. 25 AND 41.
4,210,622. MULTIPLE CLASS, INT. CLS. 25 AND 41.
4,210,623. MULTIPLE CLASS, INT. CLS. 25 AND 41.
- MILESTONE AV TECHNOLOGIES LLC, SAVAGE, MN:
4,211,065. INT. CL. 9.
- MILLENNIUM ENTERPRISES LIMITED, HONG KONG, CHINA, MILLENNIUM ENTERPRISES LIMITED, HONG KONG, CHINA:
2,605,433. REN. 8-13-12. INT. CL. 7.
- MILLER INTERNATIONAL, INC., DENVER, CO:
4,210,061. PUB. 7-3-2012. INT. CL. 25.
4,211,517. INT. CL. 25.

MILLER, PHILLIP, BROOKLYN, NY:
4,210,265, INT. CL. 25.

MILLER, TRUDY WEAVER, SHEFFIELD, MA:
4,210,730, MULTIPLE CLASS, INT. CLS. 41 AND 42.

MILLERCOORS LLC, CHICAGO, IL:
1,720,575, REN. 8-11-12, INT. CL. 32.
2,691,185, REN. 8-15-12, INT. CL. 32.
2,691,186, REN. 8-15-12, INT. CL. 32.

MILLHOUSE, BRYAN K., TUCSON, AZ:
2,526,764, CANC. INT. CL. 38.

MILLICOM INTERNATIONAL CELLULAR S.A., LU-3372
LEUDELANGE, LUXEMBOURG:
4,211,146, MULTIPLE CLASS, INT. CLS. 16 AND 36.

MILLIKEN, JAMES T., PHOENIX, AZ:
2,526,649, CANC. INT. CL. 42.

MILLIMAN, INC., OMAHA, NE:
4,208,963, PUB. 7-3-2012, INT. CL. 42.

MILWAUKEE WORLD FESTIVAL, INC., MILWAUKEE, WI:
940,211, REN. 8-15-12, U.S. CL. 107 (INT. CL. 41).

MINDBULGE LLC, CEDAR KNOLLS, NJ:
2,671,944, REN. 8-14-12, INT. CL. 35.
2,724,423, REN. 8-14-12, INT. CL. 35.

MINDEN GRILL COMPANY, INC., MINDEN, NV:
4,210,683, INT. CL. 11.

MINDSPARK INTERACTIVE NETWORK, INC., WHITE
PLAINS, NY:
3,038,306, CANC. MULTIPLE CLASS, INT. CLS. 35 AND
42.

MINE SAFETY APPLIANCES COMPANY, PITTSBURGH,
PA:
2,605,393, REN. 8-13-12, INT. CL. 9.

MINE SAFETY APPLIANCES COMPANY, CRANBERRY
TOWNSHIP, PA:
4,211,123, INT. CL. 9.

MINERAL MINE INC., FLORAL PARK, NY:
2,527,371, CANC. INT. CL. 3.

MINISTRY OF TOURISM OF THE GOVERNMENT OF THE
COMMONWEALTH OF THE BAHAMAS, NASSAU, BA-
HAMAS, DAVIS, MITCHELL P., WASHINGTON, DC, TA
BROADCAST INTERVIEW SOURCE:
1,707,144, REN. 8-11-12, INT. CL. 35.

MINN-DAK YEAST COMPANY, INC., WAHPETON, ND:
1,721,152, REN. 8-14-12, INT. CL. 30.

MINNESOTA VIKINGS FOOTBALL, LLC, EDEN PRAIRIE,
MN:
4,210,349, INT. CL. 41.

MINNESOTA WILD HOCKEY CLUB, LP, ST. PAUL, MN:
2,597,996, REN. 8-13-12, INT. CL. 16.

MINORITY CORPORATE COUNSEL ASSOCIATION, WA-
SHINGTON, DC:
2,612,400, REN. 8-11-12, INT. CL. 41.

MINISTRY OF CHALLENGE, AUSTIN, TX:
4,208,149, PUB. 7-3-2012, INT. CL. 36.

MINUS 8 INC., ST. CATHARINES, CANADA:
2,741,712, REN. 8-13-12, INT. CL. 30.

MISHA REFRIGERATION 2010 LTD., ISRAEL:
4,208,249, PUB. 7-3-2012, INT. CL. 11.

MISHKEL, GREGORY, SPRINGFIELD, IL AND KOLLURI,
RAGHU, SPRINGFIELD, IL:
4,210,848, INT. CL. 41.

MISOFT, LLC, BURR RIDGE, IL:
4,211,840, INT. CL. 9.

MISSION PHARMACAL COMPANY, SAN ANTONIO, TX:
1,784,734, REN. 8-16-12, INT. CL. 5.

MISSISSIPPI COMMUNITY COLLEGE BOARD, JACKSON,
MS:
4,208,790, PUB. 7-3-2012, INT. CL. 41.

MISTOLIN CARIBE, INC., BAYAMON, PUERTO RICO:
4,209,036, PUB. 7-3-2012, INT. CL. 3.

MITA-TEKNIK A/S, DENMARK:
4,208,250, PUB. 7-3-2012, MULTIPLE CLASS, INT. CLS. 9,
11 AND 37.
4,208,252, PUB. 7-3-2012, MULTIPLE CLASS, INT. CLS. 9,
11 AND 37.

MITCHELL K. BROWN, WINSTON-SALEM, NC:
4,208,899, PUB. 7-3-2012, INT. CL. 44.

MITCHELL, ELAINE, SAN DIEGO, CA:
4,209,358, PUB. 7-3-2012, INT. CL. 3.

MITCHELL, VANESSA, SAN DIEGO, CA:
4,208,997, PUB. 7-3-2012, INT. CL. 14.

MITEL NETWORKS CORPORATION, CHANDLER, AZ:
4,210,014, PUB. 7-3-2012, INT. CL. 38.

MITSUBISHI TANABE PHARMA CORPORATION, OSAKA,
JAPAN:
4,208,648, PUB. 7-3-2012, INT. CL. 1.

MIZUHO ORTHOPEDIC SYSTEMS INC., SACRAMENTO,
CA:
4,211,103, INT. CL. 10.

MIZUHO ORTHOPEDIC SYSTEMS, INC, SACRAMENTO,
CA:
4,211,133, INT. CL. 10.

MIZUHO ORTHOPEDIC SYSTEMS, INC., SACRAMENTO,
CA:
4,210,833, INT. CL. 10.

MIZUNO KABUSHIKI KAISHA (MIZUNO CORPORA-
TION), OSAKA, 541-8538, JAPAN:
2,601,615, REN. 8-10-12, INT. CL. 25.
2,601,615, AM. INT. CL. 25.

MJ PARTNERS LLC, NORTH HOLLYWOOD, CA:
4,211,524, INT. CL. 28.
4,211,525, INT. CL. 28.

MK DIAMOND PRODUCTS, INC., TORRANCE, CA:
2,527,448, CANC. INT. CL. 7.

MLB ADVANCED MEDIA, L.P., NEW YORK, NY:
2,630,630, REN. 8-15-12, INT. CL. 41.

MOBHEALTH, EL MONTE, CA:
4,211,305, INT. CL. 10.

MOBILE SHELTER SYSTEMS, INC., HELOTES, TX:
4,210,691, INT. CL. 6.

MOBILE WEB UP, SAN FRANCISCO, CA:
4,209,303, PUB. 7-3-2012, MULTIPLE CLASS, INT. CLS. 35
AND 42.

MODE INFORMATION HEINZ KRAMER GMBH, OVER-
ATH, FED REP GERMANY:
2,526,893, CANC. MULTIPLE CLASS, INT. CLS. 9, 16
AND 24.

MODE INFORMATION HEINZ KRAMER GMBH, 51491
OVERATH, FED REP GERMANY:
2,526,894, CANC. MULTIPLE CLASS, INT. CLS. 9, 16
AND 24.

MODELE WEDDINGS, VENTURA, CA:
4,211,768, INT. CL. 16.

MODERN BASIC 08 AB, SE-112 23 STOCKHOLM, SWEDEN:
4,208,350, PUB. 7-3-2012, MULTIPLE CLASS, INT. CLS. 9,
18 AND 25.

MODKID LLC, BLOOMINGTON, IL:
4,209,747, PUB. 7-3-2012, MULTIPLE CLASS, INT. CLS. 16
AND 25.

MOEN INCORPORATED, NORTH OLMSTED, OH:
2,611,006, REN. 8-16-12, INT. CL. 11.

MOET HENNESSY USA, INC., NEW YORK, NY:
2,632,064, REN. 8-12-12, INT. CL. 33.

MOGAN, CHELSIE, FONTANA, CA:
4,211,493, INT. CL. 41.

MOHAWK CARPET DISTRIBUTION, INC., CHATSWORTH,
GA:
4,210,593, INT. CL. 27.

MOHAWK FINE PAPERS INC., COHOES, NY:
2,635,422, REN. 8-10-12, INT. CL. 16.

MOHLER, ERIC L., ANNAPOLIS, MD:
2,943,841, CANC. INT. CL. 44.

MOLECULAR IMPRINTS, INC., AUSTIN, TX:
4,210,332, MULTIPLE CLASS, INT. CLS. 7 AND 9.

MOLECULAR MACHINES, INC., MONTCLAIR, NJ:
2,527,992, CANC. INT. CL. 42.

MOM BRANDS COMPANY, MINNEAPOLIS, MN:
4,210,844, INT. CL. 30.

MOMMY & ME COMPANY, THE, BURBANK, CA:
3,038,132, CANC. MULTIPLE CLASS, INT. CLS. 24, 25, 27
AND 28.

MOMOKO ITO FOUNDATION, SAN FRANCISCO, CA:
4,209,247, PUB. 7-3-2012, INT. CL. 35.
4,209,248, PUB. 7-3-2012, INT. CL. 35.

MONACHUS, LLC, SAN JUAN CAPISTRANO, CA:
4,210,591, INT. CL. 35.

- MONAHAN PRODUCTS LLC, HINGHAM, MA:
4,209,160, PUB. 7-3-2012. INT. CL. 12.
- MONAVIE LLC, SOUTH JORDAN, UT:
4,211,487, INT. CL. 5.
- MONDO'S, L.C., IOWA CITY, IA:
2,527,961, CANC. INT. CL. 30.
- MONITEX INDUSTRIAL CO., LTD., NEW TAIPEI CITY,
TAIWAN:
4,211,567, INT. CL. 3.
- MONOGRAM TECHNOLOGIES, SPOL. S R.O., SLOVAKIA:
4,208,408, PUB. 7-3-2012. MULTIPLE CLASS, INT. CLS. 9,
11, 37, 41 AND 42.
- MONOSOL LLC, MERRILLVILLE, IN:
4,208,548, PUB. 7-3-2012. INT. CL. 1.
- MONROE BANK & TRUST, MONROE, MI:
2,739,136, REN. 8-11-12. INT. CL. 36.
- MONSIEUR MARIO ROSA, PARIS, FRANCE:
4,208,310, PUB. 7-3-2012. MULTIPLE CLASS, INT. CLS. 18
AND 25.
- MONSTER ENERGY COMPANY, CORONA, CA:
3,434,822, AM. INT. CL. 32.
- MONSTER WORLDWIDE, INC., NEW YORK, NY:
4,210,025, PUB. 7-3-2012. INT. CL. 42.
- MONSTER, INC., BRISBANE, CA:
2,617,707, REN. 8-14-12. INT. CL. 35.
- MONTENEGRO S.R.L., ITALY:
4,208,284, PUB. 7-3-2012. MULTIPLE CLASS, INT. CLS. 5
AND 32.
- MONTEPERTUSO, INC., BOCA RATON, FL:
4,208,890, PUB. 7-3-2012. INT. CL. 41.
- MONTRES TUDOR SA, SWITZERLAND:
4,208,394, PUB. 7-3-2012. INT. CL. 14.
- MOODY GARDENS, INC., GALVESTON, TX:
4,208,636, PUB. 7-3-2012. MULTIPLE CLASS, INT. CLS.
39, 41 AND 43.
- MOORE, GRANT M., BUFORD, GA:
4,209,707, PUB. 7-3-2012. INT. CL. 37.
- MOORE, TIMOTHY MICHAEL, GRAND PRAIRIE, TX:
4,210,880, INT. CL. 36.
- MOOS, JONATHAN, PLEASANTON, CA:
4,211,250, INT. CL. 25.
- MORGAN CRUCIBLE COMPANY PLC, THE, WINDSOR,
BERKSHIRE, ENGLAND, WESTERN GOLD AND PLATI-
NUM COMPANY, BELMONT, CA:
938,483, REN. 8-11-12. U.S. CL. 14 (INT. CL. 6).
- MORITA BIOTECH CORP., TAICHUNG CITY, TAIWAN:
4,208,898, PUB. 7-3-2012. INT. CL. 3.
- MORRIS, MELVYN G., LAKE WORTH, FL:
4,209,012, PUB. 7-3-2012. U.S. CL. 200.
- MORRIS, STEVLAND, LOS ANGELES, CA, AKA STEVIE
WONDER:
2,600,739, REN. 8-13-12. INT. CL. 41.
- MORRISON, ELEANOR GRACE, MARIETTA, GA:
4,209,870, PUB. 7-3-2012. INT. CL. 41.
- MOSTAFA RIFAI, EL PASO, TX:
4,208,194, PUB. 7-3-2012. INT. CL. 43.
- MOTOROLA TRADEMARK HOLDINGS, LLC, LIBERTY-
VILLE, IL:
1,694,335, REN. 8-10-12. INT. CL. 16.
- MOULENE, KATE, LOS ANGELES, CA:
4,210,793, INT. CL. 41.
- MOUNTAIN GREENERY, L.L.C., OKLAHOMA CITY, OK:
2,730,477, REN. 8-15-12. INT. CL. 36.
- MOUNTAIN LAUREL SPIRITS, LLC, NEW HOPE, PA:
4,211,046, INT. CL. 33.
- MOUNTAIN PLEASURE HORSE ASSOCIATION, INC.,
WELLINGTON, KY:
2,601,215, REN. 8-13-12. U.S. CL. A.
2,604,956, REN. 8-13-12. INT. CL. 42.
2,625,098, REN. 8-13-12. INT. CL. 42.
- MPW, INC., AUGUSTA, MO:
2,603,745, REN. 8-15-12. INT. CL. 35.
- MR DEREK MCMINN, UNITED KINGDOM:
4,208,305, PUB. 7-3-2012. MULTIPLE CLASS, INT. CLS.
25, 41, 43 AND 44.
- MR. SANDLESS FRANCHISE, LLC, ASTON, PA:
4,208,157, PUB. 7-3-2012. INT. CL. 37.
- MRLC TRADING LLC, LEXINGTON, KY, DBA GROOVY-
CHEEKS:
4,208,916, PUB. 7-3-2012. INT. CL. 5.
- MS SHIFT, INC., NEW YORK, NY:
4,208,992, PUB. 7-3-2012. INT. CL. 9.
- MS STRUCTURED ASSET CORP., NEW YORK, NY:
2,527,539, CANC. INT. CL. 36.
- MSA CONSULTING CORPORATION, SUFFERN, NY:
4,210,342, INT. CL. 3.
- MU SIGMA NU, INC., ATLANTA, GA:
4,208,915, PUB. 7-3-2012. INT. CL. 25.
- MUD STOPPER, BURLINGTON, NJ:
4,209,587, PUB. 7-3-2012. INT. CL. 19.
- MUELLER SPORTS MEDICINE, INC., PRAIRIE DU SAC,
WI:
2,527,561, CANC. INT. CL. 5.
- MUERTO SPIRITS, INC., GOLD RIVER, CA:
4,211,072, INT. CL. 33.
- MUGLER MANFRED THIERRY C/O AKLEA SOCIÉTÉ
D'AVOCATS, FRANCE:
4,208,246, PUB. 7-3-2012. MULTIPLE CLASS, INT. CLS. 9
AND 41.
- MUHAMMAD, FAREED, NEWARK, NJ:
4,208,771, PUB. 7-3-2012. INT. CL. 25.
- MULTICHARTS, LLC, WESTERVILLE, OH:
4,209,159, PUB. 7-3-2012. INT. CL. 42.
- MULTIDECK CORPORATION, MINDEN, NV:
2,601,457, REN. 8-12-12. MULTIPLE CLASS, INT. CLS. 9
AND 42.
- MULTIMEDIA GAMES, INC., AUSTIN, TX:
4,209,610, PUB. 7-3-2012. INT. CL. 9.
- MULTIPLE SCLEROSIS FOUNDATION, FORT LAUDER-
DALE, FL:
4,208,662, PUB. 7-3-2012. INT. CL. 36.
- MULTISPORTS.COM, LLC, ENCINITAS, CA:
4,211,456, INT. CL. 41.
- MULTITEST ELEKTRONISCHE SYSTEME GMBH, ROSEN-
HEIM, 83026, FED REP GERMANY:
3,133,337.
- MUNCE, DON M., LEE'S SUMMIT, MO:
2,615,233, REN. 8-14-12. INT. CL. 16.
- MURAD, INC., EL SEGUNDO, CA:
4,210,454, INT. CL. 3.
- MURATA KIKAI KABUSHIKI KAISHA, KYOTO, JAPAN,
TA MURATA MACHINERY, LTD.:
4,208,270, PUB. 7-3-2012. MULTIPLE CLASS, INT. CLS. 7
AND 9.
- MURPHY, ANNE NILAND, PLANTSVILLE, CT:
4,210,244, INT. CL. 41.
- MURRAY, CLAIRE, OSTERVILLE, MA:
2,528,300, CANC. INT. CL. 24.
- MUS, INC., LAS VEGAS, NV, DBA THE GREEN DOOR:
4,208,195, PUB. 7-3-2012. INT. CL. 41.
- MUSCLEPHARM CORPORATION, DENVER, CO:
4,211,003, INT. CL. 5.
- MUSEUM OF THE AMERICAN COCKTAIL, INC., WA-
SHINGTON, DC:
4,209,750, PUB. 7-3-2012. INT. CL. 41.
- MUSICK, WILLIAM C., HONOLULU, HI, DBA TOWER
HILL RESOURCES:
2,715,680, REN. 8-14-12. INT. CL. 35.
- MUST WIN, INC., LOS ANGELES, CA:
4,211,669, MULTIPLE CLASS, INT. CLS. 9 AND 18.
- MUTIARA FOOD & DRINKS (M) SDN. BHD., JOHOR,
MALAYSIA:
4,211,325, INT. CL. 32.
- MYCOSKIE, LLC, SANTA MONICA, CA:
4,208,986, PUB. 3-27-2012. INT. CL. 35.
- MYDAILYTUTOR INCORPORATED, STOCKTON, CA, DBA
MYDAILYTUTOR.COM:
4,209,936, PUB. 7-3-2012. INT. CL. 41.
- MYHOMEEQ, LLC, CHICAGO, IL:
4,210,825, MULTIPLE CLASS, INT. CLS. 35, 36, 37 AND
42.
- MYLANGUAGE, SAN JOSE, CA:
4,211,050, INT. CL. 9.

- MYRIAD GENETICS, INC., SALT LAKE CITY, UT:
2,667,149. REN. 8-14-12. INT. CL. 42.
- MZ HOLDING AG, SWITZERLAND:
4,208,321. PUB. 7-3-2012. MULTIPLE CLASS, INT. CLS.
16, 35 AND 41.
- M2 COMMUNICATIONS INC., JERSEY CITY, NJ:
2,527,084. CANC. INT. CL. 9.
- N.E.T. ENTERTAINMENT TECHNOLOGY LLC, HINCKLEY, OH:
4,211,341. INT. CL. 9.
- NALS, INC., TULSA, OK:
736,568. REN. 8-10-12. U.S. CL. 200.
- NAME RITE, L.L.C., TEMECULA, CA:
3,032,060. CANC. MULTIPLE CLASS, INT. CLS. 9, 11
AND 14.
- NANCI MASSO, DALLAS, TX:
4,209,272. PUB. 7-3-2012. INT. CL. 5.
- NANOFORGE CORP., CARY, NC:
4,210,600. MULTIPLE CLASS, INT. CLS. 1 AND 2.
- NANOVAPOR FUELS GROUP, INC., CYPRESS, TX:
4,210,448. INT. CL. 1.
- NANTUCKET WHALER, LLC, NEW YORK, NY:
2,528,154. CANC. MULTIPLE CLASS, INT. CLS. 16, 18, 21,
24, 25, 30, 35 AND 42.
- NAPA VALLEY CONFERENCE & VISITORS BUREAU,
NAPA, CA:
4,211,205. INT. CL. 35.
- NAPA VALLEY VINTNERS ASSOCIATION, ST. HELENA,
CA:
2,528,647. CANC. INT. CL. 42.
- NAPOLEON, ANDRA, LANOKA HARBOR, NJ:
4,210,486. INT. CL. 35.
- NASATKA BARRIER, INC., CLINTON, MD:
4,210,879. INT. CL. 6.
- NATHAN GILBERT, CHICAGO, IL:
4,211,114. INT. CL. 41.
- NATIONAL ACADEMY OF RECORDING ARTS &
SCIENCES, INC., SANTA MONICA, CA. NATIONAL
ACADEMY OF RECORDING ARTS AND SCIENCES,
THE, BURBANK, CA:
1,239,821. REN. 8-14-12. INT. CL. 35.
- NATIONAL ACADEMY OF RECORDING ARTS &
SCIENCES, INC., SANTA MONICA, CA:
2,723,879. REN. 8-14-12. MULTIPLE CLASS, INT. CLS. 9
AND 41.
- NATIONAL APPLIED CONSTRUCTION PRODUCTS INC.,
AKRON, OH:
4,208,784. PUB. 7-3-2012. MULTIPLE CLASS, INT. CLS. 9
AND 19.
- NATIONAL ASSOCIATION OF CONVENIENCE STORES,
ALEXANDRIA, VA:
1,708,776. REN. 8-10-12. MULTIPLE CLASS, INT. CLS. 41
AND 42.
- 1,710,488. REN. 8-10-12. MULTIPLE CLASS, INT. CLS. 41
AND 42.
- NATIONAL ASSOCIATION OF REAL ESTATE INVEST-
MENT TRUSTS, INC., WASHINGTON, DC:
4,208,196. PUB. 7-3-2012. MULTIPLE CLASS, INT. CLS.
18, 21 AND 41.
- NATIONAL AUTOMATED CLEARING HOUSE ASSOCIA-
TION, HERNDON, VA:
4,210,282. INT. CL. 9.
- 4,210,283. INT. CL. 9.
- NATIONAL BILLING ASSOCIATES, INC., BIRMINGHAM,
AL:
4,211,822. INT. CL. 35.
- NATIONAL BOARD FOR CERTIFIED COUNSELORS, INC.
(NBCC), GREENSBORO, NC:
4,211,587. U.S. CL. B.
- NATIONAL CABLE SATELLITE CORPORATION, WA-
SHINGTON, DC:
2,527,286. CANC. INT. CL. 41.
- 2,527,287. CANC. INT. CL. 41.
- NATIONAL COLLEGIATE ATHLETIC ASSOCIATION, THE,
INDIANAPOLIS, IN:
2,600,599. REN. 8-13-12. INT. CL. 25.
- NATIONAL COMPUTER CORPORATION, INC., GREEN-
VILLE, SC:
4,208,841. PUB. 1-31-2012. INT. CL. 9.
- NATIONAL CONGRESS OF PARENTS AND TEACHERS,
ALEXANDRIA, VA:
2,648,370. REN. 8-15-12. INT. CL. 41.
- NATIONAL ELECTRIC COIL, INC., COLUMBUS, OH:
2,620,648. REN. 8-16-12. INT. CL. 37.
- NATIONAL ELECTRONIC ALLOYS, INC., OAKLAND, NJ:
2,744,195. REN. 8-15-12. INT. CL. 6.
- NATIONAL EXPRESS, INC., NORWALK, CT:
4,209,515. PUB. 7-3-2012. INT. CL. 8.
- NATIONAL FISHERIES INSTITUTE, MCLEAN, VA:
4,210,769. INT. CL. 25.
- NATIONAL FOOTBALL LEAGUE PLAYERS INCORPO-
RATED, WASHINGTON, DC:
2,527,061. CANC. INT. CL. 42.
- NATIONAL FOUNDATION TO PROTECT AMERICA'S
EAGLES, PIGEON FORGE, TN:
3,036,992. CANC. INT. CL. 9.
- NATIONAL INDEPENDENT AUTOMOBILE DEALERS AS-
SOCIATION, ARLINGTON, TX:
2,730,628. REN. 8-10-12. INT. CL. 41.
- NATIONAL INSTITUTE FOR TRIAL ADVOCACY,
BOULDER, CO:
1,209,100. REN. 8-15-12. INT. CL. 41.
- NATIONAL MARROW DONOR PROGRAM, MINNEAPO-
LIS, MN:
4,210,068. PUB. 7-3-2012. INT. CL. 44.
- NATIONAL OILWELL VARCO NORWAY AS, STAVAN-
GER, NORWAY:
2,571,765. REN. 8-10-12. INT. CL. 9.
- 2,571,765. CANC. INT. CL. 16.
- NATIONAL PAWNBROKERS ASSOCIATION, INC., KEL-
LER, TX:
4,208,781. PUB. 7-3-2012. INT. CL. 35.
- NATIONAL QUALITY FORUM, WASHINGTON, DC:
4,209,661. PUB. 7-3-2012. MULTIPLE CLASS, INT. CLS. 9,
16, 41 AND 42.
- NATIONAL RURAL ELECTRIC COOPERATIVE ASSOCIA-
TION, THE, ARLINGTON, VA:
1,766,329. REN. 8-10-12. INT. CL. 42.
- NATIONAL SKEET SHOOTING ASSOCIATION, SAN AN-
TONIO, TX:
1,751,683. REN. 8-10-12. INT. CL. 42.
- 1,760,442. REN. 8-10-12. INT. CL. 42.
- 1,772,027. REN. 8-10-12. INT. CL. 42.
- NATIONAL SOLAR POWER PARTNERS, MELBOURNE,
FL:
4,210,788. INT. CL. 36.
- NATIONAL STUDENT CLEARINGHOUSE, HERNDON, VA:
2,740,203. REN. 8-11-12. INT. CL. 9.
- NATIONAL TECHNICAL SYSTEMS, INC., CALABASAS,
CA:
4,210,222. PUB. 7-3-2012. INT. CL. 35.
- NATIONAL VAN LINES, INC., BROADVIEW, IL:
1,718,818. REN. 8-15-12. INT. CL. 39.
- NATIONWIDE FLOORCOVERING, INC., MILWAUKEE,
WI:
2,527,361. CANC. INT. CL. 35.
- NATIONWIDE WAREHOUSE & STORAGE, LLC, NOR-
CROSS, GA:
2,527,168. CANC. INT. CL. 35.
- NATIVE NEW YORKER OF AMERICA, INC., GILBERT, AZ:
2,615,018. REN. 8-15-12. INT. CL. 43.
- NATIXIS, F-75013 PARIS, FRANCE:
4,208,297. PUB. 7-3-2012. INT. CL. 36.
- NATROL, INC., CHATSWORTH, CA:
1,719,803. REN. 8-16-12. INT. CL. 5.
- NATUR UND TIER - VERLAG GMBH, MUNSTER, FED
REP GERMANY:
4,211,585. INT. CL. 16.
- NATURAL FACTORS NUTRITIONAL PRODUCTS LTD.,
COQUITLAM BC, CANADA:
2,611,017. REN. 8-15-12. INT. CL. 5.
- NATURAL ORGANICS, INC., MELVILLE, NY:
4,210,467. INT. CL. 5.

- NATURAL SELECTION FOODS, LLC, SAN JUAN BAUTISTA, CA:
4,211,469, INT. CL. 29.
- NATURAL SUPPLEMENT ASSOCIATION, INCORPORATED, ABBOTT PARK, IL, DBA EXPERIMENTAL AND APPLIED SCIENCES, INC.:
4,211,190, INT. CL. 5.
4,211,411, MULTIPLE CLASS, INT. CLS. 5 AND 29.
- NATURE'S SHIELD, INC., PALM, PA:
4,210,396, INT. CL. 5.
- NATURE'S SUNSHINE PRODUCTS, INC., PROVO, UT, AMTEC INDUSTRIES INCORPORATED, SPANISH FORK, UT:
1,212,076, REN. 8-14-12, INT. CL. 3.
- NATUREX, INC., SOUTH HACKENSACK, NJ:
4,210,684, INT. CL. 5.
- NAUTIC GLOBAL GROUP, INC., ELKHART, IN:
4,210,201, PUB. 7-3-2012, INT. CL. 12.
- NAVAJO SHIPPERS, INC., DENVER, CO:
2,607,358, REN. 8-16-12, INT. CL. 39.
- NAY ET AL, INC., LOS ANGELES, CA:
4,209,926, PUB. 7-3-2012, MULTIPLE CLASS, INT. CLS. 24 AND 25.
- NAYLOR, HEATHER, LOS ANGELES, CA:
4,060,367, CANC. INT. CL. 41.
- NBTV MEDIA, TROY, MI:
4,211,601, INT. CL. 16.
- NE FOODS INC., NORTH EAST, PA:
2,608,068, REN. 8-15-12, INT. CL. 30.
- NEBRASKA MUNICIPAL POWER POOL, LINCOLN, NE:
1,704,646, REN. 8-14-12, INT. CL. 9.
- NEC BIGLOBE, LTD., TOKYO, JAPAN:
4,210,908, INT. CL. 9.
- NEILL TECHNOLOGIES, HAMMOND, LA:
4,208,133, PUB. 7-3-2012, INT. CL. 41.
- NEKOOSA COATED PRODUCTS, LLC, NEKOOSA, WI:
4,208,587, PUB. 7-3-2012, INT. CL. 16.
- NEOS SURGERY, S.L., CERDANYOLA DEL VALLÉS, SPAIN:
4,211,699, INT. CL. 10.
- NEOTECH PRODUCTS, INC., VALENCIA, CA:
4,210,323, INT. CL. 10.
- NEPSIS CAPITAL MANAGEMENT, INC., SAVAGE, MN:
4,210,991, INT. CL. 36.
4,211,438, INT. CL. 36.
- NETIZEN SOLUTIONS, LLC, BREINIGSVILLE, PA:
4,209,464, PUB. 7-3-2012, INT. CL. 42.
- NETOP BUSINESS SOLUTIONS A/S, DENMARK:
4,208,233, PUB. 7-3-2012, MULTIPLE CLASS, INT. CLS. 9, 16, 38 AND 42.
4,208,234, PUB. 7-3-2012, MULTIPLE CLASS, INT. CLS. 9, 16, 38 AND 42.
- NETWORK FOR GOOD, INC., BETHESDA, MD:
4,208,863, PUB. 7-3-2012, MULTIPLE CLASS, INT. CLS. 35, 36 AND 45.
- NEUBRAF TEXTILES LIMITED, WANCHAI, HONG KONG:
4,210,533, INT. CL. 18.
- NEURAL ROBOTICS, INC., HUNTSVILLE, AL:
3,038,320, CANC. INT. CL. 12.
- NEVADA RESTAURANT SERVICES, INC., LAS VEGAS, NV:
4,210,883, INT. CL. 9.
- NEVILLE, FRANK W, NEW BRAUNFELS, TX:
4,208,468, PUB. 3-27-2012, INT. CL. 25.
- NEW AGE INVESTMENT, S.L., MADRID, SPAIN, MONERIS PLANELLES, S.A., JIJONA (ALICANTE), SPAIN:
1,202,216, REN. 8-14-12, INT. CL. 30.
- NEW ARTISAN SPIRITS, INC., HOUSTON, TX:
4,210,712, INT. CL. 33.
- NEW BIRTH COMPANY, L3C, OVERLAND PARK, KS:
4,211,672, MULTIPLE CLASS, INT. CLS. 3, 41 AND 44.
- NEW ENGLAND PATRIOTS LLC, FOXBOROUGH, MA:
4,209,517, PUB. 7-3-2012, INT. CL. 41.
- NEW ENGLAND SPORTS ENTERPRISES, LLC, BOSTON, MA:
4,210,902, INT. CL. 35.
- NEW HAIR SYSTEM, INC., LOS ANGELES, CA:
4,209,110, PUB. 7-3-2012, INT. CL. 44.
- NEW JERSEY HEALTH FOUNDATION, INC., NEW BRUNSWICK, NJ:
4,209,834, PUB. 7-3-2012, INT. CL. 36.
- NEW LIFECHART, LLC, CARLSBAD, CA:
2,526,903, CANC. INT. CL. 16.
- NEW MEXICO ORTHOPAEDIC ASSOCIATES, P.C., ALBUQUERQUE, NM:
2,528,750, CANC. INT. CL. 42.
- NEW ORLEANS CIGAR COMPANY, NEW ORLEANS, LA:
4,208,913, PUB. 2-21-2012, INT. CL. 35.
- NEW PECO, INC., ARDEN, NC:
2,621,575, REN. 8-10-12, INT. CL. 7.
- NEW PENDULUM CORP., WILMINGTON, DE:
1,728,760, REN. 8-16-12, INT. CL. 1.
4,210,834, MULTIPLE CLASS, INT. CLS. 16, 17, 22 AND 27.
4,211,495, INT. CL. 17.
- NEW TROPICANA HOLDINGS, INC., LAS VEGAS, NV:
4,209,541, PUB. 7-3-2012, MULTIPLE CLASS, INT. CLS. 35 AND 41.
- NEW VIEW GIFTS & ACCESSORIES, LTD., MEDIA, PA:
4,210,451, MULTIPLE CLASS, INT. CLS. 4, 16, 19 AND 20.
- NEW VITALITY SBP HOLDINGS, INC., CHICAGO, IL:
4,209,153, PUB. 7-3-2012, INT. CL. 5.
- NEW WORLD IMPORTS, NASHVILLE, TN:
4,210,949, INT. CL. 5.
- NEW YORK LIFE INSURANCE COMPANY, NEW YORK, NY:
4,210,760, INT. CL. 36.
- NEW YORK MINT, LLC, EDINA, MN:
4,209,453, PUB. 7-3-2012, INT. CL. 35.
- NEW YORK YANKEES PARTNERSHIP, BRONX, NY:
4,210,824, INT. CL. 14.
- NEWAYS, INC., SPRINGVILLE, UT:
3,038,207, CANC. INT. CL. 3.
- NEWDEAL, 69006 LYON, FRANCE:
2,528,594, CANC. INT. CL. 10.
- NEWELL OPERATING COMPANY, FREEPORT, IL:
3,038,335, CANC. INT. CL. 16.
3,038,336, CANC. INT. CL. 16.
- NEWELL WINDOW FURNISHINGS, INC., FREEPORT, IL, KIRSCH COMPANY, STURGIS, MI:
939,456, REN. 8-14-12, U.S. CL. 13 (INT. CL. 6).
- NEWHOUSE, KANSAS CITY, MO:
2,992,137, CANC. INT. CL. 36.
- NEWMAN, ROBERT D., SR., GREENWOOD, MO AND NEWMAN, ROBERT D., JR., GREENWOOD, MO:
2,527,689, CANC. INT. CL. 16.
- NEWTON CONSULTING, LLC, CLAYSVILLE, PA:
4,209,437, PUB. 7-3-2012, MULTIPLE CLASS, INT. CLS. 35, 36 AND 42.
- NEXT FUTURE LLC, DUBLIN, OH:
4,211,708, INT. CL. 21.
- NEXT PRODUCTS (USA) LLC, NEW YORK, NY:
4,211,204, MULTIPLE CLASS, INT. CLS. 8, 9 AND 21.
- NEXT STEP CAPITAL PARTNERS LLC, AUSTIN, TX:
4,210,773, INT. CL. 36.
- NEXTGEN COLLECTIONS, LLC, SAN ANSELMO, CA:
4,209,582, PUB. 7-3-2012, INT. CL. 37.
- NEYERS VINEYARDS, LLC, ST. HELENA, CA:
2,742,079, REN. 8-15-12, INT. CL. 33.
- NGUYEN, DAVID, CORONA, CA:
4,209,331, PUB. 7-3-2012, INT. CL. 43.
- NGUYEN, THANG M, PHILADELPHIA, PA, AKA ANDY NGUYEN:
4,209,787, PUB. 7-3-2012, INT. CL. 41.
- NICO CORPORATION, INDIANAPOLIS, IN:
4,211,649, INT. CL. 10.
- NIDEC CORPORATION, MINAMI-KU, KYOTO, JAPAN, NIDEC CORPORATION, TORRINGTON, CT:
1,723,564, REN. 8-10-12, INT. CL. 11.

NIKE, INC., BEAVERTON, OR:
 3,038,342, CANC. INT. CL. 25.
 4,210,491, INT. CL. 25.
 4,210,492, INT. CL. 25.
 4,210,493, INT. CL. 25.
 4,210,494, INT. CL. 25.
 4,210,495, MULTIPLE CLASS, INT. CLS. 18 AND 25.
 4,210,496, MULTIPLE CLASS, INT. CLS. 18 AND 25.

NIKI MOON SALON, NORTH AURORA, IL:
 4,209,483, PUB. 7-3-2012. INT. CL. 44.

NIKOLAJ POSCH, AUSTRIA:
 4,208,263, PUB. 7-3-2012. MULTIPLE CLASS, INT. CLS. 3, 5, 30, 32 AND 33.

NIKON CORPORATION, TOKYO, JAPAN, NIKON INC., MELVILLE, NY:
 1,691,237, REN. 8-14-12. INT. CL. 9.

NIKON CORPORATION, TOKYO, JAPAN:
 4,210,104, PUB. 7-3-2012. INT. CL. 9.

NILFISK-ADVANCE, INC., PLYMOUTH, MN:
 2,621,359, REN. 8-10-12. INT. CL. 7.
 4,210,539, INT. CL. 7.

NINE WEST DEVELOPMENT CORPORATION, WILMINGTON, DE:
 4,210,177, PUB. 7-3-2012. INT. CL. 35.

NINER, INC., PORTLAND, CA, DBA NINER BIKES:
 3,122,908 NEW CERT. 9-18-2012. INT. CL. 12.

NINJAI GANG, LLC, KAILUA, HI:
 4,210,278, INT. CL. 25.

NINO ANTUZZI, HUNTINGTON, NY:
 4,210,720, INT. CL. 43.

NINTENDO OF AMERICA INC., REDMOND, WA:
 1,774,715, REN. 8-15-12. INT. CL. 28.
 4,004,229, COR. INT. CL. 14.
 4,161,542, COR. INT. CL. 38.
 4,172,341, COR. INT. CL. 9.
 4,172,342, COR. INT. CL. 28.

NIPRO DIAGNOSTICS, INC., FORT LAUDERDALE, FL:
 4,208,769, PUB. 7-3-2012. INT. CL. 10.

NIRVE SPORTS, LTD., HUNTINGTON BEACH, CA:
 4,211,200, INT. CL. 12.
 4,211,202, INT. CL. 12.

NISSAN JIDOSHA KABUSHIKI KAISHA, YOKOHAMA-SHI, KANAGAWA-KEN, JAPAN, TA NISSAN MOTOR CO., LTD.:
 2,527,966, CANC. INT. CL. 12.

NISSEI DENKI KABUSHIKI KAISHA, TOKYO, JAPAN, TA NISSEI ELECTRIC CO., LTD.:
 2,527,710, CANC. INT. CL. 9.

NITE IZE, INC., BOULDER, CO:
 4,209,803, PUB. 7-3-2012. INT. CL. 11.

NITRON INTERNATIONAL LLC, CARSON CITY, NV:
 4,210,074, PUB. 7-3-2012. INT. CL. 17.

NJERI DUBLIN, ST. HUBERT, QUEBEC, CANADA, DBA CLINIQUE D'ORTHOPHONIE MONTRÉRIE:
 4,208,575, PUB. 7-3-2012. INT. CL. 28.

NJUN LLC, ATLANTA, GA:
 4,210,561, INT. CL. 11.

NL&F S.A., LUXEMBOURG:
 4,208,242, PUB. 7-3-2012. MULTIPLE CLASS, INT. CLS. 16 AND 35.

NM NEVADA TRUST, LAS VEGAS, NV:
 4,209,448, PUB. 7-3-2012. INT. CL. 35.

NO DENTURES, LLC, CHICAGO, IL:
 4,211,864, INT. CL. 44.

NOBLE JESTER, INC., DALLAS, TX:
 4,211,126, INT. CL. 9.

NOKIAN TYRES PLC, FI-37101 NOKIA, FINLAND:
 4,208,288, PUB. 7-3-2012. MULTIPLE CLASS, INT. CLS. 25 AND 35.

NOLBOO CO., LTD., GYEONGGI-DO, REPUBLIC OF KOREA:
 4,208,466, PUB. 7-3-2012. INT. CL. 21.

NOMOS GLASHÜTTE/SA; ROLAND SCHWERTNER KG, GLASHÜTTE, FED REP GERMANY:
 4,208,379, PUB. 7-3-2012. INT. CL. 14.

NONATZ INC, DUBLIN, GA:
 4,209,075, PUB. 7-3-2012. INT. CL. 5.

NORANDA ALUMINUM, INC., FRANKLIN, TN:
 4,210,393, INT. CL. 1.

NORDDOCK, INC., BOWMANVILLE, ONTARIO, CANADA:
 4,209,492, PUB. 7-3-2012. INT. CL. 7.

NORDSON CORPORATION, WESTLAKE, OH:
 2,616,170, REN. 8-10-12. INT. CL. 17.

NORMA GERMANY GMBH, FED REP GERMANY:
 4,208,266, PUB. 7-3-2012. MULTIPLE CLASS, INT. CLS. 6 AND 17.

NORMAN LIBRETT, INC., NEW ROCHELLE, NY:
 1,708,372, REN. 8-15-12. INT. CL. 27.

NORMARK CORPORATION, MINNETONKA, MN:
 2,615,839, REN. 8-16-12. INT. CL. 28.

NORTH AMERICAN CRANE BUREAU GROUP, INC., ALTAMONTE SPRINGS, FL:
 2,526,541, CANC. MULTIPLE CLASS, INT. CLS. 9 AND 41.

NORTH CAROLINA FAMILY POLICY COUNCIL, RALEIGH, NC:
 4,209,099, PUB. 7-3-2012. INT. CL. 16.

NORTHLAND ALUMINUM PRODUCTS, INC., MINNEAPOLIS, MN, PLASTICS, INC., ST. PAUL, MN:
 939,320, REN. 8-16-12. U.S. CL. 2 (INT. CL. 21).

NORTHSTAR EDUCATIONAL CONSULTING GROUP, LLC, ATLANTA, GA:
 4,209,222, PUB. 7-3-2012. INT. CL. 41.

NORTHWEST ANALYTICS, INC., PORTLAND, OR:
 4,210,950, INT. CL. 9.

NORTHWEST ENERGY EFFICIENCY ALLIANCE, PORTLAND, OR:
 2,528,558, CANC. INT. CL. 35.

NORTHWEST MOTORSPORT, INC., PUYALLUP, WA:
 4,209,689, PUB. 7-3-2012. INT. CL. 35.

NORTHWEST REGISTERED AGENT, LLC, SPOKANE, WA:
 4,209,860, PUB. 7-3-2012. INT. CL. 35.

NORTHWESTERN OHIO FOAM PACKAGING, INC., WAU-SEON, OH:
 4,209,085, PUB. 7-3-2012. INT. CL. 17.

NOURICHE NUTRITION LTD, LAKE ST. LOUIS, MO:
 4,209,929, PUB. 7-3-2012. INT. CL. 5.

NOURISH BY NATURE, INC., PORT WASHINGTON, NY:
 4,210,139, PUB. 7-3-2012. INT. CL. 16.

NOVADELTA - COMÉRCIO E INDÚSTRIA DE CAFÉS, S.A., PORTUGAL:
 4,208,358, PUB. 7-3-2012. MULTIPLE CLASS, INT. CLS. 11 AND 30.

NOVESKE RIFLEWORKS LLC, GRANTS PASS, OR:
 4,209,539, PUB. 7-3-2012. INT. CL. 13.

NOVOGRATZ, ROBERT, NEW YORK, NY AND NOVOGRATZ, CORTNEY, NEW YORK, NY:
 4,209,646, PUB. 7-3-2012. MULTIPLE CLASS, INT. CLS. 2 AND 42.

NOWPAK, INC., BURLINGAME, CA:
 4,211,550, INT. CL. 20.

NOX MEDICAL EHF, ICELAND:
 4,208,282, PUB. 7-3-2012. INT. CL. 10.

NPS PHARMACEUTICALS, INC., BEDMINSTER, NJ:
 4,210,947, INT. CL. 5.

NRCOMMUNICATION CO., LTD., SEOUL, REPUBLIC OF KOREA:
 4,211,027, INT. CL. 3.

NTH DEGREE INNOVATIONS, INC., MILLTOWN, NJ:
 4,209,469, PUB. 7-3-2012. INT. CL. 39.

NTT ADVANCED TECHNOLOGY CORPORATION, SHINJUKU-KU TOKYO, JAPAN:
 2,642,552, REN. 8-16-12. INT. CL. 9.

NU-CAPES, PHILADELPHIA, PA:
 2,527,031, CANC. INT. CL. 18.

NU-WAY WEINERS, INC., MACON, GA:
 4,208,512, PUB. 7-3-2012. INT. CL. 43.
 4,208,513, PUB. 7-3-2012. INT. CL. 43.

NUNLEY, VANESSA, WHEATON, IL:
 4,210,386, INT. CL. 41.

NUORTHO SURGICAL, INC., FALL RIVER, MA:
 4,210,313, INT. CL. 10.

NURSING ORGANIZATIONS ALLIANCE, MIDDLETON, WI:
 2,915,378, CANC. INT. CL. 35.

- NUTRIENT CONTROL SYSTEMS, INC., CHAMBERSBURG, PA:
2,619,145. REN. 8-14-12. INT. CL. 11.
2,648,758. REN. 8-14-12. INT. CL. 7.
2,683,264. REN. 8-14-12. INT. CL. 11.
- NUTRITIONAL ADDITIVES, WINNEMUCCA, NV:
2,726,909. REN. 8-15-12. INT. CL. 5.
- NUVASIVE INC., SAN DIEGO, CA:
4,211,013. INT. CL. 10.
- NYLOK LLC, MACOMB, MI:
4,211,429. MULTIPLE CLASS, INT. CLS. 6 AND 40.
- NYX, LOS ANGELES INC., COMMERCE, CA:
4,209,694. PUB. 7-3-2012. INT. CL. 3.
4,209,696. PUB. 7-3-2012. INT. CL. 3.
- O.C. SEACRETS, INC., OCEAN CITY, MD:
4,210,084. PUB. 7-3-2012. MULTIPLE CLASS, INT. CLS. 21 AND 33.
- OASIS BRANDS INC., WINCHESTER, VA:
4,210,443. INT. CL. 16.
- OBSHCHESTVO S OGRANICHENNOY OTVETSTVENNOSTYU "VORONEZHSKAYA TORGOVAYA KOMPANIA", RU-397700 VORONEZHSKAYA OBL., RUSSIAN FED.:
4,208,382. PUB. 7-3-2012. MULTIPLE CLASS, INT. CLS. 9, 35, 38 AND 42.
- OBX BOATWORKS LLC, HIGH POINT, NC, DBA OBX BOATWORKS:
4,210,651. INT. CL. 12.
- OCEAN COLONY LLC, BAY HARBOR ISLANDS, FL:
4,211,221. INT. CL. 36.
- OCEAN DUKE CORPORATION, TORRANCE, CA:
2,700,489. REN. 8-16-12. INT. CL. 29.
2,721,513. REN. 8-16-12. INT. CL. 29.
4,211,828. INT. CL. 29.
- OCHC LLC, SHAKER HEIGHTS, OH:
4,210,580. MULTIPLE CLASS, INT. CLS. 3 AND 5.
- OCV INTELLECTUAL CAPITAL, LLC, TOLEDO, OH:
2,527,976. CANC. INT. CL. 21.
- OETTINGER IMEX AG, SWITZERLAND:
3,109,418.
- OFF LEASE ONLY, INC., LAKE WORTH, FL, DBA OFFLEASEONLY.COM:
4,208,508. PUB. 1-24-2012. INT. CL. 35.
- OFFICESCAPE, INC., INDIANAPOLIS, IN:
4,211,718. MULTIPLE CLASS, INT. CLS. 35, 38 AND 42.
- OFFICIAL PILLOWTEX LLC, NEW YORK, NY:
4,211,122. INT. CL. 27.
- OINEN, EMILY, SAN FRANCISCO, CA:
4,209,719. PUB. 7-3-2012. INT. CL. 16.
- OKI ELECTRIC INDUSTRY CO., LTD., MINATO-KU, TOKYO, JAPAN:
2,527,563. CANC. INT. CL. 2.
- OKONITE COMPANY, INC., THE, RAMSEY, NJ:
1,706,755. REN. 8-11-12. INT. CL. 17.
- OLD DUTCH FOODS, INC., ST. PAUL, MN:
4,210,615. MULTIPLE CLASS, INT. CLS. 29 AND 30.
- OLD TAHOE DISTILLERY, LLC, SPOKANE, WA:
4,210,957. INT. CL. 33.
- OLDE SOUTH CANDLE COMPANY, MAYFIELD, KY:
2,632,418. COR. INT. CL. 4.
- OLIN CORPORATION, ST. LOUIS, MO:
2,684,131. REN. 8-16-12. INT. CL. 13.
- OLNATURA, INC., HOUSTON, TX:
4,209,771. PUB. 7-3-2012. INT. CL. 5.
4,209,776. PUB. 7-3-2012. INT. CL. 5.
- OLOGIC SWITCH PRODUCTS, INC., ALISO VIEJO, CA:
2,528,196. CANC. INT. CL. 9.
- OLYMPUSAT, INC., WEST PALM BEACH, FL:
4,208,657. PUB. 7-3-2012. MULTIPLE CLASS, INT. CLS. 38 AND 41.
- OMID USA, INC., TERRACE PARK, OH:
4,211,728. INT. CL. 7.
- OMNI COMPUTER SERVICES, INC., SYKESVILLE, MD, AKA OCS:
4,209,069. PUB. 5-8-2012. MULTIPLE CLASS, INT. CLS. 35 AND 40.
- OMNI FINANCIAL GROUP, INC., ROCHESTER, NY, DBA THE OMNI GROUP:
4,211,727. INT. CL. 36.
- OMNI UNITED (S) PTE LTD, SINGAPORE 048616, SINGAPORE:
4,210,855. INT. CL. 12.
- OMNICOM MEDIA GROUP HOLDINGS INC., NEW YORK, NY:
4,210,740. INT. CL. 35.
- OMS INVESTMENTS, INC., LOS ANGELES, CA:
2,601,682. REN. 8-13-12. INT. CL. 1.
- OMT BELFORTE S.R.L., BELFORTE DEL CHIENZI, MC, ITALY:
2,631,365. REN. 8-14-12. INT. CL. 11.
- ON-LINE COMMUNICATIONS, INC., BARTLESVILLE, OK, DBA OLC GLOBAL:
4,209,720. PUB. 7-3-2012. INT. CL. 35.
- ONE FUN SUMMER, SAVANNAH, GA:
4,087,289. CANC. INT. CL. 25.
- ONE SOURCE APPAREL, PORTSMOUTH, NH:
4,211,383. INT. CL. 24.
- ONE TOUCH INTELLIGENCE, LLC, GREENWOOD VILLAGE, CO:
4,210,972. MULTIPLE CLASS, INT. CLS. 35 AND 42.
- ONEIDA INDIAN NATION OF NEW YORK, THE, ONEIDA, NY, AKA THE ONEIDA INDIAN NATION OF NEW YORK, THE ONEIDA INDIAN NATION, ONEIDA INDIAN NATION, THE ONEIDA NATION OR ONEIDA NATION:
1,974,475. AM. MULTIPLE CLASS, INT. CLS. 4, 16, 20, 21, 25, 30, 34, 41 AND 42.
- ONLY HEARTS L'IL KIDS, SANTA BARBARA, CA:
4,208,170. PUB. 7-3-2012. INT. CL. 28.
- OPASTCORP, L.L.C., WASHINGTON, DC:
2,601,178. REN. 8-10-12. INT. CL. 38.
- OPEN CIRCLE ADVISORS, LLC, WOODBRIDGE, CT:
4,210,578. INT. CL. 36.
- OPERATION SPECIALITY RETAIL LLC, LAS VEGAS, NV:
4,209,859. PUB. 7-3-2012. INT. CL. 3.
- OPTICAL STORAGE TECHNOLOGY ASSOCIATION, CUPERTINO, CA:
2,527,540. CANC. INT. CL. 42.
- OPTICARE EYE HEALTH CENTERS, INC., WATERBURY, CT:
2,528,380. CANC. INT. CL. 42.
- OPTIMIZED THERMAL SYSTEMS, COLLEGE PARK, MD:
4,209,760. PUB. 7-3-2012. INT. CL. 9.
- OPTIONMONSTER HOLDINGS, INC., CHICAGO, IL:
4,210,297. MULTIPLE CLASS, INT. CLS. 36 AND 41.
- OPTOMA TECHNOLOGY, INC., FREMONT, CA:
4,210,778. INT. CL. 9.
- ORACLE AMERICA, INC., REDWOOD SHORES, CA:
2,528,149. CANC. INT. CL. 9.
4,210,254. MULTIPLE CLASS, INT. CLS. 9, 41 AND 42.
- ORANGE BRAND SERVICES, LTD, BRADLEY STOKE, UNITED KINGDOM:
4,208,123. PUB. 10-27-2009. MULTIPLE CLASS, INT. CLS. 9, 16 AND 41.
- ORANGE BRAND SERVICES, LTD., BRADLEY STOKE, BRISTOL, UNITED KINGDOM:
4,208,120. PUB. 3-30-2010. INT. CL. 35.
- ORANGE BRAND SERVICES, LTD., BRISTOL, UNITED KINGDOM:
4,208,122. PUB. 10-5-2004. MULTIPLE CLASS, INT. CLS. 12, 35 AND 36.
4,208,124. PUB. 12-30-2003. MULTIPLE CLASS, INT. CLS. 9, 16, 18, 25, 28, 35, 36, 37, 38, 39, 41 AND 42.
- ORANGE, DAVID, BRONX, NY, DBA QUESTS AND SUMMITS LLC:
4,209,216. PUB. 7-3-2012. INT. CL. 41.
- ORASURE TECHNOLOGIES, INC., BETHLEHEM, PA:
4,210,293. INT. CL. 5.
4,210,795. INT. CL. 10.
- ORBIS OPERATIONS, LLC, MCLEAN, VA:
4,209,829. PUB. 7-3-2012. INT. CL. 45.
- ORBITZ, LLC, CHICAGO, IL:
2,874,581. CANC. INT. CL. 39.
- ORCHARD ADVISORS, LLC, NASHVILLE, TN:
4,208,923. PUB. 7-3-2012. INT. CL. 35.
- ORECK HOLDINGS, LLC, CHEYENNE, WY:
2,528,344. CANC. INT. CL. 9.

ORECK HOLDINGS, LLC, NASHVILLE, TN:
 2,606,090. REN. 8-11-12. INT. CL. 7.
 4,211,238, INT. CL. 11.
 4,211,399, INT. CL. 11.
 4,211,416, INT. CL. 11.
 4,211,420, INT. CL. 7.
 4,211,455, INT. CL. 11.

OREGON CORRECTIONS ENTERPRISES, SALEM, OR,
 OREGON DEPARTMENT OF CORRECTIONS, THE,
 SALEM, OR, DBA UNIGROUP:
 1,741,404. REN. 8-16-12. INT. CL. 25.

OREGON MANIFEST, PORTLAND, OR:
 4,209,256, PUB. 7-3-2012. INT. CL. 41.

ORGANIZED 4 LIFE, LLC, GREENWOOD VILLAGE, CO,
 DBA MAJOR MOM:
 4,209,372, PUB. 7-3-2012. INT. CL. 45.

ORICO TECHNOLOGIES CO., LTD., CHINA:
 4,208,396, PUB. 7-3-2012. INT. CL. 9.

ORIGINAL BRADFORD SOAP WORKS, INC., THE, WEST
 WARWICK, RI:
 2,604,455. REN. 8-16-12. INT. CL. 40.

ORION FOOD SYSTEMS, L.L.C., SIOUX FALLS, SD:
 2,528,719, CANC. INT. CL. 30.

ORPHIONICS, LLC, SAN CLEMENTE, CA:
 4,208,948, PUB. 7-3-2012. MULTIPLE CLASS, INT. CLS. 9,
 35, 38, 41, 42 AND 45.

ORTERY TECHNOLOGIES, INC., IRVINE, CA:
 4,211,715, MULTIPLE CLASS, INT. CLS. 9 AND 42.

OSKAR BLUES BREWERY LLC, LONGMONT, CO, DBA
 OSKAR BLUES BREWERY:
 4,208,990, PUB. 7-3-2012. INT. CL. 32.

OSRAM AG, D-81543 MUENCHEN, FED REP GERMANY,
 AKA OSRAM AKTIENGESELLSCHAFT:
 4,208,404, PUB. 7-3-2012. MULTIPLE CLASS, INT. CLS. 9
 AND 11.

OTX SYSTEMS LTD., CALGARY, ALBERTA, CANADA:
 4,211,161, INT. CL. 42.

OUNCE OF PREVENTION FUND, CHICAGO, IL:
 4,209,729, PUB. 7-3-2012. MULTIPLE CLASS, INT. CLS. 9,
 35 AND 41.

OURAY LLC, SEATTLE, WA:
 4,208,900, PUB. 7-3-2012. INT. CL. 21.

OUTDOOR UNLIMITED LLC, ORLANDO, OK:
 4,210,959, INT. CL. 7.

OWEN MUMFORD LIMITED, WOODSTOCK OXFORD,
 UNITED KINGDOM:
 4,211,796, INT. CL. 10.

OWENS CORNING INTELLECTUAL CAPITAL, LLC, TO-
 LEDO, OH:
 2,528,507, CANC. INT. CL. 37.
 2,652,285. REN. 8-15-12. INT. CL. 7.

OZOOO LLC, FORT COLLINS, CO:
 4,211,064, INT. CL. 10.

O9 SOLUTIONS, INC., DALLAS, TX:
 4,209,591, PUB. 7-3-2012. MULTIPLE CLASS, INT. CLS. 35
 AND 42.
 4,209,592, PUB. 7-3-2012. MULTIPLE CLASS, INT. CLS. 35
 AND 42.
 4,210,041, PUB. 7-3-2012. MULTIPLE CLASS, INT. CLS. 35
 AND 42.

P & P POWER INC., KINCHELOE, MI:
 4,211,542, INT. CL. 7.

P DEVOS DESIGNS, INC., GRAND RAPIDS, MI, DBA
 PAMELLA ROLAND:
 2,740,479. REN. 8-13-12. INT. CL. 25.

P.T. BINTANG TOEDJOE, JAKARTA, INDONESIA:
 2,882,211, CANC. INT. CL. 32.

P.T. DJARUM, KUDUS, INDONESIA:
 4,208,155, PUB. 7-3-2012. INT. CL. 34.

PÉREZ, LEMUEL, AGUADA, PUERTO RICO:
 4,210,078, PUB. 7-3-2012. INT. CL. 43.

PA ARTESA OLOT, S.L., 17800 OLOT (GIRONA), SPAIN:
 4,208,770, PUB. 7-3-2012. MULTIPLE CLASS, INT. CLS. 30
 AND 35.

PABLO JAVIER HERMOSILLA RIOS, SPAIN:
 4,208,312, PUB. 7-3-2012. INT. CL. 9.

PACERS BASKETBALL, LLC, INDIANAPOLIS, IN:
 4,209,328, PUB. 7-3-2012. INT. CL. 25.

PACHAMAMA COFFEE COOPERATIVE OF SMALL SCALE
 COFFEE PRODUCERS, DAVIS, CA:
 4,210,599, INT. CL. 30.

PACHOPOS, GEORGIOS, ATHENS, GREECE:
 4,211,170, INT. CL. 3.

PACIFIC DIRECT LIMITED, BEDFORD, BEDFORDSHIRE,
 UNITED KINGDOM:
 4,208,598, PUB. 7-3-2012. MULTIPLE CLASS, INT. CLS. 3,
 21, 25 AND 35.

PACIFIC GAS AND ELECTRIC COMPANY, SAN FRANCIS-
 CO, CA:
 1,743,921. REN. 8-16-12. INT. CL. 16.

PACIFIC PACKAGING CONCEPTS, INC., CARSON, CA,
 DBA FRESH START VITAMINS CO. AND DBA C & A
 ENTERPRISES, INC.:
 2,656,115. REN. 8-15-12. INT. CL. 5.

PACIFIC RIM WINEMAKERS, INC., PORTLAND, OR, DBA
 VINMOTION:
 4,210,975, INT. CL. 33.

PACIFICA, INC., PORTLAND, OR:
 4,209,376, PUB. 7-3-2012. INT. CL. 3.
 4,209,377, PUB. 7-3-2012. INT. CL. 3.

PACILIO, THOMAS, WESTPORT, CT:
 4,211,843, INT. CL. 36.

PACINIAN CORPORATION, SPOKANE, WA:
 4,211,056, INT. CL. 9.

PACTIV LLC, LAKE FOREST, IL:
 4,210,406, INT. CL. 21.

PAELLA AT YOUR PLACE, LLC, CINCINNATI, OH:
 4,209,180, PUB. 7-3-2012. INT. CL. 43.

PAKFLATT (UK) LIMITED, COUNTY LONDONDERRY,
 UNITED KINGDOM:
 3,917,630, COR. INT. CL. 20.

PALLADIUM GROUP, INC., LINCOLN, MA:
 4,210,345, INT. CL. 35.

PALM BAY INTERNATIONAL, INC., PORT WASHINGTON,
 NY:
 4,210,661, INT. CL. 33.
 4,210,662, INT. CL. 33.
 4,210,678, INT. CL. 33.

PALOMA'S NEST, LLC, AUSTIN, TX:
 4,210,226, PUB. 8-23-2011. MULTIPLE CLASS, INT. CLS.
 16, 20, 26 AND 28.

PANADERIA SAN JORGE S.A., LIMA, PERU:
 4,208,795, PUB. 7-3-2012. MULTIPLE CLASS, INT. CLS. 29
 AND 30.

PANASONIC CORPORATION, OSAKA, JAPAN:
 4,208,800, PUB. 7-3-2012. INT. CL. 9.

PANFAN MARKETING LTD, TAURANGA, NEW ZEAL-
 AND:
 4,208,807, PUB. 7-3-2012. INT. CL. 11.

PANSINO, GARY, SANTA CLARA, CA:
 4,210,140, PUB. 7-3-2012. INT. CL. 35.

PANTECH CO., LTD., MAPO-GU, SEOUL, REPUBLIC OF
 KOREA:
 4,211,625, INT. CL. 9.

PAPA BEAR ENTERPRISES, LLC, WILMINGTON, DE:
 4,210,287, MULTIPLE CLASS, INT. CLS. 9, 16, 25 AND 28.

PAPA'S PIZZA, INC., FARMINGTON HILLS, MI:
 4,208,816, PUB. 7-3-2012. INT. CL. 43.

PAPERKING INC., WORCESTER, MA:
 4,208,560, PUB. 3-27-2012. INT. CL. 35.

PAR TECHNOLOGY CORPORATION, NEW HARTFORD,
 NY:
 4,209,862, PUB. 7-3-2012. MULTIPLE CLASS, INT. CLS. 9
 AND 42.
 4,209,863, PUB. 7-3-2012. MULTIPLE CLASS, INT. CLS. 9
 AND 42.

PARADOCX VINEYARD, LTD., LANDENBERG, PA:
 2,534,436. REN. 8-15-12. MULTIPLE CLASS, INT. CLS. 29
 AND 31.

PARCHMENT INC., SCOTTSDALE, AZ:
 4,209,260, PUB. 7-3-2012. INT. CL. 41.

PARFUMS CHRISTIAN DIOR, FRANCE:
 4,208,422, PUB. 7-3-2012. MULTIPLE CLASS, INT. CLS. 3
 AND 4.
 4,208,430, PUB. 7-3-2012. MULTIPLE CLASS, INT. CLS. 3
 AND 4.

- PARFÜMERIE DOUGLAS GMBH, D-58099 HAGEN, FED REP GERMANY:
3,002,049.
- PARFÜMERIE DOUGLAS GMBH, FED REP GERMANY:
3,002,050.
3,011,535.
- PARISE, CHRISTOPHER, SAN DIMAS, CA:
4,210,269, INT. CL. 9.
- PARKER INTANGIBLES LLC, CLEVELAND, OH, REESE, HARRY E., FORT WORTH, TX:
564,480, REN. 8-15-12. U.S. CL. 13 (INT. CL. 6).
- PARKER INTANGIBLES LLC, CLEVELAND, OH, WATTS FLUIDAIR INC., KITTERY, ME:
1,201,784, REN. 8-14-12. MULTIPLE CLASS, INT. CLS. 7, 9 AND 11.
- PARKER SYNERGIES LLC, WINDSOR, ONTARIO, CANADA:
4,068,747, AM. INT. CL. 25.
- PARKSITE, INC., BATAVIA, IL:
2,527,304, CANC. INT. CL. 35.
- PARKTEL, FZE, DUBAI, UNITED ARAB EMIR.:
4,211,193, INT. CL. 9.
4,211,194, INT. CL. 35.
4,211,195, INT. CL. 38.
- PARLO INC., NEW YORK, NY:
2,526,959, CANC. MULTIPLE CLASS, INT. CLS. 38 AND 41.
- PARTEK INCORPORATED, CHESTERFIELD, MO:
2,603,467, REN. 8-15-12. INT. CL. 9.
- PARTNERS FEDERAL CREDIT UNION, BURBANK, CA:
4,210,804, INT. CL. 36.
- PASCHALS' CONCESSIONS, INC., ATLANTA, GA:
2,612,322, REN. 8-15-12. INT. CL. 42.
- PATAGONIA, INC., VENTURA, CA:
4,210,088, PUB. 7-3-2012. INT. CL. 41.
- PATENTA ASIA LTD., TST HONGKONG, CHINA:
4,208,235, PUB. 7-13-2010. MULTIPLE CLASS, INT. CLS. 17, 20 AND 35.
- PATENTSTATUS LLC, INDIANAPOLIS, IN:
4,209,491, PUB. 7-3-2012. INT. CL. 42.
- PATRIOT BIODIESEL, LLC, GREENSBORO, NC:
4,209,748, PUB. 7-3-2012. INT. CL. 4.
- PATTERSON MEDICAL HOLDINGS, INC., BOLINGBROOK, IL, COMPAGNIE GENERALE DE MATERIEL ORTHOPEDIQUE, 08540 TOURNES CLIRON, FRANCE:
1,746,995, REN. 8-11-12. INT. CL. 10.
- PAUL MICHAEL SLAYTON, KINGWOOD, TX:
4,208,980, PUB. 7-3-2012. MULTIPLE CLASS, INT. CLS. 9 AND 41.
- PAULSSON, INC., VAN NUYS, CA:
4,210,976, INT. CL. 9.
- PAYLESS SHOESOURCE WORLDWIDE, INC., TOPEKA, KS:
4,209,986, PUB. 7-3-2012. INT. CL. 14.
- PAYMENTCOLLECT, LLC, ARDEN, NC:
4,211,788, INT. CL. 36.
- PBI-GORDON CORPORATION, KANSAS CITY, MO:
2,647,148, AM. INT. CL. 5.
- PBI/GORDON CORPORATION, KANSAS CITY, MO:
2,622,256, REN. 8-11-12. INT. CL. 5.
- PC DESIGN, TANGER, MOROCCO:
4,211,068, INT. CL. 3.
- PCC INCORPORATED, LOS ANGELES, CA:
2,527,358, CANC. INT. CL. 42.
- PCS WIRELESS LLC, FLORHAM PARK, NJ:
4,211,660, INT. CL. 9.
- PDC LICENSING, LLC, NEW YORK, NY:
4,210,310, INT. CL. 25.
- PEABODY ENERGY CORPORATION, ST. LOUIS, MO:
4,208,931, PUB. 7-3-2012. MULTIPLE CLASS, INT. CLS. 4 AND 35.
- PEAK 10 XODIAX, INC., CHARLOTTE, NC:
2,594,304, CANC. MULTIPLE CLASS, INT. CLS. 38 AND 42.
- PEARLSWAN COMMUNICATIONS LLC, BEVERLY HILLS, MI:
4,211,210, INT. CL. 9.
- PEARSON EDUCATION, INC., UPPER SADDLE RIVER, NJ:
2,526,706, CANC. MULTIPLE CLASS, INT. CLS. 35, 41 AND 42.
- PEDERSEN, JOHN CARL, AKRON, OH:
4,210,658, INT. CL. 44.
- PEDINOL PHARMACAL, INC., FARMINGDALE, NY:
4,209,454, PUB. 7-3-2012. INT. CL. 3.
- PEI LICENSING, INC., MIAMI, FL:
4,211,356, INT. CL. 8.
4,211,357, INT. CL. 9.
4,211,389, INT. CL. 9.
- PEISELER GMBH & CO. KG, FED REP GERMANY:
3,158,850.
- PELAGIC LURES INTERNATIONAL AB, STOCKHOLM, SWEDEN:
2,526,924, CANC. INT. CL. 28.
- PELLA CORPORATION, PELLA, IA:
4,209,981, PUB. 7-3-2012. MULTIPLE CLASS, INT. CLS. 9 AND 35.
- PENA, NAIROBY G, BROOKLYN, NY:
4,211,024, INT. CL. 30.
- PENETRATORS CANADA INC., RED DEER, ALBERTA, CANADA:
2,526,976, CANC. INT. CL. 37.
- PENGFEI ENTERPRISES INC., BALTIMORE, MD, DBA OKEYOGHI:
4,211,138, INT. CL. 30.
- PENHAKER, MARSHA G., STERLING, VA:
2,528,044, CANC. INT. CL. 42.
- PENNSYLVANIA STATE EMPLOYEES CREDIT UNION, HARRISBURG, PA:
4,211,710, INT. CL. 36.
- PENTEL OF AMERICA, LTD., TORRANCE, CA:
4,210,246, INT. CL. 16.
- PENTON BUSINESS MEDIA, INC., NEW YORK, NY:
4,210,109, PUB. 7-3-2012. MULTIPLE CLASS, INT. CLS. 16 AND 41.
- PEOPLEMED.COM, INC., LAKEWOOD, CO TO GLOBAL MED TECHNOLOGIES, INC., EL DORADO HILLS, CA:
2,528,069, CANC. INT. CL. 42.
- PEPPERS UNLIMITED INC., GRAND PRAIRIE, TX:
1,729,633, REN. 8-15-12. INT. CL. 29.
- PEPSICO, INC., PURCHASE, NY:
4,210,960, INT. CL. 30.
- PERCEPTUAL DEVELOPMENT CORPORATION, LONG BEACH, CA:
2,629,989, REN. 8-15-12. MULTIPLE CLASS, INT. CLS. 41 AND 42.
2,700,069, REN. 8-15-12. INT. CL. 44.
2,718,934, REN. 8-15-12. INT. CL. 9.
- PEREZ, JEAN MARC, PARIS, FRANCE:
4,210,531, INT. CL. 25.
- PERFECT CROSS, LLC, NASHOTAH, WI:
4,210,873, INT. CL. 5.
- PERFECTION BAKERIES, INC., FORT WAYNE, IN:
4,210,055, PUB. 7-3-2012. INT. CL. 30.
- PERFICIO NETWORKS, INC., IRVINE, CA, DBA YOR HEALTH:
4,210,059, PUB. 7-3-2012. INT. CL. 5.
- PERFORMANCE FABRICS, INC., GRAND RAPIDS, MI:
4,209,435, PUB. 7-3-2012. INT. CL. 9.
- PERGO (EUROPE) AB, TRELLEBORG, SWEDEN:
4,210,858, INT. CL. 19.
- PERIMETER TECHNOLOGIES, INC. DBA PET STOP CORPORATION, CINCINNATI, OH:
2,609,957, REN. 8-15-12. INT. CL. 9.
- PERMA-VAULT SAFE CO., WARMINSTER, PA:
2,617,677, REN. 8-15-12. INT. CL. 6.
- PERMASTORE LIMITED, SUFFOLK IP23 7HS, UNITED KINGDOM:
2,576,930, REN. 8-12-12. INT. CL. 6.
- PERMAUL, JENNIFER, CITRUS HEIGHTS, CA:
4,210,762, INT. CL. 25.
- PERMIRA I.P. LIMITED, ST. PETER'S PORT, GUERNSEY:
4,208,179, PUB. 7-3-2012. MULTIPLE CLASS, INT. CLS. 35 AND 36.
- PERNELL, CHRIS, T, NEWARK, NJ:
4,209,221, PUB. 7-3-2012. INT. CL. 44.

- PERNOD RICARD DENMARK A/S, COPENHAGEN, DENMARK, AKTIESELSKABET DE DANSKE SPRITFABRIKKER, COPENHAGEN, DENMARK:
157,846. REN. 8-12-12. U.S. CL. 49 (INT. CL. 33).
- PERSOCIETY, INC., SAN FRANCISCO, CA:
4,211,239. INT. CL. 42.
- PERSONAL TOUCH BED, LEWES, DE:
4,209,029. PUB. 7-3-2012. INT. CL. 20.
- PERVASIVE SOFTWARE INC, AUSTIN, TX, NOVELL, INC., PROVO, UT:
1,786,633. REN. 8-11-12. INT. CL. 9.
- PESEK, DAVID JAMES, WAYNESVILLE, NC:
4,208,495. PUB. 7-3-2012. MULTIPLE CLASS, INT. CLS. 9, 16, 41 AND 44.
- PET CENTER, INC., LOS ANGELES, CA:
1,703,571. REN. 8-10-12. INT. CL. 31.
- PET-AG, INC., HAMPSHIRE, IL:
2,608,762. REN. 8-16-12. INT. CL. 5.
- PETE, HUNTINGTON PARK, CA:
3,038,354. CANC. INT. CL. 25.
- PETER'S YARD LIMITED, SHREWSBURY, SHROPSHIRE, UNITED KINGDOM:
4,208,345. PUB. 7-3-2012. MULTIPLE CLASS, INT. CLS. 30 AND 43.
- PETERSON, DON, MINNEAPOLIS, MN:
4,208,450. PUB. 7-3-2012. INT. CL. 42.
4,208,451. PUB. 7-3-2012. INT. CL. 42.
- PETJAMAS LLC, SAN DIEGO, CA, DBA SNUGGLETIME:
4,208,871. PUB. 1-17-2012. INT. CL. 24.
4,208,872. PUB. 1-17-2012. INT. CL. 28.
- PETKIN, INC., MARINA DEL REY, CA:
4,209,117. PUB. 7-3-2012. INT. CL. 16.
- PETNET SOLUTIONS, INC., KNOXVILLE, TN:
2,527,837. CANC. INT. CL. 5.
- PETROLEUM ANALYZER COMPANY, L.P., HOUSTON, TX:
4,208,880. PUB. 7-3-2012. INT. CL. 9.
- PETROPOWER LLC, WICHITA, KS:
4,210,021. PUB. 7-3-2012. INT. CL. 42.
- PFLAUMER BROTHERS, INC., EWING, NJ:
2,608,489. REN. 8-10-12. INT. CL. 1.
- PHARMACIA & UPJOHN COMPANY LLC, KALAMAZOO, MI, UPJOHN COMPANY, THE, KALAMAZOO, MI:
1,740,485. REN. 8-10-12. INT. CL. 5.
- PHAROS HOSPITALITY, LLC, CHARLOTTE, NC:
4,210,550. MULTIPLE CLASS, INT. CLS. 36 AND 43.
- PHI MU FRATERNITY, PEACHTREE CITY, GA:
4,208,911. PUB. 3-20-2012. INT. CL. 36.
- PHILADELPHIA DIAMOND COMPANY, PHILADELPHIA, PA:
4,211,687. INT. CL. 14.
- PHILIPS GMBH, 20099 HAMBURG, FED REP GERMANY TO DFT DIGITAL FILM TECHNOLOGY HOLDING GMBH, WEITERSTADT, FED REP GERMANY:
2,527,791. CANC. INT. CL. 9.
- PHILLIPS EXETER ACADEMY, EXETER, NH:
1,674,335. REN. 8-16-12. INT. CL. 25.
- PHILLIPS NIZER LLP, NEW YORK, NY:
4,208,905. PUB. 7-3-2012. INT. CL. 16.
- PHILLIPS PRODUCTS COMPANY, LLC, PRINCETON, MN:
4,210,008. PUB. 7-3-2012. INT. CL. 33.
4,210,009. PUB. 7-3-2012. INT. CL. 33.
- PHILLIPS, AARON, VISALIA, CA:
4,209,635. PUB. 7-3-2012. INT. CL. 25.
- PHILLIPS, PAULA, SIMI VALLEY, CA, DBA RIGHT ROAD PRODUCTIONS:
4,209,056. PUB. 7-3-2012. INT. CL. 9.
- PHOCATOX TECHNOLOGIES, LLC, INDIANAPOLIS, IN:
4,211,409. INT. CL. 1.
- PHOENIX INTANGIBLES HOLDING COMPANY, GREENVILLE, DE:
2,528,478. CANC. INT. CL. 30.
- PHOSPHAGENICS LIMITED, CLAYTON, VIC, AUSTRALIA:
4,208,409. PUB. 7-3-2012. INT. CL. 3.
- PHOTO-ME INTERNATIONAL PLC., SURREY, UNITED KINGDOM:
2,526,390. CANC. MULTIPLE CLASS, INT. CLS. 9 AND 28.
- PHP COMPANIES, INC., KNOXVILLE, TN:
2,528,132. CANC. MULTIPLE CLASS, INT. CLS. 36 AND 42.
- PHYSICIAN ASSISTANT EDUCATION ASSOCIATION, ALEXANDRIA, VA:
4,209,898. PUB. 7-3-2012. INT. CL. 35.
- PHYSICIANS' EDUCATION RESOURCE, PLAINSBORO, NJ:
4,211,849. INT. CL. 41.
- PHYSIK INSTRUMENTE (PI) GMBH & CO. KG, 76228 KARLSRUHE, FED REP GERMANY:
2,616,674. REN. 8-11-12. INT. CL. 9.
2,616,674. CANC. MULTIPLE CLASS, INT. CLS. 35 AND 42.
- PHYSIX, LLC, PHOENIX, AZ:
4,209,394. PUB. 7-3-2012. INT. CL. 41.
- PICANO, MICHAEL J., FORT PIERCE, FL, DBA VARSITY SPORT SHOP:
4,208,655. PUB. 7-3-2012. INT. CL. 16.
- PICLINQ CORP., BURLINGAME, CA:
2,527,804. CANC. INT. CL. 9.
- PIEH, WENDY LEE, BREMEN, ME:
4,208,690. PUB. 7-3-2012. MULTIPLE CLASS, INT. CLS. 22, 35 AND 44.
- PIERRE FABRE S.A., 75008 PARIS, FRANCE:
2,912,044. CANC. MULTIPLE CLASS, INT. CLS. 3 AND 5.
- PIERRE-LOUIS, MONA, NEW YORK, NY:
4,211,082. MULTIPLE CLASS, INT. CLS. 14 AND 25.
- PIKE, JEFFFREY, CONROE, TX:
4,209,496. PUB. 7-3-2012. U.S. CL. 200.
- PILKINGTON NORTH AMERICA, INC., TOLEDO, OH:
1,747,796. REN. 8-10-12. INT. CL. 19.
- PILL PICK UP, LLC, DOWNERS GROVE, IL:
4,210,888. INT. CL. 21.
4,211,066. INT. CL. 21.
- PILLSBURY WINTHROP SHAW PITTMAN LLP, LOS ANGELES, CA:
4,208,527. PUB. 7-3-2012. MULTIPLE CLASS, INT. CLS. 35, 39 AND 42.
- PINNACLE COMPANIES, INC., SULPHUR SPRINGS, TX:
4,209,941. PUB. 7-3-2012. INT. CL. 12.
- PINNACLE ENTERTAINMENT, INC., LAS VEGAS, NV:
4,210,878. INT. CL. 25.
- PIONEER AEROSPACE CORPORATION, SOUTH WINDSOR, CT, PIONEER PARACHUTE COMPANY, INC., MANCHESTER, CT:
745,717. REN. 8-14-12. U.S. CL. 19 (INT. CL. 12).
- PIONEER KABUSHIKI KAISHA D/B/A PIONEER CORPORATION, KANAGAWA-KEN 212-0031, JAPAN:
4,208,692. PUB. 7-3-2012. MULTIPLE CLASS, INT. CLS. 9 AND 42.
- PIRELLI TYRE S.P.A., MILANO, ITALY:
4,209,504. PUB. 7-3-2012. INT. CL. 12.
- PITA, EDUARDO, BEECHHURST, NY:
2,535,888. REN. 8-16-12. INT. CL. 42.
- PITTSBURGH CORNING CORPORATION, PITTSBURGH, PA:
1,206,191. REN. 8-15-12. INT. CL. 19.
- PITTSBURGH KETTLEBELLS, LLC, SEWICKLEY, PA:
4,208,972. PUB. 7-3-2012. INT. CL. 41.
- PIV ENTERPRISES, INC., VISALIA, CA:
4,209,172. PUB. 5-29-2012. INT. CL. 5.
- PIXIE STUFF, L.L.C., ST LOUIS, MO:
4,210,340. INT. CL. 41.
- PLACO CORPORATION LIMITED, KOWLOON, HONG KONG:
2,619,148. REN. 8-16-12. INT. CL. 28.
2,626,945. REN. 8-16-12. INT. CL. 28.
- PLAN FOR WHAT IF, LLC, SARASOTA, FL:
4,209,214. PUB. 7-3-2012. INT. CL. 16.
- PLANET COFFEE ROASTERS, INC., LA PUENTE, CA:
4,208,184. PUB. 4-20-2010. INT. CL. 30.
4,208,185. PUB. 4-13-2010. INT. CL. 30.
- PLANET GRANITE BELMONT LLC, BELMONT, CA:
4,209,841. PUB. 7-3-2012. INT. CL. 41.
- PLANET SHAKERS MINISTRIES INTERNATIONAL INC, BOX HILL, VICTORIA, AUSTRALIA:
3,121,382. CANC. INT. CL. 16.

- PLANETECHS, LLC, TACOMA, WA, AKA TARMAC ACQUISITION, LLC, SEC COMPANIES OF THE USA, INC., THE, DOWNERS GROVE, IL:
1,726,103. REN. 8-11-12. INT. CL. 35.
- PLANETREE, INC., DERBY, CT:
4,211,440, MULTIPLE CLASS, INT. CLS. 35, 41 AND 44.
- PLASTI DIP INTERNATIONAL, INC., BLAINE, MN:
1,732,309. REN. 8-16-12. INT. CL. 2.
- PLASTIC EXTRUDERS LIMITED, WICKFORD, ESSEX SS11 8DN, UNITED KINGDOM:
2,608,375. REN. 8-15-12. INT. CL. 27.
- PLASTIC SURGERY NORTHWEST PLLC, SPOKANE, WA:
4,210,981, INT. CL. 44.
- PLAY VISIONS INC., WOODINVILLE, PA:
4,209,916, PUB. 7-3-2012. INT. CL. 28.
- PLAYMATES TOYS INC., EL SEGUNDO, CA:
4,211,671, MULTIPLE CLASS, INT. CLS. 28 AND 41.
- PLAYTEX PRODUCTS, LLC, SHELTON, CT:
2,601,598. REN. 8-12-12. INT. CL. 10.
- PLEASE TOUCH MUSEUM, PHILADELPHIA, PA:
1,708,794. REN. 8-16-12. MULTIPLE CLASS, INT. CLS. 41 AND 42.
- PLEWS, INC., DIXON, IL:
4,210,181, PUB. 7-3-2012. INT. CL. 4.
- PLOOM, INC., SAN FRANCISCO, CA:
4,209,479, PUB. 7-3-2012. INT. CL. 34.
- PLUSPHARMA, INC., VISTA, CA:
2,608,130. REN. 8-14-12. INT. CL. 5.
- PMA MEDIA GROUP, LEHI, UT:
4,208,919, PUB. 7-3-2012. INT. CL. 35.
- PODO, LLC, SAN FRANCISCO, CA:
4,209,561, PUB. 7-3-2012. INT. CL. 43.
- POE, MATT, NASHVILLE, TN:
4,208,830, PUB. 7-3-2012. INT. CL. 25.
- POLE ZONE, L.L.C., OKLAHOMA CITY, OK:
4,208,910, PUB. 7-3-2012. INT. CL. 41.
- POLLEN, INC., MISSION WOODS, KS:
4,209,039, PUB. 7-3-2012. INT. CL. 42.
- POLY-TEX, INC., CASTLE ROCK, MN:
2,604,022. REN. 8-16-12. INT. CL. 19.
- POLYMEDICA CORPORATION, WOBURN, MA:
2,527,097, CANC. INT. CL. 35.
- POLYPLASTICS CO., LTD., TOKYO, JAPAN:
4,210,266, MULTIPLE CLASS, INT. CLS. 1 AND 17.
- POLYTRONICS TECHNOLOGY CORP., HSINCHU SCIENCE PARK, TAIWAN:
2,703,483. REN. 8-14-12. INT. CL. 9.
- PONTA, INC., MORAGA, CA, DBA CONSTRUCTIONPLA-CE.COM:
4,209,252, PUB. 7-3-2012. INT. CL. 37.
- PONTNEUF S.P.A., MILAN, ITALY:
386,552, CANC. U.S. CL. 46.
- PONVIA TECHNOLOGY, INC., LIBERTYVILLE, IL, PONVIA TECHNOLOGY, INC., LIBERTYVILLE, IL:
2,602,416. REN. 8-10-12. INT. CL. 42.
- PORNGANIZER LLC, INDIANAPOLIS, IN:
4,209,845, PUB. 7-3-2012. INT. CL. 42.
- PORPOISE POOL & PATIO, INC., CLEARWATER, FL:
2,662,838. REN. 8-14-12. INT. CL. 35.
- PORTERS NECK COMPANY, INC., WILMINGTON, NC:
1,714,169. REN. 8-10-12. INT. CL. 37.
1,714,170. REN. 8-10-12. INT. CL. 37.
- PORTNOLOGY, INC., SAN DIEGO, CA:
4,210,405, INT. CL. 5.
- PORTNOY ABEMAYOR, DONNA, CHAPPAQUA, NY:
4,209,307, PUB. 7-3-2012. INT. CL. 44.
- PORTRAIT CITY, LLC, OVERLAND PARK, KS:
4,210,737, MULTIPLE CLASS, INT. CLS. 35, 40 AND 41.
- PORZELLANFABRIKEN CHRISTIAN SELTMANN GMBH, WEIDEN/ BAVARIA, FED REP GERMANY:
2,688,098. REN. 8-14-12. INT. CL. 35.
- POSADAS DE MEXICO, S.A. DE C.V., 11000, MEXICO, DISTRITO FEDERAL, MEXICO:
2,644,696. REN. 8-15-12. INT. CL. 42.
- POSH PUMPKINS, LLC, LUGOFF, SC:
4,211,140, MULTIPLE CLASS, INT. CLS. 22 AND 25.
- POSITEK.NET LLC, TYSONS CORNER, VA:
4,209,337, PUB. 7-3-2012. INT. CL. 42.
4,209,343, PUB. 7-3-2012. INT. CL. 42.
- POSITIVE COACHING ALLIANCE, MOUNTAIN VIEW, CA:
2,608,042. REN. 8-13-12. MULTIPLE CLASS, INT. CLS. 16 AND 41.
2,608,042, CANC. INT. CL. 9.
- POSTY CARDS, INC., KANSAS CITY, MO:
2,677,596. REN. 8-14-12. INT. CL. 16.
- POTOFFEE, HOMESTEAD, FL:
4,209,387, PUB. 7-3-2012. INT. CL. 29.
- POTOMAC RIVER RUNNING, INC., MCLEAN, VA, DBA POTOMAC RIVER RUNNING STORE:
3,676,145, COR. INT. CL. 35.
- POTTERS INDUSTRIES, LLC, WILMINGTON, DE:
4,211,651, INT. CL. 1.
- POUND PAYMENTS, INC., PALO ALTO, CA, DBA BALANCED, POUNDPAY:
4,210,198, PUB. 7-3-2012. MULTIPLE CLASS, INT. CLS. 9 AND 36.
- POWELL INVESTORS GROUP, LLC, SOUTHURRY, CT:
4,209,529, PUB. 7-3-2012. INT. CL. 42.
- POWER INTEGRATIONS, INC., SUNNYVALE, CA:
2,471,940, COR. INT. CL. 9.
2,659,810, COR. INT. CL. 9.
- POWER PLATE NORTH AMERICA, INC., IRVINE, IL:
3,709,967, COR. MULTIPLE CLASS, INT. CLS. 10 AND 28.
- POWER PLAY INTERNATIONAL, INC., JACKSON, NJ:
2,718,629. REN. 8-10-12. INT. CL. 36.
- POWER SERVICE PRODUCTS, INC., WEATHERFORD, TX:
2,678,595. REN. 8-10-12. INT. CL. 1.
- POWERS, CALI, SAN MATEO, CA AND DREW, BRENEE, SAN MATEO, CA:
4,210,963, INT. CL. 25.
- PPG ARCHITECTURAL FINISHES, INC., PITTSBURGH, PA:
2,527,649, CANC. INT. CL. 2.
- PRAI BEAUTY GROUP, INC., NEW CANAAN, CT:
2,528,189, CANC. INT. CL. 3.
2,528,190, CANC. INT. CL. 3.
- PRAIRIE FARMS DAIRY, INC., CARLINVILLE, IL:
3,120,574, CANC. MULTIPLE CLASS, INT. CLS. 30 AND 32.
- PRECIDIAN INVESTMENTS LLC, BEDMINSTER, NJ:
4,211,149, MULTIPLE CLASS, INT. CLS. 36, 42 AND 45.
4,211,150, INT. CL. 36.
- PRECISION DRILLING CORPORATION, CALGARY, ALBERTA, CANADA:
3,072,034, CANC. INT. CL. 42.
- PRECO, INC., LENEXA, KS:
2,605,796. REN. 8-13-12. INT. CL. 40.
2,605,797. REN. 8-10-12. INT. CL. 9.
- PREMERA BLUE CROSS, SEATTLE, WA:
2,744,370. REN. 8-11-12. INT. CL. 36.
- PREMIER IVF, LLC, LONE TREE, CO:
4,211,098, MULTIPLE CLASS, INT. CLS. 35 AND 44.
- PREMIO FOODS, INC., ROCHELLE PARK, NJ:
2,639,522. REN. 8-11-12. INT. CL. 29.
- PREMIUM WATERS, INC., MINNEAPOLIS, MN:
4,209,878, PUB. 7-3-2012. INT. CL. 32.
- PREMONITION RECORDS, INC., CHICAGO, IL:
2,526,398, CANC. INT. CL. 9.
- PRESIDIUM AVIATION, INC., SUGAR LAND, TX:
4,209,360, PUB. 7-3-2012. INT. CL. 35.
- PRETTY BROWN GIRL L.L.C., NOVI, MI:
4,210,122, PUB. 7-3-2012. INT. CL. 25.
- PRICE, KEVIN, HOLLISTON, MA:
4,209,166, PUB. 7-3-2012. INT. CL. 6.
- PRICEMETRIX INC., TORONTO, ON, CANADA:
4,210,638, MULTIPLE CLASS, INT. CLS. 9, 35 AND 36.
- PRIDESTAFF, INC., FRESNO, CA:
4,211,237, MULTIPLE CLASS, INT. CLS. 16 AND 41.
- PRIMARY INVESTMENTS GROUP LIMITED, ROAD TOWN, TORTOLA, BR.VIRGIN ISLANDS:
4,211,653, INT. CL. 5.
- PRIME TIME BOXING, INC., SACRAMENTO, CA:
4,209,145, PUB. 7-3-2012. INT. CL. 25.

PRIMERA COMPANIES, INC., DALLAS, TX:
2,620,568. REN. 8-11-12. INT. CL. 36.

PRIMUS PHARMACEUTICALS, INC., SCOTTSDALE, AZ:
4,211,670. INT. CL. 5.

PRIORITY FULFILLMENT SERVICES, INC., ALLEN, TX:
2,748,162. REN. 8-15-12. INT. CL. 35.

PRIORITY POWER MANAGEMENT, LP, ARLINGTON, TX:
2,527,220. CANC. INT. CL. 35.

PRIVACY DATA SYSTEMS, LLC, GREENWOOD, IN:
4,211,740. INT. CL. 38.

PRIVATE SPACE, BOONVILLE, MO:
4,208,499. PUB. 7-3-2012. INT. CL. 9.

PRO SE PLANNING, INC., MEDINA, WA, DBA DIVORCE-
WRITER:
4,209,922. PUB. 7-3-2012. INT. CL. 42.

PRO SE PLANNING, INC., MEDINA, WA, DBA LEGACY-
WRITER:
4,209,977. PUB. 7-3-2012. INT. CL. 42.

PROBELGIN, INC, CHEYENNE, WY:
4,209,197. PUB. 7-3-2012. INT. CL. 35.

PROCLAIM NUTRITION LLC, HENDERSON, NV:
4,211,222. INT. CL. 5.

PROCTER & GAMBLE BUSINESS SERVICES CANADA
COMPANY, HALIFAX, NOVA SCOTIA, CANADA:
3,038,331. CANC. INT. CL. 21.

PROCTOR, DAVID MICHAEL, NORTHBRIDGE, CA:
4,211,787. INT. CL. 36.

PRODIGY EVENTS INC., LA JOLLA, CA:
4,209,233. PUB. 7-3-2012. INT. CL. 41.

PRODUCERS ENVIRONMENTAL PRODUCTS, BATAVIA,
IL, DBA ENVIRONMENTAL SOLUTIONS INTERNA-
TIONAL:
2,628,162. REN. 8-14-12. INT. CL. 1.

PRODUCT INNOVATION RESEARCH LLC, DALLAS, TX:
4,211,292. INT. CL. 3.
4,211,293. INT. CL. 3.

PRODUCT INNOVATIONS RESEARCH LLC, DALLAS, TX:
4,210,912. INT. CL. 3.

PRODUCTION CONTROL SERVICES, INC., FREDERICK,
CO:
4,209,669. PUB. 7-3-2012. INT. CL. 9.

PRODUCTIVEMD, LLC, FRANKLIN, TN:
4,209,351. PUB. 7-3-2012. INT. CL. 44.

PRODUCTOS DEL MAR VENTISQUEROS S.A., PUERTO
MONTT, CHILE:
4,208,651. PUB. 7-3-2012. INT. CL. 29.

PROELECTRICFIREPLACE.COM, DIVISION OF TWIN
STAR INTL., DELRAY BEACH, FL:
4,208,981. PUB. 7-3-2012. INT. CL. 11.

PROFESSIONAL HEALTH AND NUTRITION, INC., TROY,
MI:
4,210,987. MULTIPLE CLASS, INT. CLS. 5 AND 32.

PROFESSIONAL PRODUCTS UNLIMITED, INC., FAYET-
TEVILLE, GA:
4,209,388. PUB. 7-3-2012. INT. CL. 3.

PROFESSIONAL RESEARCH CONSULTANTS, INC., OMA-
HA, NE:
4,211,784. INT. CL. 44.

PROFESSOR CONNOR'S, INC., SECAUCUS, NJ, DBA
FRESHPET:
4,210,970. INT. CL. 31.

PROFICIENT LEARNING, LLC, WILMINGTON, NC:
4,208,878. PUB. 7-3-2012. MULTIPLE CLASS, INT. CLS. 16
AND 41.

PROGRADE, INC., CINCINNATI, OH:
2,526,458. CANC. MULTIPLE CLASS, INT. CLS. 35 AND
42.

PROGRESS COMMERCIAL PRINTING & GRAPHICS, INC.,
OWENSBORO, KY, AKA PROGRESS PRINTING COM-
PANY:
4,208,517. PUB. 7-3-2012. INT. CL. 16.

PROGRESSIVE FASTENING, INC., SEATTLE, WA:
4,208,198. PUB. 7-3-2012. INT. CL. 6.

PROGRESSIVE LABORATORIES, INC., IRVING, TX:
4,209,007. PUB. 7-3-2012. INT. CL. 5.

PROGRESSIVE NURSING STAFFERS, INC., SPRINGFIELD,
VA:
2,549,281. REN. 8-13-12. INT. CL. 35.
2,549,282. REN. 8-13-12. INT. CL. 35.

PROMETHEUS GLOBAL MEDIA, LLC, NEW YORK, NY:
4,211,680. MULTIPLE CLASS, INT. CLS. 9, 16, 25, 41 AND
43.

PROMITOR TECHNOLOGY LLC, ISSAQUAH, WA:
4,209,379. PUB. 7-3-2012. INT. CL. 42.

PRONOVA LABORATORIES B.V., NL-1398 CP MUIDEN,
NETHERLANDS:
4,208,294. PUB. 7-3-2012. MULTIPLE CLASS, INT. CLS. 5
AND 10.

PROVEEDORES DE INGENIERIA ALIMENTARIA, SA. DE
CV., APODACA, NUEVO LEÓN, MEXICO:
4,208,526. PUB. 7-3-2012. INT. CL. 43.

PROVIDENT MARKETING, INC, DOYLESTOWN, PA:
4,210,238. INT. CL. 20.

PROXIBID, INC., OMAHA, NE:
4,211,196. INT. CL. 42.
4,211,211. INT. CL. 42.

PRYSMIAN CAVI E SISTEMI S.R.L., MILAN, ITALY:
2,630,073. REN. 8-16-12. INT. CL. 9.

PSYCH-TECH INC., RIVERDALE, NY:
4,210,456. INT. CL. 41.

PT SUMATRA TOBACCO TRADING COMPANY, SUMA-
TERA UTARA, INDONESIA:
4,209,654. PUB. 7-3-2012. INT. CL. 34.

PULS GMBH, 81925 MUNCHEN, FED REP GERMANY:
4,208,578. PUB. 7-3-2012. INT. CL. 9.

PUNK ROCK HOOPS, LLC, DALLAS, TX:
4,211,442. MULTIPLE CLASS, INT. CLS. 28 AND 41.

PUNKSTAR, LLC, LOS ANGELES, CA:
4,210,336. INT. CL. 25.
4,210,343. INT. CL. 28.

PUPLAMPU, ADITEI, KEW GARDENS, NY:
4,209,538. PUB. 7-3-2012. INT. CL. 30.

PURAPHARM INTERNATIONAL (H.K.) LIMITED, CEN-
TRAL, HONG KONG:
2,639,990. REN. 8-10-12. INT. CL. 5.

PURE FISHING, INC., SPIRIT LAKE, IA:
2,599,330. REN. 8-10-12. INT. CL. 28.

PURPLE LABS S.A., 73375 LE BOURGET DU LA, FRANCE:
4,210,314. MULTIPLE CLASS, INT. CLS. 9 AND 42.

PYUNG AN TEXTILE CO., LTD., DONGDAEMUN-KU,
SEOUL, REPUBLIC OF KOREA:
2,687,271. REN. 8-16-12. INT. CL. 25.

QSR INTERNATIONAL PTY LTD, DONCASTER, AUSTRA-
LIA, DBA QSR INTERNATIONAL PTY LTD:
4,208,555. PUB. 7-3-2012. MULTIPLE CLASS, INT. CLS. 9
AND 41.

QUACKENBUSH, MICHAEL, CHAPEL HILL, NC:
4,208,191. PUB. 12-21-2010. INT. CL. 16.

QUALITY EDGE, INC., WALKER, MI:
4,211,527. INT. CL. 6.

QUALITY NEW MEXICO, ALBUQUERQUE, NM:
4,210,715. MULTIPLE CLASS, INT. CLS. 35 AND 41.

QUALITYTECH, LP, OVERLAND PARK, KS:
4,209,447. PUB. 7-3-2012. INT. CL. 42.

QUALTECH SYSTEMS, INC., WETHERSFIELD, CT:
2,527,241. CANC. INT. CL. 9.

QUAVERMUSIC.COM, LLC, NASHVILLE, TN:
4,210,937. MULTIPLE CLASS, INT. CLS. 25 AND 41.

QUICKIE MANUFACTURING CORPORATION, CINNA-
MINSON, NJ:
4,210,749. INT. CL. 21.

QUICKSILVER ANALYTICS, INC., ABINGDON, MD:
2,735,580. REN. 8-13-12. INT. CL. 9.

QUIK-HELP, WALDORF, MD:
4,209,162. PUB. 7-3-2012. MULTIPLE CLASS, INT. CLS. 41
AND 42.

QUINN & SHERRY INC., NORTH BAY, ONTARIO, CANA-
DA:
2,744,357. REN. 8-15-12. INT. CL. 28.

QUIROGA DE PABLO JUAN LUIS, AZOFRA, LA RIOJA,
SPAIN, DBA BODEGA JUAN LUIS QUIROGA DE PABLO:
4,208,687. PUB. 7-3-2012. INT. CL. 33.

- QWEST COMMUNICATIONS INTERNATIONAL INC., DENVER, CO:
3,036,994, CANC. INT. CL. 42.
- R. TWINING AND COMPANY LIMITED, LONDON, UNITED KINGDOM:
4,209,792, PUB. 7-3-2012. INT. CL. 30.
4,210,101, PUB. 7-3-2012. INT. CL. 30.
4,211,209, INT. CL. 30.
- R.R. BOWKER LLC, NEW PROVIDENCE, NJ:
2,610,398, REN. 8-10-12. INT. CL. 35.
- R&D VINS, S.A.R.L., FRANCE:
4,208,434, PUB. 7-3-2012. INT. CL. 33.
- R&R APPAREL COMPANY, LLC, WILMINGTON, DE:
4,208,471, PUB. 7-3-2012. INT. CL. 35.
- RABA JARMUIPARI HOLDING RT., MARTIN UT 1., HUNGARY:
3,047,376, CANC. INT. CL. 6.
- RACHEL YVONNE DE BOER-VAN ECK, NETHERLANDS:
4,208,357, PUB. 7-3-2012. INT. CL. 25.
- RACING CHAMPIONS ERTL, INC., DYERSVILLE, IA:
2,528,373, CANC. INT. CL. 28.
- RACONTEUR, INC., BOCA RATON, FL:
4,211,392, INT. CL. 25.
- RADIATOR SPECIALTY COMPANY, INDIAN TRAIL, NC:
564,393, REN. 8-14-12. U.S. CL. 35 (INT. CLS. 7, 12 AND 17).
- RADIUS CORPORATION, KUTZTOWN, PA:
4,209,531, PUB. 7-3-2012. INT. CL. 21.
4,209,532, PUB. 7-3-2012. INT. CL. 21.
- RADLEY CORPORATION, SOUTHFIELD, MI:
4,210,127, PUB. 7-3-2012. INT. CL. 9.
- RADVANSKY, ANNETTE AMANDA, THE WOODLANDS, TX:
4,209,753, PUB. 7-3-2012. INT. CL. 14.
- RAE, KAREN L., RIDGEFIELD, WA:
4,210,258, INT. CL. 18.
4,211,570, INT. CL. 25.
- RAGAS, NELSON, BATON ROUGE, LA:
4,209,906, PUB. 7-3-2012. INT. CL. 41.
- RAGSDALE, CHRISTINA M., SANTA BARBARA, CA:
4,209,298, PUB. 7-3-2012. INT. CL. 3.
- RAINBOW LIGHT NUTRITIONAL SYSTEMS, INC., SANTA CRUZ, CA:
2,602,478, REN. 8-13-12. INT. CL. 5.
- RAINTREE ESSIX INC., WILMINGTON, DE:
4,211,277, INT. CL. 17.
- RAJAH MUSICAL INSTRUMENTS CO., LTD., TAIPEI, TAIWAN:
4,210,904, INT. CL. 15.
- RALEIGH PITMASTER EMPIRE, LLC, RALEIGH, NC:
4,210,202, PUB. 7-3-2012. INT. CL. 43.
- RALEY'S, WEST SACRAMENTO, CA:
2,528,354, CANC. INT. CL. 31.
- RALEY'S, WEST SACRAMENTO, CA:
2,528,350, CANC. INT. CL. 31.
- RAMCO MANUFACTURING COMPANY, INC., KENILWORTH, NJ:
1,746,294, REN. 8-11-12. INT. CL. 6.
- RAMIREZ, ROLAND, HOUSTON, TX:
3,038,513, CANC. INT. CL. 25.
- RAMSAY, CHRISTOPHER, MIAMI, FL:
4,209,122, PUB. 7-3-2012. INT. CL. 16.
4,209,123, PUB. 7-3-2012. INT. CL. 41.
- RANKIN INDUSTRIES, INC., RANCHO CUCAMONGA, CA:
4,210,982, INT. CL. 9.
- RATLIFF, DARRELL S., CASTLE ROCK, CO, DBA BORLINO LLC:
4,209,442, PUB. 7-3-2012. INT. CL. 18.
- RATNER, DOUGLAS, MORRISTOWN, NJ:
4,211,312, INT. CL. 44.
- RAVEN'S BREW COFFEE, INC., TUMWATER, WA:
2,602,415, REN. 8-10-12. INT. CL. 30.
- RAVIOLI OLI COMPANY, PALOS HEIGHTS, IL:
4,210,520, INT. CL. 43.
4,210,521, INT. CL. 43.
- RAWLINGS SPORTING GOODS COMPANY, INC., ST. LOUIS, MO:
4,211,039, INT. CL. 18.
- RAY MARKS CO. LLC, NEW YORK, NY:
4,208,572, PUB. 7-3-2012. INT. CL. 9.
- RAYMARINE UK LTD., PORTSMOUTH, HAMPSHIRE, UNITED KINGDOM:
4,210,931, INT. CL. 9.
- RAYMOND WEIL S.A., SWITZERLAND:
4,208,383, PUB. 7-3-2012. INT. CL. 14.
- RAYSTONE PRODUCTIONS, INC., SANTA MONICA, CA:
2,600,848, REN. 8-14-12. INT. CL. 9.
- RBS CITIZENS FINANCIAL GROUP, INC., PROVIDENCE, RI:
4,211,235, INT. CL. 36.
4,211,324, INT. CL. 36.
- RBS SECURITIES, INC., STAMFORD, CT:
2,528,521, CANC. INT. CL. 36.
- RC2 CORPORATION, DYERSVILLE, IA:
2,526,952, CANC. INT. CL. 28.
- RD 2 SUCCESS EXPRESS, INC. BRONX, NY:
4,209,301, PUB. 7-3-2012. INT. CL. 39.
- RE: SOURCE AMERICAS ENTERPRISES, INC., ATLANTA, GA, RENOVISIONS, INC., ATLANTA, GA:
1,712,245, REN. 8-14-12. INT. CL. 37.
- REACH PUBLISHING, LLC, CINCINNATI, OH:
2,565,383, REN. 8-15-12. INT. CL. 16.
- READY PAC PRODUCE, INC., IRWINDALE, CA:
4,210,099, PUB. 7-3-2012. INT. CL. 29.
- REALDIRECT, INC., NEW YORK, NY, AKA REALDIRECT:
4,209,312, PUB. 7-3-2012. MULTIPLE CLASS, INT. CLS. 36 AND 42.
- REALITIES FOR CHILDREN, INC., FORT COLLINS, CO:
4,209,800, PUB. 7-3-2012. MULTIPLE CLASS, INT. CLS. 35 AND 36.
- REALNETWORKS, INC., SEATTLE, WA:
4,210,071, PUB. 7-3-2012. INT. CL. 38.
4,210,196, PUB. 7-3-2012. INT. CL. 41.
- REALPAGE, INC., CARROLLTON, TX:
2,603,326, REN. 8-15-12. INT. CL. 9.
- REAVES, RAY, AUSTIN, TX:
4,211,395, INT. CL. 41.
- RECKITT BENCKISER (SWITZERLAND) AG, ZURICH, SWITZERLAND:
4,210,381, MULTIPLE CLASS, INT. CLS. 3, 5 AND 11.
- RECKITT BENCKISER N.V., 2132 WT HOOFDDORP, NETHERLANDS:
4,210,711, INT. CL. 9.
- RECOVERY CARE MATTERS, LLC, SILVER SPRING, MD:
4,209,695, PUB. 7-3-2012. INT. CL. 44.
- RECOVERY HELP NOW, INC., LOS ANGELES, CA:
4,209,380, PUB. 7-3-2012. INT. CL. 44.
- RED BLUE VOICE, LLC, PITTSBURGH, PA:
4,210,794, MULTIPLE CLASS, INT. CLS. 14, 16, 25, 26 AND 35.
- RED BOX TOY FACTORY LTD., HONG KONG, CHINA:
3,264,841, COR. INT. CL. 28.
- RED CARPET INTERNATIONAL, INC., SOUTHGATE, MI:
4,208,798, PUB. 7-3-2012. INT. CL. 36.
- RED CURBS, LLC, OCEAN CITY, NJ:
4,209,065, PUB. 7-3-2012. MULTIPLE CLASS, INT. CLS. 16, 25 AND 28.
- RED DOT SECURITY INC., SANDY, UT:
4,210,811, INT. CL. 9.
- RED E PRODUCTIONS LLC, PROSPECT, KY:
4,211,117, MULTIPLE CLASS, INT. CLS. 9 AND 38.
- REDPAW, INC., FRANKLIN, WI:
4,211,795, INT. CL. 31.
- REDUCTION ENGINEERING, INC., KENT, OH:
4,211,346, INT. CL. 7.
- REDWOOD HILL FARM & CREAMERY, INC., SEBASTOPOL, CA:
4,210,505, INT. CL. 29.
- REED GROUP, LTD., WESTMINSTER, CO:
2,528,265, CANC. INT. CL. 42.
- REELING SPIRIT PRODUCTIONS, COLLEYVILLE, TX:
4,208,668, PUB. 7-3-2012. MULTIPLE CLASS, INT. CLS. 16 AND 41.
- REGENERATION PARTNERS, LLC, NEW YORK, NY:
4,208,220, PUB. 7-13-2010. INT. CL. 25.

REGIONAL INTERNATIONAL CORP., HENRIETTA, NY:
4,209,804, PUB. 7-3-2012. INT. CL. 35.

RELIABIT, LLC, LA QUINTA, CA:
4,209,608, PUB. 7-3-2012. INT. CL. 9.

RELIANCE INTERNATIONAL CORP., TAIPEI, TAIWAN:
2,668,579. REN. 8-14-12. MULTIPLE CLASS, INT. CLS. 9,
11, 15, 16 AND 20.

RELIANCE RENT-A-CAR, LLC, BUENA PARK, CA:
4,209,409, PUB. 7-3-2012. INT. CL. 39.

REMBERTO ESTRELLA, SANTIAGO, DOMINICAN REP:
4,210,679, INT. CL. 34.

REMET PIC, INC., UTICA, NY:
4,210,471, INT. CL. 4.

REMINGTON, INC., SANTA CLARITA, CA:
4,211,723, INT. CL. 30.

RENAISSANCE EXECUTIVE FORUMS, INC., LA JOLLA,
CA:
2,601,300. REN. 8-12-12. INT. CL. 41.

RENE HERNANDEZ, ROSENBERG, TX, DBA RONNIE
RAY:
4,208,697, PUB. 7-3-2012. INT. CL. 41.

REPUBLIC OF FRIENDS, INC., ENCINITAS, CA:
4,210,376, MULTIPLE CLASS, INT. CLS. 9, 18 AND 25.

RESEARCH ENGINEERING AND MANUFACTURING,
INC., MIDDLETOWN, RI:
2,623,001. REN. 8-15-12. INT. CL. 6.

RESICOM CUSTOM PAINTING & MAINTENANCE, INC.,
LEMONT, IL:
4,211,810, INT. CL. 35.

RESOLUTION GROUP INTERNATIONAL LLC, SEA GIRT,
NJ:
4,209,383, PUB. 7-3-2012. MULTIPLE CLASS, INT. CLS. 16
AND 41.

RESPIRATORY DELIVERY SYSTEMS, INC., CHELMS-
FORD, MA:
2,724,526. REN. 8-15-12. INT. CL. 10.

RESPIRONICS (IRELAND) LIMITED, GALWAY, IRELAND:
2,528,119, CANC. INT. CL. 10.

RESTANEO, CHRISTINE MARIE, HOUSTON, PA:
2,527,550, CANC. INT. CL. 41.

RESTAURANT RESULTS, INC., CONKLIN, NY:
4,209,204, PUB. 7-3-2012. INT. CL. 37.

RESTORECORE, INC., HARRISBURG, PA:
4,209,451, PUB. 7-3-2012. MULTIPLE CLASS, INT. CLS. 37
AND 40.

RESTORING THE YEARS MINISTRIES INCORPORATED,
MARIETTA, GA:
4,209,201, PUB. 7-3-2012. INT. CL. 45.

RETAIL MEDIA NOW, LLC, OVERLAND PARK, KS:
4,211,236, INT. CL. 35.

RETAIL ROYALTY COMPANY, LAS VEGAS, NV:
4,211,377, INT. CL. 9.

RETRACTABLEDESIGNS, LLC, BRECKENRIDGE, CO:
4,183,592, COR. INT. CL. 24.

RETTER, DANIEL, NEW YORK, NY:
4,211,537, INT. CL. 16.
4,211,538, INT. CL. 16.

REV-A-SHELF COMPANY, LLC, JEFFERSONTOWN, KY:
4,210,241, INT. CL. 11.

REVERE ELECTRIC SUPPLY COMPANY, CHICAGO, IL:
4,209,765, PUB. 7-3-2012. INT. CL. 35.
4,209,784, PUB. 7-3-2012. INT. CL. 35.

REVIEW PUBLISHING LIMITED PARTNERSHIP, PHILA-
DELPHIA, PA:
2,608,322. REN. 8-11-12. INT. CL. 16.

REVONOC, INC., PARKMAN, OH:
2,718,855. REN. 8-11-12. INT. CL. 41.

REWARDSPAY, INC., MILPITAS, CA:
4,211,488, INT. CL. 36.

REY IGLESIAS, ANTONIO RAMON, PEREIRO DE
AGUIAR, SPAIN:
4,208,866, PUB. 6-12-2012. INT. CL. 44.

REYES-SMITHLEY, LLC, WILMINGTON, NC:
4,209,773, PUB. 7-3-2012. INT. CL. 35.

REYNOSO, JUAN SALVADOR, HIDALGO, TX:
4,211,367, INT. CL. 25.

RGI INFORMATICS, LLC, CORNWALLVILLE, NY:
4,209,693, PUB. 7-3-2012. INT. CL. 42.

RHAUSLER, INC., SAN CARLOS, CA:
4,211,152, INT. CL. 10.

RHEAVENDORS SERVICES S.P.A., COMO, ITALY:
2,612,122. REN. 8-13-12. MULTIPLE CLASS, INT. CLS. 9,
11, 30 AND 32.

RHEINISCH-WESFALISCHE TECHNISCHE HOCHSCHULE
AACHEN, AACHEN, FED REP GERMANY:
2,606,074. REN. 8-15-12. INT. CL. 9.

RHEINZINK GMBH & CO. KG, FED REP GERMANY:
4,208,414, PUB. 7-3-2012. MULTIPLE CLASS, INT. CLS. 6,
37 AND 40.

RHINO TECHNOLOGIES, INC., CONROE, TX:
2,606,268. REN. 8-16-12. INT. CL. 1.

RHODIA OPERATIONS, 93306 AUBERVILLIERS, FRANCE,
MIRANOL CHEMICAL COMPANY, INC., IRVINGTON,
NJ:
738,441. REN. 8-12-12. U.S. CL. 6 (INT. CL. 1).

RICARDO ALVAREZ, CHULA VISTA, CA:
4,210,649, INT. CL. 5.

RICH ICE CREAM COMPANY, INC., WEST PALM BEACH,
FL:
4,209,547, PUB. 7-3-2012. INT. CL. 30.
4,209,557, PUB. 7-3-2012. INT. CL. 30.

RICHARD AKWO, BALTIMORE, MD:
4,209,857, PUB. 7-3-2012. MULTIPLE CLASS, INT. CLS. 21
AND 25.

RICHARD KINCAID, CHICAGO, IL:
4,211,607, INT. CL. 9.

RICHARDS & TIERNEY, INC., CHICAGO, IL:
2,526,360, CANC. INT. CL. 36.

RICHELLE MELDE, SCOTTSDALE, AZ:
4,210,223, PUB. 9-13-2011. INT. CL. 41.

RICHEY, KELLY, J, CINCINNATI, OH, DBA POWERED BY
INTENTION:
4,210,611, INT. CL. 41.

RICHIN TRADING INC., ALHAMBRA, CA:
4,210,186, PUB. 7-3-2012. INT. CL. 30.

RICK T. HAMMOND, SUWANEE, GA:
4,209,485, PUB. 7-3-2012. INT. CL. 35.

RICOH COMPANY, LTD., JAPAN:
4,208,367, PUB. 7-3-2012. MULTIPLE CLASS, INT. CLS. 2,
9, 16, 20, 35, 37, 40 AND 42.

RIDING PARTNERS, INC., ASHEVILLE, NC:
4,210,898, INT. CL. 6.

RIFAAT, ISMAIL I, HOUSTON, TX:
3,029,598, CANC. INT. CL. 35.

RIGHT ASCENSION, INC., WARRENDALE, PA:
4,211,090, INT. CL. 39.

RIGHT BRAIN TRUST, LLC, THE, SOUTHURRY, CT:
2,528,681, CANC. INT. CL. 42.

RIKOCHE LIMITED, OAKLAND, CA:
4,210,964, INT. CL. 45.

RINCK, MICHAEL, EUSTIS, FL:
4,208,549, PUB. 7-3-2012. INT. CL. 31.

RINGCENTRAL, INC., SAN MATEO, CA:
4,210,945, INT. CL. 38.

RISQUE VIDEO CORP., SEWELL, NJ:
4,209,033, PUB. 7-3-2012. MULTIPLE CLASS, INT. CLS. 35
AND 41.
4,209,034, PUB. 7-3-2012. MULTIPLE CLASS, INT. CLS. 35
AND 41.

RITZ HOTEL LIMITED, LONDON SW1, ENGLAND:
1,307,072, CANC. MULTIPLE CLASS, INT. CLS. 21 AND
33.

RIVAL RABBIT MANAGEMENT, MISSISSAUGA, ONTAR-
IO, CANADA:
4,208,458, PUB. 4-24-2012. MULTIPLE CLASS, INT. CLS.
9, 25 AND 41.

RIVAS, DAVID, SUNNYVALE, CA:
2,528,271, CANC. INT. CL. 36.

RIVER LIGHT V, L.P., NEW YORK, NY:
4,209,988, PUB. 7-3-2012. INT. CL. 41.

RJS CORPORATION, AKRON, OH:
4,209,723, PUB. 7-3-2012. INT. CL. 7.

RMO, INC., DENVER, CO:
4,210,896, MULTIPLE CLASS, INT. CLS. 10, 35, 41 AND
44.

- ROB ZAPPULLA MUSIC, LLC, SOMERS, CT:
4,211,801, INT. CL. 41.
- ROBBINS, INC., CINCINNATI, OH:
1,247,704, REN. 8-14-12. INT. CL. 19.
- ROBERT G BRUECHERT ATTORNEY AT LAW PC, AMITYVILLE, NY, DBA THE BRUECHERT LAW FIRM:
4,209,344, PUB. 7-3-2012. MULTIPLE CLASS, INT. CLS. 35 AND 45.
- ROBERT HALF INTERNATIONAL INC., MENLO PARK, CA:
2,613,461, REN. 8-16-12. INT. CL. 35.
- ROBERT J & CLAUDETTE O FREEMAN, WALDORF, MD AND FREEMAN, ROBERT J., WALDORF, MD:
1,707,418, REN. 8-14-12. INT. CL. 42.
- ROBERT JOHN VINEYARDS, LLC, COLUMBUS, OH:
4,208,156, PUB. 7-3-2012. INT. CL. 33.
- ROBERTO CAVALLI S.P.A., ITALY:
4,208,277, PUB. 7-3-2012. MULTIPLE CLASS, INT. CLS. 3, 9, 14, 18 AND 25.
4,208,283, PUB. 7-3-2012. MULTIPLE CLASS, INT. CLS. 3, 9, 14, 18 AND 25.
- ROBERTS ENTERPRISES, LP, CLOVER, SC:
2,623,494, REN. 8-11-12. INT. CL. 41.
- ROBERTS, VALERIE TAYLOR, BOSTON, MA:
4,210,977, INT. CL. 35.
- ROBERTSON, LYNN, SEATTLE, WA:
4,210,929, INT. CL. 45.
- ROBOAM AGUIRRE, MIAMI, FL:
4,208,934, PUB. 7-3-2012. INT. CL. 35.
- ROC RACING INC., MARYSVILLE, WA, DBA NATIONAL HOT ROD DIESEL ASSOCIATION:
4,211,540, INT. CL. 41.
- ROCA AUTO PARTS, CORP., MIAMI, FL:
4,209,687, PUB. 7-3-2012. INT. CL. 12.
- ROCHE DIAGNOSTICS OPERATIONS, INC., INDIANAPOLIS, IN:
4,210,360, MULTIPLE CLASS, INT. CLS. 9 AND 10.
4,210,373, INT. CL. 10.
- ROCK AND ROLL RELIGION, INC., LOS ANGELES, CA:
4,210,625, INT. CL. 25.
- ROCK RIVER ARMS, INC., COLONA, IL:
4,211,541, INT. CL. 13.
- ROCK SQUARE, INC., LOS ANGELES, CA:
4,210,958, INT. CL. 35.
- ROCKET TRADEMARKS PTY. LTD, QUEENSLAND, 4220, AUSTRALIA, ROCKET TRADEMARKS PTY. LTD, QUEENSLAND, 4220, AUSTRALIA:
2,603,929, REN. 8-11-12. MULTIPLE CLASS, INT. CLS. 18, 25 AND 28.
- ROCKIN BOHEMIAN, LAKELAND, FL:
4,209,273, PUB. 7-3-2012. MULTIPLE CLASS, INT. CLS. 25 AND 35.
- ROCKIN' BELLES, LLC, DENTON, TX:
4,210,637, INT. CL. 14.
- ROCKPORT COMPANY, LLC, CANTON, MA, ROCKPORT COMPANY, INC., THE, MARLBORO, MA:
1,706,924, REN. 8-10-12. INT. CL. 25.
- ROCKY PATEL PREMIUM CIGARS, INC., BONITA SPRINGS, FL:
4,209,068, PUB. 6-26-2012. INT. CL. 34.
- ROD PATRICK INC., DENVER, CO:
4,209,948, PUB. 7-3-2012. INT. CL. 25.
- RODALE INC., EMMAUS, PA:
2,605,279, REN. 8-15-12. INT. CL. 16.
4,209,746, PUB. 7-3-2012. MULTIPLE CLASS, INT. CLS. 36 AND 41.
- RODMAN & COMPANY, INC., NORTH HOLLYWOOD, CA:
2,527,290, CANC. INT. CL. 8.
- RODRIGUEZ PINEDA, MIGUEL ANGEL, TLALNEPANTLA, ESTADO DE MEXICO, MEXICO:
4,210,424, INT. CL. 25.
- ROEDIGER VACUUM GMBH, HANAU, FED REP GERMANY:
1,184,463, CANC. MULTIPLE CLASS, INT. CLS. 7, 9 AND 11.
- ROFFE ACCESSORIES, INC., NEW YORK, NY, TBS MARKETING, INC., NEW YORK, NY:
1,705,121, REN. 8-16-12. INT. CL. 25.
- ROGER T. STAUBACH AND MARIANNE H. STAUBACH, DALLAS, TX:
1,722,431, REN. 8-10-12. INT. CL. 36.
- ROHL, LLC, IRVINE, CA:
4,210,425, INT. CL. 11.
4,210,426, INT. CL. 11.
- ROHM AND HAAS CHEMICALS LLC, PHILADELPHIA, PA:
1,714,863, REN. 8-15-12. INT. CL. 1.
- ROLAND DG CORPORATION, SHIZUOKA-KEN, JAPAN:
4,152,971, COR. INT. CL. 9.
- ROLAND KLEIN, LTD., LONDON, UNITED KINGDOM:
4,210,117, PUB. 7-3-2012. INT. CL. 25.
- ROMAN STONE CONSTRUCTION CO., BAY SHORE, NY:
4,208,472, PUB. 7-3-2012. MULTIPLE CLASS, INT. CLS. 6, 9 AND 19.
- ROMANCE & CO., INC., REGO PARK, NY:
4,211,468, INT. CL. 14.
- ROMAR UNIVERSAL, INC., FORT LAUDERDALE, FL:
4,211,173, INT. CL. 34.
- ROMERO, JOHN R., EDGEWOOD, NM:
4,211,005, INT. CL. 35.
- ROSENBAUER INTERNATIONAL AKTIENGESELLSCHAFT, LEONING, AUSTRIA:
4,210,263, INT. CL. 9.
- ROSS-SIMONS OF WARWICK, INC., CRANSTON, RI:
4,210,540, INT. CL. 35.
- ROSSI, THOMAS R., NEWPORT BEACH, CA:
4,209,785, PUB. 7-3-2012. INT. CL. 1.
- ROSTRA VERNATHERM LLC, BRISTOL, CT:
4,208,557, PUB. 7-3-2012. MULTIPLE CLASS, INT. CLS. 7, 9 AND 11.
- ROTAR, DANIEL M., YOUNGSTOWN, OH, AKA SHOCK VALUE; SHOCK VALUE GAMES:
4,209,037, PUB. 7-3-2012. INT. CL. 9.
- ROTI RESTAURANTS, LLC, NORTHBROOK, IL:
4,208,489, PUB. 7-3-2012. INT. CL. 43.
4,208,492, PUB. 7-3-2012. INT. CL. 43.
- ROUMBOS, BERNADETTE, TUCSON, AZ:
4,209,113, PUB. 7-3-2012. INT. CL. 44.
- ROUNABOUT THEATRE COMPANY, INC., NEW YORK, NY:
4,209,570, PUB. 7-3-2012. INT. CL. 41.
- ROWAN GIBSON, ESSEN, FED REP GERMANY:
4,209,502, PUB. 7-3-2012. INT. CL. 35.
4,209,594, PUB. 7-3-2012. INT. CL. 35.
4,210,100, PUB. 7-3-2012. INT. CL. 35.
- ROYAL CONSUMER PRODUCTS, LLC, NORWALK, CT:
2,601,585, REN. 8-14-12. INT. CL. 35.
- ROYAL MANAGEMENT PTY LIMITED, ALEXANDRIA NSW 2015, AUSTRALIA TO ROYAL ELASTICS HOLDINGS, LTD, TSMISHATSUI, HONG KONG:
2,526,410, CANC. INT. CL. 25.
- ROYAL ROSE SYRUPS, LLC, BROOKLYN, NY:
4,209,306, PUB. 7-3-2012. INT. CL. 30.
- RSI HOME PRODUCTS MANAGEMENT, INC., ANAHEIM, CA:
4,209,690, PUB. 7-3-2012. INT. CL. 40.
- RSL FIBER SYSTEMS, LLC, EAST HARTFORD, CT:
4,210,577, MULTIPLE CLASS, INT. CLS. 11, 37 AND 42.
- RUBBER ARM, INC., MADISON HEIGHTS, VA:
4,209,250, PUB. 7-3-2012. INT. CL. 5.
- RUBEN, MARSHALL S., HARTFORD, CT:
4,210,229, INT. CL. 32.
- RUBIN, BARRY L., CLEARWATER, FL:
2,588,523, REN. 8-15-12. INT. CL. 35.
- RUBY NANCY, BOZEMAN, MT, DBA YOGAMOTION:
1,703,854, REN. 8-15-12. INT. CL. 41.
- RUDOLPH TECHNOLOGIES, INC., BLOOMINGTON, MN:
4,210,357, INT. CL. 9.
- RUETTEN ENGINEERING, CH-8712, STAEFA, SWITZERLAND:
2,528,338, CANC. INT. CL. 7.
- RUG DOCTOR, INC., PLANO, TX:
2,624,580, REN. 8-11-12. INT. CL. 37.
2,639,439, REN. 8-11-12. INT. CL. 7.
- RUNNING OUT LOUD LLC, JACKSONVILLE, FL:
4,210,631, INT. CL. 25.

RUSSELL, JANIE, ADDISON, TX:
2,625,029. REN. 8-10-12. INT. CL. 16.

RUSSTECH ENGINEERING CO., INC., MISSION VIEJO, CA:
4,209,296. PUB. 7-3-2012. INT. CL. 9.

RUTLIN, THOMAS H., MADISON, WI:
4,211,800. MULTIPLE CLASS, INT. CLS. 28 AND 41.

RVP STUDIOS, LLC, WEST HAVEN, CT:
4,209,262. PUB. 7-3-2012. INT. CL. 41.

RWACHSBERG HOLDINGS INC., CONCORD, ONTARIO, CANADA:
4,208,187. PUB. 7-3-2012. MULTIPLE CLASS, INT. CLS. 3, 5, 29, 30, 32 AND 33.

RWE AKTIENGESELLSCHAFT, ESSEN, FED REP GERMANY:
4,208,644. PUB. 7-3-2012. MULTIPLE CLASS, INT. CLS. 4, 7, 9, 35, 36, 37, 39 AND 40.

RX DIRECT, INC., TEXARKANA, TX:
2,603,300. REN. 8-10-12. INT. CL. 35.

RYAN'S RESTAURANT GROUP, INC., EAGAN, MN, RYAN'S FAMILY STEAK HOUSES, INC., GREER, SC:
1,707,396. REN. 8-10-12. INT. CL. 42.

S M & N HOSPITALITY GROUP LLC, MIAMI BEACH, FL, DBA PUBBELLY:
4,210,603. INT. CL. 43.

S. GOLDBERG & CO., INC, HACKENSACK, NJ:
4,211,431. INT. CL. 25.

S.A.M. ITALIA S.R.L., 50059 VINCI (FIRENZE), ITALY:
4,210,951. MULTIPLE CLASS, INT. CLS. 18 AND 25.

S.C. DU CHATEAU LA FLEUR PETRUS, FRANCE:
4,208,443. PUB. 7-3-2012. INT. CL. 33.

S&S BRANDS, LLC, WILMINGTON, DE:
2,744,615. REN. 8-10-12. INT. CL. 31.
2,744,616. REN. 8-10-12. INT. CL. 31.

SABANA INVESTMENTS INC., ST. JOHNS, ANTIGUA & BARBUDA:
4,209,710. PUB. 7-3-2012. INT. CL. 41.
4,209,711. PUB. 7-3-2012. INT. CL. 41.

SABAT, JOSE H, WESTON, FL:
4,209,071. PUB. 7-3-2012. INT. CL. 42.

SABERTOOTH MOTORCYCLES, LLC, CHESTNUT HILL, MA:
4,209,078. PUB. 3-27-2012. INT. CL. 32.

SABINE, GORDON, SANTA MONICA, CA:
2,602,064. REN. 8-13-12. INT. CL. 6.

SABINSA CORPORATION, EAST WINDSOR, NJ:
4,210,872. INT. CL. 5.

SABUNO, LLC, MARINA DEL REY, CA:
4,209,659. PUB. 7-3-2012. INT. CL. 35.

SACA TUEME, VICTOR JORGE, SAN SALVADOR, EL SALVADOR:
4,208,731. PUB. 7-3-2012. INT. CL. 5.

SADOWSKI, STANLEY, PROVO, UT:
4,210,383. INT. CL. 28.

SAFARI GIRL, LLC, RICHFIELD, WI:
4,210,677. INT. CL. 25.

SAFARI PROGRAMS, INC., MIAMI GARDENS, FL:
3,212,639. CANC. INT. CL. 9.

SAFE AUTO INSURANCE COMPANY, COLUMBUS, OH:
4,211,038. INT. CL. 36.

SAFEOPERATIONS, INC., COLUMBIA, MD, SAFEOPERATIONS, INC., COLUMBIA, MD:
2,605,531. REN. 8-13-12. INT. CL. 9.

SAFEOPERATIONS, INC., COLUMBIA, MD:
2,680,648. REN. 8-11-12. MULTIPLE CLASS, INT. CLS. 9 AND 42.

SAFEVISION, L.L.C., ST. LOUIS, MO:
2,723,728. REN. 8-10-12. INT. CL. 35.

SAFEWALL, LLC, ORANGE PARK, FL:
4,210,803. INT. CL. 19.

SAFEWAY INC., PLEASANTON, CA:
4,210,231. MULTIPLE CLASS, INT. CLS. 3 AND 5.
4,210,248. MULTIPLE CLASS, INT. CLS. 29 AND 32.

SAFEWAY WATER, LLC, OCALA, FL:
4,208,840. PUB. 7-3-2012. INT. CL. 11.

SAGAX PRODUCTS, INC., KENNESAW, GA:
4,211,094. MULTIPLE CLASS, INT. CLS. 1 AND 22.

SAINT LUKE'S HEALTH SYSTEM, INC, KANSAS CITY, MO:
4,210,751. INT. CL. 44.

SAKURA & ASSOCIATES GROUP, INC., MIAMI, FL:
4,211,263. INT. CL. 9.

SALAMANDER DESIGNS LTD., BLOOMFIELD, CT:
2,602,547. REN. 8-11-12. INT. CL. 20.

SALES & PRODUCT SOLUTIONS, INC., NORTHBROOK, IL:
4,210,401. INT. CL. 25.

SALES & PRODUCT SOLUTIONS, INC., NORTHBROOK, IL:
4,210,400. INT. CL. 14.
4,210,403. INT. CL. 3.
4,210,404. INT. CL. 28.

SALESFORCE.COM, INC., SAN FRANCISCO, CA:
4,210,584. INT. CL. 42.

SALISH KOOTENAI COLLEGE, INC., PABLO, MT:
4,209,064. PUB. 7-3-2012. INT. CL. 41.

SALTWORKS, INC., WOODINVILLE, WA:
4,208,607. PUB. 7-3-2012. INT. CL. 30.

SALVATION ARMY, THE, LONG BEACH, CA:
2,527,296. CANC. INT. CL. 41.

SAMSONITE IP HOLDINGS S.A.R.L., LUXEMBOURG, LUXEMBOURG:
2,528,207. CANC. INT. CL. 18.

SAMSONITE IP HOLDINGS S.A.R.L., L-1931 LUXEMBOURG, LUXEMBOURG:
2,596,064. REN. 8-16-12. INT. CL. 18.
2,606,009. REN. 8-15-12. INT. CL. 18.

SAMSUNG ELECTRONICS CO., LTD., SUWON-SI, GYEONGGI-DO, REPUBLIC OF KOREA:
4,210,777. INT. CL. 9.

SAMUEL A YOUNG, ACWORTH, GA, DBA NATTHEKAT ENTERPRISES LLC:
4,210,690. INT. CL. 25.

SAMUEL AARON, INC., LONG ISLAND CITY, NY:
4,210,786. INT. CL. 14.

SAMUEL, LAWRENCE R., MIAMI BEACH, FL, DBA CULTURE PLANNING:
3,038,286. CANC. INT. CL. 41.

SAN ANTONIO WINERY, LOS ANGELES, CA:
4,211,616. INT. CL. 33.
4,211,617. INT. CL. 33.

SAN PASQUAL CASINO DEVELOPMENT GROUP INC., VALLEY CENTER, CA:
4,210,519. INT. CL. 35.

SAN YUN INDUSTRIAL CO., LTD., TAOYUAN COUNTY 320, TAIWAN:
4,208,836. PUB. 7-3-2012. MULTIPLE CLASS, INT. CLS. 7 AND 12.

SANCHEZ, PONCHO, NORWALK, CA:
2,600,988. REN. 8-16-12. INT. CL. 41.

SANCHEZ, ROBERT, WEED, CA AND SANCHEZ, CHARLENE, WEED, CA:
4,209,708. PUB. 7-3-2012. MULTIPLE CLASS, INT. CLS. 16, 21, 25 AND 34.

SANDALS RESORTS INTERNATIONAL 2000 LIMITED, WEST BAY ST, NASSAU, BAHAMAS:
4,210,372. INT. CL. 36.

SANDER A. KESSLER & ASSOCIATES, INC., SANTA MONICA, CA:
2,526,461. CANC. INT. CL. 36.

SANDERS, HENRY, LONG BEACH, CA:
4,209,171. PUB. 7-3-2012. INT. CL. 16.

SANDISK CORPORATION, MILPITAS, CA:
4,208,709. PUB. 7-3-2012. INT. CL. 9.

SANDOW MEDIA, LLC, BOCA RATON, FL:
4,211,156. INT. CL. 35.

SANDPIPER SOFTWARE INC., LOS ALTOS, CA:
2,528,045. CANC. INT. CL. 42.

SANDTECH, INC., MORTON GROVE, IL, FORMERLY ALFA MANUFACTURING INDUSTRIES, INC.:
2,608,957. REN. 8-10-12. INT. CL. 7.

SANFORD, L.P., ATLANTA, GA:
3,038,340. CANC. INT. CL. 25.

SANGAMENT, INC., EAST NORWICH, NY:
4,208,479. PUB. 7-3-2012. INT. CL. 41.

- SANOFI, FRANCE:
4,208,241, PUB. 7-3-2012. INT. CL. 5.
- SANOFI, PARIS, FRANCE:
4,208,500, PUB. 7-3-2012. MULTIPLE CLASS, INT. CLS. 5, 9 AND 10.
- SANTA CLAUSET TOYS LC, SOUTH JORDAN, UT:
4,208,581, PUB. 7-3-2012. MULTIPLE CLASS, INT. CLS. 16 AND 28.
- SANTA CRUZ BERRY FARMING CO., LLC, WATSONVILLE, CA:
4,209,203, PUB. 7-3-2012. INT. CL. 31.
- SANTA, PEDRO ORTUNO, 30510 YECLA, MURCIA, SPAIN:
2,603,318. REN. 8-15-12. INT. CL. 25.
- SANTE SEMPRINI CESARI, UNION CITY, NJ:
4,211,372, INT. CL. 3.
- SANTOS CABALLERO, MARIA ISABEL, MEDELLÍN, COLOMBIA AND MARROQUIN SANTOS, JUAN SEBASTIAN, MEDELLÍN, COLOMBIA:
4,208,635, PUB. 7-3-2012. INT. CL. 25.
- SANTULLI, MARIA, SUE, BRIELLE, NJ, DBA LIL' SAINT PIGNIC:
4,208,646, PUB. 7-3-2012. INT. CL. 43.
- SANWA SEIKI LTD, SAITAMA-CITY, SAITAMA-PREFECTURE, JAPAN, SANWA SEIKI MFG. CO., LTD., YONOCITY, SAITAMA-PREFECTURE, JAPAN:
1,209,627. REN. 8-15-12. INT. CL. 12.
- SANYO DENKI CO., LTD., KITAOTSUKA, TOSHIMA-KU TOKYO, JAPAN:
2,632,562. REN. 8-10-12. INT. CL. 9.
- SANYO MANUFACTURING CORPORATION, FORREST CITY, AR:
3,038,322, CANC. INT. CL. 9.
- SAPIENS STEERING BRAIN STIMULATION B.V., EINDHOVEN, 5656 AE, NETHERLANDS:
4,209,278, PUB. 7-3-2012. MULTIPLE CLASS, INT. CLS. 9, 10 AND 44.
- SARGENT MANUFACTURING COMPANY, NEW HAVEN, CT:
2,669,977. REN. 8-16-12. INT. CL. 6.
- SARKLI-REPECHAGE, LTD., SECAUCUS, NJ:
4,210,210, PUB. 7-3-2012. INT. CL. 5.
- SAS GLOBAL CORPORATION, WARREN, MI:
4,208,631, PUB. 7-3-2012. MULTIPLE CLASS, INT. CLS. 6, 7 AND 11.
4,208,632, PUB. 7-3-2012. MULTIPLE CLASS, INT. CLS. 6, 7 AND 11.
- SAS INSTITUTE INC., CARY, NC, MEMEX INFORMATION SYSTEMS LIMITED, EAST KILBRIDE G75 0YN, UNITED KINGDOM:
1,706,334. REN. 8-15-12. INT. CL. 9.
- SASI HOLDINGS PTY LTD, ENGLISHTOWN, NJ:
4,208,721, PUB. 7-3-2012. INT. CL. 3.
- SASI HOLDINGS PTY LTD, ENGLISHTOWN, NY:
4,208,722, PUB. 7-3-2012. INT. CL. 3.
- SASI HOLDINGS PTY LTD, NEW YORK, NY:
4,208,723, PUB. 7-3-2012. INT. CL. 3.
- SASI HOLDINGS PTY LTD, ENGLISHTOWN, NJ:
4,208,724, PUB. 7-3-2012. INT. CL. 3.
4,208,725, PUB. 7-3-2012. INT. CL. 3.
4,210,923, INT. CL. 3.
- SATA GMBH & CO. KG, KORNWESTHEIM, FED REP GERMANY:
2,606,146. REN. 8-13-12. INT. CL. 11.
- SAVES BY B, INC., NEW YORK, NY:
4,211,640, INT. CL. 25.
- SAVILLE, DODGEN & COMPANY, PLCC, DALLAS, TX:
4,211,791, INT. CL. 35.
- SAVOR BRANDS, INC., CHESTERFIELD, MO:
4,210,052, PUB. 7-3-2012. INT. CL. 29.
- SAY IT WITH SUGAR CAKE SHOP LLC, WYLIE, TX:
4,209,848, PUB. 7-3-2012. INT. CL. 40.
- SAYRE - HEIDNER, INC., NORTHLAKE, IL:
2,736,378. REN. 8-14-12. INT. CL. 35.
- SAZERAC COMPANY, INC., METAIRIE, LA:
4,208,961, PUB. 3-27-2012. INT. CL. 33.
4,210,318, INT. CL. 33.
- SBYKE USA LLC, LAS VEGAS, NV:
4,211,281, INT. CL. 25.
4,211,362, MULTIPLE CLASS, INT. CLS. 12 AND 25.
- SCALE COMPUTING, INC., INDIANAPOLIS, IN:
4,210,721, INT. CL. 9.
4,210,728, INT. CL. 9.
- SCAN HEALTH PLAN, LONG BEACH, CA:
2,601,450. REN. 8-10-12. INT. CL. 35.
- SCENTSIBLE, LLC, ADDISON, TX:
4,210,952, INT. CL. 5.
- SCHAEFFLER TECHNOLOGIES GMBH & CO. KG, 91074 HERZOGENAURACH, FED REP GERMANY, LAMELEN UND KUPPLUNGSBAU AUGUST HAUSSERMANN, ESSLINGEN AM NECKAR, METTINGEN, FED REP GERMANY:
727,220. REN. 8-11-12. U.S. CL. 23 (INT. CLS. 6, 7, 8, 9, 11, 12, 16, 21 AND 28).
- SCHERDEL INNOTECH, MARKTREDWITZ, FED REP GERMANY:
4,210,854, MULTIPLE CLASS, INT. CLS. 6, 7 AND 12.
- SCHIEVE PHOTO, LLC, MADISON, WI:
2,690,259. REN. 8-11-12. INT. CL. 41.
- SCHILTZ FOODS INC., SISSETON, SD:
2,528,098, CANC. INT. CL. 29.
- SCHIRALDI, GLENN R., PH.D., ASHBURN, VA:
4,210,916, INT. CL. 41.
- SCHMIDT, BRIAN M., NAZARETH, PA:
4,210,688, MULTIPLE CLASS, INT. CLS. 25 AND 35.
- SCHOLAREDGE COLLEGE CONSULTING, LLC, ST. PAUL, MN:
4,210,708, MULTIPLE CLASS, INT. CLS. 16 AND 41.
- SCHOLASTIC INC., NEW YORK, NY:
4,209,989, PUB. 7-3-2012. INT. CL. 9.
4,210,159, PUB. 7-3-2012. INT. CL. 9.
4,210,160, PUB. 7-3-2012. INT. CL. 9.
4,210,161, PUB. 7-3-2012. INT. CL. 9.
4,210,162, PUB. 7-3-2012. INT. CL. 9.
4,210,163, PUB. 7-3-2012. INT. CL. 9.
- SCHOLL, GERALD, YONKERS, NY AND MANSUETO, MICHAEL, BRICK, NJ AND MAGNETICO, JOSEPH M., GLEN COVE, NY:
4,208,136, PUB. 7-3-2012. INT. CL. 41.
- SCHRATTER FOODS INCORPORATED, FAIRFIELD, NJ:
4,210,585, MULTIPLE CLASS, INT. CLS. 29 AND 35.
- SCHROEDER INDUSTRIES, LLC, LEETSDALE, PA:
2,528,431, CANC. INT. CL. 7.
- SCHUMACHER, MONTE L., LAKE OSWEGO, OR:
4,209,951, PUB. 7-3-2012. INT. CL. 41.
4,210,044, PUB. 7-3-2012. INT. CL. 41.
- SCIENTIFIC FOOD SOLUTIONS, LLC, FAIRFIELD, CA:
4,210,268, MULTIPLE CLASS, INT. CLS. 5 AND 29.
- SCIMETRICS LIMITED CORP., WELLINGTON, CO:
2,528,459, CANC. INT. CL. 5.
- SCISBO, LLC., WILMINGTON, DE:
4,210,306, INT. CL. 42.
- SCOLMORE INTERNATIONAL LIMITED, TAMWORTH, STAFFS, UNITED KINGDOM:
4,208,488, PUB. 11-22-2011. INT. CL. 9.
- SCOOTERS COFFEE, LLC, OMAHA, NE:
4,209,045, PUB. 7-3-2012. MULTIPLE CLASS, INT. CLS. 35 AND 43.
- SCOTT KAY, INC., TEANECK, NJ:
4,210,759, INT. CL. 14.
- SCOTT MACHINE DEVELOPMENT CORPORATION, WALTON, NY:
4,209,450, PUB. 7-3-2012. INT. CL. 20.
- SCOTT USA LIMITED, UNITED KINGDOM:
4,208,323, PUB. 1-17-2012. INT. CL. 12.
4,208,344, PUB. 7-3-2012. MULTIPLE CLASS, INT. CLS. 12 AND 25.
4,208,351, PUB. 7-3-2012. MULTIPLE CLASS, INT. CLS. 12 AND 28.
- SCOTT, CORTNEY, SAN DIEGO, CA:
4,210,530, MULTIPLE CLASS, INT. CLS. 9, 25 AND 41.
- SCOTTS COMPANY, THE, MARYSVILLE, OH:
2,527,255, CANC. INT. CL. 42.

SCRIPPS NETWORKS, INC., KNOXVILLE, TN TO SCRIPPS NETWORKS, INC., KNOXVILLE, TN:
2,528,564, CANC. INT. CL. 41.

SCRIPPS NETWORKS, LLC, KNOXVILLE, TN, SCRIPPS NETWORKS, INC., KNOXVILLE, TN:
2,538,632. REN. 8-15-12. INT. CL. 41.

SCRIPPS NETWORKS, LLC, KNOXVILLE, TN:
4,210,049, PUB. 7-3-2012. INT. CL. 41.
4,210,103, PUB. 7-3-2012. INT. CL. 41.

SEA GENIE, INC., MALIBU, CA:
1,754,240. REN. 8-11-12. INT. CL. 39.

SEABLOOM & ASSOCIATES INC, ROSEVILLE, MN:
4,211,048, INT. CL. 9.

SEACURE INC, RACINE, WI, CGM, INC., RACINE, WI:
1,727,285. REN. 8-15-12. INT. CL. 9.

SEAL INNOTECH, LLC, CHANDLER, AZ, DBA APPSFREEDOM:
4,209,674, PUB. 7-3-2012. INT. CL. 42.
4,210,089, PUB. 7-3-2012. INT. CL. 9.
4,210,090, PUB. 7-3-2012. INT. CL. 9.
4,210,091, PUB. 7-3-2012. INT. CL. 9.
4,210,092, PUB. 7-3-2012. INT. CL. 9.
4,210,093, PUB. 7-3-2012. INT. CL. 9.

SEAL TRADEMARKS PTY LTD, QUEENSLAND, AUSTRALIA:
4,208,452, PUB. 7-3-2012. MULTIPLE CLASS, INT. CLS. 25, 28 AND 35.

SEAN RONES, SAN DIEGO, CA:
4,209,774, PUB. 7-3-2012. INT. CL. 20.

SEAPOINTE VILLAGE MASTER ASSOCIATION, INC., WILDWOOD CREST, NJ:
2,608,474. REN. 8-14-12. MULTIPLE CLASS, INT. CLS. 35 AND 36.

SEARS BRANDS, LLC, HOFFMAN ESTATES, IL:
2,610,542. REN. 8-11-12. INT. CL. 36.
4,210,047, PUB. 7-3-2012. INT. CL. 11.
4,210,511, INT. CL. 7.

SECRET LABS LLC, NEW YORK, NY:
4,210,576, INT. CL. 9.
4,210,590, INT. CL. 9.

SECURITY SOLUTIONS TECHNOLOGY GROUP, LLC, BUFFALO GROVE, IL:
4,211,489, INT. CL. 9.

SEEDONK, INC., FREMONT, CA:
4,211,623, INT. CL. 42.

SEIDMAN, DOV, LOS ANGELES, CA:
4,210,276, MULTIPLE CLASS, INT. CLS. 16 AND 41.

SEIGOTUNES, BERNARDSVILLE, NJ:
2,515,593, CANC. INT. CL. 9.

SEIRUS INNOVATIVE ACCESSORIES, INC., POWAY, CA:
2,601,990. REN. 8-13-12. INT. CL. 20.

SEISMIC BREWING COMPANY, LLC, SAN DIEGO, CA:
4,211,105, INT. CL. 32.

SELLIER & BELLOT J.S.C., 258 13 VLASIM, CZECH REPUBLIC:
4,211,323, INT. CL. 13.

SELLIQUEST, INC., WAYNE, PA:
2,526,636, CANC. INT. CL. 35.

SELLMAN, PASQUALE, UPPER MARLBORO, MD AND SELLMAN, TAWANA, UPPER MARLBORO, MD:
4,210,235, INT. CL. 25.

SEMICONDUCTOR COMPONENTS INDUSTRIES, L.L.C., PHOENIX, AZ:
2,600,082. REN. 8-15-12. INT. CL. 9.

SEMTECH CORPORATION, CAMARILLO, CA:
4,211,584, INT. CL. 9.

SENEARTHCO, INC., MINNEAPOLIS, MN:
2,735,204. REN. 8-16-12. INT. CL. 35.

SENERGENT, INC., LAS VEGAS, NV:
4,211,219, INT. CL. 35.

SENIORQUEST PUBLISHING, LLC, KANSAS CITY, MO, DBA SENIORQUEST:
4,052,568, CANC. INT. CL. 16.

SENSEONET, INC., CENTENNIAL, CO:
4,211,471, MULTIPLE CLASS, INT. CLS. 3, 35 AND 44.

SENSUS SPECTRUM LLC, RALEIGH, NC, ROCKWELL MANUFACTURING COMPANY, PITTSBURGH, PA:
735,984. REN. 8-14-12. U.S. CL. 26 (INT. CL. 9).

SENTIENT ENERGY, INC., BURLINGAME, CA:
4,210,413, INT. CL. 9.

SEROM FASHION COMPANY, SAN DIEGO, CA:
4,208,839, PUB. 7-3-2012. INT. CL. 25.

SERPENT AUDIO LLC, SPRING CITY, PA:
4,209,637, PUB. 7-3-2012. INT. CL. 9.

SERVICEMASTER BRANDS, L.L.C., BURLINGTON, VT:
4,209,320, PUB. 7-3-2012. INT. CL. 3.

SERVPRO INTELLECTUAL PROPERTY, INC., GALLATIN, TN:
4,211,823, MULTIPLE CLASS, INT. CLS. 37 AND 40.

SEVEN STAR TRADING, INC., SKOKIE, IL:
4,209,076, PUB. 7-3-2012. INT. CL. 30.

SEVERN TRENT WATER PURIFICATION, INC., COLMAR, PA:
2,527,134, CANC. INT. CL. 11.

SFE INVESTMENTS, LLC, SAN ANTONIO, TX:
4,210,308, INT. CL. 42.

SFP WORKS, LLC, WASHINGTON, MI:
4,209,927, PUB. 7-3-2012. INT. CL. 40.

SGE IP HOLDCO, LLC, DALLAS, TX:
4,208,199, PUB. 7-3-2012. MULTIPLE CLASS, INT. CLS. 9, 16, 35 AND 41.

SHAMBRA, MUHAMMAD, PHILADELPHIA, PA:
4,208,864, PUB. 7-3-2012. U.S. CL. A.

SHANGHAI OWMO INDUSTRIAL CO.,LTD., CHINA:
4,208,324, PUB. 7-3-2012. INT. CL. 10.

SHANNON HAMILTON, KLAMATH FALLS, OR:
4,208,716, PUB. 7-3-2012. INT. CL. 5.

SHANTOU CITY SHIJIA INDUSTRY CO., LTD., S.E.Z., CHINA:
4,208,743, PUB. 7-3-2012. INT. CL. 25.

SHAPES OF FAITH, LLC, MCDONOUGH, GA:
4,211,029, INT. CL. 30.

SHARKPRO SOFTWARE CORPORATION, HOUSTON, TX:
4,208,740, PUB. 7-3-2012. INT. CL. 9.

SHARP KABUSHIKI KAISHA, OSAKA, JAPAN, TA SHARP CORPORATION:
2,528,453, CANC. INT. CL. 11.

SHAW, CARL G., APOPKA, FL AND SHAW, STEPHANIE L., APOPKA, FL:
4,209,161, PUB. 7-3-2012. INT. CL. 37.
4,209,163, PUB. 7-3-2012. INT. CL. 37.

SHAW'S SUPERMARKETS, INC., BOISE, ID:
2,631,241. REN. 8-15-12. INT. CL. 35.

SHELTER-PRO, LLC, STEARNS, KY:
2,740,594. REN. 8-15-12. INT. CL. 25.

SHENZHEN HUASHEN IMPORT & EXPORT CO.,LTD, SHENZHEN, CHINA:
4,209,097, PUB. 7-3-2012. MULTIPLE CLASS, INT. CLS. 3, 18, 25 AND 33.

SHENZHEN MARK TECHNOLOGIES CO., LTD., BAO'AN DIST, SHENZHEN, CHINA:
4,209,636, PUB. 7-3-2012. INT. CL. 9.

SHEPPARD, GENE CAMRON, AUSTIN, TX:
2,646,333. REN. 8-15-12. INT. CL. 35.

SHERWOOD, THOMAS W., PENN'S PARK, PA:
4,211,004, MULTIPLE CLASS, INT. CLS. 41 AND 43.

SHIGEKI KANAO, HYOGO, JAPAN:
4,210,464, INT. CL. 19.

SHIMANO INC., SAKAI CITY, OSAKA, JAPAN, SHIMANO INDUSTRIAL CO., LTD., SAKAI, OSAKA 590, JAPAN:
1,757,679. REN. 8-10-12. INT. CL. 28.

SHIMANO INC., SAKAI CITY, OSAKA, JAPAN:
1,757,686. REN. 8-10-12. INT. CL. 28.

SHIPLEY BUSINESS DEVELOPMENT SERVICES, INC., KAYSVILLE, UT, DBA SHIPLEY ASSOCIATES:
4,210,579, INT. CL. 41.

SHIRAN PTY LTD, HALLAM, AUSTRALIA:
4,210,955, INT. CL. 3.

SHIRE PHARMACEUTICALS LIMITED, HAMPSHIRE, UNITED KINGDOM:
4,208,181, PUB. 3-27-2012. MULTIPLE CLASS, INT. CLS. 9, 16, 41 AND 42.

SHISEIDO CO., LTD., CHUO-KU, TOKYO 104-10, JAPAN:
1,704,063. REN. 8-10-12. INT. CL. 3.

SHISEIDO COMPANY, LTD., TOKYO, 104-10, JAPAN:
2,528,022, CANC. INT. CL. 3.

- SHOE BOND SYSTEMS, INC., NAPLES, FL, DBA SBS EQUINE PRODUCTS:
4,210,079, PUB. 7-3-2012. INT. CL. 5.
- SHOE, S.L., INCA, BALEARES, SPAIN:
4,209,578, PUB. 7-3-2012. MULTIPLE CLASS, INT. CLS. 18, 25 AND 35.
- SHOES OF PREY PTY LTD, AUSTRALIA:
4,208,256, PUB. 7-3-2012. MULTIPLE CLASS, INT. CLS. 25 AND 35.
- SHOOTSAC, MARINA DEL REY, CA:
3,494,932, CANC. INT. CL. 35.
- SHOPITPROFIT.COM, LLC, HYANNIS, MA:
4,211,644, INT. CL. 38.
- SHOP412, PITTSBURGH, PA:
4,208,846, PUB. 7-3-2012. INT. CL. 25.
- SHRUNKEN HEAD STUDIOS, NORTH HOLLYWOOD, CA:
4,210,547, INT. CL. 28.
- SI GROUP, INC., SCHENECTADY, NY:
3,038,334, CANC. INT. CL. 1.
- SICOR, INC., IRVINE, CA:
3,005,803, CANC. INT. CL. 5.
- SIDERIADIS, JON, ROCKY HILL, CT:
4,209,645, PUB. 7-3-2012. INT. CL. 16.
- SIEBERT, EDWARD J., CULVER CITY, CA:
4,211,247, INT. CL. 41.
- SIEMENS AKTIENGESELLSCHAFT, MUNICH, FED REP GERMANY:
2,526,469, CANC. INT. CL. 9.
2,596,958, REN. 8-14-12. MULTIPLE CLASS, INT. CLS. 9, 16 AND 41.
- SIEMENS INDUSTRY, INC., ALPHARETTA, GA:
2,606,865, REN. 8-15-12. INT. CL. 35.
- SIEMENS MEDICAL INSTRUMENTS PTE LTD, SINGAPORE:
4,208,440, PUB. 7-3-2012. INT. CL. 10.
- SIERRA BULLETS, LLC, SEDALIA, MO:
1,741,187, REN. 8-11-12. INT. CL. 13.
1,741,188, REN. 8-10-12. INT. CL. 13.
- SIFTEO, INC., SAN FRANCISCO, CA:
4,208,811, PUB. 7-3-2012. MULTIPLE CLASS, INT. CLS. 9 AND 28.
- SILLY CREATION, INC., LOS ANGELES, CA:
4,210,934, INT. CL. 18.
- SILVA, JIMMY, LOS ANGELES, CA:
4,209,670, PUB. 7-3-2012. INT. CL. 35.
- SILVER FACTORY, INC., ALBUQUERQUE, NM:
2,527,167, CANC. INT. CL. 14.
- SILVER FERN FARMS LIMITED, DUNEDIN, NEW ZEALAND:
2,599,889, REN. 8-12-12. INT. CL. 29.
- SILVER SPRING NETWORKS, INC., REDWOOD CITY, CA:
4,210,455, INT. CL. 42.
- SILVERADO VINEYARDS, THE, NAPA, CA:
2,607,623, REN. 8-15-12. INT. CL. 33.
2,645,762, REN. 8-15-12. INT. CL. 33.
- SILVESTRE LABS QUIMICA E FARMACEUTICA LTDA., RIO DE JANEIRO, R.J., BRAZIL:
4,210,286, MULTIPLE CLASS, INT. CLS. 9 AND 10.
- SIMANTS, KELLY A., PLANO, TX, DBA SWEET PEA EVENTS:
4,208,719, PUB. 7-3-2012. INT. CL. 41.
- SIMARD LAURIE, NICOLET, CANADA, DBA TANGKOU DOLL AND CLOUTIER JEAN-MICHEL, NICOLET, CANADA:
4,209,499, PUB. 7-3-2012. INT. CL. 28.
- SIMMONS, RUSSELL, NEW YORK, NY:
3,038,145, CANC. INT. CL. 41.
- SIMON MILNER, SAN JOSE, CA:
4,211,182, INT. CL. 9.
- SIMON YANG, INC., PALO ALTO, CA, DBA HOURSMAP:
4,211,780, INT. CL. 35.
- SIMONDS INDUSTRIES, INC., FITCHBURG, MA:
1,711,202, REN. 8-16-12. INT. CL. 7.
- SIMPLEGIVE LLC, BARTLETT, TN:
4,209,421, PUB. 7-3-2012. INT. CL. 42.
- SIMPLY WHEELZ, LLC, PARK RIDGE, NJ:
1,738,673, REN. 8-11-12. INT. CL. 39.
- SINCLAIR WORLDWIDE, INC., ONTARIO, CA:
4,210,023, PUB. 7-3-2012. MULTIPLE CLASS, INT. CLS. 16 AND 21.
- SINEQUANON GROUP INC., DALLAS, TX:
4,209,569, PUB. 7-3-2012. INT. CL. 41.
- SINGAPORE VOLITION PTE. LIMITED, SINGAPORE, SINGAPORE:
4,208,619, PUB. 7-3-2012. MULTIPLE CLASS, INT. CLS. 1, 5, 10 AND 42.
- SINGLOGEN, SOLANA BEACH, CA:
4,211,107, INT. CL. 25.
- SINMED B.V., 2811 DX REEUWIJK, NETHERLANDS:
2,610,479, REN. 8-16-12. INT. CL. 10.
- SINPHAR PHARMACEUTICAL CO., LTD., TUNG-SHAN SHINE, YEI-LAN HSIEN, TAIWAN:
2,528,139, CANC. INT. CL. 30.
- SISTEMAS ELECTRONICOS DE POTENCIA, S.A., PINTO (MADRID), SPAIN:
2,602,553, REN. 8-13-12. INT. CL. 9.
- SISYPHUS TRADING LLP, UNITED KINGDOM:
4,208,289, PUB. 7-3-2012. MULTIPLE CLASS, INT. CLS. 3, 4, 8, 9, 14, 18, 20, 21, 24, 28, 34 AND 43.
- SIX COLUMNS, LLC, CARROLLTON, MO:
4,211,287, U.S. CL. A.
- SIX-VICTOR LTD., TAICHUNG, TAIWAN:
4,210,605, INT. CL. 25.
4,210,606, INT. CL. 25.
- SIXTYWINE, INC., CORONA, CA:
4,210,446, INT. CL. 33.
- SKECHERS U.S.A., INC. II, MANHATTAN BEACH, CA:
4,211,645, INT. CL. 25.
- SKILL VISION CO., LTD., TOKYO, 103-0005, JAPAN:
2,527,396, CANC. INT. CL. 42.
- SKILLFUL COMMUNICATIONS, LLC, NEW YORK, NY:
4,209,795, PUB. 7-3-2012. INT. CL. 09.
- SKOLNIK, SAMANTHA J, PORT ORANGE, FL, TA OOGAA HOME LLC:
4,208,608, PUB. 7-3-2012. INT. CL. 10.
- SKS METAPLAST SCHEFFER-KLUTE GMBH, 59846 SUNDERN, FED REP GERMANY:
2,616,683, REN. 8-10-12. INT. CL. 12.
- SKS METAPLAST SCHEFFER-KLUTE GMBH, SUNDEM, FED REP GERMANY:
2,616,970, REN. 8-10-12. INT. CL. 12.
- SKT PRODUCTIONS, INC., NEW YORK, NY:
4,211,242, INT. CL. 21.
- SKULLCANDY, INC., PARK CITY, UT:
4,210,756, INT. CL. 35.
- SKUNKBUNKER, LLC, MEDFORD, NJ:
4,211,057, INT. CL. 25.
- SKUNKBUNKER, LLC, MEDFORD, NJ:
4,211,030, INT. CL. 25.
- SKY DIGITAL (SHENZHEN) CO., LTD., SHENZHEN, CHINA:
4,208,857, PUB. 7-3-2012. INT. CL. 35.
- SKYLINE MUSIC PUBLISHING, LLC, NASHVILLE, TN:
4,209,284, PUB. 7-3-2012. INT. CL. 9.
- SKYPORT A.S., PRAGUE, CZECH REPUBLIC:
4,208,254, PUB. 7-3-2012. MULTIPLE CLASS, INT. CLS. 12 AND 39.
- SLEEP SHOPPE, INC., MISSOULA, MT:
4,209,611, PUB. 7-3-2012. INT. CL. 43.
- SLICKFORCE, INC., LOS ANGELES, CA:
4,208,701, PUB. 7-3-2012. INT. CL. 41.
- SLSH ENTERPRISES, INC., MARINA DEL REY, CA:
4,211,676, MULTIPLE CLASS, INT. CLS. 7, 11, 20, 21 AND 24.
- SMA SOLAR TECHNOLOGY AG, NIESTETAL, FED REP GERMANY:
4,210,648, MULTIPLE CLASS, INT. CLS. 16 AND 41.
- SMALDONE, JAMES, BROOKLYN, NY:
4,211,545, INT. CL. 21.
- SMART MONKEY MARKETING, COLUMBUS, GA:
4,211,586, INT. CL. 35.
- SMARTLIDAR INC, AUSTIN, TX:
4,210,490, MULTIPLE CLASS, INT. CLS. 9 AND 42.
- SMARTPOOL, INCORPORATED, LAKEWOOD, NJ:
4,210,516, MULTIPLE CLASS, INT. CLS. 1, 7 AND 11.

SMARTPROS LTD., HAWTHORNE, NY:
2,600,238. REN. 8-13-12. MULTIPLE CLASS, INT. CLS. 35
AND 41.

SMG BRANDS, INC., WILMINGTON, DE:
4,209,315, PUB. 7-3-2012. INT. CL. 41.
4,209,316, PUB. 7-3-2012. INT. CL. 31.

SMISEK, WAYNE, COLORADO SPRINGS, CO:
4,210,656, MULTIPLE CLASS, INT. CLS. 9, 16, 18, 21, 22,
24, 25, 28, 35, 36 AND 41.

SMITH INTERNATIONAL, INC., HOUSTON, TX:
2,528,651, CANC. INT. CL. 7.

SMITH; STEPHEN B., INDIANAPOLIS, IN:
1,190,602. REN. 8-15-12. INT. CL. 11.

SMITH, CANDIS, PHILADELPHIA, PA:
4,208,138, PUB. 7-3-2012. INT. CL. 41.

SMITH, JEFFRY, NEW YORK CITY, NY:
4,209,455, PUB. 7-3-2012. INT. CL. 41.

SMITH, JESSICA MARIE, MOULTRIE, GA, DBA GEORGIA
BOY CLOTHING COMPANY:
4,209,048, PUB. 7-3-2012. INT. CL. 25.

SMITH, SUSAN KAY, LAKE LAND, FL:
2,698,160. REN. 8-15-12. INT. CL. 16.

SMITHS MEDICAL ASD, INC., ST. PAUL, MN, PHARMA-
CIA DELTEC INC., ST. PAUL, MN:
1,713,390. REN. 8-10-12. INT. CL. 10.

SMOKIN D'S CATERING & ENTERPRISE, LLC, LAND-
OVER, MD:
4,210,473, INT. CL. 43.

SMOKY MOUNTAIN NATIVE PLANTS ASSOCIATION,
ROBBINSVILLE, NC:
4,208,799, PUB. 7-3-2012. INT. CL. 30.

SMOOTH-ON INC., EASTON, PA:
2,662,230. REN. 8-14-12. INT. CL. 1.
2,711,295. REN. 8-14-12. INT. CL. 1.

SMOOTH-ON, INC., EASTON, PA:
2,604,070. REN. 8-10-12. INT. CL. 1.
2,611,897. REN. 8-13-12. INT. CL. 1.
2,641,770. REN. 8-13-12. INT. CL. 1.

SMS SIEMAG AG, FED REP GERMANY:
4,208,360, PUB. 7-3-2012. MULTIPLE CLASS, INT. CLS. 7,
9, 11 AND 42.

SMULE, INC., PALO ALTO, CA:
4,210,527, INT. CL. 9.

SNAP INSTALL, INC., MONTGOMERYVILLE, PA:
4,209,947, PUB. 7-3-2012. INT. CL. 37.

SNAP LEARNING, INC., FRESNO, CA:
4,211,608, INT. CL. 16.
4,211,610, INT. CL. 16.

SNAX IN PAX, INC., TOPEKA, IN:
4,210,725, INT. CL. 30.

SNCC LEGACY PROJECT, INC., WASHINGTON, DC:
4,211,792, MULTIPLE CLASS, INT. CLS. 35, 36 AND 41.

SNIK LLC, BERKELEY, CA:
4,211,101, INT. CL. 26.

SNIPS S.R.L., OSSAGO LODIGIANO(LODI), ITALY:
2,611,280. REN. 8-10-12. INT. CL. 21.

SNOWIZARD, INC., JEFFERSON, LA:
4,210,460, INT. CL. 30.

SO, MONICA, BROOKLYN, NY AND RYAN, SEAN,
BROOKLYN, NY:
4,208,946, PUB. 7-3-2012. INT. CL. 16.

SOAP TIME, LLC, AUSTIN, TX:
4,209,813, PUB. 7-3-2012. INT. CL. 3.

SOCERTOTS INCORPORATED, SPOKANE, WA:
4,209,114, PUB. 5-29-2012. INT. CL. 41.

SOCIETE DES PRODUITS NESTLE S.A., VEVEY, SWITZER-
LAND:
4,211,351, INT. CL. 31.
4,211,578, INT. CL. 31.

SOCIETY X LLC, MESA, AZ:
4,208,705, PUB. 7-3-2012. INT. CL. 24.

SOCIÉTÉ DES PRODUITS NESTLÉ S.A., VEVEY, SWITZER-
LAND:
4,209,597, PUB. 7-3-2012. INT. CL. 29.

SOCIUS1, LLC, DUBLIN, OH, DBA SOCIUS:
4,209,713, PUB. 7-3-2012. MULTIPLE CLASS, INT. CLS.
35, 41 AND 42.

SOERGEL, RICH C., SAN DIEGO, CA:
4,211,518, INT. CL. 14.

SOFT SHEEN/CARSON, INC., CHICAGO, IL TO L'OREAL
USA CREATIVE, INC., NEW YORK, NY:
2,527,210, CANC. INT. CL. 3.

SOFTCLOUDS LLC, SAN DIEGO, CA:
4,209,025, PUB. 7-3-2012. INT. CL. 42.
4,209,031, PUB. 7-3-2012. INT. CL. 42.

SOFTEST DESIGNS CORP., SAN ANTONIO, TX:
1,702,894. REN. 8-11-12. MULTIPLE CLASS, INT. CLS. 9,
40 AND 42.

SOFTKINETIC, SOCIÉTÉ ANONYME, B-1140 EVERE, BEL-
GIUM:
4,208,262, PUB. 7-3-2012. MULTIPLE CLASS, INT. CLS. 9,
28, 38, 41 AND 42.

SOFTPRO GMBH, BOEBLINGEN, FED REP GERMANY:
3,037,472, CANC. INT. CL. 42.

SOG SPECIALTY KNIVES & TOOLS, LLC, LYNNWOOD,
WA:
4,210,470, INT. CL. 8.

SOLAR INNOVATIONS, INC., PINE GROVE, PA:
4,211,812, INT. CL. 6.

SOLARITY CREDIT UNION, YAKIMA, WA:
4,209,354, PUB. 7-3-2012. INT. CL. 36.

SOLEMA S.R.L., ITALY:
4,208,389, PUB. 7-3-2012. MULTIPLE CLASS, INT. CLS. 7,
35 AND 42.

SOLETECH, INC., NAHANT, MA:
1,734,980. REN. 8-10-12. INT. CL. 25.

SOLO CUP OPERATING CORPORATION, LAKE FOREST,
IL:
2,601,820. REN. 8-13-12. INT. CL. 21.

SOLOWAY SOLUTIONS, INC., PALATINE, IL:
4,209,353, PUB. 7-3-2012. INT. CL. 42.

SOLUTIA INC., ST. LOUIS, MO:
4,211,678, MULTIPLE CLASS, INT. CLS. 1 AND 17.

SOLUTION FOUNDRY LLC, THE, WOODSTOCK, GA:
2,600,021. REN. 8-13-12. MULTIPLE CLASS, INT. CLS. 9
AND 35.

SOLVE-PRO SCIENTIFIC RESEARCH LIMITED, SHATIN
NT, HONG KONG:
4,209,634, PUB. 7-3-2012. INT. CL. 1.

SONIC SOLUTIONS, NOVATO, CA:
2,526,385, CANC. MULTIPLE CLASS, INT. CLS. 9, 41
AND 42.

SONOMA TECHNOLOGY, INC., PETALUMA, CA:
2,733,803. REN. 8-13-12. MULTIPLE CLASS, INT. CLS. 9
AND 42.

SONOMA WINE COMPANY, GRATON, CA:
4,209,779, PUB. 7-3-2012. INT. CL. 33.
4,211,641, INT. CL. 33.

SONRISA ENTERPRISES, INC., VAN NUYS, CA:
4,211,175, INT. CL. 25.
4,211,176, INT. CL. 9.
4,211,177, INT. CL. 25.

SONY CORPORATION, TOKYO, JAPAN, TA SONY KA-
BUSHIKI KAISHA:
2,565,664, AM. INT. CL. 9.

SONY CORPORATION, TOKYO, JAPAN:
4,208,667, PUB. 7-3-2012. INT. CL. 9.

SOPHISTICATED BUSINESS SYSTEMS, INC., DALLAS, TX,
DBA ATERAS:
4,211,446, MULTIPLE CLASS, INT. CLS. 9 AND 42.

SORCA DESIGN INCORPORATED, COCONUT CREEK, FL:
4,208,487, PUB. 7-3-2012. INT. CL. 42.

SORENSEN SEWING, INC., HYDE PARK, MA, DBA
MOORADIAN COVER COMPANY:
4,208,530, PUB. 7-3-2012. INT. CL. 15.

SORT ORDER SPACE, LOS ANGELES, CA:
4,211,531, INT. CL. 35.

SOUL AND SPIRIT, LLC, PHOENIX, AZ, DBA SOUL AND
SPIRIT:
4,210,526, INT. CL. 25.

SOUL SOUP, INC., TRAVERSE CITY, MI:
4,208,599, PUB. 9-13-2011. MULTIPLE CLASS, INT. CLS.
16 AND 20.

SOUND OPTIONS, INC., TACOMA, WA:
4,209,819, PUB. 7-3-2012. INT. CL. 44.

- SOUNDEXCHANGE, INC., WASHINGTON, DC:
2,639,580. REN. 8-16-12. INT. CL. 36.
- SOUTH FLORIDA PRIDE WIND ENSEMBLE, INC., OAKLAND PARK, FL:
4,208,748, PUB. 7-3-2012. INT. CL. 41.
4,208,749, PUB. 7-3-2012. INT. CL. 41.
4,208,750, PUB. 7-3-2012. INT. CL. 41.
- SOUTHCITY BANK, VESTAVIA HILLS, AL:
4,210,086, PUB. 7-3-2012. INT. CL. 36.
- SOUTHEAST ANESTHESIOLOGY CONSULTANTS, P.A., CHARLOTTE, NC:
4,210,374, MULTIPLE CLASS, INT. CLS. 9, 35 AND 42.
- SOUTHERN FELT COMPANY, INC., NORTH AUGUSTA, SC:
4,211,230, INT. CL. 24.
4,211,232, INT. CL. 24.
- SOUTHERN FOX LLC, SARASOTA, FL:
4,208,929, PUB. 7-3-2012. INT. CL. 9.
- SOUTHERN KNIFE, LLC, MAULDIN, SC:
4,211,802, INT. CL. 30.
- SOUTHERN PERSONNEL MANAGEMENT, INC., VAN BUREN, AR, DBA MY HR PROFESSIONALS:
4,211,857, INT. CL. 35.
- SOUTHERN STYLE NUTS, INC., DENISON, TX:
2,527,760, CANC. INT. CL. 41.
- SOUTHERN STYLE NUTS, INC., DENISON, TX TO SQUIRREL BRAND HOLDINGS, LP, MCKINNEY, TX:
2,527,761, CANC. INT. CL. 42.
- SOUTHERNPIGSKIN.COM LLC, BRUNSWICK, GA:
4,208,837, PUB. 7-3-2012. INT. CL. 41.
- SOUTHFIELD CORPORATION, PALOS HILLS, IL, DBA ILLINOIS BRICK COMPANY:
4,211,463, INT. CL. 19.
- SOUTHFRESH AQUACULTURE, LLC, INDIANOLA, MS:
2,634,886. REN. 8-11-12. INT. CL. 29.
- SOUTHWEST AIRLINES CO., DALLAS, TX:
1,738,670. REN. 8-16-12. INT. CL. 39.
- SOUTHWEST GREENS INTERNATIONAL, LLC, KENNESAW, GA:
4,208,720, PUB. 7-3-2012. MULTIPLE CLASS, INT. CLS. 27, 37, 42 AND 44.
- SOUTHWIRE COMPANY, CARROLLTON, GA:
4,208,737, PUB. 7-3-2012. INT. CL. 42.
- SOUTHWORTH COMPANY, AGAWAM, MA:
2,655,162. REN. 8-15-12. INT. CL. 16.
- SOUTHWORTH, TYSON, LANCASTER, CA, DBA CHECKERED FLAG PLUMBING:
4,209,225, PUB. 7-3-2012. INT. CL. 37.
- SPACE UPDATE, INC., HOUSTON, TX:
4,208,455, PUB. 7-3-2012. INT. CL. 9.
- SPACEFOOD 11, LLC, LOS ANGELES, CA:
4,211,581, INT. CL. 35.
- SPARITUAL, L.L.C., VAN NUYS, CA:
4,210,339, INT. CL. 3.
- SPARITUAL, LLC, VAN NUYS, CA:
4,210,512, INT. CL. 3.
- SPARTAN CHEMICAL COMPANY, INC., MAUMEE, OH:
1,711,067. REN. 8-11-12. INT. CL. 3.
1,716,788. REN. 8-15-12. INT. CL. 42.
- SPARTAN RACE, INC., NEW YORK, NY:
4,209,584, PUB. 7-3-2012. INT. CL. 41.
4,210,042, PUB. 7-3-2012. INT. CL. 41.
- SPBI, DOMPIERRE-SUR-YON, FRANCE:
4,210,498, INT. CL. 12.
- SPEARS, JENNIFER, KEMP, TX:
4,209,402, PUB. 7-3-2012. INT. CL. 9.
- SPECMED, LLC, ST. ROSE, LA:
4,208,565, PUB. 3-27-2012. INT. CL. 10.
- SPEED ACTION CORP., COMMERCE, CA:
4,211,334, INT. CL. 25.
- SPEEDO INTERNATIONAL LIMITED, LONDON, UNITED KINGDOM:
4,210,408, INT. CL. 25.
- SPELLBOUND DEVELOPMENT GROUP, INC., NEWPORT BEACH, CA:
4,209,631, PUB. 7-3-2012. INT. CL. 19.
- SPENCE, MIKE, DEKALB, IL:
4,211,724, INT. CL. 25.
- SPENCERFIELD SPIRIT COMPANY LIMITED, FIFE, UNITED KINGDOM:
4,209,143, PUB. 7-3-2012. INT. CL. 33.
- SPERIAN ENERGY CORP., SAN DIEGO, CA:
4,208,944, PUB. 7-3-2012. INT. CL. 4.
- SPERIAN HEARING PROTECTION, LLC DBA HOWARD LEIGHT HEARING PROTECTION, SAN DIEGO, CA, DBA HOWARD LEIGHT HEARING PROTECTION:
2,749,993. REN. 8-15-12. INT. CL. 9.
- SPICE INDUSTRIAL GROUP, INC., CITY OF INDUSTRY, CA:
1,703,530. REN. 8-11-12. MULTIPLE CLASS, INT. CLS. 29 AND 30.
- SPIN MASTER LTD., TORONTO, CANADA:
4,210,378, INT. CL. 28.
- SPINE VIEW, INC., FREMONT, CA:
4,210,347, INT. CL. 10.
- SPINLATE WELLNESS CENTER, LOS ANGELES, CA, FORMERLY SPINLATES BY HBHM STUDIOS:
4,209,241, PUB. 7-3-2012. INT. CL. 41.
- SPIREON, INC., KNOXVILLE, TN:
4,208,482, PUB. 7-3-2012. INT. CL. 9.
- SPIRIT AIRLINES, INC., MIRAMAR, FL:
4,208,537, PUB. 7-3-2012. INT. CL. 39.
- SPITZ, YISRAEL, BROOKLYN, NY AND SCHWARTZ, YITZCHOK, BROOKLYN, NY:
4,209,806, PUB. 7-3-2012. INT. CL. 38.
- SPITZ, YISRAEL, BROOKLYN, NY:
4,210,036, PUB. 7-3-2012. INT. CL. 38.
- SPLUNK INC., SAN FRANCISCO, CA:
4,211,026, MULTIPLE CLASS, INT. CLS. 9, 16, 35, 38, 41 AND 42.
- SPORTS & MARINE PARAFUNALIA, INC., GILFORD, NH:
1,779,319. REN. 8-10-12. INT. CL. 42.
- SPORTS EARS PTY LTD, HAWTHORN VICTORIA, AUSTRALIA:
2,948,658, CANC. MULTIPLE CLASS, INT. CLS. 9 AND 38.
- SPORTS GIANT LLC, CARLSBAD, CA:
2,731,648. REN. 8-16-12. INT. CL. 35.
- SPORTS MARKETING INTERNATIONAL, INC., ST. LOUIS PARK, MN:
2,528,498, CANC. INT. CL. 25.
- SPORTSMANSLIQUIDATION.COM LLC, GETTYSBURG, PA:
4,208,973, PUB. 7-3-2012. INT. CL. 35.
- SPRAGUE OPERATING RESOURCES LLC, PORTSMOUTH, NH:
2,618,701. REN. 8-10-12. INT. CL. 4.
- SPROMISE INT'L INC., FLUSHING, NY:
4,209,074, PUB. 7-3-2012. INT. CL. 28.
- SPX CORPORATION, CHARLOTTE, NC:
4,210,174, PUB. 7-3-2012. INT. CL. 9.
- SPX FLOW TECHNOLOGY USA, INC., OCALA, FL, DELTECH ENGINEERING, L.P., NEW CASTLE, DE:
1,724,613. REN. 8-11-12. INT. CL. 11.
- SQUARE ENIX LIMITED, LONDON, UNITED KINGDOM:
3,125,664, CANC. MULTIPLE CLASS, INT. CLS. 28 AND 41.
- SQUARETRADE, INC., SAN FRANCISCO, CA:
2,528,374, CANC. INT. CL. 42.
- SRAM, LLC, CHICAGO, IL, ROCKSHOX, INC., FLETCHER, NC:
1,704,807. REN. 8-11-12. INT. CL. 12.
- SRITHAI AUTO SEATS INDUSTRY CO., LTD., SAMUT-PRAKARN, THAILAND:
4,210,556, INT. CL. 20.
- SS SWEST, INC., LAFAYETTE, LA:
1,205,011. REN. 8-13-12. INT. CL. 42.
- SSB TECHNOLOGY PTY LTD, AUSTRALIA:
4,208,395, PUB. 4-3-2012. INT. CL. 10.
- SSE IP, LLC, NEW YORK, NY:
4,209,589, PUB. 7-3-2012. INT. CL. 30.
- ST. JAMES PLACE OF BATON ROUGE, BATON ROUGE, LA:
4,210,399, MULTIPLE CLASS, INT. CLS. 43 AND 44.
- ST. JOHNS RIVERKEEPER, INC., JACKSONVILLE, FL:
4,208,462, PUB. 5-17-2011. INT. CL. 35.

- ST. JOSEPH'S UNIVERSITY, PHILADELPHIA, PA:
2,700,648. REN. 8-16-12. MULTIPLE CLASS, INT. CLS. 38 AND 42.
- STA-CARE, INC., PORTAGE, WI:
2,527,535. CANC. INT. CL. 19.
- STACEY VITIELLO, ROSELAND, NJ:
4,209,566. PUB. 7-3-2012. INT. CL. 41.
- STACY'S PITA CHIP COMPANY, INC., RANDOLPH, MA:
4,211,647. INT. CL. 30.
- STAFFORD-MILLER (IRELAND) LIMITED, DUNGARVAN, CO. WATERFORD, IRELAND:
2,697,809. REN. 8-15-12. INT. CL. 5.
- STAGE TEE ENTWICKLUNGSGESELLSCHAFT FUR PROFESSIONELLE, D-12459 BERLIN, FED REP GERMANY:
2,603,447. REN. 8-10-12. INT. CL. 9.
- STAINLESS FOUNDRY & ENGINEERING, INC., MILWAUKEE, WI, BURGESS-PARR COMPANY, CHICAGO, IL AND BURGESS-PARR COMPANY, CHICAGO, IL:
293,368. REN. 8-16-12. U.S. CL. 14 (INT. CL. 6).
- STAINO, LLC, LONG EDDY, NY:
4,210,172. PUB. 7-3-2012. INT. CL. 21.
- STAIR PARTS NOW LLC, TRABUCO CANYON, CA:
4,209,242. PUB. 7-3-2012. INT. CL. 35.
- STALLEX SKIN CARE, INC., TENAFLY, NJ TO STALLEX SKIN CARE, INC., BURLINGTON FLATS, NY:
2,669,795. CANC. MULTIPLE CLASS, INT. CLS. 3 AND 5.
- STAM BOUWMACHINES B.V., NL-1505 GW ZAANDAM, NETHERLANDS:
4,208,237. PUB. 7-3-2012. INT. CL. 7.
- STANCORP FINANCIAL GROUP, INC., PORTLAND, OR:
4,210,843. INT. CL. 35.
- STANDARD MOTOR PRODUCTS, INC., LONG ISLAND CITY, NY:
3,037,007. CANC. INT. CL. 6.
- STANLEY N. UMOH, ATLANTA, GA, DBA SOILLFU:
4,209,144. PUB. 7-3-2012. INT. CL. 42.
- STANLEY SECURITY SOLUTIONS, INC., INDIANAPOLIS, IN, BEST LOCK CORPORATION, INDIANAPOLIS, IN:
1,202,517. REN. 8-16-12. INT. CL. 6.
- STANSFIELD, DOUG, WANTAGE, NJ:
4,209,271. PUB. 7-3-2012. INT. CL. 11.
- STAR PIPE PRODUCTS, INC., HOUSTON, TX:
1,726,996. REN. 8-10-12. INT. CL. 6.
- STAR ROC, LLC, NEW YORK, NY:
4,208,728. PUB. 7-3-2012. INT. CL. 9.
- STARBUCKS CORPORATION, SEATTLE, WA, DBA STARBUCKS COFFEE COMPANY:
2,527,989. CANC. MULTIPLE CLASS, INT. CLS. 30 AND 35.
- STARDUST CAPITAL SARL, PARIS, FRANCE:
4,209,468. PUB. 7-3-2012. MULTIPLE CLASS, INT. CLS. 14, 18 AND 25.
- STARK BRO'S NURSERIES & ORCHARDS CO., LOUISIANA, MO:
741,434. REN. 8-14-12. U.S. CL. 1 (INT. CL. 31).
- STARK, LOIS FARFEL, HOUSTON, TX:
2,669,553. REN. 8-10-12. MULTIPLE CLASS, INT. CLS. 9 AND 16.
- STARLUME, INC., BLOOMINGTON, MN:
4,208,906. PUB. 7-3-2012. MULTIPLE CLASS, INT. CLS. 3 AND 4.
- STARTMAP B.V., NL-5347 KD OSS, NETHERLANDS:
4,208,341. PUB. 7-3-2012. MULTIPLE CLASS, INT. CLS. 35, 38 AND 42.
- STASHKIW, ROBERT M., PORTLAND, OR, DBA AMERICAN MARKETING EXCHANGE:
4,209,632. PUB. 7-3-2012. MULTIPLE CLASS, INT. CLS. 35 AND 42.
- STATE ATOMIC ENERGY CORPORATION "ROSATOM", 119017 MOSCOW, RUSSIAN FED.:
4,208,463. PUB. 6-12-2012. INT. CL. 8.
- STATE FARM MUTUAL AUTOMOBILE INSURANCE COMPANY, BLOOMINGTON, IL:
3,126,997. CANC. INT. CL. 36.
4,211,539. INT. CL. 35.
4,211,626. INT. CL. 36.
4,211,627. INT. CL. 36.
4,211,628. INT. CL. 36.
4,211,629. INT. CL. 36.
- STATE OF OREGON ACTING BY AND THROUGH THE STATE BOARD OF HIGHER EDUCATION ON BEHALF OF THE UNIVERSITY OF OREGON, EUGENE, OR:
2,720,985. COR. INT. CL. 16.
- STATON, LISA, WHITESTOWN, IN:
4,210,772. INT. CL. 25.
- STEEL TUBE INSTITUTE OF NORTH AMERICA, GLENVIEW, IL:
4,209,957. PUB. 7-3-2012. INT. CL. 35.
- STEFAN BEHMER, SWITZERLAND:
3,468,124. CANC. INT. CL. 16.
- STEINHOFF, PATRICIA, MANSFIELD, MA:
4,211,504. INT. CL. 25.
- STEMCO LP, LONGVIEW, TX:
2,606,528. REN. 8-10-12. INT. CL. 17.
- STERI-CLEAN, INC., RANCHO CUCAMONGA, CA:
4,209,389. PUB. 7-3-2012. INT. CL. 37.
- STEVEN A. CASH, WASHINGTON, DC, TA DECK PRISM, LLC AND DECK PRISM, LLC, WASHINGTON, MD, DBA DECK PRISM, LLC:
4,209,254. PUB. 7-3-2012. INT. CL. 45.
- STEVEN P. DEMME, LITITZ, PA:
4,211,255. INT. CL. 16.
- STEVENSON UNIVERSITY, INC., STEVENSON, MD:
4,210,571. MULTIPLE CLASS, INT. CLS. 25 AND 41.
4,210,572. MULTIPLE CLASS, INT. CLS. 25 AND 41.
- STEWART & STEVENSON LLC, HOUSTON, TX:
1,717,909. REN. 8-15-12. INT. CL. 12.
- STHREE IP LIMITED, LONDON, UNITED KINGDOM:
4,210,469. INT. CL. 35.
- STICHTING VAN GOGH MUSEUM, NETHERLANDS:
4,208,426. PUB. 7-3-2012. MULTIPLE CLASS, INT. CLS. 16 AND 21.
- STILL GMBH, FED REP GERMANY:
4,208,290. PUB. 7-3-2012. MULTIPLE CLASS, INT. CLS. 12, 36 AND 39.
- STILL, PAYETTE S., GRAHAM, WA:
4,209,116. PUB. 7-3-2012. INT. CL. 18.
- STJ ORTHOTIC SERVICES, INC., LINDENHURST, NY:
1,704,767. REN. 8-16-12. INT. CL. 10.
- STOCK BUILDING SUPPLY HOLDINGS, INC., RALEIGH, NC:
2,622,487. REN. 8-10-12. INT. CL. 37.
- STONY CREEK BREWERY, LLC, BRANFORD, CT:
4,210,754. INT. CL. 32.
4,210,774. INT. CL. 32.
4,210,819. INT. CL. 32.
4,210,820. INT. CL. 32.
4,210,821. INT. CL. 32.
4,210,822. INT. CL. 32.
- STORAGE ASSESSMENTS, LLC, PLANO, TX:
4,209,766. PUB. 7-3-2012. INT. CL. 42.
- STRANGE INVISIBLE PERFUMES, LLC, VENICE, CA:
4,210,311. MULTIPLE CLASS, INT. CLS. 3 AND 25.
- STRAUSS MARKETING, INC., ENGLEWOOD, NJ:
4,211,422. INT. CL. 14.
- STROKIN, LLC, CHASKA, MN:
2,631,343. REN. 8-14-12. INT. CL. 35.
- STRONGLITE, LLC, SALT LAKE CITY, UT:
2,602,860. REN. 8-13-12. INT. CL. 10.
- STRUCTURED EMPLOYMENT ECONOMIC DEVELOPMENT CORPORATION, NEW YORK, NY, DBA SEEDCO:
2,528,029. CANC. MULTIPLE CLASS, INT. CLS. 35, 36, 41 AND 42.
- STRYKER CORPORATION, KALAMAZOO, MI:
4,210,289. INT. CL. 12.
- STRYKER CORPORATON, KALAMAZOO, MI AND STRYKER NV OPERATIONS LIMITED, DUBLIN 2, IRELAND:
2,599,622. REN. 8-16-12. INT. CL. 10.

- STRYKER TRAUMA AG, SELZACH, SWITZERLAND:
4,210,364, INT. CL. 10.
- STUDIO IP HOLDINGS LLC, WILMINGTON, DE:
3,036,990, CANC. INT. CL. 18.
- STUDIO MANHATTAN PRODUCTIONS, INC., LONG ISLAND CITY, NY:
4,211,834, MULTIPLE CLASS, INT. CLS. 9, 16, 18 AND 25.
- STURM, RUGER & COMPANY, INC., SOUTHPORT, CT:
4,209,763, PUB. 7-3-2012. INT. CL. 13.
- STURMAK, LINDSAY, NEW YORK, NY:
4,210,997, INT. CL. 36.
- STURMER MASCHINEN GMBH, D-96103 HALLSTADT, FED REP GERMANY:
4,208,782, PUB. 7-3-2012. MULTIPLE CLASS, INT. CLS. 7 AND 8.
- SU, FREDERICK, BELLINGHAM, WA:
2,549,886, REN. 8-14-12. INT. CL. 41.
- SUGAR GENIUS LLC, CHARLESTON, SC, DBA SWEET 185:
4,209,341, PUB. 7-3-2012. INT. CL. 44.
4,209,342, PUB. 7-3-2012. INT. CL. 44.
- SUGARGROVE HAM, LLC, VILAS, NC:
4,045,495, CANC. INT. CL. 29.
- SUISSE PROGRAMME LIMITED, CASEMATES SQUARE, GIBRALTAR:
4,208,166, PUB. 7-3-2012. INT. CL. 3.
- SULLIVAN, NADINE M., SPOKANE, WA:
4,210,290, INT. CL. 9.
- SULZER PUMP SOLUTIONS SWEDEN AB, MOLNDAL, SWEDEN:
938,069, REN. 8-11-12. U.S. CL. 23 (INT. CL. 7).
- SUMITOMO JUKIKAI KOGYO KABUSHIKI KAISHA, TOKYO, JAPAN, DBA SUMITOMO HEAVY INDUSTRIES, LTD.:
1,212,959, REN. 8-15-12. INT. CL. 7.
- SUMMER INFANT (USA), INC., WOONSOCKET, RI:
4,210,507, MULTIPLE CLASS, INT. CLS. 12, 20, 24 AND 25.
- SUMMERS PLUMBING HEATING AND COOLING, INC., NOBLESVILLE, IN:
4,209,218, PUB. 7-3-2012. MULTIPLE CLASS, INT. CLS. 11 AND 37.
- SUMMERS, BROOKE K., ELIZABETH, CO, SUMMERS, BROOKE K., ELIZABETH, CO:
1,698,129, REN. 8-15-12. INT. CL. 41.
- SUMMIT BUILDERS, INC., GREENCASTLE, IN, DBA BEAR CREEK COFFEE COMPANY:
4,209,780, PUB. 7-3-2012. INT. CL. 43.
- SUMMIT SALON BUSINESS CENTER, PLYMOUTH, MN:
4,210,647, INT. CL. 41.
- SUN LIFE ASSURANCE COMPANY OF CANADA, TORONTO, ONTARIO, CANADA:
4,210,434, MULTIPLE CLASS, INT. CLS. 16, 35, 41 AND 43.
4,210,435, MULTIPLE CLASS, INT. CLS. 9, 16, 18, 28, 35, 41 AND 43.
- SUN NATION CORP, POMPANO BEACH, FL:
4,210,814, INT. CL. 12.
- SUN TECH DEVELOPMENT, L.L.C., SCOTTSDALE, AZ:
2,589,540, REN. 8-16-12. INT. CL. 42.
2,589,541, REN. 8-16-12. INT. CL. 42.
2,589,542, REN. 8-16-12. INT. CL. 41.
2,589,544, REN. 8-16-12. INT. CL. 41.
- SUNITA TELECOM. CO., LTD., TAIPEI CITY 110, TAIWAN:
4,209,560, PUB. 7-3-2012. INT. CL. 9.
- SUNKIST GROWERS, INC., SHERMAN OAKS, CA:
2,749,729, REN. 8-16-12. INT. CL. 35.
4,209,942, PUB. 7-3-2012. MULTIPLE CLASS, INT. CLS. 29 AND 31.
4,209,943, PUB. 7-3-2012. MULTIPLE CLASS, INT. CLS. 29 AND 31.
4,210,219, PUB. 7-3-2012. INT. CL. 29.
4,211,516, INT. CL. 32.
- SUNLIGHT PHOTONICS INC., SOUTH PLAINFIELD, NJ:
4,210,478, INT. CL. 9.
- SUNNY BANKS INC., FULLERTON, CA:
4,210,298, INT. CL. 25.
- SUNNY DELIGHT BEVERAGES CO., CINCINNATI, OH:
4,209,818, PUB. 7-3-2012. INT. CL. 32.
4,209,821, PUB. 7-3-2012. INT. CL. 41.
- SUNSET FEED INCORPORATED, WINSTON-SALEM, NC:
946,879, REN. 8-16-12. U.S. CL. 46 (INT. CL. 31).
- SUNSET HEALTH PRODUCTS, INC., SHERMAN OAKS, CA:
2,527,272, CANC. INT. CL. 5.
2,527,273, CANC. INT. CL. 5.
- SUNSHINE ELECTRONIC DISPLAY CORPORATION, ST. JOSEPH, MO:
4,210,423, INT. CL. 38.
- SUNSHINE INFUSION SERVICES, INC., ELMWOOD PARK, IL:
4,211,594, INT. CL. 44.
- SUNSHINE MEDIA I, INC., CHATTANOOGA, TN:
2,607,143, REN. 8-16-12. INT. CL. 16.
2,607,144, REN. 8-16-12. INT. CL. 16.
2,607,144, AM. INT. CL. 16.
2,607,145, REN. 8-16-12. INT. CL. 16.
- SUNSHINE RAISIN CORPORATION, FOWLER, CA, DBA NATIONAL RAISIN CO.:
4,211,374, INT. CL. 29.
- SUNSPEC OF OCEAN CITY, INC., BERLIN, MD:
4,209,642, PUB. 7-3-2012. INT. CL. 28.
- SUNSWEEP GROWERS INC., YUBA CITY, CA:
2,528,492, CANC. INT. CL. 29.
- SUNTRUST BANKS, INC, ATLANTA, GA:
4,211,364, INT. CL. 36.
- SUNWEST DOCUMENT TECHNOLOGIES, INC., ANAHEIM, CA:
3,038,127, CANC. INT. CL. 42.
- SUPER BRANDS, LLC, HOUSTON, TX, LANCE, S.A. DE C.V., 07820 MEXICO D.F., MEXICO:
1,773,101, REN. 8-11-12. INT. CL. 30.
- SUPER DUPER INC., GREENVILLE, SC, DBA SUPER DUPER PUBLICATIONS:
2,714,676, REN. 8-10-12. INT. CL. 16.
- SUPER DUPER INC., GREENVILLE, SC:
2,720,106, REN. 8-10-12. INT. CL. 16.
- SUPER DUPER INC., GREENVILLE, SC, DBA SUPER DUPER PUBLICATIONS:
2,726,033, REN. 8-11-12. INT. CL. 28.
- SUPER CUTS, INC., MINNEAPOLIS, MN:
4,211,573, INT. CL. 44.
- SUPERIOR TOOL CORPORATION, CLEVELAND, OH:
2,739,928, REN. 8-11-12. INT. CL. 8.
- SUPERMEDIA LLC, DALLAS/FORT WORTH AIRPORT, TX:
4,210,341, INT. CL. 35.
- SUPLES, LTD., BOISE, ID:
4,210,670, INT. CL. 41.
- SUPPLIER DIRECT LLC, SAN FRANCISCO, CA:
4,211,613, INT. CL. 25.
- SUPPLYONE, ROCKWELL, NC:
4,209,198, PUB. 7-3-2012. INT. CL. 16.
- SUPREME GRAND LODGE OF THE ANCIENT AND MYSTICAL ORDER ROSAE CRUCIS, THE, SAN JOSE, CA:
1,723,669, REN. 8-15-12. MULTIPLE CLASS, INT. CLS. 16 AND 41.
- SUPREME REAL ESTATE, INC., CHICAGO, IL:
3,008,276, CANC. INT. CL. 36.
- SURDOC CORP., UNION CITY, CA, DBA PRODUCTION AND SALES OR SERVICE:
4,209,245, PUB. 7-3-2012. INT. CL. 42.
- SURF COWBOY, INC., RIDGEFIELD, WA:
4,211,790, INT. CL. 25.
- SURVIVOR PRODUCTIONS LLC, LOS ANGELES, CA:
4,209,835, PUB. 7-3-2012. INT. CL. 41.
- SUSTAINA BEVERAGE GROUP LLC, CARMEL, CA:
4,210,763, INT. CL. 5.
- SUSTAINABLE BUSINESS PARTNERSHIPS, LLC, HUNTINGTON BEACH, CA:
4,211,827, MULTIPLE CLASS, INT. CLS. 9, 35, 38 AND 41.
- SUSTAINABLE GROUP HOLDINGS LLC, SEATTLE, WA:
4,210,421, INT. CL. 9.
4,210,438, INT. CL. 20.

SUTTER HOME WINERY, INC., ST. HELENA, CA, DBA TRINCHERO FAMILY ESTATES:
2,600,285. REN. 8-13-12. INT. CL. 33.

SVETLANA HALL, WAYLAND, MA:
4,211,191, INT. CL. 24.

SVO TRADEMARK, INC., ORLANDO, FL:
4,208,703, PUB. 7-3-2012. INT. CL. 35.

SWEET EARTH BAKERS LLC, BOSTON, MA:
4,211,172, INT. CL. 30.

SWEET STREET DESSERTS, INC., READING, PA:
4,211,807, INT. CL. 30.

SWEET, DERRICK, FENELON FALLS, ONTARIO, CANADA:
4,211,826, INT. CL. 41.

SWENSEN'S, INC., RONKONKOMA, NY:
1,150,568, CANC. MULTIPLE CLASS, INT. CLS. 30 AND 42.

SWETREE TECHNOLOGIES AB, SWEDEN:
4,208,372, PUB. 7-3-2012. INT. CL. 1.

SWISS LUXURY BRANDS LLC, LONG ISLAND CITY, NY:
4,210,250, INT. CL. 14.

SX BRAND TRIBE, INC., FORT LAUDERDALE, FL:
4,211,171, INT. CL. 33.

SY.MED DEVELOPMENT INC., BRENTWOOD, TN:
2,604,692. REN. 8-16-12. INT. CL. 9.

SYNCHRON MANAGEMENT, LLC, RIVERTON, UT:
4,209,177, PUB. 7-3-2012. INT. CL. 42.

SYNERGIS TECHNOLOGIES, INC., QUAKERTOWN, PA:
1,702,940. REN. 8-10-12. INT. CL. 9.

SYNERGY TECHNICAL SOLUTIONS CORPORATION, BOCA RATON, FL:
2,528,634, CANC. INT. CL. 42.

SYNOVUS FINANCIAL CORP., COLUMBUS, GA:
2,743,125. REN. 8-13-12. INT. CL. 35.

SYNTHES USA, LLC, WEST CHESTER, PA:
4,210,548, INT. CL. 10.

T + T OLEOCHEMIE GMBH, D-63755 ALZENAU, FED REP GERMANY:
2,526,663, CANC. MULTIPLE CLASS, INT. CLS. 1, 4 AND 29.

T M HILES, INC, FORTVILLE, IN, DBA MR. MARBLE CARE-TH INC. MARBLE, GRANITE, TERRAZZO, CONCRETE POLISHING & RESTORATION:
2,706,879, CANC. INT. CL. 37.

T&C MARKETING MIAMI, LLC, NORTH MIAMI, FL:
4,210,601, INT. CL. 25.

T&S BRASS AND BRONZE WORKS, INC., TRAVELERS REST, SC:
2,602,710. REN. 8-13-12. INT. CL. 11.

T-MOBILE USA, INC., BELLEVUE, WA:
4,211,160, INT. CL. 9.

TÜV SÜD AMERICA INC., PEABODY, MA:
4,210,309, U.S. CL. A.

TA CARBON THE REAL MEXICAN GRILL, GLENDALE, AZ:
4,208,614, PUB. 7-3-2012. INT. CL. 43.

TABCOM, LLC, HAZLETON, PA:
4,209,325, PUB. 7-3-2012. INT. CL. 31.

TABLE FOR TWO INTERNATIONAL, JAPAN:
4,208,446, PUB. 7-3-2012. MULTIPLE CLASS, INT. CLS. 16, 21, 24, 32, 33, 35, 36, 41 AND 43.

TABOSKY, ALEJANDRO, WESTON, FL:
4,211,560, INT. CL. 39.

TABS GROUP, INC., SHELTON, CT:
4,209,420, PUB. 7-3-2012. INT. CL. 35.

TAGAWA GREENHOUSE ENTERPRISES, LLC, BRIGHTON, CO:
4,209,476, PUB. 7-3-2012. MULTIPLE CLASS, INT. CLS. 20 AND 21.

TAKARA HOLDINGS INC., KYOTO, JAPAN:
4,210,134, PUB. 7-3-2012. INT. CL. 33.

TAKASAGO INTERNATIONAL CORPORATION, ROCKLEIGH, NJ:
4,210,261, MULTIPLE CLASS, INT. CLS. 1, 3 AND 5.

TALARIA COMPANY, LLC, THE, PORTSMOUTH, RI:
2,604,362. REN. 8-11-12. INT. CL. 12.

TAMA PLASTIC INDUSTRY, MISHMAR HA'EMEK, ISRAEL:
4,208,960, PUB. 3-27-2012. INT. CL. 17.

TAMARACK INDUSTRIES, LLC, LAKEVILLE, MN:
4,208,523, PUB. 7-3-2012. INT. CL. 12.

TAMKO BUILDING PRODUCTS, INC., JOPLIN, MO:
1,758,359. REN. 8-16-12. INT. CL. 19.

TAMMING FOODS LTD., WATERLOO, ONTARIO, CANADA:
2,609,782. REN. 8-14-12. INT. CL. 30.

TAMMY KOHL, CHICAGO, IL:
4,208,186, PUB. 7-3-2012. INT. CL. 14.

TAMMY M BATLEY, YORK SPRINGS, PA, DBA POTION PANTRY:
4,209,886, PUB. 7-3-2012. INT. CL. 3.

TANGRAM INSURANCE SERVICES, PETALUMA, CA:
4,209,274, PUB. 7-3-2012. INT. CL. 36.

TANNER'S TEAM FOUNDATION, SAUK RAPIDS, MN:
4,209,365, PUB. 7-3-2012. INT. CL. 36.

TAPCO INTERNATIONAL CORPORATION, PLYMOUTH, MI:
2,662,343. REN. 8-11-12. INT. CL. 6.

TARGET BRANDS, INC., MINNEAPOLIS, MN:
2,528,083, CANC. INT. CL. 16.
4,209,553, PUB. 7-3-2012. INT. CL. 25.
4,209,755, PUB. 7-3-2012. INT. CL. 9.
4,209,757, PUB. 7-3-2012. INT. CL. 9.
4,209,992, PUB. 7-3-2012. INT. CL. 31.

TARGETED CIRCUITRY, LLC, CHICAGO, IL, DBA SQWAWK.COM:
4,208,922, PUB. 7-3-2012. INT. CL. 9.

TARTE, INC., NEW YORK, NY:
4,210,012, PUB. 7-3-2012. INT. CL. 3.
4,210,013, PUB. 7-3-2012. INT. CL. 3.
4,210,015, PUB. 7-3-2012. INT. CL. 3.

TASER INTERNATIONAL, INC., SCOTTSDALE, AZ:
4,210,350, MULTIPLE CLASS, INT. CLS. 42 AND 45.
4,210,384, INT. CL. 25.
4,210,458, INT. CL. 45.

TASTI D-LITE LLC, FRANKLIN, TN:
4,209,121, PUB. 7-3-2012. INT. CL. 32.

TATCHA LLC, SAN FRANCISCO, CA:
4,211,415, MULTIPLE CLASS, INT. CLS. 3 AND 35.

TATYANA, LLC, LAS VEGAS, NV:
4,209,744, PUB. 7-3-2012. INT. CL. 25.

TAVY ENTERPRISES, LLC, VERNON, CT:
2,528,315, CANC. INT. CL. 9.

TAYEB, RENE CHARLES, HO CHI MINH CITY, VIETNAM:
3,031,499, CANC. MULTIPLE CLASS, INT. CLS. 24 AND 25.

TAYLOR, JERRY, DAYTONA BEACH, FL:
4,211,380, INT. CL. 5.

TBM CONSULTING GROUP, INC., DURHAM, NC:
4,209,893, PUB. 7-3-2012. INT. CL. 35.

TCHUTIMA INC., LAS VEGAS, NV, DBA LOTUS OF SIAM:
4,208,544, PUB. 7-3-2012. INT. CL. 43.

TCM SUPPLY CORP, CITY OF INDUSTRY, CA, DBA WORLDWIDE TATTOO SUPPLY:
4,211,084, INT. CL. 10.

TEACHERS INSURANCE AND ANNUITY ASSOCIATION OF AMERICA, NEW YORK, NY:
4,209,206, PUB. 7-3-2012. INT. CL. 41.

TEAM TAKEOVER MARKETING, LLC, TAMPA, FL:
4,211,575, INT. CL. 35.

TEAPPLIX INC, PALO ALTO, CA:
4,209,969, PUB. 7-3-2012. INT. CL. 42.

TECH IS GOOD, LLC, RENO, NV:
4,210,846, MULTIPLE CLASS, INT. CLS. 9, 16, 18, 21 AND 25.

TECH 4 KIDS INC., MISSISSAUGA, ONTARIO, CANADA:
4,210,524, INT. CL. 28.
4,210,525, INT. CL. 28.

TECHASPECT SOLUTIONS, INC., FREMONT, CA, FORMERLY TECHASPECT SOLUTIONS, LLC:
4,209,183, PUB. 7-3-2012. INT. CL. 42.

TECHHUB EUROPE LIMITED, LONDON, UNITED KINGDOM:
4,209,762, PUB. 7-3-2012. INT. CL. 35.

- TECHNEKES, LLC, CHARLOTTE, NC:
4,208,594, PUB. 7-3-2012. INT. CL. 35.
- TECHNISAND, INC., FRESNO, TX:
2,527,488, CANC. INT. CL. 1.
- TECHNOLOGIES AVANCEES & MEMBRANES INDUSTRIELLES, 26110 NYONS, FRANCE:
2,603,599. REN. 8-13-12. MULTIPLE CLASS, INT. CLS. 1, 7 AND 11.
- TECHNOLOGIES AVANCEES ET MEMBRANES INDUSTRIELLES, FRANCE:
4,208,313, PUB. 7-3-2012. MULTIPLE CLASS, INT. CLS. 7 AND 11.
- TECHNOLOGY FOR BUSINESS, MANHATTAN BEACH, CA:
2,596,268. REN. 8-16-12. INT. CL. 42.
- TECHTRONIC FLOOR CARE TECHNOLOGY LIMITED, ROAD TOWN, TORTOLA, BR. VIRGIN ISLANDS:
2,596,896. REN. 8-10-12. INT. CL. 7.
- TECMARK, INC., SAINT PAUL, MN:
4,209,126, PUB. 7-3-2012. MULTIPLE CLASS, INT. CLS. 35 AND 42.
- TECO-WESTINGHOUSE MOTOR COMPANY, ROUND ROCK, TX:
1,715,047, CANC. INT. CL. 7.
- TEDD E. TUNES PRODUCTIONS, LLC, CHARLOTTE, NC:
2,526,896, CANC. MULTIPLE CLASS, INT. CLS. 9 AND 28.
- TEKLOGIC, INC., WEST HILLS, CA:
2,613,818. REN. 8-13-12. MULTIPLE CLASS, INT. CLS. 37 AND 42.
- TEKNON CORPORATION, SCOTTSDALE, AZ, DBA SYMMETRY SOFTWARE:
4,210,165, PUB. 7-3-2012. INT. CL. 42.
4,210,166, PUB. 7-3-2012. INT. CL. 42.
- TEKNOR APEX COMPANY, PAWTUCKET, RI:
4,209,985, PUB. 7-3-2012. INT. CL. 17.
- TELECOMMUNICATIONS INDUSTRY ASSOCIATION, ARLINGTON, VA:
2,663,529. REN. 8-10-12. MULTIPLE CLASS, U.S. CLS. A AND B.
- TELEDYNE INSTRUMENTS, INC., THOUSAND OAKS, CA, DBA TELEDYNE ISCO:
1,707,938. REN. 8-10-12. INT. CL. 9.
- TELEFONAKTIEBOLAGET L M ERICSSON, STOCKHOLM, SWEDEN:
1,703,037. REN. 8-11-12. MULTIPLE CLASS, INT. CLS. 9, 37 AND 42.
- TELEFORMULA, S.A. DE C.V., C.P. 03100, MEXICO:
2,605,404. REN. 8-16-12. MULTIPLE CLASS, INT. CLS. 38 AND 41.
- TELEMATCH, INC., SPRINGFIELD, VA:
4,208,456, PUB. 7-3-2012. MULTIPLE CLASS, INT. CLS. 35, 38 AND 39.
- TELEvisa, S.A. DE C.V., SANTA FE, MEXICO:
4,211,814, INT. CL. 41.
- TELEXPORT, INC., HIALEAH, FL:
2,527,721, CANC. INT. CL. 11.
- TELSMITH, INC., MEQUON, WI:
4,211,188, INT. CL. 7.
- TEMASEK HOLDINGS (PRIVATE) LIMITED, SINGAPORE, SINGAPORE:
4,208,497, PUB. 7-3-2012. MULTIPLE CLASS, INT. CLS. 35, 36 AND 41.
- TEMPTATION SWEETS INC., GLEN BURNIE, MD:
4,210,634, INT. CL. 35.
- TENNIS CORPORATION OF AMERICA, CHICAGO, IL:
1,744,777. REN. 8-10-12. INT. CL. 35.
- TEQUILA WORKS, S.L., SPAIN:
4,208,356, PUB. 7-3-2012. MULTIPLE CLASS, INT. CLS. 9, 16, 25 AND 28.
- TERESA THOMAS, PELHAM, AL AND SAM JONES, PELHAM, AL:
4,210,707, INT. CL. 16.
- TERMIGNONI S.P.A. PREDOsa (AL), ITALY:
2,600,842. REN. 8-14-12. INT. CL. 7.
- TERRAMERA, INC., VANCOUVER, BC, CANADA:
4,211,652, INT. CL. 5.
- TERRIO PHYSICAL THERAPY-FITNESS, INC, BAKERSFIELD, CA:
4,211,555, MULTIPLE CLASS, INT. CLS. 41 AND 44.
- TESA SE, HAMBURG, FED REP GERMANY, BEIERSDORF AKTIENGESELLSCHAFT, D-2000 HAMBURG 20, FED REP GERMANY:
1,704,988. REN. 8-10-12. INT. CL. 17.
- TEVA RESPIRATORY, LLC, HORSHAM, PA:
4,210,214, PUB. 7-3-2012. INT. CL. 5.
4,210,215, PUB. 7-3-2012. INT. CL. 5.
- TEX-RAY INDUSTRIAL CO., LTD., TAIPEI, TAIWAN:
4,210,029, PUB. 7-3-2012. INT. CL. 23.
- TEXAS ENGINEERING EXTENSION SERVICE, COLLEGE STATION, TX:
2,526,779, CANC. INT. CL. 41.
- TEXAS MUSIC EDUCATORS ASSOCIATION, AUSTIN, TX:
1,738,703. REN. 8-11-12. INT. CL. 41.
1,740,280. REN. 8-11-12. INT. CL. 41.
1,741,805. REN. 8-11-12. INT. CL. 41.
- TEXAS NATIONAL OUTFITTERS, KATY, TX:
4,211,373, INT. CL. 35.
- TEXAS TECH UNIVERSITY SYSTEM, LUBBOCK, TX:
4,210,851, INT. CL. 9.
4,210,852, INT. CL. 9.
- TEXAS-NEW MEXICO NEWSPAPERS PARTNERSHIP, EL PASO, TX:
4,211,719, INT. CL. 16.
4,211,720, INT. CL. 41.
4,211,721, INT. CL. 9.
- TEXTRON INC., PROVIDENCE, RI:
2,527,828, CANC. INT. CL. 12.
- TFI FOODS LTD., SCARBOROUGH, ONTARIO, CANADA:
4,208,163, PUB. 10-18-2011. INT. CL. 30.
- THAI HA PUBLIC COMPANY LTD., BANGKOK, THAILAND:
4,210,523, INT. CL. 30.
- THAI SWEET BASIL, INC., LIVONIA, MI, DBA THAI BASIL:
4,209,352, PUB. 7-3-2012. INT. CL. 43.
- THAI WORLD IMPORT & EXPORT CO., LTD., BANGKOK, THAILAND:
4,209,346, PUB. 7-3-2012. INT. CL. 30.
- THALES AVIONICS S.A., FRANCE:
4,208,245, PUB. 7-3-2012. MULTIPLE CLASS, INT. CLS. 9, 37 AND 38.
- THAT-A-WAY, LLC, STONE HARBOR, NJ:
4,208,859, PUB. 7-3-2012. INT. CL. 35.
- THE A GROUP, LLC, NEW YORK, NY:
4,209,275, PUB. 7-3-2012. INT. CL. 35.
- THE ACCOUNTING RESOURCE GROUP, LLC, KNOXVILLE, TN:
4,211,777, INT. CL. 35.
- THE ACTIVE NETWORK, INC., SAN DIEGO, CA:
2,747,427. REN. 8-11-12. INT. CL. 36.
- THE AGENCY ACBH, INC., LINCOLN UNIVERSITY, PA:
4,211,042, INT. CL. 11.
4,211,043, INT. CL. 11.
- THE ANNENBERG FOUNDATION, LOS ANGELES, CA:
4,210,168, PUB. 7-3-2012. MULTIPLE CLASS, INT. CLS. 36 AND 41.
4,210,170, PUB. 7-3-2012. INT. CL. 41.
4,210,212, PUB. 7-3-2012. MULTIPLE CLASS, INT. CLS. 36 AND 41.
- THE AQUA LAB LTD., CINCINNATI, OH:
4,210,718, INT. CL. 25.
- THE ARISTOTLE CORPORATION, STAMFORD, CT:
4,211,520, INT. CL. 16.
- THE B&F SYSTEM, INC., DALLAS, TX:
4,209,006, PUB. 3-27-2012. INT. CL. 35.
- THE BANK OF NEW YORK MELLON CORPORATION, NEW YORK, NY:
4,210,369, INT. CL. 36.
- THE BAPTIST STANDARD PUBLISHING COMPANY, PLANO, TX, DBA FAITHVILLAGE:
4,210,436, INT. CL. 42.
4,210,437, INT. CL. 45.
- THE BARRANDOV OPERA COMPANY LIMITED, IPSWICH, SUFFOLK, UNITED KINGDOM:
4,209,555, PUB. 7-3-2012. INT. CL. 32.

THE BLUEGREEN ALLIANCE, INC., MINNEAPOLIS, MN:
4,055,170, COR. INT. CL. 35.

THE BOEING COMPANY, SEAL BEACH, CA, BOEING
MANAGEMENT COMPANY, SEAL BEACH, CA:
2,627,272, REN. 8-16-12. MULTIPLE CLASS, INT. CLS. 38
AND 41.

THE BRITISH BROADCASTING CORPORATION, LON-
DON, UNITED KINGDOM:
4,210,252, MULTIPLE CLASS, INT. CLS. 9, 16, 18 AND 28.

THE BUBBLE LOUNGE SAN FRANCISCO, INC, SAN
FRANCISCO, CA, DBA THE BUBBLE LOUNGE CHAM-
PAGNE BAR AND COMPANY:
4,208,221, PUB. 8-24-2010. INT. CL. 43.

THE CALIFORNIA ENDOWMENT, LOS ANGELES, CA:
4,209,003, PUB. 7-3-2012. INT. CL. 36.

THE CAMBRIDGE SCHOOL OF DALLAS, DALLAS, TX:
4,209,879, PUB. 7-3-2012. INT. CL. 41.

THE CANADIAN COUNCIL OF THE BLIND, OTTAWA,
ONTARIO, CANADA:
4,208,188, PUB. 5-31-2011. INT. CL. 16.

THE CHEESE COURSE, INC., WESTON, FL:
2,602,215, REN. 8-13-12. MULTIPLE CLASS, INT. CLS. 29
AND 35.
2,602,215, CANC. INT. CL. 30.

THE CHEMITHON CORPORATION, SEATTLE, WA:
4,208,590, PUB. 7-3-2012. MULTIPLE CLASS, INT. CLS. 7,
9, 11, 40, 41 AND 42.
4,208,591, PUB. 7-3-2012. MULTIPLE CLASS, INT. CLS. 7,
9, 11, 40, 41 AND 42.

THE CHILDREN'S HOUR, LLC, SALT LAKE CITY, UT:
4,208,669, PUB. 7-3-2012. INT. CL. 35.

THE COCA-COLA COMPANY, ATLANTA, GA:
3,121,372, CANC. INT. CL. 15.

THE COLLINS CENTER FOR PUBLIC POLICY, INC.,
MIAMI, FL:
4,209,940, PUB. 7-3-2012. INT. CL. 42.

THE COMPOST OFFICE, INC., CHICAGO, IL:
4,209,024, PUB. 7-3-2012. INT. CL. 39.

THE COOKIE DEPARTMENT, INC., BERKELEY, CA:
4,209,436, PUB. 7-3-2012. INT. CL. 30.

THE COUSTEAU SOCIETY, INC., CHESAPEAKE, VA:
4,208,783, PUB. 7-3-2012. INT. CL. 41.

THE CRANKY PRINCESS, INC., STONE MOUNTAIN, GA:
3,037,468, CANC. MULTIPLE CLASS, INT. CLS. 3 AND
25.

THE DILLER CORPORATION, CINCINNATI, OH:
1,705,019, REN. 8-16-12. INT. CL. 20.

THE DOG BAR, INC., MIAMI BEACH, FL:
3,052,546, CANC. MULTIPLE CLASS, INT. CLS. 21 AND
31.

THE ELDER INSIDER, BRADFORD, MA:
4,210,942, INT. CL. 41.

THE ENDOCRINE SOCIETY, CHEVY CHASE, MD:
4,210,132, PUB. 7-3-2012. INT. CL. 41.

THE ESTER C COMPANY, PRESCOTT, AZ:
2,528,608, CANC. INT. CL. 5.

THE FOUNDATION, INC., SEBRING, FL:
2,712,690, REN. 8-11-12. INT. CL. 41.

THE FOUR 9'S GROUP, LLC, BOYNTON BEACH, FL:
4,210,129, PUB. 7-3-2012. INT. CL. 35.

THE FRANCIS E. PARKER MEMORIAL HOME, INC.,
PISCATAWAY, NJ, AKA PARKER HOME:
4,209,518, PUB. 7-3-2012. MULTIPLE CLASS, INT. CLS. 35
AND 44.

THE FRANCIS E. PARKER MEMORIAL HOME, INC.,
PISCATAWAY, NJ:
4,209,579, PUB. 7-3-2012. MULTIPLE CLASS, INT. CLS. 35
AND 44.

THE FRANK LLOYD WRIGHT FOUNDATION, SCOTTS-
DALE, AZ:
4,208,580, PUB. 7-3-2012. INT. CL. 21.

THE GET IN TOUCH FOUNDATION, INC., MILFORD, CT:
4,210,706, INT. CL. 25.

THE GLENGLAUGH DISTILLERY COMPANY LIM-
ITED, UNITED KINGDOM:
4,208,432, PUB. 7-3-2012. INT. CL. 33.

THE GREAT LAKES BREWING CO., CLEVELAND, OH:
4,208,954, PUB. 3-20-2012. INT. CL. 32.

THE GUIDANCE SL, SPAIN:
4,208,438, PUB. 7-3-2012. INT. CL. 42.

THE HARTZ MOUNTAIN CORPORATION, SECAUCUS, NJ:
4,211,168, INT. CL. 28.

THE HEALTHCENTRAL NETWORK, INC., ARLINGTON,
VA:
2,526,680, CANC. MULTIPLE CLASS, INT. CLS. 35 AND
42.

THE HONEST KITCHEN, INC., SAN DIEGO, CA:
4,211,015, INT. CL. 5.
4,211,016, INT. CL. 5.

THE HUNGRY HOUSEWIFE, INC., TAMPA, FL:
4,210,045, PUB. 7-3-2012. INT. CL. 43.

THE INSIGHTS GROUP LIMITED, DUNDEE, UNITED
KINGDOM:
4,210,273, MULTIPLE CLASS, INT. CLS. 9, 16, 35 AND 41.

THE JAMES AMBROSE JOHNSON, JR. 1999 TRUST, BUR-
BANK, CA:
4,208,892, PUB. 7-3-2012. INT. CL. 25.

THE JEWISH FEDERATIONS OF NORTH AMERICA, INC.,
NEW YORK, NY:
4,208,536, PUB. 7-3-2012. INT. CL. 36.

THE JOSEPH ROMANO, JOHN RUSSO-ZIRKEL AND
CRUISE RUSSO JOINT VENTURE, PORT MONMOUTH,
NJ:
4,208,964, PUB. 7-3-2012. INT. CL. 25.

THE MACBETH GROUP, INC., DAYTON, NJ:
4,209,655, PUB. 7-3-2012. INT. CL. 16.

THE MARRIAGE BOOT CAMP INC., MURPHY, TX:
4,209,080, PUB. 7-3-2012. INT. CL. 41.

THE MCGRAW-HILL COMPANIES, INC., NEW YORK, NY:
4,211,147, INT. CL. 41.
4,211,208, MULTIPLE CLASS, INT. CLS. 16 AND 41.
4,211,282, INT. CL. 41.

THE MEADOW MARCHE, INC., PORTLAND, OR:
4,209,724, PUB. 7-3-2012. INT. CL. 30.

THE MENTOR FACTOR LLC, BRADENTON, FL:
4,209,445, PUB. 7-3-2012. INT. CL. 41.

THE MO' MUSIC PROJECT LLC, LOS ANGELES, CA:
4,211,381, INT. CL. 41.

THE NATIONAL ASSOCIATION OF PROFESSIONAL BASE-
BALL LEAGUES, INC., ST. PETERSBURG, FL:
4,210,070, PUB. 7-3-2012. INT. CL. 25.
4,210,077, PUB. 7-3-2012. INT. CL. 25.

THE NATIONAL BOARD OF CERTIFICATION FOR COM-
MUNITY ASSOCIATION MANAGERS, FALLS CHURCH,
VA:
4,210,627, INT. CL. 35.

THE NATIONAL COLLEGIATE ATHLETIC ASSOCIATION,
INDIANAPOLIS, IN:
2,579,140, REN. 8-15-12. INT. CL. 41.
3,103,086, CANC. INT. CL. 14.

THE NATIONAL FOOTBALL FOUNDATION AND COL-
LEGE HALL OF FAME, INC., IRVING, TX:
4,209,882, PUB. 7-3-2012. INT. CL. 35.
4,209,883, PUB. 7-3-2012. INT. CL. 36.
4,209,884, PUB. 7-3-2012. INT. CL. 41.
4,210,062, PUB. 7-3-2012. INT. CL. 36.
4,210,063, PUB. 7-3-2012. INT. CL. 41.
4,210,066, PUB. 7-3-2012. INT. CL. 35.

THE NEBRASKA MEDICAL CENTER, OMAHA, NE:
4,210,402, MULTIPLE CLASS, INT. CLS. 35 AND 44.

THE NET2 GROUP, INC., NEW YORK, NY:
4,210,744, MULTIPLE CLASS, INT. CLS. 35 AND 41.

THE NEU GROUP, INC., KATONAH, NY:
2,528,129, CANC. MULTIPLE CLASS, INT. CLS. 16 AND
42.

THE NEWPORT KITCHEN LLC, NEWPORT BEACH, CA:
4,210,808, INT. CL. 29.
4,210,809, INT. CL. 29.
4,210,810, INT. CL. 29.
4,210,815, INT. CL. 29.

THE NEWSWEEK/DAILY BEAST COMPANY LLC, NEW
YORK, NY:
4,210,114, PUB. 7-3-2012. INT. CL. 41.

- THE NIELSEN COMPANY (US), LLC, SCHAUMBURG, IL, BURKE MARKETING SERVICES, INC., CINCINNATI, OH:
1,206,443. REN. 8-13-12. INT. CL. 35.
- THE OMELETTE CHEFS, INC., NAPLES, FL:
4,147,912. CANC. INT. CL. 43.
- THE ONE GROUP LLC, NEW YORK, NY:
4,208,788. PUB. 7-3-2012. INT. CL. 43.
- THE PATH OF WELLNESS AND HEALING, LLC, LOS ANGELES, CA:
4,211,021. INT. CL. 9.
- THE PERMANENTE MEDICAL GROUP, INC., OAKLAND, CA:
4,211,428. MULTIPLE CLASS, INT. CLS. 39, 41, 42 AND 44.
- THE PETER AND PATRICIA GRUBER FOUNDATION, NEW YORK, NY:
4,208,891. PUB. 7-3-2012. INT. CL. 36.
- THE PIZZA-RANT, INC., DAVIE, FL:
4,209,633. PUB. 7-3-2012. INT. CL. 43.
4,209,930. PUB. 7-3-2012. INT. CL. 43.
- THE PLANNING AND ZONING RESOURCE CORPORATION, OKLAHOMA CITY, OK, AKA PZR:
4,211,523. INT. CL. 45.
- THE POOL FACTORY INC., BROOKLYN, NY:
4,211,485. INT. CL. 35.
- THE PRIDE FOUNDATION, SEATTLE, WA:
3,200,745. CANC. INT. CL. 35.
- THE PROCTER & GAMBLE COMPANY, CINCINNATI, OH:
4,210,001. PUB. 7-3-2012. INT. CL. 3.
4,210,714. INT. CL. 43.
4,210,830. INT. CL. 3.
4,210,853. INT. CL. 36.
4,211,104. MULTIPLE CLASS, INT. CLS. 16 AND 21.
4,211,276. INT. CL. 3.
- THE PROFESSIONAL INDOOR FOOTBALL LEAGUE, KNOXVILLE, TN:
4,209,013. PUB. 7-3-2012. INT. CL. 41.
- THE QUEEN'S FLOWERS, INC., MIAMI, FL:
4,209,416. PUB. 7-3-2012. INT. CL. 31.
4,209,417. PUB. 7-3-2012. INT. CL. 31.
- THE RANDALL PARR ORGANIZATION, INC., SPRING BRANCH, TX:
4,209,668. PUB. 7-3-2012. INT. CL. 41.
- THE RED FLAG GROUP LIMITED, SHEUNG WAN, HONG KONG:
4,211,549. MULTIPLE CLASS, INT. CLS. 9 AND 41.
- THE RIGHT PREP, LLC, PEMBROKE PINES, FL:
4,208,730. PUB. 7-3-2012. INT. CL. 41.
- THE SAUL ZAENTZ COMPANY, BERKELEY, CA:
4,210,302. INT. CL. 30.
- THE SEMEX ALLIANCE, GUELPH, ONTARIO, CANADA:
4,208,449. PUB. 7-3-2012. MULTIPLE CLASS, INT. CLS. 5, 9, 10, 31, 35, 42 AND 44.
- THE SHERWIN-WILLIAMS COMPANY, CLEVELAND, OH:
4,210,315. INT. CL. 2.
- THE SOFTWARE REVOLUTION, INC., KIRKLAND, WA, AKA TSRI:
4,209,441. PUB. 7-3-2012. INT. CL. 42.
- THE SOLID WOOD CABINET COMPANY LLC, SOUTHAMPTON, PA:
4,211,736. MULTIPLE CLASS, INT. CLS. 20, 35 AND 40.
- THE SPIC AND SPAN COMPANY, IRVINGTON, NY:
3,038,299. CANC. INT. CL. 3.
- THE SPOILED HORSE, LLC, EAST HAMPTON, CT:
4,209,188. PUB. 7-3-2012. INT. CL. 37.
- THE TELEPETREE COMPANY, LLC, DUNWOODY, GA:
3,409,056. CANC. INT. CL. 38.
- THE THERAPLEX COMPANY, MEMPHIS, TN:
4,210,334. INT. CL. 5.
- THE TILE SHOP, LLC, PLYMOUTH, MN:
4,210,755. INT. CL. 20.
4,210,776. INT. CL. 19.
- THE TOPPS COMPANY, INC., NEW YORK, NY:
4,210,038. PUB. 7-3-2012. INT. CL. 41.
- THE TRANZONIC COMPANIES, CLEVELAND, OH:
4,210,280. INT. CL. 21.
- THE TRUSTEES OF THE "ISSAC ZAHARONI AND SUZANNE ZAHARONI INTER VIVOS TRUST", HAWTHORNE, CA:
4,208,672. PUB. 7-3-2012. INT. CL. 11.
- THE TRUSTEES OF THE BASKIN-KERR TRUST, A NEW ZEALAND TRUST COMPRISING VICKI CATHRYN HYDE AND TERENCE JAMES LEO FOOTE, CITIZENS OF NEW ZEALAND, CHRISTCHURCH, NEW ZEALAND:
4,209,699. PUB. 7-3-2012. INT. CL. 9.
- THE TRUSTEES OF THE WHITESTONE REIT, HOUSTON, TX:
4,210,564. INT. CL. 37.
- THE TRUSTEES OF THE WHITESTONE REIT, A MARYLAND BUSINESS TRUST, HOUSTON, TX:
4,210,563. INT. CL. 37.
- THE VALSPAR CORPORATION, MINNEAPOLIS, MN:
4,211,061. INT. CL. 2.
- THE WALKING COMPANY HOLDINGS, INC., SANTA BARBARA, CA:
3,036,995. CANC. INT. CL. 25.
- THE WISH LIST AUXILIARY BOARD, CHICAGO, IL, DBA WISH LIST CHICAGO:
4,209,228. PUB. 7-3-2012. INT. CL. 36.
- THE WOOF ROOM, LLC, ROSEVILLE, MN:
4,209,679. PUB. 7-3-2012. INT. CL. 43.
- THEFACESHOP CO., LTD., SEOUL, REPUBLIC OF KOREA:
4,208,467. PUB. 7-3-2012. INT. CL. 3.
- THERMAL CORP., WILMINGTON, DE:
2,605,636. REN. 8-13-12. INT. CL. 11.
- THERMIONICS, INC., SPRINGFIELD, IL:
4,209,032. PUB. 7-3-2012. INT. CL. 10.
- THERMO ELECTRON (KARLSRUHE) GMBH, 4D-76227 KARLSRUHE 41, FED REP GERMANY, GEBRUDER HAAKE K.G., BERLIN-STEGLITZ, FED REP GERMANY:
735,348. REN. 8-15-12. U.S. CL. 26 (INT. CL. 9).
- THINKFUSE INC., SEATTLE, WA:
4,211,273. INT. CL. 42.
- THL CREDIT ADVISORS LLC, BOSTON, MA:
4,211,470. INT. CL. 36.
- THOMAS & BETTS INTERNATIONAL, INC., WILMINGTON, DE:
4,208,937. PUB. 7-3-2012. INT. CL. 9.
- THOMAS RAMIES, PORTOLA VALLEY, CA, DBA WEST 280 AND CLAY BAKER, PORTOLA VALLEY, CA, DBA WEST 280:
4,176,011. COR. INT. CL. 9.
- THOMAS REED PUBLICATIONS, INC., SOUTH BOSTON, MA:
2,526,504. CANC. INT. CL. 16.
- THOMPSON & CO. OF TAMPA, INC., TAMPA, FL:
4,210,106. PUB. 7-3-2012. INT. CL. 34.
4,210,108. PUB. 7-3-2012. INT. CL. 34.
- THOMPSON, DENNIS K, LAUREL, MD, DBA TRUCE & SANTUARY GANG AND DRUG FREE KIDS & TEENS STOP BULLYING:
4,210,857. INT. CL. 25.
- THORNE RESEARCH, INC., DOVER, ID:
4,208,130. PUB. 7-3-2012. INT. CL. 5.
- THORNHILL RESEARCH INC., TORONTO, CANADA:
4,210,346. INT. CL. 10.
- THORNTONS INC., LOUISVILLE, KY:
4,209,651. PUB. 7-3-2012. INT. CL. 21.
- THORO'BRED RACING PLATE CO, INC., ANAHEIM, CA:
1,769,684. REN. 8-16-12. INT. CL. 6.
- THREE ANGELS BROADCASTING NETWORK, INC., WEST FRANKFORT, IL:
4,211,583. INT. CL. 41.
- THUNDER HILL, LLC, LAYTON, UT:
4,208,623. PUB. 7-3-2012. INT. CL. 35.
- TIANJUN WANG, SHREWSBURY, MA:
4,211,370. INT. CL. 5.
- TICKETWEB, INC., SAN FRANCISCO, CA:
2,750,286. REN. 8-16-12. INT. CL. 41.
- TIFCO INDUSTRIES, INC., CYPRESS, TX:
1,781,080. REN. 8-11-12. INT. CL. 6.
- TIFFANY (NJ) LLC, PARSIPPANY, NJ, TIFFANY (NJ) INC., PARSIPPANY, NJ:
2,708,223. REN. 8-16-12. INT. CL. 25.

TIGHTPAC AMERICA INC., INGLEWOOD, CA:
4,211,058, INT. CL. 21.

TILLOTTS PHARMA AG, SWITZERLAND:
4,208,415, PUB. 7-3-2012. INT. CL. 5.

TIMAC SA, 35400 SAINT-MALO, FRANCE:
2,687,046, COR. INT. CL. 1.

TIME FOR TWO, SCOTTSDALE, AZ, TIME FOR TWO,
SCOTTSDALE, AZ:
2,625,368, REN. 8-15-12. INT. CL. 35.

TIME INC., NEW YORK, NY:
2,645,123, REN. 8-13-12. INT. CL. 16.

TISCARENO, NANCY, NORCO, CA:
4,209,526, PUB. 7-3-2012. INT. CL. 36.

TISSOT SA, SWITZERLAND:
3,008,982.

TISSUESEAL, LLC, ANN ARBOR, MI:
4,208,727, PUB. 7-3-2012. INT. CL. 5.

TITAN INTERNATIONAL, INC., QUINCY, IL:
2,600,112, REN. 8-13-12. INT. CL. 12.

TITAN TIRE CORPORATION, QUINCY, IL:
2,526,797, CANC. INT. CL. 12.

TITAN UMRERFUNGSTECHNIK; GMBH & CO. KG, FED
REP GERMANY:
4,208,431, PUB. 7-3-2012. MULTIPLE CLASS, INT. CLS. 6
AND 17.

TIVALL (1993) LTD., M.P. OSHRAT, 25220, ISRAEL, TIVALL-
VEGETARIAN FOOD KIBBUTZ LOCHAMEI HAGE-
TAOT, OSHRAT 25220, ISRAEL:
1,754,567, REN. 8-15-12. INT. CL. 29.

TIVIT TERCEIRIZACAO DE PROCESSOS SERVICOS E
TECNOLOGIA S/A, CEP 08773-490, MOGI DA CRUZES /
SP, BRAZIL:
4,208,229, PUB. 6-12-2012. INT. CL. 37.
4,208,230, PUB. 6-12-2012. INT. CL. 42.

TJX COMPANIES, INC., THE, FRAMINGHAM, MA, TJX
OPERATING COMPANIES, INC., THE, FRAMINGHAM,
MA:
1,706,929, REN. 8-10-12. INT. CL. 25.

TLC ENTERPRISES INC., ROCKY RIVER, OH:
4,208,650, PUB. 7-3-2012. INT. CL. 30.

TMFS HOLDINGS, LLC, OVERLAND PARK, KS:
4,211,743, INT. CL. 36.

TODD M HALL ENTERPRISES LLC, RALEIGH, NC:
4,209,494, PUB. 7-3-2012. INT. CL. 41.

TOHKOH TSUSHO & CO., LTD., TAITO-KU, TOKYO 111-
0041, JAPAN AND FUMOTO PLANNING CORP., YOKO-
HAMA-SHI, KANAGAWA 240-0012, JAPAN:
2,526,983, CANC. INT. CL. 9.

TOKBOX, INC., SAN FRANCISCO, CA:
4,210,680, INT. CL. 38.

TOKYO ELECTRON KOREA LTD., REPUBLIC OF KOREA:
4,208,441, PUB. 7-3-2012. INT. CL. 9.

TOM HOM GROUP, LLC, THE, LA JOLLA, CA:
2,555,115, AM. MULTIPLE CLASS, INT. CLS. 35 AND 36.

TOMI OTEE, NEW YORK, NY:
4,210,966, INT. CL. 25.

TOMMY JOHN, INC., NEW YORK, NY:
4,208,612, PUB. 1-10-2012. INT. CL. 25.

TONA COLEY, SUNRISE, FL:
4,209,833, PUB. 7-3-2012. MULTIPLE CLASS, INT. CLS. 25
AND 35.

TONER HOLDINGS, LLC, DALLAS, PA, DBA COATES
TONERS:
3,038,349, CANC. INT. CL. 2.

TONNELLERIE SAINT MARTIN, FRANCE:
4,208,435, PUB. 7-3-2012. INT. CL. 20.

TONY SACCA, LAS VEGAS, NV:
4,211,733, INT. CL. 21.
4,211,734, INT. CL. 25.

TOP LAYER NETWORKS, INC., WESTBORO, MA TO
CORERO NETWORK SECURITY, INC., HUDSON, MA:
2,527,792, CANC. INT. CL. 9.

TOP PROSPECTS, INC., GRANT, AL:
4,209,688, PUB. 7-3-2012. INT. CL. 41.

TOPSIL SEMICONDUCTOR MATERIALS A/S, DENMARK:
4,120,173, COR. MULTIPLE CLASS, INT. CLS. 1, 6, 9, 11,
35 AND 40.

TORYS LLP, TORONTO, ONTARIO, CANADA:
2,918,556, CANC. INT. CL. 42.

TOSHIBA AMERICA INFORMATION SYSTEMS, INC., IR-
VINE, CA:
2,528,308, CANC. INT. CL. 9.
4,211,371, INT. CL. 9.

TOSHIBA MEDICAL SYSTEMS CORPORATION, TOCHIGI
324-8550, JAPAN:
4,210,247, MULTIPLE CLASS, INT. CLS. 9 AND 10.

TOSI & ASSOCIATES, INC., FENTON, MI:
1,694,977, REN. 8-15-12. INT. CL. 41.

TOTAL CALL INTERNATIONAL, INC., GARDENA, CA:
4,209,061, PUB. 7-3-2012. INT. CL. 38.
4,209,062, PUB. 7-3-2012. INT. CL. 38.

TOTAL CONTAINMENT SOLUTIONS, INC., FT MYERS,
FL:
4,211,306, INT. CL. 19.

TOTAL RESOURCES INTERNATIONAL, WALNUT, CA:
4,210,710, INT. CL. 20.

TOUCHSTONE ACCENT LIGHTING, LONG LAKE, MN:
2,527,377, CANC. INT. CL. 37.

TOWER CANCER RESEARCH FOUNDATION, LOS AN-
GELES, CA:
4,209,184, PUB. 7-3-2012. INT. CL. 36.
4,209,185, PUB. 7-3-2012. INT. CL. 36.

TOWN & COUNTRY DEVELOPMENT, INC., SALT LAKE
CITY, UT:
4,209,054, PUB. 7-3-2012. INT. CL. 37.
4,209,055, PUB. 7-3-2012. INT. CL. 37.

TOWNVIEW TRADING, LTD, DASOUPOLI, NICOSIA, CY-
PRUS:
4,209,675, PUB. 7-3-2012. INT. CL. 41.

TOYOTA MOTOR SALES, U.S.A., INC., TORRANCE, CA:
4,209,607, PUB. 7-3-2012. INT. CL. 41.

TRACTOR SUPPLY CO. OF TEXAS, LP, BRENTWOOD, TN:
4,210,882, INT. CL. 10.

TRAILERS Y TANQUES DE ALUMINIO, S.A. DE C.V.,
NUEVO LEON, C.P. 06745, MEXICO:
4,209,524, PUB. 7-3-2012. INT. CL. 37.

TRAINING & E-TRACKING SOLUTIONS, LLC, HUNT
VALLEY, MD:
4,211,832, MULTIPLE CLASS, INT. CLS. 35 AND 41.

TRAINING FOR WARRIORS LLC, FAIRLAWN, NJ:
4,208,494, PUB. 3-27-2012. MULTIPLE CLASS, INT. CLS.
9, 16 AND 41.

TRAK SPORTS USA, INC., BURLINGTON, VT:
3,038,161, CANC. INT. CL. 28.

TRALY (U.S.A.) INC., BOCA RATON, FL:
4,210,705, INT. CL. 16.

TRAMMELL CROW COMPANY, DALLAS, TX:
2,526,775, CANC. MULTIPLE CLASS, INT. CLS. 36 AND
39.

TRANSAMERICA CORPORATION, SAN FRANCISCO, CA:
2,458,663, COR. INT. CL. 36.

TRANSAMERICA LIFE INSURANCE COMPANY, CEDAR
RAPIDS, IA:
2,527,176, CANC. INT. CL. 36.

TRANSATLANTIC HOLDINGS, INC., NEW YORK, NY:
1,204,812, REN. 8-15-12. INT. CL. 36.
1,204,812, COR. INT. CL. 36.

TRANSIM TECHNOLOGY CORPORATION, PORTLAND,
OR:
1,734,565, REN. 8-11-12. INT. CL. 9.

TRANSIT PROS, LLC, LEE'S SUMMIT, MO:
4,208,780, PUB. 7-3-2012. INT. CL. 39.

TRANSPORTATION SAFETY EQUIPMENT INSTITUTE,
WASHINGTON, DC:
4,211,291, INT. CL. 35.

TRAVERS, ROBERT J., NEWBERG, OR:
2,528,654, CANC. INT. CL. 31.

TRAVIS, MARK E, ALBUQUERQUE, NM, DBA CAERUS
DEVELOPMENTS:
4,210,702, INT. CL. 41.

TREADMARK STUDIOS, LONG BEACH, CA:
4,209,415, PUB. 7-3-2012. INT. CL. 41.

TREETOP SOFTWARE COMPANY, LLC, LAKELAND, FL:
4,211,681, MULTIPLE CLASS, INT. CLS. 35 AND 42.

- TREK BICYCLE CORPORATION, WATERLOO, WI:
2,527,128, CANC. INT. CL. 12.
- TREXA LLC, MARINA DEL REY, CA:
4,209,823, PUB. 7-3-2012. INT. CL. 12.
- TRI FASTER, LLC, MUSKEGO, WI:
4,208,516, PUB. 7-3-2012. INT. CL. 41.
- TRI STATE RESTORATIONS, LLC, ROCKVILLE, MD:
4,210,924, INT. CL. 37.
- TRI-ISO, INC., CLAREMONT, CA:
2,527,320, CANC. INT. CL. 35.
- TRI-STATE GENERATION AND TRANSMISSION ASSOCIATION, INC., WESTMINSTER, CO:
2,621,524, REN. 8-10-12. MULTIPLE CLASS, INT. CLS. 39 AND 40.
2,654,532, REN. 8-10-12. MULTIPLE CLASS, INT. CLS. 39 AND 40.
- TRIALGRAPHIX, INC., MIRAMAR, FL:
4,211,596, INT. CL. 42.
- TRIANGLE K, INC., NEW YORK, NY:
4,209,812, PUB. 7-3-2012. U.S. CL. A.
- TRIBUNE MEDIA SERVICES, INC., CHICAGO, IL:
4,211,012, INT. CL. 28.
- TRICKSTAR INNOVATIONS LLC, WOODMERE, NY, FORMERLY TRICKSTAR INC.:
4,210,592, INT. CL. 41.
- TRICOM CARD TECHNOLOGIES, INC., SAN PEDRO, CA:
2,527,370, CANC. INT. CL. 9.
- TRINITY GUARDION, LLC, BATESVILLE, IN:
4,211,091, INT. CL. 24.
- TRINITY PACKAGING CORPORATION, ARMONK, NY:
1,675,007, REN. 8-10-12. INT. CL. 16.
- TRIODOS BANK N.V., NETHERLANDS:
4,208,330, PUB. 7-3-2012. INT. CL. 36.
- TRION WORLDS, INC., REDWOOD CITY, CA:
4,211,665, INT. CL. 16.
- TRIP ALERTZ, INC., CHESTNUT HILL, MA:
4,211,716, MULTIPLE CLASS, INT. CLS. 39 AND 43.
- TRIPAC INTERNATIONAL, FORT WORTH, TX:
4,208,942, PUB. 7-3-2012. MULTIPLE CLASS, INT. CLS. 7 AND 25.
- TRIPLE CROWN NUTRITION, INC., WAYZATA, MN:
4,210,876, INT. CL. 31.
- TRISH MCEVOY, LTD., NEW YORK, NY:
4,210,668, INT. CL. 3.
- TRISTAR FULFILLMENT SERVICES, INC., BRIDGEPORT, NJ:
1,778,062, REN. 8-10-12. INT. CL. 35.
- TRITON INDUSTRIES LLC, LOTTIE, LA:
2,623,720, REN. 8-13-12. MULTIPLE CLASS, INT. CLS. 37 AND 40.
- TRIVANTIS CORPORATION, CINCINNATI, OH:
2,607,094, REN. 8-16-12. INT. CL. 41.
- TROPIC WEAR CONFECÇÕES LTDA. - ME, PORTO ALEGRE, BRAZIL:
4,208,753, PUB. 7-3-2012. INT. CL. 25.
- TROUP, JAMES U., WASHINGTON, DC:
4,210,894, INT. CL. 38.
- TROVOGUE INC, DULUTH, GA:
4,208,774, PUB. 7-3-2012. INT. CL. 3.
- TRUE FIT CORPORATION, WOBURN, MA:
4,210,475, INT. CL. 42.
- TRUE VALUE COMPANY, CHICAGO, IL:
2,527,647, CANC. INT. CL. 35.
- TRUGLO, INC., RICHARDSON, TX:
4,211,118, INT. CL. 13.
4,211,228, INT. CL. 28.
- TRUST ASSOCIATES, TUCKER, GA, DBA TRUST ASSOCIATES SERVICES TRUST:
4,211,862, MULTIPLE CLASS, INT. CLS. 16 AND 41.
- TRUSTEES OF COLUMBIA UNIVERSITY IN THE CITY OF NEW YORK, THE, NEW YORK, NY:
2,601,876, REN. 8-13-12. INT. CL. 42.
- TRYP HOTELS WORLDWIDE, INC., PARSIPPANY, NJ AND WYNDHAM TM CORP., LAS VEGAS, NV:
4,210,118, PUB. 7-3-2012. INT. CL. 43.
- TSUI GALLEN KA-LEUNG, BRAMPTON, ONTARIO, CANADA:
2,554,817, REN. 8-15-12. INT. CL. 9.
- TUBLIN, MITCHELL E., STAMFORD, CT:
4,211,128, INT. CL. 41.
- TUFF DECKS, INC., ENGLEWOOD, CO:
4,211,675, INT. CL. 37.
- TUFFORCE LLC, PLYMOUTH, MI:
4,209,786, PUB. 7-3-2012. INT. CL. 13.
- TUILASER AG, GERMERING, FED REP GERMANY:
2,965,819, CANC. MULTIPLE CLASS, INT. CLS. 9, 40 AND 42.
- TUKAS GIDA; SANAYI VE TICARET ANONIM SIRKETI, TURKEY:
4,208,416, PUB. 7-3-2012. MULTIPLE CLASS, INT. CLS. 29 AND 30.
- TULLIO, JIM, HUNTINGTON BEACH, CA AND TULLIO, BOB, UPLAND, CA:
4,209,223, PUB. 7-3-2012. INT. CL. 41.
- TURBINE ENGINE COMPONENTS TECHNOLOGIES CORPORATION, THOMASVILLE, GA:
4,211,574, INT. CL. 40.
- TURCZYNSKI, JUDE, M., WEST SACRAMENTO, CA:
2,659,634, REN. 8-15-12. INT. CL. 12.
- TURNER, ROBERT, MT. PLEASANT, TX:
1,671,430, CANC. INT. CL. 42.
- TURNSTILE PUBLISHING COMPANY, ORLANDO, FL:
4,209,662, PUB. 7-3-2012. MULTIPLE CLASS, INT. CLS. 16 AND 41.
4,209,971, PUB. 7-3-2012. INT. CL. 41.
- TUTTLE, DEXTER, FORT WORTH, TX:
4,211,735, INT. CL. 1.
- TUTTNAUER USA COMPANY, LTD., HAUPPAUGE, NY:
1,717,852, REN. 8-10-12. INT. CL. 10.
- TV1 GMBH, 85774 UNTERFÖHRING, FED REP GERMANY:
4,208,261, PUB. 7-3-2012. MULTIPLE CLASS, INT. CLS. 9, 38, 41 AND 42.
- TWENTIETH CENTURY FOX FILM CORPORATION, LOS ANGELES, CA:
4,209,701, PUB. 7-3-2012. INT. CL. 9.
- TWENTY-NINE PALMS BAND OF MISSION INDIANS, COACHELLA, CA:
4,208,755, PUB. 12-13-2011. MULTIPLE CLASS, INT. CLS. 35 AND 42.
- TWIN TOWERS, INC., WAYZATA, MN:
4,209,280, PUB. 7-3-2012. INT. CL. 41.
- TWO TECHNOLOGIES, INC., HORSHAM, PA:
4,211,402, INT. CL. 9.
- TYCO THERMAL CONTROLS LLC, MENLO PARK, CA, RAYCHEM CORPORATION, MENLO PARK, CA:
1,219,871, REN. 8-14-12. INT. CL. 11.
- TYCOR BENEFIT ADMINISTRATORS, INC., BERWYN, PA AND TYCOR ASSET MANAGEMENT, INC., BERWYN, PA:
2,602,758, REN. 8-13-12. INT. CL. 36.
2,605,861, REN. 8-13-12. INT. CL. 36.
2,613,490, REN. 8-13-12. INT. CL. 36.
- TYLER OCZKOWSKI, OXFORD, CT AND TAMMY OCZKOWSKI, OXFORD, CT AND CHRIS OCZKOWSKI, OXFORD, CT:
4,209,621, PUB. 7-3-2012. INT. CL. 25.
- TYSON SOUTHWORTH, LANCASTER, CA, AKA LEAK WHISPERER:
4,209,581, PUB. 7-3-2012. INT. CL. 37.
- U. S. BORDER COLLIE HANDLER'S ASSOCIATION, INC., CRAWFORD, TX, AKA USBCHA:
4,209,752, PUB. 7-3-2012. INT. CL. 41.
- U.O. MERCHANDISE, INC., PHILADELPHIA, PA:
4,210,082, PUB. 7-3-2012. INT. CL. 25.
4,210,188, PUB. 7-3-2012. INT. CL. 25.
- U.S. DEPARTMENT OF HEALTH AND HUMAN SERVICES, BETHESDA, MD:
2,527,826, CANC. INT. CL. 42.
- U.S. MARINE CORPS, A COMPONENT OF THE U.S. DEPARTMENT OF THE NAVY, WASHINGTON, DC:
4,210,027, PUB. 7-3-2012. INT. CL. 41.
- U.S. ROASTERIE, INC., DES MOINES, IA:
4,210,411, INT. CL. 30.
- U.S. SOAPS MANUFACTURING COMPANY, RALEIGH, NC:
4,211,565, INT. CL. 3.

U-HAUL INTERNATIONAL, INC., PHOENIX, AZ:
4,210,155, PUB. 7-3-2012. INT. CL. 39.
4,210,639, INT. CL. 39.

UBER TECHNOLOGIES INC., SAN FRANCISCO, CA:
4,209,984, PUB. 7-3-2012. MULTIPLE CLASS, INT. CLS. 9
AND 39.

UBM MEDICA LLC, JERSEY CITY, NJ:
4,208,182, PUB. 5-31-2011. INT. CL. 42.

UHS OF DELAWARE, INC., KING OF PRUSSIA, PA:
4,210,178, PUB. 7-3-2012. INT. CL. 44.

ULLICO INC., WASHINGTON, DC:
2,654,225, REN. 8-13-12. INT. CL. 36.

ULTA SALON, COSMETICS & FRAGRANCE, INC., BO-
LINGBROOK, IL:
4,210,207, PUB. 7-3-2012. INT. CL. 36.

ULTIMA NUTRITION, LLC, LAS VEGAS, NV:
4,210,583, INT. CL. 5.

ULTIMATE SPARKLE, INC., THE, LAFAYETTE, CA:
4,211,424, INT. CL. 14.

ULTIMATE WELLNESS SYSTEMS INC., NORTH PALM
BEACH, FL:
4,211,582, INT. CL. 5.

ULTIMATE WELLNESS SYSTEMS, INC., NORTH PALM
BEACH, FL:
4,211,602, INT. CL. 5.

ULTRAFAB, INC., FARMINGTON, NY:
2,602,176, REN. 8-13-12. INT. CL. 17.

UMEVOICE, INC., NOVATO, CA:
2,737,143, REN. 8-14-12. INT. CL. 9.
2,737,143, AM. INT. CL. 9.

UMICORE BUILDING PRODUCTS FRANCE, SOCIÉTÉ PAR
ACTION SIMPLIFIÉE, F-93170 BAGNOLET, FRANCE:
4,208,306, PUB. 7-3-2012. INT. CL. 41.

UMPQUA BANK, EUGENE, OR:
4,208,150, PUB. 7-3-2012. INT. CL. 36.

UNCLAIMED SURPLUS LIQUIDATIONS LLC, CAPE GIR-
ARDEAU, MO:
4,209,288, PUB. 7-3-2012. INT. CL. 35.

UNG, LAM, SUNNYVALE, CA:
4,210,452, INT. CL. 41.

UNICEL CORPORATION, ESCONDIDO, CA:
2,609,363, REN. 8-13-12. INT. CL. 6.

UNICO NATIONAL, FAIRFIELD, NJ:
4,208,747, PUB. 7-3-2012. INT. CL. 36.

UNICODE, INC., MOUNTAIN VIEW, CA, AKA THE UNI-
CODE CONSORTIUM:
4,209,897, PUB. 7-3-2012. INT. CL. 42.

UNIFIED TRUST COMPANY, NATIONAL ASSOCIATION,
LEXINGTON, KY:
2,741,359, REN. 8-15-12. INT. CL. 36.

UNILEVER PLC, MERSEYSIDE, UNITED KINGDOM, MAS-
COLO BROTHERS LIMITED, LONDON, ENGLAND:
2,601,964, REN. 8-10-12. INT. CL. 3.

UNILIN BEHEER B.V., NETHERLANDS:
4,208,399, PUB. 7-3-2012. INT. CL. 27.

UNILUX, INC., SADDLEBROOK, NJ:
937,070, REN. 8-11-12. U.S. CL. 26 (INT. CL. 9).

UNION BANK, NATIONAL ASSOCIATION, SAN FRANCIS-
CO, CA:
4,211,805, INT. CL. 36.

UNION EDITORIALISTA, S.A. DE C.V., GUADALAJARA,
JALISCO, MEXICO:
2,527,987, CANC. INT. CL. 16.

UNION SCIENTIFIC CORPORATION, RANDALLSTOWN,
MD:
2,602,353, REN. 8-16-12. INT. CL. 9.

UNION TANK CAR COMPANY, CHICAGO, IL:
2,612,949, REN. 8-10-12. INT. CL. 42.

UNIQUE GLOBAL DESIGNS, LLC, POTOMAC, MD:
4,211,278, MULTIPLE CLASS, INT. CLS. 18 AND 25.

UNITED INDUSTRIES CORPORATION, EARTH CITY, MO,
J. T. BAKER CHEMICAL COMPANY, PHILLIPSBURG,
NJ:
1,203,346, REN. 8-15-12. INT. CL. 5.

UNITED LABORATORIES INTERNATIONAL, LLC, HOUS-
TON, TX:
4,210,719, MULTIPLE CLASS, INT. CLS. 1, 3, 37, 40 AND
42.

UNITED MCGILL CORPORATION, GROVEPORT, OH:
1,210,391, REN. 8-10-12. INT. CL. 11.

UNITED MCGLLL CORPORATION, GROVEPORT, OH:
2,548,191, REN. 8-13-12. INT. CL. 11.

UNITED SHORE FINANCIAL SERVICES, LLC, BIRMING-
HAM, MI:
4,209,842, PUB. 7-3-2012. INT. CL. 36.

UNITED STATES GOLF ASSOCIATION, FAR HILLS, NJ:
1,205,871, REN. 8-15-12. INT. CL. 41.

UNITED STATES GOLF ASSOCIATION, FAR HILLS, NJ,
AKA USGA:
1,722,672, REN. 8-15-12. INT. CL. 42.

UNITED STATES POSTAL SERVICE, WASHINGTON, DC:
2,603,119, REN. 8-13-12. MULTIPLE CLASS, INT. CLS. 35
AND 39.

UNITED STATES RACQUETBALL ASSOCIATION, COLOR-
ADO SPRINGS, CO:
2,704,221, REN. 8-11-12. INT. CL. 41.
2,704,221, AM. INT. CL. 41.

UNITED YORAM DISTRIBUTORS, INC., BROOKLYN, NY:
2,528,510, CANC. INT. CL. 7.

UNIVERSAL CITY STUDIOS LLC, UNIVERSAL CITY, CA:
4,209,705, PUB. 7-3-2012. INT. CL. 37.

UNIVERSAL GENEVE S.A., GENEVE, SWITZERLAND:
4,208,514, PUB. 7-3-2012. INT. CL. 14.

UNIVERSAL LIGHTING TECHNOLOGIES, INC., NASH-
VILLE, TN:
4,210,245, INT. CL. 9.

UNIVERSAL RELATIONS INCORPORATED, LAS VEGAS,
NV:
4,209,925, PUB. 7-3-2012. INT. CL. 8.

UNIVERSITY OF NEW MEXICO, THE, ALBUQUERQUE,
NM:
2,619,531, REN. 8-10-12. INT. CL. 25.

UNIVERSITY OF NORTH CAROLINA AT CHAPEL HILL,
CHAPEL HILL, NC:
2,610,774, REN. 8-13-12. INT. CL. 41.
4,209,321, PUB. 7-3-2012. INT. CL. 41.

UNIVERSITY OF NORTH CAROLINA AT CHARLOTTE,
THE, CHARLOTTE, NC:
1,730,630, REN. 8-16-12. MULTIPLE CLASS, INT. CLS. 6,
16, 21, 25 AND 41.

UNIVERSITY OF SOUTHERN MISSISSIPPI, THE, HATTIES-
BURG, MS:
2,600,598, REN. 8-10-12. MULTIPLE CLASS, INT. CLS. 16,
20, 21 AND 25.

UNIVERSITY OF WASHINGTON, SEATTLE, WA:
1,238,523, REN. 8-15-12. INT. CL. 25.

UNIVERSITYNOW, INC., SAN FRANCISCO, CA:
4,211,677, MULTIPLE CLASS, INT. CLS. 41 AND 42.

UNPLUGGED VENTURES, NEW YORK, NY:
4,210,147, PUB. 7-3-2012. INT. CL. 35.

UNPLUGGED VENTURES LLC, NEW YORK, NY:
4,210,146, PUB. 7-3-2012. INT. CL. 35.

UNYTITE, INC., PERU, IL:
1,600,355, CANC. INT. CL. 6.

UOP LLC, DES PLAINES, IL:
4,209,664, PUB. 7-3-2012. INT. CL. 1.
4,209,665, PUB. 7-3-2012. INT. CL. 1.
4,209,666, PUB. 7-3-2012. INT. CL. 1.

UPTILO INC., NORTHRIDGE, CA:
4,209,604, PUB. 7-3-2012. MULTIPLE CLASS, INT. CLS. 35
AND 42.

UPTON, JULIE, LAYTONSVILLE, MD:
4,210,358, INT. CL. 25.

URBAN ANIMALS, INC., MINNEAPOLIS, MN:
2,527,955, CANC. INT. CL. 28.
2,528,004, CANC. INT. CL. 28.

URBAN CODE, INCORPORATED, CLEVELAND, OH, FOR-
MERLY STARBELLY PRODUCTIONS, INCORPORATED:
4,209,263, PUB. 7-3-2012. INT. CL. 9.

URBAN PIONEER PROPERTY MANAGEMENT, INC., SAN
FRANCISCO, CA:
4,209,175, PUB. 7-3-2012. MULTIPLE CLASS, INT. CLS. 35
AND 36.

URBAN TAILS, L.L.C., HOUSTON, TX:
2,646,459, REN. 8-11-12. MULTIPLE CLASS, INT. CLS. 41
AND 42.

- URGENT CARES OF AMERICA HOLDINGS, LLC, CLAYTON, NC:
4,209,484, PUB. 7-3-2012. INT. CL. 36.
- URNOVITZ, ABBY LAUREN, SANTA MONICA, CA:
4,209,302, PUB. 7-3-2012. INT. CL. 43.
- US FOODS, INC., ROSEMONT, IL:
2,611,438. REN. 8-15-12. INT. CL. 21.
- US HIGHLAND, INC., TULSA, OK:
4,209,366, PUB. 7-3-2012. INT. CL. 12.
- US SIGNAL CORPORATION, GRAND RAPIDS, MI:
2,704,669. REN. 8-15-12. MULTIPLE CLASS, INT. CLS. 36, 37 AND 38.
2,707,115. REN. 8-15-12. MULTIPLE CLASS, INT. CLS. 36, 37 AND 38.
- US VISIONCARE, L.L.C., MOORESTOWN, NJ, DBA EYE-CARECONNECT, LLC:
2,619,002. REN. 8-16-12. INT. CL. 9.
- USA AOBOMA INTERNATIONAL CHEMICAL LLC, WALNUT, NV:
4,210,508, INT. CL. 2.
- USA FINANCIAL DISTRIBUTION CORPORATION, ADA, MI:
4,210,842, MULTIPLE CLASS, INT. CLS. 35, 36 AND 41.
- USA TAEKWONDO, INC., COLORADO SPRINGS, CO:
3,121,848, COR. INT. CL. 25.
3,121,868, COR. INT. CL. 9.
- USM HOLDING AG, GUEMLINGEN, SWITZERLAND, USM U. SCHARER SOHNE AG, 3110 MUNSINGEN, SWITZERLAND:
1,708,225. REN. 8-16-12. INT. CL. 20.
- USSEL INTERNATIONAL CORPORATION, PARAMOUNT, CA, DBA EVE TRADING CO.:
2,527,218, CANC. INT. CL. 35.
- UTAH STATE BOARD OF REGENTS, C/O THE OFFICE OF THE COMMISSIONER OF HIGHER EDUCATION, SALT LAKE CITY, UT:
4,210,211, PUB. 7-3-2012. INT. CL. 36.
- UTILIMASTER CORPORATION, WAKARUSA, IN:
2,602,658. REN. 8-10-12. INT. CL. 12.
- UTRECHT MANUFACTURING CORPORATION, CRANBURY, NJ:
2,466,111. REN. 8-15-12. MULTIPLE CLASS, INT. CLS. 2, 16 AND 35.
- UTTERMOST CO., THE, ROCKY MOUNT, VA:
2,526,908, CANC. MULTIPLE CLASS, INT. CLS. 14, 16 AND 20.
- V BEAUTE LLC, NEW YORK, NY:
4,211,695, INT. CL. 3.
- V GROUP, INC., CARLSBAD, CA:
4,210,764, INT. CL. 32.
- V.A.G. CHEMIE HANDELSGESELLSCHAFT MBH, 22605 HAMBURG, FED REP GERMANY:
4,208,381, PUB. 5-22-2012. MULTIPLE CLASS, INT. CLS. 3, 5, 14, 41 AND 44.
- VAISALA OYJ, VANTAA, FINLAND:
4,209,261, PUB. 7-3-2012. MULTIPLE CLASS, INT. CLS. 9, 37, 38, 40 AND 42.
- VALCOS S.A., 3963 CRANS, SWITZERLAND:
2,614,520. REN. 8-16-12. MULTIPLE CLASS, INT. CLS. 3, 5 AND 35.
- VALDEZ, ARTHUR F., HOLLYWOOD, CA:
2,609,301. REN. 8-16-12. INT. CL. 15.
- VALEANT INTERNATIONAL BERMUDA, HAMILTON, BERMUDA, DERMIK PHARMACAL CO., INC., SYOSSET, NY:
735,930. REN. 8-15-12. U.S. CL. 18 (INT. CL. 5).
- VALENTINE RESEARCH, INC., CINCINNATI, OH:
1,783,321. REN. 8-10-12. INT. CL. 9.
- VALERI, DINO O., NEENAH, WI, DBA HITLIST OUTDOORS:
4,210,632, INT. CL. 25.
- VALIDSOFT UK LIMITED, UNITED KINGDOM:
4,208,425, PUB. 7-3-2012. MULTIPLE CLASS, INT. CLS. 9, 42 AND 45.
- VALMONT INDUSTRIES, INC., OMAHA, NE:
4,211,858, INT. CL. 40.
4,211,859, INT. CL. 40.
4,211,860, INT. CL. 40.
- VAN DUZER VINEYARDS, LLC, WILMETTE, IL, VAN DUZER VINEYARDS, LLC, WILMETTE, IL:
2,614,129. REN. 8-13-12. INT. CL. 33.
- VAN GASTEL SHOES B.V., 5171 NLX-KAATSHEUVEL, NETHERLANDS:
2,527,117, CANC. INT. CL. 25.
- VANDERBILT UNIVERSITY, NASHVILLE, TN:
2,527,232, CANC. INT. CL. 42.
- VANESSA KESSLER, CH-8112 OTELFINGEN, SWITZERLAND:
4,208,240, PUB. 7-3-2012. MULTIPLE CLASS, INT. CLS. 35 AND 36.
- VANGUARD ENERGY PARTNERS, LLC, BRANCHBURG, NJ:
4,208,995, PUB. 7-3-2012. MULTIPLE CLASS, INT. CLS. 35, 36, 37 AND 42.
4,208,996, PUB. 7-3-2012. MULTIPLE CLASS, INT. CLS. 35, 36, 37 AND 42.
- VANHEE, CHRIS, B-8793 SINT-ELOOIS-VIJVE (WAREGEM), BELGIUM:
2,527,766, CANC. INT. CL. 16.
- VANICHKACHORN, GREG, KALISPELL, MT:
4,209,820, PUB. 7-3-2012. INT. CL. 41.
- VANILLA SUGAR PTY LTD., VICTORIA, AUSTRALIA:
4,209,598, PUB. 7-3-2012. INT. CL. 3.
- VANILLA SUGAR PTY LTD., VIC3207, AUSTRALIA:
4,210,046, PUB. 7-3-2012. INT. CL. 3.
- VANTIV, LLC, CINCINNATI, OH:
4,210,859, INT. CL. 36.
4,210,860, INT. CL. 38.
4,210,861, INT. CL. 42.
- VAREL INTERNATIONAL IND., L.P., CARROLLTON, TX:
4,210,242, INT. CL. 7.
- VARGA, ILDIKO, DOROTTYA, HUNGARY:
4,208,553, PUB. 7-3-2012. INT. CL. 21.
- VARIOUS BEVERAGES LLC, CLEARWATER, FL:
4,208,192, PUB. 7-3-2012. INT. CL. 32.
- VASSAR, PHIL, NASHVILLE, TN:
2,528,541, CANC. INT. CL. 41.
- VELAR-GASKILL, DAVID S, OAK PARK, MI:
4,210,488, INT. CL. 16.
- VELAS HISPANIOLA, S.A., SANTO DOMINGO ESTE, DOMINICAN REP, DBA VELAS HISPANIOLA, S.A.:
4,208,222, PUB. 9-13-2011. INT. CL. 4.
- VENTEGRA, LLC, GLENDALE, CA:
4,211,534, MULTIPLE CLASS, INT. CLS. 35 AND 42.
- VENTURE MEASUREMENT COMPANY LLC, SPARTANBURG, SC, VENTURE MEASUREMENT COMPANY LLC, SPARTANBURG, SC:
2,601,493. REN. 8-15-12. INT. CL. 9.
- VEOLIA WATER SOLUTIONS & TECHNOLOGIES SUPPORT, SAINT MAURICE, FRANCE:
3,165,438.
- VERATEX, INC., PANORAMA CITY, CA:
4,211,135, INT. CL. 20.
- VERBAND DER VEREINE CREDITREFORM E.V., HELLERSBERGSTRASSE 12, FED REP GERMANY:
3,041,895.
- VERBICA, PETER C., SAN JOSE, CA:
2,528,607, CANC. INT. CL. 36.
- VERIDIAN HEALTHCARE, LLC, CHICAGO, IL:
4,208,812, PUB. 1-17-2012. INT. CL. 9.
- VERIFY, INC., IRVINE, CA:
4,209,905, PUB. 7-3-2012. INT. CL. 35.
4,210,018, PUB. 7-3-2012. INT. CL. 35.
4,210,033, PUB. 7-3-2012. INT. CL. 35.
- VERMONT COFFEE COMPANY, LLC, MIDDLEBURY, VT:
2,741,902. REN. 8-14-12. INT. CL. 30.
- VERMONT HARD CIDER COMPANY, LLC, MIDDLEBURY, VT:
4,211,412, INT. CL. 33.
- VERMONT SPIRITS DISTILLING COMPANY, QUECHEE, VT:
4,211,479, INT. CL. 33.
- VERNALIS DEVELOPMENT LIMITED, BERKSHIRE RG41 5UA, UNITED KINGDOM:
4,208,132, PUB. 12-13-2011. MULTIPLE CLASS, INT. CLS. 5 AND 42.

VERPOND, INC., CARLSBAD, CA:
4,209,507, PUB. 7-3-2012. INT. CL. 42.

VERTIFI SOFTWARE, LLC, BURLINGTON, MA:
4,208,746, PUB. 7-3-2012. MULTIPLE CLASS, INT. CLS.
35, 36, 38, 39, 41 AND 45.

VESIGO STUDIOS, LLC, ROGUE RIVER, OR:
4,208,865, PUB. 1-17-2012. INT. CL. 9.

VESTA DIPPING GRILL, DENVER, CO:
2,604,715, REN. 8-16-12. INT. CL. 42.

VET BRANDS INTERNATIONAL, INC., MIRAMAR, FL:
4,209,798, PUB. 7-3-2012. INT. CL. 5.

VETRONE, MICHAEL, SAN JOSE, CA:
4,211,813, INT. CL. 25.

VIACOM INTERNATIONAL INC., NEW YORK, NY:
4,210,886, INT. CL. 41.
4,211,407, INT. CL. 41.

VIANI, PAUL L., SAN DIEGO, CA:
4,210,657, INT. CL. 42.

VIASOFT, LLC, MONTREAL, QUEBEC, CANADA:
4,211,192, INT. CL. 45.

VIBEDECK LLP, LONDON, UNITED KINGDOM:
4,208,742, PUB. 7-3-2012. INT. CL. 9.

VIBRACODE, LLC, NASHVILLE, TN:
4,211,267, MULTIPLE CLASS, INT. CLS. 35, 42 AND 45.

VIBRATION TECHNOLOGIES, LLC, SAN RAFAEL, CA:
4,210,416, INT. CL. 9.

VICTORIA PARTNERS, LAS VEGAS, NV:
4,209,970, PUB. 7-3-2012. INT. CL. 44.

VICTORIA PRINCIPAL PRODUCTIONS, INC., NASHVILLE,
TN:
2,586,015, REN. 8-15-12. INT. CL. 3.
3,038,293, CANC. INT. CL. 3.

VICTORIA'S SECRET STORES BRAND MANAGEMENT,
INC., REYNOLDSBURG, OH:
4,211,049, INT. CL. 3.

VIDISOLUTIONS, INC., NEW YORK, NY:
3,038,149, CANC. INT. CL. 38.

VIEGA LLC, WICHITA, KS:
4,211,158, MULTIPLE CLASS, INT. CLS. 11 AND 19.

VILLALOBOS AGUAYO, LILIANA, LIMA 34, PERU:
4,208,757, PUB. 7-3-2012. INT. CL. 25.

VIMAL AGRO PRODUCTS PVT. LTD., DIST. SURAT
(GUJARAT), INDIA:
2,596,966, REN. 8-13-12. INT. CL. 32.

VINING-SPARKS IBG, LIMITED PARTNERSHIP, MEM-
PHIS, TN:
4,209,027, PUB. 7-3-2012. INT. CL. 36.
4,209,028, PUB. 7-3-2012. INT. CL. 36.

VINTAGE ENTERPRISES, INC., EAST STROUDSBURG, PA:
4,210,549, INT. CL. 34.
4,210,558, INT. CL. 34.

VINTAGE SOFTWARE, LLC, JACKSON, MO:
4,208,957, PUB. 7-3-2012. INT. CL. 35.
4,208,958, PUB. 7-3-2012. INT. CL. 35.

VIRTELA TECHNOLOGY SERVICES INCORPORATED,
GREENWOOD VILLAGE, CO:
2,605,973, REN. 8-16-12. INT. CL. 38.

VIRTUAL FIELD TRIPS LLC, PITTSBURGH, PA:
4,210,827, INT. CL. 9.

VISALIA CITRUS PACKING GROUP, L.P., VISALIA, CA,
DBA GOLDEN STATE CITRUS PACKERS:
2,086,957, COR. INT. CL. 31.

VISIONARY MOVEMENTS, LLC., HOUSTON, TX:
4,211,637, INT. CL. 41.

VISIT.COM, INC., SAN FRANCISCO, CA:
2,612,187, REN. 8-10-12. INT. CL. 9.

VISITING NURSE SERVICE OF NEW YORK, NEW YORK,
NY:
4,210,002, PUB. 7-3-2012. INT. CL. 42.

VISPLAY INTERNATIONAL AG, MUTTENZ, SWITZER-
LAND:
2,600,248, REN. 8-13-12. MULTIPLE CLASS, INT. CLS. 9,
11 AND 42.
2,600,248, CANC. INT. CL. 37.
4,176,097, COR. MULTIPLE CLASS, INT. CLS. 6 AND 37.

VISTEON CORPORATION, VAN BUREN TOWNSHIP, MI,
VISTEON CORPORATION, VAN BUREN TOWNSHIP, MI:
2,625,549, REN. 8-14-12. INT. CL. 11.
2,625,550, REN. 8-14-12. INT. CL. 11.
2,625,551, REN. 8-14-12. INT. CL. 11.

VISUAL GRAPHIC SYSTEMS INC., CARLSTADT, NJ:
2,624,317, REN. 8-15-12. INT. CL. 20.

VITAL IMAGES, INC., MINNETONKA, MN:
4,209,683, PUB. 7-3-2012. INT. CL. 9.

VITRO VIDRIO Y CRISTAL, S.A. DE C.V., GARCÍA, NUEVO
LEÓN, MEXICO:
4,209,471, PUB. 7-3-2012. INT. CL. 21.

VIVIUS, INC., KANSAS, MN:
3,044,273, CANC. INT. CL. 42.

VLM LLC, CANTON, GA:
4,209,466, PUB. 7-3-2012. INT. CL. 39.

VOGEL PAINT AND WAX COMPANY, INC., ORANGE
CITY, IA:
1,773,973, REN. 8-15-12. INT. CL. 2.

VOKE TAB, INC., BOZEMAN, MT:
4,211,376, MULTIPLE CLASS, INT. CLS. 5 AND 30.

VOLITION LLC, VEAZIE, ME:
4,211,609, INT. CL. 28.

VOLT INFORMATION SCIENCES, INC., ORANGE, CA:
2,600,682, REN. 8-10-12. MULTIPLE CLASS, INT. CLS. 35,
36 AND 42.

VOLVO TRADEMARK HOLDING AB, GÖTEBORG, SWE-
DEN:
4,210,253, INT. CL. 41.

VONAGE MARKETING LLC, HOLMDEL, NJ:
4,211,679, MULTIPLE CLASS, INT. CLS. 9 AND 38.

VOXEO CORPORATION, ORLANDO, FL:
3,951,671, COR. MULTIPLE CLASS, INT. CLS. 9, 38 AND
42.
3,955,429, COR. MULTIPLE CLASS, INT. CLS. 9, 38 AND
42.

VOXSPINE LLC, ALLEN, TX:
4,211,863, INT. CL. 42.

VOYAGER OIL & GAS, INC., BILLINGS, MT:
4,210,503, INT. CL. 40.
4,210,504, INT. CL. 40.

VTECH ELECTRONICS NORTH AMERICA, LLC, ARLING-
TON HEIGHTS, IL:
4,210,992, INT. CL. 9.

VWR INTERNATIONAL, LLC, RADNOR, PA:
2,611,681, REN. 8-10-12. INT. CL. 9.

VYALITSYNA, ANNE, NEW YORK, NY:
4,209,087, PUB. 7-3-2012. MULTIPLE CLASS, INT. CLS. 35
AND 41.

VYCERA COMMUNICATIONS, INC., SAN DIEGO, CA:
3,038,139, CANC. INT. CL. 38.

W. F. TAYLOR CO., INC., FONTANA, CA:
4,211,577, INT. CL. 1.

W.F. YOUNG, INCORPORATED, EAST LONGMEADOW,
MA:
4,210,595, INT. CL. 5.

WADE, ROBERT A., GRANGER, IN:
2,680,229, REN. 8-14-12. INT. CL. 42.

WAIORA INTERNATIONAL LTD., NASSAU, BAHAMAS:
4,209,135, PUB. 7-3-2012. INT. CL. 5.

WAL-MART STORES, INC., BENTONVILLE, AR:
2,528,370, CANC. INT. CL. 9.
4,211,360, INT. CL. 35.

WALDEN BACKYARDS LLC, EDINA, MN:
4,210,723, INT. CL. 35.
4,210,724, INT. CL. 35.

WALDREP, ASHLEY R, GAY, GA, DBA SEREIA:
4,209,643, PUB. 7-3-2012. INT. CL. 25.

WALGREEN CO., DEERFIELD, IL:
4,211,264, INT. CL. 3.
4,211,265, INT. CL. 3.
4,211,667, MULTIPLE CLASS, INT. CLS. 20 AND 24.

WALKER, COREY, BRONX, NY:
4,209,903, PUB. 7-3-2012. INT. CL. 41.

WALLY BOYKO PRODUCTIONS, INC., WHITE CITY, OR:
4,208,218, PUB. 5-10-2011. INT. CL. 41.

- WALSH, PATRICIA L., SARASOTA, FL, DBA WOOLGER TRAINING:
4,209,465, PUB. 7-3-2012. INT. CL. 41.
- WALTENBURG, JAMIE L., SHEPHERDSVILLE, KY:
4,211,825, INT. CL. 25.
- WALTER P. RAWL & SONS, INC., PELION, SC:
2,601,101. REN. 8-11-12. INT. CL. 31.
- WALTERS & WOLF GLASS COMPANY, FREMONT, CA, DBA WALTERS & WOLF:
4,209,169, PUB. 7-3-2012. INT. CL. 37.
- WANNA PLAY, LLC, AUSTIN, TX:
4,208,609, PUB. 7-3-2012. INT. CL. 43.
- WANTBASKET, INC., GLENDALE, CA:
4,209,165, PUB. 7-3-2012. INT. CL. 38.
- WARIMEX WAREN-IMPORT-EXPORT-HANDELS GMBH, FED REP GERMANY:
4,208,369, PUB. 7-3-2012. INT. CL. 21.
- WARNER BROS. RECORDS INC., BURBANK, CA:
1,706,315. REN. 8-15-12. INT. CL. 9.
- WARRIOR SPORTS, INC., WARREN, MI:
2,624,477. REN. 8-14-12. INT. CL. 28.
- WASHBURN UNIVERSITY, TOPEKA, KS:
4,210,354, INT. CL. 16.
- WASHINGTON BULB CO., INC., MOUNT VERNON, WA:
1,775,397. REN. 8-11-12. INT. CL. 31.
- WASHINGTON BULB COMPANY, INC., MOUNT VERNON, WA:
1,758,616. REN. 8-11-12. INT. CL. 31.
- WATCH CLUB INC., VERNON, CA:
3,037,066, CANC. INT. CL. 8.
- WATCHME 911, INC., SUN VALLEY, CA:
4,211,201, INT. CL. 9.
- WATERMELON EXPRESS, INC., CHICAGO, IL:
4,208,801, PUB. 7-3-2012. INT. CL. 41.
- WAVECONNEX, INC., WESTLAKE VILLAGE, CA:
4,210,543, INT. CL. 9.
- WAVEMARKET, INC., EMERYVILLE, CA:
4,209,994, PUB. 7-3-2012. INT. CL. 42.
- WAXMAN, RACHEL F, LEAWOOD, KS:
4,209,546, PUB. 7-3-2012. INT. CL. 30.
- WAY OUT WAX INC., MORRISVILLE, VT:
4,208,673, PUB. 7-3-2012. INT. CL. 4.
4,208,676, PUB. 7-3-2012. INT. CL. 4.
- WCM INDUSTRIES, INC., COLORADO SPRINGS, CO, WOODFORD MANUFACTURING COMPANY, DES MOINES, IA:
964,532. REN. 8-11-12. U.S. CL. 13 (INT. CL. 6).
- WE CARD PROGRAM, INC., THE, ARLINGTON, VA:
4,208,135, PUB. 7-3-2012. MULTIPLE CLASS, INT. CLS. 35 AND 41.
- WE PACK LOGISTICS, L.P., PARIS, TX:
2,668,540. REN. 8-15-12. INT. CL. 39.
2,668,542. REN. 8-15-12. INT. CL. 39.
- WE STOW, INC., PARIS, TX:
2,665,965. REN. 8-15-12. INT. CL. 39.
- WE'LL DO DINNER LLC, POWDER SPRINGS, GA:
4,209,602, PUB. 7-3-2012. INT. CL. 43.
- WEATHERFORD/LAMB, INC., HOUSTON, TX:
4,208,621, PUB. 7-3-2012. INT. CL. 1.
- WEBB-MASON, INC., HUNT VALLEY, MD:
2,594,884. REN. 8-10-12. MULTIPLE CLASS, INT. CLS. 35 AND 36.
- WEBMAGIC VENTURES LLC, PASADENA, CA:
2,663,380. REN. 8-16-12. INT. CL. 35.
- WEBMAGIC VENTURES, LLC, PASADENA, CA:
2,607,641. REN. 8-16-12. MULTIPLE CLASS, INT. CLS. 35 AND 41.
2,615,415. REN. 8-16-12. INT. CL. 35.
2,621,393. REN. 8-16-12. INT. CL. 35.
- WEGO CO., LTD., TOKYO, JAPAN:
4,210,765, MULTIPLE CLASS, INT. CLS. 18 AND 25.
- WEI WANG, SHANGHAI, CHINA:
4,210,962, INT. CL. 9.
- WEI, HOU, ONTARIO, CA:
4,208,611, PUB. 7-3-2012. INT. CL. 12.
- WEINBERG, BRUCE, DENVER, CO:
4,210,338, INT. CL. 35.
- WEINER-DAVIS, MICHELE, BOULDER, CO:
2,674,028. REN. 8-10-12. MULTIPLE CLASS, INT. CLS. 9, 16 AND 41.
- WEINTRAUB TELECOMM, LLC, KING OF PRUSSIA, PA:
4,211,001, INT. CL. 38.
- WEISNER STEEL PRODUCTS, INC., ORINDA, CA, CALTEX CABLES & FITTINGS INC., HOUSTON, TX:
1,219,693. REN. 8-16-12. INT. CL. 6.
- WELD TOOLING CORPORATION, CANONSBURG, PA:
1,759,498. REN. 8-16-12. INT. CL. 7.
- WELLNESS INTERACTIVE, INC., SOUTH ORANGE, NJ:
4,210,006, PUB. 7-3-2012. INT. CL. 14.
4,210,007, PUB. 7-3-2012. INT. CL. 25.
- WELLS ENTERPRISES, INC., LE MARS, IA:
2,526,455, CANC. INT. CL. 30.
4,211,528, INT. CL. 30.
- WELLSTONE LABS, INC., HICKSVILLE, NY:
4,211,837, INT. CL. 5.
- WELSH, DAVE, SAN DIEGO, CA, DBA DAVE'S D.C.W. COLLECTION:
1,726,514. REN. 8-16-12. INT. CL. 42.
- WERA WERK HERMANN WERNER GMBH & CO., 42349 WUPPERTAL, FED REP GERMANY:
2,656,775. REN. 8-15-12. MULTIPLE CLASS, INT. CLS. 7 AND 8.
- WERNER MANAGEMENT, INC., OMAHA, NE:
4,209,279, PUB. 7-3-2012. MULTIPLE CLASS, INT. CLS. 35 AND 37.
- WERRES SYSTEMS, INC., FREDERICK, MD:
2,739,835. REN. 8-10-12. INT. CL. 42.
- WEST BEND HOUSEWARES, LLC, VERNON HILLS, IL:
2,528,397, CANC. INT. CL. 11.
- WEST BEND MUTUAL INSURANCE COMPANY, WEST BEND, WI:
2,526,949, CANC. INT. CL. 36.
- WEST CHESTER HOLDINGS, INC., MONROE, OH:
4,211,593, INT. CL. 24.
- WEST FACE CAPITAL INC., TORONTO, CANADA:
4,208,519, PUB. 7-3-2012. INT. CL. 36.
- WEST PUBLISHING CORPORATION, EAGAN, MN:
1,247,070. REN. 8-16-12. INT. CL. 16.
1,247,071. REN. 8-16-12. INT. CL. 16.
1,247,072. REN. 8-16-12. INT. CL. 16.
- WEST, WILLIAM, HENDERSON, NV AND TROUPE, NEIL, HENDERSON, NV AND RUSNAK, MICHAEL, HENDERSON, NV:
4,210,392, INT. CL. 25.
- WESTCOTT DISTRIBUTION, INC., MILFORD, CT:
2,632,821. REN. 8-16-12. INT. CL. 7.
- WESTERFIELD, JACOB J, BROKEN ARROW, OK, DBA EXCELLENCE PHOTO BOOTHS:
4,209,151, PUB. 7-3-2012. INT. CL. 41.
- WESTERING DESIGN, INC., MANHATTAN, MT:
2,527,235, CANC. INT. CL. 42.
- WESTERN BAGEL BAKING CORPORATION, VAN NUYS, CA:
4,211,605, INT. CL. 30.
- WESTERN FAMILY FOODS, INC., TIGARD, OR:
1,706,100. REN. 8-11-12. INT. CL. 1.
1,707,800. REN. 8-15-12. MULTIPLE CLASS, INT. CLS. 8, 11 AND 21.
- WESTERN PACIFIC DISTRIBUTING, LLC, ORANGE, CA:
2,609,547. REN. 8-16-12. INT. CL. 2.
- WESTERN PROFESSIONAL HOCKEY LEAGUE INC., GLENDALE, AZ AND CENTRAL HOCKEY LEAGUE, INC., TULSA, OK:
4,210,124, PUB. 7-3-2012. INT. CL. 38.
4,210,125, PUB. 7-3-2012. INT. CL. 41.
4,210,126, PUB. 7-3-2012. INT. CL. 41.
- WESTERN STATES ENVELOPE COMPANY, MILWAUKEE, WI:
1,781,337. REN. 8-10-12. INT. CL. 16.
- WESTFIELD MEDICAL LIMITED, UNITED KINGDOM:
4,208,385, PUB. 7-3-2012. INT. CL. 10.
- WESTGARD QC, INC., MADISON, WI:
2,600,667. REN. 8-11-12. INT. CL. 41.
2,638,256. REN. 8-11-12. INT. CL. 41.

- WESTON WOODS STUDIOS, INC., WESTPORT, CT:
2,527,557, CANC. INT. CL. 9.
- WESTWINN GROUP ENTERPRISES INC., VERNON, BC, CANADA:
4,208,993, PUB. 7-3-2012. INT. CL. 12.
- WEVO-CHEMIE GMBH, FED REP GERMANY:
4,208,251, PUB. 7-3-2012. MULTIPLE CLASS, INT. CLS. 1, 2, 17 AND 42.
- WEXFORD INDUSTRIAL CORPORATION, SANTA BARBARA, CA, DBA WEXFORD CORPORATION:
4,211,533, INT. CL. 3.
- WHAM-O HOLDING, LTD., KOWLOON, HONG KONG:
2,527,459, CANC. INT. CL. 28.
- WHARFEDALE INTERNATIONAL LIMITED, HUNTINGDON, CAMBRIDGESHIRE, PE18 6WA, UNITED KINGDOM:
2,605,374, REN. 8-10-12. INT. CL. 9.
- WHARTON-FIELDS, DONNA, MAPLEWOOD, NJ:
4,209,623, PUB. 7-3-2012. INT. CL. 18.
- WHAT WILL THEY DO NEXT, LLC, AUSTIN, TX:
4,209,593, PUB. 7-3-2012. INT. CL. 35.
- WHEAT, JARED R., NORCROSS, GA:
4,210,522, INT. CL. 5.
- WHEBLE, JOHN E., JR., KINGSTON, MA AND TAYLOR, THOMAS W. II, KINGSTON, MA AND BARKER, GREGORY C, KINGSTON, MA:
4,211,709, INT. CL. 31.
- WHELEN ENGINEERING COMPANY, INC., CHESTER, CT, WHELEN TECHNOLOGIES, INC., CHESTER, CT:
1,729,158, REN. 8-12-12. INT. CL. 11.
- WHG COMPANIES, LLC LIMITED LIABILITY COMPANY WISCONSIN, OSHKOSH, WI:
4,210,510, INT. CL. 43.
- WHISKEY RESTAURANTS INC., SCOTTSDALE, AZ:
4,211,486, INT. CL. 33.
- WHITE RIVER HARDWOODS - WOODWORKS, INC., FAYETTEVILLE, AR:
2,528,723, CANC. INT. CL. 20.
- WHITE, FRED, KINGSPORT, TN, DBA WHITE PERFORMANCE AND MACHINE:
4,208,751, PUB. 7-3-2012. INT. CL. 7.
- WHITSONS FOOD SERVICE CORP., ISLANDIA, NY:
4,209,150, PUB. 7-3-2012. MULTIPLE CLASS, INT. CLS. 35, 39, 43 AND 44.
- WHOLE HEALTH LIFESTYLE, LLC, LOS ANGELES, CA:
4,209,641, PUB. 7-3-2012. INT. CL. 5.
- WHOLE PRODUCTS GROUP, HIGHLAND, NJ:
4,211,382, INT. CL. 5.
- WHYTE AND MACKAY LIMITED, GLASGOW, UNITED KINGDOM:
4,208,213, PUB. 1-11-2011. INT. CL. 33.
- WIDOPENWEST FINANCE, LLC, ENGLEWOOD, CO:
4,211,164, INT. CL. 38.
- WIECK FAMILY LTD. PARTNERSHIP, THE, RANCHO SANTA FE, CA:
1,708,035, REN. 8-16-12. INT. CL. 14.
- WIETHE, MARKUS, 49124 GEORGMARIENHÜTT, FED REP GERMANY:
4,208,700, PUB. 7-3-2012. MULTIPLE CLASS, INT. CLS. 18, 25, 28, 35, 39 AND 45.
- WIKA ALEXANDER WIEGAND GMBH & CO. KG, KLINGENBERG, FED REP GERMANY:
2,526,634, CANC. MULTIPLE CLASS, INT. CLS. 9 AND 42.
- WILBUR-ELLIS COMPANY, SAN FRANCISCO, CA:
4,210,974, INT. CL. 5.
- WILD KARMA, INC., SAN LEANDRO, CA, DBA DIVINE HOME CARE:
4,210,179, PUB. 7-3-2012. INT. CL. 45.
- WILDBRINE LLC, WINDSOR, CA:
4,211,398, INT. CL. 29.
- WILDCARE, SAN RAFAEL, CA:
4,210,440, MULTIPLE CLASS, INT. CLS. 35, 37, 39 AND 41.
- WILDWOODS MANUFACTURING COMPANY LLC, HAYWARD, WI:
4,209,395, PUB. 7-3-2012. MULTIPLE CLASS, INT. CLS. 2 AND 20.
- WILKIE, MARTHA, KINGWOOD, TX:
4,210,713, INT. CL. 3.
- WILLIAM A. CONSULTING, INC., FLEMING ISLAND, FL:
4,208,691, PUB. 7-3-2012. INT. CL. 35.
- WILLIAM AGEE, SAINT HELENA, CA:
4,211,009, INT. CL. 42.
- WILLIAM J. CLINTON FOUNDATION, LITTLE ROCK, AR:
4,209,148, PUB. 7-3-2012. MULTIPLE CLASS, INT. CLS. 36 AND 41.
4,209,149, PUB. 7-3-2012. MULTIPLE CLASS, INT. CLS. 36 AND 41.
- WILLIAMS INDUSTRIES, INC., SHELBYVILLE, IN:
4,209,838, PUB. 7-3-2012. INT. CL. 21.
- WILLIAMS, MARK R., TEMPLE, TX:
4,208,682, PUB. 7-3-2012. INT. CL. 9.
- WILLIE CHEN, NORCROSS, GA:
4,211,739, INT. CL. 10.
- WILLOW & BLOOM LLC, SEATTLE, WA:
4,208,524, PUB. 7-3-2012. INT. CL. 31.
- WILMINGTON SAVINGS FUND SOCIETY, FSB, NEWARK, DE:
4,208,897, PUB. 7-3-2012. MULTIPLE CLASS, INT. CLS. 35 AND 42.
- WILSHIRE CLASSIFIEDS, LLC, LOS ANGELES, CA:
2,528,720, CANC. INT. CL. 16.
- WILSON TRUCKING CORPORATION, FISHERSVILLE, VA:
2,527,416, CANC. INT. CL. 39.
- WILSON, JOHN JB, LOS ALAMITOS, CA, DBA GOLDEN RASPBERRY (RAZZIE) AWARD FOUNDATION:
4,208,814, PUB. 7-3-2012. INT. CL. 41.
- WILSON, KAREN LEROHL, POTOMAC, MD:
4,209,092, PUB. 7-3-2012. INT. CL. 21.
- WILSON, STEVEN D., BALLWIN, MO:
2,604,755, REN. 8-15-12. INT. CL. 9.
- WINDMILLS CAPITAL INC, BOCA RATON, FL:
4,208,589, PUB. 7-3-2012. MULTIPLE CLASS, INT. CLS. 35, 36, 38 AND 45.
- WINDOW AUTOMATION INDUSTRY SRL, ITALY:
3,112,152.
- WINDROSE TRADING COMPANY, MADISON, VA:
2,604,492, REN. 8-11-12. INT. CL. 3.
- WINE TABLE, LLC, MOUND, MN:
4,211,400, MULTIPLE CLASS, INT. CLS. 43 AND 45.
- WINFIELD SOLUTIONS, LLC, SHOREVIEW, MN:
4,211,040, INT. CL. 1.
4,211,112, INT. CL. 2.
- WINGATE, ROBERT C., WINSTON-SALEM, NC:
2,528,689, CANC. INT. CL. 10.
- WINGSTOP RESTAURANTS, INC., RICHARDSON, TX:
4,209,249, PUB. 7-3-2012. INT. CL. 43.
- WINNING MOVES INC., DANVERS, MA:
4,211,466, INT. CL. 28.
- WINPAK LTD., WINNIPEG, MANITOBA, CANADA:
4,208,628, PUB. 7-3-2012. MULTIPLE CLASS, INT. CLS. 6, 7, 17, 40 AND 42.
- WIRE BELT COMPANY OF AMERICA, LONDONDERRY, NH:
4,211,467, INT. CL. 7.
- WIRES, GREG, HUGO, MN, DBA GOLF MINNESOTA:
2,623,157, REN. 8-13-12. MULTIPLE CLASS, INT. CLS. 16 AND 42.
- WISE, BRANDON M, LAWRENCEVILLE, NJ:
4,211,393, INT. CL. 41.
- WM. F. PUCKETT, INC., BARBERVILLE, FL:
4,211,494, INT. CL. 31.
- WM. WRIGLEY JR. COMPANY, CHICAGO, IL:
4,210,102, PUB. 7-3-2012. INT. CL. 30.
4,210,887, INT. CL. 30.
- WOLF-GORDON INC., LONG ISLAND CITY, NY:
1,718,715, REN. 8-11-12. INT. CL. 36.
- WOLVERINE WORLD WIDE, INC., ROCKFORD, MI:
1,713,847, REN. 8-15-12. INT. CL. 25.
- WOMEN'S FUNDING NETWORK, SAN FRANCISCO, CA:
4,208,926, PUB. 7-3-2012. INT. CL. 36.
- WOMEN'S UNITED SOCCER ASSOCIATION PLAYERS' ASSOCIATION, PHILADELPHIA, PA:
3,038,137, CANC. INT. CL. 41.

- WONG, AARON, NEW YORK, NY:
4,209,324, PUB. 7-3-2012. INT. CL. 42.
- WONG, TOA, STATEN ISLAND, NY:
4,211,536, INT. CL. 44.
- WOO, SUZANNE, EL CERRITO, CA:
2,526,700, CANC. INT. CL. 35.
- WOOD RUN PARTNERS, DUBLIN, OH, DBA TRUBERRY
CUSTOM HOMES:
4,209,567, PUB. 7-3-2012. INT. CL. 37.
- WORKMAN PUBLISHING CO., INC., NEW YORK, NY:
4,211,258, INT. CL. 16.
- WORKWEAR ON WHEELS, INC., AURORA, CO:
4,211,387, INT. CL. 35.
- WORLD CHOCOLATE AWARDS, BUXTON, UNITED
KINGDOM:
4,209,330, PUB. 7-3-2012. INT. CL. 41.
- WORLD OYAMA KARATE, INC., HOMEWOOD, AL:
4,209,749, PUB. 7-3-2012. INT. CL. 41.
- WORLD POETRY, INC., PHILADELPHIA, PA:
1,751,234, REN. 8-11-12. INT. CL. 16.
- WORLD'S GREATEST ICE CREAM COMPANY, INC., THE,
MIAMI BEACH, FL:
2,604,797, REN. 8-14-12. MULTIPLE CLASS, INT. CLS. 30
AND 42.
- WORLDS APART LIMITED, CORNWALL, UNITED KING-
DOM:
4,208,979, PUB. 6-12-2012. MULTIPLE CLASS, INT. CLS.
12, 18 AND 28.
- WORLDWIDE WATER, INC., DENVER, CO:
4,210,024, PUB. 7-3-2012. INT. CL. 32.
- WORTHY HEN PRODUCTIONS, LLC, BEVERLY HILLS,
CA:
4,210,604, INT. CL. 16.
- WOUNDED WARRIOR HOMES, INC., VISTA, CA:
4,209,253, PUB. 7-3-2012. INT. CL. 43.
- WOW CAFE & WINGERY FRANCHISING ACCOUNT, LLC,
COVINGTON, LA:
4,209,293, PUB. 7-3-2012. INT. CL. 43.
- WP IP, LLC, NEW YORK, NY:
4,210,766, INT. CL. 27.
- WPP PROPERTIES, NEW YORK, NY:
4,210,877, INT. CL. 35.
- WRIGHT BROTHERS INVESTMENTS, INC., SHELTON,
WA, DBA AMERIZORB:
4,209,788, PUB. 7-3-2012. INT. CL. 31.
- WWRD IRELAND IPCO LLC, WILMINGTON, DE:
1,710,077, REN. 8-10-12. INT. CL. 21.
2,608,643, REN. 8-11-12. INT. CL. 21.
- WYETH, LEONARD, IVORYTON, CT:
2,625,596, REN. 8-15-12. INT. CL. 35.
- WYSCO PRODUCTS, BALDWIN PARK, CA:
2,527,653, CANC. INT. CL. 12.
- X AND X2, LLC, NEW YORK, NY:
4,210,732, INT. CL. 30.
- X-RITE EUROPE GMBH, REGENS DORF, SWITZERLAND:
2,602,682, REN. 8-13-12. INT. CL. 9.
- X-TECHNOLOGY SWISS GMBH, WOLLERAU, SWITZER-
LAND:
4,208,386, PUB. 7-3-2012. MULTIPLE CLASS, INT. CLS.
18, 25 AND 28.
- XAD, INC., NEW YORK, NY:
4,211,375, INT. CL. 35.
- XANTI MEDIA LLC, RUTHERFORD, NJ:
4,211,096, INT. CL. 35.
- XCAD VALVE & IRRIGATION, PAUL, ID:
4,210,182, PUB. 7-3-2012. INT. CL. 11.
- XEMED LLC, DURHAM, NH:
4,209,322, PUB. 7-3-2012. MULTIPLE CLASS, INT. CLS. 42
AND 44.
- XEROX CORPORATION, NORWALK, CT:
4,211,314, INT. CL. 16.
- XHALE, INC., GAINESVILLE, FL:
4,211,833, INT. CL. 10.
- XIST FITNESS LICENSING, LLC, FENTON, MO:
4,211,564, INT. CL. 41.
- XL ENERGY DRINK CORP., NEW YORK, NY:
4,208,227, PUB. 7-3-2012. INT. CL. 32.
- XL SPECIALIZED TRAILERS, INC., MANCHESTER, IA:
4,209,516, PUB. 7-3-2012. INT. CL. 12.
- XLIT LTD, DUBLIN, IRELAND:
4,211,234, INT. CL. 36.
- XLISOFT CORPORATION, IRVINE, CA:
2,645,049, REN. 8-11-12. MULTIPLE CLASS, INT. CLS. 9
AND 42.
- XO GROUP INC., NEW YORK, NY:
4,210,506, INT. CL. 42.
- XR. LLC, HUNTINGTON BEACH, CA:
4,211,031, INT. CL. 10.
- XTREME TOOLS INTERNATIONAL, INC., MIAMI, FL:
4,210,152, PUB. 7-3-2012. INT. CL. 3.
- YABLON, ERIC, NORTH RICHLAND HILLS, TX:
4,208,776, PUB. 3-27-2012. INT. CL. 41.
- YALE UNIVERSITY, NEW HAVEN, CT:
2,728,526, REN. 8-10-12. MULTIPLE CLASS, INT. CLS. 36
AND 37.
- YAMAHA CORPORATION, HAMAMATSU-SHI, SHIZUO-
KA, JAPAN:
2,621,927, REN. 8-13-12. INT. CL. 9.
- YAMAHA CORPORATION, SHIZUOKA 430-8650, JAPAN:
4,208,421, PUB. 7-3-2012. INT. CL. 15.
- YAMASHITA RUBBER CO., LTD., SAITAMA 356-8556,
JAPAN:
1,732,859, REN. 8-16-12. MULTIPLE CLASS, INT. CLS. 12
AND 17.
- YANKEE CANDLE COMPANY, INC., THE, SOUTH DEER-
FIELD, MA:
2,528,361, CANC. INT. CL. 4.
- YARDS BREWING COMPANY, LLC, PHILADELPHIA, PA:
4,209,038, PUB. 5-29-2012. INT. CL. 32.
- YEAR ONE, INC., TUCKER, GA:
1,710,631, REN. 8-13-12. INT. CL. 42.
- YELIN ENTERPRISE CO., LTD., TAIPEI, TAIWAN:
2,721,551, REN. 8-16-12. INT. CL. 29.
2,740,546, REN. 8-16-12. INT. CL. 29.
2,742,034, REN. 8-16-12. INT. CL. 29.
- YELLOW DOG NETWORKS, INC., KANSAS CITY, MO:
4,209,309, PUB. 7-3-2012. INT. CL. 42.
- YESKE BUIE INC., SAN FRANCISCO, CA:
4,210,444, INT. CL. 36.
- YGS, INC., ORLAND PARK, IL:
4,210,414, MULTIPLE CLASS, INT. CLS. 42, 44 AND 45.
- YIWU SHENQIANG ADHESIVE CO., LTD., CHINA:
4,208,397, PUB. 7-3-2012. INT. CL. 1.
- YL HOLDINGS, INC., LEHI, UT:
4,208,825, PUB. 7-3-2012. INT. CL. 35.
- YOGAEARTH GROUP LLC, VENICE, CA, DBA YO-
GAEARTH:
4,211,547, INT. CL. 5.
- YOKO CHAN CO., LTD., MINATO-KU, TOKYO, JAPAN:
4,208,791, PUB. 7-3-2012. MULTIPLE CLASS, INT. CLS. 25
AND 35.
- YOLI, INC., SANDY, UT:
4,210,487, INT. CL. 5.
- YORK RITE SOVEREIGN COLLEGE OF NORTH AMER-
ICA, DETROIT, MI:
1,710,638, REN. 8-14-12. U.S. CL. 200.
- YOSEF, OZ, RESEDA, CA:
4,209,745, PUB. 7-3-2012. MULTIPLE CLASS, INT. CLS. 9
AND 35.
- YOST, ERIKA, DENVER, CO:
4,210,726, INT. CL. 36.
- YOUADATA, INC., HOUSTON, TX:
4,210,971, INT. CL. 35.
- YOUDESIGNIT, LLC, ORANGE, TX:
4,209,644, PUB. 7-3-2012. INT. CL. 40.
- YOUFINITY, LLC, ATLANTA, GA:
4,211,121, INT. CL. 42.
- YOUNG MONEY ENTERTAINMENT, LLC, MIAMI, FL,
AKA YOUNG MONEY ENTERTAINMENT:
4,208,579, PUB. 12-27-2011. MULTIPLE CLASS, INT. CLS.
9 AND 41.
- YOUNG, BLACK AND FABULOUS, L.L.C., ALEXANDRIA,
VA, DBA YBF:
4,208,197, PUB. 7-3-2012. INT. CL. 41.

YS HEALTH, MT. PROSPECT, IL:
4,208,695, PUB. 7-3-2012. INT. CL. 5.

YUMPTY, LLC, LOS GATOS, CA:
4,209,563, PUB. 7-3-2012. INT. CL. 43.

YVETTE MOORE, OWENSBORO, KY, DBA CYCLEWORKS PROMOTIONS:
4,211,811, INT. CL. 41.

ZABAR'S & CO., INC., NEW YORK, NY:
2,726,658. REN. 8-15-12. MULTIPLE CLASS, INT. CLS. 29 AND 30.

ZECCO HOLDINGS, INC., SAN FRANCISCO, CA:
4,210,910, MULTIPLE CLASS, INT. CLS. 36 AND 42.

ZEFKOM, LLC, BETHESDA, MD:
2,740,715. REN. 8-15-12. INT. CL. 36.

ZELLER, JARED, M, NEW ORLEANS, LA, DBA MOTHERSHIP ENTERTAINMENT:
3,017,225, CANC. INT. CL. 41.

ZENO CONSULTING GROUP, LLC, BETHESDA, MD:
4,210,736, INT. CL. 36.

ZERO CHROMA, LLC, SYKESVILLE, MD:
4,210,432, INT. CL. 9.

ZESCAS INCORPORATED, FAIRFAX, VA, TA ZESCAS:
4,209,503, PUB. 7-3-2012. INT. CL. 30.

ZEST IP HOLDINGS LLC, ESCONDIDO, CA:
2,559,602. REN. 8-15-12. INT. CL. 10.

ZETTASET, INC., MOUNTAIN VIEW, CA:
4,211,206, INT. CL. 9.

ZHANG, JAMES XIAOJIAN, POCONO SUMMIT, PA:
2,526,836, CANC. INT. CL. 25.

ZHONG MEI 888 INCORPORATED, CITY OF INDUSTRY, CA:
2,602,727. REN. 8-13-12. INT. CL. 25.

ZHONGSHAN KAXING INDUSTRY & TRADE CO., LTD., GUANGDONG PROVINCE, CHINA:
4,209,137, PUB. 7-3-2012. INT. CL. 29.

ZHU CHANGCHUN, ZHEJIANG, CHINA:
4,208,239, PUB. 7-3-2012. INT. CL. 25.

ZIEHL-ABEGG AG, FED REP GERMANY:
4,208,380, PUB. 7-3-2012. INT. CL. 11.

ZIMMERMAN, TERRESA L, SAGLE, ID:
4,211,711, INT. CL. 25.

ZIMMERMANN-GRAEFF & MÜLLER GMBH & CO. KG, FED REP GERMANY:
4,208,352, PUB. 7-3-2012. INT. CL. 33.

ZIMRIDE, INC., SAN FRANCISCO, CA:
4,209,051, PUB. 7-3-2012. MULTIPLE CLASS, INT. CLS. 38 AND 39.

ZINKIA ENTERTAINMENT, S.A., MADRID, SPAIN:
4,208,291, PUB. 7-3-2012. MULTIPLE CLASS, INT. CLS. 9, 16, 28, 35 AND 41.

ZINUS INC., HAYWARD, CA:
4,211,630, INT. CL. 20.

ZIPOPTICAL LLC, SAN BRUNO, CA:
4,209,915, PUB. 7-3-2012. INT. CL. 9.

ZIPPYKID, SAN ANTONIO, TX:
4,209,268, PUB. 7-3-2012. INT. CL. 42.

ZOE, INC., LOUISVILLE, CO:
2,650,602. REN. 8-16-12. INT. CL. 42.

ZOOM TELEPHONICS, INC., BOSTON, MA:
1,187,443. REN. 8-10-12. INT. CL. 9.

ZUIDAM DISTILLERS BV, NETHERLANDS:
4,208,427, PUB. 7-3-2012. INT. CL. 33.

ZYMTECH HOLDING AG C/O BUCHHALTUNGS- UND REVISION AG, CH-6304 ZUG, SWITZERLAND:
4,208,326, PUB. 7-3-2012. MULTIPLE CLASS, INT. CLS. 1, 5, 29, 30, 31 AND 32.

ZYNGA INC., SAN FRANCISCO, CA:
4,208,729, PUB. 7-3-2012. MULTIPLE CLASS, INT. CLS. 9 AND 41.
4,211,067, MULTIPLE CLASS, INT. CLS. 9 AND 41.
4,211,214, MULTIPLE CLASS, INT. CLS. 9 AND 41.

1-800-FLOWERS.COM, INC., CARLE PLACE, NY:
4,210,249, INT. CL. 35.

1-800-411-I.P.HOLDINGS, LLC, LAUDERDALE LAKES, FL:
2,621,497. REN. 8-10-12. MULTIPLE CLASS, INT. CLS. 35 AND 42.

1ST DETECT CORPORATION, HOUSTON, TX:
4,211,033, INT. CL. 9.

1467118 ONTARIO INC., BEAVERTON, ONTARIO, CANADA:
4,211,233, MULTIPLE CLASS, INT. CLS. 35 AND 41.

1502 VENTURE CAPITAL, LOS ANGELES, CA, DBA WET CEMENT:
4,208,477, PUB. 6-14-2011. MULTIPLE CLASS, INT. CLS. 18 AND 25.

1793161 ONTARIO INC., TORONTO, ONTARIO, CANADA:
3,037,003, CANC. INT. CL. 32.

2K INNOVATIONS INC, OLYMPIA, WA:
4,211,556, INT. CL. 11.

2ND SIGHT SOFTWARE, INC., NOVATO, CA, DBA SEMPHONIC:
3,128,033, CANC. INT. CL. 9.

2WIRE, INC., SAN JOSE, CA:
2,619,363. REN. 8-15-12. INT. CL. 9.

2023321 ONTARIO LIMITED, CAMBRIDGE, ONTARIO, CANADA:
4,210,588, INT. CL. 25.

2048 HILLSIDE RESTAURANT CORP., NEW HYDE PARK, NY, DBA EDDIES:
4,209,310, PUB. 7-3-2012. INT. CL. 43.
4,209,313, PUB. 7-3-2012. INT. CL. 43.

3:1 CINEMA, LLC, VAIL, CO:
4,210,366, INT. CL. 41.

3G CARDIO, LLC, SCOTTSDALE, AZ:
4,211,086, INT. CL. 28.

3M COMPANY, ST. PAUL, MN, CABOT SAFETY CORPORATION, BILLERICA, MA:
1,703,260. REN. 8-10-12. INT. CL. 16.

3M COMPANY, ST. PAUL, MN:
2,612,280. REN. 8-16-12. INT. CL. 9.

3M SVENSKA AKTIEBOLAG, SOLLENTUNA, SWEDEN:
2,632,861. REN. 8-11-12. MULTIPLE CLASS, INT. CLS. 9 AND 10.

360 IMAGING, INC., GARDNER, MA:
4,208,951, PUB. 7-3-2012. MULTIPLE CLASS, INT. CLS. 40 AND 41.
4,209,009, PUB. 7-3-2012. INT. CL. 40.

3681441 CANADA INC., MONTREAL, CANADA:
4,209,086, PUB. 4-24-2012. INT. CL. 25.

4LIFE TRADEMARKS, LLC, SANDY, UT:
2,528,475, CANC. INT. CL. 5.

4R ENERGY CORPORATION, YOKOHAMA-SHI, KANAGAWA, JAPAN:
4,208,510, PUB. 4-17-2012. MULTIPLE CLASS, INT. CLS. 9, 37 AND 40.

5 STAR BURGERS, INC., TAOS, NM, DBA 5 STAR BURGERS:
4,208,465, PUB. 2-15-2011. INT. CL. 43.

509, INC., BOULDER, CO, DBA 3PMOBILE:
4,209,512, PUB. 7-3-2012. INT. CL. 9.

654 MEDIA, LLC, DENVER, CO:
4,211,598, MULTIPLE CLASS, INT. CLS. 35 AND 36.

6603637 CANADA INC., TORONTO, CANADA:
3,038,141, CANC. MULTIPLE CLASS, INT. CLS. 3, 41 AND 42.

750 GROUP, LLC, SAINT HELENA, CA:
4,209,231, PUB. 7-3-2012. INT. CL. 42.
4,210,017, PUB. 7-3-2012. MULTIPLE CLASS, INT. CLS. 35 AND 42.

88 RODEO HOLDINGS INC., WILKES-BARRE, PA:
4,209,308, PUB. 7-3-2012. INT. CL. 18.

99 PERCENTILE, GRAND RAPIDS, MI:
4,210,665, INT. CL. 44.