

REQUEST FOR QUOTATION (THIS IS NOT AN ORDER)			THIS RFQ <input type="checkbox"/> IS <input checked="" type="checkbox"/> IS NOT A SMALL BUSINESS SET ASIDE		PAGE OF PAGES 1	
1. REQUEST NO. HSSCCG-05-Q-0020		DATE 07/26/2005	2. REQUISITION/PURCHASE REQUEST NO. TBD		4. CERT. FOR NAT. DEF. UNDER BDSA REG. 2 AND/OR DMS REG. 1	RATING
5a. ISSUED BY US DEPARTMENT OF HOMELAND SECURITY Citizenship and Immigrations Services 70 KIMBALL AVENUE  SOUTH BURLINGTON, VT 05403				6. DELIVERY BY (Date) See Schedule		
5b. FOR INFORMATION CALL (NO COLLECT CALLS)				7 DELIVERY <input checked="" type="checkbox"/> FOB DESTINATION <input type="checkbox"/> OTHER (See Schedule)		
NAME Peter M. Dietrich		TELEPHONE NUMBER 802-872-4102		9. DESTINATION		
8. TO			a. NAME OF CONSIGNEE DHS/USCIS			
a. NAME			b. STREET ADDRESS 20 Massachusetts Avenue, NW			
c. STREET ADDRESS			c. CITY Washington DC			
d. CITY		e. STATE	f. ZIP CODE	d. STATE NY		e. ZIP CODE 20529
10. PLEASE FURNISH QUOTATIONS TO THE ISSUING OFFICE ON OR BEFORE CLOSE OF BUSINESS (Date) 08/12/2005			IMPORTANT: This is a request for information, and quotations furnished are not offers. If you are unable to quote, please so indicate on this form and return it. This request does not commit the Government to pay any costs incurred in the preparation of the submission of this quotation or to contract for supplies or services. Supplies are of domestic origin unless otherwise indicated by quoter. Any representations and/or certifications attached to this Request for Quotations must be completed by the quoter.			
11. SCHEDULE (Include applicable Federal, State and local taxes)						
11A. ITEM NO.	11B. SUPPLIES / SERVICES		11C. QUANTITY	11D. UNIT	11E. UNIT PRICE	11F. AMOUNT
0001	See Attached Statement of Work and Associated Materials					
12. DISCOUNT FOR PROMPT PAYMENT	a. 10 CALENDAR DAYS (%)	b. 20 CALENDAR DAYS (%)	c. 30 CALENDAR DAYS (%)	CALENDAR DAYS (%)		
				NUMBER	PERCENTAGE	
NOTE: Additional provisions and representations <input checked="" type="checkbox"/> are <input type="checkbox"/> are not attached.						
13. NAME AND ADDRESS OF QUOTER				14. SIGNATURE OF PERSON AUTHORIZED TO SIGN QUOTATION		15. DATE OF QUOTATION
a. NAME OF QUOTER				16. SIGNER		
b. STREET ADDRESS				a. NAME		
a. COUNTY				b. TELEPHONE (Include Area Code)		
b. CITY		c. STATE	d. ZIP CODE	c. TITLE		

AUTHORIZED FOR LOCAL REPRODUCTION  
Previous edition not useable

STANDARD FORM 18 (REV. 6-95)  
Prescribed by GSA-FAR (48 CFR) 53.215-1(a)

# **1. DEPARTMENT OF HOMELAND SECURITY (DHS) UNITED STATES BUREAU OF CITIZENSHIP AND IMMIGRATION SERVICES (USCIS) ALIEN-FILE (A-FILE) DIGITIZATION BLANKET PURCHASE AGREEMENT (BPA)**

## **1.1 Background**

The Department of Homeland Security (DHS), U.S. Citizenship and Immigration Services (USCIS), Office of Records Services (ORS) has requirements for a Contractor to support USCIS in providing electronic access to all Alien-File (A-File) data that resides within the different USCIS offices for national security reasons. These files may include but are not limited to alien registration, I-485 forms, certificate files, master index files, flex-o-line files, and historical files. The digitization of files will expand to all file types as the processes and technologies are more fully defined.

## **1.2 Introduction**

This project is part of the overall digitization effort that would significantly reduce paper-based processes at the USCIS. To launch the digitization initiative, files will need to be physically transported from one location to another, disassembled and prepared for scanning, and stored in a secure format to be accessible by USCIS. Additionally, the contractor must maintain and operate a facility for where the indexing and processing shall be performed. USCIS will support this requirement by establishing a BPA with a selected firm on the General Services Administration (GSA) Schedule, Group 36.

USCIS recognizes the need to standardize digitization processes and tools when it acquires its customer's (applicant's) data. As depicted on the figure, any process that requires scanning will be part of the digitization process. The vision of "information acquisition" is to create a more data-centric process than an image-centric process, certainly away from the paper-based process. This will require significant system capabilities such as OCR, sophisticated metadata/indexing, record/document management, and customer data/case management capabilities; the illustration below depicts this concept. The digitization capabilities will be built on the industry standards such as PDF and XML. With such standards, we can converge both e-filing (electronic) and paper filing on common standards and tools. As an example, we plan to utilize a single set of XML based PDF template against all channels depicted above.

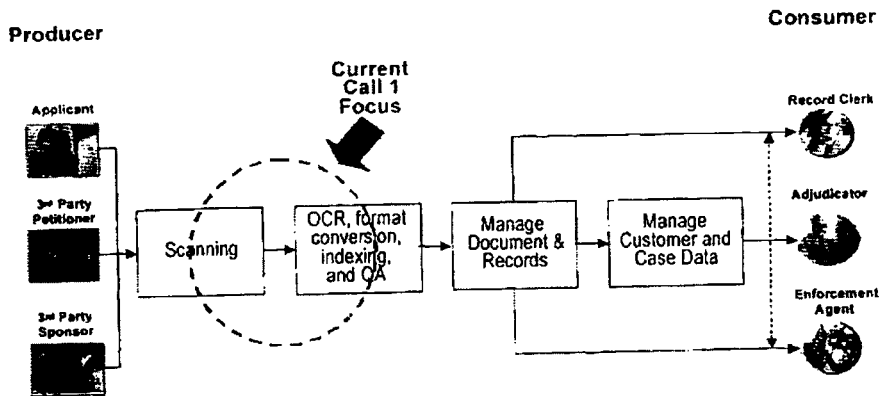

### 1.3 Acronyms

A list of related acronyms is found in attachment A.1.

## 2. BPA TERMS AND CONDITIONS

Pursuant to GSA Federal Supply Schedule (FSS) Group 36 Office Imaging and Document Solution contract, the Contractor entering into this BPA agrees to the terms and conditions of a Blanket Purchase Agreement exclusively with USCIS.

It is the responsibility of the Contractor to notify the Contracting Officer (CO) of GSA Schedule price changes affecting line items and services listed in this BPA prior to award of any Call. The Government encourages Contractors to propose discounts from the published GSA Schedule rates. The discounts shall be in terms of percentage discounts to be applied against the GSA Schedule price for the product or services. If discounts are conditional on a given dollar volume or other condition, this must be stated clearly. These discounts do not preclude the contractor from offering nor the Government from asking for further price reductions in accordance with commercial practice, market forces, and volume buying at the time of placing orders against this BPA. The relationship between the current price in the GSA Schedule and the price offered in the contractor's proposal shall remain constant.

### 2.1 BPA Scope

The contract services to be ordered under this BPA include records digitization and storage related services and will be ordered in BPA Calls in accordance with the ordering procedures described below. The scope of the support can include any Contract Line Items (CLINs) under the Contractor's GSA Schedule, Group 36. Any work performed under the BPA will be initiated on a Firm-Fixed Price or Time and Material basis depending on the nature of the work. Other Direct Costs (ODCs) will be authorized by the Contracting Officer contingent upon prior Contracting Officer's Technical Representative (COTR) approval and negotiated with each Call.

## **2.2 Federal Supply Schedule**

All Calls placed against this BPA are subject to the terms and conditions of the Contractor's GSA FSS Contract.

## **2.3 Delivery**

Delivery destination and schedule will be specified in each Call.

## **2.4 BPA Volume**

The Government estimates, but does not guarantee, that the total value of purchases made on this BPA (across multiple Calls) may reach \$150 million over the life of the BPA. Funding for work beyond FY-05 (The first call) has not been appropriated. The issuance of calls for work is contingent upon many factors including the performance under the first call, the receipt of funding and the Government's determination of the need for the continuation of work.

## **2.5 Obligation of Funding**

The BPA does not obligate any funds. Funding will be obligated through individual Calls issued under this BPA.

## **2.6 BPA Expiration**

This BPA has a duration of five (5) years, or expiration of the Contractor's GSA Schedule contract, whichever comes first. The BPA is based on the GSA Schedule and cannot exceed the GSA Schedule contract period. If GSA exercises an option to extend the term of the Schedule contract, the BPA will be extended as well not to exceed a total of five years from the date the BPA is established. The performance on any Calls issued prior to the expiration of the BPA or GSA Schedule will continue until normal completion unless terminated earlier at the request of the Government.

## **2.7 Ordering Procedures**

Calls will be placed against the BPA. The BPA Calls will be issued on a Firm-Fixed Price or Time and Materials basis depending on the nature of the work. Each Call issued under this BPA will be preceded with a Request for Quotation (RFQ) to the Contractor, which contains a performance work statement and request for price quotes. Upon receipt, evaluation, and mutual agreement of the task(s) outlined in the PWS, the Contracting Officer will issue the Call to the Contractor.

Each Call issued under this BPA will include the following information as applicable:

- BPA number and Call number.
- Date of the Call.
- Description of the work to be performed.
- The work schedule, period of performance, or required completion date.
- Place of delivery or performance.
- Deliverables.
- Performance Requirements.

- Contract Line Item Number (CLIN) and description, quantity, unit price and extended total.
- Type of task, e.g., Firm-Fixed Price or Time and Materials.
- Government Points of Contact.
- The invoicing procedures.
- Accounting and appropriation data.

### 2.7.1 Ordering Officials:

Calls under the BPA may be placed by:

Contracting Officer  
 Department of Homeland Security  
 U.S. Citizenship & Immigration Services  
 Field Support Center - Burlington  
 70 Kimball Avenue  
 South Burlington, VT 05403  
 Phone: (802) 872-4111  
 Fax: (802) 951-6455

The COTR for this BPA is:

Department of Homeland Security  
 U.S. Citizenship & Immigration Services  
 ATTN: Robert Purvis  
 111 Massachusetts Ave, NW (Second Floor, )  
 Washington, DC 20529  
 Phone: (202) 272-8226  
 Fax: (202) 272-8330  
[robert.purvis@dhs.gov](mailto:robert.purvis@dhs.gov)

### 2.8 Period of Performance for Calls

The period of performance for each Call shall be specified in each Call awarded. Calls awarded during the period a BPA is in effect may continue performance beyond the expiration date of the BPA provided the total period of performance does not exceed one year.

### 2.9 Place of Performance

The place of performance will be addressed in individual Calls.

### 2.10 Points of Contact (POCs)

Points of Contact (POCs) for this BPA will be announced at time of award and protocols for delivering reports, invoices, and other deliverables will be described at the BPA Kick-Off Meeting.

## **2.11 Invoices**

### **2.12 Invoice Submission**

The Contractor shall be required to submit monthly invoices within 10 business days of the close of the period for which the invoice is being submitted. The Contractor's invoice shall include a breakout of the costs allocated to each sub-task identified in the BPA. Each Call shall specify the method of payment and may include additional invoice submission requirements. The Contractor shall be required to submit invoices directly to the COTR for verification. When requested by the COTR, Contractor timesheets shall be delivered to the COTR and/or Program Manager for review. The Contractor shall notify the COTR in writing when 75% of the hours for each labor category have been expended on time-and-material Calls.

The COTR will forward the verified invoice to the Contracting Officer for certification and payment. The Contractor shall track the costs associated with each task listed in the Statement of Work. A proper invoice must include, at the minimum, the following information and/or attached documentation:

- Name of Contractor
- Contract number
- BPA number
- Call number
- Contract line item number
- Date of order
- Contract Line Item (CLIN)
- Quantity, unit price, and extension of each item
- Labor category, where applicable
- Performance period
- Interim payment period

To be deemed a proper invoice the services or deliverables furnished and produced, during the performance period covered by the invoice, must have received an acceptance from the Government authorized representative.

#### **2.12.1 Signed Face Page of the Invoice**

This page shall include the following identifying data: Contractor name, BPA number, Call number, period of performance, date of invoice, and accounting data. This face page shall provide a space for the name, title, and signature of the individual authorized to submit the invoice; a contact name and phone number; a "Verification" line; and "Approved" line.

#### **2.12.2 Invoice Distribution**

The Contractor must provide an original proper invoice as stated in the FSS Contract to the designated COTR as indicated on each Call. The Government Project Manager or other personnel delegated authority by the COTR, at the receiving or secure storage location will be responsible for completing the receiving report, and will forward the original receiving report and endorsed invoice to the CO. The CO will forward the original invoice and receiving report

to Finance for payment. Payment will not be rendered to the Contractor until both an original proper invoice and receiving report noting the acceptance of the products/services are submitted to the Finance office as described above. The Contractor shall submit invoices as follows:

Original invoice to the BPA COTR:

Department of Homeland Security  
U.S. Citizenship & Immigration Services  
ATTN: Robert Purvis  
111 Massachusetts Ave, NW (Second Floor,)  
Washington, DC 20529  
Phone: (202) 272-8226  
Fax: (202) 272-8330

Copy of invoice to the CO:

Department of Homeland Security  
U.S. Citizenship & Immigration Services  
Field Support Center - Burlington  
70 Kimball Avenue  
South Burlington, VT 05403  
Phone: (802) 872-4111  
Fax: (802) 951-6455

### **2.12.3 Payment to Contractor**

The USCIS will make payment to the Contractor using the Automatic Clearing House (ACH) Network.

### **2.12.4 Financial Institution for Receipt of Payment**

After the BPA is awarded, but not later than 14 calendar days before an invoice or BPA finance request is submitted to the Government, the Contractor shall designate a financial institution for receipt of electronic funds transfer payments. Submission shall be done on Standard Form (SF) 3881, *Payment Information Form ACH Vendor Payment System*.

### **2.13 Order of Precedence**

The terms and conditions included in this BPA apply to all Calls issued pursuant to it. In the event of an inconsistency between the provisions of this BPA and the terms and conditions of the Contractor's schedule contract, the terms and conditions of the GSA Schedule contract will take precedence.

### **2.14 Non-Schedule Items**

Open market items not specifically identified in the Contractors GSA Schedule contract are considered non-schedule items and may only be added to the BPA for administrative convenience in accordance with the provisions of FAR 8.402(f).

### **2.15 BPA Record Retention**

The contractor shall maintain BPA/Call records as required by the Federal Acquisition Regulation.

### **2.16 BPA Annual Review**

A review of the BPA shall be conducted annually pursuant to FAR 8.405-3(d) to determine whether the BPA is still considered a Best Value and that it meets the needs of the Government.

### **2.17 Government Quality Assurance**

The Government reserves the right to establish and maintain a quality assurance program in accordance with FAR 52.246-4 "Inspection of Services-Fixed-Price" or FAR 52.246-6 "Inspection-Time-and-Material and Labor-Hour" clause, as appropriate, and the provisions contained in the Performance Requirements Summary (PRS) of individual Calls issued under this BPA.

### **2.18 Accessibility by Individuals**

Any equipment provided or proposed by the contractor shall be capable of enhancement to provide handicapped employees with sensory, cognitive, and/or motor impairments accessibility to the equipment. The guidelines for these enhancements are established by the National Institute on Disability and Rehabilitation Research and GSA.

### **2.19 Contractor Teaming Arrangements**

USCIS encourages the establishment of Contract Teaming Arrangements in accordance with and as prescribed by FAR Subpart 9.6 if necessary to provide a total solution to the Government's requirement. Participation in a Contractor Team Arrangement is limited to Schedule contractors. Each teaming partner submits their own GSA Schedule and Calls placed under a Contractor Team Arrangement are subject to the terms and conditions of the Schedule contract holder. Each team member shall independently abide by the terms of their individual Schedule contracts. One contractor may be designated by the team as Contractor Team Leader and act as the single point of contact for the team. The discount structure for services provided by these teaming partners must conform to the discount structure in the BPA. A Contractor Teaming Arrangement is not a Prime/Subcontractor relationship and under a Contractor Teaming Arrangement the Government establishes privity of contract with each teaming partner.

If a Contractor Team Arrangement is established to provide the Government with a total solution a copy of the Arrangement shall be included with the quote response. Common element of a Contractor Team Arrangement may include, but are not limited to the following:

- o Identifies participants, GSA Schedule contract numbers, and services and products covered by the arrangement;
- o Defines terms;



- Sets forth each participant's roles, responsibilities, and obligations;
- Identifies scope, period of performance (for specific, limited purposes or longer periods covering several transactions), and termination of the arrangement;
- Establishes scope and limitations of any licenses or proprietary rights;
- Establishes representations and warranties among the parties;
- Identifies confidentiality requirements, obligations, disclosures, and remedies;
- Identifies damages, liability/limitation of liability, and any indemnification requirements among the parties;
- Addresses administrative requirements (e.g., assignments, how notices will be conveyed and recognized, how changes or amendments will occur);
- Identifies any terms that survive the arrangement or termination;
- Establishes how disputes will be addressed and resolved; and
- Addresses force majeure; i.e., addresses how an unexpected or uncontrollable event will impact a team member's obligation under the CTA.

## **2.20 Subcontracting**

Subcontracting arrangements which establish a prime/subcontractor relationship are permissible if agreed to by the Government and the Contractor in individually negotiated Calls, provided that in all cases subcontractors perform work at prices which are equal to or less than those established by the prime Contractor under the BPA. However, in cases where urgent requirements require immediate staffing not readily available through the prime, then subcontract rates may exceed the prime's rates provided adequate justification is provided to the Contracting Officer prior to starting work for approval and the higher rates can be determined to be reasonable. All security requirements must flow-down to the sub-contractor.

## **2.21 Non-Personal Services**

This is a "Non-personal Services" BPA. The personnel rendering the services are not subject, either by the BPA's terms or by the manner of its administration, to the supervision and control usually prevailing in relationships between the Government and its employees. Should any USCIS employee other than the COTR or CO ask or direct a Contract employee to deviate from established production requirements, priorities, or performance procedures and requirements, the Contractor employee will refer the matter to the designated POC for resolution.

## **2.22 Government Furnished Property (GFP)**

The Government will identify Government Furnished Property, if any, in individual Calls.

### **2.22.1 GFP Reporting**

The Government will identify the property and provide specific Government property reporting, and disposition instructions in Calls issued under the BPA, as applicable. In compliance with FAR 45.505-14, *Reports of Government Property*, the Contractor shall provide to the CO an annual report of the USCIS property for which the Contractor is accountable.

#### **2.22.1.1 HSAR 3052.245-70 Government Property Reports [DEC 2003]**

(a) The Contractor shall prepare an annual report of Government property in its possession and the possession of its subcontractors.

(b) The report shall be submitted to the Contracting Officer not later than September 15 of each calendar year on DHS Form 0700-05, Contractor Report of Government Property.

#### **2.22.2 GFP Inspection and Inventory**

Prior to the start date and end date of any BPA Call issued hereunder, the Government Project Manager will conduct an inspection and inventory of the Government facilities and equipment to document the condition and state of repair of the facilities and equipment to be operated or used by the Contractor. Based on this inspection, the Government Project Manager will prepare a condition report and will provide a copy of this report to the Contractor and to the CO. If the Contractor concurs with the report, the Contractor shall sign to acknowledge receipt and acceptance of the condition report.

#### **2.23 Rights in Government Furnished Data and Materials**

The USCIS shall retain all rights and privileges, including those of patent and copyright, to all Government furnished data. The Contractor shall neither retain nor produce for private or commercial use any data or other materials furnished under a BPA/Call. The Contractor agrees not to assert any rights at common law or in equity or establish any claim to statutory copyright to such data. These rights are not exclusive and are in addition to other rights and remedies to which the Government is otherwise entitled elsewhere in this BPA or a BPA Call.

#### **2.24 Access to Government Facilities**

The Authorized Government Representative specified in each Call will coordinate access to Government facilities by Contractor personnel when required in the performance of work on individual Calls. While on Government property, the Contractor personnel shall comply with all applicable rules and regulations, not only as they apply to themselves, but also as they apply to other personnel and property at the site. At each site, the local Government representative will have sole authority to determine when, and under what conditions, Contractor personnel can be present on site – for instance, the Government may prohibit Contractor personnel from being on site if there are no Government personnel present at the same time.

## **2.25 Commercial Records Facility**

The Contractor's facility for the data conversion services and storage of files obtained through the BPA shall meet the NARA facility standards for records storage facilities addressed in CFR Subpart B, Part 1228, Subpart K.

## **2.26 Indemnification**

The Contractor assumes full responsibility for and shall hold harmless and indemnify the Government against any and all losses or damage of whatsoever kind and nature, to any supplies and accessories or spare parts furnished, while in its custody and care for storage, repairs, or service to be performed under the terms of this BPA, resulting in whole or in part from the negligent acts or omissions of the Contractor, and subcontractor or any employee, agent or representative of the Contractor or subcontractor.

If due to fault, negligent acts (whether of commission or omission) and/or dishonesty of the Contractor or its employees, any Government-owned or controlled property is lost or damaged as a result of the Contractor's performance of this BPA, the Contractor shall be responsible to the Government for such loss or damage, and the Government may, in lieu of payment thereof, require the Contractor to replace at its own expense, all property lost or damaged.

## **2.27 Insurance**

The company shall maintain proper insurance to ensure they are licensed in accordance with State and Federal regulations. The Contractor warrants that insurance (currently in force) coverage exists in the amount not less than those specified in the FAR Subpart 28.307-2, *Liability*.

### **2.27.1 Evidence of Insurance**

The Contractor shall file with the CO within three (3) business days after award of the BPA, a certification of insurance evidencing the above coverage. The Contractor shall file with the CO within five (5) business days after receipt, notice of cancellation or reduction below the above cited amounts any insurance coverage related to this requirement.

### **2.27.2 Subcontractor Insurance**

The Contractor warrants that such insurance coverage for all subcontractors, who will work at the site, does or will exist before each subcontractor personnel enter the Government premises.

## **2.28 Accident Report Procedures**

In the event of an accident involving Government personnel or property, the Contractor shall submit a report to the CO via the on-site COTR in letterform that will include the following:

- Time and date of occurrence
- The place of occurrence
- A list of personnel directly involved
- A narrative description of the accident and circumstances

### 2.29 Permits and License

In the performance of work hereunder, the Contractor shall obtain and maintain in effect all necessary permits and licenses required by Federal, State, or Local Governments, or subdivisions thereof, or of any other duly constituted public authority. Further, the Contractor shall obey and abide by all applicable laws and ordinances.

### 2.30 Legal Holidays and Administrative Leave

The Federal Government observes the following days as holidays:

New Year's Day	M. L. King's Birthday
Presidents Day	Memorial Day
Independence Day	Labor Day
Columbus Day	Veteran's Day
Thanksgiving Day	Christmas

Observance of such days by Government personnel shall not be reason for the Contractor to request an additional period of performance, or entitlement of compensation except as set forth within this BPA. When DHS grants its employees "Liberal Leave," Contractor employees are expected to work their normal hours. If a site is closed because of inclement weather or other reasons that prohibit Contractor personnel from being on site, the Contractor shall not be paid for this non-work period.

### 2.31 Travel

The Contractor may be required to travel on an as required and assignment basis. Local travel reimbursement under this BPA is not authorized. Local travel is travel within the commuting area of the assigned work location.

#### 2.31.1 Approval for Travel

The Contractor shall obtain written approval from the Authorized Government Representative specified in each Call prior to performing any travel under this BPA and trip authorization from the COTR. Contractor travel approved in advance by the Authorized Government Representative specified in each Call will be reimbursed in accordance with FAR 31.205-46, *Travel Costs*, and the Federal Travel Regulations prescribed by the General Services Administration.

### 2.32 Key Personnel

USCIS will require the Contractor to propose a project management structure and identify key personnel on the BPA to perform the functions of project management. These key personnel will be directly responsible for management of the BPA. Additional key personnel may be required for individual BPA Calls, if the Government designates positions as being essential or "key" to the work performed under that Call. Key personnel shall be available to support the requirements of Calls issued under the BPA and ensure that all work performed meets the

requirements set forth in the Call. The Contractor shall provide resumes of the key personnel, which will be evaluated by the Technical Evaluation Committee. At the minimum, the Project Manager shall be designated as key personnel. The Project Manager must possess knowledge of Federal contract and procurement regulations and specialized experience directly related to the type of work required in this BPA.

#### **2.32.1 Substitution or Replacement of Key Personnel**

The personnel specified as key personnel in a given BPA Call are considered essential to the work performed under the BPA. In the event of either absences or resignations of any Contractor staff, the Contractor shall provide fully qualified, experienced, and trained alternates to serve as substitutes or replacements for the position. The Contractor shall notify the CO no later than 30 calendar days in advance and shall submit justification (including the names and resumes of the proposed substitutions) in sufficient detail to permit evaluation of the impact on the program. The proposed substitutions shall possess qualifications equal or superior to those of the key person(s) being replaced. The Contractor shall make no substitutions or replacements without the written consent of the CO. During the first 120 days of this BPA, no key personnel substitutions or replacements will be permitted unless an individual's sudden illness, death, or termination of employment necessitates such substitutions. In any of these events, the Contractor shall promptly notify the CO and provide the information required by the Key Personnel clause. Key personnel may be amended from time to time during the BPA either to add or delete personnel to the Call or BPA itself, as appropriate.

#### **2.32.2 Employment of Key Personnel**

Key personnel shall be full-time employees of the prime Contractor at the time of quote submission that possess familiarity with the company lines of business and business processes. The Contractor shall furnish the name, phone number, and resume of the key personnel and other pertinent information as required by the Government at the time of quote submission.

#### **2.33 Standards of Conduct**

In performing Calls issued hereunder, Contractor personnel may be required to interact with high-level Government officials. The Contractor shall ensure that all its personnel conduct their work in a professional and responsible manner. All Contractor personnel working on the Government's site shall abide by the rules and regulations as outlined in the Standards of Conduct (28 CFR part 45).

#### **2.34 Consultants**

USCIS will use acquisition support Contractor personnel to support the Government's evaluation of quotes in accordance with the Department of Homeland Security Acquisition Regulation (HSAR) 3015.207-70. The Contractor employees will have access to information contained in the Contractor's quotes and will be subject, as are all other members of the source selection organization, to the appropriate conflict of interest, standards of conduct, and confidentiality restrictions.

### **3. BPA REQUIREMENTS AND POTENTIAL TASKING**

The tasking described below include current tasks required by USCIS; as well as additional support services that may be required in the near future. The tasks are described in general terms to help delineate the scope of the BPA. Specific tasks may be further defined by USCIS who will place either Firm-Fixed Price or Time and Material Calls against the master BPA depending upon the nature of the work, but the general scope will not change. All the requirements in the BPA shall be performed in accordance with applicable DHS standards, schedules, deadlines, SDLC guidelines, and other regulations and guidance provided in this BPA and by USCIS.

Calls may include, but are not limited to, any combination of the following tasks:

- Project Management Support
- Records Management Services
- Document Conversion Services
- Scanning Documents to Digital Data
- File Control and Tracking
- Contractor Operated Records Facility
- Document Storage
- Document Shipping and Receiving
- Needs Assessment and Analysis Services
- Documentation

### **4. PERFORMANCE-BASED SERVICE CONTRACTING (PBSC)**

It is the intent of the Government that, to the maximum extent possible, Calls will be issued on this BPA using performance-based orders pursuant to FAR 8.405-2(b). The Government will strive to develop meaningful performance standards and performance measures that can be applied to the work performed under this BPA. In developing performance data the Government hopes to achieve the following goals:

- Determine reasonable, realistic, and measurable performance standards.
- Determine how performance achievement for any given month can be accurately and quantifiably measured against performance standards.
- Determine performance standards that measure significant, quantitative results to show whether overall performance is successfully achieving essential DHS objectives.
- Determine appropriate incentive for achieving acceptable quality levels of performance.

The Contractor is encouraged to offer feedback and work with the Government to achieve these goals and ensure that standards and measures are fair and contribute to producing the desired outcomes.

#### **4.1.1 PBSC Methods**

Performance-based contracting methods are intended to ensure that required performance quality levels are achieved and that total payment is related to the degree

that services performed or outcomes achieved meet BPA standards. Performance-based task orders-

- (1) Describe the requirements in terms of results required rather than the methods of performance of the work;
- (2) Use measurable performance standards (*i.e.*, in terms of quality, timeliness, quantity, etc.) and quality assurance surveillance plans;
- (3) Specify procedures for reductions of the price of a fixed-price BPA call when services are not performed or do not meet BPA call requirements; and
- (4) Include performance incentives where appropriate.

## **5. SECURITY REQUIREMENTS**

These Security requirements are applicable to each Call awarded under this BPA. Any deviation from this BPA Security Requirements section shall be specified in each BPA Call.

### **5.1.1 General**

The Department of Homeland Security (DHS) has determined that performance of this BPA requires that the Contractor, subcontractor(s), vendor(s), etc. (herein known as Contractor), requires access to sensitive but unclassified DHS information, and that the Contractor will adhere to the following.

### **5.1.2 Suitability Determination**

DHS shall have and exercise full control over granting, denying, withholding or terminating unescorted government facility and/or sensitive but unclassified Government information access for Contractor employees, based upon the results of a background investigation. DHS may, as it deems appropriate, authorize and make a favorable entry on duty (EOD) decision based on preliminary security checks. The favorable EOD decision would allow the employees to commence work temporarily prior to the completion of the full investigation. The granting of a favorable EOD decision shall not be considered as assurance that a full employment suitability authorization will follow as a result thereof. The granting of a favorable EOD decision or a full employment suitability determination shall in no way prevent, preclude, or bar the withdrawal or termination of any such access by DHS, at any time during the term of the BPA. No employee of the Contractor shall be allowed unescorted access to a Government facility without a favorable EOD decision or suitability determination by the Security Office. Contract employees assigned to the contract not needing access to sensitive but unclassified DHS information or recurring access to DHS' facilities will not be subject to security suitability screening.

### **5.1.3 Background Investigations**

Contract employees (to include applicants, temporaries, part-time and replacement employees) under the contract, needing access to sensitive but unclassified information, shall undergo a position sensitivity analysis based on the duties, outlined in the Position Designation Determination (PDD) for Contractor Personnel, each individual will perform on the contract. The results of the position sensitivity analysis shall identify the appropriate background investigation to be conducted. All background investigations will be processed through the

Security Office. Prospective Contractor employees shall submit the following completed forms to the Security Office through the COTR no less than 30 days before the starting date of the contract or 30 days prior to entry on duty of any employees, whether a replacement, addition, subcontractor employee, or vendor:

1. Standard Form 85P, "Questionnaire for Public Trust Positions"
2. DHS Form 11000-6, "Conditional Access to Sensitive But Unclassified Information Non-Disclosure Agreement"
3. FD Form 258, "Fingerprint Card" (2 copies)
4. Foreign National Relatives or Associates Statement
5. Form DHS-11000-9, "Disclosure and Authorization Pertaining to Consumer Reports Pursuant to the Fair Credit Reporting Act"
6. Position Designation Determination for Contract Personnel Form

Required forms will be provided by DHS at the time of award of the BPA. Only complete packages will be accepted by the Security Office. Specific instructions on submission of packages will be provided upon award of the BPA.

Be advised that unless an applicant requiring access to sensitive but unclassified information has resided in the US for three of the past five years, the Government may not be able to complete a satisfactory background investigation. In such cases, DHS retains the right to deem an applicant as ineligible due to insufficient background information.

The use of Non-U.S. citizens, including Lawful Permanent Residents (LPRs), is not permitted in the performance of this BPA for any position that involves access to or development of any DHS IT system. DHS will consider only U.S. Citizens and LPRs for employment on this BPA. DHS will not approve LPRs for employment on this BPA in any position that requires the LPR to access or assist in the development, operation, management or maintenance of DHS IT systems. By signing this BPA, the contractor agrees to this restriction. In those instances where other non-IT requirements contained in the BPA can be met by using LPRs, those requirements shall be clearly described.

#### **5.1.4 Continued Eligibility**

If a prospective employee is found to be ineligible for access to Government facilities or information, the COTR will advise the Contractor that the employee shall not continue to work or to be assigned to work under the BPA.

The Security Office may require drug screening for probable cause at any time and/ or when the contractor independently identifies, circumstances where probable cause exists.



DHS reserves the right and prerogative to deny and/ or restrict the facility and information access of any Contractor employee whose actions are in conflict with the standards of conduct, 5 CFR 2635 and 5 CFR 3801, or whom DHS determines to present a risk of compromising sensitive but unclassified Government information to which he or she would have access under this BPA.

The Contractor will report any adverse information coming to their attention concerning contract employees under the BPA to DHS' Security Office. The subsequent termination of employment of an employee does not obviate the requirement to submit this report. The report shall include the employees' name and social security number, along with the adverse information being reported.

The Security Office must be notified of all terminations/ resignations within five days of occurrence. The Contractor will return any expired DHS issued identification cards and building passes, or those of terminated employees to the COTR. If an identification card or building pass is not available to be returned, a report must be submitted to the COTR, referencing the pass or card number, name of individual to whom issued, the last known location and disposition of the pass or card.

#### **5.1.5 Employment Eligibility**

The Contractor must agree that each employee working on this BPA will have a Social Security Card issued and approved by the Social Security Administration. The Contractor shall be responsible to the Government for acts and omissions of his own employees and for any Subcontractor(s) and their employees to include financial responsibility for all damage or injury to persons or property resulting from the acts or omissions of the contractor's employees.

Subject to existing law, regulations and/ or other provisions of this BPA, illegal or undocumented aliens will not be employed by the Contractor, or with this BPA. The Contractor will ensure that this provision is expressly incorporated into any and all Subcontracts or subordinate agreements issued in support of this BPA.

#### **5.1.6 Security Management**

The Contractor shall appoint a senior official to act as the Corporate Security Officer. The individual will interface with the Security Office through the COTR on all security matters, to include physical, personnel, and protection of all Government information and data accessed by the Contractor.

The COTR and the Security Office shall have the right to inspect the procedures, methods, and facilities utilized by the Contractor in complying with the security requirements under this BPA. Should the COTR determine that the Contractor is not complying with the security requirements of this BPA, the Contractor will be informed in writing by the Contracting Officer of the proper action to be taken in order to effect compliance with such requirements.

The following computer security requirements apply to both Department of Homeland Security (DHS) operations and to the former Immigration and Naturalization Service operations (FINS). These entities are hereafter referred to as the Department.

### **5.1.7 Information Technology Security Clearance**

When sensitive but unclassified government information is processed on Department telecommunications and automated information systems, the Contractor agrees to provide for the administrative control of sensitive but unclassified data being processed and to adhere to the procedures governing such data as outlined in *DHS IT Security Program Publication DHS MD 4300.Pub.* Contractor personnel must have favorably adjudicated background investigations commensurate with the defined sensitivity level.

Contractors who fail to comply with Department security policy are subject to having their access to Department IT systems and facilities terminated, whether or not the failure results in criminal prosecution. Any person who improperly discloses sensitive but unclassified information is subject to criminal and civil penalties and sanctions under a variety of laws (e.g., Privacy Act).

### **5.1.8 Information Technology Security Training And Oversight**

All contractor employees using Department automated systems or processing Department sensitive but unclassified data will be required to receive Security Awareness Training. This training will be provided by the appropriate component agency of DHS.

Contractors who are involved with management, use, or operation of any IT systems that handle sensitive but unclassified information within or under the supervision of the Department, shall receive periodic training at least annually in security awareness and accepted security practices and systems rules of behavior. Department contractors, with significant security responsibilities, shall receive specialized training specific to their security responsibilities annually. The level of training shall be commensurate with the individual's duties and responsibilities and is intended to promote a consistent understanding of the principles and concepts of telecommunications and IT systems security.

All personnel who access Department information systems will be continually evaluated while performing these duties. Supervisors should be aware of any unusual or inappropriate behavior by personnel accessing systems. Any unauthorized access, sharing of passwords, or other questionable security procedures should be reported to the local Security Office or Information System Security Officer (ISSO)

### **5.1.9 Minimum Computer And Telecommunications Security Requirements**

#### **5.1.9.1 General**

Due to the sensitive nature of Department information, the Contractor is required to develop and maintain a comprehensive computer and telecommunications security (C&TS) program to address the integrity, confidentiality, and availability of sensitive but unclassified (SBU) information during collection, storage, transmission, and disposal. The Contractor's security program shall adhere to the requirements set forth in the Department's IT Security Program

Publications. The Contractor shall establish a working relationship with the Information Systems Security Manager (ISSM).

### 5.1.9.2 C&TS in the Systems Development Life Cycle (SDLC)

C&TS activities in the SDLC are outlined in each current version of the SDLC Manual. The Contractor shall assist the appropriate ISSO with development and completion of all security related activities contained in the SDLC. These activities include development of the following documents:

- *Sensitive System Security Plan (SSSP)*: This is the primary reference that describes system sensitivity, criticality, security controls, policies, and procedures.
- *Contingency Plan (CP)*: This plan describes the steps to be taken to ensure that an automated system or facility can be recovered from service disruptions in the event of emergencies and/or disasters
- *Risk Assessment (RA)*: This document identifies threats and vulnerabilities, assesses the impacts of the threats, evaluates in-place countermeasures, and identifies additional countermeasures necessary to ensure an acceptable level of security
- *Security Test and Evaluation (ST&E)*: This document evaluates each security control and countermeasure to verify operation in the manner intended. Test parameters are established based on results of the RA
- *Certifier's Statement* *The certification phase and statement testifies that the correct and effective implementation security controls are in place*

### 5.1.9.3 Security Assurances

All statements of work and BPA vehicles shall identify and document the specific security requirements for outsourced services and operations that are required by the contractor. Outsourced services and operations shall adhere to the Department's security policies. The security requirements shall include how the Department's sensitive but unclassified information is to be handled and protected at the contractor's site, including any information stored, processed, or transmitted using the contractor's computer systems, the background investigation and/or clearances required, and the facility security required. At the expiration of the BPA, statements of work and BPA vehicles shall require the return of all sensitive but unclassified Department information and IT resources provided during the life of the BPA and certification that all Department information has been purged from any contractor-owned system used to process Department information. Components shall conduct reviews to ensure that the security requirements in the BPA are implemented and enforced.

### 5.1.9.4 Data Security

SBU systems must be protected from unauthorized access, modification, and denial of service. The Contractor shall ensure that all aspects of data security requirements (i.e., confidentiality, integrity, and availability) are included in the functional requirements and system design, and ensure that they meet the minimum requirements as set forth in the most currently approved Department publications. These requirements include:

- *Integrity* – The computer systems used for processing SBU must have data integrity controls to ensure that data is not modified (intentionally or unintentionally) or repudiated by either the sender or the receiver of the information. A risk analysis and vulnerability assessment must be performed to determine what type of data integrity controls (e.g., cyclical redundancy checks, message authentication codes, security hash functions, and digital signatures, etc.) must be used.
- *Confidentiality* – Controls must be included to ensure that SBU information collected, stored, and transmitted by the system is protected against compromise. A risk analysis and vulnerability assessment must be performed to determine if threats to the SBU exist. If it exists, data encryption must be used to mitigate such threats.

*Availability* – Controls must be included to ensure that the system is continuously working and all services are fully available within a timeframe commensurate with the availability needs of the user community and the criticality of the information processed.

## 6. APPLICABLE DOCUMENTS

### 6.1 Policies and Procedures

Work performed under this BPA shall conform to current applicable Federal and DHS policies and procedures, security regulations, systems protocols, and other procedures and regulations listed in the following documents.

- *DHS MD 4300 Pub*
- *Freedom of Information Act (FOIA). Privacy Act (PA).* Available at <http://www.usdoj.gov/foia/privstat.htm>
- HSAR 3015.207-70
- HSAR 3052.245-70
- *National Archives and Records Administration (NARA) regulations.* Available at <http://www.archives.gov/>
- *National Industrial Security Program Operating Manual (NISPOM).* Available at [www.dss.mil/isec/nispom.htm](http://www.dss.mil/isec/nispom.htm)
- USCIS Office of Records Services Record Operations Handbook.

### 6.2 Forms

- DHS Form 258
- DHS Form 0700-05
- DHS Form 11000-6
- DHS Form 11000-9
- *Standard Form 85P*  
(This section will be removed upon award.)

## 7. INSTRUCTIONS TO OFFERORS

### 7.1 Introduction

This GSA Schedule BPA Request For Quote (RFQ) seeks to obtain imaging and document solution support for an A-File digitization initiative. Services for the initial Call shall be performed at a contractor facility. The USCIS intends to acquire these services by establishing a BPA to a **Single Offeror** who has a current GSA Contract under Group 36. Offerors proposing a teaming arrangement are limited to team members that are on a GSA Schedule as discussed in Section 2.19.

### 7.2 Teaming Relationship

If two or more Offerors intend to work together to meet the solicitation requirements, the quote response must clearly identify the type of relationship (i.e., joint venture agreement, prime/subcontractor arrangement) of all parties involved. Refer to FAR 9.601, *Contractor Team Arrangements*, for descriptions of the types of agreements. A signed copy of the joint venture or prime/subcontractor agreement must be submitted with the solicitation response. If a joint venture where two or more contractors for a partnership to act as a prime contractor to furnish a total solution, each partner must submit under their own GSA Schedule.

### 7.3 Prospective Offerors Questions

The Offerors may submit any questions in writing by electronic mail or facsimile to the Contracting Officer (CO) by 4:00 p.m., Eastern Standard Time, no later than July 28, 2005.

Contracting Officer  
Department of Homeland Security  
U.S. Citizenship & Immigration Services  
Field Support Center - Burlington  
70 Kimball Avenue  
South Burlington, VT 05403  
Phone: (802) 872-4111  
Fax: (802) 951-6455  
[peter.dietrich@dhs.gov](mailto:peter.dietrich@dhs.gov)

The responses will be provided to all prospective Offerors, giving due regard to the proper protection of proprietary information. In order to receive responses to questions, Offerors shall cite the section, paragraph, and page numbers of the passage in question. Statements expressing opinions, sentiments, or conjectures are not considered valid inquires or comments and will not receive a response.

### 7.4 Quote Preparation Costs

The Government shall not pay any costs incurred by any Offeror in preparation and submission of a quote in response to this BPA. The CO is the only person who can legally obligate the Government for the expenditure of public funds in connection with this procurement.

## **7.5 Quote Rejection**

The Government may reject any quote that does not address the totality of the solicitation requirements, including the BPA terms and conditions.

## **7.6 Minimum Acceptance Period**

- The Government requires a minimum acceptance period of 90 calendar days for the offer.
- Offerors may specify a longer acceptance period than the Government's minimum requirement. The Offeror shall specify the acceptance period in the quote submission.
- An offer allowing less than the Government's minimum acceptance period shall be rejected.

## **7.7 General Quote Preparation Instructions**

This section provides general guidance for preparing quotes as well as specific instructions on the format and content of the quote. The Offeror's quote must include all data and information requested by this solicitation and must be submitted in accordance with these instructions. Non-conformance with the instructions provided in this document may result in an unfavorable quote evaluation.

### **7.7.1 Quote Changes**

Changes to the quote by the Offerors shall be accomplished using amended page(s). Any changes from the original quote shall be indicated through use of a vertical line, placed adjacent to the change, within the right side margin of the page. The Offerors shall include the date of the amendment on the lower right hand footer of the page. Quote amendments shall be allowed only prior to the due date for quotes. Quote revisions shall be permitted only at the CO's request.

### **7.7.2 Notification of Non-Selection**

Offerors whose quotes are no longer considered for award or whose quotes were not selected for award will be so notified by the CO. Such notification will state in general terms the basis of non-selection. Unsuccessful Offerors may request, in writing, a post-award debriefing.

### **7.7.3 Quote Retention**

In accordance with FAR Subpart 4.8, *Government Contract Files*, the Government will retain at least one copy of each quote, successful or unsuccessful, and the remainder will be destroyed. No destruction certificate will be furnished.

### **7.7.4 Quote Organization**

The Offeror shall prepare the quote as set forth in the Quote Organization and Page Limits Table below. The contents of each quote volume are described in the paragraphs found further in this document. The quotes shall be organized in two separate volumes. Volume one will contain the technical response for the overall BPA, past performance and the technical response to the initial Call. Volume two will contain the Price Quote and includes the BPA pricing basis and initial Call Pricing.

**QUOTE ORGANIZATION AND PAGE LIMITS**

TITLE	PAGE LIMIT
<b>Volume I – Technical Quote</b> <b>BPA Response– Blanket Purchase Agreement</b> - BPA Management Approach - Resumes of Key Personnel <b>Initial Call Response</b> - Performance Approach for the Initial Call - Past Performance Narrative	<b>Volume I shall not exceed 80 pages in length [The PMP from Call 0001 is not included in the 80 page limit]</b>
<b>Volume II – Price Quote</b> <b>BPA Master Response –</b> - Business Information - Blanket Purchase Agreement Pricing Basis - Discount Table - Current Year Discounted Schedule - Assumptions and Constraints <b>Initial Call Response –</b> - Initial Call Pricing - Supporting Detail for Pricing	<b>No Page Limit</b>

**7.7.5 Quote Limitations**

The contents of the volumes shall be within the required page limits specified in the table above. Page limitations shall be treated as maximums. If exceeded, the excess pages will not be read or considered in the evaluation of the quote.

- Quotes must be submitted using Microsoft Office 200x including Word (.DOC), Excel (.XLS), and PowerPoint (PPT or PPS). Disable macros on all files.
- Quotes must be legible, single-spaced, computer-printed copy (**on one side only**).
- Except for the reproduced sections of the solicitation document, the text font will be Times New Roman and text size no less than 12-point proportional.
- Page size shall be 8.5 by 11.0 inches.
- Foldouts are not allowed.
- Elaborate brochures or documentation, binding, detailed artwork, or other embellishments are not allowed.
- Tracking, kerning, and leading values shall not be changed from the default values of the word processing or page layout software.
- Use at least 1-inch margins from the page edge to the main text on the top and bottom and ¾ inch side margins.
- Tables, charts, graphs, appendices, and attachments may be used wherever practical. These pages will be included as part of the page limitation. They should be used to illustrate items such as organization structures, systems and layout, implementation schedules, or plans. These displays shall be uncomplicated, legible and shall not exceed 8.5 by 11.0 inches.

#### **7.7.6 Other Direct Costs (ODCs)**

The Contractor shall propose anticipated ODCs with appropriate justification and explanation in its Technical and Price Quotes of Calls. The price of ODCs shall be included in the price quoted in a Firm-Fixed-Price Call. ODCs shall consist of the following:

- Planned Travel for management and oversight of personnel, and for balancing the workforce to meet workload surges to include airfare, lodging and meals.
- Cost of minor expense materials, incidental items or consumables such as supplies and postage when essential to BPA performance.

#### **7.7.7 GSA Schedule**

All Offerors, including teaming partners in Contractor Teaming Arrangements, shall submit a copy of their proposed FSS Schedule 36 Pricelist, including all applicable Terms and Conditions of their GSA Schedule Contract proposed for use by the Offeror under this solicitation. The copy of these sections of the GSA Contract shall include all modifications thereto. Failure to submit this will render the Offeror's quote deficient. This copy of the GSA Schedule contract and any modifications, if any, must be submitted with the Price Quote.

#### **7.7.8 Compliance**

Offerors are cautioned to review the RFQ and ensure that the quote submitted *fully complies* with *all requirements* of the RFQ. Each quote shall clearly demonstrate the Offeror's understanding of the overall and specific technical requirements of the BPA. The Offeror must provide the requested past performance and pricing information. Clarity and completeness of the quote is of the utmost importance. The quote must be written in a practical, clear, and concise manner. It must use quantitative terms whenever possible and must avoid qualitative adjectives to the maximum extent possible. The quote should not simply rephrase or restate the Government's requirements, but rather provide convincing rationale to address how the Offeror intends to meet these requirements. Simple statements of compliance (i.e., "understood"; "will comply") without the detailed description of how compliance will be met may not be considered sufficient evidence that the proposed services can technically meet the requirements of this RFQ. Offerors shall assume that the Government has no prior knowledge of their facilities and experience, and will base its evaluation solely on the information presented in the Offeror's quote. Accordingly, any quote in which material information requested is not furnished or where indirect or incomplete answers or information are provided may be considered not acceptable or determined to be outside the competitive range.

#### **7.7.9 Quote Receipt**

All quotes, to include the signed SF 18, must be received by 4:00 p.m., Eastern Standard Time, on August 12, 2005. No extension of the due date is permitted, unless the CO extends by issuance of an amendment to the solicitation.

**Quotes MUST be sent to the CO via electronic mail to the Contracting Officer at [peter.dietrich@dhs.gov](mailto:peter.dietrich@dhs.gov)**



#### **7.7.10 Cost Information**

All cost information shall be addressed **ONLY** in the Price Quote. No cost information shall be contained in the Technical Quote.

#### **7.8 Technical Quote**

The Offeror's Technical Quote shall consist of two parts as defined in the below paragraphs.

Part 1 BPA Master Response shall consist of two sections as follows:

- BPA Management Approach
- Resumes of Key Personnel

Part 2 Initial Call Response shall consist of two sections as follows:

- Performance Approach for the Initial Call
- Past Performance

##### **7.8.1 BPA Management Approach**

The Offeror's quote shall clearly describe its management concept for accomplishing the services described in the BPA and the rationale for how the management approach proposed will be applied to tasks specified in future Calls. The Project Management Plan shall be provided with the initial Call and shall include all requirements described in paragraph 4.2.1 of the initial call PWS.

##### **7.8.2 Performance Approach**

The Offeror's quote shall clearly describe how it intends to provide the required services described in Call 0001 and the rationale for how the performance approach proposed will be applied to the tasks specified in the PWS. The Offeror shall **provide a compliance matrix table** that maps the tasks identified in Call 0001 in their quote response.

##### **7.8.3 Past Performance**

The Offeror shall provide a list of references to establish previous relevant experience in performance for technical projects similar in size, scope, and complexity to the requirement being competed. The Offeror shall cite not less than three (3) but not more than five (5) projects performed as a Prime Contractor within the last five (5) years. A minimum of one (1) Federal Government project shall be included. To facilitate the evaluation of the Offeror's past performance, the Offeror shall present the following information:

- Customer Name and address
- Contract Number/Contract Title
- Contract Value
- Delivery Schedule/Period of Performance
- Description of the Work Performed
- Total Number of Users
- Whether work was performed onsite or offsite

- Whether personnel had security clearances and at what level
- Unique or Complex Characteristics of the Project
- Customer Point of Contact (Name, Address, Telephone Number and email address) for Business Manager and Technical Manager
- Relevance to USCIS Requirement

#### **7.8.3.1 Past Performance Questionnaire**

A Past Performance Questionnaire must be completed by each of the references identified above and submitted directly to the CO at the address shown on the Past Performance Questionnaire **no later than the close of business on or before the date that quotes are due**. Offerors should instruct their references to email/fax the completed questionnaires directly to the CO as noted on the forms.

Peter Dietrich  
 Department of Homeland Security  
 U.S. Citizenship & Immigration Services  
 Field Support Center - Burlington  
 70 Kimball Avenue  
 South Burlington, VT 05403  
 Phone: (802) 872-4111  
 Fax: (802) 951-6455  
[peter.dietrich@dhs.gov](mailto:peter.dietrich@dhs.gov)

**It is the Offeror's responsibility to forward the Past Performance Questionnaires to the required references and have those references complete the questionnaires and email/fax them no later than the due date of the RFQ to the CO. Offerors shall not submit Past Performance Questionnaires with their quotes.**

#### **7.9 Price Quote**

The Offeror's Price Quote shall consist of two parts that contain all information necessary to allow for a comprehensive evaluation as defined in the below paragraphs.

Part 1 Basic BPA Response shall consist of five sections as follows:

- Business Information
- Blanket Purchase Agreement Pricing Basis
- Discount Table
- Initial Year Discounted Schedule
- Assumptions and Constraints

Part 2 Initial Call Response shall consist of two sections as follows:

- Initial Call Pricing
- Supporting Detail for Initial Call Pricing

##### **7.9.1 Business Information**

The Price Quote shall contain the following information:

- Solicitation Number
- Name and address of Offeror(s)
- Name and Point of Contact telephone number, fax number and email address
- Name of Contract Administration Office
- Date of submission
- Whether use of Government property will be required in the performance of the contract, and if so, what property
- Teaming Arrangements and how each teaming partner's GSA Schedule prices are incorporated into the total solution to meet the Government requirement
- Name, title, and signature of authorized representative(s)
- Copy of the current GSA contract terms and conditions including all modifications for the Offeror and for any Team Member, if applicable.

**7.9.2 Blanket Purchase Agreement Pricing Basis**

All proposed prices must be based on the Offeror's and/or a team member's GSA Schedule Contract. Only current fully loaded GSA labor rates including any discounts are acceptable. The Offeror shall only use those rates, which have been negotiated with GSA and incorporated in the GSA Schedule Contract as of the date of quote submission. Composite rates (rates mapped to a given labor category in this RFQ consisting of a combination of two or more labor categories) are not permitted.

**7.9.3 BPA Discount Table**

This procurement action is being competed to establish a blanket purchase agreement under the multiple award schedule contracts issued to vendors by the General Services Administration. You must cite the GSA Schedule Contract Number on which your price quote is based. It is important that you submit your best discounted rates in response to this request. Labor rates submitted are to be fully burdened.

Vendors shall submit a percentage discount from their current GSA Schedule rates covering the base period of performance and each additional period. The discounts offered shall be expressed as a percentage reduction of the schedule rates for each CLIN in the GSA Schedule. The discounts offered do not prevent the Government from seeking additional price reductions pursuant to FAR 8.404(b)(5).

BPA Discount Table

Period of Performance	Discount %
Base Year – Award – for twelve months	
Additional Period 1– Year 2 for twelve months	
Additional Period 2– Year 3 for twelve months	
Additional Period 3– Year 4 for twelve months	
Additional Period 4– Year 5 for twelve months	

Note: If discounts are conditional on a given dollar volume or other condition, this must be stated clearly.

Vendors shall apply the discounted rates in a price quote for performance of the requirements identified in the Agency's proposed initial BPA Call.

#### **7.9.4 Initial Year Discounted Pricing Schedule**

The Offeror shall submit a Pricing Schedule that shows all the labor categories, labor rates, discounts, that are proposed for fulfillment of the BPA. Offerors shall not adjust the table file formats, except as required for formatting such as column widths, row heights, and adding columns and rows to accommodate data. The location of individual cells must not be adjusted. As appropriate, separate rates may be quoted for work performed on Government Sites and Contractor Sites.

Note: A pricing schedule based on the percentage discount table shall be added to the BPA through a modification action in each of the four additional periods upon receipt of notification by the Contractor of revised GSA Schedule rates for that period. The percentage discount identified in the BPA Discount Table may not be reduced any time during the life of the BPA.

#### **7.9.5 Labor Categories**

The Offeror shall submit a copy of all GSA Schedule position descriptions that are proposed for this BPA.

#### **7.9.6 Assumptions and Constraints**

This section of the Offeror's quote is designed to provide a comprehensive narrative discussion/explanation of all of the assumptions and constraints used in developing the quote. A complete explanation of all proposed costs shall be provided. This section shall also be used to provide (if necessary) any additional information.

#### **7.9.7 Initial Call Pricing**

The PWS for the initial Call is attached to the BPA. Section 12 of the Call PWS contains submission requirements.

The Offeror shall submit a Call Pricing Schedule that shows all the Pricing proposed for fulfillment of the Initial Call in accordance with the CLIN structure and supporting Detail for Initial Call Pricing

The Offeror shall provide a work breakdown for the Initial Call with a complete breakout of the costs, including labor categories, labor hours, discounted rates, planned travel, and a detailed explanation/justification sufficient for a comprehensive evaluation. A cross-reference to the labor categories in the Discounted Pricing Schedule shall be provided that maps categories to the requirements of the Initial Call. The Government will use this information in evaluating whether appropriate resources and skills are proposed for the work described in the Initial Call.

## **8. EVALUATION CRITERIA**

The Offeror's quote will be evaluated on the degree of relevance to the requirements of the RFQ. Evaluation will be based solely on the content of the quotes, the resumes, and any other written aspects of the quotes. No assumptions will be made that an Offeror's performance will include areas not specified in the quote.

### **8.1 Basis for award**

The award will be made based on the Best Value to the Government. The Government will make a selection and award a BPA to a single Offeror in accordance with the guidelines provided by FAR and the GSA Schedule for Best-Value/Trade-Off award. A "Best Value" award means that the BPA will be given to the responsible Offeror whose quote, conforming to the solicitation, results in the most advantageous integration of management approach, performance approach, past performance, and price factors. Ratings between competing quotes will be analyzed to determine what the difference may mean in terms of performance, and what it will cost the Government to take advantage of it. As such, the Government may reject any or all offers if such action is in the best interest of the Government, and the Government may accept an offer that is not the lowest price. A BPA will be awarded to a Single Offeror whose quote has been determined to offer the "Best Value" to the Government.

### **8.2 Discussions**

The Government intends to make an award without discussions with Offerors (except communications conducted for the purpose of clarification). Consequently, each offer should be submitted on the most favorable terms that the offering firm is able to submit to the Government. The Government reserves the right to conduct discussions if they are later determined by the CO to be necessary.

### **8.3 Non-Agency & Contractor Evaluation Support**

The Government may include personnel from other Government agencies and/or Contractor personnel to support the Government's evaluation of quotes. Those personnel will have access to information contained in the Offeror's quotes and will be subject to the appropriate conflict of interest, standards of conduct, and confidentiality restrictions. Non-Government personnel are advisors only and are not voting members of evaluation panels.

### **8.4 Evaluation Factors And Methodology**

The BPA Management Approach, Resumes of Key Personnel, Performance Approach for the Initial Call, and Past Performance are of equal importance and are individually more important than price. When combined, they are significantly more important than Price. The Special Preference Factors identified in paragraph 8.5.5 may result in added weight to an Offeror's technical score.

The award will be made based on the Best Value to the Government. Comparing the differences in the value of the non-pricing factors with the differences in the prices proposed will make the determination of "Best Value." In making this comparison, the Government is more concerned with obtaining superior technical performance than in lowest overall price. However, the

Government will not make an award at a significantly higher overall price to the Government to achieve only a slightly superior technical performance. Overall price to the Government may take on more significance as quotes are judged or determined to be more equal based on the

**PERFORMANCE WORK STATEMENT (PWS)**  
**CALL 1 – United States Citizenship and Immigration Services (USCIS),**  
**Office of Records Services (ORS)/**  
**Integrated Digitization Document Management Program (IDDMP)**  
**Alien-File Digitized Enterprise Solution**

**TABLE OF CONTENTS**

<b>1. BACKGROUND</b> .....	<b>1</b>
<b>2. SCOPE</b> .....	<b>2</b>
<b>3. ACRONYMS</b> .....	<b>3</b>
<b>4. SPECIFIC TASKING</b> .....	<b>3</b>
<b>4.1 RECORDS MANAGEMENT</b> .....	<b>3</b>
4.1.1 <i>Facility Operations</i> .....	<b>3</b>
4.1.2 <i>Shipping and Receiving (11 and 19)</i> .....	<b>4</b>
4.1.2.1 <i>Pre- and post- processing of paper documents (12 and 18)</i> .....	<b>4</b>
4.1.3 <i>Scanning Documents (13)</i> .....	<b>5</b>
4.1.4 <i>Converting Images to Desired Format (14)</i> .....	<b>5</b>
4.1.5 <i>Indexing Documents (15)</i> .....	<b>6</b>
4.1.6 <i>Quality Control (16)</i> .....	<b>6</b>
4.1.6.1 <i>Quality Review</i> .....	<b>6</b>
4.1.7 <i>Storing, Staging, Maintaining and Web Access Scan Files via Temporary Server Storage (17)</i> .....	<b>7</b>
4.1.8 <i>Access to Contractor Facility</i> .....	<b>8</b>
<b>4.2 PROJECT MANAGEMENT SUPPORT</b> .....	<b>8</b>
4.2.1 <i>Project Management Plan (PMP)</i> .....	<b>8</b>
4.2.2 <i>PMP Updates</i> .....	<b>9</b>
4.2.3 <i>EVMS</i> .....	<b>9</b>
<b>4.3 PHASE IN TRANSITION</b> .....	<b>9</b>
4.3.1 <i>Training in DHS-Specific Procedures, Policies and Systems</i> .....	<b>9</b>
4.3.2 <i>Contractor Training</i> .....	<b>10</b>
4.3.3 <i>Identification and Resolution Of Workload Problems</i> .....	<b>10</b>
<b>4.4 DOCUMENTATION</b> .....	<b>10</b>
4.4.1 <i>SDLC Documentation</i> .....	<b>10</b>
<b>5. KICK-OFF MEETING</b> .....	<b>10</b>
<b>6. CONTRACTOR FURNISHED PROPERTY (CFP)</b> .....	<b>11</b>
6.1 <b>CONTRACTOR FURNISHED INFORMATION</b> .....	<b>11</b>
<b>7. SECURITY REQUIREMENTS</b> .....	<b>11</b>
7.1 <i>General</i> .....	<b>11</b>
7.2 <i>Suitability Determination</i> .....	<b>11</b>
7.3 <i>Background Investigations</i> .....	<b>12</b>
7.4 <i>Continued Eligibility</i> .....	<b>12</b>
7.5 <i>Employment Eligibility</i> .....	<b>13</b>
7.6 <i>Security Management</i> .....	<b>13</b>
7.7 <i>Information Technology Security Clearance</i> .....	<b>14</b>

7.8	Information Technology Security Training And Oversight.....	14
7.9	Minimum Computer And Telecommunications Security Requirements.....	14
7.9.1	General.....	15
7.9.2	C&TS in the Systems Development Life Cycle (SDLC).....	15
7.9.3	Security Assurances.....	15
7.9.4	Data Security.....	16
8.	APPLICABLE DOCUMENTS.....	16
9.	DELIVERABLES.....	17
9.1	SDLC DOCUMENTATION.....	17
9.2	MONTHLY STATUS REPORT.....	17
9.3	EVMS REPORTS.....	18
9.4	MONTHLY STATUS MEETING.....	18
9.5	TRIP REPORT.....	18
9.6	GOVERNMENT PROPERTY REPORT.....	18
9.7	DELIVERABLE SCHEDULE.....	18
9.8	CRITERIA FOR ACCEPTANCE.....	19
10.	GOVERNMENT QUALITY ASSURANCE.....	19
11.	CALL TERMS AND PROVISIONS.....	22
11.1	POINTS OF CONTACT FOR CALL.....	22
11.2	PERIOD OF PERFORMANCE.....	22
11.3	PLACE OF PERFORMANCE.....	22
11.4	HOURS OF OPERATION.....	22
11.5	TRAVEL.....	22
11.6	APPROVAL FOR TRAVEL.....	23
12.	CALL QUOTE SUBMISSION REQUIREMENTS.....	23
12.1	OFFICE, IMAGING AND DOCUMENT SOLUTION.....	23
12.2	PRICE QUOTE.....	23
12.3	OTHER DIRECT COSTS.....	23
12.4	TRAVEL COSTS.....	23
12.5	PRICING SCHEDULE.....	24
12.5.1	Contract Line Item (CLIN) 0001.....	24
12.5.1.1	SubCLIN 0001AA.....	24
12.5.1.2	SubCLIN 0001AB.....	24
12.5.1.3	SubCLIN 0001AC.....	24
12.5.2	CLIN 0002.....	24
12.5.3	CLIN 0003.....	24
12.5.4	CLIN 0004.....	25
12.6	CONTRACTOR TEAMING ARRANGEMENT (CTA).....	ERROR! BOOKMARK NOT DEFINED.

**TABLES**

Performance Requirements Summary Table



**DEPARTMENT OF HOMELAND SECURITY (DHS) UNITED STATES CITIZENSHIP  
AND IMMIGRATION SERVICES (USCIS), OFFICE OF RECORDS SERVICES (ORS),  
INTEGRATED DIGITIZATION DOCUMENT MANAGEMENT PROGRAM (IDDMP)  
ALIEN-FILE DIGITIZED ENTERPRISE SOLUTION  
REQUEST FOR QUOTE (RFQ) – CALL 1**

**1. BACKGROUND**

The Department of Homeland Security (DHS), U.S. Citizenship and Immigration Services (USCIS), Office of Records Services (ORS) has requirements for a Contractor to support USCIS Records Management in providing electronic access to all Alien-File (A-File) data that resides within the different USCIS offices for national security reasons. These files may include but are not limited to alien registration, I-485 forms, certificate files, master index files, flex-o-line files, and historical files. The digitization of files will expand to all file types as the processes and technologies are more fully defined.

To consolidate the digitization initiative, files will need to be physically transported from one location to another, disassembled and prepared for scanning, and stored in a secure format to be accessible by USCIS. Additionally, the contractor shall maintain and operate a local facility for use where the indexing and processing shall be performed in accordance with the requirements identified in this Call.

Over 84 million A-Files are distributed among the National Records Center (NRC), Harrisonburg File Storage Facility (FSF), the five Service Centers, the National Archives and Records Administration (NARA), and File Control Offices (FCOs) and Case Control Offices (CCOs) worldwide. The existing A-files (22 million at the NRC, 15 million at the Service Centers, 20 million at the NARA's Federal Records Centers, 20 million at FSF, and 7 million at the various FCOs and CCOs) are bar-coded and tracked by Alien-number. The average folder may contain individual documents from one to ten pages; however, some folders may contain 100 pages or more. Additionally, some of these documents may include film, tissue or other document medium and as well as being very old and require sensitive handling. When DHS personnel require information from an A-File that is not physically located in their office, they must query the National File Tracking System (NFTS), Receipt and Alien File Accountability and Control System (RAFACS) or the Central Index System (CIS) for the location of the file, and request personnel at that location to physically mail either the A-File or a copy of it.

This project will involve different areas specifically in regards to Records Management. This call will require the Contractor to provide the following services (as specified in Section 4 below):

- 1) Maintain a "contractor owned-contractor operated" facility in accordance with *NARA Facility Standards for Records Storage Facilities* including administrative services, mail operations, shipping and receiving, and Government space for BPA administration and quality assurance;
- 2) Arrange a delivery system for the A-Files to be transferred between the facility and the NRC or other Government facilities (as required);

- 3) Scan and index Government identified paper A-Files and related documents into a digitized format;
- 4) Provide and maintain a temporary file storage solution to include digitized files format approved by the Government that will be accessible to the applicable USCIS customers.

This Call includes the scanning, indexing, optical character reading, format conversion, quality control, management of records and documents, the management of customer case data, and staging temporary file storage. The vision of Digitization is to develop person-centric records and data management capabilities. *Figure 1. ORS Scanning/Facility Operations*, illustrates a visual scenario of the digitization process.

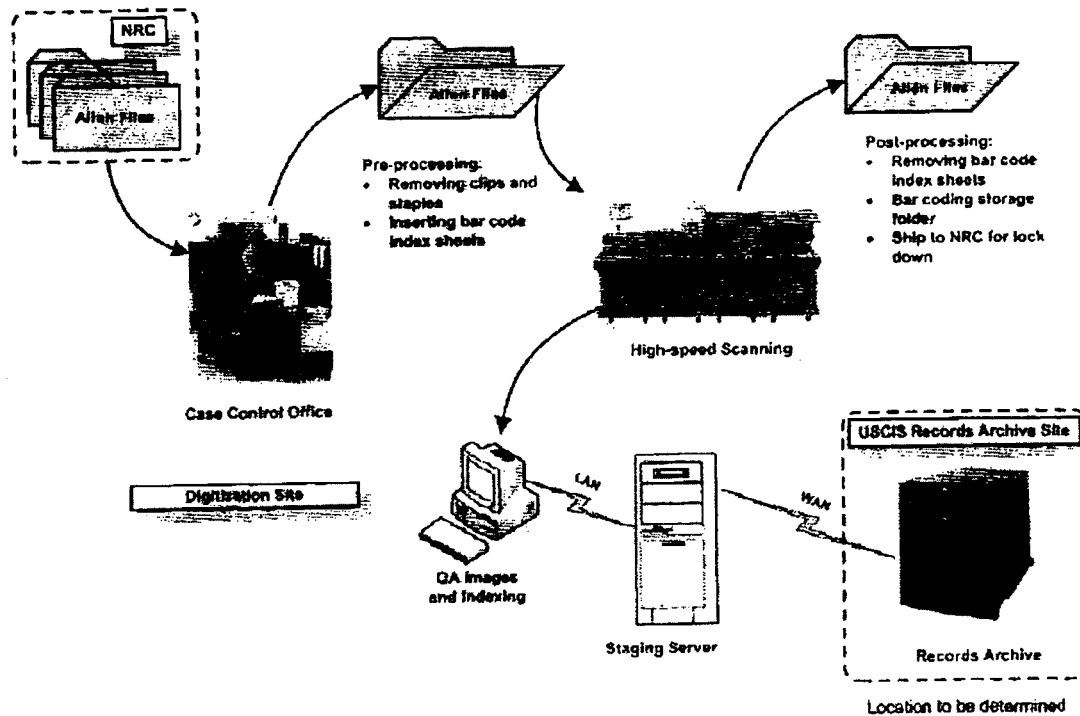

**Figure 1. ORS Scanning/Facility Operations**

## 2. SCOPE

The scope of Call 1 covers all activities related to the establishment of a Contractor operated facility that will specialize in the management of records which will include the following A-File services:

- Records management
- Shipping and receiving
- Scanning and digitization
- Records control

- Facilities operations
- Temporary file storage solution

In accordance with the blanket purchase agreement (BPA) for USCIS Office of Records Services (ORS)/ Integrated Digitization Document Management Program (IDDMP), the requirements identified below are specific to Call 1. The contractor shall perform the Call requirements in accordance with applicable DHS/USCIS standards, schedules, deadlines, and other regulations and guidance provided in this performance work statement (PWS) and by the USCIS. Call 1 is a firm-fixed price call.

### 3. ACRONYMS

Call Attachment A1 provides a table that identifies IDDMP related acronyms.

### 4. SPECIFIC TASKING

The tasking identified below is specific to this Call and is based on the IDDMP requirements identified in the BPA. All information concerning the IDDMP operating environment and workload statistics contained in the BPA are applicable to this Call unless otherwise noted. The Contractor shall comply with applicable NARA standards related to maintaining and operating a records facility, and shipping, receiving and control of archival records.

#### 4.1 Records Management

The Contractor shall provide comprehensive capability to solve the complex challenges posed by the movement, manipulation, archiving, security, and management of records. The contractor shall provide professional management and administrative support to perform effective records management services for privacy act sensitive but unclassified records. In the event that classified documents are encountered during the digitization process the contractor shall not scan these documents and shall immediately refer them to the Government representative in accordance with procedures in the Records Operations Handbook (ROH) as found in Attachment 2.

These services include the use of and/or operating contractor provided equipment to maintain and organize tracking of files, storage of files, information and documents indexing, scanning, labeling, bar-coding and filing. The contractor shall work with the ORS program and the OCIO in developing the functional requirements for the Records Management initiative. Not only must the Government approve all functional requirements, but the Government also owns all data and such data cannot be distributed or used by the Contractor for any purpose.

##### 4.1.1 Facility Operations

The Contractor shall provide, maintain, and operate a facility in accordance with the facilities ROH. The contractor shall provide the facility for housing shipping, receiving and handling of transported paper, storage for maintaining data repository; mail functionality, and maintaining the basic essentials for personnel operations. This task includes, but is not limited to the administrative services for the disassembling and reassembling of files for scanning. The ROH is a living document subject to updates and is used as a resource for facility operations Standard Operating Procedures (SOP).

The Contractor shall provide a solution to scan and index A-file records. The Contractor also shall implement the solution for the scanning, indexing and migrating the data into a temporary storage repository. There are approximately 84 million A-file folders containing various documents. The average folder may contain individual documents from one to ten pages; however, some folders may contain 100 pages or more documents. Figure 4, provides a conceptual workflow that the Contractor shall build and manage. A text description of the workflow is summarized following Figure 4. The Contractor shall provide a refined Concept of Operation representing the operation of this facility, and where new technology is applicable provide any proposed solution to Government for approval of operations to meet the scope of this Call.

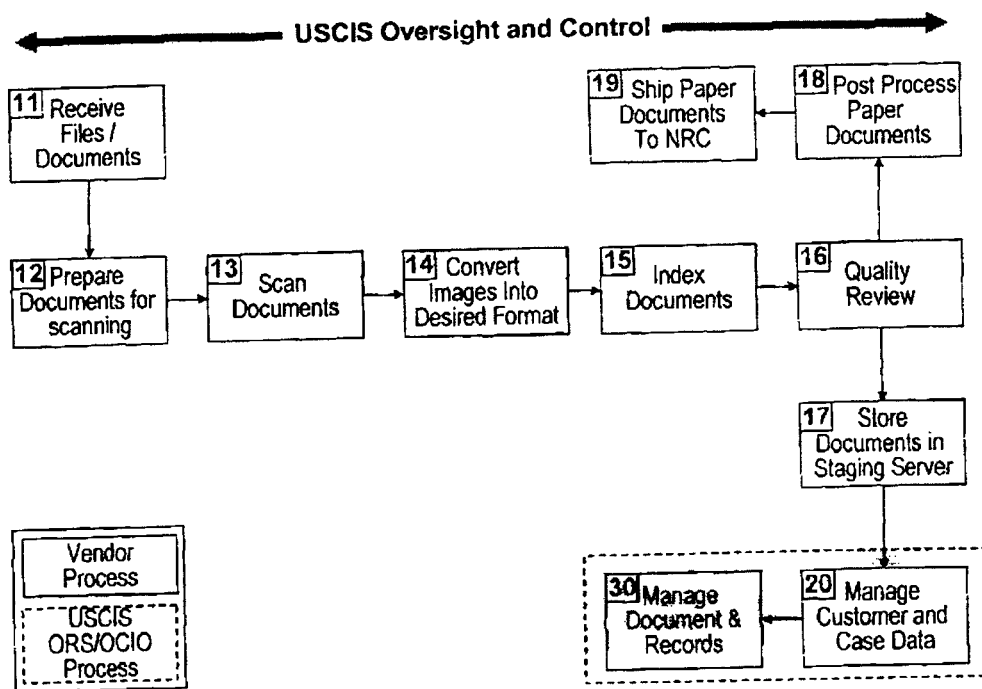

**Figure 4. Contractors Operation/USCIS Oversight and Control Concept**

#### 4.1.2 Shipping and Receiving (11 and 19)

The Contractor shall provide for the shipping, receiving and handling of transported paper and or electronic documents for the digitization processing. This includes the transportation of files, receiving mail and tracking of all documents. The contractor-shipping requirements may require 24 trips per year, with a shipping weight of approximately 40,000 pounds. The Government estimates Call 0001 volume to be two

shipments monthly each shipment comprised of approximately 43,000 A-Files. These files are packaged in boxes with 24 boxes per pallet and 24 pallets per shipment. Shipments in excess of this estimate will be eligible for an equitable adjustment.

##### 4.1.2.1 Pre- and post- processing of paper documents (12 and 18)

The Contractor shall prepare paper documents prior to scanning. The preparation includes, but not limited to:

- Remove clips, tags, and staples
- Arrange documents in sequence for scanning
- Identify missing/damaged pages and anomalies (e.g., foldouts, torn pages, incorrect pagination, etc.)
- If required, stabilize damaged pages through use of a means such as a clear sleeve
- Insert separation sheets to identify individual documents within the A-File.

Upon the successful quality review of the scanned documents, the Contractor shall prepare paper documents to ship the documents to the National Record Center or other Government site as determined by the Government. The post preparation work includes, but not limited to:

- Remove separation sheets used in scanning
- Reassemble A-File in original order

#### **4.1.3 Scanning Documents (13)**

The Contractor shall provide a solution to scan and index A-file records. The Contractor also shall implement the solution for the scanning, indexing, and migrating the data into a temporary storage repository (i.e. staging server). The Contractor will use the existing NARA Standard, "Transferred Requirements for Scanned Images of Textual Records - Image File Format standards and Image Quality Specifications." This standard addresses the following:

- Resolution
- Bit depth (1-, 8-, and 24-bit)
- Enhancements
- Image format

The Contractor shall utilize scanners that are highly reputable in terms of reliability and can meet the required capacity requirements as set within this Call. The Contractor shall maintain a high level of quality control to ensure that each page is fully rendered, properly aligned and ordered, free of distortions, and named to reflect the correct sequence of the original volume. The Contractor shall also record quality review data in format and medium identified by the Government (e.g., printed inspection worksheet, shared online database, etc.) for each volume. The Contractor shall guarantee image quality that meets the Government's specifications, including the correction of unacceptable images with no additional charge to the Government.

#### **4.1.4 Converting Images to Desired Format (14)**

The Contractor shall be required to convert scanned images into PDF format. The PDF format standard should be consistent with the DHS enterprise architecture technical standards and Acrobat Reader 6.0 or higher should be supported. PDF'ed documents will allow the Government to search converted text and images to achieve its expanded capabilities to search and mine expansive customer records, data, and associated supporting material in addition to the searching capability based on the index/metadata.

The Government believes that the PDF format containing converted text and images will be most valuable for its end users who are adjudicators, records technicians, and enforcement agents. The Government targets the future digitized or 3<sup>rd</sup>-party e-file medium in XML supported PDF format. Currently, the DHS XML technical standard is XML 1.1.

#### **4.1.5 Indexing Documents (15)**

The Contractor shall create metadata to structure, locate, and retrieve digital images by coordinating with the Government. The scanned files shall contain but not limited to the basic indexing fields listed below.

- Alien Number
- Last name
- First Name
- Middle Initial
- Date of Birth
- Country of Birth
- Sex
- Date of Entry
- Port of Entry

Additionally, the Contractor shall meet the metadata requirement specified in the DOD 5015.2-STD v2.0 "Design Criteria Standard for Electronic Records Management Software Applications." This standard is a NARA endorsed standards.

To improve the future searching capabilities, the Government plans to create a comprehensive taxonomy that supports the metadata structure. The Contractor shall aid the Government effort to create such metadata and shall incorporate the metadata structure in its system. A future enhancement could include the capturing of metadata from a standard form in an automated fashion.

#### **4.1.6 Quality Control (16)**

The Contractor shall develop a Quality Control Plan (QCP) for the Records Management operations. The QCP is part of the Project Management Plan (PM) submitted by the contractor described in section 4.2.2 *Project Management Plan* (PM) of this Call. The Contractor's Management Team shall maintain QCP over BPA activities in accordance with the PMP. The Contractor shall not implement the QCP until the Authorized Government Representative specified in each Call reviews the QCP and the COTR approves it in writing. The Government will review and approve changes submitted against the QCP.

##### **4.1.6.1 Quality Review**

The Contractor shall perform image quality review during and after scanning. Any applicable industry standards such as ANSI/ISO for Quality Control of Image Scanners should be used. The Contractor shall:

- Follow the method, level, and extent of quality review required by the Government (e.g., 100% review on-screen or of printed version) – the requirements to be determined by the Government
- Maintain a high level of quality control to ensure that each page is fully rendered, properly aligned and ordered, free of distortions, and named to reflect the correct sequence of the original volume
- Record quality review data in format and medium identified by the Government (e.g., printed inspection worksheet, shared online database, etc.) for each volume
- Guarantee image quality that meets the Government's specifications, including the correction of unacceptable images with no additional charge to the Government
- Print paper copies of digital images for quality control, facsimile production, and text conversion
- Follow the Government requirements for evaluation of image quality in printed copies
- Provide prints on demand to the Government.

Additionally, the Contractor shall perform quality review of metadata:

- Follow the method, level, and extent of quality review required by the Government (e.g., 100% accuracy in entering file header information, 100% inspection of the file names vs. inspection based on sampling), and use software and customized scripts to run automated quality check
- Record the quality review data in format and medium identified by the institution (e.g., print inspection worksheet, shared online database, etc.).

#### **4.1.7 Storing, Staging, Maintaining and Web Access Scan Files via Temporary Server Storage (17)**

The Contractor shall maintain a staging server where all digitized images, documents, and/or data (both scanned images and PDF files) including metadata will be stored. This staging server will be a temporary storage that shall be sized to hold at minimum an approximate volume of digitized medium that would be generated for a continuous operation of a four-month period. The architecture and design of the storage solution should be adhered to the DHS Enterprise Architecture Technical Reference Model System Development Life Cycle (SDLC) technical standards. See section 4.4.1 SDLC Documentation

This repository is temporary until the USCIS data repository is operational, at which time all data, will be migrated to the new USCIS repository. Subsequently, the digitized data and files will be loaded into the USCIS data repository on a daily basis as a batch. The Contractor may be required to assist the Government in preparation and execution of Data Migration Plan from temporary data storage to the USCIS OCIO data repository, as necessary.

The Contractor shall meet with the USCIS Project Manager and OCIO office before a temporary storage repository is provided to ensure the repository meets all Government approval standards. The current standards for the document management system is Documentum. The data storage can be accommodated by various storage solutions including RAID, NAS, and SAN. Whichever option the Contractor chooses, the Contractor shall work with the USCIS OCIO to ensure that