

FM 3-09.12 (FM 6-121)
MCRP 3-16.1A

Tactics, Techniques, and Procedures for
FIELD ARTILLERY TARGET ACQUISITION

JUNE 2002

DISTRIBUTION RESTRICTION:

Approved for public release; distribution is unlimited.

HEADQUARTERS,
DEPARTMENT OF THE ARMY

Field Manual
No. 3-09.12 (6-121)

Headquarters
Department of the Army
Washington, DC

Fleet Marine Force Reference
Publication
MCRP 3-16.1A

Headquarters
United States Marine Corps
Washington, DC, 21 June 2002

Tactics, Techniques, and Procedures for FIELD ARTILLERY TARGET ACQUISITION

Contents

	Page
PREFACE	viii
Chapter 1 TARGETING, TARGET ACQUISITION, AND THE MILITARY DECISION MAKING PROCESS	1-1
Definition of Targeting.....	1-1
Targeting Methodology.....	1-1
Targeting Meetings.....	1-5
The Role of Field Artillery Target Acquisition.....	1-9
Relationship of Targeting to MDMP.....	1-9
Target Acquisition Integration into the MDMP.....	1-10
Rehearsals.....	1-12
Radar Considerations for AFATDS Guidances.....	1-12
Chapter 2 FIELD ARTILLERY TARGET ACQUISITION ORGANIZATIONS	2-1
Heavy Division Target Acquisition Battery.....	2-1
Divisional MLRS Battalion Target Acquisition Battery.....	2-2
Separate Brigade Target Acquisition Platoon.....	2-3
Corps Target Acquisition Detachment.....	2-4
Interim Brigade Combat Team Target Acquisition Platoon.....	2-5

Distribution Restriction: Approved for public release, distribution is unlimited.

* This publication supersedes FM 6-121, 25 September 1990.

Interim DIVARTY HIMARS Battalion Target Acquisition Platoon	2-6
STRIKER Platoon	2-7
AN/TPQ-37(V8) Radar Section.....	2-8
AN/TPQ-36(V)8 Radar Section.....	2-8
Duties of Radar Section Personnel.....	2-9
USMC Counterbattery Radar Platoon	2-11
Duties of USMC Counterbattery Radar Platoon Personnel.....	2-13

Chapter 3 DUTIES OF FIELD ARTILLERY TARGETING AND TARGET

ACQUISITION PERSONNEL	3-1
Target Acquisition Battery/Detachment Commander	3-2
Radar Platoon Leader	3-2
Radar Platoon Sergeant	3-3
Field Artillery Battalion Target Acquisition Platoon Sergeant	3-3
Battlefield Coordination Detachment Targeting Officer	3-4
Battlefield Coordination Detachment Targeting NCO	3-4
Corps and Division Field Artillery Intelligence Officer	3-4
Corps and Division Targeting Officer	3-5
Division Counterfire Officer	3-6
Division Assistant Counterfire Officer	3-6
Senior Field Artillery Targeting NCO	3-7
Targeting NCO	3-7
Brigade Targeting Officer	3-8
Field Artillery Brigade Targeting Officer	3-8
General Support Field Artillery Battalion Targeting Officer.....	3-9
Division MLRS Battalion Targeting Officer	3-9
IBCT Targeting Officer	3-10
IBCT Targeting NCO.....	3-10
IBCT Counterfire Officer	3-11
USMC Targeting Information Officer	3-11

Chapter 4 TECHNICAL ASPECTS OF TARGET ACQUISITION RADAR

EMPLOYMENT	4-1
Section I – Detection, Verification, and Location Methodology	4-1
Hostile Mode	4-1
Detection, Verification and Location Process	4-6
Friendly Fire Mode	4-9
Section II – Radar System Characteristics	4-9

	Missions	4-9
	AN/TPQ-36(V)8.....	4-10
	AN/TPQ-37	4-19
	Section III – Technical Aspects of Site Selection, Positioning and Operations	4-27
	Site Selection	4-27
	Positioning	4-30
	Reconnaissance	4-33
	Survivability Considerations.....	4-34
	Location Averaging	4-41
	Automatic Height Correction.....	4-42
	Auto Censoring	4-43
	Firefinder Position Analysis System	4-44
	Safety Considerations.....	4-47
Chapter 5	TACTICAL EMPLOYMENT OF FIELD ARTILLERY TARGET ACQUISITION SYSTEMS	5-1
	Section I – Radar Employment	5-1
	Command and Control.....	5-1
	Command Relationships.....	5-3
	Sectors of Search	5-5
	Zones	5-5
	Zone Management.....	5-9
	Common Sensor Boundary	5-13
	Cueing.....	5-14
	Target Acquisition Radar Role During Offensive Operations	5-16
	Target Acquisition Radar Role During Defensive Operations	5-17
	Radar Tasking Procedures	5-17
	Section II – Counterfire Operations	5-18
	Corps.....	5-18
	Division	5-20
	IBCT Autonomous Operations.....	5-20
	IBCT and Division Integrated Operations	5-22
	Section III – Striker Employment	5-23
	Mission.....	5-23
	Operations	5-24
Chapter 6	STABILITY OPERATIONS AND SUPPORT OPERATIONS	6-1

	Force Projection.....	6-1
	Stability Operations.....	6-1
	Support Operations.....	6-4
	Employment Considerations for Stability Operations and Support Operations..	6-5
Appendix A	AUTOMATED TARGET DATA PROCESSING	A-1
	General	A-1
	Target Indicator Processing.....	A-2
	Suspect Target Processing.....	A-14
	Target Damage Assessment	A-19
	File Maintenance and Target Purging.....	A-19
Appendix B	CRATER ANALYSIS AND REPORTING	B-1
	Gun and Howitzer Shell Crater Analysis.....	B-1
	Survey or Crater Location.....	B-2
	Determination of Direction	B-2
	Crater Analysis.....	B-2
	Low-angle Fuze Quick Craters (Artillery).....	B-3
	Low-angle Fuze Delay Craters (Artillery).....	B-5
	High-angle Shell Craters (Mortars).....	B-6
	Rocket Craters	B-9
	Shell Fragment Analysis	B-9
	Shelling Reports.....	B-13
	Artillery Counterfire Information Form.....	B-13
	Equipment.....	B-14
Appendix C	FIREFINDER FRIENDLY FIRE MODE	C-1
	Firefinder Missions.....	C-1
	Friendly Fire Mode	C-1
	High-burst Registration	C-3
	Impact-predict Registration (Mean Point of Impact)	C-4
	Datum-plane Registration (Mean Point of Impact)	C-4
	Friendly Fire Log	C-4
Appendix D	FIREFINDER FIELD EXERCISE MODE/EMBEDDED TRAINING	D-1
	Uses	D-1
	Section and/or Platoon Training	D-1
	Gunnery Team Training.....	D-1
	Scenario Development.....	D-2

	Implementing the Scenario	D-4
Appendix E	THE AN/TPQ-47 RADAR	E-1
	Section I – Technical Aspects	E-1
	AN/TPQ-47 Equipped Target Acquisition Organizations	E-1
	AN/TPQ-47 Radar Section	E-6
	System Characteristics	E-6
	System Components.....	E-7
	System Capabilities	E-11
	Site Selection	E-15
	Positioning	E-16
	Safety	E-17
	Section II – Operational Aspects	E-19
	Theater Missile Defense Operations	E-19
	Corps Counterfire.....	E-28
	Division Counterfire.....	E-29
Appendix F	FIREFINDER MASK CONSIDERATIONS	F-1
	Definitions	F-1
	Track Volume	F-2
	Track Volume Calculations and Subsequent Actions	F-2
Appendix G	TARGET ACQUISITION TAB TO THE FIELD ARTILLERY	
	SUPPORT PLAN	G-1
	Section I – Target Acquisition TAB	G-1
	Description	G-1
	Preparation	G-1
	Target Acquisition TAB Heading.....	G-1
	Major Paragraphs	G-2
	Enclosures	G-4
	Sample Target Acquisition TAB	G-5
	Section II. Radar Deployment Order	G-12
	Description	G-12
	Responsibilities	G-12
	DA Form 5957-R.....	G-12
	Automated Radar Deployment Order Procedure	G-15
Appendix H	FIELD ARTILLERY RADAR SUPPORT REQUIREMENTS	H-1
	Survey	H-1
	Communications	H-2

	Administration	H-4
	Mess.....	H-4
	Maintenance	H-5
	Security	H-6
	Petroleum, Oils, and Lubricants.....	H-6
	Meteorological Data.....	H-6
Appendix I	AIR MOVEMENT PROCEDURES FOR TARGET ACQUISITION RADARS.....	I-1
	Section I – Helicopter Movement	I-1
	Considerations for Helicopter Movement.....	I-1
	Q-36 Sling Load Procedures	I-5
	Q-37 Sling Load Procedures	I-13
	Section II – Fixed Wing Aircraft Movement.....	I-18
	Considerations for Fixed Wing Aircraft Movement	I-18
	Q-36 Load Procedures for C-130 Aircraft.....	I-27
	Q-37 Load Procedures for C-130 Aircraft.....	I-29
Appendix J	REHEARSALS	J-1
	Rehearsal Types.....	J-1
	Rehearsal Techniques	J-2
	Scripting and Conducting the Rehearsal	J-6
	Brigade Fire Support Rehearsal	J-9
	Brigade Combined Arms Rehearsal	J-12
Appendix K	EXAMPLE TOOLS AND PROCEDURES.....	K-1
	Firefinder Radar Section Troop Leading Procedures	K-1
	Radar Section Warning Order	K-2
	Radar Deployment Order.....	K-5
	Radar Execution Matrix.....	K-6
	Quick Reference Position Selection Worksheet	K-8
	Radar Positioning and Movement Synchronization Checklist	K-9
	Voice Radar Registration Procedure	K-10
	Voice Radar Adjust Fire Mission.....	K-10
	Joint Airlift Inspection Checklist	K-12
	Risk Management Worksheet.....	K-15
Appendix L	RISK MANAGEMENT	L-1
	Section I – Risk Management Procedures	L-1
	Identify Hazards	L-1

Assess Hazards to Determine Risks	L-2
Develop Controls and Make Risk Decisions.....	L-3
Implement Controls.....	L-4
Supervise and Evaluate.....	L-4
Section II – Implementation Responsibilities	L-5
Breakdown of Risk Management Process.....	L-5
Risk Management Command Climate	L-5
Glossary	Glossary-1
Bibliography	Bibliography-1
Index	Index-1

Preface

This publication contains the doctrine, organization, tactics, techniques, and procedures required to manage field artillery target acquisition (TA) organizations, systems, personnel and equipment. It updates information formerly contained in FM 6-121 and incorporates emerging doctrine and information about targeting, the military decision making process (MDMP), new equipment, and Advanced Field Artillery Tactical Data System (AFATDS) considerations as they apply to the functions performed by the targeting officer and the radar section leader.

The material contained in this manual applies to all personnel involved in the targeting and target acquisition process. These personnel include:

- Maneuver commanders and their staffs.
- Field artillery commanders and their staffs.
- Fire support element (FSE personnel).
- Members of division artillery and FA brigade tactical operations centers.
- Personnel assigned to target acquisition batteries, target acquisition detachments, and radar platoons.
- Other personnel involved in the targeting or intelligence processes.

This manual describes current and emerging TA organizations. These organizations include target acquisition batteries and radar platoons of active and reserve components, the corps target acquisition detachment (CTAD), radar platoons of the interim brigade combat team (IBCT) and interim division artillery (IDIVARTY), and the STRIKER platoon. Technical and tactical considerations for employing weapons locating radars are discussed in detail. This includes the AN/TPQ-47 that is currently being developed. New information contained in this manual includes duties and responsibilities for key TA personnel, rehearsals, stability operations and support operations, rotary and fixed wing radar movement procedures, and automated target data processing. The methodology used by weapons locating radars to acquire, track and locate threat weapon systems is also discussed.

Users at different echelons will focus on different chapters and appendices based on their specific mission requirements and operational focus. Chapter 1 discusses targeting, MDMP, and rehearsals from a target acquisition viewpoint. Chapters 2 and 3 provide information about TA organizations and TA personnel duties and responsibilities. Chapter 4 is focused on the technical aspects of employing weapons locating radars and the associated requirements. Chapter 5 discusses tactical employment and management of radar systems. This chapter provides information required for commanders and their staff to effectively employ radars in support of military operations. Finally, Chapter 6 discusses stability operations and support operations and associated radar employment considerations. The information in the supporting appendices provides the additional technical

Chapter 1

Targeting, Target Acquisition, and the Military Decision Making Process

This chapter provides an overview of targeting fundamentals, field artillery target acquisition processes, and target acquisition integration into the military decision making process (MDMP). Target acquisition, by nature, is an integral part of the targeting process and requires the interaction among many groups within a given organization. Field artillery target acquisition plays a key role in the targeting process. Without accurate targeting data, indirect fire systems are of limited value. Targeting is a command responsibility that requires the participation of key members of maneuver and field artillery coordinating and special staffs. It is a critical component of the MDMP that focuses battlefield operating systems to achieve the commander's intent. As such, the targeting process focuses on mission requirements. The mission, commander's intent and guidance drive the targeting process. These inputs allow unit personnel to determine the targets to be engaged, how to locate and track the targets, when and how to engage the targets, along with determining if, when, and how target assessment will be accomplished. The methodology used to drive the targeting process is *Decide, Detect, Deliver and Assess (D3A)*. This chapter discusses D3A, the role of field artillery target acquisition (TA) and how TA fits into the MDMP process.

DEFINITION OF TARGETING

Targeting is the part of the military decision making process used to focus battlefield operating systems (BOSs) to achieve the commanders intent. The methodology used to translate the commander's intent into a plan is decide, detect, deliver, and assess. The functions associated with this methodology help the commander decide what to attack, how to acquire those targets, and when those targets are acquired, how to attack them in a way that disrupts, delays or limits the enemy's ability to achieve his objectives. Simply stated, *targeting is the process of selecting targets and matching the appropriate response to them, taking account of operational requirements and capabilities.*

TARGETING METHODOLOGY

Targeting is a combination of intelligence functions, planning, battle command, weaponeering, operational execution and combat assessment (CA). The D3A methodology facilitates the attack of the right target at the right time with the most appropriate asset. Integral to this process is target

tracking. Tracking is essential to the detect and deliver functions. Tracking also impacts the ability to assess a target and implement subsequent reattack decisions. Targeting is a continuous process that maintains pace with the dynamics of an ever-changing battlefield situation. In addition to the enemy situation, the inputs that drive this process come from higher headquarters' plans and orders. Specifically, they are the mission, intent, and specified/implied tasks.

DECIDE

The first and most important step in the targeting process is the decide function. Deciding the targets to be attacked provides the overall focus and sets priorities for intelligence collection and attack planning. Targeting priorities must be set for each phase or critical event of an operation. Successful targeting is directly related to the commander's battle plan. Therefore, the targeting team must understand the unit's mission. This understanding starts with mission analysis. Once the commander and staff complete the mission analysis, the commander issues the restated mission. The restated mission is the starting point for the targeting process.

Key to the decide function is the intelligence preparation of the battlefield (IPB). During this process, situational templates and event templates are developed and used to ascertain suspected enemy locations and movements for targeting purposes. IPB identifies the enemy courses of action (COA) and subsequent high value targets (HVT) are identified from a target value analysis (TVA). HVTs are those targets or assets believed to be essential for the enemy commander to accomplish his mission. As the MDMP continues friendly COAs are developed and wargamed. As a result of wargaming, HVTs whose loss to the enemy will contribute to the success of the friendly plan are identified. These targets are high payoff targets (HPT). Effective engagement of HPTs is essential to the successful execution of the friendly COAs. The inability to acquire or achieve the specified effects against a HPT always requires a reassessment of the friendly COA to make adjustments based on a changed enemy situation.

Several products are developed during the decide phase of targeting. These products are:

- High-payoff target list (HPTL) – a prioritized list of HPTs.
- Intelligence collection plan (ICP) – answers the commander's priority intelligence requirements (PIR) and intelligence requirements (IR). This includes HPT designated as PIR.
- Target selection standards (TSS) – designated target location accuracy, target posture and time requirements that must be met before attacking a target. Targets not meeting TSS requirements are considered target indicators and aren't attacked.
- Attack guidance matrix (AGM) – document addressing which targets will be attacked, how when and the desired effects. The commander approves this product.

In addition, other products are developed or refined during the decide phase. They include, but are not limited to:

- Decision support template (DST).
- Targeting synchronization matrix (TSM).
- Combat assessment (CA) requirements.
- Target nominations – air interdiction (AI), Army Tactical Missile System (ATACMS), electronic warfare (EW) etc.

As a result of the decide function, the targeting team will determine which targets will be acquired and attacked to meet the commander's intent; when and where (time and space) they may be found and by whom; how the targets will be acquired and attacked; assessment requirements; and the synchronization of sensors and attack systems with the scheme of maneuver. This results in the tasking of TA assets. The targeting synchronization matrix identifies targets designated for acquisition by field artillery TA assets.

DETECT

Detect is the next critical function in the targeting process. The detect function translates target priorities developed during the decide function into the ICP and TA tasking contained in the operations order (OPORD). The G2 or S2 is the primary staff section directing the effort to locate and identify HPTs. The collection manager oversees this effort and directs the tasking of acquisition assets against appropriate targets. Since there aren't enough assets to detect all targets, prioritization is essential. Therefore, radar schedules and zones are established to support the detection effort with focus on PIR and HPTs. It is essential that all acquisition assets be used effectively and efficiently. Duplication of effort must be avoided unless it is required to confirm a target. At the division, the analysis and control element (ACE) manages the collection plan to avoid duplication. The analysis and control team (ACT) manages the collection plan at the brigade.

HPTs must be detected in sufficient time to synchronize their attack with the commander's battle plan. Precise taskings must be given to acquisition systems designated to detect a specific target. Mobile targets must be detected and tracked until they are attacked. Further, tracking of mobile targets must be planned in sufficient detail to allow the handoff of a target from one collection asset to another when required. Tracking priorities are based on the commander's concept of the operation and targeting priorities.

Once detected, targets are passed to the fire support element (FSE) for engagement. The FSE passes the target to the appropriate command or asset for execution. HPTs may be passed directly from a sensor to a firing unit when authorized by the maneuver commander. This is accomplished by establishing a sensor-to-shooter link. This is a useful technique for engaging critical targets with a short dwell or target decay time.

Targets and suspected targets may be passed to the targeting team by a number of means. It is essential that the proper information be passed to facilitate analysis and attack. As a minimum, target reports should include:

- Reporting agency.
- Date-time group (DTG) of the sensor acquiring the target.
- Description of the activity.
- Size and orientation of the target.
- Target location and altitude.
- Target location error (TLE).
- Dwell time.
- Target posture (stationary or rate and direction of movement).

The information from the target report is compared with the TSS. If the TSS requirements are met, the target is attacked.

DELIVER

The deliver function of the targeting process executes the target attack guidance supporting the commander's battle plan. The attack of targets must satisfy the attack guidance developed during the decide function.

Successful target attack implements tactical and technical delivery decisions and supporting actions. The attack of a target starts with the review of the attack guidance. Initially, the target to be attacked is validated. Validation includes reviewing the acquisition system and its associated accuracy, time of acquisition, and target posture. The validated target is passed to a designated delivery unit/system for attack. Depending upon the delivery system, other factors warrant consideration. These include weather, Class III and V availability, planning time, SEAD capability, risk, coordination requirements, fire support coordinating measures (FSCM), and notification of unit/system conducting battle damage assessment (BDA).

ASSESS

Physically assessing effects resulting from the application of military force is a necessary task. Assessment is conducted either by direct observation or estimating damage based on the munitions delivered, target characteristics and target location error (TLE). Damage assessments provide the commander with information that expresses target damage on the basis of overall mission accomplishment. CA is used to determine the success of force employment during military operations. The requirements for CA are identified during course of action development and wargamed to ensure they can be executed. CA consists of three elements:

- BDA.
- Munitions effects assessment (MEA).
- Re-attack recommendation.

BDA is the timely and accurate estimate of damage resulting from the application of military force, either lethal or non-lethal, against a target. BDA is further analyzed to provide an objective assessment of effects against the enemy in relation to the friendly COA. The commander uses CA, to obtain a snapshot of his effects on the enemy. It provides an estimate of the

enemy's remaining combat capabilities and intentions after attack. This helps the commander determine if the targeting effort is accomplishing his objectives. As part of the CA process, BDA helps determine if target re-strike is necessary. BDA requirements are identified during the decide phase and are included in the intelligence collection plan. BDA has three components:

- Physical damage assessment.
- Functional damage assessment.
- Target system assessment.

Physical damage assessment estimates the quantitative effects of physical damage from blast, fire or fragmentation expressed as a percentage of the target damaged. Often, a unit's focus for BDA stops here. Information from physical damage assessment is sometimes displayed using a kill-board or other type of scorecard. BDA should include all three of its components to provide the commander with useful information.

Functional damage assessment estimates the effect of attack on a target's ability to perform its intended mission, when compared to operational objectives established against the target. This assessment uses multiple intelligence sources to determine the amount of time required for the enemy to replace capabilities lost during the attack.

Target system assessment is an overall assessment of targeting effectiveness against an entire target system such as enemy fire support. The same assessment can be applied to a specific unit. Unlike the functional damage assessment, target system assessment is a relatively permanent assessment.

MEA is conducted concurrently with BDA. MEA is used to determine if adjustments are needed to attack recommendations. MEA may result in a modification of the weapon system, attack methodology, munitions and/or delivery parameters used to attack a target.

The re-attack decision is the final step in CA. Based on BDA and MEA, the targeting team considers the level to which operational objectives have been achieved through the targeting process. Recommendations for re-attack are presented to the commander based on this analysis.

Results from the assess function often require changes to plans and decisions. This may result in the update of several products from the decide phase. These include:

- IPB products.
- HPTL.
- TSS.
- AGM.
- Intelligence collection plan (ICP).
- Operations plans and orders.

TARGETING MEETINGS

The targeting meeting is a critical event in a unit's battle rhythm, the timing of which serves to nest the unit's battle rhythm into the higher headquarters'

targeting process. It should be the minimum length required to present targeting information, situation updates, provide recommendations and obtain decisions. The purpose of targeting meetings is the same regardless of the level at which they are conducted. The major differences are the time focus, the number of targeting team members, and the available assets. The basic procedures for conducting targeting meetings are the same. This discussion focuses on the maneuver brigade since it has the widest applicability to FA target acquisition personnel.

The targeting meeting brings the targeting team together to synchronize the targeting process and obtain approval for and/or changes to the targeting products. It focuses and synchronizes the unit's combat power and resources toward finding, tracking, attacking and assessing HPTs. Purposes of a targeting meeting include:

- Verifying and updating the HPTL.
- Verifying, updating and re-tasking available collection assets for each HPT.
- Allocating delivery systems to engage each target.
- Confirming the assets tasked to assess the target once attacked.
- Identifying target nominations for attack by division or joint assets.
- Synchronizing lethal and non-lethal assets to include information operations (IO).

The timing of the targeting meeting is crucial. It must be effectively integrated into the unit's battle rhythm and nested into the higher headquarters' targeting cycle to ensure that the results of the targeting process can be implemented. Thus task organization changes, modifications to the reconnaissance, surveillance and security (RS&S) plan, air tasking order (ATO) nominations, changes to the HPTL and essential fire support tasks (EFST) all must be made with the awareness of the time available to prepare and execute.

Preparation and focus are keys to successful targeting meetings. Each representative must come to the meeting prepared to discuss available assets, capabilities, limitations and assessment requirements related to their staff area. This means participants must conduct detailed prior coordination and be prepared to bring inputs and/or information with them. This preparation must be focused around the commander's intent and a solid understanding of the current situation. At the maneuver brigade, the following are typical inputs by targeting team members:

- S2:
 - Current enemy situation.
 - BDA for targets engaged since last meeting.
 - Current RS&S plan.
 - Planned enemy courses of action (situation template).
 - Collection assets available and those that must be requested from higher.

- S3:
 - Current friendly situation.
 - Maneuver assets available.
 - Current combat power.
 - Requirements from higher headquarters.
 - Changes to commander's intent.
 - Changes to task organization.
 - Planned operations.
- FSO:
 - HPTL, TSS, AGM or a consolidated matrix.
 - Changes to the EFST.
 - Fire support assets available.
 - Proposed HPTL, TSS, AGM, EFST for time period discussed.
 - Recommended changes to FSCM for period being discussed.
- Targeting Officer:
 - HPTs that have been attacked and associated BDA.
 - Radar status.
 - Active radar zones.
 - Counterfire acquisitions.
- Other Staff Products: The specific situation dictates the extent of the remaining targeting team members' participation. They must be prepared to discuss in detail their own BOS assets and capabilities, the integration of their assets into targeting decisions, and the capabilities and limitations of enemy assets within their BOS.

The XO is responsible for keeping the meeting focused. He describes the agenda and specifies the time period to be addressed. He is the arbitrator of any disagreements that may arise and ensures the meeting stays on track with the stated purpose and agenda. Table 1-1 shows an agenda with the information covered by core targeting team members.

Table 1-1. Targeting Meeting Agenda

AGENDA	
<u>WHO</u>	<u>WHAT</u>
S2 Representative	<ul style="list-style-type: none"> - Weather - Enemy situation and decision points (event template) - BDA for targets engaged since last meeting - Analysis of enemy most likely and dangerous COAs for next 24-36 hrs - Recommended changes to PIR - Briefs RS&S plan

AGENDA	
<u>WHO</u>	<u>WHAT</u>
S3 Representative	<ul style="list-style-type: none"> - New requirements from higher HQ - Summarizes current situation - Provides status of combat power - CDRs guidance and intent - Planned OPS during the focus period
FSCOORD or FSO (ALO)	<ul style="list-style-type: none"> - Briefs current TGT products: HPTL, AGM, TSS, EFST etc. - Status of fire support (FS) assets - Approved preplanned air requests and TGTs planned for next 2 ATO cycles - Proposed HPTL with TGT locations for concurrence and approval - Recommend, in conjunction with (ICW) the ALO, changes to working preplanned air requests
Targeting Officer	<ul style="list-style-type: none"> - Briefs HPTs that have been attacked and associated BDA - Provided radar status and active radar zones - Briefs counterfire situation
EW Officer	<ul style="list-style-type: none"> - Brigade EW plan
Brigade XO	<ul style="list-style-type: none"> - Approve/modify proposed CCIR, force protection priorities, RS&S plan, HPTs, CAS/AI nominations

Once everyone understands the enemy's most likely COA for the next 24-36 hours, the state of current operations in relation to the plan, and the targets recommended as HPT, the XO leads the team through the D3A process for that time period. This includes:

- Deciding and prioritizing which collection asset will detect and trigger the target attack.
- Determining where the target will be found.
- Determining which system will attack the target and the effects to be achieved.
- Deciding when and where the target will be attacked.
- Determining assessment requirements to include the system to assess effects and when the assessment must be provided.
- Determining re-attack criteria.

Once all targeting decisions are made and the commander's approval is obtained, new fragmentary orders (FRAGO) and taskings are prepared and disseminated.

THE ROLE OF FIELD ARTILLERY TARGET ACQUISITION

Field Artillery (FA) target acquisition plays a key role in the targeting process. Without accurate targeting data, indirect fire systems are of limited value.

Weapons locating radars (WLR) are one of the primary means of locating enemy indirect fire systems. Tasks for WLRs are integrated into the ICP developed during the decide phase of the targeting process. These tasks often support EFSTs. Radar taskings are identified in the TA Tab of the field artillery support plan (FASP) in the radar execution matrix. When appropriate, tasks are noted on the DST for special actions at specific points in the battle. Specific functions of WLRs include:

- Locating enemy indirect systems and generating artillery target intelligence.
- Locating enemy indirect fire systems and generating fire missions.
- Registering and adjusting friendly artillery and mortars.
- Validating the location of friendly fires.
- Providing target intelligence and information to allow friendly forces to take force protection measures while generating fire missions to attack enemy indirect fire systems.

RELATIONSHIP OF TARGETING TO MDMP

Targeting is a commander-driven process and starts with the receipt of the mission. As the targeting process develops, each targeting function occurs simultaneously and sequentially.

Initially, the decide function coincides with the MDMP from the mission analysis through the issuing of the approved plan or order. The detect function starts with the commander's approval of the plan or order and is accomplished during execution of the plan or order. Once detected, targets are attacked and assessed as required. After an operation commences, the targeting process becomes cyclic with all the functions happening simultaneously. Targeting meetings are used as a vehicle to focus the targeting process within specified time periods. Figure 1-1 shows the relationship between the D3A methodology and the MDMP along with products generated during the targeting process.

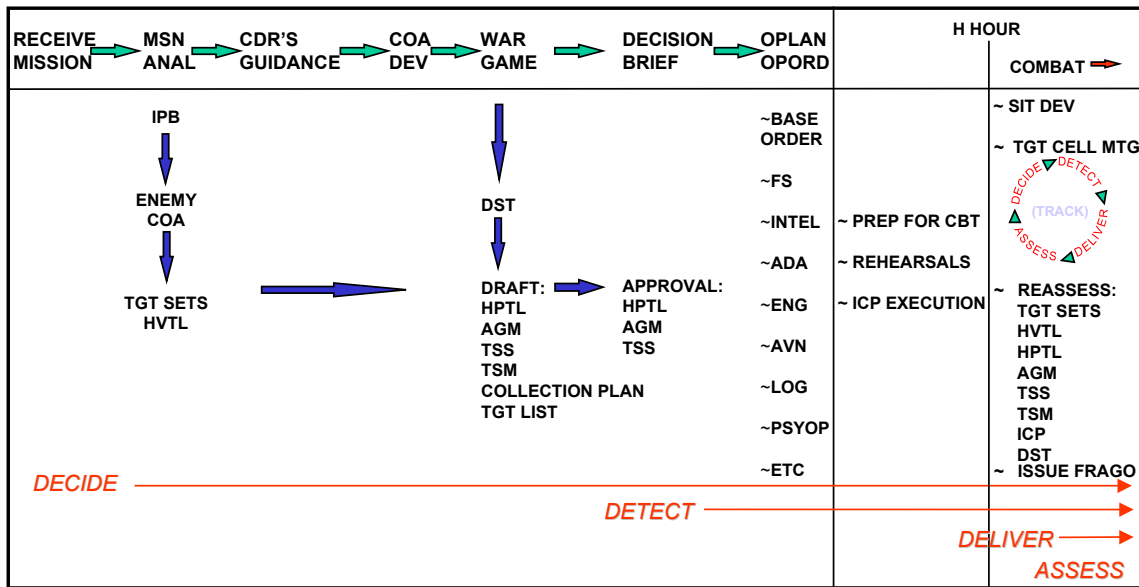

Figure 1-1. Relationship of Targeting to the MDMP

TARGET ACQUISITION INTEGRATION INTO THE MDMP

The target acquisition planning process must be integrated into the fires planning process and the MDMP if TA assets are to be effectively employed. TA planning starts when the mission is received and continues throughout the entire D3A process. The targeting officer must be focused on the requirements for TA systems throughout this process.

RECEIVE THE MISSION/MISSION ANALYSIS

The targeting officer starts his mission analysis as soon as the initial warning order is received. The targeting officer gathers all the information pertinent to TA assets for incorporation into the fire support estimate. This happens concurrently with the mission analysis. TA information contained in the fire support estimate includes a detailed status of all radars, strikers, reconnaissance and surveillance assets. Pertinent information about radars should include:

- Status of all assigned and attached radars.
- Current radar locations.
- Anticipated support requirements including:
 - Position areas.
 - Personnel.
 - Survey.
 - MET.
 - Communications.
 - Maintenance.

- Security.
- Classes of supply.

This information is updated throughout the fires planning and MDMP process.

During mission analysis the targeting officer reviews the order based on the commander's intent, concept of operation, areas of operations and interest, tasks, limitations, constraints, and anticipated enemy actions that may require special consideration. This identifies the amount of available time and the specified, implied and essential tasks. Time considerations are important because time dictates when STRIKERS and radar need to deploy to support the mission. The essential tasks become the foundation for EFST and essential field artillery tasks (EFAT) that will ultimately specify how TA assets will be employed.

COURSE OF ACTION DEVELOPMENT

The targeting officer participates in COA development at the maneuver unit TOC with the FSO and the FSCoord. This ensures that FS planning, and ultimately TA planning, is fully integrated into the maneuver MDMP. As a result of the COA development process, EFST and EFAT are developed to support each COA developed. These determine the requirements for radar coverage, zones, triggers, radar position areas, movement requirements, cueing agents and risks to the radars. This information is incorporated into the COA sketch and statement, and the RS&S plan. The COA analysis culminates with a COA brief to the commander. The commander issues his guidance and adjustments are made to each COA.

COURSE OF ACTION ANALYSIS (WARGAMING)

During wargaming, each COA is analyzed independently to determine if they are executable. Every individual EFST and EFAT is analyzed and decision points determined. Wargaming often results in adjustments to the COA and changes to TA requirements. During the wargame, every task assigned to a TA asset is analyzed for feasibility. TA tasks and actions are modified, if required, and recorded on the appropriate DST or synchronization matrix.

COURSE OF ACTION COMPARISON AND APPROVAL

After completion of COA analysis, each COA is compared against a predetermined set of criteria designed to identify which COA best accomplishes the mission. The COA that best accomplishes the mission becomes the basis for recommending a COA to the commander during the COA decision brief. Once the commander makes his decision and issues his guidance, the staff makes any adjustments to the COA that might be required. The targeting officer then makes any required adjustments to TA coverage and employment requirements. A final warning order is sent to subordinates and the information (TA plan) from the MDMP process is used in the development in the operations order or plan. The TA plan developed during the MDMP becomes part of the fire support annex and TA Tab. The

positioning and activities of strikers become part of the finalized RS&S and observation plans. The publishing of plans and orders completes the initial MDMP. TA planning and coverage is continually updated and refined throughout the operation as part of the D3A process.

REHEARSALS

TA personnel must have an understanding of the different types of rehearsals, rehearsal techniques, and the role that they play during rehearsals. The radar section leader and targeting officer regularly participate in combined arms rehearsals and support rehearsals. The specific rehearsals are the combined arms rehearsal, fire support rehearsal, and FA unit and technical rehearsals. The fire support rehearsal should always be conducted prior to the combined arms rehearsal. Further, the FA and FA technical rehearsals should be conducted prior to the fire support rehearsal if possible. A detailed discussion of rehearsals is at Appendix J.

RADAR CONSIDERATIONS FOR AFATDS GUIDANCES

Guidances contain information used in the decision making processes of AFATDS. These guidances affect the manner in which AFATDS processes information received from radar and other observers. They can be used to supply information, impose restrictions, filter and select data, and make decisions concerning data and assets. The targeting officer and the radar section leader must understand how guidances affect targeting decisions, fire mission processing and radar acquisition processing.

When a call for fire (CFF) is sent from Firefinder to AFATDS, it is processed using AFATDS guidances at the receiving AFATDS. If the CFF fails AFATDS guidances, the mission is denied. In AFATDS, the target contained in the failed CFF would be entered into the suspect target list for comparison with other targets already on file. If no solution or combination occurs, the target will remain on file and be compared with incoming suspect targets until the target decay time is reached.

When an Artillery Target Intelligence (ATI) report is sent to AFATDS from a Firefinder it may become a CFF. Based on guidances, an ATI target may generate a fire mission by combining with a target already in the suspect target list. If the target type meets the criteria for combination and the target type is in the High Payoff Target (HPT) list, it will generate a CFF. Even without combination, if the target sent by Firefinder is in the HPT list and meets the accuracy and reliability guidances, it may become a fire mission.

Guidances are used to determine if raw target data can be used to develop a fire mission. They determine fire mission precedence and mission value. Some guidances are merely record keeping tools. Others allow the information to be placed into a written plan (e.g., an OPORD, or FS Annex). Some guidances are used to determine how or when to shoot a target and the associated munitions, effects, and fire support systems. Commanders specify guidances to insure the successful engagement of targets. During fire mission

Chapter 2

Field Artillery Target Acquisition Organizations

This chapter discusses target acquisition organizations and the duties and responsibilities of radar section personnel and USMC counterbattery radar platoon personnel. The duties of other TA personnel are discussed in Chapter 3.

HEAVY DIVISION TARGET ACQUISITION BATTERY

The heavy division target acquisition battery (TAB) is responsible for locating enemy indirect fire weapons and registering and adjusting friendly artillery in the division's battlespace with sufficient accuracy and timeliness for attack by friendly units. The TAB locates indirect fire targets with its organic Q-36 and Q-37 radars. An assistant counterfire officer (WO/131A) and a target processing section are provided to the DIVARTY or FA brigade TOC to support counterfire operations. The addition of the TAB processing section to the counterfire headquarters provides viable 24-hour counterfire operations capability. The target processing section of the DIVARTY or FA brigade TOC normally controls the Q-37 radars. Q-36 radars are normally attached to DS FA battalions and controlled by the DS FA battalion S2. The TAB survey platoon provides location and directional control to TAB elements and aids the DIVARTY or FA brigade survey section as required. Table 2-1 shows the composition of the target processing section and Figure 2-1 shows the organizational structure of the heavy division TAB.

Table 2-1. Heavy Division TAB Target Processing Section

Target Processing Section			
TITLE	MOS	RANK	NUMBER
Asst Counterfire Officer	131A0	CW2	1
Senior FA Targeting NCO	13R	SFC	1
Targeting NCO	13F	SSG	1
Targeting Processing SP	13F	SGT	1
Targeting Processing SP	13F	SPC	1
Targeting Processing SP	13F	PFC	1
TOTAL			6

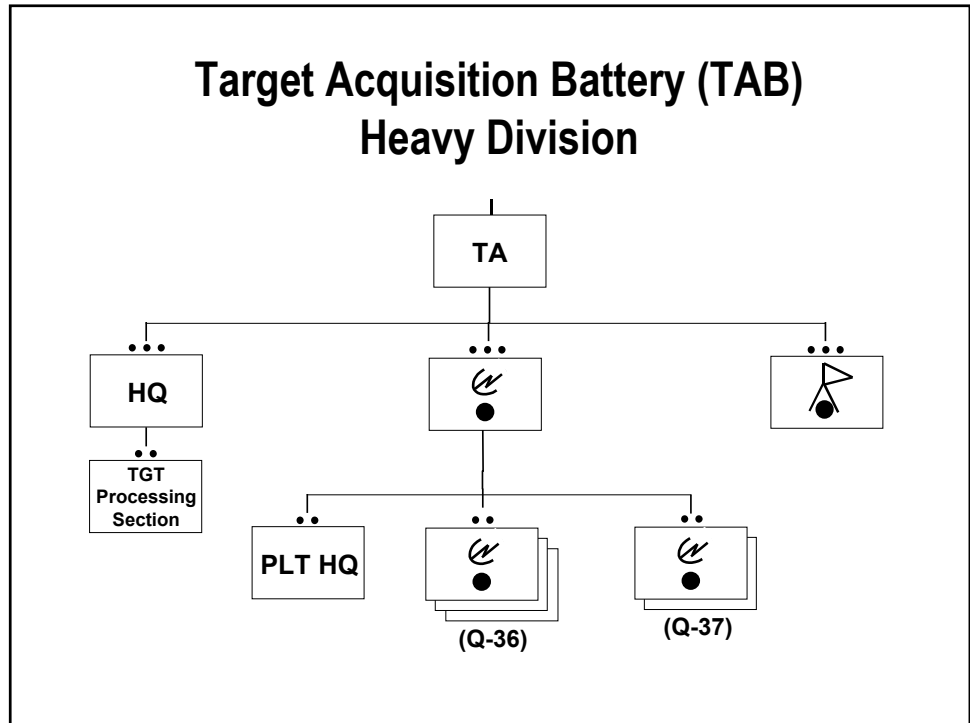

Figure 2-1. Heavy Division Target Acquisition Battery

DIVISIONAL MLRS TARGET ACQUISITION BATTERY

The Divisional MLRS battalion TAB is organic to the heavy division MLRS battalion. The divisional MLRS battalion is organized with a headquarters, headquarters and service battery (HHS), three six-launcher MLRS firing batteries and a TAB. The functions of the divisional MLRS battalion TAB are the same as for the heavy division TAB. The differences are the organizational structure and the parent headquarters. Unlike the heavy division TAB, this organization does not have a separate survey platoon. It only has a single survey section that is part of target acquisition platoon (TAP) headquarters. Further, the target processing section only has five personnel (see Table 2-2). Figure 2-2 shows the organizational structure.

Table 2-2. Division MLRS Battalion TAB Processing Section

Target Processing Section			
TITLE	MOS	RANK	NUMBER
Asst Counterfire Officer	131A0	CW2	1
Senior FA Targeting NCO	13R	SFC	1
Targeting NCO	13F	SSG	1
Targeting Processing SP	13F	SPC	1
Targeting Processing SP	13F	PFC	1
TOTAL			5

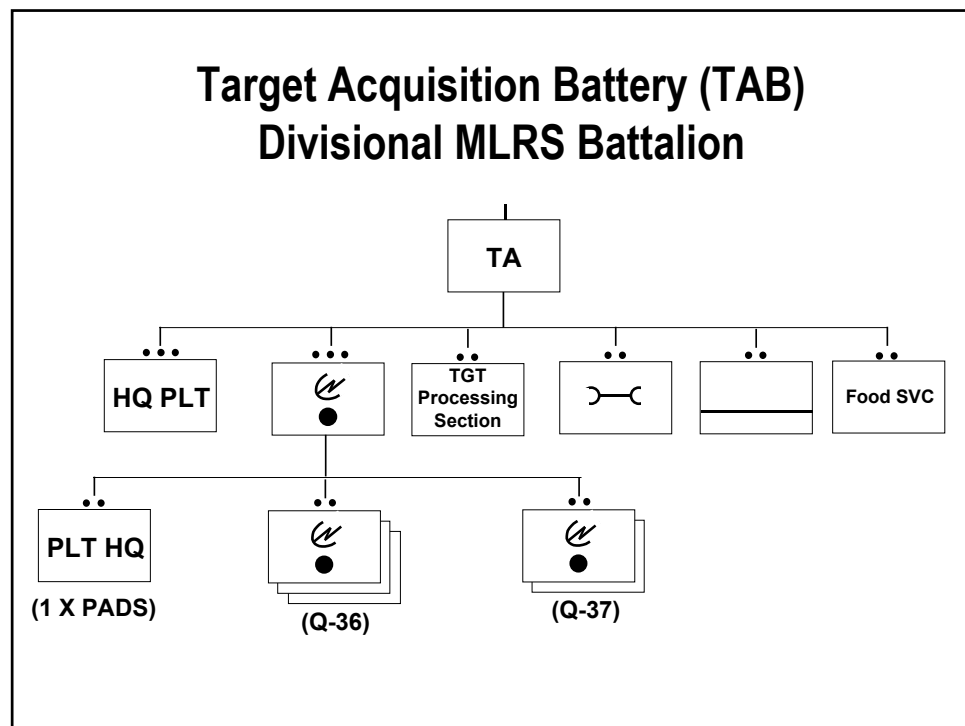

Figure 2-2. Divisional MLRS Battalion Target Acquisition Battery

SEPARATE BRIGADE TARGET ACQUISITION PLATOON

The TAP of the separate brigade provides the brigade with acquisition of threat mortar, artillery, and rocket systems to provide target intelligence and information to allow friendly forces to take force protection measures and enable counterfire mission processing. The TAP also adjusts friendly fire and registers mortars and artillery with its organic Q-36 radar. The TAP is found in the HHS of the direct support field artillery battalion in the separate infantry brigades of the National Guard. These brigades are often referred to as enhanced brigades (EB). This organization consists of a platoon headquarters, Q-36 radar section, meteorological section and a survey section. This organization is capable of supporting all of the separate brigade's target acquisition requirements. The TAP may be augmented with additional assets based on the tactical situation.

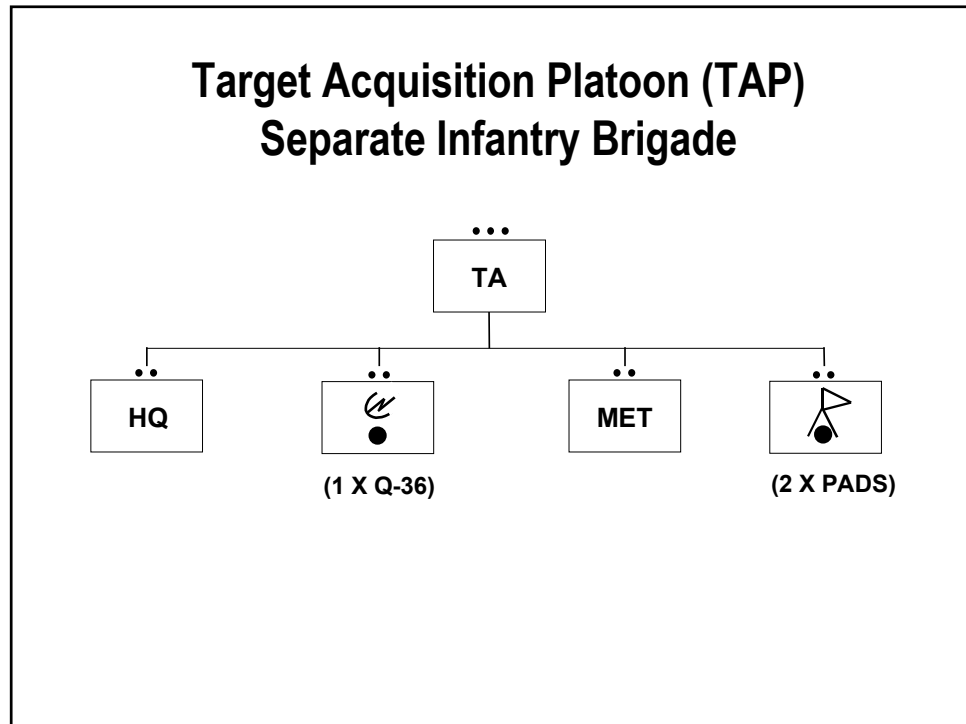

Figure 2-3. Separate Infantry Brigade Target Acquisition Platoon

CORPS TARGET ACQUISITION DETACHMENT

The Corps Target Acquisition Detachment (CTAD) is assigned to corps on the basis of one per light division. It is designed for attachment to light infantry, airborne, and air assault division artilleries or their reinforcing heavy field artillery brigade upon deployment. The CTAD acquires threat artillery, rocket, and missile systems to provide target intelligence and information to allow friendly forces to take force protection measures and enable counterfire mission processing. The CTAD consists of a headquarters section, a PADS team, and two Q-37 radar sections. The detachment headquarters is provided to each light, airborne, air assault division artillery TOC, or their designated counterfire headquarters to help process counterfire targets.

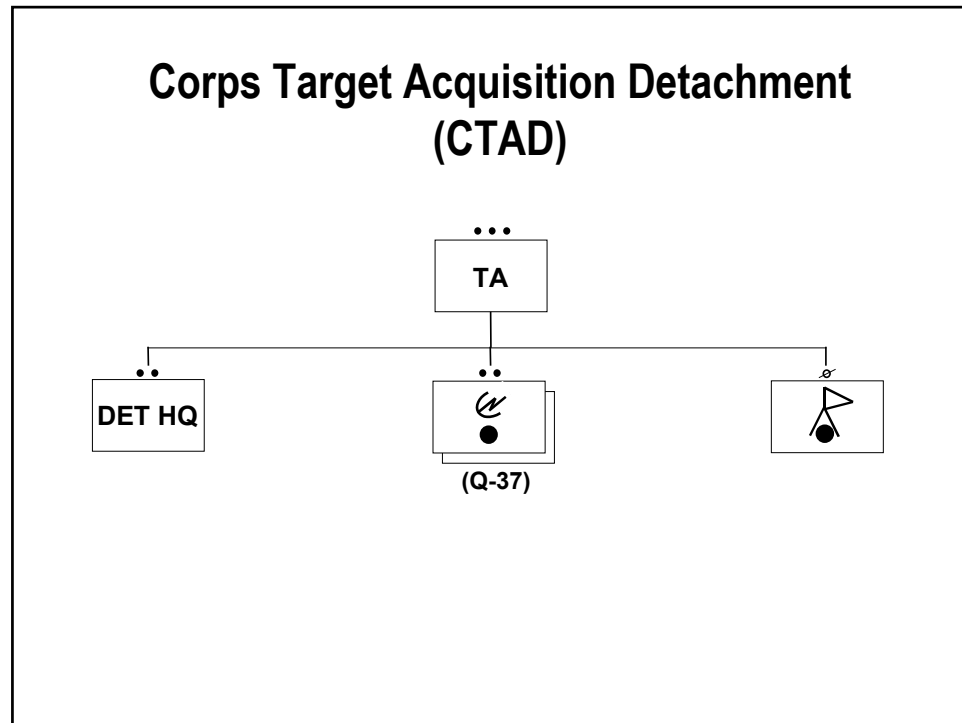

Figure 2.4 Corps Target Acquisition Detachment

The allocation of this organization will change upon fielding of the Q-47 radar. Once the Q-47 is fielded, each corps will be allocated with its own dedicated CTAD in addition to those already allocated to support light, airborne and air assault divisions.

INTERIM BRIGADE COMBAT TEAM TARGET ACQUISITION PLATOON

The interim brigade combat team (IBCT) TAP provides acquisition of threat mortar, artillery, and rocket systems to provide target intelligence and information to allow friendly forces to take force protection measures and enable counterfire mission processing. The platoon consists of one Q-36 and one Q-37 radar team, a meteorological team and a survey team. The platoon deploys in whole or part within tailored force packages. Once in theater, the Fires and Effects Coordination Cell (FECC) controls the employment of the platoon and any additional counterfire radars attached or augmenting the brigade. When in theater, whether it deploys early or with the field artillery battalion, the platoon and/or individual radars will always establish a direct digital and voice link with the FECC. It may also, on occasion, establish an AFATDS digital quick fire channel directly with a delivery unit. The meteorological section provides meteorological support to artillery, mortars and radars to enhance the accuracy of their fires. The survey team provides common survey to field artillery firing units and mortars when required. The survey capability is limited and lacks redundancy because the survey team has only one position and azimuth determining system (PADS).

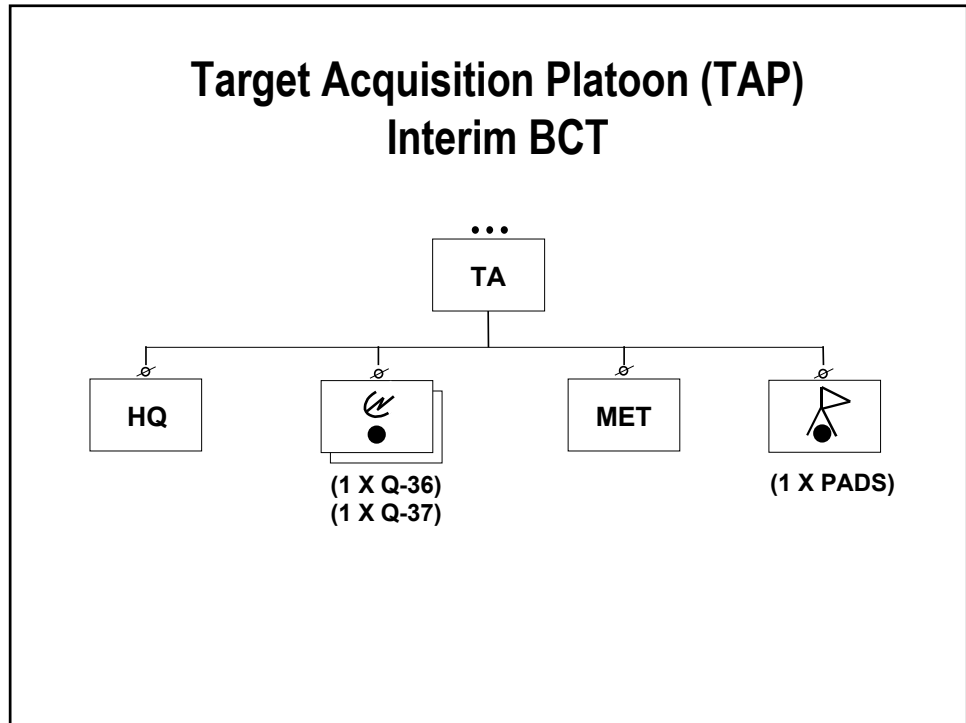

Figure 2-5. Interim BCT Target Acquisition Platoon

The composition of teams in this organizational structure is the same as for sections in the TAB.

INTERIM DIVARTY HIMARS BATTALION TARGET ACQUISITION PLATOON

The IDIVARTY HIMARS TAP provides acquisition of threat artillery, rocket, and missile systems for the interim division to provide target intelligence and information to allow friendly forces to take force protection measures and enable counterfire mission processing. The platoon consists of a platoon headquarters, three Q-37 radar sections, a meteorological section and a survey section. The platoon deploys in whole or part within tailored force packages. Once in theater, the Fires and Effects Coordination Cell (FECC) controls the employment of the platoon and any additional counterfire radars attached or augmenting the division. When in theater, whether it deploys early or with the HIMARS battalion, the platoon and/or individual radars will always establish a direct digital and voice link with the FECC and may establish a AFATDS digital quick fire channel with a delivery unit. The meteorological section provides meteorological support to artillery, radars and mortars to enhance their accuracy. Like the IBCT, the survey capability is limited to one PADS.

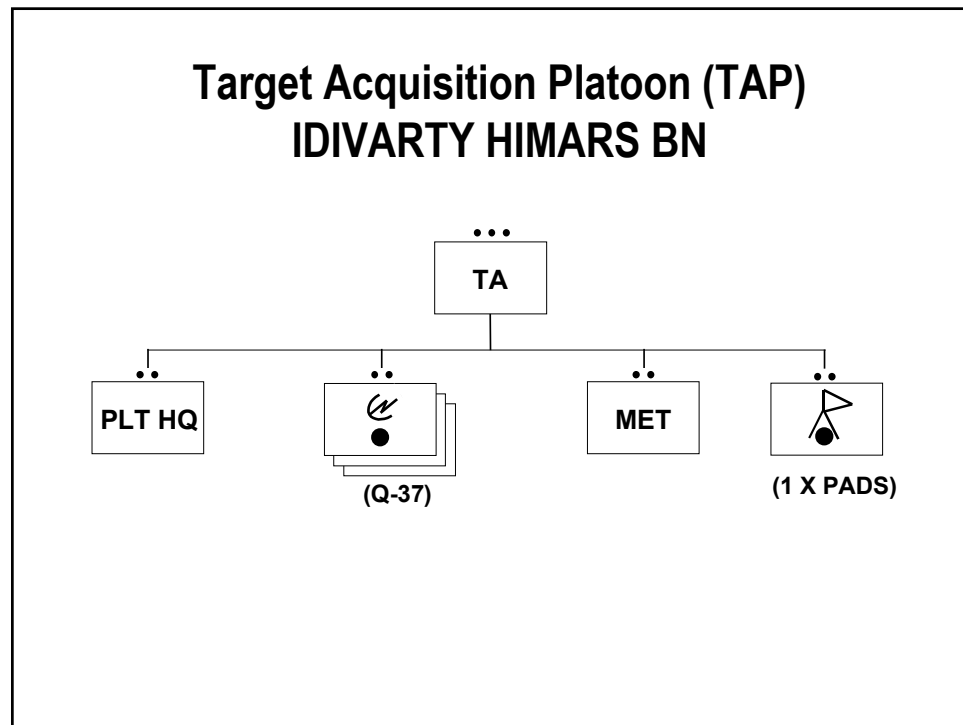

Figure 2-6. IDIVARTY HIMARS Battalion Target Acquisition Platoon

STRIKER PLATOON

The STRIKER platoon provides the maneuver brigade commander with high technology observation teams that are dedicated to executing fires throughout the depth of the brigade's battlespace. This mission includes calling for conventional artillery and rocket fires, providing laser designation for smart munitions and, as a secondary mission, providing reconnaissance and surveillance for the brigade. The STRIKER platoon is one of the brigade's main observation and surveillance assets and is heavily relied upon to provide observation and attack critical targets in the brigade deep fight. Light units are organized with three striker teams and heavy units have six striker teams. Table 2-3 shows the striker platoon's organization.

Table 2-3. STRIKER Platoon Organization

STRIKER Platoon			
TITLE	MOS	RANK	NUMBER
Platoon Leader	13A0	1LT	1
Platoon SGT	13F40	SFC	1
Driver	13F10	PFC	1
STRIKER Team			
TITLE	MOS	RANK	NUMBER
Fire Support SGT	13F20	SGT	1
Fire Support Specialist	13F10	SPC	1
Fire Support Specialist	13F10	PFC	1

AN/TPQ-37(V)8 RADAR SECTION

There are currently four versions of the Q-37 in service, the AN/TPQ-37(V)8, AN/TPQ-37(V)7, AN/TPQ-37(V)6, and the AN/TPQ-37(V)5. All four versions of the radar have a crew of 12. Table 2-4 depicts the organization of the AN/TPQ-37(V) radar section. Regardless of equipment, the mission of the Q-37 radar section is the same. The primary mission is to locate enemy artillery, rocket, and mortar firing positions. In addition, the Q-37 performs high-burst, datum-plane and impact-predict registrations, and adjust-fire mission processing. The designated counterfire headquarters controls the Q-37 radar and support is provided by the TAP or TAB.

Table 2-4. AN/TPQ-37(V) Section Personnel

Title	Rank	MOS	Number
Radar Section Leader	CW2	131A0	1
Section Chief	SSG	13R30	1
Senior Firefinder Radar Operator	SGT	13R20	2
Radar Repairer	SPC	35M10	1
Firefinder Radar Operator	SPC	13R10	3
Power-generation Equipment Repairer	SPC	52D10	1
Firefinder Radar Operator	PFC	13R10	3
Total			12

AN/TPQ-36(V)8 RADAR SECTION

The AN/TPQ-36 weapons locating radar section has a crew of six. Its primary mission is to locate enemy mortar, artillery, and rocket firing positions. This radar is optimized to detect high-angle indirect fire. However, it is equally capable of producing accurate grid locations for indirect fire units using low-angle fire. As a secondary mission the friendly fire mode can be used to perform high-burst, datum-plane, or impact-predict registrations. The fire direction center can use the impact-predict data provided by the radar in the friendly fire mode to conduct adjust-fire missions.

Use of the radar in the friendly fire mode may be required when no registration data and observers are available, and the mission dictates that the target is a high payoff target and must be destroyed. This secondary mission is performed only when absolutely necessary. Table 2-5 depicts the section organization.

Table 2-5. AN/TPQ-36(V)8 Section Personnel

Title	Rank	MOS	Number
Radar Section Leader	CW2	131A0	1
Section Chief	SSG	13R30	1
Senior Firefinder Radar Operator	SGT	13R20	1
Radar Repairer	SPC	35M10	1
Firefinder Radar Operator	SPC	13R10	1
Firefinder Radar Operator	SPC	13R10	1
Total			6

DUTIES OF RADAR SECTION PERSONNEL

The duties of radar section personnel are essentially the same for all weapons locating radars regardless of organizational structure of the assigned target acquisition unit. The following paragraphs provide duties for each section member.

RADAR SECTION LEADER

- Advises the commander and staff of tactical and technical considerations affecting employment of the radar.
- Participates in the MDMP.
- Reconnoiters and selects the site for the radar.
- Supervises the activities of all radar personnel.
- Examines and interprets standard operating procedures, orders, directives, and technical publications for data pertinent to employment of radars and associated equipment.
- Reviews and consolidates requisitions for tools, repair parts, technical supplies, publications, and equipment.
- Coordinates technical support to include MET and survey.
- Coordinates logistics and security requirements and liaises with the supported unit.
- Commands and directs the operations of the radar section
- Supervises maintenance personnel performing maintenance or repair of the radar.

SECTION CHIEF

- Supervises the operations and operator maintenance of radar equipment.
- Ensures compliance with safety procedures.
- Provides completed initialization worksheets to operators.

- Plans and supervises hasty survey.
- Instructs personnel in all aspects of radar operations and associated techniques.
- Assists the radar section leader in site selection.
- Organizes and maintains local security and unit defense.
- Assumes command of the section in the absence of the radar section leader.

SENIOR FIREFINDER RADAR OPERATOR

- Operates and supervises the operation of the radar set.
- Assists in the emplacement and concealment of the radar position.
- Assists the section chief in all of his duties.
- Provides technical guidance to radar operators.

FIREFINDER RADAR OPERATOR

- Emplaces and march-orders the radar and ancillary equipment.
- Initializes and operates all radar and ancillary equipment.
- Determines and corrects the altitudes of weapon locations from a contour map.
- Transmits the final locations to supported FDC or target processing section and keeps the necessary records.
- Operates and performs maintenance on the radar's prime movers.
- Performs hasty survey.
- Provides local security.
- Performs other duties assigned by the section chief.

RADAR REPAIRER

The radar repairer performs unit level/DS maintenance on the radar and assists the radar technician as required. He performs the following specific duties:

- Performs unit maintenance using built-in-test/built-in-test-equipment (BIT/BITE), fault detection and isolation.
- Isolates failures to a line replaceable unit (LRU) or shop replaceable unit (SRU) that can be replaced by a crewmember.
- Uses fault-isolation-test, replaces cards, modules, components and selected piece-parts.
- Troubleshoots, adjusts, aligns and repairs using BIT routines and test, measurement, and diagnostic equipment (TMDE) authorized by the maintenance allocation chart (MAC).
- Replaces and/or forwards unserviceable equipment to depot maintenance.
- Performs connector repair on certain specified cables.
- Provides local security and performs other duties assigned by the section chief.

POWER GENERATION EQUIPMENT REPAIRER

The power generation equipment repairer repairs and maintains tactical utility and precise power generation equipment. The power generation repairer is assigned only to Q-37 radar sections. Power generation repair support for Q-36 radar sections is provided by the power generation repairer assigned to the TAP or headquarters platoon of the parent TA organization or supported unit. The power generation equipment repairer performs the following duties:

- Troubleshoots mechanical and electrical systems and components; diagnoses and isolates malfunctions; tunes engine, and replaces components.
- Test operates repaired equipment.
- Assists in radar operations as required.
- Provides local security and performs other duties assigned by the section chief.

USMC COUNTERBATTERY RADAR PLATOON

The United States Marine Corps (USMC) counterbattery radar (CBR) platoon is organic to the headquarters battery of the USMC artillery regiment. The platoon consists of a headquarters section, four AN/TPQ-46A radar sections, and a target processing center (TPC). The primary mission of the CBR platoon is to locate enemy rocket, mortar, and artillery weapons and process all acquired enemy locations in a timely manner for counterfire and intelligence purposes. Secondary missions that can be assigned by the supported artillery unit are adjusting or registering artillery.

The CBR platoon is normally employed as a unit and controlled by the regimental artillery commander. The TPC is established in the regimental artillery main combat operations center (COC) or co-located with the fire support coordination center (FSCC) at the Division COC. The CBR platoon commander works closely with the regimental S2 and S3 to ensure that all CBR assets are being optimally utilized and that all counterfire and intelligence data generated by those assets are being processed correctly.

The CBR platoon commander coordinates the employment of radars operating under regimental control. The S2 and S3 provide guidance as deduced from the plan of observation and the S3 designates areas that will receive radar coverage. Based on this guidance, the CBR platoon commander selects a sector of search and general position area for each radar section. The radar section leader selects the actual radar site.

Meteorological and survey support are provided to the CBR platoon by the artillery regimental headquarters battery. If attached to a direct support field artillery battalion, the artillery battalion survey team will provide survey support. Figure 2-9 shows the organization of the CBR Radar Platoon.

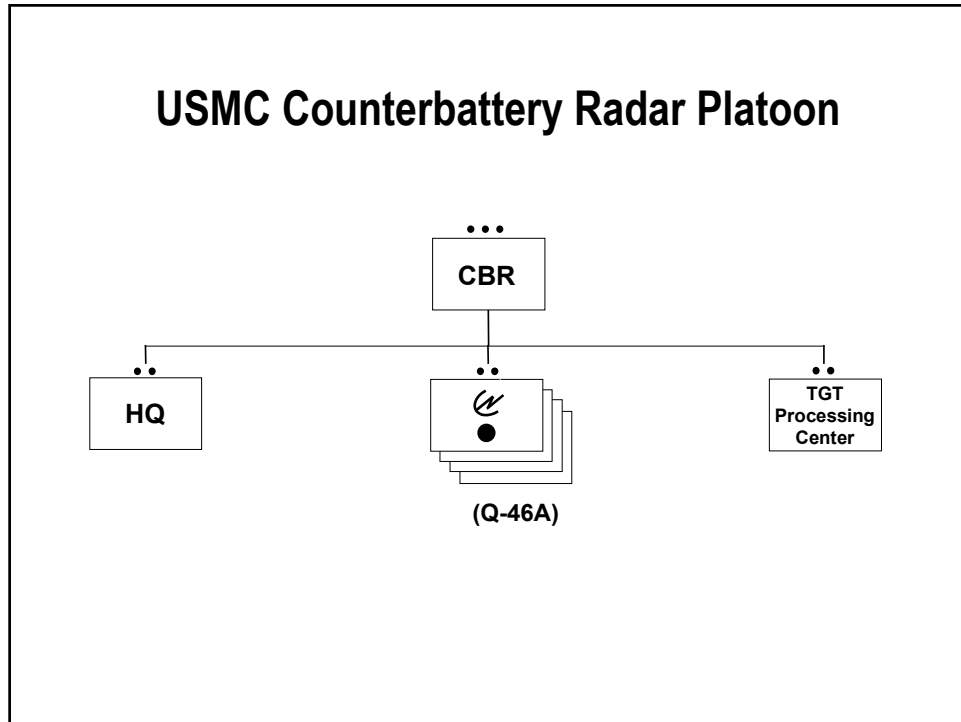

Figure 2-9. USMC Counterbattery Radar Platoon

PLATOON HEADQUARTERS

The platoon headquarters consists of the platoon commander and the radar employment chief. They perform duties similar to the radar platoon leader and platoon sergeant in U.S. Army TA organizations. Table 2-6 shows the composition of the platoon headquarters.

Table 2-6. USMC CBR Platoon Headquarters Personnel

Title	Rank	MOS	Number
Platoon Commander	CWO3	0803	1
Radar Employment Chief	MSG	0848	1
Total			2

AN/TPQ-46A RADAR SECTION

The AN/TPQ-46A weapons locating radar section has a crew of nine marines. Its primary mission is to locate enemy mortars, artillery and rocket firing positions for counterfire and intelligence purposes. This radar is optimized to detect high-angle indirect fire. It is also capable of developing accurate grid locations of indirect fire units using low-angle indirect fire. As a secondary mission the friendly fire mode can be used to perform high-burst, datum-plane, or impact-predict registrations. The fire direction center can use the impact data

provided by the radar in the friendly fire mode to conduct adjust-fire missions. Table 2-7 shows the composition of the AN/TPQ-46A radar section.

Table 2-7. AN/TPQ-46A Radar Section Personnel

Title	Rank	MOS	Number
Section Leader	SSGT	0848	1
Watch Chief	SGT	0842	1
Watch Chief/ Radar Operator	CPL	0842	2
Radar Operator	LCPL	0842	3
Radar Operator	PFC	0842	2
Total			9

The AN/TPQ-46A radar is the same as the AN/TPQ-36(V)8. Components of the radar are discussed in Chapter 4.

TARGET PROCESSING CENTER

The TPC is a detachment of the CBR Platoon. The TPC aids in processing counterfire targets and provides liaison between the supported unit and radars. Under most circumstances, the TPC is located with the regimental fire support coordination center (FSCC) to take advantage of available intelligence, facilitate clearance of counterfires and coordinate air attack of counterfire targets with the division air officer. Table 2-8 shows the composition of the TPC.

Table 2-8. Target Processing Center Personnel

Title	Rank	MOS	Number
Processing Section Leader	GYSG T	0848	1
Processing Team Leader	SGT	0844	2
Recorder/Plotter	CPL	0844	2
Recorder/Driver	PFC	0844	2
Total			7

DUTIES OF USMC COUNTERBATTERY RADAR PLATOON PERSONNEL

The following paragraphs provide the duties and responsibilities performed by USMC radar platoon personnel. The duties performed by USMC radar platoon personnel are very similar to those performed by U.S Army TA personnel.

PLATOON COMMANDER

The platoon commander's duties are similar to the target acquisition or radar platoon leader's duties in Army TA organizations. The platoon commander performs the following duties:

- Commands and directs the operations of the platoon.

- Advises the supported commander and staff on the technical considerations affecting the employment of radars and recommends the general locations of radar sites.
- Performs reconnaissance and selection of radar sites with the radar section leader.
- Examines, writes and interprets SOPs, orders, directives and technical publications for data pertinent to employment of radars and the processing of counterfire and intelligence data.
- Supervises the activities of all radar platoon personnel.
- Inspects and tests equipment to determine the adequacy of maintenance.
- Reviews and consolidates requisitions for tools, repair parts, technical supplies and equipment.
- Coordinates survey, logistical and security requirements.

RADAR EMPLOYMENT CHIEF

The duties of the radar employment chief are similar to the duties of target acquisition or radar platoon sergeant in Army TA organizations. The radar employment chief performs these duties:

- Performs the duties of the platoon commander in his absence.
- Plans, coordinates and supervises the internal functioning of the platoon, to include, maintenance, repair, inventory, logistics, administration and training.
- Assists the platoon commander.
- Orders maps and trig lists for operational areas.

RADAR SECTION PERSONNEL

Radar Section Leader

The duties of the radar section leader are similar to the radar section chief in Army TA organizations. The radar section leader performs the following duties:

- Assists the Platoon Commander in the selection of radar sites.
- Evaluates the radar site after selection to determine the location of all equipment, vehicles, and local security.
- Supervises the march order, emplacement, camouflage, local security and all other activities within the radar site.
- Provides completed initialization worksheets to the radar operators.
- Checks all initialization data entered into the radar computer prior to the operator entering into the operational program.
- Ensures adherence to safety procedures by section personnel.
- Instructs radar personnel in radar operations and MOS related skills.
- Conducts hasty survey as necessary.
- Commands the radar section.
- Plans and supervises the maintenance of all section equipment.

- Orders parts for repair/replacement of radar equipment through the radar employment chief.
- Determines all manual terrain following data.

Radar Watch Chief

The duties of the radar watch chief are similar to the duties of the senior Firefinder radar operator in Army TA organizations. The radar watch chief performs the following duties:

- Assists the radar section leader in the accomplishment of his duties.
- Performs the duties of the radar section leader in his absence.
- Initializes the radar.
- Operates or supervises the operation of the radar.
- Provides technical guidance and training to the radar operators.
- Performs other duties assigned by the radar section leader.

Radar Watch Chief/Radar Operator

This individual performs the same radar operator duties as other radar operators. When this person is the senior individual present in the radar section, he also performs duties as the radar watch chief.

Radar Operator

The duties of the radar operator are similar to the duties of the radar operator in Army TA organizations. The radar operator performs these duties:

- Operates, emplaces, and march orders the radar and all auxiliary equipment.
- Performs operator maintenance on the radar and all auxiliary equipment.
- Provides local security and unit defense.
- Camouflages the radar and all auxiliary equipment.
- Performs other duties assigned by the radar section leader or watch chief.

TARGET PROCESSING CENTER PERSONNEL

Processing Section Leader

- Performs the duties of the radar employment chief in his absence.
- Trains and supervises the personnel within the target processing section.
- Performs the duties of the Platoon Sergeant of the radar platoon.
- Assists the supported unit's S2 and S3 within the COC to ensure proper integration of the Target Processing Center into the COC, and the timely processing of counterfire and intelligence data generated by the radars.
- Ensures that the Target Processing Center is fully manned and functioning at optimum efficiency to support all operational commitments.

- Makes liaison with the supported unit's Battery Gunnery Sergeant to ensure that all Target Processing Center personnel are included in the unit local security plan.

The Processing Team Leader

- Performs the duties of the processing section chief in his absence.
- Supervises the operations of his watch section within the Target Processing Center.
- Provides technical guidance and training to the members of his watch section.
- Performs other duties assigned by the processing section chief.

The Recorder/Plotter

- Records counterfire and intelligence data received from the radar teams.
- Plots all counterfire and intelligence data received to include radar data, flash and crater analysis rays, to ensure authenticity and to produce actual target data.
- Passes all counterfire and intelligence data to the supported unit's S2 after it has been checked, and assists the S2 in processing that information.
- Performs other duties assigned by the processing section leader or processing team leader.

The Recorder/Driver

The recorder/driver performs the same duties as the recorder/plotter. In addition, the recorder/driver performs duty as a vehicle driver.

processing, guidances play a vital role in determining the best attack solution for a given target.

The types of guidances are not organized by category. They are spread across six different categories. Example, under the category Target you will find Target Selection Standards (TSS). This is a filter guidance. Also under Target you will find High Value Target List. This is a screening guidance.

The six guidance categories are:

- Target.
- FS attack.
- Unit and sensor systems.
- FA attack.
- C3 (command control and communications).
- Miscellaneous.

Guidance information is normally supplied by higher echelon units and is distributed to other units in the command and support chain. There are four types of guidances:

- Filter guidance. Determines if a target should be shot.
- Screening guidance. Determines how and when to shoot a target.
- Target analysis guidance. Determines the optimum munition and fire unit to achieve the desired effects on the target.
- Information guidance. Are information only guidances and have no affect on fire mission processing.

This section provides an explanation of the guidances that are used in mission processing and how they affect Firefinder missions. These are primarily Filter and Screening guidances. Guidances that do not affect Firefinder mission processing are not discussed.

Before guidances are applied, AFATDS classifies targets by their description. AFATDS calls these descriptions target categories. Within each target category there are Target Types. Firefinder calls these Target Type and Subtype. Many of the guidances in AFATDS allow one to specify guidance for each individual target type. When a call for fire is received at AFATDS, the target type of the mission is used to determine the specific guidance that has been established for that target type.

Some of the guidances used in fire mission processing are called FILTERS. Filter guidances determine if a target should be shot. For example, if a target is a duplicate of another target, the second call for fire is eliminated; the Target Duplication guidance filters out duplicate targets.

Other guidances determine HOW or WHEN to shoot the target. These are called screening guidances. They prioritize targets relative to one another and provide information about the munitions type, volume of fire and required effects.

Other guidances are considered preferences. These are attack analysis guidances. For these guidances, any entry specified on the CFF may not

result in the exact solution provided since other information may be taken into account. For instance, when shooting a certain target type, the preference may be to shoot DPICM, TIME, 2 PLT volleys. But if no units have DPICM, other shell/fuze combinations will be chosen. If available, alternatives will be given. Nonetheless, specified preference may be ranked higher than other alternatives and may be the suggested option. Preference guidances allow blank entries to be made; for these guidances, blank entries just mean no preference.

The first guidances applied are filters. Target duplication is a filter guidance. If AFATDS receives a target that duplicates an active fire mission and the target received is the duplicate of this target, the computer will recommend denying the second target.

Target Selection Standards (TSS) are the primary filter guidance considered when an ATI or CFF is processed by AFATDS. ATIs are always checked against TSS. If the ATI fails the TSS guidance it will be considered a "Suspect" target and be sent to the target generation function for further processing. CFFs may be checked against TSS if the operator elects to do so (simply by selecting the "Check CFFs against TSS" option on the TSS guidance window). CFFs failing TSS will likewise be sent to target generation as a suspect target. If the "Check CFFs against TSS" option is not selected, all CFFs will pass TSS. TSS consists of three primary checks:

- Accuracy. Is the TLE of the target less than or equal to the "Max TLE" in the TSS guidance.
- Report Age. Is the time difference from the "DTG Acquired" of the target to the current time less than or equal to the "Max Report Age" in the TSS guidance?
- Reliability. Is the observer reliable in reporting this type of target (if not the target will fail TSS)?

When checking TSS, AFATDS checks the Target Location Error (TLE) and "time acquired/sensed" for the target. The observer's unit data is also checked to determine if the observer is "reliable" for the specific target type. AFATDS determines these three critical elements of information as follows:

- The TLE used on the mission will be based on:
 - The TLE submitted with the target data.
 - A calculation considering the sensor's range to target (for targets sent by Q36 or Q37 Radars only).
 - The TLE value for the observer in the AFATDS database (when an ATI is received directly from the observer).
 - A default value considering the unit type that sent the ATI.
- The "DTG Acquired" used on the mission will be based on:
 - The "Time Acquired" or "Time Sensed" submitted with the target data.
 - If a time is not provided, AFATDS will use the time the target was received at the first AFATDS computer as the "DTG Acquired".

- The observer's reliability used during the TSS check is based on:
 - The reliability indicator (Reliable vs. Non Reliable by individual target type) in the observer or radar's unit data.
 - If the reporting sensor is not an observer or radar unit type, it is assumed to be reliable and will pass the "Observer Reliability" aspect of TSS. This situation occurs when a target is entered at an AFATDS.

Screening guidances are applied after filter guidance. The first screening guidance is the High Value Target List (HVTL). The HVTL specifies when to attack the target (Planned, As Acquired, Immediate or Excluded), the effects on the target (Suppress, Neutralize, Destroy or allows an operator entered effects percentage) and a weight of each target category relative to one another (each category can be given a value between 0 and 100). This information is established for each target category. The HVTL is used in two ways:

- As a starting point for creating the target management matrix (TMM).
- To provide priorities for target categories.

The TMM is also a screening guidance. For each target type, this guidance allows the target type to be placed in a High Payoff Target List (HPTL), an Excluded Target list or a non-HPT List. For HPTs and non-HPTs, it allows entry of when to attack the target and the effects on the target. For HPTs it establishes weights to be set to rank HPTs relative to one another. Weights are established as follows:

- For non-HPT targets, the HVTL weighting for a target's target category is the same as the weighting for the target type.
- For HPTs, it allows an additional weighting of a target type above the highest weighting in the HVTL. The new weighting is the highest HVTL weighting plus the assigned weighting for the HPT. For example, if the highest weighting of all categories set in the HVTL is 95 and the HPT is given a weighting of 20, the real weighting of the target type is 115.
- For all target types, the TMM specifies whether to route the target to IEW (Intel/Electronic Warfare) for coordination and/or perform TDA on the target.
- When the TMM is cleared and the window is closed without re-assigning any or all of the target types, all remaining unassigned target types will be assigned to the non-HPT or excluded list. If the target type's category is set to excluded in the HVTL, the target type will be put into the excluded list, otherwise it will be put into the non-HPT list. The "When" values (e.g., As Acquired, Immediate) and the effects values (e.g., Suppress, Neutralize) will be taken from the HVTL for the target type's category as well.

Mission Prioritization is the final screening guidance. This guidance determines the ranking of fire units and Target Areas of Interest (TAI) and determines if On Call targets have higher priority than non On Call targets.

It also allows the weighting of the four basic components that determine a mission's value. Target Type weighting (from TMM), TAI ranking, Priority of Fires ranking and On Call Targets. Finally, this window allows entry of Fire Mission Cutoff Values that a mission must meet or exceed in order to be considered by a given system.

After all screening guidances are checked and total mission value is assigned to the target, the target is sent back to filter guidances to check the mission cutoff value. The Mission Cutoff Value is a "filter" guidance that determines which systems (FA, Mortar, Naval Surface Fire System (NSFS) or Air) are allowed to shoot the mission. The mission's total value is compared with this and if the value is not GREATER than that of a certain system then the mission will not be shot by that system. For example, if the mission's value is 34 and FA is set to 30, FA will be considered if any FA assets are capable. If NSFS is set to 50, NSFS will not be recommended to shoot it.

After all filter and screening guidances have been checked and passed, the mission is sent to the attack analysis guidances. These determine the optimum munition and fire unit to achieve the desired effects on the target.

information and procedures required to facilitate the effective employment of radar systems.

The provisions of this publication are the subject of the following North Atlantic Treaty Organization (NATO) Standardization Agreements (STANAGs) and Quadripartite Standardization Agreements (QSTAGs):

- 2008/503, Bombing, Shelling, Mortaring, and Location Reports.
- 2029/514, Methods of Describing Ground Locations, Areas, and Boundaries.

The proponent of this publication is Commandant, US Army Field Artillery School (USAFAS), ATTN: Requirements Development Determination and Integration (ATSF-FD), Fort Sill, OK 73503-5600.

Unless this publication states otherwise, masculine nouns and pronouns do not refer exclusively to men.

Interim DIVARTY HIMARS Battalion Target Acquisition Platoon	2-6
STRIKER Platoon	2-7
AN/TPQ-37(V8) Radar Section.....	2-8
AN/TPQ-36(V)8 Radar Section.....	2-8
Duties of Radar Section Personnel.....	2-9
USMC Counterbattery Radar Platoon	2-11
Duties of USMC Counterbattery Radar Platoon Personnel.....	2-13

Chapter 3 DUTIES OF FIELD ARTILLERY TARGETING AND TARGET

ACQUISITION PERSONNEL	3-1
Target Acquisition Battery/Detachment Commander	3-2
Radar Platoon Leader	3-2
Radar Platoon Sergeant	3-3
Field Artillery Battalion Target Acquisition Platoon Sergeant	3-3
Battlefield Coordination Detachment Targeting Officer	3-4
Battlefield Coordination Detachment Targeting NCO	3-4
Corps and Division Field Artillery Intelligence Officer	3-4
Corps and Division Targeting Officer	3-5
Division Counterfire Officer	3-6
Division Assistant Counterfire Officer	3-6
Senior Field Artillery Targeting NCO	3-7
Targeting NCO	3-7
Brigade Targeting Officer	3-8
Field Artillery Brigade Targeting Officer	3-8
General Support Field Artillery Battalion Targeting Officer.....	3-9
Division MLRS Battalion Targeting Officer	3-9
IBCT Targeting Officer	3-10
IBCT Targeting NCO.....	3-10
IBCT Counterfire Officer	3-11
USMC Targeting Information Officer	3-11

Chapter 4 TECHNICAL ASPECTS OF TARGET ACQUISITION RADAR

EMPLOYMENT	4-1
Section I – Detection, Verification, and Location Methodology	4-1
Hostile Mode	4-1
Detection, Verification and Location Process	4-6
Friendly Fire Mode	4-9
Section II – Radar System Characteristics	4-9

	Missions	4-9
	AN/TPQ-36(V)8.....	4-10
	AN/TPQ-37	4-19
	Section III – Technical Aspects of Site Selection, Positioning and Operations	4-27
	Site Selection	4-27
	Positioning	4-30
	Reconnaissance	4-33
	Survivability Considerations.....	4-34
	Location Averaging	4-41
	Automatic Height Correction.....	4-42
	Auto Censoring	4-43
	Firefinder Position Analysis System	4-44
	Safety Considerations.....	4-47
Chapter 5	TACTICAL EMPLOYMENT OF FIELD ARTILLERY TARGET ACQUISITION SYSTEMS	5-1
	Section I – Radar Employment	5-1
	Command and Control.....	5-1
	Command Relationships.....	5-3
	Sectors of Search	5-5
	Zones	5-5
	Zone Management.....	5-9
	Common Sensor Boundary	5-13
	Cueing.....	5-14
	Target Acquisition Radar Role During Offensive Operations	5-16
	Target Acquisition Radar Role During Defensive Operations	5-17
	Radar Tasking Procedures	5-17
	Section II – Counterfire Operations	5-18
	Corps.....	5-18
	Division	5-20
	IBCT Autonomous Operations.....	5-20
	IBCT and Division Integrated Operations	5-22
	Section III – Striker Employment	5-23
	Mission.....	5-23
	Operations	5-24
Chapter 6	STABILITY OPERATIONS AND SUPPORT OPERATIONS	6-1

	Force Projection.....	6-1
	Stability Operations.....	6-1
	Support Operations.....	6-4
	Employment Considerations for Stability Operations and Support Operations..	6-5
Appendix A	AUTOMATED TARGET DATA PROCESSING	A-1
	General	A-1
	Target Indicator Processing.....	A-2
	Suspect Target Processing.....	A-14
	Target Damage Assessment	A-19
	File Maintenance and Target Purging.....	A-19
Appendix B	CRATER ANALYSIS AND REPORTING	B-1
	Gun and Howitzer Shell Crater Analysis.....	B-1
	Survey or Crater Location.....	B-2
	Determination of Direction	B-2
	Crater Analysis.....	B-2
	Low-angle Fuze Quick Craters (Artillery).....	B-3
	Low-angle Fuze Delay Craters (Artillery).....	B-5
	High-angle Shell Craters (Mortars).....	B-6
	Rocket Craters	B-9
	Shell Fragment Analysis	B-9
	Shelling Reports.....	B-13
	Artillery Counterfire Information Form.....	B-13
	Equipment.....	B-14
Appendix C	FIREFINDER FRIENDLY FIRE MODE	C-1
	Firefinder Missions.....	C-1
	Friendly Fire Mode	C-1
	High-burst Registration	C-3
	Impact-predict Registration (Mean Point of Impact)	C-4
	Datum-plane Registration (Mean Point of Impact)	C-4
	Friendly Fire Log	C-4
Appendix D	FIREFINDER FIELD EXERCISE MODE/EMBEDDED TRAINING	D-1
	Uses	D-1
	Section and/or Platoon Training	D-1
	Gunnery Team Training.....	D-1
	Scenario Development.....	D-2

	Implementing the Scenario	D-4
Appendix E	THE AN/TPQ-47 RADAR	E-1
	Section I – Technical Aspects	E-1
	AN/TPQ-47 Equipped Target Acquisition Organizations	E-1
	AN/TPQ-47 Radar Section	E-6
	System Characteristics	E-6
	System Components.....	E-7
	System Capabilities	E-11
	Site Selection	E-15
	Positioning	E-16
	Safety	E-17
	Section II – Operational Aspects	E-19
	Theater Missile Defense Operations	E-19
	Corps Counterfire.....	E-28
	Division Counterfire.....	E-29
Appendix F	FIREFINDER MASK CONSIDERATIONS	F-1
	Definitions	F-1
	Track Volume	F-2
	Track Volume Calculations and Subsequent Actions	F-2
Appendix G	TARGET ACQUISITION TAB TO THE FIELD ARTILLERY	
	SUPPORT PLAN	G-1
	Section I – Target Acquisition TAB	G-1
	Description	G-1
	Preparation	G-1
	Target Acquisition TAB Heading.....	G-1
	Major Paragraphs	G-2
	Enclosures	G-4
	Sample Target Acquisition TAB	G-5
	Section II. Radar Deployment Order	G-12
	Description	G-12
	Responsibilities	G-12
	DA Form 5957-R.....	G-12
	Automated Radar Deployment Order Procedure	G-15
Appendix H	FIELD ARTILLERY RADAR SUPPORT REQUIREMENTS	H-1
	Survey	H-1
	Communications	H-2

	Administration	H-4
	Mess.....	H-4
	Maintenance	H-5
	Security	H-6
	Petroleum, Oils, and Lubricants.....	H-6
	Meteorological Data.....	H-6
Appendix I	AIR MOVEMENT PROCEDURES FOR TARGET ACQUISITION RADARS.....	I-1
	Section I – Helicopter Movement	I-1
	Considerations for Helicopter Movement.....	I-1
	Q-36 Sling Load Procedures	I-5
	Q-37 Sling Load Procedures	I-13
	Section II – Fixed Wing Aircraft Movement.....	I-18
	Considerations for Fixed Wing Aircraft Movement	I-18
	Q-36 Load Procedures for C-130 Aircraft.....	I-27
	Q-37 Load Procedures for C-130 Aircraft.....	I-29
Appendix J	REHEARSALS	J-1
	Rehearsal Types.....	J-1
	Rehearsal Techniques	J-2
	Scripting and Conducting the Rehearsal	J-6
	Brigade Fire Support Rehearsal	J-9
	Brigade Combined Arms Rehearsal	J-12
Appendix K	EXAMPLE TOOLS AND PROCEDURES.....	K-1
	Firefinder Radar Section Troop Leading Procedures	K-1
	Radar Section Warning Order	K-2
	Radar Deployment Order.....	K-5
	Radar Execution Matrix.....	K-6
	Quick Reference Position Selection Worksheet	K-8
	Radar Positioning and Movement Synchronization Checklist	K-9
	Voice Radar Registration Procedure	K-10
	Voice Radar Adjust Fire Mission.....	K-10
	Joint Airlift Inspection Checklist	K-12
	Risk Management Worksheet.....	K-15
Appendix L	RISK MANAGEMENT	L-1
	Section I – Risk Management Procedures	L-1
	Identify Hazards	L-1

Assess Hazards to Determine Risks L-2
Develop Controls and Make Risk Decisions L-3
Implement Controls L-4
Supervise and Evaluate L-4
Section II – Implementation Responsibilities L-5
Breakdown of Risk Management Process L-5
Risk Management Command Climate L-5

Glossary Glossary-1

Bibliography Bibliography-1

Index Index-1

Chapter 3

Duties of Field Artillery Targeting and Target Acquisition Personnel

This chapter discusses the duties of key field artillery targeting and target acquisition personnel from radar platoon to battlefield coordination detachment. The field artillery targeting officer and radar section leader play key roles in the targeting and target acquisition process. FA targeting officers provide the FSCoord and maneuver commander with an invaluable resource for planning and synchronizing the integration of FA target acquisition into combined arms operations. Table 3-1 shows the duty positions discussed in this chapter.

Table 3-1. Key Target Acquisition Personnel

Rank	Position	Operational Locations
CPT/LT	Target Acquisition Battery/Detachment Commander	DIVARTY TOC
LT	Radar Platoon Leader	TAB
SFC	Radar Platoon Sergeant	TAB
CW4	Targeting Officer	Battlefield Coordination Detachment
SFC	Targeting NCO	Battlefield Coordination Detachment
CW4/CW3	FAIO	Corps and Division ACE/ISE
CW5/CW4	Targeting Officer	Corps and Division FSE
CW3	Counterfire Officer	DIVARTY TOC
CW2	Assistant Counterfire Officer	DIVARTY TOC
SFC	Senior Targeting NCO	DIVARTY TOC
SFC	Targeting NCO	DIVARTY TOC
CW2	Brigade Targeting Officer	Maneuver Brigade Main CP
CW3	FA Brigade Targeting Officer	FA Brigade TOC
CW2	GS FA Battalion Targeting Officer	FA Battalion TOC
CW2	Division MLRS BN Targeting Officer	DTAC/Aviation BDE
CW2	IBCT Targeting Officer	Targeting Cell, FECC

Rank	Position	Operational Locations
SSG	IBCT Targeting NCO	Targeting Cell, FECC
CW2	IBCT Counterfire Officer	Counterfire Cell, FECC
CWO3	(USMC) Targeting Information Center	Regimental HQ FSCC
SFC	FA Battalion Target Acquisition Platoon Sergeant	FA Battalion TOC

TARGET ACQUISITION BATTERY/DETACHMENT COMMANDER

The target acquisition battery (TAB)/detachment (TAD) commander commands the entire battery/detachment in garrison. When deployed, the commander supervises the HQ platoon element's coordination of maintenance, supply, administration, and communications support. However, supported units assume all support functions once TAB/TAD assets are committed. In addition, the commander performs the following duties:

- Acts as a special staff officer providing TA expertise and advice to the DIVARTY/FA brigade commander during the planning and execution of the counterfire battle at the counterfire headquarters or acts a TOC duty officer in the divisional MLRS battalion TOC.
- Assists in developing, writing, and disseminating TA Tab to the FASP.
- Ensures the battery is deployed and functioning in accordance with the FASP.
- Ensures the battery elements receive proper administrative, logistic, and maintenance support.
- Coordinates higher-level maintenance support to facilitate mission requirements.
- Monitors the employment of all TA assets within the division area.
- Performs other duties as directed by the DIVARTY S3 and divisional MLRS battalion commander.

RADAR PLATOON LEADER

The radar platoon leader is the officer in charge of the radar platoon. He supervises the activities of the radar platoon. Other duties include the following:

- Performs necessary tactical coordination for FA radars in general support (GS) of the division. This coordination includes communications, security/force protection support and ADA, positioning (engineers and land clearance), logistics, and administration.
- Inspects maintenance of platoon vehicles and equipment.
- Monitors the mission support requirements of all TA radars within the division area.

- Informs the TAB commander and counterfire officer on the status of field artillery TA radars.

RADAR PLATOON SERGEANT

The radar platoon sergeant is the senior enlisted soldier in the platoon. He assists the radar platoon leader in the performance of his duties. His other responsibilities are:

- Trains and rates radar section chiefs.
- Coordinates survey support for GS radars as required.
- Supervises maintenance and training of five TA radar sections.
- Provides input to radar deployment orders (RDO) as necessary.
- Provides input to the counterfire officer required to construct and maintain the TA capabilities chart.
- Monitors the deployment of the radar sections and recommends general position areas, search areas, and cueing agents to the counterfire officer.
- Coordinates the distribution of replacement personnel and administrative actions.
- Facilitates maintenance support for the TA radars.

FIELD ARTILLERY BATTALION TARGET ACQUISITION PLATOON SERGEANT

The FA target acquisition platoon sergeant is the senior field artillery targeting noncommissioned officer in the FA battalion assigned to light units and separate brigades of the National Guard. He assists the target acquisition platoon leader in the performance of his duties. His other responsibilities are:

- Coordinates survey for assigned radars as required.
- Provides input to RDOs as necessary.
- Constructs and maintains the TA capabilities chart.
- Monitors the deployment of the radar section and recommends general position areas, search areas, and cueing agents and cueing guidance to the S2/S3.
- Facilitates maintenance support for TA radars.
- Collects and disseminates information provided by the intelligence section and applies their products to the tactical employment of TA assets and counterfire operations.
- Monitors the operations, status, and current and proposed locations of FA radars in zone.
- Assists the S2 in developing TA coverage to include command and control relationships of organic and attached TA assets.
- Provides input to the S2 for consolidation into the TA Tab.
- Helps maintain the artillery order of battle database and target files.

BATTLEFIELD COORDINATION DETACHMENT TARGETING OFFICER

The battlefield coordination detachment (BCD) targeting officer is a senior warrant officer. He performs duties assigned by the plans officer. Some of the duties of the BCD targeting officer are:

- Receives and helps integrate target lists from the ARFOR TOC into the joint target list.
- Coordinates and integrates the ARFOR target list during development of the ATO.
- Answers questions regarding ARFOR target list priorities, timing of attack, desired means of attack, and effects.
- Provides update briefings as required on the status and operation of ARFOR deep operations assets.
- Supervises operation of AFATDS for target development and information exchange with the ARFOR TOC.

BATTLEFIELD COORDINATION DETACHMENT TARGETING NCO

This senior NCO performs duties assigned by the BCD plans section senior fire support noncommissioned officer and is responsible for setup and operation of the plans section. His duties include:

- Sets up the map board depicting the planned friendly situation.
- Establishes communication links with the ARFOR G3 plans section, deep operations coordination cell (DOCC), and theater missile defense (TMD) cell.
- Processes ARFOR requests for AI and CAS by using standard theater army command and control system (STACCS), theater battle management core system (TBMCS), and AFATDS.

An additional skill identifier (ASI) of F9, AFATDS operator/supervisor is required.

CORPS AND DIVISION FIELD ARTILLERY INTELLIGENCE OFFICER

Field artillery intelligence officers (FAIO) have key responsibilities in the targeting process. They are the link between the detect and deliver functions of D3A. FAIO's performs these specific duties:

- Co-locates in the analysis and control element (ACE)/intelligence support element (ISE) with the all source targeting section with access to the communications intelligence (COMINT), electronic intelligent (ELINT), imagery intelligence (IMINT) and situation development sections.
- Develops targets from available intelligence.
- Establishes connectivity between the all-source analysis system (ASAS) in the ACE/ISE and AFATDS in the FSE.

- Ensures proper translation of all-source analysis system (ASAS) to AFATDS target types facilitating target attack.
- Assists with establishing alarm criteria in the ASAS targeting computer to expedite the reporting of critical targets, defined by type, location, size, and reporting time.
- Provides fire support subject matter expertise to the ACE during the MDMP process to assist in developing the order of battle, IPB products, HVTL and likely NAIs.
- Monitors the enemy situation and recommends changes to targeting priorities and attack means.
- Provides input concerning the threat, TSS, attack guidance, and HPTL.
- Provides information to the ACE/ISE regarding accuracy requirements and timeliness of information for fire support systems.
- Ensures targets meet TSS requirements before being passed to the FSE for engagement
- Advises the FSCOORD or DFSCOORD when changes in the situation warrant reassessment of the HPTL and AGM.
- Refines and updates AI and ATACMS nominations to corps.

CORPS AND DIVISION TARGETING OFFICER

The corps and division targeting officer reviews, correlates, and prepares all targeting products and information briefed during rehearsals and targeting meetings in accordance with command directives. The targeting officer ensures that the current situation in AFATDS contains the proper guidances and FSCM. He is also responsible for consolidating, coordinating and disseminating the restricted target list. In addition, the targeting officer performs the following duties:

- Develops targets from available intelligence.
- Works with the collection manager and FAIO to integrate targeting requirements into the ICP.
- Prepares the HPTL/AGM.
- Passes targeting products to the TAC FSE and subordinate FSEs.
- Participates as a member of the targeting team.
- Keeps the FAIO informed about changes to HPTL, AGM and TSS.
- Keeps the DFSCOORD and G3 targeting chief informed about issues concerning targeting and fire support.
- Participates in the MDMP process.
- Submits CAS/AI and ATACMS nominations to corps.
- Provides the commander with a unit resident nuclear target analysis capability to support operations in a potential nuclear environment.

DIVISION COUNTERFIRE OFFICER

The counterfire officer (CFO) is assigned to the DIVARTY headquarters where he manages TA assets for the division. He develops and issues radar deployment orders (RDOs) to all radar sections controlled by the division. Duties of the counterfire officer include the following:

- Supervises the target processing section at the division counterfire headquarters.
- Follows TSS when developing enemy targets and suspected targets.
- Provides target location error (TLE) information on available FA TA assets to the FSE or FSCoord as a basis for their TSS recommendations to the targeting team.
- Acts as the principal advisor to the S2 on employment of FA TA assets.
- Writes the TA Tab to the FASP.
- Coordinates TA planning and execution with the DIVARTY or FA brigade plans officer, the order of battle (OB) officer, and the TAB commander. Recommends the following:
 - Target acquisition coverage and cueing schedule.
 - Command and control of TA assets.
 - Positions for FA target acquisitions resources.
 - Tracks TA assets.
 - Uses AFATDS/IFSAS and the target production map to ensure that TA assets are properly oriented and cued and targets are expeditiously attacked.
 - Ensures targeting information from other sources is developed to produce targets.
 - Monitors and operates the DIVARTY TA/intelligence frequency-modulated (FM), and digital nets.

DIVISION ASSISTANT COUNTERFIRE OFFICER

The assistant counterfire officer is assigned to the TAB and positioned in the counterfire headquarters when deployed. He is the assistant TOC team chief for the B shift. Some of the duties of the assistant CFO are:

- Acts as the CFO when the DIVARTY counterfire officer is absent.
- Supervises the targeting element of the counterfire headquarters.
- Ensures targets generated by the targeting element are passed to the fire control and operations elements for action.
- Ensures information from shelling reports (SHELREPs) and mortar bombing reports (MORTREPs) are integrated into the target development process.
- Recommends target selection standards for field artillery TA assets.
- Recommends general position areas for field artillery TA resources.
- Ensures that all targeting element maps, charts, and records are kept current.

- Acts as a cueing agent for radars, when required.
- Assists the DIVARTY S2 in the integration of TA assets into the intelligence collection plan.
- Assists the counterfire officer with writing the TA Tab to the FASP.

SENIOR FIELD ARTILLERY TARGETING NCO

The 13R40 (SFC) targeting NCO assigned to the CTAD performs all duties normally performed by the 1SG of a TAB. In addition, the senior field artillery targeting NCO performs the following duties:

- Conducts map reconnaissance of general position areas for location of weapon locating radars assigned to the CTAD.
- Collects and disseminates information provided by the intelligence section and applies their products to the tactical employment of TA assets and counterfire operations.
- Monitors the operations, status, and current and proposed locations of FA radars.
- Assists the CFO in developing TA coverage to include command and control relationships of organic and attached TA assets.
- Provides input to the S2 for consolidation into the TA Tab.
- Provides the CFO with recommendations for positioning GS TA assets, and establishing sectors of search and radar zones.
- Helps maintain the artillery order-of-battle database and target files.
- Assists in the development of cueing guidance for all TA assets.

TARGETING NCO

The 13F40 (SFC) targeting NCO assigned to the CTAD is responsible for setup and operation of the target processing section. His duties are:

- Leads, supervises, and trains the targeting element.
- Sets up and maintains all targeting element maps, charts, and records.
- Ensures AFATDS is properly initialized and used in conjunction with the targeting information from the target production map and other sources to produce targets.
- Assists in recommending employment of fire support means to include Naval gunfire and CAS.
- Ensures targets generated by the targeting element are passed to the fire control and operations elements for action.
- Ensures information from shelling reports (SHELREPs) and mortar bombing reports (MORTREPs) are integrated into the target development process.
- Helps maintain the artillery order of battle database and target files.

BRIGADE TARGETING OFFICER

The targeting officer from the DS FA battalion normally resides in the maneuver brigade Main CP. He facilitates the exchange of information between the analysis and control team (ACT), brigade combat team (BCT) S2, DS battalion S2 and the FSE. He performs these duties:

- Coordinates with the striker platoon leader on striker team availability and positioning.
- Helping the BCT S2 develop the target acquisition and reconnaissance and surveillance plans.
- Helps provide staff supervision of target acquisition assets attached, organic or under control of the BCT.
- Develops, recommends, and disseminates the HPTL and AGM, to the FSE, CP and subordinate elements.
- Coordinates with the BCT S2 for target acquisition coverage and processing of HPT.
- Produces the TSS matrix for TA assets working for the BCT.
- Manages target lists for planned fires.
- Works with the DS battalion S2 to integrate counterfire operations into the BCT plan.
- Coordinates and distributes the restricted target list in coordination with the FSO.
- Acts as the brigade FSO in his absence.

FIELD ARTILLERY BRIGADE TARGETING OFFICER

The FA brigade targeting officer's duties are determined by task organization and the mission assigned to the FA brigade. The field artillery targeting officer primary duty is acting as a counterfire officer when the FA brigade is assigned the mission as counterfire headquarters. The targeting officer's normal duties include:

- OIC for the targeting element.
- Advises the commander/S3 on employment of any attached TA assets.
- Develops the TA Tab to the FASP.
- Develops RDOs for any attached radars.
- Recommends radar coverage and positions for attached radars.
- Builds target files derived from radar acquisitions to identify trends in indirect fire systems positioning.
- Maintains the enemy order-of-battle database.
- Ensures target production overlays are properly maintained.
- Ensures maneuver graphics are up to date.
- Battle tracks acquisitions and friendly FA / TA assets both manually and digitally.

GENERAL SUPPORT FIELD ARTILLERY BATTALION TARGETING OFFICER

The GS FA battalion targeting officer assists the FA battalion S2 and S3 with targeting conducted at the FA battalion level. He also has additional responsibilities in counterfire and radar employment based on the battalion's assigned mission. The primary responsibilities of the GS FA battalion targeting officer are:

- Requests BDA from higher headquarters.
- Conducts predictive combat assessment (CA).
- Provides targeting input through the use of automated devices.
- Assists the FA battalion S2 in tracking the enemy order of battle.
- Assists the FA battalion in tracking the friendly scheme of maneuver.

In division and corps GS FA battalions, the targeting officer is in the intelligence section. In addition to his targeting duties, he functions as an assistant S2. His duties include the following:

- Assist the S2 and S3 in target production, processing, and administration and external targeting coordination.
- Assist the S2 with order of battle development and IPB.
- Help the battalion S2 write the intelligence, TA, and surveillance portions of the FASP, to include the RDO when applicable.
- Help plan for and manage attached, organic, and OPCON TA assets.
- Assist the battalion S2 and S3 with development and execution of the FA TA and counterfire plans.
- Assist the S2 in identifying commander's critical information requirements (CCIR).
- Supervise the intelligence section in the absence of the S2.
- Perform officer in charge (OIC) shift duties for the S2 section.
- Conducts CA and requests BDA from external sources/higher HQ.

DIVISION MLRS BATTALION TARGETING OFFICER

The division MLRS battalion (DMB) targeting officer can perform the same duties as the GS FA Battalion Targeting officer or perform alternate duties in support of the aviation brigade or division deep operations. When performing these alternate duties, the DMB targeting officer assists the aviation brigade FSO with targeting and SEAD planning to support division deep strikes with attack aviation. He also plans deep targets for future shaping operations. The primary responsibilities of the DMB targeting officer when performing these alternate duties are:

- Uses electronic intelligence (ELINT) overlays to implement/facilitate SEAD plans and conduct complementary SEAD in support of deep attack aviation assets.
- Receives targets of opportunity and BDA reports directly from Apache and Kiowa helicopters conducting attack operations.

- Supports the aviation brigade FSO by running the FSE to enable the FSE to conduct 24-hour operations.
- Recommends CFZ coverage on critical fuel and re-supply positions (FARP).

IBCT TARGETING OFFICER

The IBCT targeting officer locates in the targeting cell of the FECC and works closely with the lethal and non-lethal effects cell of the FECC to develop targets. He focuses on target information received from TA sources and uses AFATDS to collect, analyze and process this information into required target guidance and instructions. In addition, the targeting officer performs these duties:

- Develops and provides IPB products to other targeting team members.
- Works with the effects battle captain to develop, periodically assess and update:
 - TSS.
 - HPTL.
 - DBA requirements.
 - Attack/effects guidance matrix (A/EGM).
 - Target/effects synchronization matrix (T/ESM).
 - DST.
 - Targeting requirements to focus reconnaissance, surveillance and target acquisition (RSTA) assets and operations
- Requests and obtains combat assessment reports. Assess and makes recommendations to update targeting products and operations.
- Supports IBCT targeting meetings as required.

IBCT TARGETING NCO

The IBCT targeting NCO teams with the targeting officer in the targeting cell of the FECC to provide a 24-hour capability to plan and coordinate targeting operations. The targeting NCO performs these duties:

- Operates and maintains the targeting AFATDS.
- Maintains the targeting situational awareness (SA) display.
- Maintains the target production display.
- Inputs targeting SA information into the FECC SA display.
- Updates and purges targeting files.
- Ensures acquired targets are processed and forwarded to the lethal effects cell or the appropriate fires and effects assets in accordance with the T/ESM.
- Maintains classified files for the targeting and counterfire cells.
- Performs duties of the targeting officer when he is unavailable.
- Prepares and maintains required daily journals and reports.

- Ensures essential digital and voice connectivity.

IBCT COUNTERFIRE OFFICER

The IBCT counterfire officer locates in the counterfire cell of the FECC. He coordinates and controls the employment of the IBCT TAP in consultation with the deputy effects coordinator (DECOORD), the FA battalion S2 and S3 and the IBCT S2. The counterfire officer performs the following duties:

- Recommends and updates:
 - TA coverage.
 - Command and control of FA TA assets.
 - Position areas for FA TA assets.
- Orients FA TA assets to ensure required coverage of the IBCT battlespace.
- Tracks FA TA assets.
- Processes target attack with the lethal effects cell.
- Maintains situational understanding (SU) of targeting operations.
- Recommends TSS.
- Uses TSS to develop enemy artillery targets and suspect targets.
- Provides target location error (TLE) information on available TA assets to the DECOORD as a basis for TSS recommendations to the targeting team.
- Supports the targeting officer and the effects battle captain (EBC) in providing targeting products.
- Advises the IBCT commander and effects coordinator (ECOORD) on counterfire and targeting operations.
- Supports targeting meetings as required.

USMC TARGETING INFORMATION OFFICER

The USMC targeting information officer (TIO) is a member of the artillery regiment special staff. He is responsible for advising the division fire support coordinator and his staff on all targeting matters. He is intimately involved in the IPB process with the division G2 and develops targeting products for the maneuver commander. He is located at the division FSCC. His duties and responsibilities include, but are not limited to:

- Produces or assists in the production of the:
 - HVTL.
 - TSS.
 - HPTL.
 - AGM.
- Coordinates with TA agencies to facilitate rapid information gathering and responsive fires.
- Coordinates with the G2 during the execution of the intelligence collection process.

Chapter 4

Employment

To effectively employ FA radars, one must understand the technical characteristics of radars, how the radar acquires targets, and the technical requirements for radar employment. FA target acquisition personnel provide the technical expertise required to support radar employment planning by the controlling FA headquarters. TA personnel play an integral role in the MDMP process thus ensuring that radars are integrated into the operational plan. Once the plan is completed, radar operators exploit the technical aspects of the radars to maximize their effectiveness and enhance survivability.

SECTION I – DETECTION, VERIFICATION, AND LOCATION METHODOLOGY

HOSTILE MODE

Weapons locating radars spend the majority of their time operating in the hostile mode. It is important to understand how the radar acquires and tracks projectiles in flight and extrapolates weapons location from this information. Both the Q-36 and Q-37 operate in the same manner. The radar performs these basic steps to determine a hostile firing location:

- Establishes the search fence.
- Verifies penetration of the search fence.
- Validates the trajectory.
- Tracks the projectile.
- Extrapolates the firing location and determines the impact predict point.

Several conditions must exist for the radar to achieve a solution and provide a weapon location and impact predict point. First, the range to the projectile must be such that the radar beam strikes the object on the ascending branch of the trajectory. In hostile mode, the radar will only detect objects on the ascending branch of their trajectory. Further, the object must also be large enough to create a radar return and its speed must be within the radar's operational parameters for the radar to "see the object". Once the radar sees the object, it determines the trajectory of the object. The object must display a ballistic trajectory or the radar rejects it. Once, the object is detected it must be tracked for sufficient time for the radar to achieve a solution. The amount of track time required to achieve a solution differs by radar type. The required tracking times are:

- Q-36: 3-5 seconds.
- Q-37: 5-8 seconds.

The radar can only determine locations from objects presenting characteristics within the technical capabilities of the radar and that pass through the possible detection area of the radar. It is important to understand the possible area in which the radar can detect an object.

The possible detection area is a three dimensional space defined by the minimum and maximum range, search sector, and the vertical scan of the radar. Planning ranges are used for the purposes of this discussion. However, the maximum planning range for a radar is not an absolute. It is the range at which the probability of detection becomes low enough to be unsuitable for planning purposes. Nonetheless, objects may be detected beyond the maximum planning range. Conversely, objects within the planning ranges may not be detected. Planning ranges for the AN/TPQ-36(V)8 and AN/TPQ-37 are:

- AN/TPQ-36(V)8 – 14.5km for artillery, 18km for mortars, and 24km for rockets.
- AN/TPQ-37(V) – 30km for artillery and mortars, 50km for rockets.

The search sector is the area left and right of the radars azimuth of orientation where the radar can locate targets. The maximum search sector is plus or minus 800 mils from the azimuth of orientation for a total of 1600 mils. The search sector can be narrowed based on the tactical situation. Figure 4-1 depicts a possible search sector and associated range limits.

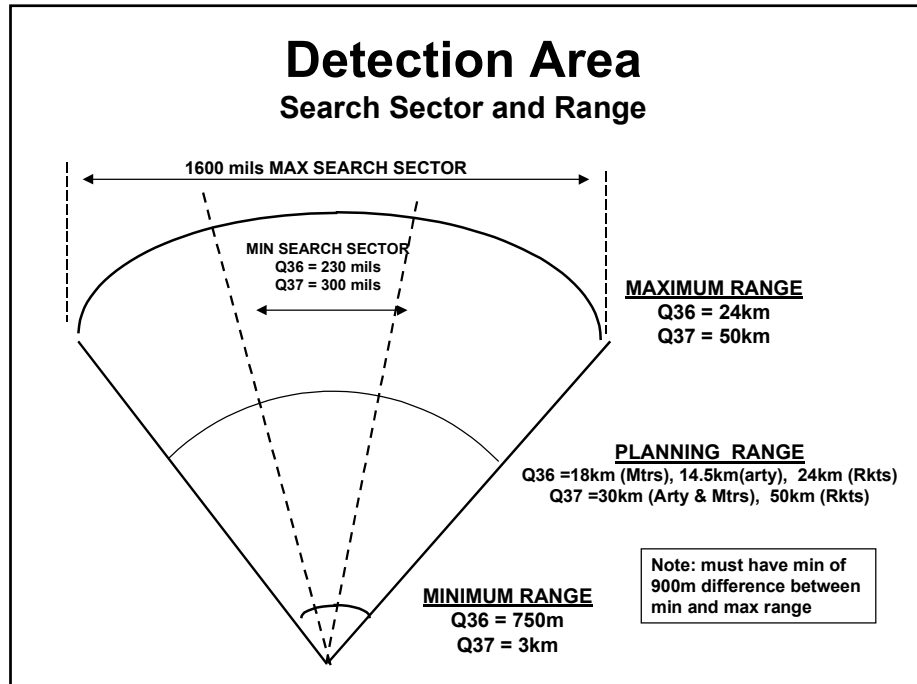

Figure 4-1. Search Sector and Range Limits

The vertical component of the detection area is vertical scan. This area extends vertically from the radar's search fence to the maximum scan elevation of the radar. Figure 4-2 shows the vertical scan capabilities for the

Q-36 and Q-37 radars. The three dimensional area shown in the diagram is the area where an object can be detected and tracked.

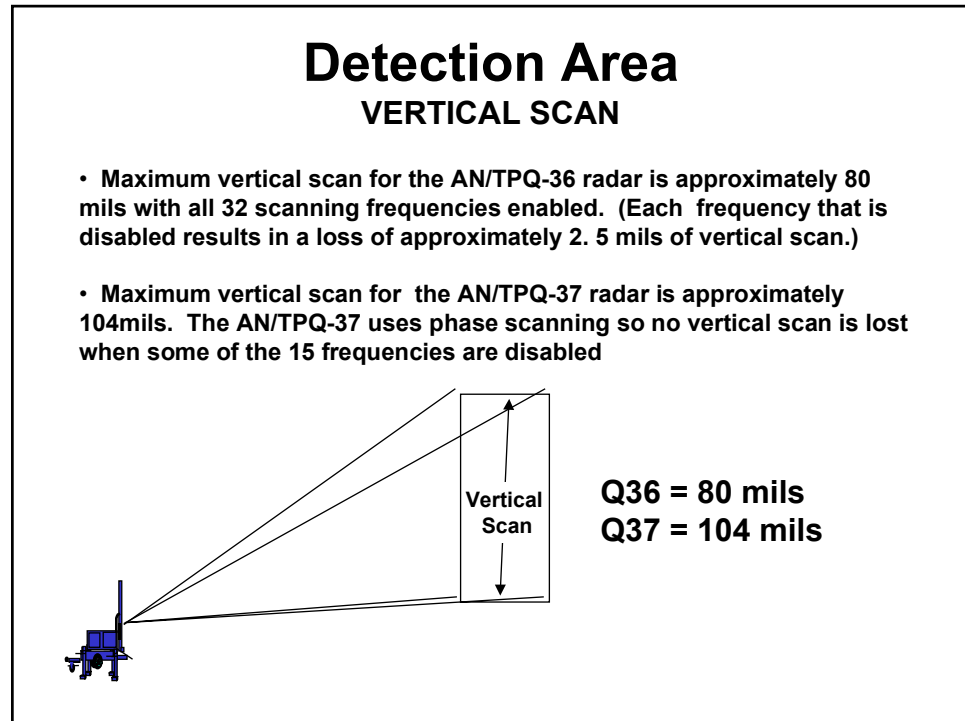

Figure 4-2. Vertical Scan

There must be a sufficient amount of vertical scan at the points where an object passes through the detection area for the radar to track it and compute a solution. The amount of available vertical scan is called track volume. Radars require a minimum of 50 mils of track volume to track a round for long enough to achieve a solution. Figure 4-3 shows the concept of track volume.

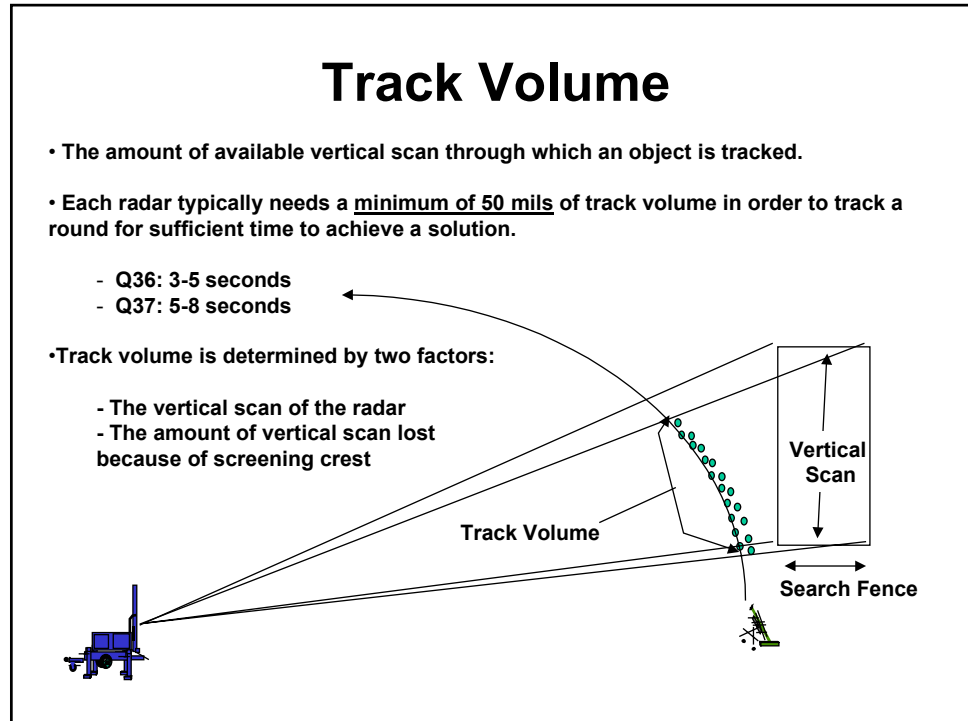

Figure 4-3. Track Volume

There are two other major factors that affect the radar's ability to detect, track and achieve a solution for a target. They are aspect angle and speed of the object. The aspect angle is the angle measured from radar antenna to the target path of the object. The aspect angle must be greater than 1600 mils. This means the object must be traveling toward the radar. Objects with aspect angles approaching 1600 mils may not be detected. The velocity of the object must also be considered. The velocity must be within the minimum and maximum velocity thresholds for the specific radar. Figure 4-4 depicts the concept of aspect angle and Figure 4-5 provides the velocity requirements for the Q-36 and Q-37 radar.

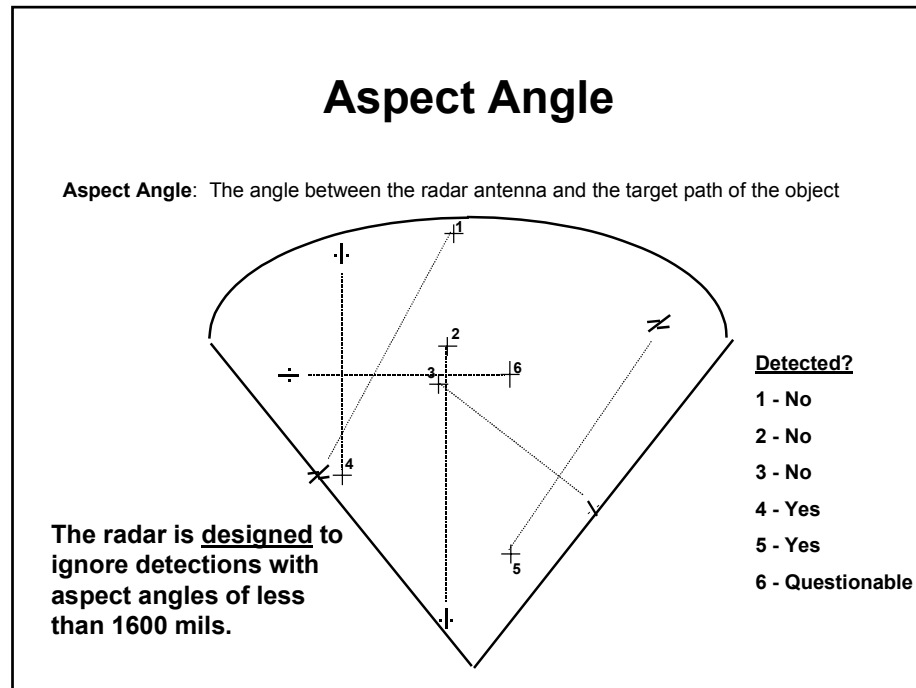

Figure 4-4. Aspect Angle

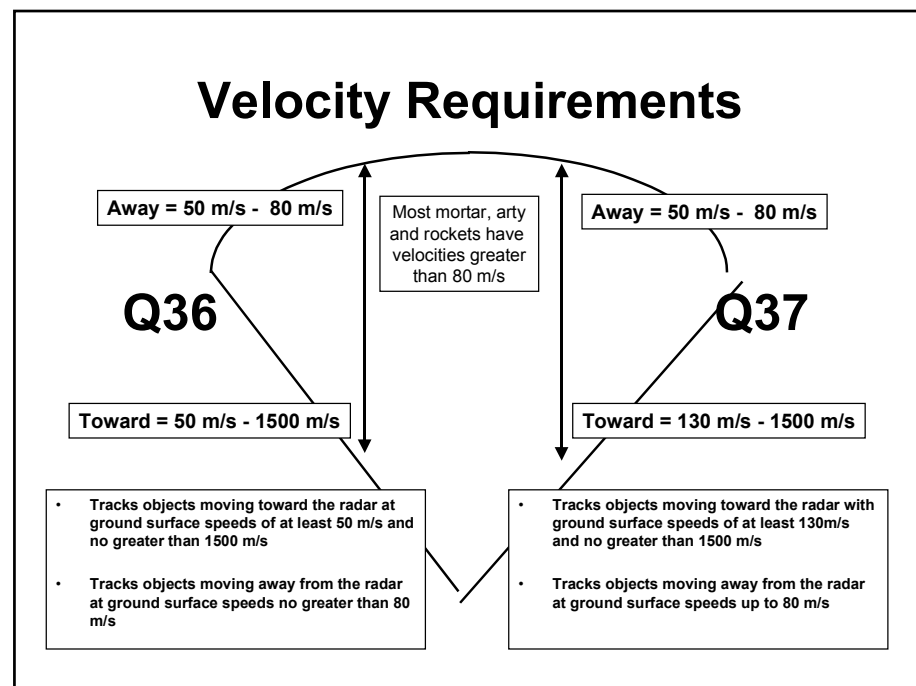

Figure 4-5. Velocity Requirements

DETECTION, VERIFICATION AND LOCATION PROCESS

Establishing the search fence is the first step performed by the radar for detecting an object. The radar accomplishes this by transmitting a series of beams that conform to the terrain. Once an object penetrates the search fence, the radar determines the object's speed, elevation, range and azimuth. The radar uses this information to predict the object's next location and to send out verification beams to determine if the object has a ballistic trajectory.

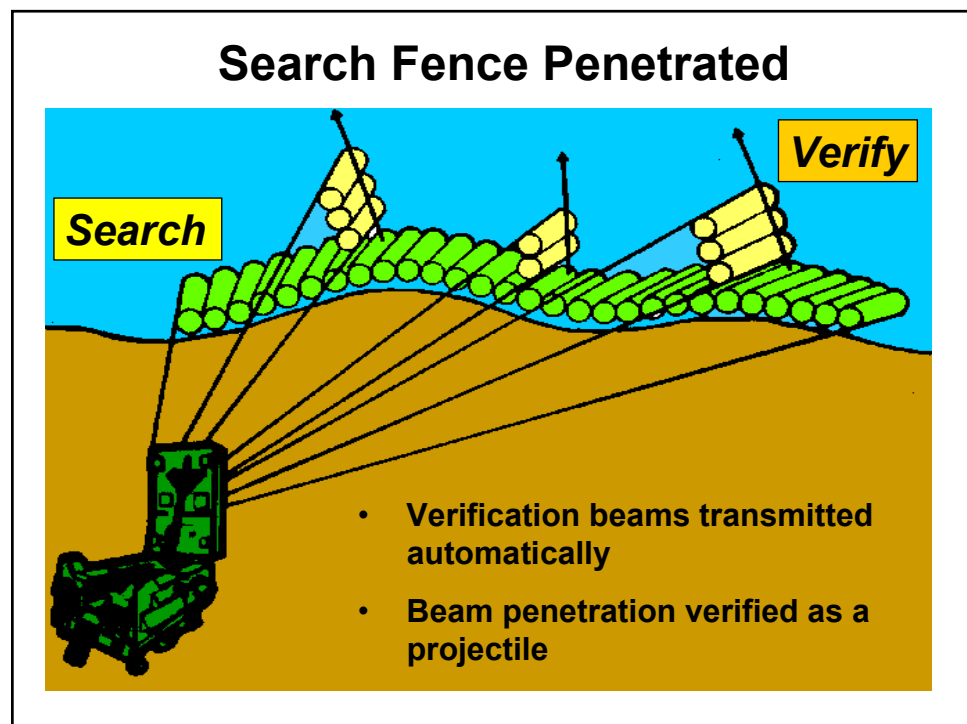

Figure 4-6. Object Verification

If a ballistic trajectory is verified, the radar sends out a series of tracking beams. These beams provide the radar with the information required to mathematically extrapolate a predicted launch and impact point. The radar stops sending out tracking beams when the following conditions exist:

- A solution is computed for the acquisition.
- Three sequential misses happen for the Q-36 or five sequential misses for the Q-37.
- The predicted azimuth for the next track update is outside the left or right limit of the radar's search sector.
- The predicted elevation of the next track is above or below the radar's minimum or maximum search elevation.

Figure 4-7 depicts how an object is tracked.

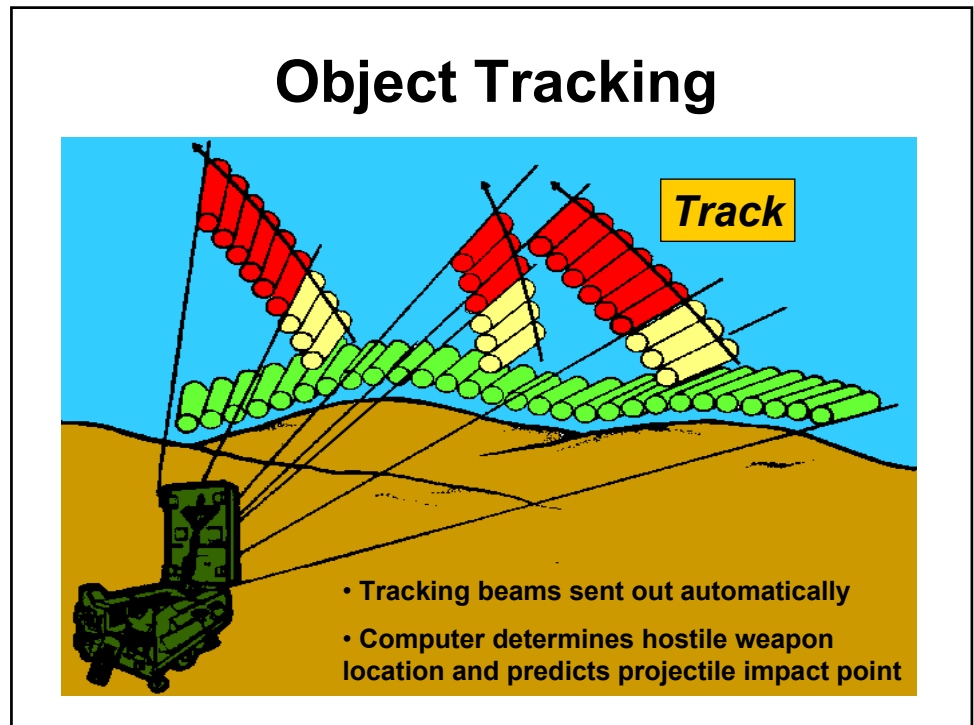

Figure 4-7. Object Tracking

THE RADAR BEAM

To completely understand how the radar functions one must understand the structure of the radar beam and how the radar uses the beam to track an object traveling through the detection area. A radar beam is actually composed of four individual beams that comprise a track cluster. We normally refer to this track cluster simply as a radar beam. Figure 4-8 shows a cross section of a radar beam.

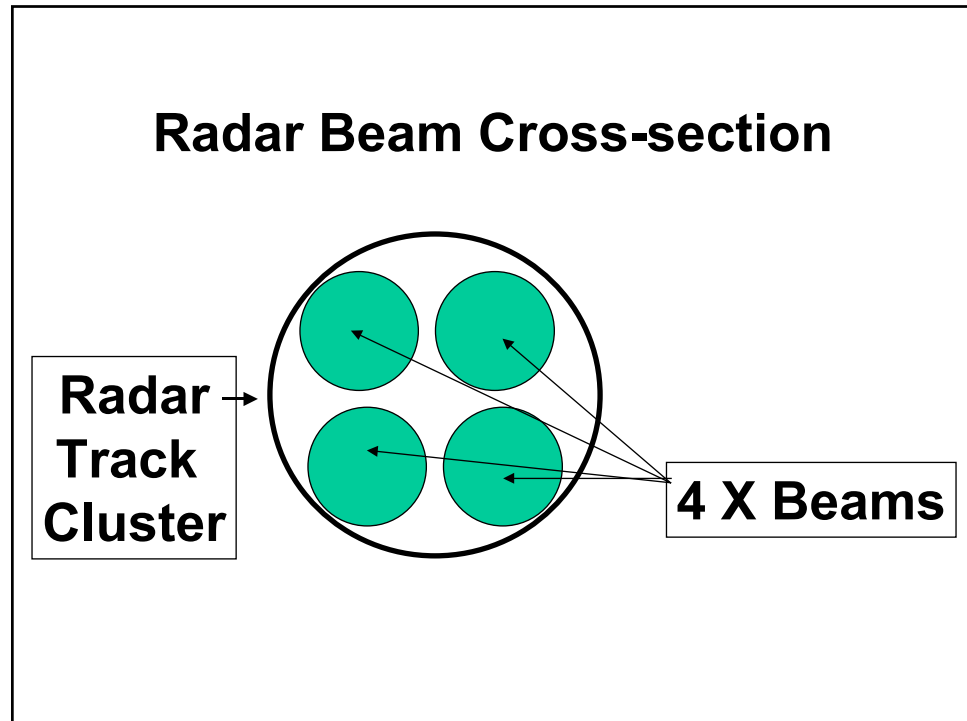

Figure 4-8. Radar Beam

There are three possible outcomes when an object passes through the search fence and the radar transmits a verification or tracking beam. The outcomes are miss, hit, or plot. A miss occurs when the projectile strikes none of the individual beams in the track cluster. A hit occurs when at least one beam in the track cluster is struck, but not all. A plot occurs when the following conditions occur:

- All four beams of the track cluster detect the object.
- The detected range of the object is within 75 meters of the predicted range.
- The detected azimuth is within 20 mils of the predicted azimuth for the Q-36 or 15 mils for the Q-37.
- The detected elevation is within 15 mils of the predicted elevation for the Q-36 and 10 mils for the Q-37.

When the radar achieves an adequate number of plots it computes a solution for the weapons location and impact predict point. The number of plots required to achieve a solution varies based on radar type, initial detection range and the tracking time. In general, the Q-36 needs between 3-15 plots depending on the reasons for track termination. The Q-37 requires 5-12 plots at ranges less than 30 km and a minimum of 15 plots at ranges greater than 30 km. Figure 4-9 summarizes the tracking process.

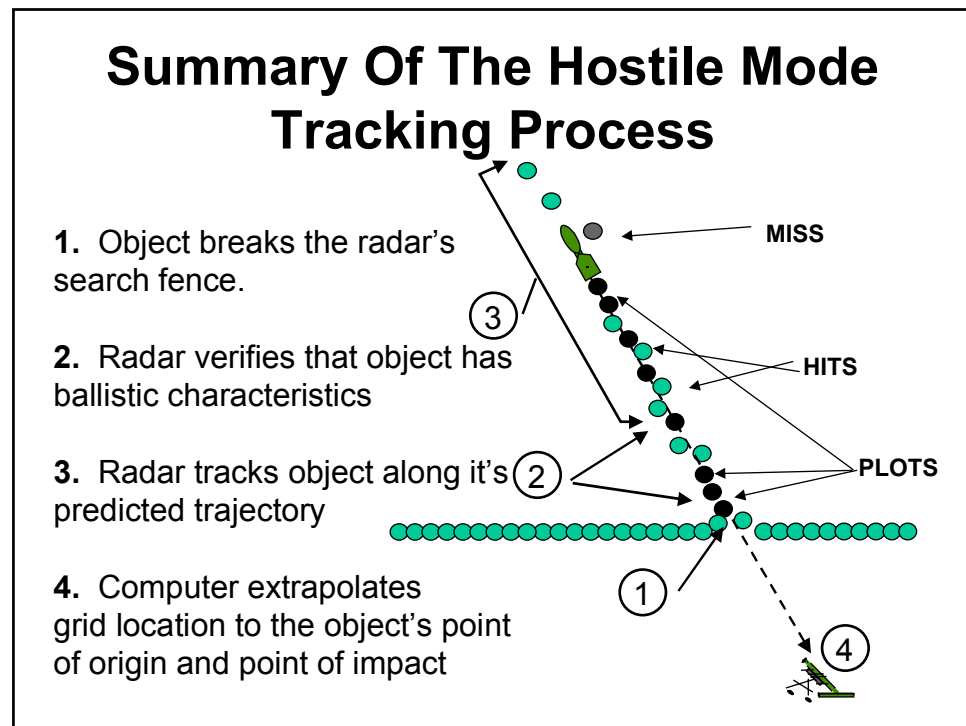

Figure 4-9. Tracking Process

FRIENDLY MODE

The methodology used by the radar to detect, track and determine an impact or burst location in the friendly mode is the same as that for the hostile mode. The major differences are the size of the search fence, angle-T and orientation of the radar. In friendly mode the radar tracks projectiles as they travel away from the radar. Therefore, the radar detects and tracks the projectile on the descending leg of its trajectory. The detection area in the friendly mode is significantly smaller since the search sector must be narrowed to approximately 440 mils. Finally, angle-T, the angle formed by the radar and gun-target lines, must be between 800 and 1200 mils. A detailed discussion of friendly fire mode procedures is contained in Appendix C.

SECTION II – RADAR SYSTEM CHARACTERISTICS

MISSIONS

The primary mission of AN/TPQ-36 and AN/TPQ-37 weapons-locating radars is to detect and locate enemy mortars, artillery, and rockets quickly and accurately enough to permit immediate engagement. Their secondary mission is to observe registrations and help the FDC adjust fire for friendly artillery units. The secondary mission should be performed only when absolutely necessary. Radiation time should be reserved for the primary mission.

AN/TPQ-36(V)8

The AN/TPQ-36 is optimized to locate shorter-range, high-angle, lower velocity weapons such as mortars and shorter-range artillery. It can also locate longer-range artillery and rockets within its maximum range. For mortars and artillery, the higher probability of detection extends to approximately 14,500 meters for artillery and 18,000 meters for mortars. Rockets can be detected with reasonable probability out to 24,000 meters. Minimum and maximum detection ranges can be established; however, at least 900 meters difference in maximum and minimum ranges is required. The radar's antenna electronically scans a horizontal sector from 230 mils to 1,600 mils in width. The Q-36 can search up to 6,400 mils by using the extended azimuth search function. With extended azimuth search, the computer automatically traverses the antenna from two to four positions and performs its target location functions.

The AN/TPQ-36(V)8 can be emplaced and ready for operation within 9 1/2 minutes with a crew of four and can be march-ordered within 4 1/2 minutes during daylight hours. (Emplacement and march-order times do not include the time needed to set up or take down camouflage nets.)

TARGET CLASSIFICATION

Q-36 legacy systems classify acquisitions as three distinct target types. The types are artillery, mortar or unknown. Both cannons and rockets are classified as artillery. The probability of a correct target classification is 90%. The Q-36 does not classify targets by subtype. Therefore, mortar targets are classified as mortar/unknown and artillery targets are classified as artillery/unknown. The unknown target type is interpreted differently depending on whether the receiving device is an initial fire support automated system (IFSAS) or AFATDS. The unknown target will default to target type personnel/unknown in IFSAS and target type terrain/feature in AFATDS.

The Q-36(V)8 radar has the added capability of classifying acquisitions as rockets. However, like Q-36 legacy systems, it does not classify targets by subtype.

PROBABILITY OF LOCATION

The probability of location varies based on target type, range, quadrant elevation, and number of projectiles being simultaneously tracked. Other factors that may affect probability of location are target elevation above the mask, wind velocity, precipitation and the electromagnetic spectrum. In general, the Q-36 can locate up to ten simultaneously firing weapons with quadrant elevations greater than 300 mils without degradation in location probability. This holds true as long as no more than two projectiles are being tracked or new firings do not occur at ranges greater than 7500 meters from acquisition being processed. When both of these conditions occur, the probability of location may decrease by as much as 55%. Wind, rain and electromagnetic countermeasures do not degrade the performance of the radar when the following conditions exist:

- Winds do not exceed 35 miles per hour.
- Rain does not exceed 2 millimeters per hour.
- When a 100-watt ground based emitter's radiation is separated by five or more beam widths from the radar azimuth.

The probability of locating a mortar projectile is 90% or greater at ranges from 3000-18,000 meters over the center 1067mils of the radar's search zone. Outside the center zone the 90% location band is from 3000-15,000 meters. For ranges from 750-3000 meters the probability of location decreases from 90% to 45% in a linear fashion based on range.

The probability of locating cannons is 70% or greater for all ranges between 3,000 and 14,500 meters over the center 1067mils of the radar's search zone. Outside the center zone the 70% location band is from 3,000 to 11,500 meters. Figure 4-10 shows the higher probability coverage areas for mortars and artillery.

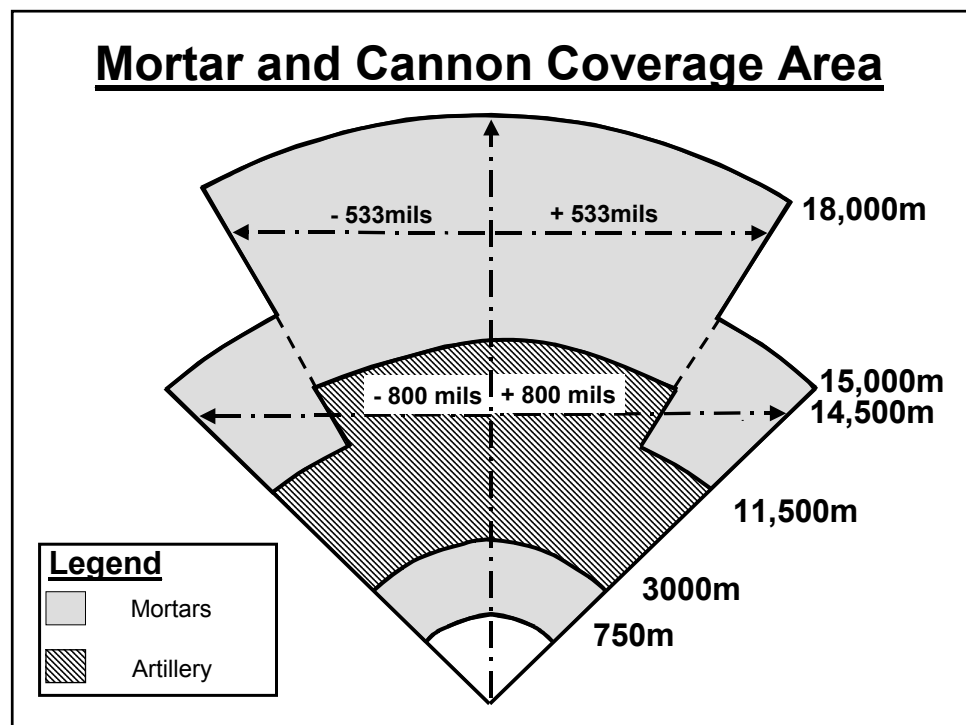

Figure 4-10. Q-36 Mortar and Cannon Coverage Areas

Finally, the probability of locating rockets is at least 80% across the entire radar sector for all ranges from 8,000-24,000 meters. As previously discussed the target will be categorized as artillery. The range to the target and the results of IPB will likely be the only indicator that a target is a rocket. Figure 4-11 depicts the coverage area for rockets.

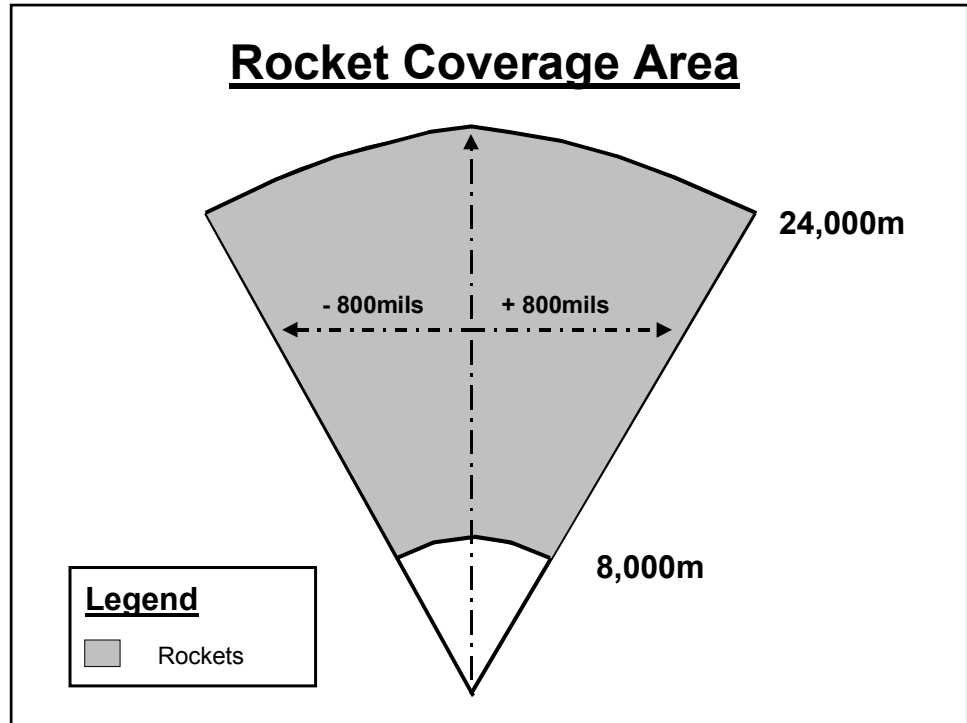

Figure 4-11. Q-36 Rocket Coverage Area

ACCURACY

The accuracy, or target location error (TLE), is generally characterized as the percentage of locations computed that are within a certain distance of the actual firing location for a specific type of projectile. TLE is generally characterized as the radius in meters from the actual weapon locations that 90% and 50% of the computed weapon locations would be located. TLE is an important factor in determining the method of target attack. The maximum 50% TLEs by projectile type are:

- Mortar – 40m or .4% of range whichever is greater.
- Cannon – 65m or .65% of range whichever is greater.
- Rocket – 120m or 1% of range whichever is greater.

The maximum 90% TLEs by projectile type are:

- Mortar – 100m or 1% of range whichever is greater.
- Cannon – 150m or 1.5% of range whichever is greater.
- Rocket – 300m or 2.5% of range whichever is greater.

Table 4-1 provides 50% TLE data and Table 4-2 provides 90% TLE data.

Table 4-1. Maximum 50% Target Location Errors

Target Category	3km	5km	8km	11km	14km	15km	18km	24km
Mortar	40m	40m	40m	44m	56m	60m	72m	
Cannon	65m	65m	65m	72m	91m			
Rocket			120m	120m	140m	150m	180m	240m

Table 4-2. Maximum 90% Target Location Errors

Target Category	3km	5km	8km	11km	14km	15km	18km	24km
Mortar	100m	100m	100m	110m	140m	150m	180m	
Cannon	150m	150m	150m	165m	210m			
Rocket			300m	300m	350m	375m	450m	600m

SYSTEM COMPONENTS

The AN/TPQ-36(V)8 consists of an operations control group (OCG), antenna transceiver group (ATG), equipment trailer group (ETG), remote control display terminal (CDT), power distribution group (PDG), trailer mounted auxiliary generator, and a M998 HMMWV for transporting the auxiliary generator trailer. Figure 4-12 depicts the complete AN/TPQ-36(V)8 system.

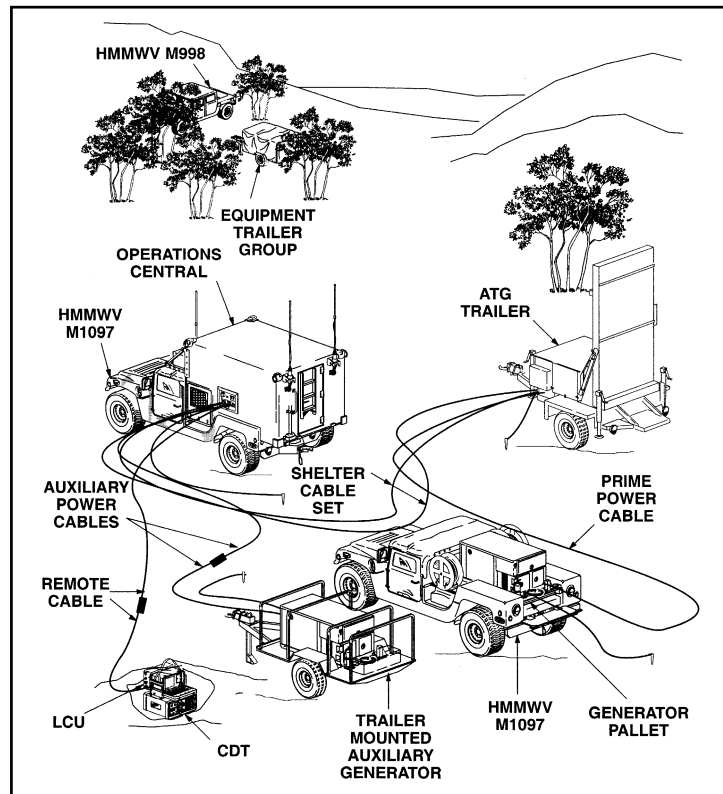

Figure 4-12. The AN/TPQ-36(V)8 Radar System

Operations Control Group

The OCG is the focal point for operating the radar. It consists of a lightweight multipurpose shelter (LMS), a M1097 HMMWV, and the vehicle cab control console (VCCC). The LMS houses the operations central (OC), which controls radar operations. The LMS consists of a paper map display, two operator control stations (OCS), a radar signal processor, two environmental control units, a gas particulate filter unit, a remotable control display terminal (CDT), a line printer and communications equipment. Each OCS consists of a LCU and a color monitor. During normal operations, the right OCS is used to control the radar set. The left OCS is used for planning and as an alternate control console. The communications equipment contained in the shelter consist of the EPLRS and remote devices to control the two SINCGARS radios contained in the ATG. The VCCC contains equipment for remote control of communications, site selection, and location reporting operations from the HMMWV cab. It contains the connections for a removable LCU that allows these functions to be performed during movement. Figure 4-13 shows the operations control group.

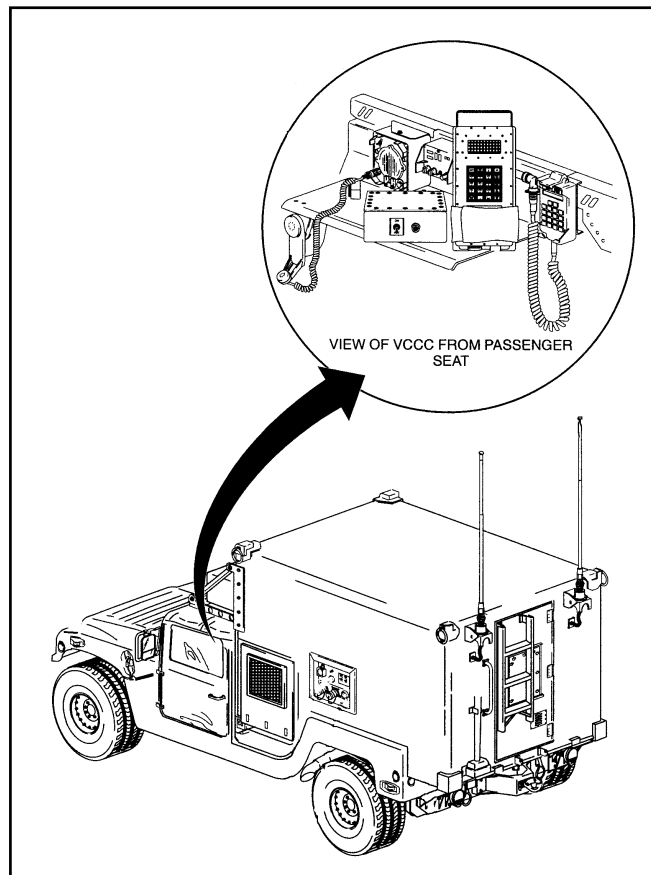

Figure 4-13. Operations Control Group

Antenna Transceiver Group

The ATG consists of the antenna, antenna trailer and all of the radiating elements and associated feed, tilt sensor, beam steering unit, and boresight telescope assembly. The antenna is erected to the vertical position during operations and lowered to the horizontal position for transport. The OCG HMMWV transports the ATG. Figure 4-14 depicts the ATG.

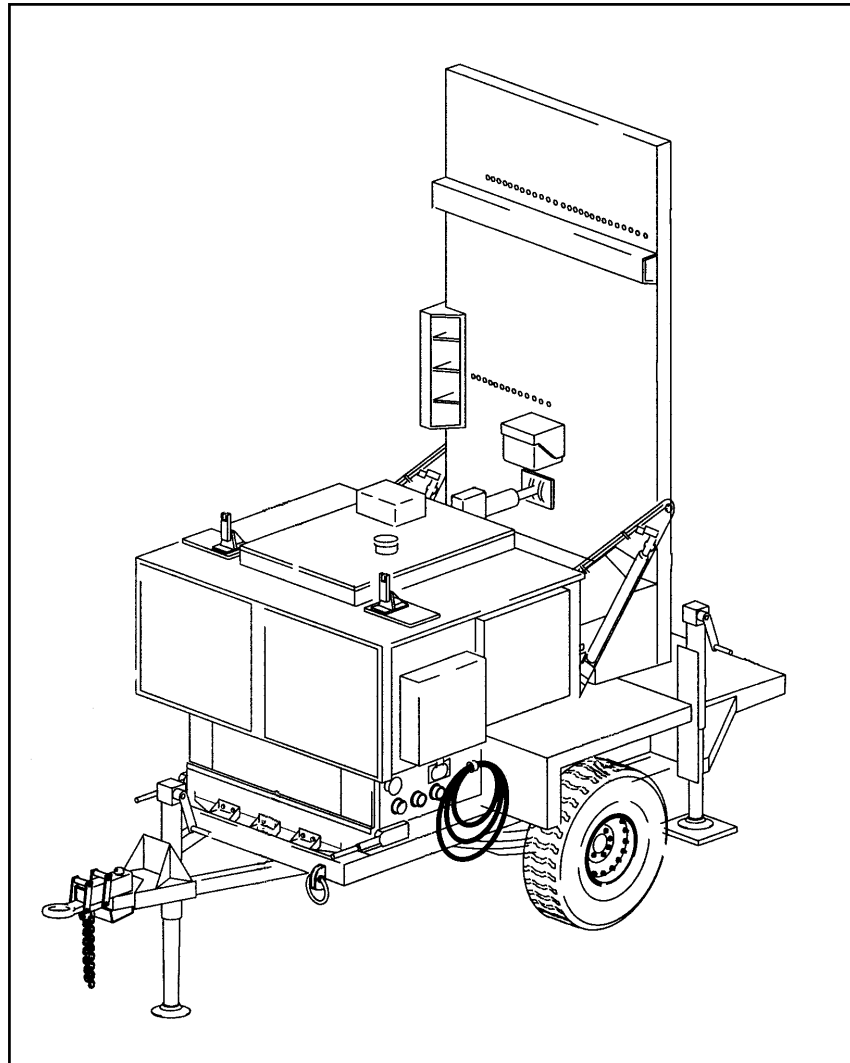

Figure 4-14. Antenna Transceiver Group

Equipment Trailer Group

The ETG consists of a modified M116A3 trailer that provides storage and transport of section equipment. The ETG contains four cable spools. The two upper center cable spools contain two 50-meter remote CDT cables. These cables connect the remote CDT to the ATG shelter. The two lower outside spools contain the shelter cable set. The shelter cable set consists of a 50-meter prime power cable that provides power from the ATG to the shelter

and a 50-meter data cable that provides signal interface between the ATG and the shelter. Refer for Figure 4-15 for cable locations.

During movement, the ETG is towed by the M1097 that contains the primary generator pallet.

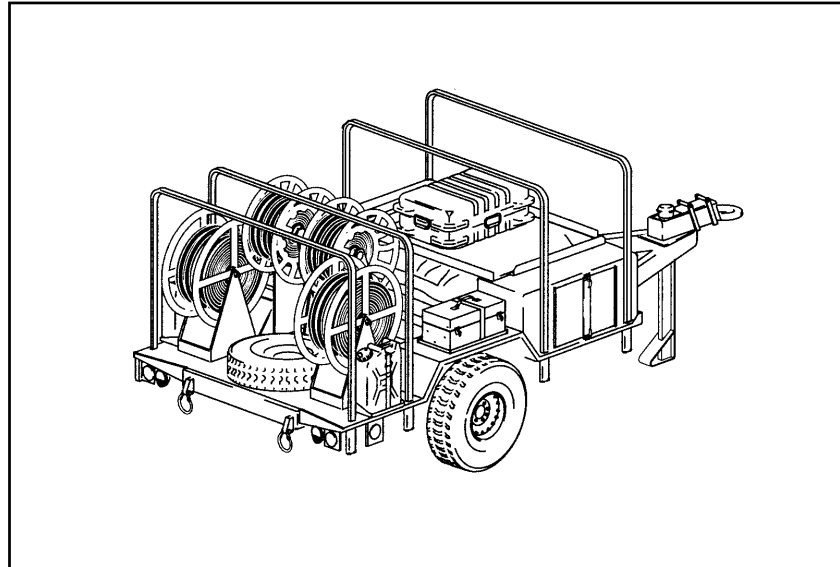

Figure 4-15. Equipment Trailer Group

Remote Control Display Terminal

The remote CDT consists of a LCU and a CDT and permits the remote operation of shelter components. The CDT is normally stored in its case inside the shelter until required for operations. It is removed for use along with one of the LCUs from inside the shelter. Normally the left LCU is removed from the shelter. The CDT can be remotod up to 90 meters from the shelter using the remote CDT cables stored on the ETG. This allows the required 10 meters of slack in the cables. Figure 4-16 shows the configuration of an operational remote CDT.

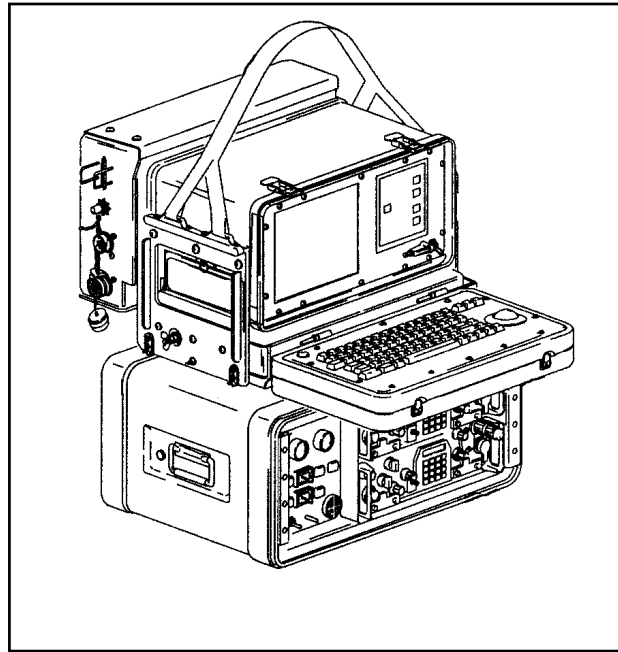

Figure 4-16. Remote Control Display Terminal

Power Distribution Group

The power distribution group consists of generator pallet mounted on a M1097 HMMWV, and the prime and auxiliary power cables. The generator is a 400HZ 10KW precise power generator mounted on a special pallet. The prime and auxiliary power cables are contained on two spools that are mounted on either side of the generator pallet. The prime power cable is a 40-meter cable that connects the PPG generator to the ATG. The auxiliary power cable is a 40-meter cable that connects the auxiliary generator to the shelter. This allows the operation of the second air conditioner contained in the shelter. Figure 4-17 depicts the PPG.

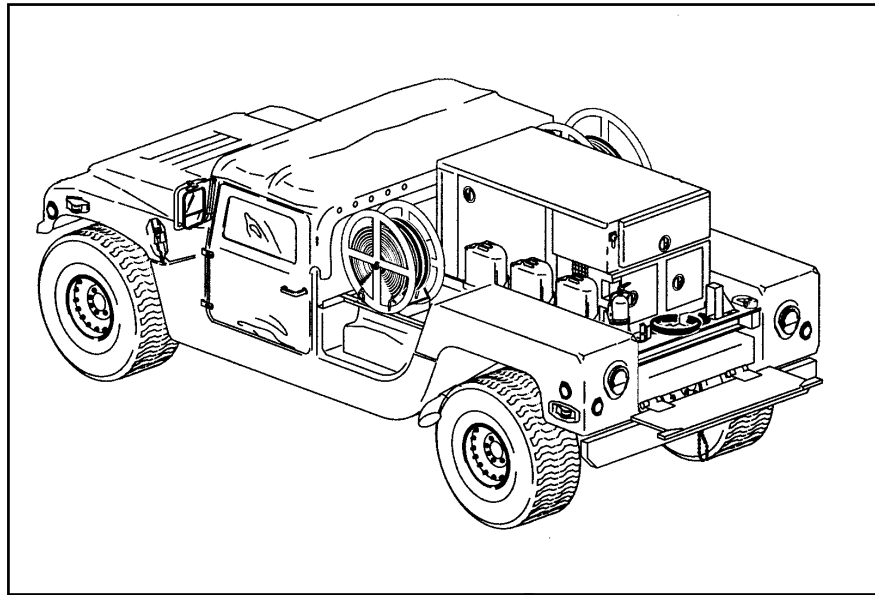

Figure 4-17. Prime Power Group

Trailer Mounted Auxiliary Generator

The trailer mounted auxiliary generator is a PU-799 or 400HZ 10KW generator mounted on a M116A2 trailer. The trailer is towed by the M998/M1038 utility HMMWV during movement. Figure 4-18 shows the trailer mounted auxiliary generator.

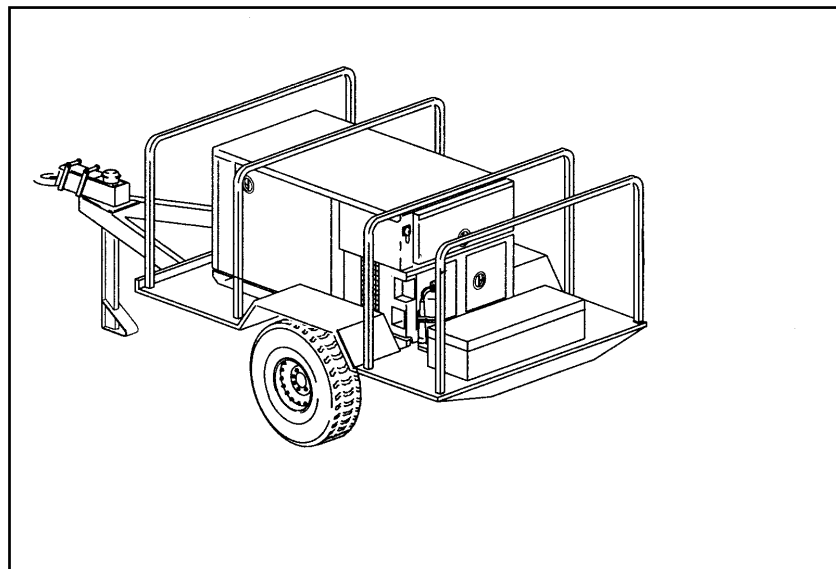

Figure 4-18. Trailer Mounted Auxiliary Generator

AN/TPQ-37

The AN/TPQ-37 is a phased-array artillery locating radar system designed to detect mortars artillery and rockets. The Q-37 is optimized to locate longer-range, low-angle, higher velocity weapons such as long-range artillery and rockets. However, it will also locate short-range, high-angle, lower velocity weapons thus complementing the AN/TPQ-36. The Q-37 has a minimum range of 3 kilometers and a maximum range of 50 kilometers. For artillery, the higher probability of detection extends out to approximately 30 kilometers. Minimum and maximum detection ranges can be established for the Q-37. However, there must be at least 900 meters difference in maximum and minimum ranges.

The Q-37 sector of search is from 300 mils to 1,600 mils. Although the Q-37 is not equipped with the extended azimuth search function, the antenna can traverse a full 6400 mils. The Q-37 is normally deployed 8 to 12 kilometers behind the FLOT and can be emplaced and ready for operation within 30 minutes and march-ordered within 15 minutes during daylight hours. (Emplacement and march-order times do not include the time needed to set up or take down camouflage nets.)

TARGET CLASSIFICATION

The Q-37 classifies acquisitions as three distinct target types. The types are artillery, mortar or rocket/missile. The Q-37 does not differentiate subtypes for these target types. The subtypes default to unknown. The target classifications generated by the Q-37 for transmission to IFSAS/AFATDS are MORT/UNK, ARTY/UNK and RKTMSL/UNK. The algorithm used to locate mortars is a post-fielding software patch designed to provide an addition capability for operation needs. The mortar functionality has not been fully tested so probability and accuracy data is not available. The acquisition ranges for mortars are the same as the ranges for artillery.

PROBABILITY OF LOCATION

The factors affecting the Q-37's probability of location are the same as for the Q-36. In general, the Q-37 can locate up to ten simultaneously firing weapons with quadrant elevations greater than 300 mils without degradation in probability of location. This is true when no more than two projectiles are being tracked or new firings do not occur at ranges less than 6,000 meters or greater than three-quarters of the specified range for a specific projectile type. When both of these conditions occur, the probability of location may decrease to a probability of detection no lower than 50%. Wind and rain do not degrade the performance of the radar when the following conditions exist:

- Winds do not exceed 40 miles per hour with gusts to 75 miles per hour.
- Rain does not exceed 5 inches per hour with horizontal wind gusts of 40 miles per hour.

The probability of locating a cannon projectile is 85% or greater at ranges from 4,000-30,000 meters when weapon quadrant elevations are greater than

200 mils at ranges less than 10,000 meters and 300 mils at ranges greater than 10,000 meters. The ranges vary depending on the size of the projectile. The range fan for detecting light cannon is from 4,000 to 20,000 meters over the entire search sector. For medium cannon, the range fan is from 4,000 to 25,000 meters over the center 1067 mils of the search sector and 4,000 to 20,000 meters over the outside sector of the search sectors. The range fan for heavy cannon is from 4,000 to 30,000 over the center 1067 mils of the search sector and 4,000-22,000 meter over the outside search sectors. Figure 4-19 shows the higher probability coverage areas for cannons.

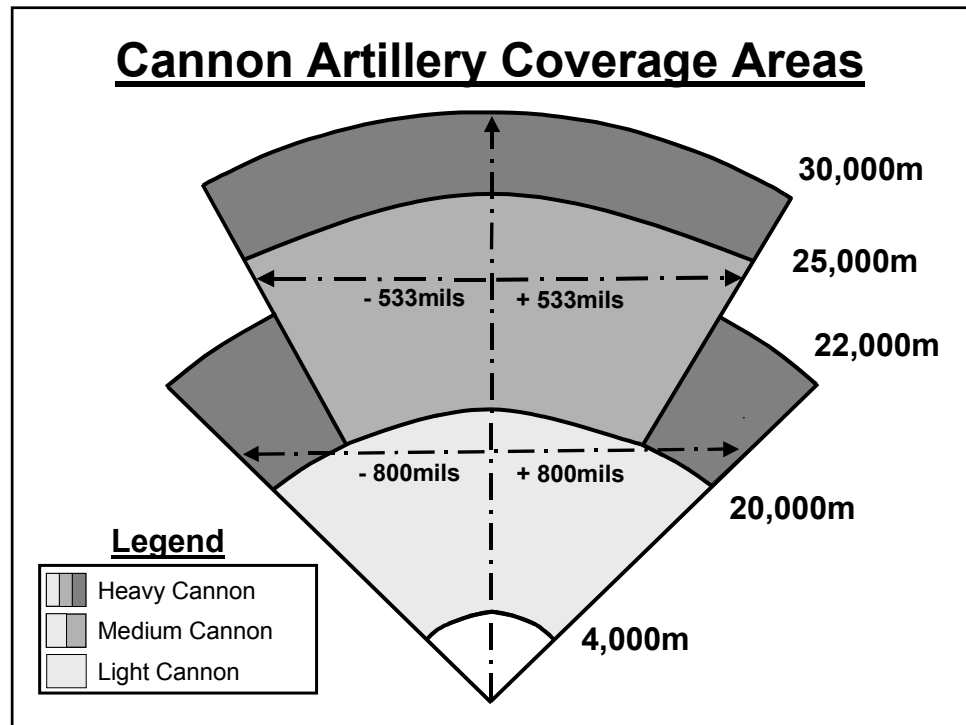

Figure 4-19. Q-37 Cannon Artillery Coverage Areas

The probability of locating long-range rockets up to 762mm in diameter is at least 85% for quadrant elevations greater than 300 mils. The detection ranges are between 4,000 and 50,000 meters over the center 1067 mils of the search sector and 4,000-37,000 meters across the outside search sectors. Figure 4-20 depicts the coverage area for long-range rockets.

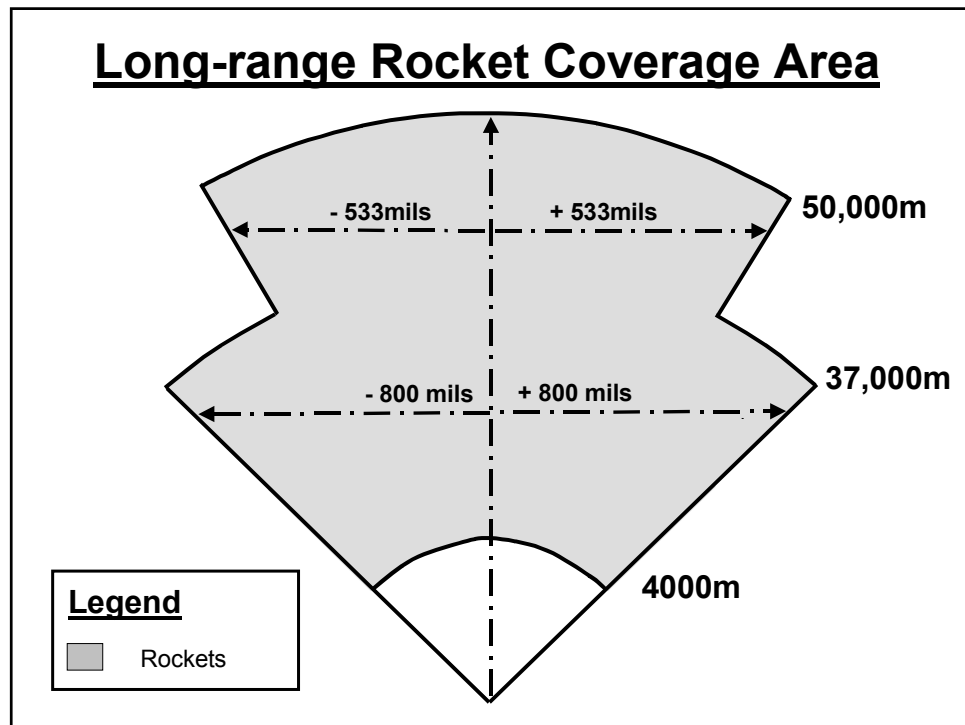

Figure 4-20. Q-37 Rocket Coverage Areas

ACCURACY

The accuracy, or target location error for the Q-37 is characterized in the same manner as for the Q-36. The maximum 50% TLEs by projectile type are:

- All cannon – 35m or .35% of range whichever is greater.
- Long-range rocket – 70m or .4% of range whichever is greater.

The maximum 90% TLEs by projectile type are:

- All cannon – 90m or .9% of range whichever is greater.
- Long-range rocket – 175m or 1% of range whichever is greater.

Table 4-3 provides 50% TLE data and Table 4-4 provides 90% TLE data.

Table 4-3. Maximum 50% Target Location Errors

Target Category	Ranges							
	4km	10km	20km	22km	25km	30km	37km	50km
Mortar	N/A	N/A	N/A	N/A	N/A	N/A		
Cannon	35m	35m	70m	77m	88m	105m		
Rocket	70m	70m	80m	88m	100m	120m	148m	200m

Table 4-4. Maximum 90% Target Location Errors

Target Category	Ranges							
	4km	10km	20km	22km	25km	30km	37km	50km
Mortar	N/A	N/A	N/A	N/A	N/A	N/A		
Cannon	90m	90m	180m	198m	225m	270m		
Rocket	175m	175m	200m	220m	250m	300m	370m	500m

SYSTEM COMPONENTS

The AN/TPQ-37(V)8 consists of an operations control group (OCG), antenna transceiver group (ATG), power distribution group (PDG), trailer power distribution unit, M998/M1038 HMMWV and a FMTV for transporting the trailer power distribution unit. Figure 4-21 depicts the major components of the AN/TPQ-37(V)8 system.

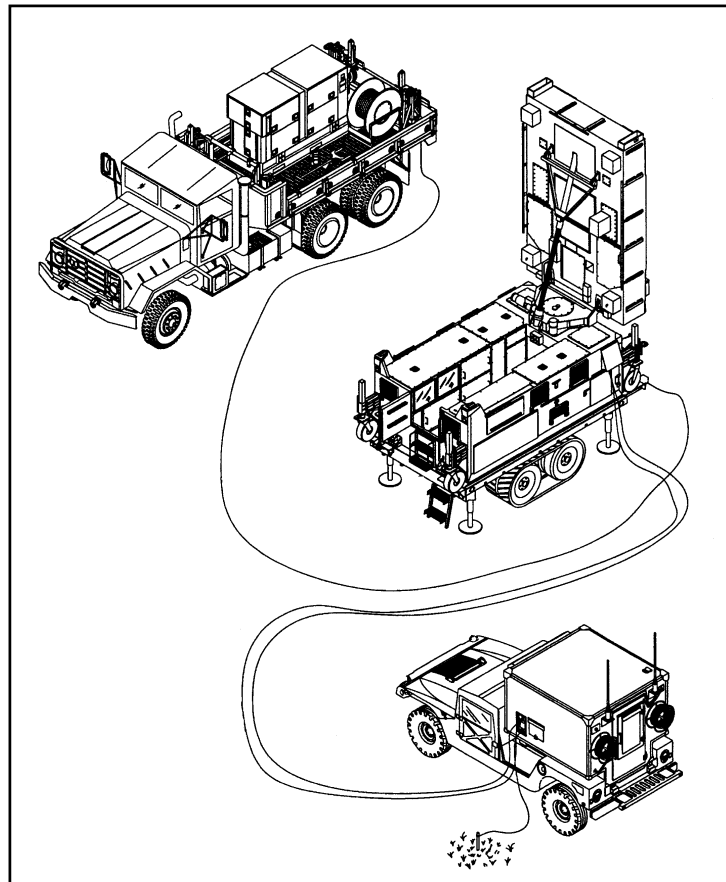

Figure 4-21. The AN/TPQ-37(V)8 Radar System

Operations Control Group

The OCG is the focal point for operating the radar. It consists of a S-250 shelter, a M1097 HMMWV, and the shelter cable set. The shelter contains the computer, printer, signal processor, displays, B-scope, weapons location unit, and the magnetic tape unit. The shelter cable set consists of two 50-foot cables. These cables connect the shelter to the ATG. One cable is a power cable that provides power from the ATG to the shelter. The second cable is a data cable that allows data exchange between the antenna and the shelter. The cables are stored on cable spools attached to the back of the shelter during movement. An alternate method of storing the cables is to place them in the HMMWV bed under the shelter. This allows the cables to remain connected to the shelter during movement. This technique is often used since it shortens the required emplacement time for the radar. Figure 4-22 shows the operations control group.

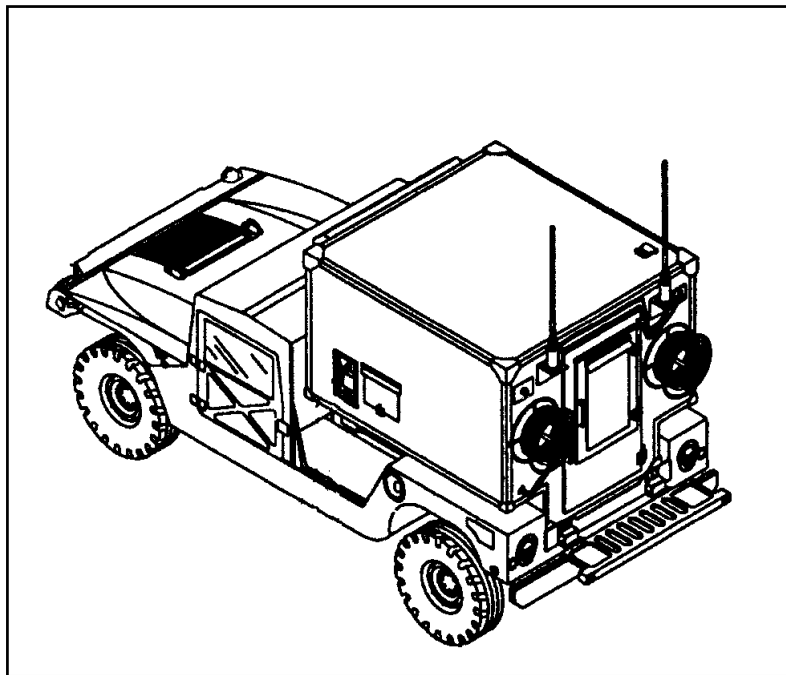

Figure 4-22. Operations Control Group

Antenna Transceiver Group

The ATG consists of the antenna, modular azimuth positioning system (MAPS), a modified M1048A1 antenna trailer and all of the radiating elements and associated feed, receiver preamplifiers and receiver protectors, azimuth and elevation positioning circuits, beam steering circuits, tilt sensor, and boresight telescope. The antenna is erected to the vertical position during operations and lowered to the horizontal position for transport. The PDG 5-ton truck tows the ATG during movement. The modified M1048A1 trailer is equipped with the medium track suspension system (MTSS). The MTSS is designed to improve the mobility of the trailer when traveling over soft soil, sand, mud and snow covered terrain. MAPS is an inertial surveying system

designed for use in the ground mobile environment. It provides the radar with an on-board position location and survey capability. MAPS uses a vehicle motion system to determine the location of the radar antenna. MAPS provides the radar with the following information:

- Horizontal position (easting and northing) to the nearest meter.
- Altitude to the nearest meter.
- Grid azimuth to the nearest mil.

Figure 4-23 depicts the ATG.

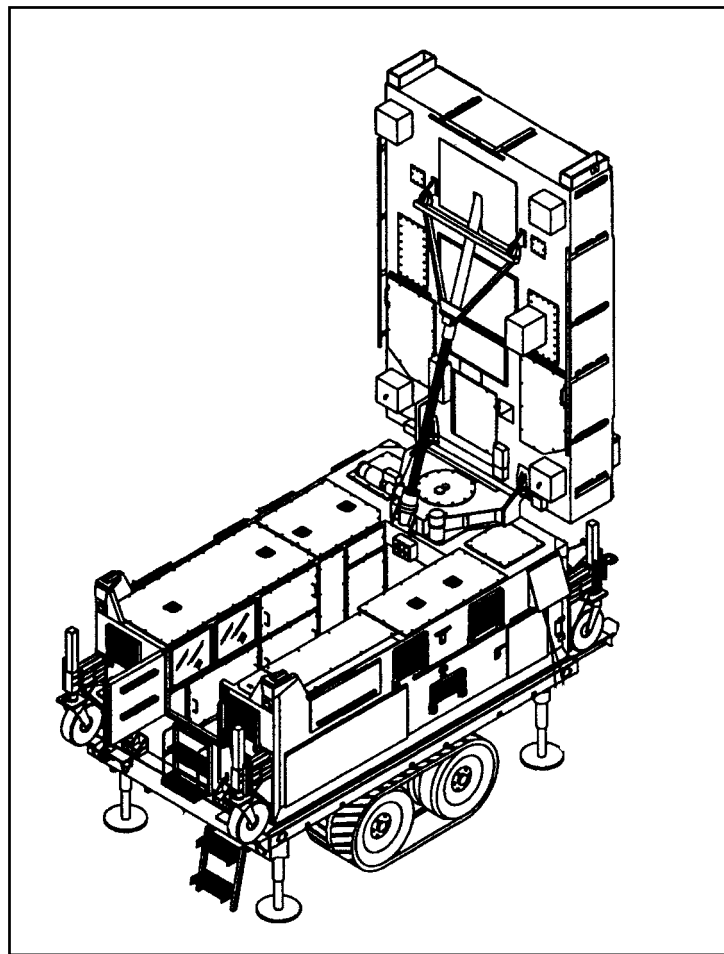

Figure 4-23. Antenna Transceiver Group

Power Distribution Group

The PDG consists of generator pallet mounted on a M923/925 5-ton truck, and the prime power cable. The generator is a 400HZ 600KW precise power tactical quiet generator mounted on a special pallet. The prime power cable is contained on a spool that is mounted on the left rear of the generator pallet. The prime power cable is a 32-meter cable that connects the PDG generator

to the ATG via a power distribution box with an eight-meter cable. This allows the PDG to be positioned up to 30 meters from the ATG given the requirement for 10 meters of slack in the cable. Figure 4-24 shows the PDG.

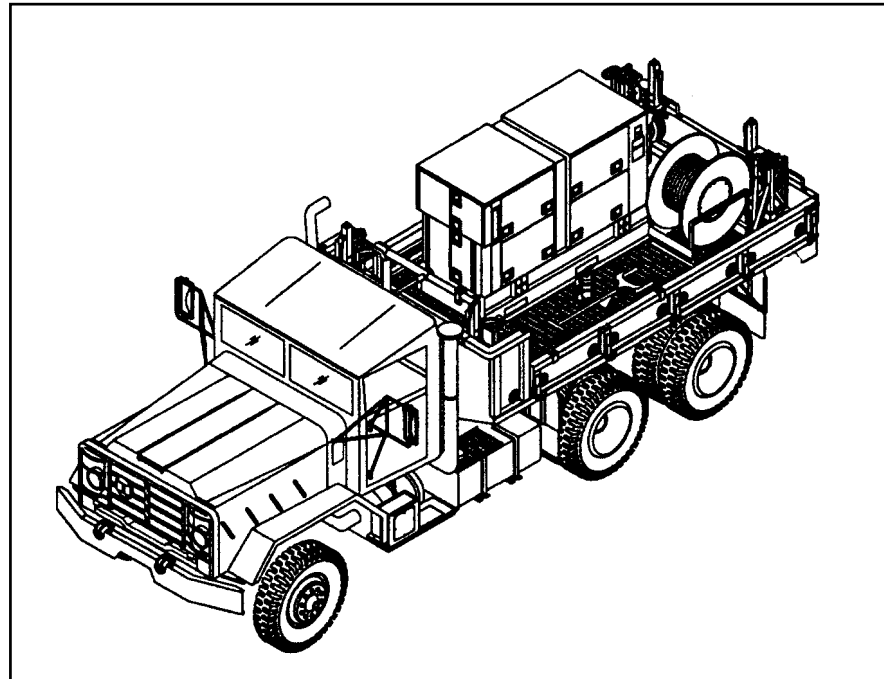

Figure 4-24. Power Distribution Group

Trailer Power Distribution Unit

The trailer power distribution unit (TPDU) is a PU-806 or 400HZ 60KW generator mounted on a M200A1 trailer. The trailer is towed by the FMTV during movement. Figure 4-25 shows the TPDU.

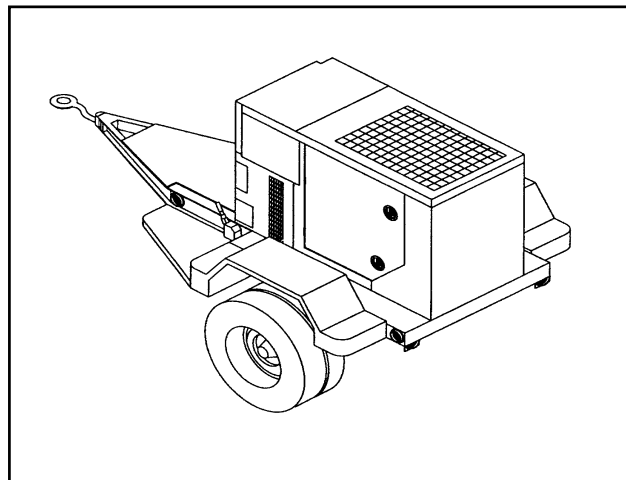

Figure 4-25. Trailer Mounted Auxiliary Generator

AN/TPQ-37 Version Differences

There are currently four versions of the Q-37 in service, the AN/TPQ-37(V)8, AN/TPQ-37(V)7, AN/TPQ-37(V)6, and the AN/TPQ-37(V)5. The upgrade between the version 5 and version 6 radar added Kevlar to the ATG. Version 7 added the modified M1048A1 trailer with MTSS. The major upgrades occurred between version 7 and version 8. The differences between version 8 and previous versions include:

- The operations central (OC) shelter is transported on a M1097 HMMWV instead of an M35A2 2-1/2 ton truck.
- The antenna is mounted on the M1048A1 trailer instead of the M1048 trailer.
- A M925 5-ton truck has replaced the M813 series generator truck.
- The 800 or 900 series cargo truck has been replaced by a medium tactical vehicle (MTV).
- The antenna transceiver group (ATG) contains a modular azimuth positioning system (MAPS).
- The ATG has an improved cooling system.
- The PDG generator pallet and ATG contain wheels that allow the components to be loaded onto C-130 and C141 aircraft without external ground equipment.
- The antenna transceiver group has fragmentation protective plating.
- The antenna contains an upgraded transmitter.
- The radar shelter contains upgraded operations control.
- The radar is Package 11 software compatible.

Figures 4-26 and 4-27 depict the operational configurations of these radars.

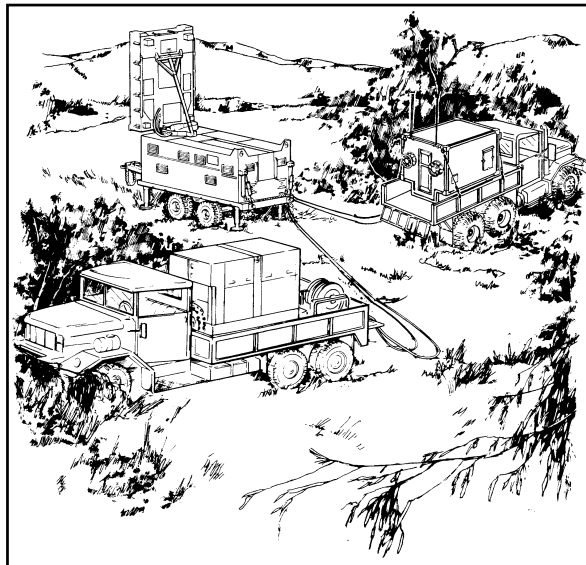

Figure 4-26. Radar Set AN/TPQ-37(V)

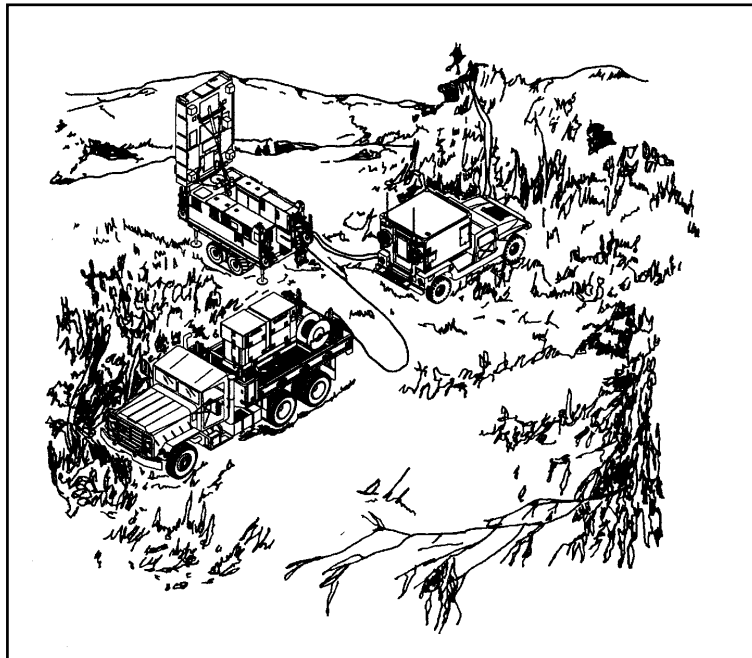

Figure 4-27. Radar Set AN/TPQ-37(V)8

SECTION III – TECHNICAL ASPECTS OF SITE SELECTION, POSITIONING AND OPERATIONS

SITE SELECTION

The technical aspects and characteristics of radars determine the requirements for site selection. The radar section leader selects the actual radar site from the position area(s) identified by the DS field artillery battalion S2 and radar section leader during the MDMP or as designated by the targeting or counterfire officer. The technical considerations for site selection include:

- Slope.
- Area in front of the radar.
- Screening Crest.
- Aspect angle.
- Electronic line of sight.
- Track volume.
- Proximity of other radars.
- Cable lengths.

SLOPE

Slope is an import consideration for the proper positioning of the radar. The slope of the terrain must be 7 degrees (120 mils) or less to ensure proper

leveling of the ATG. The ATG will not operate properly without leveling. There are also safety considerations associated with sighting the radar on slopes greater than recommended. Some slope is advantageous and enhances radar functioning. Slope also provides drainage to the radar sight that can help prevent radar components from becoming stuck during periods of heavy or continuous rainfall.

AREA IN FRONT OF THE RADAR

The area in front of the antenna should be clear of foliage that extends above the bottom of the antenna. Radar signals can be attenuated by more than 1 dB per meter of heavy foliage. A few meters of foliage can severely reduce radar effectiveness. A clear area in front of the radar minimizes attenuation of the radar beam. This area should extend 200 meters in front of the radar for the Q-36 and 300 meters in front of the radar for the Q-37. The ideal site will have a clear area in front of the radar that has a gentle downward slope for approximately 200-300 meters and then gradually rises up to the screening crest. This reduces multipath errors. Multipath errors are errors in target location created when radar transmit or return signals travel by more than one path.

SCREENING CREST

A screening crest increases the survivability of the radar by serving as a defense against enemy observation (visual and infrared), direct fire, and electronic countermeasures. The screening crest also helps attenuate sound. Ideally, the screening crest should be in friendly territory and located approximately 1000 meters in front of the radar, perpendicular to the radar's azimuth to center sector. The vertical angle to the screening crest should be between 15 and 30 mils for the Q-36 and 5 and 15 mils for the Q-37. The optimum vertical angle is 10 mils. Further, the difference between the highest and lowest points on the screening crest should not exceed 30 mils. A difference of more than 30 mils reduces the ability of the radar to produce enough track volume to compute a weapon location or impact predict point. The vertical angle between the radar antenna and the top of the screening crest is called a mask angle. Appendix F contains a detailed discussion of mask angle.

ASPECT ANGLE

The aspect angle is the angle between the radar beam and the target path. The aspect angle must be more than 1600 mils in hostile mode and between 800 and 1200 mils (angle-T) in friendly mode. Since the radar is a doppler radar, a target moving directly away or directly toward the radar produces the greatest change in frequency and a more accurate target location.

ELECTRONIC LINE OF SIGHT

The overriding consideration in the selection of a radar site is electronic line of sight. The radar must have electronic line of sight (ELOS) to the projectile being detected to acquire the weapon. However, ELOS to the weapon is not required. The radar technician should verify ELOS before occupying the site.

This can be done manually or with the Firefinder Position Analysis System. Verifying ELOS before occupying a radar site can save valuable time by eliminating untenable radar sites prior to their occupation.

TRACK VOLUME

Track volume is the amount of vertical coverage required by the radar to detect a projectile and compute a solution. The track volume is determined by the vertical scan of the radar and the amount of vertical scan lost because of the terrain contour, or screening crest in front of the radar. Firefinder radars require 50 mils of track volume to detect a projectile. Further, the difference between the high and low mask angles should not exceed 30 mils. A detailed discussion of track volume is contained in Appendix F.

PROXIMITY OF OTHER RADARS

Other radar systems or active emitters can interfere with radar coverage by attenuating or jamming the radar beam. Radars and emitters close in proximity or azimuth of search may cause jamming. Inadvertent jamming can be avoided by careful planning of radar positions.

CABLE LENGTHS

Cable lengths must be considered when selecting a radar site. The cables determine the maximum extent to which the components of the radar can be dispersed. The location of system components is determined by terrain contour, foliage, site access, and threat. Ideally, the radar components should be positioned to take advantage of naturally available cover and concealment. Nonetheless, cable lengths may dictate the actual positions. Table 4-5 provides a consolidate listing of cable lengths for the Q-36.

Table 4-5. Q-36 Cable Lengths

Cable	Length (m)
Prime Power Cable	32m (105 ft.)
ATG Power Cable	8m (26 ft.)
Shelter Power Cable	50m (164 ft.)
Shelter Data Cable	50m (164 ft.)

Based on these lengths, the Q-36's OCG can be placed up to 40 meters from the ATG and 30 meters from the PDG. The remote CDT can be located up to 90 meters from the shelter when using both CDT cables. Emplacement of system components must allow for 10 meters of slack in the cables to prevent damage to cable heads and connectors. Table 4.6 shows the cable lengths for the Q-37.

Table 4-6. Q-37 Cable Lengths

Cable	Length (m)
Prime Power Cable	40m (131 ft.)
Auxiliary Power Cable	40m (131 ft.)
CDT Cable (x2)	50m (164 ft.)
Shelter Power Cable	50m (164 ft.)
Shelter Data Cable	50m (164 ft.)

Based on the cable lengths in Table 4-6, the Q-37 OCG can be placed 40 meters from the ATG. The PDG can be placed up to 30 meters from the ATG given the combined lengths of the prime power and ATG power cable. The requirement for 10 meters of cable slack also applies to the Q-37.

SITE ACCESS

The radar site should have more than one route of approach. Routes of approach should be accessible by section vehicles, free from enemy observation, and capable of being guarded by a minimum number of personnel. The quality of access must also be considered. Some essential considerations include:

- Accessibility during poor weather conditions. Can the position be accessed during periods of rain and snow? Positions that may deteriorate during inclement weather should be avoided to prevent stranding the radar.
- Overhead clearance. Avoid locations where trees, power or telephone lines may damage radar components when entering and exiting the position. Check the clearance requirements for tunnels and overpasses to ensure section equipment does not exceed requirements.
- Bridges. Check the bridge classifications on routes to radar positions. Ensure that the bridge classification of section equipment does not exceed the load bearing capabilities of the bridge.
- Fords. Check fords to ensure they are passable to the radar section equipment. The ATG for the Q-36 and Q-37 can only ford 30 inches of water. If heavy rains are expected some positions may become untenable because of fording restrictions.
- Obstacles. Check routes for current and planned obstacles. These obstacles may include road craters, tank ditches, abates, or wire obstacles. Also check for natural obstacles such as fallen trees and rockslides. Ensure that the access is sufficient to allow egress after combat has occurred. Rubble from buildings, utilities and fallen trees should not prevent the radar section from displacing from a position.

POSITIONING

Positioning is based on the technical requirements and capabilities of the radar and tactical considerations. The overriding factor in positioning is mission accomplishment. Mission, enemy, terrain, troops, time available, and

civil considerations (METT-TC) are paramount when selecting radar positions. The DS battalion S2 in conjunction with the targeting officer or controlling FA headquarters designates general position areas for radars. The radar section leader selects the actual radar site within the position area.

TACTICAL CONSIDERATIONS

Radar position areas are selected based on IPB, the range capabilities of the radar, and METT-TC. A thorough analysis of METT-TC will dictate which factors are most important. Generally, in a traditional battlespace, radars are positioned far enough from the FLOT to acquire enemy weapons, prevent loss of the radar to enemy action, and avoid unnecessary movement. This maximizes radar coverage and cueing time. Given the radar's minimum range and the necessity to avoid conflicts with maneuvering friendly forces, the Q-37 is normally positioned 8-12km from the FLOT and the Q-36 3-6km behind the FLOT. This rule of thumb may change based on the tactical situation. In stability and support operations, radars may be positioned inside an intermediate staging base (ISB) or enclave.

Mission

Radars must be positioned where they can best accomplish their mission. Several factors drive positioning in relation to mission considerations. The supported unit, commander's guidance, associated command and support relationship, and required sector of search dictate in general where the radar must be positioned. The requirements to conduct hostile and friendly operations add specificity to positioning requirements. Further, the requirements to establish priority zones influence radar positioning.

Enemy

The enemy situation and capabilities greatly influence where a radar must be positioned. A thorough IPB is essential to determining radar locations. IPB influences positioning in two ways. First, IPB identifies the areas where enemy systems are anticipated. This information and the commander's targeting guidance dictate the positioning and orientation of the radar. Further, IPB identifies enemy threats that must be considered when positioning the radar. These threats may include suspected locations of ground threats or special purpose forces, electronic warfare threats, major ground and air avenues of approach, and anticipated requirements for repositioning.

Terrain (and Weather)

Terrain effects movement, cover, concealment, communications, and positioning. In mountainous terrain, identifying positions that maximize the radar's range and capabilities is difficult. A position with an optimum screening crest may be difficult if not impossible to find. Terrain may also narrow the search sector because of inadequate electronic line of sight. On the other hand, flat or open terrain makes concealment difficult. Heavy rains, snow, sand storms, and dust storms can attenuate the radar signal and

degrade the probability of location. Heavy rains and snow can make some terrain impassable or the soil unstable. The effects of terrain and weather upon positioning must be considered or mission accomplishment will be jeopardized.

Troops

The size of the area to be covered and the number of radars available affect both positioning and employment. When multiple radars are available to support a unit, smaller search sectors may be assigned to specified radars. Further, positions should be selected that facilitate mutual support between radars. This allows one radar to assume all of or part of another radar's search sector and priority zones during displacement and movement. The number of crewmembers assigned to a radar section can also affect positioning. Sections manned at less than authorization may require additional support to accomplish the mission. This support may include security or maintenance above normal levels. Co-locating or positioning the radar in the vicinity of another unit may be required.

Time Available

The time available for reconnaissance, liaison, movement, occupation, and position improvement must be considered. Mission requirements and the amount of time available to position radars may require that a radar initially position in a less than optimum position then reposition at a later time as mission requirements dictate.

Civil Considerations

Civilians in the battlespace may impact positioning and radar operations. Positioning requirements may include additional security considerations when there is a hostile local populace. In addition to direct threats, movement routes may become blocked or congested by the local populace, refugees, or obstacles. However, a cooperative or friendly populace may enhance positioning options. Fixed facilities or other civil structures may become available for use by the radar section. Local logistical support may also be available.

OTHER CONSIDERATIONS

Cover

When possible, section equipment should be placed in a defilade, hardened structure or prepared position to protect the radar and crew. This provides the crew and some equipment with protection from hostile fire. Even so, the radar's ATG cannot be completely covered. The ATG can only be placed in a location that provides cover to the top of the ATG trailer. This provides protection for the ATG electronics while providing an unobstructed line of sight for the antenna. Placing the radar in a covered position also helps dissipate noise from the ATG and PDG, lowers susceptibility to direct observation, and reduces the radar's thermal and infrared signatures. In situations where a defilade or prepared position is unavailable, the radar crew should consider burying the radar data and power cables. The data

cable is one of the most vulnerable components of the radar system. It is susceptible to damage by indirect fires or by a vehicle driving over the cable. One broken or damaged wire in the cable can render the cable useless. The power and data cables should be buried in hand-dug trenches six inches deep, 12 inches deep when crossing roads. The trench should be free of rock and debris, as should the soil used to fill the trench. Engineer equipment should not be used to fill the trench because damage may occur to the cables and excess soil compaction may prevent recovery of the cables during radar displacement.

Concealment

Maximum use of natural concealment, such as trees and shrubs, should be considered in selecting a sight for the radar. Care should be taken to avoid obstructions in front of the antenna that might attenuate the radar beam. Buildings and other manmade structures can be used to conceal some section equipment. Concealment is also affected by where the radar site is located. The unit's IPB should identify likely enemy observation points. When possible, radar sites should be selected that avoid direct observation from these areas.

Communications

Communications between the radar and the supported unit will normally be conducted using FM digital and/or voice communications over SINCGARS or EPLRS. Electronic line of sight is required for FM communications. Radar positions must have adequate line of sight to facilitate FM communications with the supported unit. Further, radar positions must be in range of the organic communications or retransmission support must be provided

RECONNAISSANCE

The radar section leader conducts reconnaissance of general positions areas received from the controlling FA headquarters and selects actual radar positions. The reconnaissance will normally include a map reconnaissance, a site analysis using the FireFinder Position Analysis System (FFPAS), and a ground or air reconnaissance if time permits. At a minimum, a map reconnaissance and FFPAS analysis should be conducted. FFPAS is an excellent tool. However, it cannot replace the information gained from an actual ground or air reconnaissance. An actual reconnaissance is invaluable in determining the conditions in the position area and along movement routes.

MAP RECONNAISSANCE

The map reconnaissance is used to determine the following:

- Tactical situation in the position area. This requires a thorough review of the situational template and operational graphics. This review should identify contaminated areas, obstacles, minefields, known friendly and enemy locations, enemy observation posts, and enemy avenues of approach.
- Routes into and out of the position area.

- Identifying landmarks that can aid in hasty survey and navigation.
- Bridges, fords and bypasses leading into and out of the position area.
- Possible ambush and controlling terrain sites.
- Units that may be operating in the vicinity that may assist with security or medical assistance.
- Tentative radar sites for ground reconnaissance.
- Inter-visibility lines that may provide screening crests.
- Contour lines to provide information about ground slope.
- Significant terrain features that may enhance survivability or degrade radar performance.
- Possible alternate positions.

FFPAS ANALYSIS

Once tentative radar sites are determined, FFPAS is used to analyze the suitability of the site. FFPAS can provide the following information:

- Screening crest.
- Mask angle.
- Electronic line of sight.
- Optimum search fence.
- Estimated performance of the radar.
- Slope of the terrain.

GROUND RECONNAISSANCE

A ground reconnaissance should follow the map reconnaissance to determine passability of movement routes, validate position suitability, and facilitate the rapid occupation of the position. The ground reconnaissance is based on the factors of METT-TC and the technical and tactical considerations that influence radar operations. During the ground reconnaissance the radar section leader or section chief should accomplish the following:

- Determine routes of ingress and egress to the position area.
- Search and mark the area for obstacles and mines.
- Determine alternate positions and rally points.
- Determine the exact locations for the ATG and OC.
- Select a location for the PDG that minimizes its effects on operations.
- Determine vehicle locations that facilitate displacement.
- Measure and evaluate the screening crest.
- Obtain survey control to support MAPS/GPS requirements.
- Provide local security.

SURVIVABILITY CONSIDERATIONS

Survivability of the radar must be considered when selecting radar positions. Radars are susceptible to enemy ground attack, air attack, indirect fires and electronic warfare. A through IPB will identify possible threats.

GROUND AND AIR ATTACK

The radar section can take precautions to protect itself against ground and air attacks. The best protection against a direct attack is to position the radar in areas that prevent direct observation by enemy forces. This is important since most attacks by indirect fire or special purpose forces are initiated as a result of direct observation. Positioning outside of known enemy avenues of approach and air axes of advance will help avoid attack by enemy ground and air forces. Security measures may include dedicated maneuver forces or military police to provide on-site protection, or mutual support provided by units in the vicinity of the radar position. Mutual support arrangements might consist of early warning or incorporation of the radar in the supporting unit's defense plan. In addition, the radar section can protect itself by using cover and concealment. Selecting positions with natural or existing manmade cover and concealment is best. Engineer assets may also be tasked to provided prepared positions.

ELECTRONIC WARFARE

The radars electromagnetic signature makes it susceptible to electronic attack and radio direction finding (RDF). Standard signal security procedures can reduce the radar vulnerability to RDF. Detection by air and ground-based EW systems may present a greater problem. The IPB will identify known EW threats to the radar. Possible EW threats may include the IL-20 COOT (air), NRS-1, and NRS-X (ground systems). These systems are found in former Soviet-bloc countries. Selecting sites that lower the radar's electronic signature helps protect the radar against ECM threats.

Occupy Optimum Sites

The best countermeasure to enemy EW is to occupy optimum sites. An optimum site is one in which the radar is emplaced on level terrain having a gentle downward slope for the first 200-300 meters in front of the radar then a sharp rise to a screening crest.

Screening Crest

The use of a screening crest is critical when an enemy has ECM capabilities. The screening crest diffracts the radar beam making it difficult to determine the direction of the radar beam.

Double Screening Crest

The use of two screening crests makes the radar more difficult for the enemy to locate. The second crest further diffracts the radar beam making it more difficult to accurately locate the radar.

Tunneling

Tunneling is the technique of reducing the side, top, and back lobes of radiation by careful site location. Tunneling is accomplished by sighting the radar where vegetation is located to the sides and rear of the radar antenna. Tunneling may also be accomplished by digging-in or sandbagging the

position. The use of tunneling will reduce vulnerability to direction finding of side lobe radiation.

Orient on Soft Background

If there are no terrain features or vegetation to reflect or absorb the radar beam beyond the target area, the background is open. Unrestricted access to non-reflected radar beams is an ideal situation for enemy DF operators. Orienting on a soft background such as foliage, tree lines or brush reflects the radar beam and makes it more difficult to DF. Hard backgrounds such as rock, buildings, bunkers or other structures also reflect radar beams. However, soft backgrounds are better than hard backgrounds. The reflection of radar beams causes a phenomenon known as the multipath effect. During reflection the beam is bent and phase shifting occurs. This results in the same signal being received from multiple directions and out of phase making the signal more difficult to DF. The optimum background is an open background above a screening crest.

Reduce Radiating Time

The shorter time the radar transmits the lower the probability that the enemy will DF and obtain a fix on the radar. Transmission time should be reduced based on the enemy's detection capabilities to prevent being acquired. As a general rule, continuous radiation time should not exceed two minutes when the enemy has ECM capabilities. The radar survivability matrix in Table 4-7 can be used as quick reference to determine the total amount of radiation time from a position. Total radiation time should be adjusted based on the tactical situation. In situations with no ECM threat, continuous radiation should be the norm. The survivability flow chart in Figure 4-28 provides a detailed process for evaluating the electronic threat and determining total radiating time.

Table 4-7. Survivability Matrix

RADAR	SCREENING CREST	TUNNELING	EW THREAT (AIRBORN THREAT NOT COVERED)	RADAR POSITION HAS SCREENING CREST AND TUNNELING	RADAR POSITION HAS SCREENING CREST ONLY	RADAR POSITION HAS NEITHER SCREENING CREST NOR TUNNELING
WEAPONS LOCATING RADAR AN/TPQ-36	<ul style="list-style-type: none"> WITHIN 1,000 METERS OF RADAR POSITION IN FRIENDLY TERRITORY FROM 15 TO 30 MILS <p>ENEMY CANNOT ACHIEVE ELECTRONIC LINE OF SITE WITH HIS DIRECTION-</p>	USE OF FOLIAGE, BERM, OR BUILDINGS TO REDUCE SIDE-LOBE RADIATION	GROUND EW THREAT	ACCUMULATE 15 OR MORE MINUTES OF RADIATION	ACCUMULATE 8 OR MORE MINUTES OF RADIATION	RADIATE 8 MINUTES MINUS MARCH-ORDER TIME OR 2 MINUTES WHICHEVER IS GREATOR; MAKE SURVIVABILITY MOVE
			REVIEW WITH S2 CURRENT EW THREAT TO FIREFINDER	-but-	-but-	-but-
DO NOT EXCEED 2 MINUTES OF CONTINUOUS RADIATION						
			NONE	<ul style="list-style-type: none"> NO EW TIME LIMIT RADIATE AS MISSION REQUIRES MONITOR EW SITUATION 		
WEAPONS LOCATING RADAR AN/TPQ-37	<ul style="list-style-type: none"> WITHIN 1,000 METERS OF RADAR POSITION IN FRIENDLY TERRITORY FROM 15 TO 30 MILS <p>ENEMY CANNOT ACHIEVE ELECTRONIC LINE OF SITE WITH HIS</p>		GROUND EW THREAT	ACCUMULATE 15 OR MORE MINUTES OF RADIATION	ACCUMULATE 8 OR MORE MINUTES OF RADIATION	RADIATE 8 MINUTES MINUS MARCH-ORDER TIME OR 2 MINUTES WHICHEVER IS GREATOR; MAKE SURVIVABILITY MOVE
			REVIEW WITH S2 CURRENT EW THREAT TO FIREFINDER	-but-	-but-	-but-
DO NOT EXCEED 2 MINUTES OF CONTINUOUS RADIATION						

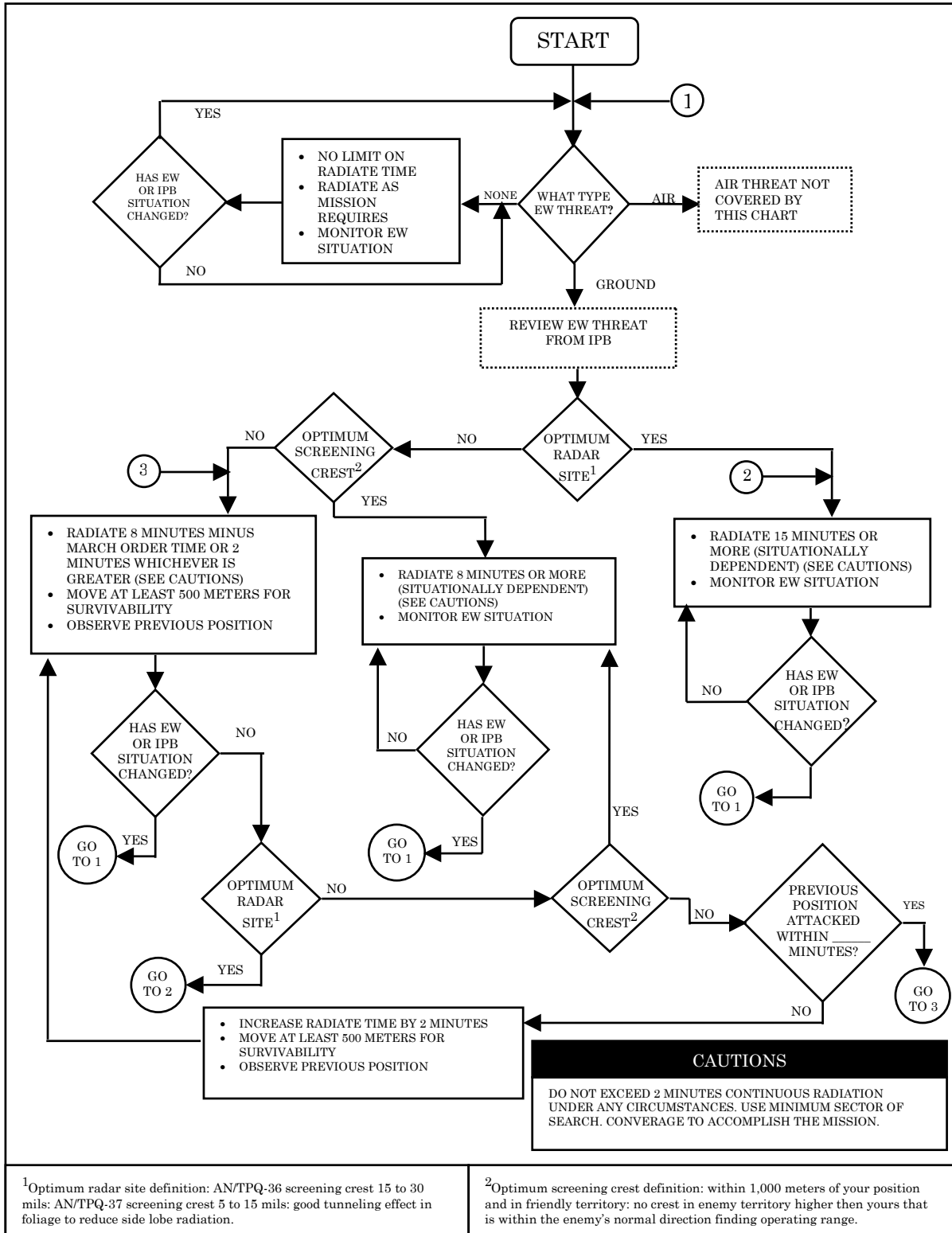

Figure 4-28. Survivability Flowchart

Operating Through Electronic Countermeasures

Operating through electronic countermeasures consists of detecting the presence of jamming or interference and performing actions to minimize or eliminate the effects of jamming.

Q-36. The radar indicates jamming by displaying a vertical line at the jamming azimuth on the operational display, by a printed jam strobe message, the INTFR/JAM indicator being lit on the operations screen, or for some types of jamming, displaying many short duration tracks on the monitor. To avoid degradation of radar performance the following tactics may be used:

- Turn on the radar's electronic counter countermeasures (ECCM) feature.
- Avoid operation within line of sight or in the same sector as the jammer.
- Operate on a different frequency than the jammer.
- Use deception.

Turning on the radar's ECCM functions allows the operator to activate the jam strobe and pulsed interference rejection functions. The jam strobe identifies jamming and identifies the azimuth of the jamming while pulsed interference rejection helps filter out interference from the jammer. If pulsed interference rejection doesn't work the other tactics can be implemented. Line of sight issues can be avoided by selecting optimal radar sights. Relocating a radar to avoid jamming may or may not be possible based on the tactical situation. Changing radar frequencies will sometimes help avoid the jammer's operating frequency. Increment frequencies one at a time and determine from the jam strobe indicator if the jammer is still present. Increase the frequency, starting at the lowest frequency, the least amount necessary to avoid degrading the radar's performance. If these steps don't work, it may be possible to fool the jammer by ceasing to radiate for a few minutes. Change frequencies then resume operations. This may help prevent the jammer from staying on the radar's operating frequency.

Q-37. The tactics for working through ECCM for the Q-36 are applicable to the Q-37. Further, the Q-37's jam strobe and pulsed interference rejection functions are similar to the Q-36. In addition, the Q-37 has a clear channel sensing (CCS) function. CCS is automatically turned on when the radar's operational program is entered. CCS passively scans the radar's 49 search beam positions using all 15 frequencies of each beam position and determines which frequencies are free of jamming or interference. A frequency report is provided to the operator. During operations, the CCS function disables frequencies and provides operator alerts based on the radar frequency mode in use. There are three frequency modes. They are:

- Single frequency.
- Diversity (the normal operating mode).
- Electronic countermeasures avoidance (ECMA).

In single frequency mode, the radar operates on a single frequency for all beams. If jamming is detected on the frequency, CCS activates the

DEGRADED/PRFM warning light indicating the radar is operating in a degraded mode. In diversity mode, a different frequency is used for each beam position. Up to five frequencies can be selected by the operator for each beam position. When operating in diversity mode, CCS disables individual frequencies within beam positions to avoid jamming. When only one frequency remains and it is not clear, CCS activates the DEGRADED/PRFM warning light. Finally, the radar can be operated in the ECMA frequency mode. This mode is used to combat ECM when ECM is seriously degrading the radar's performance. It should only be used under this condition because ECMA mode degrades the radars performance. In this mode, radar frequencies and beam positions are selected at random.

ANTIRADIATION MISSILES

Antiradiation missiles (ARM) can pose a significant threat to radars. US ARM employment uses the AGM-88 High speed Antiradiation Missile (HARM). Coalition Forces also employ the Alarm, Armat, AS-6, AS-9, AS-11 and AS-16. (Note: HARM and ARM can be used interchangeably, but the US exclusively uses the term HARM.) ARMs are of particular concern because friendly aircraft may inadvertently attack a radar (or "emitter") if unaware of its presence and operating frequencies. For example, if aircrews are unaware that an AN/TPQ-36 is radiating in the aircraft's area of operations it may be engaged as a possible SA-6 radar and attacked. Further, coalition aircraft may not have the ability to discriminate between enemy and friendly radar signatures exacerbating the risk to friendly radars. Danger to friendly radars may occur during situations where JSEAD is employed in support of deep maneuver operations, aerial interdiction or when receiving close air support. Coordination of radar information during the planning process can reduce the risk to friendly radars. The targeting technician must ensure that location is constantly updated and this information is passed to the battlefield coordination detachment (BCD). The Corps EWO must be cognizant of all emitters found on the battlefield, friendly, neutral and threat. The electronic order of battle (EOB) must include all emitters and be constantly updated to prevent a fratricide incident. It is imperative that the planners ensure that all radar locations are identified and disseminated. Pertinent information about radar in the AO can be submitted with the air support request for preplanned missions and passed directly to the aircraft by the ALO during terminal control of CAS. Information submitted for preplanned missions is analyzed at the air operations center (AOC) and aircraft rules of engagement (ROE) are developed and published in the airspace control order (ACO) and the special instructions (SPINS) of the air tasking order (ATO). The following information, as a minimum, must be passed to AOC via the BCD to deconflict radar operations and ARM employment:

- Radar type and purpose.
- Radar location.
- On-air/off-air times.
- Emitter parametrics.
- Frequency range.
- Pulse repetition frequency (PRF).

- Pulse repetition interval (PRI).
- Pulse width.
- Scan type/rate.
- Site specific patterns.
- Physical site set-up.
- Communications capabilities.
- Coordination frequencies and call signs.

If radar and ARM missions cannot be deconflicted, emitter shut down techniques must be used during ARM employment. This process can be tedious and time consuming. Preplanned CAS missions normally allow sufficient time to coordinate shutdown. However, during immediate CAS missions this may not be the case. The supported ground commander must balance the risk of fratricide with the need for SEAD to support immediate CAS. In some cases, the ground commander may decide it is neither tactically sound, nor possible, to quickly and effectively shut down friendly emitters. TTP for the employment of ARM are contained in FM 90-35, Multiservice Procedures for Antiradiation Missile Employment in a Joint Environment. Table 4.8 contains the Q-36 and Q-37 radar technical parameters for deconflicting radar operations and ARM employment.

Table 4-8. Radar Operational Parameters

Parameter	Q-36	Q-37
Radar Type	Pulse Doppler	Pulse Doppler
Frequency Range	9.37 – 9.99 Ghz	3.1 – 3.39 Ghz
PRF	7692.3 – 14,705 pps	2793.3 – 5050.1 pps
Pulse Width	1 millisecond	10.75 milliseconds
Modulation Type	Chirped pulses	Chirped pulses
Peak RF Power Output	73.6 dBm minimum	120 kW min
Duty Cycle	0.012	0.041

LOCATION AVERAGING

Location averaging is a functional part of the radar operational program that eliminates duplicate targets and prevents the loss of targets by eliminating backlogs in the radar's temporary display queue. This function is automatically turned on when the radar's operational program is loaded. Nonetheless, location averaging can be turned off if a requirement exists to identify target locations in close proximity to one another.

When a target is located it is placed in the temporary target queue pending operator action. Targets remain in the temporary queue until the operator stores or transmits the target. Storing or transmitting the target removes the target from the temporary queue and places the target in permanent storage. This frees space in the temporary queue. If the temporary queue becomes full, all further target acquisitions are lost until space is freed in the temporary queue. Location averaging automatically frees space in the temporary queue by averaging new targets with targets in permanent storage. If a new target is within 200 meters of a target in permanent storage, the radar will automatically average its location with the target in permanent storage, update the stored target's location, and remove the new target from the temporary input queue. This saves space in the input queue, eliminates duplicate targets, and saves permanent storage space. If the new target does not correlate with a stored target, it is placed in the temporary input queue pending operator action. Figure 4-29 demonstrates the concept of location averaging.

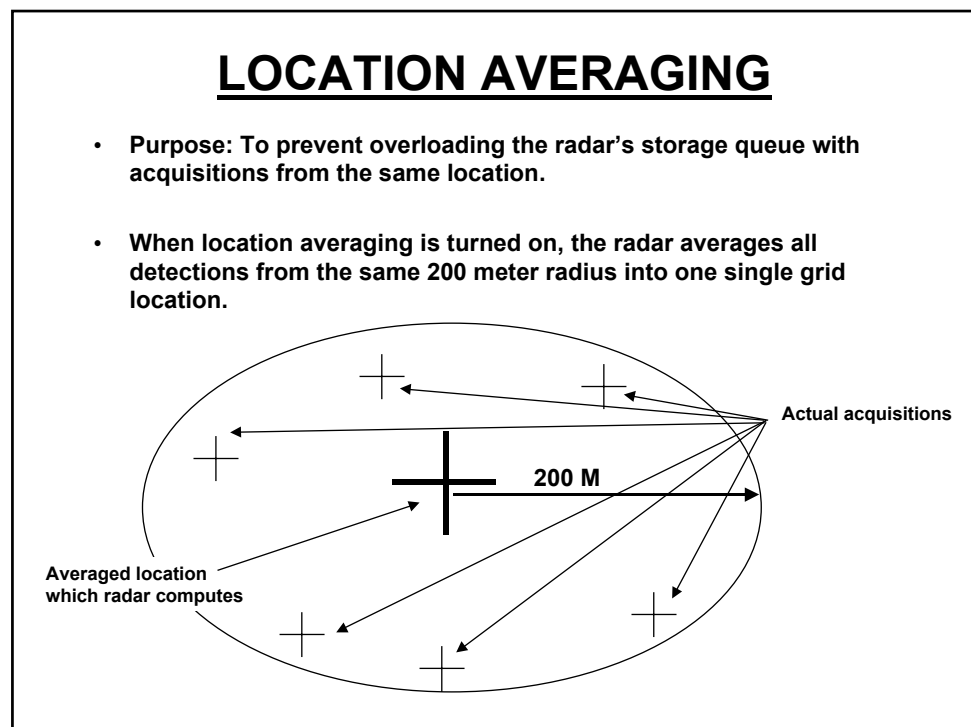

Figure 4-29. Location Averaging

AUTOMATIC HEIGHT CORRECTION

Height correction is an essential function that must be performed to accurately locate enemy weapons. Height correction is required because the radar thinks the altitude of the target is the same as the high or low datum plane depending on which was used to initialize the radar's computer. Without height correction the radar will locate a hostile weapon by backtracking the trajectory until it intersects the datum plane used during

initialization instead of using the actual terrain altitude. This can cause a significant error in target location.

The radar automatically performs height correction when digital terrain data is available, accurate, and loaded into the system. In the absence of digital terrain, manual height correction must be used. Figure 4-30 demonstrates the importance of height correction.

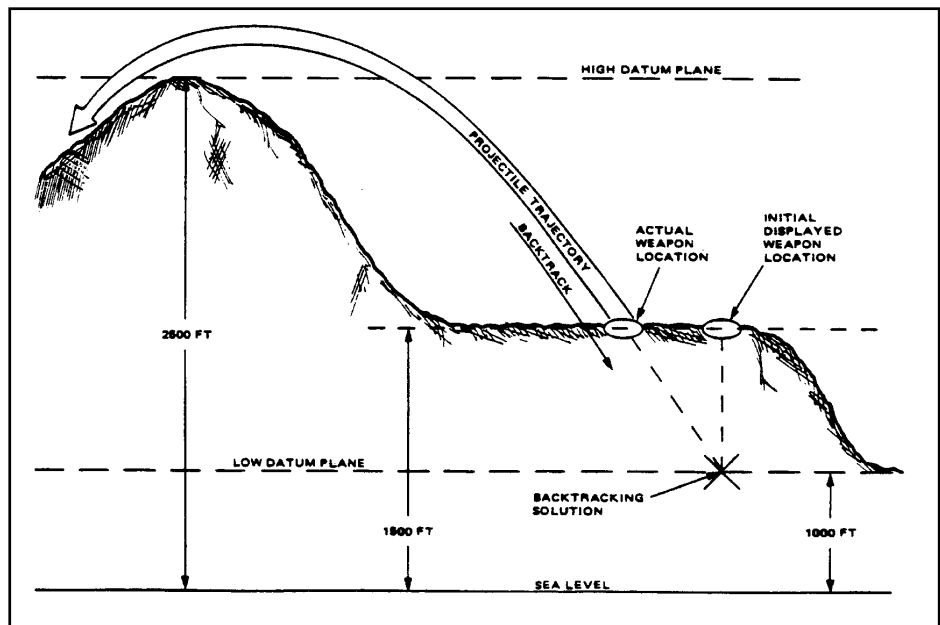

Figure 4-30. Height Correction Example

In the example shown in Figure 4-30, the initial height in the height display is 1000 feet (the height of the low datum plane), whereas the actual weapon location height is 1500 feet. Therefore, the weapon location indicated on the site map will be incorrect, and the height of this location will not agree with the height indicated by the height display. If the correct weapon location height of 1500 feet is known, it can be entered directly. When the new height is entered, the backtracking solution moves along the projectile trajectory to the intersection with the new height and that new point becomes the displayed weapon location. When the height of the location indicated on the site map and that indicated by the height display agree, no further height correction is required and the displayed location is correct.

AUTO CENSORING

The radar's auto censoring function is used during anticipated periods of heavy enemy fire or when the radar begins locating more than 10 targets per minute. Auto censoring maximizes the radar's ability to locate new firing positions, saves computer-processing time and saves space in the permanent target list. It accomplishes this by eliminating duplicate target tracks that exceed a specified threshold count. When auto censoring is on, the radar examines each new track for proximity to an existing weapon location. If the new track is within 500 meters of a known target, and exceeds the established threshold count, the track is dropped. The threshold count is the maximum number of tracks allowed from a known location. It can be set from 2-16 tracks. Normally, a lower threshold count is established during periods of higher enemy fire. Care must be exercised when using auto censoring since this function causes the radar to ignore acquisitions.

FIREFINDER POSITION ANALYSIS SYSTEM

The FireFinder Position Analysis System (FFPAS) is a computer tool that facilitates the sighting and set-up of radars. FFPAS determines radar coverage at a particular location by assessing the radar's ability to locate different types of enemy weapons. FFPAS is capable of performing, in minutes, calculations that require significantly more time when done manually. The rapid analyses capability of this computer-based system allows the radar section leader to quickly analyze alternative sites and evaluate potential radar coverage. FFPAS significantly reduces the time required to perform a detailed radar site analysis.

SITE ANALYSIS

The radar site is evaluated by specifying the position in the terrain database. The radar operator positions the radar in FFPAS by specifying the position's easting, northing and local reference datum on a pop-up menu. On a second menu, the antenna's mechanical azimuth boresight, left and right sector scan limits, and its minimum and maximum coverage ranges are specified. This information is used to construct a terrain plot. Figure 4-31 shows an example terrain plot.

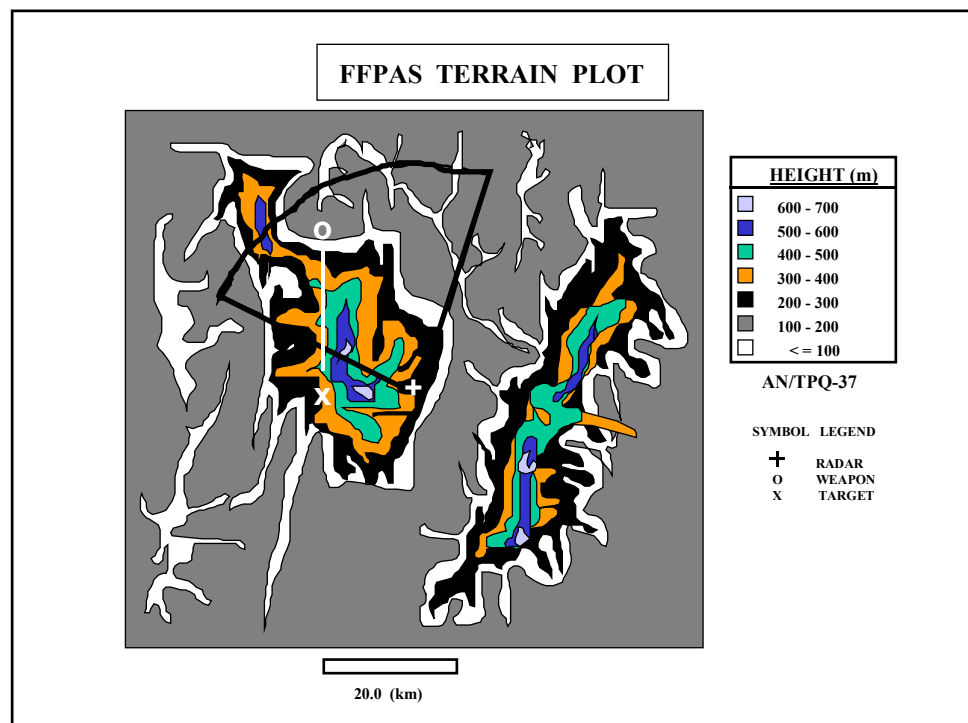

Figure 4-31. FFPAS Terrain Plot

The white "+" at the center of this figure denotes the radar location, while the annular wedge depicts the radar coverage zone for the selected site. The terrain plot provides the operator with a topographic map of the area around the radar. The color code can be quickly changed to match the height characteristics of the local terrain or those of a small area on the terrain plot.

By clicking on a particular point, the easting, northing and altitude of that point are provided to the user. The user can also magnify a region of this plot by placing a rectangle zoom box around a desired area. The user can now produce several additional plots to evaluate the radar sighting, any or all of which can be active simultaneously. The screen angle plot shown in Figure 4-32 shows a terrain profile.

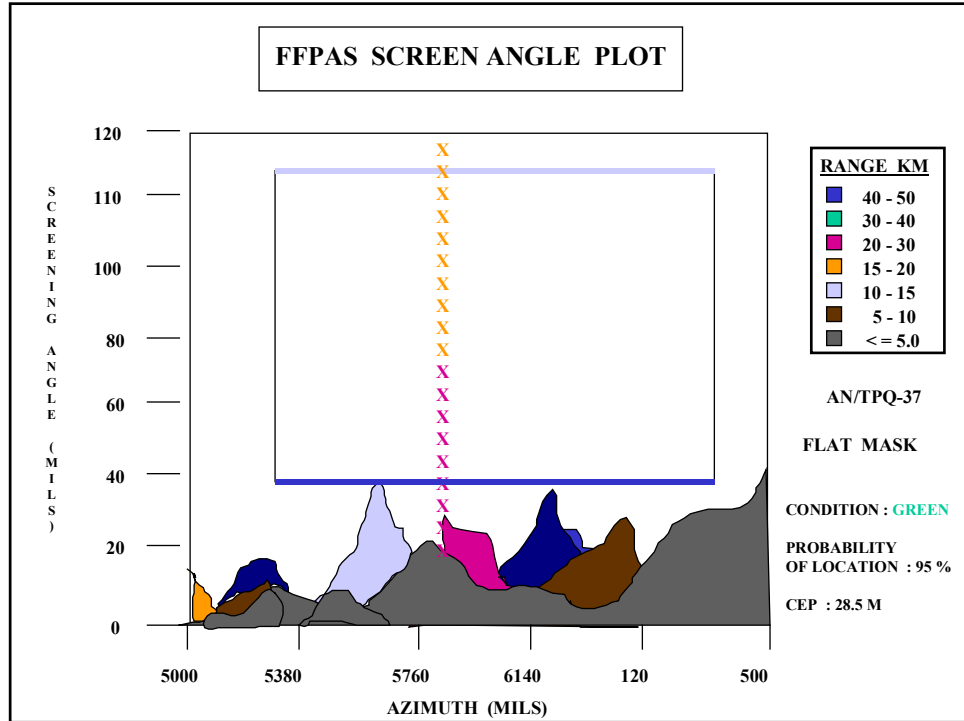

Figure 4-32. Screen Angle Plot

The screening crest as a function of range can be obtained directly from this plot. The range to the terrain is color-coded. The rectangular box on this plot denotes the left and right azimuth scan limits and the upper and lower elevation scan limits.

Figure 4-33 shows a clutter plot. This plot shows where radar returns from stationary objects can degrade radar performance.

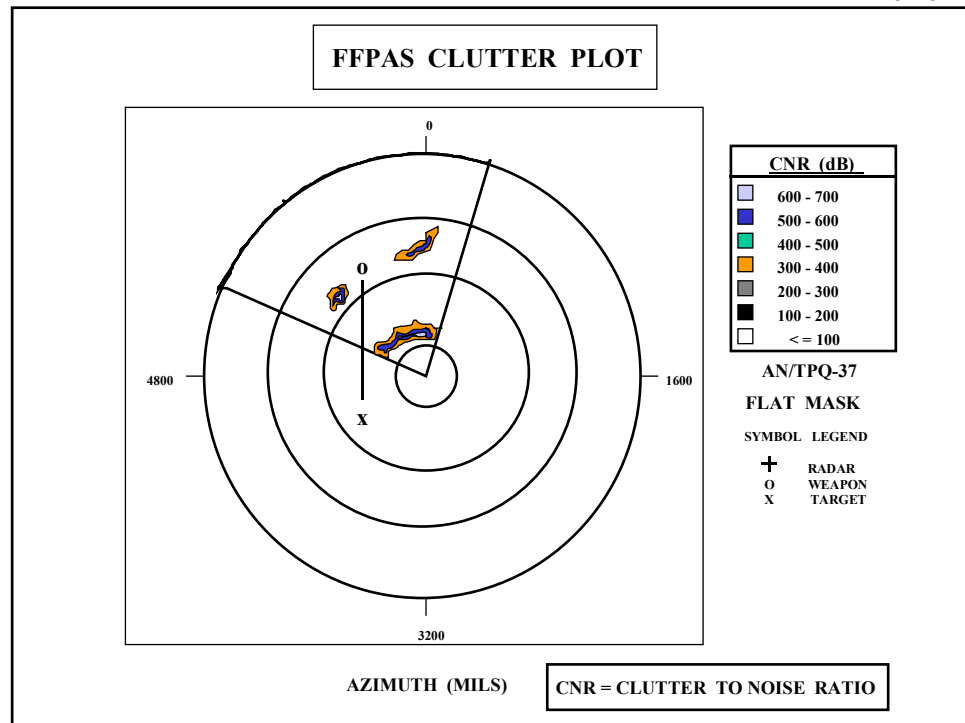

Figure 4-33. Clutter Plot

Weapon Location Analysis

FFPAS provides the ability to perform a computer analysis of the radar's performance against probable enemy weapon location and aim points. This allows the operators to assess the radar's sighting and set-up based on battlefield intelligence in a variety of scenarios. FFPAS accomplishes this task by first allowing the user to specify the weapon type, location and aim point, and both the quadrant elevation (QE), and muzzle velocity for a shot, and then by estimating the ability of the radar to determine the location of the weapon.

FFPAS models several generic weapon types, including mortars, light, medium and heavy artillery, and both light and heavy rockets. Also, specific weapon types can easily be included in the system. FFPAS will inform the operator if the shot parameters that have been input are not within the capabilities of the weapon. For achievable shot's, all relevant data (e.g., the distance from the weapon to the impact point, the range from the radar to both the weapon and the impact point, etc.) are displayed. The system automatically computes the minimum QE values. The operator may then change the muzzle velocity or the QE value to analyze other firing conditions. The maximum QE can be obtained at the push of a button.

The weapon model parameters used in FFPAS include the allowable range of values for muzzle velocity, atmospheric drag coefficients, and the radar cross-sectional area (RCS) of the projectile as a function of its aspect angle. This ensures the projectile's trajectory is correctly modeled and the radar signal strength is accurately determined. Once a shot has been specified, it can be overlaid onto all FFPAS plots.

Four additional pieces of information are provided to the operator on FFPAS plots. They are:

- P (Solution): The probability that the radar will collect a sufficient amount of data with a suitable target to interference ratio (TIR) to solve weapon location equations.
- CEP: The circular error probable for the weapon location estimate.
- P (Location): The probability that the CEP will be within the radar's specification.
- Condition Color: A simple means for characterizing the radar performance through a green/yellow/red/black color code. The condition color has been designed to give the user a rapid means of assessing the sighting evaluation, especially under stressful conditions. A thorough assessment of the results can then be performed when time permits.

In addition to the data above, tabular data describing the radar characteristics for both the projectile and the environment are provided for each point along the simulated trajectory.

SAFETY CONSIDERATIONS

Safety is an important consideration when operating and working around Firefinder radars. Possible safety concerns include radiation, wind, noise and electrical hazards.

RADIATION

When the radar transceiver is energized, it poses a microwave radiation hazard to personnel. The radiation hazard area for the AN/TPQ-36 radar extends 5 meters in front of the antenna within a 1600-mil fan about the boresight for all transmitting operations. For narrow-sector azimuth scan angles less than 400 mils, an additional sector must be controlled to a distance of 30 meters from the antenna. For fixed-beam mode, the hazard area extends to a distance of 75 meters in front of the radar. The narrow-scan hazard sector usually applies to friendly fire mode operations and fixed-beam to certain maintenance operations. In addition, microwave radiation may cause the accidental detonation of some types of live ordnance out to 268 meters, especially those electrically armed or detonated. If the radar is to be emplaced near an airfield or ammunition site, liaison should be made with the organizations responsible for the operations of those facilities. Microwave radiation poses the same types of safety hazards for the AN/TPQ-37. However, the microwave radiation produced by the AN/TPQ-37 poses a safety hazard at increased ranges. The hazard area for the AN/TPQ-37 extends 7 meters in front of the antenna within a 1600 mil fan about the boresight for all transmitting operations. For narrow-sector scan, an additional sector must be controlled out to 40 meters. For fixed-beam mode the hazard area extends out to 100 meters in front of the radar. Like the Q-36, the hazard area for electrically armed or detonated explosives is 268 meters from the antenna for the full 1600 mil sector of scan.

WIND

Because of the large surface area of the AN/TPQ-36 antenna, high wind velocity can cause serious safety hazards. Whenever wind velocity reaches a constant 52 mph or gusts up to 75 mph during operations, the antenna must be placed in the stowed position. When non-operational, the radar must be stowed when winds reach 65 mph with gusts to 100 mph. Camouflage nets also should be lowered or removed to prevent damage to equipment or injury to personnel. The same hazards exist for the AN/TPQ-37. However, the radar must be stowed when the wind velocity reaches a constant 40 mph with gusts up to 75 mph during operations. When non-operational, the antenna must be stowed when winds reach 80 mph with gusts up to 119 mph.

OTHER HAZARDS

Other hazards include noise and electrical hazards. Using hearing protection when working around power generation equipment can mitigate noise hazards. Finally, overhead power lines and improper grounding of radar equipment can cause electrical hazards. To prevent these hazards, radio antennas should be tied down during movement and position areas should be selected that eliminate overhead electrical hazards. Further, section equipment must be properly grounded during operation.

Chapter 5

Tactical Employment of Field Artillery Target Acquisition Systems

This chapter discusses concepts and procedures pertinent to the tactical employment of the field artillery target acquisition systems. The tactics, techniques and procedures (TTP) contained in this chapter are applicable to the traditional roles of target acquisition. TTP for stability operations and support operations are discussed in Chapter 6.

SECTION I – RADAR EMPLOYMENT

Sound tactical planning is required to effectively cover the division zone of responsibility with TA assets. TA planning is conducted at all tactical levels as an integral part of the MDMP process. This ensures TA assets are fully integrated into combined arms operations. The controlling FA headquarters is responsible for employing TA assets in accordance with the operational plan. This section discusses the tactical considerations for employing radars.

COMMAND AND CONTROL

Command and control are often confused with command and support relationships. Command and control is the exercise of authority and direction by a properly designated commander over assigned and attached forces in the accomplishment of the mission. Command and control functions are performed through an arrangement of personnel, equipment, communications, facilities, and procedures employed by a commander in planning, directing, coordinating, and controlling forces and operations in the accomplishment of the mission.

Command is the authoritative act of making decisions and ordering action; control is the act of monitoring and influencing this action. While command and control may be discussed separately for understanding, in practice, command and control is a unified entity. The commander cannot command effectively without control and cannot exercise control without command. The commander uses command and control, which includes the staff, to make effective decisions, to manage the uncertainty of combat, to employ military forces efficiently, and to direct the successful execution of military operations. In short, the goal of command and control is mission accomplishment.

Control is the dissemination of the commander's decisions, guidance, and intent with subsequent supervision and adjustment of subordinate forces' execution to ensure compliance with the commander's intent. Control may take place before, during, and after operations. Control may be exercised

directly or indirectly by directive, plan, or procedure. Information and time are critical to control. The commander, with the help of his staff, uses control to regulate forces and functions of subordinate and supporting units in military operations to ensure mission accomplishment. Control is based on situational information, such as mission, enemy, terrain, troops, time available, and civil considerations (METT-TC), from all sources. The commander uses this information to adjust the resources, concept, or objective of the plan or to exploit success in operations. Staffs help commanders exercise control by:

- Acquiring and applying means to accomplish the commander's intent.
- Defining limits.
- Determining requirements.
- Allocating means.
- Monitoring status and performance and reporting significant changes to the commander.
- Developing specific guidance from general guidance.
- Forecasting change.

Command and control is facilitated by establishing an organization for combat that ultimately assigns a command relationship to every TA asset. There are three command and control methodologies for employing TA radars. They are:

- Centralized control at the DIVARTY or FA brigade.
- Decentralized control by attaching radars to a subordinate FA unit.
- Combination of centralized and decentralized control.

The command and control methodology used is based solely on mission requirements.

CENTRALIZED CONTROL

TA assets may be held under the centralized control of the division artillery or its reinforcing FA brigade. Centralized control optimizes coverage to support the commander's intent. Under centralized control, the S2 in concert with the counterfire officer/targeting officer will:

- Designate a general position area, sector of search, and zones for each radar.
- Establish cueing guidance.
- Designate cueing agents.
- Control radar movement.
- Designates who receives radar targets.

When the FA brigade has control of TA assets, the division artillery should provide the target processing element from the TAB with its associated equipment to the FA brigade. Like the division artillery, the FA brigade headquarters does not have an organic target processing element and thus does not have target processing capability without augmentation. Regardless of which headquarters exercises control, subordinate battalions may be

tasked to provide logistical, survey, and security support because of the dispersal of radars across the division.

DECENTRALIZED CONTROL

Under decentralized control, TA assets are provided to subordinate units for their direct control and employment. Q-36 radar sections are normally attached to DS or reinforcing (R) FA battalions. When attached, the radar is considered an integral part of the DS Battalion support package to the brigade combat team (BCT). The FA battalion S2, in conjunction with the targeting officer, controls the radar, executing the same responsibilities as the division artillery S2 and counterfire officer. Q-36 sections are responsible for covering the supported BCT zone of responsibility. The BCT FSO and targeting officer coordinate mission requirements and priorities with the S2 based on the BCT commander's guidance and intent. Normally division artillery retains centralized control of Q37 radars. However, Q-37 radars may be placed under the control of a multiple launch rocket system (MLRS) battalion or other fire unit based on mission requirements and the tactical situation.

COMBINATION CONTROL

Any combination of centralized and decentralized operational control of radars may be used according to the situation. For example, two Q-36 radars may be assigned to the DS battalions supporting the two committed BCTs while the remaining Q-36 and two Q-37s are kept under division artillery control.

Regardless of the radar control option used, logistical support is a key factor in tactical employment. Normally, TA radar sections are attached to another FA unit for administrative and logistical support. For a discussion of the logistical support entailed by such attachment, see Appendix H.

COMMAND RELATIONSHIPS

TA assets are organized for combat to best meet the commander's intent and accomplish the assigned mission. This is done by establishing command relationships. The commander establishes command relationships for TA assets in accordance with army doctrine. An important consideration when selecting the command relationship is the desired method of control. Radars may remain under the centralized control of the controlling headquarters or decentralized control may be established. Any combination of centralized or decentralized control may be used based on the tactical situation.

Placing a TA element under another unit using one of the following methods forms a command relationship: attachment, operational control (OPCON), or tactical control (TACON). Command responsibilities, responsibilities for service support, and authority to organize or reassign component elements of a supporting force remain with the higher headquarters or parent unit unless the authorizing commander specifies otherwise. The command relationships and inherent responsibilities are depicted in Table 5-1.

Table 5-1. Command Relationships

	Inherent Responsibilities						
	Relationship with:	Task organized by:	Positioned by:	Provides liaison:	Maintains commo with:	Priorities established by:	Gaining unit can further impose:
Attached	Gaining Unit	Gaining Unit	Gaining Unit	Per Gaining Unit	Gaining Unit	Gaining Unit	Attached, OPCON, TACON, GS, GSR, R, DS
OPCON	Gaining Unit	Gaining Unit (see note)	Gaining Unit	Per Gaining Unit	Parent Unit and Gaining Unit	Gaining Unit	OPCON, TACON, GS, GSR, R, DS
TACON	Gaining Unit	Parent Unit	Gaining Unit (maneuver)	Per Gaining Unit	Parent Unit and Gaining Unit	Gaining Unit	GS, GSR, R, DS
NOTE: Except when involving Multinational forces in NATO, then Parent Unit.							

ATTACHMENT

Attachment is the placement of units or personnel in an organization where such placement is relatively temporary. Subject to the limitations imposed by the attachment order, the commander of the formation, unit, or organization receiving the attachment has the responsibility to provide the attached units with sustainment support above its organic capability. However, the parent formation, unit, or organization normally retains the responsibility for transfer, non-judicial punishment, courts martial and human resources support such as strength accounting, promotions and other essential personnel services.

OPERATIONAL CONTROL

Command authority that may be exercised by commanders at any echelon at or below the level of combatant command is operational control (OPCON). Operational control is inherent in command authority. Operational control may be delegated and is the authority to perform those functions of command over subordinate forces involving organizing and employing commands and forces, assigning tasks, designating objectives, and giving authoritative direction necessary to accomplish the mission. Operational control includes authoritative direction over all aspects of military operations and joint training necessary to accomplish missions assigned to the command. Operational control should be exercised through the commanders of subordinate organizations. Operational control provides full authority to organize commands and forces and to employ those forces, as the commander in operational control considers necessary to accomplish assigned missions. Operational control does not, in and of itself, include authoritative direction for logistics or matters of administration, discipline, internal organization, or unit training.

TACTICAL CONTROL

Tactical control (TACON) is the command authority over assigned or attached forces or commands, or military capability or forces made available for tasking, that is limited to the detailed and, usually, local direction and control of movements or maneuvers necessary to accomplish missions or tasks assigned. Tactical control is inherent in operational control. Tactical control may be delegated to, and exercised at any level at or below the level of combatant command. Tactical control allows commanders to apply force and direct the tactical use of logistics assets but does not provide authority to change organizational structure or direct administrative and logistical support.

SECTORS OF SEARCH

Sectors of search are areas on the battlefield where radars focus their capabilities. Sectors of search are determined during the IPB process and refined in the decide function of the D3A cycle. During the decide function, decisions are made concerning what targets should be acquired and attacked, where and when targets are likely to be found, and who can locate them. Doctrinal employment considerations, in conjunction with templates and intelligence produced during the IPB process, dictate the areas in which the radar search should be focused. The location of friendly boundaries, fire support coordinating measures, and the common sensor boundary (CSB) may also affect the assignment of search sectors.

ZONES

Zones are a means of prioritizing radar sectors of search into areas of greater or lesser importance. Zones focus radar coverage on the combined arms commander's battlefield priorities. A zone is a geometric figure placed around an area that designates the area as more, or less, important. Four types of zones can be entered into a Firefinder radar:

- Critical friendly zones (CFZ).
- Call-for-fire zones (CFFZ).
- Artillery target intelligence zones (ATIZ).
- Censor zones (CZ).

Targets developed by the radar are displayed for transmission in order of priority based on the zone from which they were developed. There are two categories of zones, priority and censor. The Q-36 and Q-37 can store a total of nine zones.

PRIORITY ZONES

Priority zones are prioritized areas for locating hostile weapon systems. There are three types of priority zones in order of precedence:

- Critical friendly zone (CFZ).
- Call for fire zone (CFFZ).
- Artillery target intelligence zone (ATIZ).

All other weapon firing locations identified by the radar are displayed after locations identified within priority zones. Firing locations identified within a CFZ or CFFZ generate a FM;CFF message. All other acquisitions generate an ATI;CDR message.

CFZ

A CFZ is an area established around a friendly unit or location that is critical to the success of the combined arms commander's plan. When the computer predicts an enemy round will impact in a CFZ, the radar generates a call for fire on the location from which the round was fired. This happens automatically unless overridden by the radar operator. A FM;CFF message is sent to controlling FA headquarters as a priority 1 message. The CFZ provides the most responsive submission of targets to the fire support system. The CFZ does not have to be within the radars search zone.

CFFZ

A CFFZ designates a search area from which the commander wants to attack hostile firing systems. A CFFZ would be placed around an enemy fire support position identified by IPB as a HPT. A CFFZ generates the second highest priority fire request. A target identified in a CFFZ generates a FM;CFF priority 2 message. The commander may upgrade the priority, to priority 1, for certain CFFZ. A CFFZ must be in the radar's sector of search.

ATIZ

An ATIZ is an area in enemy territory that the commander wishes to monitor closely. Any weapon detected in an ATIZ will be reported ahead of all acquisitions other than those from CFZs or CFFZs. Detections from an ATIZ generate an ATI;CDR.

CENSOR ZONES

Censor zones (CZ) are areas from which the radar is prohibited from reporting acquisitions. A CZ is normally placed around friendly weapon systems to prevent them from being acquired by other friendly radars. The CZ is most often used in non-linear situations or during cross FLOT raids or infiltration. Care must be used when employing a CZ since the radar ignores all acquisitions coming from the CZ. This remains true even if the hostile weapon is firing at a unit inside a CFZ. Figure 5-1 depicts the use of a CZ.

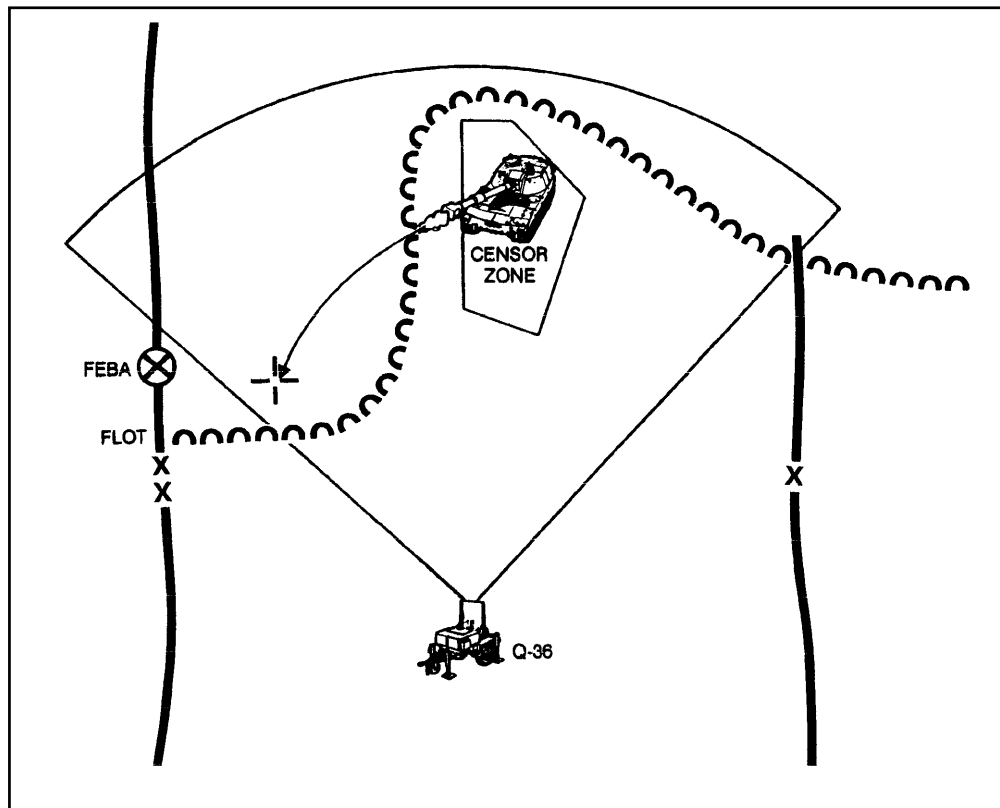

Figure 5-1. Censor Zone

DEVELOPING ZONE DATA

Zone data must support the tactical plan and satisfy the radars requirements for data input. The DS battalion S2 and the targeting officer develop zone data for the Q-36 and the counterfire officer develops zone data for Q-37's. The data is entered and transmitted from the TOC to the radar using the automated RDO (see Appendix G). The following considerations apply when developing zone data:

- Up to nine zones can be entered in the radar. All zones may be of one type or any combination of types.
- A zone must be defined by a minimum of three and a maximum of six coordinates.
- An azimuth should not intersect the boundary of a zone more than two times as shown in Figure 5-2.
- A radar zone cannot intersect or touch another zone.
- No more than two zones can be along the same search azimuth for radars using the S-250 shelter. (See Figure 5-3).
- Grid coordinates must be listed and entered sequentially.
- Zone coordinates cannot fall outside the sector of search (except for CFZ).

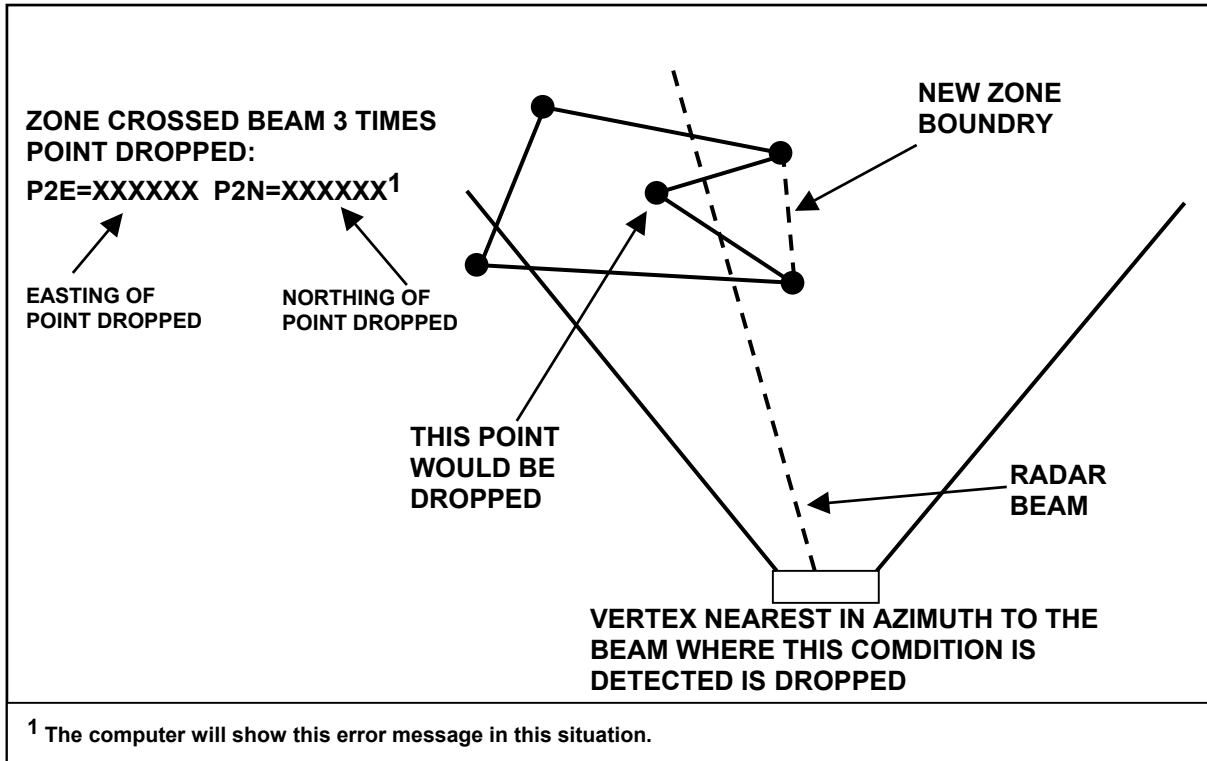

Figure 5-2. Zone Rejected Zone Crossed Beam 3 Times

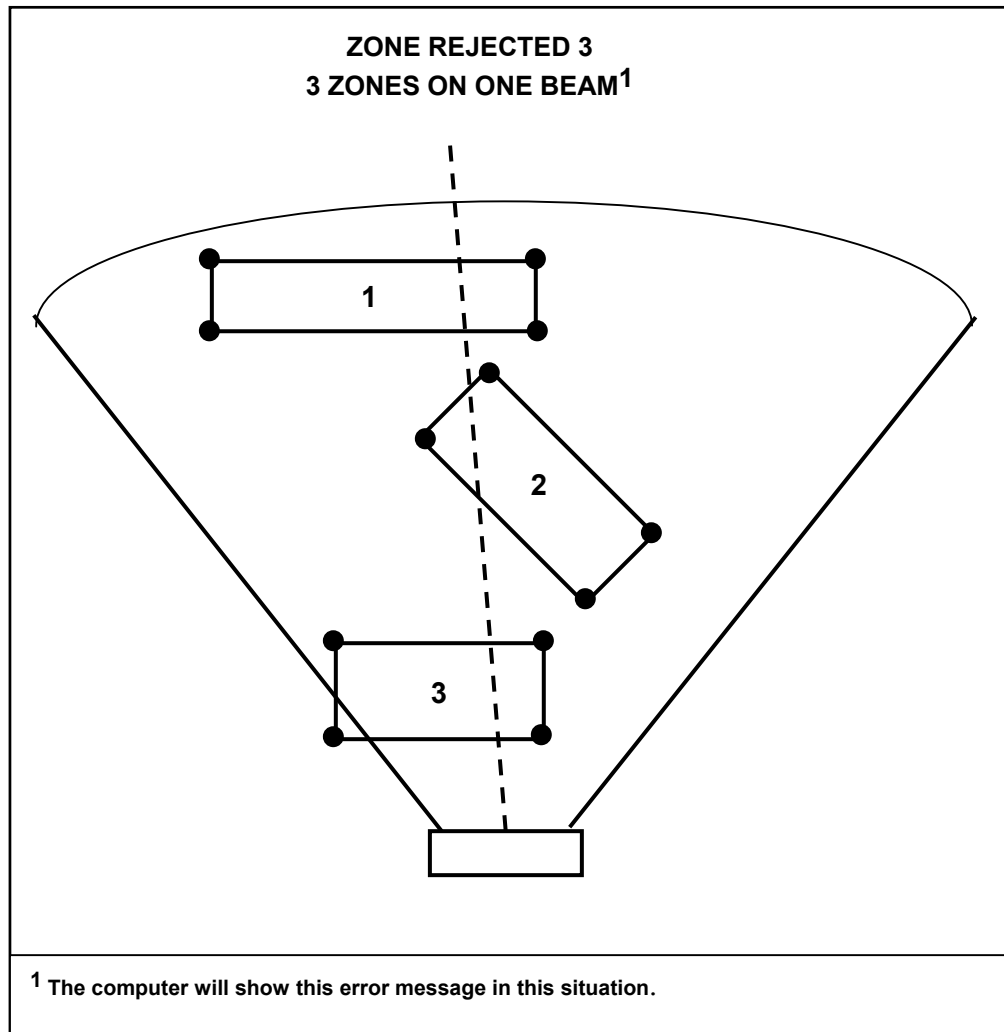

Figure 5-3. Zone Rejected 3 Zones On One Beam

ZONE MANAGEMENT

TA assets are employed to support counterfire operations. Counterfire is part of the combined arms commander's overall battle plan and not a separate operation. Radar zones are managed to comply with the commander's guidance and intent and are an important part of force protection and the prioritization of fire support efforts. Understanding the maneuver commander's plan, and integrating fire support officers into the development, refinement and triggering of planned zones is key to successful radar zone management. Planning guidance may be found in a number of different documents. These locations include the fires paragraph, tasks to subordinate units and coordinating instructions of the operations plan or order, and the fire support annex. Information from these sources provides the necessary guidance and information to initiate zone planning.

There is a distinct difference between zone management in the brigade sector, and zone management in the division sector. At the brigade combat team (BCT), BCT and task force FSOs are directly involved in the planning, refinement and triggering of the zones. Accordingly, the BCT FSE prioritizes BCT requirements and allocates radar zones to support the scheme of maneuver. The planning for and availability of redundant radar coverage by DIVARTY Q-37s is critical to the BCT's success. This coverage must be included in planning guidance and coordinated as early as possible.

The DIVARTY counterfire officer (CFO) is responsible for employing division TA assets. Accordingly, he must be involved in the planning of the BCT's counterfire operations and fully understand their TA support requirements. The BCT FSE, targeting officer, and the DS FA battalion S2 must coordinate their requirements for available GS fires and additional radar coverage with the DIVARTY CFO. Coordination between the DIVARTY CFO and BCT targeting team members is crucial to the success of the counterfire battle.

Basic guidelines for zone planning include:

- Use top down planning and bottom up refinement.
- Include the top down radar zone plan in the maneuver order.
- FSOs, S2s, and targeting officers conduct bottom up refinement that reflects the developed situation template, force protection priorities, and scheme of maneuver.
- The brigade targeting officer or division counterfire officer manages zones by resolving duplication, time phasing zones by priority, including zones on the FS execution/synchronization matrices, and providing zones to radar sections via the radar deployment order (RDO) or radar execution matrix.
- The radar section leader performs technical zone management at the radar.
- Refine and update zones as the operation progresses.

ZONE MANAGEMENT PLANNING SEQUENCE

The following procedure provides a list of activities essential for successful zone planning.

- Prioritize operational sector and scheme of maneuver events for zone planning based on the commanders intent/guidance (commander, FSCoord, FSO, targeting officer and CFO).
- Develop zones during the course of action (COA) development and the wargaming process (S2/G2, FSOs, targeting officers and CFO).
- Approve and allocate zones to subordinate FSEs that support the scheme of maneuver, meet the commander's priorities for force protection and facilitate the engagement of high payoff targets (commander, targeting team, FSE and CFO).
- Develop and assign decision points as triggers for the execution of planned zones (S2, FSE, targeting officer).
- Incorporate decision points (triggers) for planned zones and radar movement into the appropriate decision support template (DST),

synchronization/execution matrices and intelligence collection plan (ICP) (S2/G2, FSO, FAIO, targeting officer and CFO).

- Refine to ensure nominated zones facilitate the scheme of maneuver and the commander's intent for force protection (commander, targeting team and CFO).
- Rehearse planned zones (radar movement, zone activation and Counterfire Battle drill) during combined arms, FA technical and fire support rehearsals (commander, FSCoord, FSO, targeting officer, G2/S2, radar and CFO).
- Refine zones during execution as the IPB improves or the scheme of maneuver changes (FSOs, targeting officers, G2/S2 and CFO).
- Develop positioning guidance for the radar that optimizes the probability of acquisition and supports the coverage of planned zones (S2, S3, radar and CFO).

ZONE MANAGEMENT RESPONSIBILITIES

Responsibilities for radar employment and zone management must be fixed to focus the planning process and execution. The combined arms commander is ultimately responsible for counterfire and his staff's fixed responsibilities must include:

- FSCoord:
 - Translates the commander's intent for force protection and engagement of enemy indirect fire weapons.
 - Ensures force protection and counterfire priorities are articulated in the commander's fires paragraph to the OPORD.
 - Recommends zones to the commander during the planning process.
- Targeting team:
 - Synchronizes all target acquisition assets and zone development to facilitate the D3A process.
 - Ensures planned zones are synchronized with the applicable elements of the High Payoff Target List, (HPTL).
 - Allocates, verifies, and updates zones to ensure the commander's intent for force protection and engagement is met.
 - Assigns cueing agents corresponding to NAIs, TAIs, PIRs and IRs associated with planned zones. The designated cueing agents should be included in the RS&S plan and be in position to trigger activation of the zone.
- FSO/targeting officer:
 - Provides guidance to lower echelon FSOs/targeting officers and solicits force protection measures - CFZs.
 - Ensures priorities and triggers are developed for the activation and inactivation of zones.
 - Integrates planned triggers into the appropriate DST/synchronization matrixes.

- Incorporates planned zones into the combined arms and fire support rehearsals.
- Ensures zones are sent to S2s/CFOs for inclusion in the radar deployment order (RDO).
- Operations officers (G3/S3):
 - Incorporates decision points, planned zones, and radar movement into the DST and synchronization matrix.
 - Ensures the TA TAB to the Field Artillery Support Plan includes coordination measures for zone development and radar positioning.
 - Ensures land management for the radars is coordinated with maneuver elements.
 - Determines attack guidance and firing unit assignment to support the responsive engagement of counterfire acquisitions.
 - Monitors range capabilities of both the acquisition agent (radar) and engagement systems to ensure positioning and movement supports the counterfire plan (zones/force protection priorities).
- Task force FSOs:
 - Develops priority zones to support the task force plan - CFZs/CZs.
 - Nominates zones to the brigade commander (FSO/targeting officer) for approval and priority.
 - Develops precise triggers along with identifying and assigning cueing agents for priority zones.
 - Ensures the developed triggers are incorporated into the supported units DST/synchronization matrix.
 - Establishes ownership and responsibility for the zones.
 - Ensures any changes to the scheme of maneuver are compared against the planned zones.
 - Ensures refinement is completed and sent to the DS FA battalion S2 for transmission to the radar.
 - Activates and refines zones during execution.
- DS battalion S2:
 - Develops CFFZs based on the templated enemy artillery positions and known intelligence data.
 - Nominates zones to the targeting team for approval and inclusion into the ICP.
 - Receives approved zones from the BDE FSO/targeting officer for inclusion into the RDO.
 - Constructs radar employment plan and RDO in conjunction with the radar section leader.
 - Refines zones as IPB improves or the scheme of maneuver changes (updates RDO).
- Radar section leader:
 - Ensures the capabilities/limitations of the radar system are considered during the planning process.

- Selects radar positions that support the coverage of the planned zones and facilitates movement to support the scheme of maneuver.
- Identifies zone restrictions violated during the planning process.
- Performs technical zone management of the radar employment plan.

COMMON SENSOR BOUNDARY

Target duplication between Firefinder radars is likely during combat operations. In addition, the sheer volume of targets passed from the radars may overwhelm the targeting element, especially if the radars are under centralized control. An effective method of reducing or eliminating target duplication is to establish a common sensor boundary (CSB). The CSB is established by the counterfire headquarters and divides TA search areas into acquisition management areas for Q-36 and Q-37 systems. The CSB is generally depicted by using: a grid line, phase line, or major terrain feature. Q-36 radars should not limit their maximum range to the CSB or establish CFFZs beyond it. Likewise, Q-37 radars should not limit their minimum range to the CSB or establish CFFZ short of it. When possible, the CSB should be positioned in conjunction with the coordinated fire line (CFL). This eliminates the requirement to clear Q-37 generated fire missions. The CSB is not a fire support coordinating measure. It is a zone management tool used by the counterfire headquarters to enhance the effectiveness of radar coverage.

The following factors influence the placement of the CSB:

- Availability of attack systems.
- Range of attack systems.
- Range and operational mode of TA radars.
- Known and suspected locations of enemy indirect fire systems.
- Type and availability of munitions.

The location of the CSB is adjusted based on the tactical situation. Repositioning of radars, changing enemy situations, and the establishment or deletion of fire support coordinating measures (FSCM) may dictate adjustment or deletion of the CSB. Figure 5-4 shows the use of the CSB.

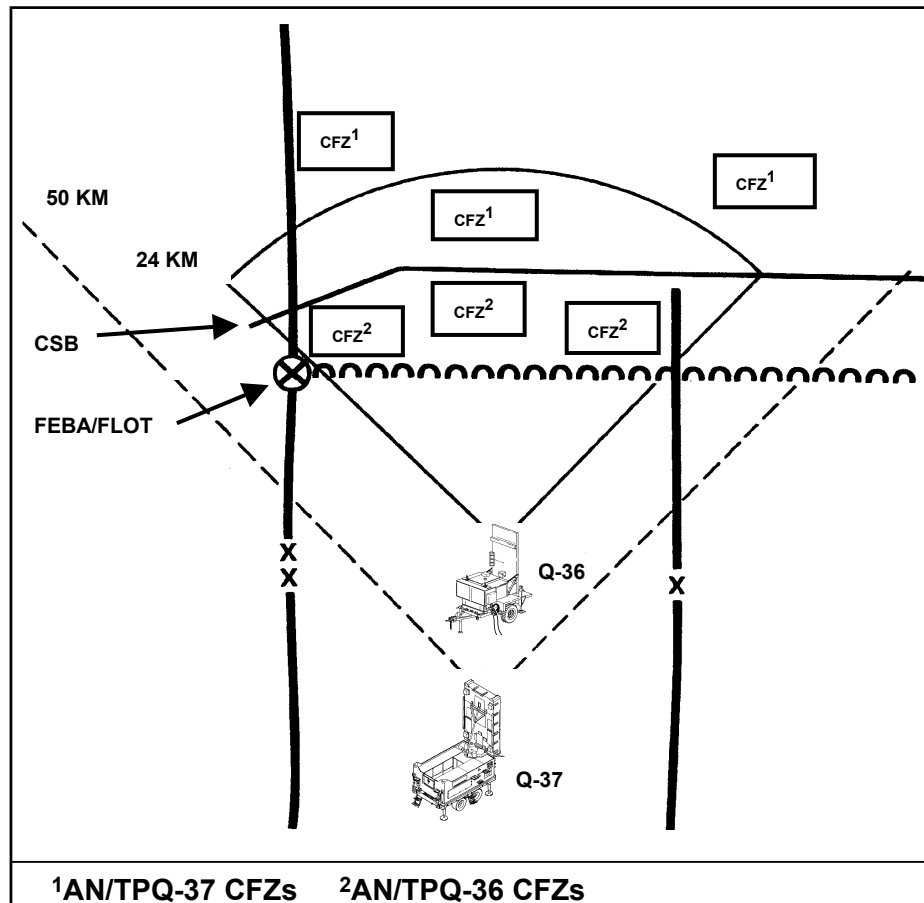

Figure 5-4. Common Sensor Boundary

CUEING

Cueing is the process designed to prompt or notify the radar to begin radiating to acquire hostile fire. Determining when and how to best cue the radar is one of the most difficult planning decisions. There are as many different methods to cue a radar as there are situations when it should be cued. Targeting technicians, S2/G2s and FSOs must establish cueing guidance based on the maneuver commanders guidance. Both authority to cue and priority for cueing requirements must be clearly understood. Planned random schedules based solely on hours of the day are not recommended and are usually ineffective. Unnecessary cueing subjects the radars to enemy direction finding. Therefore, cueing should be event driven to provide maximum support during critical phases of the battle.

The cueing of radars may be centralized or decentralized. Centralized cueing routes all cueing requests through the radar controlling headquarters. Centralized cueing may be less responsive based on the level of activity on communications nets and the number of nets the request to cue must go through. During decentralized cueing, the controlling FA headquarters establishes cueing guidance, to include authorized agents, communication

links, and conditions under which the radar may be cued. At maneuver battalion or task force (TF) level, the radar cueing instructions are given in the radar deployment order. At maneuver brigade and above, where a written operation plan (OPLAN) or operation order (OPORD) is used, the cueing guidance should be in the TA tab to the FA support plan. When cueing agents other than FA assets are designated, cueing guidance should be given in the basic order as coordinating instructions or tasks to subordinate units.

The critical factor when planning radar cueing is responsiveness. Cueing should allow the radar to locate enemy positions during initial volleys of fire, preferably the first rounds. There are two techniques for cueing; situational (pro-active), and demand (reactive). Situational and demand cueing may be used separately or in combination.

SITUATIONAL CUEING

Situational cueing is the preferred technique for cueing radars and is the most responsive. This method ties cueing to events and/or triggers that are determined during the IPB and planning process. For example, during offensive operations an event or trigger may be a breaching or air-assault operation. In a defensive operation, cueing may be tied to suspected enemy phases of fire depicted on the decision support template. Situational cueing focuses the radar on the commander's intent and what is critical.

DEMAND CUEING

Demand cueing is the activation of a radar once the enemy is known to have begun firing. For demand cueing to be effective, cueing agents must be designated and a responsive communication system between the agents and radar established. Specific cueing guidance must also be established to fully exploit the radars capabilities and minimize or eliminate unnecessary radiation. The situation will dictate who best can cue the radar and the specific conditions under which it should be cued. Possible cueing agents may include:

- Combat observation/lasing teams or strikers.
- Forward observers (FOs); (FISTS).
- Observers in OH-58D helicopters.
- Rear area CPs.
- Brigade or division-level EW systems.
- Scouts.
- G2/S2s.
- FSOs.
- CFOs/targeting officers.

Cueing must be based on real-time information so that the radar has a high probability of tracking projectiles when it is turned on. Consider the situation where a task force FSO is designated as a cueing agent (refer to Figure 5-5). The following events occur:

- 1 – The task force assembly area receives hostile artillery fires.

- 2 – The task force FSO immediately cues the radar.
- 3 – The radar responds and locates the hostile artillery firing on the task force.
- 4 – The radar transmits a call for fire to the DS FA battalion.
- 5 – The battalion FDC executes the attack in accordance with the established attack guidance.

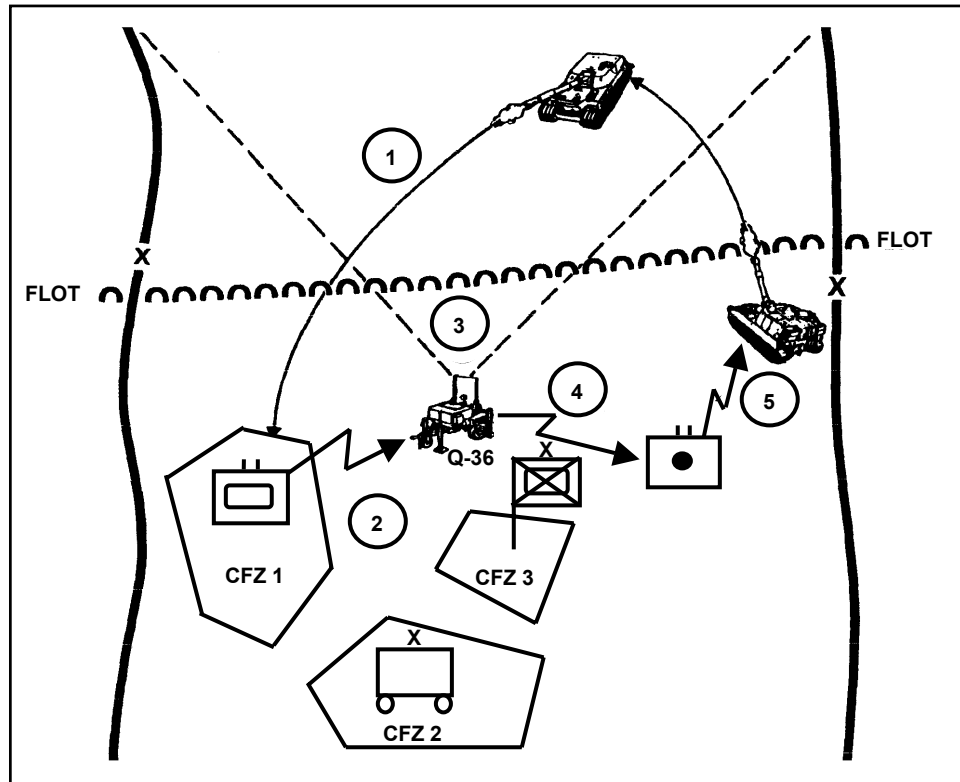

Figure 5-5. Demand Cueing

TARGET ACQUISITION RADAR ROLE DURING OFFENSIVE OPERATIONS

The primary role of TA radars in the offense is to locate enemy targets for attack by friendly fire support systems. During offensive operations, particular attention must be given to planning TA operations to facilitate future operations. TA planners must ensure a smooth transition from one phase to the next by providing continuous radar coverage across the zone of operations. Requirements for radar positioning and movement are identified during the MDMP and tied to specific events. This allows continuous coverage by facilitating mutually supporting coverage between radars. The FSCoord monitors this process closely to ensure that the use of terrain, movements and radar zones are properly coordinated.

The first consideration for radar zones in the offense is CFFZs. Establishing CFFZs facilitates immediate counterfire to suppress enemy artillery that

may disrupt the scheme of maneuver. CFZs may be planned through the zone of operation or along the axis of advance and activated when entered by friendly forces. This is particularly important in areas where friendly forces are most vulnerable, for example, at river crossings, breach sites or open areas.

Control of radars will generally be more decentralized to facilitate command, control, movement, and cueing. The controlling FA headquarters will designate cueing agents that can cue radars by calling them directly. This is necessary to streamline the TA and counterfire effort when committed maneuver forces may be particularly vulnerable to enemy indirect fire.

TARGET ACQUISITION RADAR ROLE DURING DEFENSIVE OPERATIONS

The primary role of TA radars in the defense is to provide target intelligence and information to allow friendly forces to take force protection measures and enable counterfire mission processing. TA planners must also consider transitions to offensive operations such as counterattacks. Positioning, task organization, and on-order missions should facilitate transitions.

The first consideration is the use of the radar's zone capabilities to provide coverage for critical units or installations using CFZs. The combined arms commander should indicate the assets that are deemed essential to ensure mission accomplishment. If the commander does not identify these assets, the FSO or targeting officer must query the commander for the necessary guidance. Once the guidance is obtained, the information is passed to the controlling FA headquarters for implementation.

The second consideration for the use of zones is areas in which to use CFFZs. On the basis of IPB and other target indicators, CFFZs are used to monitor suspect areas from which enemy artillery fires may jeopardize the mission. This facilitates the use of counterfire to suppress, neutralize or destroy those targets.

ATIZ may be established in areas where we are not sure about enemy artillery and need to develop the situation. They can also be used in areas of suspect enemy artillery that the commander wishes to monitor closely but are out of friendly artillery range. Finally, a CZ might be used around friendly artillery or mortar positions when their location would expose them to detection by friendly Firefinder radars.

RADAR TASKING PROCEDURES

There are several methods for specifying coverage for radar sections. They include the radar deployment order (RDO), the radar execution matrix, and the AFATDS RDO format. All three methods provide the required information for conducting radar operations. However, the primary method for orienting radars is digitally using the AFATDS RDO. IFSAS equipped units may routinely use the radar execution matrix or the traditional RDO. However, IFSAS equipped units can use the SPRT;FILTER and SPRT;SEARCH formats to orient the radar. Detailed procedures for using these methods of orienting radars is included in Appendix G.

SECTION II – COUNTERFIRE OPERATIONS

Counterfire gains freedom of action for all friendly maneuver forces. It can be accomplished by the fire support system using both lethal and nonlethal means. Counterfire is not a separate battle. It is inseparably tied to close and deep operations and is part of the overall combined arms fight to achieve fire superiority. While a fine line may exist between counterfire and attack at depth, once an indirect fire target is capable of affecting the close fight, its attack is considered counterfire. Intelligence assets must be prioritized to accurately locate targets. Attack assets (such as artillery, mortars, close air support, attack helicopters, naval gunfire and EW assets) must be brought to bear on the enemy total fire support system. Counterfire is the combined arms commander's responsibility. The FSCoord is his primary advisor and executor. Field artillery target acquisition exists to support the combined arms commander's scheme of maneuver during the offense and provide radar coverage for his most vulnerable assets during the defense. Effective use of target acquisition enhances observation of critical terrain; for example, avenues of approach, potential assembly areas, and possible enemy reconnaissance routes. Combined arms commanders must emphasize that all combat information must be reported through fire support as well as operational channels. The commander ensures proper positioning of TA assets for optimal probability of detection and maximum effectiveness of counterfire.

CORPS

The corps' counterfire role is focused on deep, proactive, counterfire. In most situations, the division orchestrates and executes counterfire in support of corps close operations. The corps resources divisions to conduct close counterfire operations. This allows an orderly and calculated division of labor. Just as the division separates and deconflicts the radar coverage and counterfire efforts of the division and maneuver brigades, so must the corps deconflict the efforts of the corps and division. The corps normally accomplishes this through the use of division forward boundaries, phase lines, or simply by deconflicting specific target sets. The corps normally assumes responsibility for locating and attacking army artillery groups (AAG) and army groups of rocket artillery (AGRA) while divisions locate and attack division artillery groups (DAG), although this is not always the case.

Corps has a myriad of assets to conduct counterfire operations to include elements of the corps artillery, corps aviation brigade, Air Force air interdiction and reconnaissance sorties, Army reconnaissance and attack helicopters, and EW. The corps facilitates the division counterfire fight by allocating resources. These resources often include FA brigades, CAS, attack helicopters, EW, and intelligence support. In the case of light divisions, the corps provides divisions with a CTAD to provide Q-37 support. CTADs are allocated based on the number of assigned light divisions. There aren't any CTADs or TABs allocated to the corps for direct corps use. In some situations, and after careful consideration, corps commanders may temporarily draw on divisional FA assets to support corps counterfire operations. However,

diversion of limited divisional acquisition, processing, and attack assets entails the risk of their destruction and non-availability to support division operations during critical phases. Equally important is the timing of their return to divisional control, particularly in the heat of battle. The return must be carefully planned and coordinated.

Corps artillery contributions to the overall counterfire effort include the responsibility to:

- Implement the organization for combat of corps artillery counterfire assets by retaining FA assets at corps level or allocating them to subordinate divisions in accordance with missions and guidance issued by the corps HQ.
- Supervise preparations and execution of counterfire responsibilities by subordinate corps elements within counterfire sectors of responsibility established concurrently with the designation of maneuver boundaries and AOs for subordinate divisions. This includes targets within a division's or adjacent unit's AO, if requests for such support have been submitted and approved by corps. Within capability, corps may also respond to requests for additional fires from adjacent units.
- Detect multiple rocket launcher battalions, helicopter forward operating bases, and other counterfire targets with organic FA assets, reinforced by collectors from the corps' military intelligence brigade, long-range reconnaissance units, and special operations forces (SOF).
- Attack threat fire support systems with MLRS and cannon battalions of corps FA brigades to a range of 30 km (60 km for guided MLRS (GMLRS)). Beyond 60 km, ATACMS, Army aviation, Air Force sorties, and ground maneuver forces may be available for target attack.
- Recommend the acquisition of additional sensor and attack assets from echelons above corps (EAC), the joint task force (JTF) commander, or other services.
- Assess the success of efforts to protect friendly units from threat fire support systems. As needed, recommend modifications to intelligence collection and attack priorities to enhance force protection through a more effective attack of enemy counterfire targets.

By allocating corps assets, issuing attack guidance, and identifying corps HPTs, corps influences how subordinate divisions fight their counterfire battle. They can shape a division's counterfire effort by attacking threat FS systems in depth, providing MLRS and ATACMS fires, and EW support. Within divisional AOs, corps commanders:

- Define areas of counterfire responsibility by establishing boundaries for subordinate units.
- Provide IPB products and critical intelligence information developed at corps or higher and adjacent HQ.
- Attack targets nominated by the divisions or tasked by corps. Corps, after coordination with division FSEs, may attack threat FS targets

within divisional AOs by massing fires to achieve required effects (for example, massing fires to neutralize a reconnaissance strike complex). Also, procedures for attacking threat systems firing across boundaries must be coordinated. However, in all cases the division must orchestrate and give final approval for all corps fire missions within its AO.

- Provide divisions with additional assets for detecting and attacking threat FS systems.

A detailed discussion of corps counterfire operations is contained in FM 3-09.6.

DIVISION

Counterfire responsibilities at the division essentially mirror those at corps. Successful prosecution of the divisional counterfire battle destroys, neutralizes, or suppresses hostile indirect fire systems in both offensive and defensive operations, thereby protecting friendly elements from the effects of enemy artillery fires. This, in turn, provides friendly combined arms forces with the necessary freedom of action and flexibility to prosecute the direct firefight relatively unencumbered by threat artillery fires. This is particularly critical for light units and any mechanized elements conducting dismounted operations, e.g., breach operations.

Since most threat FA systems are located in a division's AO, the preponderance of counterfire takes place within this area. Divisional organic FA counterfire assets are limited to the division multiple launch rocket system (MLRS) battalion in heavy divisions supported by its organic TAB. One of the two FA brigades that will normally augment a DIVARTY in an attached or reinforcing status will normally be designated as the counterfire headquarters and be given the responsibility for planning and executing the division's counterfire battle. However, even in this case, the DIVARTY commander as division FSCoord retains overall responsibility for orchestrating the division's counterfire effort. A detailed discussion of division counterfire operations is contained in FM 3-09.5.

ROLE OF FA BRIGADES IN DIVISION COUNTERFIRE OPERATIONS

Unless specifically task-organized, FA brigades do not possess organic TA capabilities. If divisions assign reinforcing or attached FA brigades the counterfire role, the division must augment the brigade HQ with acquisition and processing assets in the form of Firefinder radars and the TAB/CTAD target processing section. Assignment of the counterfire mission should receive prior corps artillery concurrence to ensure availability of the FA brigade to perform the counterfire role for the duration of the operation.

IBCT AUTONOMOUS OPERATIONS

The Army's transformation to an objective force has created designs for interim BCT (IBCT) and divisions. The interim force designs place the Q-36 and Q-37 in the IBCT adding flexibility and enhanced force capabilities. The IBCT may employ its radars while operating as an autonomous force, early

entry force, or as part of an interim division force. When acting as an early entry force, the IBCT would perform its own counterfire operations in the same manner as a traditional division. The main differences are:

- The IBCT has fewer radars, one Q-36 and one Q-37.
- May or may not have counterfire support from a division.
- Fires and effects coordination cell (FECC) performs functions as the counterfire headquarters.

In the IBCT, the FECC positions and tasks radars based on IPB and the commanders guidance. The Q-36 radar is positioned to acquire mortars and short-range artillery while the Q-37 radar is positioned to acquire longer-range artillery and rockets. Deconfliction of coverage in autonomous operations is simple since the FECC controls both radars. Even so, a CSB might be established to segregate Q-36 and Q-37 coverage areas. If established, the CSB should be placed in conjunction with the IBCT coordinated fire line when possible. This eliminates the need to clear acquisitions before firing. Radar zones are established in the traditional method based on operational needs. In more non-linear situations, call for fire zones (CFFZ) may be pre-cleared to facilitate target attack. A non-linear battlespace may place the radars in a firebase type situation instead of a typical zone of action. The CSB might be a circle surrounding the force with the Q-36 acquiring targets inside the circle and the Q-37 acquiring targets outside the circle. Figure 5-6 depicts this concept.

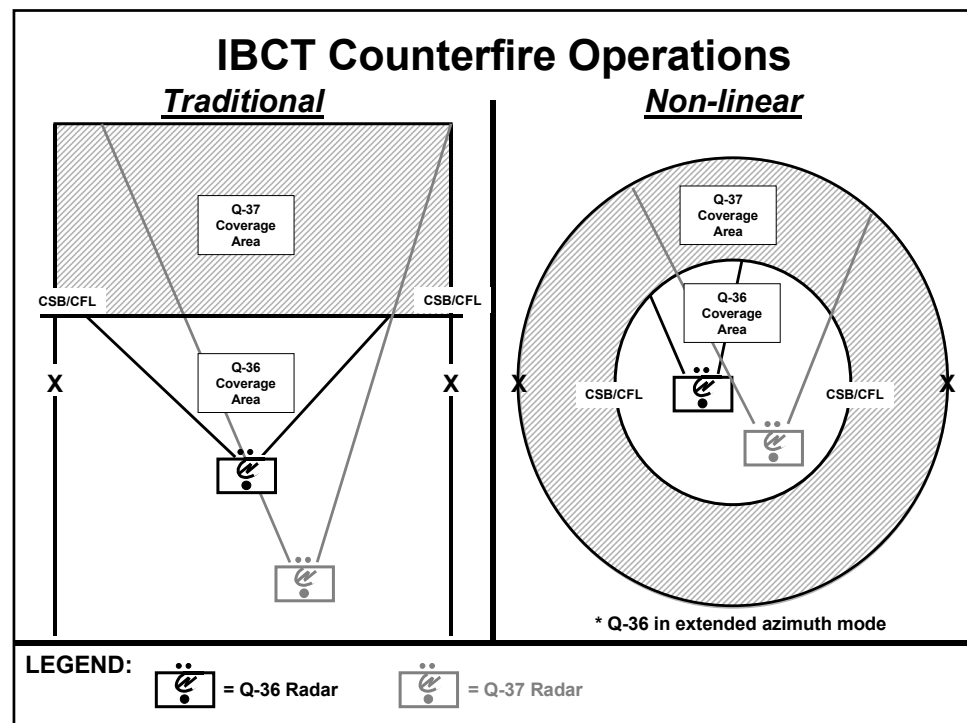

Figure 5-6. IBCT Counterfire Operations

IBCT AND DIVISION INTEGRATED OPERATIONS

There are several options for conducting counterfire operations when the interim division FECC controls counterfire operations. The interim division might conduct traditional counterfire or decentralize its counterfire operations when operating in a non-linear, non-contiguous AO. The interim division may also assume control of all IBCT Q-37s to support division operations. Further, in cases of a non-linear battlespace, the division might task the IBCT with conducting all counterfire operations for the division in a designated area.

Decentralized counterfire operations tasks IBCTs with the mission of acquiring targets and providing TA coverage traditionally performed by the division. This might be done when the division is conducting nonlinear operations or in a linear battle space when the division needs to concentrate on a specific target. For example, an IBCT might be tasked to acquire and attack DAG systems while the division focuses on an AAG or AGRA. Or, the IBCT might be tasked to provide all the radar coverage within its AO. Servicing these targets might remain a division responsibility unless the division allocates additional delivery systems to the IBCT.

INTERIM FORCE DECENTRALIZED LINEAR COUNTERFIRE OPERATIONS

Deconfliction of radar coverage during decentralized operations may be more difficult since the IBCT has its own Q-37s. CSBs are traditionally used to segregate the coverage areas of Q-36 and Q-37 radars. Unless the division is controlling IBCT Q-37s, it must establish graphical control measures to deconflict the coverage of IBCT and division Q-37 radars. Possible control methodologies may include the use of IBCT forward boundaries, phase lines, or designating specific target sets or coverage areas for IBCT Q-37s. Figure 5-7 illustrates a method of deconflicting radar coverage and responsibilities in a linear battlespace.

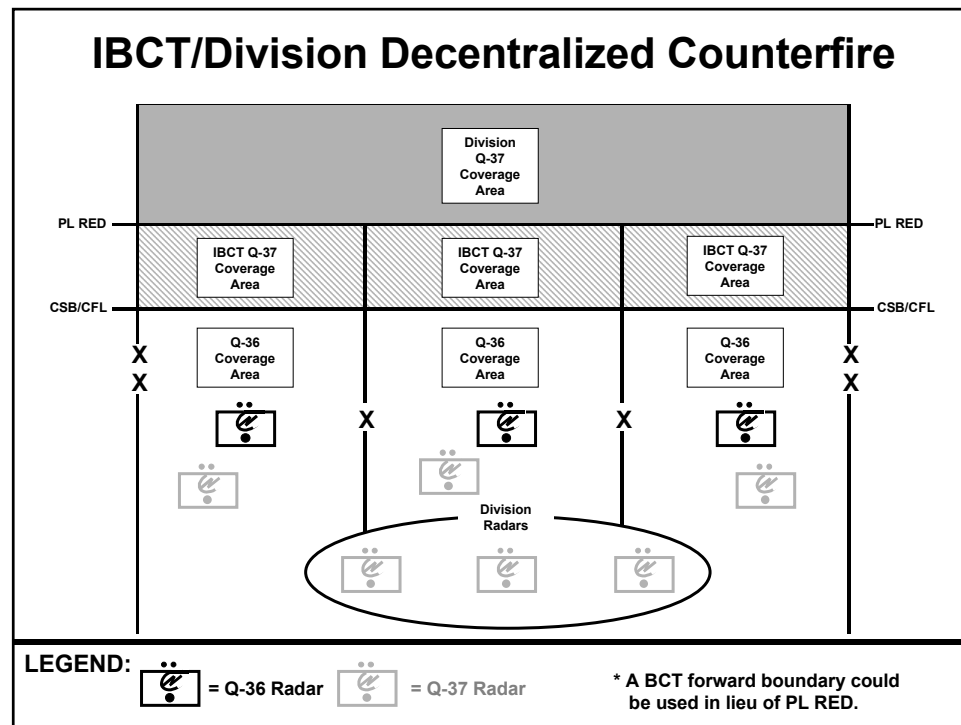

Figure 5-7. Decentralized Counterfire Operations

INTERIM FORCE DECENTRALIZED NON-LINEAR COUNTERFIRE OPERATIONS

The TA assets of the IBCT and interim division provide the force commander with a greater ability to support counterfire operations in a non-linear environment. The division can assign IBCTs autonomous counterfire responsibilities in their AOs and provide TA and counterfire coverage in the remaining division areas. The division accomplishes this by establishing graphical control measures and zones of responsibility (ZOR) to segregate the division and IBCT counterfire fights. This is very important when IBCTs are attacking along axes and have assailable flanks or when there are large gaps between IBCT AOs. IBCT radars establish their coverage areas to correspond with the IBCT's AFATDS ZOR. Each division controlled Q-37 establishes the specific coverage areas designated by the division FECC. These coverage areas are developed based on IPB and focus only on those areas affecting division operations. This allows the FECC to focus counterfire operations on critical areas and systems and eliminate coverage of areas that pose little threat to the force.

SECTION III – STRIKER EMPLOYMENT

MISSION

The mission of the striker platoon is to provide the maneuver brigade commander with high technology observation teams that are dedicated to executing specific fires tasks throughout the depth of the brigade's

battlespace. This mission includes calling for conventional artillery and rocket fires, providing laser designation for smart munitions and, as a secondary mission, providing reconnaissance and surveillance for the brigade. Although originally conceived to designate for Copperhead missions, Strikers can provide final ballistic guidance for any munition requiring reflected laser energy. At present, the team can provide laser designation for smart munitions delivered by Army, Air Force, Marine Corps or Navy aircraft.

OPERATIONS

The platoon headquarters provides leadership and control of striker platoon operations. Each striker team has the organic communications equipment to operate on two nets during mounted operations. During dismounted operations, they have the ability to operate on only one net at a time. The teams have at least four potential nets on which they may have to operate:

- Brigade digital fire support net.
- Brigade operations and intelligence net.
- Brigade voice fire support net.
- Brigade reconnaissance troop (BRT) internal net.

The primary net should be the brigade digital FS net. If striker teams have good digital communications on that net, they can perform their primary mission and most other agencies can send them digital messages. The brigade SOP or order should specify times or situations when they need to check in on one of the other nets.

The striker platoon supports the targeting process by detecting, tracking, initiating target attack and reporting BDA. During the decide phase of the targeting process, striker teams are assigned specific HPTs to observe and or attack, normally in conjunction with a specific NAI or TAI. The striker team positions to observe the NAI or TAI and attack the specified HPTs. If the target is only designated for observation, the striker will report and track the target. Or, the striker may accept a target cross-cued by a sensor or other intelligence source. If the target is designated for attack, the striker will initiate target attack passing the mission to the BCT FSE over the digital fire support net. Upon completion of attack, the striker reports any required BDA.

The BCT commander and his staff determine the role of the striker platoon. The striker platoon is normally attached to or controlled by the BRT with the platoon leader acting as the BRT FSO. In any case, the BCT commander and his staff focus the striker platoon's efforts, clearly stating the platoon's task and purpose as early as possible. This allows the striker platoon to be incorporated into the RS&S plan during the decide phase of targeting. This further enables the platoon to deploy early, well in advance of the BCT's main body, and accomplish its designated detect, track and deliver and assess functions.

Chapter 6

Stability Operations and Support Operations

Target acquisition radars are well suited to support stability operations and support operations across the entire spectrum of conflict from peacetime military engagement (PME) to major theater war (MTW). Target acquisition radars can support these operations as a single radar section or as part of a TA organization. Early entry forces are deployed to support the Commander in Chief's (CINC) or other Joint Force Commander's (JFC) concept of operations in a pre-crisis or crisis situation. They must deploy rapidly, enter the operational area, secure the lodgment, and immediately present a credible deterrent force. To do this, they must have lethal and survivable units. Target acquisition radars support these early entry requirements by providing counterfire coverage, verification of hostile and friendly fires and enhancing the accuracy of friendly fires.

FORCE PROJECTION

Force projection operations usually begin as a response to a crisis somewhere in the world. Target acquisition radars, TA platoons, or TABs will usually deploy in the initial stages of a force projection operation to provide counterfire coverage for critical assets. Many Army contingency plans call for establishing an intermediate staging base (ISB) to introduce contingency forces into a theater to demonstrate national resolve against a potential adversary. On these occasions, the Air Force will use strategic airlift (C-141s, C-17s and C-5s) to establish the ISB. If this show of force fails and U.S. forces are committed, C-130s, CH-47s and UH-60s will be likely choices to move these forces from the ISB to the area of operations. Larger equipment may be transported by rail or ship when necessary. TA radars are deployable on all Air Force standard transport aircraft. However, some radars require significant preparation and disassembly for aircraft movement.

STABILITY OPERATIONS

The TA radars may participate in a number of stability operations. Stability operations include:

- Noncombatant evacuation operations (NEO).
- Arms control.
- Humanitarian and civic assistance.
- Security assistance.
- Support to counter drug operations.
- Combating terrorism.
- Peace operations.

- Show of force.
- Support for insurgencies.
- Foreign Internal Defense (FID).

The types of stability operations and extent of participation may vary. However, TA radars are best suited to support peace operations, shows of force, FID and NEO. TA radars might, in rare circumstance, be required to provide support for insurgencies or counterinsurgencies.

PEACE OPERATIONS

Peace operations (PO) encompass three types of activities: support to diplomacy, peacekeeping operations, and peace enforcement. The environment of peace operations and related concepts, principles, and fundamentals are described in FM 3-07.3, Peace Operations. TA radars are ideally suited for participating in peace keeping and peace enforcement operations.

Peace Keeping

Peace keeping operations (PKO) support diplomatic efforts to maintain peace in areas of potential conflict. They stabilize conflict between two or more belligerent nations, and as such, require the consent of all parties involved in the dispute. The US may participate in peacekeeping operations when requested by the United Nations, with a regional affiliation of nations, with other unaffiliated countries, or unilaterally. US personnel may function as impartial observers, as part of an internal peacekeeping force, or in a supervisory and assistance role. Peacekeeping often involves ambiguous situations requiring the peacekeeping force to deal with extreme tension and violence without becoming a participant. These operations follow diplomatic negotiations that establish a mandate for the peacekeeping force. The mandate describes the scope of the PKO in detail. It typically determines the size and type of force each participating nation will contribute. It also specifies the terms or conditions the host nation intends to impose on the presence of the force or mission and a clear statement of the functions the peacekeeping force is to perform.

A peacekeeping force deters violent acts by its physical presence at violence-prone locations. It collects information through means such as observation posts, patrols, convoys and aerial reconnaissance. TA radars are ideally suited to this task. Their ability to acquire and classify targets provides a means for holding belligerents accountable for their use of indirect fire systems. These acquisitions can be used to direct peacekeeping forces to a hostile firing location or vector other intelligence gathering systems, such as the UAV, to validate the incident. This information can be used during negotiations between belligerents. Further, the possibility of using the acquisitions for attack operations also acts as a deterrent.

Peace Enforcement

Peace enforcement operations (PEO) are the application of military force, or the threat of its use, normally pursuant to international authorization, to

compel compliance with resolutions or sanctions designed to maintain or restore peace and order. Unlike PKO, PEO do not require the consent of all parties. PEO maintain or restore peace and support diplomatic efforts to reach a long-term political settlement. Army forces assigned a PEO mission must be able to conduct combat operations. PEO normally includes one or more of six subordinate operations:

- Forcible separation of belligerents.
- Establishment and supervision of protected areas.
- Sanction and exclusion zone enforcement.
- Movement denial and guarantee.
- Restoration and maintenance of order.
- Protection of humanitarian assistance.

TA radars may support PEO in a traditional counterfire role, and/or by providing accountability for fires. TA radars are particularly suited for accountability operations. They can track hostile and friendly fires and assist with developing historical records to document fires by all parties. This information can be used to support diplomatic actions. Further, the friendly fire functions of the radar may play a significant role in situations where the precision of friendly direct fires must be validated. The information generated by radars can play a key role in denying belligerents the opportunity to exploit the propaganda value resulting from collateral damage caused by intentional or errant indirect friendly or hostile fires.

SHOW OF FORCE

A show of force is a mission carried out to demonstrate US resolve in which US forces deploy to defuse a situation that may be detrimental to US interests or national objectives. Shows of force lend credibility to the nation's commitments, increase regional influence, and demonstrate resolve. These operations can influence other governments or politico-military organizations to respect US interests and international law. They can take the form of combined training exercises, rehearsals, forward deployment of military forces, or introduction and buildup of military forces in a region. The appearance of a credible military force can underscore national policy interests and commitment, improve host-nation military readiness and morale, and provide an insight into US values.

TA radars are well suited for this role. They can support shows of force by providing coverage for critical assets and, should the situation escalate, support the employed force with targeting data. Furthermore, participation in shows of force positions radars in country to support follow-on force-projection operations. TA radars can then be used to provide coverage for aerial ports of debarkation (APOD) and sea ports of debarkation (SPOD) in the deployment phase of a contingency operation.

FOREIGN INTERNAL DEFENSE

Foreign internal defense (FID) is participation by civilian and military agencies of a government in any action programs taken by another government to free or protect its society from subversion, lawlessness and

insurgency. FID consists of indirect support, direct support not involving combat operations, and combat operations. Combat operations include offensive and defensive operations conducted by U.S. forces to support a host nation's fight against insurgents or terrorists. TA radars might support combat operations where the insurgent force possesses a creditable indirect fire threat.

NONCOMBATANT EVACUATION OPERATIONS

Noncombatant evacuation operations (NEO) relocate threatened civilian noncombatants from locations in a foreign nation to secure areas. Normally, these operations involve US citizens whose lives are in danger either from the threat of hostilities or from a natural disaster. They may also include host nation citizens and third country nationals. Army forces, normally as part of a JTF, conduct NEO to assist and support the Department of State. NEO remove noncombatant Americans and others from the threat of being killed or taken hostage. Relocating these potential targets expands options available to diplomatic and military authorities.

NEO can be conducted as a prelude to combat actions, as part of deterrent actions, or as part of a PO. Most often, evacuation force commanders have little influence over the local situation. They may not have the authority to use military measures to preempt hostile actions, yet must be prepared to protect the evacuees and defend the force. The imminent threat may come from hostile forces, general lawlessness, dangerous environmental conditions, or a combination of all three. Correctly appraising the threat and the political-military environment in which forces operate is key to NEO planning.

TA radars may support NEO in cases where there is an indirect fire threat to evacuees. Radars would establish radar coverage and zones for evacuation routes, control points, evacuation centers, APOE, and SPOE.

SUPPORT OPERATIONS

In support operations, Army forces provide essential support, services, assets, or specialized resources to help civil authorities deal with situations beyond their capabilities. Army forces conduct support operations to assist foreign and domestic civil authorities to prepare for or respond to crises and relieve suffering. The overarching purpose of support operations is to meet the immediate needs of designated groups for a limited time until civil authorities can accomplish these tasks without Army assistance. TA organizations and soldiers may participate in support operations as part of a larger Army force. Radars will seldom be used. However, in certain instances, radars may be required to provide coverage for critical assets or support counterterrorism activities during foreign humanitarian assistance operations when a credible indirect fire threat exists. The following paragraphs identify the types and forms of support operations.

TYPES OF SUPPORT OPERATIONS

The two types of support operations are domestic support operations (DSO), and foreign humanitarian assistance (FHA). Army forces conduct DSO in the

US and its territories and FHA outside the US and its territories. Army forces have broader requirements and more significant and extensive obligations in DSO than FHA. Army forces normally conduct FHA operations only in a permissive environment. In uncertain and hostile environments, Army forces conduct FHA operations as part of larger stability or offensive and defensive operations. It is in these situations that radars may be used.

FORMS OF SUPPORT OPERATIONS

During DSO Army forces perform relief operations, support to incidents involving weapons of mass destruction (WMD), support to civil law enforcement, and community assistance. In FHA Army forces most often conduct relief operations; however, FHA may also involve support to incidents involving WMD and community assistance. Army forces involved in support operations execute overlapping activities. The forms of support operations are:

- Relief operations.
 - Disaster relief.
 - Humanitarian relief
- Support to incidences involving WMD.
 - Domestic preparedness.
 - Protection of critical assets.
 - Response to WMD incidents.
- Support to civil law enforcement.
 - Support to antiterrorism/force protection.
 - Support to counterdrug operations.
 - Civil disturbance operations.
 - General support.
- Community Assistance.

EMPLOYMENT CONSIDERATIONS FOR STABILITY OPERATIONS AND SUPPORT OPERATIONS

Stability operations often involve an operational area that is non-linear. This environment requires consideration of employing radars in an area that extends 6400mils around the radar. In these situations, IPB, positioning, masking and aspect angle require additional attention.

POSITIONING

The S3/S2 and the targeting officer determine position areas for radars and the radar section leader selects the final radar site based on FFPAS and visual sighting. At the division level, the S3/G3 and CFO determine position areas. Often, radars will require a position that permits 6400mil coverage. Further, the tactical situation may require positioning of the radar within the lodgment area. Positioning inside a lodgment area requires careful consideration of site improvement. The radar section leader coordinates site improvement or “hardening” directly with supporting engineers or designated host nation agencies. Site improvement normally includes

survivability of the radar, safety, and line of site. Engineers can dig positions or build berms to protect radar components. Berms should be constructed to the height of shelter and vehicles. The antenna should be bermed to the height of the antenna trailer. This provides protection for ATG electronics while providing a clear line of sight for the antenna. Engineers may also clear obstacles to provide a clear line of site. Safety for units in the vicinity of the radar is also a consideration. The heat and radiation generated by the radar poses a personnel hazard. These hazards are minimized by positioning the radar a safe distance from troops (see Chapter 4 for MSDs). Elevating the antenna above the level of personnel and vehicles can mitigate the radiation hazard. This is accomplished by sighting the radar on elevated terrain or building a berm to elevate the ATG above friendly troops and vehicles. Figures 6-1 and 6-2 depict improved radar positions.

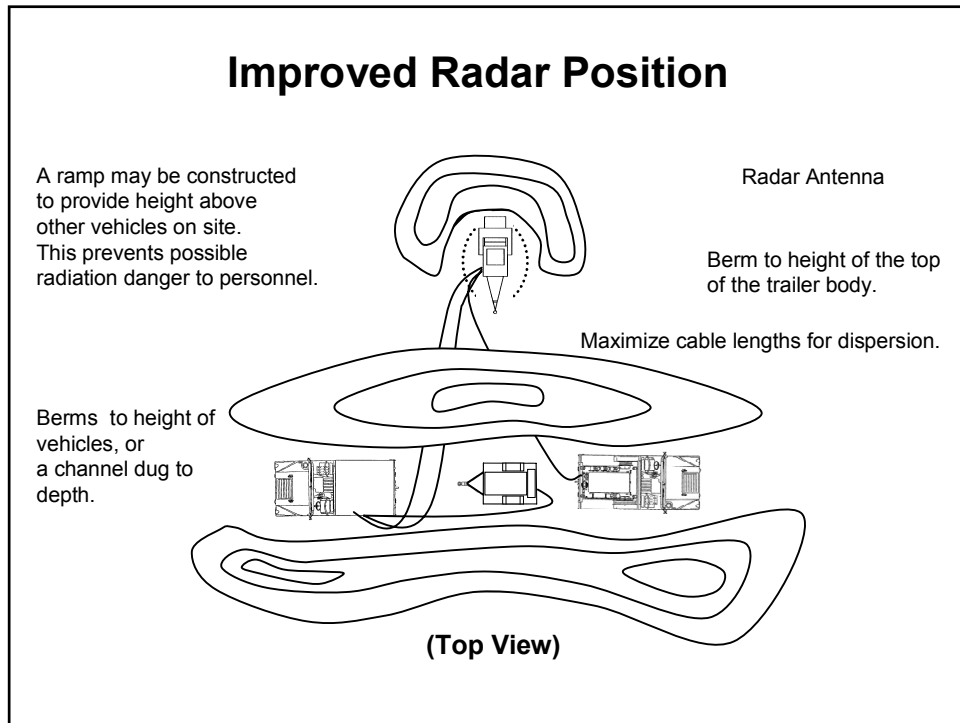

Figure 6-1. Improved Radar Position (Top View)

Other positioning considerations include providing security and eliminating interference, or jamming, between radar systems. Jamming should be considered when selecting positions and search sectors. Radars in close proximity or sectors of search that cause radars to point their antennas at one another may cause jamming. Search sectors should be planned to avoid this problem. Techniques such as frequency splitting may also be used to eliminate jamming. Care should be taken to maintain the correct vertical angle when splitting frequencies with the Q-36. Finally, security should be considered. Radar sections are not manned adequately to conduct 24-hour operations and provide their own security. Security can be provided by a dedicated security force or by collocating the radar with other friendly

elements. Dedicated security should be allocated to protect the radar when it is positioned away from other friendly units and there is a plausible threat. Operations from within a lodgment may reduce or eliminate the need for dedicated security.

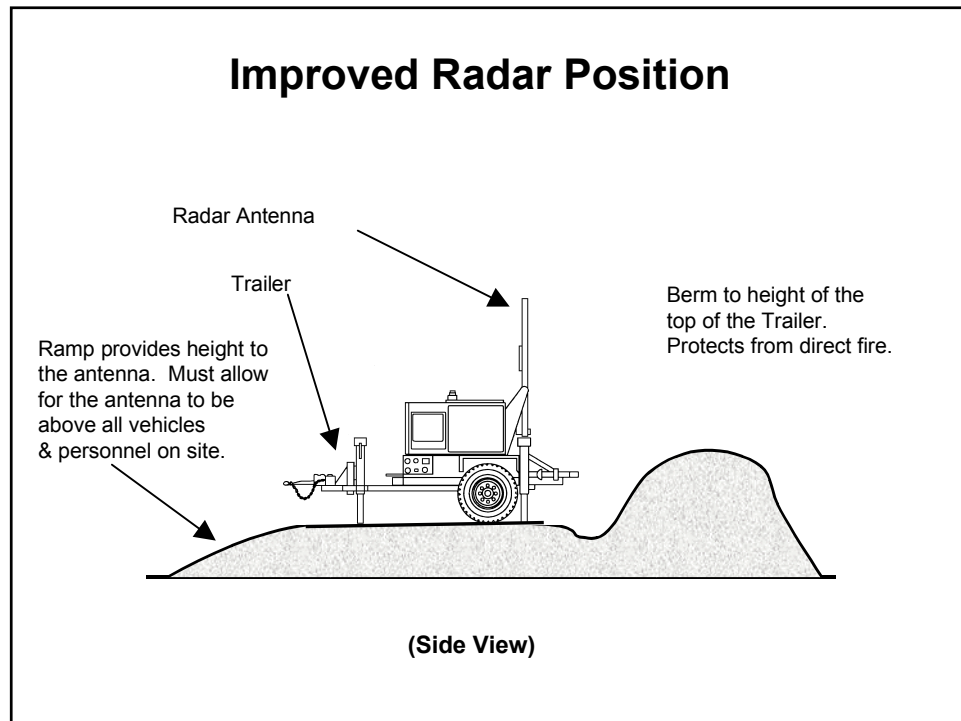

Figure 6-2. Improved Radar Position (Side View)

MASKING

The radar section leader must consider visibility (masking) when operating in an area of varied elevations, dense trees or foliage, or high buildings. This assumes a greater importance when the radar must cover a 6400mil sector. The FireFinder Position Analysis System (FFPAS) may be used to conduct site analysis and determine the optimum initialization data. Further, blind spots in the radar's coverage can be determined and reported to the S3/G3 for appropriate action. A detailed discussion of FFPAS is contained in Chapter 4.

ASPECT ANGLE

In non-linear situations, aspect angle is an important consideration. Aspect angle is the angle between the radar beam and the target path. The aspect angle must be greater than 1600mils for the radar to acquire hostile targets.

- Ensures the identification, dissemination and engagement of targets to support the maneuver commander.
- Ensures reporting and analysis of battle damage assessment and munitions effects.

Appendix A

Automated Target Data Processing

This appendix explains how AFATDS processes target indicators and suspect targets. The intent of this appendix is to provide targeting and counterfire officers with a detailed understanding of the procedures and functions that AFATDS uses to perform the functions previously performed using manual target cards. It provides the detailed information necessary to effectively use AFATDS to manage the processing of targets and target indicators. This appendix includes AFATDS target generation functions, target indicator processing, suspect target processing, target damage assessment, file maintenance and target purging.

GENERAL

The amount of processing required to develop a target varies extensively. In its simplest form, target data processing is the passing of a target from a known, accurate, and reliable source to the fire control element (FCE) or fire direction center (FDC) for attack within established attack guidance and target selection standards (TSS). In its most complex form, it is the collation of target indicators and suspect targets from diverse sources into a target identification and location accurate enough to justify attack.

In ABCS equipped units, target data is transmitted and processed automatically according to the commander's guidance and TSS stored in the AFATDS computer.

AFATDS uses the Target Generation function to automate the tasks performed by the targeting and target processing elements of the DIVARTY or Field Artillery Brigade TOC. The Target Generation function consists of a series of processes that compare and combine target information to generate targets and update the suspect target list and target indicator file. Target Generation takes suspect targets, Artillery Target Intelligence (ATI) targets, and target indicators (such as shell reports) as inputs, and through several processes eliminates duplication, determines and refines suspect target locations, and generates targets. The Target Generation function can be turned on or off based on the targeting needs in a given tactical situation. The outputs of this function are generated targets and an updated suspect target list and target indicator file. Some key definitions related to Target Generation are:

- Target Indicators are directional information that forms a ray (line) from a given point, in a given direction, to a derived maximum distance along which a possible enemy target may be located. Examples of target indicators include shelling, flash, and jam strobe reports. A target indicator will have a target type (e.g. "Artillery, Unknown", "EW Equipment").

- Target Data are grid producing information received at AFATDS via a fire request (e.g., a call for fire received from an observer or a fire mission initiated by an AFATDS operator) or intelligence information (e.g., ATI report received from an observer). Target data are also produced by AFATDS. For example, AFATDS uses intersecting target indicator rays to determine a grid location, thereby generating target data.
- A target is target data that has passed TSS, and therefore, is worthy of attacking because it meets the commander's criteria for reliability, accuracy, and timeliness. Targets undergo further mission processing to determine if a fire mission will be initiated based on comparisons to additional targeting and attack guidance, the target's relative value to other targets, and if attack systems are capable of engaging the target.
- A suspect target is target data that has failed TSS and may not be worthy of attacking because it does not meet the commander's criteria for reliability, accuracy or timeliness. Suspect targets are further refined until they pass TSS and the operator initiates a fire mission on the suspect target, or the suspect target decays (based on target decay guidance) and is deleted from the suspect target list.

TARGET INDICATOR PROCESSING

ROUTING TARGET INDICATORS

If an Operational Facility (OPFAC) does not routinely process shelling reports, a routing function is available to forward shelling reports to a designated OPFAC for processing. For example, a battalion FSE receives a shelling report from one of his observers. The battalion FSO may direct that the report be forwarded to DIVARTY (or the designated counterfire headquarters). The following procedure is used to forward a shell report. Select "Alerts & Messages" -> "Messages" -> "Configure Receiving Setup" and highlight the "Target Indicators" message type and input the DIVARTY address (make sure DIVARTY is in your communications configuration). This procedure routes the shelling report to the appropriate processing element.

AFATDS AUTOMATIC PROCESSING OF TARGET INDICATORS

AFATDS always performs certain functions when a target indicator is initially received whether it was received from an observer or created through operator input. When AFATDS receives target indicator data, some of the information required to process the indicator may or may not be present. AFATDS automatically determines missing information based on reporting observers' unit data and default data files. Missing information is determined as follows:

- Target Indicator Number - If the received target indicator does not have a target indicator number, one is assigned based on the next available target indicator number from the OPFAC target indicator number block. The target indicator number must always begin with "II". If a target indicator is received with a number that does not begin with "II", the number will automatically be replaced with an

“II” number. AFATDS maintains a target indicator numbering block, which the operator cannot edit. This block goes from “II0000 to II9999”.

Note: When you enter a target indicator into AFATDS do not enter a target number (AFATDS will automatically number the indicator).

- Target Indicator Decay DTG - If Target Indicator Decay DTG for the target indicator is not provided AFATDS computes the DTG by adding target decay guidance for the target type to the DTG of acquisition/report. The DTG of report will default to the current time if not provided.
- Target Type - If the received target indicator does not specify a target type, one is assigned based on the following rules:
 - If the weapon type is Artillery: Artillery, Unknown.
 - If weapon type is Mortar, the target type is based on the reported caliber, otherwise the target type is Mortar, Unknown. If the caliber of the mortar is reported, AFATDS will determine the target type as shown in Table A-1.

Table A-1. Mortar Caliber Target Type Mapping

Reported Caliber	Target Type
108-150mm	Mortar, Heavy
61-107mm	Mortar, Medium
< 60mm	Mortar, Light
Not given	Mortar, Unknown

- If the weapon type is Rockets or Missiles: Rocket or Missile, Unknown is used.
- If the weapon type is an Electronic Emitter (or any other electronic target), then the target type is Electronic Warfare Equipment.
- Sensor Directional Error - If the target indicator does not include the sensor directional error (mils) then it is determined based on the default value for the reporting sensor’s unit data or unit type in Table A-2.

Table A-2. Sensor Characteristics

Sensor Type	Laser On	Target Location	Directional
Sensor	Hand	Error (TLE)	Error (mils)
FO	Yes	80	10
FO	No	400	10

Sensor Type Sensor	Laser On Hand	Target Location Error (TLE)	Directional Error (mils)
FIST	Yes	80	5
FIST	No	400	5
COLT	Yes	80	5
COLT	No	400	5
Observer not FA	Yes	80	5
Observer not FA	No	400	5
Air Observer	Yes	270	5
Air Observer	No	400	5
Naval Observer	Yes	80	5
Naval Observer	No	400	5
Mortar Observer	Yes	80	5
Mortar Observer	No	400	5
ANGLICO	Yes	80	5
ANGLICO	No	400	5
AFAC	Yes	270	5
AFAC	No	400	5
FCT	Yes	270	5
FCT	No	400	5
Radar AN/TPQ-36	N/A	100 or 1.0% of range	1
Radar AN/TPQ-37	N/A	90 or 0.9% of range	1
Radar AN/TPQ-47	N/A	TBD	TBD
JSTARS	N/A	400	1
All Others	Yes	400	5
All Others	No	400	5

- Sensor Location - If the sensor location at time of report is not provided, then that sensor unit's most current location is used to determine this value. If no location for the reporting unit is available, the target indicator report is discarded.

TARGET SIMILARITY

AFATDS uses target similarity to determine if targets should be combined or if target indicators are close enough to generate target data. Table A-3 lists target categories, types and their similarity to other targets. The matrix number is the individual number for that target type. The similar to matrix numbers are the targets that are considered similar to the target type. The matrix is also used for target duplication checks.

Table A-3. Similar Target Matrix

Matrix Number	Target Type	Similar To Matrix Number
1	ADA, Heavy	1, 3, 6, 2, 4, 33, 28
2	ADA, Light	2, 3, 6, 1, 4, 33, 28
3	ADA, Medium	3, 1, 6, 2, 4, 33, 28
4	ADA, Missile	4, 6, 1, 3, 2, 33, 34
5	ADA, Position Area	5, 42, 1, 2, 3, 4, 6
6	ADA, Unknown	6, 3, 1, 2, 4, 33, 28
7	Ammunition Dump	7, 83, 84, 85, 86, 87
8	CP, Battalion	8, 11, 12, 10, 13, 9
9	CP, Division	9, 11, 8, 10, 13, 12
10	CP, Forward	10, 8, 12, 11, 9, 13
11	CP, Regiment	11, 9, 8, 19, 13, 12
12	CP, Small	12, 10, 8, 13, 9
13	CP, Unknown	13, 8, 10, 11, 12, 9
14	Guidance Equipment	14, 15, 88, 89, 94
15	Navigational Aids	15, 14, 88, 89, 94
16	Bridge, Floating Pontoon Footbridge	16, 17, 18, 45, 61, 60, 62, 63
17	Bridge, Floating Pontoon Vehicle	17, 16, 18, 45, 61, 60, 62, 63
18	Bridge, Footbridge, Raft	18, 16, 17, 45, 61, 60, 62, 63
19	Building, Concrete	19, 20, 21, 22, 23, 24
20	Building, Unknown	20, 19, 21, 22, 23, 24
21	Building, Masonry	21, 19, 20, 22, 23, 24
22	Building, Special Purpose	22, 19, 20, 21, 23, 24

Matrix Number	Target Type	Similar To Matrix Number
23	Building, Metal	23, 19, 20, 21, 22, 24
24	Building, Wood	24, 19, 20, 21, 22, 23
25	Bunker	25, 26
26	Pillbox	26, 25
27	Artillery, Heavy Self-Propelled	27, 29, 28, 31, 30
28	Artillery, Light Self-Propelled	28, 29, 30, 31, 27, 38, 35
29	Artillery, Medium Self-Propelled	29, 27, 28, 31, 30
30	Artillery, Towed	30, 31, 28, 29, 27, 38, 35
31	Artillery, Unknown	31, 29, 30, 28, 27
32	Missile, Heavy	32, 34, 33, 4
33	Missile, Light	33, 34, 40, 41, 32, 43, 4
34	Missile, Medium	34, 32, 33, 4
35	Mortar, Heavy	35, 37, 38, 39, 36, 28, 30
36	Mortar, Light	36, 37, 39, 35, 38, 28, 30
37	Mortar, Medium	37, 36, 35, 39, 38, 28, 30
38	Mortar, Very Heavy	38, 35, 37, 39, 36, 28, 30
39	Mortar, Unknown	39, 35, 37, 38, 36, 28, 30
40	Rocket-Missile, Anti-Personnel	40, 41, 33, 64, 43
41	Rocket-Missile, Anti-Tank	41, 40, 64, 33, 43
42	Rocket-Missile, Position Area	42, 5, 40, 41
43	Rocket-Missile, Unknown	43, 40, 41, 43
44	Boat	44, 48, 47, 46, 52
45	Ferry Bridge	45, 16, 17, 18, 63
46	Helicopter, Attack	46, 47, 48, 52, 44
47	Helicopter, Cargo	47, 46, 48, 52, 44
48	Helicopter, Observation	48, 46, 47, 52, 44
49	Vehicle, Heavy Wheel	49, 50, 51, 95

Matrix Number	Target Type	Similar To Matrix Number
50	Vehicle, Light Wheel	50, 49, 51, 95
51	Vehicle, Utility	51, 49, 50, 95
52	Aircraft	52, 46, 47, 48, 44
53	Defile	53, 59, 54, 57, 58, 55, 56
54	Hill	54, 59, 53, 57, 58, 55, 56
55	Landing Strip	55, 58, 56, 57, 59, 53, 54
56	Railroad Segment	56, 58, 55, 57, 59, 53, 54
57	Road Junction	57, 55, 56, 58, 59, 53, 54
58	Road Segment	58, 55, 56, 57, 59, 53, 54
59	Terrain Feature	59, 53, 54, 55, 56, 57, 58
60	Bridge, Vehicle, Concrete	60, 62, 61, 17, 16, 18, 63
61	Bridge, Vehicle, Wood	61, 18, 60, 62, 17, 16, 63
62	Bridge, Vehicle, Steel	62, 60, 61, 17, 16, 18, 63
63	Bridge Site	63, 16, 17, 18, 45, 60, 61
64	Anti-Tank Gun	64, 77, 41, 40
65	Armored Personnel Carrier	65, 66, 79, 80, 78
66	Armored Vehicle	66, 65, 79, 80, 78
67	Assembly Area, Mechanized Troops	67, 70, 69, 71, 68
68	Assembly Area, Troops	68, 70, 67, 69, 71
69	Assembly Area, Troops and Armor	69, 67, 70, 68, 71
70	Assembly Area, Troops and Vehicles	70, 67, 69, 68, 71
71	Assembly Area, Unknown	71, 68, 70, 67, 69
72	Infantry	72, 76, 81, 75, 74, 82, 73
73	Machine Gun, Heavy	73, 82, 74, 72, 76, 81
74	Machine Gun, Light	74, 82, 73, 72, 76, 81
75	Observation Post	75, 12, 76, 72, 81
76	Patrol	76, 72, 81, 75, 74, 82, 73
77	Recoilless Rifle	77, 64, 40, 41

Matrix Number	Target Type	Similar To Matrix Number
78	Tank, Heavy	78, 80, 79, 66, 65
79	Tank, Light	79, 80, 78, 66, 65
80	Tank, Medium	80, 78, 79, 66, 65
81	Work Party	81, 76, 72, 75, 74, 82, 73
82	Weapon, Crew Served	82, 73, 74, 72, 76, 81
83	Class I Supply Dump	83, 84, 7, 86, 87, 85
84	Class II Supply Dump	84, 83, 7, 86, 87, 85
85	Supply Dump, Unknown	85, 83, 84, 7, 86, 87
86	Chemical Products Complex	86, 87, 83, 84, 7, 85
87	Petroleum Products Complex	87, 86, 83, 84, 7, 85
89	Electronic Warfare Equipment	89, 88, 94, 14, 15, 93, 91, 92, 90
90	Counter-Battery Radar	90, 91, 92, 93, 94, 89, 88
91	Counter-Mortar Radar	91, 90, 92, 93, 94, 89, 88
92	Direction Finding Radar	92, 91, 90, 93, 94, 89, 88
93	Ground Surveillance Radar	93, 92, 91, 90, 94, 89, 88
94	Search Light	94, 88, 89, 14, 15, 93, 92, 91, 90
95	Reconnaissance Vehicle	95, 49, 50, 51

DIRECTION AND DISTANCE

The direction and distance of the target indicator ray is determined by:

- Direction of ray originates from the sensor/shell impact location.
- Length of ray is based on the following:
 - Use length provided, if given.
 - If a flash to bang is provided, use $\text{Distance} = 350 \times \text{Time (sec)}$. The result is the length of ray in meters.
 - If length or flash to bang time is not provided, the ray length is based on the target type as shown in Table A-4:

Table A-4. Default Target Indicator Length

Target Type	Ray Length (meters)
Mortar, Very Heavy	9700
Mortar, Heavy	7200
Mortar, Medium	7200
Mortar, Light	4200
Mortar, Unknown	7200
Artillery, Heavy, SP	37,500
Artillery, Medium, SP	24,700
Artillery, Light, SP	15,300
Artillery, Towed	24,700
Artillery, Unknown	24,700
Rocket/Missile, Anti-Personnel	30,000
Rocket/Missile, Anti-Tank	30,000
Rocket/Missile, Position Area	30,000
Rocket/Missile, Unknown	30,000
Missile, Heavy	300,000
Missile, Medium	100,000
Missile, Light	100,000
Electronic Warfare Equipment	30,000

DISPLAY

Target indicators are displayed as “fans” based on the sensor directional error. Figure A-1 shows a target indicator with a 10,000 meter length and a sensor directional error of 10 mils.

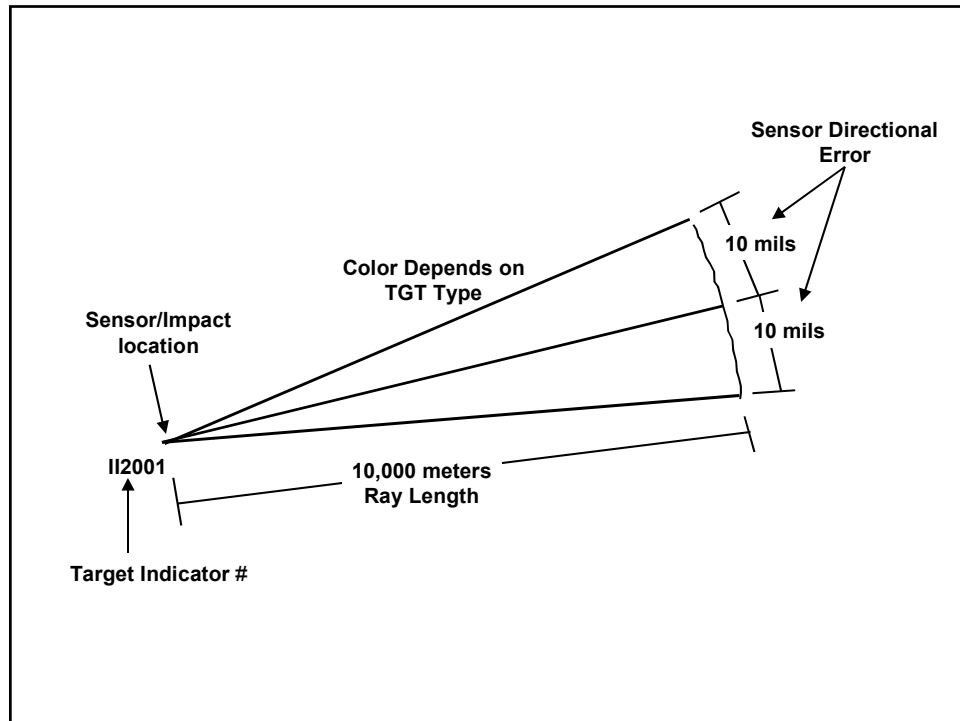

Figure A-1. Target Indicator Display

Each target indicator ray has an assigned color based on target type. The colors of target indicator rays are shown in Table A-5.

Table A-5. Default Target Indicator Color

Target Type	Ray Color
Mortar, Very Heavy	Yellow
Mortar, Heavy	Yellow
Mortar, Medium	Yellow
Mortar, Light	Yellow
Mortar, Unknown	Yellow
Artillery, Heavy, SP	Red
Artillery, Medium, SP	Green
Artillery, Light, SP	Blue

Target Type	Ray Color
Artillery, Towed	Green
Artillery, Unknown	Black
Rocket/Missile, Anti-Personnel	Orange
Rocket/Missile, Anti-Tank	Orange
Rocket/Missile, Position area	Orange
Rocket/Missile, Unknown	Orange
Missile, Heavy	Orange
Missile, Medium	Orange
Missile, Light	Orange
Electronic Warfare Equipment	Black

TARGET INDICATOR FUNCTION

Based on the tactical situation, the AFATDS operator may or may not want the system to run the Target Indicator function. AFATDS allows the operator to turn target indicator processing on or off. When the target indicator processing is “off”, AFATDS adds the target indicator to the target indicator list with no additional processing or comparisons. When Target Indicator Processing is “on”, AFATDS performs the following checks (in order):

- Compares the target indicator against the current (but non-active) target files (i.e. targets on the “On-call”, “Suspect”, “Planned” and “Inactive” target lists). If the indicator ray covers a similar target, the OPFAC with target indicator processing duty is notified of the “Target Indicator Match” via an alert and reviews information on the target indicator and all matched targets. The operator may take various actions from this alert:
 - Selectively initiate fire mission(s) against the target(s) indicated as a match. This will open the initiate fire mission screen already filled out for the selected target.
 - Add selected matched target(s) to an existing fire plan. This will place the targets on the selected fire plan.
 - Display the target indicator fan-target comparison. This graphically displays the indicator fan and the associated matched target(s) on the map.

- Selectively update matched target(s) with a new “last updated” value based on the target indicator DTG of acquisition/report.
 - Delete the target indicator. This will discard the received target indicator data and will not add it to the target indicator list.
 - Continue Processing the Target Indicator. This will add the target indicator to the target indicator list for possible combination with existing target indicators.
- Compare the target indicator with other target indicators already on file. If the target indicator did not match a target or the operator selected “Process TI” from the target match window, AFATDS will add the new target indicator to the target indicator list and determine if it can be combined with existing target indicators. See Figure A-2 for an example of target comparison. The following rules are used in this comparison:
 - The new target indicator is compared against existing target indicators in the target indicator file that have a similar target type. Only target indicators that have not passed their decay DTG are considered.
 - When target indicator rays of three or more of the compared target indicators intersect to form a point or common area, and all points are located within 400 meters, AFATDS automatically combines the rays and generates a new target number and passes the target to the TSS check for further processing. Combined TIs are deleted from the TI list.
 - If no match is found, the new target indicator is added to the target indicator file. The operator can purge the target indicator list of target indicators when their “decay time” DTG is passed. To do this simply select “automatically purge” option on the target indicator list window.

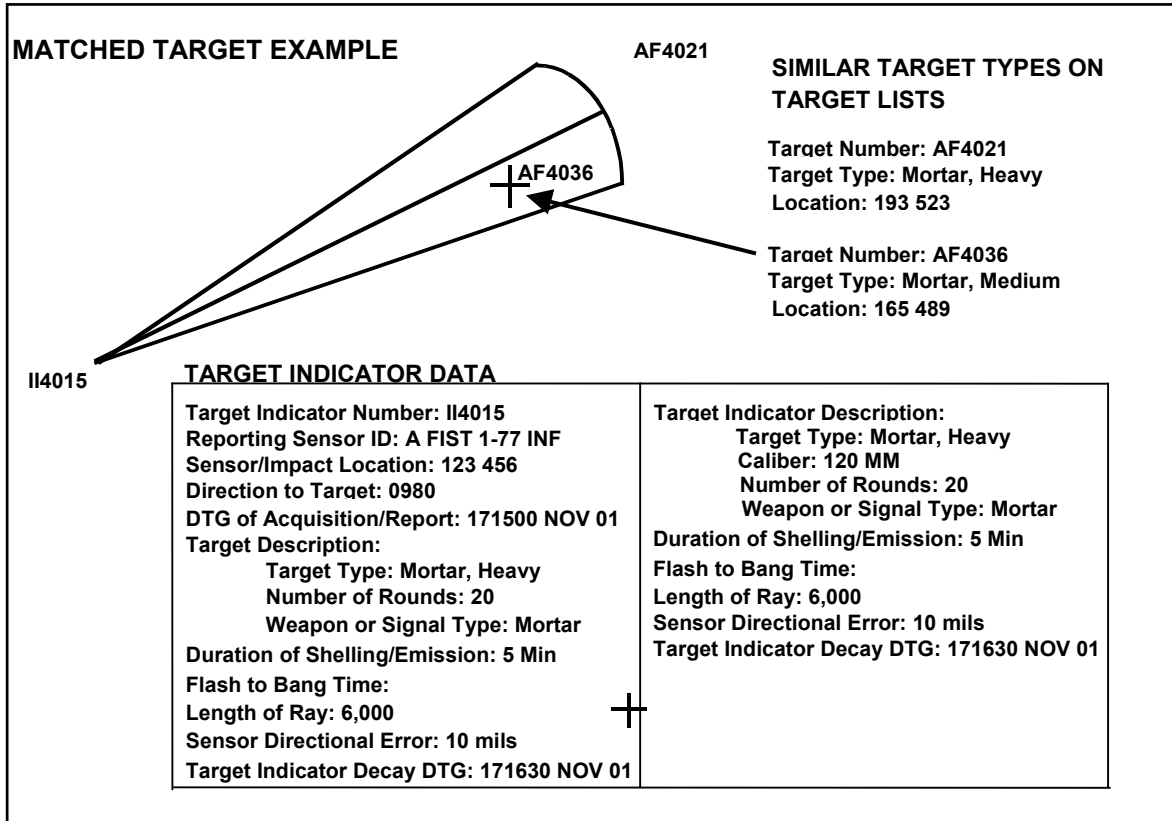

Figure A-2. Target Indicators-Target Comparison

Figure A-3 provides a summary of the possible results of target indicator processing.

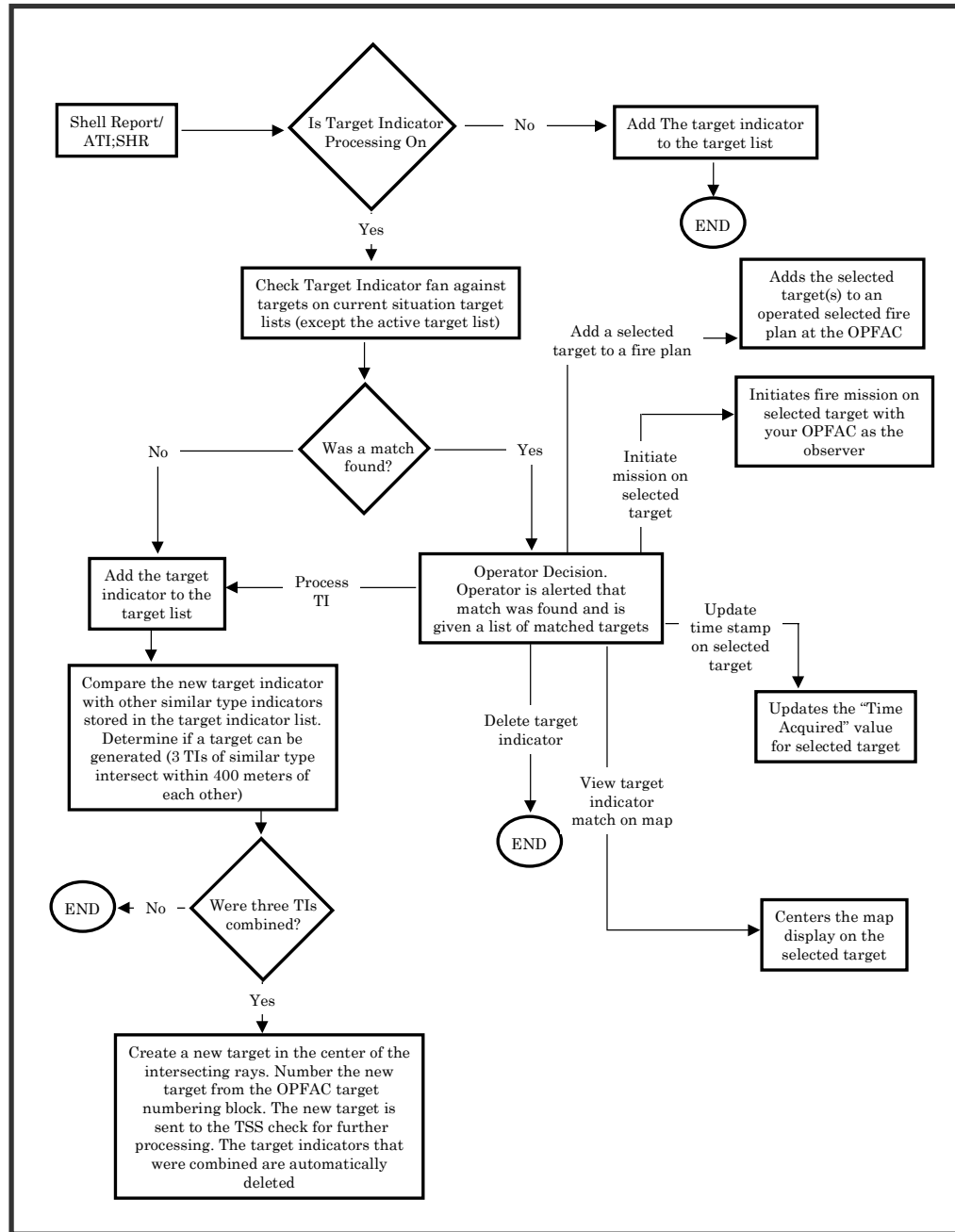

Figure A-3. Target Indicator Processing

SUSPECT TARGET PROCESSING

Suspect targets represent target information that has not passed TSS. This section discusses how AFATDS processes suspect targets after TSS failure. The operator may turn Suspect Target Processing “on” or “off”. When it is turned off, all suspect targets are simply added to the suspect target list with no further

processing. When it is turned on, AFATDS evaluates each suspect target against other suspect targets to combine the new suspect target with an existing suspect target and generate a target with a better TLE and/or more current DTG. AFATDS applies the following considerations when identifying suspect targets for combination and applying the associated target data for the "new" (combined) target:

- Decay Time. Only suspect targets that have not passed their decay DTG are considered for combination.
- Target Type. Only targets with a similar type will be considered for combination. For example, an "Artillery, Unknown" target would not be combined with a "Building, Metal" target.
- Target Size. The target size and TLE, for the new or extracted suspect targets is used to determine overlap. If an overlap exists between the new target and a single existing target and the overlap area meets or exceeds the operator established percentage of overlap required, then the two targets match. Basically, the overlap percentage tells AFATDS how close two targets must be (considering the area and TLE of each target) in order to combine them. Figure A-4 shows some examples of this comparison.

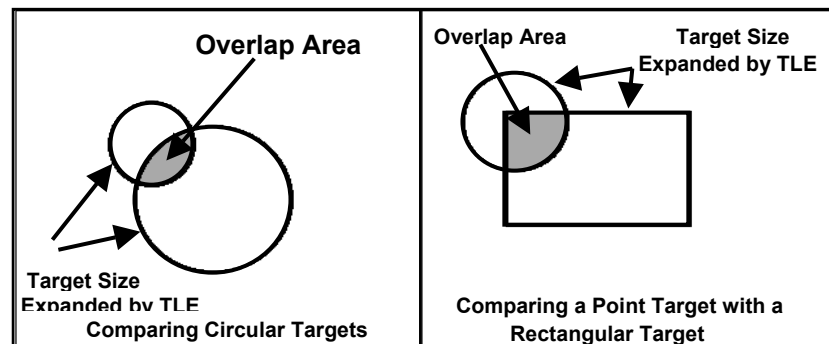

Figure A-4. Suspect Target Overlap

If multiple overlaps exist between the new suspect target and two or more existing suspect targets and each overlap area meets or exceeds the operator established percentage of overlap required, then the following rules apply:

- The suspect target with the greater degree of similarity to the new suspect target is combined with the new suspect target.
- If the degree of similarity is the same, the suspect target with the greater degree of overlap with the new suspect target is combined with the new suspect target. Figure A-5 illustrates multiple target overlap.

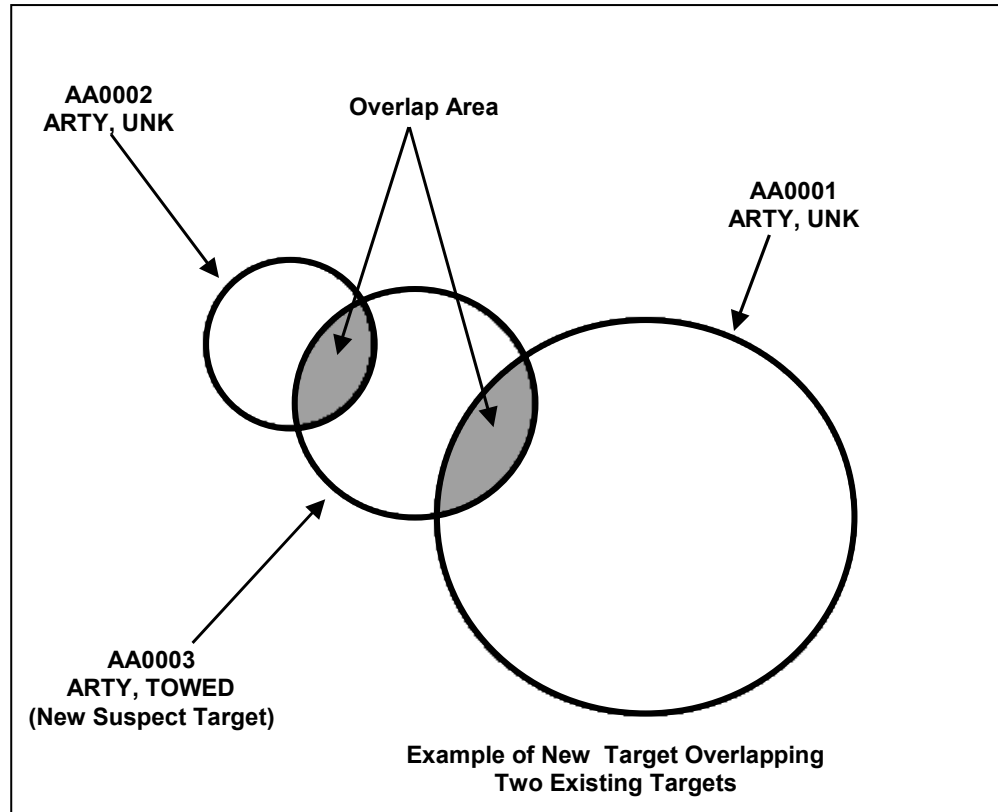

Figure A-5. Multiple Target Overlap

When two targets are combined, the new target is sent to TSS for further processing. Both of the “parent” targets (the two that were combined) are removed from the suspect target list.

The operator may specify the “Overlap %” to be used by AFATDS when considering targets for combination. A larger percentage (like 75%) will result in fewer, but more accurate, combinations than a smaller percentage (like 25%). As with the target indicator list, the operator may decide to have the suspect target list purged of targets when their “decay time” DTG is passed. To do this simply select “automatically purge” option on the suspect target list window. Finally, the operator may see the targets on the suspect target list that were generated by AFATDS (these will be the targets that have a “yes” in the “Combined?” column of the list). There is an option to “uncombine” a combined target if desired.

CONSIDERATIONS FOR RECEIVING ATI MESSAGES FROM PACKAGE 10 IFSAS.

An ATI;CDR message received from IFSAS could be treated as a fire request, intelligence data, mission fired report (MFR), On-Call Target, or Planned Target depending upon the information contained in the message. Table A-6 summarizes the various dispositions possible for an ATI message received by AFATDS.

Table A-6. ATI Results When Received From IFSAS

Fire Request Indicator	Mission Fired Indicator	Record Target Indicator	Confirm Target Location	Delete Target	Update Target	Disposition
Yes	N/A	N/A	N/A	N/A	N/A	Fire Request
No	Yes	N/A	N/A	N/A	N/A	MFR
No	No	Yes	N/A	N/A	N/A	Record As Target (On Call List)
No	No	No	Yes	N/A	N/A	Planned Target List
No	No	No	No	N/A	N/A	Suspect Target
No	N/A	N/A	N/A	Yes	N/A	Planned Target List (Update)
No	N/A	N/A	N/A	N/A	Yes	Planned Target List (Update)

CONSIDERATIONS FOR RECEIVING ATI MESSAGES FROM PACKAGE 11 IFSAS.

An ATI message received from a Package 11 device could be treated as a fire request, intelligence data, MFR, On-Call Target, or Planned Target depending upon the information contained in the message. Table A-7 summarizes the various dispositions possible for an ATI received by AFATDS.

Table A-7. Suspect Target Processing

Mission Fired Indicator Set?	Target Number Provided and Message Action is "Change" or "Delete"	Message Designator is "Shell Report"	Message Action is not Specified and Target Data (Number, Type, and Location is Provided)	Message is ATI "Coordinate" or "ATI Azimuth" and Message Action is "Add"	Disposition
Yes	N/A	N/A	N/A	N/A	MFR
No	Yes	N/A	N/A	N/A	Planned Target List (Update)
No	No	Yes	N/A	N/A	Target Indicator
No	No	No	Yes	N/A	Target Info Query Request
No	No	No	No	Yes	ATI Sent To TSS

If the message does not fit into the rules contained in Table A-7, it will be displayed upon receipt to the AFATDS operator. A summary of the possible results of suspect target processing is provided in Figure A-6.

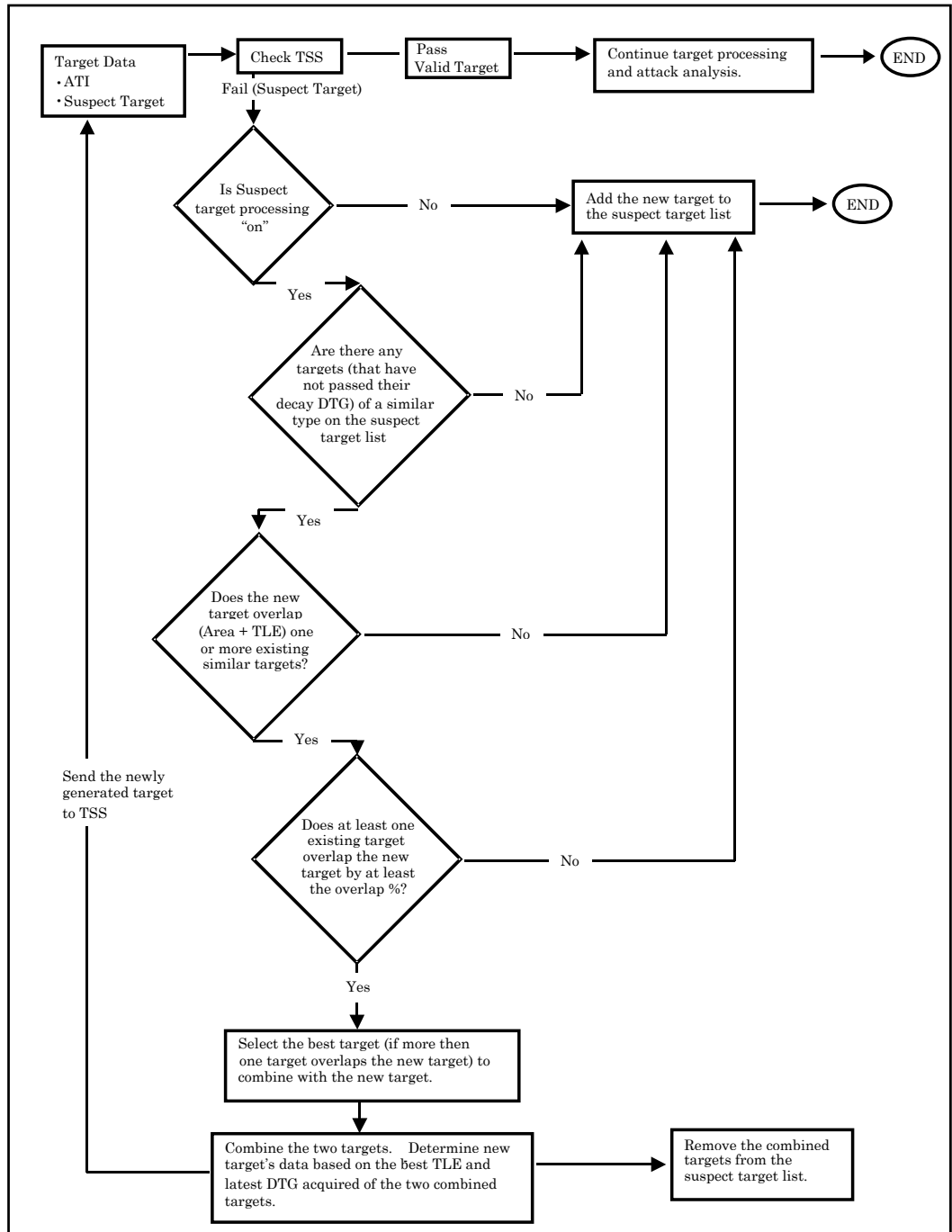

Figure A-6. Suspect Target Processing

TARGET DAMAGE ASSESSMENT

Target Damage Assessment (TDA) is a function of AFATDS that allows target disposition to be entered by the observer on the MFR after attack of a target. TDA can be flagged in the commanders guidance of AFATDS, causing targets to remain active until disposition is received from the observer for the particular target. TDA in AFATDS guidance is target type specific. Therefore, it is not very useful in the determination of TDA on a particular target generated from the suspect target processing function. Flagging an individual target type in the target management matrix (TMM) will cause that target type to remain active until the reporting sensor sends a MFR for that target that contains target damage. This requires eyes on target. A target generated by the suspect target or target indicator processing function will have the processing AFATDS station as the observer. This station very seldom has eyes on target.

FILE MAINTENANCE AND TARGET PURGING

File maintenance for suspect target and target indicator processing consists of purging targets that are no longer valid. This can be done manually or automatically. Manually deleting targets from the suspect target or target indicator list involves selecting the target list requiring maintenance and reviewing individual targets, and validating or deleting individual targets from the target list. The most effective method of performing file maintenance is to set target purging to automatic. This automatically purges targets based on the target decay time established in the TSS. This is accomplished by selecting "Automatic Purge" on the suspect target or target indicator list.

Appendix B

Crater Analysis and Reporting

Although greater reliance should be placed on reports from trained teams, all personnel should know how to analyze craters and make the proper report. Since crater analysis teams are not authorized by TOE, each unit (including units normally located in rear areas) should select and train at least one team of two or three members. To adequately support their maneuver unit, fire support personnel must know how to analyze and report crater information.

GUN AND HOWITZER SHELL CRATER ANALYSIS

The projectile direction of flight can be determined fairly accurately from the projectile crater or ricochet furrow. It is possible to obtain the azimuth of a ray that will pass through or near the enemy position by accurately locating the crater and determining the direction of flight. While it is possible to determine the direction to the firing weapons from one crater or ricochet furrow, an enemy firing unit may be located by plotting the intersection of the average azimuths from at least three widely separated groups of craters.

In crater analysis, differences in angle of fall, projectile burst patterns, directions of flight, and time fuze setting will help distinguish between enemy weapons firing on a given area.

Refer to FM 3-3 for guidance on friendly troop safety from the effects of craters contaminated with chemical agents. Refer to FM 3-3 also for guidance in marking craters containing chemical, biological, or radiological contamination.

VALUE OF ANALYSIS

By analyzing shell craters, the crater analysis team can:

- Verify, as confirmed locations, suspected locations that have been obtained by other means.
- Confirm the presence of enemy artillery, rockets, or mortars and obtain an approximate direction to them.
- Detect the presence of new types of enemy weapons, new calibers, or new ammunition manufacturing methods.

INSPECTION OF SHELLED AREAS

Shelled areas must be inspected as soon as possible after the shelling. Craters that are exposed to the elements or are abused by personnel deteriorate rapidly and thereby lose their value as a source of information.

SURVEY OR CRATER LOCATION

Areas must be located accurately enough for plotting on charts, maps, or aerial photographs. Deliberate survey is not essential; hasty survey techniques or map spotting will usually suffice. Direction can be determined by use of an aiming circle or a compass.

DETERMINATION OF DIRECTION PATTERN

A clear pattern produced on the ground by a detonating shell indicates the direction from which the shell came.

FACTORS AFFECTING PATTERN

Because of terrain irregularities and soil conditions, typical shell crater patterns are the exception, not the rule. Side spray marks are a principal part of the pattern caused by fragmentation. Base spray is negligible from gun and howitzer projectiles but is appreciable from mortars. The width, angle, and density of the side spray pattern vary with the projectile, angle of impact, type of fuze, terminal velocity of the projectile, and soil composition.

In determining direction, the following must be considered:

- Effect of stones, vegetation, stumps, and roots in the path of the projectiles.
- Variations in density and type of soil.
- The slope of the terrain at the point of impact.

From any group, only the most clearly defined and typical craters are used.

MARKS ON VEGETATION AND OTHER OBJECTS

Marks made by a round as it passes through trees, snow, and walls often indicate the direction from which the round was fired. The possible deflection of the shell upon impact with these objects must be considered. Evidence of such deflection should not be overlooked.

DRIFT AND WIND EFFECTS

Drift and lateral wind effects do not materially change the direction of the shell axis during flight.

RICOCLET FURROWS

Often, when an artillery round with a delay fuze is fired at low angle, it bounces or ricochets from the surface of the earth. In doing so, it creates a groove, which is called a ricochet furrow. This groove is an extension of the direction of fire. Care must be taken, however, to determine that the shell was not deflected before or while it was making the furrow.

CRATER ANALYSIS

The initial step in crater analysis is to locate a usable crater for use in determining the direction to the hostile weapon. The crater should be

reasonably fresh and clearly defined on the ground. Since the crater is the beginning point for plotting the direction to the enemy weapon, the grid coordinates of the crater should be determined as precisely as time and the method used will allow. The direction to the firing weapon must be determined by one of the methods described below, depending on the angle of the trajectory and type of fuze fired. Shell fragments must be collected for use in identifying the type and caliber of the weapon.

LOW-ANGLE FUZE QUICK CRATERS (ARTILLERY)

The detonation of a low-angle fuze quick projectile causes an inner crater. The burst and momentum of the shell carry the effect forward and to the sides, forming an arrow that points to the rear (toward the weapon from which the round was fired). The fuze continues along the line of flight, creating a fuze furrow. There are two methods of obtaining a direction to a hostile weapon from this type of crater. These are the fuze furrow and center of crater method and the side spray method. The best results are obtained by determining a mean, or average, of several directions obtained by using both methods.

FUZE FURROW AND CENTER OF CRATER METHOD

In the fuze furrow and center of crater method, one stake is placed in the center of the crater and another is placed in the furrow at the point where the fuze was blown forward to the front of the crater. A direction-measuring instrument is set up in line with the two stakes, and the direction to the hostile weapon is measured. A variation of this method is to place a stake where the shell entered the ground instead of in the fuze furrow and determine the direction in the same manner. This variation method is rarely possible since the explosion of the shell usually destroys indications of the point of entry. The five steps of the fuze furrow and center of crater methods are as follows:

- Place a stake in the center of the crater.
- Place a second stake in the fuze furrow.
- Set up a direction-measuring instrument in line with the stakes and away from fragments.
- Orient the instrument.
- Measure the direction to the hostile weapon.

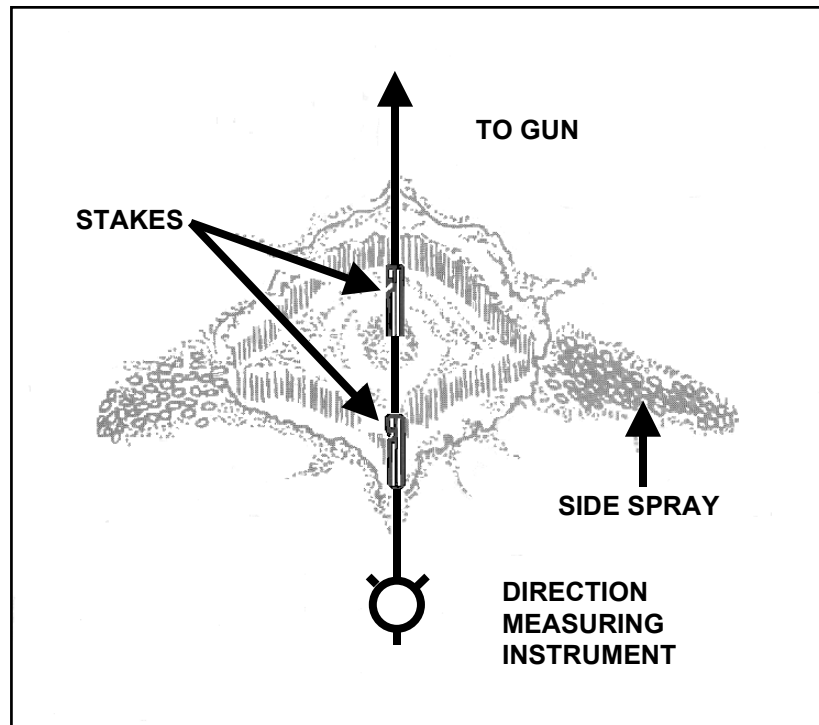

Figure B-1. Fuze Furrow and Center of Crater Method

SIDE SPRAY METHOD

Another method used to measure the direction to a hostile weapon is to bisect the angle formed by the lines of side spray. The seven steps in measuring the direction of a fuze quick crater by the side spray method are as follows:

- Place a stake in the center of the crater.
- Place two stakes, one at the end of each line of side spray, equal distant from the center stake.
- Hold a length of communications wire (or another appropriate field-expedient means) to each side spray stake, and strike an arc forward of the fuze furrow.
- Place a stake where these arcs intersect.
- Set up a direction-measuring instrument in line with the center stake and the stake at the intersection of the arcs.
- Orient the instrument.
- Measure the direction to the firing weapon.

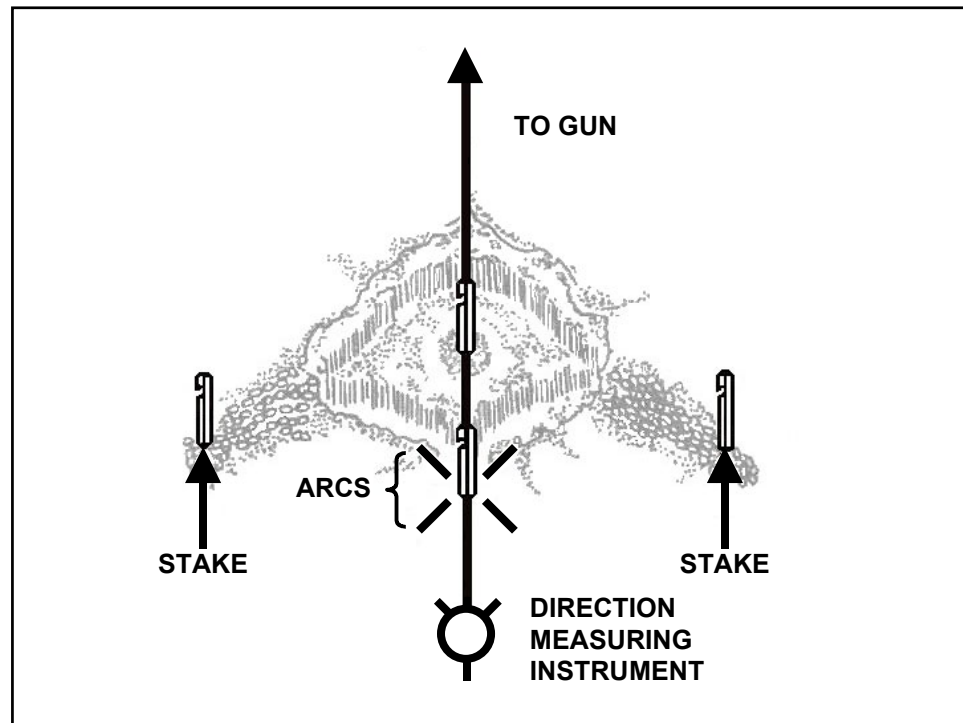

Figure B-2. Side Spray Method

LOW-ANGLE FUZE DELAY CRATERS (ARTILLERY)

There are two types of low-angle fuze delay craters - ricochet and mine action.

RICOCHET CRATERS

The projectile enters the ground in a line following the trajectory and continues in a straight line for a few feet, causing a ricochet furrow. The projectile then normally deflects upward and at the same time changes direction. The change of direction usually is to the right as the result of the spin, or rotation, of the projectile. The effect of the airburst can be noted on the ground. Directions obtained from ricochet craters are considered to be the most reliable. The five steps required to determine direction from a ricochet furrow are as follows:

- Clean out the furrow.
- Place a stake at each end of a usable straight section of the furrow.
- Set up a direction-measuring instrument in line with the stakes and away from fragments.
- Orient the instrument.
- Measure the direction to the weapon.

MINE ACTION CRATER

Mine action occurs when a shell bursts beneath the ground. Occasionally, such a burst will leave a furrow that can be analyzed in the same manner as the ricochet furrow. A mine action crater that does not have a furrow cannot be used to determine the direction to the weapon.

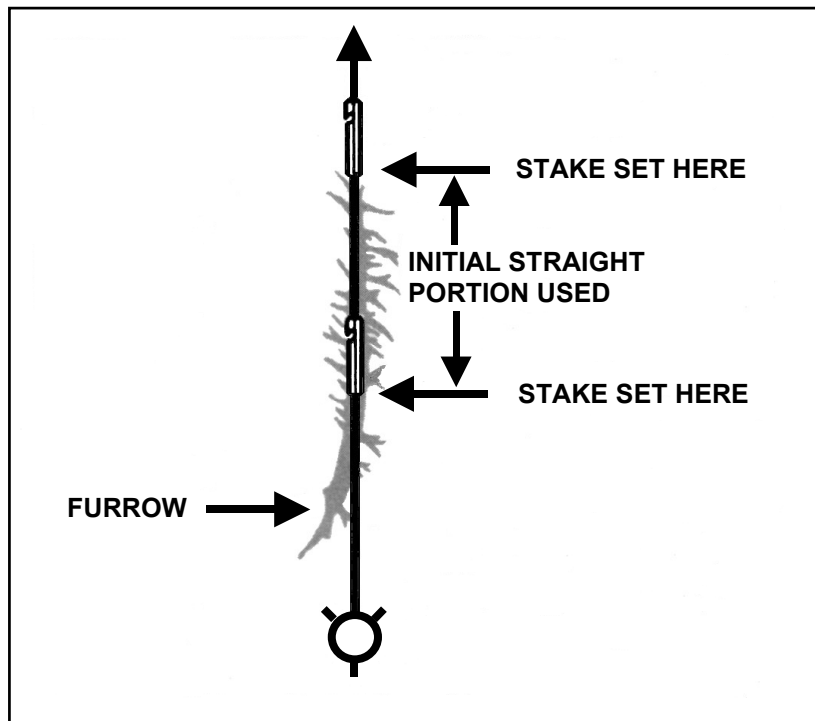

Figure B-3. Ricochet Furrow Method

HIGH-ANGLE SHELL CRATERS (MORTARS)

In a typical high-angle mortar crater, the turf at the forward edge (the direction away from the hostile mortar) is undercut. The rear edge of the crater is shorn of vegetation and grooved by splinters. When fresh, the crater is covered with loose earth, which must be carefully removed to disclose the firm burnt inner crater. The ground surrounding the crater is streaked by splinter grooves that radiate from the point of detonation. The ends of the splinter grooves on the rearward side are on an approximately straight line. This line is perpendicular to the horizontal trajectory of the round. A fuze tunnel is caused by the fuze burying itself at the bottom of the inner crater in front of the point of detonation. Three methods may be used to determine direction from a high-angle mortar shell crater-main axis, splinter groove, and fuze tunnel.

MAIN AXIS METHOD

The four steps used to determine direction by the main axis method are as follows:

- Lay a stake along the main axis of the crater, dividing the crater into symmetrical halves. The stake points in the direction of the mortar.
- Set up a direction-measuring instrument in line with the stake and away from fragments.
- Orient the instrument.
- Measure the direction to the weapon.

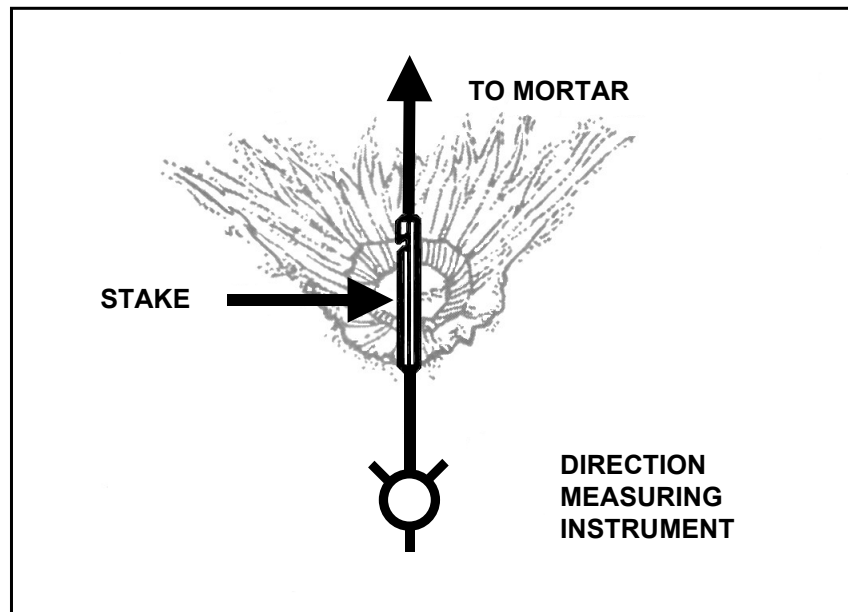

Figure B-4. Main Axis Method

SPLINTER GROOVE METHOD

The five steps used to determine direction by the splinter groove method are:

- Lay a stake along the ends of the splinter grooves that extend from the crater.
- Lay a second stake perpendicular to the first stake through the axis of the fuze tunnel.
- Set up a direction-measuring instrument in line with the second stake and away from fragments.
- Orient the instrument.
- Measure the direction to the weapon.

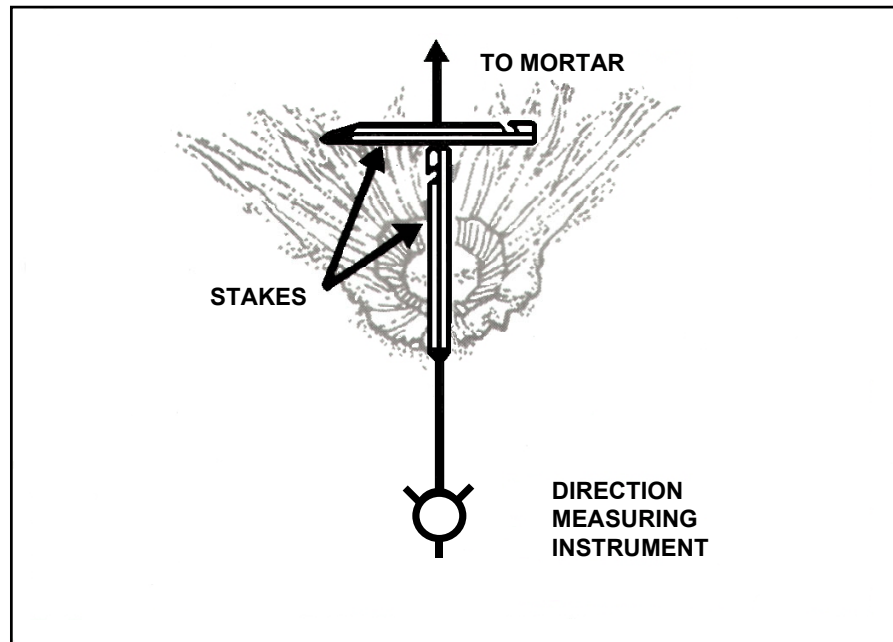

Figure B-5. Splinter Groove Method

FUZE TUNNEL METHOD

The four steps used to determine direction by the fuze tunnel method are:

- Place a stake in the fuze tunnel.
- Set up a direction-measuring instrument in line with the stake and away from fragments.
- Orient the instrument.
- Measure the direction to the weapon.

Note: If the angle of fall is too great (a 90 degree angle), the fuze tunnel method cannot be used.

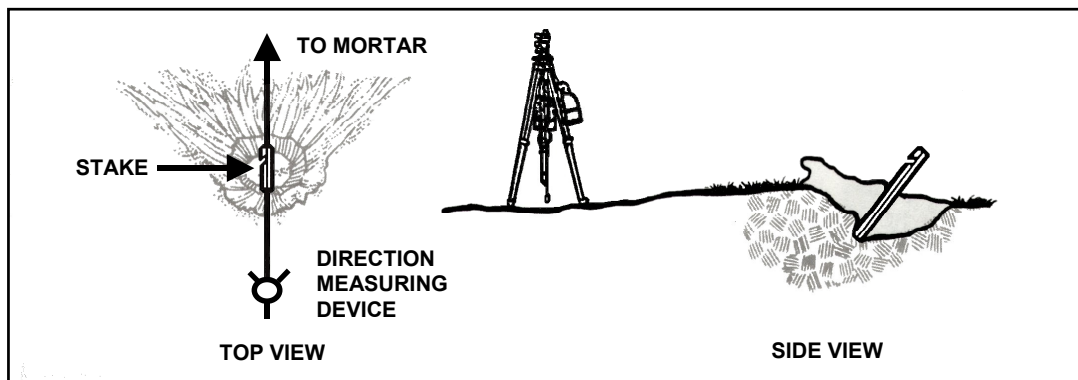

Figure B-6. Fuze Tunnel Method

ROCKET CRATERS

A rocket crater resulting from a rocket impacting with a low or medium angle of fall is analyzed in the same manner as an artillery crater resulting from a projectile armed with fuze quick. However, if the rocket impacts with a high angle of fall, the crater is analyzed in the same manner as a crater resulting from a mortar round fired with fuze quick. (See paragraph on low-angle fuze quick craters.) The tail fins, rocket motor, body, and other parts of the rocket may be used to determine the caliber and type of rocket fired.

SHELL FRAGMENT ANALYSIS

Identification by weapon type and caliber may be determined from shell fragments found in shell craters. Dimensions of the parts, as well as those of the complete shell, vary according to the caliber and type of shell.

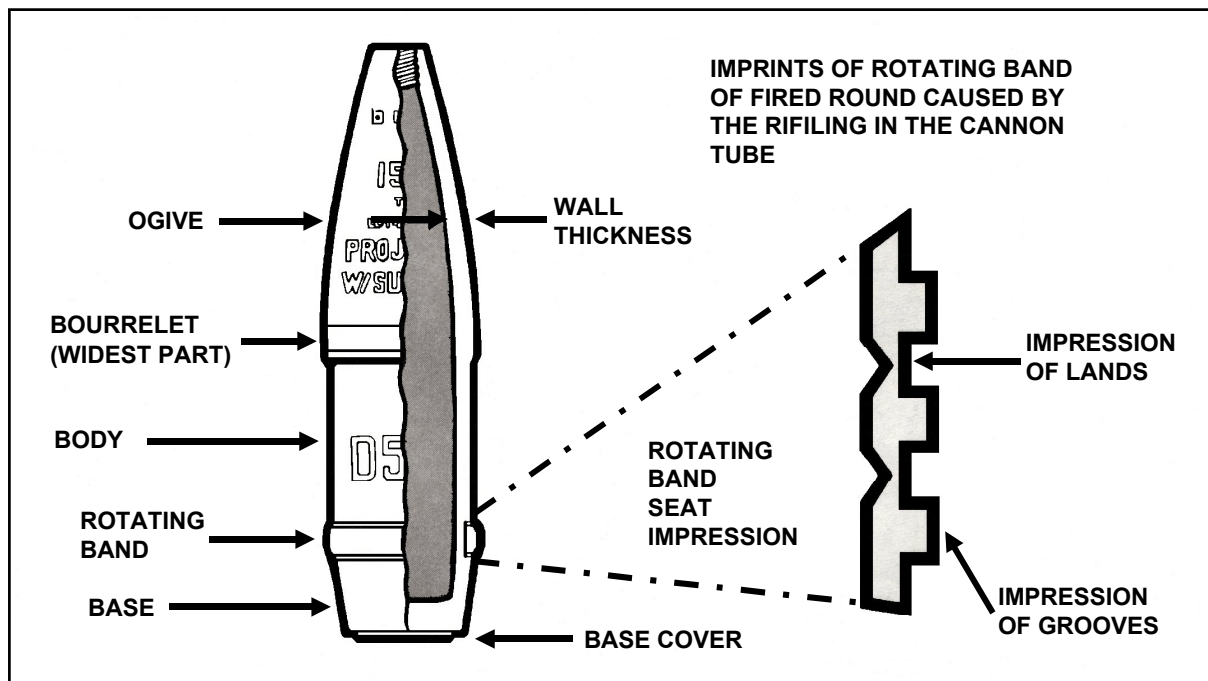

Figure B-7. Typical Shell

DUDS AND LOW-ORDER BURSTS

The most logical means of identifying the caliber of a projectile is to inspect a dud of that caliber. However, since a dud may not always be available or may be too dangerous to handle, a low-order burst is the next best means of identification. When the explosive filler is not completely detonated, a low-order burst occurs and large shell fragments result. Such large pieces can be used to identify thread count, curvature, wall thickness, and so forth.

HIGH-ORDER BURSTS

A high-order burst normally results in small-deformed fragments. These fragments are useless for identification purposes unless they include a

section of either the rotating band or the rotating band seat. Fragments of either of these sections positively identify the shell, since each shell has its own distinctive rotating band markings.

ROTATING BANDS AND BAND SEATS

A shell may be identified as to caliber, type, and nation of origin from the:

- Pattern or rifling imprints on rotating bands.
- Width, number, and size of rotating bands.
- Dimensions and pattern of keying or knurling on the rotating band seat.
- Dimensions and pattern of rotating band seat keying and knurling impressed on the rotating band.

US and former Soviet block artillery require a rotating band or band seat for spin-stabilized projectiles. Except for the rotating bands and band seats of the tail fins, different types of shells may be identical in one or more dimension (such as wall thickness). However, shells are seldom alike in two or more dimensions. Therefore, it is necessary to obtain shell fragments from two or more dimensions to make a positive identification. For a discussion of interior ballistics and how rifling imprints are made on rounds as they are fired, see FM 3-09.40 (6-40).

TAIL FINS

A mortar can be identified from the tail fins. Tail fins often are found in the fuze tunnel of the crater. A mortar that is not fin-stabilized may be identified from the pieces of the projectile on which the rifling is imprinted.

FUZES

Since the same type of fuze may be used with several different calibers or types of projectiles, it is impossible to establish the type and caliber of a weapon by this means.

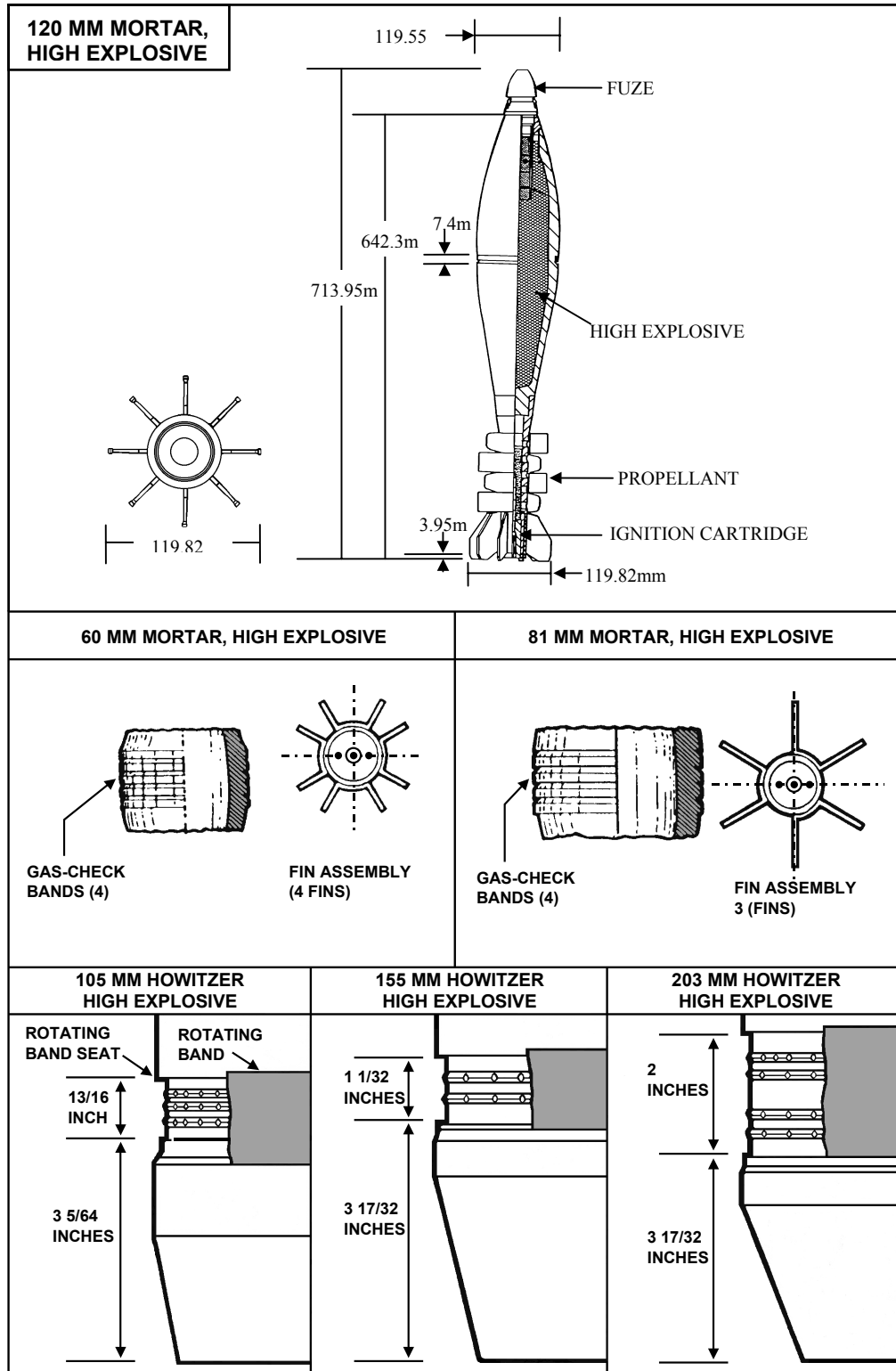

Figure B-8. Shell Fragment and Tail Fin Identification of US Ammunition

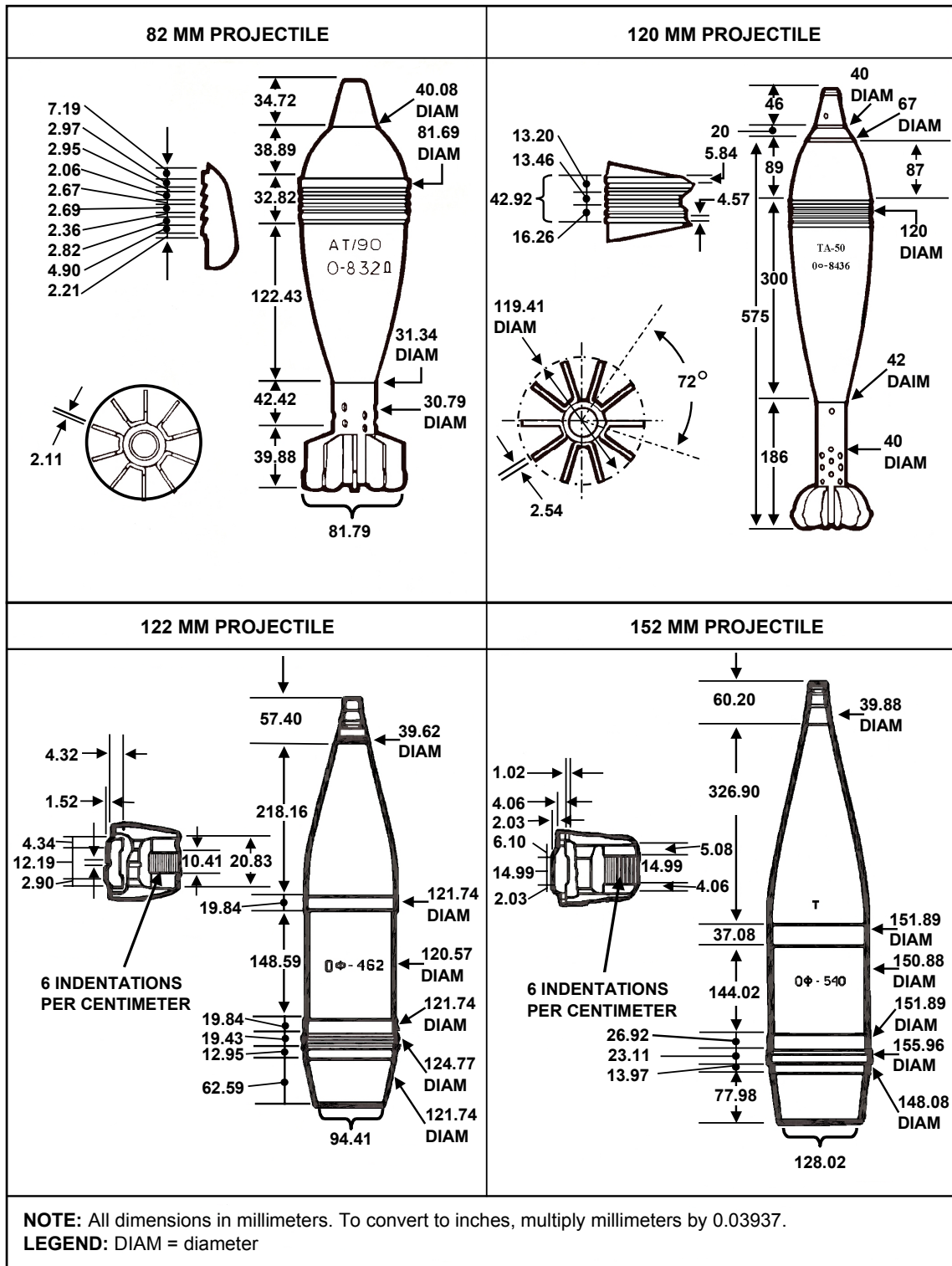

Figure B-9. Ammunition Available to Potential Enemies

This section implements STANAG 2008, Edition 6, and QSTAG 503, Edition 1.

SHELLING REPORTS

The division artillery is responsible for counterfire. Therefore, bombing reports (BOMREPs), SHELREPs, MORTREPs, and rocketing reports (ROCKREPs) should be forwarded as quickly as possible to the DIVARTY TOC or the designated counterfire headquarters through either fire direction or fire support channels. If a DS battalion receives a report and that battalion decides to attack a target developed from it, the report of action taken and a target damage assessment, if available, should be forwarded to the DIVARTY TOC or designated counterfire headquarters when the action is completed. Shelling reports are forwarded manually using the artillery counterfire information form or by using the target indicator processing functions contained in AFATDS. See Appendix A for a detailed discussion of AFATDS procedures.

ARTILLERY COUNTERFIRE INFORMATION FORM

The information obtained from a crater should be forwarded by the most rapid available means in the format of DA Form 2185-R. The artillery counterfire information form standardizes reporting procedures and complies with STANAG 2008 and QSTAG 503. No matter how little information has been obtained, do not hesitate to forward the information. Fragmentary or incomplete information (a radio or telephone report) is often of value in supplementing or confirming existing information. This radio or telephone report may be followed by a written report on DA Form 2185-R.

Any usable fragments obtained from crater analysis should be tagged and sent to the battalion S2. As a minimum, the tag should include the following information:

- Location of the crater.
- Direction to the hostile weapon.
- Date-time group of the shelling.

The DS artillery S2 forwards the information contained in a SHELREP to the counterfire officer (CFO) at the designated counterfire headquarters. The CFO plots the location of the crater and a line representing the direction measured to the weapon on a SHELREP overlay. He compares the information with that received from other sources and tries to locate enemy weapons from the intersections of direction lines to weapons of the same caliber.

EXAMPLE

The information in the following situation is illustrated on the completed DA Form 2185-R in Figure B-10. You are the executive officer of Battery A, 1st Battalion, 30th Field Artillery, located at grid NP392841. Your call sign is A3F22. At 0545, the enemy shelled your position for 2 minutes with a total of eight rounds of high explosive (HE). The tempo and pattern of bursts suggest an enemy four-gun battery. Your battery commander believes that the enemy intent is harassment. Your SHELREP team determines the direction to the enemy battery to be 4,810 mils. The team also located a fragment that

includes a part of the rotating band seat. The shell was identified as an enemy 122-mm howitzer projectile.

The SHELREP team makes entries on the DA Form 2185-R. However, personnel do not complete the four blanks in the heading of the form. (The receiving agency completes these blanks; for example, the battalion S2 section.)

The information contained in Columns B and K of Section I is encoded for security reasons. The current call sign or code name for the unit is entered in Column A. Column B is not applicable when this form is used for crater analysis.

Sections II and III are completed in the target production section of the DIVARTY TOC.

ARTILLERY COUNTERFIRE INFORMATION										
(For use of this form, see FM 6-121; the proponent agency is TRADOC.)										
RECEIVED BY		FROM			TIME		NUMBER			
SECTION I - BOMBER, SHELREP, MORTREP, OR ROCKREP (Cross out items not applicable.)										
UNIT OF ORIGIN (Current call sign address group or code name)	POSITION OF OBSERVER (Encode if HQ or important OP or if Column F gives info on location)	DIRECTION (Grid bearing of FLASH, SOUND, or GROOVE of SHELL [state which] in mils unless otherwise stated). (Omit for aircraft)	TIME FROM	TIME TO	AREA BOMBED, SHELLED, OR MORTARED (Grid ref [in clear] or grid bearing to impact in mils and distance from observer in meters [encoded]) (Dimension of the area in meters) by (the radius) or (length and width)	NUMBER AND NATURE OF GUNS (Mortars, rocket launchers, aircraft or other methods of delivery)	NATURE OF FIRE (Adjustment, fire for effect, or harassing) (May be omitted for aircraft)	NUMBER, TYPE, AND CALIBER (State whether measured or assumed) OF SHELLS, ROCKETS (or MISSILES), AND BOMBS	TIME OF FLASH-TO-BANG (Omit for aircraft)	DAMAGE (Encode if required)
F22 A	NA B	4810m C	0545 D	0547 E	392841 F	4 ARTY G	H H	8 HE 122 I	NA J	NA K
SECTION II - LOCATION REPORT						SECTION III - COUNTERFIRE ACTION				
REMARKS	SERIAL NUMBER (Each location that is produced by a locating unit is given a serial number)	TARGET NUMBER (If the weapon or activity has previously been given a target number, it will be entered here)	POSITION OF TARGET (The grid reference or grid bearing and distance of the located weapon or activity)	ACCURACY (The accuracy to which the weapon was located. CEP in meters and the means of location if possible)	TIME OF LOCATION (Actual time the location was made)	TARGET DESCRIPTION (Dimensions if possible): 1. Radius of target 2. Target length and width in meters	TIME FIRED (Against hostile target)	FIRED BY	NUMBER OF ROUNDS, TYPE OF FUZE, AND PROJECTILES	
L	M	N	P	Q	R	S	T	U	V	

DA FORM 2185-R, 1 APR 90

(Conforms with STANAG 2008)

Edition of 1 May 78 is obsolete

Figure B-10. Artillery Counterfire Information Form

EQUIPMENT

Three elements - direction, dimensions, and curvature - must be measured for crater analysis. The equipment used by the crater analysis team should consist of the following items:

- Aiming circle (M2 compass), stakes, and communications wire to obtain the direction from the crater to the weapon that fired the projectile.

- A curvature template to measure the curvature of the fragment to determine the caliber of the shell. The template can be constructed of heavy cardboard, acetate, wood, or other appropriate material.
- Defense Intelligence Agency Projectile Fragment Identification Guide for measuring fragment dimensions (DST-1160-G-029-85, with Change 1, dated 27 Jan 89).

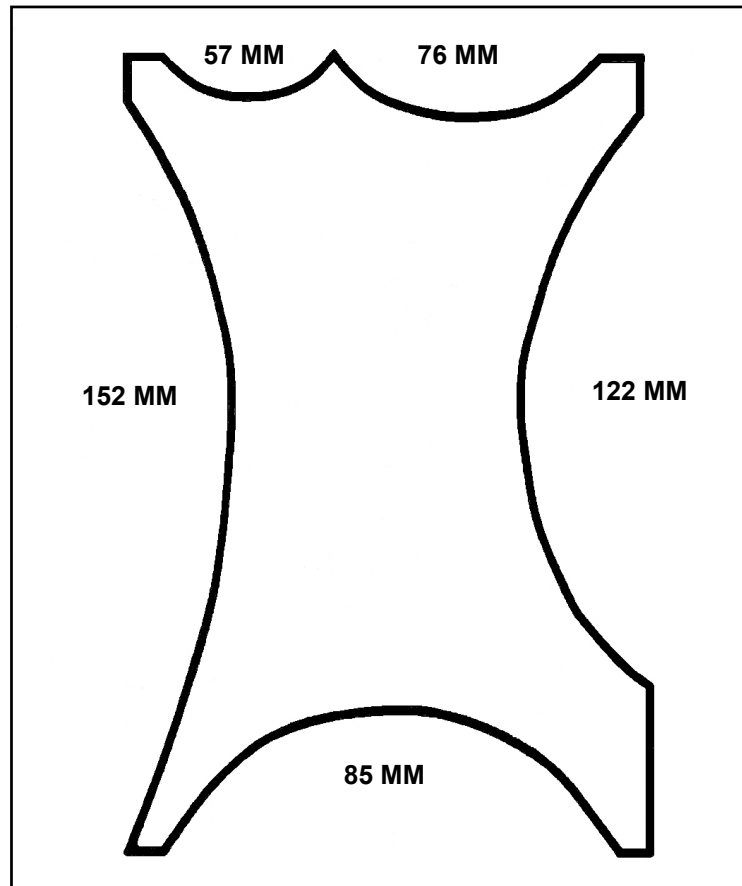

Figure B.12 Curvature Template

Appendix C

Firefinder Friendly Fire Mode

FIREFINDER MISSIONS

The secondary mission of Firefinder radars is to support friendly firing elements. This mission is performed only when the commander deems it absolutely necessary. The reason is that the secondary mission takes the radar away from its primary mission of locating hostile weapons. Also, it exposes the radar to possible location by hostile EW systems for other than its primary mission. In the friendly fire operational mode, Firefinder radars can provide accurate actual burst, datum-plane, or predicted-impact location data. These data allow firing elements to determine registration corrections for nonstandard conditions. Because the radar cannot radiate in friendly fire mode and hostile fire mode at the same time, the commander must issue specific guidance as to when and how friendly fire mode will be used. This determination is made based on METT-TC, availability of observers, and the ability of the supported unit to meet the requirements for accurate predicted fire.

FRIENDLY FIRE MODE

When operating in the friendly fire mode, the Firefinder radar sets up a horizontal “window” through which the projectile must pass. The window is referred to as the friendly fire search fence as shown in Figure C-1. For operations in friendly fire mode, the normal search fence of 1,600 mils (used in the hostile fire mode) is focused to a width of approximately 440 mils. The narrowed search fence provides the best probability of detecting and tracking rounds fired. The radar tracks projectiles until an airburst is detected, the selected datum plane altitude is intersected, or the radar has enough data to predict the point of impact.

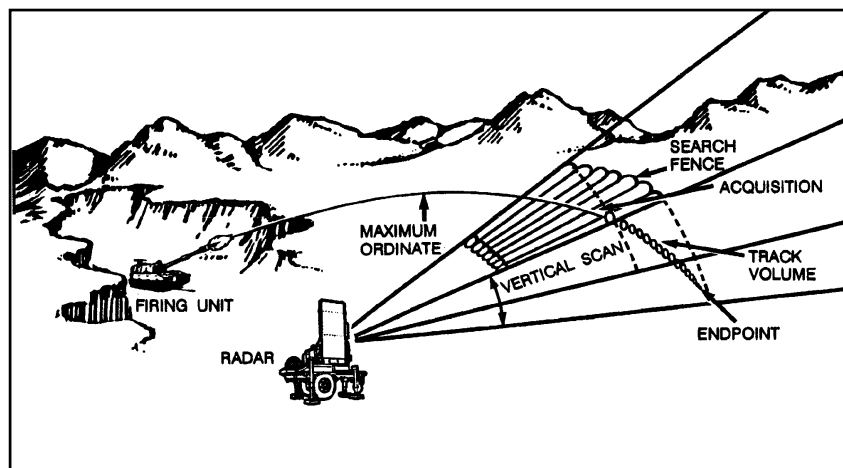

Figure C-1. Friendly Projectile Tracking

In the optimum friendly fire radar-tracking situation, the angle (angle-T) made by the radar-orienting point (radar-target) line and the gun-orienting point (gun-target) line is from 800 to 1,200 mils. See Figure C-2.

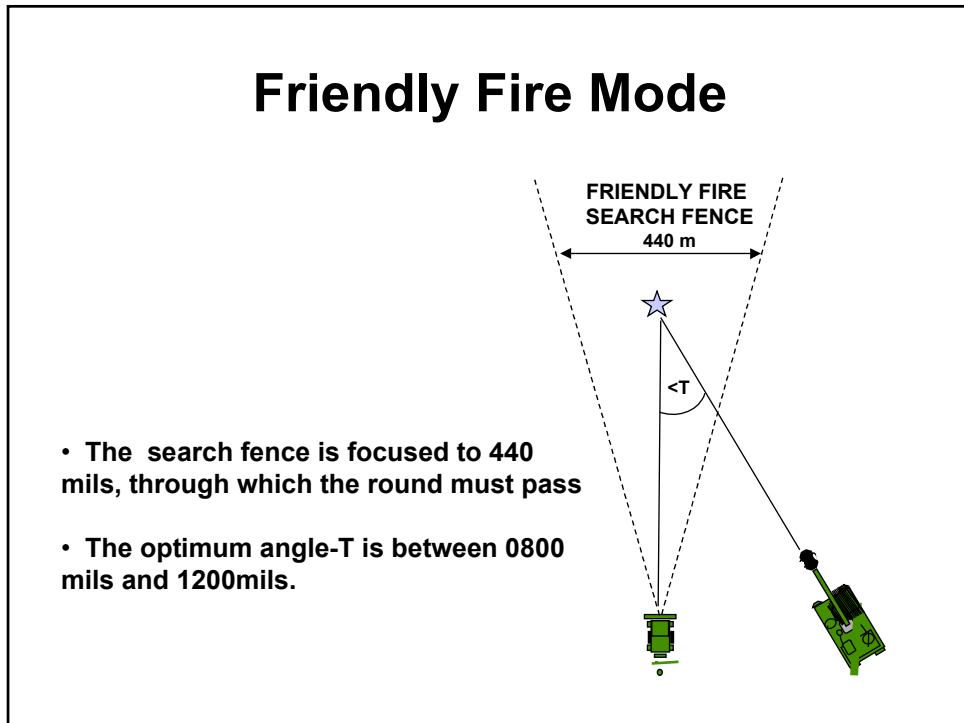

Figure C-2. Angle-T

Before the Firefinder radars can conduct a mission in friendly fire mode, specific information must be stored in the friendly fire buffer of the radar computer. Data required in the friendly fire buffer are as follows:

- Submode type of mission.
- Battery location (easting, northing, and altitude).
- Registration point location (easting, northing, and altitude).
- Maximum ordinate of the trajectory to the nearest meter from the appropriate tabular firing table (TFT) (maximum ordinate above gun).
- Quadrant elevation or fall angle from the TFT (Table G).
- Target number.

Orienting data required for the friendly fire buffer and for the actual conduct of the mission are contained in the FM;INTM and follow-up messages to observer (FM;MTO) received from BCS. During non-digital operations, the orienting data are transmitted by voice to the radar using VHF-FM radios. When the required data listed above are entered, the computer will either accept the search fence or reject it by showing an error message to the operator. The radar operator must then coordinate with the firing unit for adjustments to the firing data or orienting point that will allow the radar to

observe the rounds in the friendly fire mode. Legacy systems can store up to three sets of data in the friendly fire buffer for later use. The Q-36(V)8 can store six sets of data in the friendly fire buffer.

In friendly fire mode, the radar can perform three types of missions:

- Observe a high-burst (HB) registration (artillery airburst mode).
- Predict impact locations (artillery impact-predict mode).
- Observe a datum-plane registration (artillery datum-plane mode).

These friendly fire mode missions support the two types of registrations conducted by the FDC. The radar high-burst registration provides “did hit” observations for the FDC high-burst registration. The radar impact-predict and datum-plane registrations provide “did hit” observations for the FDC mean-point-of-impact (MPI) registration. The MPI calculations by the FDC differ for the two types of radar observation, because they correspond to different orienting points. All of these calculations are discussed in detail in FM 3-09.40 (6-40).

When operating in the friendly fire mode the radar provides friendly units with accurate actual burst, datum-plane, or predicted-impact location data. It has five different mission sub-modes that are used to provide this data. They are:

- Mortar datum plane (MD).
- Mortar impact prediction (MI).
- Artillery airburst (AA).
- Artillery datum plane (AD).
- Artillery impact prediction (AI).

The radar can also observe adjust fire missions. The observation functions performed by the radar to observe an adjust fire mission are the same as an impact predict registration.

HIGH-BURST REGISTRATION

For a high-burst registration, the high-burst altitude above the registration point is the actual orienting point for the radar. The high-burst altitude is located two probable errors in height above the registration point expressed up to the next 10 meters. The radar must be able to observe this point and begin tracking the trajectory of the round at least 350 meters before the burst. This ensures the radar can track the round to the burst point. If the radar cannot observe the orienting point, the radar operator will be notified by an error message. The radar section must then coordinate with the firing unit to select a new high-burst altitude (or orienting point for the radar) that meets the technical tracking criteria of the radar. The radar operator passes the grid coordinates and altitude of each observed burst to the firing unit. The firing unit must then determine registration corrections as it would for a regular high-burst registration.

IMPACT-PREDICT REGISTRATION (MEAN POINT OF IMPACT)

In an impact-predict mission, the radar uses the friendly fire mode to track the round on its descending trajectory toward the registration point and to predict where the round will impact without actually observing the ground burst. To provide data, the radar must track the round along its trajectory for a sufficient distance above the radar's screening crest. If the radar cannot track the round far enough along its trajectory, it will notify the operator that it has limited track coverage. Coordination must then be made with the firing unit to end the mission or to continue it by selecting a new registration point. The predicted burst locations are reported to the FDC, which then averages them as "did hit" data and compares them to the fired "should hit" data of the registration point to obtain MPI registration corrections.

DATUM-PLANE REGISTRATION (MEAN POINT OF IMPACT)

The datum-plane registration is a lesser-used capability of Firefinder radars. During a datum-plane registration, the FDC selects a registration point, for example, a grid intersection. The altitude for the datum-plane registration is the altitude of a selected horizontal datum plane above the registration point through which all rounds will pass. The radar must be able to observe the rounds in flight as they pass through this altitude. In calculating firing data, the FDC uses the altitude of the datum plane as the altitude of the registration point. If the radar cannot track along the trajectory for a sufficient distance to its datum-plane orienting point, the same error messages will be displayed to the operator as for a high-burst registration. The firing unit must then adjust the altitude of the target. When the radar observes the registration rounds, the coordinates reported to FDC are those of each penetration or intersection point of the datum plane at the datum plane altitude rather than the predicted location of impact. The FDC corrects the "should hit" data by the altitude difference between the datum plane and the actual registration point. The FDC must then compute registration corrections in the same way it would to obtain "did hit" data for an MPI registration. Detail procedures for the conduct of all friendly fire missions, digital formats and voice communications are outlined in FM 6-40. Procedures for manually recording fire mission data are provided and outlined under the friendly fire log.

FRIENDLY FIRE LOG

The radar operator uses DA Form 5310-R (Firefinder Friendly Fire Log) to record all the pertinent data for any type of friendly fire operation. The form is designed for use with either a digital or a conventional FDC. However, it is not necessary to use DA Form 5310-R when friendly fire missions are transmitted by digital means since all messages transmitted and received by the radar are recorded on the radar's printer. DA Form 5310-R should be used anytime a friendly fire mission is sent by voice or when the printer is not operational.

FIREFINDER FRIENDLY FIRE LOG							
(TO BE USED WITH AN/TPQ-36/AN/TPQ-37)							
(For use of this form, see FM 6-121. The proponent agency is TRADOC.)							
SECTION I. MESSAGE TO OBSERVER							
BLOCK	RADAR MODE (CHECK APPROPRIATE BOX)						
1	<input type="checkbox"/> AA: ARTILLERY, AIRBURST <input type="checkbox"/> AI: ARTILLERY IMPACT PREDICT <input type="checkbox"/> MI MORTAR IMPACT PREDICT <input type="checkbox"/> AD: ARTILLERY DATUM PLANE <input type="checkbox"/> MD MORTAR DATUM PLANE						
	UNIT			DATE-TIME GROUP			
2	UNIT LOCATION	▶ EASTING	NORTHING		ALTITUDE		M F
3	TARGET LOCATION END POINT	▶ EASTING	NORTHING		ALTITUDE		M F
4	MAXIMUM ORDINATE (HEIGHT ABOVE BATTERY ALTITUDE)		M F	QUADRANT ELEVATION			
	TARGET NUMBER						
5	BUFFER NUMBER (CIRCLE ONE)		1 2				
6	FRIENDLY FIRE SEARCH FENCE (FFSF) ERROR MESSAGES (CHECK APPROPRIATE BOX(ES))						
	<input type="checkbox"/> END POINT BEYOND 30 KM (Q-37)/24 KM (Q-36) <input type="checkbox"/> TRAJECTORY INCORRECT <input type="checkbox"/> END POINT _____M ABOVE MAXIMUM <input type="checkbox"/> END POINT INSIDE 3 KM (Q-37)/1 KM (Q-36) <input type="checkbox"/> END POINT ABOVE MAXIMUM ORDINATE <input type="checkbox"/> END POINT _____M BELOW MINIMUM <input type="checkbox"/> LIMITED TRACK COVERAGE						
SECTION II. MESSAGE TO FDC							
(CHECK APPROPRIATE BOX(ES))							
<input type="checkbox"/> AT MY COMMAND <input type="checkbox"/> REQUEST SPLASH <input type="checkbox"/> READY TO OBSERVE <input type="checkbox"/> REQUEST SHOT <input type="checkbox"/> REPORT WHEN READY <input type="checkbox"/> ONE GUN							
SECTION III. RECORD AND REPORT TO FDC							
ROUND NUMBER	EASTING <i>a</i>	NORTHING <i>b</i>	ALTITUDE <i>c</i>	M F	METHOD SENT <i>d</i>	TIME SENT <i>e</i>	ACKNOWLEDGED <i>f</i>
1							
2							
3							
4							
5							
6							
7							
8							
9							
REMARKS			TIME END OF MISSION RECEIVED		MISSION OBSERVED BY		

DA FORM 5310-R

Figure C-3. Friendly Fire Log

Appendix D

Field Exercise Mode/Embedded Training

USES

Field exercise mode (FEM) and embedded training are off-line, separate computer programs that function with the radar's existing operational programs to allow the radar to be used in a training mode. FEM is part of the operational program for systems equipped with (V)7 shelters and embedded training is a part of the operational program for systems equipped with (V)8 shelters. These off-line training programs provide the operator with realistic operating scenarios for the purpose of evaluating and improving proficiency. The scenarios include real-time simulation of hostile and friendly weapons fire.

FEM/embedded training increases the radar operator's ability to process targets and communicate with other net subscribers. It allows radar operators to perform all normal mission-processing functions. However, when the simulation is running the radar will not radiate when the radiate switch lamp is pressed. FEM/embedded training allows trainers to develop scenarios that present radar operators with a high density of hostile and friendly targets and conduct real or simulated communications with other net subscribers.

SECTION AND/OR PLATOON TRAINING

FEM/embedded training provides a vehicle for training an individual radar section or an entire radar platoon in either a garrison or field environment. The system's ability to simulate digital communications or communicate with actual tactical systems makes this possible. An individual section can train by itself and the scenario will replicate all digital communications. Or, a radar section or sections can send their acquisitions to an actual FDC or counterfire headquarters. This provides the opportunity to train the target processing section and targeting team members while providing realistic training for all radar operators.

GUNNERY TEAM TRAINING

The entire gunnery team can benefit from the use of FEM or the embedded training program during rehearsals, before the conduct of actual operations, or during command post exercises (CPXs), live-fire training, and maneuver exercises. These programs allow the development of scenarios that reflect the actual tactical situation or exercise event list. This facilitates training of the entire gunnery team and provides the capability to conduct fire support and technical rehearsals for actual situations.

SCENARIO DEVELOPMENT

The common steps for developing training using FEM or embedded training program are:

- Step 1. Determine training goals (mission requirements for the exercise). These should include:
 - Mission-essential task list (METL) requirements.
 - ARTEP mission training plan (AMTP) requirements.
- Step 2. Analyze resources to include:
 - Training areas available.
 - Support available:
 - IFSAS/AFATDS (battalion or DIVARTY).
 - Aggressor.
 - Pyrotechnics.
 - FIST elements.
 - Other.
- Step 3. Develop an OPORD:
 - Determine intelligence sources and estimates.
 - Determine commander's targeting criteria.
 - Determine commander's priority guidance for radar.
 - Use the FEM overlay and embedded training target table to determine the following data for the RDO:
 - Radar location.
 - Search data.
 - Zone data.
 - Reporting channels.
 - Cueing agents.
 - On the basis of the scenario and OPORD, identify simulation targets to be used.
- Step 4. Develop a plan for updating and changing the tactical situation and mission. The plan should include:
 - Tactical movements.
 - Intelligence updates.
 - Radar search and zone data.
 - Nuclear, biological, chemical (NBC) situation.
 - EW threat.
 - Cueing agents.
- Step 5. Develop the scenario target tables using the detailed procedures for selecting and loading target data into the FEM or embedded training simulation program.

EMBEDDED TRAINING

Planning and developing the embedded training scenario and simulation data should be a team effort between the S2, targeting officer, and the radar section leader. The team should follow these steps.

- Step 1. Review each phase of the tactical operation to determine and record probable enemy mortar, artillery, and rocket firing locations.
- Step 2. Once the locations have been determined for each phase and/or event they are sequenced into a simulation target table for the radar.
- Step 3. Load the target table using the Scenario Generation screen.
- Step 4. The operator selects ADD on this screen and enters each target separately with the following elements of data: Weapon Type, Weapon Velocity and Quadrant Elevation, Weapon Location (complete UTM grid/altitude), Impact Location (complete UTM grid/altitude), Firing Interval, Time On and Time Off, and Volley.
- Step 5. After entering each individual target, the operator must wait for a response to determine acceptability of the data entered. If the program accepts the target with no response, the data becomes a part of the scenario target file.
- Step 6. These targets are entered, numbered, and/or time sequenced.
- Step 7. After all targets from the target table have been entered and accepted, the scenario is saved for use in the training exercise.

Note: This is a lengthy and time-consuming process, and it must have the support and cooperation of the command elements to achieve success.

FEM

Radar equipped with the FEM program can also use the target table designed by the command team to prepare for training exercises. However, the procedures for determining and loading target data are totally different from those used in embedded training. To design and load target data into the FEM program these steps must be followed:

- Step 1. Load FEM targets from the target tables located in the radar operator's manual into the FEM program.
- Step 2. After all targets are loaded, each target is recalled individually and plotted on a transparent overlay as it appears on the radar map drum. This process is continued until all targets loaded into the FEM program are recorded on the overlay.
- Step 3. The overlay is removed from the map drum and used by the command team to determine data for the target table.
- Step 4. The overlay is positioned on the command team situation map with the radar position on the overlay aligned with the radar position on the map.
- Step 5. The overlay is traversed in azimuth until target numbers on the overlay are located over the enemy locations plotted by the team.

- Step 6. The target number corresponding to starting enemy locations is recorded and the process continues through all subsequent locations and events as determined in the scenario review.
- Step 7. The target numbers, radar location, radar azimuth, and call for fire zones around those enemy locations are recorded as part of the target table.

Note: Call for fire zones must be placed around the enemy locations for the radar to produce a fire mission. Zone data is not required if a call for fire is not desired.

- Step 8. Repeat steps 4 through 7 on all radar and enemy locations until the scenario sequence of events is complete and all target data is recorded in the table.

Scenario development is not complete until exercise control measures are developed. These measures should be developed in conjunction with the sequence of events to facilitate a productive training exercise.

IMPLEMENTING THE SCENARIO CONTROL ELEMENT

The command or exercise control element determines commander's priority guidance for radar, radar search data, cueing agents, and cueing guidance. These determinations are based on:

- The scenario.
- METT-TC.
- Intelligence estimates.
- Target value analysis (TVA).
- High-payoff target list.
- Commander's attack guidance.
- Targeting priorities.
- The FEM target overlay.
- FEM target table.
- The scenario event target table for (V) 8 systems.

The control element implements the scenario using the aforementioned considerations.

CUEING AGENTS

Cueing agents are designated and provided a copy of the scenario target tables by the command or control element. They must be able to identify the cueing criteria required and the method they are to use to cue the radar section. When the cueing criteria are met during the exercise, the cueing agent sends the cue command to the radar.

RADAR SECTION

After receiving the initial search data and commander's priority guidance, the section prepares the radar to support the mission. When notified by the command or control element, the radar operator turns on the appropriate simulation targets. The section then waits for the cue command from the cueing agent. When the section receives the cue command, the operator turns on the radar transmitter, processes the targets, and transmits them digitally to the controlling headquarters.

CONTROLLING HEADQUARTERS

The controlling headquarters processes targets received from the radar according to the commander's criteria established in their tactical fire direction system. The commander's criteria should conform to the exercise guidance issued by the command or control element. Normally, fire missions will be generated for priority targets. Artillery target intelligence reports will be sent to the TOC and/or the targeting element where they will be entered in the tactical fire direction system.

TOC AND/OR TARGETING ELEMENT

The TOC and/or targeting element will process the weapon locations and impact predictions.

FIRING ELEMENT

Upon receipt of fire missions, the firing unit generates firing commands (live or dry fire).

<p>NOTE: Use of the FEM or Embedded Training program during live-fire exercises can generate fire missions in an impact area if the proper search and zone data are entered into the radar. Other targets will provide useful training for the TOC and targeting elements.</p>
--

Appendix E

The AN/TPQ-47 Radar

This appendix contains an overview of the system components and characteristics of the AN/TPQ-47 (Q-47) radar system. It provides technical employment considerations and tactics, techniques and procedures for employing the Q-47. This appendix also includes considerations and procedures for site selection, positioning, deployment, and safety.

SECTION I – TECHNICAL ASPECTS

AN/TPQ-47 EQUIPPED TARGET ACQUISITION ORGANIZATIONS

The Q-47 radar is organic to Heavy Division Target Acquisition Batteries (TAB), the TAB of Divisional MLRS battalions and Corps Target Acquisition Detachments (CTAD). Two Q-47 radars are organic to each of these organizations. In addition, the Q-47 is organic to the Target Acquisition Platoon (TAP), DS artillery battalion of the Interim Brigade Combat Team (IBCT) and the Radar Platoon of the HIMARS battalion of the Interim DIVARTY (IDIVARTY). The IBCT contains one Q-47 and the IDVARTY contains three Q-47. In addition, each corps has two Q-47s organized in a CTAD to support TBM and counterfire operations. This CTAD is assigned to both heavy and light corps and is provided in addition to the CTADs assigned to support light and airborne divisions within a corps.

HEAVY DIVISION TARGET ACQUISITION BATTERY

The Heavy Division Target Acquisition Battery is responsible for locating enemy indirect fire weapons, and registering and adjusting friendly artillery and in the division's battlespace. It locates indirect fire targets with its organic Q-36 and Q-47 radars. An assistant counterfire officer (WO/131A) and a target processing section are provided to the DIVARTY or FA brigade TOC to support counterfire operations. Q-36 radars are normally attached to DS FA battalions and controlled by the DS FA battalion S2. The target production section of the DIVARTY or FA brigade TOC normally controls Q-47 radars. The heavy division TAB survey section provides location and directional control to TAB elements and aids the DIVARTY or FA brigade survey section as required.

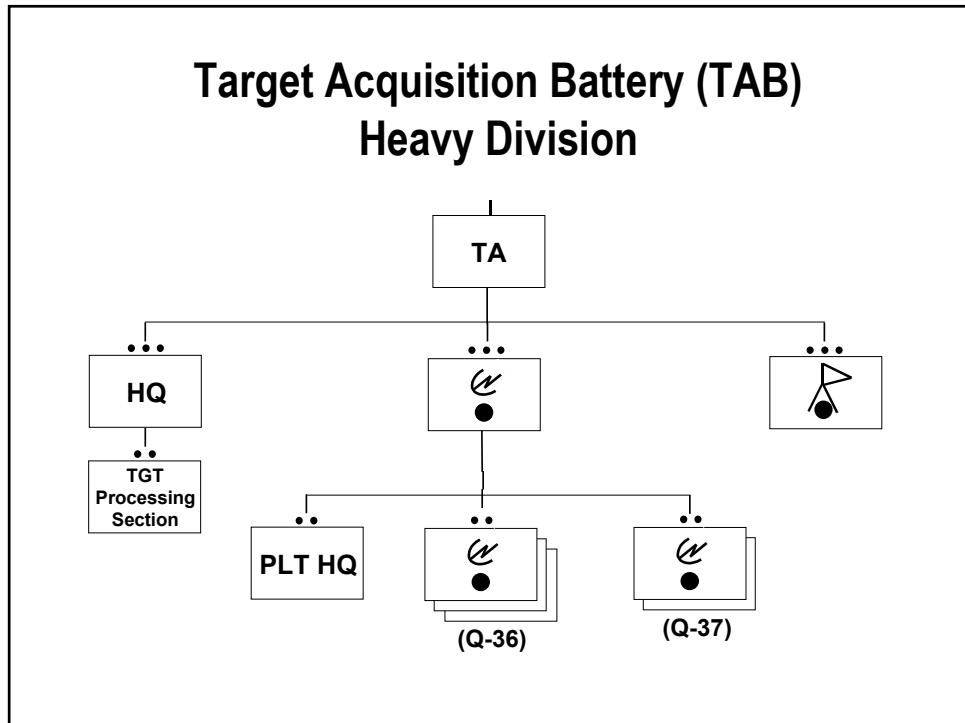

Figure E-1. Heavy Division Target Acquisition Battery

DIVISIONAL MLRS BATTALION TAB

The divisional MLRS battalion TAB is organic to the heavy divisional MLRS battalion. The divisional MLRS is organized with a HHS, Three six-launcher MLRS firing batteries and a TAB.

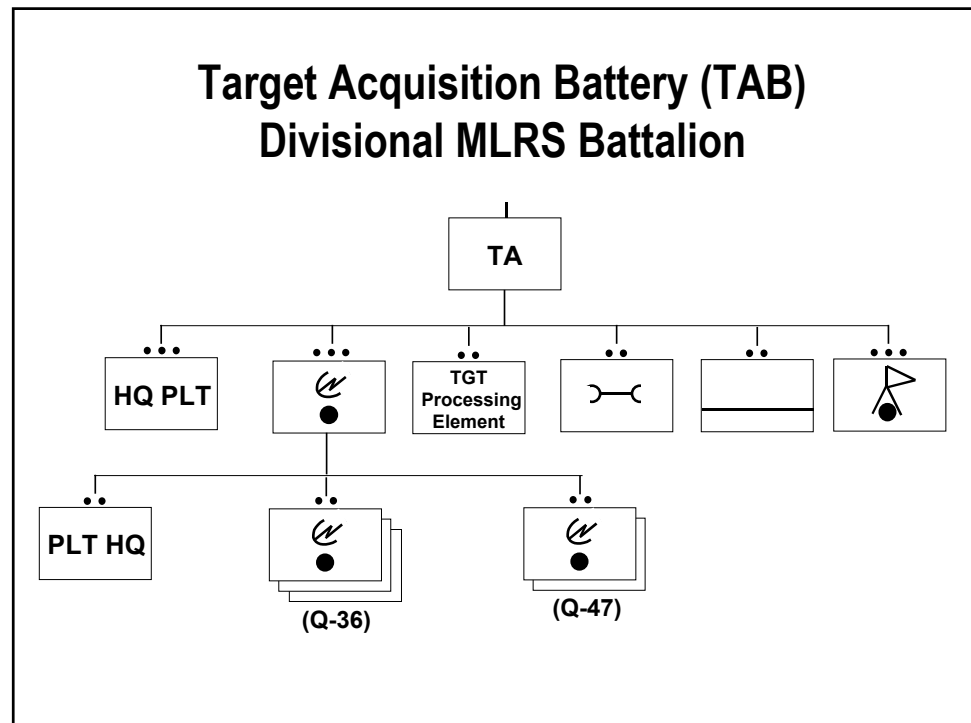

Figure E-2. Divisional MLRS Battalion Target Acquisition Battery

CORPS TARGET ACQUISITION DETACHMENT

The Corps Target Acquisition Detachment (CTAD) was originally assigned to corps on the basis of one per light division assigned to the corps. It was designed to support light infantry, airborne, and air assault division artilleries or field artillery brigades upon deployment. With the fielding of the Q-47, and additional CTAD will be assigned to each corps for retention and use by the corps. The mission of the Q-47 equipped CTAD is to provide acquisition of threat artillery, rocket, and missile systems to provide target intelligence and information to allow friendly forces to take force protection measures, enable counterfire mission processing and support TMD operations. The CTAD consists of a headquarters section, a PADS team, and two Q-47 radars. The processing (HQ) section is provided to corps artillery TOC, light, airborne, air assault division artillery TOC, or their designated counterfire headquarters to help process counterfire targets.

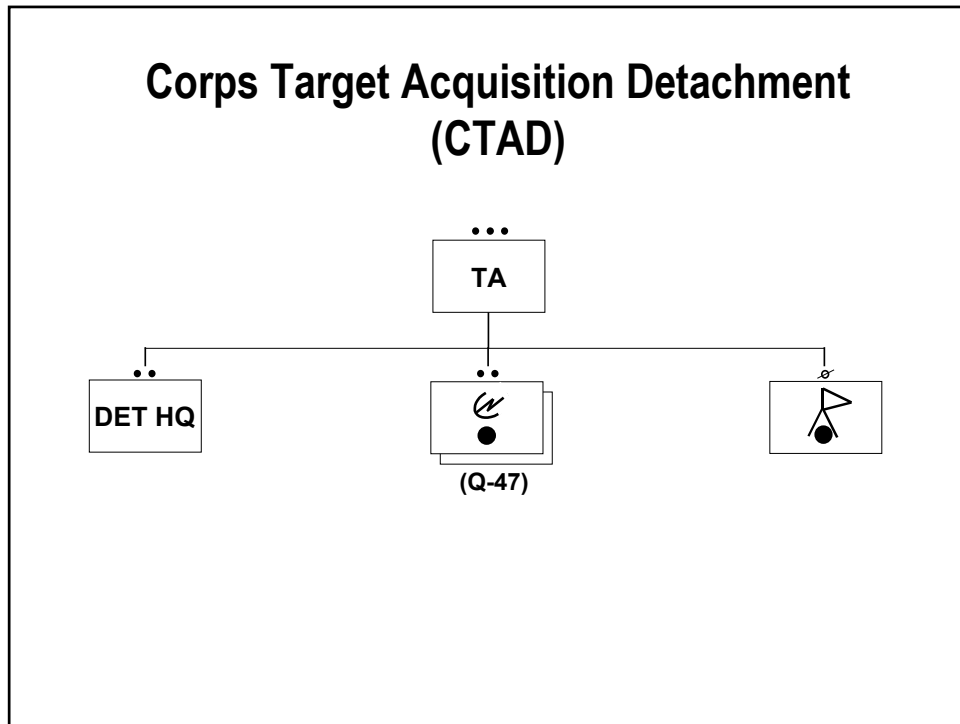

Figure E-3. Corps Target Acquisition Detachment

INTERIM BRIGADE COMBAT TEAM TARGET ACQUISITION PLATOON

The Interim Brigade Combat Team Target Acquisition Platoon (IBCT TAP) provides acquisition of threat mortar, artillery, and rocket systems to provide target intelligence and information to allow friendly forces to take force protection measures and enable counterfire mission processing. The platoon consists of one Q36 and one Q47 radar, a meteorological section and a survey section. The platoon deploys in whole or part within tailored force packages. Once in theater, the Fires and Effects Coordination Cell (FECC) controls the employment of the platoon and any additional counterfire radars attached or augmenting the brigade. When in theater, whether it deploys early or with the field artillery battalion, the platoon and/or individual radars will always establish direct digital and voice links with the FECC and may establish an AFATDS digital quick fire channel with a delivery unit. The meteorological section provides meteorological support to artillery, mortars and radars to enhance their accuracy. The survey section provides common survey to field artillery firing units and mortars when assets are available. The survey capability is limited and lacks redundancy because the section has only one position and azimuth determining system (PADS).

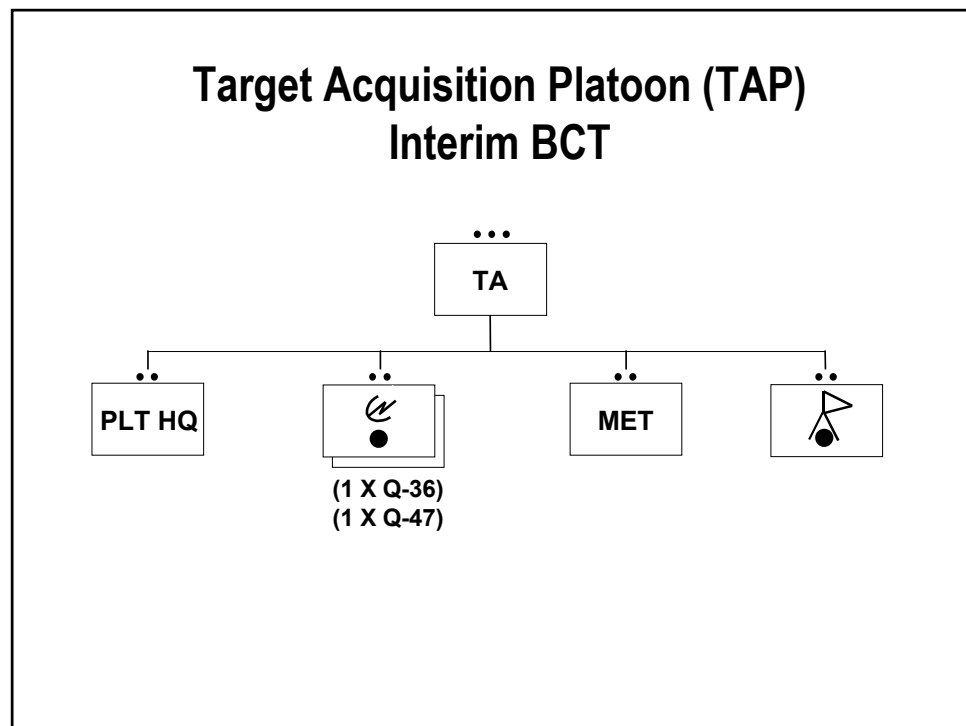

Figure E-4. Interim BCT Target Acquisition Platoon

INTERIM DIVARTY RADAR PLATOON

The Interim DIVARTY (IDIVARTY) Radar Platoon provides acquisition of threat artillery, rocket, and missile systems to provide target intelligence and information to allow friendly forces to take force protection measures, enable counterfire mission processing and support theater missile defense (TMD) operations. The platoon consists of three Q-47 radars, a meteorological section and a survey section. The platoon deploys in whole or part within tailored force packages. Once in theater, the Fires and Effects Coordination Cell (FECC) controls the employment of the platoon and any additional counterfire radars attached or augmenting the division. When in theater, whether it deploys early or with the HIMARS battalion, the platoon and/or individual radars will always establish a direct digital and voice link with the FECC and may establish an AFATDS digital quick fire channel with a delivery unit. During TMD operations, the radar may establish a direct link with the Army and Air Defense Missile Command (AAMDC) through the AFATDS in the AAMDC Attack Operations Cell. The meteorological section provides meteorological support to artillery, mortars and radars to enhance their accuracy. The survey section provides common survey to field artillery firing units and mortars when assets are available. The survey capability is severely limited and lacks redundancy because the section has only one position and azimuth determining system (PADS).

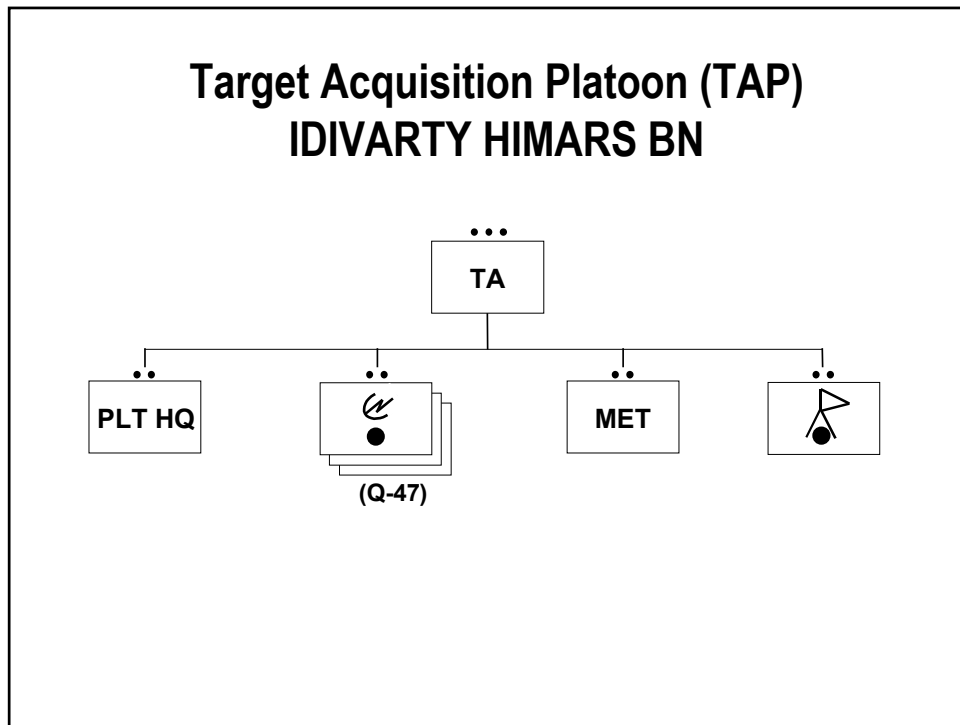

Figure E-5. IDIVARTY HIMARS Battalion Target Acquisition Platoon

AN/TPQ-47 RADAR SECTION

The Q-47 radar section is comprised of nine personnel. This is a decrease of three personnel when compared to the Q-37 section. The Q-47 section contains the same military occupational specialties as the Q-37. Table E-1 shows the section organization.

Table E-1. Radar Section Organization

Organization Title	Grade	MOS	Quantity
Target Acquisition Radar Technician	CW2	131A0	1
Section Chief	SSG	13R30	1
Senior FireFinder Radar Operator	SGT	13R20	1
FireFinder Radar Operator	PFC/SPC	13R10	4
Radar Repairer	SGT	35M20	1
Power Generation Equipment Repairer	SPC	52D10	1

SYSTEM CHARACTERISTICS

The Q-47 is the next generation replacement for the Q-37. The Q47 is a S-band phased array radar system that uses radar technology and computer-controlled signal processing to perform detection, verification, tracking, and classification of projectiles, rockets and missiles. The phased-array antenna allows the radar to switch beam positions electronically, thus providing a capability to search for new targets while simultaneously tracking targets already detected. It also enables the radar to detect and locate weapons firing

simultaneously from 25 to 50 different locations at ranges from 3-300 km while using three different modes of operation. The Q-47 is also capable of registering and adjusting friendly indirect fire while simultaneously maintaining hostile surveillance. The detection and location functions of the system are similar to the Q36(V)8 and Q37.

SYSTEM COMPONENTS

The complete Q-47 System consists of the following components:

- The Antenna Transceiver Group (ATG).
- The Operations Central (OC).
- The Portable Operations Suite (POS).
- The Prime Power Group (PPG).
- M1078 Truck Cargo.
- M1097A2 HMMWV Reconnaissance Vehicle.
- PU 806 trailer mounted generator.

The operational configuration consists of the ATG, OC, POS, and PPG as shown in Figure E-6.

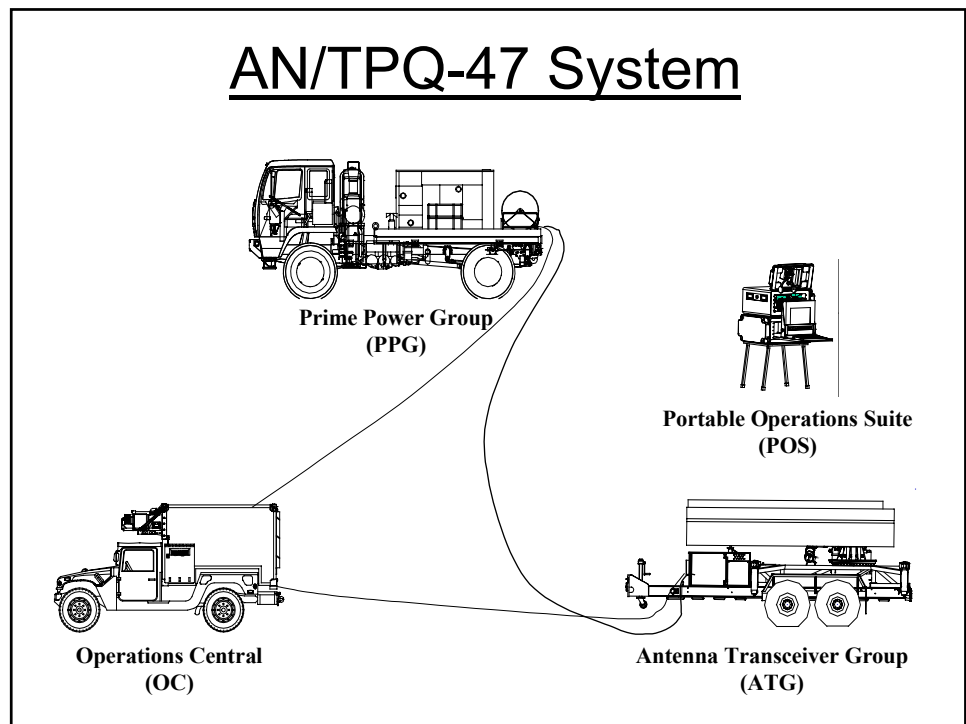

Figure E-6. The AN/TPQ-47 Operational System

ANTENNA TRANSCEIVER GROUP

The ATG is the main component of the radar. It consists of the antenna; electronics cabinet; trailer, pallet, and leveling system; and cabinet storage. The antenna contains the power amplification modules, power supplies and

MAPS/GPS. The electronics cabinet contains the power distribution unit, processor and associated software, and leveling controls.

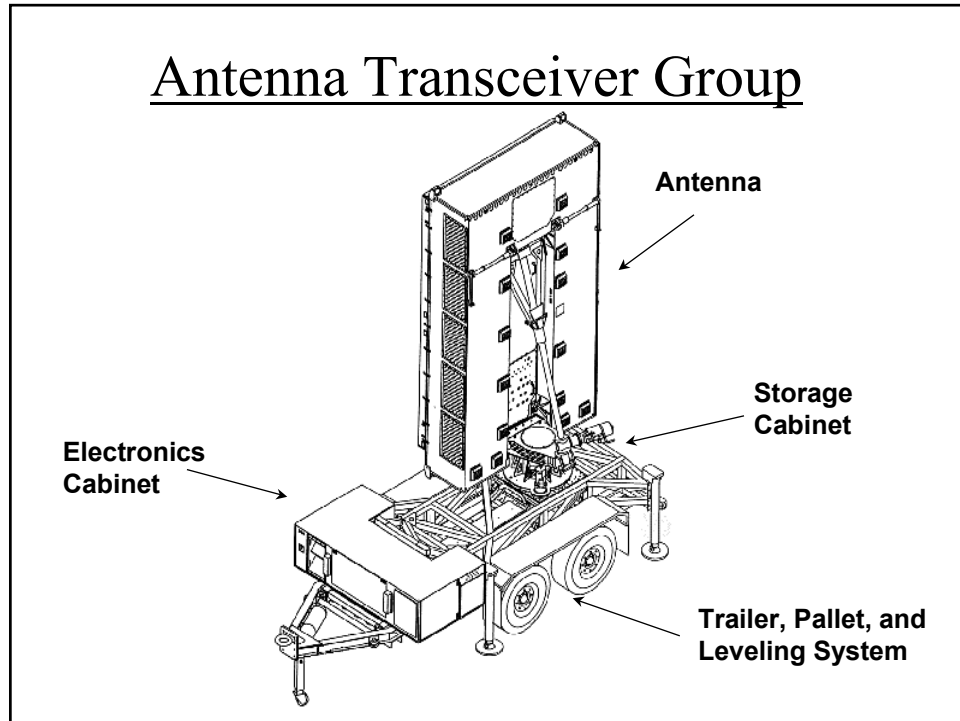

Figure E-7. The Antenna Transceiver Group

OPERATIONS CENTRAL

The operations central (OC) is the focal point for operating the Q-47. The OC consists of a modified AN/TPQ-36(V)8 shelter mounted on a HMMWV. The shelter contains two common hardware system-2 (CHS-2) computers (GD Versatile Computer Unit (VCU)), systems software, Force XXI Battle Command-Brigade and Below (FBCB2), and required communications equipment. During movement a VCU is removed from the OC and placed in the LMTV to support operations on the move. The available communications equipment includes an EPLRS, a tactical communications interface module (TCIM), an interface with the two ASIP radios contained in the ATG.

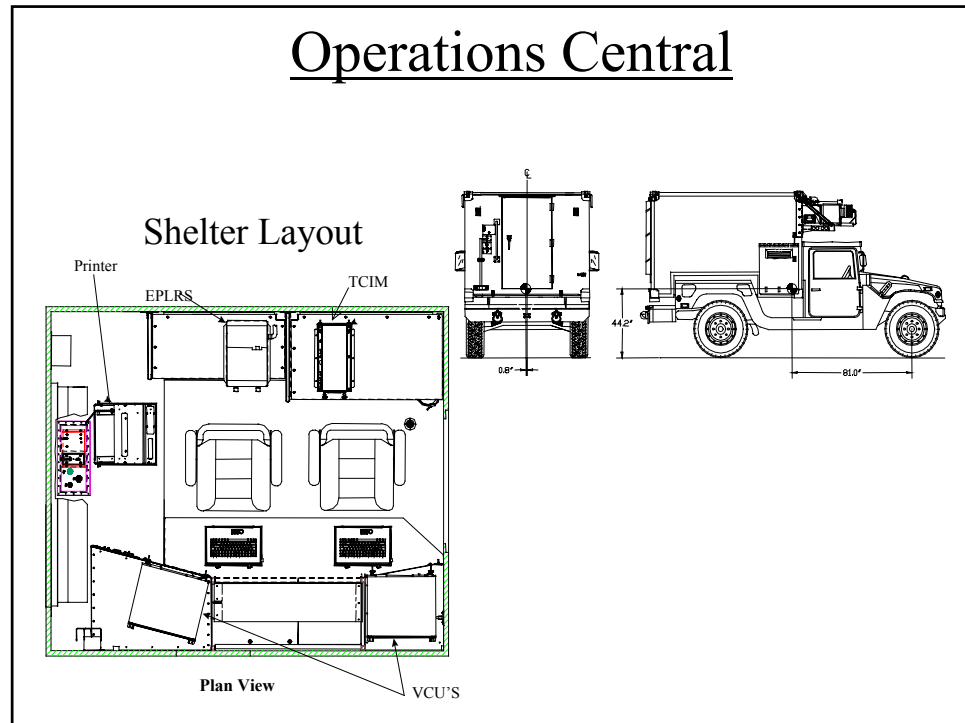

Figure E-8. Operations Central

PORTABLE OPERATIONS SUITE

The portable operations suite (POS) provides the capability to operate the radar system, with or without the OC, from a distance of up to 100 meters from the ATG. POS operations require that one VCU from the OC be removed and installed in the POS. The two ASIP radios contained in the ATG can be operated from controls on the POS. The POS can be moved and emplaced by two crewmembers.

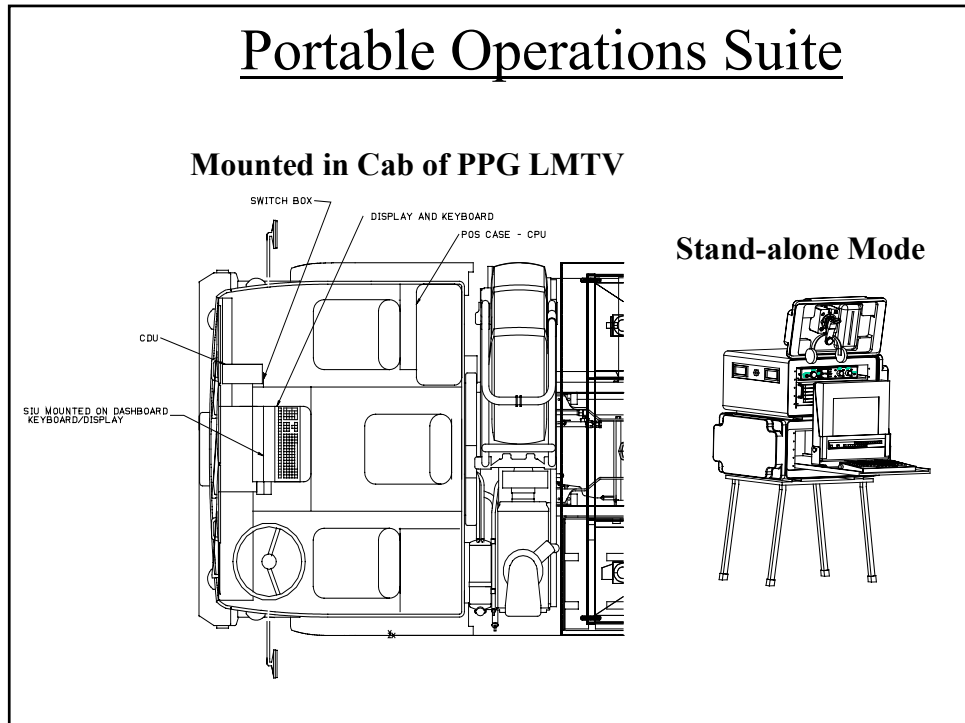

Figure E-9. The Portable Operations Suite

PRIME POWER GROUP

The PPG consists of a MEP-816A 60KW, 400 Hz generator set mounted on a Stewart and Stevens M1080 LMTV and a trailer mounted MEP 806, 60KW, 400 Hz generator set. The ATG power cables, POS cables and generator grounding equipment are mounted and stored on the LMTV. The LMTV contains a CHS-2 monitor and keyboard inside the cab to communicate with the central processing unit (CPU) and communications equipment in the ATG. This allows digital communications during movement.

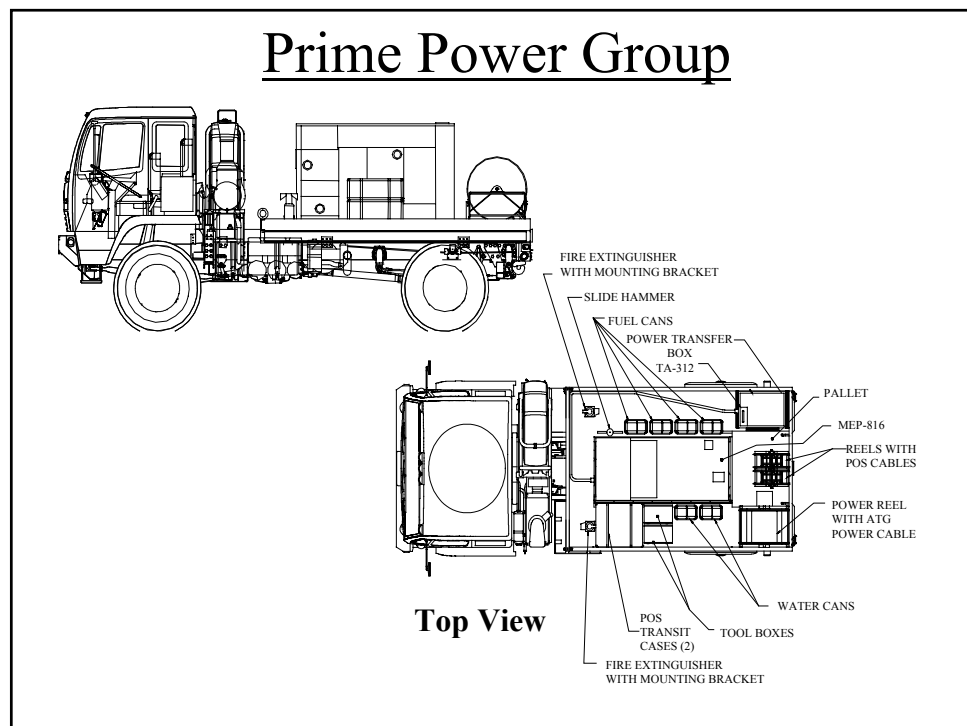

Figure E-10. The Prime Power Group

SYSTEM CAPABILITIES

MODES OF OPERATION

The Q-47 has three modes of operation. The normal mode, like the Q-37, allows the radar to detect hostile mortars, artillery and rockets. The fast scan mode increases the number of targets that can be tracked and the TBM mode allows detection of missiles and heavy rockets.

Normal Mode

Normal mode corresponds most closely to a combination of the hostile and friendly mode of the Q-37. However, the Q-47 can simultaneously perform hostile and friendly operations in the normal mode. In normal mode the Q-47 can acquire and track more than 25 simultaneous in-flight projectiles in the radar's coverage area. The radar provides target location, impact prediction and target classification. The target location error (TLE) for impact prediction is 300m. The TLE for hostile target location is discussed in paragraph later in this appendix.

Friendly operations allow the radar to register artillery at ranges of 3-60km. The radar can locate the point of airburst with a spherical error probable of 20m or .2% of range which ever is larger. The circular error probable (CEP) for a datum plane is located to the same accuracy. The in-flight projectile track capacity of the radar drops to 17 when conducting friendly fire operations.

Fast Scan Mode

Fast scan mode is very similar to normal mode. Fast scan mode allows the radar to acquire and track more than 50 simultaneous in-flight projectiles. Some degradation of range and accuracy occurs in fast scan mode with range and accuracy approaching the capabilities of the Q-37 radar.

TBM Mode

TBM mode supports theater missile defense (TMD) alerting by determining launch points, impact predict points and state vectors for TBM acquisitions. Two state vectors are determined, one at the missile's entry point and one at the missile's exit point from the radar beam. TBM data are transmitted to TMD activities with the 5.13 broadcast message using AFATDS.

Range and accuracy

The Q-47 provides a substantial increase in range and accuracy over the Q-37. Like the Q-37, the Q-47 is optimized for rockets and cannons. The probability of locating an enemy system in normal mode is .85 or higher throughout the entire range fan for a specific target category. The Q-47 can locate light and heavy mortars at ranges out to 18km and heavy mortars out to 30km with the same probability of location. It locates artillery and light rockets out to 60km and heavy rockets out to 100km. General planning ranges are 18km for mortars, 60km for artillery and light rockets and 100km for heavy rockets.

Figure E-11 shows the range fan for hostile operations in normal mode. The same range fan applies to the fast scan mode.

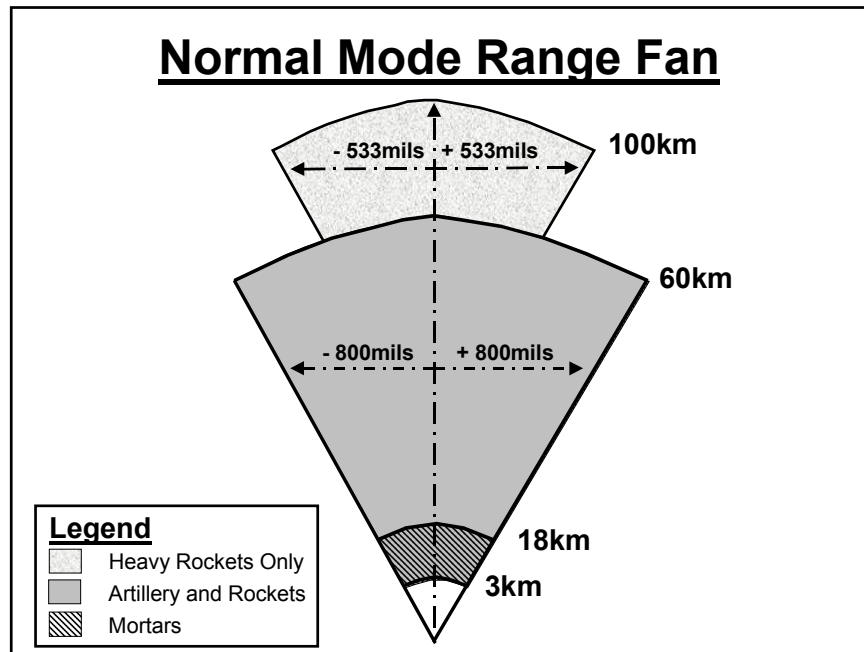

Figure E-11. Range Fan for Normal Mode Operations

In TBM mode, the Q-47 locates missiles and heavy rockets to the same accuracy as normal and fast scan modes. TBM mode provides an extend location range of 300km for missiles and 140km for heavy rockets. The radar fan extends from the radar, plus or minus 533 mils from the azimuth of orientation, to a range of 300km. The radar can also detect missiles in the area from plus or minus 533-800 mils from the azimuth of orientation. However, the range is significantly diminished. Figure E-12 depicts TBM coverage for missiles.

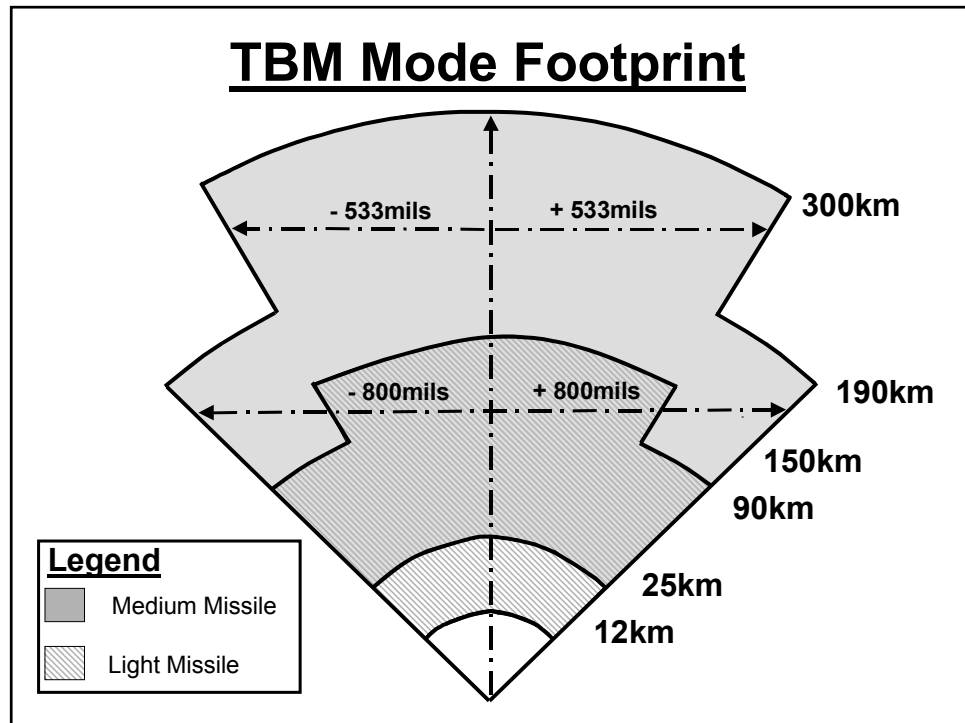

Figure E-12. TBM Coverage

TARGET LOCATION ERROR

Target location error (TLE) based on a .85 probability of location varies with range. TLE is an important consideration for determining the delivery system for attacking certain targets. The TLE is .25% range with a minimum TLE established by target type. Table E-2 provides TLE in meters by range band and target type.

Table E-2. Target Location Error

Target Category	Target Type	Ranges								
		10km	18km	30km	40km	50km	60km	100km	150km	300km
Mortar	Light	30m	45m							
	Medium	30m	45m							
	Heavy	30m	45m	75m						
Artillery	Light	30m	45m	75m	100m					
	Medium	30m	45m	75m	100m	125m				

Target Category	Target Type	Ranges								
		10km	18km	30km	40km	50km	60km	100km	150km	300km
	Heavy	30m	45m	75m	100m	125m	150m			
Rocket	Light	30m	45m	75m	100m	125m	150m			
	Heavy		50m	75m	100m	125m	150m	250m		
Missile	Light		50m	75m	100m	125m	150m	250m	375m	
	Medium			100m	100m	125m	150m	250m	375m	750m

The Q-47 has the ability to classify mortars, artillery, rockets and missiles. Table E-3 provides a break down of target types and U.S. surrogate systems.

Table E-3. Target Classifications

Target Category	Target Type	Caliber	U.S. Surrogate
Mortar	Light	60mm	60mm
	Medium	81-120mm	81mm & 120mm
	Heavy	160-240mm	None
Artillery	Light	105-122mm	105mm
	Medium	130-155mm	155mm
	Heavy	170-240mm	None
Rocket	Light	70-179mm	None
	Heavy	180-300mm	MLRS
Missile	Light	340-530mm	ATACMS
	Medium	540mm-1100mm	None

Missiles are further characterized by a combination of length, launch weight, boost phase burn-time, and range. Light missiles are generally ≤ 7 meters in length, have a launch weight of ≤ 4500 kg, have a boost phase burn-time of ≤ 45 seconds, and have a range of ≤ 300 km. Medium missiles are generally ≤ 12 meters in length, have a launch weight of ≤ 7500 kg, have a boost phase burn-time of ≤ 160 seconds, and have a range of ≤ 600 km. Table E-4 shows typical threat weapon systems by target type.

Table E-4. Threat Weapon Systems

Target Category	Target Type	Threat Systems
Mortar	Light	
	Medium	Type 63, 2S9, 2S12, 2S23, 2B9, M1992
	Heavy	M-160, M-240, 2S4
Artillery	Light	D-30, D-74, 2S1, M 1974, M1977
	Medium	M-46, D-20, 2S3, 2S5, 2A36, 2S19, 2A65, M1973, M1975 (130mm gun), G5, G6, GCT, MkF3
	Heavy	M1989 KOKSAN GUN, 2S7
Rocket	Light	BM-11, BM-21, PRIMA
	Heavy	BM22, M1991 (240mm MRL), ASTROS II, 9A52
Missile	Light	FROG-7, SS-21, SS-23, SCUD-A, SCUD-B
	Medium	SCUD-C

SITE SELECTION

The technical aspects and characteristics of the Q-47 determine the requirements for site selection. These requirements include:

- Slope.
- Area in front of the radar.
- Screening Crest.
- Aspect angle.
- Electronic line of sight.
- Track volume.
- Proximity of other radars.
- Cable lengths.

The site selection requirements for the Q-47 are basically the same as those for the Q-37. The requirements that differ include the area in front of the radar and cable lengths.

AREA IN FRONT OF THE RADAR

The area in front of the antenna should be clear of foliage that extends above the bottom of the antenna. This clear area minimizes attenuation of the radar beam. This area should extend 300 meters in front of the radar. The ideal site will have a clear area in front of the radar that has a gentle downward slope for approximately 300 meters and then gradually rises up to the screening crest. This reduces multipath errors. Multipath errors are errors in target location created when radar transmit or return signals travel by more than one path. Finally, the area in front of the radar should be clear of personnel for a distance of 217 meters. Safety considerations are discussed later in this appendix.

CABLE LENGTHS

Cable lengths must be considered when selecting a site for the Q-47 radar. The cables determine the extent to which the components of the radar can be dispersed. The required dispersal of system components is determined by the terrain contour, foliage, site access, and threat. Ideally, the radar components should be positioned to take advantage of naturally available cover and concealment. The cable lengths dictate the maximum dispersal. Table E-5 shows the cable lengths for the Q-47.

Table E-5. Cable Lengths

Cable	Length (ft.)
Signal/Control/LAN Cable (x2)	165 (50m)
ATG Power Cable	100 (30m)
OC Power Cable	100 (30m)

Based on these lengths, the OC or POS could be placed up to 90 meters from the ATG and 20 meters from the prime power group. 10 meters of slack should be maintained in the cables to prevent damage to the connectors and

cable ends. To obtain the maximum dispersal between the OC and the PPG both sections of cable must be used at the same time. Figure E-13 shows the emplaced radar and actual cable lengths.

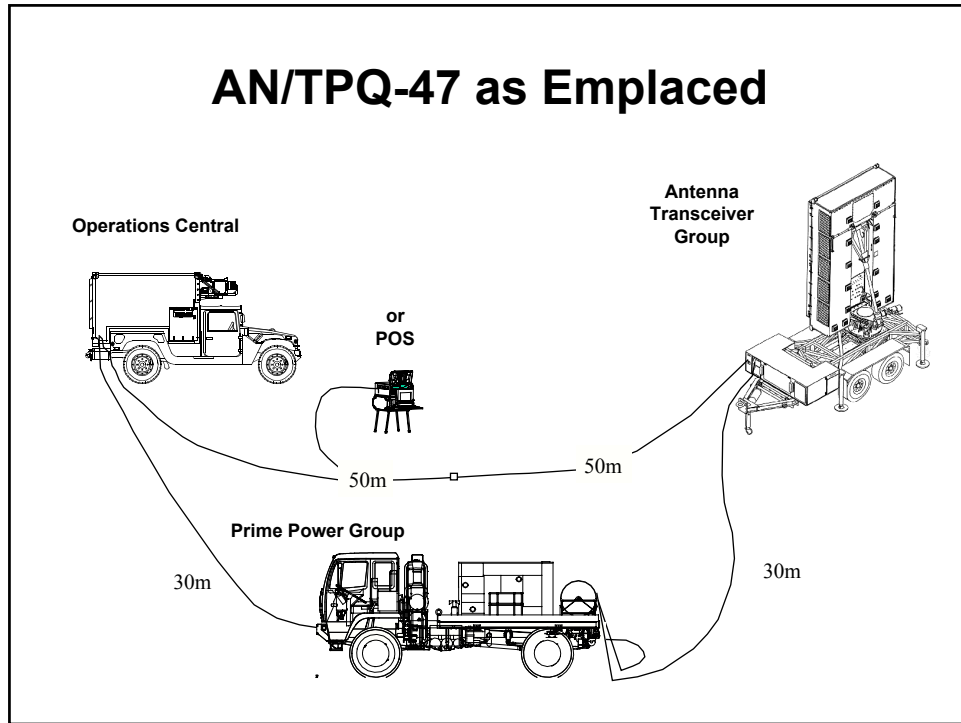

Figure E-13. Emplaced Q-47

POSITIONING

Positioning is based on the technical requirements and capabilities of the radar and tactical considerations. The overriding factor in positioning is mission accomplishment. Paramount in selecting radar positions is mission, enemy, terrain, troops, time available, and civil considerations (METT-TC). The S2/targeting officer or counterfire officer from the controlling FA headquarters designates the general position area. The radar section leader selects the actual radar sight within the position area.

TACTICAL CONSIDERATIONS

The position area for the Q-47 is selected based on the IPB, the range capabilities of the radar, and METT-TC. A through analysis of METT-TC will dictate which factors are most important. Generally, in a traditional battlespace, the Q-47 is positioned far enough from the FLOT to acquire the enemy weapons based on IPB, prevent loss of the radar to enemy action, and avoid unnecessary movement. This maximizes radar coverage and cueing time. Given the 3km minimum range and the necessity to avoid conflicts with maneuvering friendly forces, the Q-47 is normally positioned 8-12km from the FLOT. This rule of thumb may change based on the tactical situation. In early entry operations and TMD operations, the Q-47 may be positioned

further to the rear or in an intermediate staging base (ISB). In general, planning ranges for the Q-47 are 18km for mortars, 60km for artillery and 100km for rockets. Planning ranges may be modified based on the mode of operation and the target sets to be acquired. Of the tactical considerations, only the considerations for mission differ from the METT-TC considerations for other Firefinder radars.

Mission

The Q-47 must be emplaced where it can best accomplish its mission. Several factors drive positioning in relation to mission considerations. The supported unit, commander's guidance, associated command relationship, and required sector of search dictate in general where the radar must be positioned. The requirements to conduct hostile and friendly operations or operate in TBM mode add specificity to positioning requirements. Further, the requirements to establish priority zones influence where a radar must be positioned.

SURVIVABILITY CONSIDERATIONS

Survivability of the radar must be considered when selecting radar positions. Radars are susceptible to enemy ground attack, air attack, indirect fires and electronic warfare. The Q-47 also produces a significant heat signature that can be detected by infrared detection devices. A through IPB will identify threats to the Q-47.

SAFETY

Safety is an important consideration when operating and working around the Q-47. Like the Q-37, one must be aware of wind and radiation hazards. However, the Q-47's unique design presents additional considerations.

RADIATION

When the radar transceiver is energized, it poses a microwave radiation hazard to personnel. The hazard distance for the Q-47 is much greater than the distance for the Q-37. The hazard distance for troops extends in front of the radar for 217 meters over the radars full 1600-mil area of scan. The radar also poses a hazard for electrically detonated explosives. Figure E-14 depicts the radar's radiation hazard area.

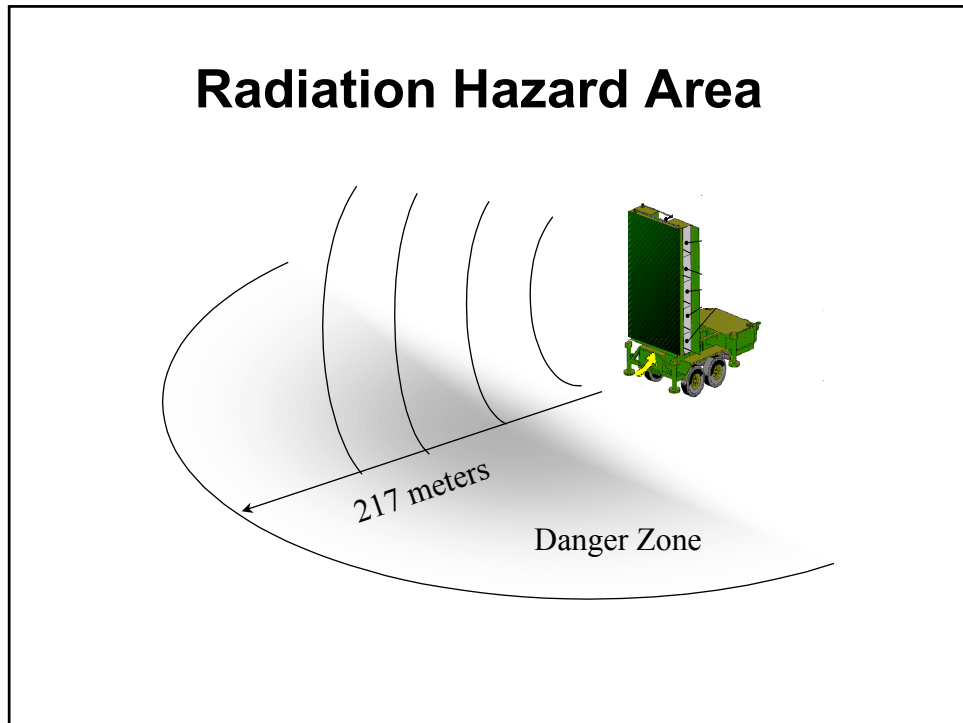

Figure E-14. Troop Radiation Hazard Area

HOT SURFACES

The Q-47 antenna is air-cooled antenna unlike the Q-37 that has a liquid-cooled antenna. Therefore, the antenna and control surfaces generally maintain a higher temperature. Some components may require a cool down period before performing maintenance. Control panel surface temperatures should normally be less than 120 degrees Fahrenheit at an ambient temperature of 77 degrees during normal operation. Other surfaces should not exceed 140 degrees Fahrenheit at an ambient temperature of 77 degrees. Surface temperatures may exceed these temperatures when ambient temperatures are higher.

WIND

Because of the large surface area of the antenna, high wind velocity can cause serious safety hazards. When the wind velocity reaches a constant speed of 40 mph or higher or wind gusts exceed 75 mph the antenna must be placed in the stowed position.

LIFTING HAZARDS

Many of the Q-47's line replaceable units (LRU) weigh in excess of the 37-pound single person lift requirement. Exercise care when removing or transporting these items. Table E-7 provides a list of LRUs exceeding the one-person lift requirement.

Table E-7. LRU Weights

LRU	Weight (lbs)
MAPS	44
Receiver	51
Exciter	56
BSC	60
ARC	63
PAM	66
PSU (1)	67
APU	73
DPU	100

ANTENNA ROLL OVER

The ATG is top heavy and can present a roll over hazard during positioning. Care should be exercised when emplacing the antenna because the antenna can unexpectedly move after leveling under certain conditions. The ATG should be sited on level ground. The ATG center of gravity (CG) may shift if sited on sloped or soft terrain. High winds may exacerbate this condition. Combinations of high wind load and CG movement may contribute to tip over. The Q-47 is equipped with software to monitor and alert the operator if the roll angle exceeds 2 degrees.

NOISE

Hearing protection should be worn when working around power generation equipment and the ATG. Noise generated by the ATG cooling fans may generate noise levels in excess of 85 decibels in areas adjacent to the ATG during operations.

SECTION II – OPERATIONAL ASPECTS

THEATER MISSILE DEFENSE OPERATIONS

The Q-47 radar provides the capability to conduct theater missile defense (TMD) operations. Depending on the theater and the theater's level of maturity, the Q-47 might be required to support a joint force headquarters, Army forces commander (ARFOR) or corps as they conduct TMD operations.

The radar may or may not be deployed as part of its parent organization. These factors will directly influence the command and support relationship established for the radar and its ultimate employment. In cases where the radar deploys or operates without its parent organization, support requirements become a major consideration. This appendix discusses TMD, doctrine, Q-47 TBM mode capabilities, and TTP for Q-47 participation in TMD operations.

TMD MISSION

Theater air and missile defense operations encompass all activities focused on the identification, integration, and employment of forces supported by theater and national capabilities to detect, identify, classify, locate, track, discriminate, minimize the effects of and destroy air and theater missile threats (to include large-caliber rockets). TMD protects the force and critical assets from attack by theater missiles, which include ballistic missiles, cruise missiles, air-to-surface missiles, and large caliber rockets. Doctrinally, tactical ballistic missiles (TBM) are surface launched missiles with ballistic trajectories. These missiles are further characterized as short-range ballistic missiles (SRBM) and medium-range ballistic missiles (MRBM). SRBM include TBMs with ranges up to 1000km. MRBM have ranges from 1000 to 3000km. The light and medium missile classifications of the Q-47 both fall into the SRBM category. SRBM include the entire family of SCUD missiles.

Attack Operations

Attack operations destroy, disrupt, or neutralize theater missile (TM) launch platforms and supporting command, control, and communications (C3) nodes, logistic structures, and reconnaissance, surveillance, and target acquisition (RSTA) platforms. Attack operations include offensive action by air, land, sea, and special operations forces. The joint force commander (JFC) normally tasks component commanders to conduct attack operations within their area of operations (AO). Subordinate commanders control attack resources and coordinate and their operations according to joint doctrine and procedures. The joint force air component commander (JFACC) is normally the supported commander to plan and conduct attack operations against TM that are outside other component commanders AO.

Attack operations can be preemptive or reactive. A sustained effort is required to reduce the enemy's TM capability and involves the execution of mutually supporting tasks. The detection, acquisition, classification, identification, tracking, and attack tasks are highly dependent on a near real time C4I process and rapid targeting capability. Attack operations use all-source intelligence, missile-warning systems, air defense radar, and Q-47 radar to locate and target enemy TM systems, their components, and supporting nodes.

Operational Objectives

The JFC employs theater missile defense forces to achieve two primary operational objectives: gain control of the air environment and protect the force and selected assets. At the operational level, the Army contributes to

theater counterair operations and to theater missile defense. Army combined arms forces provide support for offensive counterair (OCA), defensive counterair (DCA), and TMD active defense and attack operations.

Tactical Objectives

Objectives of air and missile defense operations at the tactical level are to protect corps and division forces as they plan and execute battles and engagements. Every participant in Army air and missile defense operations, maneuver, fire support, aviation, and intelligence, has a role in achieving those objectives, as do the joint forces that support corps and division operations. Air and missile defense objectives at the tactical level are an extension of the operational-level objectives, but are more specific. Tactical-level air and missile defense operations support the overall objectives of corps and divisions. The emphasis at the tactical level is on protecting the force rather than on gaining control of the air environment or protecting geopolitical assets.

THE ARMY AND AIR DEFENSE MISSILE COMMAND (AAMDC)

The AAMDC is the Army's operational lead for Army theater air and missile defense. In wartime, the AAMDC supports the ARFOR commander or, if designated, the joint force land component commander (JFLCC). The AAMDC is normally under command of the ARFOR commander, or if a JFLCC is designated, the AAMDC may be OPCON or TACON to the JFLCC. The AAMDC usually collocates with the ARFOR/JFLCC headquarters, but dependent on METT-TC, may collocate with the joint air operations center (JAOC). The location of the commander and his role is also dependent on METT-TC. Normally, the AAMDC does not have C² of any attack operations (field artillery or aviation) or passive defense forces (chemical). However, the AAMDC operations section monitors aspects of their operations/capabilities that may impact AAMDC operations. In the event of a missile launch, the operations section receives missile launch, state vectors, and TBM impact points from the Q-47 and other air defense systems, disseminates early warning, and after analysis passes targeting recommendations on the enemy's launch platforms and associated infrastructure to the deep operations coordination cell (DOCC). It also develops plans to support future operations and assists integration of TMD time sensitive and planned air tasking order (ATO) target missions.

AAMDC Attack Operations Cell

The attack operations cell supports ARFOR deep operations and joint force offensive counterair (OCA) attack operations through analysis and targeting focused specifically against the TM threat. Analysis includes such actions as developing TM intelligence requirements (IRs), building operational patterns and profiles, identifying trigger events, analyzing launch events, conducting countermobility analysis, and identifying information operations (IO) warfare vulnerabilities. Q-47 acquisition data provides input to support these analyses. Targeting actions include nominating attack strategies and submitting target nominations and mission requests. These validated TM

nominations are normally forwarded electronically to the DOCC via AFATDS for immediate or preplanned execution.

Attack Operations Cell Organization

The attack operations cell and its automated equipment are shown in Figure E-15. This equipment includes the automated deep operations coordination system (ADOCS), the advanced field artillery tactical data system (AFATDS), the all source analysis system remote workstation (ASAS RWS), the generic area limitation environment (GALE), the joint services workstation (JSWS), and laptop computers.

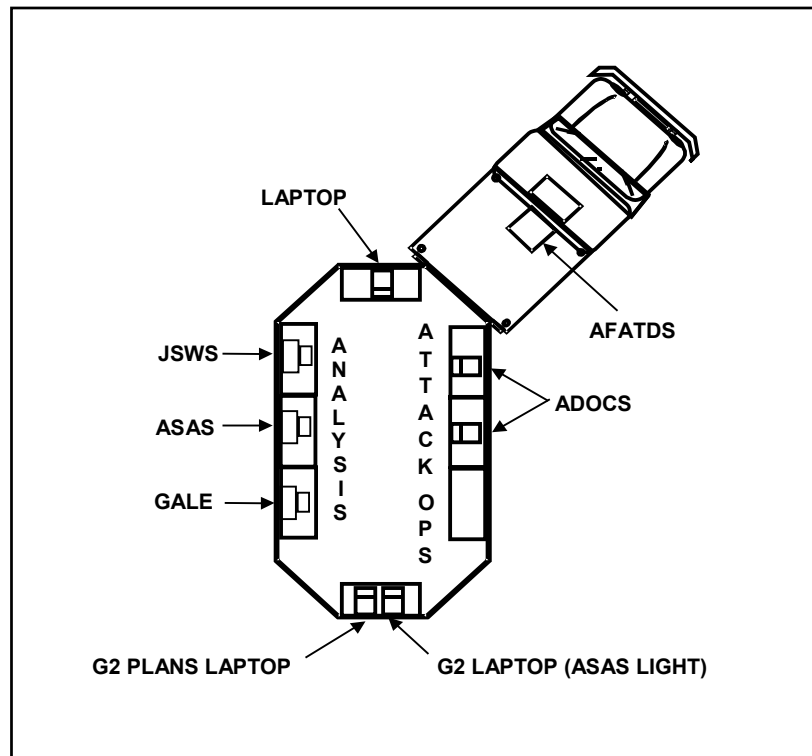

Figure E-15. Layout of Attack Operations Cell

This equipment is described below:

- ADOCS is an integrated set of automated tools used for mission planning, coordination, analysis, and data management. It displays a variety of data including friendly and enemy unit locations, air corridors, restricted fire areas, and operational graphics. It is used to submit TM target nominations to the DOCC and provide friendly artillery and fire support coordination measure (FSCM) situational awareness to the attack operations cell and LNOs.
- AFATDS is an automated workstation that displays friendly artillery database information and facilitates management of fire support operations by processing fire mission requests and air support mission requests. It is used to submit TM target nominations to the DOCC and provide friendly artillery and FSCM situational awareness to the attack operations cell and LNOs. The Q-47 transmits target location, impact predict location and state vectors from target acquisitions directly to this AFATDS.
- ASAS RWS receives and correlates data from strategic and tactical intelligence sensors and sources. This data includes electronic, signal, imagery, and human intelligence. The RWS displays the enemy and friendly situations and includes tools that can be used to perform IPB, situation and event analysis, and target planning.
- GALE is an automated workstation that contains a comprehensive terrain database. It is capable of analyzing terrain and predicting the

most probable locations of enemy launch areas, forward operating bases, hide sites, and support areas. It is also capable of modeling the movement of enemy mobile launch platforms and predicting where they are going, what roads they will be using and the time required to reach their destinations.

- The JSWS is an automated workstation that receives surveillance imagery from the joint surveillance and target attack radar system (JSTARS) platforms that are imaging fixed targets or tracking enemy mobile launch platforms. The JSWS displays this imagery, enabling the operator to provide accurate targeting information, including fixed and mobile target locations, speed, target classification, and direction of movement.
- The laptop computers are used for operational, administrative, and intelligence information dissemination purposes and providing connectivity via the SIPRNET to AAMDC staff and LNOs and other SIPRNET users.

Liaison

The AAMDC provides liaison teams to support its TMD mission. It deploys liaison teams to all major theater C2 headquarters and to the ARFOR DOCC, BCD and ACE. At the DOCC (and when necessary at the analysis and control element (ACE) based on METT-TC), the AAMDC liaison teams assist with the air and missile IPB and bring an air and missile focus to deep operations. The AAMDC nominates TAMD targets for prosecution either within the air tasking order (ATO) cycle or as a time sensitive target. The AAMDC DOCC LNOs assist in the target nomination process, provide the AAMDC with non-TMD deep targets of interest, inform the AAMDC of the availability of Army attack assets, and monitor the status of the target nomination request. These liaison teams have the ability to digitally receive and process Q-47 acquisitions. This is an important capability that provides flexibility when employing Q-47 radars in support of TBM operations.

ARFOR TMD OPERATIONS

The AAMDC is responsible for conducting TMD operations for the ARFOR when the ARFOR is responsible for TMD operations in its AO. The radar support for the ARFOR is provided by Q-47's from an IBCT, IDIVARTY, divisional TAB or CTAD depending on the size of the force acting as the ARFOR and the maturity of the theater. A division or corps headquarters is likely to act as an ARFOR. The digital architecture and command and support relationships for the Q-47 radars are basically the same whether the corps or division acts as the ARFOR. Only the parent organization of the radars would differ.

Corps as ARFOR Headquarters

When the corps acts as an ARFOR headquarters, Q-47 support should normally be provided by the CTAD allocated to the corps. The number of radars placed in the TMD mode is determined by the IPB and commander's guidance. The AAMDC conducts targeting for TMD operations. However, the Q-47s remain under the command of the corps/ARFOR. The radars have an

assigned command relationship. The Corps FSE/DOCC controls the radars. Acquisitions are reported to the corps FSE/DOCC, AAMDC and AAMDC DOCC LNO. Figure E-16 depicts the digital architecture for a corps acting as an ARFOR with a supporting AAMDC.

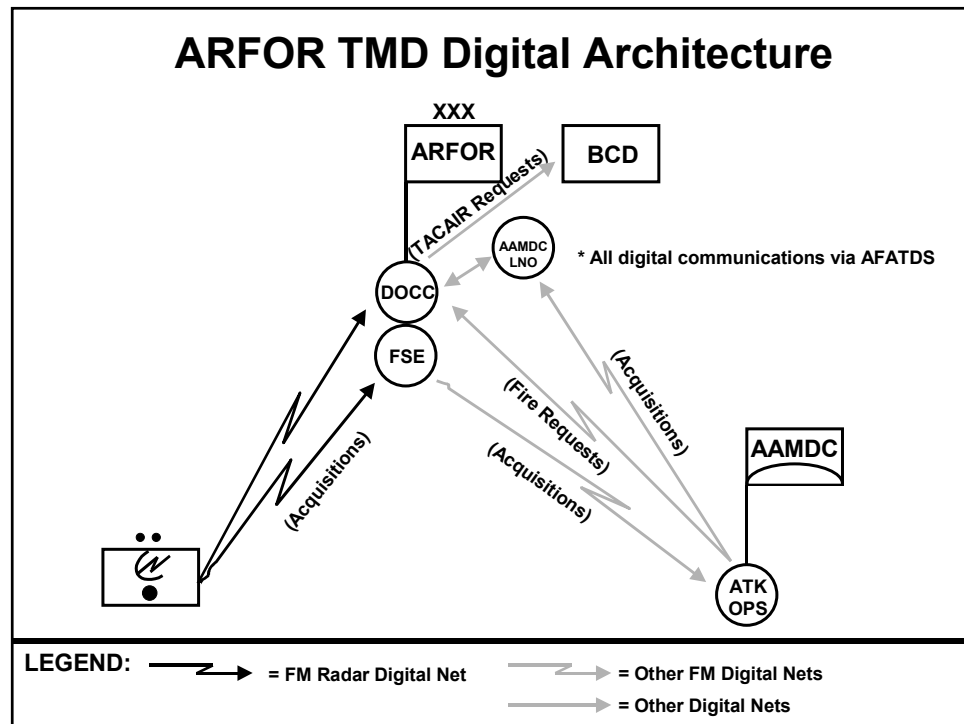

Figure E-16. ARFOR TMD Q-47 Digital Architecture

TBM acquisitions are transmitted from the radar to the DOCC/FSE, AAMDC and AAMDC LNO on one digital net via AFATDS. The information received in the DOCC is used for targeting, situational development and attack operations. The information received at the AAMDC is used for TMD targeting, passive missile defense and cross-cueing air defense systems such as the Patriot radar. Care must be taken to avoid duplication of effort. One method for preventing duplication is to specify which agency will generate target nominations or fire requests for specific targets. The DOCC/FSE should process and conduct attack operations for heavy rockets. The corps has assets to immediately attack these targets based on range and the TLE of acquisitions. The AAMDC should process missile acquisitions since the TLE of the acquisition is too large for ATACMS and the target dwell time is too short. The AAMDC can use the acquisitions in conjunction with other intelligence systems to develop a viable target for ATACMS or generate an air nomination. All target nominations and air requests are sent from the AAMDC to the DOCC for processing.

Missile targets could be attacked immediate upon detection with TACAIR. The TLE and response time requirements are such that the target can be attacked even if it departs the launch point. The options for air attack are to pass the target through the BCD to an aircraft flying a TMD AIRCAP, if

available, or to divert an AI mission. Air requests could also be sent directly from the AAMDC to the BCD through the AAMDC LNO at the BCD. This procedure should be coordinated in advance to avoid duplication of effort.

CORPS AND DIVISION TMD OPERATIONS

Corps commanders exercise control over most of the ground forces in the theater. Objectives of air and missile defense at the corps level are protecting the force, providing freedom to maneuver, controlling the air environment, and destroying enemy air and missile power on the ground and in flight. At division, the focus shifts increasingly toward providing freedom to maneuver by protecting the force. These perspectives relate directly to the different battlefield characteristics and requirements at each command level. Q-47 radars are managed to accomplish these objectives.

Corps Employment of Q-47 Radars

Corps has a CTAD to accomplish its counterfire and missile defense objectives. Depending on the TBM threat, corps may place one or both Q-47s in TBM mode. In the absence of a creditable TBM threat, both Q-47s would operate in normal or fast scan mode. Acquisitions from the Q-47s would go directly to the corps FSE/DOCC and, if so designated directly to a field artillery brigade or subordinate battalion for attack. Acquisitions would also go to the corps G2 to support intelligence operations. Figure E-17 depicts a digital architecture for corps TBM operations.

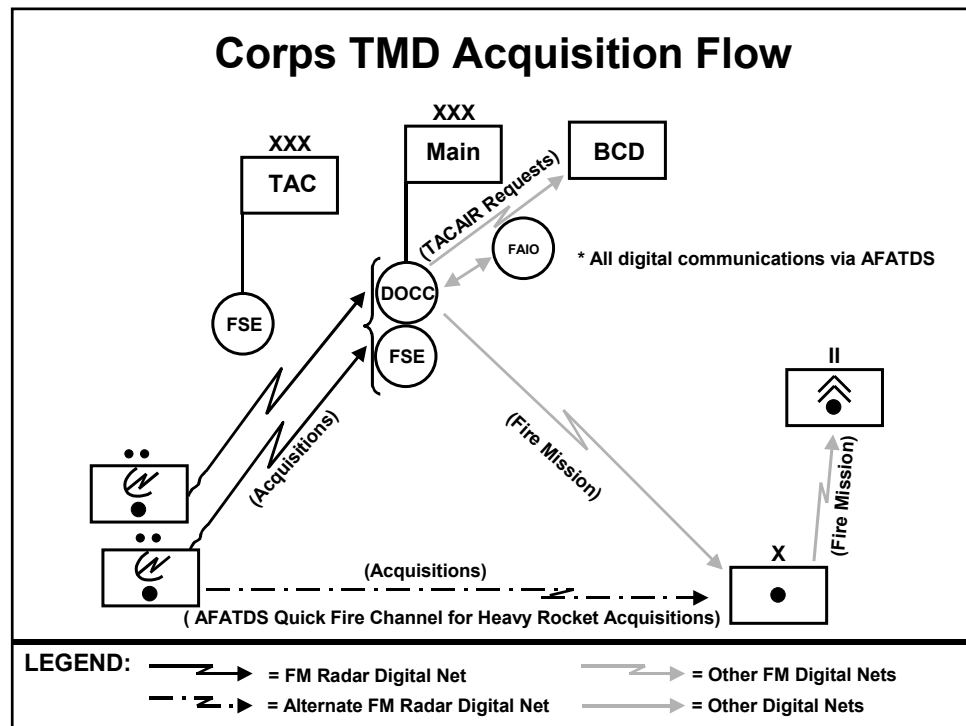

Figure E-17. Corps TBM Acquisition Architecture

Division Employment of Q-47 Radars

A division uses the two Q-47 radars from the radar platoon of its target acquisition battery to provide TBM support. In a unit organized with an IDIVARTY, three Q-47 radars are available in the TA platoon of the HIMARS battalion. Further, each IBCT has a Q-47 radar upon which the division could task. Normally, the division would be focused on counterfire and the Q-47s would operate in normal or fast scan mode. The division might place one Q-47 in TBM mode to obtain the addition range capabilities for detecting heavy rockets. Further, an AFATDS quick fire channel might be established between a Q-47 and the counterfire headquarters or a subordinate battalion to facilitate immediate engagement of targets. A division organized with an IDIVARTY has additional flexibility. A division in an early entry scenario may routinely place a radar in TBM mode when acting as an ARFOR headquarters. Q-47's in heavy or Army XXI divisions would send acquisitions to the designated counterfire headquarters and/or FSE. The FSE processing the acquisitions in the heavy division is the main FSE. The TAC FSE would receive the acquisitions in the ARMY XXI division. In divisions organized under the interim or object force structure, acquisitions would be transmitted to the fires and effects coordination cell (FECC).

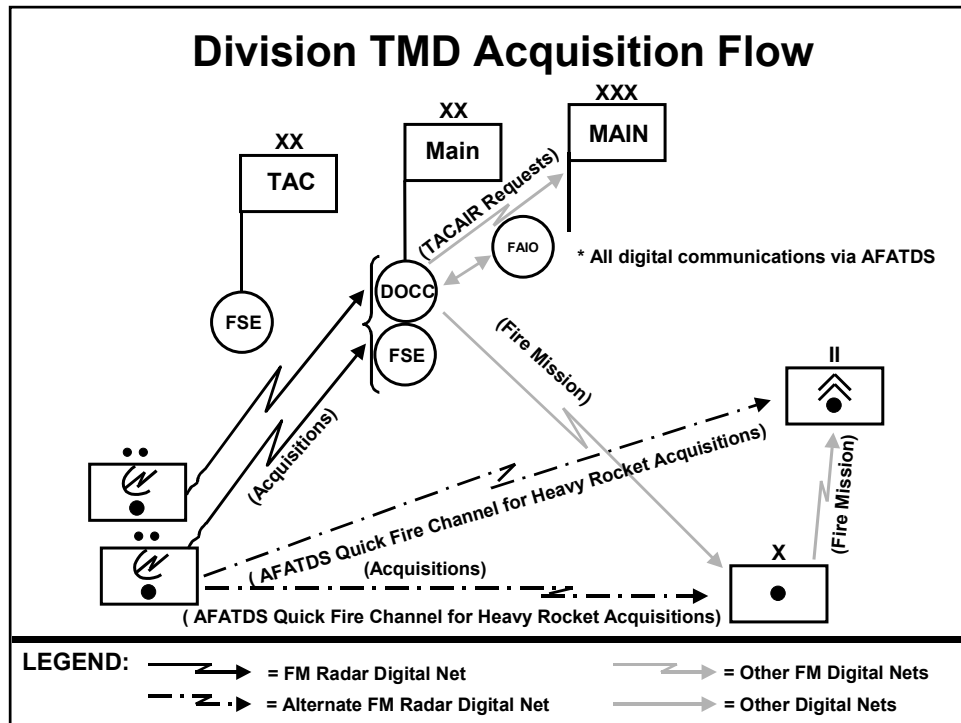

Figure E-18. Division TBM Acquisition Architecture

Q-47 TBM CAPABILITIES

In TBM mode, the Q-47 can detect TBMs at ranges from 12-300KM. The associated target location error (TLE) is 50m or .25% of range for light missiles and 100m or .25% for medium missiles whichever is greater. The maximum TLE is 750m at 300km for medium missiles. The TLE is too large to provide targetable data for ATACMS Block I/IA at most ranges without validation by a second detection source. The main detection footprint extends from the radar +/-533mils from the azimuth of orientation out to a range of 300km. The radar can also detect missiles in the area from plus or minus 533-800 mils from the azimuth of orientation. However, the range is significantly diminished. The minimum range is 12km for light missiles and 25km for medium missiles (See Figure E-12). The Q-47 can also detect heavy rockets in TBM mode. For missile targets, the Q-47 will compute and transmit a missile's state vector, launch point, and impact predict point in near real-time.

Target Categories

The Q-47 categorizes detections in TBM mode as light or medium missile or heavy rocket based on size, velocity and trajectory. Heavy missiles are not detected as their range is greater than that of the Q-47.

Light Missiles. Light missiles are guided during part of their trajectory and have a free flight stage. They are the fastest missiles during the initial burn stage and are easier to detect during the boost stage of their ascent. Typically

the range of these missiles is proportional to the weight of their warhead. Warheads filled with gaseous agents or ultra-light explosive devices would extend the range considerably. Ranges usually vary from 25km to 150km. The Q-47 classifies detections as light missiles based on size, velocity and trajectory. Velocities vary from 800 to 1500 meters per second. ATACMS is considered a light missile. Threat systems in this category include the SS-21, SS-23, SCUD-A, and SCUD-B.

Medium Missiles. Medium missiles fly from 40-300km at velocities of 1100 to 2300 meters per second. They are missiles similar in performance to the SCUD and SS-21. There is no U.S. weapon in this category. The threat system in this category is the SCUD-C. The NoDong is a heavy missile based on range.

Heavy Rockets. Heavy rockets are larger than 155mm, may be programmed internally, and may have a guidance-affected trajectory. They normally fly through more than one layer of atmosphere during their trajectory and may carry multiple payloads. These rockets have a velocity from 700 to 1200 meters per second. The Q-47 can detect heavy rockets at ranges up to 100km. MLRS is classified as a heavy rocket. Threat systems in this category include the BM22, M1991 (240mm MRL), ASTROS II and 9A52.

CORPS COUNTERFIRE

The increased range capability of the Q-47 and the allocation of two Q-47 radars to each corps provide the corps with a capability to conduct reactive counterfire without stripping a division of its assets. The level of reactive counterfire operations must be balanced with the requirements to conduct TMD operations. The introduction of reactive counterfire operations at the corps is a departure from current counterfire roles. The corps role in current doctrine is normally focused on deep, proactive, counterfire. In most situations, the division orchestrates and executes counterfire in support of corps close operations. The corps provides resources to the division. This allows an orderly and calculated division of labor. Just as the division separates and deconflicts the radar coverage and counterfire efforts of the division and maneuver brigades, so must the corps deconflict the efforts of the corps and division. The division uses the common sensor boundary (CSB) to segregate the coverage areas for the Q-36 and Q-37. The corps must also segregate the coverage areas for division and corps Q-47 to prevent duplication. One method is for the corps to establish a corps common sensor boundary (CCSB). This measure is established based upon IPB and analysis of the enemy fire support system. The corps normally places the CCSB to segregate the responsibility for locating and attacking DAGs and AAG/AGRA. The corps could also establish a phase line to delineate areas of coverage. In either case, the location of fire support coordinating measures relative to the CCSB or phase line must be considered. CCSB should be placed on or forward of the CFL or FSCL, when possible, to eliminate the need to clear targets prior to engagement.

DIVISION COUNTERFIRE

Counterfire operations at the division are enhanced by the Q-47. However, the basic procedures unchanged. Reactive counterfire is affected by the Q-47's increased range and ability to classify targets. The ability to classify targets enhances counterfire operations by identifying specific target types for generation of fire missions based on the unit's High Payoff Target List (HPTL). This target classification capability can also be leveraged by the TPS when combined with the target build-up function in AFATDS. The TPS can establish a target build-up area with an associated target type that will generate a fire mission when the designated number of targets is located in the specified area. Finally, the enhanced range provides the capability to acquire the majority of threat artillery and rocket systems. This enhanced range also provides the corps with a system capable of detecting threat systems in areas where the corps normally conducts its operations.

Appendix F

Firefinder Mask Considerations

This appendix explains how to calculate the track volume for the Firefinder radars. It is intended for use by the radar section leader to enable him to determine whether a radar site will provide enough track volume to locate hostile firing positions. It also provides procedures for correcting insufficient track volume.

DEFINITIONS

The following definitions are associated with mask:

- Flat mask is a single mask angle or a default value in the radar when no mask angle is entered into the radar computer. The flat mask default for the AN/TPQ-36 radar is 20 mils. The flat mask for the AN/TPQ-37 radar is 8 mils.
- Mask angle is the vertical angle from the radar to the top of the mask, or screening crest, at a given azimuth. The lowest mask angle and the highest mask angle are calculated and entered in the radar's computer during initialization.
- Mask variation is the difference between the lowest and highest mask angles.
- Vertical scan is the maximum vertical scanning capability of a specific type of radar. Vertical scan for the AN/TPQ-36 radar is approximately 80 mils with all scanning frequencies enabled. Each frequency that is disabled results in a loss of approximately 2.5 mils of vertical scan. Vertical scan for the AN/TPQ-37 radar is approximately 104 mils. Since this radar uses phase or phase scan rather than the phase or frequency scan used by the Q-36, no vertical scan is lost when some of the frequencies of the Q-37 are disabled.

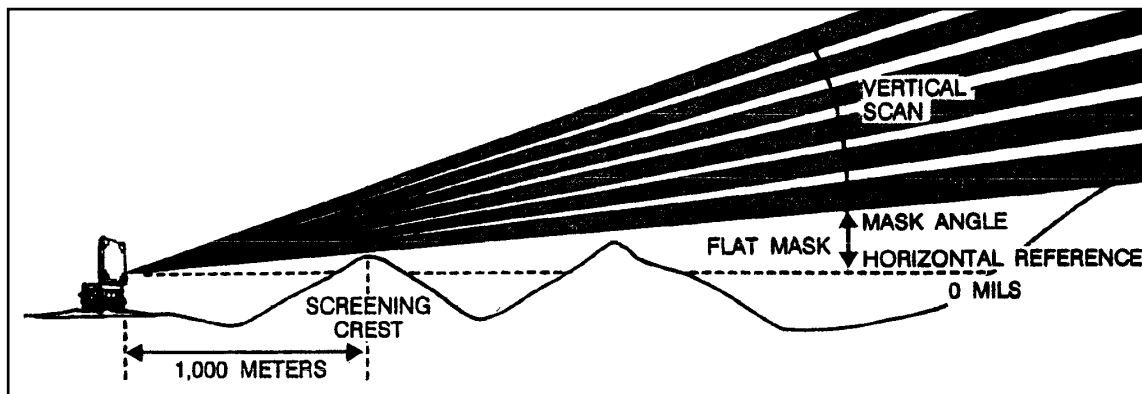

Figure F-1. Radar Characteristics

TRACK VOLUME

The amount of track volume is determined by the vertical scan of the radar and the amount of vertical scan that is lost because of the terrain contour, or screening crest, in front of the radar. From any radar position, the altitude of the screening crest along the terrain contour in front of the position will vary across the radar's sector of search. This varying screening crest altitude results in varying mask angles along the terrain contour. The variance between the smallest mask angle and the largest mask angle reduces the radar's vertical scan.

Sometimes this reduction is enough that the available scan coverage is less than the 50-mil track volume required by the radar to extrapolate weapon locations. When the track volume is reduced below 50 mils, the radar section leader must compensate by artificially adjusting the low mask angle, narrowing the search sector, or by moving the radar to a new position that provides adequate track volume.

Whenever possible, an aiming circle or other accurate measuring device should be used to determine mask angles along the terrain contour. These measured mask angles are entered in the computer to depict the terrain contour. Otherwise, the radar will radiate into hill masses that are higher than the flat mask default in the radar computer. The Q-36 has the ability to conduct automatic terrain following to determine mask angles. Automatic terrain following can be used when digital terrain is available for the location of the radar site. This capability allows the radar section leader to compute mask angles before occupying a radar site. Automatic terrain following is not as accurate as taking manual measurements from the radar site. Therefore, manual mask measurements should be taken as soon as practical after occupying a new radar site.

TRACK VOLUME CALCULATION AND SUBSEQUENT ACTIONS

The Firefinder search fence starts at the lowest mask angle entered in the radar computer (or at the flat mask default value if no lowest mask angle is entered) and goes to the highest point of the vertical scan. The first step in calculating track volume for the radar site and search sector is to subtract the low mask angle from the high mask angle. This difference must then be subtracted from the vertical scan of the radar. The result is the track volume for the radar site. Figure F-2 shows the procedure for calculating track volume.

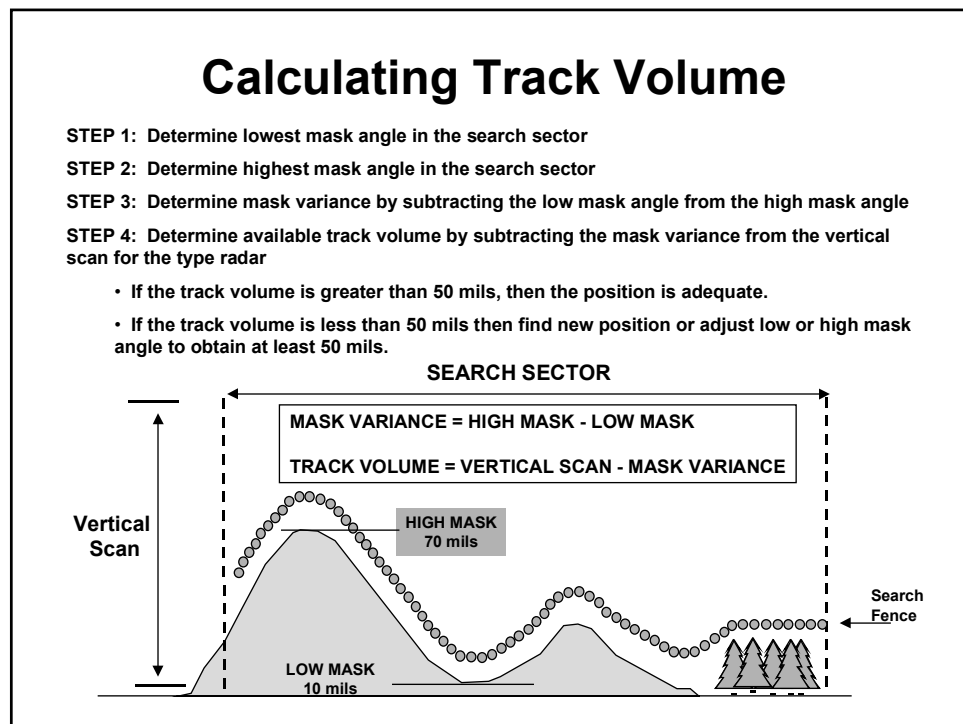

Figure F-2. Track Volume

Although the ideal mask variation may be met, the maximum allowable mask variation for a radar can be calculated by subtracting the 50 mils of track volume required for firing weapon location from the vertical scan of the radar. The maximum allowable mask variations are:

- Q-36 – 30 mils.
- Q-37 – 54 mils.

Thus, any mask variation exceeding the allowable maximum variation would not allow enough track volume for the radar to determine firing weapon locations. In that event, some action must be taken to regain enough track volume to perform the radar mission. Possible actions include doing nothing, raising the low mask angle, narrowing the search sector, or moving the radar. If nothing is done a dead space is created where projectiles cannot be detected. Figure F-3 depicts a dead space area.

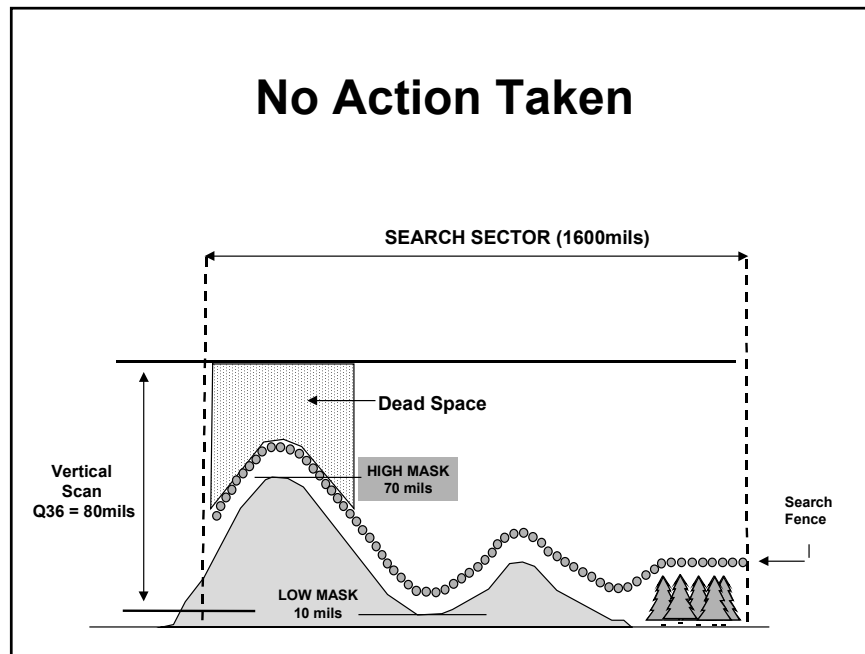

Figure F-3. Dead Space Area

In the example in Figure F-3, the mask variation is 60 mils, which only allows 20 mils of track volume over portions of the search sector. This creates a dead space area. The result is an area where hostile weapons cannot be detected. Figure F-4 shows the possible adverse effects of a dead space area.

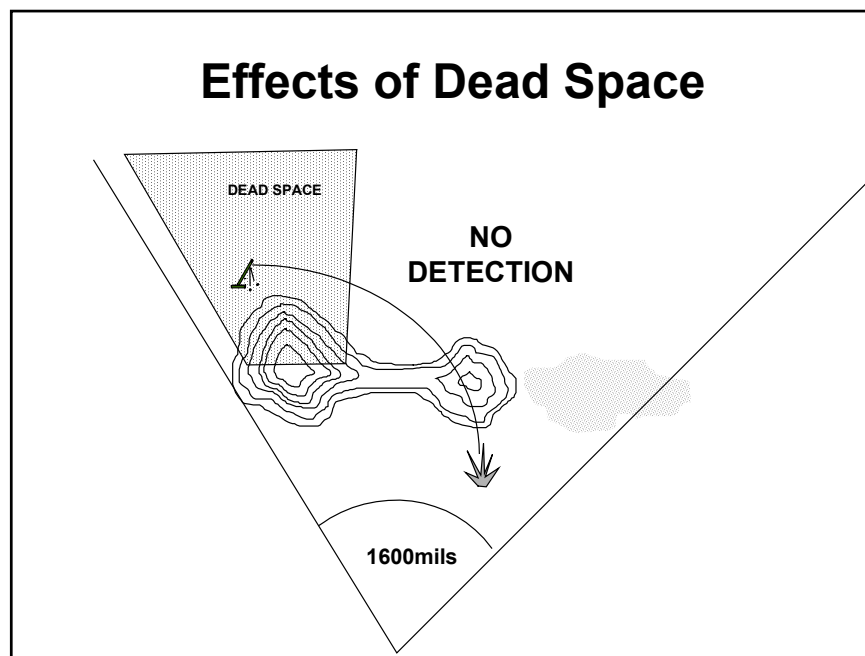

Figure F-4. Effects of a Dead Space Area

The first solution is to raise the low mask angle. This will provide enough track volume to eliminate the large dead space area. Nonetheless, this solution will produce a small dead space area under the low mask area. This may or may not be acceptable. Figure F-5 shows the result of raising the low mask angle.

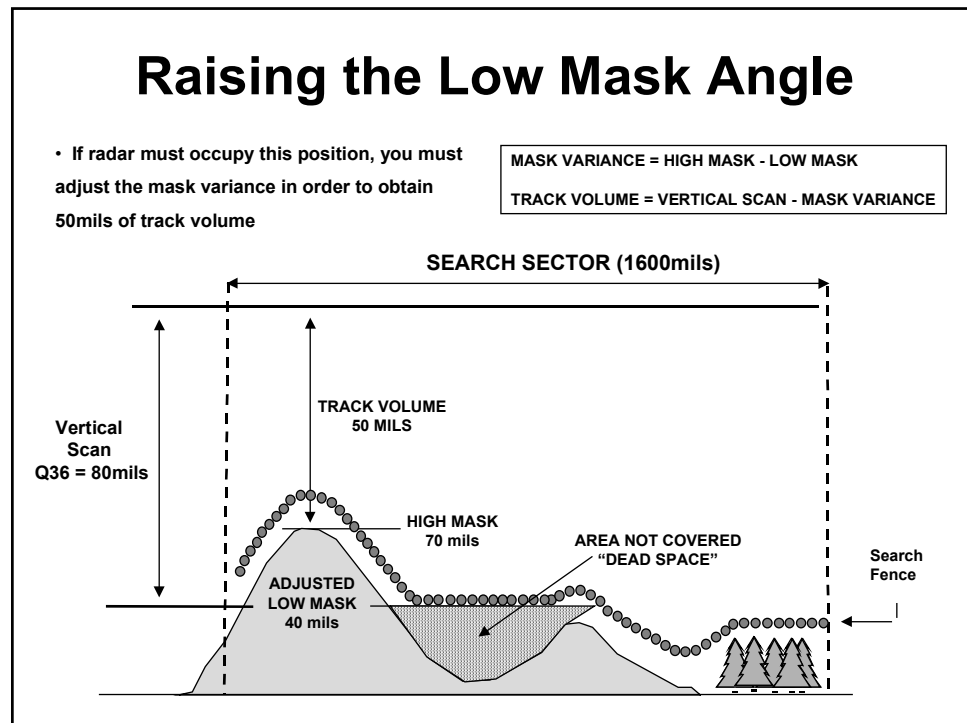

Figure F-5. Raising the Low Mask Angle

The next solution might be to narrow the search sector or move the search sector. This will lower the mask variation and eliminate the dead space in the search sector. This still leaves an area with no radar coverage. Narrowing the search may not be acceptable based on the tactical situation. Figure F-6 depicts narrowing the search sector.

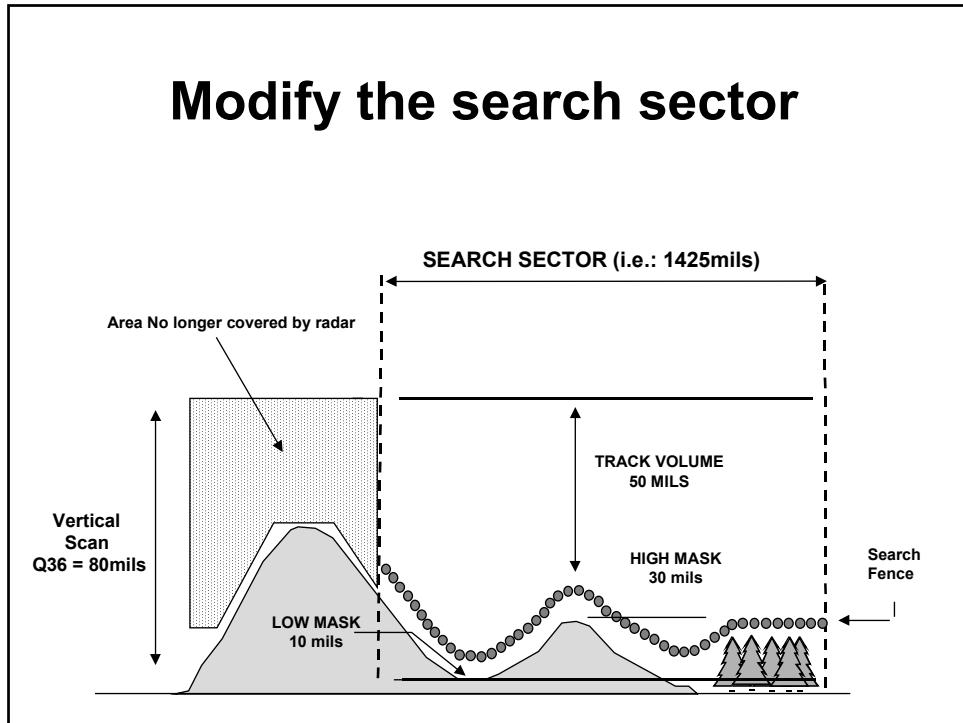

Figure F-6. Modifying the Search Sector

If none of these solutions are acceptable, the radar must be moved to another site to provide the required coverage. The radar section leader must recompute mask angles and track volume at the new location.

Appendix G

Target Acquisition TAB to the Field Artillery Support Plan

The purpose of the TA tab to the FA support plan appendix is to assign missions, consolidate field artillery TA assets, establish target processing flow, and assign and coordinate responsibilities not covered in unit SOPs. This appendix explains the preparation of the TA tab and its enclosures.

SECTION I - TARGET ACQUISITION TAB

DESCRIPTION

The TA tab is a managerial tool used primarily by the DIVARTY (or FA brigade) and DS battalion staffs. It is used to ensure that all TA assets are employed to support the overall combined arms operation. Although no specific format for the tab is prescribed, the five-paragraph operation order format is used when the TA tab is issued separately from the FA support plan. The TA tab is an integral part of the field artillery support plan, which is an appendix to the fire support annex of the operation order. This hierarchy is shown below:

- Operation Order _____(52d Mech Inf Div).
- Annex D (Fire Support).
- Appendix _____(Field Artillery Support Plan).
- Tab _____(Target Acquisition).
- Enclosures_____ (ex. Capabilities Overlay).

PREPARATION

In the DIVARTY headquarters, the DIVARTY S2 is responsible for the preparation of the TA tab. He is assisted by the counterfire officer, the TAB commander, the assistant counterfire officer, and the targeting officer. In the FA brigade, the TA tab also is developed by the S2 assisted by the targeting officer. In separate maneuver brigades, the TA tab is produced jointly by the FA battalion S2 with assistance from the S3, and targeting officer. The TA tab usually consists of the heading, five major paragraphs, and the enclosures. The TA TAB is normally produced at the DIVARTY/ FA BDE.

TARGET ACQUISITION TAB HEADING

The tab heading includes the security classification, the title line, references, and the time zone used throughout the operation. The classification is shown at the top and bottom of each page of the document. Refer to figure G-1.

<p>(CLASSIFICATION)</p> <p>TAB A (TARGET ACQUISITION) TO APPENDIX _____ (FA SUPPORT PLAN) TO ANNEX D (FIRE SUPPORT) TO OPORD _____.</p> <p>References: Map, Series (Number and Geographic Area, If Necessary), Sheet Number(S) (And Name, If Necessary), Edition _____, Scale _____.</p> <p>Time Zone Used Throughout: <u>(ALL CAPS) _____</u></p>

Figure G-1. Target Acquisition Tab Heading

MAJOR PARAGRAPHS

SITUATION (PARAGRAPH 1)

This paragraph includes the friendly situation, supported units, and other TA assets in sector. Include specific enemy and friendly information that form a basis for threat assessments required for the radar deployment order.

MISSION (PARAGRAPH 2)

This paragraph should be a clear, concise statement of the target acquisition mission. It contains who, what, when, where and why.

EXECUTION (PARAGRAPH 3)

The execution paragraph explains how the mission will be accomplished. It contains the following subparagraphs:

- **Concept of the Operation.** This subparagraph (3a) gives the commander's concept for target acquisition. This should include identification of designated cueing agents and general cueing guidance. Specific cueing guidance is listed in the coordination subparagraph (3e).
- **Processing.** The processing subparagraph (3b) is used to denote target processing flow. This targeting information flow describes the relationship between the target acquisition asset and the headquarters controlling it. This paragraph does not represent the actual communications nets used but shows the destination flow of targeting information. This paragraph should list all field artillery TA assets and headquarters controlling them. The following are examples of the types of information that may be included in the processing subparagraph:
 - AN/TPQ-36 section reports targets to the controlling DS battalion FDC.

- AN/TPQ-37 section reports targets to the DIVARTY (or FA brigade) target processing section.
- Aerial observers report targets to the controlling headquarters TOC.
- DS battalions report targeting data to the DIVARTY TOC.
- DIVARTY TOC will exchange targeting information with the supporting FA brigade TOC (especially when it acts as the alternate DIVARTY TOC).

The target processing flow is based on the tactical situation and command relationships.

- Visual Observation. This subparagraph (3c) covers ground observation. Ground observation is also covered in Enclosure 1 to the TA tab, which is the consolidated visibility diagram. This diagram covers the entire division sector to include forward observers. Time is a critical factor in assembling this enclosure.
- Radar. This subparagraph (3d) deals with the command relationships assigned to FA radars. FA radars may be assigned a command relationship of attached/OPCON/TACON to FA battalions or higher FA headquarters. An example mission for an AN/TPQ-36 section might be as follows: AN/TPQ-36, Section 3, Btry C, 1-30 FA; Mission: Attached to 1-51 FA (See RDO, Enclosure 5.)
- Coordination. The coordination subparagraph (3e) covers information that is not addressed in the unit tactical standing operating procedure (TACSOP). As a minimum, the paragraph should contain the following:
 - The requirement for the supported DS battalion to report radar locations and sectors of search to the DIVARTY target processing section.
 - Cueing guidance established by the DIVARTY counterfire officer.
 - Common sensor boundary (CSB). Firefinder radars sharing or having overlapping search sectors need to be identified. Consideration must then be given to the establishment of a CSB. The CSB is indicated by a series of grid coordinates to define its location.
 - Coordination for communications nets and relays, if required.
 - Additional coordination for survey and security, if required.

SERVICE SUPPORT (PARAGRAPH 4)

This paragraph lists service support requirements as required. It may refer to the service support annex.

COMMAND AND SIGNAL (PARAGRAPH 5)

The fifth paragraph lists required information as necessary. It may refer to the fire support annex.

ENCLOSURES

Enclosures to the TA tab should include the following:

- Enclosure 1 is a consolidated visibility diagram. Contains visibility information for non-radar type observers (i.e. STRIKERS).
- Enclosure 2 is a capabilities overlay. It normally contains the following:
 - Major unit boundaries, FEBA, and FLOT.
 - Major search sectors to include primary and alternate sectors, zones with type and number, and radar type and section description. Primary zones are depicted by solid lines, alternate zones, by dotted lines. Section SOPs should specify color coding for individual radar data.
 - Common sensor boundary, drawn as a solid line labeled with CSB and the effective DTG.
 - Major unit locations, especially those covered by the CFZ.
 - Overlay title, classification, and register marks.
- Enclosures 3 through 5 are the AN/TPQ-36 RDOs.
- Enclosures 6 through 7 are the AN/TPQ-37 RDOs.

It may not always be possible to include all RDOs as enclosures. This is especially true for radars attached to subordinate FA battalions.

The following sample TA TAB provides an example of how a TA TAB might be constructed.

SAMPLE TA TAB TO FA SUPPORT PLAN

UNCLASSIFIED

TAB A (TARGET ACQUISITION) TO APPENDIX 2 (FA SUPPORT PLAN) TO ANNEX D (FIRE SUPPORT) TO OPERATION ORDER 01-1 (GOLD DRAGON), 52D Mech Div.

References: Map, series M745, DEUTSCHLAND, sheet L5118
(Marburg)
Edition: Ausgabe 4 DMG
Scale: 1:50,000

Map, series M745, DEUTSCHLAND, sheet L5120
(Ziegenheim)
Edition: Ausgabe 4 DMG
Scale: 1:50,000

Map, series M745, DEUTSCHLAND, sheet L5318
(Amonenburg)
Edition: Ausgabe 4 DMG
Scale: 1:50,000

Map, series M745, DEUTSCHLAND, sheet L5320
(Alsfeld)
Edition: Ausgabe 4 DMG
Scale: 1:50,000

Time Zone Used Throughout: ZULU

1. SITUATION.

The enemy offensive has been halted, resulting in the current dispositions. Intelligence reports indicate the enemy is regrouping and is capable of launching a new offensive within 48 hours. See Annex B (Intelligence).

2. MISSION.

On order, the target acquisition assets of the 52d Mech Div, Btry C [TA], 1-30 FA, and STRIKER teams will acquire targets, initiate fire missions, and report combat and/or targeting information in support of offensive operations in zone to defeat the enemy and prevent his massing for a new offensive.

UNCLASSIFIED

D-1-A-1

SAMPLE TA TAB TO FA SUPPORT PLAN (CONTINUED)

UNCLASSIFIED

TAB A (TARGET ACQUISITION) TO APPENDIX 2 (FA SUPPORT PLAN) TO ANNEX D (FIRE SUPPORT) TO OPERATION ORDER 01-1 (GOLD DRAGON), 52D Mech Div.

3. EXECUTION

a. Concept of Operation. 52d Mech Div target acquisition assets will deploy well forward in sector to locate high-payoff targets and protect friendly forces, with long-range TA assets acquiring targets at maximum range to support the offensive operation to reestablish the international border. Priority of TA effort to 1st Bde then 2d Bde.

b. Processing. General support radars will send their targeting information directly to the DIVARTY TOC. Radars direct support to DS FA battalions will report information to their respective battalions. Targeting information developed at DS battalion level will be sent to DIVARTY.

c. Visual Observation. STRIKERs will report location and zone of observation thru BDE FSE to the DS FA Battalion.

d. Radar. See capabilities overlay at Enclosure 2.

(1) AN/TPQ-36, Sec 1, Btry C (TA), 1-30th FA
Mission: Attached to 1-90 FA (155, SP)
See RDO, Encl 3 (omitted)

(2) AN/TPQ-36, Sec 2, Btry C (TA), 1-30th FA
Mission: Attached to 2-90 FA (155, SP)
See RDO, Encl 4 (omitted)

(3) AN/TPQ-36, Sec 3, Btry C (TA), 1-30th FA
Mission: Attached to 3-90 FA (155, SP)
See RDO, Encl 5 (omitted)

UNCLASSIFIED

D-1-A-2

SAMPLE TA TAB TO FA SUPPORT PLAN (CONTINUED)

UNCLASSIFIED

TAB A (TARGET ACQUISITION) TO APPENDIX 2 (FA SUPPORT PLAN) TO ANNEX D (FIRE SUPPORT) TO OPERATION ORDER 01-1 (GOLD DRAGON), 52D Mech Div.

(4) AN/TPQ-37, Sec 4, Btry C (TA), 1-30th FA
Mission: Attached 52d DIVARTY (155, SP)
See RDO, Encl 6

(5) AN/TPQ-37, Sec 5, Btry C (TA), 1-30th FA
Mission: Attached 52d DIVARTY
See RDO, Encl 7 (omitted)

e. Coordination.

(1) Survey. Radar Sections 1 through 3 will receive survey support from their respective DS battalions. Cdr, Btry C (TA), 1-30th FA will provide survey support for Radar Sections 4 and 5.

(2) Common Sensor Boundary. Effective 0100001Z a common sensor boundary will be established along PL DOG. Once 1st Bde has completed fording operations vic NB191353 and secured Objective BONE, a new common sensor boundary will be established along PL CAT.

(3) Reports. DS battalions will report radar locations, sectors of search, and planned CFFZs, and CFZs to DIVARTY for all attached radars.

(4) Met. Q-36 coordinates for met data from DS battalion TOC; Q-37 receives data from DIVARTY TOC.

(5) Cueing. Maximum radiation time is based on the current ELINT threat assessment. The DIVARTY S2/CFO will update the ELINT threat throughout the mission on the DIVARTY CF net. Designated cueing agents for Q-36 are DS battalion S2, task force FSO, and brigade FSO. Q-37 cueing agents will be the DIVARTY CFO and reinforcing FA brigade S2.

(6) Firefinder Zones. Commander's guidance states all maneuver objectives when occupied will be covered by CFZs within the radar boundaries. DS battalion S2s will ensure that suspected artillery positions are covered by CFFZs. 2d Bde Q-36 ensure that a CFFZ is input for the town of STRANG vic NB1045. No CFFZs are to be placed outside boundaries. Force protection zones (CFZs) will be planned by the appropriate FSEs.

UNCLASSIFIED

D-1-A-3

SAMPLE TA TAB TO FA SUPPORT PLAN (CONTINUED)

UNCLASSIFIED

TAB A (TARGET ACQUISITION) TO APPENDIX 2 (FA SUPPORT PLAN) TO ANNEX D (FIRE SUPPORT) TO OPERATION ORDER 01-1 (GOLD DRAGON), 52D Mech Div.

4. SERVICE SUPPORT

Radar Sections 1 through 3 will receive logistical support from their respective DS battalions. Cdr, 2-19 FA (MLRS) will provide logistical support for Radar Sections 4 and 5.

5. COMMAND AND SIGNAL

a. Command. Btry C (TA), 1-30 FA TOC located at NB050670.

b. Signal. Current SOI KTU 1062, Edition BB in effect.

Encl 1: Visibility Diagram.

Encl 2: Capabilities Overlay.

Encl 3-5: RDO. Radar Sections 1 through 3 (AN/TPQ-36) (omitted)

Encl 6: RDO, Radar Section 4 (AN/TPQ-37).

Encl 7: RDO, Radar Section 5 (AN/TPQ-37) (omitted).

UNCLASSIFIED

D-1-A-4

SAMPLE TA TAB TO FA SUPPORT PLAN (CONTINUED)

UNCLASSIFIED

ENCLOSURE 1 (VISIBILITY DIAGRAM) TAB A (TARGET ACQUISITION)
TO APPENDIX 2 (FA SUPPORT PLAN) TO ANNEX D (FIRE SUPPORT) TO
OPERATION ORDER 01-1 (GOLD DRAGON), 52D Mech Div.

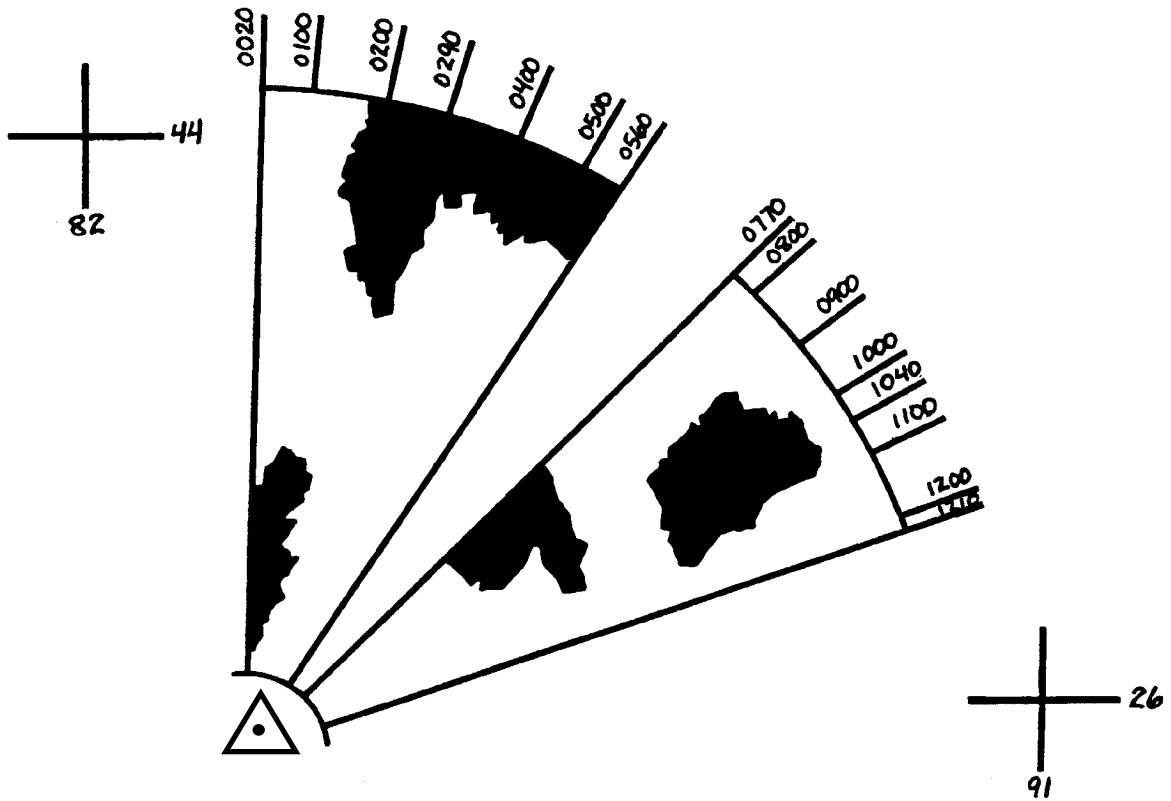

UNCLASSIFIED

D-1-A-1-1

SAMPLE TA TAB TO FA SUPPORT PLAN (CONTINUED)

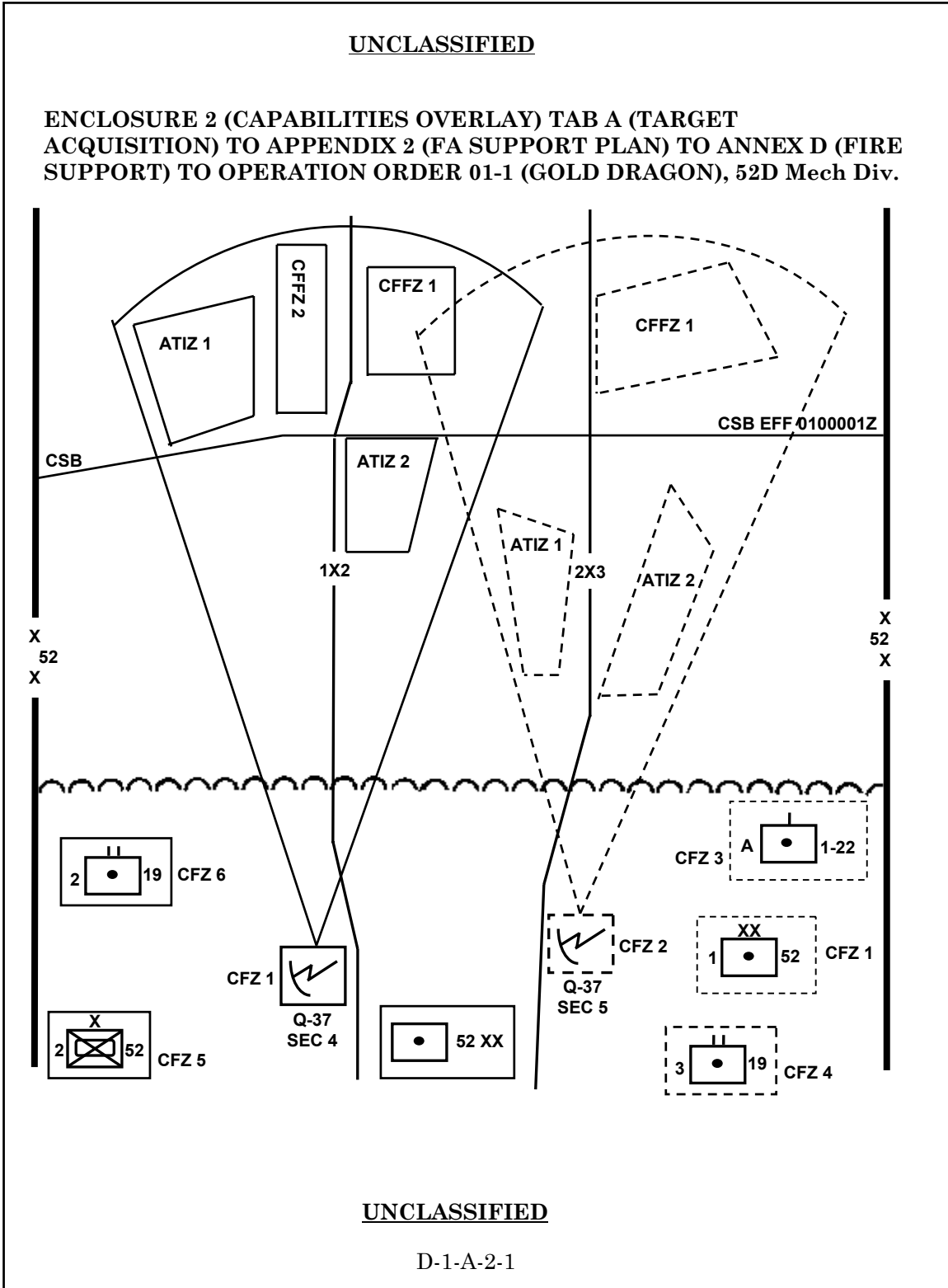

SAMPLE TA TAB TO FA SUPPORT PLAN (CONTINUED)

ENCLOSURE 6, TAB A (TARGET ACQUISITION) TO APPENDIX 2 (FA SUPPORT PLAN) TO ANNEX D (FIRE SUPPORT) TO OPERATION ORDER 01-1 (GOLD DRAGON), 52D Mech Div.

UNCLASSIFIED

(CLASSIFICATION WHEN FILLED IN)

RADAR DEPLOYMENT ORDER						
For use of this form, see FM 6-121. The proponent agency is TRADOC.						
SECTION 1/A/1-30 FA			MISSION ATTACHED 52 DIVARTY			
LOCATION Primary			Alternate			
SEARCH SECTOR						
		Left Edge	Right Edge	Minimum Range	Maximum Range	
Primary Azimuth	0290	0020 mils	056 mils	450 meters	18,280 meters	
Alternate Azimuth	1040	077 mils	1210 mils	450 meters	18,280 meters	
EW THREAT ASSESSMENT						
EW Threat (Yes) or No)		Affecting Friendly Assets (Yes) or No)		Type of Threat (Air or Ground)		
NOTE: Use the Firefinder survivability flowchart in FM 6-121 to determine emission limits.						
CUEING AGENTS (CALL SIGN AND DESIGNATION) IN PRIORITY						
M4T43 52 DIVARTY TOC		T6B41 52 DIV G2		K7C10 20FA BDE TOC		
A4C72 OH-58D, SEC 3						
REPORTING CHANNELS						
DIVARTY TA/INTEL M4T51			DIVARTY CMD M4T30			
ZONE DATA						
Type and Number	Description and/or Command Priority	Grid Coordinates of Zone Corner Points				
ATIZ-2	SUSPECT ARTY	NB025752	NB025730	NB971702	NB962750	
ATIZ-3	SUSPECT ARTY	NB100470	NB120470	NB120450	NB100450	
CFFZ-4	DAG PRI 1	NB100783	NB124783	NB124710	NB100710	
CFFZ-5	AAG PRI 2	NB030785	NB067785	NB067695	NB030695	

DA FORM 5957-R, OCT 2000

UNCLASSIFIED

(CLASSIFICATION WHEN FILLED IN)

D-1-A-3-1

SECTION II - RADAR DEPLOYMENT ORDER

DESCRIPTION

The RDO (DA Form 5957-R) is an enclosure to the TA tab. DA Form 5957-R replaces DA Form 5364-R (Commander's Target Criteria Message). The RDO designates the information required by each radar section leader to deploy his radar section and begin operations. **NOTE:** This form may be modified.

RESPONSIBILITIES

DIRECT SUPPORT BATTALION S2

The DS battalion S2 is the TA manager for assets attached/OPCON/organic to the battalion. He is responsible for developing and issuing the RDO to the radar section leader (MOS 131A). When developing an RDO, the S2 must coordinate with the maneuver brigade targeting officer (brigade FSE) to integrate TA assets into the overall scheme of maneuver and collection plan.

DIVISION ARTILLERY COUNTERFIRE OFFICER

The counterfire officer is the TA manager for the division artillery. He is responsible for developing and issuing RDOs to radar sections that are controlled by division artillery.

FA BRIGADE COUNTERFIRE OFFICER

The brigade CFO has the same responsibilities as the DIVARTY CFO for TA assets under control of the FA brigade.

DA FORM 5957-R

The instructions for completing DA Form 5957-R are explained below.

- **Heading.** In the first block, list the radar section number, and circle the type of radar involved. In the second block, enter the mission.
- **Location.** Enter a primary and an alternate general position area for the section. The radar section leader will select the actual site and report its location.
- **Search Sector.** In this section, describe the search sector. Select a primary azimuth only. Then determine the left and right sector edges. These edges are normally approximately 800 mils left and right of the primary azimuth. Range search limits can be specified.
- **EW Threat Assessment.** In this section indicate the EW threat assessment. Specify whether an EW threat exists, if it is affecting friendly assets, and the type of threat. If there is an EW threat you may use the Firefinder survivability flow chart in conjunction with the commanders risk assessment and METT-TC to determine emission limits.
- **Cueing Agents.** In this section list, in priority by call sign, agents that can cue the radar.

- **Reporting Channels.** In this section list the communications nets on which the radar is to operate. Include the call sign for each.
- **Zone Data.** In this section include zone data. List the type of zone and zone number (for example CFZ1), and coordinates of the zones (minimum of three points and maximum of six points). In the description column, list the description of the activity (if any) in the zone. Also list the command priority for CFFZs when upgraded from priority 2. (See sample RDO Figure G-2). Procedures for developing zone data are found in Chapter 4.

UNCLASSIFIED

(CLASSIFICATION WHEN FILLED IN)

RADAR DEPLOYMENT ORDER								
For use of this form, see FM 6-121. The proponent agency is TRADOC.								
SECTION		2/C/1-30 FA		MISSION		ATTACHED 2-90 FA		
LOCATION		Primary NB230200		Alternate				
SEARCH SECTOR								
		Left Edge		Right Edge		Minimum Range	Maximum Range	
Primary Azimuth		1100		-800 mils		+800 mils	750 meters	24,000 meters
Alternate Azimuth				mils		mils	meters	meters
EW THREAT ASSESSMENT								
EW Threat		<input checked="" type="radio"/> Yes or No		Affecting Friendly Assets		<input checked="" type="radio"/> Yes or No		
						Type of Threat (Air or <input checked="" type="radio"/> Ground)		
NOTE: Use the Firefinder survivability flowchart in FM 6-121 to determine emission limits.								
CUEING AGENTS (CALL SIGN AND DESIGNATION) IN PRIORITY								
A4Q02		S2, 2-90		B2N44		FIST A/1-44AR		
C2O22		FSO, 2 BDE		N2N08		OH-58D, SEC		
N2N09		OH-58D, SEC 2		D6C01		9 th DIVARTY TOC		
REPORTING CHANNELS								
FD1 (1-30 FA)		A4Q01		1-30 FA CMD NET		A4Q06		
ZONE DATA								
Type and Number	Description and/or Command Priority	Grid Coordinates of Zone Corner Points						
CFFZ 1	RAG PRI 1	NB290245	NB300250	NB320250	NB330245	NB320240	NB300240	
CFFZ 2	DAG PRI 2	NB370270	NB430250	NB390220				
CFFZ 3	SUSP ARTY PRI 2	NB30022	NB320220	NB320190	NB300190			
CFZ 1	2/F/25	NB228202	NB232202	NB232198	NB228198			
CFZ 2	1-30FA TOC	NB205233	NB210235	NB220235	NB225233	NB220230	NB210230	
CFZ 3	3-30FA TOC	NB240350	NB250360	NB260350	NB250345			
CFZ 4	1 BDE TOC	NB160215	NB170220	NB180220	NB180210	NB175205	NB170205	
CFZ 5	1/F/25	NB268182	NB27218	NB272178	NB268178			
ATIZ 1	SUSP ARTY	NB400190	NB430210	NB450210	NB450170	NB43017		

DA FORM 5957-R, OCT 2000

UNCLASSIFIED

(CLASSIFICATION WHEN FILLED IN)

Figure G-2. Radar Deployment Order (DA Form 5957-R)

AUTOMATED RADAR DEPLOYMENT ORDER PROCEDURE

The radar deployment order (RDO) is used to establish the location and/or coverage area of a radar unit. The normal method used to send a RDO to a radar from an AFATDS equipped unit is to open the radar unit icon menu and select RDO. The user then selects Current Location: or Next Location: radio button to determine the unit location to be sent for the deployment. The Next Location: field can be used to inform the AFATDS operator of a possible future deployment location. Unlike the NEXT radio button that acts as a movement order, the Next Location field is information only. This information remains resident in the AFATDS and is not transmitted to the radar. The Effective Time: is the time that the unit is operational at the new location or capable of a new coverage area. The range fan is then determined by entering the Direction Of Search (mils), Right Azimuth (mils), and Left Azimuth (mils). Radar Zones are added or removed from the list as required. Radar zones must be built in the geometry files before they can be added to the RDO. The Send button then saves the data to the database and transmits the RDO. See Figure G-3.

Figure G-3. Radar Deployment Order (AFATDS)

The radar will not receive the RDO itself. The AFATDS will convert data in the RDO to the SPRT;SEARCH and SPRT;FILTER formats for transmission to the radar unit. Complete procedures for the AFATDS RDO can be found in TM 11-7025-297-10 and TB 11-7025-297-10. From an IFSAS equipped unit the operator sends SPRT;SEARCH and one or more SPRT;FILTER messages

to the radar. Regardless of who sends the information, the radar will receive the following information:

- Radar Search Area Message (SPRT;SEARCH). This message is used to provide the radar with new search area data. If the RADIATE ON switchlamp is lit, the message is followed by ****CAUTION** SET RADIATE OFF BEFORE ENTERING DATA**. If the message data is unCAKed, it may be semi-automatically stored by entering function code 20 and answering yes to the RSDSTORE? prompt. Otherwise, you must unCAK the data and enter it manually using function code 20. See Figure G-4.

```
SPRT;SEARCH
****NEW ASIGNED SEARCH AREA****
ANT AZIMUTH XXXX  FREQ  LIM XX-XX
L SECT  EDGE XXXX  MAX RANGE XXXXX
R SECT  EDGE XXXX  MNI RANGE XXXXX
EFFECTIVE:XXXXXX
USE FC20 TO ENTER SEARCH DATA
```

Figure G-4. Assigned Search Area.

- Priority/Censor Zone Message (SPRT;FILTER). This message is used to provide the radar with data for adding or deleting priority or censor zones. Each zone message contains the coordinates of up to three zone points. If a zone is defined by more than three points, then two zone messages are required. If the entire set of zone points has been received, **ZONE MESSAGE COMPLETE** is displayed. Otherwise, **ADDITIONAL ZONE MESSAGE REQUIRED** is displayed. A complete zone data message is automatically stored if all of the following conditions are met:
 - One is operating in secure mode.
 - Sequence number is correct,
 - Data not CAKed, and zone data valid. **ZONE DATA STORED** is then displayed, and no operator action is needed.

If you are operating in unsecure mode and the message data is unCAKed, you may store the new zone semi-automatically by entering function code 26 and answering yes to the **ZONESTORE?** prompt. Otherwise, you must unCAK the message data off-line and enter it manually. See Figure G-5.

```
TACFIRE-R-3BINDX:16 MRN=0 HHMMSS
SPRT;FILTER
*****NEW ASSIGNED ZONE**** *****

ZONE TYPE:XXX           ZONE NUMBER:X
1E:XXXXXX             1N:XXXXXXX   GZI :X
2E:XXXXXX             2N:XXXXXXX
3E:XXXXXX             3N:XXXXXXX

IFSAS SEQ INDEX IS OK

ZONE MESSAGE COMPLETE

XXX ZONE X STORED
```

Figure G-5. Assigned Zone

If you receive this message from an AFATDS equipped unit you will first receive a delete filter message for each of the one to nine zones you have stored. Behind the delete messages you will have the new filter or filters.

Appendix H

Field Artillery Radar Support Requirements

TA radars will often be widely dispersed across the battlefield and require support from units that may not be familiar with radar support requirements. This appendix outlines the major support requirements for TA radars.

SURVEY

Common datum/common survey is critical for successful employment of TA assets as well as all other battlefield operating systems. The specific survey data required for each TA radar system is described below.

- AN/TPQ-36:
 - Grid zone.
 - Site location (universal transverse mercator (UTM) coordinates within 10 meters CEP).
 - Distance from near stake (radar location) to far stake (orienting point). This distance should be at least 250 meters. The minimum distance is 100 meters. However the further out the distance the better the accuracy that the system will report.
 - Azimuth from near stake to far stake (0.4 mil probable error (PE)).
 - Vertical angle from near stake to far stake (0.5 mil PE).
 - Altitude of the near stake (10 meters PE).
- AN/TPQ-37:
 - Grid zone.
 - Site location (UTM coordinates within 10 meters CEP).
 - Distance from near stake (radar location) to far stake (orienting point). This distance should be at least 250 meters. The minimum distance is 100 meters. However, the further the distance the better the accuracy that the system will report.
 - Azimuth from near stake to far stake (0.4 mil PE).
 - Altitude of the near stake (3 meters PE).

MODULAR AZIMUTH POSITIONING SYSTEM

The AN/TPQ-36(V)8 and AN/TPQ-37(V)8 radars are equipped with the Modular Azimuth Positioning System (MAPS). MAPS provides required survey for Firefinder systems. However, MAPS requires external survey support to provide the initialization data and update points required for operation. MAPS initialization requires the use of an initial survey control point of 5th order or higher. Before MAPS can be initialized, the ATG must be parked over the survey control point. Once initialization begins it takes between 9 and 15 minutes to complete. Once the initialization data is stored,

the ATG can be moved to a different location in preparation for operations. The MAPS can be turned off after initialization and as long as the ATG is not moved it will maintain all data. MAPS must be turned on and operational before the ATG can be moved.

COMMUNICATIONS

Firefinder radars use voice and digital communications to communicate with the supported unit. The primary method of communications is always digital. Radar acquisitions and mission data are transmitted digitally to the supported FDC or controlling headquarters for receipt by IFSAS, AFATDS, BCS or FDS.

The use of wire enhances communication responsiveness, security, minimizes the effects of jamming, and minimizes the possibility of enemy intercept by radio direction finders. The supported unit is responsible for providing and installing wire. Nonetheless, the use of wire may be impractical in situations requiring frequent moves or widely dispersed positions. FM radio becomes the primary means of communication in these situations.

The enemy situation must be considered when planning and conducting communications. Enemy EW capabilities may dictate changes in normal radar communication procedures.

COMMUNICATION NETS

The AN/TPQ-36 section normally operates in a battalion operations/fire net digitally and a command net for voice communications. Usually, these two nets belong to the supported DS battalion. However, these operating nets may be modified by individual units depending on command instruction and SOP.

The AN/TPQ-37 section normally operates on the TA/intel net digitally and a command net for voice communications. The AN/TPQ-37 usually is under the control of the DIVARTY or FA brigade TOC and passes target information directly to the counterfire officer at the controlling TOC. The radar may also be directed to pass targets to a DS or GS FA battalion. In such cases, the supported unit must provide all communications data. This includes signal operating instructions (SOIs).

DIGITAL COMMUNICATIONS

Digital communications addresses and authentication codes are prescribed in current cryptographic and authentication manuals. If digital communications are not available, the radar operator uses standard voice procedures to pass target information over the DS battalion operations/fire net or the force artillery command/fire net to the supported unit FDC.

Firefinder radar systems interface digitally with IFSAS, AFATDS, BCS, and FDS. Computer data needed for interface are input during initialization and can be changed by use of function codes or functional displays depending on the version of the system control shelter.

The digital messages used by Firefinder radars are divided into two groups - receive messages and transmit messages. Messages are displayed according to the priority level of the message. There are three priority levels for messages - 1 (highest), 2, and 3 (lowest). See the digital message format table for a display of which messages are received and/or transmitted.

The Firefinder radar can store net member data (member identifications and unit types) for up to ten receivers of various types. These receivers include:

- TACFIRE/IFSAS/AFATDS
- BCS (Battery Computer System)
- MLRS (Multiple-Launch Rocket System)
- FF (Firefinder)
- PALADIN (Howitzer system)

Firefinder radars can communicate digitally with any of the receivers listed above. However, only one net member at a time may be selected for communications.

Table H-1. Digital Message Formats

MESSAGE TYPE	TRANSMITT / RECIEVE	FORMAT NAME	PRIORITY
Priority/Censor Zone	R	SPRT;FILTER	3
Radar Search Area	R	SPRT;SEARCH	3
MET Data	R	MET;TA	3
Radar Location	T/R	FM;OBCO	3
Friendly Fire Battery	R	FM;INTM	2
Friendly Fire Target	R	FM;MTO	2
Radar Ready/Registration	T/R	FM;SUBS	2
Fire Mission	T/R	FM;FOCMD	1
Priority target report	T	FM;CFF	1
Target report	T	ATI;CDR	3
Free Text	T/R	SYS;PTM	1

MESSAGE TYPE	TRANSMITT / RECIEVE	FORMAT NAME	PRIORITY
Communication Test	T/R	MD;XMT5	3
Datum Report	T	SPRT;DATUM	3

NOTE: The Firefinder radar is able to communicate with other digital devices. However it is still limited to 35 characters in the free text message format.

VOICE COMMUNICATIONS

When digital communications are not possible, the radar section must report targets by voice. A target that would normally be sent digitally in FM;CFE format will be sent as a voice call for fire. The radar section should initiate a fire-for-effect mission with the supported FDC. The call for fire contains six elements. These elements are listed below in the order in which they are used. For a detailed explanation of each element, see FM 3-09.30 (6-30).

- Observer identification (or radar call sign).
- Warning order (for example, fire for effect).
- Target location (grid of target).
- Target description (for example, enemy artillery).
- Method of engagement.
- Method of fire and control.

Although direction is not one of the six elements of the call for fire, it is transmitted by the radar section as part of the initial call for fire. Radar observer direction is always reported as 6400 mils.

COMMUNICATIONS EQUIPMENT

Each radar section operates in two tactical FM radio nets as directed by the controlling headquarters. Two AN/VRC-92A radios are available for this purpose. These radios are equipped with speech secure devices for secure voice transmissions. The radar section also has radio equipment in the command/reconnaissance vehicle; however, the unit TOE will determine the types and quantities. In addition, some sections are equipped with an EPLRS. EPLRS provides near real time, jam resistant, secure data distribution and communications, identification, position location, navigation aid, and automatic reporting for tactical forces.

ADMINISTRATION

When the radar section is attached to a unit, the unit of attachment is responsible for providing routine personnel and administrative support. The radar section's parent unit forwards mail, pay, and routine distribution to the unit of attachment's headquarters for distribution to the radar section.

MESS

The unit to which the radar is attached supports the section with rations and water.

MAINTENANCE

NON-RADAR MAINTENANCE

The supported unit provides organizational and direct support maintenance of all non-radar specific equipment.

RADAR-SPECIFIC MAINTENANCE

FA radar systems are maintained at four maintenance levels, operator/crew, organizational, direct support, and depot.

Unit-Level Maintenance

Unit maintenance consists of operator performed scheduled preventive maintenance checks and services (PMCS) and organizational level scheduled and unscheduled maintenance as prescribed by the maintenance allocation chart. Each radar section should have on hand the parts authorized by the mandatory parts list to perform organizational and direct support maintenance. These parts are mandatory and do not require demand support. The radar repairer (MOS 35M) is responsible for performing organizational and direct support maintenance and the supervision of operator performed PMCS. The 35M is also responsible for identifying equipment faults that require higher-level maintenance. The radar section leader performs supervisory maintenance tasks.

The radar repairer is responsible for requesting depot maintenance under supervision of the radar section leader. These requests go through the controlling unit headquarters.

The radar repairer (35M) from the radar section performs selected tests and repairs and replaces components. He has a complete set of tools, test equipment, and repair parts at his disposal. If on-site repairs cannot be made, the radar will be evacuated to a rear location for major repairs. In addition to the section radar repairer, each TAB and CTAD has a radar repairer and DS-level test, measurement, and diagnostic equipment (TMDE) to isolate DS-level faults to facilitate repair of Firefinder radars.

Depot Maintenance

The depot can completely overhaul and recondition major end items and assemblies that are beyond the capabilities of field maintenance units. The appointed depot for Firefinder is Tobyhanna Army Depot.

Repair Parts

The logistics concept for FA radar systems does not place any unusual demands on the supply system. The MPL governs the supply of Firefinder peculiar items. Each radar section deploys with its MPL. The supported unit

provides common expendables and the parent unit forwards system-peculiar expendables to the section on an as required basis.

SECURITY

Because of its small size, the FA radar section cannot provide its own security in a tactical situation. For this reason, the radar section must fall under the security of an adjacent unit or be augmented with personnel and weapon systems to provide security. Similarly, when deployed, the section cannot perform other security or administrative functions, such as forming NBC or crater analysis teams. The deployed section falls under the responsibility of the supported unit for these functions.

PETROLEUM, OILS, AND LUBRICANTS

The supported FA unit supplies Class III petroleum products to the radar section as part of its normal petroleum, oils, and lubricants (POL) distribution process. The supported unit must understand the fuel consumption rates for radar systems so their fuel requirements can be incorporated in supported unit's logistics plan. The consumption rates for Q-36 and Q-37 are:

- AN/TPQ 36 Generator Set MEP 813A.
 - Fuel consumption. 1.07 gallons per hour.
 - Fuel capacity. 12.5 gallons (DF-1,DF-2, DF-A, JP4, JP5 or JP8).
- AN/TPQ 37 Generator Set MEP-816A.
 - Fuel consumption. 5.37 gallons per hour.
 - Fuel capacity. 43 gallons (DF-1,DF-2, DF-A, JP4, JP5 or JP8).

METEOROLOGICAL DATA

MET data are crucial to the accuracy of hostile weapon location and friendly fire data. The MET parameters entered during radar initialization affect radar performance by correcting for atmospheric refraction. They are also important in estimating the effect of wind, temperature, and density on the projectile's trajectory. However, the greatest effect on the accuracy of hostile and friendly weapon impact prediction is caused by wind.

The MET data required for the Q-36 and Q-37 differ in the MET data elements used by the radar. The Q-36 only uses wind speed and direction from the target acquisition MET whereas the Q-37 requires relative humidity and temperature from the target acquisition MET along with barometric pressure from the computer MET.

Digital MET messages are transmitted to the radar using the MET;TA and MET;CM message formats. Data elements used by the radar are:

- Relative humidity (RH)(Q-37 only).
- Temperature in degrees Kelvin (Q-37 only).
- Barometric pressure in millibars (Q-37 only).
- Altitude of MET data station.
- Wind speed (must be entered when greater than 20 knots).

- Wind direction in mils.

Current software extrapolates temperature, pressure, and relative humidity back to the radar's altitude assuming the standard atmospheric lapse rate and constant relative humidity. However, the most accurate correction for refraction is obtained from the temperature and relative humidity measured at the surface as near the radar as possible. Therefore, the header and line 00 of the most current target acquisition MET message should be used to obtain temperature and relative humidity. The wind speed and direction should also be taken from the target acquisition MET. The MET line used for wind speed and direction is determined by the altitude of the radar and the altitude of the expected detection area based on screening crest, and the difference between the radar and MET station altitudes. Generally speaking, the line used should provide the wind speed and direction approximately 1000 meters above the radar altitude. Barometric pressure is also required. This comes from the corresponding computer MET. The line used from the computer MET must correspond to the same altitude as the line used from the target acquisition MET. For example: if you use line 11 of the target acquisition MET (900 to 1000 meters), you would then use line 3 of the computer MET (1000 meters). See Table H-2.

Table H-2. MET Altitude Comparison

Line Number	Computer MET Altitude	TA MET Mdp Altitude	TA MET Altitude Range
00	MET Station Alt.	MET Station Alt	MET Station Alt
01	200	25	0/50
02	500	75	50/100
03	1000	150	100/200
04	1500	250	200/300
05	2000	350	300/400
06	2500	450	400/500
07	3000	550	500/600
08	3500	650	600/700
09	4000	750	700/800
10	4500	850	800/900

Line Number	Computer MET Altitude	TA MET Mdp Altitude	TA MET Altitude Range
11	5000	950	900/1000
12	6000	1050	1000/1100
13	7000	1150	1100/1200
14	8000	1250	1200/1300
15	9000	1350	1300/1400
16	10000	1450	1400/1500
17	11000	1550	1500/1600
18	12000	1650	1600/1700
19	13000	1750	1700/1800
20	14000	1850	1800/1900
21	15000	1950	1900/2000
22	16000	2050	2000/2100
23	17000	2150	2100/2200
24	18000	2250	2200/2300
25	19000	2350	2300/2400
26	20000	2450	2400/2500
27	NA	2550	2500/2600

It is also necessary to determine the MET station altitude. This can be determined from the header line of either the target acquisition MET or the computer MET. Station height in the header of both MET messages is entered in tens of meters and is equal to altitude. Figure H-1 shows the header line of the computer MET message.

COMPUTER MET MESSAGE								
For use of this form, see FM 6-15; the proponent agency is TRADOC.								
IDENTIFI- CATION	OCTANT	LOCATION		DATE	TIME	DURATION	STATION	MDP
		LaLaLa	LoLoLo		(GMT)	(HOURS)	HEIGHT	PRESSURE
		or	or				(10s M)	MB
METCM	Q	xxx	xxx	YY	G _o G _o G _o	G	hhh	P _d P _d P _d
METCM	1	347	984	25	138	0	036	974
		ZONE VALUES						
ZONE HEIGHTS METERS	LINE NUMBER	WIND DIRECTION (10s M)	WIND SPEED (KNOTS)	TEMPERATURE (1/10°K)	PRESSURE (MILLIBARS)			
	ZZ	ddd	FFF	TTTT	PPPP			
SURFACE	00	310	004	2923	0974			
200	01	250	011	2931	0962			

Figure H-1. Identification line

COMPUTER MET

The following paragraphs explain the entries in the computer MET message. Refer to figure H-1.

- Identification Line. The ID line is arranged in four six-digit groups. Thus the symbols for the ID line are METCMQ, LaLaLaLoLoLo, YYG_oG_oG_oG, and hhhP_dP_dP_d. The ID line is shown in Figure H-1.
 - Group 1. Group 1 consists of METCMQ. The symbol METCM is placed at the beginning of each computer MET message. This symbol indicates that it is a MET message and that it contains computer-type MET data. The digit under the symbol Q represents the global octant in which the MET section is located. For convenience in determining the geographical location of the reporting MET section, the globe was divided into octants numbered 0 through 8.
 - Group 2. Group 2 consists of LaLaLaLoLoLo or XXXXXX. These six spaces are used to specify the location to the nearest tenth of a degree. The symbol LaLaLa represents the latitude to the nearest tenth of a degree. The symbol LoLoLo represents the longitude to

the nearest tenth of a degree. When the longitude is over 100°, the first digit is dropped. The XXXXXX is used to signify standard six digit grid coordinates.

- Group 3. Group 3 consists of YYG_oG_oG_oG. The symbol YY represents two digits for reporting the Greenwich date of the observation on which the message is based. The Greenwich date may differ from the local date, depending on the location and the hour of the day. The symbol G_oG_oG_o represents three digits for reporting hours in tens, units, and tenths of hours. The symbol G represents the duration of validity of the message in hours. US forces always enter 0 in the space under G since the period of validity is not predicted. Other NATO forces use digits 1 through 8 in this space. A code of 9 indicates a predicted validity of 12 hours.
- Group 4. Group 4 consists of hhhP_aP_aP_a. The symbol hhh represents the MET station altitude in tens of meters above mean sea level. The symbol P_aP_aP_a represents the surface pressure in millibars. When the surface pressure is 1,000 mb or higher, the first digit is dropped.
- Explanation. The identification line (for transmittal) is shown in Figure H-1 and explained as follows:
 - The METCM1 indicates a computer-type MET message and a station location in octant 1. (The only difference between a computer MET and a target acquisition MET identification line would be in this field. The target acquisition MET would read METTAQ).
 - The 347984 indicates station location at 34°42'N latitude and 98°24'W longitude.
 - The 251380 indicates the date of the message is the 25th day of the month, GMT date, at 1348, and it is from a US Army artillery MET section.
 - The 036974 indicates the station altitude is 360 meters above mean sea level and the surface pressure is 974 mb.
- Message Body. (METCM) The remaining lines of the computer MET message (ZZdddFFF TTTTPPPP) represent surface and zone MET data. The symbol ZZ represents the line number that identifies the reported MET information with the appropriate atmospheric layer. The line numbers begin with 00 (surface) and are numbered consecutively through line 26 (line 27 for the target acquisition MET). The symbol ddd represents the true direction from which the wind is blowing. The direction is reported in tens of mils. The symbol FFF represents the true wind speed in knots. The symbol TTTT represents the virtual temperature. This temperature is expressed to the nearest 0.1°K. The symbol PPPP represents the air pressure. This pressure is expressed to the nearest millibar. The lines of the computer MET message are encoded and transmitted in eight-digit groups with two groups for each line.

TARGET ACQUISITION MET

The header line of the target acquisition MET is nearly the same as the computer MET. The only difference is the first six characters will be METTAQ instead of METCMQ. The following paragraphs explain the rest of the entries in the target acquisition MET. Refer to Figure H-2.

```
MET;TA;_/_/_/_/_/_;Q:9;POSI:xxxxxx;DTI:YY/GG.G/V;HGT:HHH;ATMS:PPP;CMBRI:CCC/NNN;  
LNA:ZZ/DDD/FFF/TTTT/UU/,ZZ/DDD/FFF/TTTT/UU/,ZZ/DDD/FFF/TTTT/UU;  
LNB:ZZ/DDD/FFF/TTTT/UU/,ZZ/DDD/FFF/TTTT/UU/,ZZ/DDD/FFF/TTTT/UU;
```

Figure H-2. Target Acquisition MET

- Message Body (METTA). The remaining lines of the target acquisition MET consist of additional groups. In the target acquisition MET message zones are equal to lines in the computer MET message depicted in Figure H-1.
 - Group 5 consists of CCCNNN. The symbol CCC represents the height of the base of the lowest cloud at the point of observation. It is given in tens of meters and is not used by Firefinder. The symbol NNN represents mean refractive index at the surface in N units. If NNN is not to be included in the message, these missing data will be indicated by three slashes (///).
 - Group 6 consists of Z_tZ_tdddFFF. The symbol Z_tZ_t represents the zone number code. The symbol ddd represents the mean wind direction for the zone given in thousands, hundreds, and tens of mils. For zone number 00, the value is the wind direction at the MET section location. The symbol FFF represents the mean wind speed of the zone in hundreds, tens, and units of knots. For zone number 00, the value is the wind speed at surface.
 - Group 7. This group consists of ttttUU. The symbol tttt represents the mean air temperature of the zone in hundreds, tens, units, and tenths of a degree Kelvin. For zone number 00, the value is the air temperature at surface. The symbol UU represents the mean RH expressed as a percentage in tens and units. A mean RH of 100 percent is denoted by 00.
 - Group 8. Group 8 consists of 99999. This group is a message terminator. It is used only when the message is transmitted by telegraphic means.

For additional information on the atmospheric structure of MET messages and an in-depth explanation of header and data lines of the MET;TA and MET;CM messages see FM 3-09.15 (6-15), Field Artillery Meteorology.

Appendix I

Air Movement Procedures for Target Acquisition Radars

Mission requirements may dictate that TA radars be moved by fixed wing or rotary wing aircraft. This is often the case when a radar must be operated from a forward operating base (FOB) and ground movement is not feasible, or the initial deployment was conducted without some or all of the radar sections prime movers or equipment transporters. Tactical movements will normally be conducted by C-130, UH-60 or CH-47D. The movement distance, airfield and aircraft availability will determine the method of movement.

SECTION I – HELICOPTER MOVEMENT

CONSIDERATIONS FOR HELICOPTER MOVEMENT

Adequate planning is essential for the air assault or air movement of a radar section or TA organization. The radar section or TA organization's immediate higher headquarters conducts planning for these operations. The higher headquarters may be the DIVARTY, DS battalion or other task force headquarters. Elements assigned to the higher headquarters will normally assist the TA organization or radar sections with loading, staging, landing zone (LZ) and pickup zone (PZ) operations. The planning for an air assault uses the reverse planning process and consists of the ground tactical plan, the landing plan, air movement plan, and loading and staging plan.

The ground tactical plan is the foundation for a successful air assault. All other plans support this plan. It specifies actions in the objective area required to accomplish the mission and set the stage for subsequent operations. Tactical employment requirements for radars are part of the ground tactical plan.

The landing plan enables accomplishment of the ground tactical plan. It sequences elements into the AO. Units must arrive at the designated locations and times prepared to execute the ground tactical plan.

The air movement plan supports the ground tactical plan and the landing plan. It specifies the schedule and provides instructions for air movement of troops, equipment, and supplies from the PZ to landing zone (LZ). It also addresses coordinating instructions regarding air routes; air control points; aircraft speeds, altitudes, and formations; and the planned use of attack and reconnaissance helicopters, including security and link-up operations. The air movement plan reflects the detailed coordination with the air mission commander (AMC) and the aviation LNO, who provide the technical and tactical assistance and recommendations.

The loading and staging plan depends on the air movement plan and ensures that troops, equipment and supplies are loaded on the correct aircraft. It prescribes arrival times of ground units and their equipment at the PZ in the proper order and location for movement. A good loading and staging plan incorporates unit integrity, cross loading, a bump plan and bump priorities.

The plan for conducting the air assault operation is provided to key participants during the air mission brief (AMB). All details of the operation are coordinated and synchronized prior to the AMB.

LOADING

The radar section conducts pre-combat inspections (PCI) and rehearsals well before the staging phase to ensure leaders and soldiers are adequately prepared to execute the mission. The radar section will ensure loads are packed according to the load plan and will begin pre-rigging loads without losing operational capabilities. A checklist may be used to facilitate loading. Figure I-1 provides an example section level checklist.

RADAR SECTION PRE-COMBAT INSPECTIONS

SECTION/TEAM: FIRE FINDER RADAR _____ Date: _____

SECTION CHIEF: _____

A. EQUIPMENT MAINTENANCE

Section Vehicles, Generators, Antenna Transceiver Group (ATG), Power
Chief's Distribution Group (PDG), Sling Legs
Initials _____

- _____ 1. Proper PMCS, current -14 (DA 2404) completed, -10 on hand for each item.
 - _____ a. No fuel leaks, cap serviceable and secure
 - _____ b. Fluid levels correct (engine, transmission, radiator), caps secure
 - _____ c. Battery levels correct, caps secure
 - _____ d. Air filters clean
 - _____ e. Lights operational
 - _____ f. No exhaust system leaks
 - _____ g. Interior clean and orderly
 - _____ h. All gauges operational
 - _____ i. Parking brakes functional
 - _____ j. Tire pressure correct to include ATG/PDG to 100 PSI
 - _____ k. Fire extinguisher present and serviceable
- _____ 2. Vehicles dispatched and drivers license current
- _____ 3. Load plans checked and verified by section chief
- _____ 4. All OVM/BII 100% accounted for
- _____ 5. First aid kit complete
- _____ 6. Fuel tanks topped off at least ¾ tank
- _____ 7. Insure winches are operational on ATG/PDG
- _____ 9. Communications
 - _____ a. All commo equipment operational w/PMCS & -10 on hand
_____ Radios; _____ OE-254; _____ TA-312; _____ Remotes
 - _____ b. Required secure items (ANCD/Radar MAG tapes)
 - _____ c. Correct frequencies pre-set
- _____ 10. Crew served weapons
 - _____ a. Cleaned and operational
 - _____ b. Before firing PMCS complete
 - _____ c. Accessory bags and cleaning material complete

B. MISSION SPECIFIC ITEMS

- _____ 1. Advance Party Equipment
 - _____ a. PLGR
 - _____ b. Aiming Circle
 - _____ c. OE-254
 - _____ d. Chemlites (red and orange for marking LZ)
 - _____ e. VS-17 Panel (2 ea.)
 - _____ f. Strobe
 - _____ g. Combat Life Savers Bag
- _____ 2. Main Body Equipment
 - _____ a. Class I - Take 72 hrs worth of MRE's
 - _____ b. 8 ea Water cans (minimum) full
 - _____ c. 20 ea Fuel cans full and stored in radar well
 - _____ d. Class IV - 16-20 rolls concertina, 20 long/10 short pickets
 - _____ e. Class V - Items drawn (individual/crew served, claymores, smoke, grenades, flares)
 - _____ f. Compass
 - _____ g. Radar and Generator tool kits
 - _____ h. 2 ea Slave Cables
 - _____ i. NBC Equipment drawn (M8, Radiac Meter, M8/M9 paper)
- _____ 3. Air Assault Equipment
 - _____ a. 3 ea Sling Set, 25,000-lb. capacity
 - _____ b. 1 additional apex fitting (25,000-lb capacity) for rear hook up on Q-37.
 - _____ c. 1 ea Sling Set, 10,000-lb. capacity (recon vehicle)
 - _____ d. 5 ea sling set safety clamps
 - _____ e. 5 ea Reach Pendants
 - _____ f. 3 cut sheets of plywood to protect face of radar
 - _____ g. 5 ea Cargo straps 5K capacity
 - _____ h. 2 each airload tie down chains
 - _____ i. 2 roll Tape, adhesive, pressure sensitive, 2 inch wide
 - _____ j. 2 Spool Cord, nylon, type III, 550 BS
 - _____ k. 2 Spool Cotton webbing, ¼ in, 80-lb ES
 - _____ l. Cardboard or suitable padding material
 - _____ m. Chemlites (blue, green, red and orange for marking PZ)

_____ **C. INDIVIDUAL EQUIPMENT**

_____ **D. OPERATIONS BRIEF**

_____ **E. REHEARSALS (SAND TABLE, CRAWL, WALK, RUN)**

Figure I-1. Example Section Checklist

STAGING

During staging the radar section moves to the PZ at the designated time to rig the section's equipment. Loads are staged in accordance with the staging plan. Loads should be separated in line by 100 meters during daylight hours or 150 meters during limited visibility, and by 35 meters laterally. Whenever possible, personnel will stage near their loads and move from their loads to the aircraft for loading. Each chalk leader provides the aircraft crew chief with a load manifest.

PICKUP ZONE OPERATIONS

The supported headquarters establishes PZ security, marks the PZ, provides a NCOIC and/or hook-up teams. Security sweeps are conducted, listening and observation posts established, and counter-reconnaissance initiated. These actions must occur early enough to ensure the security of the unit assuming PZ posture. Finally, the PZ is marked. Figure I-2 provides an example of a pickup zone for a Q-37 air assault mission.

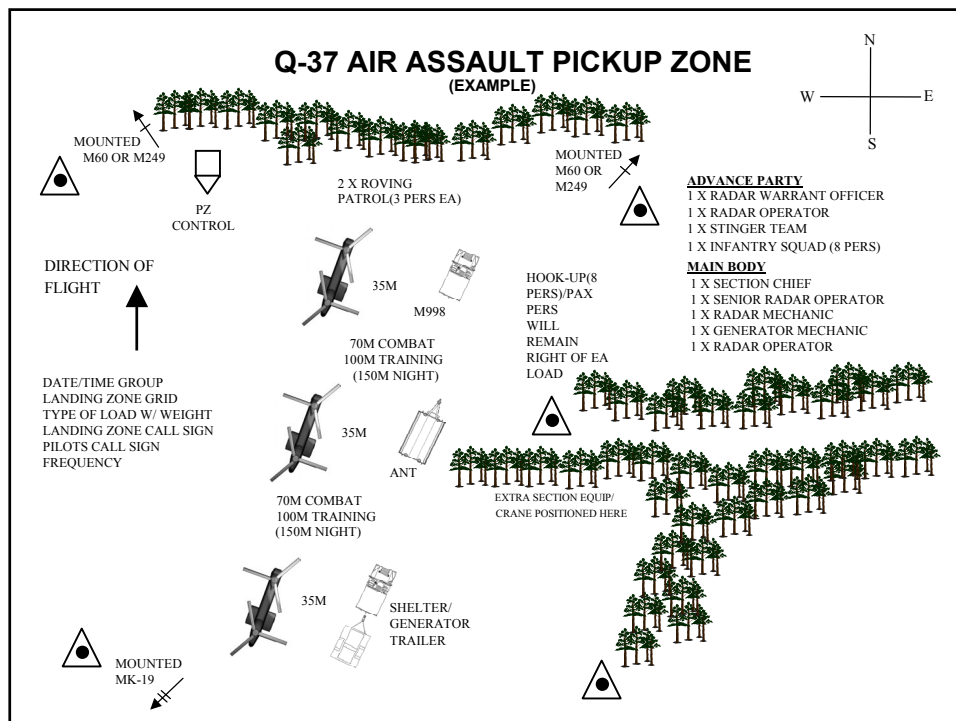

Figure I-2. Example Pickup Zone

HOOKUP

Hookup teams require two persons per hook, one to hookup the load and one to stabilize the hookup person. A third person is required for a static probe if reach pendants aren't available. Teams face the aircraft during hookup and wear helmets, gloves and goggles (a set of NVGs should be available at night). Once the load is hooked, teams exit the load, move outside the rotar

disk area and monitor the load for problems. The team must be prepared to re-rig the load if required.

LANDING ZONE OPERATIONS

The advance party secures the area and prepares for the arrival of the main body. During movement of Q-37 radars, the primary purpose of the advance party is to ensure the ATG is set down in the correct location. Emplacement procedures start as soon as the main body arrives. Figure I-3 shows an example landing zone for a Q-37 section.

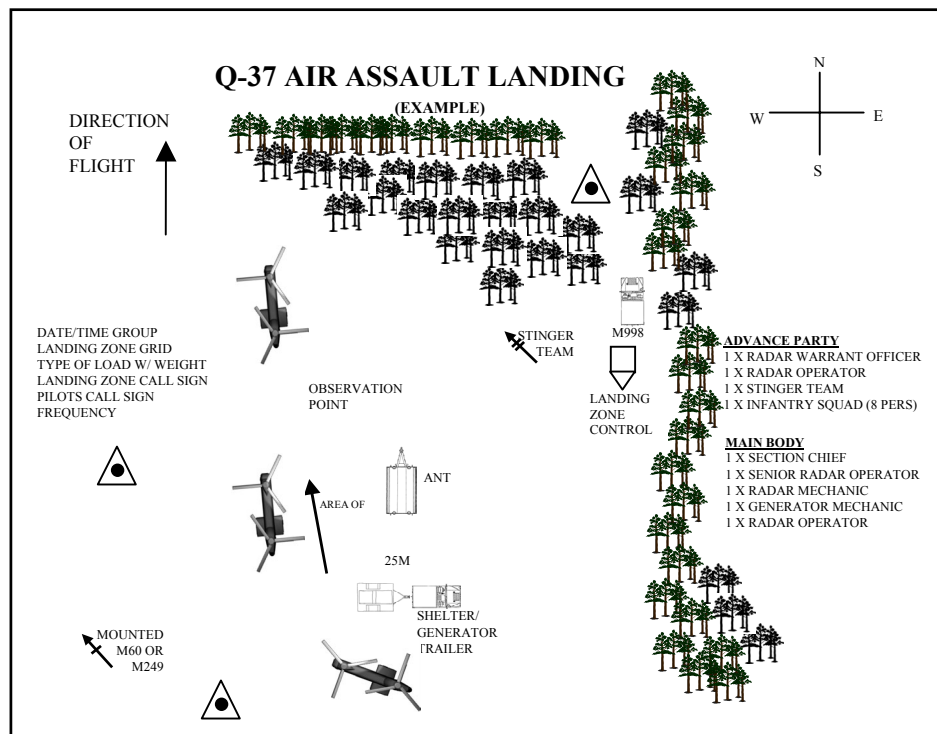

Figure I-3. Example Landing Zone

Q-36 SLING LOAD PROCEDURES

The Q-36 radar section can be sling loaded and moved by CH47D and UH-60 helicopters. The Q-36 section requires a minimum of four UH-60 or two CH-47D aircraft to air lift an operational system. A combination of UH-60 and CH-47D aircraft may also be used to airlift the radar section. However, the Lightweight Multipurpose Shelter (LMS) must be removed from the M1097 HMMWV before sling loading by the UH-60 because the OC's weight exceeds the helicopter's external lift capacity. Further, an external lifting device capable of lifting at least 3300 pounds is required to remove the LMS in preparation for sling loading. Detailed procedures for removing the LMS from the HMMWV are contained in TM 11-5840-380-10. Single point sling procedures for use with the UH-60 are contained in FM 4-20.199 (10-450-4).

NOTE: The Q-36 radar's issued antenna cover is prone to tear and separate from the load and should be replaced with a sheet of plywood, 4 feet x 8 feet x $\frac{3}{4}$ inches. This is a critical step in preparing the Q-36 for sling load to protect the antenna face in the event the pilot does not offset the load prior to releasing the clevis. Severe damage may occur if the clevis lands on an unprotected antenna array.

The Q-36 radar section can be airlifted by CH47D without disassembly of radar components. Tandem dual point rigging procedures are used to transport the OC with ATG, PDG HMMWV with PU-799 and reconnaissance HMMWV with cargo trailer. Additional load combinations are possible. They are outlined in FM 4-20.196 (10-450-4) and FM 4-20-199 (10-450-5). Some rigging procedures require adjustments based on changes from Q-36(V)7 to the Q-36(V)8 and will require local certification until certified by the Combined Arms Support Command.

OC RIGGING PROCEDURES

The OC can be moved by one CH-47D using a dual-point load. Two persons can prepare and rig this load in 15 minutes. The following materials are required to rig the OC for movement:

- Chain length, part number 38850-00053-101, from a 10,000-pound capacity sling set (4 each).
- Coupling link, part number 577-0615, from a 10,000-pound sling set (4 each).
- Tape, adhesive, pressure-sensitive, 2-inch wide roll.
- Cord, nylon, Type III, 550-pound breaking strength.
- Webbing, cotton, 1/4-inch, 80-pound breaking strength.
- Felt sheet, cattle hair, Type IV, 1/2-inch or suit-able padding.
- Padding, cellulose.

Once the materials are secured the load is prepared for rigging. The load is prepared using the following steps:

- Extend the sling leg chains by connecting one additional chain length to each chain on a 10,000-, 25,000- or 40,000-pound capacity sling set with coupling links.
- Fold mirrors forward in front of the windshield for added protection and tie together with Type III nylon cord.
- Secure the shelter to the truck using wire rope or tie-down assemblies.
- Secure all equipment inside the shelter with tape, nylon cord, or lashings; close and secure shelter vents and door with nylon cord or tape.
- Secure environmental control unit cover with duct tape.
- Disconnect the power cord from the rear panel and secure it to the rear platform with Type III nylon cord. Lower the power panel door and secure the door.
- Secure all equipment and cargo inside the vehicle with tape, nylon cord, or lashings. Secure the doors shut if installed.

- Ensure the fuel tank is not over 3/4 full. Inspect fuel tank cap, oil filler cap, and battery caps for proper installation.
- Engage the vehicle parking brake and put the transmission in neutral.
- Ensure the front wheels are pointed straight ahead. Tie down the steering wheel, using the securing device attached under the dashboard.
- Tape the windshield in an X formation from corner to corner.
- Install the lift provisions on the outer ends of the rear bumper.
- Remove the upper antenna mounting bracket if installed.

Once preparations are completed the load can be rigged using the following steps:

- Connect 2 sling legs to apex fitting number 1. Position the apex fitting on top of the shelter.
- Loop the chain end of the sling legs through their respective lift provisions that protrudes through the hood. Place link number 3 in the grab hook.
- Connect 2 sling legs to apex fitting number 2. Position the apex fitting on top of the shelter.
- Loop the chain end of the sling legs through their respective lift provisions located on the outer ends of the rear bumper. Place link number 40 in the grab hook. Do not use the lifting shackles located near the center of the rear bumper for sling load lift provisions.
- Wrap the rear slings with padding where they contact the shelter sides.
- Secure all excess chain with tape or Type III nylon cord.
- Cluster and tie or tape (breakaway technique) the sling legs in each sling set on top of the vehicle to prevent entanglement during hookup and lift-off.

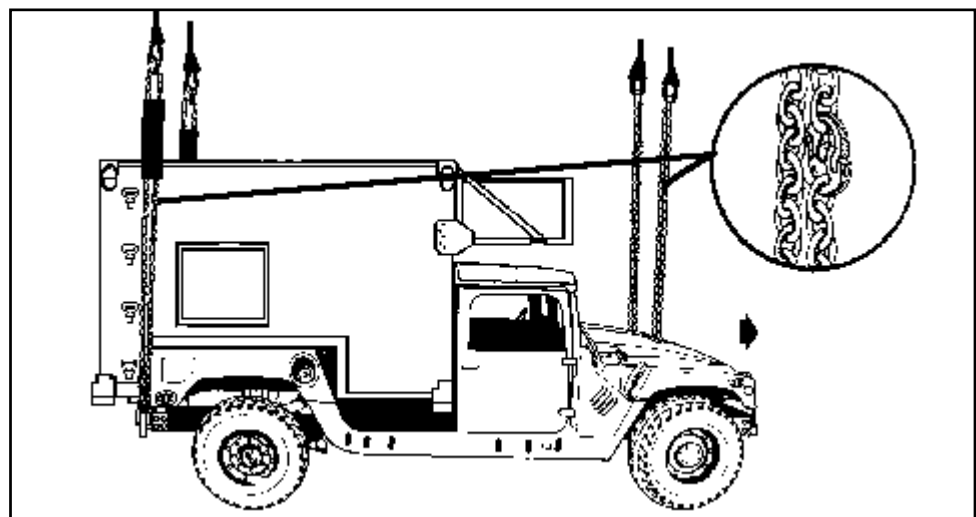

Figure I-4. LMS Shelter Mounted on the M1097

After the rigging is complete, the load is attached to the helicopter's cargo hooks. The hookup team stands on top of the shelter. The static wand person discharges the static electricity with the static wand. The forward hookup person places apex fitting 1 onto the forward cargo hook. The aft hookup person places apex fitting 2 onto the aft cargo hook. The hookup team then carefully dismounts the vehicle and remains close to the load as the helicopter removes slack from the sling legs. When successful hookup is assured, the hookup team quickly exits the area underneath the helicopter to the designated rendezvous point. The procedures for derigging are the reverse of the preparation and rigging procedures.

ATG RIGGING PROCEDURES

The ATG can be moved by a CH-47D using a single-point load. The same procedures are certified for the UH-60. Two persons can prepare and rig this load in 20 minutes. The following materials are required to rig the ATG for movement:

- Sling set (10,000-pound capacity).
- Chain length, part number 38850-00053-101, from a 10,000-pound capacity sling set (4 each).
- Coupling link, part number 577-0615, from a 10,000-pound sling set (4 each).
- Plywood, 4 feet x 8 feet x $\frac{3}{4}$ inches with edging.
- Tape, adhesive, pressure-sensitive, 2-inch wide roll.
- Cord, nylon, Type III, 550-pound breaking strength.
- Webbing, cotton, 1/4-inch, 80-pound breaking strength.
- Felt sheet, cattle hair, Type IV, 1/2-inch or suitable padding.
- Padding, Cellulose.

Once the materials are assembled the load is prepared for rigging using the following procedures:

- Connect one additional chain length to each chain of the sling set with the coupling link.
- Engage the trailer parking brake.
- Secure the doors closed with Type III nylon cord.
- Place the radar set in the travel mode and place the sheet of plywood on top of the antenna, firmly against the BSU. Route and secure a CGU-1/B across the width of the plywood at the center of the array. Hook a second CGU-1/B to the front right tiedown provision of the trailer. Route the tiedown diagonally over plywood and secure to the ratchet to the left rear of the stowed ground rod, the lower tiedown provision, or the trailer frame. Repeat the procedure on the left side of the antenna routing the tiedown diagonally over the plywood.

After preparation the load is rigged for movement. The procedures are:

- Position apex fitting on top of the trailer (but not on top of the radar panel). Route outer sling legs 1 and 2 to the front of the trailer

(lunette end) and inner sling legs 3 and 4 to the rear. Sling legs 1 and 3 must be on the left side of the load.

- Loop the chain end of sling leg 1 under the trailer A-frame just aft of the lunette and through the keeper from left to right on the left side of the drawbar. Place the link number 3 in the grab hook. Repeat with sling leg 2 on the right side of the drawbar.
- Route the chain end of sling leg 3 through the left rear lift provision located on the rear of the trailer. Place link number 25 in the grab hook. Repeat with sling leg 4 through the right rear lift provision. Secure the excess chain with Type III nylon cord.
- Cluster and tie or tape (breakaway technique) all sling legs together on top of the trailer to prevent entanglement during hookup and lift-off.

After rigging, the load is attached to the helicopter. The hookup team stands on top of the ATG trailer frame. The static wand person discharges the static electricity with the static wand. The hookup person places the apex fitting onto the aircraft cargo hook. The hookup team then carefully dismounts the ATG and remains close to the load as the helicopter removes slack from the sling legs. When successful hookup is assured, the hookup team quickly exits the area underneath the helicopter to the designated rendezvous point. The hookup team must use care to avoid damaging the radar antenna. The following precautions are applicable:

- Do not stand on the radar panel during hookup.
- Due to limited clearance between the helicopter and the top of the ATG, the hookup team may want to use an extended sling system on this load and hook this load from the ground or the bed of a truck. Polyester round slings are recommended for use as vertical pendants. The extended sling legs may not be ideal for flying this load "nap of the earth" in a tactical environment.
- Hookup of this load presents substantial risk of damage to the load or injury to the hookup personnel. Use of a reach pendant is recommended for this load.

The procedures for derigging are the reverse of the preparation and rigging procedures. When releasing the apex fitting after setting the load down, the helicopter pilot should hover to the side to prevent damaging the radar panel.

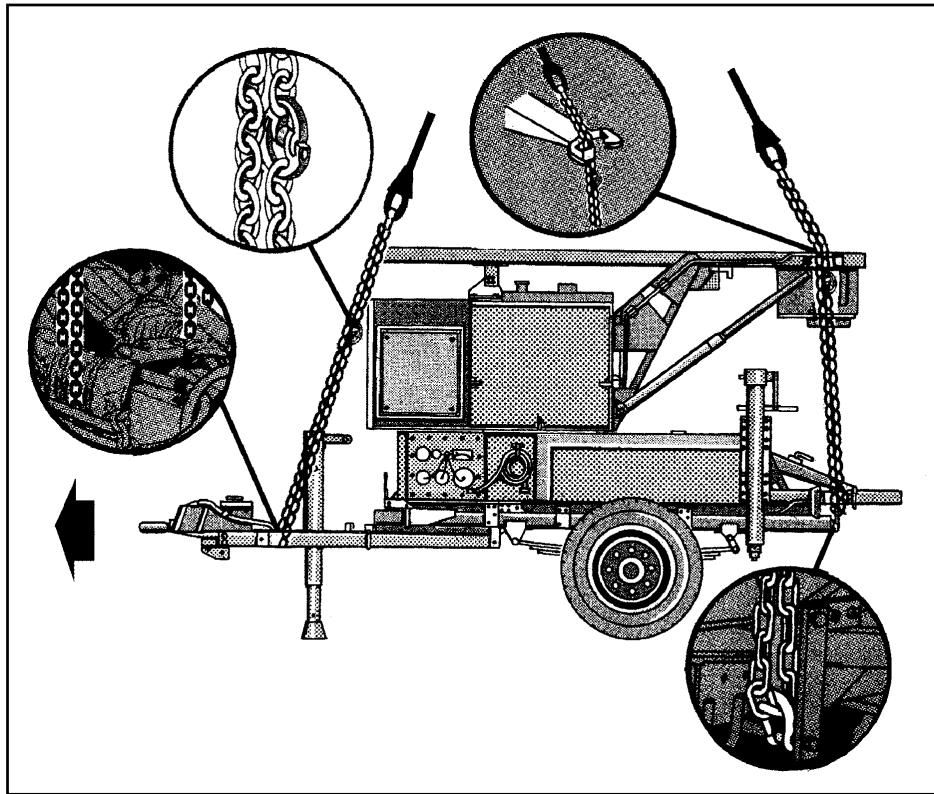

Figure I-5. AN/TPQ-36 Antenna Transceiver Group

UTILITY HMMWV WITH TRAILER MOUNTED GENERATOR

The utility HMMWV and trailer-mounted generator can be moved by a CH-47D using a dual-point tandem load. Two persons can prepare and rig the HMMWV in 15 minutes and the generator set in 10 minutes. The following materials are required to rig this load:

- Sling set (10,000-pound capacity) (2 each).
- Tape, adhesive, pressure-sensitive, 2-inch wide roll.
- Cord, nylon, Type III, 550-pound breaking strength.
- Webbing, cotton, 1/4-inch, 80-pound breaking strength.
- Strap, cargo, tie-down, CGU-1/B (2 each, or more as required to secure cargo).
- Felt sheet, cattle hair, Type IV, 1/2-inch or suitable substitute.

Once the materials are assembled the load is prepared for rigging. Attach the generator set to the truck by placing the lunette on the pintle hook and securing the latch. Secure the safety chains, cables, and hoses. Position the vehicle on level ground so both the truck and generator set are in a straight line. The load is prepared using the following procedures:

- Fold mirrors forward in front of the windshield and tie together with Type III nylon cord. Remove the doors and secure to the seats with Type III nylon cord.
- Secure all equipment and cargo inside the truck with tiedown straps, tape, or Type III nylon cord.
- Ensure the fuel tanks are not over 3/4 full. Inspect the fuel tank cap, oil filler cap, and battery caps for proper installation.
- Engage the vehicle parking brake and put the transmission in neutral.
- Ensure the front wheels are pointed straight ahead. Tie down the steering wheel, using the securing device attached under the dashboard.
- Retract the lunette leg and secure with Type III nylon cord.
- Secure all lids, doors, and caps with tape or Type III nylon cord.
- Ensure the trailer parking brakes are set.
- Route the hook portion of a CGU-1/B tiedown strap through the left rear inboard tiedown provision located near the pintle on the rear bumper of the truck and through the mounting bracket on the front of the trailer A-frame. Connect the hook to the ratchet of the CGU-1/B.
- Repeat the above procedure on the right side of the load.
- Tighten both CGU-1/B tiedown straps at the same time. Secure the excess strap and safety the ratchet handles in the closed position with tape.

One the load is prepared it can be rigged using the following steps:

- Position the apex fitting of sling set 1 in the bed of the vehicle. Route outer sling legs 1 and 2 to the front of the vehicle and inner sling legs 3 and 4 to the rear. Sling legs 1 and 3 must be on the left side of the load.
- Loop the chain end of sling leg 1 through the left front lift provision that protrudes through the hood. Place link number 79 in the grab hook. Repeat with sling leg 2 and the right front lift provision. Secure excess chain with tape or Type III nylon cord.
- Route the chain end of sling leg 3 through the sling guide in the upper left corner of the tailgate. Loop the chain end through the left lift provision on the bumper and thread back through the sling guide in the tailgate. Place link number 3 in the grab hook. Repeat with sling leg 4 and the right rear lift provision.
- Cluster and tie or tape (breakaway technique) all sling legs together on top of the vehicle to prevent entanglement during hookup and lift-off.
- Position apex fitting of sling set 2 on the trailer but not on top of the generator. Route outer sling legs 1 and 2 to the front of the trailer and inner sling legs 3 and 4 to the rear. Sling legs 1 and 3 must be on the left side of the load.

- Loop the chain end of sling leg 1 through the left front lift provision located near the A-frame on the front of the trailer. Place link number 52 in the grab hook. Repeat with sling leg 2 through the right front lift provision. Secure excess chain with tape or Type III nylon cord.
- Route the chain end of sling leg 3 through the left rear lift provision. Place link number 36 in the grab hook. Repeat with sling leg 4 through the right rear lift provision. Secure excess chain with tape or Type III nylon cord.
- Pad the chains where they contact the load.
- Cluster and tie or tape (breakaway technique) all sling legs together on top of the trailer to prevent entanglement during hookup and lift-off.

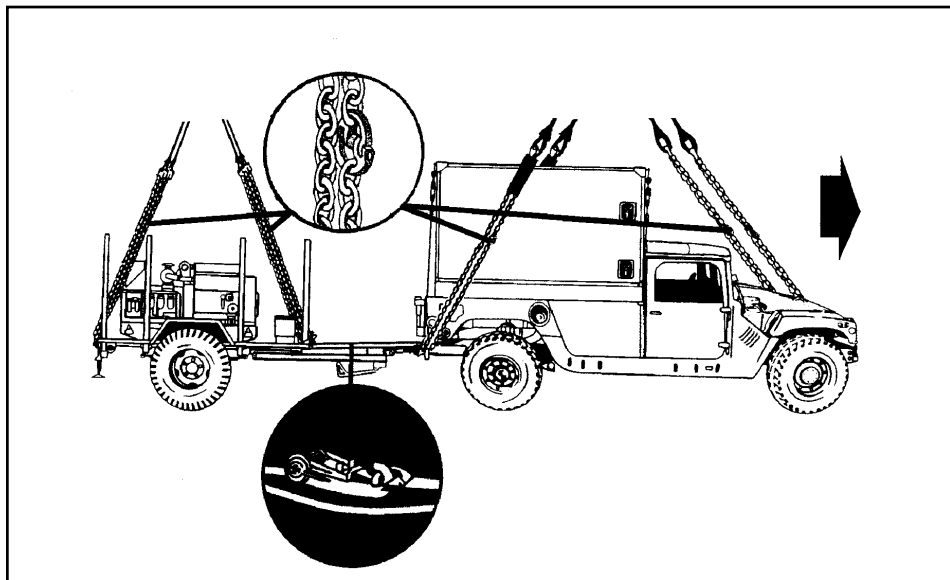

Figure I-6. M998/M1038 HMMWV and Trailer Mounted Generator

Once rigging is complete, the load can be hooked up to the helicopter. Two hookup teams are required for this load. The static wand person discharges the static electricity with the static wand. The forward hookup person stands in the bed of the truck and places apex fitting 1 onto the forward cargo hook. The aft hookup person stands on the generator fender and places apex fitting 2 onto the aft cargo hook. The hookup team then carefully dismounts the trailer and remains close to the load as the helicopter removes slack from the sling legs. When successful hookup is assured, the hookup team quickly exits the area underneath the helicopter to the designated rendezvous point. The procedures for derigging are the reverse of the preparation and rigging procedures.

M1097 AND ETG RIGGING PROCEDURES

The procedures for this equipment are the same as for the HMMWV with trailer mounted generator.

Q-37 SLING LOAD PROCEDURES

The AN/TPQ-37(V)8 is certified for CH-47D helicopter sling load in the dual point configuration. The antenna must be removed from the ATG trailer before sling loading. A 40-ton crane is required to remove the antenna from the antenna trailer and reconfigure the system after movement. Therefore, the ATG becomes stationary after movement. If the trailer is to accompany the antenna, it must be rigged as a separate load. The threat must be carefully evaluated before deciding to move the radar by helicopter since the radar is unable to displace without external support. Helicopter movement of the radar is used in exceptional circumstances and is used only when mission requirements make this type of movement an absolute necessity. The following procedures provide data for moving the minimum essential equipment using non-standard rigging procedures. These procedures require local certification. The minimum essential equipment can be moved with two CH-47Ds. However, it is preferable to use three CH-47Ds with separate lifts for the OC and PU-806. In addition, a UH-60 or CH-47D is required to move the advance party. The primary section personnel travel on the CH-47Ds with the radar components. The remaining section equipment with drivers will normally move forward by ground with the 40-ton crane. Procedures for rigging the remaining section equipment are found in FM 4-20.199 (10-450-5).

ATG RIGGING PROCEDURES

The ATG antenna can be moved by one CH-47D using a dual-point load configuration. Two persons can prepare and rig this load in 15 minutes once the antenna is removed from the M1048 transporter. The following materials are required to rig the antenna for movement.

- Sling Set, 25,000-lb. capacity with one additional apex fitting (25,000-lb capacity).
- Reach Pendant Assembly, NSN 4020-01-337-3185 (2 each).
- Tape, adhesive, pressure sensitive, 2-inch wide roll.
- Cord, nylon, type III, 550-pound breaking strength (1 spool).
- Webbing, cotton, 1/4-inch, 80-pound breaking strength (1 spool).
- Plywood, sheet, 3/4-inch thickness (3 each).
- Cargo straps, 5,000-pound capacity, CGU-1/B (5 each).

Once the materials are assembled the load is prepared for rigging using the following procedures:

- Configure the Antenna unit for march order. If the antenna unit is mounted on its transport trailer, a 40-ton crane must be used to remove it for helicopter transport. If the trailer is to accompany the unit, it must be rigged and transported as a separate load. Detailed procedures for removing the antenna from the transport trailer are contained in TM 11-5480-355-10.
- Ensure that the maintenance tent frame and cover are stowed and secured in their proper position.

- Ensure that all cover panels, cabinet doors and vents are installed and secure.
- Secure all loose equipment with tape or nylon cord.
- Ensure that the rear door is closed and secured with its locking handle. Door rods must be secured in their cups.
- Ensure that the antenna transport cover is secured tightly to the lacing brackets with its bungee cord. If necessary, secure the antenna with additional nylon cord.

Once preparations are complete the load is rigged using the following procedures

- Cover top of radar with 3/4-inch plywood and secure with 5K straps. Figure I-7 shows the preparation and placement of plywood on the antenna. Do not stand on top of the load until the plywood is in place.
- Rotate both antenna tie-down ratchet handles toward the center to prevent sling interference.
- Turn pear-shaped lift rings to rotate the apex of each ring upwards, in the direction of lift.

NOTE: This load is rigged to fly so that lift provisions on TOP are forward.

- Forward sling set (2 sling legs):
 - Connect two sling legs to apex fitting number 1 (for front cargo hook). Position apex fitting on top of the load and secure one reach pendant to the apex fitting.
 - Forward lift rings are on top of antenna. Loop the chain end of sling leg 1 through front left lift ring and insert link 55 in the grab-hook. Repeat with sling leg 2, passing chain end through front right lift ring and inserting link 55.
 - Remove slack from front sling legs, and tie securely with breakaway tape on the top corner of the sling guides to prevent tangling.
- Aft sling set (2 sling legs):
 - Connect two sling legs to the apex fitting number 2 (for rear cargo hook). Position apex fitting on top of the load.
 - Rear lift rings are at the aft end of antenna. Loop the chain end of sling leg 3 through the left rear lift ring and pass through the sling guide. Insert link 10 into the grab-hook. Repeat with sling leg 4.
 - Remove slack from rear sling legs, and tie securely with breakaway tape on the top corner of the sling guides to prevent tangling.
- Wrap excess chains and secure with tape or nylon cord.
- Secure padding to the slings in the areas where the chain may rub antenna.
- Cluster and tie, with cotton webbing (breakaway technique), the slings of each sling set together on top of the antenna to prevent entanglement during hookup and lift-off.

Once rigging is complete, the load is hooked up to the helicopter. The hookup team remains close to the load as the helicopter removes slack from the sling legs. When the helicopter is overhead, the forward hookup person places reach pendant 1 onto the forward cargo hook, and the aft hookup person places reach pendant 2 onto the aft cargo hook. When successful hookup is assured, the hookup team quickly exits the area underneath the helicopter and move to the designated rendezvous point. De-rigging is the reverse of the preparation and rigging procedures in steps 1 and 2. Caution the pilot to hover to one side before releasing the sling load to prevent damage to the radar unit.

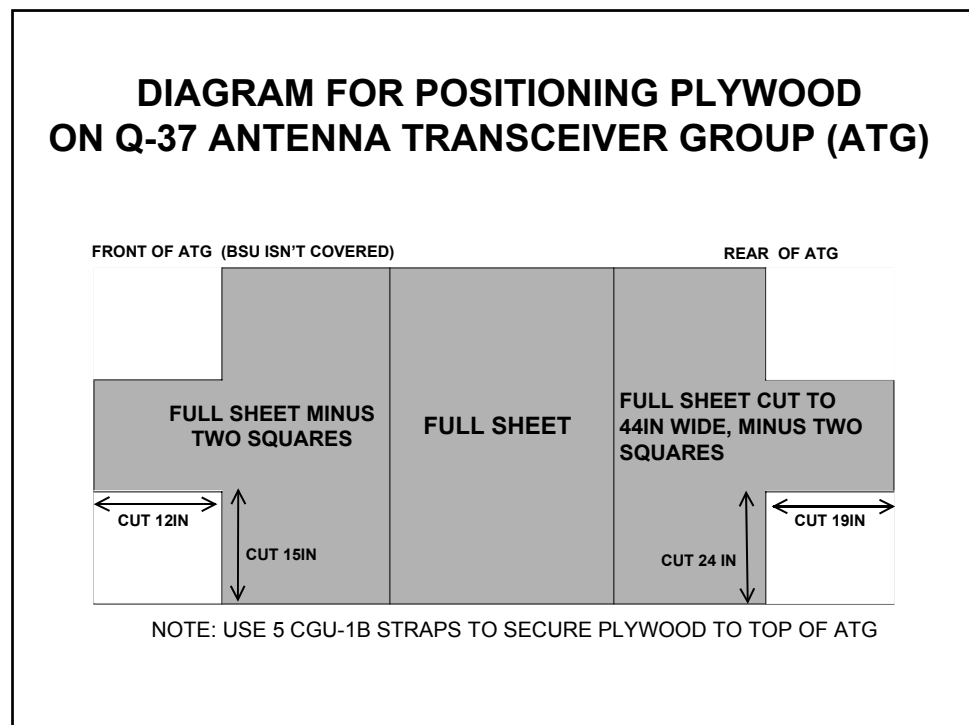

Figure I-7. ATG Plywood Preparation

RIGGING PROCEDURES FOR THE OC AND TRAILER POWER DISTRIBUTION GROUP

The OC and the trailer power distribution group (TPDU) can be moved by one CH-47D using a dual-point load configuration. Two persons can prepare and rig the OC or AGU in 15 minutes. This load can be completely rigged by four persons in 15 minutes. The following materials are required to rig the antenna for movement:

- Sling sets, 25,000-pound capacity (2 each).
- Sling set safety clamps (2 each).
- Reach Pendant Assembly, NSN 4020-01-337-3185 (2 each).
- Tie-down chains (load binders), air cargo, (2 each).
- Cord, nylon, Type III, 550 pound breaking strength (1 spool).

- Tape, adhesive, pressure sensitive, 2 inch wide roll.
- Webbing, cotton, 1/4 inch, 80 pound breaking strength (1 spool).
- Cellulose or felt padding.

NOTE: The tongue weight of the trailer exceeds the pintle weight of the M1097 and will require local certification. Use separate loads rigged IAW FM 10-450-5 when three aircraft are available.

The following actions are required to prepare the load for rigging:

- Attach the trailer to the truck.
 - Place the trailer lunette in the truck pintle hook ensuring the trailer brakes are disengaged. Lock and tape the pintle and connect the trailer safety chains to the truck.
 - Raise landing leg and lock in stowed position. Secure the landing leg with pins and tape.
 - Install truck lift provisions on the outer ends of the rear bumper. Remove tiedown provisions from the front bumper and install on the inner lift points of the rear bumper.
 - Secure the trailer to the truck to prevent it from pivoting in flight by routing one end of the cargo chain through the left (driver side) truck inner lift provision located on the rear bumper. Route the other end of the cargo chain strap through the A frame to trailer mounting bracket.
 - Repeat with another cargo chain strap on the right side of the truck and trailer.
 - Tighten both cargo chain straps simultaneously to ensure straight alignment during flight. Secure the ratchet handles in the closed position using tape or nylon cord.
- M1097 HMMWV.
 - Remove antennas and fold down the mounting brackets to their stowed positions. Secure all loose equipment inside the shelter with tape, nylon cord, and/or tiedowns. Close and secure door.
 - Ensure the fuel tank is no more than 3/4 full. Inspect fuel tank cap, oil filler cap, and battery caps for proper installation.
 - Fold the truck mirrors rearward into cab area and tie them together with nylon cord. Remove the doors and secure them inside the truck.
 - Secure all loose equipment, cargo and antennas inside the truck with nylon cord, tape and/or tiedowns.
 - Engage the truck parking brake. Place the transmission in neutral.
 - Ensure the truck's front wheels are positioned straight and forward. Secure the steering wheel using either the securing device under the dash or nylon cord.
- PU-806.
 - Engage parking brake
 - Secure door latches shut with tape

After preparations are complete, the load is rigged in the following manner:

- M1097 HMMWV.
 - Attach one of the pendants to the apex fitting of one of the sling sets. Position the sling set (sling set 1) on top of the shelter. Route outer sling legs 1 and 2 to the front of the truck and inner sling legs 3 and 4 to the rear of the truck. Sling legs 1 and 3 must be on the left side of the truck.
 - Loop the chain end of sling leg 1 through the left front lift provision that protrudes through the hood and insert link 35 in the grabhook. Repeat with sling leg 2 and the right front lift provision.
 - The rear lift provisions are located at the outer ends of the rear bumper. Do not loop the chain ends through the tie-down shackles located near the center of the bumper. Loop the chain end of sling leg 3 through the left provision and insert link 10 in the grabhook. Repeat with sling leg 4 and the right rear lifting shackle.
 - Secure excess chain with tape or nylon cord.
 - Raise the pendant and apex fitting above the truck. Secure the rear sling legs to the rear lift rings of the shelter with 80 pound breakaway webbing. Ensure that the front legs are to the sides of the truck.
 - Take up slack in all truck sling legs, cluster and tie (breakaway technique) together on top of the truck, to prevent entanglement during hookup and lift-off.
- PU-806.
 - Attach the remaining pendant to the apex fitting of sling set 2. Position sling set 2 on top of the trailer. Route outer sling legs 1 and 2 to the front of the trailer and inner slings 3 and 4 to the rear of the trailer. Sling legs 1 and 3 are routed to the left side of the trailer.
 - Route the chain end of sling leg 1 through the lift point near the A frame at the front left of the trailer. Insert link 68 into the grab hook. Pull sling tight and pad area of sling that will make contact with the antenna and plywood. Tie a breakaway through a hole drilled through the plywood. Repeat with sling leg 2 at the right front of the trailer.
 - Loop the chain end of sling leg 3 through the left rear lift provision, insert link 80 into the grab hook. Place the sling leg through the sling guide on the antenna and pull up until tight. Remove the sling leg from the guide, pad it where it makes contact with the antenna. Replace it in the guide, pull up tight and tie a breakaway to prevent it from slipping down. Repeat with sling leg 4 at the right rear lift provision.
 - Secure excess chain with tape or nylon cord.
 - Take up slack, cluster trailer sling legs together, and tie a breakaway to prevent entanglement during hookup and lift off.

Two hookup teams are required for this load. One hookup team stands on the cab of the truck and the other stands on a fender of the trailer. The truck hookup team places the reach pendant of sling set 1 into the forward cargo hook. The trailer hookup team places the reach pendant of sling set 2 onto the rear cargo hook. Do not use the center cargo hook. The hookup teams then carefully dismount the truck and trailer and remain close to the load as the helicopter removes the slack from the sling legs. Ensure the apex remains in the proper position on the loop of the reach pendants. If the tiedown straps connecting the truck and trailer loosen upon liftoff, the load should be set down and the ratchets tightened. When successful hookup is assured, the hookup team quickly exits the area underneath the helicopter to the designated rendezvous point. De-rigging is the reverse of the preparation and rigging procedures in steps 1 and 2.

SECTION II – FIXED WING AIRCRAFT MOVEMENT

CONSIDERATIONS FOR FIXED WING AIRCRAFT MOVEMENT

Air transport is used to move vehicles, personnel and equipment when time is a critical factor. When transit time is not critical, other modes of transport should be used. The type of aircraft will vary based on the operational requirements, aircraft availability, movement distance, airfield availability, threat, amount of equipment to be moved, equipment preparation time, and external support requirements. Radar sections will normally be transported by C-5A, C-17, C141, or C-130. The C-5A and C-141 are designed for strategic intertheater transport. The C-17 can function as a strategic intertheater or a tactical intratheater transporter. The C-130 is tactical intratheater aircraft. The C-130 will normally be the aircraft of choice for tactical movements. The basic procedures are the same for both strategic and tactical air movement.

There are specific requirements for preparing radar section equipment for loading on specific aircraft. The AN/TPQ-36(V)8 can be loaded on all of the aforementioned aircraft without disassembly of components. The only special requirement is that the OC Shelter/HMMWV must be driven cab first into C-130 and C-141 aircraft. The AN/TPQ-37(V)8 can be transported in roll-on/roll-off configuration on C-5A and C-17 aircraft. For transport on C-130 and C-141 aircraft, the generator group must be removed from the generator truck and the ATG must be removed from the transporter to fit into the aircrafts' cargo holds. A crane and K-loader (or additional empty M925 5-ton truck with winch) are required to remove the ATG and generator group from their transporters and load them onto the aircraft. The same equipment is required for off-loading and reassembly of components.

AIR LOADING OPERATIONS

Planning for air load operations begins with receipt of the mission at the TA organization or radar section's higher headquarters. Just as in sling load operations, air loading is planned using the reverse planning process. The plan for air loading must address preparation and coordination, air movement, re-configuration of equipment, and execution of the ground tactical operation. Once the mission analysis is completed a warning order is

issued to the deploying elements. The warning order should contain the following information:

- Type of mission.
- Number and type of aircraft.
- Time and location of Joint Inspection (JI).
- Departure airfield and time.
- Arrival airfield and time.
- Area of Interest.
- Special Instructions.
- Attachments/ Detachments.

Upon receipt of the warning order the radar section will conduct PCIs for air load operations, section rehearsals and begin preparing loads without losing operational capability. PCIs specific to air loading include:

- Winches are operational and complete, including slave cables, control unit, all hooks and chains.
- 25K sling sets are available to lift equipment at the JI scales.
- Required bridge plates and shoring are on-hand.
- T-handle lead bars are present and serviceable.

Once preparations are complete the radar section moves to the departure airfield. Unit equipment is initially placed in a marshaling area. In the marshaling area, personnel and cargo manifests are prepared, equipment and vehicles are assembled into chocks or loads, and moved to the alert holding area. At the alert holding area, the departure airfield control group (DACG) accepts the Army's equipment and supplies. They inspect them and ensure all passengers are accounted for and available. From the alert holding area, the load is directed to the call forward area where a joint inspection is carried out by the aerial port element of the Air Force tanker airlift control element (TALCE) and the DACG. Final briefings are given, manifests reviewed for accuracy, and personnel and baggage escorted to the aircraft for loading. The aerial port element of TALCE then receives the cargo at the airfield loading ramp/ready line and, in conjunction with the loadmaster, loads and secures it aboard the aircraft.

A variety of techniques can be used to load aircraft. Aircraft are usually loaded according to the unit's load plans. However, the aircraft loadmaster is the final authority on how cargo is to be loaded and positioned aboard an aircraft. The DACG normally does the loading under the supervision of the loadmaster.

DEPARTURE AIRFIELD OPERATIONS

The air terminal commander or civilian operator is responsible for air terminal operations at the departure airfield. The Army or other service component commander will provide a DACG to control Army activities at the terminal. The DACG may also be responsible for loading and unloading aircraft and cargo at these facilities. Deploying units coordinate with the DACG for their responsibilities in processing through the terminal. The

TALCE supervises Air Force operations at the air terminal. The DACG and the TALCE must coordinate support responsibilities prior to the start of operations. Departure airfield operations consist of four separate areas of activity for the unit, DACG, and TALCE. These areas are the marshaling area, the alert holding area, the call forward area, and the loading ramp area. The TALCE coordinates the overall airlift operations at the departure airfield.

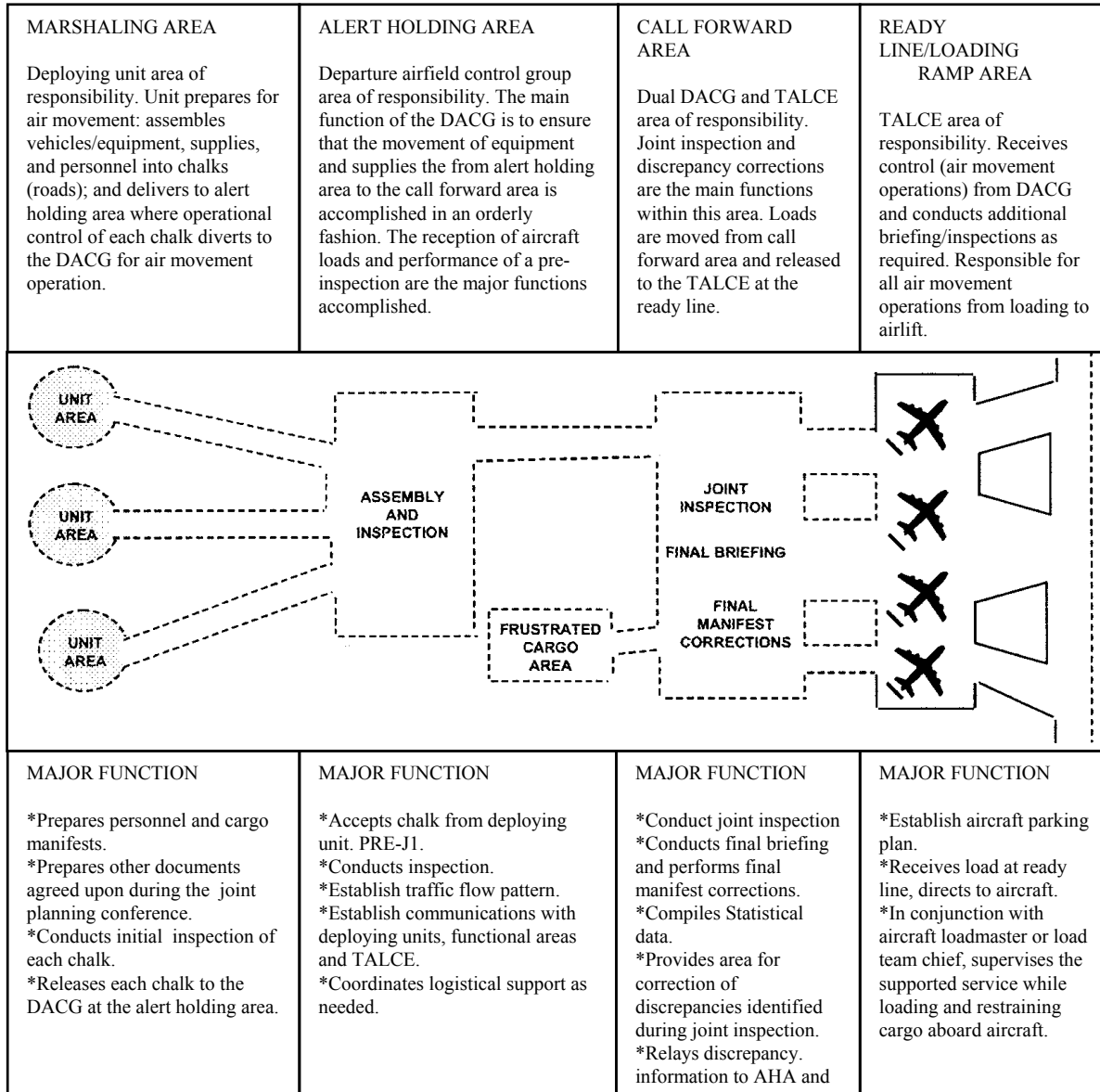

Figure I-10. Departure Airfield Operations

Marshaling Area Activities

The marshaling area is provided by the installation or base commander of the geographic area of responsibility (AOR) from which the deploying unit stages its departure. Marshaling area activities are the responsibility of the deploying commander. These activities may take place within the deploying unit's permanent area or in another area to ease movement and control. In either case, the marshaling area activities should take place as close as possible to the departure airfield. Its location should not cause unnecessary congestion to airfield operations or undue hardship to the deploying unit. It may be the area where units may start, continue, or complete preparation for loading.

The installation/base commander (or the parent organization) who provides the marshaling area will assist the deploying forces. The deploying unit should not be required to perform support functions thus permitting concentration on preparation for the deployment.

The home station installation or parent organization is responsible for the movement of its subordinate units. The deploying unit should do the following:

- Establish liaison with the DACG and other activities.
- Coordinate a joint planning conference.
- Perform final preparation of vehicles and equipment according to air transport guidelines (to include weighing and marking center of balance).
- Ensure that adequate shoring material is on hand and readily available.
- Prepare personnel and cargo manifests.
- Assemble personnel, supplies, and equipment into aircraft loads according to established load plans.
- Ensure planeload or troop commanders are appointed and properly briefed on their responsibilities.
- Develop alternate (bump) plan for chocks in the event aircraft becomes non-mission capable.
- Pass control of unit aircraft loads to the DACG at the alert holding area.

The DACG is responsible for the following:

- Maintaining liaison with the deploying unit.
- Arranging with the TALCE for Air Force technical assistance required by the deploying unit.
- Establishing communications.
- Maintaining liaison with the aerial port section of the TALCE.
- Calling aircraft loads forward from the marshaling area and assuming control in the alert holding area.

Alert Holding Area

The alert holding area is the equipment, vehicle, and passenger control area. It is normally located in the vicinity of the departure airfield. It is used to assemble, inspect, hold, and service aircraft loads. Control of the load is transferred from the individual unit to the DACG at this point. The deploying unit is responsible for the following:

- Ensuring that the aircraft load arrives at the alert holding area at the time specified by the DACG.
- Providing the DACG with passenger and/or cargo manifests and required documentation.
- Correcting load discrepancies identified during pre-inspection.
- Ensuring vehicle drivers remain with the vehicles until released.

The DACG is responsible for the following:

- Ensuring loads arrive at the alert holding area at the time agreed upon by the deploying unit and TALCE.
- Receiving, inventorying, and controlling aircraft loads as they arrive at the alert holding area.
- Inspecting aircraft loads to ensure that they are complete and correctly prepared. Ensure required shoring, floor protection materials, and 463L dunnage are available.
- Verifying accuracy of weight and balance markings.
- Establishing a discrepancy correction area.
- Inspecting documentation for accuracy and completeness.
- Providing emergency maintenance, POL, and related services, as needed, to accomplish the out-loading mission.
- Directing or guiding aircraft loads to the joint inspection area (call forward area).

The TALCE will assist the DACG as required.

Call Forward Area

The call forward area is that portion of the departure airfield where the joint inspection is conducted. A final briefing is provided to deploying troops and all manifests reviewed for accuracy. The deploying unit will correct all discrepancies found by the DACG/TALCE joint inspection. The DACG is responsible for the following:

- Establishing communications with TALCE and deploying units.
- Assisting in the joint inspection of aircraft loads and manifests.
- Ensuring that passenger/cargo manifests are correct.
- After loads have passed inspection, moving equipment forward to the ready line segregated by load.
- In the event of aircraft aborts or discrepancies in the planned allowable cabin load (ACL), reassembling aircraft loads with the assistance of the TALCE and preparing required manifest changes.

- Ensuring that discrepancies found during the joint inspection are corrected.
- Maintaining statistical data to account for the current status of all unit personnel and equipment scheduled for air movement.
- Ensuring the deploying unit adheres to the established movement timetable.
- Providing loading team personnel and support equipment to include one pusher vehicle per load team.
- Providing gloves, goggles, ear protection, and reflective devices for load team members.
- Escorting aircraft loads to the ready line and ensuring that all personnel are briefed. (Personnel will be briefed on flight line safety, including driving procedures, smoking rules, and other applicable local safety requirements.)
- Retaining a final corrected copy of each passenger/cargo manifest and inspection record.
- Ensuring that deficiencies noted during the joint inspection are relayed to the alert holding area and the unit. This action will prevent recurrence of the same deficiencies. The DACG provides emergency services as required and agreed upon at the joint planning conference to ensure uninterrupted operations.
- Providing fueling and de-fueling capability and emergency maintenance for vehicles to be transported.
- Providing passenger holding areas as required.

The TALCE is responsible for the following:

- Coordinating with the DACG on all changes required to the aircraft configuration.
- Together with the DACG, conducting the joint inspection using DD Form 2133.
- Providing passenger briefing guide for the passengers' representative to brief the troops for on/off load procedures.
- Briefing vehicle drivers and passengers on flight line safety, driving procedures, smoking rules, and special precautions.
- Providing a team chief for each loading team.
- Providing passenger escort to the aircraft.
- Notifying the DACG when loads are to be dispatched to the loading ramp area ready line.
- Accepting loads at the ready line and load aboard the aircraft. (If a TALCE is not available, the aircraft loadmaster will accept the load.)
- Providing airflow information to the D/AACG.

DD Form 2133, Joint Airlift Inspection Record is used for conducting the joint inspection. A copy of this form is at Appendix K.

Loading Ramp Area

The loading ramp area, including ready line area, is controlled by the TALCE. The planeload commander or troop commander is responsible for the following:

- Following directions of load team chief or passenger escort.
- Monitoring and controlling aircraft passengers.
- Retaining one copy of the final passenger/cargo manifest.
- Providing assistance in loading and securing the aircraft load as requested by the load team chief.
- Ensuring that vehicle drivers and equipment operators follow the instructions of the load team chief or primary loadmaster while loading equipment on the aircraft.

The DACG is responsible for the following:

- Transferring control of the aircraft load to the TALCE at the ready line and monitoring the loading.
- Providing load teams to assist in loading and securing aircraft load as required by the load team chief.
- Maintaining coordination with the deploying unit representative and TALCE.
- Obtaining individual aircraft load completion time from the TALCE.

The TALCE is responsible for the following:

- Accepting planeloads from the DACG at the ready line.
- Ensuring that all drivers have been briefed on flight line safety.
- Ensuring that each aircraft load is positioned at the proper aircraft at the specified time.
- Maintaining liaison with the aircraft crew and the DACG.
- Coordinating with the aircraft primary loadmaster and ensuring that loads are placed aboard the aircraft in time to meet the scheduled departure time.
- Providing (if required) and operating MHE and special loading equipment according to AR 59-105/AFR 76-7/OPNAVINST 4630.13D/MCO 4660.2 and agreements established during the joint planning conference.
- Maintaining communications with the DACG and deploying units.
- Providing aircraft primary loadmaster with required copies of the passenger/cargo manifests and retaining a copy for TALCE files.
- Briefing aircrews, as required.

The load team chief is responsible for the following:

- Receiving loads at the ready line.
- Directing and supervising the loading teams and vehicle drivers.
- Coordinating with the aircraft primary loadmaster, directing all loading operations, and ensuring all equipment and supplies are properly restrained in the aircraft.

- Coordinating with the TALCE ready line coordinator for any special assistance or equipment needed.
- Collecting required copies of the passenger/cargo manifest and making sure that they are given to the aircraft primary loadmaster.
- Passing load completion time to the airlift operations center (AOC) section of the TALCE.

ARRIVAL AIRFIELD OPERATIONS

Activities at the arrival airfield (aerial port of debarkation (APOD)) are similar to those of the departure airfield. Loads are off-loaded, equipment is reconfigured, and the unit moves from the airfield to its area of operations. The main areas of the arrival airfield are the off-load ramp, the holding area, and the unit marshaling area. The TALCE will supervise off-loading arriving aircraft. The arrival airfield control group (AACG) will escort loads to the holding area and assist the unit in assembling and moving to the marshaling area. Figure I-11 depicts a notional APOD.

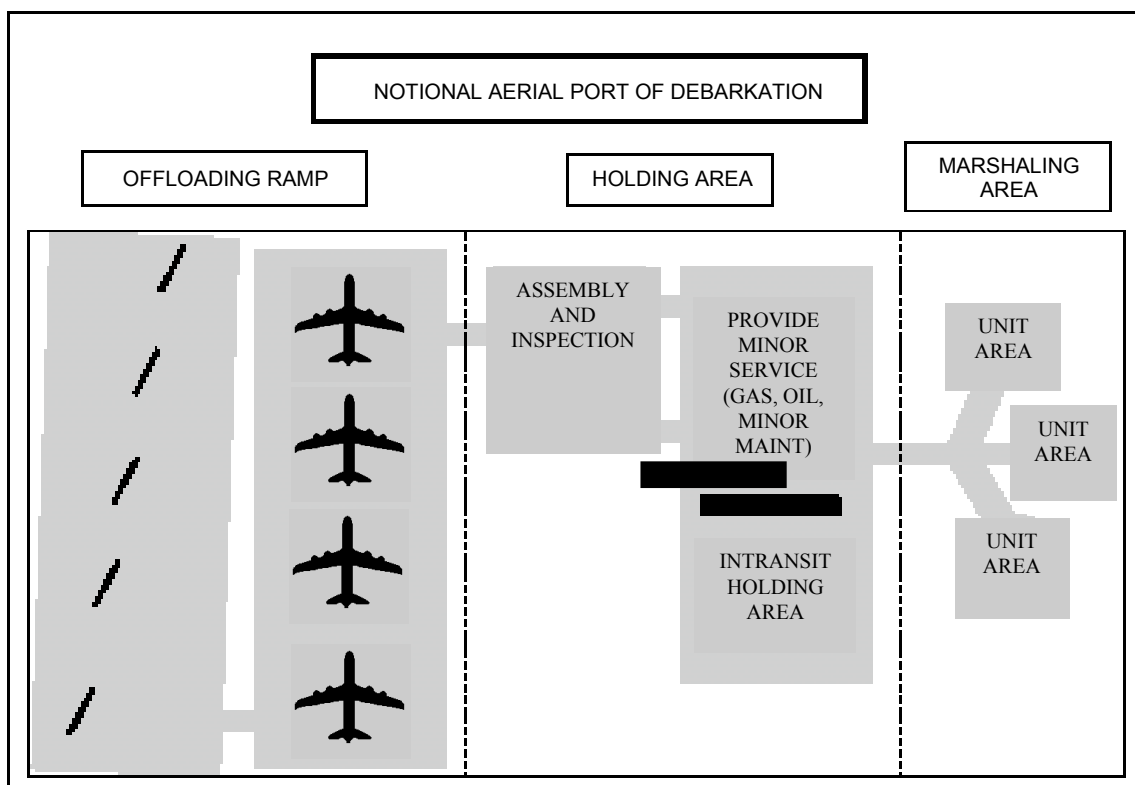

Figure I-11. Notional Aerial Port of Debarkation

Off-Load Ramp Area Activities

The off-load ramp area activities are controlled by the TALCE. Each load will be released to the AACG for return to unit control at the holding area. The chalk leader or troop commander will perform the following:

- Provide assistance to the loadmaster.
- Comply with instructions from the off-load team chief when unlash and off-loading from the aircraft.
- Ensure that all aircraft tie-down equipment is returned to the TALCE.
- Retain all shoring and dunnage for redeployment.
- Provide one copy of the passenger and cargo manifests to the arrival airfield control group (AACG).

The AACG will perform the following:

- Maintain coordination with the deploying unit and TALCE representative.
- Provide off-load teams and support equipment as required.
- Accept each planeload from the TALCE at the established release point.
- Remove shoring and dunnage from the aircraft and transfer it to the unit.

The TALCE will perform the following:

- Advise the AACG of the airflow and expected arrival of aircraft.
- Plan and supervise aircraft parking.
- Receive passenger and cargo manifests from the aircraft loadmaster.
- Supervise off-loading the aircraft, including removal of shoring and dunnage.
- Provide all MHE and special off-loading equipment including operators, as required, in accordance with AR 59-105/AFR 76-7 and agreements established during joint planning conferences.
- Provide ITV by reporting arrival of loads and release to the AACG.

Holding Area Activities

The deploying units are responsible for providing unit liaison personnel to AACG and for assisting the AACG as required. The AACG will perform the following:

- Coordinate with the TALCE and the deploying unit.
- Provide support to arriving units as determined during the joint planning conference.
- Maintain in-transit visibility of arriving loads.
- Release aircraft load to the deploying unit commander or his representative at a predesignated location.
- Coordinate MHE and transport of the movement of aircraft pallets to the unit marshaling area for pallet breakdown.
- Provide fuel, oil, and minor maintenance for transported vehicles.
- Provide emergency services to accomplish the mission.

Unit Marshaling Area

The deploying unit terminates the air movement at its marshaling area. Equipment is reconfigured for onward movement. Units will perform the following:

- Install equipment previously removed for transport.
- Ensure that all aircraft pallets and nets are returned to the TALCE or AACG.
- Perform required maintenance checks, including refueling.
- Prepare and organize for movement (convoy, rail, airlift, and inland water).

Q-36 LOAD PROCEDURES FOR C-130 AIRCRAFT

The AN/TPQ-36(V)8 section can be loaded into two C-130 aircraft. The following procedure provides the tasks required to prepare and load the radar into the C-130. The OC shelter must be driven into the aircraft cab end first. The other vehicles and equipment are backed into the aircraft. All other procedures for loading the aircraft are in accordance with the aircraft general cargo loading manual and the aircraft loadmaster. Figure I-12 depicts section equipment loaded into the aircraft cargo hold. Notice that to load the aircraft in this configuration the PPG tows the ATG and the OC tows the ETG. This is opposite of the normal operational configuration.

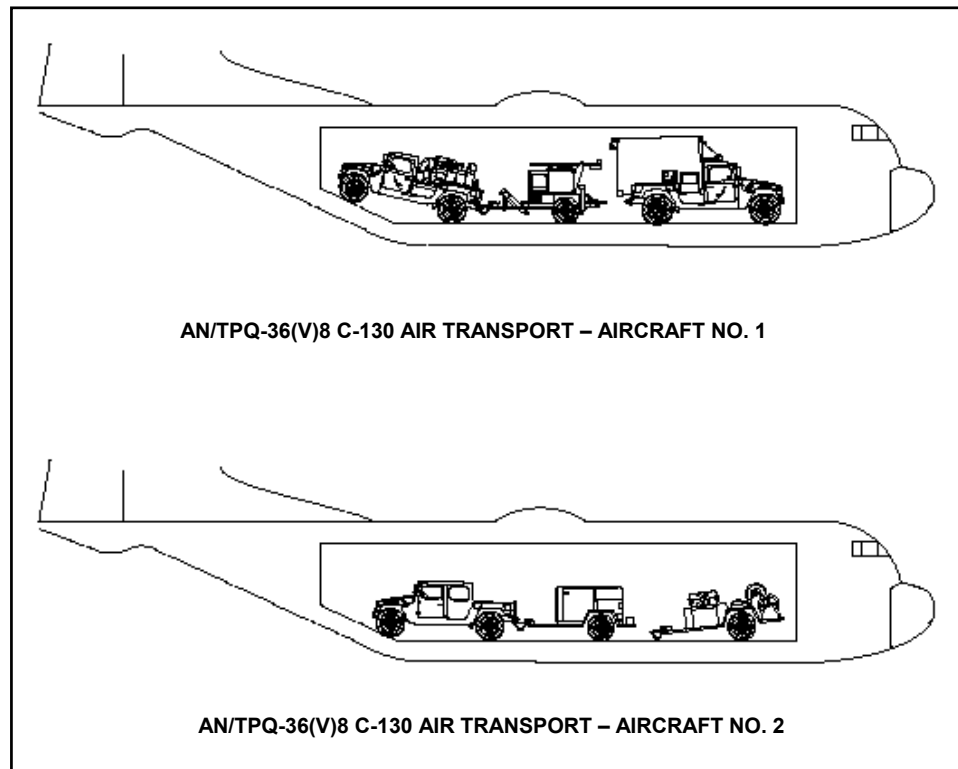

Figure I-12. C-130 Load Configuration

OC LOAD PREPARATIONS

The following procedures are used to prepare the OC for air loading. Refer to Figure I-13.

- Remove drain plug (1) from shelter floor.
- Loosen 10 captive screws (2) and lower pressure relief vent (3).
- Remove shelter antennas and store inside the shelter. Lower the three antenna Brackets (4). Confirm that the hinges are down.
- Prepare the shelter for movement by stowing and securing all loose equipment and supplies inside the shelter.
- Check to see if the HMMWV contains less than 3/4 tank of fuel. If not, drain tank to less than 3/4 full.

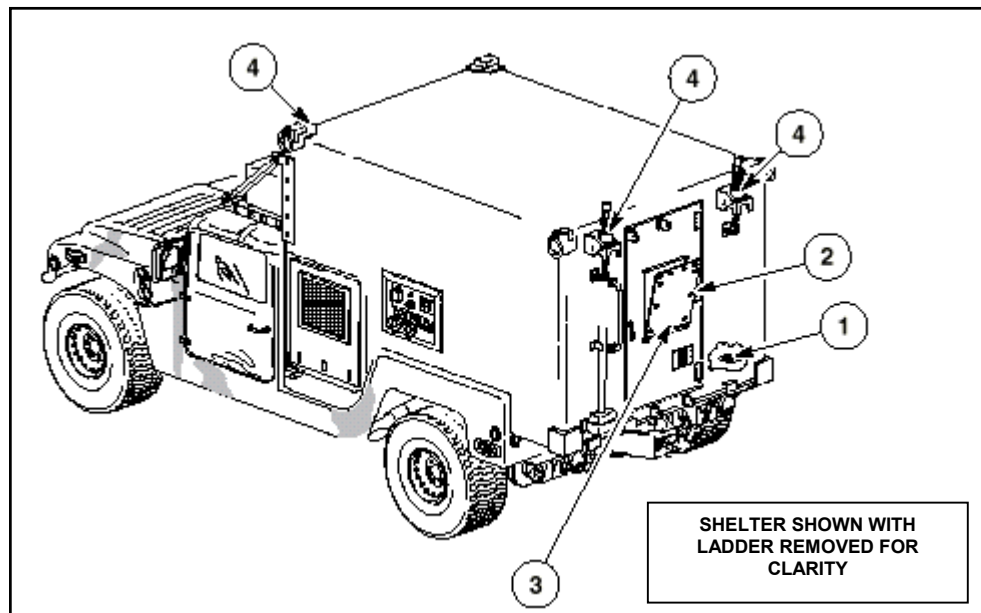

Figure I-13. OC Shelter

ATG LOAD PREPARATIONS

The following procedures are used to prepare the ATG for movement. These procedures are the same as those required for towing by a HMMWV.

- Secure all ATG trailer equipment.
- Stow the antenna.
- Stow the primary power cable. The cable is rewound onto the curbside reel of the PPG.
- Lower the ATG trailer.
- Stow the ATG trailer and ground strap. The ground strap is wound around the retaining clip on the roadside of the ATG trailer. The rod is stowed in the retaining brackets on the back of the ATG trailer.

- Install the antenna weather cover and secure with four tiedown straps.
- Couple the ATG trailer to the PPG HMMWV.

Q-37 LOAD PROCEDURES FOR C-130 AIRCRAFT

The AN/TPQ-37(V)8 radar section can be loaded into five C-130 aircraft. Prior to loading the radar, the antenna must be removed from the M1048 trailer and the generator pallet must be removed from the MTV/M925 5-ton truck. The overall preparations for loading the Q-37(V)8 are the same as for the Q-36(V)8. The required equipment is assembled, vehicles cleaned, fuel load adjusted to 3/4 tank or less and loose equipment and secondary loads secured. The aircraft loads are organized as follow:

- Chalk 1: The generator pallet prime mover (MTV/M925) is backed into the aircraft and tied down by AF personnel. This chalk is loaded after chalks 2 and 3, but should arrive at the APOD first to off load the generator pallet. There are no special requirements for the M925; use procedures for chalk 4 when loading the MTV.
- Chalk 2: ATG and Trailer. This load requires the C-130 ramp to be positioned horizontally, at a level even with the top of the trailer. This requires shoring under the ramp support, a solid or built up wooden block, commonly called a “milk crate” (Figure I-15). The amount of shoring will depend on how level the ground is. Locally manufactured bridge plates (see Figure I-16) are used to span the gap between the trailer and the aircraft’s ramp. Additional shoring is required under the ATG and trailer leveling jacks. The onboard winch is used to pull the ATG onto the C-130, guided by personnel using the T-handled lead bars (see Figure I-17). The winch on the trailer acts as a break for the load. Once the ATG is in position, the ramp is lowered, and the trailer is backed onto the aircraft and the loads secured. Figure I-14 provides a detailed checklist of preparations and procedures.

ATG/TRAILER (Chalk 2)

EQUIPMENT REQUIRED:

- __ 2 ea. 2"x 12" x 12'-0" (shoring for ATG)
- __ 2 ea. 3/4" x 24" x 24" (shoring for trailer jack pads {front})
- __ 2 ea. bridge plates
- __ 1 ea. NATO slave cables
- __ 1 ea. Winch, complete with hooks and control unit
- __ 2 ea. lead bar (T-handle)
- __ 2 ea. chain (to connect winch cables to ATG)
- __ Shoring for "milk crate" under aircraft ramp 20-24" high, 24" square, adjustable.

PREPARATION:

- __ ATG wheels are set to 100 psi.
- __ ATG wheels are set in position (rear of trailer turned in, backward, and free, front of trailer turned out and locked).
- __ Chains are attached across front and rear of antenna to hook up to the winch.
- __ All tie-downs and clamps are removed from ATG Trailer.
- __ Connected slave cables to winch.
- __ Winch control box hooked up.
- __ Trailer winch connected to front chain
- __ Shoring used under AF "milk crate."

LOADING:

Chalk 2 (Must be loaded first)

- __ Trailer backed to aircraft, within 5-6" of ramp.
- __ Bridge plates placed between ATG trailer and aircraft ramp.
- __ Lead bars attached to loading wheels.
- __ Aircraft winch attached to rear chain.
- __ ATG jacked up by wheels 5-6" higher.
- __ Aircraft winch pulls ATG in, trailer winch brakes ATG.

NOTE: Lead bars are used to turn wheels only when ATG is moving. If ATG starts to run away lead bar personnel drop lead bars, which will brake the ATG

- __ 2" x 12" x 12' shoring placed under ATG.
- __ ATG jacked down on shoring
- __ ATG loading wheels are turned and locked for removal: front (trailer-tongue) turned in/locked, rear (trailer-rear) turned out and locked
- __ Lead bars are stowed, ramp "milk crate" shoring stowed.
- __ Trailer winch disconnected and reeled in
- __ Stow slave cable, winch control.
- __ Trailer pulled ahead 5-10'
- __ Aircraft ramp lowered.
- __ Trailer backed into aircraft.
- __ 3/4" x 24" sq. shoring put down under front jack pads.
- __ Trailer disconnected from truck using front trailer jacks only.
- __ ATG/Trailer tied down by AF personnel.

Figure I-14. ATG and Trailer Loading Checklist

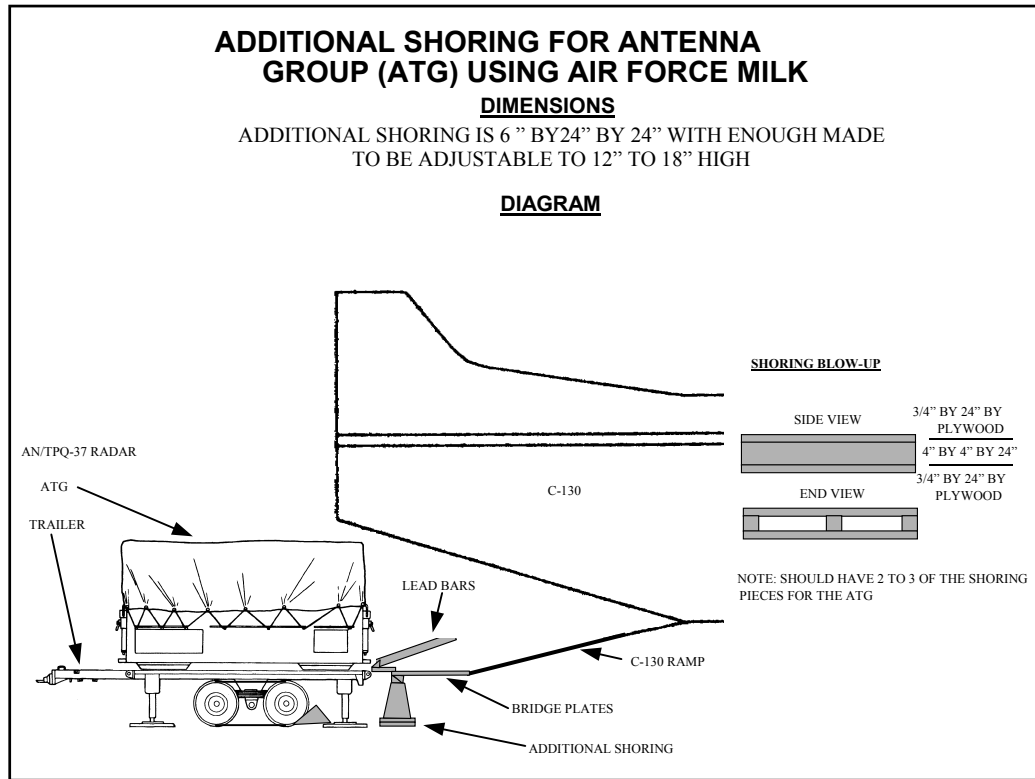

Figure I-15. Ramp Support and Shoring

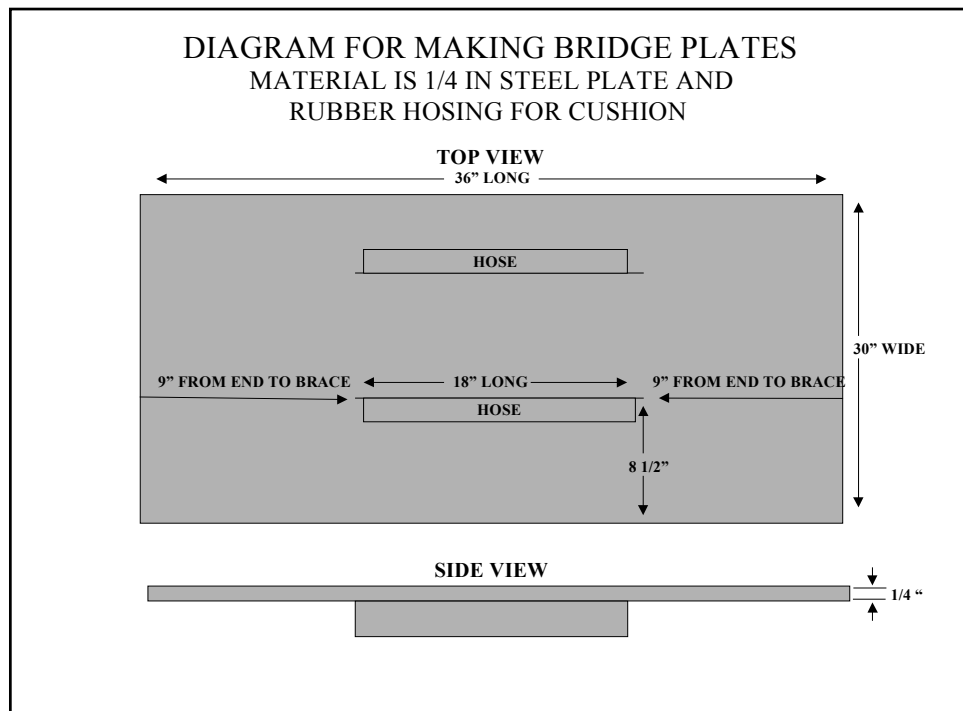

Figure I-16. Bridge Plates

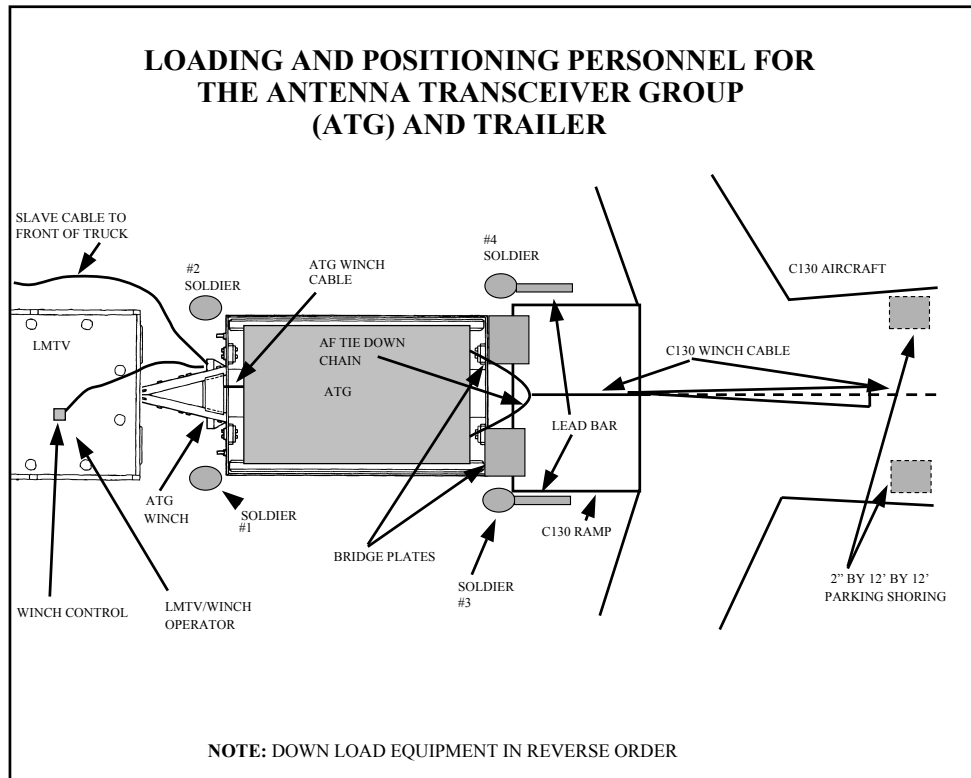

Figure I-17. ATG and Trailer Loading

- Chalk 3: PDG (Generator) and HMMWV w/S250 Shelter. This chalk is loaded similarly to chalk 2. The load also requires shoring to support the ramp, at a level even with the back of the MTV/M925 truck (see Figure I-19), unless a K-loader is used. When using the truck, the different heights of the C-130 and the truck bed create a steep incline with the ramp. Personnel must use extreme care that the load does not get out of control. When using the MTV, kneeling the rear tires will reduce the height difference. Once the PDG is loaded, and the truck or K-loader is pulled away from the aircraft, the shelter truck is backed into the aircraft, and both loads are secured. Figure I-18 contains a detailed checklist for this load.

Appendix J

Rehearsals

A rehearsal is the act or process of practicing an action in preparation for the actual performance of that action. Rehearsing key combat actions allows participants to become familiar with the operation and to translate the relatively dry recitation of the tactical plan into visual impression. This visual impression helps them orient themselves to both their environment and to other units during the execution of the operation. Moreover, the repetition of combat tasks during the rehearsal leaves a lasting mental picture of the sequence of key actions within the operation. Rehearsals are conducted at all force levels. However, the discussions in this appendix focus on the brigade level since the basic procedures are the same at all levels.

REHEARSAL TYPES

There are five types of rehearsals. They are the confirmation brief, backbrief, combined arms rehearsal, support rehearsal, and battle drill or SOP rehearsal. Each type of rehearsal achieves a specific result and has a specific place in the MDMP time line. The purposes of these rehearsals are:

- Confirmation brief. The confirmation brief is routinely performed by a subordinate leader immediately after receiving any instructions, OPORD, FRAGO, etc. Subordinate leaders brief the higher commander on:
 - Their understanding of his intent.
 - Their specific task and purpose.
 - The relationship between their unit's mission and the mission of other units.
- Backbrief. The backbrief is normally performed throughout the MDMP. This rehearsal allows the commander to clarify his intent early in the subordinate's tactical estimate process. The higher commander uses backbriefs to:
 - Identify problems in his concept of operation.
 - Identify problems in subordinate unit commander's concept of operations.
- Determine how a subordinate intends to accomplish the mission.
- Combined arms rehearsal. The combined arms rehearsal is normally conducted by a maneuver unit headquarters and performed after the subordinate units have issued their OPORD. This rehearsal ensures:
 - The subordinate units plans are synchronized with the other units in the organization.

- The plans of all subordinate commander's will properly achieve the intent of the higher commander.
- Support rehearsal. Support rehearsals are normally performed within the framework of a single or limited number of BOS. Examples include the FS rehearsal or the CSS rehearsal. Support rehearsals are performed throughout the MDMP timeline. Although these rehearsals differ slightly by BOS, they achieve the same result:
 - Ensure the soldiers responsible for a particular BOS can support the higher commander's plan.
 - Ensure all assigned missions will be performed.
 - Synchronize the particular BOS support plan with the maneuver plan.
- Battle drill rehearsal or SOP rehearsal. The purpose of a battle drill or SOP rehearsal is to ensure all participants understand a technique or a specific set of procedures. This rehearsal is performed by all echelons, but most extensively at platoon, squad, and section levels. These rehearsals are performed throughout the MDMP timeline. This type of rehearsal is not limited to published battle drills. It could be the rehearsal of a TOC shift change, obstacle breach lane-marking SOP, actions a POL section takes at a ROM site or a section action in the defense of a radar site.

REHEARSAL TECHNIQUES

Techniques for performing rehearsals are limited only by the resourcefulness of the unit. Generally six techniques are used:

- Full dress.
- Reduced force.
- Terrain model.
- Sketch map.
- Map.
- Radio.

These six techniques range from extensive preparation, in time and resources, to minimal preparation. As they are listed, each takes a decreasing amount of time and resources to prepare and conduct. Each rehearsal technique provides different degrees of understanding for the participants and has different security risks. Figure J-1 shows the rehearsal techniques in their relative positions, considering: time, resourcing, OPSEC, participation, and level of understanding gained.

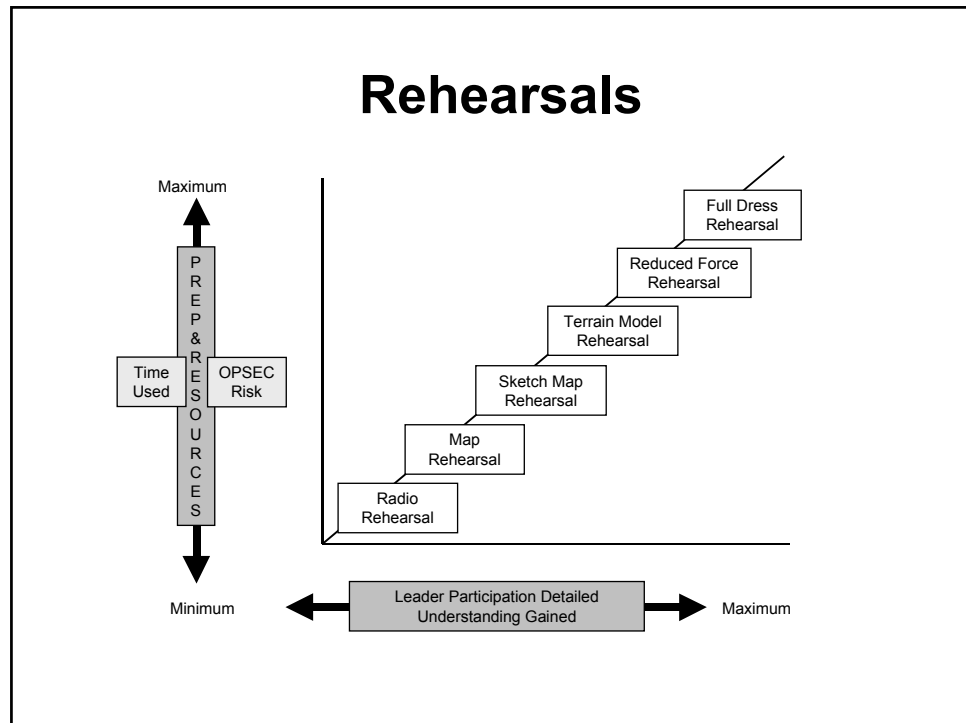

Figure J-1. Benefits and Resourcing for Rehearsal Techniques

Considerations for these six rehearsal techniques are discussed based on time, echelon, operational security (OPSEC), and terrain.

FULL DRESS REHEARSAL

The full dress rehearsal produces the most detailed understanding of the mission. It involves every soldier and system participating in the operation. If possible, units should conduct full dress rehearsal under the same conditions, weather, time of day, terrain, etc., as the force will encounter during the actual operation. This may include the use of live ammunition. The full dress rehearsal is the most difficult to accomplish, especially at higher command levels.

Considerations for the full dress rehearsal include:

- **Time.** Full dress rehearsals are normally the most time consuming of all the rehearsal techniques. At the BDE and TF levels, ensure you do not encroach subordinate unit timelines by scheduling a full dress rehearsal at your own convenience. For smaller units (company and below), full dress rehearsals are the most effective technique for ensuring everyone in the operation understands their part of the mission.
- **Technique.** Immediately prior to the full dress rehearsal, units might consider holding a reduced force rehearsal to ensure the leaders thoroughly understand the mission. Although this may look like it

will require more time, the time spent with just the leaders will ensure the full dress rehearsal goes smoothly and efficiently.

- Echelon. A subordinate unit can perform a full dress rehearsal as part of a larger unit's reduced force rehearsal.
- OPSEC. The movement of a large body of the force will certainly attract attention from the enemy. Units must develop a plan to ensure the rehearsal is protected from the eyes of the enemy.
- Terrain. Terrain management for the full dress technique can be difficult if it is not planned into the initial array of forces. The rehearsal area must be identified, secured, cleared and maintained throughout the rehearsal process. During offensive operations, a second set of graphics must be developed for the rehearsal to mirror the actual plan. During the defense, the rehearsing unit may already be occupying the terrain, and a second set of graphics may not be necessary.

REDUCED FORCE REHEARSAL

This rehearsal technique normally takes less time and resources than a full dress rehearsal because it involves only the unit's and subordinate unit's key leaders. Terrain requirements are the same as for a full dress rehearsal, only the number of participants changes. The commander first decides the level of leader involvement desired. The selected leaders then rehearse the plan while traversing the actual or like terrain. Commanders often use this rehearsal to rehearse the fire control measures in an engagement area. However, as during full dress rehearsal, it is highly susceptible to enemy combat intelligence activities. The reduced force rehearsal allows the leadership to rehearse the mission before moving to the full dress rehearsal.

Considerations for the reduced force rehearsal include:

- Time. The reduced force rehearsal normally requires less time than the full dress technique. This is an excellent way for smaller units to ensure leaders understand all required missions before moving to a full dress rehearsal. However, consider the subordinate unit's time table prior to scheduling the rehearsal.
- Echelon. A small, subordinate unit can perform a full dress rehearsal as part of a larger unit's reduced force rehearsal.
- OPSEC. This rehearsal is not as likely to become an OPSEC problem as the full dress because the rehearsing unit is smaller. However, the number of radio transmissions remains about the same as the full dress and must be considered.
- Terrain. Terrain management for the reduced force rehearsal can be just as difficult as the full dress. The rehearsal area must be identified, secured, cleared and maintained throughout the rehearsal process. As with the full dress rehearsal, a second graphic may have to be developed mirroring the actual plan but modified to fit the rehearsal terrain.

TERRAIN MODEL REHEARSAL

This rehearsal takes less time and fewer resources than the key leader rehearsal and is the most popular technique. The commander decides on the level of leader involvement, and then has a scale terrain model of the area of operations constructed. An accurate terrain model can help subordinate leaders visualize the battle and their commanders' intentions. When possible, the commander should place the terrain model where it overlooks the actual terrain of the area of operations. However, if the situation requires more security, the terrain model can be placed on the reverse slope within walking distance of a point overlooking the area of operations. The model's orientation should coincide with the actual orientation of the terrain to help participants orient to the actual area of operations. The size of the terrain model can vary from where icons are moved to represent units to a large model on which the participants can walk. A large model helps reinforce participants' perception of relative positions of units on the actual terrain.

Considerations for the terrain model rehearsal:

- **Time.** The most time-consuming part of the technique can be the construction of the terrain model. Units must have a clear SOP stating who builds it, how it is built, and when it is built to ensure the model is accurate, large enough, and in sufficient detail to rehearse the mission.
- **Echelon.** Terrain model rehearsals can easily involve many different types of leaders. This, combined with the efficient use of time, makes it a very effective multi-echelon technique.
- **OPSEC.** This rehearsal can become an OPSEC problem if the area around the rehearsal site is not secured. The collection of commanders and their vehicles can bring attention from the enemy. Upon completion of the rehearsal, ensure the terrain model is sanitized.
- **Terrain.** Terrain management is not as difficult as the previous techniques. The location of the site must be easy to find for the friendly commanders, yet invisible to the enemy. The optimum location is overlooking the terrain on which the mission will be performed.

SKETCH MAP REHEARSAL

Units can use this technique almost anywhere day or night. The procedures are the same as for a terrain model rehearsal, except the commander uses a sketch in place of a model. Sketches must be large enough for all participants to see as each subordinate walks through the interactive verbal execution of the operation. Units move symbols to represent their maneuver and location on the sketch. This technique is very effective for confirmation briefs and backbriefs.

Considerations for the sketch map rehearsal:

- **OPSEC.** As with the terrain model, this rehearsal can become an OPSEC problem if it is performed outside and the area around the

rehearsal site is not secured. Another concern is that the collection of commanders and their vehicles can bring attention from the enemy.

- Terrain. The optimum location is overlooking the terrain on which the mission will be performed.

MAP REHEARSAL

The map rehearsal procedures are similar to the sketch map rehearsal, except the commander uses a map and operation overlay of the same scale as being used to plan and control the operation.

Considerations for the map rehearsal:

- Time. The most time-consuming part is the rehearsal itself. The setup for this rehearsal is normally the easiest because it only requires maps and the current operational graphics.
- OPSEC. As with the terrain model technique, this may be an OPSEC problem if it is performed outside and the area around the rehearsal site is not secured. Another concern is the collection of commanders and their vehicles can bring attention from the enemy.
- Terrain. The optimum location is overlooking the terrain on which the mission will be performed.

RADIO REHEARSAL

The commander and his staff conduct radio rehearsals by interactively and verbally executing critical portions of the operation over established communications networks. This is accomplished in a general sequence of events that the commander establishes. Because of the obvious dangers involved with using this particular rehearsal, only the essential, most-critical portions of the operation are rehearsed. When used, these rehearsals include all communications facilities and equipment necessary to conduct that actual portion of the operation. To be effective, all participants must have working communications equipment and a copy of the OPORD and overlays. The TOC can rehearse tracking the battle simultaneously.

Considerations for the radio rehearsal:

- Time. This method can be very time consuming if the unit does not have a clear SOP for performing this rehearsal. Using this technique requires all units to have operational communications systems.
- OPSEC. As with the full dress and key leader rehearsals, this rehearsal can become an OPSEC problem because of the volume of the radio transmissions and potential compromise of information through enemy radio monitoring. A different set of frequencies should be used to protect the ones to be used for the operation. The use of wire systems is an option but does not exercise the radio systems, which is the strong point of this rehearsal technique.

SCRIPTING AND CONDUCTING THE REHEARSAL

An effective technique for controlling the rehearsals is to use a script. The script keeps the rehearsal on track and serves as the checklist to ensure that

all BOS are represented and all outstanding issues are addressed during the rehearsal. The script has four major parts:

- The agenda.
- The response sequence.
- Unit actions checklist (friendly and enemy).
- Sequence of events.

AGENDA

Rehearse using the tools you will use when fighting the battle: the OPORD, synchronization matrix, and the DST. Use these tools to drive the rehearsal and to also help keep the rehearsal focused. During fire support rehearsals, use the fire support execution matrix. These products can be used as a rehearsal agenda from company through brigade. If time is short, use the agenda as the menu to select events to be rehearsed. Since these items are issued to the subordinates during the OPORD, subordinates are more prepared for the rehearsal because they know which events will be rehearsed.

RESPONSE SEQUENCE

Ensure the players respond in a logical sequence. This sequence must be determined prior to the rehearsal. One sequence might be by BOS; another might be by unit as the organization is deployed from front to rear. Whatever sequence you use, it must be determined before the rehearsal. Posting the response sequence at the rehearsal site is helpful.

UNIT ACTIONS CHECKLIST

- Friendly. Each player uses a standard format to describe his unit or staff action. Use of this type of checklist ensures that all significant points are covered quickly. This also helps increase the understanding of the other players because they are able to key on a common sequence of information. Properly used, the checklist allows the rehearsal to move quickly and improves comprehension.
- Enemy. The enemy force must be portrayed effectively and quickly without distracting from the rehearsal. A technique is to establish a unit action checklist like that of the friendly units, but from the enemy perspective.

SEQUENCE OF EVENTS

The following paragraphs provide a generic sequence of events for a rehearsal. Although developed for a combined arms rehearsal, this sequence can be used for FS rehearsals with a few modifications. This example can be used for BDE-, BN/TF-, or CO/TM-level rehearsals and will support any rehearsal technique.

- Step 1. Ground rules.
 - Call roll; **START ON TIME**.
 - Quickly review your SOP to see if you have new players at the rehearsal.

- Ensure a recorder is ready.
- State the agenda being used (OPORD, synchronization matrix or DST) and the rehearsal type.
- Provide an orientation to the rehearsal tools (terrain model or visible key terrain, unit icons, etc.) and important graphic control measures.
- Designate the point in the operation that the rehearsal will start. One event prior to the first event being rehearsed allows for proper deployment of forces.
- Ensure everyone understands the parts of the plan to be rehearsed.
- Step 2. Deploy the enemy. Deploy the enemy on the rehearsal product, as they would look at the rehearsal start point. Restating the enemy equipment should not be required.
- Step 3. Deploy the friendly. Deploy the friendly forces (including adjacent units) at the rehearsal start point. As friendly units are initially posted to the rehearsal product, they should state their:
 - Task and purpose, task organization and strength.
 - Some units may need to brief their subordinate unit positions at the start time, as well as any particular points of emphasis to include FARPs, and ROM.
- Step 4. Advance the enemy. Begin advancing the enemy on his most likely course of action (situational template) as it pertains to the point on the execution matrix. Since in Step 2 the enemy was deployed up to the point the rehearsal will start, the enemy continues to maneuver from there. Depiction must be definitive, tying enemy actions to specific terrain or friendly units' actions. An accurate portrayal of the situational template developed for the staff wargaming process must be communicated. The enemy is uncooperative, but not invincible.
- Step 5. Decision point. Upon completion of the enemy action, conditions must be assessed to determine if a decision point has been reached. These are the decision points taken directly from the DST.
 - At a decision point: as decision points are reached, the XO states the conditions for success. The commander states his decision to continue on the current course or select a branch.
 - If the commander decides to continue the current COA, the next event from the matrix is stated and the friendly units are advanced (Step 2).
 - If a branch is selected, the commander states why he has selected that branch. The first event of that branch is stated, and the rehearsal continues from that point until all events of the branch are rehearsed.

Not at a Decision Point: if the unit is not at a decision point and not at the desired end state, then the rehearsal continues with the XO stating the next event on the synchronization matrix, and friendly units are advanced (Step

2). Use the predetermined sequence as units continue to act out and verbalize their actions.

- Step 6. End state of the branch is reached. End the initial phase of the rehearsal after the desired end state of the COA or the branch is achieved. In an attack this will usually be on the objective after consolidation and casualty evacuation are complete. In the defense, this will usually be after the decisive actions such as the commitment of the reserve, the final destruction or withdrawal of the enemy, and casualty evacuation are complete.
- Step 7. Recock. After the initial phase, "recock" to the situation at the first decision point. The XO should state the criteria for a decision to change the plan. Assume these criteria have been met and then re-fight the fight from that point forward, all the way until the desired end state is attained. Complete any coordination to ensure understanding and requirements are met; record any changes. Go to the next decision point and assume that the criteria have been met. Repeat the previous steps until all decision points and branches have been rehearsed.
- Step 8. Follow-up and coordination. As small issues arise during the rehearsal, they are recorded. At the end of the rehearsal, the recorder states these issues for review and final decision. This ensures the flow of the rehearsal is not interrupted. "War stopping" issues raised anytime during the rehearsal must be immediately addressed. This coordination is one of the key points of the rehearsals. If it is not done immediately, it will be difficult to get the word to all the players later.

STAFF SUPPORT ACTIONS

The staff updates the DSM/DST and provides it to each leader prior to departure. The targeting officer and radar section leader will be personally involved in updating TA related products. These include input to the RS&S plan, radar zones, cueing agents, triggers and radar movement and positioning. This is the final opportunity for subordinates to identify and resolve dangling issues. Make sure all coordination done at the rehearsal is clearly understood by all players and captured by the recorder. All changes to the published order are, in effect, verbal FRAGOs. As soon as possible, the battle staff should collect the verbal FRAGOs into a written change to the order.

BRIGADE FIRE SUPPORT REHEARSAL

Fire support rehearsals are important for ensuring the synchronization of the fire support plan with the scheme of maneuver. Technical fire control details should be addressed in the DS FA battalion and FA technical rehearsals. The fire support rehearsal should focus on maximizing the ability of the fire support system to support the plan and achieve the commander's intent.

Although this is a FS rehearsal, the brigade must be closely involved to ensure synchronization of the FS plan with the maneuver plan. Whenever possible, the brigade commander should participate as well. Normally the

brigade sends the XO, S-3, S-4, S-2, engineer, FSO, ALO, targeting officer, army aviation LNO, forward support battalion (FSB) representative, and the striker platoon leader and strikers, if available. Key representatives from the DS FA battalion include the commander, S3, S2, FDO, and radar section leader. From the maneuver TFs, the commander, if available, S-3, FSO, scout platoon leader, and mortar platoon leader. The DS FA battalion commander normally conducts this rehearsal for the brigade commander. The brigade FSO and the targeting officer assist him.

The FS rehearsal normally lasts about 1 to 1½ hours. There is seldom time to rehearse every target. Rehearse at a minimum the priority targets. The purpose of the FS rehearsal is to ensure synchronization of the FS effort within the unit and to ensure that the FS plan supports the commander's intent. FS rehearsals should occur prior to the combined arms rehearsal. Normally the technique selected for the rehearsal is the radio technique, although the terrain model technique works as well.

REHEARSAL SCRIPT

- Step 1. - Agenda. Use the fire support execution matrix. Normally prior to the rehearsal, the DS FA battalion FDO will announce the brigade consolidated target list by number, grid and any special instruction for the targets. Establish the response sequence early, and post where all participants can see it. See Figure J-2. If the FS rehearsal occurs prior to the combined arms rehearsal, then selection of branches to rehearse is done by the FSCoord. If it occurs after the combined arms rehearsal, then the sequence the branches are rehearsed mirrors that of the proceeding combined arms rehearsal.

<p style="text-align: center;">Friendly Unit Actions</p> <ul style="list-style-type: none">• What is the task and purpose of the action or target?• When are the conditions or trigger met?• Where is the target, and where is the observer location?• Who is responsible for the target, the backup, which radio net and backup?• What are the desired effects?

Figure J-2. Friendly Unit Actions

- Step 2 – Deploy the enemy. Intelligence update as required.
- Step 3 – Deploy the friendly. The FSCoord states the FSCM in effect at the starting point of the rehearsal and provides last-minute guidance.
- Step 4 – Advance the enemy. The DS FA battalion S2 and targeting officer advance the enemy one critical event at a time. When the S2

finishes describing the event, all fire supporters execute their portion of the fire support plan triggered by the action.

- Example scenario:
 - The following is a deliberate attack example. The response sequence is front to rear; several units were left out for brevity. The sequence is: striker, TF Mech, TF 1-1, . . . ALO, . . . and S2. The DS FA battalion S2 states: It is now H+6. SBF Mech has been established; all three enemy platoon positions are being obscured by smoke and suppressed by SBF Mech. TF 1-1 is moving on Axis Slam just approaching PP1.
 - The striker team would respond: This is striker team 2; I am backup for TGT AE0005 vicinity NA123456. TF 1-1's closure on PP1 is the trigger to fire. I will observe the TGT from vicinity NA 345678 and call it on FS net. . . . The alternate method is. . . .The TGT purpose is. . . .The desired effects are. . . . Break. . . .FDC, this is striker team 2 fire TGT AE0005, over. The FDO would repeat the call for fire and issue a message to observer to include time of flight. The observer would end the mission.
 - The TF Mech FSO would respond: No Action.
 - The TF1-1 FSO would respond: This is TF 1-1 FSO; I am the priority for TGT AE0005. Our closure on PP1 is the trigger to fire TGT AE0005, NA 123456. Alpha Team FIST will observe the TGT from vicinity NA 234567 and call it on FS net. . . .The alternate method is. . . .The TGT purpose is. . . . The desired effects are. . . .Break. . . .FDC, this is TF1-1 FSO fire TGT AE0005, over. The FDO would repeat the call for fire and issue a message to observer to include time of flight. If the Alpha Team FIST is participating, then he would fire the TGT instead of the TF FSO. The observer would end the mission.
 - The ALO would state: This is BDE ALO, TF 1-1 closure on PP1 is my trigger. Four A-10s with Mavericks are at IP Cheese. The ALO would continue with magnetic heading from IP to TGT, TGT description, location, and elevation, method of marking location of friendlies, egress, time from IP to target. Any SEAD or ACA changes in support of CAS should be rehearsed with the CAS mission.
 - The S2 or targeting officer states: radar section 1 , this is S2/targeting officer. TF 1-1 closure on PP1 is my trigger, call for fire zone number 1, and critical friendly zones 4, 5, and 6 are in effect now. Cue radar schedule Jane, 12 minutes, over.
 - The radar section leader would respond: S2/targeting officer, this is radar section leader, call for fire zone number 1, and critical friendly zones 4, 5, and 6 are in effect. Cue radar schedule Jane, 12 minutes, out.

For each target rehearse grid location, trigger point, engagement criteria, primary and backup observer and communications method, method of engagement and attack guidance. Ensure the DS battalion S3 presents the battery movement plans and out-of-action cycles. Rehearse the radar target

handoff and include clearing the fires at the TF level if TF FSOs are involved. The rehearsal of priority counterfire targets is required when rehearsing priority targets. Have the radar section leader insert one or two acquisitions per phase of the rehearsal.

- Steps 5 – 8 are conducted as previously discussed.

RESULTS

This rehearsal ensures the validity of the FS plan. It illustrates why fires are needed in relation to specific maneuver events and what they are intended to accomplish. It crosswalks observers with shooters and ties them to a condition or event on the battlefield. It ensures that FS performs the assigned EFSTs and meets the commander's intent. When properly performed, the rehearsal practices the redundancy of observers and nets by having both the backup and primary shoot the targets. The FS plan is validated with the scheme of maneuver, the commander's intent, and attack guidance. It ensures the obstacle plan is coordinated with the FS plan and both support the maneuver plan. Finally it ensures the control measures for protecting and controlling aerial and ground forces are in place, integrated, and understood by all.

BRIGADE COMBINED ARMS REHEARSAL

After receiving an OPORD, subordinate leaders must be afforded the necessary time to complete their own planning prior to a parent unit's combined arms rehearsal. This planning window provides time for critical mission analysis, course-of-action development and analysis, and OPORD publishing. This ensures subordinate commanders have time to assign responsibility for specified tasks and resolve issues discovered in the parent commander's OPORD.

The commander, XO, and primary staff, the subordinate unit commanders and their S3, targeting officer, S2, and FSO must attend. Other pivotal players in the unit mission must attend as well. These include the normal leadership slice along with units operating in direct support such as aviation units and strikers. Whenever possible, flank units and the higher unit should be invited to attend. When time is short, attendance may be modified.

Usually, there is insufficient time to rehearse the entire operation. About 1 to 1 1/2 hours is a good rule but is METT-TC dependant. If too much time is consumed, separate BOS support rehearsals and subordinate unit combined arms rehearsals will lack sufficient time. Ensure you prioritize those critical events that demand leader visualization of their synchronization. Rehearse the most important event first, and, as time permits, continue to rehearse subsequent events. Subordinates should arrive prepared to rehearse the prioritized events.

REHEARSAL SCRIPT

- Agenda. Use the DST and the synchronization matrix to facilitate the rehearsal. Establish the response sequence before the rehearsal starts. Post it where all participants can see it.

Appendix K

Example Tools And Procedures

There are numerous factors that must be considered when employing target acquisition assets on the battlefield. The purpose of this appendix is to provide a collection of formats, procedures, and ideas that have been collected from Combat Training Centers (CTCs), and TO&E units that can be used to facilitate radar mission planning and employment. Most of the forms and procedures can be modified to meet changing unit requirements

FIREFINDER RADAR SECTION TROOP LEADING PROCEDURES

Employment of Firefinder radars must meet the commander's intent/guidance and be synchronized with the scheme of maneuver. Troop leading procedures and the radar section leader's involvement in the planning process are essential for successful radar employment and responsive counterfire. The radar section leader requires usable tools to facilitate mission preparation and execution. The ability to develop and issue clear warning orders, time lines, pre-combat checks, pre-combat inspections, and priorities of work are key to any successful mission.

Troop leading procedures provide the required guidance to focus the radar section's preparation for and execution of the radar employment plan. Using standard troop leading procedures helps clarify mission requirements, fix responsibilities and make the best use of available time. Troop leading procedures provide a vehicle for preparing the section for operation and help free the radar section leader to participate in the DS battalion's counterfire planning process.

SUGGESTED TROOP LEADING PROCEDURES

- Receive the mission (SITTEMP, operations graphics, RDO/execution matrix).
 - Perform mission analysis, assess threat (S2/G2, radar section leader, section chief).
 - Review critical tasks, positioning guidance, planned zones (S2/G2, radar section leader, section chief).
 - Prioritize pre-combat inspections (PCIs) and pre-combat checks (PCCs), (radar section leader, section chief).
 - Prepare a timeline (radar section leader, section chief).
 - Conduct risk assessment/management.
- Issue a concise warning order to your section, (radar section leader).
 - Section mission.
 - Positioning guidance.

- Threat and counter measures.
- PCI priorities.
- Timeline.
- Make a tentative plan, (radar section leader, section chief).
 - METT-TC Considerations.
 - Logistical resupply.
 - Survivability measures.
 - Section rehearsals, (site occupations/displacements, defense, etc.).
- Initiate movement, (radar section leader, section chief).
 - Conduct PCIs.
 - Perform rehearsals.
 - Issue movement order and risk assessment.
- Conduct reconnaissance, (radar section leader or section chief).
 - Select sites to support mission requirements.
 - Perform/coordinate survey requirements.
 - Make site assessments for survivability, maneuver support, site defense, etc.
- Complete the plan, (radar section leader, section chief).
 - Report site assessments to S2/G2.
 - Prepare a verbal order for section.
 - Develop route strip maps, preliminary site defense plan.
 - Develop battle-tracking overlays for reconnaissance vehicle and shelter.
- Issue the order, (radar section leader, section chief).
 - Focus on movement, positioning, site defense and survivability measures.
 - Be clear and concise.
 - Require a back brief from the section chief and senior radar operators. This should be a section huddle, each member must understand their role.
- Supervise, (radar section leader, section chief).
 - Final PCIs.
 - Crew drill rehearsals for occupations, site, defense, shelter, and NBC operations.
 - Execution.

Troop leading procedures can and should be modified to facilitate planning and execution of each mission. The steps do not have to happen sequentially and may happen simultaneously as METT-TC dictates.

RADAR SECTION WARNING ORDER (WARNO)

The warning order (WARNO) given to the radar section must specify the initial mission statement and tasks required to perform the mission. The example in Figures K-1 and K-2, Radar Section WARNO, provide a tool for

the extraction of pertinent information from the MDMP and subsequent briefings. This example can be modified as required.

RADAR SECTION WARNO			
SITUATION		DTG:	
ENEMY:	THIS UNIT FACES THE FOLLOWING ENEMY FORCES;		
SIZE:		FORMATION:	
ENEMY ARTILLERY:			
ELINT THREAT:			
FRIENDLY:	THIS UNIT WILL CONDUCT	OFFENSIVE OR DEFENSIVE OPNS	
	WE WILL LD OR BE READY TO DEFEND NLT:	DTG:	
SECTION MISSION		DS OR GS	
EXECUTION:			
CRITICAL TASKS:			
CONDUCT THE FOLLOWING PCCs IN PRIORITY:			
(2)	(3)	(4)	(1)
(5)	(6)	(7)	
TIMELINE OF CRITICAL EVENTS:		DTG:	
EVENT:		TIME/LOCATION IF APPROPRIATE	
FA ROCK DRILL			
FA TECH REH/CF BATTLE DRILL			
FS REHEARSAL			
PCC/PCIs COMPLETED NLT:			
OPORD BRIEF			
RECON/SITE SELECTION			
MOVEMENT/R3P			
READY TO OBSERVE NLT:			

Figure K-1. Radar Section Warning Order

RADAR SECTION WARNO (CONT.)			
SERVICE AND SUPPORT			
CLASS:	RESUPPLY TRIGGER:		
I			
III			
IV			
V			
VIII			
LRP/R3P DATA:			
COORDINATION FOR EXTERNAL SUPPORT:			
DS RDR/MAINT:			
VEHICLE RECOVERY:			
COMMAND AND SIGNAL			
SOI ADDITION/DIGITAL COMSEC:			
REPORTING FREQUENCIES: VOICE:		DIGITAL:	
MEDEVAC/CAS FREQUENCY:		CALL SIGN:	
CHALLENGE/PASSWORD:		DTG:	
PRIORITIES OF WORK			
1			
2			
3			
4			
5			
6			
7			
8			

Figure K-2. Radar Section Warning Order (cont.)

RADAR DEPLOYMENT ORDER DA FORM 5957-R

(CLASSIFICATION WHEN FILLED IN)

RADAR DEPLOYMENT ORDER							
For use of this form, see FM 6-121. The proponent agency is TRADOC.							
SECTION		Q-36/Q-37		MISSION			
LOCATION	Primary			Alternate			
SEARCH SECTOR							
	Left Edge	Right Edge	Minimum Range	Maximum Range			
Primary Azimuth	mils	mils	meters	meters			
Alternate Azimuth	mils	mils	meters	meters			
EW THREAT ASSESSMENT							
EW Threat (Yes or No)		Affecting Friendly Assets (Yes or No)			Type of Threat (Air or Ground)		
NOTE: Use the Firefinder survivability flowchart in FM 6-121 to determine emission limits.							
CUEING AGENTS (CALL SIGN AND DESIGNATION) IN PRIORITY							
REPORTING CHANNELS							
ZONE DATA							
Type and Number	Description and/or Command Priority	Grid Coordinates of Zone Corner Points					

DA FORM 5957-R, OCT 2000

(CLASSIFICATION WHEN FILLED IN)

Figure K-3. Radar deployment Order

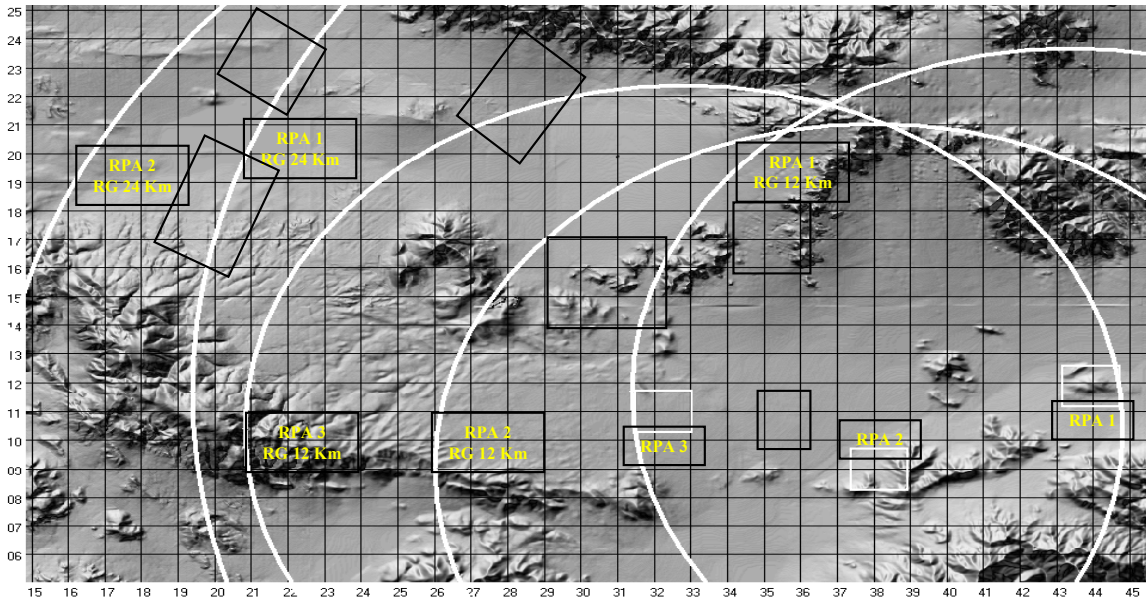

Enemy: Remnants of the 173d MRR(-) opposite 3 BCT to est. an MRB(-) sized security zone to delay & attrit the BCT and gain time & space for follow on forces from the 71st MRR(-) to build a main Defensive area.				PCC/PCI: CASEVAC, React to NBC & Atk.				Risk Management: Accidental/Tactical Risk Conducted at section level.							
Mission: 3BCT, 52ID, attacks in zone to destroy 25th MIBR & to seize key terrain vic NV 2224 & NV 2319 to protect the flank of the 52ID Main Effort (1BCT).				Phase I 181800L				Phase II TF 1-12 crosses LD				Phase III Obj Meade secured			
EFST: Disrupt effective RAG fires against TF 1-12 in its SBF position, TF 2-34 during breaching operations, and TF 1-14 during their assault on OBJ MEADE.				RDR Loc.				21601952				17082055			
EFAT: Destroy 18 of 36 RAG cannon systems.				AOS				5200				5200			
Security Assets Inf Sec / A 1-12 TF Survivability Assets: None				CUE Schd				IVY				IVY			
Q37 Coverage: DIVARTY provides coverage once TF 1-12 LDs				Ready to Cue				181800L				190800L			
Q36 Mvmt Plan: O/O Follows TF 1-12				Alt Loc.				500 mtrs				N/C			
				L Sector				-800				N/C			
				R Sector				800				N/C			
				Digital Freq.				FH 109				N/C			
				Voice Freq.				FH 107				N/C			
Name	Type	Purpose	Trigger	Grids											
Raider 2	CFZ	Protection of TF 1-12 in SBF, Breach & Obj Patton	TF 1-12 Crosses PL PIG	5123, 5523, 5519, 5119	OFF	ON	ON								
Dragon 1	CFZ	Protection of TF 1-14 in Obj Meade	TF 1-14 Crosses PL Rat	5816, 6216, 6221, 5721	OFF	ON	ON								
Thunder 1	CFFZ	Facilitate the Destruction of enemy FA systems in the RAG.	181800L	5318, 6215, 6210, 5310	ON	ON	ON								

Figure K-5. Example Modified RDO/Execution Matrix

QUICK REFERENCE POSITION SELECTION WORKSHEET

The following is an example of a quick reference position selection worksheet. This tool may be used with other IPB products in the selection of radar positions.

QUICK REFERENCE POSITION SELECTION WORKSHEET	
METT-TC	
MISSION:	Know the critical fire support tasks, the maneuver commanders force protection priorities and understand the scheme of maneuver, (FA ORDERS PROCESS, combined Arms and Fire Support rehearsals).
ENEMY:	Know the enemy situation, most recent spot reports, templated chemical strike locations, FASCAM, obstacles, avenues of approach, (SITE MP, S2, Intel SIT map).
TERRAIN:	(Weather), Know the terrain so it can be used to your advantage. Use it to mask your movement, provide cover and concealment, screening crests etc. Additionally, know the severely restricted terrain areas, slope and masking problem areas. Don't forget weather, heavy rains and high winds can degrade operations.
TROOPS:	Know the adjacent unit and concentration of friendly troops in the AO, also coordinate support for MEDEVAC, AID station, DECON and EPW requirements.
TIME:	Consider the time available for reconnaissance, coordination, movement, occupation and site preparation.
CIVIL:	Consider radar impact on civilian population, hostile local populace and security of section personnel
SITE ASSESSMENT CHECKLIST	
Does this position optimize the probability of the acquisition of templated enemy artillery fires?	
Considering the doctrinal phases and focus of enemy fires, does this position provide the optimum aspect angle?	
Does the position maximize the usage and cover and concealment?	
Is the position defensible?	
Does this position provide good counter measures for an ELINT threat, (screening crest, tunneling etc.)?	
Is there an adjacent unit to provide security?	
NOTE: Plot as much data as possible on the map used to navigate and battle track. Monitor the appropriate frequencies to receive intell updates. Always prepare a site assessment for each site selected and back brief the S2. Plan and mark the routes to and from selected radar sites, make a strip map and ensure you give copies to the section chief.	

Figure K-6. Quick Reference Position Selection Worksheet

RADAR POSITIONING AND MOVEMENT SYNCHRONIZATION CHECKLIST

The radar positioning and movement synchronization checklist can be used in conjunction with the RDO or Execution Matrix, and the quick reference position selection worksheet to assist in synchronizing the radar with the fire support plan.

RADAR POSITIONING AND MOVEMENT SYNCHRONIZATION CHECKLIST	
REQUIRED INFORMATION/LOCATION	KNOWN DATA
TEMPLATED THREAT ARTILLERY LOCATIONS, RAG: SITEMP	
OBJECTIVE AREAS, (WHERE THE ENEMY WILL FOCUS INDIRECT FIRES): OPNS MAP	
ENEMY AVENUES OF APPROACH AND OTHER KNOWN THREAT DATA	
MAIN AVEs OF APPROACH	
RECON AVEs OF APPROACH	
TEMPLATED CHEM STRIKES, FASCAM, OBSTICLES	
TERRAIN RESTRICTIONS: MCOO	
MOVEMENT/POSITIONING TERRAIN LIMITATIONS, I.E. RESTRICTED OR SEVERLY RESTRICTED TERRAIN, SLOPE AND SCREENING CREST	
VISIBILITY PROBLEM AREAS, INTERVENING CRESTS, OPTIMUM ASPECT ANGLE/RANGE CONSIDERATIONS	
COMMUNICATION CONSIDERATIONS, RANGE, RETRANS, REPORTING CHANNELS, DIGITAL LINKS	
SERVIVABILITY MEASURES, (ADJACENT UNIT COORDINATION, EW CONSIDERATIONS	
REMARKS:	
NOTE: Fill in required data in known data field, the majority of this information should be posted on a battle map and used to navigate and facilitate site selection.	

Figure K-7. Radar Position and Movement Synchronization Checklist

VOICE RADAR REGISTRATION PROCEDURE

The following is an example of how to perform a radar registration using FM voice communications.

- **BN FDC** (BTRY FDC), this is (BN FDC), Perform (type) (Radar) registration at grid _____, altitude _____, over.
- **(BTRY) FDC** Perform (type) (Radar) registration at grid _____, Altitude _____, out.
- **(BTRY) FDC** (Radar) This is (BTRY FDC), prepare to copy, over.
- **(RADAR)** (BTRY FDC) This is (Radar), prepare to copy, out.
- **(BTRY) FDC** (Radar) This is (BTRY FDC), observe (type) (IE: MPI, High burst, datum plane) registration, at grid _____, altitude _____, MAX ORD _____, QE _____ (specify if meters or feet), and HEIGHT OF BURST _____ (if a high burst or datum plane), firing unit grid _____, firing unit altitude _____, report ready to observe, over.
- **(RADAR)** Observe (type) registration at grid _____, altitude _____, max ord _____, QE _____, and height of burst _____ (if necessary), firing unit grid _____, firing unit altitude _____, will report ready to observe, out.
- **(RADAR)** (BTRY FDC) this is (Radar), ready to observe, request shot and splash, over.
- **(BTRY) FDC** Request shot and splash, out.
- **(BTRY) FDC** (BTRY), Shot, over.
- **(RADAR)** (BTRY), Shot, out.
- **(BTRY) FDC** (BTRY), Splash, over.
- **(RADAR)** (BTRY), Splash, out.
- **(RADAR)** (BTRY FDC) Did hit grid _____, over.
- **(BTRY) FDC** Did hit grid _____, out.

At this point repeat the last 6 steps until the necessary number of good rounds have been observed by radar. BN FDC will end mission.

- **(BN FDC)** (Radar) and (BTRY FDC), this is (BN FDC), End of mission, over.
- **(RADAR)** End of mission, out.
- **(BTRY) FDC** End of mission, out.

NOTE: Height of burst for Radar Registrations is the height of registration point plus height of ground above sea level (The height of the registration point above sea level). Radar will forward did hit information for each to BN/BTRY FDC via normal mode of communication.

VOICE RADAR ADJUST FIRE MISSION

The following is an example for performing a Radar adjust fire mission using voice FM communications.

- **(RADAR)** (BN FDC), This is (Radar), Hostile weapon (Number and type of possible) firing, at grid _____, Altitude _____, Time _____, over.
- **BN FDC** Hostile weapons firing at grid _____, out.
- **BN FDC** (BTRY FDC), This is (BN FDC), conduct adjust fire mission with (Radar), at grid _____, Altitude _____, over.
- **(BTRY) FDC** Conduct (Radar) Fire Mission, at grid _____, altitude _____, out.
- **(BTRY) FDC** (Radar), This is (BTRY FDC), authenticate _____, over.
- **(RADAR)** I authenticate _____, out.
- **(BTRY) FDC** (Radar), This is (BTRY FDC), MAX ORD _____, QE _____, ALTITUDE _____. Request ready to observe, over.

NOTE: (BTRY) will also have to provide grid and altitude of firing BTRY (center gun) if Radar does not have this information already.

- **(RADAR)** Max ord _____, QE _____, ALTITUDE _____ out. (At this point, wait while Radar loads their computer with information.)
- **(RADAR)** (BTRY FDC), This is (Radar). Ready to observe, request shot and splash, 1 round, over.
- **(BTRY) FDC** Request shot and splash, 1 round, out. (Wait for guns to fire.)
- **(BTRY) FDC** (BTRY), Shot, over.
- **(RADAR)** (BTRY), Shot, out.
- **(BTRY) FDC** (BTRY), Splash, over.
- **(RADAR)** (BTRY), Splash, out.
- **(RADAR)** (BTRY FDC), Did-hit grid is _____, over.
- **(BTRY) FDC** Did-hit grid _____, out. (At this point (BTRY) makes corrections.) NOTE: Subsequent adjust rounds may be required.
- **(RADAR)** (BTRY FDC), This is (Radar), fire for effect, request shot and splash, over.
- **(BTRY) FDC** Fire for effect, request shot and splash, out.

At this point, Radar will follow the mission, like a friendly fire mission, to compile did-hit information.

- **(BTRY) FDC** (BTRY FDC), Shot, over.
- **(RADAR)** (BTRY FDC), Shot, out.
- **(BTRY) FDC** (BTRY FDC), Splash, over.
- **(RADAR)** (BTRY FDC), Splash, out.

Repeat the previous 4 steps until (BTRY) completes rounds and Radar logs did-hit information.

- **(BTRY) FDC** (Radar), This is (BTRY FDC), Rounds complete, over.
- **(RADAR)** (BTRY FDC), Rounds complete, out.
- **(RADAR)** (BTRY FDC), This is (Radar). End of mission, over.
- **(BTRY) FDC** (Radar), End of mission, out.

Radar will then forward did-hit information to BN/BTRY FDC via normal mode of communications.

JOINT AIRLIFT INSPECTION CHECKLIST

DD Form 2133 is used by the Military Airlift Command for the inspection of equipment to be loaded on military aircraft.

JOINT AIRLIFT INSPECTION RECORD								PAGE	OF	PAGES		
<i>(See Instructions on back.)</i>												
1. UNIT BEING AIRLIFTED				2. DEPARTURE AIRFIELD				3. DATE (YYYYMMDD)				
4. AIRCRAFT TYPE AND MISSION NUMBER				5. LOAD/CHALK NO.	6. START TIME	7. COMPLETE TIME	8. TALCE/CDF					
LEGEND <i>(Mark blocks after each item as follows)</i> ✓ = SATISFACTORY X = UNSATISFACTORY IF NOT APPLICABLE, LEAVE BLANK				INCREMENT/SERIAL/BUMPER NUMBER AND TYPE								
A. DOCUMENTATION												
9. MANIFESTS/LOAD PLANS												
10. SHIPPERS DECLARATION												
11. HAZARDOUS MATERIALS PREPARATION												
12. LOAD LISTS/CARGO TRANSFER FORMS												
B. VEHICLES/NON-POWERED EQUIPMENT												
13. CLEAN												
14. FLUID LEAKS												
15. MECHANICAL CONDITION												
a. ENGINE RUNS												
b. BRAKES OPERATIONAL												
16. BATTERY												
a. SECURE - NO LEAKS												
b. POST/CABLES PROTECTED												
17. FUEL TANK(S) LEVELS												
a. AS REQUIRED												
b. FUEL TANK CAPS INSTALLED												
18. JERRY CANS												
a. DOT 5L (Metal)												
b. POP (Plastic)												
19. DIMENSIONS <i>(Fits A/C Profile or Contour)</i>												
20. CENTER OF BALANCE <i>(Both Sides)</i>												
21. SCALE WEIGHT <i>(Both Sides)</i>												
22. AXLE WEIGHTS <i>(Both Sides)</i>												
23. TIEDOWN POINTS <i>(Serviceable)</i>												
24. PINTLE HOOKS/CLEAVISES												
a. SERVICEABLE												
b. SAFETY PIN ATTACHED <i>(Safety Chains)</i>												
25. VEHICLE EQUIPMENT SECURE <i>(Tools, tires, etc.)</i>												
26. TIRE PRESSURE												
27. SHORING <i>(Rolling, Parking, Sleeper, Approach)</i>												
28. ACCOMPANYING LOAD												
a. WITHIN VEHICLE RATED CAPACITY												
b. SECURE TO VEHICLE												
29. LOX/NITROGEN CART <i>(Vent Kill)</i>												
C. PALLETS/PALLET TRAINS												
30. CLEAN												
31. SCALE WEIGHT												
32. DIMENSIONS <i>(Fits A/C Profile or Contour)</i>												
33. CARGO PROPERLY SECURED												
a. NETTED												
b. CHAINED/STRAPPED												
34. DUNNAGE <i>(3 Pieces Per Pallet)</i>												
D. HELICOPTERS <i>(Flyaway)</i>												
35. FUEL QUANTITY <i>(Gallons)</i>												
36. BATTERY <i>(Disconnected/Taped)</i>												
37. CENTER OF BALANCE <i>(Both Sides)</i>												
38. SCALE WEIGHT <i>(Both Sides)</i>												
39. SHORING <i>(Rolling, Parking, Approach)</i>												
40. SPECIAL LOADING EQUIPMENT <i>(Towbars, etc.)</i>												
41. REMARKS												
THE ABOVE LISTED ITEMS HAVE BEEN INSPECTED FOR PROPER SHIPPING CONFIGURATION.												
42. DEPLOYING FORCE REPRESENTATIVE <i>(Signature/Rank/Unit of Assignment)</i>						43. MOBILITY FORCE INSPECTOR <i>(Signature/Rank/Unit of Assignment)</i>						

DD FORM 2133, OCT 1998 (EG)

PREVIOUS EDITION IS OBSOLETE.

Figure K-8. Joint Airlift Inspection Record (side 1)

INSTRUCTIONS	
<u>1. RESPONSIBILITIES</u>	
1.1. Qualified TALCE/CDF or aerial port personnel are responsible for acceptance of cargo for airlift.	
1.2. The deploying unit is responsible for the preparation of cargo, including weighing, marking, palletization, and the preparation of all documentation.	
1.3. The joint inspection, including documentation and inspection of all items prepared for air shipment, must be accomplished prior to loading. This inspection will be performed by qualified TALCE/CDF or aerial port personnel with a representative from the transported force.	
<u>2. INSPECTION PROCEDURES</u>	
2.1. All inspections will be conducted by qualified inspectors and transported force representatives. The TALCE/CDF or aerial port representative accepting cargo for air shipment must have completed hazardous materials inspector training required by paragraph 1.17.3, AFJMAN 24-204/TM 38-250/NAVSUP PUB 505/MCO P4030.19F/DLAM4145.3. The completed form will indicate to the aircraft loadmaster that the required inspection has been accomplished.	
2.2. This form will be used as the source document for joint inspection. Three copies will be completed for each aircraft load and sign by the appropriate personnel.	
(1) One signed copy will be attached to the aircraft cargo manifest.	
(2) One signed copy for the TALCE/CDF or aerial port station file.	
(3) One signed copy for the transported force.	
<u>3. PREPARATION INSTRUCTIONS</u>	
3.1. Heading.	
(1) Block 1, Unit Being Airlifted. Enter the numerical designation and geographic location of the military unit responsible for the equipment being airlifted. For example, 1st Tactical Fighter Wing, Langley AFB VA.	
(2) Block 2, Departure Airfield. Enter the name of the facility the airlifted unit is departing, i.e., Langley AFB VA.	
(3) Block 3, Date. Day, month and year that the inspection is accomplished.	
(4) Block 4, Aircraft Type and Mission Number. Enter the aircraft type on which the equipment is to be loaded and the airlift mission number as designated in the plan or operations order.	
(5) Block 5, Load/Chalk Number. Enter the deploying force assigned aircraft load number that establishes the desired load movement sequence.	
(6) Block 6, Start Time. Enter the local time that the inspection was started.	
(7) Block 7, Complete Time. Enter the local time that the load was checked, and is ready for movement.	
(8) Block 8, TALCE/CDF. Enter the numerical designation of the unit that has TALCE/CDF or aerial port responsibility for the operating location.	
3.2. Body.	
(1) Enter the increment/serial/bumper number and type of equipment in the appropriate block. The legend for completing the inspection is contained in the block on the left. Annotate the appropriate entry in the proper column. Make only one entry in each inspection block for each item.	
(2) Enter items not initially accepted in the remarks section and indicate corrective action.	
(3) Blocks 42 and 43. Signature must be legible. Indicate the rank and unit of assignment of the individual signing the form.	

DD FORM 2133 (BACK), OCT 1998

Figure K-9. Joint Airlift Inspection Record (side 2)

RISK MANAGEMENT WORKSHEET

The risk management worksheet provides a starting point to logically track the process of assessing hazards and risks. It is used to document risk management steps taken during the planning, preparation, and execution of training and combat missions and tasks. Use the following guidelines for completing the worksheet:

- Block A-D: Self explanatory.
- Block E: Identify the specific task relating to the mission or overall task to be performed.
- Block F: Identify Hazards – Identify hazards by reviewing METT-TC factors for the mission or task.
- Block G: Assess Hazards – Assessment includes historical lessons learned, intuitive analysis, experience, judgment, equipment characteristics and warnings, and environmental considerations. Determine the initial risk for each hazard by assessing the probability and severity.
- Block H: Develop Controls – Develop one or more controls for each hazard that will either eliminate the hazard or reduce the risk of a hazardous incident. Specify who, what, where, why, when and how for each control.
- Block I: Determine Residual Risk – Determine the residual risk for each hazard by assessing the probability and severity.
- Block K: Determine Overall Mission/Task Risk – Select the highest residual risk level and circle it. This becomes the overall mission or task risk level. The commander decides whether the controls are sufficient to accept the level of residual risk. If the risk is too great to continue the mission or task, the commander directs development of additional controls or modifies, changes, or rejects the COA.
- Supervise and Evaluate – This step is not on the worksheet. Plan how each control will be monitored for implementation and reassess hazards as the situation changes. Determine if the controls worked and if they can be improved. Pass on lessons learned.

A. Mission or Task:		B. Date/Time Group: Begin: End:		C. Date Prepared:	
D. Prepared By: (Rank, Last Name, Duty Position)					
E. Task:	F. Identify Hazards	G. Asses Hazards	H. Develop Controls	I. Determine Residual Risk	J. Implement Controls ("HOW TO")
<p>K. Determine overall mission/task risk level after controls are implemented (circle one)</p> <p>LOW (L) MODERATE (M) HIGH (H) EXTREMELY HIGH (E)</p>					

Figure K-10. Risk Management Worksheet

- Sequence of Events. Use the steps discussed in the general discussion about rehearsals.
- Rehearsal activities. The FSO, targeting officer, strikers and radar section leader rehearse the same task, purpose and actions for the events rehearsed during the fire support rehearsal. Incorporating these activities in the combined arms rehearsal ensures that all fire support and target acquisition activities are synchronized with the maneuver plan.

PDG GENERATOR AND HMMWV WITH S-250 SHELTER (Chalk 3)

EQUIPMENT NEEDED:

- ___ 1 ea. NATO slave cables
- ___ 1 ea. Winch, complete with hooks and control unit
- ___ 2 ea lead bars (T-handle)
- ___ 2 ea bridge plates
- ___ Shoring for AF “milk crate” 20” - 24” high, 24” square
- ___ 2 ea. 2”x 12” x 12’-0” (shoring for ATG)

PREPARATION (Prior to backing generator truck to aircraft).

- ___ Loading wheels are set to 100 psi.
- ___ Tailgate is lowered.
- ___ Slave cable connected to winch.
- ___ Generator winch is connected to skid.
- ___ Loading wheels positioned [front (truck front) turned out locked, rear (truck rear) turned in, free]

LOADING:

Chalk 4

- ___ M925 backed to aircraft.
- ___ Shoring used under ramp “milk crate”.
- ___ M925 backed to with 5-6” of aircraft ramp.
- ___ Bridge plates set.
- ___ Aircraft winch connected to skid
- ___ Lead bars attached to wheels.
- ___ Skid jacked up 5-6” higher.
- ___ Aircraft winch pulls skid into aircraft, truck winch acts as brake.

NOTE: Lead bars are used to turn wheels only when ATG is moving. If ATG starts to run away lead bar personnel drop lead bars which will brake ATG

- ___ 2” x 12” x 12’ shoring placed under skid.
- ___ Skid jacked down onto shoring.
- ___ Loading wheels turned for removal and locked (front [truck front] - turned in, locked rear [truck rear] turned out, locked).
- ___ Lead bars are stowed, “milk crate” shoring stowed.
- ___ Stow slave cable, winch control.
- ___ Tailgate raised.
- ___ M925 driven to next aircraft.
- ___ Shelter backed into aircraft with generator
- ___ The equipment is tied down by AF personnel.

NOTE: LOADING WHEELS ARE LOCKED ON AIRCRAFT-UNLOCK THE LEADING WHEELS WHEN GETTING READY TO WINCH OUT OF AIRCRAFT.

Figure I-18. PDG Generator and HMMWV with S250 Shelter Loading Checklist

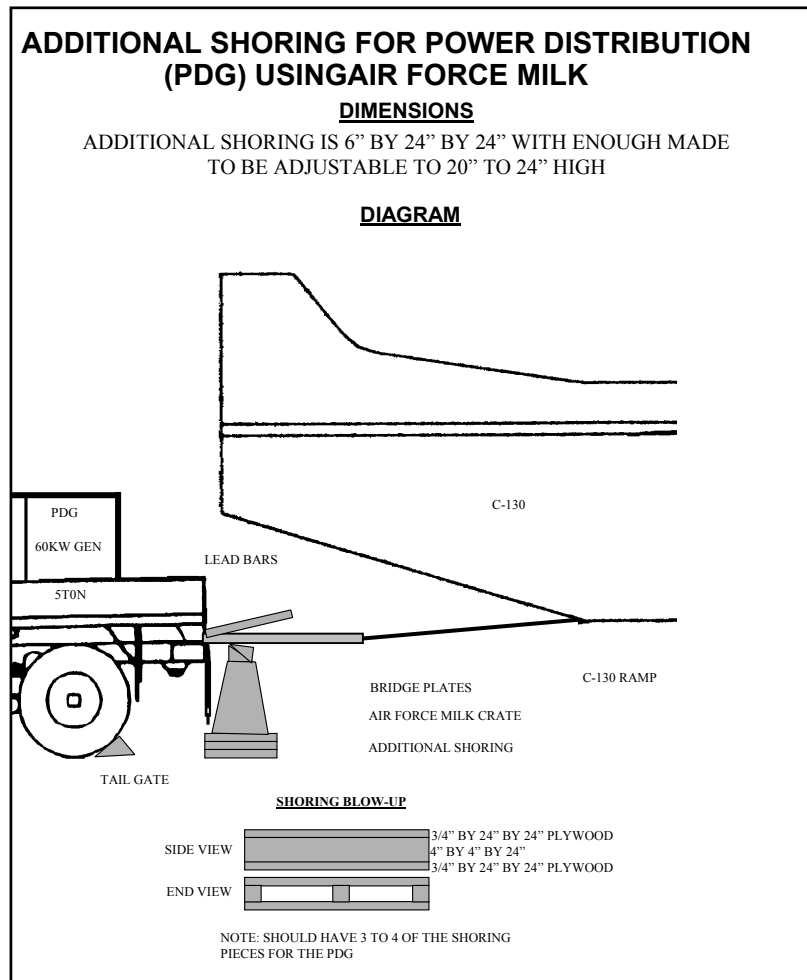

Figure I-19. Shoring for PDG Generator

- Chalk 4: MTV. Section personnel “kneel” the MTV by letting the air out of the tires, reducing the height to clear the top of the C-130 door. The MTV is then backed onto the aircraft and tied down. This chalk is loaded after chalk 3, but should arrive at the APOD second to facilitate down loading of the ATG and trailer (Figure I-20).

MTV (Chalk 4)

MTV driven to the aircraft, positioned to back in.

MTV is “kneeled.”

MTV backed into aircraft.

MTV tied down by AF personnel.

Figure I-20. MTV Loading Checklist

- Chalk 5: RECON (M998)/ PU 806, 60 KW GENERATOR TRAILER. The generator is pushed into the aircraft using the pintle mounted to the front bumper of the vehicle. The push vehicle is backed out of the aircraft, and then the RECON vehicle is backed into the aircraft. Crew ties equipment down. Figure I-21 contains a checklist for this load.

RECON VEHICLE / GENERATOR TRAILER (Chalk 5)

EQUIPMENT REQUIRED:

- __ Blocking to drive HMMVW on to disconnect/ connect generator trailer.
- __ 1 each 3/4" x 24" sq. shoring for trailer jack when disconnect/connect in aircraft.

LOADING:

- __ C-130 ramp is lowered to the ground.
- __ Generator is pushed on aircraft w/front bumper hitch.
- __ The truck front wheels are driven up on the blocks.
- __ The 3/4 shoring is placed under the trailer landing leg.
- __ The trailer is jacked off the truck.
- __ The truck is backed out of the aircraft, turned around, and backed into the aircraft and backed up on the blocks.
- __ The trailer is connected back to the truck, the truck is driven off of the blocks, the blocks and shoring is stowed.
- __ Aircrew ties equipment down.

Figure I-21. RECON Vehicle and Generator Trailer Loading Checklist

Appendix L

Risk Management

Risk is the chance of injury or death to individuals and damage to or loss of vehicles and equipment. Risk, or the potential for risk, is present in every combat and training situation. Risk is mitigated through the use of risk management procedures. The primary objective of risk management is to protect combat power through accident prevention thus enabling units to win the battle quickly and decisively with minimal loss. Risk management takes place at all levels during every operation. It is an integral part of tactical planning. Radar section leaders, section chiefs, and soldiers must understand and use risk management and fratricide reduction measures to ensure that the mission is accomplished in the safest possible manner consistent with mission constraints. This appendix outlines the process used to identify and address individual hazards. It also provides a discussion of responsibilities for implementing a risk management program. Additional information about risk management is contained in FM 3-100.14 (100-14).

SECTION I – RISK MANAGEMENT PROCEDURES

This section outlines the five steps of risk management. Leaders must always remember that the effectiveness of the process depends on situational awareness. One should never approach risk management with “one size fits all” solutions to possible hazards. Rather, in performing the steps, consider the essential tactical and operational factors that make each situation unique.

IDENTIFY HAZARDS

A hazard is a source of danger. It is any existing or potential condition that could entail injury, illness, or death of personnel; damage to or loss of equipment and property; or some other sort of mission degradation. Tactical and training operations pose many types of hazards. Leaders’ must identify the hazards associated with all aspects of the mission, paying particular attention to the factors of METT-TC. Risk management must never be an afterthought. Leaders must begin the process during their troop-leading procedures and continue it throughout the operation. Table L-1 lists possible sources of risk that a unit might face during tactical operations. The list is organized according to the factors of METT-TC.

Table L-1. Sources of Battlefield Risks

Sources of Battlefield Risk
<p>Mission</p> <ul style="list-style-type: none"> • Duration of the operation. • Complexity/clarity of the plan. (Is the plan well-developed and easily understood?) • Proximity and number of maneuvering units.
<p>Enemy</p> <ul style="list-style-type: none"> • Knowledge of the enemy situation. • Enemy capabilities. • Availability of time and resources to conduct reconnaissance.
<p>Terrain and Weather</p> <ul style="list-style-type: none"> • Visibility conditions, including light, dust, fog, rain, snow, and smoke. • Precipitation and its effect on mobility. • Extreme heat or cold. • Additional natural hazards (broken ground, steep inclines, water obstacles).
<p>Troops</p> <ul style="list-style-type: none"> • Equipment status. • Experience that units conducting the operation have working together. • Danger areas associated with weapon systems. • Soldier/leader proficiency. • Soldier/leader rest situation. • Degree of acclimatization to environment. • Impact of new leaders or crewmembers. • Friendly unit situation. • NATO or multinational military actions combined with U.S. forces.
<p>Time Available</p> <ul style="list-style-type: none"> • Time available for troop-leading procedures and rehearsals by subordinates. • Time available for PCCs/PCIs.
<p>Civil Considerations</p> <ul style="list-style-type: none"> • Applicable ROE or rules of interaction (ROI). • Potential stability operations and support operations involving contact with civilians (such as NEOs, refugee or disaster assistance, or counterterrorism). • Potential for media contact and inquiries. • Interaction with host nation or other participating nation support.

ASSESS HAZARDS TO DETERMINE RISKS

Hazard assessment is the process of determining the direct impact of each hazard on an operation (in the form of hazardous incidents). Use the following steps.

- Determine which hazards can be eliminated or avoided.
- Assess each hazard that cannot be eliminated or avoided to determine the probability that the hazard can occur.
- Assess the severity of hazards that cannot be eliminated or avoided. Severity, defined as the result or outcome of a hazardous incident, is expressed by the degree of injury or illness (including death), loss of or damage to equipment or property, environmental damage, or other

mission-impairing factors (such as unfavorable publicity or loss of combat power).

- Taking into account both the probability and severity of a hazard, determine the associated risk level (extremely high, high, moderate, and low). Table L-2 summarizes the four risk levels.
- Based on the factors of hazard assessment (probability, severity, and risk level, as well as the operational factors unique to the situation), complete the risk management worksheet. (Refer to Appendix K for a risk management worksheet.)

Table L-2. Risk Levels and Impact on Mission Execution

Risk Level	Mission Effects
Extremely High (E)	Mission failure if hazardous incidents occur in execution.
High (H)	Significantly degraded mission capabilities in terms of required mission standards. Not accomplishing all parts of the mission or not completing the mission to standard (if hazards occur during mission).
Moderate (M)	Expected degraded mission capabilities in terms of required mission standards. Reduced mission capability (if hazards occur during the mission).
Low (L)	Expected losses have little or no impact on mission success.

DEVELOP CONTROLS AND MAKE RISK DECISIONS

This step is accomplished in two substeps: develop controls and make risk decisions. These substeps are accomplished during the “make a tentative plan” step of troop-leading procedures.

- **Develop Controls.** After assessing each hazard, develop one or more controls that will either eliminate the hazard or reduce the risk (probability, severity, or both) of potential hazardous incidents. When developing controls, consider the reason for the hazard, not just the hazard by itself.
- **Make Risk Decisions.** A key element in the process of making a risk decision is determining whether accepting the risk is justified or, conversely, is unnecessary. The decision-maker (commander or the unit leader, if applicable) must compare and balance the risk against mission expectations. He alone decides if the controls are sufficient and acceptable, and whether to accept the resulting residual risk. If he determines the risk is unnecessary, he directs the development of additional controls or alternative controls; as another option, he can modify, change, or reject the selected COA for the operation.

IMPLEMENT CONTROLS

Controls are the procedures and considerations the unit uses to eliminate hazards or reduce their risk. Implementing controls is the most important part of the risk management process; this is the chain of command's contribution to the safety of the unit. Implementing controls includes coordination and communication with appropriate superior, adjacent, and subordinate units and with individuals executing the mission. Leaders must ensure that specified controls are integrated into OPLANs, OPORDs, SOPs, and rehearsals. The critical check for this step is to ensure that controls are converted into clear, simple execution orders understood at all levels. If leaders have conducted a thoughtful risk assessment, the controls will be easy to implement, enforce, and follow. Examples of risk management controls include the following:

- Brief all aspects of the mission, including related hazards and controls.
- Conduct thorough PCCs and PCIs.
- Allow adequate time for rehearsals at all levels.
- Drink plenty of water, eat well, and get as much sleep as possible (at least 4 hours in any 24-hour period).
- Use buddy teams.
- Enforce speed limits, use of seat belts, and driver safety.
- Establish recognizable visual signals and markers to distinguish maneuvering units.
- Enforce the use of ground guides in assembly areas and on dangerous terrain.
- Establish marked and protected sleeping areas in assembly areas.
- Limit single-vehicle movement.
- Establish SOPs for the integration of new personnel.

SUPERVISE AND EVALUATE

During mission execution, leaders must ensure that risk management controls are properly understood and executed. They must continuously evaluate the unit's effectiveness in managing risks to gain insight into areas that need improvement.

- Supervision. Leadership and unit discipline are the keys to ensuring that effective risk management controls are implemented.
 - All leaders are responsible for supervising mission rehearsals and execution to ensure standards and controls are enforced. In particular, NCOs must enforce established safety policies as well as controls developed for a specific operation or task. Techniques include spot checks, inspections, SITREPs, confirmation briefs, buddy checks, and close supervision.
 - During mission execution, leaders must continuously monitor risk management controls, both to determine whether they are effective and to modify them as necessary. Leaders must also anticipate, identify, and assess new hazards. They ensure that

imminent danger issues are addressed on the spot and that ongoing planning and execution reflect changes in hazard conditions.

- Evaluation. Whenever possible, the risk management process should also include an after-action review (AAR) to assess unit performance in identifying risks and preventing hazardous situations. Leaders should then incorporate lessons learned from the process into unit SOPs and plans for future missions.

SECTION II – IMPLEMENTATION RESPONSIBILITIES

Leaders and individuals at all levels are responsible and accountable for managing risk. They must ensure that hazards and associated risks are identified and controlled during planning, preparation, and execution of operations. The unit leader and his senior NCOs must look at both tactical risks and accident risks. The same risk management process is used to manage both types. The unit leader alone determines how and where he is willing to take tactical risks. The unit leader manages accident risks with the assistance of his platoon sergeant, NCOs, and individual soldiers.

BREAKDOWN OF RISK MANAGEMENT PROCESS

Despite the need to advise higher headquarters of a risk taken or about to be assumed, the risk management process may break down. Such a failure can be the result of several factors; most often, it can be attributed to the following:

- The risk denial syndrome in which leaders do not want to know about the risk.
- A soldier who believes that the risk decision is part of his job and does not want to bother his unit leader or section leader.
- Outright failure to recognize a hazard or the level of risk involved.
- Overconfidence on the part of an individual or the unit in being able to avoid or recover from a hazardous incident.
- Subordinates who do not fully understand the higher commander's guidance regarding risk decisions.

RISK MANAGEMENT COMMAND CLIMATE

Leaders provide direction, set priorities, and establish command climate (values, attitudes, and beliefs). Successful preservation of combat power requires leaders to embed risk management into individual behavior. To fulfill this commitment, one must exercise creative leadership, innovative planning, and careful management. Most importantly, one must demonstrate support for the risk management process.

Leaders and others in the unit chain of command can establish a command climate favorable to risk management integration by taking the following actions:

Glossary

AACG	arrival airfield control group
AAG	army artillery group
AAMDC	Army and Air Defense Missile Command
AAR	after-action review
ABCS	army battle command system
ACE	analysis and control element
ACC	air component commander
ACL	allowable cabin load
ACT	analysis and control team
ADOCs	automated deep operations coordination system
A/EGM	attack/effects guidance matrix
AFATDS	advanced field artillery tactical data system
AGM	attack guidance matrix
AGRA	army group of rocket artillery
AI	air interdiction
ALO	air liaison officer
AMB	air mission brief
AMC	air mission commander
AO	area of operations
AOC	air operations center
AOE	army of excellence
AOR	area of responsibility
APOD	aerial port of debarkation
ASAS	all-source analysis system
ASAS RWS	all-source analysis system remote work station
ASIP	advanced lightweight single channel ground and airborne radio system improvement program
ARFOR	army force
ARM	antiradiation missile
ATACMS	army tactical missile system
ATG	antenna transceiver group

ATI	artillery target intelligence
ATIZ	artillery target intelligence zone
ATO	air tasking order
BCD	battlefield coordination detachment
BCT	brigade combat team
BDA	battle damage assessment
BDE	brigade
BIT	built-in-test
BITE	built-in-test-equipment
BN	battalion
BOMREP	bombing report
BOS	battlefield operating systems
BRT	brigade reconnaissance troop
BTRY	battery
C2	command and control
C3	command, control, and communications
C4I	command, control, communications, computers, and intelligence
CA	combat assessment, civil affairs
CAS	close air support
CBR	counterbattery radar
CCIR	commander's critical information requirements
CCSB	corps common sensor boundary
CDT	control display terminal
CEP	circular error probable
CFFZ	call for fire zone
CFL	coordinated fire line
CFO	counterfire officer
CFZ	critical friendly zone
CG	center of gravity
CHS-2	common hardware system-2
CINC	commander in chief
CMP	collection management plan
COA	course of action

COC	combat operations center
COMINT	communications intelligence
CP	command post
CPU	central processing unit
CSB	common sensor boundary
CSS	combat service support
CTAD	corps target acquisition detachment
CTAPS	contingency theater automated planning system
CZ	sensor zone
D/AACG	departure/arrival airfield control group
DACG	departure airfield control group
DAG	division artillery group
DECOORD	deputy effects coordinator
DFSCOORD	deputy fire support coordinator
DIVARTY	division artillery
DOCC	deep operations coordination cell
DRU	dynamic reference unit
DS	direct support
DSO	domestic support operations
DST	decision support template
DTG	date, time group
D3A	decide, detect, deliver, assess methodology
EA	engagement area, electronic attack
EAC	echelons above corps
EB	enhanced brigade
EBC	effects battle captain
ECM	electronic countermeasures
ECCM	electronic counter countermeasures
ECMA	electronic countermeasures avoidance
ECOORD	effects coordinator
ELINT	electronic intelligence
ELOS	electronic line of sight
EOB	electronic order of battle

EPLRS	enhanced position locating system
ER-MLRS	extended range multiple launch rocket system
EW	electronic warfare
FA	field artillery
FAIO	field artillery intelligence officer
FARP	fuel and re-supply position
FASP	field artillery support plan
FBCB2	force XXI battle command-brigade and below
FCE	fire control element
FDC	fire direction center
FDS	fire direction system
FECC	fires and effects coordination cell
FEM	field exercise mode
FFPAS	Firefinder position analysis system
FHA	foreign humanitarian assistance
FID	foreign internal defense
FM	frequency modulation
FRAGO	fragmentary order
FSC	fire support center
FSCC	fire support coordination center
FSCL	fire support coordination line
FSCM	fire support coordinating measure
FSCOORD	fire support coordinator
FSE	fire support element
GALE	generic area limitation environment
GPS	global positioning system
GS	general support
GSR	general support reinforcing
HBMPI	high burst mean point of impact
HIMARS	high mobility artillery rocket system
HMMWV	high mobility multi-purpose wheeled vehicle
HPT	high payoff target
HPTL	high payoff target list

HVT	high value target
HVTL	high value target list
HZ	hertz
IBCT	interim brigade combat team
ICP	intelligence collection plan
ICW	in conjunction with
IDIVARTY	interim division artillery
IFSAS	initial fire support automated system
IMINT	imagery intelligence
IO	information operations
IPB	intelligence preparation of the battlefield
IR	intelligence requirement
ISB	intermediate staging base
ISE	intelligence support element
JAOC	joint air operations center
JFAAC	Joint Force Air Component Commander
JFC	Joint Force Commander
JFLCC	Joint Force Land Component Commander
JI	joint inspection
JSTARS	joint surveillance and target attack radar system
JSWS	joint services workstation
JTF	joint task force
KG	kilogram
KM	kilometer
LCU	lightweight computer unit
LMS	lightweight multipurpose shelter
LMTV	light medium tactical vehicle
LNO	liaison officer
LOS	line of sight
LZ	landing zone
LRU	line replaceable unit
MAC	maintenance allocation chart
MAPS	modular azimuth positioning system

MDMP	military decision-making process
MEA	munitions effects analysis
METCM	computer meteorological message
METTA	target acquisition meteorological message
METT-TC	mission, enemy, terrain, troops, time available, and civil considerations
MFR	mission fired report
MHE	material handling equipment
MLRS	multiple launch rocket system
MORTREP	mortar bombing report
MPI	mean point of impact
MPL	mandatory parts list
MRBM	medium range ballistic missile
MSD	minimum safe distance
MTO	message to observer
MTSS	medium track suspension system
MTV	medium tactical vehicle
MTW	major theater war
NAI	named area of interest
NATO	North Atlantic Treaty Organization
NEO	noncombatant evacuation order
NGO	nongovernmental organization
NSFS	naval surface fire system
OC	operations central
OCA	offensive counterair
OCG	operations control group
OCS	operator control station
OOTW	operations other than war
OPCON	operational control
OPLAN	operations plan
OPORD	operations order
OPSEC	operations security
PADS	position and azimuth positioning system

PAM	power amplifier module
PCI	pre-combat inspections
PDG	power distribution group
PE	probable error
PEO	peace enforcement operations
PIR	priority intelligence requirement
PKO	peace keeping operations
PMCS	preventative maintenance checks and services
PME	peacetime military engagement
PO	peace operations
POS	portable operations suite
PPG	prime power group
PRF	pulse repetition frequency
PSU	power supply unit
PZ	pickup zone
QE	quadrant elevation
QSTAG	quadripartite standardization agreement
R	reinforcing
RCS	radar cross-sectional area
RDO	radar deployment order
RDF	radio direction finding
RH	relative humidity
ROCKREP	rocketing report
ROE	rules of engagement
ROI	rules of interaction
RFA	restrictive fire area
RS&S	reconnaissance security and surveillance
RSTA	reconnaissance, surveillance, and target acquisition
RWS	remote work station
SA	situational awareness
SEAD	suppression of enemy air defense

SHELREP	shelling report
SINCGARS	single channel ground and airborne radio system
SIPRNET	secret internal protocol router network
SOF	special operations forces
SOI	signal operating instructions
SOP	standard operating procedure
SPINS	special instructions
SPOD	sea port of debarkation
SRBM	short range ballistic missile
SSC	small scale contingency
ST	special text
STACCS	standard theater army command and control system
STANAG	standardization agreement
SU	situational understanding
TA	target acquisition, theater air
TAB	target acquisition battery
TACAIR	tactical air
TAC FSE	tactical fire support element
TACON	tactical control
TACSOP	tactical standard operating procedures
TAI	target area of interest
TALCE	tanker airlift control element
TAMD	theater air and missile defense
TAP	target acquisition platoon
TBM	tactical ballistic missile
TBMCS	theater battle management core system
TCIM	tactical communications interface module
T/ESM	targeting/effects synchronization matrix
TF	task force
TFT	tabular firing table
TIO	targeting information officer
TIR	target to interface ratio
TLE	target location error

TM	theater missile
TMD	theater missile defense
TMM	target management matrix
TOC	tactical operations center
TOE	table of organization and equipment
TPC	target processing center
TPDU	trailer power distribution group
TPS	target processing section
TSM	targeting synchronization matrix
TSS	target selection standards
TTP	tactics, techniques and procedures
TVA	target value analysis
UAV	unmanned aerial vehicle
VCCU	vehicle cab control console
VCU	versatile computer unit
WLR	weapon locating radar
WMD	weapons of mass destruction
ZOR	zone of responsibility

- Demonstrate consistent and sustained risk management behavior through leadership by example and emphasis on active participation throughout the risk management process.
- Provide adequate resources for risk management. Every leader is responsible for obtaining the assets necessary to mitigate risk and for providing them to subordinate leaders.
- Understand your own and your soldiers' limitations, as well as your unit's capabilities.
- Allow subordinates to make mistakes and learn from them.
- Prevent a "zero defects" mindset from creeping into the unit's culture.
- Demonstrate full confidence in subordinates' mastery of their trade and their ability to execute a chosen COA.
- Keep subordinates informed.
- Listen to subordinates.

Leader, subordinate leader, and individual soldier risk management responsibilities include the following:

- Make informed risk decisions. Establish and then clearly communicate risk decision criteria and guidance.
- Establish clear, feasible risk management policies and goals.
- Train the risk management process. Ensure subordinates understand the who, what, when, where, and why of managing risk and how these factors apply to their situation and assigned responsibilities.
- Accurately evaluate the unit's effectiveness, as well as subordinates' execution of risk controls during the mission.
- Inform higher headquarters when risk levels exceed established limits.

Bibliography

SOURCES USED

These are the sources quoted or paraphrased in this publication.

Joint and Multiservice Publications

- FM 1-02 (101-5-1). Operational Terms and Graphics. MCRP 5-2A. 30 Sep 97.
- FM 2-00.2 (90-35). Multiservice Procedures for Antiradiation Missile Employment in a Joint Environment. FMFM 5-58, NDC TACNOTE 3-01.41, ACCPAM 10-750, PACAFPAM 10-750, USAFEPAM 10-750. 20 Jun 95.
- FM 3-07 (100-20). Stability Operations and Support Operations (Military Operations in Low Intensity Conflict). AFP 3-20. 5 Dec 90.
- FM 3-09.15 (6-15). Tactics, Techniques, and Procedures for Field Artillery Meteorology. MCWP 3-16.5. 13 Aug 97.
- FM 3-09.40 (6-40). Tactics, Techniques, and Procedures for Field Artillery Manual Cannon Gunnery with Change 1. MCWP 3-16.4. 1 Oct 99.
- FM 3-09.50 (6-50). Tactics, Techniques, and procedures for the Field Artillery Cannon Battery. MCWP 3-1.6.23. 23 Dec 91.
- FM 4-20.198 (10-450-4). Multiservice Helicopter Sling Load: Single-point Rigging Procedures. MCRP 4-23E Volume II, NWP 3-04.12, AFJMAN 11-223 Volume II, COMDTINST M13482.3A. 1 Feb 00.
- FM 4-20.199 (10-450-5). Multiservice Helicopter Sling Load: Dual-point Rigging Procedures. MCRP 4-23E Volume III, NWP 3-04.13, AFJMAN 11-223 Volume III, COMDTINST M13482.4A. 30 Aug 99.
- TB 11-7025-297-10 and Marine Corps UM 10690A-10/5. Operator's Notebook, Advanced Field Artillery Tactical Data System (AFATDS). 24 Mar 00.
- TB 55-45. Certification of Military Equipment for Transport in AMC/CRAF Aircraft. AFJ PAM 24-308, NAVFAC P-1056, NAVMC 2753. 15 Jan 95.
- TM 9-6115-642-10, Air Force TO 35C2-3-445-11, and Marine Corps TM 09247A/09248A-10/1. Operators Manual, Generator Set Skid Mounted, Tactical Quiet, 10 KW, 60 and 100 HZ, MEP-803A/MEP-813A. 30 Dec 92.
- TM 9-6115-645-10, Air Force TO 35C2-3-444-11, and Marine Corps TM 09244A/09245A-10/1. Operators Manual, Generator Set Skid Mounted, Tactical Quiet, 60 KW(50/60 HZ), and 400 HZ, MEP-806A/MEP-816A. 30 Jul 93.
- TM 11-7025-297-10 and Marine Corps UM 10690A-10. Operator's Manual, Advanced Field Artillery Tactical Data System (AFATDS). 15 Apr 00.

Index

A

abbreviations and acronyms,
Glossary

additional skill identifier (ASI), 3-4

administrative support, H-4

 maintenance, H-5

 mess, H-4

 meteorological data, H-6

 petroleum, oils, and lubricants
(POL), H-6

 security, H-6

Advanced Field Artillery Tactical
Data System (AFATDS), 3-4,
3-5, 3-6, 3-7, 3-10, A-1

 assigned zones, G-17

 direction and distance, A-8

 display, A-9

 initial fire support automated
 system (IFSAS), A-16

 priority/censor zone message
(SPRT;FILTER), G-16

 Q-47 TBM mode, E-12

 quick fire channel, 2-5, E-5, E-
 26

 radar considerations, 1-12

 radar deployment order, G-15

 radar search area message
(SPRT;SEARCH), G-16

 suspect target processing, A-
 14

 target damage assessment, A-
 19

 target generation, A-1

 target indicator function, A-11

 target indicator processing, A-
 2, B-13

 target overlap, A-15

 target similarity, A-4

 theater missile defense (TMD),
 E-22, E-24

 zones of responsibility, 5-23

advanced lightweight single
channel ground and airborne
program (ASIP), E-8, E-9

air interdiction (AI), 1-3, 1-8, 3-4,
3-5

air movement, I-1,

 C-130 aircraft (Q-36), I-27

 C-130 aircraft (Q-37), I-29

 fixed wing, I-18

 helicopter, I-1

air operations center (AOC), 4-40

air tasking order (ATO), 1-6, 1-8,
3-4

airspace control order (ACO), 4-40

all-source analysis system
(ASAS), 3-4, 3-5

all-source analysis system remote
work station (ASAS RWS), E-
22

AN/TPQ-36 radar,

 centralized control, 5-2

 combination control, 5-3

 coverage area, cannon, 4-11

 coverage area, mortar, 4-11

 coverage area, rocket, 4-12

 decentralized control, 5-3

 heavy division, E-1

 IBCT 5-21

 load procedures for C-130
 aircraft, I-27

 mission, 4-10

 probability of location, 4-10

 sling load procedures, I-5

 survey requirements, H-1

 system components, 4-13

 target classification, 4-10

 target location error, 4-12

 zones, 5-5

AN/TPQ-37 radar

 centralized control, 5-2

 combination control, 5-3

 coverage area, cannon, 4-20

 coverage area, rocket, 4-21

 decentralized control, 5-3

 IBCT, 5-21

 load procedures for C-130
 aircraft, I-29

 mission, 4-19

 probability of location, 4-19

 section, 2-8

 sling load procedures, I-13

 survey requirements, H-1

 system components, 4-22

 target classification, 4-19

 target location error, 4-21

 versions, 4-26

 zones, 5-5

AN/TPQ-46A radar section, 2-12

AN/TPQ-47 radar, 2-5, E-1, E-6

 components, E-7

 corps employment, E-25

 coverage, artillery, E-12

 coverage, mortars, E-12

 coverage, rockets, E-12

 coverage, tactical ballistic

 missile (TBM), E-13

 division employment, E-26

 equipped organizations, E-1

 heavy division, E-1

 range and accuracy, E-12, E-
 13

 section organization, E-6

 tactical ballistic missile (TBM)

 mode, E-12, E-27

 target categories, E-27

 target classification, E-14

 target location error, E-13

 theater missile defense, E-19

 threat weapon systems, E-14

analysis and control element (ACE), 1-3, 3-4, 3-4, 3-5
analysis control team (ACT), 1-3, 3-8
Angle-T, 4-9, C-2
antenna rollover, E-19
antenna transceiver group (ATG)
AN/TPQ -36, 4-13, 4-14, 4-15, 4-16
AN/TPQ -37, 4-22, 4-23, 4-24, 4-26
AN/TPQ -47, E-7, E-8, E-9, E-10, E-19
antiradiation missiles, 4-40
Army and Air Defense Missile Command (AAMDC) E-5, E-21
attack operations cell, E-21
army force (ARFOR), 3-4
army tactical missile system (ATACMS), 1-3, 3-5, E-28
arrival airfield control group (AACG), I-26, I-27
artillery,
crater analysis, B-1, B-3, B-5
detection, 4-10, 4-11, 4-19
artillery counterfire information form (DA Form 2185-R), B-13
artillery target intelligence (ATI), 1-12, 1-14
artillery target intelligence zone (ATIZ), 5-5, 5-6, 5-17
aspect angle, 4-5, 4-28, 4-46, 6-7
assistant counterfire officer, 2-1, 3-6
attachment, 5-4
attack guidance matrix (AGM), 1-2, 1-5, 1-7, 1-8, 3-5, 3-8, 3-11
attack/effects guidance matrix (A/EGM), 3-10
auto censoring, 4-43
automated deep operations coordination system (ADOCS), E-22
automatic height correction, 4-42

B

battle damage assessment (BDA), 1-4, 1-5, 1-7, 1-8, 3-9

battlefield coordination detachment, 4-40
targeting NCO, 3-4
battlefield operating system (BOS), 1-1, 1-7
berms, 6-6
bombing reports (BOMREPs), B-13
brigade combat team (BCT), 3-8, 5-10
brigade counterfire officer, G-12
brigade targeting officer, 3-8, G-12

C

C-130 air movement (Q-36), I-27
ATG load preparations, I-28
OC load preparations, I-28
C-130 air movement (Q-37), I-29
ATG and trailer loading checklist, I-30
ATG and trailer loading figure, I-32
bridge plates, I-31
PDG generator and HMMWV with S250 shelter loading checklist, I-33
ramp support and shoring, I-31
recon vehicle and generator trailer loading checklist, I-35
shoring for PDG generator, I-34
cables,
Q-36, 4-17, 4-29
Q-37, 4-23, 4-24, 4-25, 4-30
Q-47, E-15
call for fire (CFF), 1-12
call-for-fire zone (CFFZ), 5-5, 5-6, 5-12, 5-13, 5-16, 5-17, 5-21
cannon,
crater analysis, B-1, B-3, B-5
detection, 4-10, 4-11, 4-19
censor zone (CZ), 5-5, 5-6, 5-7, 5-17
central processing unit (CPU), E-10
centralized control, 5-2, 5-14
CH47D, I-5
circular error probable (CEP), E-11
civil considerations, METT-TC, 4-32
Class III, 1-4
Class V, 1-4
clear channel sensing (CCS), 4-39, 4-40
close air support (CAS), 1-8, 3-4, 3-5, 3-7
combat assessment (CA), 1-1, 1-3, 1-4, 1-5, 3-9
combat operations center (COC), 2-11
combination control, 5-3
command and control, 5-1
command and signal, G-3
command relationships, 5-3
attachment, 5-4
operational control, 5-4
tactical control, 5-5
commander TAB/TAD, 3-2
commander's critical information requirements (CCIR), 1-8, 3-9
commanders guidance, 5-14
common hardware system-2 computer (CHS-2), E-8, E-10
common sensor boundary (CSB), 5-5, 5-13, 5-21, E-28
communications, 4-33, H-2
digital, H-2
equipment, H-4
nets, H-2
voice, H-4
communications intelligence (COMINT), 3-4
computer MET, H-9
concealment, 4-33
coordinated fire line (CFL), 5-13, 5-21
corps,
counterfire, 5-18, E-28
Q-47 employment, E-25
theater missile defense, E-23, E-25

corps common sensor boundary (CCSB), E-28
corps field artillery intelligence officer (FAIO), 3-4
corps target acquisition detachment (CTAB), 2-4, 3-6, E-1, E-3, E-4
counterbattery radar (CBR) platoon, 2-11
counterfire,
 acquisitions, 1-7
 operations, 2-1, 5-18
counterfire headquarters, 5-13
counterfire officer (CFO), 3-6, 3-7, 5-2, 5-7, 5-10, G-12
course of action (COA), 1-2, 1-4, 1-8
 analysis, 1-11
 comparison and approval, 1-11
 development, 1-11, 5-10
cover, 4-32
crater analysis, B-1
 artillery, B-1, B-3, B-5
 mortar, B-6
 rocket, B-9
critical friendly zone (CFZ), 3-10, 5-5, 5-6, 5-17, 5-17
cueing, 5-11, 5-14
 demand, 5-15
 situational, 5-15
curvature template, B-15

D

datum-plane registration, C-4
dead space, F-3, F-4, F-5
decentralized control, 5-3, 5-14, 5-17
decentralized counterfire, 5-22, 5-23
decide, detect, deliver, and assess (D3A) methodology, 1-1, 1-8, 1-12, 3-4, 5-5, 5-11
 assess, 1-4
 decide, 1-2
 deliver, 1-4
 detect, 1-3

decision making process,
 target acquisition integration, 1-1, 1-10
 targeting relationship, 1-9
decision support template (DST), 1-3, 3-10, 5-10
deconfliction of radar coverage, 5-22
deep operations coordination cell (DOCC), 3-4, E-24
defensive operations, 5-15, 5-17
degraded performance
 Q-36, 4-10
 Q-37, 4-19
departure airfield control group (DACG), I-19 - 24
deputy effects coordinator (DECOORD), 3-11
deputy fire support coordinator (DFSCOORD), 3-5
detection, verification, location process, 4-6
detection area,
 search sector and range, 4-2
 vertical scan, 4-3
digital message formats, H-3
DIVARTY, 3-6
DIVARTY counterfire officer, 3-6, 5-10
division,
 counterfire, 5-20, E-28
 field artillery intelligence officer, 3-4
 Q-47 employment, E-26
 theater missile defense, E-25
divisional MLRS battalion target acquisition battery, 2-1, E-1, E-2, E-3
divisional MLRS battalion targeting officer, 3-9
domestic support operations, 6-4

E

effects battle captain (EBC), 3-11
effects coordinator (ECOORD), 3-11

electronic countermeasures (ECM), 4-36, 4-39, 4-40
electronic counter countermeasures (ECCM), 4-39
electronic countermeasures avoidance (ECMA), 4-39, 4-40
electronic intelligence (ELINT), 3-4, 3-9
electronic line of sight (ELOS), 4-28, 4-34
electronic order of battle (EOB), 4-40
electronic warfare, 1-3, 1-8, 4-35, 4-39
electronic warfare officer, 1-8
embedded training, D-1, D-2
employment considerations,
 aspect angle, 6-7
 centralized control, 5-2
 combination control, 5-3
 command and control, 5-1
 decentralized control, 5-3
 masking, 6-7
 positioning, 6-5, E-16
 stability operations and support operations, 6-5
 tactical considerations, 5-1, E-16
enclosures (TA TAB to FA support plan), G-4
enemy
 METT-TC, 4-31
enhanced brigade (EB), 2-3
enhanced position locating system (EPLRS), 4-14, E-8
equipment trainer group (ETG), 4-13, 4-15
essential field artillery tasks, 1-11
essential fire support tasks (EFST), 1-6, 1-7, 1-8, 1-9, 1-11
execution paragraph, G-2
executive officer (XO), 1-7, 1-8

F

fast scan mode, E-12

field artillery battalion target acquisition platoon sergeant, - 3-3

field artillery brigade plans officer, 3-6

field artillery brigades
counterfire, 5-20
tactical operations center (TOC), E-1

field artillery intelligence officer (FAIO), 3-4, 3-5

field artillery support plan (FASP), 3-9, 5-15, G-1

field artillery targeting officer, 3-8

field artillery targeting process, 1-9

field exercise mode, D-1, D-3

fire support coordinating measures (FSCM), 1-4, 1-7, 3-5, 5-13

fire support coordination center (FSCC), 2-11, 2-13, 3-10, 3-11

fire support coordinator (FSCOORD), 1-8, 1-11, 3-5, 3-6, 5-10, 5-11

fire support element, 1-3, 3-5, 3-6, 3-8, 5-10, E-24

fire support officer (FSO), 1-7, 1-8, 1-11, 3-8, 5-10, 5-11, 5-12, 5-14, 5-17, A-2
aviation brigade, 3-9, 3-10

Firefinder Position Analysis System (FFPAS), 4-33, 4-34, 4-44
clutter plot, 4-46
electronic line of sight, 4-29
masking, 6-7
screen angle plot, 4-45
site analysis, 4-44
terrain plot, 4-44

fires and effects coordination center (FECC), 2-5, 2-6, 5-21, 5-23, E-4, E-5, E-26

fires planning, 1-10, 1-11

fixed wing movement, I-18
air loading operations, I-18
alert holding area, I-22
arrival airfield operations, I-25

C-130 aircraft (Q-36), I-27
C-130 aircraft (Q-37), I-29
call forward area, I-22
departure airfield operations, I-19
holding area activities, I-26
loading ramp area, I-24
marshalling area activities, I-21
off-load ramp area activities, I-25
unit marshalling area, I-27

flat mask, F-1

force projection, 6-1

Force XXI Battle Command-Brigade and Below (FBCB2), E-8

foreign humanitarian assistance (FHA), 6-4

Foreign Internal Defense (FID), 6-3

forward line of troops (FLOT), 4-19, 4-31

fragmentary orders (FRAGO), 1-9

friendly fire log, C-4

friendly fire mode, 2-13, C-1

fuel and re-supply positions (FARP), 3-10

functional damage assessment, 1-5

G

G2, 1-3, 3-4, 3-11, 5-14
G3, 3-4, 3-5
general support (GS) field artillery battalion targeting officer, 3-9
generator
MEP-806 60KW, E-10
MEP-813A, H-6
MEP-816A 60KW, E-10, H-6
trailer mounted auxiliary, 4-18
generic area limitation environment (GALE), E-22

H

Headquarters, headquarters and service battery (HHS), 2-2

heavy division target acquisition battery, 2-1, E-1, E-2
height correction, 4-42, 4-43
helicopter air movement, I-1
hookup, I-4
landing zone operations, I-5
loading, I-2
pickup zone operations, I-4
Q-36 sling load procedures, I-5
staging, I-4

high-burst registration, C-3

high mobility artillery rocket system (HIMARS), 2-6, E-1, E-5, E-26

high mobility multi-purpose wheeled vehicle M1097 (HMMWV), 4-14, 4-15, 4-17, 4-22, 4-23

high payoff target list (HPTL), 1-2, 1-5, 1-6, 1-7, 1-8, 1-15, 3-5, 3-8, 3-10, 3-11, 5-11, E-29

high payoff targets (HPT), 1-2, 1-3, 1-6, 1-7, 1-8, 1-12, 1-15, 3-8

high value target list (HVTL), 1-13, 1-15, 3-5

high value targets (HVT), 1-2

hot surfaces, E-18

I

imagery intelligence (IMINT), 3-4
impact-predict registration, C-4
improved radar positioning, 6-6
information operations (IO), 1-6
initial fire support automated system (IFSAS), 3-6, 5-17, A-16
intelligence collection plan (ICP), 1-2, 1-3, 1-5, 1-9, 3-5, 5-11, 5-12
intelligence preparation of the battlefield (IPB), 1-2, 1-5, 3-5, 3-9, 3-10, 3-11, 4-31, 4-34, 4-35, 5-5, 5-11, 5-12, 5-17, 5-23
intelligence requirements (IR), 1-2, 5-11
intelligence support element (ISE), 3-4, 3-5
interference, 6-6

Interim BCT

counterfire, 5-20, 5-22, 5-23
counterfire officer, 3-11
Q-47 employment, E-26
target acquisition platoon (IBCT TAP), 2-5, E-1, E-4, E-5
targeting NCO, 3-10
targeting officer, 3-10

Interim DIVARTY (IDIVARTY)

Q-47 employment, E-26
radar platoon, 2-6, E-1, E-5, E-6

interim division, 5-22

intermediate staging base (ISB), 4-31

J

joint airlift inspection checklist, K-12

DD Form 2133 (blank), K-13

joint services workstation (JSWS), E-23

joint STARS, E-23

L

liaison, E-23

liaison officer (LNO) E-24

lifting hazards, E-18

light medium tactical vehicle, E-8, E-10

lightweight multipurpose shelter (LMS), 4-14

line replaceable units, 2-10, E-19

location averaging, 4-41, 4-42

M

maintenance, H-5

depot maintenance, H-5

non-radar maintenance, H-5

radar specific maintenance, H-5
repair parts, H-5

unit-level maintenance, H-5

mask angle, 4-34, F-1, F-2, F-5, F-6

mask variation, F-1, F-3, F-4

masking, 6-7, F-1

medium tactical vehicle (MTV), 4-26

medium track suspension system (MTSS), 4-23

mess support, H-4

MET altitude comparison table, H-7

meteorological

data, H-6

section, 2-3, E-5

military decision making process (MDMP), 1-1, 1-9, 1-10, 1-11, 1-12, 3-5, 4-1, 4-27

mission, 4-9

METT-TC, 4-31

mission, enemy, terrain, troops, time available, and civil considerations (METT-TC), 4-31, 4-34

mission analysis, 1-10

Mission Cutoff Value, 1-16

mission paragraph, G-2

modular azimuth positioning system (MAPS), 4-23, 4-24, 4-26, H-1

mortaring reports (MORTREPs), 3-6, 3-7, B-13

crater analysis, B-6

detection, 4-10, 4-11

mortar,

crater analysis, B-6, B-7, B-8, B-11

detection, 4-10, 4-11

multiple launch rocket system (MLRS), 2-2

munitions effects assessment (MEA), 1-4, 1-5

N

named area of interest (NAI), 3-5, 5-11

noise, E-19

noncombatant evacuation operations (NEO), 6-4

nonlinear/noncontiguous operations, 5-23

normal mode, E-11

O

object tracking, 4-7

object verification, 4-6

offensive operations, 5-15, 5-16

operational control (OPCON), 5-4
operations central (OC), 4-14, 4-26, E-8, E-9

operations control group (OCG)

AN/TPQ -36, 4-13, 4-14

AN/TPQ -37, 4-22, 4-23

operations officer, 5-12

operations order (OPORD), 1-3, 5-11, 5-15

operations plan (OPLAN), 5-15

operator control stations (OCS), 4-14

order of battle (OB) officer, 3-6

P

peace operations (PO), 6-2

peace enforcement operations (PEO), 6-2

peace keeping operations (PKO), 6-2

petroleum, oils, and lubricants (POL), H-6

platoon commander, 2-14

portable operations suite (POS), E-9, E-10

position and azimuth determining system (PADS), E-5

positioning, 4-30

civil considerations, 4-32

enemy, 4-31

interference, 6-6

mission, 4-19, 4-31, E-17

tactical operations, 4-31, E-16

terrain and weather, 4-31

time available, 4-32

troops, 4-32

power distribution group,

Q-36, 4-13, 4-17

Q-37, 4-22, 4-23, 4-24, 4-26

power distribution unit, trailer, 4-25

pre-combat inspections checklist, I-3

prime power group (PPG), 4-17, E-10, E-11
priority/censor zone message (SPRT;FILTER), G-16
priority intelligence requirement (PIR), 1-2, 1-3, 5-11
probability of location
 Q-36, 4-10
 Q-37, 4-19
processing section leader, 2-15
processing team leader, 2-16
protection, 4-35

Q

quick fire, 2-5, E-5, E-26
quick reference position selection worksheet, K-8

R

radar
 beam, 4-7
 detection area, 4-3
 employment, 4-1, 5-1
 employment chief, 2-14
 improved position, 6-6
 missions, 4-9
 operational parameters, 4-41
 operator, 2-15
 planning ranges, 4-2
 platoon leader, 3-2
 platoon sergeant, 3-3
 positioning and movement synchronization checklist, K-9
 range limits, 4-2, 4-11, 4-19, 4-20, 4-21
 search sector, 4-2, 4-10, 4-11, 4-19, 4-20, 4-21, 5-5, F-3, F-5, F-6
 section, 2-1
 section leader, 1-12, 2-9, 2-14, 5-12, F-2, F-6
 status, 1-7
 tasking procedures, 5-17
 vertical scan, 4-3
 watch chief, 2-15
radar deployment order (RDO), 3-6, 3-8, 5-12, 5-15, 5-17

AFATDS automated, 5-7, G-15
cueing agents, G-12
DA Form 5957-R, G-12
DA Form 5957-R (blank), K-5
EW threat assessment, G-12
heading, G-12
location, G-12
reporting channels, G-13
sample, G-14
search sector, G-12
zone data, G-13
zone management, 5-10, 5-12
radar execution matrix, 5-17
 blank, K-6
 example, K-7
 zone management, 5-10
radar modes,
 fast scan mode, E-12
 friendly mode, 2-13, 4-9
 hostile mode, 4-1
 normal mode, E-11
 tactical ballistic missile mode, E-12
radar search area message (SPRT;SEARCH), G-16
radar zones, 1-7, 5-5, 5-21
 censor, 5-6
 developing data, 5-7
 management, 5-9, 5-11, 5-13
 planning, 5-10
 priority, 5-5
radiation, 4-47, E-17
radio direction finding (RDF), 4-35
reconnaissance, 4-33
 Firefinder Position Analysis System (FFPAS), 4-34
 ground, 4-34
 map, 4-33
reconnaissance, security and surveillance (RS&S), 1-6, 1-7, 1-8, 1-12
 plan, 5-24
reconnaissance, surveillance, and target acquisition (RSTA), 3-10
recorder/driver, 2-16

recorder/plotter, 2-16
registration
 datum-plane, C-4
 high-burst, C-3
 impact-predict, C-4
rehearsal, 1-12, J-1
 backbrief, J-1
 battle drill rehearsal, J-2
 combined arms, J-1
 confirmation brief, J-1
 support rehearsal, J-2
 zone management, 5-12
rehearsal, brigade fire support, J-9
rehearsal scripting and conducting, J-6
 agenda, J-7
 brigade, combined arms, J-9
 response sequence, J-7
 results, J-12
 script, J-10, J-12
 sequence of events, J-7
 staff support actions, J-9
 unit actions checklist, J-7
rehearsal techniques, J-2
 full dress rehearsal, J-3
 map rehearsal, J-6
 radio rehearsal, J-6
 reduced force rehearsal, J-4
 sketch map rehearsal, J-5
 terrain model rehearsal, J-5
remote control display terminal (CDT), 4-13, 4-14, 4-15, 4-16

<p>risk. L-1</p> <p>command climate, L-5</p> <p>control development, L-3</p> <p>controls, L-4</p> <p>hazard assessment, L-2</p> <p>hazard identification, L-1</p> <p>responsibilities, L-5</p> <p>risk decisions, L-3</p> <p>supervision and evaluation, L-4</p> <p>management, L-1</p> <p>management process, L-5</p> <p>management worksheet, K-15 - 16</p> <p>rocket</p> <p>crater analysis, B-9</p> <p>detection, 4-10, 4-11, 4-12</p> <p>rocketing reports (ROCKREPs), B-13</p> <p style="text-align: center;">S</p> <p>S2, 1-3, 1-6, 2-1, 2-11, 2-15, 3-3, 3-6, 3-7, 3-8, 3-9, 4-27, 4-31, 5-2, 5-3, 5-7, 5-10, 5-12, 5-14, G-1, G-12</p> <p>brigade combat team (BCT), 3-8</p> <p>direct support (DS) battalion, 3-8</p> <p>S3, 1-6, 1-8, 2-11, 2-15, 3-3, 3-8, 3-9, G-1</p> <p>S-250 shelter, 4-23, 5-7</p> <p>safety, 4-47, E-17</p> <p>antenna roll over, E-19</p> <p>hot surfaces, E-18</p> <p>lifting hazards, E-18</p> <p>noise, E-19</p> <p>other hazards, 4-48</p> <p>positioning, 6-6</p> <p>radiation, 4-47, E-17</p> <p>wind, 4-48, E-18</p> <p>scenario development, D-2</p> <p>scenario implementation, D-4</p> <p>control element, D-4</p> <p>controlling headquarters, D-5</p> <p>cueing agents, D-4</p>	<p>firing element, D-5</p> <p>radar section, D-5</p> <p>TOC and/or targeting element, D-5</p> <p>screening crest, 4-28, 4-34, 4-35, F-1, F-2</p> <p>search fence, 4-6, 4-34</p> <p>sector of search, 4-2, 4-10, 4-11, 4-19, 4-20, 4-21, 5-5, F-3, F-5, F-6</p> <p>security, 6-6, H-6</p> <p>senior field artillery targeting NCO, 3-7</p> <p>service support paragraph, G-3</p> <p>shell fragment analysis, B-9</p> <p>shelling reports (SHELREPs), 3-6, 3-7, B-13</p> <p>shop replaceable unit (SRU), 2-10</p> <p>show of force, 6-3</p> <p>single channel ground and airborne radio system (SINCGARS), 4-14</p> <p>site selection, 4-27, E-15</p> <p>access, 4-30</p> <p>analysis, 4-44</p> <p>area in front of the radar, 4-28, E-15</p> <p>aspect angle, 4-28</p> <p>cable lengths, 4-29, E-15</p> <p>electronic line of sight, 4-28</p> <p>screening crest, 4-28</p> <p>slope, 4-27</p> <p>proximity of other radars, 4-29</p> <p>track volume, 4-29</p> <p>situation paragraph, G-2</p> <p>situational awareness (SA), 3-10</p> <p>situational understanding (SU), 3-11</p> <p>slingshot procedures</p> <p>antenna transceiver group (ATG) (Q-36), I-8</p> <p>antenna transceiver group (ATG) (Q-37), I-13</p> <p>distribution group (Q-37), I-15</p> <p>M1097 and ETG rigging procedures (Q-36), I-12</p>	<p>operations central (OC) (Q36), I-6</p> <p>operations central (OC) and trailer power Q-36, I-5</p> <p>Q-37, I-13</p> <p>utility HMMWV with trailer mounted generator (Q-36), I-10</p> <p>slope, 4-27, 4-34</p> <p>spherical error probable, E-11</p> <p>stability and support operations, 6-1</p> <p>employment considerations, 6-5</p> <p>force projection, 6-1</p> <p>foreign internal defense (FID), 6-3</p> <p>noncombatant evacuation operations (NEO), 6-4</p> <p>peace operations, 6-2</p> <p>show of force, 6-3</p> <p>stability operations, 6-1</p> <p>standard theater army command and control system (STACCS), 3-4</p> <p>STRIKER, 1-11</p> <p>communications, 5-24</p> <p>employment, 5-23</p> <p>operations, 5-24</p> <p>platoon, 2-7</p> <p>support operations, 6-4</p> <p>domestic support operations (DSO), 6-4</p> <p>foreign humanitarian assistance (FHA), 6-4</p> <p>suppression of enemy air defense (SEAD), 1-4, 3-9</p> <p>survey, E-5, H-1</p> <p>platoon, 2-1, 2-2</p> <p>section, 2-2, 2-3, E-1</p> <p>survivability, 4-34, E-17</p> <p>electronic warfare, 4-35</p> <p>flowchart, 4-38</p> <p>ground and air attack, 4-35</p> <p>matrix, 4-37</p>
---	--	---

T

tactical ballistic missile (TBM) mode, E-12, E-27	target acquisition TAB to the field artillery support plan (FASP), 1-9, 3-6, 3-7, 3-8	officer, corps and division, 3-5 senior field artillery targeting NCO, 3-7
tactical control (TACON), 5-5	command and signal, G-3	team, 5-11
tactical interface module (TCIM), E-8	enclosures, G-4	technicians, 5-14
tanker airlift control group (TALCE), I-19 - 27	execution, G-2	USMC targeting information officer, 3-11
target	heading, G-1	targeting synchronization matrix (TSM), 1-3
categories, E-27	mission, G-2	terrain, METT-TC, 4-31
classifications, 4-10, 4-19, E- 14	plan, G-1	theater battle management core system (TBMCS), 3-4
damage assessment, A-19	sample, G-5	theater missile defense (TMD), 3- 4, E-5, E-19
intelligence, 5-17	service support, G-3	ARFOR operations, E-23
target acquisition, 3-6	situation, G-2	attack operations, E-20
corps TA detachment 2-4, E-1, E-3, E-4	target area of interest (TAI), 1-15, 5-11	operational objectives, E-20
counterfire, 1-7	target location error (TLE), 1-4, 1- 14, 3-6, 3-11, 4-12, 4-21, E-11, E-13, E-14	tactical objectives, E-20
decision making process, 1-1, 1-9	TBM, E-27	threat weapon systems, E-14
division MLRS TA battery, 2-2, E-1, E-2, E-3	target management matrix (TMM), 1-15	time available, METT-TC, 4-32
Firefinder radar operator duties, 2-10	target processing center (TAC), 2- 11	track volume, 4-4, 4-29, F-2, F-4, F-5
heavy division TA battery, 2-1, E-1, E-2	target selection standards (TSS), 1-2, 1-4, 1-5, 1-7, 1-8, 1-13, 1- 14, 1-15, 3-5, 3-6, 3-8, 3-10, 3- 11	calculations, F-2, F-3
IDIVARTY radar platoon, 2-6, E-1, E-5, E-6	target system assessment, 1-5	tracking, 1-2
interim BCT TA platoon, 2-5, E-1, E-4, E-5	target value analysis (TVA), 1-2	times, 4-1
meteorological (MET), H-11	target/effects synchronization matrix (T/ESM), 3-10	trailer
planning, 1-10, 1-11, 1-12	targeting, 1-1	M1048, 4-26
power generation equipment repairer duties, 2-11	artillery brigade targeting officer, 3-8	M1048A1, 4-23, 4-26
processing section, 2-1	brigade targeting officer, 3-8	M116A2, 4-18
radar repairer duties, 2-10	division MLRS battalion field general support field artillery battalion targeting officer, 3-9	M116A3, 4-15, 4-16
senior Firefinder radar operator duties, 2-10	information officer (TIO), 3-11	M200A1, 4-25
separate brigade TA platoon, 2-3	Interim BCT targeting NCO, 3- 10	trailer power distribution unit (TPDU), 4-25
tasking assets, 1-3	Interim BCT targeting officer, 3-10	training, D-1
target acquisition battery commander, 3-6	meetings, 1-5, 1-7, 1-8	gunnery team, D-1
target acquisition platoon (TAP), 2-2, 2-3, 2-4, 2-5, 2-6	methodology, 1-1	embedded training, D-2
	NCO, 3-7, 5-11	section and/or platoon, D-1
	officer, 1-7, 1-8, 1-10, 1-11, 1- 12, 3-1, 3-9, 5-2, 5-3	troop leading procedures, K-1
		troops, METT-TC, 4-32
		truck,
		2-1/2 ton, M35A2, 4-26
		5-ton, M923/925, 4-24
		5-ton, M925, 4-26
		M813 generator truck, 4-26

tunneling, 4-35

U

UH-60, I-5

USMC counter battery platoon, 2-1, 2-11, 2-12

AN/TPQ-46A radar section, 2-12

platoon commander duties, 2-14

platoon headquarters 2-12
radar employment chief duties, 2-14

radar section leader duties, 2-14

radar watch chief duties, 2-15

radar watch chief/radar operator duties, 2-15

USMC target processing center, 2-13

processing section leader duties, 2-15

processing team leader duties, 2-16

recorder driver duties, 2-16

recorder/plotter duties, 2-16

USMC targeting information officer, 3-11

V

vehicle cab control console (VCCC), 4-14

velocity requirements, 4-5

versatile computer unit (VCU), E-8, E-9

vertical scan, F-1, F-2

voice radar adjust fire mission (example), K-10

voice radar registration procedure (example), K-10

W

warning order, K-2 - 4

weapons locating radars (WLR), 1-9

weather, 4-48

wind, 4-31

Z

zone data, 5-7

zone management, 5-9, 5-10
responsibilities, 5-11

zones, 5-5

artillery target intelligence zones (ATIZ), 5-5, 5-6

call-for-fire zones (CFFZ), 5-5, 5-6

cursor zones, (CZ), 5-5, 5-6

critical friendly zones (CFZ), 5-5, 5-6

priority zones, 5-5

zones of responsibility (ZOR), 5-23

Army Publications

- BST 6-20-40. Brigade Special Text, Tactics, Techniques and Procedures for Fires and Effects for Interim Brigade Combat Team (IBCT) Operations. 30 Jun 01.
- FM 3-0. Operations. 14 Jun 01.
- FM 3-01 (44-100). U.S. Army Air and Missile Defense Operations. 5 Mar 00.
- FM 3-04.100 (1-100). Army Aviation Operations. 21 Feb 97.
- FM 3-04.113 (1-113). Utility and Cargo Helicopter Operations. 25 Jun 97.
- FM 3-07.3 (100-23). Peace Operations. 30 Dec 94.
- FM 3-09.12 (6-121). Tactics, Techniques and Procedures for Field Artillery Target Acquisition. 25 Sep 90.
- FM 3-09.22 (6-20-2) Tactics, Techniques and Procedures for Corps Artillery, Division Artillery, and Field Artillery Brigade Headquarters, 2 Mar 01.
- FM 3-09.60 (6-60). Tactics, Techniques, and Procedures for the Multiple Launch Rocket System (MLRS) Operations, 23 Apr 96.
- FM 3-10.94 (44-94). Air and Missile Defense Command Operations. 31 Mar 00.
- FM 3-11.3 (3-3). Chemical and Biological Contamination Avoidance with Change 1. 29 Sep 94.
- FM 3-13 (100-6). Information Operations. 27 Aug 96.
- FM 3-60 (6-20-10). Tactics, Techniques, and Procedures for the Targeting Process. 8 May 96.
- FM 3-97.16 (71-100-3). Air Assault Division Operations, Tactics, Techniques, and Procedures. 29 Oct 96.
- FM 3-100.13 (100-13). Battlefield Coordination Detachment (BCD). 5 Sep 96.
- FM 3-100.14 (100-14). Risk Management. 23 Apr 98.
- FM 3-100.15 (100-15). Corps Operations. 29 Oct 96.
- FM 4-01.11 (55-65). Strategic Deployment. 3 Oct 95.
- FM 5-0 (101-5). Staff Organization and Operations. 31 May 97.
- ST 6-3-1. AFATDS Digital Leader Guide. 28 Feb 01.
- ST 6-20-92. Tactics, Techniques, and Procedures for the Strike / Recon Platoon. Jul 98.
- TM 11-5840-355-10. Operator's Manual for Radar Sets for AN/TPQ-37(V)6 and AN/TPQ37(V)8. 1 Aug 00.
- TM 11-5840-355-10-1. Operator's Manual for Radar Sets for AN/TPQ-37(V)3, AN/TPQ-37(V)5, AN/TPQ-37(V)6 and AN/TPQ37(V)8 with Change 14. 20 Jul 81.

- TM 11-5840-355-10-2. Operator's Manual for Radar Sets for AN/TPQ-37(V)3, AN/TPQ-37(V)5, AN/TPQ-37(V)6 and AN/TPQ37(V)8. 29 Jan 96.
- TM 11-5840-355-10-3. Operator's Manual (Camouflage Procedures) for Radar Sets for AN/TPQ-37(V)3, AN/TPQ-37(V)5, AN/TPQ-37(V)6 and AN/TPQ37(V)8 with Change 3. 1 May 87.
- TM 11-5840-380-10. Operator's Manual, Radar Set AN/TPQ-36(V)8. 1 May 99.
- TM 11-5840-380-23-1. Unit and Direct Support Maintenance Manual, Radar Set AN/TPQ-36(V)8. 1 May 99.
- TM 55-2320-272-14-1. Transport Guidance Truck 5-Ton, 6x6 M939-Series/M939A1-Series/M939A2-Series. 30 Sep 93.
- TM 55-2320-280-14. Transportability Guidance M998 Series High-Mobility Multipurpose Wheeled Vehicles (HMMWV). 25 Aug 88.
- TRADOC Regulation 25-30. Preparation, Production, and Processing of Armywide Doctrinal and Training Literature (ADTL). 30 Mar 90.
- XST 6-20-10. Tactics, Techniques and Procedures for Targeting in the First Digital Division. 2 Oct 00.

Other Publications

- 101st Airborne Division Tactics, Techniques, and Procedures for Air Assaulting the AN/TPQ-37(V)8 Firefinder Radar. 30 Jun 99.
- 101st Airborne Division Tactics, Techniques, and Procedures for Air Movement of the AN/TPQ-37(V)8 Firefinder Radar. 30 Jun 99.
- Call Newsletter Number 98-5. Rehearsals. Mar 98
- Information Operations Planning Tactics, Techniques and Procedures for Field Support Teams. 6th Edition. May 99.
- Memorandum, Headquarters, U.S. Army Center for Health Promotion and Preventive Medicine, ATTN: MCHB-DC-ORF, dated 25 Sep 97, subj: Nonionizing Radiation Protection Consultation No. 24-ME-7193-97, Firefinder Radar Technical Manuals.
- Memorandum, Headquarters, CECOM, ATTN: AMSEL-SF-SEC, dated 12 Mar 98, subj: Review of Nonionizing Radiation Protection Consultation No. 24-ME-7193-97, Firefinder Radar Technical Manuals, dated 25 Sep 97.
- MTMCTEA Reference 99-55-24. Vehicle Preparation Handbook for Fixed Wing Air Movements, First Edition. Jul 99.
- Operational Requirements Document (ORD) for the FireFinder AN/TPQ-47 Radar. 25 Sep 96.
- Operational and Organizational Concept for the Traditional Interim Brigade Concept Team. 11 Jun 00.
- Operational and Organizational Concept for the Radical Interim Division. 11 Jun 00.
- Performance Specification for Firefinder AN/TPQ-36(V)8, Revision 1, 4 Nov 92.

Performance Specification for Firefinder AN/TPQ-47 Revision 3. 9 Jun 00.

FireFinder AN/TPQ-37(V)9 Block II Preplanned Product Improvement (P3I)
Integrated Logistics Support Plan (ILSP). Jun 97.

TR-82-V4-04. Final Transportation Engineering Analysis for the High Mobility
Multipurpose Wheeled Vehicle (HMMWV). Sep 89

TR 89-4v-24. Final Transportability Engineering Analysis for the High Mobility
Multipurpose Wheeled Vehicle (HMMWV) Heavy Variant (XM1097). May
92.

US Army Command and General Staff College Briefing. Radar 101. 7 Aug 99.

FM 3-09.12 (FM 6-121)
MCRP 3-16.1A
21 JUNE 2002

By order of the Secretary of the Army:

ERIC K. SHINSEKI
General, United States Army
Chief of Staff

Official:

JOEL B. HUDSON
Administrative Assistant to the
Secretary of the Army
0215608

DISTRIBUTION:

Active Army, Army National Guard, and U.S. Army Reserve: To be distributed in accordance with the initial distribution number 110068 for FM 3-09.12.

By direction of the Commandant of the Marine Corps

EDWARD HANLON JR.
Lieutenant General, U.S. Marine Corps
Commanding General

PIN: 080009-000