

✓ *Pos*
ARMY FM 10-573

AIR FORCE TO 13C7-27-141



AIRDROP OF SUPPLIES AND EQUIPMENT

RIGGING 130G MOTOR GRADER

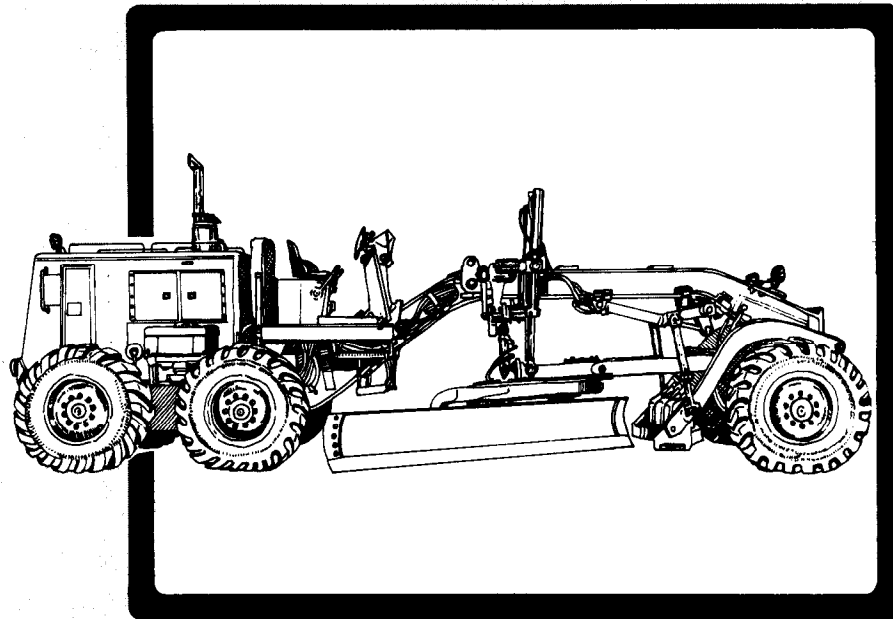

DISTRIBUTION RESTRICTION: This publication contains technical or operational information that is for official government use only. Distribution is limited to US government agencies. Requests from outside the US government for release of this publication under the Freedom of Information Act or the Foreign Military Sales Program must be made to HQ TRADOC, Fort Monroe, VA 23651-5000.

DEPARTMENTS OF THE ARMY AND OF THE AIR FORCE



REPLY TO
ATTENTION OF

DEPARTMENT OF THE ARMY
AERIAL DELIVERY AND FIELD SERVICES DEPARTMENT
U.S. ARMY QUARTERMASTER CENTER AND SCHOOL
1010 SHOP ROAD
FORT LEE, VIRGINIA 23801-1502

ATSM-ADFSD

7 October 1998

MEMORANDUM FOR Commander, US Army Training Support Center, ATTN: ATIC-
TIST (Mr. Baston), Fort Eustis, VA 23604

SUBJECT: Distribution Restriction Notice on Airdrop Rigging Manuals

1. As proponent for development of all 10-500 series airdrop rigging field manuals and the 10-450 sling load manuals, it has been determined that the distribution restriction on these field manuals should be changed to read: Approved for public release, distribution unlimited.
2. It is requested that unrestricted release of these field manuals be made via the Army Training Digital Library.
3. The new distribution notice will be added to the cover pages as future changes/revisions are made to the manuals.
4. Enclosed you will find a numerical list and the number of changes of the manuals that have unlimited distribution.
5. The point of contact for this action is Mr. Roger Hale, DSN 687-4769.

Encl

THEODORE J. DLUGOS
Director, Aerial Delivery and
Field Services Department

Distribution restrictions for the following Airdrop field manuals should read "**Approved for public release; distribution is unlimited.**"

10-450-3	10-524, c2	10-552, c2
10-450-4	10-526, c3	10-554
10-500-2, c2	10-527, c3	10-555, c2
10-500-3, c1	10-528, c6	10-556
10-500-7, c1	10-529, c1	10-557
10-500-45	10-530	10-558, c1
10-500-53	10-531, c2	10-562
10-500-66, c1	10-532, c4	10-564, c6
10-500-71	10-533	10-567, c1
10-508, c1	10-534, c2	10-569, c1
10-510, c3	10-535	10-571
10-512, c4	10-537, c4	10-572
10-513, c3	10-539, c3	10-573, c1
10-515, c1	10-540, c2	10-574, c4
10-516	10-541, c1	10-575, c2
10-517, c5	10-542, c2	10-576, c1
10-518	10-543, c2	10-577
10-519, c3	10-546	10-579, c2
10-520, c3	10-547, c1	10-584
10-521, c2	10-548, c1	10-586
10-522, c1	10-549	10-588
10-523, c2	10-550, c3	10-591, c1



DEPARTMENT OF THE ARMY

HEADQUARTERS UNITED STATES ARMY TRAINING AND DOCTRINE COMMAND
FORT MONROE, VIRGINIA 23651-5000

REPLY TO
ATTENTION OF

ATCD-SL (70-1f)

21 Oct 96

MEMORANDUM FOR DEPUTY CHIEF OF STAFF OPERATIONS AND PLANS,
400 ARMY PENTAGON, ATTN: DAMO-FDL, WASHINGTON
DC 20310-0400

SUBJECT: Quartermaster (QM) Functional Area Assessment (FAA)
Response

1. References:

a. Message, HQDA, DAMO-FDL, 231825Z Apr 96, subject: QM FAA Results.

b. Memorandum, HQ TRADOC, ATCG, 29 Jul 96, Army Airdrop Capabilities Assessment.

2. At the 29 Mar 96 QM FAA briefing to the Director of Army Staff, the decision was reached to revisit the Army's decision to "shelf" Low Altitude Parachute Extraction System (LAPES) (reference 1a).

a. Reference 1b, solicited CINCs input for their positions on LAPES and assessments of airdrop capabilities. The CINCs responses will be used to chart the direction and role for airdrop in the 21st century.

b. Based on the responses received (enclosure), there is no strong support for LAPES airdrop capability at this time. The consensus for the airdrop capabilities is to continue support for current Low Velocity Airdrop System (LVAD), develop a 500-foot LVAD and further explore Advanced Precision Aerial Delivery System (APADS).

3. Further, we will continue to maintain a range of airdrop capabilities to support all contingencies throughout the Army. The results of the Army Airdrop Capabilities Assessment also will be incorporated into the Operational Concept for Aerial Delivery Operations and Improved Cargo Aerial Delivery Capability Mission Needs Statement being developed by the Quartermaster Directorate of Combat Developments, U.S. Army Combined Arms Support Command (CASCOM).

4. The HQ TRADOC POC is MAJ Higgins, Airborne Airlift Action Office, ATCD-SL, E-mail: higginsn@emh10.monroe.army.mil, DSN 680-2469/3921, datafax DSN 680-2520.

ATCD-SL

SUBJECT: Quartermaster (QM) Functional Area Assessment (FAA)
Response

FOR THE DEPUTY CHIEF OF STAFF FOR COMBAT DEVELOPMENTS:

Encl

JOHN A. MANDEVILLE
Colonel, GS
Director, Combat Service Support

CF:

USACASCOM (ATCL-CG/ATCL-QC/ATCL-MES)

USAQMC&S (ATSM-CG/ATSM-ABN/FS)

USANRDEC (SSCNC-UT/AMSSC-PM)

ORGANIZATION	LAPES	LVAD	500' LVAD	APADS	SPTS/ NOT SPEC
USSOCOM		X	X	X	
EUCOM					X
CENTCOM		X	X		
FORSCOM		X	X	X	
TRANSCOM					X
SOUTHCOM	X			X	
VIII ARMY					X
ACOM					X

USSOCOM: Memorandum specifically states that the command does not support LAPES airdrop capability, but supports LVAD as well as APADS.

EUCOM: Draft memorandum specifically states that the command support the need for a low level airdrop capability. However, memorandum summarizes that the specific capability is not important as to have a capability to meet the required mission/threat profile.

CENTCOM: Memorandum specifically states that the command does not support LAPES airdrop capability, but support both current LVAD and 500-foot LVAD airdrop capabilities.

FORSCOM: 1st Endorsement specifically states that the command does not support LAPES airdrop capability, however supports LVAD, 500-foot LVAD and APADS.

TRANSCOM: Memorandum does not specifically address any airdrop capability as it talks to the 21st century requiring the full spectrum of tactical delivery methods.

SOUTHCOM: Memorandum specifically supports LAPES and APADS airdrop capabilities for their command.

VIII ARMY: E-Mail note for VIII Army states that the command has no input to the assessment as their plans call for a limited employment of airdrop.

ACOM: Sent request for input on 30 Sep 96. Received verbal response on 16 Oct 96 stating command is indifferent on the specific capability received.



DEPARTMENT OF THE ARMY
HEADQUARTERS UNITED STATES ARMY TRAINING AND DOCTRINE COMMAND
FORT MONROE, VIRGINIA 23651-3000

REPLY TO
ATTENTION OF

6 SEP 1995

ATCD-SL (70-1f)

MEMORANDUM FOR

Major General Thomas W. Robison, Commander, U.S. Army Combined
Arms Support Command and Fort Lee, Fort Lee, VA 23801-6000
Major General Robert K. Guest, Commander, U.S. Army Quartermaster
Center and School, Fort Lee, VA 23801-5030

SUBJECT: Low Altitude Parachute Extraction System (LAPES)
Disassembly.

1. References:

a. Message, HQ TRADOC, ATCD-SL, 100930Z Jan 95, subject:
LAPES.

b. OVVM Note, HQ USACASCOM, 30 March 95, subject: TRADOC
Disassembly of LAPES.

2. The U.S. Army and other services recently have concurred that
LAPES will be terminated, as this capability is no longer required
as a viable wartime contingency airdrop option. However,
Headquarters, Department of the Army (DA), Deputy Chief of Staff
for Operations and Plans, has agreed that LAPES technology will be
shelved, and all specialized equipment preserved for possible
future use.

3. Take the necessary steps to terminate training and leader
development concerning LAPES operations. Major General Guest's
questions regarding the disassembly of LAPES (enclosed) with
following guidance will be utilized:

a. "Does the U.S. Army Quartermaster Center and School
(USAQMC&S) continue to publish LAPES procedures in their joint
field manual (FMs)/technical order manuals?" "Do we publish the
LAPES procedures that have been written but not been printed yet?"
Publishing LAPES procedures in all joint publications, Army FMs,
regulations, etc., will be discontinued and addressed in the next
revision of the aforementioned documents. Concurrently, all LAPES
procedures that have been written and not printed will not be
published.

6 SEP 1995

ATCD-SL
SUBJECT: Low Altitude Parachute Extraction System (LAPES)
Disassembly

b. "Do we keep LAPES in our programs of instruction (POIs)?" "Do we teach LAPES to other services and our allies?" The USAQMC&S will remove LAPES procedures from PCI and cease teaching LAPES to other services and/or allies.

c. "What do we teach to folks that have LAPES equipment in their war reserves?" All instruction concerning LAPES procedures will be discontinued whether LAPES equipment is located in units or in war reserves.

d. "What is the DA/TRADOC guidance on disposition of unit, depot, and war reserves LAPES equipment?" All LAPES equipment in war reserves and depot should be preserved with the exception of a few items that can be utilized in other existing airdrop capabilities. Specifically, the Type V airdrop platforms and attitude control bars of the LAPES system are being utilized to augment current Low Velocity Airdrop Systems (LVADS) loads.

e. "What is the guidance to U.S. Army Test and Experimentation Command on force development test and experimentation certification of LAPES loads?" The certification of all LAPES loads at the Airborne Special Operations Test Directorate will be redirected toward testing and certification of LVADS loads.

4. HQ TRADOC POC is CPT Higgins or CPT Phillips, ATCD-SL, DSN 680-2469/3921, datafax DSN 680-2520.

FOR THE COMMANDER:

Encl



JOE N. BALLARD
Major General, GS
Chief of Staff

CF:
HQDA (DAMO-FDL)
CDR, NRDEC (SAFNC-UA)
CDR, FORSCOM (FCJ3-FC)
CDR, OPTEC (CSTE-CS, CSTE-OPM)
CDR, ATCOM (AMSAT-W-TD)
DIR, ABNSOTD (ATCT-AB)
HQ TRADOC (ATCD-L, ATCD-RM, ATDO-A, ATTG-IT)

Date and time 07/18/95 10:28:11

From: HIGGINSN--MON1
To: HIGGINSN--MON1

From: OPT NEIL HIGGINS, (AAACO), 680-2464
Subject: TRADOC "DISASSEMBLY" OF LAPES

* AIRBORNE AIRLIFT ACTION OFFICE *
* (AAACO) *

** Forwarding note from BRUNEAUN--OMSNAMES 07/18/95 10:27 ***
Received: from LEE-EMH2.ARMY.MIL by MONROE-EMH2.ARMY.MIL (IBM VM SMTP V2R2)
with TCP; Tue, 18 Jul 95 10:27:22 EDT
Received: from LEE1 by LEE-EMH2.ARMY.MIL (IBM VM SMTP V2R2) with SMTP id 3547;
Tue, 18 Jul 95 10:29:34 EDT
Comments: Converted from PROFS to RFC822 format by PUMP V2.2X
Date: Tue, 18 Jul 95 10:29:26 EDT
From: NORMAN BRUNEAU <BRUNEAUN@LEE-EMH2.ARMY.MIL>
Subject: TRADOC "DISASSEMBLY" OF LAPES
To: "NEIL HIGGINS- AAACO " <HIGGIN@MONROE-EMH1.ARMY.MIL>

** Resending note of 06/30/95 09:23

From: LARRY MC MILLIAN AAA <MCMILLI@MONROE-EMH1.ARMY.MIL>
To: NORMAN BRUNEAU
Subject: TRADOC "DISASSEMBLY" OF LAPES

NEIL- HERE ARE THE QUESTIONS THAT MG GUEST WANTS DA/ TRADOC TO ANSWER RE LAPES, AS I UNDERSTAND HIS GUIDANCE. I HAVE DISCUSSED THESE W/ OUR ABN DPT. IF THESE QUESTIONS MAKE SENSE, GIVE ME AN "UP" BEFORE I FORMALLY SEND ANYTHING OUT. MG GUEST WANTS SPECIFIC GUIDANCE FM TRADOC ON LAPES, RESPONSE NEEDS TO BE CLEAR AND TO THE POINT. A LOT OF THIS WILL HINGE ON WHAT ACC PLANS TO DO W/ LAPES NOW THAT THE AIR STAFF HAS GIVEN THEM THE GREEN LIGHT TO KILL IT. IF THEY PLAN TO PLACE IT ON THE SHELF OR KEEP A LIMITED OR CONTINGENCY CAPABILITY, THAT WILL DRIVE YOUR ANSWER TO US, AT THIS POINT I THINK ACC WILL DO WHATEVER THE ARMY WANTS, AS THEIR PRIMARY CUSTOMER. I WILL NOT REHASH HOW THE ARMY DECIDED THEY DIDNT NEED LAPES. QUESTIONS FOLLOW:

- DOES THE GMS CONTINUE TO PUBLISH LAPES PROCEDURES IN THEIR JOINT FM/TO MANUALS?
- DO WE PUBLISH THE LAPES PROCEDURES THAT HAVE BEEN WRITTEN BUT HAVE NOT BEEN PRINTED YET?
- DO WE REMOVE ALL LAPES PROCEDURES FROM ALREADY PUBLISHED MANUALS?
- DO WE KEEP LAPES IN OUR POI?
- DO WE TEACH LAPES TO OTHER SERVICES AND OUR ALLIES?
- WHAT DO WE TEACH TO FOLKS THAT HAVE LAPES EQUIPMENT IN THEIR WAR RESERVES?
- WHAT IS THE DA/TRADOC GUIDANCE ON DISPOSITION OF UNIT, DEPOT, AND WAR RESERVE LAPES EQUIPMENT?
- WHAT IS THE GUIDANCE TO TEXCOM ON THE FUTE CERTIFICATION OF LAPES LOADS?

I KNOW THESE ARE TOUGH QUESTIONS, BUT THEY HAVE TO BE ASKED. HQ STAFFS CANNOT SIMPLY SAY "KILL IT" AND MOVE ON TO THE NEXT ISSUE. I DONT THINK WE ARE DOING OUR JOB IF WE LEAVE IT UP TO THE SCHOOLHOUSE TO INTERPRET SKETCHY GUIDANCE. THAT PLACES US IN THE POSSIBLE POSITION OF BEING ACCUSED OF NOT FOLLOWING ORDERS.

LETS TALK.....NORM

TRK 2/47

SEP 11 11 08:30AM CSSRD FT MONROE VA

File 1

DEPARTMENT OF THE ARMY
QUARTERMASTER CENTER AND SCHOOL
1201 22D STREET
FORT LEE, VIRGINIA 23801-1601

ATSM-ABN-FS

15 Dec 96

MEMORANDUM FOR RECORD

SUBJECT: Airdrop Equipment Update

Reference:

- a. Phone conversation between CW4 Mahon, CASCOM and Dick Harper, Weapons System Management Office, Army Aviation Troop Command. Subject : sab
- b. Phone conversation between CW4 Mahon, CASCOM and Don Stump, Logistics Management Specialist, Office, Deputy Chief of Staff for Logistics. Subject. sab
- c. Phone conversation between CW4 Mahon, CASCOM and Chief Msgt Okraneck, Hqrs Air Combat Command. Subject sab
- d. msg dtg R 181348Z Feb 94. subject: FCIF item: Type II platforms, PEFTC and SL/CS for Air Force unilateral training

1. Based on information received from the references a-c above, the following update is provided per request ref c, above.
 - a. The type II modular platform no longer exists within any contingency stocks. Therefore, maintaining Joint Inspection training program is no longer required for this equipment.
 - b. The Parachute Extraction Transfer Force Coupling (PEFTC) no longer exists within any contingency stocks. Therefore, maintaining Joint Inspection training program is no longer required for this equipment.
 - c. The metric platform interim rigging procedures are no longer valid as they apply to metric platforms. Those rigging procedures which have dual application with the type V platform are still valid for the type V platform.
 - d. The static line connector strap (SL/CS) currently has limited application. Only those loads that specifically require this system are authorized use of this system. The SL/CS is not an across the board substitute for the Extraction Force Transfer Coupling (EFTC). These authorized loads are specific in nature and will normally be found in the special operations arena of airdrop loads. This system is not authorized for use IAW ref d, above.
2. For additional questions/information contact the undersigned at DSN 687-4733, Fax 3084.

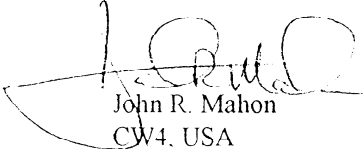
John R. Mahon
CW4, USA
Senior Airdrop Systems
Technician

CHANGE
NO 1

HEADQUARTERS
DEPARTMENTS OF THE ARMY
AND THE AIR FORCE
Washington, DC, 14 June 1990

**AIRDROP OF SUPPLIES AND EQUIPMENT:
RIGGING 130G MOTOR GRADER**

This change adds the procedures for rigging the type I and II, 130G motor graders for low-velocity and LAPE airdrop on the type V platform. FM 10-573/TO 13C7-27-141, 27 September 1988, is changed as follows:

1. New or changed material is identified by a vertical bar in the margin opposite the changed material.
2. Remove old pages and insert new pages as indicated below:

<u>Remove pages</u>	<u>Insert pages</u>
i through ii	i through iv
	3-1 through 3-116
Glossary-1	Glossary-1
References-1	References-1

3. File this transmittal sheet in front of the publication.

DISTRIBUTION RESTRICTION. Distribution authorized to U.S. Government agencies only to protect technical or operational information from automatic dissemination under the International Exchange Program or by other means. This determination was made on 5 February 1990. Other requests for this document will be referred to Commander, U.S. Army Quartermaster Center and School (PROV), ATTN: ATSM-DTP, Fort Lee, Virginia 23801-5036.

DESTRUCTION NOTICE. Destroy by any method that will prevent disclosure of contents or reconstruction of the document.

By Order of the Secretaries of the Army and the Air Force:

CARL E. VUONO
General, United States Army
Chief of Staff

Official:

WILLIAM J. MEEHAN II
Brigadier General, United States Army
The Adjutant General

DISTRIBUTION:

Active Army, USAR, and ARNG: To be distributed in accordance with DA Form 12-11-E, requirements for FM 10-573, Airdrop of Supplies and Equipment: Rigging 130G Motor Grader (Qty rqr block no. 3837).

**AIRDROP OF SUPPLIES AND EQUIPMENT:
 RIGGING 130G MOTOR GRADER**

TABLE OF CONTENTS

	Paragraph	Page
PREFACE		iii
INTRODUCTION		iv
CHAPTER 1 RIGGING TYPE I AND II, 130G MOTOR GRADERS FOR LAPE AIRDROP ON THE TYPE V AIRDROP PLATFORM		
Description of Load	1-1	1-1
Preparing Platform	1-2	1-2
Building and Placing Honeycomb Stacks	1-3	1-3
Building Front-End Supports	1-4	1-15
Preparing Grader	1-5	1-19
Installing Lifting Slings	1-6	1-24
Positioning Grader	1-7	1-25
Preparing Grader After Positioning	1-8	1-27
Lashing Grader	1-9	1-30
Installing Extraction System	1-10	1-40
Positioning Extraction System	1-11	1-44
Marking Rigged Load	1-12	1-44
Equipment Required	1-13	1-44
CHAPTER 2 RIGGING TYPE I AND II, 130G MOTOR GRADERS FOR LV AIRDROP ON A NONSTANDARD, TYPE II MODULAR PLATFORM		
Description of Load	2-1	2-1
Preparing Platform	2-2	2-1
Building and Placing Honeycomb Stacks	2-3	2-5
Building Front-End Supports	2-4	2-14
Preparing Grader	2-5	2-21
Installing Suspension Slings	2-6	2-26
Positioning Grader	2-7	2-27
Preparing Grader After Positioning	2-8	2-29
Lashing Grader	2-9	2-33

DISTRIBUTION RESTRICTION. Distribution authorized to U.S. Government agencies only to protect technical or operational information from automatic dissemination under the International Exchange Program or by other means. This determination was made on 5 February 1990. Other requests for this document will be referred to Commander, U.S. Army Quartermaster Center and School (PROV), ATTN: ATSM-DTP, Fort Lee, Virginia 23801-5036.

DESTRUCTION NOTICE. Destroy by any method that will prevent disclosure of contents or reconstruction of the document.

* This publication supersedes FM 10-573/TO 13C7-27-141, 2 May 1985.

	Paragraph	Page
Building and Installing Cargo Parachute		
Stowage Platform	2-10	2-36
Stowing Cargo Parachutes	2-11	2-43
Installing Extraction System	2-12	2-44
Installing Release Assembly	2-13	2-46
Positioning Extraction Parachutes	2-14	2-48
Installing Emergency Restraints	2-15	2-48
Marking Rigged Load	2-16	2-51
Equipment Required	2-17	2-51

CHAPTER 3 RIGGING TYPE I AND II, 130G MOTOR GRADERS FOR AIRDROP ON A 28-FOOT, TYPE V PLATFORM

Section I LOW-VELOCITY AIRDROP

Description of Load	3-1	3-1
Preparing Platform	3-2	3-2
Building and Placing Honeycomb Stacks	3-3	3-3
Building Wooden Supports	3-4	3-11
Preparing Grader	3-5	3-19
Installing Suspension Slings	3-6	3-24
Positioning Grader	3-7	3-25
Preparing Grader After Positioning	3-8	3-26
Lashing Grader	3-9	3-31
Building and Installing Cargo Parachute		
Stowage Platform	3-10	3-38
Stowing Cargo Parachutes	3-11	3-43
Installing Extraction System	3-12	3-44
Installing Release Assembly	3-13	3-46
Positioning Extraction Parachutes	3-14	3-49
Installing Provisions for Emergency		
Restraints	3-15	3-49
Marking Rigged Load	3-16	3-50
Equipment Required	3-17	3-50

Section II LAPE AIRDROP

Description of Load	3-18	3-54
Preparing Platform	3-19	3-54
Building and Placing Honeycomb Stacks	3-20	3-54
Building Wooden Supports	3-21	3-66
Preparing Grader	3-22	3-68
Positioning Grader	3-23	3-72
Preparing Grader After Positioning	3-24	3-76
Lashing Grader	3-25	3-78
Securing Engine Compartment and Attaching		
28-Foot Extraction Lines	3-26	3-84
Building and Installing Parachute		
Extraction System	3-27	3-87
Placing Extraction Parachutes	3-28	3-113
Marking Rigged Load	3-29	3-113
Equipment Required	3-30	3-113

GLOSSARY Glossary-1

REFERENCES References-1

PREFACE

SCOPE

This manual tells and shows how to rig the type I and II, 130G motor graders for LAPE airdrop from C-130 aircraft and LV airdrop from C-130 or C-141 aircraft. This manual is designed for use by all parachute riggers.

USER INFORMATION

The proponent of this publication is HQ TRADOC. You are encouraged to report any errors or omissions and to suggest ways for making this a better manual. Army personnel, send your comments on DA Form 2028 (Recommended Changes to Publications and Blank Forms) directly to:

Commander
US Army Quartermaster Center and School (Provisional)
ATTN: ATSM-DTP
Fort Lee, VA 23801-5036

Air Force personnel, send your reports on AFTO Form 22 (Technical Order Publication Improvement Report) through:

Headquarters
Military Airlift Command
(MAC/DOXT)
Scott AFB, IL 62225-5001

to:

Commander
US Army Quartermaster Center and School (Provisional)
ATTN: ATSM-DTP
Fort Lee, VA 23801-5036

Also send information copies of AFTO Form 22 to:

San Antonio ALC/MMILRA
Kelly AFB, TX 78241-5000

INTRODUCTION

DESCRIPTION OF ITEMS

The type I, 130G motor grader with the fuel tank 3/4 full weighs 31,395 pounds. This weight can be reduced to 29,940 pounds by removing the components described in paragraph 1-5a. The grader is 330 inches long. Its width is 144 inches (reducible to 95 1/2 inches). Its height is 126 inches (reducible to 91 inches). The type II, 130G motor grader with the fuel tank 3/4 full weighs 31,750 pounds. This weight can be reduced to 30,150 pounds by removing the components described in paragraph 1-5a. The grader is 330 inches long. Its width is 144 inches (reducible to 95 1/2 inches). Its height is 126 inches (reducible to 91 inches).

SPECIAL CONSIDERATIONS

The loads covered in this manual may include hazardous material as defined in AFR 71-4/TM 38-250. If hazardous material is included, it must be packaged, marked, and labeled as required by AFR 71-4/TM 38-250. A copy of this manual must be available to the joint airdrop inspectors during the before- and after-loading inspections.

CHAPTER 3

RIGGING TYPE I AND II, 130G MOTOR GRADERS FOR AIRDROP ON A 28-FOOT, TYPE V PLATFORM

Section I

LOW-VELOCITY AIRDROP

3-1. Description of Load

The type I and II, 130G motor graders (Figure 3-1) are rigged on a 28-foot, type V platform for low-velocity airdrop from C-130 and C-141 aircraft. The graders are rigged with eight G-11C parachutes and other items of airdrop equipment. The type I and II graders are rigged the same, except where noted.

CAUTION: Close attention **MUST** be given to the rigging procedures in this manual. This load differs in many ways from other loads and has very close tolerances to meet airdrop requirements.

- NOTES:**
1. Tiedown provisions 1A through 7A on the left side of the grader are in the same location as tiedown provisions 1 through 7 on the right side of the grader. Tiedown provisions for the type II grader are the same as the type I.
 2. Tiedown provisions 6 and 6A are located to the rear of the differential housing.



Figure 3-1. Type I and II, 130G motor graders with tiedown provisions

3-2. Preparing Platform

Prepare a 28-foot, type V platform using two tandem links and 56 tiedown clevises as shown in Figure 3-2.

- NOTES:**
1. The nose bumper may or may not be installed.
 2. Measurements given in this section are from the front edge of the platform, **NOT** from the front edge of the nose bumper.

NOTE: Due to the different locations of the tiedown lashings, the clevises are bolted to different bushings on the right and left rails.

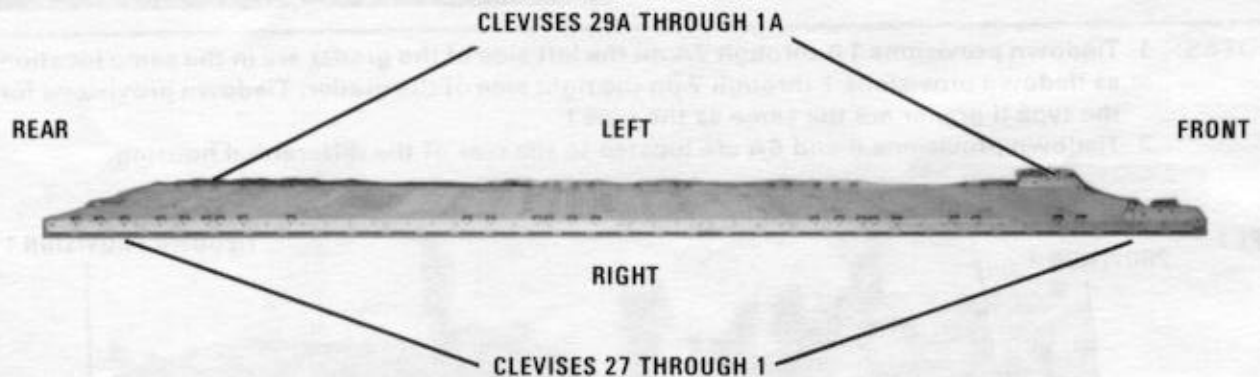

Step:

1. Inspect, or assemble and inspect, the platform as outlined in TM 10-1670-268-20&P/TO 13C7-52-22.
2. Install a tandem link on the front of each platform side rail using holes 1, 2, and 3.
3. Install clevises on bushings 2, 3, and 4 on each tandem link.
4. Starting at the front of the right platform side rail, install a tiedown clevis using the bushings bolted on holes 6, 7, 11, 12, 15, 16, 17, 18, 19, 30, 31, 32, 33, 35, 36, 45, 47, 48, 49, 50, 51, 53, 54, and 55.
5. Starting at the front of the left platform side rail, install a tiedown clevis using the bushings bolted on holes 6, 7, 14, 15, 16, 18, 19, 24, 25, 27, 30, 31, 32, 33, 34, 35, 36, 45, 47, 48, 49, 50, 51, 53, 54, and 55.
6. Starting at the front of the platform, number the clevises bolted to the right side rail from 1 through 27 and those bolted to the left side rail from 1A through 29A.

Figure 3-2. Platform prepared

3-3. Building and Placing Honeycomb Stacks

Build 12 honeycomb stacks using the materials listed in Table 3-1 and as shown in Figures 3-3 through 3-8. Place the stacks on the platform as shown in Figures 3-9 and 3-10.

NOTE: Do NOT glue the stacks of honeycomb to the platform.

Table 3-1. Materials required to build honeycomb stacks

Stack Number	Pieces	Width (Inches)	Length (Inches)	Material	Instructions
1	6	55	15	Honeycomb	See Figure 3-3.
	2	4	15	2- by 4- inch lumber	
	1	55	15	Honeycomb	
	1	55	15	3/4-inch plywood	
2	1	20	30	Honeycomb	See Figure 3-9.
3	1	20	30	Honeycomb	See Figure 3-9.
4	3	54	23	Honeycomb	See Figure 3-4.
	2	54	23	3/4-inch plywood	
	1	54	23	Honeycomb	
5	10	24	18	Honeycomb	See Figure 3-5.
	2	24	18	3/4-inch plywood	
	1	24	18	Honeycomb	
6	3	96	14	Honeycomb	See Figure 3-6.
	3	48	14	Honeycomb	
	1	96	14	3/4-inch plywood	
	1	48	14	3/4-inch plywood	
	2	4	144	2- by 4- inch lumber	
	10	4	14	2- by 4- inch lumber	
7	4	36	84	Honeycomb	See Figure 3-7.
	4	24	84	Honeycomb	
	4	4	84	2- by 4- inch lumber	
	1	36	84	Honeycomb	
	1	24	84	Honeycomb	
	1	18	10	Honeycomb	

Table 3-1. Materials required to build honeycomb stacks (continued)

Stack Number	Pieces	Width (Inches)	Length (Inches)	Material	Instructions
	1	18	5	Honeycomb	
	2	24	8	2- by 8- inch lumber	
	2	8	18	3/4- inch plywood	
8	1	20	36	Honeycomb	See Figure 3-9.
9	1	20	36	Honeycomb	See Figure 3-9.
10	1	20	36	Honeycomb	See Figure 3-9.
11	1	20	36	Honeycomb	See Figure 3-9.
12	9	42	25	Honeycomb	See Figure 3-8.
	2	42	7	Honeycomb	
	6	7	7	3/4- inch plywood	
	6	6	18	Honeycomb	
	2	6	15	3/4- inch plywood	

NOTE: This drawing is not drawn to scale.

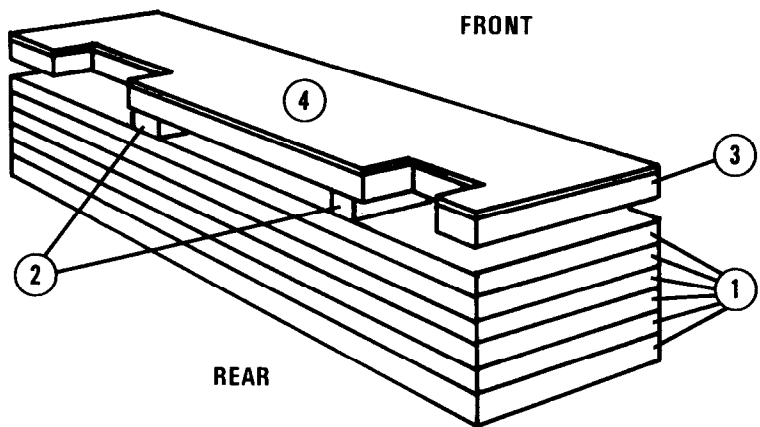

- ① Form a base using six pieces of 55- by 15-inch honeycomb.
- ② Place two pieces of 2- by 4- by 15-inch lumber on top of the base. Place each piece of lumber 16 inches from the 15-inch sides.
- ③ Use one piece of 55- by 15-inch honeycomb. Make two 9- by 5-inch cutouts 5 inches from each side. Place the honeycomb on top of the 2- by 4- by 15-inch pieces of lumber with the cutouts to the rear.
- ④ Use one piece of 3/4- by 55- by 15-inch plywood. Make two 9- by 5-inch cutouts 5 inches from each side. Place the plywood on top of the base with the cutouts to the rear.

Figure 3-3. Stack 1 prepared

NOTE: This drawing is not drawn to scale.

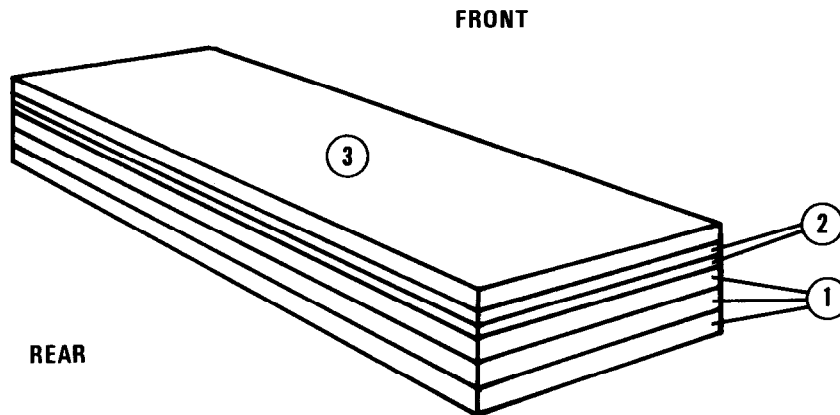

- ① Form a base using three pieces of 54- by 23-inch honeycomb.
- ② Place two pieces of 3/4- by 54- by 23-inch plywood on top of the base.
- ③ Place one piece of 54- by 23-inch honeycomb on top of the plywood placed in step 2 above.

Figure 3-4. Stack 4 prepared

NOTE: This drawing is not drawn to scale.

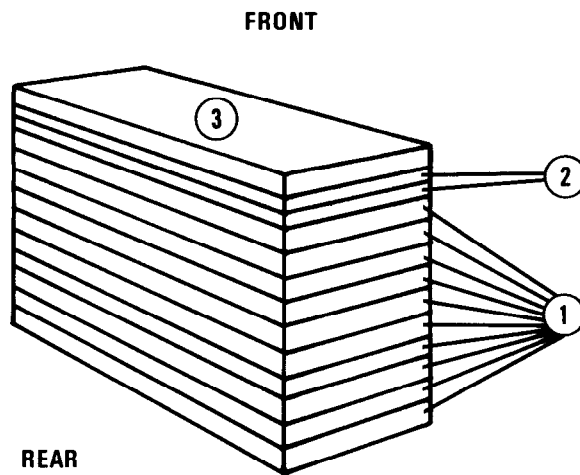

- ① Form a base using 10 pieces of 24- by 18-inch honeycomb.
- ② Place two pieces of 3/4- by 24- by 18-inch plywood on top of the base.
- ③ Place one piece of 24- by 18-inch honeycomb on top of the plywood placed in step 2 above.

Figure 3-5. Stack 5 prepared

NOTE: This drawing is not drawn to scale.

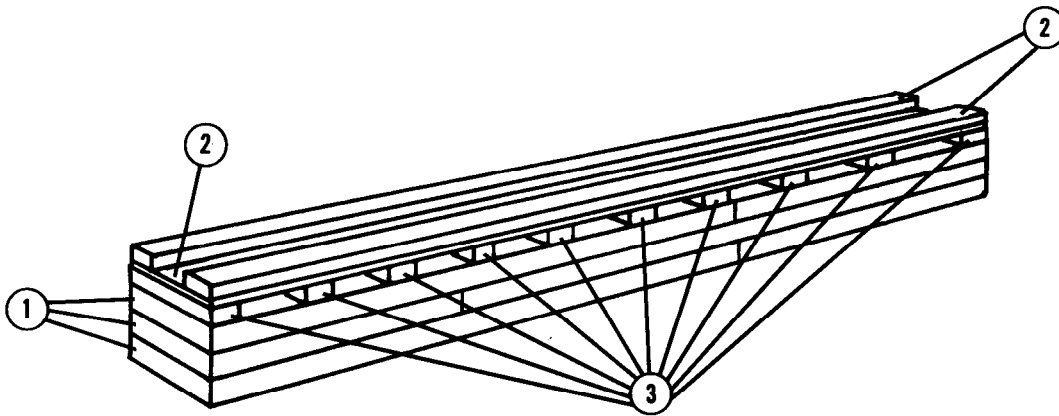

- ① Form a base using three pieces of 14- by 96-inch honeycomb and three pieces of 14- by 48-inch honeycomb. Form each layer of honeycomb by using one piece of 14- by 96-inch and one piece of 14- by 48-inch honeycomb. Alternate the pieces of honeycomb in each layer.
- ② Place one piece of 3/4- by 96- by 14-inch plywood and one piece of 3/4- by 48- by 14-inch plywood side by side. Use eightpenny nails to nail a piece of 2- by 4- by 144-inch lumber along each 144-inch edge of the plywood.
- ③ Use tenpenny nails to nail 10 pieces of 2- by 4- by 14-inch lumber to the bottom of the plywood. Nail one piece on each 14-inch edge. Nail the other pieces 16 inches apart measuring from the center of each piece. Place this load spreader on top of the honeycomb stack.

Figure 3-6. Stack 6 prepared

NOTE: This drawing is not drawn to scale.

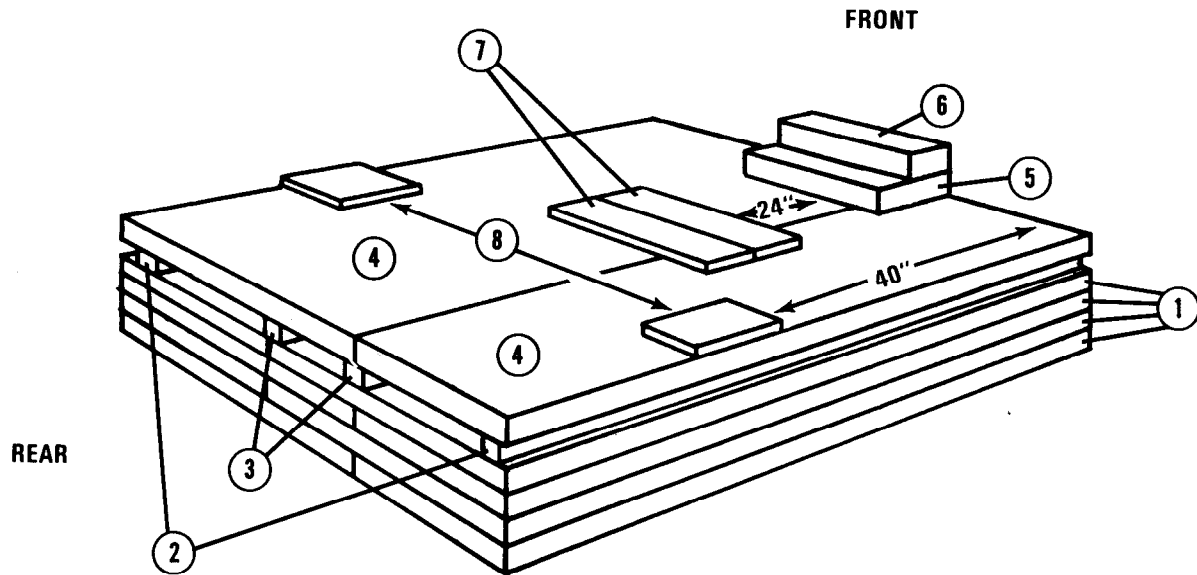

- ① Form a base using four pieces of 36- by 84-inch honeycomb and four pieces of 24- by 84-inch honeycomb. Form each layer of honeycomb by using one piece of 36- by 84-inch and one piece of 24- by 84-inch honeycomb. Alternate the pieces of honeycomb in each layer.
- ② Place one piece of 2- by 4- by 84-inch lumber 4 inches from each 84-inch edge.
- ③ Place one piece of 2- by 4- by 84-inch lumber 22 inches from each 84-inch edge.
- ④ Place one piece of 36- by 84-inch honeycomb and one piece of 24- by 84-inch honeycomb on top of the lumber to form a layer.
- ⑤ Center one piece of 18- by 10-inch honeycomb flush with the front edge of the stack.
- ⑥ Place one piece of 18- by 5-inch honeycomb flush with the front edge of the honeycomb placed in step 5.
- ⑦ Place two pieces of 2- by 8- by 24-inch lumber, one behind the other, 24 inches from the honeycomb placed in step 5 above.
- ⑧ Place one piece of 3/4- by 8- by 18-inch plywood 40 inches from the front edge on each side of the stack.

Figure 3-7. Stack 7 prepared

NOTE: This drawing is not drawn to scale.

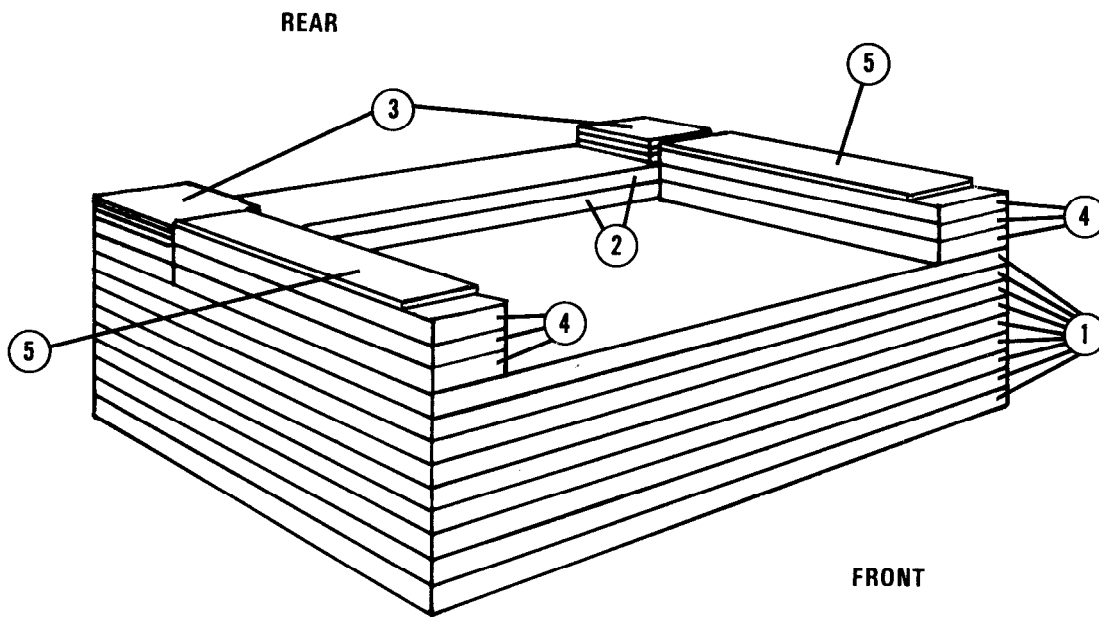

- ① Form a base using nine pieces of 42- by 25-inch honeycomb.
- ② Place two pieces of 42- by 7-inch honeycomb flush with the rear edge of the base.
- ③ Cut six pieces of 3/4- by 7- by 7-inch plywood. Stack three pieces on each end of the honeycomb placed in step 2 above.
- ④ Cut six pieces of 6- by 18-inch honeycomb. Stack three pieces flush with each 25-inch side of the base.
- ⑤ Cut two pieces of 3/4- by 6- by 15-inch plywood. Place each piece flush with the rear edge of each stack of honeycomb placed in step 4 above.

Figure 3-8. Stack 12 prepared

- NOTES:** 1. This drawing is not drawn to scale.
 2. Broken lines show the lumber placed between stacks.

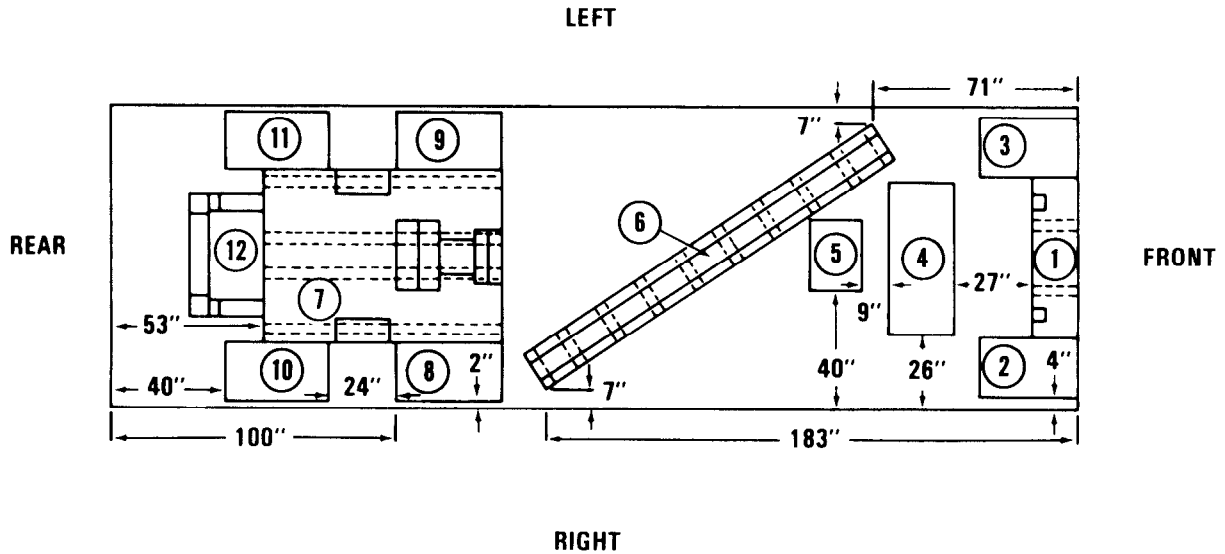

Stack Number	Instructions
1	Center stack flush with the front edge of the platform. Lay two 10-foot pieces of 1/2-inch tubular nylon webbing under the honeycomb stack lengthwise along the platform. Tape the edges of the honeycomb where the nylon webbing will touch.
2	Place honeycomb flush with the front right side of stack 1.
3	Place honeycomb flush with the front left side of stack 1.
4	Center stack 27 inches from stack 1.
5	Center stack 9 inches from stack 4.
6	Place stack diagonally on the platform with the rear left corner 71 inches from the front edge of the platform and 7 inches from the left side rail. Make sure the right front corner is 183 inches from the front edge of the platform and 7 inches from the right side rail.

Figure 3-9. Honeycomb stacks and webbing placed on platform

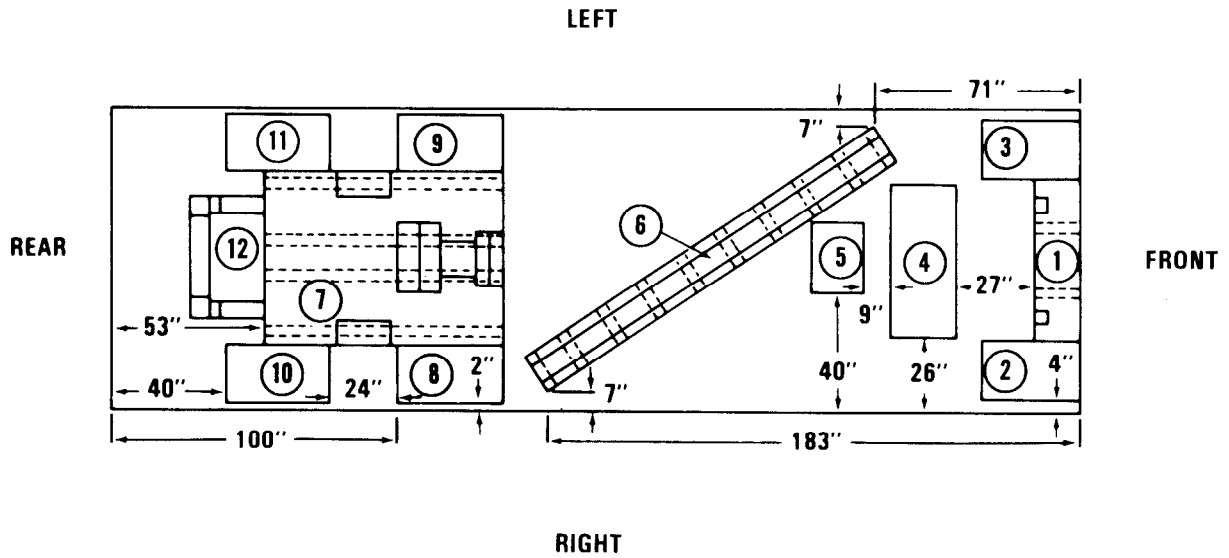

Stack Number	Instructions
7	Center stack 53 inches from the rear edge of the platform.
8	Place honeycomb against right side of stack 7 and 100 inches from the rear edge of the platform.
9	Place honeycomb against left side of stack 7 and 100 inches from the rear edge of the platform.
10	Place honeycomb against right side of stack 7 and 40 inches from the rear edge of the platform.
11	Place honeycomb against left side of stack 7 and 40 inches from the rear edge of the platform.
12	Center stack flush against stack 7.

Figure 3-9. Honeycomb stacks and webbing placed on platform (continued)

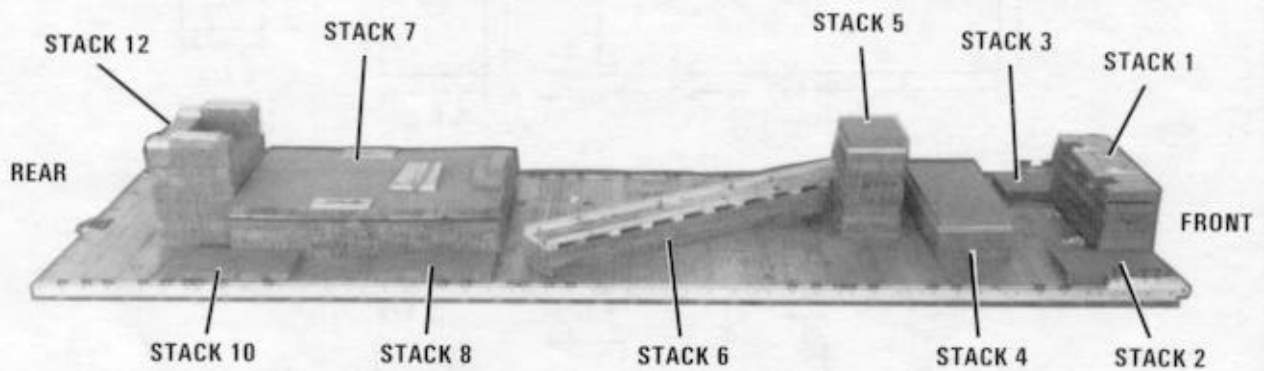

Figure 3-10. Side view of honeycomb stacks placed on platform

3-4. Building Wooden Supports

Build the wooden supports as described below.

a. Building Front-End Frame Support. Build the front-end frame support as shown in Figure 3-11.

- NOTES:** 1. These drawings are not drawn to scale.
 2. Use eightpenny nails and glue to join the individual pieces.

INDIVIDUAL PIECES

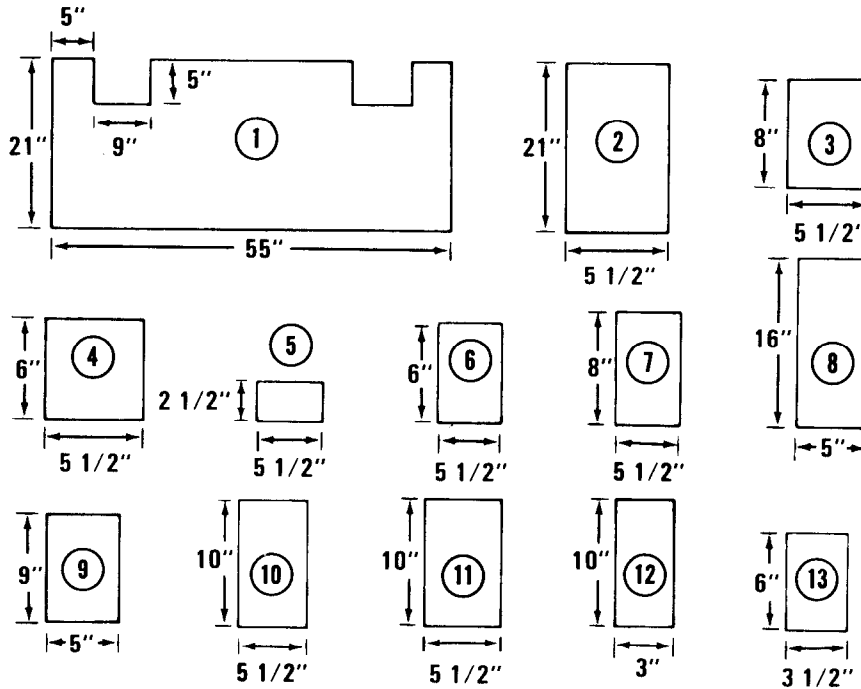

Item Number	Pieces	Width (Inches)	Length (Inches)	Material
1	1	21	55	3/4-inch plywood
2	6	5 1/2 (actual)	21	2- by 6-inch lumber
3	5	5 1/2 (actual)	8	2- by 6-inch lumber
4	1	5 1/2 (actual)	6	2- by 6-inch lumber
5	2	2 1/2	5 1/2	3/4-inch plywood
6	1	5 1/2	6	3/4-inch plywood
7	1	5 1/2	8	3/4-inch plywood
8	6	5	16	3/4-inch plywood
9	6	5	9	3/4-inch plywood
10	2	5 1/2 (actual)	10	2- by 6-inch lumber
11	2	5 1/2	10	3/4-inch plywood
12	2	3	10	1/2-inch plywood
13	2	3 1/2	6	1/2-inch plywood

Figure 3-11. Construction details for front-end frame support

- NOTES: 1. These drawings are not drawn to scale.
 2. The circled numbers refer to item numbers in the chart on the previous page.
 3. Support stacks 1 and 5 are the same and hang 2 inches over the rear edge of the base.
 4. Support stack 2 is a mirror image of stack 4.

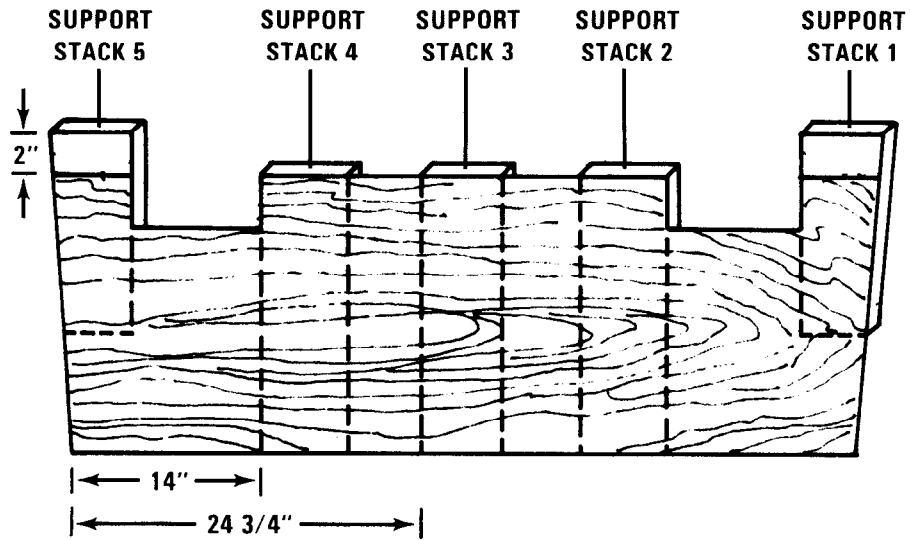

PERSPECTIVE VIEW

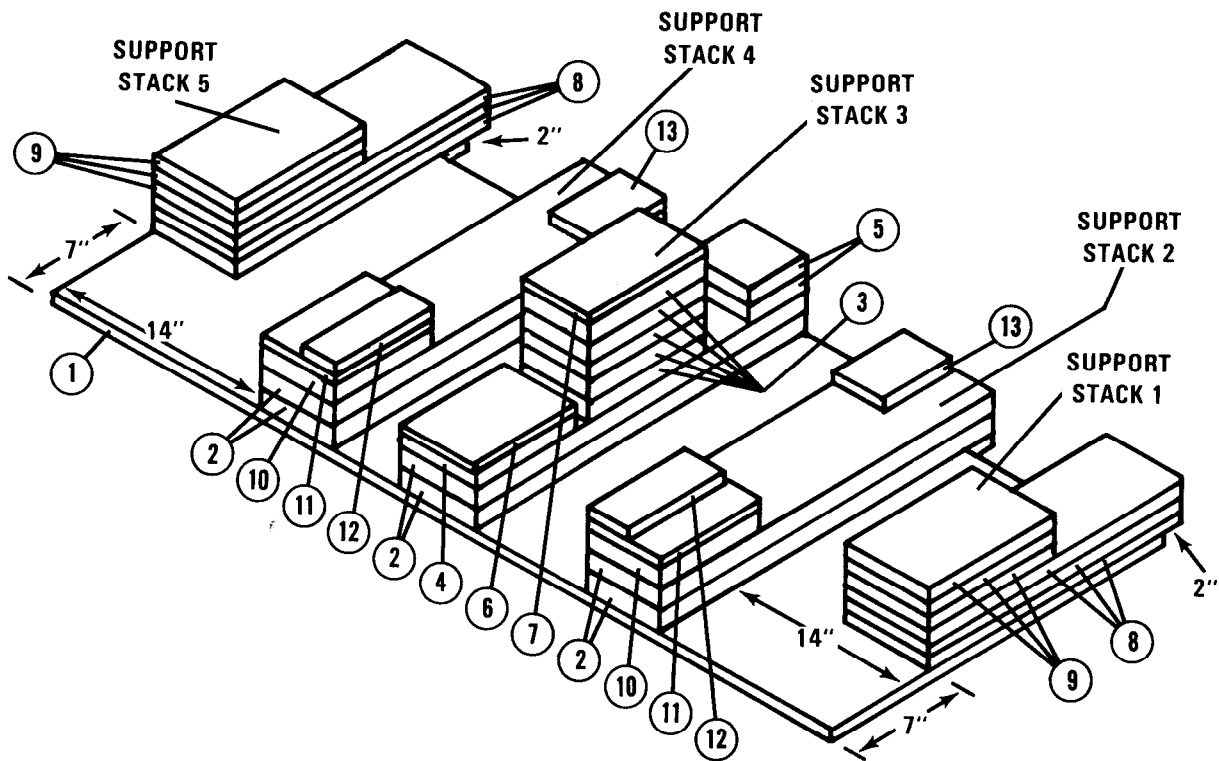
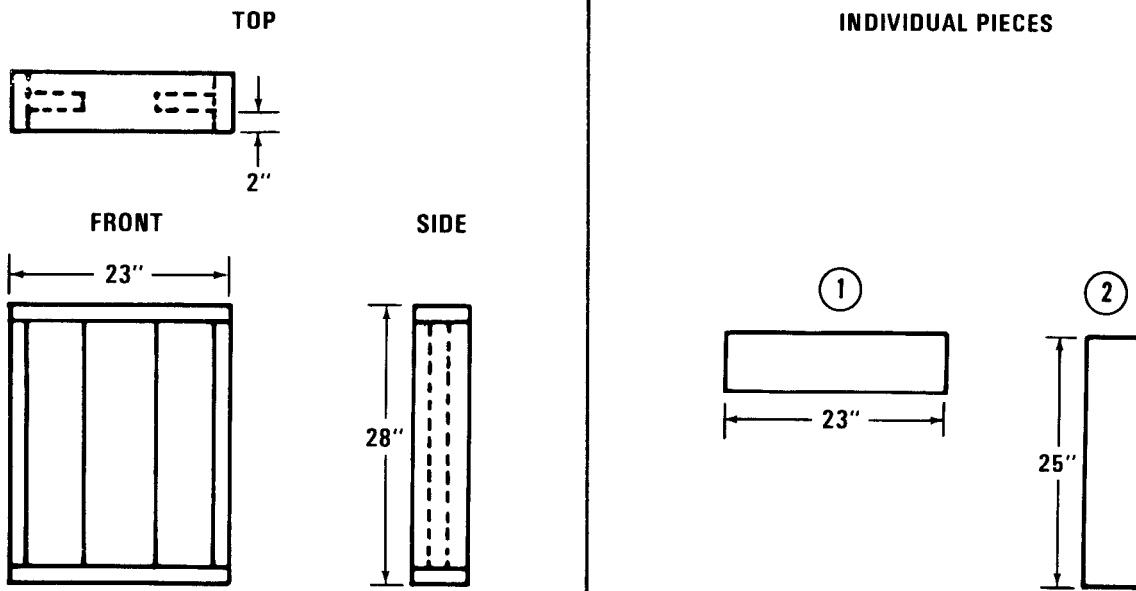

Figure 3-11. Construction details for front-end frame support (continued)

b. *Building Drawbar and Scarifier Support.*
 Build the drawbar and scarifier support as shown in Figure 3-12.

- NOTES:**
1. These drawings are not drawn to scale.
 2. The circled numbers refer to item numbers.
 3. Use sixteen-penny nails to join the individual pieces.
 4. Broken lines show the placement of other pieces of lumber.



PERSPECTIVE VIEW

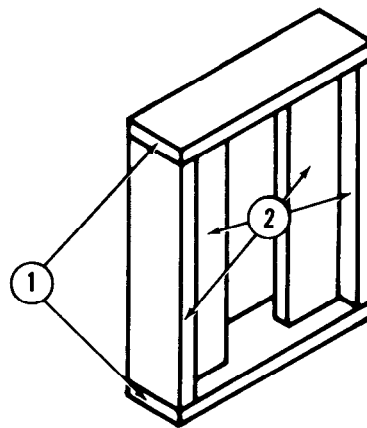

Item Number	Pieces	Width (Inches)	Length (Inches)	Material
1	2	5 1/2 (actual)	23	2- by 6-inch lumber
2	4	5 1/2 (actual)	25	2- by 6-inch lumber

Figure 3-12. Construction details for drawbar and scarifier support

c. Building Front Frame and Drawbar Support.

Build the front frame and drawbar support as shown in Figures 3-13.

- NOTES:**
1. These drawings are not drawn to scale.
 2. The circled numbers refer to item numbers.
 3. Use sixpenny nails to join the individual pieces.
 4. Broken lines show the placement of other pieces of lumber.

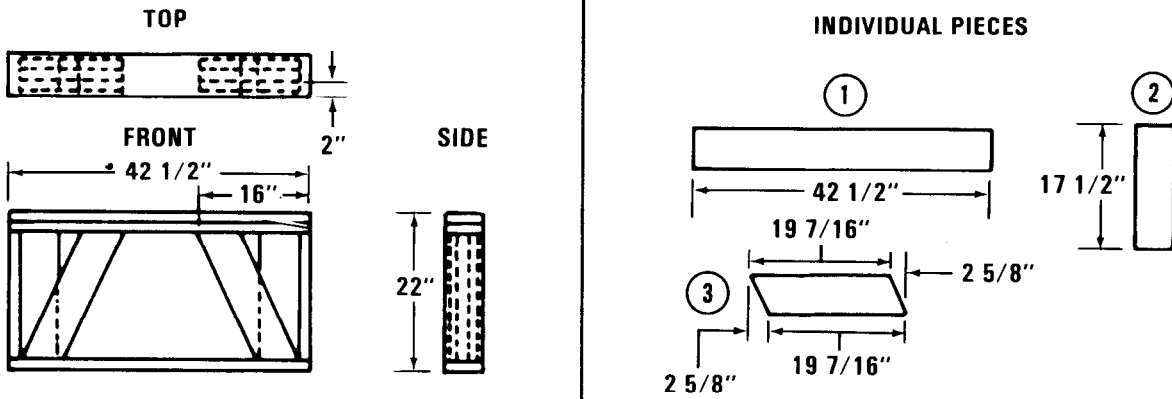

PERSPECTIVE VIEW

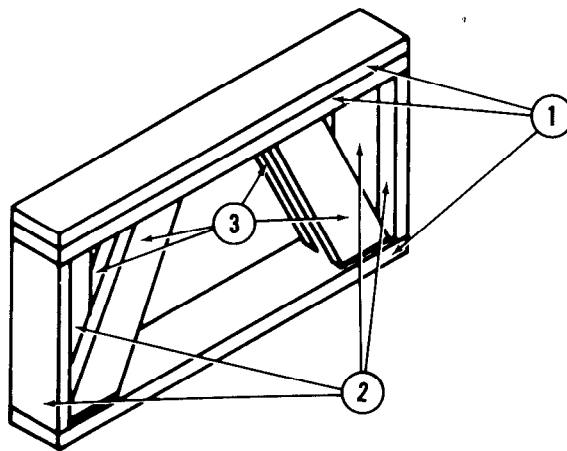

Item Number	Pieces	Width (Inches)	Length (Inches)	Material
1	3	5 1/2 (actual)	42 1/2	2- by 6-inch lumber
2	4	5 1/2 (actual)	17 1/2	2- by 6-inch lumber
3	4	5 1/2 (actual)	19 7/16	2- by 6-inch lumber

Figure 3-13. Construction details for front frame and drawbar support

d. *Building Left Side Controls Protector.* Build the protector for the controls located on the left side of the operator compartment as shown in Figure 3-14.

- NOTES:**
1. These drawings are not drawn to scale.
 2. The circled numbers refer to item numbers.
 3. Use eightpenny nails to join the individual pieces.

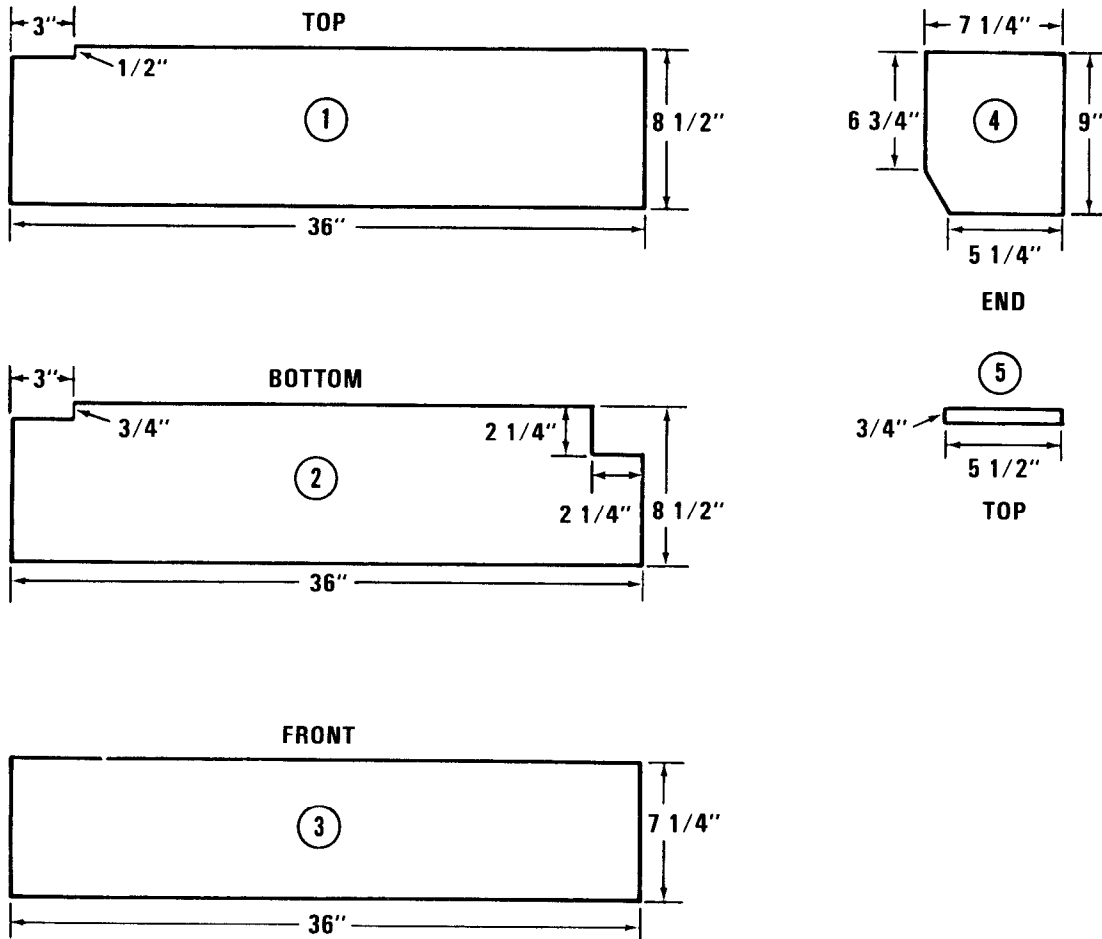

Item Number	Pieces	Width (Inches)	Length (Inches)	Material
1	2	8 1/2	36	3/4-inch plywood
2	1	8 1/2	36	3/4-inch plywood
3	1	7 1/4	36	1/2-inch plywood
4	1	7 1/4	9	1/2-inch plywood
5	1	3/4	5 1/2	3/4-inch plywood

Figure 3-14. Construction details for left side controls protector

- NOTES: 1. These drawings are not drawn to scale.
 2. The circled numbers refer to item numbers.
 3. Use eightpenny nails to join the individual pieces.

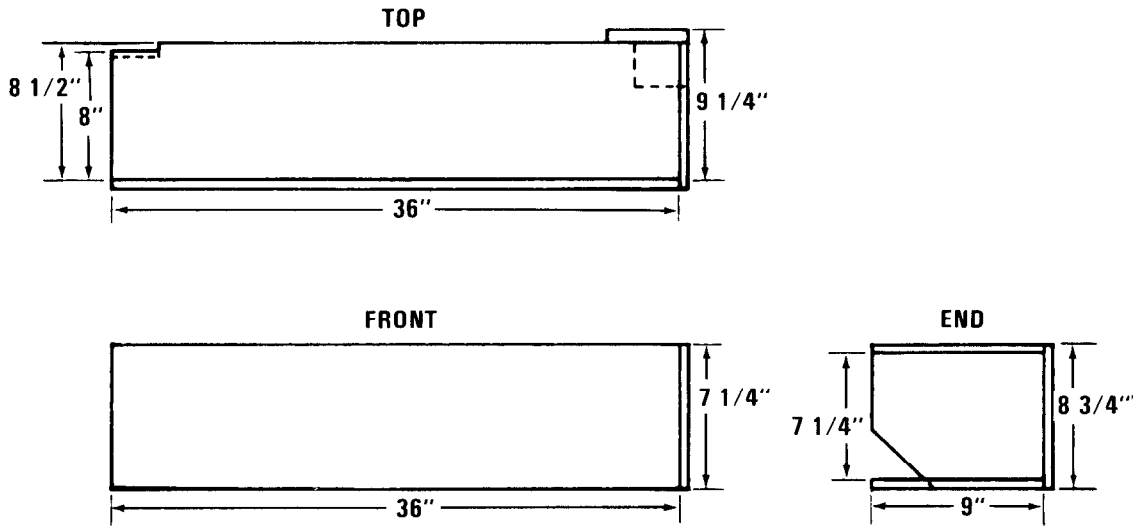

PERSPECTIVE VIEW

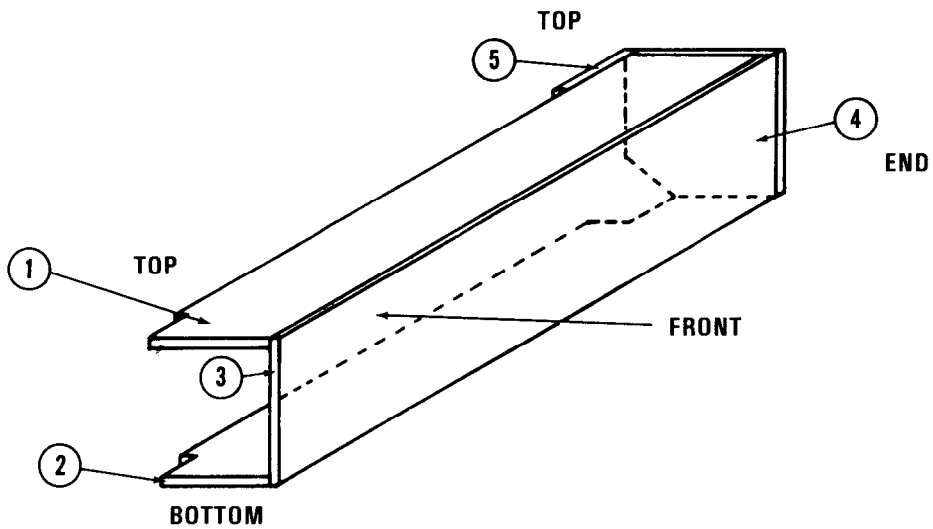
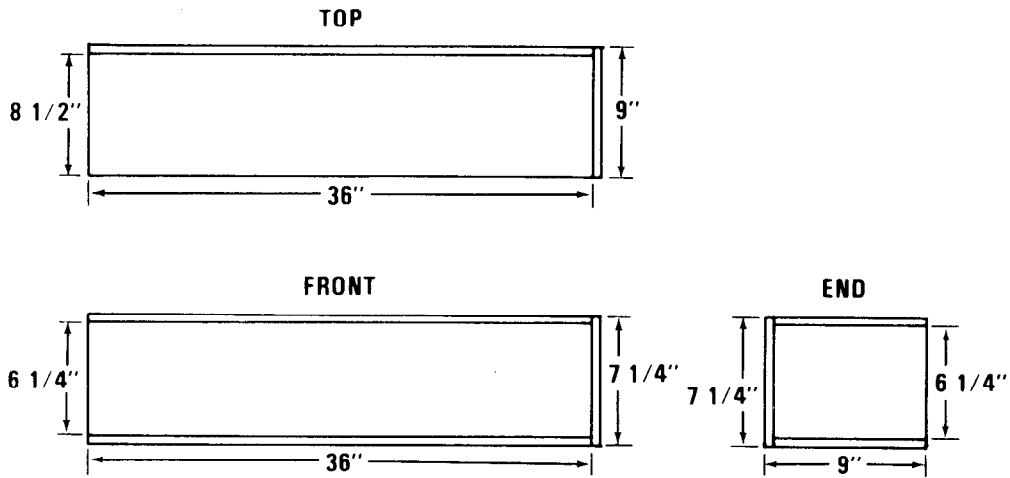

Figure 3-14. Construction details for left side controls protector (continued)

e. *Building Right Side Controls Protector.* Build the protector for the controls located on the right

side of the operator compartment as shown in Figure 3-15.

- NOTES:**
1. These drawings are not drawn to scale.
 2. The circled numbers refer to item numbers.
 3. Use eightpenny nails to join the individual pieces.



PERSPECTIVE VIEW

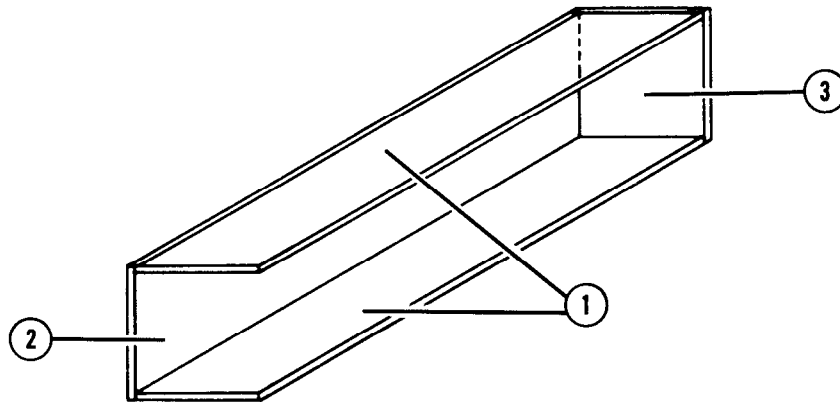

Item Number	Pieces	Width (Inches)	Length (Inches)	Material
1	2	8 1/2	36	1/2-inch plywood
2	1	7 1/4	36	1/2-inch plywood
3	1	7 1/4	9	1/2-inch plywood

Figure 3-15. Construction details for right side controls protector

3-5. Preparing Grader

Prepare the grader as described below.

a. Removing Components. Remove the following items from the grader: ROPS, suspension brackets on front bolster, mounting bolt sleeves and spacers that are in the stowage compartment, and the rear lifting handles on the engine compartment side panels. These items will not be airdropped.

b. Preparing Grader Before Positioning. Make the following preparations before positioning the grader.

CAUTION: Items (1) through (9) listed below must be performed **ONLY** by qualified maintenance personnel.

(1) Torque the scarifier hydraulic group mounting bracket bolts to 1,040 foot-pounds, plus or minus 75 foot-pounds.

(2) Remove the scarifier teeth. Place them upside down in the block assembly. Tie each shank in place with type III nylon cord.

(3) Place the center shift lock pin in the frame center hole. Move the center shift control to the locked position.

(4) Place the antiarticulation pin, located behind the left side of the operator compartment, in the locked position.

(5) Install the front axle antilean pin.

(6) Make sure the remote control box mounting bolts are tight and that the hoses and control cables are secured to the top of the frame (type II grader only).

(7) Make sure the fuel tank is no more than 1/2 full.

(8) Make sure the tire pressure is 35 pounds psi.

(9) Pad and tape all lights, except the rear light, with cellulose wadding. Loosen the U-clamps on the bar, rotate the front lights down, and rotate the bar 90°.

(10) Install the pintle link on the rear towing pintle pin. Secure the pin in place with the safety bolt.

(11) Install the front-end frame support and the antitilt straps as shown in Figure 3-16.

NOTE: The antitilt straps and antilean bar pin will be removed after the grader is positioned on the platform.



- ① Place the front-end frame support (Figure 3-11) under the front axle and oscillation arm.
- ② Holding the support in place, pass a 15-foot tiedown lashing around the axle, antilean bar, and oscillation arm on the right side. Fasten the lashing with a D-ring and a load binder. Repeat this step for the left side.
- ③ Install a front axle antitilt tiedown strap by passing a 15-foot tiedown lashing through the front right lifting provision, inside the tie rods and lean cylinders, and through the kingpin bracket. Fasten the lashing with a D-ring and a load binder. Repeat this step for the axle on the left side.

Figure 3-16. Front-end frame support and antitilt straps installed

(12) Install the drawbar and scarifier support as shown in Figure 3-17.

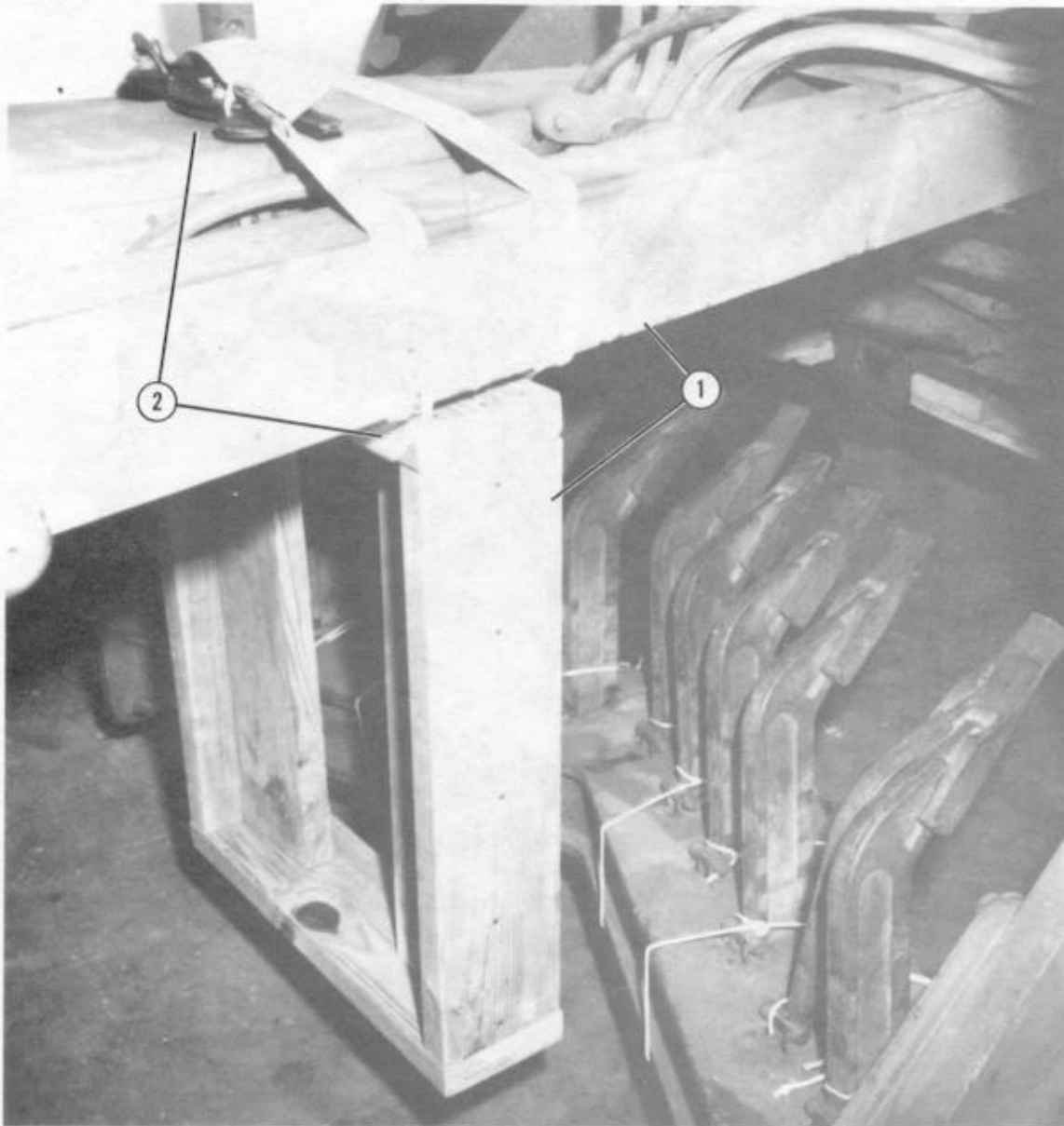

- ① Align the drawbar parallel to the grader with the moldboard at a 90° angle. Place the support (Figure 3-12) under the drawbar at the rear of the scarifier. Align the support on the rear edge of the drawbar cross brace.
- ② Holding the support in place, pass a 15-foot tiedown lashing over the drawbar, through the opening of the support, up and over the drawbar, and back through the support. Fasten the ends of the lashing on top of the drawbar with a D-ring and a load binder.

Figure 3-17. Drawbar and scarifier support installed

(13) Install the front frame and drawbar support as shown in Figure 3-18.

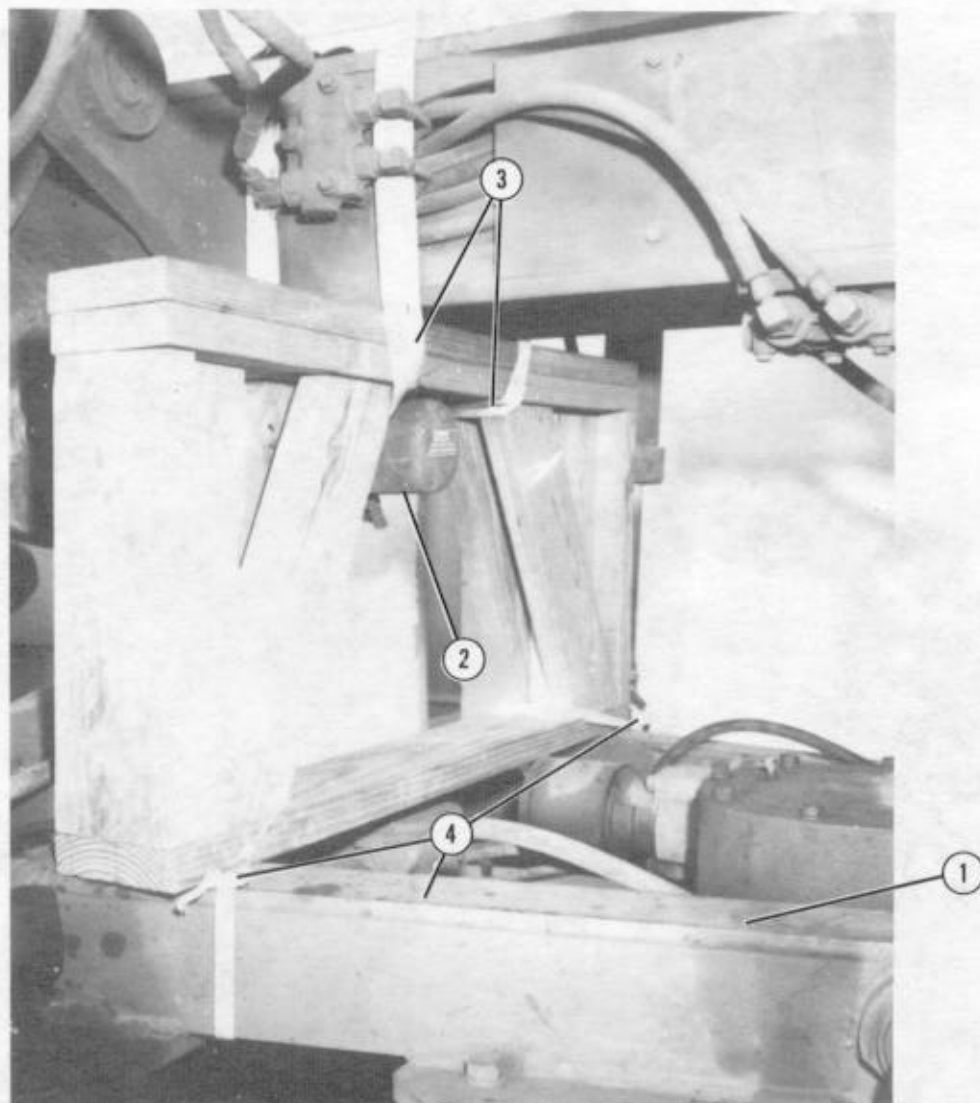

- ① Lower the drawbar until there is enough space between the drawbar and the front frame to fit the support (Figure 3-13).
- ② Place the support under the front frame and over the center shift locking pin housing.
- ③ Holding the support in place, pass a 15-foot tiedown lashing over the frame, through the opening of the support, up and over the frame, and through the support again. Fasten the ends of the lashing together on top of the frame with a D-ring and a load binder.
- ④ Raise the drawbar until it is firm against the bottom of the support. Tie the lower corners of the support to the drawbar with 1/2-inch tubular nylon webbing.

Figure 3-18. Front frame and drawbar support installed

(14) Position the scarifier and moldboard as shown in Figure 3-19.

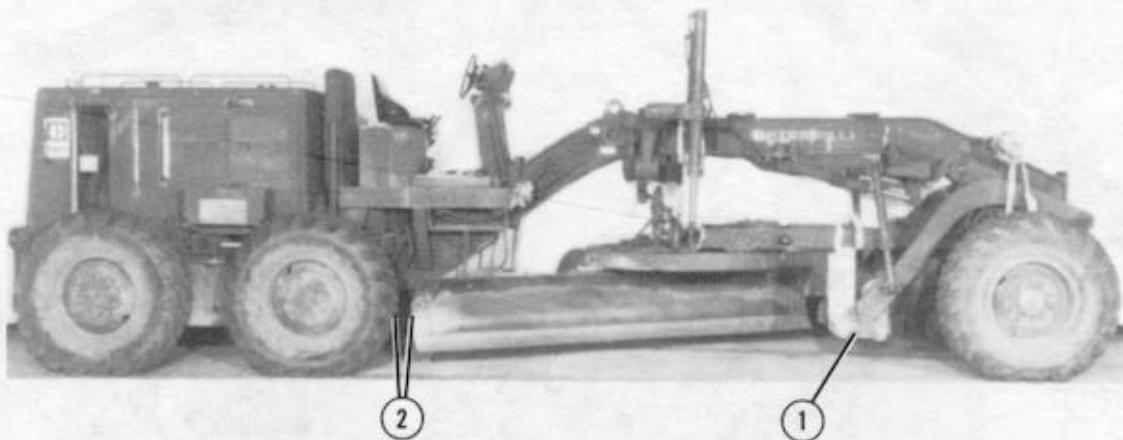

- ① Make sure the grader is on a level surface. Raise the scarifier until the bottom of the block assembly is 11 inches above the ground. Tie the drawbar support to the scarifier with 1/2-inch tubular nylon webbing.
- ② Tilt the moldboard to the full back position. Rotate it until the right end is centered and 4 inches from the right intermediate tire.

Figure 3-19. Scarifier and moldboard positioned

3-6. Installing Suspension Slings

Use four large screw-pin clevises and two 9-foot and two 16-foot (4-loop), type XXVI nylon webbing slings for suspension. Bolt and safety the slings to the grader as shown in Figure 3-20.

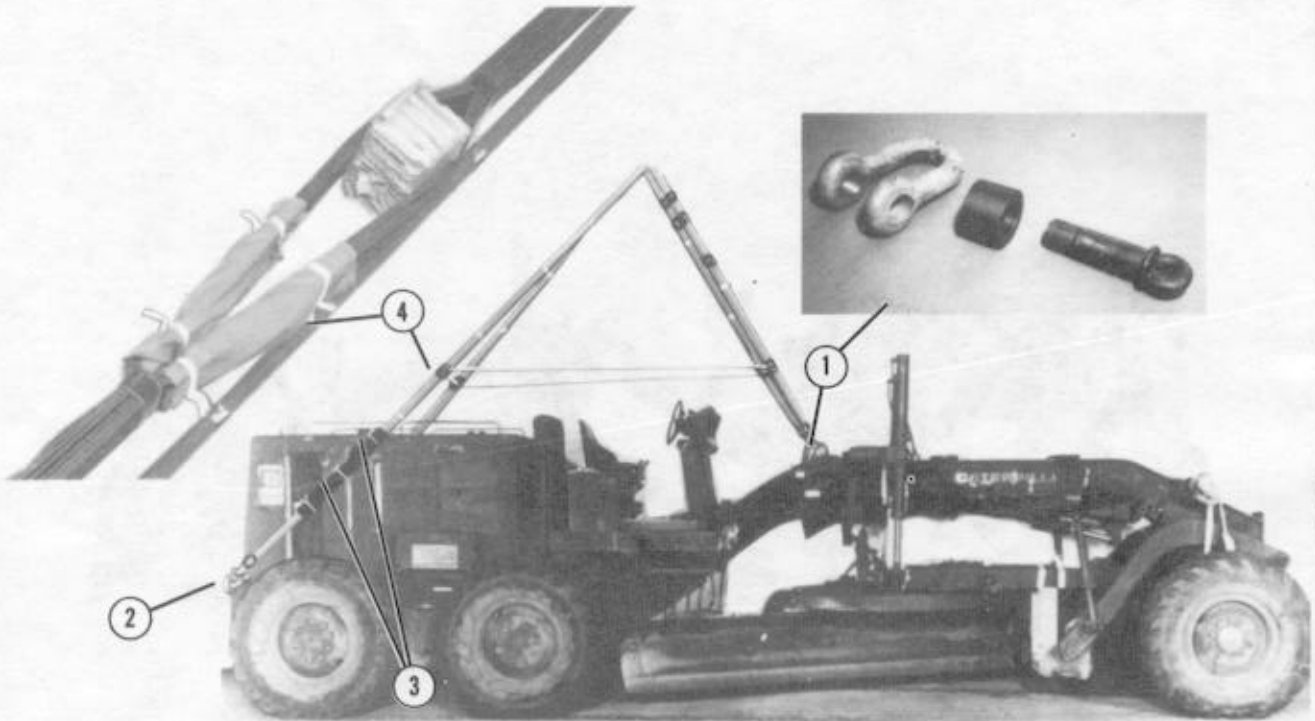

- ① Bolt a 9-foot sling to each of the front lifting provisions with a screw-pin suspension clevis.
- ② Bolt a 16-foot sling to each of the upper rear tiedown provisions with a screw-pin suspension clevis.
- ③ Pad the 16-foot slings with a piece of 18- by 36-inch felt. Tie the felt in place to the handrails on top of the engine compartment with type III nylon cord.
- ④ Using eight 10- by 10-inch pieces of muslin cloth, center one piece of cloth on each sling 8 to 10 inches from the top of the load. Wrap this piece around four of the eight plies, and secure it with two lengths of type I, 1/4-inch cotton webbing. Repeat the same procedure for the remaining four plies. Safety the slings with a deadman's tie according to FM 10-500/TO 13C7-1-5.
- ⑤ Tape all exposed nuts and bolts on the engine compartment that are in line with the suspension slings (not shown).

Figure 3-20. Suspension slings installed

3-7. Positioning Grader

Position the grader on the platform as shown in Figure 3-21.

CAUTION: Make sure the grader overhang at the front of the platform is **EXACTLY 14 inches**.



- ① Place the transmission control lever in neutral, and release the parking brake (not shown).
- ② Center the base of the front-end frame support on honeycomb stack 1. Tie the stack to the front axle with the pre-positioned lengths of tubular nylon webbing that were placed in Figure 3-9.
- ③ Remove the antilean pin. Place the pin in the toolbox.
- ④ Remove the antitilt straps (installed in Figure 3-16) (not shown).

NOTE: Make sure that the rear tiedown provisions are 1 inch from the rear edge of stack 12.

Figure 3-21. Grader positioned

3-8. Preparing Grader After Positioning

Finish preparing the grader as shown in Figure 3-22, after it has been positioned on the platform.



- ① Safety the antiarticulation pin at the top and bottom with type III nylon cord. If the safety pin is missing on the antiarticulation pin, make a tie only at the top.
- ② Remove the exhaust pipe, muffler, air precleaner, and rear light. Tape over the openings (not shown).
- ③ Stow the rear light with the lens portion facing the bottom of the air precleaner. Tape the light in place.

Figure 3-22. Grader prepared after positioning

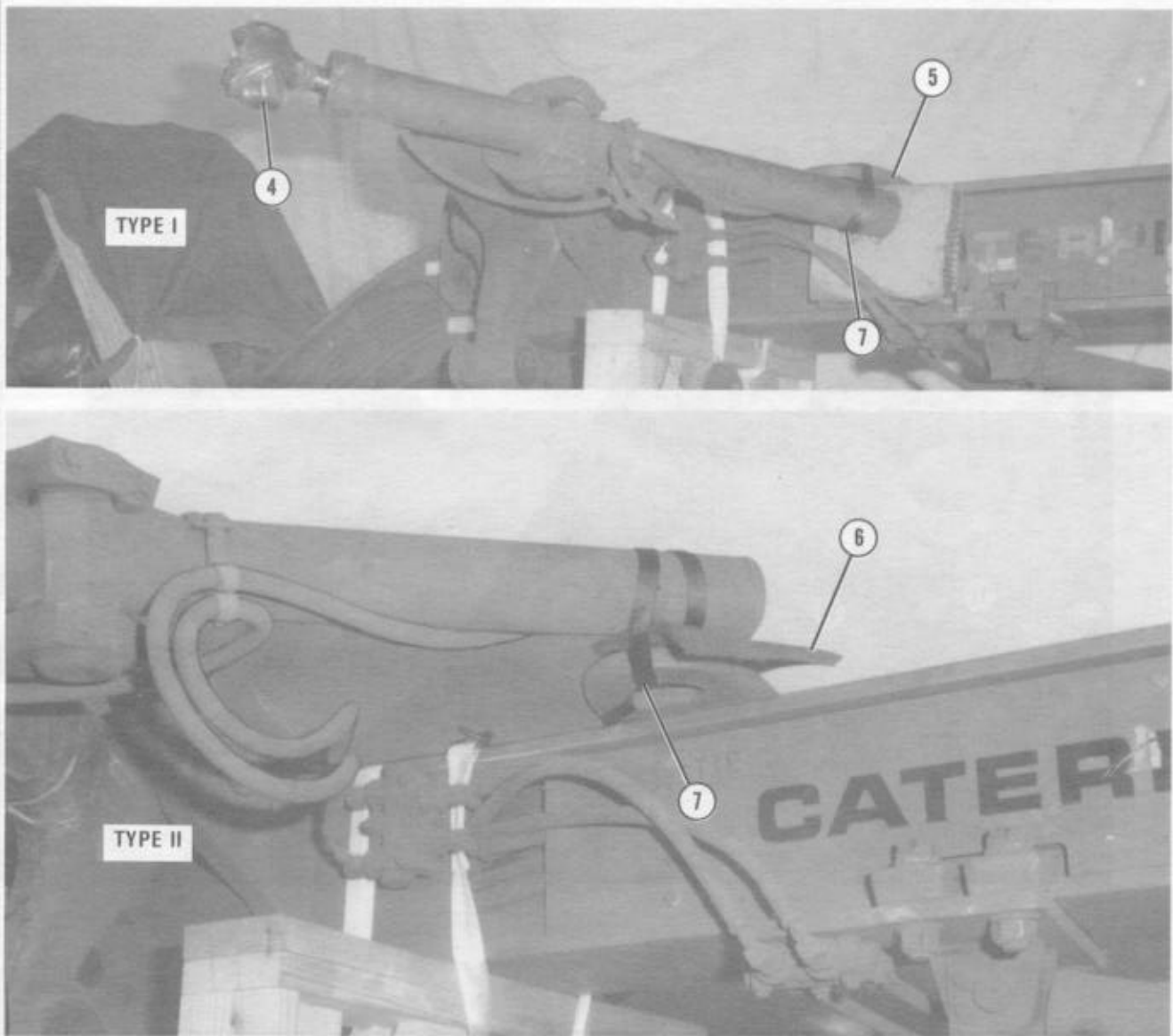

- ④ Remove the left and right blade lifting cylinders from their ball joints. Reinstall spacers, caps, and bolts on their cylinder rods. Cover each ball and ball joint with plastic. Tape the plastic in place.
- ⑤ Place a piece of 8- by 8-inch honeycomb under the front frame tiedown provision of the type I grader. Rotate the cylinders to press against the honeycomb.
- ⑥ Place a piece of 6- by 8-inch felt on top of the front tiedown provisions of the type II grader. Rotate the cylinders to sit on top of the felt.
- ⑦ Tie the cylinders to the tiedown provisions with 1-inch tubular nylon webbing.

NOTE: Due to critical clearance in the aircraft, the cylinders must be properly positioned and securely restrained to prevent shifting.

Figure 3-22. Grader prepared after positioning (continued)

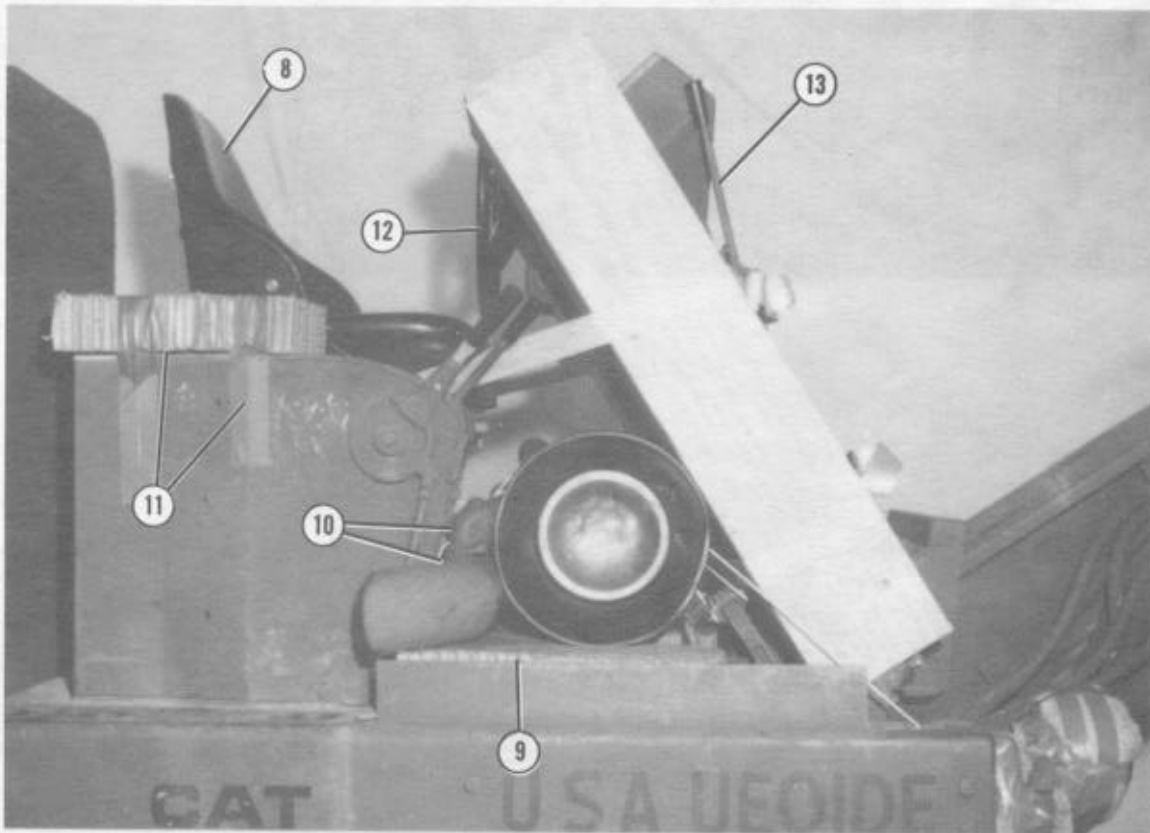

- ⑧ Slide the operator seat to the full rear position.
- ⑨ Make a cutout for the accelerator pedal in a piece of 16- by 45-inch honeycomb. Place the honeycomb on the floor of the operator compartment.
- ⑩ Place the exhaust pipe, muffler, and air precleaner on top of the honeycomb. Tie them in place with type III nylon cord.
- ⑪ Place a piece of 13- by 16-inch honeycomb over the control switches next to the operator seat. Make indents in the honeycomb to fit the switches. Tape the honeycomb in place.
- ⑫ Release the steering wheel lock pin (not shown). Move the steering wheel to the full down position. Lock the steering wheel pin.
- ⑬ Release the console locking levers. Move the console to the full rear position. Lock the locking levers.

Figure 3-22. Grader prepared after positioning (continued)

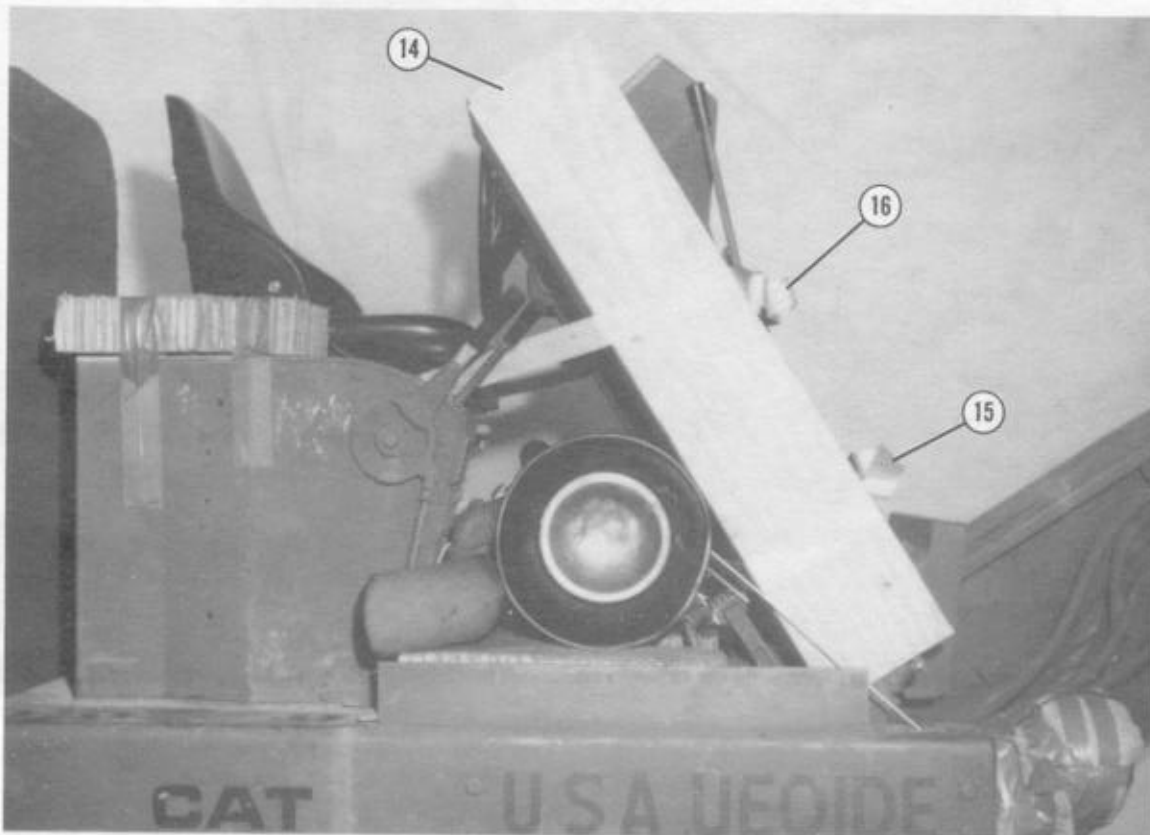

- ⑭ Place the protectors for the left and right side controls (Figures 3-14 and 3-15) over the control levers. Face the open end of the protectors toward the console.
- ⑮ Pass one 15-foot tiedown lashing around the protectors and the base of the console. Fasten with a D-ring and a load binder.
- ⑯ Pass one 15-foot tiedown lashing around the protectors and the rear of the operator seat. Fasten with a D-ring and a load binder.

Figure 3-22. Grader prepared after positioning (continued)



- ①⑦ Use type III nylon cord to tie a piece of 5- by 8-foot cotton duck cloth over the operator compartment.
- ①⑧ Make cutouts for the fuel cap and air precleaner in a piece of 33- by 74-inch honeycomb. Place the honeycomb on top of the engine compartment. Tie the honeycomb in place with type III nylon cord.

Figure 3-22. Grader prepared after positioning (continued)

3-9. Lashing Grader

Lash the grader to the platform using 46 tiedown assemblies according to FM 10-500/TO 13C7-1-5 and as shown in Figures 3-23 and 3-24.

TIEDOWN PROVISION 2



TIEDOWN PROVISION 3

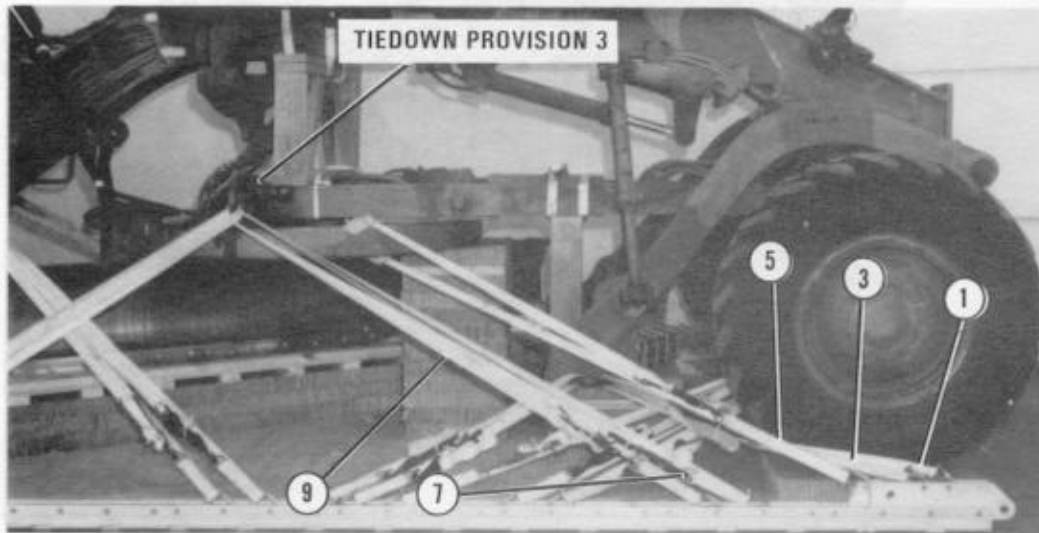

5 4 3 2 1

Lashing Number	Tiedown Clevis Number	Instructions
1	1	Pass lashing: Through tiedown provision 2. Through tiedown provision 2. Around the circle assembly padded with cellulose wadding. Through tiedown provision 3. Through tiedown provision 3.
3	2	
5	3	
7	4	
9	5	

Figure 3-23. Lashings installed on right side

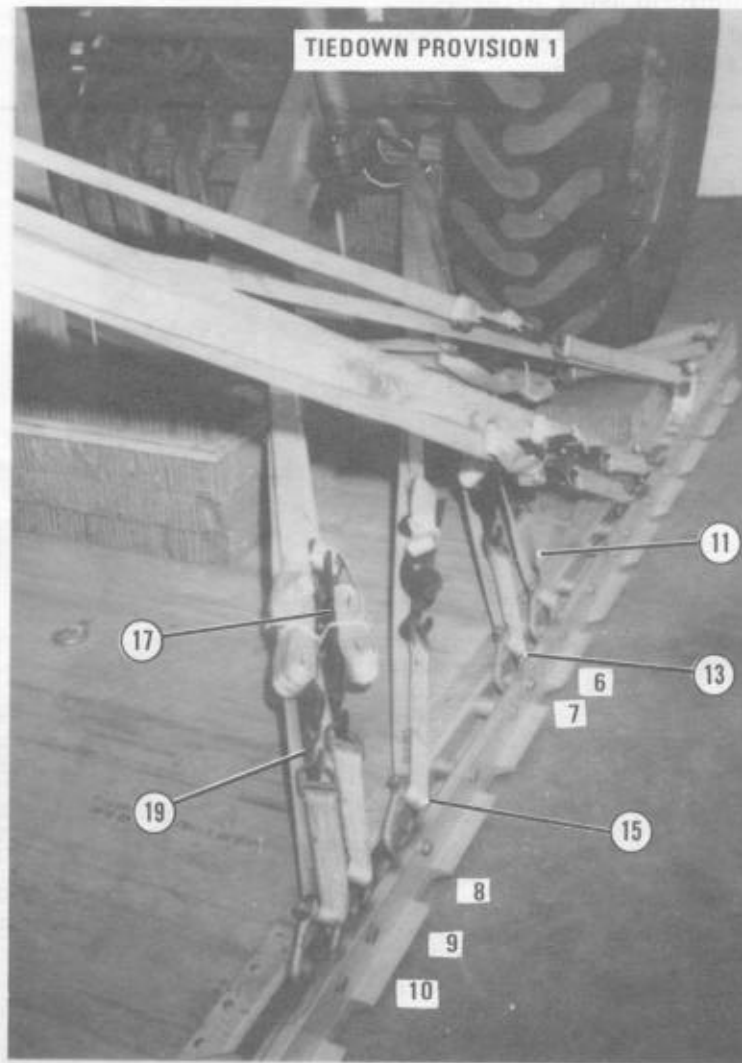

Lashing Number	Tiedown Clevis Number	Instructions
11	6	Pass lashing: Through tiedown provision 1. Through tiedown provision 1. Through tiedown provision 1. Through tiedown provision 2. Through tiedown provision 2.
13	7	
15	8	
17	9	
19	10	

Figure 3-23. Lashings installed on right side (continued)

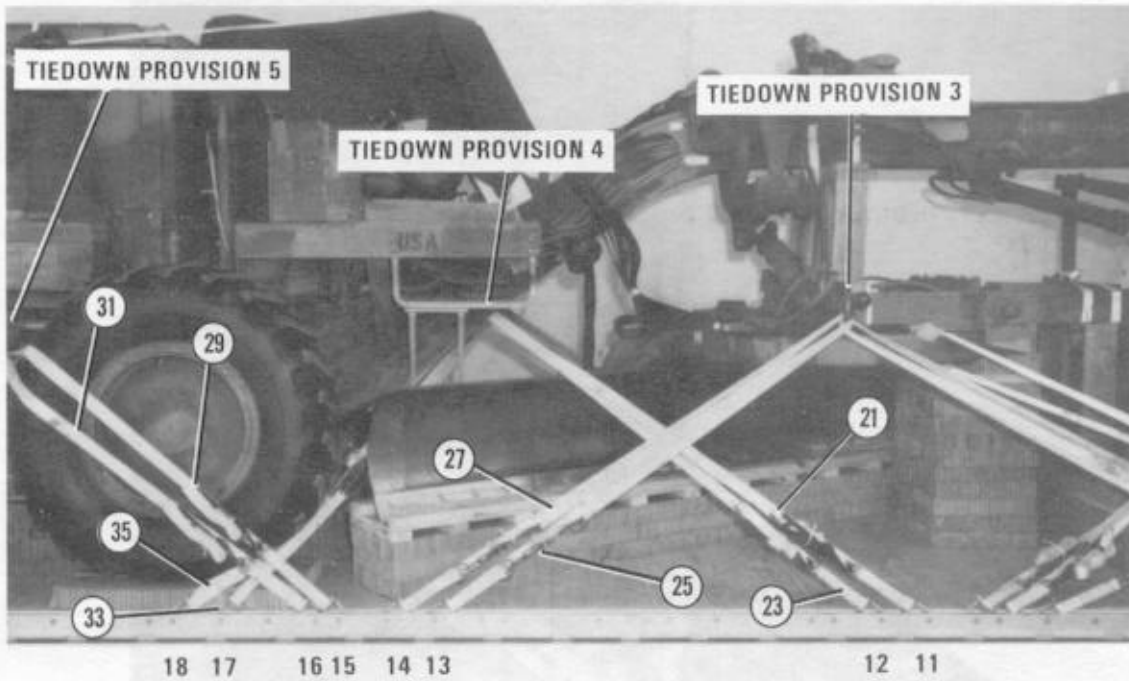

Lashing Number	Tiedown Clevis Number	Instructions
21	11	Pass lashing:
23	12	Through tiedown provision 4.
25	13	Through tiedown provision 4.
27	14	Through tiedown provision 3.
29	15	Through tiedown provision 3.
31	16	Through tiedown provision 5.
33	17	Through tiedown provision 5.
35	18	Through tiedown provision 4.

Figure 3-23. Lashings installed on right side (continued)

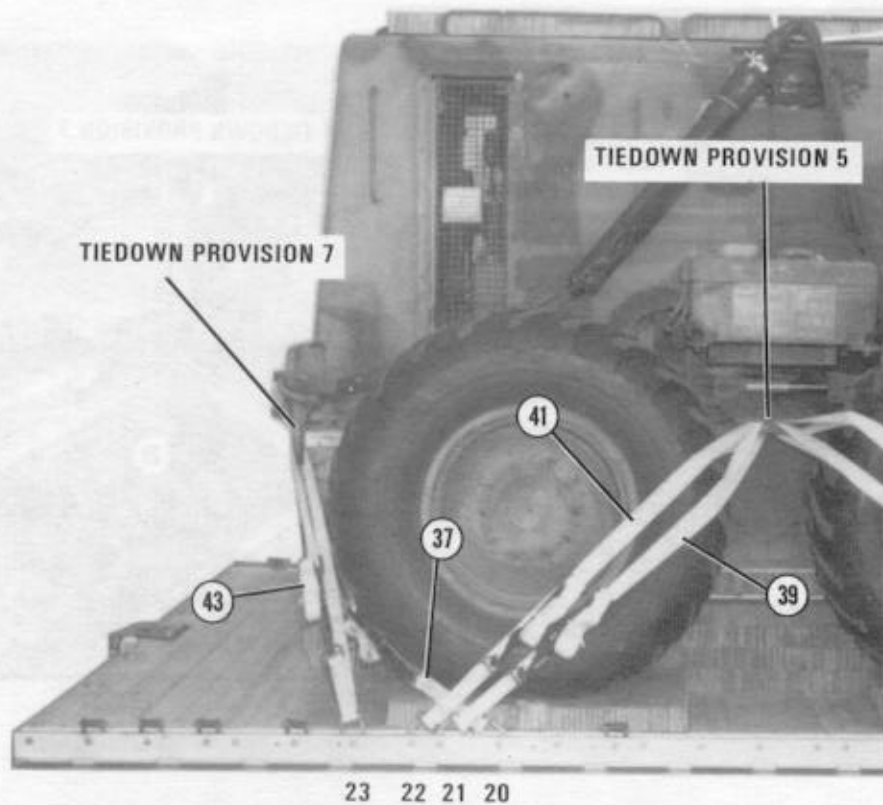

Lashing Number	Tiedown Clevis Number	Instructions
37	20	Pass lashing: Through tiedown provision 7. Through tiedown provision 5. Through tiedown provision 5. Through tiedown provision 7.
39	21	
41	22	
43	23	

Figure 3-23. Lashings installed on right side (continued)

NOTE: Tiedown provision 1A is located behind the tire as shown on page 3-36.

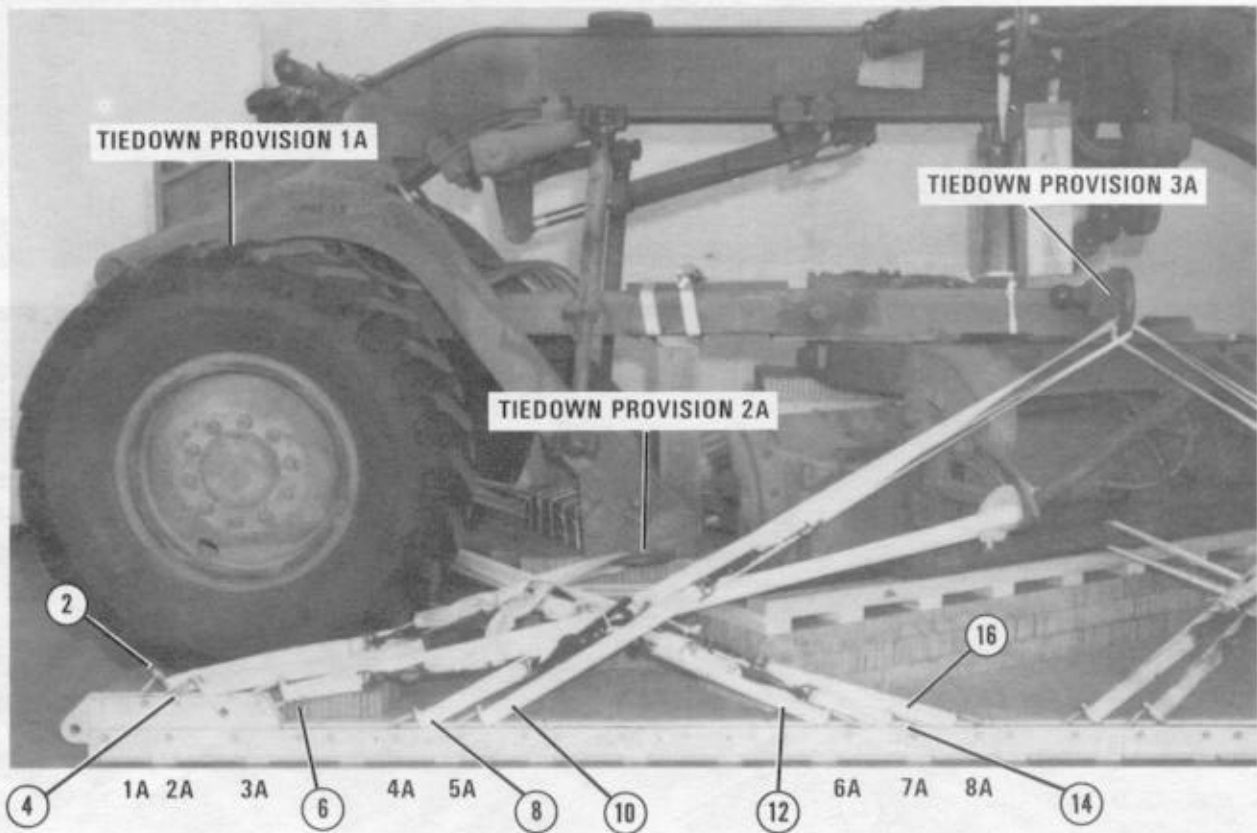

Lashing Number	Tiedown Clevis Number	Instructions
2	1A	Pass lashing: Through tiedown provision 2A. Through tiedown provision 2A. Through blade tilt bracket padded with cellulose wadding. Through tiedown provision 3A. Through tiedown provision 3A. Through tiedown provision 1A. Through tiedown provision 1A. Through tiedown provision 1A.
4	2A	
6	3A	
8	4A	
10	5A	
12	6A	
14	7A	
16	8A	

Figure 3-24. Lashings installed on left side

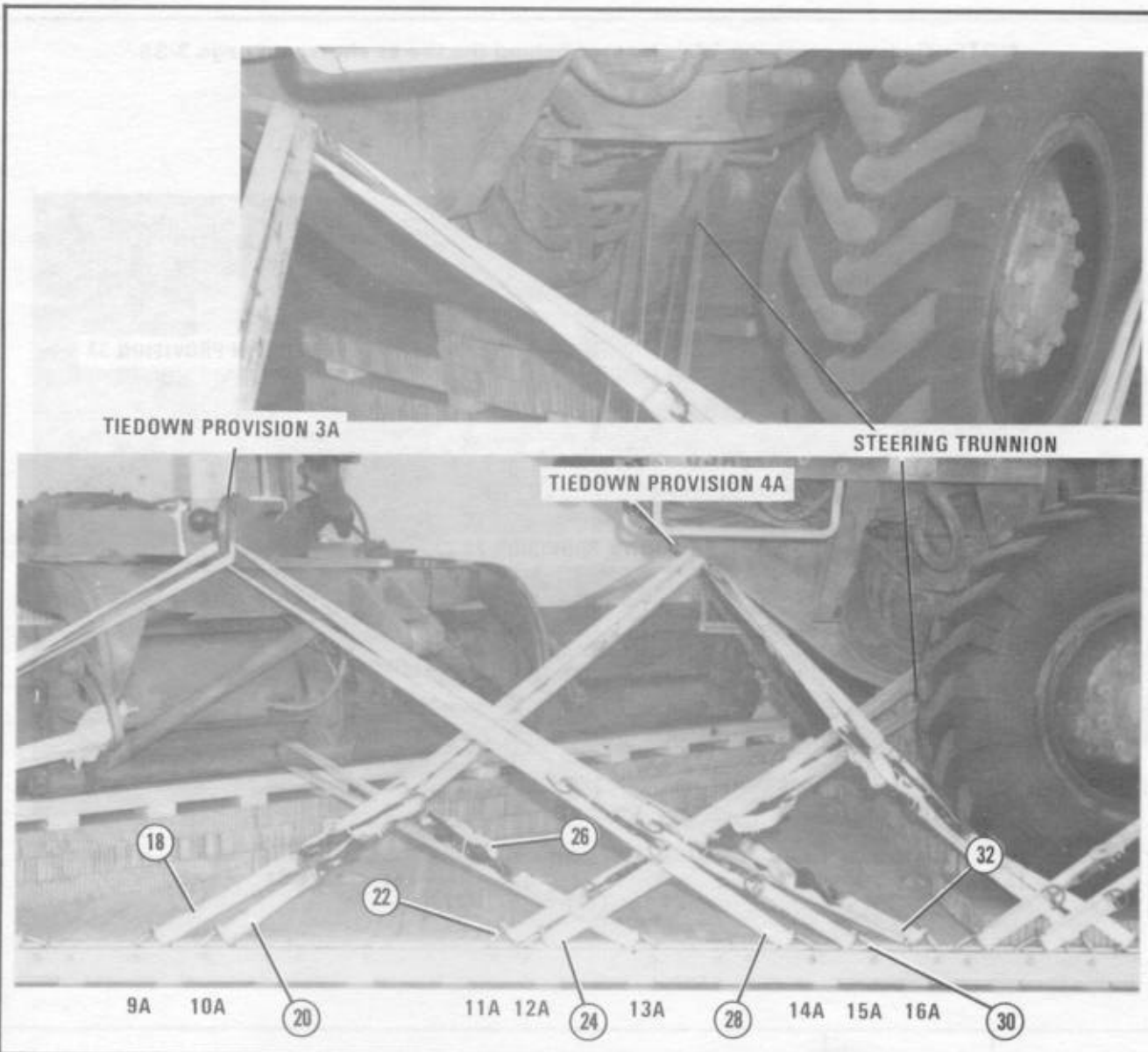

Lashing Number	Tiedown Clevis Number	Instructions
18	9A	Pass lashing:
20	10A	Through tiedown provision 4A.
22	11A	Through tiedown provision 4A.
24	12A	Around front frame lower support brace in front of steering trunnion.
26	13A	Around front frame lower support brace in front of steering trunnion.
28	14A	Around horizontal blade bracket and left of the center brace.
30	15A	Through tiedown provision 3A.
32	16A	Through tiedown provision 3A.
		Around horizontal blade bracket and left of the center brace (not shown).

Figure 3-24. Lashings installed on left side (continued)

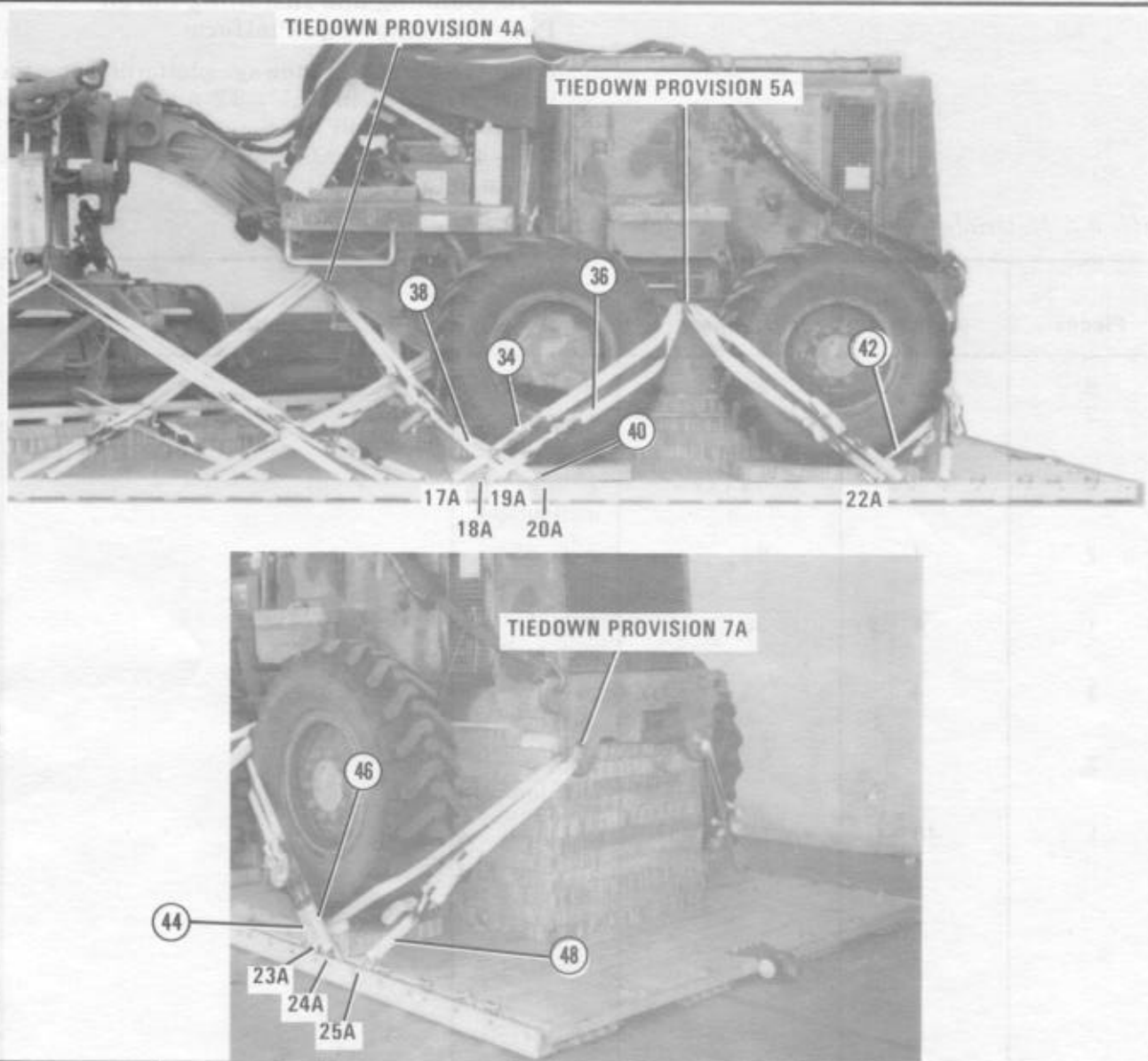

Lashing Number	Tiedown Clevis Number	Instructions
34	17A	Pass lashing: Through tiedown provision 5A. Through tiedown provision 5A. Through tiedown provision 4A. Through tiedown provision 4A. Through tiedown provision 7A. Through tiedown provision 5A. Through tiedown provision 5A. Through tiedown provision 7A.
36	18A	
38	19A	
40	20A	
42	22A	
44	23A	
46	24A	
48	25A	

Figure 3-24. Lashings installed on left side (continued)

3-10. Building and Installing Cargo Parachute Stowage Platform

Build the parachute stowage platform using the materials listed in Table 3-2 and as shown in Figure 3-25. Install the parachute stowage platform using four 15-foot tiedown assemblies as shown in Figure 3-26.

Table 3-2. Materials required to build parachute stowage platform

Pieces	Width (Inches)	Length (Inches)	Material	Instructions
9	29	88	Honeycomb	See Figure 3-25. See Figure 3-25.
2	4	43 1/2	4- by 4- inch lumber	
4	6	43 1/2	2- by 6- inch lumber	
2	4	96	2- by 4- inch lumber	
1	4	38	4- by 4- inch lumber	
2	4	23	2- by 4- inch lumber	
2	4	14	2- by 4- inch lumber	
1	48	96	3/4-inch plywood	

NOTE: Do not glue honeycomb stack to platform.

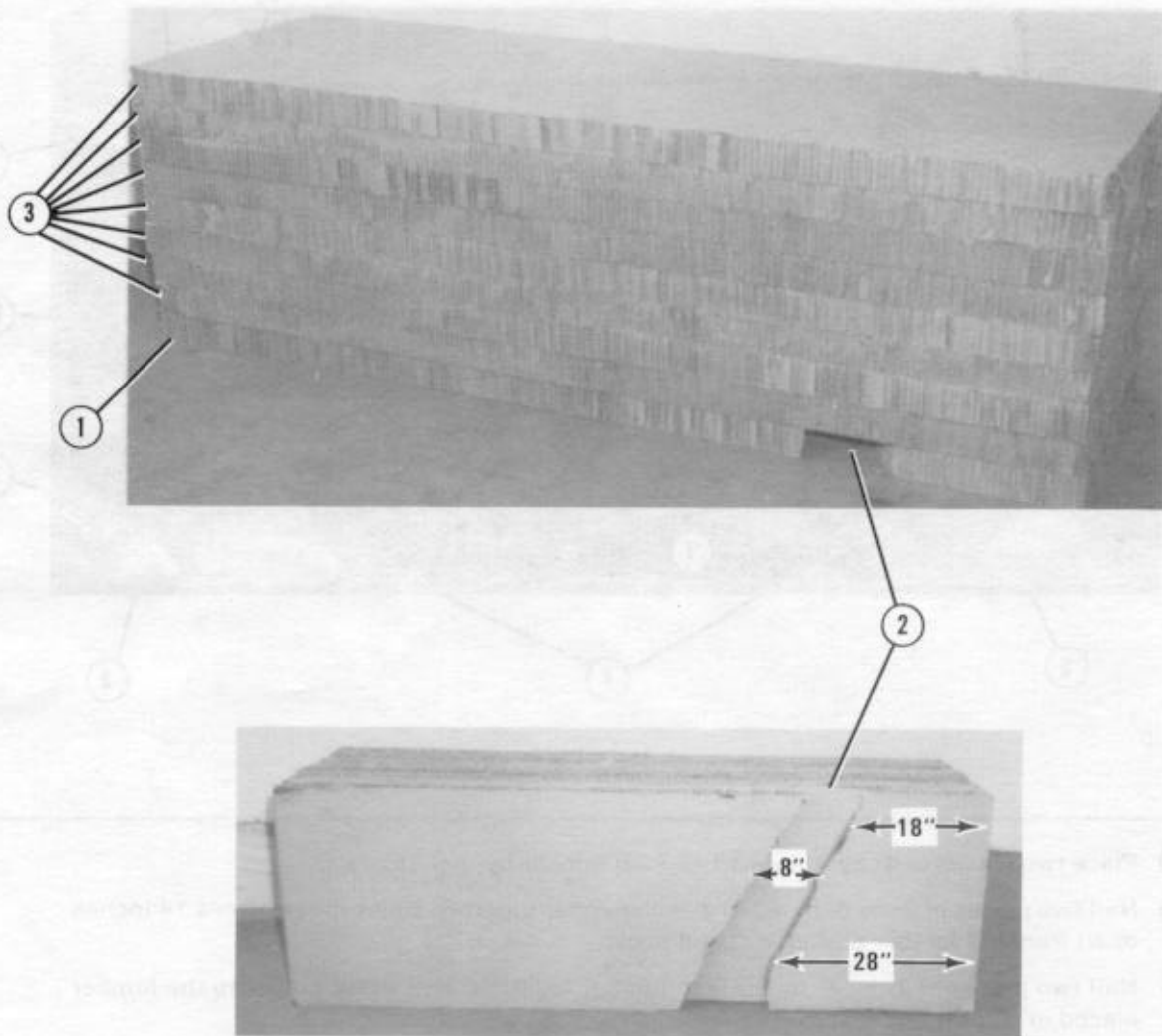

- ① Form a base using one piece of 29- by 88-inch honeycomb.
- ② Make an 8-inch cutout in the honeycomb 18 inches from the left front edge and 28 inches from the left rear edge. The cutout should be angled toward the rear.
- ③ Place eight pieces of 29- by 88-inch honeycomb on top of the base.

Figure 3-25. Parachute stowage platform constructed

NOTE: Use either eightpenny or tenpenny nails.

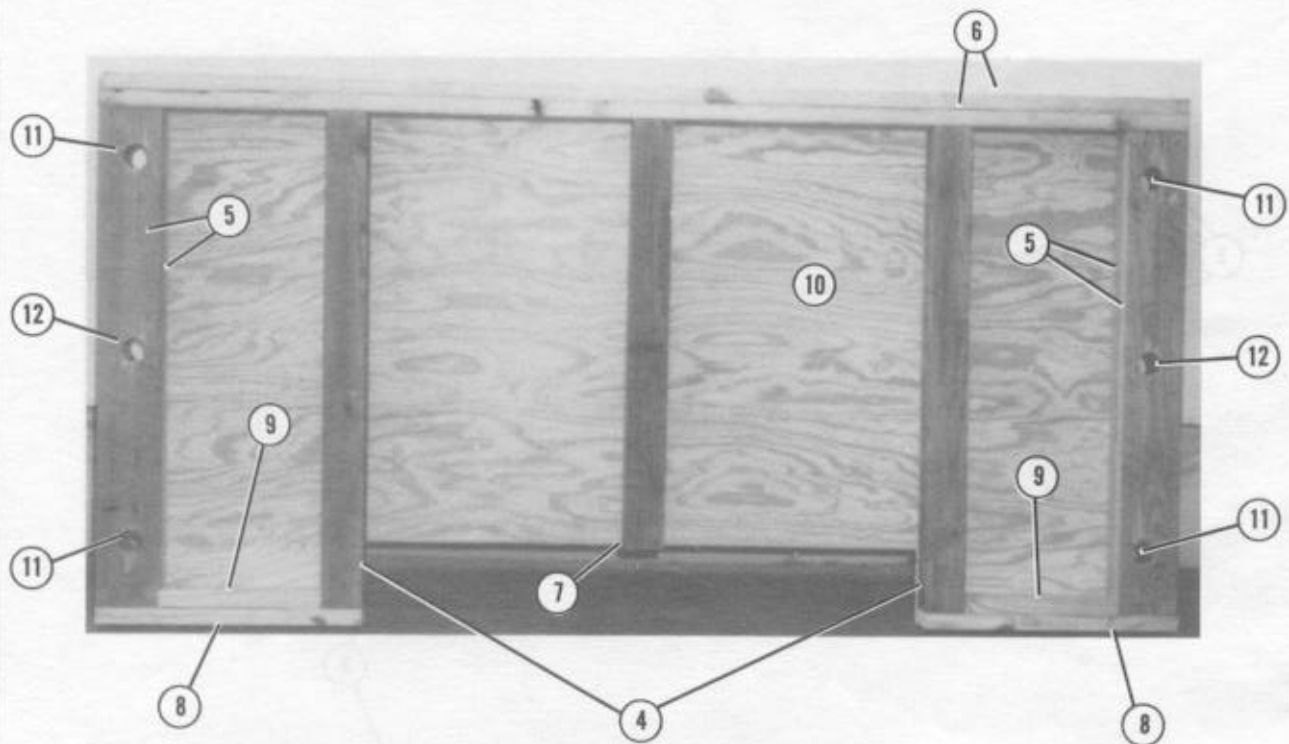

- ④ Place two pieces of 4- by 4- by 43 1/2-inch lumber 50 inches apart.
- ⑤ Nail two pieces of 2- by 6- by 43 1/2-inch lumber together. Place these pieces 14 inches apart from the lumber placed in step 4 above.
- ⑥ Nail two pieces of 2- by 4- by 96-inch lumber together. Nail these pieces to the lumber placed in steps 4 and 5 above.
- ⑦ Center one piece of 4- by 4- by 38-inch lumber between the lumber placed in step 4 above, and nail it to the 96-inch lumber.
- ⑧ Nail a piece of 2- by 4- by 23-inch lumber to the ends of the lumber placed in steps 4 and 5 above.
- ⑨ Nail a piece of 2- by 4- by 14-inch lumber to the lumber placed in step 8 above.
- ⑩ Make a 7- by 50-inch cutout in a piece of 3/4- by 48- by 96-inch plywood. Nail this piece of plywood on top of the constructed wood frame (steps 4 through 9 above).
- ⑪ Drill a 2 1/4-inch-diameter hole 8 inches from the outer edge of the 96-inch lumber and another 2 1/4-inch-diameter hole 8 inches from the outer edge of the 23-inch lumber.
- ⑫ Drill one 2 1/4-inch-diameter hole 24 inches from the outer edge of the 96-inch lumber.

Figure 3-25. Parachute stowage platform constructed (continued)

NOTE: Pad the rear towing pintle link with cellulose wadding. Tape the wadding in place with cloth-backed tape.

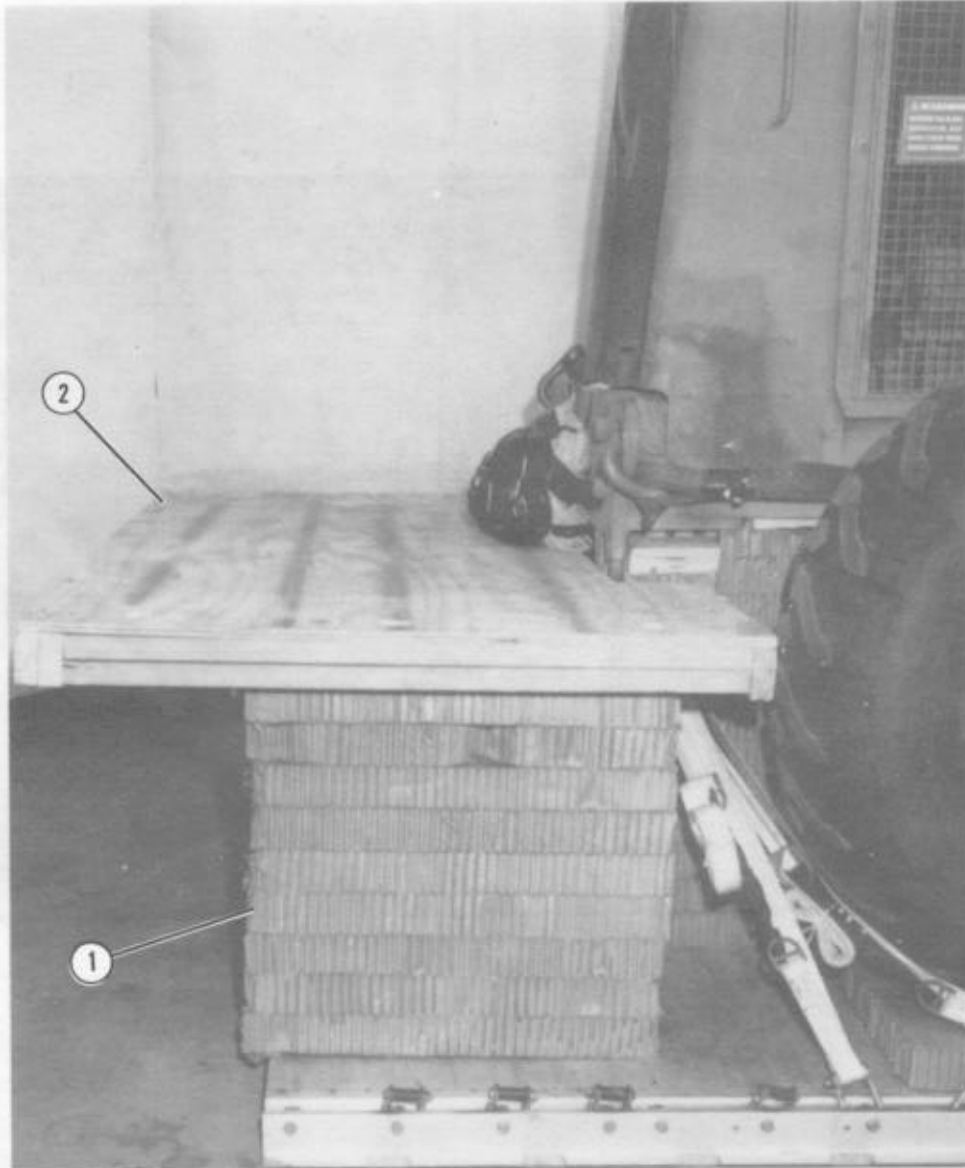

- ① Center the honeycomb stack between the rails and overhanging the rear edge of the platform by 2 inches.
- ② Place the wooden parachute stowage platform on the honeycomb stack.

Figure 3-26. Parachute stowage platform installed

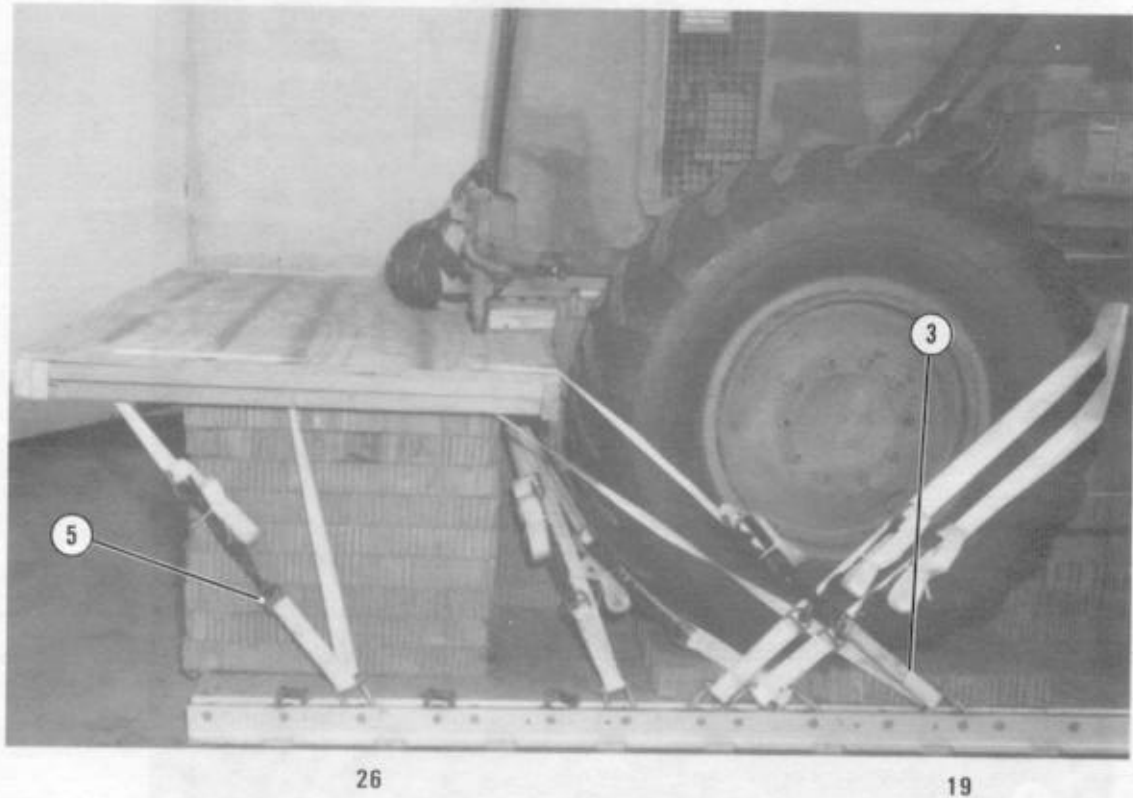

- ③ Pass a lashing from clevis 19 up through the front hole in the parachute stowage platform. Secure the lashing with a D-ring and a load binder.
- ④ Repeat step 3 for clevis 21A.
- ⑤ Pass a lashing from clevis 26 up through the center hole in the parachute stowage platform and back down through the rear hole. Secure the lashing with a D-ring and a load binder.
- ⑥ Repeat step 5 for clevis 28A.

Figure 3-26. Parachute stowage platform installed (continued)

11. Stowing Cargo Parachutes

Stow eight G-11C parachutes according to FM 10-500/TO 13C7-1-5 and as shown in Figure 3-27.

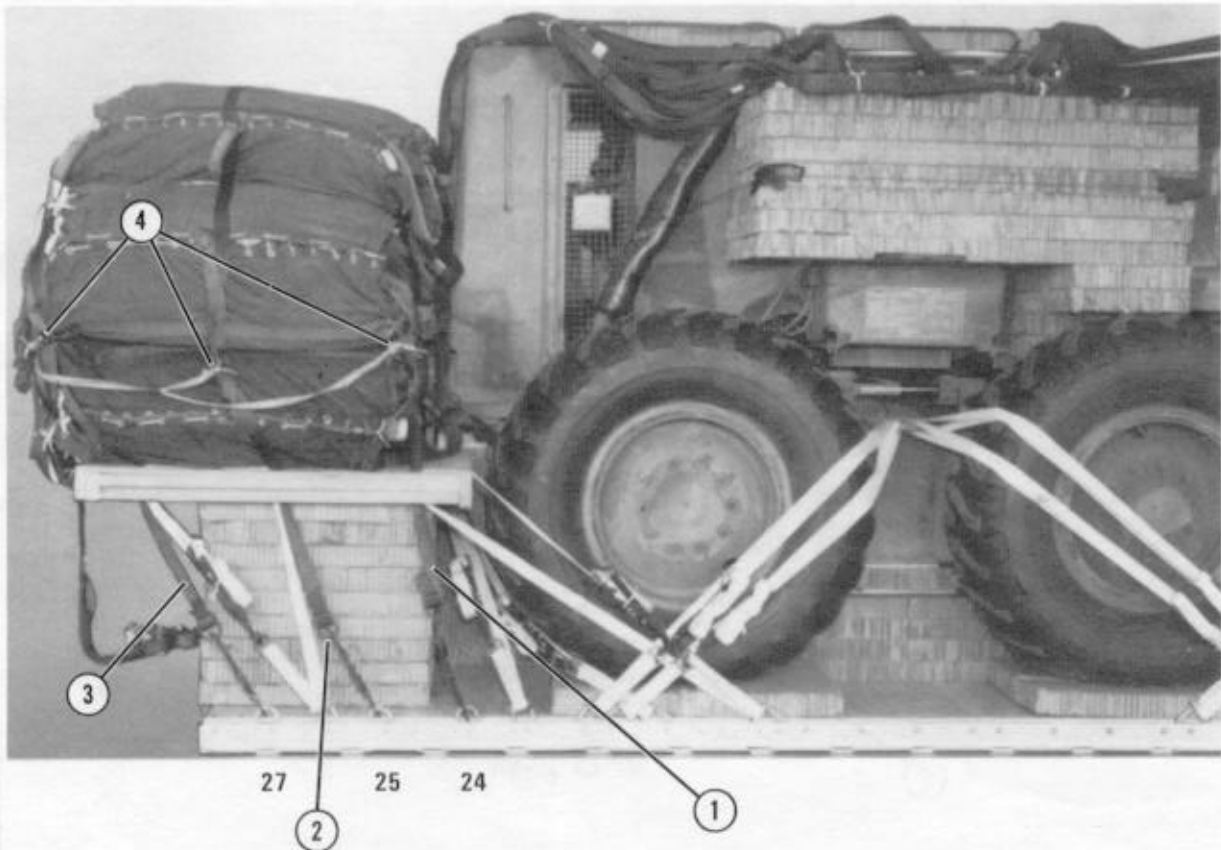

- ① Secure the parachutes using three lengths of type X nylon webbing, load binders, and D-rings. Attach the first strap from clevises 24 to 26A.
- ② Attach the second strap from clevises 25 to 27A.
- ③ Attach the third strap from clevises 27 to 29A.
- ④ Install the parachute release knives according to FM 10-500/TO 13C7-1-5.

Figure 3-27. Cargo parachutes stowed

3-12. Installing Extraction System

Use the EFTC on this load. Install the components of the EFTC according to FM 10-500/TO 13C7-1-5 and as shown in Figure 3-28.

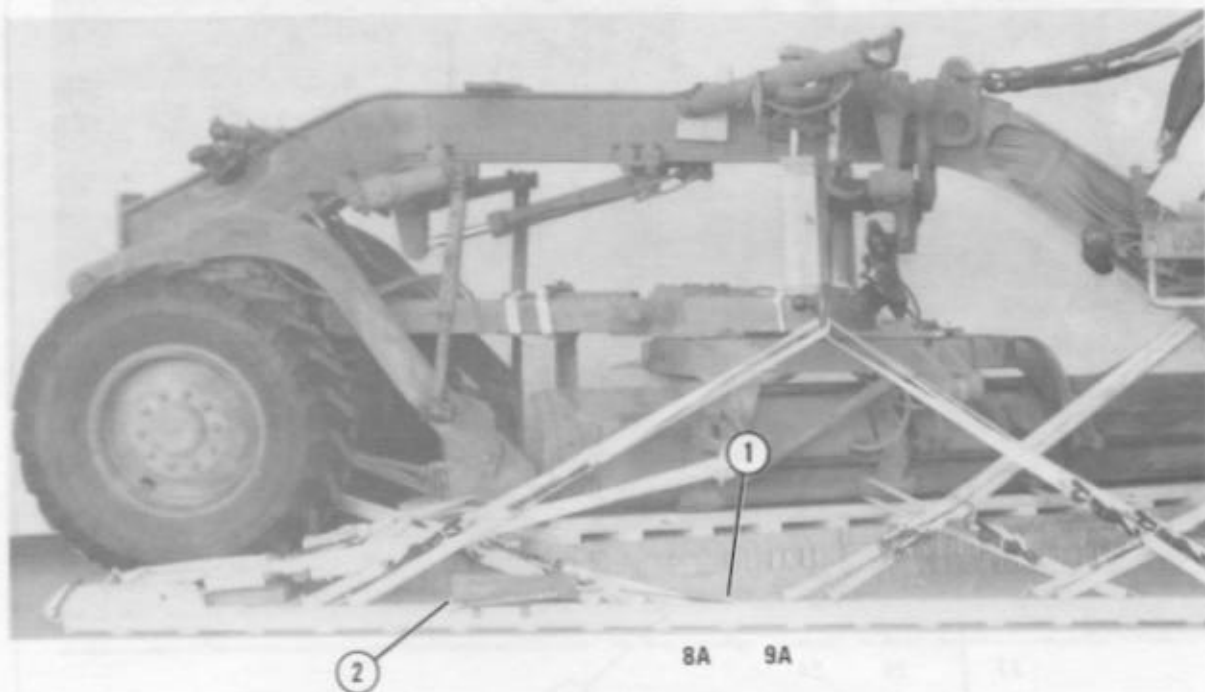

- ① Route a 28-foot release cable rearward along the left rail. Tie it to convenient clevises with type I, 1/4-inch cotton webbing.
- ② Bolt the actuator bracket to the rear EFTC mounting holes. Bolt the actuator assembly to the bracket.

Figure 3-28. EFTC installed

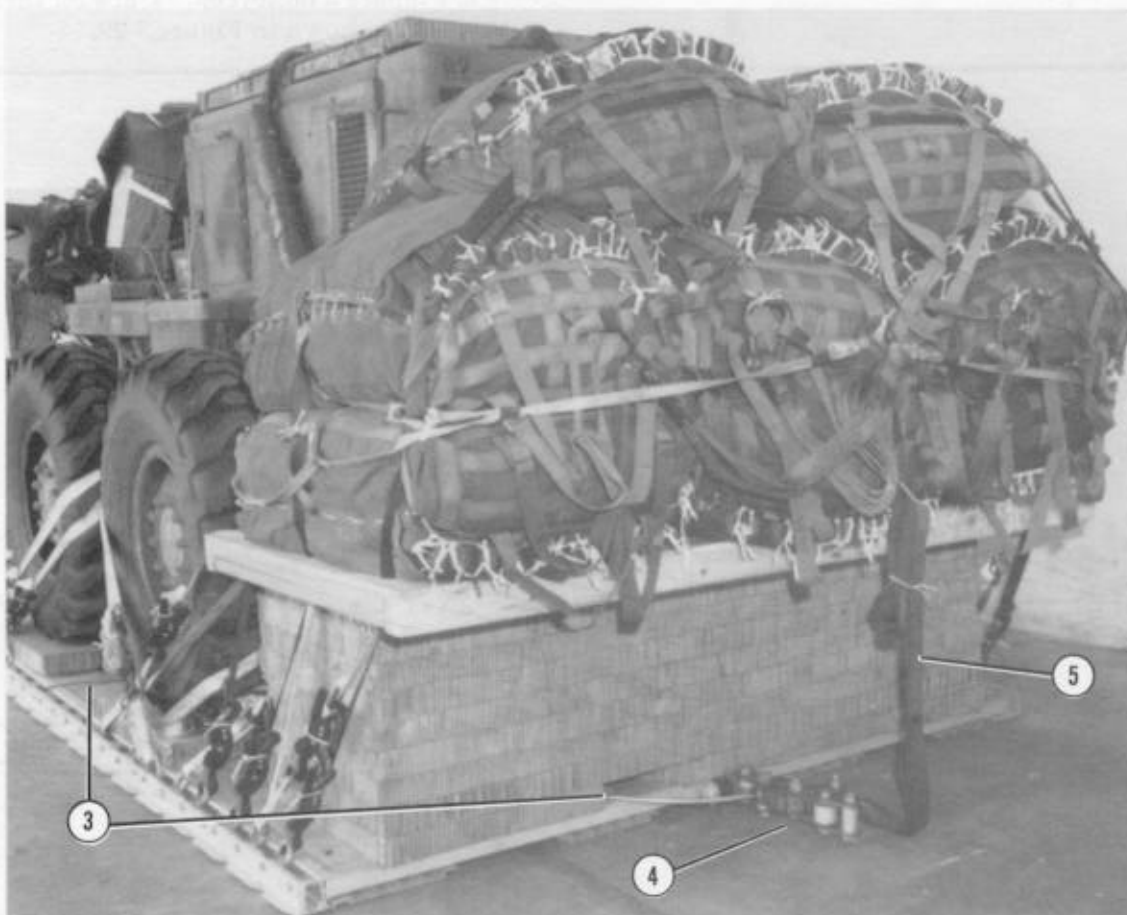

- ③ Run the cable between the dual wheels, under the rear axle, through the cutout in the honeycomb parachute stowage tray, and to the extraction bracket system.
- ④ Bolt the latch assembly to the towing pintle extraction link.
- ⑤ Use a 12-foot (2-loop), type XXVI nylon webbing sling for the deployment line.

NOTE: For preparation and transportation purposes, secure the latch assembly to the large clevis on the parachute with a length of type I, 1/4-inch cotton webbing (to be removed when the load is in the aircraft).

Figure 3-28. EFTC installed (continued)

3-13. Installing Release Assembly

Prepare the M-2 parachute release assembly according to FM 10-500/TO 13C7-1-5. Only the M-2 parachute release assembly may be used on this load.

a. Prepare a honeycomb stack for the parachute release as shown in Figure 3-29.

NOTE: This drawing is not drawn to scale.

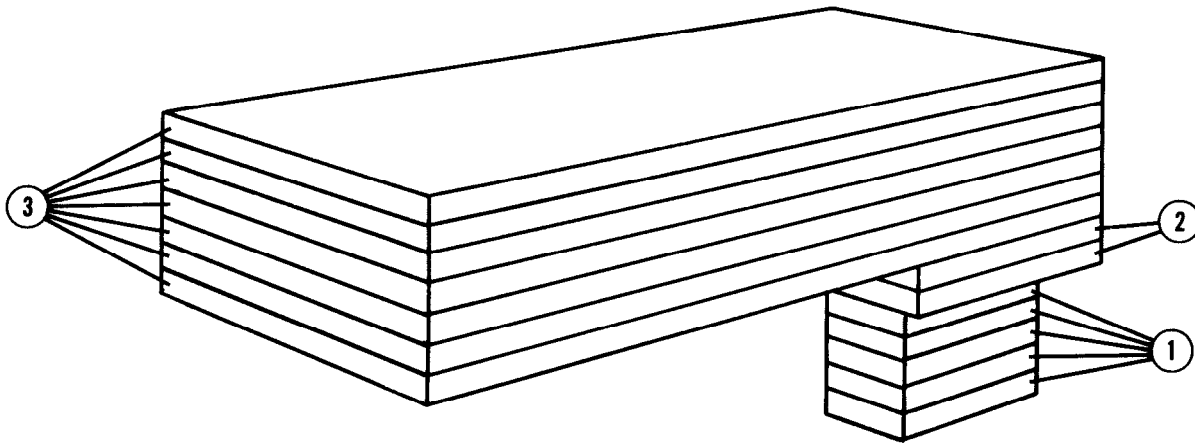

- ① Form a base using five pieces of 12- by 15-inch honeycomb.
- ② Place two pieces of 15- by 20-inch honeycomb on top of the base. Place the honeycomb flush with the rear edge.
- ③ Place seven pieces of 20- by 56-inch honeycomb on top of the honeycomb placed in step 2 above.

Figure 3-29. Honeycomb stack prepared for parachute release

b. Position the M-2 parachute release as shown in Figure 3-30.

c. Install the release according to FM 10-500/TO 13C7-1-5 and as shown in Figure 3-30.

- NOTES:**
1. The M-2 parachute release has the modified items for the 42K system.
 2. Make sure the M-2 parachute release is not higher than the honeycomb layer on top of the engine compartment.

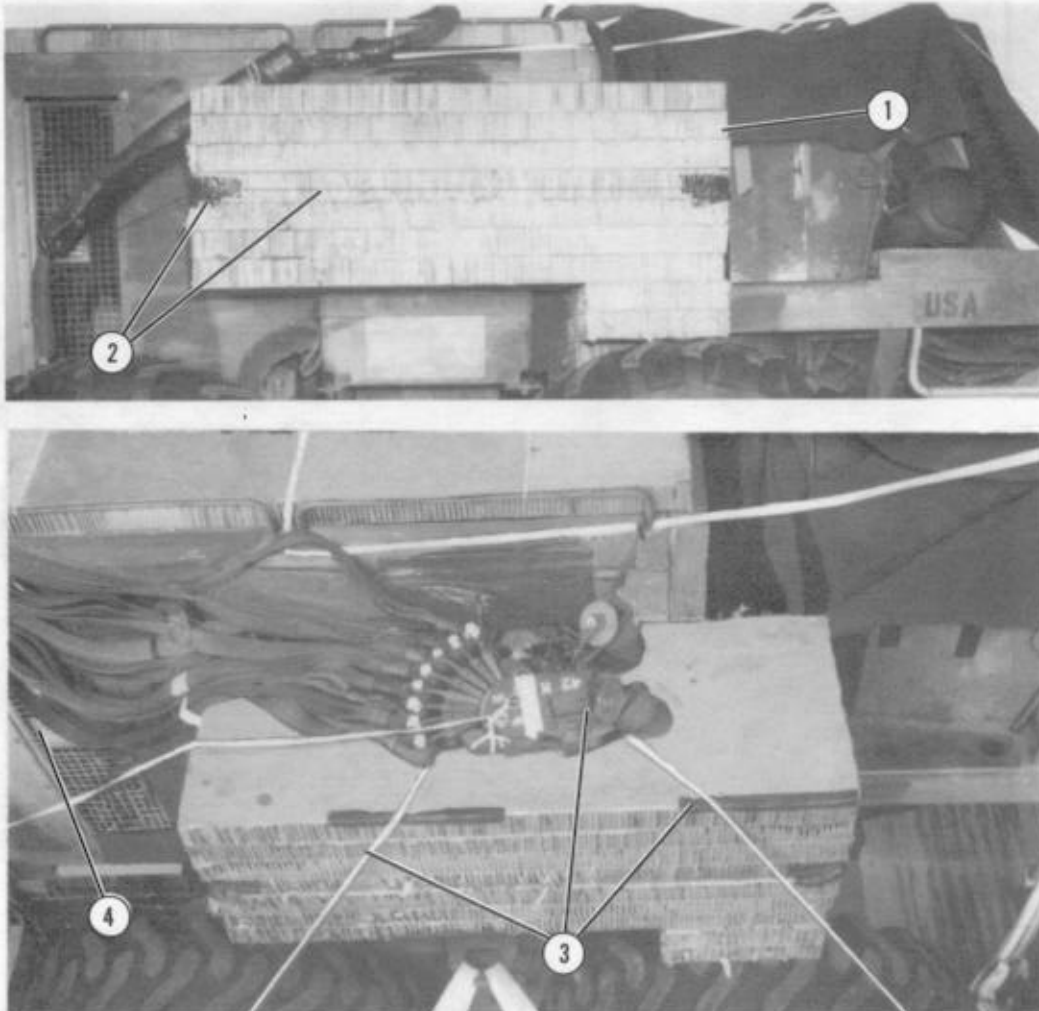

- ① Place the honeycomb stack on the right side of the grader above the battery box with the leg on the tandem housing.
- ② Place a piece of tape on the edges of the honeycomb where the type III nylon cord will touch. Tie the stack in place with type III nylon cord.
- ③ Place the release on top of the honeycomb stack. Tape the honeycomb where the type III nylon cord will touch. Tie the release in place with type III nylon cord.
- ④ Route the parachute riser extensions around the right side of the engine compartment (not shown). Connect them to the release according to FM 10-500/TO 13C7-1-5.

Figure 3-30. M-2 parachute release installed

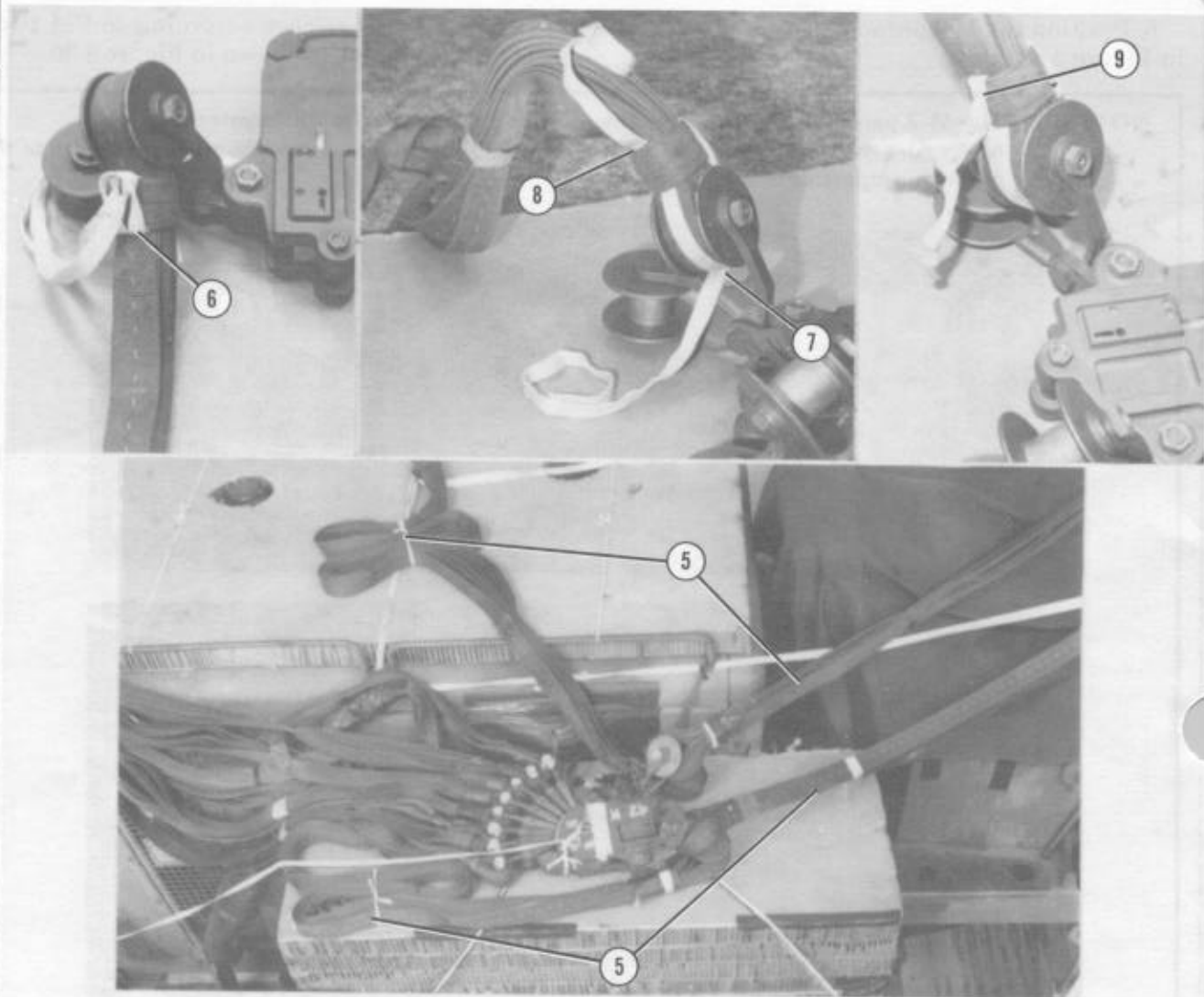

- ⑤ Route the suspension slings over the operator compartment and engine compartment. Connect them to the release according to FM 10-500/TO 13C7-1-5. S-fold and tie the rear slings in place with type I, 1/4-inch cotton webbing.
- ⑥ Form a girth hitch around one side of a sliding keeper with a 60-inch length of 1/2-inch tubular nylon webbing. Make sure the ends are equal.
- ⑦ Route both ends around the looped end of the sling and through the lower suspension link.
- ⑧ Route one end of the 1/2-inch tubular nylon webbing through the sliding keeper.
- ⑨ Slide the keeper as close to the lower suspension link as possible using the 1/2-inch tubular nylon webbing. Tie the running ends of the webbing together with two alternating half hitches and an overhand knot.
- ⑩ Tie the risers to the engine compartment with type I, 1/4-inch cotton webbing (not shown).

Figure 3-30. M-2 parachute release installed (continued)

3-14. Positioning Extraction Parachutes

Place two heavy-duty, 28-foot cargo extraction parachutes on the load for installation in the aircraft. A 60-foot (6-loop), type XXVI nylon extraction line is required when the load is airdropped from a C-130 aircraft. A 120-foot (6-loop), type XXVI nylon extraction line is required when the load is airdropped from a C-141 aircraft. Attach the extraction parachutes and the extraction line according to FM 10-500/TO 13C7-1-5.

3-15. Installing Provisions for Emergency Restraints

Install provisions for emergency restraints if the grader is airdropped from a C-141 aircraft. Attach a large clevis to each front multipurpose link as shown in Figure 3-31.



Figure 3-31. Provisions for emergency restraints installed

3-16. Marking Rigged Load

Mark the rigged load according to FM 10-500/TO 13C7-1-5 and as shown in Figure 3-32. Complete DD Form 1387-2 (Special Handling Data/Certification), and securely attach it to the load. Indicate on DD Form 1387-2 that the vehicle fuel tank and the batteries have been prepared according to AFR 71-4/TM 38-250. If the load

varies from the one shown in Figure 3-32, the weight, height, and CB must be recomputed.

3-17. Equipment Required

Use the equipment listed in Table 3-3 to rig this load.

CAUTION: Make the final rigger inspection required by FM 10-500/TO 13C7-1-5 before the load leaves the rigging site.

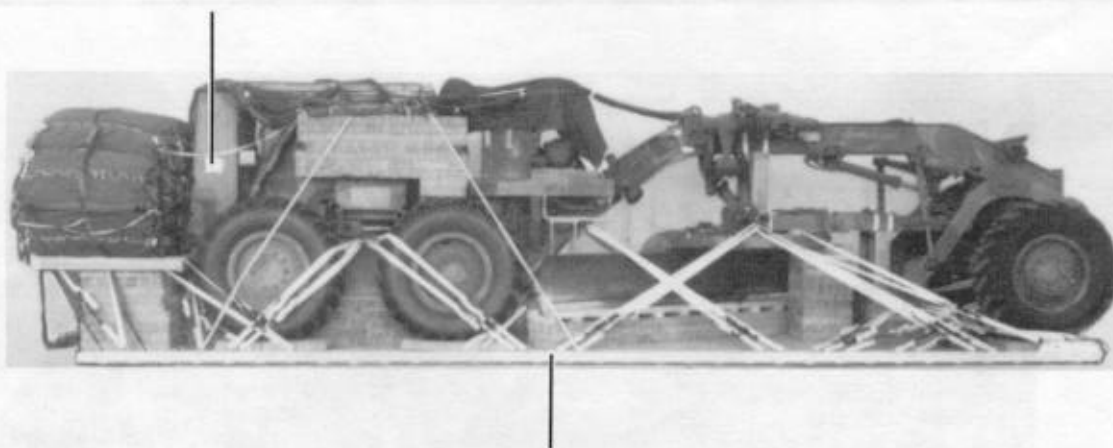

RIGGED LOAD DATA

		Type I	Type II
Weight:	Load shown	36,220 pounds	36,430 pounds
	Maximum allowed	36,600 inches	37,000 pounds
Height		98 inches	98 inches
Width		108 inches	108 inches
Length		374 inches	374 inches
Overhang:	Front	14 inches	14 inches
	Rear	24 inches	24 inches
CB (from front edge of platform)		181 inches	181 inches
Extraction System		EFTC	EFTC

Figure 3-32. 130G motor grader rigged for low-velocity airdrop (Type I shown)

Table 3-3. Equipment required for rigging the 130G motor grader on a type V airdrop platform for low-velocity airdrop

National Stock Number	Item	Quantity
8040-00-273-8713	Adhesive, paste, 1-gal	As required
4030-00-432-2516	Clevis, screw-pin	4
4030-00-090-5354	Clevis, suspension, 1-in (large)	6
8305-00-242-3593	Cloth, cotton duck, 60-in	As required
4020-00-240-2146	Cord, nylon, type III, 550-lb	As required
1670-00-157-6527	Coupling, airdrop, extraction force transfer w 28-ft cable	1
8135-00-664-6958	Cushioning material, packaging, cellulose wadding	As required
8305-00-958-3685	Felt, 1/2-in thick	As required
1670-01-183-2678	Leaf, extraction line (line bag)	2
1670-00-003-1957	Line, extraction: 60-ft (6-loop), type XXVI nylon webbing (for C-130) (Use w 28-ft parachute.) <u>or</u>	1
1670-01-064-4454	60-ft (6-loop), type XXVI nylon webbing (for C-130) (Use w 28-ft parachute.)	1
1670-01-062-6312	120-ft (6-loop), type XXVI nylon webbing (for C-141) (Use w 28-ft parachute.)	1
1670-00-006-2752	Link assembly, four-point	1
5510-00-220-6146	Lumber: 2- by 4-in: 14-in	12
	15-in	2
	23-in	2
	84-in	4
	96-in	2
	144-in	2
5510-00-220-6448	2- by 6-in: 6-in	1
	8-in	5
	10-in	2
	17 1/2-in	4
	19 7/16-in	4
	21-in	8
	23 1/2-in	4
	42 1/2-in	3
	43 1/2	4
5510-00-220-6246	2- by 8- by 24-in	2
5510-00-220-6274	4- by 4-in: 38-in	1
	43 1/2-in	2
5315-00-010-4659	Nail, steel wire, common: 8d	As required
5315-00-010-4661	10d	As required
1670-00-753-3928	Pad, energy-dissipating, honeycomb, 3- by 36- by 96-in:	32 sheets

Table 3-3. Equipment required for rigging the 130G motor grader on a type V airdrop platform for low-velocity airdrop (continued)

National Stock Number	Item	Quantity
	6- by 18-in	(6)
	8- by 8-in	(1)
	12- by 15-in	(5)
	13- by 16-in	(1)
	15- by 20-in	(2)
	16- by 45-in	(1)
	18- by 5-in	(1)
	18- by 10-in	(1)
	20- by 30-in	(2)
	20- by 36-in	(4)
	20- by 56-in	(7)
	24- by 18-in	(11)
	24- by 84-in	(5)
	29- by 88-in	(9)
	33- by 74-in	(1)
	36- by 84-in	(5)
	42- by 7-in	(2)
	42- by 25-in	(9)
	48- by 14-in	(3)
	48- by 96-in	(1)
	54- by 23-in	(4)
	55- by 15-in	(7)
	96- by 14-in	(3)
	Parachute:	
1670-01-016-7841	Cargo, G-11C	8
1670-00-040-8135	Cargo extraction, 28-ft, heavy-duty	2
8135-00-579-6489	Plastic sheet, 12- by 100- by 6-ft	As required
	Platform, airdrop, type V, 28-ft:	1
	Bracket:	
1670-01-162-2375	Inside EFTA	(1)
1670-01-162-2374	Outside EFTA	(1)
1670-01-162-2372	Clevis, load tiedown	(56)
1670-01-162-2376	Extraction bracket assembly	(1)
1670-01-162-2381	Tandem link	(2)
	Plywood:	
5530-00-129-7777	1/2-in:	
	3- by 10-in	2
	5 1/2- by 6-in	2
	8 1/2- by 36-in	2
	9- by 7 1/4-in	2
	36- by 7 1/4-in	2
5530-00-128-4981	3/4-in:	
	3/4- by 5 1/2-in	1
	5- by 9-in	6
	5- by 16-in	6
	5 1/2- by 2 1/2-in	2
	5 1/2- by 6-in	1

Table 3-3. Equipment required for rigging the 130G motor grader on a type V airdrop platform for low-velocity airdrop (continued)

National Stock Number	Item	Quantity
	5 1/2- by 8-in	1
	5 1/2- by 10-in	2
	6- by 15-in	2
	7- by 7-in	3
	8- by 18-in	2
	8 1/2- by 36-in	2
	24- by 18-in	2
	33- by 74-in	1
	48- by 14-in	1
	54- by 23-in	4
	55- by 15-in	1
	55- by 21-in	1
	96- by 14-in	1
1670-01-097-8817	Release, cargo parachute, M-2 (with modified components):	1
	Bolts, clevis (w sleeve), hardened	(2)
	Bolts, sleeve, hardened	(4)
	Shaft, toggle, reinforced	(1)
	Spacers, steel, 2 3/8-in	(4)
	Sling, cargo airdrop:	
	For deployment line:	
1670-00-753-3788	3-ft (3-loop), type X nylon webbing <u>or</u>	4
1670-01-062-6301	3-ft (2-loop), type XXVI nylon webbing	4
1670-00-823-5041	12-ft (3-loop), type X nylon webbing <u>or</u>	2
1670-01-062-6303	12-ft (2-loop), type XXVI nylon webbing	1
	For lifting:	
1670-00-432-2501	9-ft (4-loop), type XXVI nylon webbing <u>or</u>	2
1670-01-062-6305	9-ft (4-loop), type XXVI nylon webbing	2
1670-00-432-2507	16-ft (4-loop), type XXVI nylon webbing <u>or</u>	2
1670-00-003-7237	16-ft (4-loop), type XXVI nylon webbing <u>or</u>	2
1670-01-062-6308	16-ft (4-loop), type XXVI nylon webbing	2
	For riser extension:	
1670-00-432-2494	120-ft (3-loop), type X nylon webbing <u>or</u>	8
1670-01-062-6311	120-ft (2-loop), type XXVI nylon webbing	8
1670-00-998-0116	Strap, parachute release, multicut (comes w 3 knives)	2
8125-00-074-5124	Tape, adhesive, cloth-backed, type IV, 2-in	As required
1670-00-937-0271	Tiedown assembly, 15-ft	76
	Webbing:	
8305-00-268-2411	Cotton, 1/4-inch, type I	As required
	Nylon:	
8305-00-082-5752	Tubular, 1/2-in, 1,000-lb, natural	As required
8305-00-268-2453	Tubular, 1/2-in, 1,000-lb, olive drab	As required
8305-00-268-2455	Tubular, 1-in, 4,000-lb, olive drab	As required
8305-00-261-8584	Type X, treated, 8,700-lb, olive drab <u>or</u>	As required
8305-00-260-6890	Type X, untreated, 8,700-lb	As required

GLOSSARY

AFB Air Force base

AFR Air Force regulation

AFTO Air Force technical order

attn attention

CB center of balance

■ cir circumference

d penny

DA Department of the Army

DD Department of Defense

diam diameter

■ EFTA extraction force transfer actuator

EFTC extraction force transfer coupling

FM field manual

ft foot/feet

gal gallon

headquarters

■ ill Illinois

in inch

LAPE low-altitude parachute extraction

LAPES low-altitude parachute extraction system

lb pound

LV low-velocity

NSN national stock number

psi pounds per square inch

ROPS roll-over protection structure

TM technical manual

TO technical order

TRADOC US Army Training and Doctrine Command

TX Texas **■**

US United States (of America)

VA Virginia **■**

w with

REFERENCES

FM 10-500/TO 13C7-1-5	Airdrop of Supplies and Equipment: Rigging Airdrop Platforms
TM 5-3805-261-14&P-1	Grader, Heavy, Road; Motorized, Diesel Engine Driven, SSN R038, Operation
TM 5-3805-261-14&P-3	Grader, Heavy, Road; Motorized, Diesel Engine Driven, SSN R038, Maintenance
TM 5-3805-261-14&P-4	Grader, Heavy, Road; Motorized, Diesel Engine Driven, SSN 12308, Repair Parts
TM 10-1670-208-20&P/ TO 13C3-4-12	Organizational Maintenance Manual Including Repair Parts and Special Tools List for Platforms, Type II Modular and LAPES/Airdrop Modular
TM 10-1670-268-20&P/ TO 13C7-52-22	Organizational Maintenance Manual With Repair Parts and Special Tools List: Type V Airdrop Platform
TM 10-1670-286-20/ TO 13C5-2-41	Unit Maintenance Manual for Sling/Extraction Line Panel (Including Stowing Procedures)
TM 38-250/AFR 71-4	Packaging and Materials Handling: Preparing Hazardous Materials for Military Air Shipments
AFTO Form 22	Technical Order Publication Improvement Report
DA Form 2028	Recommended Changes to Publications and Blank Forms
DD Form 1387-2	Special Handling Data/Certification

PIN: 047506-001