

ANNEX D

GUIDELINES FOR GEODETIC CONTROL POINT DESIGNATIONS

A geodetic control point is a monumented or otherwise marked, survey point, established for the purpose of providing geodetic reference for mapping and charting activities and for a wide variety of engineering and scientific applications. A control point is normally identified by a number, an alphanumeric symbol, or a concise, intelligible name which is usually stamped on the disk marker. In principle, the designation by which a control point is identified should closely resemble the stamping that appears on the respective marker. However, extraneous information is frequently present which should not be included as part of the designation. In every case, the designation assigned to a control point for processing purposes must be identical to the designation that appears in the heading of the station description.

These guidelines have been established to provide consistent control point designations and facilitate automated processing of the data. Implementation of these guidelines may sometimes result in two or more control points having the same designation. In such cases it will be necessary to refer to other information in the description to completely identify the control point. Sample formats for the various designations are given in this annex.

GUIDELINES

1. A control point designation must not exceed 40 alphanumeric characters, including all imbedded blanks. When necessary, abbreviate and/or edit an existing designation to conform to this limit.
2. The year the mark was set is considered extraneous information and is not to be carried as part of a control point designation. For marks whose designations have not been altered when they were reset, the word RESET must be appended to the original designations. This also holds true for control points which have been reset more than once. In such cases the year given in the "year set" field will be used to distinguish the marks.

Monument	Stamped	Designation
USGS BM Disk	TT 8 RESET 1965	TT 8 RESET
CGS BM Disk	LAKE WASHINGTON RESET 1970	LAKE WASHINGTON RESET
CGS Tri Sta Disk	BRADY 1951	BRADY
CGS BM Disk	ONEAL 1 1954	ONEAL 1
CGS BM Disk	DE KALB 1934	DEKALB
NCGS Trav Sta Disk	MC CALL 1968	MCCALL
CGS Tri Sta Disk	DODGE 2 1969	DODGE 2
CGS Tri Sta Disk	SPIT 1953 1983	SPIT RESET
USGS Survey Disk	PRIM TRAV STA NO 185 1915	PTS 185

3. The acronym or abbreviation of the agency or organization whose name is precast or sometimes stamped in the survey marker is considered extraneous information and should not be included in the control point designation.

Monument	Stamped	Designation
FLGS BM Disk	203 RESET 1950	203 RESET
FLGS BM Disk	203 RESET 1967	203 RESET
FLGS BM Disk	203 RESET 1967 MAY	203 RESET MAY
USGS BM Disk	2903	2903
MORC Gaging Sta	GAGING STA	GAGING STA
RIRR Disk	RV 16	RV 16
USGS Chis Square		WO 23 RM=148 RM
USGS Survey Disk	WO 23 1933	WO 23
USGS Survey Disk	WO 23 1933 RESET 1962	WO 23 RESET
PP+L Survey Disk	P 11 PPL RESET 1976	P 11 RESET

4. The following special characters are the only ones allowed in a control point designation. They are the blank (), plus (+), minus or hyphen (-), equals (=), slash (/), and decimal point (.). When used, these special characters must not be separated from adjacent characters by any blanks. Commas and parentheses are not allowed within a designation.

4.1 Most alpha and numeric character groupings in a designation should be separated by a single blank (). Some exceptions are allowed, see the set of Abbreviations and Formats.

Monument	Stamped	Designation
USGS Survey Disk	TT17B	TT 17 B
USGS Survey Disk	TT-17B	TT 17 B
USGS Survey Disk	TT-1 7B	TT 1 7 B

4.2 A plus sign (+) is permitted within a designation when the control point was previously used for stationing in alignment surveys. In these cases the plus sign (+) must be immediately preceded and followed by a digit, not a blank.

Monument	Stamped	Designation
AZDT Disk	STATION 11+14	ROUTE 244 STA 11+14
Highway Disk	2623 + 00	I95 STA 2623+00

4.3 The minus or hyphen (-) is allowed only when indicating a negative elevation stamped on a mark. An elevation stamped on a mark is used as the designation only when there is no other means to identify the mark. When a minus or hyphen (-) is used, it must be the first character of the designation and must be immediately followed by a digit.

Monument	Stamped	Designation
USGS Nail (Tag)	-227.10 5-23-55	-227.10
CGS BM Disk	-193.097 F 70 1928	F 70
USGS BM Disk	ELEV -7.325 FT	-7.325

4.4 The equal sign (=) is used as a separator for control points which carry multiple stamped designations. The designations involved should be concatenated with the equal sign. The combined designation length must not exceed the 40-character limit and the designation preceding the equal sign should be the designation used by the originating agency.

Monument	Stamped	Designation
USGS Chis Square		WO 23 RM=148 RM
CADH Survey Disk	CH 1174	297+00 (A) CH 1174=297+00 A
Unk Survey Disk	STA. NO. 3	MI. 182.5 STA 3=MI 182.5
CGS Ref Mark Disk	LEE NO 1 1932	R 13 LEE RM 1=R 13
CGS Tri Sta Disk	68.399 B 22	ATKINSON 1918 ATKINSON=B 22
USGS Cap	U 276 1942	VA 45 1917 45=U 276

NOTE: In situations where there are multiple designations that either do not appear stamped on the mark or are too long to be accommodated by the 40-character designation, the secondary designation may be given as a separate data item and carried as an alias in the appropriate field.

4.5 A slash (/) may be used to indicate a numerical fraction.

Monument	Stamped	Designation
USGLO Survey Disk	T1N R3E S35 S36 1/4 1943	T1N R3E SECS 35 36 1/4 COR

4.6 A period (.) may not appear imbedded in or adjacent to a grouping of alpha characters, but may be used as a decimal point if imbedded in (but not adjacent to) a grouping of numeric characters.

Monument	Stamped	Designation
MADPW Survey Disk	ELEV. B.M. NO. F 40	F 40
CGS Ref Mark Disk	W. BASE NO 4 1965	CHARLESTON W BASE RM 4
CADWR Survey Disk	MI. 0.9 1967	AMERICAN CANAL MI 0.9
CGS Tri Sta Disk	PALMER N.E. BASE	PALMER NE BASE
CGS BM Disk	MT. MORRIS 1941	MT MORRIS

5. Nonspecific descriptive terms are not to be treated as "double designations" and are not to be carried as aliases.

Published as	Stamped	Designation
BENCH MARK 2		2
114.3, Chis Square		114.3
C 1, Bolt		C 1

6. The characters "BM", "BENCH MARK", and "PBM", even when stamped on a disk, are not to be included in a designation unless the control point has no other stamping (e.g., BM USGS) or the characters "BM" do not represent the words "BENCH MARK."

7. The elevation stamped on the disk marker on the monument is not to be carried as a part of the respective designation. The exception is when the elevation is the only means of identifying the survey mark.

Monument	Stamped	Designation
CGS BM Disk	H 325 230.695FT	H 325
MORC Disk	140B ELEV 95.3 FT	140 B
USGS BM Disk	-9.825 FT	-9.825
BOR Survey Disk	ELEV. 101.6	101.6

8. The characters "NO" or "No.", when used as an abbreviation for the word "number", should not be included in the designation, even when they are stamped in the disk.

Monument	Stamped	Designation
CGS Ref Mark Disk	MONROE NO 1 1944	MONROE RM 1
CGS BM Disk	BENCH MARK No. 6	6

9. The designation for a reference mark disk should be formed by appending the symbols RM 1, RM 2, ..., RM 13, etc. to the name of the horizontal control point for reference marks stamped NO 1, NO 2, ..., NO 13, etc., respectively.

Monument	Stamped	Designation
CGS Ref Mark Disk	CHARLOTTE NO. 1 1945	CHARLOTTE RM 1
CGS Ref Mark Disk	BOULDER 1935 NO 6 1968	BOULDER RM 6
CGS Ref Mark Disk	CHICO 1948 NO 3 RESET 1971	CHICO RM 3 RESET

10. The designation for an azimuth mark disk is formed by appending the characters "AZ MK" to the name of the respective horizontal control point. In the case of multiple azimuth marks, the numbers "2", "3", etc. are added for azimuth marks stamped NO 2, NO 3, etc.

Monument	Stamped	Designation
CGS Az Mark Disk	CHARLOTTE 1934	CHARLOTTE AZ MK
CGS Az Mark Disk	BOULDER 1935 NO. 3	BOULDER AZ MK 3
CGS Az Mark Disk	NORWASH AZI 1932	NORWASH AZ MK
CGS Az Mark Disk	PARK AZ RESET 1965	PARK AZ MK RESET

11. A temporary bench mark (TBM) must carry the letters "TBM" as the first three characters of the designation.

Monument	Stamped	Designation
Spike		TBM 1 A
Sidewalk		TBM 14

12. The National Ocean Service (NOS) has instituted a standard system of designations for all tidal and water level stations operated by NOS. The system provides for the unique identification of all disks, staffs, etc., located at such stations (e.g., see Formats in this annex).

Tidal and water level bench mark designations must conform to standard designations adopted by the National Ocean Service. For information concerning specific tide gage bench marks, etc., communicate with:

NOAA, National Ocean Service
OPSD, User Services, N/CS44
Attn: Water Levels
1305 East-West Highway
Silver Spring, MD 20910-3281

Telephone: 1-301-713-2877 ext. 176
E-mail Address: lyles@wlnet.nos.noaa.gov
Internet Web Site: www.opsd.nos.noaa.gov

Whenever the need arises for a guideline to deal with a situation not covered herein, the user is encouraged to communicate with the following technical office in NGS:

Spatial Reference System Division, N/NGS2
National Geodetic Survey, NOAA
1315 East-West Highway
Silver Spring, MD 20910-3282

Telephone: 1-301-713-3191
E-mail Address: edm@ngs.noaa.gov
Internet Web Site: www.ngs.noaa.gov

ABBREVIATIONS

A list of standard abbreviations has been adopted for use in designating geodetic control points. These abbreviations are for terms that commonly occur in designations and are the only accepted forms of abbreviation. This list may be extended as the need arises.

Geodetic control point abbreviations

A POINT	A PT
ACADEMY	ACAD
ADMINISTRATION	ADM
AGENCY	AGY
AGRICULTURE	AGRI
AHEAD	AHD
AIRCRAFT	ARCFT
AIRPORT	APT
AIRWAY	AWY
AIR FORCE BASE	AFB
ALLEGHENY	ALGHNY
AMBASSADOR	AMB
AMENDED	AMD
AMENDED MONUMENT (AM)	AMD MON
AMERICAN	AMER
ANGLE	ANG
ANGLE POINT (AP)	ANG PT
ANTENNA	ANT
APPALACHIAN	APLCN
APPROXIMATELY	APPROX
ASSOCIATION	ASSOC
ASTRONOMICAL	ASTRO
ASYLUM	ASY
ATLANTIC	AT
AUTHORITY	AUTH
AUXILIARY	AUX
AUXILIARY MEANDER CORNER (AMC)	AUX MDR COR
AVENUE	AVE

Notes:

1. Abbreviations listed with () are used by the Bureau of Land Management.
2. The cardinal directions (E, S, W, N, NE, SE, SW, and NW) are to be abbreviated only when they are not the first word of the designation.

Geodetic control point abbreviations (Continued)

AVIATION	AVN
AZIMUTH	AZ
BACK	BCK
BANK	BK
BANKING	BKG
BAPTIST	BAP
BATTERY	BTRY
BEACON	BCN
BEARING	BRG
BEARING OBJECT (BO)	BRG OBJ
BEARING TREE (BT)	BRG TREE
BELFRY	BFRY
BETWEEN	BET
BOULEVARD	BLVD
BOUNDARY	BDRY
BREAKWATER	BRKWTR
BRICK	BR
BROADCASTING	BCSTG
BROTHER	BRO
BROTHERS	BROS
BUILDING	BLDG
BUREAU	BUR
CAPITOL	CAP
CATHEDRAL	CATHL
CATHOLIC	CATH
CEMETERY	CEM
CENTER (C)	CEN
CENTERLINE	CL
CERAMIC	CERAM
CHEMICAL	CHEM
CHIMNEY	CHIM
CHURCH	CH
CLOCK	CLK
CLOSING CORNER (CC)	CC
COLLEGE	COLL
COMMERCE	COM
COMMERCIAL	COML
COMMISSION	COMM
COMPANY	CO
COMPRESS	COMP
CONCENTRATION	CONCN
CONCEPTION	CON
CONCRETE	CONC
CONGREGATIONAL	CONG

Geodetic control point abbreviations (Continued)

CONSOLIDATED	CONSOL
CONSTRUCTION	CONSTR
CONTINENTAL	CONTL
CONTROL	CTRL
COOPERATIVE	COOP
CORNER	COR
CORPORATION	CORP
CORRECTIONAL	CORR
COUNTRY	CTRY
COUNTY	CNTY
COURTHOUSE	CTHSE
CUPOLA	CUP
DAYBEACON	DBCN
DEFENSE	DEF
DEPARTMENT	DEPT
DISTRIBUTOR	DISTR
DIVISION	DIV
DOMESTIC	DOM
DORMITORY	DORM
DRAWBRIDGE	DBRIDGE
EAST	E
ECCENTRIC	ECC
EDUCATION	EDUC
ELECTRIC	ELEC
ELEMENTARY	ELEM
ELEVATION	ELEV
ELEVATED	ELEVVD
ELEVATOR	ELEVR
ENGINEERING	ENG
ENGRAVING	ENGR
ENTRANCE	ENTR
EPISCOPAL	EPIS
EQUIPMENT	EQPT
EVANGELICAL	EVAN
EXCHANGE	EXCH
EXPERIMENTAL	EXPTL
FEDERAL	FED
FINIAL	FIN
FIRST	1ST
FLAGPOLE	FP
FLAGSTAFF	FS
FOURTH	4TH
FRONT RANGE	FRGE
FURNITURE	FURN

Geodetic control point abbreviations (Continued)

GABLE	GAB
GENERAL	GEN
GEODETIC	GEOD
GEOGRAPHIC	GEOG
GEOLOGICAL	GEOL
GOVERNMENT	GOVT
GROWERS	GROS
HARBOR	HBR
HARDWARE	HDWE
HEADQUARTERS	HQ
HEIGHTS	HTS
HIGHWAY	HWY
HISTORICAL	HIST
HOSPITAL	HOSP
HOUSE	HSE
HYDRO	HYD
IMMACULATE	IMM
IMPLEMENT	IMPL
IMPORT	IMP
INCINERATOR	INCIN
INCORPORATED	INC
INDEPENDENT	IND
INDUSTRIAL	INDL
INDUSTRY	INDY
INFIRMARY	INFIRM
INSTITUTE	INST
INSTITUTION	INSTN
INSURANCE	INS
INTERNATIONAL	INTL
INTERSTATE	INTST
INTERSECT	INT
INVESTMENT	INVT
IRRIGATION	IRRIG
ISLAND	IS
JUNCTION	JCT
LABORATORY	LAB
LANDING	LDG
LATITUDE	LAT
LATTER DAY SAINTS	LDS
LEATHER	LEA
LEFT	LT **

**The abbreviations R, T, LT, and RT must be adjacent to at least one numeric character.

Geodetic control point abbreviations (Continued)

LIGHT	LT
LIGHTHOUSE	LH
LOCAL	LCL
LOCATION	LOC
LOCATION MONUMENT (LM)	LOC MON
LOOKOUT	LO
LOOKOUT HOUSE	LOH
LOOKOUT TOWER	LOT
LONGITUDE	LON
LUMBER	LUM
LUTHERAN	LUTH
MACHINERY	MACH
MAGAZINE	MAGZ
MAGNETIC	MAG
MAINTENANCE	MAINT
MANUFACTURED	MFD
MANUFACTURING	MFG
MARK	MK
MARKET	MKT
MAST	MST
MEANDER	MDR
MEANDER CORNER (MC)	MDR COR
MERCHANDISE	MDSE
MERCANTILE	MERC
METHODIST	METH
METROPOLITAN	MET
MICROWAVE	MV
MILE or MILES	MI
MILEPOST	MP
MILITARY	MIL
MILLING	MILL
MONUMENT	MON
MOUNT	MT
MOUNTAIN	MTN
MUNICIPAL	MUN
MUSEUM	MUS
NATIONAL	NAT
NAVIGATION	NAV
NEAR	NR
NORTH	N
NORTHEAST	NE
NORTHWEST	NW
OBJECT	OBJ
OBSERVATION	OBS

Geodetic control point abbreviations (Continued)

OBSERVATORY	OBSY
OBSTRUCTION	OBSTR
OFFICE	OFF
ORDNANCE	ORD
ORGANIZATION	ORG
ORTHODOX	ORTH
PEAK	PK
PENINSULA	PEN
PETROLEUM	PET
PINNACLE	PCLE
PLANT	PLT
POINT	PT
POINT A	PTA
POINT OF CURVE	POC
POINT OF INTERSECTION	PI
POINT OF TANGENT	POT
POLICE	POL
POWER	PWR
POWERHOUSE	PHSE
PRESBYTERIAN	PRESB
PRIMARY	PRIM
PRIMARY TRAVERSE STATION	PTS
PRINTING	PTG
PROCESS	PRCS
PRODUCING	PRODG
PRODUCT	PROD
PROPERTIES	PROP
PROTESTANT	PROT
PUBLIC	PUB
PUBLISHING	PUBG
QUARTER	QTR
RADIO	RAD
RAILROAD	RR
RAILWAY	RWY
RANGE	RGE
RANGE (Township)	R **
REAR RANGE	RRGE
REFERENCE	REF
REFERENCE MARK	RM
REFERENCE MONUMENT (RM)	REF MON
REFERENCE POINT	RP

**The abbreviations R, T, LT, and RT must be adjacent to at least one numeric character.

Geodetic control point abbreviations (Continued)

REFINING	REFG
REFORMED	REFM
REFRIGERATING	REFRIG
RESET	RST
RIGHT	RT **
RIGHT OF WAY	ROW
ROAD	RD
ROMAN	ROM
ROUTE	RTE
RUNWAY	RNWX
SAINT	ST
SANITARY	SANIT
SANITORIUM	SAN
SAVINGS	SVGS
SCHOOL	SCH
SCHOOLHOUSE	SCHSE
SCIENTIFIC	SCI
SECOND	2ND
SECTION	SEC
SECTIONS	SECS
SEMINARY	SEM
SERVICE	SERV
SOCIETY	SOC
SOUTH	S
SOUTHEAST	SE
SOUTHWEST	SW
SPECIAL	SPL
SPECIAL MEANDER CORNER (SMC)	SPL MDR COR
SPIRE	SP
SQUARE	SQ
STACK	STK
STANDARD	STD
STANDARD CORNER (SC)	SC
STANDPIPE	SPIPE
STATION	STA
STEEPLE	STPE
STORAGE	STGE
STREET	STR
SUBURBAN	SUBR
SUPERINTENDENT	SUPT
TANK	TK

**The abbreviations R, T, LT, and RT must be adjacent to at least one numeric character.

Geodetic control point abbreviations (Continued)

TANGENT	TAN
TANGENT OFFSET	TOS
TECHNICAL	TECH
TELEGRAPH	TELG
TELEPHONE	TEL
TELEVISION	TV
TEMP POINT A	TP A
TERMINAL	TERM
TERRITORY	TERR
THEOLOGICAL	THEO
THIRD	3RD
TOWER	TWR
TOWNSHIP	TWP
TOWNSHIP (Tier)	T **
TRACT	TR
TRANSCONTINENTAL	TRANSCON
TRANSMISSION	TRANSM
TRANSPORTATION	TRANSP
TRAVERSE	TRAV
TRAVERSE STATION	TS
TRIANGLE	TRI
TURNPIKE	TPK
UNITARIAN	UNIT
UNIVERSITY	UNIV
VACUUM	VAC
VERTEX	VTX
VILLAGE	VIL
WATER	WT
WEST	W
WAREHOUSE	WHSE
WINDMILL	WMILL
WITNESS CORNER (WC)	WC
WITNESS POST (WP), wood	WP
WITNESS POST, metal	MWP
WITNESS POST, fiberglass	FWP

**The abbreviations R, T, LT, and RT must be adjacent to at least one numeric character.

FORMATS

Only NGS employees and agents may set brass disks and aluminum flanges precast with NGS logo. Such marks must be stamped with designations supplied by the agency. Each geodetic control point designation should be unique among all the designations located within a defined region.

Format	Page
Geodetic Control Points	D-15
Tide Station Bench marks	D-17
Staffs or ETG RMs at Tide or Water-Level Stations	D-19
Water Level Station Bench Marks	D-21
Airport Runways	D-23
Political Boundaries	D-24
Highways and Roads	D-25
Railroads, Canals and Rivers	D-26
Landmarks	D-27
Township and Range Control Point Information	D-28

Geodetic control points

FORMAT: NAME SPECIAL

1. NAME

- A. The following method is generally used for naming vertical control points (bench marks). The first mark established in a state is designated "A", then "B" and so on through the alphabet, except the letters "I" and "O" which are not used because they are too easily confused with the numbers "1" and "0". The next series of marks is identified as "A 1", "B 1", etc.; then "A 2", "B 2", etc., and so on through the alphabet. In some cases, more than one letter is used to distinguish between bench marks that have accidentally been given the same name in the same state.

- B. The following method is generally used for naming a horizontal control point (triangulation or traverse). The name should serve not only to identify the station but to suggest the local geographic location or feature. The name should be used only once within a county and preferably a given state. Therefore, use sufficient variety to avoid duplication. A short name is desirable, but if a longer name is required to properly serve the purpose, it should be used. In those cases where a well known geographical feature in the vicinity is used, or the name of a local landowner, the name should be spelled correctly.

2. SPECIAL USE

- A. These terms are used with vertical control points to distinguish between names used more than once in a state or to indicate disturbance of the original bench mark (e.g., "RESET").

 - B. These terms are used with horizontal control points to explain a local use or disturbance to the original mark or its designation.
-

Examples:

Geodetic control points

NAME		SPECIAL
Station	Number	Use
A		
L	690	
L	690	RESET
YY	1150	
C	1244	X
LEON		
LEON		ECC
LEON		RESET
LEON	RM 1	
LEON	RM 2	
LEON	AZ MK	
LEON	AZ MK	RESET
LEON	AZ MK	PTA
LEON	AZ MK 2	
LEON 2		
LEON 2	RM 3	
LEON 2	RM 4	
LEON 2	AZ MK	
LEON 2	AZ MK 2	

Tide station bench marks

FORMAT: LOCATION OBJECT SPECIAL

1. LOCATION Code and Station

- A. The location has two parts, the first part, the CODE, is a 3-digit State code given for each geographical region.
- B. The second part of the location, the STATION NUMBER, is an unique 4-digit number assigned to a particular tide station within a given geographical area.

2. OBJECT Identification

- A. The MARK USE gives information on the nature of the object which was used.
- B. The PUBLICATION NAME is used to give the proper identification of the object. In most cases, this field should be based on the stamping. If there is no stamping, use the name given in the tidal publication. In either case, this field is subject to the guidelines given in this Annex.

3. SPECIAL Use

This term is used to explain a local use or disturbance to the original mark.

NOTE: If other types of marks are used in tidal surveys, see other format rules for their primary designations; and add aliases according to the following examples:

Mark type	DS (Triangulation Station Mark)
Stamping	BREACH 1963
Primary designation	BREACH
Alias	866 5552 TIDAL

Mark type	DB (Bench Mark Disk)
Stamping	V 163 RESET 1984
Primary designation	V 163 RESET
Alias	872 9871 TIDAL

Examples

Tide station bench marks set before or about 1976

LOCATION		OBJECT		SPECIAL
Code State	Station No.	Mark use	Identification Publication name	Use
866	1684	TIDAL	HB 1	
857	4680	TIDAL	BASIC	
872	0030	TIDAL	37	RESET
944	0886	TIDAL	USE 5	

Tide station bench marks set after about 1976

LOCATION		OBJECT		SPECIAL
Code State	Station No.	Identification Publication name	Mark use	Use
872	0051	D	TIDAL	
872	9554	C	TIDAL	RESET

Staffs or electric tape gage (ETG) reading marks
at tide or water-level stations

FORMAT: TEMPORAL LOCATION OBJECT SPECIAL

1. TEMPORAL Reference

The Temporal Reference is identified by setting the term "TBM" in front of the location.

2. LOCATION Code and Station

A. The location has two parts, the first, the CODE, is either a 3-digit STATE number code for a State or a 3-digit CUTTER code for defining a part of a lake or channel.

B. The second part of the location, the STATION NUMBER, is an unique 4-digit number assigned to a particular tide or water level station within a given geographical area.

3. OBJECT Identification

The Object Identification gives information on the nature of the object that was used.

4. SPECIAL Use

These terms are used to indicate the graduation of the tide or water level staff on which the level rod was placed.

Examples

Staffs located at tide stations

TEMPORAL	LOCATION		OBJECT	SPECIAL
Reference	Code State	Station No.	Identification	Use
TBM	872	2029	STAFF	6 FT

Electric (or "zero electric") tape gage reading marks at tide stations

TEMPORAL	LOCATION		OBJECT	SPECIAL
Reference	Code State	Station No.	Identification	Use
TBM	872	9678	ETG READ MK	

Staffs located at water level stations

TEMPORAL	LOCATION		OBJECT	SPECIAL
Reference	Code Cutter	Station No.	Identification	Use
TBM	906	3000	STAFF	6 FT

Electric tape gage (ETG) reading marks at water level stations

TEMPORAL	LOCATION		OBJECT	SPECIAL
Reference	Code Cutter	Station No.	Identification	Use
TBM	907	5099	ETG READ MK	

Water level station bench marks

FORMAT: LOCATION OBJECT SPECIAL

1. LOCATION Code and Station

- A. The first part of the location is the 3-digit code for defining a part of a lake or channel within the CUTTER Code System.
- B. The second part of the location, the STATION NUMBER, is a unique 4-digit number assigned to the water level station within a given geographical area.

2. OBJECT Identification

In most cases, this field should be based on the stamping. If there is no stamping, use the name given in the water level publication. In either case, this field is subject to the guidelines given in this annex.

3. SPECIAL Use

These character strings are used to explain some local use or disturbance to the original mark.

NOTE: If other types of marks are used in water level surveys, see other format rules for their primary designation and add an alias according to the following example:

Mark type	F	(flange-encased rod)
Stamping	C 234 1980	(on logo cap)
Primary designation	C 234	
Alias	906 3087	

Examples

Water level station bench marks set before or about 1976

LOCATION		OBJECT	SPECIAL
Code	Station	Identification	Use
Cutter	No		
907	5098	ROAD A	
907	5098	ROAD A	RESET

Water level station bench marks set after about 1976

LOCATION		OBJECT	SPECIAL
Code	Station	Identification	Use
Cutter	No.		
907	5085	F	
907	5085	F	RESET

Airport runways

FORMAT: ALIGNMENT OBJECT LOCATION SPECIAL

1. ALIGNMENT Survey Name

Use the proper NAME of the town, city, or a geographic location within the area for the airport.

2. OBJECT Identification

Enter the type of alignment object, in this case it is the airport RUNWAY.

3. LOCATION Station (Runway Number) and Tangent Offset (TOS)

A. The location has two parts, the first part is called the runway number and should be a 2-digit numerical value. These two digits are taken from the first two digits of the 3-digit runway (measured from north) azimuth, i.e., 01, 13, 22, or 34 which were taken from the azimuths of 010, 130, 220, and 340 respectively.

B. The second part of the location, the tangent offset (TOS), is the location of the control point in question with respect to the center of the alignment, that is, the distance (in meters/feet) either left or right.

4. SPECIAL Use

Terms such as A PT, ECC, HUB, PTA, RESET, and TP A are used to explain a local use or disturbance to the original mark.

Examples

Airport runways

ALIGNMENT	OBJECT	LOCATION		SPECIAL
Survey name	Identification	Station	TOS	Use
KENNEWICK AIRPORT				
KENNEWICK AIRPORT				ECC
KENNEWICK AIRPORT				RESET
KENNEWICK APT AZ MK				
KENNEWICK APT	RUNWAY	00	OFFSET	HUB
KENNEWICK APT	RUNWAY	36	CL	
KENNEWICK APT	RNWX	02	CL	
KENNEWICK APT	RNWX	20	CL	

Political boundaries

FORMAT:	ALIGNMENT	OBJECT	DESIGNATE	POLITICAL	SPECIAL
1.	ALIGNMENT	Survey			
					The term BOUNDARY is used when two or more participants are in common or adjacent to an alignment.
2.	OBJECT	Identification			
					Enter the type of alignment object, such as name, station, miles, mileposts, monuments, reference points, etc.
3.	DESIGNATE	Reference			
					The designate reference is used to identify the unique number, letters, or symbols that describe the control point.
4.	POLITICAL	Participants			
					A. All participants in common or adjacent to the alignment boundary are listed in alphabetical order.
					B. The political participants to be selected and entered first will be by the following order: international, federal, reservations, state, county, municipal, and private.
					C. The selection order will provide the correct entries for the country/state and county fields used within the NGS data base.
5.	SPECIAL	Use			
					Terms such as A PT, ECC, HUB, PTA, RESET, and TP A are used to explain a local use or disturbance to the original mark.

Examples

Political boundaries

ALIGNMENT	OBJECT	DESIGNATE	POLITICAL	SPECIAL
Survey	Identification	Reference	Participants	Use
BOUNDARY	MONUMENT	84 A	MX US	RESET
BOUNDARY	MILEPOST	360	ND SD	
BOUNDARY	TRAVERSE STATION	110 A	CD US	ECC
BOUNDARY	ARC STONE	14	DE PA	RESET
BOUNDARY	CORNER STONE	2	MD PA	
BOUNDARY	TANGENT STONE	1	DE MD	
BOUNDARY	INTERSECT STONE	OFFSET	DE PA	
BOUNDARY	POINT	24	CD US	
BOUNDARY	REFERENCE POINT	22	AZ CA	

Highways and roads

FORMAT: ALIGNMENT OBJECT LOCATION SPECIAL

1. ALIGNMENT Survey Name

- A. Use the term Ixxx for all Interstate highways.
- B. Use the term HIGHWAY for all Federal highways.
- C. Use the term ROUTE for all State highways.
- D. Use the term ROAD for all county roads.
- E. Use the municipality name for all local streets, avenues, boulevards, pikes, roads, etc.

2. OBJECT Identification

- A. Enter the type of alignment object, such as the name and station, miles, mileposts, monuments, reference points, etc.
- B. Or enter the proper name of the alignment, such as the name of the city street.

3. LOCATION Station and Tangent Offset

- A. The location uses two parts, the first part is called the stationing. This part should be, for most cases, a numeric value.
- B. The second part of the location, the tangent offset (TOS), is the location of the point in question with respect to the center of the alignment, that is, the distance (in meters/feet) either left or right.

4. SPECIAL Use

Terms such as A PT, ECC, HUB, PTA, RESET, and TP A are used to explain a local use or disturbance to the original mark.

Examples Highways and roads

ALIGNMENT	OBJECT	LOCATION	SPECIAL
Survey name	Identification	Station	TOS Use
I495	MILEPOST	99.387	ECC
HIGHWAY 50	STATION	1234+00	CL
ROUTE 355	STATION MARK	233+16	50LT
ROUTE 193	REFERENCE POINT	21+00	POC
ROAD 2786	MILEPOST	37.3	RESET
ROCKVILLE	MAPLE AVE STA	1+32	39RT
ROCKVILLE	MAPLE AVE STA	2+50	POT
PASCO	MAIN STREET	PI 9	

Railroads, canals and rivers

FORMAT: ALIGNMENT OBJECT LOCATION SPECIAL

1. ALIGNMENT Survey

- A. The terms RAILROAD or RAILWAY for alignments which follow these right-of-ways.
- B. Use the characters CANAL or REACH for those man made waterways.
- C. Use the characters RIVER for all natural waterways.

2. OBJECT Identification

Enter the type of alignment object, such as name, station, miles, mileposts, monuments, reference points, etc.

3. LOCATION Station and Tangent Offset

- A. The location uses two parts, the first part is called the stationing. This part should be, for most cases, a numeric value.
- B. The second part of the location, the tangent offset (TOS), is the location of the point in question with respect to the center of the alignment, that is, the distance (in meters/feet) either left or right.

4. SPECIAL Use

Terms such as A PT, ECC, HUB, PTA, RESET, and TP A are used to explain a local use or disturbance to the original mark.

Examples

Railroads, canals and rivers

ALIGNMENT	OBJECT	LOCATION	SPECIAL
Survey	Identification	Station	TOS Use
RAILROAD	MILEPOST	347.8	CL RESET
RAILWAY	MILEPOST	216.455	OFFSET
REACH	1	22+00	400LT ECC
REACH	1	PI 2	
REACH	3	295+00	400LT
RIVER	SNAKE MILEPOST	37.3	

Landmarks

FORMAT: LOCATION OWNERSHIP OBJECT SPECIAL

1. LOCATION

- A. The general area in which the landmark is located should be used, such as the nearest city, town, or local geographic area.
- B. However, some landmarks by the nature of their name alone will be enough to give a general location, e.g. STATUE OF LIBERTY (New York), SEARS TOWER (Chicago), and SEATTLE SPACE NEEDLE (Seattle).

2. OWNERSHIP

- A. The ownership should be the proper name of the existing owner at the time the landmark was positioned. Later recovery information will reflect the changes of ownership.
- B. If the ownership is a political group, such as a state or county, do not include the name of the state or county.

3. OBJECT Identification

For a landmark, enter a general name in order to identify it.

4. SPECIAL Target

The special target is used to uniquely identify the exact object sighted as the landmark.

Examples
Landmarks

LOCATION	OWNERSHIP	OBJECT	SPECIAL
		Identification	Target
ASHLAND	MUNICIPAL	AIRPORT	BEACON
BETHESDA	GREEK ORTHODOX	CHURCH	CROSS
CARSON CITY	STATE POLICE	RADIO STATION	MAST
FRANKLIN	COUNTY	HOSPITAL	FLAGPOLE
KEY WEST	FORT MONROE	BATTERY	RED LIGHT
LAS VEGAS		TV STATION KLAS	MAST
LOVELOCK		RADIO STATION KOB 893	MAST
NEW YORK	PORT AUTHORITY	BUILDING	FLAGPOLE
PASCO	COUNTY	COURTHOUSE	DOME
POTOMAC	ST MARKS CATHOLIC	CHURCH	SPIRE
ROCKVILLE	HUGHES AIRCRAFT	BUILDING	APEX
ROCKVILLE	MUNICIPAL	GAS TANK	FINIAL
ROCKVILLE	MUNICIPAL	WATER TANK	BALL
ROCKVILLE	MUNICIPAL	STANDPIPE	FINIAL
SALEM	1ST METHODIST	CHURCH	WEST SPIRE
SALEM	STATE	HOSPITAL CLOCK	APEX
WINNEMUCCA		RADIO STATION KWNA	MAST

T15N R22E	31	32	T15N R23E				36	T15N R24E
36			33	34	35		3	
1	6	5	4	3	2	1	6	
12	7	8	9	10	11	12	7	
13	18	17	16	15	14	13	18	
T14N R22E			T14N R23E					T14N R24E
24	19	20	21	22	23	24	19	
25	30	29	28	27	26	25	30	
36	31	32	33	34	35	36	31	
1	6	5	4	3	2	1	6	
T13N R22E			T13N R23E					T13N R24E

Figure D.2 - T14N R23E SECS (1 - 36) as shown in Figure D.1.

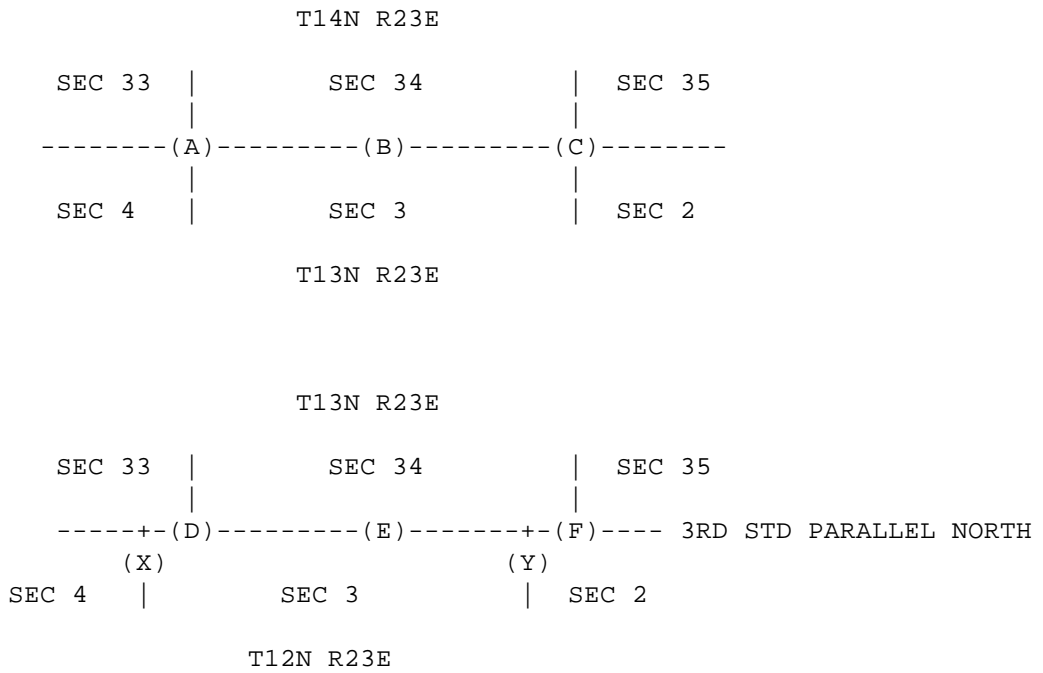

Figure D.3 - Designations for East/West Boundary Corners.

Examples

	TOWNSHIP	RANGE	SECTION	LOCATION
A	T13 14N	R23E	SECS 3 4 33 34	
B	T13 14N	R23E	SECS 3 34	1/4 COR
C	T13 14N	R23E	SECS 2 3 34 35	
D	T13N	R23E	SECS 33 34	SC
or D	T13N	R23E	SEC 33	SE COR
E	T13N	R23E	SEC 34	1/4 COR
F	T13N	R23E	SECS 34 35	SC
or F	T13N	R23E	SEC 34	SE COR
X	T12N	R23E	SECS 3 4	CC
Y	T12N	R23E	SECS 2 3	CC

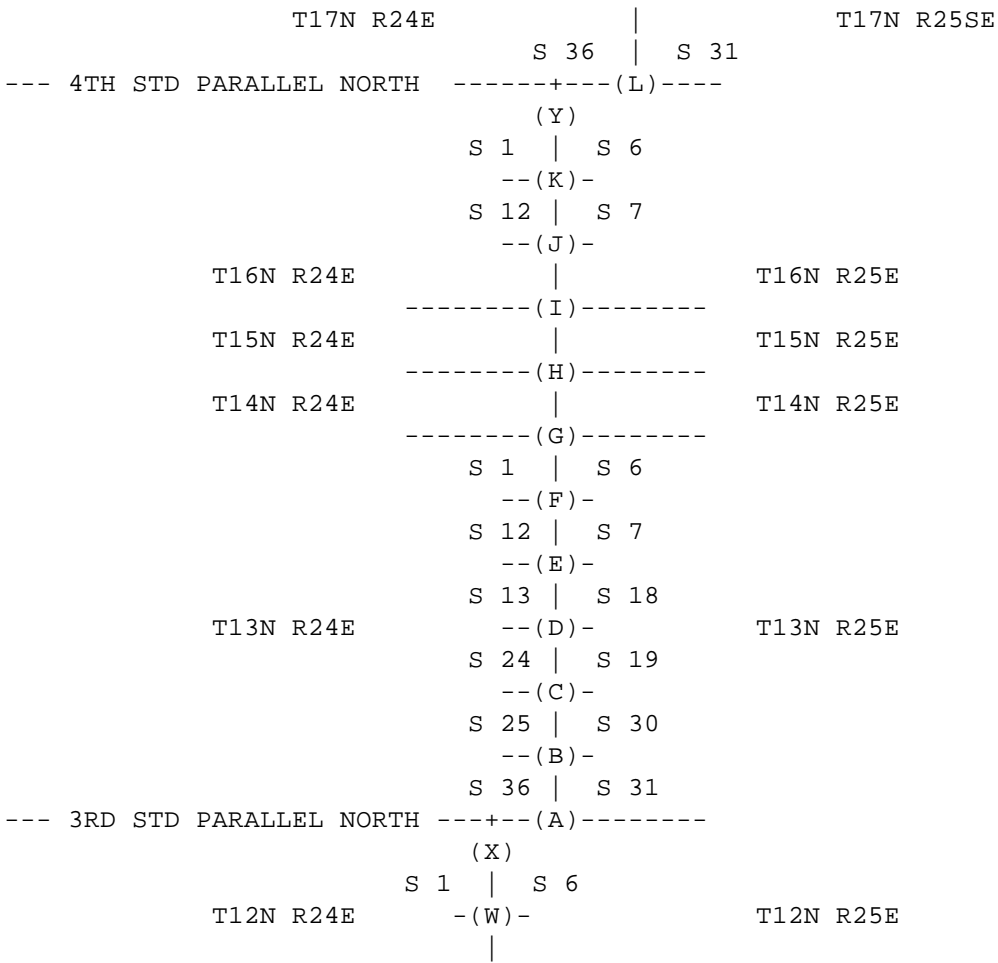

Figure D-4 - Designations for North/South Boundary Corners.

Examples

	TOWNSHIP	RANGE	SECTION	LOCATION
W	T12N	R24 25E	SECS 1 6 7 12	
X	T12N	R24 25E	SECS 1 6	CC
A	T13N	R24 25E	SECS 31 36	SC
B	T13N	R24 25E	SECS 25 30 31 36	
C	T13N	R24 25E	SECS 19 24 25 30	
D	T13N	R24 25E	SECS 13 18 19 24	
E	T13N	R24 25E	SECS 7 12 13 18	
F	T13N	R24 25E	SECS 1 6 7 12	
G	T13 14N	R24 25E	SECS 1 6 31 36	
H	T14 15N	R24 25E	SECS 1 6 31 36	
I	T15 16N	R24 25E	SECS 1 6 31 36	
J	T16N	R24 25E	SECS 7 12 13 18	
K	T16N	R24 25E	SECS 1 6 7 12	
Y	T16N	R24 25E	SECS 1 6	CC
L	T17N	R24 25E	SECS 31 36	SC